



City and Borough of Wrangell
2020-4-14 Borough Assembly Meeting & Public Hearing
AGENDA

Tuesday, April 14, 2020
6:00 PM

Location: Borough Assembly Chambers
City Hall

Resolution No. 03-20-1520 allows for the temporary suspension of in-person Assembly Meetings and allows for teleconference meetings, due to COVID-19, until further notice.

Teleconference Information for anyone wishing to call into the meeting and speak under

Persons to be Heard

If you wish to call into the meeting to speak under Persons to be Heard, please contact the Borough Clerk at 907-874-2381 or email: clerk@wrangell.com no later than Tuesday, April 14th at 5:00 p.m. so that you can be added to the Sign-Up sheet.

You will be called in the order that your request is received.

Please note that KSTK is still broadcasting the Borough Assembly meetings. Therefore, if you wish only to listen in, you may do so by tuning into KTSK!

Here is the Call-in information for Persons to be Heard:

To Join by Computer:

<https://zoom.us/j/9078742381?pwd=MTNqSEdncjRyakh2UCtMVUNxMndYUT09>

And Enter the Meeting ID: 907 874 2381

Then Enter Password: 99929

OR

To use your phone, call one of the following numbers:

+1 669 900 9128 US

+1 346 248 7799 US

+1 301 715 8592 US

+1 312 626 6799 US

+1 646 558 8656 US

+1 253 215 8782 US

And enter the Meeting ID: 907 874 2381

Then enter the Password: 99929

1. CALL TO ORDER

a. PLEDGE OF ALLEGIANCE led by Assembly Member Mya DeLong

b. CEREMONIAL MATTERS

2. ROLL CALL

3. PERSONS TO BE HEARD

- [a.](#) Temporary Telephonic Process for Persons to be Heard

4. AMENDMENTS TO THE AGENDA

5. CONFLICT OF INTEREST

6. CONSENT AGENDA

- [a.](#) MOTION ONLY - Consent Agenda
- [b.](#) Minutes from the March 22, 2020 Special Emergency Assembly Meeting
- [c.](#) Minutes from the March 24, 2020 Regular Assembly Meeting
- [d.](#) Minutes from the April 6th and 8th, 2020 Special Emergency Assembly Meeting
- [e.](#) Liquor License Renewal - Totem Bar & Liquor Store
- [f.](#) POA-2020-00111 Permit Application SEARCH for Employee Housing

7. BOROUGH MANAGER'S REPORT

- a. COVID-19 Emergency Report
- [b.](#) Nolan Center Winter 2020 Newsletter

8. BOROUGH CLERK'S FILE

- [a.](#) Borough Clerk's Report

9. MAYOR AND ASSEMBLY BUSINESS

10. MAYOR AND ASSEMBLY APPOINTMENTS

11. PUBLIC HEARING

- [a.](#) Modification to a Contract Zone Agreement allowing a Third Storage Unit Building on Lot C, Torgramsen-Glasner Subdivision, Plat No. 2016-2, Zoned Light Industrial per the original Contract Zone Agreement, Requested by Owner Don Glasner

12. UNFINISHED BUSINESS

13. NEW BUSINESS

- [a.](#) Approval of a Contract Award to Heller High Water, LLC. in the Amount of \$67,000 for the City Dock Summer Float Procurement Project Rebid

14. ATTORNEY'S FILE – Available for Assembly review in the Borough Clerk's office

15. EXECUTIVE SESSION

16. ADJOURNMENT

National Library Week
April 19-25, 2020
Proclamation

WHEREAS, our nation's school, academic, public and special libraries make a difference in the lives of millions of Americans; and

WHEREAS, libraries are places of opportunity providing programs that teach all forms of literacy, promoting continuing education and encouraging lifelong learning; and

WHEREAS, in times of economic hardship, Americans turn to – and depend on – their libraries and librarians; and

WHEREAS, librarians are trained, tech-savvy professionals, providing technology training and access to downloadable content like eBooks; and

WHEREAS, libraries play a vital role in supporting the quality of life in their communities; and

WHEREAS, libraries continuously grow and evolve in how they provide for the needs of every member of their communities; and

WHEREAS, libraries help people of all ages discover a world of knowledge, both in person and online, as well as provide personal service and assistance in finding needed information; and

WHEREAS, libraries are narrowing the “digit divide”, by providing no-fee public computer and internet access to accommodate the growing need for access to digital and online information; and

WHEREAS, libraries, librarians, library workers, and supporters across America are celebrating National Library Week.

NOW, THEREFORE, be it resolved that I, Stephen Prysunka, Mayor of the City & Borough of Wrangell, Alaska, do hereby proclaim April 19-25, 2020:

National Library Week

and I encourage all residents to visit the library this week and take advantage of the wonderful library resources available at your library. Lives change at your library!

 Stephen Prysunka, Mayor

Attest: _____
 Kim Lane, MMC, Borough Clerk

PUBLIC NOTICE

TEMPORARY TELEPHONIC PROCESS FOR PERSONS TO BE HEARD FOR WRANGELL BOROUGH ASSEMBLY MEETINGS

The Wrangell Borough Assembly will hold their Regular Meeting on **Tuesday, April 14, 2020** via teleconference. The following alternate methods for Persons to be Heard have been created:

How To Submit Your Name for Persons To Be Heard:

- Email your written comments to clerk@wrangell.com no later than **5:00 p.m. Tuesday, April 14, 2020** to be read aloud by the Borough Clerk; or
- If you wish to call into the meeting to speak under Persons to be Heard, please call the Borough Clerk at (907) 874-2381, or send your contact information to clerk@wrangell.com, including your full name and the subject you wish to comment on and she will provide you with the call-in information.

Calls or emails for Persons to be Heard must be received by the Borough Clerk, no later than 5:00 p.m. on Tuesday, April 14, 2020.

Comments will be read, and persons will be called upon in the order they were received by the Borough Clerk. All comments may be limited to three minutes.

If you wish to listen to the Regular Assembly meeting, please tune into KSTK Stikine River Radio as they will be broadcasting the meeting, as usual.

Thank You For Your Cooperation!

The critical need to follow healthcare guidelines cannot be emphasized enough right now. We must do everything we can to protect the health and safety of our community. Receiving input from citizens is very important to everyone in the Borough and we appreciate everyone's cooperation in respecting our request to attend the meeting virtually.

CITY & BOROUGH OF WRANGELL, ALASKA

Consent Agenda MOTION

Move to approve the Consent Agenda as submitted.

SUBMITTED BY:

Kim Lane, Borough Clerk

INFORMATION:

Consent agenda. Items listed on the consent agenda or marked with an asterisk () are considered routine and will be passed in one motion; provided, upon the request of any member, the manager, or the clerk, an item on the consent agenda shall be removed from the consent agenda and placed under New Business for assembly action.*

**Minutes of Special Emergency Assembly Meeting
Held on March 22, 2020**

Mayor Stephen Prysunka called the Special Emergency Assembly meeting to order at 3:00 p.m., March 22, 2020, in the Borough Assembly Chambers.

PRESENT (*by teleconference*): PRYSUNKA, GILBERT, LARRABEE, DELONG (joined at 3:30 p.m.), POWELL, DECKER, MORRISON

ABSENT:

Borough Manager Von Bargen, Borough Clerk Lane, and Dr. Lynn Prysunka were also in attendance.

CONFLICT OF INTEREST – None.

PERSONS TO BE HEARD

Rocky Constantino, Sea Level Seafoods, commented that they would be following the set guidelines that the City sets up.

Diana Nore, resident, stated that she believed that we could be more stringent in socially isolating; concerned about grocery store social distancing.

John Taylor, resident, questioned if the City goes into total shutdown, could he still go to his shop.

Joan Sargent, resident, encouraged anyone who has friends or neighbors coming in, to do their 14-day quarantine; questioned if the City could mandate people to quarantine for 14 days.

Angela Allen, resident, stated that for the community to issue a Shelter in Place order was premature and that people should take responsibility for their own actions that they make when traveling; not being able to do anything recreational seems like it’s a little too much at this point.

ITEM(s) OF BUSINESS

13a Consideration of Factors (Shelter in Place Emergency Order)

Von Bargen gave an administrative explanation of what this Order means; Capacity of our hospital could be very quickly overwhelmed; imperative that we try and get in front of this; several other Alaska Communities are issuing similar orders.

Von Bargen went through each of the twelve steps that were outlined in the proposed order.

Prysunka stated that this order at this point, does not restrict people in the community from getting outside and recreating; this keeps stores and hardware stores open as well.

Prysunka asked if we could get rid of the wording “as much as possible”; the Assembly had not objections to removing this language.

At the request of EMS Captain Dorianne Sprehe, the Clinic's phone number be added to number 11.

Prysunka stated that the City is asking Sealevel, the Crossings Program and the Forest Service to curtail all of their staffing increases and/or bringing clients to the island, until May 1, 2020 with a review on April 15, 2020; doing out best to make sure that we can take care of our citizens that are here now.

Decker asked that number 2 in the Order, that we add other things that the Governor had determined to be critical Workforce Infrastructure in his order issued on March 12, 2020 (attachment A), such as fishing and fish processing being one of those critical items since those are part of the food supply industry.

Von Bargaen said that she would review and add that to the order.

Decker asked if number 9 could be amended to clarify distancing requirements. Von Bargaen stated that she would make the amendment.

Dr. Prysunka stated that there were currently no confirmed cases of COVID-19 in Wrangell; screening is occurring at all SEARHC facilities to reduce risk; taking steps to protect the vulnerable by looking into video calling as a visiting option, possibly doing house calls when necessary, and postponing routine visits. At this time, State is not recommending that if you are a close contact of a person who is being investigated for the virus, that you be taken out of the workforce; would devastate our workforce; able to recommend this since there is increased testing.

Gilbert suggested that for number 13, that wording be added that citizens either call or email the elderly, or their neighbors, to check on their health, concerns, or their needs; some of our community members live by themselves or are elderly and may need assistance.

Tom Rolland, resident and business owner stated that they were planning on going to the online only ordering system and encouraged other grocery stores to do this also.

In response to Decker on the effective date and distribution of this order, Von Bargaen stated that the effective date would be today, March 22, 2020 at 6:00 p.m. and we would send this to the media and post. Decker asked if we also get it to the stores around town as well.

M/S: Decker/Morrison to approve Emergency Order 03-22-20.

Larrabee asked how this order would be enforced.

Prysunka stated we could not create a law and put people in jail for not following the order; Police could issue a warning; this is a strong recommendation and not a mandate; not following this order is putting the community at risk.

Motion approved unanimously by polled vote.

Prysunka stated that it is incredibly important for the community to know that we are reacting as quickly as we can; please be patient and kind and realize that the City, SEARHC and our Fire Department are doing everything possible to get through this as a community.

Special Emergency Assembly meeting adjourned at 3:47 p.m.

-

Stephen Prysunka, Mayor

ATTEST: _____
Kim Lane, MMC, Borough Clerk

**Minutes of Regular Assembly Meeting
Held on March 24, 2020**

Mayor Prysunka called the telephonically held Regular Assembly meeting to order at 6:12 p.m., March 24, 2020. The pledge was led by Assembly Member Gilbert and the roll was called.

PRESENT BY TELECONFERENCE: POWELL, DECKER, GILBERT, LARRABEE, DELONG, PRYSUNKA, MORRISON

ABSENT:

Borough Manager Von Bargen and Borough Clerk Lane were also in attendance via telephone.

CEREMONIAL MATTERS

The Wrangell Public School District’s FY2021 Annual Budget was presented.

PERSONS TO BE HEARD

AMENDMENTS TO THE AGENDA

M/S: Gilbert/Powell to remove Agenda Item 15a (Executive Session) from the Agenda. Motion approved unanimously by polled vote.

CONFLICT OF INTEREST- None.

CONSENT AGENDA

- a. Minutes from the March 10, 2020 Regular Assembly Meeting
- b. Minutes from the March 17, 2020 Special Emergency Meeting

M/S: Decker/Gilbert to approve the Consent Agenda, as presented. Motion approved unanimously by polled vote.

Mayor Prysunka asked the following community leaders to provide a report:

Leatha Mercurieff, Wrangell Medical Center CEO reported on several items including: planning for alternate care sites; long-term care patients relocation, if needed; Wrangell Medical Center and the Long-term care units are on complete lock-down at the moment; asking the community to go directly through the Emergency Room so that you can be pre-screened; all elective procedures have been canceled; Health Fair has been canceled; Appreciates the donation of PPE equipment from community members/businesses; about 100 tests have been performed throughout SEARHC, as a whole; cannot specifically give out the total numbers in Wrangell, due to patient and provider protection; no positive cases currently in Wrangell; supplies here in Wrangell at this time, are adequate; drive-up COVID-19 trailer is up and running; asking residents to call the clinic first and not to simply drive-up to the trailer to be tested; trying to put out weekly press releases (typically Thursday or Friday morning).

Dorianne Sprehe, EMS Captain reported on Command Center Operations with EMS and Fire Response; main goal for the Fire Department is making sure that the Fire and EMS are trained and up to date on all of the new and ever changing protocols; safe and ensuring minimal exposure; utilizing telephonic measures; keeping on top of EOC; NIXLE working very well; reminded the public of the State Mandate with anyone coming from out of state, that they are required to quarantine for 14 days; thanked the grocery stores for creating time for the elders to shop.

Tom Radke, Wrangell Police Chief reported on mandatory travel; taking on educational role at the airport; some people not understanding the rules; reaching out to some people; encouraging people to stay home as much as possible; reported on the mandated order from the Governor.

BOROUGH MANAGER'S REPORT

Von Bargaen provided updates on the following:

- Working tirelessly to keep our Community safe
- SEAPA Annual Spring maintenance has been postponed to the Fall due to the COVID-19
- Working on issues dealing with access to the community
- Finance Director working to get the Budget numbers gathered
- Looking at postponing the Board of Equalization process
- Working on temporary alternate staffing schedules

Decker requested if we could investigate having the local surveyor who works for R&M do the survey for the Institute Property. Von Bargaen stated that yes, she could investigate that.

BOROUGH CLERK'S FILE

No report.

MAYOR AND ASSEMBLY BUSINESS

DeLong stated that this was a good time for people to look at our Website at the businesses; thanked Carol for keeping this up.

Morrison suggested that we keep an eye on what's coming out of Washington; might have funding opportunities.

Gilbert reported that the IFA was deemed a critical infrastructure by the Governor and if needed, will run to provide supply services and possibly other emergency service operations.

Decker reported that she spearheaded an initial conversation between Southeast Conference, Southwest Municipal Southwest Association, and Pacific Seafoods Association regarding fish processing and what maybe can happen, working through these difficult times; a lot of upcoming meetings and discussions are forthcoming.

Prysunka spoke about the limitations with our hospital; will be having a joint meeting with Sealevel Seafoods, Alaska Crossings Program, and the Forest Service on April 15, 2020 to discuss how the community and more importantly, the hospital with its limited capacity, would be

impacted with bringing additional people to town to work; will make sure to report to the Assembly.

Prysunka and Von Barga spoke extensively on the current situation of COVID-19; trying to come up with some state-level strategies; attending numerous teleconferences a day; been in contact with some legislators about concerns that might be coming our way; have to have plans in play, just in case; appreciative to the Governor for giving “teeth” to incoming travelers with regard to traveler requirements.

MAYOR AND ASSEMBLY APPOINTMENTS – None.

PUBLIC HEARING – None.

UNFINISHED BUSINESS – None.

NEW BUSINESS

13a RESOLUTION No 03-20-1520 1523 OF THE ASSEMBLY OF THE CITY AND BOROUGH OF WRANGELL ALASKA ESTABLISHING ALTERNATIVE 1: SPILLWAY TRENCH AND SIPHON AS THE PREFERRED ALTERNATIVE FOR THE RESERVOIR BYPASS PROJECT

M/S: Gilbert/DeLong to approve Resolution No. 03-20-1523.

Amber Al-Haddad provided the background and explanation of the project.

In response to Powell on if we would be abandoning the bypass line altogether, Al-Haddad state that no, we would be connecting to that line: trenching a line through the spillway and that line would meet up with that existing line that was put in place in the early 2000’s.

Motion approved unanimously by polled vote.

13b RESOLUTION No 03-20-1521 OF THE ASSEMBLY OF THE CITY AND BOROUGH OF WRANGELL, ALASKA ADOPTING THE WRANGELL MULTI-JURISDICTIONAL HAZARD MITIGATION PLAN

M/S: Gilbert/Morrison to approve Resolution No. 03-20-1521.

Von Barga explained that if there are amendment required for this plan, Staff would be bringing those back to the Assembly for approval.

Motion approved unanimously by polled vote.

13c RESOLUTION No 03-20-1522 OF THE ASSEMBLY OF THE CITY AND BOROUGH OF WRANGELL, ALASKA AMENDING THE JOB DESCRIPTION OF THE ASSISTANT DIESEL MECHANIC TO INCLUDE METER READING RESPONSIBILITIES

M/S: DeLong/Morrison to approve Resolution No. 03-20-1522. Motion approved unanimously by polled vote.

13d Approval to Purchase Quantifit Respirator Fit Testing System in the Amount of \$8,373.10

M/S: Morrison/DeLong to approve the purchase of Quantifit Respirator Fit Testing System in the amount of \$8,873.10. Motion approved unanimously by polled vote.

ATTORNEY'S FILE

14 Available for Assembly review in the Borough Clerk's office.

EXECUTIVE SESSION

15a Executive Session: Collective Bargaining Strategy (*removed from the Agenda under Amendments to the Agenda*)

Regular Assembly meeting adjourned at 7:26 p.m.

Stephen Prysunka, Mayor

ATTEST: _____
Kim Lane, MMC, Borough Clerk

**Minutes of Special Emergency Assembly Meeting
Held on April 6, 2020**

Mayor Stephen Prysunka called the Special Emergency Assembly meeting to order at 5:30 p.m., April 6, 2020, in the Borough Assembly Chambers.

PRESENT (*by teleconference*): PRYSUNKA, GILBERT, LARRABEE, DELONG, POWELL, DECKER, MORRISON

ABSENT:

Borough Manager Von Bargaen and Borough Clerk Lane were also in attendance.

CONFLICT OF INTEREST

Prysunka declared a potential Conflict of Interest due to his son owning a Fishing Vessel and he and his wife being shareholders in that business; this action might affect his business. Vice-Mayor Gilbert stated that she did not see a Conflict of Interest; there were no objections from the Assembly.

Decker declared a potential Conflict of Interest due to her family owning a fishing boat operation; Mayor Prysunka declared that she did not see a Conflict of Interest; there were no objections from the Assembly.

DeLong declared a potential Conflict of Interest due to her family having income from the fishing industry; Mayor Prysunka declared that she did not see a Conflict of Interest; there were no objections from the Assembly.

ITEM(s) OF BUSINESS

6a EMERGENCY ORDINANCE No. 977 OF THE ASSEMBLY OF THE CITY AND BOROUGH OF WRANGELL, ALASKA INSTITUTING THREE LOCAL HEALTH MANDATES RELATED TO THE COVID-19 PANDEMIC EMERGENCY: 1) 14-DAY SELF QUARANTINE REQUIRED FOR INTRASTATE TRAVELERS; 2) MODIFIED QUARANTINE IS PERMITTED FOR CRITICAL WORKFORCE INFRASTRUCTURE; AND 3) REQUIREMENT THAT TRAVEL SAFETY AND MODIFIED QUARANTINE PLANS FOR CRITICAL WORKFORCE INFRASTRUCTURE BE SUBMITTED TO THE CITY AND BOROUGH OF WRANGELL FOR APPROVAL, PRIOR TO TRAVEL

Von Bargaen gave an administrative explanation of what this Mandate would mean

M/S: Gilbert/Powell to approve Emergency Ordinance No. 977.

Von Bargaen provided an administrative report on the proposed Ordinance. Von Bargaen stated that the purpose of this Ordinance was to put some safety measures in place that would protect Wrangell while still allowing for commerce in the community.

There were extensive questions from the Assembly which were answered by Von Bargaen.

Von Bargaen stated that she had received email notification today from SEARHC, that Dr. Bruhl had emailed them to say that SEARHC has one Hub Hospital, which is in Sitka (Mount Edgecumbe Medical Center).

Decker thanked Von Bargaen for the information on the HUB Hospital determination but would still like confirmation from the State on if Wrangell Medical Center was considered a HUB Hospital or not.

In response to Decker on who would be receiving the plans and what criteria would be followed, Von Bargaen stated that our Parks & Recreation Director as well as Dorianne Sprehe, Police Chief Radke and Harbormaster Meissner would be the initial reviewers.

Von Bargaen further stated that we are not looking for anything more complex than what the State is asking for; looking to review and ask the submitter to make modifications, if needed; not looking to create hurdles or roadblocks, just making sure that folks are following guidelines.

M/S: Gilbert/Morrison to amend the ordinance to add the words “or travelers” in Section 7 and after “... Plan are requested by Borough”.

After extensive discussion and clarification by Von Bargaen, Gilbert withdrew her amendment to the motion. There were no objections from the Assembly on the withdrawal of the amendment.

M/S: Gilbert/Morrison to amend the Ordinance to approve Manager Von Bargaen inserting a sentence in Section 7 that addresses the traveler submitting a modified travel plan or amendment, to be reviewed within 24 hours by the Borough. Amendment to the motion was approved with Gilbert, Larrabee, Morrison, Decker, Powell and Prysunka voting yes; DeLong was not on the line to vote on the amendment.

Hearing no objections from the Assembly, Von Bargaen stated that she would additionally add language to Section 8 to allow for Emergency travel situations that need immediate review and approval that would take place immediately and not fall under the 48-hour window. There were no objections to having Manager Von Bargaen add the emergency language.

After more extensive information was given and questions answered, the following Persons to be Heard were invited to speak.

PERSONS TO BE HEARD

Brennon Eagle, Fisherman stated that he didn't believe this was something that the Assembly should be trying to demonstrate expertise on; believed that the language in the Ordinance had medical expertise requirements and wasn't comfortable that the Assembly had that expertise. Mr. Eagle stated that in the Ordinance, there were several things that were lacking; among those were the definition of travel relating to what is defined as travel and the sunset date being 6 months in the future seemed too long and should be maybe two or three months.

Chris Guggenbickler, Resident and Fisherman stated that the fishing industry was working on a comprehensive plan; no way intending to increase the liability to the community; stated that he was working on a plan now that would be submitted to the State and the City and would hopefully go through the summer.

Von Bargaen stated that with regard to the Sunset Date, it's the same Sunset Date that was used in the Shelter in Place Order; allows for the mandate to be shorter if this is no longer considered a federal or local emergency; Borough would be flexible and work with people on plans to the maximum ability possible; trusting people to do the right thing; asking that people will not "raft up" with other vessels.

Decker commented on what Cordova is requiring; not sure if Cordova was actually reviewing plans, and requesting changes be made.

M/S: Decker/Gilbert amended the Ordinance to have the effective date section read: this ordinance shall be effective on Wednesday, April 8, 2020 at 5:00 p.m.

Decker stated that this would allow for the answer from the State to come in on if Wrangell qualified as a "Small Community"; also there is a meeting tomorrow with Fishing Community Stakeholders, Manager, Mayor and Decker to talk through some details on how to implement this.

Amendment to change the effective date on the Ordinance was approved unanimously by polled vote.

M/S: Powell/Morrison to recess meeting and reconvene on Wednesday, April 8, 2020 at 5:30 p.m. Motion approved unanimously by polled vote.

Special Emergency Assembly meeting **recessed** at 6:59 p.m.

Mayor Stephen Prysunka **reconvened** the Special Emergency Assembly meeting at **5:30 p.m., April 6, 2020**, in the Borough Assembly Chambers.

PRESENT (*by teleconference*): PRYSUNKA, GILBERT, LARRABEE, DELONG, POWELL, DECKER, MORRISON

ABSENT:

Borough Manager Von Bargaen and Borough Clerk Lane were also in attendance.

Prysunka read the motion on the floor: to approve Emergency Ordinance No. 977, amended to approve Manager Von Bargaen inserting a sentence in Section 7 that addresses the traveler submitting a modified travel plan or amendment, to be reviewed within 24 hours by the Borough and to have the effective date read: this Ordinance shall be effective on Wednesday, April 8, 2020 at 5:00 p.m.

Von Barga reported that she had received email confirmation Alaska State Hospital and Nursing Home Association, and they stated that Wrangell does meet the criteria for what the State defines as a Hub Hospital; with this information, Wrangell no longer qualifies as a "Small Community", to enact more stringent travel restrictions for Wrangell; have no choice but to appeal to the Governor to ask that they allow Wrangell to adopt travel restrictions that are more stringent than what the State has in place; Cordova has put measures in place so that their fishing fleet submits a travel plan to the City for approval.

Prysunka stated that since this was an Emergency Meeting to adopt an Emergency Ordinance, he was not comfortable with moving forward with the Ordinance; asked Clerk Lane for guidance on how to move forward.

Lane stated that since we advertised for the Emergency Ordinance and not for a discussion on possibly going to the Governor to ask for more stringent measures, may be others community members who might want to comment on that discussion.

Prysunka stated that he was concerned with transparency and complying with the open meetings act.

Decker stated that she wanted to still have discussion on the motion because they it was important in moving forward; new information has come forward with meetings that were held today from the by the State.

Prysunka asked that the Assembly have a procedural vote on if to move forward on the discussion or not; since this was an Emergency Meeting to take action, not comfortable in moving forward to have a discussion.

Lane stated that she believed that the cleanest way to handle this was for the maker of the motion (Gilbert) to request that her motion be withdrawn; could call a Work Session for tomorrow evening, if need be, to discuss the options with the Assembly and Manager Von Barga.

Powell stated that he wanted to know why we couldn't take action; not understanding why we are not moving forward with this action just because someone from the State said that our hospital was considered a Hub Hospital; still feels that this is critical to the safety of our community.

Prysunka stated that we had been told by SEARHC that our medical center was not a Hub Hospital; we are being told now that it is considered a Hub Hospital; so the communities ability to take more restrictive action is based on that criteria; we do not meet that criteria now and if we still take that more restrictive action, we open ourselves to legal action; would like to proceed in a more deliberative manner.

Gilbert stated that she did agree with Powell however if it was the Assembly's wished, she would withdraw her motion.

Procedural Vote to withdraw the motion and move forward with Manager Von Barga leading a Work Session tomorrow evening: Decker, Larrabee, Gilbert, Morrison and Prysunka voted yes to Withdraw; DeLong and Powell voted no to Continue.

With the Procedural Vote, Gilbert withdrew her motion.

Special Emergency Assembly Meeting adjourned at 6:00 p.m.

-

Stephen Prysunka, Mayor

ATTEST: _____
Kim Lane, MMC, Borough Clerk



THE STATE
of **ALASKA**
GOVERNOR MIKE DUNLEAVY

Department of Com Item e.
**Community,
and Economic Development**
ALCOHOL & MARIJUANA CONTROL OFFICE
550 West 7th Avenue, Suite 1600
Anchorage, AK 99501
Main: 907.269.0350

March 13, 2020

Wrangell, City and Borough
Via Email: clerk@wrangell.com

Notice of 2020/2021 Liquor License Renewal Application

License #	DBA	License Type
1159	Totem Bar & Liquor Store	Beverage Dispensary
1160	Totem Bar & Liquor Store	Package Store

We have received completed renewal applications for the above listed licenses (see attached application documents) within your jurisdiction. This is the notice required under AS 04.11.480.

A local governing body may protest the approval of an application(s) pursuant to AS 04.11.480 by furnishing the director **and** the applicant with a clear and concise written statement of reasons for the protest within 60 days of receipt of this notice, and by allowing the applicant a reasonable opportunity to defend the application before a meeting of the local governing body, as required by 3 AAC 304.145(d). If a protest is filed, the board will deny the application unless the board finds that the protest is arbitrary, capricious, and unreasonable.

To protest the application referenced above, please submit your written protest within 60 days, and show proof of service upon the applicant and proof that the applicant has had a reasonable opportunity to defend the application before a meeting of the local governing body.

Sincerely,

Glen Klinkhart, Director
amco.localgovernmentonly@alaska.gov



Item e.

Alaska Alcoholic Beverage Control Board
 Package Store License

Form AB-17b: 2020/2021 Renewal License Application

What is this form?

This renewal license application form is required for all individuals or entities seeking to apply for renewal of an existing package store liquor license that is due to renew by December 31, 2019. All fields of this form must be complete and correct, or the application will be returned to you in the manner in which it was received, per AS 04.11.270 and 3 AAC 304.105. The Community Council field only should be verified/completed by licensees whose establishments are located within the Municipality of Anchorage or outside of city limits within the Matanuska-Susitna Borough.

This form must be completed and submitted to AMCO's main office before any license renewal application will be reviewed. Receipt and/or processing of renewal payments by AMCO staff neither indicates nor guarantees that an application will be considered complete, or that a license will be renewed.

Section 1 – Establishment and Contact Information

Enter information for the business seeking to have its license renewed. If any populated information is incorrect, please contact AMCO.

Licensee:	Totem Bar & Liquor Store, LLC	License #:	1160
License Type:	Package Store		
Doing Business As:	Totem Bar & Liquor Store		
Premises Address:	116 Front Street		
Local Governing Body:	City & Borough of Wrangell		
Community Council:	None		

Mailing Address:	PO Box 499				
City:	WRANGELL	State:	AK	ZIP:	99929

Enter information for the individual who will be designated as the primary point of contact regarding this application. This individual **must be a licensee** who is required to be listed in and authorized to sign this application.

Contact Licensee:	AARON E Powell	Contact Phone:	907-305-0113
Contact Email:	AP_800@YAHOO.COM OR TotemBar2018@OUTLOOK.COM		

Optional: If you wish for AMCO staff to communicate with an individual who is not a licensee named on this form (eg: legal counsel) about this application and other matters pertaining to the license, please provide that person's contact information in the fields below.

Name of Contact:		Contact Phone:	
Contact Email:			



Alaska Alcoholic Beverage Control Board
Form AB-17b: 2020/2021 Package Store Renewal License Application

Section 2 - Entity or Community Ownership Information

Licensees who directly hold a license as an individual or individuals should skip to Section 3. General partnerships and local governments should skip to the second half of this page. All licensees that are corporations or LLCs must complete this section. Corporations and LLCs are required to be in good standing with the Alaska Division of Corporations, Business & Professional Licensing (CBPL). The CBPL Entity # below is neither your EIN/Tax ID number, nor your business license number. You may view your entity's status or find your CBPL entity number by visiting the following site: <https://www.commerce.alaska.gov/cbp/main/search/entities>

Alaska CBPL Entity #: 10022557

You must ensure that you are able to certify the following statement before signing your initials in the box to the right: Initials

I certify that this entity is in good standing with CBPL and that all current entity officials and stakeholders (listed below) are also currently and accurately listed with CBPL.

Initials box containing 'M' and 'X' with a checkmark.

This subsection must be completed by any community or entity, including a corporation, limited liability company, partnership, or limited partnership, that is applying for renewal. If more space is needed, please attach additional completed copies of this page.

- If the applicant is a corporation, the following information must be completed for each shareholder who owns 10% or more of the stock in the corporation, and for each president, vice-president, secretary, and managing officer.
- If the applicant is a limited liability organization, the following information must be completed for each member with an ownership interest of 10% or more, and for each manager.
- If the applicant is a partnership, including a limited partnership, the following information must be completed for each partner with an interest of 10% or more, and for each general partner.

Important Note: The information provided in the below fields (including spelling of names, specific titles, and percentages held) must match that which is listed with CBPL. If one individual holds multiple titles mentioned in the bullets above, all titles must be listed for that individual on this application and with CBPL. Failure to list all required titles constitutes an incomplete application. You must list ALL of your qualifying officials, additional copies of this page or a separate sheet of paper may be submitted if necessary.

Form fields for Aaron Powell: Name of Official, Title(s) (Owner/Member), Phone (907-325-0113), % Owned (100), Mailing Address (Po Box 499), City (Wrangell), State (AK), ZIP (99929).

Empty form fields for Name of Official, Title(s), Phone, % Owned, Mailing Address, City, State, ZIP.

Empty form fields for Name of Official, Title(s), Phone, % Owned, Mailing Address, City, State, ZIP.



Alaska Alcoholic Beverage Control Board

Form AB-17b: 2020/2021 Package Store Renewal License Application

Section 3 - Sole Proprietor Ownership Information

Entities, such as corporations or LLCs, should skip this section. This section must be completed by any licensee who directly holds the license as an individual or multiple individuals and is applying for license renewal. If more space is needed, please attach a separate sheet that includes all of the required information.

The following information must be completed for each licensee and each affiliate.

This individual is an: [] applicant [] affiliate

Form with fields: Name, Contact Phone, Mailing Address, City, State, ZIP, Email

This individual is an: [] applicant [] affiliate

Form with fields: Name, Contact Phone, Mailing Address, City, State, ZIP, Email

Section 4 - Alcohol Server Education

Read the line below, and then sign your initials in the box to the right of the statement: Initials

I certify that all licensees, agents, and employees who sell or serve alcoholic beverages or check identification of a patron have completed an alcohol server education course approved by the ABC Board and keep current, valid copies of their course completion cards on the licensed premises during all working hours, as set forth in AS 04.21.025 and 3 AAC 304.465.

AP

Section 5 - License Operation

Check a single box for each calendar year that best describes how this liquor license was operated: 2018 2019

The license was regularly operated continuously throughout each year. [X] [X]

The license was regularly operated during a specific season each year. [] []

The license was only operated to meet the minimum requirement of 240 total hours each calendar year. If this box is checked, a complete copy of Form AB-30: Proof of Minimum Operation Checklist, and all necessary documentation must be provided with this application. [] []

The license was not operated at all or was not operated for at least the minimum requirement of 240 total hours each year, during one or both of the calendar years. If this box is checked, a complete copy of Form AB 29: Waiver of Operation Application and corresponding fees must be submitted with this application for each calendar year during which the license was not operated for at least the minimum requirement, unless a complete copy of the form (including fees) has already been submitted for that year. [] []



Section 6 - Written Orders

Written orders in calendar years 2020 and 2021: Yes No

Do you intend to sell alcoholic beverages and ship them to another location in response to written solicitation in calendar years 2020 and/or 2021? [] [X]

Section 7 - Violations and Convictions

Applicant violations and convictions in calendar years 2018 and 2019: Yes No

Have any notices of violation (NOVs) been issued for this license in the calendar years 2018 or 2019? [] [X]

Has any person or entity named in this application been convicted of a violation of Title 04, of 3 AAC 304, or a local ordinance adopted under AS 04.21.010 in the calendar years 2018 or 2019? [] [X]

If "Yes" to either of the previous two questions, attach a separate page to this application listing all NOVs and/or convictions.

Section 8 - Certifications

Read each line below, and then sign your initials in the box to the right of each statement: Initials

I certify that all current licensees (as defined in AS 04.11.260) and affiliates have been listed on this application, and that in accordance with AS 04.11.450, no one other than the licensee(s) has a direct or indirect financial interest in the licensed business. [AP]

I certify that I have not altered the functional floor plan or reduced or expanded the area of the licensed premises, and I have not changed the business name or the ownership (including officers, managers, general partners, or stakeholders) from what is currently approved and on file with the Alcoholic Beverage Control (ABC) Board. [AP]

I certify on behalf of myself or of the organized entity that I understand that providing a false statement on this form or any other form provided by AMCO is grounds for rejection or denial of this application or revocation of any license issued. [AP]

As an applicant for a liquor license renewal, I declare under penalty of perjury that I have read and am familiar with AS 04 and 3 AAC 304, and that this application, including all accompanying schedules and statements, is true, correct, and complete. I agree to provide all information required by the Alcoholic Beverage Control Board or AMCO staff in support of this application and understand that failure to do so by any deadline given to me may result in this application being returned to me as incomplete.

Signature of licensee [Signature]

Printed name of licensee Aaron Powell



Signature of Notary Public [Signature]

Notary Public in and for the State of ALASKA

My commission expires: 06-08-2020

Subscribed and sworn to before me this 4 day of November, 2020.

Seasonal License? [] Yes [X] No

If "Yes", write your six-month operating period: _____

Table with columns: License Fee (\$ 1500.00), Application Fee (\$ 300.00), TOTAL (\$ 1800.00), Miscellaneous Fees, GRAND TOTAL (if different than TOTAL)



US Army Corps
of Engineers
Alaska District

Public Notice of Application for Permit

ANCHORAGE
Regulatory Division (1145)
CEPOA-RD
Post Office Box 6898
JBER, Alaska 99506-0898

PUBLIC NOTICE DATE:	March 20, 2020
EXPIRATION DATE:	April 20, 2020
REFERENCE NUMBER:	POA-2020-00111
WATERWAY:	Unnamed Stream

Interested parties are hereby notified that a Department of the Army permit application has been received for work in waters of the United States (U.S.) as described below and shown on the enclosed project drawings.

All comments regarding this Public Notice (PN) should be sent to the address noted above. If you desire to submit your comments by email, you should send it to the Project Manager's email as listed below or to: regpagemaster@usace.army.mil. All comments should include the PN reference number listed above.

All comments should reach this office no later than the expiration date of this PN to become part of the record and be considered in the decision. Please contact Emily Vullo at (907) 753-2704, toll free from within Alaska at (800) 478-2712, by fax at (907) 753-5567, or by email at: Emily.N.Vullo@usace.army.mil if further information is desired concerning this notice.

APPLICANT: Southeast Alaska Regional Health Consortium (SEARHC) - Charles Clement; email: ccllement@searhc.org; phone: 907-966-8850

AGENT: R&M Engineering-Ketchikan, Inc. - Trevor Sande; email: trevorsande@rmketchikan.com; phone: 907-225-7917

LOCATION: The project site is located at Latitude 56.4609 ° N., Longitude 132.3776 ° W.; 1064 Zimovia Hwy, Wrangell, Alaska.

PURPOSE: The applicant's stated purpose is to provide employee housing due to the construction of a new hospital in Wrangell.

PROPOSED WORK: Discharge 5,400 cubic yards of shot rock and 675 cubic yards of D rock into 0.84-acre of forested wetlands to construct an access road and a building pad for employee housing. The access road would be 24 feet wide at the top of the road (32 feet at the toe of the slope) and 676 feet long leading to a cul-de-sac. The pad would support six duplexes with parking. The southern end of the pad would have a width of 222 feet and the east side of the pad would have an approximate length of 710 feet. There would be no stream impacts. All work would be performed in accordance with the enclosed plan (sheets 1-5), dated March 2020.

APPLICANT PROPOSED MITIGATION: The applicant proposes the following mitigation measures to avoid, minimize, and compensate for impacts to waters of the U.S. from activities involving discharges of dredged or fill material.

a. Avoidance: The applicant states, "The availability of sites able to accommodate new housing in the community of Wrangell is limited and all of the sites looked at contain forested wetlands. This site was better than most as much of the site contained uplands and the small stream on the site could be avoided by limiting development to the south side of the property."

b. Minimization: The applicant states, "Minimization was achieved by sharing access and parking between the proposed structures and locating the improvements on the south side of the property away from the small steam on the north. The access road will have the minimum dimensions for emergency vehicle access."

c. Compensatory Mitigation: The applicant states, "SEARHC proposes to work with the Southeast Alaska Land Trust (SEAL) for compensatory mitigation for the project."

The following alternatives were also assessed by the applicant:

- 1) City of Wrangell Property located within the City's Industrial Park. This property is 100% wetlands and also a bit further than desirable for a suitable walking distance. Also the depth of the muskeg was estimated in excess of 30 feet and very expensive to develop. Site No. 1 was not selected due to its location adjacent to an industrial property and high costs to develop due to wetlands.
- 2) City of Wrangell Property located near the USFS administration building. This property is also 100% wetlands with deep muskeg to excavate. Site No. 2 was not selected due to high cost to develop and wetlands.
- 3) Etolin Avenue. This property was a good location but contained 100% wetlands. Site No. 3 was a good location but did contain wetlands so it was not selected.
- 4) City of Wrangell Institute Property. This property was well out of town and required the City and Borough of Wrangell to perform a subdivision and install utilities which are several years out yet. Site No. 4 is a good long range plan for future housing but not yet available.

5) Applicant's preferred alternative. The site selected contained only partial wetlands. The topography of all of the sites are similar to that of the selected site. Impacts to wetlands of the sites would have been much higher due to the fact that there was no existing development. The preferred site was selected because of the limited impact to wetlands due to the existing building and also considerable uplands within the property.

WATER QUALITY CERTIFICATION: A permit for the described work will not be issued until a certification or waiver of certification, as required under Section 401 of the Clean Water Act (Public Law 95-217), has been received from the Alaska Department of Environmental Conservation.

CULTURAL RESOURCES: The latest published version of the Alaska Heritage Resources Survey (AHRS) has been consulted for the presence or absence of historic properties, including those listed in or eligible for inclusion in the National Register of Historic Places. There are cultural resources in the permit area or within the vicinity of the permit area. The permit area has been determined to be the direct footprint of the fill in waters of the U.S. and in uplands on the lot. Consultation of the AHRS constitutes the extent of cultural resource investigations by the Corps of Engineers (Corps) at this time, and we are otherwise unaware of the presence of such resources. The Corps has made a No Historic Properties Affected (No Effect) determination for the proposed project. This application is being coordinated with the State Historic Preservation Office (SHPO). Any comments SHPO may have concerning presently unknown archeological or historic data that may be lost or destroyed by work under the requested permit will be considered in our final assessment of the described work. The Corps is requesting the SHPO's concurrence with this determination.

ENDANGERED SPECIES: No threatened or endangered species are known to use the project area. We have determined the described activity would have no effect on any listed or proposed threatened or endangered species, and would have no effect on any designated or proposed critical habitat, under the Endangered Species Act of 1973 (87 Stat. 844). Therefore, no consultation with the U.S. Fish and Wildlife Service or the National Marine Fisheries Service (NMFS) is required. However, any comments they may have concerning endangered or threatened wildlife or plants or their critical habitat will be considered in our final assessment of the described work.

ESSENTIAL FISH HABITAT: The Magnuson-Stevens Fishery Conservation and Management Act, as amended by the Sustainable Fisheries Act of 1996, requires all Federal agencies to consult with the NMFS on all actions, or proposed actions, permitted, funded, or undertaken by the agency, that may adversely affect Essential Fish Habitat (EFH).

No EFH species are known to use the project area. We have determined the described activity would not adversely affect EFH in the project area.

TRIBAL CONSULTATION: The Alaska District fully supports tribal self-governance and government-to-government relations between Federally recognized Tribes and the Federal

government. Tribes with protected rights or resources that could be significantly affected proposed Federal action (e.g., a permit decision) have the right to consult with the Alaska District on a government-to-government basis. Views of each Tribe regarding protected rights and resources will be accorded due consideration in this process. This PN serves as notification to the Tribes within the area potentially affected by the proposed work and invites their participation in the Federal decision-making process regarding the protected Tribal right or resource. Consultation may be initiated by the affected Tribe upon written request to the District Commander during the public comment period.

PUBLIC HEARING: Any person may request, in writing, within the comment period specified in this notice, that a public hearing be held to consider this application. Requests for public hearings shall state, with particularity, reasons for holding a public hearing.

EVALUATION: The decision whether to issue a permit will be based on an evaluation of the probable impacts, including cumulative impacts of the proposed activity and its intended use on the public interest. Evaluation of the probable impacts, which the proposed activity may have on the public interest, requires a careful weighing of all the factors that become relevant in each particular case. The benefits, which reasonably may be expected to accrue from the proposal, must be balanced against its reasonably foreseeable detriments. The outcome of the general balancing process would determine whether to authorize a proposal, and if so, the conditions under which it will be allowed to occur. The decision should reflect the national concern for both protection and utilization of important resources. All factors, which may be relevant to the proposal, must be considered including the cumulative effects thereof. Among those are conservation, economics, aesthetics, general environmental concerns, wetlands, cultural values, fish and wildlife values, flood hazards, floodplain values, land use, navigation, shore erosion and accretion, recreation, water supply and conservation, water quality, energy needs, safety, food and fiber production, mineral needs, considerations of property ownership, and, in general, the needs and welfare of the people. For activities involving 404 discharges, a permit will be denied if the discharge that would be authorized by such permit would not comply with the Environmental Protection Agency's 404(b)(1) guidelines. Subject to the preceding sentence and any other applicable guidelines or criteria (see Sections 320.2 and 320.3), a permit will be granted unless the District Commander determines that it would be contrary to the public interest.

The Corps is soliciting comments from the public; Federal, State, and local agencies and officials; Indian Tribes; and other interested parties in order to consider and evaluate the impacts of this proposed activity. Any comments received will be considered by the Corps to determine whether to issue, modify, condition or deny a permit for this proposal. To make this decision, comments are used to assess impacts on endangered species, historic properties, water quality, general environmental effects, and the other public interest factors listed above. Comments are used in the preparation of an Environmental Assessment and/or an Environmental Impact Statement pursuant to the National Environmental Policy Act. Comments are also used to determine the need for a public hearing and to determine the overall public interest of the proposed activity.

AUTHORITY: This permit will be issued or denied under the following authority: Item f.
(X) Discharge dredged or fill material into waters of the United States – Section 404 Clean Water Act (33 U.S.C. 1344). Therefore, our public interest review will consider the guidelines set forth under Section 404(b) of the Clean Water Act (40 CFR 230).

Project drawings and a Notice of Application for State Water Quality Certification are enclosed with this Public Notice.

District Commander
U.S. Army, Corps of Engineers

Enclosures

STATE OF ALASKA

DEPT. OF ENVIRONMENTAL CONSERVATION
DIVISION OF WATER

Wastewater Discharge Authorization Program (WDAP) / 401 Certification

DEPARTMENT OF ENVIRONMENTAL CONSERVATION
WDAP/401 CERTIFICATION
555 CORDOVA STREET
ANCHORAGE, ALASKA 99501-2617
PHONE: (907) 269-6285 | EMAIL: dec-401cert@alaska.gov

NOTICE OF APPLICATION FOR STATE WATER QUALITY CERTIFICATION

Any applicant for a federal license or permit to conduct an activity that might result in a discharge into navigable waters, in accordance with Section 401 of the Clean Water Act of 1977 (PL95-217), also must apply for and obtain certification from the Alaska Department of Environmental Conservation that the discharge will comply with the Clean Water Act, the Alaska Water Quality Standards, and other applicable State laws. By agreement between the U.S. Army Corps of Engineers and the Department of Environmental Conservation, application for a Department of the Army permit to discharge dredged or fill material into navigable waters under Section 404 of the Clean Water Act also may serve as application for State Water Quality Certification.

Notice is hereby given that the application for a Department of the Army Permit described in the Corps of Engineers' Public Notice (PN) Reference Number **POA-2020-00111, Unnamed Stream**, serves as application for State Water Quality Certification from the Department of Environmental Conservation.

After reviewing the application, the Department may certify there is reasonable assurance the activity, and any discharge that might result, will comply with the Clean Water Act, the Alaska Water Quality Standards, and other applicable State laws. The Department also may deny or waive certification.

Any person desiring to comment on the project with respect to Water Quality Certification, may submit written comments to the address above or via email to dec-401cert@alaska.gov by the expiration date of the Corps of Engineer's Public Notice. All comments should include the PN reference number listed above. Mailed comments must be postmarked on or before the expiration date of the public notice.

Disability Reasonable Accommodation Notice

The State of Alaska, Department of Environmental Conservation complies with Title II of the Americans with Disabilities Act of 1990. If you are a person with a disability who may need special accommodation in order to participate in this public process, please contact Kate Orozco at 907-465-6171 or TDD Relay Service 1-800-770-8973/TTY or dial 711 within 5 days of the expiration date of this public notice to ensure that any necessary accommodations can be provided.

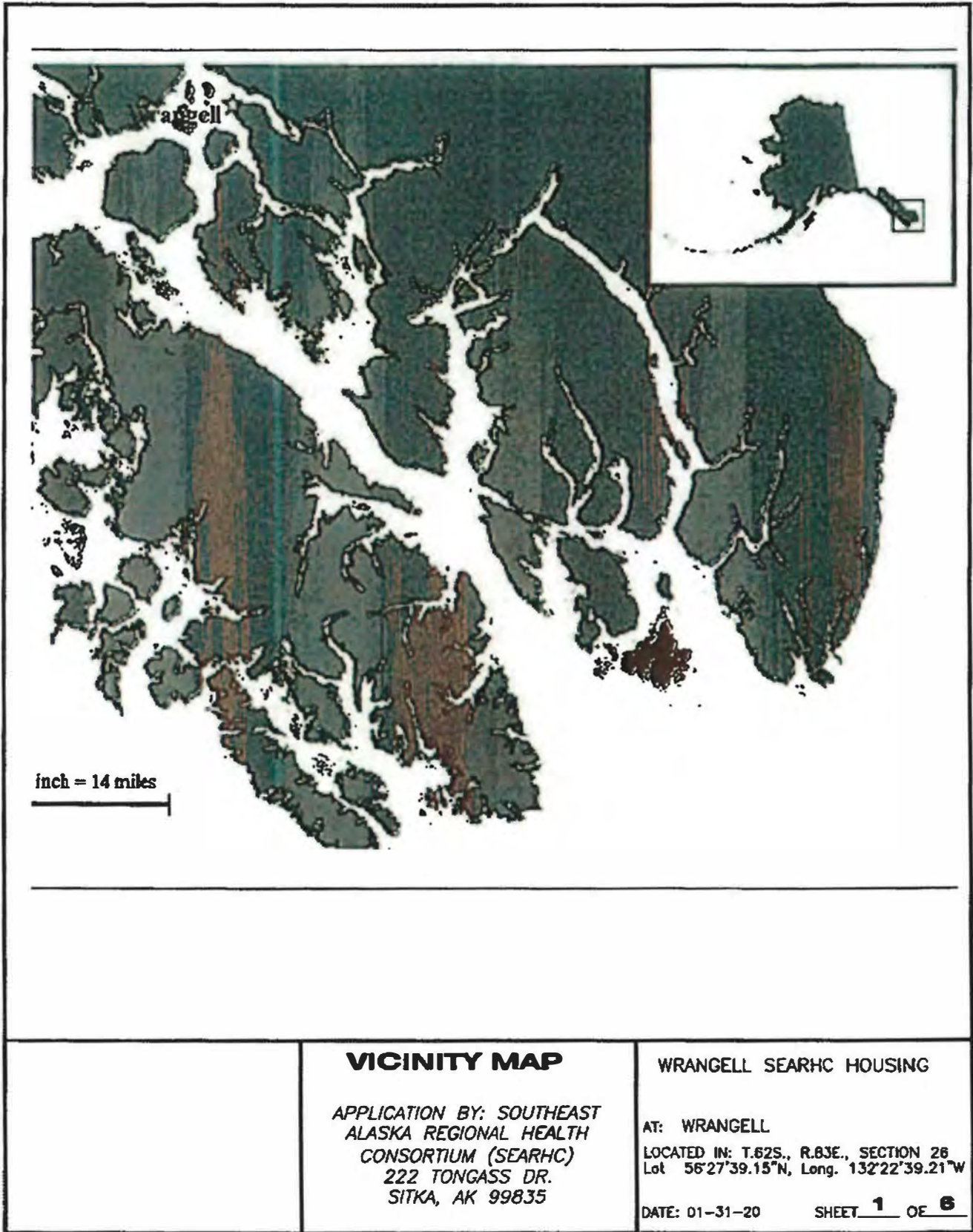



ed with TOPCON ©2005 National Geographic

VICINITY MAP

APPLICATION BY: SOUTHEAST ALASKA REGIONAL HEALTH CONSORTIUM (SEARHC) 222 TONGASS DR. SITKA, AK 99835

WRANGELL SEARHC HOUSING

AT: WRANGELL
LOCATED IN: T.62S., R.83E., SECTION 28
Lat 56°27'39.15"N, Long. 132°22'39.21"W
DATE: 01-31-20 SHEET **2** OF **6**

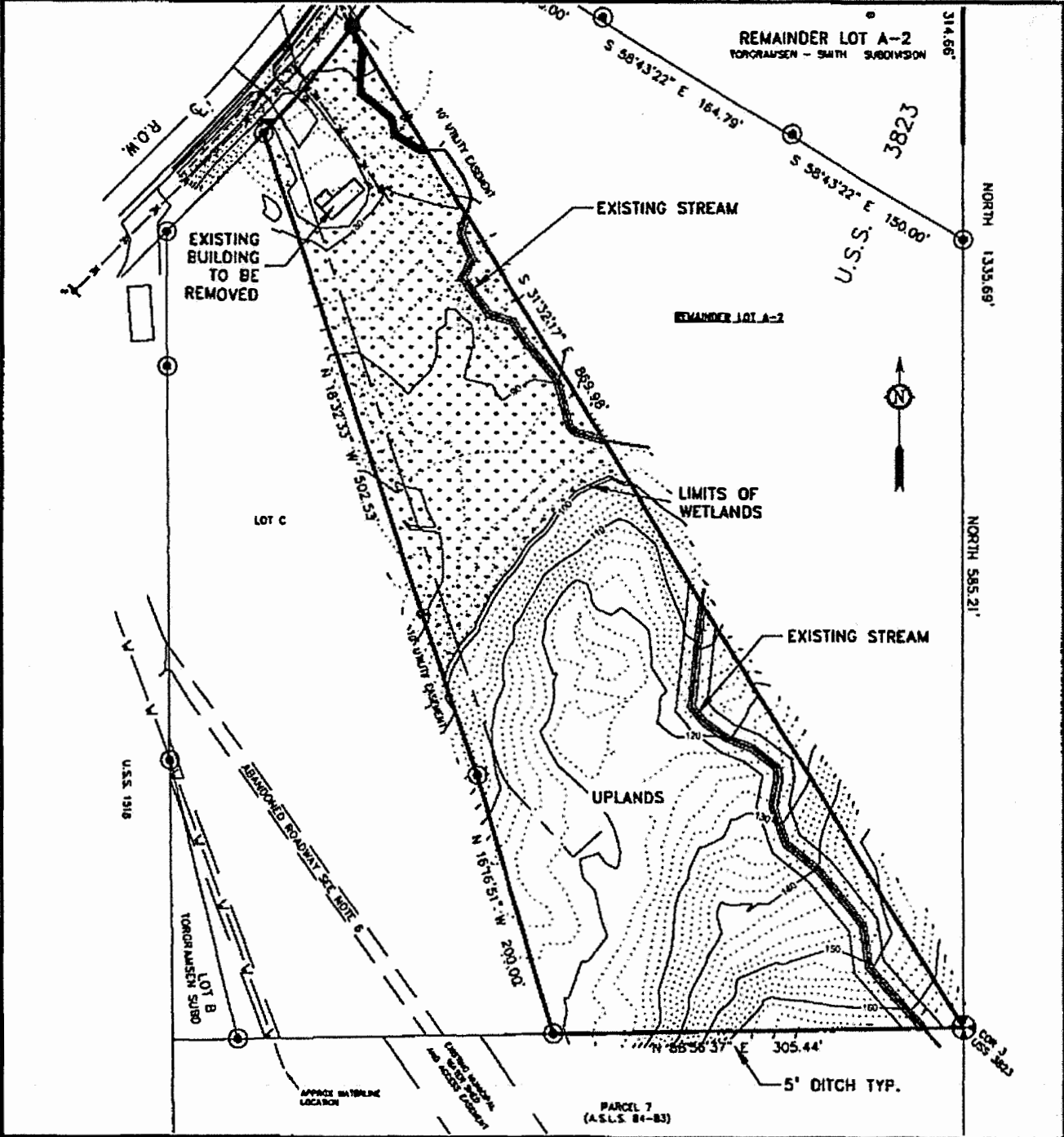

	<p align="center">SITE PLAN</p> <p>APPLICATION BY: SOUTHEAST ALASKA REGIONAL HEALTH CONSORTIUM (SEARHC) 222 TONGASS DR. SITKA, AK 99835</p>	<p align="center">WRANGELL SEARHC HOUSING</p> <p>AT: WRANGELL LOCATED IN: T.62S., R.83E., SECTION 26 Lot 56°27'39.15"N, Long. 132°22'39.21"W</p> <p>DATE: 01-31-30 SHEET <u>3</u> OF <u>6</u></p>
--	--	--

Item f.

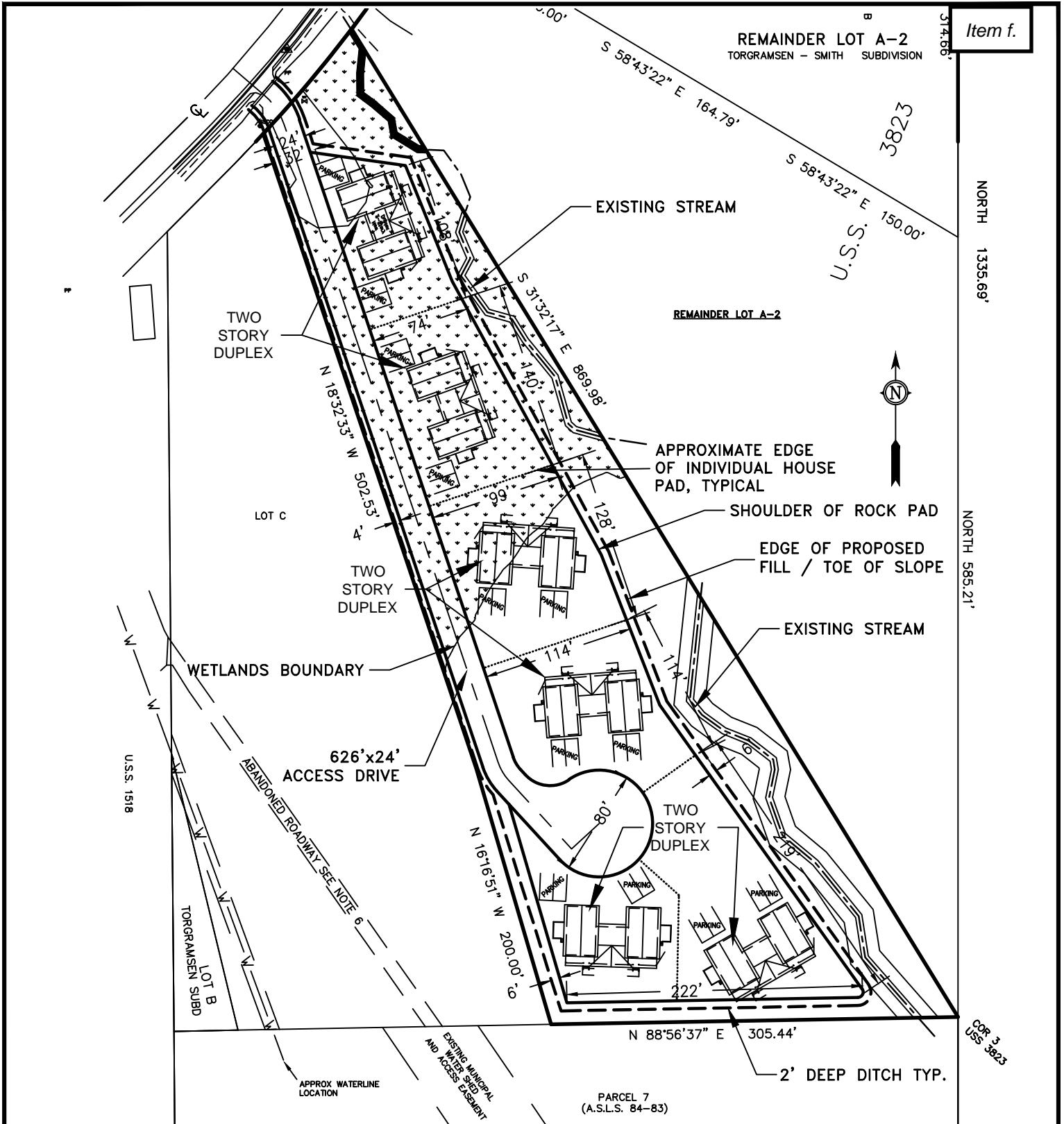

PROJECT QUANTITIES

2.30 AC TOTAL PROEJCT AREA
 0.84 AC WETLANDS IMPACTED
 4100 CY MUSKEG REMOVED
 5,400 CY SHOT ROCK FILL
 700 CY D-1 GRAVEL FILL

SITE PLAN

APPLICATION BY: SOUTHEAST
 ALASKA REGIONAL HEALTH
 CONSORTIUM (SEARHC)
 222 TONGASS DR.
 SITKA, AK 99835

WRANGELL SEARHC HOUSING

AT: WRANGELL
 LOCATED IN: T.62S., R.83E., SECTION 26
 Lat 56°27'39.15"N, Long. 132°22'39.21"W

DATE: 03-18-20 SHEET **4** OF **6**

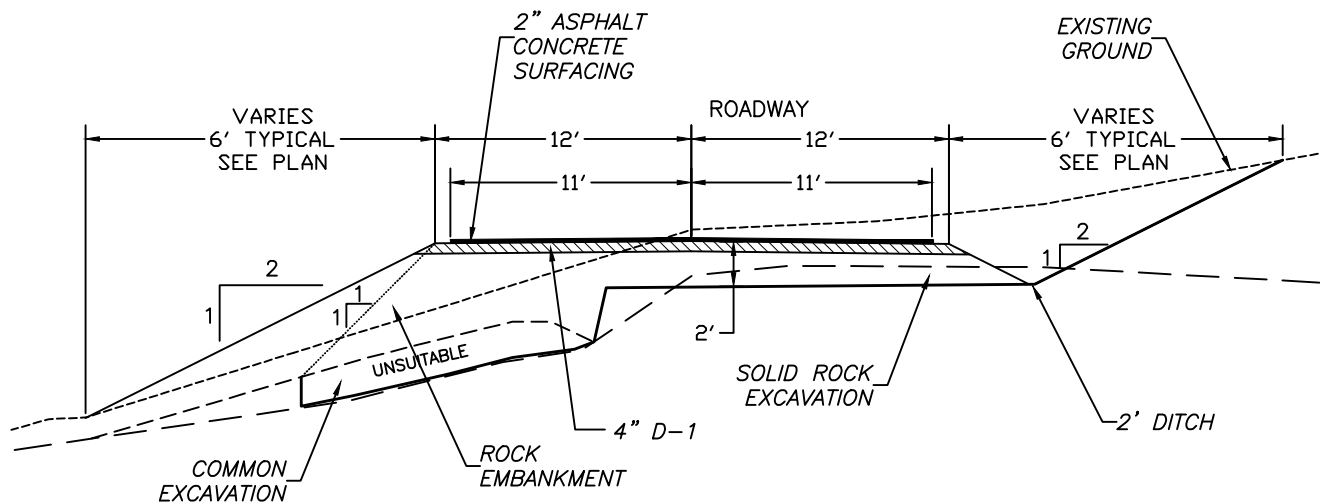

TYPICAL ROADWAY SECTION

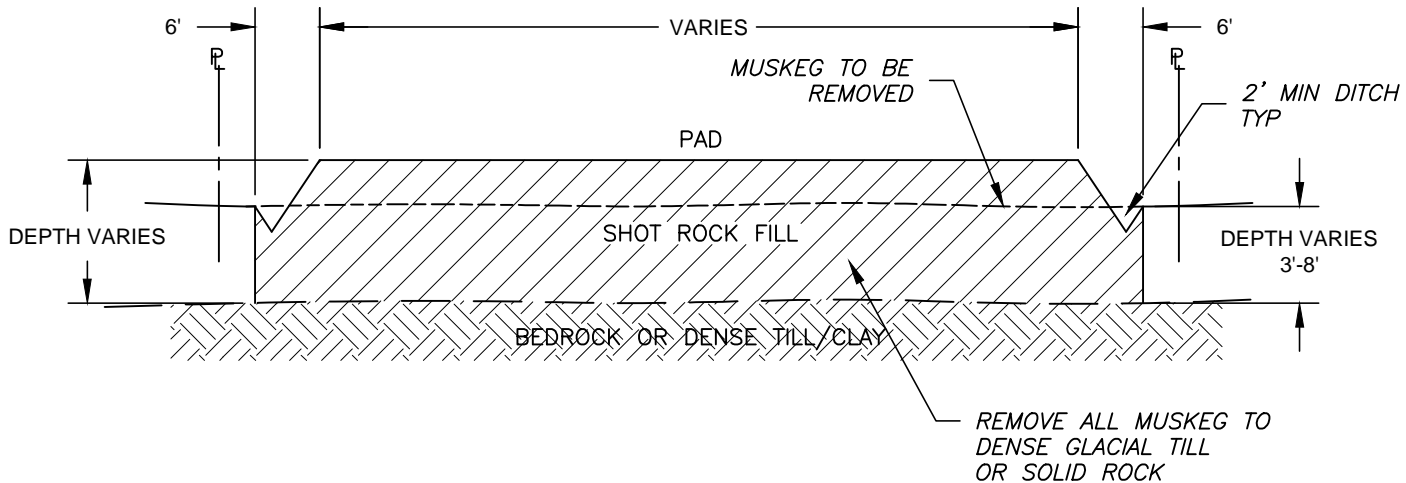

TYPICAL BUILDING PAD

TYPICAL SECTIONS

APPLICATION BY: SOUTHEAST ALASKA REGIONAL HEALTH CONSORTIUM (SEARHC)
 222 TONGASS DR.
 SITKA, AK 99835

WRANGELL SEARHC HOUSING

AT: WRANGELL
 LOCATED IN: T.62S., R.83E., SECTION 26
 Lat 56°27'39.15"N, Long. 132°22'39.21"W

DATE: 03-18-20 SHEET **5** OF **6**

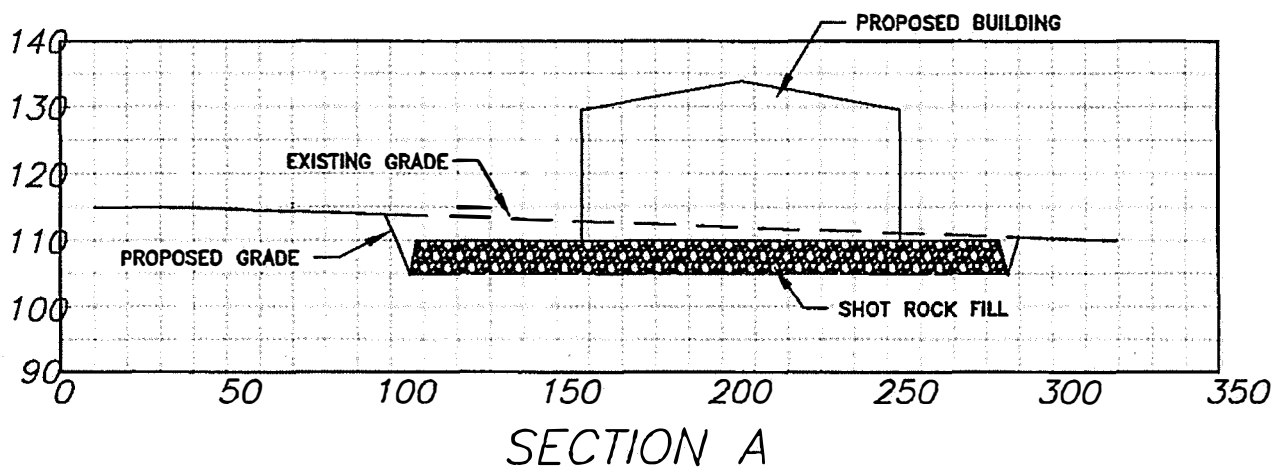

SECTION A

TYPICAL SECTIONS

APPLICATION BY: SOUTHEAST
ALASKA REGIONAL HEALTH
CONSORTIUM (SEARHC)
222 TONGASS DR.
SITKA, AK 99835

WRANGELL SEARHC HOUSING

WRANGELL
LOCATED IN: T.62S., R.83E., SECTION 26
Lot 56°27'39.15"N, Long. 132°22'39.21"W

DATE: 01-31-20

SHEET **6** OF **6**

**CITY & BOROUGH OF WRANGELL, ALASKA
BOROUGH ASSEMBLY AGENDA STATEMENT**

<u>AGENDA ITEM TITLE:</u>	<u>DATE:</u>	April 14, 2020
	<u>Agenda Section</u>	13

Nolan Center Winter 2020 Newsletter

SUBMITTED BY:

Cyni Crary, Nolan Center Director

FISCAL NOTE:

Expenditure Required: \$XXX Total		
FY 20: \$	FY 21: \$	FY22: \$
Amount Budgeted:		
	FY20 \$XXX	
Account Number(s):		
	XXXXX XXX XXXX	
Account Name(s):		
	Enter Text Here	
Unencumbered Balance(s) (prior to expenditure):		
	\$XXX	

Reviews/Approvals/Recommendations

<input type="checkbox"/>	Commission, Board or Committee
Name(s)	
Name(s)	
<input type="checkbox"/>	Attorney
<input type="checkbox"/>	Insurance

ATTACHMENTS: 1. Nolan Center Winter 2020 Newsletter

RECOMMENDATION MOTION:
None. Newsletter only.

SUMMARY STATEMENT:
The Nolan Center Winter 2020 Newsletter is attached for review by the Assembly. If there is interest in reading previous newsletter editions, please follow the link below:
<https://www.nolancenter.org/newsletters.html>

The Nolan Center

Newsletter

Winter Issue

January, February, March 2020

Museum

- Featured Exhibit
- Museum Spotlight
- Lobby Displays
- Accessions/Archives
- Museum Highlight

Events

- Eskimo Ninja
- Ready, Set, Grow!
- Elizabeth Peratrovich Day
- Quilt Show Open House

Theater

- Highlights

Gift Shop

- Featured Books

Winter Highlights

Winter is slowly winding down and hopefully Spring will bring new hope to this uncertain time we are currently facing with the global pandemic.

This quarter we focused on some local partnerships. We reached out to the elementary school and partnered with the 4th & 5th grade students to celebrate Elizabeth Peratrovich Day in a really special way. We also decided to go local with our next exhibit and feature a Quilt Show during the month of March.

When we closed our facility in March due to the virus, we decided to put a virtual tour of our museum on our website!





Saying Goodbye...

The Nolan Center said goodbye to Cocoa Massin at the end of February. Although it's sad to see her go we are happy for her new opportunity at City Market. Cocoa will be greatly missed!



Thank you Cocoa for all your years of hard work!



Nolan Center Staff

- | | |
|----------------|--------------------|
| Director | Cyni Crary |
| Manager | Keeleigh Solverson |
| Collections | Cindy Kilpatrick |
| Photo Archives | Tracy Churchill |
| Attendant | Kiara Meissner |

Kiara re-joined the team in March!

Friends of the Museum

- | | |
|----------------|---------------|
| President | Michael Bania |
| Vice-President | Nancy McQueen |
| Treasurer | Loretta Rice |
| Secretary | Olinda White |
| Director | Olga Norris |
| Director | Anne Morrison |
| Director | Frank Roppel |
| Director | Gig Decker |



The Friends of the Museum supports the activities and acquisitions of the Wrangell Museum through advocacy, fundraising, special programming and activities. Foremost will be efforts to maintain the stability and preservation of Wrangell's history, secure grants, promote a volunteer program and join in the partnership with the Wrangell Museum and its staff.

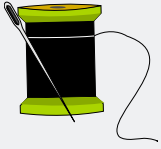

The Wrangell Quilt Show



The Wrangell Quilt Show opened on March 5th, 2020 and it was intended to close on March 31st but due to our facility closure The Wrangell Quilt Show will remain open for a period of time when the facility re-opens. In the meantime you can view the amazing quilts made by our talented local artists on our website and The Nolan Center Facebook page .

Thank you to the Stikine Stitchers and The Friends of the Museum for your efforts in making this exhibit possible. A special thank you to Michael Bania and Chris Ellis for the hours put into hanging the quilts with our staff.





*A Legacy of Stitches
Sandra E. Andersen*

*A Legacy of Stitches is what we leave behind;
the imprint of our very soul that lasts beyond our time.*

*The heart that quilts knows, oh, so well the peace that can be found,
as needle meets with fabric, for there is no sweeter sound.*

*Whether quiet piecing done by hand or on our sewing machine,
there's rhythm to our stitches as we sew along each seam.*

*Those stitches tell the story of our lives as they unfold as we think of
quilts that Grandma made with stories left untold.*

*The humdrum of our daily lives grows elegant and grand,
when we start to cut the pieces, then stitch the fabric in our hands.*

*And whatever is the reason for the quilts we piece and sew,
and whoever is the maker, there is one thing that we know.*

*Each quilt is full of memories, and is a treasured thing.
If quilts could talk, imagine how some quilts would surely sing!*

*For some quilts are sewn in happy times and others when we're sad,
and some are sewn in laughter and others when we're mad.*

*Some are sewn to warm us, and some sewn just for fun, and some are
"works in progress" that never quite get done!*

*Some quilts are sewn for beauty, a quilt made just for "show"
but the heart of the true quilter is the one who really knows.*

*That no matter how the quilt is stitched, we leave our mark in time.
This Legacy of Stitches is what we leave behind.*

Making Alaska Better... For All

Martin Luther King Day and Elizabeth Peratrovich Day was inspiration for a new exhibit that rolled out in February. It focused on Alaskan civil rights leaders, their issues, and their accomplishments.

Founders of important Native Alaskan programs such as health care, housing, language studies, and environmental protection rules were also acknowledged. History of the principal Native Alaskan organizations behind the civil rights movement was examined. Alaska Native Brotherhood (ANB) and Alaska Native Sisterhood (ANS) have successfully lobbied the legislature since their formation in 1912 and 1914. Their achievements in racial equality, desegregation, anti-discrimination, and land settlement compensation built the Alaska we all enjoy today. The display included images of the Elizabeth Peratrovich \$1 coin to become available later this year, the book "Fighter in Velvet Gloves" by Annie Boochever, and a copy of the inspiring poster "We Can Do It!" by Dillingham artist Apayo Moore.



Old Calendars & Polar Bears

We started the new year with a display appropriately called, Old Calendars and Polar Bears- It's A Wrangell Thing...! With featured calendars from our collection, we remember exclusively Wrangell businesses or local fundraiser calendar projects starting in 1912 to the most recent 2010 example. Many have vividly colorful photos that generate a lot of interest with our local community. Two examples are from the 1970's lumber and pulp mill. It was a major economic engine of the time, and completely gone today. A more recent calendar is called Men of Wrangell, a fun look at various guys from around town hard at work (and play). Each New Year's Day the informal and daring Wrangell Polar Bears waded out into Shoemaker Harbor for a 1 minute dip. An enthusiastic support group waits on shore with warming fires and plenty of hot chocolate. Some photos from these times past are sprinkled among the old calendars to add a bit of cool comedy.

Celebrating Iditarod 2020

The Iditarod Trail Sled Dog race might be a distance away from Wrangell but not its appeal. Followers here eagerly look forward to March each year for the big event and stay tuned to daily progress reports. This is a great time to bring out a display of Wrangell Museum's large collection of Iditarod posters by artist Jon Van Zyle. Our antique exhibit case has just enough space for the 5 featured examples. The display includes the Musher's roster and this year's Anchorage to Nome trail route, then somehow a few husky puppies from the Museum gift shop found a good spot right in front. As the theme suggests, Good Luck Musher's 2020!

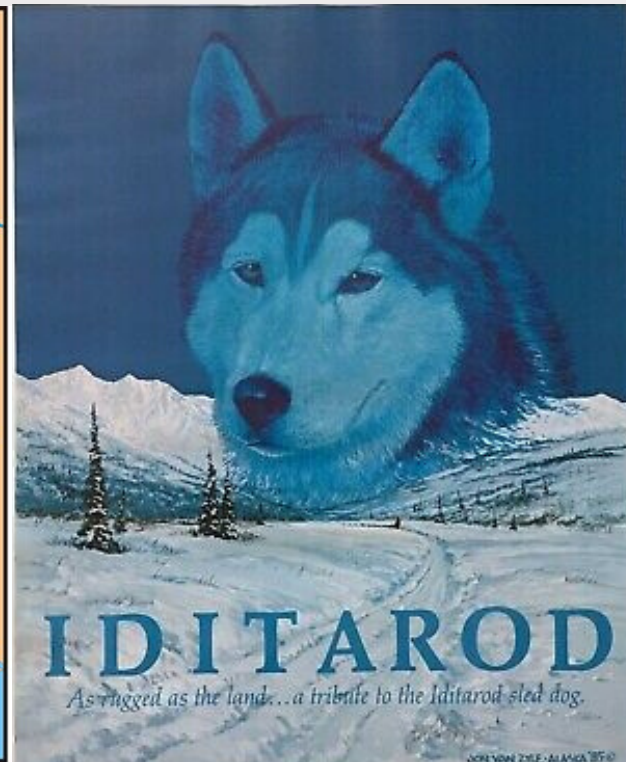
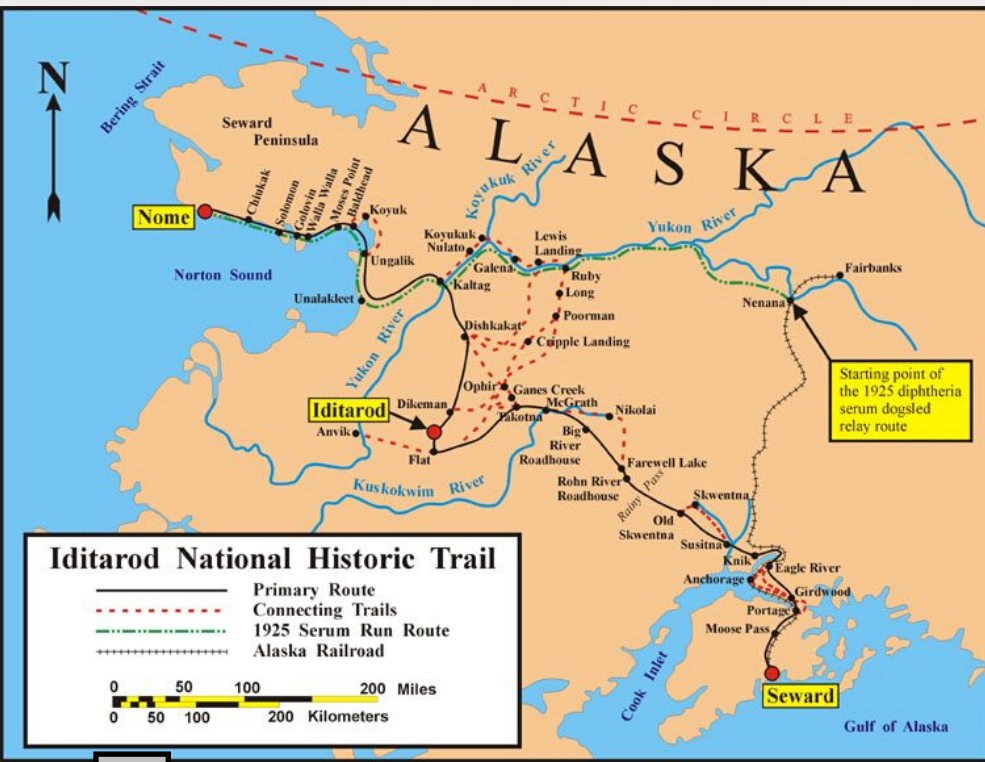

What happens to my donation?

Ever wonder how the museum processes your donation? A condensed answer would go something like this. If it is made of organic materials, it visits the freezer for freeze/thaw cycles, and waits in a quarantine area. This prevents unseen pest invasion into our collection. The donation is assigned a unique reversible catalog number, which is affixed in a manner appropriate for its composition. It is gently cleaned if necessary, then described, photographed, measured, its provenience recorded, condition assessed, and storage location is all entered in our digital data base. If the donation needs special physical support, it receives custom housing. Examples include rolled storage tubes for large textiles, protective sleeves for photos and archives, possibly archival boxes with custom supports or padding for smaller textiles and fragile objects. Some donations are in sound condition and can be simply stored on cushioned shelving or hung on padded hangers. Framed two-dimensional art is placed on our new sliding cable hanging system. Wrangell Museum has a variety of mobile display cases in the exhibit gallery and lobby areas. They allow us to rotate the stored collection into public view on a regular basis. The museum gratefully accepts donations relating to Wrangell history and culture. We encourage you to contact Wrangell Museum at 907-874-3770 if you are considering a donation.

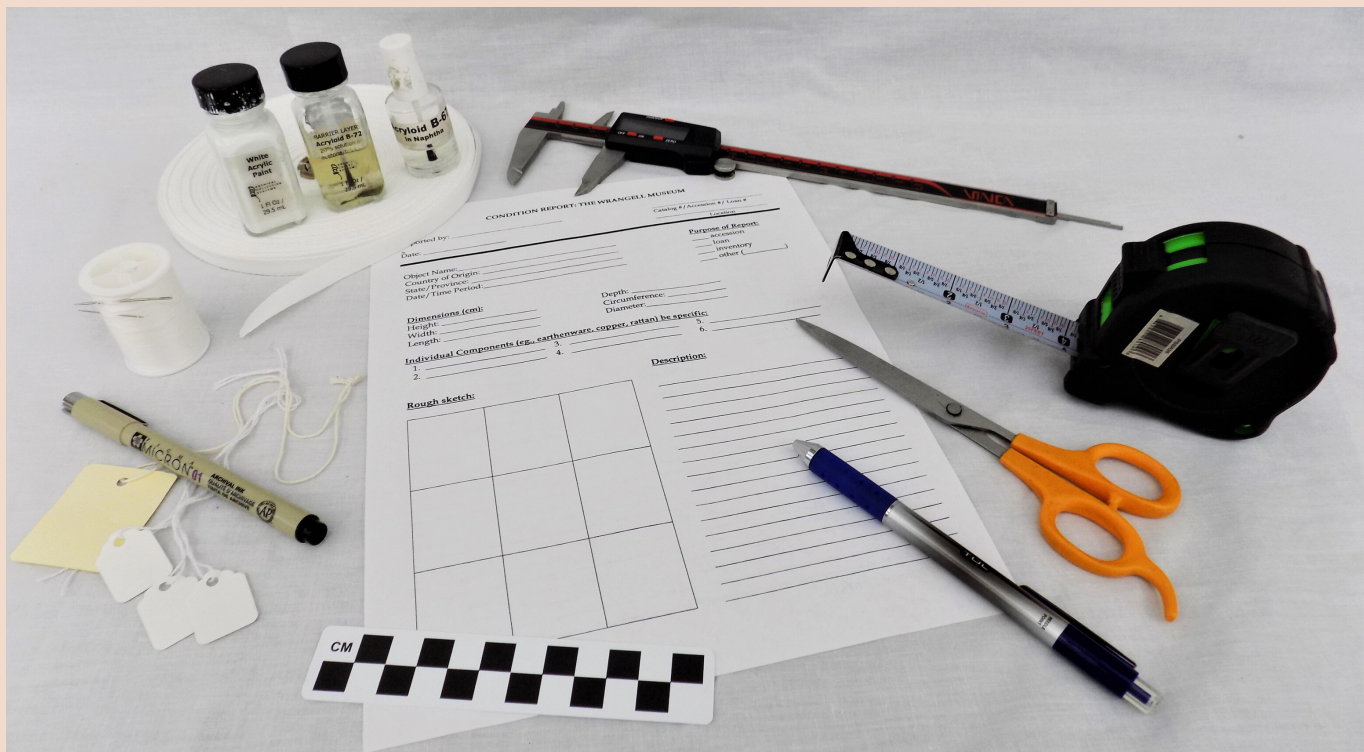

Donations

Thank you to our generous donors this quarter:

- Stephanie Counts- Walrus ivory slab necklace in original gift box from W.C. Waters Bear Totem Store.
- Alicia Armstrong- 1970s era rotary dial desktop telephone, 1920s Tapper Hut style reproduction.
- Olga Norris- Photo album of prints and negatives documenting WRG Museum move from original building, large quartz crystal.

Loans

- Bruce & Darlene Harding- Watercolor painting “3 Frog Totem” by Mark Wheeler.

Addition to our Collection

Wrangell Museum collects materials relating to the history and culture of our area, in safekeeping for the future. These donations and occasional loans are then made available for educational viewing and research. We are grateful for the contributions made this winter quarter 2020. If you are interested in donating objects to the Wrangell Museum, contact us at 907-874-3699, Director Cyni Cray.

Ivory pendant from Waters Store

A beautiful walrus tusk pendant in the original gift box was generously donated to Wrangell Museum by Stephanie Counts of Elk Grove, California. This ivory piece can be seen on permanent display in our exhibit gallery Trading Post Store. The necklace seemed to immediately fit right in. A wonderful bonus is the original gift box included with this donation. The box came from a prominent front street business operating many years in Wrangell, known as W.C. Waters Curios Bear Totem Store, and helps document when and where her relative made the purchase.





About The Digital Archives

The large majority of photographs that are donated to the museum do not have information on people, date or location included on image. A special thank you goes out to those people in Wrangell that have included the “full” information or have later researched and confirmed persons and locations. There are several local people who have been involved with the museum for decades, whose input and information is irreplaceable!

People who have been working on the archive for many years have familiarized themselves with Wrangell history, Tracy Churchill, who started working on the digital photo archive 18 years ago with Ken Mason, learned a lot about photo identification. However, although she has been working on the collection for several years, the collection is ever-evolving with new people to identify and further information subject matter. Tracy plans to build a portfolio including identification of local persons, at least up to 1940 to assist in identification of photographs in the future.

We have a great appreciation for local Wrangell authors who have done extensive research on historical photographs for publications about local business, industry and historical events, all add to the unique place we call home.

If you can remember to label your photographs (if you are one that still prints photographs) if you have a collection from the past, or present, that will be much appreciated by people in the future.

Is there a Wrangell subject you would like to see more information or possible photographs included in the next newsletter, please submit your suggestions.

Thank you,

*Tracy Churchill
Photo Archives*

The Museum Virtual Tour

This March was all about bringing the The Nolan Center Museum online. We released part one of the museum 360° virtual tour.

With just a click of your mouse and you can move around this section of the gallery. If something catches your eye you can even zoom in for detail!

We have also been featuring the Natural History portion of the museum online for everyone to explore. Skulls and birds are always fun for the little ones to check out and try to guess what each one is!

If you would like to join in on the fun visit our website:
<https://www.nolancenter.org/museum-virtual-tour.html>

or our Facebook page:

The Nolan Center - Museum & Civic Center





The Eskimo Ninja

Nick Hanson also known as the Eskimo Ninja from the show American Ninjas came to Wrangell to share his motivational presentation and challenge the audience to some seal hop.

Wrangell Chamber of Commerce Dinner

This year Vincent Balansag & Rich Einert were awarded Citizen of the Year, Jing O'Brien received Young Leader, Jenn Yancey was awarded Educator of the Year and Groundswell received Business of the Year.



Ready, Set, Grow!

The first event in this year's Chautauqua Series "Ready, Set, Grow!" featuring local gardeners to answer your gardening questions. A very popular subject for this time of year when people are getting ready to start their vegetable starts!





PAPER TIGERS

One high school's unlikely success story.



Paper Tigers

Eli Michael & Crossings teamed up together to show the movie Paper Tigers at The Nolan Center. Paper Tigers follows a high school that radically changed its approach of discipline to break the cycle of poverty, violence & disease that affects families

Derek Peterson

Before Derek Peterson retired Wrangell was lucky enough to host Derek one last time! Derek spent two days at The Nolan Center inspiring both the adults and youth in our community to appreciate the value of support through relationships.

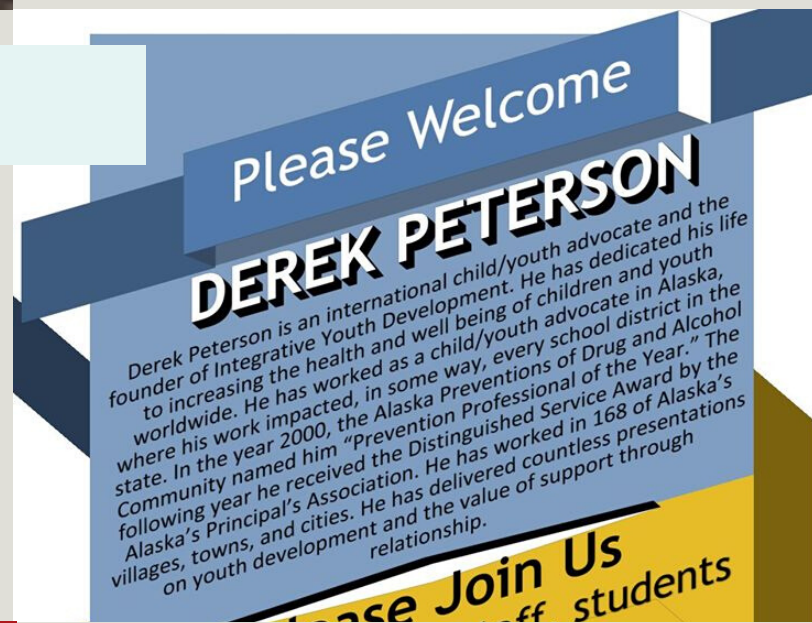

Attention Wrangell

Need help filing your tax return?



Tax Aid

This season the residents of Wrangell had many opportunities to receive help with their taxes. AARP of Wrangell was available for tax aid every Saturday from 1pm to 5pm. Tlingit and Haida spent a day at the facility with their Volunteer Income Tax Help Program.

Elizabeth Peratrovich Day



Our open house celebration honoring Elizabeth Peratrovich was such a pleasure. Many thanks to Virginia Oliver and the JOM dancers, Sandy Churchill, and Laura Davies' 5th grade students! We celebrated local culture by showcasing the students beautiful art in which they incorporated FlipGrid videos using QR codes that provided a video timeline of Elizabeth Peratrovich's life. Each dancer, elder and student received one of the commemorative coins!



Wrangell Quilt Show Open House

The Nolan Center in collaboration with the Stikine Stitchers and The Friends of the Museum put together the Wrangell Quilt Show. To celebrate all the hard work and countless hours that went into each quilt we hosted an Open House event to gather the community! Many of the quilt makers were in attendance to share their amazing stories on how their quilts came to be. Each quilt is more than just fabric and string, the quilt represents a story or memory that is then passed down through the generations.





THE NOLAN CENTER THEATER PRESENTS:

MOVIES PLAYED THIS WINTER

A Beautiful Day in the
Neighborhood
Jumanji : The Next Level
Spies in Disguise
Star Wars: The Rise of
Skywalker
Bad Boys For Life
Dolittle
Sonic The Hedgehog
The Call of the Wild

TRIVIA

In one year how many large &
small popcorn buckets were
sold?

In 2019 what movie was most
attended?

What candy gets dropped on
the theater floor the most?

ANSWERS

Large popcorn - 1,685 buckets
Small popcorn - 1,124 buckets

Aladdin

Nerds

WATCH NEW MOVIES AT HOME

We are ending the Winter season with quarantine. Not a new box office hit but our new reality. Thankfully, Universal Studios is bringing the theater to your home! You can now stream brand new Universal movies from most online movie applications (fees do apply). Be on the look out for Trolls World Tour which premieres April 10th.

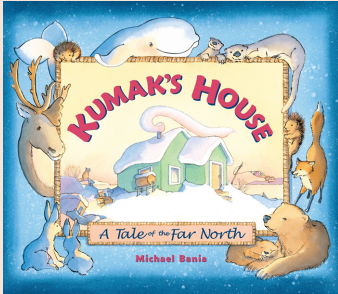

Kumak Series

Wrangell's very own Michael Bania is the Author and Illustrator of the Kumak collection. The three book series follows Kumak and his family who live in the Arctic. Each book has its own lesson to learn which is inspired by Eskimo traditional folktales. The Kumak series is a must for every young child's personal library.

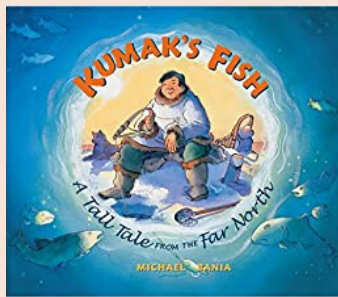
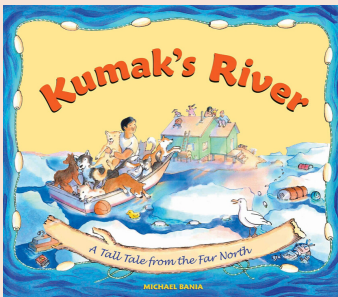

Fighter In Velvet Gloves

Fighter In Velvet Gloves is the biography of Elizabeth Peratrovich who despite adversity never gave up as she struggled for equality. This book is written for young adults who will be able to identify with Elizabeth during her battle for Civil Rights. This book is truly inspiring!

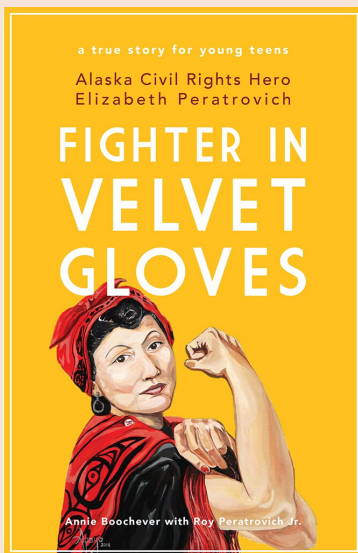

Southeast Alaska's Natural World

Discover the fascinating secrets of Southeast Alaska's Natural World with this visually stunning book. Learn how lupines "communicate" with bumblebees, or why western toads are disappearing from Southeast Alaska and how bald eagles care for their young. This book is easy to read and chalk full of information. Anyone interested in Alaska and its wildlife will truly enjoy this book.

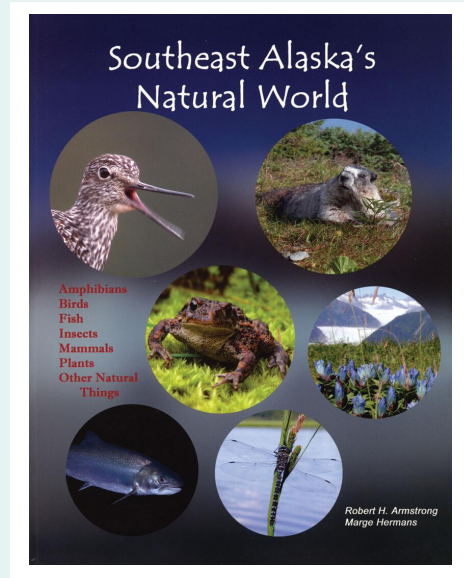



Friends of the Museum

Friends of the Museum Membership

Contact Information

Name

Mailing Address

City, State, Zip

Phone Number

Email

Membership Options

- INDIVIDUAL - \$25
- FAMILY - \$50
- CONTRIBUTOR - \$100
- BENEFACTOR - \$500+

Payment Options

Send Membership Checks to:
 Friends of the Wrangell Museum
 P.O. Box 34
 Wrangell, AK 99929

If you're not already a member, you might consider this an invitation to become a Friend of the Wrangell Museum.

A Note From the President...

Newsletter Issue 3

Spring is here just barely. Winter seems determined to hang on and on. But look around! There are bulbs popping up and soon our town will be in full bloom again. Unfortunately we are all sequestering at home and praying that Wrangell will be spared from this terrible disease. So plans for the spring activities planned by the Friends have been put on hold!

We had only just helped with the opening of the beautiful quilt show on Friday, March 6th, with lots of delicious cookies thanks to our members, when the following week, the Nolan Center closed its doors to help prevent the spread of the virus.

The Friends also held what was to be the first of several Wrangell gardening information meetings which was planned to culminate with the highly anticipated Garden Tour scheduled for the weekend of June 20th. However, with the uncertainty of everything right now, we will just have to cross our fingers to see if that becomes possible this year.

Those who attended the "Ready, Set, Grow!" meeting had much to share and learn about growing flowers, veggies, berries and trees but we were only able to scratch the surface. Kathy Appleman, Alice Rooney and Katherine Ivy shared their local growing experiences. The attendees were eager for their gardening tips and expertise and voiced enthusiasm for more meetings of this type. Kathy also brought some seedlings of plants she uses in her hanging baskets that we sold for a small donation for the Friends. Kathy had very helpful information on dirt and soil preparation so at least we can get our gardens started.

Be sure to check out the quilts of Wrangell's talented quilters at the Nolan Center website. Hope to see all of you around town soon. In the meantime stay safe.

Michael Bania, President of the Friends of the Museum



The Nolan Center & Harbor Light Church

COMMUNITY DRIVE-IN MOVIE

HOW TO TRAIN YOUR DRAGON
SATURDAY, APRIL 4TH
7:30 PM
HARBOR LIGHT CHURCH PARKING LOT
FREE



TUNE IN 88.1 FM



Everyone **MUST** stay within their vehicle.
A police officer will be on site.
NO restrooms available.



CLERK'S FILE

SUBMITTED BY:

Kim Lane, Borough Clerk

Upcoming Meeting/Informational dates:

4-28 Regular Assembly meeting at 6:00 p.m. by Teleconference

Until the Assembly can meet again for in-person meetings, here are some tips for Teleconference meetings:

- Each member should identify himself or herself before speaking.
- If the Assembly is taking action, a roll call vote should be taken. This isn't anything new 😊
- Please use the "hand raise" feature when you wish to speak.

The Wrangell Chamber of Commerce is maintaining a list of Local Business temporary closures and limitations. Here is the link to that page: <https://www.wrangellchamber.org/covid-19.html>

Withdrawing a Motion

A common misconception on Withdrawing a Motion is that both the member that moved and the member that seconded the motion must withdraw. That is not accurate.

Here is how this works: A motion may be withdrawn by the mover only with the *permission* of the **group**.

The mover may ask to withdraw a motion and the chair would then ask for any objections. If there are none, the motion is withdrawn.

A polled vote is not required, the Mayor can ask if there are any objections to the motion being withdrawn.

If there is an objection, then a vote must be taken, and the motion withdrawn only with a majority vote.

CITY & BOROUGH OF WRANGELL, ALASKA BOROUGH ASSEMBLY AGENDA STATEMENT

<u>AGENDA ITEM TITLE:</u>	<u>DATE:</u>	4/14/2020
	<u>Agenda Section</u>	11

Modification to a Contract Zone Agreement allowing a Third Storage Unit Building on Lot C, Torgramsen-Glasner Subdivision, Plat No. 2016-2, Zoned Light Industrial per the Original Contract Zone Agreement, requested by owner Don Glasner

SUBMITTED BY:

Carol Rushmore, Economic Development Director

<u>FISCAL NOTE:</u>		
Expenditure Required: \$XXX Total		
FY 20: \$	FY 21: \$	FY22: \$
Amount Budgeted:		
FY20 \$XXX		
Account Number(s):		
XXXXX XXX XXXX		
Account Name(s):		
Enter Text Here		
Unencumbered Balance(s) (prior to expenditure):		
\$XXX		

<u>Reviews/Approvals/Recommendations</u>	
<input type="checkbox"/> XX	Commission, Board or Committee
Name(s)	Planning and Zoning Commission
Name(s)	
<input type="checkbox"/>	Attorney
<input type="checkbox"/>	Insurance

ATTACHMENTS: 1. Existing Contract Zone 2. Letter from applicant requesting modification 3. Proposed Modified Contract Zone 4. Aerial of property

MAYOR PROCEDURE: Declare the Public Hearing open. The Mayor shall ask if there is any administrative report on the Public Hearing Item. Please then ask if there are any Persons to be Heard.

Once all persons have been heard, declare the Public Hearing closed and entertain a motion from the Assembly.

RECOMMENDATION MOTION:

Move to Approve the Modification to a Contract Zone Agreement allowing a Third Storage Unit Building on Lot C, Torgramsen-Glasner Subdivision, Plat No. 2016-2, Zoned Light Industrial per the Original Contract Zone Agreement.

SUMMARY STATEMENT:

Mr. Glasner purchased Lot C, Torgramsen-Glasner Subdivision in 2016. He sought and received a contract zone specifically for a single building indoor storage facility. Mr. Glasner requested a modification to his contract zone in late 2016 to add a second storage facility on the same property.

Mr. Glasner's original proposal changed the Single-Family zone to Light Industrial for only a single storage building. His first modification added a second storage unit building. He constructed two steel buildings of 120' X 45' and 84' X 30'.

Mr. Glasner is now submitting a modified site plan and seeking to construct a third building with 4 garage units with a footprint of 60' x 38'.

Access to the facility is currently via an existing driveway from Zimovia Highway. He widened the driveway after comments and concerns of his neighbor regarding the close proximity of vehicles and concern of conflicts of access. Based on the proposed site plan and aerial, the new building will be 25 feet from the property line with the trailer park and approximately 40+ feet from building 1, in a portion of the area that looks like it is currently used for parking and storage. Additional parking and staging is available between buildings 1 and 2 and can be made available on the sides of building 3.

Contract Zones modify the underlying zone, in this case, Single Family Residential, to Light Industrial for a very specific use as outlined in the applicant's proposal, and on which all reviews are made. The Contract Agreement is then prepared between the applicant and the Borough based on the specific request and approval. To amend or modify the proposed use and activities, requires approval and a modification to the agreement, as changes could create new or adverse impacts not originally anticipated.

The Commission determined that the proposed expansion will not create additional impacts in the area and affect the Contract Zone Agreement. The Commission is making a recommendation to the Assembly to approve the modification with the following findings as to appropriateness for the area and effects on property owners. Findings address requirements of WMC 20.76.030 (C):

- 1) Justification for the proposed change, including the effect on the objectives of the comprehensive plan
- 2) Effect of the proposed change on property owners, including traffic flow, population, density, parking, sewer and water
- 3) Approval or Disapproval

FINDINGS OF FACT:

- 1. Justification for the proposed change, including the effect on the objectives of the comprehensive plan:** The Commission deems it in the best interest of the community to approve the requested modification to the contract zone allowing a third building per the proposed modified site plan. The activities of the proposed use is in high demand and provides positive benefits to the community. The proposed use may not meet the objectives of the Future Residential Growth of the Comprehensive Plan (Ch 6.8.2) nor does it fall within the Future Growth Map 6-18 for Residential development per the underlying zone prior to the agreed zone change, but it does meet Land Use Policy 32 designating areas for commercial and industrial development. The existing use has not seemed to create major impacts to neighbors. The one complaint received by staff regarding the conflicting driveway access was addressed during the last modification request. Implementing the conditions meets Policy 33 promoting compatibility.
- 2. Effect of the proposed change on property owners, including traffic flow, population, density, parking, sewer and water:** The Commission finds that the impacts of an additional storage building to adjacent property owners will be minimal. Lighting can be directed downward and access times limited to minimize noise and visual impacts. The access driveway was shifted over previously to avoid traffic flow and access conflicts with the adjacent landowner and no additional complaints or comments have been received by staff. The condition requiring a 25-foot vegetative buffer remains as part of the agreement.
- 3. Approval or Disapproval:** The Commission recommends approval of the contract zone agreement modification request.

rev'd
2/28/20

February 25, 2020

City and Borough Of Wrangell
Carole Rushmore
P.O. Box 531
Wrangell, Ak 9929

Re: Contract Zone Modification Request

1068 Zimovia Wrangell, Ak 99929
Harbor View Storage

I have enclosed our Plat Survey Dated 7-30-15 for your review of existing structures and the location of a proposed building we would ask approval for building, now referred to as (building # 3)

The new building would be located as drawn on the survey , we would maintain 25' from property lines and not encroaching both easements that currently are located along both sides of lot property lines.

The building would be metal have 4 garage units in total, with a foot print of 60' x 38' x 16 ' Each garage would be enclosed with a single 14' high roll up door. Each unit will not have any climate control system , one light ceiling light controlled by wall switch in each unit.

Ours of operation would be limited to 7 am and 9 pm . Most of the rental units we have now are occupied by out of state boat owners and I feel we would not see any increase in vehicle traffic with the addition of 4 more garages.

Roof ridge height will be 19' at the peak and gutter height will be 16' as are the existing buildings on the property.

Thank You for the consideration of our proposed modification request.

Donald Glasner

Donald Glasner
P.O. Box 192
Hillsdale, NJ 07642

Nadia G Post

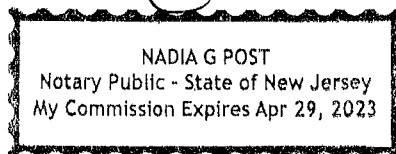

2/25/2020

03-002-300
Plat NO. 2014-2

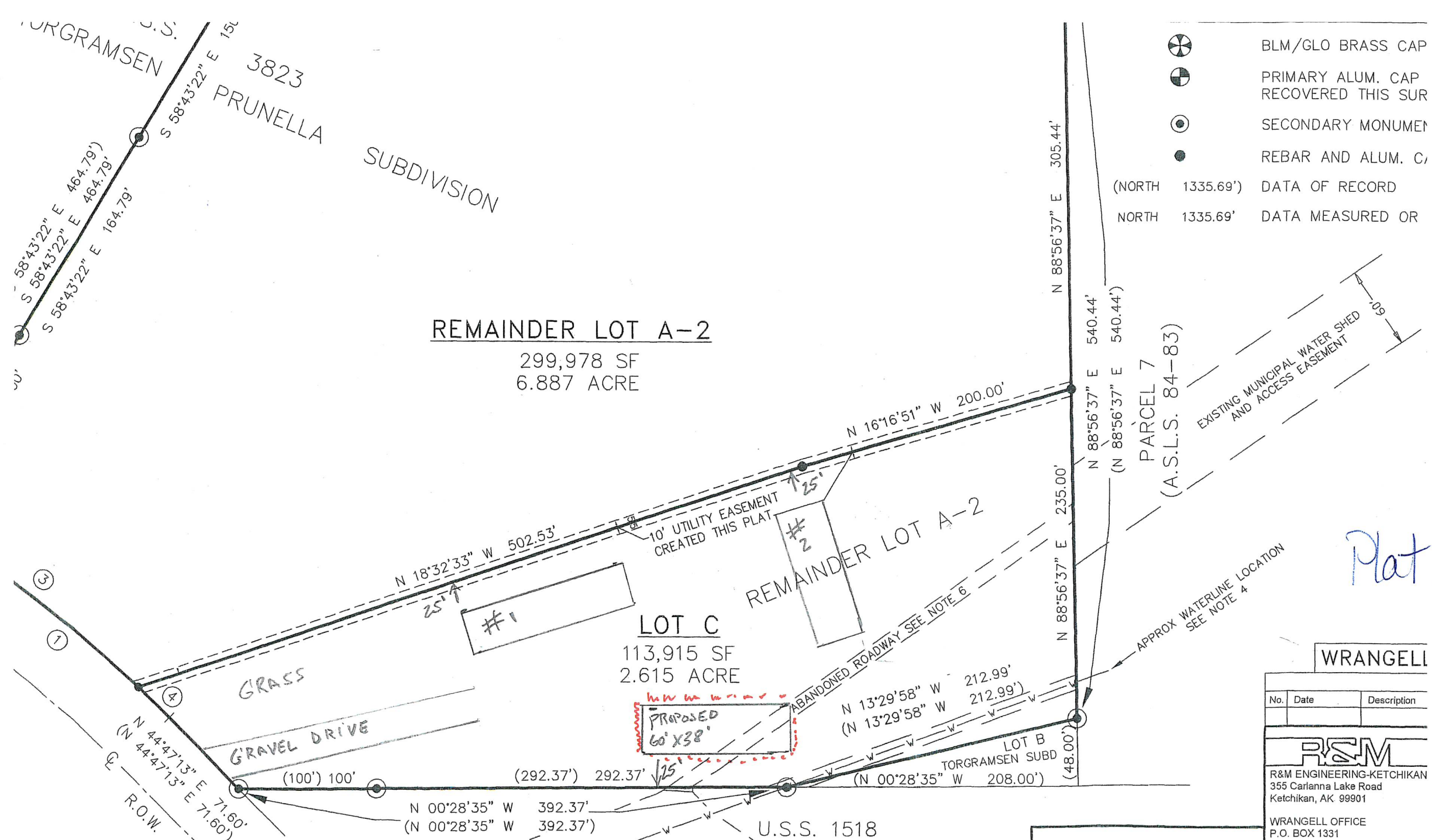

Plat No. 2016-2

WRANGELL

No.	Date	Description

RSM
R&M ENGINEERING-KETCHIKAN
355 Carlanna Lake Road
Ketchikan, AK 99901

WRANGELL OFFICE
P.O. BOX 1331
Wrangell, AK 99929

PROJECT:
TORGRAMSEN - GLASNER SUBDIV.

A SUBDIV
TORGR
CREATING
TORGRA
WIT

PROPOSED BUILDING #3
60' X 38' X 16' METAL DRY STORAGE
TOTAL OF 4 GARAGE UNITS

CLIENT: DON GLASNER
BOX 192
HILLSDALE, NEW JERSEY 07642

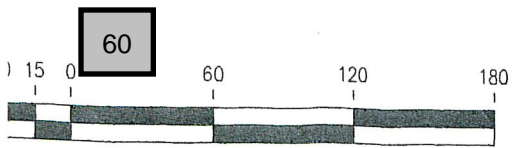
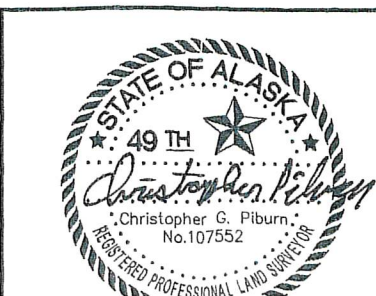

Return to: City of Wrangell
P.O. Box 531
Wrangell, Alaska 99929

Wrangell Recording District

Page 1 of 6

MODIFIED CONTRACT ZONING AGREEMENT

THIS MODIFIED AGREEMENT is made 29 day of Dec, 2016, between DONALD AND GAIL GLASNER, herein as "Glasner's.", whose address is 227 Doxy Drive, Park Ridge, NJ 07656, and the CITY & BOROUGH OF WRANGELL, referred herein as "Borough" whose address is Post Office Box 531, Wrangell, Alaska 99929.

The parties to this agreement, in consideration of the mutual covenants and promises contained herein, agree as follows:

RECITALS

1. The Glasner's are the new owners of the following described real property, to-wit:

Lot C, of the Torgramsen-Glasner Subdivision, according to Plat No. 2016-2, Wrangell Recording District, First Judicial District, State of Alaska.

2. The Wrangell Borough Assembly approved a Modified Contract Zoning Agreement to rezone the property from Single Family Residential to Light Industrial, for only the specific use as set forth below for a period 10 years and with the following condition(s):

- a. Approval of a Contract Zone for a storage unit, on 2.615 acres on Lot C, of the Torgramsen-Glasner Subdivision.
- b. Site obscuring vegetated buffer of at least 25 feet must be maintained pursuant to WMC 20.52.200 to adjacent residential properties; and
- c. Lighting at the facility should be angled downward and guarded from the sides so as to not to disturb adjacent residences; and

- d. Operating hours should be restricted to between 7:00 a.m. and 8:00 p.m. at night; and
 - e. The driveway entrance to the storage until will be widened and moved over 10 feet to avoid all conflict with the adjacent residential driveway.
3. The requirements and procedure for a Contract Zone are set forth in Chapter 20.76.020-040 and Chapter 20.77 of the Wrangell Municipal Code.

CONVENANTS

4. The Glasner's and the Borough agree that the real property described in paragraph one (1) above, shall be rezoned for a period often (10) years from the effective date above. The effective date of this Agreement is the later of the date showing the signatures of the Glasner's and the Borough Manager.
5. The Glasner's agree that the real property subject to this agreement shall be used only for the placement of two storage units ~~a storage unit~~, in addition to those uses permitted in the existing Single Family Residential zone. The storage units shall be no larger than as specified in the Petition for re-zone and the description as provided by the Glasner's, all of which are attached as Appendix A.
6. The Glasner's and the Borough agree that the real property described above will be zoned Light Industrial only so long as the property is used for the placement of a the two storage units. Should the property cease to be so used for a period of more than six (6) months for a the two storage units, the zoning classification of the property shall automatically revert to Single Family Residential, without any further notice from the Borough and without any further action necessary by the Borough. In such event, all structures not permitted in the Single Family Residential zone shall be removed within ninety (90) days of the zone cessation. If the Glasner's fail to remove the structures within the 90 days, the structures shall be deemed owned by the Borough and the Borough may maintain the structures or remove the structures in its sole discretion. Any personal property left in the structure shall become the property of the Borough. If

the Borough removes the structure at the Borough's expense, the Glasner's shall pay the Borough the full amount of all removal costs, fees and expenses.

7. The Glasner's agree that the real property subject to this agreement shall be used only for a two single storage units, in addition to those uses permitted in the existing Single Family Residential zone. The Glasner's and the Borough agree that should the real property subject to this agreement be rezoned Light Industrial or any other zoning classification which permits use of the property for the placement of a the two storage units, then the provisions of this agreement restricting the use of the property shall be null and void. It is further agreed that should any petition or application be filed by the Glasner's, with one or more adjoining property owners, to rezone the real property described above, no weight shall be given to the provisions of this agreement in considering such petition.

8. The Glasner's and the Borough s additionally agree that limitations will be and are placed upon Light Industrial use of the above described property as follows:

ADMINISTRATION AND ENFORCEMENT

9. The remedies provided for in this Agreement shall be in addition to those remedies provided for the administration and enforcement of planning and zoning laws by the State of Alaska, the Charter and Ordinances of the City & Borough of Wrangell, and the rules and regulation promulgated and adopted by the Borough.

10. This Contract Zoning agreement may be renewed for an additional ten (10) year term. The option herein created may be exercised only by notice in writing from the Glasner's, to the Borough , received by the Borough at least ninety (90), but no more than one hundred and eighty (180) days before the expiration of the initial ten (10) year term. The second term shall be subject to the additional following conditions:

- a. A determination by the Planning and Zoning Commission and the Borough Assembly that all provisions of this agreement have been complied with by the

Glasner's.

11. As an additional remedy and/or enforcement device, and not by way of limitation of any other right or remedy which may be available to the Borough, in the event that the Glasner's or any of their agents, successors or employees, violate any of the agreements, covenants or conditions of this agreement, the City shall give the Glasner's at least thirty (30) days written notice specifying the particulars of any claimed violation. If at the end of such thirty (30) day period, the Glasner's have not remedied the cause of any claimed violation, then this contract shall be automatically and immediately terminated. In the event of termination under this provision, the Glasner's will be required to fully comply with Paragraph 6 above and the Borough will be entitled to all the rights and remedies specified in Paragraph 6 above. It is specifically agreed that enforcement by termination shall be available to the Borough against the Glasner's during any period when the property has ceased to be used as required in this Agreement, or for any renewal period.

12. The Glasner's shall be required to comply with all applicable Federal, State, and Local laws, rules and regulations and this Agreement shall not be construed or interpreted as to authorize what would otherwise be precluded by any Federal, State or local law.

13. This agreement shall be binding upon all of the heirs, successors, assigns, transferees of the parties hereto, operation of law or otherwise. This Agreement shall not be assigned or transferred except in writing and approved by the Borough Assembly. The Borough Assembly will not approve a transfer to a LLC unless all the members of the LLC sign as guarantors of the performance of this Agreement.

14. The Superior Court for the State of Alaska, First Judicial District at Wrangell, Alaska, shall be the exclusive jurisdiction and venue for any action of any kind and any nature arising out of or relating to this Agreement or arising out of or relating to any performance or non-performance of this Agreement. If any action is brought to enforce this Agreement, the prevailing party shall be entitled to full, actual reasonable attorney's fees and all reasonable costs and expenses.

15. The Glasner's acknowledge and agree that they have not been promised anything by any employee, representative, Assembly member, Commission member, or the Mayor of the Borough other than as specifically stated in this Agreement. The Glasner's acknowledge and agree that they have had the opportunity to consult with independent counsel of their choice before signing this Agreement and they are signing this Agreement freely and voluntarily. The Glasner's acknowledge and agree that they have not received any advice from the Borough attorneys.

16. This Agreement shall not be modified or changed in any manner whatsoever except upon a written amendment signed by the Glasner's and the Borough after approval by the Borough Assembly. The Glasner's acknowledge and agree that no employee, representative, Assembly Member, Commission Member or the Mayor of the Borough has any actual or apparent authority to orally modify or change this Agreement.

~~has any actual or apparent authority to orally modify or change this Agreement.~~



IN WITNESS WHEREOF, the parties have executed this Agreement as of the date as signed below.

By: Donald Glasner

Name: Donald Glasner

Kelly Merlo 12/20/16

Date:

By: Jeff Jabusch

Name: Jeff Jabusch,

Title: Borough Manager

12-30-2016

Date:



By: Gail Glasner

Name: Gail Glasner

12/20/16

Date:

ACKNOWLEDGEMENT

STATE OF ALASKA)
)ss:
First Judicial District)

On this _____ day of _____, in the year 2016, before me, the undersigned notary public, personally appeared: Donald Glasner and Gail Glasner, known to me to be the person(s) whose name(s) is/are subscribed to the within instrument and acknowledged that he/she executed the same for the purposes therein contained.

In witness whereof, I hereunto set my hand and official seal.

Notary Public for Alaska
Commission expires: _____

Return to: City and Borough of Wrangell
P.O. Box 531
Wrangell, Alaska 99929

Wrangell Recording District

SECOND MODIFICATION TO CONTRACT ZONING AGREEMENT

THIS SECOND MODIFIED AGREEMENT is made ____ day of _____, 2020, between DONALD AND GAIL GLASNER, herein as "Glasner's.", whose address is 227 Doxy Drive, Park Ridge, NJ 07656, and the CITY & BOROUGH OF WRANGELL, referred herein as "Borough" whose address is Post Office Box 531, Wrangell, Alaska 99929.

The parties to this agreement, in consideration of the mutual covenants and promises contained herein, agree as follows:

RECITALS

1. The Glasner's are the owners of the following described real property, to-wit:

Lot C, of the Torgramsen-Glasner Subdivision, according to Plat No. 2016-2, Wrangell Recording District, First Judicial District, State of Alaska.

2. The Wrangell Borough Assembly approved a Contract Zoning Agreement and a subsequent Modified Agreement to rezone the property from Single Family Residential to Light Industrial and allow two storage units. This second Modified Agreement, is for only the specific uses as set forth below for a period 10 years and with the following condition(s):

- a. Approval of a Modified Contract Zone for a third storage unit, on 2.615 acres on Lot C, of the Torgramsen-Glasner Subdivision.
- b. Site obscuring vegetated buffer of at least 25 feet must be maintained pursuant to WMC 20.52.200 to adjacent residential properties; and
- c. Lighting at the facility should be angled downward and guarded from the sides so

- as to not to disturb adjacent residences; and
 - d. Operating hours should be restricted to between 7:00 a.m. and 8:00 p.m. at night; and
 - e. The driveway entrance to the storage until will be widened and moved over 10 feet to avoid all conflict with the adjacent residential driveway (completed).
3. The requirements and procedure for a Contract Zone are set forth in Chapter 20.76.020-040 and Chapter 20.77 of the Wrangell Municipal Code.

CONVENANTS

4. The Glasner's and the Borough agree that the real property described in paragraph one (1) above, shall be rezoned for a period often (10) years from the effective date above. The effective date of this Agreement is the later of the date showing the signatures of the Glasner's and the Borough Manager.
5. The Glasner's agree that the real property subject to this agreement shall be used only for the placement of three two storage units, in addition to those uses permitted in the existing Single-Family Residential zone. The storage units shall be no larger than as specified in the Petition for re-zone and the description as provided by the Glasner's, all of which are attached as Appendix A.
6. The Glasner's and the Borough agree that the real property described above will be zoned Light Industrial only so long as the property is used for the placement of the three two storage units. Should the property cease to be so used for a period of more than six (6) months for a the three two storage units, the zoning classification of the property shall automatically revert to Single Family Residential, without any further notice from the Borough and without any further action necessary by the Borough. In such event, all structures not permitted in the Single Family Residential zone shall be removed within ninety (90) days of the zone cessation. If the Glasner's fail to remove the structures within the 90 days, the structures shall be deemed owned by the Borough and the Borough may maintain the structures or remove the structures in its sole discretion.

Any personal property left in the structure shall become the property of the Borough. If the Borough removes the structure at the Borough's expense, the Glasner's shall pay the Borough the full amount of all removal costs, fees and expenses.

7. The Glasner's agree that the real property subject to this agreement shall be used only for three ~~two~~ storage units, in addition to those uses permitted in the existing Single-Family Residential zone. The Glasner's and the Borough agree that should the real property subject to this agreement be rezoned Light Industrial or any other zoning classification which permits use of the property for the placement of the two storage units, then the provisions of this agreement restricting the use of the property shall be null and void. It is further agreed that should any petition or application be filed by the Glasner's, with one or more adjoining property owners, to rezone the real property described above, no weight shall be given to the provisions of this agreement in considering such petition.

8. The Glasner's and the Borough additionally agree that limitations will be and are placed upon Light Industrial use of the above described property as follows:

ADMINISTRATION AND ENFORCEMENT

9. The remedies provided for in this Agreement shall be in addition to those remedies provided for the administration and enforcement of planning and zoning laws by the State of Alaska, the Charter and Ordinances of the City & Borough of Wrangell, and the rules and regulation promulgated and adopted by the Borough.

10. This Contract Zoning agreement may be renewed for an additional ten (10) year term. The option herein created may be exercised only by notice in writing from the Glasner's, to the Borough, received by the Borough at least ninety (90), but no more than one hundred and eighty (180) days before the expiration of the initial ten (10) year term. The second term shall be subject to the additional following conditions:

- a. A determination by the Planning and Zoning Commission and the Borough Assembly that all provisions of this agreement have been complied with by the

Glasner's.

11. As an additional remedy and/or enforcement device, and not by way of limitation of any other right or remedy which may be available to the Borough, in the event that the Glasner's or any of their agents, successors or employees, violate any of the agreements, covenants or conditions of this agreement, the City shall give the Glasner's at least thirty (30) days written notice specifying the particulars of any claimed violation. If at the end of such thirty (30) day period, the Glasner's have not remedied the cause of any claimed violation, then this contract shall be automatically and immediately terminated. In the event of termination under this provision, the Glasner's will be required to fully comply with Paragraph 6 above and the Borough will be entitled to all the rights and remedies specified in Paragraph 6 above. It is specifically agreed that enforcement by termination shall be available to the Borough against the Glasner's during any period when the property has ceased to be used as required in this Agreement, or for any renewal period.

12. The Glasner's shall be required to comply with all applicable Federal, State, and Local laws, rules and regulations and this Agreement shall not be construed or interpreted as to authorize what would otherwise be precluded by any Federal, State or local law.

13. This agreement shall be binding upon all of the heirs, successors, assigns, transferees of the parties hereto, operation of law or otherwise. This Agreement shall not be assigned or transferred except in writing and approved by the Borough Assembly. The Borough Assembly will not approve a transfer to a LLC unless all the members of the LLC sign as guarantors of the performance of this Agreement.

14. The Superior Court for the State of Alaska, First Judicial District at Wrangell, Alaska, shall be the exclusive jurisdiction and venue for any action of any kind and any nature arising out of or relating to this Agreement or arising out of or relating to any performance or non-performance of this Agreement. If any action is brought to enforce this Agreement, the prevailing party shall be entitled to full, actual reasonable attorney's fees and all reasonable costs and expenses.

15. The Glasner's acknowledge and agree that they have not been promised anything by any employee, representative, Assembly member, Commission member, or the Mayor of the Borough other than as specifically stated in this Agreement. The Glasner's acknowledge and agree that they have had the opportunity to consult with independent counsel of their choice before signing this Agreement and they are signing this Agreement freely and voluntarily. The Glasner's acknowledge and agree that they have not received any advice from the Borough attorneys.

16. This Agreement shall not be modified or changed in any manner whatsoever except upon a written amendment signed by the Glasner's and the Borough after approval by the Borough Assembly. The Glasner's acknowledge and agree that no employee, representative, Assembly Member, Commission Member or the Mayor of the Borough has any actual or apparent authority to orally modify or change this Agreement.

Item a.

CITY AND BOROUGH OF WRANGELL, ALASKA

Item a.

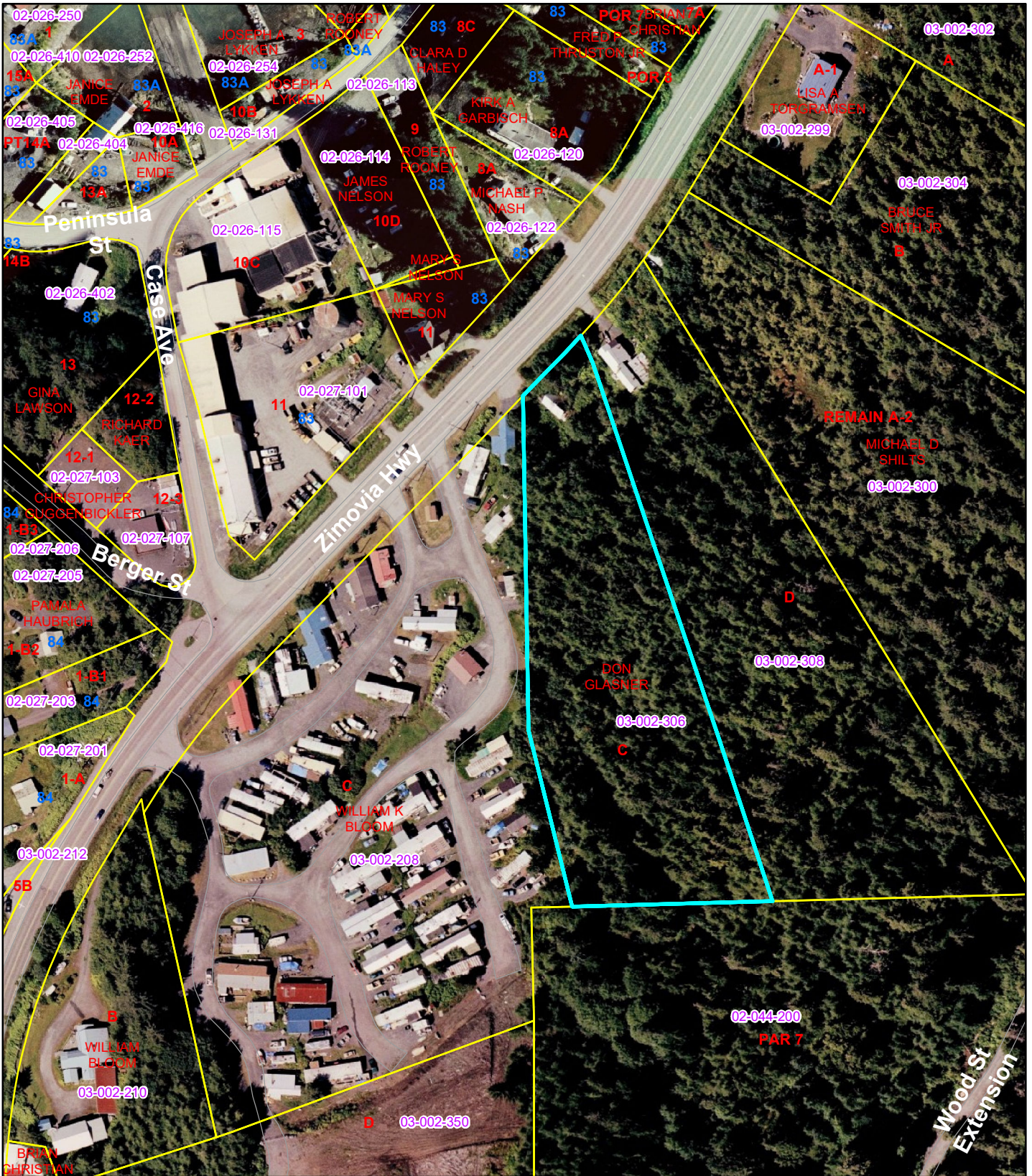

1 in 74 61.658994 feet
Date: 8/14/2020

Public Map



DISCLAIMER: THESE MAPS ARE FOR PLANNING PURPOSES ONLY. PROPERTY LINES ARE APPROXIMATE. AERIAL 2002.

glasner aerial

Item a.



March 14, 2020

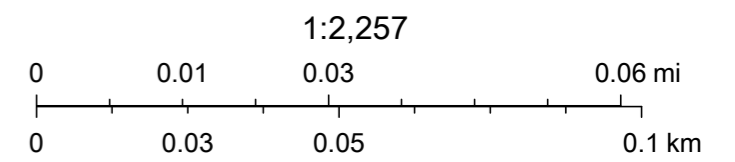

Source: Esri, DigitalGlobe, GeoEye, Earthstar Geographics, CNES/Airbus DS, USDA, USGS, AeroGRID, IGN, and the GIS User Community

**CITY & BOROUGH OF WRANGELL, ALASKA
BOROUGH ASSEMBLY AGENDA STATEMENT**

<u>AGENDA ITEM TITLE:</u>	<u>DATE:</u>	March 14, 2020
	<u>Agenda Section</u>	13

Approval of a Contract Award to Heller High Water, LLC in the Amount of \$67,000 for the City Dock Summer Float Procurement Project Rebid

SUBMITTED BY:

Amber Al-Haddad, Capital Facilities Director

FISCAL NOTE:

Expenditure Required: \$67,000		
FY 19: \$	FY 20: \$67,000	FY21: \$
Amount Budgeted:		
	FY20 \$85,000	
Account Number(s):		
Account Name(s):		
	CIP Fund for Summer Float Procurement	
Unencumbered Balance(s) (prior to expenditure):		
	\$85,000	

Reviews/Approvals/Recommendations

<input type="checkbox"/>	Commission, Board or Committee
Name(s)	
Name(s)	
<input type="checkbox"/>	Attorney
<input type="checkbox"/>	Insurance

ATTACHMENTS: 1. Bid Opening Checklist and Tabulation Summary for Rebid of City Dock Summer Float Procurement Project

RECOMMENDATION MOTION:
Move to approve a contract award to Heller High Water, LLC in the amount of \$67,000 for the City Dock Summer Float Procurement Project Rebid.

SUMMARY STATEMENT:

The cruise ship and local charter industries have indicated the need for additional mooring capacity at City Dock due to the industry's growth over the last several years. On days where more than two cruise ships are in town, the process of lightering (transferring) the passengers between an off-shore anchored ship, to the dock, is time consuming and a loss of passenger experience in Wrangell. The Harbor Department currently has three summer floats that are configured for the north side of City Dock approach dock, and there is one configured for the south side of the approach dock. The subject new summer float has been designed to be added to the existing float for the south side, and it is designed as a 10' (w) x 130' (l) mixed steel and timber floating dock.

Under the FY20 Budget, the Harbor Department scheduled the procurement of one City Dock Summer Float with funding from the Commercial Passenger Vessel Excise Tax Fund. The dock procurement was estimated at \$55,000. Additional project costs were estimated at \$30,000 for the lumber and hardware package, which the Harbor Department plans to procure and install on the steel float once it arrives in Wrangell. All work is anticipated to be complete in time for the new float to be placed in the water for use by the beginning of the summer season.

A recommendation to award this project to the low bidder, Heller High Water, LLC, was approved by the Assembly in February. Prior to issuing the contract, staff learned that the low bidder's pipe material did not meet specification, nor did the second low bidder's pipe material meet specification, both due to the lack of availability of the pipe material that met the standard specified in the Borough's solicitation. Upon counsel's recommendation, the Borough manager rejected all bids and the project was rebid, with the opening of the rebids on March 24, 2020. The apparent lowest, responsive and responsible bid was received from Heller High Water, LLC (the original low bidder) in the amount of \$67,000. Two other bids were received from Tamico (\$75,000) and Island Construction (\$118,70). Staff recommends awarding the procurement contract to Heller High Water, LLC who confirmed that the material specified in our solicitation rebid is included in their bid.

The original low bid in February was \$66,301.07. The difference between the two is \$698.93.

Rebid of City Dock Summer Float Procurement Project
 Bid Opening: Tuesday, March 24, 2020 at 2:00 p.m.
 Assembly Chambers via Teleconference

Bidder's Name	Signed Bid Proposal	Addenda		Bid	Bid Modification	Total Bid with Modification	Total Based on 5% Local Bidder Preference (applicable)
		#1					
Tamico Inc	X	X		\$ 75,000.00		\$ 75,000.00	
Island Contractors	X	X		\$ 160,000.00	\$ (41,300.00)	\$ 118,700.00	
Heller Highwater LLC	X	X		\$ 67,000.00			

Verified By: [Signature]

Witnessed By: [Signature]

Item a.