MEETING NOTICE

The Planning and Zoning Commission of the City of Woodcreek, Texas will conduct a meeting at Woodcreek City Hall, 41 Champions Circle, Woodcreek, Texas. The meeting will be held on Wednesday, June 07, 2023 at 5:00 PM.

All attendees are encouraged to wear face coverings when a minimum of six-foot social distancing cannot be maintained. Smoking is not allowed anywhere on the property of City Hall.

The public may watch this meeting live at the following link:

<https://zoom.us/j/91095919772?pwd=dll2RC9uRmRiSVd5L3RES20yQXJrdz09;>

Meeting ID: 910 9591 9772; Passcode: 554364

A recording of the meeting will be made and will be available to the public in accordance with the Texas Public Information Act upon written request. This notice, as amended, is posted pursuant to the Texas Open Meetings Act (Vernon's Texas Codes Ann. Gov. Code Chapter 551).

The City of Woodcreek is committed to compliance with the Americans with Disabilities Act. Reasonable modifications and equal access to communications will be provided upon request. Please call the City Secretary's Office at 512-847-9390 for information. Hearing-impaired or speech disabled persons equipped with telecommunications devices for the deaf may call 7-1-1 or may utilize the statewide Relay Texas program at 1-800-735-2988.

Pursuant to Section 30.07, Penal Code (trespass by license holder with an openly carried handgun), a person licensed under Subchapter H, Chapter 411, Government Code (handgun licensing law), may not enter this property with a handgun that is carried openly.

It is anticipated that members of other City Boards, Commissions, Panels and/or Committees may attend the meeting in numbers that may constitute a quorum of the other City Boards, Commissions, Panels and/or Committees. Notice is hereby given that this meeting, to the extent required by law, is also noticed as a meeting of the other City Boards, Commissions, Panels and/or Committees of the City, whose members may be in attendance. The members of the City Boards, Commissions, Panels and/or Committees may participate in discussions on the items listed on this agenda, which occur at this meeting, but no action will be taken by those in attendance unless such action item is specifically listed on an agenda during a regular or special meeting for the respective Board, Commission, Panel and/or Committee subject to the Texas Open Meetings Act.

The City Council may retire to Executive Session any time during this meeting, under Texas Government Code, Subchapter D. Action, if any, will be taken in open session.

This agenda has been reviewed and approved by the City's legal counsel and the presence of any subject in any Executive Session portion of the agenda constitutes a written interpretation of Texas Government Code Chapter 551 by legal counsel for the governmental body and constitutes an opinion by the attorney that the items discussed therein may be legally discussed in the closed portion of the meeting considering available opinions of a court of record and opinions of the Texas Attorney General known to the attorney. This provision has been added to this agenda with the intent to meet all elements necessary to satisfy Texas Government Code Chapter 551.144(c) and the meeting is conducted by all participants in reliance on this opinion.

Any citizen shall have a reasonable opportunity to be heard at any and all meetings of the Governing Body in regard to: (1) any and all matters to be considered at any such meeting, or (2) any matter a citizen may wish to bring to the Governing Body's attention. No member of the Governing Body may discuss or comment on any citizen public comment, except to make: (1) a statement of specific, factual information given in response to the inquiry, or (2) a recitation of existing policy in response to the inquiry. Any deliberation of or decision about the subject of the inquiry shall be limited to a proposal to place the subject on the agenda for a subsequent meeting per Texas Local Government code Sec. 551.042

Citizen comments will be allowed at the beginning of every meeting, or alternatively, before an item on the agenda upon which the citizen wishes to speak is to be considered. All citizens will be allowed to comment for **three (3) minutes** per person and shall be allowed more time at the Mayor or Chair's discretion. In addition, citizens may pool their allotted speaking time. To pool time, a speaker must present the names individuals present in the audience who wish to yield their three(3) minutes. Citizens may present materials regarding any agenda item to the City Secretary at or before a meeting, citizens attending any meeting are requested to complete a form providing their name, address, and agenda item/concern, but are not required to do so before speaking and presenting it to the City Secretary prior to the beginning of such meeting. Comments may only be disallowed and/or limited as per Government Code § 551.007(e).

Submit written comments by email to woodcreek@woodcreektx.gov by **NOON**, the day prior to the meeting. Please include your full name, home or work address, and the agenda item number. Written comments will be part of the official written record only.

AGENDA

CALL TO ORDER

ROLL CALL and ESTABLISH QUORUM

PUBLIC COMMENTS

CONSENT AGENDA

1. Approval of Regular Meeting Minutes from May 3, 2023.

REPORTS FROM OFFICERS AND COUNCIL LIAISONS

Report by Planning and Zoning Commission Liaison.

Report by City Manager.

REGULAR AGENDA

2. Public Hearing to Consider Recommending to City Council The Adoption of An Ordinance, Amending the Existing Ordinance at TITLE XV ("Land Usage"), Chapter 156.058 ("Above Ground Pools").
3. Discuss and Take Action Regarding the Possible Recommendation to City Council to Adopt An Ordinance, Amending the Existing Ordinance at TITLE XV ("Land Usage"), Chapter 156.058 ("Above Ground Pools").

ANNOUNCEMENTS

ADJOURN

POSTING CERTIFICATION

I certify that the above notice was posted on the **2nd day of June 2023 at 2:30 PM**

By: 

Suzanne J. MacKenzie, City Secretary

PLANNING AND ZONING COMMISSION MEETING (CITY HALL)
May 03, 2023; 5:00 PM
Woodcreek, Texas

MINUTES

CALL TO ORDER

Chair Davenport Called the Meeting to Order at 5:02P.

ROLL CALL and ESTABLISH QUORUM

PRESENT

Chairperson Andy Davenport
Vice-Chairperson Lydia Johns
Commissioner Tamara Robertson
Alt. Commissioner Carson Bledsoe
Alt. Commissioner Josh Erwin
Council Liaison Chrys Grummert

ABSENT

Commissioner Tomas Palm
Commissioner Chris Sonnier

STAFF PRESENT

City Manager, Kevin Rule
City Secretary, Suzanne Mac Kenzie

PUBLIC COMMENTS

Public Comments were offered by Nikki and Joseph Smith.

CONSENT AGENDA

1. Approval of Special Meeting Minutes from February 8, 2023.

Motion was made by Vice-Chair Johns to accept the minutes. Motion was seconded by Alt. Commissioner Erwin.

A roll call vote was held.

Voting Yea: Vice-Chair Johns, Commissioner Robertson, Alt. Commissioner Bledsoe, Alt. Commissioner Erwin, Chair Davenport

Motion passed: 5-0-0.

2. Approval of Regular Meeting Minutes from March 1, 2023.

Motion was made by Vice-Chair Johns to accept the minutes, with the correction on Item 4 to amend the motion as "passed". Motion was seconded by Alt. Commissioner Erwin.

A roll call vote was held.

Voting Yea: Commissioner Robertson, Alt. Commissioner Bledsoe, Alt. Commissioner Erwin, Chair Davenport, Vice-Chair Johns

Motion passed: 5-0-0.

REPORTS FROM OFFICERS AND COUNCIL LIAISONS.

Report by Planning and Zoning Liaison.

Additional handout that was prepared by Council Member Hines has been presented to review, in addition to information in the packet.

Report by City Manager. – No report offered.

REGULAR AGENDA

1. Workshop to Discuss Adoption of A New Ordinance for Above Ground Pools.

Workshop Opened at 5:13P.

Discussion that above ground pools should be inspected every 2 years, for structural integrity and safety.

Staff answered questions about the inspection process and the number of inspections performed by ATS, the City Engineer.

Workshop Closed at 5:58P

2. Discuss and Take Possible Action on the Adoption of A New Ordinance for Above Ground Pools.

Motion was made by Alt. Commissioner Bledsoe to recommend the adoption of the Above Ground Pool Ordinance with the amendment to strike letter "B" and remove the word "disuse" from letter "E".

A roll call vote was held.

Voting Yea: Chair Davenport, Vice-Chair Johns, Commissioner Robertson, Alt. Commissioner Bledsoe, Alt. Commissioner Erwin

Motion passed: 5-0-0.

An amendment to the main motion was made by Commissioner Robertson to not strike out letter "B", but change it to read as the initial inspection [at installation] and a reinspection after two years as a final inspection. Amended motion was seconded by Vice-Chair Johns.

A roll call vote was held.

Voting Yea: Alt. Commissioner Erwin, Chair Davenport, Vice-Chair Johns, Commissioner Robertson

Motion passed: 4-0-0.

A motion was passed by Alt. Commissioner Bledsoe to hold a Public Hearing at the next meeting, June 7, 2023. Motion was seconded by Commissioner Robertson.

A roll call vote was held.

Voting Yea: Vice-Chair Johns, Commissioner Robertson, Alt. Commissioner Bledsoe, Alt. Commissioner Erwin, Chair Davenport

Motion passed: 4-0-0.

ADJOURN

Chair Davenport Adjourned the Meeting at 6:09P.

Andy Davenport, Chairperson

Suzanne Mac Kenzie, City Secretary

ORDINANCE NO. 22-XXX

CITY OF WOODCREEK, TEXAS

AMENDMENT TO CHAPTER 156 OF THE CODE OF ORDINANCES LAND USAGE ORDINANCE

AN ORDINANCE AMENDING THE CITY OF WOODCREEK CODE OF ORDINANCES AT TITLE XV ("LAND USAGE"), CHAPTER 156.058 ("Above-Ground Pools"); PROVIDING FOR ENACTMENT, REPEALER, SEVERABILITY, CODIFICATION, AND EFFECTIVE DATE, AND FINDING PROPER NOTICE AND MEETING.

WHEREAS, the Ordinances of the City should be amended to better provide an attractive living environment and to protect the health, safety and welfare of the present and future residents of the City;

WHEREAS, the citizens and citizen groups have been afforded time to provide comment and make recommendations on the provisions and content of this Ordinance;

WHEREAS, the content and provisions of this Ordinance have been considered at a multiple public meetings at which citizen review and comment was solicited;

WHEREAS, the Planning and Zoning Commission recommended the foregoing Ordinance to the City Council after having first given notice and held Public Hearings as required by Chapter 211, Tex. Loc. Government Code;

And

WHEREAS, the City Council having given notice and held Public Hearings in compliance with Chapter 211, finds the terms and provisions of this Ordinance are advocated and supported by the citizens of the City, and are reasonable and necessary to accomplish the intended and legitimate public purpose;

NOW, THEREFORE, BE IT ORDAINED by the City Council of the City of Woodcreek:

2. FINDINGS OF FACT

The foregoing recitals are incorporated into this Ordinance by reference as findings of fact as if expressly set forth herein.

2. ENACTMENT

Chapters 156.058 (“Above-Ground Pools”) of the Code of Ordinances of the City of Woodcreek is amended so as to read in accordance with Attachment A, which is attached hereto and incorporated into this Ordinance for all intents and purposes.

3. REPEALER

All ordinances, resolutions, or parts thereof, that are in conflict or inconsistent with any provision of this Ordinance are hereby repealed to the extent of such conflict, and the provisions of this Ordinance shall be and remain controlling as to the matters regulated, herein.

4. SEVERABILITY

Should any of the clauses, sentences, paragraphs, sections or parts of this Ordinance be deemed invalid, unconstitutional, or unenforceable by a court of law or administrative agency with jurisdiction over the matter, such action shall not be construed to affect any other valid portion of this Ordinance.

5. CODIFICATION

The City Secretary is hereby authorized and directed to record and publish the language of Chapter 156.058 as amended by this Ordinance, in the City's Code of Ordinances.

6. EFFECTIVE DATE

This Ordinance shall be effective immediately upon its passage and the publication of caption of this ordinance as provided by law.

7. PROPER NOTICE & MEETING

It is hereby officially found and determined that the meeting at which this Ordinance was passed was attended by a quorum of the City Council, was open to the public, and that public notice of the time, place and purpose of said meeting was given as required by the Open Meetings Act, Texas Government Code, Chapter 551. 27.

PASSED & APPROVED this, the ___ day of _____ 2023, by a vote of _____ (ayes) to _____ (nays) and _____ (abstentions) of the City Council of Woodcreek, Texas.

City of Woodcreek:

Attest _____

Jeff Rasco, Mayor

Suzanne Mac Kenzie, City Secretary

Attachment "A"
City of Woodcreek
CODE OF ORDINANCES
TITLE XV: LAND USAGE
CHAPTER 156.058: ABOVE-GROUND POOLS

§ 156.060 Above-Ground Pools

- (A) Permits are required for all above-ground swimming pools.
- (B) An above-ground pool permit is required to complete an initial inspection upon installation and is subject to a final inspection after two (2) years.
- (C) Filling a newly installed pool or refilling an existing pool over 15% of its capacity must be performed using water sources outside of the City. Pool water filling receipts must be provided for the City's approval of the permit or renewal.
- (D) Above-ground pools must comply with the following requirements:
 - 1) Subject to Impervious Coverage requirements under §50.37(c)(6);
 - 2) Subject to Water Quality rules in outlined in Chapter 50;
 - 3) Subject to the requirements of the most recently adopted copy of the International Swimming Pool and Spa Code. Located in the office of the City Secretary; and
 - 4) Subject to applicable City Ordinances and state laws.
- (E) Pools in disrepair, damaged or without water must be dismantled and fully removed from the premises.
- (F) Above-ground pools may not be located within the front yard of any property and must abide by the applicable property setbacks.

CHAPTER 7

ONGROUND STORABLE RESIDENTIAL SWIMMING POOLS

SECTION 701
GENERAL

701.1 Scope. This chapter describes certain criteria for the design, manufacturing, and testing of *onground storable pools* intended for *residential* use. This includes portable pools with flexible or nonrigid side walls that achieve their structural integrity by means of uniform shape, support frame or a combination thereof, and that can be disassembled for storage or relocation. This chapter includes what has been commonly referred to in past standards or codes as onground or above-ground pools.

701.1.1 Permanent inground residential swimming pool. This chapter does not apply to permanent inground *residential* pools, as defined in Chapter 8.

701.2 General. In addition to the requirements of this chapter, onground storable *residential* swimming pools shall comply with the requirements of Chapter 3.

701.3 Floor slopes. Floor slopes shall be uniform and in accordance with Sections 701.3.1 through 701.3.4.

701.3.1 Shallow end. The slope of the floor from the shallow end wall towards the deep area shall not exceed 1 unit vertical in 7 units horizontal (14-percent slope) to the point of the first slope change.

701.3.2 Transition. The slope of the floor from the point of the first slope change towards the deepest point shall not exceed 1 unit vertical in 3 units horizontal (33-percent slope).

701.3.3 Adjacent. The slope adjacent to the shallow area shall not exceed 1 unit vertical in 3 units horizontal (33-percent slope) and the slope adjacent to the side walls shall not exceed 1 unit vertical in 1 unit horizontal (100-percent slope).

701.3.4 Change point. The point of the first slope change shall be defined as the point at which the shallow area slope exceeds 1 unit vertical in 7 units horizontal (14-percent slope) and is not less than 6 feet (1889 mm) from the shallow end wall of the pool.

701.4 Identification. For onground storable *residential* pools with a vinyl liner, the manufacturer's name and the liner identification number shall be affixed to the liner. For onground storable *residential* pools without a liner, the manufacturer's name and identification number shall be affixed to the exterior of the pool structure.

701.5 Installation. *Onground storable pools* shall be installed in accordance with the manufacturer's instructions.

SECTION 702
LADDERS AND STAIRS

702.1 Ladders and stairs. Pools shall have a means of entry and exit consisting of not less than one ladder or a ladder and staircase combination.

702.2 Type A and Type B ladders. Type A, double access, and Type B, limited access, A-frame ladders shall comply with Sections 702.2.1 through 702.2.7. See Figure 702.2.

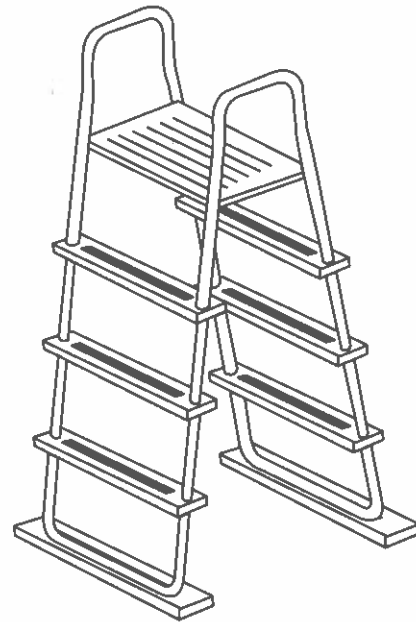

FIGURE 702.2
TYPICAL A-FRAME LADDER, TYPES A AND B

702.2.1 Barrier required. Ladders in the pool shall have a physical barrier to prevent children from swimming through the riser openings or behind the ladder.

Exception: Barriers for ladders shall not be required where the ladder manufacturer provides a certification statement that the ladder complies with the ladder entrapment test requirements of APSP 4.

702.2.2 Platform. Where an A-frame ladder has a platform between the handrails, the platform shall have a width of not less than 12 inches (305 mm) and a length of not less than 12 inches (305 mm). The platform shall be at or above the highest ladder tread. The walking surface of the platform shall be slip resistant.

702.2.3 Handrails or handholds. A-frame ladders shall have two handrails or handholds that serve all treads. The height of the handrails and handholds shall be not less than 20 inches (508 mm) above the platform or uppermost tread, whichever is higher.

702.2.4 Diameter. The outside diameter of handrails and handholds shall be not less than 1 inch (25 mm) and not greater than 1.9 inches (48 mm).

702.2.5 Clear distance. The clear distance between ladder handrails shall be not less than a space of 12 inches (305 mm).

702.2.6 Treads. Ladder treads shall have a horizontal uniform depth of not less than 2 inches (51 mm).

702.2.7 Riser height. Risers, other than the bottom riser, shall be of uniform height that is not less than 7 inches (178 mm) and not greater than 12 inches (305 mm). The bottom riser height shall be not less than 7 inches (178 mm) and not greater than 12 inches (305 mm). The vertical distance from the platform or top of the pool structure to the uppermost tread shall be the same as the uniform riser heights.

702.3 Type C staircase ladders (ground to deck). Type C staircase ladders shall comply with Sections 702.3.1 through 702.3.6. See Figure 702.3.

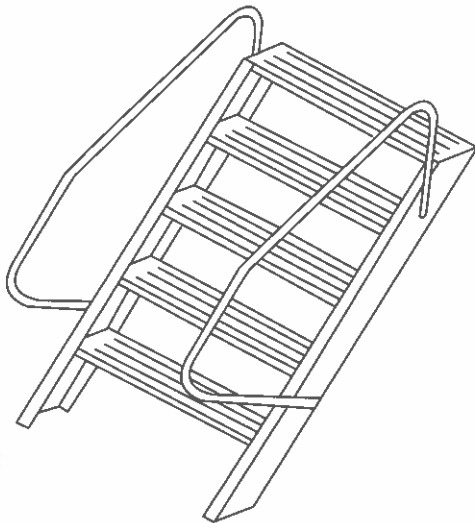

FIGURE 702.3
TYPICAL STAIRCASE LADDER, TYPE C

702.3.1 Handrails or handholds. Staircase ladders shall have not less than two handrails or handholds that serve all treads. The height of the handrails and handholds shall be not less than 20 inches (508 mm) above the platform or uppermost tread, whichever is higher.

702.3.2 Diameter. The outside diameter of handrails and handholds shall be not less than 1 inch (25 mm) and not greater than 1.9 inches (48 mm).

702.3.3 Treads. Ladder treads shall have a horizontal uniform depth of not less than 4 inches (102 mm).

702.3.4 Riser height. Risers, other than the bottom riser, shall be of uniform height that is not less than 7 inches (178 mm) and not greater than 12 inches (305 mm). The bottom riser height shall be not less than 7 inches (178 mm) and not greater than 12 inches (305 mm). The vertical distance from the platform or top of the pool structure to the uppermost tread shall be the same as the uniform riser heights.

702.3.5 Top step. The top step of a staircase ladder shall be flush with the deck or 7 inches (178 mm) to 12 inches (305 mm) below the deck level.

702.3.6 Width. Steps shall have a minimum unobstructed width of 19 inches (483 mm) between the side rails.

702.4 Type D in-pool ladders. Type D in-pool ladders shall be in accordance with Sections 702.4.1 through 702.4.7. See Figure 702.4.

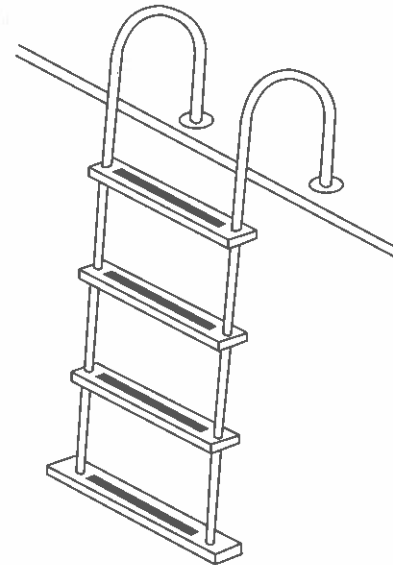

FIGURE 702.4
TYPICAL IN-POOL LADDER, TYPE D

702.4.1 Clearance. There shall be a clearance of not less than 3 inches (76 mm) and not greater than 6 inches (152 mm) between the pool wall and the ladder.

702.4.2 Handrails or handholds. Ladders shall be equipped with two handrails or handholds that extend above the platform or deck not less than 20 inches (508 mm).

702.4.3 Clear distance. The clear distance between ladder handrails shall be not less than 12 inches (305 mm).

702.4.4 Diameter. The outside diameter of handrails and handholds shall be not less than 1 inch (25 mm) and not greater than 1.9 inches (48 mm).

702.4.5 Riser height. Risers, other than the bottom riser, shall be of uniform height that is not less than 7 inches (178 mm) and not greater than 12 inches (305 mm). The bottom riser height shall be not less than 7 inches (178 mm) and not greater than 12 inches (305 mm).

702.4.6 Top tread. The vertical distance from the pool coping, deck, or step surface to the uppermost tread shall be not less than 7 inches (178 mm) and not greater than 12 inches (305 mm) and uniform with other riser heights.

702.4.7 Tread depth. Ladder treads shall have a horizontal uniform depth of not less than 2 inches (51 mm).

702.5 Type E protruding in-pool stairs. Type E protruding in-pool stairs shall be in accordance with Sections 702.5.1 through 702.5.7. See Figure 702.5.

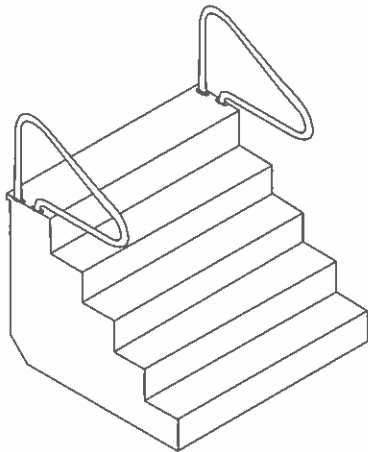

FIGURE 702.5
TYPICAL IN-POOL STAIRCASE TYPES, E AND F

702.5.1 Barrier required. In-pool stairs shall have a physical barrier to prevent children from swimming through the riser openings or behind the in-pool stairs.

702.5.2 Handrails or handholds. In-pool stairs shall be equipped with not less than one handrail or handhold that serves all treads with a height of not less than 20 inches (508 mm) above the platform or uppermost tread, whichever is higher.

702.5.3 Removable handrails. Where handrails are removable, they shall be installed such that they cannot be removed without the use of tools.

702.5.4 Leading edge distance. The leading edge of handrails shall be 18 inches (457 mm) ± 3 inches (± 76 mm), horizontally from the vertical plane of the bottom riser.

702.5.5 Diameter. The outside diameter of handrails and handholds shall be not less than 1 inch (25 mm) and not greater than 1.9 inches (48 mm).

702.5.6 Tread width and depth. Treads shall have an unobstructed horizontal depth of not less than 10 inches (254 mm) and an unobstructed surface area of not less than 240 square inches (0.15 m²).

702.5.7 Uniform riser height. Risers, other than the bottom riser, shall be of uniform height that is not less than 7 inches (178 mm) and not greater than 12 inches (305 mm). The bottom riser height shall be not less than 7 inches (178 mm) and not greater than 12 inches (305 mm). The verti-

cal distance from the pool coping, deck or step surface to the uppermost tread of the stairs shall be the same as the uniform riser heights.

702.6 Type F recessed in-pool stairs. Type F recessed in-pool stairs shall be in accordance with Sections 702.6.1 through 702.6.7. See Figure 702.5.

702.6.1 Barrier required. In-pool stairs shall have a physical barrier to prevent children from swimming through the riser openings or behind the in-pool stairs.

702.6.2 Handrails or handholds. In-pool stairs shall be equipped with not less than one handrail or handhold that serves all treads with a height of not less than 20 inches (508 mm) above the platform or uppermost tread, whichever is higher.

702.6.3 Removable handrails. Where handrails are removable, they shall be installed such that they cannot be removed without the use of tools.

702.6.4 Leading edge distance. The leading edge of handrails shall be 18 inches (457 mm) ± 3 inches (± 76 mm), horizontally from the vertical plane of the bottom riser.

702.6.5 Diameter. The outside diameter of handrails and handholds shall be not less than 1 inch (25 mm) and not greater than 1.9 inches (48 mm).

702.6.6 Tread width and depth. Treads shall have an unobstructed horizontal depth of not less than 10 inches (254 mm) at all points and an unobstructed surface area of not less than 240 square inches (0.15 m²).

702.6.7 Uniform riser height. Risers, other than the bottom riser, shall be of uniform height that is not less than 7 inches (178 mm) and not greater than 12 inches (305 mm). The bottom riser height shall be not less than 7 inches (178 mm) and not greater than 12 inches (305 mm). The vertical distance from the pool coping, deck or step surface to the uppermost tread of the stairs shall be the same as the uniform riser heights.

SECTION 703 DECKS

703.1 General. Decks provided by the pool manufacturer shall be installed in accordance with the manufacturer's instructions. Decks fabricated on-site shall be in accordance with the *International Residential Code*.

703.2 Cantilevered. The top surface of a cantilevered deck shall be not greater than 1 inch (25 mm) higher than the top of the pool wall. See Figure 703.4. The top surface of a noncantilevered deck shall be not higher than the top of the pool wall.

703.3 No gaps. Decks that are installed flush with the top rail of the pool shall have all gap openings between the deck and top rails closed-off or capped.

703.4 Extension over pool. Where a deck extends inside the top rail of the pool, it shall extend not more than 3 inches (76 mm) beyond the inside of the top rail of the pool in accordance with Figure 703.4 and shall have a smooth finish.

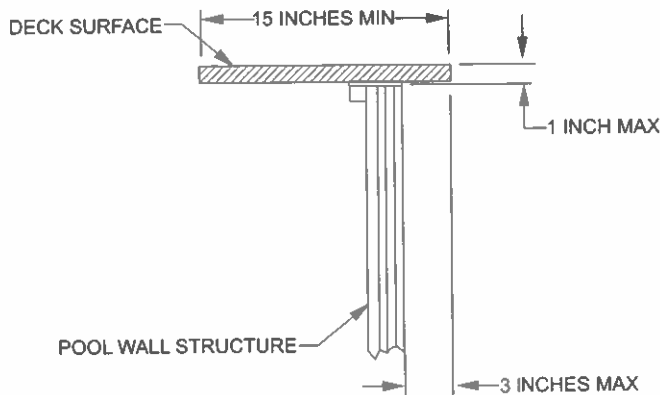

For SI: 1 inch = 25.4 mm.

FIGURE 703.4
TYPICAL CANTILEVERED DECK SUPPORT

703.5 Slip resistant. The deck walking surface shall be slip resistant.

703.6 Walk-around decks. Walk-around decks shall have a level walking surface of not less than 15 inches (381 mm) in width, as measured from the inside edge of the pool top rail to the outside of the pool walk-around. See Figure 703.6.

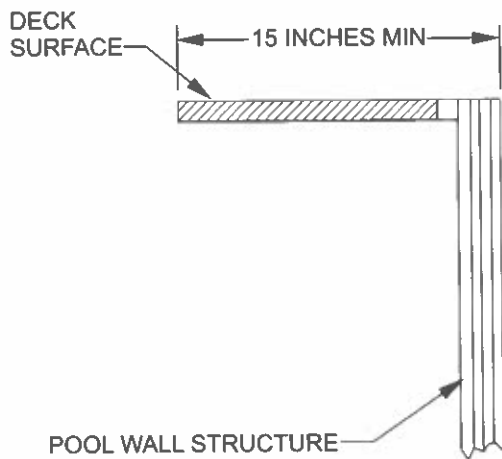

For SI: 1 inch = 25.4 mm.

FIGURE 703.6
WALK-AROUND DECK WIDTH

SECTION 704
CIRCULATION SYSTEM

704.1 General. A circulation system consisting of pumps, hoses, tubing, piping, return inlets, suction outlets, filters and other related equipment that provides for the circulation of water throughout the pool shall be located so that such items cannot be used by young children as a means of access to the pool.

704.2 Installation and support. Circulation equipment shall be installed, mounted and supported in accordance with the manufacturer's instructions.

704.3 Draining the system. In climates subject to freezing, circulation system equipment shall be designed and fabricated to drain the pool water from the equipment and exposed piping, by removal of drain plugs and manipulating valves or by other methods in accordance with the manufacturer's instructions.

704.4 Turnover. A pump including a motor shall be provided for circulation of the pool water. The equipment shall be sized to provide a turnover of the pool water not less than once every 12 hours. The system shall be designed to provide the required turnover rate based on the manufacturer's specified maximum flow rate of the filter, with a clean media condition of the filter. The system flow shall not exceed the filter manufacturer's maximum filter flow rate.

704.5 Piping and fittings. The process piping of the circulation system, including but not limited to hoses, tubing, piping, and fittings, shall be made of nontoxic material and shall be capable of withstanding an internal pressure of not less than 1½ times the rated pressure of the pump. Piping on the suction side of the pump shall not collapse when flow into such piping is blocked.

704.6 Filters. Pressure-type filters shall have an automatic internal means or a manual external means to relieve accumulated air pressure inside the filter tank. Filter tanks composed of upper and lower tank lids that are held in place by a perimeter clamp shall have a perimeter clamp that provides for a slow and safe release of air pressure before the clamp disengages the lids.

704.6.1 Automatic internal air relief. Filter tanks incorporating an automatic internal air relief as the principal means of air release shall be designed with a means to provide for a slow and safe release of pressure.

704.6.2 Separation tank. A separation tank used in conjunction with a filter tank shall have a manual air release or the tank shall be designed to provide for a slow and safe release of pressure when the tank is opened.

704.7 Pumps. Pool pumps shall be tested and certified by a nationally recognized testing laboratory in accordance with UL 1081.

704.7.1 Cleanable strainer. Where a pressure-type filter is installed, a cleanable strainer or screen that captures materials such as solids, debris, hair and lint shall be provided upstream of the circulation pump.

704.7.2 Accessible pumps and motors. Pumps and motors shall be accessible for inspection and service in accordance with the pump and motor manufacturer's instructions.

704.7.3 Pump shutoff valves. An accessible means of shut off of the suction and discharge piping for the pump shall be provided for maintenance and removal of the pump.

704.8 Outlets and return inlets. Outlets or suction outlets and return inlets shall be provided and arranged to produce

uniform circulation of water so that sanitizer residual is maintained throughout the pool. Where installed, submerged suction outlets shall conform to APSP 16.

704.9 Surface skimmer systems. The surface skimming system provided shall be designed and constructed to skim the pool surface when the water level is maintained between the minimum and maximum fill level of the pool.

704.9.1 Coverage where used as a sole outlet. Where surface skimmers are used as the only pool water outlet system, not less than one skimmer shall be provided for each 800 square feet (74.3 m²), or fraction thereof, of the water surface area.

704.9.2 Coverage where used in combination with other outlets. Where surface skimmers are not the only outlet for pool water, they shall be considered to cover only that fraction of the 800 square feet (74.3 m²).

704.9.3 Location and venting. Skimmers shall be equipped with a vent that serves as a vacuum break.

**SECTION 705
SAFETY SIGNS**

705.1. Signs to be installed prior to final inspection. Safety signage such as “NO DIVING” signs and other safe use instruction signs that are provided by the pool and ladder manufacturer shall be posted in accordance with the manufacturer’s instructions prior to final inspection.

705.2 Safety signs for ladders. Safety signage for ladders shall be in accordance with Sections 705.2.1 through 705.2.3.2.

705.2.1 A-frame ladders. Safety signage for A-frame ladders shall be in accordance with Sections 705.2.1.1 through 705.2.1.4.1. The words on the signage shall be readable by persons standing in the pool and standing outside of the pool as applicable for the required location of each sign.

705.2.1.1 No diving warning. A-frame ladders shall have the following words posted on the in-pool side of the ladder and on the pool entry side of the ladder: “NO DIVING.” The location of the words shall be above the elevation of the design water level of the pool.

705.2.1.2 Entrapment warning. A-frame ladders shall have the following words posted on the pool side of the ladder: “TO PREVENT ENTRAPMENT OR DROWNING DO NOT SWIM THROUGH, BEHIND, OR AROUND LADDER.”

705.2.1.3 Type A, A-frame ladders. Type A double access A-frame ladders shall have the following words posted on the ladder: “REMOVE AND SECURE LADDER WHEN POOL IS NOT OCCUPIED.”

705.2.1.4 Type B, A-frame ladders. Type B limited access A-frame ladders shall have the following words posted on the ladder: “SECURE LADDER WHEN POOL IS NOT OCCUPIED.”

705.2.1.4.1 Swing up or slide up secured ladders. Type B limited access A-frame ladders that utilize

swing-up or slide-up sections for limiting access to the pool shall have the following words posted on the ladder as applicable for the type of securing method:

1. “WHEN POOL IS NOT OCCUPIED, SWING UP AND SECURE.”
2. “WHEN POOL IS NOT OCCUPIED, LIFT OFF.”
3. “WHEN POOL IS NOT OCCUPIED, SLIDE UP AND SECURE.”

705.2.2 Type C staircase ladders. Type C staircase ladders that swing up to limit access to the pool or that are removed to limit access to the pool shall have the following words posted on the ladder: “WHEN NOT IN USE SWING UP AND SECURE OR REMOVE.”

705.2.3 Type D in-pool ladder. Safety signage for Type D in-pool ladders shall be in accordance with Sections 705.2.3.1 and 705.2.3.2. The words on the signage shall be readable by persons standing in the pool or standing outside the pool as applicable for the required location of each sign.

705.2.3.1 No diving warning. Type D in-pool ladders shall have the following words posted on the in-pool side of the ladder and on the pool entry side of the ladder: “NO DIVING.” The location of the words shall be above the elevation of the design water level of the pool.

705.2.3.2 Entrapment warning. Type D in-pool ladders shall have the following words posted on the ladder: “WARNING: TO PREVENT ENTRAPMENT OR DROWNING, DO NOT SWIM THROUGH, BEHIND, OR AROUND LADDER.”