



CITY COUNCIL MEETING

December 01, 2025 at 6:00 PM

Wolfforth City Hall - 302 Main Street Wolfforth, TX

AGENDA

CALL MEETING TO ORDER

INVOCATION - Councilmember McDonald

PLEDGE OF ALLEGIANCE - Councilmember Worley

ROLL CALL AND ESTABLISH A QUORUM

SAFETY REVIEW

CITIZEN ENGAGEMENT

This is an opportunity for the public to address the City Council regarding an item on the agenda, except public hearings that are included on the agenda. Comments related to public hearings will be heard when the specific hearing begins. Citizen comments are limited to three (3) minutes per speaker, unless the speaker requires the assistance of a translator, in which case the speaker is limited to six (6) minutes, in accordance with applicable law. Each speaker shall approach the designated speaker location, complete the citizen engagement sign-in sheet and state his/her name and city of residence before speaking. Speakers shall address the City Council with civility that is conducive to appropriate public discussion. Speakers can address only the City Council and not individual city officials or employees. The public cannot speak from the gallery but only from the designated speaker location.

CONSENT AGENDA #1

Items considered to be routine are enacted by one motion without separate discussion. If the City Council desires to discuss an item, the item is removed from the Consent Agenda and considered separately.

1. Consider and take appropriate action on City Council Meeting Minutes from November 3 and November 17, 2025.
2. Consider and take appropriate action on October 2025 Departmental Reports
3. Consider and take appropriate action on Resolution 2025-052 First Reading

A RESOLUTION OF THE CITY COUNCIL OF THE CITY OF WOLFFORTH
AUTHORIZING THE ECONOMIC DEVELOPMENT CORPORATION TO ISSUE AN
INCENTIVE FOR CONSTRUCTION OF A RETAIL GROCERY STORE AND RELATED
INFRASTRUCTURE TO UNITED SUPERMARKETS, LLC.

REGULAR SESSION

4. PUBLIC COMMENT: Receive public comment pertaining to Stormwater Management Program.
5. Consider and take appropriate action on Frenship Youth Baseball annual report
6. Consider and take appropriate action on request from Public Utility Commission for City of Wolfforth to accept Temporary Manager appointment for Casey Home Estates Water System.
7. Consider and take appropriate action on proposals for monument signage at City Hall and City Library.
8. Consider and take appropriate action on Resolution No. 2025-054
Authorizing Kimley Horn to perform engineering services for Lubbock sewer interconnect.
9. Consider and take appropriate action on presentation of recommendations from Traffic Impact Analysis for the United development
10. Consider and take appropriate action on Capital Improvements Plan progress update from City Manager
11. Consider and take appropriate action on 2026 City Council Calendar

COUNCIL REQUESTS FOR FUTURE AGENDA ITEMS

ADJOURN

RIGHT TO ENTER EXECUTIVE SESSION:

The City Council for the City of Wolfforth reserves the right to adjourn into executive session at any time during the course of this meeting to discuss any matters listed on this agenda, as authorized by the Texas Government Code Sections 551.071 (Consultation with Attorney), 551.072 (Deliberations about Real Property), 551.073 (Deliberations about Gifts and Donations), 551.074 (Personnel Matters), 551.076 (Deliberations about Security Devices) and 551.087 (Economic Development).

In accordance with the Americans with Disability Act any person with a disability requiring reasonable accommodation to participate in this meeting should call the City Secretary at 806-855-4120 or send written request to P.O. Box 36 Wolfforth Texas 79382 at least 48 hours in advance of the meeting date.

Certification

I, the undersigned authority do hereby certify that the Notice of Meeting was posted at City Hall of the City of Wolfforth, Texas was posted on November 21, 2025.

/s/ Terri Robinette, City Secretary



CITY COUNCIL MEETING

November 03, 2025 at 6:00 PM

WolfForth City Hall - 302 Main Street WolfForth, TX

MINUTES

CALL MEETING TO ORDER

Meeting was called to order at 6:00 PM by Mayor Addington

INVOCATION - Councilmember Stout

PLEDGE OF ALLEGIANCE - Councilmember McDonald

ROLL CALL AND ESTABLISH A QUORUM

PRESENT

Mayor Charles Addington

Councilmember Place 1 David Cooper

Councilmember Place 2 Wesley Houck

Councilmember Place 3 Gregory Stout

Councilmember Place 5 Karen Worley

ABSENT

Councilmember Place 4 Charlotte McDonald

SAFETY REVIEW

CITIZEN ENGAGEMENT

This is an opportunity for the public to address the City Council regarding an item on the agenda, except public hearings that are included on the agenda. Comments related to public hearings will be heard when the specific hearing begins. Citizen comments are limited to three (3) minutes per speaker, unless the speaker requires the assistance of a translator, in which case the speaker is limited to six (6) minutes, in accordance with applicable law. Each speaker shall approach the designated speaker location, complete the citizen engagement sign-in sheet and state his/her name and city of residence before speaking. Speakers shall address the City Council with civility that is conducive to appropriate public discussion.

(unapproved draft)

Speakers can address only the City Council and not individual city officials or employees. The public cannot speak from the gallery but only from the designated speaker location.

There were no public comments.

CONSENT AGENDA #1

Items considered to be routine are enacted by one motion without separate discussion. If the City Council desires to discuss an item, the item is removed from the Consent Agenda and considered separately.

Motion to approve Consent Agenda #1

Motion made by Councilmember Place 5 Worley, Seconded by Councilmember Place 2 Houck.

Voting Yea: Councilmember Place 1 Cooper, Councilmember Place 2 Houck, Councilmember Place 3 Stout

1. Consider and take appropriate action on City Council Meeting Minutes from October 6, 2025 and October 20, 2025
2. Consider and take appropriate action on September 2025 Departmental Reports
3. Consider and take appropriate action on Resolution 2025-046

A RESOLUTION OF THE CITY OF WOLFFORTH, TEXAS, APPROVING THE INVESTMENT PORTFOLIO SUMMARY FOR THE QUARTER ENDED SEPTEMBER 30, 2025 AND PROVIDING AN EFFECTIVE DATE.

CONSENT AGENDA #2

Items considered to be routine are enacted by one motion without separate discussion. If the City Council desires to discuss an item, the item is removed from the Consent Agenda and considered separately.

Motion to approve consent agenda #2

Motion made by Councilmember Place 1 Cooper, Seconded by Councilmember Place 2 Houck.

Voting Yea: Councilmember Place 1 Cooper, Councilmember Place 2 Houck, Councilmember Place 3 Stout, Councilmember Place 5 Worley

4. Consider and take appropriate action on Payment Request #8 from UCA for the Loop 88 East Water Supply Construction.

(unapproved draft)

5. Consider and take appropriate action on Payment Request #8 from UCA for the Lubbock North Interconnect Construction

REGULAR SESSION

6. Consider and take appropriate action on Resolution 2025-047 First Reading

A RESOLUTION OF THE CITY COUNCIL OF THE CITY OF WOLFFORTH
AUTHORIZING THE ECONOMIC DEVELOPMENT CORPORATION TO PURCHASE
LAND TO PROMOTE NEW AND EXPANDED BUSINESS.

Motion to approve Resolution 2025-047 First Reading

Motion made by Councilmember Place 2 Houck, Seconded by Councilmember Place 1 Cooper.
Voting Yea: Councilmember Place 1 Cooper, Councilmember Place 2 Houck, Councilmember
Place 3 Stout, Councilmember Place 5 Worley

7. PUBLIC HEARING: Consider and take appropriate action on public hearing on expenditure of funds not to exceed \$500,000 by the Wolfforth Economic Development Corporation to facilitate commercial development by United Supermarkets.

A public hearing is held by the governing body in order for the public to hear the facts and offer their opinions. The governing body is not obligated to engage in dialogue with those present.

United Supermarkets will begin construction of their grocery store on Donald Preston Drive in January 2026. They will not receive any funds until the store is open to the public.

Public Hearing was opened at 6:03 PM

There were no public comments

Public Hearing was closed at 6:04 PM

8. Consider and take appropriate action on report from NewGen Strategies pertaining to water rate analysis and recommendations.

Chris Ekrut with NewGen Strategies presented to the City Council a current study of the Utility Fund revenues and expenses. The Utility Fund is an enterprise fund and should be operated as a business. To adequately service current debt, future debt and the cost of purchasing water from both the City of Lubbock and Loop 88, LLC, NewGen Strategies is recommending an increase

(unapproved draft)

of water rates effective January 1, 2026. There is no need for any changes to sewer rates at this time as the City is still working to complete a Wastewater Master Plan.

Customer impact of the recommended water rate increase on the base rate is a 4% increase or \$4.71 for a base customer.

Customer Affordability Analysis shows that Wolfforth's cost of water and wastewater is 2.13% of Wolfforth's Median Household Income, well below the defined affordability percentage of 4.5%.

Motion to accept the report as presented and authorize staff to bring back an ordinance based on these recommendations.

Motion made by Councilmember Place 1 Cooper, Seconded by Councilmember Place 2 Houck. Voting Yea: Councilmember Place 1 Cooper, Councilmember Place 2 Houck, Councilmember Place 3 Stout, Councilmember Place 5 Worley

9. Consider and take appropriate action on Ordinance 2025-016

AN ORDINANCE OF THE CITY COUNCIL OF THE CITY OF WOLFFORTH, TEXAS, AMENDING THE CODE OF ORDINANCES BY AMENDING CHAPTER 6, HEALTH AND SANITATION, ARTICLE 6.02 GARBAGE REGULATIONS BY ADDING DIVISION 3 BULKY WASTE FACILITY; REGULATING THE USE OF THE BULKY WASTE FACILITY; PROVIDING A PENALTY CLAUSE; PROVIDING A REPEAL CLAUSE; PROVIDING A SEVERABILITY CLAUSE; AND PROVIDING AN EFFECTIVE DATE.

The Bulky Waste facility is almost complete at this time. It is for use by residents only with an active utility account in good standing. Residents will be issued a code to use during daylight hours, 7 days per week. The site will be unmanned and monitored by cameras and electric gates.

Motion to approve Ordinance 2025-016

Motion made by Councilmember Place 5 Worley, Seconded by Councilmember Place 3 Stout. Voting Yea: Councilmember Place 1 Cooper, Councilmember Place 2 Houck, Councilmember Place 3 Stout

10. Demonstration of new online public budget interface

(unapproved draft)

A short presentation was given to the Council by Brandon Lopez, MPA Intern, over the FY 2026 Budget Publication. The City is publishing its budget in an interactive, online format that allows users to explore revenues, expenditures, capital projects, and department goals in a more intuitive and engaging way. This transition reflects the City's ongoing commitment to transparency, accessibility, and modernization of public services. The Budget can be found on the City's website under the Government tab.

EXECUTIVE SESSION

In accordance with Texas Government Code, section 551-001, et seq., the City Council will recess into executive session (closed meeting) to discuss the following:

The City Council of the City of Wolfforth convened into Executive Session on November 3, 2025 at 7:02 PM.

11. 551.071 Consultation with Attorney: To consult with Attorney on a matter in which the duty of the attorney to the governmental body under the Texas Disciplinary Rules of Professional Conduct of the State Bar of Texas clearly conflicts with Chapter 551 – Open Meetings (i) PID Management Contracts
12. 551.072. Deliberation Regarding Real Property; Closed Meeting. A governmental body may conduct a closed meeting to deliberate the purchase, exchange, lease, or value of real property if deliberation in an open meeting would have a detrimental effect on the position of the governmental body in negotiations with a third person.

RECONVENE INTO OPEN SESSION

In accordance with Texas Government Code, chapter 551, the City Council will reconvene into regular session to consider action, if any, on matters discussed in executive session.

The City Council of the City of Wolfforth reconvened into Regular Session on November 3, 2025 at 7:57 PM

There was no action resulting from Executive Session.

ADJOURN

Motion to adjourn at 7:58 PM

(unapproved draft)

Motion made by Councilmember Place 5 Worley, Seconded by Councilmember Place 3 Stout.

Voting Yea: Councilmember Place 1 Cooper, Councilmember Place 2 Houck, Councilmember Place 3 Stout, Councilmember Place 5 Worley

PASSED AND APPROVED THIS 1ST DAY OF DECEMBER 2025

David Cooper, Mayor Pro Tem
City of Wolfforth, Texas

ATTEST:

Terri Robinette, City Secretary

DRAFT

AFFIDAVIT OF CONFLICT OF INTEREST

THE STATE OF TEXAS §

COUNTY OF LUBBOCK §

I, Gregory Stout, as alderman of the City of Wolfforth do make this affidavit and hereby on oath state the following: I, and/or a person or persons related to me in the first degree by either consanguinity or affinity, have a substantial interest in a business entity or real property that will receive a special economic effect by a vote or decision of the Wolfforth City Council as those terms are defined in Chapter 171 of the Texas Local Government Code.

Date of Meeting: 11/03, 2025

Agenda Item Number:

The business entity or real property is:

I have a substantial interest in this business entity or real property for the following reasons: (check all which are applicable)

- Ownership of 10% or more of the voting stock or shares of the business entity.
- Ownership of 10% or \$15,000 or more of the fair market value of the business entity.
- Funds received from the business entity exceed 10% of his gross income for the previous year.
- Have an equitable or legal ownership with a fair market value of \$2,500 or more.

Upon the filing of this affidavit with the Official Record Keeper of the City, I affirm that I will abstain from discussion, vote and decision involving this business entity or real property unless a majority of the members of the governmental entity of which I am a member is likewise required to file and has filed affidavits declaring similar interests on the same official action.

Signed this 3 day of November, 2025.

[Signature]
Signature of Official
Councilman
Title

BEFORE ME, the undersigned authority, this day personally appeared Gregory Stout and on oath stated that the facts hereinabove stated are true to the best of their knowledge or belief.

SWORN TO AND SUBSCRIBED BEFORE ME on this 3rd day of November, 2025.

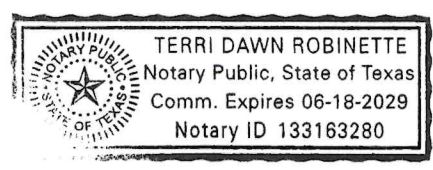

[Signature]
Notary Public in and for the State of Texas



CITY COUNCIL MEETING

November 17, 2025 at 6:00 PM

WolfForth City Hall - 302 Main Street WolfForth, TX

MINUTES

CALL MEETING TO ORDER

Meeting was called to order at 6:00 PM by Mayor Addington.

INVOCATION - Councilmember McDonald

PLEDGE OF ALLEGIANCE - Councilmember Worley

ROLL CALL AND ESTABLISH A QUORUM

PRESENT

Mayor Charles Addington

Councilmember Place 1 David Cooper

Councilmember Place 2 Wesley Houck

Councilmember Place 3 Gregory Stout

Councilmember Place 4 Charlotte McDonald

Councilmember Place 5 Karen Worley

SAFETY REVIEW

CITIZEN ENGAGEMENT

This is an opportunity for the public to address the City Council regarding an item on the agenda, except public hearings that are included on the agenda. Comments related to public hearings will be heard when the specific hearing begins. Citizen comments are limited to three (3) minutes per speaker, unless the speaker requires the assistance of a translator, in which case the speaker is limited to six (6) minutes, in accordance with applicable law. Each speaker shall approach the designated speaker location, complete the citizen engagement sign-in sheet and state his/her name and city of residence before speaking.

Speakers shall address the City Council with civility that is conducive to appropriate public discussion.

Speakers can address only the City Council and not individual city officials or employees. The public cannot speak from the gallery but only from the designated speaker location.

Larry Holland - Lubbock, Texas In favor of the Sanctuary City for the Unborn

(unapproved draft)

Kim Hicks - A Little Slice of Heaven Cafe was lost in a tragic fire at their location in Abernathy. They are relocating the cafe to Wolfforth on the access road of Hwy 62/82 and would like to invite everyone to come try them.

Jim Baxa- Lubbock, Texas West Texas For Life, In favor of the Sanctuary City for the Unborn.

Mark Dickson - Sanctuary Cities for the Unborn, 84 cities have passed the sanctuary city for the unborn along with 13 counties. In favor of the Sanctuary City for the Unborn in Wolfforth

CONSENT AGENDA #1

Items considered to be routine are enacted by one motion without separate discussion. If the City Council desires to discuss an item, the item is removed from the Consent Agenda and considered separately.

Motion to approve Consent Agenda #1

Motion made by Councilmember Place 4 McDonald, Seconded by Councilmember Place 3 Stout.

Voting Yea: Councilmember Place 1 Cooper, Councilmember Place 2 Houck, Councilmember Place 3 Stout, Councilmember Place 4 McDonald, Councilmember Place 5 Worley

1. Consider and take appropriate action on Resolution 2025-047 Second Reading

A RESOLUTION OF THE CITY COUNCIL OF THE CITY OF WOLFFORTH
AUTHORIZING THE ECONOMIC DEVELOPMENT CORPORATION TO PURCHASE
LAND TO PROMOTE NEW AND EXPANDED BUSINESS.

2. Consider and take appropriate action on Resolution 2025-048

A RESOLUTION OF THE CITY COUNCIL OF THE CITY OF WOLFFORTH, TEXAS,
ADOPTING THE CITY OF WOLFFORTH INVESTMENT POLICY ATTACHED HERETO
AS EXHIBIT "A"; DECLARING THAT THE CITY COUNCIL HAS COMPLETED ITS
REVIEW OF THE INVESTMENT POLICY AND INVESTMENT STRATEGIES OF THE
CITY AND THAT EXHIBIT "A" RECORDS ANY CHANGES TO EITHER THE
INVESTMENT POLICY OR INVESTMENT STRATEGIES; PROVIDING A REPEALING
CLAUSE; PROVIDING A SEVERABILITY CLAUSE; AND PROVIDING FOR AN
EFFECTIVE DATE.

3. Consider and take appropriate action on Ordinance 2025-017

(unapproved draft)

ORDINANCE DECLARING WOLFFORTH A SANCTUARY CITY FOR THE UNBORN,
MAKING VARIOUS PROVISIONS AND FINDINGS, PROVIDING FOR SEVERABILITY,
AND ESTABLISHING AN EFFECTIVE DATE.

4. Consider and take appropriate action on Resolution 2025-049

A RESOLUTION OF THE CITY COUNCIL OF THE CITY OF WOLFFORTH
EXTENDING A MORATORIUM ON NEW MULTIFAMILY DEVELOPMENT

5. Consider and take appropriate action on Resolution 2025-050

A RESOLUTION OF THE CITY COUNCIL OF THE CITY OF WOLFFORTH, TEXAS,
APPROVING AND ADOPTING A POLICY MANUAL FOR FEDERAL AWARDS; AND
PROVIDING AN EFFECTIVE DATE.

6. Consider and take appropriate action on Resolution 2025-053 casting votes for the Lubbock
Central Appraisal District Board of Directors

CONSENT AGENDA #2

Items considered to be routine are enacted by one motion without separate discussion. If the City Council desires to discuss an item, the item is removed from the Consent Agenda and considered separately.

Motion to approve Consent Agenda #2

Motion made by Councilmember Place 5 Worley, Seconded by Councilmember Place 4 McDonald.

Voting Yea: Councilmember Place 1 Cooper, Councilmember Place 2 Houck, Councilmember Place 4 McDonald, Councilmember Place 5 Worley

Voting Abstaining: Councilmember Place 3 Stout

7. Consider and take appropriate action on Payment Request #11 from Landmark Structures for the Alcove EST Construction
8. Consider and take appropriate action on Payment Request #9 from UCA for the Loop 88 East Water Supply Construction.
9. Consider and take appropriate action on Payment Request #9 from UCA for the Lubbock North Interconnect Construction

REGULAR SESSION

(unapproved draft)

10. Consider and take appropriate action on presentation of City of Wolfforth Library Master Plan, Phase 1

Mia Ovcina with 720 Designs presented the Library Master Plan Phase 1. The planning process included information gathering, community input, space standards, programs, costs and next steps. The current Library building is a 7,800 square foot structure, built in 2007 and is in very good condition. The current building has serviced the population of the community well until recently. With the rapid population increases Wolfforth is experiencing, the Library is maxed out on space for programs, circulation materials and even seating.

Community input included responses from over 930 participants including library and non-library users, online surveys and teen focus groups. Most popular categories were teen spaces, children's spaces, outdoor spaces and creative spaces.

Cost estimates were prepared based on the needs outlined and the community priorities. Initial cost estimate based on a 2026 start date is \$28 million.

Phase 2 of the Comprehensive Plan will include a site analysis, program alignment with input from the City Council, and a final concept design. Average timeline for a project of this size is around 30 months.

There was no action taken at this time. Mayor Addington stated that the presentation was very informative and would be considered by the Council over the next 60-90 days.

11. Consider and take appropriate action on presentation of Water and Wastewater Master Plans from Kimley Horn.

Engineers from Kimley Horn presented a Water/Wastewater Master Plan that will address and plan for future infrastructure needs as rapid growth continues. This plan's objectives included a proactive approach to growth, provide for transparency of costs and impacts, meet TCEQ requirements and provide a clear path for sustainable City growth.

Projected growth was considered at 375 new connections per year over the period ending in 2040. Land Use was a factor in determining types of connections such as single family, schools, commercial etc.

Capital Improvement Plan was outlined over 5 year periods.

Water CIP

(unapproved draft)

2025-2030: Pump Station and 12-inch Transmission Line, Lubbock North Pump Station Expansion.

2030-2035: Additional Pumping Capacity

2035-2040: Elevated Storage Tank to service west Wolfforth

Wastewater CIP

2025-2030: Decommission current wastewater treatment facility

2030-2035: Northern Lift Station and Force Main

2035-2040: 15in Wastewater line to service west Wolfforth

Budget through 2040 is \$26,030,000 for water and \$18,583,000 for wastewater. This investment will serve 13,650 people at 5,250 new connections.

This plan will be used for future discussions and updates to the City's Capital Improvement Plan. The Council took no action at this time.

12. Consider and take appropriate action on Resolution No. 2025-051

A RESOLUTION OF THE CITY OF WOLFFORTH, TEXAS, AWARDED A LANDSCAPING SERVICES CONTRACT TO S&J LAWN SERVICE AND AUTHORIZING THE CITY MANAGER, OR DESIGNEE, TO EXECUTE ALL AGREEMENTS NECESSARY TO IMPLEMENT THE CONTRACT.

Five proposals were submitted for Landscaping Services. A tabulation sheet was provided to the Council to summarize those proposals. The Staff is recommending this bid award to S&J Lawn Services. A contract will be drafted by the City Attorney and executed by the City Manager.

Motion to approve Resolution No. 2025-051

Motion made by Councilmember Place 4 McDonald, Seconded by Councilmember Place 3 Stout.

Voting Yea: Councilmember Place 1 Cooper, Councilmember Place 2 Houck, Councilmember Place 3 Stout, Councilmember Place 4 McDonald, Councilmember Place 5 Worley

13. Consider and take appropriate action on Resolution 2025-052 First Reading

A RESOLUTION OF THE CITY COUNCIL OF THE CITY OF WOLFFORTH AUTHORIZING THE ECONOMIC DEVELOPMENT CORPORATION TO ISSUE AN

(unapproved draft)

INCENTIVE FOR CONSTRUCTION OF A RETAIL GROCERY STORE AND RELATED INFRASTRUCTURE TO UNITED SUPERMARKETS, LLC.

Motion to approve Resolution 2025-052 First Reading

Motion made by Councilmember Place 5 Worley, Seconded by Councilmember Place 2 Houck.

Voting Yea: Councilmember Place 1 Cooper, Councilmember Place 2 Houck, Councilmember Place 3 Stout, Councilmember Place 4 McDonald, Councilmember Place 5 Worley

14. Consider and take appropriate action on preliminary plat for Wolfforth United Addition Tract C through R.

Motion to approve preliminary plat for Wolfforth United Addition Tract C through R.

Motion made by Councilmember Place 2 Houck, Seconded by Councilmember Place 1 Cooper.

Voting Yea: Councilmember Place 1 Cooper, Councilmember Place 2 Houck, Councilmember Place 3 Stout, Councilmember Place 4 McDonald, Councilmember Place 5 Worley

15. PUBLIC HEARING: Conduct a Public Hearing on amending Chapter 14 Zoning; Deleting 14.02.006, Special Use Review; Amending 14.02.005 Conditional Use Review; Amending 14.03.002 Zoning of Newly Annexed Areas; Amending 14.03.008(5) Use Table; 14.03.012(F) Removing Cemeteries as an Allowed Use Under Parks and Open Areas; and Amending 14.03.013 Commercial Use Categories.

A public hearing is held by the governing body in order for the public to hear the facts and offer their opinions. The governing body is not obligated to engage in dialogue with those present.

This public hearing is to consider changes to the Zoning Ordinance including removing cemeteries from open spaces, outlining the process to include zoning at annexation of property, and amending the use table definitions including tobacco shops.

Public Hearing was opened at 7:10 PM

There were no public comments

Public Hearing was closed at 7:10 PM

16. Consider and take appropriate action on Ordinance 2025-018

AN ORDINANCE OF THE CITY COUNCIL OF THE CITY OF WOLFFORTH
AMENDING THE CITY OF WOLFFORTH ZONING ORDINANCE BY AMENDING

(unapproved draft)

CHAPTER 14 ZONING; DELETING § 14.02.006 SPECIAL USE REVIEW; AMENDING § 14.02.005 CONDITIONAL USE REVIEW; AMENDING § 14.03.002 ZONING OF NEWLY ANNEXED AREAS; AMENDING § 14.03.008(5) USE TABLE; AMENDING § 14.03.012(F) REMOVING CEMETERIES AS AN ALLOWED USE UNDER PARKS AND OPEN AREAS; AMENDING § 14.03.013 COMMERCIAL USE CATEGORIES; PROVIDING A SEVERABILITY CLAUSE; PROVIDING FOR THE REPEAL OF ORDINANCES IN CONFLICT HEREWITH; AND PROVIDING AN EFFECTIVE DATE.

Motion to approve Ordinance 2025-018

Motion made by Councilmember Place 4 McDonald, Seconded by Councilmember Place 2 Houck.

Voting Yea: Councilmember Place 1 Cooper, Councilmember Place 2 Houck, Councilmember Place 3 Stout, Councilmember Place 4 McDonald, Councilmember Place 5 Worley

17. Consider and take appropriate action on Ordinance No. 2025-019

AN ORDINANCE OF THE CITY COUNCIL OF THE CITY OF WOLFFORTH, TEXAS, AMENDING THE CODE OF ORDINANCES BY AMENDING CHAPTER 13 UTILITIES ARTICLE 13.05 WATER AND SEWER, DIVISION 2 WATER RATES; PROVIDIING FOR THE ASSESSMENT OF RATES FOR UTILITY SERVICES WITHIN THE CITY; PROVIDING A REPEAL CLAUSE; PROVIDING A SEVERABILITY CLAUSE; AND PROVIDING AN EFFECTIVE DATE.

Motion to approve Ordinance No. 2025-019

Motion made by Councilmember Place 1 Cooper, Seconded by Councilmember Place 5 Worley.

Voting Yea: Mayor Addington, Councilmember Place 1 Cooper, Councilmember Place 2 Houck, Councilmember Place 3 Stout, Councilmember Place 4 McDonald, Councilmember Place 5 Worley

ADJOURN

Motion to adjourn at 7:12 PM

Motion made by Councilmember Place 4 McDonald, Seconded by Councilmember Place 1 Cooper.

Voting Yea: Councilmember Place 1 Cooper, Councilmember Place 2 Houck, Councilmember Place 3 Stout

(unapproved draft)

PASSED AND APPROVED THIS 1ST DAY OF DECEMBER 2025

David Cooper, Mayor Pro Tem
City of Wolfforth, Texas

ATTEST:

Terri Robinette, City Secretary

DRAFT

AFFIDAVIT OF CONFLICT OF INTEREST

THE STATE OF TEXAS §

COUNTY OF LUBBOCK §

I, Gregory Stout, as Council Member of the City of Wolfforth do make this affidavit and hereby on oath state the following: I, and/or a person or persons related to me in the first degree by either consanguinity or affinity, have a substantial interest in a business entity or real property that will receive a special economic effect by a vote or decision of the Wolfforth City Council as those terms are defined in Chapter 171 of the Texas Local Government Code.

Date of Meeting: 11/17, 2025

Agenda Item Number:

The business entity or real property is:

I have a substantial interest in this business entity or real property for the following reasons: (check all which are applicable)

- Ownership of 10% or more of the voting stock or shares of the business entity.
- Ownership of 10% or \$15,000 or more of the fair market value of the business entity.
- Funds received from the business entity exceed 10% of his gross income for the previous year.
- Have an equitable or legal ownership with a fair market value of \$2,500 or more.

Upon the filing of this affidavit with the Official Record Keeper of the City, I affirm that I will abstain from discussion, vote and decision involving this business entity or real property unless a majority of the members of the governmental entity of which I am a member is likewise required to file and has filed affidavits declaring similar interests on the same official action.

Signed this 17th day of November, 2025.

Greg Stout
Signature of Official

Council member
Title

BEFORE ME, the undersigned authority, this day personally appeared Gregory Stout and on oath stated that the facts hereinabove stated are true to the best of their knowledge or belief.

SWORN TO AND SUBSCRIBED BEFORE ME on this 17th day of November, 2025

[Signature]
Notary Public in and for the State of Texas

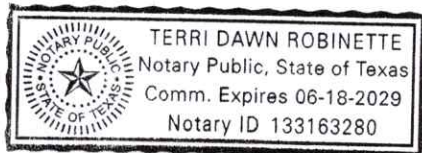

Departmental Reports October 2025

Public Works Reports
October 2025

Daily Pumpage from Wells and Lubbock Take

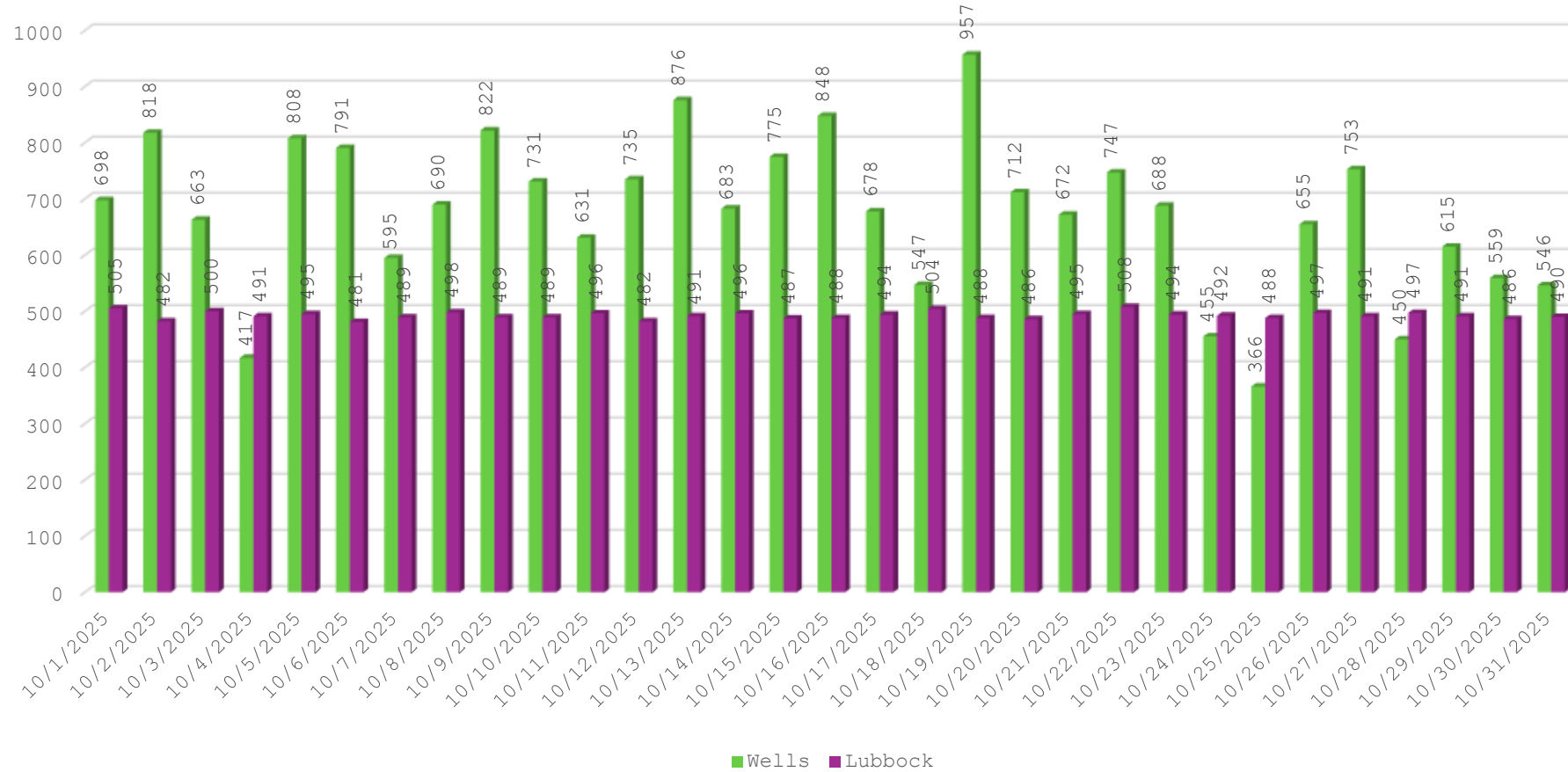

Lubbock Take and Well Pumpage Monthly Comparison

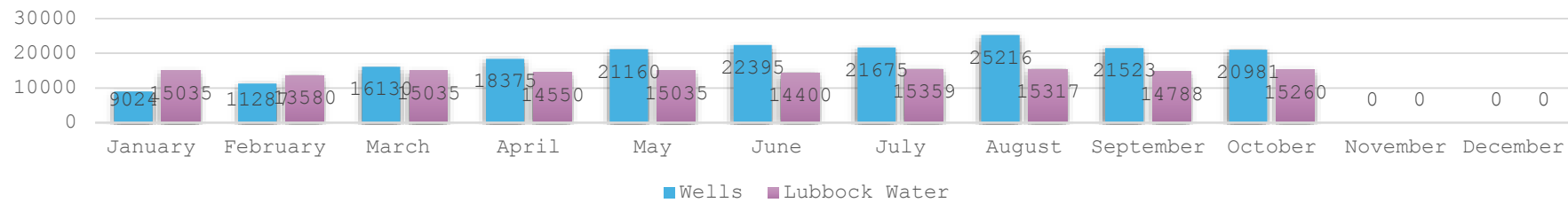

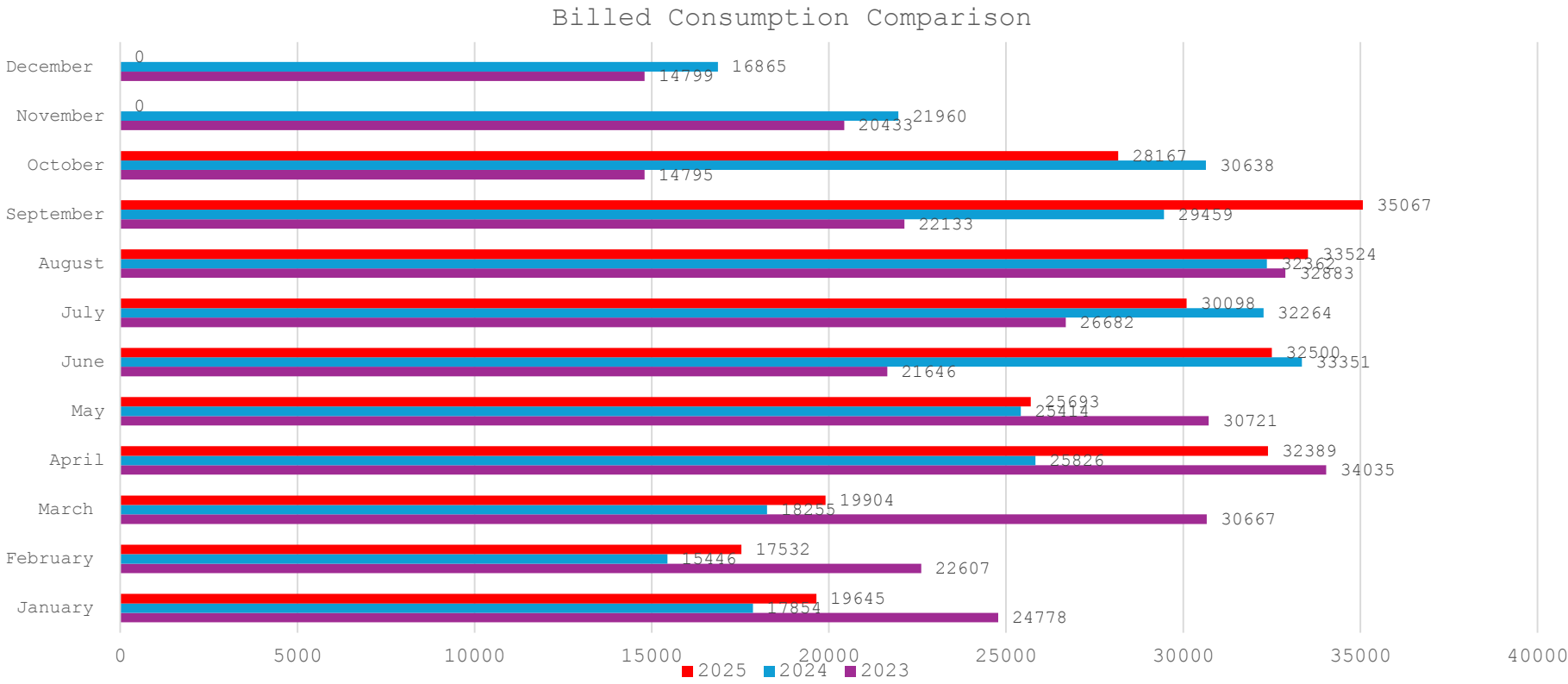
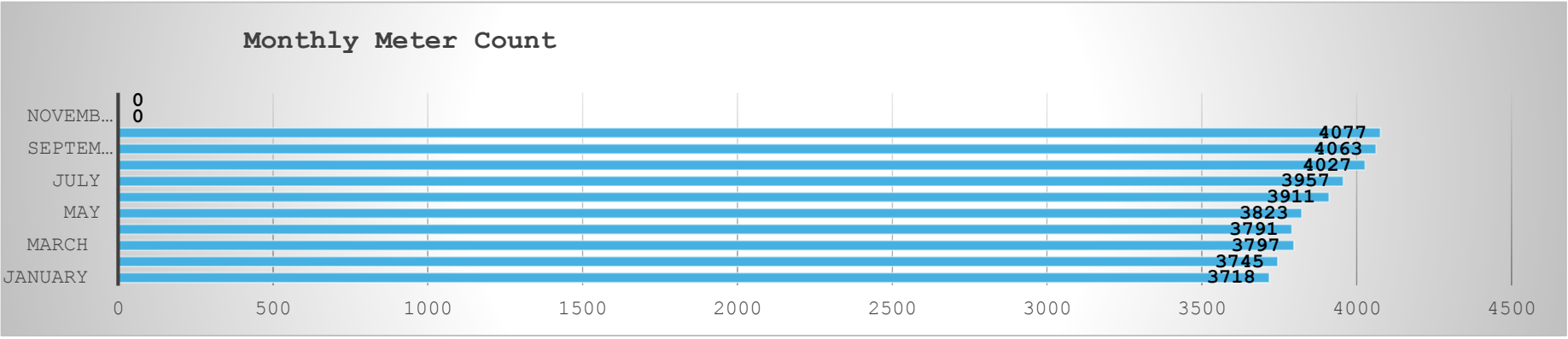

Sewer Flow

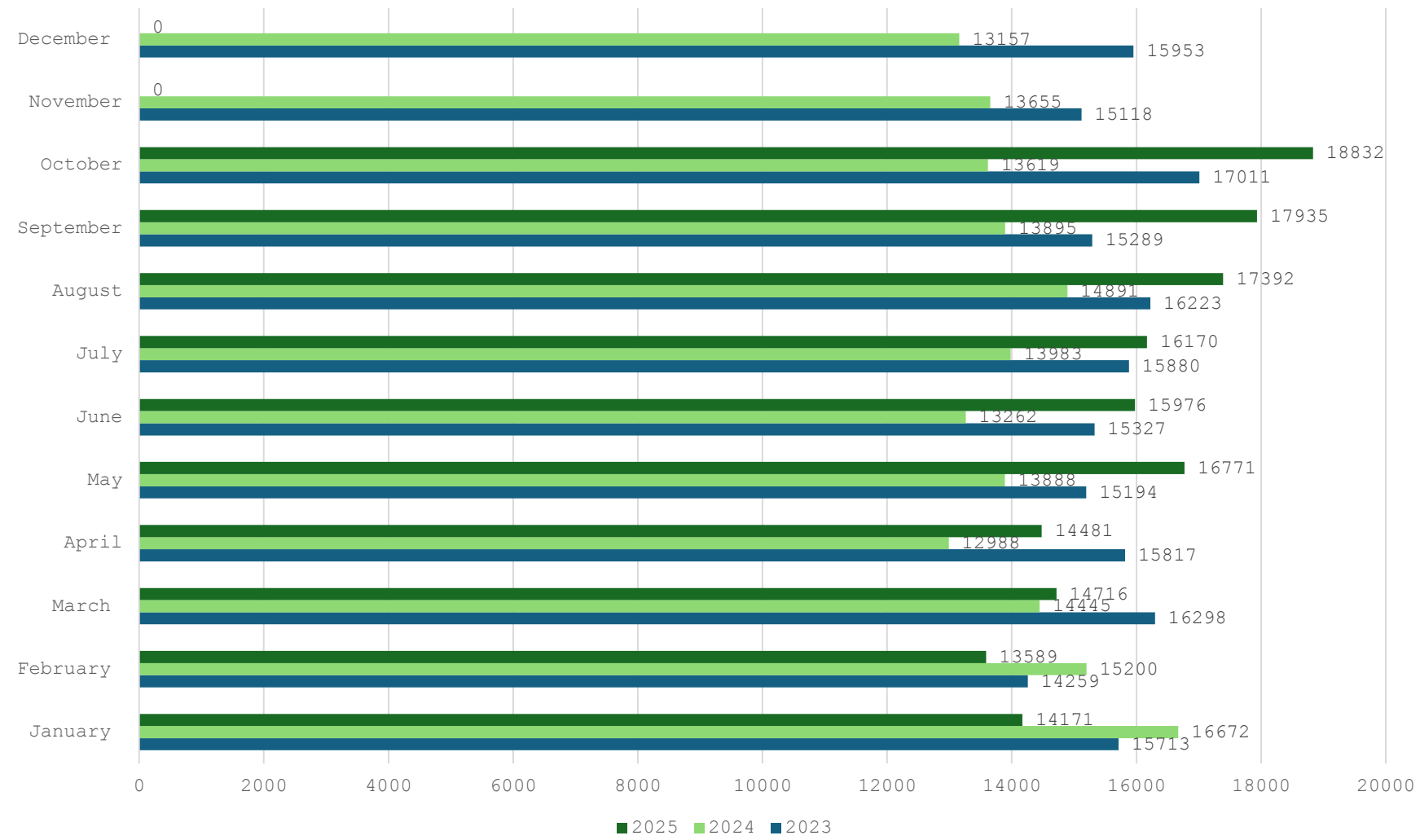

811 locates		81				
Iwork summary		233 Work orders				
Building maintenance		Water Leak	1	Non Payment Disconnect	3	Verify occupancy
					4	3
Container check		Install Meter	4	Non Payment Reconnect	45	66 Connect
						23
Data Log		Low Pressure	8	Sewer	3	0 Disconnect
						21
Detect leak		Meter Issues	4	Signs	4	0 CSI
						0
Door tag		Meter read	18	Streets	10	Debris Removal
						0
Furniture		Locks	0	Water	0	Other-Water
						12
Grade Alley		Meter can repair	0	Pothole repair	0	Animal at Large
						1
Garbage		Re read	0	Repairs	3	Bulky Item
						0
		Meter replace			0	

Development Reports

October 2025

Monthly Report October 2025

New Construction: 38-Residential

Estimated Value: \$ 8,075,715.00

Subdivision: Harvest-25, Overlook-11, Overlook West-2

38-Single Family

Ongoing Construction: 1-Commercial, 185-Residential

Subdivision: Harvest-101, Overlook West-21, Frenship Mesa-2, Overlook-34, Windsor-10, Iron Horse-14, Preston Manor-3

185-Single Family

1-Commerical (UMC Drive-through Clinic)

Completed Construction: 53-Residential

Subdivision: Harvest- 28, Overlook-7, Overlook West-14, Iron Horse-4

53-Single Family

Impact Fees: 29-Residential

- Total collected- October: \$58,000
- Total collected- YTD (FY25): \$218,800
- Total collected- YTD (FY26): \$58,00
- Total collected- In all: \$276,800

Plat and Commercial Update October 2025

Platting:

Harvest 8A- TCEQ Approval Granted, Council Approved 12-18-23 (On pause)

Harvest 24- Construction began- City Council approved 11-18-24- Waterlines approved by Engineers; Walk-through scheduled November 6, 2025

Overlook at Alcove- Approved by City Council on 9-15-25

Harvest 10 and 26- Civil plans have been approved by engineers

Harvest 23- Civil plans have been submitted to engineers

Commercial:

UMC- Permitted

Development:

- 10-1-2025 through 10-2-2025- Attended with Danielle Sweat Plains-to-Ports Conference
- 10-8-2025- Randy Criswell and I meet with Tyler Gentry from 17 Services about a possible easement.
- 10-9-2025- Randy Criswell, Terri Robinette, Rick Scott and I meet with NewGen about Draft Results of water rates
- 10-14-2025- Randy Criswell, Terri Robinette, Rick Scott and I meet with Kimley-Horn to discuss Comprehensive plan Update.
- 10-15-2025- I met with WTHBA for our Monthly Liaison Meeting
- 10-16-2025- Met with GovWell to discuss contract for new software for Code Enforcement
- 10-16-2025- Danielle Sweat and I attended the Chamber Harvest Luncheon
- 10-16-2025- Water Team meeting with Randy Criswell, Randy Hall, Michael Adams, and Kimley-Horn.
- 10-20-2025- Danielle Sweat, Kimley-Horn, and I meet at lunch with property owner in our ETJ.
- 10-20-2025- Joint Meeting with City Council, Planning and Zoning Commission, and EDC for Comprehensive Plan
- 10-22-2025- Patrick Payne and I meet with SafeBuilt Supervisors
- 10-23-2025- Meeting with GovWell about set up process
- 10-23-2025- Meeting with Jimmy McDaniels from AMD and Ronnie Wallace from Betenbough about preliminary plats, upcoming phases, and timelines
- 10-23-2025- Pre-Development Meeting with Kimley-Horn, Randy Hall, and property owners along Main Street
- 10-28-2025- Attended Hero Home Ribbon Cutting
- 10-28-2025- Randy Criswell, Terri Robinette, and I met with NewGen about revisions to water rates
- 10-29-2025- Meeting with Code Enforcement about new program with GovWell
- 10-30-2025- GovWell Kick-off meeting

Permit Title	Permit Description	Project Address	Applicant	Date Started	Project Square Feet	Estimated Valuation
Building Permit New (R)	New Single Family	2414 Bryan Avenue	Betenbough Homes	10/27/2025	2121	\$218,463.00
Building Permit New (R)	New Single Family	2413 Bryan Avenue	Betenbough Homes	10/27/2025	2318	\$238,754.00
Building Permit New (R)	New Garden Home	513 E 24th Street	Betenbough Homes	10/09/2025	1719	\$177,057.00
Building Permit New (R)	New Garden Home	514 E 24th Street	Betenbough Homes	10/09/2025	1655	\$170,465.00
Building Permit New (R)	New Garden Home	516 E 24th Street	Betenbough Homes	10/09/2025	1428	\$147,084.00
Building Permit New (R)	New Garden Home	2407 Bryan Avenue	Betenbough Homes	10/09/2025	2001	\$206,103.00
Building Permit New (R)	New Single Family	2409 Bryan Avenue	Betenbough Homes	10/09/2025	2121	\$218,463.00
Building Permit New (R)	New Single Family	2408 Bryan Avenue	Betenbough Homes	10/09/2025	2112	\$217,536.00
Building Permit New (R)	New Single Family	2410 Bryan Avenue	Betenbough Homes	10/09/2025	2250	\$231,750.00
Building Permit New (R)	New Single Family	1505 Good Prairie Avenue	Lennar Homes	10/27/2025	1837	\$189,211.00
Building Permit New (R)	New Single Family	902 E 34th Street	Betenbough Homes	10/09/2025	2755	\$283,765.00
Building Permit New (R)	New Garden Home	508 E 24th Street	Betenbough Homes	10/27/2025	1584	\$163,152.00
Building Permit New (R)	New Single Family	2418 Bryan Avenue	Betenbough Homes	10/27/2025	2422	\$249,466.00
Building Permit New (R)	New Single Family	612 E 14th Street	Ismael Sanchez, medinas partners	10/17/2025	2775	\$285,825.00
Building Permit New (R)	New Single Family	2416 Bryan Avenue	Betenbough Homes	10/27/2025	2163	\$222,789.00
Building Permit New (R)	New Garden Home	510 E 24th Street	Betenbough Homes	10/21/2025	1458	\$150,174.00
Building Permit New (R)	New Garden Home	511 E 24th Street	Betenbough Homes	10/21/2025	1835	\$189,005.00
Building Permit New (R)	New Single Family	2411 Bryan Avenue	Betenbough Homes	10/21/2025	2211	\$227,733.00
Building Permit New (R)	New Garden Home	2412 Bryan Avenue	Betenbough Homes	10/21/2025	2001	\$206,103.00
Building Permit New (R)	New Garden Home	512 E 24th Street	Betenbough Homes	10/09/2025	1425	\$146,775.00
Building Permit New (R)	New Single Family	1509 Good Prairie Avenue	Lennar Homes	10/27/2025	1828	\$188,284.00
Building Permit New (R)	New Garden Home	2424 Aberdeen Avenue	Betenbough Homes	10/27/2025	2001	\$206,103.00
Building Permit New (R)	New Single Family	602 15th Street	Brock Baker, D.R. Horton	10/28/2025	2237	\$230,411.00
Building Permit New (R)	New Single Family	223 17th Street	Brock Baker, D.R. Horton	10/02/2025	2346	\$241,638.00
Building Permit New (R)	New Single Family	707 E 14th Street	Hunter Hicks, hunter@ridgeline.homes	10/31/2025	1667	\$171,701.00
Building Permit New (R)	New Garden Home	2406 Bryan Avenue	Betenbough Homes	10/02/2025	2012	\$207,236.00
Building Permit New (R)	New Single Family	1203 E 30th Street	Betenbough Homes	10/03/2025	2802	\$288,606.00
Building Permit New (R)	New Single Family	2906 Ranch Avenue	Betenbough Homes	10/03/2025	3250	\$334,750.00
Building Permit New (R)	New Single Family	701 E 14th Street	Hunter Hicks, hunter@ridgeline.homes	10/28/2025	1655	\$170,465.00
Building Permit New (R)	New Single Family	3220 Bryan Ave	Betenbough Homes	10/29/2025	2575	\$265,225.00
Building Permit New (R)	New Single Family	1517 Good Prairie Avenue	Lennar Homes	10/28/2025	2590	\$266,770.00
Building Permit New (R)	New Single Family	1515 Good Prairie Avenue	Lennar Homes	10/28/2025	1692	\$174,276.00
Building Permit New (R)	New Single Family	1513 Good Prairie Avenue	Lennar Homes	10/28/2025	2292	\$236,076.00
Building Permit New (R)	New Single Family	1237 Good Prairie Avenue	Lennar Homes	10/03/2025	1837	\$189,211.00
Building Permit New (R)	New Single Family	1511 Good Prairie Avenue	Lennar Homes	10/28/2025	1692	\$174,276.00
Building Permit New (R)	New Garden Home	509 E 24th Street	Betenbough Homes	10/27/2025	1428	\$147,084.00
Building Permit New (R)	New Single Family	1813 HARVEST	Douglas Smith	10/07/2025	2017	\$207,751.00
Building Permit New (R)	New Single Family	2417 Bryan Avenue	Betenbough Homes	10/27/2025	2293	\$236,179.00

78405

\$8,075,715.00



Case Details Report

This report will summarize case details.

Date Started from Cases feed: 10/01/2025 - 10/31/2025

CASE NUMBER	CASE TITLE	CASE DESCRIPTION	STATUS	CASE OFFICER	DATE STARTED	DATE COMPLETED	ELAPSED TIME	VIOLATIONS	REQUIRED CORRECTIONS	PROPERTY CONTACTS	LOCATION ENFORCEMENT AREA	ADDRESS	CODE OFFICER AREA
25-000924	Unwholesome Conditions	VACANT LOT	active	Kathran Lewallen	10/02/2025 at 11:04 AM		1 month 4 days 3 hours 20 mins	1	1	Rick Scott (owner)		Donald Preston Dr	
25-000925	Unwholesome Conditions	vacant lot	active	Kathran Lewallen	10/02/2025 at 11:07 AM		1 month 4 days 3 hours 17 mins	1	1	Rick Scott (owner)		Arthur St	
25-000926	Unwholesome Conditions	vacant lot	active	Kathran Lewallen	10/02/2025 at 11:10 AM		1 month 4 days 3 hours 14 mins	1	1	Rick Scott (owner)		Donald Preston Dr	
25-000927	Unwholesome Conditions	vacant lot	active	Kathran Lewallen	10/02/2025 at 11:13 AM		1 month 4 days 3 hours 11 mins	1	1	Rick Scott (owner)		Donald Preston Dr	
25-000928	Unwholesome Conditions	vacant lot	active	Kathran Lewallen	10/02/2025 at 11:14 AM		1 month 4 days 3 hours 10 mins	1	1	Rick Scott (owner)		Donald Preston Dr	
25-000929	Unwholesome Conditions	vacant lot	active	Kathran Lewallen	10/02/2025 at 11:16 AM		1 month 4 days 3 hours 8 mins	1	1	Rick Scott (owner)		Donald Preston Dr	
25-000930	MS4 Inspection/Violation	PASSED	complete	Kathran Lewallen	10/02/2025 at 11:59 AM	10/02/2025 at 12:00 PM	1 min	1	1			409 Essex Lane	
25-000931	MS4 Inspection/Violation	PASSED	complete	Kathran Lewallen	10/02/2025 at 12:00 PM	10/02/2025 at 12:01 PM	1 min	1	1			613 15th Street	

CASE NUMBER	CASE TITLE	CASE DESCRIPTION	STATUS	CASE OFFICER	DATE STARTED	DATE COMPLETED	ELAPSED TIME	VIOLATIONS	REQUIRED CORRECTIONS	PROPERTY CONTACTS	LOCATION ENFORCEMENT AREA	ADDRESS	CODE OFFICER AREA
25-000932	MS4 Inspection/Violation	PASSED	complete	Kathran Lewallen	10/02/2025 at 12:02 PM	10/02/2025 at 12:02 PM	less than 1 min	1	1			2903 Tractor Avenue	
25-000933	MS4 Inspection/Violation	PASSED	complete	Kathran Lewallen	10/02/2025 at 12:03 PM	10/02/2025 at 12:03 PM	less than 1 min	1	1			801 E 30th Street	
25-000934	MS4 Inspection/Violation	PASSED	complete	Kathran Lewallen	10/02/2025 at 12:03 PM	10/02/2025 at 12:04 PM	1 min	1	1			701 15th Street	
25-000935	Unwholesome Conditions	VACANT LOT - WEEDS	active	Kathran Lewallen	10/02/2025 at 12:05 PM		1 month 4 days 2 hours 19 mins	1	1	Treze Alcove Llc (owner)		1209 Kingston St	
25-000936	Unwholesome Conditions	w-alley	active	Audry Martinez	10/02/2025 at 3:16 PM		1 month 3 days 23 hours 8 mins	1	1	Garcia Vince E & Erica (owner), Vince E & Erica Garcia (owner)		824 13th St	
25-000937	Unwholesome Conditions	w-alley	active	Audry Martinez	10/02/2025 at 3:26 PM		1 month 3 days 22 hours 58 mins	1	1	Colton & Whitney Ashcraft (owner)		820 13th St	
25-000938	Unwholesome Conditions	w-alley	active	Audry Martinez	10/02/2025 at 3:35 PM		1 month 3 days 22 hours 49 mins	1	1	Amanda D & Jerry K Pewsorth (owner)		816 13th St	
25-000939	Unwholesome Conditions	w-alley	active	Audry Martinez	10/02/2025 at 3:43 PM		1 month 3 days 22 hours 41 mins	1	1	PAUL A & CLAIRE E RUCKER (owner)		812 13th St	
25-000940	Unwholesome Conditions	w-alley	active	Audry Martinez	10/02/2025 at 3:51 PM		1 month 3 days 22 hours 33 mins	1	1	Nicklaus & Megan Wilson (owner)		804 13th St	

CASE NUMBER	CASE TITLE	CASE DESCRIPTION	STATUS	CASE OFFICER	DATE STARTED	DATE COMPLETED	ELAPSED TIME	VIOLATIONS	REQUIRED CORRECTIONS	PROPERTY CONTACTS	LOCATION ENFORCEMENT AREA	ADDRESS	CODE OFFICER AREA
25-000941	Unwholesome Conditions	w-rub alley	active	Audry Martinez	10/02/2025 at 3:53 PM		1 month 3 days 22 hours 31 mins	1	1	Jason & Jennifer Denise Wright (owner)		803 12th St	
25-000942	Unwholesome Conditions	w/r alley	active	Audry Martinez	10/02/2025 at 3:54 PM		1 month 3 days 22 hours 30 mins	2	2	Jason & Jennifer Denise Wright (owner)		803 12th St	
25-000943	Unwholesome Conditions	w-alley	active	Audry Martinez	10/02/2025 at 3:56 PM		1 month 3 days 22 hours 28 mins	1	1	JACOBO & JUSTINE M FLORES (owner)		807 12th St	
25-000944	Unwholesome Conditions	w-alley	active	Audry Martinez	10/02/2025 at 3:59 PM		1 month 3 days 22 hours 25 mins	1	1	LUIS & RYLEE RAMIREZ (owner)		811 12th St	
25-000945	Unwholesome Conditions	w-alley	active	Audry Martinez	10/02/2025 at 4:02 PM		1 month 3 days 22 hours 22 mins	1	1	Miranda Landin (owner)		815 12th St	
25-000946	Unwholesome Conditions	w-vl	active	Audry Martinez	10/02/2025 at 4:06 PM		1 month 3 days 22 hours 18 mins	1	1	LEROY & VON E DANIELS (owner)		815 13th St	
25-000947	Unwholesome Conditions	w-vl	active	Audry Martinez	10/02/2025 at 4:09 PM		1 month 3 days 22 hours 15 mins	1	1	Andy & Berenice C Villarreal (owner)		819 13th St	
25-000948	Zoning Violation	sign violations. Feather flag, bandit/banner	active	Audry Martinez	10/02/2025 at 4:21 PM		1 month 3 days 22 hours 3 mins	0	0				
25-000949	Unwholesome Conditions	You Drive Dealership	active	Audry Martinez	10/09/2025 at 12:52 PM		27 days 1 hour 32 mins	1	1	WWRG LC (owner)		214 E Hwy 62-82	

CASE NUMBER	CASE TITLE	CASE DESCRIPTION	STATUS	CASE OFFICER	DATE STARTED	DATE COMPLETED	ELAPSED TIME	VIOLATIONS	REQUIRED CORRECTIONS	PROPERTY CONTACTS	LOCATION ENFORCEMENT AREA	ADDRESS	CODE OFFICER AREA
25-000950	MS4 Inspection/Violation	passed	complete	Kathran Lewallen	10/16/2025 at 3:09 PM	10/16/2025 at 3:10 PM	1 min	1	1			2304 Corpus Avenue	
25-000951	MS4 Inspection/Violation	Passed	complete	Kathran Lewallen	10/16/2025 at 3:10 PM	10/16/2025 at 3:11 PM	1 min	1	1			2306 Corpus Avenue	
25-000952	MS4 Inspection/Violation	Passed	complete	Kathran Lewallen	10/16/2025 at 3:11 PM	10/16/2025 at 3:12 PM	1 min	1	1			406 Essex Lane	
25-000953	MS4 Inspection/Violation	Passed	complete	Kathran Lewallen	10/16/2025 at 3:12 PM	10/16/2025 at 3:13 PM	1 min	1	1			2913 Tractor Avenue	
25-000954	MS4 Inspection/Violation	Passed	complete	Kathran Lewallen	10/16/2025 at 3:13 PM	10/16/2025 at 3:14 PM	1 min	1	1			2421 Aberdeen Avenue	
25-000955	MS4 Inspection/Violation	Passed	complete	Kathran Lewallen	10/16/2025 at 3:14 PM	10/16/2025 at 3:15 PM	1 min	1	1			2419 Aberdeen Avenue	
25-000956	MS4 Inspection/Violation	Passed	complete	Kathran Lewallen	10/16/2025 at 3:15 PM	10/16/2025 at 3:16 PM	1 min	1	1			2308 Corpus Avenue	
25-000957	MS4 Inspection/Violation	Passed	complete	Kathran Lewallen	10/16/2025 at 3:17 PM	10/16/2025 at 3:18 PM	1 min	1	1			809 E 30th Street	
25-000958	MS4 Inspection/Violation	Passed	complete	Kathran Lewallen	10/16/2025 at 3:18 PM	10/16/2025 at 3:19 PM	1 min	1	1			805 E 30th Street	
25-000959	Unwholesome Conditions	Wa*	complete	Kathran Lewallen	10/17/2025 at 10:39 AM	10/30/2025 at 8:06 AM	12 days 21 hours 27 mins	1	1	Moises Plasencia (owner)		616 Calvin Dr	

CASE NUMBER	CASE TITLE	CASE DESCRIPTION	STATUS	CASE OFFICER	DATE STARTED	DATE COMPLETED	ELAPSED TIME	VIOLATIONS	REQUIRED CORRECTIONS	PROPERTY CONTACTS	LOCATION ENFORCEMENT AREA	ADDRESS	CODE OFFICER AREA
25-000960	Unwholesome Conditions	Wa*	complete	Kathran Lewallen	10/17/2025 at 10:41 AM	10/30/2025 at 8:06 AM	12 days 21 hours 25 mins	1	1	Clearview Custom Homes Llc (owner)		611 Calvin Dr	
25-000961	Unwholesome Conditions	Wa*	complete	Kathran Lewallen	10/17/2025 at 10:43 AM	10/30/2025 at 8:06 AM	12 days 21 hours 23 mins	1	1	Geraldo R Mercado (owner)		806 N 2nd St	
25-000962	Unwholesome Conditions	Rub lot/alley. Inspector spoke to property manager who stated they will get it cleaned up. The previous cleaning people where fired.	active	Audry Martinez	10/17/2025 at 1:27 PM		19 days 57 mins	1	1			723 E 17th Street	
25-000963	Unwholesome Conditions	w-VL	active	Audry Martinez	10/17/2025 at 1:35 PM		19 days 49 mins	1	1			703 E 18TH ST	
25-000964	Unwholesome Conditions	w-alley	active	Audry Martinez	10/17/2025 at 1:48 PM		19 days 36 mins	1	1			714 E 18th Street	
25-000965	Prohibited Signs	CBC	complete	Kathran Lewallen	10/21/2025 at 8:02 AM	10/21/2025 at 8:03 AM	1 min	1	0	Wolfforth Land Company Llc (owner)		7205 S Fm 179	
25-000966	Prohibited Signs	CBC	complete	Kathran Lewallen	10/21/2025 at 8:03 AM	10/21/2025 at 8:04 AM	1 min	0	0	Wolfforth Land Company Llc (owner)		7205 S Fm 179	
25-000967	Prohibited Signs	CBC	complete	Kathran Lewallen	10/21/2025 at 8:04 AM	10/21/2025 at 8:05 AM	1 min	0	0	Wolfforth Land Company Llc (owner)		7205 S Fm 179	

CASE NUMBER	CASE TITLE	CASE DESCRIPTION	STATUS	CASE OFFICER	DATE STARTED	DATE COMPLETED	ELAPSED TIME	VIOLATIONS	REQUIRED CORRECTIONS	PROPERTY CONTACTS	LOCATION ENFORCEMENT AREA	ADDRESS	CODE OFFICER AREA
25-000968	Recreational Vehicle/Equipment/Trailer Parking in Street	TRAILER PARKED IN THE STREET	active	Kathran Lewallen	10/21/2025 at 8:06 AM		15 days 6 hours 18 mins	1	1	Dynamic Homes Llc (owner)		833 N 6th Cir	
25-000969	Off-Street Recreational Vehicle Parking and Storage	ENCLOSED TRAILER IN THE DRIVEWAY	active	Kathran Lewallen	10/21/2025 at 8:10 AM		15 days 6 hours 14 mins	2	2	Dynamic Homes Llc (owner)		827 N 6th Cir	
25-000970	Tree / Limb Obstructions	TREE LIMBS PILED IN THE ALLEY	active	Kathran Lewallen	10/21/2025 at 8:13 AM		15 days 6 hours 11 mins	1	1	Rebecca Tarango Aguilar (owner), Rebecca Tarango Aguilar (owner)		708 N 3rd St	
25-000971	Unwholesome Conditions	VACANT LOT	active	Kathran Lewallen	10/21/2025 at 8:17 AM		15 days 6 hours 7 mins	1	1	Wolfforth Land Company Llc (owner)		307 N 9th St	
25-000972	Unwholesome Conditions	VACANT LOT	active	Kathran Lewallen	10/21/2025 at 8:20 AM		15 days 6 hours 4 mins	1	1	Wolfforth Land Company Llc (owner)		305 N 9th St	
25-000973	Unwholesome Conditions	VACANT LOT	active	Kathran Lewallen	10/21/2025 at 8:22 AM		15 days 6 hours 2 mins	1	1	Wolfforth Land Company Llc (owner)		303 N 9th St	
25-000974	Unwholesome Conditions	VACANT LOT	active	Kathran Lewallen	10/21/2025 at 8:24 AM		15 days 6 hours	1	1	Wolfforth City Of (owner)		301 N 9th St	
25-000975	Prohibited Signs	CBC	complete	Kathran Lewallen	10/22/2025 at 4:10 PM	10/22/2025 at 4:12 PM	2 mins	0	0	Wolfforth Land Company Llc (owner)		7205 S Fm 179	
25-000976	Prohibited Signs	Sign cbc	complete	Kathran Lewallen	10/22/2025 at 4:12 PM	10/22/2025 at 4:13 PM	1 min	1	0			806 N 6th Cir	

CASE NUMBER	CASE TITLE	CASE DESCRIPTION	STATUS	CASE OFFICER	DATE STARTED	DATE COMPLETED	ELAPSED TIME	VIOLATIONS	REQUIRED CORRECTIONS	PROPERTY CONTACTS	LOCATION ENFORCEMENT AREA	ADDRESS	CODE OFFICER AREA
25-000977	Prohibited Signs	Sign cbc	complete	Kathran Lewallen	10/22/2025 at 4:14 PM	10/22/2025 at 4:15 PM	1 min	1	0			806 N 6th Cir	
25-000978	Prohibited Signs	Sign cbc	complete	Kathran Lewallen	10/22/2025 at 4:15 PM	10/22/2025 at 4:16 PM	1 min	1	0			806 N 6th Cir	
25-000979	Prohibited Signs	Sign cbc	complete	Kathran Lewallen	10/22/2025 at 4:16 PM	10/22/2025 at 4:17 PM	1 min	1	0	1010 Donald Preston Partners Llc (owner)		Donald Preston Dr	
25-000980	Prohibited Signs	Sign cbc	complete	Kathran Lewallen	10/22/2025 at 4:17 PM	10/22/2025 at 4:18 PM	1 min	1	0	1010 Donald Preston Partners Llc (owner)		Donald Preston Dr	
25-000981	Prohibited Signs	Sign cbc	complete	Kathran Lewallen	10/22/2025 at 4:19 PM	10/22/2025 at 4:20 PM	1 min	1	0	1010 Donald Preston Partners Llc (owner)		Donald Preston Dr	
25-000982	Prohibited Signs	Sign cbc	complete	Kathran Lewallen	10/22/2025 at 4:20 PM	10/22/2025 at 4:22 PM	2 mins	1	0	1010 Donald Preston Partners Llc (owner)		Donald Preston Dr	
25-000983	Prohibited Signs	Sign cbc	complete	Kathran Lewallen	10/22/2025 at 4:22 PM	10/22/2025 at 4:23 PM	1 min	1	0	1010 Donald Preston Partners Llc (owner)		Donald Preston Dr	
25-000984	Prohibited Signs	Sign cbc	complete	Kathran Lewallen	10/22/2025 at 4:23 PM	10/22/2025 at 4:25 PM	2 mins	1	0	1010 Donald Preston Partners Llc (owner)		Donald Preston Dr	
25-000985	Prohibited Signs	Sign cbc	complete	Kathran Lewallen	10/22/2025 at 4:25 PM	10/22/2025 at 4:26 PM	1 min	1	0	1010 Donald Preston Partners Llc (owner)		Donald Preston Dr	

CASE NUMBER	CASE TITLE	CASE DESCRIPTION	STATUS	CASE OFFICER	DATE STARTED	DATE COMPLETED	ELAPSED TIME	VIOLATIONS	REQUIRED CORRECTIONS	PROPERTY CONTACTS	LOCATION ENFORCEMENT AREA	ADDRESS	CODE OFFICER AREA
25-000986	Prohibited Signs	Sign cbc	complete	Kathran Lewallen	10/22/2025 at 4:26 PM	10/22/2025 at 4:30 PM	4 mins	1	0	1010 Donald Preston Partners Llc (owner)		Donald Preston Dr	
25-000987	Prohibited Signs	Sign cbc	complete	Kathran Lewallen	10/22/2025 at 4:30 PM	10/22/2025 at 4:31 PM	1 min	1	0	1010 Donald Preston Partners Llc (owner)		Donald Preston Dr	
25-000988	Prohibited Signs	Sign cbc	complete	Kathran Lewallen	10/22/2025 at 4:31 PM	10/22/2025 at 4:32 PM	1 min	1	0	1010 Donald Preston Partners Llc (owner)		Donald Preston Dr	
25-000989	Prohibited Signs	Sign cbc	complete	Kathran Lewallen	10/22/2025 at 4:32 PM	10/22/2025 at 4:33 PM	1 min	1	0	1010 Donald Preston Partners Llc (owner)		Donald Preston Dr	
25-000990	Prohibited Signs	Sign cbc	complete	Kathran Lewallen	10/23/2025 at 8:11 AM	10/23/2025 at 8:12 AM	1 min	1	0	Giselle Sendejo (owner)		902 N 7th St	
25-000991	Prohibited Signs	Sign cbc	complete	Kathran Lewallen	10/23/2025 at 8:12 AM	10/23/2025 at 8:13 AM	1 min	1	0	Giselle Sendejo (owner)		902 N 7th St	
25-000992	Prohibited Signs	Sign cbc	complete	Kathran Lewallen	10/23/2025 at 8:13 AM	10/23/2025 at 8:15 AM	2 mins	1	0	Giselle Sendejo (owner)		902 N 7th St	
25-000993	Prohibited Signs	Sign cbc	complete	Kathran Lewallen	10/23/2025 at 8:15 AM	10/23/2025 at 8:16 AM	1 min	1	0	Giselle Sendejo (owner)		902 N 7th St	
25-000994	Prohibited Signs	Sign cbc	complete	Kathran Lewallen	10/23/2025 at 8:16 AM	10/23/2025 at 8:18 AM	2 mins	1	0	Giselle Sendejo (owner)		902 N 7th St	
25-000995	Prohibited Signs	Sign cbc	complete	Kathran Lewallen	10/23/2025 at 8:18 AM	10/23/2025 at 8:19 AM	1 min	1	0	Giselle Sendejo (owner)		902 N 7th St	

CASE NUMBER	CASE TITLE	CASE DESCRIPTION	STATUS	CASE OFFICER	DATE STARTED	DATE COMPLETED	ELAPSED TIME	VIOLATIONS	REQUIRED CORRECTIONS	PROPERTY CONTACTS	LOCATION ENFORCEMENT AREA	ADDRESS	CODE OFFICER AREA
25-000996	Prohibited Signs	Sign cbc	complete	Kathran Lewallen	10/23/2025 at 8:19 AM	10/23/2025 at 8:20 AM	1 min	1	0	Giselle Sendejo (owner)		902 N 7th St	
25-000997	Prohibited Signs	Sign cbc	complete	Kathran Lewallen	10/23/2025 at 8:20 AM	10/23/2025 at 8:21 AM	1 min	1	0	Giselle Sendejo (owner)		902 N 7th St	
25-000998	Prohibited Signs	CBC	complete	Kathran Lewallen	10/27/2025 at 10:39 AM	10/27/2025 at 10:41 AM	2 mins	1	0			510 Donald Preston Dr	
25-000999	Prohibited Signs	Cbc	complete	Kathran Lewallen	10/27/2025 at 10:41 AM	10/27/2025 at 10:42 AM	1 min	1	0	Pharmacy Inc Cvs (owner)			
25-001000	Prohibited Signs	Cbc	complete	Kathran Lewallen	10/27/2025 at 10:42 AM	10/27/2025 at 10:43 AM	1 min	1	0	Pharmacy Inc Cvs (owner)			
25-001001	Prohibited Signs	Cbc	complete	Kathran Lewallen	10/27/2025 at 10:43 AM	10/27/2025 at 10:44 AM	1 min	1	0	Pharmacy Inc Cvs (owner)			
25-001002	Prohibited Signs	Cbc	complete	Kathran Lewallen	10/27/2025 at 10:44 AM	10/27/2025 at 10:45 AM	1 min	1	0	Pharmacy Inc Cvs (owner)			
25-001003	Illegal Dumping	Mattress dumped in the alley	active	Kathran Lewallen	10/27/2025 at 3:38 PM		8 days 22 hours 46 mins	1	1	Kyle R & Teresa N Kuehler (owner)		311 E 16th St	
25-001004	Illegal Dumping	Branches dumped in the alley	active	Kathran Lewallen	10/27/2025 at 3:41 PM		8 days 22 hours 43 mins	1	1	Jeremy N & Mari E Richardson (owner)		301 Augustine Ave	
25-001005	Prohibited Signs	CBC	complete	Kathran Lewallen	10/30/2025 at 8:10 AM	10/30/2025 at 8:18 AM	8 mins	1	0	Rick Scott (owner)		Donald Preston Dr	

CASE NUMBER	CASE TITLE	CASE DESCRIPTION	STATUS	CASE OFFICER	DATE STARTED	DATE COMPLETED	ELAPSED TIME	VIOLATIONS	REQUIRED CORRECTIONS	PROPERTY CONTACTS	LOCATION ENFORCEMENT AREA	ADDRESS	CODE OFFICER AREA
25-001006	MS4 Inspection/Violation	Passed	complete	Kathran Lewallen	10/30/2025 at 8:18 AM	10/30/2025 at 8:19 AM	1 min	1	1			223 17th Street	
25-001007	MS4 Inspection/Violation	Passed	complete	Kathran Lewallen	10/30/2025 at 8:19 AM	10/30/2025 at 8:20 AM	1 min	1	1			616 15th Street	
25-001008	MS4 Inspection/Violation	passed	complete	Kathran Lewallen	10/30/2025 at 8:20 AM	10/30/2025 at 8:22 AM	2 mins	1	1			2421 Bryan Avenue	
25-001009	MS4 Inspection/Violation	Passed	complete	Kathran Lewallen	10/30/2025 at 8:22 AM	10/30/2025 at 8:23 AM	1 min	1	1			3411 Tractor Avenue	
25-001010	MS4 Inspection/Violation	Passed	complete	Kathran Lewallen	10/30/2025 at 8:23 AM	10/30/2025 at 8:24 AM	1 min	1	1			519 E 24th Street	
25-001011	MS4 Inspection/Violation	Passed	complete	Kathran Lewallen	10/30/2025 at 8:26 AM	10/30/2025 at 8:27 AM	1 min	1	1			2420 Aberdeen Avenue	
25-001012	MS4 Inspection/Violation	Passed	complete	Kathran Lewallen	10/30/2025 at 8:27 AM	10/30/2025 at 8:28 AM	1 min	1	1			3213 Tractor Avenue	
25-001013	Prohibited Signs	sn row cbc	complete	Audry Martinez	10/30/2025 at 3:02 PM	10/30/2025 at 3:03 PM	1 min	1	0				
25-001014	Prohibited Signs	sn row cbc	complete	Audry Martinez	10/30/2025 at 3:03 PM	10/30/2025 at 3:05 PM	2 mins	0	0				
25-001015	Prohibited Signs	sn row cbc	complete	Audry Martinez	10/30/2025 at 3:07 PM	10/30/2025 at 3:09 PM	2 mins	1	0				
25-001016	Prohibited Signs	sn row cbc	complete	Audry Martinez	10/30/2025 at 3:09 PM	10/30/2025 at 3:10 PM	1 min	1	0				
25-001017	Prohibited Signs	sn row cbc	complete	Audry Martinez	10/30/2025 at 3:10 PM	10/30/2025 at 3:12 PM	2 mins	0	0			302 E 26th Street	

CASE NUMBER	CASE TITLE	CASE DESCRIPTION	STATUS	CASE OFFICER	DATE STARTED	DATE COMPLETED	ELAPSED TIME	VIOLATIONS	REQUIRED CORRECTIONS	PROPERTY CONTACTS	LOCATION ENFORCEMENT AREA	ADDRESS	CODE OFFICER AREA
25-001018	Prohibited Signs	sn row cbc	complete	Audry Martinez	10/30/2025 at 3:12 PM	10/30/2025 at 3:14 PM	2 mins	1	0			302 E 22nd	
25-001019	Prohibited Signs	sn row cbc	complete	Audry Martinez	10/30/2025 at 3:14 PM	10/30/2025 at 3:15 PM	1 min	1	0			302 E 24th Street	
25-001020	Prohibited Signs	sn row cbc	complete	Audry Martinez	10/30/2025 at 3:16 PM	10/30/2025 at 3:18 PM	2 mins	1	0	Bw Gas & Convenience Real Estate Llc (owner)		701 Dowden Rd	
25-001021	Prohibited Signs	sn row cbc	complete	Audry Martinez	10/30/2025 at 3:19 PM	10/30/2025 at 3:19 PM	less than 1 min	0	0	Bw Gas & Convenience Real Estate Llc (owner)		701 Dowden Rd	
25-001022	Prohibited Signs	sn row cbc	complete	Audry Martinez	10/30/2025 at 3:20 PM	10/30/2025 at 3:21 PM	1 min	0	0	Isd Frenship (owner)		501 7th St	
25-001023	Prohibited Signs	sn row cbc	complete	Audry Martinez	10/30/2025 at 3:26 PM	10/30/2025 at 3:29 PM	3 mins	1	0	Em Properties Llc (owner)		207 Hwy 62-82	
25-001024	Prohibited Signs	sn row cbc	complete	Audry Martinez	10/30/2025 at 3:34 PM	10/30/2025 at 3:41 PM	7 mins	1	0	Overlook Land Group Llc (owner), Overlook Land Group Llc (owner)			
25-001025	Prohibited Signs	CBC	complete	Kathran Lewallen	10/31/2025 at 8:21 AM	10/31/2025 at 8:23 AM	2 mins	1	0	Copano Bay Holdings Llc (owner)		7907 Fm 179	
25-001026	Prohibited Signs	Cbc	complete	Kathran Lewallen	10/31/2025 at 8:23 AM	10/31/2025 at 8:24 AM	1 min	1	0	Rick Scott (owner)		520 Donald Preston Dr	
25-001027	Prohibited Signs	Cbc	complete	Kathran Lewallen	10/31/2025 at 8:24 AM	10/31/2025 at 8:25 AM	1 min	1	0	Pharmacy Inc Cvs (owner)			

CASE NUMBER	CASE TITLE	CASE DESCRIPTION	STATUS	CASE OFFICER	DATE STARTED	DATE COMPLETED	ELAPSED TIME	VIOLATIONS	REQUIRED CORRECTIONS	PROPERTY CONTACTS	LOCATION ENFORCEMENT AREA	ADDRESS	CODE OFFICER AREA
25-001028	Prohibited Signs	CBC	complete	Kathran Lewallen	10/31/2025 at 8:26 AM	10/31/2025 at 8:27 AM	1 min	1	0	Copano Bay Holdings Llc (owner)		7907 Fm 179	
25-001029	Prohibited Signs	CBC	complete	Kathran Lewallen	10/31/2025 at 8:27 AM	10/31/2025 at 8:28 AM	1 min	1	0	Rick Scott (owner)		520 Donald Preston Dr	
25-001030	Prohibited Signs	CBC	complete	Kathran Lewallen	10/31/2025 at 8:29 AM	10/31/2025 at 8:29 AM	less than 1 min	1	0	Rick Scott (owner)		520 Donald Preston Dr	
25-001031	Prohibited Signs	CBC	complete	Kathran Lewallen	10/31/2025 at 8:30 AM	10/31/2025 at 8:31 AM	1 min	1	0	Rick Scott (owner)		Donald Preston Dr	
25-001032	Prohibited Signs	CBC	complete	Kathran Lewallen	10/31/2025 at 8:31 AM	10/31/2025 at 8:32 AM	1 min	1	0	Rick Scott (owner)		Donald Preston Dr	
25-001033	Prohibited Signs	CBC	complete	Kathran Lewallen	10/31/2025 at 8:32 AM	10/31/2025 at 8:33 AM	1 min	1	0	Rick Scott (owner)		Donald Preston Dr	
25-001034	Prohibited Signs	Cbc	complete	Kathran Lewallen	10/31/2025 at 8:33 AM	10/31/2025 at 8:34 AM	1 min	1	0	Rick Scott (owner)		Donald Preston Dr	
25-001035	Prohibited Signs	CBC	complete	Kathran Lewallen	10/31/2025 at 8:34 AM	10/31/2025 at 8:35 AM	1 min	1	0	Rick Scott (owner)		Donald Preston Dr	
25-001036	Prohibited Signs	sn row cbc	complete	Audry Martinez	10/31/2025 at 2:24 PM	10/31/2025 at 2:29 PM	5 mins	1	0	Betenbough Homes Llc (owner)			
25-001037	Prohibited Signs	sn row cbc	complete	Audry Martinez	10/31/2025 at 2:30 PM	10/31/2025 at 2:32 PM	2 mins	1	0	Betenbough Homes Llc (owner)			

CASE NUMBER	CASE TITLE	CASE DESCRIPTION	STATUS	CASE OFFICER	DATE STARTED	DATE COMPLETED	ELAPSED TIME	VIOLATIONS	REQUIRED CORRECTIONS	PROPERTY CONTACTS	LOCATION ENFORCEMENT AREA	ADDRESS	CODE OFFICER AREA
25-001038	Unwholesome Conditions	w-vl	active	Audry Martinez	10/31/2025 at 2:36 PM		4 days 23 hours 48 mins	1	1	Peter D Nance (owner)		38 Bennett Cir	
25-001039	Unwholesome Conditions	w-vl	active	Audry Martinez	10/31/2025 at 2:57 PM		4 days 23 hours 27 mins	1	1	Peter & Grace Nance (owner)		42 Bennett Cir	
25-001040	Unwholesome Conditions	w-vl	active	Audry Martinez	10/31/2025 at 3:02 PM		4 days 23 hours 22 mins	1	1	Peter D & Grace S Nance (owner)		44 Bennett Cir	
25-001041	Unwholesome Conditions	rubbish in the alley	active	Audry Martinez	10/31/2025 at 3:23 PM		4 days 23 hours 1 min	1	1	Pearson Robert Constr Llc (owner)		1405 Corpus Ave	
25-001042	Unwholesome Conditions	rub alley	active	Audry Martinez	10/31/2025 at 3:24 PM		4 days 23 hours	1	1	Pearson Robert Constr Llc (owner)		1405 Corpus Ave	
25-001043	Unwholesome Conditions	rub alley	active	Audry Martinez	10/31/2025 at 3:25 PM		4 days 22 hours 59 mins	1	1	Pearson Robert Constr Llc (owner)		1405 Corpus Ave	
25-001044	Unwholesome Conditions	w-all	active	Audry Martinez	10/31/2025 at 3:28 PM		4 days 22 hours 56 mins	1	1	Isaac Gomez (owner)		1602 Bryan Ave	

AVERAGE								0.95	0.54				
TOTAL								115.00	65.00				

100
80
60
40
20
0

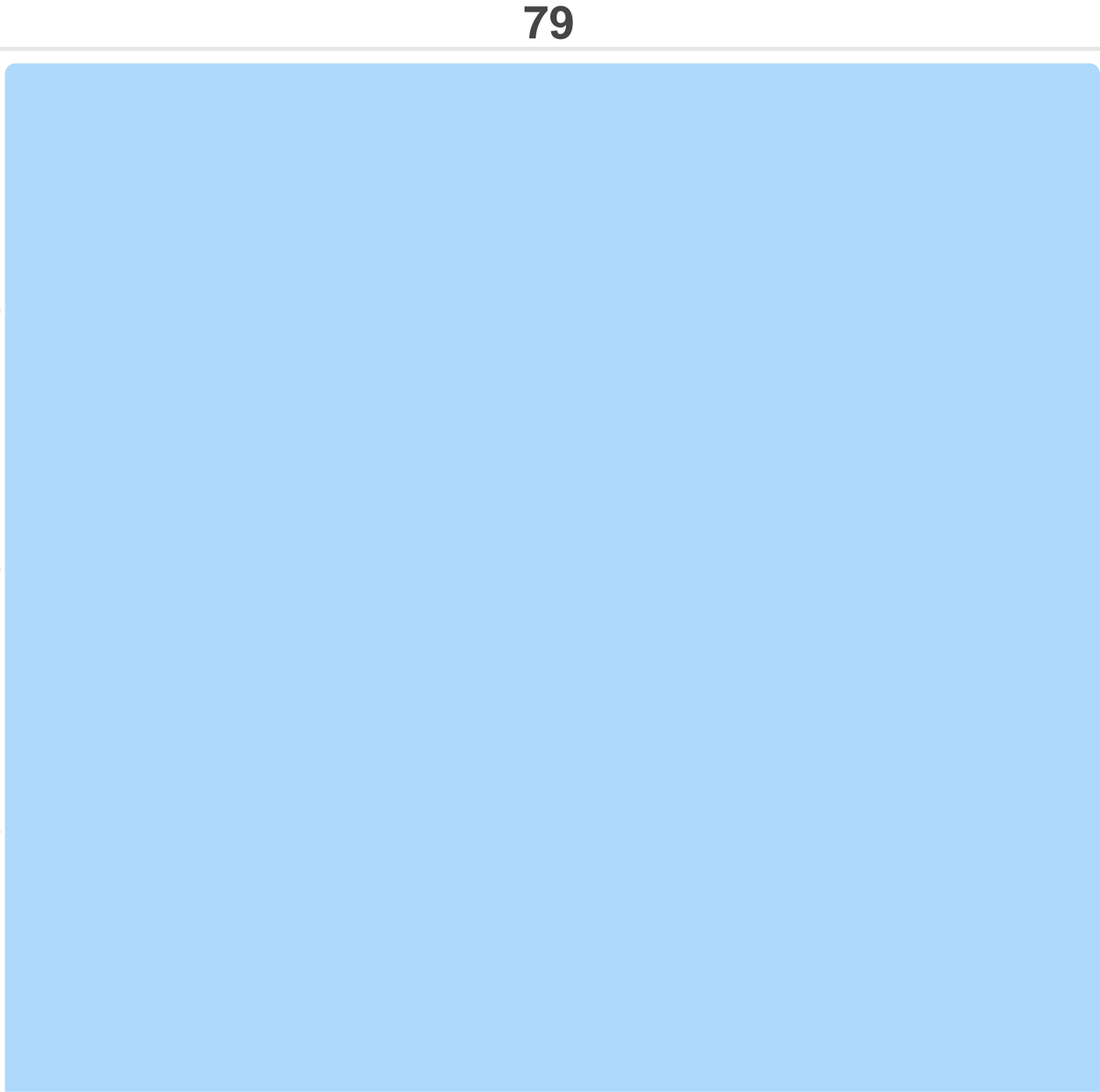

Oct 25

Police Reports October 2025

WOLFFORTH POLICE DEPARTMENT

Item # 2.

Calls - By Type

10\01\2025
thru 10\31\2025

Type	Description	# Of Calls
8	911 HANGUP	1
5	ACCIDENT (BLUE FORM)	4
7	ACCIDENT (REPORTABLE)	15
9	ALARM (FALSE BUSINESS)	5
1	ALARM (FALSE RESIDENTIAL)	5
3	ALARM (FALSE SCHOOL)	4
10	ANIMAL COMPLAINT	17
13	ASSAULT (PHYSICAL)	2
14	ASSAULT (SEXUAL)	1
15	ASSAULT (THREAT)	2
16	ASSIST OTHER AGENCY (FIRE EMS)	3
17	ASSIST OTHER AGENCY (MENTAL HEALTH)	3
18	ASSIST OTHER AGENCY (OTHER)	7
21	BURGLARY (BUSINESS)	1
30	CE (HEALTH & SANITATION)	1
35	CE (VEHICLE)	1
24	CHECK BUSINESS	65
25	CHECK RESIDENCE	2
26	CHECK WELFARE (PERSON)	19
27	CITY ORDINANCE VIOLATION	3
28	CIVIL DISPUTE	6
29	CIVIL MATTER	11
36	CPS INVESTIGATION	1
37	CRIMINAL MISCHIEF (ALL OTHERS)	1
39	CRIMINAL TRESPASS	6
43	DISORDERLY CONDUCT	4
45	DOMESTIC (NON ARREST)	5
47	DRUG PARAPHERNALIA	1
50	DUIM	1
51	DWI	3
52	EMERGENCY DETENTION	1
55	FIRE (NON STRUCTURE)	1
57	FORGERY	1
59	HARASSMENT	5
60	INFORMATION	33
62	K9 DEPLOYMENT	2
65	MISSING PERSON (JUVENILE)	1
66	MOTORIST ASSIST	7
70	PROWLER	2
71	PUBLIC INTOXICATION	1
101	RADAR CHECK	73
102	REPORT	31
73	RUNAWAY	1
100	S.T.E.P	2
74	SCHOOL PATROL	52
75	SPECIAL ASSIGNMENT	1
78	SUSPICIOUS ACTIVITY (PERSON)	16
79	SUSPICIOUS ACTIVITY (VEHICLE)	17
80	THEFT	4
81	TRAFFIC	1

Type	Description	# Of Calls
82	TRAFFIC COMPLAINT	13
85	TRAFFIC CONTACT (WARNING)	2
83	TRAFFIC CONTACT (ARREST)	1
84	TRAFFIC CONTACT (CITATION)	6
86	TRAFFIC HAZARD (LIGHTS OUT, WIRES DOWN, DEBRIS IN ROADWAY, ETC)	4
90	VEHICLE (ABANDONED)	1
91	VEHICLE (DISABLED)	1
96	WARRANT SERVICE (CRIMINAL)	1
97	WARRANT SERVICE (TRAFFIC)	1
98	ZONE PATROL	1,604
Total		2,086

OffenseStopCount

*This report does not include voided, test, or deleted records,
but does include warnings (if *ALL* or WARNINGS is selected in the Stop Result field.*

	302 Stops	364 Violations
	300 Stops	362 Violations
Cut Corner Left Turn		1
Defective Head Lamps		16
Defective Tail Lamps		25
Expired Driver License		2
Expired Registration		24
Fail to Stop Proper Place - Traffic Light		2
Fail to Stop-Designated Point - Stop Sign		13
Failed To Signal Lane Change		14
Failed To Signal Turn		19
Failure to Maintain Financial Responsibility		7
Improper Turn		11
Minor in Possession of Tobacco		2
No Driver License		10
No License Plate Light		13
No Tail Lamps		5
Open Container in Motor Vehicle - Driver		3
Possession of Drug Paraphernalia		3
Ran Red Light		6
Ran Stop Sign		14
Defective Stop Lamps		16
Disregarded Lane Control Signal		2
Driving While License Suspended		2
Drove Wrong Way On One-way Roadway		1
Fail to Display Driver License		1
Speeding		101
Unrestrained Child - Safety Seat Violation		3
Disregarded Traffic Control Device		1
Failed To Drive In Single Lane		4
Failed To Signal Distance Before Turn		1



OffenseStopCount

Open Container in Motor Vehicle - Passenger		1
Operate Motor Vehicle Without Plates		2
Public Intoxication		1
Speeding in School Zone		17
Did Not Use Designated Lane Or Direction		2
Display Unclean License Plates		2
Drove Without Lights When Required		8
Failed to Dim Headlights - Meeting		1
Failed To Yield Right Of Way		1
Driving While License Invalid		1
Drove Center Lane - Not Pass or Left Turn		1
Impeding Traffic		1
Fail to move over or reduce speed passing Authorized Emergency Vehicle		1
Child Not Secured By Seat Belt		1
Zone 06	2 Stops	2 Violations
Speeding		2

Fire Department Reports October 2025

Wolfforth Fire EMS										
2025 Run Totals										
	Wolfforth	Lubbock Co.	Lubbock	Ropesville	Hockley Co.	Yoakum Co	Monthly Total	EMS Transport	YTD Total	Training Hours
January										
Fire	47	28	3	0	2	0	80		80	
EMS	62	41	1	4	9	0	117	75	117	
February										
Fire	28	35	2	1	3		69		149	
EMS	52	55	5	9	0		121	64	238	
March										
Fire	48	46	3	0	0		97		246	
EMS	65	38	0	3	3		109	63	347	
April										
Fire	55	41	1	2	1		100		346	
EMS	58	41	1	2	1		103	62	450	
May										
Fire	85	42	0	4	4		135		481	
EMS	67	40	0	5	5		117	68	567	
June										
Fire	78	45	1	2	2		128		609	
EMS	62	46	2	3	2		115	62	682	
	Wolfforth	Lubbock Co.	Lubbock	Ropesville	Hockley Co	Yoakum Co	Monthly Total	EMS Transport	YTD Total	Training Hours
July										
Fire	78	49	1	2	2		132		741	1073.00
EMS	58	51	0	4	2		115	63	797	76.00

August										
Fire	73	48	1	3	4		129		870	1189
EMS	65	51	2	3	4		125	63	922	293
September										
Fire	66	35	0	2	1		104		974	531
EMS	56	43	2	3	0		104		1026	42
October										
Fire	57	32	0	1	3		93		1067	640
EMS	63	37	0	3	2		105		1131	21
November										
Fire							0		1067	
EMS							0		1131	
December										
Fire							0		1067	
EMS							0		1131	



Station Report

WOLFFORTH FIRE DEPARTMENT

October 2025

Total # of CFS 115

Date Time_Call Create	Call Type Description	Unit	Address
2025-10-01 04:29:19.707	ASSIST AGENCY	WFD1	1506 ARNETT ST/ROPEVILLE,
2025-10-01 09:37:20.050	ASSIST AGENCY	WFD2	HWY 62-82/F M 41,
2025-10-01 13:22:56.313	ASSIST AGENCY	WFDTR2	7102 ALCOVE AVE, WOLFFORTH
2025-10-01 16:07:51.777	TRAFFIC STOP	WFD1	DOWDEN RD / BROOKE BLVD, WOLFFORTH
		WFDTR2	DOWDEN RD / BROOKE BLVD, WOLFFORTH
2025-10-01 16:13:03.413	ACCIDENT	WFD1	HWY 62-82 FRD / DOWDEN RD, WOLFFORTH
		WFDTR2	HWY 62-82 FRD / DOWDEN RD, WOLFFORTH
2025-10-01 17:24:20.277	FIRE OTHER	WFD1	314 E 18TH ST, WOLFFORTH
		WFDTR2	314 E 18TH ST, WOLFFORTH
2025-10-01 19:26:21.710	MEDICAL EMERGENCY	WFDTR2	15104 C R 1200, LUBBOCK CO
2025-10-01 20:45:20.657	MEDICAL EMERGENCY	WFDTR2	7102 ALCOVE AVE, WOLFFORTH
2025-10-02 07:41:26.853	ASSIST AGENCY	WFDE5	109 E 5TH ST, WOLFFORTH
2025-10-02 18:59:19.920	ASSIST AGENCY	WFDE5	111 LOOP 193, WOLFFORTH
2025-10-02 20:39:12.767	ASSIST AGENCY	WFDE5	301 E 5TH ST, WOLFFORTH
2025-10-02 21:46:55.427	MEDICAL EMERGENCY	WFDE5	5505 C R 1240, LUBBOCK CO
2025-10-03 11:56:38.410	ACCIDENT	WFD1	7901 82ND ST, WOLFFORTH
		WFDE4	7901 82ND ST, WOLFFORTH
2025-10-03 12:57:08.053	GRASS FIRE	WFD1	F M 1585-C R 7400 / F M 179-C R 1400, LUBBOCK CO
		WFDTA2	F M 1585-C R 7400 / F M 179-C R 1400, LUBBOCK CO
2025-10-03 13:34:27.723	ASSIST AGENCY	WFDE4	106 PARK RD, WOLFFORTH
2025-10-03 18:36:51.997	CHECK WELFARE	WFD1	111 LOOP 193, WOLFFORTH
		WFDE4	111 LOOP 193, WOLFFORTH
2025-10-03 21:14:13.963	ACCIDENT W/INJURIES	WFDE3	82ND ST / ALCOVE AVE, WOLFFORTH
		WFDE4	82ND ST / ALCOVE AVE, WOLFFORTH
2025-10-03 22:20:30.860	ACCIDENT W/INJURIES	WFDRESCUE	130TH ST / C R 2300, LUBBOCK CO
2025-10-04 05:46:46.000	ASSIST AGENCY	WFDE4	9320 C R 7640, LUBBOCK CO
2025-10-04 15:19:15.650	FIRE ALARM	WFD1	509 BRITAIN AVE, WOLFFORTH
		WFDTR2	509 BRITAIN AVE, WOLFFORTH
2025-10-05 06:59:08.043	ASSIST AGENCY	WFDE5	213 14TH ST, WOLFFORTH
2025-10-05 17:28:14.630	ASSIST AGENCY	WFDE5	301 E 5TH ST, WOLFFORTH
2025-10-06 15:07:36.350	ACCIDENT	WFD1	1111 DONALD PRESTON DR, WOLFFORTH
		WFDE4	1111 DONALD PRESTON DR, WOLFFORTH
2025-10-06 17:04:39.567	ASSIST AGENCY	WFDE4	9120 F M 1585-C R 7400, LUBBOCK CO
2025-10-06 21:25:26.450	MEDICAL EMERGENCY	WFDE4	5909 P R 1250, LUBBOCK CO

2025-10-07 08:43:26.780	ASSIST AGENCY	WFDTR2	8202 C R 7700, LUBBOCK CO
2025-10-07 10:28:41.223	ASSIST AGENCY	WFDTR2	502 N DOWDEN RD, WOLFFORTH
2025-10-07 10:49:14.420	ACCIDENT W/INJURIES	WFD1	902 N DOWDEN RD, WOLFFORTH
		WFDC1	902 N DOWDEN RD, WOLFFORTH
		WFDTR2	902 N DOWDEN RD, WOLFFORTH
2025-10-07 15:09:24.603	ASSIST AGENCY	WFDTR2	7921 96TH ST, LUBBOCK CO
2025-10-07 17:13:32.100	ASSIST AGENCY	WFDC1	8016 C R 7700, LUBBOCK CO
		WFDTR2	8016 C R 7700, LUBBOCK CO
2025-10-08 09:27:48.487	ASSIST AGENCY	WFDTR2	31 BENNETT CIR, WOLFFORTH
2025-10-08 14:17:00.883	ASSIST AGENCY	WFD1	8907 C R 6820, LUBBOCK CO
		WFDTA1	8907 C R 6820, LUBBOCK CO
		WFDTR2	8907 C R 6820, LUBBOCK CO
2025-10-08 16:22:19.167	ACCIDENT	WFD1	902 N DOWDEN RD, WOLFFORTH
		WFDTR2	902 N DOWDEN RD, WOLFFORTH
2025-10-09 09:44:13.523	ACCIDENT	WFD1	502 N DOWDEN RD, WOLFFORTH
		WFDTR2	502 N DOWDEN RD, WOLFFORTH
2025-10-09 10:14:13.037	ASSIST AGENCY	WFDE4	109 E 5TH ST, WOLFFORTH
2025-10-10 07:04:46.483	ACCIDENT W/INJURIES	WFD1	11513 HWY 62-82, LUBBOCK CO
		WFDTR2	11513 HWY 62-82, LUBBOCK CO
2025-10-10 08:55:56.837	ASSIST AGENCY	WFDTR2	109 E 5TH ST, WOLFFORTH
2025-10-10 16:43:25.420	ACCIDENT W/INJURIES	WFD1	INLER AVE / C R 7000, LUBBOCK
		WFDTR2	INLER AVE / C R 7000, LUBBOCK
2025-10-10 19:34:17.890	TRAFFIC STOP	WFDTR2	901 N DOWDEN RD, WOLFFORTH
2025-10-10 20:35:56.017	ASSIST AGENCY	WFDTR2	1305 NOTTINGHAM AVE, WOLFFORTH
2025-10-11 00:48:46.200	ASSIST AGENCY	WFDTR2	4305 WREN,
2025-10-11 05:10:21.683	ASSIST AGENCY	WFDTR2	8408 C R 6910, LUBBOCK CO
2025-10-12 00:23:23.070	ASSIST AGENCY	WFDTR2	10109 C R 6100, LUBBOCK CO
2025-10-12 10:32:48.577	ASSIST AGENCY	WFDE4	8804 C R 7310, LUBBOCK CO
2025-10-12 16:38:34.900	ASSIST AGENCY	WFDE4	7102 ALCOVE AVE, WOLFFORTH
2025-10-13 18:44:41.507	DISCIPLINE PROBLEM	WFD1	828 9TH ST, WOLFFORTH
		WFDTR2	828 9TH ST, WOLFFORTH
2025-10-13 20:31:11.620	ASSIST AGENCY	WFDE3	609 N 7TH ST, WOLFFORTH
		WFDTR2	609 N 7TH ST, WOLFFORTH
2025-10-14 21:07:55.857	ASSIST AGENCY	WFDTR2	301 E 5TH ST, WOLFFORTH
2025-10-14 23:58:52.977	ASSIST AGENCY	WFDTR2	1502 FLINT AVE, WOLFFORTH
2025-10-15 03:24:00.517	ASSIST AGENCY	WFDTR2	8817 P R 7370, LUBBOCK CO
2025-10-15 15:30:14.897	ACCIDENT W/INJURIES	WFD1	HWY 62-82 FRD / DONALD PRESTON DR, WOLFFORTH
		WFDE4	HWY 62-82 FRD / DONALD PRESTON DR, WOLFFORTH
2025-10-15 17:30:10.297	ASSIST AGENCY	WFDE4	109 E 5TH ST, WOLFFORTH
2025-10-16 01:43:28.163	ASSIST AGENCY	WFDC1	5302 P R 1040, LUBBOCK CO
		WFDE4	5302 P R 1040, LUBBOCK CO
2025-10-16 07:32:05.017	ASSIST AGENCY	WFDC1	5214 RESEARCH BLVD, LUBBOCK CO
		WFDE4	5214 RESEARCH BLVD, LUBBOCK CO

2025-10-16 19:25:37.747	ASSIST AGENCY	WFDTR2	808 MAIN ST, WOLFFORTH
2025-10-17 01:29:40.027	ASSIST AGENCY	WFDTR2	303 STECK AVE, WOLFFORTH
2025-10-17 19:44:31.127	FIRE OTHER	WFD1	F M 1585-C R 7400 / HARVEST AVE, LUBBOCK CO
2025-10-17 20:18:18.513	DISTURBANCE	WFDTR2	F M 1585-C R 7400 / HARVEST AVE, LUBBOCK CO
2025-10-18 00:04:40.640	MEDICAL EMERGENCY	WFDTR2	1006 PRESTON TRAILS, WOLFFORTH
2025-10-18 01:51:14.947	TRAFFIC STOP	WFDTR2	109 E 5TH ST, WOLFFORTH
2025-10-18 06:04:51.087	ASSIST AGENCY	WFD2	N 3RD ST / CAMBRIDGE AVE, WOLFFORTH
2025-10-18 08:13:57.827	ASSIST AGENCY	WFDE5	6808 C R 1100, LUBBOCK CO
2025-10-18 14:22:45.470	FIRE ALARM	WFDE4	109 E 5TH ST, WOLFFORTH
2025-10-19 01:31:52.093	ASSIST AGENCY	WFD1	810 7TH ST, WOLFFORTH
2025-10-19 14:55:30.903	ASSIST AGENCY	WFDE4	9007 BARTON AVE, LUBBOCK CO
2025-10-19 19:32:02.280	GRASS FIRE	WFDTR2	MAIN ST / C R 1300, WOLFFORTH
2025-10-20 00:39:02.210	ASSIST AGENCY	WFD1	F M 179-C R 1400 / C R 7440, LUBBOCK CO
2025-10-20 10:28:01.147	ASSIST AGENCY	WFDTA1	F M 179-C R 1400 / C R 7440, LUBBOCK CO
2025-10-20 20:21:40.570	FIRE OTHER	WFDTR2	F M 179-C R 1400 / C R 7440, LUBBOCK CO
2025-10-20 23:23:18.757	ASSIST AGENCY	WFDTR2	301 E 5TH ST, WOLFFORTH
2025-10-21 04:50:27.660	ASSIST AGENCY	WFDE4	318 WILDCAT ST, WOLFFORTH
2025-10-21 07:40:25.833	ACCIDENT	WFDE4	14012 C R 1420, LUBBOCK CO
2025-10-21 09:12:15.273	VEHICLE FIRE	WFDE5	14012 C R 1420, LUBBOCK CO
2025-10-21 10:42:06.023	ASSIST AGENCY	WFDE5	302 MANCHESTER AVE, WOLFFORTH
2025-10-21 10:56:35.420	ASSIST AGENCY	WFDE5	711 N 3RD ST, WOLFFORTH
2025-10-21 16:17:37.890	ASSIST AGENCY	WFDE4	F M 41-C R 7800 / C R 1240, LUBBOCK CO
2025-10-21 17:51:25.343	ACCIDENT W/INJURIES	WFDE4	1818 114TH ST, LUBBOCK CO
2025-10-21 17:52:27.453	ALARM	WFDE4	8002 C R 6920, LUBBOCK CO
2025-10-21 21:13:07.917	DOMESTIC VIOLENCE	WFDE4	19 CIRCLE DR, WOLFFORTH
2025-10-22 00:42:49.190	MEDICAL EMERGENCY	WFDE4	1205 BROOKSHIRE AVE, WOLFFORTH
2025-10-22 10:29:20.810	ASSIST AGENCY	WFDE4	8720 C R 7100, LUBBOCK CO
2025-10-22 16:17:54.117	ASSIST AGENCY	WFDE4	8720 C R 7100, LUBBOCK CO
2025-10-22 23:52:02.333	CHECK WELFARE	WFD1	614 E C R 7200, LUBBOCK CO
2025-10-23 07:17:39.360	ACCIDENT	WFD1	5402 C R 1160, LUBBOCK CO
2025-10-23 08:26:20.807	ASSIST AGENCY	WFD1	1514 WINDSOR AVE, WOLFFORTH
2025-10-23 16:06:17.543	ACCIDENT	WFDTR2	13211 UPLAND AVE, LUBBOCK CO
2025-10-23 17:58:13.427	ASSAULT	WFDTR2	5613 C R 1240, LUBBOCK CO
2025-10-23 22:07:42.617	MEDICAL EMERGENCY	WFD1	109 E 5TH ST, WOLFFORTH
2025-10-24 11:31:31.037	ASSIST AGENCY	WFD1	902 N DOWDEN RD, WOLFFORTH
2025-10-24 12:27:16.087	FIRE ALARM	WFDE5	902 N DOWDEN RD, WOLFFORTH
		WFDE5	14006 C R 1420, LUBBOCK CO
		WFD1	DOWDEN RD / HWY 62-82 FRD, WOLFFORTH
		WFDE5	DOWDEN RD / HWY 62-82 FRD, WOLFFORTH
		WFDE5	5606 C R 1260, LUBBOCK CO
		WFDE5	701 DOWDEN RD, WOLFFORTH
		WFDE5	109 E 5TH ST, WOLFFORTH
		WFD1	5809 C R 7670, LUBBOCK CO

2025-10-24 12:27:16.087	FIRE ALARM	WFDE5	5809 C R 7670, LUBBOCK CO
2025-10-24 16:03:18.613	ASSIST AGENCY	WFDE5	203 SOONER ST, WOLFFORTH
2025-10-24 21:19:36.067	ASSIST AGENCY	WFDE5	427 DOWDEN RD, WOLFFORTH
2025-10-24 21:39:08.320	ASSIST AGENCY	WFDE5	3205 ABBEVILLE AVE, WOLFFORTH
2025-10-25 01:03:44.300	MEDICAL EMERGENCY	WFDE5	1101 PRESTON TRAILS, WOLFFORTH
2025-10-25 01:33:36.997	ACCIDENT W/INJURIES	WFD1	16114 F M 179, LUBBOCK CO
		WFDC1	16114 F M 179, LUBBOCK CO
2025-10-25 16:48:53.283	FIRE OTHER	WFD1	7601 WOODROW RD, LUBBOCK CO
		WFDTR2	7601 WOODROW RD, LUBBOCK CO
2025-10-26 00:50:10.620	ASSIST AGENCY	WFDTR2	C R 7400 / KILLDEE RD, LUBBOCK CO
2025-10-26 06:25:39.550	ASSIST AGENCY	WFDTR2	5606 C R 1260, LUBBOCK CO
2025-10-26 19:49:18.157	ASSIST AGENCY	WFDE5	10109 C R 6900, LUBBOCK CO
2025-10-26 21:11:46.060	PROWLER	WFDE5	7102 ALCOVE AVE, WOLFFORTH
2025-10-27 07:50:32.030	FIRE OTHER	WFD1	13TH ST / ELM AVE, LUBBOCK CO
		WFDE5	13TH ST / ELM AVE, LUBBOCK CO
2025-10-27 17:01:58.407	ACCIDENT W/INJURIES	WFD1	13TH ST / DOWDEN RD, WOLFFORTH
		WFDE5	13TH ST / DOWDEN RD, WOLFFORTH
2025-10-27 20:29:42.763	ASSIST AGENCY	WFDE5	301 E 5TH ST, WOLFFORTH
2025-10-28 16:44:27.557	ASSIST AGENCY	WFDTR2	5612 RESEARCH BLVD, LUBBOCK CO
2025-10-29 02:26:36.900	ASSIST AGENCY	WFDTR2	1302 HARTFORD AVE, WOLFFORTH
2025-10-29 07:49:08.153	ACCIDENT	WFDE4	CAMBRIDGE AVE / DONALD PRESTON DR, WOLFFORTH
		WFDTR2	CAMBRIDGE AVE / DONALD PRESTON DR, WOLFFORTH
2025-10-29 15:56:49.050	GRASS FIRE	WFD1	F M 2378-C R 1000 / C R 7100, LUBBOCK CO
		WFDTA1	F M 2378-C R 1000 / C R 7100, LUBBOCK CO
2025-10-29 17:14:15.737	ASSIST AGENCY	WFD1	608 N 5TH ST, WOLFFORTH
2025-10-30 11:45:13.003	ASSIST AGENCY	WFDE5	7102 ALCOVE AVE, WOLFFORTH
2025-10-30 13:46:15.653	ASSIST AGENCY	WFDE5	109 E 5TH ST, WOLFFORTH
2025-10-30 15:00:02.053	ACCIDENT W/INJURIES	WFD1	DONALD PRESTON DR / CAMBRIDGE AVE, WOLFFORTH
		WFDE5	DONALD PRESTON DR / CAMBRIDGE AVE, WOLFFORTH
2025-10-31 10:17:48.010	FIRE OTHER	WFD1	903 W 5TH ST, WOLFFORTH
		WFDTR2	903 W 5TH ST, WOLFFORTH
2025-10-31 15:36:47.103	ASSIST AGENCY	WFDTR2	14008 C R 1430, LUBBOCK CO
2025-10-31 16:55:42.363	ASSIST AGENCY	WFDTR2	9120 F M 1585-C R 7400, LUBBOCK CO
2025-10-31 19:43:24.343	ACCIDENT W/INJURIES	WFD1	146TH ST / UPLAND AVE, LUBBOCK
		WFDTR2	146TH ST / UPLAND AVE, LUBBOCK

Library Reports October 2025

Library Report

Dates included: October 1, 2025 – October 31, 2025

Circulation Statistics: 5,151 Checkouts (779 more than October 2024)

Cards issued: 252 total new cards | 223 in-person cards | 29 website sign-ups
(136 more than October 2024 – this month we also set up cards for FMS 6th grade students)

Materials Added: 51 Items Value: \$2,235.57

Materials Weeded: 680 Items Value: \$14,111.90

Overdrive (WT Digital Consortium) – 3,687 eBooks, 4,050 eAudiobooks, and 606 eMagazines

Overdrive New User Registrations – 54 new users

Total number of visitors: 2,562

Total number of computer users: 189

Total number of reference questions: 934

Meeting Room reservations: 17

Program totals: 42 Total Programs: (7 more programs than October 2024)

Family – 5 | Preschool – 18 | School Age – 0 | Teen – 2 | Adult – 7 | Outreach – 10 | Passive – 0 |

Total Participation: 943 Total

231 Giveaways (83 sponsored by Literacy Lubbock – National Night Out book giveaways purchased at a significant discount with special partnership with Scholastic Literacy Partners) |

487 Babies/Toddlers (0-5) | 50 Children (6-11) | 22 Teens (12-18) | 384 adults

Volunteer Hours: 80:30 hours (70:05 more than October 2024)

During our Master Planning process, a weakness was noted in the number of volunteers the library has in relation to our usage and program attendance. Because of this, and the fact that often times our staff is stretched very thin, we have increased our recruitment of volunteers. While managing volunteers is somewhat time consuming initially, it has been worth it and we have had some much-needed help during our programs, exceptionally busy times, and prepping for programs and outreach.

We have continued to work on reorganizing and updating our physical collection to make the best use of our space and ensure that materials are easy for our patrons to find. This includes reclassifying portions of the adult and teen collections and weeding items that are outdated, no longer circulating, or simply no longer suitable for the collection. This project will continue through the end of the year as we address all sections of the collection. As we work through this, we are also working diligently on collection development to ensure that our material purchases are relevant and of interest to our community.

As part of our goal to increase our presence in the community and support community engagement we participated in the Frenship High School resource fair. This opportunity allowed us to meet parents and teens and share the many programs and resources we have for our families in our community.

Taylor and I collaborated with Danielle and Wolfforth EDC to organize a new community-wide Trick-or-Treat event in partnership with local businesses, and it was a tremendous success. Taylor hosted a special storytime

at the library and designed a “passport” for families to use as they visited participating businesses throughout the day. In total, 12 businesses joined the initiative. We hope this event continues to raise awareness of Wolfforth’s growing retail community. Our storytime drew the largest attendance we’ve ever had with 158 people, including 93 children under the age of five. While we don’t yet have data on how many families visited each business, every attendee received a passport listing all participating locations, providing an affordable and effective way to spotlight many of Wolfforth’s wonderful businesses. We plan to do this again next year and hope to be able to work with Danielle again in the future with other similar initiatives.

EDC Report October 2025



Wolfforth Economic Development Corporation Monthly Report

October 2025

- Attend Ports to Plains Conference at the Overton
- Call with retail broker for two retail spots
- Strategic planning in person meetings
- Multiple calls/emails regarding Graco development
- Attend FMS ribbon cutting
- Attend reception for new Lubbock Chamber CEO
- Brainstorm library fundraising event
- Attend LBK Chamber Harvest Luncheon
- Call with Haley Archer regarding a project
- Lunch with Ryan Smith and Kimley-Horn
- Retail Site Selector special called EDC meeting and site visit
- Teach at the Rural Economic Development Institute
- Attend annual meeting for the High Ground of Texas
- Data Center Webinar
- Hero Home Ribbon Cutting
- Attend annual Texas Economic Development Council conference
- Data collection for site selectors

On-Going Monthly Activity:

- Continue to create social media content, monitor all social media platforms, like and comment on business posts
- Monitor website activity and create content articles as needed
- Work on content management platform
- Pop into businesses to say hi and check in, in between business retention and expansion visits.
- Communicate with LeadingEDG on business activities
- Agenda building
- Monitor comptroller site for new sales tax permits

Budget Reports October 2025



		Original Total Budget	Current Total Budget	Period Activity	Fiscal Activity	Variance Favorable (Unfavorable)	Percent Used
Fund: 01 - General Fund							
Revenue							
Department: 000 - Non-departmental							
01-000-31100-000	Property Taxes	6,500,000.00	6,500,000.00	5,188.68	5,188.68	-6,494,811.32	0.08 %
01-000-31300-000	Sales Tax	1,450,000.00	1,450,000.00	0.00	0.00	-1,450,000.00	0.00 %
01-000-31600-000	Franchise Fees	450,000.00	450,000.00	30,148.96	30,148.96	-419,851.04	6.70 %
01-000-32200-000	Building Permits	282,000.00	282,000.00	28,657.60	28,657.60	-253,342.40	10.16 %
01-000-32310-000	Electrical Permits	175,000.00	175,000.00	17,216.00	17,216.00	-157,784.00	9.84 %
01-000-32320-000	Mechanical Permits	165,000.00	165,000.00	25,139.60	25,139.60	-139,860.40	15.24 %
01-000-32330-000	Plumbing Permits	182,000.00	182,000.00	21,020.00	21,020.00	-160,980.00	11.55 %
01-000-32340-000	Sprinkler Permits	15,000.00	15,000.00	1,330.00	1,330.00	-13,670.00	8.87 %
01-000-32400-000	Re-Inspection Fees	2,500.00	2,500.00	210.00	210.00	-2,290.00	8.40 %
01-000-32450-000	Engineer Review Fees	13,000.00	13,000.00	0.00	0.00	-13,000.00	0.00 %
01-000-32500-000	Alarm Permits and Fees	500.00	500.00	0.00	0.00	-500.00	0.00 %
01-000-32600-000	Fire Inspections	1,000.00	1,000.00	13,194.94	13,194.94	12,194.94	1,319.49 %
01-000-32700-000	Solar Panel Permit	1,000.00	1,000.00	0.00	0.00	-1,000.00	0.00 %
01-000-32800-000	Plat Fee	5,000.00	5,000.00	700.00	700.00	-4,300.00	14.00 %
01-000-32900-000	Miscellaneous Permits	3,000.00	3,000.00	120.00	120.00	-2,880.00	4.00 %
01-000-33800-000	County Library Funds	30,000.00	30,000.00	0.00	0.00	-30,000.00	0.00 %
01-000-33801-000	Library Revenue	6,000.00	6,000.00	362.68	362.68	-5,637.32	6.04 %
01-000-33860-000	Billboard Lease	3,000.00	3,000.00	250.00	250.00	-2,750.00	8.33 %
01-000-33900-000	Training Center Rental Fee	4,800.00	4,800.00	0.00	0.00	-4,800.00	0.00 %
01-000-33950-000	City Building Leases	56,388.00	56,388.00	4,699.00	4,699.00	-51,689.00	8.33 %
01-000-33955-000	Lease Income	12,360.00	12,360.00	0.00	0.00	-12,360.00	0.00 %
01-000-34200-000	County Fire Funds	198,835.00	198,835.00	198,835.00	198,835.00	0.00	100.00 %
01-000-34205-000	Fire Suppression Revenue	20,000.00	20,000.00	0.00	0.00	-20,000.00	0.00 %
01-000-34500-000	EMS Billing Revenue	349,000.00	349,000.00	4,341.50	4,341.50	-344,658.50	1.24 %
01-000-34520-000	EMS Standby Revenue	6,000.00	6,000.00	0.00	0.00	-6,000.00	0.00 %
01-000-34700-000	Kennel Fees	1,000.00	1,000.00	69.00	69.00	-931.00	6.90 %
01-000-35100-000	Municipal Court Revenue	135,000.00	135,000.00	11,966.21	11,966.21	-123,033.79	8.86 %
01-000-36110-000	Interest income	144,000.00	144,000.00	0.00	0.00	-144,000.00	0.00 %
01-000-36600-000	Abatement Reimbursement	0.00	0.00	415.00	415.00	415.00	0.00 %
01-000-36610-000	Abatement Administration	0.00	0.00	1,000.00	1,000.00	1,000.00	0.00 %
01-000-36910-000	Other Income	2,000.00	2,000.00	42.00	42.00	-1,958.00	2.10 %
01-000-36920-001	EDC Administration Reimbursemen	98,951.00	98,951.00	7,546.25	7,546.25	-91,404.75	7.63 %
01-000-37100-000	Municipal Park Income	12,000.00	12,000.00	0.00	0.00	-12,000.00	0.00 %
01-000-38250-000	Credit Card/PCard Rebate	0.00	0.00	91.34	91.34	91.34	0.00 %
01-000-39950-000	Transfers in	730,000.00	730,000.00	0.00	0.00	-730,000.00	0.00 %
	Department: 000 - Non-departmental Total:	11,054,334.00	11,054,334.00	372,543.76	372,543.76	-10,681,790.24	3.37%
	Revenue Total:	11,054,334.00	11,054,334.00	372,543.76	372,543.76	-10,681,790.24	3.37%

My Budget Report

For Fiscal: 2025-2026 Period Ending Item # 2. 25

Expense	Original Total Budget	Current Total Budget	Period Activity	Fiscal Activity	Variance Favorable (Unfavorable)	Percent Used
Department: 000 - Non-departmental						
01-000-48500-000 380/Tax Incentives	600,000.00	600,000.00	0.00	0.00	600,000.00	0.00 %
Department: 000 - Non-departmental Total:	600,000.00	600,000.00	0.00	0.00	600,000.00	0.00%

		Original Total Budget	Current Total Budget	Period Activity	Fiscal Activity	Variance Favorable (Unfavorable)	Percent Used
Department: 100 - Admin							
01-100-41000-000	Wages	551,475.12	551,475.12	42,817.37	42,817.37	508,657.75	7.76 %
01-100-41005-000	Longevity	2,520.00	2,520.00	170.76	170.76	2,349.24	6.78 %
01-100-41006-000	Certification Pay	9,600.00	9,600.00	738.46	738.46	8,861.54	7.69 %
01-100-41007-000	Vehicle Allowance	18,000.00	18,000.00	1,384.62	1,384.62	16,615.38	7.69 %
01-100-41008-000	Deduction Reimbursements	12,000.00	12,000.00	923.08	923.08	11,076.92	7.69 %
01-100-41010-000	Vacation Buy Back	14,000.00	14,000.00	1,915.60	1,915.60	12,084.40	13.68 %
01-100-41200-000	Retirement	109,890.88	109,890.88	8,592.47	8,592.47	101,298.41	7.82 %
01-100-41200-001	Retirement-CM	14,894.44	14,894.44	1,203.02	1,203.02	13,691.42	8.08 %
01-100-41300-000	FICA	44,492.03	44,492.03	2,323.11	2,323.11	42,168.92	5.22 %
01-100-41400-000	Hospitalization	55,690.70	55,690.70	4,364.36	4,364.36	51,326.34	7.84 %
01-100-41400-001	Surency Admin Fees	0.00	0.00	159.55	159.55	-159.55	0.00 %
01-100-41700-000	Unemployment	468.00	468.00	0.00	0.00	468.00	0.00 %
01-100-42010-000	Office Supplies	8,000.00	8,000.00	78.54	78.54	7,921.46	0.98 %
01-100-42021-000	Cleaning Supplies	850.00	850.00	0.00	0.00	850.00	0.00 %
01-100-42025-000	Food/Drinks	650.00	650.00	0.00	0.00	650.00	0.00 %
01-100-42030-000	Office Equipment	500.00	500.00	0.00	0.00	500.00	0.00 %
01-100-42035-000	Computer Equipment	1,500.00	1,500.00	0.00	0.00	1,500.00	0.00 %
01-100-42195-000	Special Events and Awards	22,000.00	22,000.00	0.00	0.00	22,000.00	0.00 %
01-100-43101-000	Legal Services	28,000.00	28,000.00	0.00	0.00	28,000.00	0.00 %
01-100-43105-000	Onboarding Employee Services	500.00	500.00	0.00	0.00	500.00	0.00 %
01-100-43109-000	Professional Services	150,000.00	150,000.00	37,500.00	37,500.00	112,500.00	25.00 %
01-100-43110-000	Other Professional Services	12,250.00	12,250.00	1,271.88	1,271.88	10,978.12	10.38 %
01-100-43125-000	IT Services	159,000.00	159,000.00	11,836.05	11,836.05	147,163.95	7.44 %
01-100-43130-000	Software Licensing	6,050.00	6,050.00	2,550.00	2,550.00	3,500.00	42.15 %
01-100-43140-000	Legal Publications	4,500.00	4,500.00	0.00	0.00	4,500.00	0.00 %
01-100-43145-000	Election Services	20,000.00	20,000.00	0.00	0.00	20,000.00	0.00 %
01-100-43147-000	GIS Mapping Services	12,000.00	12,000.00	900.00	900.00	11,100.00	7.50 %
01-100-43195-000	Electricity/Gas/Phone	134,000.00	134,000.00	3,690.86	3,690.86	130,309.14	2.75 %
01-100-43201-000	Janitorial	34,000.00	34,000.00	0.00	0.00	34,000.00	0.00 %
01-100-43301-000	Insurance	361,372.00	361,372.00	362,278.56	362,278.56	-906.56	100.25 %
01-100-43310-000	Records Management Systems	5,500.00	5,500.00	5,000.00	5,000.00	500.00	90.91 %
01-100-43320-000	Postage/Freight	3,000.00	3,000.00	0.00	0.00	3,000.00	0.00 %
01-100-43401-000	Travel/Training	10,000.00	10,000.00	640.00	640.00	9,360.00	6.40 %
01-100-43501-000	Dues/Memberships	4,350.00	4,350.00	458.75	458.75	3,891.25	10.55 %
01-100-43505-000	Fees	12,000.00	12,000.00	37.94	37.94	11,962.06	0.32 %
01-100-43510-000	Tax Appraisal/Collection	65,000.00	65,000.00	0.00	0.00	65,000.00	0.00 %
01-100-43900-000	Other Contractual	36,400.00	36,400.00	11,668.22	11,668.22	24,731.78	32.06 %
	Department: 100 - Admin Total:	1,924,453.17	1,924,453.17	502,503.20	502,503.20	1,421,949.97	26.11 %

My Budget Report

For Fiscal: 2025-2026 Period Ending Item # 2. 25

	Original Total Budget	Current Total Budget	Period Activity	Fiscal Activity	Variance Favorable (Unfavorable)	Percent Used
Department: 120 - Municipal Court						
01-120-41000-000	Wages	39,705.12	39,705.12	3,054.40	3,054.40	36,650.72 7.69 %
01-120-41002-000	Overtime	200.00	200.00	0.00	0.00	200.00 0.00 %
01-120-41005-000	Longevity	240.00	240.00	13.84	13.84	226.16 5.77 %
01-120-41006-000	Certification Pay	1,200.00	1,200.00	92.30	92.30	1,107.70 7.69 %
01-120-41200-000	Retirement	7,430.65	7,430.65	574.90	574.90	6,855.75 7.74 %
01-120-41300-000	FICA	3,147.60	3,147.60	241.78	241.78	2,905.82 7.68 %
01-120-41400-000	Hospitalization	8,115.48	8,115.48	624.19	624.19	7,491.29 7.69 %
01-120-41700-000	Unemployment	117.00	117.00	0.00	0.00	117.00 0.00 %
01-120-42010-000	Office Supplies	250.00	250.00	0.00	0.00	250.00 0.00 %
01-120-42030-000	Office Equipment	500.00	500.00	0.00	0.00	500.00 0.00 %
01-120-43101-000	Legal Services	13,000.00	13,000.00	0.00	0.00	13,000.00 0.00 %
01-120-43102-000	Collections	8,000.00	8,000.00	734.77	734.77	7,265.23 9.18 %
01-120-43103-000	Judge Professional Service	13,000.00	13,000.00	1,000.00	1,000.00	12,000.00 7.69 %
01-120-43130-000	Software Licensing	5,490.00	5,490.00	0.00	0.00	5,490.00 0.00 %
01-120-43401-000	Travel/Training	3,900.00	3,900.00	0.00	0.00	3,900.00 0.00 %
01-120-43501-000	Dues/Memberships	130.00	130.00	0.00	0.00	130.00 0.00 %
Department: 120 - Municipal Court Total:		104,425.85	104,425.85	6,336.18	6,336.18	98,089.67 6.07%

		Original	Current	Period	Fiscal	Variance	Percent
		Total Budget	Total Budget	Activity	Activity	Favorable (Unfavorable)	Used
Department: 150 - Financial Administration							
01-150-41000-000	Wages	49,489.44	49,489.44	3,802.05	3,802.05	45,687.39	7.68 %
01-150-41002-000	Overtime	150.00	150.00	35.92	35.92	114.08	23.95 %
01-150-41005-000	Longevity	360.00	360.00	23.08	23.08	336.92	6.41 %
01-150-41200-000	Retirement	9,002.62	9,002.62	702.33	702.33	8,300.29	7.80 %
01-150-41300-000	FICA	3,813.48	3,813.48	277.57	277.57	3,535.91	7.28 %
01-150-41400-000	Hospitalization	14,527.52	14,527.52	1,097.99	1,097.99	13,429.53	7.56 %
01-150-41700-000	Unemployment	117.00	117.00	0.00	0.00	117.00	0.00 %
01-150-42010-000	Office Supplies	2,000.00	2,000.00	0.00	0.00	2,000.00	0.00 %
01-150-43105-000	Audit Services	34,000.00	34,000.00	0.00	0.00	34,000.00	0.00 %
01-150-43130-000	Software Licensing	53,625.00	53,625.00	26,625.00	26,625.00	27,000.00	49.65 %
01-150-43401-000	Travel/Training	4,750.00	4,750.00	74.20	74.20	4,675.80	1.56 %
01-150-43900-000	Other Contractual	90,000.00	90,000.00	0.00	0.00	90,000.00	0.00 %
Department: 150 - Financial Administration Total:		261,835.06	261,835.06	32,638.14	32,638.14	229,196.92	12.47%

		Original Total Budget	Current Total Budget	Period Activity	Fiscal Activity	Variance Favorable (Unfavorable)	Percent Used
Department: 160 - Building and Grounds							
01-160-41000-000	Wages	71,329.44	71,329.44	5,486.40	5,486.40	65,843.04	7.69 %
01-160-41002-000	Overtime	3,000.00	3,000.00	88.94	88.94	2,911.06	2.96 %
01-160-41005-000	Longevity	240.00	240.00	9.24	9.24	230.76	3.85 %
01-160-41200-000	Retirement	12,925.17	12,925.17	1,015.84	1,015.84	11,909.33	7.86 %
01-160-41300-000	FICA	5,475.06	5,475.06	427.21	427.21	5,047.85	7.80 %
01-160-41400-000	Hospitalization	16,230.96	16,230.96	1,242.36	1,242.36	14,988.60	7.65 %
01-160-41700-000	Unemployment	234.00	234.00	0.00	0.00	234.00	0.00 %
01-160-42021-000	Cleaning Supplies	200.00	200.00	0.00	0.00	200.00	0.00 %
01-160-42115-000	Apparel	0.00	0.00	8.78	8.78	-8.78	0.00 %
01-160-42155-000	Vehicle Supplies	1,200.00	1,200.00	0.00	0.00	1,200.00	0.00 %
01-160-42215-000	Chemical Supplies	250.00	250.00	0.00	0.00	250.00	0.00 %
01-160-42225-000	Mowing Supplies	2,000.00	2,000.00	0.00	0.00	2,000.00	0.00 %
01-160-42230-000	Plumbing Supplies	250.00	250.00	0.00	0.00	250.00	0.00 %
01-160-42280-000	Senior Citizen Maint Supplies	500.00	500.00	0.00	0.00	500.00	0.00 %
01-160-42900-000	Non-Capital Tools & Equipment	1,000.00	1,000.00	0.00	0.00	1,000.00	0.00 %
01-160-42905-000	Other Operating Supplies	500.00	500.00	0.00	0.00	500.00	0.00 %
01-160-43195-000	Electricity/Gas/Phone	4,000.00	4,000.00	0.00	0.00	4,000.00	0.00 %
01-160-43210-000	Lawn Care	20,000.00	20,000.00	560.00	560.00	19,440.00	2.80 %
01-160-43225-000	R & M Building	35,000.00	35,000.00	0.00	0.00	35,000.00	0.00 %
01-160-43230-000	R & M Grounds	4,500.00	4,500.00	0.00	0.00	4,500.00	0.00 %
01-160-43245-000	R & M Equipment	6,300.00	6,300.00	0.00	0.00	6,300.00	0.00 %
01-160-43250-000	R & M Vandalism	500.00	500.00	0.00	0.00	500.00	0.00 %
01-160-43255-000	R & M Other	500.00	500.00	0.00	0.00	500.00	0.00 %
01-160-43900-000	Other Contractual	250.00	250.00	0.00	0.00	250.00	0.00 %
Department: 160 - Building and Grounds Total:		186,384.63	186,384.63	8,838.77	8,838.77	177,545.86	4.74%

		Original Total Budget	Current Total Budget	Period Activity	Fiscal Activity	Variance Favorable (Unfavorable)	Percent Used
Department: 210 - Police							
01-210-41000-000	Wages	1,392,770.60	1,392,770.60	92,997.36	92,997.36	1,299,773.24	6.68 %
01-210-41002-000	Overtime	30,000.00	30,000.00	1,988.09	1,988.09	28,011.91	6.63 %
01-210-41004-000	Stipend Pay	7,800.00	7,800.00	907.50	907.50	6,892.50	11.63 %
01-210-41005-000	Longevity	6,600.00	6,600.00	392.28	392.28	6,207.72	5.94 %
01-210-41006-000	Certification Pay	36,000.00	36,000.00	1,704.17	1,704.17	34,295.83	4.73 %
01-210-41200-000	Retirement	242,310.85	242,310.85	17,824.28	17,824.28	224,486.57	7.36 %
01-210-41300-000	FICA	110,402.55	110,402.55	7,346.40	7,346.40	103,056.15	6.65 %
01-210-41400-000	Hospitalization	232,862.53	232,862.53	13,428.09	13,428.09	219,434.44	5.77 %
01-210-41700-000	Unemployment	2,223.00	2,223.00	29.71	29.71	2,193.29	1.34 %
01-210-41900-000	Other Benefits-	16,320.00	16,320.00	361.27	361.27	15,958.73	2.21 %
01-210-42010-000	Office Supplies	5,000.00	5,000.00	0.00	0.00	5,000.00	0.00 %
01-210-42035-000	Computer Equipment	13,900.00	13,900.00	0.00	0.00	13,900.00	0.00 %
01-210-42125-000	Fuel/Oil	66,000.00	66,000.00	0.00	0.00	66,000.00	0.00 %
01-210-42135-000	CID	1,500.00	1,500.00	0.00	0.00	1,500.00	0.00 %
01-210-42140-000	Firearm Supplies	7,902.00	7,902.00	0.00	0.00	7,902.00	0.00 %
01-210-42145-000	K-9 Program	6,000.00	6,000.00	0.00	0.00	6,000.00	0.00 %
01-210-42165-000	Vehicle Equipment	4,710.00	4,710.00	0.00	0.00	4,710.00	0.00 %
01-210-42195-000	Special Events and Awards	4,500.00	4,500.00	0.00	0.00	4,500.00	0.00 %
01-210-42900-000	Non-Capital Tools & Equipment	104,528.00	104,528.00	185.80	185.80	104,342.20	0.18 %
01-210-43101-000	Legal Services	16,500.00	16,500.00	0.00	0.00	16,500.00	0.00 %
01-210-43105-000	Onboarding Employee Services	3,030.00	3,030.00	0.00	0.00	3,030.00	0.00 %
01-210-43110-000	Other Professional Services	84,055.00	84,055.00	343.58	343.58	83,711.42	0.41 %
01-210-43125-000	IT Services	2,000.00	2,000.00	638.13	638.13	1,361.87	31.91 %
01-210-43195-000	Electricity/Gas/Phone	6,500.00	6,500.00	0.00	0.00	6,500.00	0.00 %
01-210-43235-000	R & M Radio	25,200.00	25,200.00	0.00	0.00	25,200.00	0.00 %
01-210-43240-000	R & M Vehicle	40,000.00	40,000.00	3,949.68	3,949.68	36,050.32	9.87 %
01-210-43255-000	R & M Other	3,500.00	3,500.00	348.80	348.80	3,151.20	9.97 %
01-210-43260-000	Equipment Lease	1,900.00	1,900.00	88.64	88.64	1,811.36	4.67 %
01-210-43310-000	Records Management Systems	43,500.00	43,500.00	10,706.91	10,706.91	32,793.09	24.61 %
01-210-43401-000	Travel/Training	18,000.00	18,000.00	816.00	816.00	17,184.00	4.53 %
01-210-43501-000	Dues/Memberships	500.00	500.00	0.00	0.00	500.00	0.00 %
01-210-46230-000	Vehicles	181,350.00	181,350.00	0.00	0.00	181,350.00	0.00 %
Department: 210 - Police Total:		2,717,364.53	2,717,364.53	154,056.69	154,056.69	2,563,307.84	5.67%

		Original Total Budget	Current Total Budget	Period Activity	Fiscal Activity	Variance Favorable (Unfavorable)	Percent Used
Department: 220 - Fire							
01-220-41000-000	Wages	1,358,403.69	1,358,403.69	106,355.24	106,355.24	1,252,048.45	7.83 %
01-220-41001-000	Part Time Wages	25,000.00	25,000.00	1,049.67	1,049.67	23,950.33	4.20 %
01-220-41002-000	Overtime	174,600.00	174,600.00	14,199.95	14,199.95	160,400.05	8.13 %
01-220-41003-000	Standby Pay	0.00	0.00	1,600.00	1,600.00	-1,600.00	0.00 %
01-220-41005-000	Longevity	3,420.00	3,420.00	143.08	143.08	3,276.92	4.18 %
01-220-41006-000	Certification Pay	57,600.00	57,600.00	5,514.56	5,514.56	52,085.44	9.57 %
01-220-41200-000	Retirement	281,880.50	281,880.50	23,423.19	23,423.19	258,457.31	8.31 %
01-220-41240-000	Firefighters Retirement	12,000.00	12,000.00	6,220.00	6,220.00	5,780.00	51.83 %
01-220-41300-000	FICA	108,585.91	108,585.91	9,589.13	9,589.13	98,996.78	8.83 %
01-220-41400-000	Hospitalization	268,444.33	268,444.33	21,509.03	21,509.03	246,935.30	8.01 %
01-220-41700-000	Unemployment	2,574.00	2,574.00	51.88	51.88	2,522.12	2.02 %
01-220-42010-000	Office Supplies	4,000.00	4,000.00	0.00	0.00	4,000.00	0.00 %
01-220-42020-000	Building Supplies	10,000.00	10,000.00	54.45	54.45	9,945.55	0.54 %
01-220-42021-000	Cleaning Supplies	2,000.00	2,000.00	20.00	20.00	1,980.00	1.00 %
01-220-42030-000	Office Equipment	1,000.00	1,000.00	0.00	0.00	1,000.00	0.00 %
01-220-42035-000	Computer Equipment	5,000.00	5,000.00	0.00	0.00	5,000.00	0.00 %
01-220-42110-000	Turnout Gear	90,000.00	90,000.00	0.00	0.00	90,000.00	0.00 %
01-220-42115-000	Apparel	10,000.00	10,000.00	0.00	0.00	10,000.00	0.00 %
01-220-42120-000	Medical Supplies	40,000.00	40,000.00	1,398.04	1,398.04	38,601.96	3.50 %
01-220-42125-000	Fuel/Oil	27,000.00	27,000.00	0.00	0.00	27,000.00	0.00 %
01-220-42130-000	Pager/Radio Supplies	2,500.00	2,500.00	0.00	0.00	2,500.00	0.00 %
01-220-42150-000	Training Supplies	15,000.00	15,000.00	0.00	0.00	15,000.00	0.00 %
01-220-42155-000	Vehicle Supplies	40,000.00	40,000.00	93.40	93.40	39,906.60	0.23 %
01-220-42195-000	Special Events and Awards	9,000.00	9,000.00	0.00	0.00	9,000.00	0.00 %
01-220-42900-000	Non-Capital Tools & Equipment	50,000.00	50,000.00	189.95	189.95	49,810.05	0.38 %
01-220-42905-000	Other Operating Supplies	9,600.00	9,600.00	0.00	0.00	9,600.00	0.00 %
01-220-43101-000	Legal Services	500.00	500.00	0.00	0.00	500.00	0.00 %
01-220-43105-000	Onboarding Employee Services	2,000.00	2,000.00	0.00	0.00	2,000.00	0.00 %
01-220-43110-000	Other Professional Services	24,000.00	24,000.00	0.00	0.00	24,000.00	0.00 %
01-220-43125-000	IT Services	1,000.00	1,000.00	0.00	0.00	1,000.00	0.00 %
01-220-43130-000	Software and Licensing	20,000.00	20,000.00	10,684.97	10,684.97	9,315.03	53.42 %
01-220-43195-000	Electricity, Gas, Phone	25,500.00	25,500.00	0.00	0.00	25,500.00	0.00 %
01-220-43201-000	Janitorial	4,000.00	4,000.00	0.00	0.00	4,000.00	0.00 %
01-220-43225-000	R & M Building	15,000.00	15,000.00	0.00	0.00	15,000.00	0.00 %
01-220-43230-000	R & M Grounds	3,000.00	3,000.00	0.00	0.00	3,000.00	0.00 %
01-220-43235-000	R & M Radio	1,000.00	1,000.00	0.00	0.00	1,000.00	0.00 %
01-220-43240-000	R & M Vehicle	45,000.00	45,000.00	11.00	11.00	44,989.00	0.02 %
01-220-43245-000	R & M Equipment	20,000.00	20,000.00	898.85	898.85	19,101.15	4.49 %
01-220-43265-000	Annual Services Fees	20,000.00	20,000.00	0.00	0.00	20,000.00	0.00 %
01-220-43320-000	Postage/Freight	1,500.00	1,500.00	0.00	0.00	1,500.00	0.00 %
01-220-43401-000	Travel/Training	45,000.00	45,000.00	2,537.35	2,537.35	42,462.65	5.64 %
01-220-43501-000	Dues/Memberships	5,000.00	5,000.00	300.00	300.00	4,700.00	6.00 %
01-220-43600-000	Licenses and Certifications	4,600.00	4,600.00	0.00	0.00	4,600.00	0.00 %
01-220-43900-000	Other Contractual	1,000.00	1,000.00	0.00	0.00	1,000.00	0.00 %
01-220-46230-000	Vehicles	20,000.00	20,000.00	0.00	0.00	20,000.00	0.00 %
01-220-46290-000	Radio Equipment	43,000.00	43,000.00	0.00	0.00	43,000.00	0.00 %
01-220-46300-000	Other Equipment	95,000.00	95,000.00	0.00	0.00	95,000.00	0.00 %
	Department: 220 - Fire Total:	3,003,708.43	3,003,708.43	205,843.74	205,843.74	2,797,864.69	6.85 %

		Original Total Budget	Current Total Budget	Period Activity	Fiscal Activity	Variance Favorable (Unfavorable)	Percent Used
Department: 250 - Animal/Vector Control							
01-250-42021-000	Cleaning Supplies	100.00	100.00	0.00	0.00	100.00	0.00 %
01-250-42155-000	Vehicle Supplies	100.00	100.00	0.00	0.00	100.00	0.00 %
01-250-42215-000	Vector Chemicals	10,000.00	10,000.00	0.00	0.00	10,000.00	0.00 %
01-250-42240-000	Kennel Supplies	2,000.00	2,000.00	0.00	0.00	2,000.00	0.00 %
01-250-42900-000	Non-Capital Tools & Equipment	500.00	500.00	0.00	0.00	500.00	0.00 %
01-250-42905-000	Other Operating Supplies	500.00	500.00	0.00	0.00	500.00	0.00 %
01-250-43110-000	Other Professional Services	3,000.00	3,000.00	162.40	162.40	2,837.60	5.41 %
01-250-43255-000	R & M Other	20,000.00	20,000.00	0.00	0.00	20,000.00	0.00 %
01-250-43265-000	Annual Services Fees	100.00	100.00	0.00	0.00	100.00	0.00 %
01-250-43600-000	Licenses and Certifications	1,500.00	1,500.00	0.00	0.00	1,500.00	0.00 %
Department: 250 - Animal/Vector Control Total:		37,800.00	37,800.00	162.40	162.40	37,637.60	0.43%

		Original Total Budget	Current Total Budget	Period Activity	Fiscal Activity	Variance Favorable (Unfavorable)	Percent Used
Department: 260 - Library							
01-260-41000-000	Wages	192,421.32	192,421.32	17,409.29	17,409.29	175,012.03	9.05 %
01-260-41005-000	Longevity	1,680.00	1,680.00	129.22	129.22	1,550.78	7.69 %
01-260-41006-000	Certification Pay	7,200.00	7,200.00	553.86	553.86	6,646.14	7.69 %
01-260-41200-000	Retirement	31,721.76	31,721.76	2,430.72	2,430.72	29,291.04	7.66 %
01-260-41300-000	FICA	15,399.55	15,399.55	1,384.05	1,384.05	14,015.50	8.99 %
01-260-41400-000	Hospitalization	37,187.81	37,187.81	1,908.13	1,908.13	35,279.68	5.13 %
01-260-41700-000	Unemployment	936.00	936.00	20.44	20.44	915.56	2.18 %
01-260-42010-000	Office Supplies	5,000.00	5,000.00	0.00	0.00	5,000.00	0.00 %
01-260-42011-000	Processing Supplies	7,000.00	7,000.00	0.00	0.00	7,000.00	0.00 %
01-260-42012-000	Marketing Supplies	2,500.00	2,500.00	0.00	0.00	2,500.00	0.00 %
01-260-42013-000	Periodicals	500.00	500.00	0.00	0.00	500.00	0.00 %
01-260-42020-000	Building Supplies	1,250.00	1,250.00	0.00	0.00	1,250.00	0.00 %
01-260-42021-000	Cleaning Supplies	1,000.00	1,000.00	0.00	0.00	1,000.00	0.00 %
01-260-42025-000	Food/Drinks	1,000.00	1,000.00	0.00	0.00	1,000.00	0.00 %
01-260-42030-000	Office Equipment	2,000.00	2,000.00	0.00	0.00	2,000.00	0.00 %
01-260-42035-000	Computer Equipment	18,000.00	18,000.00	0.00	0.00	18,000.00	0.00 %
01-260-42190-001	Regular Programs/Community Outr	7,500.00	7,500.00	105.00	105.00	7,395.00	1.40 %
01-260-42190-002	Summer Reading	8,250.00	8,250.00	0.00	0.00	8,250.00	0.00 %
01-260-42190-003	Family Place	3,000.00	3,000.00	0.00	0.00	3,000.00	0.00 %
01-260-42200-000	Print/Physical Books	18,000.00	18,000.00	6,948.27	6,948.27	11,051.73	38.60 %
01-260-42201-000	Digital Books	7,500.00	7,500.00	0.00	0.00	7,500.00	0.00 %
01-260-42202-000	Other Material Types	5,000.00	5,000.00	0.00	0.00	5,000.00	0.00 %
01-260-42905-000	Other Operating Supplies	1,000.00	1,000.00	0.00	0.00	1,000.00	0.00 %
01-260-43101-000	Legal Services	1,000.00	1,000.00	0.00	0.00	1,000.00	0.00 %
01-260-43125-000	IT Services	500.00	500.00	0.00	0.00	500.00	0.00 %
01-260-43130-000	Software Licensing	9,250.00	9,250.00	2,465.75	2,465.75	6,784.25	26.66 %
01-260-43195-000	Electricity/Gas/Phone	7,000.00	7,000.00	0.00	0.00	7,000.00	0.00 %
01-260-43201-000	Janitorial	7,250.00	7,250.00	0.00	0.00	7,250.00	0.00 %
01-260-43225-000	R & M Building	12,500.00	12,500.00	0.00	0.00	12,500.00	0.00 %
01-260-43230-000	R & M Grounds	7,500.00	7,500.00	300.00	300.00	7,200.00	4.00 %
01-260-43260-000	Equipment Lease	5,400.00	5,400.00	163.00	163.00	5,237.00	3.02 %
01-260-43320-000	Postage/Freight	200.00	200.00	0.00	0.00	200.00	0.00 %
01-260-43401-000	Travel/Training	5,000.00	5,000.00	0.00	0.00	5,000.00	0.00 %
01-260-43501-000	Dues/Memberships	1,250.00	1,250.00	0.00	0.00	1,250.00	0.00 %
01-260-43505-000	Fees	300.00	300.00	21.62	21.62	278.38	7.21 %
01-260-43900-000	Other Contractual	1,000.00	1,000.00	0.00	0.00	1,000.00	0.00 %
01-260-46200-000	Capital Expense and Comprehensiv	40,000.00	40,000.00	0.00	0.00	40,000.00	0.00 %
Department: 260 - Library Total:		473,196.44	473,196.44	33,839.35	33,839.35	439,357.09	7.15%

		Original Total Budget	Current Total Budget	Period Activity	Fiscal Activity	Variance Favorable (Unfavorable)	Percent Used
Department: 310 - Streets							
01-310-41000-000	Wages	38,744.16	38,744.16	2,980.80	2,980.80	35,763.36	7.69 %
01-310-41005-000	Longevity	240.00	240.00	13.84	13.84	226.16	5.77 %
01-310-41200-000	Retirement	7,040.39	7,040.39	544.72	544.72	6,495.67	7.74 %
01-310-41300-000	FICA	2,982.29	2,982.29	226.54	226.54	2,755.75	7.60 %
01-310-41400-000	Hospitalization	8,106.84	8,106.84	627.59	627.59	7,479.25	7.74 %
01-310-41700-000	Unemployment	117.00	117.00	0.00	0.00	117.00	0.00 %
01-310-42115-000	Apparel	0.00	0.00	53.74	53.74	-53.74	0.00 %
01-310-42155-000	Vehicle Supplies	1,000.00	1,000.00	0.00	0.00	1,000.00	0.00 %
01-310-42210-000	Asphalt Products	22,000.00	22,000.00	0.00	0.00	22,000.00	0.00 %
01-310-42220-000	Signage	2,500.00	2,500.00	0.00	0.00	2,500.00	0.00 %
01-310-42255-000	Street Lighting	48,000.00	48,000.00	0.00	0.00	48,000.00	0.00 %
01-310-42900-000	Non-Capital Tools & Equipment	5,000.00	5,000.00	0.00	0.00	5,000.00	0.00 %
01-310-42905-000	Other Operating Supplies	3,000.00	3,000.00	0.00	0.00	3,000.00	0.00 %
01-310-43115-000	Engineering Services	20,000.00	20,000.00	0.00	0.00	20,000.00	0.00 %
01-310-43221-000	Sealcoating/Street Maintenance	317,915.00	317,915.00	-239,658.30	-239,658.30	557,573.30	-75.38 %
01-310-43222-000	Signal Control	3,500.00	3,500.00	0.00	0.00	3,500.00	0.00 %
01-310-43245-000	R & M Equipment	300.00	300.00	0.00	0.00	300.00	0.00 %
01-310-43247-000	R & M Streets	25,000.00	25,000.00	10,900.00	10,900.00	14,100.00	43.60 %
01-310-43255-000	R & M Other	1,500.00	1,500.00	0.00	0.00	1,500.00	0.00 %
01-310-43900-000	Other Contractual	2,000.00	2,000.00	0.00	0.00	2,000.00	0.00 %
01-310-46300-000	Other Equipment	16,500.00	16,500.00	0.00	0.00	16,500.00	0.00 %
	Department: 310 - Streets Total:	525,445.68	525,445.68	-224,311.07	-224,311.07	749,756.75	-42.69%

		Original Total Budget	Current Total Budget	Period Activity	Fiscal Activity	Variance Favorable (Unfavorable)	Percent Used
Department: 350 - Parks							
01-350-41000-000	Wages	36,975.12	36,975.12	3,044.80	3,044.80	33,930.32	8.23 %
01-350-41002-000	Overtime	2,000.00	2,000.00	673.86	673.86	1,326.14	33.69 %
01-350-41005-000	Longevity	240.00	240.00	13.84	13.84	226.16	5.77 %
01-350-41200-000	Retirement	6,720.91	6,720.91	678.94	678.94	6,041.97	10.10 %
01-350-41300-000	FICA	2,846.96	2,846.96	272.73	272.73	2,574.23	9.58 %
01-350-41400-000	Hospitalization	14,859.58	14,859.58	1,115.57	1,115.57	13,744.01	7.51 %
01-350-41700-000	Unemployment	117.00	117.00	0.00	0.00	117.00	0.00 %
01-350-42220-000	Signage	3,000.00	3,000.00	0.00	0.00	3,000.00	0.00 %
01-350-42250-000	Electricity Baseball Field	23,000.00	23,000.00	0.00	0.00	23,000.00	0.00 %
01-350-42905-000	Other Operating Supplies	2,500.00	2,500.00	0.00	0.00	2,500.00	0.00 %
01-350-43195-000	Electricity/Gas/Phone	20,000.00	20,000.00	0.00	0.00	20,000.00	0.00 %
01-350-43210-000	Lawn Care	48,000.00	48,000.00	2,700.00	2,700.00	45,300.00	5.63 %
01-350-43230-000	R & M Grounds	15,000.00	15,000.00	0.00	0.00	15,000.00	0.00 %
01-350-43250-000	R & M Vandalism	250.00	250.00	0.00	0.00	250.00	0.00 %
01-350-43255-000	R & M Other	7,500.00	7,500.00	290.00	290.00	7,210.00	3.87 %
01-350-43900-000	Other Contractual	5,000.00	5,000.00	0.00	0.00	5,000.00	0.00 %
	Department: 350 - Parks Total:	188,009.57	188,009.57	8,789.74	8,789.74	179,219.83	4.68%

		Original Total Budget	Current Total Budget	Period Activity	Fiscal Activity	Variance Favorable (Unfavorable)	Percent Used
Department: 400 - Development							
01-400-41000-000	Wages	235,981.20	235,981.20	18,153.36	18,153.36	217,827.84	7.69 %
01-400-41002-000	Overtime	750.00	750.00	178.04	178.04	571.96	23.74 %
01-400-41005-000	Longevity	840.00	840.00	32.30	32.30	807.70	3.85 %
01-400-41006-000	Certification Pay	14,400.00	14,400.00	1,107.70	1,107.70	13,292.30	7.69 %
01-400-41200-000	Retirement	45,369.58	45,369.58	3,541.85	3,541.85	41,827.73	7.81 %
01-400-41300-000	FICA	19,218.42	19,218.42	1,424.44	1,424.44	17,793.98	7.41 %
01-400-41400-000	Hospitalization	51,715.33	51,715.33	3,944.52	3,944.52	47,770.81	7.63 %
01-400-41700-000	Unemployment	468.00	468.00	0.00	0.00	468.00	0.00 %
01-400-42010-000	Office Supplies	1,500.00	1,500.00	0.00	0.00	1,500.00	0.00 %
01-400-42030-000	Office Equipment	1,500.00	1,500.00	0.00	0.00	1,500.00	0.00 %
01-400-42035-000	Computer Equipment	500.00	500.00	0.00	0.00	500.00	0.00 %
01-400-42115-000	Apparel	550.00	550.00	0.00	0.00	550.00	0.00 %
01-400-42125-000	Fuel/Oil	3,500.00	3,500.00	0.00	0.00	3,500.00	0.00 %
01-400-42155-000	Vehicle Supplies	1,500.00	1,500.00	0.00	0.00	1,500.00	0.00 %
01-400-42195-000	Special Events and Awards	800.00	800.00	340.00	340.00	460.00	42.50 %
01-400-43101-000	Legal Services	7,000.00	7,000.00	0.00	0.00	7,000.00	0.00 %
01-400-43115-000	Engineering Services	90,000.00	90,000.00	0.00	0.00	90,000.00	0.00 %
01-400-43116-000	Inspection Services	350,000.00	350,000.00	0.00	0.00	350,000.00	0.00 %
01-400-43130-000	Software Licensing	21,660.00	21,660.00	0.00	0.00	21,660.00	0.00 %
01-400-43140-000	Legal Publications	4,000.00	4,000.00	0.00	0.00	4,000.00	0.00 %
01-400-43155-000	Abatement/Demolition	32,000.00	32,000.00	0.00	0.00	32,000.00	0.00 %
01-400-43195-000	Electricity/Gas/Phone	1,500.00	1,500.00	0.00	0.00	1,500.00	0.00 %
01-400-43240-000	R & M Vehicle	750.00	750.00	24.00	24.00	726.00	3.20 %
01-400-43320-000	Postage/Freight	750.00	750.00	0.00	0.00	750.00	0.00 %
01-400-43401-000	Travel/Training	3,250.00	3,250.00	91.00	91.00	3,159.00	2.80 %
01-400-43501-000	Dues/Memberships	850.00	850.00	0.00	0.00	850.00	0.00 %
Department: 400 - Development Total:		890,352.53	890,352.53	28,837.21	28,837.21	861,515.32	3.24%

		Original Total Budget	Current Total Budget	Period Activity	Fiscal Activity	Variance Favorable (Unfavorable)	Percent Used
Department: 752 - Economic Development							
01-752-41000-000	Wages	88,517.52	88,517.52	6,809.04	6,809.04	81,708.48	7.69 %
01-752-41005-000	Longevity	180.00	180.00	0.00	0.00	180.00	0.00 %
01-752-41006-000	Certification Pay	2,400.00	2,400.00	184.62	184.62	2,215.38	7.69 %
01-752-41007-000	Vehicle Allowance	4,800.00	4,800.00	369.24	369.24	4,430.76	7.69 %
01-752-41200-000	Retirement	17,318.72	17,318.72	1,339.32	1,339.32	15,979.40	7.73 %
01-752-41300-000	FICA	7,336.16	7,336.16	513.94	513.94	6,822.22	7.01 %
01-752-41400-000	Hospitalization	20,688.36	20,688.36	1,564.19	1,564.19	19,124.17	7.56 %
01-752-41700-000	Unemployment	117.00	117.00	0.00	0.00	117.00	0.00 %
Department: 752 - Economic Development Total:		141,357.76	141,357.76	10,780.35	10,780.35	130,577.41	7.63%
Expense Total:		11,054,333.65	11,054,333.65	768,314.70	768,314.70	10,286,018.95	6.95%
Fund: 01 - General Fund Surplus (Deficit):		0.35	0.35	-395,770.94	-395,770.94	-395,771.29	77,411.43%

	Original Total Budget	Current Total Budget	Period Activity	Fiscal Activity	Variance Favorable (Unfavorable)	Percent Used
Fund: 02 - Enterprise Fund						
Revenue						
Department: 000 - Non-departmental						
02-000-32420-000	Engineering Inspection Fees	50,000.00	50,000.00	0.00	0.00	-50,000.00 0.00 %
02-000-36110-000	Interest income	450,000.00	450,000.00	0.00	0.00	-450,000.00 0.00 %
02-000-36200-000	MS4 Permits	6,000.00	6,000.00	570.00	570.00	-5,430.00 9.50 %
02-000-36300-000	Well Permit Fees	250.00	250.00	0.00	0.00	-250.00 0.00 %
02-000-36500-000	Meter Set and Sewer Access	325,000.00	325,000.00	36,900.00	36,900.00	-288,100.00 11.35 %
02-000-36800-000	Long/Short	0.00	0.00	-8.40	-8.40	-8.40 0.00 %
02-000-38100-000	Water Revenue	5,713,000.00	5,713,000.00	461,819.94	461,819.94	-5,251,180.06 8.08 %
02-000-38200-000	Sewer Revenue	1,365,000.00	1,365,000.00	117,672.68	117,672.68	-1,247,327.32 8.62 %
02-000-38250-000	Credit Card/PCard Rebate	3,500.00	3,500.00	91.35	91.35	-3,408.65 2.61 %
02-000-38300-000	Water Treatment	330,000.00	330,000.00	29,648.43	29,648.43	-300,351.57 8.98 %
02-000-38600-000	Late Charges	115,000.00	115,000.00	12,579.40	12,579.40	-102,420.60 10.94 %
02-000-38700-000	Disconnect/Cut Off Fees	26,000.00	26,000.00	2,380.00	2,380.00	-23,620.00 9.15 %
02-000-38750-000	Reconnect Fees	29,000.00	29,000.00	3,500.00	3,500.00	-25,500.00 12.07 %
02-000-38800-000	NSF Fees	7,000.00	7,000.00	650.00	650.00	-6,350.00 9.29 %
02-000-38850-000	Collections Fee	0.00	0.00	270.63	270.63	270.63 0.00 %
02-000-38900-000	Contract Utility Revenue	0.00	0.00	539.76	539.76	539.76 0.00 %
Department: 000 - Non-departmental Total:		8,419,750.00	8,419,750.00	666,613.79	666,613.79	-7,753,136.21 7.92%
Revenue Total:		8,419,750.00	8,419,750.00	666,613.79	666,613.79	-7,753,136.21 7.92%

		Original Total Budget	Current Total Budget	Period Activity	Fiscal Activity	Variance Favorable (Unfavorable)	Percent Used
Expense							
Department: 000 - Non-departmental							
02-000-44005-000	Operating Transfers Out	600,000.00	600,000.00	0.00	0.00	600,000.00	0.00 %
02-000-48100-000	2013 CO Principal	340,000.00	340,000.00	0.00	0.00	340,000.00	0.00 %
02-000-48101-000	2013 CO Interest	82,600.00	82,600.00	0.00	0.00	82,600.00	0.00 %
02-000-48102-000	2015 Refunding CO Principal	140,855.00	140,855.00	0.00	0.00	140,855.00	0.00 %
02-000-48103-000	2015 Refunding CO Interest	24,010.00	24,010.00	0.00	0.00	24,010.00	0.00 %
02-000-48104-000	2017A CO Principal	70,000.00	70,000.00	0.00	0.00	70,000.00	0.00 %
02-000-48105-000	2017A CO Interest	27,900.00	27,900.00	0.00	0.00	27,900.00	0.00 %
02-000-48110-000	2020 CO Sewer Principal	205,000.00	205,000.00	0.00	0.00	205,000.00	0.00 %
02-000-48111-000	2020 CO Sewer Interest	89,938.00	89,938.00	0.00	0.00	89,938.00	0.00 %
02-000-48112-000	2021 CO Water Principal	280,000.00	280,000.00	0.00	0.00	280,000.00	0.00 %
02-000-48113-000	2021 CO Water Interest	147,369.00	147,369.00	0.00	0.00	147,369.00	0.00 %
02-000-48118-000	2024 CO Water Principal	195,000.00	195,000.00	0.00	0.00	195,000.00	0.00 %
02-000-48119-000	2024 CO Water Interest	548,975.00	548,975.00	0.00	0.00	548,975.00	0.00 %
02-000-48150-000	Debt Service Paying Agent Fees	1,530.00	1,530.00	0.00	0.00	1,530.00	0.00 %
Department: 000 - Non-departmental Total:		2,753,177.00	2,753,177.00	0.00	0.00	2,753,177.00	0.00%

		Original Total Budget	Current Total Budget	Period Activity	Fiscal Activity	Variance Favorable (Unfavorable)	Percent Used
Department: 100 - Admin							
02-100-41000-000	Wages	222,353.04	222,353.04	17,301.36	17,301.36	205,051.68	7.78 %
02-100-41005-000	Longevity	3,240.00	3,240.00	235.38	235.38	3,004.62	7.26 %
02-100-41006-000	Certification Pay	18,000.00	18,000.00	1,153.85	1,153.85	16,846.15	6.41 %
02-100-41010-000	Vacation Buy back	500.00	500.00	0.00	0.00	500.00	0.00 %
02-100-41200-000	Retirement	43,991.97	43,991.97	3,399.80	3,399.80	40,592.17	7.73 %
02-100-41300-000	FICA	18,634.87	18,634.87	1,409.44	1,409.44	17,225.43	7.56 %
02-100-41400-000	Hospitalization	31,090.54	31,090.54	2,385.48	2,385.48	28,705.06	7.67 %
02-100-41400-001	Surency Admin Fees	0.00	0.00	10.45	10.45	-10.45	0.00 %
02-100-41700-000	Unemployment	351.00	351.00	0.00	0.00	351.00	0.00 %
02-100-42010-000	Office Supplies	500.00	500.00	0.00	0.00	500.00	0.00 %
02-100-42025-000	Food/Drinks	500.00	500.00	0.00	0.00	500.00	0.00 %
02-100-42115-000	Apparel	10,000.00	10,000.00	57.34	57.34	9,942.66	0.57 %
02-100-42125-000	Fuel/Oil	30,000.00	30,000.00	0.00	0.00	30,000.00	0.00 %
02-100-42141-000	Employee Supplies	3,200.00	3,200.00	-128.25	-128.25	3,328.25	-4.01 %
02-100-42160-000	Safety Equipment	1,000.00	1,000.00	0.00	0.00	1,000.00	0.00 %
02-100-43101-000	Legal Services	7,500.00	7,500.00	0.00	0.00	7,500.00	0.00 %
02-100-43105-000	Onboarding Employee Services	500.00	500.00	0.00	0.00	500.00	0.00 %
02-100-43109-000	Professional Services	150,000.00	150,000.00	37,500.00	37,500.00	112,500.00	25.00 %
02-100-43110-000	Other Professional Services	27,850.00	27,850.00	1,271.87	1,271.87	26,578.13	4.57 %
02-100-43130-000	Software Licensing	12,000.00	12,000.00	12,000.00	12,000.00	0.00	100.00 %
02-100-43150-000	Marketing	7,000.00	7,000.00	0.00	0.00	7,000.00	0.00 %
02-100-43195-000	Electricity/Gas/Phone	214,580.00	214,580.00	0.00	0.00	214,580.00	0.00 %
02-100-43201-000	Janitorial	5,700.00	5,700.00	0.00	0.00	5,700.00	0.00 %
02-100-43240-000	R & M Vehicle	500.00	500.00	31.20	31.20	468.80	6.24 %
02-100-43255-000	R & M Generator	17,000.00	17,000.00	0.00	0.00	17,000.00	0.00 %
02-100-43256-000	Insurance Covered Repairs	0.00	0.00	-100.00	-100.00	100.00	0.00 %
02-100-43270-000	Railroad Permit Fees	18,000.00	18,000.00	0.00	0.00	18,000.00	0.00 %
02-100-43501-000	Dues/Memberships	500.00	500.00	226.00	226.00	274.00	45.20 %
02-100-43505-000	Fees	72,000.00	72,000.00	0.00	0.00	72,000.00	0.00 %
02-100-43900-000	Other Contractual	1,000.00	1,000.00	2,291.20	2,291.20	-1,291.20	229.12 %
02-100-46400-000	Capital Reserves	324,638.00	324,638.00	0.00	0.00	324,638.00	0.00 %
	Department: 100 - Admin Total:	1,242,129.42	1,242,129.42	79,045.12	79,045.12	1,163,084.30	6.36 %

My Budget Report

For Fiscal: 2025-2026 Period Ending Item # 2. 25

	Original Total Budget	Current Total Budget	Period Activity	Fiscal Activity	Variance Favorable (Unfavorable)	Percent Used
Department: 130 - Engineering						
02-130-43115-000 Engineering Services	150,000.00	150,000.00	0.00	0.00	150,000.00	0.00 %
02-130-43116-000 Inspection Services	200,000.00	200,000.00	10,845.80	10,845.80	189,154.20	5.42 %
Department: 130 - Engineering Total:	350,000.00	350,000.00	10,845.80	10,845.80	339,154.20	3.10%

	Original Total Budget	Current Total Budget	Period Activity	Fiscal Activity	Variance Favorable (Unfavorable)	Percent Used
Department: 315 - Utility Billing						
02-315-41000-000	135,408.00	135,408.00	10,457.85	10,457.85	124,950.15	7.72 %
02-315-41002-000	1,000.00	1,000.00	370.44	370.44	629.56	37.04 %
02-315-41005-000	420.00	420.00	18.46	18.46	401.54	4.40 %
02-315-41200-000	24,530.02	24,530.02	1,973.02	1,973.02	22,557.00	8.04 %
02-315-41300-000	10,390.84	10,390.84	804.64	804.64	9,586.20	7.74 %
02-315-41400-000	37,519.98	37,519.98	2,376.23	2,376.23	35,143.75	6.33 %
02-315-41700-000	351.00	351.00	0.00	0.00	351.00	0.00 %
02-315-42010-000	750.00	750.00	0.00	0.00	750.00	0.00 %
02-315-43102-000	2,000.00	2,000.00	0.00	0.00	2,000.00	0.00 %
02-315-43130-000	15,000.00	15,000.00	0.00	0.00	15,000.00	0.00 %
02-315-43320-000	22,000.00	22,000.00	349.62	349.62	21,650.38	1.59 %
02-315-43401-000	4,000.00	4,000.00	32.20	32.20	3,967.80	0.81 %
02-315-43505-000	22,000.00	22,000.00	0.00	0.00	22,000.00	0.00 %
02-315-43900-000	17,000.00	17,000.00	164.40	164.40	16,835.60	0.97 %
Department: 315 - Utility Billing Total:	292,369.84	292,369.84	16,546.86	16,546.86	275,822.98	5.66%

		Original Total Budget	Current Total Budget	Period Activity	Fiscal Activity	Variance Favorable (Unfavorable)	Percent Used
Department: 330 - Compliance							
02-330-41000-000	Wages	48,353.76	48,353.76	3,720.00	3,720.00	44,633.76	7.69 %
02-330-41006-000	Certification Pay	2,400.00	2,400.00	0.00	0.00	2,400.00	0.00 %
02-330-41200-000	Retirement	8,732.50	8,732.50	676.66	676.66	8,055.84	7.75 %
02-330-41300-000	FICA	3,699.06	3,699.06	284.58	284.58	3,414.48	7.69 %
02-330-41400-000	Hospitalization	8,115.48	8,115.48	630.63	630.63	7,484.85	7.77 %
02-330-41700-000	Unemployment	117.00	117.00	0.00	0.00	117.00	0.00 %
02-330-42010-000	Office Supplies	1,500.00	1,500.00	0.00	0.00	1,500.00	0.00 %
02-330-42030-000	Office Equipment	750.00	750.00	0.00	0.00	750.00	0.00 %
02-330-42035-000	Computer Equipment	1,500.00	1,500.00	0.00	0.00	1,500.00	0.00 %
02-330-42905-000	Other Operating Supplies	500.00	500.00	0.00	0.00	500.00	0.00 %
02-330-43101-000	Legal Services	1,000.00	1,000.00	0.00	0.00	1,000.00	0.00 %
02-330-43110-000	Other Professional Services	2,000.00	2,000.00	0.00	0.00	2,000.00	0.00 %
02-330-43150-000	Marketing	1,000.00	1,000.00	0.00	0.00	1,000.00	0.00 %
02-330-43265-000	Annual Services Fees	500.00	500.00	0.00	0.00	500.00	0.00 %
02-330-43270-000	Regulatory Licensing/Permittin	9,000.00	9,000.00	1,250.00	1,250.00	7,750.00	13.89 %
02-330-43900-000	Other Contractual	1,000.00	1,000.00	0.00	0.00	1,000.00	0.00 %
	Department: 330 - Compliance Total:	90,167.80	90,167.80	6,561.87	6,561.87	83,605.93	7.28%

		Original Total Budget	Current Total Budget	Period Activity	Fiscal Activity	Variance Favorable (Unfavorable)	Percent Used
Department: 341 - Water Production							
02-341-41000-000	Wages	120,393.52	120,393.52	6,443.91	6,443.91	113,949.61	5.35 %
02-341-41002-000	Overtime	5,000.00	5,000.00	314.74	314.74	4,685.26	6.29 %
02-341-41005-000	Longevity	480.00	480.00	18.46	18.46	461.54	3.85 %
02-341-41006-000	Certification Pay	6,000.00	6,000.00	276.92	276.92	5,723.08	4.62 %
02-341-41200-000	Retirement	20,405.73	20,405.73	1,283.12	1,283.12	19,122.61	6.29 %
02-341-41300-000	FICA	9,705.82	9,705.82	539.63	539.63	9,166.19	5.56 %
02-341-41400-000	Hospitalization	29,491.44	29,491.44	1,251.44	1,251.44	28,240.00	4.24 %
02-341-41700-000	Unemployment	351.00	351.00	0.00	0.00	351.00	0.00 %
02-341-42115-000	Apparel	0.00	0.00	30.88	30.88	-30.88	0.00 %
02-341-42155-000	Vehicle Supplies	500.00	500.00	0.00	0.00	500.00	0.00 %
02-341-42220-000	Signage	1,500.00	1,500.00	0.00	0.00	1,500.00	0.00 %
02-341-42265-000	Well Repair Supplies	3,000.00	3,000.00	0.00	0.00	3,000.00	0.00 %
02-341-42400-000	Purchased Water	2,000,000.00	2,000,000.00	0.00	0.00	2,000,000.00	0.00 %
02-341-42900-000	Non-Capital Tools & Equipment	5,000.00	5,000.00	0.00	0.00	5,000.00	0.00 %
02-341-42905-000	Other Operating Supplies	2,500.00	2,500.00	0.00	0.00	2,500.00	0.00 %
02-341-43120-000	Laboratory Services	17,000.00	17,000.00	450.00	450.00	16,550.00	2.65 %
02-341-43195-000	Electricity/Gas/Phone	200.00	200.00	0.00	0.00	200.00	0.00 %
02-341-43232-000	R & M Wells	25,000.00	25,000.00	0.00	0.00	25,000.00	0.00 %
02-341-43240-000	R & M Vehicle	5,000.00	5,000.00	604.05	604.05	4,395.95	12.08 %
02-341-43245-000	R & M Equipment	6,000.00	6,000.00	0.00	0.00	6,000.00	0.00 %
02-341-43255-000	R & M Other	2,000.00	2,000.00	0.00	0.00	2,000.00	0.00 %
02-341-43401-000	Travel/Training	900.00	900.00	0.00	0.00	900.00	0.00 %
02-341-43501-000	Dues/Memberships	500.00	500.00	0.00	0.00	500.00	0.00 %
02-341-43600-000	Licenses and Certifications	1,000.00	1,000.00	0.00	0.00	1,000.00	0.00 %
02-341-43900-000	Other Contractual	500.00	500.00	0.00	0.00	500.00	0.00 %
Department: 341 - Water Production Total:		2,262,427.51	2,262,427.51	11,213.15	11,213.15	2,251,214.36	0.50%

		Original Total Budget	Current Total Budget	Period Activity	Fiscal Activity	Variance Favorable (Unfavorable)	Percent Used
Department: 342 - Water Distribution							
02-342-41000-000	Wages	148,302.96	148,302.96	8,266.72	8,266.72	140,036.24	5.57 %
02-342-41002-000	Overtime	4,000.00	4,000.00	532.16	532.16	3,467.84	13.30 %
02-342-41005-000	Longevity	180.00	180.00	0.00	0.00	180.00	0.00 %
02-342-41006-000	Certification Pay	1,200.00	1,200.00	184.60	184.60	1,015.40	15.38 %
02-342-41200-000	Retirement	24,236.67	24,236.67	1,634.10	1,634.10	22,602.57	6.74 %
02-342-41300-000	FICA	11,450.75	11,450.75	684.19	684.19	10,766.56	5.98 %
02-342-41400-000	Hospitalization	37,574.64	37,574.64	1,866.65	1,866.65	35,707.99	4.97 %
02-342-41700-000	Unemployment	468.00	468.00	0.00	0.00	468.00	0.00 %
02-342-42115-000	Apparel	0.00	0.00	23.60	23.60	-23.60	0.00 %
02-342-42155-000	Vehicle Supplies	2,000.00	2,000.00	0.00	0.00	2,000.00	0.00 %
02-342-42215-000	Chemical Supplies	11,000.00	11,000.00	0.00	0.00	11,000.00	0.00 %
02-342-42270-000	Meters	130,000.00	130,000.00	64,496.13	64,496.13	65,503.87	49.61 %
02-342-42410-000	Water mains and valves	125,000.00	125,000.00	0.00	0.00	125,000.00	0.00 %
02-342-42900-000	Non-Capital Tools & Equipment	3,000.00	3,000.00	0.00	0.00	3,000.00	0.00 %
02-342-42905-000	Other Operating Supplies	25,000.00	25,000.00	2,056.00	2,056.00	22,944.00	8.22 %
02-342-43125-000	IT Services	500.00	500.00	0.00	0.00	500.00	0.00 %
02-342-43130-000	Software Licensing	500.00	500.00	0.00	0.00	500.00	0.00 %
02-342-43240-000	R & M Vehicle	5,000.00	5,000.00	31.20	31.20	4,968.80	0.62 %
02-342-43255-000	R & M Other	67,500.00	67,500.00	0.00	0.00	67,500.00	0.00 %
02-342-43401-000	Travel/Training	650.00	650.00	0.00	0.00	650.00	0.00 %
02-342-43600-000	Licenses and Certifications	1,000.00	1,000.00	0.00	0.00	1,000.00	0.00 %
02-342-43900-000	Other Contractual	100,000.00	100,000.00	21,082.18	21,082.18	78,917.82	21.08 %
02-342-46300-000	Other Equipment	100,000.00	100,000.00	0.00	0.00	100,000.00	0.00 %
Department: 342 - Water Distribution Total:		798,563.02	798,563.02	100,857.53	100,857.53	697,705.49	12.63%

		Original Total Budget	Current Total Budget	Period Activity	Fiscal Activity	Variance Favorable (Unfavorable)	Percent Used
Department: 343 - Water Treatment							
02-343-41000-000	Wages	35,227.92	35,227.92	948.64	948.64	34,279.28	2.69 %
02-343-41002-000	Overtime	2,000.00	2,000.00	0.00	0.00	2,000.00	0.00 %
02-343-41006-000	Certification Pay	0.00	0.00	230.77	230.77	-230.77	0.00 %
02-343-41200-000	Retirement	6,362.03	6,362.03	214.54	214.54	6,147.49	3.37 %
02-343-41300-000	FICA	2,694.94	2,694.94	89.25	89.25	2,605.69	3.31 %
02-343-41400-000	Hospitalization	20,621.04	20,621.04	365.33	365.33	20,255.71	1.77 %
02-343-41700-000	Unemployment	117.00	117.00	0.00	0.00	117.00	0.00 %
02-343-42021-000	Cleaning Supplies	500.00	500.00	0.00	0.00	500.00	0.00 %
02-343-42115-000	Apparel	0.00	0.00	31.16	31.16	-31.16	0.00 %
02-343-42215-000	Chemical Supplies	100,000.00	100,000.00	6,560.00	6,560.00	93,440.00	6.56 %
02-343-42275-000	Testing Supplies	5,000.00	5,000.00	2,589.00	2,589.00	2,411.00	51.78 %
02-343-42285-000	Filters	35,000.00	35,000.00	0.00	0.00	35,000.00	0.00 %
02-343-42900-000	Non-Capital Tools & Equipment	3,000.00	3,000.00	348.54	348.54	2,651.46	11.62 %
02-343-42905-000	Other Operating Supplies	12,500.00	12,500.00	1,422.54	1,422.54	11,077.46	11.38 %
02-343-43120-000	Laboratory Services	17,000.00	17,000.00	0.00	0.00	17,000.00	0.00 %
02-343-43245-000	R & M Equipment	19,000.00	19,000.00	4,241.78	4,241.78	14,758.22	22.33 %
02-343-43255-000	R & M Other	2,000.00	2,000.00	31.20	31.20	1,968.80	1.56 %
02-343-43401-000	Travel/Training	200.00	200.00	0.00	0.00	200.00	0.00 %
02-343-43900-000	Other Contractual	4,000.00	4,000.00	0.00	0.00	4,000.00	0.00 %
Department: 343 - Water Treatment Total:		265,222.93	265,222.93	17,072.75	17,072.75	248,150.18	6.44%

		Original Total Budget	Current Total Budget	Period Activity	Fiscal Activity	Variance Favorable (Unfavorable)	Percent Used
Department: 361 - Waste Water Collection							
02-361-41000-000	Wages	35,227.92	35,227.92	2,710.40	2,710.40	32,517.52	7.69 %
02-361-41002-000	Overtime	100.00	100.00	0.00	0.00	100.00	0.00 %
02-361-41005-000	Longevity	60.00	60.00	0.00	0.00	60.00	0.00 %
02-361-41200-000	Retirement	6,372.86	6,372.86	493.02	493.02	5,879.84	7.74 %
02-361-41300-000	FICA	2,699.53	2,699.53	207.34	207.34	2,492.19	7.68 %
02-361-41400-000	Hospitalization	8,115.48	8,115.48	620.85	620.85	7,494.63	7.65 %
02-361-41700-000	Unemployment	117.00	117.00	0.00	0.00	117.00	0.00 %
02-361-42115-000	Apparel	0.00	0.00	16.20	16.20	-16.20	0.00 %
02-361-42215-000	Chemical Supplies	3,000.00	3,000.00	0.00	0.00	3,000.00	0.00 %
02-361-42900-000	Non-Capital Tools & Equipment	500.00	500.00	0.00	0.00	500.00	0.00 %
02-361-42905-000	Other Operating Supplies	500.00	500.00	0.00	0.00	500.00	0.00 %
02-361-43245-000	R & M Equipment	20,000.00	20,000.00	14,120.20	14,120.20	5,879.80	70.60 %
02-361-43600-000	Licenses and Certifications	2,000.00	2,000.00	0.00	0.00	2,000.00	0.00 %
02-361-46210-000	Lift Station	80,000.00	80,000.00	0.00	0.00	80,000.00	0.00 %
02-361-46300-000	Other Equipment	97,000.00	97,000.00	0.00	0.00	97,000.00	0.00 %
Department: 361 - Waste Water Collection Total:		255,692.79	255,692.79	18,168.01	18,168.01	237,524.78	7.11%

		Original Total Budget	Current Total Budget	Period Activity	Fiscal Activity	Variance Favorable (Unfavorable)	Percent Used
Department: 362 - Waste Water Treatment							
02-362-42215-000	Chemical Supplies	12,500.00	12,500.00	0.00	0.00	12,500.00	0.00 %
02-362-42220-000	Signage	2,500.00	2,500.00	0.00	0.00	2,500.00	0.00 %
02-362-42900-000	Non-Capital Tools & Equipment	500.00	500.00	0.00	0.00	500.00	0.00 %
02-362-42905-000	Other Operating Supplies	2,000.00	2,000.00	0.00	0.00	2,000.00	0.00 %
02-362-43120-000	Laboratory Services	5,000.00	5,000.00	92.75	92.75	4,907.25	1.86 %
02-362-43245-000	R & M Equipment	12,000.00	12,000.00	0.00	0.00	12,000.00	0.00 %
02-362-43255-000	R & M Other	500.00	500.00	0.00	0.00	500.00	0.00 %
02-362-43600-000	Licenses and Certifications	1,000.00	1,000.00	0.00	0.00	1,000.00	0.00 %
02-362-43900-000	Other Contractual	500.00	500.00	0.00	0.00	500.00	0.00 %
02-362-46300-000	Other Equipment	73,500.00	73,500.00	0.00	0.00	73,500.00	0.00 %
Department: 362 - Waste Water Treatment Total:		110,000.00	110,000.00	92.75	92.75	109,907.25	0.08%
Expense Total:		8,419,750.31	8,419,750.31	260,403.84	260,403.84	8,159,346.47	3.09%
Fund: 02 - Enterprise Fund Surplus (Deficit):		-0.31	-0.31	406,209.95	406,209.95	406,210.26	35,467.74%

My Budget Report

For Fiscal: 2025-2026 Period Ending Item # 2. 25

	Original Total Budget	Current Total Budget	Period Activity	Fiscal Activity	Variance Favorable (Unfavorable)	Percent Used
Fund: 04 - Debt Service						
Revenue						
Department: 000 - Non-departmental						
<u>04-000-31100-000</u> Property Taxes	1,768,794.54	1,768,794.54	1,562.13	1,562.13	-1,767,232.41	0.09 %
Department: 000 - Non-departmental Total:	1,768,794.54	1,768,794.54	1,562.13	1,562.13	-1,767,232.41	0.09%
Revenue Total:	1,768,794.54	1,768,794.54	1,562.13	1,562.13	-1,767,232.41	0.09%

		Original Total Budget	Current Total Budget	Period Activity	Fiscal Activity	Variance Favorable (Unfavorable)	Percent Used
Expense							
Department: 000 - Non-departmental							
04-000-48102-000	2015 Refunding CO Principal	134,145.00	134,145.00	0.00	0.00	134,145.00	0.00 %
04-000-48103-000	2015 Refunding CO Interest	22,866.00	22,866.00	0.00	0.00	22,866.00	0.00 %
04-000-48108-000	2020 Tax Note Principal	230,000.00	230,000.00	0.00	0.00	230,000.00	0.00 %
04-000-48109-000	2020 Tax Note Interest	17,750.00	17,750.00	0.00	0.00	17,750.00	0.00 %
04-000-48114-000	2021 Tax Note Principal	220,000.00	220,000.00	0.00	0.00	220,000.00	0.00 %
04-000-48115-000	2021 Tax Note Interest	17,250.00	17,250.00	0.00	0.00	17,250.00	0.00 %
04-000-48118-000	2020 Refunding CO Principal	40,000.00	40,000.00	0.00	0.00	40,000.00	0.00 %
04-000-48119-000	2020 Refunding CO Interest	18,400.00	18,400.00	0.00	0.00	18,400.00	0.00 %
04-000-48120-000	Fire Apparatus Principal	78,993.00	78,993.00	78,992.01	78,992.01	0.99	100.00 %
04-000-48121-000	Fire Apparatus Interest	13,219.00	13,219.00	13,218.60	13,218.60	0.40	100.00 %
04-000-48122-000	2024 PS Tax Note Principal	270,000.00	270,000.00	0.00	0.00	270,000.00	0.00 %
04-000-48123-000	2024 PS Tax Note Interest	59,084.00	59,084.00	0.00	0.00	59,084.00	0.00 %
04-000-48124-000	2025 CO Principal	110,000.00	110,000.00	0.00	0.00	110,000.00	0.00 %
04-000-48125-000	2025 CO Interest	511,065.00	511,065.00	0.00	0.00	511,065.00	0.00 %
04-000-48145-000	Cardiac Monitor Debt	24,200.54	24,200.54	0.00	0.00	24,200.54	0.00 %
04-000-48150-000	Debt Service Paying Agent Fees	1,822.00	1,822.00	0.00	0.00	1,822.00	0.00 %
Department: 000 - Non-departmental Total:		1,768,794.54	1,768,794.54	92,210.61	92,210.61	1,676,583.93	5.21%
Expense Total:		1,768,794.54	1,768,794.54	92,210.61	92,210.61	1,676,583.93	5.21%
Fund: 04 - Debt Service Surplus (Deficit):		0.00	0.00	-90,648.48	-90,648.48	-90,648.48	0.00%

	Original Total Budget	Current Total Budget	Period Activity	Fiscal Activity	Variance Favorable (Unfavorable)	Percent Used
Fund: 07 - Economic Development Corporation						
Revenue						
Department: 000 - Non-departmental						
07-000-31300-000 Economic Development Sales Tax	725,000.00	725,000.00	0.00	0.00	-725,000.00	0.00 %
07-000-36110-000 Interest income	50,000.00	50,000.00	0.00	0.00	-50,000.00	0.00 %
Department: 000 - Non-departmental Total:	775,000.00	775,000.00	0.00	0.00	-775,000.00	0.00%
Revenue Total:	775,000.00	775,000.00	0.00	0.00	-775,000.00	0.00%

		Original Total Budget	Current Total Budget	Period Activity	Fiscal Activity	Variance Favorable (Unfavorable)	Percent Used
Expense							
Department: 752 - Economic Development							
07-752-42010-000	Office Supplies & Expense	250.00	250.00	234.52	234.52	15.48	93.81 %
07-752-42192-000	Meeting Expense	3,000.00	3,000.00	0.00	0.00	3,000.00	0.00 %
07-752-42195-000	Special Events and Awards	18,000.00	18,000.00	0.00	0.00	18,000.00	0.00 %
07-752-43101-000	Legal services	6,500.00	6,500.00	0.00	0.00	6,500.00	0.00 %
07-752-43140-000	Legal Publications	1,600.00	1,600.00	0.00	0.00	1,600.00	0.00 %
07-752-43150-000	Marketing	72,500.00	72,500.00	2,210.00	2,210.00	70,290.00	3.05 %
07-752-43151-000	Customer Appreciation	5,000.00	5,000.00	0.00	0.00	5,000.00	0.00 %
07-752-43230-000	R & M Grounds	14,000.00	14,000.00	0.00	0.00	14,000.00	0.00 %
07-752-43320-000	Postage/Freight	50.00	50.00	0.00	0.00	50.00	0.00 %
07-752-43401-000	Travel/Training/Conferences	25,000.00	25,000.00	444.00	444.00	24,556.00	1.78 %
07-752-43501-000	Memberships	6,500.00	6,500.00	1,500.00	1,500.00	5,000.00	23.08 %
07-752-43505-000	Fees and Charges	1,200.00	1,200.00	0.00	0.00	1,200.00	0.00 %
07-752-43900-000	Contract Services	152,000.00	152,000.00	9,865.00	9,865.00	142,135.00	6.49 %
07-752-43905-000	EDC Administration Reimbursemen	0.00	0.00	7,546.25	7,546.25	-7,546.25	0.00 %
07-752-44001-000	Business Support	379,400.00	379,400.00	0.00	0.00	379,400.00	0.00 %
07-752-44001-001	Business Improvement Grant	50,000.00	50,000.00	0.00	0.00	50,000.00	0.00 %
07-752-44001-002	Business Marketing Grant	20,000.00	20,000.00	0.00	0.00	20,000.00	0.00 %
07-752-44002-000	Sponsorships	20,000.00	20,000.00	0.00	0.00	20,000.00	0.00 %
07-752-46180-000	Land & Building Acquisition	0.00	0.00	5,000.00	5,000.00	-5,000.00	0.00 %
Department: 752 - Economic Development Total:		775,000.00	775,000.00	26,799.77	26,799.77	748,200.23	3.46%
Expense Total:		775,000.00	775,000.00	26,799.77	26,799.77	748,200.23	3.46%
Fund: 07 - Economic Development Corporation Surplus (Deficit):		0.00	0.00	-26,799.77	-26,799.77	-26,799.77	0.00%

My Budget Report

For Fiscal: 2025-2026 Period Ending Item # 2. 25

		Original Total Budget	Current Total Budget	Period Activity	Fiscal Activity	Variance Favorable (Unfavorable)	Percent Used
Fund: 08 - PID #2							
Revenue							
Department: 000 - Non-departmental							
08-000-36114-000	PID Assessments	486,250.00	486,250.00	1,366.73	1,366.73	-484,883.27	0.28 %
08-000-36115-000	Preston Manor Memberships	0.00	100,000.00	0.00	0.00	-100,000.00	0.00 %
08-000-36910-000	Other Income	0.00	1,500.00	0.00	0.00	-1,500.00	0.00 %
08-000-37201-000	Event Income	0.00	25,000.00	0.00	0.00	-25,000.00	0.00 %
08-000-37205-000	Guest Fees	0.00	6,000.00	0.00	0.00	-6,000.00	0.00 %
08-000-37210-000	Tennis Income	0.00	4,000.00	0.00	0.00	-4,000.00	0.00 %
08-000-37215-000	Food Sales	0.00	3,500.00	0.00	0.00	-3,500.00	0.00 %
Department: 000 - Non-departmental Total:		486,250.00	626,250.00	1,366.73	1,366.73	-624,883.27	0.22%
Revenue Total:		486,250.00	626,250.00	1,366.73	1,366.73	-624,883.27	0.22%

	Original Total Budget	Current Total Budget	Period Activity	Fiscal Activity	Variance Favorable (Unfavorable)	Percent Used
Expense						
Department: 000 - Non-departmental						
08-000-42010-000	Office Supplies	0.00	10,500.00	0.00	0.00	10,500.00 0.00 %
08-000-42012-000	Marketing	0.00	800.00	0.00	0.00	800.00 0.00 %
08-000-42025-000	Food/Drinks	0.00	3,300.00	0.00	0.00	3,300.00 0.00 %
08-000-42125-000	Fuel/Oil	0.00	100.00	0.00	0.00	100.00 0.00 %
08-000-42185-000	Community Outreach	0.00	1,250.00	0.00	0.00	1,250.00 0.00 %
08-000-42195-000	Special Events and Awards	0.00	5,700.00	0.00	0.00	5,700.00 0.00 %
08-000-43101-000	Legal Services	1,500.00	1,500.00	0.00	0.00	1,500.00 0.00 %
08-000-43110-000	Other Professional Services	0.00	6,020.00	600.00	600.00	5,420.00 9.97 %
08-000-43111-000	PID Administrative Services	26,400.00	26,400.00	0.00	0.00	26,400.00 0.00 %
08-000-43112-000	PID Management Services	454,350.00	0.00	0.00	0.00	0.00 0.00 %
08-000-43195-000	Electricity/Gas/Phone	0.00	61,000.00	86.88	86.88	60,913.12 0.14 %
08-000-43201-000	Janitorial	0.00	8,550.00	550.00	550.00	8,000.00 6.43 %
08-000-43225-000	R & M Building	0.00	28,000.00	633.90	633.90	27,366.10 2.26 %
08-000-43230-000	R & M Grounds	0.00	150,000.00	12,151.00	12,151.00	137,849.00 8.10 %
08-000-43245-000	R & M Equipment	0.00	7,500.00	0.00	0.00	7,500.00 0.00 %
08-000-43253-000	R & M Pools	0.00	60,000.00	0.00	0.00	60,000.00 0.00 %
08-000-43301-000	Insurance	0.00	2,500.00	0.00	0.00	2,500.00 0.00 %
08-000-43320-000	Postage/Freight	0.00	325.00	0.00	0.00	325.00 0.00 %
08-000-43501-000	Dues/Memberships	0.00	780.00	0.00	0.00	780.00 0.00 %
08-000-43505-000	Fees	0.00	2,200.00	0.00	0.00	2,200.00 0.00 %
08-000-43510-000	Tax Appraisal/Collection	4,000.00	4,000.00	0.00	0.00	4,000.00 0.00 %
08-000-43900-000	Other Contractual	0.00	7,000.00	0.00	0.00	7,000.00 0.00 %
08-000-43905-000	Payroll Reimbursement	0.00	102,500.00	0.00	0.00	102,500.00 0.00 %
08-000-46400-000	Capital Reserves	0.00	136,325.00	0.00	0.00	136,325.00 0.00 %
Department: 000 - Non-departmental Total:		486,250.00	626,250.00	14,021.78	14,021.78	612,228.22 2.24%
Expense Total:		486,250.00	626,250.00	14,021.78	14,021.78	612,228.22 2.24%
Fund: 08 - PID #2 Surplus (Deficit):		0.00	0.00	-12,655.05	-12,655.05	-12,655.05 0.00%

My Budget Report

For Fiscal: 2025-2026 Period Ending Item # 2. 25

	Original Total Budget	Current Total Budget	Period Activity	Fiscal Activity	Variance Favorable (Unfavorable)	Percent Used
Fund: 12 - Sanitation Fund						
Revenue						
Department: 000 - Non-departmental						
<u>12-000-38400-000</u> Sanitation Revenue	1,340,000.00	1,340,000.00	117,281.56	117,281.56	-1,222,718.44	8.75 %
Department: 000 - Non-departmental Total:	1,340,000.00	1,340,000.00	117,281.56	117,281.56	-1,222,718.44	8.75%
Revenue Total:	1,340,000.00	1,340,000.00	117,281.56	117,281.56	-1,222,718.44	8.75%

		Original	Current	Period	Fiscal	Variance	Percent
		Total Budget	Total Budget	Activity	Activity	Favorable (Unfavorable)	Used
Expense							
Department: 320 - Sanitation Dept.							
12-320-43205-000	Solid Waste Collection	1,210,000.00	1,210,000.00	0.00	0.00	1,210,000.00	0.00 %
12-320-46220-000	Bulky Waste Site	0.00	0.00	558.00	558.00	-558.00	0.00 %
12-320-49995-000	Transfers out	130,000.00	130,000.00	0.00	0.00	130,000.00	0.00 %
Department: 320 - Sanitation Dept. Total:		1,340,000.00	1,340,000.00	558.00	558.00	1,339,442.00	0.04%
Expense Total:		1,340,000.00	1,340,000.00	558.00	558.00	1,339,442.00	0.04%
Fund: 12 - Sanitation Fund Surplus (Deficit):		0.00	0.00	116,723.56	116,723.56	116,723.56	0.00%

	Original Total Budget	Current Total Budget	Period Activity	Fiscal Activity	Variance Favorable (Unfavorable)	Percent Used
Fund: 22 - Grants & Donations Fund						
Revenue						
Department: 000 - Non-departmental						
22-000-30000-000 Grant Revenue	0.00	0.00	22,727.27	22,727.27	22,727.27	0.00 %
22-000-31000-000 Donation Revenue	0.00	0.00	384.21	384.21	384.21	0.00 %
Department: 000 - Non-departmental Total:	0.00	0.00	23,111.48	23,111.48	23,111.48	0.00%
Revenue Total:	0.00	0.00	23,111.48	23,111.48	23,111.48	0.00%
Fund: 22 - Grants & Donations Fund Total:	0.00	0.00	23,111.48	23,111.48	23,111.48	0.00%

	Original Total Budget	Current Total Budget	Period Activity	Fiscal Activity	Variance Favorable (Unfavorable)	Percent Used
Fund: 23 - Court Fund						
Revenue						
Department: 000 - Non-departmental						
23-000-35103-000	0.00	0.00	65.00	65.00	65.00	0.00 %
23-000-35104-000	0.00	0.00	101.00	101.00	101.00	0.00 %
23-000-35105-000	0.00	0.00	7.40	7.40	7.40	0.00 %
23-000-35107-000	0.00	0.00	312.39	312.39	312.39	0.00 %
23-000-35108-000	0.00	0.00	1,028.72	1,028.72	1,028.72	0.00 %
Department: 000 - Non-departmental Total:	0.00	0.00	1,514.51	1,514.51	1,514.51	0.00%
Revenue Total:	0.00	0.00	1,514.51	1,514.51	1,514.51	0.00%
Fund: 23 - Court Fund Total:	0.00	0.00	1,514.51	1,514.51	1,514.51	0.00%

My Budget Report

For Fiscal: 2025-2026 Period Ending Item # 2. 25

	Original Total Budget	Current Total Budget	Period Activity	Fiscal Activity	Variance Favorable (Unfavorable)	Percent Used
Fund: 24 - Hotel / Motel Fund						
Revenue						
Department: 000 - Non-departmental						
<u>24-000-31400-000</u>	0.00	0.00	6,499.85	6,499.85	6,499.85	0.00 %
Hotel Occupancy Tax						
Department: 000 - Non-departmental Total:	0.00	0.00	6,499.85	6,499.85	6,499.85	0.00%
Revenue Total:	0.00	0.00	6,499.85	6,499.85	6,499.85	0.00%
Fund: 24 - Hotel / Motel Fund Total:	0.00	0.00	6,499.85	6,499.85	6,499.85	0.00%

	Original Total Budget	Current Total Budget	Period Activity	Fiscal Activity	Variance Favorable (Unfavorable)	Percent Used
Fund: 26 - Events						
Expense						
Department: 000 - Non-departmental						
<u>26-000-49360-000</u> Events disbursements	0.00	0.00	800.00	800.00	-800.00	0.00 %
Department: 000 - Non-departmental Total:	0.00	0.00	800.00	800.00	-800.00	0.00%
Expense Total:	0.00	0.00	800.00	800.00	-800.00	0.00%
Fund: 26 - Events Total:	0.00	0.00	800.00	800.00	-800.00	0.00%

	Original Total Budget	Current Total Budget	Period Activity	Fiscal Activity	Variance Favorable (Unfavorable)	Percent Used
Fund: 27 - Water & Sewer Impact Fees						
Revenue						
Department: 000 - Non-departmental						
<u>27-000-38350-000</u>						
Water and Sewer Impact Fees	0.00	0.00	58,000.00	58,000.00	58,000.00	0.00 %
Department: 000 - Non-departmental Total:	0.00	0.00	58,000.00	58,000.00	58,000.00	0.00%
Revenue Total:	0.00	0.00	58,000.00	58,000.00	58,000.00	0.00%
Fund: 27 - Water & Sewer Impact Fees Total:	0.00	0.00	58,000.00	58,000.00	58,000.00	0.00%

My Budget Report

For Fiscal: 2025-2026 Period Ending Item # 2. 25

	Original Total Budget	Current Total Budget	Period Activity	Fiscal Activity	Variance Favorable (Unfavorable)	Percent Used
Fund: 30 - Public Safety Tax Note 2024						
Expense						
Department: 220 - Fire						
<u>30-220-46232-000</u> Fire Apparatus	0.00	0.00	454,507.00	454,507.00	-454,507.00	0.00 %
Department: 220 - Fire Total:	0.00	0.00	454,507.00	454,507.00	-454,507.00	0.00%
Expense Total:	0.00	0.00	454,507.00	454,507.00	-454,507.00	0.00%
Fund: 30 - Public Safety Tax Note 2024 Total:	0.00	0.00	454,507.00	454,507.00	-454,507.00	0.00%

My Budget Report

For Fiscal: 2025-2026 Period Ending Item # 2. 25

	Original Total Budget	Current Total Budget	Period Activity	Fiscal Activity	Variance Favorable (Unfavorable)	Percent Used
Fund: 50 - Water & Sewer CO 2024						
Expense						
Department: 341 - Water Production						
<u>50-341-46150-000</u> Other Improvements	0.00	0.00	-187,318.58	-187,318.58	187,318.58	0.00 %
Department: 341 - Water Production Total:	0.00	0.00	-187,318.58	-187,318.58	187,318.58	0.00%
Expense Total:	0.00	0.00	-187,318.58	-187,318.58	187,318.58	0.00%
Fund: 50 - Water & Sewer CO 2024 Total:	0.00	0.00	-187,318.58	-187,318.58	187,318.58	0.00%
Report Surplus (Deficit):	0.04	0.04	-181,803.31	-181,803.31	-181,803.35	98,275.00%

Fund Summary

Fund	Original Total Budget	Current Total Budget	Period Activity	Fiscal Activity	Variance Favorable (Unfavorable)
01 - General Fund	0.35	0.35	-395,770.94	-395,770.94	-395,771.29
02 - Enterprise Fund	-0.31	-0.31	406,209.95	406,209.95	406,210.26
04 - Debt Service	0.00	0.00	-90,648.48	-90,648.48	-90,648.48
07 - Economic Development Corp.	0.00	0.00	-26,799.77	-26,799.77	-26,799.77
08 - PID #2	0.00	0.00	-12,655.05	-12,655.05	-12,655.05
12 - Sanitation Fund	0.00	0.00	116,723.56	116,723.56	116,723.56
22 - Grants & Donations Fund	0.00	0.00	23,111.48	23,111.48	23,111.48
23 - Court Fund	0.00	0.00	1,514.51	1,514.51	1,514.51
24 - Hotel / Motel Fund	0.00	0.00	6,499.85	6,499.85	6,499.85
26 - Events	0.00	0.00	-800.00	-800.00	-800.00
27 - Water & Sewer Impact Fees	0.00	0.00	58,000.00	58,000.00	58,000.00
30 - Public Safety Tax Note 2024	0.00	0.00	-454,507.00	-454,507.00	-454,507.00
50 - Water & Sewer CO 2024	0.00	0.00	187,318.58	187,318.58	187,318.58
Report Surplus (Deficit):	0.04	0.04	-181,803.31	-181,803.31	-181,803.35



AGENDA ITEM COMMENTARY

MEETING NAME:	City Council
MEETING DATE:	November 17, 2025
ITEM TITLE:	Consider and take appropriate action on Resolution 2025-052 First Reading A RESOLUTION OF THE CITY COUNCIL OF THE CITY OF WOLFFORTH AUTHORIZING THE ECONOMIC DEVELOPMENT CORPORATION TO ISSUE AN INCENTIVE FOR CONSTRUCTION OF A RETAIL GROCERY STORE AND RELATED INFRASTRUCTURE TO UNITED SUPERMARKETS, LLC.
STAFF INITIATOR:	Terri Robinette, City Secretary

BACKGROUND:

The City Council held a public hearing on November 3, 2025, to hear details of this proposed economic development project by the Wolfforth Economic Development Corporation (WEDC). The next step in the approval process is for the City Council to consider a Resolution of Support for the expenditure of funds. This resolution will have two readings as required by the Texas Local Government Code, Section 505—scheduled for November 17 and December 1, 2025.

This project represents a performance-based economic development incentive. The WEDC has structured the agreement so that no funds are disbursed until project completion and business opening. The incentive is tied directly to the company meeting specific conditions outlined in the performance agreement, such as investment in the Wolfforth site and opening the doors to the public.

Once the second reading is completed and the required 60-day public comment period ends on December 16, 2025, the WEDC will be authorized to issue funds only after all performance terms have been verified.

EXHIBITS:

Resolution

COUNCIL ACTION/STAFF RECOMMENDATION:

Approve Resolution – First Reading

RESOLUTION 2025-052

A RESOLUTION OF THE CITY COUNCIL OF THE CITY OF WOLFFORTH AUTHORIZING THE ECONOMIC DEVELOPMENT CORPORATION TO ISSUE AN INCENTIVE FOR CONSTRUCTION OF A RETAIL GROCERY STORE AND RELATED INFRASTRUCTURE TO UNITED SUPERMARKETS, LLC.

WHEREAS, the City of Wolfforth created the Wolfforth Economic Development Corporation (the “WEDC”), which is a Type B economic development corporation; and

WHEREAS, the Texas Legislature in Local Government Code 505.158 allows Type B economic development corporations created by a municipality with a population under 20,000 to promote new or expanded business within the community; and

WHEREAS, the City of Wolfforth currently has a population of under 20,000; and

WHEREAS, the WEDC at their November 3, 2025, regular meeting, held a public hearing regarding a proposed economic development incentive to United Supermarkets, LLC for construction of a retail grocery store and related infrastructure in Wolfforth, Texas, not to exceed \$500,000.00; and

WHEREAS, at the November 3, 2025, meeting, the WEDC Board of Directors found that the construction of the retail grocery store and related infrastructure will create new jobs and generate new sales tax revenue in the City; and

WHEREAS, the Wolfforth City Council held a public hearing on November 3, 2025, and gave this Resolution readings on November 17, 2025, and December 1, 2025, to consider authorizing an incentive by the Wolfforth Economic Development Corporation to United Supermarkets, LLC.

NOW, THEREFORE, BE IT RESOLVED BY THE CITY COUNCIL OF THE CITY OF WOLFFORTH, TEXAS, THAT:

SECTION 1. That the recitals, findings, and determinations contained in the preamble to this Resolution are incorporated into the body of this Resolution as if fully set forth in this Section and are hereby found and declared to be true and correct legislative findings and are adopted as part of this Resolution for all purposes.

SECTION 2. That the Wolfforth Economic Development Corporation is hereby authorized to enter into a performance agreement for a \$500,000.00 economic development incentive to United Supermarkets, LLC to assist in the construction of a new retail grocery store in Wolfforth, Texas (attached hereto as Exhibit A.)

SECTION 3. It is hereby officially found and determined that the meeting at which this resolution is passed was open to the public as required and that public notices of the time, place, and purpose of said meeting was given as required by the Open Meetings Act, Chapter 551, of the Texas Government Code.

SECTION 4. That the officers of the City are hereby authorized and directed to take such action as may be necessary to carry this Resolution into effect.

SECTION 5. This Resolution shall take effect immediately upon its passage as provided by law.

**Passed and approved by the City Council on First Reading on November 17, 2025.
Passed and approved by the City Council on Second Reading on December 1, 2025**

CITY OF WOLFFORTH, TEXAS

David Cooper, Mayor Pro Tem

Attest

Terri Robinette, City Secretary



AGENDA ITEM COMMENTARY

MEETING NAME:	City Council
MEETING DATE:	December 1, 2025
ITEM TITLE:	PUBLIC COMMENT: Receive public comment pertaining to Stormwater Management Program.
STAFF INITIATOR:	Tara Tomlinson, Director of Development

BACKGROUND:

As part of our MS4 Stormwater Management Program, and in accordance with the requirements of Minimum Control Measure (MCM) 2: Public Involvement and Participation, the City is required to host at least one public meeting each year to solicit input on the development, implementation, and effectiveness of the program.

This meeting may be conducted as part of an existing public forum—such as a City Council meeting, Board meeting, or other stakeholder meeting—provided that the MS4 Program is included on the agenda and an opportunity for public participation is offered.

Public comments should focus on evaluating the effectiveness of the program's Best Management Practices (BMPs), identifying areas for improvement, and ensuring that the program reflects community needs and expectations.

EXHIBITS:

COUNCIL ACTION/STAFF RECOMMENDATION:

Open the floor for public comment on MS4 effectiveness.



AGENDA ITEM COMMENTARY

MEETING NAME: City Council
MEETING DATE: November 17, 2025
ITEM TITLE: Consider and take appropriate action on Frenship Youth Baseball annual report
STAFF INITIATOR: Randy Criswell, City Manager

BACKGROUND:

Per our contract with Frenship Youth Baseball, Mr. Carey Sallee will present the annual report.

EXHIBITS:

COUNCIL ACTION/STAFF RECOMMENDATION:

Staff recommends approval of the resolution extending the moratorium on multi-family permits.

Frenship Youth Baseball (FYB)

2025 League Summary for City of Wolfforth

FYB League Summary

- **Spring League (March 1 – June 10)**
Served **1,032 players** (ages 4–12) across two leagues:
 - **Draft League:** 24 teams, 280 players
 - **Open League:** 70 teams, 752 players
 - Spring league was successful and will continue next year.
 - **Summer League**
No summer league held in 2025. Instead, additional tournaments were added in August and September.
-

FYB Tournaments

- Hosted **9 weekend tournaments** (March–October) in **Wolfforth and Lubbock** for ages 7–14.
- **7 of 9 tournaments** have been completed; one (State Warm-Up) was rained out.
- **Over 650 teams** from West Texas and New Mexico participated or are registered.

Tournament Breakdown:

Tournament	Date	Teams
Knocksville Freeze	March 1–2	163
March Triple Play	March 29–30	149
BWW	May 3–4	114
May Double Play	May 17–18	114
State Warm-Up (Canceled)	June 7–8	122*
August Heat	August 2–3	57
August Sizzle	August 16–17	36

Frenship Youth Baseball (FYB)

2025 League Summary for City of Wolfforth

Tournament	Date	Teams
September Slugfest	September 27–28	74
October Scream	October 18–19	46*

*Registered, not completed yet

Summary: Strong tournament turnout benefiting the cities of Lubbock and Wolfforth with local and travel teams; will continue March–October tournaments next year.

Field Improvements

- **Upgrades Made:**
 - Rye overseeding last fall; next overseeding planned for October, 2025
 - New sod installed on Fields 4 & 5 infields last year
 - Improved irrigation and sprinkler maintenance (in partnership with Henry High)
 - Consistent watering and good rainfall improved field conditions
 - Added additional dirt to infields to level them out

Field Summary: Ongoing investment in field quality is paying off; condition improvements have been well-received.

Frenship Youth Baseball (FYB)

2025 League Summary for City of Wolfforth

Proposed Capital Improvements

FYB respectfully requests city support for the following upgrades:

Improvement	Purpose/Notes
LED Field Lights	Long-term energy efficiency; city plans already in motion
Concrete Walkway (F1–F2)	Improve grass growth, reduce dirt walking areas
Concrete Driveway (F3–F4)	Emergency/service vehicle access; parent convenience
Paved Parking Lots	Current lots are dirt; paving would enhance access and safety
Expanded Parking Lot	Needed due to residential development reducing space
Southwest Street Connection	Add an additional traffic exit
Fence Replacement Plan	Aging fencing needs long-term replacement strategy
Dirt Removal Around Complex	Helps level parking and improve site layout
Full Grass Replacement	Estimated cost: \$250,000 for new sod complex-wide



AGENDA ITEM COMMENTARY

MEETING NAME:	City Council
MEETING DATE:	December 1, 2025
ITEM TITLE:	Consider and take appropriate action on request from Public Utility Commission for City of Wolfforth to accept Temporary Manager appointment for Casey Home Estates Water System
STAFF INITIATOR:	Randy Criswell, City Manager

BACKGROUND:

Early in November, we received an email from Mr. Nima Momtahan from the Public Utility Commission of Texas, requesting that we have a conversation with him about a small private water system south of town called the Casey Home Estates Water Utility. I agreed to the request, and Rick, Randy and I visited with Mr. Momtahan on November 7. The PUCT is looking to appoint a Temporary Manager for the Casey system due to the desire of the current owner to relieve itself of the system.

A Temporary Manager would be responsible for managing the system, including meter reading, billing, collections, etc. In return, the Temporary Manager would receive \$15/month/connection.

I promised Mr. Momtahan we'd have an answer for him after the Council was able to discuss the matter, since, clearly, taking on another system would be a policy decision the Council would need to make.

EXHIBITS:

Original email from PUC

COUNCIL ACTION/STAFF RECOMMENDATION:

Council direction.

Request for Call: Temporary Manager Needed for Casey Home Estates Water Utility

From Nima Momtahan <Nima.Momtahan@puc.texas.gov>

Date Tue 2025-11-04 2:32 PM

To Rick Scott <rscott@wolfforthtx.us>; Randy Criswell <rcriwell@wolfforthtx.us>

Cc PUC DUO <duo@puc.texas.gov>

Caution: This email originated from outside the organization. Do not click links or open attachments unless you recognize the sender and know the content is safe.

Hi Mr. Criswell and Mr. Scott,

My name is Nima Momtahan, and I'm with the Division of Utility Outreach at the Public Utility Commission of Texas (PUCT). I'm reaching out regarding an urgent situation that could impact residents close to the City of Wolfforth who receive water service from Casey Home Estates Water Utility (CCN No. 12231).

Would you be available for a brief call to discuss the possibility of the city, taking over Casey Home Estates, or serving as a Temporary Manager (TM) for this system until a long-term solution is achieved? We believe this is an opportunity for the city to make a meaningful difference for these customers.

If you'd like to review the details before we speak, here is an overview of the situation:

Background

- **Utility Name:** Casey Home Estates Water
- **Connections:** 104
- **Ownership:** Private (currently in transition)
- **CCN No.:** 12231
- **PWS Name:** Seven Estates (PWS ID No. 1520188)

The system has faced ongoing ownership and operational challenges. In 2022, the owner announced plans to abandon the utility due to health reasons. PUCT intervention and assistance from Central States Water Resources (CSWR) prevented immediate abandonment, but CSWR has now withdrawn its application to acquire the Utility due to unresolved land use issues. Without a Temporary Manager, the system will likely be abandoned, potentially putting 104 connections of the system at risk of losing access to continuous and adequate water service.

View the CCN service area here: <https://arcg.is/1OeDzX0>

Role of Temporary Manager

- Assume operational control of the water system.
- Send bills based on the utility's approved tariff (https://interchange.puc.texas.gov/Documents/53075_82_1184253.PDF) and collect funds.
- Ensure continuous and adequate water service for all customers.
- Submit monthly reports to PUCT.

Compensation

A TM fee of around \$15 per connection per month would be set to compensate the TM for its time and services. The TM would add this fee to customer bills as a separate line item. Additionally, if the utility's

approved tariff does not cover operating costs, the TM can apply for a temporary rate increase under PUCT rules.

Item # 6.

I'd appreciate the chance to discuss this with you and answer any questions. Please let me know a convenient time for a call, or feel free to reach me directly at (512) 936-7113 or nima.momtahan@puc.texas.gov.

Thank you for considering this opportunity to support the community.

Thanks,
Nima



Nima Momtahan, PhD

Receivership Coordinator

Division of Utility Outreach

Public Utility Commission of Texas

W: 512.936.7113 | nima.momtahan@puc.texas.gov



AGENDA ITEM COMMENTARY

MEETING NAME:	City Council
MEETING DATE:	December 1, 2025
ITEM TITLE:	Consider and take appropriate action on proposals for Monument Signage at City Hall and City Library
STAFF INITIATOR:	Randy Criswell, City Manager

BACKGROUND:

Per your direction, Mayor pro tem Cooper and I have worked with Fusion Signs to develop proposed designs for Monument Signs at City Hall and at the Library. The signs will be similar to the large Monument Sign on Donald Preston Drive, but somewhat smaller. The proposed sign at City Hall would include a message board as well.

Drawing packages for each proposed sign are included as an exhibit for your review. If you like the proposed designs, I will request authorization to negotiate pricing and execute the appropriate documents to have these signs constructed.

Based on previous estimates, I request authorization to expend up to \$250,000 for the construction of these signs.

EXHIBITS:

Drawing package for City Hall Sign

Drawing package for Library Sign

COUNCIL ACTION/STAFF RECOMMENDATION:

Authorize the City Manager to negotiate and execute agreements to construct monument signs at City Hall and the Library, up to \$250,000.

SCHEDULE

N1 - (1) DOUBLE SIDED MONUMENT SIGN

302 Main St #2940,
Wolfforth, TX 79382

Item # 7.



12226 Coast Drive
Whittier, CA 90601
Tel: (562) 946-7545
Fax: (562) 949-5707
St. Lic.: 894662
www.fusionsign.com
Los Angeles, CA

SIGN CODE

.....

ALLOWABLE SQ. FT. 000

PROPOSED SQ. FT. 000

DRAWING/REVISION NO.:

06-25-0008

PAGE NO.:

1 OF 4

CLIENT:

Wolfforth

ADDRESS

302 Main St #2940,
Wolfforth, TX 79382

Approval Signature

DATE:

06/05/2025

PROJECT MANAGER

Dan L.

DESIGNER:

Jose Soria

REVISION DATE:

.....

REVISION BY:

.....

ALL IDEAS, PLANS, AND ELECTRONIC ART INDICATED ON THIS DRAWING ARE COPYRIGHTED AND OWNED BY FUSION SIGN AND DESIGN AND SHALL NOT BE REPRODUCED, USED BY OR DISCLOSED TO ANY PERSONS, FIRM OR CORPORATION FOR ANY PURPOSE WHATSOEVER WITHOUT THE PERMISSION OF FUSION SIGN AND DESIGN

APPROVAL

X	Title	Date
---	-------	------

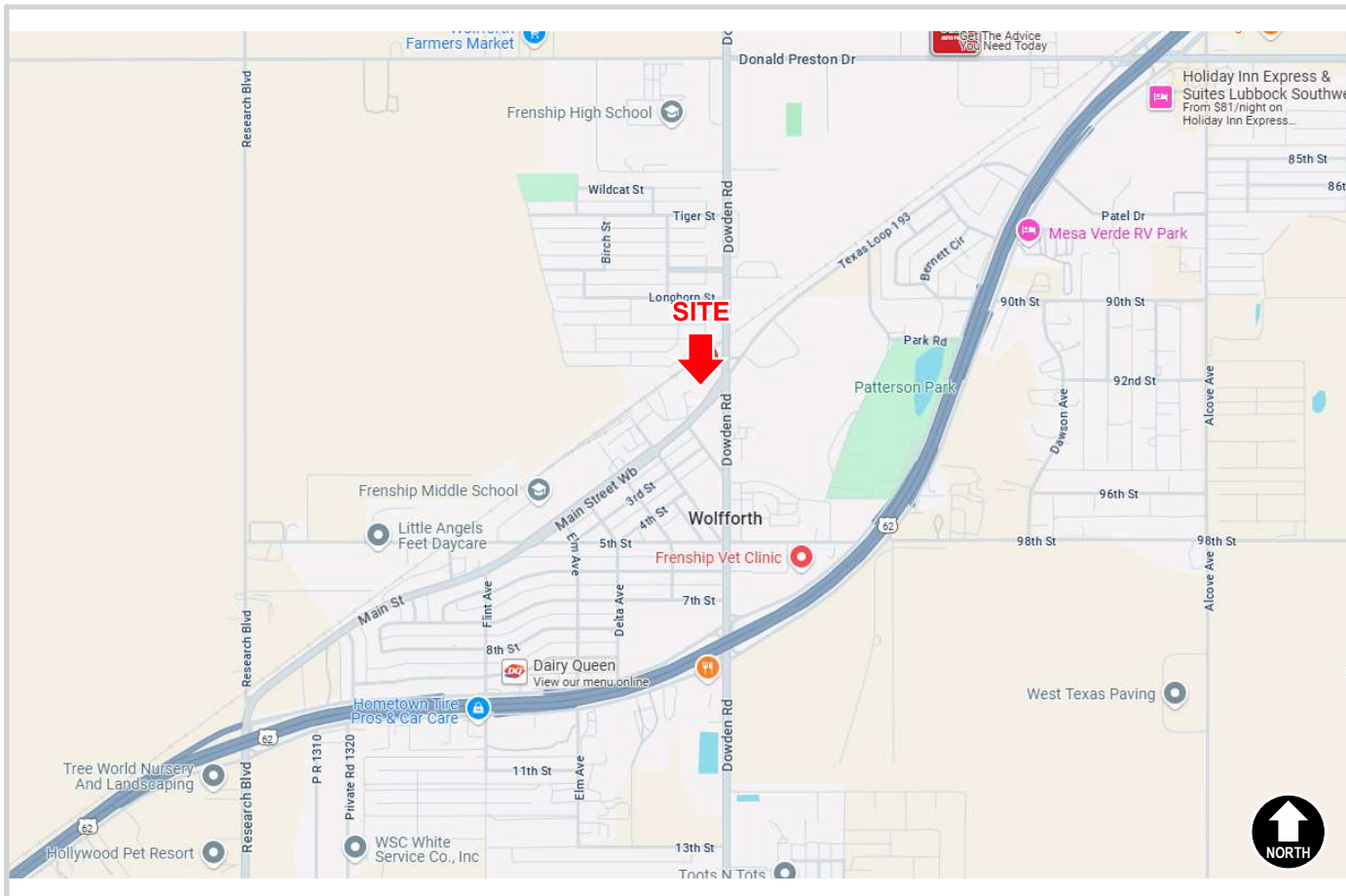

VICINITY MAP

NOT TO SCALE



AERIAL PHOTO / SITE PLAN

NOT TO SCALE



ELEVATION

NTS



SITE PLAN

NTS

Item # 7.



12226 Coast Drive
Whittier, CA 90601
Tel: (562) 946-7545
Fax: (562) 949-5707
St. Lic.: 894662
www.fusionsign.com
Los Angeles, CA

DRAWING/REVISION NO.:

06-25-0008

PAGE NO.:

2 OF 4

CLIENT:

Wolfforth

ADDRESS

302 Main St #2940,
Wolfforth, TX 79382

Approval Signature

DATE:

06/05/2025

PROJECT MANAGER

Dan L.

DESIGNER:

Jose Soria

REVISION DATE:

REVISION BY:

ALL IDEAS, PLANS, AND ELECTRONIC ART INDICATED ON THIS DRAWING ARE COPYRIGHTED AND OWNED BY FUSION SIGN AND DESIGN AND SHALL NOT BE REPRODUCED, USED BY OR DISCLOSED TO ANY PERSONS, FIRM OR CORPORATION FOR ANY PURPOSE WHATSOEVER WITHOUT THE PERMISSION OF FUSION SIGN AND DESIGN.

12226 Coast Drive
Whittier, CA 90601
Tel: (562) 946-7545
Fax: (562) 949-5707
St. Lic.: 894662
www.fusionsign.com
Los Angeles, CA

DRAWING/REVISION NO.:
06-25-0008

PAGE NO.:
3 OF **4**

CLIENT:
Wolfforth
ADDRESS:
302 Main St #2940,
Wolfforth, TX 79382

Approval Signature

DATE:
06/05/2025

PROJECT MANAGER
Dan L.

DESIGNER:
Jose Soria

REVISION DATE:

REVISION BY:

ALL IDEAS, PLANS, AND ELECTRONIC ART INDICATED ON THIS DRAWING ARE COPYRIGHTED AND OWNED BY FUSION SIGN AND DESIGN AND SHALL NOT BE REPRODUCED, USED BY OR DISCLOSED TO ANY PERSONS, FIRM OR CORPORATION FOR ANY PURPOSE WHATSOEVER WITHOUT THE WRITTEN PERMISSION OF FUSION SIGN AND DESIGN.

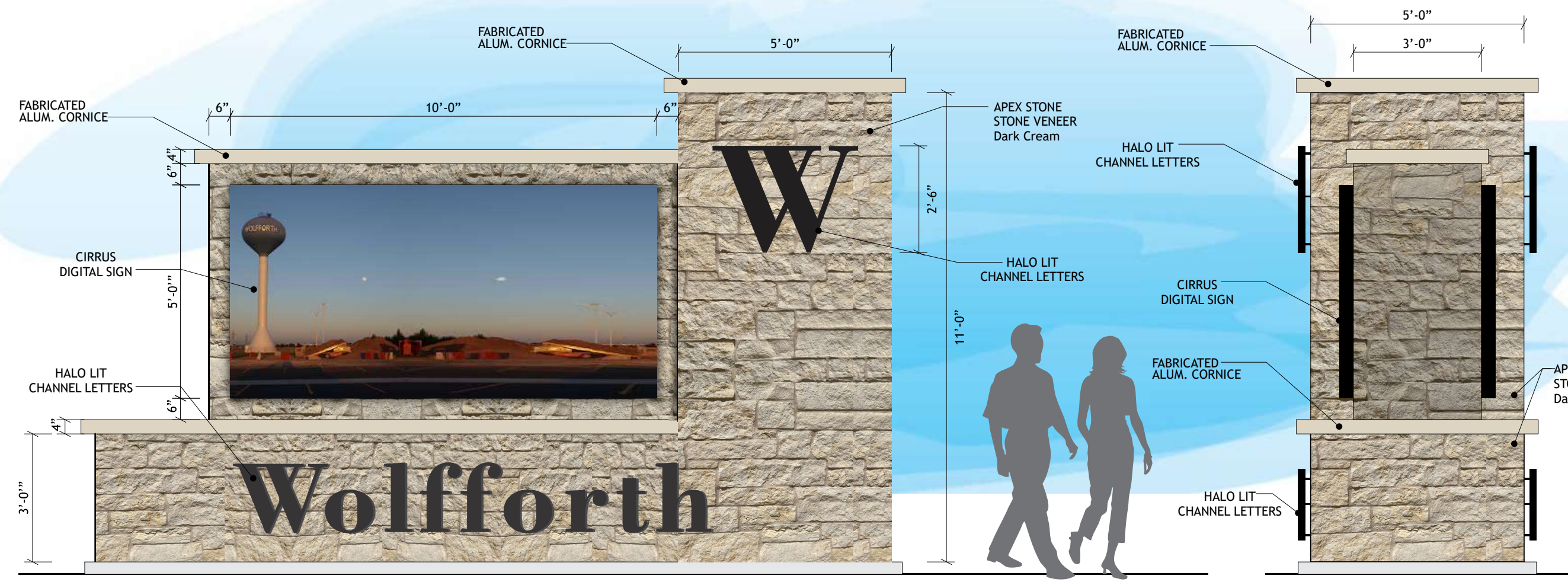

N1 MONUMENT SIGN

Scale: 3/8" = 1'-0"



NOTE
GRAPHIC TO BE PROVIDED
PRIOR TO MANUFACTURING

12226 Coast Drive
Whittier, CA 90601
Tel: (562) 946-7545
Fax: (562) 949-5707
St. Lic.: 894662
www.fusionsign.com
Los Angeles, CA

DRAWING/REVISION NO.:
06-25-0008

PAGE NO.:
4 OF 4

CLIENT:
Wolfforth

ADDRESS
302 Main St #2940,
Wolfforth, TX 79382

Approval Signature

DATE:
06/05/2025

PROJECT MANAGER
Dan L.

DESIGNER:
Jose Soria

REVISION DATE:

REVISION BY:

ALL IDEAS, PLANS, AND ELECTRONIC ART INDICATED ON THIS DRAWING ARE COPYRIGHTED AND OWNED BY FUSION SIGN AND DESIGN AND SHALL NOT BE REPRODUCED, USED BY OR DISCLOSED TO ANY PERSONS, FIRM OR CORPORATION FOR ANY PURPOSE WHATSOEVER WITHOUT THE WRITTEN PERMISSION OF FUSION SIGN AND DESIGN.

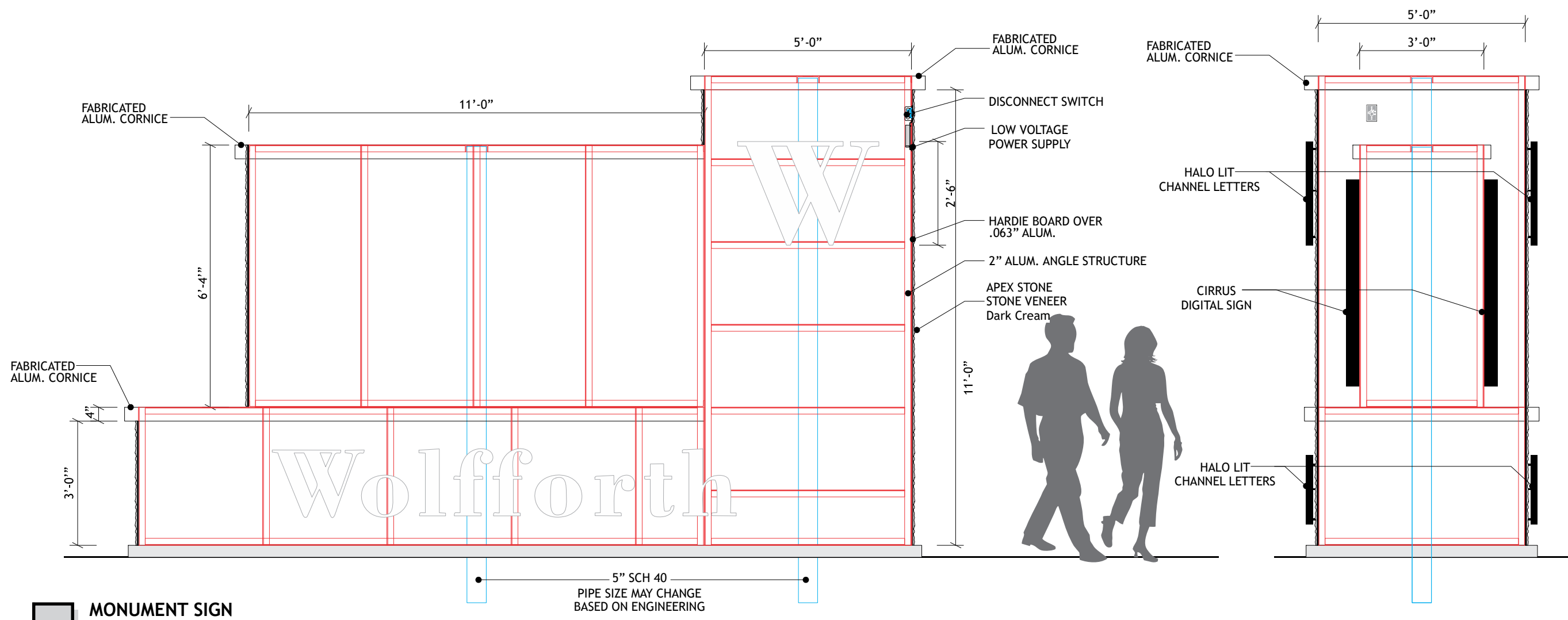

MONUMENT SIGN

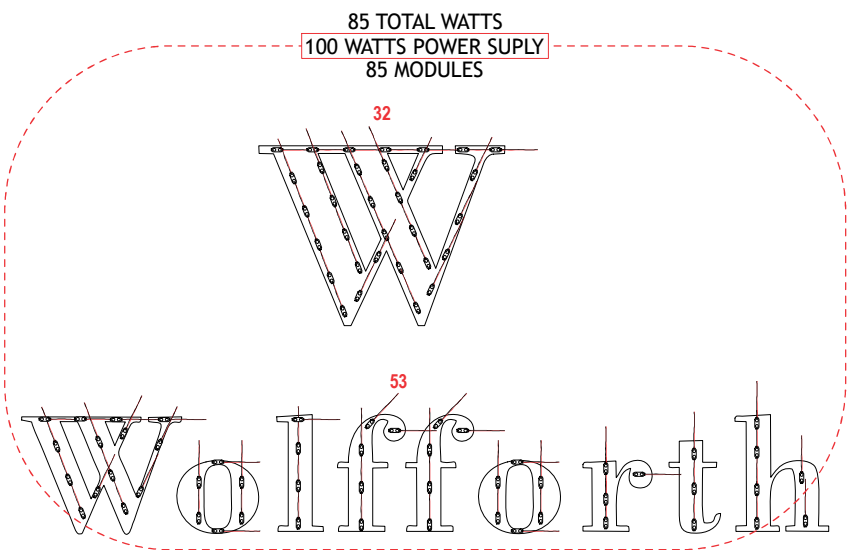

ELECTRICAL SPECIFICATIONS:
(170) WHITE LED MODULES @ 1.0W EA= 170W TOTAL
(2) 12V 100W POWER SUPPLIES @ 2.2 AMPS EA.
(1) CUSTOMER PROVIDED 120V/20A/60HZ DEDICATED CIRCUIT REQUIRED
**TOTAL CIRCUIT LOAD:
4.4 AMPS @ 120 VAC**

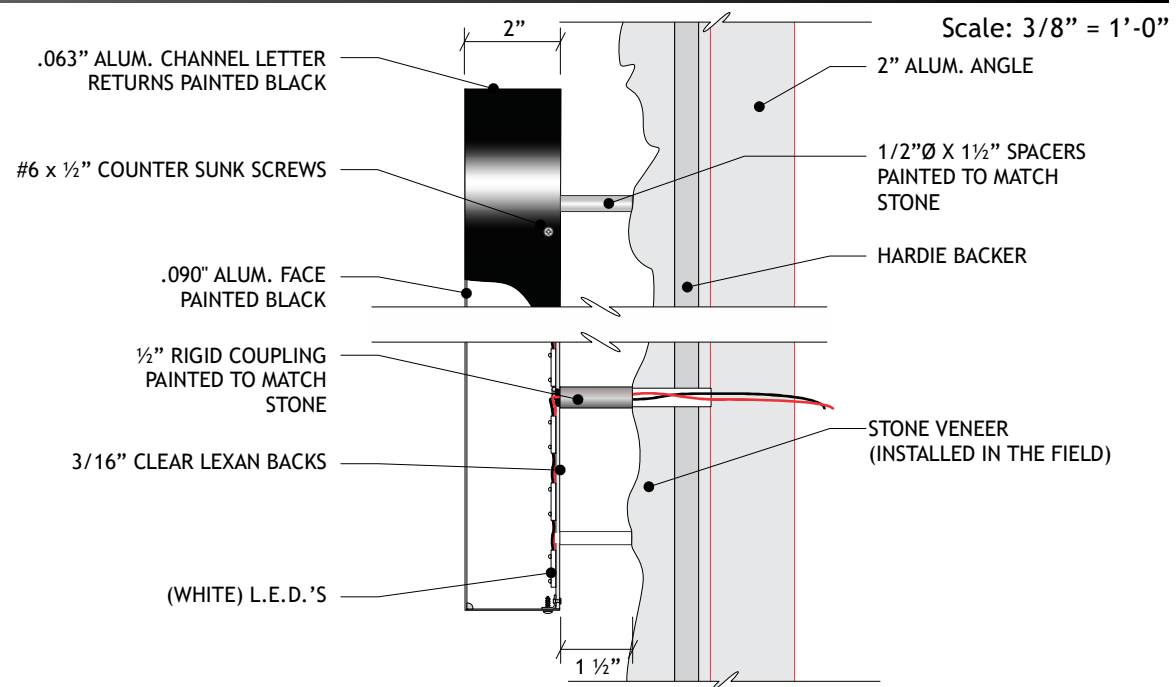

SECTION DETAIL (REVERSE HALO LIT CHANNEL LETTERS)

Scale: 3/8" = 1'-0"

SCHEDULE

N1 - (1) D/F INTERNALLY ILLUMINATED MONUMENT SIGN

APPROVAL		
X	Title	Date

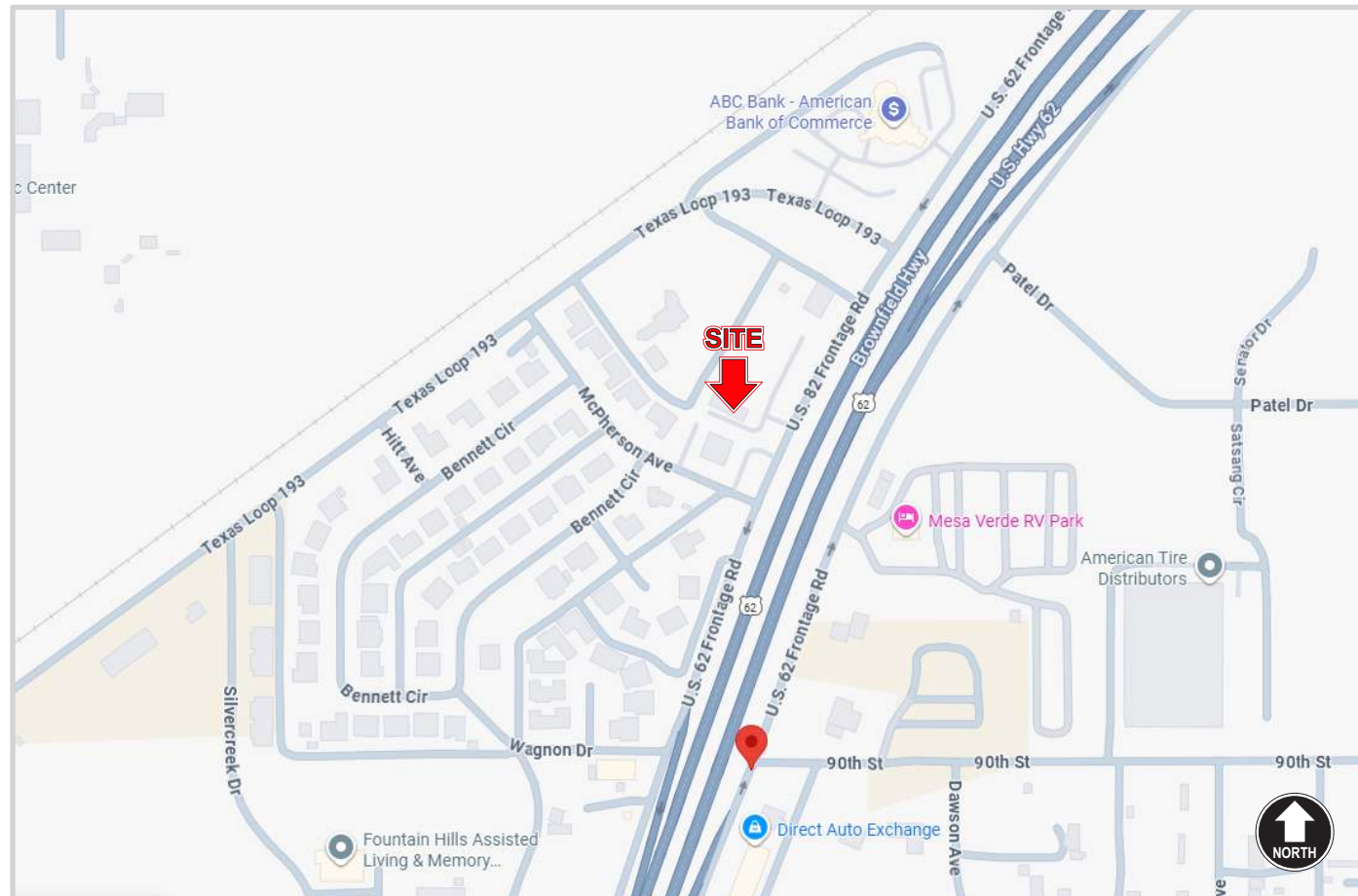

VICINITY MAP

NOT TO SCALE



Wolfforth

508 East US-62
Wolfforth Tx.

SIGN CODE

ALLOWABLE SQ. FT.	PROPOSED SQ. FT.

LEGEND

- N1 NEW PROPOSED
- R1 EXISTING SIGN TO BE REPLACED
- X1 EXISTING SIGN TO BE REMOVED
- S1 EXISTING SIGN TO REMAIN



AERIAL PHOTO / SITE PLAN

NOT TO SCALE

Item # 7.



12226 Coast Drive
Whittier, CA 90601
Tel: (562) 946-7545
Fax: (562) 949-5707
St. Lic.: 894662
www.fusionsign.com
Los Angeles, CA



Wolfforth

DRAWING/REVISION NO.:

07-25-0044

PAGE NO.:

1 OF 5

CLIENT:

Wolfforth

ADDRESS

508 East US-62
Wolfforth Tx.

Approval Signature

DATE:

08/11/2025

PROJECT MANAGER

Dan I.

DESIGNER:

Jake P.

REVISION DATE:

REVISION BY:

ALL IDEAS, PLANS, AND ELECTRONIC ART INDICATED ON THIS DRAWING ARE COPYRIGHTED AND OWNED BY FUSION SIGN AND DESIGN AND SHALL NOT BE REPRODUCED, USED BY OR DISCLOSED TO ANY PERSONS, FIRM OR CORPORATION FOR ANY PURPOSE WHATSOEVER WITHOUT THE PERMISSION OF FUSION SIGN AND DES



DRAWING/REVISION NO.:
07-25-0044

PAGE NO.:
2 OF 5

CLIENT:
Wolfforth

ADDRESS:
508 East US-62
Wolfforth Tx.

Approval Signature

DATE:
08/11/2025

PROJECT MANAGER:
Dan I.

DESIGNER:
Jake P.

REVISION DATE:

REVISION BY:

ALL IDEAS, PLANS, AND ELECTRONIC ART INDICATED ON THIS DRAWING ARE COPYRIGHTED AND OWNED BY FUSION SIGN AND DESIGN AND SHALL NOT BE REPRODUCED, USED BY OR DISCLOSED TO ANY PERSONS, FIRM OR CORPORATION FOR ANY PURPOSE WHATSOEVER WITHOUT THE PERMISSION OF FUSION SIGN AND DESIGN.

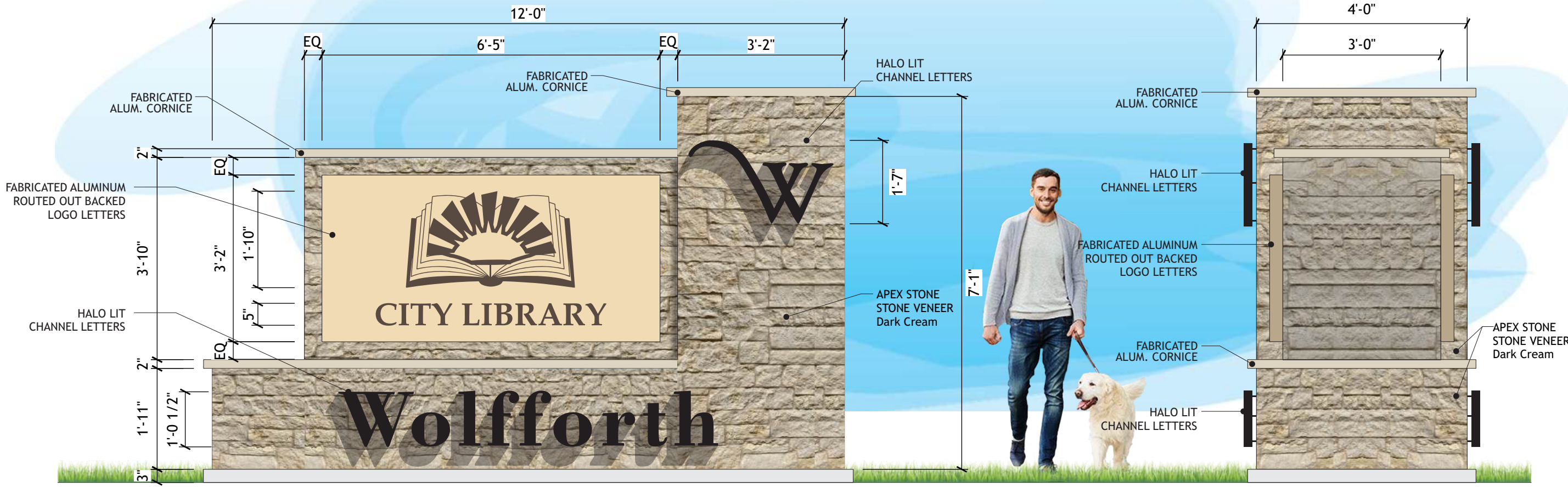

N1 MONUMENT SIGN

Scale: 1/2" = 1'-0"

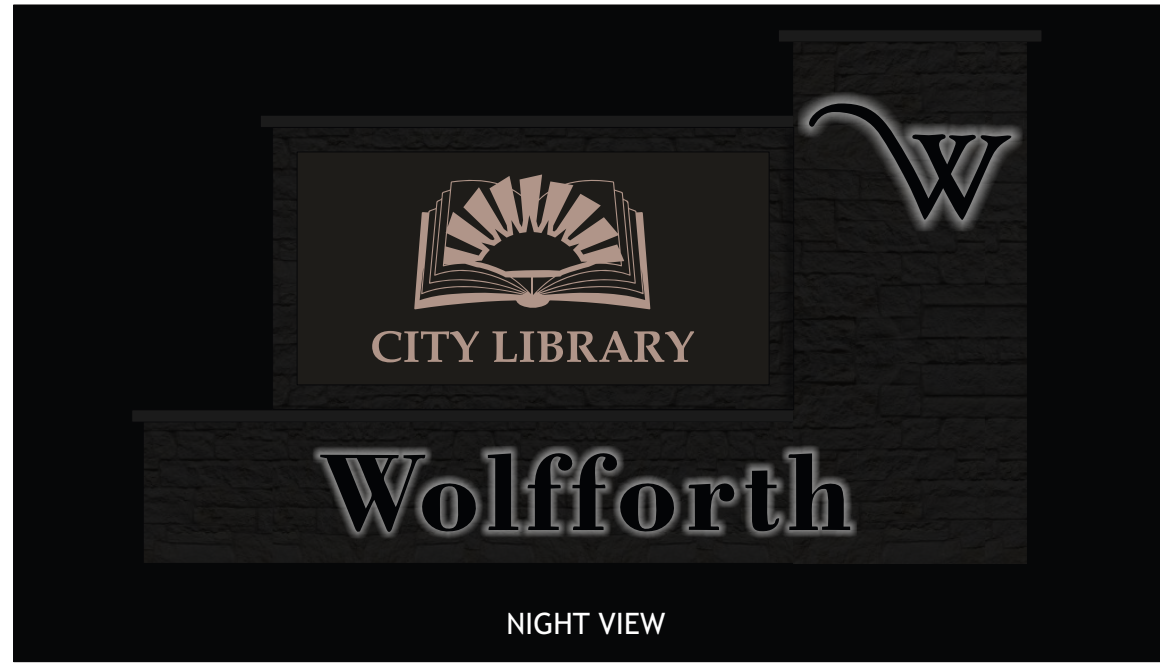

NIGHT VIEW



DRAWING/REVISION NO.:
07-25-0044

PAGE NO.:
3 OF 5

CLIENT:
Wolfirth

ADDRESS
508 East US-62
Wolfirth Tx.

Approval Signature

DATE:
08/11/2025

PROJECT MANAGER
Dan I.

DESIGNER:
Jake P.

REVISION DATE:

REVISION BY:

ALL IDEAS, PLANS, AND ELECTRONIC ART INDICATED ON THIS DRAWING ARE COPYRIGHTED AND OWNED BY FUSION SIGN AND DESIGN AND SHALL NOT BE REPRODUCED, USED BY OR DISCLOSED TO ANY PERSONS, FIRM OR CORPORATION FOR ANY PURPOSE WHATSOEVER WITHOUT THE PERMISSION OF FUSION SIGN AND DESIGN.

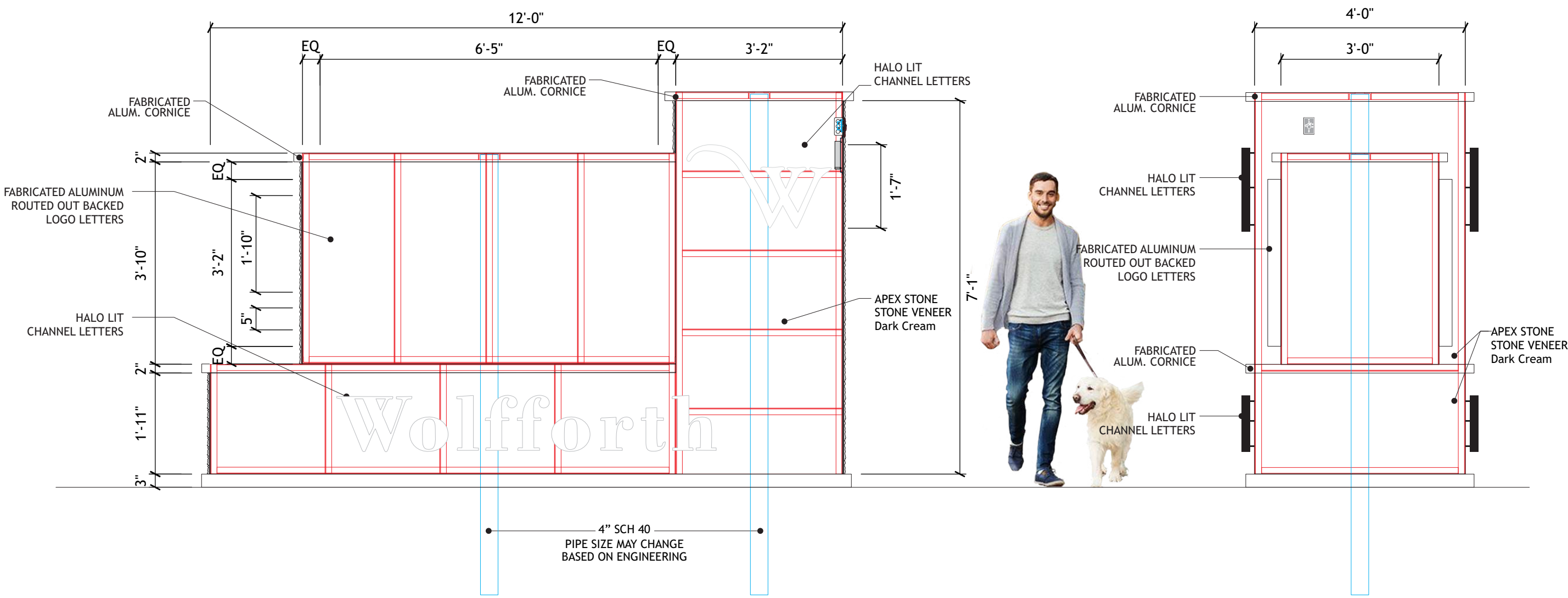

MONUMENT SIGN

Scale: 3/8" = 1'-0"

12226 Coast Drive
Whittier, CA 90601
Tel: (562) 946-7545
Fax: (562) 949-5707
St. Lic.: 894662
www.fusionsign.com
Los Angeles, CA



DRAWING/REVISION NO.:

07-25-0044

PAGE NO.:

4 OF 5

CLIENT:

Wolfirth

ADDRESS

508 East US-62
Wolfirth Tx.

Approval Signature

DATE:

08/11/2025

PROJECT MANAGER

Dan I.

DESIGNER:

Jake P.

REVISION DATE:

REVISION BY:

ALL IDEAS, PLANS, AND ELECTRONIC ART INDICATED ON THIS DRAWING ARE COPYRIGHTED AND OWNED BY FUSION SIGN AND DESIGN AND SHALL NOT BE REPRODUCED, USED BY OR DISCLOSED TO ANY PERSONS, FIRM OR CORPORATION FOR ANY PURPOSE WHATSOEVER WITHOUT THE PERMISSION OF FUSION SIGN AND DESIGN.

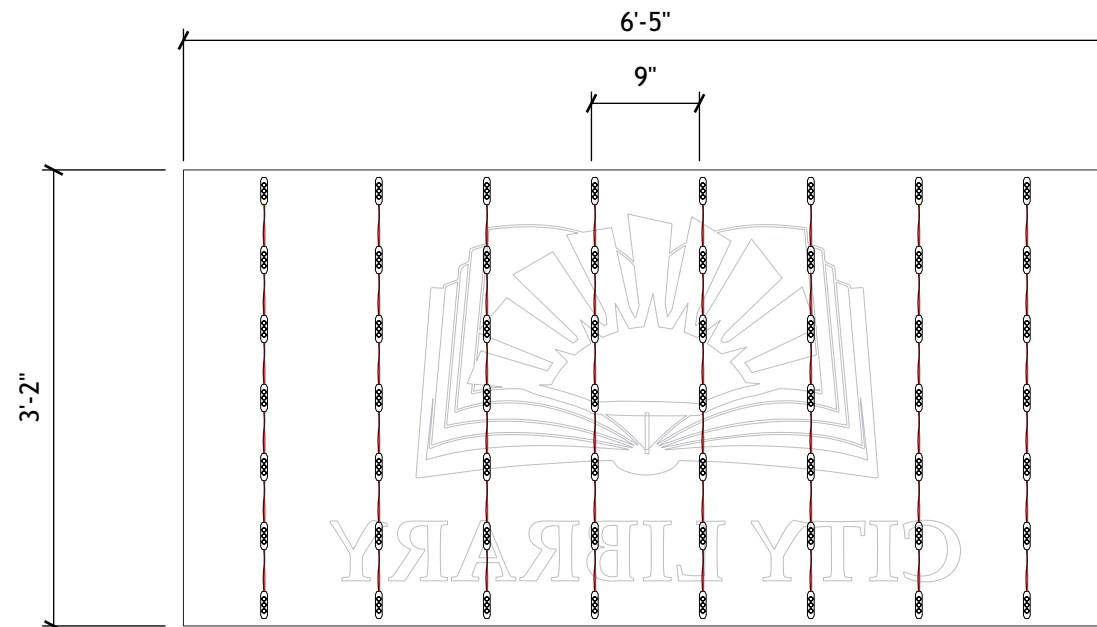

LED DETAIL

QTY: 2

SCALE: 3/4" = 1'-0"

ELECTRICAL SPECIFICATIONS:

- (56) WHITE LED MODULES @ 1W EA= 36.W TOTAL
- (1) 12V 60W POWER SUPPLIES @ 1.2 AMPS EA.
- (1) CUSTOMER PROVIDED 120V/20A/60HZ DEDICATED CIRCUIT REQUIRED

**TOTAL CIRCUIT LOAD:
1.2 AMPS @ 120 VAC**

GENERAL NOTES:

- 1.) INSTALLATION OF THIS SIGN SHALL CONFORM TO THE REQUIREMENTS OF ARTICLE 600 OF NEC, UL48 AND/OR OTHER APPLICABLE LOCAL CODES.
- 2.) BRANCH CIRCUIT:
 - A.) ALL BRANCH CIRCUITS FOR SIGNS MUST BE TOTALLY DEDICATED TO SIGNS (INCLUDING DEDICATED GROUND AND DEDICATED NEUTRAL PER CIRCUIT).
 - B.) SIGN CIRCUITS MUST NOT BE SHARED WITH OTHER LOADS SUCH AS LIGHTING, AIR CONDITIONING AND OTHER EQUIPMENT.
 - C.) PROPERTY SIZED GROUND WIRE THAT CAN BE TRACKED TO THE BREAKER PANEL MUST BE PROVIDED.
- 3.) U.L. AND DATA LABELS REQUIRED
- 4.) SIGN SATISFIES ALL REQUIREMENTS OF TITLE 24.
- 5.) OUTDOOR SIGNAGE TO EMPLOY EITHER PHOTOCCELL OR OUTDOOR ASTRONOMICAL TIMER



ELECTRIC SIGN SECTION

THIS SIGN IS INTENDED TO BE INSTALLED IN ACCORDANCE WITH THE REQUIREMENTS OF ARTICLE 600 OF THE NATIONAL ELECTRICAL CODE AND/OR OTHER APPLICABLE LOCAL CODES.

THIS INCLUDES PROPER GROUNDING AND BONDING OF THE SIGN.

NOTES:

ELECTRICAL COMPONENTS TO BE UL LISTED AND INSTALLED IN ACCORDANCE WITH THE NATIONAL ELECTRIC CODE (NEC)

ALL WIRING SHALL BE 12 GA

(1) 20 AMP-120V CIRCUIT TO BE BROUGHT TO JOB SITE BY LICENCED ELECTRICIAN.

ALL SIGNAGE WILL BE UL2161 COMPLIANT AND CARRY UL LABELS.



DRAWING/REVISION NO.:
07-25-0044

PAGE NO.:
5 OF 5

CLIENT:
Wolfforth

ADDRESS
508 East US-62
Wolfforth Tx.

Approval Signature

DATE:
08/11/2025

PROJECT MANAGER
Dan I.

DESIGNER:
Jake P.

REVISION DATE:

REVISION BY:

ALL IDEAS, PLANS, AND ELECTRONIC ART INDICATED ON THIS DRAWING ARE COPYRIGHTED AND OWNED BY FUSION SIGN AND DESIGN AND SHALL NOT BE REPRODUCED, USED BY OR DISCLOSED TO ANY PERSONS, FIRM OR CORPORATION FOR ANY PURPOSE WHATSOEVER WITHOUT THE WRITTEN PERMISSION OF FUSION SIGN AND DESIGN.

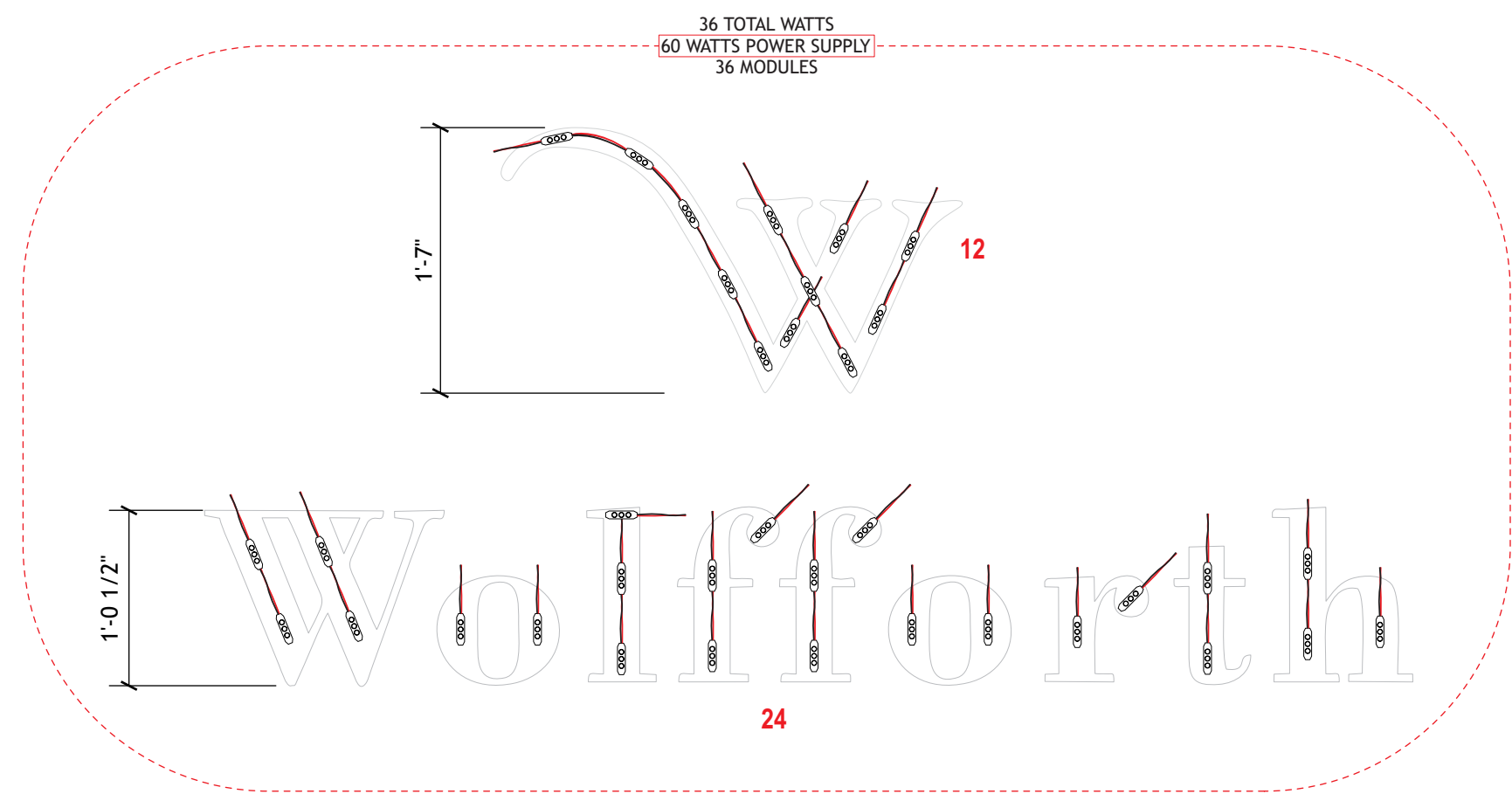

LED DETAIL

QTY: 2
SCALE: 1" = 1'-0"

ELECTRICAL SPECIFICATIONS:
(36) WHITE LED MODULES @ 1W EA= 36.W TOTAL
(1) 12V 60W POWER SUPPLIES @ 1.2 AMPS EA.
(1) CUSTOMER PROVIDED 120V/20A/60HZ DEDICATED CIRCUIT REQUIRED
**TOTAL CIRCUIT LOAD:
1.2 AMPS @ 120 VAC**

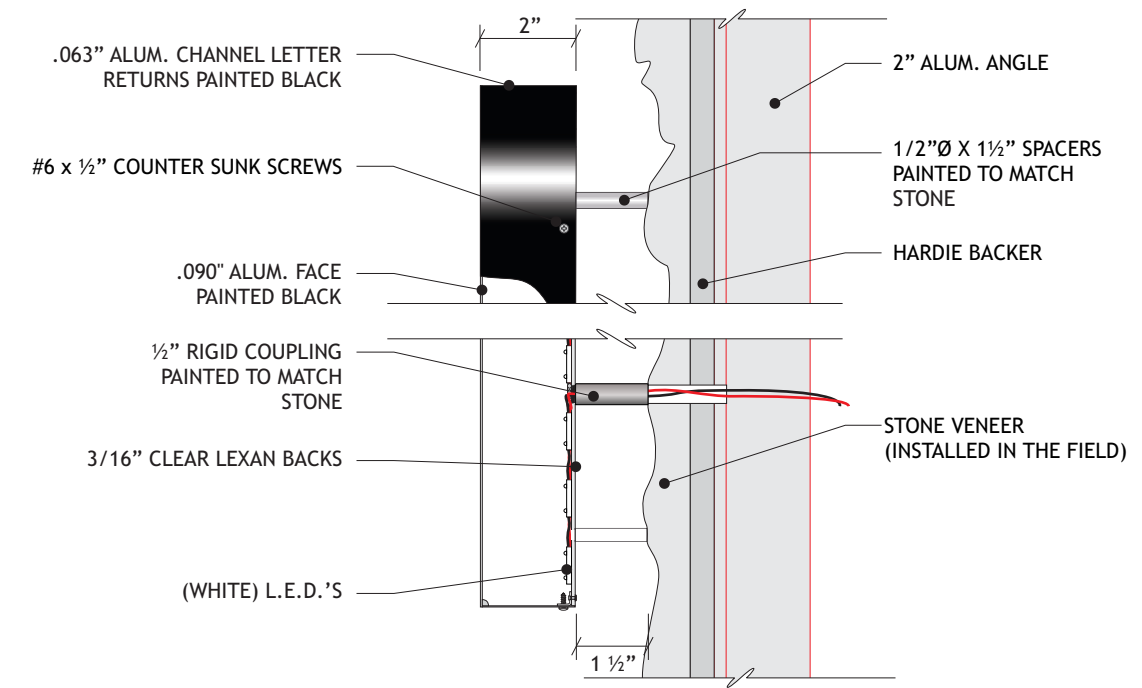

SECTION DETAIL (REVERSE HALO LIT CHANNEL LETTERS)

Scale: 3/8" = 1'-0"



AGENDA ITEM COMMENTARY

MEETING NAME:	City Council
MEETING DATE:	December 1, 2025
ITEM TITLE:	Consider and take appropriate action on presentation of recommendations from Traffic Impact Analysis for the United development
STAFF INITIATOR:	Randy Criswell, City Manager

BACKGROUND:

The Traffic Impact Analysis for the United development has been completed by Kimley Horn, has been reviewed by staff, provided to the United development team, and discussed with the United development team. I've included the first few pages of the report so you can see how detailed it is, and the "Conclusions and Recommendations" page from the report. I previously emailed everyone a link to the full report.

The report is based on two phases of development. The first phase is the United store and a small amount of adjacent construction, and phase two is the remainder. The recommendations of the Analysis are:

Phase 1:

- a. Construct a dedicated right turn lane at Drive 4 by 2027
- b. Install a dedicated WB acceleration lane on MSF frontage road from Alcove to the south
- c. Relocate Drive 4 to avoid left-turn conflicts – move drive to the east

Phase 2:

- a. Construct a dedicated NB right-turn lane at Drive 3 by 2032
- b. Install a WB right-turn lane at Cambridge with traffic signal head modifications
- c. Add capacity to Donald Preston Drive at MSF by adding lanes
- d. Add traffic signal to one of the drive intersections on Cambridge to funnel traffic to a main entrance and alleviate delay

After discussing these findings with the United team, they are supportive of Phase 1, recommendation c., relocating Drive 4, which was one of their original proposed changes. At this point they have not agreed to participate in the cost of any of the other recommendations. They are aware of tonight's discussion.

EXHIBITS:

Excerpts from the TIA

COUNCIL ACTION/STAFF RECOMMENDATION:

Authorize the City Manager to negotiate and execute agreements to construct monument signs at City Hall and the Library, up to \$250,000.

 **Traffic Impact Analysis**

United Supermarket and Retail Development
Wolfforth, Texas

Kimley-Horn and Associates, Inc.
Richardson, Texas

Project #066079915
Registered Firm F-928

Kimley»Horn

Traffic Impact Analysis

United Supermarket and Retail Development Wolfforth, Texas

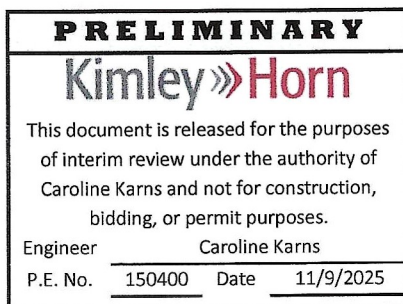

Prepared by:

Kimley-Horn and Associates, Inc.
2600 North Central Expressway, Suite 400
Richardson, Texas 75080
Registered Firm F-928
Project Number: 066079915

Contact:

Caroline Karns, P.E., RSP
214-617-0535
November 10, 2025

TABLE OF CONTENTS

- EXECUTIVE SUMMARY iii
- I. INTRODUCTION..... 1
 - A. PURPOSE 1
 - B. METHODOLOGY 1
 - C. ROADWAY CHARACTERISTICS..... 1
 - D. EXISTING STUDY AREA..... 1
 - E. PROPOSED SITE IMPROVEMENTS..... 2
 - F. EXISTING TRAFFIC VOLUMES..... 3
- II. PROJECT TRAFFIC CHARACTERISTICS 8
 - A. SITE-GENERATED TRAFFIC..... 8
 - B. TRIP DISTRIBUTION AND ASSIGNMENT..... 9
 - C. OTHER DEVELOPMENT TRAFFIC MODELING..... 9
 - D. DEVELOPMENT OF BACKGROUND AND TOTAL TRAFFIC..... 10
- III. TRAFFIC OPERATIONS ANALYSIS..... 23
 - A. ANALYSIS METHODOLOGY 23
 - B. ANALYSIS RESULTS..... 23
 - C. 2025 EXISTING TRAFFIC OPERATIONS 26
 - D. 2027 BACKGROUND TRAFFIC OPERATIONS..... 26
 - E. 2027 BACKGROUND PLUS SITE-GENERATED TRAFFIC OPERATIONS..... 26
 - F. 2032 BACKGROUND TRAFFIC OPERATIONS..... 27
 - G. 2032 BACKGROUND PLUS SITE-GENERATED TRAFFIC OPERATIONS..... 27
 - H. RIGHT-TURN LANE ANALYSIS 29
- IV. CONCLUSIONS AND RECOMMENDATIONS..... 30
- APPENDIX A 31
 - ROADWAY CHARACTERISTICS 31
- APPENDIX B 33
 - ANALYSIS METHODOLOGY 33
- APPENDIX C 34
 - TRAFFIC COUNTS AND HISTORICAL DATA 34
- APPENDIX D 35
 - SYNCHRO™ OUTPUT – 2025 EXISTING TRAFFIC..... 35
- APPENDIX E 36
 - SYNCHRO™ OUTPUT – 2027 BACKGROUND TRAFFIC 36
- APPENDIX F 37
 - SYNCHRO™ OUTPUT – 2027 BACKGROUND PLUS SITE TRAFFIC..... 37
- APPENDIX G 38
 - SYNCHRO™ OUTPUT – 2032 BACKGROUND TRAFFIC 38
- APPENDIX H 39
 - SYNCHRO™ OUTPUT – 2032 BACKGROUND PLUS SITE TRAFFIC..... 39
- APPENDIX I 40
 - PASS-BY DISTRIBUTION AND VOLUMES EXHIBITS..... 40

LIST OF TABLES

TABLE 1 – TRIP GENERATION (PHASE 1)8

TABLE 2 – TRIP GENERATION (PHASE 2)8

TABLE 3 – TRIP GENERATION: BACKGROUND DEVELOPMENT (IRON HORSE)9

TABLE 4 – TRIP GENERATION: BACKGROUND DEVELOPMENT (THE SOLID WASTE FACILITY)9

TABLE 5 – DEVELOPMENT SCENARIO INCLUDED TRAFFIC10

TABLE 6 – TRAFFIC OPERATIONAL RESULTS – WEEKDAY AM PEAK HOUR24

TABLE 7 – TRAFFIC OPERATIONAL RESULTS – WEEKDAY PM PEAK HOUR25

TABLE 8 – RIGHT-TURN LANE ANALYSIS29

TABLE 9 – LEVEL OF SERVICE DEFINITIONS33

LIST OF EXHIBITS

EXHIBIT 1: VICINITY MAP4

EXHIBIT 2: CONCEPTUAL SITE PLAN5

EXHIBIT 3: LANE ASSIGNMENTS AND INTERSECTION CONTROL6

EXHIBIT 4: 2025 EXISTING TRAFFIC VOLUMES7

EXHIBIT 5: TRIP DISTRIBUTION AND TRAFFIC ASSIGNMENT – PHASE 111

EXHIBIT 6: SITE-GENERATED TRAFFIC VOLUMES – PHASE 112

EXHIBIT 7: TRIP DISTRIBUTION AND TRAFFIC ASSIGNMENT – PHASE 213

EXHIBIT 8: SITE-GENERATED TRAFFIC VOLUMES – PHASE 214

EXHIBIT 9: 2027 BACKGROUND TRAFFIC VOLUMES15

EXHIBIT 10: 2027 BACKGROUND PLUS-SITE GENERATED TRAFFIC VOLUMES16

EXHIBIT 11: 2032 BACKGROUND TRAFFIC VOLUMES17

EXHIBIT 12: 2032 BACKGROUND PLUS-SITE GENERATED TRAFFIC VOLUMES18

EXHIBIT 13: TRIP DISTRIBUTION AND TRAFFIC ASSIGNMENT – IRON HORSE19

EXHIBIT 14: SITE-GENERATED TRAFFIC VOLUMES – IRON HORSE20

EXHIBIT 15: TRIP DISTRIBUTION AND TRAFFIC ASSIGNMENT – THE SOLID WASTE FACILITY21

EXHIBIT 16: SITE-GENERATED TRAFFIC VOLUMES – THE SOLID WASTE FACILITY22

EXECUTIVE SUMMARY

The proposed United Supermarket and Retail development is located between Cambridge Drive and Alcove Avenue along the northern side of Donald Preston Drive and US 62 in Wolfforth, Texas. Phase 1 of the site is proposed to be a 90,477 SF shopping center with grocery store. Phase 2 of the site is assumed to be built as 200,000 SF of shopping center retail uses. This study is intended to identify traffic generation characteristics, identify potential traffic related impacts on the local street system, and develop mitigation measures recommended for identified impacts.

The following existing intersections were selected to be part of this study:

- Donald Preston Drive at US 62 SBFR
- Donald Preston Drive at US 62 NBFR
- Donald Preston Drive at Cambridge Drive
- Donald Preston Drive at Alcove Avenue
- Alcove Avenue at US 62 SBFR

The analysis also includes the following driveways providing access for the site, all of which provide cross-access among Phases 1 and 2:

- Drive 1, which is a full-access driveway to Cambridge Drive and will be built with Phase 1.
- Drive 2, which is a full-access driveway to Cambridge Drive and will be built with Phase 1.
- Drive 3, which is an existing full-access driveway to Cambridge Drive.
- Drive 4, which is an existing full-access driveway to Donald Preston Drive and will be relocated with Phase 1.
- Drive 5, which is a full-access driveway to Alcove Avenue and will be built with Phase 2.

Traffic operations were analyzed at the study intersections for 2025 existing volumes, 2027 and 2032 background traffic volumes, and 2027 and 2032 background plus site-generated traffic volumes. The future years correspond to the expected buildout year of the Phase 1 and Phase 2, respectively. Conditions were analyzed for the weekday AM and PM peak hours. The background traffic conditions include existing traffic with compound growth rates, plus explicit modeling of the following developments in the vicinity:

- Iron Horse Single Family Residential site – a development consisting of approximately 195 single family units to the north of the proposed United Supermarket and Retail site. The site is expected to be fully built out by 2028.
- City of Lubbock Solid Waste Facility – a development of approximately 147,906 SF to the east of Alcove Avenue. The site is expected to be fully build out by 2027.

Phase 1 of the United Supermarket and Retail development is expected to generate approximately 320 new weekday AM peak hour one-way vehicle trips and 621 new weekday

PM peak hour one-way vehicle trips at buildout. Phase 2 is expected to generate an additional 255 new weekday AM peak hour one-way vehicle trips and 668 new weekday PM peak hour one-way vehicle trips at buildout. The distribution of the site-generated traffic volumes onto the street system was based on the surrounding roadway network, existing traffic patterns, and the project's proposed access locations.

The following improvements are recommended at proposed driveways.

- (Phase 1) Construct a dedicated westbound right-turn lane at Drive 4 by 2027.
- (Phase 2) Construct a dedicated northbound right-turn lane at Drive 3 by 2032.
- Relocate or modify the proposed configuration of Drive 4 along Donald Preston Drive to avoid left-turn path overlap safety concerns. See **Appendix J** for alternatives.

In Phase 1, the following additional improvements to the external roadway network are recommended.

- US 62 SBFR & Alcove Ave:
 - Heavy southbound delay is expected from vehicles exiting the site.
 - It is recommended to install a dedicated westbound acceleration lane to serve southbound right-turning traffic. This would allow vehicles to turn onto the frontage road without waiting for a gap.

In Phase 2, the following additional improvements to the external roadway network are recommended.

- Donald Preston Drive & Cambridge Drive:
 - Heavy westbound, northbound, and southbound delay is expected at this intersection with the addition of site traffic.
 - It is recommended to install a westbound right-turn lane and a corresponding right-turn overlap head to accommodate the added traffic and reduce delay at the intersection.
- Donald Preston Road & US 62 Frontage Roads:
 - Heavy eastbound and westbound delay is expected at the intersections with the US 62 frontage roads.
 - Signal timing adjustments are not expected to relieve the excessive delay on their own.
 - To mitigate delay, capacity would need to be added to the Donald Preston Road approaches through the addition of eastbound and westbound through lanes.
- Drives 1, 2, and 3:
 - With the addition of Phase 2 traffic, these driveways are expected to have excessive westbound (exiting) delay.
 - A signal is recommended at one of these intersections to funnel traffic to a main entrance and alleviate delay.

I. INTRODUCTION

A. Purpose

Kimley-Horn was retained to conduct a Traffic Impact Analysis (TIA) of future traffic conditions associated with the development of the United Supermarket and Retail site located between Cambridge Drive and Alcove Avenue along the northern side of Donald Preston Drive. A site vicinity map is provided as **Exhibit 1**. **Exhibit 2** shows the proposed conceptual site plan. This study is intended to identify traffic generation characteristics, identify potential traffic related impacts on the local street system, and develop mitigation measures required for identified impacts.

B. Methodology

Traffic operations were analyzed at the study intersections for AM and PM peak hours for the following scenarios:

- 2025 existing traffic
- 2027 background traffic
- 2027 background plus site traffic
- 2032 background traffic
- 2032 background plus site traffic

The capacity analyses were conducted using the *Synchro*[™] software package and its associated *Intersection* reports for signalized intersections and *Highway Capacity Manual* reports for unsignalized intersections.

C. Roadway Characteristics

The following signalized intersections were evaluated as part of this study:

- Donald Preston Drive at US 62 SBFR
- Donald Preston Drive at US 62 NBFR
- Donald Preston Drive at Cambridge Drive

The following unsignalized intersection was evaluated as part of this study:

- US 62 SBFR at Alcove Avenue

The major study area roadways are described in **Appendix A**. **Exhibit 3** illustrates the intersection geometry used for the traffic analysis.

D. Existing Study Area

The property is zoned in a C-2 General Commercial District. The property has an existing United Gas Station store on the southwest corner of the lot.

E. Proposed Site Improvements

The proposed development includes two phases. Phase 1 of the site is proposed to be a 90,477 SF shopping center with grocery store. Phase 2 of the site has not yet been designed but is expected to be a mix of commercial land uses. To be conservative, it is assumed that the remainder of the site be developed as general retail. A Floor Area Ratio (FAR) of 0.15 was used to estimate the density of retail. Therefore, it is assumed that Phase 2 is proposed to be built with 200,000 SF of shopping center retail uses. Phase 1 is assumed to be built out by 2027 while Phase 2 is assumed to be built out by 2032.

As shown in **Exhibit 3**, the site has five proposed driveways. All driveways will provide cross-access among Phases 1 and 2. The driveways to be modeled in this analysis are as follows:

Drive 1

- Full-Access to Cambridge Drive
- North of West Drive 2, south of 2nd street
- One inbound, one outbound lane
- Built in Phase 1

Drive 2

- Full-Access to Cambridge Drive
- South of West Drive 1, North of West Drive 3
- One inbound, one outbound lane
- Built in Phase 1

Drive 3

- Full-Access to Cambridge Drive
- South of West Drive 2, existing drive for United Gas Station
- One inbound, one outbound lane
- Built in Phase 1

Drive 4

- Full-Access to Donald Preston Drive
- East of Cambridge Drive, existing drive for United Gas Station
- One inbound, one outbound lane
- Closed in Phase 1

Drive 4 (Relocated)

- Full-Access to Donald Preston Drive
- East of Cambridge Drive and east of existing Drive 4 location
- One inbound, one outbound lane
- Built in Phase 1

Drive 5

- Full-Access to Alcove Avenue
- North of US 62 SBFR
- One inbound, one outbound lane
- Built in Phase 2

Intersection sight distance at the proposed driveways is acceptable, with each on relatively flat and straight segments of their respective roadway.

F. Existing Traffic Volumes

Traffic data was collected on Tuesday September 9, 2025. **Exhibit 4** shows the existing weekday AM and PM peak hour traffic volumes. 24-hour machine counts were collected near the site on Donald Preston Drive and Alcove Avenue. The raw count sheets, as well as a comparison between the 24-hour volumes collected and previous 24-hour counts, are provided in **Appendix C**.

The 24-hour count shows the daily volume on the roadway links as follows:

- Donald Preston Drive: 20,468 vehicles per day
- Alcove Avenue: 4,183 vehicles per day

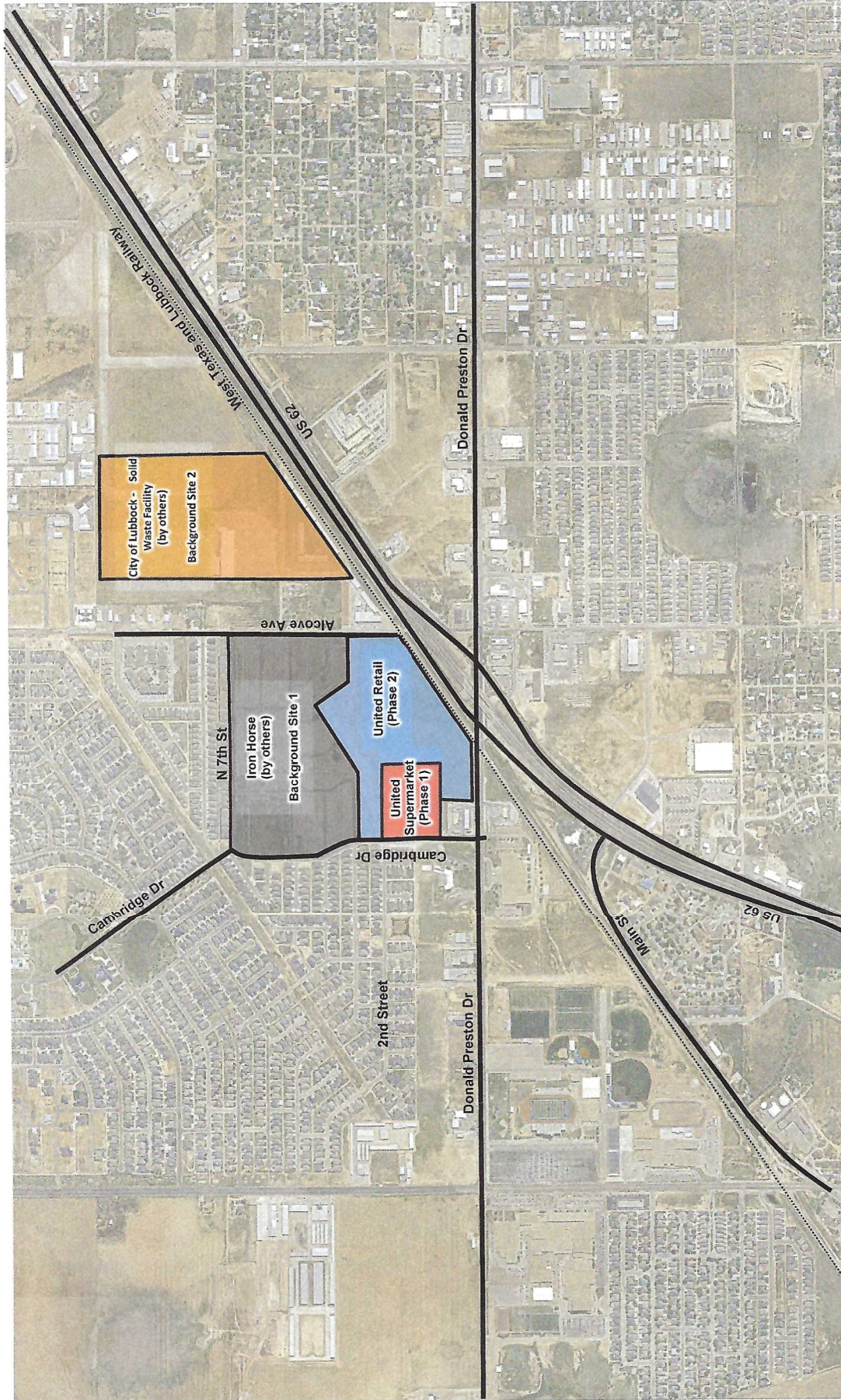

North
 ↑
 Not To Scale

EXHIBIT 1

Vicinity Map
 United United Supermarket and Retail - Wolfforth, Texas



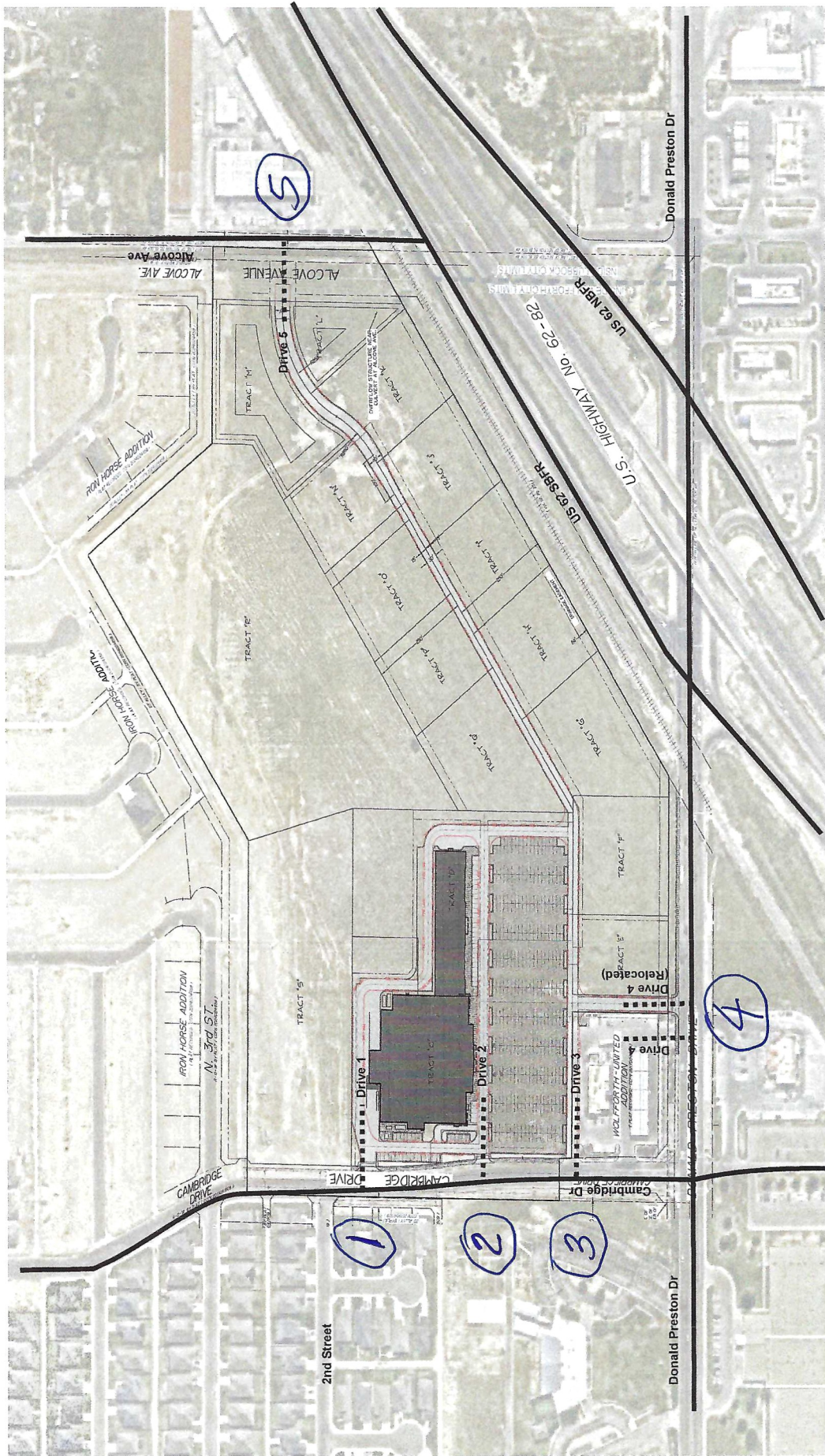

North
 ↑
 Not To Scale

EXHIBIT 2
 Conceptual Site Plan
 United Supermarket and Retail - Wolfforth, Texas
Kimley»Horn

IV. CONCLUSIONS AND RECOMMENDATIONS

Based on the analysis presented in this report, the proposed United Supermarket and Retail development, located between Cambridge Drive and Alcove Avenue along the southern side of Donald Preston Drive in Wolfforth, Texas, can be successfully incorporated into the surrounding roadway network with mitigations. The proposed site driveways provide the appropriate level of access going into the development but may pose challenges going out of the development due to the high traffic volumes.

The following improvements are recommended at proposed driveways.

- (Phase 1) Construct a dedicated westbound right-turn lane at Drive 4 by 2027.
- (Phase 2) Construct a dedicated northbound right-turn lane at Drive 3 by 2032.
- Relocate or modify the proposed configuration of Drive 4 along Donald Preston Drive to avoid left-turn path overlap safety concerns. See **Appendix J** for alternatives.

In Phase 1, the following additional improvements to the external roadway network are recommended.

- US 62 SBFR & Alcove Ave:
 - Heavy southbound delay is expected from vehicles exiting the site.
 - It is recommended to install a dedicated westbound acceleration lane to serve southbound right-turning traffic. This would allow vehicles to turn onto the frontage road without waiting for a gap.

In Phase 2, the following additional improvements to the external roadway network are recommended.

- Donald Preston Drive & Cambridge Drive:
 - Heavy westbound, northbound, and southbound delay is expected at this intersection with the addition of site traffic.
 - It is recommended to install a westbound right-turn lane and a corresponding right-turn overlap head to accommodate the added traffic and reduce delay at the intersection.
- Donald Preston Road & US 62 Frontage Roads:
 - Heavy eastbound and westbound delay is expected at the intersections with the US 62 frontage roads.
 - Signal timing adjustments are not expected to relieve the excessive delay on their own.
 - To mitigate delay, capacity would need to be added to the Donald Preston Road approaches through the addition of eastbound and westbound through lanes.
- Drives 1, 2, and 3:
 - With the addition of Phase 2 traffic, these driveways are expected to have excessive westbound (exiting) delay.
 - A signal is recommended at one of these intersections to funnel traffic to a main entrance and alleviate delay.



AGENDA ITEM COMMENTARY

MEETING NAME: City Council
MEETING DATE: December 1, 2025
ITEM TITLE: Consider and take appropriate action on Capital Improvements Plan progress update from City Manager
STAFF INITIATOR: Randy Criswell, City Manager

BACKGROUND:

It's been nearly two years since we started on Phase 1 of our Water Capital Improvements Plan, and I wanted to provide an update with a little more detail than what you see monthly. I've prepared a slide show I hope you'll enjoy.

EXHIBITS:

COUNCIL ACTION/STAFF RECOMMENDATION:

Report only, no action.



AGENDA ITEM COMMENTARY

MEETING NAME: City Council
MEETING DATE: December 1, 2025
ITEM TITLE: Consider and take appropriate action on 2026 City Council Calendar
STAFF INITIATOR: Terri Robinette, City Secretary

BACKGROUND:

The New Year is just around the corner and our regular City Council meetings will fall on City holidays in both January and February. We would like some discussion by Council as to the replacement or cancellation of the City Council meetings on January 19 (MLK Day) and February 16 (Presidents Day)

EXHIBITS:

- 2026 City Holiday Calendar
- January and February 2026 Calendars

COUNCIL ACTION/STAFF RECOMMENDATION:

2026

IMPORTANT DATES

JANUARY

SUN	MON	TUE	WED	THU	FRI	SAT
				1	2	3
4	5	6	7	8	9	10
11	12	13	14	15	16	17
18	19	20	21	22	23	24
25	26	27	28	29	30	31

FEBRUARY

SUN	MON	TUE	WED	THU	FRI	SAT
1	2	3	4	5	6	7
8	9	10	11	12	13	14
15	16	17	18	19	20	21
22	23	24	25	26	27	28

MARCH

SUN	MON	TUE	WED	THU	FRI	SAT
1	2	3	4	5	6	7
8	9	10	11	12	13	14
15	16	17	18	19	20	21
22	23	24	25	26	27	28
29	30	31				

APRIL

SUN	MON	TUE	WED	THU	FRI	SAT
			1	2	3	4
5	6	7	8	9	10	11
12	13	14	15	16	17	18
19	20	21	22	23	24	25
26	27	28	29	30		

MAY

SUN	MON	TUE	WED	THU	FRI	SAT
					1	2
3	4	5	6	7	8	9
10	11	12	13	14	15	16
17	18	19	20	21	22	23
24	25	26	27	28	29	30
31						

JUNE

SUN	MON	TUE	WED	THU	FRI	SAT
	1	2	3	4	5	6
7	8	9	10	11	12	13
14	15	16	17	18	19	20
21	22	23	24	25	26	27
28	29	30				

JULY

SUN	MON	TUE	WED	THU	FRI	SAT
			1	2	3	4
5	6	7	8	9	10	11
12	13	14	15	16	17	18
19	20	21	22	23	24	25
26	27	28	29	30	31	

AUGUST

SUN	MON	TUE	WED	THU	FRI	SAT
						1
2	3	4	5	6	7	8
9	10	11	12	13	14	15
16	17	18	19	20	21	22
23	24	25	26	27	28	29
30	31					

SEPTEMBER

SUN	MON	TUE	WED	THU	FRI	SAT
		1	2	3	4	5
6	7	8	9	10	11	12
13	14	15	16	17	18	19
20	21	22	23	24	25	26
27	28	29	30			

OCTOBER

SUN	MON	TUE	WED	THU	FRI	SAT
				1	2	3
4	5	6	7	8	9	10
11	12	13	14	15	16	17
18	19	20	21	22	23	24
25	26	27	28	29	30	31

NOVEMBER

SUN	MON	TUE	WED	THU	FRI	SAT
1	2	3	4	5	6	7
8	9	10	11	12	13	14
15	16	17	18	19	20	21
22	23	24	25	26	27	28
29	30					

DECEMBER

SUN	MON	TUE	WED	THU	FRI	SAT
		1	2	3	4	5
6	7	8	9	10	11	12
13	14	15	16	17	18	19
20	21	22	23	24	25	26
27	28	29	30	31		

JANUARY 1

New Year's Day

January 19

Martin Luther King Jr. Day

February 16

Presidents Day

April 3

Good Friday

May 25

Memorial Day

June 19

Juneteenth

July 3

Independence Day (Observed)

September 7

Labor Day

October 12

Columbus Day

November 11

Veterans Day Observed

November 26-27

Thanksgiving Observed

December 24

Christmas Eve Observed

December 25

Christmas Day

Key:

14 City Holidays

January 2026

Item # 11.

Sun	Mon	Tue	Wed	Thu	Fri	Sat
				1 New Year's Day - City Offices Closed	2	3
4	5 City Council Meeting 6PM	6 EDC Meeting - 11:30AM	7	8	9	10
11	12	13 Planning & Zoning 5:30PM	14	15	16	17
18	19 Martin Luther King Day - City Offices Closed	20	21	22	23	24
25	26	27	28	29	30	31

February 2026

Item # 11.

Sun	Mon	Tue	Wed	Thu	Fri	Sat
1	Groundhogs Day City Council Meeting - 6PM	2	EDC Meeting - 11:30AM	3	4	5
6	7	8	9	Planning & Zoning - 5:30PM	10	11
12	13	14	Valentine's Day	15	16	17
18	Presidents' Day - City Offices Closed	19	20	21	22	23
24	25	26	27	28	29	30