



DEVELOPMENT REVIEW BOARD PANEL A AGENDA

March 11, 2024 at 6:30 PM

Wilsonville City Hall & Remote Video Conferencing

PARTICIPANTS MAY ATTEND THE MEETING AT:

City Hall, 29799 SW Town Center Loop East, Wilsonville, Oregon

Zoom: <https://us02web.zoom.us/j/85843043229>

TO PROVIDE PUBLIC TESTIMONY:

Individuals must submit a testimony card online:

<https://www.ci.wilsonville.or.us/DRB-SpeakerCard>

and email testimony regarding Resolution No. 422

to Georgia McAlister, Associate Planner at

gmcalister@ci.wilsonville.or.us

by 2:00 PM on March 11, 2024.

Email testimony regarding Resolution No. 430

to Sarah Pearlman, Assistant Planner at

spearlman@ci.wilsonville.or.us

by 2:00 PM on March 11, 2024.

CALL TO ORDER

CHAIR'S REMARKS

ROLL CALL

Yara Alatawy Rob Candrian
Jordan Herron Clark Hildum
Jean Svadlenka

CITIZEN INPUT

This is an opportunity for visitors to address the Development Review Board on items not on the agenda. Staff and the Board will make every effort to respond to questions raised during citizens input before tonight's meeting ends or as quickly as possible thereafter.

CONSENT AGENDA

1. [Approval of minutes of the February 12, 2024 DRB Panel A meeting](#)

PUBLIC HEARINGS

2. [Resolution No. 422. ParkWorks Industrial Building and Partition.](#) The applicant is [requesting approval of a Stage I Preliminary Plan, Stage 2 Final Plan, Site Design Review, Type C Tree Removal Plan and Tentative Partition Plat for development of an industrial spec building with accessory office space and associated road and site improvements at 26600 SW Parkway Avenue.](#)

Case Files:

[DB22-0009 ParkWorks Industrial Building and Partition](#)

[-Stage 1 Preliminary Plan \(STG122-0007\)](#)

[-Stage 2 Final Plan \(STG222-0009\)](#)

[-Site Design Review \(SDR22-0009\)](#)

[-Type C Tree Removal Plan \(TPLN22-0007\)](#)

[-Tentative Partition Plat \(PART22-0002\)](#)

[***This item was continued to this date certain at the February 12, 2024 DRB Panel A meeting.***](#)

3. [Resolution No. 430. Boeckman Creek Primary School Readerboard.](#) The applicant is [requesting approval of a Class 3 Sign Permit and Waiver for a new electronic reader board sign at Boeckman Creek Primary School.](#)

Case Files:

[DB23-0009 Boeckman Creek Primary School Reader Board](#)

[-Class 3 Sign Permit \(SIGN23-0009\)](#)

[-Waiver \(WAIV23-0002\)](#)

BOARD MEMBER COMMUNICATIONS

4. [Results of the February 26, 2024 DRB Panel B meeting](#)
5. [Recent City Council Action Minutes](#)

STAFF COMMUNICATIONS

ADJOURN

The City will endeavor to provide the following services, without cost, if requested at least 48 hours prior to the meeting by contacting Shelley White, Administrative Assistant at 503-682-4960: assistive listening devices (ALD), sign language interpreter, and/or bilingual interpreter. Those who need accessibility assistance can contact the City by phone through the Federal Information Relay Service at 1-800-877-8339 for TTY/Voice communication.

Habr  interpretes disponibles para aqu llas personas que no hablan Ingl s, previo acuerdo. Comun quese al 503-682-4960.

DEVELOPMENT REVIEW BOARD MEETING
MARCH 11, 2024
6:30 PM

Item 1.

Consent Agenda:

1. Approval of minutes of the February 12, 2024 DRB
Panel A meeting



**DEVELOPMENT REVIEW BOARD PANEL A
MEETING MINUTES**

February 12, 2024 at 6:30 PM

Wilsonville City Hall & Remote Video Conferencing

CALL TO ORDER

A regular meeting of the Development Review Board Panel A was held at City Hall beginning at 6:30 p.m. on Monday, February 12, 2024. Chair Jean Svadlenka called the meeting to order at 6:30 p.m.

CHAIR'S REMARKS

The Conduct of Hearing and Statement of Public Notice were read into the record.

ROLL CALL

Present for roll call were: Jean Svadlenka, Rob Candrian, Yara Alatawy, and Jordan Herron. Clark Hildum was absent.

Staff present: Daniel Pauly, Stephanie Davidson, Amanda Guile-Hinman, and Shelley White

CITIZENS INPUT – This is an opportunity for visitors to address the Development Review Board on items not on the agenda. There were no comments.

Chair Svadlenka motioned to amend the agenda to move the Chair and Vice-Chair elections to the end of the agenda. Jordan Herron seconded the motion, which passed unanimously.

The Board proceeded to the Consent Agenda at this time.

CONSENT AGENDA

3. Approval of Minutes of the December 11, 2023 DRB Panel A meeting

Jordan Herron moved to approve the December 11, 2023 DRB Panel A meeting minutes as presented. Rob Candrian seconded the motion, which passed unanimously.

4. Approval of Minutes of the January 8, 2024 DRB Panel A meeting

Rob Candrian moved to approve the January 8, 2024 DRB Panel A meeting minutes as presented. Jordan Herron seconded the motion, which passed unanimously.

PUBLIC HEARINGS

5. **Resolution No. 422. ParkWorks Industrial Building and Partition.** The applicant is requesting approval of a Stage I Preliminary Plan, Stage 2 Final Plan, Site Design Review, Type C Tree Removal Plan and Tentative Partition Plat for development of an industrial spec building with accessory office space and associated road and site improvements at 26600 SW Parkway Avenue.

Case Files:

DB22-0009 ParkWorks Industrial Building and Partition
 -Stage 1 Preliminary Plan (STG122-0007)
 -Stage 2 Final Plan (STG222-0009)
 -Site Design Review (SDR22-0009)
 -Type C Tree Removal Plan (TPLN22-0007)
 -Tentative Partition Plat (PART22-0002)

This item was continued to this date certain at the January 8, 2024 DRB Panel A meeting.

The applicant has requested a continuance to the March 11, 2024 DRB Panel A meeting.

Chair Svadlenka called the public hearing to order at 6:37 pm.

Chair Svadlenka moved to continue the public hearing on Resolution No. 422 to a date certain of March 11, 2024. Jordan Herron seconded the motion, which passed 4 to 0.

Stephanie Davidson, Assistant City Attorney, noted for the record that the March 11th DRB Panel A meeting would be held at 6:30 pm.

BOARD MEMBER COMMUNICATIONS:

6. Results of the January 22, 2024 DRB Panel B meeting
7. Recent City Council Action Minutes

There were no comments.

STAFF COMMUNICATIONS

There were no comments.

The Board returned to the Election of 2024 Chair and Vice-Chair at this time.

ELECTION OF 2024 CHAIR AND VICE-CHAIR

Stephanie Davidson, Assistant City Attorney, reviewed the rules for nominating and electing the Chair and Vice-Chair.

1. Chair

Jordan Herron nominated Jean Svadlenka for 2024 Development Review Board Chair.

Jean Svadlenka nominated Clark Hildum for 2024 Development Review Board Chair.

Following a roll call vote, Jean Svadlenka was elected 2024 Development Review Board Chair by a 3 to 1 vote.

2. Vice-Chair

Rob Candrian volunteered for the Vice-Chair position.

Jordan Herron nominated Rob Candrian for 2024 Development Review Board Chair.

Following a roll call vote, Rob Candrian was elected 2024 Development Review Board Vice-Chair by a 4 to 0 vote.

ADJOURN

The meeting adjourned at 6:44 p.m.

Respectfully submitted,

Paula Pinyerd, ABC Transcription Services, LLC. for
Shelley White, Planning Administrative Assistant

Public Hearing:

- 2. Resolution No. 422. ParkWorks Industrial Building and Partition.** The applicant is requesting approval of a Stage I Preliminary Plan, Stage 2 Final Plan, Site Design Review, Type C Tree Removal Plan and Tentative Partition Plat for development of an industrial spec building with accessory office space and associated road and site improvements at 26600 SW Parkway Avenue.

Case Files:

- DB22-0009 ParkWorks Industrial Building and Partition
- Stage 1 Preliminary Plan (STG122-0007)
- Stage 2 Final Plan (STG222-0009)
- Site Design Review (SDR22-0009)
- Type C Tree Removal Plan (TPLN22-0007)
- Tentative Partition Plat (PART22-0002)

This item was continued to this date certain at the February 12, 2024 DRB Panel A meeting

**DEVELOPMENT REVIEW BOARD
RESOLUTION NO. 422**

A RESOLUTION ADOPTING FINDINGS AND CONDITIONS OF APPROVAL, APPROVING WITH CONDITIONS A STAGE 1 PRELIMINARY PLAN, STAGE 2 FINAL PLAN, SITE DESIGN REVIEW, TYPE C TREE REMOVAL PLAN, AND TENTATIVE PARTITION PLAT REVIEW FOR DEVELOPMENT OF AN INDUSTRIAL SPEC BUILDING WITH ACCESSORY OFFICE SPACE AND ASSOCIATED ROAD AND SITE IMPROVEMENTS AT 26600 SW PARKWAY AVENUE.

WHEREAS, an application, together with planning exhibits for the above-captioned development, has been submitted by John Olivier with ScanlanKemperBard (SKB), Applicant, in accordance with the procedures set forth in Section 4.008 of the Wilsonville Code, and

WHEREAS, the subject site is located at 26600 SW Parkway Avenue, Taxlot 00511, Section 12, Township 3 South, Range 1 West, Willamette Meridian, Clackamas County, Oregon, and

WHEREAS, the Planning Staff has prepared the staff report on the above-captioned subject dated December 4, 2023, and

WHEREAS, on December 11, 2023, the Development Review Board opened the public hearing and after hearing from staff, the applicant, and other parties continued the public hearing to a date certain of January 8, 2024, and

WHEREAS, on January 8, 2024, the Development Review Board continued the public hearing to a date certain of February 12, 2024, and

WHEREAS, on February 12, 2024, the Development Review Board continued the public hearing to a date certain of March 11, 2024, and

WHEREAS, the Planning Staff as prepared an amended staff report on the above captioned subject dated March 4, 2024, and

WHEREAS, said planning exhibits and staff report were duly considered by the Development Review Board Panel A at scheduled meetings conducted on December 11, 2023 and March 11, 2024, at which time exhibits, together with findings and public testimony were entered into the public record, and

WHEREAS, the Development Review Board considered the subject and the recommendations contained in the staff report, and

WHEREAS, interested parties, if any, have had an opportunity to be heard on the subject.

NOW, THEREFORE, BE IT RESOLVED that the Development Review Board of the City of Wilsonville does hereby adopt the staff report dated March 4, 2024, as amended, attached hereto as Exhibit A1, with findings and recommendations contained therein, approving the requests with conditions, and authorizes the Planning Director to issue permits consistent with the Development Review Board approval for:

The Parkworks Industrial Spec Development (DB22-0009): Stage 1 Preliminary Plan (STG122-0007), Stage 2 Final Plan (STG222-0009), Site Deigns Review (SDR22-0009), Type C Tree Removal Plan (TPLN22-0007), Tentative Partition Plat Review (PART22-0002).

ADOPTED by the Development Review Board of the City of Wilsonville at a regular meeting thereof this 11th day of March, 2024, and filed with the Planning Administrative Assistant on _____. This resolution is final on the 15th calendar day after the postmarked date of the written notice of decision per *WC Sec 4.022(.09)* unless appealed per *WC Sec 4.022(.02)* or called up for review by the Council in accordance with *WC Sec 4.022(.03)*.

Jean Svedlenka, Chair - Panel A
Wilsonville Development Review Board

Attest:

Shelley White, Planning Administrative Assistant



Exhibit A1
Staff Report
Wilsonville Planning Division
ParkWorks Industrial Building

Development Review Board Panel 'A' Quasi-Judicial Public Hearing
Revised March 4, 2024

Added language ***approve with conditions***
Removed language ~~struck through~~

1st Hearing Date: December 11, 2023

Continued Hearing Date: ***March 11, 2024***

Date of Report: December 4, 2023

Date of Revised Report: ***March 4, 2024***

Application No.: DB22-0009 SKB Parkworks Industrial Spec Building

Request/Summary: The requests before the Development Review Board include a Stage 1 Preliminary Plan, Stage 2 Final Plan, Site Design Review, Type C Tree Plan, and Tentative Partition Plat.

Location: Tax Lot 00511, Section 12, Township 3 South, Range 1 West, Willamette Meridian, Clackamas County, Oregon

Owner/Applicant: SKB-Parkworks LLC (John Olivier)

Authorized Representative: Desmond Amper (LRS Architects)

Comprehensive Plan Designation: Industrial

Zone Map Classification: PDI (Planned Development Industrial)

Staff Reviewers: Georgia McAlister, Associate Planner
Amy Pepper, Development Engineering Manager
Kerry Rappold, Natural Resources Program Manager

Staff Recommendation: **Approve with conditions** the requested Stage 1 Master Plan, Stage 2 Final Plan, Site Design Review, Type C Tree Plan, and Tentative Partition Plat.

Applicable Review Criteria:

<u>Development Code:</u>	
Section 4.001	Definitions
Section 4.008	Application Procedures-In General
Section 4.009	Who May Initiate Application
Section 4.010	How to Apply
Section 4.011	How Applications are Processed
Section 4.014	Burden of Proof
Section 4.031	Authority of the Development Review Board
Subsection 4.035 (.04)	Site Development Permit Application
Subsection 4.035 (.05)	Complete Submittal Requirement
Section 4.110	Zones
Section 4.117	Standards Applying to Industrial Development in All Zones
Section 4.118	Standards Applying to Planned Development Zones
Section 4.135	Planned Development Industrial (PDI) Zone
Section 4.140	Planned Development Regulations
Section 4.154	On-site Pedestrian Access and Circulation
Section 4.155	Parking, Loading, and Bicycle Parking
Section 4.167	Access, Ingress, and Egress
Section 4.171	Protection of Natural Features and Other Resources
Section 4.175	Public Safety and Crime Prevention
Section 4.176	Landscaping, Screening, and Buffering
Section 4.177	Street Improvement Standards
Section 4.179	Mixed Solid Waste and Recycling
Sections 4.199.20 through 4.199.60	Outdoor Lighting
Sections 4.200 through 4.290	Land Divisions
Sections 4.300 through 4.320	Underground Utilities
Sections 4.400 through 4.440 as applicable	Site Design Review
Sections 4.600 through 4.640.20	Tree Preservation and Protection
<u>Other Planning Documents:</u>	
Wilsonville Comprehensive Plan	
Previous Land Use Approvals	
Transportation System Plan	

Vicinity Map:



Background:

ParkWorks (previously known as Parkway Woods) is one of the oldest industrial office parks in the City of Wilsonville. First developed in the 1970s as the site of the Tektronix campus, the site has continued to expand over the years. SKB has continued the development of the site with improvements to the existing tenant spaces and site, with minor site and architectural improvements approved in recent years. This proposal for the partition of the property and addition of a 91,773 square foot industrial warehouse will create an additional opportunity for new industrial development on an undeveloped portion of ParkWorks.

Summary:

Stage 1 Preliminary Plan

The Stage 1 Preliminary Plan proposes a new 91,773 sq ft industrial office and warehouse building, parking and associated improvements for the ParkWorks development. The overall development and layout are consistent with the Planned Development Industrial Zone (PDI).

Stage 2 Final Plan

The Stage 2 Final Plan includes an approximately 91,773 sq ft industrial office and warehouse building. The proposed uses of the development are consistent with the Planned Development Industrial (PDI) Zone. All services are available for the site or will be with conditions of approval. The site includes parking, circulation areas, pedestrian connection, and landscaping meeting or exceeding City standards.

Site Design Review

The applicant used appropriate professional services to design the proposed industrial flex building using quality materials and design. The proposed building has been designed with the existing campus in mind, referencing the color of the bricks through the rust orange accent colors incorporated in the entrances and throughout the façade. The configuration of the site will allow for efficient freight loading and unloading while also creating safe access throughout the parking area for employees and visitors. Landscaping is incorporated throughout the site providing shade, stormwater mitigation and aesthetic value.

Type C Tree Removal Plan

The applicant proposes the removal of nineteen (19) trees on the proposed development site. The tree species on site are a mix of native and non-native trees including Oregon white oak, ponderosa pine, Douglas fir, black pine, red oak, western red cedar, Norway maples, sweet cherry, English Hawthorne and Oregon ash. The trees proposed for removal are not high quality trees and removal is necessary for the development of the site. The applicant proposes replanting 108 new trees on the subject property, which is in excess of the 1:1 mitigation ratio as required by the development code.

Tentative Partition Plat

The proposed tentative plat meets technical platting requirements, demonstrates consistency with the Stage 2 Final Plan, and does not create barriers to the future development of adjacent neighborhoods and sites.

Public Comments and Responses:

No public comments were received during the comment period for the project.

Discussion Points – Verifying Compliance with Standards:

This section provides a discussion of key clear and objective development standards that apply to the proposed applications. The Development Review Board will verify compliance of the proposed applications with these standards. The ability of the proposed applications to meet these standards may be impacted by the Development Review Board's consideration of discretionary review items as noted in the next section of this report.

Traffic

The addition of a new 91,000 square foot industrial building along Parkway Avenue will impact traffic along Parkway Avenue, Printer Parkway and the surrounding area. The Traffic Impact Analysis (see Exhibit A3) performed by the City's traffic consultant, DKS Associates, calculates that the proposed warehouse building will generate 504 new daily trips in relation to the operation of the site including employees and visitors. These new daily trips will result in an increase in use of the surrounding roadways and intersections. Traffic operations at the three intersections studied as part of the traffic impact analysis are shown to continue meeting the LOS D standard. The Transportation System Plan identifies project UU-05 (SW Parkway Avenue Urban Upgrade along the proposed development's frontage, which is not currently constructed to City standards.

The traffic impact analysis and Transportation System Plan identify several existing safety deficiencies adjacent to the proposed development including components of Parkway Avenue, Printer Parkway and the intersections of Printer Parkway/Parkway Avenue and Xerox Drive/Parkway Avenue. This is of high concern for the development as increases in traffic volume are anticipated at the Printer Parkway/Parkway Avenue and Xerox Drive/Parkway Avenue intersections. Parkway Avenue is a freight route with a high speed limit of 45 miles per hour a lack of queuing lanes, and no separation for modes of transportation. All of these factors contribute to the importance of addressing the identified safety deficiencies along Parkway Avenue, specifically the addition of pocket left turn lanes to prevent queuing and reduce risk of accidents.

Development and Associated Transportation Improvements

Transportation and infrastructure improvements roughly proportional to the impact of a development are required within the City of Wilsonville for all new development. The proposed industrial flex building is no different from other new development within the City and thus is required to improve a proportional share of the transportation infrastructure adjacent to the development site in accordance to City Code Section 4.177 and the Transportation System Plan.

The proposed development is adjacent to SW Parkway Avenue and SW Printer Parkway and will take access from both streets. ~~The City has conditioned i~~Improvements **are required** along both Parkway Avenue and SW Printer Parkway in accordance to the data presented in the Traffic Impact Analysis provided by DKS (Exhibit A3) that estimates the new development's impact on

traffic patterns and volume within the City. These improvements include half street improvements to both Parkway Avenue and Printer Parkway for the purpose of upgrading the existing streets to be in compliance with current Public Works Construction Standards and the Transportation System Plan with the applicant qualifying for SDC credits for any portion of those improvements that exceed their proportionate impact and responsibility. The applicant has objected to their proportional responsibility of the required improvements as noted in Exhibit B3.

Once a complete application was received by the City in April, with the applicant's objection noted, the City engaged in negotiations with the applicant regarding the required improvements with the intention of entering a development agreement acceptable to both parties. ~~to The 120-day timeline for a land use decision ends on December 31, 2023, and without a final negotiated Development Agreement ; the Conditions of Approval will dictate the required improvements.~~ The 120-day timeline for a land use decision was set to end on December 31, 2023. Without a final agreement and the end of the 120-day timeline quickly approaching, the Development Review Board (DRB) held a public hearing on the application on December 11, 2023, with the Conditions of Approval dictating the improvements required of the applicant. At the December 11, 2023 hearing the applicant expressed opposition to the Conditions of Approval and a desire to continue negotiations with the City regarding the infrastructure improvements. The DRB continued the hearing to January 8, 2024, leaving the record open for additional information, and the applicant agreed to an extension of the 120-day timeline to accommodate this. Following the December 11, 2023 hearing the applicant met with the City to discuss potential solutions for partnership on constructing required infrastructure. On December 27, 2023, the applicant signed another 120-day timeline extension to the maximum date allowed by state statute, April 5, 2024. Since discussions resumed after the December 11, 2023 hearing, the hearing was subsequently continued to February 12, 2024 and then March 11, 2024.

During this time period an agreement was reached between the applicant and the City to establish a Local Improvement District (LID) to construct the necessary road and infrastructure improvements. An LID is a financing mechanism that can create capital for infrastructure construction. The LID covers an area in which one party (typically a City) builds infrastructure that benefits multiple property owners. The cost of the infrastructure is divided among those property owners in an equitable manner and is paid for through an assessment. LIDs require a majority (50% plus one) of property owners (weighted by the amount of area they own) to sign a petition in support of initiating the district. Assessments may be paid in a lump sum or financed over time at the property owner's discretion. Assessments are due upon allocation of costs. The LID creates a lien against each individual property until all assessments are paid in full. The lien creates a secure income stream against which the City could issue a bond debt. The LID debt is always issued by a government agency taking advantage of lower interest rates. A draft Memorandum of Understanding between the City and applicant regarding establishment of an LID, which is still under negotiation, is included as Exhibit A6.

The total area and extent of the LID is to be determined at a future date. To ensure the establishment of the LID occurs in a timely manner, Condition of Approval PF 2 requires the

applicant to sign a waiver of remonstrance against the formation of a local improvement district which is to be recorded in the Clackamas County Recorder's Office as well as the City's Lien Docket.

At the time of the first public hearing on the application, the applicant objected to the improvements required by the City as described in Exhibit A2 The applicant's objection to the improvements required of the City is in regards to proportionality. It wasis the applicant's opinion that the cost of the requirements set forth in the staff report and associated exhibits are not proportional to the impact of proposed development and therefore would be considered a taking as it is defined in the Fifth Amendment of the US Constitution and Article I, Section 18 of the Oregon Constitution.

Given the draft Memorandum of Understanding and proposed revisions to the Conditions of Approval, the Essential Nexus/Rough Proportionality analysis in Exhibit A2 is no longer the basis for the funding and construction of the required improvements. However, for clarity staff prepared a response to the applicant's claims raised at the December 11, 2023 which is included as Exhibit A5 .In response to the applicant's claims, the City has prepared Essential Nexus/Rough Proportionality Findings (Exhibit A2), which serve to establish the basis for the required improvements and describe the applicant's proportionate responsibility for the cost of these improvements. These findings describe the required improvements, why they are to be required, what the applicant's proportional share of the work is, and why it is proportional to the proposed development. While the improvements are referenced throughout this document (Exhibit A1) the details of the justification for the City's improvement requirements are within the Essential Nexus/Rough Proportionality attachment.

Building Design Compatibility

Harmonious development is an important consideration for the design of new development within Wilsonville. Wilsonville Code Section 4.400, Site Design Review, declares the City Council's goals of preventing, "Excessive uniformity, inappropriateness or poor design of the exterior appearance of structures and signs". Additionally, Wilsonville Code Section 4.421 (.03) states, "The Board shall also be guided by the purpose of Section 4.400, and such objectives shall serve as additional criteria and standards." In recognition of this, the Development Review Board can condition the applicant modify the design by increasing articulation or adding screening, in order to reduce the uniformity of an industrial building.

The proposed industrial flex building will be a large tilt up building exceeding these thresholds. Without variation in articulation on portions of the proposed building, particularly along the I-5 frontage on the northwest corner of the building, its massing is overwhelming in scale. As the proposed project is adjacent to the I-5 Freeway, it will be a prominent building in Wilsonville. The building will be one of the first large industrial developments seen in by travelers in vehicles headed south on I-5. Due to the prominence of the building and lack of articulation on this corner of the building it is staff's recommendation that the design be enhanced to reflects the City's goal of harmonious development. A condition of approval will require enhancement of the building

~~facade the addition of architectural articulation and/or variation in materials~~ at the northwest corner of the building to include metal panels also used at the entrances of the building in order to enhance the appearance of the building and the site from offsite locations.

Discussion Points – Discretionary Review:

This section provides a discussion of discretionary review requests that are included as part of the proposed applications. The Development Review Board may approve or deny items in this section based upon a review of evidence submitted by the applicant. There are no discretionary review requests included as part of the proposed application.

Conclusion and Conditions of Approval:

Staff reviewed the Applicant’s analysis of compliance with the applicable criteria. The Staff report adopts the applicant’s responses as Findings of Fact except as noted in the Findings. Based on the Findings of Fact and information included in this Staff Report, and information received from a duly advertised public hearing, Staff recommends that the Development Review Board approve the proposed application (DB22-0009) with the following conditions:

Planning Division Conditions:

Request A: Stage 1 Preliminary Plan (STG122-0007)

No conditions for this request

Request B: Stage 2 Final Plan (STG222-0009)

PDB 1.	General: The approved modified final plan shall control the issuance of all building permits and shall restrict the nature, location and design of all uses. Minor changes in an approved preliminary or final development plan may be approved by the Planning Director through the Class 1 Administrative Review Process if such changes are consistent with the purposes and general character of the development plan. All other modifications shall be processed in the same manner as the original application and shall be subject to the same procedural requirements. See Finding A13.
PDB 2.	Prior to Non-Grading Building Permit Issuance: All bicycle parking spaces will comply with the 2’ width and 6’ length requirement and include 5 feet of maneuvering space behind each space. Twelve (12) bicycle parking spaces are to be provided with 50% of the spaces to be dedicated to long term parking.
PDB 3.	Prior to Non-Grading Building Permit Issuance: Thirteen parking spaces are to be marked as carpool/vanpool spaces. See finding B46.
PDB 4.	Prior to Final Occupancy: All exterior, roof and ground mounted, mechanical and utility equipment shall be screened from ground level off-site view from adjacent streets or properties.

Request C: Site Design Review (SDR22-0009)

PDC 1.	General: Construction, site development, and landscaping shall be carried out in substantial accord with the Development Review Board approved plans, drawings, sketches, and other documents. Minor revisions may be approved by the Planning Director through administrative review pursuant to Section 4.030. See Finding C15.
PDC 2.	Prior to Temporary Occupancy: All landscaping required and approved by the Board shall be installed prior to issuance of any occupancy permits, unless security equal to one hundred and ten percent (110%) of the cost of the landscaping as determined by the Planning Director is filed with the City assuring such installation within six (6) months of occupancy. "Security" is cash, certified check, time certificates of deposit, assignment of a savings account or such other assurance of completion as shall meet with the approval of the City Attorney. In such cases the developer shall also provide written authorization, to the satisfaction of the City

	<p>Attorney, for the City or its designees to enter the property and complete the landscaping as approved. If the installation of the landscaping is not completed within the six-month period, or within an extension of time authorized by the Board, the security may be used by the City to complete the installation. Upon completion of the installation, any portion of the remaining security deposited with the City will be returned to the applicant. See Finding C38.</p>
<p>PDC 3.</p>	<p>Ongoing: The approved landscape plan is binding upon the applicant/owner. Substitution of plant materials, irrigation systems, or other aspects of an approved landscape plan shall not be made without official action of the Planning Director or Development Review Board, pursuant to the applicable sections of Wilsonville’s Development Code. See Finding C39.</p>
<p>PDC 4.</p>	<p>Ongoing: All landscaping shall be continually maintained, including necessary watering, weeding, pruning, and replacing, in a substantially similar manner as originally approved by the Board, unless altered as allowed by Wilsonville’s Development Code. See Findings C40 and C41.</p>
<p>PDC 5.</p>	<p>Prior to Temporary Occupancy: The following requirements for planting of shrubs and ground cover shall be met:</p> <ul style="list-style-type: none"> • Non-horticultural plastic sheeting or other impermeable surface shall not be placed under landscaping mulch. • Native topsoil shall be preserved and reused to the extent feasible. • Surface mulch or bark dust shall be fully raked into soil of appropriate depth, sufficient to control erosion, and shall be confined to areas around plantings. • All shrubs shall be well branched and typical of their type as described in current AAN Standards and shall be equal to or better than 2-gallon containers and 10” to 12” spread. • Shrubs shall reach their designed size for screening within three (3) years of planting. • Ground cover shall be equal to or better than the following depending on the type of plant materials used: gallon containers spaced at 4 feet on center minimum, 4” pot spaced 2 feet on center minimum, 2-1/4” pots spaced at 18 inch on center minimum. • No bare root planting shall be permitted. • Ground cover shall be sufficient to cover at least 80% of the bare soil in required landscape areas within three (3) years of planting. • Appropriate plant materials shall be installed beneath the canopies of trees and large shrubs to avoid the appearance of bare ground in those locations. • Compost-amended topsoil shall be integrated in all areas to be landscaped, including lawns. See Finding C42.
<p>PDC 6.</p>	<p>Prior to Temporary Occupancy: Plant materials shall be installed to current industry standards and be properly staked to ensure survival. Plants that die shall be replaced in kind, within one growing season, unless appropriate substitute species are approved by the City. See Finding C45.</p>

Prior to Non-Grading Building Permit Issuance: To meet the objectives and standards of Section 4.400(.01)-(.02) and 4.421 (.03) the applicant shall submit revised architectural elevations for the northwest corner of the property to include additional architectural treatments. Treatments shall include ~~the incorporation of materials used at the entrances of the building, or substantially similar,~~ for the purpose of façade articulation breaking up the massing of the building metal panels used at the entrances of the building (MP-1) applied in place of the areas painted Dark Marmalade (PT-7), breaking up the façade and uniform massing of that corner of the building.

Request D: Type C Tree Plan (TPLN22-0007)

PDE 1. General: This approval for removal applies only to the 19 trees identified in the applicant’s submitted materials. All other trees on the property shall be maintained unless removal is approved through separate application.

PDE 2. Prior to Grading Permit Issuance: The Applicant shall submit an application for a Type ‘C’ Tree Removal Permit on the Planning Division’s Development Permit Application form, together with the applicable fee. In addition to the application form and fee, the applicant shall provide the City’s Planning Division an accounting of trees to be removed within the project site, corresponding to the approval of the Development Review Board. The applicant shall not remove any trees from the project site until the tree removal permit, including the final tree removal plan, have been approved by the Planning Division staff.

PDE 3. Prior to Temporary Occupancy / Ongoing: The permit grantee or the grantee’s successors-in-interest shall cause the replacement trees to be staked, fertilized and mulched, and shall guarantee the trees for two (2) years after the planting date. A “guaranteed” tree that dies or becomes diseased during the two (2) years after planting shall be replaced.

PDE 4. Prior to Commencing Site Grading: Prior to site grading or other site work that could damage trees, the applicant/owner shall install 6-foot-tall chain-link fencing around the drip line of preserved trees. Removal of the fencing around the identified trees shall only occur if it is determined the trees are not feasible to retain. The fencing shall comply with Wilsonville Public Works Standards Detail Drawing RD-1230. Protective fencing shall not be moved or access granted within the protected zone without arborist supervision and notice of the City of the purpose of proposed movement of fencing or access. See Finding D6.

Request E: Tentative Partition Plat (PART22-0002)

PDF 1. Prior to Final Plat Approval: Any necessary easements or dedications shall be identified on the Final Subdivision Plat.

PDF 2. General: The applicant / owner shall submit an application for Final Plat review and approval on the Planning Division Site Development Application and Permit form. The applicant/owner shall also provide materials for review by the City’s Planning Division in accordance with Section 4.220 of the City’s Development Code. The final plat shall be prepared in substantial accord with the tentative partition

plat as approved by this action and as amended by these conditions, except as may be subsequently altered by minor revisions approved by the Planning Director.

The following Conditions of Approval are provided by the Engineering, Natural Resources, or Building Divisions of the City’s Community Development Department or Tualatin Valley Fire and Rescue, all of which have authority over development approval. A number of these Conditions of Approval are not related to land use regulations under the authority of the Development Review Board or Planning Director. Only those Conditions of Approval related to criteria in Chapter 4 of Wilsonville Code and the Comprehensive Plan, including but not limited to those related to traffic level of service, site vision clearance, recording of plats, and concurrency, are subject to the Land Use review and appeal process defined in Wilsonville Code and Oregon Revised Statutes and Administrative Rules. Other Conditions of Approval are based on City Code chapters other than Chapter 4, state law, federal law, or other agency rules and regulations. Questions or requests about the applicability, appeal, exemption or non-compliance related to these other Conditions of Approval should be directed to the City Department, Division, or non-City agency with authority over the relevant portion of the development approval.

Engineering Division Conditions:

Request: DB22-0009 Stage 2 Final Plan

PF 1.	Public Works Plans and Public Improvements shall conform to the “Public Works Plan Submittal Requirements and Other Engineering Requirements” in Exhibit C1.
PF 2.	With the Public Works Permit application: Submit construction plans to Engineering showing street improvements along Parcel 5 and Parcel 6’s frontage on SW Parkway Avenue, including street widening to accommodate a travel lane, one center median, curb, planter strip, street trees, buffered bike lane, sidewalk, streetlights and associated stormwater facilities, along the site frontage on SW Parkway Avenue. Street improvements shall be constructed in accordance with the Public Works Standards. Consistent with the proportionality analysis, any oversized street improvements are eligible for System Development Charge (SDC) Credits and/or reimbursement from the City. When eligible, SDC credits will be issued in accordance with City Code Section 11.110. <u>Prior to final completeness of the Public Works Permit:</u> All street improvements shall be constructed, inspected and approved by the City. <u>Within 90 days from the Land Use Decision, prior to submittal of any City permits, or prior to Final Plat Review, whichever occurs first: A waiver of remonstrance against formation of a local improvement district (LID) shall be recorded in the Clackamas County Recorder’s Office as well as the City’s Lien Docket.</u>
PF 3.	<u>With the Public Works Permit application:</u> Submit construction plans to Engineering showing the closure of the existing driveway onto SW Parkway Avenue. The development shall take access via a drive aisle that connects Printer Parkway and Xerox Drive.
PF 4.	<u>With the Public Works Permit application:</u> Submit construction plans to Engineering showing southbound left turn lane improvements up to 75 feet in length along SW Parkway Avenue to facilitate southbound left turn movements as the intersection of SW Parkway Avenue and Printer Parkway. Consistent with the proportionality analysis, any oversized street improvements constructed above the applicant’s

	<p>proportionate share shall be eligible for System Development Charge (SDC) Credits and/or reimbursement from the City. When eligible, SDC credits will issued in accordance with City Code Section 11.110. <u>Prior to final completeness of the Public Works Permit:</u> All street improvements shall be constructed, inspected and approved by the City.</p>
PF 5.	<p><u>With the Public Works Permit application:</u> Submit construction plans to Engineering showing southbound left turn lane improvements up to 75 feet in length along SW Parkway Avenue to facilitate southbound left turn movements as the intersection of SW Parkway Avenue and Xerox Drive. Left turn lane improvements at this intersection serve other properties and may be eligible for reimbursement in accordance with City Code Section 3.116. <u>Prior to final completeness of the Public Works Permit:</u> All street improvements shall be constructed, inspected and approved by the City.</p>
PF 64.	<p><u>With the Public Works Permit application:</u> Submit construction plans to Engineering showing separate domestic, irrigation and fire services to serve the new building. All fire hydrants needed to serve the new development shall be publically owned and located in a public water pipeline easement, if necessary. <u>Prior to final completeness of the Public Works Permit:</u> All water system improvements shall be constructed, inspected and approved by the City.</p>
PF 7.	<p><u>With the Public Works Permit application:</u> Submit construction plans to Engineering showing street improvements along proposed Parcel 5's frontage on SW Printer Parkway, including street widening to accommodate two travel lanes, curb, planter strip, street trees, sidewalk, streetlights and associated stormwater facilities, along the site frontage on Printer Parkway. Street improvements shall be constructed in accordance with the Public Works Standards. <u>Prior to final completeness of the Public Works Permit:</u> All street improvements shall be constructed, inspected and approved by the City.</p>
PF 8.	<p><u>With the Public Works Permit application:</u> Submit construction plans to Engineering showing bus stop improvements along Printer Parkway including a bench, shelter and pedestrian lighting in accordance with City Code Section 4.177(.06)(B). <u>Prior to final completeness of the Public Works Permit:</u> All bus stop improvements shall be installed, inspected and approved by the City.</p>
PF 95.	<p><u>With the Public Works Permit application:</u> A final stormwater report shall be submitted for review and approval. The stormwater report shall include information and calculations to demonstrate how the proposed development meets the treatment, flow control, and source control requirements for all new or replacement impervious areas. <u>Prior to final completeness of the Public Works Permit:</u> All stormwater facilities shall be installed, inspected and approved by the City.</p>
PF 106.	<p><u>Prior to Issuance of any other City Permits:</u> Applicant shall obtain an NPDES 1200C permit from the Oregon Department of Environmental Quality and a Local Erosion Control Permit from the City of Wilsonville. All erosion control measures shall be in place prior to starting any construction work, including any demolition work. Permits</p>

	shall remain active until all construction work is complete and the site has been stabilized.
PF 11.	With the Public Works Permit application: The construction drawings shall show vaults and conduit for City Fiber in the SW Parkway Avenue right of way. Prior to final completeness of the Public Works Permit: All conduit and vaults necessary for City Fiber shall be installed, inspected and approved by the City.
PF 12.	With the Public Works Permit: The construction drawings shall show all existing overhead utilities along the proposed development's frontage on SW Parkway Avenue will be placed underground. Prior to final completeness of the Public Works Permit: All existing overhead utilities along the proposed development's frontage on SW Parkway Avenue shall be placed underground.
PF 13.	With the Public Works Permit: The applicant shall provide to the City a copy of correspondence that plans have been distributed to the franchise utilities. Prior to the issuance of the Public Works Permit: The applicant shall have coordinate the proposed locations and associated infrastructure design for the franchise utilities. Should permanent/construction easement or right of way be required to construct or relocate a franchise utility, the applicant shall provide a copy of the recorded documents.
PF 147.	Prior to Any Paving: Onsite stormwater facilities must be constructed and vegetated facilities planted. Prior Issuance of Final Building Certificate of Occupancy: The applicant must execute and record with the County a Stormwater Maintenance and Access Easement Agreement with the City.
PF 15.	Prior to Any Paving: Offsite stormwater facilities must be constructed and vegetated facilities planted. Prior Issuance of Final Building Certificate of Occupancy: The applicant must execute and record with the County a Stormwater Maintenance Agreement with the City.
PF 167.	Prior to Final Building Certificate of Occupancy: The applicant shall record a 36.5-foot right-of-way dedication along Printer Parkway.
PF 178.	Prior to Final Building Certificate of Occupancy: The applicant shall dedicate an 8-foot public utility easement along the Printer Parkway right-of-way.
PF 189.	Prior to Issuance of Any Occupancy Permits: All public infrastructure improvements including but not limited to street, stormwater drainage, water quality and flow control, sanitary sewer, and water facilities shall be substantially complete with approval from the Community Development Director pursuant to Section 4.220 of the Development Code.
PF 1910.	Prior to Issuance of Any Occupancy Permits: All necessary easements shall be recorded with the County, including public water line, public access, public utility, stormwater maintenance and access easements and all private utility easements.
PF 2011.	Prior to Issuance of Final Building Certificate of Occupancy: The applicant shall provide a site distance certification by an Oregon Registered Professional Engineer for all driveway access per the Traffic Impact Study.

Master Exhibit List:

The entry of the following exhibits into the public record by the Development Review Board confirms its consideration of the application as submitted. The exhibit list below includes exhibits for Planning Case File DB22-0009. The exhibit list below reflects the electronic record posted on the City's website and retained as part of the City's permanent electronic record. Any inconsistencies between printed or other electronic versions of the same Exhibits are inadvertent and the version on the City's website and retained as part of the City's permanent electronic record shall be controlling for all purposes.

Planning Staff Materials

- A1. Staff report and findings (this document)
- A2. Essential Nexus/Rough Proportionality Findings
- A3. Staff's Presentation Slides for Public Hearing (to be presented at Public Hearing)
- A4. DKS Traffic Impact Analysis and Memo
- A5. *Supplemental Nollan/Dolan Findings*
- A6. *Draft Memorandum of Understanding*

Materials from Applicant

- B1. Land Use Narrative
 - Tax Map and Title Report
 - Transportation Impact Study
 - Arborist Report
 - Geotechnical Report
 - Storm water Report
 - Waste and Recycle Hauler Letter
 - Design Narrative
 - TVFR Service Provider Letter
- B2. **Drawing Package:**
 - Part "A" Drawings (Site Design)
 - Part "B" Drawings (Tentative Partition Plat)
- B3. Attorney Communication from Applicant to City Objecting to Improvement Requirements
- B4. June 8, 2023 120-Day Extension Form
- B5. August 9, 2023 120-Day Extension Form
- B6. Color Materials Boards
- B7. *Applicants Alternative Façade Design Rendering – Submitted March 4, 2024*

Development Review Team Correspondence

- C1. Engineering Division Conditions

Procedural Statements and Background Information:

1. The statutory 120-day time limit applies to this application. The applicant first submitted the application for Stage 1 Preliminary Plan, Stage 2 Final Plan, Site Design Review, and Type C Tree Plan on October 11, 2022. Staff conducted a completeness review within the statutorily allowed 30-day review period and found the application to be incomplete on November 10, 2022. The applicant submitted the Tentative Partition Plat Application on November 10, 2022. Staff conducted a completeness review within the statutorily allowed 30-day review period and found the application to be incomplete on December 9, 2022. As these applications are related and typically reviewed together, staff has added the application to this broader land use application for the Parkworks Industrial Building. The applicant submitted additional material for the combined application on January 4, 2023. Staff conducted a completeness review within the statutorily allowed 30-day review period and found the application to be incomplete on January 27, 2023. The applicant submitted additional material for the combined application on April 7, 2023. Staff conducted a completeness review within the statutorily allowed 30-day review period and found the application to be complete on April 7, 2023. On June 8, 2023 the applicant chose to extend the 120-day review timeline 45-days to September 19, 2023 pursuant to ORS 227.178(5). Prior to the end of that extension,, on August 9, 2023, the applicant extended the 120-day timeline an additional 144-days ending on December 31, 2023. The City must render a final decision for all requests, including any appeals, by December 31, 2023. The Development Review Board held a public hearing on these applications on December 11, 2023. At the hearing the applicant expressed opposition to the Conditions of Approval and a desire to continue discussions with the City regarding the application. The DRB continued the hearing, leaving the record open, until January 8, 2024. At the December 11, 2023 hearing, the applicant extended the 120- day timeline for a third time for an additional 74 days ending on February 23, 2024. Prior to the January 8, 2024, hearing date the applicant signed a forth extension to the 120-day timeline on December 27, 2023, for an additional 42 days ending on April 5, 2024, to allow negotiations between the applicant and the City to continue. A final decision regarding this application must be rendered by April 5, 2024.

2. Surrounding land uses are as follows:

Compass Direction	Zone:	Existing Use:
North:	PDI/PDR-6	Industrial / Multifamily Residential
East:	PDI	Industrial / Multifamily Residential
South:	PDI	Industrial
West:	N/A	I-5 Freeway

3. Previous Planning Approvals:

74DR08 – Tektronix Preliminary Site Plan & Final Site Plan

74RZ03 – Zone Change
 78DR05 – Site Development and Architectural Plan (Building 63)
 79DR35 - Site Development and Architectural Plan (Building 83)
 80DR22 – Final Site Approval (Building 83)
 88AR40- Minor Partition
 91AR59 – Modification to Existing Building
 91PC39 – Stage II (Building 63)
 90PC03 – Parking Lot Expansion
 95AR10- Architectural Revisions
 97AR15- Storage Addition
 97AR56- Modifications to Existing Building
 97AR73- Modifications to Existing Building
 97DB13- Modifications to Existing Building
 97DB18 – Stage II Final Plans and Site Design Plans
 97DB33 – Parking Expansion
 97DB35 – Stage I Final Plan and Site Design Plan for Parking Expansion
 97DB36- Modifications to Existing Building
 98AR59 – Landscape Installation
 AR15-0031 – Tentative Partition Plat
 AR16-0037 – Tentative Partition Plat
 AR18-0008 – Final Partition Plat
 DB20-0031 – Stage II Final Plan Modification, Site Design Review, Type C Tree Plan,
 Master Sign Plan
 SI20-0002 – SROZ Review
 AR21-0016 – Minor Architectural and Site Modifications

4. The applicant has complied with Sections 4.013-4.031 of the Wilsonville Code, said sections pertaining to review procedures and submittal requirements. The required public notices have been sent and all proper notification procedures have been satisfied.

Findings:

NOTE: Pursuant to Section 4.014 the burden of proving that the necessary findings of fact can be made for approval of any land use or development application rests with the applicant in the case.

General Information

Application Procedures-In General

Section 4.008

The processing of the application is in accordance with the applicable general procedures of this Section.

Initiating Application

Section 4.009

The application has the signature of John Olivier, Executive Vice President of ScanlanKemperBard (SKB), an authorized signer for the property owner, SKB.

Pre-Application Conference

Subsection 4.010 (.02)

The City held a Pre-application conference on November 18, 2021 (PA21-0024) in accordance with this subsection.

Lien Payment before Approval

Subsection 4.011 (.02) B.

No applicable liens exist for the subject property. The application can thus move forward.

General Submission Requirements

Subsection 4.035 (.04) A.

The applicant has provided all of the applicable general submission requirements.

Zoning-Generally

Section 4.110

This proposed development is in conformity with the applicable zoning district and City review uses the general development regulations listed in Sections 4.150 through 4.199.

Request A: Stage 1 Preliminary Plan (STG122-0007)

As described in the Findings below, the request meets the applicable criteria or will by Conditions of Approval.

Planned Development Regulations

Planned Development Purpose & Lot Qualifications

Subsections 4.140 (.01) and (.02)

- A1.** The property is of sufficient size to be developed in a manner consistent the purposes and objectives of Section 4.140. The subject property is greater than 2 acres and is designated for industrial development in the Comprehensive Plan. The property will be developed as a planned development in accordance with this subsection.

Ownership Requirements

Subsection 4.140 (.03)

- A2.** All the land subject to change under the proposal is under a single ownership of SKB-Parkworks, LLC. and the application has been signed by John Olivier, Executive Vice President, authorized to sign on behalf of SKB-Parkworks, LLC.

Professional Design Team

Subsection 4.140 (.04)

- A3.** As can be found in the applicant’s submitted materials, appropriate professionals have been involved in the planning and permitting process. The project architect is Amalia Mohr with LRS Architecture, and the civil engineer is Brad Berry with Atwell.

Planned Development Permit Process

Subsection 4.140 (.05)

- A4.** The subject property is greater than 2 acres, is designated for industrial development in the Comprehensive Plan, and is zoned Planned Development Industrial. The property will be developed as a planned development in accordance with this subsection.

Comprehensive Plan Consistency

Subsection 4.140 (.06)

- A5.** The proposed project, as found elsewhere in this report, complies with the Planned Development Industrial zoning designation, which implements the Comprehensive Plan proposed designation of “Industrial” for this property.

Application Requirements

Subsection 4.140 (.07)

- A6.** Review of the proposed revised Stage 1 Preliminary Plan has been scheduled for a public hearing before the Development Review Board, in accordance with this subsection, and the applicant has met all the applicable submission requirements as follows:

- The property affected by the revised Stage 1 Preliminary Plan is under the sole ownership of SKB-Parkworks, LLC. and the application has been signed by John Olivier, Executive Vice President, authorized to sign on behalf of SKB-Parkworks, LLC.
- The application for a Stage 1 Preliminary Plan has been submitted on a form prescribed by the City.
- The professional design team and coordinator have been identified. See Finding A3.
- The applicant has stated the various uses involved in the Preliminary Plan and their locations.
- The boundary affected by the Stage 1 Preliminary Plan has been clearly identified and legally described.
- Sufficient topographic information has been submitted.
- Information on the land area to be devoted to various uses has been provided.
- Any necessary performance bonds will be required.

Planned Development Industrial (PDI) Zone

Purpose of PDI Zone

Subsection 4.135 (.01)

- A7.** The uses proposed in the portion of the Stage 1 Preliminary Plan area within the PDI zone are limited to industrial uses, supporting the purpose stated in this subsection.

Uses Typically Permitted

Subsection 4.135 (.03)

- A8.** The proposed development consists of an industrial building where the intended uses are office space and warehousing/manufacturing. These uses are consistent with the uses typically permitted and are therefore allowed uses.

Prohibited Uses

Subsection 4.135 (.04)

- A9.** No prohibited uses are proposed by the applicant. Performance standards will be required to be met as part of the Stage 2 Final Plan review.

Block and Access Standards

Subsections 4.135 (.04) and 4.131 (.03)

- A10.** The drawings submitted by the applicant show development on the subject property providing adequate pedestrian, bicycle, and vehicle connectivity along SW Parkway Avenue and Printer Parkway. The proposed development will be accessed off of Printer Parkway and Xerox Drive.

PDI Performance Standards

Industrial Performance Standards

Subsections 4.135 (.06) A. through N.

A11. The Stage 1 Preliminary Plan enables conformance with the Industrial performance standards. Final compliance will be reviewed with the Stage 2 Final Plans. See Finding B23.

Other Standards for PDI Zone

Lot Size

Subsections 4.135 (.07) A.

A12. Nothing in the Stage 1 Preliminary Plan would prevent lot size requirements from being met.

Setbacks

Subsections 4.135 (.07) C. through E.

A13. Nothing in the Stage 1 Preliminary Plan would prevent setback requirements from being met.

Request B: Stage 2 Final Plan (STG222-0009)

As described in the Findings below, the request meets the applicable criteria or will by Conditions of Approval.

Planned Development Regulations-Generally

Planned Development Purpose & Lot Qualifications

Subsection 4.140 (.01) and (.02)

B1. The proposed Stage 2 Final Plan for development of the subject property is consistent with the Planned Development Regulations purpose statement.

Ownership Requirements

Subsection 4.140 (.03)

B2. All the land subject to change under the proposal is under a single ownership of SKB-Parkworks, LLC and the application has been signed by John Olivier, Executive Vice President, authorized to sign on behalf of SKB-Parkworks, LLC.

Professional Design Team

Subsection 4.140 (.04)

B3. The applicant has utilized a professional design team from a variety of firms in accordance with this subsection. The project architect is Amalia Mohr with LRS Architecture, and the civil engineer is Brad Berry with Atwell.

Stage 2 Final Plan Submission Requirements and Process

Stage 2 Submission Within 2 Years of Stage 1

Subsection 4.140 (.09) A.

- B4.** The applicant is requesting approval of both Stage 1 and Stage 2 Approval, together with Site Design Review, as part of this application. The final plan provides sufficient information regarding conformance with both the preliminary development plan and Site Design Review.

Development Review Board Role

Subsection 4.140 (.09) B.

- B5.** The Development Review Board review considers all applicable permit criteria set forth in the Planning and Land Development Code and staff recommends the Development Review Board approve the application with conditions of approval.

Stage 1 Conformance, Submission Requirements

Subsection 4.140 (.09) C.

- B6.** The Stage 2 plans conforms to the proposed Stage 1 Master Plan. The applicant's submitted drawings and other documents show all the additional information required by this subsection.

Stage 2 Final Plan Detail

Subsection 4.140 (.09) D.

- B7.** The applicant's submitted materials provide sufficiently detailed information to indicate fully the ultimate operation and appearance of the development, including a detailed site plan, landscape plans, and elevation drawings.

Submission of Legal Documents

Subsection 4.140 (.09) E.

- B8.** The Development Review Board does not require any additional legal documentation for dedication or reservation of public facilities.

Expiration of Approval

Subsection 4.140 (.09) I. and Section 4.023

- B9.** The Stage 2 Approval, along with other associated applications, will expire two (2) years after approval, absent the granting of an extension in accordance with these subsections.

Consistency with Plans

Subsection 4.140 (.09) J. 1.

- B10.** The site's zoning, Planned Development Industrial, is consistent with the Industrial designation in the Comprehensive Plan. The Transportation Systems Plan calls for frontage and road improvements along Parkway Ave and Printer Parkway. ~~The plans submitted by the applicant show the full extent of the required improvements.~~ Conditions of Approval will ensure the road improvements are constructed consistent with the Transportation Systems Plan and Public Works Construction Standards.

Traffic Concurrency

Subsection 4.140 (.09) J. 2.

- B11.** The City's traffic consultant, DKS Associates, calculates that the proposed 91,733 square foot warehouse building will generate 504 new daily trips with 58 AM peak hour trips (44 in, 14 out) and 52 PM peak hour trips (16 in, 36 out). It will generate 5 new trips through the I-5/Wilsonville Road Interchange area, and 20 new trips through the I-5 Elligsen Road Interchange Area. Traffic operations at the three intersections studied as part of the traffic impact analysis are shown to continue meeting the LOS D standard. Southbound left-turn lanes on SW Parkway Avenue at Printer Parkway and Xerox Drive meet the left-turn criteria established by ODOT and improvements are necessary. A traffic impact analysis is included in in Exhibit A3.

The traffic impact analysis and Transportation System Plan identifies several existing safety deficiencies including components of Parkway Avenue, Printer Parkway and the intersections of Printer Parkway/Parkway Avenue and Xerox Drive/Parkway Avenue which is of high concern for the development as a 25% increase in volume to capacity on the Printer Parkway/Parkway Avenue intersection, and a 41.67% increase in volume to capacity at the Xerox Drive/Parkway Avenue intersection is predicted. Parkway Avenue is a freight route with a high speed limit of 45 miles per hour a lack of queuing lanes, and no separation for modes of transportation. All of these factors contribute to the importance of addressing the identified safety deficiencies along Parkway Avenue, specifically the addition of pocket left turn lanes to prevent queuing and reduce risk of accidents.

Facilities and Services Concurrency

Subsection 4.140 (.09) J. 3.

- B12.** Facilities and services, including utilities in SW Parkway Ave, are available and sufficient or will be with conditions of approval to serve the proposed development. A new water meter and backflow device is proposed off SW Parkway Ave to serve Building 63.

The new development will have frontage along Parkway Avenue and Printer Parkway and take access from both. Neither of these streets have been improved to an urban level in accordance with the City's Public Works Standards and Transportation System Plan. Existing facilities and services relating to transportation are not sufficient to support the proposed development according the Traffic Impact Analysis. ~~Improvements to Parkway Avenue, Printer Parkway, and the left turn lanes turning onto SW Printer Parkway and Xerox Drive are included as Conditions of Approval to ensure the facilities will be sufficient for the proposed development.~~ *Pursuant to the draft Memorandum of Understanding in Exhibit A6, improvements to Parkway Avenue, Printer Parkway and the left turn lanes turning onto SW Printer Parkway and Xerox Drive will be completed with the creation of a Local Improvement District. Condition of Approval PF 2. requires a waiver of remonstrance against formation of local improvement district be recorded in the Clackamas County Recorder's Office as well as the City Lien Docket within 90 days from the Land Use Decision and prior to submittal of any City permits or Final Plat Review.*

Adherence to Approved Plans
Subsection 4.140 (.10) A.

- B13.** Condition of Approval PDB 1 ensures adherence to approved plans except for minor revisions by the Planning Director.

Standards Applying in All Planned Development Zones

Underground Utilities
Subsection 4.118 (.02)

- B14.** The applicant's "full scope of improvements" (Sheet C101 of Exhibit B2 Part "A") plans show all utilities underground. A condition of approval will ensure the undergrounding of utilities as required.

Waivers
Subsection 4.118 (.03)

- B15.** The applicant does not request any waivers.

Other Requirements or Restrictions
Subsection 4.118 (.03) E.

- B16.** ~~Staff does not recommend any additional requirements or restrictions pursuant to this subsection.~~ As was agreed upon between the applicant and the City, pursuant to the draft Memorandum of Understanding in Exhibit A6, improvements to Parkway Avenue, Printer Parkway and the left turn lanes turning onto SW Printer Parkway and Xerox Drive will be completed with the creation of a Local Improvement District. Condition of Approval PF 2 requires a waiver of remonstrance against formation of a local improvement district be recorded in the Clackamas County Recorder's Office as well as the City Lien Docket within 90 days from the Land Use Decision and prior to submittal of any City permits or Final Plat Review.

Impact on Development Cost
Subsection 4.118 (.04)

Implementation of standards and imposing conditions beyond minimum standards and requirements does not unnecessarily increase the cost of development. ~~As noted Exhibit B3, the Applicant does not agree with the City's determination regarding required improvements. See Exhibits A2 for the relevant findings regarding proportionality as it relates to the required improvements.~~ Condition of Approval PDC 7 requires the enhancement of the northwest corner building facade to include metal panels used at the entrances of the building ~~either a variety of materials or articulation.~~ These requested enhancements are not expected to increase costs unnecessarily for the applicant. See findings C1, C3, C5 and C8 for details regarding the proposed design and how enhancements are necessary to meet the objectives of 4.400 and the standards of 4.421 (.03).

Requiring Tract Dedications or Easements for Recreation Facilities, Open Space, Public Utilities

Subsection 4.118 (.05)

B17. Staff does not recommend any additional tract dedication for recreational facilities, open space, or easements for orderly extension of public utilities consistent with this subsection.

Habitat Friendly Development Practices

Subsection 4.118 (.09)

B18. The applicant will implement habitat-friendly development practices to the extent practicable. Grading will be limited to that needed for the proposed improvements, no significant native vegetation would be retained by an alternative site design, the City's stormwater standards will be met, thus limiting adverse hydrological impacts on water resources, and no impacts on wildlife corridors or fish passages have been identified.

Planned Development Industrial (PDI) Zone

Purpose of PDI Zone

Subsection 4.135 (.01)

B19. The stated purpose of the PDI zone is to provide opportunities for a variety of industrial operations and associated uses. The proposed development includes an industrial spec building intended for warehousing or manufacturing with accessory office space and is consistent with the purpose stated in this subsection.

Typically Permitted Uses

Subsection 4.135 (.03)

B20. The uses proposed in the Stage 2 Final Plan are consistent with the Stage 1 Master Plan. The proposed development consists of an industrial spec building where the intended uses are office space, warehousing or manufacturing. These uses are consistent with the uses typically permitted and are allowed outright within the PDI zone.

Block and Access Standards

Subsections 4.135(.04) and 4.131 (.03)

B21. Conditions of approval will ensure block and access standards are met including half street improvements on Parkway Avenue, pedestrian connections, a bike path along Parkway Avenue and two bus stops.

Industrial Performance Standards

Industrial Performance Standards

Subsection 4.135 (.05)

B22. The proposed project meets the performance standards of this subsection as follows:

- Pursuant to standard A (enclosure of uses and activities), all non-parking activities and uses will be completely enclosed.

- Pursuant to standard B (vibrations), there is no indication that the proposed development will produce vibrations detectable off site without instruments.
- Pursuant to standard C (emissions), there is no indication the proposed use would produce the odorous gas or other odorous matter.
- Pursuant to standard D (open storage), no outdoor storage of mixed solid waste and recycling is proposed.
- Pursuant to standard E (night operations and residential areas), the proposed use is proposed further than 100 feet from any residential area.
- Pursuant to standard F (heat and glare), the applicant proposes no exterior operations creating heat and glare.
- Pursuant to standard G (dangerous substances), there are no prohibited dangerous substances expected on the development site.
- Pursuant to standard H (liquid and solid wastes), staff has no evidence that the operations would violated standards defined for liquid and solid waste.
- Pursuant to standard I (noise), staff has no evidence that noise generated from the proposed operations would violate the City's Noise Ordinance and noises produced in violation of the Noise Ordinance would be subject to the enforcement procedures established in WC Chapter 6 for such violations.
- Pursuant to standard J (electrical disturbances), staff has no evidence that the proposed use would have any prohibited electrical disturbances.
- Pursuant to standard K (discharge of air pollutants), staff has no evidence that the proposed use would produce any prohibited discharge.
- Pursuant to standard L (open burning), the applicant proposes no open burning.
- Pursuant to standard M (outdoor storage), the applicant does not propose outdoor storage.
- Pursuant to standard N (unused area landscaping), no unused areas will be bare.

On-site Pedestrian Access and Circulation

Continuous Pathway System

Subsection 4.154 (.01) B. 1.

- B23.** As shown on the applicant's site plan in Exhibit B2 Part "A" Sheet A001, the proposed pedestrian pathway system (sidewalks) will provide pedestrian access to the new development along Parkway Avenue and Printer Parkway. Pathways extend from the sidewalk along Parkway Avenue east to connecting the sidewalk directly to the new building. Similarly, on the north side of the property, a pathway from Printer Parkway sidewalk provides access for pedestrians to the new building. Sidewalks are proposed throughout the parking area, providing safe access for employees and visitors.

Safe, Direct, Convenient Pathways

Subsection 4.154 (.01) B. 2.

- B24.** Proposed pedestrian pathways are flat, paved, ADA compliant sidewalks. Where crossing the parking area, the applicant proposes a 5-foot wide concrete sidewalk. The pathways

provide direct access to the building from the parking area on all sides of the site. Pathways connect to all primary (and secondary) building entrances.

Vehicle/Pathway Separation-Vertical or Horizontal

Subsection 4.154 (.01) B. 3.

B25. The proposed design of pedestrian pathways provide for vertical separation from vehicle circulation areas.

Crosswalks Clearly Marked

Subsection 4.154 (.01) B. 4.

B26. The use of concrete for the internal sidewalks and pathways clearly differentiates the pathways from the parking area.

Pathways Width and Surface-5 Foot Wide, Durable Surface

Subsection 4.154 (.01) B. 5.

B27. The applicant proposes concrete pathways for pedestrian access throughout the site. Review at time of building permit will confirm all pathways are a minimum of five feet wide.

Parking and Loading

Parking Design Standards

Section 4.155 (.02) and (.03)

B28. The applicable parking designs standards are met as follows:

Standard	Met	Explanation
Subsection 4.155 (.02) General Standards		
B. All spaces accessible and usable for Parking	<input checked="" type="checkbox"/>	The applicant proposes standard parking spaces that are at least 9' by 18' and compact spaces that are at least 9' by 15', and 24' wide drive aisles, meeting the Development Code's standards.
I. Sturdy bumper guards or curbs of at least 6 inches to prevent parked vehicles crossing property line or interfering with screening or sidewalks.	<input checked="" type="checkbox"/>	Curbs of at least 6 inches in width are provided where required to prevent interference with sidewalks, especially for the ADA spaces.
J. Surfaced with asphalt, concrete or other approved material.	<input checked="" type="checkbox"/>	Surfaced with asphalt.
Drainage meeting City standards	<input checked="" type="checkbox"/>	Drainage is professionally designed and being reviewed to meet City standards

K. Lighting won't shine into adjoining structures or into the eyes of passers-by.	<input checked="" type="checkbox"/>	Lighting is proposed to be fully shielded and meet the City's Outdoor Lighting Standard
N. No more than 40% of parking compact spaces.	<input checked="" type="checkbox"/>	26 of the 260 parking spaces are compact, well below the maximum of 40%.
O. Where vehicles overhang curb, planting areas at least 7 feet in depth.	<input checked="" type="checkbox"/>	The narrowest planting area adjacent to parking spaces exceeds the 7 foot depth requirement.
Subsection 4.155 (.03) General Standards		
A. Access and maneuvering areas adequate.	<input checked="" type="checkbox"/>	Access drive and drive aisle are 24 feet or more, providing an adequate 12 foot travel lane each direction.
A.1. Loading and delivery areas and circulation separate from customer/employee parking and pedestrian areas.	<input checked="" type="checkbox"/>	The loading and delivery area is located on the east side of the property. Employee and visitor parking is concentrated on the north and south portions of the site. No pedestrian pathways are located within the loading and delivery areas safely separating pedestrians from vehicles.
Circulation patterns clearly marked.	<input checked="" type="checkbox"/>	The proposed design is typical industrial parking lot design and intuitive to a driver familiar with typical industrial parking lots.
A.2. To the greatest extent possible, vehicle and pedestrian traffic separated.	<input checked="" type="checkbox"/>	The plans clearly delineate separate vehicle and pedestrian traffic areas and separate them except for crosswalks.
C. Safe and Convenient Access, meet ADA and ODOT Standards.	<input checked="" type="checkbox"/>	The proposed parking and access enable the meeting of ADA and ODOT standards.
For parking areas with more than 10 spaces, 1 ADA space for every 50 spaces.	<input checked="" type="checkbox"/>	The proposal provides 8 ADA parking spaces for 262 parking spaces exceeding the required ADA spaces by 2.
D. Where possible, parking areas connect to adjacent sites.	<input checked="" type="checkbox"/>	The parking areas connect to the existing industrial development to the east.
Efficient on-site parking and circulation	<input checked="" type="checkbox"/>	The careful and professional design of the parking provides for safety and efficiency and is a typical design with standard parking space and drive aisle size and orientation.

Minimum and Maximum Number of Parking Spaces
 Subsections 4.155 (.03) G., Table 5

B29. The proposed industrial building requires a minimum of 191 parking spaces. The applicant proposes 262 parking spaces. There is no maximum parking for the site due to the proposed manufacturing use. Based on an evaluation of the site plan provided by the applicant the

development meets the off-street parking requirements of the above subsections. The calculation of parking spaces is as follows:

Use and Parking Standard	Square Feet	Minimum Off-street Spaces Required	Maximum Off-street Spaces Allowed	Proposed Off-street Spaces	Minimum Bicycle Parking Spaces	Proposed Bicycle Parking Spaces
Office or flex space (except medical and dental)	20,263 sf	2.7 per 1,000 = 54	4.1 per 1,000 = 83	--	1.0 per 5,000 (min 2) = 4	--
Manufacturing	71,470 sf	1.6 per 1,000 = 115	No limit	--	1.0 per 10,000 (min 6) = 8	
Warehouse	71,470 sf	.3 per 1,000 = 22	.5 per 1,000 = 36	--	1.0 per 20,000 (min 2) = 4	
Total	91,733 sf	191	No limit	262	12	10

Parking Area Landscaping

Minimizing Visual Dominance of Parking

Subsection 4.155 (.03) B.

B31. The applicant proposes landscaping throughout the parking area helping to minimize the visual dominance of the paved parking area.

B32.—

10% Parking Area Landscape Requirement

Subsection 4.155 (.03) B. 1.

B323. According to the applicant’s narrative the parking area is 90,418 square feet. 24,416 square feet of the parking area is landscaped providing 27% of landscaped area. The landscape area provided is well in excess of the 10% requirement.

B34.—

Landscape Screening of Parking

Subsection 4.155 (.03) B. 1.

B335. The proposed design screens the parking area from adjacent properties and adjacent rights-of-way by physical distance and proposed landscaping and vegetation. The low-screen standard is to be applied on the west and north edges of the parking area to screen parking from the adjacent right of ways.

Tree Planting Area Dimensions

Subsection 4.155 (.03) B. 2.

B346. The landscape plan shows 54 new trees planted in the parking lot areas. The proposed trees meet the dimensional requirements of the above section.

Parking Area Tree Requirement

Subsection 4.155 (.03) B. 2. and 3 a

B357. The proposed development contains 262 surface parking spaces. One (1) tree is required for every six (6) parking spaces. The tree planting requirement for the parking lot is 44 trees. The applicant proposes 54 new trees within the parking lot area, which exceeds the minimum requirement.

Parking Area Tree Clearance

Subsection 4.155 (.03) B. 2.b.

B368. The applicant will maintain all trees listed for planting in the parking area and expected to overhang the parking areas to provide a 7-foot vertical clearance.

Parking Area Shading

Subsection 4.155 (.03) B. 3.b.

B379. The applicant's landscape plan and narrative confirm 40% of the parking area will be shaded by the proposed parking area trees.

B40.

Parking Area Internal Pedestrian Circulation

Subsection 4.155 (.03) B. 3.c.

B3841. Internal pedestrian walkways are provided throughout the parking area at a minimum of 5ft in width with safe connections to the building meeting this standard.

Parking Area Low-Screening

Subsection 4.155 (.03) B. 3.e.

B3942. The landscape plan shows landscape buffers of at least 12 feet in depth on the north and west perimeters of the parking area. These landscape buffers will be planted to meet the low screen standard to shield the parking from the adjacent right of way.

Bicycle Parking

Required Bicycle Parking

Section 4.155 (.04) A. 1.

B403. Office uses require one bicycle parking space per 5,000 square feet or a minimum of two (2) bicycle parking spaces. Warehouse uses require one bicycle parking space per 20,000 square feet or a minimum of two (2) bicycle parking spaces. Manufacturing requires the applicant to provide one (1) bicycle parking space for every 10,000 square feet or a minimum of 6. The requirement for the office portion of the site is four (4) bicycle parking spaces. The requirement for the warehouse portion of the site is four (4) bicycle parking spaces. The requirement for the warehouse portion of the site is eight (8) bicycle parking spaces. The overall requirement for the site is twelve (12) spaces. The applicant has proposed to provide ten (10) bicycle parking spaces. Condition of approval PDB 2 will require twelve (12) bicycle parking spaces are provided.

While the applicant provides bike racks on the property the code requires 50% of the total parking requirement for bicycles to be developed as long term bicycle parking spaces when six (6) or more bicycle parking spaces are required. Although the applicant's narrative states that the applicant will provide bicycle parking according to these standards long term bicycle parking is not shown on the plans. Condition of approval PDB2 will ensure 50% of the bicycle parking is long term parking.

Bicycle Parking Standards

Section 4.155 (.04) B.

B414. The applicant's plans show bicycle parking at the main entrance of the building and adjacent to the secondary entrance on the east side of the building. The applicant's narrative states that the bicycle parking spaces will comply with the 2' width and 6' length requirement with 5 feet of maneuvering space behind each space. Sheet A001 demonstrates compliance with this standard for the short term bicycle parking spaces, however this is not shown for the long term bicycle parking spaces, therefore a condition of approval PDB2 ensures compliance with this standard.

Other Parking Standards

Minimum Off-Street Loading Requirements

Section 4.155 (.05)

B425. The subject property will be a warehousing or manufacturing use. The building will include five (5) loading docks to facilitate the use of the site. Based on the square footage of the use two (2) off-street loading space would be required. The applicant provides five (5) off street loading berths meeting the size requirements of 12 feet wide, 35 feet long, with a height clearance of 14 feet.

Carpool and Vanpool Parking Requirements

Section 4.155 (.06)

B436. Condition of approval PDB 3 will require thirteen (13) of the provided parking spaces to be marked as carpool/vanpool in accordance to this standard.

Other Development Standards

Access, Ingress, and Egress

Section 4.167

B447. Site access is proposed in two locations with an access point from the south off of Xerox Drive and from the north off of Printer Parkway.

B48.

Natural Features and Other Resources

Section 4.171

B459. While the property is currently undeveloped and contains 22 trees located on site the arborist report did not identify trees of high enough quality to warrant preservation of the

trees. The applicant will follow development practices that align with the protection of natural features.

Outdoor Lighting

Sections 4.199.20 through 4.199.60

B4650. The outdoor lighting standards apply to the proposal is required to meet the Outdoor Lighting Standards. See Request C, Findings C47 through C51.

Underground Installation of Utilities

Sections 4.300-4.320

B4751. All utilities are required to be underground. Condition of approval PF 12 will ensure utilities are undergrounded as a part of the development.

Public Safety and Crime Prevention

Design for Public Safety, Surveillance and Access

Subsections 4.175 (.01) and (.03)

B4852. The proposed development is designed to a reasonable extent to deter crime and ensure public safety. The proposed development includes lighting throughout the parking area. The site has been designed in such a way that visibility is clear throughout the site.

Addressing and Directional Signing

Subsection 4.175 (.02)

B4953. Addressing will meet public safety standards. The building permit process will ensure conformance.

Lighting to Discourage Crime

Subsection 4.175 (.04)

B504. Lighting design is in accordance with the City's outdoor lighting standards, which will provide sufficient lighting to discourage crime.

Landscaping Standards

Landscaping Standards Purpose

Subsection 4.176 (.01)

B515. In complying with the various landscape standards in Section 4.176 the applicant has demonstrated the Stage 2 Final Plan is in compliance with the landscape purpose statement.

Landscape Code Compliance

Subsection 4.176 (.02) B.

B526. The applicant requests no waivers or variances to landscape standards. All landscaping and screening must comply with standards of this section.

Intent and Required Materials

Subsections 4.176 (.02) C. through I.

B537. The applicant's planting plan implements the landscaping standards and integrates general and low screen landscaping throughout the site, consistent with professional landscaping and design best practices. Plantings meeting the low screen standard will be utilized along the north and west perimeters of the parking areas.

Landscape Area and Locations

Subsection 4.176 (.03)

B548. The proposed development will exceed the 15% landscaping requirement. The subject property is 279,568 square feet and provides 56,210 square feet of landscaping which is 20.1% of the site. Of the 90,418 square feet of parking area, 27% or 24,416 square feet will be landscaped. 43% of the site's landscaping is within the parking area. The remaining 57% of landscaping is distributed throughout the site within stormwater swales and along the north, south and west property lines. Plantings are proposed along the entire frontage of SW Parkway Avenue to soften the appearance of the new building, as well as the parking areas of the site. The landscaping will include trees, shrubs, ground cover and grasses planted in parking areas, general landscape areas, and stormwater facilities.

Buffering and Screening

Subsection 4.176 (.04)

B559. The subject property is zoned PDI and borders PDI zoning to the north, east, and south with the I-5 Freeway to the west. Low-screen standards will be met on the perimeter of the parking areas on the north and west property lines to shield the parking area from public view and the right of way.

Landscape Plan Requirements

Subsection 4.176 (.09)

B560. The applicant's submitted landscape plans are drawn to scale and show the type, installation size, number and placement of materials. Plans include a plant material list identifying plants by both their scientific and common names. A note on the landscape plan indicates the irrigation method.

Street Improvement Standards

Development and Associated Improvement Standards

Subsection 4.177 (.01) and 4.262 (.01)

B5761. As required by these subsections, Conditions of Approval will ensure that improvements proportional to the impact of the proposed development are completed on Parkway Avenue and Printer Parkway in order to bring the streets into compliance with the City's Public Works Construction Standards and Transportation Systems Plan (TSP). See Exhibits A2 and A5 and findings F11- F15 for findings regarding the required improvements ~~and proportionality calculations.~~ Pursuant to the draft Memorandum of Understanding in

Exhibit A6, a Condition of Approval requiring the recording of a waiver of remonstrance against formation of a local improvement district (LID) will ensure that all improvements to Parkway Avenue and Printer Parkway are completed in order to bring the streets into compliance with the City's Public Works Construction Standards and Transportation Systems Plan (TSP).

Street Design Standards

Subsection 4.177 (.02) and 4.262 (.01)

B5862. Half street improvements consistent with the cross sections identified in the TSP are required along Parkway Avenue including street widening to accommodate a travel lane, one center median, curb, planter strip, street trees, buffered bike lane, sidewalk, streetlights and associated storm water facilities, along the site frontage on SW Parkway Avenue. See ~~Condition of Approval PF 2.~~ Improvements consistent with the cross sections identified in the TSP will also be required along Printer Parkway including street widening to accommodate two travel lanes, curb, planter strip, street trees, sidewalk, streetlights and associated stormwater facilities, along the site frontage on Printer Parkway. See ~~Condition of Approval PF 7.~~ In addition to the street improvements along Parkway Avenue and Printer Parkway, improvements are required to the southbound left-turn lane along SW Parkway Avenue to facilitate southbound left-turn movements at the intersection of SW Parkway Avenue and Printer Parkway. See ~~Condition of Approval PF 3.~~ Improvements are also required to the southbound left-turn lane along SW Parkway Avenue to facilitate southbound left-turn movements onto Xerox Drive, which is a private drive that will remain private at this time, at the intersection of SW Parkway Avenue and Xerox Drive. *Pursuant to the draft Memorandum of Understanding in Exhibit A6, to ensure all improvements are completed a Condition of Approval requires the recording of a waiver of remonstrance against formation of a local improvement district (LID) within 90 days from the Land Use Decision, prior to submittal of any City permits, or prior to Final Plat Review, whichever occurs first. See Condition of Approval PF 2.* See ~~Condition of Approval PF 5.~~ See finding B11 for additional information regarding traffic concurrency in relation to the required improvements.

Sidewalks

Subsection 4.177 (.03) and 4.262 (.03)

B5963. Sidewalks are required along street frontages for all developments at a minimum of 5 ft in width. Conditions of approval PF 2 ~~and PF 7~~ will ensure the construction of the required sidewalks along Parkway Avenue and Printer Parkway.

Bicycle Facilities

Subsection 4.177 (.04) and 4.262 (.0)

B604. In accordance with this subsection and the cross sections identified in the TSP, buffered bike lanes are required along Parkway Avenue. See ~~Condition of Approval PF 2.~~ *Condition of Approval PF 2 will ensure buffered bike lanes are constructed along Parkway Ave.*

Transit Improvements
Subsection 4.177 (.06)

B615. The proposed development will generate more than 49 or more pm peak hour trips and therefore a bus stop improvement consistent with the Public Work Standards shall be provided. ~~Condition of approval PF 8 will require~~ Condition of Approval PF 2 will ensure bus stop improvements along Printer Parkway including a bench, shelter and pedestrian lighting are constructed in accordance with this subsection.

Access Drives and Driveway Approaches
Subsection 4.177 (.08)

B626. The design of the access drives provides clear travel lanes, free from obstructions. The design shows all drive aisles as asphalt. The development shall take access via a drive aisle that connects Printer Parkway and Xerox Drive. Condition of Approval PF 3 requires the existing access onto Parkway Avenue is closed.

Mixed Solid Waste and Recyclables Storage

DRB Review of Adequate Storage Area, Minimum Storage Area
Subsections 4.179 (.01)

B637. The proposed development includes one combined solid waste and recyclable storage area within the building. The enclosure is shown on Sheets A001 and in Exhibit B2. The trash enclosure is 549 square feet. The minimum requirement for the site is 510 square feet based on the following calculations:

Building	Use	Size	Min. Storage
Administration Building	Office	20,263	81 square feet
Warehouse Building	Warehouse/Manufacturing	71,470	429 square feet

Review by Franchise Garbage Hauler
Subsection 4.179 (.07).

B648. The applicant’s Exhibit B1 contains a letter from Republic Services indicating coordination with the franchised hauler, and that the proposed storage area and site plan meets Republic Services requirements.

Request C: Site Design Review (SDR22-0009)

As described in the Findings below, the request meets the applicable criteria or will by Conditions of Approval.

Site Design Review

Excessive Uniformity, Inappropriateness Design
Subsection 4.400 (.01) and Subsection 4.421 (.03)

C1. Staff summarizes the compliance with this subsection as follows:

Excessive Uniformity: The proposed development is unique to the particular development context and does not create excessive uniformity.

Inappropriate or Poor Design of the Exterior Appearance of Structures: While the applicant used appropriate professional services to design structures on the site using quality materials and design the new industrial flex building is lacking in articulation on portions of the building, particularly on the northwest corner along the I-5 frontage. Along this frontage, the building design relies primarily on variation in paint color in an attempt to break up the massing of the building, which will be a large tilt up concrete building. Without variation in articulation or materials, the massing of the building is overwhelming in scale and monotonous. As the proposed project is adjacent to the I-5 Freeway, it will be a prominent building in Wilsonville. The building will be one of the first large industrial developments seen by travelers in vehicles headed south on I-5. Due to the prominence of the building and lack of articulation or variation in materials on this corner, it is staff's recommendation that the design is enhanced to meet the standards of this section and reflect the City's goal of harmonious development. Condition of approval PDC 7 will require the addition of architectural articulation and variation in materials on the northwest corner of the building in order to enhance the appearance of the building.

Inappropriate or Poor Design of Signs: No building signs are proposed.

Lack of Proper Attention to Site Development: The applicant employed the skills of the appropriate professional services to design the site, demonstrating appropriate attention to site development.

Lack of Proper Attention to Landscaping: The applicant proposes landscaping exceeding the area requirements professionally designed by a landscape architect, incorporating a variety of plant materials, demonstrating appropriate attention to landscaping.

Objectives and Standards of Site Design Review

Proper Functioning of the Site

Subsection 4.400 (.02) A. and Subsection 4.421 (.03)

C2. The professionally designed site demonstrates significant thought to make the site functional and safe. A drive aisle wide enough for two-way traffic, standard size parking stalls, a complete pathway network, and access meeting City standards are among the site design features contributing to functionality and safety.

High Quality Visual Environment

Subsection 4.400 (.02) A. and Subsection 4.421 (.03)

C3. The project includes professionally designed building, landscaping and a professional, site specific, layout supports a quality visual environment. Landscaping is thoughtfully planted along the sidewalk to both provide shade and enhance the visual environment. Condition of approval PDC 7 will ensure the building's architecture is enhanced at the northwest corner.

Encourage Originality, Flexibility, and Innovation

Subsection 4.400 (.02) B. and Subsection 4.421 (.03)

- C4. The applicant proposes buildings, landscaping, and other site elements professionally designed specifically for the site. Sufficient flexibility exists to fit the planned development within the site without seeks waivers or variances.

Discourage Inharmonious Development

Subsection 4.400 (.02) C. and Subsection 4.421 (.03)

- C5. As indicated in Findings C1, C3, and C8 while the professional unique design of landscaping a high quality visual environment and thus prevent monotonous, drab, unsightly, dreary development the façade of the proposed building has not met this objective. Variation in materials is applied at the entrances of the buildings but not throughout the façade, particularly adjacent to the high-visibility I-5 frontage. Paint is relied on as the sole technique to break up the massing of the façade. Condition of approval PDC 7 ensure the building's architecture is enhanced at the building's northwest corner to meet this objective. Use of long lasting materials as well as landscaping will make the site more harmonious with adjacent and nearby development.

Proper Relationships with Site and Surroundings

Subsection 4.400 (.02) D. and Subsection 4.421 (.03)

- C6. The applicant prepared a professional site-specific design that carefully considers the relationship of the building, landscaping, and other improvements with other improvements on and adjacent to the site, existing and planned.

Regard to Natural Aesthetics

Subsection 4.400 (.02) D. and Subsection 4.421 (.03)

- C7. The site contains does not have native vegetation of high enough quality to warrant preservation. While they will not retain natural features the applicant will be replanting a variety of trees onsite including natives such as vine maples and western red cedars.

Attention to Exterior Appearances

Subsection 4.400 (.02) D. and Subsection 4.421 (.03)

- C8. The applicant used appropriate professional services to design the exterior of the building. Section 4.421 (.03) authorizes the Development Review Board to apply the objectives outlined in the purpose statement of Section 4.400 as additional criteria and standards for site design review. The main entrance of the building has been emphasized through the addition of a rust colored metal panel emphasizing the prominence of the entrance and breaking up the large massing of the building which in turn will present as a more comfortable scale for pedestrians entering the building. Red cedar, glazing and dark brown coping are also utilized in the façade surrounding the entrance of the building to differentiate from the rest of the building and create a more aesthetically pleasing look. While attention has been paid to enhancing the entrances of the building, the majority of

the building relies on variation in paint color without incorporating material variation or articulation in the design. Given this, a condition of approval PDC 7 will ensure the building's architecture is enhanced to break up the excessive uniformity present throughout the majority of the façade. See Finding C1 for additional details regarding how the proposed design is does not achieve the objective of preventing excessive uniformity and inappropriate design by discouraging monotonous developments.

ELEVATION DESIGN
NE Approach View



ELEVATION DESIGN
NW Approach View



ELEVATION DESIGN

SW Approach View



Protect and Enhance City's Appeal

Subsection 4.400 (.02) E. and Subsection 4.421 (.03)

- C9.** The applicant is proposing a new industrial flex building. The proposed development will enhance the appeal of the city by creating job opportunities and utilizing available land within the City.

Stabilize Property Values/Prevent Blight

Subsection 4.400 (.02) F. and Subsection 4.421 (.03)

- C10.** The applicant is developing an undeveloped site within the city, and thus prevents blight.

Adequate Public Facilities

Subsection 4.400 (.02) G. and Subsection 4.421 (.03)

- C11.** As found in the Stage 2 Final Plan review, see Request B, adequate public facilities serve the site or will with conditions of approval.

Pleasing Environments and Behavior

Subsection 4.400 (.02) H. and Subsection 4.421 (.03)

- C12.** The proposed development provides a clearly defined layout and is designed in a configuration that meets defensible space guidelines such as the inclusion of clear sightlines that allow for surveillance and clearly identified structures.

Civic Pride and Community Spirit

Subsection 4.400 (.02) I. and Subsection 4.421 (.03)

- C13.** The proposed development will help foster civic pride and community spirit as it supports the City's long standing successful industrial areas that are central to the City's identity.

Favorable Environment for Residents

Subsection 4.400 (.02) J. and Subsection 4.421 (.03)

- C14.** Adding a new industrial development with a quality design will create jobs, improve the surrounding industrial area, and provide a favorable environment to residents and potential employees.

Jurisdiction and Power of the DRB for Site Design Review

Development Must Follow DRB Approved Plans

Section 4.420

- C15.** Condition of Approval PDC 1 ensures construction, site development, and landscaping are carried out in substantial accord with the Development Review Board approved plans, drawings, sketches, and other documents. The City will not issue any building permits for portions of the improvements requiring DRB review prior to DRB approval.

Design Standards

Preservation of Landscaping

Subsection 4.421 (.01) A.

- C16.** The development will occupy the entirety of the site and thus natural features will not be retained. Due to the nature of the industrial building it is not practical to preserve the existing trees that will be in the path of the loading trucks. No substantial changes to the existing elevation are proposed.

Harmony of Proposed Buildings to Environment

Subsection 4.421 (.01) B.

- C17.** The applicant used appropriate professional services to design the exterior of the building to ensure harmony with the environment. The area surrounding the subject property is predominantly industrial. The applicant has utilized materials that relate to the existing brick buildings throughout the adjacent industrial campus with a modern perspective. The orange rust color incorporated throughout provides an accent color that reflects the current aesthetic. The applicant has utilized materials that are typically employed in industrial development, but has utilized a variety of colors, materials, and textures to add interest and create harmony with the adjacent environment. Condition of approval PDC 7 will ensure that the design of the building is enhanced. Landscaping is included around all structures to either enhance the appearance of or screen industrial uses.

Special Attention to Drives, Parking, and Circulation- Access Points

Subsection 4.421 (.01) C.

C18. All new access points are existing and will be conditioned to meet City standards. No changes are proposed to existing access points.

Special Attention to Drives, Parking, and Circulation- Interior Circulation
Subsection 4.421 (.01) C.

C19. The interior circulation is at least 24 feet wide allowing for adequate space for pulling out of the individual spaces and for two-way traffic to pass. The loading area is separate from the main parking areas preventing conflict between pedestrians and freight vehicles.

Special Attention to Drives, Parking, and Circulation- Pedestrian and Vehicle Separation
Subsection 4.421 (.01) C.

C20. The design separates pedestrian and vehicle circulation except at necessary cross walks. Pedestrian connections are provided throughout the parking area for safe access.

Special Attention to Drives, Parking, and Circulation- Safe and Convenient Parking Areas
Subsection 4.421 (.01) C.

C21. The applicant has worked with a professional design team to ensure the new parking area is safe and convenient. The parking area is conveniently located for access to the building. The parking space size and drive aisle width is a typical design allowing adequate area for safe maneuvering.

Special Attention to Drives, Parking, and Circulation- Parking Detracting from Design
Subsection 4.421 (.01) C.

C22. The proposed development adequately separates vehicular and pedestrian traffic. Drive aisles and crosswalks are clearly indicated. The proposed parking areas are convenient and designed to be screened from off site view either through landscaping or by being located below grade.

Special Attention to Surface Water Drainage
Subsection 4.421 (.01) D.

C23. The proposed development provides parking areas which will contain water quality features consistent with City standards. These features are dispersed throughout the parking lot and will help improve water quality throughout the property. Four facilities are included as part of the development in the following locations: the east and west corners of the northern parking area and the east perimeter and center of the southern parking area. The proposed improvements will not adversely affect neighboring properties through the storm drainage system.

Indication of Sewage Disposal
Subsection 4.421 (.01) E.

C24. All sewage disposal will be via standard sewer connections to City sewer lines found to be adequate to serve the site as part of the Stage 2 Final Plan.

Advertising Features Do Not Detract

Subsection 4.421 (.01) F.

C25. No signs or advertising features are proposed with this development.

Screening and Buffering of Special Features

Subsection 4.421 (.01) G.

C26. The applicant does not propose any special features requiring additional screening or buffering.

Design Standards Apply to All Buildings, Structures, Signs, and Features

Subsection 4.421 (.02)

C27. No accessory structures or signs are proposed with this development.

Conditions of Approval to Ensure Proper and Efficient Function

Subsection 4.421 (.05)

C28. Staff does not recommend any additional conditions of approval to ensure the proper and efficient functioning of the development.

Color or Materials Requirements

Subsection 4.421 (.06)

C29. The colors and materials proposed by the applicant are appropriate but not incorporated throughout. Condition of approval PDC 7 will require a variation in materials or articulation at the northwest corner of the proposed building.

Standards for Mixed Solid Waste and Recycling Areas

Mixed Solid Waste and Recycling Areas Colocation

Subsection 4.430 (.02) A.

C30. The proposal provides an interior storage area for both solid waste and recyclables.

Exterior vs Interior Storage, Fire Code, Number of Locations

Subsections 4.430 (.02) C.-F.

C31. The applicant proposes a single interior location. Review of the Building Permit will ensure meeting of building and fire code.

Collection Vehicle Access, Not Obstruct Traffic or Pedestrians

Subsections 4.430 (.02) G.

C32. The applicant has included a letter from Republic Services in Exhibit B1 which indicates the location and arrangement is accessible to collection vehicles. The location of the storage area does impede sidewalks, parking area aisles, or public street right-of-way.

Dimensions Adequate to Accommodate Planned Containers
Subsections 4.430 (.03) A.

- C33. Pursuant to a letter from Republic Services in Exhibit B1, the dimensions are adequate to accommodate the planned containers.

Site Design Review Submission Requirements

Submission Requirements
Section 4.440

- C34. The applicant submitted a site plan drawn to scale and a detailed landscape plan.

Time Limit on Site Design Review Approvals

Void after 2 Years
Section 4.442

- C35. The Applicant plans to develop the proposed project within two years and understands that the approval will expire after two years unless the City grants an extension.

Installation of Landscaping

Landscape Installation or Bonding
Subsection 4.450 (.01)

- C36. Condition of Approval PDC 2 will assure installation or appropriate security.

Approved Landscape Plan Binding
Subsection 4.450 (.02)

- C37. Condition of Approval PDC 3 provides ongoing assurance approved landscaping is installed and maintained.

Landscape Maintenance and Watering
Subsection 4.450 (.03)

- C38. Condition of Approval PDC 4 will ensure continual maintenance of landscaping in a substantially similar manner as originally approved by the Board.

Limitation to Modifications of Landscaping
Subsection 4.450 (.04)

- C39. Condition of Approval PDC 4 provides ongoing assurance of conformance with this criterion by preventing modification or removal without the appropriate City review.

Landscaping Standards

Shrubs and Groundcover Materials Requirements
Subsection 4.176 (.06) A.

C40. Condition of Approval PDC 5 requires meeting the detailed requirements of this subsection. Of particular note, the applicant's landscape plan, shows at least 2-gallon containers for shrubs and 1-gallon containers for groundcover. A combination of over 700 shrubs were selected for planting including kaleidoscope abelia, golden euyonmus, compact escallonia, gulf stream heavenly bamboo, fire power heavenly bamboo, ballerina Indian hawthorne. Ground cover plantings will include bearberry kinninnick and colorata wintercreeper.

Plant Materials Requirements-Trees

Subsection 4.176 (.06) B.

C41. As stated on the applicant's landscape plans, the plant material requirements for trees will be met as follows:

- Trees are B&B (Balled and Burlapped)
- Tree are 2" caliper.

A mix of trees has been selected to be planted throughout the site in appropriate locations including green vase zelkova, green spire little leaf linden, western red cedar, kousa dogwood, Armstrong red maple, and vine maples.

Plant Species Requirements

Subsection 4.176 (.06) E.

C42. The applicant's landscape plan provides sufficient information showing the proposed landscape design meets the standards of this subsection related to use of native vegetation and prohibited plant materials.

Landscape Installation and Maintenance Standards

Subsection 4.176 (.07)

C43. The installation and maintenance standards are met or will be met by Condition of Approval PDC 6 as follows:

- Plant materials are required to be installed to current industry standards and be properly staked to ensure survival.
- Within one growing season, the applicant must replace in kind plants that die, unless the City approves appropriate substitute species.
- Notes on the applicant's landscape plans provides for an irrigation system.

Landscape Plan Requirements

Subsection 4.176 (.09)

C44. The applicant's landscape plan shows all existing and proposed landscape areas. The to-scale plans show the type, installation size, number and placement of materials. Plans include a plant material list. Plants identification is by both their scientific and common names.

Completion of Landscaping

Subsection 4.176 (.10)

C45. The applicant has not requested to defer installation and thus must install landscaping prior to occupancy.

Outdoor Lighting

Applicability of Outdoor Lighting Standards

Sections 4.199.20 and 4.199.60

C46. The proposed development will install new lighting throughout the parking area and site for safety and function thus the outdoor lighting standards apply.

Outdoor Lighting Zones

Section 4.199.30

C47. The subject property is within LZ2.

Optional Lighting Compliance Methods

Subsection 4.199.40 (.01) A.

C48. The applicant has the option of the performance or prescriptive method. The applicant has selected to comply with the performance method.

Maximum Lamp Wattage and Shielding

Subsection 4.199.40 (.01) C. 1. and Table 9

C49. The applicant has selected the performance option for the project's outdoor lighting design. The applicant's narrative states that the proposed luminaires comply with the maximum percentage of direct upright lumens and shielding requirements within Table 9. The photometric diagram is included in Exhibit B2.

Maximum Mounting Height

Subsection 4.199.40 (.01) C. 3.

C50. Nothing in the applicant's materials indicates the maximum mounting height will be surpassed.

Lighting Curfew

Subsection 4.199.40 (.01) D.

C51. The applicant proposes the standard LZ 2 curfew of 10 PM.

Request D: Type C Tree Removal Plan (TPLN22-0007)

Type C Tree Removal-General

Tree Related Site Access

Subsection 4.600.50 (.03) A.

D1. It is understood the City has access to the property to verify information regarding trees.

Review Authority

Subsection 4.610.00 (.03) B.

- D2.** The requested removal is connected to site plan review by the Development Review Board for new development. The tree removal is thus being reviewed by the Development Review Board.

Conditions of Approval

Subsection 4.610.00 (.06) A.

- D3.** No additional conditions are recommended pursuant to this subsection.

Completion of Operation

Subsection 4.610.00 (.06) B.

- D4.** It is understood the tree removal will be completed prior to construction of the proposed building, which is a reasonable time frame for tree removal.

Security for Permit Compliance

Subsection 4.610.00 (.06) C.

- D5.** No bond is anticipated to be required to ensure compliance with the tree removal plan as a bond is required for overall landscaping.

Tree Removal Standards

Subsection 4.610.10 (.01)

- D6.** The standards of this subsection are met as follows:
- Standard for the Significant Resource Overlay Zone: No trees proposed for removal are located in the SROZ.
 - Preservation and Conservation. The arborist report inventoried 50 trees located on the subject property. Of the 50 trees inventoried, 21 are located on future Parcel 5 where the development will occur. Of the 21 trees located on the development site one was confirmed dead by the arborist and another was confirmed to have a DBH less than 6 inches and therefore does not count toward mitigation requirements. The tree species on site are a mix of native and non-native trees including, Oregon white oak, ponderosa pine, Douglas fir, black pine, red oak, western red cedar, Norway maples, sweet cherry, English Hawthorne and Oregon ash. The applicant proposes to preserve thirty one (31) of the existing trees all on future Parcel 6. 19 trees are proposed for removal on future Parcel 5. The applicant proposes to plant 108 new trees to mitigate for the 19 trees proposed for removal, which exceeds the 1:1 mitigation requirement. Condition of approval PDD 4 will ensure that protective fencing is placed around the drip line of preserved trees prior to site grading or other site work that could damage the trees.
 - Development Alternatives: The proposed tree removal has been minimized to the extent possible in order to redevelop the subject property.

- Land Clearing: Land clearing and grading is proposed and will be limited to areas necessary for construction of the proposed building, structures, and other site improvements.
- Compliance with Statutes and Ordinances: The necessary tree replacement and protection is planned according to the requirements of the tree preservation and protection ordinance.
- Limitation: Tree removal is limited to where it is necessary for construction (as discussed in Development Alternatives above) or to address nuisances or where the health of the trees warrants removal.
- Additional Standards: A tree survey has been provided, and no utilities are proposed to be located where they would cause adverse environmental consequences.

Review Process

Subsection 4.610.40 (.01)

D7. The plan is being reviewed concurrently with the Stage 2 Final Plan.

Tree Maintenance and Protection Plan

Section 4.610.40 (.02)

D8. The applicant has provided information on tree maintenance and protection in Exhibit B1 sheet C003. The tree protection fencing shown indicates fencing around the trees preserved to the east of the site, however no tree protection fencing is shown on Parcel 5 where development will occur as no trees are proposed for preservation.

Replacement and Mitigation

Tree Replacement Requirement

Subsection 4.620.00 (.01)

D9. The applicant proposes removing 19 trees and replanting 108 trees as mitigation on the project site, exceeding a one-to-one ratio and the requirements of this subsection.

Basis for Determining Replacement and Replacement

Subsection 4.620.00 (.02) and (.03)

D10. Replacement trees will meet the minimum caliper and other replacement requirements. Tree species selected for replacement include October glory red maple, espresso Kentucky coffee tree, Armstrong red maple, kousa dogwood, blue Colorado spruce, western red cedar, green spire little leaf linden, green vase zelkova and vine maple. This mix of evergreen and deciduous trees are compatible for the function of the site while maintaining a diversity of species.

Replacement Tree Stock Requirements

Subsection 4.620.00 (.04)

D11. The planting notes on the applicant's Sheet L101 in Exhibit B2 indicate the appropriate quality.

Replacement Trees Locations
Subsection 4.620.00 (.05) A.

D12. The applicant proposes to mitigate for all removed trees on site and in the appropriate locations for the proposed development.

Protection of Preserved Trees

Tree Protection During Construction
Section 4.620.10

D13. Condition of Approval PDD 4 ensures the applicable requirements of this section will be met.

Request E: Tentative Partition Plat (PART22-0002)

Land Division Authorization

Plat Review Authority
Subsection 4.202 (.01) through (.03)

F1. The tentative partition plat is being reviewed by the Development Review board as is it is associated with a development proposal. The final plat will be reviewed by the Planning Division under the authority of the Planning Director to ensure compliance with the tentative partition plat.

Legally Lot Requirement
Subsection 4.202 (.04) A.

F2. It is understood that no parcels will be sold or transferred until the final plat has been approved by the Planning Director and recorded.

Undersized Lots Prohibited
Subsection 4.202 (.04) B.

F3. No parcels will be divided into a size smaller than allowed by the Planned Development Industrial Zone designation. There is no minimum lot size in the PDI zone. The resulting two parcels are 6.418 acres (Parcel 5) and 78.725 acres (Parcel 6).

Plat Application Procedure

Pre-Application Conference
Subsection 4.210 (.01)

F4. A pre-application conference (PA21-0024) was held on November 18, 2021 in accordance with this subsection.

Tentative Plat Preparation
Subsection 4.210 (.01) A.

- F5. The applicant's Exhibit B2 Part "B" includes a preliminary partition plat prepared in accordance with this subsection.

Tentative Plat Submission
Subsection 4.210 (.01) B.

- F6. The tentative partition plat has been submitted with the required information.

Phases to Be Shown
Subsection 4.210 (.01) D.

- F7. No phasing for development or improvements to the subject property has been submitted.

Remainder Tracts
Subsection 4.210 (.01) E.

- F8. All affected property has been incorporated into the tentative partition plat.

Street Requirements for Land Divisions

Adjoining Streets Relationship
Subsection 4.236 (.02)

- F9. No new streets are required or proposed related to the subject partition. However, improvements to Parkway Avenue and Printer Parkway are required as conditions of approval to bring the street up to City standards. Printer Parkway is also to be dedicated to the City in accordance to the Transportation System Plan.

General Land Division Requirements- Easements

Utility Line Easements
Subsection 4.237 (.02) A.

- F10. New utility line easements will be required for public water lines, sewer, stormwater and all private utilities. See Condition of Approval PF 19 and Exhibit B2 "Part B" sheets 1-4.

General Land Division Requirements- Lot Size and Shape

Lot Size and Shape Appropriate
Subsection 4.237 (.05)

- F11. The proposed parcels meet the minimum lot width, depth, and size standards.

Lot Size and Shape Meet Zoning Requirements
Subsection 4.237 (.05)

- F12. The proposed parcels meet the requirements of the PDI zone, where there is no minimum. See Finding F3. The proposed lot shapes are consistent with other lots within the surrounding area.

On-Site Sewage Disposal
Subsection 4.237 (.05) A.

F13. The property is currently served by public sewer; therefore an on-site sewage disposal permit is not required from the City.

Appropriate Commercial and Industrial Lots
Subsection 4.237 (.05) B.

F14. Parking on Parcel 6 will not be impacted by the land division or development. Adequate parking is provide for both the existing building and future development. See findings B29-B30 for Parcel 5's parking details.

Lot Size and Width for Planned Developments
Subsection 4.237 (.05) C.

F15. The proposed partition has two (2) industrial lots ranging in size from 6.418 square feet to 78.725 square feet. There is no minimum lot size in the PDI zone.

General Land Division Requirements- Access

Minimum Street Frontage
Subsection 4.237 (.06)

F16. There is no minimum street frontage requirement in the PDI zone.

Standards Applying to Planned Development Industrial Development

Minimum Front Yard Setback
Subsection 4.135 (.06) C.

F17. The existing building on Parcel 6 is set back 136 feet from SW Parkway Avenue at its closest point, the northeast corner, and continues to conform to the minimum 30 foot setback. The building proposed on Parcel 5 will be setback 112 feet from SW Parkway Avenue.

Minimum Side Yard Setback
Subsection 4.135 (.06) D.

F18. The minimum side setback is 30 feet. The existing building on Parcel 6 will continue to meet the 30' setback requirement on the east side of the parcel. The setback on the west side will not be impacted by the proposed partition and the 30' setback will continue to be met. The future building on Parcel 5 will be setback 30' from Parkway Avenue and 100' from Parcel 6 meeting the 30' setback requirement.

Minimum Rear Yard Setback
Subsection 4.135 (.06) D.

F19. The existing building on Parcel 6 is set back 144 feet from Xerox Drive at its closest point, the southwest corner, exceeding the 30-foot minimum. The proposed building on Parcel 5 is setback 313 feet from Xerox Drive, exceeding the 30-foot minimum.

General Land Division Requirements- Other

Through Lots

Subsection 4.237 (.07)

- F20.** The existing property where the proposed partition will occur is on an existing through lot. No additional requirements will be applied.

Lot Side Lines

Subsection 4.237 (.08)

- F21.** The existing parcel proposed for partition is irregularly shaped thus achieving right angles is challenging. The side lot lines are as perpendicular with the roadways as possible with the existing site constraints.

Large Lot Divisions

Subsection 4.237 (.09)

- F22.** There is no indication that the partition of this parcel will prevent future division.

Land for Public Purposes

Subsection 4.237 (.12)

- F23.** No property reservation is recommended as described in this subsection.

Corner Lots

Subsection 4.237 (.13)

- F24.** The corner radius on Parcel 5 currently meets the 10' requirement and no changes to this corner radius are proposed.

Lots of Record

Defining Lots of Record

Section 4.250

- F25.** The existing parcel is a lot of record, and the resulting parcels will be of record.

EXHIBIT A5

Supplemental *Nollan/Dolan* Findings

These Supplemental *Nollan/Dolan* Findings are in response to issues raised at the December 11, 2023 public hearing before the Development Review Board concerning case file DB22-0009 for the Parkworks Industrial Building and Partition development application (the “Proposed Development”).

I. INTENDED PLAN FOR FINANCING AND CONSTRUCTING OFF-SITE STREET IMPROVEMENTS

As noted in the Staff Report and the revised Conditions of Approval, the City and Applicant have identified an alternative path to fund and construct the needed off-site improvements related to the reconstruction of SW Parkway Avenue (“Parkway”) and the construction of SW Printer Parkway (“Printer Parkway”). The Staff Report and revised Conditions of Approval no longer require Applicant to construct the required improvements, and instead, City staff, based on negotiations with the Applicant, recommend pursuing a local improvement district to finance the City’s construction of Parkway and Printer Parkway.

Notwithstanding this alternate approach to funding and construction of Parkway and Printer Parkway, arguments were presented both prior to and at the public hearing as to whether the City had an “essential nexus” to require Applicant to construct the off-site improvements and whether Applicant’s financial responsibility for the improvements were “roughly proportional” to the Proposed Development’s impact on the public systems. Thus, the City submits these supplemental *Nollan/Dolan* findings in response to those arguments that are on the record. To be clear, the revised Conditions of Approval no longer require Applicant to construct Parkway and Printer Parkway, and so the City does not anticipate that a *Nollan/Dolan* challenge to the prior Conditions of Approval is forthcoming, but wants to ensure that it preserves any arguments if such a challenge is made.

II. SUPPLEMENTAL *NOLLAN/DOLAN* FINDINGS

1. An Essential Nexus Exists to Require the Off-Site Improvements

Applicant argued that the City has not demonstrated that an essential nexus exists between the impact of the Proposed Development and the off-site improvements the City previously sought to require for Parkway and Printer Parkway. To show an essential nexus, the City must demonstrate that it could otherwise deny the Application if the improvements are not done with the Proposed Development. *Pengilly v. Multnomah County*, 810 F. Supp. 1111, 1112 (D. Or. 1992) (citing *Nollan v. California Coastal Commission*, 483 U.S. 825, 837 (1987)). The City may require these improvements for the following reasons, and could otherwise deny the Application if Applicant does not construct the improvements:

- Applicant proposes an industrial development with freight traffic and other traffic accessing the site from both Parkway (via Xerox Drive) and Printer Parkway. The current



street infrastructure is not constructed to standards that accommodate freight and other urban-level traffic. Adjacent to the Proposed Development, Parkway is a 45-mph street constructed to county standards, that anticipate more rural types of uses (no bicycle, pedestrian, or other types of alternative transportation options) and less frequent use. Additional industrial development increases conflicts between vehicle traffic, bicycles, and pedestrians, and, importantly, freight traffic speeding up, slowing down, turning, and traveling at 45-mph speeds, and such conflicts can be fatal. Printer Parkway is a private drive that has never been constructed to a public street standard. The risk of injury, damage, and loss of life is much higher on Parkway and Printer Parkway when utilized by industrial development than on other streets with less intense uses. Thus, the Proposed Development causes traffic safety concerns that require a left turn lanes at Printer Parkway and Xerox Drive, medians to accommodate vehicles that are speeding up or slowing down to and from these access points and to reduce the probability of vehicle crashes, as well as protected bicycle lanes to prevent vehicle and bicycle crashes. *See* Attachment 2 to Exhibit A2 (DKS Traffic Impact Analysis), pp. 17-18; Attachment 3 to Exhibit A2 (DKS Proportionate Share Evaluation), pp. 2-3.

- The City specifically designates freight routes like Parkway for industrial development like the Proposed Development and requires enhanced improvements to minimize risks and protect all travelers on Parkway. *See* Attachment 1 to Exhibit A2, pp. 11-12. Applicant's Proposed Development is exactly the type of use that triggers these improvements to be made to City streets.
- If Applicant does not provide the necessary street improvements, access to the site will be required by way of Canyon Creek Road instead of Parkway to avoid safety issues, as it is the only improved urbanized facility adjacent to the site.
- The Proposed Development lacks access for multimodal transportation, as there is no existing bicycle lane and no ADA-compliant sidewalk along Parkway. Printer Parkway, as a current private drive, does not have any bicycle lane or sidewalk. The lack of these required transportation systems to the Proposed Development is grounds to deny the Application if they are not provided. Bicycle lanes and sidewalks are required components of development, which must not only accommodate them onsite, but also provide the off-site facilities to access the onsite facilities (e.g., onsite bicycle storage is required for developments and thus, bicycle lanes on adjacent roadways are also required).
- Pre-existing safety issues do not alleviate Applicant's requirement to construct the off-site improvements when Applicant contributes to those safety issues. *See* Exhibit A2, pp. 27-30.

The essential nexus to require the improvements for Parkway and Printer Parkway has been established. Again, however, the Staff Report and proposed, revised Conditions of Approval do not contemplate Applicant constructing such improvements as part of development approval.

2. If Applicant Constructs, Applicant Is Financially Responsible for Roughly 19.0% of the Parkway Improvements

Applicant has alleged that, if it is required to construct the improvements on Parkway, it will be responsible for more than 19.8% of the Parkway improvements. As explained in Exhibit A-2, Applicant is only financially responsible for **19.0%** of Parkway improvements from median to face-of-curb. Even taking into account the sidewalk and planter strip, which increases the percentage responsibility to 24%, Applicant seeks to increase building square-footage by almost 24% (23.7%) (*see* Attachment 4¹, page 2) and to increase vehicle parking by over 23% (*see* Exhibit A-2, page 30). Thus, Applicant's impacts are roughly proportional to Applicant's impact on the transportation system.

Applicant questioned that, if it was only responsible for 19.8% of Parkway improvements, why were some of the percentages in the City's calculations different than 19.8%. The 19.8% figure is derived from additional vehicle trips that the Proposed Development will add to Parkway compared to the rest of the industrial campus. As noted above, from face of curb to the turn lane/median, the City calculated the Applicant's proportionate share as equal to 19.0% of the improvements to Parkway.

The only portion of the cross-section of the right-of-way for Parkway that the City assigned a percentage higher than 19.8% was the bicycle lane, where the City portioned that as 80% the responsibility of the Applicant and 20% the responsibility of the City. Since a bicycle lane does not exist, and the Proposed Development contemplates [insert] onsite bicycle facilities, the Proposed Development's impact is significantly higher than current bicycle usage on Parkway. The City assigned 20% responsibility to the City for the two-foot buffer between the bicycle lane and the northbound vehicle travel lane as representative of the "oversized" portion of the bicycle lane. However, even with the 80% responsibility assigned to the Proposed Development for the bicycle lane, the Applicant is only financially responsible for 19.0% of the Parkway improvements from median to face-of-curb.

3. Requiring "Oversizing" with City Compensation Is Allowed under Oregon Law

Applicant appears to imply that being required to build the improvements, even though the City will compensate for improvements beyond Applicant's rough proportionality, is unconstitutional. Applicant offers no legal basis for this argument. Regardless, requiring construction of off-site public improvements, even if a portion of the improvements are beyond the impact of private development, is commonplace so long as the government compensates the developer for the "oversized" portion of the improvement. For example, if a development needs an 8" water line, but the overall system needs a 12" line, the government pays back to the developer (usually in the form of SDC credits) for the cost of the additional 4" of capacity. Similarly, if an improved street is needed for a development, as is the case here, but the development is not the sole reason that the improved street is needed, the government pays for that portion that is over and above the development's impact. As explain in Section 1 above, the Proposed Development needs to have the Parkway and Printer Parkway improvements done to construct and operate the Proposed Development. The City acknowledges that Applicant is not fully responsible for these costs and

¹ References to Attachments 1-13 refer to the Attachments to Exhibit A2.

thus will compensate Applicant for the costs that are above Applicant's roughly proportionate share.

Government paying for improvements that are beyond the financial responsibility of an applicant is exactly what constitutional takings analysis examines and the purpose of SDC credits as provided under Oregon law. Under the Oregon SDC statutes, local government is required to provide a means of issuing credits when development constructs public improvements that are larger than what is needed for the specific development. ORS 223.304 explains:

“(4) The ordinance or resolution that establishes or modifies an improvement fee shall also provide for a credit against such fee for the construction of a qualified public improvement. A ‘qualified public improvement’ means a capital improvement that is required as a condition of development approval, identified in the plan and list adopted pursuant to ORS 223.309 and either:

- (a) Not located on or contiguous to property that is the subject of development approval; or
- (b) Located in whole or in part on or contiguous to property that is the subject of development approval and required to be built larger or with greater capacity than is necessary for the particular development project to which the improvement fee is related.”
(emphasis added).

If the City were to require Applicant to construct Parkway, the City would meet the constitutional takings requirements by compensating Applicant for the larger/greater capacity portion of the Parkway improvements.

4. Parkway Industrial Campus Responsible for Parkway Half-Street Improvement; Proposed Development Accounts for 19.8% of that Responsibility

Applicant's main argument is that it should only be responsible for 2.8% of Parkway improvements because it is projected to generate only 2.8% of all Parkway traffic. Applicant believes that all Parkway traffic should be evaluated, not just the industrial campus's traffic. As discussed in Exhibit A2, the industrial uses on the campus generate sufficient traffic to justify that the campus be responsible for upgrading the half-street of Parkway. *See* Exhibit A2, pp. 27-30. Thus, the City assigns Applicant's responsibility for the half-street improvements compared to the rest of the campus.

By way of example, a new master planned residential community may be responsible for the half-street improvement of an adjacent street, but each subdivision within that master planned area is only financially responsible for its proportionate share.

There is no evidence that Applicant's responsibility for Parkway improvements was vested under prior development approvals. In fact, the only evidence in the record states that each individual development would be evaluated to determine its proportionate share. *See* Attachment 11 to

Exhibit A2 (1997 Traffic Study), pp. 2-3. Thus, Applicant is responsible for its proportionate share of the Parkway improvements related to the larger industrial campus.

5. Construction of Printer Parkway Half-Street Improvements

Applicant entered no evidence in the record contradicting the City's findings regarding the Printer Parkway requirements and rough proportionality. Applicant also provided no evidence or argument against the City's finding that Applicant is currently out of compliance with its 2016 development approval regarding Printer Parkway. Thus, all Printer Parkway evidence, findings, and compliance resolution offered by the City in Exhibit A-2 justify the Printer Parkway half-street improvement requirements.

The City also reiterates that Printer Parkway is the main access point and possible future bus route and bus stop for the Proposed Development. *See* WC 4.177(.06). Applicant identifies the driveway at Printer Parkway to be the location where most (if not all) of its freight traffic will access the site. Printer Parkway, thus, cannot be treated as an afterthought, implying that it does not need to be improved.

6. Benefits to Applicant from Off-Site Improvements Can Be Considered

Applicant argued at the public hearing that Board cannot consider benefits to Applicant's development as part of the *Nollan/Dolan* analysis – that the Board is limited to considering only the impacts of the development on public systems. However, benefits to the development can be considered. The Oregon Court of Appeals explained that benefits can be part of a *Dolan* analysis:

“It is probably impossible to formulate a universal rule concerning how ‘benefits’ of that kind are to be factored into the rough proportionality calculus. Nonetheless, it is clear that, insofar as the facts of particular cases may indicate, conditions that in whole or in part serve the needs of the development itself should be weighed differently than pure ‘exactions’ of the kind that serve only to mitigate an impact of the development on the public or public facilities. It also seems clear that the mix of ‘beneficial’ and other conditions, as well as the mix of ‘beneficial’ and other effects that may be attributable to a particular condition, can vary enormously from case to case. Given that, the absolute rule for which petitioner contends, that beneficial effects may only be considered if they are the *only* effects present, is not logically supportable. Without deciding whether his application of the analysis was or was not correct in all of its particulars, we conclude that the hearings officer's consideration of ‘benefits’ was not erroneous as an analytical approach. We emphasize, however, that that approach can be an appropriate *consideration* in *applying* the *Dolan* test, where the facts for it are present, but it should not be misunderstood as *being* the test.” 142 Or App 327, 337 (1996) (emphasis in original).

In a footnote further articulating the Court’s reasoning for considering benefits to the development, the Court noted that *Dolan* analysis “allows consideration and appropriate weighing of whether and to what extent a condition serves needs of the development upon which it is imposed, as distinct from serving *only* general public needs in response to the public impacts of the development.” *Id.* at 337, n. 4 (emphasis in original). Thus, the Board can consider the off-site improvements’ benefits to the Proposed Development as part of the *Dolan* analysis.

7. City Has Sufficient Funds to Pay for Portion of Off-Site Improvements That Are Beyond Applicant’s Rough Proportionality

Applicant stated that the City cannot force Applicant to construct improvements simply because the City does not have the funds available to pay for the improvements. Applicant appears to be misconstruing a statement that was made during prior negotiations with City staff. When the City initially laid out the required Parkway improvements, it included the need for concrete paving instead of asphalt because Parkway is a freight route. Concrete is required for freight routes due to heavy truck traffic. *See* Wilsonville Transportation System Plan, 3-8; Attachment 1 to Exhibit A2, p. 12. Heavy trucks significantly shorten the lifespan of asphalt streets and so freight routes use concrete instead of asphalt. When Applicant contended that the City should construct the Parkway improvements and the Applicant instead pay the City for its share of the cost, staff had said that the City did not have funds to pay that large of a sum for the full Parkway cross-section, and thus would no longer be requiring the full cross-section of Parkway (inclusive of the southbound travel lane) to be constructed. Instead, the City would eliminate the need to reconstruct the southbound travel lane. Since the full cross-section would not be constructed, the City similarly no longer required concrete paving because the southbound travel lane would retain its asphalt paving.

In other words, the City does have funds, through SDC credits and additional City funds (if necessary), to pay for the portion of the Parkway and Printer Parkway improvements that are beyond Applicant’s proportionate share, given that the City would not require Applicant to reconstruct the southbound travel lane along Parkway nor require Applicant to use concrete for paving.

8. Reducing Vehicle Trips Is a Faulty Argument

Applicant argued that, currently, the industrial campus is producing fewer vehicle trips than originally approved. Applicant thus contends that the Proposed Development’s vehicle trips can be encompassed within the previously approved development. This argument is faulty because it assumes that the industrial campus would not see an increase in vehicle trips or, potentially that an increase of vehicle trips would not occur without some land use process with the City. Applicant’s argument is based on a faulty premise because the City cannot impose additional requirements on previously approved developments, even if ownership changes or use changes, unless the change of use requires a modification to the original approval.

A change of use in a Planned Development zone may trigger new public improvement requirements based on the prior approved Stage II Master Plan and the extent that a request for a change of use modifies that approval. While Stage I Plans establish “bubble diagram” level uses,

Stage II requires a “map indicating the types and locations of all proposed uses” enabling analysis of impacts of those uses for the purpose of traffic and other infrastructure impacts and concurrency evaluation. *See* WC 4.140 (.09) C., C.5., J.2.; WC 4.008 (.02) I. Wilsonville policy and practice is that impacts, as approved in a Stage II Master Plan, are vested and remain in effect unless the approval expires without substantial development of at least some of the phases. This may even last for decades for unbuilt phases. Vesting of traffic trips is discussed in WC 4.140 (.09) I. and vesting of other impacts is inferred in WC 4.008 (.02) I.-J. Vesting is made clearer by consistent City practice. The City diligently tracks traffic vesting in a spreadsheet that is incorporated into each traffic study. The City also consistently tracks SDC payments and offers credits when changes occur on a property. For example, sewer credits are given in a remodel for removed sinks and toilets towards new sinks and toilets.

Thus, while the current uses in existing buildings on the industrial campus may generate fewer vehicle trips than contemplated in the Stage II Master Plan, if a new tenant or owner occupies the buildings and does not change the use or changes to a use that does not rise to the level of requiring new public improvements, that new tenant or owner may have more vehicle trips than the current tenant(s).

Furthermore, if Applicant were to utilize the vehicle trips approved for prior developments, those developments would lose their “fair share” of public improvements they previously constructed or paid to the City to construct. For example, Xerox Corporation previously dedicated land and compensated the City for improvements at Printer Parkway and on SW Canyon Creek Road. Xerox also dedicated to the City as part of its partition approval in 2015, 27 feet of right-of-way along Parkway and a 10-foot public utilities easement to the east of the Parkway dedication. The requirements in prior land use decisions were based on the anticipated impact of those developments. Applicant is not entitled to use those analyses for other developments to avoid paying its fair share of its impact. This is also why the City does not require Applicant to pay for 100% of the “developer responsibility” portion of the needed improvements on Parkway. The City recognizes that other developments within the industrial campus impact Parkway, and so the City examines the net new impact based on prior development approvals and the Proposed Development.

9. Undergrounding Can Be Required at Applicant’s Expense

A key disagreement between the City and the Applicant was in regard to undergrounding overhead utilities. Three key points were discussed in the prior public hearing: (1) whether the requirement to underground utilities only applied to new utilities to be installed; (2) the cost of undergrounding the overhead utilities along Parkway; and (3) whether the City can require Applicant to bear the cost of undergrounding utilities.

First, undergrounding is not limited to new utilities. WC 4.300(.01) states:

“The City Council deems it reasonable and necessary in order to accomplish the orderly and desirable development of land within the corporate limits of the City, to require the underground installation of utilities in all new developments.” (emphasis added).

As soon as an applicant proposes a new development, utilities are required to be undergrounded. WC 4.300(.02) further states that new lines must be placed underground as well. Thus, in this Proposed Development, the overhead utilities must be undergrounded and the lines that connect the Proposed Development to those utilities must also be undergrounded.

Second, the City reviewed other recent overhead undergrounding projects within the City within the last year. Such projects include the Frog Pond Ridge residential development in Frog Pond West, Delta Logistics industrial development in Coffee Creek, and the City's Boeckman Road Corridor Project. Based on these projects, design costs with Portland General Electric are estimated to be between \$40 and \$100 per linear-foot, equal to \$40,000 to \$100,000 for 1,000 linear feet of utilities. The price of installation was approximately \$150,000 for 1,000 linear feet of utilities. In total, the conservative cost estimate for all undergrounding costs, including design, trenching, conduit, line pull, and PGE fees, is \$250,000 for 1,000 linear feet of utilities.

Third, the City notes that the City is empowered to legislate the standards for development within the City. In other words, the City has the right to say how a development should be developed. Regulations such as zoning, height restrictions, setbacks, character of materials and methods of construction, are legislative regulations that apply to broad swaths of private property, not a specific development that must mitigate its impact. *See Village of Euclid, Ohio v. Ambler Realty Co.*, 272 US 365 (1926) (discussed in *Dolan*, 512 US at 384-85); *see also Schultz v. City of Grants Pass*, 131 Or App 220, 227 (1990) (explaining the distinction because legislative enactments that apply generally to all similarly situated properties). If such requirements are subject to Takings analysis, despite being required throughout the City, then it puts into jeopardy the City's inherent police power to regulate where and how development occurs in the City. *Village of Euclid*, 272 US at 388-89, 395. Unlike the street dedication and construction requirements that are specific to the Proposed Development due to its adjacency to Parkway and Printer Parkway, undergrounding utilities is a general, legislative requirement for all development in the City. The utilities are necessary for the Proposed Development to operate, and so when Applicant installs its needed utilities, the utilities must be placed underground.

10. Clarification Regarding Applicant's Submitted Plan Set (Exhibit B)

The City seeks to clarify one argument and evidence in its original *Nollan/Dolan* findings. Figure 1 in the City's *Nollan/Dolan* findings (Exhibit A2) refers to off-site improvements proposed by the Applicant. Figure 1 is a prior version of Applicant's Exhibit B – Construction Plan Set. A later version of Exhibit B was submitted by Applicant, which is the version that is in the Development Review Board packet. The later version of Applicant's Construction Plan Set does not include Figure 1 and so the City unintentionally included and relied on Figure 1 in its *Nollan/Dolan* findings. The City hereby withdraws Figure 1 and its argument in the paragraph below Figure 1 found at the bottom of page 5 and the top of page 6 of its *Nollan/Dolan* findings in Exhibit A2.

MEMORANDUM OF UNDERSTANDING FOR ESTABLISHING A LOCAL IMPROVEMENT DISTRICT TO PROVIDE PUBLIC INFRASTRUCTURE IMPROVEMENTS

THIS MEMORANDUM OF UNDERSTANDING (“MOU”) is made and entered into as of the ____ day of _____ 2024 (“Effective Date”) by and between the **City of Wilsonville**, an Oregon municipal corporation (“City”) and **ScanlanKemperBard Companies, LLC**, an Oregon limited liability company and **SKB-Parkworks, LLC**, a Delaware limited partnership (collectively “SKB”). The City and SKB may each be referred to herein as “Party” and collectively as the “Parties.”

RECITALS

A. SKB-Parkworks, LLC owns the real property located at 26600 SW Parkway Avenue, Wilsonville, Clackamas County, Oregon (the “Property”).

B. SKB proposes to partition the Property into two parcels – proposed Parcel 5 and Parcel 6 – with Parcel 6 housing the existing development and Parcel 5 serving as the location for a new industrial manufacturing/warehouse development (the “Proposed Development”). If approved, the Proposed Development will consist of a 91,773 square-foot building and related improvements which would front SW Parkway Avenue to the west (“Parkway”) and SW Printer Parkway to the north (“Printer Parkway”).

C. The Parties have actively negotiated in good faith to resolve outstanding issues surrounding the City’s requirements for improvements to Parkway and Printer Parkway along SKB’s frontage (“Street Improvements”).

D. The Parties acknowledge that neither is well-positioned to carry the burden of constructing the Street Improvements with compensation provided by the other Party due to the uncertainty of construction costs and timing of payments, and the Parties further acknowledge that neither Party is fully responsible for the cost of the Street Improvements, as demonstrated by the City’s traffic impact analysis performed for the Proposed Development.

E. As a result of the ongoing negotiations, the Parties understand that the formation of a local improvement district, pursuant to ORS 223.387 *et seq.* (“LID”), appears to be an appropriate method to fund the Street Improvements and for the City to finance construction of the Street Improvements, which process will provide the Parties, and potentially other third-party real property owners, the opportunity to determine assessments reflective of benefits received as a result of the projects constructed from financing and assessments provided through LID.

F. This MOU provides the Parties with a framework to continue to cooperatively engage with one another to establish a LID (the “Project”). This MOU is not otherwise binding to either Party to require the formation of a LID.

NOW, THEREFORE, in the context of the above Recitals, which are incorporated herein as part of the Mutual Understandings, and in the interest of furthering negotiations and achieving a fair and reasonable result, the City and SKB acknowledge the following Mutual Understandings:

MUTUAL UNDERSTANDINGS

1. **Project Managers.** The City's Project Manager is _____ [insert name, email, phone]. SKB's Project Manager is _____ [insert name, email, phone].

2. **Communication.** The Project Managers will coordinate regularly (not less than monthly) regarding Project progress and issues encountered. At a minimum, this will consist of a phone call, but may also include in-person meetings as requested by either Party.

3. **Timeline.** The Parties will endeavor to meet the following timeline for establishing a LID:

3.1. **Resolution for Preliminary Engineer's Report.** On March 4, 2024, the City intends to provide to the City Council for consideration a resolution to direct the City to pursue a preliminary engineering report to recommend the LID boundary, infrastructure improvements, and estimated costs.

3.2. **Intergovernmental Agreement.** The City will pursue an intergovernmental agreement ("IGA") with the City of Portland for technical assistance regarding the formation and implementation of a LID. Assuming the City of Portland's willingness, the City anticipates City Council consideration of an IGA on or before May 20, 2024.

3.3. **Property Owner Outreach.** The Parties will collaborate on outreach to adjacent property owners to discuss the possibility of inclusion in a LID. The Parties intend to promote a LID as a reasonable financing tool for public infrastructure that is needed for both private development and public benefit.

3.4. **Procedural Resolution.** The Parties will collaborate on drafting a procedural resolution described in ORS 223.389(1) for City Council consideration, anticipated to occur in Summer or Fall 2024.

3.5. **Enacting Resolution.** The Parties will collaborate on drafting a resolution establishing the LID and the assessments against each benefiting property for City Council consideration, anticipated to occur early in calendar year 2025.

4. **Duration.** The term of this MOU will be from the Effective Date until passage of an enacting resolution described in subsection 3.5 above or not later than twenty-four (24) months from the Effective Date, whichever is earlier.

5. **Due Diligence.** The City and its authorized representatives, consultants, contractors, agents, and employees may conduct due diligence and inspections of the Property,

including such physical, legal, and engineering inspections, tests, and investigations as it may deem necessary or desirable, including soils and environmental studies along, within, over, under, and adjacent to Parkway and Printer Parkway for the purpose of determining scope, type, need, and feasibility of public infrastructure. Such studies and investigations may include, without limitation, environmental, title, design review, project feasibility, and related matters (the “Due Diligence Information”). The scope and cost of the due diligence and inspections shall be the responsibility of the City but the City may elect to include such costs as reimbursement in a future LID assessment. The City, or its authorized representatives, consultants, contractors, or agents, will repair or restore any damage caused by the entry of or testing by the City or its authorized representatives, consultants, contractors, agents, and employees upon or under the Property.

5.1. SKB Approval to Enter Site. Prior to the City or its authorized representatives, consultants, contractors, agents, and employees commencing any onsite due diligence, the City will request, no less than seventy-two hours (72) hours prior to entry, to the SKB Project Manager approval to enter the site and to conduct specific testing. SKB’s approval to enter the site and to conduct testing will not be unreasonably withheld. The City will make all reasonable efforts to avoid disrupting any tenant business operations on the Property when entering the site and conducting testing.

6. Communications with the Public and Property Owners. Both Parties shall work in good faith to coordinate Project-related public communications, including press releases, statements to the media, public testimony, and communications to adjacent property owners.

7. Miscellaneous Provisions.

7.1. Integration. This MOU, including all exhibits attached hereto, contains the entire and integrated understanding between the Parties and supersedes all prior written or oral discussions, representations, or agreements. In case of conflict among these or any other documents, the provisions of this MOU shall control.

7.2. No Assignment. SKB may not assign this MOU, nor delegate the performance of any obligations hereunder, unless agreed to in advance and in writing by the City.

7.3. Governing Law. This MOU shall be construed in accordance with and governed by the laws of the State of Oregon, regardless of any conflicts of laws.

7.4. Jurisdiction. Jurisdiction and venue for any dispute will be in Clackamas County Circuit Court, Clackamas County, Oregon.

7.5. Modification. This MOU may not be modified except by written instrument executed by SKB and the City.

7.6. Good Faith and Cooperation. The Parties agree that they will exercise good faith, cooperation, and due diligence in the performance of all understandings set forth in this MOU

7.7. Interpretation. The Parties acknowledge that this MOU has been collaboratively prepared by the Parties, and any uncertainty or ambiguity existing within the MOU shall not be construed against any Party.

7.8. Counterparts. This MOU may be executed in one or more counterparts, each of which shall constitute an original MOU but all of which together shall constitute one and the same instrument.

7.9. Authority. Each party signing on behalf of SKB and the City hereby warrants actual authority to bind their respective party.

IN WITNESS WHEREOF, each Party has caused its authorized representative to execute this MOU on its behalf.

**SCANLANKEMPERBARD
COMPANIES, LLC**

CITY OF WILSONVILLE

By: _____

By: _____

Print Name: _____

Print Name: _____

As Its: _____

As Its: _____

SKB-PARKWORKS, LLC

By: _____

Print Name: _____

As Its: _____

APPROVED AS TO FORM:

Christe White, Counsel for SKB

Amanda Guile-Hinman, City Attorney
City of Wilsonville, Oregon

I:\prop dev\skb parkworks\doc\mou skb local improvement district (ag1).docx

DRAFT

NORTHWEST CORNER

From Multi-Use Path



LRS
ARCHITECTS

NORTHWEST CORNER

From Multi-Use Path - Matured Landscaping



NORTHWEST CORNER

From SW Parkway Ave



NORTHWEST CORNER

From SW Parkway Ave - Matured Landscaping

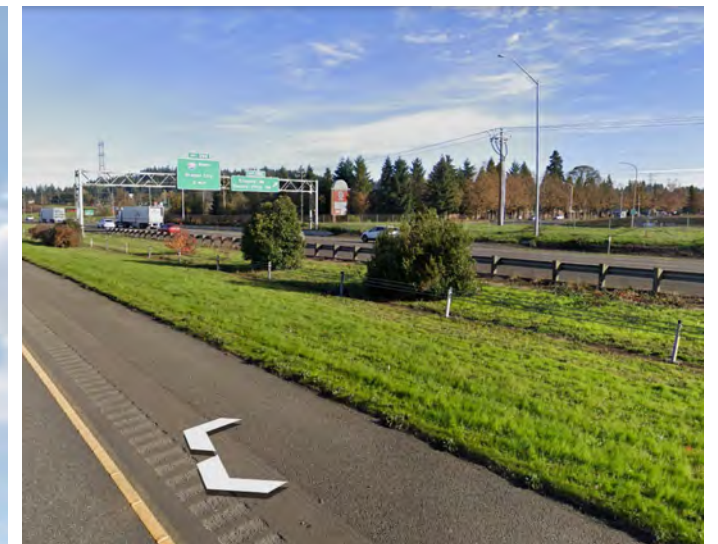

TOP IMAGE – VIEW OF TARGET SOUTH FAÇADE FROM I-5 NORTHBOUND
BOTTOM IMAGE – VIEW OF TARGET SOUTH FAÇADE FROM SW PARKWAY AVENUE

DEVELOPMENT REVIEW BOARD MEETING
MARCH 11, 2024
6:30 PM

Item 3.

Public Hearing:

3. **Resolution No. 430. Boeckman Creek Primary School Readerboard.** The applicant is requesting approval of a Class 3 Sign Permit and Waiver for a new electronic reader board sign at Boeckman Creek Primary School.

Case Files:

- DB23-0009 Boeckman Creek Primary School Reader Board
- Class 3 Sign Permit (SIGN23-0009)
- Waiver (WAIV23-0002)

**DEVELOPMENT REVIEW BOARD
RESOLUTION NO. 430**

A RESOLUTION ADOPTING FINDINGS AND CONDITIONS OF APPROVAL, APPROVING A CLASS 3 SIGN PERMIT AND WAIVER FOR A NEW ELECTRONIC READER BOARD SIGN AT BOECKMAN CREEK PRIMARY SCHOOL.

WHEREAS, an application, together with planning exhibits for the above-captioned development, has been submitted by Tony McCormick, Meyer Sign Company of Oregon – Applicant and Jeff Chambers, West Linn-Wilsonville School District – Owner in accordance with the procedures set forth in Section 4.008 of the Wilsonville Code, and

WHEREAS, the subject site is located at 6700 SW Wilsonville Road on Tax Lot 100, Section 13, Township 3 South, Range 1 West, Willamette Meridian, Clackamas County, Oregon, and

WHEREAS, the Planning Staff has prepared the staff report on the above-captioned subject dated March 4, 2024 and

WHEREAS, said planning exhibits and staff report were duly considered by the Development Review Board Panel B at a scheduled meeting conducted on March 11, 2024, at which time exhibits, together with findings and public testimony were entered into the public record, and

WHEREAS, the Development Review Board considered the subject and the recommendations contained in the staff report, and

WHEREAS, interested parties, if any, have had an opportunity to be heard on the subject.

NOW, THEREFORE, BE IT RESOLVED that the Development Review Board of the City of Wilsonville does hereby adopt the staff report dated March 4, 2024, attached hereto as Exhibit A1, with findings and recommendations contained therein, and authorizes the Planning Director to issue permits consistent with said recommendations for:

DB23-0009 Boeckman Creek Primary School Reader Board Sign: Class 3 Sign Permit (SIGN23-0009) and Waiver (WAIV23-0002).

ADOPTED by the Development Review Board of the City of Wilsonville at a regular meeting thereof this 11th day of March, 2024, and filed with the Planning Administrative Assistant on _____. This resolution is final on the 15th calendar day after the postmarked date of the written notice of decision per *WC Sec 4.022(.09)* unless appealed per *WC Sec 4.022(.02)* or called up for review by the Council in accordance with *WC Sec 4.022(.03)*.

Jean Svedlenka, Chair - Panel A
Wilsonville Development Review Board

Attest:

Shelley White, Planning Administrative Assistant



Exhibit A1
Staff Report
Wilsonville Planning Division
Boeckman Creek Primary School Reader Board Sign

Development Review Board Panel 'A'
Quasi-Judicial Public Hearing

Hearing Date:	March 11, 2024
Date of Report:	March 4, 2024
<hr/>	
Application Nos.:	DB23-0009 Boeckman Creek Primary School Reader Board Sign
Request/Summary:	The requests before the Development Review Board include a Class 3 Sign Permit and Waiver to install an electronic reader board sign in place of the existing monument sign at Boeckman Creek Primary School.
Location:	6700 SW Wilsonville Road. The property is specifically known as Tax Lot 100, Section 13, Township 3 South, Range 1 West, Willamette Meridian, City of Wilsonville, Clackamas County, Oregon
Owner:	West Linn-Wilsonville School District (Contact: Jeff Chambers)
Applicant:	Meyer Sign Company of Oregon (Contact: Tony McCormick)
Comprehensive Plan Designation:	Public
Zone Map Classification:	PF (Public Facility)
Staff Reviewers:	Sarah Pearlman, Assistant Planner
Staff Recommendation:	<u>Approve with conditions</u> the requested Class 3 Sign Permit and Waiver.

Applicable Review Criteria:

<u>Development Code:</u>	
Section 4.008	Application Procedures-In General
Section 4.009	Who May Initiate Application
Section 4.010	How to Apply
Section 4.011	How Applications are Processed
Section 4.014	Burden of Proof
Section 4.031	Authority of the Development Review Board
Subsection 4.035 (.04)	Site Development Permit Application
Subsection 4.035 (.05)	Complete Submittal Requirement
Section 4.110	Zones
Section 4.136	Public Facility Zone
Section 4.156.01 through 4.156.11 as applicable	Sign Code Regulations
Sections 4.400 through 4.450 as applicable	Site Design Review
<u>Other Planning Documents:</u>	
Wilsonville Comprehensive Plan	
Previous Land Use Approvals	

Vicinity Map

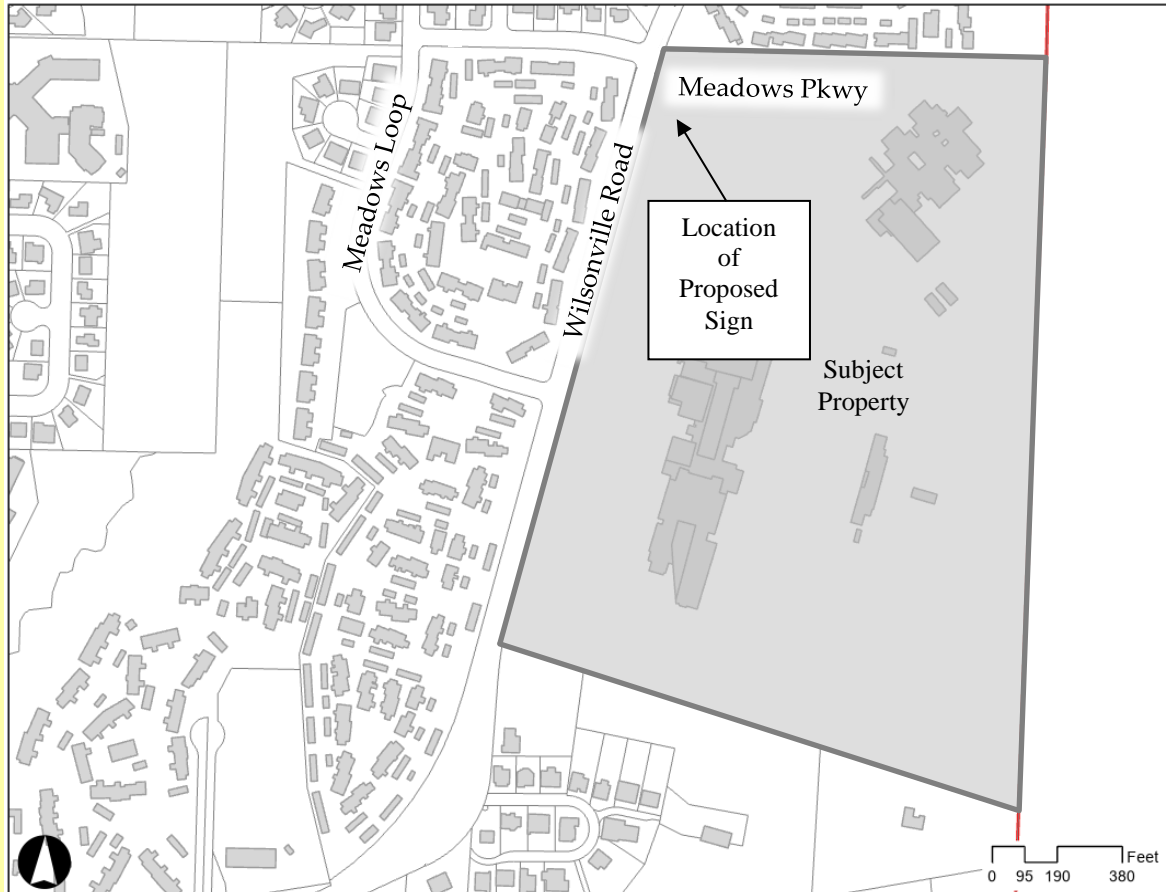

Background:

In 1989, the Planning Commission approved the conditional use of site for an elementary school (See Case File No. 89PC36) and the Design Review Board approved the architecture, landscaping, and original monument sign for Boeckman Creek Primary School (See Case File No. 89DR26). The approved monument sign was approximately 2 feet in height with an area of 18.67 square feet. In 2005, the Development Review Board approved an approximately 6-foot tall, 32-square-foot manual reader board sign replacing the original monument sign (See Case File No. DB05-0100). This reader board was revised to its current design through a Class 1 Sign Permit in 2005.

Summary:

Class 3 Sign Permit and Waiver (DB23-0009)

The request for Class 3 Sign Permit and Waiver applies to the monument sign for Boeckman Creek Primary School at the northeast corner of the property. It would allow replacement of the cabinet and existing manual reader board with a new sign cabinet and electronic reader board of the same size. The existing, previously approved, monument sign conforms to standards set forth by the Code and is appropriately designed to be consistent with the type of freestanding signs

seen in schools in the PF zone throughout Wilsonville. However, the electronic message board is not permitted without an approved waiver. The applicant has provided response findings to the waiver criteria, addressing why the conversion to an electronic display conforms to the waiver requirements.



Current Reader Board Sign



Proposed Electronic Reader Board Sign

Discussion Points:

Approving a Prohibited Sign

Changeable copy signs are listed as prohibited signs in Subsection 4.156.06 (.01) D. However, language is added that a waiver may be granted to allow them as long as it is ensured specific criteria or conditions are met including:

1. The sign shall be equipped with automatic dimming technology which automatically adjusts the sign’s brightness in direct correlation with ambient light conditions and the sign owner shall ensure appropriate functioning of the dimming technology for the life of the sign.
2. The luminance of the sign shall not exceed five thousand (5000) candelas per square meter between sunrise and sunset, and five hundred (500) candelas per square meter between sunset and sunrise.

By definition, changeable copy signs must maintain a copy hold-time of at least fifteen (15) minutes.

While grouped under prohibited signs, the intention of the code is to make the signs conditionally permitted. No conditionally permitted sign section exists currently, so they were grouped in the prohibited sign section as that is where language regarding these signs previously existed in the code.

Similar Changeable Copy Signs at Other Schools

Similar changeable copy signs have been approved at other schools throughout Wilsonville, including Wilsonville High School, Meridian Creek Middle School, and Inza R. Wood Middle School. Except at Meridian Creek, where the sign was constructed with the new school, each of these signs replaced an existing, manual, reader board sign with an electronic reader board.

Conclusion and Conditions of Approval:

Staff has reviewed the applicant’s analysis of compliance with the applicable criteria. The Staff Report adopts the applicant’s responses as Findings of Fact except as noted in the Findings. Based on the Findings of Fact and information included in this Staff Report, and information received from a duly advertised public hearing, Staff recommends that the Development Review Board approve, with the conditions below, the proposed Class 3 Sign Permit and Waiver (DB23-0009) for the Boeckman Creek Primary School Reader Board Sign project.

Planning Division Conditions:

Request A: SIGN23-0009 Class 3 Sign Permit

PDA 1.	Ongoing: Approved signs shall be installed in a manner substantially similar to the plans approved by the DRB and stamped approved by the Planning Division.
PDA 2.	Ongoing: The Applicant/Owner of the property shall obtain all necessary building and electrical permits for the approved sign, prior to its installation, and shall ensure that the sign is maintained in a commonly-accepted, professional manner.
PDA 3.	Prior to Building Permit Issuance: The address of the building shall be added to the monument sign unless the Applicant/Owner obtains approval from TVF&R to leave the sign without an address. See Finding A19.

Request B: WAIV23-0002 Waiver

PDB 1.	Ongoing: The Applicant/Owner shall ensure that the brightness of the approved sign automatically adjusts in direct correlation with ambient light conditions, and appropriate functioning of the dimming technology for the life of the sign. See Finding B5.
PDB 2.	Ongoing: The Applicant/Owner shall ensure that the approved sign does not exceed 5000 candelas per square meter between sunrise and sunset, or 500 candelas per square meter between sunset and sunrise. See Finding B6.
PDB 3.	Ongoing: The Applicant/Owner shall ensure the approved sign maintains a copy hold time of at least fifteen (15) minutes. See Finding B7.

Master Exhibit List:

Entry of the following exhibits into the public record by the Development Review Board confirms its consideration of the application as submitted. The list below includes exhibits for Planning Case File No. DB23-0009 and reflects the electronic record posted on the City’s website and retained as part of the City’s permanent electronic record. Any inconsistencies between printed

or other electronic versions of the same exhibits are inadvertent and the version on the City's website and retained as part of the City's permanent electronic record shall be controlling for all purposes.

Planning Staff Materials

- A1. Staff Report and Findings (this document)
- A2. Staff's Presentation Slides for Public Hearing (to be presented at Public Hearing)

Materials from Applicant – *Available Under Separate Cover*

- B1. Applicant's Narrative and Submitted Materials
 - Application
 - Narrative including Responses to Code Criteria
- B2. Drawing Package
 - Site Plan
 - New Electronic Reader Board at Existing Monument Sign
 - Sign Engineering and Structural Calculations

Procedural Statements and Background Information:

- 1. The statutory 120-day time limit applies to this application. The application was received on August 1, 2023. Staff conducted a completeness review within the statutorily allowed 30-day review period and found the application to be incomplete on August 28, 2023. The applicant submitted additional materials on December 20, 2023. Staff conducted a second completeness review within the statutorily allowed 30-day review period and found the application to be complete on January 12, 2024. The City must render a final decision for the request, including any appeals, by May 11, 2024.
- 2. Surrounding land uses are as follows:

Compass Direction	Zone:	Existing Use:
North:	PDR-4, PDR-5	Multi-family Residential
East:	EFU	Rural
South:	FDA-H, PDR-2	Single-family Residential
West:	PDR-5	Multi-family Residential

- 3. Previous Planning Approvals:
 - 89PC36 – Conditional Use Permit
 - 89DR26 – Architectural and Landscape Review
 - 90SR07A – Signage (Plans Not Available)
 - 92PC26 – Zone Map Amendment, Stage 1 Master Plan, Stage 2 Final Plan, and Height Variance for Wilsonville High School
 - DB05-0100 – Reader Board Sign Review
 - SR05-0035 – Class 1 Sign Permit (Reader Board)
- 4. The applicant has complied with Sections 4.008 through 4.011, 4.013-4.031, 4.034 and 4.035 of the Wilsonville Code, said sections pertaining to review procedures and submittal requirements. The required public notices have been sent and all proper notification procedures have been satisfied.

Findings:

NOTE: Pursuant to Section 4.014 the burden of proving that the necessary findings of fact can be made for approval of any land use or development application rests with the applicant in the case.

General Information

Application Procedures-In General Section 4.008

The application is being processed in accordance with the applicable general procedures of this Section.

Initiating Application Section 4.009

The application has been submitted on behalf of the property owner, West Linn-Wilsonville School District, and is signed by an authorized representative.

Pre-Application Conference Subsection 4.010 (.02)

The Planning Division determined a pre-application conference was not required for this request.

Lien Payment before Approval Subsection 4.011 (.02) B.

No applicable liens exist for the subject property. The application can thus move forward.

General Submission Requirements Subsection 4.035 (.04) A.

The applicant has provided all of the applicable general submissions and the application was deemed completed on January 12, 2024.

Zoning-Generally Section 4.110

This proposed development is in conformity with the applicable zoning district (PF) and general development regulations listed in Sections 4.140 through 4.199 have been applied in accordance with this Section.

Request A: Class 3 Sign Permit (SIGN23-0009)

As described in the Findings below, the applicable criteria for this request are met or will be met by Conditions of Approval.

Sign Review and Submission

Review Process

Subsection 4.031 (.01) M. and Subsection 4.156.02 (.03)

A1. The application qualifies as a Class 3 Sign Permit and is being reviewed by the Development Review Board.

Class 3 Sign Permits Generally

Subsection 4.156.02 (.06)

A2. While the request involves a singles sign for a previously approved development and is less than 8 feet tall, it involves a waiver request and therefore qualifies to be reviewed through the Class 3 Sign Permit process.

Class 3 Sign Permit Submission Requirements

Subsection 4.156.02 (.06) A.

A3. As indicated in the table below the applicant has satisfied the submission requirements:

Requirement	Submitted	Waiver Granted		Condition of Approval	Not Applicable	Additional findings/ notes
		Info Already Available	Info Not Necessary for Review			
Completed Application Form	<input checked="" type="checkbox"/>	<input type="checkbox"/>	<input type="checkbox"/>	<input type="checkbox"/>	<input type="checkbox"/>	
Sign Drawings or Descriptions	<input checked="" type="checkbox"/>	<input type="checkbox"/>	<input type="checkbox"/>	<input type="checkbox"/>	<input type="checkbox"/>	
Documentation of Building/Tenant Space Lengths	<input type="checkbox"/>	<input type="checkbox"/>	<input type="checkbox"/>	<input type="checkbox"/>	<input checked="" type="checkbox"/>	
Drawings of Sign Placement of Building Facades	<input type="checkbox"/>	<input type="checkbox"/>	<input type="checkbox"/>	<input type="checkbox"/>	<input checked="" type="checkbox"/>	
Project Narrative	<input checked="" type="checkbox"/>	<input type="checkbox"/>	<input type="checkbox"/>	<input type="checkbox"/>	<input type="checkbox"/>	
Information on Any Requested Waivers or Variances	<input checked="" type="checkbox"/>	<input type="checkbox"/>	<input type="checkbox"/>	<input type="checkbox"/>	<input type="checkbox"/>	

Class 3 Sign Permit Review Criteria

Class 2 Sign Permit Review Criteria: Generally and Site Design Review
 Subsection 4.156.02 (.05) F.

A4. As indicated in the Findings in this section these criteria are met.

Class 2 Sign Permit Review Criteria: Compatibility with Zone
Subsection 4.156.02 (.05) F. 1.

- A5.** The proposed sign is similar in size, shape, and color to the previously approved monument sign with the exception of replacing the existing cabinet and manual reader board with a new cabinet and electronic reader board of the same size. No evidence exists nor has testimony been received that the subject sign would detract from the visual appearance of the surrounding development.

Class 2 Sign Permit Review Criteria: Nuisance and Impact on Surrounding Properties
Subsection 4.156.02 (.05) F. 2.

- A6.** There is no evidence, and no testimony has been received suggesting the subject sign would create a nuisance or negatively impact the value of surrounding properties. The proposed sign improves its functionality by facilitating remote regulation of the sign's operation and allowing easy message changes and real-time updates. It will have brightness controls such to avoid nuisances with the surrounding development; see Finding B6. Condition of Approval PDB 3 ensures the sign will maintain a hold-time of at least 15 minutes for messages.

Class 2 Sign Permit Review Criteria: Items for Special Attention
Subsection 4.156.02 (.05) F. 3.

- A7.** The previously approved freestanding monument sign is located in a sparsely landscaped area along SW Wilsonville Road. No landscaping, including trees, will be altered as a result of replacing the cabinet and manual reader board sign with a new cabinet and electronic reader board.

Sign Measurement

Measurement of Cabinet Signs and Similar
Subsection 4.156.03 (.01) A.

- A8.** The proposed monument sign, which is 8 feet wide by 4 feet tall with a total area of 32 square feet, is measured consistent with this subsection.

Measurement of Sign Height Above Ground
Subsection 4.156.03 (.02) A.

- A9.** The previously approved sign was measured consistent with this subsection and no change to the sign height above ground is proposed.

Measurement of Sign Height and Length
Subsection 4.156.03 (.03) A.-B.

- A10.** The previously approved monument sign was measured consistent with this subsection and no change is proposed.

Freestanding and Ground Mounted Signs in the PDC, PDI, and PF Zones

General Allowance

Subsection 4.156.08 (.01) A.

A11. The school property has frontage on SW Wilsonville Road and is eligible for the previously approved monument sign, which is located on the southwest side of the north drive aisle (SW Meadows Parkway) providing access to the school.

Allowed Height

Subsection 4.156.08 (.01) B.

A12. The applicant proposes to replace the sign cabinet within the existing support structure. The allowed sign height is 20 feet and the existing monument sign has an overall height of 6 feet. No change is proposed to the height of the sign.

Allowed Area

Subsection 4.156.08 (.01) C.

A13. The applicant is allowed 32 square feet of sign area based on the allowance for PF zoned properties. The proposed sign is 32 square feet consistent with this maximum and with the previously approved monument sign (Case File No. DB05-0100).

Pole or Sign Support Placement

Subsection 4.156.08 (.01) D.

A14. Sign supports on the existing monument sign are in a full vertical position and no change is proposed to support placement.

Extending Over Right-of-Way, Parking, and Maneuvering Areas

Subsection 4.156.08 (.01) E.

A15. The existing monument sign does not extend into or above the listed areas and no change is proposed that would cause the sign to be noncompliant.

Design of Freestanding Signs to Match or Complement Design of Buildings

Subsection 4.156.08 (.01) G.

A16. The existing monument sign has a simple frame and colors that are complementary to the school architecture.

Width vs. Height of Signs Over 8 Feet

Subsection 4.156.08 (.01) H.

A17. The proposed monument sign is less than 8 feet tall.

Sign Setback

Subsection 4.156.08 (.01) J.

A18. No change is proposed to the location of the sign. It will continue to be in the location that was approved in Case File Nos. 89DR26 and DB05-0100, approximately 19 feet from the property line, which is greater than 15 feet, and 19 feet from the hard surface of the right-of-way, more than the minimum 2 feet.

Address Requirement

Subsection 4.156.08 (.01) K.

A19. The current application does not propose to add an address to the sign. Condition of Approval PDA 3 ensures the sign will meet the address requirement unless approval is obtained from TVF&R to leave the sign without an address.

Design of Sign Based on Initial Tenant Configuration and Size

Subsection 4.156.08 (.01) L.

A20. The existing monument sign was designed for Boeckman Creek Primary School, a single tenant, and no change is proposed to the tenant configuration or size that would warrant a change in its design.

Site Design Review

Excessive Uniformity, Inappropriateness of Design

Subsections 4.400 (.01) and 4.421 (.03)

A21. Staff summarizes the compliance with this subsection as follows:

Excessive Uniformity: The only change to the existing freestanding sign is replacement of the cabinet and manual reader board with a new cabinet and electronic reader board, which does not contribute to excessive uniformity on site or in the general area.

Inappropriate or Poor Design of Signs: The proposed monument sign is a simple design that is typical of other school sites found to be appropriate throughout the City.

Lack of Proper Attention to Site Development: The appropriate professional services were used to design the existing sign in relation to, and in coherence with, the building on site.

Lack of Proper Attention to Landscaping: The proposed modification of the existing monument sign will not have an effect on the landscaping on site.

Purposes of Objectives of Site Design Review

Subsections 4.400 (.02) and 4.421 (.03)

A22. It is staff's professional opinion that the previously approved freestanding sign complies with the purposes and objectives of site design review. The existing sign is of a scale and design appropriately related to the subject site, the appropriate amount of attention has been given to visual appearance, and no change is proposed that would take the sign out of compliance with the standards.

Site Design Review-Design Standards

Subsection 4.421 (.01)

A23. There is no indication that the size, location, design, color, texture, lighting or material of the existing sign detracts from the design of the building and the surrounding properties, and updating the cabinet and changing the manual reader board to an electronic one will not affect compliance with these standards.

Applicability of Design Standards to Signs Subsection 4.421 (.02)

A24. Design standards have been applied to the existing exterior sign, as applicable.

Site Design Review-Conditions of Approval Subsection 4.421 (.05)

A25. No additional conditions of approval are recommended to ensure the proper and efficient functioning of the school campus in relation to signs.

Color or Materials Requirements Subsection 4.421 (.06)

A26. Staff does not recommend any additional requirements for materials or colors related to proposed sign modifications.

Site Design Review-Procedures Section 4.440

A27. The applicant has submitted a sign plan as required by this section.

Request B: Sign Waiver (WAIV23-0002)

SIGN WAIVER

Sign Waiver Criteria: Design Subsection 4.156.02 (.08) A. 1.

B1. As described in the applicant's narrative and illustrated in the plans, the cabinet and reader board portion of the existing monument sign is proposed to be replaced with an electronic changeable copy sign. The location of the previously approved monument sign will not change, and the only differences in design are an updated cabinet and replacement of the mechanical reader board with an electronic one of the same dimension. This change in design of the sign improves its functionality by facilitating remote regulation of the sign's operation by the school, and allowing easy message changes and real-time updates. An example of how this would be helpful is in the event of inclement weather or cancellation of scheduled events.

Sign Waiver Criteria: Compatibility Subsection 4.156.02 (.08) A. 2.

B2. The proposed monument sign and electronic reader board is typical of, proportional to, and compatible with school sites within the PF zone. The sign location will remain unchanged.

The applicant proposes an updated cabinet and replacement of the manual reader board with an electronic sign. The proposed cabinet sign features an updated logo with colors and design typically of and compatible with the primary school. No flashing display of any kind is proposed. No evidence exists nor has testimony been received that the subject sign would detract from the visual appearance of the surrounding development.

Sign Waiver Criteria: Public Safety

Subsection 4.156.02 (.08) A. 3.

- B3.** There is no evidence the proposed sign will negatively impact public safety, especially traffic safety. The current sign location will be retained, which complies with vision clearance standards, allowing for proper visibility near the intersection of the parking lot driveway and SW Wilsonville Road. As noted earlier, the electronic display will not be overly bright, animated, or distracting in any way that could compromise traffic safety. The nearest residence on the north side of SW Wilsonville Road is over 120 feet to the east and buffered by a solid fence and vegetation. The nearest residence on the south side of SW Wilsonville Road is over 200 linear feet from the sign and buffered by trees and landscaping.

Sign Waiver Criteria: Content

Subsection 4.156.02 (.08) A. 4.

- B4.** The content of the subject sign is not being reviewed as part of this application.

Changeable Copy Sign Waiver Criteria: Dimming Technology

Subsection 4.156.06 (.01) D. 1.

- B5.** The proposed Watchfire 16 MM RGB LED Display electronic sign comes equipped with automatic, scheduled and manual control options for dimming brightness. Condition of Approval PDB 1 requires the sign's brightness to automatically adjust in direct correlation with ambient light conditions, and that the sign owner ensures appropriate functioning of the dimming technology for the life of the sign.

Changeable Copy Sign Waiver Criteria: Luminance

Subsection 4.156.06 (.01) D. 2.

- B6.** The proposed reader board will display can display text in multiple colors as needed by the school and has a maximum potential brightness of 10,000 nits, which is equivalent to 10,000 candelas per square meter. Condition of Approval PDB2 ensures the sign will not surpass the 5000 candelas per square meter between sunrise and sunset. The sign is equipped with a manual control option which can be used to set the maximum brightness to 500 or fewer candelas per square meter between sunset and sunrise; Condition of Approval PDB 2 also ensures this brightness is not exceeded.

Definitions: Changeable Copy Sign

Subsection 4.001 267. F.

B7. The sign will not have moving structural elements, flashing or sequential lights, elements, prisms, or other methods that result in movement. Condition of Approval PDB 3 ensures the frequency of text copy changes will not exceed once every 15 minutes except in emergency situations as requested by the City Manager or designee.



29799 SW Town Center Loop E, Wilsonville, OR 97070
Phone: 503.682.4960 Fax: 503.682.7025
Web: www.ci.wilsonville.or.us

Planning Division Development Permit Application

Final action on development application or zone change is required within 120 days in accordance with provisions of ORS 227.175

A pre application conference is normally required prior to submittal of an application. Please visit the City's website for submittal requirements

Pre-Application Meeting Date: _____

Incomplete applications will not be scheduled for public hearing until all of the required materials are submitted.

Applicant:

Name: Tony McCormick
Company: Meyer Sign Co. of Oregon
Mailing Address: 15205 SW 74th Ave.
City, State, Zip: Tigard, OR 97224
Phone: 971-247-4325 Fax: _____
E-mail: permits@meyersignco.com

Authorized Representative:

Name: Jeff Chambers
Company: WLWV School District
Mailing Address: 2755 SW Berkeley Rd.
City, State, Zip: Tualatin OR, 97062
Phone: 503-673-9994 Fax: _____
E-mail: Chamberj@WLWV.K12.OR.US

Property Owner:

Name: _____
Company: Myrtle Cumberland
Mailing Address: 22210 SW Stafford Rd
City, State, Zip: Tualatin, OR 97062-7738
Phone: _____ Fax: _____
E-mail: _____

Property Owner's Signature:

Printed Name: Jeff Chambers Date: 7-25-23

Applicant's Signature: (if different from Property Owner)

Printed Name: Tony McCormick Date: 7/21/23

Site Location and Description:

Project Address if Available: 6700 SW Wilsonville Rd. Wilsonville, OR 97070 Suite/Unit _____
Project Location: NW Corner
Tax Map #(s): 31W13 Tax Lot #(s): 00100 County: Washington Clackamas

Request:

Removing existing cabinet and existing changeable copy message unit and replacing them with new like cabinet and Electronic message center using existing poles and footings.

Project Type: **Class I** **Class II** **Class III**

Residential Commercial Industrial Other: Public Facility

Application Type(s):

- | | | | |
|--|---|--|---|
| <input type="checkbox"/> Annexation | <input type="checkbox"/> Appeal | <input type="checkbox"/> Comp Plan Map Amend | <input type="checkbox"/> Parks Plan Review |
| <input type="checkbox"/> Final Plat | <input type="checkbox"/> Major Partition | <input type="checkbox"/> Minor Partition | <input type="checkbox"/> Request to Modify Conditions |
| <input type="checkbox"/> Plan Amendment | <input type="checkbox"/> Planned Development | <input type="checkbox"/> Preliminary Plat | <input type="checkbox"/> Site Design Review |
| <input type="checkbox"/> Request for Special Meeting | <input type="checkbox"/> Request for Time Extension | <input checked="" type="checkbox"/> Signs | <input type="checkbox"/> Stage II Final Plan |
| <input type="checkbox"/> SROZ/SRIR Review | <input type="checkbox"/> Staff Interpretation | <input type="checkbox"/> Stage I Master Plan | <input type="checkbox"/> Variance |
| <input type="checkbox"/> Type C Tree Removal Plan | <input type="checkbox"/> Tree Permit (B or C) | <input type="checkbox"/> Temporary Use | <input type="checkbox"/> Other (describe) |
| <input type="checkbox"/> Villebois SAP | <input type="checkbox"/> Villebois PDP | <input type="checkbox"/> Villebois FDP | |
| <input type="checkbox"/> Zone Map Amendment | <input type="checkbox"/> Waiver(s) | <input type="checkbox"/> Conditional Use | |



Class II Sign Permit Application Requirements

Excerpt from 4.156.02.(05)F:

F. Class II Sign Permit Review Criteria.

Class II Sign Permits shall satisfy the sign regulations for the applicable zoning district and the Site Design Review Criteria in Sections 4.400 through 4.421, as well as the following criteria:

1. The proposed signage is compatible with developments or uses permitted in the zone in terms of design, materials used, color schemes, proportionality, and location, so that it does not interfere with or detract from the visual appearance of surrounding development;
2. The proposed signage will not create a nuisance or result in a significant reduction in the value or usefulness of surrounding development; and
3. Special attention is paid to the interface between signs and other site elements including building architecture and landscaping, including trees.

Class II Sign Permit Application Conformance

1. The proposed signage is compatible with developments or uses permitted in the zone in terms of design, materials used, color schemes, proportionality, and location, so that it does not interfere with or detract from the visual appearance of surrounding development;

Meyer Response:

Meyer's proposed sign is in conformance with base zone regulations, with exception of the use of a digitally changeable LED electronic message unit, of which the DRB may provide a Waiver for such use if they deem it necessary.

2. The proposed signage will not create a nuisance or result in a significant reduction in the value or usefulness of surrounding development; and

Meyer Response:

No negative impact is anticipated from the approval of the above mentioned Waiver from DRB with the proposed design.

3. Special attention is paid to the interface between signs and other site elements including building architecture and landscaping, including trees.

Meyer Response:

The location of the sign is not changing and is essentially a refurbishment of the current sign. No new holes, footings, electrical dredging, etc. that would impact trees in the area is anticipated, and therefore compliant with the code.

	sales@meyersignco.com www.meyersignco.com phone: 503 620-8200 fax: 503 620-7074	Boeckman Creek Primary School 6700 SW Wilsonville Rd. Wilsonville, OR 97070	FILE INFO: DRAWING: _____ SHEET _____ OF _____	REVISIONS: <table border="1"> <thead> <tr> <th></th> <th>DATE:</th> <th>BY:</th> </tr> </thead> <tbody> <tr><td>1-</td><td>0</td><td>0</td></tr> <tr><td>2-</td><td>0</td><td>0</td></tr> <tr><td>3-</td><td>0</td><td>0</td></tr> <tr><td>4-</td><td>0</td><td>0</td></tr> <tr><td>5-</td><td>0</td><td>0</td></tr> <tr><td>6-</td><td>0</td><td>0</td></tr> </tbody> </table>		DATE:	BY:	1-	0	0	2-	0	0	3-	0	0	4-	0	0	5-	0	0	6-	0	0	CUSTOMER APPROVAL: _____ INITIALS DATE LANDLORD APPROVAL: _____ INITIALS DATE	<small>This is an original unpublished drawing created for Meyer Sign Company's customer and the project planned for the specific needs of Meyer Sign Customers. These drawings are not to be shown outside your organization nor used, copied, reproduced, or exhibited in any way unless authorized in writing by an officer of Meyer Sign Company of Oregon.</small>	Attention: <small>Colors shown on this artwork are for representational purposes only. An inkjet printer, printing on copier or computer monitor display cannot exactly duplicate the true color of the materials used in the actual sign making process.</small>	<div style="border: 1px solid black; padding: 2px; width: 20px; text-align: center;">97</div>
		DATE:	BY:																										
1-	0	0																											
2-	0	0																											
3-	0	0																											
4-	0	0																											
5-	0	0																											
6-	0	0																											
<small>Meyer Sign Company of Oregon</small>																													

EXHIBIT A: City of Wilsonville Development Code Excerpts & Notes

Code Excerpts:
Section 4.156.08. - Sign Regulations in the PDC, TC, PDI, and PF Zones.

(.01) Freestanding and Ground Mounted Signs:
 A. One freestanding or ground mounted sign is allowed for the first 200 linear feet of site frontage. One additional freestanding or ground mounted sign may be added for through and corner lots having at least 200 feet of frontage on one street or right-of-way and 100 feet on the other street or right-of-way.

Site has approximately 1,830 lineal feet of property frontage, and therefore is allowed multiple freestanding/ground mounted signs.

B. The allowed height above ground of a freestanding or ground mounted sign is 20 feet except as noted in 1-2 below. ← Proposed sign does not exceed twenty (20) feet above grade.

1. The maximum allowed height above ground for signs along the frontage of Interstate 5, and parallel contiguous portions of streets, as identified in Figure S-4, associated with multiple tenants or businesses may be increased by three feet for each tenant space of 10,000 square feet or more of gross floor area up to a maximum of 35 feet. ← Not applicable in this scenario.

2. The allowed height above ground for signs in the TC Zone, Old Town Overlay Zone, and PDI Zone is eight feet, except those signs along the frontage of Interstate 5 and parallel contiguous portions of streets identified in Figure S-4.C. The maximum allowed area for each freestanding or ground-mounted sign is determined based on gross floor area and number of tenant spaces:

1. For frontages along streets other than those indicated in two below sign area allowed is calculated as follows: a. The sign area allowed ← Proposed sign is less than 64 sqft for signs pertaining to a single tenant:

Gross Floor Area in a Single Building	Maximum Allowed Sign Area
Less than 11,000 sq. ft.	32 sq. ft.
11,000--25,999 sq. ft.	32 sq. ft. + 2 sq. ft. per 1,000 sq. ft. of floor area greater than 10,000 rounded down to the nearest 1,000 sq. ft.
26,000 sq. ft. or more	64 sq. ft.

i. For PF (Public Facility) zoned properties adjacent to residential zoned land the maximum allowed area is 32 square feet. ←

Proposed sign is 32 sqft, which is an additional requirement for signs with PDR zones neighboring the PF zone.

- D. Pole or sign support placement shall be installed in a full vertical position.
- E. Freestanding and ground mounted signs shall not extend into or above public rights-of-way, parking areas, or vehicle maneuvering areas.
- F. The location of free standing or ground mounted signs located adjacent to or near the Public Right-of-Way shall be in compliance with the City's Public Works Standards for sight distance clearance. Prior to construction, the location of the sign shall be approved by the City of Wilsonville Engineering Division.
- G. Freestanding and ground mounted signs shall be designed to match or complement the architectural design of buildings on the site.
- H. For freestanding and ground mounted signs greater than eight feet in height, the width of the sign shall not exceed the height. I. Along street frontages in the TC Zone and Old Town Overlay Zone monument style signs are required.
- J. Freestanding and ground mounted signs shall be no further than 15 feet from the property line and no closer than two feet from a sidewalk or other hard surface in the public right-of-way.
- K. Except for those signs fronting Interstate 5, freestanding and ground mounted signs shall include the address number of associated buildings unless otherwise approved in writing by the City and the Fire District.
- L. When a sign is designed based on the number of planned tenant spaces it shall remain a legal, conforming sign regardless of the change in the number of tenants or configuration of tenant spaces.

Proposed sign conforms with all aspects of 4.156.08D-L

See Exhibit B - City of Wilsonville Zoning Map

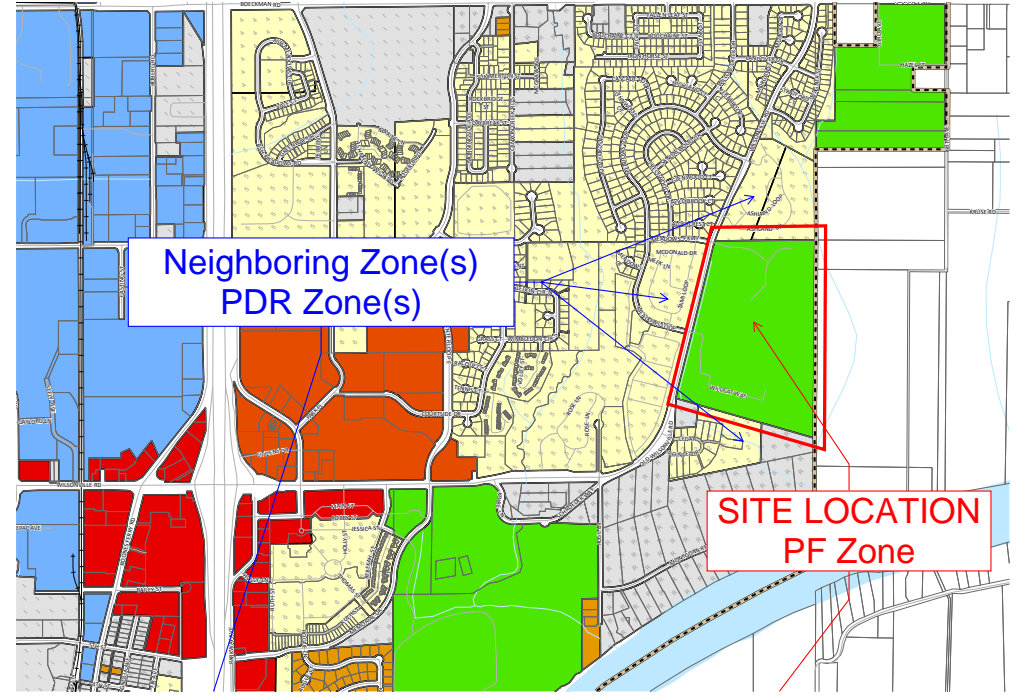

sales@meyersignco.com
 www.meyersignco.com
 phone: 503 620-8200
 fax: 503 620-7074

Boeckman Creek Primary School
 6700 SW Wilsonville Rd.
 Wilsonville, OR 97070

FILE INFO:

DRAWING: _____

SHEET _____ OF _____

REVISIONS:

DATE:	BY:
1- 0	0
2- 0	0
3- 0	0
4- 0	0
5- 0	0
6- 0	0

CUSTOMER APPROVAL:

INITIALS _____ DATE _____

LANDLORD APPROVAL:

INITIALS _____ DATE _____

This is an original unpublished drawing created for Meyer Sign Company's customer and the project planned for the specific needs of Meyer Sign Customers. These drawings are not to be shown outside your organization nor used, copied, reproduced, or exhibited in any way unless authorized in writing by an officer of Meyer Sign Company of Oregon.

Attention:
 Colors shown on this artwork are for representational purposes only. An inkjet printer, printing on copier or computer monitor display cannot exactly duplicate the true color of the materials used in the actual sign making process.

98

EXHIBIT A: City of Wilsonville Development Code Excerpts & Notes

Code Excerpts:

Section 4.156.06. - Prohibited Signs.

(.01)Prohibited Signs. The following signs are prohibited and shall not be placed within the City:

A. Search lights, strobe lights, and signs containing strobe lights or other flashing lights, unless specifically approved in a sign permit.

B. Obstructing signs, a sign or sign structure such that any portion of its surface or supports will interfere in any way with the free use of any fire escape, exit, hydrant, standpipe, or the exterior of any window; any sign projecting more than 12 inches from a wall, except projecting signs that are specifically permitted through the provisions of this Code.

C. Changing image signs, including those within windows.

D. Changeable copy signs that use lighting changed digitally, unless specifically approved through a waiver process connected with a Class III Sign Permit or Master Sign Plan. In granting a waiver for a digital changeable copy signs the DRB shall ensure the following criteria will be met:

1. The sign shall be equipped with automatic dimming technology which automatically adjusts the sign's brightness in direct correlation with ambient light conditions and the sign owner shall ensure appropriate functioning of the dimming technology for the life of the sign.

2. The luminance of the sign shall not exceed 5,000 candelas per square meter between sunrise and sunset, and 500 candelas per square meter between sunset and sunrise.

Proposed sign has a digitally changeable EMC (Electronic Message Center), instead of the current manually changed readerboard. See following pages for narrative for Waiver Criteria.

	sales@meyersignco.com www.meyersignco.com phone: 503 620-8200 fax: 503 620-7074	Boeckman Creek Primary School 6700 SW Wilsonville Rd. Wilsonville, OR 97070	FILE INFO: DRAWING: SHEET _____ OF _____	REVISIONS: <table border="1"> <thead> <tr> <th></th> <th>DATE:</th> <th>BY:</th> </tr> </thead> <tbody> <tr> <td>1-</td> <td>0</td> <td>0</td> </tr> <tr> <td>2-</td> <td>0</td> <td>0</td> </tr> <tr> <td>3-</td> <td>0</td> <td>0</td> </tr> <tr> <td>4-</td> <td>0</td> <td>0</td> </tr> <tr> <td>5-</td> <td>0</td> <td>0</td> </tr> <tr> <td>6-</td> <td>0</td> <td>0</td> </tr> </tbody> </table>		DATE:	BY:	1-	0	0	2-	0	0	3-	0	0	4-	0	0	5-	0	0	6-	0	0	CUSTOMER APPROVAL: _____ INITIALS DATE LANDLORD APPROVAL: _____ INITIALS DATE	This is an original unpublished drawing created for Meyer Sign Company's customer and the project planned for the specific needs of Meyer Sign Customers. These drawings are not to be shown outside your organization nor used, copied, reproduced, or exhibited in any way unless authorized in writing by an officer of Meyer Sign Company of Oregon.	Attention: Colors shown on this artwork are for representational purposes only. An inkjet printer, printing on copier or computer monitor display cannot exactly duplicate the true color of the materials used in the actual sign making process.	99
		DATE:	BY:																										
1-	0	0																											
2-	0	0																											
3-	0	0																											
4-	0	0																											
5-	0	0																											
6-	0	0																											

EXHIBIT B CITY OF WILSONVILLE ZONING MAP



Zoning Map

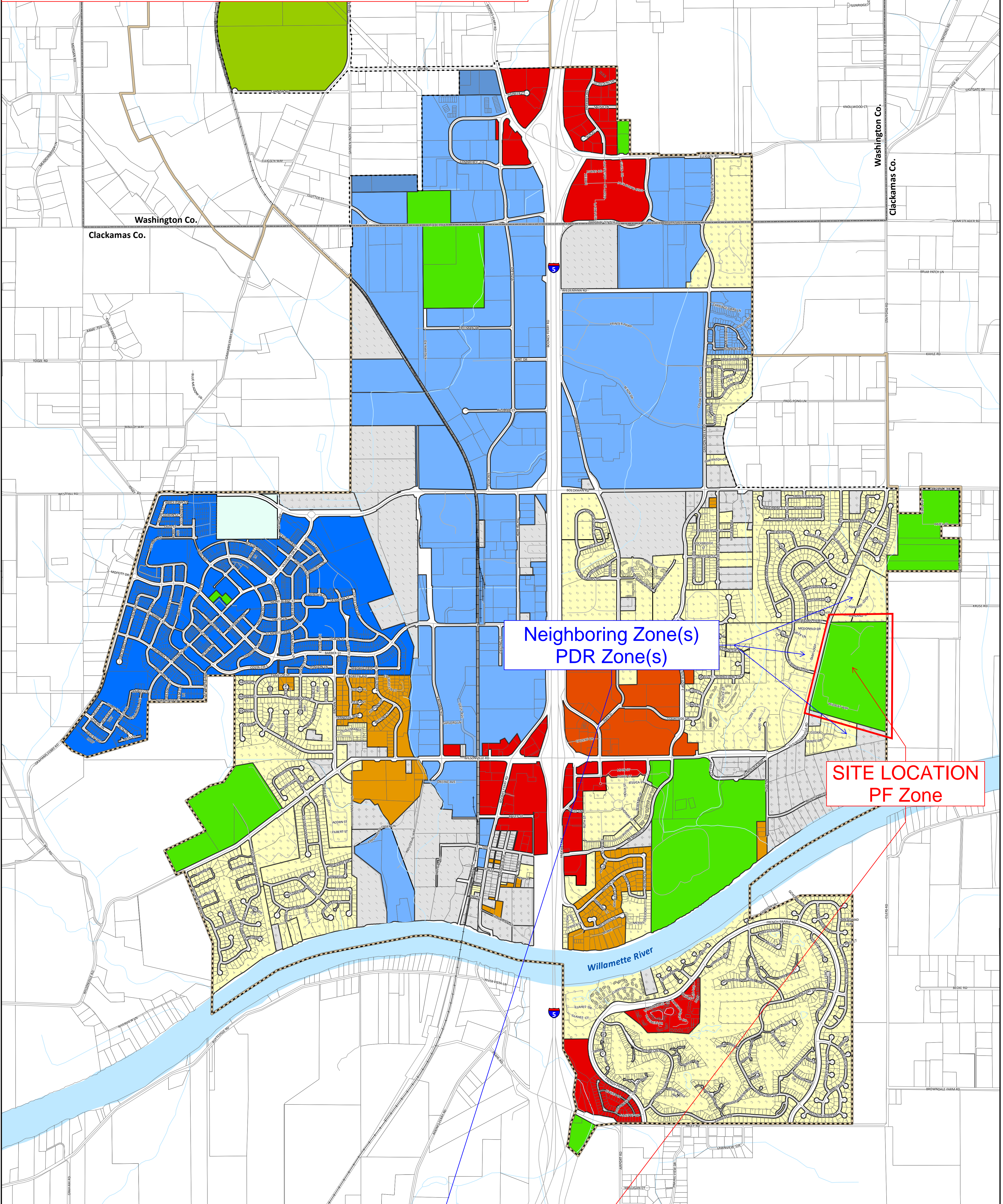

0 0.5 Mile

June 5, 2017

Zoning Designations

- Residential Agricultural Holding (RA-H)
- Residential (R)
- Planned Development Residential (PDR)
- Village (V)
- Planned Development Commercial (PDC)
- Planned Development Commercial Town Center (PDC-TC)
- Planned Development Industrial (PDI)
- PDI - Regionally Significant Industrial Area (PDI-RSIA)
- Public Facility (PF)
- Public Facility - Corrections (PF-C)
- Exclusive Farm Use (EFU)
- County Boundary
- City Boundary
- Urban Growth Boundary
- Taxlots

Note: Refer to individual overlay zone maps for overlay district boundaries

Disclaimer: The City of Wilsonville makes no representations, express or implied, as to the accuracy, completeness and timeliness of the information displayed. Data errors and omissions may exist in map and report. This map is not suitable for legal, engineering, or surveying purposes. Please contact the City of Wilsonville Planning Division to verify report information is complete and accurate.



Official Zoning Map

Mayor _____ Date _____

City Recorder _____ Date _____

Resolution Number: _____

SR:\GIS\COG\GIS\GIS\Zoning\Zoning_Map_2017.mxd

Class III Sign Permit Application Narrative

Scope of Work:

Replacement of existing monument sign cabinet at Boeckman Creek Primary School. Existing sign has a manually changeable reader board, and the school is desiring to upgrade it to a digitally changeable reader board.

The existing footings and vertical pipe structure will remain in place. The cabinet (box) between the pipe structure will be modified to a new LED illuminated cabinet, and new LED electronic message unit, which offers remote changeability.

Compatibility With Existing Code & Considerations:

Please see Exhibit A on following pages, showing conformance with Base zone regulations for freestanding signs in the PF (Public Facility) zone.

All base zone regulations are being followed. Briefly:

-Size of the sign follows current code, and only modifies the existing sign to remain the same size as what is existing today, +/- 1".

-The school's logo will be refreshed and used in the upper section of the sign's design.

-Sign is relatively no different from the existing sign, with exception of the EMC (Electronic Message Center). This will not be a nuisance for drivers, as it will fit within the profile of the existing sign and employ dimming technology so the sign will not exceed 5,000 candelas per square meter between sunrise and sunset, and 500 candelas per square meter between sunset and sunrise.

-Similar to the Wilsonville High School sign next door, this sign's requested modifications are to improve the functionality of the school's ability to communicate with the public. More specifically:

1. Sharing information with parent, students and the community about unexpected school closures & delays.
2. Safety alerts can be communicated immediately to staff, students & parents. A recent example was an active shooter situation which would not have reached the public via alerts/emails, and having the sign be able to change right away can improve the speed of communication in these scenarios.
3. Reminders of planned events, early release days, etc. the school wants to communicate to the public.
4. Communications of praise for individual student/staff successes at various events, testing, awards, etc.
5. Improved pride in school and public perception due to an upgrade and functioning sign present on site, instead of the current sign which does not illuminate.

Distance to the Property Line

The distance from the Monument sign to the property line to the North is 65', and the distance from the property line to the West is 19'.

Distance to the Hard surface in the Right-of-Way

The distance from the Monument sign to the hard surface in the Right-of-Way is 9' to the North, and the distance from the Monument sign to the hard surface in the Right-of-Way to the West is 19'.

	sales@meyersignco.com www.meyersignco.com phone: 503 620-8200 fax: 503 620-7074	Boeckman Creek Primary School 6700 SW Wilsonville Rd. Wilsonville, OR 97070	FILE INFO: DRAWING: _____ SHEET _____ OF _____	REVISIONS: <table border="1"> <thead> <tr> <th></th> <th>DATE:</th> <th>BY:</th> </tr> </thead> <tbody> <tr><td>1-</td><td>0</td><td>0</td></tr> <tr><td>2-</td><td>0</td><td>0</td></tr> <tr><td>3-</td><td>0</td><td>0</td></tr> <tr><td>4-</td><td>0</td><td>0</td></tr> <tr><td>5-</td><td>0</td><td>0</td></tr> <tr><td>6-</td><td>0</td><td>0</td></tr> </tbody> </table>		DATE:	BY:	1-	0	0	2-	0	0	3-	0	0	4-	0	0	5-	0	0	6-	0	0	CUSTOMER APPROVAL: _____ INITIALS DATE	This is an original unpublished drawing created for Meyer Sign Company's customer and the project planned for the specific needs of Meyer Sign Customers. These drawings are not to be shown outside your organization nor used, copied, reproduced, or exhibited in any way unless authorized in writing by an officer of Meyer Sign Company of Oregon.	Attention: Colors shown on this artwork are for representational purposes only. An inkjet printer, printing on copier or computer monitor display cannot exactly duplicate the true color of the materials in the actual sign making process.	<div style="border: 1px solid black; padding: 2px; text-align: center;">101</div>
		DATE:	BY:																										
1-	0	0																											
2-	0	0																											
3-	0	0																											
4-	0	0																											
5-	0	0																											
6-	0	0																											
LANDLORD APPROVAL: _____ INITIALS DATE																													

Waivers Code Excerpt

Excerpt From Section 4.156.02. - Sign Review Process and General Requirements.

(.08)Waivers and Variances.

Waivers and variances are similar in that they allow deviation from requirements such as area, and height from ground. They differ in that waivers are granted by the DRB as part of a comprehensive review of the design and function of an entire site to bring about an improved design and variances are granted by either the Planning Director or DRB to relieve a specific hardship caused by the regulations.

A.Waivers. The DRB may grant waivers for sign area, sign height from ground (no waiver shall be granted to allow signs to exceed 35 feet in height), number of signs, or use of electronic changeable copy signs in order to better implement the purpose and objectives of the sign regulations as determined by making findings that all of the following criteria are met:

- 1.The waiver will result in improved sign design, in regards to both aesthetics and functionality.
- 2.The waiver will result in a sign or signs more compatible with and complementary to the overall design and architecture of a site, along with adjoining properties, surrounding areas, and the zoning district than signs allowed without the waiver.
- 3.The waiver will result in a sign or signs that improve, or at least do not negatively impact, public safety, especially traffic safety.
- 4.Sign content is not being considered when determining whether or not to grant a waiver.

Waiver Narrative

The following information is presented to show conformance with 4.156.02.08:

Comptability With Existing Code & Considerations:

1.The waiver will result in improved sign design, in regards to both aesthetics and functionality.

Meyer Response:

Sign will be updated to have cellular communications with an electronic message center (EMC) which will functionally help the staff and parents communicate to parents, students and fellow staff. Additionally, the logo has been incorporated and the sign will light properly, giving a new and finished look, compared to the sign currently in place. The existing sign could use some "love".

2.The waiver will result in a sign or signs more compatible with and complementary to the overall design and architecture of a site, along with adjoining properties, surrounding areas, and the zoning district than signs allowed without the waiver.

Meyer Response:

The new sign still falls within all existing code compliance, with exception of a digitally changeable LED electronic message unit being incorporated into the design. Per 4.156.02.08.A,the DRB may specifically grant a waiver for the incorporation of that design element.

3.The waiver will result in a sign or signs that improve, or at least do not negatively impact, public safety, especially traffic safety.

Meyer Response:

No negative impact to the public safety is anticipated, especially traffic safety. Contrarily, public safety is anticipated to be improved due to increased messaging capability to the public via cellular communications, allowing for more real-time messaging to reach the public quickly.

4.Sign content is not being considered when determining whether or not to grant a waiver.

Meyer Response:

No contest - all content for the message unit will be school/educationally motivated.

(Site Plan)

Item 3.



SITE PLAN
6700 SW Wilsonville Rd.
Wilsonville, OR 97070

Description of work: Removing existing cabinet and existing changeable copy message unit and replacing them with new like cabinet and Electronic message center using existing poles and footings.

Sign Contractor:
 Meyer Sign Co. of Oregon
 15205 SW 74th Ave
 Tigard, OR 97224
 (503) 620-8200
 Contact: Tony McCormick

Business to receive sign:
Boeckman Creek School
6700 SW Wilsonville Rd.
Wilsonville, OR 97070

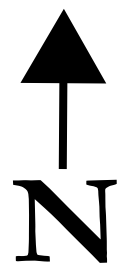

Scale: 1/16" = 15'-0"

City of Wilsonville
 Exhibit B2 DB23-0009



sales@meyersignco.com
 www.meyersignco.com
 phone: 503 620-8200
 fax: 503 620-7074

PROJECT: *Boeckman Creek School* ACCT. MGR: _____
 ADDRESS: *6700 SW Wilsonville Rd.* SHOP MGR: _____
 PHONE: *Wilsonville, OR 97070* SCALE: _____
 DESIGNER: *TLM* DATE: _____

FILE INFO: _____
 DRAWING: _____
 SHEET _____ OF _____

REVISIONS:		
NO.	DATE:	BY:
1-	0	0
2-	0	0
3-	0	0
4-	0	0
5-	0	0
6-	0	0

CUSTOMER APPROVAL:

 INITIALS DATE

LANDLORD APPROVAL:

 INITIALS DATE

This is an original unpublished drawing created for Meyer Sign Company's customer and the project planned for the specific needs of Meyer Sign Customers. These drawings are not to be shown outside your organization nor used, copied, reproduced, or exhibited in any way unless authorized in writing by an officer of Meyer Sign Company of Oregon.

Attention:
 Colors shown on this artwork are for representational purposes only. An inkjet printer, printing on copier or computer monitor cannot exactly duplicate the true color of the materials in the actual sign making process.

(Enlarged Site Plan)

Item 3.



PERMIT COPY



sales@meyersignco.com
 www.meyersignco.com
 phone: 503 620-8200
 fax: 503 620-7074

PROJECT: *Boeckman Creek Primary* ACCT. MGR: _____
 ADDRESS: *6700 SW Wilsonville Rd.* SHOP MGR: _____
 PHONE: *Wilsonville, OR 97070* SCALE: _____
 DESIGNER: *TLM* DATE: _____

FILE INFO:	
DRAWING:	_____
SHEET _____ OF _____	

REVISIONS:		
DATE:	BY:	
1- 0	0	
2- 0	0	
3- 0	0	
4- 0	0	
5- 0	0	
6- 0	0	

CUSTOMER APPROVAL:	
INITIALS _____	DATE _____
LANDLORD APPROVAL:	
INITIALS _____	DATE _____

This is an original unpublished drawing created for Meyer Sign Company's customer and the project planned for the specific needs of Meyer Sign Customers. These drawings are not to be shown outside your organization nor used, copied, reproduced, or exhibited in any way unless authorized in writing by an officer of Meyer Sign Company of Oregon.

Attention:
 Colors shown on this artwork are for representational purposes only. An inkjet printer, printing on copier or computer monitor display cannot exactly duplicate the true color of the materials in the actual sign making process.

(Building Footprint Calcs)



PERMIT COPY



sales@meyersignco.com
 www.meyersignco.com
 phone: 503 620-8200
 fax: 503 620-7074

PROJECT: *Boeckman Creek Primary* ACCT. MGR: _____
 ADDRESS: *6700 SW Wilsonville Rd.* SHOP MGR: _____
 PHONE: *Wilsonville, OR 97070* SCALE: _____
 DESIGNER: *TLM* DATE: _____

FILE INFO:	
DRAWING: _____	
SHEET _____ OF _____	

REVISIONS:		
DATE:	BY:	
1- 0	0	
2- 0	0	
3- 0	0	
4- 0	0	
5- 0	0	
6- 0	0	

CUSTOMER APPROVAL:	
INITIALS _____	DATE _____
LANDLORD APPROVAL:	
INITIALS _____	DATE _____

This is an original unpublished drawing created for Meyer Sign Company's customer and the project planned for the specific needs of Meyer Sign Customers. These drawings are not to be shown outside your organization nor used, copied, reproduced, or exhibited in any way unless authorized in writing by an officer of Meyer Sign Company of Oregon.

Attention:
 Colors shown on this artwork are for representational purposes only. An inkjet printer, printing on copier or computer monitor display cannot exactly duplicate the true color of the materials in the actual sign making process.

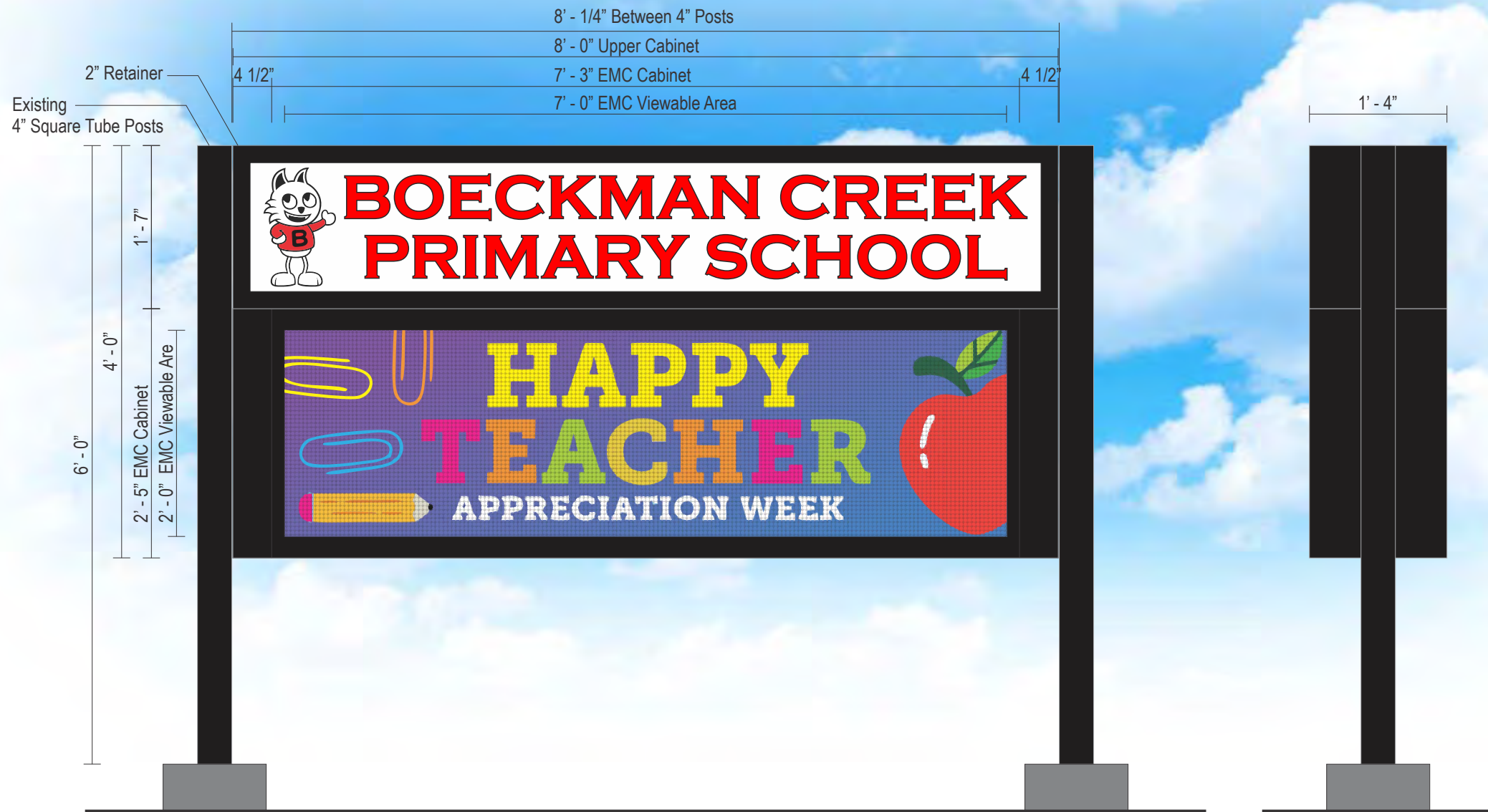

SCOPE OF WORK:

Item 3.

Manufacture & Install:
One (1) Double Face Internally Illuminated Monument With EMC

Upper Cabinet
Fabricated Aluminum Cabinet
2" Aluminum Retainer
3/16" Polycarbonate Face
Vinyl Graphics
Internally Illuminated with 7100k White LEDs

EMC
16mm RGB LED Message Center
Wireless Communication
Cloud Software
Fabricated Aluminum Spacers

Installation
Remove Existing Sign
Install Between Existing Posts

- Vinyl
230-33 Red
- Vinyl
220-12 Black
- Paint
Black (Satin Finish)

PERMIT COPY



www.meyersignco.com
sales@meyersignco.com
503-620-8200

Project Name: Boeckman Creek Primary School
Street Address: 6700 SW Wilsonville Road
City/State/Zip: Wilsonville, OR 97070

Acct Manager: Tony Montoya
Designer: JC
Date: 4/26/23

Drawing: Boeckman Creek Primary School.cdr
Server: J:\Boeckman Creek Primary School\Rendering

Approval: _____
Title: _____
Date: _____

This is an original unpublished drawing created for Meyer Sign Company's Client and the project planned for the specific needs of Meyer Sign Clients. These Drawings are not to be shown outside your organization nor used, copied, reproduced, or exhibited in any way unless authorized in writing by an officer of Meyer Sign Company of Oregon.





PERMIT COPY

	sales@meyersignco.com www.meyersignco.com phone: 503 620-8200 fax: 503 620-7074	PROJECT: <i>Boeckman Creek Primary</i> ACCT. MGR: _____ ADDRESS: <i>6700 SW Wilsonville Rd.</i> SHOP MGR: _____ PHONE: <i>Wilsonville, OR 97070</i> SCALE: _____ DESIGNER: <i>TLM</i> DATE: _____	FILE INFO: DRAWING: _____ SHEET _____ OF _____	REVISIONS: <table border="1" style="font-size: small;"> <thead> <tr> <th>DATE:</th> <th>BY:</th> </tr> </thead> <tbody> <tr><td>1- 0</td><td>0</td></tr> <tr><td>2- 0</td><td>0</td></tr> <tr><td>3- 0</td><td>0</td></tr> <tr><td>4- 0</td><td>0</td></tr> <tr><td>5- 0</td><td>0</td></tr> <tr><td>6- 0</td><td>0</td></tr> </tbody> </table>	DATE:	BY:	1- 0	0	2- 0	0	3- 0	0	4- 0	0	5- 0	0	6- 0	0	CUSTOMER APPROVAL: _____ INITIALS DATE	This is an original unpublished drawing created for Meyer Sign Company's customer and the project planned for the specific needs of Meyer Sign Customers. These drawings are not to be shown outside your organization nor used, copied, reproduced, or exhibited in any way unless authorized in writing by an officer of Meyer Sign Company of Oregon.
	DATE:	BY:																		
1- 0	0																			
2- 0	0																			
3- 0	0																			
4- 0	0																			
5- 0	0																			
6- 0	0																			
		LANDLORD APPROVAL: _____ INITIALS DATE	Attention: Colors shown on this artwork are for representational purposes only. An inkjet printer, printing on copier or computer monitor display cannot exactly duplicate the true color of the materials in the actual sign making process.																	

Scope of work is for the connection of the replacement sign cabinets to the existing tubes.
 The new cabinet are the same size as the original cabinets and therefore the existing elements are not required to be evaluated.
 Verify all existing elements being reused do not show any signs of deterioration or damage. See following pages for structural notes.

LOADING:

Code: ASCE7-16
 $V_{ult} = 98$ mph (3 second gust)
 Exposure = B
 Overall Height, $h = 6.50$ ft
 Cabinet Area = 35 ft²
 Est. Cabinet wt. = 10 psf
 Est. Pylon Mass = 350 lb = 35*10psf
 Center of mass = 4.50 ft (cabinet)
 $I, pole = 8.8$ in⁴ (4x4x1/8)*(2)
 Roark's Table 16.1, Case 3c
 Nat. freq., $n_1 = 11.19 > 1.0$, consider rigid
 $G_f = 0.85$
 $K_{zt} = 1.00$ (Eqn. 26.8-1)
 $K_d = 0.85$ (Table 26.6-1)
 $C_f = 1.64$ (Figure 29.3-1)
 $s = 4.00$ ft $s/h = 0.62$
 $B = 8.69$ ft $B/s = 2.17$
 $0.2*B = 1.74$ ft (code offset, for wind load)
 offset = 0.00 ft (horizontal cabinet offset)
 $x = 8.35$ ft (c-c dist. btwn. poles)
 $F_1 = 71\%$ of load to single pole due to 20% wind offset
 OOP = _____ ft (out-of-plane offset)

F = qz*G*Cf*0.6: (allowable)

Kz	qz	F(psf)	h
0.57	11.91	10.0	0 - 7 ft

FORCES:

Width	Height to bottom (ft)	Height to top (ft)	Area (sq. ft.)	Wind load* (psf)	Force (lb)	Height to center (ft)	Moment (ft-lb)
8.69	4.92	6.50	13.8	10.0	138	5.71	788
8.69	2.50	4.92	21.0	10.0	210	3.71	779
0.67	0.50	2.50	1.3	10.0	13	1.50	20
3.00	0.00	0.50	1.5	10.0	15	0.25	4
		0.00	0.0	0.0	0	0.00	0
		0.00	0.0	0.0	0	0.00	0
		0.00	0.0	0.0	0	0.00	0
		0.00	0.0	0.0	0	0.00	0
		0.00	0.0	0.0	0	0.00	0
		0.00	0.0	0.0	0	0.00	0
		0.00	0.0	0.0	0	0.00	0
		0.00	0.0	0.0	0	0.00	0
		0.00	0.0	0.0	0	0.00	0
		0.00	0.0	0.0	0	0.00	0
		0.00	0.0	0.0	0	0.00	0
		0.00	0.0	0.0	0	0.00	0
		0.00	0.0	0.0	0	0.00	0
		0.00	0.0	0.0	0	0.00	0
					$\Sigma = 376$		
						$\Sigma = 1591$	at base

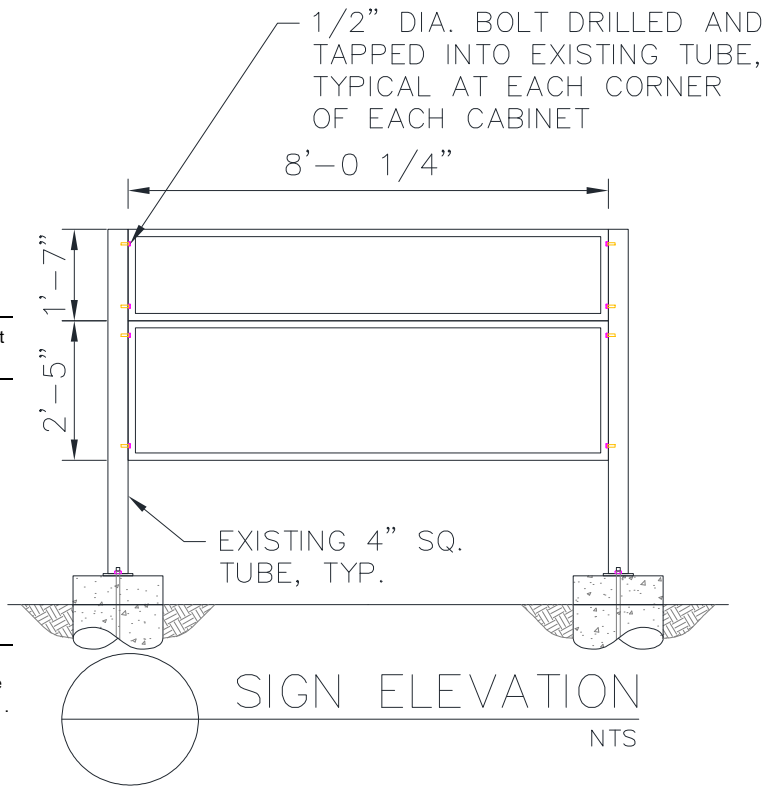

Large Cabinet Area = 21.0
 $V, cabinet = 210$ lb = 21*10
 # of Bolts = 4
 $V, bolt = 53$ lb = 210/(4)
 $Vc, bolt = 2350$ lb
 2350 > 53 OK
Use 1/2" diameter bolts

EXPIRES: 12-31-2024



Project Name Boeckman Creek Primary School Monument Sign Project # 231063
 Location 6700 SW Wilsonville Road, Willsonville, OR
 Client Meyer Sign Company of Oregon

GENERAL

Item 3.

THE CONTRACTOR IS RESPONSIBLE FOR VERIFICATION AND CORRELATION OF ALL ITEMS AND WORK NECESSARY FOR COMPLETION OF THE PROJECT AS INDICATED BY THE CONTRACT DOCUMENTS. SHOULD ANY QUESTION ARISE REGARDING THE CONTRACT DOCUMENTS OR SITE CONDITIONS, THE CONTRACTOR SHALL REQUEST INTERPRETATION AND CLARIFICATION FROM THE ENGINEER BEFORE BEGINNING THE PROJECT. THE ABSENCE OF SUCH REQUEST SHALL SIGNIFY THAT THE CONTRACTOR HAS REVIEWED AND FAMILIARIZED HIMSELF WITH ALL ASPECTS OF THE PROJECT AND HAS COMPLETE COMPREHENSION THEREOF. THE CONTRACTOR SHALL BE RESPONSIBLE FOR CONFORMANCE TO ALL SAFETY REGULATIONS DURING CONSTRUCTION.

THE CONTRACT DRAWINGS AND SPECIFICATIONS REPRESENT THE FINISHED STRUCTURE. UNLESS OTHERWISE SPECIFICALLY NOTED, THEY DO NOT INDICATE THE METHOD OF CONSTRUCTION OR CONSTRUCTION LOADS. ONLY THE CONTRACTOR SHALL PROVIDE ALL METHODS, DIRECTION AND RELATED EQUIPMENT NECESSARY TO PROTECT THE STRUCTURE, WORKMEN AND OTHER PERSONS AND PROPERTY DURING CONSTRUCTION. THE CONTRACTOR SHALL, AT HIS OWN EXPENSE, ENGAGE PROPERLY QUALIFIED PERSONS TO DETERMINE WHERE AND HOW TEMPORARY PRECAUTIONARY MEASURES SHALL BE USED AND INSPECT SAME IN THE FIELD. ANY MATERIAL NOT AS SPECIFIED OR IMPROPER MATERIAL INSTALLATION OR WORKMANSHIP SHALL BE REMOVED AND REPLACED WITH SPECIFIED MATERIAL IN A WORKMANLIKE MANNER AT THE CONTRACTOR'S EXPENSE.

THESE PLANS, SPECIFICATIONS, ENGINEERING AND DESIGN WORK ARE INTENDED SOLELY FOR THE PROJECT SPECIFIED HEREIN. MILLER CONSULTING ENGINEERS DISCLAIMS ALL LIABILITY IF THESE PLANS AND SPECIFICATIONS OR THE DESIGN, ADVICE AND INSTRUCTIONS ATTENDANT THERETO ARE USED ON ANY PROJECT OR AT ANY LOCATION OTHER THAN THE PROJECT AND LOCATION SPECIFIED HEREIN. OBSERVATION VISITS TO THE JOB SITE AND SPECIAL INSPECTIONS ARE NOT PART OF THE STRUCTURAL ENGINEER'S RESPONSIBILITY UNLESS THE CONTRACT DOCUMENTS SPECIFY OTHERWISE.

NON STRUCTURAL PORTIONS OF PROJECT, INCLUDING BUT NOT LIMITED TO PLUMBING, FIRE PROTECTION, LAND USE, SITE PLANNING, EROSION CONTROL, ELECTRICAL, MECHANICAL, FLASHING AND WATER-PROOFING ARE BEYOND THE SCOPE OF THESE DRAWINGS AND ARE PROVIDED BY OTHERS. EXISTING STRUCTURAL ELEMENTS ARE DESIGNED BY OTHERS. ANALYSIS FOR MOVEMENT DUE TO VORTEX SHEDDING OF WIND FORCES IS NOT INCLUDED IN THE SCOPE OF WORK. IF MOVEMENT CAUSED BY VORTEX SHEDDING IS A CONCERN, WIND TUNNEL TESTING OR OTHER ANALYTICAL MODELS SHALL BE UTILIZED TO EVALUATE THE STRUCTURE.

CONTRACTOR TO VERIFY ALL CONDITIONS PRIOR TO FABRICATION OR INSTALLATION. ENGINEER OF RECORD FOR THE PROJECT IS TO BE NOTIFIED IF CONDITIONS DIFFER FROM WHAT IS SHOWN ON THE DRAWINGS.

BUILDING CODE

ALL PHASES OF THE WORK SHALL CONFORM TO THE 2022 OREGON STRUCTURAL SPECIALTY CODE, BASED ON THE 2021 INTERNATIONAL BUILDING CODE, INCLUDING ALL REFERENCE STANDARDS, UNLESS NOTED OTHERWISE.

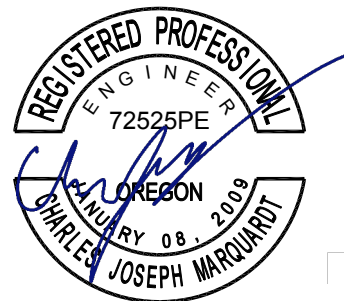

EXPIRES: 12-31-2024



9600 SW Oak St #400
Portland, OR 97223

503.246.1250
miller-se.com

Project Name Boeckman Creek Primary School Monument Sign Project # 231063

Location 6700 SW Wilsonville Road, Willsonville, OR

Client Meyer Sign Company of Oregon

By CJM Ck'd ERW Date 7/25/2023 Page 2 of 3

DESIGN LOADS

THE FOLLOWING ARE THE DESIGN REQUIREMENTS:

STRUCTURAL DESIGN CRITERIA	
RISK CATEGORY	II
WIND DESIGN DATA	
BASIC WIND SPEED (3 SEC GUST)	98 MPH
EXPOSURE	B

STRUCTURAL STEEL

ALL STRUCTURAL AND MISCELLANEOUS STEEL SHALL BE ASTM A992 FOR W-SECTIONS AND ASTM A36 FOR ALL OTHER SECTIONS, PLATES AND BARS. ALL RECTANGULAR HSS SECTIONS SHALL BE ASTM A500, GRADE B, FY= 46000 PSI AND ALL ROUND HSS SECTIONS SHALL BE ASTM A500, GRADE B, FY = 42000 PSI. ALL STRUCTURAL STEEL PIPE SHALL BE ASTM A53, GRADE B, TYPE E OR S, FY= 35000 PSI. ALL STEEL IN CONTACT WITH ALUMINUM TO BE HOT DIPPED GALVANIZED OR HAVE A PROTECTIVE BARRIER TO PREVENT CORROSION.

UNLESS NOTED OTHERWISE, ALL BOLTS TO BE ASTM A307 AND ALL ANCHOR RODS TO BE ASTM F1554 GRADE 36, WITH MATCHING NUTS. ALL FASTENERS IN CONTACT WITH ALUMINUM TO BE HOT DIPPED GALVANIZED WITH MATCHING NUTS OR HAVE A PROTECTIVE BARRIER TO PREVENT CORROSION. NUTS SHALL BE TIGHTENED TO A SNUG TIGHT CONDITION PER RESEARCH COUNCIL ON STRUCTURAL CONNECTIONS (RCSC) SPECIFICATION FOR STRUCTURAL JOINTS, SECTION 8.1.

ALL STRUCTURAL STEEL SHALL HAVE ONE COAT OF PRIMER, EXCEPT SURFACES TO BE EMBEDDED IN CONCRETE OR MASONRY. EMBEDDED SURFACES SHALL BE FREE OF CONTAMINANTS. ALL ZINC (GALV.) COATINGS ON IRON AND STEEL PRODUCTS SHALL CONFORM TO ASTM A123. REPAIRS OF GALVANIZED COATINGS ARE TO CONFORM TO ASTM A780. ALL EXPOSED STRUCTURAL STEEL TO HAVE ONE FINISH COAT OF RUST INHIBITING PAINT, COLOR BY OWNER.

ALL WELDING SHALL CONFORM TO AMERICAN WELDING SOCIETY (AWS) D1.1 USING E70XX ELECTRODES. WELD LENGTHS SHOWN ARE EFFECTIVE AS SPECIFIED PER THE SPECIFICATIONS OF THE AMERICAN INSTITUTE OF STEEL CONSTRUCTION (AISC). WELDING SHALL BE PERFORMED BY AWS CERTIFIED WELDERS FOR WELD TYPES SPECIFIED. WHERE WELD LENGTHS ARE NOT SHOWN, THE WELD SHALL BE FULL LENGTH OF MEMBERS BEING JOINED. ALL BUTT WELDS SHALL BE FULL PENETRATION WELDS UNLESS NOTED OTHERWISE ON STRUCTURAL DRAWINGS. ALL WELDS SHALL RECEIVE THE SAME FINISH COAT AS THE MEMBER BEING WELDED.

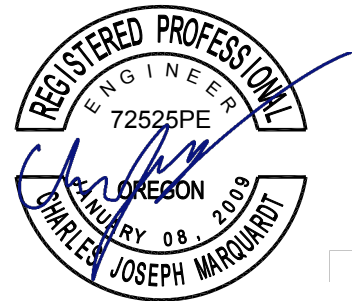

EXPIRES: 12-31-2024



9600 SW Oak St #400
Portland, OR 97223
503.246.1250
miller-se.com

Project Name Boeckman Creek Primary School Monument Sign Project # 231063

Location 6700 SW Wilsonville Road, Willsonville, OR

Client Meyer Sign Company of Oregon

By CJM Ck'd ERW Date 7/25/2023 Page 3 of 3

DEVELOPMENT REVIEW BOARD MEETING
MARCH 11, 2024
6:30 PM

Item 4.

Board Member Communications:

4. Results of the February 26, 2024 DRB Panel B meeting

City of Wilsonville

**Development Review Board Panel B Meeting
Meeting Results**

DATE:	FEBRUARY 26, 2024	
LOCATION:	29799 SW TOWN CENTER LOOP EAST, WILSONVILLE, OR	
TIME START:	6:32 P.M.	TIME END: 8:32 P.M.

ATTENDANCE LOG

BOARD MEMBERS	STAFF
Rachelle Barrett	Daniel Pauly
Alice Galloway	Miranda Bateschell
John Andrews	Amanda Guile-Hinman
Kamran Mesbah	Stephanie Davidson
	Amy Pepper
	Kimberly Rybold
	Cindy Luxhoj
	Georgia McAlister
	Shelley White

AGENDA RESULTS

AGENDA	ACTIONS
CITIZENS' INPUT	None.
CONSENT AGENDA	
1. Approval of January 22, 2024 Minutes	1. Unanimously approved as presented.
PUBLIC HEARING	
2. Resolution No. 428. PGE Memorial Substation. The applicant is requesting approval of a Conditional Use Permit and Site Design Review for development of the PGE Memorial Substation adjacent to SW Parkway Avenue and the I-5 Freeway. Case Files: DB23-0012 PGE Memorial Substation -Site Design Review (SDR23-0005) -Conditional Use Permit (CUP23-0001)	2. Resolution No 428 along with the Staff report were unanimously approved as presented.
3. Resolution No. 429. Appeal of Administrative Decision. The applicant is appealing the Planning Director's determination of non-conformance in Case File ADMN23-0029. Case File: DB24-0002 Appeal of Administrative Decision	3. Unanimous approval to keep the record open for Resolution No. 429 until March 4, 2024 at 5 pm. Exhibit C1 was added to the record. Follow up meeting to be scheduled.
BOARD MEMBER COMMUNICATIONS	
2. Results of the February 12, 2024 DRB Panel A Meeting 3. Recent City Council Action Minutes	There were no comments to any Board Member Communications
STAFF COMMUNICATIONS	None.

DEVELOPMENT REVIEW BOARD MEETING
MARCH 11, 2024
6:30 PM

Item 5.

Board Member Communications:

5. Recent City Council Action Minutes

City Council Meeting Action Minutes
January 29, 2024

COUNCILORS PRESENT

Mayor Fitzgerald
 Council President Akervall
 Councilor Linville
 Councilor Berry
 Councilor Dunwell – Excused for Work Session

STAFF PRESENT

Bryan Cosgrove, City Manager
 Amanda Guile-Hinman, City Attorney
 Andrew Barrett, Capital Projects Eng. Manager
 Kimberly Veliz, City Recorder
 Miranda Bateschell, Planning Director
 Zoe Mombert, Assistant to the City Manager

AGENDA ITEM	ACTIONS
EXECUTIVE SESSION	START: 5:03 p.m.
A. ORS 192.660(2)(e) Real Property Transactions B. ORS 192.660(2)(h) Legal Counsel/Litigation	Council met in Executive Session pursuant to Oregon Revised Statutes 192.660(2)(e) and 192.660(2)(h).
WORK SESSION	
A. City Charter – Term Limits (Continued)	Council discussed whether to consider advancing a charter amendment to the Wilsonville electorate to clarify mayoral term limits and to direct staff regarding next steps.
ADJOURN	7:44 p.m.

City Council Meeting Action Minutes
February 22, 2024

Item 5.

COUNCILORS PRESENT

Mayor Fitzgerald
Council President Akervall
Councilor Linville
Councilor Berry
Councilor Dunwell

Bill Evans, Communications & Marketing Manager
Bryan Cosgrove, City Manager
Chris Neamtzu, Community Development Director
Kerry Rappold, Natural Resources Manager
Kimberly Veliz, City Recorder
Mark Ottenad, Public/Government Affairs Director
Robert Wurpes, Chief of Police
Stephanie Davidson, Assistant City Attorney
Zach Weigel, City Engineer
Zoe Mombert, Assistant to the City Manager

STAFF PRESENT

Amanda Guile-Hinman, City Attorney
Andrew Barrett, Capital Projects Eng. Manager

AGENDA ITEM	ACTIONS
WORK SESSION	
START: 5:01 p.m.	
A. Draft Stormwater Master Plan	Staff sought the Council’s feedback on a draft of the Stormwater Master Plan Update, developed to identify and prioritize capital needs, and to present strategies aimed at maintaining, restoring, and enhancing local watersheds and meeting engineering, environmental and land use needs.
B. Public Contracting Code Update	Staff shared an update on a project to review the City’s public contracting code, and sought the Council’s direction on several changes under consideration to make the City’s procurement of goods and services more efficient, less confusing, more equitable, and in alignment with current public contracting laws.
REGULAR MEETING	
<u>Mayor’s Business</u>	
A. Declaration of 35 th Anniversary of Sister City Relationship	The Mayor read a declaration of the 35 th anniversary of the Sister City relationship of Wilsonville, Oregon and Kitakata, Japan. Council 5-0 ratified the declaration.
B. Upcoming Meetings	Upcoming meetings were announced by the Council President as well as the regional meetings she attended on behalf of the City.

<p>C. Appointment of Council Member to Willamette Valley Commuter Rail Advisory Committee</p>	<p>Council asked to consider appointed to Willamette Valley Commuter Rail Advisory Committee.</p>
<p><u>Communications</u> A. Crime Stats</p>	<p>The Wilsonville Police Chief provided a summary of data on the volume and types of crimes taking place in Wilsonville. Chief Wurpes noted a decline in property-related crimes in 2023.</p> <p>Following the presentation Council discussed and moved to accept the Measure 110. Legislative House Bill (HB) 4002-24 pre booking diversion letter. Passed 5-0.</p>
<p><u>Consent Agenda</u> A. <u>Resolution No. 3114</u> A Resolution Of The City Of Wilsonville Authorizing The City Manager To Execute A Professional Services Agreement With Brown And Caldwell, Inc. For Engineering Consulting Services For The Boeckman Creek Flow Mitigation Project (Capital Improvement Project No. 7068)</p> <p>B. Minutes of the January 18, 2024 Council Meeting.</p>	<p>The Consent Agenda was approved 5-0.</p>
<p><u>New Business</u> A. <u>Resolution No. 3123</u> A Resolution Of The City Of Wilsonville Amending Resolution No. 3046 To Further Phase-In The Implementation Of The Parks System Development Charge For Single-Family Residential Development.</p> <p>B. <u>Resolution No. 3124</u> A Resolution Of The City Of Wilsonville Adopting The Findings And Recommendations Of The 2023 Solid Waste Collection Rate Report, Amended January 2024, And Modifying The Republic Services Rate Schedule For Collection And Disposal Of Solid Waste, Recyclables, Organic Materials And Other Materials, Effective February 1, 2024, Amended On February 22, 2024.</p>	<p>Resolution No. 3123 was adopted, 5-0.</p> <p>Resolution No. 3124 was adopted, 5-0.</p>

<p>C. <u>Resolution No. 3125</u> A Resolution Of The City Of Wilsonville Referring To The Electors Of The City Of Wilsonville The Question Of Amending The City Charter To Refine Mayoral Term Limits In Certain Circumstances.</p> <p>D. <u>Resolution No. 3126</u> A Resolution Of The City Of Wilsonville Referring To The Electors Of The City Of Wilsonville The Question Of Amending The City Charter To Clarify The Calculation Of Years Of Service Relating To Term Limits.</p>	<p>Resolution No. 3125 was amended and adopted, 5-0.</p> <p>Resolution No. 3126 was amended and adopted, 5-0.</p>
<p><u>Continuing Business</u></p> <p>A. <u>Ordinance No. 886</u> An Ordinance Of The City Of Wilsonville Annexing Approximately 5.00 Acres Of Property Located At 7252 SW Frog Pond Lane For Development Of A 17-Lot Residential Subdivision.</p> <p>B. <u>Ordinance No. 887</u> An Ordinance Of The City Of Wilsonville Approving A Zone Map Amendment From The Clackamas County Rural Residential Farm Forest 5-Acre (RRFF-5) Zone To The Residential Neighborhood (RN) Zone On Approximately 5.00 Acres Located At 7252 SW Frog Pond Lane For Development Of A 17-Lot Residential Subdivision.</p>	<p>Ordinance No. 886 was adopted on second reading by a vote of 5-0.</p> <p>Ordinance No. 887 was adopted on second reading by a vote of 5-0.</p>
<p><u>Public Hearing</u></p> <p>A. None.</p>	
<p><u>City Manager’s Business</u></p>	<p>The City Manager shared staff had no contact with the Village at Main Center new property owners.</p>
<p><u>Legal Business</u></p>	<p>No report.</p>
<p>ADJOURN</p>	<p>10:28 p.m.</p>