



City of Willowick
CITY COUNCIL REGULAR MEETING

Tuesday, April 07, 2026 at 6:30 PM
City Council Chambers

ADA NOTICE

In compliance with the Americans with Disabilities Act, individuals needing special accommodations (including auxiliary communicative aids and services) during this meeting should notify the City of Willowick at 440-585-3700 at least three working days before the meeting.

AGENDA

CALL MEETING TO ORDER

PLEDGE ALLEGIANCE

INVOCATION

ROLL CALL OF COUNCIL

APPROVAL OF MINUTES

1. Motion to approve the Minutes from the Regular Council Meeting of March 17, 2026.

APPOINTMENTS, SPECIAL RESOLUTIONS & PROCLAMATIONS

2. A Resolution declaring the month of April as Child Abuse Prevention Month in the City of Willowick.

ADMINISTRATIVE APPEALS

REPORTS & COMMUNICATIONS FROM THE MAYOR/SAFETY DIRECTOR

COUNCIL DISCUSSION OF THE MAYOR'S REPORT

GENERAL COMMUNICATIONS & REPORTS – Directors & Officials

Service Director – Todd Shannon

Recreation Director – Julie Kless

City Engineer – Tim McLaughlin

Finance Director – Goran Vrhovac

Law Director – Mandy Gwartz

Police Chief – Rob Daubenmire

Fire Chief – Bill Malovrh

Chief Housing/Zoning Inspector – Sean Brennan

WARD MATTERS

PUBLIC PARTICIPATION

- a) *Public statement (1 minute maximum)*
- b) *Council response to the public*
- c) *Public clarification (30 seconds to 1 minute for the purpose of restating or rearticulating an original question, concern, suggestion or idea)*

REPORTS OF STANDING COMMITTEES

- Finance** – Bisbee, Mohorcic, Antosh
- Safety** – Phares, Malta, McFarland
- Service, Utilities & Public Lands** – Malta, Phares, McFarland
- Streets, Sidewalks & Sewers** – Malta, Bisbee, Mohorcic
- Tax Compliance** – Koudela, Antosh, McFarland
- Moral Claims** – Antosh, Phares, Koudela
- Budget** – Mohorcic, Koudela, Bisbee

LIAISON REPORTS

- Planning** – Phares/Alternate Antosh
- Board of Zoning Appeals** – McFarland/Alternate Koudela
- Volunteer Fire Fighters' Dependents Fund Board** – Antosh, Phares
- Recreation Board** – Bisbee/Alternate Phares
- Plan Review Board** – Antosh

FUND TRANSFERS & BID AUTHORIZATIONS

CONTRACT APPROVALS

- 3. Motion authorizing the Mayor to enter a contact with RJK Roofing Solutions for the Willowick Roofing Project in the amount of \$119,765.00.
- 4. Motion authorizing the Mayor to enter a contact with Geauga Highway Co. for the Base and Alternate for the 2026 Road Program in the amount of \$777,640.20.

INTRODUCTION & CONSIDERATION OF LEGISLATION

5. ORDINANCE NO. 2026- 12:

AN ORDINANCE AMENDING CHAPTER 549 OF THE CODIFIED ORDINANCES OF THE CITY OF WILLOWICK, OHIO, TITLED “WEAPONS AND EXPLOSIVES;” SPECIFICALLY SECTION 549.10, TITLED “FIREWORKS,” TO PROVIDE AN EXCEPTION FOR THOSE IN THE CITY TO POSSESS, DISCHARGE, IGNITE AND EXPLODE FIREWORKS ON CERTAIN HOLIDAYS.

First Reading 3/3/26, Second Reading 3/17/26, Item is on Third Reading.

6. ORDINANCE NO. 2026- 14:

AN ORDINANCE AMENDING ORDINANCE 2026- 6 TO PROVIDE FOR ADDITIONAL APPROPRIATIONS FROM The General Fund (101); Street Lighting Fund (204); Sewer Revenue Fund (205); Police & Fire Cap. Levey Fund (207); OneOhio Opioid Fund (229); Violent Crime Reduction Grant (233)The Municipal Tax Incentive Fund (302); FOR

CURRENT EXPENSES AND OTHER EXPENDITURES OF THE CITY OF WILLOWICK, STATE OF OHIO, DURING THE CALENDAR YEAR ENDING DECEMBER 31, 2026, AND DECLARING AN EMERGENCY.

7. ORDINANCE NO. 2026- 15:

AN ORDINANCE FIXING THE COMPENSATION OF ADULT SCHOOL GUARDS, REPEALING CERTAIN ORDINANCES AND DECLARING AN EMERGENCY.

8. RESOLUTION NO. 2026- 13:

A RESOLUTION AUTHORIZING THE MAYOR OF THE CITY OF WILLOWICK TO PREPARE AND SUBMIT ANY AND ALL APPLICATIONS TO PARTICIPATE IN THE COMPETITIVE COMMUNITY DEVELOPMENT BLOCK GRANT (CDBG) PROGRAM FOR FISCAL YEAR 2026, AND TO EXECUTE CONTRACTS AS REQUIRED FOR THE PROGRAM, AND DECLARING AN EMERGENCY

9. RESOLUTION NO. 2026- 14:

A RESOLUTION TO APPROVE AUTHORIZATIONS (THEN AND NOW CERTIFICATE) TO FLOCK GROUP INC. DBA FLOCK SAFETY IN THE AMOUNT OF \$7,500.00 FOR THE CITY OF WILLOWICK, AND DECLARING AN EMERGENCY

10. RESOLUTION NO. 2026- 15:

A RESOLUTION AUTHORIZING THE CITY OF WILLOWICK TO PARTICIPATE IN THE OHIO DEPARTMENT OF TRANSPORTATION CONTRACT (2025) FOR THE PURCHASE OF ROAD SALT, AND DECLARING AN EMERGENCY

MISCELLANEOUS

11. Motion to approve a purchase order in the amount of \$115,905.00 to Valley Freightliner for the purchased of a new 5-ton cab and chassis.
12. Motion to approve a purchase order in the amount of \$96,350.00 to Cenweld Corp. for the purchase of a dump body package, central hydraulics, and a new 10' plow.
13. Motion Authorizing an expenditure to the Willoughby Eastlake school district in the amount of \$123,977.57 for the first half TY/25CY26 Pilot reimbursement and \$47,000.00 for the Pupil Payment per the compensation Agreement for the Shoreland Crossings TIF.
14. Motion authorizing Change Order #2-FINAL to Municipal and Contractors Sealing Products, Inc in the deduct amount \$23,842.86 for the Lakeshore Boulevard Trunk Sewer West Rehabilitation.
15. Motion authorizing the Release of Retainage in the amount of \$37,982.40 to Municipal and Contractors Sealing Products, Inc for the Lakeshore Boulevard Trunk Sewer West Rehabilitation.
16. Motion authorizing the expenditure of \$39,969.44 to Communication Services for the start up cost for equipment and installation (\$11,161.64) and first year's payment (\$28,807.80). This is for the purchase of 7 new dash mounted cameras and 18 new body worn cameras.

17. Motion to authorize the expenditure of \$25,717.70 to Communication Services for the software and components (\$21,118.50) and the cost of installation plus one year support (\$4,599.20). This is for the purchase of phone/radio software recording system.
18. A Motion authorizing the Mayor to enter into an agreement with Sedgwick to re-enroll for the 2027 Ohio Association of Public Treasurers Retro Group at the cost of \$3,360.
19. Motion authorizing the expenditure of \$1,160.00 to Magnet Forensics for the cost for equipment and user licenses. This purchase will aid the police department to preserve cell phone evidence.
20. A Motion authorizing the expenditure of \$2,884.67 to Worldpoint for the cost of CPR dummies and CPR training equipment.

PUBLIC PARTICIPATION

- a) Public statement (1 minute maximum)*
- b) Council response to the public*
- c) Public clarification (30 seconds to 1 minute for the purpose of restating or rearticulating an original question, concern, suggestion or idea)*

EXECUTIVE SESSION

21. Discussion of Collective Bargaining with the Law Director and Finance Director.
22. Discussion of compensation, sick and vacation benefits of a Public Employee with Law Director and Finance Director.
23. Discussion of pending litigation with Law Director.

CLOSE EXECUTIVE SESSION

ADJOURNMENT



City of Willowick
CITY COUNCIL REGULAR MEETING

Tuesday, March 17, 2026 at 6:30 PM
 City Council Chambers

ADA NOTICE

In compliance with the Americans with Disabilities Act, individuals needing special accommodations (including auxiliary communicative aids and services) during this meeting should notify the City of Willowick at 440-585-3700 at least three working days before the meeting.

MINUTES

CALL MEETING TO ORDER

The meeting was called to order at 6:30 p.m. by Council President Koudela.

PLEDGE ALLEGIANCE

INVOCATION

ROLL CALL OF COUNCIL

All members in attendance.

APPROVAL OF MINUTES

1. Motion to approve the Minutes of the Regular Council Meeting of March 3, 2026.

MOTION: Mr. Malta motions to approve. Ms. Bisbee second.

ROLL CALL: Mr. Mohorcic, yea. Ms. Bisbee, yea. Mr. Phares, yea. Mr. Malta, yea. Mr. McFarland, yea. Ms. Koudela, yea. Ms. Antosh, yea.

APPOINTMENTS, SPECIAL RESOLUTIONS & PROCLAMATIONS

2. Motion to approve the mayoral appointment of Nicole Hastings to the Willowick Recreation Board for 3 years term expiring on Dec. 31, 2029.

MOTION: Ms. Antosh motions to approve. Ms. Bisbee second.

ROLL CALL: Mr. Mohorcic, yea. Ms. Bisbee, yea. Mr. Phares, yea. Mr. Malta, yea. Mr. McFarland, yea. Ms. Koudela, yea. Ms. Antosh, yea.

3. Peace Officer Commission and Oath of Office – Police Officer Sydney Prochazka

Mayor Vanni administers the Oath of Office to Officer Sydney Prochazka.

4. Peace Office Commission and Oath of Office – Sergeant Donald Slapnicker

Mayor Vanni administers the Oath of Office to Sergeant Donald Slapnicker.

ADMINISTRATIVE APPEALS

5. ADMINISTRATIVE APPEAL ORDER NO. 2026-6: (CHEN)

AN ORDER GRANTING A VARIANCE AND EXCEPTION OF 22 SQUARE FEET FOR

THE CONTRUCTION OF A 162 SQUARE FOOT METAL ACCESSORY BUILDING IN THE APPLICATION OF SECTION 1171.02(c) OF THE CODIFIED ORDINANCES OF THE CITY OF WILLOWICK.

MOTION: Ms. Antosh motions to approve. Mr. Malta second.

Mr. Phares asks what they want to store?

Ms. Koudela says that from what she read in the minutes, it is supplies.

Mr. McFarland says they go through a lot of to-go containers and would like to not run to the store so frequently.

Law Director Gwartz says that her understanding is that this applicant has already gone to building with another proposed plan that would not require a variance.

Sean Brennan says they did come in after the meeting last week and wanted to know what they needed to do after going to BZA to maybe get something that is smaller. He gave them another copy of the Ordinances and an application. He told them this still goes to Council.

Ms. Antosh asks if they are considering building a shed? This is a metal storage container.

Mr. Brennan says what they submitted originally is a metal storage trailer. They have not submitted anything regarding their secondary plan, but it sounded like a regular storage shed in compliance with the Ordinances.

ROLL CALL: Mr. Mohorcic, no. Ms. Bisbee, no. Mr. Phares, no. Mr. Malta, no. Mr. McFarland, no. Ms. Koudela, no. Ms. Antosh, no. Motion denied.

6. ADMINISTRATIVE APPEAL ORDER NO. 2026-7: (CHEN)

AN ORDER GRANTING A VARIANCE AND EXCEPTION FOR THE CONSTRUCTION OF A METAL ACCESSORY BUILDING THAT DOES NOT ANCHOR THE METAL ACCESSORY BUILDING ON A FOUR (4) INCH THICK CONCRETE BASE IN APPLICATION OF SECTION 1171.02(d) OF THE CODIFIED ORDINANCES OF THE CITY OF WILLOWICK.

MOTION: Ms. Antosh motions to approve. Ms. Bisbee second.

Mr. McFarland recommends we table this one. He thinks there is the suggestion they will be coming back with a slightly different option. If they are still going with a shipping container, they are big and heavy. If they are moving, we have a bigger problem. If it ever becomes necessary, he feels tabling it might be easier.

Law Director Gwartz says she is not sure it's the same as the previous case last month. They go hand in hand together that this would be required because of the type of structure. She is not sure there is a lot of logic... they will have to go back to BZA anyway to get possible variance for the structure. The other case they were trying to avoid going back to BZA at all. At that time, that applicant had reached out to Council and had appeared at the BZA meeting and had already submitted new plans for the house (last month) whereas nothing has been submitted yet for this.

Mr. Mohorcic says for what it is worth, we had 70 mph winds Friday. He would like to have 4" thick for that reason.

Ms. Koudela says if this is denied today, they won't have to wait 6 months because it would be a different plan.

Mr. McFarland says he wishes to retract his request to table then.

Mr. Brennan says if they submitted something per the Ordinance, it says if it was a metal construction. That would need to be anchored to a 4" base. If they submitted a wood construction to the City, it does not have to be on the 4" base.

ROLL CALL: Mr. Mohorcic, no. Ms. Bisbee, no. Mr. Phares, no. Mr. Malta, no. Mr. McFarland, no. Ms. Koudela, no. Ms. Antosh, no. Motion denied.

7. ADMINISTRATIVE APPEAL ORDER NO. 2026-8: (STRANO)

AN ORDER GRANTING A VARIANCE AND EXCEPTION OF 285 SQUARE FEET FOR THE CONSTRUCTION OF A 285 SQUARE FOOT ADDITION TO THE DETACHED GARAGE AND TO ALLOW THE PROPOSED LOCATION OF THE DETACHED GARAGE ADDITION IN APPLICATION OF SECTION 1163.07 OF THE CODIFIED ORDINANCES OF THE CITY OF WILLOWICK

MOTION: Ms. Antosh motions to approve. Mr. Malta second.

ROLL CALL: Mr. Mohorcic, yea. Ms. Bisbee, yea. Mr. Phares, yea. Mr. Malta, yea. Mr. McFarland, yea. Ms. Koudela, yea. Ms. Antosh, yea.

8. ADMINISTRATIVE APPEAL ORDER NO. 2026-9: (STRANO)

AN ORDER GRANTING A VARIANCE TO ALLOW THE PROPOSED LOCATION PROVIDED ON THE DRAWING OF A DETACHED GARAGE ADDITION NO MORE THAN 16" FROM THE SIDE LINE AND 5' FROM THE REAR PROPERTY LINE IN THE APPLICATION OF SECTION 1163.07 OF THE CODIFIED ORDINANCES OF THE CITY OF WILLOWICK.

MOTION: Ms. Antosh motions to approve. Mr. Phares second.

ROLL CALL: Mr. Mohorcic, yea. Ms. Bisbee, yea. Mr. Phares, yea. Mr. Malta, yea. Mr. McFarland, yea. Ms. Koudela, yea. Ms. Antosh, yea.

REPORTS & COMMUNICATIONS FROM THE MAYOR/SAFETY DIRECTOR

Mayor Vanni introduces Nick Janek, the liaison for the Lake County Health District.

Nick brings up the complaints on the rats. Overall, rat related complaints peaked in 2023, declined a bit in 2024, and fell by about half in 2025. For Willowick, 2023 had 16 complaints, declined to 9 for 2024, and 7 complaints for 2025. No complaints yet in 2026. If you are not calling in, it does not go into the stats.

Mayor Vanni wishes everyone a Happy St. Patrick's Day. Last Wednesday we had that rain/wind storm, over the weekend we had wind, and apparently got hit with a meteor today. He and Todd were at the County for a meeting with all the Service Directors. It was pretty much County wide. All in all, they only go 3 phone calls of potential basement flooding. We want residents to call, that's how they track. All in all, he thinks we got off okay with the interesting week of weather.

Last week we had 3 fires. The Fire Department did a great job. No injuries in all 3 of them. The one in the basement was not super serious, but the other two were pretty bad. One was a garage

fire and they did a great job containing it. He thanks them for all the hard work there preventing damage and making sure everyone stayed safe.

We got a complaint over kids riding their e-bikes in the parks. This was at Manry on the sidewalk. They are going to get signage up there at the park to prohibit them. Hopefully that will take care of it.

He thanks everyone who came to State of the Cities. The presentation is on Facebook and the City website.

We also had, last Wednesday in the afternoon, the Rt. 2 maintenance meeting. We are still ongoing. Have another meeting scheduled for April 2. Did present with a draft of an updated maintenance agreement which we are still going through. Then also the lights, which is a separate issue. We are making progress on that which is a good sign. Slow, but still progress.

We got \$334,000 grant that is going to Vine Street Corridor Project.

COUNCIL DISCUSSION OF THE MAYOR'S REPORT

Mr. Malta says State of the Cities, Mike represented the City very well and he was proud. Great job. Had to be nerve wracking, especially going first.

It was nice that \$1500 was donated to Hearts and Hammers in Rich Regovich's name.

Mayor Vanni says in addition to that donation, they also at their annual awards ceremony, they renamed the Morley Scholarship to Morley Regovich Scholarship.

GENERAL COMMUNICATIONS & REPORTS – Directors & Officials

Service Director – Todd Shannon

Recreation Director – Julie Kless

There are a few items on the agenda this evening. There is a motion for a PO for the pickleball courts. That was a budgeted item. There is another motion authorizing the Mayor to enter into an agreement for the installation as well.

City Engineer – Tim McLaughlin

There is one item on the agenda for consideration. Legislation 2026-12. This is another resolution to apply for funding through the US Senate. This will be for the rec improvements.

Finance Director – Goran Vrhovac

Final budget reading is tonight. He has taken over the final camera/mic project for the Council room. He is looking at working with service to get the equipment themselves and seeing if we could get it work. We would have a mic in the middle and a camera in the back that would be wide angle. If we did it that way, we could get it to \$2000. Would run everything to that room and record it there and then put it on the City Website and Youtube the next day. Would not be live. Also on the agenda, we want to apply for a grant. We need the City's emails and websites switched over to .gov apply for the bigger grants. Also, SHI contract on the agenda. No change there, just a continuance.

Law Director – Mandy Gwartz

No report, but open for questions.

Police Chief – Rob Daubenmire

The three live action cameras are up and running at Lakeshore/Vine, Lakeshore in the area of Aaron's rental, and Euclid Ave at 305. They are not red light cameras or speed cameras, just live action to keep an eye on intersections.

Fire Chief – Bill Malovrh

No formal report, but open for questions.

Ms. Antosh asks where were the 3 fires?

He says 323 was a garage fire, an hour before that was a basement fire, and on Saturday we had a garage fire extending into a house. Like the Mayor said, no injuries. Great job by all departments. The house on Sylvan had damage to the neighbor's house.

Chief Housing/Zoning Inspector – Sean Brennan

No formal report. Spoke with Mandy and asked her to look at an Ordinance for them which is proposed as OR 2026-13. Couple words taken out of it. Some properties in the City where we have vacant lots do have sidewalks. The Ordinance said it had to have a dwelling on the property to go through point of sale.

Ms. Antosh asks if there are any vacant lots without a sidewalk, do we require them to install one at time of sale?

He says we do have lots in the City that do not have sidewalks and we do not require them to have at point of sale.

WARD MATTERS

Ms. Antosh says she spoke with the Mayor about this. Those of you that were around in the mid-80s, George Maxwell was an auxiliary officer and he was working the crosswalk at Christmas Eve and he was hit and killed. They were wondering if that sidewalk could be named the George Maxwell walkway. Not the street, just that walkway and maybe a memorial sign. What would have to be done to try to get this?

Ms. Koudela asks if she's referring to just the cross walk?

Law Director Gwartz doesn't believe there's a legal restriction, it would just be what the costs are for the City. Maybe service can work on signage.

PUBLIC PARTICIPATION

a) Public statement (1 minute maximum)

b) Council response to the public

c) Public clarification (30 seconds to 1 minute for the purpose of restating or rearticulating an original question, concern, suggestion or idea)

No one wishes to speak.

REPORTS OF STANDING COMMITTEES

Finance – Bisbee, Mohorcic, Antosh

Safety – Phares, Malta, McFarland

Service, Utilities & Public Lands – Malta, Phares, McFarland

Streets, Sidewalks & Sewers – Mohorcic, Bisbee, Malta

Tax Compliance – McFarland, Antosh, Phares

Moral Claims – Antosh, Phares, Koudela

She has one Moral Claim. Will get with the Committee to likely meet before the next meeting.

Budget – Mohorcic, Koudela, Bisbee

LIAISON REPORTS

Planning – Phares/Alternate Antosh

Board of Zoning Appeals – McFarland/Alternate Koudela

Volunteer Fire Fighters’ Dependents Fund Board – Antosh, Phares

Recreation Board – Bisbee/Alternate Phares

Plan Review Board – Antosh

FUND TRANSFERS & BID AUTHORIZATIONS

CONTRACT APPROVALS

INTRODUCTION & CONSIDERATION OF LEGISLATION

9. ORDINANCE NO. 2026- 13

AN ORDINANCE AMENDING CHAPTER 1355 OF THE CODIFIED ORDINANCES OF THE CITY OF WILLOWICK, OHIO, TITLED “POINT OF SALE INSPECTIONS;” SPECIFICALLY, AMENDING SECTION 1355.01, TITLED “POINT OF SALE CERTIFICATE REQUIRED” AND DECLARING AN EMERGENCY.

MOTION: Ms. Antosh motions to suspend the rule requiring separate readings and readings in full. Mr. Malta second.

ROLL CALL: Mr. Mohorcic, yea. Ms. Bisbee, yea. Mr. Phares, yea. Mr. Malta, yea. Mr. McFarland, yea. Ms. Koudela, yea. Ms. Antosh, yea.

MOTION: Ms. Antosh motions to approve. Ms. Bisbee second.

ROLL CALL: Mr. Mohorcic, yea. Ms. Bisbee, yea. Mr. Phares, yea. Mr. Malta, yea. Mr. McFarland, yea. Ms. Koudela, yea. Ms. Antosh, yea.

10. RESOLUTION NO. 2026-11:

A RESOLUTION AUTHORIZING THE MAYOR OF THE CITY OF WILLOWICK TO PREPARE AND SUBMIT ANY AND ALL APPLICATIONS TO PARTICIPATE IN THE CYBEROHIO ROUND 3 .GOV GRANT PROGRAM FOR FISCAL YEAR 2026, AND TO EXECUTE CONTRACTS AS REQUIRED FOR THE PROGRAM, AND DECLARING AN EMERGENCY

MOTION: Ms. Antosh motions to suspend the rule requiring separate readings and readings in full. Ms. Bisbee second.

ROLL CALL: Mr. Mohorcic, yea. Ms. Bisbee, yea. Mr. Phares, yea. Mr. Malta, yea. Mr. McFarland, yea. Ms. Koudela, yea. Ms. Antosh, yea.

MOTION: Ms. Antosh motions to approve. Mr. McFarland second.

ROLL CALL: Mr. Mohorcic, yea. Ms. Bisbee, yea. Mr. Phares, yea. Mr. Malta, yea. Mr. McFarland, yea. Ms. Koudela, yea. Ms. Antosh, yea.

11. RESOLUTION NO. 2026- 12:

A RESOLUTION AUTHORIZING THE MAYOR TO PREPARE AND SUBMIT A FUNDING REQUEST TO THE UNITED STATES SENATE AND THE CONGRESSIONALLY DIRECTED SPENDING AND APPROPRIATIONS BILL, TO SUBMIT ANY APPLICATIONS, EXECUTE ANY NECESSARY CONTRACTS OR DOCUMENTS ASSOCIATED THEREWITH, AND DECLARING AN EMERGENCY.

MOTION: Ms. Antosh motions to suspend the rule requiring separate readings and readings in full. Mr. McFarland second.

ROLL CALL: Mr. Mohorcic, yea. Ms. Bisbee, yea. Mr. Phares, yea. Mr. Malta, yea. Mr. McFarland, yea. Ms. Koudela, yea. Ms. Antosh, yea.

MOTION: Mr. Malta motions to approve. Ms. Antosh second.

ROLL CALL: Mr. Mohorcic, yea. Ms. Bisbee, yea. Mr. Phares, yea. Mr. Malta, yea. Mr. McFarland, yea. Ms. Koudela, yea. Ms. Antosh, yea.

12. AMENDED ORDINANCE NO. 2026- 6:

AN ORDINANCE TO MAKE APPROPRIATIONS FOR CURRENT EXPENSES AND OTHER EXPENDITURES OF THE CITY OF WILLOWICK, STATE OF OHIO, DURING THE CALENDAR YEAR ENDING DECEMBER 31, 2026, AND DECLARING AN EMERGENCY.

First Reading 2/17/26, Second Reading 3/3/26, Item is on Third Reading.

MOTION: Ms. Antosh motions to approve. Mr. Malta second.

ROLL CALL: Mr. Mohorcic, yea. Ms. Bisbee, yea. Mr. Phares, yea. Mr. Malta, yea. Mr. McFarland, yea. Ms. Koudela, yea. Ms. Antosh, yea.

13. ORDINANCE NO. 2026- 12:

AN ORDINANCE AMENDING CHAPTER 549 OF THE CODIFIED ORDINANCES OF THE CITY OF WILLOWICK, OHIO, TITLED "WEAPONS AND EXPLOSIVES;" SPECIFICALLY SECTION 549.10, TITLED "FIREWORKS," TO PROVIDE AN EXCEPTION FOR THOSE IN THE CITY TO POSSESS, DISCHARGE, IGNITE AND EXPLODE FIREWORKS ON CERTAIN HOLIDAYS.

First Reading 3/3/26, Item is on Second Reading.

MISCELLANEOUS

14. Motion Authorizing the Mayor and/or Police Chief to enter into an agreement with Axon Enterprise, Inc. to provide taser certification training to the Willowick Police Department for the cost of \$23,386.00.

MOTION: Ms. Antosh motions to approve. Ms. Bisbee second.

Mr. McFarland asks if this is for the whole department?

Chief says the actual price includes the training, it is for the purchase of the tasers. He believes there will be 8 people being trained.

ROLL CALL: Mr. Mohorcic, yea. Ms. Bisbee, yea. Mr. Phares, yea. Mr. Malta, yea. Mr. McFarland, yea. Ms. Koudela, yea. Ms. Antosh, yea.

15. A Motion to Authorize the Mayor and/or Service Director to Enter Into an Agreement with Cintas to provide Uniform Rental to the Service Department.

MOTION: Ms. Antosh motions to approve. Mr. Malta second.

ROLL CALL: Mr. Mohorcic, yea. Ms. Bisbee, yea. Mr. Phares, yea. Mr. Malta, yea. Mr. McFarland, yea. Ms. Koudela, yea. Ms. Antosh, yea.

16. Motion Authorizing the Mayor to enter into an agreement with SHI to provide Anti-virus/Anti-Malware software for the city for the cost of \$5,924.16.

MOTION: Ms. Antosh motions to approve. Mr. Malta second.

ROLL CALL: Mr. Mohorcic, yea. Ms. Bisbee, yea. Mr. Phares, yea. Mr. Malta, yea. Mr. McFarland, yea. Ms. Koudela, yea. Ms. Antosh, yea.

17. Motion to authorize the purchase order in the amount of \$19,000 to South Coast Sports Construction for the installation of 3 pickleball courts at Dudley Park.

MOTION: Ms. Antosh motions to approve. Mr. Malta second.

ROLL CALL: Mr. Mohorcic, yea. Ms. Bisbee, yea. Mr. Phares, yea. Mr. Malta, yea. Mr. McFarland, yea. Ms. Koudela, yea. Ms. Antosh, yea.

18. Motion authorizing the Mayor to enter into a agreement with South Coast Sports Construction for the installation of 3 pickleball courts at Dudley Park.

MOTION: Ms. Antosh motions to approve. Ms. Bisbee second.

Mr. Malta asks if there was a timeframe for install?

Julie says 2 weeks.

Mayor Vanni says Julie did a lot of work to get this price cut in half. He thanks her.

Julie says this includes the repairs and the purchasing of the nets. This includes everything.

ROLL CALL: Mr. Mohorcic, yea. Ms. Bisbee, yea. Mr. Phares, yea. Mr. Malta, yea. Mr. McFarland, yea. Ms. Koudela, yea. Ms. Antosh, yea.

19. Motion authorizing a Liquor Permit to Lakeshore Gas LLC located at 29000 Lakeshore Blvd., Willowick, OH 44095.

MOTION: Ms. Antosh motions to approve. Ms. Bisbee second.

ROLL CALL: Mr. Mohorcic, yea. Ms. Bisbee, yea. Mr. Phares, yea. Mr. Malta, yea. Mr. McFarland, yea. Ms. Koudela, yea. Ms. Antosh, yea.

20. Motion authorizing the approval of a new business, College Tree Removal, located at P#28A0230000450.

MOTION: Ms. Antosh motions to approve. Ms. Bisbee second.

ROLL CALL: Mr. Mohorcic, yea. Ms. Bisbee, yea. Mr. Phares, yea. Mr. Malta, yea. Mr. McFarland, yea. Ms. Koudela, yea. Ms. Antosh, yea.

21. Motion authorizing a new business, Bombshell Beauty & Spa LLC, Located at 28902 Lakeshore Blvd. Willowick, OH 44095.

MOTION: Ms. Antosh motions to approve. Ms. Bisbee second.

ROLL CALL: Mr. Mohorcic, yea. Ms. Bisbee, yea. Mr. Phares, yea. Mr. Malta, yea. Mr. McFarland, yea. Ms. Koudela, yea. Ms. Antosh, yea.

PUBLIC PARTICIPATION

a) Public statement (1 minute maximum)

b) Council response to the public

c) Public clarification (30 seconds to 1 minute for the purpose of restating or rearticulating an original question, concern, suggestion or idea)

Phil Ditering, 469 Bayridge, says you were talking about naming a sidewalk for someone who did something for the City and died because of it? If you come up with a good idea, he had a neighbor who did that, George Maxin, he was not a full police officer.

Ms. Antosh says that is who she is talking about. He was an auxiliary police officer.

Mr. McFarland asks if the microphone is just for the recording or would it be for audience as well?

Goran says it would capture the podium and us.

Mr. Malta says anyone who supported the SMM St. Patrick's Day festival, it was an incredible event. That day, we kept his wife's brother's name alive. In 1969, his buddy went through the ice and he died saving him. It is amazing SMM has kept his name alive in the scholarship. It is an incredible event. Next year when it comes around, he will bring it up again. He thanks everyone who was there. It's usually the first Saturday in March.

If you ever get a chance to see the Broadmoor Coaches Game, it's a great time. To see the children who can't really play basketball, but that day they do, it's a great school for the children. That day it is really cool. If you get a chance, come out. He thanks Mike Vanni for being there with 5 of the western Lake County Mayors.

EXECUTIVE SESSION

22. Executive Session inviting the Law Director and Finance Director to discuss the status of a Collective Bargaining Agreement.

MOTION: Ms. Antosh motions to adjourn into executive session at 7:23 p.m. Ms. Bisbee second.

ROLL CALL: Mr. Mohorcic, yea. Ms. Bisbee, yea. Mr. Phares, yea. Mr. Malta, yea. Mr. McFarland, yea. Ms. Koudela, yea. Ms. Antosh, yea.

CLOSE EXECUTIVE SESSION

MOTION: Mr. Malta motions to return from executive session at 8:24 Ms. Antosh second.

ROLL CALL: Mr. Mohorcic, yea. Ms. Bisbee, yea. Mr. Phares, yea. Mr. Malta, yea. Mr. McFarland, yea. Ms. Koudela, yea. Ms. Antosh, yea.

ADJOURNMENT

Ms. Koudela calls for a Motion to Adjourn the Meeting.

MOTION: Ms. Antosh motions to approve. Ms. Bisbee second.

ROLL CALL: Mr. Mohorcic, yea. Ms. Bisbee, yea. Mr. Phares, yea. Mr. Malta, yea. Mr. McFarland, yea. Ms. Koudela, yea. Ms. Antosh, yea.

Motion carried. Meeting Adjourned at 8:24 p.m.

Clerk of Council

Council President

Date

ORDINANCE NO. 2026- 12

AN ORDINANCE AMENDING CHAPTER 549 OF THE CODIFIED ORDINANCES OF THE CITY OF WILLOWICK, OHIO, TITLED “WEAPONS AND EXPLOSIVES;” SPECIFICALLY SECTION 549.10, TITLED “FIREWORKS,” TO PROVIDE AN EXCEPTION FOR THOSE IN THE CITY TO POSSESS, DISCHARGE, IGNITE AND EXPLODE FIREWORKS ON CERTAIN HOLIDAYS.

WHEREAS, Section 549.10 of the Codified Ordinances of the City of Willowick prohibits the possession, igniting, discharging and exploding fireworks within the city of Willowick; and

WHEREAS, certain members of council have requested to amend 549.10 of the Codified Ordinances of the City of Willowick to allow residents to possess and discharge fireworks on certain holidays.

NOW THEREFORE, BE IT ORDAINED BY THE COUNCIL OF THE CITY OF WILLOWICK, COUNTY OF LAKE AND STATE OF OHIO:

Section 1: That Chapter 549 of the Codified Ordinances of the City of Willowick, Ohio, titled “WEAPONS AND EXPLOSIVES;” specifically, Section 549.10, titled “FIREWORKS,” and specifically Section 549.10(f) is hereby amended to read and provide as follows:

549.10 FIREWORKS

(f) Possession, Sale, Discharge and Advertising; Falsification.

~~—(1) No person shall possess fireworks in this municipality or shall possess for sale or sell fireworks in this municipality, except a licensed manufacturer of fireworks as authorized by R.C. §§ 3743.02 through 3743.08, a licensed wholesaler of fireworks as authorized by R.C. §§ 3743.15 through 3743.21, a shipping permit holder as authorized by R.C. § 3743.40, an out-of-state resident as authorized by R.C. § 3743.44, a resident of this state as authorized by R.C. § 3743.45, or a licensed exhibitor of fireworks as authorized by R.C. §§ 3743.50 through 3743.55, or as authorized by any municipal ordinance that is substantially equivalent to any of these statutes, and except as provided in R.C. § 3743.80 or a substantially equivalent municipal ordinance.~~

~~—(2) Except as provided in R.C. § 3743.80 or a substantially equivalent municipal ordinance, and except for licensed exhibitors of fireworks authorized to conduct a fireworks exhibition pursuant to R.C. §§ 3743.50 through 3743.55 or a substantially equivalent municipal ordinance, no person shall discharge, ignite, or explode any fireworks in this municipality.~~

~~—(3) No person shall use in a theater or public hall what is technically known as fireworks showers, or a mixture containing potassium chlorate and sulphur.~~

~~—(4) No person shall sell fireworks of any kind to a person under 18 years of age. No person under 18 years of age shall enter a fireworks sales showroom unless that person is accompanied by a parent, legal guardian or other responsible adult. No person under 18 years of age shall touch or possess fireworks on a licensed premises without the consent of the licensee. A licensee may eject any person from a licensed premises that is in any way disruptive to the safe operation of the premises.~~

~~—(5) Except as otherwise provided in R.C. § 3743.44, no person, other than a licensed manufacturer, licensed wholesaler, licensed exhibitor, or shipping permit holder shall possess 1.3G fireworks in this municipality.~~

~~—(6) No owner of property within the municipality shall permit the possession or discharge of fireworks on or from his/her/its property in violation of this chapter.~~

(1) No person shall possess fireworks in this Municipality or shall possess for sale or sell fireworks in this Municipality, except a licensed manufacturer of fireworks as authorized by Ohio R.C. 3743.02 to 3743.08, a licensed wholesaler of fireworks as authorized by Ohio R.C. 3743.15 to 3743.21, any person authorized by Ohio R.C. 3743.44, any person a resident of this State as authorized by Ohio R.C. 3743.45 in accordance with this Section, or a licensed exhibitor of fireworks as authorized by Ohio R.C. 3743.50 to 3743.55 and Section 549.10(e) and except as provided in Section 549.10(h) .

(2) Except as provided in Section 549.10(h) and except for licensed exhibitors of fireworks authorized to conduct a fireworks exhibition pursuant to Ohio R.C. 3743.50 to 3743.55 and Section 549.10(e) and any person authorized by Ohio R.C. 3743.45 and in accordance with Section 549.10(f)(6) no person shall discharge, ignite or explode any fireworks in this Municipality.

(3) No person shall use in a theater or public hall, what is technically known as fireworks showers, or a mixture containing potassium chlorate and sulphur.

(4) No person shall sell fireworks of any kind to a person under eighteen years of age. No person under eighteen years of age shall enter a fireworks sales showroom unless that person is accompanied by a parent, legal guardian, or other responsible adult. No person under eighteen years of age shall touch or possess fireworks on a licensed premises without the consent of the licensee. A licensee may eject any person from a licensed premises that is in any way disruptive to the safe operation of the premises.

(5) Except as otherwise provided in Ohio R.C. 3743.44, no person, other than a licensed manufacturer, licensed wholesaler, licensed exhibitor, or shipping permit holder, shall possess 1.3 G fireworks.

(6) A person in this Municipality authorized pursuant to Ohio R.C. 3743.45 to possess fireworks may discharge, ignite, or explode fireworks on private property with the authorization from the property owner only from 4:00 PM until 11:59 PM on the following days each year:

- (i) The first day of January

- (ii) Chinese new year’s day
- (iii) The fifth day of May
- (iv) The last Monday in May and the Saturday and Sunday immediately preceding that day
- (v) The nineteenth day of June
- (vi) The third, fourth, and fifth days of July
- (vii) The first Friday, Saturday, and Sunday before and after the fourth day of July
- (viii) The first Monday of September, and the Saturday and Sunday immediately preceding that day;
- (ix) Diwali
- (x) The thirty-first day of December.

Section 2: The existing Section 549.10(f) of the City’s Codified Ordinances is hereby repealed in that said Section to the extent inconsistent herewith is superseded by this legislation.

Section 3: All formal actions of this Council concerning the passage of this Ordinance were adopted in an open meeting, and that all deliberations of this Council, or any of its Committees, which resulted in such formal action, were in meetings open to the public, in compliance with all legal requirements, including Chapter 107 of the Codified Ordinances and Section 121.22 of the Ohio Revised Code.

PASSED: _____, 2026

Monica Koudela, President of
Council

SUBMITTED to the Mayor for his
approval on _____, 2026

APPROVED by the Mayor on
_____, 2026

ATTEST:

Alyssa Moran, Clerk of Council

Michael J. Vanni, Mayor

ORDINANCE NO. 2026 - 14

AN ORDINANCE AMENDING ORDINANCE 2026- 6 TO PROVIDE FOR ADDITIONAL APPROPRIATIONS FROM The General Fund (101); Street Lighting Fund (204); Sewer Revenue Fund (205); Police & Fire Cap. Levey Fund (207); OneOhio Opiod Fund (229); Violent Crime Reduction Grant (233)The Municipal Tax Incentive Fund (302); FOR CURRENT EXPENSES AND OTHER EXPENDITURES OF THE CITY OF WILLOWICK, STATE OF OHIO, DURING THE CALENDAR YEAR ENDING DECEMBER 31, 2026, AND DECLARING AN EMERGENCY.

e

SECTION 1. Be it ordained by the Council of the City of Willowick, State of Ohio, that to provide for the current expenses and other expenditures of said City of Willowick during the calendar year ending December 31, 2026, that the following sums be and they are hereby set aside and appropriated as follows:

SECTION 2. That there be appropriated from the General Fund:

GENERAL FUND

Transportation Department

PERS	101.601.5220	16,255.00
Transportation Department		16,255.00

Parks Department

Gas & Oil	101.704.5420	10,000.00
Stormwater Management	101.704.5604	9,000.00
Service Department		19,000.00

TOTAL GENERAL FUND: 35,255.00

SECTION 3. That there be appropriated from the Street Lighting Fund:

Street Lighting Department

County Treasurers Fees	204.502.5390	3,500.00
Street Lighting Department		3,500.00

Street Lighting Fund: 3,500.00

SECTION 4. That there be appropriated from the Sewer Revenue Fund:

Street Lighting Department

County Treasurers Fees	205.503.5390	10,000.00
Sewers Department		10,000.00

Sewer Revenue Fund: 10,000.00

SECTION 5. That there be appropriated from the Police & Fire Cap. Levey Fund:

Administrative Support Department

Lease Intrest - Fire	207.711.5704	1,700.00
Transportation Department		1,700.00

Police & Fire Cap. Levey Fund: 1,700.00

SECTION 6. That there be appropriated from the OneOhio Opiod Fund:

Police Department

Capital Improvements	229.101.5600	10,065.72
Police Department		10,065.72

TOTAL OneOhio Opiod Fund: 10,065.72

SECTION 7. That there be appropriated from the Violent Cime Reduction Fund:

Police Department

Miscellaneous Expenses	233.101.5568	9,450.00
Police Department		9,450.00

Violent Cime Reduction Fund: 9,450.00

SECTION 8. That there be appropriated from the Municipal Tax Incentive Fund:

Administrative Support

Pilot Reimbursment to WE Schools	302.711.5720	11,000.00
Administrative Support		11,000.00

Municipal Tax Incentive Fund: 11,000.00

SECTION 9. That the Finance Director is hereby authorized to make expenditures or payments from any of the foregoing appropriations upon receiving proper certification and vouchers therefore, approved by the Board of Officers authorized by law to approve the same, or an Ordinance or Resolution of Council to make the expenditures; provided that no warrants shall be drawn or paid for salaries or wages except to persons employed by authority of and in accordance with law or ordinance.

SECTION 10. All formal actions of this Council concerning the passage of this Ordinance were adopted in an open meeting, and that all deliberations of this Council, or any of its Committees, which resulted in such formal action, were in meetings open to the public, in compliance with all legal requirements, including Section 3.12 of the Charter of the City of Willowick and Section 121.22 of the Ohio Revised Code.

SECTION 11. That the Clerk of Council be and she is hereby requested to deliver a certified copy of this Ordinance to the Lake County Auditor.

SECTION 12. That this Ordinance is hereby declared and determined to be an emergency measure necessary for the preservation of the public peace, health and safety of said City for the reason that immediate provision must be made for the appropriation herein provided for and it shall, therefore, be in effect immediately upon its approval by the Mayor of the City.

PASSED: _____, 2026

Submitted to the Mayor for his approval
on _____, 2026

Council President

Approved by the Mayor on
_____, 2026

ATTEST:

Clerk of Council

Mayor

ORDINANCE NO. 2026- 15

AN ORDINANCE FIXING THE COMPENSATION OF ADULT SCHOOL GUARDS, REPEALING CERTAIN ORDINANCES AND DECLARING AN EMERGENCY.

BE IT ORDAINED BY THE COUNCIL OF THE CITY OF WILLOWICK, LAKE COUNTY, STATE OF OHIO:

SECTION 1: That effective with the first full pay period in April 2026, adult school guards shall receive compensation at a rate of Twelve Dollars (\$15.00) per hour; provided, however, that in no event shall the compensation paid to any adult school guard for any on day of the work be less than \$15.00.

SECTION 2: That school guards will be paid up to five (5) days pay, per school year when schools are closed for inclement weather.

SECTION 3: That Ordinance No. 2025-21, passed on April 15, 2025 and any other ordinances or parts thereof in conflict herewith be and the same are hereby repealed effective April 8, 2026.

SECTION 4: That this Ordinance constitutes an emergency measure in that the same provides for the immediate preservation of the public peace, health, safety and welfare of the inhabitants of the City of Willowick and further, provides for the usual daily operation of a municipal department; wherefore, this Ordinance shall be in full force and effect from and after its passage and approval by the Mayor.

PASSED: _____, 2026

Monica Koudela, President of Council

SUBMITTED to the Mayor for his approval on _____, 2026

APPROVED by the Mayor on _____, 2026

ATTEST:

Alyssa Moran, Clerk of Council

Michael J. Vanni, Mayor

RESOLUTION NO. 2026- 13

A RESOLUTION AUTHORIZING THE MAYOR OF THE CITY OF WILLOWICK TO PREPARE AND SUBMIT ANY AND ALL APPLICATIONS TO PARTICIPATE IN THE COMPETITIVE COMMUNITY DEVELOPMENT BLOCK GRANT (CDBG) PROGRAM FOR FISCAL YEAR 2026, AND TO EXECUTE CONTRACTS AS REQUIRED FOR THE PROGRAM, AND DECLARING AN EMERGENCY

Whereas, the Community Development Block Grant (CDBG) Program is a flexible program that provides communities with resources to address a wide range of unique community development needs; and

Whereas, the Lake County Commissioners, as funding permits, allocates CDBG funds pursuant to an application process from communities within Lake County; and

Whereas, the Council agrees that it is in the best interests of the City and its residents to authorize the Mayor to make application to the Lake County Commissioners and request CDBG funds to the following proposed projects: Senior Center roofing project.

Now therefore, be it resolved by the City Council of the City of Willowick, Ohio, as follows:

Section 1. The City of Willowick hereby authorizes the Mayor to make any applications necessary to the Lake County Commissioners to request funds from the CDBG program for the following proposed projects: Senior Center roofing project.

Section 2. It is found and determined that all formal actions of this Council concerning and relating to the passage of this Resolution were conducted in an open meeting of this Council and that all deliberations of this Council and any of its committees that resulted in such actions were conducted in meetings open to the public in compliance with all legal requirements including Chapter 123 of the Codified Ordinances of the City of Willowick.

Section 3. This Resolution constitutes an emergency measure in that the same provides for the immediate preservation of the public peace, health, safety and welfare of the inhabitants of the City of Willowick and further provides for the usual and necessary daily operation of the Lakefront Park; wherefore, this Resolution shall be in full force and take effect immediately upon its passage by Council and approval by the Mayor.

PASSED: _____, 2026

Monica Koudela, President of
Council

SUBMITTED to the Mayor for his
approval on _____, 2026

APPROVED by the Mayor on
_____, 2026

ATTEST:

Alyssa Moran, Clerk of Council

Michael J. Vanni, Mayor

Flock Group Inc dba Flock Safety
www.flocksafety.com

Invoice Number: INV-81850
 Invoice Date: 12/16/2025
 Due Date: 1/15/2026
 Payment Terms: Net 30
 PO#:
 W-9 Form [\[Download\]](#)
 Certificates of Insurance [\[Download\]](#)

Bill To: OH - Willowick PD
 30435 Lake Shore Blvd
 Eastlake, Ohio, 44095

Ship To: OH - Willowick PD
 30435 Lake Shore Blvd
 Eastlake, Ohio 44095

Billing Company Name: OH - Willowick PD
 Billing Contact Name: Rob Daubenmire
 Billing Email Address: rdaubenmire@cityofwillowick.com

Payment Terms: Net 30
 Contracted Billing Structure: Annual

Notes: OH - Willowick PD - Co-Term: Year 3 of 60 Month Term, 2025 - 2026

Please note a minor change to our invoices starting February 1, 2025 updating product/SKU names listed in each line item. This change is only to naming conventions and will not affect the products, functionality, or services you receive from Flock Safety. Please update your payment system to reflect these new product/SKU names as needed.

ITEMS	QTY	UNIT PRICE	SALES TAX	TOTAL
Flock Safety LPR, fka Falcon	3	\$2,500.00	\$0.00	\$7,500.00
Flock Safety Platform	1	\$0.00	\$0.00	\$0.00

Unless otherwise noted on the Order Form, the Term shall commence upon first installation and validation of Flock Hardware.

Link to Location of Services:

Subtotal: \$7,500.00
Sales Tax: \$0.00
Credit: \$0.00
Payments: \$0.00
Balance Due: \$7,500.00

If you have questions about your invoice, are providing an exemption certificate or need to update your billing contact information, please email billing@flocksafety.com or call 866-901-1781, option 3.



INVOICE

Item #9.

Flock Group Inc dba Flock Safety
www.flocksafety.com

Invoice Number: INV-81850
Invoice Date: 12/16/2025
Due Date: 1/15/2026
Payment Terms: Net 30
PO#:

Payment Remittance Information

Pay by Check:

Payable to: Flock Group Inc
Memo: INV-81850
Mail to: PO Box 121923
Dallas, TX 75312-1923

If paying by check, please include the remittance slip below.

Pay by ACH:

Account Legal Name: Flock Group Inc.
Account Number: 3302113966
Account Type: Checking
Routing / SWIFT Code: 121140399 / SVBKUS6S

If paying by ACH, please include your invoice number in the memo section of the ACH transfer request.

Please be aware that failure to pay the invoice by the due date may result in an interest penalty or disconnection of service, as specified in your contract.

.....
Detach and Return with Payment

Make Checks Payable to: Flock Group Inc

If sending via Flock Group Inc
USPS: PO Box 121923
Dallas, TX 75312-1923

Or

If sending via Flock Group Inc
UPS, FedEx or 891923
USPS: 885 East Collins Boulevard,
Suite 110
Richardson, TX 75081

Account: OH - Willowick PD

Invoice #: INV-81850

Amount Due: **\$7,500.00**

Amount Enclosed: \$ _____

RESOLUTION NO. 2026- 14:

A RESOLUTION TO APPROVE AUTHORIZATIONS (THEN AND NOW CERTIFICATE) TO FLOCK GROUP INC. DBA FLOCK SAFETY IN THE AMOUNT OF \$7,500.00 FOR THE CITY OF WILLOWICK, AND DECLARING AN EMERGENCY

WHEREAS, Ohio Revised Code 5705.41(D)(1) provides that if prior certification of funds by the Fiscal Officer was not obtained before the contract or order involving the expenditure of money was made, then the Fiscal Officer may instead certify; and

WHEREAS, that there was at the time of the making of such contract or order and at the time of the execution of such certificate, a sufficient sum appropriated for the purpose of such contract and in the treasury or in process of collection to the credit of an appropriate fund, free from any previous encumbrances; and

WHEREAS, the Fiscal Officer is accordingly certifying that there were appropriations available and funds in the treasury or in the process of collection at the time the contract or order was made (then), and there are still sufficient appropriations and funds in the treasury or in the process of collection at the time the certificate is being issued (now); and

WHEREAS, the amount of the certificate exceeds \$3,000.00; and

WHEREAS, the attached invoice, INV-81850, from Flock Group Inc. dba Flock Safety in the amount of \$7,500.00 represents annual service costs for the Police Department's license plate reader system for the 2025–2026 term.

BE IT ORDAINED BY THE COUNCIL OF THE CITY OF WILLOWICK, LAKE COUNTY, STATE OF OHIO:

SECTION 1: It is hereby certified that both at the time of the making of the attached contract(s) or order(s) and at the date of execution of this certificate, the amount of funds required to pay this contract(s) or order(s) has been appropriated for the purpose of this contract or order, attached hereto, and is in the treasury or in the process of collection to the credit of the fund free from any previous encumbrances.

SECTION 2: It is found and determined that all formal actions of this Council concerning and relating to the passage of this Resolution were conducted in an open meeting of this Council and that all deliberations of this Council and any of its committees that resulted in such actions were conducted in meetings open to the public in compliance with all legal requirements including Chapter 123 of the Codified Ordinances of the City of Willowick.

SECTION 3: This Resolution constitutes an emergency measure in that the same provides for the immediate preservation of the public peace, health, safety and welfare of the inhabitants of the City of Willowick; and so that the certificate meets the timeliness requirement of the Ohio State Auditor; wherefore, this Resolution shall be in full force and take effect immediately upon its passage by Council and approval by the Mayor.

PASSED: _____, 2026

Monica Koudela, President of
Council

SUBMITTED to the Mayor for his
approval on _____, 2026

APPROVED by the Mayor on
_____, 2026

ATTEST:

Alyssa Moran, Clerk of Council

Michael J. Vanni, Mayor

**RESOLUTION AUTHORIZING PARTICIPATION
IN THE ODOT ROAD SALT CONTRACTS AWARDED IN 2026**

WHEREAS, the City of Willowick, Lake County, (hereinafter referred to as the “Political Subdivision”) hereby submits this written agreement to participate in the Ohio Department of Transportation’s (ODOT) annual road salt bid in accordance with Ohio Revised Code 5513.01(B) and hereby agrees to all of the following terms and conditions in its participation of the ODOT road salt contract:

a. The Political Subdivision hereby agrees to be bound by all terms and conditions established by ODOT in the road salt contract and acknowledges that upon award of the contract by the Director of ODOT it shall be bound by all such terms and conditions included in the contract; and

b. The Political Subdivision hereby acknowledges that upon the Director of ODOT’s signing of the road salt contract, it shall effectively form a contract between the awarded salt supplier and the Political Subdivision; and

c. The Political Subdivision agrees to be solely responsible for resolving all claims or disputes arising out of its participation in the ODOT road salt contract and agrees that each party hereto shall be responsible for liability associated with that party’s own errors, actions, and failures to act.

d. The Political Subdivision’s electronic order for Sodium Chloride (Road Salt) will be the amount the Political Subdivision agrees to purchase from its awarded salt supplier at the delivered bid price per ton awarded by the Director of ODOT; and

e. The Political Subdivision hereby agrees to purchase a minimum of 85% of its electronically **submitted** salt quantities from its awarded salt supplier during the contract’s effective period; and

f. The Political Subdivision hereby agrees to place orders with and directly pay the awarded salt supplier on a net 30 basis for all road salt it receives pursuant to ODOT salt contract; and

g. The Political Subdivision acknowledges that should it wish to rescind this participation agreement it will do so by written, emailed request by no later than Friday, May 1, **by 5:00 p.m.** The written, emailed request to rescind this participation agreement must be received by the ODOT Office of Contract Sales, Purchasing Section email: Contracts.Purchasing@dot.ohio.gov by the deadline. The Department, upon receipt, will respond that it has received the request and that it has effectively removed the Political Subdivision’s participation request. Furthermore, it is the sole responsibility of the Political Subdivision to ensure ODOT has received this participation agreement as well as the receipt of any request to rescind this participation agreement. The Department shall not be held responsible or liable for failure to receive a Political Subdivision’s participation agreement and/or a Political Subdivision’s request to rescind its participation agreement.

NOW, THEREFORE, be it ordained by the following authorized person(s) that this participation agreement for the ODOT road salt contract is hereby approved, funding has been authorized, and the Political Subdivision agrees to the above terms and conditions regarding participation on the ODOT salt contract:

_____ (Authorized Signature) _____ Approval Date
_____ (Authorized Signature) _____ Approval Date
_____ (Authorized Signature) _____ Approval Date
_____ (Authorized Signature) _____ Approval Date
_____ (Authorized Signature) _____ Approval Date

THIS RESOLUTION MUST BE UPLOADED TO THE SALT PARTICIPATION WEBSITE BY NO LATER THAN MAY 1, 2026.

PLEASE NOTE: THE DEPARTMENT WILL NOT ACCEPT TYPED SIGNATURES. PARTICIPATION AGREEMENTS SUBMITTED WITH TYPED SIGNATURES WILL BE INVALID AND INELIGIBLE FOR APPROVAL. YOU CANNOT SUBMIT A WORD DOCUMENT VERSION OF THIS PARTICIPATION AGREEMENT. NO EXCEPTIONS.

RESOLUTION NO. 2026- 15:**A RESOLUTION AUTHORIZING THE CITY OF WILLOWICK TO PARTICIPATE IN THE OHIO DEPARTMENT OF TRANSPORTATION CONTRACT (2025) FOR THE PURCHASE OF ROAD SALT, AND DECLARING AN EMERGENCY**

WHEREAS, the City of Willowick, Lake County, Ohio (hereinafter referred to as the “Political Subdivision”) hereby submits this written agreement to participate in the Ohio Department of Transportation’s (ODOT) annual road salt bid in accordance with Ohio Revised Code 5513.01(B) and hereby agrees to all of the following terms and conditions in its participation of the ODOT road salt contract:

- a. The Political Subdivision hereby agrees to be bound by all terms and conditions established by ODOT in the road salt contract and acknowledges that upon award of the contract by the Director of ODOT it shall be bound by all such terms and conditions included in the contract; and
- b. The Political Subdivision hereby acknowledges that upon the Director of ODOT’s signing of the road salt contract, it shall effectively form a contract between the awarded salt supplier and the Political Subdivision; and
- c. The Political Subdivision agrees to be solely responsible for resolving all claims or disputes arising out of its participation in the ODOT road salt contract and agrees that each party hereto shall be responsible for liability associated with that party’s own errors, actions, and failures to act.
- d. The Political Subdivision’s electronic order for Sodium Chloride (Road Salt) will be the amount the Political Subdivision agrees to purchase from its awarded salt supplier at the delivered bid price per ton awarded by the Director of ODOT; and
- e. The Political Subdivision hereby agrees to purchase a minimum of 85% of its electronically **submitted** salt quantities from its awarded salt supplier during the contract’s effective period; and
- f. The Political Subdivision hereby agrees to place orders with and directly pay the awarded salt supplier on a net 30 basis for all road salt it receives pursuant to ODOT salt contract; and
- g. The Political Subdivision acknowledges that should it wish to rescind this participation agreement it will do so by written, emailed request by no later than Friday, May 1, **by 5:00 p.m.** The written, emailed request to rescind this participation agreement must be received by the ODOT Office of Contract Sales, Purchasing Section email: Contracts.Purchasing@dot.ohio.gov by the deadline. The Department, upon receipt, will respond that it has received the request and that it has effectively removed the Political Subdivision’s participation request. Furthermore, it is the sole responsibility of the Political Subdivision to ensure ODOT has received this participation agreement as well as the receipt of any request to rescind this participation agreement. The Department shall not be held responsible or liable for failure to receive a Political Subdivision’s

participation agreement and/or a Political Subdivision’s request to rescind its participation agreement.

Section 2. It is found and determined that all formal actions of this Council concerning and relating to the passage of this Resolution were conducted in an open meeting of this Council and that all deliberations of this Council and any of its committees that resulted in such actions were conducted in meetings open to the public in compliance with all legal requirements including Chapter 123 of the Codified Ordinances of the City of Willowick.

Section 3. This Resolution constitutes an emergency measure in that the same provides for the immediate preservation of the public peace, health, safety and welfare of the inhabitants of the City of Willowick and further provides for the usual and necessary daily operation of the Lakefront Park; wherefore, this Resolution shall be in full force and take effect immediately upon its passage by Council and approval by the Mayor.

PASSED: _____, 2026

Monica Koudela, President of Council

SUBMITTED to the Mayor for his approval on _____, 2026

APPROVED by the Mayor on _____, 2026

ATTEST:

Alyssa Moran, Clerk of Council

Michael J. Vanni, Mayor

Prepared for:
RUSS TENEROVE
WILLOWICK CITY OF
30435 LAKESHORE BLVD
WILLOWICK, OH 44095
Phone: 440-585-0963

Prepared by:
Greg Simonic
CLEVELAND FREIGHTLINER, INC.
10901 Brookpark Rd
Parma, OH 44130
Phone: 216-267-4800

A proposal for
WILLOWICK CITY OF

Prepared by
CLEVELAND FREIGHTLINER, INC.
Greg Simonic

Oct 21, 2025

Freightliner 108SD Plus

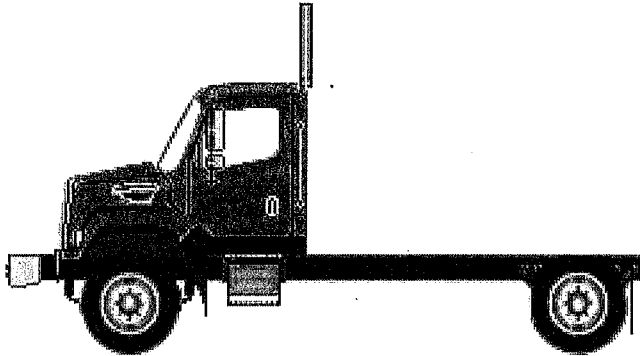

Components shown may not reflect all spec'd options and are not to scale

Application Version 12.0.501
Data Version PRL-30D.010
FTL 108 PLUS ODOT 023A-26 ITEM 3
- WILLOWICK



10/21/2025 1:43 PM

Page 1 of 19

Prepared for:
 RUSS TENEROVE
 WILLOWICK CITY OF
 30435 LAKESHORE BLVD
 WILLOWICK, OH 44095
 Phone: 440-585-0963

Prepared by:
 Greg Simonic
 CLEVELAND FREIGHTLINER, INC.
 10901 Brookpark Rd
 Parma, OH 44130
 Phone: 216-267-4800

S P E C I F I C A T I O N P R O P O S A L

Data Code	Description	Weight Front	Weight Rear
Price Level			
PRL-30D	SD PRL-30D (EFF:MY27 ORDERS)		
Data Version			
DRL-010	SPECPRO21 DATA RELEASE VER 010		
Vehicle Configuration			
	001-176	108SD PLUS CONVENTIONAL CHASSIS	6,829 3,748
	004-227	2027 MODEL YEAR SPECIFIED	
	002-004	SET BACK AXLE - TRUCK	
N	019-008	TOWING PROVISION AT END OF FRAME WITH SAE J560, WITHOUT END OF FRAME AIR CONNECTIONS	15 15
	003-001	LH PRIMARY STEERING LOCATION	
General Service			
	AA1-003	TRUCK/TRAILER CONFIGURATION	
	AA6-002	DOMICILED, USA 50 STATES (EPA CLEAN IDLE LABEL OR NO CLEAN IDLE REQUIRED)	
	99D-027	EPA CLEAN IDLE LABEL - (INCLUDES 6X4 INCH LABEL ON LOWER FORWARD OF DRIVER DOOR)	
	A85-010	UTILITY/REPAIR/MAINTENANCE SERVICE	
	A84-1GM	GOVERNMENT BUSINESS SEGMENT	
	AA4-010	DIRT/SAND/ROCK COMMODITY	
	AA5-002	TERRAIN/DUTY: 100% (ALL) OF THE TIME, IN TRANSIT, IS SPENT ON PAVED ROADS	
	AB1-008	MAXIMUM 8% EXPECTED GRADE	
	AB5-001	SMOOTH CONCRETE OR ASPHALT PAVEMENT - MOST SEVERE IN-TRANSIT (BETWEEN SITES) ROAD SURFACE	
	995-1A0	FREIGHTLINER SD VOCATIONAL WARRANTY	
	A66-99D	EXPECTED FRONT AXLE(S) LOAD : 14780.0 lbs	
	A68-99D	EXPECTED REAR DRIVE AXLE(S) LOAD : 23000.0 lbs	
	A63-99D	EXPECTED GROSS VEHICLE WEIGHT CAPACITY : 37780.0 lbs	
	A70-99D	EXPECTED GROSS COMBINATION WEIGHT : 80000.0 lbs	

Application Version 12.0.501
 Data Version PRL-30D.010
 FTL 108 PLUS ODOT 023A-26 ITEM 3
 - WILLOWICK



10/21/2025 1:43 PM

Page 2 of 19

Prepared for:
 RUSS TENEROVE
 WILLOWICK CITY OF
 30435 LAKESHORE BLVD
 WILLOWICK, OH 44095
 Phone: 440-585-0963

Prepared by:
 Greg Simonic
 CLEVELAND FREIGHTLINER, INC.
 10901 Brookpark Rd
 Parma, OH 44130
 Phone: 216-267-4800

Data Code	Description	Weight Front	Weight Rear
Truck Service			
AA3-018	FRONT PLOW/END DUMP BODY		
AF3-1W0	HENDERSON		
Engine			
101-3BP	CUM L9 330 HP @ 2200 RPM; 2200 GOV RPM, 1000 LB-FT @ 1200 RPM		
Electronic Parameters			
79A-070	70 MPH ROAD SPEED LIMIT		
79B-000	CRUISE CONTROL SPEED LIMIT SAME AS ROAD SPEED LIMIT		
79M-001	PTO ENGINE SPEED CONTROL DEACTIVATED BY SERVICE BRAKE LIGHTLY APPLIED (STATIONARY APPLICATIONS)		
79Q-007	PTO RPM WITH CRUISE RESUME SWITCH - 1100 RPM		
79U-007	PTO GOVERNOR RAMP RATE - 250 RPM PER SECOND		
79V-001	FUEL DOSING OF AFTERTREATMENT ENABLED IN PTO MODE-CLEANS HYDROCARBONS AT HIGH TEMPERATURES ONLY		
79W-024	CRUISE CONTROL BUTTON PTO CONTROL		
80G-006	PTO MINIMUM RPM - 825		
80J-001	REGEN INHIBIT SPEED THRESHOLD - 0 MPH		
80S-004	PTO 1, DASH SWITCH, ENGAGE WHILE DRIVING		
80V-002	ENGINE MOUNT PTO, DASH SWITCH ENGAGES PTO MODE, DRIVING OPERATION		
Engine Equipment			
99C-024	EPA 2010/GHG 2024 CONFIGURATION		
13E-001	STANDARD OIL PAN		
105-001	ENGINE MOUNTED OIL CHECK AND FILL		
014-108	SIDE OF HOOD AIR INTAKE WITH FIREWALL MOUNTED DONALDSON AIR CLEANER WITH SAFETY ELEMENT AND INSIDE/OUTSIDE AIR WITH SNOW DOOR	10	
124-1E1	DR 12V 200 AMP 28-SI QUADRAMOUNT PAD ALTERNATOR WITH REMOTE BATTERY VOLT SENSE		
292-235	(2) DTNA GENUINE, FLOODED STARTING, MIN 2000CCA, 370RC, THREADED STUD BATTERIES		
290-017	BATTERY BOX FRAME MOUNTED		
281-001	STANDARD BATTERY JUMPERS		
282-001	SINGLE BATTERY BOX FRAME MOUNTED LH SIDE UNDER CAB		
291-017	WIRE GROUND RETURN FOR BATTERY CABLES WITH ADDITIONAL FRAME GROUND RETURN		



Prepared for:
 RUSS TENEROVE
 WILLOWICK CITY OF
 30435 LAKESHORE BLVD
 WILLOWICK, OH 44095
 Phone: 440-585-0963

Prepared by:
 Greg Simonic
 CLEVELAND FREIGHTLINER, INC.
 10901 Brookpark Rd
 Parma, OH 44130
 Phone: 216-267-4800

Data Code	Description	Weight Front	Weight Rear
289-001	NON-POLISHED BATTERY BOX COVER		
293-058	NON-ESSENTIAL POSITIVE LOAD DISCONNECT, IN CAB CONTROL SWITCH MOUNTED OUTBOARD OF DRIVER SEAT	2	
295-003	POSITIVE AND NEGATIVE POSTS FOR JUMPSTART CHASSIS MOUNTED LH BACK OF CAB	4	
306-015	PROGRESSIVE LOW VOLTAGE DISCONNECT AT 12.3 VOLTS FOR DESIGNATED CIRCUITS	2	
107-032	CUMMINS TURBOCHARGED 18.7 CFM AIR COMPRESSOR WITH INTERNAL SAFETY VALVE		
152-041	ELECTRONIC ENGINE INTEGRAL SHUTDOWN PROTECTION SYSTEM		
128-076	CUMMINS ENGINE INTEGRAL BRAKE WITH VARIABLE GEOMETRY TURBO ON/OFF	20	
016-1C2	RH OUTBOARD UNDER STEP MOUNTED HORIZONTAL AFTERTREATMENT SYSTEM ASSEMBLY WITH RH B-PILLAR MOUNTED VERTICAL TAILPIPE	30	25
28F-014	ENGINE AFTERTREATMENT DEVICE, AUTOMATIC OVER THE ROAD REGENERATION AND VIRTUAL REGENERATION REQUEST SWITCH IN CLUSTER		
239-026	10 FOOT 06 INCH (126 INCH+0/-5.9 INCH) EXHAUST SYSTEM HEIGHT		
233-017	STANDARD CURVE BRIGHT UPPER STACK(S)		
237-1CR	RH CURVED VERTICAL TAILPIPE B-PILLAR MOUNTED ROUTED FROM STEP		
23U-001	6 GALLON DIESEL EXHAUST FLUID TANK	-35	-10
30N-003	100 PERCENT DIESEL EXHAUST FLUID FILL		
23Y-001	STANDARD DIESEL EXHAUST FLUID PUMP MOUNTING		
43X-002	LH MEDIUM DUTY STANDARD DIESEL EXHAUST FLUID TANK LOCATION		
43Y-001	STANDARD DIESEL EXHAUST FLUID TANK CAP		
242-001	STAINLESS STEEL AFTERTREATMENT DEVICE/MUFFLER/TAILPIPE SHIELD		
273-058	AIR POWERED ON/OFF ENGINE FAN CLUTCH		
276-001	AUTOMATIC FAN CONTROL WITHOUT DASH SWITCH, NON ENGINE MOUNTED		
110-003	CUMMINS SPIN ON FUEL FILTER		
118-008	COMBINATION FULL FLOW/BYPASS OIL FILTER		
266-104	1115 SQUARE INCH ALUMINUM RADIATOR		
103-039	ANTIFREEZE TO -34F, OAT (NITRITE AND SILICATE FREE) EXTENDED LIFE COOLANT		
171-007	GATES BLUE STRIPE COOLANT HOSES OR EQUIVALENT		



Prepared for:
 RUSS TENEROVE
 WILLOWICK CITY OF
 30435 LAKESHORE BLVD
 WILLOWICK, OH 44095
 Phone: 440-585-0963

Prepared by:
 Greg Simonic
 CLEVELAND FREIGHTLINER, INC.
 10901 Brookpark Rd
 Parma, OH 44130
 Phone: 216-267-4800

Data Code	Description	Weight Front	Weight Rear
172-001	CONSTANT TENSION HOSE CLAMPS FOR COOLANT HOSES		
270-016	RADIATOR DRAIN VALVE		
360-013	1350 ADAPTER FLANGE FOR FRONT PTO PROVISION	20	
132-004	ELECTRIC GRID AIR INTAKE WARMER		
155-058	DELCO 12V 38MT HD STARTER WITH INTEGRATED MAGNETIC SWITCH		

Transmission

342-582 ALLISON 3000 RDS AUTOMATIC TRANSMISSION WITH PTO PROVISION

Transmission Equipment

343-339 ALLISON VOCATIONAL PACKAGE 223 - AVAILABLE ON 3000/4000 PRODUCT FAMILIES WITH VOCATIONAL MODELS RDS, HS, MH AND TRV

84B-012 ALLISON VOCATIONAL RATING FOR ON/OFF HIGHWAY APPLICATIONS AVAILABLE WITH ALL PRODUCT FAMILIES

84C-023 PRIMARY MODE GEARS, LOWEST GEAR 1, START GEAR 1, HIGHEST GEAR 6, AVAILABLE FOR 3000/4000 PRODUCT FAMILIES ONLY

84D-021 SECONDARY MODE GEARS, LOWEST GEAR 1, START GEAR 1, HIGHEST GEAR 4, AVAILABLE FOR 3000/4000 PRODUCT FAMILIES ONLY

84E-013 S1 PERFORMANCE PRIMARY SHIFT SCHEDULE, AVAILABLE FOR 3000/4000 PRODUCT FAMILIES ONLY

84F-016 S5 PERFORMANCE LIMITING SECONDARY SHIFT SCHEDULE, AVAILABLE FOR 3000/4000 PRODUCT FAMILIES ONLY

84G-014 2200 RPM PRIMARY MODE SHIFT SPEED

84H-014 2200 RPM SECONDARY MODE SHIFT SPEED

84K-002 2ND GEAR ENGINE BRAKE ALTERNATE PRESELECT WITH MODERATE DOWNSHIFT STRATEGY

84N-200 FUEL SENSE 2.0 DISABLED - PERFORMANCE - TABLE BASED

84U-000 DRIVER SWITCH INPUT - DEFAULT - NO SWITCHES

84V-001 DIRECTION CHANGE ENABLED WITH MULTIPLEXED SERVICE BRAKES - ALLISON 5TH GEN TRANSMISSIONS

85E-011 MAXIMUM ENGINE SPEED FOR PTO ENGAGEMENT 1000 RPM

85F-038 MAXIMUM ENGINE SPEED FOR PTO OPERATION 2200 RPM



Prepared for:
 RUSS TENEROVE
 WILLOWICK CITY OF
 30435 LAKESHORE BLVD
 WILLOWICK, OH 44095
 Phone: 440-585-0963

Prepared by:
 Greg Simonic
 CLEVELAND FREIGHTLINER, INC.
 10901 Brookpark Rd
 Parma, OH 44130
 Phone: 216-267-4800

Data Code	Description	Weight Front	Weight Rear
85G-031	MAXIMUM OUTPUT SPEED FOR PTO ENGAGEMENT 800 RPM		
85H-119	MAXIMUM OUTPUT SPEED FOR PTO OPERATION 3000 RPM - ALLISON 5TH GEN TRANSMISSIONS		
353-074	QUICKFIT BODY LIGHTING CONNECTOR UNDER CAB, WITH BLUNTCUTS		
34C-011	ELECTRONIC TRANSMISSION WIRING TO CUSTOMER INTERFACE CONNECTOR		
362-2JT	CUSTOMER INSTALLED CHELSEA 281 SERIES PTO	50	
363-001	PTO MOUNTING, LH SIDE OF MAIN TRANSMISSION ALLISON		
341-018	MAGNETIC PLUGS, ENGINE DRAIN, TRANSMISSION DRAIN, AXLE(S) FILL AND DRAIN		
345-078	HEAVY DUTY ELECTRONIC TRANSMISSION SHIFT CONTROL, COLUMN MOUNTED		
97G-004	TRANSMISSION PROGNOSTICS - ENABLED 2013		
370-015	WATER TO OIL TRANSMISSION COOLER, IN RADIATOR END TANK	15	
346-013	TRANSMISSION OIL CHECK AND FILL WITH CROSSOVER TO CLEAR LH PTO AND DIRECT MOUNT PUMP		
35T-001	ATF-SYNTHETIC AUTOMATIC TRANSMISSION FLUID		

Front Axle and Equipment

400-1BA	DETROIT DA-F-18.0-5 18,000# FL1 71.0 KPI/3.74 DROP SINGLE FRONT AXLE	210	
402-075	BENDIX ADB22X AIR DISC FRONT BRAKES	30	
403-002	NON-ASBESTOS FRONT BRAKE LINING		
419-004	FRONT DISC BRAKE ROTORS		
427-001	FRONT BRAKE DUST SHIELDS	5	
409-006	FRONT OIL SEALS		
408-001	VENTED FRONT HUB CAPS WITH WINDOW, CENTER AND SIDE PLUGS - OIL		
416-022	STANDARD SPINDLE NUTS FOR ALL AXLES		
405-030	FRONT AIR DISC BRAKE INTERNAL ADJUSTERS		
406-001	STANDARD KING PIN BUSHINGS		
536-012	TRW TAS-85 POWER STEERING	40	
539-003	POWER STEERING PUMP		
534-003	4 QUART POWER STEERING RESERVOIR	5	
533-001	OIL/AIR POWER STEERING COOLER	5	
40T-001	MINERAL SAE 80/90 FRONT AXLE LUBE		

Front Suspension

Application Version 12.0.501
 Data Version PRL-30D.010
 FTL 108 PLUS ODOT 023A-26 ITEM 3
 - WILLOWICK



10/21/2025 1:43 PM

Page 6 of 19

Prepared for:
 RUSS TENEROVE
 WILLOWICK CITY OF
 30435 LAKESHORE BLVD
 WILLOWICK, OH 44095
 Phone: 440-585-0963

Prepared by:
 Greg Simonic
 CLEVELAND FREIGHTLINER, INC.
 10901 Brookpark Rd
 Parma, OH 44130
 Phone: 216-267-4800

Data Code	Description	Weight Front	Weight Rear
620-005	18,000# FLAT LEAF FRONT SUSPENSION	290	
619-004	GRAPHITE BRONZE BUSHINGS WITH SEALS - FRONT SUSPENSION		
410-001	FRONT SHOCK ABSORBERS		

Rear Axle and Equipment

420-051	MERITOR RS-23-160 23,000# R-SERIES SINGLE REAR AXLE		180
421-563	5.63 REAR AXLE RATIO		
424-001	IRON REAR AXLE CARRIER WITH STANDARD AXLE HOUSING		
386-073	MXL 17T MERITOR EXTENDED LUBE MAIN DRIVELINE WITH HALF ROUND YOKES	20	20
452-001	DRIVER CONTROLLED TRACTION DIFFERENTIAL - SINGLE REAR AXLE		20
878-018	(1) DRIVER CONTROLLED DIFFERENTIAL LOCK REAR VALVE FOR SINGLE DRIVE AXLE		
87B-015	INDICATOR LIGHT FOR EACH DIFFERENTIAL LOCKOUT SWITCH, ENGAGE <5 MPH, DISENGAGE >25 MPH		
423-075	BENDIX ADB22X AIR DISC REAR BRAKES		-30
433-002	NON-ASBESTOS REAR BRAKE LINING		
434-012	BRAKE CAMS AND CHAMBERS ON REAR SIDE OF DRIVE AXLE(S)		
451-005	REAR DISC BRAKE ROTORS		
425-002	REAR BRAKE DUST SHIELDS		5
440-006	REAR OIL SEALS		
426-1AH	AIR DISC LONGSTROKE 1-DRIVE AXLE SPRING PARKING CHAMBERS		
428-030	REAR AIR DISC BRAKE INTERNAL ADJUSTERS		
41T-002	CURRENT AVAILABLE SYNTHETIC 75W-90 REAR AXLE LUBE		
42T-001	STANDARD REAR AXLE BREATHER(S)		

Rear Suspension

N	622-1DF	30,000# FLAT LEAF SPRING REAR SUSPENSION WITH HELPER AND RADIUS ROD	160
	621-004	SPRING SUSPENSION - 1.50" AXLE SPACER	10
	431-001	STANDARD AXLE SEATS IN AXLE CLAMP GROUP	
	623-005	FORE/AFT CONTROL RODS	

Pusher / Tag Equipment

429-998	NO PUSHER/TAG BRAKE DUST SHIELDS
---------	----------------------------------

Brake System

490-1AU	WABCO 4S/4M ABS WITH TRACTION CONTROL WITH ATC SHUT OFF SWITCH
---------	--



Prepared for:
 RUSS TENEROVE
 WILLOWICK CITY OF
 30435 LAKESHORE BLVD
 WILLOWICK, OH 44095
 Phone: 440-585-0963

Prepared by:
 Greg Simonic
 CLEVELAND FREIGHTLINER, INC.
 10901 Brookpark Rd
 Parma, OH 44130
 Phone: 216-267-4800

Data Code	Description	Weight Front	Weight Rear
871-001	REINFORCED NYLON, FABRIC BRAID AND WIRE BRAID CHASSIS AIR LINES		
904-001	FIBER BRAID PARKING BRAKE HOSE		
412-001	STANDARD BRAKE SYSTEM VALVES		
46D-002	STANDARD AIR SYSTEM PRESSURE PROTECTION SYSTEM		
413-002	STD U.S. FRONT BRAKE VALVE		
432-003	RELAY VALVE WITH 5-8 PSI CRACK PRESSURE, NO REAR PROPORTIONING VALVE		
480-088	WABCO SYSTEM SAVER HP WITH INTEGRAL AIR GOVERNOR AND HEATER		
479-015	AIR DRYER FRAME MOUNTED		
460-007	ALUMINUM AIR BRAKE RESERVOIRS	-10	-15
477-008	BW DV-2 AUTO DRAIN VALVE WITH HEATER - WET TANK, PETCOCKS ALL OTHERS		
Trailer Connections			
476-998	NO AIR HOSE HANGER		
296-010	PRIMARY CONNECTOR/RECEPTACLE WIRED FOR SEPARATE STOP/TURN, ABS CENTER PIN POWERED THROUGH IGNITION		
303-026	SAE J560 7-WAY PRIMARY TRAILER CABLE RECEPTACLE TEMPORARY TIED & COILED IN CHASSIS END OF FRAME WITH 2' ADDITIONAL; NO BRACKETS		
Wheelbase & Frame			
545-385	3850MM (152 INCH) WHEELBASE		
546-102	7/16X3-9/16X11-1/8 INCH STEEL FRAME (11.11MMX282.6MM/0.437X11.13 INCH) 120KSI	110	170
548-803	TEM TO EVALUATE AND INSTALL FRAME RAIL REINFORCEMENT AS NEEDED FOR FRONT FRAME MOUNTED EQUIPMENT		
552-037	1775MM (70 INCH) REAR FRAME OVERHANG		
55W-006	FRAME OVERHANG RANGE: 61 INCH TO 70 INCH		
549-002	24 INCH INTEGRAL FRONT FRAME EXTENSION	140	-20
AC8-99D	CALC'D BACK OF CAB TO REAR SUSP C/L (CA) : 86.02 in		
AE8-99D	CALCULATED EFFECTIVE BACK OF CAB TO REAR SUSPENSION C/L (CA) : 83.02 in		
AE4-99D	CALC'D FRAME LENGTH - OVERALL : 286.63 in		
FSS-0LH	CALCULATED FRAME SPACE LH SIDE : 49.27 in		
FSS-0RH	CALCULATED FRAME SPACE RH SIDE : 53.4 in		
AM6-99D	CALC'D SPACE AVAILABLE FOR DECKPLATE : 0.0 in		
553-001	SQUARE END OF FRAME		



Prepared for:
 RUSS TENEROVE
 WILLOWICK CITY OF
 30435 LAKESHORE BLVD
 WILLOWICK, OH 44095
 Phone: 440-585-0963

Prepared by:
 Greg Simonic
 CLEVELAND FREIGHTLINER, INC.
 10901 Brookpark Rd
 Parma, OH 44130
 Phone: 216-267-4800

Data Code	Description	Weight Front	Weight Rear
550-001	FRONT CLOSING CROSSMEMBER		
559-003	LIGHTWEIGHT HEAVY DUTY ALUMINUM ENGINE CROSSMEMBER	-12	
562-001	STANDARD MIDSHIP #1 CROSSMEMBER(S)		
572-001	STANDARD REARMOST CROSSMEMBER		
565-001	STANDARD SUSPENSION CROSSMEMBER		
Chassis Equipment			
556-1CP	14 INCH PAINTED STEEL CUTOFF BUMPER	-35	
574-001	BUMPER MOUNTING FOR SINGLE LICENSE PLATE		
585-043	BETTS B-35 PAINTED MUDFLAP BRACKETS		15
590-001	BLACK MUDFLAPS		15
551-007	GRADE 8 THREADED HEX HEADED FRAME FASTENERS		
44Z-005	EXTERIOR HARNESSSES WRAPPED IN ABRASION TAPE, SECONDARY COVERING, & CONNECTOR PROTECTION		
Fifth Wheel			
578-998	NO FIFTH WHEEL		
Fuel Tanks			
204-151	60 GALLON/227 LITER ALUMINUM FUEL TANK - LH		
218-006	25 INCH DIAMETER FUEL TANK(S)		
215-007	PLAIN ALUMINUM/PAINTED STEEL FUEL/HYDRAULIC TANK(S) WITH POLISHED STAINLESS STEEL BANDS		
212-007	FUEL TANK(S) FORWARD		
664-001	PLAIN STEP FINISH		
205-002	CHROME FUEL TANK CAP(S)		
122-1H4	DETROIT FUEL/WATER SEPARATOR WITH WATER IN FUEL SENSOR AND 12 VOLT PREHEATER	-5	
216-020	EQUIFLO INBOARD FUEL SYSTEM		
202-016	HIGH TEMPERATURE REINFORCED NYLON FUEL LINE		
Tires			
093-994	MICHELIN XZE 12R22.5 16 PLY RADIAL FRONT TIRES	50	
094-1RY	BRIDGESTONE M726ELA 295/75R22.5 14 PLY RADIAL REAR TIRES		48
Hubs			
418-060	CONMET PRESET PLUS PREMIUM IRON FRONT HUBS		



Prepared for:
 RUSS TENEROVE
 WILLOWICK CITY OF
 30435 LAKESHORE BLVD
 WILLOWICK, OH 44095
 Phone: 440-585-0963

Prepared by:
 Greg Simonc
 CLEVELAND FREIGHTLINER, INC.
 10901 Brookpark Rd
 Parma, OH 44130
 Phone: 216-267-4800

Data Code	Description	Weight Front	Weight Rear
450-060	CONMET PRESET PLUS PREMIUM IRON REAR HUBS		
Wheels			
502-1HH	ACCURIDE 50300 22.5X9.00 10-HUB PILOT 6.5 INSET 5-HAND STEEL DISC FRONT WHEELS	68	
505-428	ACCURIDE 28828 22.5X8.25 10-HUB PILOT 2-HAND HD STEEL DISC REAR WHEELS		52
496-011	FRONT WHEEL MOUNTING NUTS		
497-011	REAR WHEEL MOUNTING NUTS		
Cab Exterior			
829-1A5	108 INCH BBC FLAT ROOF ALUMINUM CONVENTIONAL CAB		
650-008	AIR CAB MOUNTING		
705-012	CAB ROOF REINFORCEMENTS FOR ROOF MOUNTED COMPONENTS	2	
648-002	NONREMOVABLE BUGSCREEN MOUNTED BEHIND GRILLE		
667-037	SHORT FENDER WITH MUDFLAP		
754-017	BOLT-ON MOLDED FLEXIBLE FENDER EXTENSIONS	10	
678-067	SAFETY YELLOW LH AND RH INTERIOR GRAB HANDLES AND LH AND RH EXTERIOR GRAB HANDLES WITH SINGLE RUBBER INSERT		
645-002	BRIGHT FINISH RADIATOR SHELL/HOOD BEZEL		
646-042	STATIONARY BLACK GRILLE WITH BRIGHT ACCENTS		
65X-003	CHROME HOOD MOUNTED AIR INTAKE GRILLE		
644-004	FIBERGLASS HOOD		
652-001	FREIGHTLINER NAME PLATES		
690-998	NO NOISE SHIELD-ENG COMPARTMENT		
727-1AF	SINGLE 14 INCH ROUND HADLEY AIR HORN UNDER LH DECK		
726-001	SINGLE ELECTRIC HORN		
575-001	REAR LICENSE PLATE MOUNT END OF FRAME		
312-067	HALOGEN COMPOSITE HEADLAMPS WITH BRIGHT BEZELS		
302-047	LED AERODYNAMIC MARKER LIGHTS		
314-823	WIRING AND SWITCH FOR CUSTOMER FURNISHED SNOW PLOW LAMPS WITH SINGLE CONNECTION AT LH FORWARD		
311-998	NO DAYTIME RUNNING LIGHTS		
294-1AY	INTEGRAL LED STOP/TAIL/BACKUP LIGHTS		
300-015	STANDARD FRONT TURN SIGNAL LAMPS		
744-1BC	DUAL WEST COAST BRIGHT FINISH HEATED MIRRORS WITH LH AND RH REMOTE		



Prepared for:
 RUSS TENEROVE
 WILLOWICK CITY OF
 30435 LAKESHORE BLVD
 WILLOWICK, OH 44095
 Phone: 440-585-0963

Prepared by:
 Greg Simonic
 CLEVELAND FREIGHTLINER, INC.
 10901 Brookpark Rd
 Parma, OH 44130
 Phone: 216-267-4800

Data Code	Description	Weight Front	Weight Rear
797-001	DOOR MOUNTED MIRRORS		
796-001	102 INCH EQUIPMENT WIDTH		
743-204	LH AND RH 8 INCH BRIGHT FINISH CONVEX MIRRORS MOUNTED UNDER PRIMARY MIRRORS		
729-001	STANDARD SIDE/REAR REFLECTORS		
677-055	RH AFTERTREATMENT SYSTEM CAB ACCESS WITH POLISHED DIAMOND PLATE COVER		
768-043	63X14 INCH TINTED REAR WINDOW		
661-004	TINTED DOOR GLASS LH AND RH WITH TINTED OPERATING WING WINDOWS		
654-011	RH AND LH ELECTRIC POWERED WINDOWS		
663-029	1-PIECE BONDED HEATED WIPER PARK SOLAR GREEN GLASS WINDSHIELD		
659-007	8 LITER (2 GAL) WINDSHIELD WASHER RESERVOIR, CAB MOUNTED, WITHOUT FLUID LEVEL INDICATOR		

Cab Interior

055-019	RUGGED TRIM PACKAGE		
707-107	GRAY & CARBON VINYL INTERIOR "RUGGED"		
70K-020	CARBON WITH PREMIUM GUNMETAL ACCENT (RUGGED)		
706-013	MOLDED DOOR PANEL		
708-013	MOLDED PLASTIC DOOR PANEL		
772-006	BLACK MATS WITH SINGLE INSULATION		
785-035	ASH CUP AND (1)LIGHTER,(1)DASH MOUNTED DUAL USB-C OUTLET		
691-001	FORWARD ROOF MOUNTED CONSOLE		
696-012	CENTER STORAGE CONSOLE MOUNTED ON BACKWALL	20	
693-019	LH AND RH DOOR STORAGE POCKETS INTEGRATED INTO MOLDED DOOR PANELS		
738-021	DIGITAL ALARM CLOCK IN DRIVER DISPLAY		
742-007	(2) CUP HOLDERS LH AND RH DASH		
680-029	M2/SD DASH		
700-002	HEATER, DEFROSTER AND AIR CONDITIONER		
701-008	STANDARD HVAC DUCTING WITH SNOW SHIELD FOR FRESH AIR INTAKE		
703-005	MAIN HVAC CONTROLS WITH RECIRCULATION SWITCH		
170-015	STANDARD HEATER PLUMBING		
130-041	VALEO HEAVY DUTY A/C REFRIGERANT COMPRESSOR		
702-002	BINARY CONTROL, R-134A		
739-034	PREMIUM INSULATION		



Prepared for:
 RUSS TENEROVE
 WILLOWICK CITY OF
 30435 LAKESHORE BLVD
 WILLOWICK, OH 44095
 Phone: 440-585-0963

Prepared by:
 Greg Simonic
 CLEVELAND FREIGHTLINER, INC.
 10901 Brookpark Rd
 Parma, OH 44130
 Phone: 216-267-4800

Data Code	Description	Weight Front	Weight Rear
285-013	SOLID-STATE CIRCUIT PROTECTION AND FUSES		
280-007	12V NEGATIVE GROUND ELECTRICAL SYSTEM		
324-1B2	PREMIUM LED CAB LIGHTING		
787-998	NO SECURITY DEVICE		
657-001	DOOR LOCKS AND IGNITION SWITCH KEYED THE SAME		
78G-004	KEY QUANTITY OF 4		
655-028	LH AND RH ELECTRIC DOOR LOCKS WITH AUTO UNLOCK FEATURE WHEN DOOR IS SET FROM OPEN TO CLOSED POSITION		
740-998	NO MATTRESS	-20	-15
756-339	PREMIUM ISRINGHAUSEN HIGH BACK AIR SUSPENSION DRIVERS SEAT WITH 2 AIR LUMBAR, INTEGRATED CUSHION EXTENSION, TILT AND ADJUSTABLE SHOCK	70	
760-335	BASIC ISRI HIGH BACK NON SUSPENSION PASSENGER SEAT		
759-005	DUAL DRIVER AND PASSENGER SEAT ARMRESTS	8	
711-004	LH AND RH INTEGRAL DOOR PANEL ARMRESTS		
758-014	BLACK CORDURA PLUS CLOTH DRIVER SEAT COVER		
761-014	BLACK CORDURA PLUS CLOTH PASSENGER SEAT COVER		
763-101	BLACK SEAT BELTS		
532-002	ADJUSTABLE TILT AND TELESCOPING STEERING COLUMN		
540-070	4-SPOKE 18 INCH (450MM) LEATHER WRAPPED STEERING WHEEL WITH CHROME SWITCH BEZELS		
765-002	DRIVER AND PASSENGER INTERIOR SUN VISORS		

Instruments & Controls

106-002	ELECTRONIC ACCELERATOR CONTROL
732-998	NO INSTRUMENT PANEL-DRIVER
734-022	FULLY CONFIGURABLE CENTER INSTRUMENT PANELS
87L-001	ENGINE REMOTE INTERFACE WITH PARK BRAKE INTERLOCK
870-002	BRIGHT ARGENT FINISH GAUGE BEZELS
486-001	LOW AIR PRESSURE INDICATOR LIGHT AND AUDIBLE ALARM
840-001	DUAL NEEDLE PRIMARY AND SECONDARY AIR PRESSURE GAUGE
198-025	INTAKE MOUNTED AIR RESTRICTION INDICATOR WITHOUT GRADUATIONS



Prepared for:
 RUSS TENEROVE
 WILLOWICK CITY OF
 30435 LAKESHORE BLVD
 WILLOWICK, OH 44095
 Phone: 440-585-0963

Prepared by:
 Greg Simonic
 CLEVELAND FREIGHTLINER, INC.
 10901 Brookpark Rd
 Parma, OH 44130
 Phone: 216-267-4800

Data Code	Description	Weight Front	Weight Rear
149-015	ELECTRONIC CRUISE CONTROL WITH CONTROLS ON STEERING WHEEL SPOKES		
156-007	KEY OPERATED IGNITION SWITCH AND INTEGRAL START POSITION; 4 POSITION OFF/RUN/START/ACCESSORY		
811-044	PREMIUM INSTRUMENT CLUSTER WITH 5.0 INCH TFT COLOR DISPLAY		
81B-003	DIGITAL PANEL LAMP DIMMER SWITCH IN DRIVER DISPLAY		
160-038	HEAVY DUTY ONBOARD DIAGNOSTICS INTERFACE CONNECTOR LOCATED BELOW LH DASH		
844-001	2 INCH ELECTRIC FUEL GAUGE		
148-072	ENGINE REMOTE INTERFACE WITH ONE OR MORE SET SPEEDS		
48H-002	QUICKFIT POWERTRAIN INTERFACE CONNECTOR LOCATED BETWEEN SEATS WITH BLUNTCUTS		
* 4CG-006	6 EXTRA PROGRAMMABLE SWITCHES/INDICATORS \$C1B0191ZZ,C1C0071ZZ,C1D0127ZZ,C1E0082ZZ,C1F0083ZZ,C2A0228ZZ		
48C-002	QUICKFIT PROGRAMMABLE INTERFACE CONNECTOR(S) BETWEEN SEATS WITH BLUNTCUTS		
163-014	ENGINE REMOTE INTERFACE CONNECTOR AT POWERTRAIN INTERFACE CONNECTOR		
856-001	ELECTRICAL ENGINE COOLANT TEMPERATURE GAUGE		
852-002	ELECTRIC ENGINE OIL PRESSURE GAUGE		
864-001	2 INCH TRANSMISSION OIL TEMPERATURE GAUGE		
867-004	ELECTRONIC OUTSIDE TEMPERATURE SENSOR DISPLAY IN DRIVER MESSAGE CENTER		
830-017	ENGINE AND TRIP HOUR METERS INTEGRAL WITHIN DRIVER DISPLAY		
372-123	PTO CONTROLS FOR ENHANCED VEHICLE ELECTRIC/ELECTRONIC ARCHITECTURE		
736-998	NO OBSTACLE DETECTION SYSTEM		
72J-998	NO DR ASSIST SYSTEM		
49B-998	NO VEHICLE STABILITY ADVISOR OR CONTROL		
73B-998	NO LANE DEPARTURE WARNING SYSTEM		
679-998	NO OVERHEAD INSTRUMENT PANEL		
35M-010	1 QUICKFIT PROGRAMABLE MODULE (QPM/XMC)	10	



Prepared for:
 RUSS TENEROVE
 WILLOWICK CITY OF
 30435 LAKESHORE BLVD
 WILLOWICK, OH 44095
 Phone: 440-585-0963

Prepared by:
 Greg Simonic
 CLEVELAND FREIGHTLINER, INC.
 10901 Brookpark Rd
 Parma, OH 44130
 Phone: 216-267-4800

Data Code	Description	Weight Front	Weight Rear
746-143	7" B-PANEL INTERACTIVE TOUCHSCREEN DISPLAY RADIO W/ USB-C, APPLE CARPLAY, ANDROID AUTO, BLUETOOTH/AM/FM/SXM/WB, WITH MICROPHONE		
747-001	DASH MOUNTED RADIO		
750-002	(2) RADIO SPEAKERS IN CAB		
753-998	NO AM/FM RADIO ANTENNA		
748-006	POWER AND GROUND WIRING PROVISION OVERHEAD		
749-001	ROOF/OVERHEAD CONSOLE CB RADIO PROVISION		
75W-002	SHARKFIN MULTI-BAND ANTENNA, RIGHT HAND BIAS ROOF MOUNTING LOCATION: AM/FM/WEATHERBAND, WIFI/BLUETOOTH, SDAR/SIRIUSXM, GNSS/GPS		
78C-003	INTEROPERABLE SDAR ANTENNA		
810-027	ELECTRONIC MPH SPEEDOMETER WITH SECONDARY KPH SCALE, WITHOUT ODOMETER		
817-001	STANDARD VEHICLE SPEED SENSOR		
812-001	ELECTRONIC 3000 RPM TACHOMETER		
813-1C8	DETROIT CONNECT PLATFORM HARDWARE		
8D1-313	3 YEARS DAIMLER CONNECTIVITY BASE PACKAGE ON (FEATURES VARY BY MODEL) POWERED BY DETROIT CONNECT ON CUMMINS ENGINES		
6TS-005	TMC RP1226 ACCESSORY CONNECTOR LOCATED BEHIND PASSENGER SIDE REMOVEABLE DASH PANEL		
162-002	IGNITION SWITCH CONTROLLED ENGINE STOP		
4E1-004	8 SWITCH SLOTS, DRIVER OVERHEAD CONSOLE		
81Y-005	PRE-TRIP INSPECTION FEATURE FOR EXTERIOR LAMPS ONLY		
264-030	(1) OVERHEAD MOUNTED LANYARD CONTROL FOR DRIVER AIR HORN		
883-998	NO TRAILER HAND CONTROL BRAKE VALVE		
842-006	DIGITAL TURBO AIR PRESSURE IN DRIVER DISPLAY		
836-015	DIGITAL VOLTAGE DISPLAY INTEGRAL WITH DRIVER DISPLAY		
660-025	SINGLE ELECTRIC WINDSHIELD WIPER MOTOR WITH DELAY WHEN PARK BRAKE SET, TRANSITION TO SLOWEST SPEED		
304-030	ROTARY HEADLAMP SWITCH, MARKER LIGHTS/HEADLIGHTS SWITCH WITH PULL OUT FOR OPTIONAL FOG/ROAD LAMPS		
882-009	ONE VALVE PARKING BRAKE SYSTEM WITH WARNING INDICATOR		



Prepared for:
 RUSS TENEROVE
 WILLOWICK CITY OF
 30435 LAKESHORE BLVD
 WILLOWICK, OH 44095
 Phone: 440-585-0963

Prepared by:
 Greg Simonic
 CLEVELAND FREIGHTLINER, INC.
 10901 Brookpark Rd
 Parma, OH 44130
 Phone: 216-267-4800

Data Code	Description	Weight Front	Weight Rear
299-020	SELF CANCELING TURN SIGNAL SWITCH WITH DIMMER, HEADLAMP FLASH, WASH/WIPE/INTERMITTENT		
298-046	INTEGRAL ELECTRONIC TURN SIGNAL FLASHER WITH 40 AMP (20 AMP PER SIDE) TRAILER LAMP CAPACITY		
87T-998	NO WRG/SW-OPTL #2, CHAS, AIR		

Design

065-000	PAINT: ONE SOLID COLOR		
---------	------------------------	--	--

Color

980-2PW	CAB COLOR A: L0662EY SCHOOL BUS YELLOW ELITE EY		
986-020	BLACK, HIGH SOLIDS POLYURETHANE CHASSIS PAINT		
962-972	POWDER WHITE (N0006EA) FRONT WHEELS/RIMS (PKWHT21, TKWHT21, W, TW)		
966-972	POWDER WHITE (N0006EA) REAR WHEELS/RIMS (PKWHT21, TKWHT21, W, TW)		
964-020	STANDARD BLACK BUMPER PAINT		
963-003	STANDARD E COAT/UNDERCOATING		

Extended Front Axle Coverage

WA4-035	AXLE: DETROIT FRONT ONLY: HD MODERATE 5 YEARS/100,000 MILES/161,000 KM EXTENDED AXLE COVERAGE		
---------	---	--	--

Certification / Compliance

996-001	U.S. FMVSS CERTIFICATION, EXCEPT SALES CABS AND GLIDER KITS		
---------	---	--	--

TOTAL VEHICLE SUMMARY

Weight Summary

	Weight Front	Weight Rear	Total Weight
Factory Weight ⁺	7973 lbs	4393 lbs	12366 lbs
Total Weight ⁺	7973 lbs	4393 lbs	12366 lbs

Extended Warranty

WAI-47H	CUM 2017 L9: HD1 MD DTY 5 YEARS / 100,000 MILES / 161,000 KM EXTENDED WARRANTY. FEX APPLIES		
---------	---	--	--



Prepared for:
RUSS TENEROVE
WILLOWICK CITY OF
30435 LAKESHORE BLVD
WILLOWICK, OH 44095
Phone: 440-585-0963

Prepared by:
Greg Simonic
CLEVELAND FREIGHTLINER, INC.
10901 Brookpark Rd
Parma, OH 44130
Phone: 216-267-4800

WBB-2VP EXT ULTIMATE TRUCK CHASSIS: US MD STANDARD-MODERATE 5
YEARS/100,000 MILES/161,000 KM
WAL-231 AXLE: NON-DETROIT SINGLE REAR ONLY: MD MODERATE 5
YEARS/100,000 MILES/161,000 KM EXTENDED COVERAGE

(+) Weights shown are estimates only.
If weight is critical, contact Customer Application Engineering.

(***) All cost increases for major components (Engines, Transmissions, Axles, Front and Rear Tires) and government mandated requirements, tariffs, and raw material surcharges will be passed through and added to factory invoices.



Prepared for:
 RUSS TENEROVE
 WILLOWICK CITY OF
 30435 LAKESHORE BLVD
 WILLOWICK, OH 44095
 Phone: 440-585-0963

Prepared by:
 Greg Simonic
 CLEVELAND FREIGHTLINER, INC.
 10901 Brookpark Rd
 Parma, OH 44130
 Phone: 216-267-4800

D I M E N S I O N S

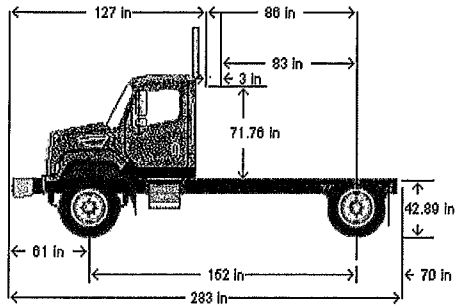

VEHICLE SPECIFICATIONS SUMMARY - DIMENSIONS

Wheelbase (545)	3850MM (152 INCH) WHEELBASE
Rear Frame Overhang (552).....	1775MM (70 INCH) REAR FRAME OVERHANG
Fifth Wheel (578).....	NO FIFTH WHEEL
Mounting Location (577)	NO FIFTH WHEEL LOCATION
Maximum Forward Position (in).....	0
Maximum Rearward Position (in)	0
Amount of Slide Travel (in).....	0
Slide Increment (in).....	0
Desired Slide Position (in).....	0.0
Cab Size (829).....	108 INCH BBC FLAT ROOF ALUMINUM CONVENTIONAL CAB
Sleeper (682).....	NO SLEEPER BOX/SLEEPER/CAB
Exhaust System (016)	RH OUTBOARD UNDER STEP MOUNTED HORIZONTAL AFTERTREATMENT SYSTEM ASSEMBLY WITH RH B-PILLAR MOUNTED VERTICAL TAILPIPE
Cab to Body Clearance (in).....	3.0

TABLE SUMMARY - DIMENSIONS



Prepared for:
 RUSS TENEROVE
 WILLOWICK CITY OF
 30435 LAKESHORE BLVD
 WILLOWICK, OH 44095
 Phone: 440-585-0963

Prepared by:
 Greg Simonic
 CLEVELAND FREIGHTLINER, INC.
 10901 Brookpark Rd
 Parma, OH 44130
 Phone: 216-267-4800

Dimensions	Inches
Bumper to Back of Cab (BBC)	127.0
Bumper to Centerline of Front Axle (BA)	61.4
Front Axle to Back of Cab (AC)	65.6
Min. Cab to Body Clearance (CB)	3.0
Back of Cab to Centerline of Rear Axle(s) (CA)	86.0
Effective Back of Cab to Centerline of Rear Axle(s) (Effective CA)	83.0
Back of Cab Protrusions (Exhaust/Intake) (CP)	2.0
Back of Cab Protrusions (Side Extenders/Trim Tab) (CP)	0.0
Back of Cab Protrusions (CNG Tank)	0.0
Back of Cab Clearance (CL)	3.0
Back of Cab to End of Frame	155.9
Cab Height (CH)	71.8
Wheelbase (WB)	151.6
Frame Overhang (OH)	69.9
Overall Frame Length	286.6
Overall Length (OAL)	282.9
Rear Axle Spacing	0.0
Unladen Frame Height at Centerline of Rear Axle	42.9

Performance calculations are estimates only. If performance calculations are critical, please contact Customer Application Engineering.



Prepared for:
 RUSS TENEROVE
 WILLOWICK CITY OF
 30435 LAKESHORE BLVD
 WILLOWICK, OH 44095
 Phone: 440-585-0963

Prepared by:
 Greg Simonic
 CLEVELAND FREIGHTLINER, INC.
 10901 Brookpark Rd
 Parma, OH 44130
 Phone: 216-267-4800

Q U O T A T I O N

108SD PLUS CONVENTIONAL CHASSIS

SET BACK AXLE - TRUCK
 CUM L9 330 HP @ 2200 RPM; 2200 GOV RPM, 1000 LB-
 FT @ 1200 RPM
 ALLISON 3000 RDS AUTOMATIC TRANSMISSION WITH
 PTO PROVISION
 MERITOR RS-23-160 23,000# R-SERIES SINGLE REAR
 AXLE
 30,000# FLAT LEAF SPRING REAR SUSPENSION WITH
 HELPER AND RADIUS ROD
 DETROIT DA-F-18.0-5 18,000# FL1 71.0 KPI/3.74 DROP
 SINGLE FRONT AXLE
 18,000# FLAT LEAF FRONT SUSPENSION

108 INCH BBC FLAT ROOF ALUMINUM CONVENTIONAL
 CAB
 3850MM (152 INCH) WHEELBASE
 NO FIFTH WHEEL
 7/16X3-9/16X11-1/8 INCH STEEL FRAME
 (11.1MMX282.6MM/0.437X11.13 INCH) 120KSI
 1775MM (70 INCH) REAR FRAME OVERHANG
 TEM TO EVALUATE AND INSTALL FRAME RAIL
 REINFORCEMENT AS NEEDED FOR FRONT
 FRAME MOUNTED EQUIPMENT

		PER UNIT	TOTAL
VEHICLE PRICE	TOTAL # OF UNITS (1)	\$ 110,717	\$ 110,717
EXTENDED WARRANTY		\$ 3,700	\$ 3,700
DEALER INSTALLED OPTIONS		\$ 0	\$ 0
CUSTOMER PRICE BEFORE TAX		\$ 114,417	\$ 114,417

TAXES AND FEES			
TAXES AND FEES		\$ 0	\$ 0
OTHER CHARGES		\$ 0	\$ 0

TRADE-IN			
TRADE-IN ALLOWANCE		\$ (0)	\$ (0)

BALANCE DUE	(LOCAL CURRENCY)	\$ 114,417	\$ 114,417
--------------------	-------------------------	-------------------	-------------------

The proposed vehicle/vehicles may be available with safety and collision mitigation options outlined in the specifications if included. If this is a chassis order, please consult with your bodybuilder to ensure the specification includes all dimensions, ratings, and necessary components for body installation. All specifications and pricing are subject to final production, engineering review, availability, Mfg. surcharges and tariffs. The purchasing entity is responsible for determining eligibility and requesting permission for cooperative purchase programs. Invoicing will occur upon delivery to the customer or dropship point and will be payable upon receipt. Payment is due on receipt of the invoice. Titles will be transferred and delivered promptly upon receipt of payment. Reconfirm pricing after 30 days. A purchase order or signed proposal agrees to the pricing, specifications, and terms, and the cooperative contract rules if applicable unless other arrangements are agreed upon but does not guarantee production. Vehicle/Chassis is proposed under Ohio Department of Transportation State contract number DOT023A26-9 cooperative pricing. Pricing is valid for Ohio municipal purchases and eligibility coincides with contract terms and dates. Contracts information can be found at the link below.

https://ohiobuys.ohio.gov/page.aspx/en/ctr/contract_manage_public/32231

\$115,905



TARIFF & PRICE INCREASE

APPROVAL:

Please indicate your acceptance of this quotation by signing below:

Customer: X _____ Date: ___ / ___ / ___.



Quantity	Description	Unit Price	Amount
1 EA	<p>Gallon 43U-10 Heavy Duty Stainless Steel Dump Body</p> <p>10' long x 7' wide body, 30" sides & 40" ends 6.4 to 8.7 yard capacity 7 gauge 304-2B stainless steel construction on sides 7 gauge 304-2B stainless steel construction on tailgate 10" x 7 ga. 100k steel formed trapezoidal long members Crossmemberless design One piece 1/4" AR450 steel floor Cast stainless "Tarp Friendly" upper tailgate hardware 6 panel double-acting tailgate with long chains and two sets of banjo plates Fully boxed top rail, material shedding lower rail Full width rear panel, full depth rear post Zero intermediate vertical side braces Full length 3/4" stainless steel round tarp rail each side Standard LED light kit includes cab shield marker lights, side marker lights, One set oval stop/turn/tail lights in rear corner posts, and ICC cluster Lights to comply with FMVSS108</p> <p>Included body options: 1/2 X 84" wide integral cab protector Air tailgate release w/ push/pull valve Stainless steel folding ladder assembly w/ grab handles, street-side front Stainless steel shovel holder, street-side (4) stainless steel standoffs for spreader tie-down on exterior of body (2) Clear LED spinner lights, (1) street-side, (1) curbside In-cab power distribution panel Solid vinyl pull-tarp w/ spring assist retract and aluminum wind deflector 5/8" heavy duty hitch plate w/ 1" forged offset D-rings 20-ton bolt-on rigid pintle 6-way round pin trailer receptacle Pilot electric trailer brake controller Full length rubber mudflaps w/ stainless steel mounts behind rear axle Stainless steel splash guards w/ rubber 1/2 flaps forward of rear axle</p> <p>Champion U850 double acting under body hoist NTEA class 50, 39,000 lbs. max lift capacity 8" cylinder bore, 20" stroke, 2.5" rod diameter 1,800 psi operating pressure</p> <p>Force America hydraulic system to operate body hoist, plow, and spreader Eaton 420 crankshaft driven load sensing piston pump, 4.88 CID Low oil shutdown w/ emergency override</p> <p>Add-A-Stack 4020 valve to operate:</p>	\$96,350.00	\$96,350.00

Freightliner	108 SD	Year	CA	VIN
--------------	--------	------	----	-----

Customer: 11964
 City Of Willowick
 30435 Lakeshore Bl
 Att:A/P
 Willowick, OH 44094
 Contact: Russell Tenrove
 Phone: (440) 585-3700
 Email Address: RTenrove@CityofWillowick.com
 Salesperson: Dan Mittocky



FVS - Genweld Corp
 4502 Boyce Parkway
 Stow OH 44224
 Phone:(330) 923-9717
 Fax:(330) 923-5872
 www.genweld.com

Quote ID: Q17633
 Quote Date: 2/10/2026
 Quote Valid Until: 2/20/2026
 Page 1 of 6

Sub Total:	\$96,350.00
Sales Tax:	\$0.00
Grand Total:	\$96,350.00

Quantity	Description	Unit Price	Amount
	<p>Heavy duty low profile plow hitch Fold flat, non-tilt hitch for fixed grille application 4" x 10" double acting lift cylinder, telescopic arm Tor-lock / arrowhead receiver Heavy duty cheek plate mounting kit Formed steel bumperettes painted black Heated LED headlights w/ stainless steel mounting brackets</p> <p>Snow Plow Manufacturer: Buyers Products Model: SnowDog 1662120212 Full Trip Stainless Plow Assembly Length: 10' Height: 42" Moldboard: 10 ga. 304 stainless steel Trip Mechanism: Full moldboard trip Vertical Ribs: (8) 1/2" x 3-1/2" Trip springs: (2) adjustable compression style Cutting Edge: 5/8" x 8" 1080 steel top punched Angling Rams: 4" x 10" double-acting Weight: 1,934 Misc: Tor-Lock oscillating loop installed, rubber deflector, curbside mailbox cut, 36" fluorescent markers, cross-over relief valve</p>		
	<p>Whelen strobe lighting: (1) Whelen 6" amber LED strobe in each rear corner post (1) Whelen amber LED beacon w/ brush guard and self-leveling mount front center of CP All strobe lighting to be activated by single aux. switch in cab</p> <p>Heavy duty low profile plow hitch Fold flat, non-tilt hitch for fixed grille application 4" x 10" double acting lift cylinder, telescopic arm Tor-lock / arrowhead receiver Heavy duty cheek plate mounting kit Formed steel bumperettes painted black Heated LED headlights w/ stainless steel mounting brackets</p>		
	<p>Intermediate chassis mounted stainless steel seamless hydraulic tubing Short hoses each end for plow and spreader connections Stainless steel poppet style hydraulic couplers w/ caps for plow and spreader connections Hydraulic system fully tested for all functions to be operational</p> <p>Whelen strobe lighting: (1) Whelen 6" amber LED strobe in each rear corner post (1) Whelen amber LED beacon w/ brush guard and self-leveling mount front center of CP All strobe lighting to be activated by single aux. switch in cab</p> <p>Heavy duty low profile plow hitch Fold flat, non-tilt hitch for fixed grille application 4" x 10" double acting lift cylinder, telescopic arm Tor-lock / arrowhead receiver Heavy duty cheek plate mounting kit Formed steel bumperettes painted black Heated LED headlights w/ stainless steel mounting brackets</p>		

QUOTE
 Quote ID: Q17633
 Quote Date: 2/10/2026
 Quote Valid Until: 2/20/2026

FVS - Genweld Corp
 4502 Boyce Parkway
 Stow OH 44224
 Phone: (330) 923-9717
 Fax: (330) 923-5872
 www.genweld.com



- * Labor and installation is included in all pricing (Unless Noted).
- * Terms are Due Upon Receipt unless prior credit arrangements are made at the time of order.
- * Payment is required for COD Customers before equipment/vehicles can be released
- * ALL CREDIT CARD PAYMENTS WILL BE CHARGED A 2.95% MERCHANT FEE. NO EXCEPTIONS.
- * For Cash Customers no personal checks accepted. Must be Cashiers Check.
- ** NOTICE: We are closely monitoring the tariff and potential surcharges very carefully. We are working closely with all our suppliers to minimize the impact of tariffs or surcharges to the equipment included in this quotation. We are committed to accurate pricing at the time of our quotations, we do not control external pricing or the impact of tariffs and surcharges from our suppliers. Therefore, we must reserve the right to adjust pricing to pass through those costs without a markup. We will communicate all pricing changes directly to customers as quickly as possible.

Accepted by:	
Date:	
P.O. Number:	

Customer must fill out the information below before the order can be processed. By accepting this quote, you (buyer/customer) agree with the Terms and Conditions stated below.

Notes:



FVS - Genweld Corp
 4502 Boyce Parkway
 Stow OH 44224
 Phone:(330) 923-9717
 Fax:(330) 923-5872
 www.genweld.com

Quote ID: Q17633
 Quote Date: 2/10/2026
 Quote Valid Until: 2/20/2026
 Page 3 of 6

QUOTE

Time is of the essence for the payment of all amounts due to Seller under any Confirmed Order. If Customer fails to make payments of any amount when due, Customer shall pay interest to Seller at the rate of one percent (1%) per month or such lesser amount as may be permitted by applicable law starting from the due date until payment to Seller of such amount in full. In addition to the interest, Seller may, at its sole discretion, charge the Customer a flat fee of \$40 for each reminder notice issued to Customer due to late payments. If Customer fails to comply with these Terms or a Confirmed Order, or if Customer becomes insolvent, all balances then due and owing to Seller shall become due immediately, notwithstanding any payment terms agreed by the parties. All costs and expenses incurred by Seller with respect to the collection of overdue payments (including, without limitation, reasonable attorney's fees, expert fees, and other expenses of litigation) shall be borne by Customer. Every payment by Customer shall first be applied to pay for Seller's cost of collection, then interest owed by Customer, and then to the oldest outstanding claim.

If the parties agreed on installment payments in a Confirmed Order and Customer fails to make any installment payment when due, the remaining balance including accrued interest, and any expenses incurred by Seller shall be due and payable to Seller promptly upon Customer's receipt of written notice of delinquency from Seller.

2 Pricing and Adjustments

1.1 Payment Terms and Fees

1.1.1 Payment Terms

All invoices are due and payable in full within the term limits stated on the invoice. Payment must be made in accordance with the terms outlined in the invoice. Failure to comply with payment terms will result in penalties, including storage and late payment fees as outlined below.

1.2 Storage Fees

A storage fee of \$25 per day shall be charged to the Customer if goods and/or services provided are not picked up within 7 days of the invoice date. Such storage charges will accrue daily from the 7th day after the invoice date until the vehicle is picked up or delivered. The vehicle will not be returned until all accrued storage charges have been paid in full.

1.3 Late Payment

Late payments will incur a penalty of 5% of the total invoice amount, excluding taxes, added to the outstanding balance per month, calculated from the invoice due date until the payment is received. Penalties will be compounded and applied until full payment is processed.

1.4 Tariffs and Taxes

Any tariffs, duties, or taxes applicable to the goods and services provided by the Seller (such as those imposed by local, state, or federal authorities) will be passed through to the Customer without markup. The Customer shall be responsible for payment of all such charges, in addition to the costs of services rendered.

1.5 Surcharges

Any surcharges imposed by suppliers or affiliates in connection with the provision of goods and services will be passed through to the Customer without markup. The Customer shall be responsible for these charges, in addition to the costs of services rendered.

1.6 Payment Timing Guidelines

The purchase price for the Products and all other amounts due under a Confirmed Order shall be due and payable in US dollars within ten (10) days following the date of Seller's invoice for such Products without any discount, deduction or offset whatsoever. In no event shall any loss, damage, injury or destruction, Force Majeure (as defined below), or any other event beyond Customer's control release Customer from its obligation to make the payments required herein. Payment of all amounts due hereunder shall be made by bank transfer or in any other manner set forth on Seller's invoice. Customer shall be solely responsible for any bank fees, or other fees, incurred due to the wire transfer or any other selected payment method. If Seller agrees to payment by credit card, Seller shall charge an appropriate transaction fee, which the Customer shall also pay.

In the event Seller becomes aware of circumstances or has reason to believe that there are circumstances that may have an adverse effect on Customer's financial condition, Seller may require the Customer to pay the total amount of the purchase price or fees, or a portion thereof prior to the delivery of the Products. Seller may, without any liability to Customer, refuse the delivery of any Product in the event the Customer fails to make the payment as required.

TERMS AND CONDITIONS FOR TRUCK AND VAN UPLIFTING SERVICES

By engaging in upfit services provided Genweld, ("Seller"), you ("Customer"/"Buyer") agree to the following terms and conditions:



FVS - Genweld Corp
 4502 Boyce Parkway
 Stow OH 44224
 Phone:(330) 923-9717
 Fax:(330) 923-5872
 www.genweld.com

Quote ID: Q17633
 Quote Date: 2/10/2026
 Quote Valid Until: 2/20/2026
 Page 4 of 6

Genweld Inc reserves the right to adjust the pricing of goods and services without prior notice, including but not limited to changes due to tariffs, material cost fluctuations, or other unforeseen factors. Any price changes by suppliers will be the responsibility of the Customer and added to the final invoice.

In case of lead delivery times of more than two (2) months, Customer hereby acknowledges and agrees that Seller, may, at its sole discretion, increase or decrease the agreed prices on any Confirmed Order in the event of material price changes in wages, materials, energy or raw material after the date of the Confirmed Order. Price changes will be communicated directly to customers within 3 business days once notified.

2.2 No Refunds
All sales are final. No refunds will be issued under any circumstances.

2.3 Order Status Reporting and Material Ordering Delays
Material ordering and delivery may be delayed due to chassis production or other manufacturer-related delays. The Customer acknowledges that delays beyond the Seller's control may affect the estimated completion date. The Seller shall not be responsible for any penalties, fees, or losses incurred by the Customer due to such delays.

For customer ordered chassis, customer must provide OEM order production date and status updates to ensure FVS production scheduling can be properly planned. Customer orders without status updates may be significantly delayed as a result.

3. Deposits and Cancellations
3.1 Deposit Requirements
For orders over \$5,000, a deposit of 25% shall be required before the equipment is ordered or work is scheduled. The deposit is due within [30] days from order confirmation. Unpaid deposits will result in delays in order processing, scheduling, and material purchases. The deposit will be applied to the final invoice upon completion of work.

3.2 Cancellations and Restocking Fees
Cancellations of orders after the deposit has been made, shall result in the forfeiture the deposit and are subject to a restocking fee of 25% of the order total.

3.3 Special Builds
For special builds or custom work, a 100% prepayment for materials and equipment may be required before production or scheduling can begin. The deposit or prepayment amount will be determined based on the specifications of the build and any associated factors, including but not limited to the type of equipment and materials required.

4. Change Orders and Modifications
4.1 Change Requests
Any changes to the order, including requests for additional equipment or modifications after the purchase order (PO) is issued, must be submitted in writing and approved by both parties. Changes may incur restocking or change order fees, which will be added to the final invoice. Such changes may delay the completion of goods and/or services initially agreed upon.

5. Chassis and Specifications
5.1 OEM Chassis Delays or Incorrect Specifications
Delays or errors in OEM chassis production or incorrect specifications may result in incremental costs. The Customer is responsible for ensuring that the chassis specifications provided are accurate and complete. NOTE: The Seller is responsible for ensuring that the chassis specifications provided are accurate and complete. The Seller is also responsible for ensuring that the chassis specifications provided are accurate and complete. The Seller is also responsible for ensuring that the chassis specifications provided are accurate and complete.

6. Warranty Terms
6.1 Warranty Coverage For Services
All services provided are covered under a limited warranty for one (1) year from the date of receipt. Warranty claims are subject to the conditions of the manufacturer and applicable guidelines. The warranty covers only defects in materials and workmanship and is voided if the goods or services are used improperly or for unintended purposes. Genweld Inc. expressly disclaims all other warranties, express, or implied, including, without limitation, any implied warranty of merchantability or fitness for a particular purpose, and does not assume or authorize any other person to assume for it any liability in connection with the sale.

6.2 Warranty Coverage For Parts and Equipment
The sole warranty provided for any part or equipment sold by Seller is to assign the warranty offered by the manufacturer or supplier to the Buyer. Seller makes no representation or warranty to the effectiveness or extent of such manufacturer or supplier warranty. Seller expressly disclaims all other warranties, express or implied, including, without limitation, any implied warranty of merchantability or fitness for a particular purpose, and does not assume or authorize any other person to assume or authorize any other person to assume for it any liability in connection with the sale.

6.3 Warranty Coverage For Parts and Equipment
The sole warranty provided for any part or equipment sold by Seller is to assign the warranty offered by the manufacturer or supplier to the Buyer. Seller makes no representation or warranty to the effectiveness or extent of such manufacturer or supplier warranty. Seller expressly disclaims all other warranties, express or implied, including, without limitation, any implied warranty of merchantability or fitness for a particular purpose, and does not assume or authorize any other person to assume or authorize any other person to assume for it any liability in connection with the sale.

6.1 Warranty Coverage For Services
All services provided are covered under a limited warranty for one (1) year from the date of receipt. Warranty claims are subject to the conditions of the manufacturer and applicable guidelines. The warranty covers only defects in materials and workmanship and is voided if the goods or services are used improperly or for unintended purposes. Genweld Inc. expressly disclaims all other warranties, express, or implied, including, without limitation, any implied warranty of merchantability or fitness for a particular purpose, and does not assume or authorize any other person to assume for it any liability in connection with the sale.

6.2 Warranty Coverage For Parts and Equipment
The sole warranty provided for any part or equipment sold by Seller is to assign the warranty offered by the manufacturer or supplier to the Buyer. Seller makes no representation or warranty to the effectiveness or extent of such manufacturer or supplier warranty. Seller expressly disclaims all other warranties, express or implied, including, without limitation, any implied warranty of merchantability or fitness for a particular purpose, and does not assume or authorize any other person to assume or authorize any other person to assume for it any liability in connection with the sale.

6.3 Warranty Coverage For Parts and Equipment
The sole warranty provided for any part or equipment sold by Seller is to assign the warranty offered by the manufacturer or supplier to the Buyer. Seller makes no representation or warranty to the effectiveness or extent of such manufacturer or supplier warranty. Seller expressly disclaims all other warranties, express or implied, including, without limitation, any implied warranty of merchantability or fitness for a particular purpose, and does not assume or authorize any other person to assume or authorize any other person to assume for it any liability in connection with the sale.

QUOTE

Quote ID: Q17633
Quote Date: 2/10/2026
Quote Valid Until: 2/20/2026
Page 5 of 6

FVS - Genweld Corp
4502 Boyce Parkway
Stow OH 44224
Phone:(330) 923-9717
Fax:(330) 923-5872
www.genweld.com



intended purpose. Customer shall use the Products solely for their intended purpose and pursuant to Seller's instructions and agrees to use only qualified personnel for the handling of the Products. Customer shall ensure that its customers, employees, agents, and other representatives comply with this Section 0. and shall be responsible for their actions and omissions.

7. Force Majeure
 The Seller shall not be held responsible for any delays or failure to perform due to causes beyond its reasonable control, including but not limited to natural disasters, labor disputes, war, acts of terrorism, fire, flood, epidemic, pandemic, quarantine, national or state declared emergency, or other force majeure events. Acceptance of the goods or services shall constitute a waiver of all claims for damages occasioned by delay in delivery or failure to perform.

8. Limitations of Liability
 In no event shall Cenweld, Inc., be liable for any punitive, indirect, incidental, consequential, special, or unknown damages, including but not limited to, loss of property or equipment, loss of data, loss of use, loss of time, loss of revenue, loss of profit, or loss of income, whether the damages be in contract or tort. Cenweld Inc's total liability for any parts, equipment or services sold shall not exceed the amount paid to Cenweld Inc for such parts, equipment, or services causing the liability.

9. Indemnification
 Buyer shall indemnify, defend, and hold harmless Seller, its affiliates, officers, directors, employees, agents, successors, and assigns (collectively, the "Indemnified Parties") from and against any and all claims, demands, causes of action, liabilities, losses, damages, judgments, fines, penalties, and expenses (including reasonable attorneys' fees and costs) arising out of or related to:
 1. any installation, use, misuse, or modification of the products by Buyer or any third party;
 2. any breach of this Agreement by Buyer;
 3. any representation or warranty made by Buyer to its customers or third parties that is inconsistent with Seller's product documentation or specifications;
 4. any personal injury, death, or property damage caused by or related to the use of the products after delivery to Buyer, except to the extent caused by Seller's gross negligence or willful misconduct.
 This indemnification obligation shall survive the termination, expiration, or completion of this Agreement.

10. Miscellaneous
 10.1 Entire Agreement
 These terms and conditions, along with any accompanying documentation or agreements, constitute the entire understanding between the parties regarding the upfitting services. Any changes to this agreement must be in writing and signed by both parties.
 10.2 Scope and Validity
 No other terms or conditions shall be of any force or effect unless otherwise specifically agreed upon by Seller in a writing duly executed by an authorized officer of Seller. These Terms supersede any and all prior oral quotations, communications, agreements, or understandings of the parties in respect to the sale and delivery of the Products. The Seller may issue additional Terms and Conditions of Sale for certain products. These shall apply in addition to the present Terms. Any additional or different terms or conditions contained in Customer's Order (as defined below), response to Seller's confirmation, or any other form or document supplied by Customer are hereby expressly rejected and are rendered null, void, and of no effect. These Terms may not be modified, amended, waived, superseded, or rescinded, except by a written agreement signed by an authorized officer of Seller. Delivery of the Products by Seller does not constitute acceptance of any of Customer's terms and conditions and do not serve to modify or amend these Terms.
 10.3 Choice of Law and Venue
 This Agreement shall be governed by and construed in accordance with the laws of the State of Ohio, without regard to conflict of law principles. Customers are irrevocably and unconditionally consents to submit to the sole and exclusive jurisdiction of the state and federal courts located within Cuyahoga County, State of Ohio for any litigation arising out of or relating to this Agreement and the transactions contemplated hereby.
 By confirming your order and engaging in the upfitting service, the Customer acknowledges and agrees to abide by the terms and conditions set forth above.

QUOTE

Quote ID: Q17633
 Quote Date: 2/10/2026
 Quote Valid Until: 2/20/2026
 Page 6 of 6

FVS - Cenweld Corp
 4502 Boyce Parkway
 Stow OH 44224
 Phone:(330) 923-9717
 Fax:(330) 923-5872
 www.cenweld.com



Customer: Willowick Police Dept.

Date: 11/24/2025

Quantity			COST	EXT. COST
1	NexLog 740 DS-Series base system: 3U rack-mountable, Core i5 CPU, 16GB DDR4 Ram, 2x2TB fixed-Mount HDDs (RAID1), 1 Blu-ray Multi-Drive, 2 Network Ports (100/1000), Embedded Linux, Nexlog DX-Series software, web-based configuration manager, audio controls & amplified speaker on front panel, dual hot-swap 120-240VAC 50/60Hz power supplies.	NexLog 740DX	\$ 10,296.00	\$ 10,296.00
0	Upgrade NexLog 740 DX-Series (at time of order) 2x2TB HotSwap MegaRAID1=2TB storage	DX705-1	\$ -	\$ -
1	Standard NexLog 740 DX-Series Archive: 1 Blu-ray Drive (also supports single-side DVD-RAM media)	DX730	\$ -	\$ -
2	Internal IP Recorder with First 8 G.711 Channels	271052	\$ 3,022.50	\$ 6,045.00
1	8-Channel Analog Pcle (PCI Express) Card, 8 Ch. Licenses	DXANA8	\$ 3,412.50	\$ 3,412.50
1	8-pack MediaWorks DX (web) concurrent license	271083	\$ 1,160.25	\$ 1,160.25
1	Eventide MP3 option for MediaWorks DX	271111	\$ 204.75	\$ 204.75
1	TLS Recording Encryption EnPabler	271109	\$ -	\$ -
1	Active Directory Authentication Enabler (Does not include configuration assistance or professional services,	271146	\$ -	\$ -
			Product Sub-Total	\$ 21,118.50

Services and Miscellaneous Products

1	Installation, Travel, Programming and Training	Pro Services	\$ 2,000.00	\$ 2,000.00
1	Bronze Support - Remote Service Agreement Including Enhanced HW Warranty and DXSUS, during Regular Business Hours.	Bronze	\$ 2,599.20	\$ 2,599.20
			Services and Misc. Sub-Total	\$ 4,599.20

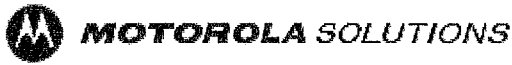

QUOTE-3387025

Billing Address:
 WILLOWICK, CITY OF
 30435 LAKE SHORE BLVD
 WILLOWICK, OH 44095
 US

Quote Date:11/13/2025
 Expiration Date:01/12/2026
 Quote Created By:
 Samantha Spaulding
 sam@comm-serv.com

End Customer:
 WILLOWICK, CITY OF
 Chief Daubenmire
 rdaubenmire@cityofwillowick.com
 440-585-1234

Contract: 21336 - OHIO, STATE OF
 534628
 AGREEMENT: WG AGREEMENT
 Payment Terms:30 NET

Line #	Item Number	Description	Qty	Term	List Price	Ext. List Price	Sale Price	Ext. Sale Price	Refresh Duration
Video as a Service									
1	AAS-BWC-5YR-001	BODY WORN CAMERA AND VIDEO MANAGER EL CLOUD - 5 YEARS VIDEO-AS-A-SERVICE	18	5 YEAR	\$4,140.00	\$74,520.00	\$3,933.00	\$70,794.00	
2	WGB-0176AAS	V300 WIFI BASE FOR M5 VAAS	7		Included	Included	Included	Included	
3	WGB-0178AAS	VIDEO EQUIPMENT, V700 USB DESKTOP DOCK VAAS	2		Included	Included	Included	Included	
4	WGC02001-VAAS	VIDEOMANAGER EL CLOUD, ANNUAL UNLIMITED STORAGE PER BODY WORN CAMERA VAAS*	18	5 YEAR	Included	Included	Included	Included	
5	WGB-0741A	V700 BODY WORN CAMERA FIRSTNET READY	18		Included	Included	Included	Included	3 YEAR
6	WGP02798-KIT	V700 MAGNETIC MOUNT WITH BWC BOX	18		Included	Included	Included	Included	



Any sales transaction following Motorola's quote is based on and subject to the terms and conditions of the valid and executed written contract between Customer and Motorola (the "Underlying Agreement") that authorizes Customer to purchase equipment and/or services or license software (collectively "Products"). If no Underlying Agreement exists between Motorola and Customer, then Motorola's Standard Terms of Use and Motorola's Standard Terms and Conditions of Sales and Supply shall govern the purchase of the Products.
 Motorola Solutions, Inc.: 500 West Monroe, United States - 60661 ~ #: 36-1115800



Line #	Item Number	Description	Qty	Term	List Price	Ext. List Price	Sale Price	Ext. Sale Price	Refresh Duration
7	AAS-BWC-WIF-DOC	V300/V700 WIFI CHARGE/UPLOAD DOCK - VIDEO-AS-A-SERVICE	7	5 YEAR	\$300.00	\$2,100.00	\$285.00	\$1,995.00	
8	AAS-BWC-USB-DOC	V300/V700 USB CHARGE/UPLOAD DOCK - VIDEO-AS-A-SERVICE	2	5 YEAR	\$240.00	\$480.00	\$228.00	\$456.00	
9	WGP02950	V700 BATTERY, 3.8V, 4180MAH, REMOVABLE	18		\$137.50	\$2,475.00	\$130.63	\$2,351.34	
10	SSV00S01450B	LEARNER LXP SUBSCRIPTION*	18	5 YEAR	\$0.00	\$0.00	\$0.00	\$0.00	
11	WGB-0138AAS	TRANSFER STATION, 8 SLOTS, FOR V300/V700 VAAS	2		Included	Included	Included	Included	
12	LSV07S05139A	HARDWARE REPAIR - TRANSFER STATION / SMARTDOCK	2	5 YEARS	\$810.00	\$1,620.00	\$769.50	\$1,539.00	
13	AAS-BWC-XFS-DOC	V300/V700 TRANSFER STATION - VIDEO-AS-A-SERVICE	2	5 YEARS	\$1,800.00	\$3,600.00	\$1,710.00	\$3,420.00	
14	PSV00S05486A	MOBILE VIDEO ONSITE CLOUD DEPLOYMENT	1		\$8,999.00	\$8,999.00	\$8,549.05	\$8,549.05	
15	LSV07S03512A	ESSENTIAL SERVICE W/ACC DMG AND ADV REPLACEMENT - V700	18	5 YEAR	Included	Included	Included	Included	
Video as a Service									
16	AAS-M5-5YR-001	M500 IN-CAR VIDEO SYSTEM AND VIDEO MANAGER EL CLOUD - 5 YEARS VIDEO-AS-A-SERVICE	7	5 YEAR	\$9,900.00	\$69,300.00	\$9,405.00	\$65,835.00	
17	WGB-0700A	M500 IN-CAR SYSTEM FRONT/PASSENGER CAM	7		Included	Included	Included	Included	
18	WGW00502	M500 EXTENDED WARRANTY	7	5 YEAR	Included	Included	Included	Included	
19	SSV00S01450B	LEARNER LXP SUBSCRIPTION*	7	5 YEAR	\$0.00	\$0.00	\$0.00	\$0.00	



Any sales transaction following Motorola's quote is based on and subject to the terms and conditions of the valid and executed written contract between Customer and Motorola (the "Underlying Agreement") that authorizes Customer to purchase equipment and/or services or license software (collectively "Products"). If no Underlying Agreement exists between Motorola and Customer, then Motorola's Standard Terms of Use and Motorola's Standard Terms and Conditions of Sales and Supply shall govern the purchase of the Products.
 Motorola Solutions, Inc.: 500 West Monroe, United States - 60661 - #: 36-1115800



Line #	Item Number	Description	Qty	Term	List Price	Ext. List Price	Sale Price	Ext. Sale Price	Refresh Duration
20	WGC02002-VAAS	VIDEOMANAGER EL CLOUD, ANNUAL UNLIMITED STORAGE PER IN-CAR VIDEO SYSTEM WITH 2 CAMERAS VAAS*	7	5 YEAR	Included	Included	Included	Included	
21	WGB-0189A	MTIK CONF KIT,802.11AC,M500P OE,5GHZANT	7		Included	Included	Included	Included	
22	WGP01394-001	4RE/M500 RADIO ANTENNA CABLE, 17FT	7		Included	Included	Included	Included	
23	WGP02225-130-KIT2	BRKT4RE DISP/ VISTA/CAMVR POST 2020+EXPL	7		Included	Included	Included	Included	
24	WGP01566-350	ACCESS POINT, MIKROTIK, 802.11AC, 5GHZ	1		\$250.00	\$250.00	\$237.50	\$237.50	
25	WGP01567	BRKT KIT POINT UNIVERSAL J-MOUNT	1		\$25.00	\$25.00	\$23.75	\$23.75	

Grand Total

\$155,200.64(USD)



Any sales transaction following Motorola's quote is based on and subject to the terms and conditions of the valid and executed written contract between Customer and Motorola (the "Underlying Agreement") that authorizes Customer to purchase equipment and/or services or license software (collectively "Products"). If no Underlying Agreement exists between Motorola and Customer, then Motorola's Standard Terms of Use and Motorola's Standard Terms and Conditions of Sales and Supply shall govern the purchase of the Products.

Motorola Solutions, Inc.: 500 West Monroe, United States - 60661 ~ #: 36-1115800



Pricing Summary

	Payment Term	Upfront Sale Price
Upfront Costs*		\$11,161.64
Upfront Subscription Fee		
Video as a Service	Annually	\$28,807.80
Sub Total:		\$39,969.44

	Payment Term	Sale Price	Annual Sale Price
Year 2 Subscription Fee			
Video as a Service	Annually	\$28,807.80	\$28,807.80
Year 3 Subscription Fee			
Video as a Service	Annually	\$28,807.80	\$28,807.80
Year 4 Subscription Fee			
Video as a Service	Annually	\$28,807.80	\$28,807.80
Year 5 Subscription Fee			
Video as a Service	Annually	\$28,807.80	\$28,807.80
Sub Total:			\$115,231.20
Grand Total System Price (Inclusive of Upfront and Annual Costs)			\$155,200.64

*Upfront costs include the cost of Hardware, Accessories and Implementation, where applicable.

Notes:

- The Pricing Summary is a breakdown of costs and does not reflect the frequency at which you will be invoiced.
- Additional information is required for one or more items on the quote for an order.
- This quote contains items with approved price exceptions applied against them.
- Unless otherwise noted, this quote excludes sales tax or other applicable taxes (such as Goods and Services Tax, sales tax, Value Added Tax and other taxes of a similar nature). Any tax the customer is subject to will be added to invoices.
- Unless otherwise noted in this quote / order, installation of equipment is not included.



Any sales transaction following Motorola's quote is based on and subject to the terms and conditions of the valid and executed written contract between Customer and Motorola (the "Underlying Agreement") that authorizes Customer to purchase equipment and/or services or license software (collectively "Products"). If no Underlying Agreement exists between Motorola and Customer, then Motorola's Standard Terms of Use and Motorola's Standard Terms and Conditions of Sales and Supply shall govern the purchase of the Products.
Motorola Solutions, Inc.: 500 West Monroe, United States • 60661 ~ #: 36-1115800

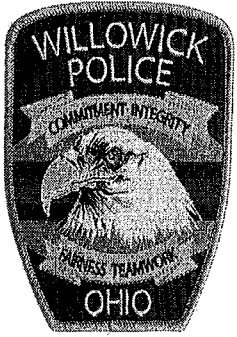

Willowick Police Department

Item #16.



Rob T. Daubenmire, Chief of Police

30435 Lake Shore Boulevard
Willowick, OH 44095- 4600

(Lake County)
(440) 585-1234

www.cityofwillowick.com

Detective Bureau
(440) 585-1234

Facsimile
(440) 585-3770

4/2/2026

Members of Council,

I respectfully make a motion to authorize the expenditure of \$39,969.44 to Communication Services. This expenditure includes the startup cost for equipment and installation (\$11,161.64) and first year's payment (\$28,807.80). This is for the purchase of (7) new dash mounted cameras and (18) new body worn cameras.

I would also respectfully make a motion to authorize the expenditure of \$25,717.70 to Communication Services. This expenditure includes the software and components (\$21,118.50) and the cost of installation plus one year support (\$4,599.20). This is for the purchase of Phone/Radio software recording system.

These items were previously approved in the 2026 Police Budget.

Thank you for your consideration.

Sincerely,
Rob T. Daubenmire
Chief of Police

Date: March 17, 2026

DAWN SNYDER
 CITY OF WILLOWICK
 30435 LAKE SHORE BLVD.
 WILLOWICK, OH 44095

Re: Group Retrospective Rating Enrollment for Policy # 34305902

We are pleased to announce that your organization has qualified for re-enrollment in the 2027 Ohio Association of Public Treasurers Retro Group. With your enrollment, you have access to significant refund opportunities and Sedgwick's industry-leading claims and risk management support. Our programs are successful because of our focus on safety best practices, client education, and aggressive claims management.

2027 Group Retrospective Rating Projection:		Max Refund	Max Assessment
Projected Premium	\$109,512		
Target Refund %	32%	62.90%	5%
Target Refund \$	\$35,044	\$68,883	\$ 5,476

Actual group refunds/assessments will be dependent on the performance of the entire group. BWC will conduct three (3) annual evaluations to determine the refund/assessment. Evaluations will take place at 12, 24, and 36 months after the end of the policy year.

To discuss our Group Retrospective Rating Program or related services, please contact **Ben Shutler** at **740-827-0640** or **Ben.Shutler@sedgwick.com**.

Enroll today to receive these workers' compensation services

- Claims Management
- Hearing Representation
- Review of BWC rates and invoices
- Educational opportunities
- Online account access
- BWC Updates

To re-enroll, simply sign and return the enclosed U-153 enrollment form with invoice and payment, or enroll online at www.sedgwick.com/ohiotpa/enroll.

As a reminder, when enrolling in a group retrospective rating program, BWC does not allow the stacking of discounts with any of the following programs: \$15k Medical Deductible, Claim Impact Reduction and Substance Use Prevention & Recovery Bonus. However, Group Retro has the potential to provide **significant refunds** in comparison to these other alternative rating programs.



INSTRUCTIONS

- * Please print or type
* Return completed statement to the attention of the sponsoring organization you are joining.
* The sponsoring organization's third-party administrator will submit this form.
* If you have any questions, please call BWC at 614-466-6773.

NOTE: This application must be reviewed and approved by BWC's employers program unit BEFORE it becomes effect

Employer Name: CITY OF WILLOWICK, Telephone number: (440)585-3700, BWC policy number: 34305902, Address: 30435 LAKE SHORE BLVD., City: WILLOWICK, State: OH, 9-digit Zip Code: 44095

Group-retrospective-rating program enrollment

I agree to comply with the Ohio Bureau of Workers' Compensation Group Retrospective Rating Program rules (Ohio Administrative Rule 4123-17-73). I understand that my participation in the program is contingent on such compliance.

This form super-sedes any previously executed U-153.

I understand that only a BWC Group Retrospective Rating Program certified sponsor can offer membership into the program. I also understand that if the sponsoring organization listed below, is not certified, this application is null and void.

I am a member of the Ohio Association of Public Treasurers Retro Group sponsoring organizations or a certified affiliate organization and would like to be included in the Group-Retrospective-Rating Program it sponsors for the policy year beginning January 1, 2027.

I understand the sponsoring organization's representative Sedgwick #000900-80 (currently, as determined by the sponsoring organization) is the only representative I may have in risk-related matters while I remain a member of the group.

I understand a new U-153 shall be filed each policy year I participate in the Group-Retrospective-Rating Program.

I am associated with the sponsoring organization or a certified affiliate sponsoring organization Ohio Association of Public Treasurers Retro Group 1581124

Name of sponsor or affiliate sponsor

Sponsor or affiliate sponsor policy

Note: For injuries that occur during the period an employer is enrolled in the Group Retrospective Rating Program, employers may not use or participate in the Deductible Program, Group Rating, Retrospective Rating, \$15,000 Medical-Only Program, or the Drug-Free Safety Program.

Certification

(Officer Name) certifies that he/she is the (Title) of

(Employer Name), the employer referred to above, and that all of the

information is true to the best of his/her knowledge, information, and belief, after careful investigation.

X (Officer Signature)

(Date)

2027 Group Retrospective Rating Analysis

Employer: City Of Willowick
Policy No.: 34305902

Projections based on: TM: -8% EMR: 0.92

Estimated Standard Premium:	\$109,512
BWC Assessments:	\$0
Estimated Individual Premium:	\$109,512

BWC will conduct three (3) annual evaluations to determine the refund/assessment. Evaluations will take place at 12, 24, and 36 months after the end of the policy year.

Max Refund: 62.90%	Max Assessment: 5%
Projected Maximum Refund: \$68,883	Projected Maximum Assessment: \$5,476

Estimated Refund Range

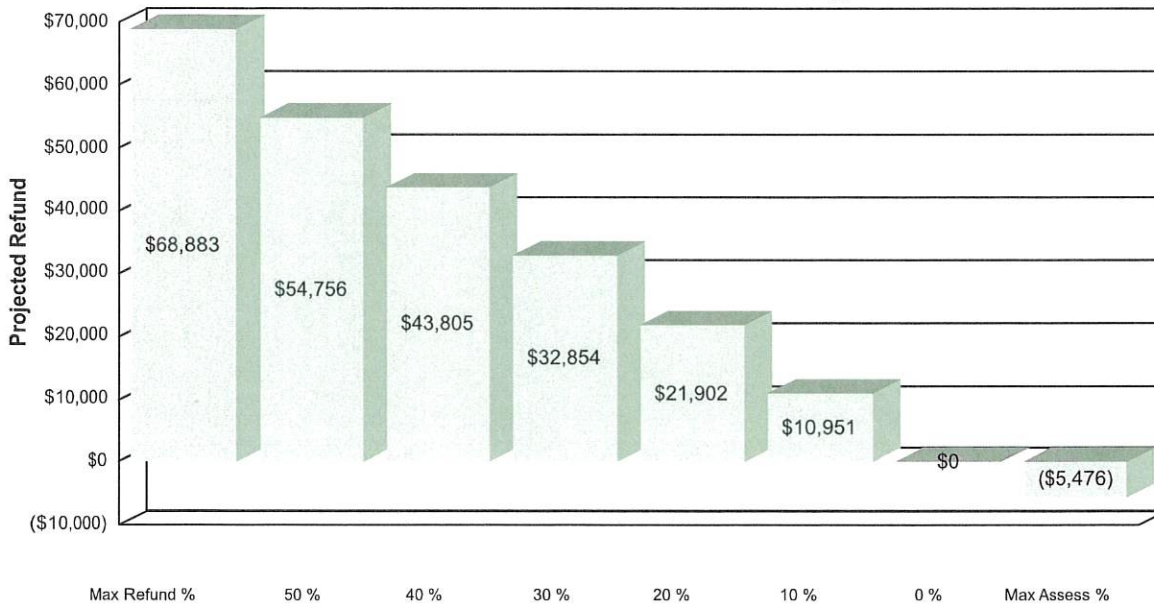

*The 2027 premium amounts are for the payroll period from 1/01/2027 to 12/31/2027.

Actual group refunds/assessments will be dependent on the performance of the entire group. This projection is to be used as a guideline only for decision making purposes. The results should not be construed as actual.

Copyright (c) 2026 Sedgwick. ALL RIGHTS RESERVED. Any use of this material, including reproduction, modification, distribution or republication, without the prior written consent of Sedgwick is strictly prohibited.

Policy Number	Invoice Date
34305902	March 17, 2026
Invoice Number	Payment Due Date
1612248	UPON RECEIPT
Group Number	
06142	
Rating Year	Annual Fee
2027	\$3,360

Bill To:

DAWN SNYDER
 CITY OF WILLOWICK
 30435 LAKE SHORE BLVD.
 WILLOWICK, OH 44095

Ohio Workers' Compensation Group Retrospective Rating Program

The enrollment fee of \$3,360 includes:

- Services for the annual contract period beginning 09/01/2026
- Policy Year: Group Retrospective Rating enrollment for January 1, 2027 to December 31, 2027

* Ohio Association of Public Treasurer membership dues

<p>To enroll online quickly and securely using your credit card, visit www.sedgwick.com/ohiotpa/enroll</p>	<p>To enroll by mail, make the check payable to Sedgwick, and include the signed enrollment forms and invoice with your payment. Mail to: Sedgwick PO Box 89456 Cleveland OH 44101-6456</p>
--	---

By returning this invoice or by remittance of the service fee, Client acknowledges and accepts all terms and conditions of the workers' compensation service agreement. Said agreement is hereby incorporated by reference herein <https://viaoneohio.sedgwick.com/Rating/2027PEgroupcontract.pdf> password: group2027

This invoice is for Sedgwick's workers' compensation third party administration services pursuant to a service agreement between your company and Sedgwick. Client acknowledges that payment of this invoice does not constitute or guarantee enrollment in any workers' compensation discount/alternative rating program.

X

Signature	Printed Name	Title	Date
dsnyder@cityofwillowick.com		(440)585-3700	
Email Address		Phone Number	

Questions? Contact Ben Shutler at 740-827-0640 or Ben.Shutler@sedgwick.com

If your organization has merged with or acquired another company in the last year, or plans to up through the policy year noted above, initial here and contact our office immediately to review your options.

If a W-9 is needed visit <https://viaoneohio.sedgwick.com/Rating/SedgwickW9.pdf>

Invoice #: 1612248 Ohio Association of Public Treasurers Retro Group Grp # 06142 (2027) GRC-M
 Ohio Association of Public Treasurers - C / policy # 34305902