



Urban Forestry Commission

Cravath Lakefront room 2nd floor 312 West
Whitewater Str, Whitewater, WI, 53190 *In Person
and Virtual

Monday, May 13, 2024 - 4:30 PM

**Citizens are welcome (and encouraged) to join our webinar via computer, smart phone, or telephone.
Citizen participation is welcome during topic discussion periods.**

Please click the link below to join the webinar:

Join Zoom Meeting

<https://us02web.zoom.us/j/82908100883?pwd=WWdyUjc0VFRqd096V1MwMit2cWVCUT09>

Meeting ID: 829 0810 0883

Passcode: 123382

Dial by your location

- +1 312 626 6799 US (Chicago)

Meeting ID: 829 0810 0883

Passcode: 123382

Find your local number: <https://us02web.zoom.us/j/82908100883?pwd=WWdyUjc0VFRqd096V1MwMit2cWVCUT09>

Please note that although every effort will be made to provide for virtual participation, unforeseen technical difficulties may prevent this, in which case the meeting may still proceed as long as there is a quorum. Should you wish to make a comment in this situation, you are welcome to call this number: (262) 473-0108.

AGENDA

CALL TO ORDER

ROLL CALL

APPROVAL OF AGENDA

A board member can choose to remove an item from the agenda or rearrange its order; however, introducing new items to the agenda is not allowed. Any proposed changes require a motion, a second, and approval from the committee to be implemented. the agenda shall be approved at reach meeting even if no changes are being made at that meeting.

APPROVAL OF MINUTES

- 1. Minutes for March 25, 2024

HEARING OF CITIZEN COMMENTS

No formal Committee action will be taken during this meeting although issues raised may become a part of a future agenda. Participants are allotted a three minute speaking period. Specific items listed on the agenda may not be discussed at this time; however, citizens are invited to speak to those specific issues at the time the Committee discusses that particular item.

To make a comment during this period, or during any agenda item: On a computer or handheld device, locate the controls on your computer to raise your hand. You may need to move your mouse to see these controls. On a traditional telephone, dial *6 to unmute your phone and dial *9 to raise your hand.

ELECTIONS OF CHARIPERSON, VICE CHAIRPERSON AND REPRESENTATIVE

ELECTIONS OF CHARIPERSON, VICE CHAIRPERSON AND REPRESENTATIVE

ELECTIONS OF CHARIPERSON, VICE CHAIRPERSON AND REPRESENTATIVE

- 2. Discussion and creating report regarding tree sale

ELECTIONS OF CHARIPERSON, VICE CHAIRPERSON AND REPRESENTATIVE

- 3. Report regarding Purple Martins.

NEW BUSINESS

CONSIDERATIONS / DISCUSSIONS / REPORTS

- 4. Discussion and possible approval of the landscape plan for the Irvin L Young Library located at 431 W Center Street, Tax Parcel Id #/OT 000196 and /OT 000197.

FUTURE AGENDA ITEMS

ADJOURNMENT

A quorum of the Common Council may be present. This notice is given to inform the public that no formal action will be taken at this meeting.

Anyone requiring special arrangements is asked to call the Office of the City Manager / City Clerk (262-473-0102) at least 72 hours prior to the meeting.



Urban Forestry Commission Meeting
Monday, March 25, 2024 – 4:30 PM
Cravath Lakefront Room
312 W. Whitewater Street
Whitewater, WI 53190
Hybrid Meeting

Meeting Minutes

1. Call to Order and Roll Call

Present: Sherry Stanek, Bill Chandler, Rose Mary Leaver, Brienne Brown

Absent: Ryan Tevis, Nick Alt

Staff: Brian Neumeister, Kevin Boehm

Guests: Kristy Martin, Theresa Stegemann

Meeting called to order at 4:34 by Stanek

2. Approval of Minutes from September 20, 2023

Motioned by Brienne Brown. Seconded by Rose Mary Leaver. Ayes: Stanek, Chandler, Brown, Leaver. Nays: None Absent: Tevis, Alt

3. Hearing of Citizen Comments

No Comments

4. Staff Report

Brian Neumeister gave an update on city staff's tree trimming and stump grinding activities. Staff has received a quote on GIS equipment and is waiting on a quote for tree inventory services.

5. Tree City

1. Tree sale dates and hours are as follows:

a. April 26 11am -6pm

b. April 27 8am – 4pm

c. April 28 12pm-4pm

2. Stanek will update the dates on the yard signs and get those out.

3. Stanek will draft an article for the Banner and submit for publication.

4. Stanek asked Boehm to secure \$150 in small bills as petty cash for tree sale change.
5. Nick Alt has a guarantor to purchase remaining trees left over from tree sale.
6. Brad Marquart may be able to use some trees for the landscaping at the water barn facility at Starin.
7. Stanek mentioned that there currently is 1 open space on the committee and soon to be a 2nd with Patrick Taylor moving to California.
8. Stanek shared that Jim Neis will be creating the flyer for the tree sale.
9. Boehm stated the banner can go above main street on April 22nd and come down on the 29th.
10. Brian will look for the Arboretum at Starin Park banner to install prior to the tree sale.
11. Stanek said the purpose of the tree sale is to get native trees into the community.

6. Future Agenda Items

- a. Determine if the group wishes to participate in the City Market.
- b. Determine if the group wishes to participate in International Children's Day.
- c. Discussion on the use of the oak trees at the Library.
- d. Birds

7. Adjournment

- a. Motioned by Brienne Brown to adjourn at 5:12 PM. Seconded by Bill Chandler. Ayes: Stanek, Chandler, Brown, Leaver. Nays: None Absent: Tevis, Alt

Respectfully Submitted,

Kevin Boehm

Kevin Boehm

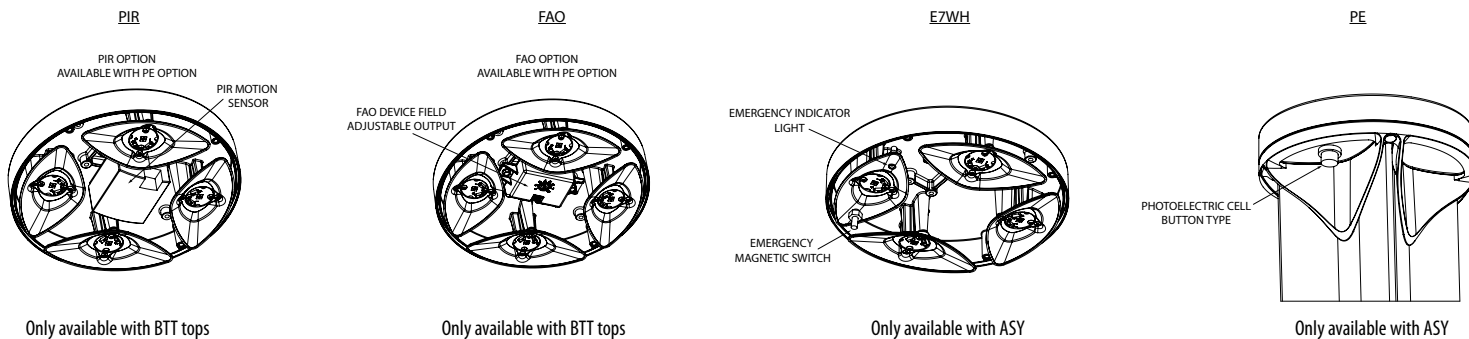

Performance Data

Lumen values are from photometric tests performed in accordance with IESNA LM-79-08. Data is considered to be representative of the configurations shown, within the tolerances allowed by Lighting Facts. Actual performance may differ as a result of end-user environment and application. Actual wattage may differ by +/- 8% when operating between 120-480V +/- 10%.

Performance Data DNAXD Finish*

Light Engines	Performance Package	System Watts	2700K					3000K					3500K					4000K					5000K				
			Lumens	B	U	G	LPW	Lumens	B	U	G	LPW	Lumens	B	U	G	LPW	Lumens	B	U	G	LPW	Lumens	B	U	G	LPW
"Symmetric (4 light engines)"	P1	5	345	0	1	0	66	362	0	1	0	69	370	0	1	0	71	380	0	1	0	73	382	0	1	0	73
	P2	8	644	0	1	0	81	677	0	1	0	85	692	0	1	0	87	711	0	1	0	89	713	0	1	0	89
	P3	13	1036	1	1	0	77	1088	1	1	0	81	1112	1	1	0	83	1142	1	1	0	85	1146	1	1	0	85
	P4	19	1460	1	1	0	79	1534	1	1	0	83	1568	1	1	0	84	1610	1	1	0	87	1616	1	1	0	87
	P5	32	2314	1	1	0	72	2430	1	1	0	75	2484	1	1	0	77	2551	1	1	0	79	2561	1	1	0	79
"Asymmetric (2 light engines)"	P1	5	312	0	1	0	60	328	0	1	0	63	335	0	1	0	64	344	0	1	0	66	346	0	1	0	66
	P2	8	584	0	1	0	73	613	0	1	0	77	627	0	1	0	78	644	0	1	0	81	646	0	1	0	81
	P3	13	938	0	1	0	70	985	0	1	0	73	1007	0	1	0	75	1035	0	1	0	77	1038	0	1	0	77
	P4	19	1323	0	1	0	71	1390	0	1	0	75	1420	0	1	0	76	1459	0	1	0	78	1464	0	1	0	79

*Note: Lumen output varies based on finish. Silver color shown, for black (worst) or white (best) photometry, see specific photometric files downloadable from www.acuitybrands.com

Projected LED Lumen Maintenance

Data references the extrapolated performance projections for the platforms noted in a 25°C ambient, based on 10,000 hours of LED testing (tested per IESNA LM-80-08 and projected per IESNA TM-21-11).

To calculate LLF, use the lumen maintenance factor that corresponds to the desired number of operating hours below. For other lumen maintenance values, contact factory.

	Projected LED Lumen Maintenance			
	25,000	50,000	75,000	100,000
P1	0.94	0.89	0.85	0.80
P2	0.94	0.89	0.85	0.80
P3	0.94	0.89	0.85	0.80
P4	0.94	0.89	0.85	0.80
P5	0.94	0.89	0.85	0.80

Lumen Ambient Temperature (LAT) Multipliers

Use these factors to determine relative lumen output for average temperatures from 0-40°C (32-104°F).

Ambient	LAT Factor	
0	32°F	1.03
5	41°F	1.03
10	50°F	1.02
15	59°F	1.01
20	68°F	1.01
25	77°F	1
30	86°F	0.99
35	95°F	0.99
40	104°F	0.98

Electrical Load

	Current (Amp)						Current (Amp)			
	Watts @120V (W)	Watts @277V (W)	@120V (A)	@208V (A)	@240V (A)	@277V (A)	Watts (@347V)	Watts (@480V)	@347V (A)	@480V (A)
P1 ASY	5	6	0.0445	0.0299	0.0276	0.0262	10	10	0.0443	0.0319
P2 ASY	9	10	0.0751	0.0471	0.0429	0.0399	14	14	0.0505	0.0364
P3 ASY	14	15	0.1147	0.0699	0.0627	0.0571	18	18	0.0611	0.0441
P4 ASY	19	19	0.1586	0.0928	0.0819	0.0735	23	23	0.0709	0.0513
P1 SYM	5	6	0.0444	0.0301	0.0279	0.0265	9	9	0.0441	0.0319
P2 SYM	9	10	0.0734	0.0461	0.0421	0.0391	13	13	0.0502	0.0363
P3 SYM	13	14	0.112	0.067	0.0598	0.0544	18	18	0.0602	0.0435
P4 SYM	18	19	0.1535	0.0902	0.0796	0.0713	22	22	0.0691	0.0499
P5 SYM	31	31	0.2597	0.1527	0.1326	0.1149	35	36	0.1079	0.079

Isofootcandle plots for the RADB. Distances are in units of mounting height (3.5').

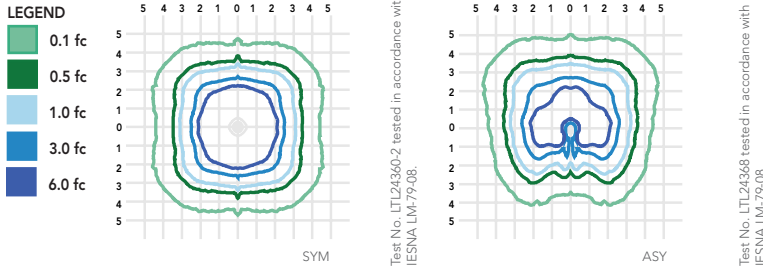

FEATURES & SPECIFICATIONS

INTENDED USE

The rugged construction and maintenance-free performance of the Radean LED Bollard is ideal for illuminating building entryways, walking paths and pedestrian plazas, as well as any other location requiring a low-mounting-height light source.

CONSTRUCTION

One-piece extruded aluminum shaft with thick side walls for extreme durability, and die-cast reflector and top cap. Four 3/8" x 7" anchor bolts with double nuts and washers and 5-2/3" max. bolt circle template ensure stability. Overall height is 42" standard.

FINISH

Exterior parts are protected by a zinc-infused super durable TGIC thermoset powder coat finish that provides superior resistance to corrosion and weathering for maximum retention of gloss and luster. A tightly controlled multi-stage process ensures a minimum 3-mil thickness for a finish that can withstand the elements without cracking or peeling. Available in both textured and non-textured finishes.

OPTICS

Two optical distributions are available: symmetrical and asymmetrical. IP66 sealed LED light engine provides smoothly graduated illumination. Light engines are available in 2700K, 3000K, 3500K, 4000K or 5000K.

ELECTRICAL

Light engines consist of high-efficacy LEDs mounted to metal-core circuit boards to maximize heat dissipation and promote long life (L80/100,000 hours at P5 at 25°C). Class 2 electronic drivers are designed for an expected life of 100,000 hours with < 1% failure rate. Electrical components are mounted on a removable power tray.

LISTINGS

CSA certified to U.S. and Canadian standards. Light engines are IP66 rated. Rated for -40°C minimum ambient. Emergency battery backup rated for -10°C minimum ambient. International Dark-Sky Association (IDA) Fixture Seal of Approval (FSA) is available for all products on this page utilizing 3000K color or less. U.S. Patent No. D912,850S

BUY AMERICAN ACT

This product is assembled in the USA and meets the Buy America(n) government procurement requirements under FAR, DFARS and DOT regulations. Please refer to www.acuitybrands.com/buy-american for additional information.

WARRANTY

Five-year limited warranty. This is the only warranty provided and no other statements in this specification sheet create any warranty of any kind. All other express and implied warranties are disclaimed. Complete warranty terms located at: www.acuitybrands.com/support/warranty/terms-and-conditions

Note: Actual performance may differ as a result of end-user environment and application and color. All values are design or typical values, measured under laboratory conditions at 25 °C. Specifications subject to change without notice.

TYPE: _____ QUANTITY: _____ PROJECT: _____

CATALOG NUMBER:

MODEL LED LIGHT SELECTION VOLTAGE FINISH OPTION OPTION OPTION OPTION



- 1- Cast aluminum LED heat sink.
- 2- Optical system assembly w/tempered glass lens.
- 3- Set of two cast aluminum supporting struts.
- 4- Removable cast aluminum cover for easy access to electrical components and driver.
- 5- Cast aluminum LED driver housing. Fits with 4" (102mm) or 5" (127mm) pole. 6" (152mm) O.D available on request.
- 6- Optional 90° strut position. (Option 90D)

*Optional Ø 30" aluminum shade. (Option S30)

MA20



MA20-S30*



MATERIALS

Maya is made of corrosion resistant 356 aluminum alloy with a copper (CU) content of less than 0.1%. The MA20 features a high efficiency LED light engine, mounted on a thick base integral to the housing shell, designed with a heat sink pattern to optimize heat dissipation and luminaire efficacy. The power supply is enclosed in a thermally isolated chamber allowing a quick access for electrical maintenance without disturbing the optical light chamber, and providing long lifetime.

ELECTRICAL

POWER SUPPLY Standard driver is 0-10V dimming-ready (dims to 10%) with: 120-277 multi-volt compatibility (50-60Hz), operating temperature range of -40°C to +55°C / -40°F to +131°F, output over voltage protection, output over current protection and output short circuit protection with auto-recovery. Optional 347/480V available on selected models.

LED/Optics

Type II, III, IV or V light distribution via high performance optical lenses. Offered in 2700K, 3000K, 3500K, 4000K. See the CCT options for details.

Optional true amber LED for turtle sensitive areas. Wavelengths: 585nm to 597nm.

LIFE

60,000hrs (L₇₀B₅₀) based on LM-80 report for lumen maintenance.

FINISH

Five-stage preparation process includes preheating of cast aluminum parts for air extraction. Polyester powder coating is applied through an electrostatic process, and oven cured for long term finish.

MOUNTING

Maximum weight: 35 lbs (16 kg)

Maya is designed for ease of access and installation. Designed for wall or pole mount to fit with a 4" (102mm) or 5" (127mm) pole. 6" (152mm) available on request. Alternate poles or wall attachments are available to meet multiple installation conditions. (Refer to pages 4 and 5)

CERTIFICATION

Certified and Approved as per CSA C22.2 No.: 250.0 standard and ANSI/UL 1598 standard, for wet location. Rated IP65. Photometric testing performed by an independent laboratory in accordance with IES LM-79-08 standards at 25°C/77°F. Lumen depreciation in accordance with IESNA LM80 standards.



LUMINAIRE SELECTION

1 MODEL#



MA20

2 LED LIGHT SELECTION

WHITE LED SELECTION (4000K/70CRI)

TYPE	SUFFIX	DELIVERED LUMENS	INPUT WATTS
Type II	<input type="checkbox"/> L1L40-TYP2	3822	36
	<input type="checkbox"/> L1L80-TYP2	7352	80
	<input type="checkbox"/> L1L120-TYP2	11646	118
	<input type="checkbox"/> L1L160-TYP2	15443	169
Type III	<input type="checkbox"/> L1L40-TYP3	4007	36
	<input type="checkbox"/> L1L80-TYP3	7709	80
	<input type="checkbox"/> L1L120-TYP3	12211	118
	<input type="checkbox"/> L1L160-TYP3	16191	169
Type IV	<input type="checkbox"/> L1L40-TYP4	3943	36
	<input type="checkbox"/> L1L80-TYP4	7586	80
	<input type="checkbox"/> L1L120-TYP4	12010	118
	<input type="checkbox"/> L1L160-TYP4	15925	169
Type V	<input type="checkbox"/> L1L40-TYP5	4071	36
	<input type="checkbox"/> L1L80-TYP5	7832	80
	<input type="checkbox"/> L1L120-TYP5	12411	118
	<input type="checkbox"/> L1L160-TYP5	16456	169

AMBER LED SELECTION - TURTLE FRIENDLY

TYPE	SUFFIX	DELIVERED LUMENS	INPUT WATTS
Type II	<input type="checkbox"/> L1LK2A-TYP2	1994	47
Type III	<input type="checkbox"/> L1LK2A-TYP3	2091	47
Type IV	<input type="checkbox"/> L1LK2A-TYP4	2057	47
Type V	<input type="checkbox"/> L1LK2A-TYP5	2125	47

DS OPTION 7

Dual switching Amber/4000K- 70CRI. Applicable with Amber Led selection

SUFFIX	DELIVERED LUMENS		INPUT WATTS
	WHITE/AMBER		
<input type="checkbox"/> DSL1L60	6205/ 1062	83	
<input type="checkbox"/> DSL1L80	8228/ 1062	109	

Lumens indicated are both LEDs at 100%, with Type 5 optics.
(1st dimmer intensity CH1, 2nd dimmer intensity CH2).
For alternate CCT Please consult factory.

3 VOLTAGE 1 4 FINISH

- 120V
 208V
 240V
 277V

- Optional
 347V
 480V

STANDARD COLORS

- WHT Snow white
 BKT Jet black
 BZT Bronze
 MST Matte silver
 GRT Titanium gray
 DGT Gun metal
 CHT Champagne
 SGT Steel gray
 BGT English cream

OPTIONAL COLORS

- CS Custom color
 RAL RAL# color

(Refer to color chart)

NOTE: Above wattage values are based on 120V, tested at 25°C/ 77°F ambient temperature.

Wattage may vary by approx. +/- 10% for other voltages, or due to changes in ambient temperature.
 Lumen output will remain constant.

LUMINIS®

LUMINIS | Toll free: 866.586.4647 Fax: 514.683.8872 Email: info@luminis.com
 260 Labrosse, Pointe-Claire (QC) Canada H9R 5L5

Luminaires may be altered for design improvement or discontinued without prior notice.

LUMINIS.COM

OPTION

ELECTRICAL

- FS** Fuse²
- MS** Motion Sensor⁴. Color will be selected by default to best match fixture color.
- PH** Photocell
- PHSC** NEMA C136.41 7-PIN receptacle & shorting cap. Please consult factory to ensure electrical compliance.
- PH7** NEMA C136.41 7-PIN receptacle & photocell sensor
- SP** 10kV Surge Protector

CCT/CRI

Alternate CCT °K LED (LCF: Lumen conversion factor). (Apply multiplier to listed values for lumens output reference).

- K27E** 2700K / 70CRI (LCF: 0.91)
 - K30E** 3000K / 70CRI (LCF: 0.94)
 - K35E** 3500K / 70CRI (LCF: 0.983)
 - K40E** 4000K / 70CRI
 - K35** 3500K / 80CRI (LCF: 0.8)
 - K40** 4000K / 80CRI (LCF: 0.83)
- NOTE: Other CCT & higher CRI available, please consult factory.

MOUNTING

- 90D** Dual struts spaced 90° apart
- 180D** Dual struts spaced 180° apart
- AC8** Pole mount attachment with 45° support
- ACW** Wall mount attachment with 45° support
- EC8P** Pole mount attachment with stacked arm
- EC8PS** Pole mount attachment with short stacked arm⁶
- EC8W** Wall mount attachment with stacked arm
- EC8WS** Wall mount attachment with short stacked arm⁶
- TN3** 3" Tenon pole adaptor (for 3" pole by others)¹²
- PR8** Pedestal mount adaptor. Brings total height of MA20 to 33.25".
- ECM4T** Post top mounting on 4" (102mm) pole (pole by others)
- EMC5T** Post top mounting on 5" (127mm) pole⁵ (pole by others)

ACCESSORIES

- HS** House side shield³ (LCF 0.8)
- S30** 30" Shade

CONTROL

- NLTAIR2** nLight AIR Control gen2, Pole mounted black sensor,^{8, 9, 10, 11}



For IDA certification compliance, luminaire must be ordered with 3000K or warmer.

NOTES

- 1- If no voltage is specified, luminaires are factory prewired by default for 120V. For other voltages, please specify with catalog number, or consult factory.
- 2- Fuse option is normally installed with poles when specified with Luminis luminaires. (Except for other types of mounting.)
- 3- HS not available on Type V. HS can be installed in the field on existing fixtures.
- 4- Motion sensor option is not compatible with photocell options.
- 5- For 1/8" wall thickness. For other wall thickness contact factory.
- 6- Not compatible with S30 option.
- 7- DS option not available with options MS, PH, PHSC, PH7, 347V, TN3 and PR8.
- 8- Not compatible with MS, PH, PHSC, PH7, Wall mounts, Double fixture mounts, TN3, PR8.
- 9- Compatible with Amber Led.
- 10- Only available with PAA5xx (Ø5" poles).
- 11- White sensor available upon request.
- 12- TN3 is not available with L1L120 and L1L160 at any voltages. TN3 is not available with L1L80 at 347V and 480V.

OPTION DETAILS

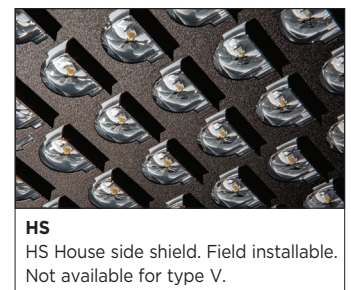
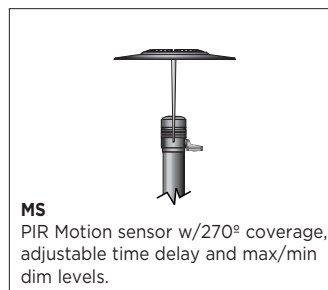
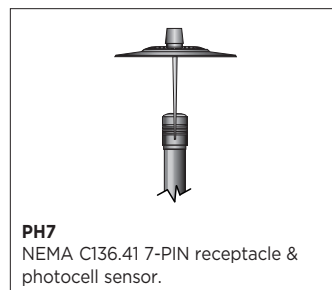
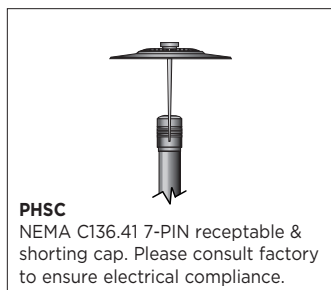

LUMINIS®

LUMINIS | Toll free: 866.586.4647 Fax: 514.683.8872 Email: info@luminis.com
260 Labrosse, Pointe-Claire (QC) Canada H9R 5L5

LUMINIS.COM

Luminaires may be altered for design improvement or discontinued without prior notice.

MA20 SERIES MAYA - LED

POLE MOUNT

AC8
1" X 3" (25mm X 76mm) extruded aluminum extended arm pole mounting adaptor designed to fit with Ø 4 to 5" poles. Ø 1/2" X 45° standard natural stainless steel rod support. (EPA: 0.7)

EC8P
Set of (2) 1" X 3" (25mm X 76mm) extruded aluminum side pole straight mounting. Pole mounting adaptor fits with Ø 4 to 5" poles. (EPA: 0.97)

EC8PS*
Set of (2) 1" X 3" (25mm X 76mm) extruded aluminum side pole straight mounting. Pole mounting adaptor fits with Ø 4 to 5" poles. (EPA: 0.72). Not compatible with S30.

These 3 options below are for reference only. They must be selected with the pole. Refer to the separate pole specification for details.

To specify this assembly:
Double the fixture quantity, and include **2AC8** on the Luminis pole catalog number.

To specify this assembly:
Double the fixture quantity, and include **2EC8P** on the Luminis pole catalog number.

To specify this assembly:
Double the fixture quantity, and include **2EC8PS** on the Luminis pole catalog number.
Not compatible with S30.

EC4T
To be installed on Ø 4" (102mm) pole. (Pole by others)

ECM5T
To be installed on Ø 5" (127mm) pole. For 1/8" wall thickness. For other wall thickness contact factory. (Pole by others)

NLTAIR2 
Control gen2, Pole mounted black sensor. 270° coverage. Installed at 180° from hand hole. Only available with PAA5xx (Ø5" poles).

MATCHING POLE SELECTION

Ø 4"	Ø 5"	Tapered Pole	Ø 4"	Height
PAA410	PAA510	-----	PSB10	10 Ft. (3 M)
PAA412	PAA512	-----	PSB12	12 Ft. (3,6 M)
PAA414	PAA514	-----	PSB14	14 Ft. (4,2 M)
PAA416	PAA516	PTA16	PSB16	16 Ft. (4,8 M)
PAA418	PAA518	PTA18	PSB18	18 Ft. (5,5 M)
PAA420	PAA520	PTA20	PSB20	20 Ft. (6,0 M)
-----	-----	PTA25	-----	25 Ft. (7,6 M)

For additional pole details, please refer to separate pole specification sheet.
Ø 4" = 102mm Ø5" = 127mm
1/8" wall thickness. Please consult factory for other thicknesses.

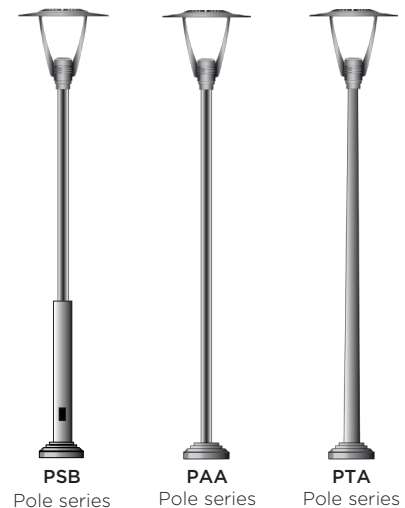

WALL MOUNT

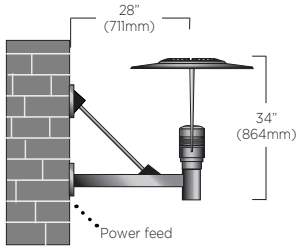

ACW
1" X 3" (25mm X 76mm) extruded aluminum extended arm wall mounting adaptor with cast aluminum covers and galvanized steel mounting plates.
Ø 1/2" X 45° standard natural stainless steel rod support.

Mounting

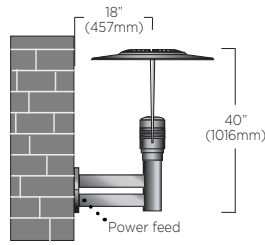
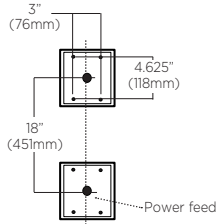

EC8W
Set of (2) 1" X 3" (25mm X 76mm) extruded aluminum wall mount arms with cast aluminum wall plate.

Mounting

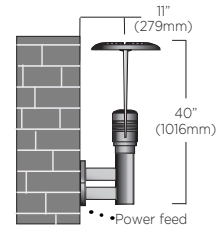
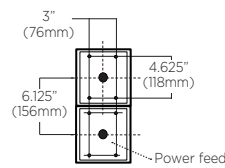

EC8WS *
Set of (2) 1" X 3" (25mm X 76mm) extruded aluminum wall mount arms with cast aluminum wall plate.
*Not compatible with S30 option

Mounting

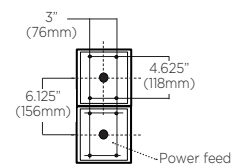

TYPICAL PHOTOMETRY SUMMARY

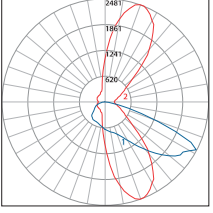
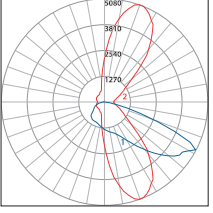
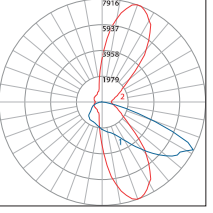
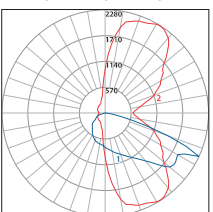
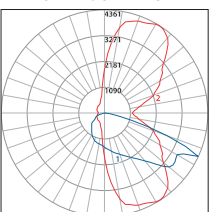
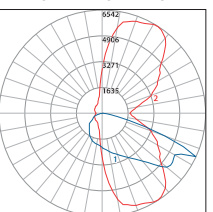
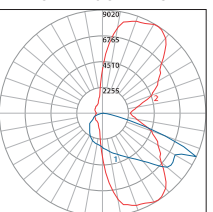
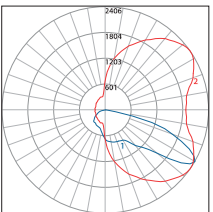
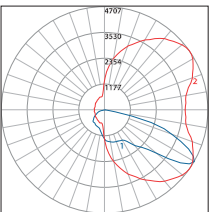
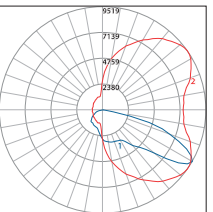
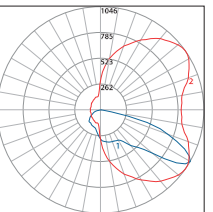
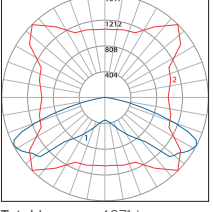
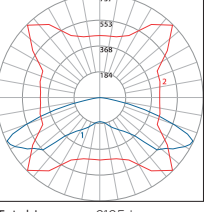
Type	MA20-L1L40-TYP2	MA20-L1L80-TYP2	MA20-L1L120-TYP2	MA20-L1L160-TYP2	MA20-L1LK2A-TYP2
TYPE II	 <p>Total Lumens: 3822 Lms Total Input Watts: 36W Efficacy: 106 Lms/W BUG Rating: B1-U0-G1 Cutoff Class: Full Cutoff CCT/CRI: 4000K/70 Max Candela: 2481.15 (67.5H, 62.5V)</p>	 <p>Total Lumens: 7352 Lms Total Input Watts: 80W Efficacy: 92 Lms/W BUG Rating: B1-U0-G1 Cutoff Class: Full Cutoff CCT/CRI: 4000K/70 Max Candela: 5080.45 (67.5H, 62.5V)</p>	 <p>Total Lumens: 11646 Lms Total Input Watts: 118W Efficacy: 99 Lms/W BUG Rating: B2-U0-G2 Cutoff Class: Full Cutoff CCT/CRI: 4000K/70 Max Candela: 7916.05 (67.5H, 62.5V)</p>	 <p>Total Lumens: 15443 Lms Total Input Watts: 169W Efficacy: 91 Lms/W BUG Rating: B2-U0-G2 Cutoff Class: Full Cutoff CCT/CRI: 4000K/70 Max Candela: 10515.35 (67.5H, 62.5V)</p>	 <p>Total Lumens: 1994 Lms Total Input Watts: 47W Efficacy: 42 Lms/W BUG Rating: B0-U0-G0 Cutoff Class: Full Cutoff CCT/CRI: Amber Max Candela: 1063.35 (67.5H, 62.5V)</p>
TYPE III	 <p>Total Lumens: 4007 Lms Total Input Watts: 36W Efficacy: 111 Lms/W BUG Rating: B1-U0-G1 Cutoff Class: Full Cutoff CCT/CRI: 4000K/70 Max Candela: 2279.76 (57.5H, 65V)</p>	 <p>Total Lumens: 7709 Lms Total Input Watts: 80W Efficacy: 96 Lms/W BUG Rating: B1-U0-G2 Cutoff Class: Full Cutoff CCT/CRI: 4000K/70 Max Candela: 4361.28 (57.5H, 65V)</p>	 <p>Total Lumens: 12211 Lms Total Input Watts: 118W Efficacy: 103 Lms/W BUG Rating: B2-U0-G2 Cutoff Class: Full Cutoff CCT/CRI: 4000K/70 Max Candela: 6541.92 (57.5H, 65V)</p>	 <p>Total Lumens: 16191 Lms Total Input Watts: 169W Efficacy: 96 Lms/W BUG Rating: B3-U0-G2 Cutoff Class: Full Cutoff CCT/CRI: 4000K/70 Max Candela: 9019.92 (57.5H, 65V)</p>	 <p>Total Lumens: 2091 Lms Total Input Watts: 47W Efficacy: 44 Lms/W BUG Rating: B1-U0-G1 Cutoff Class: Full Cutoff CCT/CRI: Amber Max Candela: 991.2 (57.5H, 65V)</p>
TYPE IV	 <p>Total Lumens: 3943 Lms Total Input Watts: 36W Efficacy: 110 Lms/W BUG Rating: B2-U0-G1 Cutoff Class: Full Cutoff CCT/CRI: 4000K/70 Max Candela: 1539.6 (35H, 62.5V)</p>	 <p>Total Lumens: 7586 Lms Total Input Watts: 80W Efficacy: 95 Lms/W BUG Rating: B1-U0-G2 Cutoff Class: Full Cutoff CCT/CRI: 4000K/70 Max Candela: 4707 (35H, 60V)</p>	 <p>Total Lumens: 12010 Lms Total Input Watts: 118W Efficacy: 102 Lms/W BUG Rating: B2-U0-G2 Cutoff Class: Full Cutoff CCT/CRI: 4000K/70 Max Candela: 7426.6 (35H, 60V)</p>	 <p>Total Lumens: 15925 Lms Total Input Watts: 169W Efficacy: 94 Lms/W BUG Rating: B2-U0-G3 Cutoff Class: Full Cutoff CCT/CRI: 4000K/70 Max Candela: 9518.6 (35H, 60V)</p>	 <p>Total Lumens: 2057 Lms Total Input Watts: 47W Efficacy: 44 Lms/W BUG Rating: B0-U0-G1 Cutoff Class: Full Cutoff CCT/CRI: Amber Max Candela: 1134.84 (35H, 60V)</p>
TYPE V	 <p>Total Lumens: 4071 Lms Total Input Watts: 36W Efficacy: 113 Lms/W BUG Rating: B2-U0-G1 Cutoff Class: Full Cutoff CCT/CRI: 4000K/70 Max Candela: 1616.58 (135H, 62.5V)</p>	 <p>Total Lumens: 7832 Lms Total Input Watts: 80W Efficacy: 98 Lms/W BUG Rating: B3-U0-G1 Cutoff Class: Full Cutoff CCT/CRI: 4000K/70 Max Candela: 3117.69 (135H, 62.5V)</p>	 <p>Total Lumens: 12411 Lms Total Input Watts: 118W Efficacy: 105 Lms/W BUG Rating: B3-U0-G2 Cutoff Class: Full Cutoff CCT/CRI: 4000K/70 Max Candela: 4863.54 (135H, 65V)</p>	 <p>Total Lumens: 2125 Lms Total Input Watts: 169W Efficacy: 97 Lms/W BUG Rating: B4-U0-G2 Cutoff Class: Full Cutoff CCT/CRI: 4000K/70 Max Candela: 6705.79 (135H, 65V)</p>	 <p>Total Lumens: 2125 Lms Total Input Watts: 47W Efficacy: 45 Lms/W BUG Rating: B0-U0-G1 Cutoff Class: Full Cutoff CCT/CRI: Amber Max Candela: 736.9 (135H, 65V)</p>



TYPE: _____ QUANTITY: _____ PROJECT: _____

CATALOG NUMBER:

FIXTURE SUFFIX REFLECTOR VOLTAGE FINISH OPTION OPTION OPTION

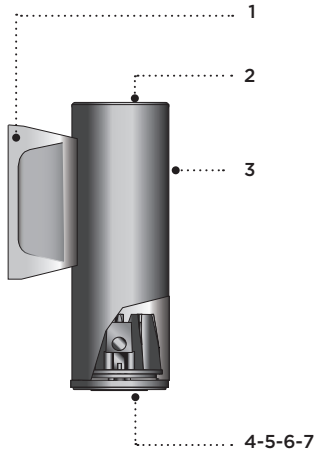

- 1- Cast aluminum driver housing, includes galvanized steel wall mount pressure plate.
- 2- Cast aluminum top cover.
- 3- Extruded aluminum cylindrical housing.
- 4- Fully sealed cast aluminum light assembly.
- 5- Sealed cast aluminum lens frame.
- 6- Clear tempered glass lens.
- 7- Faceted specular aluminum reflector.

All stainless steel hardware.

SY300



ADA Compliant

MATERIALS

Syrios is made of corrosion resistant 356 aluminum alloy with a copper (CU) content of less than 0.1%. The main housing is made of seamless extruded aluminum, with an integrally sealed LED light module designed for optimal heat dissipation, and lighting performance. Syrios SY300 series is standard with 29° optic. See options section for alternate selection.

ELECTRICAL

DRIVER Standard driver is 0-10V dimming-ready (dims to 10%) with: 120-277 multi-volt compatibility (50-60Hz), operating temperature range of -30°C/-22°F to 55°C/131°F, output over voltage protection, output over current protection and output short circuit protection with auto-recovery.

LED Standard 4000K/80CRI. Optional 2700K, 3000K & 3500K. Optional Amber LED for turtle sensitive areas. Wavelengths: 584.5nm to 597nm.

LIFE

60,000hrs L₇₀B₅₀ (based on IESNA TM-21 Test Method and LM-80 data). Up to 95,000hrs L₇₀B₅₀ (calculated projection from LM-80 data).

FINISH

Five-stage preparation process including preheating of cast aluminum parts for air extraction, and an environmentally friendly alloy sealant. Polyester powder coating is applied through an electrostatic process and oven cured for long term finish.

MOUNTING

Maximum weight: 2.5 lbs (1.1 kg)
The mounting plate is designed to fit on a 2X4" (51x102mm) rectangular electrical box using 3.156" (80mm) C/C mounting holes. Optional trimming plate for octagonal jbox (option MT4).

CERTIFICATION

Certified and approved as per CSA C22.2 No.: 250.0 standard and ANSI/UL 1598 standard, for wet location. Rated IP66.

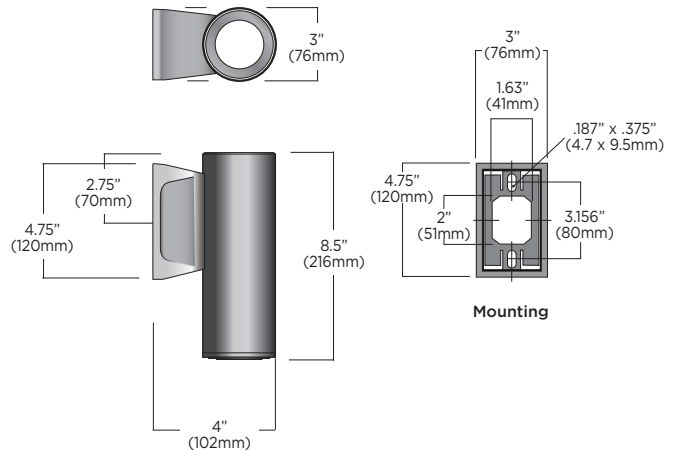

SY300 SERIES

SYRIOS

ADA Compliant

LUMINAIRE SELECTION

1 MODEL#

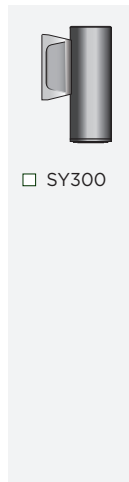

2 LED LIGHT SELECTION

SUFFIX	DELIVERED LUMENS	INPUT WATTS	CRI	CCT °K
<input type="checkbox"/> L1L10	924	13W	80	4000
AMBER LED				
<input type="checkbox"/> L1L1K2A	124	7W	AMBER	

VERY NARROW DISTRIBUTION				
<input type="checkbox"/> L1L5NR	539	10W	80	4000

3 REFLECTORS*

- R30 Flood optics 29° (standard)
- R40 Wide flood optics 42°

*Depending on direction fixture is installed add U (for upright) or D (for downlight) to suffix for all reflectors listed above. (i.e. R40U is 42° upright)

- R9 Very narrow optics 9°
Field angle 21°
(12,018 candela)

4 VOLTAGE

- 120V
- 277V

5 FINISH

STANDARD COLORS*

- WHT Snow white
- BKT Jet black
- BZT Bronze
- MST Matte silver
- GRT Titanium gray
- DGT Gun metal
- CHT Champagne
- SGT Steel gray
- BGT English cream

OPTIONAL COLORS

- CS Custom color
- RAL RAL# color

ENVIRONMENT

- MG Marine grade⁵
- NT Natatorium⁶

*Refer to color chart

OPTIONS

ELECTRICAL

- FS Fuse
- REML2-50 7W remote emergency battery backup for LED, 90 min. Remote mount 50ft - 12" (305mm) square enclosure with access cover¹

LIGHT & OPTICS

Alternate CCT °K LED (LCF: Lumen conversion factor)

- K27 2700K CCT 80 CRI (LCF: 0.91)³
- K3 3000K CCT 80 CRI (LCF: 0.94)
- K35 3500K CCT 80 CRI (LCF: 0.983)³

NOTE: Other CCT & higher CRI available, please consult factory.



For IDA certification compliance, luminaire must be ordered with 3000K or warmer.

FAUX WOOD COLORS⁴

- ADG American douglas
- BRC Birch
- CHN Chestnut
- CRY Cherry
- KNP Knotty pine
- MPL Maple
- OFL Oak
- RSW Rosewood
- TEK Teak
- WLN Walnut

ACCESSORIES

- SL Solite lens (light loss factor [LLF]: 0.9)
- LSL Linear spread lens
- SNT 1.5" (38mm) snoot²
- HL Hexcell louver

MOUNTING

- SWK Adaptor box for surface 3/4" conduit feed
- MT4 Trimming plate for octagonal box
- UP Option required for upright installation
- UH Uniform height matching SY302

NOTES

- The remote enclosure must be interior.
- To prevent reflections, interior painted black when a light color finish is selected (ex. WHT, MST, GRT and CHT).
- K27 and K35 options not available with the R9 optics.
- Faux wood finish not applied to driver housing, lens frame or accessories.
- For harsh, coastal environment and exposure to salt water. Longer lead time may apply please contact factory for info.
- Only available in WHT and BKT.

LUMINIS®

LUMINIS | Toll free: 866.586.4647 Fax: 514.683.8872 Email: info@luminis.com
260 Labrosse, Pointe-Claire (QC) Canada H9R 5L5

Luminaires may be altered for design improvement or discontinued without prior notice.

LUMINIS.COM

SY300 SERIES SYRIOS ADA Compliant

TYPICAL PHOTOMETRY SUMMARY

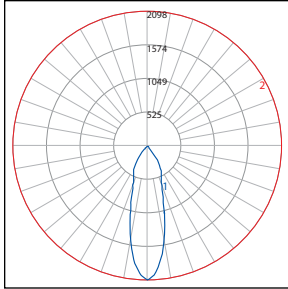

Descriptive information
 SY300-L1L10-R30
 Total Lms: 924 lumens
 Total input watts: 13 W
 Efficacy: 74 Lumens/Watt
 BUG: B1-U0-G0
 CCT/CRI: 4000K/80
 Maximum candela: 2098 @ 0°

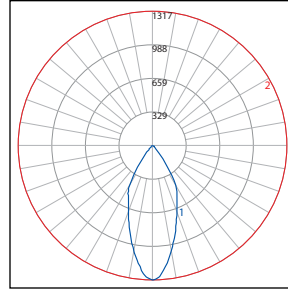

Descriptive information
 SY300-L1L10-R40
 Total Lms: 846 lumens
 Total input watts: 13 W
 Efficacy: 68 Lumens/Watt
 BUG: B1-U0-G0
 CCT/CRI: 4000K/80
 Maximum candela: 1317 @ 0°

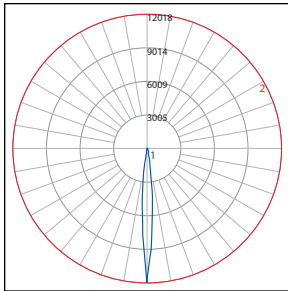

Descriptive information
 SY300-L1L5NR-R9
 Total Lms: 539 lumens
 Total input watts: 10 W
 Efficacy: 53 Lumens/Watt
 BUG: B1-U0-G0
 CCT/CRI: 4000K/80
 Maximum candela: 12018 @ 0°

Please visit our web site www.luminis.com for complete I.E.S. formatted download data.



FEATURES & SPECIFICATIONS

INTENDED USE — Typical applications include corridors, lobbies, conference rooms and private offices.

CONSTRUCTION — Galvanized steel mounting/plaster frame; galvanized steel junction box with bottom-hinged access covers and spring latches. Reflectors are retained by torsion springs.

Vertically adjustable mounting brackets with commercial bar hangers provide 3-3/4" total adjustment.

Two combination 1/2"-3/4" and four 1/2" knockouts for straight-through conduit runs. Capacity: 8 (4 in, 4 out). No. 12 AWG conductors, rated for 90°C.

Accommodates 12"-24" joist spacing.

Passive cooling thermal management for 25°C standard; high ambient (40°C) option available. Light engine and drivers are accessible from above or below ceiling.

Max ceiling thickness 1-1/2".

OPTICS — LEDs are binned to a 3-step MacAdam Ellipse; 80 CRI minimum. 90 CRI optional.

LED light source concealed with diffusing optical lens.

General illumination lighting with 1.0 S/MH and 55° cutoff to source and source image.

Self-flanged anodized reflectors in specular, semi-specular, or matte diffuse finishes. Also available in white and black painted reflectors.

A+ CAPABLE LUMINAIRE — This item is an A+ capable luminaire, which has been designed and tested to provide consistent color appearance and out-of-the-box control compatibility with simple commissioning when used with Acuity Brands controls products. All configurations of this luminaire are calibrated and tested to meet the Acuity Brands' specifications for chromatic consistency – including color rendering, color fidelity and color temperature tolerance around standard CIE chromaticity coordinates. To learn more about A+ standards, specifications, and testing visit www.acuitybrands.com/aplus.

UGR — UGR is zero for fixtures aimed at nadir with a cut-off equal to or less than 60deg, per CIE 117-1996 Discomfort Glare in Interior Lighting.

ELECTRICAL — Multi-volt (120-277V, 50/60Hz) 0-10V dimming drivers mounted to junction box, 10% or 1% minimum dimming level available.

0-10V dimming fixture requires two (2) additional low-voltage wires to be pulled.

LUMEN MAINTENANCE — 70% lumen maintenance at 60,000 hours. L70/60,000 hours

LISTINGS — Certified to US and Canadian safety standards. Wet location standard (covered ceiling). IP55 rated. ENERGY STAR® certified product. Drivers are RoHS compliant

BUY AMERICAN ACT — Product with the BAA option is assembled in the USA and meets the Buy America(n) government procurement requirements under FAR, DFARS and DOT regulations. Please refer to www.acuitybrands.com/buy-american for additional information.

WARRANTY — 5-year limited warranty. This is the only warranty provided and no other statements in this specification sheet create any warranty of any kind. All other express and implied warranties are disclaimed.

Complete warranty terms located at: www.acuitybrands.com/support/warranty/terms-and-conditions

Note: Actual performance may differ as a result of end-user environment and application.

All values are design or typical values, measured under laboratory conditions at 25 °C. Specifications subject to change without notice.

PERFORMANCE DATA

LDN6 3500K AR LSS 80CRI			
Nominal Lumens	Lumens	Wattage	Lm/W
500	527.9	5.8	90.5
750	758.1	8.9	85.1
1000	950.1	10.4	91.0
1500	1514	17.5	86.4
2000	2006	22.5	89.1
2500	2504	28.3	88.6
3000	3021	34.8	86.9
4000	4008	44.3	90.6
5000	4975	57.7	86.3

Notes

- Tested in accordance with IESNA LM-79-08.
- Tested to current IES and NEMA standards under stabilized laboratory conditions.
- CRI: 80 typical.



Catalog Number	Item 4.
Notes	
Type	

LDN6 STATIC WHITE

6" Open and Wallwash LED
Non-IC
New Construction Downlight

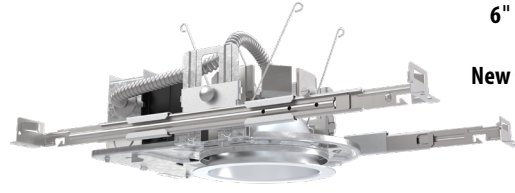

Open Trim



Wallwash Trim

DISTRIBUTIONS

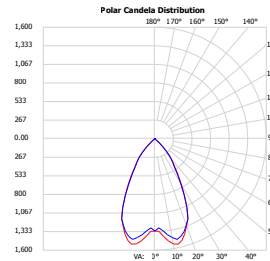

Open

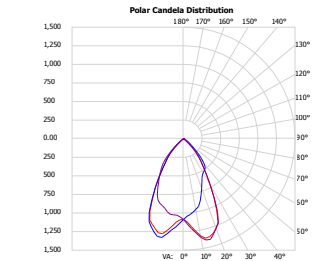

Wallwash

DIMENSIONS

LDN6 500-3000 Lumens

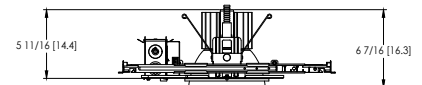
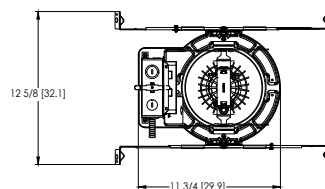

Aperture: \varnothing 6-1/4" [15.9]
Ceiling Cutout: \varnothing 7-1/8" [18.1] Self-flanged
Overlap Trim: \varnothing 7-1/2" [19.1]

See page 4 for other fixture dimensions

ORDERING INFORMATION

Lead times will vary depending on options selected. Consult with your sales representative.

Example: LDN6 35/15 L06 AR LSS MVOLT EZ10

LDN6 Series	Color temperature	Lumens ‡	Trim Style	Trim Color	Trim Finish	Flange Color ‡	Voltage
LDN6 6" round	27/ 2700K 30/ 3000K 35/ 3500K 40/ 4000K 50/ 5000K	05 500 lumens 07 750 lumens 10 1000 lumens 15 1500 lumens 20 2000 lumens 25 2500 lumens 30 3000 lumens 40 4000 lumens 50 5000 lumens	L06 Downlight LW6 Wallwash	AR Clear WR ‡ White BR ‡ Black TCPC ‡ Custom painted trim TRALTBD ‡ RAL painted trim	LSS Semi-specular LD Matte diffuse LS Specular	TRW White painted flange TRBL Black painted flange FCPC Custom painted flange only FRALTBD RAL painted flange only	MVOLT Multi-volt 120 120V 277 277V 347 ‡ 347V

Driver	Emergency ‡	Control Input ‡	Options
GZ10 0-10V driver dims to 10%	(blank) No Emergency Needed	(blank) No Control Input Needed	HAO ‡ High ambient option (40°C)
GZ1 0-10V driver dims to 1%	EL Battery pack (10W constant power), non-T20 compliant, integral test switch	JOT Wireless room control with "Just One Touch" pairing	CP ‡ Chicago Plenum
D10 Minimum dimming 10% driver for use with JOT	ELR Battery pack (10W constant power), non-T20 compliant, remote test switch	NPP16D nLight® network power/relay pack with 0-10V dimming for non-eldoLED drivers (GZ10, GZ1).	RRL___ RELOC®-ready luminaire connectors enable a simple and consistent factory installed option across all ABL luminaire brands. Refer to RRL for complete nomenclature. Available only in RRLA, RRLB, RRLAE, and RRLC12S.
D1 Minimum dimming 1% driver for use with JOT	ELSD Self-diagnostic battery pack (10W constant power), non-T20 compliant, integral test switch	NPP16DER nLight® network power/relay pack with 0-10V dimming for non-eldoLED drivers (GZ10, GZ1). ER controls fixtures on emergency circuit.	BAA Buy America(n) Act Compliant
EZ1 0-10V eldoLED driver with smooth and flicker-free deep dimming performance down to 1% dim to dark	ELRSD Self-diagnostic battery pack (10W constant power), non-T20 compliant, remote test switch	NPS80EZ nLight® dimming pack controls 0-10V eldoLED drivers (EZ1).	90CRI High CRI (90+)
EDAB eldoLED DALI SOLDRIVE dim to dark	E10WCP Battery pack (10W constant power), T20 compliant, integral test switch	NPS80EZER nLight® dimming pack controls 0-10V eldoLED drivers (EZ1). ER controls fixtures on emergency circuit.	SF ‡ Single fuse
	E10WCPR Battery pack (10W constant power), T20 compliant, remote test switch	N80 nLight™ Lumen Compensation	
	E10WRSTAR Emergency battery pack, 10W with remote test switch and Iota STAR technology	NLTAIR2 nLight® Air enabled	
		NLTAIRER2 nLight® AIR Dimming Pack Wireless Controls. Controls fixtures on emergency circuit, not available with battery pack options	
		NLTAIREM2 nLight® AIR Dimming Pack Wireless Controls. UL924 Emergency Operation, via power interrupt detection. Available with battery pack options.	

‡ Option Value Ordering Restrictions

Option value	Restriction
Lumens	Overall height varies based on lumen package; refer to dimensional chart.
WR, BR	Not available with finishes.
347	Not available with emergency options.
SF	Must specify voltage 120V or 277V.
TRW, TRBL	Available with clear (AR) reflector only.
EL, ELR, ELSD, ELRSD, E10WCP, E10WCPR	12.5" of plenum depth or top access required for battery pack maintenance.
NPP16D, NPP16DER, NPS80EZ, NPS80EZER	Specify voltage. ER for use with generator supply EM power. Will require an emergency hot feed and normal hot feed. See UL 924 Sequence of Operation table.
N80	Fixture begins at 80% light level. Must be specified with NPS80EZ or NPS80EZ ER. Only available with EZ1 drivers.
NLTAIR, NLTAIR2, NLTAIRER2, NLTAIREM2	Not available with CP, NPS80EZ, NPS80EZER, NPP16D, NPP16DER or N80 options. not recommended for metal ceiling installations.
HAO	Fixture height is 6.5" for all lumen packages with HAO.
CP	Must specify voltage for 3000lm and above. 5000lm with marked spacing 24 L x 24 W x 14 H. Not available with emergency battery pack option.
JOT	Must specify D10 or D1 driver. Not available with nLight options. Not available with CP. Not recommended for metal ceiling installation. Not for use with emergency backup power systems other than battery packs.
Reloc® Options	Refer to RRL specification sheet on acuitybrands.com for further details.
RRLAE	Commercial fixtures should disconnect the TSPL before unplugging the RRL so it does not go into discharge mode.
RRLC12S	RRLC12S option is to be used with the OnePass OCU, OCS, OD, OFC and OD for 0-24V integrated single-circuit or 0-10V low voltage controls applications. Not available with integral dimming sensors.
TRALTBD, FRALTBD	RALTBD for pricing only. Replace with applicable RAL number and finish when ready to order. See the RAL BROCHURE for available color options.
TCPC, FCPC	CPC options for pricing only. Custom color chip needs to be sent in to your Customer Resolution specialist before order can be processed. Click HERE for more details
E10WRSTAR	Not available with wet location, EC1, EC6, QDS, CP, 347V, NPS80EZ ER, NLTAIRER2, NLTAIREM2, AL03 & AL04 w/DALI, OR 2000-4500 lumens w/JOT. Top access installation or 17.5" plenum clearance required for roomside installation. Not available with integral test switch

Accessories: Order as separate catalog number.

EAC ISSM 375	Compact interruptible emergency AC power system	SCA6 Sloped Ceiling Adapter. Degree of slope must be specified (5D, 10D, 15D, 20D, 25D, 30D). Ex: SCA6 10D
EAC ISSM 125	Compact interruptible emergency AC power system	
GRA68 JZ	Oversized trim ring with 8" outside diameter	



Items marked by a shaded background qualify for the Design Select program and ship in 15 days or less. To learn more about Design Select, visit www.acuitybrands.com/designselect. *See ordering tree for details

(Maximum order quantity for design select lead times is 112.)

Emergency Battery Pack Options - Field Installable

Battery Model Number	Wattage	Runtime (Minutes)	Lumen Output* @ 120 Lumens/Watt	Other
ILB CP07 2H A	7W	120	840	Storm Shelter / 2 Hour Runtime
ILB CP10 A	10W	90	1200	
ILBLP CP10 HE SD A+	10W	90	1200	Title 20, Self Diagnostic
ILBLP CP15 HE SD A+	15W	90	1800	Title 20, Self Diagnostic
ILB CP20 HE A	20W	90	2400	Title 20
ILB CP20 HE SD A	20W	90	2400	Title 20, Self Diagnostic
ILBHI CP10 HE SD A+	10W	90	1200	347-480V AC Input, Title 20, Self Diagnostic
ILBHI CP15 HE SD A+	15W	90	1800	347-480V AC Input, Title 20, Self Diagnostic

All the above are UL Listed products that are certified for field install external/remote to the fixture.

*Minimum delivered lumen output to assist in product selection for increased fixture mounting height.

The CP10 delivered emergency illumination outperforms legacy 1400 lumen fluorescent emergency ballast.

Please contact us at techsupport@iotaengineering.com for any Emergency Battery related questions.

PHOTOMETRY

Distribution Curve Distribution Data Output Data Illuminance Data at 30" Above Floor for a Single Luminaire

LDN6 35/10 L06AR, input watts: 10.44, delivered lumens: 987.10, LM/W = 94.54, spacing criterion at 0= 1.02, test no. ISF 30716P262.

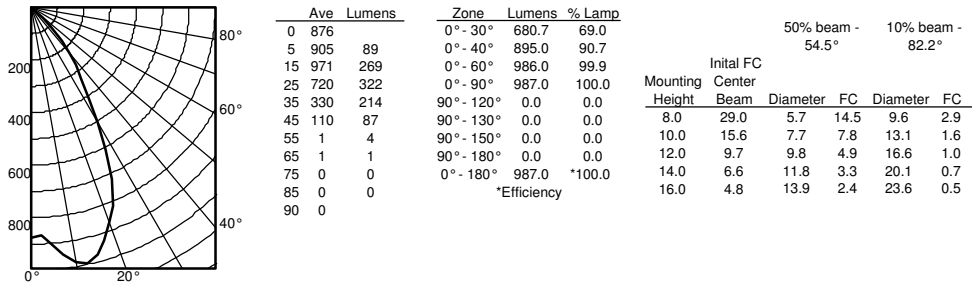

LDN6 35/15 L06AR, input watts: 17.52, delivered lumens: 1572.9, LM/W = 89.77, spacing criterion at 0= 1.02, test no. ISF 30716P265.

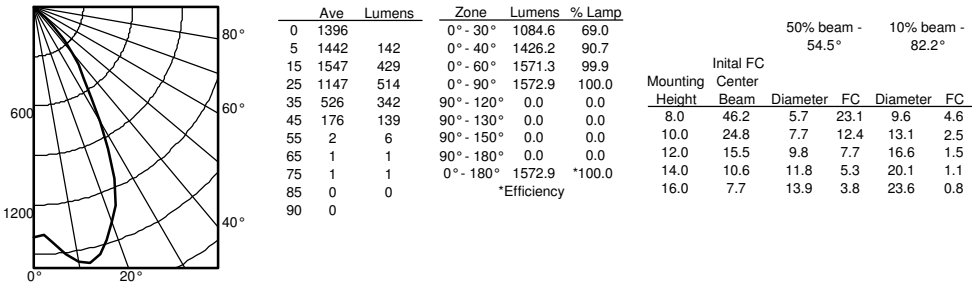

LDN6 35/30 L06AR, input watts: 34.75, delivered lumens: 3138.5, LM/W = 90.31, spacing criterion at 0= 1.02, test no. ISF 30716P274.

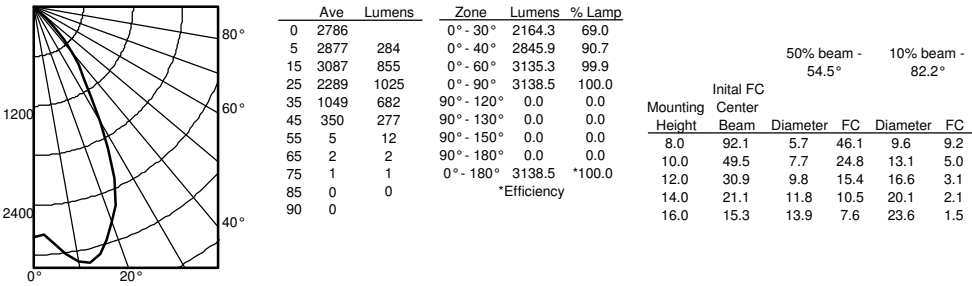

HOW TO ESTIMATE DELIVERED LUMENS IN EMERGENCY MODE

Use the formula below to estimate the delivered lumens in emergency mode

Delivered Lumens = 1.25 x P x LPW

P = Output power of emergency driver. P = 10W for PS1055CP

LPW = Lumen per watt rating of the luminaire. This information is available on the ABL luminaire spec sheet.

The LPW rating is also available at Designlight Consortium.

Notes

- Tested in accordance with IESNA LM-79-08.
- Tested to current IES and NEMA standards under stabilized laboratory conditions.
- CRI: 80 typical.

LUMEN OUTPUT MULTIPLIERS - FINISH			
	Clear (AR)	White (WR)	Black (BR)
Specular (LS)	1.0	N/A	N/A
Semi-specular (LSS)	0.950	N/A	N/A
Matte diffuse (LD)	0.85	N/A	N/A
Painted	N/A	0.87	0.73

LUMEN OUTPUT MULTIPLIERS - CRI	
80	1.0
90	0.874

LUMEN OUTPUT MULTIPLIERS - CCT					
	2700K	3000K	3500K	4000K	5000K
80CRI	0.950	0.966	1.000	1.025	1.101

* All dimensions are inches (centimeters) unless otherwise noted.

LDN6 500-3000 Lumens

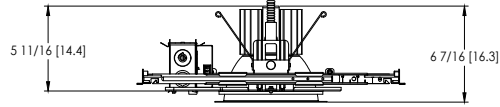
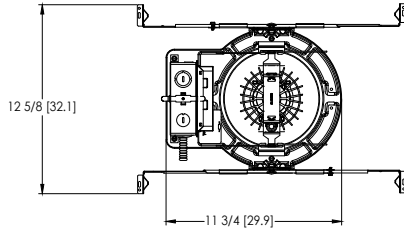

Aperture: \varnothing 6-1/4" [15.9]
 Ceiling Cutout: \varnothing 7-1/8" [18.1] Self-flanged
 Overlap Trim: \varnothing 7-1/2" [19.1]

LDN6 4000-5000 Lumens

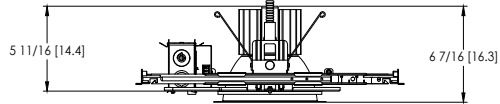
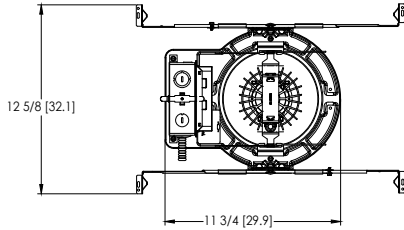

Marked Spacing: 24" x 24" x 10"
 Aperture: \varnothing 6-1/4" [15.9]
 Ceiling Cutout: \varnothing 7-1/8" [18.1] Self-flanged
 Overlap Trim: \varnothing 7-1/2" [19.1]

LDN6 CP

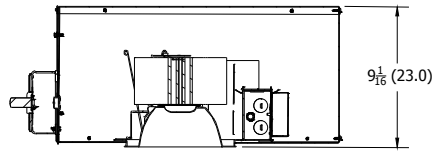
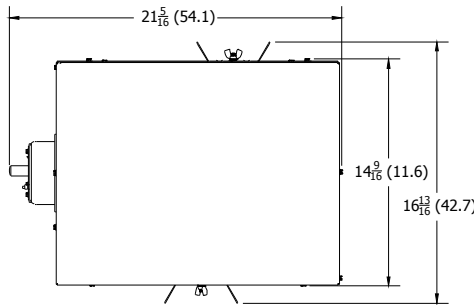

Aperture: 6-1/4 (15.9)
 Ceiling Opening: 7-1/8 (18.1)
 Overlap Trim: 7-1/2 (19.1)

LDN6 EL

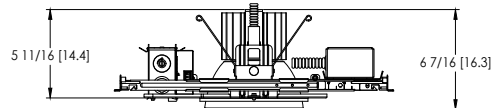
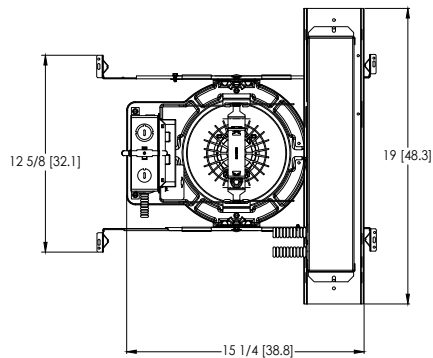

Marked Spacing above 3000lm: 24" x 24" x 10"
 Aperture: \varnothing 6-1/4" [15.9]
 Ceiling Cutout: \varnothing 7-1/8" [18.1] Self-flanged
 Overlap Trim: \varnothing 7-1/2" [19.1]

ADDITIONAL DATA



The Sensor Switch JOT enabled solution offers a wireless, app-free approach to single room lighting control. JOT enabled products use Bluetooth® Low Energy (BLE) technology to enable wireless dimming and switching.

Diagram



LDN6 Series



Sensor Switch
WSXA JOT

1. **Power:** Install JOT enabled fixtures and controls as instructed.
2. **Pair:** Insert the pairing tool into the pinhole on the wall switch; press and hold any button for 6 seconds.
3. **Play:** Once paired, each fixture will individually dim down to 10% brightness. All products will be fully functional.

COMPATIBLE 0-10V WALL-MOUNT DIMMERS		
MANUFACTURER	PART NO.	POWER BOOSTER AVAILABLE
Lutron®	Diva® DVTV	
	Diva® DVSCTV	
	Nova T® NTFTV	
	Nova® NFTV	
Leviton®	AWSMT-7DW	CN100
	AWSMG-7DW	PE300
	AMRMG-7DW	
	Leviton Centura Fluorescent Control System	
	IllumaTech® IP7 Series	
Synergy®	ISD BC	RDMFC
	SLD LPCS	
	Digital Equinox (DEQ BC)	
Douglas Lighting Controls	WPC-5721	
Entertainment Technology	Tap Glide TG600FAM120 (120V)	
	Tap Glide Heatsink TGH1500FAM120 (120V)	
	Oasis OA2000FAMU	
Honeywell	EL7315A1019	EL7305A1010 (optional)
	EL7315A1009	
HUNT Dimming	Preset slide: PS-010-IV and PS-010-WH	
	Preset slide: PS-010-3W-IV and PS-010-3W-WH	
	Preset slide, controls FD-010: PS-IFC-010-IV and PS-IFC-010-WH-120/277V	
	Preset slide, controls FD-010: PS-IFC-010-3W-IV and PS-IFC-010-3W-WH-120/277V	
	Remote mounted unit: FD-010	
Lehigh Electronic Products	Solitaire	PBX
PDM Electrical Products	WPC-5721	
Starfield Controls	TR61 with DALI interface port	RT03 DALI.net Router
WattStopper®	LS-4 used with LCD-101 and LCD-103	

EXAMPLE

Group Fixture Control*

*Application diagram applies for fixtures with eldoLED drivers only.

nPS 80 EZ Dimming/Control Pack (qty: 2 required)

nPODM 2P DX Dual On/Off/Dim Push-Button WallPod

nCM ADCX Daylight Sensor with Automatic Dimming Control

nCM PDT 9 Dual Technology Occupancy Sensor

Description: This design provides a dual on/off/dim wall station that enables manual control of the fixtures in Row A and Row B separately. Additionally, a daylight harvesting sensor is provided so the lights in Row B can be configured to dim automatically when daylight is available. An occupancy sensor turns off all lights when the space is vacant.

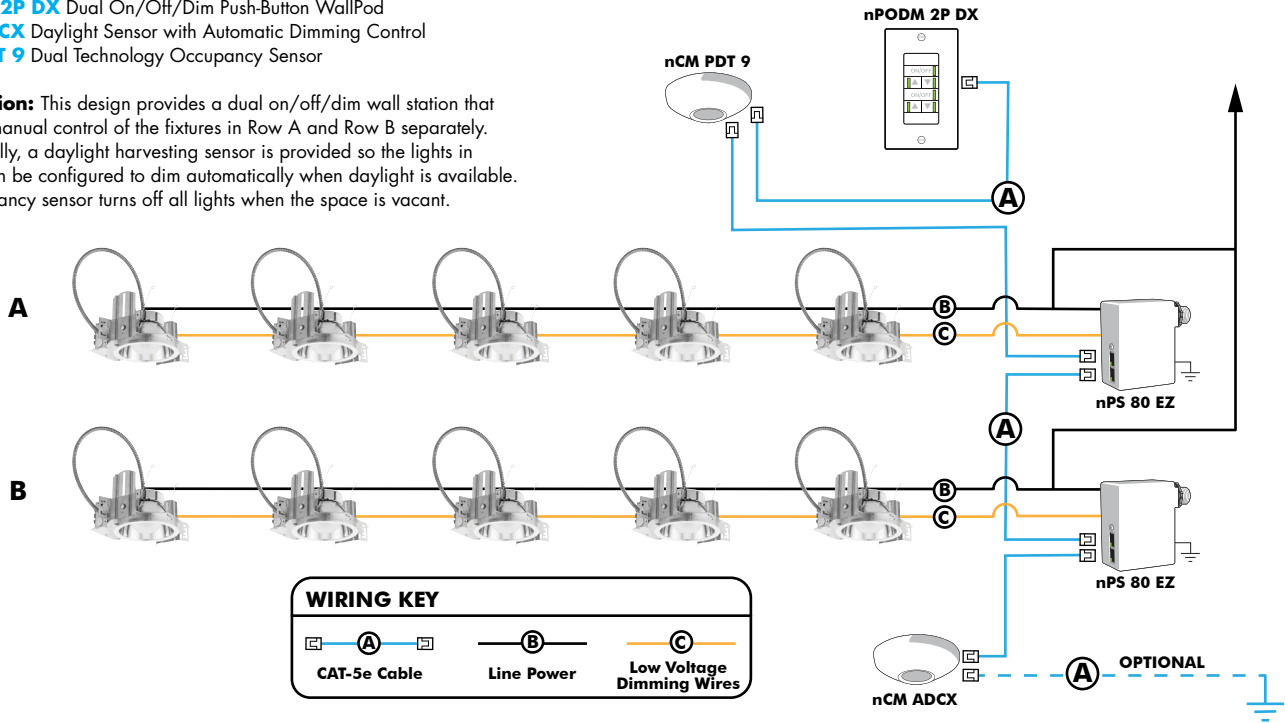

Choose Wall Controls

nLight offers multiple styles of wall controls - each with varying features and user experience.



Push-Button Wallpod
Traditional tactile buttons and LED user feedback



Graphic Wallpod
Full color touch screen provides a sophisticated look and feel

nLight® Wired Controls Accessories:

Order as separate catalog number. Visit www.acuitybrands.com/products/controls/nlight for complete listing of nLight controls.

WallPod Stations	Model number	Occupancy sensors	Model Number
On/Off	nPODM (Color)	Small motion 360°, ceiling (PIR/dual Tech)	nCM 9 / nCM PDT 9
On/Off & Raise/Lower	nPOD DX (Color)	Large motion 360°, ceiling (PIR/dual tech)	nCM 10 / nCM PDT 10
Graphic Touchscreen	nPOD GFX (Color)	Wide View (PIR/dual tech)	nWV 16 / nWV PDT 16
Photocell controls	Model Number	Wall Switch w/ Raise/Lower (PIR/dual tech)	nWSX LV DX / nWSX PDT LV DX
Dimming	nCM ADCX	Cat-5 cables (plenum rated)	Model Number
		10', CAT5 10FT	CAT5 10FT J1
		15, CAT5 15FT	CAT5 15FT J1

nLight® AIR Control Accessories:

Order as separate catalog number. Visit www.acuitybrands.com/products/controls/nlightair.

Wall switches	Model number
On/Off single pole	rPODB [color]
On/Off two pole	rPODB 2P [color]
On/Off & raise/lower single pole	rPODB DX [color]
On/Off & raise/lower two pole	rPODB 2P DX [color]
On/Off & raise/lower single pole	rPODBZ DX WH ¹

Notes

- 1 Can only be ordered with the RES7Z zone control sensor version.

UL924 Sequence of Operation

The below information applies to all nLight AIR devices with an EM option.

- EM devices will remain at their high-end trim and ignore wireless lighting control commands, unless a normal-power-sensed (NPS) broadcast is received at least every 8 seconds.
- Using the CLAIRITY+ mobile app, EM devices must be associated with a group that includes a normal power sensing device to receive NPS broadcasts.
- Only non-emergency rPP20, rLSXR, rSBOR, rSDGR, and nLight AIR luminaires with version 3.4 or later firmware can provide normal power sensing for EM devices. See specification sheets for control devices and luminaires for more information on options that support normal power sensing.

nLight AIR

nLight AIR is the ideal solution for retrofit or new construction spaces where adding communication is cost prohibitive. The integrated nLight AIR rPP20 Power Pack is part of each Lithonia LDN Luminaire. These individually addressable controls offer the ultimate in flexibility during initial setup and for space repurposing.



Simple as 1,2,3

1. Install the nLight® AIR fixtures with embedded smart sensor
2. Install the wireless battery-powered wall switch
3. With CLAIRITY app, pair the fixtures with the wall switch and if desired, customize the sensor settings for the desired outcome





Photos Courtesy: Spring Hill Nursery, MOBOT



NATIVAR



APRIL

JUNE

FALL

Autumn Brilliance Serviceberry
Amelanchier x grandiflora 'Autumn Brilliance'

H = 20'; W = 15'



Item 4.



NATIVE

Photos Courtesy: MOBOT & Lurveys



JUNE

WINTER

Common Hackberry
Celtis occidentalis

H = 50'; W = 50'



Photos Courtesy: MOBOT



NATIVAR



FALL

Skyline Honeylocust
Gleditsia triacanthos inermis 'Skycole'

H = 40'; W = 30'



Photos Courtesy: Wikipedia



NATIVE



SUMMER

FALL

WINTER

American Sweetgum
Liquidambar styraciflua

H = 50'; W = 30'



NON-NATIVE

Photos Courtesy: MOBOT



APRIL - MAY

Betty Magnolia
Magnolia "Betty"

H = 15'; W = 12'

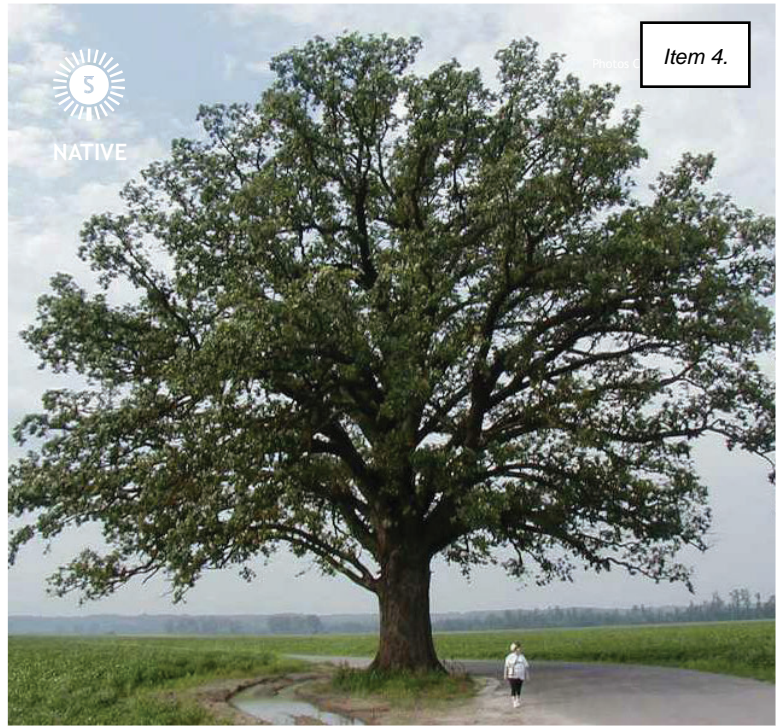

NATIVE

Item 4.



ACORN



FALL

Bur Oak
Quercus macrocarpa

H = 60'; W = 60'



NON-NATIVE

Photos Courtesy: Bailey Nurseries



MAY-JUNE

Ivory Silk Japanese Tree Lilac
Syringa reticulata 'Ivory Silk'

H = 25'; W = 20'

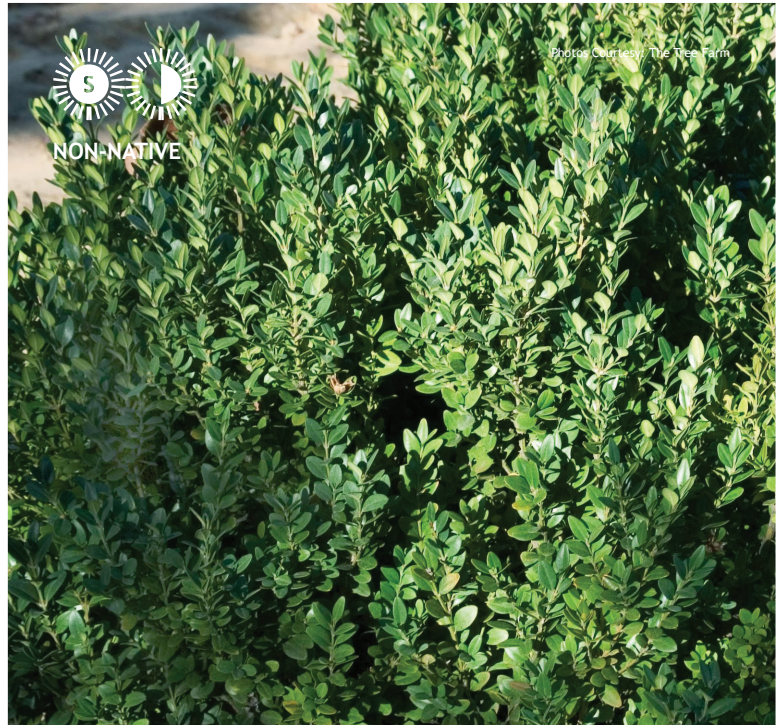

NON-NATIVE

Photos Courtesy: The Tree Farm



EVERGREEN

Green Mountain Boxwood
Buxus 'Green Mountain'

H = 48" x W



NON-NATIVE

Photos Courtesy: Walter's Gardens, Inc.



SPRING-FALL

Karl Foerster Reed Grass
Calamagrostis 'Karl Foerster'

H = 48"; W = 36"

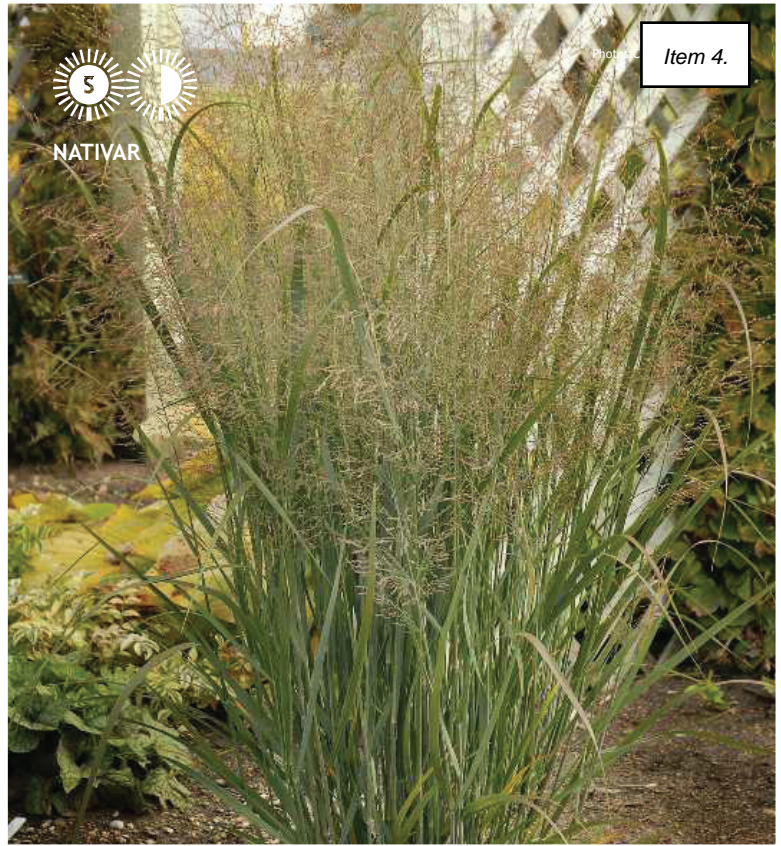

NATIVAR

Photos Courtesy: Walter's Gardens, Inc.

Item 4.

Northwind Switch Grass
Panicum virgatum 'Northwind'

H = 60"; W = 24"



NATIVE

Photos Courtesy: Walter's Gardens, Inc.

Prairie Dropseed
Sporobolus heterolepis

H = 24"; W = 24"



Photos Courtesy: Spring Meadow II, The Growing Place



NAT'VAR

NON-NATIVE



MID-SPRING



SUMMER



FALL

Iriquois Beauty Chokeberry
Aronia melanocarpa "Merton"

H = 36" x W = 36"



Photos Courtesy: Spring Meadow



NON-NATIVE



JUNE



LATE-SUMMER



FALL

Little Quick Fire Hydrangea
Hydrangea paniculata "SWIRLPLG"

H = 4' x W = 4'

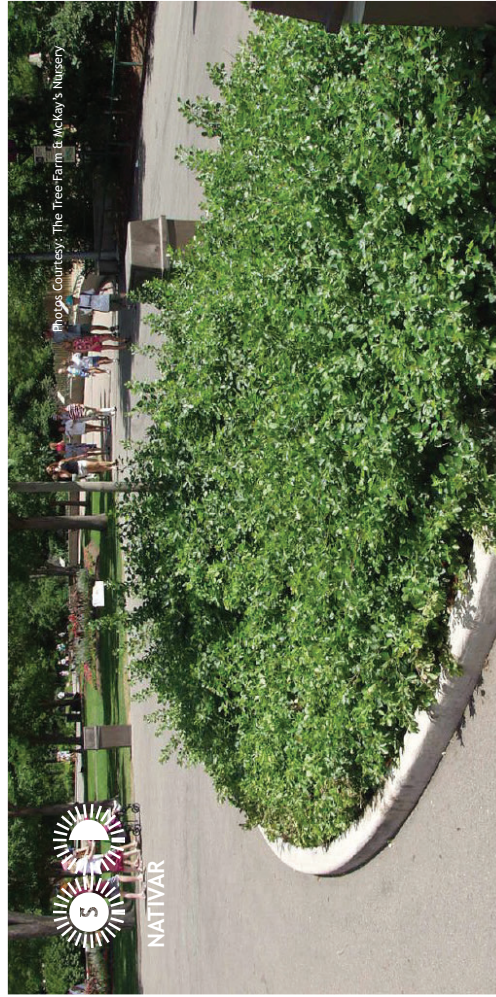

Photos Courtesy: The Tree Farm B. McKay's Nursery



NAT'VAR



FALL

Low Fragrant Sumac
Rhus typhina "Gro-Low"

H = 24" x W = 60"



Photos Courtesy: Knockout Roses



NAT'VAR



MAY - SEPTEMBER

Double Pink Knockout Rose
Rosa "Double Pink"

H = 48" x W = 48"

Item 4.



Photos Courtesy: Knockout Roses



NATiVAR



MAY - SEPTEMBER

Double Pink Knockout Rose
Rosa 'Double Pink'

H = 48" x W = 48"



Photos Courtesy: Dave's Nursery



NON-NATIVE



JUNE - OCTOBER

Ruby Sentinel Daylily
Hemerocallis 'Ruby Sentinel'

H = 30" x W = 24"



Photos Courtesy: MOBOT



NON-NATIVE



MAY

Blue Periwinkle
Vinca 'Dart's Blue'

H = 6" x W = 18"

Item 4.

EXISTING AREA

TOTAL	BUILDING	SIDEWALK	PARKING LOT	GRASS
72520 SF	14219 SF	2995 SF	19733 SF	35573 SF

PROPOSED AREA

TOTAL	BUILDING	SIDEWALK	PARKING LOT	GRASS	PAVER
72520 SF	18719 SF	2211 SF	18976 SF	27986 SF	4628 SF

DRAINAGE NOTES:

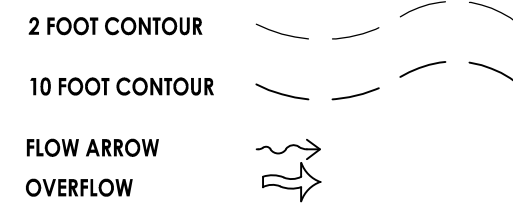

LEGAL DESCRIPTION: (PER SURVEY BY LAND-MARK SURVEYING)

LOT 11, LOT 12, PART OF LOT 13, PART OF LOT 14 OF BLOCK 15 OF THE ORIGINAL PLAT OF THE VILLAGE (NOW CITY) OF WHITEWATER AND LOTS 17 AND 18 OF O'CONNORS SUBDIVISION OF PART OF LOTS 11 AND 12 OF BLOCK 15 OF THE ORIGINAL PLAT OF THE VILLAGE (NOW CITY) OF WHITEWATER, ALL LOCATED IN THE SOUTHWEST 1/4 OF SECTION 4, TOWN 4 NORTH, RANGE 15 EAST, CITY OF WHITEWATER, WALWORTH COUNTY, WISCONSIN.

NOTES:

- ALL DIMENSIONS ALONG CURB LINES ARE TO FACE OF CURB, UNLESS NOTED OTHERWISE.
- BUILDINGS AND ADJACENT TO BUILDING IMPROVEMENTS SHOWN ON THESE PLANS ARE BASED UPON THE BUILDING PLANS PROVIDED BY OTHERS AT THE DATE OF THESE PLANS BEING PREPARED. BUILDING PLANS NORMALLY CONTINUE TO CHANGE AFTER SITE PLANS HAVE BEEN APPROVED. THEREFORE THE CONTRACTOR SHALL USE THE BUILDING PLANS FOR FINAL BUILDING IMPROVEMENTS, AND VERIFY THAT ALL ADJACENT IMPROVEMENTS ARE CONSISTENT WITH THE DESIGN INTENT AND REQUIREMENTS OF THE SITE PLANS. THE CONTRACTOR SHALL NOTIFY ENGINEER IMMEDIATELY IF CLARIFICATION IS NEEDED, OR IF CONFLICTS OR INCONSISTENCIES EXIST.
- ADA DETECTIBLE WARNING STRIPS SHALL BE CAST IRON TILES, WET SET INTO CONCRETE SURFACE, PER MANUFACTURERS INSTALLATION RECOMMENDATIONS.
- TOPOGRAPHIC AND BOUNDARY SURVEY PREPARED BY LAND-MARK SURVEYING

(X) SIGNING AND STRIPING SCHEDULE

- A. 4" YELLOW STRIPING
- B. YELLOW HANDICAP PARKING STRIPING (SEE DETAIL)
- C. "ACCESSIBLE" PARKING STALL SIGN ASSEMBLY
- D. "STOP" SIGN R1-1 (30"x30")
- E. 24" WHITE THERMOPLASTIC STOP BAR
- F. 4" PAINTED CROSS STRIPING 4' C-C
- G. DIRECTIONAL ARROW

(X) PARKING SUMMARY

	EXISTING	PROPOSED
REGULAR STALLS (9'x18')	33	44
ACCESSIBLE STALLS (16'x18')	2	2
TOTAL STALL COUNT	35	46

LEGEND:

- ADA TRUNCATED DOMES
- EXISTING CURB AND GUTTER
- EXISTING CURB AND GUTTER - DEPRESSED
- B6.18 CURB AND GUTTER UNLESS NOTED OTHERWISE
- BARRIER CURB
- BARRIER CURB - DEPRESSED
- SAWCUT LINE
- PROPOSED FULL-DEPTH REGULAR ASPHALT PAVEMENT.
- PROPOSED FULL-DEPTH HEAVY-DUTY ASPHALT PAVEMENT.
- PROPOSED CONCRETE PAVEMENT.
- PROPOSED CONCRETE SIDEWALK.
- PROPOSED PERMEABLE PAVERS FOR STORMWATER AREA.
- EXISTING BUILDING TO BE REMOVED.

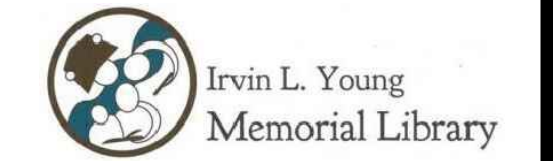
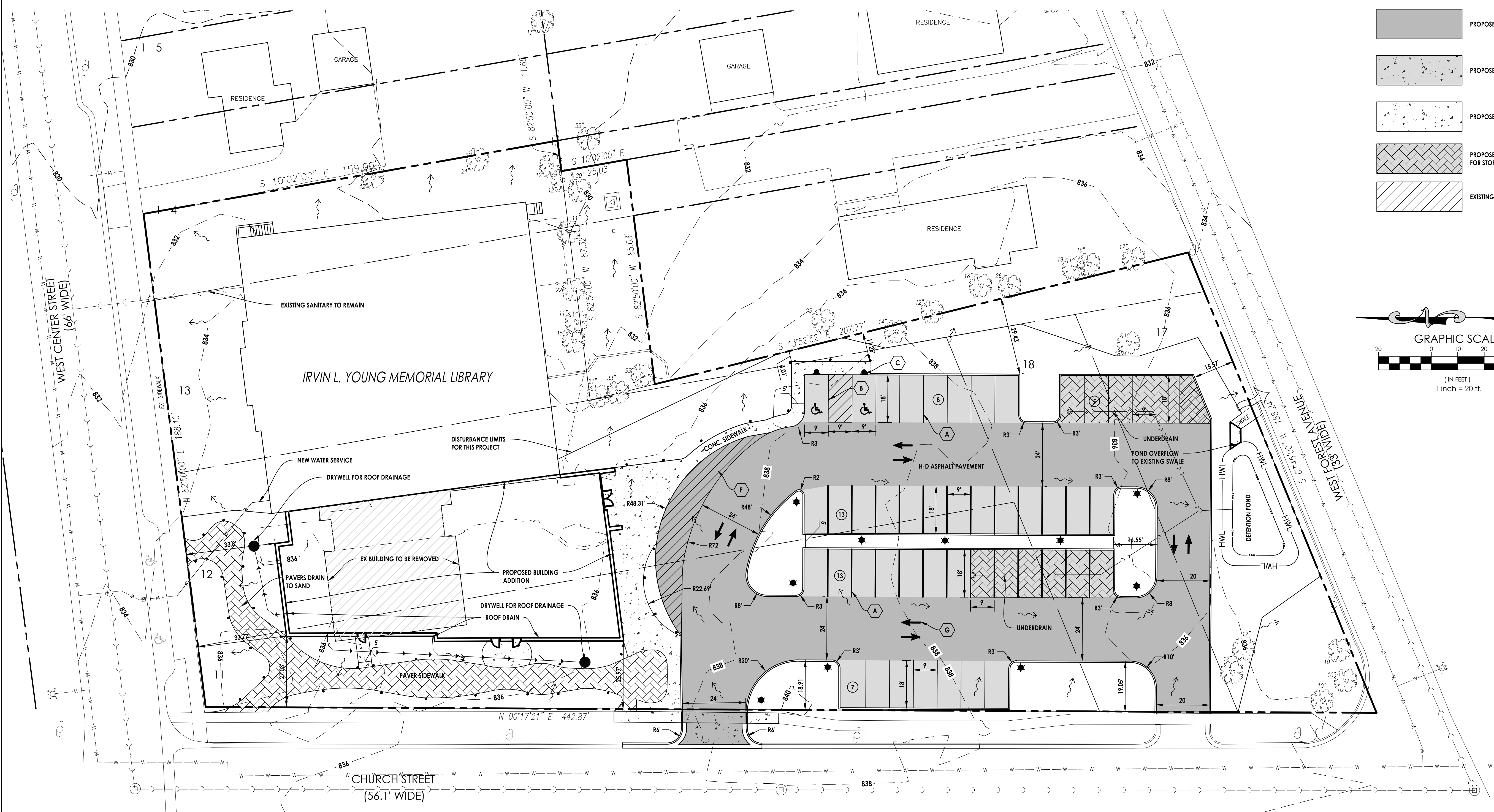
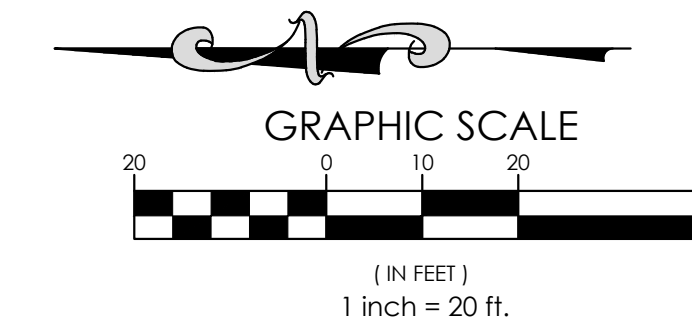

223 West Jackson Boulevard, Suite 1200
Chicago, Illinois 60606
(312) 253-3400



650 E. Algonquin Road | Suite 250
Schaumburg, IL 60173
ph: 847.404.5239
IL Design Firm: 184006777-0002

Additions and Renovations

Irvin L. Young Memorial Library
431 W. Center Street, Whitewater, WI 53190

NO	ISSUE	DATE
•	ARCH REVIEW	03.11.24
•	SUBMISSION	
•		
•		
•		
•		
•		
•		
•		

SITE PLAN

C200

User: lucasbellier File: J:\2023\SGC\0504\8864\Irvin L. Young Memorial Library\03 DESIGN DRAWINGS\02 SHEET SET\SITE PLAN EXHIBIT.dwg Time: Mar 08, 2024 - 12:31pm

NO	ISSUE	DATE
	ARCH REVIEW	03.11.24
	SUBMISSION	

Architectural
Site Plan



1 Architectural Site Plan - Demolition
1" = 30'-0"

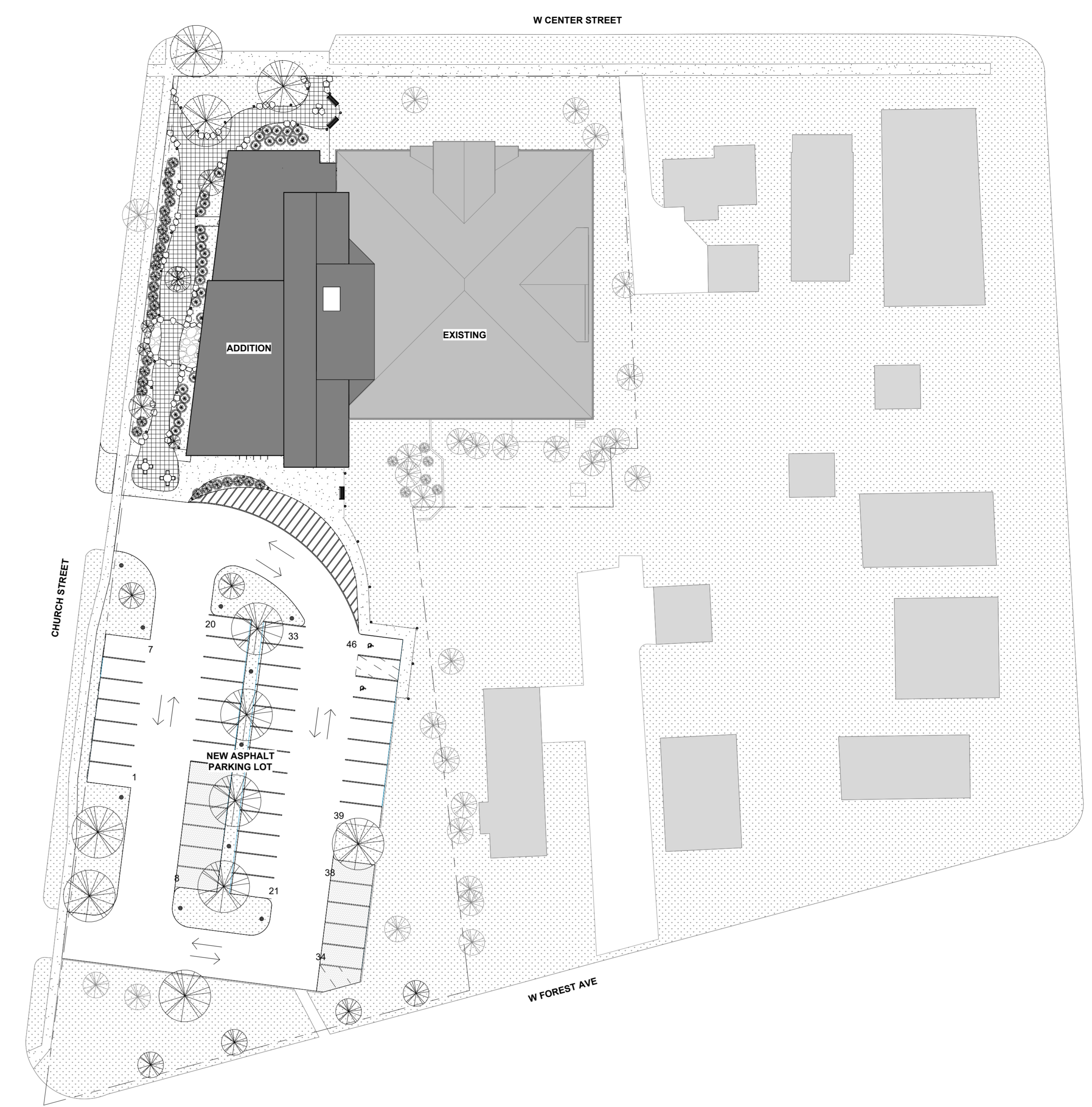

2 Architectural Site Plan - New
1" = 30'-0"

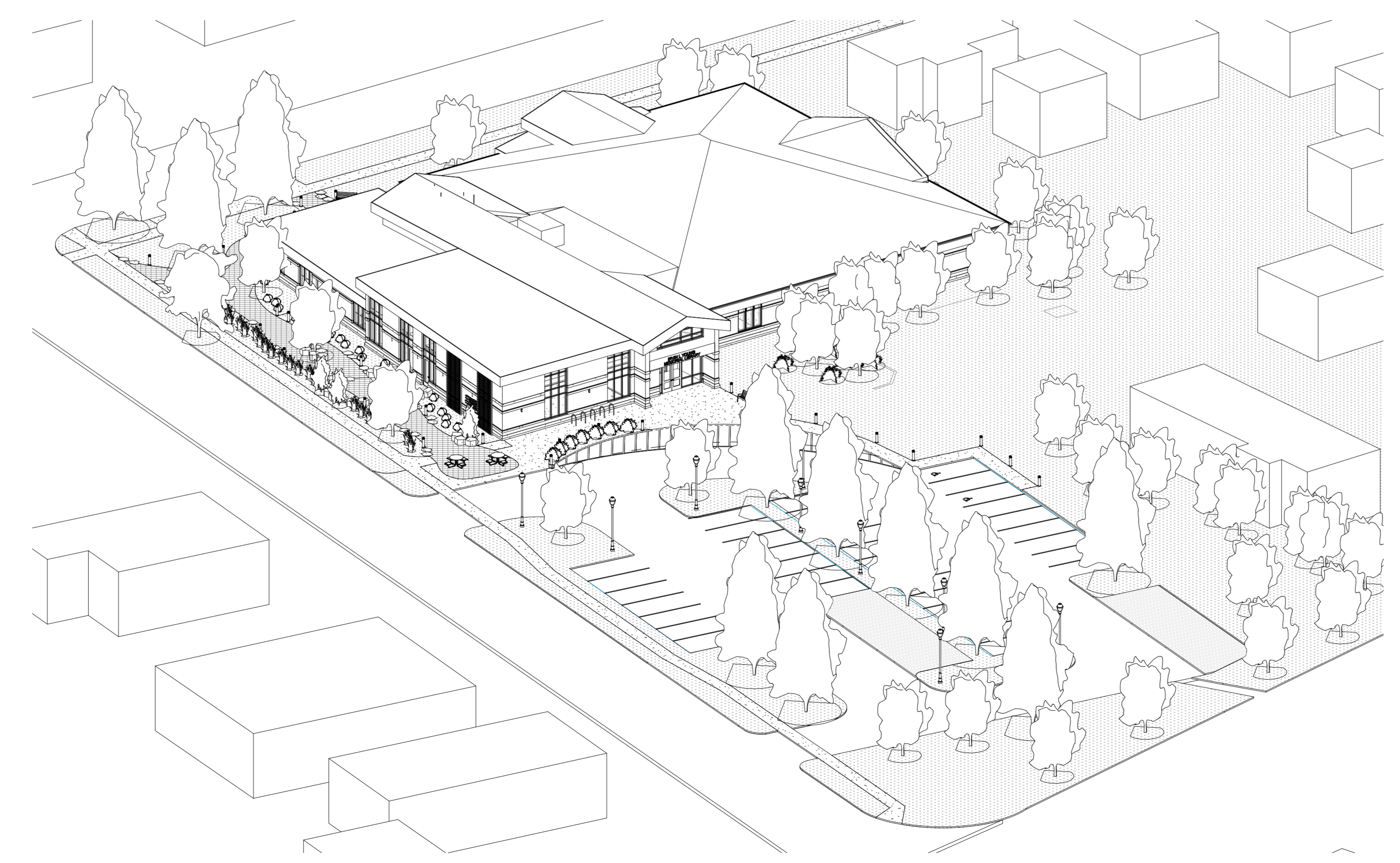

3 Site Axon

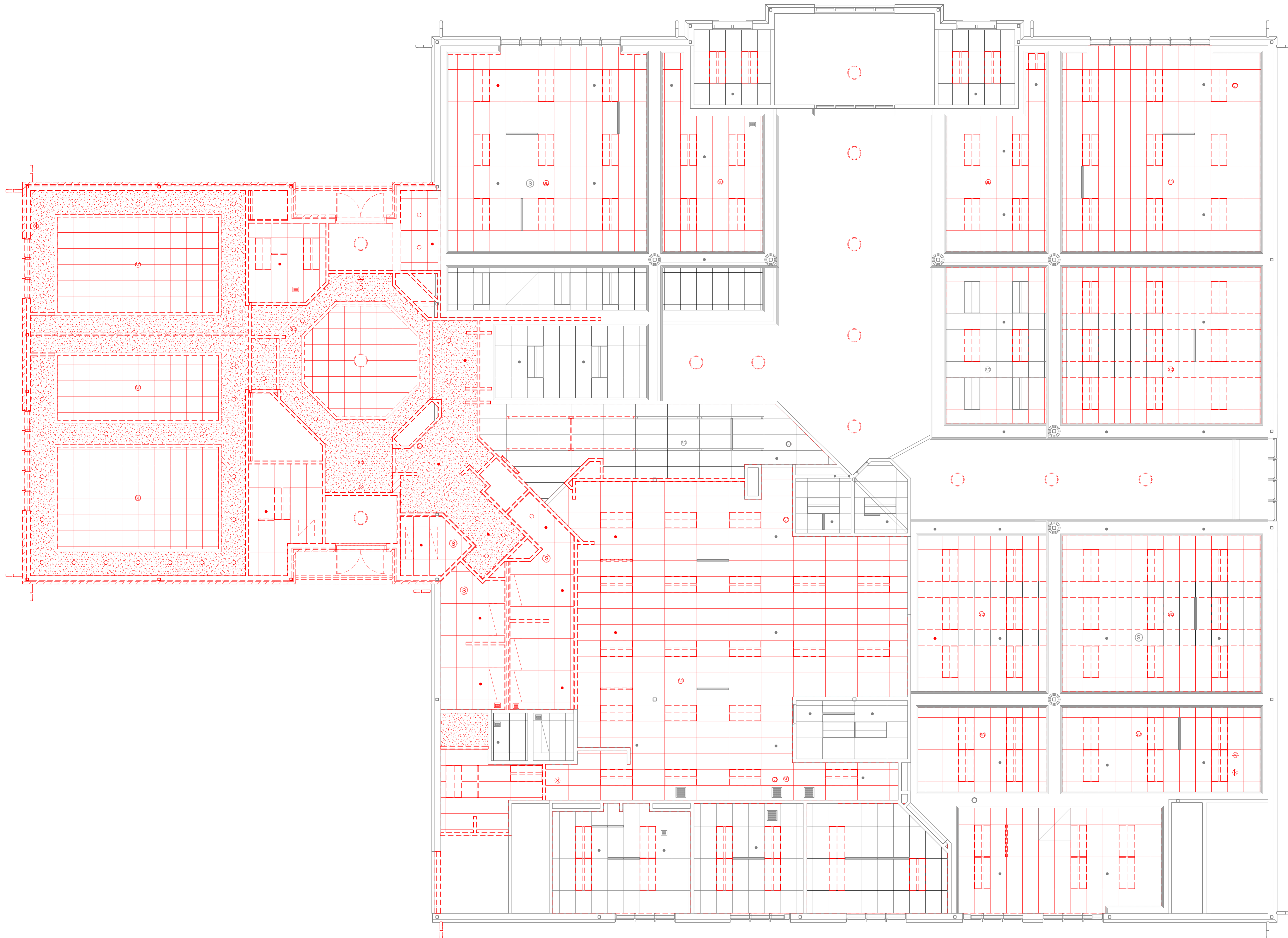

① Reflected Ceiling Plan - Demolition
3/16" = 1'-0"

NO	ISSUE	DATE
•	ARCH REVIEW	03.11.24
•	SUBMISSION	
•		
•		
•		
•		
•		
•		
•		

Reflected Ceiling
Plan - Demolition



1 Reflected Ceiling Plan - New Work
3/16" = 1'-0"

NO	ISSUE	DATE
1	ARCH REVIEW SUBMISSION	03.11.24
2		
3		
4		
5		
6		
7		
8		
9		
10		

Reflected Ceiling
Plan - New Work

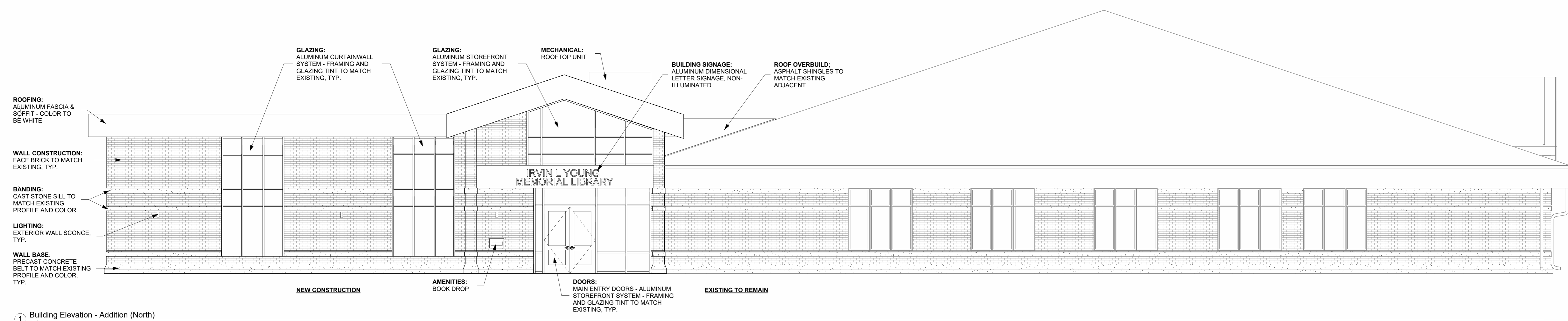

1 Building Elevation - Addition (North)
3/16" = 1'-0"

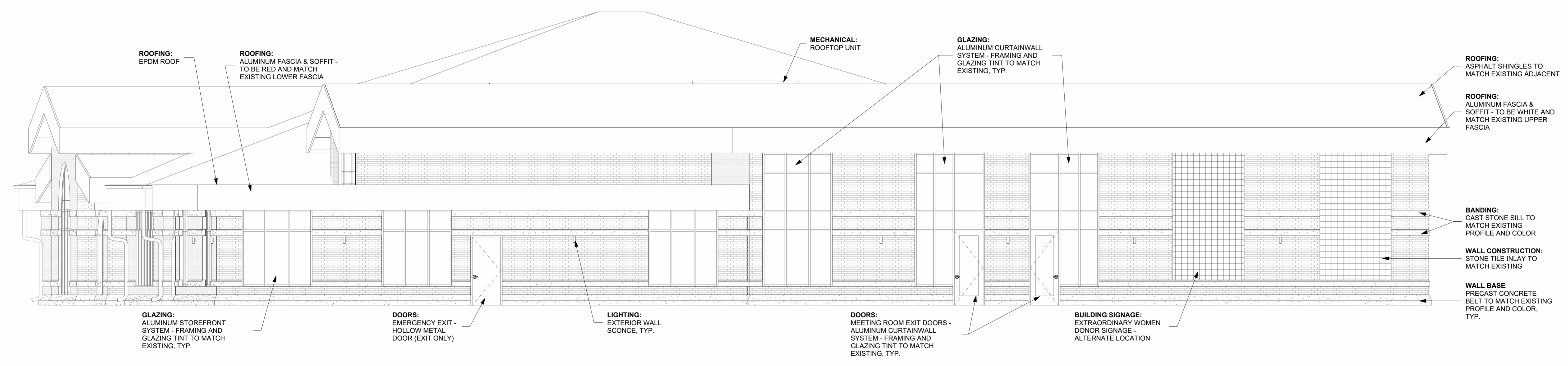

2 Building Elevation - Addition (East)
3/16" = 1'-0"

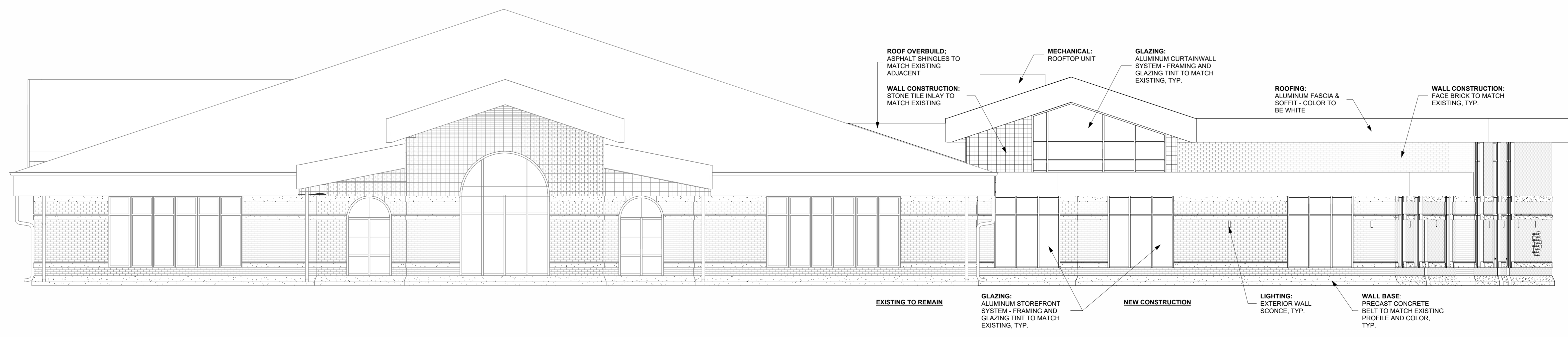

3 Building Elevation - Addition (South)
3/16" = 1'-0"

Additions and Renovations

Irvin L. Young Memorial Library
431 W. Center Street, Whitewater, WI 53190

NO	ISSUE	DATE
•	ARCH REVIEW	03.11.24
•	SUBMISSION	
•		
•		
•		
•		
•		
•		
•		

Building Elevations

A5.0



① Building Elevation - Addition (North) - Realistic
3/16" = 1'-0"



② Building Elevation - Addition (East) - Realistic
3/16" = 1'-0"



③ Building Elevation - Addition (South) - Realistic
3/16" = 1'-0"

Additions and Renovations

Irvin L. Young Memorial Library
431 W. Center Street, Whitewater, WI 53190

NO	ISSUE	DATE
•	ARCH REVIEW	03.11.24
•	SUBMISSION	•
•	•	•
•	•	•
•	•	•
•	•	•
•	•	•
•	•	•
•	•	•
•	•	•

Building Elevations -
Realistic

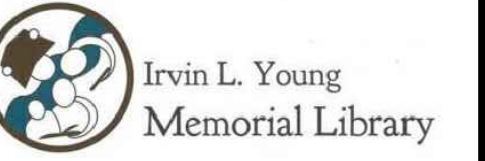

223 West Jackson Boulevard, Suite 1200
Chicago, Illinois 60606
(312) 253-3400



350 E. Algonquin Road | Suite 250
Schaumburg, IL 60173
ph: 847.404.5239
IL Design Firm: 184006777-0002

Symbol	Description	Quantity	Notes
○	Light Pole	1	
⊙	Light Pole	1	
⊕	Light Pole	1	
⊖	Light Pole	1	
⊗	Light Pole	1	
⊘	Light Pole	1	

Statistics						
Description	Symbol	Avg	Max	Min	Max/Min	Avg/Min
OVERALL	+	0.8 fc	17.3 fc	0.0 fc	N/A	N/A
PARKING	X	1.5 fc	2.8 fc	0.6 fc	4.7:1	2.5:1

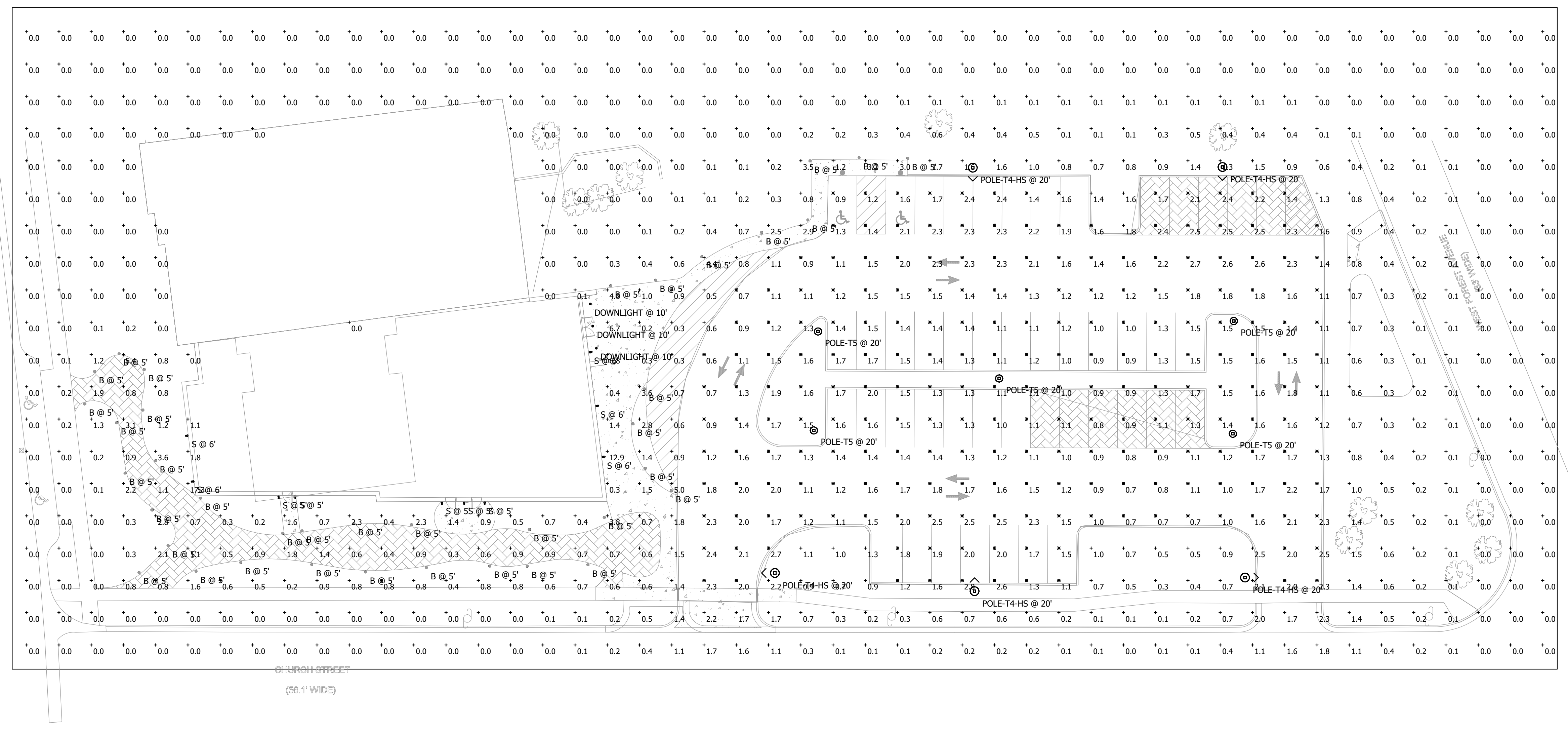

Plan View
Scale - 1" = 20ft

Additions and Renovations

Irvin L. Young Memorial Library
431 W. Center Street, Whitewater, WI 53190

NO	ISSUE	DATE
•	ARCH REVIEW	• 03.11.24
•	SUBMISSION	•
•		•
•		•
•		•
•		•
•		•
•		•
•		•

Electrical Site Plan
- Photometrics

ES100

20118A