

CITY OF WESTLAKE



AGENDA

Art in Public Places Advisory Board Meeting

Monday, February 06, 2023 at 6:00 PM

Westlake Council Chambers
4005 Seminole Pratt Whitney Road
Westlake, Florida 33470

CITY STAFF:

Ken Cassel, City Manager
Zoie P. Burgess, CMC, City Clerk
Nilsa Zacarias, AICP, Planning and Zoning Director
Donald J. Doody, Esq., City Attorney

[TENTATIVE: SUBJECT TO REVISION]

This is a Public Meeting and members of the public may attend in-person; however, the option to attend and participate via Communications Media Technology is available via the Cisco WebEx Platform and may be accessed as follows:

1. Join the Webex meeting from your computer, tablet or smartphone at the following link:
<https://cityofwestlake.my.webex.com/>

Meeting ID: 2630 626 6075

Password: hello

2. Participants may also dial in using your phone with any of the following number(s):

United States Toll: +1-408-418-9388

Meeting ID: 2630 626 6075

For participants attending the meeting via WebEx, public comments will be accepted via an electronic comment card, at least 24 hours prior to the public meeting and also acknowledged during the meeting when participants utilize the “raise your hand” feature during the designated time.

Procedures for Public Comment are also provided via the City website:
<https://www.westlakegov.com/cityclerk/page/covid-19-public-meetings>

CALL TO ORDER

ROLL CALL

PLEDGE OF ALLEGIANCE

APPROVAL OF AGENDA

OATH OF OFFICE

- A. Oath of Office - Paul Abrams

APPROVAL OF MINUTES

- A. [Minutes Art](#) in Public Places Meeting - 09.22.2022 DRAFT

NEW BUSINESS

- A. **AIPP-2022-01:** The applicant is requesting approval of a proposed Art sculpture installation called "ORANGE WITH 3 BLOSSOMS" for the James Business Park development. The subject application is located at 17035 & 16935 Persimmon Boulevard West.

Submitted By: Planning and Zoning

BOARD & STAFF COMMENTS

PUBLIC COMMENTS

This section of the agenda allows for comments from the public to speak. Each speaker will be given a total of three (3) minutes to comment. A public comment card should be completed and returned to the City Clerk. When you are called to speak, please go to the podium or unmute your device, and prior to addressing the Board, state your name and address for the record.

ADJOURNMENT

NOTICE: If a person, firm or corporation decides to appeal any decision made by the Board with respect to any matter considered at this meeting, you will need a record of the proceedings, and you may need to ensure that a verbatim record of the proceedings is made, which record includes the testimony and evidence upon which the appeal is to be based. (The above notice is required by State Law. Anyone desiring a verbatim transcript shall have the responsibility, at his own cost, to arrange for the transcript). The City of Westlake does not prepare or provide such verbatim record.

In accordance with the Americans with Disabilities Act, persons who need an accommodation in order to attend or participate in this meeting should contact the City Clerk at (561) 530-5880 at least three (3) business days prior to the meeting in order to request such assistance.

File Attachments for Item:

Minutes_Art in Public Places Meeting - 09.22.2022 DRAFT

CITY OF WESTLAKE



MINUTES

Art in Public Places Advisory Board Meeting

Thursday, September 22, 2022 at 6:00 PM

Westlake Council Chambers
4005 Seminole Pratt Whitney Road
Westlake, Florida 33470

This meeting took place at the Westlake Community Center/City Council Chambers located at 4005 Seminole Pratt Whitney Road, Westlake, Florida, 33470 and publicly viewed Via Communications Media Technology.

Members of the public participated in the meeting through electronic means and may have access as follows:

1. Joined the Webex meeting from a computer, tablet or smartphone at the following link: <https://cityofwestlake.my.webex.com/>

Meeting ID: 2634 990 9329
Password: hello

2. Participants may have also dialed in using phone with f the following number:

United States Toll: +1-408-418-9388
Meeting ID: 2634 990 9329

As a preliminary matter, Ms. Burgess noted that Board Member Gail Blair Lewis, Board Member Lauren Mondell, Board Member Jennifer Estis, and Board Member Nancy Bongiovanni were present physically constituting a quorum. Paul Abrams was not present.

Board Liaison, Mayor O'Connor, Nilsa Zacarias and Osniel Leon were also present physically.

City Attorney, Mr. Doody was present via communications media technology.

Ms. Burgess provided further instruction regarding public comments, noting that comments will be acknowledged by the mayor and accepted at the appropriate times as indicated in the agenda and those who wish to speak may use the "virtual" hand raise feature.

Ms. Burgess provided the disclaimer that the meeting is being recorded by both voice and video, reminding the audience microphones are live.

Ms. Burgess further explained that microphones will be muted; audience members can unmute themselves and anyone that has called in should mute their device.

Ms. Burgess noted that anyone causing a disruption or being inappropriate will be removed from the meeting. Ms. Burgess reminded Board Members physically present to utilize microphones.

CALL TO ORDER

Ms. Burgess called the meeting to order at 6:03 PM.

ROLL CALL

Present and constituting a quorum were:

Board Member Bongiovanni
Board Member Blair Lewis
Board Member Estis
Board Member Mondell

Also, present:

Zoie Burgess, CMC, City Clerk
Donald J. Doody, Interim City Attorney (Via Communications Media Technology)
Mery Ramirez, Recording Clerk

Mr. Abrams was absent.

PLEDGE OF ALLEGIANCE

Ms. Burgess led the audience in the Pledge of Allegiance.

OATH OF OFFICE

A. Oath of Office

Paul Abrams

Gail Blair
Nancy Bongiovanni
Jennifer Estis
Lauren Mondell

Ms. Burgess gave the Oath of Office to Ms. Blair Lewis, Ms. Bongiovanni, Ms. Estis and Ms. Mondell.

APPROVAL OF AGENDA

Ms. Burgess called for a motion to approve the agenda.

Motion by Board Member Bongiovanni to approve the agenda, seconded by Board Member Estis.

UPON ROLL CALL:

Board Member Bongiovanni	YES
Board Member Blair Lewis	YES
Board Member Estis	YES
Board Member Mondell	YES

With all in favor, motion carried without dissent (4-0)

NEW BUSINESS

A. Board Organization - Selection of Board Chair and Vice Chair (City Attorney)

Mr. Doody discussed the board member roles and the need to appoint a Board Chair and Vice Chair.

Ms. Bongiovanni volunteered as Board Chair and Ms. Jennifer Estis volunteered as Vice Chair.

Ms. Burgess called for a motion to appoint Ms. Bongiovanni as Board Chair.

Motion by Board Member Estis to appoint Nancy Bongiovanni as Board Chair, seconded by Board Member Blair Lewis.

UPON ROLL CALL:

Board Member Blair Lewis	YES
Board Member Estis	YES
Board Member Mondell	YES
Board Member Bongiovanni	YES

With all in favor, motion carried without dissent (4-0)

Ms. Burgess called for a motion to appoint Vice Chair.

Motion by Board Member Blair Lewis to appoint Ms. Estis as Vice Chair, seconded by Board Member Mondell.

UPON ROLL CALL:

Board Member Estis	YES
Board Member Mondell	YES
Board Member Bongiovanni	YES
Board Member Blair Lewis	YES

With all in favor, motion carried without dissent (4-0)

B. Legal Orientation - Sunshine Law (City Attorney)

Mr. Doody gave an overview of Florida Law and Sunshine Law. Mr. Doody also discussed public records, legislative content, awareness of being recorded and conducting business in the public.

C. Planning & Zoning Orientation - Ordinance Review - Roles & Responsibilities (City Planner)

Ms. Zacarias presented a PowerPoint presentation:

- Why the City of Westlake Established the Art Program
- Discussed the Vision of Municipal Public arts Program
- Gave examples of artwork incorporated into the city
- How artwork affects the city in a positive way

Mr. Leon discussed the city code language for Ordinance 2021-12 – Chapter 24 – Art in Public Places.

BOARD & STAFF COMMENTS

Ms. Bongiovanni inquired if planning and zoning had an RFP template for requirements of what is to be considered by the board. Ms. Zacarias further explained the process that is in place for the applicant but noted that at this time there are no guidelines on how to review the artwork once it is proposed. Ms. Bongiovanni explained that she would like to see a consistent mechanism of guidelines be provided.

Ms. Bongiovanni inquired if there should be a liaison relationship with the Art in Public Places in Palm Beach. Ms. Zacarias requested clarification if board Chair was referring to the Palm Beach County or the Town of Palm Beach. Ms. Bongiovanni confirmed that she is referring to Palm beach County. Ms. Zacarias explained that is not something that has been considered. Ms. Burgess further explained that it would be discussed with legal, as there wasn't a provision in the code to have a liaison with Palm Beach County.

Ms. Bongiovanni inquired of the percentage from the vertical construction and if there is a methodology to identify if they are truly donating that 1% to the arts. Ms. Zacarias read into the record the definition of Building construction costs and highlighting that the building official will be a part of the process: construction cost means the total cost associated with the construction or renovation of a building, as determined by the Building Official issuing a building permit for construction or renovation of the building. This includes all buildings on the project site, except for site infrastructure, temporary buildings or structures, and parking garages. The building construction costs include labor, structural materials, plumbing, electrical, mechanical, infrastructure, design, permitting, architecture, engineering, lighting, signage, and site work associated with the building's construction or renovation.

Ms. Estis asked if developers are required to provide the space for the art. Ms. Zacarias confirmed that the applicants must provide the space for the art.

There being no further board comments or discussion, next item followed.

PUBLIC COMMENTS

This section of the agenda allows for comments from the public to speak. Each speaker will be given a total of three (3) minutes to comment. A public comment card should be completed and returned to the City Clerk. When you are called to speak, please go to the podium or unmute your device, and prior to addressing Board, state your name and address for the record.

Ms. Burgess noted that no public comment cards were received prior to the meeting.

Ms. Burgess gave the virtual participants a moment to raise a virtual hand or unmute their devices and provided a reminder to state name and address.

Board Liaison, Mayor O'Connor commented and expressed his excitement of the future of the board. Mr. O'Connor encouraged the board to reach out to him with any questions or discussions. Mr. O'Connor stated, although, the members could not communicate to each other they could communicate directly with him.

There being no further comments, the next item followed.

ADJOURNMENT

There being no further business, Chair Bongiovanni adjourned the meeting at 6:56 PM.

Zoie P. Burgess, City Clerk

Nancy Bongiovanni, Board Chair

File Attachments for Item:

A. AIPP-2022-01: The applicant is requesting approval of a proposed Art sculpture installation called "ORANGE WITH 3 BLOSSOMS" for the James Business Park development. The subject application is located at 17035 & 16935 Persimmon Boulevard West.

Submitted By: Planning and Zoning



Meeting Agenda Item Coversheet

MEETING DATE:		2/6/2023	Submitted By: Planning and Zoning		
SUBJECT: <i>This will be the name of the Item as it will appear on the Agenda</i>		AIPP-2022-01: The applicant is requesting approval of a proposed Art sculpture installation called "ORANGE WITH 3 BLOSSOMS" for the James Business Park development. The subject application is located at 17035 & 16935 Persimmon Boulevard West.			
STAFF RECOMMENDATION: (MOTION READY)		Motion to recommend approval of AIPP-2022-01 Pod G SW "James Business Park" Art Sculpture.			
SUMMARY and/or JUSTIFICATION:		<p>In accordance with Ordinance No. 2021-12, all non-residential development projects with building constructions costs of one million dollars (\$1,000,000.00) as determined by the City's Building Official or more shall be subject to the requirements of the Art in Public Places program. The non-residential development must either contribute one percent (1%) of the building constructions cots of the project as a fee to the Art Acquisition Fund, or provide artwork that has an appraised value equal to three quarters of a percent (0.75%) of the building construction costs.</p> <p>The applicant has chosen to provide artwork onsite. Per the applicant's submitted estimated cost of vertical construction, the total for both buildings is approximately \$13,000,000.00 and the proposed artwork is approximately \$100,000.00 (required \$97,500.00). The proposed sculpture will be located at the northwest corner of the site. The applicant has revised the previously approved Master Signage Plan to accommodate the <u>proposed art sculpture installation and monument sign.</u></p>			
SELECT, if applicable		AGREEMENT:		BUDGET:	
		STAFF REPORT:	X	PROCLAMATION:	
		EXHIBIT(S):	X	OTHER:	
IDENTIFY EACH ATTACHMENT. <i>For example, an agreement may have 2 exhibits, identify the agreement and Exhibit A and Exhibit B</i>		Agenda Item Sheet Final Staff Report Application Justification Statement Artist Biography & Statement Sculpture Plans Revised Master Signage Plan			
SELECT, if applicable		RESOLUTION:		ORDINANCE:	

**IDENTIFY FULL
RESOLUTION OR
ORDINANCE TITLE**

*(if Item is not a
Resolution or Ordinance,
please erase all default
text from this field's
textbox and leave blank)*

**Please keep text
indented.**

FISCAL IMPACT *(if any):*

\$



City of Westlake

Planning and Zoning Department – Staff Report

Arts in Public Places Advisory Board Meeting (2/6/2023)

PETITION DESCRIPTION

PETITION NUMBER: AIPP-2022-01 Pod G SW “James Business Park” Art Sculpture
OWNER: Minto PBLH, LLC
APPLICANT: Cotleur & Hearing
ADDRESS: 17035 & 16935 Persimmon Boulevard West
PCN: 77-40-43-01-00-000-1010
REQUEST: The applicant is requesting approval of a proposed art sculpture installation called “ORANGE WITH 3 BLOSSOMS’ for the James Business Park development.

SUMMARY

The applicant is requesting approval for a public art sculpture installation for the James Business Park development located within the Pod G Southwest. On September 7, 2022, the City Council approved site plan (SPR-2022-01) for a 145,643 square feet (sq. ft.) of light-industrial warehouse development.

In accordance with Ordinance No. 2021-12, all non-residential development projects with building constructions costs of one million dollars (\$1,000,000.00) as determined by the City’s Building Official or more shall be subject to the requirements of the Art in Public Places program. The non-residential development must either contribute one percent (1%) of the building constructions costs of the project as a fee to the art Acquisition Fund, or provide artwork that has an appraised value equal to three quarters of a percent (0.75%) of the building construction costs.

The applicant has chosen to provide artwork onsite. Per the applicant’s submitted estimated cost of vertical construction, the total for both buildings is approximately \$13,000,000.00 and the proposed artwork is approximately \$100,000.00 (required \$97,500.00). The proposed sculpture will be located at the northwest corner of the site. The applicant has revised the previously approved Master Signage Plan to accommodate the proposed art sculpture installation and monument sign.

STAFF RECOMMENDATION

Based upon the facts and findings contained herein, **the Planning and Zoning and Engineering Department** recommends **approval** of the subject application with the following conditions :

1. The sign shall be relocated as to not encroach into the landscape buffers.
2. An executed Maintenance Agreement shall be provided to the City prior to building permit issuance.

PETITION FACTS

- a. Artwork Name: ORANGE WITH 3 BLOSSOMS
- b. Artwork Type: Stainless Steel Sculpture
- c. Artwork Specifications: 3 - (30" x 14") - 3/8" Aluminum Bases & 1 x (14" Circular Base) - 3/4"
- d. Letters: 3 x (34" x 20") - 1" Aluminum Bases & 8 x (3" x 3" x 1/4") Wall Stiffener
- e. Artwork Cost: \$100,000 (req. 0.75% of vertical construction)
- f. Land Use and Zoning
Future Land Use: Downtown Mixed Use
Zoning: Mixed Use

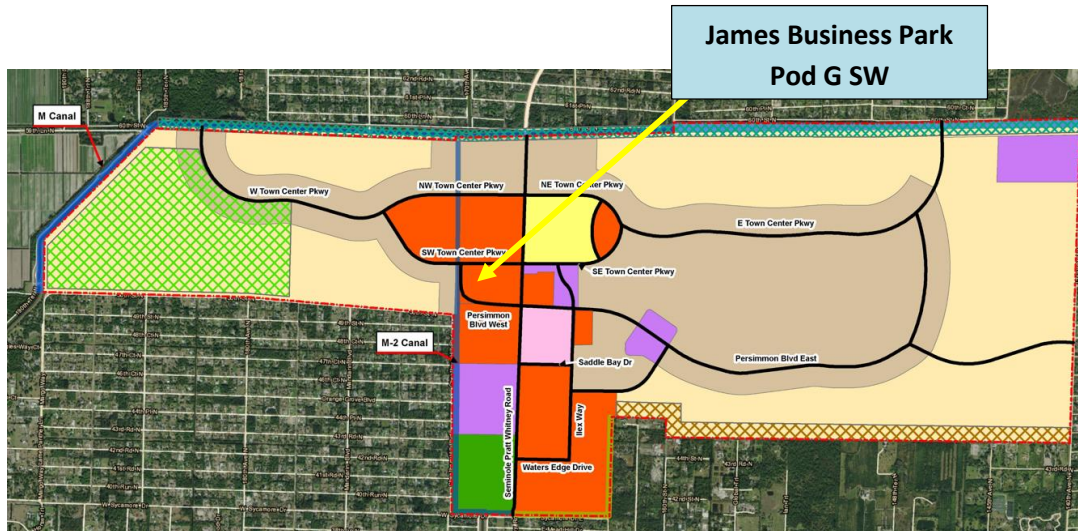

STAFF ANALYSIS

Per Chapter 24. Article 24.1. *Art or Artwork means all tangible creations by artists exhibiting the highest quality of skill and aesthetic principles, and includes all forms of the visual arts conceived in any medium, material, or combination thereof, including, but not limited to, painting, sculpture, fountains, engraving, carving, frescos, mobiles, murals, collages, mosaics, bas-reliefs, tapestries, photographs, drawings, artist-designed seating, iconic or placemaking architecture, or other functional art pieces and collaborative design projects between architects and/or landscape architects and artists, together with all hard costs and soft costs such as, but not limited to, design, engineering, permitting, artistic fees, lighting, landscaping, or other aesthetic effects or enhancements integrated with the art and approved by the City Planner. The city council shall not consider for approval art objects which are mass-produced in unlimited quantities.*

Ineligible artwork. The following shall not be considered artwork:

- a. *Art objects which are mass produced or of standard manufacture, such as playground equipment, fountains, statuary elements, signage, maps, corporate logos or other functional elements, unless incorporated into an artwork by an artist commissioned for that purpose.*
- b. *Reproductions, by mechanical or other means, of original artwork, except in the cases of limited editions controlled by the artist, cast sculpture, film, video, photography, printmaking, or other media arts.*

- c. Commercial expression, including design elements related to the visual identity of a developer or occupant of a building such as a logo, trademark iconography, color scheme or theme, even if created by an artist.
- d. Services or utilities necessary to operate and maintain an artwork over time.

Background

The 11.66 acre site received a site plan approval by City Council on September 7, 2022, (SPR-2022-01) for a 145,643 square feet (sq. ft.) of light-industrial warehouse facility. The development includes a one-story north building with 135,540 sq. ft.; and a one-story south building with 10,103 sq.ft. within Pod G Southwest. On July 5, 2022, the City Council granted approval for a Master Signage Plan including the following waivers: Eight (8) for Principal Tenant Wall Signs, four (4) for Secondary Tenant Wall Signs, two (2) for Principal Tenant Rear Wall Signs, six (6) for Building ID Signs, and two (2) for Tenant Directional Signs totaling twenty-two (22) waivers.

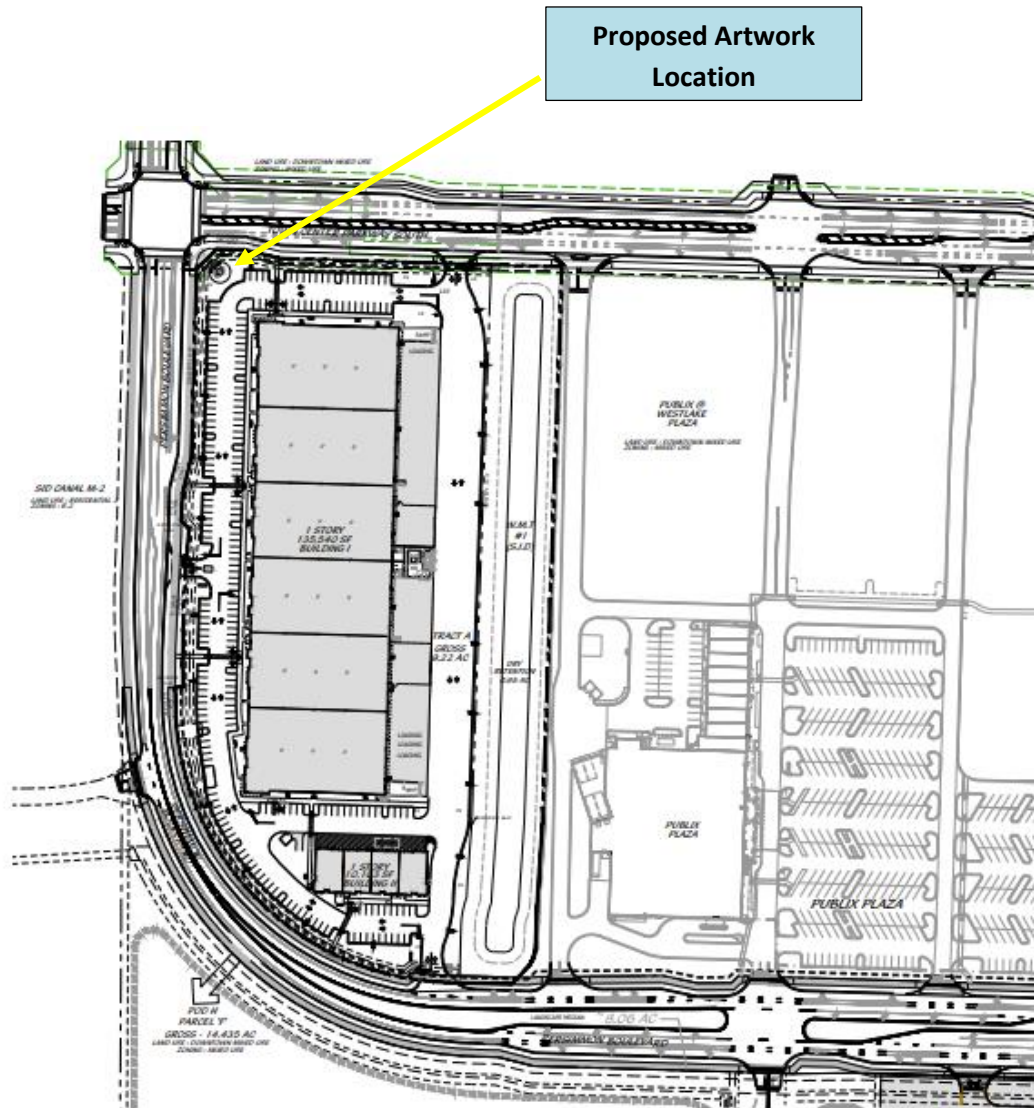

Review of Artwork:

The City zoning code includes the following criteria for reviewing the artwork.

1. Exhibition and experience of the artist

According to the submitted artist Statement, the artist, Mr. Ralfonso provides 20 plus years designing large monumental kinetic, light and interactive sculptures for public places around the world, including Russia, China, Europe, Taiwan, United Arab Emirates and the USA. Sculpture designs ranging in size from 2 feet to 1,00 feet in height.

2. The ability of the artist to complete the project within a specified schedule

The artist will be able to complete the project within schedule. The artist possesses extensive experience and specializes in the design and execution of large to monumental environmentally interactive kinetic and light sculptures for public places.

3. The compliance with the standards of this Chapter.

The proposed sculpture complies with the established standards of Ordinance No. 2021-12, and the zoning requirements for setbacks and landscaping.

Standards for the Artwork:

a. Display

The proposed sculpture designed as static movement is called “Orange With 3 Blossoms”, includes three (3) orange blossom flowers, each with 13 anthers (totaling 39 anthers, which represent the Westlake as the 39th Municipality). Per the artist Statement, *“the proposed dynamic design, showing an Orange Peel in “static movement” provides the viewer with the optical illusion of movement, as they walk or drive by the sculpture. The anthers are a vital part of the flower, responsible for the pollination, seeds and the new and next generation of Orange Blossoms, just as Westlake is building a new city for the next generations. The signage’s arial font and silver color connects to the silver accents on the buildings, and compliments the spherical shape of the artwork.”*

The artwork includes a monument sign which is an integral part of the sculpture, fabricated with 3/16” Aluminum with a base structure. The applicant has revised the previously approved Master Signage Plan to accommodate the art sculpture installation and the monument sign.

Dimensions Displayed in FEET

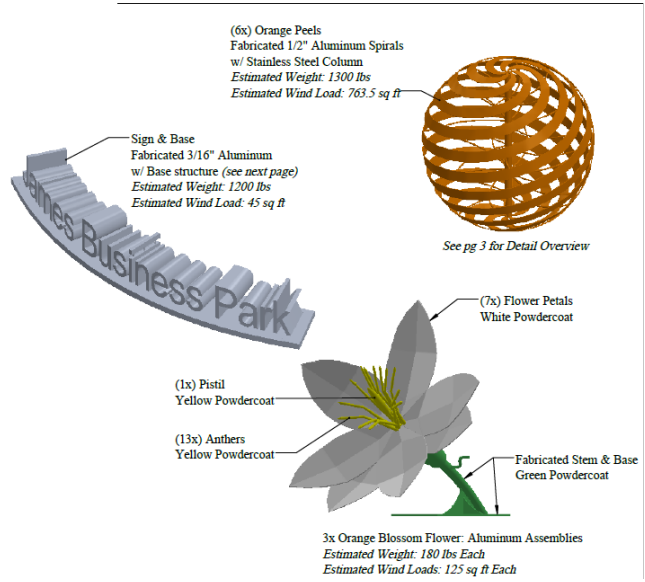
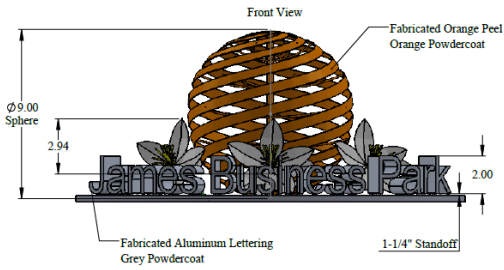
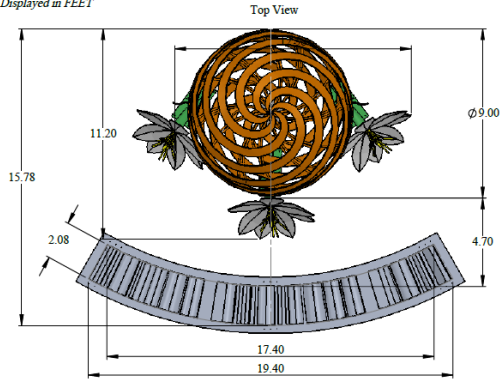

b. Integration

The sculpture will be located at the northwest corner of the site and is complemented by landscaping. The proposed landscaping plan proposes small ligustrum trees behind the art to create a green barrier, flowering shrubs lined up in front for a layered affect. At the base of the sculpture will be covered with blue glass rocks, and large palms are provided for scale.

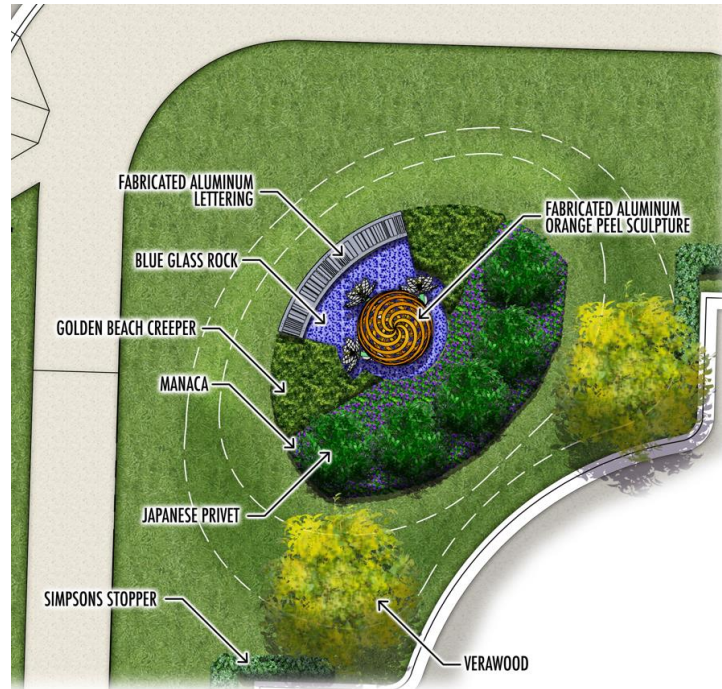

c. Lighting

The proposed sculpture will be lit from dusk until midnight with In-Ground LED Spotlight around the Orange Sphere and In-Ground directional LED Spotlights (2 per Blossom). The proposed lighting complies with lighting standards to prevent excessive lighting, energy waste, glare, light trespass, and sky glow.

d. Removal

Pursuant to Ordinance 2021-12. The artwork shall not be altered or removed from the site without prior approval of the City Council.

e. Maintenance

According to the applicant, there will be a Maintenance Agreement between property owner and the company that fabricates and installs the art, to perform regular maintenance. The applicant must submit an executed Maintenance Agreement prior to issuance of building permit (condition of approval).

f. Compliance with building, zoning, and fire codes.

The proposed sculpture complies with applicable building, zoning and fire codes requirements. However, additional comments might be forthcoming prior to issuance of building permits.

FINAL REMARKS

The subject application AIPP-2022-01, will be heard by the Art in Public Places Advisory Board on February 6, 2023. City Council on March 7, 2023.



CITY OF WESTLAKE
Planning and Zoning Department
4001 Seminole Pratt Whitney Road Westlake, Florida 33470
Phone: (561) 530-5880
www.westlakegov.com

DEPARTMENTAL USE ONLY
Ck. #
Fee:
Intake Date:
PROJECT #

APPLICATION FOR ART IN PUBLIC PLACES (AIPP)

ART IN PUBLIC PLACES ADVISORY BOARD MEETING DATE:

INSTRUCTIONS TO APPLICANTS:

- 1. Please complete all sections of this application. If not applicable, indicate with N/A.
2. Provide all required documents as shown on the Art in Public Places Review Application Checklist (see page 6). If not applicable, indicate with N/A.
3. The applicant must be present at scheduled Art in Public Places Advisory Board meeting.

I. PROJECT DESCRIPTION & APPLICANT INFORMATION

DEVELOPMENT ORDER APPROVING PROJECT FOR WHICH AIPP IS PROPOSED Application SPR-2022-01, approved on July 22, 2022 for a 145,643 s.f. light-industrial warehouse consisting of two one-story buildings.

PROJECT NAME: James Business Park - Pod G Southwest

PROJECT ADDRESS: Largest Building: 17035 Persimmon Blvd. West
Smaller Building: 16935 Persimmon Blvd. West

Property Owner(s) of Record (Developer)

Name: Jamlyn Supply, Inc.

Address: 6051 Southern Blvd. , Suite 800, West Palm Beach, FL 33413

Phone No.: 561-312-6318 Fax No.: E-mail Address: Bristano.Jamlyn@gmail.com

Applicant/Agent (if other than owner, complete Acknowledgement and Consent section (on next page):

Name: Donaldson E. Hearing

Address: 1934 Commerce Lane, Suite 1, Jupiter, FL 33458

Phone No.: 561-747-6336 Fax No.: E-mail Address: Dhearing@cotleur-hearing.com

II. OWNER AND APPLICANT/AGENT ACKNOWLEDGEMENT AND CONSENT

Consent statement (to be completed if owner is using an agent)

I/we, the owners, hereby give consent to Donaldson Hearing to act on my/our behalf to submit this application, all required material and documents, and attend and represent me/us at all meetings and public hearings pertaining to the application and property I/we own described in the application.

By signing this document, I/we affirm that I/we understand and will comply with the provisions and regulations of the City of Westlake, Florida, Code of Ordinances. I/we further certify that all of the information contained in this application and all the documentation submitted is true to the best of my/our knowledge.

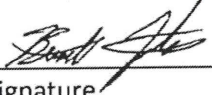
Ben Tristano
Owner's Name (please print)

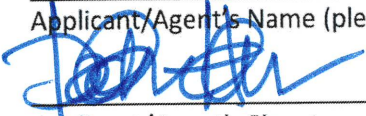
Owner's Signature
11 | 22 | 22
Date

Donaldson Hearing
Applicant/Agent's Name (please print)

Applicant/Agent's Signature
12.23.2022
Date

III. APPLICATION FEES

See City of Westlake Fee Schedule

IV. ADMINISTRATIVE COSTS

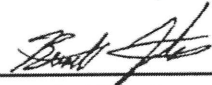
The owner/applicant agrees to compensate the City for all additional administrative costs, actual or anticipated, including, but not limited to, engineering fees, consultant fees, and special studies prior to the processing of the application or not later than 30 days after final application approval whichever is determined as appropriate by the City. **Failure to make such payment shall be grounds for withholding a building or zoning permit.** Costs associated with advertising for public hearings and other public notice requirements are the responsibility of the owner/applicant. The fee shall be paid prior to such application being scheduled for a public hearing requiring notice.

Owner's Signature to Acknowledge
11 | 22 | 22
Date

James Business Park
Art in Public Places
Project Narrative
January 03, 2023

Introduction:

On behalf of the Applicant, Jamlyn Supply, Inc., please accept this as our formal request for approval of the proposed Public Art installation for the James Business Park project. On July 5, 2022, the site plan and master signage plan were approved by the City of Westlake. Pod G has a Mixed-Use zoning designation allowing commercial, retail, and industrial uses.

The James Business Park development consists of 145,643 square feet of light industrial e-commerce warehouse consisting of two (2) one-story buildings of 135,540 sq. ft. and 10,103 sq. ft. and will be located within the southwest portion of Pod G, to the west of the Publix Plaza (currently under construction) adjacent to Persimmon Boulevard West (Phase 2), running north to connect with Town Center Parkway.

Background

The Minto Westlake site is located East and West of Seminole Pratt Whitney Blvd., South of 60th Street North, and North of 50th Street N, East of Mead Hill Drive, and 44th Street North, East of 190th Terrace North and West of 140th Avenue North. Per the newly adopted Comprehensive Plan, the 3,788.60-acre property has FLUA designations of R1, R2, DTMU, Civic, OS&R and SE Overlay.

Minto Westlake is roughly co-extensive with Seminole Improvement District (SID), a legislatively created special district with the authority to provide public infrastructure and services and to operate district facilities. SID provides drainage, water, and wastewater services for the subject property, and owns a canal right-of-way and/or easement for access and drainage from the subject site running approximately four miles south to the C-51 Canal.

Historic and Recent Planning and Zoning Entitlements

Prior to the City's incorporation, Palm Beach County issued several Development Orders to Minto permitting development on Minto's property that is now within the City of Westlake. Specifically, the County approved Resolution 2014-1646 (as later amended by 2014-1892) rezoning the Westlake Property, and Resolutions 2014-1647 and 2014-1648 approving Hotel and College/University as requested uses on the Westlake Property. At that same time, Palm Beach County revised its Comprehensive Plan and Unified Land Development Code ("ULDC") to facilitate development of the Westlake Property pursuant to Ordinances 2014-030 and 2014-031. At the same time, to address the County's traffic concurrency requirements related to the approved density and intensity, Minto entered into a Proportionate Fair Share Agreement with Palm Beach County dated October 29, 2014.

The Applicant, Jamlyn Supply, Inc., is an E-commerce company that sells thousands of various products and ships to its customers. Categories ranging from pet supplies, lawn and garden, pool supplies and household items. Product comes into the warehouse, gets counted, stored and processed, then ships out to their customers. Jamlyn Supply works with manufacturers and Brands to help increase their online presence and sales.

The James Business Park development will showcase a proposed Sculpture designed by renowned artist, Ralfonso. Ralfonso's passion in life is kinetic art for public places, and since 1980 he has been designing environmentally interactive, kinetic and light sculptures all over the world as well as in the United States. The sculpture designed for James Business Park has been appropriately scaled to be consistent with the proposed development and match the quality of construction and aesthetics, taking the place of one of the approved ground monument signs at the northwest corner of the site. Ralfonso's kinetic sculptures move as they interact with water, wind, electricity, as well as with the natural environment and most importantly, the viewer. The Orange Sphere designed represents an Orange peel and the three flowers are Orange Blossoms as an ode to pre-existing Callery Judge orange groves. Each orange blossom has 13 Anthers at its center, totaling 39 Anthers in all, representing Westlake, as the 39th Municipality established in Palm Beach County, Florida.

Proposed Public Art

The "Orange Peel" kinetic sculpture will be the first installation of public art in the City of Westlake. This proposed powder coated aluminum structure will consist of an orange-colored orange peel sphere, three (3) orange blossom flowers (white with green anthers) and grey powder coated sign lettering identifying "James Business Park". The orange peel, being the main focal point of the sculpture, will stand 9 ft. Each flower is 4 ft. high and be placed symmetrically at the front of the base of the sphere. The sign will be 2 ft. tall and span almost 9.5 ft. centrally across the front of the entire sculpture. This will be a "static" piece of art and is non-moving physically, however, the design provides the viewer with the optical illusion of movement as they walk or drive pass the sculpture. The artist's statement is attached.

Artwork Specifications

Orange Sphere & Blossoms

3 - (30" x 14") - 3/8" Aluminum Bases & 1 x (14" Circular Base) - 3/4" Stainless Steel

Letters

3 x (34" x 20") - 1" Aluminum Bases & 8 x (3" x 3" x 1/4") Wall Stiffener

Site to be drilled and anchors installed using a provided template

Lighting

Per Ordinance No. 2021-02, Section 78-262(d), the art will be lit at a minimum from dusk until midnight. The lighting shall be designed and located in order to prevent excessive lighting, energy waste, glare, light trespass, and sky glow, and shall conform to all lighting requirements in Chapter 5 of these LDRs. Lighting proposed will consist of: (as pictured below):

8 - Equidistant In-Ground "UP" LED Spotlights around the Orange Sphere

6 - In-Ground " Directional" LED Spotlights - 2 per Blossom



AIPP Cost Estimate

The cost of the proposed artwork is approximately \$100,000.00, substantially higher than the applicant’s required 0.75% of vertical construction (\$97,500,00.00). The estimated cost of vertical construction of both buildings is approximately \$13,000,000.00. This estimate has been determined based on the latest construction costs index. A detailed cost estimate has been provided with this submittal.

Art Safety

In order to discourage climbing, the landscape design incorporates strategic landscaping around and behind the art. No walkways will be present leading up to the piece itself. The art is set back from the street and sidewalk and elevated on two (2) foot plateau. In addition, security cameras will be installed to surveil the art, providing additional discouragement to any negative activity by the public.

Art Maintenance

The applicant will have a maintenance agreement with the company who is fabricating and installing the Art. This will include regular inspections and cleaning. The maintenance schedule will keep the Art looking like new for decades to come.

Landscaping

The landscape for the corner of Town Center Parkway and Persimmon Blvd. has been revised to complement the proposed art. Small Ligustrum trees are used behind the art to create a green barrier approximately 5’ in height. Flowering shrubs will line up in front of the Ligustrums for a layered affect. Mexican beach pebble is used at the base of the art to reduce long term maintenance. Larger Palms are provided for scale. Careful attention to the size and heights of the landscape has been given so that the art remains dominant.

James Business Park AIPP
CH 13-1518.98.01
January 3, 2023

Conclusion:

The proposed Art in Public Places is consistent with the City's Comprehensive Plan and zoning regulations. The public art has been designed by Ralfonso with great pleasure as the first public art sculpture to be installed within the City of Westlake. The Applicant looks forward to working with Staff to respond to any questions or issues that might arise as a result of your review.

Dimensions Displayed in FEET

Top View

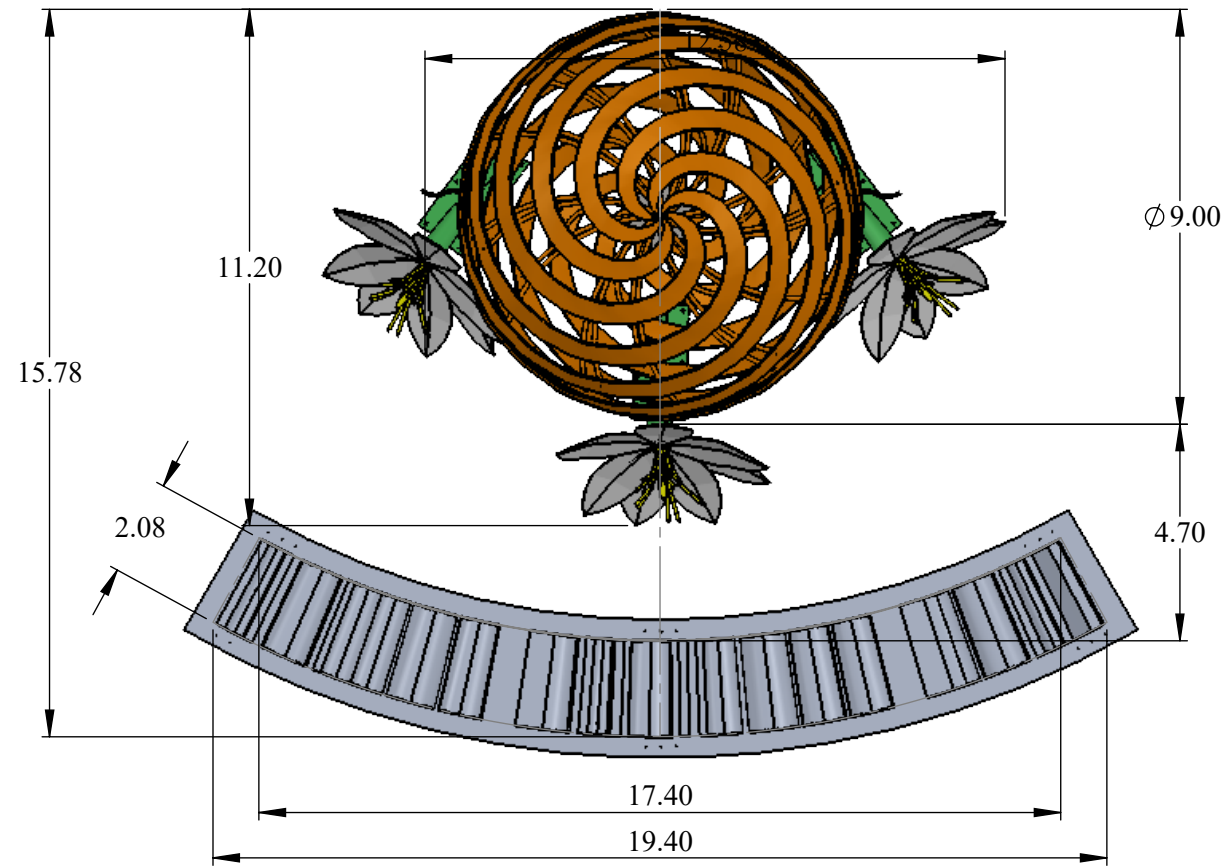

Front View

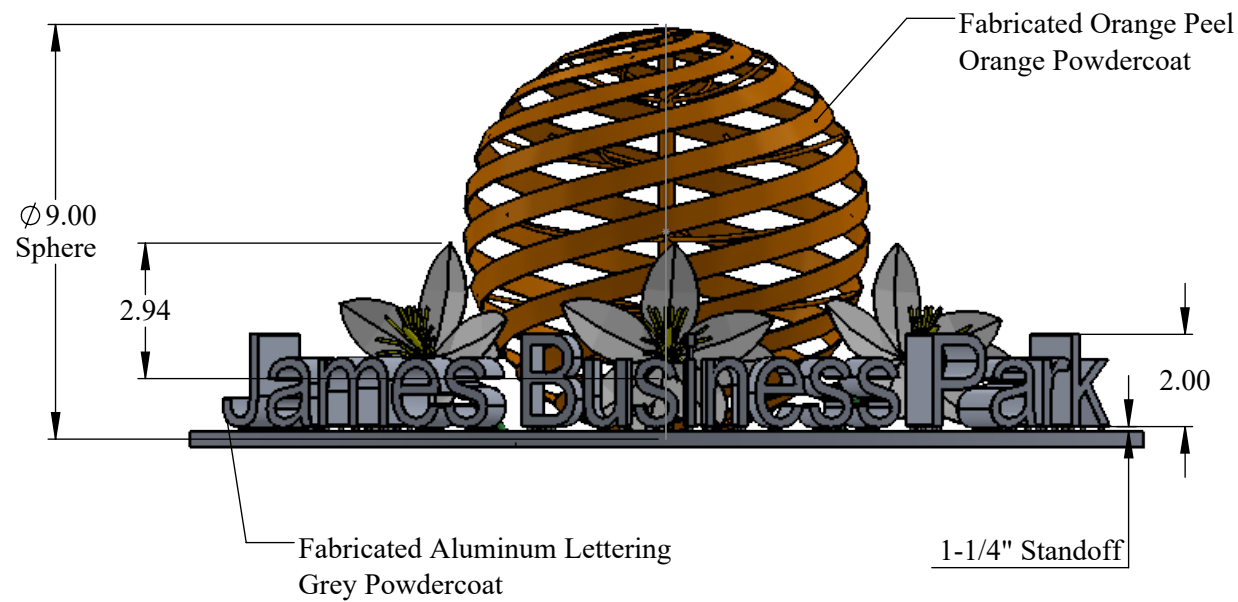

1-1/4" Standoff

Fabricated Aluminum Lettering
Grey Powdercoat

1-1/4" Standoff

PROPRIETARY AND CONFIDENTIAL
THE INFORMATION CONTAINED IN THIS DRAWING IS THE SOLE PROPERTY OF **EES DESIGN LLC**. ANY REPRODUCTION IN PART OR AS A WHOLE WITHOUT THE WRITTEN PERMISSION OF **EES DESIGN LLC** IS PROHIBITED.

REVISIONS				
ZONE	REV.	DESCRIPTION	DATE	APPROVED
	A	Updated with Feedback from Customer	12/7/2022	EES
	B	Further Updates and more Details added (see pgs 3-4)	1/9/2023	EES

(6x) Orange Peels
Fabricated 1/2" Aluminum Spirals
w/ Stainless Steel Column
Estimated Weight: 1300 lbs
Estimated Wind Load: 763.5 sq ft

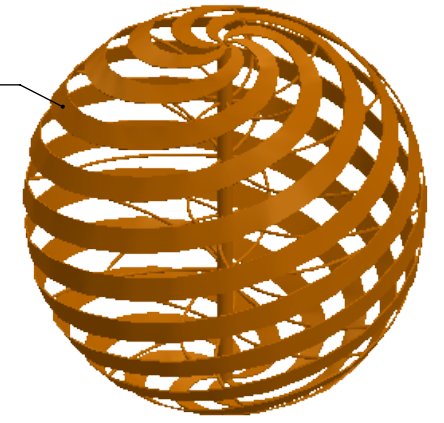

See pg 3 for Detail Overview

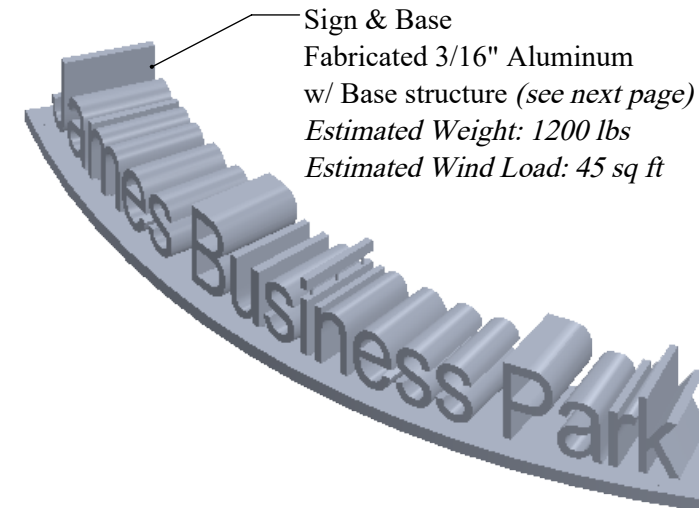

Sign & Base
Fabricated 3/16" Aluminum
w/ Base structure (see next page)
Estimated Weight: 1200 lbs
Estimated Wind Load: 45 sq ft

(1x) Pistil
Yellow Powdercoat

(13x) Anthers
Yellow Powdercoat

(7x) Flower Petals
White Powdercoat

Fabricated Stem & Base
Green Powdercoat

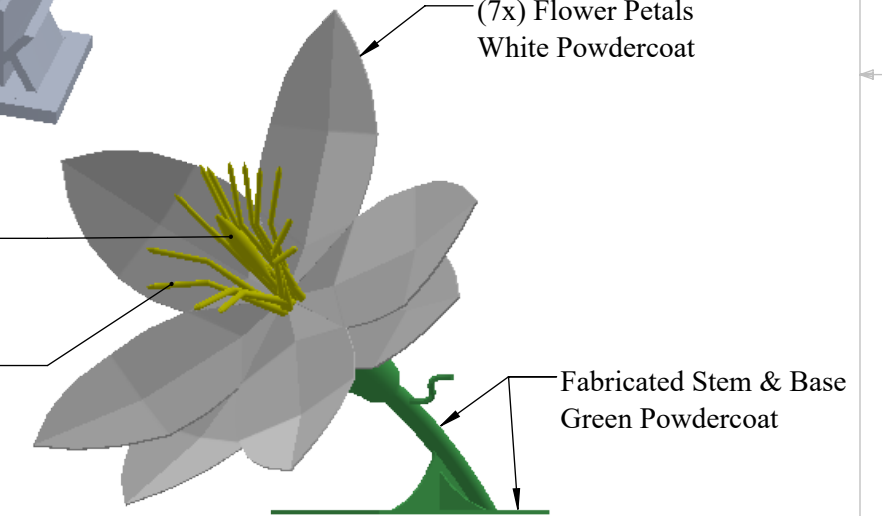

3x Orange Blossom Flower: Aluminum Assemblies
Estimated Weight: 180 lbs Each
Estimated Wind Loads: 125 sq ft Each

		UNLESS OTHERWISE SPECIFIED:		NAME	DATE	EES DESIGN, LLC
		DIMENSIONS ARE IN INCHES TOLERANCES: FRACTIONAL \pm ANGULAR: MACH \pm BEND \pm TWO PLACE DECIMAL \pm THREE PLACE DECIMAL \pm		DRAWN	JV	
		INTERPRET GEOMETRIC TOLERANCING PER:		CHECKED		TITLE:
		MATERIAL		ENG APPR.		<i>Orange Peel Sculpture</i>
		FINISH		MFG APPR.		SIZE DWG. NO.
NEXT ASSY	USED ON			Q.A.		B 22159-EN-1122
APPLICATION		DO NOT SCALE DRAWING		COMMENTS:		REV B
						SCALE: 1:50 WEIGHT: SHEET 1 OF 4

BOTTOM VIEW

(8x) 3 x 3 x 1/4" Wall Stiffener

34" x 20.00
1" Aluminum
3 Places

27.27°

(6x) Ø 1"
each Base

(6x) Ø 3/4"
each Base

30" x 14.00
1/2" Aluminum
3 Places

Ø 18" OD
3/4" Stainless Steel
Ø 15.00 Bolt Circle

(6x) Ø 3/4"

Site to be drilled and anchors installed using a provided template

PROPRIETARY AND CONFIDENTIAL
THE INFORMATION CONTAINED IN THIS DRAWING IS THE SOLE PROPERTY OF **EES DESIGN LLC**. ANY REPRODUCTION IN PART OR AS A WHOLE WITHOUT THE WRITTEN PERMISSION OF **EES DESIGN LLC** IS PROHIBITED.

		UNLESS OTHERWISE SPECIFIED:		NAME	DATE	EES DESIGN, LLC TITLE: <i>Orange Peel Sculpture Base Detail</i> SIZE DWG. NO. B 22159-EN-1122 REV B SCALE: 1:30 WEIGHT: SHEET 2 OF 4	
		DIMENSIONS ARE IN INCHES		DRAWN	JV		1/9/2023
		TOLERANCES:		CHECKED			
		FRACTIONAL ±		ENG APPR.			
		ANGULAR: MACH ± BEND ±		MFG APPR.			
		TWO PLACE DECIMAL ±		Q.A.			
		THREE PLACE DECIMAL ±		COMMENTS:			
		INTERPRET GEOMETRIC TOLERANCING PER:					
		MATERIAL					
NEXT ASSY	USED ON	FINISH					
APPLICATION		DO NOT SCALE DRAWING					

8

7

6

5

4

3

2

1

D

D

C

C

B

B

A

A

8

7

6

5

4

3

2

1

Support Tubes plug welded and outside surface blended smooth

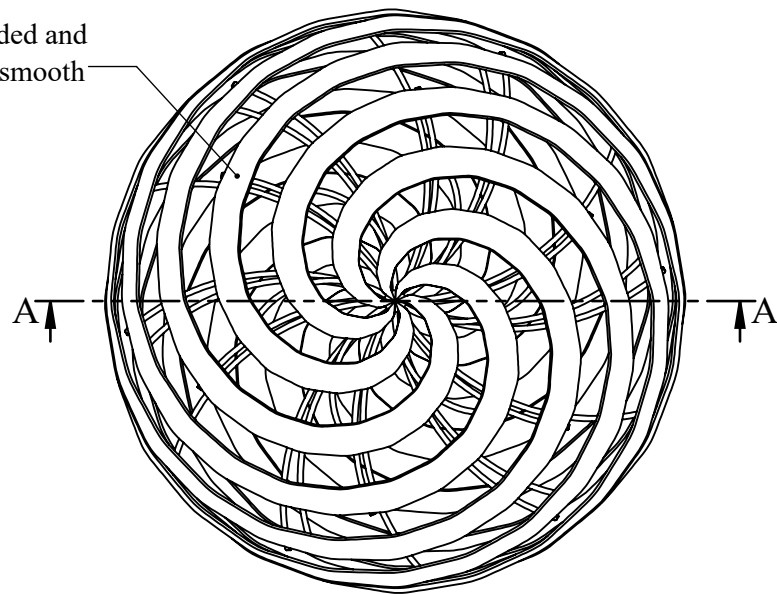

Top View

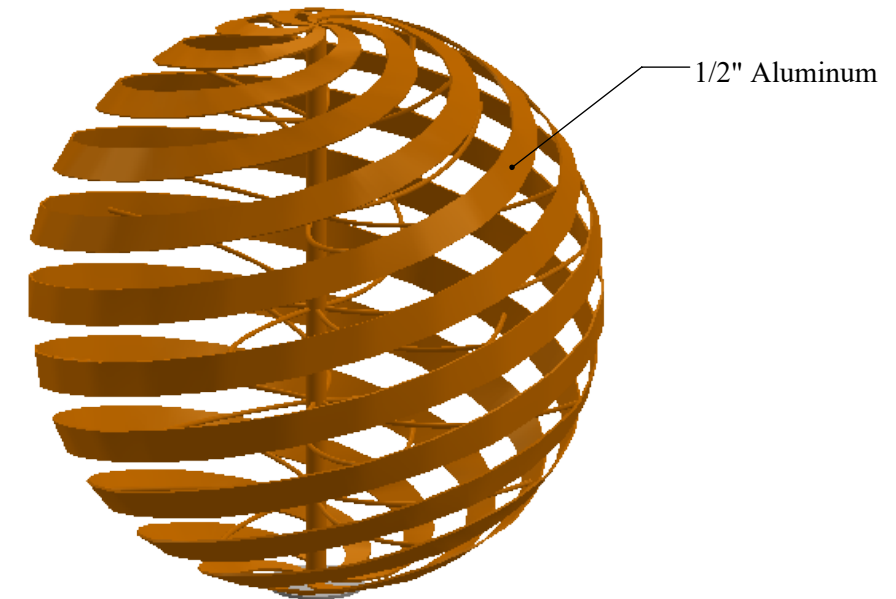
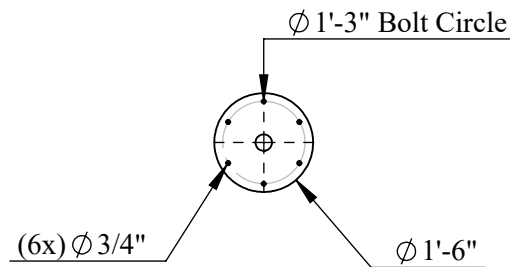

9ft Aluminum "Orange Peel" sphere, Current Concept:
Solid welded assembly with $\phi 1"$ rolled support arms

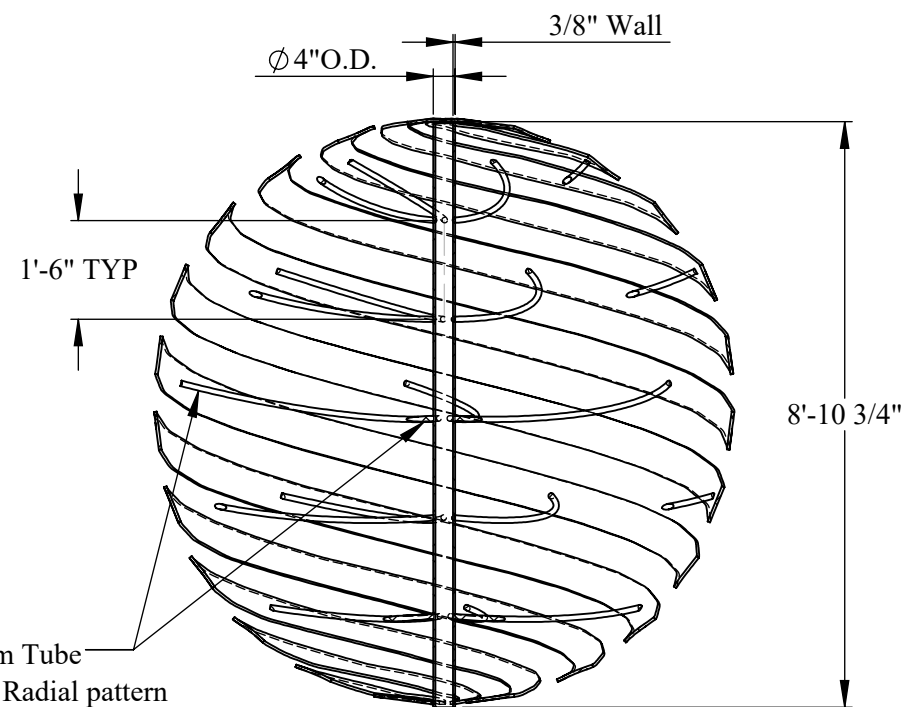

SECTION A-A
Front View

Edges of Orange Peel ribbons can be rounded over with a 1/4" or 3/16" radius to discourage climbing on the piece

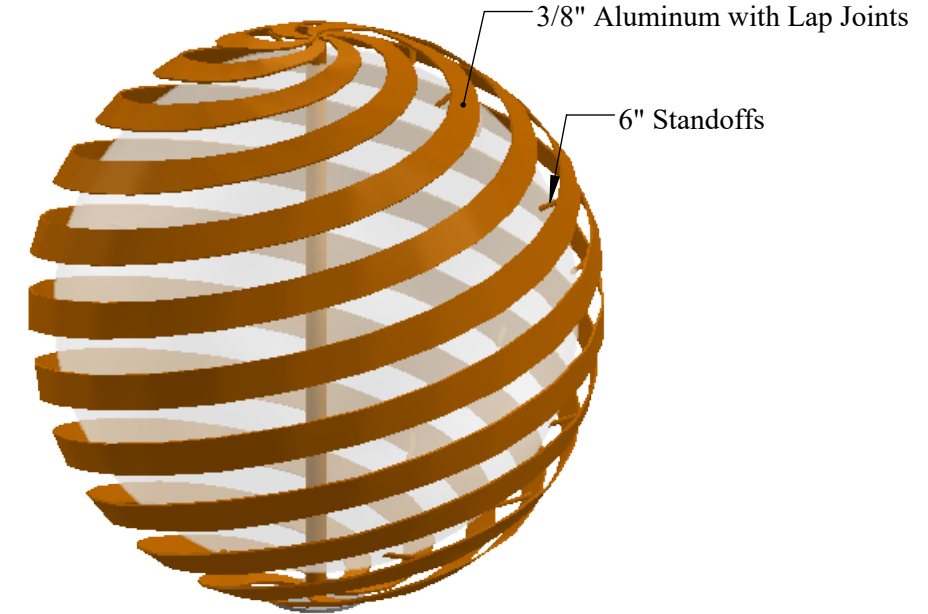
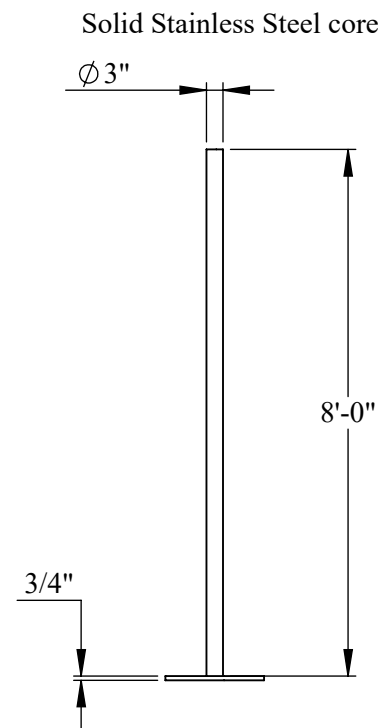

9ft Aluminum "Orange Peel" sphere, Alternate Concept:
Top/Bottom Half over 8ft Acrylic Hemispheres, with 6" standoffs

PROPRIETARY AND CONFIDENTIAL
THE INFORMATION CONTAINED IN THIS DRAWING IS THE SOLE PROPERTY OF **EES DESIGN LLC**. ANY REPRODUCTION IN PART OR AS A WHOLE WITHOUT THE WRITTEN PERMISSION OF **EES DESIGN LLC** IS PROHIBITED.

		UNLESS OTHERWISE SPECIFIED:		NAME	DATE	EES DESIGN, LLC
		DIMENSIONS ARE IN INCHES		DRAWN	JV	
		TOLERANCES:		CHECKED		TITLE:
		FRACTIONAL \pm		ENG APPR.		<i>Orange Peel Detail Overview</i>
		ANGULAR: MACH \pm BEND \pm		MFG APPR.		
		TWO PLACE DECIMAL \pm		Q.A.		22159-EN-1122
		THREE PLACE DECIMAL \pm		COMMENTS:		REV
		INTERPRET GEOMETRIC TOLERANCING PER:				B
		MATERIAL				
NEXT ASSY	USED ON	FINISH				
APPLICATION		DO NOT SCALE DRAWING				SCALE: 1:35
						WEIGHT:
						SHEET 3 OF 4

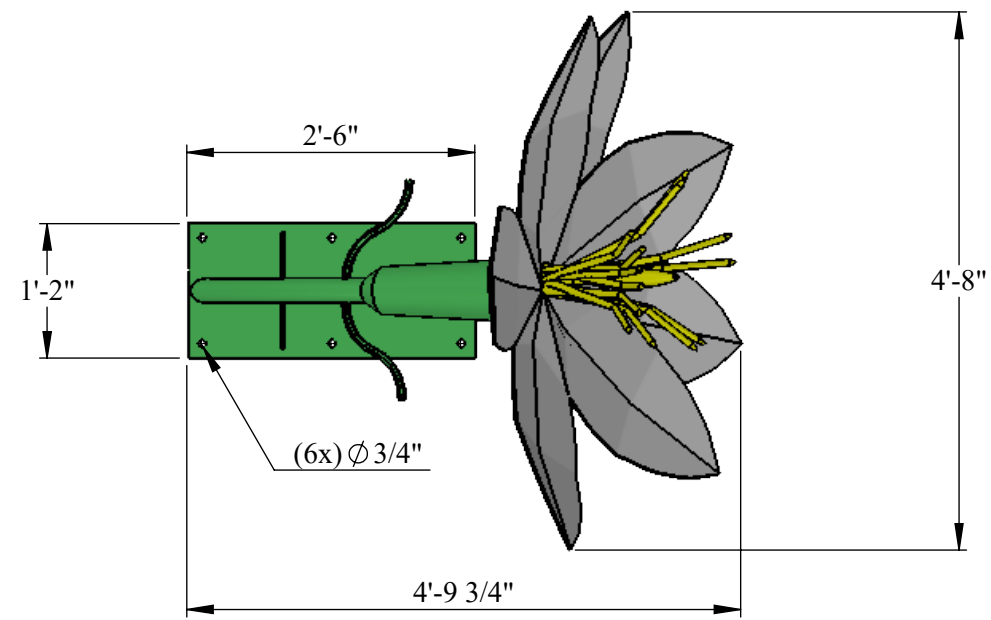

Anthers/Pistil and Flower Petal Sub-Assemblies
Mechanically fastened into Body with Stainless
Steel Tamper-Proof hardware

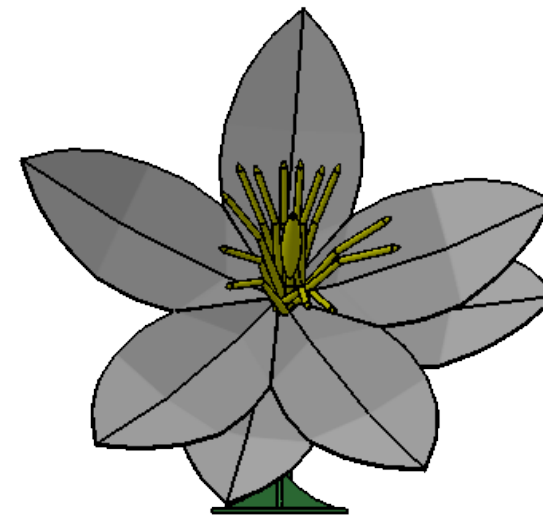
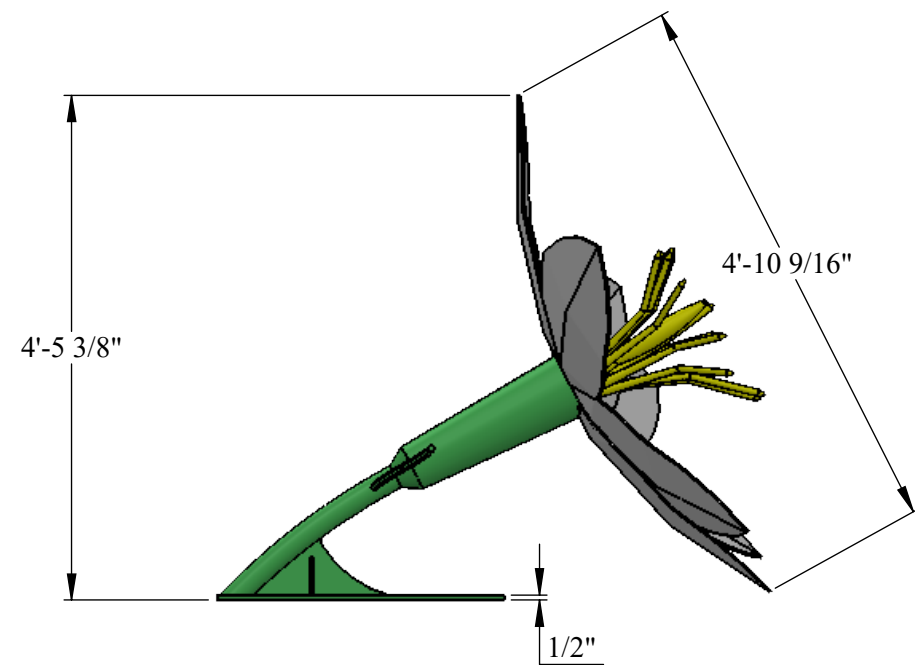
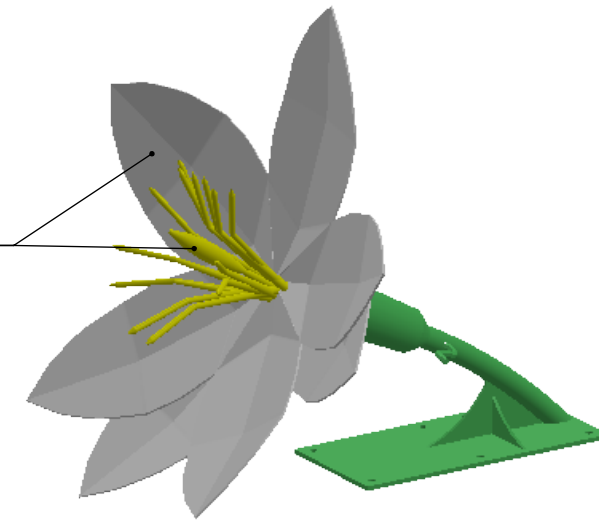

NOTE: Final fabrication model Anthers will have to be arranged in a more circular pattern

PROPRIETARY AND CONFIDENTIAL
THE INFORMATION CONTAINED IN THIS
DRAWING IS THE SOLE PROPERTY OF
EES DESIGN LLC. ANY REPRODUCTION
IN PART OR AS A WHOLE WITHOUT THE
WRITTEN PERMISSION OF
EES DESIGN LLC IS PROHIBITED.

		UNLESS OTHERWISE SPECIFIED:		NAME	DATE	EES DESIGN, LLC	
		DIMENSIONS ARE IN INCHES		DRAWN	JV	1/9/2023	TITLE: <i>Orange Blossom Flower Detail Overview</i>
		TOLERANCES:		CHECKED			
		FRACTIONAL ±		ENG APPR.			
		ANGULAR: MACH ± BEND ±		MFG APPR.			
		TWO PLACE DECIMAL ±		Q.A.			
		THREE PLACE DECIMAL ±		COMMENTS:			
		INTERPRET GEOMETRIC TOLERANCING PER:					
		MATERIAL					
		FINISH					
NEXT ASSY	USED ON					SIZE DWG. NO.	REV
						B 22159-EN-1122	B
						SCALE: 1:20	WEIGHT:
						SHEET 4 OF 4	
						28	

APPLICATION DO NOT SCALE DRAWING



Short Biography Ralfonso Kinetic, Light & Interactive Sculptures for Public Places

Ralfonso: Designer of environmentally interactive, kinetic and light sculptures (sculptures that interact with the environment such as wind, water, etc.) since 1980. Since 1999 he specializes in the design and execution of large to monumental kinetic and light sculptures for public places from his studios in West Palm Beach, Florida, USA and Geneva, Switzerland.

His passion in life is Kinetic Art for Public Places. With this passion, as president from its inception, he co-founded the Kinetic Art Organization (KAO) www.kinetic-art.org in 2001 with a German and a US fellow Kinetic Artist. Now, with more than 1,000 members in over 60 Countries around the world, KAO has become the largest kinetic art organization in the world.

All Ralfonso kinetic sculptures move, as they interact with water, wind, electricity, as well as with the natural environment and most importantly, the viewer.

Sculpture designs range in size from 60cm (2ft.) to 300m (1,000ft.) Sculptures have been exhibited or commissioned or permanently installed in **Switzerland, Netherlands, Russia, China, Germany, Hong Kong, United Arab Emirates, France, Taiwan and the USA.**

Selected Exhibitions: "Art in Motion", Netherlands; "Ralfonso Kinetic Art", St. Petersburg, Russia; "MomentuM", Grounds for Sculpture in New Jersey, USA; "The Art and Science Biennale" both in Beijing and Shanghai, "Finalist of the Cultural Olympics", the Olympic Museum in Lausanne, Switzerland; "Sculpture in Motion", Atlanta, USA; Changchun International Sculpture Conference, China; Inaugural Exhibition at Cuadro Gallery in Dubai, UAE, Inaugural Exhibition at "Homo Ludens" exhibition, the Netherlands; "Sculpture on the Green" Cashier, NC, USA; Inaugural Exhibition at the Simons Center for Geometry and Physics at Stony Brook University, New York; "Mouvements et Lumières" at the Frank Popper Center, Marcigny, France; Florida State University, USA; Museum of Contemporary Art MoCA, Beijing, China, Montreux, Switzerland; Changchun World Sculpture Park, China; Wuhan City, China; Overland City, USA; Kansas, Beihai Guanxi, China; Kinetic Art Exhibition Boynton Beach, Florida; Qingdao Sculpture Art Museum, etc.

RALFONSO - SELECTED ACHIEVEMENTS:

- August 2004 **St. Petersburg, Russia** - Solo show at Grand Hotel Kempinski & permanent installation of the 16ft (5m) Moving on UP.
- September 2004 **Beijing, China** - KAO kinetic art exhibition at the Library of the Academy of Science – THE FIRST IN CHINA!
- March 2005 **Eugene, Oregon, USA** - Commission for the 40ft by 20ft, 160 disc, suspended mobile “ExoCentric Spirits #1”.
- May 2005 **W. Palm Beach, Florida, USA** - 1st Prize Winner of USD 425,000 BAP International Sculpture Competition for Opera.
- April 2006 **Beijing, China** - Recipient of the Outstanding Award and Money Prize in the International Sculpture Competition.
- May 2006 **New Jersey, USA** - 3 Ralfonso Sculptures at Kinetic Art Group Exhibition “Momentum” at Grounds for Sculpture.
- September 2006 **CAFA & Tsinghua University, Beijing** - Keynote speaker at the “Public Art for the 2008 Olympics” conference.
- November 2006 **Beijing, China** - Exhibition of AD INFINITUM at the 2nd Art & Science Biennale the Tsinghua University.
- November 2006 French fine **cognac company Martell** (Pernod Ricard) licenses Ralfonso G-Ring Design for 5,000 small sculptures.
- December 2006 **MTR Corp., Hong Kong** – Commissions 50ft by 33ft (15m by 10m) ExoCentric Spirit #2 for Elements Mall in HK.
- March 2007 **City of Zhengzhou, China** commissions and licenses a 23ft (7m) Ralfonso AD INFINITUM sculpture design.
- May 2007 **Shanghai, China** - Group Exhibition and Prize Winner at the Art & Science Biennale.
- July 2007 **National Guiding Committee for Public Sculpture, China** awards Ralfonso 2nd Honor Award.
- October 2007 **Beijing Olympic Arts Committee** commissions 10m/33ft (with base) kinetic sculpture for the 2008 Olympic Games.
- May 2008 **City of Atlanta, USA** - “Dance with the Wind” at 6 months “Sculpture in Motion” Exhibition Botanical Garden.
- June 2008 **Chinese Olympic Art Committee** – awards Olympic Bronze Prize in the 2008 Olympic Landscape Sculpture Competition for OLYMPIAD - 1 year exhibitions through 12 Cities in China, USA, the Olympic Museum in Lausanne, Italy, etc.
- August 2008 **China Sculpture Institute** elects Ralfonso and Dennis Oppenheim as Advisor to CSI.
- November 2008 **Dubai, United Arab Emirates** - 3 Ralfonso 3m/10ft kinetic sculptures at inaugural 1 year Cuadro Gallery exhibition.
- January 2009 **Pittsburgh, USA** - ExoCentric Spirits #3 Commission for central lobby of new Children’s Hospital.
- October 2009 **Leeuwarden, Netherlands** - Ex-Strata #1 (5m/16.5ft) and Tubus #1 (15m/50ft) 1 year “Homo Ludens” exhibition.
- May 2010 **Geneva, Switzerland** - “Sabrina” Sculpture auction by Christie’s Asia Chairman Francois Curiel.
- May 2010 **Cashier, NC, USA** - 6 months Exhibition of “Dance with the Wind” (3m/10ft) at “Sculpture on the Green”.
- November 2010 **Tsinghua University, Beijing** - 100 Year Celebration Commission & perm. exhibition of EX STRATA#2 (6m/20ft).
- December 2010 **Shenzhen, China** - MTL International Commission & exhibition of BIRD OF PARADISE (6m/20ft).
- March 2011 **Simons Center for Geometry & Physics at Stony Brook University, NY** - Ralfonso solo inaugural exhibition.
- September 2011 **Changchun Int’l Sculpture Park, China** - Commission of UNION #1 (6m/20ft) for their permanent collection.
- April 2012 **“Wuhu Liu Kaiqu” Int’l Sculpture Park, China** - Commission of MAGIC TREE (6m/20ft) for their collection.
- July 2012 **Changchun Int’l Sculpture Park, China** - Commission of CUBE TOWER (8m/26ft) for their permanent collection.
- Nov. 2012 **Geneva, Switzerland** - “Dance with the Wind” Sculpture auction by Christie’s Asia Chairman Francois Curiel.
- Feb. 2013 **City of Orlando, Florida** - Commission of UNION #2 Sculpture Group (7.6m/25ft) for their permanent collection.
- Feb. 2013 **Boynton Beach, Florida, USA** - 4 months at the Int’l Kinetic Art Exhibition & Keynote Speaker.
- June 2013 **Frank Popper Center, France** - 6 months at the Int’l Kinetic Art Exhibition “Mouvements et Lumières”.
- August 2013 **“Kaohsiung World Trade Center”, Taiwan** - 2nd place with Honorarium for the \$200,000 new commission.
- August 2013 **Madison, WI, USA** – Winner - TOP 100 CoD+A (Collaboration of Design + Art) International Public Sculpture Award.
- November 2013 **Tsinghua University, Beijing China** - 1 month invited as Teacher of the first ever Kinetic Art Course in China.
- September 2014 **NHL University, Netherlands** - Commission of EX STRATA#3 (8.5m/28ft w. base) for their permanent collection.
- September 2014 **Museum of Contemporary Art (MoCA), Beijing, China** - KARO at the “Critical Connection” Exhibition.
- November 2014 **City of Qingdao Sculpture Park, China** - Commission of UNION #3 (10m/33ft) for their permanent collection.
- January 2015 **CNN INTERNATIONAL** airs “ART OF MOVEMENT” documentary about Ralfonso’s sculptures around the world.
- Feb. 2015 **Boynton Beach, Florida, USA** - “TWIST” 4 months at the Int’l Kinetic Art Exhibition & Keynote Speaker.
- August 2015 **Changbai Mountain Sculpture Park, China** - Commission EX STRATA#4 (4m/15ft) for their permanent collection.
- December 2015 **Beijing Museum of Contemporary Art, China** - Acquisition for the permanent collection of “Dance with the Wind”.
- February 2016 **FORBES Magazine** article re. Ralfonso’s new small kinetic works for private homes, galleries & museums.
- February 2016 **Florida State Univ., Brevard, USA** - Ralfonso Exhibition & Keynote speaker at THE ART OF SUSTAINABILITY.
- March 2016 **SOTHEBY’S INTERNATIONAL, New York** - successfully auctions the first Ralfonso kinetic work above estimate.
- April 2016 **Singer Island Beach, USA** - Commission of FLAMENCO #1 (2.5m/8ft) for a private ocean front residence.
- September 2016 **London, Britain** - Top British Architecture Award - BEST ENVIRONMENTALLY INTERACTIVE SCULPTURES.
- November 2016 **Montreux, Switzerland** - Ralfonso Group Exhibition at the **Montreux** Music & Convention Center - Miles Davis Hall.
- January 2017 **Putian International Sculpture “Master Sculpture” Award & Commission of the 4m/14ft SPHERICAL CHI (S-CHI).**
- February 2017 **Ningbo** - Hangzhou Bay Int’l Sculpture Grand Prix Silver Award & Commission of the 12m/42ft FAMILY UNION.
- April 2017 **Changchun City 2017 Int’l Sculpture Competition Award & Commission of the 7m/23ft LOVING HEART.**
- October 2017 **Wuhan City** - East Lake International Ecological Sculpture Biennial (27 Degree) exhibition and permanent acquisition.
- April 2018 **Shenzhen Pingshan City, China** - Ralfonso kinetic sculptures exhibited at the International Sculpture Exhibition.
- April 2018 **Overland City, Kansas** - Kinetic sculpture “Dance with the Wind” exhibited at inaugural 1st. one year exhibition.
- May 2018 **Hangzhou City, China** - Special Invited Artist, commissioned for design of iconic landmark sculpture (300m/1000ft).
- June 2018 **Fuqing City** - Special Invited Artist & commissioned for a 5m kinetic sculpture for the 1st Int’l Sculpture Exhibition.
- April 2019 **Beihai City, Guangxi, China** - Commission of AD INFINITUM (5m/16.5ft) for 1st inaugural Kinetic Art Park.
- April 2020 **West Palm Beach, Florida, USA** – Installation of the LIGHT CLOCK SENSE #1 in Galleria Int’l lobby.
- April 2020 **Boynton Beach, Florida, USA** - Commission of REFLECTION (8.2m/27ft) for the new Town Square Complex.
- July 2021 **Steamboat Springs, Colorado, USA** – Commission of UNION in 1m for a private residence.
- August 2021 **City of Qingdao**, 5 kinetic sculptures including S-CHI exhibited for 50 days at the Qingdao Sculpture Art Museum.

International Press Coverage (partial list):

PRINT: International Library of Photography Books, Art International Catalog, Architectural Record Magazine, American Style Magazine, Aargauer Zeitung (CH), NeoCity Architecture Magazine (Russia), Guild Book, Russian National TV, Public Art Review, International Sculpture Center Photo Gallery, **Cosmopolitan Magazine**, **Aeroflot Inflight Magazine**, **Elle Magazine**, 100% RED, Interior and Design, World and Home, Construction Weekly, Real Estate and Construction, Pravda, St. Petersburg monthly, **American Airline Magazine**, Palm Beach Daily "Shiny" Sheet, Sun Sentinel Miami, Florida Wise Magazine, Star Daily (China), China-JSB, Sculpture Magazine-China, American Art Collector, IN Magazine (Hong Kong), 24 Hours – Sculpture Network – Europe – July & August 2008 Edition, **HINGE Architecture Magazine** – Hong Kong, Perspective Plus Architecture – Hong Kong 2008 & 2009, Palm Beach Post, Palm Beach Illustrated, Palm Beach Society Magazine, Art of the Times, ART NOW Online, **The Gulf Today - Dubai**, Urban Art China, **China Sculpture Magazine**, World Art China, Hong Kong Post Magazine, TAN – **The Art Newspaper** – China #190 and #193, Le Journal, **United Nations Magazine** - September 2013, Technogaia Magazine, Sculptures Pacific Magazine, Florida Today, Wide Walls, Art Versed, **FORBES INTERNATIONAL**, **CNN INTERNATIONAL**, **Trajectoire Magazine**, **AMA Art Media Agency Magazine**, Art Versed Magazine, **BENTLEY Magazine**, Palm Beach Post, Art Hive Magazine, etc.

TV: Russian National TV - [TV-tsentr](#) and [TVC](#), USA - Channel 5, 17, 25, Dubai TV and CNN INTERNATIONAL - <http://www.cnn.com/videos/tv/2015/01/28/spc-art-movement-wind-sculptures.cnn> . **Burt Wolf on PBS**, etc.

Art Related Memberships (partial list):

- Member of the German Press Association, #17221
- Member of the International Press Association
- Member of Americans for the Arts, (AFTA), USA
- Member of French Union of Sculptors - Syndicat National des Sculpteurs et Plasticiens, France
- Member of Art & Science Collaborations, Inc. (ASCI)
- Colleague (ret.) of the National Sculpture Society, (NSS), USA
- Professional Circle Member (ret.) of the Sculpture Network-Europe
- Co-Founder and Ex-Member of the Board (ret.) of the European Kinetic Art Society, Kineticus
- Co-Founder and President of the international Kinetic Art Organization (KAO) www.kinetic-art.org, USA since 2001. With members in over 60 Countries, now the largest kinetic art organization in the world
- Co-Founder and Ex-Co-Chairman (ret.) of the annual EXPOSURE Art Festival W. Palm Beach, Florida, USA
- Co-Founder of SwissArtMiami, (ret.)
- Manager USA for AIESM, (ret.) – Int’l Association of Monumental Sculpture Events (ret.)
- Official Advisor to the China Sculpture Institute, Beijing, China (ret.)
- Member of the “Centre d’art Contemporain Frank Popper”, France
- Board member and Trustee of the ISC (2010-2013) – International Sculpture Center and publisher of Sculpture magazine, New Jersey, USA (ret.)
- Board member of the Beijing Museum of Contemporary Art (MoCA-Beijing) (ret.)
- Academic Advisor and Committee Member at YOUTH +, Beijing China (ret.)
- Member of the Royal Society of Sculptors, London
- Author of KINETIC ART Vol. 1 – AMAZON - <http://a.co/dYR190K> - also available in Chinese.
- Co-Author of KINETIC ART Vol. 2 – AMAZON - <https://www.amazon.com/dp/B08P9VD193>

THE END

Ralfonso

Kinetic Sculptures for Public Places

ralfonso@ralfonso.com

www.ralfonso.com



“ORANGE WITH 3 BLOSSOMS”

**For James Business Park
City of Westlake, Florida**

Artist Statement Amended:

By way of introduction, we specialize in the design and execution of large to monumental environmentally interactive kinetic & light sculptures for public places from our studio in West Palm Beach, Florida. For the last 20 plus years, we have custom designed large to monumental kinetic, light and interactive sculptures for public places around the world, including Russia, China, Europe, Taiwan, United Arab Emirates – and certainly in the USA.

We custom-design public sculptures site specifically for our clients. For the James Business Park, we were commissioned to design an iconic corner landmark signage and sculpture.

With guidance and in close cooperation with the client, we based our design on the following guiding principles:

- The City of Westlake was previously mostly orange groves.
- The Florida State Flower is the Orange Blossom, so in our design we included 3 blossoms, each with 13 anthers (totaling 39 anthers - representing Westlake as Palm Beach Counties 39th Municipality).
- The anthers are a vital part of the flower, responsible for the pollination, seeds and the new and next generations of Orange Blossoms, just as Westlake is building a new city for the next many generations to come.
- Signage is an integral part of the public art perception as a whole

With this in mind, we wanted to design a new and contemporary interpretation of the Orange & Blossom theme, in line with the new and forward-looking design principles of Westlake and the James Business Park.

Avoiding the traditional orange fruit form sculptures, we designed a stylized, more transparent and visually more engaging Orange Peel with 3 blossoms, with clean lines, complementing and in harmony with the clean lines of the surrounding modern building architecture.

Given the modern architecture and the "birth" of the new Westlake, we designed the signage to be an important and integral part of the art and its surrounding space. We specifically selected the ARIAL Font because its rounded modern form compliments the spherical shape of the artwork well. The silver color of the signage connects subtly to the silver accents on the buildings in the background.

We opted for a dynamic design, showing an Orange Peel in "static movement". This design provides the viewer with the optical illusion of movement, as they walk or drive by the sculpture, making this an iconic and memorable landmark.

We thank you for your trust and look forward to work with you, to realize "ORANGE WITH 3 BLOSSOMS" as the first contemporary public sculpture in Westlake.

With kinetic regards,

Ralfonso

JAMES BUSINESS PARK
AT
WESTLAKE™



LAND PLANNING + LANDSCAPE ARCHITECTURE

Cotleur & Hearing

1934 COMMERCE LANE, SUITE 1
JUPITER, FL 33458
561-747-6336
www.cotleurhearing.com







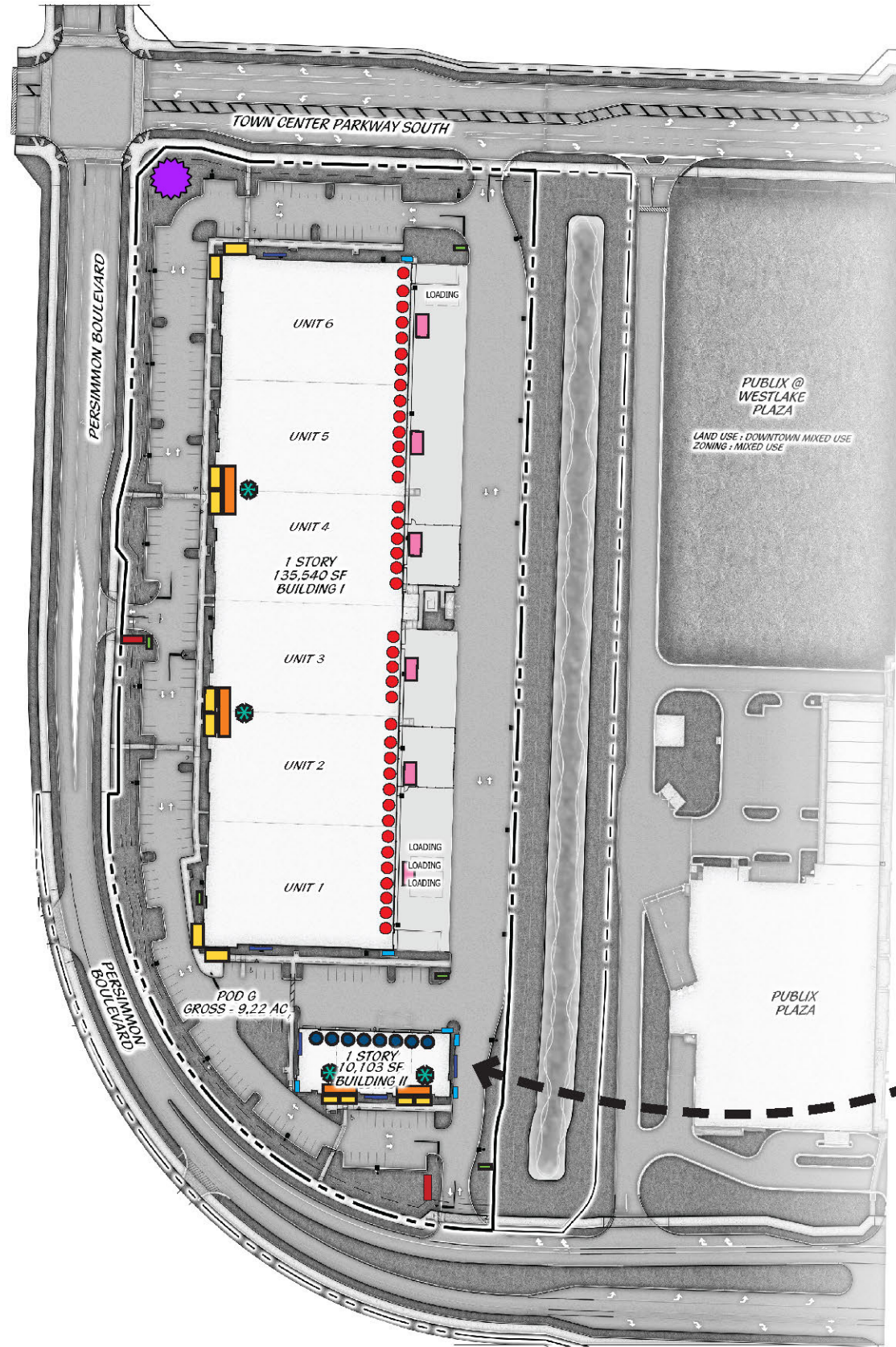



POD G SOUTHWEST
MASTER SIGNAGE PROGRAM

JANUARY 25, 2023

- 1 SIGN LOCATION MAP
- 2 POD G SOUTHWEST - EXAMPLE LEASING SCENARIO #1
- 3 POD G SOUTHWEST - EXAMPLE LEASING SCENARIO #2
- 4 PRIMARY GROUND SIGNS
- 5 TENANT DIRECTIONAL SIGNS
- 6 BUILDING #1 SIGN VIEWS
 - A. PRINCIPAL TENANT WALL SIGN
 - B. SECONDARY TENANT WALL SIGN
 - C. TENANT REAR WALL SIGN
 - D. BUILDING ADDRESS
 - E. BUILDING ID SIGN
 - F. LOADING BAY ID SIGN
- 7 BUILDING #2 SIGN VIEWS
 - A. PRINCIPAL TENANT WALL SIGN
 - B. SECONDARY TENANT WALL SIGN
 - C. BUILDING ADDRESS
 - D. BUILDING ID SIGN
 - E. LOADING BAY ID SIGN
- 8 ART IN PUBLIC PLACES WITH INTEGRATED PROJECT IDENTIFICATION SIGN



SIGN LOCATION MAP

-  ART IN PUBLIC PLACES WITH INTEGRATED PROJECT IDENTIFICATION SIGN
-  GROUND SIGN
-  PRINCIPAL TENANT WALL SIGN
-  SECONDARY TENANT WALL SIGN
-  TENANT REAR WALL SIGN
-  BUILDING ADDRESS
-  BUILDING ID SIGN
-  DIRECTIONAL SIGN
-  BLDG #1 BAY DOOR SIGNS
-  BLDG #2 BAY DOOR SIGNS
-  IF A TENANT OCCUPIES TWO (2) CONTINUOUS UNITS THAT SHARE AN ENTRANCE PARAPET (UNITS 2 AND THREE AND FOUR AND FIVE RESPECTIVELY). THE TENANT CAN CHOOSE TO UTILIZE THE PRINCIPAL TENANT WALL SIGN.

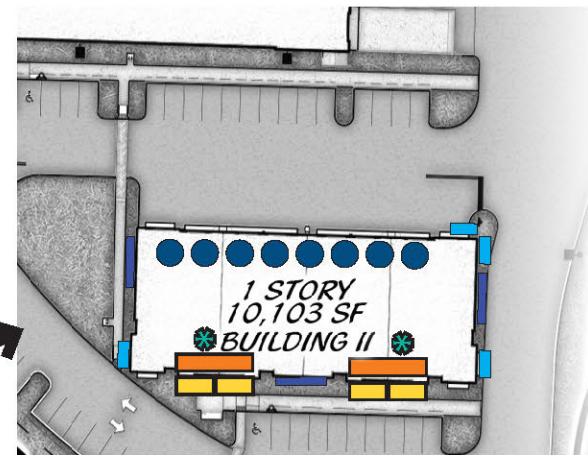

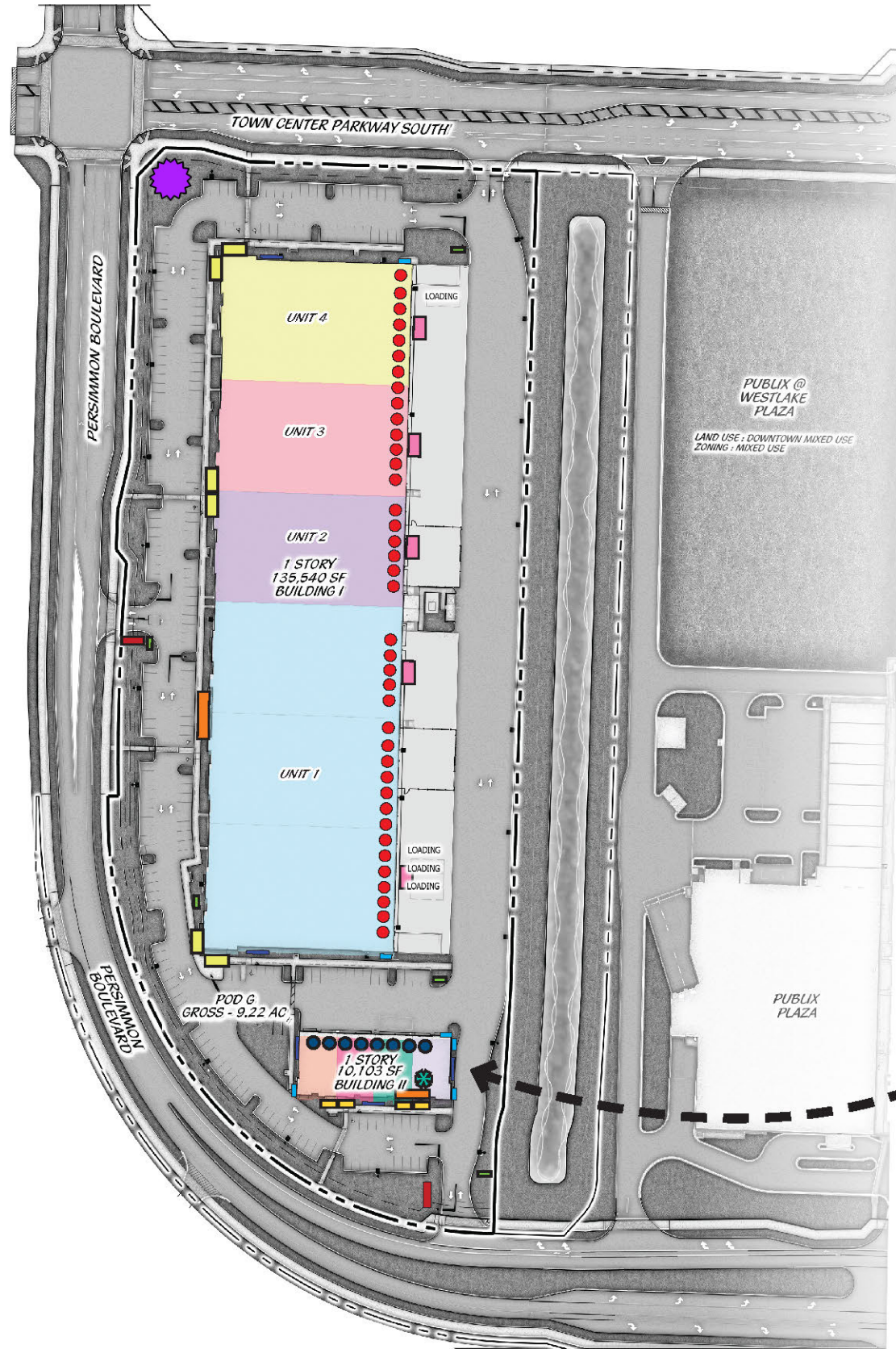

SIGN LOCATION MAP

- TENANT DIRECTIONAL SIGN
- PRINCIPAL TENANT WALL SIGN
- SECONDARY TENANT WALL SIGN
- TENANT REAR WALL SIGN
- BUILDING ADDRESS
- BUILDING ID SIGN
- BLDG #1 BAY DOOR SIGNS
- BLDG #2 BAY DOOR SIGNS
- IF A TENANT OCCUPIES TWO (2) CONTINUOUS UNITS THAT SHARE AN ENTRANCE PARAPET (UNITS 2 AND THREE AND FOUR AND FIVE RESPECTIVELY). THE TENANT CAN CHOOSE TO UTILIZE THE PRINCIPAL TENANT WALL SIGN.

NOTES

- TENANTS WILL BE PERMITTED TO SELECT EITHER ONE (1) PRINCIPAL TENANT WALL SIGN, OR ONE (1) SECONDARY TENANT WALL SIGN, BUT NOT BOTH.
- A TENANT MAY BE PERMITTED AN ADDITIONAL SECONDARY TENANT WALL SIGN IF THEY ARE LOCATED ON A BUILDING CORNER
- EACH TENANT WILL BE PERMITTED ONE (1) TENANT REAR WALL SIGN. PRINCIPAL TENANT MAY BE PERMITTED TWO (2) REAR WALL SIGNS.

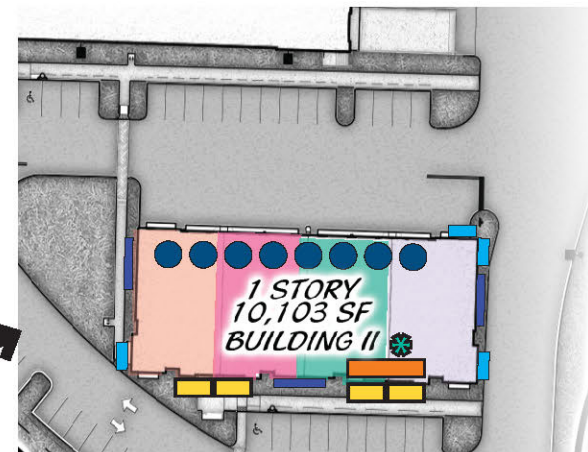

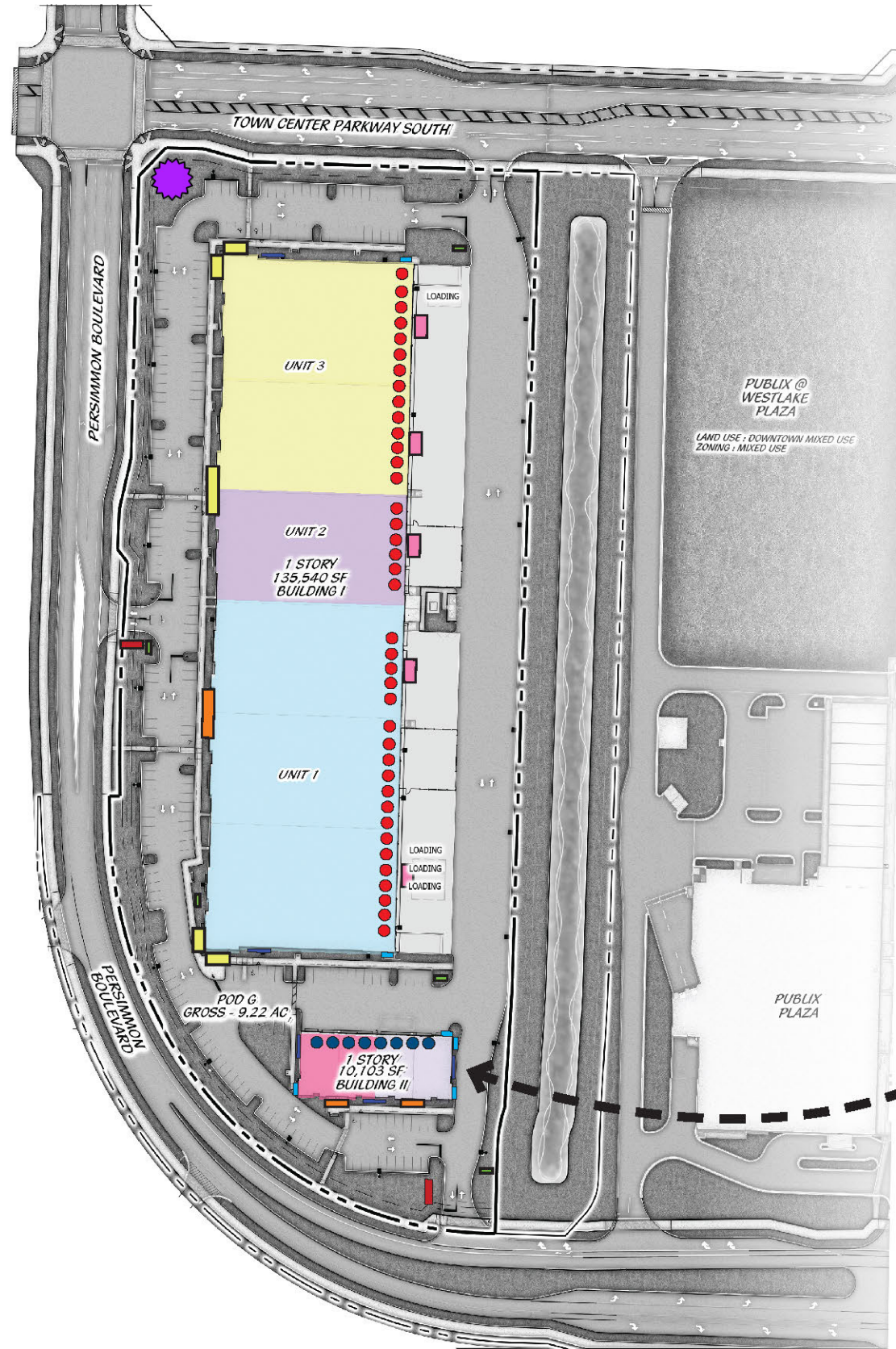

SIGN LOCATION MAP

- TENANT DIRECTIONAL SIGN
- PRINCIPAL TENANT WALL SIGN
- SECONDARY TENANT WALL SIGN
- TENANT REAR WALL SIGN
- BUILDING ADDRESS
- BUILDING ID SIGN
- BLDG #1 BAY DOOR SIGNS
- BLDG #2 BAY DOOR SIGNS

NOTES

- TENANTS WILL BE PERMITTED TO SELECT EITHER ONE (1) PRINCIPAL TENANT WALL SIGN, OR ONE (1) SECONDARY TENANT WALL SIGN, BUT NOT BOTH.
- A TENANT MAY BE PERMITTED A SECOND, EITHER PRINCIPAL TENANT WALL SIGN OR SECONDARY TENANT WALL SIGN, IF THEY ARE LOCATED ON A BUILDING CORNER
- EACH TENANT WILL BE PERMITTED ONE (1) TENANT REAR WALL SIGN. PRINCIPAL TENANT MAY BE PERMITTED TWO (2) REAR WALL SIGNS.

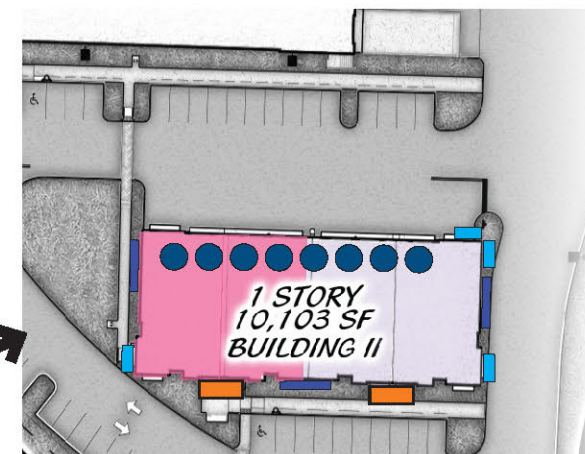

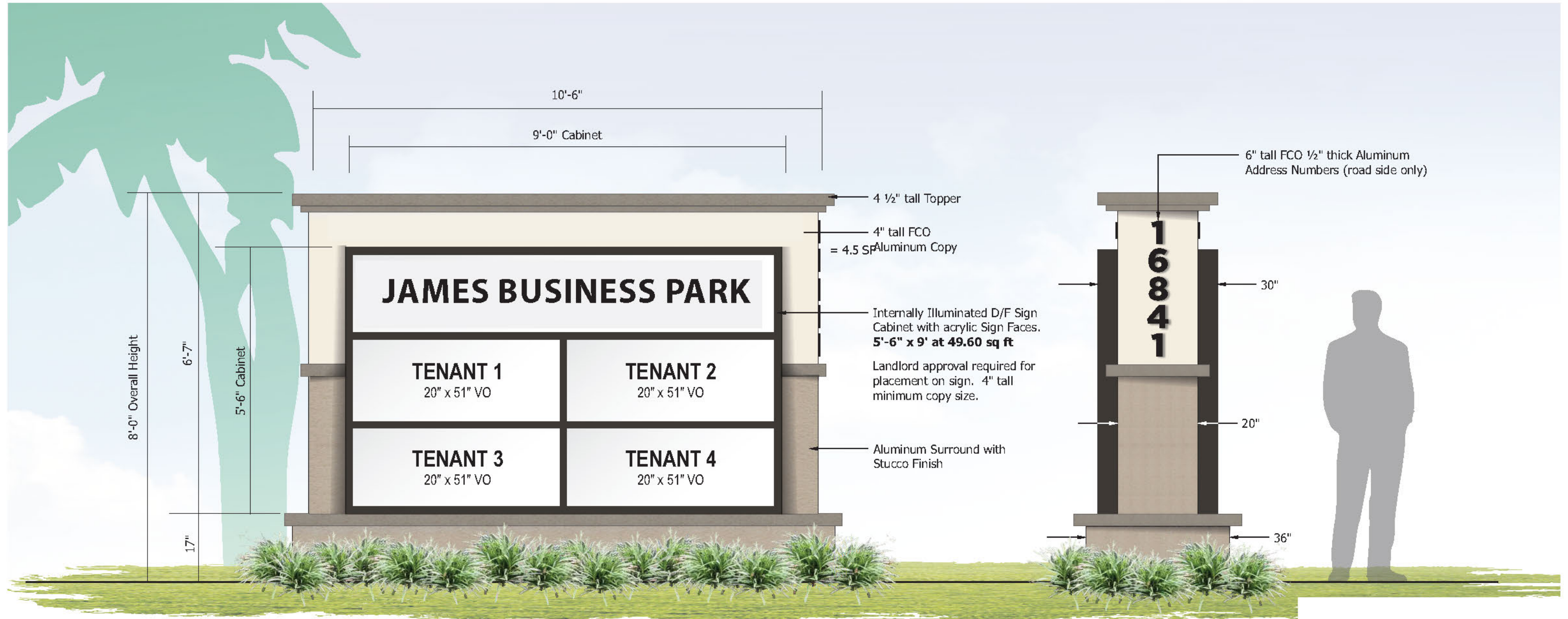

S21 S22 Secondary Ground Sign
Scale: 1/2" = 1'-0"

8' x 10'-6" = 84.00 sq ft

Side View

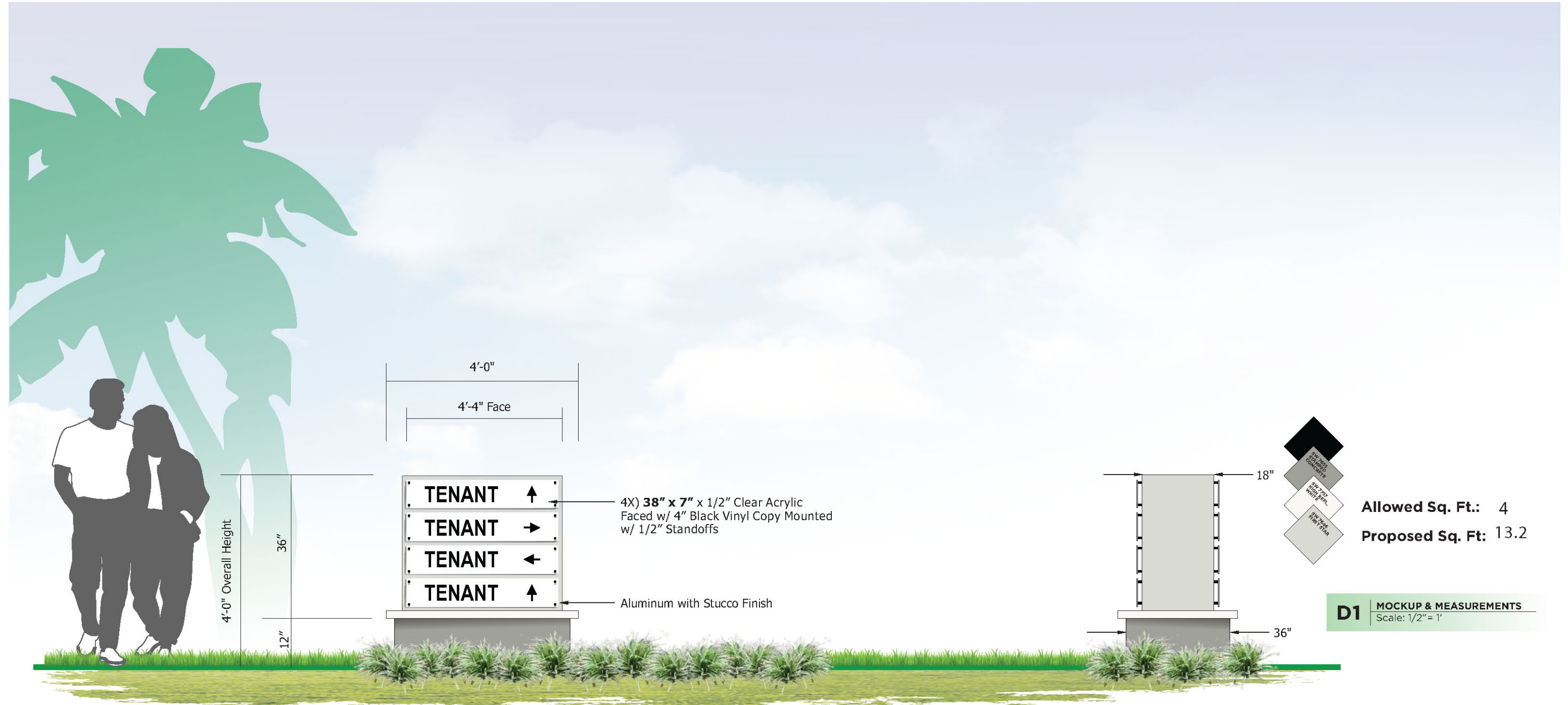

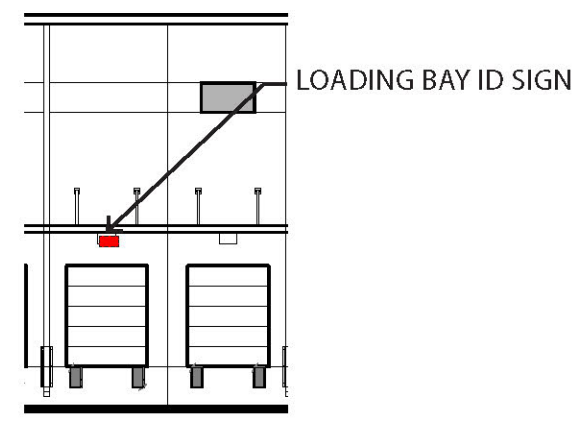
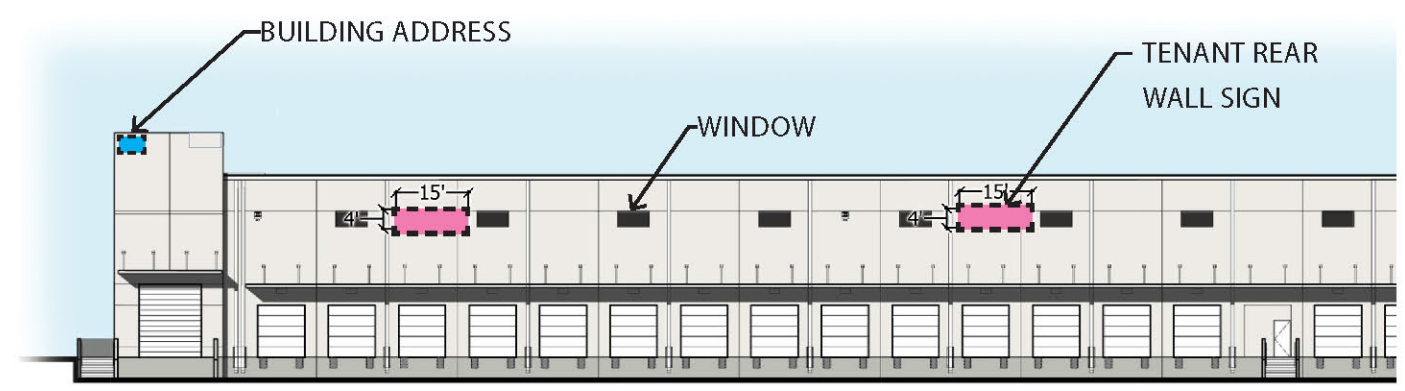
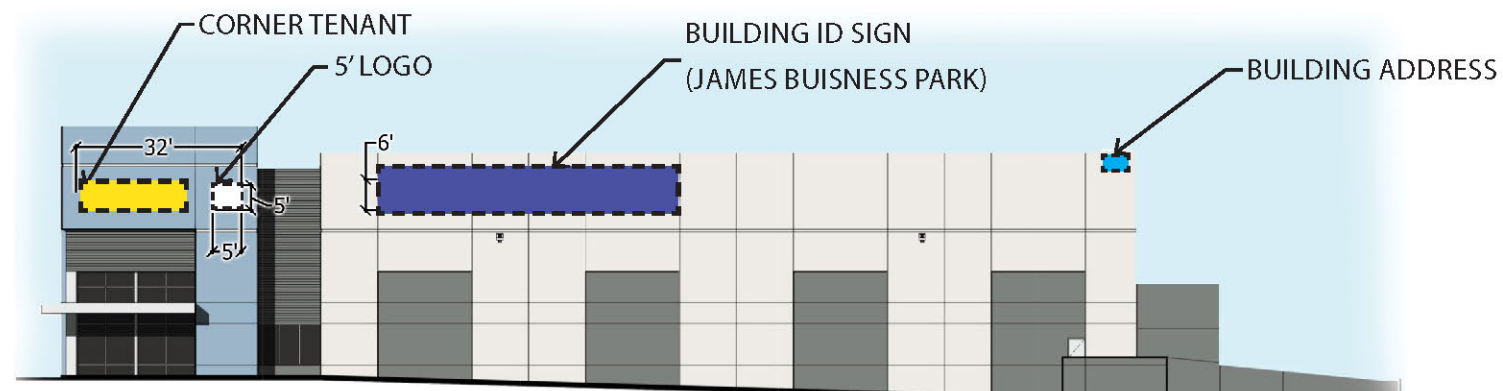
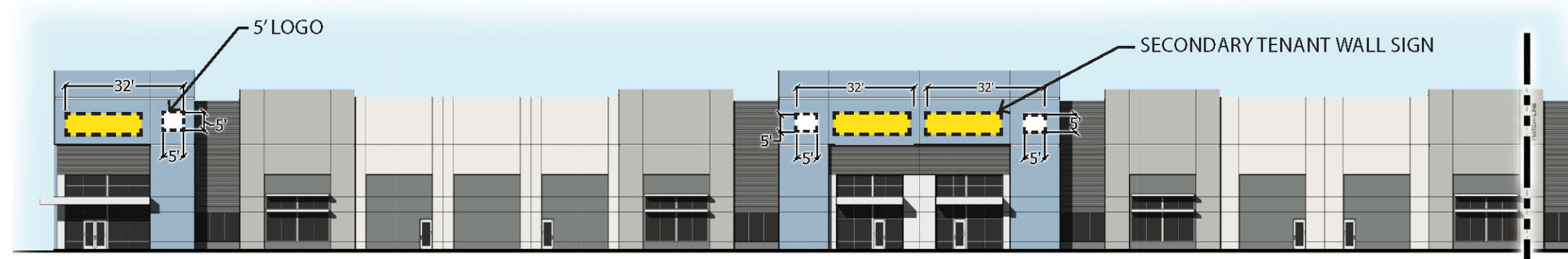
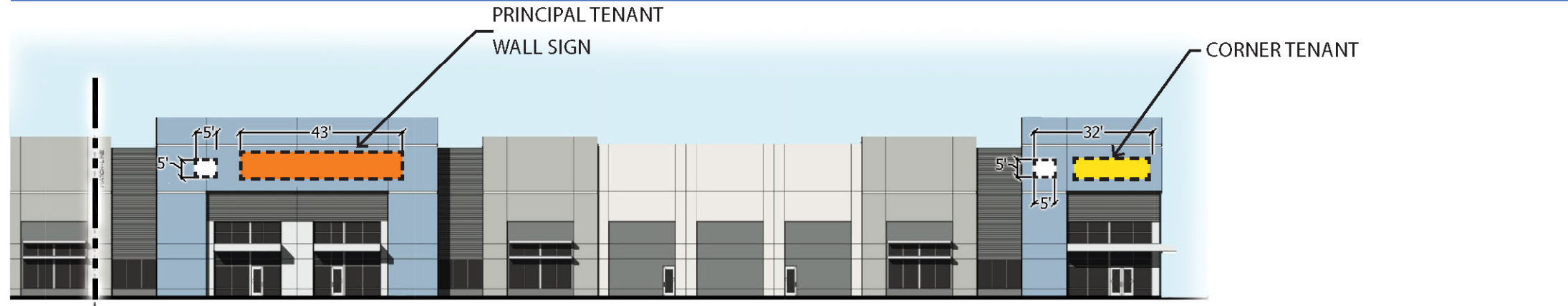

WALL SIGN CRITERIA - BLDG 1

PRINCIPAL TENANT WALL SIGN
 MAX 36" LETTERS, 2 LINES OF COPY,
 215 SF (5' X 43'), PLUS 5' X 5' LOGO MAX 25 SF

SECONDARY TENANT WALL SIGN
 MAX 36" LETTERS, 2 LINES OF COPY, 5' MAX LOGO
 160 SF (5' X 32')

TENANT REAR WALL SIGN
 MAX 24" LETTERS, 2 LINES OF COPY, 4' MAX LOGO
 60 SF (4' X 15')

BUILDING ADDRESS
 MAX 36" NUMBER SIZE (12" MINIMUM)

BUILDING ID SIGN
 MAX 48" LETTERS, 2 LINES OF COPY, 6' MAX LOGO
 144 SF (6' X 24')

LOADING BAY ID SIGN
 12" MAX NUMBER/LETTER SIZE

NOTES

- WALL SIGN LETTERS SHALL BE EITHER 1/4" THICK FLAT CUT METAL OR INDIVIDUAL DIMENSIONAL CHANNEL LETTERS.
- LETTER STYLE, COLOR, AND FONT TO BE DETERMINED BY TENANT AND LANDLORD. STANDARD DEFAULT STYLE SHALL BE HELVETICA MEDIUM OR AMERICANA EXTRA BOLD.
- LETTERS SHALL BE ALL CAPS UNLESS APPROVED BY LANDLORD.
- LOGOS ARE PERMISSABLE IF APPROVED BY LANDLORD.
- WINDOW SIGNS SHALL CONFORM TO SECTION 6.9 OF THE WESTLAKE SIGN CODE. WINDOW SIGNAGE SHALL NOT EXCEED 20% OF THE GLASS AREA.
- ALL WINDOW SIGNS MUST BE APPROVED BY THE LANDLORD

WALL SIGN CRITERIA - BLDG 2

PRINCIPAL TENANT WALL SIGN
 MAX 36" LETTERS, 2 LINES OF COPY,
 160 SF (5' X 32') PLUS 5' X 5' MAX LOGO 25 SF

SECONDARY TENANT WALL SIGN
 MAX 24" LETTERS, 2 LINES OF COPY, 4' MAX LOGO
 75 SF (5' X 15')

BUILDING ADDRESS
 MAX 36" NUMBER SIZE (12" MINIMUM)

BUILDING ID SIGN
 MAX 36" LETTERS, 2 LINES OF COPY, 5' MAX LOGO
 120 SF (5' X 24')

LOADING BAY ID SIGN
 12" MAX NUMBER/LETTER SIZE

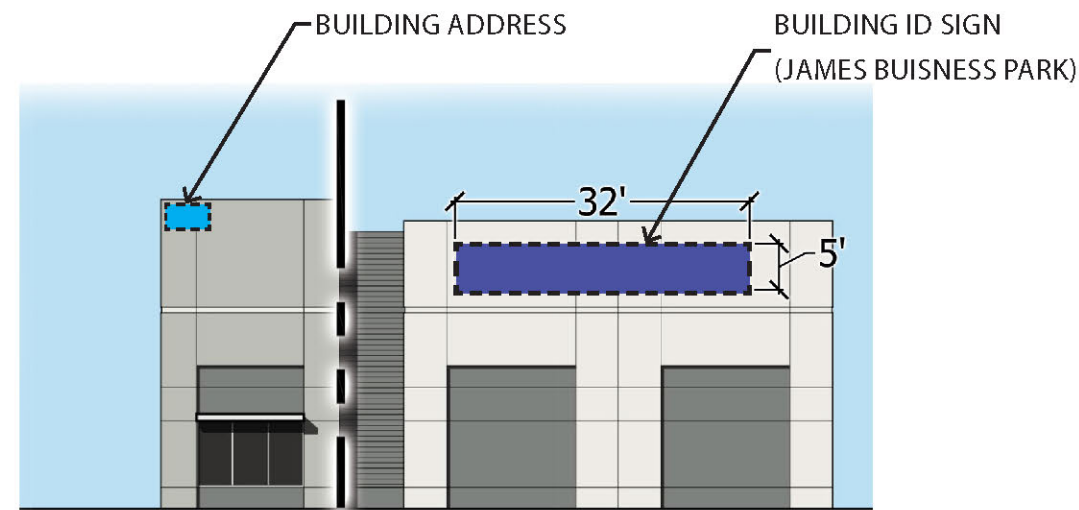
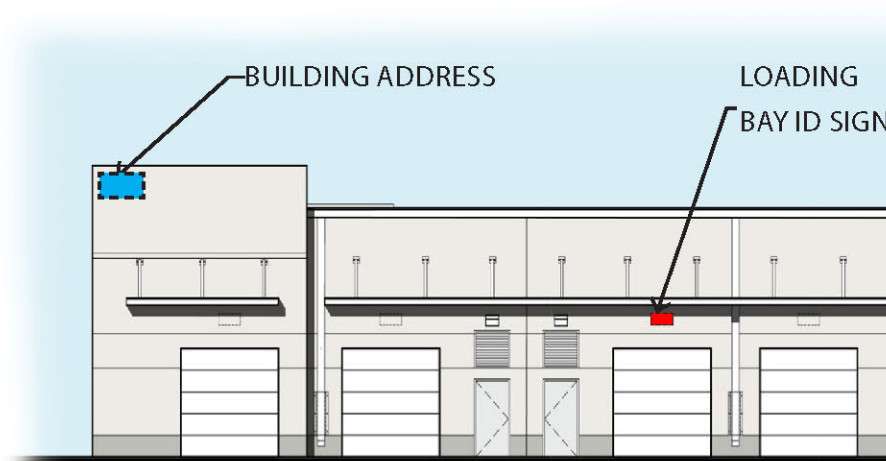
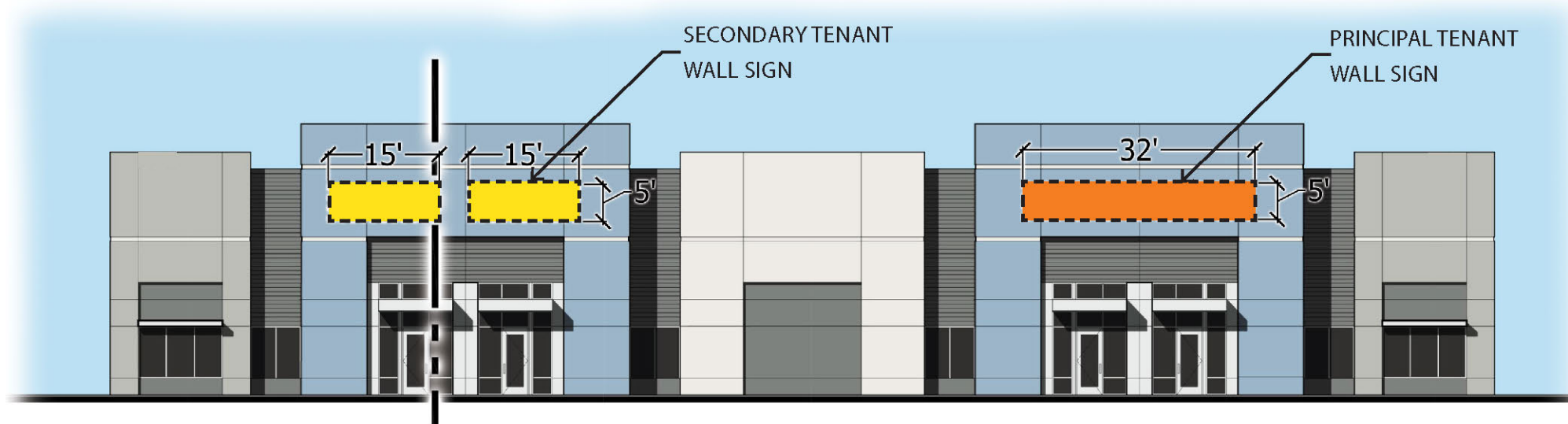

NOTES

- WALL SIGN LETTERS SHALL BE EITHER 1/4" THICK FLAT CUT METAL OR INDIVIDUAL DIMENSIONAL CHANNEL LETTERS.
- LETTER STYLE, COLOR, AND FONT TO BE DETERMINED BY TENANT AND LANDLORD. STANDARD DEFAULT STYLE SHALL BE HELVETICA MEDIUM OR AMERICANA EXTRA BOLD.
- LETTERS SHALL BE ALL CAPS UNLESS APPROVED BY LANDLORD.
- LOGOS ARE PERMISSABLE IF APPROVED BY LANDLORD.
- WINDOW SIGNS SHALL CONFORM TO SECTION 6.9 OF THE WESTLAKE SIGN CODE. WINDOW SIGNAGE SHALL NOT EXCEED 20% OF THE GLASS AREA.
- ALL WINDOW SIGNS MUST BE APPROVED BY THE LANDLORD
- WALL SIGNS FOR BUILDING ARE DIFFERENT FROM THE STANDARDS PROPOSED FOR BUILDING TO ADDRESS ARCHITECTURAL SCALE

Front View

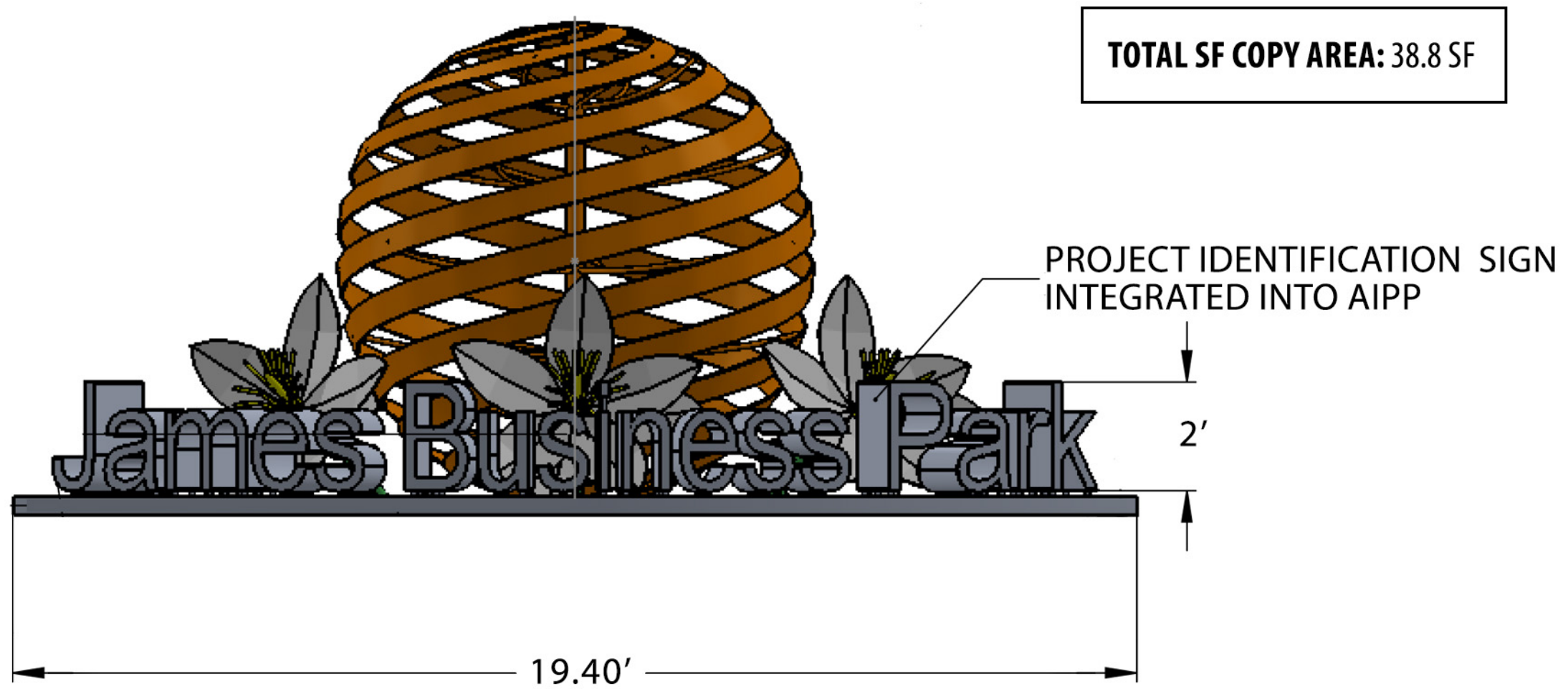

WAIVERS

SIGN TYPE	CODE REQUIREMENT	APPLICANT REQUEST	DEVIATION
Ground Sign (for Commercial)	Width : 15'	19.4'	+4.4'
	Base : 30% of overall height	No structured base	In Lieu of base, there will be a landscape terrace/plateau
	Letter Height : 4"	Letter Height – 24"	+ 20"