

CITY OF WESTLAKE



AGENDA

City Council Regular Meeting
Tuesday, May 07, 2024, at 6:00 PM

The Lodge at Westlake Adventure Park
5490 Kingfisher Blvd.
Westlake, Florida 33470

Live Broadcasting:

<https://cityofwestlake.my.webex.com>

Meeting ID: 2632 888 9851 | Password: hello

or

United States Toll: 408-418-9388

CITY COUNCIL:

JohnPaul O'Connor, Mayor
Greg Langowski, Vice Mayor
Gary Werner, Council Member – Seat 1
Julian Martinez, Council Member – Seat 2
Charlotte Leonard, Council Member – Seat 3

CITY STAFF:

Ken Cassel, City Manager
Zoie P. Burgess, CMC, City Clerk
Donald J. Doody, Esq., City Attorney
Nilsa Zacarias, AICP, Planning and Zoning Director
Suzanne Dombrowski, P.E., ENV SP, City Engineer

[TENTATIVE: SUBJECT TO REVISION]

CALL TO ORDER

ROLL CALL

PLEDGE OF ALLEGIANCE

ADDITIONS, DELETIONS OR MODIFICATIONS, AND APPROVAL OF AGENDA

PUBLIC COMMENTS AND REQUESTS

This section of the agenda allows for comments from the public to speak. Each speaker will be given a total of three (3) minutes to comment. A public comment card should be completed and returned to the City Clerk. When you are called to speak, please go to the podium, and prior to addressing Council, state your name and address for the record.

CONSENT AGENDA

This section of the agenda consists of routine or administrative items that require final approval by the City Council and may be approved in its entirety by a single motion. There will be no discussion of these items unless a Council Member requests such, in which event, the item will be removed from the Consent Agenda and considered on a future agenda.

- [A.](#) Minutes_City Council Regular Meeting - 02.06.2024 DRAFT
- [B.](#) Minutes_City Council Regular Meeting - 03.05.2024 DRAFT
- [C.](#) Minutes_City Council Regular Meeting - 04.02.2024 DRAFT
- [D.](#) Monthly Financial Report - March

PRESENTATIONS/PROCLAMATIONS

- [A.](#) Proclamation 2024-08 - Water Reuse
- [B.](#) Proclamation 2024-09 - National Days of Remembrance
- [C.](#) Proclamation 2024-10 - 55th Annual Professional Municipal Clerk's Week
- [D.](#) Proclamation 2024-11 - Mental Health Awareness Month
- E. Presentation - Palm Beach County Commission on Ethics

Presented By: Gina A. Levesque, CFE, Intake and Compliance Manager

PUBLIC HEARING - QUASI JUDICIAL

- [A.](#) **A Resolution for the Plat of Westlake Pod G – North**

Submitted By: Engineering

RESOLUTION 2024-08

A RESOLUTION OF THE CITY COUNCIL FOR THE CITY OF WESTLAKE, FLORIDA, APPROVING THE PLAT OF WESTLAKE POD G – NORTH, BEING

A PORTION OF SECTION 1, TOWNSHIP 43 SOUTH, RANGE 40 EAST, CITY OF WESTLAKE, PALM BEACH COUNTY, FLORIDA, AND BEING, IN PART, A REPLAT OF ALL OF TRACT "B", TOWN CENTER PARKWAY SOUTH - WEST, PLAT BOOK 132, PAGES 57 AND 58, AND A PORTION OF OPEN SPACE TRACT #1, PERSIMMON BOULEVARD WEST - PLAT 2, PLAT BOOK 134, PAGES 164 THROUGH 166, INCLUSIVE, BOTH OF THE PUBLIC RECORDS OF PALM BEACH COUNTY, FLORIDA. PROVIDING FOR RECORDATION, PROVIDING FOR CONFLICTS; PROVIDING FOR SEVERABILITY; AND PROVIDING AN EFFECTIVE DATE.

NEW BUSINESS

- A.** Resolution 2024-09 - An Interlocal Agreement with the Palm Beach County Commission on Ethics

Submitted By: Administration

RESOLUTION 2024-09

A RESOLUTION OF THE CITY COUNCIL OF THE CITY OF WESTLAKE, FLORIDA, APPROVING AND AUTHORIZING THE MAYOR OR VICE MAYOR TO EXECUTE THE INTERLOCAL AGREEMENT BETWEEN THE CITY OF WESTLAKE, FLORIDA AND PALM BEACH COUNTY RELATIVE TO THE PALM BEACH COUNTY COMMISSION ON ETHICS; PROVIDING FOR CONFLICTS; PROVIDING FOR SEVERABILITY; AND PROVIDING AN EFFECTIVE DATE.

CITY COUNCIL COMMENTS

- A. Councilwoman Charlotte Leonard
- B. Councilman Julian Martinez
- C. Councilman Gary Werner
- D. Vice Mayor Greg Langowski
- E. Mayor JohnPaul O'Connor

REPORT - STAFF

REPORT - CITY ATTORNEY

REPORT - CITY MANAGER

PUBLIC COMMENTS AND REQUESTS

This section of the agenda allows for comments from the public to speak. Each speaker will be given a total of three (3) minutes to comment. A public comment card should be completed and returned to the City Clerk. When you are called to speak, please go to the podium, and prior to addressing Council, state your name and address for the record.

ADJOURNMENT

NOTICE: If a person, firm or corporation decides to appeal any decision made by the City Council with respect to any matter considered at this meeting, you will need a record of the proceedings, and you may need to ensure that a verbatim record of the proceedings is made, which record includes the testimony and evidence upon which the appeal is to be based. (The above notice is required by State Law. Anyone desiring a verbatim transcript shall have the responsibility, at his own cost, to arrange for the transcript). The City of Westlake does not prepare or provide such verbatim record.

In accordance with the Americans with Disabilities Act, persons who need an accommodation in order to attend or participate in this meeting should contact the City Clerk at (561) 530-5880 at least three (3) business days prior to the meeting in order to request such assistance.

AGENDA POSTED: Monday, April 29, 2024

File Attachments for Item:

A. Minutes_City Council Regular Meeting - 02.06.2024 DRAFT

CITY OF WESTLAKE



MINUTES

City Council Regular Meeting

Tuesday, February 06, 2024, at 6:00 PM

The Lodge at Westlake Adventure Park
5490 Kingfisher Blvd.
Westlake, Florida 33470

CITY COUNCIL:

JohnPaul O'Connor, Mayor
Greg Langowski, Vice Mayor
Gary Werner, Council Member – Seat 1
Julian Martinez, Council Member – Seat 2
Charlotte Leonard, Council Member – Seat 3

CITY STAFF:

Ken Cassel, City Manager
Zoie P. Burgess, CMC, City Clerk
Donald J. Doody, Esq., City Attorney
Nilsa Zacarias, AICP, Planning and Zoning Director
Suzanne Dombrowski, PE, ENV SP, City Engineer

A regular meeting of the City Council of the City of Westlake was held on Tuesday, February 6, 2024, at 6:00 PM., at The Lodge at Westlake Adventure Park, 5490 Kingfisher Blvd. Members of the public also attended the meeting through electronic means and accessed as follows:

1. Webex Meeting: <https://cityofwestlake.my.webex.com/>

Meeting ID: 2630 557 5663

Password: hello

2. By Phone:

United States Toll: +1-408-418-9388

Meeting ID: 2630 557 5663

CALL TO ORDER

Mayor O'Connor called the City of Westlake Regular City Council meeting of Tuesday, February 6, 2024, to order at 6:00 PM.

ROLL CALL

Present and constituting a quorum:

Councilwoman Charlotte Leonard

Councilman Julian Martinez

Councilman Gary Werner

Vice Mayor Greg Langowski

Mayor JohnPaul O'Connor

Also present:

Kenneth Cassel, City Manager

Donald J. Doody, Esq., City Attorney

Zoie Burgess, City Clerk

Osniel Leon, Assistant City Planner

PLEDGE OF ALLEGIANCE

Mayor O'Connor led the Pledge of Allegiance.

ADDITIONS, DELETIONS OR MODIFICATIONS, AND APPROVAL OF AGENDA

Mayor O'Connor called for any additions, deletions, or modifications to the agenda.

There being none, Mayor O'Connor called for a motion to approve the agenda as presented.

Motion by Vice Mayor Langowski to approve the agenda as presented, seconded by Councilman Werner.

UPON ROLL CALL:

Councilwoman Leonard	YES
Councilman Martinez	YES
Councilman Werner	YES
Vice Mayor Langowski	YES
Mayor O'Connor	YES

With all in favor, motion carried without dissent (5-0).

PUBLIC COMMENTS AND REQUESTS

Mayor O'Connor called for public comments.

Ms. Burgess noted there was a public comment card received prior to the meeting from Ms. Tara Duhy from Lewis, Longman and Walker.

Public Comment - Tara Duhy of Lewis Longman and Walker on behalf of Minto Communities – Ms. Duhy discussed the development and history of 60th Street North and Minto.

Mayor O'Connor called for additional Public Comments. Ms. Burgess stated no other public comment cards were received.

Mayor O'Connor acknowledged a resident from the audience.

Public Comment - Hammocks Resident – Inaudible Address – Resident discussed his concerns regarding the effect development will have on 60th Street regarding noise level, pollution and decrease in property value.

Mayor O'Connor called for additional public comments, there being none, next item followed.

CONSENT AGENDA

- A. Minutes_City Council Regular Meeting - 01.08.2024 DRAFT
- B. Financial Report - December

Mayor O'Connor identified the consent agenda items and called for a motion to approve.

Motion by Councilman Martinez to approve the Consent Agenda, seconded by Councilwoman Leonard.

UPON ROLL CALL:

Councilman Martinez	YES
Councilman Werner	YES
Vice Mayor Langowski	YES
Mayor O'Connor	YES
Councilwoman Leonard	YES

With all in favor, motion carried without dissent (5-0).

PRESENTATIONS/PROCLAMATIONS

A. Proclamation 2024-02 - Declaring February Heart Health Month

Mayor O'Connor identified the Heart Health Proclamation sponsored by Councilwoman Leonard and read item into record.

B. Proclamation 2024-04 - Declaring February Black History Month

Mayor O'Connor identified the Black History Proclamation sponsored by Vice Mayor Greg Langowski that was previously approved by Council and read item into record.

NEW BUSINESS

A. Education Advisory Board Consideration and Appointment of Members

Submitted By: City Clerk's Office

RESOLUTION NO. 2024-03

A RESOLUTION OF THE CITY COUNCIL OF THE CITY OF WESTLAKE, FLORIDA, APPOINTING FIVE (5) MEMBERS AND ONE (1) ALTERNATE MEMBER TO SERVE ON THE EDUCATION ADVISORY BOARD; PROVIDING FOR CONFLICTS, PROVIDING FOR SEVERABILITY; AND PROVIDING FOR AN EFFECTIVE DATE.

Mayor O'Connor introduced the item and asked for Mr. Doody to read the item into the record. Mr. Doody deferred reading item into record until the appointments are made.

Council discussion.

Motion by Vice Mayor Langowski to appoint Ms. Lisa Barron, Ms. Anita Kaplan, and Ms. Krystal Lexima, seconded by Councilman Werner.

Council discussion regarding the term of office, the remaining open positions, and the role of the Council Liaison counting towards the board's quorum as identified in the Ordinance.

Mayor O'Connor requested the ordinance be revised and brought back before Council clarifying the Council liaison not counting towards the Board's quorum.

Additional council discussion.

With a motion on the table, roll call resumed.

UPON ROLL CALL:

Councilman Werner	YES
Vice Mayor Langowski	YES
Mayor O'Connor	YES
Councilwoman Leonard	YES
Councilman Martinez	YES

With all in favor, motion carried without dissent (5-0).

Mr. Doody read item by title only into the record.

Motion by Councilman Werner to adopt Resolution 2024-03 appointment of the three applicants to report to the board, seconded by Councilwoman Leonard.

UPON ROLL CALL:

Vice Mayor Langowski	YES
----------------------	-----

Mayor O'Connor	YES
Councilwoman Leonard	YES
Councilman Martinez	YES
Councilman Werner	YES

With all in favor, motion carried without dissent (5-0).

CITY COUNCIL COMMENTS

A. Councilwoman Charlotte Leonard – No additional comments.

B. Councilman Julian Martinez – Councilman Martinez discussed the City of Westlake’s First 5K Run and money raised being donated to a local school. Mr. Doody advised money raised and any possibility of donation of funds should be discussed after the race as a Council agenda item.

C. Councilman Gary Werner – Councilman Werner discussed his attendance at Palm Beach County Day in Tallahassee and his discussion with representatives regarding park funding. Mr. Werner discussed an accident that involved a bicycle and an automobile at Town Center Parkway and Cresswind Place.

D. Vice Mayor Greg Langowski – Vice Mayor Langowski asked Ms. Alicia Torres to please keep sharing news regarding board vacancies in hopes of filling vacant board seats. Vice Mayor Langowski proposed three proclamations: Florida Bicycle Month, Women’s History Month, and Water Conservation Month. Update regarding his travels with Florida and Palm Beach League of Cities visiting each member of the delegation regarding upcoming legislation.

E. Mayor JohnPaul O’Connor – Mayor O’Connor proposed the Digital Vibes Let’s Move proclamation for the following month. Mayor O’Connor also mentioned the upcoming SpringFest the City is hosting to be held on the Saturday before Easter.

REPORT - STAFF

A. PBSO 2023 Annual Report

Discussion of the monthly report followed by a discussion of the annual report for the City.

Mayor O’Connor called for Palm Beach County Fire Rescue to discuss their monthly report presented at dais.

REPORT - CITY ATTORNEY – No comments.

REPORT - CITY MANAGER – Mayor O’Connor asked Mr. Cassel for the number of residential Certificate of Occupancies issued last month. Mr. Cassel stated they have been averaging 40 to 45 in the last two and a half years. Councilman Werner inquired about the event coordinator position.

PUBLIC COMMENTS AND REQUESTS

Mayor O’Connor called for any public comments. Ms. Burgess stated no comment cards were received prior to the meeting.

Public Comment – Anita Kaplan - 5459 Santa Rosa Lane – Ms. Kaplan expressed her concerns regarding the lack of interested applicants for the Education Advisory Board vacancies.

Public Comment – Alicia Torres – 5847 Whipoorwill Circle – Ms. Torres inquired about the previous company providing Public Relation services for City events.

ADJOURNMENT

There being no further business, Mayor O'Connor adjourned the meeting at 7:06 PM

Zoie P. Burgess, City Clerk

JohnPaul O'Connor, Mayor

Note: These summary minutes are prepared in compliance with 286.011 F.S. and are not verbatim transcripts of the meeting. A verbatim audio record is available from the office of the City Clerk. All referenced attachments are on file in the City Clerk's office.

File Attachments for Item:

B. Minutes_City Council Regular Meeting - 03.05.2024 DRAFT

CITY OF WESTLAKE



MINUTES

City Council Regular Meeting

Tuesday, March 05, 2024, at 6:00 PM

The Lodge at Westlake Adventure Park
5490 Kingfisher Blvd.
Westlake, Florida 33470

CITY COUNCIL:

JohnPaul O'Connor, Mayor
Greg Langowski, Vice Mayor
Gary Werner, Council Member – Seat 1
Julian Martinez, Council Member – Seat 2
Charlotte Leonard, Council Member – Seat 3

CITY STAFF:

Ken Cassel, City Manager
Zoie P. Burgess, CMC, City Clerk
Donald J. Doody, Esq., City Attorney
Nilsa Zacarias, AICP, Planning and Zoning Director
Suzanne Dombrowski, PE, ENV SP, City Engineer

A regular meeting of the City Council of the City of Westlake was held on Tuesday, March 5, 2024, at 6:00 PM., at The Lodge at Westlake Adventure Park, 5490 Kingfisher Blvd. Members of the public also live streamed the meeting through electronic means and accessed as follows:

1. Webex meeting from a computer, tablet or smartphone at the following link:
<https://cityofwestlake.my.webex.com/>

Meeting ID: 2632 888 9851

Password: hello

2. Participants also dialed in using phone with the following number:

United States Toll: +1-408-418-9388

Meeting ID: 2632 888 9851

CALL TO ORDER

Mayor O'Connor called the City of Westlake Regular City Council meeting of Tuesday March 5, 2024, to order at 6:00 PM.

ROLL CALL

Present and constituting a quorum:

Councilwoman Charlotte Leonard (absent)

Councilman Julian Martinez

Councilman Gary Werner

Vice Mayor Greg Langowski

Mayor JohnPaul O'Connor

Also present:

Kenneth Cassel, City Manager

Donald J. Doody, Esq., City Attorney

Zoie Burgess, City Clerk

PLEDGE OF ALLEGIANCE

Mayor O'Connor led the Pledge of Allegiance.

ADDITIONS, DELETIONS OR MODIFICATIONS, AND APPROVAL OF AGENDA

Mayor O'Connor called for any additions, deletions, or modifications to the agenda.

Mr. Cassel recommended the minutes be pulled from the consent agenda and added to the following City Council meeting to allow for some corrections.

Mayor O'Connor called for a motion to entertain the City Manager's request to remove minutes from the consent agenda.

Motion by Councilman Werner to hold off on minutes for the council meeting of February 6 until the next meeting to allow the City Manager and staff to make additions or deletions, seconded by Vice Mayor Langowski.

UPON ROLL CALL:

Councilman Martinez	YES
Councilman Werner	YES
Vice Mayor Langowski	YES
Mayor O'Connor	YES

With all in favor, motion carried without dissent (4-0).

Mayor O'Connor called for a motion to approve the agenda as amended.

Motion by Councilman Werner to approve the agenda as amended, seconded by Vice Mayor Langowski.

UPON ROLL CALL:

Councilman Martinez	YES
Councilman Werner	YES
Vice Mayor Langowski	YES
Mayor O'Connor	YES

With all in favor, motion carried without dissent (4-0).

PUBLIC COMMENTS AND REQUESTS

Mayor O'Connor called for public comments. Ms. Burgess noted a comment card was received from Ms. Alicia Torres.

Public Comment - Alicia Torres - 5847 Whippoorwill Circle - Ms. Torres asked why fishing is not allowed in the lakes and stated the incoming KFC is bright red, which does not follow the aesthetics that Westlake is known to have.

Public Comment - James Kelly - 5551 Starfish Road - Mr. Kelly stated he is interested in heading a tennis program at the Adventure Park Lodge and stated he could provide the tennis nets.

Public Comment - (Name Inaudible) - 1608 Whippoorwill Circle - Ms. (inaudible) asked what the plans were for 60th Street and what has been approved or will be approved and if it will come before the City for approval.

CONSENT AGENDA

- A. Monthly Financial Report - January
- B. Minutes_City Council Regular Meeting - 02.06.2024 DRAFT

Mayor O'Connor identified the consent agenda items and called for a motion to approve.

Motion by Councilman Martinez to approve the Consent Agenda, seconded by Councilman Werner.

UPON ROLL CALL:

Councilman Werner	YES
Vice Mayor Langowski	YES
Mayor O'Connor	YES
Councilman Martinez	YES

With all in favor, motion carried without dissent (4-0).

PRESENTATIONS/PROCLAMATIONS

- A. Proclamation 2024-03 - Let's Move Palm Beach County
- B. Proclamation 2024-05 - Women's History Month
- C. Proclamation 2024-06 - Florida Bicycle Month
- D. Proclamation 2024-07 - Water Conservation Month

Mayor O'Connor identified the Proclamations and read them into record.

PUBLIC HEARING

- A. MPA-2023-04:** The applicant is requesting an amendment to the Master Site Plan for Pod H. The request is limited to Parcel B, to modify the 2,572 square foot Bank with Drive through use to a Fast-Food Restaurant with Drive Through; Parcel C-3, to increase the allocation of Fast Food with Drive Through by 238 square feet to accommodate a minor increase in building area for Taco Bell; and Parcel F, to create three (3) sub-parcels identified on the master plan as Parcels F-1, F-2 and F-3. The subject Plaza is located west of Seminole Pratt Whitney Road on 50.826 acres.

Submitted By: Planning and Zoning

Mayor O'Connor introduced the item and asked for any staff presentations.

Mr. Doody asked to first swear in any witnesses who were to testify.

Mr. Leon, on behalf of the City gave a staff presentation.

Council discussed the item in further detail with the following applicants and staff; Osniel Leon, Kathryn Rossmell, Donaldson Hearing and John Carter. Mr. Carter gave a brief history of the City of Westlake to further educate council on the current matter.

Applicant presentation, presented by Kathryn Rossmell with Lewis, Longman and Wlaker, P.A., on behalf of Minto PBLH, LLC.

Council continued to discuss item.

Mr. Doody asked Mayor O'Connor to call for public comments.

Public Comment - Alicia Torres - 5847 Whipoorwill Circle - Ms. Torres asked what the name of the restaurant is that replaced the bank and she also asked for information on parcel F1.

Public Comment - Mary Ellen Manning - 15780 Cresswind Place - Ms. Manning advised Council to revisit the review of parcels and pods to limit drive-throughs to avoid issues in the long run.

Public Comment – Ted Sarandis - 15780 Cresswind Place - Mr. Sarandis asked Council to delay all amendments from the applicants and developers. Mr. Sarandis stated the City needs a sit-down restaurant and a bank, not more drive-throughs.

Council continued to discuss item and asked if it was possible to table the item.

Mr. Doody stated a motion to table the item does not entertain a discussion, if council wanted to continue to discuss the item, discussions must be made before the motion is made. Mr. Doody also stated if a motion to table the item is made, he asks the item to be tabled for a specific date, to not table indefinitely.

Council continued to discuss item.

Mr. Doody provided a procedural comment, noting that four council members are present, and a two-two vote would be a denial.

Council discussion continued addressing the inconsistencies in the application and possible remedies.

Mayor O'Connor called for a motion.

Motion by Vice Mayor Langowski to approve MPA-2023-04 as a fast casual with a drive-thru not as a bank and to clean up the application, Mayor O'Connor passed the gavel to Vice Mayor Langowski, and seconded the motion.

UPON ROLL CALL:

Vice Mayor Langowski	YES
Mayor O'Connor	YES
Councilman Martinez	NO
Councilman Werner	NO

All not in favor, motion failed, with Councilmembers Martinez and Werner dissenting (2-2).

Councilman Werner called for a motion to table item for the next regular council meeting along with a special study session with the applicant and Minto present to discuss other development related issues that are in the background so everyone has better knowledge of what is possibly coming, the Mayor has his thumb on the pulse and he does not have that opportunity himself unless he learns it from the Mayor on how to do that, and he would like to hear from Minto and the developer prior to the first Tuesday in April.

Mr. Doody stated Councilman Werner must simplify the motion to table the item and if he wishes to call a workshop that would be a separate item.

Councilman Werner called for a motion to table the item to the first meeting in April, seconded by Vice Mayor Langowski.

UPON ROLL CALL:

Mayor O'Connor	YES
Councilman Martinez	YES
Councilman Werner	YES
Vice Mayor Langowski	YES

With all in favor, motion carried without dissent (4-0).

Mr. Doody called Ms. Kathryn Rossmell, on behalf of the applicant, to the podium and asked, if by the action of City Council, she is willing to agree to tabling the next two items, not to be prejudice but is advising, as counsel, since the Master Plan amendment was not approved, they cannot approve the site plan.

Ms. Rossmell asked for clarification, noting procedurally the item was not approved and is now being moved to being tabled and asked to verify that the item is not denied, only tabled. Ms. Rossmell requested a three-minute recess.

Mayor O'Connor recessed the meeting at 7:37 PM.

Mayor O'Connor reconvened the meeting at 7:44 PM.

Ms. Rossmell requested reconsideration of the table and motion, noting for the record, that the application before Council is completely within the requirement of the Code and within staff approval and Council can waive the typo on the one page of the application. Ms. Rossmell further noted that a denial be preferred to allow an avenue forward for a lawsuit. Ms. Rossmell respectfully asked for the item to be removed from the table and reconsider the application.

Mr. Jacob Gerb, on behalf of the applicant DKC Westlake Landings, LLC (431 Fairway Drive, Deerfield Beach, FL). Mr. Gerb requested reconsideration of the motion.

Council continued discussion of item with applicant.

Motion by Vice Mayor Langowski to reconsider MPA-2023-04, Mayor O'Connor passed the gavel to Vice Mayor Langowski, and seconded the motion.

UPON ROLL CALL:

Councilman Martinez	NO
Councilman Werner	NO
Vice Mayor Langowski	YES
Mayor O'Connor	YES

All not in favor, motion failed, with Councilmembers Martinez and Werner dissenting (2-2).

Ms. Rossmell withdrew the additional applications on the agenda.

Motion by Vice Mayor Langowski to table the item to the April 2nd meeting along with MPA-2023-04, SPM-2023-14 and SPM-2023-15, seconded by Councilman Martinez.

UPON ROLL CALL:

Councilman Martinez	YES
Councilman Werner	YES
Vice Mayor Langowski	YES
Mayor O'Connor	YES

With all in favor, motion carried without dissent (4-0).

- B. SPM-2023-14:** The applicant is requesting a Site Plan Modification of Parcel B within Shoppes of Westlake Landings commercial plaza in Pod H. The proposed amendment is limited to the North Building to replace a previously approved 2,572 square feet Bank with drive through on the south end of the north building with a 2,572 square feet Fast Food Restaurant use with drive through including a 400 square foot outdoor seating area. There are no proposed changes to the overall total of 16,515 Square Feet for the two (2) buildings. The subject site is located at 4951 Seminole Pratt Whitney Road, Westlake, Florida, 33470.

Submitted By: Planning and Zoning

Item tabled for April 2, 2024, meeting.

- C. SPM-2023-15:** The applicant is requesting Site Plan Modification approval for a proposed fast food restaurant with drive through located in Parcel C (Taco Bell). The subject application proposes to increase building area by 238 square feet; removal of outdoor seating area; removal of second drive through lane; and modifications to building elevations and colors. The subject building is one of three on a 3.68 acres site at Parcel C within Shoppes of Westlake Landings commercial plaza in Pod H. The subject site is located at 4751 Seminole Pratt Whitney Road.

Submitted By: Planning and Zoning

Item tabled for April 2, 2024, meeting.

- D. A Resolution for the Plat of Pod PC-3**

Submitted By: Engineering

RESOLUTION 2024-04

A RESOLUTION OF THE CITY COUNCIL FOR THE CITY OF WESTLAKE, FLORIDA, A REPLAT OF A PORTION OF OPEN SPACE TRACT #2, PERSIMMON BOULEVARD EAST - PLAT 2, PLAT BOOK 128, PAGES 16 THROUGH 19, INCLUSIVE, PUBLIC RECORDS OF PALM BEACH COUNTY, FLORIDA, AND LYING IN PORTIONS OF SECTIONS 1 AND 12, TOWNSHIP 43 SOUTH, RANGE 40 EAST, AND SECTIONS 6 AND 7 TOWNSHIP 43 SOUTH, RANGE 41 EAST, CITY OF WESTLAKE, PALM BEACH COUNTY, FLORIDA. PROVIDING FOR RECORDATION, PROVIDING FOR CONFLICTS; PROVIDING FOR SEVERABILITY; AND PROVIDING AN EFFECTIVE DATE.

Mayor O'Connor introduced the item.

Mr. Doody read item by title only into the record and swore in all witnesses who would be providing testimony.

Applicant presentation by Donaldson Hearing on behalf of Minto PBLH, LLC.

Staff presentation by Suzanne Dombrowski, on behalf of the City.

Council discussed item further.

Mayor O'Connor opened for public hearing, there being no public comments, the public hearing was closed.

Mr. Cassel noted the item was approved by the Seminole Improvement District the day before at their meeting.

Mayor O'Connor called for a motion.

Motion by Councilman Werner to approve Plat 2 of Plat Book 128 pages 16 through 19 inclusive of public records of Palm Beach County, Florida as recommended by staff, seconded by Vice Mayor Langowski.

UPON ROLL CALL:

Councilman Werner	YES
Vice Mayor Langowski	YES
Mayor O'Connor	YES
Councilman Martinez	YES

With all in favor, motion carried without dissent (4-0).

NEW BUSINESS

- A. Education Advisory Board Consideration and Appointment of Members

Submitted By: City Clerk

RESOLUTION 2024-05

A RESOLUTION OF THE CITY COUNCIL OF THE CITY OF WESTLAKE, FLORIDA, APPOINTING TWO (2) MEMBERS AND ONE (1) ALTERNATE MEMBER TO SERVE ON THE EDUCATION ADVISORY BOARD; PROVIDING FOR CONFLICTS, PROVIDING FOR SEVERABILITY; AND PROVIDING FOR AN EFFECTIVE DATE.

Mayor O'Connor introduced the item.

Council discussed item in further detail.

Motion by Vice Mayor Langowski to approve Colleen Forlizzi and Keith Miller as regular members and Harris Gropper as the Alternate Member of the board, encouraging the alternate member to attend meetings even though he will not have a vote unless someone is absent during the meeting, seconded by Councilman Werner.

UPON ROLL CALL:

Vice Mayor Langowski	YES
Mayor O'Connor	YES
Councilman Martinez	YES
Councilman Werner	YES

With all in favor, motion carried without dissent (4-0).

Mr. Doody read the item, by title only, into the record.

Motion by Vice Mayor Langowski to approve the Resolution, seconded by Councilman Werner.

UPON ROLL CALL:

Mayor O'Connor	YES
Councilman Martinez	YES
Councilman Werner	YES
Vice Mayor Langowski	YES

With all in favor, motion carried without dissent (4-0).

- B. Amending Ordinance 2023-09 Reconstituting the Education Advisory Board

Submitted By: Administration

ORDINANCE 2024-01

AN ORDINANCE OF THE CITY COUNCIL OF THE CITY OF WESTLAKE, FLORIDA, AMENDING ORDINANCE 2023-09 REGARDING THE CITY'S EDUCATION ADVISORY BOARD BY SPECIFICALLY AMENDING SECTION 3 (2) ENTITLED "COMPOSITION; APPOINTMENTS; TERM; AND VACANCY" FOR THE PURPOSES OF CLARIFYING THE ROLE OF THE CITY COUNCILMEMBER SERVING AS A LIAISON TO THE EDUCATION ADVISORY BOARD; PROVIDING FOR SEVERABILITY; PROVIDING FOR CODIFICATION; AND PROVIDING AN EFFECTIVE DATE.

Mayor O'Connor introduced the item.

Mr. Doody read the item, by title only, into the record and discussed the item in further detail.

Mayor O'Connor called for council comments.

Motion by Councilman Werner to approve Ordinance 2024-01, as recommended by staff, seconded by Vice Mayor Langowski.

UPON ROLL CALL:

Councilman Martinez	YES
Councilman Werner	YES
Vice Mayor Langowski	YES
Mayor O'Connor	YES

With all in favor, motion carried without dissent (4-0).

CITY COUNCIL COMMENTS

- A. Councilwoman Charlotte Leonard – Absent.
- B. Councilman Julian Martinez – Discussed the upcoming City of Westlake 5k.
- C. Councilman Gary Werner – Suggested to council to conduct a special meeting with Minto and any other developers to learn of current updates and issues relative to Westlake's future. Councilman Werner also asked staff to review if Kolter's Billboard Sign along Town Center Parkway is in the public right of way.
- D. Vice Mayor Greg Langowski – Vice Mayor Langowski asked if Seminole Improvement District and the City of Westlake could have another workshop to discuss the parks and get resident input.
- E. Mayor JohnPaul O'Connor – Mayor O'Connor thanked the public for their attendance.

Mayor O'Connor adjourned the meeting at 8:20 PM.

Motion by Vice Mayor Langowski to readjourn the meeting, seconded by Councilman Werner.

UPON ROLL CALL:

Councilman Martinez	YES
Councilman Werner	YES
Vice Mayor Langowski	YES
Mayor O'Connor	YES

With all in favor, motion carried without dissent (4-0).

Mayor O'Connor reinstated the meeting at 8:28 PM.

REPORT – STAFF

District Chief, Amanda Vomero discussed the Palm Beach County Fire Rescue monthly response times report for the City of Westlake.

Public Comment – Jackie Campbell – 15938 Key Biscayne Lane – Ms. Campbell asked if the Palm Beach County Fire Department would be able to host a shredding event.

Ms. Vomero stated Palm Beach County Fire, works with Palm Beach County Sheriff's Office and host pill drop events and stated they can provide those services in the City of Westlake if requested.

Lieutenant Darla Sowers discussed the Palm Beach Sheriff's Office monthly report for the City of Westlake.

Public Comment – Anita Kaplan – 5459 Santa Rosa Lane – Ms. Kaplan discussed the scholarships that are being offered to two students at Seminole Ridge High School from the Women's Club at Cresswind and encouraged interested parties to apply.

Public Comment – Ted Serandis - 15780 Cresswind Place – Mr. Serandis asked Council to delete the monthly financial reports on the consent agenda and asked for it to be published on the website and make it public. Mr. Serandis also asked for the meeting room to be expanded and more agendas be distributed for the council meetings.

Public Comment – Jackie Campbel – 15938 Key Biscayne Lane – Ms. Campbell asked for shopping stores to be brought to the City, such as a HomeGoods, Ross or Marshalls.

Public Comment - Alicia Torres – 5847 Whipoorwill Circle – Ms. Torres expressed her disappointment with the denial of the Plats.

Mayor O'Connor announced Chase Bank has signed the lease in the plaza with Winn Dixie.

REPORT - CITY ATTORNEY

No additional comments.

REPORT - CITY MANAGER

Mr. Cassel stated Solid Waste Authority is currently working on their facilities which is causing delivery backups and pickups and is therefore affecting their regular scheduled pickup times and days.

PUBLIC COMMENTS AND REQUESTS

ADJOURNMENT

There being no further business, Mayor O'Connor adjourned the meeting at 8:36 PM.

Zoie P. Burgess, City Clerk

JohnPaul O'Connor, Mayor

Note: These summary minutes are prepared in compliance with 286.011 F.S. and are not verbatim transcripts of the meeting. A verbatim audio record is available from the office of the City Clerk. All referenced attachments are on file in the City Clerk's office.

File Attachments for Item:

C. Minutes_City Council Regular Meeting - 04.02.2024 DRAFT

CITY OF WESTLAKE



MINUTES

City Council Regular Meeting

Tuesday, April 02, 2024, at 6:00 PM

The Lodge at Westlake Adventure Park
5490 Kingfisher Blvd.
Westlake, Florida 33470

CITY COUNCIL:

JohnPaul O'Connor, Mayor
Greg Langowski, Vice Mayor
Gary Werner, Council Member – Seat 1
Julian Martinez, Council Member – Seat 2
Charlotte Leonard, Council Member – Seat 3

CITY STAFF:

Ken Cassel, City Manager
Zoie P. Burgess, CMC, City Clerk
Donald J. Doody, Esq., City Attorney
Nilsa Zacarias, AICP, Planning and Zoning Director
Suzanne Dombrowski, PE, ENV SP, City Engineer

A regular meeting of the City Council of the City of Westlake was held on Tuesday, April 2, 2024, at 6:00 PM., at The Lodge at Westlake Adventure Park, 5490 Kingfisher Blvd. Members of the public also live streamed the meeting through electronic means and accessed as follows:

1. Webex Meeting: <https://cityofwestlake.my.webex.com/>

Meeting ID: 2632 888 9851

Password: hello

2. By Phone:

United States Toll: +1-408-418-9388

Meeting ID: 2632 888 9851

OATH OF OFFICE

A. Seat # 3 - Charlotte Leonard

B. Seat # 1 - Gary Werner

Mayor O'Connor requested Ms. Burgess to administer the Oath of Office.

Ms. Burgess administered the Oath of Office to Ms. Charlotte Leonard and Mr. Gary Werner.

CALL TO ORDER

Mayor O'Connor called the City of Westlake Regular City Council meeting of Tuesday, April 2, 2024, to order at 6:03 PM.

ROLL CALL

Present and constituting a quorum:

Councilwoman Charlotte Leonard

Councilman Julian Martinez

Councilman Gary Werner

Vice Mayor Greg Langowski

Mayor JohnPaul O'Connor

Also present:

Kenneth Cassel, City Manager

Donald J. Doody, Esq., City Attorney

Zoie Burgess, City Clerk

Osniel Leon, Assistant City Planner

PLEDGE OF ALLEGIANCE

Mayor O'Connor led the Pledge of Allegiance.

ADDITIONS, DELETIONS OR MODIFICATIONS, AND APPROVAL OF AGENDA

Mayor O'Connor called for any additions, deletions, or modifications to the agenda.

There being none, Mayor O'Connor called for a motion to approve the agenda as presented.

Motion by Vice Mayor Langowski to approve, seconded by Councilman Werner.

UPON ROLL CALL:

Councilwoman Leonard	YES
Councilman Martinez	YES
Councilman Werner	YES
Vice Mayor Langowski	YES
Mayor O'Connor	YES

With all in favor, motion carried without dissent (5-0).

PUBLIC COMMENTS AND REQUESTS

Mayor O'Connor called for public comments, there being none, next item followed.

CONSENT AGENDA

A. Financial Report – February

Mayor O'Connor identified the consent agenda item and called for a motion to approve.

Motion by Vice Mayor Langowski to approve, seconded by Councilwoman Leonard.

UPON ROLL CALL:

Councilman Martinez	YES
Councilman Werner	YES
Vice Mayor Langowski	YES
Mayor O'Connor	YES
Councilwoman Leonard	YES

With all in favor, motion carried without dissent (5-0).

PUBLIC HEARING - QUASI JUDICIAL

- A. **MPA-2023-04:** The applicant is requesting approval for a Master Site Plan amendment to the Westlake Landings Commercial Plaza on 50.826 acres in Pod H. The request is limited to Parcel B, to modify the approved 2,572 square foot Bank with Drive-through use to a Restaurant with Drive-Through; Parcel C-3, to increase the allocation of Restaurant with Drive-Through by 238 square feet to accommodate a

minor increase in building area for Taco Bell; and Parcel F, to create three (3) sub-parcels identified on the master site plan as Parcels F-1, F-2 and F-3. The previously approved Adrenaline World development is being replaced with 10,400 square feet of Retail Sales and Services on F-1; 47,529 square feet of Retail Sales and Services on F-2; and 73,800 square feet of light industrial on parcel F-3. The subject development is located west of Seminole Pratt Whitney Road on 50.826 acres.

Submitted By: Planning and Zoning

Mayor O'Connor introduced item and asked for Mr. Doody to swear in any witnesses. Mr. Doody swore in all witnesses who would be providing testimony. Mr. Doody explained that it is a continuation of a tabled item from the last Regular City Council meeting, noting that the record from the last meeting will be part of the record for the current meeting.

Mayor O'Connor asked for members to disclose any ex-parte communications if any; there were none.

Staff presentation by Mr. Leon, on behalf of the City.

Ms. Kathryn Rossmell of Lewis, Longman & Walker, P.A., on behalf of MINTO PBLH, LLC, stated the record should also include the items that were resubmitted by request of the City Council between the last meeting and the current meeting. An application clarifying the uses and the updated corresponding site plan were submitted to both the Planning Department and the City Clerk's office.

Applicant presentation, presented by Nicole Plunkett partner with Cotleur & Hearing.

Mayor O'Connor opened for public comment, there being none, council discussion followed.

Mayor O'Connor called for a motion.

Motion by Councilwoman Leonard to approve the Master Plan MPA-2023-04 for the amendment to the Westlake Landing Commercial Plaza, seconded by Vice Mayor Langowski.

UPON ROLL CALL:

Councilman Werner	NO
Vice Mayor Langowski	YES
Mayor O'Connor	YES
Councilwoman Leonard	YES
Councilman Martinez	YES

Motion carried, with Councilmember Werner dissenting (4-1).

- B. SPM-2023-14:** Application of DKC Westlake Landings, LLC for a Site Plan Modification of Parcel B within Shoppes of Westlake Landings commercial plaza in Pod H. The proposed amendment is limited to the North Building to replace a previously approved 2,572 square feet Bank with drive through on the south end of the north building with a 2,572 square feet Restaurant with drive through use including a 400 square foot outdoor seating area. There are no proposed changes to the overall total of 16,515 Square Feet for the two (2) buildings. North Building is located at 4951 Seminole Pratt Whitney Road, Westlake, Florida, 33470. South Building is located at 4901 Seminole Pratt Whitney Road, Westlake, Florida, 33470.

Submitted By: Planning and Zoning

Mayor O'Connor introduced the item.

Mr. Doody swore in all witnesses who would be providing testimony.

Staff presentation by Mr. Leon, on behalf of the City.

Applicant presentation by Ms. Nicole Plunkett, PLA, ASLA, with Cotleur & Hearing.

Mayor O'Connor called for public comments.

Public Comment – Anni Rodriguez 5991 Whippoorwill Circle – Mr. Rodriguez asked Council what their thoughts were when voting for the multiple fast-food restaurants that are coming to the city.

Public Comment – Melanie Haines – 5194 Liberty Lane – Ms. Haines asked why development in the City is taking so long compared to other municipalities.

Mr. Doody stated this can be addressed after this hearing as it does not relate to the application at hand.

Mr. Doody asked for any ex-parte communication to be identified regarding this application. There being none, Mayor O'Connor called for Council comments. Council Discussion.

Mayor O'Connor called for a motion.

Motion by Councilwoman Leonard to approve SPM-2023-14 application for the modification of Parcel B within the shops of Westlake Landings, seconded by Councilman Martinez.

UPON ROLL CALL:

Vice Mayor Langowski	YES
Mayor O'Connor	YES
Councilwoman Leonard	YES
Councilman Martinez	YES
Councilman Werner	YES

With all in favor, motion carried without dissent (5-0).

- C. SPM-2023-15:** The applicant is requesting Site Plan Modification approval for a proposed restaurant with drive through located in Parcel C (Taco Bell). The subject application proposes to increase building area by 238 square feet; removal of outdoor seating area; removal of second drive through lane; and modifications to building elevations and colors. The subject building is one of three located in a 3.68 acres site at Parcel C within Shoppes of Westlake Landings commercial plaza in Pod H. The subject site is located at 4751 Seminole Pratt Whitney Road.

Submitted By: Planning and Zoning

Mayor O'Connor introduced the item.

Mr. Doody swore in all witnesses who would be providing testimony.

Staff presentation by Mr. Leon, on behalf of the City.

Applicant presentation by Ms. Plunkett with Cotleur & Hearing.

Mayor O'Connor opened for public comment.

Mr. Doody asked for any ex-parte communication to be identified regarding this application.

Mayor O'Connor called for council comments. Council discussion regarding the elevation color.

Applicant excepted the condition of reverting to the original elevation color of grey.

Mayor O'Connor called for a motion.

Motion by Vice Mayor Langowski to approve SPM-2023-15 site modification as presented tonight but reverting to the original elevation color of grey instead of copper, seconded by Councilwoman Leonard.

UPON ROLL CALL:

Mayor O'Connor	YES
Councilwoman Leonard	YES
Councilman Martinez	YES
Councilman Werner	YES
Vice Mayor Langowski	YES

With all in favor, motion carried without dissent (5-0).

PUBLIC HEARING

- A. SECOND READING Amending Ordinance 2023-09 Reconstituting the Education Advisory Board
Submitted By: Administration

ORDINANCE 2024-01

AN ORDINANCE OF THE CITY COUNCIL OF THE CITY OF WESTLAKE, FLORIDA, AMENDING ORDINANCE 2023-09 REGARDING THE CITY'S EDUCATION ADVISORY BOARD BY SPECIFICALLY AMENDING SECTION 3 (2) ENTITLED "COMPOSITION; APPOINTMENTS; TERM; AND VACANCY" FOR THE PURPOSES OF CLARIFYING THE ROLE OF THE CITY COUNCILMEMBER SERVING AS A LIAISON TO THE EDUCATION ADVISORY BOARD; PROVIDING FOR SEVERABILITY; PROVIDING FOR CODIFICATION; AND PROVIDING AN EFFECTIVE DATE.

Mayor O'Connor introduced the item.

Mr. Doody read the item, by title only, into the record.

Mayor O'Connor opened the public hearing, there being no comments, the public hearing was closed.

Mayor O'Connor called for a motion.

Motion by Councilman Werner to approve Ordinance 2024-01, seconded by Councilman Martinez.

UPON ROLL CALL:

Councilwoman Leonard	YES
----------------------	-----

Councilman Martinez	YES
Councilman Werner	YES
Vice Mayor Langowski	YES
Mayor O'Connor	YES

With all in favor, motion carried without dissent (5-0).

NEW BUSINESS

- A. Select a Member of City Council to serve in the position of Vice-Mayor Until April 1, 2025.

Submitted By: City Clerk's Office

RESOLUTION 2024-06

A RESOLUTION OF THE CITY COUNCIL FOR THE CITY OF WESTLAKE, FLORIDA, SELECTING A MEMBER OF THE CITY COUNCIL TO SERVE IN THE POSITION OF VICE-MAYOR UNTIL APRIL 1, 2025, PURSUANT TO THE CITY'S CHARTER; PROVIDING FOR CONFLICTS; PROVIDING FOR SEVERABILITY; AND PROVIDING AN EFFECTIVE DATE.

Mayor O'Connor introduced the item.

Council discussed the item and revised the language to include the first regular Council meeting in April.

Mayor O'Connor called for a motion for the appointment of the Vice Mayor. Councilwoman Leonard recommended Councilmember Greg Langowski. Council discussed the item further.

Motion by Councilwoman Leonard to select Greg Langowski as Vice Mayor for the period of April 2025, seconded by Councilman Werner.

UPON ROLL CALL:

Councilman Martinez	YES
Councilman Werner	YES
Vice Mayor Langowski	YES
Mayor O'Connor	YES
Councilwoman Leonard	YES

With all in favor, motion carried without dissent (5-0).

Council discussion.

Mayor O'Connor called for a motion to amend the Resolution to read the first regular Council Meeting in April.

Motion by Councilman Werner to approve amendment to Resolution 2024-06 and have it end the first regular meeting of the city council in April 2025, seconded by Councilwoman Leonard.

UPON ROLL CALL:

Councilman Werner	YES
Vice Mayor Langowski	YES
Mayor O'Connor	YES
Councilwoman Leonard	YES
Councilman Martinez	YES

With all in favor, motion carried without dissent (5-0).

Mr. Doody read the item by title only, into record.

Mayor O'Connor called for a motion to approve the Resolution as amended.

Motion by Vice Mayor Langowski to approve resolution as amended, seconded by Councilwoman Leonard.

UPON ROLL CALL:

Vice Mayor Langowski	YES
Mayor O'Connor	YES
Councilwoman Leonard	YES
Councilman Martinez	YES
Councilman Werner	YES

With all in favor, motion carried without dissent (5-0).

- B. Appointing a Voting Delegate and Alternate Voting Delegates to the Palm Beach County League of Cities

Submitted By: City Clerk's Office

RESOLUTION 2024-07

A RESOLUTION OF THE CITY COUNCIL OF THE CITY OF WESTLAKE, FLORIDA, APPOINTING JOHNPAUL O'CONNOR, GREG LANGOWSKI, GARY WERNER, JULIAN MARTINEZ, CHARLOTTE LEONARD, KENNETH CASSEL AS THE CITY'S VOTING DELEGATE AND ALTERNATES TO THE PALM BEACH COUNTY LEAGUE OF CITIES, INC.; PROVIDING FOR CONFLICTS; PROVIDING FOR SEVERABILITY; AND PROVIDING AN EFFECTIVE DATE.

Mayor O'Connor introduced the item.

Mayor O'Connor called for Mr. Doody to read Resolution, by title only, into the record.

Mayor O'Connor called for a motion.

Motion by Councilwoman Leonard to accept Resolution 2024-07 appointing JohnPaul O'Connor and all Councilmembers and the City Manager to be voting delegates and alternates to the Palm Beach County League of Cities, seconded by Vice Mayor Langowski.

UPON ROLL CALL:

Mayor O'Connor	YES
Councilwoman Leonard	YES
Councilman Martinez	YES
Councilman Werner	YES
Vice Mayor Langowski	YES

With all in favor, motion carried without dissent (5-0).

CITY COUNCIL COMMENTS

- A. Councilwoman Charlotte Leonard – Ms. Leonard discussed the development of the City regarding the types of businesses coming into the City and asked for council consensus on a Proclamation for Mental Health Awareness Month for the month of May.
- B. Councilman Julian Martinez – Mr. Martinez discussed the 5K run and its success and asked council thoughts making it an annual event. Mr. Doody advised Mr. Martinez to instruct staff to have the item brought back to Council to discuss how much they want to spend, and when they want to hold it. Mr. Cassel stated they will bring back target dates for the event at the May meeting.
- C. Councilman Gary Werner – Mr. Werner discussed his attendance at town hall meetings regarding the county proposal to alter or amend the transportation information map. Mr. Werner also requested Council approval for proclamation in May for the National Day of Remembrance. Mr. Werner discussed his views on the City's comprehensive plan and current development concerns.
- D. Vice Mayor Greg Langowski – Mr. Langowski thanked Council for his reappointment of Vice Mayor. He also discussed his attendance for the discussion of 60th and 140th and it was nice to hear the surrounding areas consensus on the matter. Mr. Langowski asked for consensus on a Proclamation for the 55th Annual Professional Municipal Clerks week, May 5th through the 11th. Mr. Langowski asked staff for status regarding the joint meeting with the Seminole Improvement District to discuss the park. He also suggested a city-wide survey directed at residents inquiring about what they would want. Mr. Langowski also announced that the first meeting for the Education Advisory Board will be held at the Lodge on April 16th at 6:00 PM.
- E. Mayor JohnPaul O'Connor – Mr. O'Connor inquired of a Budget Workshop. Mr. O'Connor addressed the development of the city, Council's role, and surrounding cities. Mr. O'Connor recognized Autism awareness month. Mr. O'Connor discussed the success of the recent SpringFest event.

REPORT – STAFF

District Chief, Amanda Vomero discussed the Palm Beach County Fire Rescue monthly response times report for the City of Westlake.

REPORT - CITY ATTORNEY

Mr. Doody congratulated council members.

REPORT - CITY MANAGER

Mr. Cassel congratulated the new council members. Mr. Cassel stated Persimmon and River Bend heading east should be completed in the next 90 days. Fitness trail forecasted to be operational by the end of April. FourthFest is under planning. Staff is currently working with the School District on building the multi modal path.

PUBLIC COMMENTS AND REQUESTS

Public Comment – Ani Rodriguez - 5991 Whippoorwill Circle – Inquired about the law in Westlake regarding fishing in the lakes.

Ms. Rodriguez asked if Minto is in charge of building the berm on 60th road and if the City is able to enforce and require Minto to build a proper berm that will take care of the noise, lights and pollution.

Public Comment – Jackie Campbell – 15938 Key Biscayne Lane – Ms. Campbell discussed her concerns regarding the noise and asked if the ordinance could be reviewed. Ms. Campbell asked if the County owns Persimmon Blvd. Ms. Campbell asked if a car wash is coming to the City of Westlake.

ADJOURNMENT

There being no further business, Mayor O'Connor adjourned the meeting at 7:53 PM.

Zoie P. Burgess, City Clerk

JohnPaul O'Connor, Mayor

Note: These summary minutes are prepared in compliance with 286.011 F.S. and are not verbatim transcripts of the meeting. A verbatim audio record is available from the office of the City Clerk. All referenced attachments are on file in the City Clerk's office.

File Attachments for Item:

D. Monthly Financial Report - March



MEMORANDUM

TO: Members of the City Council, City of Westlake
FROM: Steven Fowler, Accountant
CC: Ken Cassel, City Manager
DATE: April 26, 2024
SUBJECT: March Financial Report

Please find attached the March 2024 financial report. During your review, please keep in mind that the goal is for revenue to meet or exceed the year-to-date budget and for expenditures to be at or below the year-to-date budget. An overview of the City's funds is provided below. Should you have any questions or require additional information, please contact me at Steven.Fowler@inframark.com.

General Fund

- Total Revenues through March were approximately 86% of the annual budget. Collections of the FY2024 Ad Valorem Tax and Special Assessments were approximately 96% and 98%, respectively.
- Total Expenditures and Contingency through March were approximately 44% of the annual budget.

Special Revenue Fund – Housing Assistance Program

- Total Revenues through March were approximately 165% of the annual budget, which was a result of a higher than anticipated rate of construction and donations on commercial permits. A donation of \$1,500 per Single Family Residence building permit is paid into the Housing Assistance Program.

Special Revenue Fund – Comprehensive Planning Services

- Total Revenues through March were approximately 22% of the annual budget.
- Total Expenditures through March were approximately 39% of the annual budget.

City of Westlake

Financial Report

March 31, 2024



Table of Contents

<u>FINANCIAL STATEMENTS</u>	Page #
Balance Sheet	1 - 2
Statement of Revenues, Expenditures and Changes in Fund Balance	
General Fund	3 - 6
Special Revenue Fund (Housing Assistance Program)	7
Special Revenue Fund (Comprehensive Planning Services)	8 - 9
 <u>SUPPORTING SCHEDULES</u>	
Cash and Investment Report	10

City of Westlake

Financial Statements

March 31, 2024

Balance Sheet
March 31, 2024

ACCOUNT DESCRIPTION	GENERAL FUND	SPECIAL REVENUE FUND - HOUSING ASSISTANCE PROGRAM	SPECIAL REVENUE FUND - COMPREHENSIVE PLANNING SVCS	TOTAL
<u>ASSETS</u>				
Current Assets				
Cash - Checking Account	\$ 2,084,736	\$ -	\$ -	\$ 2,084,736
Assessments Receivable	41,406	-	-	41,406
Due From Other Districts	11,685	-	-	11,685
Due From Other Funds	-	-	293,174	293,174
Investments:				
Money Market Account	5,922,282	4,273,922	-	10,196,204
Prepaid Items	96,981	-	-	96,981
Deposits	666	-	-	666
Total Current Assets	8,157,756	4,273,922	293,174	12,724,852
Noncurrent Assets				
Mortgages Receivable	-	598,373	-	598,373
Total Noncurrent Assets	-	598,373	-	598,373
TOTAL ASSETS	\$ 8,157,756	\$ 4,872,295	\$ 293,174	\$ 13,323,225
<u>LIABILITIES</u>				
Current Liabilities				
Accounts Payable	\$ 276,131	\$ -	\$ 230,505	\$ 506,636
Accrued Expenses	123,265	-	-	123,265
DBPR surcharge	4,225	-	-	4,225
DCA surcharge	6,043	-	-	6,043
Impact Fees	283,801	-	-	283,801
Unearned Revenue	468,700	-	-	468,700
Deferred Revenue-Developer Submittals (Minto)	-	-	62,220	62,220
Due To Other Funds	293,174	-	-	293,174
Total Current Liabilities	1,455,339	-	292,725	1,748,064
Long-Term Liabilities				
Deferred Inflow of Resources	41,406	-	-	41,406
Total Long-Term Liabilities	41,406	-	-	41,406
TOTAL LIABILITIES	1,496,745	-	292,725	1,789,470

Balance Sheet
March 31, 2024

ACCOUNT DESCRIPTION	GENERAL FUND	SPECIAL REVENUE FUND - HOUSING ASSISTANCE PROGRAM	SPECIAL REVENUE FUND - COMPREHENSIVE PLANNING SVCS	TOTAL
<u>FUND BALANCES</u>				
Nonspendable:				
Prepaid Items	96,981	-	-	96,981
Deposits	666	-	-	666
Restricted for:				
Special Revenue	-	4,872,295	449	4,872,744
Unassigned:	6,563,364	-	-	6,563,364
TOTAL FUND BALANCES	\$ 6,661,011	\$ 4,872,295	\$ 449	\$ 11,533,755
TOTAL LIABILITIES & FUND BALANCES	\$ 8,157,756	\$ 4,872,295	\$ 293,174	\$ 13,323,225

Statement of Revenues, Expenditures and Changes in Fund Balances
For the Period Ending March 31, 2024

ACCOUNT DESCRIPTION	ANNUAL ADOPTED BUDGET	YEAR TO DATE BUDGET	YEAR TO DATE ACTUAL	VARIANCE (\$) FAV(UNFAV)
<u>REVENUES</u>				
Interest - Investments	\$ -	\$ -	\$ 84,147	\$ 84,147
Ad Valorem Taxes	4,721,257	4,721,257	4,527,338	(193,919)
Ad Valorem Taxes - Prior Years	-	-	1,894	1,894
Ad Valorem Taxes - Discounts	(188,850)	(188,850)	(179,226)	9,624
FPL Franchise	365,200	182,600	215,797	33,197
Gas	60,100	30,050	17,412	(12,638)
Solid Waste	22,200	11,100	11,988	888
Electricity	430,600	215,300	209,002	(6,298)
Water	109,000	54,500	73,743	19,243
Gas	102,900	51,450	53,175	1,725
Communication Services Taxes	148,400	74,200	70,304	(3,896)
Occupational Licenses	6,100	3,050	6,393	3,343
Building Permits - Admin Fee	95,700	47,850	41,437	(6,413)
Licenses, Fees & Permits	-	-	367	367
State Revenue Sharing Proceeds	43,200	21,600	21,572	(28)
Other Public Safety Chrgs/Fees	5,400	2,700	3,905	1,205
Garbage/Solid Waste Revenue	228,900	114,450	31,733	(82,717)
Other Operating Revenues	13,200	6,600	5,738	(862)
Special Events	-	-	5,950	5,950
Event Sponsors	-	-	21,150	21,150
Judgements and Fines	-	-	3,127	3,127
Interest - Tax Collector	-	-	42	42
Special Assmnts- Tax Collector	499,468	499,468	488,675	(10,793)
Special Assmnts- Delinquent	-	-	281	281
Special Assmnts- Discounts	(19,979)	(19,979)	(19,303)	676
Other Miscellaneous Revenues	-	-	815	815
Lien Search Fee	5,900	2,950	5,415	2,465
TOTAL REVENUES	6,648,696	5,830,296	5,702,871	(127,425)

Statement of Revenues, Expenditures and Changes in Fund Balances
For the Period Ending March 31, 2024

ACCOUNT DESCRIPTION	ANNUAL ADOPTED BUDGET	YEAR TO DATE BUDGET	YEAR TO DATE ACTUAL	VARIANCE (\$) FAV(UNFAV)
<u>EXPENDITURES</u>				
<u>Legislative</u>				
Mayor/Council Stipend	60,000	30,000	30,000	-
FICA Taxes	4,600	2,300	2,295	5
ProfServ-Legislative Expense	24,000	12,000	-	12,000
Telephone, Cable & Internet Service	3,800	1,900	2,366	(466)
Lease - Building	16,000	8,000	4,500	3,500
Public Officials Insurance	4,200	4,200	4,557	(357)
Misc-Election Fee	-	-	240	(240)
Misc-Event Expense	250,000	50,000	33,615	16,385
Council Expenses	50,000	25,000	41,767	(16,767)
Dues, Licenses, Subscriptions	1,600	1,300	3,042	(1,742)
Total Legislative	414,200	134,700	122,382	12,318
<u>City Manager</u>				
Contracts-City Manager	220,000	110,000	110,000	-
Office Supplies	12,300	6,150	4,897	1,253
Dues, Licenses, Subscriptions	2,900	1,450	2,420	(970)
Total City Manager	235,200	117,600	117,317	283
<u>City Clerk</u>				
ProfServ-Web Site Maintenance	6,100	2,300	5,274	(2,974)
Contracts-City Clerk	218,600	109,300	109,300	-
Postage and Freight	1,500	750	184	566
Printing	15,500	7,750	7	7,743
Legal Advertising	23,200	11,600	4,631	6,969
Miscellaneous Services	1,300	650	404	246
Miscellaneous Expenses	-	-	545	(545)
Office Supplies	2,900	1,450	-	1,450
Dues, Licenses, Subscriptions	19,700	10,870	9,858	1,012
Total City Clerk	288,800	144,670	130,203	14,467
<u>Finance</u>				
Auditing Services	7,000	-	-	-
Contracts-Finance	85,600	42,800	42,800	-
Total Finance	92,600	42,800	42,800	-

Statement of Revenues, Expenditures and Changes in Fund Balances
For the Period Ending March 31, 2024

ACCOUNT DESCRIPTION	ANNUAL ADOPTED BUDGET	YEAR TO DATE BUDGET	YEAR TO DATE ACTUAL	VARIANCE (\$) FAV(UNFAV)
<u>Legal Counsel</u>				
ProfServ-Legal Services	101,400	50,700	37,798	12,902
Total Legal Counsel	101,400	50,700	37,798	12,902
<u>Other Administrative Services</u>				
ProfServ-Info Technology	81,100	40,550	40,902	(352)
Contracts-Admin. Service	286,100	143,050	140,968	2,082
Misc-Assessment Collection Cost	5,000	5,000	4,334	666
General Government	150,000	75,000	12,001	62,999
Total Other Administrative Services	522,200	263,600	198,205	65,395
<u>Facility Services</u>				
Telephone, Cable & Internet Service	16,200	8,100	6,336	1,764
Lease - Copier	12,500	6,250	6,375	(125)
Lease - Building	86,700	43,350	-	43,350
Insurance (Liab,Auto,Property)	8,100	8,100	11,017	(2,917)
Miscellaneous Services	1,700	850	523	327
Cleaning Services	26,000	13,000	9,469	3,531
Principal-Capital Lease	18,200	9,773	11,800	(2,027)
Interest-Capital Lease	4,400	2,232	3,131	(899)
Total Facility Services	173,800	91,655	48,651	43,004
<u>Community Services</u>				
Contracts-Solid Waste	926,300	463,150	514,129	(50,979)
Contracts-Sheriff	1,025,600	512,800	512,792	8
Electricity	142,700	71,350	67,074	4,276
R&M-Community Maintenance	29,100	14,550	14,550	-
Operating Supplies	57,300	28,650	27,955	695
Roadway Services	28,000	14,000	15,000	(1,000)
Total Community Services	2,209,000	1,104,500	1,151,500	(47,000)
<u>Capital Expenditures & Projects</u>				
Capital Improvements	50,000	50,000	-	50,000
Cap Outlay - Equipment	-	-	38,266	(38,266)
Total Capital Expenditures & Projects	50,000	50,000	38,266	11,734

Statement of Revenues, Expenditures and Changes in Fund Balances
For the Period Ending March 31, 2024

ACCOUNT DESCRIPTION	ANNUAL ADOPTED BUDGET	YEAR TO DATE BUDGET	YEAR TO DATE ACTUAL	VARIANCE (\$) FAV(UNFAV)
<u>Reserves</u>				
Misc-Contingency	201,900	100,950	4,022	96,928
1st Quarter Operating Reserves	1,059,800	529,900	-	529,900
Reserve - Capital Projects	200,000	100,000	-	100,000
Total Reserves	1,461,700	730,850	4,022	726,828
TOTAL EXPENDITURES & RESERVES	5,548,900	2,731,075	1,891,144	839,931
Excess (deficiency) of revenues				
Over (under) expenditures	1,099,796	3,099,221	3,811,727	712,506
<u>OTHER FINANCING SOURCES (USES)</u>				
Contribution to (Use of) Fund Balance	1,099,796	-	-	-
TOTAL FINANCING SOURCES (USES)	1,099,796	-	-	-
Net change in fund balance	\$ 1,099,796	\$ 3,099,221	\$ 3,811,727	\$ 712,506
FUND BALANCE, BEGINNING (OCT 1, 2023)	2,849,284	2,849,284	2,849,284	
FUND BALANCE, ENDING	\$ 3,949,080	\$ 5,948,505	\$ 6,661,011	

Statement of Revenues, Expenditures and Changes in Fund Balances
For the Period Ending March 31, 2024

ACCOUNT DESCRIPTION	ANNUAL ADOPTED BUDGET	YEAR TO DATE BUDGET	YEAR TO DATE ACTUAL	VARIANCE (\$) FAV(UNFAV)
<u>REVENUES</u>				
Interest - Investments	\$ -	\$ -	\$ 90,454	\$ 90,454
Dividends	-	-	15,603	15,603
Donations	300,000	150,000	388,500	238,500
TOTAL REVENUES	300,000	150,000	494,557	344,557
<u>EXPENDITURES</u>				
<u>Public Assistance</u>				
Misc-Admin Fee (%)	21,000	10,500	3,990	6,510
Assistance Program	279,000	139,500	-	139,500
Total Public Assistance	300,000	150,000	3,990	146,010
TOTAL EXPENDITURES	300,000	150,000	3,990	146,010
Excess (deficiency) of revenues Over (under) expenditures	-	-	490,567	490,567
Contribution to (Use of) Fund Balance	-	-	-	-
Net change in fund balance	\$ -	\$ -	\$ 490,567	\$ 490,567
FUND BALANCE, BEGINNING (OCT 1, 2023)	4,381,728	4,381,728	4,381,728	
FUND BALANCE, ENDING	\$ 4,381,728	\$ 4,381,728	\$ 4,872,295	

Statement of Revenues, Expenditures and Changes in Fund Balances
For the Period Ending March 31, 2024

ACCOUNT DESCRIPTION	ANNUAL ADOPTED BUDGET	YEAR TO DATE BUDGET	YEAR TO DATE ACTUAL	VARIANCE (\$) FAV(UNFAV)
<u>REVENUES</u>				
Building Permits	\$ 2,284,500	\$ 1,142,250	\$ 487,628	\$ (654,622)
Reinspection Fees	4,800	2,400	250	(2,150)
Building Permits - Surcharge	4,200	2,100	3,280	1,180
Other Building Permit Fees	30,000	15,000	48,000	33,000
Building Permits - Admin Fee	135,400	67,700	65,710	(1,990)
Engineering Permits	330,500	165,250	41,272	(123,978)
Planning & Zoning Permits	293,200	146,600	31,291	(115,309)
TOTAL REVENUES	3,082,600	1,541,300	677,431	(863,869)
<u>EXPENDITURES</u>				
<u>Comprehensive Planning</u>				
ProfServ-Engineering	308,500	154,250	79,677	74,573
ProfServ-Info Technology	200,800	100,400	135,097	(34,697)
ProfServ-Legal Services	75,300	37,650	14,520	23,130
ProfServ-Planning/Zoning Board	293,200	146,600	151,288	(4,688)
ProfServ-Compliance Service	185,800	92,900	90,000	2,900
ProfServ-Consultants	22,000	11,000	-	11,000
ProfServ-Building Permits	1,796,000	898,000	644,538	253,462
Outside Legal Services	1,800	900	-	900
Telephone, Cable & Internet Service	5,300	2,650	2,805	(155)
Lease - Copier	6,800	3,400	2,777	623
Lease - Building	43,400	21,700	-	21,700
Printing	2,200	1,100	713	387
Miscellaneous Services	1,300	650	9,352	(8,702)
Misc-Admin Fee (%)	116,600	58,300	58,299	1
Office Supplies	2,100	1,050	136	914
Cleaning Services	15,900	7,950	7,500	450
Principal-Capital Lease	4,500	2,393	-	2,393
Interest-Capital Lease	1,100	558	-	558
Total Comprehensive Planning	3,082,600	1,541,451	1,196,702	344,749
TOTAL EXPENDITURES	3,082,600	1,541,451	1,196,702	344,749

Statement of Revenues, Expenditures and Changes in Fund Balances
For the Period Ending March 31, 2024

ACCOUNT DESCRIPTION	ANNUAL ADOPTED BUDGET	YEAR TO DATE BUDGET	YEAR TO DATE ACTUAL	VARIANCE (\$) FAV(UNFAV)
Excess (deficiency) of revenues				
Over (under) expenditures	-	(151)	(519,271)	(519,120)
Net change in fund balance	\$ -	\$ (151)	\$ (519,271)	\$ (519,120)
FUND BALANCE, BEGINNING (OCT 1, 2023)	519,720	519,719	519,720	
FUND BALANCE, ENDING	\$ 519,720	\$ 519,568	\$ 449	

City of Westlake

Supporting Schedules

March 31, 2024

Cash and Investment Report

March 31, 2024

GENERAL FUND

<u>Account Name</u>	<u>Bank Name</u>	<u>Investment Type</u>	<u>Yield</u>	<u>Balance</u>
Checking Account - Operating	BankUnited	Checking Account	n/a	\$2,084,736
Money Market	BankUnited	MMA	5.25%	\$5,922,282
		Subtotal		<u>\$8,007,018</u>

SPECIAL REVENUE FUND

Money Market	BankUnited	MMA	5.25%	\$1,152,459
Government Checking	Valley Bank	Checking Account	5.25%	\$1,290,853
Brokerage Account	Valley Bank	Government Fund Class A	4.93%	\$1,830,610
		Subtotal		<u>\$4,273,922</u>
		Total		<u>\$12,280,940</u>

File Attachments for Item:

A. Proclamation 2024-08 - Water Reuse

Proclamation

DECLARING MAY 14-20, 2024 AS FLORIDA WATER REUSE WEEK

WHEREAS, safe, clean and sustainable water resources are essential to Florida’s environment, economy, citizens, and visitors and

WHEREAS, although Florida’s water supplies are finite, the state’s population and need for water resources continues to increase; and

WHEREAS, water reuse provides a means for conserving and augmenting Florida’s precious water resources and is key to the state’s sustainable water future; and

WHEREAS, Florida has established the encouragement and promotion of water reuse as state objectives in Chapters 373 and 403, Florida Statutes; and

WHEREAS, Florida’s permitted reuse capacity is more than 1.8 billion gallons per day (approximately 70 percent of Florida’s total permitted capacity for all domestic wastewater treatment facilities); and

WHEREAS, Florida has risen to be the national leader in water reuse -- reusing nearly 820 million gallons of reclaimed water per day to conserve freshwater supplies and recharge our freshwater resources; and

WHEREAS, May, typically a dry month when water demands are high, is a good time to educate residents about how they can help save Florida’s precious water resources through water reuse; and

WHEREAS, Water Reuse Florida, the state section of the Water Reuse Association, has proclaimed the week of May 14-20, 2024, as Florida Water Reuse Week; and

WHEREAS, the City of Westlake has joined with Water Reuse Florida, the Florida Department of Environmental Protection, and South Florida Water Management District in encouraging and promoting water reuse and conservation; and

WHEREAS, the City of Westlake encourages efficient and effective use of reclaimed water; and

NOW, THEREFORE, ON BEHALF OF THE CITY COUNCIL AND THE PEOPLE OF THE CITY OF WESTLAKE, I, JOHNPAUL O’CONNOR, MAYOR OF THE CITY OF WESTLAKE, BY VIRTUE OF THE AUTHORITY VESTED IN ME, DO HEREBY OFFICIALLY PROCLAIM AND RECOGNIZE MAY 14 THROUGH MAY 20, 2024, AS:

WATER REUSE WEEK

The foregoing proclamation was sponsored by Vice Mayor Greg Langowski, and upon unanimous consent of the Council, the Mayor declared the proclamation duly enacted.

IN WITNESS WHEREOF, I have hereunto set my hand and caused the seal of the City of Westlake, Florida to be affixed this 7th day of May 2024.

JohnPaul O’Connor, Mayor

ATTEST:

Zoie P. Burgess, CMC
City Clerk

File Attachments for Item:

B. Proclamation 2024-09 - National Days of Remembrance

Proclamation

DECLARING MAY 5-12, 2024 AS NATIONAL DAYS OF REMEMBRANCE

WHEREAS, the Holocaust was the state-sponsored, systematic persecution and annihilation of European Jewry by Nazi Germany and its collaborators between 1933 and 1945. Jews were the primary victims-six million Jews were murdered; Roma, people with disabilities, and Poles were also targeted for destruction or decimation for racial, ethnic, or national reasons. Millions more, including gay men, Jehovah's Witnesses, Soviet prisoners of war, and political dissidents, also suffered grievous oppression and death under Nazi tyranny; and

WHEREAS, the history of the Holocaust offers an opportunity to reflect on the moral responsibilities of individuals, societies, and governments; and

WHEREAS, we the people of the City of Westlake should always remember the terrible events of the Holocaust and remain vigilant against hatred, persecution, and tyranny; and

WHEREAS, we the people of the City of Westlake should actively rededicate ourselves to the principles of individual freedom in a just society; and

WHEREAS, the Days of Remembrance have been set aside for the people of the City of Westlake to remember the victims of the Holocaust as well as to reflect on the need for respect of all peoples; and

WHEREAS, pursuant to an Act of Congress (Public Law 96-388, October 7, 1980), the United States Holocaust Memorial Council designates the Days of Remembrance of the Victims of the Holocaust to be Sunday, May 5, through Sunday, May 12, 2024, including the Day of Remembrance known as Yom Hashoah, May 6, 2024.

NOW, THEREFORE, ON BEHALF OF THE CITY COUNCIL AND THE PEOPLE OF THE CITY OF WESTLAKE, I, JOHNPAUL O'CONNOR, MAYOR OF THE CITY OF WESTLAKE, DO HEREBY PROCLAIM THE WEEK OF SUNDAY, MAY 5, THROUGH SUNDAY, MAY 12, 2024, AS:

DAYS OF REMEMBRANCE

in memory of the victims of the Holocaust and in honor of the survivors as well as the rescuers and liberators, and further proclaim that we, as citizens of the City of Westlake, should work to promote human dignity and confront hate whenever and wherever it occurs.

The foregoing proclamation was sponsored by Council Member Gary Werner, and upon unanimous consent of the Council, the Mayor declared the proclamation duly enacted.

IN WITNESS WHEREOF, I have hereunto set my hand and caused the seal of the City of Westlake, Florida to be affixed this 7th day of May 2024.

JohnPaul O'Connor, Mayor

ATTEST:

Zoie P. Burgess, CMC
City Clerk

File Attachments for Item:

C. Proclamation 2024-10 - 55th Annual Professional Municipal Clerk's Week

Proclamation

55TH ANNUAL PROFESSIONAL MUNICIPAL CLERKS WEEK MAY 5 – 11, 2024

WHEREAS, The Office of the Professional Municipal Clerk, a time honored and vital part of local government exists throughout the world, and

WHEREAS, The Office of the Professional Municipal Clerk is the oldest among public servants, and

WHEREAS, The Office of the Professional Municipal Clerk provides the professional link between the citizens, the local governing bodies, and agencies of government at other levels, and

WHEREAS, Professional Municipal clerks have pledged to be ever mindful of their neutrality and impartiality, rendering equal service to all.

WHEREAS, The Professional Municipal Clerk serves as the information center on functions of local government and community.

WHEREAS, Professional Municipal Clerks continually strive to improve the administration of the affairs of the Office of the Professional Municipal Clerk through participation in education programs, seminars, workshops and the annual meetings of their state, provincial, county and international professional organizations.

WHEREAS, it is most appropriate that we recognize the accomplishments of the Office of the Professional Municipal Clerk.

NOW, THEREFORE, I, JOHNPAUL O’CONNOR, MAYOR OF THE CITY OF WESTLAKE, DO RECOGNIZE THE WEEK OF MAY 5 THROUGH 11, 2024, AS PROFESSIONAL MUNICIPAL CLERKS WEEK, AND FURTHER EXTEND APPRECIATION TO OUR PROFESSIONAL MUNICIPAL CLERK, ZOIE BURGESS AND TO ALL PROFESSIONAL MUNICIPAL CLERKS FOR THE VITAL SERVICES THEY PERFORM AND THEIR EXEMPLARY DEDICATION TO THE COMMUNITIES THEY REPRESENT.

The foregoing proclamation was sponsored by Vice Mayor Greg Langowski, and upon unanimous consent of the Council, the Mayor declared the proclamation duly enacted.

IN WITNESS WHEREOF, I have hereunto set my hand and caused the seal of the City of Westlake, Florida to be affixed this 7th day of May 2024.

JohnPaul O’Connor, Mayor

ATTEST:

Zoie P. Burgess, CMC
City Clerk

File Attachments for Item:

D. Proclamation 2024-11 - Mental Health Awareness Month

Proclamation

DECLARING THE MONTH OF MAY MENTAL HEALTH AWARENESS MONTH

WHEREAS, each year in May, Mental Health Awareness Month is recognized to support efforts at fighting the stigma associated with mental health, providing support, educating the public, and advocating for equal care; and

WHEREAS, according to the National Institute of Mental Health, studies show there are an estimated 52.9 million adults aged 18 or older in the United States suffering from mental illness, representing over 20 percent of all U.S. adults; and

WHEREAS, these studies also reveal that one-half of all chronic mental illness begins by the age of 14 and that young adults between the ages of 18-25 have the highest prevalence of mental illness; and

WHEREAS, Americans of all ages, genders, races, and socioeconomic status can experience times of difficulty and stress in their lives that contribute to their mental health; and

WHEREAS, the stigma surrounding mental illness can cause sufferers to postpone or neglect seeking treatment. With early and effective diagnoses and treatment, individuals with mental health conditions can manage their needs and lead full, productive lives; and

WHEREAS, every business, government agency, school, healthcare provider, organization, and individual citizen shares a responsibility in promoting and supporting mental health awareness.

NOW, THEREFORE, ON BEHALF OF THE CITY COUNCIL AND THE PEOPLE OF THE CITY OF WESTLAKE, I, JOHNPAUL O’CONNOR, MAYOR OF THE CITY OF WESTLAKE, BY VIRTUE OF THE AUTHORITY VESTED IN ME, DO HEREBY OFFICIALLY PROCLAIM AND RECOGNIZE THE MONTH OF MAY AS:

MENTAL HEALTH AWARENESS MONTH

in the City of Westlake and encourage all citizens to help to reduce the stigma, normalize mental health challenges, and encourage those who are experiencing mental health struggles to know that recovery is possible.

The foregoing proclamation was sponsored by Council Member Charlotte Leonard, and upon unanimous consent of the Council, the Mayor declared the proclamation duly enacted.

IN WITNESS WHEREOF, I have hereunto set my hand and caused the seal of the City of Westlake, Florida to be affixed this 7th day of May 2024.

JohnPaul O’Connor, Mayor

ATTEST:

Zoie P. Burgess, CMC
City Clerk

File Attachments for Item:

A. A Resolution for the Plat of Westlake Pod G – North.

Submitted By: Engineering

RESOLUTION 2024-08

A RESOLUTION OF THE CITY COUNCIL FOR THE CITY OF WESTLAKE, FLORIDA, APPROVING THE PLAT OF WESTLAKE POD G – NORTH, BEING A PORTION OF SECTION 1, TOWNSHIP 43 SOUTH, RANGE 40 EAST, CITY OF WESTLAKE, PALM BEACH COUNTY, FLORIDA, AND BEING, IN PART, A REPLAT OF ALL OF TRACT "B", TOWN CENTER PARKWAY SOUTH - WEST, PLAT BOOK 132, PAGES 57 AND 58, AND A PORTION OF OPEN SPACE TRACT #1, PERSIMMON BOULEVARD WEST - PLAT 2, PLAT BOOK 134, PAGES 164 THROUGH 166, INCLUSIVE, BOTH OF THE PUBLIC RECORDS OF PALM BEACH COUNTY, FLORIDA. PROVIDING FOR RECORDATION, PROVIDING FOR CONFLICTS; PROVIDING FOR SEVERABILITY; AND PROVIDING AN EFFECTIVE DATE.



Meeting Agenda Item Coversheet

MEETING DATE:		May 7, 2024	Submitted By: Engineering	
SUBJECT: <i>This will be the name of the Item as it will appear on the Agenda</i>		A Resolution for the Plat of Westlake Pod G – North.		
STAFF RECOMMENDATION: (MOTION READY)		Motion to Approve		
SUMMARY and/or JUSTIFICATION:		The City of Westlake has the exclusive jurisdiction to approve the plat pursuant to Florida Statutes, §177.071. The application has been reviewed and approved by a Professional Surveyor and Mapper for the City of Westlake, and said Surveyor and Mapper has found the application to be consistent with the requirement under Florida Statutes, Chapter 177. The plat includes 57.595 acres of land. The plat has been reviewed and approved by the City Engineer, SID, and the City Attorney.		
SELECT, if applicable	AGREEMENT:		BUDGET:	
	STAFF REPORT:	X	PROCLAMATION:	
	EXHIBIT(S):	X	OTHER:	
IDENTIFY EACH ATTACHMENT. <i>For example, an agreement may have 2 exhibits, identify the agreement and Exhibit A and Exhibit B</i>	Agenda Item Cover Sheet Staff Report Resolution Legal Description Plat Boundary Survey Approval Letter(s)			
SELECT, if applicable	RESOLUTION:	X	ORDINANCE:	
IDENTIFY FULL RESOLUTION OR ORDINANCE TITLE <i>(if Item is <u>not</u> a Resolution or Ordinance, please erase all default text from this field's textbox and leave blank)</i>	A RESOLUTION OF THE CITY COUNCIL FOR THE CITY OF WESTLAKE, FLORIDA, APPROVING THE PLAT OF WESTLAKE POD G – NORTH, BEING A PORTION OF SECTION 1, TOWNSHIP 43 SOUTH, RANGE 40 EAST, CITY OF WESTLAKE, PALM BEACH COUNTY, FLORIDA, AND BEING, IN PART, A REPLAT OF ALL OF TRACT "B", TOWN CENTER PARKWAY SOUTH - WEST, PLAT BOOK 132, PAGES 57 AND 58, AND A PORTION OF OPEN SPACE TRACT #1, PERSIMMON BOULEVARD WEST - PLAT 2, PLAT BOOK 134, PAGES 164 THROUGH 166, INCLUSIVE, BOTH OF THE PUBLIC RECORDS OF PALM BEACH COUNTY, FLORIDA. PROVIDING FOR RECORDATION, PROVIDING FOR CONFLICTS; PROVIDING FOR SEVERABILITY; AND PROVIDING AN EFFECTIVE DATE.			
FISCAL IMPACT (if any):			\$	

RESOLUTION 2024-08

A RESOLUTION OF THE CITY COUNCIL FOR THE CITY OF WESTLAKE, FLORIDA, APPROVING THE PLAT OF WESTLAKE POD G – NORTH, BEING A PORTION OF SECTION 1, TOWNSHIP 43 SOUTH, RANGE 40 EAST, CITY OF WESTLAKE, PALM BEACH COUNTY, FLORIDA, AND BEING, IN PART, A REPLAT OF ALL OF TRACT "B", TOWN CENTER PARKWAY SOUTH - WEST, PLAT BOOK 132, PAGES 57 AND 58, AND A PORTION OF OPEN SPACE TRACT #1, PERSIMMON BOULEVARD WEST - PLAT 2, PLAT BOOK 134, PAGES 164 THROUGH 166, INCLUSIVE, BOTH OF THE PUBLIC RECORDS OF PALM BEACH COUNTY, FLORIDA. PROVIDING FOR RECORDATION, PROVIDING FOR CONFLICTS; PROVIDING FOR SEVERABILITY; AND PROVIDING AN EFFECTIVE DATE.

WHEREAS, Minto PBLH, LLC, a Florida Limited Liability Company, as the Owner has requested approval for the plat of Westlake Pod G – North, being a portion of Section 1, Township 43 South, Range 40 East, City of Westlake, Palm Beach County, Florida, and being, in part, a replat of all of Tract “B”, Town Center Parkway South – West, Plat Book 132, Pages 57 and 58, and a portion of Open Space Tract #1, Persimmon Boulevard West – Plat 2, Plat Book 134, pages 164 through 166, inclusive, both of the Public Records of Palm Beach County, Florida, in the City of Westlake, Palm Beach County, containing approximately 57.595 acres as described in Exhibit "A", attached hereto; and

WHEREAS, the City of Westlake has the exclusive jurisdiction to approve the plat and boundary survey pursuant to Florida Statutes, §177.071; and

WHEREAS, the application has been reviewed and approved by a Professional Surveyor and Mapper for the City of Westlake, and said Surveyor and Mapper has found the application to be consistent with the requirements under Florida Statutes, Chapter 177; and

WHEREAS, the Building staff, Engineering staff and Planning staff for the City of Westlake have reviewed the application, the final plat, attached hereto as “Exhibit B”, and the boundary survey, attached hereto as “Exhibit C”, and the collective staff has recommended approval; and

WHEREAS, after careful review and consideration, the collective staff has determined that this application has complied with the City’s Land Development Regulations and Florida law.

NOW THEREFORE, BE IT RESOLVED BY THE CITY COUNCIL FOR THE CITY OF WESTLAKE, FLORIDA, THAT:

Section 1: **INCORPORATION.** The above recitals are true and correct and are incorporated herein by this reference.

Section 2: **CITY COUNCIL APPROVALS.** The City Council for the City of Westlake hereby approves the final plat, “Exhibit B” and boundary survey, “Exhibit C” for Westlake Pod G – North, as described in the attached Exhibit "A", containing approximately 57.595 acres, which is located in the City of Westlake, and in Palm Beach County, Florida.

Section 3: **RECORDATION.** The applicant shall provide a certified copy of the recorded plat and the applicant shall cover the costs of recording the plat in the public records in and for Palm Beach County Florida.

Section 4: **SCRIVENER'S ERRORS.** This Resolution can be renumbered or re-lettered and typographical errors and clarification of ambiguous wording that do not affect the intent can be corrected with the authorization of the City Manager and City Attorney without the need for public hearing.

Section 5: **EFFECTIVE DATE.** This resolution shall take effect immediately upon its adoption.

Section 6: **CONFLICTS.** All resolutions or parts of resolutions in conflict herewith are hereby repealed to the extent of such conflict.

Section 7: **SEVERABILITY.** If any clause, section, other part or application of this Resolution is held by any court of competent jurisdiction to be unconstitutional or invalid, in part or application, it shall not affect the validity of the remaining portions or applications of this Resolution.

PASSED AND APPROVED by City Council for the City of Westlake, on this ____ day of _____, 2024.

PUBLISHED on this ____ day of _____ in the Palm Beach Post.

City of Westlake
JohnPaul O' Connor, Mayor

Zoie Burgess, City Clerk

Approved as to Form and Sufficiency
_____, City Attorney
(PRINT NAME)



CITY OF WESTLAKE
Engineering Department
 4001 Seminole Pratt Whitney Road
 Westlake, Florida 33470
 Phone: (561) 530-5880
 www.westlakegov.com

STAFF MEMORANDUM

DATE: 4/18/2024
PETITION NO.: ENG-2024-01
DESCRIPTION: Review of Plat for Westlake Pod G - North
APPLICANT: Cotleur and Hearing
OWNER: Minto PBLH, LLC
REQUEST: Owner (Minto PBLH, LLC) is requesting approval of the Plat for Westlake Pod G – North

Final Recommendation

The Office of the City Engineer has reviewed the documents associated with the application referenced above and recommends approval by the Council. Approval by the Seminole Improvement District’s Engineering Department is scheduled for May 6, 2024, and approval by the Board of Supervisors is scheduled for May 7, 2024.

Discussion

Westlake Pod G – North will contain 57.595 acres of land. Westlake Pod G – North is located in the northern portion of Westlake, south of Pod E, southwest of Pod F, west of Pod L, and bounded by Town Center Parkway N and Town Center Parkway South, as shown in the graphics below. The primary access points to Westlake Pod G – North have yet to be determined and will be specified later with a site plan submittal. However, access is available through Town Center Parkway South and Town Center Parkway North.



Location Map

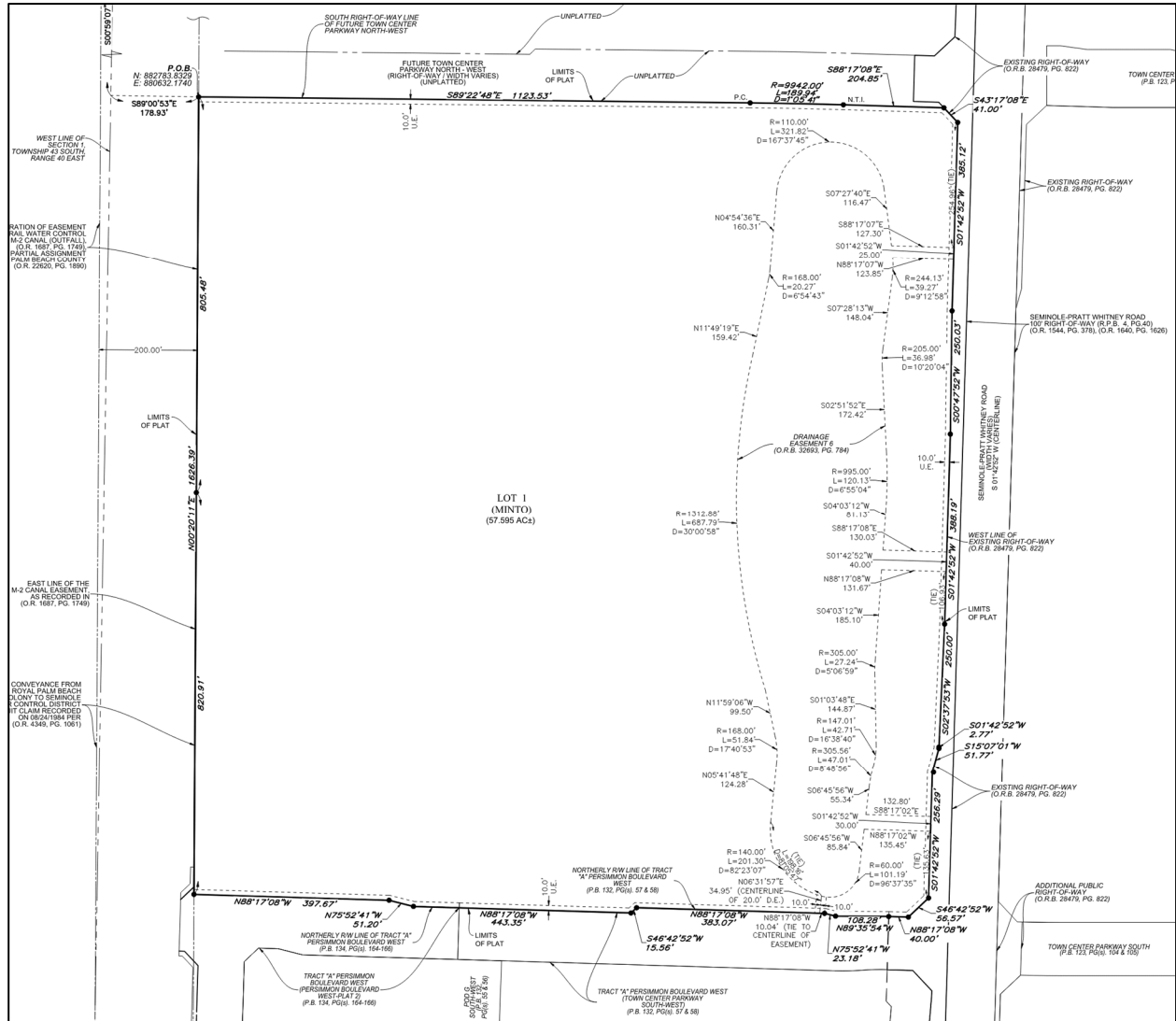

Westlake Pod G – North is comprised of a portion of Section 1, Township 43 South, Range 40 East, City of Westlake, Palm Beach County, Florida, and being, in part, a replat of all of Tract “B”, Town Center Parkway South – West, Plat Book 132, pages 57 and 58, and a portion of Open Space Tract #1, Persimmon Boulevard West – Plat 2, Plat Book 134, pages 164 through 166, inclusive, both of the Public Records of Palm Beach County, Florida. Images from the plats of Town Center Parkway South – West showing the location of Tract “B” and Persimmon Boulevard West – Plat 2 showing the location of O.S.T. #1 U.E. are shown in Figure 1 and Figure 2, respectively.

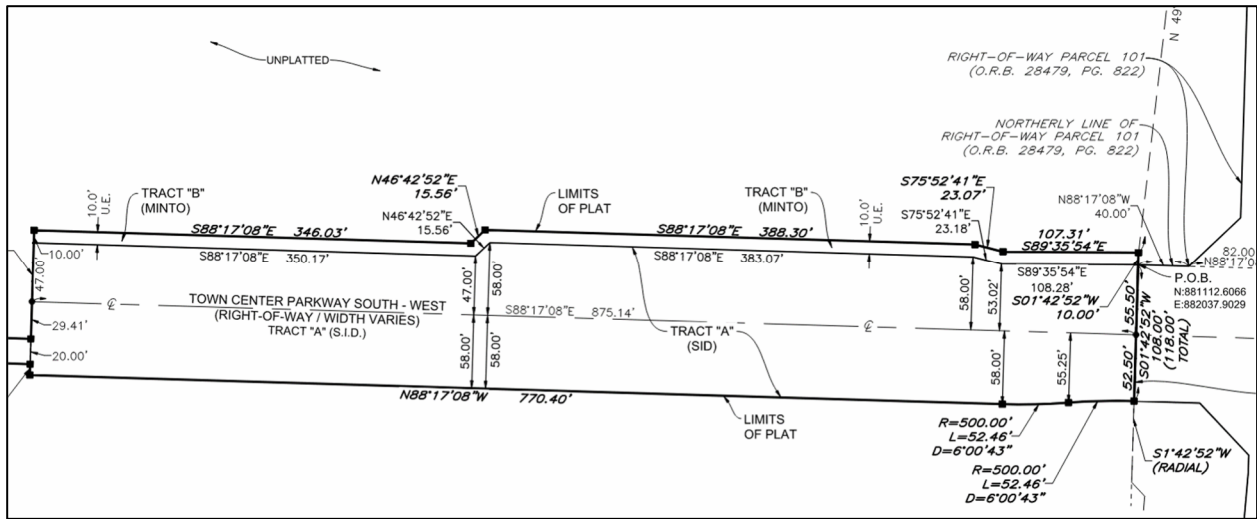

Figure 1. Image from Town Center Parkway South – West (P.B. 132, P.G. 57 – 58) showing the location of Tract “B” (MINTO).

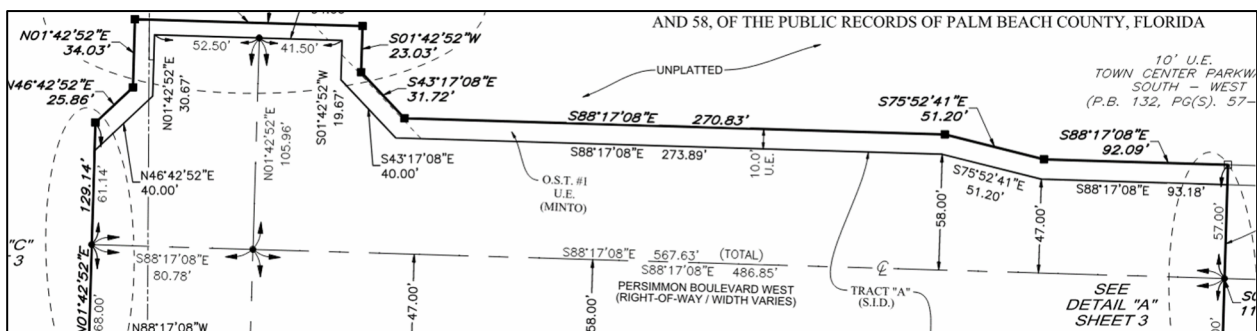

Figure 2. Image from Persimmon Boulevard West – Plat 2 (P.B. 134, P.G. 164 – 166) showing the location of O.S.T. #1 U.E. (MINTO).

The Legal Description of the Plat can be found in Exhibit A, and replications of the plat and plat topographical survey can be found in Exhibits B and C.

Review Criteria

Plats shall be prepared in accordance with the provisions of Chapter 177 F.S., as amended, and the City of Westlake Land Development Regulations. The plat was reviewed for clarity, legibility, and conformance with this statute and City requirements. The plat provides a graphic depiction of the legal description through geometric data. The data includes but is not limited to parcel, block, tract, right-of-way, street and associated names, easement, permanent reference monuments and permanent control points, and interior excepted parcels. Other requirements such as paper size, line work, layout of sheet and required content including the subdivision name, title, legal description, key map, vicinity map, north arrow, scale, and legend are verified in the Engineering Department review.

Conclusion

Two (2) reviews of the plat occurred, which resulted in an acceptable plat. The review was done for compliance with Chapters 177, 5J-17, Florida Statutes, and the City of Westlake’s codes and ordinances. All comments have been adequately addressed and the plat is in compliance. We therefore recommend that the plat be approved for recording.

Exhibit 'A'
WESTLAKE POD G – NORTH
LEGAL DESCRIPTION

THIS PAGE WAS LEFT BLANK ON PURPOSE

DESCRIPTION: POD G NORTH

BEING A PORTION OF SECTION 1, TOWNSHIP 43 SOUTH, RANGE 40 EAST, CITY OF WESTLAKE, PALM BEACH COUNTY, FLORIDA, AND BEING, IN PART, A REPLAT OF ALL OF TRACT "B", TOWN CENTER PARKWAY SOUTH - WEST, PLAT BOOK 132, PAGES 57 AND 58, AND A PORTION OF OPEN SPACE TRACT #1, PERSIMMON BOULEVARD WEST - PLAT 2, PLAT BOOK 134, PAGES 164 THROUGH 166, INCLUSIVE, BOTH OF THE PUBLIC RECORDS OF PALM BEACH COUNTY, FLORIDA, BEING MORE PARTICULARLY DESCRIBED AS FOLLOWS:

COMMENCE AT THE NORTHWEST CORNER OF SECTION 1, TOWNSHIP 43 SOUTH, RANGE 40 EAST; THENCE S.00°59'07"W., ALONG THE WEST LINE OF SAID SECTION 1, TOWNSHIP 43 SOUTH, RANGE 40 EAST, A DISTANCE OF 1825.69 FEET; THENCE S.89°00'53"E., DEPARTING SAID WEST LINE OF SECTION 1, A DISTANCE OF 178.93 FEET TO A POINT ON THE EAST LINE OF M-2 CANAL EASEMENT, AS RECORDED IN OFFICIAL RECORDS BOOK 1687, PAGE 1749, PUBLIC RECORDS OF PALM BEACH COUNTY, FLORIDA AND THE POINT OF BEGINNING; THENCE ALONG THE SOUTH RIGHT-OF-WAY LINE OF FUTURE TOWN CENTER PARKWAY NORTH-WEST FOR THE FOLLOWING THREE (3) COURSES: 1) THENCE S.89°22'48"E., A DISTANCE OF 1123.53 FEET TO A POINT OF CURVATURE OF A CURVE CONCAVE TO THE SOUTHWEST, WITH A RADIUS OF 9942.00 FEET; 2) THENCE EASTERLY, ALONG THE ARC OF SAID CURVE THROUGH A CENTRAL ANGLE OF 01°05'41", A DISTANCE OF 189.94 FEET TO A POINT OF NON-TANGENCY; 3) THENCE S.88°17'08"E., A DISTANCE OF 204.85 FEET TO A POINT ON THE WESTERLY LINE OF EXISTING RIGHT-OF-WAY FOR SEMINOLE-PRATT WHITNEY ROAD, AS RECORDED IN OFFICIAL RECORDS BOOK 28479, PAGE 822, OF THE PUBLIC RECORDS OF PALM BEACH COUNTY, FLORIDA; THENCE ALONG SAID WESTERLY LINE OF EXISTING RIGHT-OF-WAY FOR SEMINOLE-PRATT WHITNEY ROAD FOR THE FOLLOWING TEN (10) COURSES: 1) THENCE S.43°17'08"E., A DISTANCE OF 41.00 FEET; 2) THENCE S.01°42'52"W., A DISTANCE OF 385.12 FEET; 3) THENCE S.00°47'52"W., A DISTANCE OF 250.03 FEET; 4) THENCE S.01°42'52"W., A DISTANCE OF 388.19 FEET; 5) THENCE S.02°37'53"W., A DISTANCE OF 250.00 FEET; 6) THENCE S.01°42'52"W., A DISTANCE OF 2.77 FEET; 7) THENCE S.15°07'01"W., A DISTANCE OF 51.77 FEET; 8) THENCE S.01°42'52"W., A DISTANCE OF 256.29 FEET; 9) THENCE S.46°42'52"W., A DISTANCE OF 56.57 FEET; 10) THENCE N.88°17'08"W., A DISTANCE OF 40.00 FEET TO A POINT ON THE NORTHERLY RIGHT-OF-WAY LINE OF TRACT "A", AS SHOWN ON THE PLAT OF TOWN CENTER PARKWAY SOUTH-WEST, RECORDED IN PLAT BOOK 132, PAGES 57 AND 58, OF SAID PUBLIC RECORDS; THENCE ALONG SAID NORTHERLY RIGHT-OF-WAY LINE OF TRACT "A" AND ALONG THE NORTHERLY RIGHT-OF-WAY LINE OF TRACT "A", AS SHOWN ON THE PLAT OF PERSIMMON BOULEVARD WEST - PLAT 2, RECORDED IN PLAT BOOK 134, PAGES 164 THROUGH 166, OF SAID PUBLIC RECORDS FOR THE FOLLOWING SEVEN (7) COURSES; 1) THENCE N.89°35'54"W., A DISTANCE OF 108.28 FEET; 2) THENCE N.75°52'41"W., A DISTANCE OF 23.18 FEET; 3) THENCE N.88°17'08"W., A DISTANCE OF 383.07 FEET; 4) THENCE S.46°42'52"W., A DISTANCE OF 15.56 FEET; 5) THENCE N.88°17'08"W., A DISTANCE OF 443.35 FEET; 6) THENCE N.75°52'41"W., A DISTANCE OF 51.20 FEET; 7) THENCE N.88°17'08"W., A DISTANCE OF 397.67 FEET TO A POINT ON THE EAST LINE OF M-2 CANAL EASEMENT, AS RECORDED IN OFFICIAL RECORDS BOOK 1687, PAGE 1749, OF SAID PUBLIC RECORDS; THENCE N.00°20'11"E., ALONG SAID EAST LINE OF M-2 CANAL EASEMENT, A DISTANCE OF 1626.39 FEET TO THE POINT OF BEGINNING.

CONTAINING: 2,508,849 SQUARE FEET OR 57.595 ACRES, MORE OR LESS.

Exhibit 'B'
WESTLAKE POD G – NORTH
PLAT

THIS PAGE WAS LEFT BLANK ON PURPOSE

WESTLAKE POD G - NORTH

BEING A PORTION OF SECTION 1, TOWNSHIP 43 SOUTH, RANGE 40 EAST, CITY OF WESTLAKE, PALM BEACH COUNTY, FLORIDA, AND BEING, IN PART, A REPLAT OF ALL OF TRACT "B", TOWN CENTER PARKWAY SOUTH - WEST, PLAT BOOK 132, PAGES 57 AND 58, AND A PORTION OF OPEN SPACE TRACT #1, PERSIMMON BOULEVARD WEST - PLAT 2, PLAT BOOK 134, PAGES 164 THROUGH 166, INCLUSIVE, BOTH OF THE PUBLIC RECORDS OF PALM BEACH COUNTY, FLORIDA.

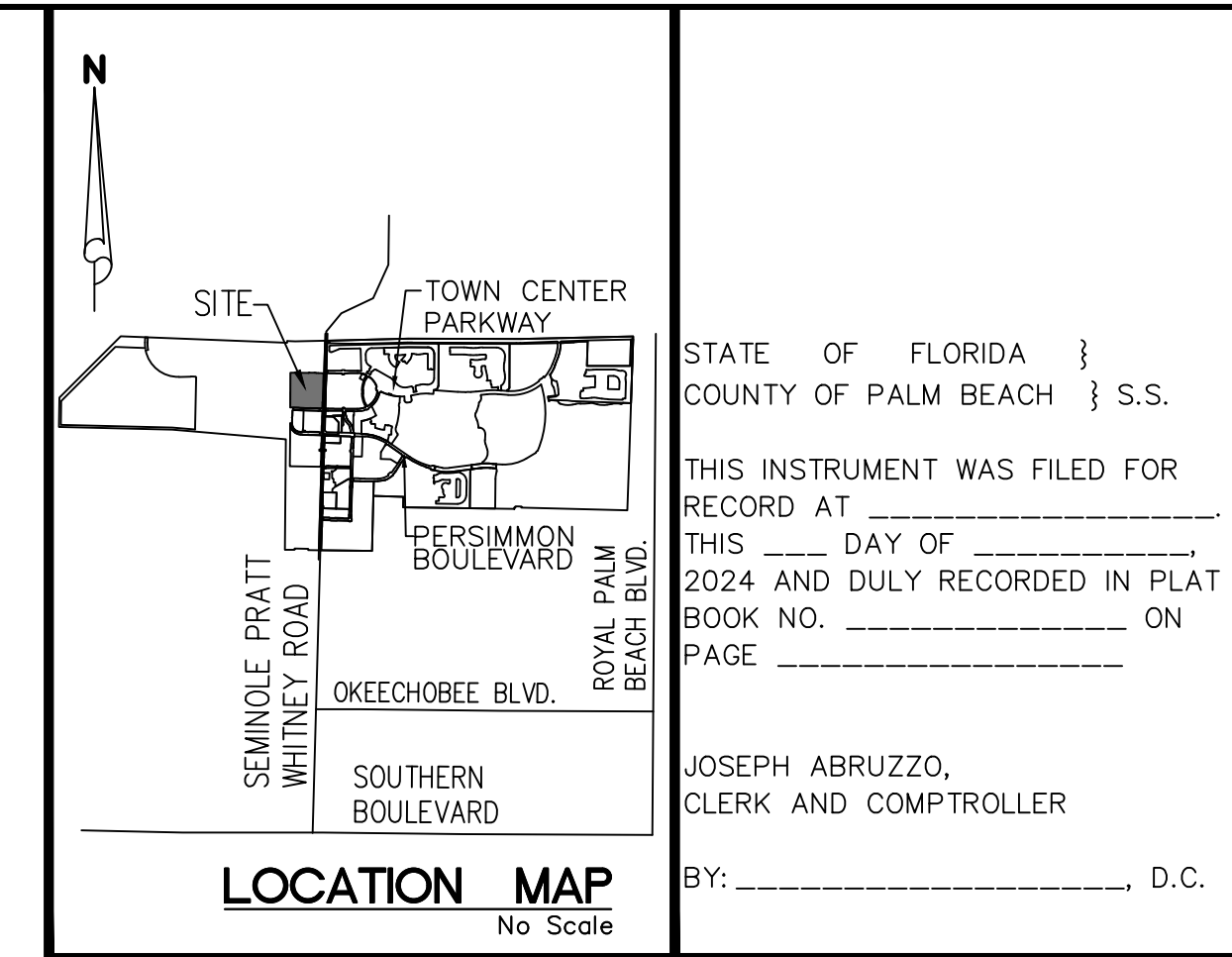

STATE OF FLORIDA }
COUNTY OF PALM BEACH } S.S.

THIS INSTRUMENT WAS FILED FOR
RECORD AT _____
THIS ____ DAY OF _____
2024 AND DULY RECORDED IN PLAT
BOOK NO. _____ ON
PAGE _____

JOSEPH ABRUZZO,
CLERK AND COMPTROLLER
BY: _____, D.C.

LOCATION MAP
No Scale

CLERK'S SEAL

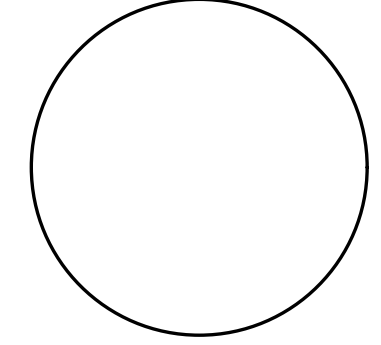

DEDICATION:

KNOW ALL MEN BY THESE PRESENTS THAT MINTO PBLH, LLC, A FLORIDA LIMITED LIABILITY COMPANY, OWNER OF THE LAND SHOWN AND DESCRIBED HEREON AS WESTLAKE POD G - NORTH, BEING A PORTION OF SECTION 1, TOWNSHIP 43 SOUTH, RANGE 40 EAST, CITY OF WESTLAKE, PALM BEACH COUNTY, FLORIDA, AND BEING, IN PART, A REPLAT OF ALL OF TRACT "B", TOWN CENTER PARKWAY SOUTH - WEST, PLAT BOOK 132, PAGES 57 AND 58, AND A PORTION OF OPEN SPACE TRACT #1, PERSIMMON BOULEVARD WEST - PLAT 2, PLAT BOOK 134, PAGES 164 THROUGH 166, INCLUSIVE, BOTH OF THE PUBLIC RECORDS OF PALM BEACH COUNTY, FLORIDA, BEING MORE PARTICULARLY DESCRIBED AS FOLLOWS:

COMMENCE AT THE NORTHWEST CORNER OF SECTION 1, TOWNSHIP 43 SOUTH, RANGE 40 EAST; THENCE S.00°59'07"W., ALONG THE WEST LINE OF SAID SECTION 1, TOWNSHIP 43 SOUTH, RANGE 40 EAST, A DISTANCE OF 1825.69 FEET; THENCE S.89°00'53"E., DEPARTING SAID WEST LINE OF SECTION 1, A DISTANCE OF 178.93 FEET TO A POINT ON THE EAST LINE OF M-2 CANAL EASEMENT, AS RECORDED IN OFFICIAL RECORDS BOOK 1687, PAGE 1749, PUBLIC RECORDS OF PALM BEACH COUNTY, FLORIDA AND THE POINT OF BEGINNING; THENCE ALONG THE SOUTH RIGHT-OF-WAY LINE OF FUTURE TOWN CENTER PARKWAY NORTH-WEST FOR THE FOLLOWING THREE (3) COURSES: 1) THENCE S.89°22'48"E., A DISTANCE OF 1123.53 FEET TO A POINT OF CURVATURE OF A CURVE CONCAVE TO THE SOUTHWEST, WITH A RADIUS OF 9942.00 FEET; 2) THENCE EASTERLY, ALONG THE ARC OF SAID CURVE THROUGH A CENTRAL ANGLE OF 01°05'41", A DISTANCE OF 189.94 FEET TO A POINT OF NON-TANGENCY; 3) THENCE S.88°17'08"E., A DISTANCE OF 204.85 FEET TO A POINT ON THE WESTERLY LINE OF EXISTING RIGHT-OF-WAY FOR SEMINOLE-PRATT WHITNEY ROAD, AS RECORDED IN OFFICIAL RECORDS BOOK 28479, PAGE 822, OF THE PUBLIC RECORDS OF PALM BEACH COUNTY, FLORIDA; THENCE ALONG SAID WESTERLY LINE OF EXISTING RIGHT-OF-WAY FOR SEMINOLE-PRATT WHITNEY ROAD FOR THE FOLLOWING TEN (10) COURSES: 1) THENCE S.43°17'08"E., A DISTANCE OF 41.00 FEET; 2) THENCE S.01°42'52"W., A DISTANCE OF 385.12 FEET; 3) THENCE S.00°47'52"W., A DISTANCE OF 250.03 FEET; 4) THENCE S.01°42'52"W., A DISTANCE OF 388.19 FEET; 5) THENCE S.02°37'53"W., A DISTANCE OF 250.00 FEET; 6) THENCE S.01°42'52"W., A DISTANCE OF 2.77 FEET; 7) THENCE S.15°07'01"W., A DISTANCE OF 51.77 FEET; 8) THENCE S.01°42'52"W., A DISTANCE OF 256.29 FEET; 9) THENCE S.46°42'52"W., A DISTANCE OF 56.57 FEET; 10) THENCE N.88°17'08"W., A DISTANCE OF 40.00 FEET TO A POINT ON THE NORTHERLY RIGHT-OF-WAY LINE OF TRACT "A", AS SHOWN ON THE PLAT OF TOWN CENTER PARKWAY SOUTH-WEST, RECORDED IN PLAT BOOK 132, PAGES 57 AND 58, OF SAID PUBLIC RECORDS; THENCE ALONG SAID NORTHERLY RIGHT-OF-WAY LINE OF TRACT "A" AND ALONG THE NORTHERLY RIGHT-OF-WAY LINE OF TRACT "A", AS SHOWN ON THE PLAT OF PERSIMMON BOULEVARD WEST - PLAT 2, RECORDED IN PLAT BOOK 134, PAGES 164 THROUGH 166, OF SAID PUBLIC RECORDS FOR THE FOLLOWING SEVEN (7) COURSES: 1) THENCE N.89°35'54"W., A DISTANCE OF 108.28 FEET; 2) THENCE N.75°52'41"W., A DISTANCE OF 23.18 FEET; 3) THENCE N.88°17'08"W., A DISTANCE OF 383.07 FEET; 4) THENCE S.46°42'52"W., A DISTANCE OF 15.56 FEET; 5) THENCE N.88°17'08"W., A DISTANCE OF 443.35 FEET; 6) THENCE N.75°52'41"W., A DISTANCE OF 51.20 FEET; 7) THENCE N.88°17'08"W., A DISTANCE OF 397.67 FEET TO A POINT ON THE EAST LINE OF M-2 CANAL EASEMENT, AS RECORDED IN OFFICIAL RECORDS BOOK 1687, PAGE 1749, OF SAID PUBLIC RECORDS; THENCE N.00°20'11"E., ALONG SAID EAST LINE OF M-2 CANAL EASEMENT, A DISTANCE OF 1626.39 FEET TO THE POINT OF BEGINNING.

CONTAINING: 2,508,849 SQUARE FEET OR 57.595 ACRES, MORE OR LESS.

HAS CAUSED THE SAME TO BE SURVEYED AND PLATTED AS SHOWN HEREON AND DO HEREBY DEDICATE AND RESERVE AS FOLLOWS:

(SEAL)

UTILITY EASEMENTS

ALL UTILITY EASEMENTS DESCRIBED ON THIS PLAT ARE PRIVATE NON-EXCLUSIVE EASEMENTS UNLESS EXPRESSLY STATED OTHERWISE THEREIN. ALL UTILITY RIGHTS AND EASEMENTS ESTABLISHED BY OR RESERVED BY THIS PLAT ARE HEREBY DEDICATED IN PERPETUITY TO THE SEMINOLE IMPROVEMENT DISTRICT, (A LOCAL UNIT OF SPECIAL PURPOSE GOVERNMENT ESTABLISHED PURSUANT TO CHAPTERS 189 AND 298, FLORIDA STATUTES, AS A PUBLIC UTILITY PROVIDER OF WATER, SEWER AND RECLAIMED WATER), ITS SUCCESSORS AND ASSIGNS, SUBJECT TO THOSE CERTAIN RESTRICTIONS OF RIGHTS, COVENANTS AND DEDICATIONS AS MAY HEREAFTER BE IMPOSED BY GRANTOR; PROVIDED FURTHER SAID GRANTS OR ASSIGNMENTS SHALL NOT BE DEEMED A PUBLIC DEDICATION OF SAID RIGHTS OR EASEMENTS. THE SEMINOLE IMPROVEMENT DISTRICT SHALL HAVE THE RIGHT TO GRANT OTHER UTILITY PROVIDERS THE ABILITY TO USE THE EASEMENT, IN ITS SOLE DISCRETION.

IN FURTHERANCE OF THE FOREGOING, THERE IS HEREBY GRANTED TO FLORIDA POWER & LIGHT COMPANY, A FLORIDA CORPORATION, ITS AFFILIATES, LICENSEES, AGENTS, SUCCESSORS, AND ASSIGNS ("FPL"), A NON-EXCLUSIVE EASEMENT FOREVER OVER, UNDER, IN, ON, UPON AND ACROSS THE UTILITY EASEMENTS DESCRIBED ON THE PLAT, FOR THE CONSTRUCTION, OPERATION AND MAINTENANCE OF UNDERGROUND ELECTRIC UTILITY FACILITIES (INCLUDING CABLES, CONDUITS, APPURTENANT EQUIPMENT, AND APPURTENANT ABOVE-GROUND EQUIPMENT) TO BE INSTALLED FROM TIME TO TIME; TOGETHER WITH THE RIGHT TO PERMIT FLORIDA POWER & LIGHT TO ATTACH OR PLACE WIRES TO OR WITHIN ANY FACILITIES HEREUNDER AND LAY CABLE AND CONDUIT WITHIN THE EASEMENT AREA AND TO OPERATE THE SAME FOR FLORIDA POWER & LIGHT'S COMMUNICATIONS PURPOSES IN CONNECTION WITH ELECTRIC SERVICE AND THE RIGHT OF INGRESS AND EGRESS TO THE UTILITY EASEMENTS AT ALL TIMES.

DRAINAGE EASEMENTS

THE DRAINAGE EASEMENTS (D.E.) AS SHOWN HEREON IS HEREBY DEDICATED IN PERPETUITY TO THE SEMINOLE IMPROVEMENT DISTRICT, AN INDEPENDENT SPECIAL DISTRICT OF THE STATE OF FLORIDA, ITS SUCCESSORS AND ASSIGNS, IN PERPETUITY FOR DRAINAGE PURPOSES. THE MAINTENANCE OF ALL DRAINAGE FACILITIES LOCATED THEREIN SHALL BE THE PERPETUAL MAINTENANCE OBLIGATION OF THE SEMINOLE IMPROVEMENT DISTRICT WITHOUT RECOURSE TO THE CITY OF WESTLAKE.

CITY OF WESTLAKE SHALL HAVE THE RIGHT, BUT NOT THE OBLIGATION, TO MAINTAIN ANY PORTION OF THE DRAINAGE SYSTEM ENCOMPASSED BY THIS PLAT WHICH IS ASSOCIATED WITH THE DRAINAGE OF PUBLIC STREETS, INCLUDING THE RIGHT TO UTILIZE FOR DRAINAGE PURPOSES ANY AND ALL DRAINAGE, LAKE MAINTENANCE, AND LAKE MAINTENANCE ACCESS EASEMENTS, AND PRIVATE STREETS ASSOCIATED WITH SAID DRAINAGE SYSTEM.

LOT

LOT 1, AS SHOWN HEREON, IS HEREBY RESERVED FOR MINTO PBLH, LLC, A FLORIDA LIMITED LIABILITY COMPANY, ITS SUCCESSORS AND ASSIGNS FOR PROPER PURPOSES AND IS THE PERPETUAL MAINTENANCE OBLIGATION OF SAID MINTO PBLH, LLC, A FLORIDA LIMITED LIABILITY COMPANY, ITS SUCCESSORS AND ASSIGNS, WITHOUT RECOURSE TO THE CITY OF WESTLAKE.

IN WITNESS WHEREOF, MINTO PBLH, LLC, A FLORIDA LIMITED LIABILITY COMPANY HAS CAUSED THESE PRESENTS TO BE SIGNED BY ITS MANAGER AND ITS COMPANY SEAL TO BE AFFIXED HERETO BY AND WITH THE AUTHORITY OF ITS MEMBERS THIS ____ DAY OF _____, 2024.

WITNESS: _____
MINTO PBLH, LLC
A FLORIDA LIMITED LIABILITY COMPANY

PRINT NAME: _____ BY: _____
JOHN F. CARTER, MANAGER

WITNESS: _____

PRINT NAME: _____

ACKNOWLEDGEMENT

STATE OF FLORIDA
COUNTY OF PALM BEACH

THE FOREGOING INSTRUMENT WAS ACKNOWLEDGED BEFORE ME BY MEANS OF PHYSICAL PRESENCE OR ONLINE NOTARIZATION, THIS ____ DAY OF _____, 20____, BY JOHN CARTER, AS MANAGER FOR MINTO PBLH, LLC, A FLORIDA LIMITED LIABILITY COMPANY, ON BEHALF OF THE COMPANY, WHO IS PERSONALLY KNOWN TO ME OR HAS PRODUCED _____ AS IDENTIFICATION.

MY COMMISSION EXPIRES: _____ SIGNATURE _____

(PRINT NAME) - NOTARY PUBLIC

(SEAL)

ACCEPTANCE OF DEDICATION

STATE OF FLORIDA
COUNTY OF PALM BEACH

SEMINOLE IMPROVEMENT DISTRICT, AN INDEPENDENT SPECIAL DISTRICT OF THE STATE OF FLORIDA, HEREBY ACCEPTS THE DEDICATIONS AND RESERVATIONS TO SAID DISTRICT AS STATED AND SHOWN HEREON, AND ITS MAINTENANCE OBLIGATIONS FOR SAME, AND HEREBY JOINS IN AND CONSENTS TO THE UTILITY EASEMENTS DEDICATION, DATED THIS ____ DAY OF _____, 2024.

WITNESS: _____ SEMINOLE IMPROVEMENT DISTRICT
AN INDEPENDENT SPECIAL DISTRICT
OF THE STATE OF FLORIDA

PRINT NAME: _____ BY: _____
SCOTT MASSEY, PRESIDENT

WITNESS: _____

PRINT NAME: _____

ACKNOWLEDGEMENT

STATE OF FLORIDA
COUNTY OF PALM BEACH

THE FOREGOING INSTRUMENT WAS ACKNOWLEDGED BEFORE ME BY MEANS OF PHYSICAL PRESENCE OR ONLINE NOTARIZATION, THIS ____ DAY OF _____, 20____, BY SCOTT MASSEY AS PRESIDENT FOR SEMINOLE IMPROVEMENT DISTRICT, AN INDEPENDENT SPECIAL DISTRICT OF THE STATE OF FLORIDA, ON BEHALF OF THE DISTRICT, WHO IS PERSONALLY KNOWN TO ME OR HAS PRODUCED _____ AS IDENTIFICATION.

MY COMMISSION EXPIRES: _____ SIGNATURE _____

(PRINT NAME) - NOTARY PUBLIC

(SEAL)

TITLE CERTIFICATION

STATE OF FLORIDA
COUNTY OF MIAMI-DADE

WE, WINSTON & STRAWN LLP, MEMBERS OF THE FLORIDA BAR, DO HEREBY CERTIFY THAT WE HAVE EXAMINED THAT CERTAIN PLAT PROPERTY INFORMATION REPORT PREPARED BY OLD REPUBLIC NATIONAL TITLE INSURANCE COMPANY (THE "TITLE EVIDENCE") WITH AN EFFECTIVE DATE OF JANUARY 10, 2024 AT 5:00 P.M. (THE "EFFECTIVE DATE"), WITH RESPECT TO THE PROPERTY MORE PARTICULARLY DEPICTED AND DESCRIBED HEREIN AS "WESTLAKE POD G - NORTH" (THE "PROPERTY").

BASED SOLELY ON OUR REVIEW OF THE TITLE EVIDENCE, AND WITHOUT INDEPENDENT INVESTIGATION, WE HEREBY CERTIFY THAT, AS OF THE EFFECTIVE DATE, (1) FEE SIMPLE TITLE TO THE PROPERTY WAS VESTED IN MINTO PBLH, LLC, A FLORIDA LIMITED LIABILITY COMPANY (THE "OWNER"), (2) REAL ESTATE TAXES FOR THE PROPERTY FOR THE YEAR 2023 HAVE BEEN PAID, AND (3) THERE ARE NO RECORDED MORTGAGES ENCUMBERING THE PROPERTY.

THIS TITLE CERTIFICATION IS FURNISHED BY US TO THE CITY OF WESTLAKE (THE "CITY") AND IS RENDERED SOLELY IN CONNECTION WITH THE OWNER'S SUBMISSION OF THIS PLAT TO THE CITY. THIS TITLE CERTIFICATION MAY BE RELIED ONLY BY THE CITY SOLELY IN CONNECTION WITH THE OWNER'S SUBMISSION OF THIS PLAT AND MAY NOT BE RELIED UPON BY ANY OTHER PERSON OR ENTITY IN ANY MANNER WHATSOEVER.

DATED THIS ____ DAY OF _____, 2024.

WINSTON & STRAWN LLP

BY: _____
RAFAEL A. AGUILAR, PARTNER

CITY OF WESTLAKE'S APPROVAL

THIS CERTIFIES THAT THIS PLAT HAS BEEN ACCEPTED AND APPROVED BY THE CITY COUNCIL FOR THE CITY OF WESTLAKE BY A RESOLUTION DULY ADOPTED BY THE CITY COUNCIL THIS ____ DAY OF _____, 2024, IN ACCORDANCE WITH SEC. 177.071(2), F.S., AND HAS BEEN REVIEWED BY A PROFESSIONAL SURVEYOR & MAPPER EMPLOYED BY THE CITY OF WESTLAKE IN ACCORDANCE WITH SEC. 177.081(1), F.S.

ATTEST: _____ BY: _____
CITY MANAGER, KEN CASSEL CITY MAYOR, JOHN PAUL O'CONNOR

AREA TABULATION (IN ACRES)

LOT 1:	42.756
W.M.T. #1:	14.919
TOTAL:	57.675 TOTAL ACRES, MORE OR LESS

SURVEYORS NOTES

- PERMANENT REFERENCE MONUMENTS ARE SHOWN THUS: SET "●" A 1/2" IRON ROD WITH PRM CAP STAMPED "PRM LB7768". PERMANENT CONTROL POINTS ARE SHOWN AS THUS: "●" A MAGNETIC NAIL AND DISK STAMPED "PCP LB7768". (UNLESS OTHERWISE NOTED)
- BEARINGS SHOWN HEREON ARE BASED ON THE NORTH BOUNDARY OF SECTION 1, TOWNSHIP 43 SOUTH, RANGE 40 EAST, HAVING A GRID BEARING OF N.89°51'15"E. BEARINGS SHOWN HEREON, REFER TO THE STATE PLANE COORDINATE SYSTEM, NORTH AMERICAN DATUM OF 1983 (NAD 83 / 97) FOR THE EAST ZONE OF FLORIDA. SAID BASIS OF BEARING IS THE SAME IN THE NORTH AMERICAN DATUM OF 1983 (NAD 83 / 90).
- NO BUILDING OR ANY KIND OF CONSTRUCTION OR TREES OR SHRUBS SHALL BE PLACED ON ANY EASEMENT WITHOUT PRIOR WRITTEN CONSENT OF ALL EASEMENT BENEFICIARIES AND ALL APPLICABLE CITY OR SEMINOLE IMPROVEMENT DISTRICT APPROVALS OR PERMITS AS REQUIRED FOR SUCH ENCROACHMENTS. THERE WILL BE NO ABOVE GROUND ENCROACHMENTS WHERE LAKE MAINTENANCE EASEMENTS AND UTILITY EASEMENTS OVERLAP.
- THE BUILDING SETBACKS SHALL BE AS REQUIRED BY THE CITY OF WESTLAKE ZONING REGULATIONS.
- NOTICE: THIS PLAT, AS RECORDED IN ITS GRAPHIC FORM, IS THE OFFICIAL DEPICTION OF THE SUBDIVIDED LANDS DESCRIBED HEREIN AND WILL IN NO CIRCUMSTANCES BE SUPPLANTED IN AUTHORITY BY ANY OTHER GRAPHIC OR DIGITAL FORM OF THE PLAT. THERE MAY BE ADDITIONAL RESTRICTIONS THAT ARE NOT RECORDED ON THIS PLAT THAT MAY BE FOUND IN THE PUBLIC RECORDS OF PALM BEACH COUNTY.
- IN THOSE CASES WHERE EASEMENTS OF DIFFERENT TYPES CROSS OR OTHERWISE COINCIDE, DRAINAGE EASEMENTS SHALL HAVE FIRST PRIORITY, UTILITY EASEMENTS SHALL HAVE SECOND PRIORITY, ACCESS EASEMENTS SHALL HAVE THIRD PRIORITY, AND ALL OTHER EASEMENTS SHALL BE SUBORDINATE TO THESE WITH THEIR PRIORITIES BEING DETERMINED BY USE RIGHTS GRANTED.
- ALL LINES INTERSECTING CIRCULAR CURVES ARE RADIAL UNLESS OTHERWISE NOTED.
- COORDINATES SHOWN HEREON ARE FLORIDA STATE PLANE GRID DATUM = NAD83 2007 ADJUSTMENT ZONE = FLORIDA EAST LINEAR UNITS = US SURVEY FEET COORDINATE SYSTEM = 1983 STATE PLANE PROJECTION = TRANSVERSE MERCATOR ALL DISTANCES ARE GROUND SCALE FACTOR: 1.0000 GROUND DISTANCE X SCALE FACTOR = GRID DISTANCE PLAT BEARING = GRID BEARING NO ROTATION ALL TIES TO SECTION CORNERS AND QUARTER CORNERS ARE GENERATED FROM MEASURED VALUES

SURVEYOR & MAPPER'S CERTIFICATE

THIS IS TO CERTIFY THAT THE PLAT SHOWN HEREON IS A TRUE AND CORRECT REPRESENTATION OF A SURVEY MADE UNDER MY RESPONSIBLE DIRECTION AND SUPERVISION; THAT SAID SURVEY IS ACCURATE TO THE BEST OF MY KNOWLEDGE AND BELIEF; THAT PERMANENT REFERENCE MONUMENTS ("P.R.M.S.") HAVE BEEN PLACED AS REQUIRED BY LAW, AND THAT PERMANENT CONTROL POINTS ("P.C.P.S.") AND MONUMENTS ACCORDING TO SEC. 177.091(9), F.S., WILL BE SET UNDER THE GUARANTEES POSTED WITH THE CITY OF WESTLAKE FOR THE REQUIRED IMPROVEMENTS; AND, FURTHER, THAT THE SURVEY DATA COMPLIES WITH ALL THE REQUIREMENTS OF CHAPTER 177, FLORIDA STATUTES, AS AMENDED, AND THE ORDINANCES OF CITY OF WESTLAKE, FLORIDA.

DATE: _____ GARY A. RAGER, P.S.M.
LICENSE NO. LS4828
STATE OF FLORIDA

THIS INSTRUMENT PREPARED BY
GARY A. RAGER, P.S.M.
LS4828 STATE OF FLORIDA.
GEOPOINT SURVEYING, INC.
4152 WEST BLUE HERON BOULEVARD, SUITE 105,
RIVIERA BEACH, FLORIDA 33404.
CERTIFICATE OF AUTHORIZATION NO. LB7768

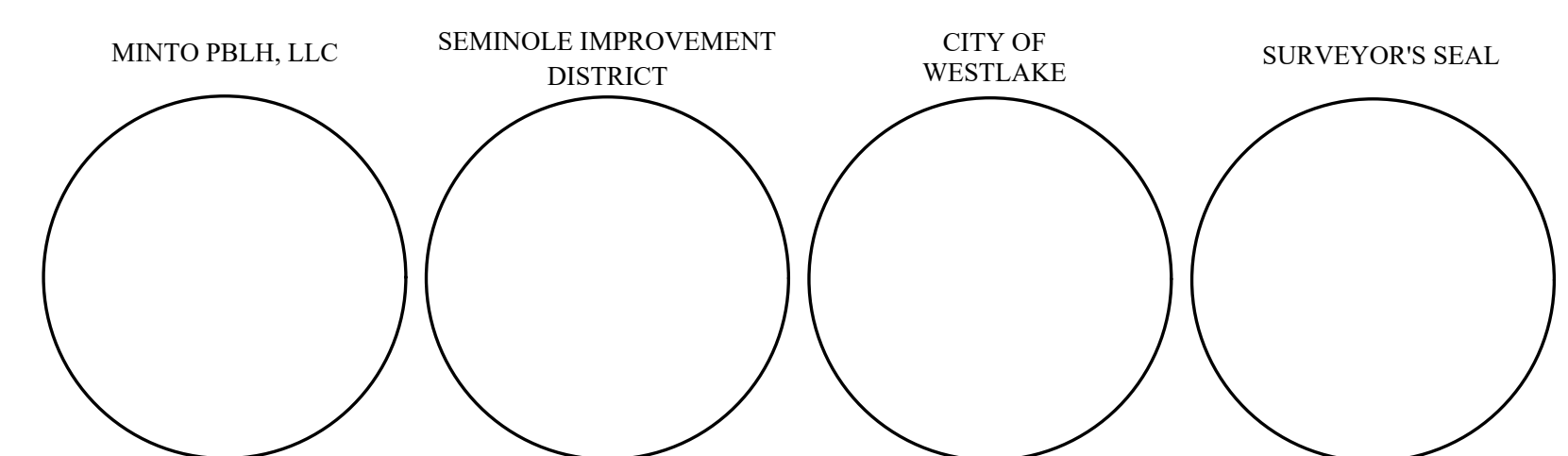

4152 W. Blue Heron Blvd.
Suite 106
Riviera Beach, FL 33404
Phone: (561) 444-2720
www.geopointsurvey.com
Licensed Business Number LB 7768

SHEET 1 OF 3 SHEETS

WESTLAKE POD G - NORTH

BEING A PORTION OF SECTION 1, TOWNSHIP 43 SOUTH, RANGE 40 EAST, CITY OF WESTLAKE, PALM BEACH COUNTY, FLORIDA, AND BEING, IN PART, A REPLAT OF ALL OF TRACT "B", TOWN CENTER PARKWAY SOUTH - WEST, PLAT BOOK 132, PAGES 57 AND 58, AND A PORTION OF OPEN SPACE TRACT #1, PERSIMMON BOULEVARD WEST - PLAT 2, PLAT BOOK 134, PAGES 164 THROUGH 166, INCLUSIVE, BOTH OF THE PUBLIC RECORDS OF PALM BEACH COUNTY, FLORIDA.

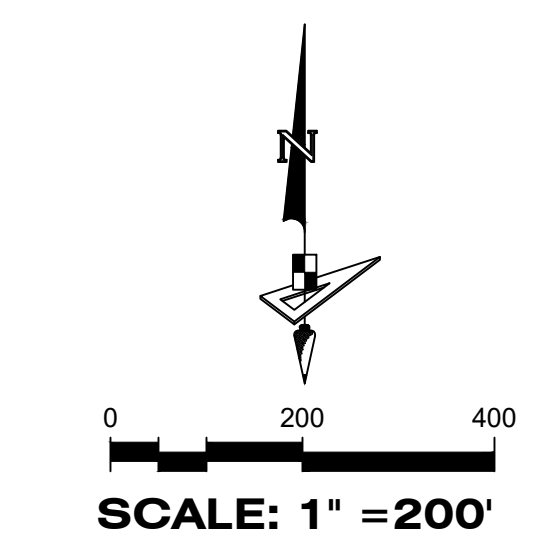
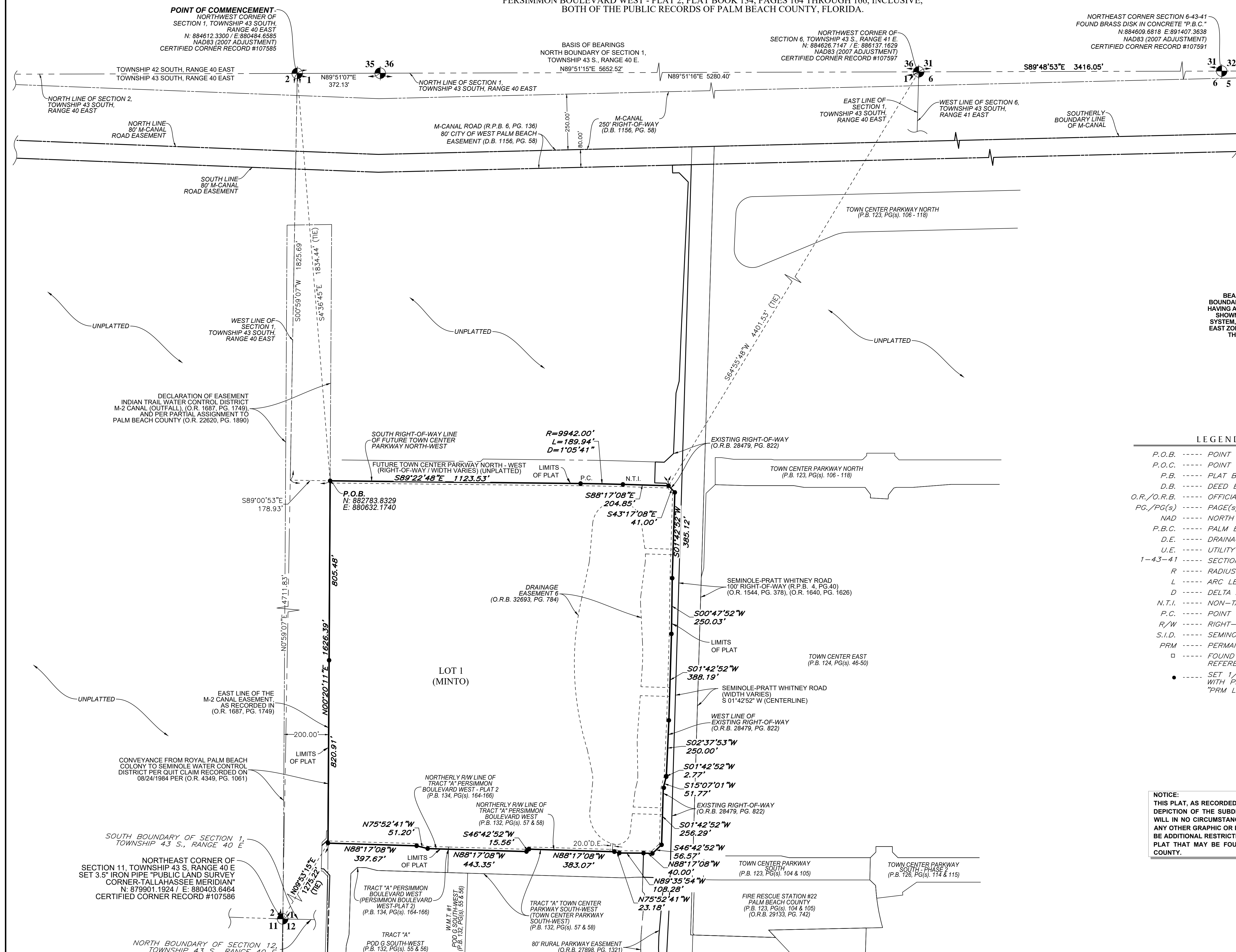

COORDINATES SHOWN HEREON ARE FLORIDA STATE PLANE GRID DATUM = NAD83 2007 ADJUSTMENT ZONE = FLORIDA EAST LINEAR UNITS = US SURVEY FEET COORDINATE SYSTEM = 1983 STATE PLANE PROJECTION = TRANSVERSE MERCATOR ALL DISTANCES ARE GROUND SCALE FACTOR: 1.0000 GROUND DISTANCE X SCALE FACTOR = GRID DISTANCE PLAT BEARING = GRID BEARING NO ROTATION ALL TIES TO SECTION CORNERS AND QUARTER CORNERS ARE GENERATED FROM MEASURED VALUES

BASIS OF BEARINGS
BEARINGS SHOWN HEREON ARE BASED ON THE NORTH BOUNDARY OF SECTION 1, TOWNSHIP 43 SOUTH, RANGE 40 EAST, HAVING A GRID BEARING OF S89°51'16\"/>

LEGEND

-----	P.O.B.	POINT OF BEGINNING
-----	P.O.C.	POINT OF COMMENCEMENT
-----	P.B.	PLAT BOOK
-----	D.B.	DEED BOOK
-----	O.R./O.R.B.	OFFICIAL RECORDS BOOK
-----	PG./PG(s)	PAGE(S)
-----	NAD	NORTH AMERICAN DATUM
-----	P.B.C.	PALM BEACH COUNTY
-----	D.E.	DRAINAGE EASEMENT
-----	U.E.	UTILITY EASEMENT
-----	1-43-41	SECTION-TOWNSHIP-RANGE
R	R	RADIUS
L	L	ARC LENGTH
D	D	DELTA ANGLE
N.T.I.	N.T.I.	NON-TANGENT INTERSECTION
P.C.	P.C.	POINT OF CURVATURE
R/W	R/W	RIGHT-OF-WAY
S.I.D.	S.I.D.	SEMINOLE IMPROVEMENT DISTRICT
PRM	PRM	PERMANENT REFERENCE MONUMENT
□	□	FOUND PERMANENT REFERENCE MONUMENT
●	●	SET 1/2" IRON ROD WITH PRM CAP STAMPED "PRM LB 7768"

NOTICE:
THIS PLAT, AS RECORDED IN ITS GRAPHIC FORM, IS THE OFFICIAL DEFINITION OF THE SUBDIVIDED LANDS DESCRIBED HEREIN AND WILL IN NO CIRCUMSTANCES BE SUPPLANTED IN AUTHORITY BY ANY OTHER GRAPHIC OR DIGITAL FORM OF THE PLAT. THERE MAY BE ADDITIONAL RESTRICTIONS THAT ARE NOT RECORDED ON THIS PLAT THAT MAY BE FOUND IN THE PUBLIC RECORDS OF THIS COUNTY.

GeoPoint
Surveying, Inc.

4152 W. Blue Heron Blvd.
Suite 106
Riviera Beach, FL 33404

Phone: (561) 444-2720
www.geopointsurvey.com
Licensed Business Number LB 7768

SHEET 2 OF 3 SHEETS

DRAWN BY: WESTLAKE WESTLAKE - NAD83PALSPODGP01A.PDF/CAN/TAMMS.DWG PLOTTED BY: SERGIO MACHADO ON: 3/11/2024 11:18 AM LAST SAVED BY: SERGIO ON: 3/11/2024 11:09 AM

WESTLAKE POD G - NORTH

BEING A PORTION OF SECTION 1, TOWNSHIP 43 SOUTH, RANGE 40 EAST, CITY OF WESTLAKE, PALM BEACH COUNTY, FLORIDA, AND BEING, IN PART, A REPLAT OF ALL OF TRACT "B", TOWN CENTER PARKWAY SOUTH - WEST, PLAT BOOK 132, PAGES 57 AND 58, AND A PORTION OF OPEN SPACE TRACT #1, PERSIMMON BOULEVARD WEST - PLAT 2, PLAT BOOK 134, PAGES 164 THROUGH 166, INCLUSIVE, BOTH OF THE PUBLIC RECORDS OF PALM BEACH COUNTY, FLORIDA.

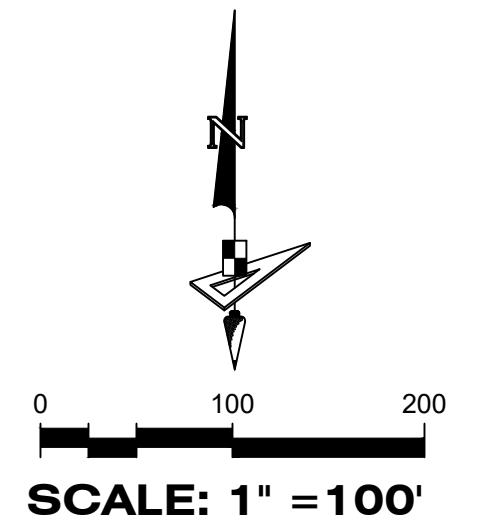

COORDINATES SHOWN HEREON ARE FLORIDA STATE PLANE GRID DATUM = NAD83 2007 ADJUSTMENT ZONE = FLORIDA EAST LINEAR UNITS = US SURVEY FEET COORDINATE SYSTEM = 1983 STATE PLANE PROJECTION = TRANSVERSE MERCATOR ALL DISTANCES ARE GROUND SCALE FACTOR: 1.0000 GROUND DISTANCE X SCALE FACTOR = GRID DISTANCE PLAT BEARING = GRID BEARING NO ROTATION ALL TIES TO SECTION CORNERS AND QUARTER CORNERS ARE GENERATED FROM MEASURED VALUES

BASIS OF BEARINGS

BEARINGS SHOWN HEREON ARE BASED ON THE NORTH BOUNDARY OF SECTION 1, TOWNSHIP 43 SOUTH, RANGE 40 EAST, HAVING A GRID BEARING OF S.89°51'16"E. (MEASURED). BEARINGS SHOWN HEREON, REFER TO THE STATE PLANE COORDINATE SYSTEM, NORTH AMERICA DATUM OF 1983 (NAD 83 - '07) FOR THE EAST ZONE OF FLORIDA. SAID BASIS OF BEARING IS THE SAME IN THE NORTH AMERICAN DATUM OF 1983 (NAD 83 - '90).

LEGEND

- P.O.B. ----- POINT OF BEGINNING
- P.O.C. ----- POINT OF COMMENCEMENT
- P.B. ----- PLAT BOOK
- D.B. ----- DEED BOOK
- O.R./O.R.B. ----- OFFICIAL RECORDS BOOK
- PG./PG(s) ----- PAGE(S)
- NAD ----- NORTH AMERICAN DATUM
- P.B.C. ----- PALM BEACH COUNTY
- D.E. ----- DRAINAGE EASEMENT
- U.E. ----- UTILITY EASEMENT
- 1-43-41 ----- SECTION-TOWNSHIP-RANGE
- R ----- RADIUS
- L ----- ARC LENGTH
- Δ ----- DELTA ANGLE
- N.T.I. ----- NON-TANGENT INTERSECTION
- P.C. ----- POINT OF CURVATURE
- R/W ----- RIGHT-OF-WAY
- S.I.D. ----- SEMINOLE IMPROVEMENT DISTRICT
- PRM ----- PERMANENT REFERENCE MONUMENT
- ----- FOUND PERMANENT REFERENCE MONUMENT
- ----- SET 1/2" IRON ROD WITH PRM CAP STAMPED "PRM LB 7768"

NOTICE:
THIS PLAT, AS RECORDED IN ITS GRAPHIC FORM, IS THE OFFICIAL DEPICTION OF THE SUBDIVIDED LANDS DESCRIBED HEREIN AND WILL IN NO CIRCUMSTANCES BE SUPPLANTED IN AUTHORITY BY ANY OTHER GRAPHIC OR DIGITAL FORM OF THE PLAT. THERE MAY BE ADDITIONAL RESTRICTIONS THAT ARE NOT RECORDED ON THIS PLAT THAT MAY BE FOUND IN THE PUBLIC RECORDS OF THIS COUNTY.

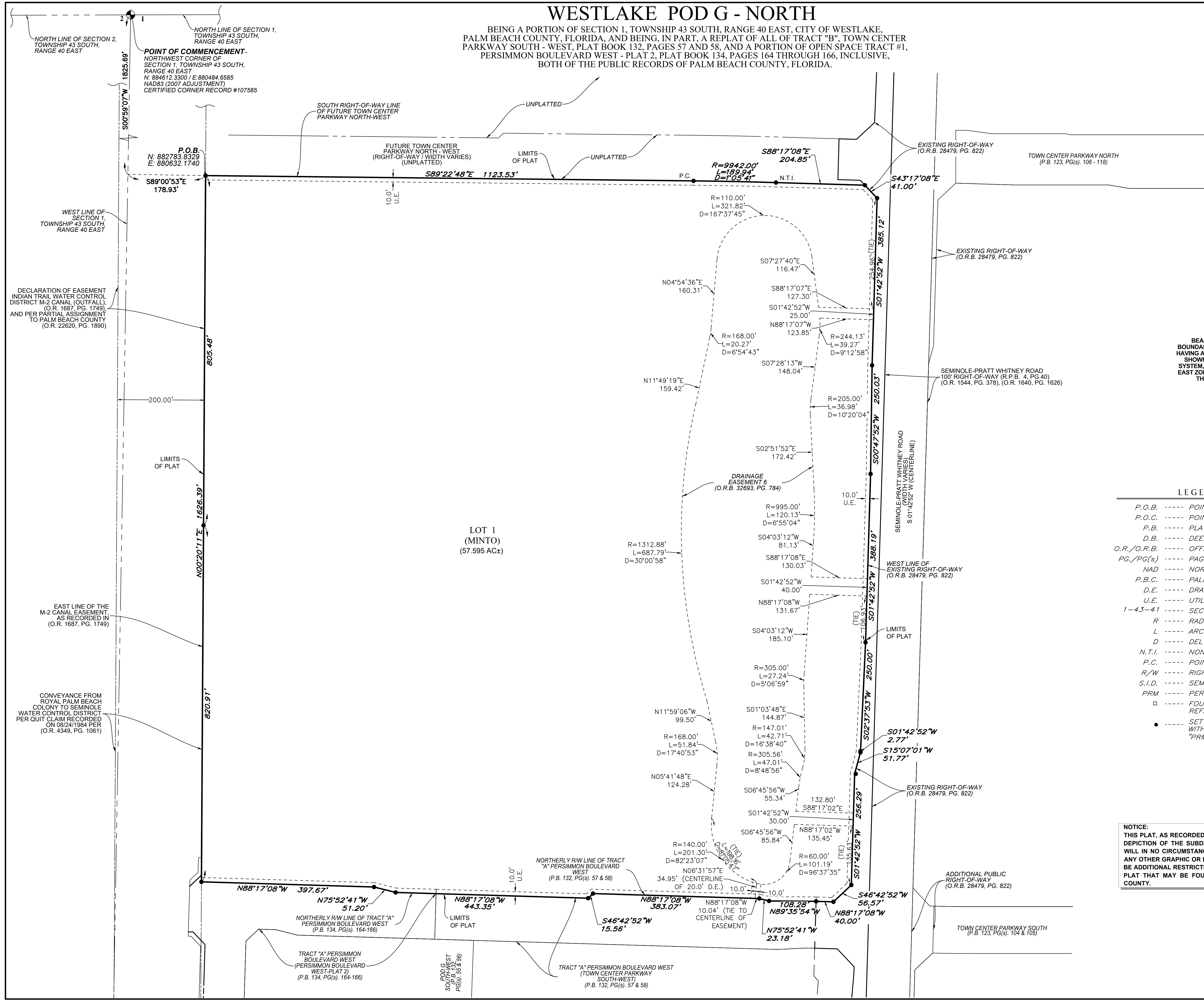

NORTH LINE OF SECTION 2, TOWNSHIP 43 SOUTH, RANGE 40 EAST
 NORTH LINE OF SECTION 1, TOWNSHIP 43 SOUTH, RANGE 40 EAST
POINT OF COMMENCEMENT - NORTHWEST CORNER OF SECTION 1, TOWNSHIP 43 SOUTH, RANGE 40 EAST
 N: 894612.3300 / E: 880484.6585
 NAD83 (2007 ADJUSTMENT)
 CERTIFIED CORNER RECORD #107585

P.O.B.
 N: 882783.8329
 E: 880632.1740
 WEST LINE OF SECTION 1, TOWNSHIP 43 SOUTH, RANGE 40 EAST

DECLARATION OF EASEMENT INDIAN TRAIL WATER CONTROL DISTRICT M-2 CANAL (OUTFALL) (O.R. 1687, PG. 1749) AND PER PARTIAL ASSIGNMENT TO PALM BEACH COUNTY (O.R. 22620, PG. 1890)

EAST LINE OF THE M-2 CANAL EASEMENT AS RECORDED IN (O.R. 1687, PG. 1749)

CONVEYANCE FROM ROYAL PALM BEACH COLONY TO SEMINOLE WATER CONTROL DISTRICT PER QUIT CLAIM RECORDED ON 08/24/1984 PER (O.R. 4349, PG. 1061)

LOT 1 (MINTO)
 (57.595 AC±)

GeoPoint
 Surveying, Inc.
 4152 W. Blue Heron Blvd.
 Suite 106
 Riviera Beach, FL 33404
 Phone: (561) 444-2720
 www.geopointsurvey.com
 Licensed Business Number LB 7768

PLOTTED BY: SERGIO MACHADO ON 3/11/2024 11:19 AM. LAST SAVED BY: SERGIO ON 3/11/2024 11:09 AM

Exhibit 'C'
WESTLAKE POD G – NORTH
TOPOGRAPHICAL SURVEY

THIS PAGE WAS LEFT BLANK ON PURPOSE

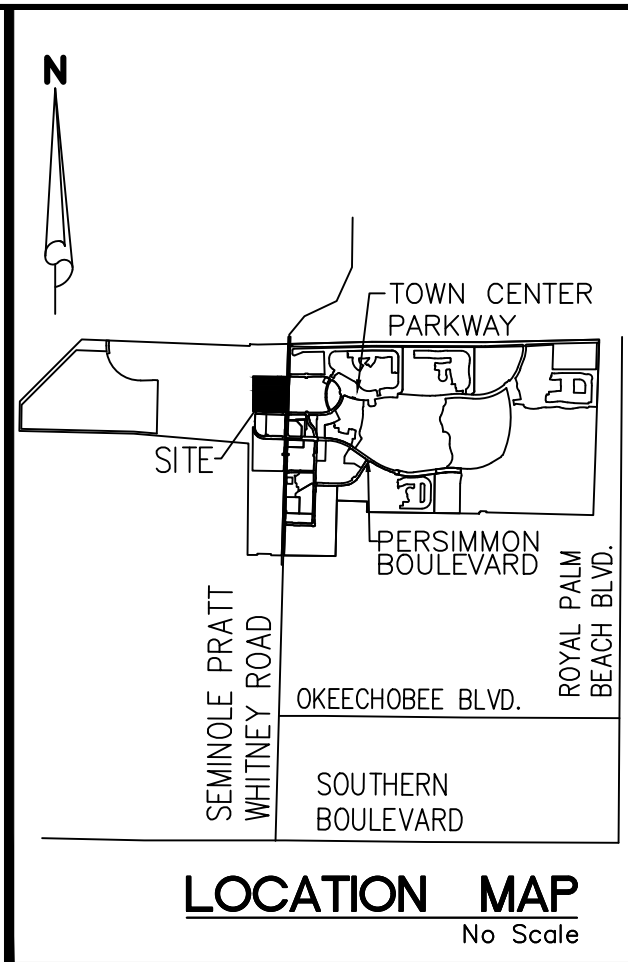

DESCRIPTION:

BEING A PORTION OF SECTION 1, TOWNSHIP 43 SOUTH, RANGE 40 EAST, CITY OF WESTLAKE, PALM BEACH COUNTY, FLORIDA, AND BEING, IN PART, A REPLAT OF ALL OF TRACT "B", TOWN CENTER PARKWAY SOUTH - WEST, PLAT BOOK 132, PAGES 57 AND 58, AND A PORTION OF OPEN SPACE TRACT #1, PERSIMMON BOULEVARD WEST - PLAT 2, PLAT BOOK 134, PAGES 164 THROUGH 166, INCLUSIVE, BOTH OF THE PUBLIC RECORDS OF PALM BEACH COUNTY, FLORIDA, BEING MORE PARTICULARLY DESCRIBED AS FOLLOWS:

COMMENCE AT THE NORTHWEST CORNER OF SECTION 1, TOWNSHIP 43 SOUTH, RANGE 40 EAST; THENCE S.00°59'07"W., ALONG THE WEST LINE OF SAID SECTION 1, TOWNSHIP 43 SOUTH, RANGE 40 EAST, A DISTANCE OF 1825.69 FEET; THENCE S.89°00'53"E., DEPARTING SAID WEST LINE OF SECTION 1, A DISTANCE OF 178.93 FEET TO A POINT ON THE EAST LINE OF M-2 CANAL EASEMENT, AS RECORDED IN OFFICIAL RECORDS BOOK 1687, PAGE 1749, PUBLIC RECORDS OF PALM BEACH COUNTY, FLORIDA AND THE **POINT OF BEGINNING**; THENCE ALONG THE SOUTH RIGHT-OF-WAY LINE OF FUTURE TOWN CENTER PARKWAY NORTH-WEST FOR THE FOLLOWING THREE (3) COURSES: 1) THENCE S.89°22'48"E., A DISTANCE OF 1123.53 FEET TO A POINT OF CURVATURE OF A CURVE CONCAVE TO THE SOUTHWEST, WITH A RADIUS OF 9942.00 FEET; 2) THENCE EASTERLY, ALONG THE ARC OF SAID CURVE THROUGH A CENTRAL ANGLE OF 01°05'41", A DISTANCE OF 189.94 FEET TO A POINT OF NON-TANGENCY; 3) THENCE S.88°17'08"E., A DISTANCE OF 204.85 FEET TO A POINT ON THE WESTERLY LINE OF EXISTING RIGHT-OF-WAY FOR SEMINOLE-PRATT WHITNEY ROAD, AS RECORDED IN OFFICIAL RECORDS BOOK 28479, PAGE 822, OF THE PUBLIC RECORDS OF PALM BEACH COUNTY, FLORIDA; THENCE ALONG SAID WESTERLY LINE OF EXISTING RIGHT-OF-WAY FOR SEMINOLE-PRATT WHITNEY ROAD FOR THE FOLLOWING TEN (10) COURSES: 1) THENCE S.43°17'08"E., A DISTANCE OF 41.00 FEET; 2) THENCE S.01°42'52"W., A DISTANCE OF 385.12 FEET; 3) THENCE S.00°47'52"W., A DISTANCE OF 250.03 FEET; 4) THENCE S.01°42'52"W., A DISTANCE OF 388.19 FEET; 5) THENCE S.02°37'53"W., A DISTANCE OF 250.00 FEET; 6) THENCE S.01°42'52"W., A DISTANCE OF 2.77 FEET; 7) THENCE S.15°07'01"W., A DISTANCE OF 51.77 FEET; 8) THENCE S.01°42'52"W., A DISTANCE OF 256.29 FEET; 9) THENCE S.46°42'52"W., A DISTANCE OF 56.57 FEET; 10) THENCE N.88°17'08"W., A DISTANCE OF 40.00 FEET TO A POINT ON THE NORTHERLY RIGHT-OF-WAY LINE OF TRACT "A", AS SHOWN ON THE PLAT OF TOWN CENTER PARKWAY SOUTH-WEST, RECORDED IN PLAT BOOK 132, PAGES 57 AND 58, OF SAID PUBLIC RECORDS; THENCE ALONG SAID NORTHERLY RIGHT-OF-WAY LINE OF TRACT "A" AND ALONG THE NORTHERLY RIGHT-OF-WAY LINE OF TRACT "A", AS SHOWN ON THE PLAT OF PERSIMMON BOULEVARD WEST - PLAT 2, RECORDED IN PLAT BOOK 134, PAGES 164 THROUGH 166, OF SAID PUBLIC RECORDS FOR THE FOLLOWING SEVEN (7) COURSES: 1) THENCE N.89°35'54"W., A DISTANCE OF 108.28 FEET; 2) THENCE N.75°52'41"W., A DISTANCE OF 23.18 FEET; 3) THENCE N.88°17'08"W., A DISTANCE OF 383.07 FEET; 4) THENCE S.46°42'52"W., A DISTANCE OF 15.56 FEET; 5) THENCE N.88°17'08"W., A DISTANCE OF 443.35 FEET; 6) THENCE N.75°52'41"W., A DISTANCE OF 51.20 FEET; 7) THENCE N.88°17'08"W., A DISTANCE OF 397.67 FEET TO A POINT ON THE EAST LINE OF M-2 CANAL EASEMENT, AS RECORDED IN OFFICIAL RECORDS BOOK 1687, PAGE 1749, OF SAID PUBLIC RECORDS; THENCE N.00°20'11"E., ALONG SAID EAST LINE OF M-2 CANAL EASEMENT, A DISTANCE OF 1626.39 FEET TO THE **POINT OF BEGINNING**.

CONTAINING: 2,508,849 SQUARE FEET OR 57.595 ACRES, MORE OR LESS.

SURVEYOR'S NOTES:

- CURRENT TITLE INFORMATION ON THE SUBJECT PROPERTY HAD NOT BEEN FURNISHED TO GEOPOINT SURVEYING, INC. AT THE TIME OF THIS SURVEY, AND IS SUBJECT TO TITLE REVIEW AND/OR ABSTRACT. GEOPOINT SURVEYING, INC. MAKES NO REPRESENTATIONS OR GUARANTEES PERTAINING TO EASEMENTS, RIGHTS-OF-WAY, SET BACK LINES, RESERVATIONS, AGREEMENTS, AND OTHER SIMILAR MATTERS.
- THIS SURVEY IS LIMITED TO ABOVE GROUND VISIBLE IMPROVEMENTS ALONG AND NEAR THE BOUNDARY LINES, EXCEPT AS SHOWN HEREON, AND THAT NOTHING BELOW THE GROUND WAS LOCATED INCLUDING, BUT NOT LIMITED TO FOUNDATIONS (FOOTINGS), UTILITIES, ETC.
- BEARINGS SHOWN HEREON ARE BASED ON THE NORTH LINE OF SECTION 1, TOWNSHIP 43 SOUTH, RANGE 40 EAST, PALM BEACH COUNTY, FLORIDA, HAVING A GRID BEARING OF N.89°51'16"E. THE GRID BEARINGS AS SHOWN HEREON REFER TO THE STATE PLANE COORDINATE SYSTEM, NORTH AMERICA HORIZONTAL DATUM OF 1983 (NAD 83-2011 ADJUSTMENT) FOR THE EAST ZONE OF FLORIDA.
- THIS SURVEY IS INTENDED TO BE DISPLAYED AT 1" = 100' OR SMALLER.
- ALL DIMENSIONS, UNLESS OTHERWISE NOTED, ARE SURVEY DIMENSIONS.
- ADDITIONS OR DELETIONS TO SURVEY MAPS OR REPORTS BY OTHER THAN THE SIGNING PARTY OR PARTIES IS PROHIBITED WITHOUT THE WRITTEN CONSENT OF THE SIGNING PARTY OR PARTIES.
- THE SUBJECT PARCEL LIES IN FLOOD ZONE "AE", ACCORDING TO FLOOD INSURANCE RATE MAP, MAP NO. 12099C0345F FOR PALM BEACH COUNTY, COMMUNITY NO. 120192, PALM BEACH COUNTY, FLORIDA, DATED OCTOBER 05, 2017 AND ISSUED BY THE FEDERAL EMERGENCY MANAGEMENT AGENCY. LINES SHOWN HAVE BEEN DIGITALLY TRANSLATED FROM DFIRM DATABASE INFORMATION SUPPLIED BY THE FEMA MAP SERVICE CENTER ([HTTPS://MSC.FEMA.GOV](https://msc.fema.gov)).
- ELEVATIONS SHOWN HEREON ARE BASED ON THE NORTH AMERICAN VERTICAL DATUM OF 1988 (NAVD 88) BASED ON NATIONAL GEODETIC SURVEY BENCHMARK "CUTBACK 6", HAVING A PUBLISHED ELEVATION OF 22.57' FEET (NAVD 88).
- USE OF THIS SURVEY FOR PURPOSES OTHER THAN INTENDED, WITHOUT WRITTEN VERIFICATION, WILL BE AT THE USER'S SOLE RISK AND WITHOUT LIABILITY TO THE SURVEYOR. NOTHING HEREON SHALL BE CONSTRUED TO GIVE ANY RIGHTS OR BENEFITS TO ANYONE OTHER THAN THOSE CERTIFIED TO.
- ON THIS DRAWING, CERTIFY MEANS TO STATE OR DECLARE A PROFESSIONAL OPINION OF CONDITIONS REGARDING THOSE FINDINGS OR FACTS WHICH ARE THE SUBJECT OF THE CERTIFICATION AND DOES NOT CONSTITUTE A WARRANTY OR GUARANTEE, EITHER IMPLIED OR EXPRESSED. THIS CERTIFICATION IS ONLY FOR THE LANDS AS DESCRIBED. THIS CERTIFICATION IS NOT A CERTIFICATE OF TITLE, EASEMENTS, ZONING, OR FREEDOM OF ENCUMBRANCES.
- THE LANDS DESCRIBED HEREON MAY CONTAIN LANDS THAT ARE CONSIDERED ENVIRONMENTALLY SENSITIVE WETLANDS THAT ARE SUBJECT TO CLAIM OR RESTRICTION BY ONE OR MORE OF THE FOLLOWING AGENCIES: ARMY CORP. OF ENGINEERS, SOUTH FLORIDA WATER MANAGEMENT DISTRICT (S.F.W.M.D.), OR DEPARTMENT OF ENVIRONMENTAL PROTECTION (D.E.P.). WETLAND LINES AND AREAS, IF ANY, ARE NOT SHOWN HEREON.
- THIS SURVEY IS BASED ON PREVIOUS FIELD SURVEYS, DOCUMENTS OF RECORD, FOUND MONUMENTS, EXHIBITS, AND HISTORICALLY USED CORNERS, AS WELL AS THE LEGAL DESCRIPTION SHOWN HEREON. THE FOLLOWING ARE REFERENCE SURVEYS USED IN DETERMINING THE BOUNDARY LOCATION FOR CALLERY JUDGE GROVES:
 - THE 'M' CANAL ROAD RIGHT OF WAY MAP, RECORDED IN ROAD PLAT BOOK 6, PAGE 136.
 - STATE OF FLORIDA PALM BEACH COUNTY RIGHT OF WAY MAP FOR SEMINOLE-PRATT WHITNEY ROAD, RECORDED IN ROAD PLAT BOOK 4, PAGE 34.
 - BOUNDARY SURVEY OF RESIDENTIAL AT CALLERY JUDGE GROVES, PREPARED BY LIDBERG LAND SURVEYING, INC. (JOB NO.: 04-106-101C), DATED OCTOBER 5, 2007.
 - SKETCH OF SURVEY, PREPARED BY S.P. MUSICK, DATED MARCH 5, 1965.

LEGEND

- P.B. ----- Flat Book
- O.R.B. ----- Official Records Book
- D.B. ----- Deed Book
- Pg(s). ----- Page(s)
- NAD ----- North American Datum
- NAVD ----- North American Vertical Datum
- R ----- Curve Radius
- L ----- Curve Length
- D ----- Curve Delta
- N.T.I. ----- Non-Tangent Intersection
- N.T.C. ----- Non-Tangent Curvature
- P.C. ----- Point of Curvature
- P.T. ----- Point of Tangency
- FIR ----- Found Iron Rod
- FCM ----- Found Concrete Monument
- ----- Set 5/8" Iron Rod and Cap LB7768
- LB ----- Licence Business
- Ⓢ ----- Centerline of Road
- BD ----- Brass Disk
- PBC ----- Palm Beach County
- FPL ----- Florida Power & Light
- (TYP.) ----- Typical
- INV ----- Invert Elevation
- Elev ----- Elevation
- PVC ----- Polyvinyl Chloride Pipe
- CMP ----- Corrugated Metal Pipe
- MES ----- Mitered End Section
- W ----- Buried Water Main Warning Marker
- RWM GV >----- Reclaimed Water Meter Gate Valve
- RWM BFV >----- Reclaimed Water Butterfly Valve
- ICV >----- Irrigation Control Valve
- Ⓜ ----- Water Meter
- Ⓜ ----- Fire Hydrant
- RWM Ⓜ ----- Reclaimed Water Meter
- Ⓟ ----- Utility Pole
- CLF ----- Chain Link Fence
- B ----- Ballard
- Ⓢ ----- Sign
- Ⓢ ----- Guy Anchor
- NAVD ----- North American Vertical Datum
- OU ----- Overhead Utility Lines
- Y ----- Top Of Bank
- Edge Of Water
- o ----- Chain Link Fence
- X ----- Location of reading
- 24.8 ----- Spot Elevation

The seal appearing on this document was authorized by Gary A. Rager, Professional Surveyor and Mapper, State of Florida, License No. LS4828

This item has been electronically signed and sealed by Gary A. Rager, P.S.M., on 3/15/2024 using a SHA authentication code.

Printed copies of this document are not considered signed and sealed and the SHA authentication code must be verified on any electronic copies.

CREW #1 PARTY CHIEF: ED G. FIELD BOOK: 2023-47W/58 DATA FILE: PRM US88_8 01-23-24 CREW #2 PARTY CHIEF: FIELD BOOK: DATA FILE: CREW #3 PARTY CHIEF: FIELD BOOK: DATA FILE:	Revisions <table border="1"> <thead> <tr> <th>DATE</th> <th>DESCRIPTION</th> <th>DRAWN</th> <th>P.CHEF</th> </tr> </thead> <tbody> <tr> <td> </td> <td> </td> <td> </td> <td> </td> </tr> </tbody> </table>		DATE	DESCRIPTION	DRAWN	P.CHEF					Surveyor's Certification I do hereby certify that this survey was made under my supervision and meets the "Standards of Practice" set forth by the Florida Board of Professional Surveyors and Mappers stated in Rules 6A-17.051, 6A-17.052, and 6A-17.053, Florida Administrative Code, pursuant to section 427.027 of the Florida Statutes. FIELD SURVEY DATE: January 17, 2024	THIS SURVEY IS VALID ONLY WITH A SIGNATURE & ORIGINAL SEAL IN HARD COPY FORM, OR A DIGITAL SEAL IN ELECTRONIC FORM PURSUANT TO RULES 6A-17.060 AND 6A-17.062, SECTION 427.027 OF THE FLORIDA STATUTES. Digitally signed by Gary A. Rager DN: cn=LS4828, o=GeoPoint Surveying, Inc., ou=Professional Surveyor and Mapper, email=Gary.Rager@geopointsurvey.com, c=FL, date=2024.03.20 07:35:53 -0400 Gary A. Rager LS4828	www.geopointsurvey.com Licensed Business No.: LB 7768 North Florida 327 S. County Hwy 393 Santa Rosa Beach, Florida 32459 Phone: (850) 740-0650 West Florida 213 Hobbs Street Tampa, Florida 33619 Phone: (813) 248-8888 Fax: (813) 248-2266 Central Florida 528 Northlake Blvd, Suite 1040 Altamonte Springs, Florida 32701 Phone: (321) 270-0440 East Florida 4152 West Blue Heron Blvd Suite 105 Riviera Beach, Florida 33404 Phone: (561) 444-2720	Boundary and Topographic Survey Westlake - POD G PREPARED FOR: Minto Communities, LLC LOCATED IN: Section 1, Township 43 S., Range 40 E., Palm Beach County, Florida	JOB #: POD G N BS-TP DRAWN BY: SWM DATE: 01/29/2024 LIDAR CREW: XXXX DATE: XX/XX/XX SURFACE BY: XXXX H.DATUM: FL-East NAD(83)-2011 V.DATUM: NAVD (1988) OFC CHECK: GAR FLD CHECK: GR3 SHEET: 01 of 02
	DATE	DESCRIPTION	DRAWN	P.CHEF											
FILE PATH: W:\WESTLAKE\WESTLAKE - NAVD88\SURVEY\POD G\POD G_BS-TP\POD G-N_BS-TP.DWG PLOTTED BY: SERGIO MACHADO ON: 3/20/2024 7:20 AM LAST SAVED BY: SERGIOM ON: 3/15/2024 7:35 AM		73													

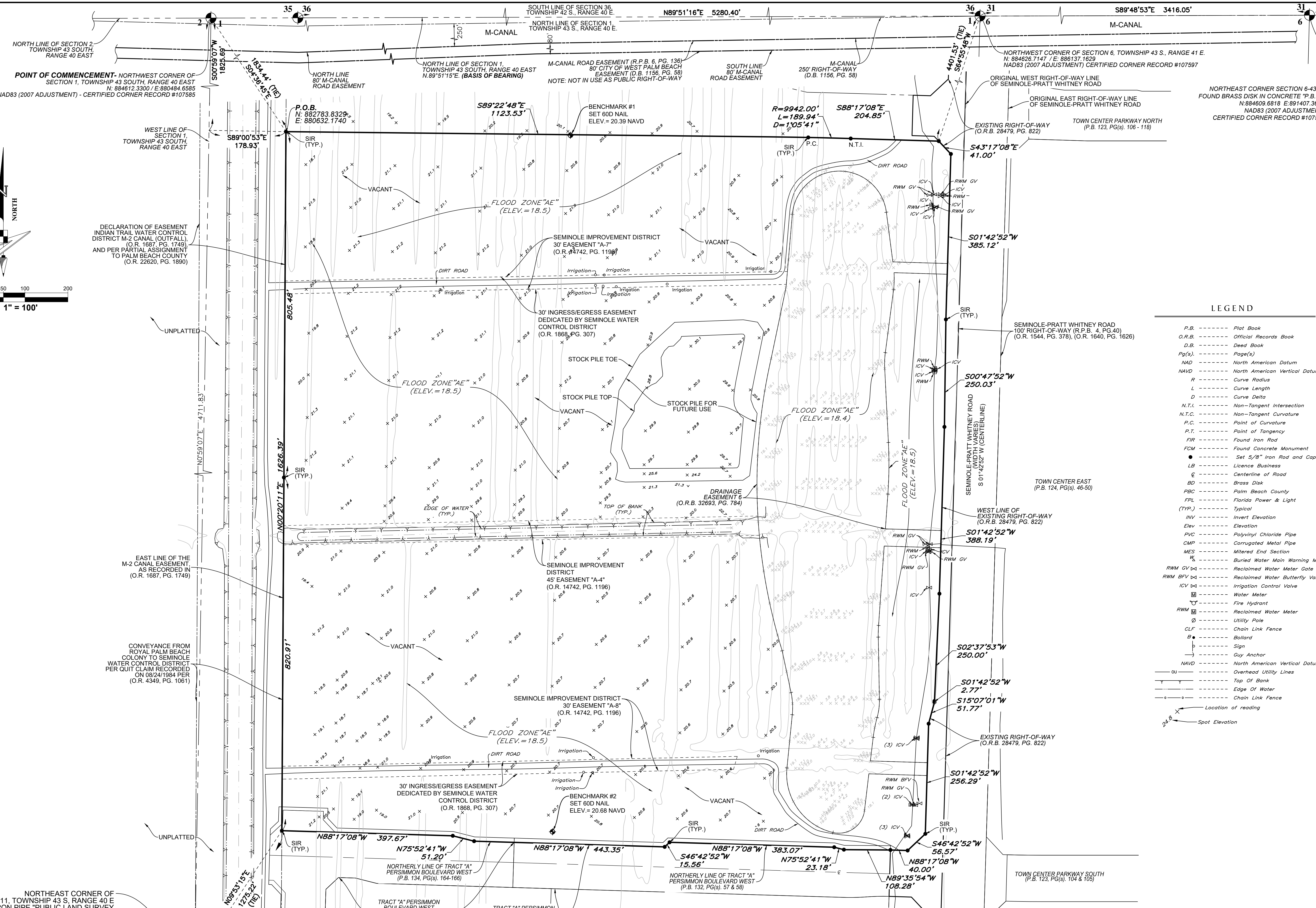
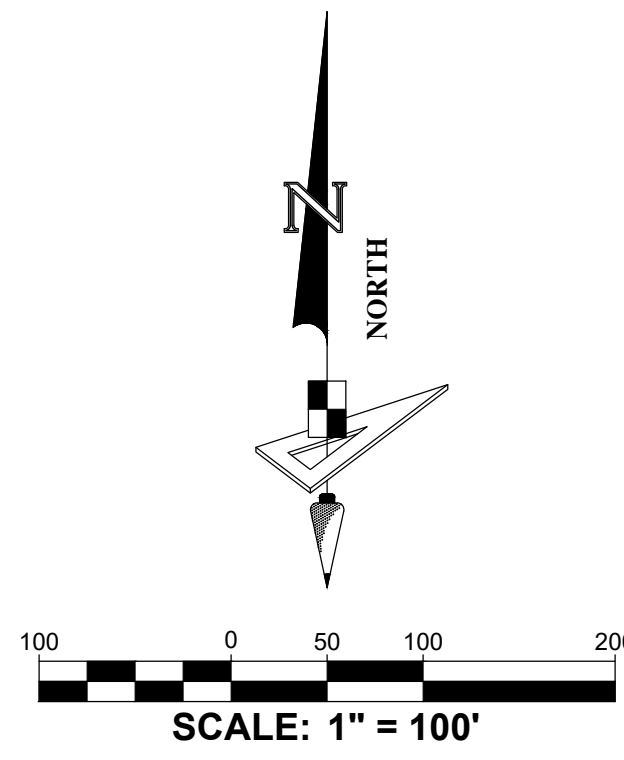

LEGEND

- P.B. ----- Plat Book
- O.R.B. ----- Official Records Book
- D.B. ----- Deed Book
- Pg(s) ----- Page(s)
- NAD ----- North American Datum
- NAVD ----- North American Vertical Datum
- R ----- Curve Radius
- L ----- Curve Length
- D ----- Curve Delta
- N.T.I. ----- Non-Tangent Intersection
- N.T.C. ----- Non-Tangent Curvature
- P.C. ----- Point of Curvature
- P.T. ----- Point of Tangency
- FIR ----- Found Iron Rod
- FCM ----- Found Concrete Monument
- ----- Set 5/8" Iron Rod and Cap LB7768
- LB ----- Licence Business
- ⊕ ----- Centerline of Road
- BD ----- Brass Disk
- FBC ----- Palm Beach County
- FPL ----- Florida Power & Light
- (TYP.) ----- Typical
- INV ----- Invert Elevation
- Elev ----- Elevation
- PVC ----- Polyvinyl Chloride Pipe
- CMP ----- Corrugated Metal Pipe
- MES ----- Mitered End Section
- W ----- Buried Water Main Warning Marker
- RWM GV ----- Reclaimed Water Meter Gate Valve
- RWM BV ----- Reclaimed Water Butterfly Valve
- ICV ----- Irrigation Control Valve
- ⊕ ----- Water Meter
- ⊕ ----- Fire Hydrant
- RWM ----- Reclaimed Water Meter
- ⊕ ----- Utility Pole
- CLF ----- Chain Link Fence
- B ----- Ballard
- ⊕ ----- Sign
- ⊕ ----- Guy Anchor
- NAVD ----- North American Vertical Datum
- OU ----- Overhead Utility Lines
- ⊕ ----- Top Of Bank
- ⊕ ----- Edge Of Water
- ⊕ ----- Chain Link Fence
- ⊕ ----- Location of reading
- 24.8 ----- Spot Elevation

NORTHEAST CORNER OF SECTION 11, TOWNSHIP 43 S, RANGE 40 E SET 3.5" IRON PIPE "PUBLIC LAND SURVEY CORNER-TALLAHASSEE MERIDIAN" N: 879901.1924 / E: 880403.6464 CERTIFIED CORNER RECORD #107586

CONVEYANCE FROM ROYAL PALM BEACH COLONY TO SEMINOLE WATER CONTROL DISTRICT PER QUIT CLAIM RECORDED ON 08/24/1984 PER (O.R. 4349, PG. 1061)

DECLARATION OF EASEMENT INDIAN TRAIL WATER CONTROL DISTRICT M-2 CANAL (OUTFALL) (O.R. 1887, PG. 1749) AND PER PARTIAL ASSIGNMENT TO PALM BEACH COUNTY (O.R. 22620, PG. 1890)

www.geopointsurvey.com
 Licensed Business No.: 1B 7768

GeoPoint
 Surveying, Inc.

North Florida
 327 S. County Hwy 393
 Santa Rosa Beach, Florida 32459
 Phone: (850) 740-0650

West Florida
 213 Hobbs Street
 Tampa, Florida 33619
 Phone: (813) 248-8888
 Fax: (813) 248-2266

Central Florida
 528 Northlake Blvd, Suite 1040
 Altamonte Springs, Florida 32701
 Phone: (321) 270-0440

East Florida
 4132 West Blue Heron Blvd
 Suite 105
 Riviera Beach, Florida 33404
 Phone: (561) 444-2720

Boundary and Topographic Survey Westlake - POD G

PREPARED FOR:
 Minto Communities, LLC

LOCATED IN:
 Section 1, Township 43 S., Range 40 E., Palm Beach County, Florida

See Sheet 1 for
 Certifications,
 Signature, & Revisions.
 Not valid without all Sheets

SHEET: 02 of 02



CITY OF WESTLAKE
Engineering Department
4001 Seminole Pratt Whitney Road
Westlake, Florida 33470
Phone: (561) 530-5880
www.westlakegov.com

DATE: 4/15/2024
PETITION NUMBER: ENG-2024-01
DESCRIPTION: Pod G North – Plat
APPLICANT: Cotleur & Hearing
OWNER: Minto PBLH, LLC
REQUEST: Plat & Boundary Survey Review
LOCATION: Westlake, Florida
STAFF REVIEW: **RECOMMENDED APPROVAL**

This is the second review of this plat. This review is done for compliance with Chapters 177, Florida Statutes, and the City of Westlake’s codes and ordinances. All previous comments have been adequately addressed. This plat is now in compliance with Chapter 177 Florida Statutes, and the City of Westlake’s codes and ordinances. We therefore recommend that the plat be approved for recording.

The following documents were reviewed as part of this submittal:

- 0) Transmittal - Chen Moore & SID dated 2/8/2024
- 1) Pod G North Application for Plat Review dated 2/7/2024
- 2) DESCRIPTION POD G-NORTH dated 2/8/2024
- 3) POD G-CLOSURE dated 2/8/2024
- 4) POD G-N BS-TP_ds plotted 2/6/2024
- 5) POD G-N Platmas dated 2/8/2024
- 6a) ENG-2024-01_Fee Detail_Plat Review dated 1/8/2024
- 6b) Pod G North Plat CWL Permit Fee Authorization dated 2/7/2024
- 7a) SID-ENG-2024-01 Pod G North Plat Review 01-08-2024 dated 1/8/2024
- 7b) Pod G North Plat SID Permit Fee Authorization dated 2/7/2024
- 1) ENG-2024-01 POD G North Response 1_3-11-24 dated 3/11/2024
- 2) ENG-2024-01 Pod G Plat Legal Description dated 3/20/2024
- 3) ENG-2024-01 POD G-N BS-TP_ds plotted 3/20/2024
- 4) ENG-2024-01 POD G-N Platmas dated 3/20/2024

This letter has been prepared by the following individual, in association with their consultants and subconsultants:

Suzanne Dombrowski, P.E.
Chen Moore and Associates
Tel: 561.746.6900 x 1035
Email: sdombrowski@chenmoore.com

File Attachments for Item:

A. Resolution 2024-09 - An Interlocal Agreement with the Palm Beach County Commission on Ethics

Submitted By: Administration

RESOLUTION 2024-09

A RESOLUTION OF THE CITY COUNCIL OF THE CITY OF WESTLAKE, FLORIDA, APPROVING AND AUTHORIZING THE MAYOR OR VICE MAYOR TO EXECUTE THE INTERLOCAL AGREEMENT BETWEEN THE CITY OF WESTLAKE, FLORIDA AND PALM BEACH COUNTY RELATIVE TO THE PALM BEACH COUNTY COMMISSION ON ETHICS; PROVIDING FOR CONFLICTS; PROVIDING FOR SEVERABILITY; AND PROVIDING AN EFFECTIVE DATE.



Meeting Agenda Item Coversheet

MEETING DATE:		May 7, 2024	Submitted By: Administration	
SUBJECT: <i>This will be the name of the Item as it will appear on the Agenda</i>		An Interlocal Agreement with the Palm Beach County Commission on Ethics		
STAFF RECOMMENDATION: (MOTION READY)		Motion to approve Interlocal Agreement with the Palm Beach County Commission on Ethics		
SUMMARY and/or JUSTIFICATION:		<p>Part I of Chapter 163, Florida Statutes, permits public agencies as defined therein to enter into local agreements with each other to jointly exercise any power, privilege, or authority which such agencies share in common and which each might exercise separately.</p> <p>The City of Westlake entered into a 3-year interlocal agreement with the Palm Beach County Commission on Ethics, February 2, 2021, and needs to be renewed.</p> <p>This agreement allows the Commission on Ethics to exercise the authority, functions and powers granted by the Commission on Ethics Ordinance as to the City's operations.</p>		
SELECT, if applicable	AGREEMENT:		BUDGET:	
	STAFF REPORT:		PROCLAMATION:	
	EXHIBIT(S):		OTHER:	
IDENTIFY EACH ATTACHMENT. <i>For example, an agreement may have 2 exhibits, identify the agreement and Exhibit A and Exhibit B</i>				
SELECT, if applicable	RESOLUTION:		ORDINANCE:	
IDENTIFY FULL RESOLUTION OR ORDINANCE TITLE <i>(if Item is not a Resolution or Ordinance, please erase all default text from this field's textbox and leave blank)</i> <u>Please keep text indented.</u>				
FISCAL IMPACT (if any):				\$

1
2
3
4
5
6
7
8
9
10
11
12
13
14
15
16
17
18
19
20
21
22
23
24
25
26
27
28
29
30
31
32
33
34
35
36
37
38
39
40

CITY OF WESTLAKE

RESOLUTION NO. 2024-09

A RESOLUTION OF THE CITY COUNCIL OF THE CITY OF WESTLAKE, FLORIDA, APPROVING AND AUTHORIZING THE MAYOR OR VICE MAYOR TO EXECUTE THE INTERLOCAL AGREEMENT BETWEEN THE CITY OF WESTLAKE, FLORIDA AND PALM BEACH COUNTY RELATIVE TO THE PALM BEACH COUNTY COMMISSION ON ETHICS; PROVIDING FOR CONFLICTS; PROVIDING FOR SEVERABILITY; AND PROVIDING AN EFFECTIVE DATE.

WHEREAS, the City Council deems it to be in the best interests of the City to approve and authorize the Mayor or Vice Mayor to execute the Interlocal Agreement between the City of Westlake, Florida and Palm Beach County relative to the Palm Beach County Commission on Ethics;

NOW, THEREFORE, BE IT RESOLVED BY THE CITY COUNCIL OF THE CITY OF WESTLAKE, FLORIDA:

SECTION 1. The foregoing "WHEREAS" clause is hereby ratified and confirmed by the City Council and incorporated herein by this reference.

SECTION 2. The City Council of the City of Westlake, Florida, hereby approves and authorizes the Mayor or Vice Mayor to execute the Interlocal Agreement between the City of Westlake, Florida and Palm Beach County relative to the Palm Beach County Commission on Ethics. A copy of the Interlocal Agreement is attached hereto as Exhibit "A".

SECTION 3. CONFLICTS. All resolutions or parts of resolutions in conflict herewith are hereby repealed to the extent of such conflict.

SECTION 4. SEVERABILITY. If any clause, section, other part or application of this Resolution is held by any court of competent jurisdiction to be unconstitutional or invalid, in part or application, it shall not affect the validity of the remaining portions or applications of this Resolution.

SECTION 5. EFFECTIVE DATE. This Resolution shall take effect immediately upon its passage and adoption.

1
2
3
4
5
6
7
8
9
10
11
12
13
14
15
16
17
18
19
20

PASSED AND APPROVED by City Council for the City of Westlake, on this
7th day of May 2024.

City of Westlake
JohnPaul O'Connor, Mayor

Zoie Burgess, City Clerk

INTERLOCAL AGREEMENT

This Interlocal Agreement ("Agreement") is made on _____, 2024, between the City of Westlake, a municipality located in Palm Beach County, Florida ("Public Entity"), and Palm Beach County, a political subdivision of the State of Florida ("County"), each one constituting a public agency as defined in Part I of Chapter 163, Florida Statutes.

WITNESSETH

WHEREAS, Part I of Section 163.01, Florida Statutes, known as the "Florida Interlocal Cooperation Act of 1969" authorizes local governments to make the most efficient use of their powers by enabling them to cooperate with other localities on a basis of mutual advantage and thereby to provide services and facilities that will harmonize geographic, economic, population and other factors influencing the needs and development of local communities; and

WHEREAS, Part I of Chapter 163, Florida Statutes, permits public agencies as defined therein to enter into interlocal agreements with each other to jointly exercise any power, privilege, or authority which such agencies share in common and which each might exercise separately; and

WHEREAS, the Palm Beach County Commission on Ethics Ordinance (the Commission on Ethics Ordinance) permits the Commission on Ethics of Palm Beach County ("the Commission on Ethics"), subject to approval by the Board of County Commissioners, to negotiate agreements or memoranda of understanding with municipalities, special districts, and other public offices and entities, authorizing the Commission on Ethics to exercise any and all authority, functions and powers set forth in the Commission on Ethics Ordinance and the Lobbyist Registration Ordinance for the benefit of such Public Entity.

WHEREAS, Public Entity wishes to have the Commission on Ethics exercise such authority, functions, and powers for Public Entity's benefit.

NOW THEREFORE, in consideration of the mutual representations, terms, and covenants hereinafter set forth, the parties hereby agree as follows:

Section 1. Purpose

The purpose of this Agreement is to have the Commission on Ethics exercise the authority, functions and powers granted by the Commission on Ethics Ordinance as to Public Entity's operations.

Section 2. Representative/Monitoring Position

The County's representative/contract monitor during the term of this Agreement shall be Rhonda Giger, General Counsel, Palm Beach County Commission on Ethics, whose telephone number is (561) 355-1915.

The Public Entity's representative/contract monitor during the term of this Agreement shall be Public Entity's City Manager, Kenneth Cassel, whose telephone number is (954) 826-0056.

Section 3. Effective Date and Term

This Agreement shall be first executed by Public Entity and shall be retroactive and in effect as of February 2, 2024 and will remain in effect through February 2, 2027, subject to and upon approval and execution of this Agreement by the BCC. This Agreement will then be in effect for three (3) years. This Agreement may be terminated by either party, with or without cause, upon ninety (90) days written notice to the other party. Upon notice of termination by Public Entity, any ongoing Public Entity investigations being conducted by the Commission on Ethics pursuant to this Agreement shall continue until completed.

Section 4. Responsibilities and Duties

The Commission on Ethics shall exercise any and all authority, functions and powers provided for in the Commission on Ethics Ordinance, the Code of Ethics Ordinance, and the Lobbyist Registration Ordinance as set forth in the Palm Beach County Code of Ordinances as may be amended or revised, in regard to Public Entity's operations.

Those functions, authority and powers include, but are not limited to, the following:

- (A) The Commission on Ethics shall have the authority to: (1) review, interpret, render advisory opinions and enforce the Code of Ethics, (2) investigate legally sufficient complaints within the jurisdiction of the Commission on Ethics and conduct public hearings as provided by the Commission on Ethics ordinance; and (3) develop and deliver, training programs and ensure that effective and meaningful training experiences are delivered in a timely and efficient manner.
- (B) The Commission on Ethics shall have the power to conduct investigations, and receive full and unrestricted access to the records of the Public Entity, all elected and appointed Public Entity officials and employees, Public Entity departments, divisions, agencies and instrumentalities, contractors and other persons and entities doing business with the Public Entity and/or receiving Public Entity funds regarding any such contracts or transactions with the Public Entity.

- (C) In the case of a refusal to obey a request for documents or for an interview, the Commission on Ethics shall have the power to subpoena witnesses, administer oaths, and require the production of records in a manner consistent with §162.08 Florida Statutes. The Commission on Ethics shall not interfere with any ongoing criminal investigation or prosecution of the State Attorney or the U.S. Attorney for the Southern District of Florida.
- (D) Where the Commission on Ethics suspects a possible violation of any state, federal or local law, or rule, regulation or policy, the Executive Director or designee shall notify the appropriate civil, criminal or administrative agencies. In the case of a possible violation of a rule, regulation or policy governing a Public Entity employee, the Executive Director or designee shall also notify the city manager of the Public Entity.
- (E) The Commission on Ethics shall have the power to require officials and employees to participate in ethics training on a regular basis. The administrator of the public entity shall establish by policy a mandatory training schedule for all officials and employees, which shall include mandatory periodic follow-up sessions. The commission on ethics shall develop and deliver, or contract with other entities to develop and deliver, training programs. The commission on ethics shall coordinate and cooperate with the public entity to ensure that effective and meaningful training experiences are delivered in a timely and efficient manner.
- (F) The Commission on Ethics' "hotline" will receive complaints related to Public Entity operations. The Public Entity will support and assist the Commission on Ethics in publicizing the "hotline" and encouraging the reporting of ethics violations by local citizens, officials and employees.
- (G) The Commission on Ethics may exercise any of the powers contained in the Commission on Ethics Ordinance upon its own initiative.
- (H) All records held by the Commission on Ethics and its staff related to an active preliminary investigation are confidential and exempt from disclosure in a manner consistent with the provisions in §112.3188(2) and §112.324, Florida Statutes.
- (I) The Commission on Ethics and its staff shall be considered "an appropriate local official" of the Public Entity for purposes of whistleblower protection provided by §112.3188(1), Florida Statutes.

- (J) The Commission on Ethics may recommend remedial actions and may provide prevention and training services to Public Entity officials, employees, and any other persons covered by this Agreement. The Commission on Ethics may follow up to determine whether recommended remedial actions have been taken.
- (K) The Commission on Ethics shall monitor the costs of investigations undertaken. The Commission on Ethics shall cooperate with other governmental agencies to recover restitution from other entities involved in willful misconduct in regard to Public Entity funds.
- (M) As part of its obligation under this Agreement, Public Entity's staff will in all instances cooperate fully with Commission on Ethics staff regarding issues of staff and vendor training and in timely providing records requested by staff investigators.
- (N) In any case in which the Commission on Ethics determines that the complaining party filed a frivolous or groundless complaint as defined in §57.105 Florida Statutes, or a complaint with malicious intent and with the knowledge that the complaint contains material false allegations, the commission shall order the complaining party to pay any costs and attorney's fees incurred by the commission and/or the alleged violator.
- (O) The Commission on Ethics will maintain a website and all required databases including gift reports, voting conflict disclosures, outside employment waivers, complaints, letters of instruction/reprimand, final orders, and advisory opinions.

Section 5. Funding and Budgeting by Public Entity

Under this Agreement, all costs associated with the duties and responsibilities of the Commission on Ethics are funded by The Palm Beach County Board of County Commissioners. County funding shall include all staff services and other resources to be provided in furtherance of this Agreement. However, the County's performance and obligation to pay under this Agreement for subsequent fiscal years is contingent upon annual appropriations for its purpose by the Board of County Commissioners.

Section 6. Delegation of Duty

Nothing contained herein shall be deemed to authorize the delegation of the constitutional or statutory duties of state, county, or municipal officers.

Section 7. Liability

The parties to this Agreement and their respective officers and employees shall not be deemed to assume any liability for the acts, omissions, and negligence of the other party. Further, nothing

herein shall be construed as a waiver of sovereign immunity by either party, pursuant to Section 768.28, Florida Statutes.

Section 8. Controlling Law

This Agreement shall be interpreted and construed according to, and governed by, the laws of the State of Florida. Any and all legal action necessary to enforce the Agreement will be held in Palm Beach County.

Section 9. Remedies

No remedy herein conferred upon any party is intended to be exclusive of any other remedy, and each and every such remedy shall be cumulative and shall be in addition to every other remedy given hereunder or now or hereafter existing at law or in equity or by statute or otherwise. No single or partial exercise by any party of any right, power, or remedy hereunder shall preclude any other or further exercise thereof.

Section 10. Severability

In the event any term or provision of this Agreement is determined by a court of competent jurisdiction to be illegal or otherwise invalid, such provision shall be construed or deleted and shall not affect the remaining portions of this Agreement and the remainder shall be construed to be in full force and effect.

Section 11. Notice and Point of Contact

All notices required to be given under this Agreement shall be deemed sufficient to each party when delivered by United States Mail, by hand delivery, or by overnight delivery service to the point of contact. For purposes of fulfilling the duties and responsibilities of this Agreement, the points of contact will be as follows:

Commission on Ethics:	300 North Dixie Highway, Suite 450 West Palm Beach, FL 33401 Ethics@pbcgov.org 561-355-1915	City of Westlake:	4005 Seminole Pratt Whitney Road Westlake, FL 33470 kcassel@westlakegov.com 954-826-0056
--------------------------	--	----------------------	--

Section 12. Filing

A copy of this Agreement shall be filed with the Clerk of the Circuit Court in and for Palm Beach County.

Section 13. Time of the Essence

The parties expressly agree that time is of the essence in this Agreement and the failure by a party to complete performance within the time specified, or within a reasonable time if no time is specified herein, shall, at the option of the other party without liability, in addition to any other rights or remedies, relieve the other party of any obligation to accept such performance.

Section 14. Equal Opportunity Provision

Commission on Ethics and Public Entity agree that no person shall, on the grounds of race, color, religion, sex, age, national origin, ancestry, marital status, sexual orientation, gender identity and expression, or disability be excluded from the benefits of, or be subjected to any form of discrimination under any activity carried out by the performance of this Agreement.

Section 15. Captions

The captions and section designations herein set forth are for convenience only and shall have no substantive meaning.

Section 16. Entirety of Agreement

This Agreement represents the entire understanding between the parties, and supersedes all other negotiations, representations, or agreements, written or oral, relating to this Agreement.

[the remainder of this page left intentionally blank]

ATTEST:
Joseph Abruzzo, Clerk & Comptroller

PALM BEACH COUNTY, FLORIDA, THROUGH
ITS BOARD OF COUNTY COMMISSIONERS

By: _____
Clerk

By: _____
Maria Sachs, Mayor

[SEAL]

APPROVED AS TO FORM
AND LEGAL SUFFICIENCY

APPROVED AS TO TERMS AND CONDITIONS

By: _____
David Behar
County Attorney

By: _____
Christie Kelley, Executive Director
Commission on Ethics

ATTEST:

CITY OF WESTLAKE, FLORIDA, THROUGH
ITS CITY COUNCIL

By: _____
Zoie P. Burgess, City Clerk

By: _____
JohnPaul O'Connor, Mayor

[SEAL]

APPROVED AS TO FORM
AND LEGAL SUFFICIENCY

By: _____
Donald J. Doody, City Attorney

Code of Ethics

(Effective Date July 1, 2021)

Sec. 2-441. Title; statement of purpose.

This article shall be known as the Palm Beach County Code of Ethics. This code of ethics is enacted pursuant to Florida Constitution, Article VIII, section 1(g), Florida Statutes, Ch. 125, and the Charter of Palm Beach County. The Municipalities located within Palm Beach County are subject to the provisions of this code of ethics pursuant to referendum. The purpose of this code is to provide additional and more stringent ethics standards as authorized by Florida Statutes, §112.326. This code shall not be construed to authorize or permit any conduct or activity that is in violation of Florida Statutes, Ch. 112, pt. III. This code of ethics shall be deemed additional and supplemental to any and all state and federal laws governing ethical conduct of officials and employees, as well as all local laws, rules, regulations and policies.

Officials and employees in the public service shall be conscious that public service is a public trust, shall be impartial and devoted to the best interests of the people of Palm Beach County, and shall act and conduct themselves so as not to give occasion for distrust of their impartiality.

Nothing herein shall abridge employees' constitutional right to collective bargaining.

(Ord. No. 2011-011, §1(Exh. 1), 5-17-11)

Sec. 2-442. Definitions.

The following words, terms, and phrases, when used in this article, shall have the meanings ascribed to them in this section, except where the context clearly indicates a different meaning, or where expressly provided herein to the contrary:

Advisory board shall mean any advisory or quasi-judicial board created by the board of county commissioners, by the local municipal governing bodies, or by the mayors who serve as chief executive officers or by mayors who are not members of local municipal governing bodies.

Customer or client means any person or entity to which an official or employee's outside employer or business has supplied goods or services during the previous twenty-four (24) months, having, in the aggregate, a value greater than ten thousand dollars (\$10,000).

Domestic partner is an adult, unrelated by blood, with whom an unmarried or separated official or employee has an exclusive committed relationship and maintains a mutual residence.

Financial benefit includes any money, service, license, permit, contract, authorization, loan, travel, entertainment, hospitality, gratuity, or any promise of any of these, or anything else of value. This term does not include campaign contributions authorized by law.

Gift shall refer to the transfer of anything of economic value, whether in the form of money, service, loan, travel, entertainment, hospitality, item or promise of these, or in any other form, without adequate and lawful consideration. Food and beverages consumed at a single setting or a meal shall be considered a single gift, and the value of the food and beverage provided at that sitting or meal shall be considered the value of the gift. In determining the value of the gift, the recipient of the gift may consult, among other sources, Florida Statutes, §112.3148, and the Florida Administrative Code as may be amended.

Household member includes anyone whose primary residence is in the official or employee's home, including non-relatives who are not renters or employees of the head of the household.

Inspector general shall mean the office established in article XII of this chapter.

Lobbying shall mean seeking to influence a decision through oral or written communication or an attempt to obtain the goodwill of any county commissioner, any member of a local municipal governing body, any mayor or chief executive officer that is not a member of a local municipal governing body, any advisory board member, or any employee with respect to the passage, defeat or modification of any item which may foreseeably be presented for consideration to the advisory board, the board of county commissioners, or the local municipal governing body lobbied as applicable.

Lobbyist shall mean any person who is employed and receives payment, or who contracts for economic consideration, or who registers in the county's central lobbyist registration database or with any municipality, for the purpose of lobbying on behalf of a principal, and shall include an employee whose principal responsibility to the employer is overseeing the employer's various relationships with government or representing the employer in its contacts with government.

"Lobbyist" shall not include:

- (1) Any employee, contract employee, or independent contractor of a governmental agency or entity lobbying on behalf of that agency or entity, any elected local official when the official is lobbying on behalf of the governmental agency or entity which the official serves, or any member of the official's staff when such staff member is lobbying on an occasional basis on behalf of the governmental agency or entity by which the staff member is employed.
- (2) Any person who is retained or employed for the purpose of representing an employer, principal or client only during a publicly noticed quasi-judicial hearing or comprehensive plan hearing, provided the person identifies the employer, principal or client at the hearing, and providing that the person is not otherwise registered as a lobbyist in the county's central lobbyist registration database, or with any municipal lobbyist registration system when that municipality has its own lobbyist registration process.
- (3) Any expert witness who is retained or employed by an employer, principal or client to provide only scientific, technical or other specialized information provided in agenda materials or testimony only in public hearings, so long as the expert identifies the employer, principal or client at the hearing.
- (4) Any person who lobbies only in his or her individual capacity for the purpose of self-representation and without compensation.
- (5) Any employee, contract employee, or independent contractor of the Palm Beach County League of Cities, Inc., lobbying on behalf of that entity.

Official or employee means any official or employee of the county or the municipalities located within the county, whether paid or unpaid. The term "employee" includes but is not limited to all managers, department heads, and personnel of the county or the municipalities located within the county. The term also includes volunteers of the county or the municipalities located within the county when such volunteers exercise discretionary police, fire, or parking enforcement department authority. The term "employee" also includes the chief executive officer of the county or any municipality, who is not part of the local governing body. If the county or municipality utilizes and contracts for "privatized" chief administrative officers or chief executive officers, then the person providing such

services, or the officers, directors, and employees of any entity providing such services, shall be considered the employees of the county or municipality that he or she serves. However, it shall not include local government attorneys as defined in Florida Statutes § 112.313, or attorneys who render contracted services to the county or municipality that are limited in scope to a specific issue or subject, to specific litigation, or to a specific administrative proceeding. The term "official" shall mean members of the board of county commissioners, a mayor, members of local municipal governing bodies, and members appointed by the board of county commissioners, members of local municipal governing bodies or mayors or chief executive officers that are not members of local municipal governing body, as applicable, to serve on any advisory, quasi-judicial, or any other board of the county, state, or any other regional, local, municipal, or corporate entity.

Outside employer or business includes:

- (1) Any entity, other than the county, the state, or any other federal, regional, local, or municipal government entity, of which the official or employee is a member, official, director, proprietor, partner, or employee, and from which he or she receives compensation for services rendered or goods sold or produced. For purposes of this definition, "compensation" does not include reimbursement for necessary expenses, including travel expenses; or
- (2) Any entity located in the county or which does business with or is regulated by the county or municipality as applicable, in which the official or employee has an ownership interest. For purposes of this definition, an "ownership interest" shall mean at least five (5) percent of the total assets or common stock owned by the official or employee or any combination of the official or employee's household members, spouse, child, step-child, brother, sister, parent or step-parent, or a person claimed as a dependent on the official or employee's latest individual federal tax return.
- (3) The term outside employer or business shall not apply to an employee who is employed by a certified bargaining agent solely to represent employees.

Palm Beach County Commission on Ethics means the commission established in section 2-254 et seq. to administer and enforce the ethics regulations set forth herein, and may also be referred to as the "commission on ethics" in this article.

Persons and entities shall be defined to include all natural persons, firms, associations, joint ventures, partnerships, estates, trusts, business entities, syndicates, fiduciaries, corporations, and all other organizations.

Principal shall mean the person or entity a lobbyist represents, including a lobbyist's employer, for the purpose of lobbying.

Relative unless otherwise specified in this article, means an individual who is related to an official or employee as father, mother, son, daughter, brother, sister, uncle, aunt, first cousin, nephew, niece, husband, wife, father-in-law, mother-in-law, son-in-law, daughter-in-law, brother-in-law, sister-in-law, stepfather, stepmother, stepson, stepdaughter, stepbrother, stepsister, half-brother, half-sister, grandparent, great grandparent, grandchild, great grandchild, step grandparent, step great grandparent, step grandchild, step great grandchild, person who is engaged to be married to the official or employee or who otherwise holds himself or herself out as or is generally known as the person whom the official or employee intends to marry or with whom the official or employee intends to form a household, or any other natural person having the same legal residence as the official or employee.

Transaction shall refer to the purchase or sale by the county or municipality of goods or services for a consideration.

Vendor means any person or entity who has a pending bid proposal, an offer or request to sell goods or services or to sell or lease real or personal property, or who currently sells goods or services, or sells or leases real or personal property to the county or municipality involved in the subject contract or transaction as applicable. For the purposes of this definition, a vendor entity includes an owner, director, manager or employee. Currently sells goods or services shall mean the period of time of an actual transaction or contract between a vendor and the government entity if such transaction or contract exceeds \$500. Where no formal contract exists for the sale or lease of goods and services, it shall include the period of time from the point the government entity orders or otherwise agrees to purchase goods and services from a vendor, to the point that all obligations on the part of both the vendor and the government entity have been satisfied by delivery of the goods and/or services by the vendor, and payment has been received for those goods and services by the vendor, and where no other obligations by either party concerning the purchase of the goods and/or services remain unsatisfied. However, it shall not include any warranty period provided by the vendor once payment for the goods and services has been received and the goods and services have been delivered, even where an obligation to provide warranty service on the part of the vendor shall exist.

(Ord. No. 2011-011, §1(Exh. 1), 5-17-11, 4-6-21)

Sec. 2-443. Prohibited conduct.

- (a) **Misuse of public office or employment.** An official or employee shall not use his or her official position or office, or take or fail to take any action, or influence others to take or fail to take any action, or attempt to do any of these things, in a manner which he or she knows or should know with the exercise of reasonable care will result in a special financial benefit, not shared with similarly situated members of the general public, for any of the following persons or entities:
- (1) Himself or herself;
 - (2) His or her spouse or domestic partner, household member or persons claimed as dependents on the official or employee's latest individual federal income tax return, or the employer or business of any of these people;
 - (3) A sibling or step-sibling, child or step-child, parent or step-parent, niece or nephew, uncle or aunt, or grandparent or grandchild of either himself or herself, or of his or her spouse or domestic partner, or the employer or business of any of these people;
 - (4) An outside employer or business of his or hers, or of his or her spouse or domestic partner, or someone who is known to such official or employee to work for such outside employer or business;
 - (5) A customer or client of the official or employee's outside employer or business;
 - (6) A substantial debtor or creditor of his or hers, or of his or her spouse or domestic partner— "substantial" for these purposes shall mean at least ten thousand dollars (\$10,000) and shall not include forms of indebtedness, such as a mortgage and note, or a loan between the official or employee and a financial institution;
 - (7) A civic group, union, social, charitable, or religious organization, or other organization of which he or she (or his or her spouse or domestic partner) is an officer or director. However, this sub-section shall not apply to any official or employee who is required to serve on the board of directors of any organization solely based on his or her official position (ex-officio), regardless of whether he or she has

voting rights on the board, and who receives no financial compensation for such service on the board of directors, and otherwise has no personal ownership interest in the organization.

- (b) **Corrupt misuse of official position.** An official or employee shall not use or attempt to use his or her official position or office, or any property or resource which may be within his or her trust, to corruptly secure or attempt to secure a special privilege, benefit, or exemption for himself, herself, or others. For the purposes of this subsection, "corruptly" means done with a wrongful intent and for the purpose of obtaining, or compensating or receiving compensation for, any benefit resulting from some act or omission of an official or employee which is inconsistent with the proper performance of his or her public duties.
- (c) **Disclosure of voting conflicts.** County and municipal officials as applicable shall abstain from voting and not participate in any matter that will result in a special financial benefit as set forth in subsections (a)(1) through (7) above. The term "participate" as used in this section shall be defined as: "To take any action, or to influence others to take any action, or to attempt to do any of these things, in order to affect the passage or defeat of the specific matter before the voting body in which the official is required to abstain from voting." The official shall publicly disclose the nature of the conflict and when abstaining from the vote, shall complete and file a State of Florida Commission on Ethics Conflict Form 8B pursuant to the requirements of Florida Statutes, §112.3143. Simultaneously with filing Form 8B, the official shall submit a copy of the completed form to the county commission on ethics. Officials who abstain and disclose a voting conflict as set forth herein, shall not be in violation of subsection (a), provided the official does not otherwise use his or her office to take or fail to take any action, or influence others to take or fail to take any action, in any other manner which he or she knows or should know with the exercise of reasonable care will result in a special financial benefit, not shared with similarly situated members of the general public, as set forth in subsections (a)(1) through (7).
- (d) **Contractual relationships.** No official or employee shall enter into any contract or other transaction for goods or services with his or her respective county or municipality. This prohibition extends to all contracts or transactions between the county or municipality as applicable or any person, agency or entity acting for the county or municipality as applicable, and the official or employee, directly or indirectly, or the official or employee's outside employer or business. Any such contract, agreement, or business arrangement entered into in violation of this subsection may be rescinded or declared void by the board of county commissioners pursuant to section 2-448(c) or by the local municipal governing body pursuant to local ordinance as applicable. This prohibition shall not apply to employees who enter into contracts with Palm Beach County or a municipality as part of their official duties with the county or that municipality. This prohibition also shall not apply to officials or employees who purchase goods from the county or municipality on the same terms available to all members of the public. This prohibition shall also not apply to advisory board members provided the subject contract or transaction is disclosed at a duly noticed public meeting of the governing body and the advisory board member's board provides no regulation, oversight, management, or policy-setting recommendations regarding the subject contract or transaction.
- (e) **Exceptions and waiver.** The requirements of subsection (d) above may be waived as it pertains to advisory board members where the advisory board member's board is purely advisory and provides regulation, oversight, management, or policy-setting recommendations regarding the subject contract or transaction. No waiver shall be allowed where the advisory board member's board is not purely advisory and provides regulation, oversight, management, or policy-setting recommendations regarding the subject contract or

transaction. Waiver may be effected by the board of county commissioners or by the local municipal governing body as applicable upon full disclosure of the contract or transaction prior to the waiver and an affirmative vote of a majority plus one (1) of the total membership of the board of county commissioners or the local municipal governing body as applicable. In instances in which appointment to the advisory board is made by an individual, waiver may be effected, after full disclosure of the contract or transaction at a public hearing, by the appointing person. In addition, no official or employee shall be held in violation of subsection (d) if:

- (1) The business is awarded under a system of sealed, competitive bidding to the lowest bidder and:
 - a. The official or employee, or his or her relative or household member, has in no way participated in the determination of the bid specifications or the determination of the lowest bidder;
 - b. The official or employee, or his or her relative or household member, has in no way used or attempted to use the official or employee's influence to persuade the agency, governmental entity or any personnel thereof to enter such a contract other than by the mere submission of the bid; and
 - c. The official or employee, prior to or at the time of the submission of the bid, has filed a statement with the supervisor of elections and the commission on ethics, disclosing the nature of the interest in the outside employer or business submitting the bid.
- (2) An emergency purchase or contract, which would otherwise violate a provision of subsection (d), must be made in order to protect the health, safety, or welfare of the citizens of the county or municipality as applicable.
- (3) The outside employer or business involved is the only source of supply within the county or municipality under applicable law or county or municipal policy, and there is full disclosure by the official or employee of his or her interest in the outside employer or business to the county or municipality as applicable and the ethics commission prior to the purchase, rental, sale, leasing, or other business being transacted.
- (4) The total amount of the contracts or transactions in the aggregate between the outside employer or business and the county or municipality as applicable does not exceed five hundred dollars (\$500) per calendar year.
- (5) Notwithstanding any provision to the contrary, subsection (d) shall not be construed to prevent an employee from seeking part-time employment with an outside employer who has entered into a contract for goods or services with the county or municipality as applicable provided that:
 - a. The employee or his or her spouse, domestic partner, household member, or relative does not work in the county or municipal department as applicable which will enforce, oversee or administer the subject contract; and
 - b. The outside employment would not interfere with or otherwise impair his or her independence of judgment or otherwise interfere with the full and faithful performance of his or her public duties to the county or municipality as applicable; and
 - c. The employee or his or her spouse, domestic partner, household member, or relative has not participated in determining the subject contract requirements or awarding the contract; and

- d. The employee's job responsibilities and job description will not require him or her to be involved in the outside employer's contract in any way including, but not limited to, its enforcement, oversight, administration, amendment, extension, termination or forbearance; and
 - e. The employee demonstrates compliance with applicable county or municipal policy regarding outside employment and obtains written permission from his or her supervisor; and
 - f. The employee has obtained a conflict of interest waiver signed by the chief administrative officer, or his or her designee, and the employee's direct supervisor, or his or her designee, based on a finding that no conflict exists. The employee shall submit the request for waiver in writing and under oath or affirmation on an approved form provided by the commission on ethics. The document shall contain written acknowledgment of compliance with the provisions of subsection (5)a. through (5)e. of this subsection, together with such pertinent facts and relevant documents that support such waiver. A waiver under this subsection must be approved by both the employee's direct supervisor and the chief administrative officer of the county or municipality or their designees. The county or municipality shall record such waiver in the employee's personnel file and shall submit a copy of the waiver and all related documents to the commission on ethics. The commission on ethics in its discretion may elect to review, comment on, or investigate any waiver. The commission on ethics review or investigation shall not delay an employee's ability to take the part-time employment.
 - g. *Official law enforcement or fire rescue overtime or extra duty details approved by the county or municipality of the employee.* The provisions of subsection (d) shall be waived for outside employment when that employment consists of a certified police agency extra duty detail or a certified firefighter or paramedic extra duty detail when contracted or administered by the police or fire rescue agency as applicable. For the purpose of this subsection, all records of external, extra duty or overtime security details, including supervisor approval, identity of contracting parties, and including time, date and manner of detail shall be maintained by the individual contracting or administering police or fire rescue agency, records of which shall be accessible to the public subject to state public records disclosure exemptions.
- (f) **Accepting travel expenses.** No official or employee shall accept, directly or indirectly, any travel expenses including, but not limited to, transportation, lodging, meals, registration fees and incidentals from any county or municipal contractor, vendor, service provider, bidder or proposer as applicable. The board of county commissioners or local municipal governing body as applicable may waive the requirements of this subsection by a majority vote of the board or local municipal governing body. The provisions of this subsection shall not apply to travel expenses paid by other governmental entities or by organizations of which the county or municipality as applicable is a member if the travel is related to that membership.
- (g) **Contingent fee prohibition.** No person shall, in whole or in part, pay, give or agree to pay or give a contingency fee to another person. No person shall, in whole or in part, receive or agree to receive a contingency fee. As used herein, "contingency fee" means a fee, bonus, commission, or nonmonetary benefit as compensation, which is dependent on or in any way contingent on the passage, defeat, or modification of: an ordinance, resolution, action or decision of the board of county commissioners or local municipal governing body as applicable, any employee authorized to act on behalf of the board of county commissioners or local municipal governing body as applicable, the county administrator or municipal

administrator as applicable, or any action or decision of an advisory board or committee. This prohibition does not apply to real estate brokers when acting in the course of their profession as regulated by Florida Statutes, §§475.001—475.5018, as may be amended. Nothing in this section may be construed to prohibit any salesperson from engaging in legitimate government business on behalf of a company from receiving compensation or commission as part of a bona fide contractual arrangement with that company provided such compensation or commission is ordinary and customary in the industry. Nothing in this section may be construed to prohibit an attorney from representing a client in a judicial proceeding or formal administrative hearing pursuant to a contingent fee arrangement if allowed by the rules of the Florida Bar.

- (h) **Honesty in applications for positions.** No person seeking to become an official or employee, or seeking any promotion or job reassignment within the public entity that currently employs them, or seeking to enter into a contract or otherwise seeking to provide goods or services to the county or municipality as applicable, may make any false statement, submit any false document, or knowingly withhold information about wrongdoing in connection with employment by or services to the county or municipality as applicable.
- (i) **Disclosure or use of certain information.** A current or former official or employee shall not disclose or use information not available to members of the general public and gained by reason of his or her official position, except for information relating exclusively to governmental practices, for his or her personal gain or benefit or for the personal gain or benefit of any other person.

(Ord. No. 2011-011, §1(Exh. 1), 5-17-11, 4-6-21)

Sec. 2-444. Gift law.

- (a) (1) No county commissioner, member of a local governing body, mayor or chief executive when not a member of the governing body, or employee, or any other person or business entity on his or her behalf, shall knowingly solicit or accept directly or indirectly, any gift with a value of greater than one hundred dollars (\$100) in the aggregate for the calendar year from any person or business entity that the recipient knows, or should know with the exercise of reasonable care, is a vendor, lobbyist, or any principal or employer of a lobbyist who lobbies, sells, or leases to the county or municipality as applicable.
- (2) No vendor, lobbyist, or principal or employer of a lobbyist that lobbies, sells, or leases to the county or a municipality as applicable, shall knowingly give, directly or indirectly, any gift with a value greater than one hundred dollars (\$100) in the aggregate for the calendar year to a person who the vendor, lobbyist, or principal knows, or should know with the exercise of reasonable care, is an official or employee of that county or municipality. For the purposes of this subsection (a)(2), the term vendor also includes any person or entity that, because of the nature of their business, may respond to an invitation to bid, request for proposal or other procurement opportunity that has been published by the county or a municipality.
- (b) (1) No advisory board member, or any other person on his or her behalf, shall knowingly solicit or accept directly or indirectly, any gift with a value of greater than one hundred dollars (\$100) in the aggregate for the calendar year from any person or business entity that the recipient knows, or should know with the exercise of reasonable care, is a vendor, lobbyist, or any principal or employer of a lobbyist, who lobbies, sells, or leases to the recipient's advisory board or any county or municipal department as applicable that is subject in any way to the advisory board's authority, influence or advice.

- (2) No vendor, lobbyist, or principal or employer of a lobbyist who lobbies, sells, or leases to an advisory board or any county or municipal department as applicable that is subject in any way to the advisory board's authority, influence or advice, shall knowingly give, directly or indirectly, any gift with a value greater than one hundred dollars (\$100) in the aggregate for the calendar year to a person who the vendor, lobbyist, or principal knows, or should know through the exercise of reasonable care, is a member of that advisory board. For the purposes of this subsection (b)(2), the term vendor also includes any person or entity that, because of the nature of their business, may respond to an invitation to bid, request for proposal or other procurement opportunity that has been published by the county or a municipality.
- (c) No county commissioner, member of a local governing body, mayor or chief executive officer when not a member of the governing body, or employee, or any other person or business entity on his or her behalf, shall knowingly solicit a gift of any value from any person or business entity that the recipient knows, or should know with the exercise of reasonable care, is a vendor, lobbyist, or any principal or employer of a lobbyist who lobbies, sells, or leases to the county or municipality as applicable, where the gift is for the personal benefit of the official or employee, another official or employee, or any relative or household member of the official or employee. No advisory board member or any other person or business entity on his or her behalf, shall knowingly solicit a gift of any value from any person or business entity that the recipient knows, or should know with the exercise of reasonable care, is a vendor, lobbyist, or any principal or employer of a lobbyist who lobbies, sells, or leases to the recipient's advisory board or any county or municipal department as applicable that is subject in any way to the advisory board's authority, influence or advice, where the gift is for the personal benefit of the advisory board member, another advisory board member, another official or employee, or any relative or household member of the official or employee.
- (d) For purposes of this section, a principal or employer of a lobbyist shall include any officer, partner or director of the principal or employer entity, or any employee of a principal or employer who is not an officer, partner or director, provided that the employee knows or should know with the exercise of reasonable care that the principal or employer employs a lobbyist.
- (e) No person or entity shall offer, give, or agree to give an official or employee a gift, and no official or employee shall accept or agree to accept a gift from a person or entity, because of:
- (1) An official public action taken or to be taken, or which could be taken;
 - (2) A legal duty performed or to be performed or which could be performed; or
 - (3) A legal duty violated or to be violated, or which could be violated by any official or employee.
- (f) **Gift reports.** Any official or employee who receives a gift in excess of one hundred dollars (\$100) shall report that gift in accordance with this section.
- (1) ***Gift reports for officials and employees identified by state law as reporting individuals.*** Those persons required to report gifts pursuant to state law shall report those gifts in the manner provided by Florida Statutes, §112.3148, as may be amended, including, but not limited to, the state's definition of gift, exceptions thereto, and gift valuations. The county code of ethics' definition of gift and exceptions thereto shall not be used by reporting individuals to complete and file state gift reporting disclosures. When a state reporting individual files or is required to file a gift report with the state, a copy of each report shall also be filed with the county commission on ethics no later than ten (10) days after the

report is filed with the state. Failure to file a State of Florida Quarterly Gift Disclosure Form with the county commission on ethics within the required timeframe shall be a violation of this section.

(2) **All other officials and employees who are not reporting individuals under state law.**

a. **Personal gifts.** All officials and employees who are not reporting individuals under state law are not required to report gifts in excess of one hundred dollars (\$100) so long as those gifts are given to the official or employee by a personal friend or co-worker and the circumstances demonstrate that the motivation for the gift was the personal or social relationship rather than an attempt to obtain the goodwill or otherwise influence the official or employee in the performance of his or her official duties. Factors to be considered in determining whether a gift was motivated by a personal or social relationship may include but shall not be limited to: whether the relationship began before or after the official or employee obtained his or her office or position; the prior history of gift giving between the individuals; whether the gift was given in connection with a holiday or other special occasion; whether the donor personally paid for the gift or sought a tax deduction or business reimbursement; and whether the donor gave similar gifts to other officials or employees at or near the same time. If the personal friend or co-worker is a vendor, lobbyist or principal or employer of a lobbyist that lobbies the county or municipality as applicable, then the official or employee shall not accept a gift in excess of one hundred dollars (\$100) in accordance with subsections (a)(1) and (b)(1).

b. **All other gifts.** All officials or employees who are not reporting individuals under state law and who receive any gift in excess of one hundred dollars (\$100), which is not otherwise excluded or prohibited pursuant to this subsection, shall complete and submit an annual gift disclosure report with the county commission on ethics no later than January 31 of each year for the previous calendar year (January 1 through December 31). All officials or employees, who are not reporting individuals under state law and who do not receive a gift in excess of one hundred dollars (\$100) during a given reporting period shall not file an annual gift disclosure report. The annual gift disclosure report shall be created by the county commission on ethics and shall be in a form substantially similar in content as that required by state law. The county code of ethics' definition of gift and exceptions thereto shall be used by non-state-reporting individuals in completing and filing annual gift disclosure reports required by this section.

(g) Exceptions. For the purposes of this section, the following shall not be considered a gift:

- (1) Political contributions specifically authorized by state or federal law;
- (2) Gifts from any relatives, domestic partners, and dependents named on the official's or employee's latest federal income tax return, or one's household member;
- (3) Awards for professional or civic achievement;
- (4) Materials such as books, reports, periodicals or pamphlets that are solely informational or of an advertising nature;
- (5) Gifts solicited or accepted by county or municipal officials or employees as applicable on behalf of the county or municipality in performance of their official duties for use solely by the county or municipality for a public purpose;
- (6) Publicly advertised offers for goods or services from a vendor under the same terms and conditions as are offered or made available to the general public;

- (7) Inheritance or other devise;
 - (8) Registration fees and other related costs associated with educational or governmental conferences, meetings or seminars and travel expenses either properly waived or inapplicable pursuant to section 2-443(f), provided that attendance is for governmental purposes, and attendance is related to his or her duties and responsibilities as an official or employee of the county or municipality;
 - (9) A ticket, pass or admission in connection with public events, appearances or ceremonies related to official county or municipal business, if furnished by a nonprofit sponsor organization of such public event, or if furnished pursuant to a contract between the event's non-profit sponsor and the county or municipality as applicable, provided the sponsor organization does not employ a lobbyist, and further provided the ticket, pass or admission is given by a representative of the sponsor organization who is not otherwise a lobbyist or a principal or employer of a lobbyist. Notwithstanding the exception as provided in this subsection, the ticket, pass, or admission must be disclosed in accordance with the gift law reporting requirements of subsections (f)(1) and (f)(2);
 - (10) Expenditures made in connection with an event sponsored by a nonprofit organization funded in whole or in part with public funds whose primary function is to encourage and attract tourism or other business opportunities for the benefit of Palm Beach County or the municipalities as applicable, provided the sponsor organization does not employ a lobbyist, and further provided that the invitation to the event is made by a representative of the sponsor organization and the representative is not otherwise a lobbyist or a principal or employer of a lobbyist. Notwithstanding the exception as provided in this subsection, the expenditure must be disclosed in accordance with the gift law reporting requirements of subsections (f)(1) and (f)(2).
- (h) Solicitation of contributions on behalf of a non-profit charitable organization.
- (1) Notwithstanding the prohibition on gifts as outlined in subsections (a) and (b), the solicitation of funds by a county or municipal official or employee for a non-profit charitable organization, as defined under the Internal Revenue Code, is permissible so long as there is no quid pro quo or other special consideration, including any direct or indirect special financial benefit to the official or employee or to the person or entity being solicited. The solicitation by an official or employee as contemplated herein, is expressly prohibited if made to any person or entity with a pending application for approval or award of any nature before the county or municipality as applicable.
 - (2) To promote the full and complete transparency of any such solicitation, officials and employees shall disclose, on a form provided by the commission on ethics, the name of the charitable organization, the event for which the funds were solicited, the name of any person or entity that was contacted regarding a solicitation or pledge by the official or employee, and the amount of the funds solicited or pledged if known. The form shall be completed legibly and shall be filed with the commission on ethics. The form shall be filed within thirty (30) days from the occurrence of the event for which the solicitation was made, or if no event, within thirty (30) days from the occurrence of the solicitation.

(Ord. No. 2011-011, §1(Exh. 1), 5-17-11, 4-6-21)

Sec. 2-445. Anti-nepotism law.

An official may not appoint, employ, promote, advance, or advocate for appointment, employment, promotion, or advancement in or to a position in the county or municipality as applicable in which the official is

serving or over which the official exercises jurisdiction or control, any individual who is a relative or domestic partner of the official. An individual may not be appointed, employed, promoted, or advanced in or to a position in the county or a municipality if such appointment, employment, promotion, or advancement has been advocated by an official, serving in or exercising jurisdiction or control over the county or municipality as appropriate, who is a relative or domestic partner of the individual or if such appointment, employment, promotion, or advancement is made by a collegial body of which a relative or domestic partner of the individual is a member. However, this section shall not apply to appointments to boards other than those with land-planning or zoning responsibilities in those municipalities with less than thirty-five thousand (35,000) population. This section does not apply to persons serving in a volunteer capacity who provide emergency medical, firefighting, or police services. Such persons may receive, without losing their volunteer status, reimbursements for the costs of any training they get relating to the provision of volunteer emergency medical, firefighting, or police services and payment for any incidental expenses relating to those services that they provide. Mere approval of budgets shall not be sufficient to constitute "jurisdiction or control" for the purposes of this section.

- (1) For the purposes of this section, "official" means any official or employee in whom is vested the authority by law, rule, or regulation, or to whom the authority has been delegated to appoint, employ, promote, or advance individuals or to recommend individuals for appointment, employment, promotion, or advancement in connection with employment in the county or municipality as applicable.
- (2) For the purposes of this section, "relative" means spouse, parent, child, sibling, uncle, aunt, first cousin, nephew, niece, father-in-law, mother-in-law, son-in-law, daughter-in-law, brother-in-law, sister-in-law, stepfather, stepmother, stepson, stepdaughter, stepbrother, stepsister, half-brother, or half-sister.

(Ord. No. 2011-011, §1(Exh. 1), 5-17-11, 4-6-21)

Sec. 2-446. Ethics training.

- (a) Officials and employees, as public servants, are considered stewards of the public trust and should aspire to the highest level of integrity and character. Officials and employees shall be informed of their ethical responsibilities at the start of their public service, and shall receive updates and training materials on ethics issues throughout the span of their public service. The county administrator or municipal administrator, as applicable, shall establish, by policy, a mandatory training schedule for all officials, employees, and local government attorneys as defined in Florida Statutes §112.313, which shall include mandatory periodic follow-up sessions. This policy may also address ethics training for entities that receive county or municipal funds as applicable.
- (b) The commission on ethics shall develop and deliver, or contract with other entities to develop and deliver, training programs. The commission on ethics shall coordinate and cooperate with all affected county or municipal entities, departments, agencies, boards, councils and commissions to ensure that effective and meaningful training experiences are delivered in a timely and efficient manner.

(Ord. No. 2011-011, §1(Exh. 1), 5-17-11, 4-6-21)

Sec. 2-447. Noninterference.

It shall be a violation of this article for any person: (a) to retaliate against, punish, threaten, harass, or penalize any person for communicating, cooperating with, or assisting the commission on ethics or the inspector

general; or (b) to interfere, obstruct or attempt to interfere or obstruct without valid legal basis any investigation conducted by the commission on ethics or the inspector general.

(Ord. No. 2011-011, §1(Exh. 1), 5-17-11)

Sec. 2-448. Administration, enforcement and penalties.

- (a) The commission on ethics shall be empowered to review, interpret, render advisory opinions, and enforce this code of ethics pursuant to the procedures established in the county commission on ethics ordinance. Jurisdiction of the commission on ethics with respect to advisory opinions rendered shall extend to all county and municipal officials and employees, and all other persons and entities required to comply with the provisions of this code and the county lobbyist registration ordinance, including but not limited to lobbyists, their employers and principals, and contractors and vendors and their employees.
- (b) A finding by the commission on ethics of a violation of any part of this article shall subject the person or entity to public reprimand, a fine of up to five hundred dollars (\$500), or both. The commission on ethics may also order the person or entity to pay restitution when the person or entity or a third party has received a pecuniary benefit as a result of the person's violation.
- (c) Upon a finding of the commission on ethics or hearing officer that a violation of this article or the lobbyist registration ordinance resulted in a contract, grant, subsidy, license, permit, franchise, use, certificate, development order or other benefit conferred by the county or municipality as applicable, then such contract, grant, subsidy, license, permit, franchise, use, certificate, development order or other benefit may be rescinded or declared void by the board of county commissioners or the local municipal governing body as applicable.
- (d) The commission on ethics may refer willful violations of sections 2-443, 2-444(a), 2-444(b), 2-444(c), 2-444(e), or 2-447 to the state attorney when deemed appropriate. Pursuant to Florida Statutes, §125.69, a person who violates the sections of the article set forth in this section 2-448(d) shall be subject to prosecution in the name of the state in the same manner as first degree misdemeanors are prosecuted, and upon conviction, such person may be punished by a fine not to exceed one thousand dollars (\$1,000), imprisonment not to exceed one (1) year, or both.

(Ord. No. 2011-011, §1(Exh. 1), 5-17-11, 4-6-21)