



A G E N D A
CITY OF WAUPUN SPECIAL COUNCIL MEETING
201 E Main St., Waupun, WI 53963
Tuesday, October 29, 2024 at 5:30 PM

VIRTUAL AND TELECONFERENCE ACCESS AVAILABLE

Join Virtually: <https://us02web.zoom.us/j/81751337789?pwd=R2V6MDhuMUthSGNsd1QvYjRybWJ1QT09>

Join Teleconference: 312 626 6799

Meeting ID: 817 5133 7789

Passcode: 746846

CALL TO ORDER

ROLL CALL

CONSENT AGENDA

1. Future Meetings & Gatherings, License and Permit Applications, Expenses

CONSIDERATION - ACTION

2. Review Spring Flooding Areas of Concern and Approve Recommended Flood Mitigation Engineering Study
3. JF Brennan Agreement for Cofferdam Installation and Removal to Repair Dam Gate Valve
4. 2025 Business Improvement District Operating Plan, Budget, and Assessment Rate
5. Amended and Restate Health Care Services Agreement with Waupun Memorial Hospital
6. Order/purchase a 2025 Freightliner 114SD and Equipment

CONSIDERATION - ACTION

7. Discuss Aerial Ladder Truck Purchase Terms
8. Budget Workshop – 2025 Estimated Tax Rates
9. Proposed Changes to the 2025 Fee Schedule
10. Discuss City Ordinance 6.10 Bicycles
11. Ordinance Pipeline

ADJOURNMENT

Upon reasonable notice, efforts will be made to accommodate disabled individuals through appropriate aids and services. For additional information, contact the City Clerk at 920-324-7915.



AGENDA SUMMARY SHEET

MEETING DATE: 10-29-24

TITLE: Future Meetings & Gatherings, License and Permit Applications, Expenses

AGENDA SECTION: CONSENT AGENDA

PRESENTER: Angela Hull, Clerk

FUTURE MEETINGS

Tuesday, November 14, 2023	Common Council	6:00PM
Tuesday, November 28, 2023	Committee of the Whole	5:30PM
Tuesday, December 12, 2023	Common Council	6:00PM

LICENSE/PERMIT APPLICATIONS

Operator: Jennifer Blecher, Reagan Baley, Jeanna Barrett, Nehmiah Watson

Temporary Operator: Kristen Schultz, Derek Drews, Luke Ganz, Marni Lemmenes, Amber Baley, Maranda Kunz, Jordan Oosterhouse, Christine Gantner, Benjamin Ruch, Katie Dejager, Alyssa Schreur

Taxi Drivers: Donna Donovan, Craig Rosenkranz, William Donovan, Joseph Donovan

Temporary Class B: Horicon Marsh Ducks Unlimited 11/19/24 located at 220 Grandview Ave, Waupun; Downtown Promotions 11/02/24 Downtown Fall Wine Walk

Solicitor: Spectrum Wendy Baker and Robert Farber

EXPENSES

Attached

RECOMENDED MOTION:

Motion to approve the Consent Agenda. *(Roll Call)*

Report Criteria:

Report type: Summary

Invoice.Batch = "10724","101724","102924"

Check Issue Date	Check Number	Payee	Amount
10/07/2024	108671	FOND DU LAC COUNTY CLERK OF C	500.00
10/17/2024	108720	PURCHASE POWER	3,547.25
10/17/2024	108721	WALMART COMMUNITY/CAPITAL ONE	75.00
10/17/2024	108722	WAUPUN UTILITIES	29,500.96
10/24/2024	108723	AMAZON CAPITAL SERVICES	1,265.75
10/24/2024	108724	AIRGAS USA LLC	25.00
10/24/2024	108725	ALLIANT ENERGY/WP&L	511.33
10/24/2024	108726	ANYTHING & EVERYTHING HOME MN	1,225.00
10/24/2024	108727	AT&T MOBILITY	1,176.92
10/24/2024	108728	BADGER PEST CONTROL	615.00
10/24/2024	108729	BAKER TILLY US LLP	6,434.00
10/24/2024	108730	BALLWEG IMPLEMENT	112.01
10/24/2024	108731	BISHOP, ROHN	140.00
10/24/2024	108732	BLACKSTONE TECHNOLOGIES LLC	2,751.25
10/24/2024	108733	BOUND TREE MEDICAL LLC	579.99
10/24/2024	108734	BRH ENTERPRISES LLC	336.60
10/24/2024	108735	BROWN CAB SERVICE INC	10,666.18
10/24/2024	108736	BUCHHOLZ, DAN	2,300.00
10/24/2024	108737	CAPITAL AUTOBODY LLC	59,044.54
10/24/2024	108738	CARTRIDGE WORLD	691.00
10/24/2024	108739	CHARTER COMMUNICATIONS	880.97
10/24/2024	108740	CHARTER COMMUNICATIONS	280.03
10/24/2024	108741	CITY OF BEAVER DAM	860.00
10/24/2024	108742	COLUMN SOFTWARE PBC	205.95
10/24/2024	108743	SSM HEALTH LABORATORIES	120.00
10/24/2024	108744	CONWAY SHIELD	628.50
10/24/2024	108745	COUNTRY HILLS PET HOSPITAL	234.18
10/24/2024	108746	CRACK FILLING SERVICE CORP	17,000.00
10/24/2024	108747	D'SIGNS UNLIMITED LLC	575.00
10/24/2024	108748	EDGEWOOD COMMUNITY CHURCH	200.00
10/24/2024	108749	EFFERT, EMMA	543.93
10/24/2024	108750	FIRE SAFETY USA	234.99
10/24/2024	108751	FOND DU LAC COUNTY	261.71
10/24/2024	108752	FOND DU LAC COUNTY TREASURER	2,747.82
10/24/2024	108753	FORWARD CONTRACTORS LLC	72,811.10
10/24/2024	108754	GAPPA SECURITY SOLUTIONS LLC	508.00
10/24/2024	108755	GFC LEASING - WI	135.97
10/24/2024	108756	GORDON FLESCH CO INC	193.99
10/24/2024	108757	H & R SAFETY SOLUTIONS LLC	316.70
10/24/2024	108758	HALRON LUBRICANTS INC	545.15
10/24/2024	108759	HALVERSON, ANDREW	58.01
10/24/2024	108760	TIMOTHY S HAMMES	43.00
10/24/2024	108761	HARMSSEN, MARGARET A	177.00
10/24/2024	108762	HERITAGE RIDGE TRAVEL PLAZA	115.16
10/24/2024	108763	HOMAN AUTO - RIPON	94.53
10/24/2024	108764	LYLE HULL & SON EQUIPMENT LLC	200.00
10/24/2024	108765	JOHN FABICK TRACTOR CO	289.16
10/24/2024	108766	KIMBALL MIDWEST	1,125.66
10/24/2024	108767	LAPPEN SECURITY PRODUCTS	34.00

M = Manual Check, V = Void Check

Check Issue Date	Check Number	Payee	Amount
10/24/2024	108768	MSA PROFESSIONAL SERVICES INC	2,132.31
10/24/2024	108769	MARCO TECHNOLOGIES LLC	160.91
10/24/2024	108770	MENARDS - BEAVER DAM	209.29
10/24/2024	108771	MONROE TRUCK EQUIPMENT INC	552.16
10/24/2024	108772	NAPA AUTO PARTS-WAUPUN	280.67
10/24/2024	108773	NEW PIG CORPORATION	853.16
10/24/2024	108774	NORTHEAST ASPHALT	132,686.20
10/24/2024	108775	O'REILLY AUTOMOTIVE INC	1,458.93
10/24/2024	108776	OSHKOSH FIRE & POLICE EQUIPMNT	179.50
10/24/2024	108777	PIGGLY WIGGLY DISCOUNT FOODS	231.71
10/24/2024	108778	PROS 4 TECHNOLOGY INC	249.95
10/24/2024	108779	RADIO PLUS	961.65
10/24/2024	108780	REACH	1,000.00
10/24/2024	108781	RENNERTS	2,774.72
10/24/2024	108782	SSM HEALTH AT WORK	6,336.58
10/24/2024	108783	SAN-A-CARE INC	54.77
10/24/2024	108784	SELECTIVE INSURANCE COMPANY	823.00
10/24/2024	108785	SHERWIN INDUSTRIES	474.72
10/24/2024	108786	SMA CONSTRUCTION SERVICES	257,785.00
10/24/2024	108787	SPECIALTY CLOSURES & EQUIPMEN	3,775.00
10/24/2024	108788	TORRES TREE SERVICE	3,400.00
10/24/2024	108789	TOWN OF WAUPUN	71.40
10/24/2024	108790	TRACTOR SUPPLY CREDIT PLAN	27.37
10/24/2024	108791	TRUCK EQUIPMENT INC	1,176.14
10/24/2024	108792	VANDEZANDE & KAUFMAN, LLP	3,790.00
10/24/2024	108793	VERTICAL CONSULTANTS LLC	711.00
10/24/2024	108794	VON BRIESEN & ROPER, S.C.	345.00
10/24/2024	108795	WAUKESHA CTY TECH COLLEGE	165.00
10/24/2024	108796	WAUPUN LITTLE LEAGUE	100,000.00
10/24/2024	108797	WAUPUN UTILITIES	2,589.44
10/24/2024	108798	WERNER-HARMSSEN	3,830.60
10/24/2024	108799	WILLIAMS, ROBERT	47.46
10/24/2024	108800	WINTERHACK, STEVE	150.00
10/24/2024	108801	WI DEPT OF JUSTICE	126.00
10/24/2024	108802	WI DEPART OF JUSTICE	345.75
10/24/2024	108803	WI DEPT OF REVENUE	781.33
10/24/2024	108804	INSIGHT FS	592.50
10/24/2024	108805	TRANSCENDENT TECHNOLOGIES	906.00
10/24/2024	108806	TOP PACK DEFENSE	660.35
Grand Totals:			<u>755,613.86</u>

Report Criteria:

Report type: Summary

Invoice.Batch = "10724","101724","102924"

M = Manual Check, V = Void Check

Report Criteria:

Report type: Invoice detail
 Check.Type = {<->} "Adjustment"
 Invoice.Batch = "10724","101724","102924"

Payee	Description	Check Issue Date	Invoice Number	Invoice GL Account	Invoice Amount	Check Amount
AIRGAS USA LLC						
AIRGAS USA LLC	OXYGEN RENTAL - FD	10/24/2024	5510874548	100-50-5230-3-38	25.00	25.00
Total AIRGAS USA LLC:						25.00
ALLIANT ENERGY/WP&L						
ALLIANT ENERGY/WP&L	ICE ARENA MONTHLY FUEL-SEPT 2024 - CITY	10/24/2024	2831330000-S	100-70-5410-3-32	213.56	213.56
ALLIANT ENERGY/WP&L	CITY HALL MONTHLY FUEL CHARGES - SEPT 2024	10/24/2024	1780510000-S	100-70-5410-3-32	59.17	59.17
ALLIANT ENERGY/WP&L	GARAGE MONTHLY FUEL - SEPT 2024	10/24/2024	3264610000-S	100-70-5412-3-32	84.06	84.06
ALLIANT ENERGY/WP&L	AQUATIC CENTER - SEPT 2024	10/24/2024	5374620000-S	100-20-5523-3-32	63.24	63.24
ALLIANT ENERGY/WP&L	MUSEUM MONTHLY FUEL CHARGE - SEPT 2024	10/24/2024	3425110000-S	100-20-5512-3-32	14.84	14.84
ALLIANT ENERGY/WP&L	SENIOR CENTER - SEPT 2024	10/24/2024	7255200000-S	100-20-5513-3-32	14.84	14.84
ALLIANT ENERGY/WP&L	FIRE DEPT - MONTHLY FUEL CHARGES - SEPT 2024	10/24/2024	5946940000-S	100-50-5231-3-32	61.62	61.62
Total ALLIANT ENERGY/WP&L:						511.33
AMAZON CAPITAL SERVICES						
AMAZON CAPITAL SERVICES	DYMO LABELS - ELECTION	10/24/2024	16KQ-VDHL-	100-10-5142-3-38	40.91	40.91
AMAZON CAPITAL SERVICES	FLEETGUARD FUEL WATER FILTER - FILTERS FOR TRUCKS	10/24/2024	1LT3-NVDD-W	100-70-5411-3-36	245.37	245.37
AMAZON CAPITAL SERVICES	PARTS - REPLACE DAM GATE VALVE	10/24/2024	1FYF-YMT1-D	700-10-5192-3-36	214.99	214.99
AMAZON CAPITAL SERVICES	MOP BUCKET - NEW COMM CENTER	10/24/2024	1FYF-YMT1-N	100-20-5511-3-38	51.00	51.00
AMAZON CAPITAL SERVICES	COMMUNITY CENTER CLEANING SUPPLIES	10/24/2024	1L1K-FRNC-D	100-20-5511-3-30	125.50	125.50
AMAZON CAPITAL SERVICES	HANDICAPP PARKING STALL SIGNS - NEW COMM CENTER	10/24/2024	1LTQ-MRDY-	100-20-5511-3-38	55.48	55.48
AMAZON CAPITAL SERVICES	OFFICE SUPPLIES - THUMB DRIVES, CLIPS, PENS, EXT HARD DRIVE	10/24/2024	1HKV-3VWR-L	100-40-5211-3-30	293.00	293.00
AMAZON CAPITAL SERVICES	HALLOWEEN ON MAIN ST SUPPLIES	10/24/2024	141C-RYQQ-P	100-40-5211-3-38	232.31	232.31
AMAZON CAPITAL SERVICES	ADMINISTRATIVE OFFICE SUPPLIES	10/24/2024	1Q9G-7QYL-P	100-10-5191-3-30	7.19	7.19
Total AMAZON CAPITAL SERVICES:						1,265.75
ANYTHING & EVERYTHING HOME MNT						
ANYTHING & EVERYTHING HOME MN	STUMP GRINDING	10/24/2024	5615	100-70-5443-3-38	1,225.00	1,225.00
Total ANYTHING & EVERYTHING HOME MNT:						1,225.00
AT&T MOBILITY						
AT&T MOBILITY	FIRSTNET MOBILE AIRCARDS - AUG 24-SEPT 23 2024 PD	10/24/2024	287307537700	100-40-5211-3-31	508.71	508.71
AT&T MOBILITY	IPAD - FD	10/24/2024	AUG24-SEPT	220-50-5231-3-38	668.21	668.21
Total AT&T MOBILITY:						1,176.92
BADGER PEST CONTROL						
BADGER PEST CONTROL	PEST CONTROL CITY GARAGE	10/24/2024	3539	100-70-5410-3-36	300.00	300.00
BADGER PEST CONTROL	PEST CONTROL CITY HALL	10/24/2024	3538	100-70-5410-3-36	315.00	315.00
Total BADGER PEST CONTROL:						615.00

Payee	Description	Check Issue Date	Invoice Number	Invoice GL Account	Invoice Amount	Check Amount
BAKER TILLY US LLP						
BAKER TILLY US LLP	12/31/23 AUDIT FEES TID 5	10/24/2024	BT2937526	401-70-5436-3-39	6,434.00	6,434.00
Total BAKER TILLY US LLP:						6,434.00
BALLWEG IMPLEMENT						
BALLWEG IMPLEMENT	SENSOR - REPLACE ENGINE OIL SENSOR - 163-08	10/24/2024	P01775	100-70-5411-3-36	112.01	112.01
Total BALLWEG IMPLEMENT:						112.01
BISHOP, ROHN						
BISHOP, ROHN	DC SQUAD DETAIL	10/24/2024	10-14-24	100-40-5211-3-36	140.00	140.00
Total BISHOP, ROHN:						140.00
BLACKSTONE TECHNOLOGIES LLC						
BLACKSTONE TECHNOLOGIES LLC	COLD PATCH FOR STREETS	10/24/2024	242559	100-70-5431-3-36	2,751.25	2,751.25
Total BLACKSTONE TECHNOLOGIES LLC:						2,751.25
BOUND TREE MEDICAL LLC						
BOUND TREE MEDICAL LLC	AED BATTERY	10/24/2024	85520561	100-50-5232-3-36	579.99	579.99
Total BOUND TREE MEDICAL LLC:						579.99
BRH ENTERPRISES LLC						
BRH ENTERPRISES LLC	REIMBURSE - ERROR - TOWN OF CHESTER PERMIT SENT TO WAUPUN	10/24/2024	10-9-24	100-13850	246.60	246.60
BRH ENTERPRISES LLC	REIMBURSE - ERROR - OVERAGE OF ADMIN FEE'S ON PERMITS - GOULD/HUMMELMEIER	10/24/2024	10-9-24/1	100-13850	90.00	90.00
Total BRH ENTERPRISES LLC:						336.60
BROWN CAB SERVICE INC						
BROWN CAB SERVICE INC	SEPTEMBER 2024 TAXI SERVICES	10/24/2024	5156	501-10-5154-3-38	10,666.18	10,666.18
Total BROWN CAB SERVICE INC:						10,666.18
BUCHHOLZ, DAN						
BUCHHOLZ, DAN	2000 GALLON CALCIUM CHLORIDE TANK	10/24/2024	10-29-24	100-70-5435-3-36	2,300.00	2,300.00
Total BUCHHOLZ, DAN:						2,300.00
CAPITAL AUTOBODY LLC						
CAPITAL AUTOBODY LLC	HAIL REPAIRS - 2023 FORD EXPLORER - PD	10/24/2024	11472	100-10-5194-3-38	7,210.50	7,210.50
CAPITAL AUTOBODY LLC	HAIL REPAIRS - 2021 DODGE DURANGO - PD	10/24/2024	11471	100-10-5194-3-38	7,126.65	7,126.65
CAPITAL AUTOBODY LLC	HAIL REPAIRS - 2021 DODGE CHARGER - PD	10/24/2024	11469	100-10-5194-3-38	9,000.50	9,000.50
CAPITAL AUTOBODY LLC	HAIL REPAIRS - 2017 FORD TAURUS - PD	10/24/2024	11470	100-10-5194-3-38	8,136.01	8,136.01
CAPITAL AUTOBODY LLC	HAIL REPAIRS - 2017 FORD EXPLORER	10/24/2024	11474	100-10-5194-3-38	4,566.00	4,566.00
CAPITAL AUTOBODY LLC	HAIL REPAIRS - 2015 CHEVY TAHOE	10/24/2024	11475	100-10-5194-3-38	10,673.13	10,673.13
CAPITAL AUTOBODY LLC	HAIL REPAIRS - 2021 FORD F-250	10/24/2024	11484	100-10-5194-3-38	7,125.45	7,125.45
CAPITAL AUTOBODY LLC	HAIL REPAIRS - 2020 DODGE DURANGO	10/24/2024	11473	100-10-5194-3-38	5,206.30	5,206.30

Payee	Description	Check Issue Date	Invoice Number	Invoice GL Account	Invoice Amount	Check Amount
Total CAPITAL AUTOBODY LLC:						59,044.54
CARTRIDGE WORLD						
CARTRIDGE WORLD	INK CARTRIDGES	10/24/2024	96123	100-40-5211-3-38	177.00	177.00
CARTRIDGE WORLD	INK CARTRIDGES	10/24/2024	96131	100-40-5211-3-38	514.00	514.00
Total CARTRIDGE WORLD:						691.00
CHARTER COMMUNICATIONS						
CHARTER COMMUNICATIONS	ACCT# 171154501 - PD - INTERNET - SERVS 10-1-24 TO 10-31-24	10/24/2024	171154501-O	100-40-5211-3-38	71.51	71.51
CHARTER COMMUNICATIONS	ACCT# 171153401 - PD - INTERNET - SERVS 10-1-24 TO 10-31-24	10/24/2024	171153401-O	100-40-5211-3-38	490.00	490.00
CHARTER COMMUNICATIONS	AQUATIC CENTER	10/24/2024	171154201-O	100-20-5523-3-38	114.97	114.97
CHARTER COMMUNICATIONS	GARAGE - TV, INTERNET	10/24/2024	171154001-O	100-70-5412-3-38	204.49	204.49
CHARTER COMMUNICATIONS	SENIOR CENTER - TV, INTERNET	10/24/2024	16011-OCT24	100-20-5513-3-38	180.04	180.04
CHARTER COMMUNICATIONS	MUSEUM - INTERNET - BILLED/PD BY HISTORICAL SOCIETY	10/24/2024	84621-OCT24	100-13850	99.99	99.99
Total CHARTER COMMUNICATIONS:						1,161.00
CITY OF BEAVER DAM						
CITY OF BEAVER DAM	EMS CALL 10-6-24	10/24/2024	22580	100-10-5255-3-38	860.00	860.00
Total CITY OF BEAVER DAM:						860.00
COLUMN SOFTWARE PBC						
COLUMN SOFTWARE PBC	2025 BUDGET PUBLIC HEARING	10/24/2024	3EC85C3A-00	100-10-5110-3-35	205.95	205.95
Total COLUMN SOFTWARE PBC:						205.95
CONWAY SHIELD						
CONWAY SHIELD	STRUCTURE FIREFIGHTING BOOTS - A. BILLE	10/24/2024	0528600	100-50-5232-3-38	555.00	555.00
CONWAY SHIELD	JOB SHIRT	10/24/2024	0528751	100-50-5232-3-38	73.50	73.50
Total CONWAY SHIELD:						628.50
COUNTRY HILLS PET HOSPITAL						
COUNTRY HILLS PET HOSPITAL	K9 - EXAM, NEXGARD, SIMPLERA OTIC SOLUTION	10/24/2024	242560	220-40-5212-3-38	234.18	234.18
Total COUNTRY HILLS PET HOSPITAL:						234.18
CRACK FILLING SERVICE CORP						
CRACK FILLING SERVICE CORP	CRACK SEALING VARIOUS STREETS	10/24/2024	10-8-24	100-70-5431-3-36	17,000.00	17,000.00
Total CRACK FILLING SERVICE CORP:						17,000.00
D'SIGNS UNLIMITED LLC						
D'SIGNS UNLIMITED LLC	SIGN - LISTING OF MAYORS - COUNCIL CHAMBERS	10/24/2024	9426	100-70-5410-3-36	575.00	575.00
Total D'SIGNS UNLIMITED LLC:						575.00
EDGEWOOD COMMUNITY CHURCH						
EDGEWOOD COMMUNITY CHURCH	BUILDING RENTAL 10-14-24	10/24/2024	OCT14RENTA	100-50-5234-3-38	200.00	200.00

Payee	Description	Check Issue Date	Invoice Number	Invoice GL Account	Invoice Amount	Check Amount
Total EDGEWOOD COMMUNITY CHURCH:						200.00
EFFERT, EMMA						
EFFERT, EMMA	CLOTHING ALLOWANCE	10/24/2024	10-22-24	100-12634	193.22	193.22
EFFERT, EMMA	STREAMLIGHT FLASHLIGHT - LOST DURING KAYAK CALL/INCIDENT	10/24/2024	10-22-24-1	100-40-5211-3-38	350.71	350.71
Total EFFERT, EMMA:						543.93
FIRE SAFETY USA						
FIRE SAFETY USA	"PROBATIONARY" HELMET SHIELDS	10/24/2024	191917	100-50-5232-3-38	234.99	234.99
Total FIRE SAFETY USA:						234.99
FOND DU LAC COUNTY						
FOND DU LAC COUNTY	DELL DOCK, MONITOR SOUNDBAR, DOCKING STATION	10/24/2024	IS-2024-W02	410-40-5211-4-00	261.71	261.71
Total FOND DU LAC COUNTY:						261.71
FOND DU LAC COUNTY CLERK OF COURTS						
FOND DU LAC COUNTY CLERK OF C	PAID WARRANT - KIKENDALE	10/07/2024	10-7-24	100-13850	500.00	500.00
Total FOND DU LAC COUNTY CLERK OF COURTS:						500.00
FOND DU LAC COUNTY TREASURER						
FOND DU LAC COUNTY TREASURER	COMPUTER UPGRADES - FD	10/24/2024	IS-2024-W03	410-50-5231-4-00	2,747.82	2,747.82
Total FOND DU LAC COUNTY TREASURER:						2,747.82
FORWARD CONTRACTORS LLC						
FORWARD CONTRACTORS LLC	WEDC VIB SPC 53535 2024 FOOD TRUCK ALLEY	10/24/2024	PAY REQUES	405-70-5437-8-00	72,811.10	72,811.10
Total FORWARD CONTRACTORS LLC:						72,811.10
GAPPA SECURITY SOLUTIONS LLC						
GAPPA SECURITY SOLUTIONS LLC	COMMUNITY CENTER KEYS/KEY BOX	10/24/2024	30523	100-20-5511-3-38	482.00	482.00
GAPPA SECURITY SOLUTIONS LLC	COMMUNITY CENTER KEYS	10/24/2024	30623	100-20-5511-3-36	26.00	26.00
Total GAPPA SECURITY SOLUTIONS LLC:						508.00
GFC LEASING - WI						
GFC LEASING - WI	COMMUNITY CENTER COPY MACHINE CANON C39261 10/20/24 - 11/19/24	10/24/2024	I00958683	100-20-5511-3-38	135.97	135.97
Total GFC LEASING - WI:						135.97
GORDON FLESCH CO INC						
GORDON FLESCH CO INC	RICOH IMC4500 - CITY HALL COLOR COPIER - 09/11/24-10/14/24	10/24/2024	IN14885193	100-10-5141-3-36	193.99	193.99
Total GORDON FLESCH CO INC:						193.99
H & R SAFETY SOLUTIONS LLC						
H & R SAFETY SOLUTIONS LLC	GLOVES/LENS CLEANING TOWELETES	10/24/2024	8997	100-70-5412-3-38	145.10	145.10
H & R SAFETY SOLUTIONS LLC	SAFETY GLASSES AND EAR PLUGS	10/24/2024	8998	100-50-5232-3-38	171.60	171.60

Payee	Description	Check Issue Date	Invoice Number	Invoice GL Account	Invoice Amount	Check Amount
Total H & R SAFETY SOLUTIONS LLC:						316.70
HALRON LUBRICANTS INC	BULK OIL - SPIRAX SHELL/GREASE	10/24/2024	156882-00	100-70-5411-3-36	545.15	545.15
HALRON LUBRICANTS INC	VALVOLINE/GEAR LUBE					
Total HALRON LUBRICANTS INC:						545.15
HALVERSON, ANDREW	REIMBURSE HALVERSON DOG FOOD	10/24/2024	10-29-24	220-40-5212-3-38	58.01	58.01
HALVERSON, ANDREW						
Total HALVERSON, ANDREW:						58.01
HARMSSEN, MARGARET A	ELECTION MAINTENANCE OF RECORDS 10/11/24 THROUGH 10/22/24	10/24/2024	10-29-24	100-10-5142-1-10	177.00	177.00
HARMSSEN, MARGARET A						
Total HARMSSEN, MARGARET A:						177.00
HERITAGE RIDGE TRAVEL PLAZA	DPW FUEL - SWEEPER - 12-18	10/24/2024	25929	700-10-5191-3-38	115.16	115.16
HERITAGE RIDGE TRAVEL PLAZA						
Total HERITAGE RIDGE TRAVEL PLAZA:						115.16
HOMAN AUTO - RIPON	2023 FORD - SQUAD 7 - RADIATOR HOSE & ANTI-FREEZE	10/24/2024	317587	100-40-5212-3-36	94.53	94.53
HOMAN AUTO - RIPON						
Total HOMAN AUTO - RIPON:						94.53
INSIGHT FS	SEEDER RENTAL/GREEYARD GRAND SLAM - PATCH AREAS OF FIELDS THAT DIED OFF FROM WEEDS	10/24/2024	57047517	100-20-5525-3-36	592.50	592.50
INSIGHT FS						
Total INSIGHT FS:						592.50
JOHN FABICK TRACTOR CO	TURBO EXTENTION	10/24/2024	PIMK0359200	100-70-5411-3-36	289.16	289.16
JOHN FABICK TRACTOR CO						
Total JOHN FABICK TRACTOR CO:						289.16
KIMBALL MIDWEST	CUTTERS AND DRILL BITS	10/24/2024	102664870	100-70-5411-3-38	1,125.66	1,125.66
KIMBALL MIDWEST						
Total KIMBALL MIDWEST:						1,125.66
LAPPEN SECURITY PRODUCTS	KEY FOR ICE ARENA	10/24/2024	LSPQ51573	100-70-5410-3-36	34.00	34.00
LAPPEN SECURITY PRODUCTS						
Total LAPPEN SECURITY PRODUCTS:						34.00
LYLE HULL & SON EQUIPMENT LLC	LIFT RENTAL - REPAIR WATER LEAK @ CITY GARAGE	10/24/2024	645	100-70-5411-3-38	200.00	200.00
LYLE HULL & SON EQUIPMENT LLC						
Total LYLE HULL & SON EQUIPMENT LLC:						200.00

Payee	Description	Check Issue Date	Invoice Number	Invoice GL Account	Invoice Amount	Check Amount
MARCO TECHNOLOGIES LLC						
MARCO TECHNOLOGIES LLC	KONICA MINOLTA C3001 COPIER - CONTRACT 10/1/24 TO 11/1/24, COLOR COPY OVERAGE	10/24/2024	539913517	100-40-5211-3-38	160.91	160.91
Total MARCO TECHNOLOGIES LLC:						160.91
MENARDS - BEAVER DAM						
MENARDS - BEAVER DAM	SENIOR CENTER MOVING/HALLOWEEN - ROLLING STORAGE/PUMPKIN SCRAPER GLOVE/CONCRETE MIX	10/24/2024	63141	100-20-5513-3-38	77.86	77.86
MENARDS - BEAVER DAM	DOOR STOPS, OFFICE CHAIRS & RUG PROTECTORS	10/24/2024	63713	100-20-5511-3-38	131.43	131.43
Total MENARDS - BEAVER DAM:						209.29
MONROE TRUCK EQUIPMENT INC						
MONROE TRUCK EQUIPMENT INC	PUMP - REPLACE SALT BRINE PUMP	10/24/2024	854186	100-70-5411-3-36	552.16	552.16
Total MONROE TRUCK EQUIPMENT INC:						552.16
MSA PROFESSIONAL SERVICES INC						
MSA PROFESSIONAL SERVICES INC	2024 WAUPUN DAM INSPECTION	10/24/2024	009342	700-10-5192-3-38	922.43	922.43
MSA PROFESSIONAL SERVICES INC	SWMP REVIEW KWIK TRIP	10/24/2024	009148	100-13850	1,209.88	1,209.88
Total MSA PROFESSIONAL SERVICES INC:						2,132.31
NAPA AUTO PARTS-WAUPUN						
NAPA AUTO PARTS-WAUPUN	OIL DRY	10/24/2024	421608	100-50-5232-3-38	144.90	144.90
NAPA AUTO PARTS-WAUPUN	PARTS - REPLACE HYDRAULIC COUPLER FOR WING - 103-10	10/24/2024	420401	100-70-5411-3-36	11.99	11.99
NAPA AUTO PARTS-WAUPUN	SNAP RING KIT	10/24/2024	420690	100-70-5411-3-36	29.97	29.97
NAPA AUTO PARTS-WAUPUN	ADAPTER - AIR LINE REPAIR	10/24/2024	421555	100-70-5411-3-36	13.16	13.16
NAPA AUTO PARTS-WAUPUN	FUEL TANK STRAP HARDWARE KIT - 28-03	10/24/2024	421451	100-70-5411-3-36	11.87	11.87
NAPA AUTO PARTS-WAUPUN	SHOP SUPPLIES - COPPER GASKET/GASKET MAKER/ANTI-SEIZE	10/24/2024	421734	100-70-5411-3-36	51.76	51.76
NAPA AUTO PARTS-WAUPUN	FITTING	10/24/2024	422450	100-70-5411-3-36	6.88	6.88
NAPA AUTO PARTS-WAUPUN	SPIN ON FLUID FILTER - SERVICE TRUCK	10/24/2024	420785	100-70-5411-3-36	10.14	10.14
Total NAPA AUTO PARTS-WAUPUN:						280.67
NEW PIG CORPORATION						
NEW PIG CORPORATION	PIG ABSORBENT SOCKS SHIPPING	10/24/2024	24448630-00	100-50-5251-3-38	853.16	853.16
Total NEW PIG CORPORATION:						853.16
NORTHEAST ASPHALT						
NORTHEAST ASPHALT	MILL & OVERLAY STREETS	10/24/2024	810119-PMT1	400-70-5436-8-00	132,886.20	132,886.20
Total NORTHEAST ASPHALT:						132,886.20
O'REILLY AUTOMOTIVE INC						
O'REILLY AUTOMOTIVE INC	OIL FILTER/HYD FILTER/FUEL FILTER - 8-20	10/24/2024	2391-159430	100-70-5411-3-36	129.64	129.64
O'REILLY AUTOMOTIVE INC	ANTIFREEZE - 8-20	10/24/2024	2391-159568	100-70-5411-3-36	17.99	17.99
O'REILLY AUTOMOTIVE INC	AIR FILTER - 8-20	10/24/2024	2391-159439	100-70-5411-3-36	149.09	149.09
O'REILLY AUTOMOTIVE INC	AIR FILTER - 8-20	10/24/2024	2391-159468	100-70-5411-3-36	54.11	54.11
O'REILLY AUTOMOTIVE INC	K9 SQUAD 3 - BRAKE PADS AND ROTORS	10/24/2024	2391-156248	100-40-5212-3-36	149.99	149.99

Payee	Description	Check Issue Date	Invoice Number	Invoice GL Account	Invoice Amount	Check Amount
O'REILLY AUTOMOTIVE INC	K9 SQUAD 3 - THROTTLE BODY	10/24/2024	2391-160219	100-40-5212-3-36	98.88	98.88
O'REILLY AUTOMOTIVE INC	SQUAD 4 - 2017 FORD - BRAKE PADS & ROTORS, EXH PIPE	10/24/2024	2391-160361	100-40-5212-3-36	159.15	159.15
O'REILLY AUTOMOTIVE INC	OIL FILTER/HYD FILTER/AIR FILTERS/FUEL FILTER	10/24/2024	2391-160882	100-70-5411-3-36	152.64	152.64
O'REILLY AUTOMOTIVE INC	AIR FILTER/FUEL/AT FILTER - SERVICE 30-06	10/24/2024	2391-160362	100-70-5411-3-36	275.80	275.80
O'REILLY AUTOMOTIVE INC	PWR STR FILTER/OIL FILTER/FUEL FILTER/AIR FILTER - SERVICE 103-22	10/24/2024	2391-160363	100-70-5411-3-36	214.70	214.70
O'REILLY AUTOMOTIVE INC	2023 FORD - SQUAD 7 - AIR & OIL FILTER	10/24/2024	2391-161272	100-40-5212-3-36	56.94	56.94
Total O'REILLY AUTOMOTIVE INC:						1,458.93
OSHKOSH FIRE & POLICE EQUIPMNT	REPLACE VALVE ON REFILL STATION	10/24/2024	195377	100-50-5232-3-36	179.50	179.50
Total OSHKOSH FIRE & POLICE EQUIPMNT:						179.50
PIGGLY WIGGLY DISCOUNT FOODS	SUPPLIES - GARAGE	10/24/2024	9660	100-70-5410-3-38	104.13	104.13
PIGGLY WIGGLY DISCOUNT FOODS	ELECTION 11-5-24 SUPPLIES	10/24/2024	2724	100-10-5142-3-38	127.58	127.58
Total PIGGLY WIGGLY DISCOUNT FOODS:						231.71
PROS 4 TECHNOLOGY INC	COMMUNITY CENTER KEY FOBS	10/24/2024	53145	400-20-5513-8-00	210.00	210.00
PROS 4 TECHNOLOGY INC	WIRELESS KEYBOARD AND MOUSE	10/24/2024	53155	100-10-5197-3-38	39.95	39.95
Total PROS 4 TECHNOLOGY INC:						249.95
PURCHASE POWER	ADMIN FEE	10/17/2024	10-17-24	100-10-5141-3-36	3,547.25	3,547.25
Total PURCHASE POWER:						3,547.25
RADIO PLUS	OCTOBER 5TH EVENT	10/24/2024	7290-00004-0	430-70-5436-3-38	200.00	200.00
RADIO PLUS	OCTOBER 5TH EVENT	10/24/2024	7290-00005-0	430-70-5436-3-38	195.00	195.00
RADIO PLUS	OCTOBER 5 EVENT	10/24/2024	7290-00006-0	430-70-5436-3-38	150.00	150.00
RADIO PLUS	OCTOBER 5TH EVENT	10/24/2024	7290-00007-0	430-70-5436-3-38	416.65	416.65
Total RADIO PLUS:						961.65
REACH	DONATION - FUND RAISING DINNER 2024 - HOMAN FUNRAISING EVENT FOR REACH	10/24/2024	10-16-24	100-10-5110-3-38	1,000.00	1,000.00
Total REACH:						1,000.00
RENNERTS	591 TURBO REPAIR	10/24/2024	3063	100-50-5232-3-36	2,774.72	2,774.72
Total RENNERTS:						2,774.72
SAN-A-CARE INC	BUILDING SUPPLIES	10/24/2024	633167	100-70-5410-3-38	54.77	54.77

Payee	Description	Check Issue Date	Invoice Number	Invoice GL Account	Invoice Amount	Check Amount
Total SAN-A-CARE INC:						54.77
SELECTIVE INSURANCE COMPANY	ZOLLNER PARK/ROUNSVILLE ST GARAGE PREMIUM	10/24/2024	10-17-24	100-10-5194-3-38	823.00	823.00
Total SELECTIVE INSURANCE COMPANY:						823.00
SHERWIN INDUSTRIES	CONCRETE COLD PATCH	10/24/2024	SS104678	100-70-5431-3-36	474.72	474.72
Total SHERWIN INDUSTRIES:						474.72
SMA CONSTRUCTION SERVICES	FLAG POLE SOLAR LIGHT	10/24/2024	PAY REQUES	220-20-5514-3-38	257,785.00	257,785.00
Total SMA CONSTRUCTION SERVICES:						257,785.00
SPECIALTY CLOSURES & EQUIPMENT CO INC	PAY APP #2 - SLEEVES & WALL PADS	10/24/2024	4093	400-20-5513-8-00	3,775.00	3,775.00
Total SPECIALTY CLOSURES & EQUIPMENT CO INC:						3,775.00
SSM HEALTH AT WORK	EAP QUARTERLY FEE	10/24/2024	43818	100-10-5143-3-38	468.75	468.75
SSM HEALTH AT WORK	WELLNESS CLINIC UTILITIES SHARE - SEPT 2024	10/24/2024	43795	100-13850	5,867.83	5,867.83
Total SSM HEALTH AT WORK:						6,336.58
SSM HEALTH LABORATORIES	BLOOD DRAWS - SEPTEMBER 2024	10/24/2024	4608919	100-40-5213-3-38	120.00	120.00
Total SSM HEALTH LABORATORIES:						120.00
TIMOTHY S HAMMES	EXTINGUISHER RECHARGE - VEHILCE FIRE	10/24/2024	42768	100-50-5232-3-38	43.00	43.00
Total TIMOTHY S HAMMES:						43.00
TOP PACK DEFENSE	CLOTHING ALLOWANCE - NAVIS	10/24/2024	14223	100-12634	34.40	34.40
TOP PACK DEFENSE	CLOTHING ALLOWANCE - CUPERY	10/24/2024	14224	100-12634	265.00	265.00
TOP PACK DEFENSE	CLOTHING ALLOWANCE - NAVIS	10/24/2024	14275	100-12634	87.98	87.98
TOP PACK DEFENSE	CLOTHING ALLOWANCE - NAVIS	10/24/2024	14392	100-12634	272.97	272.97
Total TOP PACK DEFENSE:						660.35
TORRES TREE SERVICE	REMOVE 2 ASH TREES - 620 E JEFFERSON/1105 ROCK AVE	10/24/2024	1827	100-70-5443-3-38	3,400.00	3,400.00
Total TORRES TREE SERVICE:						3,400.00
TOWN OF WAUPUN	BUILDING PERMIT FEE - REIMBURSE TO TOWN OF WAUPUN	10/24/2024	8-12-24 (2)	100-13850	71.40	71.40

Payee	Description	Check Issue Date	Invoice Number	Invoice GL Account	Invoice Amount	Check Amount
Total TOWN OF WAUPUN:						71.40
TRACTOR SUPPLY CREDIT PLAN						
TRACTOR SUPPLY CREDIT PLAN	33" WAND/FILTER WASHER - WATER TANK FOR FLOWERS	10/24/2024	10-7-24	100-70-5410-3-36	27.37	27.37
Total TRACTOR SUPPLY CREDIT PLAN:						27.37
TRANSCENDENT TECHNOLOGIES						
TRANSCENDENT TECHNOLOGIES	FDL CTY TAX SYSTEM ANNUAL MAINT	10/24/2024	M7488	100-10-5141-3-38	906.00	906.00
Total TRANSCENDENT TECHNOLOGIES:						906.00
TRUCK EQUIPMENT INC						
TRUCK EQUIPMENT INC	POWER STEERING HOSE/SEAL KIT/POWER STEERING RETURN - REPAIR LEAKING POWER STEERING PUMP - 9-12	10/24/2024	1116672-00	100-70-5411-3-36	141.75	141.75
TRUCK EQUIPMENT INC	PARTS - REPLACE FRONT REAR AXLE BRAKES	10/24/2024	1118424-00	100-70-5411-3-36	657.98	657.98
TRUCK EQUIPMENT INC	TANK CAP - REPLACE RADIATOR CAP	10/24/2024	1118435-00	100-70-5411-3-36	17.79	17.79
TRUCK EQUIPMENT INC	BUSHING/CROSS TUBE - REPLACE REAR CROSS TUBE 11-01	10/24/2024	1116115-00	100-70-5411-3-36	358.62	358.62
Total TRUCK EQUIPMENT INC:						1,176.14
VANDEZANDE & KAUFMAN, LLP						
VANDEZANDE & KAUFMAN, LLP	TRAFFIC MONTHLY ATTORNEY FEES - SEPT 2024	10/24/2024	15886	100-10-5161-3-38	1,125.00	1,125.00
VANDEZANDE & KAUFMAN, LLP	MONTHLY CITY ATTORNEY FEES - SEPT 2024	10/24/2024	SEPT2024	100-10-5161-3-38	2,665.00	2,665.00
Total VANDEZANDE & KAUFMAN, LLP:						3,790.00
VERTICAL CONSULTANTS LLC						
VERTICAL CONSULTANTS LLC	CONSULTING SERVICES - US CELL/CELL SITE LEASE	10/24/2024	18602	404-10-5711-3-38	711.00	711.00
Total VERTICAL CONSULTANTS LLC:						711.00
VON BRIESEN & ROPER, S.C.						
VON BRIESEN & ROPER, S.C.	GENERAL PD RECORDS REQUEST	10/24/2024	473278	100-10-5194-3-38	207.00	207.00
VON BRIESEN & ROPER, S.C.	GENERAL PD RECORDS REQUEST	10/24/2024	473279	100-10-5194-3-38	138.00	138.00
Total VON BRIESEN & ROPER, S.C.:						345.00
WALMART COMMUNITY/CAPITAL ONE						
WALMART COMMUNITY/CAPITAL ONE	SENIOR CENTER CRAFTS	10/17/2024	10-17-24	100-20-5513-3-30	75.00	75.00
Total WALMART COMMUNITY/CAPITAL ONE:						75.00
WAUKESHA CTY TECH COLLEGE						
WAUKESHA CTY TECH COLLEGE	TRAINING - KNUDSON - INV REPORT WRITING	10/24/2024	S0841639	100-40-5215-3-37	165.00	165.00
Total WAUKESHA CTY TECH COLLEGE:						165.00
WAUPUN LITTLE LEAGUE						
WAUPUN LITTLE LEAGUE	LITTLE LEAGUE TURF CONTRIBUTION	10/24/2024	101724	100-20-5527-3-38	100,000.00	100,000.00

Payee	Description	Check Issue Date	Invoice Number	Invoice GL Account	Invoice Amount	Check Amount
Total WAUPUN LITTLE LEAGUE:						100,000.00
WAUPUN UTILITIES						
WAUPUN UTILITIES	STORMWATER BILLING & COLLECTION FEES - SEPT 2024	10/24/2024	6254	700-10-5192-3-38	875.25	875.25
WAUPUN UTILITIES	BAKER TILLY SINGLE AUDIT 2023	10/24/2024	6255	100-10-5157-3-38	1,646.00	1,646.00
WAUPUN UTILITIES	MONTHLY UTILITY CHARGES	10/17/2024	SEPT2024	100-50-5251-3-32	29,473.36	29,473.36
WAUPUN UTILITIES	FOOD TRUCK ALLEY	10/17/2024	SEPT1-OCT1	405-70-5436-3-38	27.60	27.60
WAUPUN UTILITIES	VERIZON CHARGES - DPW I-PADS - OCT 2024	10/24/2024	6258	100-70-5420-3-31	68.19	68.19
Total WAUPUN UTILITIES:						32,090.40
WERNER-HARMSSEN						
WERNER-HARMSSEN	COMMUNITY CENTER FURNITURE	10/24/2024	21198	100-20-5511-3-38	3,830.60	3,830.60
Total WERNER-HARMSSEN:						3,830.60
WI DEPART OF JUSTICE						
WI DEPART OF JUSTICE	TIME SYSTEM-QUARTERLY BILLING 10/1/24-12/31/24	10/24/2024	455TIME-0000	100-40-5212-3-38	345.75	345.75
Total WI DEPART OF JUSTICE:						345.75
WI DEPT OF JUSTICE						
WI DEPT OF JUSTICE	G3369 - BACKGROUND CHECKS - SEPT 2024	10/24/2024	G3369-SEPT2	100-40-5213-3-38	112.00	112.00
WI DEPT OF JUSTICE	L1409T - BACKGROUND CHECKS - SEPT 2024 - CITY HALL SYSTEM WAS DOWN	10/24/2024	L1409T	100-40-5213-3-38	14.00	14.00
Total WI DEPT OF JUSTICE:						126.00
WI DEPT OF REVENUE						
WI DEPT OF REVENUE	MANUFACTURING PROPERTY ASSESSMENT - FDL	10/24/2024	10-29-24/1	100-30-5152-3-38	69.50	69.50
WI DEPT OF REVENUE	MANUFACTURING PROPERTY ASSESSMENT - DODGE	10/24/2024	10-29-24	100-30-5152-3-38	711.83	711.83
Total WI DEPT OF REVENUE:						781.33
WILLIAMS, ROBERT						
WILLIAMS, ROBERT	OFFICE SUPPLY - THUMB DRIVE	10/24/2024	10-29-24	100-40-5211-3-30	47.46	47.46
Total WILLIAMS, ROBERT:						47.46
WINTERHACK, STEVE						
WINTERHACK, STEVE	RADIO COVERAGE - FIRE DEPT OPEN HOUSE	10/24/2024	10-18-24	100-50-5231-3-38	150.00	150.00
Total WINTERHACK, STEVE:						150.00
Grand Totals:						755,613.86

Summary by General Ledger Account Number

GL Account	Debit	Credit	Proof
001-11000	.00	.00	.00
100-10-5110-3-35	205.95	.00	205.95
100-10-5110-3-38	1,000.00	.00	1,000.00
100-10-5141-3-36	241.24	.00	241.24
100-10-5141-3-38	906.00	.00	906.00
100-10-5142-1-10	177.00	.00	177.00
100-10-5142-3-38	168.49	.00	168.49
100-10-5143-3-38	468.75	.00	468.75
100-10-5157-3-38	1,646.00	.00	1,646.00
100-10-5161-3-38	3,790.00	.00	3,790.00
100-10-5191-3-30	7.19	.00	7.19
100-10-5194-3-38	60,212.54	.00	60,212.54
100-10-5197-3-38	39.95	.00	39.95
100-10-5255-3-38	860.00	.00	860.00
100-10-5256-3-38	3,911.89	.00	3,911.89
100-12634	1,042.29	.00	1,042.29
100-13850	4,173.81	.00	4,173.81
100-16210	3,500.00	.00	3,500.00
100-20-5511-3-30	125.50	.00	125.50
100-20-5511-3-36	26.00	.00	26.00
100-20-5511-3-38	4,686.48	.00	4,686.48
100-20-5512-3-32	168.84	.00	168.84
100-20-5513-3-30	75.00	.00	75.00
100-20-5513-3-32	274.36	.00	274.36
100-20-5513-3-38	257.90	.00	257.90
100-20-5523-3-32	2,108.62	.00	2,108.62
100-20-5523-3-38	114.97	.00	114.97
100-20-5525-3-32	4,444.96	.00	4,444.96
100-20-5525-3-36	592.50	.00	592.50
100-20-5527-3-38	100,000.00	.00	100,000.00
100-21100	.00	260,699.55-	260,699.55-
100-30-5152-3-38	781.33	.00	781.33
100-40-5211-3-30	560.46	.00	560.46
100-40-5211-3-31	508.71	.00	508.71
100-40-5211-3-32	1,150.84	.00	1,150.84
100-40-5211-3-36	30.00	.00	30.00
100-40-5211-3-38	1,587.72	.00	1,587.72
100-40-5212-3-36	669.49	.00	669.49
100-40-5212-3-38	345.75	.00	345.75
100-40-5213-3-38	246.00	.00	246.00
100-40-5215-3-37	165.00	.00	165.00
100-50-5230-3-31	39.91	.00	39.91
100-50-5230-3-38	25.00	.00	25.00
100-50-5231-3-31	199.56	.00	199.56
100-50-5231-3-32	672.30	.00	672.30
100-50-5231-3-38	150.00	.00	150.00
100-50-5232-3-36	3,534.21	.00	3,534.21
100-50-5232-3-38	1,222.99	.00	1,222.99
100-50-5234-3-38	200.00	.00	200.00
100-50-5251-3-31	26.61	.00	26.61
100-50-5251-3-32	16.00	.00	16.00
100-50-5251-3-38	83.16	.00	83.16
100-70-5410-3-32	6,655.57	.00	6,655.57
100-70-5410-3-36	1,251.37	.00	1,251.37
100-70-5410-3-38	158.90	.00	158.90
100-70-5411-3-36	4,049.73	.00	4,049.73
100-70-5411-3-38	1,325.66	.00	1,325.66
100-70-5412-3-32	1,033.37	.00	1,033.37

GL Account	Debit	Credit	Proof
100-70-5412-3-38	349.59	.00	349.59
100-70-5420-3-31	68.19	.00	68.19
100-70-5431-3-36	20,225.97	.00	20,225.97
100-70-5435-3-36	2,300.00	.00	2,300.00
100-70-5441-3-32	197.80	.00	197.80
100-70-5442-3-32	11,017.13	.00	11,017.13
100-70-5443-3-38	4,625.00	.00	4,625.00
210-21100	.00	2,210.56-	2,210.56-
210-60-5511-3-32	2,210.56	.00	2,210.56
220-20-5514-3-38	567.00	.00	567.00
220-21100	.00	2,031.32-	2,031.32-
220-40-5212-3-38	292.19	.00	292.19
220-50-5231-3-38	1,172.13	.00	1,172.13
400-20-5513-8-00	261,203.00	.00	261,203.00
400-21100	.00	393,889.20-	393,889.20-
400-70-5436-8-00	132,686.20	.00	132,686.20
401-21100	.00	3,681.00-	3,681.00-
401-70-5436-3-39	3,681.00	.00	3,681.00
404-10-5711-3-38	711.00	.00	711.00
404-21100	.00	711.00-	711.00-
405-21100	.00	72,838.70-	72,838.70-
405-70-5436-3-38	27.60	.00	27.60
405-70-5437-8-00	72,811.10	.00	72,811.10
410-21100	.00	3,009.53-	3,009.53-
410-40-5211-4-00	261.71	.00	261.71
410-50-5231-4-00	2,747.82	.00	2,747.82
418-21100	.00	2,753.00-	2,753.00-
418-70-5436-3-39	2,753.00	.00	2,753.00
430-21100	.00	961.65-	961.65-
430-70-5436-3-38	961.65	.00	961.65
501-10-5154-3-38	10,666.18	.00	10,666.18
501-21100	.00	10,666.18-	10,666.18-
700-10-5191-3-38	115.16	.00	115.16
700-10-5192-3-32	34.34	.00	34.34
700-10-5192-3-36	214.99	.00	214.99
700-10-5192-3-38	1,797.68	.00	1,797.68
700-21100	.00	2,162.17-	2,162.17-
Grand Totals:	755,613.86	755,613.86-	.00

Dated: _____

Mayor: _____

City Council: _____

City Recorder: _____

Report Criteria:

Report type: Invoice detail

Check.Type = {<>} "Adjustment"

Invoice.Batch = "10724","101724","102924"



AGENDA SUMMARY SHEET

MEETING DATE: 10/29/24

TITLE: Review Spring Flooding Areas of Concern and Approve Recommended Flood Mitigation Engineering Study

AGENDA SECTION: BOARD/COMMITTEE/COMMISSION RECOMMENDATIONS

PRESENTER: Jeff Daane, Public Works Director

DEPARTMENT GOAL(S) SUPPORTED <i>(if applicable)</i>	FISCAL IMPACT	
Public Infrastructure	\$24,750 (Storm Water Funds)	

ISSUE SUMMARY:

Climate change is increasing the frequency and intensity of heavy rains in Wisconsin, leading to more flooding. The City experienced significant flooding in May and June of 2024. The Board of Public Works recently reviewed several areas of the city most impacted by this spring flooding. The attached Power Point highlights the areas of Hazel-Pattee-W Lincoln Streets, and along Edgewood Drive. Both areas have experienced consistent patterns of flooding that last for an extended period of time and have resulted in repeated road closures and resident complaints. We know there are other areas in the city that have flooding during heavy rainfall events that will need to be studied but the identified areas are elevated due to the sustained nature of the flooding experienced. The Board of Public Works is recommending the use of storm water funds to approve engineering studies in the areas outlined with the goal of identifying possible solutions that will mitigate flood issues. The proposed study would help us understand estimated costs to improve drainage in the studied areas so that we can consider projects in our overall capital improvement plans and/or prepare for grant applications if they become available.

STAFF RECOMMENDATION:

Accept the recommendation of the Board of Public Works to enter into an agreement MSA for the purpose of studying flooding concerns in the identified areas.

ATTACHMENTS:

Power Point

RECOMMENDED MOTION:

Motion to approve use stormwater funds in the amount of \$24,750 for Hazel-Pattee-W. Lincoln St. and Edgewood Dr. flood studies.



WAUPUN FLOODING AREAS

WAUPUN HAS SEVERAL AREAS IN OR AROUND THE CITY THAT FLOOD CAUSING STREET CLOSURES AND PROPERTY DAMAGE. WE ARE LOOKING AT JUST A FEW OF THE MORE PROMINENT AREAS.

GATEWAY DR. JUST EAST OF FOND DU LAC ST.

In 2015 the City had a flood reduction study done on the South Branch of the Rock River. The purpose of the document was analyze the flow rates and determine the elevations produced by those rates at Gateway Dr.



GATEWAY DR NEAR HOMAN AUTO

The analysis found that even a very large floodwater storage area (100 acres, 6' deep, with an estimated cost of nearly \$5 million) would reduce flow rates to a degree only sufficient enough to lower flood elevations at Gateway Drive by approximately 1.5 inches.

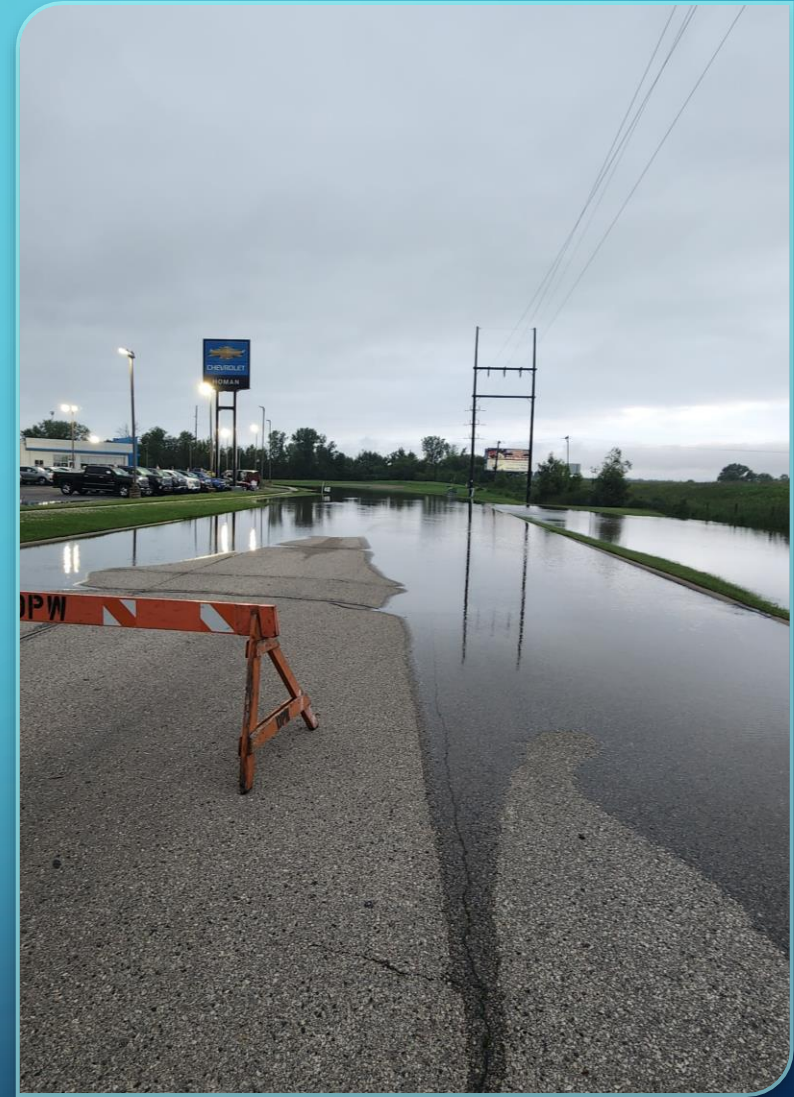

THE ROCK GOLF COURSE AREA

The flood control area was modeled as a 100-acre wetland area – this is about the size of the golf course. The area would have a two-foot-deep low-flow channel for the river and an additional six feet above the channel for flood storage. Flows in excess of two feet deep would flood into the wetland, which would temporarily store floodwater and diminish peak rates. If the cost of construction of such a basin is estimated as \$5 per cubic yard of excavation, six feet of excavation over a 100-acre area is 968,000 CY, for a total estimated cost of \$4.84 million (in 2015).

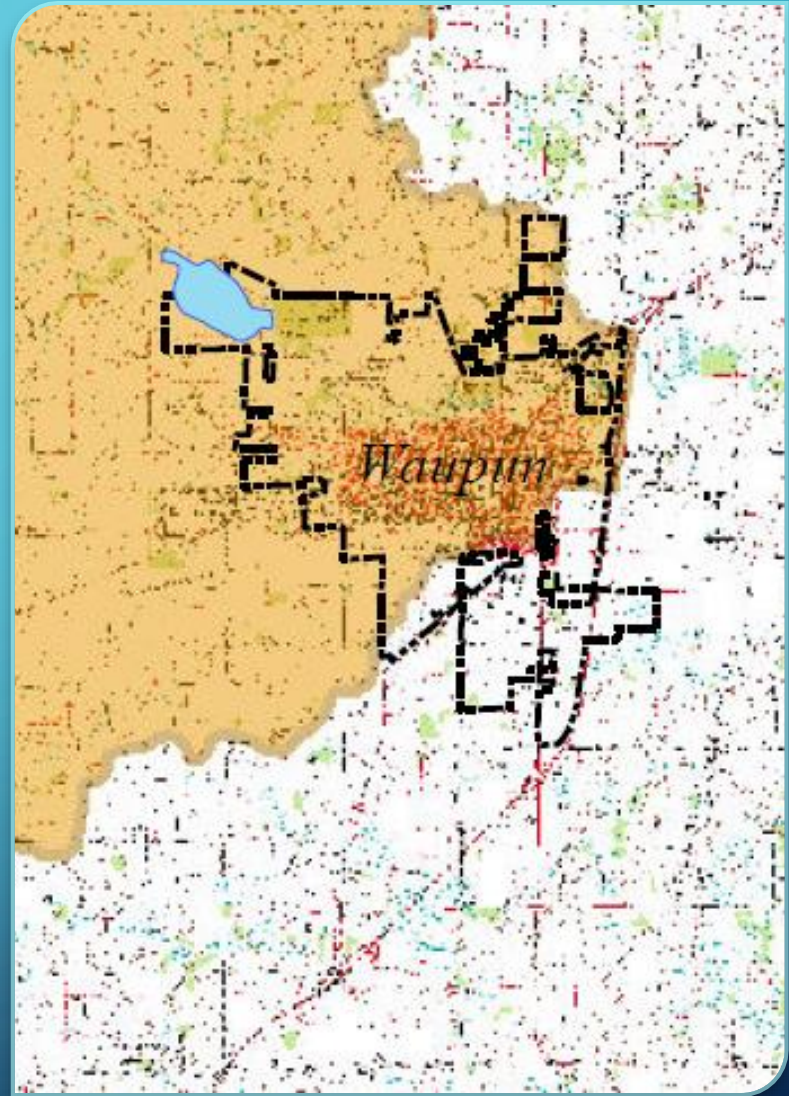

EDGEWOOD DRIVE

Similar to Rensway, there is ~ 50 acres of agricultural land draining to this location.



W. LINCOLN ST., HAZEL AND PATTEE AREA

There are two primary issues in this location – A.) Lots of farmland to the south draining onto the site and B.) really small capacity storm sewer.



CURRENT STORMSEWER

. The 24" pipe that was put in place as part of the Fairway Estates project to drain this field is only a 24" at 0.42% only has about 15 cfs capacity – which might be enough to carry the 1-yr storm (2.2") – if the water actually collect in this location.

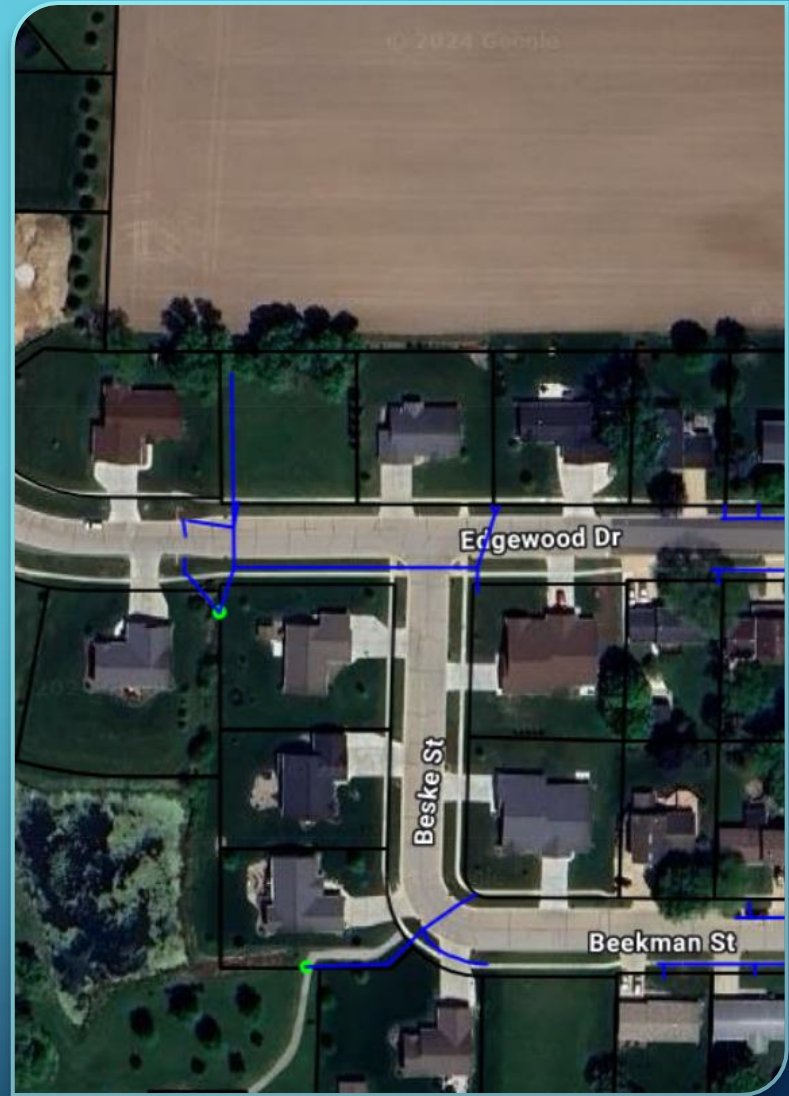

POSSIBLE POND AND BERM OR SWALE

. Probably the solution here is to acquire some land from the farmer and build a swale to be sure water gets to here, and then either a pond upstream from the pipe (best option) or an overflow route added above the pipe (this looks to still be a vacant lot?). This could be a potential water quality treatment improvement option.



POND #1

Currently this area all drains to Fairway estates pond #1 – and this pond was only designed to accommodate 8.0 acres of land. The fact that the farm field is discharging to the pond will not only negatively affect its performance, but also its lifespan as the farm field will have a very large sediment load. If you can't work with the farm owner, then you might have to look at a swale system along the north lot lines of the residences, bringing to flows west to a new larger storm sewer, then across Edgewood Drive as a new outfall to the River.





FARM FIELD SOUTH OF HAZEL AND PATTEE

Possible pond location



W. LINCOLN ST

Pipe capacity is full



MEDEMA FIELD

Pipe capacity is full

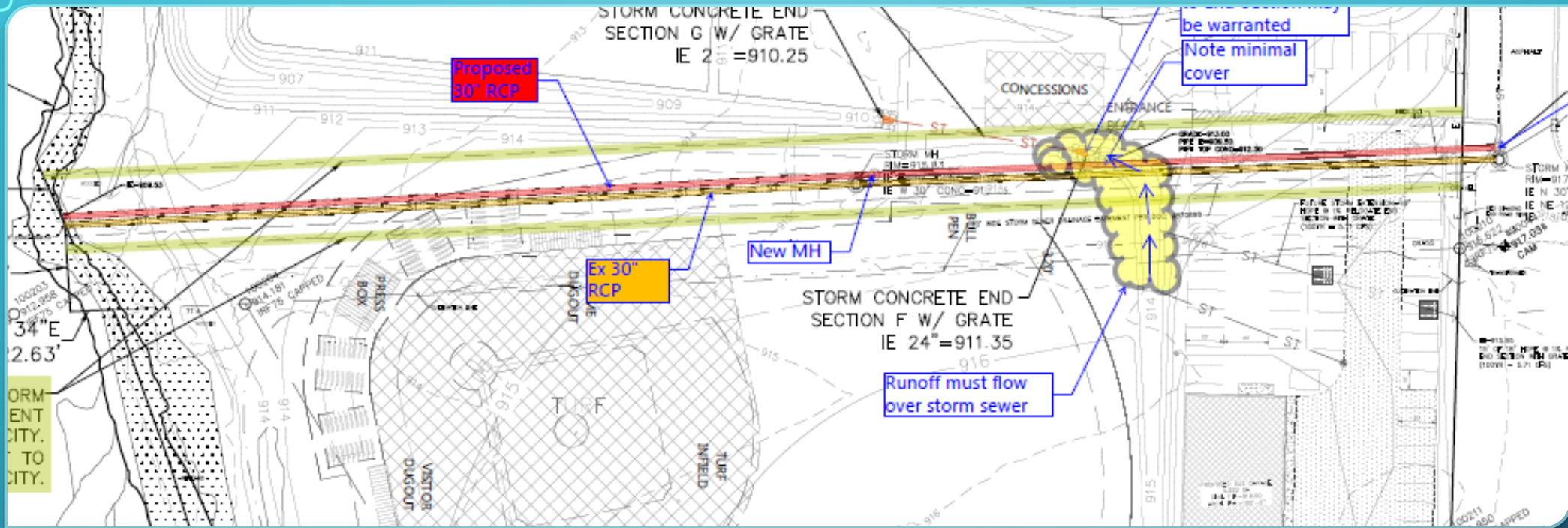

EASEMENT WEST OF W. LINCOLN ST.

There should be enough room to add another pipe in the easement. Moving forward with an agreement with MSA would help get us the size needed and an approximate cost of the work.

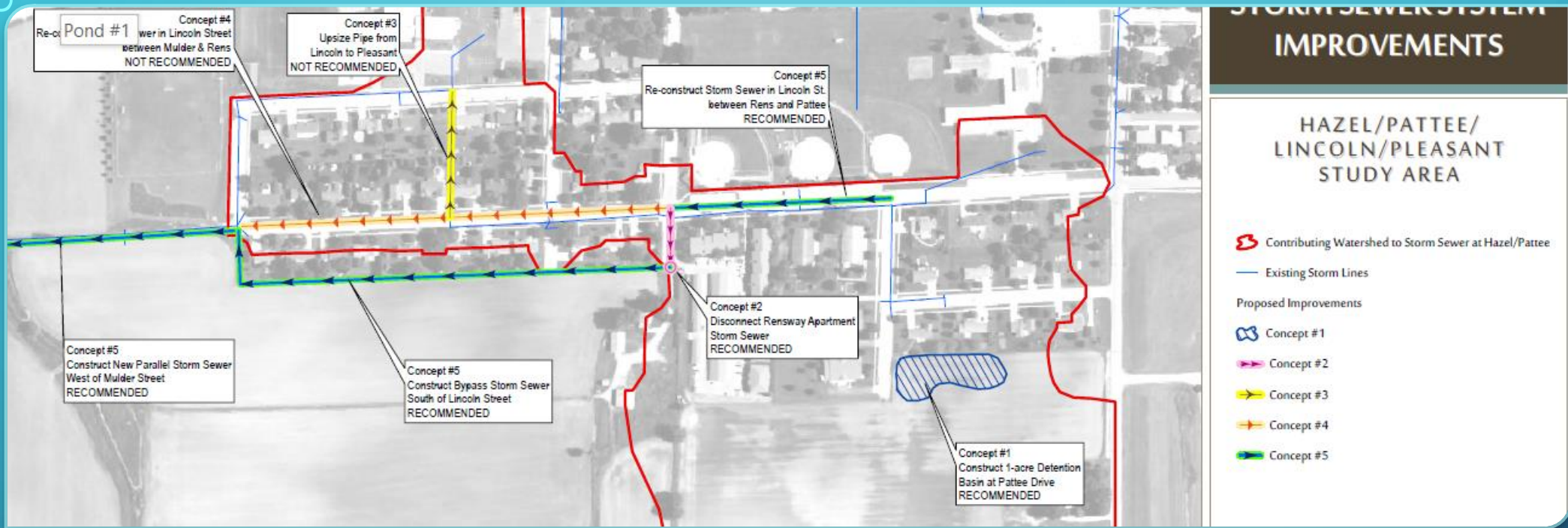

CONCEPTS THAT SHOW POSSIBLE SOLUTIONS TO THE FLOODING IN THIS AREA

IN CONCLUSION

- Hazel- Pattee-W. Lincoln Flood Study

- **Introduction:**

- MSA will complete a flood study for the approximately 75-acre area draining to/through the Hazell/Patee/Lincoln/Pleasant Street storm sewer system. The purpose of the study is to develop cost estimates for new drainage infrastructure capable of safely collecting and conveying peak 100-yr runoff rates from the farm fields south of the City of Waupun through to the existing storm sewer system outfall to Harris Creek.
- One basic alternative will be evaluated consisting of collection and conveyance of storm flows from the farm fields west around the perimeter of the existing City development.
- The primary purpose of the study is to determine cost estimates for construction of both options. MSA will rely on the City of Waupun to identify the cost for acquisition of farmlands.
- \$13,250

- Edgewood Dr. Flood Study

- **Introduction:**

- MSA will complete a flood study for the approximately 65-acre area draining to the intersection of Beske Drive and Beekman Street and the adjacent detention pond. The purpose of the study is to develop cost estimates for new drainage infrastructure capable of safely collecting and conveying peak 100-yr runoff rates from the farm fields north of the City of Waupun through to the existing detention pond.
- Two basic alternatives will be evaluated; the first consists of an enlarged storm sewer system capable of conveying 100-yr peak flows as generated by the farm lands; the second alternative will involve a concept design for stormwater detention within the farm field such that peak flows are reduced to the capacity of the existing storm sewer system. It is anticipated that both options will require some level of berming within the farm field to convey runoff from the farm field to the proposed new infrastructure.
- The primary purpose of the study is to determine cost estimates for construction of both options. MSA will rely on the City of Waupun to identify the cost for acquisition of farmlands.
- \$11,500



AGENDA SUMMARY SHEET

MEETING DATE: 10/29/24
AGENDA SECTION: CONSIDERATION-ACTION
PRESENTER: Jeff Daane, Public Works Director

TITLE: Approve JF Brennan Agreement for Cofferdam Installation and Removal to Repair Dam Gate Valve

DEPARTMENT GOAL(S) SUPPORTED <i>(if applicable)</i>	FISCAL IMPACT	
Public Infrastructure	\$15,669	

ISSUE SUMMARY:

This agreement is for J. F. Brennan to help set up and take down the cofferdam needed to repair the gate valve. This agreement is a worst-case scenario and it could come in at a lesser cost if things go well. The city will provide the super sacks and sandbags. The city will also hire the crane to assist in lifting the sacks. We continue to work with the WDNR on securing the permit needed for the work. Once the new gate valve arrives we will coordinate the work with both Sabel Mechanical and J.F. Brennan

STAFF RECOMMENDATION:

Approve the Waupun dam dive assist agreement with J. F. Brennan

ATTACHMENTS:

Waupun dam dive assist agreement

RECOMMENDED MOTION:

Motion to approve the agreement with J. F. Brennan to assist with dam dive setup of the cofferdam for the amount of \$15,669.



Prepared for:
The City of Waupun



Waupun Dam Dive Assist

Waupun, Wisconsin
October 14, 2024

Prepared by:
J.F. Brennan Company, Inc.
818 Bainbridge Street
La Crosse, WI 54603
Phone: 608.784.7173
jfbrennan.com

COST PROPOSAL



ISO 9001
Quality
Management
Systems
CERTIFIED

FS 719120

ISO 14001
Environmental
Management
CERTIFIED

EMS 719118

ISO 45001
Occupational
Health and Safety
Management
CERTIFIED

OHS 719119



October 14, 2024

Jeff Daane
Director of Public Works
jeff@cityofwaupunwi.gov
City of Waupun
201 E. Main St.
Waupun Wi. 53963
920-324-7918

Overview of Work

The following proposal outlines the services J.F. Brennan Company (Brennan) can provide to The City of Waupun at their Waupun Dam Dive Assist Project in Waupun, Wisconsin. Brennan understands that the scope of the proposed project includes:

- Mobilization and demobilization of dive crew and equipment to and from the project site.
- Perform work as outlined by The City of Waupun.
 - *Assist with the placement and future removal of sand filled super sacks, sandbags, and plastic sheeting to create a coffer dam upstream of a damaged gate.*

Project Schedule

Brennan proposes that the work be performed with two mobilizations. Brennan assumes three x eight-hour days using a two-person Association of Diving Contractors International (ADCI) United Brotherhood of Carpenters (UBC) team. Work to begin once an agreed upon contract is met. Additional work will be billed at the listed Time and Material (T and M) Rates below.

Budgetary Estimate – T and M

Location	Item	Description	Quantity	Unit	Unit Price	Amount
Waupun, Wisconsin	1	Assist	3.00	DY	\$3,543.00	\$10,629.00
	2	Mobilization	2.00	EA	\$2,520.00	\$5,040.00
	3	Overtime Hour	1.00	HR	\$496.00	
Total:						\$15,669.00

*Wages based on local union agreed-upon rates.

*No Dive Ops, Dry or Hot Water Suits Only.

General Clarifications

- Pricing
 - T and M final billing will occur. Owner to pay for services used.
 - Working days will be charged a minimum of eight hours once onsite; no partial days are assumed.



- Material, trucking, rental, other outside services billed at cost plus 15%. However, none are assumed.
- Standby rates may apply if factors outside of Brennans' control occur and prevent the crew from working.
- Assumptions and Exclusions
 - This proposal assumes the following:
 - Safe, secure, open site access provided by the owner.
 - Flows and weather conditions conducive for safe operations.
 - Lock out/tag out (LOTO) provided as needed. Less than ½ hour of down time between water diversion efforts.
 - Owner to provided material handling equipment (crane or excavator), operator, and material (super sacks, sandbags, plastic, rigging, etc.).
 - Owner to provide relevant drawings prior to mobilization.
 - This proposal excludes the following:
 - Weekend or Holiday work or mobilization.
 - Commercial diving operations as outlined in the ADCI Consensus Standards.
 - Permitting, licensing, or submittals.
 - Off-site training. Less than ½ hour of onsite training is assumed.
 - This proposal assumes a contract with agreed upon terms and conditions will be arrived at prior to any work or incurring any other costs.
 - This proposal is good for 30 days.

J. F. Brennan Company, Inc. appreciates the opportunity to submit this proposal. After you have reviewed our proposal, if you have any questions, comments, or concerns, please feel free to contact me at 608-519-5288 or Justin Scherf, Underwater Services Director at 608-519-5244.

Respectfully Submitted,

Adam Thorson

Underwater Services – Dive Project Manager

direct 608.519.5288 | cell 507.450.8366

office 608.784.7371

athorson@jfbrennan.com

**J.F. BRENNAN COMPANY, INC.****GENERAL TERMS AND CONDITIONS**

These Terms and Conditions ("Terms") are provided and shall be effective as of _____, 202_, by and between J.F. Brennan Company, Inc., a duly organized corporation located at 818 Bainbridge Street, La Crosse, Wisconsin 54603 ("Brennan"), and _____, a _____ located at _____ ("Client"), for certain services ("Services") for the _____ project ("Project"), located at _____.

1. Applicability. The accompanying proposal from Brennan, the specific purchase order ("**Purchase Order**") or work order ("**Work Order**") issued to Brennan by Client, and these Terms (collectively, this "**Agreement**") comprise the entire agreement between the parties, and supersede all prior or contemporaneous understandings, agreements, negotiations, representations and warranties, and communications, both written and oral. These Terms prevail over any of Client's general terms and conditions, regardless of whether or when Client has submitted its proposal, sales confirmation, or such terms. This Agreement expressly limits Client's acceptance to the terms of this Agreement.

2. Performance of Services.

(a) Brennan shall provide the Services as described and in accordance with the Services, Brennan's proposal, attached hereto, and in accordance with the date(s) or schedule either provided or mutually agreed upon by both parties.

(b) Brennan shall furnish all labor and cover all construction related costs, exclusive of insurance and taxes, incidental to such labor, necessary to carry out the Services.

(c) Brennan shall comply at all times with any instructions given by the designated representative of the Client, provided that Brennan shall retain full control of its patented materials and processes, and provided that such instructions are not inconsistent with the provisions of this Agreement. In furtherance of the foregoing, the Client understands and agrees that Brennan shall be solely responsible for, and shall have control over, all construction means, methods, techniques, sequences, processes, and procedures and for coordinating all portions of the Services. Brennan shall not be required to train employees of the Client or of other contractors in any of its methods, processes and procedures, and Brennan shall be sole judge as to the number of its supervisory and other employees which will be required to ensure quality of the Services.

3. Client's Responsibilities.

(a) Client shall, before the date on which the Work is to start, obtain, and at all times during the term of this Agreement, maintain, all necessary licenses, permits and consents and comply with all relevant laws applicable to the provision of the Services.

(b) Client shall furnish Brennan with drawings, showing the locations of all services and utility lines. No responsibility will be accepted by Brennan for striking and/or breaking any services and utility lines unless the foregoing obligation is fulfilled by Client.

(c) Client shall provide Brennan with a storage site and plant site suitable for the performance of the Services.

(d) Client shall be solely responsible for the payment of any applicable taxes or insurance premiums for coverages required to be maintained by Brennan at the direction of Client.

4. Price. The price of the Services is the mutually agreed upon price stated in either the Purchase Order or Work Order issued to Brennan ("**Price**"). If no Price is included in the Purchase Order or Work Order, the Price shall be the price set out in Brennan's proposal attached hereto.

5. Payment Terms. Brennan shall issue an invoice to Client and Client shall pay all properly invoiced amounts due to Brennan within thirty (30) days after Client's receipt of such invoice, unless otherwise indicated otherwise on the Purchase Order or Work Order. In no event shall the payment term be more than forty-five (45) days. All payments must be in US dollars and made by check or ACH.

6. Mutual Indemnification.

(a) Brennan shall defend, indemnify and hold harmless Client, Client's respective subsidiaries, affiliates, successors or assigns, and their respective directors, officers, shareholders and employees (collectively, "**Client Indemnitees**"), against any and all loss, injury, death, damage, liability, claim, deficiency, action, judgement, interest, award, penalty, fine, cost or expense, including reasonable attorney and professional fees and costs, and the cost of enforcing any right to indemnification hereunder and the cost of pursuing any insurance providers



(collectively, “**Client Losses**”) arising in the performance of the Services under this Agreement due to Brennan’s negligence, willful misconduct or breach of the Terms.

(b) Client shall defend, indemnify and hold harmless Brennan, Brennan’s respective subsidiaries, affiliates, successors or assigns, and their respective directors, officers, shareholders and employees (collectively, “**Brennan Indemnitees**”), against any and all loss, injury, death, damage, liability, claim, deficiency, action, judgement, interest, award, penalty, fine, cost or expense, including reasonable attorney and professional fees and costs, and the cost of enforcing any right to indemnification hereunder and the cost of pursuing any insurance providers (collectively, “**Brennan Losses**”) arising out of, resulting from, or in any manner due to Client’s negligence, willful misconduct or breach of the Terms.

7. Limitation of Liability. Notwithstanding anything contained herein, to the maximum extent permitted by applicable law, the maximum aggregate liability of Brennan shall not exceed the total amount for the Services as outlined in the Purchase Order or Work Order issued by Client to Brennan, incorporated herein.

8. Insurance. During the term of this Agreement, Brennan shall maintain in full force and effect, Commercial General Liability Coverage with a limit of \$2,000,000 aggregate, \$1,000,000 each occurrence; Comprehensive Automobile Liability Coverage with a combined single limit of no less than \$1,000,000; Workers Compensation and Occupational Disease Coverage with limits of no less than \$1,000,000 each, bodily injury and disease; and Umbrella/Excess Coverage providing additional limits of no less than \$4,000,000. Upon Client’s request, Brennan shall provide Client with a certificate of insurance from Brennan’s insurer evidencing the insurance coverages specified in this Agreement. The certificate of insurance shall name Client as an additional insured. Brennan shall provide Client with thirty (30) days advance written notice in the event of cancellation or material change in Brennan’s insurance policy, unless such cancellation is for the non-payment of premium wherein a ten (10) day notice shall apply.

9. Compliance with Law. Both Brennan and Client shall comply with all applicable statutes, laws, rules, regulations, and ordinances.

10. Changes. No changes shall be made unless agreed upon in writing by Brennan.

11. Termination. Either party may terminate this Agreement upon ten (10) days written notice to the other party. Brennan shall be entitled to payment for all Services completed up to time of termination, as well as for all material already purchased by Brennan but not paid for yet by Client under this Agreement.

12. Damages. Notwithstanding any other provisions of this Agreement to the contrary, in no event shall Brennan or Client be liable to the other for any indirect, special, incidental or consequential loss or damage including, but not limited to, loss of profits or revenue, loss of opportunity or use incurred by either Party to the other, or like items or damage, and each Party hereby releases the other Party therefrom.

13. Waiver. No waiver by Brennan of any of the provisions of this Agreement is effective unless explicitly set forth in writing and signed by Brennan. No failure to exercise, or delay in exercising any right, remedy, power or privilege arising from this Agreement operates, or may be construed, as a waiver thereof. No single or partial exercise of any right, remedy, power or privilege hereunder precludes any other or further exercise thereof or the exercise of any other right, remedy, power or privilege.

14. Confidential Information. All non-public, confidential or proprietary information of Brennan, including but not limited to, specifications, samples, patterns, designs, plans, drawings, documents, data, business operations, customer lists, pricing, discounts or rebates, disclosed by Brennan to Client, whether disclosed orally or disclosed or accessed in written, electronic or other form or media, and whether or not marked, designated or otherwise identified as “confidential” in connection with this Agreement is confidential, solely for the purpose of performing this Agreement and may not be disclosed or copied unless authorized in advance by Brennan in writing. Upon Brennan’s request, Client shall promptly return all documents and other materials received from Brennan. Brennan shall be entitled to injunctive relief for any violation of this Section. This Section does not apply to information that is: (a) in the public domain; (b) known to Client at the time of disclosure; or (c) rightfully obtained by Brennan on a non-confidential basis from a third party.

15. Force Majeure. No party shall be liable or responsible to the other party, or be deemed to have defaulted under or breached this Agreement, for any failure or delay in fulfilling or performing any term of this Agreement (except for any obligations to make payments to the other party hereunder), when and to the extent such party’s (the “**Impacted Party**”) failure or delay is caused by or results from the following force majeure events (“**Force Majeure Event(s)**”): (a) acts of God; (b) flood, fire, earthquake, pandemics or epidemics, or explosion; (c) war, invasion, hostilities (whether war is declared or not), terrorist threats or acts, riot or other civil unrest; (d) government order, law, or action; (e) embargoes or blockades in effect on or after the date of this Agreement; and (f) national or regional emergency; and (g) strikes, labor stoppages or slowdowns or other industrial disturbances; and (h) telecommunication breakdowns, power outages or shortages, lack of warehouse or storage space, inadequate transportation services, or inability or delay in obtaining supplies of adequate or suitable materials; and (i) other similar events beyond the reasonable control of the Impacted Party. The Impacted Party shall give notice within three (3) days of the Force Majeure Event to the other party, stating the period of time the occurrence is expected to continue. The Impacted Party shall use diligent efforts to end the failure or delay and ensure the effects of such Force Majeure Event are minimized. The Impacted Party shall resume the performance of its obligations as soon as reasonably practicable after the removal of the cause. In the event that the Impacted Party’s failure or



delay remains uncured for a period of thirty (30) consecutive days following written notice given by it under this Section 18, the other party may thereafter terminate this Agreement upon ten (10) days' written notice.

16. Assignment. Neither party shall assign, transfer, delegate, or subcontract any of its rights or obligations under this Agreement without the prior written consent of the other party. No assignment or delegation shall relieve either party from any of their obligations hereunder.

17. Relationship of the Parties. The relationship between the parties is that of independent contractors. Nothing contained in this Agreement shall be construed as creating any agency, partnership, joint venture or other form of joint enterprise, employment, or fiduciary relationship between the parties, and neither party shall have authority to contract for or bind the other party in any manner whatsoever.

18. No Third-Party Beneficiaries. Except for the parties for whom the Services are provided under the Purchase Order or Work Order, this Agreement is for the sole benefit of the parties hereto and their respective successors and permitted assigns; and nothing herein, express or implied, is intended to or shall confer upon any other person or entity any legal or equitable right, benefit or remedy of any nature whatsoever under or by reason of this Agreement.

19. Governing Law. All matters arising out of or relating to this Agreement are governed by and construed in accordance with the internal laws of the State of Wisconsin without giving effect to any choice or conflict of law provision or rule (whether of the State of Wisconsin or any other jurisdiction) that would cause the application of the laws of any jurisdiction other than those of the State of Wisconsin.

20. Submission to Jurisdiction. Any legal suit, action or proceeding arising out of or relating to this Agreement shall be instituted in the federal courts of the United States of America or the courts of the State of Wisconsin in each case located in the City of La Crosse and County of La Crosse (or Western District of Wisconsin, if applicable), and each party irrevocably submits to the exclusive jurisdiction of such courts in any such suit, action or proceeding.

21. Notices. All notices, requests, consents, claims, demands, waivers and other communications hereunder (each, a "Notice") shall be in writing and addressed to the parties at the addresses set forth on the face of the purchase order or to such other address that may be designated by the receiving party in writing. All Notices shall be delivered by personal delivery, nationally recognized overnight courier (with all fees pre-paid), certified mail (in each case, return receipt requested, postage prepaid), or electronic transmission (via facsimile or email with date/time of sending recorded).

22. Severability. If any term or provision of this Agreement is invalid, illegal, or unenforceable in any jurisdiction, such invalidity, illegality or unenforceability shall not affect any other term or provision of this Agreement or invalidate or render unenforceable such term or provision in any other jurisdiction.

23. Survival. Provisions of these Terms which by their nature should apply beyond their terms will remain in force after any termination or expiration of this Agreement including, but not limited to, the following provisions: Insurance, Compliance with Laws, Confidential Information, Governing Law, Submission to Jurisdiction/Arbitration and Survival.

24. Amendment and Modification. These Terms may only be amended or modified in a writing stating specifically that it amends these Terms and is signed by an authorized representative of each party.

25. Integration of Contract Documents. There are no terms, conditions, understandings, or agreements between Brennan and Client other than those negotiated and expressly stated herein. All proposals, quotations and negotiations are merged in this Agreement and all other terms and conditions contained in any such document are superseded and replaced in their entirety by this Agreement. No terms and conditions in any way altering or modifying the provisions of this Agreement shall be binding upon Brennan unless in writing and signed by an authorized representative of Brennan.

IN WITNESS WHEREOF, Brennan and the Client each individually represent that it has the necessary financial resources to fulfill its obligations under this Agreement, and each has the necessary corporate approvals to execute this Agreement.

CLIENT:

BRENNAN:
J.F. Brennan Company, Inc.

By:

By:

Title:

Title:

Printed Name:

Printed Name:

Date:

Date:

|



AGENDA SUMMARY SHEET

MEETING DATE: 10/29/2024

TITLE: 2025 Business Improvement District Operating Plan, Budget, and Assessment Rate

AGENDA SECTION: CONSIDERATION-ACTION

PRESENTER: Kathy Schlieve, City Administrator

DEPARTMENT GOAL(S) SUPPORTED <i>(if applicable)</i>	FISCAL IMPACT	
Economic Vitality	--	

ISSUE SUMMARY

The BID Board unanimously approved the 2025 operating plan as included in this packet. The assessment of \$1.85 per \$1,000 of assessed value remains unchanged from 2024. According to State Statute and per the BID operating plan, you are required to adopt the plan.

RECOMMENDATION:

Approve the BID Operating Plan and Budget as presented

ATTACHMENTS:

DRAFT 2025 BID Operating Plan Document and Budget

MOTIONS FOR CONSIDERATION:

Motion to approve the 2025 BID Operating Plan and to maintain the BID assessment rate at \$1.85 per \$1,000 of assessed value for the 2024 tax collection year.



WAUPUN
CITY OF SCULPTURE

CITY OF WAUPUN
2025 BUSINESS IMPROVEMENT DISTRICT
DRAFT - OPERATING PLAN

BID Adoption: 10/15/2024

Common Council Adoption: XX/XX/2024

DRAFT

THE WAUPUN BUSINESS IMPROVEMENT DISTRICT 2025 OPERATING PLAN (DRAFT)

INTRODUCTION

In 1984, the Wisconsin legislature created Sec. 66.1109 of the Statutes enabling cities to establish Business Improvement Districts (BID) upon the petition of at least one property owner within the proposed district. The purpose of the law is “to allow businesses within those proposed district to develop, manage, and promote the districts and to establish an assessment method to fund these activities”. Upon petition from property owners within the Waupun Business Improvement District (hereafter “BID”), the City’s Common Council created the BID and adopted its initial operating plan in 1988.

Section 66.1109(3)(b), Wis. Stats., requires that a BID Board “shall annually consider and make changes to the operating plan. The board shall then submit the operating plan to the local legislative body for approval”. The Board of the Waupun BID submits this BID operating plan in fulfillment of the statutory requirement.

This plan proposes a continuation and expansion of the activities described in the initial 1988 BID operating plan. Therefore, it incorporates by reference the earlier plans as adopted by the City’s Common Council. In the interest of brevity, this plan emphasizes the elements, which are required by Sec. 66.1109, Wis. Stats. This plan does not repeat the background information that is contained in the initial operating plan.

DISTRICT BOUNDARIES

A calculation of the BID assessment and the original 1988 map of the district is provided in Appendix A and Appendix B.

2025 OPERATING PLAN

The goals, objectives, and strategies of the 2025 Operating Plan as provided in Appendix C. Estimated revenues and expenditures can be seen in Appendix D.

PROMOTION OF ORDERLY DEVELOPMENT OF THE CITY

Under §66.1109(1)(f)(4), the Operating Plan must specify how the BID promotes the orderly development of the municipality, including its relationship to any municipal master plan.

The Waupun Business Improvement District was created through private sector initiative to further city goals. The creation of the BID is consistent with the City’s plans and promotes the orderly development of the City in general and the business district in particular. This proposal is consistent with the City’s Comprehensive Plan and all other City Ordinances and Plans.

METHOD OF ASSESSMENT

A. Assessment Rate and Method

As of December 31, 2024, the properties in the district have estimated total BID assessable value of \$13,033,600. This plan proposes to assess the taxable property in the district at a rate of \$1.85 per \$1,000 of assessed value for the purposes of the BID. Appendix A shows the projected BID assessment for property included in the district.

The principle behind the assessment methodology is that each property owner should contribute to the BID in proportion to the benefit derived from the BID. After consideration of the assessment methods, it was determined that the assessed value of a property was the characteristic most directly related to the potential benefit provided by the BID. Therefore, a uniform rate applied on the assessed value of each property was selected as the basic assessment method for the Waupun BID

Information on specific assessed values, budget amounts, and assessment amounts are based on 2024 conditions. Greater detail about subsequent years' activities will be provided in the required annual plan updates. Approval by the City's Common Council of such operating plan updates shall be conclusive evidence of compliance with this operating plan and the BID law.

In later years, the BID operating plan will continue to apply the assessment formula, as adjusted, to raise funds to meet the next annual budget. The method of assessing shall not be materially altered, except with the consent of the City of Waupun.

B. Excluded and Exempt Property

Wisconsin law specifies certain properties, which are exempt from the assessment, and allows the municipality to determine whether businesses operating specifically for manufacturing purposes are exempt.

- Wisconsin Statutes § 66.1109(1)(f) 1m: This section details what must be included in a Standard Operating Plan. "Whether real property used exclusively for manufacturing purposes will be specially assessed." Property used exclusively for manufacturing purposes will not be assessed.
- Wisconsin Statutes §66.1109(5)(a): "Property used exclusively for residential purposes will not be assessed."
- Wisconsin Statutes § 66.1109(5)(a): "Real property that is exempted from general property taxes under §70.11 will not be assessed." Owners of property that is exempt from the special assessment may not receive the direct financial benefits of the Business Improvement District, such as in the case of a façade improvement grant or any other grant.

Owners of property that is exempt from the special assessment may not receive the direct financial benefits of the BID, such as in the case of the Façade Improvement Program.

CITY ROLE IN DISTRICT OPERATION

The City of Waupun is committed to helping private property owners in the district promote its development. To this end, the City has played a significant role in the creation of the BID and in the implementation of its operating plan. In particular, the City will continue to:

- Provide funding to the BID for administration and promotion of the Façade Improvement Grant program, business and development recruitment, and other initiatives. This is updated on an annual basis and is reviewed each budget year.
- Monitor and, when appropriate, apply for outside funds, which could be used in support of the district.
- Collect and disperse BID assessments to the district.
- Receive annual audits, as required per Sec. 66.1109(3)(c) of the BID law.
- Encourage partners to support the activities of the district.

BOARD MEMBERS AND STAFF

The Mayor shall appoint the members of the BID Board subject to confirmation by the Common Council. Upon confirmation, board members serve a 3-year term expiring April 30th.

The Board is comprised of six (6) representatives from the BID District and four (4) representatives at-large. The current BID Board and staff are comprised as follows:

REPRESENTATIVE FROM BID DISTRICT		4/30/2025	Tyler Schulz
REPRESENTATIVE FROM BID DISTRICT		4/30/2025	Rich Matravers
REPRESENTATIVE FROM BID DISTRICT		4/30/2026	Steve Daute
REPRESENTATIVE FROM BID DISTRICT		4/30/2026	Gary DeJager
REPRESENTATIVE FROM BID DISTRICT		4/30/2026	Bryan Yohn
REPRESENTATIVE FROM BID DISTRICT		4/30/2027	Mitch Greenfield
REPRESENTATIVE AT-LARGE		4/30/2025	Craig Much
REPRESENTATIVE AT-LARGE		4/30/2026	Jodi Mallas
REPRESENTATIVE AT-LARGE		4/30/2027	Katie Bohn
REPRESENTATIVE AT-LARGE		4/30/2027	Teresa Ruch
MAYOR	Ex Officio		

Responsibilities of the Board include implementation of this operating plan and preparing annual reports of the District. The Board will also annually consider and make changes to the operating plan and submit the operating plan to the Common Council for approval. The Board will conduct its business consistent with the open meeting law and keep minutes as a matter of public record.

FUTURE YEARS' OPERATING PLANS

It is anticipated that the BID will continue to revise and develop the operating plan annually in response to changing development needs and opportunities in the district, in accordance with the purpose and goals in this operating plan.

Section 66.1109(3)(a) of the BID law requires the BID Board and the City to annually review and make changes as appropriate in the operating plan. Therefore, while this document outlines in general terms the complete development project, it focuses upon 2025 activities. Information on specific assessed values, budget amounts, and assessment amounts are based on 2024 conditions. Greater detail about subsequent years' activities will be provided in the required annual plan updates. Approval by the City Common council of such operating plan updates shall be conclusive evidence of compliance with this operating plan and the BID law.

In later years, the BID operation plan will continue to apply the assessment formula, as adjusted, to raise funds to meet the next annual budget. The method of assessing shall not be materially altered, except with the consent of the City of Waupun.

AMENDMENT, SEVERABILITY, AND EXPANSION

The BID has been created under the authority of Section 66.1109 of the Statutes of the Statues of the State of Wisconsin. Should any court find any portion of the statue invalid or unconstitutional, its decision will not be invalidate or terminate the BID and this BID operating plan shall be amended to conform to the law without need of re-establishment.

Should the legislature amend the statue to narrow or broaden the process of a BID to exclude or include as assessable properties of a certain class or classes of properties, as and when it conducts its annual review and approval of the operating plan and without necessity to undertake any other act. This is specifically authorized under Se. 66.1109(3)(b)

Appendix A – Calculation of 2024 Assessed Values

Appendix B – 1988 Original BID Map

Appendix C – 2025 Operating Plan Goals, Objectives, and Strategies

Appendix D – 2025 Budget

Appendix A – Calculation of 2024 Assessed Values

2024 Assessment Total			\$	13,033,600.00
Divided by \$1,000			\$	13,033.60
Assessment Rate: \$1.85/\$1,000				
2024 BID Assessment			\$	24,112.16
	TOTAL INCOME:		\$	24,112.16

DRAFT

Appendix B – 1988 Original BID District Map

City of Waupun Bid District

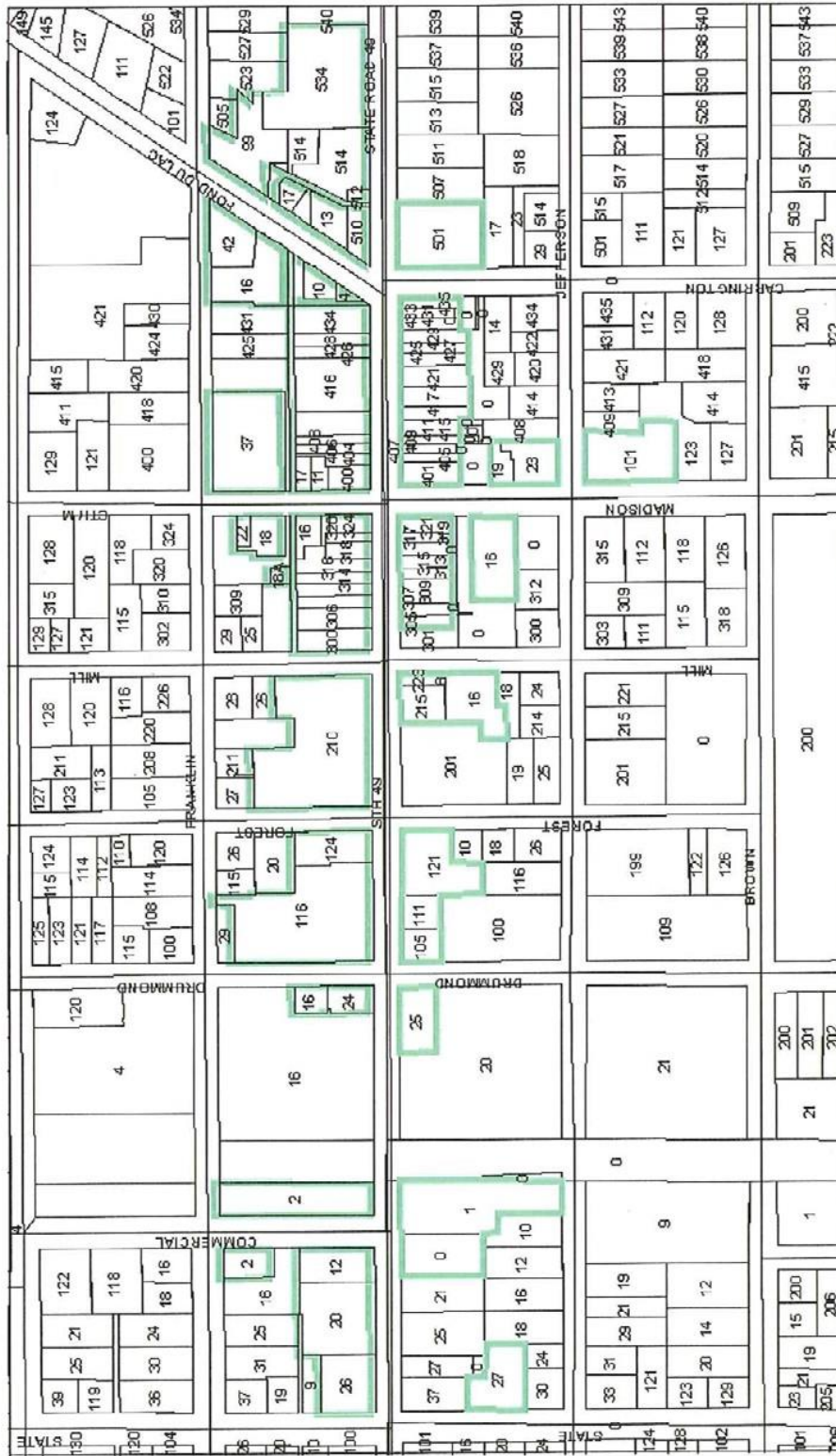

Legend
 Bid District

Appendix C – 2025 Operating Plan Goals, Objectives, and Strategies

1. Be a voice for the Downtown Business Community.

- a. Communicate and solicit feedback from members.
 - i. Review, update and execute the operating plan.
 - ii. Build networks that strengthen working relationships/partnerships to promote the district.
 - iii. Pursue interest to expand the BID boundaries based on business inquiry.
 - iv. Complete annual audits as required by WI Statute.
 - v. Publish and distribute annual reports to members.
- b. Board development and administration
 - i. Recruit, develop and engage board members.
 - ii. Partner with city for administrative support and execution of operating plan.
- c. Strengthen collaboration among community partners to benefit the district.
 - i. Strengthen collaboration among community partner organizations.
 - ii. Maintain Connect Community status through WEDC.

2. Promote Downtown Waupun as a Destination.

- a. Underwrite a shared resource with Downtown Promotions to market the district.
- b. Contribute to annual marketing / events calendar to encourage traffic in the district.

3. Improve the aesthetic / visual appeal of Downtown Waupun.

- a. Support façade improvements in the District.
 - i. Façade improvement grants (50% match to \$2,100)
 - ii. Educate property owners on various financial assistance programs to encourage property redevelopment.
- b. Support implementation of Streetscaping Plan.
 - i. Maintain downtown spaces that are clean, safe, comfortable and welcoming.
 - ii. Partner with city departments to manage safety, parking, snow removal, and planter program.
 - iii. Partner with the CDA on implementation of Streetscaping/Design WI Plan.

4. Attract, retain, and facilitate development of a unique mix of businesses in coordination with district partners.

- a. Work to retain businesses in the district.
 - i. Maintain a business retention program to identify business retention and expansion opportunities.

- ii. Provide educational opportunities to support the growth of downtown businesses.
- b. Work to attract new businesses to the district.
 - i. Leverage market analysis report to improve business mix.
 - ii. Follow up on leads of business looking to open, expand or relocate.
 - iii. Provide entrepreneurial startup business coaching through Ignite network.
 - iv. Offer a business attraction / pop-up grant program.

Appendix D – 2025 Budget

INCOME:			
2024 Assessment Total		\$	13,033,600
Divided by \$1,000		\$	13,034
Assessment Rate: \$1.85/\$1,000			
2024 BID Assessment		\$	24,112
TOTAL INCOME:		\$	24,112
EXPENSES:			
Design		\$	15,600
Economic Vitality		\$	4,000
Organization		\$	2,012
Promotions		\$	2,500
TOTAL EXPENSE:		\$	24,112



AGENDA SUMMARY SHEET

MEETING DATE: 10/29/2024

TITLE: Approve Amended and Restate Health Care Services Agreement with Waupun Memorial Hospital

AGENDA SECTION: CONSIDERATION-ACTION

PRESENTER: Kathy Schlieve, City Administrator

DEPARMTENT GOAL(S) SUPPORTED <i>(if applicable)</i>	FISCAL IMPACT	
High Performance Government	--	

ISSUE SUMMARY

DeAnn Thurmer of Waupun Memorial Hospital is requesting that the attached agreement be signed between the City and Waupun Memorial Hospital. WMH is part of a federal program that allows the hospital to receive certain drugs at a discounted price—called 340 B program. According to Thurmer this is important for local dialysis and IV infusion patients and requires that the agreement as presented be formalized between the city and the hospital.

RECOMMENDATION:

Approve the agreement as presented

ATTACHMENTS:

MOTIONS FOR CONSIDERATION:

Motion to approve the amended and restated health services agreement between Waupun Memorial Hospital and the City of Waupun as presented.

AMENDED AND RESTATED HEALTH CARE SERVICES AGREEMENT

THIS AMENDED AND RESTATED HEALTH CARE SERVICES AGREEMENT (“Agreement”), effective as _____ (“Effective Date”), by and between Waupun Memorial Hospital, Inc. d/b/a SSM Health Waupun Memorial Hospital (“Hospital”) and the City of Waupun, Wisconsin, (“City”).

WHEREAS, Hospital and City have entered into a Health Services Agreement (“Prior Agreement”), and now desire to amend and restate the Prior Agreement as set forth below and is acceptable to both parties;

WHEREAS, Hospital qualifies as a disproportionate share hospital as that term is used and defined in Section 1886(d)(5)(F) of the Social Security Act and provides health care services to residents of the City, including the uninsured and underinsured;

WHEREAS, Hospital desires to participate in the drug discount program established under Section 340B of the Public Health Service Act (the “340B Program”);

WHEREAS, in order to participate in the 340B Program, Hospital must enter into an agreement with a state or local unit of government pursuant to which Hospital agrees to provide health care services to low income individuals without Medicare or Medicaid benefits; and

WHEREAS, City recognizes it is in the public interest for the citizens of City to have access to health care services and benefit from Hospital’s participation in the 340B Program.

NOW, THEREFORE, WITNESSETH:

1. Duties. During the term of this Agreement, Hospital agrees to continue to provide health care services to low-income individuals, who are not entitled to benefits under Title XVIII of the Social Security Act or eligible for assistance under the State plan adopted under Title XIX of the Social Security Act according to Hospital’s Charity Care Policy. In addition, Hospital agrees to continue to ensure that all patients presenting to its Emergency Department receive a medical screening examination and stabilizing treatment as required by law, without regard to the patient’s ability to pay.

2. Compensation. Hospital may seek reimbursement as may be provided under the terms and provisions of the Social Security Act or from responsible third party payors. This Agreement shall not apply to any individual who is covered by a private health insurance plan of any type. All individuals eligible for services hereunder shall be low-income individuals, who are not otherwise entitled to benefits under Titles XVIII or XIX of the Social Security Act and any related provisions. Hospital may require information from patients seeking medical services to determine the patient’s eligibility for services pursuant to this Agreement.

3. Term. This Agreement shall remain in full force and effect for a period of one (1) year after the date hereof (the “Initial Term”).

4. Renewal. This Agreement shall be deemed to renew itself annually at the end of the Initial Term, provided Hospital has recertified its eligibility under the 340b Program, unless at least ninety (90) days prior to the end of the Initial Term or any extended term either party gives notice to the other of the non-renewal of this Agreement.

5. Termination. Either party may cancel this Agreement upon ninety (90) days’ written notice to the other party to this Agreement.

6. Notices. All notices or other communications required or permitted to be given under this Agreement shall be in writing and shall be mailed or personally delivered to the other party to this Agreement. If notices are mailed, such shall be mailed by certified mail, postage prepaid thereon, to the other party's business address. Notices shall be deemed given when mailed. If notice is given to the Hospital, it shall be sent to the following address: SSM Health, Attn: Contracts, 12800 Corporate Hill Drive, St. Louis, Missouri 63131.

7. Applicable Law. This Agreement shall be construed and enforced in accordance with the substantive laws of the State of Missouri, without regard to Missouri's conflict of laws provisions.

8. Assignment. Either party may, without the prior consent of the other party, assign its rights and obligations under this Agreement to another legal entity owned or controlled by or under common control with the party. In no event shall City assign this Agreement to an entity or organization that does not qualify as a local or governmental agency.

9. Third-Party Beneficiaries. This Agreement has been entered into by the parties for the limited purposes set forth herein and shall not inure to the benefit of any third parties, which are not parties to this Agreement; provided, however, that low-income patients as defined in this Agreement and by applicable law may receive services pursuant to this Agreement.

10. Affirmative Action Statement. Hospital is an equal opportunity employer. As part of its affirmative action policies and obligations, Hospital is subject to and will comply with the provisions governing federal contractors as set forth in 41 CFR 60-1.4(a), 41 CFR 60-741.5(a) and 41 CFR 60-250.5(a), and these regulations are hereby incorporated into this Agreement by reference.

11. Entire Agreement. This Agreement constitutes the entire agreement between Hospital and City and supersedes all prior proposals, negotiations, representations, communications, writings and agreements between Hospital and City with respect to the subject matter hereof, whether oral or written. This Agreement may only be amended or modified by a subsequent written agreement between duly authorized representatives of Hospital and City. This Agreement shall be binding on the parties, their successors, and permitted assigns.

City:

City of Waupun, Wisconsin

By: _____
Name: Rohn W Bisop
Title: Mayor
Address: 201 E Main St
Waupun, WI 53963

Date: _____

Hospital:

Waupun Memorial Hospital, Inc. d/b/a SSM Health
Waupun Memorial Hospital

By: _____
Name: DeAnn Thurmer
Title: President
Address: 620 W. Brown Street
Waupun, WI 53963

Date: _____



AGENDA SUMMARY SHEET

MEETING DATE: 10/29/24

TITLE: Order/purchase a 2025 Freightliner 114SD plus with equipment

AGENDA SECTION: CONSIDERATION-ACTION

PRESENTER: Jeff Daane, Public Works Director

DEPARTMENT GOAL(S) SUPPORTED <i>(if applicable)</i>	FISCAL IMPACT	
High Performance Government	Truck Country \$144,855 Monroe \$164,262	

ISSUE SUMMARY:

The 2026 vehicle equipment schedule calls for the replacement of a dump truck, replacing a 25-year old truck. Due to lead times and a forecasted price increase in 2025 (40%), we are recommending that we place an order for this truck now. The manufacturer has one available build spot in late 2025 for trucks delivering in 2026. The truck would be paid for in the year it is delivered (2026). The prices for Truck Country and Monroe include state and Sourcewell pricing, allowing for a sole bid per policy.

STAFF RECOMMENDATION:

Approve order of a Freightliner 114SD Plus with winter attachments.

ATTACHMENTS:

- Truck Country Pricing
- Monroe Pricing

RECOMMENDED MOTION:

Motion to approve purchase from the 2026 capital equipment budget for a 2025 Freightliner 114SD and equipment from Truck Country in the amount of \$144,855 and from Monroe in the amount of \$164,262.



1151 W Main Avenue
 DePere, WI 54115
 Sales Rep: Troy Redfearn
 Ph: (920) 360-4446
 www.MonroeTruck.com

J.O. #
 Quotation ID: 2MAW003957
 Date: 10/4/2024
 Valid thru: 11/3/2024
 Terms: NET 30
 Quoted by: Mark Woelfel
 Ph/Fax: 920-347-4181 / 920-336-8118

Quoted to:
 WAUPUN, CITY OF (ATTN:)
 201 EAST MAIN STREET
 WAUPUN, WI 53963
Ph: 920-324-7918 / **Fax:**
Email:

Chassis Information

Year: 2016	Make: FREIGHTLINER	Model: 114 SD	Chassis Color:	Cab Type: REGULAR
Single/Dual: DRW	CA:	CT: 120	Wheelbase: 218	Engine: DIESEL
			F.O. Number #:	Vin:

Notes:
 Monroe Truck Equipment, Inc. is pleased to offer the following quote for your review:

Description	Amount
CRYSTEEL DUMP BODY PACKAGE - 13' x ID 84" x OD 96" - 1/2 x 78 STAINLESS STEEL CABSHIELD - 52" STRAIGHT FRONT MADE OF 1/4" STAINLESS STEEL - 36" SINGLE PANEL W/ RUBRAIL SIDES MADE OF 1/4" STAINLESS STEEL, OUTER 7 GA - 46" STRAIGHT REAR MADE OF 1/4" STAINLESS STEEL - 8 WESTERN TUBULAR, 1/4" STAINLESS STEEL - 1/4 STAINLESS STEEL FLOOR - 18" REAR PILLAR W/ 1.5 THICK/7 OFFSET - 3.5" SINGLE PANEL W/PRESSED HORIZONTAL W/ AIR RELEASE - STAINLESS STEEL REAR PILLAR/PILLAR CAP/RUBRAIL - 2 OVALS CUTOUTS IN REAR POST - STAINLESS HARDWARE BELOW THE FLOOR - 2 STEP LADDER - 1 BOLTED STEP - VIBRATOR, ELECTRIC - DOT TAPE - FRONT OF DRIVES AND BEHIND DRIVES RUBBER MUDFLAPS - BARE STAINLESS STEEL FINISH, NOT PAINTED MARATHON M53117DA INVERTED TELESCOPIC HOIST - REAR HINGE - DUAL BODY PROPS PINTLE MOUNT; 1" PLATE WITH 3/4" D-RINGS PLUMB FACTORY SUPPLIED AIR/ELECTRIC INTO PLATE PH-20 PINTLE HOOK TRUCK PORTION - FLAT-FOLD LIFT ARM HITCH W/ INTEGRAL QCP RECEIVER (REQUIRES MINIMUM OF 18" FRONT FRAME EXTENSION) MONROE TORSION TRIP EDGE REVERSIBLE PLOW MP44R11-ISTT - 10 GAUGE ROLL FORM MOLDBOARD - (6) 1/2" X 4" TAPERED ONE-PIECE FLAME CUT RIBS - 2" X 3" X 3/8" TOP ANGLE - 4" X 4" X 1/2" UPPER BOTTOM ANGLE - (6) NON-ADJUSTABLE 3/4" TORSION SPRING ASSEMBLIES FOR A THREE-SECTION TRIP EDGE - .75 x 6 x 11' CARBIDE W/ COVER CUTTING EDGE - 4" X 4" X 3/8" CROSS-TUBE SUPPORT - 3-1/2" X 3-1/2" X 1/2" SEMI-CIRCLE - (2) 3" X 10" DOUBLE ACTING REVERSE CYLINDERS WITH CUSHION VALVE - BUILT-IN MONROE LEVEL LIFT ASSEMBLY	



Description	Amount
<ul style="list-style-type: none"> - MOLDBOARD AND PUSHFRAME TO BE 100% CONTINUOUSLY WELDED - MOLDBOARD POWDER COATED ORANGE - PUSH FRAME POWDER COATED BLACK - PARKING JACK - RUBBER SNOW DEFLECTOR 	
<ul style="list-style-type: none"> 9' MONROE, DOUBLE FUNCTION, STRAIGHT, TRIP-EDGE PATROL WING (RIGHT SIDE) - RH FRONT PARA-GLIDE - 35" HIGH INBOARD & OUTBOARD, 3/16" THICK MOLDBOARD - 4" X 4" X 3/4", A36 STEEL, BOTTOM ANGLE W/ 1" THICK WELDED TRIP HINGE BLOCKS - TOP OF BOTTOM ANGLE BOXED TO THE MOLDBOARD W/ 1/4" PLATE FOR ADDITIONAL STRENGTH - 1/2" THICK ONE-PIECE VERTICAL & INTERLACED DESIGNED HORIZONTAL RIBS - STANDARD 100% WELDED * CARBIDE CUTTING EDGE W/ COVER BLADE - TRIP SECTION ANGLE ASSEMBLY: 3/4" X 3" X 4", A36 STEEL W/ 3/4" THICK TRIP HINGE BLOCKS - ANGLES PIVOT ON 1-1/4" COLD ROLLED, 1040 STEEL HELD IN PLACE BY 1/4" X 2" EXPANSION PINS - (6) 3/4" SQUARE WIRE TORSION SPRINGS W/ 3-3/4" OUTSIDE DIAMETER & 11" COILS - SHOT BLASTED & POWDER COATED ORANGE - POWDER COATED BLACK HARDWARE * HYDRAULIC PUSHARM W/ REAR HEEL LIFT - WING SIDE AIR BAG 	
<ul style="list-style-type: none"> MONROE UNDER-TAILGATE, DIRECT DRIVE SPREADER (MS966-OW/DD-DD) W/ SPEED SENSOR - 201 STAINLESS STEEL - 6" DIA. AUGER W/ ONE-WAY FLIGHTING FOR LEFT OR RIGHT DISCHARGE - 7 GA., 96" TROUGH W/ 1/4" END PLATES - ONE-PIECE, REMOVABLE & HINGED, COMBINATION COVER & REAR PANEL - HEAVY-DUTY, STEEL ROD, CAPTIVE LATCHES - QUICK DETACH MOUNTING BRACKETS - EXTENDED END PLATES - STAINLESS STEEL SPINNER ASSY W/ POLY DISC 	
<ul style="list-style-type: none"> PRE-WET: - TWO 120 GAL BEHIND CAB PRE-WET TANKS W/ S/S FRAME - CLOSED LOOP HYDRAULIC BASE KIT W/ PLUMBING KIT - 7 GPM HYDRAULIC PUMP W/ 14" X 7" X 6.5" ENCLOSURE AND PLUMBING KIT W/O HYDRAULIC VALVE - S/S TUBE IN AUGER TROUGH - BULK FILL, CROSS OVER AND FLUSH - QUICK LIQUID SPREADER DISCONNECT 	
<ul style="list-style-type: none"> ELECTRIC HYDRAULICS PACKAGE - CONSTANT MESH PTO - TXV92 PUMP - STAINLESS STEEL VALVE/TANK COMBO - FORCE ADD-A-FOLD VALVING: <ul style="list-style-type: none"> - D/A HOIST, D/A PLOW LIFT, D/A PLOW ANGLE, D/A WING TOE, D/A WING HEEL, D/A WING HYD PUSHARM, AUGER/SPINNER/PRE-EWT - HYDRAULIC ENCLOSURE WILL BE MOUNTED ON FRAME RAIL - FORCE SSC6100 GROUND BASED SPREADER CONTROL W/ IGRIP JOYSTICK * (2) CAMERAS, ONE WITH PUFFER * S/S COUPLERS, PLOW ANGLE, WING HEEL, WING PUSHARM, AUGER, SPINNER * STAINLESS STEEL LINES, PLOW, WING, AUGER, SPINNER * RUBBER:, WHIP HOSES, PRE-WET, HYD PUSHARM * FIBERGLASS ELECTRICAL BOX 	
<ul style="list-style-type: none"> LIGHTING: - JW SPEAKER LED PLOW LIGHTS MOUNTED ON S/S HOOD BRACKETS - LED AMB/ERGREEN LIGHTBAR MOUNT ON EACH MIRROR - LED OVAL AMBER/GREEN STROBE MOUNTED IN REAR POST - LED RED STEADY BURN LIGHT ON WING HEEL - LED CLEAR WING LIGHT - LED CLEAR SPINNER LIGHT - (2) LED CLEAR WORK LIGHTS WIRE INTO BACK UP CIRCUIT MOUNTED ON TG SPREADER 	<p style="text-align: right;">Quote Total: \$164,262.00</p>

Sourcewell Contract number 062222-AEB-1



**** DUE TO CURRENT MARKET CONDITIONS, IF THE CHASSIS WILL NOT BE ON-GROUND AT MONROE TRUCK EQUIPMENT WITHIN 240 CALENDAR DAYS OF ORDER DATE, WE WILL REQUIRE A MINIMUM 50% DOWN PAYMENT BEFORE THE 210TH DAY. IF YOU ARE NOT ABLE TO PROVIDE A DOWN PAYMENT, YOUR MUNICIPALITY COULD BE SUBJECT TO A MINIMUM OF 3% - 5% PRICE INCREASE ON BID PRICE AT TIME OF INVOICE!**

Down Payment Due Date: _____

Terms & Conditions

- Terms are Due Upon Receipt unless prior credit arrangements are made at the time of order.
- Please note if chassis is furnished, it is as a convenience and terms are Net Due on Receipt of Chassis.
- State and Federal taxes will be added where applicable. **Out-of-state municipal entities may be subject to Wisconsin sales tax.**
- Restocking fees may be applicable for cancelled orders.
- MTE is not responsible or liable for equipment that does not meet local/state regulations if those laws are not made known at time of order.

By signing and accepting this quote, the customer agrees to the terms listed above and has confirmed that all chassis information listed above is accurate to chassis specs.

Re-Assign (Required for all pool units): <input type="checkbox"/> Fleet <input type="checkbox"/> Retail	MSO/MCO (ONLY check if legally required): <input type="checkbox"/> MCO <input type="checkbox"/> MSO	
Customer Signature:	Customer P.O. Number:	Date of Acceptance:

General Terms and Conditions for the Sale of Goods by Subsidiaries of ASH North America, Inc.

1. SCOPE AND VALIDITY

1.1. These General Terms and Conditions for the Sale of Goods (these "Terms") govern the sale and delivery of all goods and products (the "Products"), and all transactions incidental thereto, by such subsidiary of ASH North America, Inc. identified on the respective Con-firmed Order (as defined below) as the seller or supplier ("Seller") to any of its customers (each a "Customer"). The liability of each such subsidiary under these Terms or any Confirmed Order shall be several and not joint. Customer acknowledges and agrees that nothing in these Terms or any Confirmed Order shall be construed as implying joint liability in any case of ASH North America, Inc. or any of its subsidiaries. Each Seller shall be solely responsible for its own acts or omissions under the respective agreement with Customer.

1.2. No other terms or conditions shall be of any force or effect unless otherwise specifically agreed upon by Seller in a writing duly executed by an authorized officer of Seller. These Terms supersede any and all prior oral quotations, communications, agreements, or understandings of the parties in respect to the sale and delivery of the Products. The Seller may issue additional Terms and Conditions of Sale for certain products. These shall apply in addition to the present Terms. Any additional or different terms or conditions contained in Customer's Order (as defined below), response to Seller's confirmation, or any other form or document supplied by Customer are hereby expressly rejected and are rendered null, void, and of no effect. These Terms may not be modified, amended, waived, superseded, or rescinded, except by written agreement signed by an authorized officer of Seller. Delivery of the Products by Seller does not constitute acceptance of any of Customer's terms and conditions and do not serve to modify or amend these Terms.

1.3. The issuance of an Order (as defined below) by Customer to Seller or any communication or conduct of Customer which confirms an agreement for the delivery of Products by Seller, as well as acceptance in whole or in part by Customer of any delivery of Products by Seller, shall be construed as Customer's acceptance of these Terms.

2. OFFERS, ORDERS AND CONFIRMATION

2.1. Unless otherwise specified by Seller in writing, all offers made by Seller are not binding and may be revoked by Seller at any time without any liability to Customer.

2.2. Customer shall issue to Seller orders for the purchase of Products, in written form via the order process determined by Seller from time to time (each, an "Order"). By issuing an Order to Seller, Customer makes an offer to purchase the Products pursuant to these Terms and the terms set forth on such Order. Provided that the Order contains the same terms as in Seller's corresponding offer, the Order shall be binding on Customer for six (6) weeks after Seller's receipt of such Order.

2.3. Seller may refuse an Order for any or no reason. No Order is binding upon Seller until Seller's acceptance of the Order in writing, the issuance of any governmental permit, license, or authority to Seller, as may be required under applicable laws, rules and regulations, and the receipt by Seller of a resale license to be provided by Customer (a "Confirmed Order").

2.4. Specifications and other information on drawings, data sheets, pictures, plans, brochures, catalogs, or Seller's website shall not be binding on Seller unless such specifications and information have been agreed to in writing by Seller in a Confirmed Order. Notwithstanding a Confirmed Order, Seller shall have no obligation to deliver Products to Customer or otherwise fulfill any of its obligations set forth in a Con-firmed Order if Customer is in breach of any of its obligations hereunder or any Confirmed Order.

2.5. Customer may submit to Seller written requests to change the terms of a Confirmed Order (each such request, a "Change Order Re-quest"). Seller may, at its sole discretion, consider such Change Order Request, provided that Seller will have no obligation to perform any Change Order Request unless and until Seller has agreed in writing to adopt such



Change Order Request. If Seller elects to consider such a Change Order Request, then Seller shall promptly notify Customer of any adjustment to the applicable purchase price for the Products.

2.6. In the event Customer cancels any Confirmed Order for any reason, Customer shall reimburse to Seller all of Seller's costs and expenses associated with or incurred due to such cancellation, including but not limited to the cost of raw materials, labor, and storage if cancellation occurs before Seller's commencement of production. In the event Customer cancels any Confirmed Order for any reason and Seller has started the production of the Product on the respective Confirmed Order, Customer shall pay to Seller the full purchase price.

2.7. Each Confirmed Order shall be considered a separate agreement between the parties, and any failure to deliver the Products under any Confirmed Order shall have no consequences for other deliveries of Products.

3. PRICES

3.1. Unless otherwise agreed to by the parties in the applicable Confirmed Order, the prices of the Products shall be FCA (agreed delivery location on the applicable Confirmed Order), Incoterms 2022.

3.2. Unless otherwise agreed by the parties in a Confirmed Order, the price of the Products shall not include transportation, insurance, packaging, and Tooling (as defined below) and other materials used for the manufacturing and delivery, sales or Heavy Vehicle Use Tax (HVUT), other use tax or any other similar applicable federal, state or foreign taxes, duties, levies, or charges in any jurisdiction in connection with the sale or delivery of the Products ("Taxes"). Such Taxes shall be payable by Customer, and if Seller is responsible for the collection thereof, such Taxes shall either be added to the price invoiced or be separately invoiced by Seller to Customer. Any special requests concerning shipping, transportation, and insurance shall be communicated to Seller in a timely manner and subject to Seller's prior written approval. Customer shall bear all costs resulting from such requests.

In case of lead delivery times of more than two (2) months, Customer hereby acknowledges and agrees that Seller, may, at its sole discretion, increase or decrease the agreed prices on any Confirmed Order in the event of material price changes in wages, materials, energy or raw material after the date of the Confirmed Order.

4. PAYMENT TERMS

4.1. Except as set forth in Section 4.2 or unless otherwise agreed in writing by Seller, the purchase price for the Products and all other amounts due under a Confirmed Order shall be due and payable in US dollars within thirty (30) days following the date of Seller's invoice for such Products without any discount, deduction or offset whatsoever. In no event shall any loss, damage, injury or destruction, Force Majeure (as defined below), or any other event beyond Customer's control re-lease Customer from its obligation to make the payments required herein. Payment of all amounts due hereunder shall be made by bank transfer or in any other manner set forth on Seller's invoice. Customer shall be solely responsible for any bank fees, or other fees, incurred due to the wire transfer or any other selected payment method. If Seller agrees to payment by credit card, Seller shall charge an appropriate transaction fee, which the Customer shall also pay.

4.2. In the event Seller becomes aware of circumstances or has reason to believe that there are circumstances that may have an adverse effect on Customer's financial condition, Seller may require the Customer to pay the total amount of the purchase price or fees, or a portion thereof prior to the delivery of the Products. Seller may, without any liability to Customer, refuse the delivery of any Product in the event the Customer fails to make the payment as required under this Section 4.2.

4.3. Time is of the essence for the payment of all amounts due to Seller under any Confirmed Order. If Customer fails to make payments of any amount when due, Customer shall pay interest to Seller at the rate of one percent (1%) per month or such lesser amount as may be permitted by applicable law starting from the due date until payment to Seller of such amount in full. In addition to the interest, Seller may, at its sole discretion, charge the Customer a flat fee of \$40 for each re-reminder notice issued to Customer due to late payments. If Customer fails to comply with these Terms or a Confirmed Order, or if Customer becomes insolvent, all balances then due and owing to Seller shall become due immediately, notwithstanding any payment terms agreed by the parties. All costs and expenses incurred by Seller with respect to the collection of overdue payments (including, without limitation, reasonable attorney's fees, expert fees, and other expenses of litigation) shall be borne by Customer. Every payment by Customer shall first be applied to pay for Seller's cost of collection, then interest owed by Customer, and then to the oldest outstanding claim.

4.4. Notwithstanding anything in the foregoing Section 4.3 or Section 5, if the parties agreed on installment payments in a Confirmed Order and Customer fails to make any installment payment when due, the remaining balance including accrued interest, and any expenses incurred by Seller shall be due and payable to Seller promptly upon Customer's receipt of written notice of delinquency from Seller.

5. SECURITY INTEREST

5.1. If Seller extends credit to Customer for the purchase price for any Products (including but not limited to pursuant to Section 4.1.), or any other amounts due to Seller, Customer hereby grants to Seller as security for the timely payment and performance of all Customer's payment obligations to Seller, a first priority security interest (the "Security Interest") in all Products heretofore or in the future delivered to Customer and in the proceeds thereof for as long as such Products shall not have been sold by Customer in the ordinary course of business (the "Collateral"). Seller shall be entitled to file any and all financing, continuation, or similar statements under the Uniform Commercial Code in any jurisdiction and take any and all other action necessary or desirable, in Seller's sole and absolute discretion, to perfect its Security Interest in the Collateral and to establish, continue, preserve, and protect Seller's Security Interest in the Collateral. Customer agrees to take any and all actions and provide Customer with all information necessary to enable Seller to perfect and enforce its Security Interest in all jurisdictions and vis-à-vis any of Customer's creditors, and hereby irrevocably grants to Seller a power of attorney to execute all necessary statements or documents in Customer's name for the perfection and enforcement of such Security Interest. The Security Interest shall remain in force until payment in full of the entire purchase price for such Products, and any other amounts due to Seller by Customer. Seller may, without notice, change or withdraw extensions of credit at any time.

6. OBLIGATIONS OF CUSTOMER

6.1. Customer shall use the Products solely for their intended purpose and pursuant to Seller's instructions, and agrees to use only qualified personnel for the handling of the Products. Customer shall ensure that its customers, employees, agents, and other representatives comply with this Section 6.1. and shall be responsible for their acts and omissions.

7. DELIVERY AND ACCEPTANCE

7.1. Unless otherwise agreed in writing by Seller, all deliveries of Products shall be made FCA (agreed delivery location) (Incoterms 2020) and title to and risk of loss for the Products shall pass to Customer upon delivery pursuant to this Section 7.1.

7.2. Any delivery and performance times or dates communicated by or on behalf of Seller are estimates and shall not be binding on Seller. Seller may make partial delivery of Products to be delivered under any Confirmed Order and invoice Customer separately for such partial deliveries or performance. If Customer has not received the Products after six (6) weeks from the estimated delivery date, Customer may make a written request to Seller for delivery. Customer hereby acknowledges and agrees that the actual delivery date of the Products is conditioned upon the complete, accurate and timely delivery of materials from Seller's vendors and suppliers. No delay in delivery of any Products shall relieve Customer of its obligation to accept the delivery or performance thereof and make payments of any amounts due in accordance with these Terms, including but not limited to delays caused governmental restrictions on exports or imports and similar measures.

7.3. Customer's failure to accept the delivery of Products pursuant to a Confirmed Order shall not release or excuse Customer from its obligation to timely pay all amounts due in connection with such Confirmed Order. The Products shall be deemed delivered at the time they have been made available to Customer. If Customer rejects or revokes acceptance of

Products, or fails to pay any amounts when due, Seller, in its sole and absolute discretion, may extend the period of delivery of Products by such period as Seller may deem reasonable with such period not exceeding three (3) months from the agreed delivery date, or withhold or cancel delivery of any Products, or cancel any or all Con-firmed Orders without any further obligations to Customer whatsoever.

In such event, Customer shall be responsible for any and all costs and expenses incurred, or damages or losses suffered by Seller in connection with any such delay notwithstanding any action or inaction by Seller with regard to such delay. Any remaining Products that have not been accepted by Customer within the extended delivery period determined by Seller will be delivered and invoiced by Seller to Customer and Customer agrees to accept such delivery and pay for the purchase price and other amounts payable for the delivered Products.

8. EXAMINATION AND CONFORMITY TO ORDER

8.1. Promptly upon receipt of any Products, Customer shall conduct a full and complete inspection of such Products as to any defects and to confirm compliance with all requirements of the applicable Confirmed Order. Customer shall notify Seller in writing of any packaging defects, apparent defects, or non-compliance of such Products with the applicable Confirmed Order that Customer has or could reasonably have discovered during such inspection within seven (7) days from the date of receipt of such Products, and Customer shall notify Seller in writing within three (3) days of the date on which Customer shall first have become aware of any hidden defect or non-compliance which could not reasonably have been discovered during Customer's initial inspection of the Products. Such notification shall include reasonable details (including images) on the alleged defects including lot, batch, or Order numbers.

8.2. If Customer fails to timely notify Seller of any defects or other non-compliance of any Products delivered or Customer (or its customers, employees, agents, or representatives) uses, destroys, or modifies any Products that Customer knows or should have known to be defective or non-compliant without Seller's prior written consent, Customer shall be deemed to have unconditionally accepted such Products and waived all of its claims for breach of warranty or otherwise in respect of such Products.

8.3. Customer may only return the Products to Seller with Seller's prior written approval. If the return has been approved by Seller, Customer shall return the Products to Seller at Customer's sole risk and expense to the destination directed by Seller.

8.4. Complaints of Customer in connection with the shipping or transport shall be directed to the carrier promptly upon receipt of the delivery or the freight documents.

9. LIMITED PRODUCT WARRANTY

9.1. Seller warrants to Customer that the Products will be free of defects in material and workmanship and conform with the requirements set forth in the applicable Confirmed Order for a period of twelve (12) months from the date of delivery for new business Products and ninety (90) days for after sales Products. (the "Limited Product Warranty").

9.2. Unless expressly agreed to in writing by Seller, Seller makes no warranty that the Products comply with applicable law, regulations, or specifications in any jurisdiction in which the Products may be used, integrated or incorporated. Any governmental or other approvals necessary in connection with the use, integration or incorporation of the Products shall be Customer's sole responsibility.

9.3. The Limited Product Warranty shall be void if the Defect (as defined below) resulted from (a) improper or inadequate use, storage, handling, operation, integration, incorporation, assembly, maintenance, or unauthorized alteration, modification, repair of the Products (including without limitation, the use storage, handling, operation, or integration of the Products contrary to written instructions and/or recommendations of Seller or inadequate training of personnel), (b) changes to construction and materials pursuant to Customer's re-quests, (c) use of improper tools, resources, or accessories including those but not limited to any third party tools, resources, or accessories that are not approved by Seller or not in accordance with Seller's recommendations, instructions, or directions, (d) acts or omissions of Customer or third parties following delivery of the Product, (e) Customer's failure to properly communicate Seller's instructions and warnings to users of the Products, (f) Customer's, its employees, agents, representatives, customers or any third party's non-compliance with applicable laws, rules and regulation, (g) Force Majeure, or (h) ordinary wear and tear of the Products (e.g., sweep bristles).

9.4. In the event of an alleged breach of the Limited Product Warranty (a "Defect"), Customer shall, at Customer's sole expense, send the Product to Seller. Seller shall conduct the necessary tests on such Product within a reasonable period. If Seller confirms the Defect, Seller shall, at its sole option and discretion, repair or replace the Defective Product. If the repair or replacement of the Defective Product is commercially unreasonable to Seller, Seller may, at its sole discretion, issue a refund to Customer in the amount Seller deems adequate. Such repair, replacement, or refund shall be the sole liability of Seller and the sole remedy of Customer with respect to a Defect. In no event shall any warranty claims for a Defect be made after twelve (12) months from the date of Customer's receipt of the Products. Any Products or parts returned to Seller for removal or repair under this Section 9.4 shall be the property of Seller. Any applicable Limited Product Warranty period shall not start anew with the repair or replacement of the Defective Product (or any portion thereof).

9.5. Except for Limited Product Warranty, SELLER HEREBY EXPRESSLY EXCLUDES AND DISCLAIMS ANY AND ALL OTHER WARRANTIES, WHETHER EXPRESS OR IMPLIED, INCLUDING BUT NOT LIMITED TO THE IMPLIED WARRANTIES OF MERCHANTABILITY, FITNESS FOR A PARTICULAR PURPOSE OR NONINFRINGEMENT. Seller makes no other warranties with respect to the Products, and no person is authorized to make any warranties on behalf of Seller that are inconsistent with the warranties set forth under this Section 9.

10. LIMITATION OF LIABILITY

10.1. IN NO EVENT SHALL SELLER BE LIABLE TO CUSTOMER, ITS CUSTOMERS, EMPLOYEES, AGENTS, AND OTHER REPRESENTATIVES FOR ANY INDIRECT, INCIDENTAL, PUNITIVE, SPECIAL OR CONSEQUENTIAL DAMAGES, INCLUDING BUT NOT LIMITED TO, DAMAGES FOR LOSS OF PROFITS, REVENUE, GOODWILL, OR USE, WHETHER IN AN ACTION IN CONTRACT, TORT, STRICT LIABILITY, OR IMPOSED BY STATUTE, OR OTHERWISE, EVEN IF SELLER WAS ADVISED OF THE POSSIBILITY OF SUCH DAMAGES. NOTWITHSTANDING ANY OF THE TERMS CONTAINED HEREIN, SELLER'S LIABILITY FOR ANY CLAIM – WHETHER BASED UPON CONTRACT, TORT, EQUITY, NEGLIGENCE, OR ANY OTHER LEGAL CONCEPT – SHALL IN NO EVENT EXCEED THE PURCHASE PRICE PAID BY THE CUSTOMER FOR THE PRODUCTS, GIVING RISE TO SUCH CLAIM. CUSTOMER HEREBY ACKNOWLEDGES AND AGREES THAT THE PROVISIONS OF THESE TERMS FAIRLY ALLOCATE THE RISKS BETWEEN SELLER AND CUSTOMER, THAT SELLER'S PRICING REFLECTS THIS ALLOCATION OF RISK, AND BUT FOR THIS ALLOCATION AND LIMITATION OF LIABILITY, SELLER WOULD NOT HAVE ENTERED INTO AN AGREEMENT WITH CUSTOMER FOR THE SALE OF THE PRODUCTS.

10.2. Seller shall not be liable for, and Customer assumes responsibility and shall indemnify, defend, and hold Seller harmless for any and all claims, including without limitation claims for personal injury or property damages, resulting from (a) the improper or inadequate use, storage, handling, operation, assembly, integration, incorporation, assembly, maintenance, or unauthorized alteration, modification, or repair of the Products (including without limitation, the use storage, handling, operation, or integration of the Products contrary to written instructions and/or recommendations of Seller or inadequate training of personnel), (b) changes to construction and materials pursuant to Customer's re-quests, (c) use of improper tools, resources, or accessories including those but not limited to any third party tools, resources, or accessories that are not approved by Seller or not in accordance with Seller's recommendations, instructions, or directions, (d) acts or omissions of Customer or third parties following the delivery of the Products, (e) Customer's failure to properly communicate Seller's instructions and warnings to users of the Products, or (f) Customer's, its employees, agents, representatives, customers or any third party's non-compliance with applicable laws, rules and regulation, (g) Force Majeure, or (h) ordinary wear and tear of the Products (e.g., sweep bristles).

10.3. In jurisdictions that limit or preclude limitations or exclusion of remedies, damages, or liability, such as liability for gross negligence or willful misconduct or do not allow implied warranties to be excluded, the limitation or exclusion of warranties, remedies, damages, or liability set forth in these Terms are intended to apply to the maximum extent permitted by applicable law, and these Terms shall be deemed amended to comply with such limitations or exclusions. Customer may also have other rights that vary by state, country or other jurisdiction.

11. CONFIDENTIALITY

11.1. "Confidential Information" means: (i) any know-how, trade secrets, and other business or technical information of Seller that is confidential or proprietary or due to its nature or under the circumstances of its disclosure the Customer knows or has reason to know should be treated as confidential or proprietary, including but not limited to quotations, drawings, project documentation, samples and models.

11.2. Confidential Information does not include information that: (i) is or becomes generally known to the public through no fault or breach of these Terms by the Customer; (ii) is rightfully known by the Customer at the time of disclosure without an obligation of confidentiality; (iii) is independently developed by the Customer without use of Seller's Confidential Information; (iv) is rightfully received by the Customer from a third party without restriction on use or disclosure; or (v) is disclosed with Seller's prior written approval.

11.3. Customer shall not use Seller's Confidential Information except as necessary to use the Products and will not disclose such Confidential Information to any third party except to those of its employees, agents, subcontractors, or representatives who have a bona fide need to know such Confidential Information to enable Customer to use the Products; provided that each such employee, agent, subcontractor, and/or representative is/are bound by a written agreement that contains use and nondisclosure restrictions not less stringent than the terms set forth in this Section 11.3. The Customer will employ all reasonable steps to protect Seller's Confidential Information from unauthorized use or disclosure, including, but not limited to, all steps that it takes to protect its own information of like importance. The foregoing obligations will not restrict the Customer from disclosing Seller's Confidential Information: (i) pursuant to the order or requirement of a court, administrative agency, or other governmental body, provided that the Customer gives reasonable notice to Seller to contest such order or requirement; (ii) to its legal or financial advisors; and (iii) as required under applicable securities regulations.

11.4. In the event of a violation or threatened violation of Customer's obligations under this Section 11, Seller shall be entitled to seek equitable relief, including in the form of a restraining order, orders for pre-liminary or permanent injunction, specific performance and any other relief that may be available from any court, without the requirement to secure or post any bond, or show actual monetary damages in connection with such relief. These remedies shall not be deemed to be exclusive but in addition to all other remedies available under these Terms, at law, or in equity.

12. INTELLECTUAL PROPERTY

12.1 Seller reserves the sole and exclusive ownership of the intellectual property rights in the Products (including but not limited to the technology used to manufacture the Products) and any improvements thereof regardless of inventorship or authorship. Customer shall not (and shall cause its employees, agents, representatives and customers to not) reverse engineer, decompile, disassemble, or decode any of Seller's intellectual property embedded or used in any of the Product.

13. FORCE MAJEURE

13.1. Seller shall not be responsible for any failure or delay in its performance under these Terms due to causes beyond its reasonable control, including, but not limited to, disruptions of the public power supply, communications, and transportation infrastructure, government measures, malware or hacker attacks, fire, extraordinary weather events, epidemics, pandemics (or any government restrictions implemented as a result thereof), nuclear and chemical accidents, earthquakes, war, terrorist attacks, labor disputes, strikes, lockouts, shortages of or inability to obtain labor, energy, raw materials or supplies, or other acts of God.

14. MISCELLANEOUS

14.1. If any provision contained in these Terms or any Confirmed Order is held by final judgment of a court of competent jurisdiction to be invalid, illegal, or unenforceable, such invalid, illegal, or unenforceable provision shall be severed from the remainder of these Terms or such Confirmed Order, and the remainder of these Terms or such Confirmed Order shall be enforced. In addition, the invalid, illegal, or unenforceable provision shall be deemed to be automatically modified, and, as so modified, to be included in these Terms, such modification being made to the minimum extent necessary to render such provision valid, legal, and enforceable.

14.2. Seller may assign its rights and/or delegate its liabilities under any Confirmed Order at any time. Customer may not assign its rights or delegate its responsibilities under a Confirmed Order without Seller's prior written consent.

14.3. Seller's waiver of any breach or violation of these Terms or the provisions of any Confirmed Order by Customer shall not be construed as a waiver of any other present or future breach or breaches by Customer.

14.4. The parties hereto are independent contractors and nothing in these Terms will be construed as creating a joint venture, partnership, employment, or agency relationship between the parties.

14.5. Notices by a party regarding the exercise of rights and obligations under these Terms must be signed by authorized representatives of such party, and delivered via courier, mail, or e-mail to the other party's address indicated in the applicable Confirmed Order, provided that a notice by e-mail shall only be validly given if receipt thereof is acknowledged in writing by the recipient.

15. ENTIRE AGREEMENT; CONFLICTS.

15.1. These Terms, including the applicable Confirmed Order, constitute the entire and exclusive agreement of the parties regarding the subject matter hereof and supersede any and all prior or contemporaneous agreements, communications, and understandings (both written and oral) regarding such subject matter. In the event of a conflict between the provisions of these Terms and the provisions of a Confirmed Order, the provisions of the Confirmed Order will govern and control. Seller may amend or modify these Terms from time to time. Seller may, at its sole discretion, provide Customer with written notice of any such changes, revisions, amendments, or modifications, provided, however that any such changes, revisions, amendments, or modifications shall become effective without any further action by any party and that they shall not apply to any Confirmed Order prior to the effective date of such changes, revisions, amendments, or modifications.

16. APPLICABLE LAW AND JURISDICTION

16.1. These Terms and the Confirmed Orders shall be governed by and construed in accordance with the laws of the State of Wisconsin without giving effect to any choice or conflict of law provision or rule that would defer to or cause the application of the substantive laws of any jurisdiction other than Wisconsin. The parties hereby expressly exclude the application of the 1980 United Nations Convention on Contracts for the International Sale of Goods.

16.2. Any dispute, controversy, or claim arising out of or relating to these Terms and any Confirmed Order, including but not limited to the execution, performance, or termination thereof or to any issue of liability arising out of the performance of these Terms or any Confirmed Order, which the parties have not been able to settle amicably shall be submitted to the

exclusive jurisdiction of the state or federal courts with jurisdiction in the County of Calumet, Wisconsin, provided that notwithstanding the foregoing, Seller shall be entitled to seek specific performance and injunctive relief in any court of competent jurisdiction. Each party hereby waives any and all claims, pleas, or defenses (including without limitation a plea for *forum non conveniens*) that would permit such party to seek the jurisdiction of any courts or arbitration tribunals other than those set forth in the preceding sentence.

16.3. EACH PARTY HEREBY WAIVES, TO THE FULLEST EXTENT PERMITTED BY APPLICABLE LAW, ANY RIGHT IT MAY HAVE TO A TRIAL BY JURY IN ANY LEGAL PROCEEDING DIRECTLY OR IN-DIRECTLY ARISING OUT OF OR RELATING TO THESE TERMS.

WISCONSIN DEPARTMENT OF ADMINISTRATION
 DIVISION OF ENTERPRISE OPERATIONS
 DOA-3051 (R 04/2019)
 S. 51.01(5) WIS. STATS.; AND
 S. 111.32(13M) WIS. STATS



STATE BUREAU OF PROCUREMENT
 101 EAST WILSON STREET, 6TH FLOOR
 POST OFFICE BOX 7867
 MADISON, WI 53707-7867
 FAX (608) 267-0600
 TTY (608) 267-9629
 HTTP://VENDORNET.STATE.WI.US

Contract Amendment

Contract No.: 505ENT-M23-MDHDCHASSIS-04		Amendment No.: 01	
Contract Title: State of Wisconsin MY2022 or Newer Medium and Heavy Duty Chassis' - Classes 6 and Larger			
This Amendment is entered into by and between the State of Wisconsin, <u>Department of Administration</u> , and the Contractor, whose name, address and principal officer appears below.			
Contractor Name		Truck Country of Wisconsin	
Contractor Address		5000 Cake Pkwy	
City: DeForest	State: WI	Zip: 53532	
Principal Officer: Frank Anderson, Sales Representative			
The parties wish to change the terms of the above-referenced Contract in the following manner: This amendment is to renew contract 505ENT-M23-MDHDCHASSIS-04 with Truck Country of Wisconsin. The renewal is the first of two optional one-year renewal periods. The contract dates will be from 06-15-2024 to 06-14-2025.			
Except as expressly changed by this Amendment, the terms, conditions, rights and obligations of Contract No.: <u>505ENT-M23-MDHDCHASSIS-04</u> shall remain in effect unchanged. In the event of any inconsistency or conflict in the Contract and this Amendment, the provision of this Amendment shall control.			

To Be Completed by Contractor

For State of Wisconsin
 Department of Administration
 Cheryl Edgington
 Director, State Bureau of Procurement

DocuSigned by:

 E70A1AADB106453...
 Signature

6/11/2024 | 1:58 PM CDT
 Date

For Truck Country of Wisconsin
 Company Name
 5000 Cake Pkwy.

Address
 DeForest WI 53532
 City State Zip

By Frank Anderson

Printed Name

DocuSigned by:

 3198C1745B8F461...
 Signature

Sales Representative

Title
 6/6/2024 | 9:50 AM CDT

Date

Prepared for:
Jeff Daane
WAUPUN CITY OF
201 E MAIN ST
WAUPUN, WI 53963
Phone: 920-210-8200

Prepared by:
Jay Szymanski
TRUCK CTY OF WISCONSIN,
INC.
2401 PROGRESS WAY
KAUKAUNA, WI 541309559
Phone: 920-766-5222

A proposal for
WAUPUN CITY OF

Prepared by
TRUCK CTY OF WISCONSIN, INC.
Jay Szymanski

Oct 07, 2024

Freightliner 114SD Plus



Components shown may not reflect all spec'd options and are not to scale



Prepared for:
 Jeff Daane
 WAUPUN CITY OF
 201 E MAIN ST
 WAUPUN, WI 53963
 Phone: 920-210-8200

Prepared by:
 Jay Szymanski
 TRUCK CTY OF WISCONSIN,
 INC.
 2401 PROGRESS WAY
 KAUKAUNA, WI 541309559
 Phone: 920-766-5222

S P E C I F I C A T I O N P R O P O S A L

Data Code	Description
Price Level	
PRL-29D	SD PRL-29D (EFF:MY26 ORDERS)
Data Version	
DRL-012	SPECPRO21 DATA RELEASE VER 012
Vehicle Configuration	
001-177	114SD PLUS CONVENTIONAL CHASSIS
004-226	2026 MODEL YEAR SPECIFIED
002-004	SET BACK AXLE - TRUCK
019-006	TRAILER TOWING PROVISION AT END OF FRAME WITH SAE J560
003-001	LH PRIMARY STEERING LOCATION
General Service	
AA1-003	TRUCK/TRAILER CONFIGURATION
AA6-002	DOMICILED, USA (EXCLUDING CALIFORNIA AND CARB OPT-IN STATES)
99D-027	EPA EMISSIONS CERTIFICATION FOR REGISTRATION IN EPA OR ACT STATES - EPA CLEAN IDLE (INCLUDES 6X4 INCH LABEL ON LOWER FORWARD OF DRIVER DOOR)
A85-010	UTILITY/REPAIR/MAINTENANCE SERVICE
A84-1GM	GOVERNMENT BUSINESS SEGMENT
AA4-010	DIRT/SAND/ROCK COMMODITY
AA5-002	TERRAIN/DUTY: 100% (ALL) OF THE TIME, IN TRANSIT, IS SPENT ON PAVED ROADS
AB1-008	MAXIMUM 8% EXPECTED GRADE
AB5-001	SMOOTH CONCRETE OR ASPHALT PAVEMENT - MOST SEVERE IN-TRANSIT (BETWEEN SITES) ROAD SURFACE
995-1A0	FREIGHTLINER SD VOCATIONAL WARRANTY
A66-99D	EXPECTED FRONT AXLE(S) LOAD : 20000.0 lbs
A68-99D	EXPECTED REAR DRIVE AXLE(S) LOAD : 46000.0 lbs



Prepared for:
 Jeff Daane
 WAUPUN CITY OF
 201 E MAIN ST
 WAUPUN, WI 53963
 Phone: 920-210-8200

Prepared by:
 Jay Szymanski
 TRUCK CTY OF WISCONSIN,
 INC.
 2401 PROGRESS WAY
 KAUKAUNA, WI 541309559
 Phone: 920-766-5222

Data Code	Description
A67-99D	EXPECTED PUSHER AXLE(S) LOAD : 0.0 lbs
A63-99D	EXPECTED GROSS VEHICLE WEIGHT CAPACITY : 66000.0 lbs
A70-99D	EXPECTED GROSS COMBINATION WEIGHT : 80000.0 lbs

Truck Service

AA3-018	FRONT PLOW/END DUMP BODY
A89-99D	BRAKING-EXPECTED CAB TO BODY CLEARANCE : 15.0 in
AF3-142	MONROE TRUCK EQUIPMENT

Tractor Service

AA2-005	FLATBED TRAILER
AH6-001	SINGLE (1) TRAILER

Engine

101-3BU	CUM L9 370 HP @ 2100 RPM; 2100 GOV RPM, 1250 LB-FT @ 1200 RPM
---------	---

Electronic Parameters

79A-070	70 MPH ROAD SPEED LIMIT
79B-000	CRUISE CONTROL SPEED LIMIT SAME AS ROAD SPEED LIMIT
79G-106	10 MINUTE IDLE SHUTDOWN - TIMER RESET WITH CLUTCH AND SERVICE BRAKE
79K-011	PTO MODE ENGINE RPM LIMIT - 1400 RPM
79P-032	PTO RPM CONTROL WITH STEERING WHEEL SWITCHES
79Q-006	PTO RPM WITH CRUISE RESUME SWITCH - 1050 RPM
79U-004	PTO GOVERNOR RAMP RATE - 100 RPM PER SECOND
79W-024	CRUISE CONTROL BUTTON PTO CONTROL
79X-015	PTO SPEED 1 SETTING - 1125 RPM
80G-003	PTO MINIMUM RPM - 750
80J-002	REGEN INHIBIT SPEED THRESHOLD - 5 MPH
80S-004	PTO 1, DASH SWITCH, ENGAGE WHILE DRIVING
80V-002	ENGINE MOUNT PTO, DASH SWITCH ENGAGES PTO MODE, DRIVING OPERATION

Engine Equipment

99C-024	EPA 2010/GHG 2024 CONFIGURATION
13E-001	STANDARD OIL PAN



Prepared for:
 Jeff Daane
 WAUPUN CITY OF
 201 E MAIN ST
 WAUPUN, WI 53963
 Phone: 920-210-8200

Prepared by:
 Jay Szymanski
 TRUCK CTY OF WISCONSIN,
 INC.
 2401 PROGRESS WAY
 KAUKAUNA, WI 541309559
 Phone: 920-766-5222

Data Code	Description
105-015	OIL FILL AND DIPSTICK LOCATED FOR ENHANCED SERVICEABILITY
014-1B5	SIDE OF HOOD AIR INTAKE WITH DONALDSON HIGH CAPACITY AIR CLEANER WITH SAFETY ELEMENT, FIREWALL MOUNTED
124-1D9	DR 12V 180 AMP 28-SI QUADRAMOUNT PAD ALTERNATOR WITH REMOTE BATTERY VOLT SENSE
292-235	(2) DTNA GENUINE, FLOODED STARTING, MIN 2000CCA, 370RC, THREADED STUD BATTERIES
290-017	BATTERY BOX FRAME MOUNTED
281-001	STANDARD BATTERY JUMPERS
282-001	SINGLE BATTERY BOX FRAME MOUNTED LH SIDE UNDER CAB
291-017	WIRE GROUND RETURN FOR BATTERY CABLES WITH ADDITIONAL FRAME GROUND RETURN
289-001	NON-POLISHED BATTERY BOX COVER
295-029	POSITIVE AND NEGATIVE POSTS FOR JUMPSTART LOCATED ON FRAME NEXT TO STARTER
306-015	PROGRESSIVE LOW VOLTAGE DISCONNECT AT 12.3 VOLTS FOR DESIGNATED CIRCUITS
107-032	CUMMINS TURBOCHARGED 18.7 CFM AIR COMPRESSOR WITH INTERNAL SAFETY VALVE
152-041	ELECTRONIC ENGINE INTEGRAL SHUTDOWN PROTECTION SYSTEM
128-076	CUMMINS ENGINE INTEGRAL BRAKE WITH VARIABLE GEOMETRY TURBO ON/OFF
016-1C2	RH OUTBOARD UNDER STEP MOUNTED HORIZONTAL AFTERTREATMENT SYSTEM ASSEMBLY WITH RH B-PILLAR MOUNTED VERTICAL TAILPIPE
28F-014	ENGINE AFTERTREATMENT DEVICE, AUTOMATIC OVER THE ROAD REGENERATION AND VIRTUAL REGENERATION REQUEST SWITCH IN CLUSTER
239-032	11 FOOT 00 INCH (132 INCH+0/-5.9 INCH) EXHAUST SYSTEM HEIGHT
233-017	STANDARD CURVE BRIGHT UPPER STACK(S)
237-1CR	RH CURVED VERTICAL TAILPIPE B-PILLAR MOUNTED ROUTED FROM STEP
23U-002	13 GALLON DIESEL EXHAUST FLUID TANK
30N-003	100 PERCENT DIESEL EXHAUST FLUID FILL
23Y-001	STANDARD DIESEL EXHAUST FLUID PUMP MOUNTING



Prepared for:
 Jeff Daane
 WAUPUN CITY OF
 201 E MAIN ST
 WAUPUN, WI 53963
 Phone: 920-210-8200

Prepared by:
 Jay Szymanski
 TRUCK CTY OF WISCONSIN,
 INC.
 2401 PROGRESS WAY
 KAUKAUNA, WI 541309559
 Phone: 920-766-5222

Data Code	Description
23Z-001	POLISHED ALUMINUM DIAMOND PLATE DIESEL EXHAUST FLUID TANK COVER
43X-002	LH MEDIUM DUTY STANDARD DIESEL EXHAUST FLUID TANK LOCATION
43Y-001	STANDARD DIESEL EXHAUST FLUID TANK CAP
242-001	STAINLESS STEEL AFTERTREATMENT DEVICE/MUFFLER/TAILOPIPE SHIELD
273-058	AIR POWERED ON/OFF ENGINE FAN CLUTCH
276-001	AUTOMATIC FAN CONTROL WITHOUT DASH SWITCH, NON ENGINE MOUNTED
110-003	CUMMINS SPIN ON FUEL FILTER
118-008	COMBINATION FULL FLOW/BYPASS OIL FILTER
120-998	NO COOLANT FILTER
266-017	1300 SQUARE INCH ALUMINUM RADIATOR
103-039	ANTIFREEZE TO -34F, OAT (NITRITE AND SILICATE FREE) EXTENDED LIFE COOLANT
171-007	GATES BLUE STRIPE COOLANT HOSES OR EQUIVALENT
172-001	CONSTANT TENSION HOSE CLAMPS FOR COOLANT HOSES
270-016	RADIATOR DRAIN VALVE
138-011	PHILLIPS-TEMRO 1000 WATT/115 VOLT BLOCK HEATER
140-038	CHROME ENGINE HEATER RECEPTACLE MOUNTED UNDER LH DOOR WITH CURRENT SENSOR LIGHT
132-004	ELECTRIC GRID AIR INTAKE WARMER
155-058	DELCO 12V 38MT HD STARTER WITH INTEGRATED MAGNETIC SWITCH

Transmission

342-582	ALLISON 3000 RDS AUTOMATIC TRANSMISSION WITH PTO PROVISION
---------	--

Transmission Equipment

343-339	ALLISON VOCATIONAL PACKAGE 223 - AVAILABLE ON 3000/4000 PRODUCT FAMILIES WITH VOCATIONAL MODELS RDS, HS, MH AND TRV
84B-012	ALLISON VOCATIONAL RATING FOR ON/OFF HIGHWAY APPLICATIONS AVAILABLE WITH ALL PRODUCT FAMILIES
84C-023	PRIMARY MODE GEARS, LOWEST GEAR 1, START GEAR 1, HIGHEST GEAR 6, AVAILABLE FOR 3000/4000 PRODUCT FAMILIES ONLY

Prepared for:
 Jeff Daane
 WAUPUN CITY OF
 201 E MAIN ST
 WAUPUN, WI 53963
 Phone: 920-210-8200

Prepared by:
 Jay Szymanski
 TRUCK CTY OF WISCONSIN,
 INC.
 2401 PROGRESS WAY
 KAUKAUNA, WI 541309559
 Phone: 920-766-5222

Data Code	Description
84D-020	SECONDARY MODE GEARS, LOWEST GEAR 1, START GEAR 1, HIGHEST GEAR 3, AVAILABLE FOR 3000/4000 PRODUCT FAMILIES ONLY
84E-017	S5 PERFORMANCE LIMITING PRIMARY SHIFT SCHEDULE, AVAILABLE FOR 3000/4000 PRODUCT FAMILIES ONLY
84F-016	S5 PERFORMANCE LIMITING SECONDARY SHIFT SCHEDULE, AVAILABLE FOR 3000/4000 PRODUCT FAMILIES ONLY
84G-013	2100 RPM PRIMARY MODE SHIFT SPEED
84H-013	2100 RPM SECONDARY MODE SHIFT SPEED
84K-002	2ND GEAR ENGINE BRAKE ALTERNATE PRESELECT WITH MODERATE DOWNSHIFT STRATEGY
84N-004	FUEL SENSE 2.0 PLUS - DYNACTIVE: PERFORMANCE, NEUTRAL AT STOP: ACTIVE
84U-000	DRIVER SWITCH INPUT - DEFAULT - NO SWITCHES
84V-001	DIRECTION CHANGE ENABLED WITH MULTIPLEXED SERVICE BRAKES - ALLISON 5TH GEN TRANSMISSIONS
85E-009	MAXIMUM ENGINE SPEED FOR PTO ENGAGEMENT 900 RPM
85F-042	MAXIMUM ENGINE SPEED FOR PTO OPERATION 2400 RPM
85G-009	MAXIMUM OUTPUT SPEED FOR PTO ENGAGEMENT 250 RPM
85H-159	MAXIMUM OUTPUT SPEED FOR PTO OPERATION 4000 RPM - ALLISON 5TH GEN TRANSMISSIONS
85T-998	NO AMT HOLD MODE
353-074	QUICKFIT BODY LIGHTING CONNECTOR UNDER CAB, WITH BLUNTCUTS
34C-011	ELECTRONIC TRANSMISSION WIRING TO CUSTOMER INTERFACE CONNECTOR
362-823	CUSTOMER INSTALLED CHELSEA 280 SERIES PTO
363-001	PTO MOUNTING, LH SIDE OF MAIN TRANSMISSION ALLISON
341-018	MAGNETIC PLUGS, ENGINE DRAIN, TRANSMISSION DRAIN, AXLE(S) FILL AND DRAIN
345-078	HEAVY DUTY ELECTRONIC TRANSMISSION SHIFT CONTROL, COLUMN MOUNTED
97G-004	TRANSMISSION PROGNOSTICS - ENABLED 2013



Prepared for:
 Jeff Daane
 WAUPUN CITY OF
 201 E MAIN ST
 WAUPUN, WI 53963
 Phone: 920-210-8200

Prepared by:
 Jay Szymanski
 TRUCK CTY OF WISCONSIN,
 INC.
 2401 PROGRESS WAY
 KAUKAUNA, WI 541309559
 Phone: 920-766-5222

Data Code	Description
370-015	WATER TO OIL TRANSMISSION COOLER, IN RADIATOR END TANK
346-013	TRANSMISSION OIL CHECK AND FILL WITH CROSSOVER TO CLEAR LH PTO AND DIRECT MOUNT PUMP
35T-001	SYNTHETIC TRANSMISSION FLUID (TES-295 COMPLIANT)

Front Axle and Equipment

400-1BB	DETROIT DA-F-20.0-5 20,000# FL1 71.0 KPI/3.74 DROP SINGLE FRONT AXLE
402-013	MERITOR 16.5X6 Q+ CAST SPIDER HEAVY DUTY CAM FRONT BRAKES, DOUBLE ANCHOR, FABRICATED SHOES
403-002	NON-ASBESTOS FRONT BRAKE LINING
419-023	CONMET CAST IRON FRONT BRAKE DRUMS
427-001	FRONT BRAKE DUST SHIELDS
409-006	FRONT OIL SEALS
408-016	STEMCO SERIES 340/343/346 TRADITIONAL ALUMINUM FRONT HUB CAPS WITH WINDOW AND RED VENT PLUGS - OIL
416-022	STANDARD SPINDLE NUTS FOR ALL AXLES
405-031	HALDEX AUTOMATIC FRONT SLACK ADJUSTERS WITH STAINLESS STEEL CLEVIS PINS
406-001	STANDARD KING PIN BUSHINGS
536-055	TRW THP-60 POWER STEERING WITH RCH45 AUXILIARY GEAR
539-003	POWER STEERING PUMP
534-003	4 QUART POWER STEERING RESERVOIR
533-001	OIL/AIR POWER STEERING COOLER
40T-002	CURRENT AVAILABLE SYNTHETIC 75W-90 FRONT AXLE LUBE

Front Suspension

620-068	23,000# FLAT LEAF FRONT SUSPENSION
619-004	GRAPHITE BRONZE BUSHINGS WITH SEALS - FRONT SUSPENSION
410-001	FRONT SHOCK ABSORBERS

Rear Axle and Equipment

420-103	MERITOR RT-46-160 46,000# R-SERIES TANDEM REAR AXLE
421-563	5.63 REAR AXLE RATIO



Prepared for:
 Jeff Daane
 WAUPUN CITY OF
 201 E MAIN ST
 WAUPUN, WI 53963
 Phone: 920-210-8200

Prepared by:
 Jay Szymanski
 TRUCK CTY OF WISCONSIN,
 INC.
 2401 PROGRESS WAY
 KAUKAUNA, WI 541309559
 Phone: 920-766-5222

Data Code	Description
424-001	IRON REAR AXLE CARRIER WITH STANDARD AXLE HOUSING
386-073	MXL 17T MERITOR EXTENDED LUBE MAIN DRIVELINE WITH HALF ROUND YOKES
388-073	MXL 17T MERITOR EXTENDED LUBE INTERAXLE DRIVELINE WITH HALF ROUND YOKES
452-006	DRIVER CONTROLLED TRACTION DIFFERENTIAL - BOTH TANDEM REAR AXLES
878-022	(1) INTERAXLE LOCK VALVE, (1) DRIVER CONTROLLED DIFFERENTIAL LOCK FORWARD-REAR AXLE VALVE AND (1) REAR-REAR AXLE VALVE
87A-017	INDICATOR LIGHT FOR EACH INTERAXLE LOCKOUT SWITCH, DISENGAGE INTERAXLE LOCK WITH IGNITION OFF
87B-025	INDICATOR LIGHT FOR EACH DIFFERENTIAL LOCKOUT SWITCH, ENGAGE AT SPEEDS 5MPH OR LESS, DISENGAGE W/IGN OFF
423-020	MERITOR 16.5X7 Q+ CAST SPIDER CAM REAR BRAKES, DOUBLE ANCHOR, FABRICATED SHOES
433-002	NON-ASBESTOS REAR BRAKE LINING
434-005	BRAKE CAMS AND CHAMBERS ON FORWARD SIDE OF DRIVE AXLE(S) WITH AUXILIARY SUPPORT BRACKETS
451-023	CONMET CAST IRON REAR BRAKE DRUMS
425-002	REAR BRAKE DUST SHIELDS
440-006	REAR OIL SEALS
426-1B3	BENDIX EVERSURE LONGSTROKE 2-DRIVE AXLES SPRING PARKING CHAMBERS
428-031	HALDEX AUTOMATIC REAR SLACK ADJUSTERS WITH STAINLESS STEEL CLEVIS PINS
41T-002	CURRENT AVAILABLE SYNTHETIC 75W-90 REAR AXLE LUBE
42T-001	STANDARD REAR AXLE BREATHER(S)

Rear Suspension

622-199	AIRLINER 46,000# REAR SUSPENSION
621-007	AIRLINER HIGH POSITION RIDE HEIGHT
431-004	WELDED AXLE SEATS SUPPLIED ON REAR AXLE
624-016	51 INCH AXLE SPACING
888-078	IGNITION CONTROLLED ELECTRIC DUMP SWITCH FOR AIR SUSPENSION WITH STATE RETENTION AND GAUGE



Prepared for:
 Jeff Daane
 WAUPUN CITY OF
 201 E MAIN ST
 WAUPUN, WI 53963
 Phone: 920-210-8200

Prepared by:
 Jay Szymanski
 TRUCK CTY OF WISCONSIN,
 INC.
 2401 PROGRESS WAY
 KAUKAUNA, WI 541309559
 Phone: 920-766-5222

Data Code	Description
87D-012	REAR AIR SUSPENSION DUMP VALVE AUTOFILL >5 MPH WITH INDICATOR LIGHT
910-004	DUAL AIR REAR SUSPENSION LEVELING VALVES
623-002	TRANSVERSE CONTROL RODS
625-006	HEAVY DUTY SUSPENSION OPTION - 23,000#,46,000#, 69,000# AIRLINER SUSPENSIONS
439-005	REAR SHOCK ABSORBERS - TWO AXLES (TANDEM) (AIR RIDE SUSPENSION)

Pusher / Tag Equipment

429-998	NO PUSHER/TAG BRAKE DUST SHIELDS
---------	----------------------------------

Brake System

490-100	WABCO 4S/4M ABS
871-001	REINFORCED NYLON, FABRIC BRAID AND WIRE BRAID CHASSIS AIR LINES
904-001	FIBER BRAID PARKING BRAKE HOSE
412-001	STANDARD BRAKE SYSTEM VALVES
46D-002	STANDARD AIR SYSTEM PRESSURE PROTECTION SYSTEM
413-002	STD U.S. FRONT BRAKE VALVE
432-003	RELAY VALVE WITH 5-8 PSI CRACK PRESSURE, NO REAR PROPORTIONING VALVE
480-088	WABCO SYSTEM SAVER HP WITH INTEGRAL AIR GOVERNOR AND HEATER
479-004	AIR DRYER MOUNTED OUTBOARD ON LH RAIL
N 460-008	STEEL AIR BRAKE RESERVOIRS MOUNTED INSIDE RAIL
477-004	PULL CABLES ON ALL AIR RESERVOIR(S)

Trailer Connections

481-998	NO TRAILER AIR HOSE
476-998	NO AIR HOSE HANGER
914-012	AIR CONNECTIONS TO END OF FRAME WITH GLAD HANDS FOR TRUCK WITH 36 INCHES ADDITIONAL LINE END OF FRAME
296-027	PRIMARY CONNECTOR/RECEPTACLE WIRED FOR COMBINATION STOP/TURN, CENTER PIN POWERED THROUGH IGNITION WITH STOP SIGNAL PREWIRE PACKAGE
303-025	SAE J560 7-WAY PRIMARY TRAILER CABLE RECEPTACLE MOUNTED END OF FRAME
310-998	NO TRAILER ELECTRICAL CABLE



Prepared for:
 Jeff Daane
 WAUPUN CITY OF
 201 E MAIN ST
 WAUPUN, WI 53963
 Phone: 920-210-8200

Prepared by:
 Jay Szymanski
 TRUCK CTY OF WISCONSIN,
 INC.
 2401 PROGRESS WAY
 KAUKAUNA, WI 541309559
 Phone: 920-766-5222

Data Code	Description
Wheelbase & Frame	
545-475	4750MM (187 INCH) WHEELBASE
546-1B2	1/2X3.64X11-7/8 INCH STEEL FRAME (12.7MMX301.6MM/0.5X11.88 INCH) 120KSI
547-034	PARTIAL INNER FRAME REINFORCEMENT AT FRONT SUSPENSION
548-803	TEM TO EVALUATE AND INSTALL FRAME RAIL REINFORCEMENT AS NEEDED FOR FRONT FRAME MOUNTED EQUIPMENT
552-037	1775MM (70 INCH) REAR FRAME OVERHANG
55W-006	FRAME OVERHANG RANGE: 61 INCH TO 70 INCH
549-002	24 INCH INTEGRAL FRONT FRAME EXTENSION
AC8-99D	CALC'D BACK OF CAB TO REAR SUSP C/L (CA) : 121.46 in
AE8-99D	CALCULATED EFFECTIVE BACK OF CAB TO REAR SUSPENSION C/L (CA) : 106.46 in
AE4-99D	CALC'D FRAME LENGTH - OVERALL : 326.51 in
FSS-0LH	CALCULATED FRAME SPACE LH SIDE : 39.16 in
FSS-0RH	CALCULATED FRAME SPACE RH SIDE : 64.34 in
AM6-99D	CALC'D SPACE AVAILABLE FOR DECKPLATE : 0.0 in
553-001	SQUARE END OF FRAME
587-003	REAR TOW HOOKS
550-001	FRONT CLOSING CROSSMEMBER
559-001	STANDARD WEIGHT ENGINE CROSSMEMBER
562-001	STANDARD MIDSHIP #1 CROSSMEMBER(S)
572-001	STANDARD REARMOST CROSSMEMBER
565-002	HEAVY DUTY SUSPENSION CROSSMEMBER
Chassis Equipment	
556-1E5	14 INCH PAINTED STEEL BUMPER
558-001	FRONT TOW HOOKS - FRAME MOUNTED
585-998	NO MUDFLAP BRACKETS
590-998	NO REAR MUDFLAPS
551-002	HUCK-SPIN ROUND COLLAR CHASSIS FASTENERS
44Z-002	EXTERIOR HARNESES WRAPPED IN ABRASION TAPE
Fifth Wheel	
578-998	NO FIFTH WHEEL



Prepared for:
 Jeff Daane
 WAUPUN CITY OF
 201 E MAIN ST
 WAUPUN, WI 53963
 Phone: 920-210-8200

Prepared by:
 Jay Szymanski
 TRUCK CTY OF WISCONSIN,
 INC.
 2401 PROGRESS WAY
 KAUKAUNA, WI 541309559
 Phone: 920-766-5222

Data Code	Description
Fuel Tanks	
204-152	70 GALLON/264 LITER ALUMINUM FUEL TANK - LH
218-006	25 INCH DIAMETER FUEL TANK(S)
215-006	POLISHING OF FUEL/HYDRAULIC TANK(S) WITH POLISHED STAINLESS STEEL BANDS
212-007	FUEL TANK(S) FORWARD
664-001	PLAIN STEP FINISH
205-002	CHROME FUEL TANK CAP(S)
122-1H8	DAVCO 245 FUEL/WATER SEPARATOR WITH 12 VOLT HEAT AND WATER IN FUEL SENSOR
216-020	EQUIFLO INBOARD FUEL SYSTEM
202-016	HIGH TEMPERATURE REINFORCED NYLON FUEL LINE
213-001	INSULATION FOR FUEL LINES
Tires	
093-10C	CONTINENTAL INTELLIGENT HSC3 315/80R22.5 20 PLY RADIAL FRONT TIRES
094-12V	CONTINENTAL HDR2+ 11R22.5 16 PLY RADIAL REAR TIRES
Hubs	
418-058	CONMET PRESET PLUS PREMIUM ALUMINUM FRONT HUBS
450-060	CONMET PRESET PLUS PREMIUM IRON REAR HUBS
Wheels	
502-664	ALCOA ULTRA ONE 89U63X 22.5X9.00 10-HUB PILOT 3.12 INSET 10-HD ALUMINUM FRONT WHEELS
505-754	ACCURIDE 43644 ACCU-LITE ALUMINUM OUTSIDE, MAXION WHEELS 91541 STEEL INSIDE; 22.5X8.25 10-HUB PILOT DISC REAR WHEELS
496-011	FRONT WHEEL MOUNTING NUTS
497-011	REAR WHEEL MOUNTING NUTS
Cab Exterior	
829-1A2	114 INCH BBC FLAT ROOF ALUMINUM CONVENTIONAL CAB
650-008	AIR CAB MOUNTING
648-002	NONREMOVABLE BUGSCREEN MOUNTED BEHIND GRILLE



Prepared for:
 Jeff Daane
 WAUPUN CITY OF
 201 E MAIN ST
 WAUPUN, WI 53963
 Phone: 920-210-8200

Prepared by:
 Jay Szymanski
 TRUCK CTY OF WISCONSIN,
 INC.
 2401 PROGRESS WAY
 KAUKAUNA, WI 541309559
 Phone: 920-766-5222

Data Code	Description
667-037	SHORT FENDER WITH MUDFLAP
754-017	BOLT-ON MOLDED FLEXIBLE FENDER EXTENSIONS
678-018	LH AND RH EXTERIOR GRAB HANDLES WITH SINGLE RUBBER INSERT
645-002	BRIGHT FINISH RADIATOR SHELL/HOOD BEZEL
646-042	STATIONARY BLACK GRILLE WITH BRIGHT ACCENTS
65X-003	CHROME HOOD MOUNTED AIR INTAKE GRILLE
644-004	FIBERGLASS HOOD
690-017	HOOD LINER, ADDED FIREWALL AND FLOOR HEAT INSULATION
727-1AM	DUAL 24 INCH ROUND POLISHED ALUMINUM AIR HORNS ROOF MOUNTED
726-002	DUAL ELECTRIC HORNS
728-002	DUAL HORN SHIELDS
575-001	REAR LICENSE PLATE MOUNT END OF FRAME
312-067	HALOGEN COMPOSITE HEADLAMPS WITH BRIGHT BEZELS
302-047	LED AERODYNAMIC MARKER LIGHTS
314-824	WIRING AND SWITCH FOR CUSTOMER FURNISHED SNOW PLOW LAMPS WITH DUAL CONNECTIONS AT BUMPER
311-021	HEADLIGHTS ON WITH WIPERS, NO DAYTIME RUNNING LIGHTS
294-042	FREIGHTLINER LED FLANGE MOUNTED STOP/TAIL/TURN LIGHTS WITH SEPARATE INCANDESCENT BACKUP LIGHTS
300-015	STANDARD FRONT TURN SIGNAL LAMPS
744-1BC	DUAL WEST COAST BRIGHT FINISH HEATED MIRRORS WITH LH AND RH REMOTE
797-001	DOOR MOUNTED MIRRORS
796-001	102 INCH EQUIPMENT WIDTH
743-204	LH AND RH 8 INCH BRIGHT FINISH CONVEX MIRRORS MOUNTED UNDER PRIMARY MIRRORS
74A-001	RH DOWN VIEW MIRROR
74B-1B4	RH AND LH 8 INCH HEATED STAINLESS STEEL FENDER MOUNTED CONVEX MIRRORS WITH TRIPOD BRACKETS
729-001	STANDARD SIDE/REAR REFLECTORS
677-055	RH AFTERTREATMENT SYSTEM CAB ACCESS WITH POLISHED DIAMOND PLATE COVER



Prepared for:
 Jeff Daane
 WAUPUN CITY OF
 201 E MAIN ST
 WAUPUN, WI 53963
 Phone: 920-210-8200

Prepared by:
 Jay Szymanski
 TRUCK CTY OF WISCONSIN,
 INC.
 2401 PROGRESS WAY
 KAUKAUNA, WI 541309559
 Phone: 920-766-5222

Data Code	Description
764-010	COMPOSITE EXTERIOR SUN VISOR
768-043	63X14 INCH TINTED REAR WINDOW
661-003	TINTED DOOR GLASS LH AND RH WITH TINTED NON-OPERATING WING WINDOWS
654-011	RH AND LH ELECTRIC POWERED WINDOWS
769-002	LOWER RH DOOR WINDOW WITH FRESNEL LENS
663-029	1-PIECE BONDED HEATED WIPER PARK SOLAR GREEN GLASS WINDSHIELD
659-007	8 LITER (2 GAL) WINDSHIELD WASHER RESERVOIR, CAB MOUNTED, WITHOUT FLUID LEVEL INDICATOR
647-001	WHITE WINTERFRONT

Cab Interior

055-018	ELITE TRIM PACKAGE
707-106	MIST CLOTH & CARBON VINYL INTERIOR "ELITE"
70K-019	CARBON WITH PREMIUM WOOD ACCENT (ELITE)
706-013	MOLDED PLASTIC DOOR PANEL
708-013	MOLDED PLASTIC DOOR PANEL
772-006	BLACK MATS WITH SINGLE INSULATION
785-026	(1)DASH MOUNTED 12V POWER OUTLET, (1)DASH MOUNTED DUAL USB-C OUTLET
691-001	FORWARD ROOF MOUNTED CONSOLE
696-012	CENTER STORAGE CONSOLE MOUNTED ON BACKWALL
693-036	LH DOOR STORAGE POCKET
738-021	DIGITAL ALARM CLOCK IN DRIVER DISPLAY
742-007	(2) CUP HOLDERS LH AND RH DASH
680-029	M2/SD DASH
720-003	5 LB. FIRE EXTINGUISHER
700-002	HEATER, DEFROSTER AND AIR CONDITIONER
701-008	STANDARD HVAC DUCTING WITH SNOW SHIELD FOR FRESH AIR INTAKE
703-005	MAIN HVAC CONTROLS WITH RECIRCULATION SWITCH
170-045	STANDARD HEATER PLUMBING WITH BALL SHUTOFF VALVES AT SUPPLY LINES ONLY
130-041	VALEO HEAVY DUTY A/C REFRIGERANT COMPRESSOR



Prepared for:
 Jeff Daane
 WAUPUN CITY OF
 201 E MAIN ST
 WAUPUN, WI 53963
 Phone: 920-210-8200

Prepared by:
 Jay Szymanski
 TRUCK CTY OF WISCONSIN,
 INC.
 2401 PROGRESS WAY
 KAUKAUNA, WI 541309559
 Phone: 920-766-5222

Data Code	Description
702-002	BINARY CONTROL, R-134A
739-034	PREMIUM INSULATION
285-013	SOLID-STATE CIRCUIT PROTECTION AND FUSES
280-007	12V NEGATIVE GROUND ELECTRICAL SYSTEM
324-1B2	PREMIUM LED CAB LIGHTING
787-998	NO SECURITY DEVICE
657-1A1	ALL UNIT(S) KEYED ALIKE WITH CUSTOMER SPECIFIED KEY NUMBER FT1014
78G-004	KEY QUANTITY OF 4
655-005	LH AND RH ELECTRIC DOOR LOCKS
740-998	NO MATTRESS
722-002	TRIANGULAR REFLECTORS WITHOUT FLARES
756-340	ELITE ISRINGHAUSEN HIGH BACK AIR SUSPENSION DRIVERS SEAT W/2 AIR LUMBAR, INTEGRATED CUSHION EXTENSION, TILT, ADJUSTABLE SHOCK, HEAT
760-335	BASIC ISRI HIGH BACK NON SUSPENSION PASSENGER SEAT
759-007	DUAL DRIVER SEAT ARMRESTS, NO PASSENGER SEAT ARMRESTS
711-004	LH AND RH INTEGRAL DOOR PANEL ARMRESTS
758-121	BLACK LAREDO LEATHER DRIVER SEAT COVER
761-014	BLACK CORDURA PLUS CLOTH PASSENGER SEAT COVER
763-101	BLACK SEAT BELTS
532-002	ADJUSTABLE TILT AND TELESCOPING STEERING COLUMN
540-070	4-SPOKE 18 INCH (450MM) LEATHER WRAPPED STEERING WHEEL WITH CHROME SWITCH BEZELS
765-002	DRIVER AND PASSENGER INTERIOR SUN VISORS

Instruments & Controls

106-002	ELECTRONIC ACCELERATOR CONTROL
732-998	NO INSTRUMENT PANEL-DRIVER
734-022	FULLY CONFIGURABLE CENTER INSTRUMENT PANELS
87L-001	ENGINE REMOTE INTERFACE WITH PARK BRAKE INTERLOCK
870-002	BRIGHT ARGENT FINISH GAUGE BEZELS



Prepared for:
 Jeff Daane
 WAUPUN CITY OF
 201 E MAIN ST
 WAUPUN, WI 53963
 Phone: 920-210-8200

Prepared by:
 Jay Szymanski
 TRUCK CTY OF WISCONSIN,
 INC.
 2401 PROGRESS WAY
 KAUKAUNA, WI 541309559
 Phone: 920-766-5222

Data Code	Description
486-001	LOW AIR PRESSURE INDICATOR LIGHT AND AUDIBLE ALARM
840-001	DUAL NEEDLE PRIMARY AND SECONDARY AIR PRESSURE GAUGE
198-034	INTAKE MOUNTED AIR RESTRICTION INDICATOR W/ COLOR LED WARNING LIGHT, 18 INCH AND 20 INCH LIMITS
721-025	97 DB BACKUP ALARM MOUNTED INBOARD OF RAIL
149-015	ELECTRONIC CRUISE CONTROL WITH CONTROLS ON STEERING WHEEL SPOKES
156-007	KEY OPERATED IGNITION SWITCH AND INTEGRAL START POSITION; 4 POSITION OFF/RUN/START/ACCESSORY
811-044	PREMIUM INSTRUMENT CLUSTER WITH 5.0 INCH TFT COLOR DISPLAY
81B-003	DIGITAL PANEL LAMP DIMMER SWITCH IN DRIVER DISPLAY
160-038	HEAVY DUTY ONBOARD DIAGNOSTICS INTERFACE CONNECTOR LOCATED BELOW LH DASH
844-001	2 INCH ELECTRIC FUEL GAUGE
148-072	ENGINE REMOTE INTERFACE WITH ONE OR MORE SET SPEEDS
48H-002	QUICKFIT POWERTRAIN INTERFACE CONNECTOR LOCATED BETWEEN SEATS WITH BLUNTCUTS
48C-002	QUICKFIT PROGRAMMABLE INTERFACE CONNECTOR(S) BETWEEN SEATS WITH BLUNTCUTS
856-001	ELECTRICAL ENGINE COOLANT TEMPERATURE GAUGE
852-002	ELECTRIC ENGINE OIL PRESSURE GAUGE
864-022	DIGITAL TRANSMISSION OIL TEMPERATURE IN DRIVER DISPLAY
867-004	ELECTRONIC OUTSIDE TEMPERATURE SENSOR DISPLAY IN DRIVER MESSAGE CENTER
830-017	ENGINE AND TRIP HOUR METERS INTEGRAL WITHIN DRIVER DISPLAY
372-123	PTO CONTROLS FOR ENHANCED VEHICLE ELECTRIC/ELECTRONIC ARCHITECTURE
736-998	NO OBSTACLE DETECTION SYSTEM
72J-998	NO DR ASSIST SYSTEM
49B-998	NO VEHICLE STABILITY ADVISOR OR CONTROL



Prepared for:
 Jeff Daane
 WAUPUN CITY OF
 201 E MAIN ST
 WAUPUN, WI 53963
 Phone: 920-210-8200

Prepared by:
 Jay Szymanski
 TRUCK CTY OF WISCONSIN,
 INC.
 2401 PROGRESS WAY
 KAUKAUNA, WI 541309559
 Phone: 920-766-5222

Data Code	Description
73B-998	NO LANE DEPARTURE WARNING SYSTEM
72K-998	NO REVERSE PROXIMITY SENSOR
679-998	NO OVERHEAD INSTRUMENT PANEL
35M-011	1 QUIKFIT PROGRAMABLE MODULE (QPM/XMC) W/ (4) 20AMP FUSED RELAYS
746-143	7" B-PANEL INTERACTIVE TOUCHSCREEN DISPLAY RADIO W/ USB-C, APPLE CARPLAY, ANDROID AUTO, BLUETOOTH/AM/FM/SXM/WB, WITH MICROPHONE
747-001	DASH MOUNTED RADIO
750-002	(2) RADIO SPEAKERS IN CAB
753-998	NO AM/FM RADIO ANTENNA
748-006	POWER AND GROUND WIRING PROVISION OVERHEAD
749-001	ROOF/OVERHEAD CONSOLE CB RADIO PROVISION
75W-002	SHARKFIN MULTI-BAND ANTENNA: AM/FM/WEATHERBAND, WIFI/BLUETOOTH, SDAR/SIRIUSXM, GNSS/GPS
78C-003	INTEROPERABLE SDAR ANTENNA
810-027	ELECTRONIC MPH SPEEDOMETER WITH SECONDARY KPH SCALE, WITHOUT ODOMETER
817-001	STANDARD VEHICLE SPEED SENSOR
812-001	ELECTRONIC 3000 RPM TACHOMETER
813-1C8	DETROIT CONNECT PLATFORM HARDWARE
8D1-313	3 YEARS DAIMLER CONNECTIVITY BASE PACKAGE ON (FEATURES VARY BY MODEL) POWERED BY DETROIT CONNECT ON CUMMINS ENGINES
8DE-998	NO ASE DATA SVCE EXTENSION
RDE-998	NO EXTENSIONS
6TS-005	TMC RP1226 ACCESSORY CONNECTOR LOCATED BEHIND PASSENGER SIDE REMOVEABLE DASH PANEL
162-002	IGNITION SWITCH CONTROLLED ENGINE STOP
329-128	THREE EXTRA HARDWIRED SWITCHES IN DASH, ROUTE TO UNDER CAB, BLUNTCUT
4C1-025	HARDWIRE SWITCH #1, ON/OFF LATCHING, 20 AMPS IGNITION POWER
4C2-025	HARDWIRE SWITCH #2, ON/OFF LATCHING, 20 AMPS IGNITION POWER
4C3-016	HARDWIRE SWITCH #3, ON/OFF LATCHING, 20 AMPS IGNITION POWER



Prepared for:
 Jeff Daane
 WAUPUN CITY OF
 201 E MAIN ST
 WAUPUN, WI 53963
 Phone: 920-210-8200

Prepared by:
 Jay Szymanski
 TRUCK CTY OF WISCONSIN,
 INC.
 2401 PROGRESS WAY
 KAUKAUNA, WI 541309559
 Phone: 920-766-5222

Data Code	Description
81Y-005	PRE-TRIP INSPECTION FEATURE FOR EXTERIOR LAMPS ONLY
264-030	(1) OVERHEAD MOUNTED LANYARD CONTROL FOR DRIVER AIR HORN
482-001	BW TRACTOR PROTECTION VALVE
883-001	TRAILER HAND CONTROL BRAKE VALVE
842-006	DIGITAL TURBO AIR PRESSURE IN DRIVER DISPLAY
836-015	DIGITAL VOLTAGE DISPLAY INTEGRAL WITH DRIVER DISPLAY
660-025	SINGLE ELECTRIC WINDSHIELD WIPER MOTOR WITH DELAY WHEN PARK BRAKE SET, TRANSITION TO SLOWEST SPEED
304-030	ROTARY HEADLAMP SWITCH, MARKER LIGHTS/HEADLIGHTS SWITCH WITH PULL OUT FOR OPTIONAL FOG/ROAD LAMPS
882-004	TWO VALVE PARKING BRAKE SYSTEM WITH WARNING INDICATOR
299-020	SELF CANCELING TURN SIGNAL SWITCH WITH DIMMER, HEADLAMP FLASH, WASH/WIPE/INTERMITTENT
298-046	INTEGRAL ELECTRONIC TURN SIGNAL FLASHER WITH 40 AMP (20 AMP PER SIDE) TRAILER LAMP CAPACITY
87T-998	NO WRG/SW-OPTL #2, CHAS, AIR

Design

065-000 PAINT: ONE SOLID COLOR

Color

980-6KK CAB COLOR A: L6389EY OMAHA ORANGE ELITE EY
 986-020 BLACK, HIGH SOLIDS POLYURETHANE CHASSIS PAINT
 966-972 POWDER WHITE (N0006EA) REAR WHEELS/RIMS (PKWHT21, TKWHT21, W, TW)
 964-020 STANDARD BLACK BUMPER PAINT
 976-995 SUNVISOR PAINTED SAME AS CAB COLOR A
 963-003 STANDARD E COAT/UNDERCOATING

Certification / Compliance

996-001 U.S. FMVSS CERTIFICATION, EXCEPT SALES CABS AND GLIDER KITS

Secondary Factory Options

998-001 CORPORATE PDI CENTER IN-SERVICE ONLY



Prepared for:
 Jeff Daane
 WAUPUN CITY OF
 201 E MAIN ST
 WAUPUN, WI 53963
 Phone: 920-210-8200

Prepared by:
 Jay Szymanski
 TRUCK CTY OF WISCONSIN,
 INC.
 2401 PROGRESS WAY
 KAUKAUNA, WI 541309559
 Phone: 920-766-5222

Data Code	Description
* 999-062	DEALER/CUSTOMER ADVISED AND ACCEPTS BUMPER SHOULD BE REMOVED PRIOR TO RECOVERING/TOWING THE VEHICLE PER FRACAS:11687

Extended Warranty

WAK-251	ALLISON 3000 RDS SERIES TRANSMISSION EXTEND WARRANTY, 5 YEARS/UNLIMITED MILES FEX
WAG-074	TOWING: 1 YEAR/UNLIMITED MILES/KM EXTENDED TOWING COVERAGE \$750 CAP FEX APPLIES

Dealer Installed Options

		Weight Front	Weight Rear
1	FLOOR MATS	0	0
3	FLAMING RIVER BATTERY SHUT OFF 6 MIN	0	0
4	PROGRAM SMART SWITCHCES	0	0
Total Dealer Installed Options		0 lbs	0 lbs

(***) All cost increases for major components (Engines, Transmissions, Axles, Front and Rear Tires) and government mandated requirements, tariffs, and raw material surcharges will be passed through and added to factory invoices.



Prepared for:
 Jeff Daane
 WAUPUN CITY OF
 201 E MAIN ST
 WAUPUN, WI 53963
 Phone: 920-210-8200

Prepared by:
 Jay Szymanski
 TRUCK CTY OF WISCONSIN,
 INC.
 2401 PROGRESS WAY
 KAUKAUNA, WI 541309559
 Phone: 920-766-5222

D I M E N S I O N S

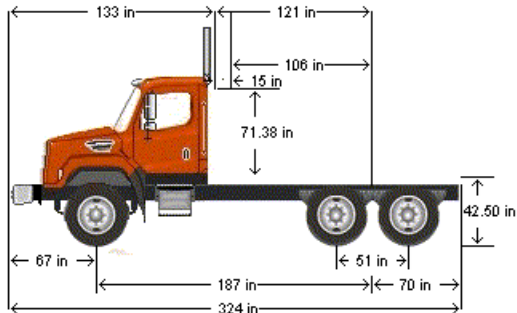

VEHICLE SPECIFICATIONS SUMMARY - DIMENSIONS

Model 114SD
 Wheelbase (545) 4750MM (187 INCH) WHEELBASE
 Rear Frame Overhang (552) 1775MM (70 INCH) REAR FRAME OVERHANG
 Fifth Wheel (578) NO FIFTH WHEEL
 Mounting Location (577) NO FIFTH WHEEL LOCATION
 Maximum Forward Position (in) 0
 Maximum Rearward Position (in) 0
 Amount of Slide Travel (in) 0
 Slide Increment (in) 0
 Desired Slide Position (in) 0.0
 Cab Size (829) 114 INCH BBC FLAT ROOF ALUMINUM CONVENTIONAL CAB
 Sleeper (682) NO SLEEPER BOX/SLEEPER CAB
 Exhaust System (016) RH OUTBOARD UNDER STEP MOUNTED HORIZONTAL AFTERTREATMENT SYSTEM ASSEMBLY WITH RH B-PILLAR MOUNTED VERTICAL TAILPIPE

TABLE SUMMARY - DIMENSIONS



Prepared for:
 Jeff Daane
 WAUPUN CITY OF
 201 E MAIN ST
 WAUPUN, WI 53963
 Phone: 920-210-8200

Prepared by:
 Jay Szymanski
 TRUCK CTY OF WISCONSIN,
 INC.
 2401 PROGRESS WAY
 KAUKAUNA, WI 541309559
 Phone: 920-766-5222

Dimensions	Inches
Bumper to Back of Cab (BBC)	132.9
Bumper to Centerline of Front Axle (BA)	67.3
Front Axle to Back of Cab (AC)	65.6
Min. Cab to Body Clearance (CB)	15.0
Back of Cab to Centerline of Rear Axle(s) (CA)	121.5
Effective Back of Cab to Centerline of Rear Axle(s) (Effective CA)	106.5
Back of Cab Protrusions (Exhaust/Intake) (CP)	2.0
Back of Cab Protrusions (Side Extenders/Trim Tab) (CP)	0.0
Back of Cab Protrusions (CNG Tank)	0.0
Back of Cab Clearance (CL)	15.0
Back of Cab to End of Frame	191.4
Cab Height (CH)	71.4
Wheelbase (WB)	187.0
Frame Overhang (OH)	69.9
Overall Frame Length	326.5
Overall Length (OAL)	324.2
Rear Axle Spacing	51.0
Unladen Frame Height at Centerline of Rear Axle	42.5

Performance calculations are estimates only. If performance calculations are critical, please contact Customer Application Engineering.



Prepared for:
 Jeff Daane
 WAUPUN CITY OF
 201 E MAIN ST
 WAUPUN, WI 53963
 Phone: 920-210-8200

Prepared by:
 Jay Szymanski
 TRUCK CTY OF WISCONSIN,
 INC.
 2401 PROGRESS WAY
 KAUKAUNA, WI 541309559
 Phone: 920-766-5222

G V W R

VEHICLE SPECIFICATIONS SUMMARY - GVWR

Model 114SD
 Cab Size (829)..... 114 INCH BBC FLAT ROOF ALUMINUM CONVENTIONAL CAB
 Expected Front Axle(s) Load (lbs)..... 20000.0
 Expected Pusher Axle(s) Load (lbs)..... 0.0
 Expected Rear Axle(s) Load (lbs)..... 46000.0
 Expected Tag Axle(s) Load (lbs)..... 0.0
 Expected GVW (lbs) 66000
 Expected GCW (lbs)..... 80000.0
 Front Axle (400)..... DETROIT DA-F-20.0-5 20,000# FL1 71.0 KPI/3.74 DROP SINGLE FRONT AXLE
 Front Suspension (620) 23,000# FLAT LEAF FRONT SUSPENSION
 Front Hubs (418) CONMET PRESET PLUS PREMIUM ALUMINUM FRONT HUBS
 Front Disc Wheels (502)ALCOA ULTRA ONE 89U63X 22.5X9.00 10-HUB PILOT 3.12 INSET 10-HD ALUMINUM FRONT WHEELS
 Front Tires (093)..... CONTINENTAL INTELLIGENT HSC3 315/80R22.5 20 PLY RADIAL FRONT TIRES
 Front Brakes (402)MERITOR 16.5X6 Q+ CAST SPIDER HEAVY DUTY CAM FRONT BRAKES, DOUBLE ANCHOR, FABRICATED SHOES
 Steering Gear (536)..... TRW THP-60 POWER STEERING WITH RCH45 AUXILIARY GEAR
 Rear Axle (420) MERITOR RT-46-160 46,000# R-SERIES TANDEM REAR AXLE
 Rear Suspension (622)..... AIRLINER 46,000# REAR SUSPENSION
 Rear Hubs (450)..... CONMET PRESET PLUS PREMIUM IRON REAR HUBS
 Rear Disc Wheels (505)..... ACCURIDE 43644 ACCU-LITE ALUMINUM OUTSIDE, MAXION WHEELS 91541 STEEL INSIDE; 22.5X8.25 10-HUB PILOT DISC REAR WHEELS
 Rear Tires (094) CONTINENTAL HDR2+ 11R22.5 16 PLY RADIAL REAR TIRES
 Rear Brakes (423)MERITOR 16.5X7 Q+ CAST SPIDER CAM REAR BRAKES, DOUBLE ANCHOR, FABRICATED SHOES
 Pusher / Tag Axle (443)..... NO PUSHER OR TAG AXLE
 Pusher / Tag Suspension (626) NO PUSHER OR TAG SUSPENSION
 Pusher / Tag Hubs (449)..... NO PUSHER OR TAG HUBS
 Dead/Pusher/Tag Disc Wheels (509)..... NO PUSHER/TAG DISC WHEELS
 Pusher / Tag Tires (095)..... NO PUSHER/TAG TIRES
 Pusher / Tag Brakes (456)..... NO PUSHER/TAG BRAKES

TABLE SUMMARY - GVWR



Prepared for:
 Jeff Daane
 WAUPUN CITY OF
 201 E MAIN ST
 WAUPUN, WI 53963
 Phone: 920-210-8200

Prepared by:
 Jay Szymanski
 TRUCK CTY OF WISCONSIN,
 INC.
 2401 PROGRESS WAY
 KAUKAUNA, WI 541309559
 Phone: 920-766-5222

	Front	Rear 1	Rear 2
Axle Component Weight Ratings			
Axles	20000	23000	23000
Suspension	23000	23000	23000
Hubs	20000	26000	26000
Brakes	20000	23000	23000
Wheels	20000	29600	29600
Tires	20400	24020	24020
Power Steering	22000	N/A	N/A
GAWR (per axle)	20000	23000	23000
GAWR (per axle system)	20000		46000
Expected Load (per axle system)	20000		46000
GVWR due to Frame	90000		
GVWR due to Transmission	80000		
Vehicle GVWR Summary			
Calculated GVWR	66000		
Expected GVWR	66000		
All weights displayed in pounds			

Performance calculations are estimates only. If performance calculations are critical, please contact Customer Application Engineering.



Prepared for:
 Jeff Daane
 WAUPUN CITY OF
 201 E MAIN ST
 WAUPUN, WI 53963
 Phone: 920-210-8200

Prepared by:
 Jay Szymanski
 TRUCK CTY OF WISCONSIN,
 INC.
 2401 PROGRESS WAY
 KAUKAUNA, WI 541309559
 Phone: 920-766-5222

Q U O T A T I O N

114SD PLUS CONVENTIONAL CHASSIS

SET BACK AXLE - TRUCK
 CUM L9 370 HP @ 2100 RPM; 2100 GOV RPM, 1250 LB-
 FT @ 1200 RPM
 ALLISON 3000 RDS AUTOMATIC TRANSMISSION WITH
 PTO PROVISION
 MERITOR RT-46-160 46,000# R-SERIES TANDEM REAR
 AXLE
 AIRLINER 46,000# REAR SUSPENSION
 DETROIT DA-F-20.0-5 20,000# FL1 71.0 KPI/3.74 DROP
 SINGLE FRONT AXLE
 23,000# FLAT LEAF FRONT SUSPENSION

114 INCH BBC FLAT ROOF ALUMINUM CONVENTIONAL
 CAB
 4750MM (187 INCH) WHEELBASE
 NO FIFTH WHEEL
 1/2X3.64X11-7/8 INCH STEEL FRAME
 (12.7MMX301.6MM/0.5X11.88 INCH) 120KSI
 1775MM (70 INCH) REAR FRAME OVERHANG
 PARTIAL INNER FRAME REINFORCEMENT AT FRONT
 SUSPENSION
 TEM TO EVALUATE AND INSTALL FRAME RAIL
 REINFORCEMENT AS NEEDED FOR FRONT
 FRAME MOUNTED EQUIPMENT

		PER UNIT		TOTAL
VEHICLE PRICE	TOTAL # OF UNITS (1)	\$ 141,503	\$	141,503
EXTENDED WARRANTY		\$ 852	\$	852
DEALER INSTALLED OPTIONS		\$ 2,500	\$	2,500
CUSTOMER PRICE BEFORE TAX		\$ 144,855	\$	144,855

TAXES AND FEES

TAXES AND FEES	\$	0	\$	0
OTHER CHARGES	\$	0	\$	0

TRADE-IN

TRADE-IN ALLOWANCE	\$	(0)	\$	(0)
---------------------------	----	-----	----	-----

BALANCE DUE		(LOCAL CURRENCY) \$ 144,855	\$	144,855
--------------------	--	------------------------------------	-----------	----------------

COMMENTS:

Projected delivery on ___ / ___ / ___ provided the order is received before ___ / ___ / ___.

APPROVAL:

Please indicate your acceptance of this quotation by signing below:

Customer: X _____ Date: ___ / ___ / ___.

Daimler Truck Financial

Financing that works for you.

See your local dealer for a competitive quote from Daimler Truck Financial, or contact us at Information@dtfoffers.com.

Daimler Truck Financial offers a variety of finance, lease and insurance solutions to fit your business needs. For more information about our products and services, visit our website at www.daimler-truckfinancial.com.



Prepared for:
Jeff Daane
WAUPUN CITY OF
201 E MAIN ST
WAUPUN, WI 53963
Phone: 920-210-8200

Prepared by:
Jay Szymanski
TRUCK CTY OF WISCONSIN,
INC.
2401 PROGRESS WAY
KAUKAUNA, WI 541309559
Phone: 920-766-5222





AGENDA SUMMARY SHEET

MEETING DATE: 10/29/24

TITLE: Discuss Aerial Ladder Truck Purchase Terms

AGENDA SECTION: DISCUSSION

PRESENTER: Schlieve/Langenfeld/DeMaa

DEPARTMENT GOAL(S) SUPPORTED <i>(if applicable)</i>	FISCAL IMPACT	
High Performance Government	Planned 2025 Capital Expenditure	

ISSUE SUMMARY:

Staff have obtained a single quote on an aerial ladder truck to verify cost to help plan for debt issuance for 2025 capital and equipment purchases. The quote received shows the truck cost to be just under \$2.1M. However, there is an option to prepay the full purchase amount within 30 days of bid receipt to obtain a prepayment discount, resulting in cost savings of \$285,000 and a purchase price just under \$1.8M. Note that there will be an additional cost of ~ \$40K for equipment to outfit the vehicle once it is received. We have been told to anticipate a price increase effective 11/1/24 (~+15K). Lead time on the purchase is 45 to 48 months. In accordance with the city purchasing policy, a purchase contract will need to be secured using a sealed bid process. As we prepare for debt issuance, we are recommending that you consider prepayment of the full amount of the truck to take advantage of available discounts. If you opt to forego prepayment, we estimate that the city would incur an additional \$480K in cost between loss of prepayment discount, estimated cost increases, and additional interest expense over the term of the loan. Once a purchase contract is approved, we have 30 days to issue payment in full to qualify for the prepayment discount. This requires that we plan for debt issuance simultaneously with the bidding process. The purpose of this discussion is to review the payment terms available and gather consensus on strategy as this decision will impact timing and approach for our upcoming debt issuance.

STAFF RECOMMENDATION:

Prepayment

ATTACHMENTS:

RECOMMENDED MOTION:

Discussion Only



AGENDA SUMMARY SHEET

MEETING DATE: 10/29/2024

TITLE: Estimated tax rates 2025

AGENDA SECTION: Discussion

PRESENTER: Casey Langenfeld, Finance Director

DEPARTMENT GOAL(S) SUPPORTED <i>(if applicable)</i>	FISCAL IMPACT	

SUMMARY: The City received its final Statement of Assessment reports from the Department of Revenue for Dodge and Fond du Lac Counties. The attached document will provide an updated review of the estimated tax rates for the City of Waupun.

STAFF RECOMMENDATION:

ATTACHMENTS:

Estimated City of Waupun Tax Rates for 2025

RECOMMENDED MOTION: None

ESTIMATED TAX RATES

City of Waupun – Dodge County Residents	Tax Year 2023	Tax Year 2024	Change	% Change
Average Home Value	\$152,630	\$153,122	\$492	0.3%
Mill Rate (per \$1K)	\$6.152	\$6.548	\$0.40	6.4%
City of Waupun Taxes	\$938	\$1,002	\$64	6.8%

City of Waupun – Fond du Lac County Residents	Tax Year 2023	Tax Year 2024	Change	% Change
Average Home Value	\$185,673	\$187,785	\$2,112	1.1%
Mill Rate (per \$1K)	\$6.210	\$6.602	\$0.39	6.3%
City of Waupun Taxes	\$1,153	\$1,240	\$87	7.5%





AGENDA SUMMARY SHEET

MEETING DATE: 10/29/2024

TITLE: Proposed Changes to the 2025 Fee Schedule

AGENDA SECTION: Discussion

PRESENTER: Casey Langenfeld, Finance Director

DEPARTMENT GOAL(S) SUPPORTED <i>(if applicable)</i>	FISCAL IMPACT	

SUMMARY: As part of the budget process, we are annually evaluating fees. A matrix that outlines proposed changes for 2025 is attached for review and discussion.

STAFF RECOMMENDATION:

ATTACHMENTS:

2025 Proposed Fee Change Matrix

RECOMMENDED MOTION: None



**City of Waupun Fee Schedule
2024**

Some items require the collection of sales tax. This will be calculated during the transaction.

	DESCRIPTION	ADDITIONAL INFORMATION	2024 RATE	PROPOSED 2025 RATE	MUNICIPAL CODE CHAPTER
1	GENERAL GOVERNMENT				
2	GENERAL GOVERNMENT				
6	Room Tax		7.50%	8.00%	3.11(1)
7	LICENSES/PERMITS				
8	Dogs/Cats - Neutered or Spayed	Annually April 1 - March 31	\$2.00	\$10.00	11.09(1)
9	Dogs/Cats - Non - Neutered or Spayed	Annually April 1 - March 32	\$5.00	\$20.00	11.09(1)
10	Late Fee for Dog/Cat Licenses		\$5.00	\$5.00	11.09(3)
11	LIQUOR LICENSES	State Fee Law			
12	Class "A" Beer	no max / no min	\$75.00	\$100.00	11.01(3)(a)
13	"Class A" Liquor	\$500 max / \$50 min	\$150.00	\$350.00	11.01(3)(f)
14	Class "B" Beer	\$100 max/ no min	\$100.00	\$100.00	11.01(3)(b)(1)
15	"Class B" Liquor	\$500 max / \$50 min	\$250.00	\$475.00	11.01(3)(g)
16	"Class C" Wine	\$100 max / no min	\$100.00	\$100.00	11.01(3)(k)
17	Picnic License		\$10.00	\$10.00	11.01(3)(b)(2)
18	Wholesalers Fermented Malt Beverage		\$25.00	\$25.00	11.01(3)(c)
19	Special Wholesaler's License		\$25.00	\$25.00	11.01(3)(d)
20	Club License		\$25.00	\$25.00	11.01(3)(h)
21	Operators License		\$20.00	\$40.00	11.01(3)(e)(1)
22	Operators Provisional		\$10.00	\$15.00	11.01(3)(e)(2)(c)
23	SODA				
24	Soda Water		\$5.00	eliminate	11.01(3)(j)
25	CIGARETTE				
26	Cigarette		\$50.00	\$175.00	11.13
27	MILK				
28	Milk - Sale and Distribution		\$25.00	eliminate	10.03(3)(c)
29	Milk Vendor's License		\$10.00	eliminate	10.03(5)(c)
30	PARKING				
42	Street and Sidewalk Excavation Permit Application		\$15.00	\$150.00	7.05(1)(b)
93	ZONING				
95	Special Assessment Letters		\$10.00	\$40.00	



AGENDA SUMMARY SHEET

MEETING DATE: 10/29/2024

TITLE: Discuss City Ordinance 6.10 Bicycles

AGENDA SECTION: DISCUSSION

PRESENTER: Rasch/Lagenfeld/Schlieve

DEPARMTENT GOAL(S) SUPPORTED <i>(if applicable)</i>	FISCAL IMPACT	
High Performance Government	--	

ISSUE SUMMARY:

Current City Ordinance 6.10 on Bicycles is attached as well as a draft of community survey questions to solicit community input as we seek to update our current ordinance. 2019 Wisconsin Act 34 provides some regulation on e-bikes. Currently the City has no regulations pertaining to e-bikes, e-scooters, e-skateboards, etc. We are looking for input on changes the council would like to see addressed in an ordinance revision so that we can begin our community input process prior to creating a first draft of ordinance revisions.

RECOMMENDATION:

Discussion only

ATTACHMENTS:

MOTIONS FOR CONSIDERATION:

N/A

6.10 BICYCLES.

- (1) REGISTRATION. All bicycles operated upon any street or public way within the City must be registered by the owner and properly licensed as hereinafter provided. As used herein, the term "bicycle" shall be defined as a single wheel unicycle, a 2-wheel bicycle and a 3-wheel tricycle, subject to such exceptions as set forth in subsection (5) hereof.
- (2) REGISTRATION AND LICENSING PROCEDURES. All bicycles shall be registered, and the cost therefor shall be established annually by the Common Council on the Fee Schedule.
 - (a) Each bicycle shall be inspected by the Police Department at the time of registration and must meet the following standards:
 1. A brake on at least one wheel that will skid the wheel on dry pavement.
 2. A serial number that is legible. Owner must arrange to have a number stamped on by a reputable bicycle shop if it is missing or illegible.
 3. Proof of ownership if requested.
 4. A jiffy or other type stand which will hold bicycle when parked.
 5. A clear reflector attached to the rear fender or several strips of reflector tape appropriately attached to the bicycle.
 - (b) Upon payment of the appropriate fee, if registration and mechanical requirements have been met, the owner will be issued a license sticker that must be securely fastened to the back of the seat or rear fender in such a manner so as to be easily visible.
 - (c) Bicycle license stickers, as with automobile licenses in Wisconsin, belong to and remain with the owner of the bicycle and are not transferable.
 - (d) Within 10 days after any bicycle has changed hands or been dismantled and taken out of use, the person in whose name the bicycle has been registered shall report such information to the Police Department. In case of change of ownership, the registration shall thereupon be cancelled and the new owner shall have 10 days in which to register such bicycle and, upon payment of the appropriate fee and meeting other requirements, shall be issued a new license. In case of dismantling and taking out of operation, the registration shall be cancelled and the license plate returned to the Police Department.
 - (e) Any purchaser of a new or used bicycle must, within 10 days, register and purchase a new license sticker, except as provided in paragraph (c) above.
 - (f) Merchants and/or dealers in bicycles who trade in used bicycles or buy used bicycle parts or junk bicycles must give full report to Police Department once each month, giving the license and serial numbers on all transactions, as well as the names of the parties involved.
 - (g) All registrants will be given a copy of the Bicycle Safety Handbook.
 - (h) All licenses presently issued shall remain in effect for the period of their original issuance and at the time of expiration the above paragraphs shall take effect. With regard to bicycles that have not been previously licensed in the City, stickers should be obtained within 10 days of the passage of publication of this subsection.
- (3) GENERAL REGULATION AND EQUIPMENT.
 - (a) No person shall operate a bicycle in the City without the consent of the registered owner.
 - (b) Every license issued hereunder shall be deemed to be granted, subject to the following conditions:

-
1. Every person propelling or riding a bicycle upon a public roadway shall be subject to the provision of all ordinances and State laws applicable to the operator of any vehicle, except those provisions with reference to equipment of vehicle and except those provisions which by their nature would have no application.
 2. No person may operate a bicycle upon a highway, bicycle lane or bicycle way during hours of darkness, unless such bicycle is equipped with or the operator is wearing a lamp emitting a white light visible from a distance of at least 500 feet to the front of such bicycle. Such bicycle shall also be equipped with a red reflector that has a diameter of at least 2 inches of surface area on the rear so mounted and maintained as to be visible from all distances from 50 to 500 feet to the rear when directly in front of lawful upper beams of headlamps on a motor vehicle. A lamp emitting a red light visible from a distance of 500 feet to the rear may be used in addition to but not in lieu of the red reflector.
 3. Any type of siren on a bicycle is unlawful.
 4. No person over 10 years of age shall ride a bicycle on any public sidewalk, school playground or public park in the City of Waupun, except roadways. This section shall not apply when riders are taking part in a sponsored festivity or parade, nor to newsboys while actively engaged in delivering newspapers.
 5. No person regardless of age or occupation shall ride or park a bicycle on the sidewalk in the downtown area of the City of Waupun. The downtown area is defined as follows: E. Main St. from the railroad tracks to the intersection with Watertown St., and that portion of Fond du Lac St., Carrington St., Madison St., Mill St., Forest St. and Drummond St. lying within one block of E. Main St.
 6. Every bicycle must have an adequate brake maintained in good working condition.
 7. Bicycles, when operated on a highway, shall be kept as close to the right-hand curb as possible.
 8. Bicycles must always be operated in single file.
 9. No more than one person shall ride a bicycle at one time, except on special bicycles built for 2 or more people with 2 or more seats and handlebars, except that in addition to the operator, a bicycle otherwise designed to carry only the operator may be used to carry or transport a child seated in an auxiliary child's seat or trailer designed for attachment to a bicycle if the seat or trailer is securely attached to the bicycle according to the direction of the manufacturer of the seat or trailer.
 10. No person shall cling to or be towed by another vehicle or bicycle while riding on a public street or highway.
 11. No bicycle shall tow anything behind, such as a sled, another bicycle, trailer or person on skates, except that in addition to the operator a bicycle otherwise designed to carry only the operator may be used to carry or transport a child seated in an auxiliary child's seat or trailer designed for attachment to a bicycle if the seat or trailer is securely attached to the bicycle according to the directions of the manufacturer of the seat or trailer.
 12. No person while riding a bicycle shall participate in a race, speed or endurance contest while on a public street.
 13. Trick riding and riding a bicycle without at least one hand on the handlebars and both feet on the pedals is unlawful.
 14. Bicycle riders must obey all traffic laws when riding on public streets and highways in the City, such as:

-
- a. Giving hand signals for left turns, right turns and stopping.
 - b. Stopping for arterials.
 - c. Giving pedestrians on crosswalks the right-of-way.
 - d. Being in the proper lane when making turns.
 - e. Staying in your lane and not weaving in and out.
 - f. Riding at safe speeds for conditions.
 - g. Slowing down for turns to avoid skids.
 - h. Stopping before coming out of driveways.
15. The license plate must always be prominently displayed on the rear of the bicycle. New replacement license plates may be purchased, when necessary, with the approval of the Police Department for a fee established annually by the Common Council on the Fee Schedule.
 16. A unicycle shall not be required to be equipped with a wheel brake or handle bars.
- (4) ENFORCEMENT PROCEDURES AND PENALTIES.
- (a) The City Police Department will have all the necessary records, files, tickets and authority to properly record, control and penalize to facilitate the enforcement of this section for the safety and protection of all bicycle riders in the City.
 1. Any violator of the bicycle ordinances accused by a police officer will be informed on his violation by the officer who will fill out a special "Bicycle Violation" ticket including:
 - a. Name of alleged violator.
 - b. Address.
 - c. License number.
 - d. Parents name, address and phone number.
 - e. Violation.
 - f. The officer will record his explanation on the reverse side of the ticket proper and any remarks he may have and turn in the ticket to the Police Department. The Police Department shall cause written notice of the alleged offense and the date and time for hearing to be mailed to the parent or guardian of every first offender.
 - g. The stub of the ticket shall be given to the alleged violator stating the violations complained of and the date and time to report.
 2. The alleged violator will be required to report to the City Hall or the Police Department as determined by the accusing officer. The accused violator must present his stub at the time of appearance.
 3. Each accused violator appearing at the City Hall or Police Station as required will be given an opportunity to discuss their violation with the Chief of Police or an officer appointed by the Chief to preside at such session. After the discussion or hearing with the Chief or their delegate, the following penalty or penalties shall be imposed by the presiding officer:
 - a. First Offense: A forfeiture as established annually by the Common Council on the Fee Schedule.

-
- b. Second Offense: A forfeiture as established annually by the Common Council on the Fee Schedule.
 - c. Third Offense: A forfeiture as established annually by the Common Council on the Fee Schedule. The parent or guardian of the violator shall accompany the violator at such discussion or hearing.
 - d. Fourth Offense: Formal charge to be tried in juvenile court.
 - e. Any violation of penalties necessitates charging offender with an additional offense.
4. Violation ticket shall be filled out by the presiding officer as to the sentence imposed and same shall be filed with offender's registration card.
- (b) As an alternate penalty to the provisions of § 6.10(4)(a)3., any violator who is over the age of 18 years shall, upon conviction of such violation, be subject to the penalties set forth in § 6.11.
- (5) EXCEPTIONS. The term "bicycle" as used herein shall not include what is normally known as a tricycle operated by children under 10 years of age, nor shall it include the 20-inch bicycle when used with 2 training wheels, provided that neither tricycles nor bicycles with training wheels shall be operated upon the city streets or public ways at any time, nor shall tricycles or 20-inch bicycles be ridden or parked on the sidewalk in the downtown area as defined heretofore.
- (6) ENFORCEMENT. The Chief of Police may designate and authorize the school crossing guards as his agents and representatives with limited police powers to aid in the enforcement of this section. Such school crossing guards as designated by the Chief of Police may issue citations to persons they observe violating the provisions of this section.
- (Ord. No. 15-06, § 1, 7-14-2015; Ord. No. 23-09, § 3, 11-28-2023)

DRAFT – Proposed Bicycles/e-bikes/scooters Community Survey Questions
9/24/24

DEFINITIONS

Bicycle: A vehicle composed of two wheels held in a frame one behind the other, propelled by pedals and steered with handlebars attached to the front wheel.

e-bike: A low-speed bicycle with a small electric motor that assists the rider in pedaling or propelling the bike.

Class 1 e-bikes assist riders up to 20 mph when pedaling

Class 2 e-bikes offer propulsion up to 20 mph but can be solely motor-driven

Class 3 e-bikes assist up to 28 mph, but riders must be pedaling to activate the motor. Per State Law, individuals under 16 cannot operate Class 3 e-bikes.

Class 4 e-bikes are high powered and are not a street legal electric bike under the U.S. electric bike classification system. Speeds can be greater than 28 mph and the motor output is greater than 750W. This class of bike is treated as a motorized vehicle that needs to be licensed and registered similar to a moped.

Electric scooter or e-scooter: a personal transport device that has two or more wheels, a standing platform, an electric motor, and are steered by a handlebar

Electric skateboard: a personal transportation device that is based on a skateboard. It has a floorboard, an electrical propulsion system, and is designed to be ridden by one person at a time. An electric skateboard is controlled by tilting the board to the left or right. The speed of an electric skateboard is usually controlled by a wireless remote or by shifting the riders weight.

QUESTIONS:

1. The current City ordinance on bicycles prohibits the use of bicycles on any public sidewalk, school playground, or public park for those who are over 10 years of age.
 - Should the city allow bicycles on public sidewalks regardless of the age of the rider?
YES/NO
 - Should the city allow bicycles in public parks regardless of the age of the rider?
YES/NO
2. The current City ordinance on bicycles prohibits all bicycles, regardless of age, on the sidewalks in the downtown area of the City. The downtown area is defined as E. Main St. from the railroad tracks to the intersection with Watertown St., and that portion of Fond du Lac St., Carrington St., Madison St., Forest St. and Drummond St. lying within one block of E. Main St.
 - Should bicycles be allowed on the sidewalks in this area of the City?
YES/NO
3. E-bikes have become a popular means of transportation in the City. The City would like to establish guidelines for their use on public streets and roads.
 - Should e-bikes be permitted on non-motorized roads, sidewalks and paths in the City?
YES/NO

DRAFT – Proposed Bicycles/e-bikes/scooters Community Survey Questions

9/24/24

- Should e-bikes be permitted on non-motorized roads, sidewalks and paths in the City if the motor is turned off? YES/NO
 - What are your concerns, if any, with e-bikes?
4. E-scooters have become a popular means of transportation for all ages. The City would like to establish guidelines for their use on public sidewalks, public streets, parks and roads.
- Should the City allow e-scooters on public sidewalks?
YES/NO
 - Should the City allow e-scooters on public streets?
YES/NO
 - Should the City allow e-scooters in city parks?
YES/NO
 - Should the City allow e-scooters on roads?
YES/NO
5. Should restrictions be put into place that e-scooters are not allowed to carry more than one passenger at a time?
YES/NO
6. Should restrictions be put into place that e-scooters are not allowed to tow anything behind, such as a sled, another scooter, bike, trailer, person on skates?
YES/NO
7. Electric skateboards have become a popular means of transportation for all ages. The City would like to establish guidelines for their use on public sidewalks, public streets, parks and roads.
- Should the City allow Electric skateboards on public sidewalks?
YES/NO
 - Should the City allow Electric skateboards on public streets?
YES/NO
 - Should the City allow Electric skateboards in city parks?
YES/NO
 - Should the City allow Electric skateboards on roads?
YES/NO
8. Should restrictions be put into place that Electric skateboards are not allowed to carry more than one passenger at a time?
YES/NO
9. Should restrictions be put into place that Electric skateboards are not allowed to tow anything behind, such as a sled, another scooter, bike, trailer, person on skates?
YES/NO
10. Research has shown that an alert tone can significantly improve pedestrian detectability of an approaching electric vehicle. For example, in a 50 decibel environment, pedestrians could detect a silent scooter from about 15.8 feet away, but with a 56 decibel alert tone, they could detect it from 98.5 feet away. 50 decibels is similar to a

DRAFT – Proposed Bicycles/e-bikes/scooters Community Survey Questions
9/24/24

quiet office setting or a refrigerator, 56 decibels is comparable to light traffic or a moderate conversation.

- Should the city impose sound level restrictions on all electric bikes, scooters, and skateboards? For example, sound not to exceed 56 decibels.
11. Research has shown that electric skateboards can be modified to go faster than 20-25 miles per hour by installing bigger wheels.
- Should the city impose speed limits for electric skateboards? YES/NO
12. Modifications are also made to e-bikes and e-scooters. Should the city impose a speed limit for these types of vehicles?
- 10-15 miles per hour
 - 15-20 miles per hour
 - 20-25 miles per hour

City of Waupun Ordinance Revision Progress Timeline

Last Update 10/25/2024

Muni. Code Chapter	Description	Requested By	Date requested	Assigned To	Priority	Status	Deadline	Additional Notes
2	Remote Meeting Attendance / Voting	Kathy	3/22/2024	Angie	1	Researching	12/1/2024	
3	Record Retention - Social Media Archive	Casey	4/22/2024	Casey	1	In Draft Form	10/1/2024	Discussion draft document prepared, sent to legal for review
6	Bicycles on Sidewalks	Mayor	5/13/2024	Casey	1	Community Feedback	12/31/2024	Draft on community survey on bike ordinance to include questions on e-bikes, e-scooters, etc. Oct COW discussion for input prior to launch.
8	Dog Leash	Jeremy	2/1/2024	Jeremy	1	Draft Form	10/30/2024	Drafting language to include a stepped penalty, i.e., 1st offense, 2nd offense and moving through legal review. Moving to legal review prior to appearing for first read.
11	Public Art	Kathy	3/18/2024	Kathy	1	Draft Form	12/1/2024	Initial Discussion with Council 3/26/24; Pending legal review before bringing for 1st read
11	Liquor License Changes	Angie	3/22/2024	Angie	1	Researching	12/1/2024	DOR information recently released. Evaluating current ordinance
16	Tires	Kathy	3/1/2024	Casey	1	Researching	6/1/2024	Have talked with area businesses to review proposed ordinance changes and found concerns with being overly restrictive to prevent normal business operation; Working with legal to determine best course of action.
8 and 11	Vaping	Angie	3/22/2024	Angie	1	Researching	12/1/2024	
	Vacant Building Registration and Maintenance	Kathy	8/23/2024	Kathy	1	Researching	12/1/2024	Discussed at August COW. Completing further research and drafting language for legal review.
16	Fence	Building Inspector	1/1/2022	Zoning Administrator	2	Researching	3/15/2025	
16.13	Home Occupations	Kathy	3/1/2024	Casey	2	Researching	6/1/2024	
9	Nuisance	Fire Dept	1/1/2022	BJ	2	Researching	8/30/2024	
25	Downtown Design Guidelines	CDA	3/19/2024	Kathy	2	Researching	12/1/2024	
11	Business Licensing	Casey	4/1/2024	Casey	2	Researching	12/1/2024	
	ROW Easement Small Cell Tower	Utilities	4/1/2024	Utilities	2	Researching	12/1/2024	
17	Subdivision Ordinance updates	Kathy	4/1/2024	Kathy	2	Researching	6/1/2025	Reviewing Planning Proposals to facilitate process
COMPLETED								
8	Sexting	Jeremy	5/3/2023	Jeremy		Complete	5/3/2024	
8	Truancy	Municipal Judge	2/13/2024	Jeremy		Complete	5/14/2024	
16	Projecting Signage Amendment	BID	3/20/2024	Kathy		Complete	6/1/2024	
18	Municipal Court Fees	Municipal Judge	2/13/2024	Jeremy		Complete	5/14/2024	
11.02	Peddler, Solicitors, and Transient Merchants and Mobile Food Trucks	Kathy	3/18/2024	Kathy		Complete	6/1/2024	
	Floodplain Ordinance	Building Inspector	8/15/2024	Building Inspector		Complete	9/24/2024	
	Sidewalk Construction & Repair	Jeff	9/10/2024	Jeff		Complete	10/31/2024	