



A G E N D A
CITY OF WAUPUN BUSINESS IMPROVEMENT
DISTRICT MEETING
Waupun City Hall – 201 E. Main Street, Waupun WI
Wednesday, June 09, 2021 at 7:00 AM

Join Zoom Meeting

<https://us02web.zoom.us/j/84937905633?pwd=THJEQW9neThtOFpMSGRnME5WdIFBZz09>

Meeting ID: 849 3790 5633

Passcode: 892679

-or-

Dial by your location

(312) 626-6799 US (Chicago)

Meeting ID: 849 3790 5633

Passcode: 892679

CALL TO ORDER

ROLL CALL OF BOARD MEMBERS

PUBLIC COMMENT – *State name, address, and subject of comments (2 minutes).*

CONSIDER APPROVAL OF THE FOLLOWING AGENDA ITEMS:

1. Approval of Agenda/Motion to Deviate
- [2.](#) Approval of May 12, 2021 Business Improvement District Minutes
- [3.](#) Approval of May 2021 Financial Statement

PRIOR OUTSTANDING APPLICATIONS: (if expired, possible extension or cancellation)

- [4.](#) Tom Kulczewski - Real Sportscards (324 E. Main St.)

NEW APPLICATIONS FOR REVIEW AND CONSIDERATION:

- [5.](#) Ashley VandeKolk - The Parlor Hair Boutique (8 W. Main Street)
- [6.](#) Cassandra VerHage - c.verhage.photo (426 E. Main St.)
- [7.](#) Krista Bishop - Weaving It Up To You (307 E. Main St.)
- [8.](#) Jonathan Leonard - Thrivent Financial (407 E. Main St.)

DISCUSSION ITEMS:

9. 2021 Operating Plan Update
10. BID Assessment
11. Waupun Area Chamber of Commerce Update
12. Administrator Update

ADVANCED PLANNING:

13. Potential Agenda Items
14. Date of Next Meeting - July 14, 2021 at 7:00 a.m.

ADJOURNMENT

Upon reasonable notice, efforts will be made to accommodate disabled individuals through appropriate aids and services. For additional information, contact the City Clerk at 920-324-7915.



MINUTES
CITY OF WAUPUN – BUSINESS IMPROVEMENT
DISTRICT MEETING
In-Person & Teleconference
Wednesday, May 12, 2021 at 7:00 AM

Committee Members Present:

- Krista Bishop
- Kate Bresser
- Terri Crisp
- Gary DeJager (arrived 7:07 a.m.)
- Jonathan Leonard
- Rich Matravers (left at 7:45 a.m.)
- Teresa Ruch (arrived at 7:05 a.m.)
- Tyler Schulz

Committee Members Absent:

- Austin Armga
- Jodi Mallas

Waupun Area Chamber of Commerce

Zac Dickhut (arrived at 7:04 a.m.) Interim Executive Director

Staff Present:

- Kathy Schlieve Administrator
- Sarah Van Buren Community & Economic Development Coordinator

Other:

Andrea Oosterhouse The Clothing Pallet

CALL TO ORDER:

Ms. Van Buren called the meeting to order at 7:00 a.m.

ROLL CALL OF BOARD MEMBERS:

Roll call and quorum determined.

PUBLIC COMMENT:

None.

CONSIDER APPROVAL OF THE FOLLOWING AGENDA ITEMS:

1. Approval of Agenda/Motion to Deviate

Ms. Van Buren informed the group that item 5 on the agenda should read "Selection of the Day of Month and Time of Business Improvement District Board Meetings".

A motion to approve the agenda, as amended, was made by Mr. Matravers and seconded by Ms. Bishop, passing unanimously.

2. Recognition of Mayoral Appointment of Members of the Business Improvement District

Recognition of Ms. Crisp to the BID Board is heard.

3. Nominations and Appointment of Chair of the Business Improvement District

A motion to appoint Ms. Bishop as Chair of the BID Board was made by Ms. Bishop and seconded by Ms. Bressar. A motion to appoint Mr. DeJager as Chair was made by Mr. Schulz and seconded by Mr. Leonard, Through a roll call vote, Ms. Bishop was appointed Chair by a 4-2 vote.

4. Nominations and Appointment of Vice-Chair of the Business Improvement District

A motion to appoint Ms. Ruch as Vice-Chair of the BID Board was made by Ms. Bishop and seconded by Mr. DeJager, passing unanimously.

5. Selection of the Day of Month and Time of Business Improvement District Board Meetings

A motion to continue with the second Wednesday at 7:00 a.m. for holding the monthly meeting was made by Mr. Schulz and seconded by Mr. DeJager, passing unanimously.

6. Approval of March 10, 2021 Minutes

A motion to approve the March 10, 2021 minutes was made by Mr. Matravers and seconded by Mr. Schulz passing unanimously.

7. Approval of the March 2021 Financial Statement

A motion to approve the March 2021 financial statement was made by Mr. DeJager and seconded by Mr. Leonard, passing unanimously.

8. Approval of April 2021 Financial Statement

A motion to approve the April 2021 financial statement was made by Mr. DeJager and seconded by Mr. Leonard, passing unanimously.

9. 2021 Business Improvement District Audit

As required by Wisconsin Statutes regulating Business Improvement Districts, Baker Tilly completed the 2020 Waupun Business Improvement District audit, as part of the City's annual audit process. No material modifications to the financial statements were needed in order to comply with accounting principles.

A motion accepting the 2020 audit was made by Mr. DeJager and seconded by Mr. Schulz, passing unanimously.

NEW APPLICATIONS FOR REVIEW AND CONSIDERATION:

10. Maria Ruissen – The Clothing Pallet (18 N. Madison St.)

In the absence of Maria Ruissen, co-owner of The Clothing Pallet, Andrea Oosterhouse presented their request for funding from the Façade Improvement Program application for the property located at 18 N. Madison St. The project will be installing new windows, painting the exterior of the building, and installing a new sign and new lighting. The total project cost is \$11,438.56. Staff recommends approval. Motion made by Mr. Leonard and seconded by Mr. Schulz to approve 50% of the total project cost, not to exceed \$2,000, passing unanimously.

DISCUSSION ITEMS:

11. 2021 Operational Plan Updates

- Design
 - Adopt-A-Planter participants will receive their planters the morning of May 25th.
 - After working with the Terri Costello, the Main Street Planters will contain grass, petunias, and sweet potato vines. High school students will once again be able to do the plantings. Planting day will be the afternoon of May 25th.
- Economic Vitality
 - Still looking for space to be able to hold the 2021 Pop-Up program.
 - Three proposals were received, and interviews were conducted, for the Downtown Market Analysis. Through this process, staff feels the proposal from UW-Extension best aligns with the goal of this activity. Administrator Schlieve shared an example of their work that was done for Sauk Prairie. The group feels the work is important and looks forward to working on this effort with UW-Extension staff.
- Organization
 - 2022 Operating Plan will need to start being worked on this summer so will be engaging the small working group.
- Promotions
 - The Waupun Downtown Promotions Committee have the following upcoming events:
 - Farmers Market will start June 5th. Casey has been hired as the Farmers Market manager.
 - Wine Walk is being planned for August 20th
 - Group has been brainstorming ideas on how to bring more family friendly activities to the downtown.
 - Discussion with Nancy Vanderkin regarding 2021 Winter Wonderland. Currently the event is scheduled for November 12-14.
 - Work has started on the Discover Waupun website. Every downtown business will be listed with links to their respective websites. There will also

be a section for specials being offered and job opportunities.

12. Waupun Chamber of Commerce Update

Mr. Dickhut provided the following updates:

- Open house yesterday – descent participation and to get a feel as to what the chamber members are looking for in 2021
- Board currently has 5 vacancies.
- Annually meeting will be planned soon and will hopefully be able to get more board members.
- New chamber space has been updated. Fine Arts group is interested in also interested in sharing the space with monthly artist highlighting their art. Hope this is a start of more collaboration between entities that have shared goals
- Idea – also of businesses/spaces used to be two store fronts and might be something to take into consideration for future

13. Administrator Update

Administrator Schlieve provided the following updates:

- At the April CDA meeting, the board approved one Downtown Small Business COVID-19 Technology Grant, one Downtown Revitalization Grant, and three Downtown Targeted Reinvestment Grants All of the proposed projects will be bringing big, positive changes to our Downtown
- Continue to look at broader state programs to facilitate work in our downtown.
- Wayfinding signage was put on hold in 2020 due to COVID. The goal for 2021 is to design and install the new signage throughout the City.
- Our tourism partner, Destination Lake Winnebago Region, will be coming back to our community to film more tourism videos to help market our assets.
- Staff is reaching out and collaborating with eligible entities on the Restaurant Revitalization Fund and continues to research other opportunities identified in the ARPA legislation.
- Working on several industrial attraction projects and there will be continue to be a workforce issue and housing issue.

ADVANCED PLANNING:

14. Potential Agenda Items

- Grant Requests, if any

15. Date of Next Scheduled Meeting

The next meeting is scheduled for June 9, 2021 at 7:00 a.m.

ADJOURNMENT

The motion to adjourn was made by Mr. DeJager and seconded by Ms. Bishop passing unanimously. The meeting adjourned at 7:50 a.m.

CASH ON HAND

Prior Month Ending Balance	\$ 28,651.32
Plus Current Month Deposits	\$ -
Less Current Month Expenses	\$ (1,014.99)
Total Cash on Hand	\$ 27,636.33

DESIGN:

FACADE IMPROVEMENT GRANT PROGRAM

2021 Budget	\$ 8,000.00
2020 Carryover	\$ 273.32
Less Approved Grants	\$ (4,000.00)
Funds Available for Distribution	\$ 4,273.32

Expense Details:

<u>Date Approved</u>	<u>Expiration Date</u>	<u>Applicant Name</u>	<u>Grant Amount</u>	<u>Date Paid</u>	<u>Check #</u>
3/10/2021	6/10/2021	Tom Kulczewski/Real Sportscards	\$ 2,000.00		
5/12/2021	8/12/2021	The Clothing Pallet	\$ 2,000.00		
		Total Approved Grants	\$ 4,000.00		

BEAUTIFICATION EXPENSES (MAIN STREET AND SIDE STREET PLANTING PROGRAM AND IMPLEMENTATION)

2021 Budget	\$ 3,500.00
2020 Carryover	\$ 298.11
Less Year-to-Date Expense	\$ (14.99)
Funds Available for Distribution	\$ 3,783.12

Expense Details:

<u>Date Issued</u>	<u>Vendor</u>	<u>Description</u>	<u>Amount Paid</u>	<u>Check #</u>
5/11/2021	Marten's Ace Hardwa	Replacement planter for Adopt-A	\$ 14.99	531
		Total Beautification Expense	\$ 14.99	

Promotions:

MARKETING & PROMOTION EXPENSES (BID DISTRICT ADVERTISING)

2021 Budget	\$ 500.00
Less Year-to-Date Expense	\$ -
Funds Available for Distribution	\$ 500.00

Expense Details:

<u>Date Issued</u>	<u>Vendor</u>	<u>Description</u>	<u>Amount Paid</u>	<u>Check #</u>
		Total Marketing & Promo Expense	\$ -	

ECONOMIC VITALITY: SEMINARS, MARKET ANALYSIS, POP-UP WAUPUN

2021 Budget	\$	12,362.19
2020 Carryover	\$	3,515.62
Less Year-to-Date Expense & Budgeted Rent Expense for 2021	\$	(1,297.92)
Funds Available for Distribution	\$	<u>14,579.89</u>

Expense Details:

<u>Date Issued</u>	<u>Vendor</u>	<u>Description</u>	<u>Amount Paid</u>	<u>Check #</u>
1/4/2021	Dustin Bruntjen	Pop-up Shop Rent Jan'21	\$ 400.00	521
2/4/2021	Dustin Bruntjen	Pop-up Shop Rent Feb '21	\$ 400.00	525
2/16/2021	Waupun Utilities	Pop-up Shop utilities Jan '21	\$ 123.48	526
2/23/2021	Alliant Energy	Pop up shop utilities for Jan '21	\$ 115.68	527
3/9/2021	Alliant Energy	Pop-up Shop utilities Feb '21	\$ 130.89	528
3/12/2021	Waupun Utilities	Pop-up shop utilities Feb '21	\$ 127.87	529
		Total Economic Vitality Expense	\$ <u>1,297.92</u>	

ORGANIZATION: AUDIT AND BOARD MEMBER WORKSHOP

2021 Budget	\$	1,500.00
2020 Carryover	\$	-
Less Year-to-Date Expenses	\$	(1,000.00)
Funds Available for Distribution	\$	<u>500.00</u>

Expense Details:

<u>Date Issued</u>	<u>Vendor</u>	<u>Description</u>	<u>Amount Paid</u>	<u>Check #</u>
5/5/2021	City of Waupun	Audit Fee	\$ 1,000.00	530
		Total Audit and Board Member Workshop Expense	\$ <u>1,000.00</u>	



324 E. Main St, Waupun, WI 53963

June 2, 2021

Sarah Van Buren
201 E. Main St.
Waupun, WI 53963

RE: 324 E. Main St BID Grant – Application is Expiring; Request for Extension

Sarah:

Thank you for the letter on my application due to expire on June 10, 2021. I would like to provide you, and the BID Committee an update.

Like many items this year, our windows are delayed in production. Currently, the tentative ship date is 6/20/2021. The original plan was to have them installed in the month of May. With this delay, I did decide to have the brick mold and jam stops replaced around the windows, adding to the project. This work is taking place this week. You may have noticed the lift in the air all week for this work.

Due to this delay, I am asking the BID Committee for a Sixty (60) Day Extension on this application. Baring no unforeseen issues, this will allow the windows to arrive, work to take place and payment to be made.

I will not be able to attend the meeting on June 10, 2021. That week is the first week of summer vacation for our children. We are taking a family vacation to Northern Michigan. I understand Zoom is an option, but I am assuming (and frankly hoping) there is no internet access where we will be.

Please include this letter to the committee in the pre meeting materials.

I would be happy to answer any questions you, city employees, the committee or the general public may have. I can best be reach at takulcz@gmail.com or 920-691-6214.

Thank you!

Tom Kulczewski, Owner
Real Sportscards



CITY OF WAUPUN - ECONOMIC DEVELOPMENT
Waupun City Hall
201 E. Main Street, Waupun WI
920-324-7900

June 2, 2021

Tom Kulczewski
324 E. Main St.
Waupun, WI 53963

RE: 324 E. Main St. BID Grant – Application is Expiring

Mr. Kulczewski,

At the March 10, 2021 Business Improvement District meeting, you submitted an application for reimbursement from the Façade Improvement Program for your project at the estimated total of \$24,000, which the Board approved you to be reimbursed up to 50% of the actual expenses, not to exceed \$2,000.

As that time, the stipulation for this funding was that the project must be completed within 90 days of approval and have copies of the paid invoices turned into me.

Your application is due to expire on **June 10, 2021**.

If your project is complete, please provide me with the paid receipts so a reimbursement check can be issued to you.

If your project will not be completed by the expiration date, you will be placed on the June 9, 2021 agenda and need to appear before the Board to request an extension. I understand you will be on vacation during this time and will not be able to attend the meeting. I recommend providing a written summary of the delay, when the project is expected to be completed, and how long of an extension you are requesting.

Please email me (sarah@cityofwaupun.org) to inform me of the progress of your project.

Sincerely,

A handwritten signature in blue ink that reads "Sarah Van Buren".

Sarah Van Buren, Community & Economic Development Coordinator

Waupun Business Improvement District (BID)
~ Façade Improvement Program – Grant Application ~

Applications missing any materials will be returned for completion.

Date: June 2 2021
Applicant Name: Ashley Vandekolk
Applicant Address: 8 W Main St
Phone: 920.382.2024 Fax: _____ Email: parlorhairboutique@gmail.com
Name of Business/Property: The Parlor Hair Boutique
Property Address: 8 W Main St Waupun
Property Use: Hair Salon
Property owner, if different than applicant: Jill Vanderkin
Owner address: 12 W Main St Owner Phone: 920.960.4875

Project Summary:

Brief Project Summary: Hanging a projected exterior sign \$750⁰⁰
asking for forgiveness of the conditional use permit \$150⁰⁰

Total Estimated Cost: \$ 900

Total Grant Request: \$ 450

Projected Start Date: July 2021

Projected Completion Date: July 2021

Name of Contractor: _____

Issue Payment if approved: Applicant or Business (circle)

Approval of City Building Inspector: JL (Inspector's initials)

pending CUP Approval by Plan Commission

Required attachments:

Project plan(s) to 1/4" scale, if applicable

Current photo(s) of property

Release of Information Letter (attached)

Paint color(s) or material sample(s), if applicable

Quotes/Estimates

Submit application form and attachments to:

Waupun Business Improvement District – City Clerk, Waupun City Hall
201 E. Main Street, Waupun WI 53963
920-324-7915 ext. 5

To be completed by City staff only:

Date application received: 6/2/21

Application reviewed for completeness by 6/2/21 (initials). Date: 6/2/21

Applicant notified of scheduled BID meeting by 6/2/21 (initials). Date: 6/2/21

Waupun Business Improvement District (BID)
~ Façade Improvement Program - Release of Information Letter ~

Date: June 2, 2021

To: Waupun Business Improvement District – Clerk’s Office, Waupun City Hall
201 E. Main Street, Waupun WI 53963

To Whom It May Concern:

I hereby authorize the Waupun Business Improvement District (BID) permission to share all application materials with BID board members who will be reviewing my application. I acknowledge that information provided to the BID may be released upon request in compliance with the open record requirements and in accordance with the freedom of information act. I acknowledge that I am to attend the BID board meeting in which this request will be reviewed and that the City of Waupun will notify me of that meeting.

Signed,

Name (print): Ashley VandeKolk

Signature: Ashley VandeKolk

Date: June 2, 2021

Sarah Van Buren

From: Sarah Van Buren
Sent: Wednesday, June 2, 2021 10:22 AM
To: Jill Vanderkin
Subject: RE:

Thanks, Jill. I will include this email with the application.

Sarah

-----Original Message-----

From: Jill Vanderkin <vanderkinplumbing@sbcglobal.net>
Sent: Wednesday, June 2, 2021 10:18 AM
To: Sarah Van Buren <sarah@cityofwaupun.org>
Subject:

Hi Sarah,

I just talked to Ashley Vande Kolk, she told me about the issue with her sign. I am aware she is hanging a sign, and she has my permission to do so. Hope that things can proceed for her. She asked me to talk to you.

Consider this text my signature. I can sign in I person next week.

Thanks much 😊

Jill Vanderkin

Sent from my iPhone

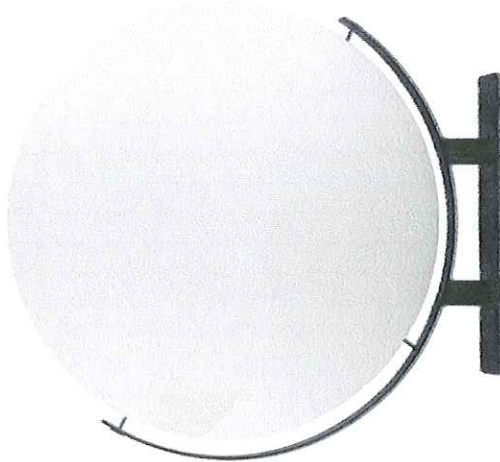

36" Eclipse Fixed Mount Sign Bracket
Sign Substrate: 1" Thick - 36" PVC Circle
Double-sided vinyl print

\$750.00

Installation done by customer

Mounting Type	Wall Mount
Color	Black
Material	Iron, Steel
Shape	Round
Style	Fixed, Round

NOTES:

1. (3) $\varnothing 1/2"$ SIGN MOUNTING HOLES EVENLY SPACED AROUND FRAME

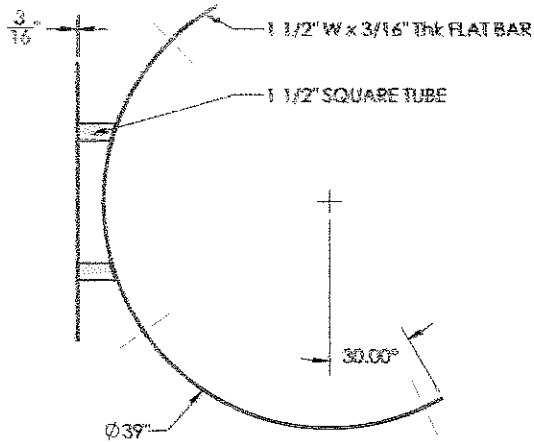

FRONT VIEW

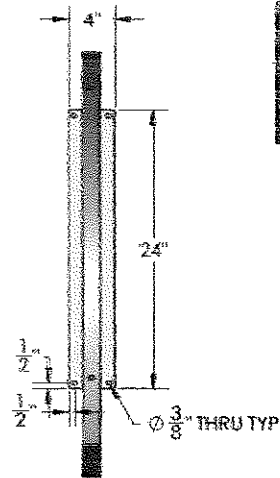

SIDE VIEW

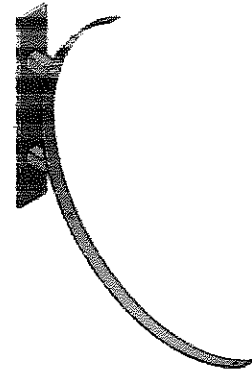

Material:
Steel

Content: Eclipse 36" Sign Bracket

PN: 406B-36

Color/Finish: Textured Black Powder Coat

Waupun Business Improvement District (BID)
~ Façade Improvement Program – Grant Application ~

Applications missing any materials will be returned for completion.

Date: 5-25-21

Applicant Name: Cassandra VerHage

Applicant Address: 426 E. Main Street - Waupun

Phone: 920-210-6973 Fax: _____ Email: cassandra@cverhagephoto.com

Name of Business/Property: c.verhage.photo LLC

Property Address: 426 E. Main Street

Property Use: Photography Studio

Property owner, if different than applicant: _____

Owner address: _____ Owner Phone: _____

Project Summary:

Brief Project Summary: remove existing porch and replace with a Juliet balcony, replace door & frame, add signage, repaint wall with current paint color (greige), add gooseneck lights to create an attractive clean & appearance to the back half of the building that faces a busy alleyway.

Total Estimated Cost: \$ \$7871.73

Total Grant Request: \$ \$2000

Projected Start Date: asap

Projected Completion Date: 9-1-21

Name of Contractor: Eric TerBeest - Nick Paul
Warrior Fabrications

Issue Payment if approved: Applicant or Business (*circle*)

Approval of City Building Inspector: SKL (*Inspector's initials*)

Required attachments:

- | | |
|--|---|
| <input checked="" type="checkbox"/> Project plan(s) to 1/4" scale, if applicable | <input checked="" type="checkbox"/> Current photo(s) of property |
| <input checked="" type="checkbox"/> Release of Information Letter (attached) | <input checked="" type="checkbox"/> Paint color(s) or material sample(s), if applicable same as current color |
| <input checked="" type="checkbox"/> Quotes/Estimates | |

Submit application form and attachments to:

Waupun Business Improvement District – City Clerk, Waupun City Hall
201 E. Main Street, Waupun WI 53963
920-324-7915 ext. 5

To be completed by City staff only:

Date application received: 5/25/21
Application reviewed for completeness by SV (initials). Date: 5/25/21
Applicant notified of scheduled BID meeting by SV (initials). Date: 5/25/21

Waupun Business Improvement District (BID)
~ Façade Improvement Program - Release of Information Letter ~

Date: 5-25-21

To: Waupun Business Improvement District – Clerk’s Office, Waupun City Hall
201 E. Main Street, Waupun WI 53963

To Whom It May Concern:

I hereby authorize the Waupun Business Improvement District (BID) permission to share all application materials with BID board members who will be reviewing my application. I acknowledge that information provided to the BID may be released upon request in compliance with the open record requirements and in accordance with the freedom of information act. I acknowledge that I am to attend the BID board meeting in which this request will be reviewed and that the City of Waupun will notify me of that meeting.

Signed,

Name (print): Cassandra VerHage







Signature:  _____

Date: 5-25-21



Printed: 6/1/2021

My Store:
SUN PRAIRIE, WI
355 S GRAND AVE
SUN PRAIRIE, WI 53590
Tuesday: 6:00 AM to 10:00 PM

Product	How to Get It	Qty	Total Price
 <p><u>Master Mark Plastics® 10" Black Terrace Board Landscape Edging Stakes - 10 Pack</u> Black SKU: 2680313 Model #: 99410</p>	<p>Ship To Home Available for immediate shipment</p> <p>Deliver From Store Qualifies for Same-Day Delivery!</p> <p>Pick Up At Store - Menards Picks</p>	<p>2</p> <p>\$7.99/each</p>	\$15.98
 <p><u>Master Mark Plastics® 40' Black Terrace Board Landscape Edging</u> Black SKU: 2680311 Model #: 94440</p>	<p>Ship To Home Available for immediate shipment</p> <p>Deliver From Store Qualifies for Same-Day Delivery!</p> <p>Pick Up At Store - Menards Picks</p>	<p>1</p> <p>\$18.99/each</p>	\$18.99
 <p><u>NuPlay Black Rubber Mulch Nuggets - .8 Cu. Ft.</u> Black SKU: 1803020 Model #: NP8BK</p>	<p>Ship To Home Available for immediate shipment</p> <p>Deliver From Store Qualifies for Same-Day Delivery!</p> <p>Pick Up At Store - Customer Picks</p>	<p>15</p> <p>\$6.73/each</p>	\$100.95
 <p><u>Schlage® Matte Black Single Cylinder Door Deadbolt with Collins Trim</u> Matte Black SKU: 4403064 Model #: B60G622COL</p>	<p>Ship To Home Available for immediate shipment</p> <p>Deliver From Store Qualifies for Same-Day Delivery!</p> <p>✓ Pick Up At Store - Menards Picks</p>	<p>1</p> <p>\$41.99/each</p>	\$41.99
 <p><u>Schlage® Century Matte Black Lower Half Door Handleset and Latitude Door Lever with Century Trim</u> Matte Black SKU: 4403066 Model #: FE285GCEN622LATCEN</p>	<p>Ship To Home Available for immediate shipment</p> <p>Deliver From Store Qualifies for Same-Day Delivery!</p> <p>✓ Pick Up At Store - Menards Picks</p>	<p>1</p> <p>\$100.99/each</p>	\$100.99
 <p><u>Mastercraft® 36"W x 80"H Primed Steel Full Lite Composite Frame Exterior Door System - Left Inswing</u> Primed Steel SKU: 4145621 Model #: 4145621</p>	<p>Ship To Home Estimated arrival date 06/11/2021</p> <p>Deliver From Store Qualifies for Same-Day Delivery!</p> <p>✓ Ship To Store - Free! Estimated arrival date at store 06/09/2021</p>	<p>1</p> <p>\$418.00/each</p>	\$418.00



Save BIG With your Menards®
BIG Card
Earn a 2% rebate on all Menards® purchases or take advantage of financing offers when you use your Big Card.

Order Summary

Merchandise Subtotal:	\$696.90
Pretax Subtotal	\$696.90

Proposal

C. Braaksma Electric Inc.

259 N. Watertown St.
 Waupun, WI 53963
 Office#920-324-9403, Cell #920-319-1614

<i>PROPOSAL SUBMITTED TO</i> C. VERHAGE PHOTOGRAPHY		<i>PHONE</i> 920-948-0964	<i>PROPOSAL DATE</i> 4/6/2021
<i>STREET</i> 426 E. MAIN ST.		<i>JOB NAME</i> REAR SIGN LIGHTS	
<i>CITY, STATE, ZIP CODE</i> WAUPUN, WI 53963		<i>JOB LOCATION</i> 426 E. MAIN ST. WAUPUN, WI 53963	
<i>ARCHITECT</i>	<i>DATE OF PLANS</i>	<i>MISCELLANEOUS</i>	

We hereby submit specifications and estimates for:

Description

A) All Labor and Material to complete the following electrical work:

WIRING AND INSTALLATION OF 3 SIGN LIGHTS ON REAR OF BUILDING

- 1) install power from breaker panel and tork 7day timer in basement
- 2) install surface mount conduit and wiring on exterior of building to 3 boxes above proposed sign
- 3) install 3 customer provided sign lights

We Propose hereby to furnish material and labor-complete in accordance with above specifications for the sum of:
 SEVEN HUNDRED NINTY FIVE AND 0/100 DOLLARS---dollars(\$795.00)

PAYMENTS TO BE MADE AS FOLLOWS: PAYMENT DUE UPON COMPLETION

All material is guaranteed to be as specified. All work to be complete in a workmanlike manner according to standard practices. Any alteration or deviation from above specifications involving extra work will become an extra charge over and above this proposal. It is mutually agreed that the contractor shall not be held responsible or liable for any loss or delay caused fire, strikes, civil or military authority, or by insurrection, or by any other issues beyond his control. Owner to carry fire, tornado, and any other necessary insurance.

Authorized Signature By: _____
 For CB Electric

Note: This estimate may be withdrawn if not accepted within 30 days

ACCEPTANCE OF PROPOSAL

The above prices, specifications, and conditions are satisfactory and are hereby accepted. We understand that a 1.5% per month service charge will be added to all past due accounts. You are authorized to do the work specified. Payment will be made as outlined above.

Date _____

Signature _____

Harv's



Painting LLC

Commercial and Residential Painting

Harvey K. Schaub
N3387 Lori Lane
Waupun, WI 53963

Federal Identification Number: 27-0420280
WI Identification Number: 036102702126702

Cell: 920.948.3818
Fax: 920.324.2596

Wisconsin Business Certificate ID: 1118750
Office phone: 920.324.5718

Verhage Studio
Paint North Block Wall
Labor & Materials
\$1200.⁰⁰/₌

3-302021

Harvey K. Schaub owner

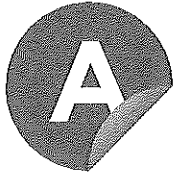
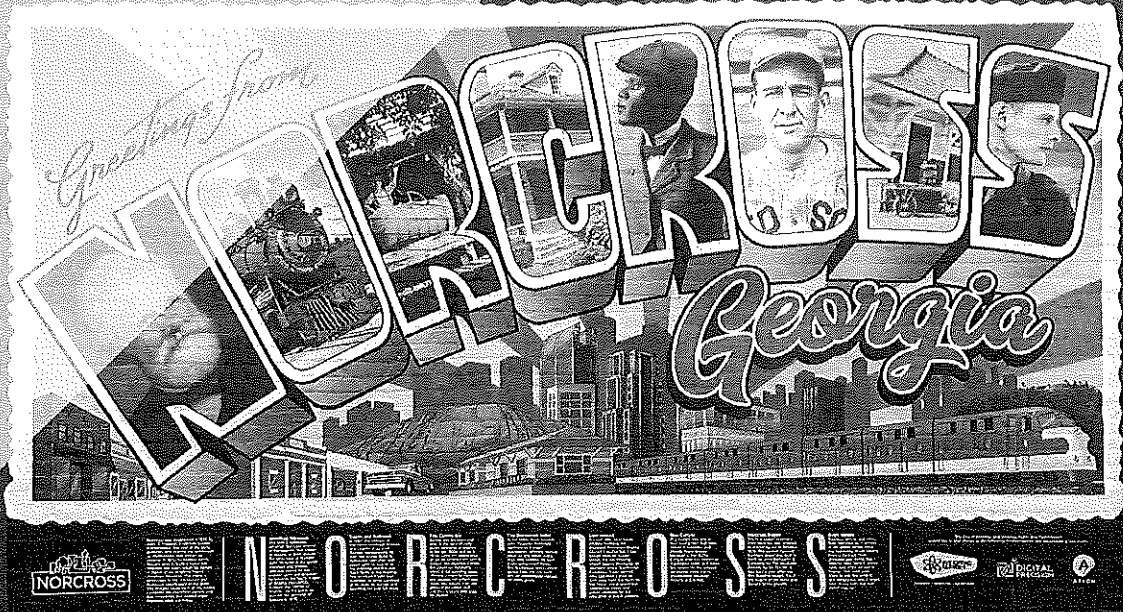

ARLON

DPF 6700

DPF 6700 is a highly conformable film for interior and exterior wall wraps. Apply with heat to provide your graphic with a paint-like finish. DPF 6700 is formulated to conform to textured unpainted* masonry surfaces such as brick, stucco and concrete. Combine DPF 6700 with Series 3220 overlaminates to get the perfect gloss, matte, satin or luster finish for your wall graphic applications.

** If surface is painted, surface vinyl compatibility testing is recommended prior to installation.*

Unique Features:

- ▶ Highly Conformable, Paint-Like Finish
- ▶ Superior Bond to Textured Surfaces
- ▶ Cast Film for Lasting Results

Applications:

- ▶ Building Wraps
- ▶ Wall Graphics (Interior, Exterior)

Performance & Physical Data

Finish:	Gloss
Durability (Unprinted):	7 Years
Roll Widths:	30" (0,76 m), 48" (1,22 m) 54" (1,37 m), 60" (1,52 m)
Roll Lengths:	50 Yards (45,72 m)
Adhesive:	Permanent (Clear)
Release Liner:	Lay-Flat Polycoated
Ink Compatibility:	Eco-Solvent Solvent UV Latex
Compatible Overlaminates:	Series 3200 Series 3210 Series 3220 Series 3310



USA: 200 Boysenberry Lane, Placentia, CA 92870, USA
 EUROPE: North Sea Building, Gevers Deynootweg 93, 4th Floor, 2586BK Den Haag, The Netherlands

800 232 7161 / 714 985 6300
 +31 0 70 354 4311
 800 329 2756
 +31 0 70 355 7721

arlon.com

October 2018

C. VerHage Photo

Exterior mural on back side of building

Graphic mural applied to painted cinder block - various small pieces to enhance the astetic

Size: - TBD (36" H or larger)

Length: 10' - 15'L

Material

Digital print on Arlon DPF 6700 cast film with Eco-Solvent ink.

Gloss Overlamine (3220) to produce a paint-like finish

Film will be heat sealed to conform to the painted cinder block

Preliminary Design: 8 hours

Installation

Wall will be pressure washed - dry for 24-48 hours

A bucket lift or scaffolding will be required - if rental of equipment is needed - additional costs will be incurred by the customer.

2 person install / 10 - 16 hours

Estimated Cost: \$3,250.00

Cart

Summary

Subtotal

Qty

Price

Estimate Shipping

\$1,754.85

\$1,754.85

1

1x Ellipse Faux Balcony

AL-6012-36H-BT

Length: 60in Length

Height: 36"H Included in price

Color: Bronze-Tone - \$75.00

Subtotal

Shipping (Ship

Estimate - Ent

Code For Acct

Order Total



UPDATE SHOPPING CART

PROCEED

C.VERHAGE.PHOTO



c.verhage.photo



Vintage
PHOTO

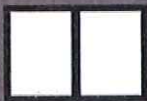

SW 7031

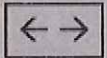

Mega Greige

Interior / Exterior

Locator Number: 243-C3

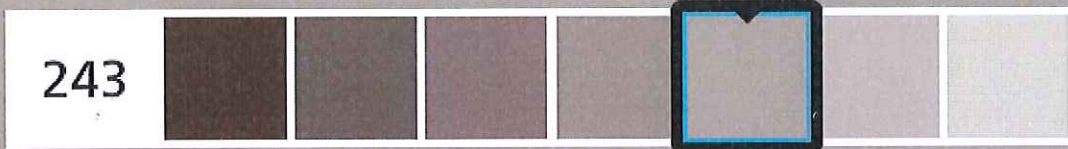

Waupun Business Improvement District (BID)
~ Façade Improvement Program – Grant Application ~

Applications missing any materials will be returned for completion.

Date: 6-3-21

Applicant Name: KRISTA BISHOP

Applicant Address: 307 E MAIN ST WAUPUN, WI 53963

Phone: 920.296.3542 Fax: N/A Email: kristabishop@man.com

Name of Business/Property: WEAVING IT UP TO YOU!

Property Address: 307 E MAIN ST WAUPUN, WI 53963

Property Use: RETAIL STORE

Property owner, if different than applicant: —

Owner address: SAME Owner Phone: SAME

Project Summary:

Brief Project Summary: NEW SIGN PROJECTING OUT OVER THE SIDEWALK
BASED ON CONDITIONAL USE PERMIT - PLAN IS TO HAVE
SINGLE BRACKET - UNLESS PERMIT STATES OTHERWISE

Total Estimated Cost: \$ 500.00 ^{Permit = 150⁰⁰} _{Sign = 150⁰⁰} Total Grant Request: \$ 250⁰⁰

Projected Start Date: 7-15-21 Projected Completion Date:

Name of Contractor: J&O RIVERS SIGNS Issue Payment if approved: Applicant or Business (circle)

Approval of City Building Inspector: OK (Inspector's initials)

Required attachments:

- Project plan(s) to 1/4" scale, if applicable
- Release of Information Letter (attached)
- Quotes/Estimates
- Current photo(s) of property
- Paint color(s) or material sample(s), if applicable

Submit application form and attachments to:

Waupun Business Improvement District – City Clerk, Waupun City Hall
201 E. Main Street, Waupun WI 53963
920-324-7915 ext. 5

To be completed by City staff only:

Date application received: 6/14/21
Application reviewed for completeness by SV (initials). Date: 6/14/21
Applicant notified of scheduled BID meeting by SV (initials). Date: 6/14/21

Application review for delinquency:
SV 6/14/21

Waupun Business Improvement District (BID)
~ Façade Improvement Program - Release of Information Letter ~

Date: 6-3-21

To: Waupun Business Improvement District – Clerk’s Office, Waupun City Hall
201 E. Main Street, Waupun WI 53963

To Whom It May Concern:

I hereby authorize the Waupun Business Improvement District (BID) permission to share all application materials with BID board members who will be reviewing my application. I acknowledge that information provided to the BID may be released upon request in compliance with the open record requirements and in accordance with the freedom of information act. I acknowledge that I am to attend the BID board meeting in which this request will be reviewed and that the City of Waupun will notify me of that meeting.

Signed,

Name (print): KRISTA L. BISHOP

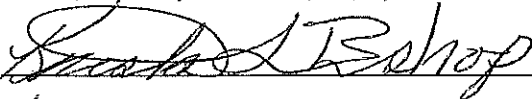
Signature: 

Date: 6/3/21

Fee: \$150.00

Paid: PAID 11/16/21

Date: 5/28/21



CITY OF WAUPUN
201 E. Main Street
WAUPUN, WISCONSIN 53963

Conditional Use Permit Application

Applicant Name: KRISTA L. BISHOP Phone # 920.296.3546

Address: 307 E MAIN E-mail: Krista.bishop@msn.com

City, State, Zip WAUPUN, WI 53963

Property Description and address:

307 E MAIN - COMMERCIAL BUSINESS - SELLING
YARNS & FINISHED GOOD - 2 STORY SIDE FRONT

Conditional Use Requested:

HANG A SIGN FROM THE FRONT OF THE STORE
OVER THE SIDE WALK. THE SIGN IS 18" HIGH X 36"
LONG. PREFERRED A SINGLE BRACKET - BOTTOM OF
SIGN TO BE A MINIMUM OF 10' FROM SIDE WALK

Zoning Ordinance Section Involved:

16.11 Signs (2a) Projecting Sign

Date Presented to Plan Commission:

6/16/21 4:45 pm

CONDITIONAL USE: Granted Denied

Comments:

Signature of Applicant (s)

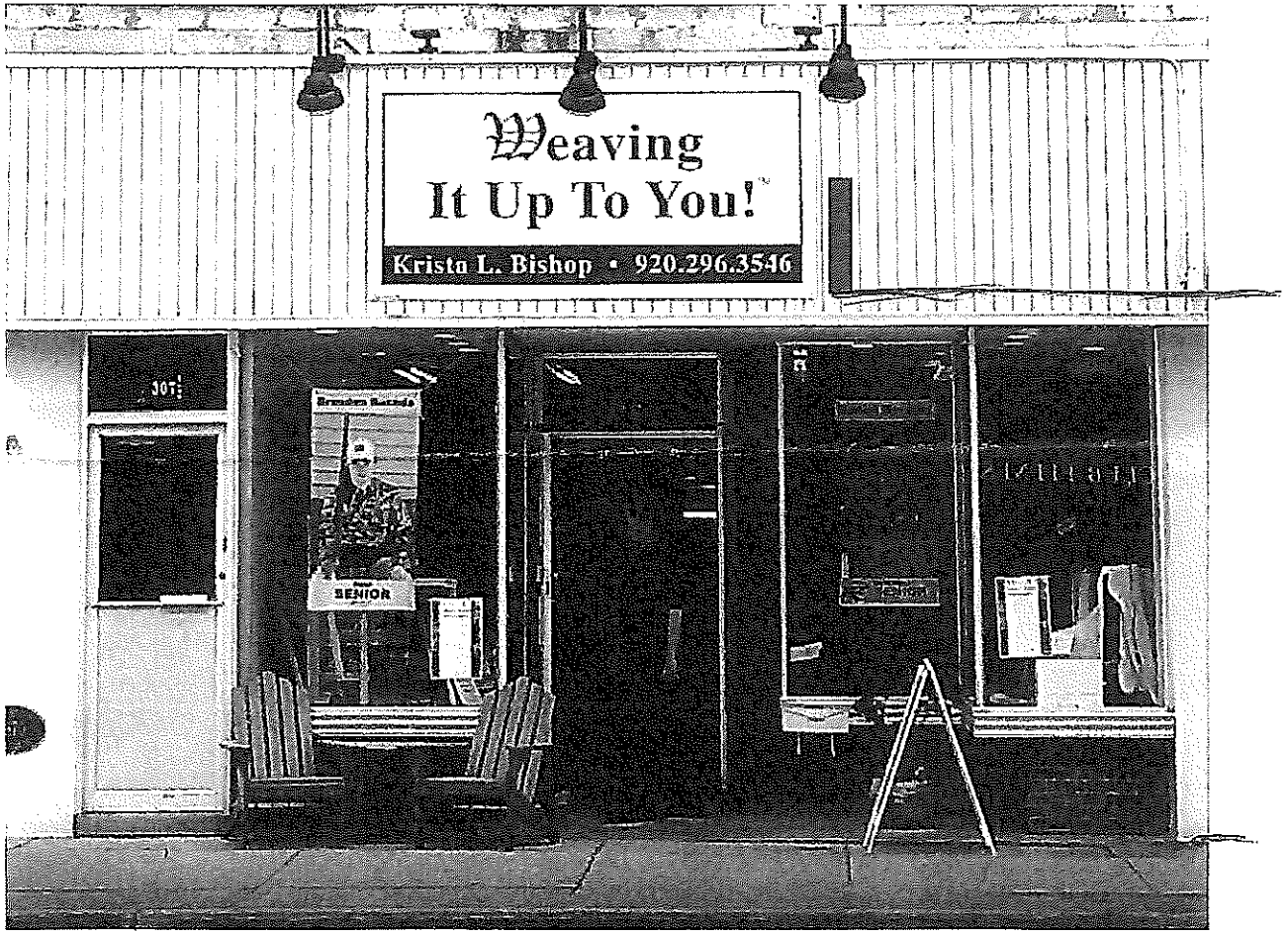

36" SCROLL BRACKET

QTY 2

\$95.00 EACH OR 190.00 FOR PAIR

18" X 36"



*RED/BURGARDY
& WHITE
BLACK BRACKET(S)*

6MM ACM SIGN PANEL

DOUBLE SIDED

STANDARD 3M RED VINYL

\$150.00 FOR THE SIGN READY TO INSTALL

*10' MIN. CLEARANCE
FROM SIDEWALK TO
BTM OF SIGN*

Waupun Business Improvement District (BID)
~ Façade Improvement Program – Grant Application ~

Applications missing any materials will be returned for completion.

Date: 5/18/2021
Applicant Name: Jonathan Leonard
Applicant Address: 407 E. main St. Waupun
Phone: 920-345-1335 Fax: _____ Email: Jonathan.Leonard@
Name of Business/Property: Thrivent Financial Thrivent.Com
Property Address: 407 E. main St Waupun
Property Use: Thrivent Financial Office
Property owner, if different than applicant: _____
Owner address: 708 Winter Ave Owner Phone: 920-296-3598

Project Summary:

Brief Project Summary: We are fixing up the exterior of the building
specifically the windows on the outside of the building for
24-business and those windows that face the street

Total Estimated Cost: \$ 7000 Total Grant Request: \$ 2000

Projected Start Date: July 1, 2021 Projected Completion Date: ??

Name of Contractor: Window World/Power Issue Payment if approved: Applicant or Business (circle)
Om

Approval of City Building Inspector: OKL (Inspector's initials)

Required attachments:

- Project plan(s) to 1/4" scale, if applicable
 Release of Information Letter (attached)
 Quotes/Estimates
 Current photo(s) of property
 Paint color(s) or material sample(s), if applicable

Submit application form and attachments to:
Waupun Business Improvement District – City Clerk, Waupun City Hall
201 E. Main Street, Waupun WI 53963
920-324-7915 ext. 5

To be completed by City staff only:

Date application received: 5/14/21
Application reviewed for completeness by SV (initials). Date: 5/14/21
Applicant notified of scheduled BID meeting by SV (initials). Date: 5/14/21

Review for delinquency:
SV 5/14/21

Waupun Business Improvement District (BID)
~ Façade Improvement Program - Release of Information Letter ~

Date: 5/18/21

To: Waupun Business Improvement District – Clerk’s Office, Waupun City Hall
201 E. Main Street, Waupun WI 53963

To Whom It May Concern:

I hereby authorize the Waupun Business Improvement District (BID) permission to share all application materials with BID board members who will be reviewing my application. I acknowledge that information provided to the BID may be released upon request in compliance with the open record requirements and in accordance with the freedom of information act. I acknowledge that I am to attend the BID board meeting in which this request will be reviewed and that the City of Waupun will notify me of that meeting.

Signed,

Name (print): Jonathan Leonard

Signature: 

Date: 5/18/21

WINDOW WORLD OF FOND DU LAC
 235 Morris Street
 Fond du Lac, WI 54935
 (920) 923-4189
 fonddulac@windowworld.com



WINDOW WORLD OF MADISON
 202 Regas Road
 Madison, WI 53714
 (608) 268-9040
 madison@windowworld.com

1-800 NEXT WINDOW
WindowWorld.com

Customer: Jonathan Leonard Phone (h) 920-296-3598
 Install Address: 407 E Main St Wausau WI Phone (w) _____
 Bill Address: Same 53963 E-mail _____

WINDOW WORLD	
<u>6</u> 2000 Series DH All-Weld	\$315 <u>1890</u>
4000 Series DH All-Weld	\$345
6000 Series DH All-Weld	\$355
<u>1</u> 2 Lite Slider Up to 93 U.I.	\$325 <u>325</u>
2 Lite Slider Up to 119 U.I.	\$350
2 Lite Slider Over 120 U.I.	\$375
3 Lite Slider * (1/3, 1/3, 1/3) (1/4, 1/2, 1/4)	\$1000
Picture	\$670
Awning/Casement	\$375
2 Lite Casement *	\$800
3 Lite Casement * (1/3, 1/3, 1/3) (1/4, 1/2, 1/4)	\$1300
Bay Window *	\$3500
Bow Window *	\$3700
Garden Window *	\$
Specialty Window	\$
Beige/Almond *	\$45
Wood Grain Interior *	\$125
Colored Exterior *	\$220
Window Color <u>White</u> / <u>White</u>	
<i>Inside</i>	<i>Outside</i>

GLASS OPTIONS	
<u>7</u> 1/2 Screens	\$9 INCLUDED
<u>7</u> Foam Insulation on Jamb and Head	\$11 INCLUDED
<u>7</u> Double Strength Glass	\$15 INCLUDED
<u>7</u> Double Locks (> 24")	\$5 INCLUDED
<u>7</u> Lifetime Warranty	\$ INCLUDED
<u>7</u> Lifetime Glass Breakage Warranty	\$25
<u>7</u> Double Pane SolarZone*	\$99 <u>693</u>
Triple Pane SolarZone*	\$139

WINDOW OPTIONS	
Full Screens	\$55
Colonial Contoured Grids (BSO) (TSO)	\$85
Grids (BSO) (TSO)	\$100
Tempered DH Sash (BSO) (TSO)	\$80/Sash
Obscure Glass (BSO) (TSO)	\$50/Sash
Oriel Style (40/60 or 60/40)	\$60
Mounting Fin	\$60
Foam Enhanced Frame **	\$45

PRE 1978 BUILT HOMES (WI DHS Lead Law)	
<u>7</u> Fee Per Section	\$35 <u>245</u>
Fee Per Multiple	\$50
MY HOME WAS BUILT IN THE YEAR <u>pre 78</u> Initial	

DOORS	
(XO) (OX) Viewed from outside X is operating panel	
Vinyl Rolling Patio Door 6ft.	\$1700
Vinyl Rolling Patio Door 8ft.	\$1900
Vinyl Rolling Patio Door 9ft.	\$2200
Custom Size PD	\$
Colonial Contoured Grids	\$170
Double Pane SolarZone	\$250
Triple Pane SolarZone	\$450
Patio Door Exterior Trim	\$200
Facing Color	
Wood Grain Interior / Beige/Almond*	\$300
Colored Exterior *	\$450
Storm Door	\$
Door Color _____ / _____	
<i>Inside</i>	<i>Outside</i>

MISCELLANEOUS	
<u>7</u> Custom Exterior Trim	\$100 <u>700</u>
Facing Color	
Specialty Window Exterior Trim	\$
Mull to Form Unit/Mullion Removal	\$85
<u>4</u> Metal Window Extra Labor/ <u>vinyl</u>	\$85 <u>340</u>
Insulate Weight Boxes	\$45
Interior Stops (RAW)	\$75
<u>4</u> Exterior Stops	\$55 <u>220</u>
Bay Roof (Install or Removal)	\$500
Interior Casing (Bay/Bow/PD) (RAW)	\$250
Interior Casing (Window/Door) (RAW)	\$175
Exterior Casing	\$75
Repair Sill, Jamb, Brickmold, WRB	\$65
Remove and Install A/C or Awning	\$100
J-Channel Color	\$50
Remove and Install Shutters/Security Bars	\$35
Paint / Stain Woodwork Color	\$

Disclaimer: Estimate Valid For 30 Days.
 *Price is per section ** Available in DH & Picture Only **ROUND-UP FOR WINDOW WORLD CARES**
 St. Jude Children's Research Hospital \$ _____

NO EXTRA WORK IF NOT IN WRITING!

Customer agrees to the terms of payment as follows:
 Extra Labor \$ _____

Beige/Almond
 Wood Grain Interior * \$125
 Colored Exterior * \$220
 Window Color white / white
 Inside *Outside*

PRE 1978 BUILT HOMES (WI DHS Lead Law)
 3 Fee Per Section \$35 105
 Fee Per Multiple \$50
 MY HOME WAS BUILT IN THE YEAR 1978 Initial _____

DOORS
 (XO) (OX) Viewed from outside
 X is operating panel
 Vinyl Rolling Patio Door 6ft. \$1700
 Vinyl Rolling Patio Door 8ft. \$1900
 Vinyl Rolling Patio Door 9ft. \$2200
 Custom Size PD \$
 Colonial Contoured Grids \$170
 Double Pane SolarZone \$250
 Triple Pane SolarZone \$450
 Patio Door Exterior Trim \$200
 Facing Color _____
 Wood Grain Interior / Beige/Almond* \$300
 Colored Exterior * \$450
 Storm Door \$
 Door Color _____ / _____
 Inside *Outside*

MISCELLANEOUS
 3 Custom Exterior Trim \$100 300
 Facing Color _____
 Specialty Window Exterior Trim \$
 Mull to Form Unit/Mullion Removal \$65
 Metal Window Extra Labor/Vinyl \$85
 Insulate Weight Boxes \$45
 Interior Stops (RAW) \$75
 Exterior Stops \$55
 Bay Roof (Install or Removal) \$500
 Interior Casing (Bay/Bow/PD) (RAW) \$250
 Interior Casing (Window/Door) (RAW) \$175
 Exterior Casing \$75
 Repair Sill, Jamb, Brickmold, WRB \$65
 Remove and Install A/C or Awning \$100
 J-Channel Color \$50
 Remove and Install Shutters/Security Bars \$35
 Paint / Stain Woodwork Color \$

Disclaimer: Estimate Valid For 30 Days.
 *Price is per section ** Available in DH & Picture Only

ROUND-UP FOR WINDOW WORLD CARES
 St. Jude Children's Research Hospital \$

NO EXTRA WORK IF NOT IN WRITING!

HOMEOWNER RESPONSIBLE FOR ALL PAINTING & STAINING
 Loan Term _____
 Approval # _____

Customer agrees to the terms of payment as follows:
 Extra Labor \$ _____
 Site set up and Disposal Fee \$ \$175.00
 Total Amount \$ 2147
 Custom Order Deposit 50% \$ _____ Ck# _____
 Balance Paid to Installer upon Completion \$ _____
 Amount Financed \$ _____

You the buyer may cancel this transaction at any time prior to midnight of the third business day after the date of this transaction. Notice of cancellation must be in writing postmarked no later than midnight of the following third business day. THIS IS A CUSTOM ORDER NOT FOR RESALE!

_____ Owner _____ Date _____
 _____ Salesman _____ Date _____ Owner _____ Date _____

This Window World® Franchise is independently owned and operated by Xterior Plus L.L.C. d/b/a Window World of Fond du Lac/Madison, W.I. under license from Window World, Inc.
 Fond du Lac/Madison 01-21 White Copy - Original Yellow Copy - File Pink Copy - Customer Hayes Printing 336.667.1116





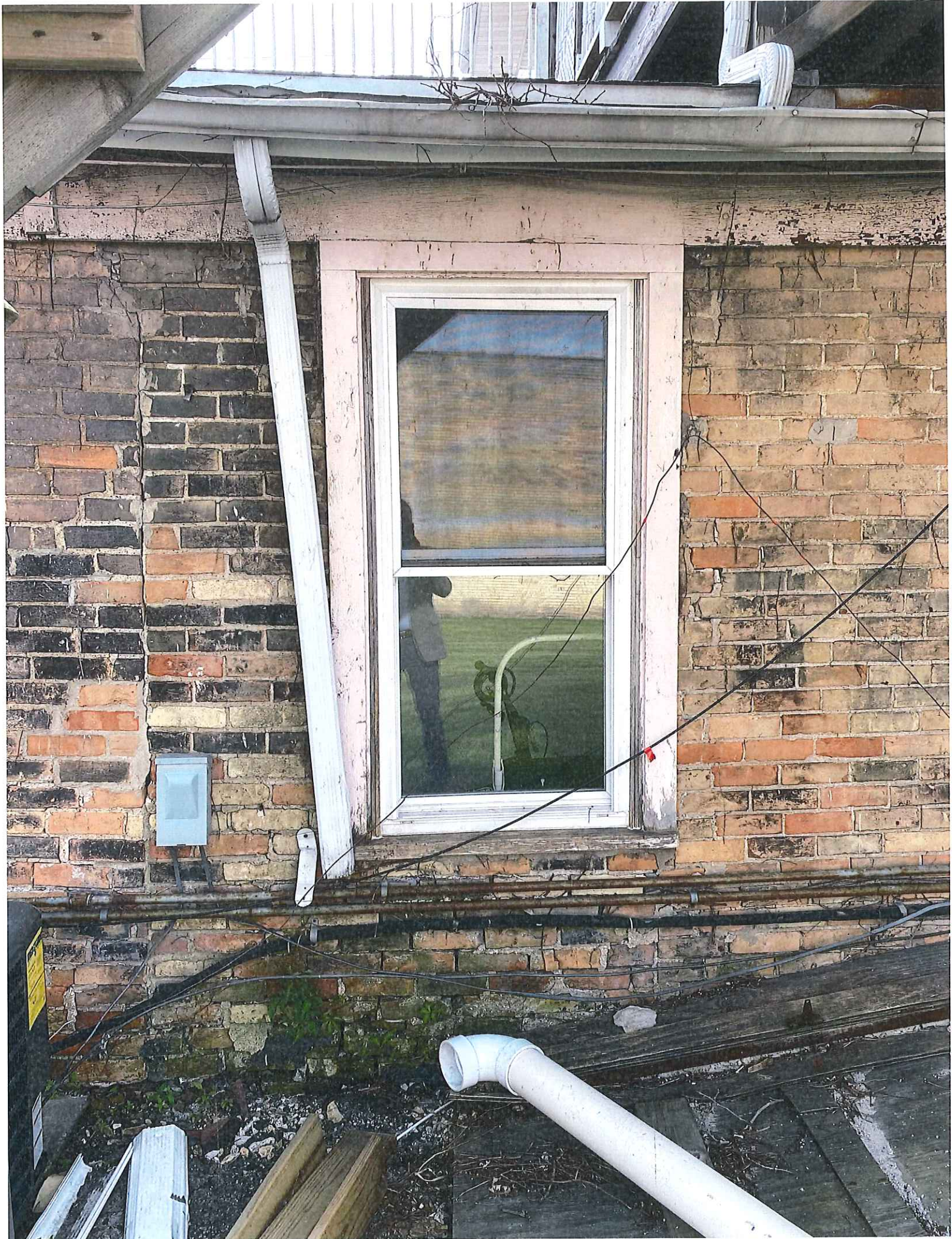



Advanced Disposal