



AMENDED AGENDA
CITY OF WAUPUN BOARD OF PUBLIC WORKS AND
FACILITIES COMMITTEE
Waupun City Hall – 201 E. Main Street, Waupun WI
Tuesday, February 13, 2024 at 4:30 PM

The Board of Public Works and Facilities Committee will meet in person, virtual, and teleconference. Instructions to join the meeting are provided below:

Join Zoom Meeting

<https://us02web.zoom.us/j/81987138114>

Meeting ID: 819 8713 8114

By Phone: (312) 626-6799 US (Chicago)

CALL TO ORDER

ROLL CALL

PERSONS WISHING TO ADDRESS THE BOARD OF PUBLIC WORKS--State name, address, and subject of comments.
(2 Minutes)

No Public Participation after this point.

FUTURE MEETINGS AND GATHERING INVOLVING THE BOARD OF PUBLIC WORKS

CONSIDERATION - ACTION

- [1.](#) Approve minutes of the January 9, 2024 meeting.
- [2.](#) 2024 Equipment Rates
- [3.](#) Approve 5 year street plan
- [4.](#) Approve 2024 Spring Cleanup dates
- [5.](#) Approve 2024 Asphalt Paving contract bid
- [6.](#) Recommendation to Council for Heritage Museum Restoration (Tuck pointing and front Step repair)
- [7.](#) Recommendation to Council - Community/Senior Center Door access and Security Camera systems
- [8.](#) **Approve/Recommend purchase of 2024 Chevrolet Silverado 1500 4WD Regular Cab**

ADJOURNMENT

Upon reasonable notice, efforts will be made to accommodate disabled individuals through appropriate aids and services. For additional information, contact the City Clerk at 920-324-7915.



MINUTES—CITY OF WAUPUN BOARD OF PUBLIC WORKS & FACILITIES

Tuesday, 9-January-2024 – City Council Chambers

CALL TO ORDER

Chairman Peter Kaczmarki called the meeting to order at 4:31PM

ROLL CALL

Roll call was taken:

Alders—Peter Kaczmarki, Mike Matoushek, Kambria Ledesma

Citizens—Dale Heeringa, Dave Rens, Andrew Sullivan, Gregg Zonnefeld

Ex-officio—DPW Director Jeff Daane, Mayor Rohn Bishop, City Administrator Kathy Schlieve, Recreation Director Rachel Kaminski

FUTURE MEETINGS AND GATHERINGS OF THE BOARD OF PUBLIC WORKS & FACILITIES COMMITTEE

Next meeting will be on Tuesday, February 13, 2024 at 4:30PM.

CONSIDERATION - ACTION

1. Approve minutes of the November 14, 2023 Board of Public Works & Facilities Meeting.
Minutes of the November 14, 2023 meeting were presented. Motion (Zonnefeld/Matoushek) to approve minutes as presented. **MOTION CARRIED (7-0)**
2. Wilson and Shaler Drive Extension Project
DPW Director Jeff Daane shared the current status of the Wilson and Shaler Drive extension. The first layer of blacktop is laid and speed limit sign has been added. Some savings may be realized, and negotiations are in process with hopes of remaining at our under the budget.
3. 2022 and 2023 Bayberry Lane Extension Project
DPW Director Daane summarized the project update on Bayberry Lane. Most of the fill that was left has been consumed by other projects. The second layer of blacktop will be needed after more development takes place. Project is wrapped up and came in \$15,972.55 under budget.
4. 2024 Projects Update
DPW Director Jeff Daane shared the current status of the budgeted projects for 2024. Bids are out on mill and overlay, with bid specs in finalization mode. Final plans for the Downtown Plaza should be in hand by the end of this week. Storm water grant applications are being explored for 2025, as our next pond project will be coming 2025. Progress on the Community Center is going very well – right on scheduled or even a bit ahead.
5. 2023 Project Overview
DPW Director Jeff Daane shared financial summaries from some major areas that the BPW oversees: Aquatic Center, Snow Removal, Mowing, Yard Waste, Sidewalk Replacement, and Storm Sewers. Budgeting looked to be sufficient with the exception of some costs to the Aquatic Center.

ADJOURNMENT

Motion (Matoushek/Heeringa) to adjourn the meeting of the BPW & Facilities at 4:52PM. **MOTION CARRIED (7-0).**

Respectfully submitted,

Gregg Zonnefeld, BPW Clerk



AGENDA SUMMARY SHEET

MEETING DATE: 2/13/24

TITLE: 2024 Equipment Rates

AGENDA SECTION: Consideration/Action

PRESENTER: Jeff Daane Director of Public Works

DEPARMTENT GOAL(S) SUPPORTED <i>(if applicable)</i>	FISCAL IMPACT	

ISSUE SUMMARY:

Each year the Department of Public Works updates their equipment rates. These rates come from the Wisconsin DOT website. These rates help the city to get funding or reimbursement in the event of a weather event or accident cleanup.

STAFF RECOMENDATION:

Approve 2024 equipment rates

ATTACHMENTS:

2024 equipment rates

MOTIONS FOR CONSIDERATION:

Recommend 2024 equipment rates for public works equipment to Council for approval.

--	--

--	--

2024 Equipment Rates

ID	Description	Manufacturer	Model	Year	VIN
1-16	Ford Escape	Ford	Escape	2017	1FMCU9G97HUA 52025
	Ratesub				
	Name		Date	Rate	DOT #
	Default		1/1/2024	\$16.76	119
3-08	Tandem Dump Truck	Sterling	LT-7501	2008	2FZHATBS78AY7 9046
	Ratesub				
	Name		Date	Rate	DOT #
	Truck		1/1/2024	\$90.46	118
	Power Reversible		1/1/2024	\$15.78	633
	Tailgate-Mounted-computerized		1/1/2024	\$16.06	426
	Widening Wing		1/1/2024	\$14.82	635
5-09	Tandem Dump Truck	Freightliner	M2106V	2009	1FVHC3BS19HAJ 1444
	Ratesub				
	Name		Date	Rate	DOT #
	Truck		1/1/2024	\$90.46	118
	Power Reversible		1/1/2024	\$15.78	633
	Tailgate-Mounted-computerized		1/1/2024	\$16.06	426
	Widening Wing		1/1/2024	\$14.82	635
6-13	Single Axle Dump Truck	Freightliner	108SD	2013	1FVAG5BS0DHF B9538
	Ratesub				
	Name		Date	Rate	DOT #
	Truck		1/1/2024	\$68.52	106
	Power Reversible		1/1/2024	\$15.78	633
	Tailgate - mounted - computerized		1/1/2024	\$16.06	426
	Spar bar applicator		1/1/2024	\$8.28	638
	Widening Wing		1/1/2024	\$14.82	635
7-03	Tandem Dump Truck	Sterling	LT-7501	2003	2FZHATAKX3AM 13718
	Ratesub				
	Name		Date	Rate	DOT #
	Truck		1/1/2024	\$90.46	118
	Power Reversible		1/1/2024	\$15.78	633
	Widening Wing		1/1/2024	\$14.82	635
8-20	Tandem Dump Truck	Freightliner	114SD	2020	1FVHG3FE9LHLW7783
	Ratesub				
	Name		Date	Rate	DOT #
	Truck		1/1/2024	\$90.46	118
	Power Reversible		1/1/2024	\$15.78	633
	Tailgate - mounted - computerized		1/1/2024	\$16.06	426
	Spray Bar Applicator		1/1/2024	\$8.28	638
	Widening Wing		1/1/2024	\$14.82	635
9-12	Tandem Dump Truck	Freightliner	M280	2012	1FVHC3BS3CHB R5339
	Ratesub				
	Name		Date	Rate	DOT #
	Truck		1/1/2024	\$90.46	118
	Power Reversible		1/1/2024	\$15.78	633
	Tailgate - mounted - computerized		1/1/2024	\$16.06	426
	Widening Wing		1/1/2024	\$14.82	635
11-01	Tandem Dump Truck	Sterling	LT-7501	2001	2FZHATAK01AJ9 3549
	Ratesub				
	Name		Date	Rate	DOT #
	Truck		1/1/2024	\$ 90.46	118
	Power Reversible		1/1/2024	\$ 15.78	633
	Widening Wing		1/1/2024	\$ 14.82	635

ID	Description	Manufacturer	Model	Year	VIN
12-18	Global Street Sweeper	Global	M4HSD	2017	1G9GS4HL3HS4 62010
	Ratesub				
	Name		Date	Rate	DOT #
	Default		1/1/2024	\$136.30	433
15-17	3/4 Ton Pick-up Truck	Chevrolet	Silverado 15	2017	1GCNKNEC4HZ1 85094
	Ratesub				
	Name		Date	Rate	DOT #
	Default		1/1/2024	\$16.58	101
19-03	1/2-Ton Pickup Truck	Chevrolet	1500	2003	1GCEK14T63Z26 3023
	Ratesub				
	Name		Date	Rate	DOT #
	Default		1/1/2024	\$16.58	101
22-13	1/2-Ton Pickup Truck	Chevrolet	Silverado	2013	1GCNKPE01DZ1 65235
	Ratesub				
	Name		Date	Rate	DOT #
	Default		1/1/2024	\$16.58	101
27-20	1-Ton Flatbed Truck w/hoist	Chevrolet	Silverado 35	2020	1GB3YSEY8LF278652
	Ratesub				
	Name		Date	Rate	DOT #
	Default		1/1/2024	\$16.58	101
28-03	1-Ton Flatbed Truck w/hoist	Chevrolet	3500	2003	1GBJK34173E26 6968
	Ratesub				
	Name		Date	Rate	DOT #
	Default		1/1/2024	\$16.58	101
29-11	1/2 Ton Pick-up	Chevrolet	Silverado	2011	1GCNKPE03BZ3 61139
	Ratesub				
	Name		Date	Rate	DOT #
	Default		1/1/2024	\$16.58	101
30-06	1-Ton Flatbed Truck w/hoist	Chevrolet	3500	2006	1GBJK34266E12 6374
	Ratesub				
	Name		Date	Rate	DOT #
	Default		1/1/2024	\$16.58	101
34-09	1-Ton Pickup Truck w/ hoist	Chevrolet	3500	2009	1GBJK74649F15 8829
	Ratesub				
	Name		Date	Rate	DOT #
	Default		1/1/2024	\$16.58	101
34-12-A	Wideout Plow	Western		2012	
	Ratesub				
	Name		Date	Rate	DOT #
	Default		1/1/2024	\$15.78	633
38-22	F350 Pick-Up Truck	Ford	F350	2022	1FDRF3H4NDA 19380
	Ratesub				
	Name		Date	Rate	DOT #
	Default		1/1/2024	\$16.58	101
39-06	1-Ton Flatbed Truck w/hoist	Chevrolet	3500	2006	1GBJK34296E12 5381
	Ratesub				
	Name		Date	Rate	DOT #
	Default		1/1/2024	\$16.58	101
40-07	1-Ton Flatbed Truck	Chevrolet	Silverado	2007	1GBJK34667E52 5564
	Ratesub				
	Name		Date	Rate	DOT #
	Default		1/1/2024	\$16.58	101

ID	Description	Manufacturer	Model	Year	VIN
52-23	1-Ton Flatbed Pickup Truck	Ford	F350	2023	1FDRF3HN9PED13202
	Ratesub				
	Name		Date	Rate	DOT #
	Default		1/1/2024	\$16.58	101
101-88	Track Loader	Caterpillar	953	1988	20Z01628
	Ratesub				
	Name		Date	Rate	DOT #
	Default		1/1/2024	\$66.60	217
102-84	Grader	Caterpillar	140G	1984	72V06860
	Ratesub				
	Name		Date	Rate	DOT #
	Default		1/1/2024	\$77.20	307
	Ripper Attachment		1/1/2024	\$137.22	907
	Widening Wing		1/1/2024	\$37.82	612
103-10	Caterpillar Payloader	Caterpillar	930H	2010	CAT0930HPDHC 02116
	Ratesub				
	Name		Date	Rate	DOT #
	Default		1/1/2024	\$75.10	208
103-22	Snowblower	Larue	D40	2022	D40186
	Ratesub				
	Name		Date	Rate	DOT #
	Default		1/1/2024	\$190.94	9296
103-10-B	Payloader Wausau Plow	Wausau	HSP4212H	2010	17494
	Ratesub				
	Name		Date	Rate	DOT #
	Default		1/1/2024	\$15.78	633
103-10-C	Payloader Wausau Wing	Wausau	PW10 RHTE Wing	2010	17494
	Ratesub				
	Name		Date	Rate	DOT #
	Default		1/1/2024	\$37.82	612
103-10-D	GEM Grapple Bucket		GEM	2023	
	Ratesub				
	Name		Date	Rate	DOT #
	Default		1/1/2024	\$18.46	9113
104-18	New Holland Backhoe	New Holland	895CSC	2018	NJHH01346
	Ratesub				
	Name		Date	Rate	DOT #
	Default		1/1/2024	\$74.48	250
104-18-A	Compactor	New Holland		2018	
	Ratesub				
	Name		Date	Rate	DOT #
	Default		1/1/2024	\$41.16	9254
104-18-B	Breaker	New Holland		2018	12986
	Ratesub				
	Name		Date	Rate	DOT #
	Default		1/1/2024	\$33.32	9054
105-08	Front End Loader	Caterpillar	930H	2008	CAT0930HLDHC 00679
	Ratesub				
	Name		Date	Rate	DOT #
	Default		1/1/2024	\$75.10	208
105-08-C	Payloader Wausau Plow	Wausau	SS4212H	2008	08172
	Ratesub				
	Name		Date	Rate	DOT #
	Default		1/1/2024	\$15.78	633

ID	Description	Manufacturer	Model	Year	VIN
105-08-D	Payloader Wausau Wing	Wausau	PW9RHTE	2008	08172
	Ratesub				
	Name		Date	Rate	DOT #
	Default		1/1/2024	\$37.82	612
106-96	Backhoe / Tractor	Caterpillar	311	1996	9LJ00491
	Ratesub				
	Name		Date	Rate	DOT #
	Default		1/1/2024	\$58.76	558
107-23	CAT 259 Skid Loader	Caterpillar	259D	2023	
	Ratesub				
	Name		Date	Rate	DOT #
	Default		1/1/2024	\$38.48	222
151-76	Tractor	Massey Ferguson	MF-20	1976	9A236875
	Ratesub				
	Name		Date	Rate	DOT #
	Default		1/1/2024	\$41.20	204
	Roto-tiller		1/1/2024	\$50.94	9114
152-20	Groundsmaster Mower/Snowblower	Toro	7210	2020	405498862
	Ratesub				
	Name		Date	Rate	DOT #
	Default		1/1/2024	\$29.98	411
	Plow		1/1/2024	\$47.70	9090
153-98	Floor Sweeper	Clarke	575-100	1998	350802
	Ratesub				
	Name		Date	Rate	DOT #
	Default		1/1/2024	\$77.66	9258
					PER DAY
154-08	Compactor	Honda	WP 1550AW	2008	7576 121 6644032
	Ratesub				
	Name		Date	Rate	DOT #
	Default		1/1/2024	\$41.74	906
155-96	Leaf Vac	Giant Vac	6600 JD	1996	96267144
	Ratesub				
	Name		Date	Rate	DOT #
	Default		1/1/2024	\$36.24	9284
156-10	Leaf Vac	Giant Vac	6600JDT-TR14	2010	111910001
	Ratesub				
	Name		Date	Rate	DOT #
	Default		1/1/2024	\$36.24	9284
157-18	Toro Groundsmaster	Toro	30695	2018	403155061
	Ratesub				
	Name		Date	Rate	DOT #
	Default		1/1/2024	\$29.98	411
	Plow		1/1/2024	\$47.70	9090
158-84	Tractor	John Deere	430	1984	M00430X360056
	Ratesub				
	Name		Date	Rate	DOT #
	Default		1/1/2024	\$18.90	410
159-24	Mower	John Deere	1600 Turbo Cut	2024	1TC1600TCPH680270
	Ratesub				
	Name		Date	Rate	DOT #
	Default		1/1/2024	\$29.98	411

ID	Description	Manufacturer	Model	Year	VIN
160-96	Tractor / Blade / Broom	John Deere	455	1996	00455C040252
	Ratesub				
	Name		Date	Rate	DOT #
	Default		1/1/2024	\$18.90	410
	Broom		1/1/2024	\$46.52	431
	Sprayer		1/1/2024	\$16.06	925
162-85	Tractor	John Deere	430	1985	
	Ratesub				
	Name		Date	Rate	DOT #
	Default		1/1/2024	\$18.90	410
163-08	John Deere 6330 Premium Tractor	John Deere	6330	1988	LO6330H535002
	Ratesub				
	Name		Date	Rate	DOT #
	Default		1/1/2024	\$49.60	224
	2 pan section		1/1/2024	\$29.42	415
164-94	Roller / Vibrating	Wacker	RD880	1994	629601130
	Ratesub				
	Name		Date	Rate	DOT #
	Default		1/1/2024	\$40.78	533
165-07	Brush Chipper	Brush Bandit	1290H Drum Bandit	2007	007231
	Ratesub				
	Name		Date	Rate	DOT #
	Default		1/1/2024	\$40.06	902
166-12	Rustler 120 4X4	New Holland	120	2012	CM1234-304085
	Ratesub				
	Name		Date	Rate	DOT #
	Default		1/1/2024	\$24.14	9201
167-03	Toyota Fork Lift	Toyota	7FGU25	2003	69064
	Ratesub				
	Name		Date	Rate	DOT #
	Default		1/1/2024	\$68.70	9352
168-00	Versa Vac Trailer		1266	2000	1J911172XYC124 266
	Ratesub				
	Name		Date	Rate	DOT #
	Default		1/1/2024	\$69.26	9375
169-22	50 Gallon Sprayer	Master MFG		2022	
	Ratesub				
	Name		Date	Rate	DOT #
	Default		1/1/2024	\$16.06	925
200-18	Walk behind concrete saw		FS400	2018	20181400182
	Ratesub				
	Name		Date	Rate	DOT #
	Default		1/1/2024	\$75.42	934
201	Makita Concrete Saw	Makita	DPC7311		0507096193
	Ratesub				
	Name		Date	Rate	DOT #
	Default		1/1/2024	\$75.42	934
202	Cement Saw	ICS	613GC		4470492
	Ratesub				
	Name		Date	Rate	DOT #
	Default		1/1/2024	\$75.42	934

ID	Description	Manufacturer	Model	Year	VIN
203	Cement Saw	Dolmar	309		309000150
	Ratesub				
	Name		Date	Rate	DOT #
	Default		1/1/2024	\$75.42	934
211-15	Cement Saw	Stihl	TS500i		4250-351-0500B
	Ratesub				
	Name		Date	Rate	DOT #
	Default		1/1/2024	\$75.42	934
250-98	Air Compressor	Atlas	XAS90JD	1998	4500A0717WH60 6309
	Ratesub				
	Name		Date	Rate	DOT #
	Default		1/1/2024	\$20.28	402
251-73	Trailer	Roller Trailer	8-12	1973	Home Made
	Ratesub				
	Name		Date	Rate	DOT #
	Default		1/1/2024	\$16.30	491
252-01	Paint Striper	Line Laze II		3900	2001 BA5980
	Ratesub				
	Name		Date	Rate	DOT #
	Default		1/1/2024	\$24.82	9036
253	Paint / Cone Trailer				Home Made
	Ratesub				
	Name		Date	Rate	DOT #
	Default		1/1/2024	\$11.42	490
254	425 Gal. Water Tank & Pump		PG2		5806936
	Ratesub				
	Name		Date	Rate	DOT #
	Default		1/1/2024	\$35.44	926
255	Toro Mower Trailer	Toro			Home Made
	Ratesub				
	Name		Date	Rate	DOT #
	Default		1/1/2024	\$16.30	491
256-12	3" Diaphragm Pump	Wacker - Neuson PD3	PDT3A	2012	20059729
	Ratesub				
	Name		Date	Rate	DOT #
	Default		1/1/2024	\$23.24	924
257-13	Generator	Honda	EU2000I	2013	EACT-1120920
	Ratesub				
	Name		Date	Rate	DOT #
	Default		1/1/2024	\$28.64	805
258	Compactor	Wacker	B5-604		0501310334
	Ratesub				
	Name		Date	Rate	DOT #
	Default		1/1/2024	\$41.74	906
260	Tiller	Gilson			13D2C1-433
	Ratesub				
	Name		Date	Rate	DOT #
	Default		1/1/2024	\$50.94	9114
261	Portable Generator	OHV	OVH50		H934107
	Ratesub				
	Name		Date	Rate	DOT #
	Default		1/1/2024	\$28.64	805

ID	Description	Manufacturer	Model	Year	VIN
262-22	H&H ATV Utility Trailer		H&H	2022	5JWU11412MR556409
	Ratesub				
	Name		Date	Rate	DOT #
	Default		1/1/2024	\$16.30	491
263	Bobcat Flatbed Trailer				Home Made
	Ratesub				
	Name		Date	Rate	DOT #
	Default		1/1/2024	\$24.48	493
265-94	CAT Flatbed Trailer	Trail King	TK40LP	1994	1TKC02422RM11 5296
	Ratesub				
	Name		Date	Rate	DOT #
	Default		1/1/2024	\$54.06	496
269	Power Washer	Alkota	5181		D02-05181
	Ratesub				
	Name		Date	Rate	DOT #
	Default		1/1/2024	\$67.20	960
277-12	All Seasons Sprayer	Monroe	ASSU 325	2012	12-04-9001
	Ratesub				
	Name		Date	Rate	DOT #
	Default		1/1/2024	\$23.26	9255
278-13	Anti-Icer	Monroe	Anti Icer Unit	2013	18-08-9000
	Ratesub				
	Name		Date	Rate	DOT #
	Default		1/1/2024	\$41.66	9257
282	Floor Cleaner	Advance		393670	1162169
	Ratesub				
	Name		Date	Rate	DOT #
	Default		1/1/2024	\$77.66	9258 PER DAY
283	Cement Trailer	Radius			Home Made
	Ratesub				
	Name		Date	Rate	DOT #
	Default		1/1/2024	\$16.30	491
285-05	Cement Trailer			2005	Home Made
	Ratesub				
	Name		Date	Rate	DOT #
	Default		1/1/2024	\$16.30	491
346	Miller Arc Welder	Miller			JD724859
	Ratesub				
	Name		Date	Rate	DOT #
	Default		1/1/2024	\$6.06	976
366-13	Air Compressor	Rolair	D2002HPV5	2013	13103350
	Ratesub				
	Name		Date	Rate	DOT #
	Default		1/1/2024	\$15.00	9006
376	Air Compressor	NAPA	NAC82-309-VBT		0006995
	Ratesub				
	Name		Date	Rate	DOT #
	Default		1/1/2024	\$20.28	402
379-13	Pressure Washer	MI-T-M	cv-2400-4mbc	2013	10663263
	Ratesub				
	Name		Date	Rate	DOT #
	Default		1/1/2024	\$51.20	947

ID	Description	Manufacturer	Model	Year	VIN
380-14	Pressure Washer	MI-T-M	cv-2600-ommc	2014	10702320
	Ratesub				
	Name		Date	Rate	DOT #
	Default		1/1/2024	\$51.20	947
381-14	Pressure Washer	Clean Blue	AR142plus	2014	13019-0813040
	Ratesub				
	Name		Date	Rate	DOT #
	Default		1/1/2024	\$51.20	947
382-14	Laser Level		Stabila	LAR200	2014 08044LAR2
	Ratesub				
	Name		Date	Rate	DOT #
	Default		1/1/2024	\$6.08	9159
900	Cub Cadet Volunteer 4x2 625		625		
	Ratesub				
	Name		Date	Rate	DOT #
	Default		1/1/2024	\$24.14	9201
901	John Deere Gator CX	John Deere	Gator CX		1M00CXRAEEM1 20288
	Ratesub				
	Name	Date	Rate	DOT #	
	Default	1/1/2024	\$24.14	9201	
902	John Deere 3 Wheeler	John Deere	1200A		TC1200A14480
	Ratesub				
	Name	Date	Rate	DOT #	
	Default	1/1/2024	\$24.14	9201	



AGENDA SUMMARY SHEET

MEETING DATE: 2/13/24

TITLE: Approve 5 year street plan

AGENDA SECTION: Consideration/Action

PRESENTER: Jeff Daane

DEPARMTENT GOAL(S) SUPPORTED <i>(if applicable)</i>	FISCAL IMPACT	
Maintain public infrastructure	Estimated yearly reconstruction and mill/overlay costs	

ISSUE SUMMARY

Each year the City updates their 5 year street plan. This has changed from past years in that now total reconstruct project are proposed every third year. While mill and overlay streets would happen during none reconstruct years. We work with the Utilities on evaluation of underground infrastructure. This plan also allows us to use this when applying for grants.

STAFF RECCOMENDATION:

Approve the street plan

ATTACHMENTS:

5 year plan

RECCOMENDED MOTION:

1. Approve 5 year street plan

City of Waupun									
Long Range Street Plan w/ Proposed Funding									
12/21/2023									
Construction						Mill & Overlay			Funding
Year	Street	Estimated Street Cost	Estimated Storm Water	Construction Engineering	Design Engineering	Street	Estimated Cost	Total	
2025	Newton Ave (Rock Ave to N Harris) Rock Ave (Newton Ave to N Harris) Rock Ave (CTH M to Newton/Rock)	\$ 911,178.00	\$ 328,024.08	\$ 272,624.46	\$ -			\$ 1,511,826.54	Debt Financing / Pay-As-You-Go / \$400,000 LRIP Grant
2026	Alley (N Mill to N Madison)	\$ 234,380.00	\$ -	\$ -		STH 26 (Doty to Barnes) DOT Project Parking Lot across from Community Center Parking Lot - Schlieve Field Sunset Ct	\$ 240,330.12	\$ 474,710.12	Tanner Park fund
2027	None (Design Engineering for 2028 Projects)	\$ -	\$ -	\$ -	\$ 60,821.17	W Brown St (County Park Rd to Termini) River Rd (E Spring to Frontage Rd) W Brown St (Beaver Dam to RR Tracks) Utilities may need to do work here	\$ 188,850.96	\$ 249,672.13	Debt Financing
2028	N Grove (Park to Franklin) Franklin St	\$ 285,300.05	\$ 229,521.02	\$ 113,260.64			\$ -	\$ 628,082	
2029	S Forest St (Main to Jefferson) S Mill St (Main to Jefferson) Roosevelt St (N Grove to N Watertown) Park St (N Grove to N Watertown) Young St (Wilcox to Main) W Jefferson St (S Harris to Liberty) Sawyer St (S Grove to Termini) River St (Pioneer to Rock River Ave) E Jefferson St (S Watertown to S Grove) Wilcox Ct (Wilcox St to Termini) Grace St (Beaver Dam to Hillyer)	\$3,043,712.40	\$1,126,173.59	\$917,374.92		Sunset Ct (N West to Termini) N Harris (Newton Ave to Oriole) Church St (N Harris Ave to Termini) Doty St (S Madison to Maxon)	\$125,946.58	\$ 5,213,207	



AGENDA SUMMARY SHEET

MEETING DATE: 2/13/24

TITLE: Approve 2024 Spring Cleanup dates

AGENDA SECTION: Consideration/Action

PRESENTER: Jeff Daane

DEPARTMENT GOAL(S) SUPPORTED <i>(if applicable)</i>	FISCAL IMPACT	
	\$	

ISSUE SUMMARY

Each year we approve dates for spring cleanup. The dates for 2023 to be considered are April 8^h through April 29th. This is the week after bulk pickup.

STAFF RECCOMENDATION:

Approve recommended dates

ATTACHMENTS:

RECCOMENDED MOTION:

1. Approve April 8th through April 29th for Spring cleanup.



AGENDA SUMMARY SHEET

MEETING DATE: 2/13/24

TITLE: Approve 2024 Asphalt Paving contract bid

AGENDA SECTION: Consideration/Action

PRESENTER: Jeff Daane Director of Public Works

DEPARMTENT GOAL(S) SUPPORTED <i>(if applicable)</i>	FISCAL IMPACT	
Sustainability	\$146,495.60	

ISSUE SUMMARY:

The City received three bids for this years paving work.

STAFF RECOMENDATION:

Accept low bid

ATTACHMENTS:

Bid tab

MOTIONS FOR CONSIDERATION:

1. Recommend low bid from Northeast Asphalt in the amount \$146,495.60 to city council.

--	--

--	--

**CITY OF WAUPUN
 BID TAB FOR
 ASPHALT PAVING
 2024 Mill & Overlay**

			Northeast Asphalt 20 Camelot Dr Fond du Lac, WI 54935			Kartechner Brothers LLC N11829 County Rd I Waupun, WI 53963			Tri-County Paving PO Box 394 DeForest, WI 53532			
Item No	Item Description	Quantity	Mill Unit Price	Surface Unit Price	Total Price	Mill Unit Price	Suface Unit Price	Total Price	Mill Unit Price	Surface Unit Price	Total Price	
1	2" Profile Mill											
	2" Blacktop Surface (4LT 58-28s)											
	Gateway Dr (From Hwy 26 to Kelly Ave)	13161	\$1.10	\$8.10	\$121,081.20	\$1.50	\$7.80	\$122,397.30	\$1.28	\$10.10	\$149,772.18	
	Grandview Ave (From S State St to S Division St)	1809	\$1.30	\$9.30	\$19,175.40	\$1.95	\$8.90	\$19,627.65	\$2.45	\$11.60	\$25,416.45	
	Alley (Between N Division St.and N State St	367	\$4.50	\$12.50	\$6,239.00	\$3.65	\$13.50	\$6,294.05	\$3.50	\$12.50	\$5,872.00	
					\$146,495.60				\$148,319.00			\$181,060.63



AGENDA SUMMARY SHEET

MEETING DATE
2/13/24

TITLE: Recommendation to Council for Heritage
Museum Restoration (Tuck pointing and front
Step repair)

AGENDA SECTION: Consideration/ Action

PRESENTER: Public
Works Director
Daane

DEPARMTENT GOAL(S) SUPPORTED <i>(if applicable)</i>	FISCAL IMPACT	
Sustainability	\$17,000	

ISSUE SUMMARY

Engineering and bid information needs to be put together for the Museum project. We have received two quotes for this work.

Cedar Corporation Quote to include analysis, design, construction documents and bidding in the amount of \$17,000

Legacy Architecture Quote included schematic design, design development, construction documents and procurement in the amount of \$35,000. There quote included all services i asked what it would be if I do the construction administration.

STAFF RECCOMENDATION:

Approve quote with Cedar Corp

ATTACHMENTS:

Cedar Corporation Quote
Legacy Architecture Quote

RECOMMENDED MOTION:

1. Recommend to council the low quote of Cedar Corporation for the amount of \$17,000



605 Erie Avenue, Suite 101
Sheboygan, Wisconsin 53081
(920) 783-6303
info@legacy-architecture.com
www.legacy-architecture.com

January 30, 2024

Jeff Daane
City of Waupun
201 E. Main Street
Waupun, WI 53963

Re: Exterior Projects at the
Waupun Heritage Museum
22 S. Madison Street
Waupun, Wisconsin

Dear Jeff:

It was a pleasure to meet with you about the abovementioned project. From our discussion, we understand that you would like to undertake some exterior projects which would include replacing the stairs and railing, replacing spalling brick or stone, and re-pointing brick and stone, particularly around windows and at the chimney.

Our scope of basic services for this Agreement shall include the following:

ARCHITECTURE & ENGINEERING SERVICES

Schematic Design

- Visit the site to photograph existing conditions and take field measurements via laser scan.
- Draft existing first floor plan and elevations.
- Meet with you once in person to review owner-supplied data and define project requirements.
- Prepare Schematic Design documents.
- Meet with you once virtually to review and approve the Schematic Design documents.

Design Development

- Continue to develop and refine the documents.
- Meet with you once virtually to finalize and approve the Design Development documents.

Construction Documents

- Prepare Construction Documents for the project including a Title Sheet, First Floor Plan, Elevations, Sections, Details, and Project Manual/Specifications.
- Meet with you once in person to finalize and approve the Construction Documents.
- Email PDF files of Construction Documents to you.

Procurement

- Assist you in soliciting bids from prospective bidders.

- Participate in one in person pre-bid conference with prospective bidders so they can familiarize themselves with the existing conditions.
- Consult with prospective bidders and issue any Addenda for clarification purposes during bidding. (We have included an allowance of 12 hours, which equates to four hours per week for three weeks of bidding.)
- Conduct one in person bid opening and distribute bid results.
- Draft a Contract for Construction for City of Waupun Corporate Council to finalize.

Construction Contract Administration

- Visit the site at appropriate intervals to determine if the Work is in general conformance with the Construction Documents. (We have included a total of four visits including two Progress, one Substantial Completion, and one Final Completion visit.)
- Advise and consult with you and the contractors during construction via phone and email and respond to Requests for Information. (We have included an allowance of 20 hours, which equates to one and one-half hour per week for thirteen weeks of construction.)
- Review and certify up to three Change Orders and three Applications for Payment.
- Review and approve Shop Drawings, Product Data, and Samples for general conformance with the Construction Documents.
- Issue Certificate of Substantial Completion.
- Prepare one Punch List citing deficiencies or non-conforming work observed during the final job site visit.

HISTORIC PRESERVATION CONSULTING SERVICES

State Historic Preservation Office (SHPO) Compliance Review and Approval

As the building is listed in the National Register and State Register, it is considered a historic property. Pursuant to Wis. Stats. §§ 44.42 and 66.1111, the city shall notify the SHPO about a proposed action affecting a historic property in the earliest stage of planning. The SHPO will determine whether the action will have an adverse effect. If so, the SHPO may require negotiations with the city to reduce such effects. If the negotiations result in an agreement as to the means of reducing such effects, that agreement shall be incorporated into the proposed action of the city. The SHPO shall prepare a written report on the effects and the status of all negotiations. The SHPO shall submit the report to the governor and to the chief clerk of each house of the legislature for distribution to the appropriate standing committees

To initiate this process, we propose the following scope of work:

- Research and gather additional data regarding the historic significance, historic integrity, and historic context of the building.
- Prepare a Request for SHPO Review and Comment on a Local Unit of Government Action form.
- Prepare letter report and plans that address the following:
 - General Information
 - Project Narrative Description: Describe the project briefly including the problem or needs being addressed, the options which have been considered, and the option chosen to pursue. Will the project change, replace, augment, add to, diminish, or otherwise alter physical properties of the listed property itself or its setting, whether such impact is perceived to be positive or negative? Attach information including activity summary, plan drawings/specifications, current and historic photographs of the affected property.
 - Area of Potential Effect (APE): Describe the space within which the project will have immediate impact and the space within which there may be collateral/secondary impact. Attach copy of

USGS 7.5 minute topographic quadrangle showing APE, and/or other maps as appropriate, including plat or street to assist in identifying the project location.

- Identification of National Register or State Register-Listed Historic Properties: Attach supporting information identifying said property.
- Findings: The proposed undertaking may affect a National Register and/or State Register-Listed Historic Property withing the APE. Assess any effect(s). Attached supporting documentation.
- Submit the above-mentioned work products digitally to the SHPO for review and approval.

The above work can be performed during the Bidding and Negotiation Phase. Please note, the law requires SHPO to respond within 30 days of their receipt of the submittal. If necessary, SHPO may request an additional 30 days to review the project. If SHPO does not respond within 30 days of their receipt of the submittal, there is a statutory presumption that SHPO has no further comments on the project. The project may then proceed as designed at the time of the submittal. Legacy Architecture, Inc. has no control over the process, scheduling, or timeline of the SHPO.

EXCLUDED SERVICES

In addition to the Scope of Services to be provided under this Agreement, certain other services may be necessary or advisable for the Project. The Client has decided to include such services from another source or to forgo those services. The following services are therefore excluded from this Agreement:

- Additional work not specifically mentioned in the Scope of Services above
 - Construction Document phase services not specifically mentioned above including, but not limited to, applications to and meetings with the City of Waupun, Dodge or Fond du Lac County, or State of Wisconsin, etc. (As this is primarily a repair type project, the only application required should be for a building permit, which will be obtained by the successful contractor(s).)
 - Procurement phase services not specifically mentioned above including, but not limited to, revising and “value engineering” the construction documents, etc.
 - Construction phase services not specifically mentioned above including, but not limited to, revising and “value engineering” the construction documents, etc.
- ALTA Land Title, Existing Conditions, and Topographic Survey
- Civil, structural, fire protection, plumbing, mechanical, and electrical engineering services
- Landscape architecture services
- Interior design services

In consideration of the risks to the Consultant as a result of the Client’s decision to exclude these services from this Agreement, the Client hereby agrees, to the fullest extent permitted by law, to indemnify and hold harmless the Consultant, its officers, directors, employees and subconsultants (collectively, Consultant) from any damages, liabilities, or costs arising out of or in any way connected with the Consultant’s not providing these Excluded Services. If these, or any other services are desired at a later date, they will be performed at our regular hourly rates.

FEES

Professional Service Fees

The professional service fees for the above will be \$42,500.

Reimbursable Expenses

Reimbursable expenses such as AIA Contract Documents, printing, mileage, shipping, and postage are in addition to these fees.

Additional Services

Should additional services be required, our 2024 Schedule of Rates is as follows:

Principal Architect or Interior Designer.....	\$175/hour
Senior Project Manager.....	\$130 - \$145/hour
Project Designer.....	\$85-\$90/hour
Historic Preservation Staff.....	\$80/hour
Business/Administrative Staff	\$75/hour
Reimbursable Expenses	Cost + 10%

The Schedule of Rates is evaluated annually at the beginning of each calendar year.

TERMS & CONDITIONS

Invoices shall be submitted by the Consultant monthly on the basis of work completed and are due on the 21st of each month and shall be considered past due if not paid by the end of the same month. If payment in full is not received by the Consultant within 30 calendar days, invoices shall bear interest at 1.5% or the maximum rate allowable by law, whichever is less, of the past due amount per month, which shall be calculated from the invoice date. Payment thereafter shall be first applied to accrued interest and then to the unpaid principal.

If the Client fails to make payments when due and the Consultant incurs any costs in order to collect overdue sums from the Client or in the event legal action is necessary to enforce the payment terms of this Agreement, the Consultant shall be entitled to collect from the Client any judgment or settlement sums due, plus collection agency fees and expenses, collection bonds, reasonable attorney’s fees, court costs, and other expenses incurred by the Consultant for such collection action and, in addition, the reasonable value of the Consultant’s time and expenses spent for such collection action, computed according to the Consultant’s prevailing fee schedule and expense policies. The obligation of the Client to pay the Consultant’s collection costs shall survive the term of this Agreement or any earlier termination by either party.

If the Client fails to make payments when due or otherwise is in material breach of the Agreement, the Consultant may suspend performance of service. The Consultant shall have no liability whatsoever to the Client for any costs or damages as a result of such suspension caused by any breach of this Agreement by the Client. Upon payment in full by the Client, the Consultant shall resume services under this Agreement, and the time schedule and compensation shall be equitably adjusted to compensate for the period of suspension plus any other reasonable time and expense necessary for the Consultant to resume performance.

If the Client fails to make payment to the Consultant in accordance with the payment terms herein, this shall constitute a material breach of the Agreement and shall be cause for termination of this Agreement by the Consultant. In the event of termination of this Agreement by either party, the Client shall within 30 calendar days of termination pay the Consultant for all services rendered and all reimbursable costs incurred by the Consultant up to the date of termination, in accordance with the payment provisions of this Agreement.

If, during the term of this Agreement, circumstances or conditions that were not originally contemplated by or known to the Consultant are revealed, to the extent that they affect the scope of services, compensation, schedule, allocation of risks or other material terms of this Agreement, the Consultant may call for renegotiation of appropriate portions of this Agreement. The Consultant shall notify the Client of the changed conditions

necessitating renegotiation, and the Consultant and the Client shall promptly and in good faith enter into renegotiation of this Agreement to address the changed conditions. In establishing fees for any additional services to be performed, the Consultant shall utilize the same fee schedule included herein. If terms cannot be agreed to, the parties agree that either party has the absolute right to terminate this Agreement in accordance with the termination provision thereof.

If the Consultant for any reason is not allowed to complete all the services called for by this Agreement, the Consultant shall not be held responsible for the accuracy, completeness, or constructability of the construction documents prepared by the Consultant if used, reused, changed, or completed by the Client or by another party. Accordingly, the Client agrees, to the fullest extent permitted by law, to indemnify and hold harmless the Consultant, its officers, directors, employees, and subconsultants (collectively, Consultant) from any damages, liabilities, or costs, including reasonable attorneys' fees and defense costs, arising or allegedly arising from such use, change, or completion by any other party of any construction documents prepared by the Consultant.

In an effort to resolve any conflicts that arise during the design and construction of the Project or following the completion of the Project, the Client and the Consultant agree that all disputes between them arising out of or relating to this Agreement or the Project shall be submitted to nonbinding mediation. The Client and the Consultant further agree to include a similar mediation provision in all agreements with independent contractors and consultants retained for the Project and to require all independent contractors and consultants also to include a similar mediation provision in all agreements with their subcontractors, subconsultants, suppliers and fabricators, thereby providing for mediation as the primary method for dispute resolution among the parties to all those agreements.

In the event the parties to this Agreement are unable to reach a settlement of a fee dispute involving an amount of less than \$10,000, arising out of this Agreement or related to the services under this Agreement, in accordance with the paragraph above, then such dispute may, with the consent of both parties, be settled by binding arbitration in accordance with the rules of the Construction Industry Arbitration Rules of the American Arbitration Association current as of the date of this Agreement then pertaining. The Client and the Consultant shall mutually agree over the choice of a qualified arbitrator with construction industry experience free of any conflicts of interest among the parties. The Client and the Consultant also agree that discovery and rules of evidence shall be in accordance with the code of civil procedure in the State of Wisconsin. The decision of the arbitrator may be excepted to, challenged, and appealed according to law.

The Consultant agrees, to the fullest extent permitted by law, to indemnify and hold harmless the Client, its officers, directors, and employees (collectively, Client) against all damages, liabilities or costs, including reasonable attorneys' fees and defense costs, to the extent caused by the Consultant's negligent performance or professional services under this Agreement and that of its subconsultants or anyone for whom the Consultant is legally liable. The Client agrees, to the fullest extent permitted by law, to indemnify and hold harmless the Consultant, its officers, directors, employees and subconsultants (collectively, Consultant) against all damages, liabilities, or costs, including reasonable attorneys' fees and defense costs, to the extent caused by the Client's negligent acts in connection with the Project and the acts of its contractors, subcontractors, or consultants or anyone for whom the Client is legally liable. Neither the Client nor the Consultant shall be obligated to indemnify the other party in any manner whatsoever for the other party's own negligence or for the negligence of others.

The Client agrees, to the fullest extent permitted by law, to limit the liability of the Consultant and Consultant's officers, directors, employees, shareholders, owners and subconsultants for any and all claims, losses, costs, damages of any nature whatsoever or claims expenses from any cause or causes, including attorneys' fees and costs and expert witness fees and costs, so that the total aggregate liability of the Consultant and Consultant's officers, directors, employees, shareholders, owners and subconsultants shall not exceed \$50,000, or the Consultant's total fee for services rendered on this project, whichever is greater. It is intended that this limitation apply to any and all liability or cause of action however alleged or arising, unless otherwise prohibited by law.

We appreciate the opportunity to provide this proposal and look forward to working with you. Please contact us if there are any questions or if you require further information.

Sincerely,

Legacy Architecture, Inc.

Jennifer L. Lehrke

Jennifer L. Lehrke, AIA, NCARB
Principal Architect, Interior Designer & Historic Preservation Consultant

ACCEPTANCE

Signing and dating of this letter and returning it to Legacy Architecture, Inc. will indicate your acceptance.

Signature

Date

**Confirmation of Client Request for Services
between Cedar Corporation (ENGINEER)
and City of Waupun (CLIENT)**

Authorization to Perform Professional Engineering Services

ARCHITECT/ENGINEER is hereby authorized to proceed with the project listed below.

Project: Museum Heritage Museum Restoration

Scope of Work: ARCHITECT/ENGINEER will complete Scope of Work as identified in Attachment A.

Method of Compensation: Work will be completed on a Lump Sum basis for \$13,750.

Additional Services: Additional Services that may be required and provided upon request of the CLIENT will be completed on an Hourly basis estimated as follows:

- Bidding: \$3,250
- Construction Administration: \$14,850

Payments are due and payable thirty (30) days from the date of the ENGINEER’s invoice. Amounts unpaid thirty (30) days after the invoice date shall bear interest at the rate of one percent (1%) per month from invoice date.

Timetable: Work will be completed in a timely manner to have project bid in the Spring of 2024.

THIS AGREEMENT is hereby approved and executed this ____ day of _____, 20__.

CITY OF WAUPUN

CEDAR CORPORATION

By: _____

By: 

Name: _____

Name: Kris Dressler, RA

Title: _____

Title: Architect

By: _____

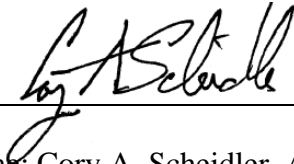
By: 

Name: _____

Name: Cory A. Scheidler, AIA

Title: _____

Title: Architect

Attachment A

Scope of Work

Project Understanding:

We understand the project consists of repointing select areas of the entire stone masonry façade and two chimneys, including rebuilding or replacing displaced or deteriorated stones to match. Restoring previously repaired mortar joints to match existing. Applying water repellent to extend life of masonry work.

The project will also include repair of the concrete stairs to the front entrance and the replacement of existing steel railing to meet current code required while maintaining the historical nature of the building.

Scope of Services:

ARCHITECT/ENGINEER will complete the following Scope of Services for the Project, as follows.

I. Analysis

- a. Kick-Off Meeting with the Designated Staff to review project scope, schedule, and budget.
- b. Site Documentation:
 - Examine current conditions of the building's exterior masonry, steel lintel, flashings, joint sealants, concrete stairs, and railing.

II. Design

- a. Design:
 - Design Documents including the following:
 - Staging Plan
 - Elevations/Exterior Views and Images
 - Renovation Details
 - Outline Specifications
 - (1) Meeting with the Designated Staff to review design, gain feedback, evaluate staging, phasing, and occupant impacts, etc.
 - Revisions to Design Documents per the Designated Staff comments and/or additional requirements.
 - Deliverables
 - Provide staging layout, Elevations, exterior views/images, renovation details, and outline specifications of the facility.
- b. Cost Analysis:
 - Assist Designated Staff with probable construction cost estimates.

III. Construction Documents

- a. Architectural & Structural Design:
 - Plans and design documentation required for bidding and construction of the project including but not limited to the following items: Staging plan, Exterior elevations, Details as necessary for a complete set of construction documents.
 - Full specification manual.

IV. Additional Services:

a. Bidding

- Bidding and Negotiation:
 - Assemble and provide plans and specifications as necessary for bid package.
 - Conduct (1) pre-bid conference.
 - Address bidding questions.
 - Prepare bidding addendums.
 - Review requests for equals.
 - Conduct (1) electronic bid opening

b. Construction Administration

- Construction Administration:
 - Conduct (1) preconstruction meeting.
 - Shop Drawing Review.
 - Answer questions during the construction process.
 - Bi-weekly Job Site Observations.
 - Bi-weekly Construction Progress Meetings.
 - Review and Approve Applications for Payment.
 - Review Change Orders.
 - Complete Final Inspection and draft a punch list.
 - Review and approve final payment request.

V. Services Not Included

- a. The following services are typically not included but could be added if you would like
- Plan reproduction.
 - Building Model.

Attachment C - Standard Conditions

PART I - DESCRIPTION OF SERVICES

- 1.1 CEDAR CORPORATION** agrees to provide professional services for the PROJECT as more completely described in this Agreement.
- 1.2 CEDAR CORPORATION** agrees to provide all professional services within a reasonable period of time following the date of authorization to proceed by OWNER. If a special time schedule must be met for a PROJECT, it shall be specifically set forth in this Agreement.

PART II - CLIENT'S RESPONSIBILITIES

Client, at its expense, shall do the following in a timely manner so as not to delay the services,

2.1 INFORMATION/REPORTS

Furnish Cedar Corporation with all reports, studies, site characterizations, regulatory orders, and similar information in its possession relating to the Project. Unless otherwise specified in Part I, Cedar Corporation may rely upon Client-furnished information without independent verification in performing the Service.

2.2 REPRESENTATIVE

Designate a representative for the project who shall have the authority to transmit instructions, receive information, interpret and define Client's policies, and make decisions with respect to the services.

2.3 GIVE NOTICE

Give prompt written notice to Cedar Corporation whenever Client observes or otherwise becomes aware of any defect in the Project or other event which may substantially affect performance of services under this Agreement.

PART III - BILLING, AND PAYMENT

- 3.1** Cedar Corporation will periodically bill the client with net payment due in 30 days. Unless Client provides Cedar

Corporation with a written objection to the bill within 15 days of receipt, Client shall be deemed to accept the bill as submitted.

- 3.2** Where Client disputes some portion of the charges contained in Cedar Corporation's bill for services, he shall make payment of that portion of the bill which is undisputed. In no case may Client elect to withhold payment to Cedar Corporation of the entire amount due.
- 3.3** If Client fails to make any payment due Cedar Corporation for services and expenses after receipt of Cedar Corporation's bill therefore, the amounts due Cedar Corporation shall bear interest from invoice date at the rate set forth in this agreement, or in the absence thereof at the legal rate prevailing from time to time at the principal place of business of Cedar Corporation. In addition Cedar Corporation may, after giving ten (10) days written notice to Client, suspend services under this agreement until paid in full all amounts due under this agreement. In the event Client does not pay, or does not pay timely, Cedar Corporation shall be entitled to collect from Client all amounts due plus expenses, including but not limited to attorney fees, incurred by Cedar Corporation in connection with collection efforts, in addition, the reasonable value of Cedar Corporation's time spent in connection with collection efforts, computed at Cedar Corporation's prevailing fee schedule.

PART IV - STANDARD TERMS AND CONDITIONS

- 4.1 STANDARD OF CARE.** Services shall be performed in accordance with the standard of professional practice ordinarily exercised by the applicable profession at the time and within the locality where the services are performed. Professional services are not subject to, and Cedar Corporation cannot provide any warranty or guarantee, either express or implied. Any such warranties or guarantees contained in any purchase orders, Client action, requisitions or notices to proceed issued by Client are specifically

objected to by Cedar Corporation.

- 4.2 CHANGE OF SCOPE.** The Scope of Services set forth in this Agreement and in any addenda to the Agreement is based on facts known at the time of execution of this Agreement, including, if applicable, information supplied by Client. For some projects involving conceptual or process development services, scope may not be fully definable during initial phases. As the project progresses, facts discovered may indicate that scope must be redefined.
- 4.3 SAFETY.** Cedar Corporation has established and maintains corporate programs and procedures for the safety of its employees. Unless specifically included as a service to be provided under this Agreement, Cedar Corporation specifically disclaims any authority or responsibility for general job site safety and safety of persons other than Cedar Corporation employees.
- 4.4 DELAYS.** If events beyond the control of Client or Cedar Corporation, including, but not limited to, fire, flood, explosion, riot, strike, war, process shutdown, act of god or the public enemy, and act or regulation of any government agency, result in delay to any schedule established in this Agreement or in any Addenda to this Agreement, then such schedule shall be amended to the extent necessary to compensate for such delay. In the event such delay exceeds 60 days, Cedar Corporation shall be entitled to an equitable adjustment in compensation.
- 4.5 TERMINATION.** Either party may terminate this Agreement at the end of the term hereof, or any extension thereof, upon 30 days written notice to the other party as provided at PART I above.

Also, this Agreement may be terminated by either party if the other party fails to fulfill its obligations under this Agreement through no fault of the terminating party. No such termination may be effected unless the other party is given not less than ten calendar day's

written notice of intent to terminate and an opportunity for correcting the default and for consultation with the terminating party before termination. If Cedar Corporation terminates as a result of Client default or the Client terminates for cause, Cedar Corporation shall be paid for services performed to the termination date including reimbursable expenses due. Upon receipt of the terminating action, Cedar Corporation shall promptly discontinue all services unless the notice directs otherwise, and upon receipt of final compensation make available to Client all appropriate documents prepared under the Agreement whether completed or in process.

- 4.6 OPINIONS OF PROBABLE CONSTRUCTION COST.** Any opinion of probable construction costs prepared by Cedar Corporation is supplied for the general guidance of the Client only. Since Cedar Corporation has no control over competitive bidding or market conditions, Cedar Corporation cannot guarantee the accuracy of such opinions as compared to contract bids or actual costs to Client.
- 4.7 RELATIONSHIP WITH CONTRACTORS.** Cedar Corporation shall serve as Client's professional representative for the services, and may make recommendations to Client concerning action relating to Client's contractors. However, Cedar Corporation specifically disclaims any authority to direct or supervise the means, methods, techniques, sequences or procedures of construction selected by Client's contractors.

- 4.8 CONSTRUCTION REVIEW.** For projects involving construction, Client acknowledges that under generally accepted professional practice, interpretations of construction documents in the field are normally required, and that performance of construction-related services by the design professional for the municipal project permits errors or omissions to be identified and corrected at comparatively low cost. Client agrees to hold Cedar

Corporation harmless from any claims resulting from performance of municipal services by persons other than Cedar Corporation.

4.9 INSURANCE. Cedar Corporation will maintain insurance coverage for Professional Liability, Comprehensive General, Automobile, Workers Compensation, and Employer's Liability in amounts in accordance with applicable legal requirements as well as Cedar Corporation's business requirements. Certificates evidencing such coverage will be provided to Client upon request.

4.10 ALLOCATION OF RISKS. To the fullest extent permitted by law, Cedar Corporation shall indemnify and hold harmless, Client, Client's officers, directors, partners, and employees from and against any and all costs, losses, and damages (including but not limited to all fees and charges of engineers, architects, attorneys, and other professionals, and all court or arbitration or other dispute resolution costs) caused solely by the negligent acts or omissions of Cedar Corporation or Cedar Corporation's officers, directors, partners, employees, and Cedar Corporation's consultants in the performance and furnishing of Cedar Corporation's services under this Agreement.

To the fullest extent permitted by law, Client shall indemnify and hold harmless Cedar Corporation, Cedar Corporation's officers, directors, partners, employees, and Cedar Corporation's consultants from and against any and all costs, losses, and damages (including but not limited to all fees and charges of engineers, architects, attorneys, and other professionals, and all court or arbitration or other dispute resolution costs) caused solely by the negligent acts or omissions of Client or Client's officers, directors, partners, employees, and Client's consultants with respect to this Agreement or the Project.

To the fullest extent permitted by law, Cedar Corporation's total liability to Client and anyone claiming by, through, or under

Client for any cost, loss, or damages caused in part by the negligence of Cedar Corporation and in part by the negligence of Client or any other negligent entity or individual, shall not exceed the percentage share that Cedar Corporation's negligence bears to the total negligence of Client, Cedar Corporation, and all other negligent entities and individuals.

4.11 HAZARDOUS MATERIAL. Hazardous materials may exist at a site where there is no reason to believe they could or should be present. Cedar Corporation and Client agree that the discovery of unanticipated hazardous materials constitutes a changed condition mandating a renegotiation of the Project scope of work. Cedar Corporation agrees to notify Client as soon as practically possible should unanticipated hazardous materials or suspected hazardous materials are encountered. Client acknowledges and agrees that it retains title to all hazardous material existing on the site and shall report to the appropriate federal, state or local public agencies, as required, any conditions at the site may present a potential danger to the public health, safety or the environment. Client shall execute any manifests or forms in connection with transporting or storage and disposal of hazardous materials resulting from the site or work on the site or shall authorize Cedar Corporation to execute such documents as Client's agent. Client waives any claim against Cedar Corporation and agrees to defend, indemnify, and save Cedar Corporation harmless from any claim or liability for injury or loss arising from Cedar Corporation's discovery of unanticipated hazardous materials or suspected hazardous materials.

4.12 ACCESS. Client shall provide Cedar Corporation safe access to any premises necessary for Cedar Corporation to provide the services.

4.13 REUSE OF PROJECT DELIVERABLES. Reuse of any documents or other deliverables, including electronic media, pertaining to the project by Client for any purpose other than that for which such documents or deliverables were originally prepared, or alteration

of such documents or deliverables without written verification or adaptation by Cedar Corporation for the specific purpose intended, shall be at the Client's risk. Further, all title blocks and the engineer's seal, if applicable, shall be removed if and when Client provides deliverables in electronic media to another entity. Client agrees that relevant analyses, findings and reports provided in electronic media shall also be provided in "hard copy" and that the hard copy shall govern in the case of a discrepancy between the two versions, and shall be held as the official set of drawings, as signed and sealed. Client shall be afforded a period of thirty (30) days in which to check the hard copy against the electronic media. In the event that any error or inconsistency is discovered within such thirty (30) day period it shall be corrected at no additional cost to Client. Following the expiration of this thirty (30) day period, Client shall bear all responsibility for the care, custody and control of the electronic media. In addition, Client represents that it shall retain the necessary mechanisms to read the electronic media, which Client acknowledges to be of only limited duration. Client agrees to defend, indemnify, and hold harmless Cedar Corporation from all claims, damages, and expenses (including reasonable litigation costs), arising out of such reuse or alteration by Client or others acting through Client. Cedar Corporation agrees that all plans, engineering designs, electronic and computer data and imagery relating to Client's projects are the property of the Client and shall be presented to Client at no additional cost upon written request.

4.14 AMENDMENT. This Agreement, upon execution by both parties hereto, can be amended only by a written instrument signed by both parties.

4.15 ASSIGNMENT. Except for assignments (a) to entities which control, or are controlled by, the parties hereto or (b) resulting from operation of law, the rights and obligations of this Agreement cannot be assigned by either party without written permission of the other party. This Agreement shall be binding upon and inure to the benefit of

any permitted assigns.

4.16 DISPUTE RESOLUTION. Parties shall attempt to settle disputes arising under this agreement by discussion between the parties senior representatives of management. If any dispute cannot be resolved in this manner within a reasonable length of time, parties agree to attempt non-binding mediation or any other method of alternative dispute resolution prior to filing any legal proceedings. In the event any actions are brought to enforce this Agreement, the prevailing party shall be entitled to collect its litigation costs, including attorneys' fees from the other party.

4.17 NO WAIVER. No waiver by either party of any default by the other party in the performance of any particular section of this Agreement shall invalidate any other section of this Agreement or operate as a waiver of any future default, whether like or different in character.

4.18 NO THIRD-PARTY BENEFICIARY. Nothing contained in this Agreement, nor the performance of the parties hereunder, is intended to benefit, nor shall inure to the benefit of, any third party, including Client's municipal project contractors.

4.19 SEVERABILITY. The various terms, provisions and covenants contained in this Agreement or any addenda shall be deemed to be separate and severable, and the invalidity or unenforceability of any of them shall not affect or impair the validity or enforceability of the remainder.

4.20 AUTHORITY. The persons signing this Agreement warrant that they have the authority to sign as, or on behalf of, the party for whom they are signing.

4.21 OTHER. Cedar Corporation reserves the right to enter into agreements with other design professionals for portions of the work included under this Agreement. Where this subagreement would represent a major portion of the design work, Cedar Corporation shall receive approval of Client for this subagreement.



AGENDA SUMMARY SHEET

MEETING DATE
2/13/24

TITLE: Recommendation to Council -
Community/Senior Center Door access and
Security Camera systems

AGENDA SECTION: Consideration/ Action

PRESENTER: Public
Works Director
Daane

DEPARMTENT GOAL(S) SUPPORTED <i>(if applicable)</i>	FISCAL IMPACT	
Sustainability		

ISSUE SUMMARY

Construction is well underway for the new facility. The next step is to approve door access and camera systems. I have contacted four vendors that could do both systems. Each has equipment and staff to handle the project. I have been working with Gappa here in Waupun during the project for door hardware and equipment specs. The hardware that is getting installed and the keys will be able to be serviced by Gappa.

Gappa’s Quote features a Continental access system and hardware needed for the system to work. In the Reach Waupun space, they asked to be able to have access control as their mentors do change periodically. The Proxess system would allow them to control that space. The camera system is an avigilon. We currently have at a few other facilities. All data will be stored onsite with this system. Total cost for the installation and equipment is \$61,078.45

Pros4 Quote uses and HID Signo reader system for the door access. The way this system works different people can have access to certain doors, so the Reach Waupun group could have access control of their doors, while the City would have controls of all the doors. The camera system uses mostly Hanwha equipment. Currently Pros4 is our computer IT provider. The total cost for installation and equipment is \$24,003.48 plus a monthly recurring charge for the cloud based system of \$96.

Accurate Controls Quote features a Premisys door access system and hardware. The Camera system is Hanwha. The Reach area would be included in the building system. They would not have souls access to their doors. The total cost for the installation and equipment is \$64,400.

Verkada Quote met virtually with them a couple times. This system is similar to Pros4 in how it operates. As of getting the agenda out I have not received their quote.

The systems are a apples to oranges comparison. The Gappa and Accurate Controls quotes are all onsite equipment. With these two systems there is more equipment to install and all storage of data is onsite.

The Pros4 and Verkada systems use less equipment use less onsite equipment and use the cloud for storage. They both have monthly fees for use of the cloud.

STAFF RECCOMENDATION:

All of these systems will work for the facility.

ATTACHMENTS:

Gappa Quote (Possible second quote at meeting)

Pros4 Quote

Accurate Controls Quote

Verkada 2 Quotes

RECCOMENDED MOTION:

1. Recommend Pros4 for the amount of \$24,003.48 and monthly charge of \$96 for cloud hosting
2. Recommend Gappa for the amount of \$61,078.45
3. Recommend Accurate Controls for the amount of \$64,400.
4. Recommend Verkada for the amount of \$24,291.05 plus yearly fees of \$3,059.14
5. Recommend Verkada for the amount of \$40,003.31 This option includes the 10 year fees



1203 Storbeck Drive
 Waupun, WI 53963

Proposal

Date	Proposal #
1/18/2024	21329

Name / Address:

Waupun, City of
 Jeff Daane
 201 E. Main Street
 Waupun, WI 53963

Revision	Project / Entered By	Terms	Rep
G	Senior Center/JS	25% Down, N30 Progressing	GS...

Qty	Description	Total
	*****REVISED from Proposal 21286***** To Provide and Install Continental Access IP Solution for WAUPUN SENIOR CENTER located at 520 McKinley St.: (Door Locations Include: Main Entrance Exterior 100, Main Office Room 101, Room 103, Hallway Door 119A, Door 142 - Door Contacts Only, Door 131 Exterior Door, Room 300, Room 106, Hallway 119B, Room 301, Room 306, Room 306 Overhead Door - Door Contacts Only, Room 112, and Door 114C - Door Contacts Only)	
1	Continental Access - CA4K Five User Software	700.00
1	Continental Access - (5) User Yearly Upgrade Program - This purchase entitles the dealer to 1 copy of the newest major software release available for shipment within 1 year of upgrade program purchase date.	410.00
1	Continental Access - Accelaterm - Eight (8) Reader Access Control Panel (for use with CA3000 version 2.9 or higher), with ethernet adapter. C1CP18ACCNETBD is Included.	5,035.00
1	Continental Access - Reader Expansion Board for Accelaterm (Mandatory purchase for 16 door Accelaterm configuration)	3,440.00
1	Power Supply Charger, 16 Fused Outputs, 24VDC @ 10 Amp, 115VAC, Grey Enclosure	475.00
1	Power Cord for Power Supplies	8.50
4	Back - Up Battery	128.00
11	Continental Access - HID Signo Wall Switch Smartcard Reader - Black	4,125.00
11	REX Motion with Screw Terminals	1,199.00
14	Brown Door Contacts - 3/4" stubby recessed door contact with terminal connections, SPDT	371.70
2	Overhead Door Mini Switch with Universal Magnet Featuring No Dead Spot Technology	49.00
1	Relay Logic Module, Time Delay Relay (Replaces MCLINX1&2)	147.00
1	12-24VDC Relay DPDT	16.75
	Installation includes up to 2 Hours of Basic Software Training. Advanced training or more extensive software customization is available for an additional charge. Our technicians will assist in adding items to the software if requested, but all other software work, including adding users, creating schedules, providing documentation, and applying rules is the responsibility of the end user. If our assistance is required for these items, additional charges will apply.	16,300.00

Please Call or Email with Any Additional Questions!

Total

Phone #	Fax #	E-mail	Web Site
920-324-2260	888-558-0458	orders@gappasecuritysolutions.com	www.gappasecuritysolutions.com



1203 Storbeck Drive
 Waupun, WI 53963

Proposal

Date	Proposal #
1/18/2024	21329

Name / Address:

Waupun, City of
 Jeff Daane
 201 E. Main Street
 Waupun, WI 53963

Revision	Project / Entered By	Terms	Rep
G	Senior Center/JS	25% Down, N30 Progressing	GS-...

Qty	Description	Total
	<p>First Annual Maintenance Visit: First annual maintenance on-site check in by GSS technician, including system inspection, configuration backup, and any free software updates that may be available.</p> <p>NOTES: 1. City of Waupun will need to provide a computer/server that will meet minimum system requirements for CA4K. Gappa technicians will need full admin privileges. 2. For the highest level of security and functionality, we recommend that all electronic access systems be set up on a separate VLAN from the end user's primary network. We also recommend that all users schedule routine password changes for their individual logins and keep all windows servers updated. 3. Gappa Security Solutions will only install and make final connections at card readers, door position switches, and access control panel. Electric Strikes will be provided and installed by others. Gappa will make final connections. 4. All necessary wire to be provided and pulled BY OTHERS from access control panel location to locations of electric strikes, card readers, and door position switches. This includes others fishing wire in frames or running conduit as needed. 5. Upon request GSS will provide electronic documentation on the materials we are installing and all manufacturer and labor warranties, but will not be providing any CAD-based riser diagrams or as-builts. Any such CAD-based drawings will need to be produced by the Electrician (GSS can advise as to the placement of items in the diagram). Additionally, there will be an additional \$300 charge if physical hard copies of the documentation are required. 6. This proposal does NOT include any work pertaining to design, submittals, or fees relating to permitting from the City of Waupun, Dodge County, or the local fire authorities. If Gappa Security Solutions is required to do this, there will be an additional \$1000 design charge plus the costs of any fees required by these third parties. 7. This proposal does NOT include any work pertaining to additions to or connections to the fire alarm system. 8. This proposal does not include any time for Gappa technicians to attend on-site meetings or to provide consulting services. Any time spent doing this by Gappa technicians will be billed on a time and materials basis with a labor rate of \$150/hr. 9. Unless otherwise specified, all work is quoted to be done during normal business hours.</p>	150.00

Please Call or Email with Any Additional Questions!

Total

Phone #	Fax #	E-mail	Web Site
920-324-2260	888-558-0458	orders@gappasecuritysolutions.com	www.gappasecuritysolutions.com



1203 Storbeck Drive
 Waupun, WI 53963

Proposal

Date	Proposal #
1/18/2024	21329

Name / Address:

Waupun, City of
 Jeff Daane
 201 E. Main Street
 Waupun, WI 53963

Revision	Project / Entered By	Terms	Rep
G	Senior Center/JS	25% Down, N30 Progressing	GS-...

Qty	Description	Total
	<p>WORK DONE BY OTHERS:</p> <ol style="list-style-type: none"> IT personnel to provide the following upon request: IP address(s), Subnet and Gateway information, potential firewall exceptions, forwarding of ports to devices, available switch port openings (with or without PoE, depending on need), assistance in configuring the routing of information across the network, and assistance in installing and setting up servers, workstations, and/or software. Finally, an adequate number of power outlets is the responsibility of the owner of the building. Any delay in getting help or assistance with the information required above may result in Gappa Security Solutions not being able to finish the project(s) in the time in which the project was quoted. Such delays may also incur additional charges. Some of this information may be requested or provided in advance of the project. If remote connections to the software are required, Customer must rely on their IT personnel. If you desire Gappa Security Solutions to do this work, we can contract an IT company to make this connection for additional charges. <p>TERMS: 25% Due Upon Receipt of Order, Net 30 Progressing Billing for Remainder. Wisconsin Sales Tax-Exempt</p>	0.00

Please Call or Email with Any Additional Questions!

We are working hard to ensure the pricing on this proposal is good for approximately 15 days. Due to the volatile nature of supply chains at the moment, however, sudden cost increases from our suppliers can force us to have to revise pricing unexpectedly.
 All quoted prices subject to correction for clerical error
 Credit Card purchases will be assessed an additional 3% credit card fee
 For Warranty Information please see our website

Total	\$32,554.95
--------------	--------------------

Phone #	Fax #	E-mail	Web Site
920-324-2260	888-558-0458	orders@gappasecuritysolutions.com	www.gappasecuritysolutions.com



1203 Storbeck Drive
 Waupun, WI 53963

Proposal

Date	Proposal #
1/11/2024	21287

Name / Address:

Waupun, City of
 Jeff Daane
 201 E. Main Street
 Waupun, WI 53963

Revision	Project / Entered By	Terms	Rep
G	Senior Center/JS	Due on receipt	GS-...

Qty	Description	Total
	To Provide and Install a Proxess Smartphone-Based Access Control System for the REACH CENTER Door 400B and Room 401:	
1	Proxess - Perpetual License for LoxIQ Android Mobile Phone-Based Software (Server and Client capable)	160.00
1	Proxess - FOB, Read/Write enforced, Mifare DESFire EV2 compatible, with initialized Proxess application and encrypted identification, 4K Bytes, Re-usable & Re-assignable. (Minimum Order 25)	6.50
1	Proxess - 25-pack of Mobile Phone Access Credential Licenses - BLE (Bluetooth Low Energy); iOS & Android Compatible: Each credential is valid only for a single User at a time. Re-usable & Re-assignable.	150.00
1	Proxess - Gen2 Enrollment Reader and Programmer for Smart Credentials, USB Input at Server, Client, or with App	240.00
2	Proxess - CX Cylindrical Intelligent Lockset, 15 Style Lever, 2-3/4 Backset, Less Core, Satin Chrome Finish	1,140.00
	Installation includes Basic System Training	1,125.00
	First Annual Maintenance Visit: Includes first annual maintenance check-in to provide firmware update on wireless locks.	150.00
	NOTES: 1. Customer will need to be present during the installation, and provide their mobile phone for system set-up and training on programming the locks. 2. Unless otherwise specified, all work is quoted to be done during normal business hours. Wisconsin Sales Tax-Exempt	0.00

Please Call or Email with Any Additional Questions!

We are working hard to ensure the pricing on this proposal is good for approximately 15 days. Due to the volatile nature of supply chains at the moment, however, sudden cost increases from our suppliers can force us to have to revise pricing unexpectedly.

All quoted prices subject to correction for clerical error

Credit Card purchases will be assessed an additional 3% credit card fee

For Warranty Information please see our website

Total	\$2,971.50
--------------	-------------------

Phone #	Fax #	E-mail	Web Site
920-324-2260	888-558-0458	orders@gappasecuritysolutions.com	www.gappasecuritysolutions.com



1203 Storbeck Drive
 Waupun, WI 53963

Proposal

Date	Proposal #
1/11/2024	21288

Name / Address:

Waupun, City of
 Jeff Daane
 201 E. Main Street
 Waupun, WI 53963

Revision	Project / Entered By	Terms	Rep
G	Senior Center/JS	25% Down, N30 Progressing	GS-V

Qty	Description	Total
	To Provide and Install Avigilon's Cutting Edge Video Management System for the SENIOR CENTER located at 520 McKinley St.:	
	(Camera Locations Include: East Side, West Exterior, Gym, Main Lobby Hallway, Hallway 119 Corner, and Hallway by Room 307)	
1	Avigilon - 9TB HD Video Appliance 3X Pro 16-port unit, NA. Licenses sold separately	5,135.00
6	Avigilon - Unity Standard Edition camera license	960.00
3	Avigilon - 2x 3MP H5A Dual Head Camera. Outdoor camera with built-in IR	4,080.00
2	Avigilon - H5 Multisensor Camera, 3 x 8 MP, WDR, 270 degree max field of view, LightCatcher, 3.3-5.7mm, Camera Only	4,620.00
1	Avigilon - H5 Multisensor Camera, 4 x 8 MP, WDR, 360 degree max field of view, LightCatcher, 4mm, Camera Only	2,755.00
3	Avigilon Indoor Single Port PoE Injector Gigabit, 95W, NA power cord	1,233.00
2	Avigilon - Wall Mount for large pendant camera	212.00
3	Avigilon - Junction box with side cable entry for H5A Dual Head camera.	279.00
3	Avigilon - Dome Bubble and Cover, for Outdoor Surface Mount or Pendant Mount H5A Multisensor Cameras, Clear	525.00
3	Avigilon - Outdoor Pendant Mount Adaptor, for use with H5A Multisensor Cameras	525.00
1	Avigilon - 1.5 Inch NPT Adapter for Large Pendant Mount Camera	58.00
3	Avigilon - Optional IR Illuminator Ring, up to 30mm (100 ft.)	1,020.00
	Lift Rental	700.00
	Installation includes up to 1 Hour of Basic Software Training, which includes installation of ACC camera software on up to two workstations, has also been figured into this proposal. Advanced training or more extensive software customization is available for an additional charge. Our technicians will assist in adding items to the software if requested, but all other software work, including adding users, creating schedules, providing documentation, and applying rules is the responsibility of the end user. If our assistance is required for these items, additional charges will apply.	3,375.00
	First Annual Maintenance Visit: First annual maintenance on-site check in by GSS technician, including system inspection, configuration backup, and any free software updates that may be available.	75.00

Please Call or Email with Any Additional Questions!

Total

Phone #	Fax #	E-mail	Web Site
920-324-2260	888-558-0458	orders@gappasecuritysolutions.com	www.gappasecuritysolutions.com



1203 Storbeck Drive
 Waupun, WI 53963

Proposal

Date	Proposal #
1/11/2024	21288

Name / Address:

Waupun, City of
 Jeff Daane
 201 E. Main Street
 Waupun, WI 53963

Revision	Project / Entered By	Terms	Rep
G	Senior Center/JS	25% Down, N30 Progressing	GS-V

Qty	Description	Total
	<p>NOTES:</p> <ol style="list-style-type: none"> All wire to be pulled BY OTHERS from the video appliance location to the locations of each camera. For the highest level of security and functionality, we recommend that all camera systems be set up on a separate VLAN from the end user's primary network. We also recommend that all users schedule routine password changes for their individual logins and keep all windows servers updated. Upon request GSS will provide electronic documentation on the materials we are installing and all manufacturer and labor warranties, but will not be providing any CAD-based riser diagrams or as-builts. Any such CAD-based drawings will need to be produced by the Electrician (GSS can advise as to the placement of items in the diagram). Additionally, there will be an additional \$300 charge if physical hard copies of the documentation are required. This proposal does NOT include any work pertaining to design, submittals, or fees relating to permitting from the City of Waupun, Dodge County, or the local fire authorities. If Gappa Security Solutions is required to do this, there will be an additional \$1000 design charge plus the costs of any fees required by these third parties. This proposal does not include any time for Gappa technicians to attend on-site meetings or to provide consulting services. Any time spent doing this by Gappa technicians will be billed on a time and materials basis with a labor rate of \$150/hr. Unless otherwise specified, all work is quoted to be done during normal business hours. <p>WORK DONE BY OTHERS:</p> <ol style="list-style-type: none"> IT personnel to provide the following upon request: IP address(s), Subnet and Gateway information, potential firewall exceptions, forwarding of ports to devices, available switch port openings (with or without PoE, depending on need), assistance in configuring the routing of information across the network, and assistance in installing and setting up servers, workstations, and/or software. Finally, an adequate number of power outlets is the responsibility of the owner of the building. Any delay in getting help or assistance with the information required above may result in Gappa Security Solutions not being able to finish the project(s) in the time in which the project was quoted. Such delays may also incur additional charges. Some of this information may be requested or provided in advance of the project. If remote connections to the software are required, Customer must rely on their IT personnel. If you desire Gappa Security Solutions to do this work, we can contract an IT company to make this connection for additional charges. 	

Please Call or Email with Any Additional Questions!

Total

Phone #	Fax #	E-mail	Web Site
920-324-2260	888-558-0458	orders@gappasecuritysolutions.com	www.gappasecuritysolutions.com



1203 Storbeck Drive
 Waupun, WI 53963

Proposal

Date	Proposal #
1/11/2024	21288

Name / Address:

Waupun, City of
 Jeff Daane
 201 E. Main Street
 Waupun, WI 53963

Revision	Project / Entered By	Terms	Rep
G	Senior Center/JS	25% Down, N30 Progressing	GS-V

Qty	Description	Total
	TERMS: 25% Due Upon Receipt of Order, Net 30 Progressing Billing for Remainder. Wisconsin Sales Tax-Exempt	0.00

Please Call or Email with Any Additional Questions!

We are working hard to ensure the pricing on this proposal is good for approximately 15 days. Due to the volatile nature of supply chains at the moment, however, sudden cost increases from our suppliers can force us to have to revise pricing unexpectedly.
 All quoted prices subject to correction for clerical error
 Credit Card purchases will be assessed an additional 3% credit card fee
 For Warranty Information please see our website

Total	\$25,552.00
--------------	-------------

Phone #	Fax #	E-mail	Web Site
920-324-2260	888-558-0458	orders@gappasecuritysolutions.com	www.gappasecuritysolutions.com



**818 East Clifford Street
Plymouth, WI 53073
920-400-1279**

ESTIMATE FOR CITY OF WAUPUN SENIOR CENTER CAMERA PROJECT

Revised January 23, 2024

**By:
David Becker
Pros 4 Technology, Inc.
www.pros4technology.com**



Proprietary Notice & Non-Disclosure Statement

Information contained in this document is provided under an exclusive, perpetual non-disclosure agreement and cannot be copied, transmitted, excerpted, or otherwise communicated to anyone without the prior written consent of Pros 4 Technology, Inc.

This package contains proprietary and trade secret information. All data furnished in connection with this package is intended for use in evaluating potential business opportunities with Pros 4 Technology, Inc. and is considered proprietary information.

Intended recipients of this document shall have the right to duplicate, use, or disclose the data contained herein to the extent necessary to perform their duties in the interest of formulating a business relationship with Pros 4 Technology, Inc., **but may not use this information as the basis to obtain competitive quotes from other vendors.**

These restrictions do not limit the right to use information contained herein if said data is obtained from another source, without restriction. These restrictions apply to all media comprising this package.



NDAA Compliance Statement

What is NDAA Section 889?

Section 889 of the 2019 National Defense Authorization Act prohibits the federal government, government contractors, and grant and loan recipients from procuring or using certain “covered telecommunication equipment or services” that are produced by Huawei, ZTE, Hytera, Hikvision, and Dahua and their subsidiaries as a “substantial or essential component of any system, or as critical technology as part of any system.”

Specifically, Sec. 889 has two specific phases of prohibition:

Sec. 889(a)(1)(A) required the federal government, as of August 13, 2019, to not “procure or obtain or extend or renew a contract to procure or obtain any equipment, system, or service that uses covered telecommunication equipment or services as a substantial or essential component of any system, or as critical technology as part of any system.”

Sec. 889(a)(1)(B), which went into effect on August 13, 2020, prohibits the federal government from entering into or extending or renewing contracts with any entity that “uses any equipment, system, or service that uses covered telecommunication equipment or services as a substantial or essential component of any system, or as critical technology as part of any system.”

What does this mean?

Per Section 889, any federal government, government contractors, or agency or organization who receives federal grant or loan money is required to follow NDAA compliance. This means cameras and telecommunications devices that are produced by Huawei, ZTE, Hytera, Hikvision, and Dahua and their subsidiaries are not allowed to be used.

Pros 4 Technology and the NDAA

Pros 4 Technology understands the importance of cybersecurity which is why we provide cameras and systems that are fully NDAA compliant. All camera listed on this estimate fall under NDAA and TAA compliance.



City of Waupun Senior Center Camera Project

City of Waupun Camera Project

1 – Hanwha QNF-8010 6MP Fisheye Gym	\$587.44
1 – Hanwha QNV-8080R 5MP Vandal Dome with Flush Mount Area 133	\$660.54
2 – Hanwha PNM-9022V 180 Degree Camera with Wall Mount East and West Exterior Walls	\$3,400.00
2 – Hanwha PNM-12082RVD 6MP Dual Head Cameras Hallway Cameras	\$2,958.93
1 – Lenovo M75S NVR with 4TB Hard Drive	\$966.64
6 – Hanwha WAVE Recording Licenses	\$826.50
Wiring Supplies Security Cable, patch cords, misc. supplies (Caulk, Fasteners, zip ties, etc.).	\$72.00
Wiring and Install Labor	\$1,440.00
Programming Labor	\$1,000.00
Total Cost	\$11,912.05

Terms and Conditions

Sales Tax will be added when applicable, hardware will be billed before ordering, labor will be billed after completion, prices and specifications subject to change. Although we strive to be as accurate as possible, this estimate is an approximation and is not guaranteed. The estimate is based on information provided from the client regarding project requirements and what we could see during the initial walk through. Actual costs may change once the project starts due to unforeseen circumstances, any need for changes, or any changes requested by the client. Prior to any changes of cost, the client will be notified. Estimate valid for 30 days. **This estimate has network cable installed and provided by others. Pros 4 Technology will only provide the cameras, mounting hardware, and will install and make all cameras live and operational.**

Acceptance of Estimate

I have reviewed and accept the above prices, specifications, terms, and conditions. Pros 4 Technology is authorized to perform the work specified.

Printed Name

Signature

Date



**Optional Camera Managed Services Plan
For the City of Waupun**

Plan Description	Current Plan
Remote Emergency Response Time 30 Minutes or Less	✓
On-Site Emergency Response Time Within 1 Business Day	✓
Regular Scheduled On-Site Tech Maintenance Visits Semi-Annually	✓
Help Desk Remote Support for Any Camera Viewing on Computer or Camera Mobile App Help	✓
NVR Monitoring and Management - for down/offline devices including Cameras - We Make Sure It Is Online!	✓
NVR Manage Microsoft Updates and Microsoft Security Patches	✓
NVR Software Updates as Needed	✓
Camera Cleanings as Needed	✓
Camera Adjustments as Needed	✓
Includes any Pros 4 Labor Cost for Replacing or Removing Camera for Repairs	✓
Includes Any Pros 4 Labor for Any NVR Repairs Like a Failed Drive	✓
Strategic Planning for New Technology	✓
Employee Training as Needed	✓
Recycling and Properly Disposing of Old Equipment	✓
Designing and Help in Future Camera Additions	✓
Annual Agreement Billed Per Month	\$75.00

Terms and Conditions

The above quoted monthly rate will stay the same for a period of 2 years, unless you exceed your current camera count of 13 cameras, 1 NVR(s). Sales tax will be added when applicable. Lift rental is not included in the above rate. If a lift is needed, a lift charge will be billed separately to cover the cost of the lift rental.

Acceptance of Managed Service Plan

- I have reviewed and accept the above managed service agreement and agree to the terms and conditions. I understand that the managed service plan will automatically renew after the initial two years, annually until cancelled by me. I understand that to cancel the managed service plan Pros 4 Technology requests 90 days' notice prior to the end of the managed service term.

- I have reviewed the above managed service agreement, terms, and conditions, and I decline the managed service agreement. I understand that the services listed in the above managed service plan will not be provided to me by Pros 4 Technology and that any future service calls will be billed per service call and that no camera/NVR monitoring will be done by Pros 4 Technology.

Printed Name

Signature

Date

Waupun Senior Center | January 22, 2024

Overview

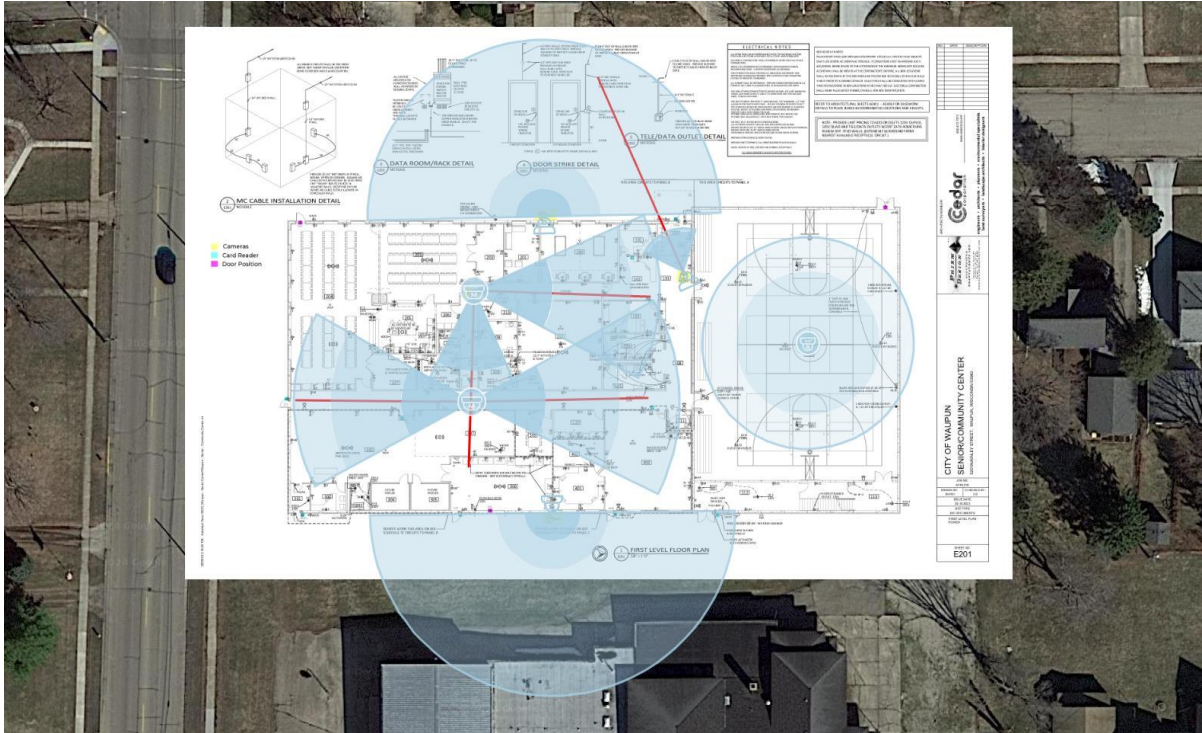

Camera 1



Model: Hanwha QNV-8080R Resolution: 5MP
 HAOV: 80° Distance: 20ft Width: 28.1ft PPF: 92.1
 Imager: 1/2.8" Focal Length: 3.2 - 10mm Camera Height: 10.00ft Tilt: -30.00° Scene Height: 10.00ft

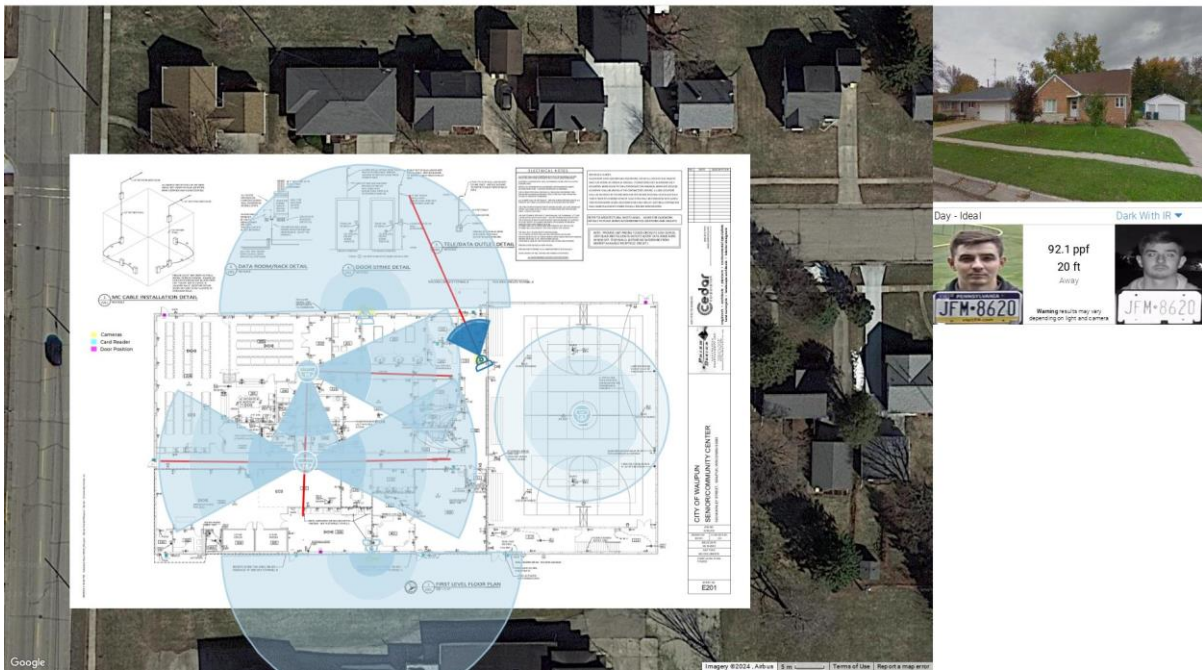

Camera 2



Model: Hanwha QNF-8010 Resolution: 2048x2048
 HAOV: 360° Distance: 49ft Width: 309.9ft PPF: 13.2
 Imager: 1/1.8" Focal Length: 1.14mm Camera Height: 10.00ft Tilt: -180.00° Scene Height: 10.00ft

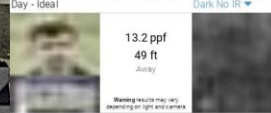
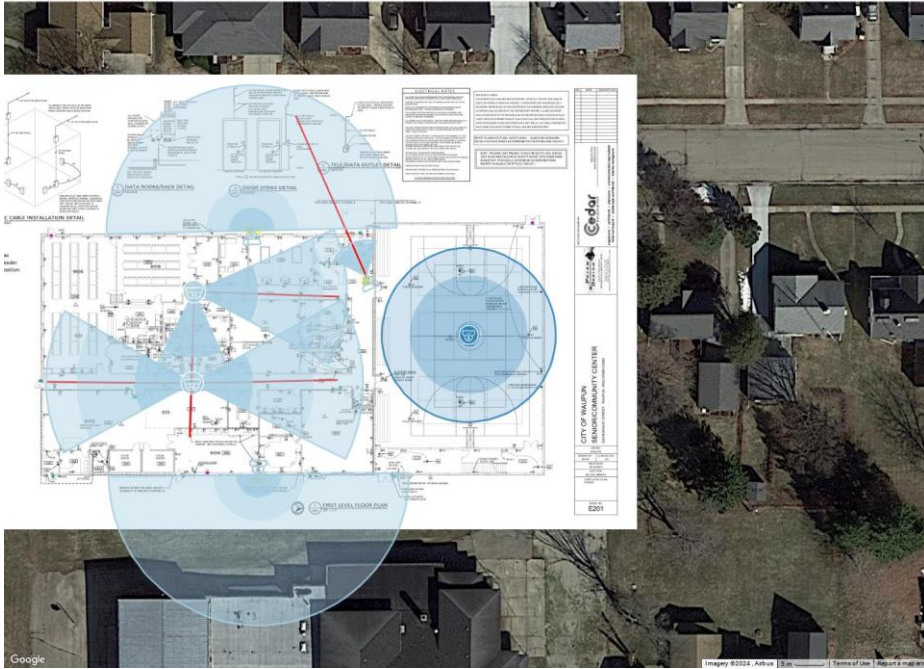

Camera 3



Model: Hanwha PNM-9022V 180° Resolution: 4096 x 1800
 HAOV: 180° Distance: 82ft Width: 258.5ft PPF: 15.8
 Imager: 1/2.8" Focal Length: 2.8mm Camera Height: 10.00ft Tilt: -39.55° Scene Height: 10.00ft

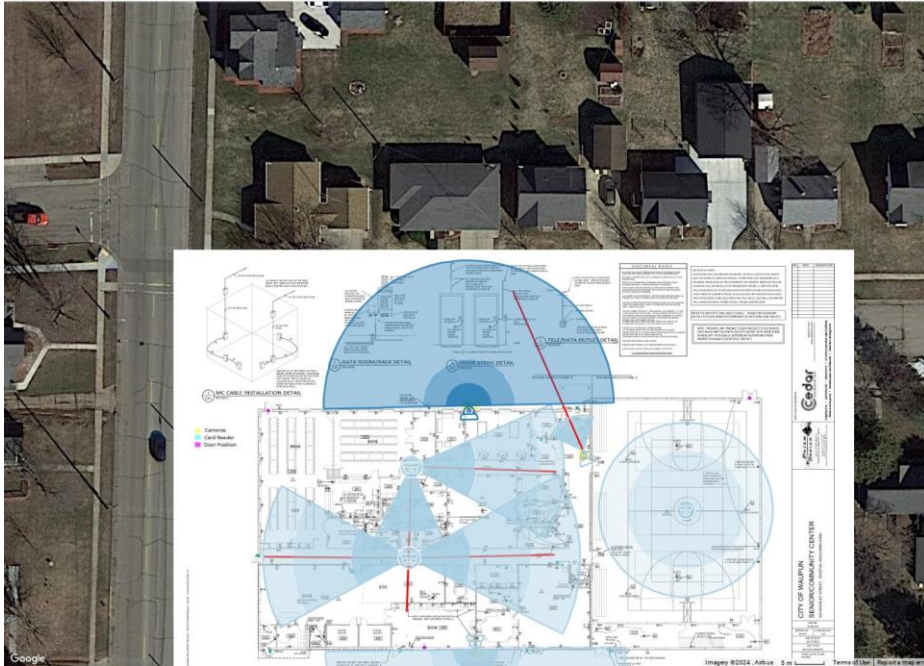

Camera 4



Model: Hanwha PNM-9022V 180° Resolution: 4096 x 1800
 HAOv: 180° Distance: 85ft Width: 267.3ft PPF: 15.3
 Imager: 1/2.8" Focal Length: 2.8mm Camera Height: 10.00ft Tilt: -39.55° Scene Height: 10.00ft

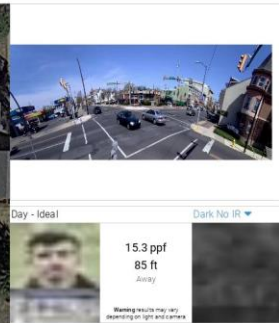

Camera 5: Imager 1



Model: Hanwha PNM-12082RVD (Single Imager) Resolution: 3528x1872
 HAOv: 52° Distance: 87ft Width: 78.5ft PPF: 42.4
 Imager: 1/2.8" Focal Length: 3.5 - 6.6mm Camera Height: 10.00ft Tilt: -14.62° Scene Height: 10.00ft

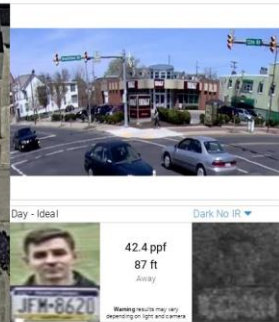
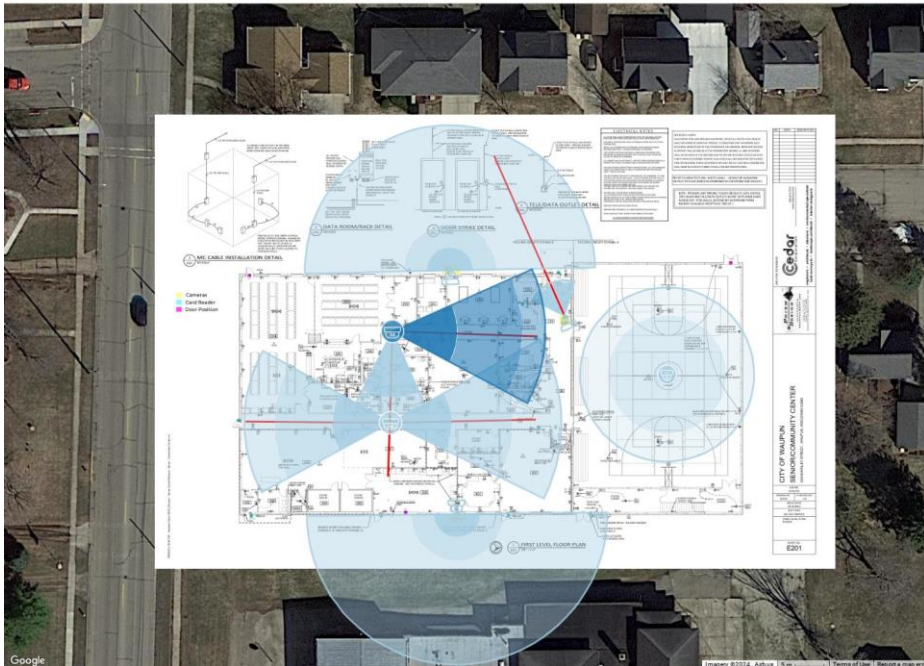

Camera 5: Imager 2



Model: Hanwha PNM-12082RVD (Single Imager) Resolution: 3328x1872
 HAOv: 51° Distance: 47ft Width: 41.6ft PPF: 79.9
 Imager: 1/2.8" Focal Length: 3.5 - 6.6mm Camera Height: 10.00ft Tilt: -14.33° Scene Height: 10.00ft

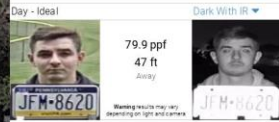
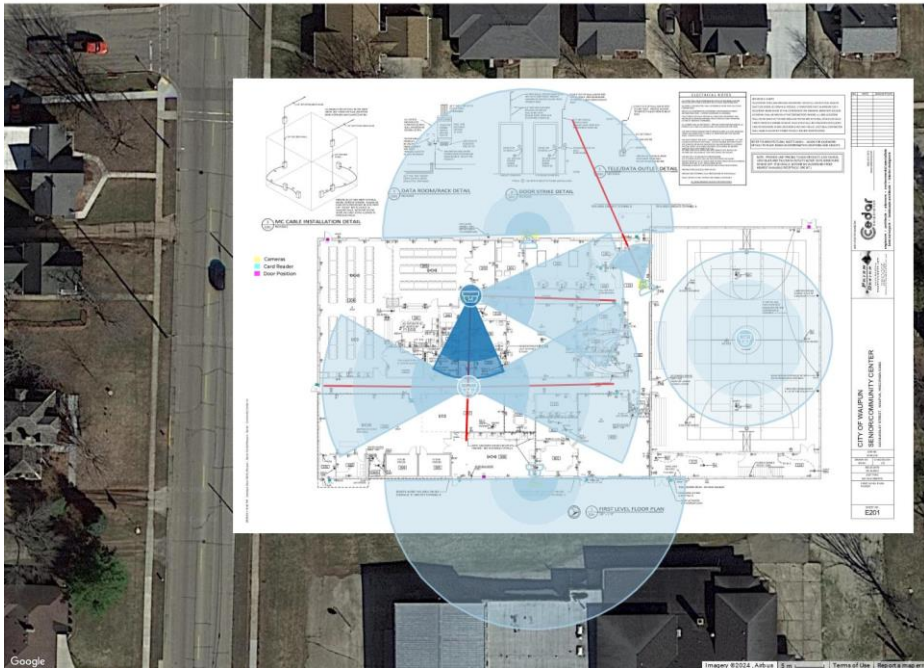

Camera 6: Imager 1



Model: Hanwha PNM-12082RVD (Single Imager) Resolution: 3328x1872
 HAOv: 55° Distance: 97ft Width: 93.6ft PPF: 35.6
 Imager: 1/2.8" Focal Length: 3.5 - 6.6mm Camera Height: 10.00ft Tilt: -15.58° Scene Height: 10.00ft

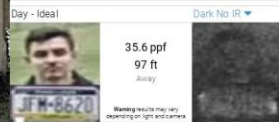
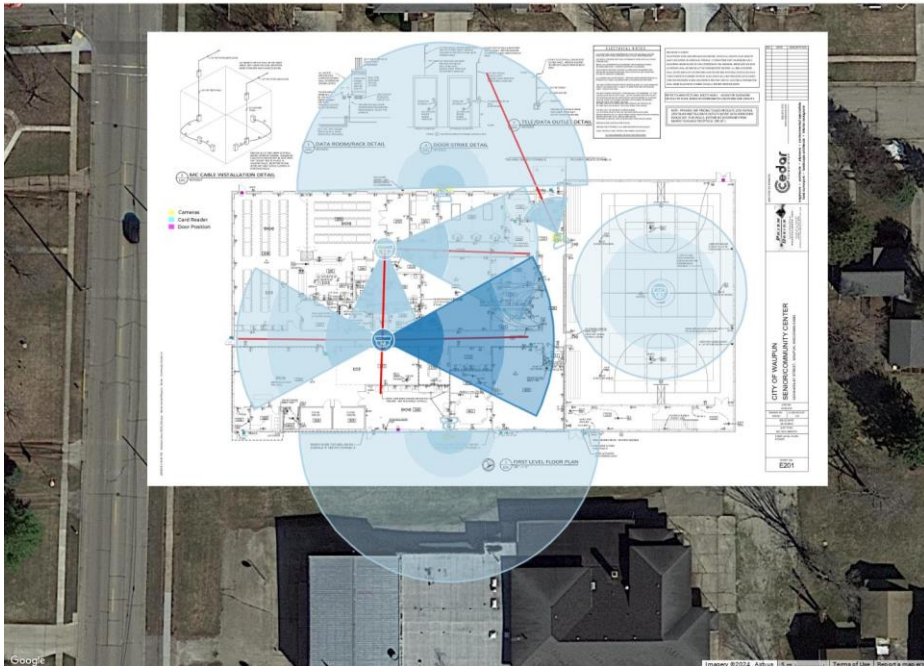

Camera 6: Imager 2



Model: Hanwha PNM-12082RVD (Single Imager) Resolution: 3328x1872
HxV: 58° Distance: 83ft Width: 83.8ft PPF: 39.7
Imager: 1/2.8" Focal Length: 3.5 - 6.6mm Camera Height: 10.00ft Tilt: -16.28° Scene Height: 10.00ft

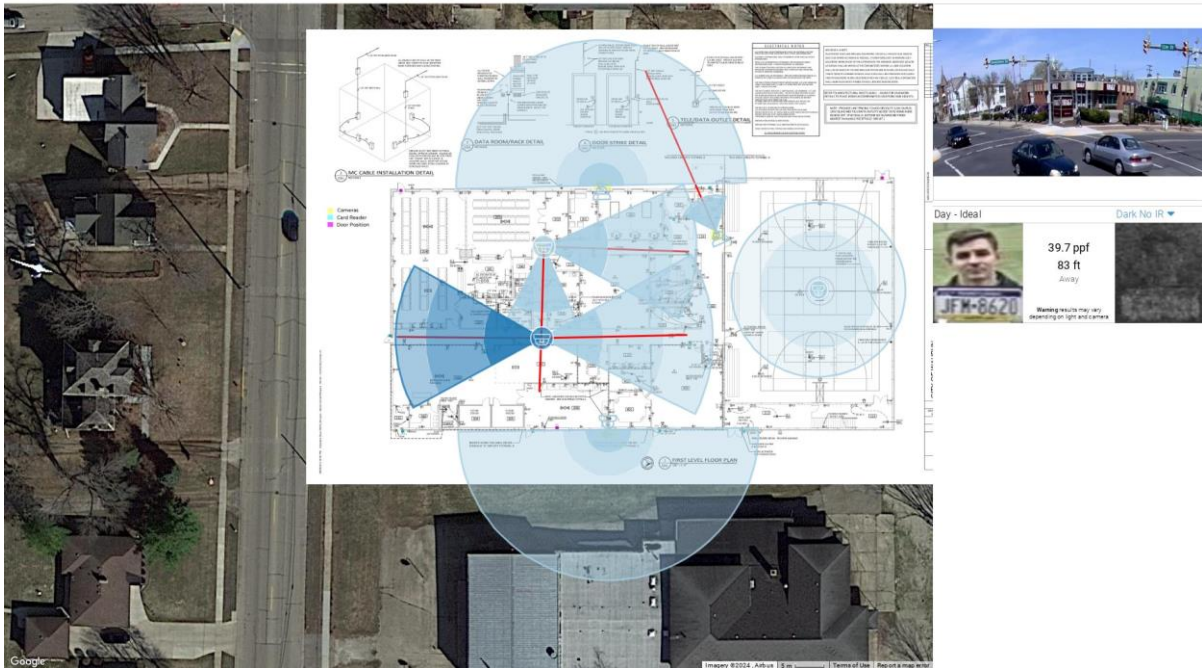

This presentation is an output of the IPVM Designer / Calculator but is the work product of the individual who created it. IPVM does not guarantee nor warranty the work therein nor its implementation. Issues that may impact actual performance include but are not limited to lighting conditions, lens quality, and compression level.

QNF-8010

6MP Network Fisheye Camera



Key Features

- 30fps@2048 x 2048
- H.265, H.264, MJPEG codec
- On-camera dewarping with multi-channel support: Original fisheye view, Single panorama, Double panorama, Quad view
- WDR 120dB, WiseStreamII
- Digital PTZ
- People counting, Heatmap
- Micro SD/SDHC/SDXC 1 slot maximum 256 GB, PoE powered

Compatible Accessories (Optional)



Dimensions

Unit : mm (inch)

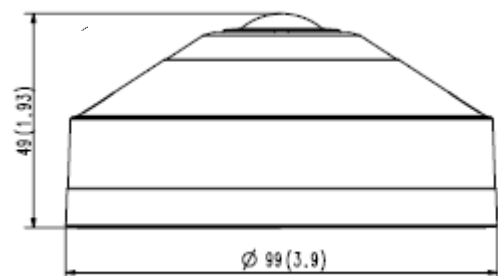
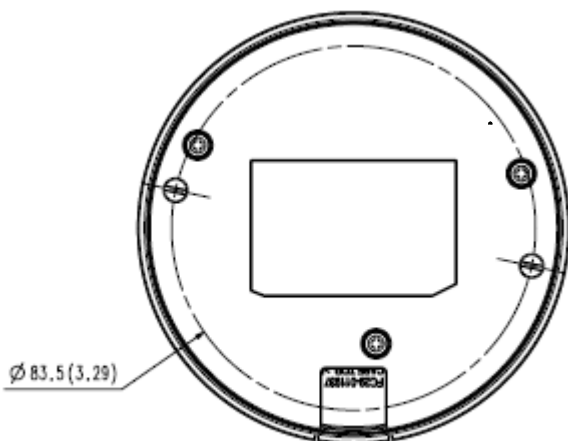

Video	
Imaging Device	1/1.8" 6MP CMOS
Resolution	Original view: 2048x2048, 1280x1280, 1080x1080, 960x960, 768x768, 720x720, 640x640, 480x480 Single panorama: 2048x512, 1920x480, 1280x320, 640x160, 704x176 Double panorama: 2048x1024, 1920x960, 1280x640, 640x320, 704x352 Quad view: 2048x1536, 1600x1200, 1280x960, 1024x768, 800x600, 640x480, 704x576 Q1/2/3/4: 1024x768, 800x600, 640x480
Maximum Framerate	H.264/H.265 : 30fps@2048x2048 MJPEG : 15fps
Minimum Illumination	Color: 0.2 Lux (F2.5, 1/30sec)
Video Out	CVBS : 1.0 Vp-p / 75Ω composite, 720x480, for Installation
Lens	
Focal Length (Zoom Ratio)	1.14mm fixed focal
Maximum Aperture Ratio	F2.5
Angular Field of View	H: 187° / V: 187° / D: 187°
Minimum Object Distance	0.3m
Operational	
Camera Title	Displayed up to 85 characters
Day & Night	Auto (Electrical)
Backlight Compensation	BLC, HLC, WDR, SDR
Wide Dynamic Range	120dB
Digital Noise Reduction	SSNR V
Motion Detection	8ea, polygonal zones
Privacy Masking	6ea, Rectangle zones - Color: Grey/Green/Red/Blue/Black/White - Mosaic
Gain Control	Low / Middle / High
White Balance	ATW / AWC / Manual / Indoor / Outdoor
Electronic Shutter Speed	Minimum / Maximum / Anti flicker (2~1/12,000sec)
Video Rotation	Flip, Mirror
Analytics	Defocus detection, Motion detection, Tampering
Business Intelligence	People counting, Heatmap
Alarm Triggers	Analytics, Network disconnect
Alarm Events	File upload via FTP and e-mail Notification via e-mail SD/SDHC/SDXC or NAS recording at event triggers
Network	
Ethernet	RJ-45(10/100BASE-T)
Video Compression	H.265/H.264: Main/Baseline/High, MJPEG
Smart Codec	WiseStream II

Bitrate Control	H.264/H.265: CBR or VBR MJPEG: VBR
Streaming	Unicast(6 users) / Multicast Multiple streaming(Up to 3 profiles), 2 virtual channels
Protocol	IPv4, IPv6, TCP/IP, UDP/IP, RTP(UDP), RTP(TCP), RTCP, RTSP, NTP, HTTP, HTTPS, SSL/TLS, DHCP, FTP, SMTP, ICMP, IGMP, SNMPv1/v2c/v3(MIB-2), ARP, DNS, DDNS, QoS, PIM-SM, UPnP, Bonjour
Security	HTTPS(SSL) Login Authentication Digest Login Authentication IP Address Filtering User access log 802.1X Authentication(EAP-TLS, EAP-LEAP)
Application Programming Interface	ONVIF Profile S/G/T SUNAPI(HTTP API) Wisenet open platform

General

Webpage Language	English, French, German, Spanish, Italian, Chinese, Korean, Russian, Japanese, Swedish, Portuguese, Czech, Polish, Turkish, Dutch, Hungarian, Greek
Web Viewer	Supported OS: Windows 7, 8.1, 10, Mac OS X 10.12, 10.13, 10.14 Recommended Browser: Google Chrome Supported Browser : MS Internet Explorer 11, MS Edge, Mozilla Firefox (Windows 64-bit only), Apple Safari (Mac OS X only)
Edge Storage	Micro SD/SDHC/SDXC 1 slot maximum 256GB
Memory	1024MB RAM, 256MB Flash

Environmental & Electrical

Operating Temperature / Humidity	-10°C ~ +55°C(+14°F ~ +131°F) / Less than 90% RH
Storage Temperature / Humidity	-50°C ~ +60°C(-58°F ~ +140°F) / Less than 90% RH
Certification	IP42
Input Voltage	PoE(IEEE802.3af, Class3)
Power Consumption	PoE: Maximum 6.4W, typical 4.6W

Mechanical

Color / Material	White / Plastic
RAL Code	RAL9003
Product Dimensions / Weight	Ø99x49mm(Ø3.9x1.93"), 320g(0.705 lb)

DORI (EN62676-4 standard)

Detect	25m (82.02ft)
Observe	10m (32.81ft)
Recognize	5m (16.40ft)
Identify	2.5m (8.2ft)

- The latest product information / specification can be found at hanwhasecurity.com
- Design and specifications are subject to change without notice.
- Wisenet is the proprietary brand of Hanwha Techwin, formerly known as Samsung Techwin.

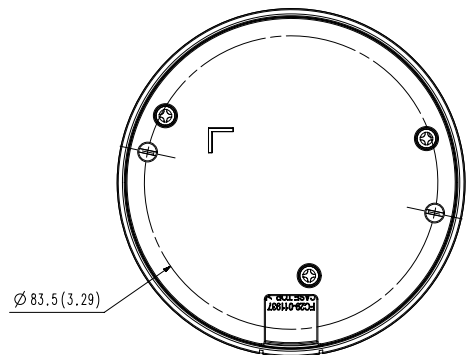
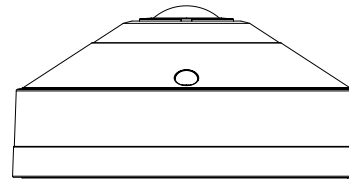
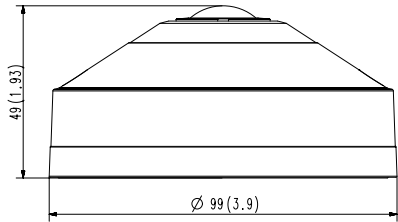
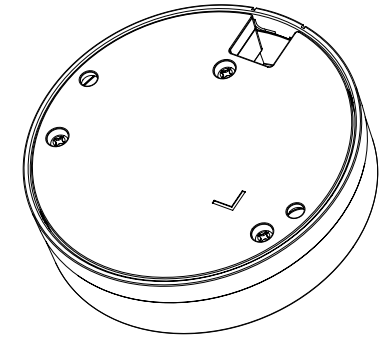
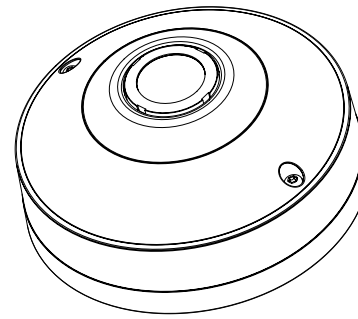
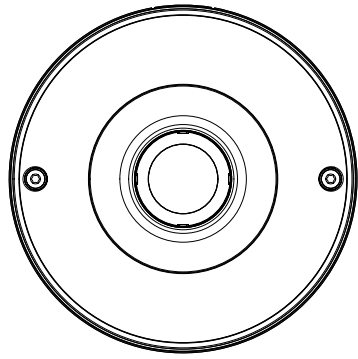

3		
2	QNF-9010	'19.11.29
1	QNF-8010	'19.09.02
No.	MODEL NAME	DATE
Unit:mm(inch)		SCALE:1/1
© Hanwha Techwin		

© Hanwha Techwin Co.,Ltd. All rights reserved.

A2

QNV-8080R

5 MP Network IR Dome Camera



Key Features

- 5 Megapixel (2592 x 1944) resolution
- 3.2~10mm(3.1x) motorized varifocal lens
- 0.15Lux (Color), 0Lux (B/W, IR LED on)
- 30fps@5 MP (H.265 / H.264)
- H.265, H.264, MJPEG codec support, Multiple streaming
- Day & Night, WDR (120dB)
- Defocus detection, Directional/Virtual Line detection, Motion detection, Enter/Exit, Tampering
- Micro SD / SDHC / SDXC memory slot (Maximum 128GB)
- Hallway view, WiseStream II support
- IR Viewable length 30m
- IP66, IK10, PoE

Dimensions

Unit : mm (inch)

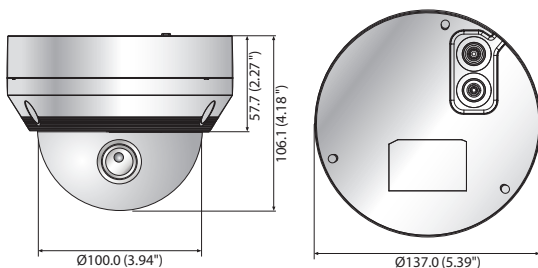

Accessories (Optional)



QNV-8080R

VIDEO	
Imaging Device	1/2.8" 5 MP CMOS
Effective Pixels	2592(H) x 1944(V)
Minimum Illumination	Color : 0.15Lux (F1.6, 1/30sec) BW : 0Lux (IR LED on)
Video Out	CVBS : 1.0 Vp-p / 75Ω composite, 720 x 480 for installation
LENS	
Focal Length (Zoom Ratio)	3.2~10mm (3.1x) motorized varifocal
Maximum Aperture Ratio	F1.6 (Wide)~F2.9 (Tele)
Angular Field of View	H : 100.3°(Wide)~31.2°(Tele) / V : 72.3°(Wide)~23.5°(Tele) / H : 133.1°(Wide)~38.8°(Tele)
Focus Control	Simple focus
PAN / TILT / ROTATE	
Pan / Tilt / Rotate Range	0°~350° / 0°~67° / 0°~355°
OPERATIONAL	
IR Viewable Length	30m (98.42ft)
Camera Title	Displayed up to 85 characters, 5 lines, English / Numeric / Special & International characters, 6 colors, Transparency, Auto scale by resolution
Day & Night	Auto (ICR)
Backlight Compensation	BLC, WDR, SSSDR
Wide Dynamic Range	120dB
Digital Noise Reduction	SSNR
Motion Detection	4ea, polygonal zones
Privacy Masking	6ea, rectangular zones
Gain Control	Low / Middle / High
White Balance	ATW / AWC / Manual / Indoor / Outdoor
LDC	Support
Electronic Shutter Speed	Minimum / Maximum / Anti flicker (1/5~1/12,000sec)
Video Rotation	Flip, Mirror, Hallway view (90°/270°)
Analytics	Defocus detection, Directional/Virtual Line detection, Motion detection, Enter/Exit, Tampering
Alarm I/O	Input 1ea / Output 1ea
Alarm Triggers	Analytics, Network disconnect, Alarm input
Alarm events	File upload via FTP and e-mail, Notification via e-mail, SD/SDHC/SDXC or NAS recording at event triggers, Alarm output, Handover
NETWORK	
Ethernet	RJ-45 (10/100BASE-T)
Video Compression	H.265/H.264 : Main/High, MJPEG
Resolution	2592 x 1944, 1920 x 1080, 1280 x 960, 1280 x 720, 800 x 600, 800 x 448, 720 x 576, 720 x 480, 640 x 480, 640 x 360
Maximum Framerate	H.265/H.264 : Maximum 30fps MJPEG : Maximum 15fps
Smart Codec	Manual (5ea area), WiseStream II
Video Quality Adjustment	H.264/H.265 : Target bitrate level control / MJPEG : Quality level control
Bitrate Control	H.264/H.265 : CBR or VBR / MJPEG : VBR
Streaming	Unicast (6 users) / Multicast, Multiple streaming (Up to 3 profiles)
Protocol	IPv4, IPv6, TCP/IP, UDP/IP, RTP(UDP), RTP(TCP), RTCP, RTSP, NTP, HTTP, HTTPS, SSL/TLS, DHCP, FTP, SMTP, ICMP, IGMP, SNMPv1/v2c/v3(MIB-2), ARP, DNS, DDNS, QoS, UPnP, Bonjour, LLDP
Security	HTTPS(SSL) login authentication, Digest login authentication, IP address filtering, User access log, 802.1X authentication(EAP-TLS, EAP-LEAP)
Edge Storage	Micro SD/SDHC/SDXC 1 slot maximum 128GB
Application Programming Interface	ONVIF Profile S/G/T SUNAPI (HTTP API) Wisenet open platform
Webpage Language	English, Korean, Chinese, French, Italian, Spanish, German, Japanese, Russian, Swedish, Portuguese, Czech, Polish, Turkish, Dutch

QNV-8080R

Web Viewer	Supported OS : Windows 7, 8.1, 10, Mac OS X 10.10, 10.11, 10.12, 10.13, 10.14 Recommended Browser : Google Chrome Supported Browser : MS Explorer 11, MS Edge, Mozilla Firefox (Windows 64 bit only), Apple Safari (Mac OS X only)
Memory	512MB RAM, 256MB Flash
ENVIRONMENTAL	
Operating Temperature / Humidity	-30°C ~ +55°C (-22°F ~ +131°F) / Less than 90% RH * Start up should be done at above -20°C
Storage Temperature / Humidity	-30°C ~ +60°C (-22°F ~ +140°F) / Less than 90% RH
Certification	IP66, IK10
ELECTRICAL	
Input Voltage	PoE (IEEE802.3af, Class3)
Power Consumption	PoE : Maximum 8.9W, typical 6.6W
MECHANICAL	
Color / Material	White / Aluminum
RAL Code	RAL9003
Product dimensions / weight	Ø137.0 x 106.1mm (Ø5.39 x 4.18"), 700g (1.543 lb)

* The latest product information / specification can be found at hanwhasecurity.com

* Design and specifications are subject to change without notice.

* Wisenet is the proprietary brand of **Hanwha Techwin**.

PNM-9022V

2MP x 4CH H.265 Panoramic 209° Camera



Key Features

- 2MP x 4CH stitched panoramic camera, 8.3MP / 7.3MP resolution
- 209° Mode, 180° Mode switchable
- 2.8mm fixed focal lens x 4
- H.265/H.264/MJPEG : 30fps stitched image
- extreme WDR (120dB)
- H.265, H.264, MJPEG codec, WiseStreamII supported
- Digital PTZ Support
- Intelligent Video Analytics, Visual Heatmap support
- IP66, IK10, NEMA4X

Dimensions

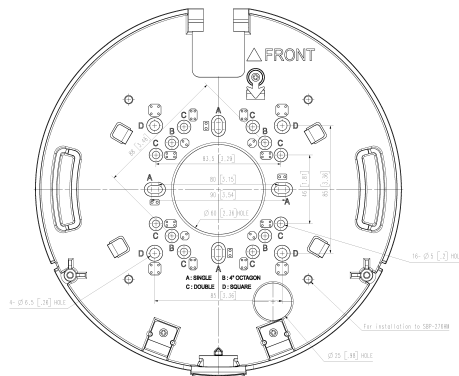
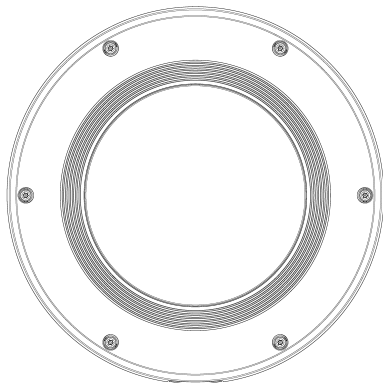
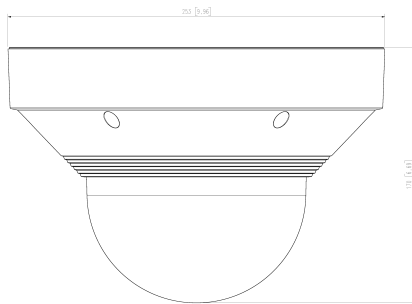

Video	
Imaging Device	1/2.8" CMOS x 4
Resolution	[209° Mode] 4608X1800, 4032X1576, 3456X1352, 2864X1124, 2304X900, 1728X676, 1152X452, 560X224, 720x576 [180° Mode] 4096X1800, 3584X1576, 3072X1352, 2560X1124, 2048X900, 1536X676, 1024X452, 512X224, 720X576
Maximum Framerate	H.265/H.264: 30fps MJPEG: 30fps
Minimum Illumination	Color: 0.1Lux(F1.6, 1/30sec) B&W: 0.01Lux(F1.6, 1/30sec)
Video Out	USB : Micro USB Type B, 1280x720 for installation
Lens	
Focal Length (Zoom Ratio)	2.8mm fixed focal x 4
Maximum Aperture Ratio	F1.6
Angular Field of View	H: 209°/180°, V: 83.3°
Minimum Object Distance	1.5m
Focus Control	Fixed
Pan / Tilt / Rotate	
Pan / Tilt / Rotate Range	0°~355° / 0°~60° / -
Operational	
Camera Title	Displayed up to 85 characters
Day & Night	Auto (ICR)
Backlight Compensation	BLC, HLC, WDR, SDDR
Wide Dynamic Range	extreme WDR(120dB)
Digital Noise Reduction	SSNR V
Defog	Support
Motion Detection	8ea, 8point polygonal zones
Privacy Masking	32ea, polygonal zones - Color: Grey/Green/Red/Blue/Black/White - Mosaic
Gain Control	Low / Middle / High
White Balance	ATW / AWC / Manual / Indoor / Outdoor
Electronic Shutter Speed	Minimum / Maximum / Anti flicker (2~1/12,000sec)
Video Rotation	Flip, Mirror
Analytics	Defocus detection, Motion detection, Appear/Disappear, Enter/Exit, Tampering, Virtual line, Audio detection
Business Intelligence	Heatmap
Alarm I/O	Selectable 2 port
Alarm Triggers	Analytics, Network disconnect, Alarm input
Alarm Events	File upload via FTP and e-mail Notification via e-mail SD/SDHC/SDXC recording at event triggers Alarm output

Audio In	Selectable(microphone in/line in) Supply voltage: 2.5VDC(4mA), Input impedance: 2K Ohm
Audio Out	Line out, Maximum output level: 1Vrms
Network	
Ethernet	Metal shielded RJ-45(10/100BASE-T)
Video Compression	H.265/H.264: Main/Baseline/High, MJPEG
Audio Compression	G.711 u-law /G.726 Selectable G.726(ADPCM) 8KHz, G.711 8KHz G.726: 16Kbps, 24Kbps, 32Kbps, 40Kbps AAC-LC: 48Kbps at 16KHz
Smart Codec	Manual(5ea area), WiseStreamII
Bitrate Control	H.264/H.265: CBR or VBR MJPEG: VBR
Streaming	Unicast(20 users) / Multicast Multiple streaming(Up to 10 profiles)
Protocol	IPv4, IPv6, TCP/IP, UDP/IP, RTP(UDP), RTP(TCP), RTCP,RTSP, NTP, HTTP, HTTPS, SSL/TLS, DHCP, FTP, SMTP, ICMP, IGMP, SNMPv1/v2c/v3(MIB-2), ARP, DNS, DDNS, QoS, PIM-SM, UPnP, Bonjour, LLDP, SRTP
Security	HTTPS(SSL) Login Authentication Digest Login Authentication IP Address Filtering User access log 802.1X Authentication(EAP-TLS, EAP-LEAP) Device Certificate(Hanwha Techwin Root CA)
Application Programming Interface	ONVIF Profile S/G/T SUNAPI(HTTP API) Wisenet open platform
General	
Webpage Language	English, Korean, Chinese, French, Italian, Spanish, German, Japanese, Russian, Swedish,, Portuguese, Czech, Polish, Turkish, Dutch, Hungarian, Greek Micro
Edge Storage	SD/SDHC/SDXC 2 slots 1TB (512GB X 2)
Memory	4GB RAM, 512MB Flash
Environmental & Electrical	
Operating Temperature / Humidity	Normal : -40°C~+55°(-40°F ~ +131°F) / Intermittent : -40°C~+60°C(-40°F ~+140°F) Less than 95% RH(Non-condensing)
Storage Temperature / Humidity	-50°C ~ +60°C(-58°F ~ +140°F) / Less than 90% RH
Certification	IP66, IK10, NEMA4X
Input Voltage	PoE+(IEEE802.3at, Class4), 12VDC
Power Consumption	PoE+: Maximum 18W, Typical 10.4W 12VDC: Maximum 16W, Typical 9W
Mechanical	
Color / Material	White / Aluminum
RAL Code	RAL9003
Product dimensions / weight / Gangbox compatibility	Ø9.96"x6.5" (Ø253x165mm), 7.05lbs (3200g) Single, double, 4" octagon, square

- The latest product information / specification can be found at hanwhasecurity.com
- Design and specifications are subject to change without notice.
- Wisenet is the proprietary brand of Hanwha Techwin , formerly known as Samsung Techwin.



Network

Multi-sensor

PNM-12082RVD

6MP x 2CH Multi-directional Camera



Key Features

- WiseNR, WiseStream II, extremeWDR (120dB)
- Maximum 3328x1872 resolution
- Maximum 15fps@6M
- Color: 0.16lux(F1.67, 1/30sec, 30IRE), 0 Lux (IR LED on)
- 3.54~6.69mm motorized varifocal, 78° tilt angle
- IR viewable length: IR 25m(82ft) based on scene
- TPM 2.0(FIPS 140-2 certified)
- IP66, IK10, NEMA4X

PNM-12082RVD

6MP x 2CH Multi-directional Camera



Specifications

Video

Imaging Device	1/2.8" CMOS x 2CH
Resolution	3328x1872, 3072x1728, 2592x1944, 2688x1520, 1920x1080, 1600x1200, 1280x1024, 1280x960, 1280x720, 1024x768, 800x600, 800x448, 720x576, 720x480, 640x480, 640x360, 320x240
Max. Framerate	H.265/H.264: 6MP Max.15fps MJPEG: Max.15fps
Min. Illumination	Color: 0.16lux(F1.67, 1/30sec, 30IRE) BW: 0.016lux(F1.67, 1/30sec, 30IRE), 0lux(IR LED on)
Video Out	USB: micro USB Type B, 1280x720 for installation

Lens

Focal Length (Zoom Ratio)	3.54~6.69mm(1.9x) motorized varifocal
Max. Aperture Ratio	F1.67(Wide)~F2.64(Tele)
Angular Field of View	H: 96(Wide)~47(Tele) V: 51(Wide)~26(Tele) D: 113(Wide)~54(Tele)
Min. Object Distance	1.5m(4.92ft)
Focus Control	Simple focus
Lens Type	Fixed IRIS

Pan / Tilt / Rotate

Pan / Tilt / Rotate Range	0~355° / 0~78° / 0~180°
---------------------------	-------------------------

Operational

Camera Title	Displayed up to 85 characters
Day & Night	Auto(ICR)
Backlight Compensation	BLC, HLC, WDR, SSSDR
Wide Dynamic Range	extremeWDR(120dB)
Digital Noise Reduction	WiseNR, SSSNR V
Defog	Support
Motion Detection	8ea, 8point Polygonal zones
Privacy Masking	32ea, 4point Quadrangle zones - Color: Grey/Green/Red/Blue/Black/White - Mosaic
Gain Control	Low / Middle / High
White Balance	ATW / AWC / Manual / Indoor / Outdoor
LDC	Support
Electronic Shutter Speed	Minimum / Maximum / Anti flicker (2 ~1/12,000sec)
Video Rotation	Flip, Mirror, Hallway view (90°/270°)
Analytics	Analytics events* - Defocus detection, Motion detection, Tampering, Virtual line(Crossing/Direction), Virtual area(Loitering/Enter/Exit) * Support Audio detection, Sound classification via optional SPM-4210 I/O box
Alarm I/O	* Support Alarm via optional SPM-4210 I/O box
Alarm Triggers	Analytics, Network disconnect, Alarm input via optional SPM-4210 I/O box

Alarm Events	When alarm trigger occurred - File upload(image) : e-mail/FTP - Notification : e-mail - Recording : SD/SDHC/SDXC or NAS recording at event triggers - Handover(PTZ preset, Send message by HTTP/HTTPS/TCP) - Alarm output via optional SPM-4210 I/O box
Audio In	* Audio in via optional SPM-4210 I/O box
Audio Out	* Audio out via optional SPM-4210 I/O box
IR Viewable Length	25m(82ft)

Network

Ethernet	Metal shielded RJ-45 (10/100/1000BASE-T)
Video Compression	H.265/H.264: Main/Baseline/High, MJPEG
Smart Codec	Manual(5ea area), WiseStream II
Bitrate Control	H.264/H.265: CBR or VBR MJPEG: VBR
Streaming	Unicast(20 users) / Multicast Multiple streaming(Up to 10 profiles)
Protocol	IPv4, IPv6, TCP/IP, UDP/IP, RTP(UDP), RTP(TCP), RTCP, RTSP, NTP, HTTP, HTTPS, SSL/TLS, DHCP, FTP, SMTP, ICMP, IGMP, SNMPv1/v2c/v3(MIB-2), ARP, DNS, DDNS, QoS, UPnP, Bonjour, LLDP, SRTP (TCP, UDP Unicast)
Security	TPM 2.0 (FIPS 140-2 level 2) HTTPS(SSL) Login Authentication Digest Login Authentication IP Address Filtering User access log 802.1X Authentication(EAP-TLS, EAP-LEAP, EAP-PEAP MSCHAPv2) Device Certificate(Hanwha Techwin Root CA, pre-installed) Secure by default certificate Secure OS/Boot/Storage, Verify firmware forgery
Application Programming Interface	ONVIF Profile S/T SUNAPI(HTTP API) Open platform

General

Webpage Language	English, Korean, Chinese, French, Italian, Spanish, German, Japanese, Russian, Swedish, Portuguese, Czech, Polish, Turkish, Dutch, Greek, Hungarian
Edge Storage	Micro SD/SDHC/SDXC 1slot Max. 512GB
Memory	4GB RAM, 512MB Flash

Environmental & Electrical

Operating Temperature / Humidity	-40°C~+55°C(-40°F ~ +131°F) / Less than 95% RH(Non-condensing) * Start up should be above at -35C
Storage Temperature / Humidity	-50°C~+60°C(-58°F~+140°F) / Less than 95% RH(Non-condensing)
Certification	IP66/IP67, NEMA4X, IK10
Input Voltage	PoE+(IEEE802.3at, Class4)
Power Consumption	PoE+: Max 18.3W, typical 13.5W

Mechanical

Color / Material	White / Aluminum Hard-coated dome bubble
RAL Code	RAL9003
Product Dimensions / Weight	215(W)x135(D)x93.2(H)mm(8.46"x5.31"x3.67") / 1330g
Compatible Conduit hole / Gangbox	3/4" (M25) single, double, 4" octagon, 4" square
Hanging Mount (Dome)	SBP-215HMW

Certifications & Standards

EMC	FCC 47 CFR 15 Subpart B Class A ICES-3(A)/NMB-3(A) CE/UKCA - EN 55032 Class A, EN 50130-4 VCCI CISPR 32 Class A RCM AS/NZS CISPR 32 Class A KS C 9832 Class A, KS C 9835
------------	--

Safety UL 62368-1, CAN/CSA C22.2 NO. 62368-1
IEC/EN 62471

Environment IEC/EN 63000
IEC/EN 60529 IP66/67, IEC/EN 62262 IK10
NEMA 250 type 4X

DORI (EN62676-4 standard)

Detect (25PPM/ 8PPF) Wide: 59.9m(196.62ft) / Tele: 153.1m(502.22ft)

Observe (63PPM/ 19PPF) Wide: 24.0m(78.65ft) / Tele: 61.2m(200.89ft)

Recognize (125PPM/ 38PPF) Wide: 12.0m(39.32ft) / Tele: 30.6m(100.44ft)

Identify (250PPM/ 76PPF) Wide: 6.0m(19.66ft) / Tele: 15.3m(50.22ft)

PNM-12082RVD

6MP x 2CH Multi-directional Camera



CAD

Unit: mm [inch]

4	PNM-12082RVD	'22.03.17
3	PNM-7082RVD	'22.03.17
2	PNM-C12083RVD	'22.03.17
1	PNM-C7083RVD	'22.03.17
No.	MODEL NAME	DATE

© Hanwha Techwin Co., Ltd. All rights reserved.

Unit:mm[inch] SCALE:1/1 © Hanwha Techwin



**818 East Clifford Street
Plymouth, WI 53073
920-400-1279**

ESTIMATE FOR CITY OF WAUPUN SENIOR CENTER DOOR ACCESS CONTROL PROJECT

January 22, 2024

**By:
David Becker
Pros 4 Technology, Inc.
www.pros4technology.com**



Proprietary Notice & Non-Disclosure Statement

Information contained in this document is provided under an exclusive, perpetual non-disclosure agreement and cannot be copied, transmitted, excerpted, or otherwise communicated to anyone without the prior written consent of Pros 4 Technology, Inc.

This package contains proprietary and trade secret information. All data furnished in connection with this package is intended for use in evaluating potential business opportunities with Pros 4 Technology, Inc. and is considered proprietary information.

Intended recipients of this document shall have the right to duplicate, use, or disclose the data contained herein to the extent necessary to perform their duties in the interest of formulating a business relationship with Pros 4 Technology, Inc., **but may not use this information as the basis to obtain competitive quotes from other vendors.**

These restrictions do not limit the right to use information contained herein if said data is obtained from another source, without restriction. These restrictions apply to all media comprising this package.



City of Waupun Senior Center Door Access Control Project

City of Waupun Door Access Control Project

7 – HID Signo 20 Mullion Size* \$2,070.53
100A, 119A, 119B, 127, 131, 301A, 400A

6 – HID Signo 40 1-Gang Size* \$1,774.74
101, 103, 106, 112, 300, 400B

1 –PDK Red Cloud Node – Ethernet Only \$753.99
Will require a power outlet

1 – PDK Red Max Door Controller – Ethernet Only \$2,485.29
Will require a power outlet

2 – PDK 4-Door Expansion Boards for Red Max \$1,365.88
Total Space for 16 doors

Wiring Supplies \$121.00
Security Cable, patch cords, misc. supplies (Caulk, Fasteners, zip ties, etc.).

Wiring and Install Labor \$1,520.00

Programming Labor \$2,000.00

Total Cost	\$12,091.43
-------------------	--------------------

Monthly Recurring Charge for Access Control Cloud Hosting \$96.00

HID iClass Key Fobs **\$7.00/ea.**

HID iClass Key Cards **\$6.00/ea.**

*This reader is not Bluetooth capable

Terms and Conditions

Sales Tax will be added when applicable, hardware will be billed before ordering, labor will be billed after completion, prices and specifications subject to change. Although we strive to be as accurate as possible, this estimate is an approximation and is not guaranteed. The estimate is based on information provided from the client regarding project requirements and what we could see during the initial walk through. Actual costs may change once the project starts due to unforeseen circumstances, any need for changes, or any changes requested by the client. Prior to any changes of cost, the client will be notified. Estimate valid for 30 days. ***This estimate has security wire and install provided by others, electric strikes provided by others, and door contacts/door position sensors provided by others. Pros***



4 Technology will only provide readers, door controllers, access cards or FOBs, and will make all devices live and operational with the system. THIS SYSTEM REQUIRES STRIKES THAT ARE 12V AND WILL NOT WORK WITH A 24V SYSTEM.

Acceptance of Estimate

I have reviewed and accept the above prices, specifications, terms, and conditions. Pros 4 Technology is authorized to perform the work specified.

Printed Name

Signature

Date

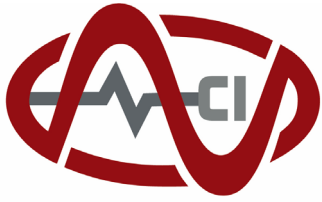

ACCURATE CONTROLS, INC.

January 25th, 2024

**RE: Price Quotation for the Waupun Community Center
VMS and Card Access Systems
Waupun, WI**

VMS and Card Access Systems

Summary of Scope:

This proposal is a base bid proposal to for Accurate Controls to provide the facility with new Premisys card access and Hanwha video system. Accurate Controls will be providing the headend equipment, field devices (limited to card readers and cameras), and labor for Accurate Controls scope of work. Some of the other items that will be included in this proposal will include a video viewing/ card access enrollment workstation, headend equipment rack, a network switch, VMS server, and UPS units. The only equipment that is included in this proposal is listed below.

If this proposal is accepted Accurate Controls will assign a Project Manager to the project. They will work with the facility to come up with a payment and construction schedule. Then at that time Accurate Controls will order all parts for the project and have then shipped to ACI for assembly/programming. Once the equipment is built and tested at Accurate Controls, all equipment will be sent to the facility for installation by Accurate Controls.

Accurate Controls will schedule a coordination meeting with the General Contractor and the Electrical to coordinate all wire, raceway, and back box requirements for Accurate Controls.

The camera locations that are included in this quotation for this proposal are as follows: (1) exterior of building by room 200, (1) in corridor 119, (1) corridor 133, (1) in un-named corridor outside room 307, (1) in the center of the gymnasium, and (1) exterior of building by room 401.

The card access locations that are included in this quotation for this proposal are as follows: (1) exterior to door 131, (1) on door 300, (1) exterior to door 301, (1) on door 106, (1) exterior to door 127, (1) exterior to door 400A, (1) on door 400B, (1) on door 119B (1) on door 119A, (1) on door 103, (1) on door 101, (1) exterior to door 100A, and (1) exterior to door 112.

The doors to receive monitoring from owner provided position switch will be door 114C and door 126.

This proposal includes adding the following new security electronics equipment:

- (1) Lowell rack with vented front door, fan kit, power strip, and cable management
- (3) Rack labels
- (1) HP programming rack monitor
- (1) HP 24 port PoE network switch
- (1) 24 port patch panel
- (6) Cat 6 patch cables
- (1) Phoenix Contact surge protector
- (1) Eaton Power workstation UPS unit
- (1) Eaton Power rack UPS unit
- (1) Premisys Life Safety wall cabinet
- (1) Premisys Controller boards
- (6) Premisys two reader boards
- (1) Premisys software with license
- (13) HID proximity readers
- (100) HID key fobs

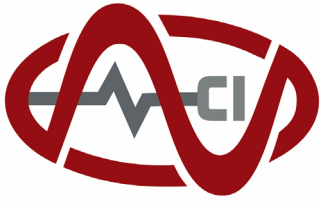

ACCURATE CONTROLS, INC.

- (1) VMS viewing/ Card Access enrollment workstation
- (1) HP monitor for the workstation
- (3) Wisenet 2MP x 2 sensor dome camera
- (3) Wisenet 8MP x 4 sensor dome camera
- (3) Wisenet Mounting caps
- (2) Wisenet wall mount accessory
- (1) Wisenet 8TB application/ storage server
- (1) Wisenet additional Wave pro license

Inclusions:

- System engineering
- System programming
- Project management
- Head end equipment installation in new rack, wall cabinet, and final terminations
- Onsite system startup, testing and certification.
- Quotation includes Accurate Controls technician on site for installation
- As-built drawings

Exceptions:

- Spare equipment
- All work to be completed on 1st shift Monday thru Friday 7:00 am to 4:30 pm
- Some work will require the disruption of normal operations
- Sales tax on materials
- Electrified door hardware will be the responsibility of the owner
- All wire, conduit, back boxes, complete raceway will be responsible of the owner
- Any 120VAC if additional is required.
- Accurate Controls, Inc. may adjust the contract price to reflect the revised actual cost of the labor and materials. Accurate Controls, Inc. shall provide to prime contractor or Owner documentation supporting our claim for additional compensation. If there is an increase in the actual cost of labor or materials charged to Accurate Controls, Inc. in excess of 5% subsequent to signing contract or purchase order, the price set forth in said contract or purchase order shall be increased accordingly with a written change order or amendment.
- Accurate Controls, Inc. shall submit production and labor schedule extensions to contractor or Owner in a timely fashion that result from changes to global supply chain and construction manufacturing that are out of our control.

Assumptions/Clarifications:

- Prevailing wages do not apply.

Quotation:

Base Bid Total = \$64,400.00

Add 1.25% to the above referenced proposal if payment and performance bond is required.

Warranty:

Accurate Controls, Inc. shall guarantee our labor and materials to be free from defects for a period of one (1) year from final acceptance of installation. We shall replace defective materials in a timely fashion after diagnosis.

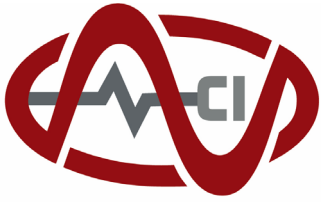

ACCURATE CONTROLS, INC.

Accurate Controls, Inc. will not replace or warrant hardware which is damaged due to negligence, acts of god or vandalism.

Summary:

Quotation valid for 60 days and subject to change thereafter.

Accurate Controls, Inc. is a national UL508A integrator of the preceding equipment with all of our project coordinators, technicians, and engineers being factory authorized. For more information about Accurate Controls, Inc. please visit our website at www.accuratecontrols.com. If you have any questions, comments or suggestions, please feel free to call me at 920-748-6603 ext. 240.

Respectfully,

Jeromy Dahlke
Jeromy Dahlke
Director of Customer Service
jdahlke@accuratecontrols.com

Please accept this signature as an approval of this quotation and an authorization to proceed.

PO#: _____

Date: _____

Authorized Signature

Print Name

Title

Five Star Telecom Inc.
 Phone: 608.796-9088
 Fax: 608.519-3599
 5136 Mormon Coulee Rd
 La Crosse, WI 54601



Quote
 No.: **27846**
 Date: 1/31/2024

Prepared for:
 Jeff Daane (920) 324-7918
 City of Waupun
 201 East Main Street
 Waupun, WI 53963 U.S.A.

Prepared by: Andy Smith
 Account No.: 4347
 Phone: (608) 324-7900

Quantity	Item ID	Description	UOM	Sell	Total
10 Year License Option					
Senior / Community Center - Installation of Cameras and Access Control					
Please see Job Scope for additional details					
1	AC62-HW	AC62 16 Door Controller	EA	\$2,331.56	\$2,331.56
1	ACC-BAT-18AH	18AH Backup Battery for AC62	EA	\$307.56	\$307.56
14	AD33-HW	AD33 Multi-Format Card Reader	EA	\$153.56	\$2,149.84
3	BR31-HW	Wireless Door Sensor	EA	\$87.56	\$262.68
2	BH61-HW	Wireless Sensor Hub	EA	\$263.56	\$527.12
3	CM42-256-HW	Indoor Mini Dome Camera, 5MP, Fixed Lens, 256GB of Storage, Maximum 30 Days of Retention	EA	\$307.56	\$922.68
3	CF81-30E-HW	Indoor/Outdoor Fisheye Camera, 30 Days of Storage	EA	\$879.56	\$2,638.68
2	ACC-MNT-7	Angle Mount Kit	EA	\$65.56	\$131.12
6	LIC-10Y	10 Year License	EA	\$692.62	\$4,155.72
14	LIC-AC-10Y	10 Year Door License	EA	\$703.65	\$9,851.10
1	LIC-BA-10Y	10 Year Alarm License	EA	\$5,775.00	\$5,775.00

Cabling and Installation Total: \$10,571.25

One (1) Year Parts and Labor Warranty
Ten (10) Year Verkada Equipment Warranty

Your Price:	\$39,624.31
Freight:	\$379.00
SubTotal:	\$40,003.31
Total:	\$40,003.31

Prices are firm until 3/1/2024

Terms: 50% on Signing, 40% on Delivery, 10% on Completion

Prepared by: Andy Smith, asmith@5startel.com

Date: 1/31/2024

Quote

No.: **27846**

Date: 1/31/2024

Job Scope

- 1. Installation of Access Control Cabling for 14 Doors.
 - A. 100A
 - B. 101
 - C. 103
 - D. 106
 - E. 119B
 - F. 131
 - G. 300
 - H. 400B
 - I. 301A
 - J. 127
 - K. 400A
 - L. 112
 - M. 119A
 - N. Door from Room 400 to 401
- 2. Installation of 1 - Verkada 16 Door Controller with 18AH battery backup.
- 3. Installation of 2 Wireless Hubs for Door Contact sensors.
 - A. 142 - Wireless Contact
 - B. 114C - Wireless Contact.
 - C. 126 - Overhead Door Wireless Contact.
- 4. Installation of 6 total cameras:
 - A. 2 - Exterior 180 Degree Cameras.
 - B. 1 - Interior Fisheye Camera.
 - C. 3 - Interior Fixed Lens dome cameras for hallways.
- 5. Supply and apply 6 - 10 Year Verkada Camera Licenses.
- 6. Supply and apply 14 - 10 Year Verkada Door Licenses.
- 7. Supply and apply 1 - 10 Year Verkada Alarm License.
- 8. Complete installation, testing and training.

Accepted by: _____ **Date:** _____

Disclaimer

The above price, specifications and conditions are satisfactory. You are authorized to do the work described, payment will be made as indicated above. Cancellation of this proposal once accepted as an order is subject to restocking charges of 15% of contract price. Seller shall not be liable for failure to deliver due to strikes, casualty, loss or delay of carriers of suppliers. Unless Specified otherwise on proposal, all new products are warranted to be free from defects in material and workmanship for one year following date of installation. Defective equipment will be repaired or replaced at Five Star Telecom's option without charge during normal working hours. (Normal workday 8:00 A.M. – 4:30 P.M. Monday-Friday excluding Holidays.) Any service performed after hours shall be subject to a minimum of 2 hour labor charge and overtime rates of time and a half. This warranty does not apply to equipment subject to misuse, abuse, tampering, negligence, accidents, unsuitable electrical conditions, lightning, or forces of nature. Any call for service not directly caused by the failure of equipment provided by Five Star Telecom shall be subject to service charges. Equipment moved or serviced by anyone other than an authorized Five Star Telecom representative shall void warranty. This agreement bears interest on any unpaid balance at the rate of 18% per year

Five Star Telecom Inc.
 Phone: 608.796-9088
 Fax: 608.519-3599
 5136 Mormon Coulee Rd
 La Crosse, WI 54601



Quote
 No.: **27842**
 Date: 1/31/2024

Prepared for:
 Jeff Daane (920) 324-7918
 City of Waupun
 201 East Main Street
 Waupun, WI 53963 U.S.A.

Prepared by: Andy Smith
 Account No.: 4347
 Phone: (608) 324-7900

Quantity	Item ID	Description	UOM	Sell	Total
1 Year License Option					
Senior / Community Center - Installation of Cameras and Access Control					
Please see Job Scope for additional details					
1	AC62-HW	AC62 16 Door Controller	EA	\$2,623.00	\$2,623.00
1	ACC-BAT-18AH	18AH Backup Battery for AC62	EA	\$346.00	\$346.00
14	AD33-HW	AD33 Multi-Format Card Reader	EA	\$172.76	\$2,418.64
3	BR31-HW	Wireless Door Sensor	EA	\$49.00	\$147.00
2	BH61-HW	Wireless Sensor Hub	EA	\$296.50	\$593.00
3	CM42-256-HW	Indoor Mini Dome Camera, 5MP, Fixed Lens, 256GB of Storage, Maximum 30 Days of Retention	EA	\$346.00	\$1,038.00
3	CF81-30E-HW	Indoor/Outdoor Fisheye Camera, 30 Days of Storage	EA	\$989.50	\$2,968.50
2	ACC-MNT-7	Angle Mount Kit	EA	\$73.76	\$147.52
6	LIC-1Y	1 Year License	EA	\$98.50	\$591.00
14	LIC-AC-1Y	1 Year Door License	EA	\$123.26	\$1,725.64
1	LIC-BA-1Y	1 Year Alarm License	EA	\$742.50	\$742.50
Cabling and Installation Total:					\$10,571.25

One (1) Year Parts and Labor Warranty
Ten (10) Year Verkada Equipment Warranty

Your Price:	\$23,912.05
Freight:	\$379.00
SubTotal:	\$24,291.05
Total:	\$24,291.05

Prices are firm until 3/1/2024

Terms: 50% on Signing, 40% on Delivery, 10% on Completion

Prepared by: Andy Smith, asmith@5startel.com

Date: 1/31/2024

Quote

No.: **27842**

Date: 1/31/2024

Job Scope

- 1. Installation of Access Control Cabling for 14 Doors.
 - A. 100A
 - B. 101
 - C. 103
 - D. 106
 - E. 119B
 - F. 131
 - G. 300
 - H. 400B
 - I. 301A
 - J. 127
 - K. 400A
 - L. 112
 - M. 119A
 - N. Door from Room 400 to 401
- 2. Installation of 1 - Verkada 16 Door Controller with 18AH battery backup.
- 3. Installation of 2 Wireless Hubs for Door Contact sensors.
 - A. 142 - Wireless Contact
 - B. 114C - Wireless Contact.
 - C. 126 - Overhead Door Wireless Contact.
- 4. Installation of 6 total cameras:
 - A. 2 - Exterior 180 Degree Cameras.
 - B. 1 - Interior Fisheye Camera.
 - C. 3 - Interior Fixed Lens dome cameras for hallways.
- 5. Supply and apply 6 - 1 Year Verkada Camera Licenses.
- 6. Supply and apply 14 - 1 Year Verkada Door Licenses.
- 7. Supply and apply 1 - 1 Year Verkada Alarm License.
- 8. Complete installation, testing and training.

Accepted by: _____ **Date:** _____

Disclaimer

The above price, specifications and conditions are satisfactory. You are authorized to do the work described, payment will be made as indicated above. Cancellation of this proposal once accepted as an order is subject to restocking charges of 15% of contract price. Seller shall not be liable for failure to deliver due to strikes, casualty, loss or delay of carriers of suppliers. Unless Specified otherwise on proposal, all new products are warranted to be free from defects in material and workmanship for one year following date of installation. Defective equipment will be repaired or replaced at Five Star Telecom's option without charge during normal working hours. (Normal workday 8:00 A.M. – 4:30 P.M. Monday-Friday excluding Holidays.) Any service performed after hours shall be subject to a minimum of 2 hour labor charge and overtime rates of time and a half. This warranty does not apply to equipment subject to misuse, abuse, tampering, negligence, accidents, unsuitable electrical conditions, lightning, or forces of nature. Any call for service not directly caused by the failure of equipment provided by Five Star Telecom shall be subject to service charges. Equipment moved or serviced by anyone other than an authorized Five Star Telecom representative shall void warranty. This agreement bears interest on any unpaid balance at the rate of 18% per year



AGENDA SUMMARY SHEET

MEETING DATE
2/13/24

TITLE: Approve/Recommend purchase of 2024
Chevrolet Silverado 1500 4WD Regular Cab

AGENDA SECTION: Consideration/ Action

PRESENTER:Public
Works Director
Daane

DEPARMTENT GOAL(S) SUPPORTED <i>(if applicable)</i>	FISCAL IMPACT	
Sustainability	\$39,017	

ISSUE SUMMARY

Quotes were received for a 2024 ½ ton pickup truck. The quotes are as follows

- Ewald \$39,017
- Holiday \$39,908.60
- Homan \$39,911
- Napleton \$41,334.50

STAFF RECCOMENDATION:

Purchasing policy allows local to have priority within 1% of the lowest quote. Ewald is the lowest and the local quotes do not come within that percentage

ATTACHMENTS:

RECOMMENDED MOTION:

1. Recommend the purchase of 2024 Chevrolet Silverado 1500 4WD Regular Cab from Ewald for \$39,017 to Council