



**PUBLIC WORKS COMMISSION MEETING AGENDA**

**TUESDAY, FEBRUARY 24, 2026 AT 5:30 PM**

**COUNCIL CHAMBERS, SECOND FLOOR, MUNICIPAL BUILDING - 106 JONES STREET,  
WATERTOWN, WI 53094**

---

**Virtual Meeting Info:** <https://us06web.zoom.us/join> Meeting ID: 225 151 7335 Passcode: 589577 One tap mobile +16469313860

<https://us06web.zoom.us/j/9178580897?pwd=eUOpCUyvIV65zIPMYImMdPU1LVLx5l.1>

All public participants' phones will be muted during the meeting except during the public comment period.

**1. CALL TO ORDER**

**2. COMMENTS AND SUGGESTIONS FROM CITIZENS PRESENT**

*Each individual who would like to address the Committee will be permitted up to three minutes for their comments*

**3. REVIEW AND APPROVE MINUTES**

A. Public Works minutes from February 10, 2026

**4. BUSINESS**

A. Review and Discuss: Update on Leaf Collection Program

B. Review and take possible action: Downtown Main Street Reconstruction Project - Street Lighting Review & Direction

C. Review and take possible action: 2026 Sidewalk Repair Program Area

D. Review and take possible action: Award Pavement Marking Contract #1-26 Base Bids A & B, and Alternate Bids 1, 2 & 3 to Brickline, Inc. for \$20,609.25

E. Review and take possible action: Award Rout and Crack Fill Contract #2-26 Base Bids A & B, and Alternate Bids 1 & 2 to Thunder Road, LLC for \$54,380.00

F. Review and take possible action: Award Seal Coating Contract #3-26 Base Bid A, and Alternate Bid 1 to the low bidder, Scott Construction, Inc. for \$94,165.95

G. Review and take possible action: Award 2026 Annual Street and Utility Project Contract #4-26 Base Bids A & B, and Alternate Bids 1, 2 & 5 to Forest Landscaping & Construction, Inc. for \$926,828.00

H. Review and take possible action: Award 2026 Storm Sewer Cleaning & Televising Project Contract #5-26 Base Bid A and Alternate Bids 1, 2 & 3 to Green Bay Pipe & TV, LLC for \$129,288.53

I. Review and take possible action: Award Bituminous Surfacing Contract #6-26 Base Bids A, B, C, D, E, F, G, & H, and Alternate Bids 1, 2, 3, 4, 5, & O to Wolf Paving Co., Inc. for \$1,141,831.95

J. Review and take possible action: Award LRIP 2026/2027 Bituminous Surfacing Project-2026 Market Way Contract #10-26 Base Bid A to Wolf Paving Co., Inc for \$209,919.33

**5. ADJOURNMENT**

*Persons requiring other reasonable accommodations for any of the above meetings, may contact the office of the City Clerk at [cityclerk@watertownwi.gov](mailto:cityclerk@watertownwi.gov) phone 920-262-4000*

*A quorum of any City of Watertown Council, Committee, Board, Commission, or other body, may be present at this meeting for observing and gathering of information only*

# PUBLIC WORKS COMMISSION

Tuesday, February 10, 2026

5:30 p.m.

The Public Works Commission met at the above date and time. The following members were present: Alderpersons Brad Blanke, Dan Bartz, Myron Moldenhauer, and Tony Arnett; Citizen member Pete Thompson. Also present: City Staff Pete Hartz.

1. **Call to order.** Chairperson Arnett called the meeting to order at 5:30 p.m.
2. **Comments and Suggestions from Citizens Present.** None.
3. **Review and take possible action. Minutes of PWC meeting of January 13th, 2026.** Mr. Moldenhauer moved to approve the minutes as presented, seconded by Mr. Thompson. Motion carried by unanimous voice vote.
4. **Review and take possible action: Enter into a professional services agreement with VMC Inc. for not more than \$10,000 for a new cellular upgrade project with T-Mobile at the Western water tower.** T-Mobile requested an upgrade project, which includes installing a standby generator. As part of our contract, we have the right for an outside consultant to review the project, with T-Mobile to cover that cost (so at no cost to the city.) The original recommendation was amended to amount not to exceed \$15,400 (with a \$15,500 escrow) due to the generator work. Mr. Thompson moved and Mr. Bartz seconded to approve at the amended amounts. The motion carried by unanimous voice vote.
5. **Review and take possible action: Enter into a professional services agreement with Mead–Hunt for the Geographical Informational System (GIS) annual asset mapping conducted each year on an as-needed basis.** The city has used Mead-Hunt for some aspects of GIS work for a number of years. This renews that annual contract, which is on a time-and-materials as-needed basis. Commission members asked that staff seek additional quotes from other potential service providers prior to next year’s renewal. Mr. Blanke moved to approve, with Mr. Thompson seconding. The motion carried by unanimous voice vote.
6. **Review and take possible action: Purchase Subsurface LC-5000 Digital Dual Correlator System from USA Bluebook for a total cost of \$24,225.** This purchase was in the budget, with an estimate of \$50,000. 3 bids were received, with USA Bluebook being the lowest and best bid. Mr. Bartz moved to approve, with Mr. Blanke seconding. The motion carried by unanimous voice vote.
7. **Review and take action: Approve 2025 Utility bill write-off of account refunds & credits.** The Water Utility is paying back customer refunds and credits given in 2025 by “writing off” the refund/credit amounts at the end of the year. Mr. Moldenhauer moved to approve, seconded by Mr. Bartz. The motion carried by unanimous voice vote.
8. **Adjournment.** Mr. Thompson moved to adjourn at 5:51 p.m., seconded by Mr. Moldenhauer. Motion carried by unanimous voice vote.

Respectfully submitted,

Tony Arnett, Chairperson

Note: These minutes are uncorrected, and any corrections made thereto will be noted in the proceedings at which these minutes are approved.

# MEMO

## DPW – Street/Solid Waste Division

To: Alderperson Arnett and Public Works Commission Members

From: Stacy Winkelman

Date: February 17, 2026

Subject: Leaf Collection Program

### Background

At the December 9, 2025, meeting this commission expressed the desire to continue with the curbside vacuum style collection of leaves. We have gotten five quotes on the cost of a new leaf vacuum machine. They range from \$129,000.00 to \$195,000.00.

Furthermore, I had informed the commission members that we had taken one of the leaf machines out of service due to repair needs. We have since started to rebuild that machine with costs coming in so far at around \$12,000.00. Andrew and I have discussed; the 2026 budget can support these repairs.

### Budget Goal

Storm Water Utility Equipment Repairs Account #16-58-16-22 for existing machine repairs

Storm Water Utility Capital Account #16-58-16-60 for new machine purchase

### Financial Impact

High dollar amounts for both repairs/maintenance of existing machines and the cost of new machines

### Recommendation

If the recommendation of the commission is still to remain using the leaf vacuum system, we would recommend budgeting for a new machine in the 2027 budget

# MEMO

## Department of Public Works

**To:** Alderperson Arnett & the Public Works Commission  
**From:** Andrew Beyer, P.E., Director of Public Works  
**Date:** February 19, 2026  
**Subject:** Downtown Main Street Reconstruction Project – Street Lighting Review & Direction

### Background

Review and take possible action: Downtown Main Street Reconstruction Project – Street Lighting Review & Direction

At its January 13 meeting, the Public Works Commission requested that City Staff further evaluate street lighting options for the Downtown Main Street Reconstruction Project. Specifically, the Commission asked Staff to review:

1. Whether the existing pedestrian lighting could be reused.
2. Whether a more cost effective decorative light pole option could be identified.

City Staff met in January and February to review the existing system, evaluate vendor options, and assess cost and project schedule considerations. The following summarizes Staff's findings.

#### Existing Lighting System Evaluation

Staff evaluated the feasibility of reusing or refurbishing the existing downtown lighting system. Based on field review and coordination with vendors, refurbishment is not considered feasible for the following reasons:

- Pole bases appear to be nearing structural fatigue .
- Ballasts, luminaires, and glass components have largely failed and are discontinued. Newly available components do not fit the existing style of light.
- Older fixtures have little to no salvage value.

Some recently purchased fixtures are salvageable and could potentially be reused in another corridor such as Third Street. However, reuse within the Main Street project area is not recommended. Photos are attached as a reference.

#### Vendor and Light Pole Evaluation



# MEMO

Staff evaluated reputable manufacturers with a target service life of 30 years or greater. Recent regional installations were reviewed for performance and durability.

Two manufacturers were evaluated in greater detail:

- Sternberg Lighting (currently selected luminaire)
- Sun Valley Lighting

Staff compared the Sun Valley pole to the currently selected Sternberg pole and found that overall quality and aesthetics were similar. Shop drawings of each pole are attached. The Sun Valley pole was determined to be high quality, carried a similar aesthetic to the selected Sternberg light pole, and represents a more cost effective option.

Staff recommends retaining functional accessories such as banner arms, GFI outlets, and related pole features to avoid future retrofits and additional maintenance costs.

### Preliminary Cost Comparison

Below is a summary of estimated pole quantities and placeholders for cost comparison between the Sternberg and Sun Valley options. Final pricing is subject to updated vendor quotations.

Item	Quantity	Sternberg Option	Sun Valley Option
Decorative Street Light Poles (30')	42	\$689,514.00	\$489,562.50
Decorative Pedestrian Light Poles (12')	30	\$141,930.00	\$117,075.00
Decorative Street Light for Top of Signal	16	\$310,144.00	\$174,240.00
<b>Subtotal</b>		<b>\$1,141,588.00</b>	<b>\$780,877.50</b>
Contractor Overhead & Profit (35%)		\$399,555.80	\$273,307.13
15% Contingency		\$231,171.57	\$158,127.69
<b>Total Estimated Cost</b>		<b>\$1,772,315.37</b>	<b>\$1,212,312.32</b>

Contractor overhead and profit are estimated at 35 percent. This cost could be reduced if the City were to procure the poles directly and supply them to the contractor for installation. Due to fabrication lead times, this procurement would need to occur in 2027 to support the 2028 construction schedule.

### WisDOT Coordination and Project Impacts

Staff requested high level guidance from WisDOT regarding potential impacts of changing the currently approved decorative luminaire.

WisDOT indicated:

- Changes to the appearance of decorative lighting would require revisiting the Section 106 review process, including additional coordination with the State Historic Preservation Office. This process alone could take approximately 30 days, followed by additional documentation updates.
- Project documents including the Design Study Report, plats, real estate acquisition documents, and utility coordination could be delayed a minimum of two months.
- Schedule impacts would likely jeopardize the planned PS&E date and potentially delay the project LET, which could move the project out of the 2028 construction season.
- WisDOT's consultant, AECOM, may need to re-run the lighting analysis to confirm compliance with lighting standards, requiring a contract amendment at City expense.
- Any cost differential above a standard WisDOT lighting system remains the responsibility of the City and would be incorporated into the State/Municipal Financial Agreement update.

WisDOT emphasized that the current schedule is already tight due to earlier Section 106 coordination delays.

## Financial Impact

Decorative street lighting is considered a City cost participation item under the State Municipal Financial Agreement. Any cost above a standard WisDOT lighting system is the responsibility of the City.

Based on updated pricing, the estimated total costs are as follows:

### Sternberg Option

- Material Cost: \$1,141,588.00
- 35% Contractor Overhead, Profit, and Installation: \$399,555.80
- 15% Contingency: \$231,171.57
- **Total Estimated Cost: \$1,772,315.37**

### Sun Valley Option

- Material Cost: \$780,877.50
- 35% Contractor Overhead, Profit, and Installation: \$273,307.13
- 15% Contingency: \$158,127.69
- **Total Estimated Cost: \$1,212,312.32**

The difference between the Sternberg and Sun Valley options is approximately \$560,003.05, with the Sun Valley option representing the lower cost alternative while maintaining comparable quality and aesthetics.

If the City elects to directly procure lighting poles in 2027 for contractor installation, contractor overhead and profit may be reduced, resulting in additional savings. Direct procurement would require advance City funding due to fabrication lead times.

If a substantially different lighting style beyond the currently approved decorative concept is pursued, additional redesign costs would be incurred, along with potential schedule impacts that could delay the project and increase overall project costs.

## Recommendation

Based on:

- The infeasibility of reusing the existing lighting system,
- Comparable quality and aesthetics between Sternberg and Sun Valley products,
- The potential cost savings associated with the Sun Valley option, and
- The significant schedule risks associated with pursuing a substantially different lighting concept,

Staff is seeking Commission direction on:

1. Whether to maintain the currently approved decorative lighting concept.
2. Whether to pursue the Sun Valley pole as a cost effective alternative consistent with the approved aesthetic.
3. Whether the City should consider advance procurement of poles in 2027 to reduce contractor overhead and profit.

Staff will continue coordination with WisDOT as directed by the Commission.



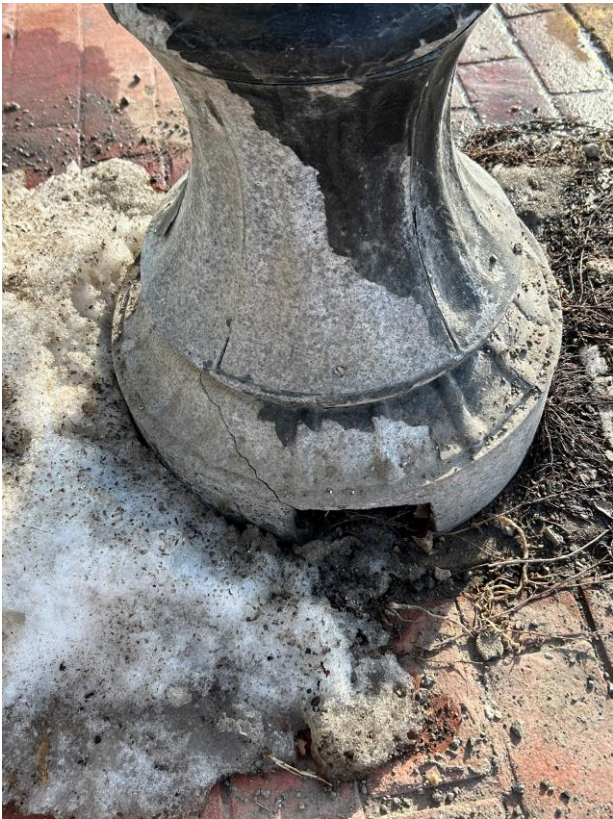







**ROADWAY ASSEMBLY:** (MOD) LCLS-PLD-III-48LED-1050MA-40K-UNV-1-LA/ (MOD)XPYS-1-6/RAL9005T  
**ROADWAY FIXTURE/ARM:** (MOD) LCJ1-PLD-III-20LED-875MA-40K-UNV-PT-CFA/XAC-1-WM/RAL9005T  
**PEDESTRIAN FIXTURE/ARM:** (MOD) LCJ1-PLD-III-20LED-875MA-40K-UNV-PT-CFA/XAC-1-WM/RAL9005T  
**POLE / SHAFT:** SB28-RNTA-306-.250-(4)BBA-(2)FFH-GFIIU-BC-RAL9005T

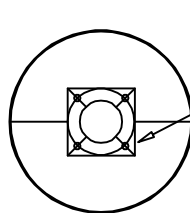
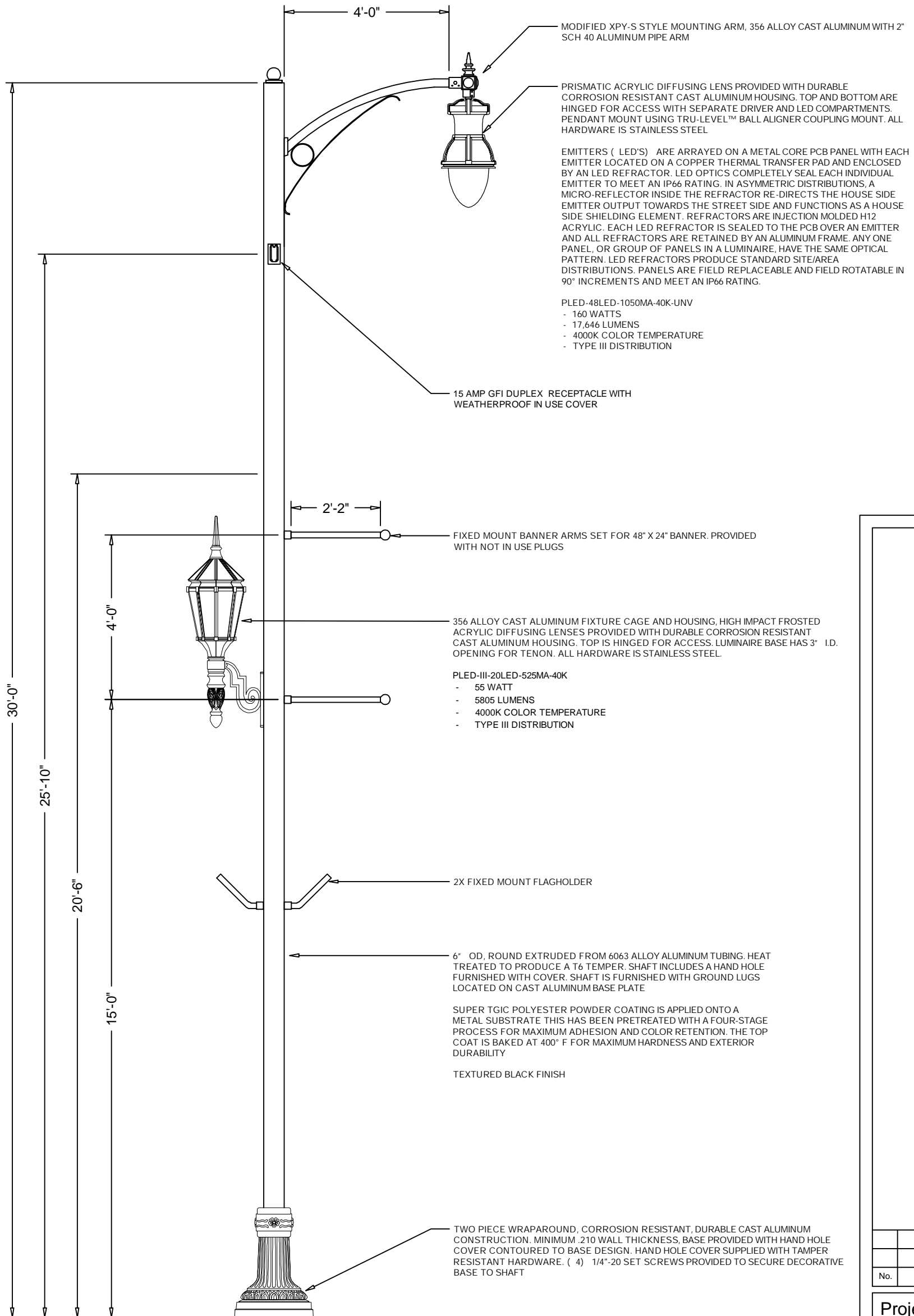

BASE PLATE FABRICATED FROM STRUCTURAL QUALITY HOT ROLLED STEEL. MEETS OR EXCEEDS MINIMUM YIELD STRENGTH OF 36,000 P.S.I. BASE TELESCOPES AND IS CIRCUMFERENTIALLY WELDED TO POLE SHAFT. SLOTTED BOLT HOLES PROVIDE 1" FLEXIBILITY ON EITHER SIDE OF BOLT CIRCLE CENTERLINE.

ANCHORAGE ( 4 ) ANCHOR BOLTS FABRICATED FROM HOT ROLLED STEEL BAR. MINIMUM YIELD STRENGTH OF 50,000 P.S.I. BOLTS HAVE "L" BEND ON ONE END AND ARE THREADED ON THE OTHER. BOLTS ARE FULLY GALVANIZED AND ARE FURNISHED WITH TWO NUTS AND TWO WASHERS.

ANCHOR BOLTS TO BE F1554 GR 55 STEEL, 1" DIA X 36" LONG  
 BOLT CIRCLE TO BE DETERMINED



No.	Revision/Issue	Date

**Project Name:**  
Watertown WI

**Part No:**

Drawn By: S.S.	Sheet:
Date: 1/15/26	SS011526A
Scale: NTS	

**PEDESTRIAN ASSEMBLY:**

FIXTURE/ARM: DS6S-PLED-XX-XXLED-XXXMA-XXK-UNV-PT/XPD/STD FINISH  
 POLE / SHAFT: 7-1070-12'-PT27-GFIIU-RAL9005T

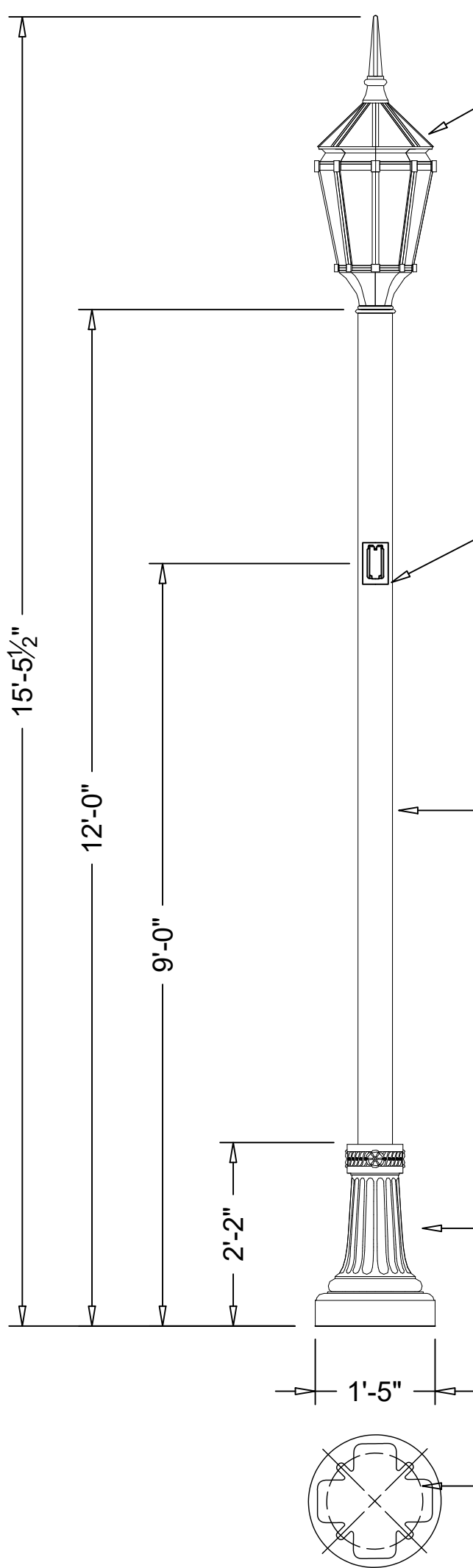

356 ALLOY CAST ALUMINUM FIXTURE CAGE AND HOUSING, HIGH IMPACT FROSTED ACRYLIC DIFFUSING LENSES PROVIDED WITH DURABLE CORROSION RESISTANT CAST ALUMINUM HOUSING. TOP IS HINGED FOR ACCESS. LUMINAIRE BASE HAS 3/4" I.D. OPENING FOR TENON. ALL HARDWARE IS STAINLESS STEEL.

- PLED-III-20LED-525MA-40K
- 55 WATT
  - 5805 LUMENS
  - 4000K COLOR TEMPERATURE
  - TYPE III DISTRIBUTION

15 AMP GFI DUPLEX RECEPTACLE WITH WEATHERPROOF IN USE COVER

ROUND EXTRUDED STRAIGHT SMOOTH POLE SHAFT, 6063 ALLOY ALUMINUM, 5" DIAMETER. HEAT TREATED TO PRODUCE A T6 TEMPER.

ELECTROSTATICALLY APPLIED TGIC POLYESTER POWDER COAT ON SUBSTRATE PREPARED WITH 20 PSI POWER WASH AT 140°F. FOUR STEP MEDIA BLAST AND IRON PHOSPHATE PRETREATMENT FOR PROTECTION AND PAINT ADHESION. 400°F BAKE FOR MAXIMUM HARDNESS AND DURABILITY. FINISH TO BE TEXTURED BLACK (RAL 9005T)

ONE PIECE CORROSION RESISTANT, DURABLE CAST ALUMINUM CONSTRUCTION. MINIMUM .210 WALL THICKNESS. BASE CONSISTS OF A SMOOTH, TAPERED BOTTOM SECTION, AND A HIGHLY DETAILED, DECORATIVE FLUTED SECTION, A DECORATIVE CAST ALUMINUM COLLAR AND A FLUTED HAND HOLE COVER CONTOURED TO BASE DESIGN. HAND HOLE COVER SUPPLIED WITH TAMPER RESISTANT HARDWARE. GROUNDING LUG PROVIDED INSIDE BASE OPPOSITE HAND HOLE.

A 3/4" CAST ALUMINUM ANCHOR RING IS WELDED 1" ABOVE BOTTOM OF BASE TO ACCEPT (4) FULLY GALVANIZED ANCHOR BOLTS. EACH BOLT SUPPLIED WITH TWO NUTS AND TWO WASHERS. ANCHORAGE IS FASTENED THROUGH HAND HOLE.

12" DIA BOLT CIRCLE FOR 3/4" DIA ANCHOR BOLTS



No.	Revision/Issue	Date

**Project Name:**  
Watertown WI

**Part No:**

Drawn By: S.S.	Sheet:
Date: 1/15/26	SS011526B
Scale: NTS	

# MEMO

## Engineering Division of the Public Works Department

To: Chairperson Arnett and Commission Members

From: Andrew Beyer P.E., Director of Public Works/City Engineer

Date: February 17, 2026

Subject: Public Works Commission Meeting of February 24, 2026

### Review and take possible action: 2026 Annual Sidewalk Repair Program Area

#### Background

Agenda Item:

Review and take possible action: 2026 Annual Sidewalk Repair Program Area

#### BACKGROUND:

A component of the Annual Street Program is a sidewalk repair area. Attached are site maps laying out this year's proposed areas. This year's areas are areas that have not been part of an Annual Sidewalk Repair Program in several decades. This year's program also includes the replacement of existing curb ramps on E. Spaulding Street at Center Street and on Clark Street at S. Third Street with WisDOT ADA Compliant curb ramps. Roughly \$80,000 is available in the Sidewalk Reserve Account for 2026 sidewalk repairs.

#### Budget Goal

1. Proactively maintains and improves our parks and infrastructure to ensure safety, quality, and equity
4. Maintains a safe and healthy community, with an eye toward future needs and trends

#### Financial Impact

Roughly \$80,000 is available in the Sidewalk Reserve Account for 2026 sidewalk repairs. Repair costs will initially be charged to the Sidewalk Reserve Account (05-58-11-73). The Engineering Division will then invoice the property owners for the total repair cost.



# MEMO

## Recommendation





The Public Works Department recommends approval of the 2026 Annual Sidewalk Repair Program Area.

Motion: Motion to forward a Resolution to the Common Council approving the 2026 Annual Sidewalk Repair Program Area for the aforementioned estimated cost.

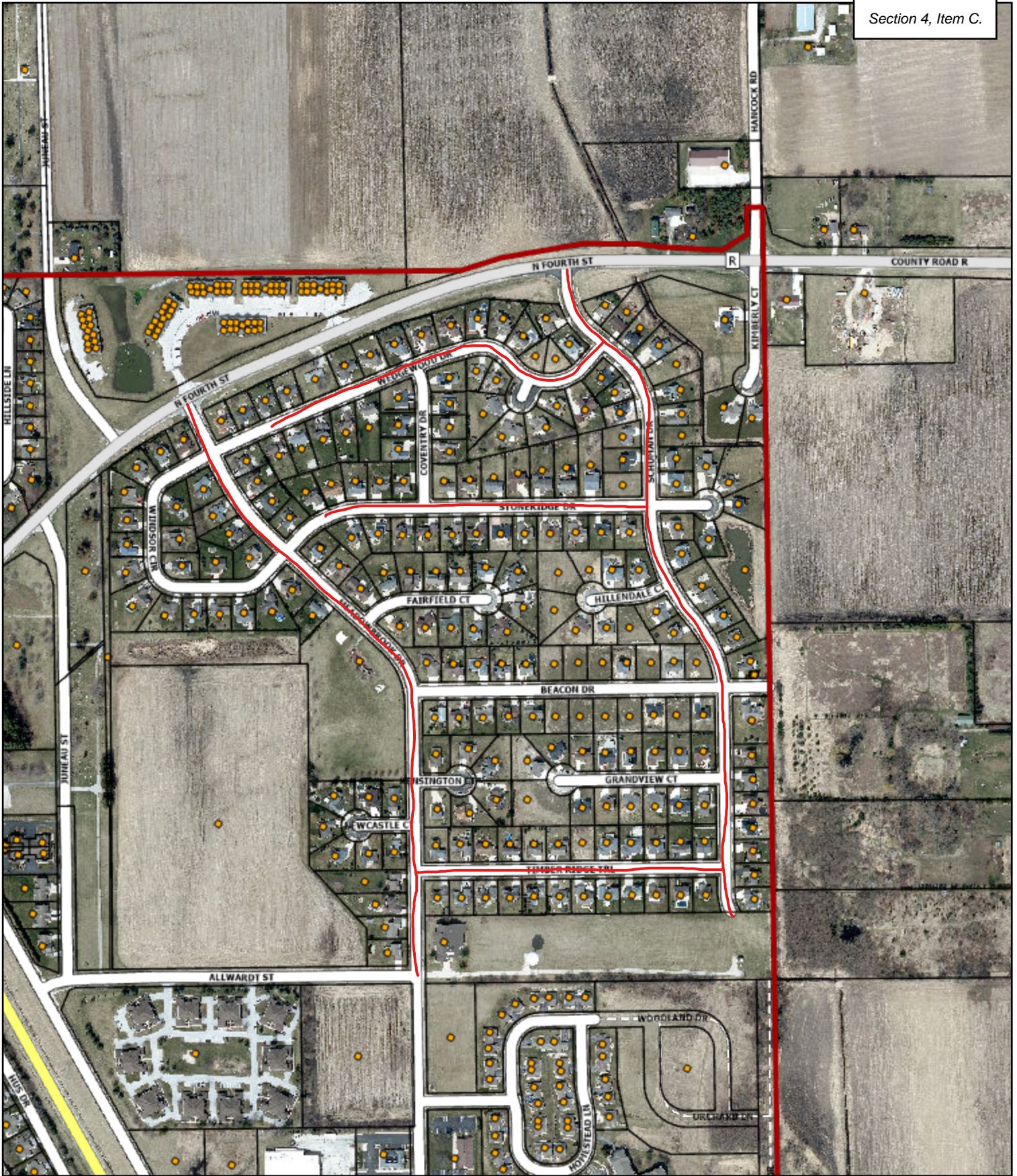
Attachments:

- 2026 Annual Sidewalk Repair Program Area Resolution
- 2026 Sidewalk Repair Program Maps



	Municipal Boundary		Common Areas
	Parcels Boundaries		Addresses



**THE CITY OF WATERTOWN**  
*Opportunity runs through it.*





**City of Watertown Geographic Information System**

Scale: 1:5,717      Printed on: January 18  
 Author:      SCALE BAR = 1"

DISCLAIMER: This map is not a substitute for an actual field survey or onsite investigation. The accuracy of this map is limited to the quality of the records from which it was assembled. Other ineluctable inaccuracies occur during the compilation process. City of Watertown makes no warranty whatsoever concerning this information.

Section 4, Item C.



	Municipal Boundary		Common Areas
	Parcels Boundaries		Addresses



**THE CITY OF**  
**WATERTOWN**  
*Opportunity runs through it.*





**City of Watertown Geographic Information System**

Scale: 1:5,717      Printed on: January  
SCALE BAR = 1"      Author:

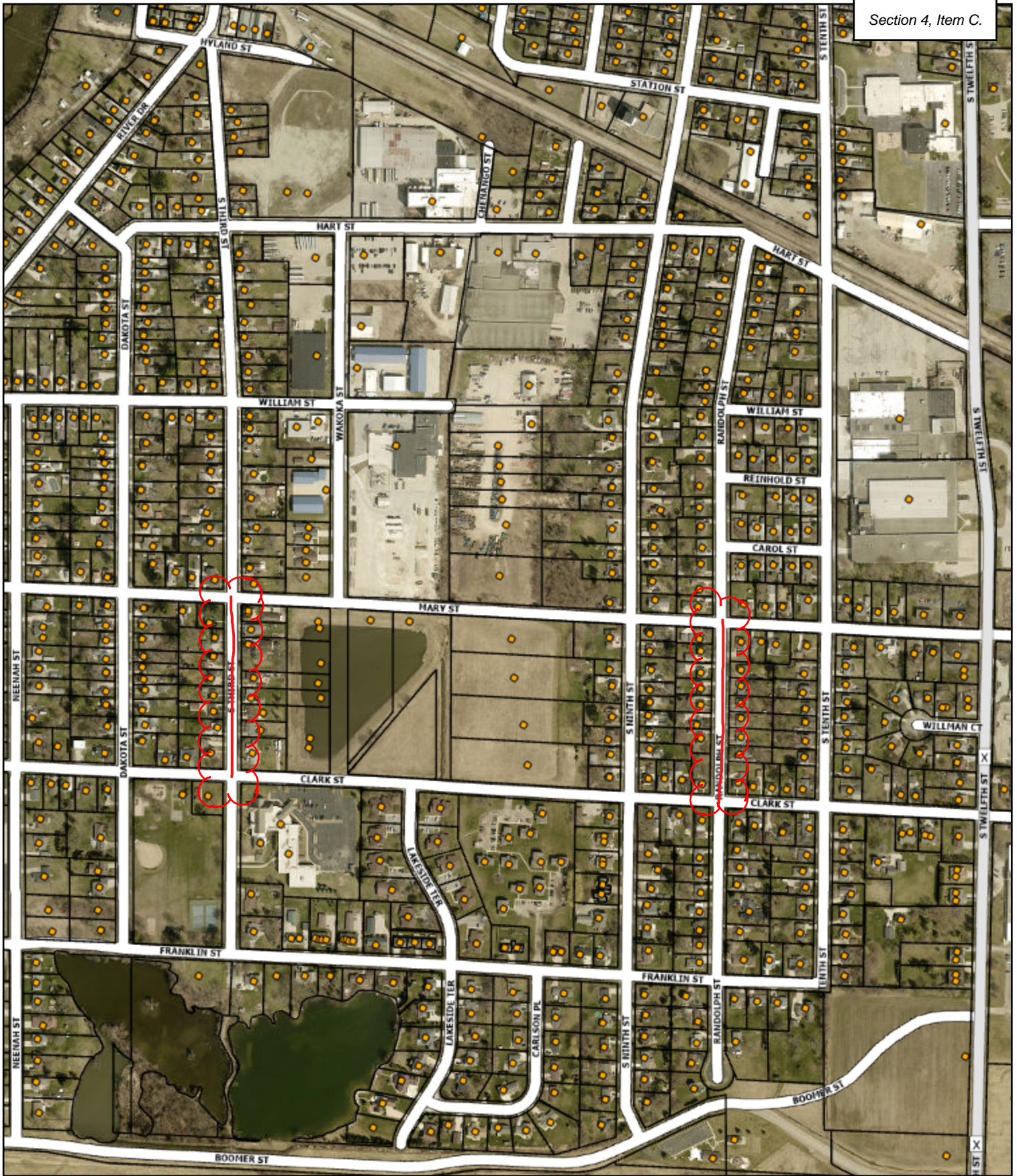
DISCLAIMER: This map is not a substitute for an actual field survey or onsite investigation. The accuracy of this map is limited to the quality of the records from which it was assembled. Other inherent inaccuracies occur during the compilation process. City of Watertown makes no warranty whatsoever concerning this information.

19



	Municipal Boundary		Common Areas
	Parcels Boundaries		Addresses



**THE CITY OF**  
**WATERTOWN**  
*Opportunity runs through it.*

**City of Watertown Geographic Information System**

Scale: 1:5,717      Printed on: January  
SCALE BAR = 1"      Author:

DISCLAIMER: This map is not a substitute for an actual field survey or onsite investigation. The accuracy of this map is limited to the quality of the records from which it was assembled. Other inherent inaccuracies occur during the compilation process. City of Watertown makes no warranty whatsoever concerning this information.

20

**RESOLUTION  
2026 ANNUAL SIDEWALK REPAIR PROGRAM AREA**

**SPONSOR: ALDERPERSON ARNETT  
FROM: PUBLIC WORKS COMMISSION**

**BE IT RESOLVED** by the Common Council of the City of Watertown that the City Engineer, through the designated Sidewalk Inspector, be and is hereby authorized to cause the repaired or replaced any defective or unsafe sidewalk within the City, commencing with and directly abutting the described areas and properties in 2026 in accordance with the State Statute 66.0907(3), and by herein described by the attached exhibit:

- Both sides of Meadowbrook Drive – Alwardt Street to N. Fourth Street
- North side of Wedgewood Drive – #1406 to Schuman Drive
- North side of Timber Ridge Trail – Meadowbrook Drive to Schuman Drive
- North side of Stoneridge Drive – #1402 to Schuman Drive
- Both sides of Schuman Drive – Termini to N. Fourth Street
- Both sides of Prospect Street – E. Spaulding Street to E. Leonard Street
- Both sides of E. Spaulding Street – N. Second Street to Center Street
- East side of Randolph Street – Clark Street to Mary Street
- West side of Randolph Street – #1410 to #1406
- Both sides of S. Third Street – Clark Street to Mary Street

**BE IT FURTHER RESOLVED** THAT SAID Sidewalk Inspector shall notify the property owners in writing, with defective or unsafe sidewalk to repair or replace the sidewalk. In compliance with the requirements of the City policy governing such construction. Property owner is given fourteen (14) days from the date of notice to notify City of how repairs will be completed, and that if not so repaired or replaced within the said says, as set in the written notice, the City of Watertown shall cause such sidewalk to be repaired or replaced and charge the cost thereof to the abutting property. Said money is to be charged to the 2026 Sidewalk Capital Account Number 05-58-11-73.

	YES	NO
DAVIS		
LAMPE		
BERG		
BARTZ		
BLANKE		
SMITH		
ARNETT		
WETZEL		
MOLDENHAUER		
MAYOR STOCKS		
TOTAL		

ADOPTED March 3, 2026

\_\_\_\_\_  
CITY CLERK

APPROVED March 3, 2026

\_\_\_\_\_  
MAYOR



Andrew Beyer, P.E.  
920.262.4050

Maureen McBroom, ENV SP  
920.206-4264

Nathan Williams  
920-262-4052

Ritchie

Section 4, Item D.

920.262.4034

Christopher Newberry  
920-390-

Administrative Assistant  
Wanda Fredrick 920.262.4060

MEMO

TO: Chairperson Arnett and Commission Members  
FROM: Andrew M. Beyer, P.E.  
DATE: February 19, 2026  
RE: Public Works Commission Meeting of February 24, 2026

Review and take possible action: Award Pavement Marking Contract #1-26 Base Bids A & B, and Alternate Bids 1, 2, & 3 to Brickline, Inc. for \$20,609.25

Background

The Engineering Division publicly opened bids for the 2026 Pavement Marking contract on February 12, 2026. Two bids were received. The Engineering Division is recommending awarding the following Base Bids and Alternate Bid to the low bidder, Brickline, Inc., Madison, WI:

Base Bid A: Pavement Marking Reconstruction Streets: \$2,948.10

Base Bid B: Pavement Marking Summit Ave.: \$6,468.80

Alternate Bid 1: Pavement Marking Micro-Surfacing Street: \$1,160.10

Alternate Bid 2: Pavement Marking Resurfacing Streets: \$8,145.25

Alternate Bid 3: Pavement Marking Mill & Overlay Street: \$1,887.00

Total cost to perform the proposed work is \$20,609.25 from funding account #05-58-11-69 (\$19,449.15), Annual Streets Reserve, and funding account #05-58-11-92 (\$1,160.10), Seal Coat Reserve.

Attached is the bid tab. Work being awarded is within the approved 2026 budgets.

Enclosed:

- Bid Tab



**Pavement Marking (#9963232)**  
**Owner: City of Watertown**  
**Solicitor: Watertown WI, City of**  
**02/12/2026 10:00 AM CST**

Section Title	Line Item	Item Code	Item Description	UofM	Quantity	Brickline Inc		Century Traffic, LLC	
						Unit Price	Extension	Unit Price	Extension
Base Bid A: Pavement Marking Reconstruction Streets: S. Eighth St. and Market St.							<b>\$2,948.10</b>		<b>\$4,551.00</b>
	1A	1A	Marking Line Epoxy 6-Inch, Yellow (Double)	LF	912	\$2.60	\$2,371.20	\$4.00	\$3,648.00
	2A	2A	Marking Parking Stall Epoxy, White	LF	54	\$6.10	\$329.40	\$10.00	\$540.00
	3A	3A	Marking Diagonal Epoxy 6-Inch, Yellow	LF	33	\$7.50	\$247.50	\$11.00	\$363.00
Base Bid B: Pavement Marking: Summit Ave.							<b>\$6,468.80</b>		<b>\$5,224.80</b>
	1B	1B	Marking Line Epoxy 6-Inch, Yellow (Double)	LF	1278	\$2.60	\$3,322.80	\$2.10	\$2,683.80
	2B	2B	Marking Line Epoxy 6-Inch, White	LF	1210	\$2.60	\$3,146.00	\$2.10	\$2,541.00
Alternate Bid 1: Pavement Marking Micro-Surface Street: S. Concord Ave.							<b>\$1,160.10</b>		<b>\$4,698.00</b>
	1C	1C	Marking Removal Line 4-Inch, Yellow (Double)	LF	216	\$1.50	\$324.00	\$6.50	\$1,404.00
	2C	2C	Marking Line Epoxy 6-Inch, Yellow (Double)	LF	216	\$2.60	\$561.60	\$13.50	\$2,916.00
	3C	3C	Marking Stop Line Epoxy 18-Inch	LF	18	\$15.25	\$274.50	\$21.00	\$378.00

Alternate Bid 2: Pavement Marking Resurfacing Streets: River Dr., Hospital Dr., and Meadowbrook Dr.							<b>\$8,145.25</b>		<b>\$11,421.00</b>
	1D	1D	Marking Stop Line Epoxy 18-Inch	LF	61	\$15.25	\$930.25	\$21.00	\$1,281.00
	2D	2D	Marking Crosswalk Epoxy Block Style 24-Inch	LF	390	\$18.50	\$7,215.00	\$26.00	\$10,140.00
Alternate Bid 3: Pavement Marking Mill & Overlay Street: Market St.							<b>\$1,887.00</b>		<b>\$2,201.50</b>
	1E	1E	Marking Removal Line 4-Inch, Yellow (Double)	LF	1258	\$1.50	\$1,887.00	\$1.75	\$2,201.50
<b>Base Bid Total:</b>							<b>\$20,609.25</b>		<b>\$28,096.30</b>

Andrew Beyer, P.E.  
920.262.4050

Maureen McBroom, ENV SP  
920.206-4264

Nathan Williams  
920-262-4052

Ritchie

Section 4, Item E.

920.262.4034

Christopher Newberry  
920-390-

Administrative Assistant  
Wanda Fredrick 920.262.4060

## MEMO

TO: Chairperson Arnett and Commission Members  
FROM: Andrew M. Beyer, P.E.  
DATE: February 19, 2026  
RE: Public Works Commission Meeting of February 24, 2026

Review and take possible action: Award Rout and Crack Fill Contract #2-26 Base Bids A & B, and Alternate Bids 1 & 2 to Thunder Road LLC for \$54,380.00

### Background

The Engineering Division publicly opened bids for the 2026 Rout and Crack Fill contract on February 12, 2026. Three bids were received. The Engineering Division is recommending awarding the following Base Bids and Alternate Bids to the low bidder, Thunder Road LLC:

Base Bid A: Rout and Crack Fill Prior to Seal Coating: \$24,195.00

Base Bid B: Rout and Crack Fill Prior to Micro Surfacing: \$5,090.00

Alternate Bid 1: Rout and Crack Fill: Street Department Employee Parking Area: \$5,095.00

Alternate Bid 2: Rout and Crack Fill Only: Airport taxiway 23/05: \$20,000.00

Total cost to perform the proposed work is \$54,380.00 from funding account #05-58-11-92 (\$54,380.00), Seal Coat Reserve.

Attached is the bid tab. Work being awarded is within the approved 2026 budgets.

### Enclosed:

- Bid Tab



**Routing and Crack Fill of Various Streets and Airport Taxiway (#9966374)**

**Owner: City of Watertown**

**Solicitor: Watertown WI, City of**

**02/12/2026 10:00 AM CST**

Section Title	Line Item	Item Code	Item Description	UofM	Quantity	Thunder Road LLC		Denler, Inc.		Fahrner Asphalt Sealers, LLC	
						Unit Price	Extension	Unit Price	Extension	Unit Price	Extension
Base Bid A: Rout and Crack Fill: Prior to Seal Coating											
							<b>\$24,195.00</b>		<b>\$22,086.80</b>		<b>\$38,869.80</b>
	1A	1A	3405 Classification Hot-poured elastic type crack sealant of 2026 Seal Coat Streets	LS	1	\$20,235.00	\$20,235.00	\$16,600.00	\$16,600.00	\$35,825.00	\$35,825.00
	2A	2A	Flex leveling of cupped cracks, 18-Inch Width	LF	440	\$9.00	\$3,960.00	\$12.47	\$5,486.80	\$6.92	\$3,044.80
Base Bid B: Rout and Crack Fill: Prior to Micro Surfacing											
							<b>\$5,090.00</b>		<b>\$2,400.00</b>		<b>\$8,030.20</b>
	1B	1B	3405 Classification Hot-poured elastic type crack sealant of 2026 Micro Surfacing Streets	LS	1	\$4,550.00	\$4,550.00	\$1,500.00	\$1,500.00	\$7,615.00	\$7,615.00
	2B	2B	Flex leveling of cupped cracks, 18-Inch Width	LF	60	\$9.00	\$540.00	\$15.00	\$900.00	\$6.92	\$415.20
Add Alternate Bid 1: Rout and Crack Fill: Street Department Employee Parking Area											
							<b>\$5,095.00</b>		<b>\$10,500.00</b>		<b>\$5,975.00</b>
	1C	1C	3405 Classification Hot-poured elastic type crack sealant.	LS	1	\$5,095.00	\$5,095.00	\$10,500.00	\$10,500.00	\$5,975.00	\$5,975.00

Add Alternate Bid 2: Rout and Crack Fill: Airport Taxiway 23/05							\$20,000.00		\$21,200.00		\$9,934.00
	1D	1D	3405 Classification Hot-poured elastic type crack sealant.	LS	1	\$13,700.00	\$13,700.00	\$12,800.00	\$12,800.00	\$5,090.00	\$5,090.00
	2D	2D	Flex leveling of cupped cracks, 24-Inch Width	LF	700	\$9.00	\$6,300.00	\$12.00	\$8,400.00	\$6.92	\$4,844.00
<b>Base Bid Total:</b>							<b>\$54,380.00</b>		<b>\$56,186.80</b>		<b>\$62,809.00</b>



Andrew Beyer, P.E.  
920.262.4050

Maureen McBroom, ENV SP  
920.206-4264

Nathan Williams  
920-262-4052

Ritchie

Section 4, Item F.

920.262.4034

Christopher Newberry  
920-390-

Administrative Assistant  
Wanda Fredrick 920.262.4060

## MEMO

TO: Chairperson Arnett and Commission Members  
 FROM: Andrew M. Beyer, P.E.  
 DATE: February 19, 2026  
 RE: Public Works Commission Meeting of February 24, 2026

Review and take possible action: Award Seal Coating Contract #3-26 Base Bid A, and Alternate Bid 1 to the low bidder, Scott Construction, Inc. for \$94,165.95

### Background

The Engineering Division publicly opened bids for the 2026 Seal Coating contract on February 12, 2026. Two bids were received. The Engineering Division is recommending awarding the following Base Bid and Alternate Bid to Scott Construction, Inc.:

Base Bid A: Seal Coating Streets: \$73,342.50

Alternate Bid 1: Micro Surfacing Street: \$20,823.45

Total cost to perform the proposed work is \$94,165.95 from funding account #05-58-11-92, Seal Coat Reserve.

Attached are the Bid Tab and Seal Coating & Micro Surfacing Location Maps. Work being awarded is within the approved 2026 budget.

### Enclosed:

- Bid Tab
- Seal Coating & Micro Surfacing Location Maps



**Seal Coating of Various Streets (#9966378)**

**Owner: City of Watertown**

**Solicitor: Watertown WI, City of**

**02/12/2026 10:00 AM CST**

						Scott Construction, Inc		Fahrner Asphalt Sealers, LLC	
Section Title	Line Item	Item Code	Item Description	UofM	Quantity	Unit Price	Extension	Unit Price	Extension
Base Bid A: Seal Coating Streets (Est. Quantities Only)							<b>\$73,342.50</b>		<b>\$74,142.60</b>
	1A	1A	Bituminous seal coat with FA2 crushed granite aggregate	SY	26670	\$2.75	\$73,342.50	\$2.78	\$74,142.60
Alternate Bid 1: Micro Surfacing Street: S. Concord Ave. (Est. Quantities Only)							<b>\$20,823.45</b>		<b>\$25,562.58</b>
	1B	1B	Aggregate and Emulsified Asphalt Micro Surface	SY	4787	\$4.35	\$20,823.45	\$5.34	\$25,562.58
<b>Base Bid Total:</b>							<b>\$73,342.50</b>		<b>\$74,142.60</b>





Municipal Boundary



Addresses



Parcels Boundaries

Address Labels



Common Areas

Parcel Acreage



City of Watertown Geographic Information System







Scale: 1:622 Printed on: January  
 SCALE BAR = 1" Author:

DISCLAIMER: This map is not a substitute for an actual field survey or onsite investigation. The accuracy of this map is limited to the quality of the records from which it was assembled. Other inherent inaccuracies occur during the compilation process. City of Watertown makes no warranty whatsoever concerning this information.

Dodge Street-S First St to S Third St

Section 4, Item F.



	Municipal Boundary		Addresses
	Parcels Boundaries		Address Labels
	Common Areas		Parcel Acreage



**THE CITY OF WATERTOWN**  
Opportunity runs through it.

*City of Watertown Geographic Information System*







Scale: 1:923      Printed on: January  
SCALE BAR = 1"      Author:

DISCLAIMER: This map is not a substitute for an actual field survey or onsite investigation. The accuracy of this map is limited to the quality of the records from which it was assembled. Other inexactnesses occur during the compilation process. City of Watertown makes no warranty whatsoever concerning this information.

32



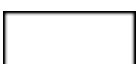

	Municipal Boundary		Addresses
	Parcels Boundaries		Address Labels
	Common Areas		Parcel Acreage



**THE CITY OF WATERTOWN**  
Opportunity runs through it.





*City of Watertown Geographic Information System*

Scale: 1:1,539      Printed on: January 31, 2017  
SCALE BAR = 1"      Author: [Redacted]

DISCLAIMER: This map is not a substitute for an actual field survey or onsite investigation. The accuracy of this map is limited to the quality of the records from which it was assembled. Other ineluctable inaccuracies occur during the compilation process. City of Watertown makes no warranty whatsoever concerning this information.

Section 4, Item F.



	Municipal Boundary		Addresses
	Parcels Boundaries		Address Labels
	Common Areas		Parcel Acreage



**THE CITY OF WATERTOWN**  
Opportunity runs through it.

*City of Watertown Geographic Information System*

Scale: 1:1,539      Printed on: January  
SCALE BAR = 1"      Author:





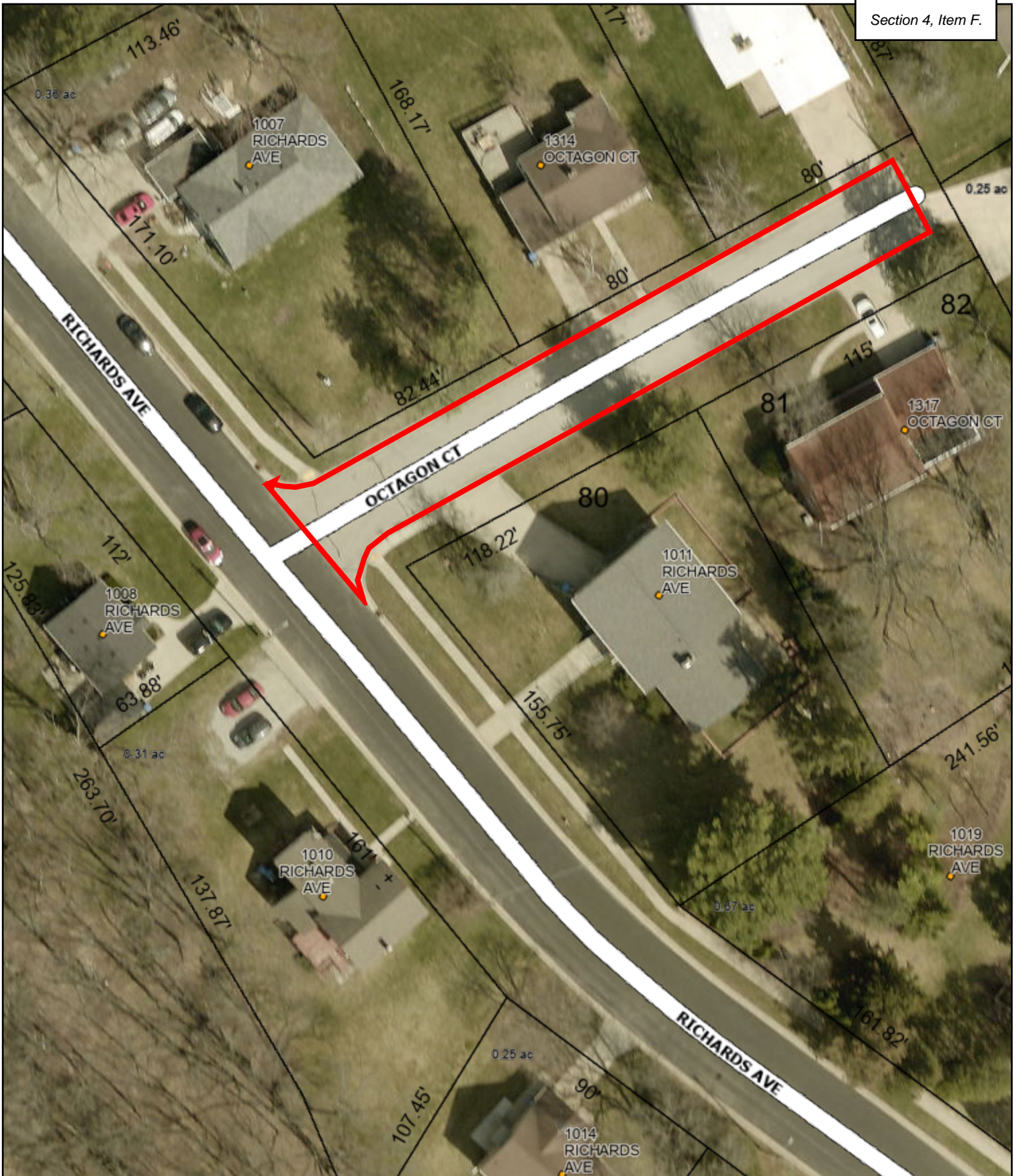

35

DISCLAIMER: This map is not a substitute for an actual field survey or onsite investigation. The accuracy of this map is limited to the quality of the records from which it was assembled. Other inherent inaccuracies occur during the compilation process. City of Watertown makes no warranty whatsoever concerning this information.

Octagon Court-Richards Ave to Termini

Section 4, Item F.



	Municipal Boundary		Addresses
	Parcels Boundaries		Address Labels
	Common Areas		Parcel Acreage



**THE CITY OF WATERTOWN**  
Opportunity runs through it.





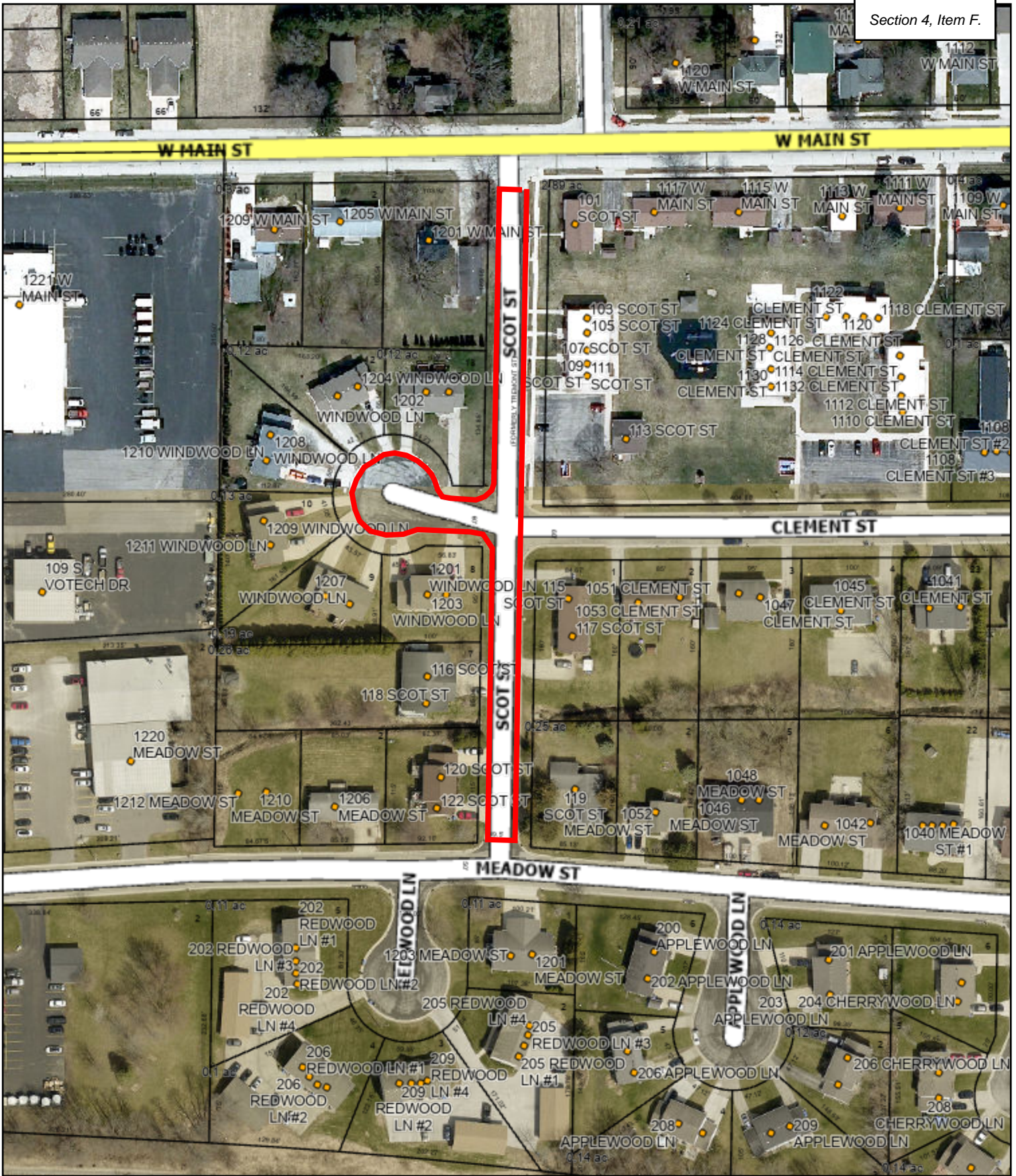

*City of Watertown Geographic Information System*

Scale: 1:554      Printed on: January  
SCALE BAR = 1"      Author:

DISCLAIMER: This map is not a substitute for an actual field survey or onsite investigation. The accuracy of this map is limited to the quality of the records from which it was assembled. Other inherent inaccuracies occur during the compilation process. City of Watertown makes no warranty whatsoever concerning this information.

36

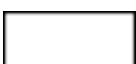

	Municipal Boundary		Addresses
	Parcels Boundaries		Address Labels
	Common Areas		Parcel Acreage







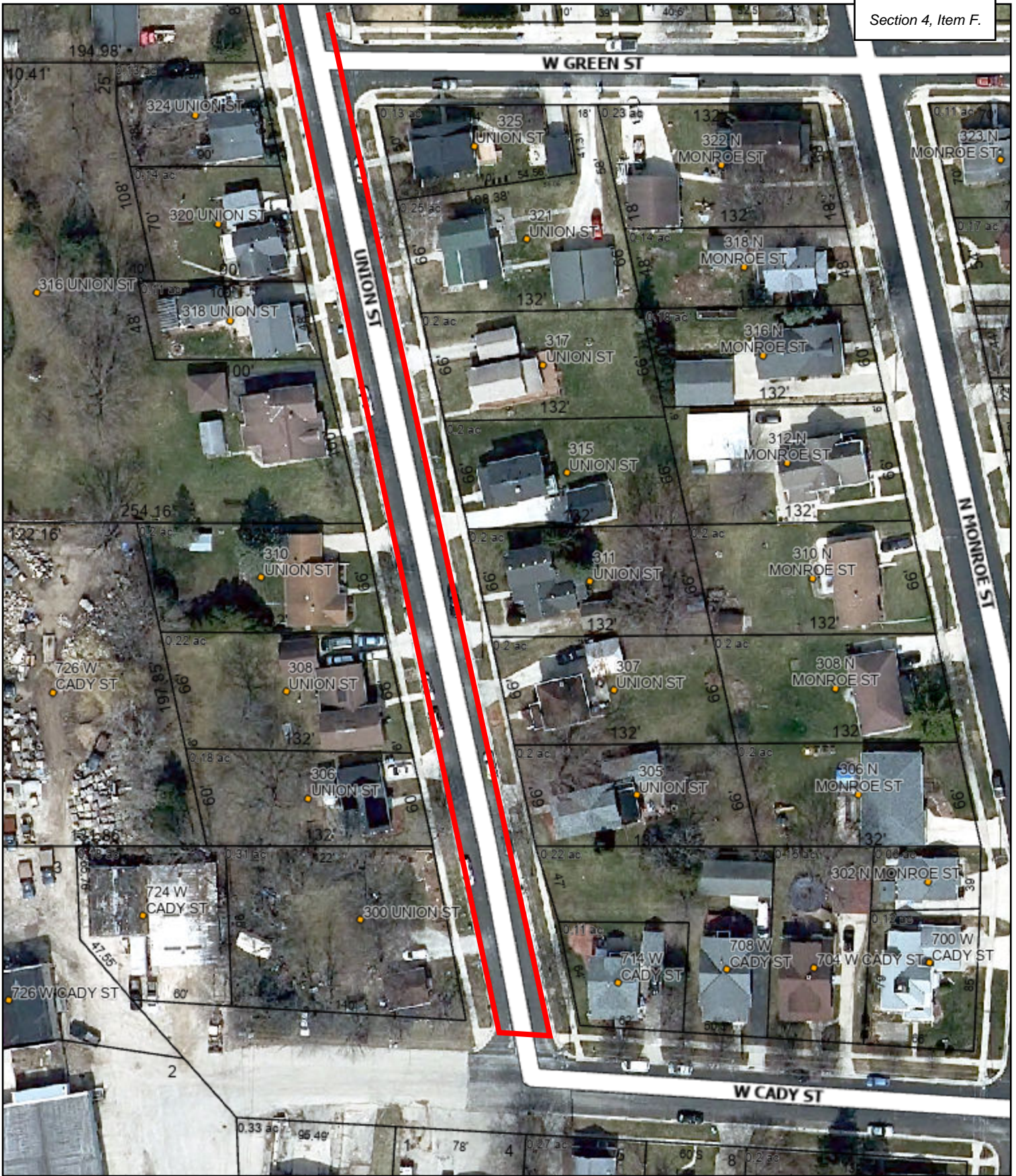

**THE CITY OF WATERTOWN**  
Opportunity runs through it.

*City of Watertown Geographic Information System*

Scale: 1:1,539      Printed on: January 31, 2023  
SCALE BAR = 1"      Author: [Redacted]

DISCLAIMER: This map is not a substitute for an actual field survey or onsite investigation. The accuracy of this map is limited to the quality of the records from which it was assembled. Other inherent inaccuracies occur during the compilation process. City of Watertown makes no warranty whatsoever concerning this information.



	Municipal Boundary		Addresses
	Parcels Boundaries		Address Labels
	Common Areas		Parcel Acreage



**THE CITY OF**  
**WATERTOWN**  
*Opportunity runs through it.*





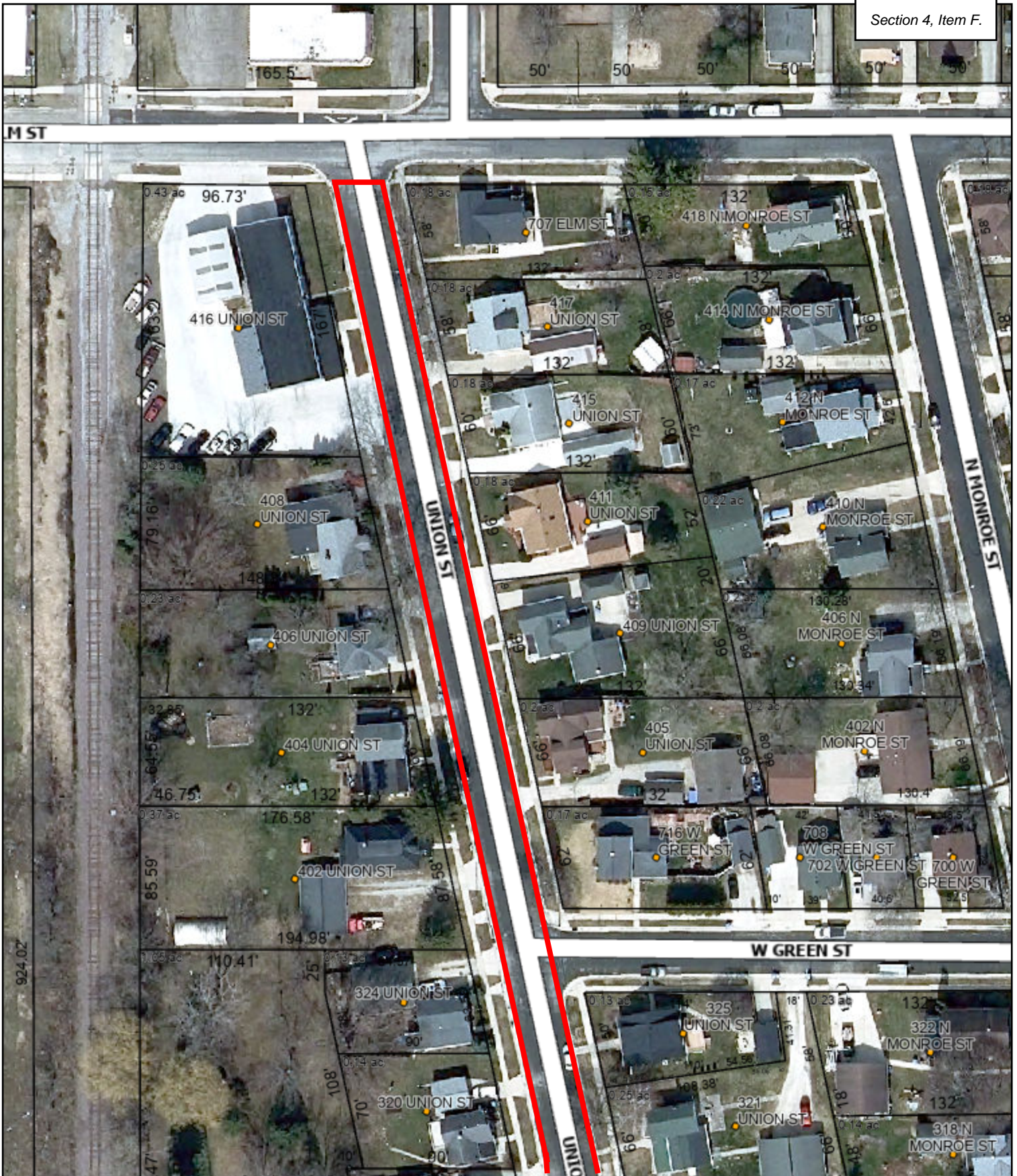

**City of Watertown Geographic Information System**

Scale: 1:923      Printed on: January  
SCALE BAR = 1"      Author:

DISCLAIMER: This map is not a substitute for an actual field survey or onsite investigation. The accuracy of this map is limited to the quality of the records from which it was assembled. Other inexactitudes occur during the compilation process. City of Watertown makes no warranty whatsoever concerning this information.

38



	Municipal Boundary		Addresses
	Parcels Boundaries		Address Labels
	Common Areas		Parcel Acreage



**THE CITY OF**  
**WATERTOWN**  
*Opportunity runs through it.*





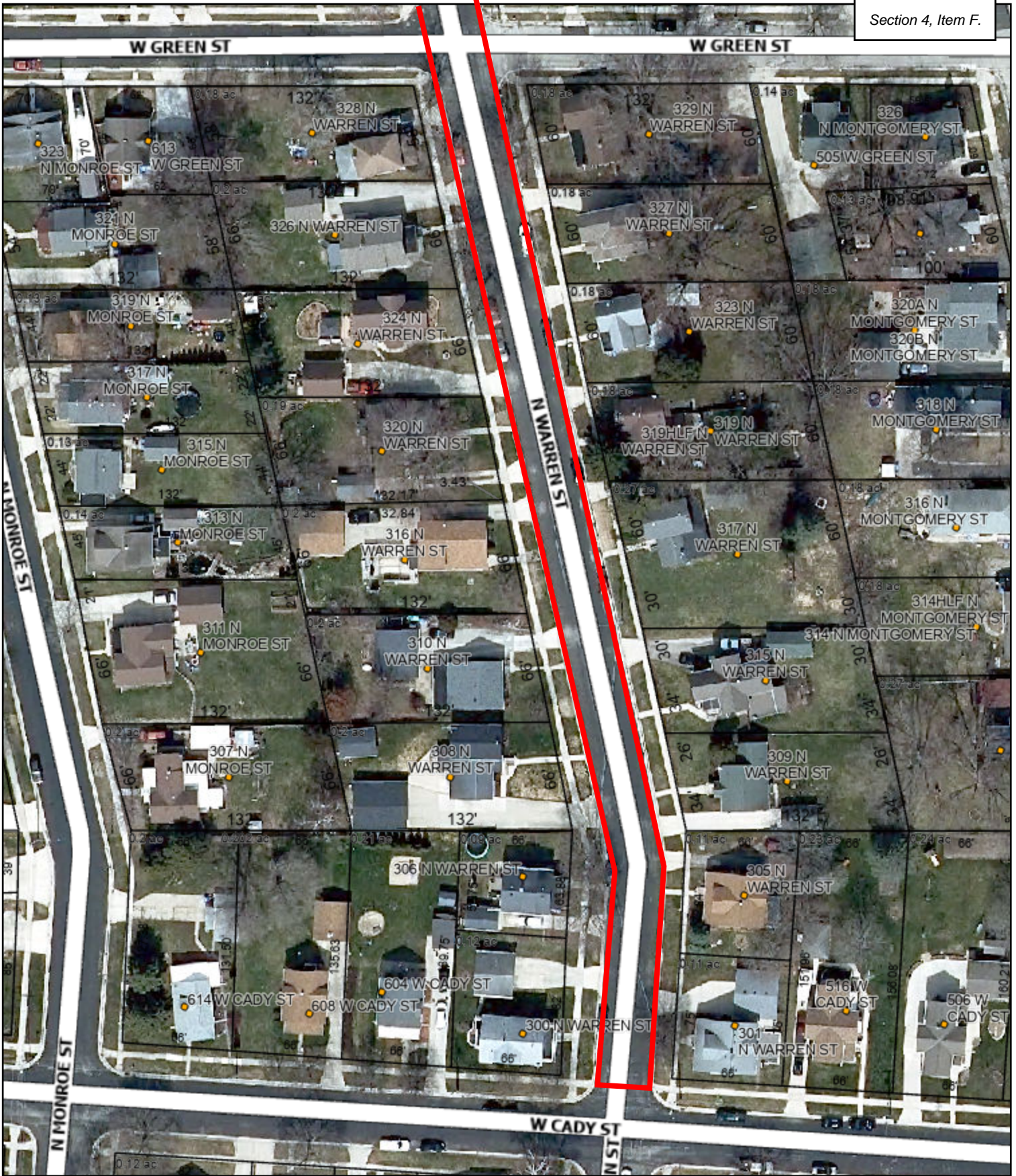

**City of Watertown Geographic Information System**

Scale: 1:923      Printed on: January  
SCALE BAR = 1"      Author:

DISCLAIMER: This map is not a substitute for an actual field survey or onsite investigation. The accuracy of this map is limited to the quality of the records from which it was assembled. Other inherent inaccuracies occur during the compilation process. City of Watertown makes no warranty whatsoever concerning this information.

39

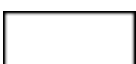

	Municipal Boundary		Addresses
	Parcels Boundaries		Address Labels
	Common Areas		Parcel Acreage



**THE CITY OF WATERTOWN**  
Opportunity runs through it.





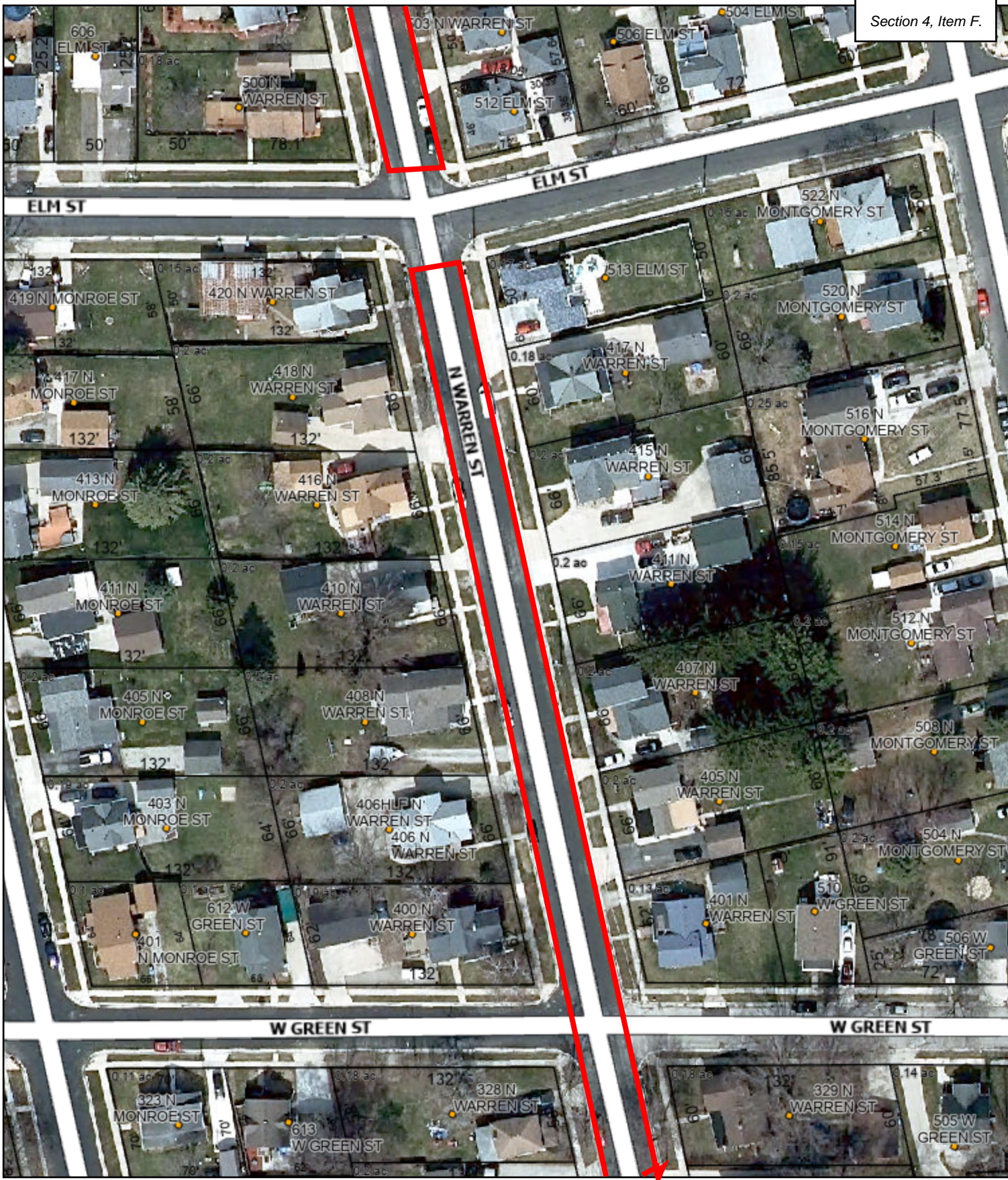

*City of Watertown Geographic Information System*

Scale: 1:923      Printed on: January  
SCALE BAR = 1"      Author: 40

DISCLAIMER: This map is not a substitute for an actual field survey or onsite investigation. The accuracy of this map is limited to the quality of the records from which it was assembled. Other interested inaccuracies occur during the compilation process. City of Watertown makes no warranty whatsoever concerning this information.

Section 4, Item F.



	Municipal Boundary		Addresses
	Parcels Boundaries		Address Labels
	Common Areas		Parcel Acreage



**THE CITY OF WATERTOWN**  
Opportunity runs through it.

*City of Watertown Geographic Information System*







Scale: 1:923      Printed on: January  
SCALE BAR = 1"      Author:

DISCLAIMER: This map is not a substitute for an actual field survey or onsite investigation. The accuracy of this map is limited to the quality of the records from which it was assembled. Other inherent inaccuracies occur during the compilation process. City of Watertown makes no warranty whatsoever concerning this information.

41

Section 4, Item F.

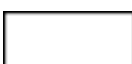

	Municipal Boundary		Addresses
	Parcels Boundaries		Address Labels
	Common Areas		Parcel Acreage



**THE CITY OF WATERTOWN**  
Opportunity runs through it.

*City of Watertown Geographic Information System*

Scale: 1:923      Printed on: January  
SCALE BAR = 1"      Author:







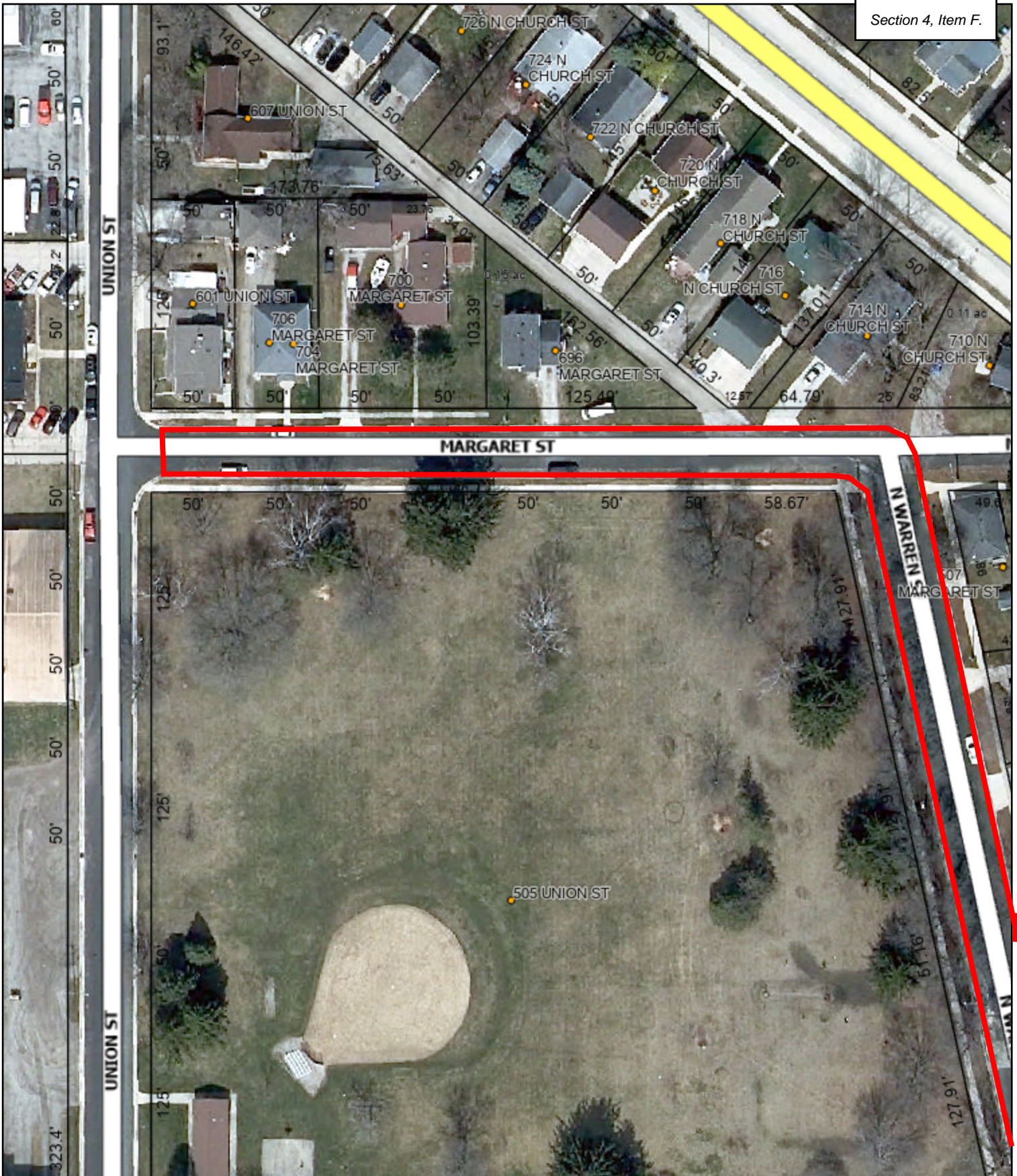

42

DISCLAIMER: This map is not a substitute for an actual field survey or onsite investigation. The accuracy of this map is limited to the quality of the records from which it was assembled. Other interested inaccuracies occur during the compilation process. City of Watertown makes no warranty whatsoever concerning this information.

Section 4, Item F.

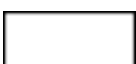

	Municipal Boundary		Addresses
	Parcels Boundaries		Address Labels
	Common Areas		Parcel Acreage







**THE CITY OF WATERTOWN**  
Opportunity runs through it.

*City of Watertown Geographic Information System*

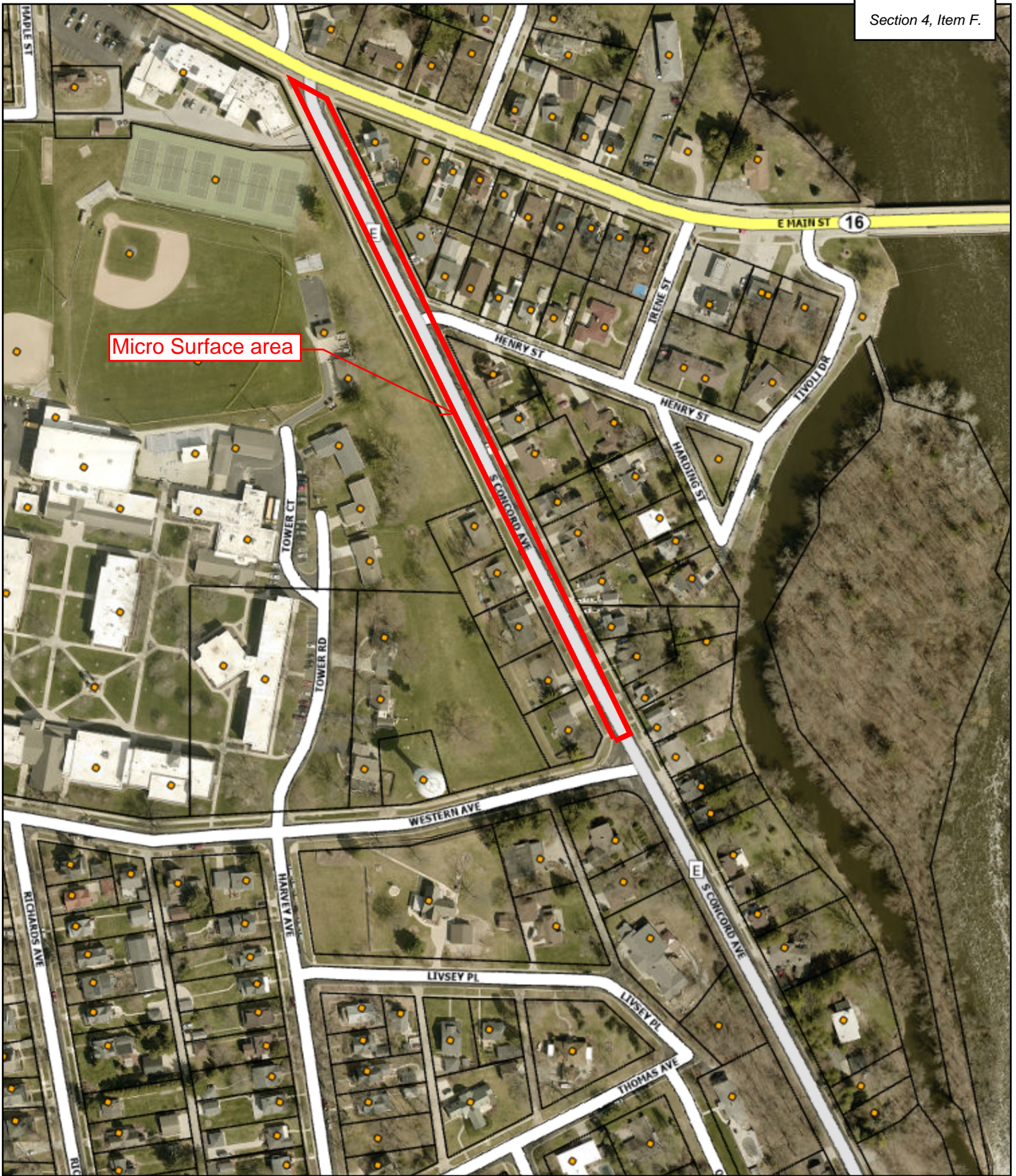
Scale: 1:923      Printed on: January  
SCALE BAR = 1"      Author: 43

DISCLAIMER: This map is not a substitute for an actual field survey or onsite investigation. The accuracy of this map is limited to the quality of the records from which it was assembled. Other inherent inaccuracies occur during the compilation process. City of Watertown makes no warranty whatsoever concerning this information.



	Municipal Boundary		Common Areas
	Parcels Boundaries		Addresses



**THE CITY OF WATERTOWN**  
Opportunity runs through it.

*City of Watertown Geographic Information System*

Scale: 1:2,565      Printed on: January  
SCALE BAR = 1"      Author:

DISCLAIMER: This map is not a substitute for an actual field survey or onsite investigation. The accuracy of this map is limited to the quality of the records from which it was assembled. Other inherent inaccuracies occur during the compilation process. City of Watertown makes no warranty whatsoever concerning this information.

44



Andrew Beyer, P.E.  
920.262.4050

Maureen McBroom, ENV SP  
920.206-4264

Nathan Williams  
920-262-4052

Ritchie Section 4, Item G.  
920.262.4034

Christopher Newberry  
920-390-

Administrative Assistant  
Wanda Fredrick 920.262.4060

## MEMO

TO: Chairperson Arnett and Commission Members  
FROM: Andrew M. Beyer, P.E.  
DATE: February 19, 2026  
RE: Public Works Commission Meeting of February 24, 2026

Review and take possible action: Award 2026 Annual Street and Utility Project Contract #4-26 Base Bids A & B, and Alternate Bids 1, 2, & 5 to Forest Landscaping & Construction, Inc. for \$822,963.00

### Background

The Engineering Division publicly opened bids for the 2026 Annual Street and Utility Reconstruction Project Contract on February 12, 2026. Bid work includes water main reconstruction, sanitary sewer spot repairs, storm sewer construction, and street & sidewalk reconstruction in the 2026 Annual Street and Utility Program area. One bid was received. The Engineering Division is recommending awarding the following Base Bids and Alternate Bids to the sole bidder, Forest Landscaping & Construction, Inc.:

Base Bid A: Market St. and S. Eighth St. Reconstruction - \$480,620.00  
Base Bid B: Willman Court Reconstruction - \$180,035.00  
Alternate Bid 1: Market St. and S. Eighth St. Restoration - \$2,640.00  
Alternate Bid 2: Willman Court Restoration - \$3,512.00  
~~Alternate Bid 3: Kathryn Court Reconstruction - \$87,845.00~~  
~~Alternate Bid 4: Kathryn Court Restoration - \$16,020.00~~  
Alternate Bid 5: S. Fifth St. Extension - \$156,156.00

Total cost to perform the proposed work is \$822,963.00 from funding account #05-58-11-69, Annual Street Reserve \$114,498.00; account #16-58-16-60, Storm Water Utility Capital Outlay \$186,900.00; account #03-99-99-99, Water Utility Capital Outlay \$357,845.00; account #02-97-30-11, Wastewater Utility Sewer Rehabilitation \$9,900.00; and TID 7 \$103,520.00.

Attached is the bid tab. Work being awarded is within approved 2026 budgets.

Enclosed:

Bid Tab



**Annual Street & Utility Reconstruction (#10022406)**  
**Owner: City of Watertown**  
**Solicitor: Watertown WI, City of**  
**02/12/2026 01:00 PM CST**

						Forest Landscaping & Construction, Inc	
Section Title	Line Item	Item Code	Item Description	UofM	Quantity	Unit Price	Extension
Street Reconstruction Program Base Bid A: Market Street and S. Eighth Street							<b>\$480,620.00</b>
	1A	1A	Mobilization, Bonds, and Insurance	L.S.	1	\$20,000.00	\$20,000.00
	2A	2A	Storm Structure Removal	Ea.	12	\$500.00	\$6,000.00
	3A	3A	Storm Sewer Removal	L.F.	620	\$25.00	\$15,500.00
	4A	4A	Sanitary Manhole Rim Adjustment	Ea.	3	\$500.00	\$1,500.00
	5A	5A	Market Street Sanitary Manhole (at S. Eighth Street)	Ea.	1	\$7,500.00	\$7,500.00
	6A	6A	Existing Hydrant Assembly Removal	Ea.	2	\$1,500.00	\$3,000.00
	7A	7A	Abandon Existing Water Main Valve	Ea.	2	\$750.00	\$1,500.00
	8A	8A	Connection to Existing Water Main	Ea.	5	\$5,000.00	\$25,000.00
	9A	9A	Water Main, 6-Inch w/Granular Backfill	L.F.	50	\$155.00	\$7,750.00
	10A	10A	Water Main, 8-Inch w/Granular Backfill	L.F.	725	\$140.00	\$101,500.00
	11A	11A	Hydrant Lead, 6-Inch w/Granular Backfill	L.F.	22	\$155.00	\$3,410.00
	12A	12A	Hydrant Assembly	Ea.	2	\$9,800.00	\$19,600.00
	13A	13A	Water Main Valves, 6-Inch Gate Valve	Ea.	2	\$4,400.00	\$8,800.00
	14A	14A	Water Main Valves, 8-Inch Gate Valve	Ea.	7	\$5,000.00	\$35,000.00
	15A	15A	Water Service, 1-Inch w/ Granular Backfill	L.F.	125	\$110.00	\$13,750.00
	16A	16A	1-Inch Tap, Saddle and Corporation Valve with Box	Ea.	4	\$1,000.00	\$4,000.00
	17A	17A	Insulate Water Main Pipeline	L.F.	60	\$16.00	\$960.00
	18A	18A	Storm Sewer, 12-Inch RCP CL V w/ Granular Backfill	L.F.	205	\$95.00	\$19,475.00

	19A	19A	Storm Sewer, 18-Inch RCP CL V w/ Granular Backfill	L.F.	45	\$105.00	\$4,725.00
	20A	20A	Storm Sewer, 24-Inch RCP CL V w/ Granular Backfill	L.F.	440	\$130.00	\$57,200.00
	21A	21A	Storm Manhole, 60-inch	Ea.	5	\$7,000.00	\$35,000.00
	22A	22A	2'x3' Catch Basin	Ea.	8	\$3,000.00	\$24,000.00
	23A	23A	4' DIA Catch Basin	Ea.	5	\$5,000.00	\$25,000.00
	24A	24A	Concrete Curb and Gutter, 30-Inch (Vertical)	L.F.	565	\$21.00	\$11,865.00
	25A	25A	Concrete Curb and Gutter, 30-Inch (Flush)	L.F.	280	\$21.00	\$5,880.00
	26A	26A	Concrete Driveway Approach, 6- Inch Thick	S.Y.	5	\$70.00	\$350.00
	27A	27A	Concrete Driveway Approach, 7- Inch Thick	S.Y.	65	\$75.00	\$4,875.00
	28A	28A	Concrete Sidewalk, 4-Inch Thick	S.F.	800	\$6.00	\$4,800.00
	29A	29A	Concrete Sidewalk, 5-Inch Thick	S.F.	1000	\$7.00	\$7,000.00
	30A	30A	Concrete Sidewalk, 6-Inch Thick	S.F.	110	\$8.00	\$880.00
	31A	31A	Detectable Warning Fields	S.F.	96	\$50.00	\$4,800.00
Street Reconstruction Program Base Bid B: Willman Court							<b>\$180,035.00</b>
	1B	1B	Mobilization, Bonds, and Insurance	L.S.	1	\$19,000.00	\$19,000.00
	2B	2B	Temporary Mailboxes	L.S.	1	\$850.00	\$850.00
	3B	3B	Sanitary Manhole Rim Adjustment	Ea.	1	\$500.00	\$500.00
	4B	4B	Existing Hydrant Assembly Removal	Ea.	1	\$750.00	\$750.00
	5B	5B	Abandon Existing Water Main Valve	Ea.	1	\$1,200.00	\$1,200.00
	6B	6B	Connection to Existing Water Main	Ea.	2	\$6,500.00	\$13,000.00
	7B	7B	Water Main, 8-Inch w/Granular Backfill	L.F.	290	\$150.00	\$43,500.00
	8B	8B	Water Main, 10-Inch w/Granular Backfill	L.F.	15	\$175.00	\$2,625.00
	9B	9B	Water Main, 12-Inch w/Granular Backfill	L.F.	30	\$185.00	\$5,550.00
	10B	10B	Hydrant Lead, 6-Inch w/Granular Backfill	L.F.	10	\$165.00	\$1,650.00

	11B	11B	Hydrant Assembly	Ea.	1	\$9,800.00	\$9,800.00
	12B	12B	Water Main Valves, 6-Inch Gate Valve	Ea.	2	\$4,400.00	\$8,800.00
	13B	13B	Water Main Valves, 8-Inch Gate Valve	Ea.	1	\$5,000.00	\$5,000.00
	14B	14B	Water Main Valves, 12-Inch Gate Valve	Ea.	1	\$6,500.00	\$6,500.00
	15B	15B	Water Service, 1-Inch w/ Granular Backfill	L.F.	280	\$100.00	\$28,000.00
	16B	16B	1-Inch Tap, Saddle and Corporation Valve with Box	Ea.	7	\$1,000.00	\$7,000.00
	17B	17B	Insulate Water Main Pipeline	L.F.	10	\$20.00	\$200.00
	18B	18B	Concrete Curb and Gutter, 30-Inch (Vertical)	L.F.	500	\$22.00	\$11,000.00
	19B	19B	Concrete Curb and Gutter, 30-Inch (Flush)	L.F.	150	\$22.00	\$3,300.00
	20B	20B	Concrete Driveway Approach, 6-Inch Thick	S.Y.	135	\$70.00	\$9,450.00
	21B	21B	Concrete Sidewalk, 4-Inch Thick	S.F.	40	\$7.00	\$280.00
	22B	22B	Concrete Sidewalk, 5-Inch Thick	S.F.	110	\$8.00	\$880.00
	23B	23B	Detectable Warning Fields	S.F.	24	\$50.00	\$1,200.00
Street Reconstruction Program Alternate Bid 1: Market Street and S. Eighth Street							<b>\$2,640.00</b>
	1C	1C	Imported Topsoil, Seed, Fertilizer and Erosion Matting (Class 1 Type A)	S.F.	330	\$8.00	\$2,640.00
Street Reconstruction Program Alternate Bid 2: Willman Court							<b>\$3,512.00</b>
	1D	1D	Imported Topsoil, Seed, Fertilizer and Erosion Matting (Class 1 Type A)	S.F.	439	\$8.00	\$3,512.00
Street Reconstruction Program Alternate Bid 3: Kathryn Court							<b>\$87,845.00</b>
	1E	1E	Mobilization, Bonds, and Insurance	L.S.	1	\$3,000.00	\$3,000.00
	2E	2E	Temporary Mailboxes	L.S.	1	\$1,000.00	\$1,000.00
	3E	3E	Sanitary Manhole Rim Adjustment	Ea.	2	\$700.00	\$1,400.00
	4E	4E	2'x3' Catch Basin	Ea.	3	\$4,000.00	\$12,000.00

	5E	5E	Storm Sewer, 12-Inch HDPE w/ Granular Backfill	L.F.	260	\$95.00	\$24,700.00
	6E	6E	Mini Storm System, 6-Inch Schedule 40 PVC	L.F.	240	\$50.00	\$12,000.00
	7E	7E	Mini Storm System, 6x6-Inch Schedule 40 PVC Wye	Ea.	2	\$300.00	\$600.00
	8E	8E	Concrete Curb and Gutter, 30-Inch (Vertical)	L.F.	1000	\$22.00	\$22,000.00
	9E	9E	Concrete Driveway Approach, 6- Inch Thick	S.Y.	87	\$75.00	\$6,525.00
	10E	10E	Concrete Sidewalk, 4-Inch Thick	S.F.	660	\$7.00	\$4,620.00
Street Reconstruction Program Alternate Bid 4: Kathryn Court							<b>\$16,020.00</b>
	1F	1F	Imported Topsoil, Seed, Fertilizer and Erosion Matting (Class 1 Type	S.Y.	890	\$18.00	\$16,020.00
Street Reconstruction Program Alternate Bid 5: S. Fifth Street							<b>\$156,156.00</b>
	1G	1G	Mobilization, Bonds, and Insurance	L.S.	1	\$3,000.00	\$3,000.00
	2G	2G	Connection to Existing Water Main	Ea.	1	\$5,000.00	\$5,000.00
	3G	3G	Water Main, 8-Inch w/Granular Backfill	L.F.	322.75	\$140.00	\$45,185.00
	4G	4G	Hydrant Lead, 6-Inch w/Granular Backfill	L.F.	8	\$165.00	\$1,320.00
	5G	5G	Hydrant Assembly	Ea.	1	\$9,000.00	\$9,000.00
	6G	6G	Water Main Valves, 6-Inch Gate Valve	Ea.	2	\$4,400.00	\$8,800.00
	7G	7G	Water Main Valves, 8-Inch Gate Valve	Ea.	1	\$5,000.00	\$5,000.00
	8G	8G	Water Service, 1-Inch w/ Granular Backfill	L.F.	49	\$100.00	\$4,900.00
	9G	9G	1-Inch Tap, Saddle and Corporation Valve with Box	Ea.	2	\$1,200.00	\$2,400.00
	10G	10G	Insulate Water Main Pipeline	L.F.	10	\$20.00	\$200.00
	11G	11G	Connection to Existing Sanitary Sewer Main	Ea.	1	\$7,500.00	\$7,500.00
	12G	12G	Sanitary Sewer Main, 8-Inch w/Granular Backfill	L.F.	94	\$130.00	\$12,220.00
	13G	13G	Sanitary Sewer Lateral, 4-Inch w/ Granular Backfill	L.F.	8	\$200.00	\$1,600.00
	14G	14G	Sanitary Sewer Manhole, including outside drop and connection to existing private lateral, complete	Ea.	1	\$11,800.00	\$11,800.00

	15G	15G	Connection to Existing Storm Sewer Main	Ea.	1	\$1,500.00	\$1,500.00
	16G	16G	Storm Sewer, 12-Inch HDPE w/ Granular Backfill	L.F.	32	\$100.00	\$3,200.00
	17G	17G	Storm Manhole, 48-inch	Ea.	1	\$5,000.00	\$5,000.00
	18G	18G	2'x3' Catch Basin	Ea.	4	\$4,000.00	\$16,000.00
	19G	19G	Concrete Curb and Gutter, 30-Inch (Vertical)	L.F.	70	\$25.00	\$1,750.00
	20G	20G	Concrete Curb and Gutter, 30-Inch (Flush)	L.F.	200	\$25.00	\$5,000.00
	21G	21G	Concrete Driveway Approach, 6-Inch Thick	S.Y.	12.3	\$70.00	\$861.00
	22G	22G	Concrete Driveway Approach, 7-Inch Thick	S.Y.	65.6	\$75.00	\$4,920.00
<b>Base Bid Total:</b>							<b>\$926,828.00</b>



Andrew Beyer, P.E.  
920.262.4050  
Maureen McBroom, ENV SP  
920.206-4264  
Nathan Williams  
920-262-4052

Ritchie  
920.262.4034  
Christopher Newberry  
920-390-  
Administrative Assistant  
Wanda Fredrick 920.262.4060

Section 4, Item H.

MEMO

TO: Chairperson Arnett and Commission Members  
FROM: Andrew M. Beyer, P.E.  
DATE: February 19, 2026  
RE: Public Works Commission Meeting of February 24, 2026

Review and take possible action: Award Storm Sewer Cleaning & Televising Contract #5-26 Base Bid A, and Alternate Bids 1, 2, & 3 to Green Bay Pipe & TV, LLC for \$129,288.53

Background

The Engineering Division publicly opened bids for the 2026 Storm Sewer Cleaning and Televising contract on February 12, 2026. Five bids were received. The Engineering Division is recommending awarding the following Base Bid and Alternate Bids to the low bidder, Green Bay Pipe & TV, LLC:

Base Bid A: 2026 Stormwater Cleaning and Televising: \$105,774.49

Alternate Bid 1: 2026 Storm Pipe Deep Cleaning: \$11,850.00

Alternate Bid 2: S. Washington St.: \$213.63

Alternate Bid 3: Ninth St. to Bridge, along E. Main St.: \$11,450.41

Total cost to perform the proposed work is \$129,288.53 from funding account #16-58-16-43 Storm Water Utility MS4 Maintenance. \$160,000 was allotted to storm sewer cleaning and televising of the \$220,000 total budgeted amount in account #16-58-16-43, MS4 Maintenance.

Attached is the bid tab. Work being awarded is within the approved 2026 budget.

Enclosed:

- Bid Tab



**Storm Sewer Cleaning and Televising (#9980155)**  
**Owner: City of Watertown**  
**Solicitor: Watertown WI, City of**  
**02/12/2026 11:00 AM CST**

Section Title	Line Item	Item Code	Item Description	UofM	Quantity	Green Bay Pipe & TV, LLC		Visu-Sewer		AQUALIS		Insituform Technologies USA, LLC		National Power Rodding Corp	
						Unit Price	Extension	Unit Price	Extension	Unit Price	Extension	Unit Price	Extension	Unit Price	Extension
Base Bid A: 2026 Stormwater Cleaning and Televising							<b>\$105,774.49</b>		<b>\$163,734.69</b>		<b>\$214,753.97</b>		<b>\$309,071.73</b>		<b>\$418,077.00</b>
	1A	1A	Clean Manholes	EA	145	\$69.00	\$10,005.00	\$10.00	\$1,450.00	\$107.85	\$15,638.25	\$243.41	\$35,294.45	\$200.00	\$29,000.00
	2A	2A	Clean Inlets	EA	117	\$69.00	\$8,073.00	\$10.00	\$1,170.00	\$107.85	\$12,618.45	\$243.41	\$28,478.97	\$250.00	\$29,250.00
	3A	3A	Clean Catch Basins	EA	221	\$95.00	\$20,995.00	\$102.50	\$22,652.50	\$107.85	\$23,834.85	\$243.41	\$53,793.61	\$400.00	\$88,400.00
	4A	4A	Clean Outfalls	EA	26	\$650.00	\$16,900.00	\$200.00	\$5,200.00	\$107.85	\$2,804.10	\$486.51	\$12,649.26	\$3,500.00	\$91,000.00
	5A	5A	Clean & Televis 4-Inch PVC	LF	28.1	\$1.25	\$35.13	\$7.50	\$210.75	\$4.43	\$124.48	\$17.61	\$494.84	\$5.00	\$140.50
	6A	6A	Clean & Televis 6-Inch PVC	LF	156.5	\$1.25	\$195.63	\$3.69	\$577.49	\$4.43	\$693.30	\$3.41	\$533.67	\$5.00	\$782.50
	7A	7A	Clean & Televis 8-Inch PVC	LF	503.3	\$1.25	\$629.13	\$3.69	\$1,857.18	\$4.43	\$2,229.62	\$2.72	\$1,368.98	\$5.00	\$2,516.50
	8A	8A	Clean & Televis 10-Inch PVC	LF	1227.2	\$1.30	\$1,595.36	\$3.69	\$4,528.37	\$4.43	\$5,436.50	\$2.74	\$3,362.53	\$5.00	\$6,136.00
	10A	10A	Clean & Televis, 12-Inch PVC	LF	774.3	\$1.25	\$967.88	\$3.69	\$2,857.17	\$4.43	\$3,430.15	\$2.74	\$2,121.58	\$5.00	\$3,871.50
	11A	11A	Clean & Televis, 18-Inch PVC	LF	21.1	\$1.35	\$28.49	\$3.69	\$77.86	\$4.43	\$93.47	\$23.36	\$492.90	\$5.00	\$105.50
	12A	12A	Clean & Televis, 12-Inch HDPE	LF	122	\$1.25	\$152.50	\$3.69	\$450.18	\$4.43	\$540.46	\$4.30	\$524.60	\$5.00	\$610.00
	13A	13A	Clean & Televis, 15-Inch HDPE	LF	625.3	\$1.85	\$1,156.81	\$3.69	\$2,307.36	\$4.43	\$2,770.08	\$2.64	\$1,650.79	\$5.00	\$3,126.50
	14A	14A	Clean & Televis, 12-Inch RCP	LF	15875	\$1.35	\$21,431.25	\$3.69	\$58,578.75	\$4.43	\$70,326.25	\$5.17	\$82,073.75	\$5.00	\$79,375.00
	15A	15A	Clean & Televis, 15-Inch RCP	LF	9361.2	\$1.40	\$13,105.68	\$3.69	\$34,542.83	\$4.43	\$41,470.12	\$5.17	\$48,397.40	\$5.00	\$46,806.00
	16A	16A	Clean & Televis, 18-Inch RCP	LF	3523.5	\$1.40	\$4,932.90	\$3.69	\$13,001.72	\$4.43	\$15,609.11	\$5.17	\$18,216.50	\$5.00	\$17,617.50
	17A	17A	Clean & Televis, 21-Inch RCP	LF	132.2	\$1.44	\$190.37	\$3.69	\$487.82	\$4.43	\$585.65	\$5.17	\$683.47	\$5.00	\$661.00
	18A	18A	Clean & Televis, 24-Inch RCP	LF	3457.8	\$1.44	\$4,979.23	\$3.69	\$12,759.28	\$4.43	\$15,318.05	\$5.17	\$17,876.83	\$5.00	\$17,289.00
	19A	19A	Clean & Televis, 36-Inch RCP	LF	179.1	\$1.44	\$257.90	\$3.69	\$660.88	\$4.43	\$793.41	\$3.02	\$540.88	\$5.00	\$895.50
	20A	20A	Clean & Televis, 38x24-Inch HERCP	LF	98.8	\$1.45	\$143.26	\$3.69	\$364.57	\$4.43	\$437.68	\$5.23	\$516.72	\$5.00	\$494.00
Alternate Bid 1: 2026 Storm Pipe Deep Cleaning							<b>\$11,850.00</b>		<b>\$14,925.00</b>		<b>\$35,256.00</b>		<b>\$13,353.00</b>		<b>\$45,000.00</b>
	1B	1B	Deep Clean, 8-Inch Pipe	LF	300	\$3.00	\$900.00	\$2.25	\$675.00	\$14.69	\$4,407.00	\$5.02	\$1,506.00	\$10.00	\$3,000.00
	2B	2B	Deep Clean, 12-Inch Pipe	LF	300	\$3.00	\$900.00	\$2.35	\$705.00	\$14.69	\$4,407.00	\$5.02	\$1,506.00	\$10.00	\$3,000.00
	3B	3B	Deep Clean, 15-Inch Pipe	LF	300	\$4.50	\$1,350.00	\$3.90	\$1,170.00	\$14.69	\$4,407.00	\$5.02	\$1,506.00	\$10.00	\$3,000.00
	4B	4B	Deep Clean, 18-Inch Pipe	LF	300	\$4.50	\$1,350.00	\$4.10	\$1,230.00	\$14.69	\$4,407.00	\$5.02	\$1,506.00	\$10.00	\$3,000.00
	5B	5B	Deep Clean, 21-Inch Pipe	LF	300	\$4.50	\$1,350.00	\$5.90	\$1,770.00	\$14.69	\$4,407.00	\$5.57	\$1,671.00	\$10.00	\$3,000.00
	6B	6B	Deep Clean, 24-Inch Pipe	LF	300	\$6.00	\$1,800.00	\$6.25	\$1,875.00	\$14.69	\$4,407.00	\$5.57	\$1,671.00	\$25.00	\$7,500.00
	7B	7B	Deep Clean, 42-Inch Pipe	LF	300	\$6.00	\$1,800.00	\$16.50	\$4,950.00	\$14.69	\$4,407.00	\$8.27	\$2,481.00	\$25.00	\$7,500.00
	8B	8B	Deep Clean, Arch CMP and HERCP	LF	300	\$8.00	\$2,400.00	\$8.50	\$2,550.00	\$14.69	\$4,407.00	\$5.02	\$1,506.00	\$50.00	\$15,000.00

Alternate Bid 2: 2026 South Washington St							<b>\$213.63</b>		<b>\$928.50</b>		<b>\$1,732.55</b>		<b>\$1,234.95</b>		<b>\$12,892.50</b>
	1C	1C	Clean Storm Drain Cleanout	EA	1	\$69.00	\$69.00	\$350.00	\$350.00	\$1,220.00	\$1,220.00	\$486.37	\$486.37	\$10,000.00	\$10,000.00
	2C	2C	Clean & Televis 6-Inch PVC	LF	115.7	\$1.25	\$144.63	\$5.00	\$578.50	\$4.43	\$512.55	\$6.47	\$748.58	\$25.00	\$2,892.50
Alternate Bid 3: 2026 Ninth St to Bridge							<b>\$11,450.41</b>		<b>\$16,867.63</b>		<b>\$41,726.45</b>		<b>\$34,546.06</b>		<b>\$52,732.00</b>
	1D	1D	Clean Manholes	EA	17	\$69.00	\$1,173.00	\$10.00	\$170.00	\$348.57	\$5,925.69	\$243.27	\$4,135.59	\$200.00	\$3,400.00
	2D	2D	Clean Inlets	EA	9	\$69.00	\$621.00	\$10.00	\$90.00	\$348.57	\$3,137.13	\$243.27	\$2,189.43	\$400.00	\$3,600.00
	3D	3D	Clean Catch Basins	EA	26	\$69.00	\$1,794.00	\$102.50	\$2,665.00	\$348.57	\$9,062.82	\$243.27	\$6,325.02	\$500.00	\$13,000.00
	4D	4D	Clean Outfalls	EA	3	\$650.00	\$1,950.00	\$200.00	\$600.00	\$348.57	\$1,045.71	\$243.27	\$729.81	\$5,000.00	\$15,000.00
	5D	5D	Clean & Televis 6-Inch PVC	LF	29.5	\$1.25	\$36.88	\$7.50	\$221.25	\$6.36	\$187.62	\$16.64	\$490.88	\$5.00	\$147.50
	6D	6D	Clean & Televis 8-Inch PVC	LF	11.8	\$1.25	\$14.75	\$7.50	\$88.50	\$6.36	\$75.05	\$41.37	\$488.17	\$5.00	\$59.00
	7D	7D	Clean & Televis, 12-Inch PVC	LF	26	\$1.25	\$32.50	\$7.50	\$195.00	\$6.36	\$165.36	\$18.87	\$490.62	\$5.00	\$130.00
	8D	8D	Clean & Televis, 12-Inch RCP	LF	2207.7	\$1.85	\$4,084.25	\$3.69	\$8,146.41	\$6.36	\$14,040.97	\$5.02	\$11,082.65	\$5.00	\$11,038.50
	9D	9D	Clean & Televis, 15-Inch RCP	LF	951.5	\$1.35	\$1,284.53	\$3.69	\$3,511.04	\$6.36	\$6,051.54	\$7.00	\$6,660.50	\$5.00	\$4,757.50
	10D	10D	Clean & Televis, 18-Inch RCP	LF	28.6	\$1.40	\$40.04	\$3.69	\$105.53	\$6.36	\$181.90	\$17.17	\$491.06	\$5.00	\$143.00
	11D	11D	Clean & Televis, 24-Inch RCP	LF	291.3	\$1.44	\$419.47	\$3.69	\$1,074.90	\$6.36	\$1,852.67	\$5.02	\$1,462.33	\$5.00	\$1,456.50
<b>Base Bid Total:</b>							<b>\$129,288.53</b>		<b>\$196,455.82</b>		<b>\$293,468.98</b>		<b>\$358,205.73</b>		<b>\$528,701.50</b>



Andrew Beyer, P.E.  
920.262.4050

Maureen McBroom, ENV SP  
920.206-4264

Nathan Williams  
920-262-4052

Ritchie M. Section 4, Item I.  
920.262.4034

Christopher Newberry  
920-390-

Administrative Assistant  
Wanda Fredrick 920.262.4060

## MEMO

TO: Chairperson Arnett and Commission Members  
FROM: Andrew M. Beyer, P.E.  
DATE: February 19, 2026  
RE: Public Works Commission Meeting of February 24, 2026

Review and take possible action: Award Bituminous Surfacing Contract #6-26 Base Bids A, B, C, D, E, F, G, & H, and Alternate Bids 1, 2, 3, 4, 5, & O to Wolf Paving Co., Inc. for \$1,141,831.95

### Background

The Engineering Division publicly opened bids for the 2026 Bituminous Surfacing contract on February 12, 2026. Three bids were received. The Engineering Division is recommending awarding the following Base Bids and Alternate Bids to the low bidder, Wolf Paving Co., Inc.:

Base Bid A: Misc. Pavement Patches: \$231,610.00

Base Bid B: Reconstruction Streets: Willman Ct., Market St., & S. Eighth St.: \$79,612.20

Base Bid C: Street Extension S. Fifth St.: \$31,249.20

Base Bid D: Wilbur St.: \$94,989.05

Base Bid E: Street Department Front Lot: \$57,636.00

Base Bid F: West St. Water Tower Lot: \$43,808.20

Base Bid G: Resurface and Overlay Bailey St.: \$44,873.00

Base Bid H: Mill & Overlay Market St.: \$73,721.00

Alternate Bid 1: Full-Depth Resurface Colonial Dr.: \$84,782.40

Alternate Bid 2: Wedge Mill & Overlay E. Main St.: \$62,085.90

Alternate Bid 3: Full-Depth Resurface Hospital Dr. & Meadowbrook Dr.: \$138,808.40

Alternate Bid 4: Full Depth Resurface River Dr.: \$125,345.40

Alternate Bid 5: Full Depth Resurface Endeavour Dr. Shared Use Path: \$52,954.20

~~Alternate Bid 6: Reconstruction Street: Kathryn Ct.: \$38,917.40~~

Alternate Bid O: Resurfacing Taxiway "C": \$20,357.00



Andrew Beyer, P.E.  
920.262.4050

Maureen McBroom, ENV SP  
920.206-4264

Nathan Williams  
920-262-4052

Ritchie M. Section 4, Item 1.  
920.262.4034

Christopher Newberry  
920-390-

Administrative Assistant  
Wanda Fredrick 920.262.4060

Total cost to perform the proposed work is \$1,141,831.95 from funding account #05-58-11-69, Annual Street Reserve \$949,664.91; account #16-58-16-39, Storm Water Utility Street Repairs, \$67,166.90; account #16-58-16-60 Storm Water Utility Capital Outlay \$96,712.93; account #03-99-99-99, Water Utility Capital Outlay \$207,688.04; account #02-97-30-11, Wastewater Utility Sewer Rehabilitation \$22,597.73; account #05-58-11-92 Seal Coat Reserve \$20,357.00; and TID 4 \$94,989.05.

Attached is the bid tab. Work being awarded is within the approved 2026 budgets.

Enclosed:

- Bid Tab
- 2026 Bituminous Resurfacing Location Map



**Bituminous Surfacing (#10022429)**  
**Owner: City of Watertown**  
**Solicitor: Watertown WI, City of**  
**02/12/2026 11:00 AM CST**

Section Title	Line Item	Item Code	Item Description	UofM	Quantity	Wolf Paving		Payne & Dolan, Inc.		Kartechner Brothers LLC	
						Unit Price	Extension	Unit Price	Extension	Unit Price	Extension
Street Program Base Bid A: Misc. Pavement Patches							<b>\$231,610.00</b>		<b>\$172,223.00</b>		<b>\$156,710.00</b>
	1A	1A	HMA Pavement 3 LT 58-28 S and 4 LT 58-28 S, 3-Inch	TON	150	\$150.00	\$22,500.00	\$110.00	\$16,500.00	\$105.77	\$15,865.50
	2A	2A	HMA Pavement 3 LT 58-28 S and 4 LT 58-28 S, 4-Inch	TON	800	\$150.00	\$120,000.00	\$110.00	\$88,000.00	\$101.97	\$81,576.00
	3A	3A	HMA Pavement 3 LT 58-28 S and 4 LT 58-28 S, 5-Inch	TON	400	\$150.00	\$60,000.00	\$110.00	\$44,000.00	\$101.84	\$40,736.00
	4A	4A	HMA Pavement 3 LT 58-28 S and 4 LT 58-28 S, 6-Inch	TON	100	\$200.00	\$20,000.00	\$135.00	\$13,500.00	\$102.31	\$10,231.00
	5A	5A	HMA Driveway 4 LT 58-28 S, 2 1/2-Inch	TON	50	\$175.00	\$8,750.00	\$200.00	\$10,000.00	\$139.97	\$6,998.50
	6A	6A	Tack Coat	GAL	100	\$3.60	\$360.00	\$2.23	\$223.00	\$13.03	\$1,303.00
Street Program Base Bid B: Reconstruction Streets: Willman Court, Market Street, and S. Eighth Street							<b>\$79,612.20</b>		<b>\$93,011.21</b>		<b>\$101,007.56</b>
	1B	1B	Tack Coat	GAL	277	\$3.60	\$997.20	\$2.23	\$617.71	\$13.03	\$3,609.31
	2B	2B	HMA Pavement 3 LT 58-28 S, 3-Inch	TON	375	\$69.00	\$25,875.00	\$81.30	\$30,487.50	\$86.99	\$32,621.25
	3B	3B	HMA Pavement 3 LT 58-28 S, 2 1/4-Inch	TON	300	\$73.00	\$21,900.00	\$87.50	\$26,250.00	\$87.02	\$26,106.00
	4B	4B	HMA Pavement 4 LT 58-28 S, 2-Inch	TON	250	\$76.00	\$19,000.00	\$80.30	\$20,075.00	\$102.54	\$25,635.00
	5B	5B	HMA Pavement 4 LT 58-28 S, 1 3/4-Inch	TON	140	\$81.00	\$11,340.00	\$100.65	\$14,091.00	\$89.90	\$12,586.00
	6B	6B	HMA Driveway 4 LT 58-28 S, 2 1/2-Inch	TON	2	\$250.00	\$500.00	\$745.00	\$1,490.00	\$225.00	\$450.00
Street Program Base Bid C: Street Extension S. Fifth Street							<b>\$31,249.20</b>		<b>\$26,921.06</b>		<b>\$30,878.50</b>

	1C	1C	MS-2 Tack Coat	GAL	72	\$3.60	\$259.20	\$2.23	\$160.56	\$13.05	\$939.60
	2C	2C	HMA Pavement 3 LT 58-28 S, 2 1/4-Inch	TON	150	\$84.00	\$12,600.00	\$89.78	\$13,467.00	\$86.98	\$13,047.00
	3C	3C	HMA Pavement 4 LT 58-28 S, 1 3/4-Inch	TON	110	\$99.00	\$10,890.00	\$87.80	\$9,658.00	\$89.94	\$9,893.40
	4C	4C	HMA Pavement 4 LT 58-28 S, 2 1/2-Inch Driveway Aprons	TON	50	\$150.00	\$7,500.00	\$72.71	\$3,635.50	\$139.97	\$6,998.50
Street Program Base Bid D: Wilbur Street							<b>\$94,989.05</b>		<b>\$103,799.32</b>		<b>\$118,862.79</b>
	1D	1D	Concrete Curb & Gutter, 30-Inch	LF	1419	\$19.05	\$27,031.95	\$19.40	\$27,528.60	\$25.14	\$35,673.66
	2D	2D	Concrete Flume	SF	54	\$6.00	\$324.00	\$6.11	\$329.94	\$22.10	\$1,193.40
	3D	3D	Concrete Sidewalk, 4-Inch	SF	3210	\$4.45	\$14,284.50	\$4.60	\$14,766.00	\$5.47	\$17,558.70
	4D	4D	Concrete Sidewalk, 5-Inch	SF	175	\$6.00	\$1,050.00	\$6.11	\$1,069.25	\$9.67	\$1,692.25
	5D	5D	MS-2 Tack Coat	GAL	191	\$3.60	\$687.60	\$2.23	\$425.93	\$13.04	\$2,490.64
	6D	6D	HMA Pavement 3 LT 58-28 S, 2 1/4-Inch	TON	391	\$73.00	\$28,543.00	\$87.40	\$34,173.40	\$86.98	\$34,009.18
	7D	7D	HMA Pavement 4 LT 58-28 S, 1 3/4-Inch	TON	292	\$79.00	\$23,068.00	\$87.35	\$25,506.20	\$89.88	\$26,244.96
Streets Program Base Bid E: Street Department Front Lot							<b>\$57,636.00</b>		<b>\$61,174.05</b>		<b>\$67,726.30</b>
	1E	1E	MS-2 Tack Coat	GAL	160	\$3.60	\$576.00	\$2.23	\$356.80	\$13.03	\$2,084.80
	2E	2E	HMA Pavement 3 LT 58-28 S, 3-Inch	TON	460	\$72.00	\$33,120.00	\$81.50	\$37,490.00	\$87.00	\$40,020.00
	3E	3E	HMA Pavement 4 LT 58-28 S, 2-Inch	TON	285	\$84.00	\$23,940.00	\$81.85	\$23,327.25	\$89.90	\$25,621.50
Streets Program Base Bid F: West St Water Tower Lot							<b>\$43,808.20</b>		<b>\$47,155.61</b>		<b>\$48,419.93</b>
	1F	1F	MS-2 Tack Coat	GAL	147	\$3.60	\$529.20	\$2.23	\$327.81	\$13.03	\$1,915.41
	2F	2F	HMA Pavement 3 LT 58-28 S, 3-Inch	TON	302	\$77.00	\$23,254.00	\$88.90	\$26,847.80	\$87.01	\$26,277.02
	3F	3F	HMA Pavement 4 LT 58-28 S, 2-Inch	TON	225	\$89.00	\$20,025.00	\$88.80	\$19,980.00	\$89.90	\$20,227.50
Street Program Base Bid G: Resurface and Overlay Bailey Street							<b>\$44,873.00</b>		<b>\$48,986.15</b>		<b>\$53,279.25</b>
	1G	1G	MS-2 Tack Coat	GAL	230	\$3.60	\$828.00	\$2.23	\$512.90	\$13.03	\$2,996.90
	2G	2G	HMA Pavement 3 LT 58-28 S, 2 1/4-Inch, Binder Course	TON	140	\$86.00	\$12,040.00	\$104.90	\$14,686.00	\$86.98	\$12,177.20

	3G	3G	HMA Pavement 4 LT 58-28 S, 1-Inch Leveling Course	TON	100	\$95.00	\$9,500.00	\$97.95	\$9,795.00	\$136.06	\$13,606.00
	4G	4G	HMA Pavement 4 LT 58-28 S, 1 3/4-Inch, Surface Course	TON	235	\$83.00	\$19,505.00	\$90.35	\$21,232.25	\$89.89	\$21,124.15
	5G	5G	HMA Pavement 4 LT 58-28 S, 2 1/2-Inch Driveway Aprons	TON	15	\$200.00	\$3,000.00	\$184.00	\$2,760.00	\$225.00	\$3,375.00
Street Program Base Bid H: Mill & Overlay Market Street, S Fourth St to S Seventh St							<b>\$73,721.00</b>		<b>\$87,799.55</b>		<b>\$118,857.14</b>
	1H	1H	Removing Asphaltic Surface Milling, 2 1/2-Inch	SY	2625	\$3.40	\$8,925.00	\$5.30	\$13,912.50	\$5.85	\$15,356.25
	2H	2H	HMA Pavement 4 LT 58-28 S, 1-Inch Leveling Course	TON	155	\$89.00	\$13,795.00	\$89.40	\$13,857.00	\$136.05	\$21,087.75
	3H	3H	Geotextile Pavement Interlayer	SY	2625	\$9.00	\$23,625.00	\$9.30	\$24,412.50	\$13.12	\$34,440.00
	4H	4H	Tack Coat	GAL	185	\$3.60	\$666.00	\$2.23	\$412.55	\$86.99	\$16,093.15
	5H	5H	HMA Pavement 4 LT 58-28 S, 2-Inch Surface Course	TON	330	\$77.00	\$25,410.00	\$88.50	\$29,205.00	\$89.91	\$29,670.30
	6H	6H	Traffic Control	LS	1	\$1,300.00	\$1,300.00	\$6,000.00	\$6,000.00	\$2,209.69	\$2,209.69
Street Program Alternate Bid 1: Full-Depth Resurface Colonial Drive							<b>\$84,782.40</b>		<b>\$85,232.62</b>		<b>\$103,275.84</b>
	1I	1I	MS-2 Tack Coat	GAL	314	\$3.60	\$1,130.40	\$2.23	\$700.22	\$13.04	\$4,094.56
	2I	2I	HMA Pavement 3 LT 58-28 S, 2 1/4-Inch	TON	643	\$71.00	\$45,653.00	\$74.95	\$48,192.85	\$86.99	\$55,934.57
	3I	3I	HMA Pavement 4 LT 58-28 S, 1 3/4-Inch	TON	481	\$79.00	\$37,999.00	\$75.55	\$36,339.55	\$89.91	\$43,246.71
Street Program Alternate Bid 2: Wedge Mill & Overlay E. Main Street							<b>\$62,085.90</b>		<b>\$76,855.82</b>		<b>\$96,340.17</b>
	1J	1J	Traffic Control	LS	1	\$1,300.00	\$1,300.00	\$6,000.00	\$6,000.00	\$2,209.69	\$2,209.69

	2J	2J	Wedge Mill, 10-Foot width x 2-1/2-Inch along Pavement Edge and 25-Foot length x Full Width at Project Ends	SY	2446	\$3.25	\$7,949.50	\$5.00	\$12,230.00	\$5.85	\$14,309.10
	3J	3J	MS-2 Tack Coat	GAL	259	\$3.60	\$932.40	\$2.23	\$577.57	\$13.04	\$3,377.36
	4J	4J	HMA Pavement 4 LT 58-28 S, 1-Inch Leveling Course	TON	213	\$85.00	\$18,105.00	\$97.00	\$20,661.00	\$136.00	\$28,968.00
	5J	5J	HMA Pavement 4 LT 58-28 S, 2-Inch Surface Course	TON	463	\$73.00	\$33,799.00	\$80.75	\$37,387.25	\$102.54	\$47,476.02
Street Program Alternate Bid 3: Full-Depth Resurface Hospital Drive and Meadowbrook Drive							<b>\$138,808.40</b>		<b>\$143,085.17</b>		<b>\$182,195.88</b>
	1K	1K	MS-2 Tack Coat	GAL	554	\$3.60	\$1,994.40	\$2.23	\$1,235.42	\$13.04	\$7,224.16
	2K	2K	HMA Pavement 3 LT 58-28 S, 2 1/4-Inch	TON	1135	\$66.00	\$74,910.00	\$70.25	\$79,733.75	\$87.00	\$98,745.00
	3K	3K	HMA Pavement 4 LT 58-28 S, 1 3/4-Inch	TON	848	\$73.00	\$61,904.00	\$73.25	\$62,116.00	\$89.89	\$76,226.72
Street Program Alternate Bid 4: Full-Depth Resurface River Drive							<b>\$125,345.40</b>		<b>\$132,458.22</b>		<b>\$161,229.06</b>
	1L	1L	MS-2 Tack Coat	GAL	489	\$3.60	\$1,760.40	\$2.23	\$1,090.47	\$13.04	\$6,376.56
	2L	2L	HMA Pavement 3 LT 58-28 S, 2 1/4-Inch	TON	1005	\$67.00	\$67,335.00	\$73.55	\$73,917.75	\$87.00	\$87,435.00
	3L	3L	HMA Pavement 4 LT 58-28 S, 1 3/4-Inch	TON	750	\$75.00	\$56,250.00	\$76.60	\$57,450.00	\$89.89	\$67,417.50
Street Program Alternate Bid 5: Full-Depth Resurface Endeavour Drive Shared Use Path							<b>\$52,954.20</b>		<b>\$58,500.16</b>		<b>\$63,314.97</b>
	1M	1M	MS-2 Tack Coat	GAL	192	\$3.60	\$691.20	\$2.23	\$428.16	\$13.04	\$2,503.68
	2M	2M	HMA Pavement 3 LT 58-28 S, 2 1/4-Inch	TON	394	\$72.00	\$28,368.00	\$83.00	\$32,702.00	\$87.01	\$34,281.94
	3M	3M	HMA Pavement 4 LT 58-28 S, 1 3/4-Inch	TON	295	\$81.00	\$23,895.00	\$86.00	\$25,370.00	\$89.93	\$26,529.35

Street Program Alternate Bid 6: Reconstruction Street, Kathryn Court							<b>\$38,917.40</b>		<b>\$40,569.82</b>		<b>\$44,629.61</b>
	1N	1N	MS-2 Tack Coat	GAL	134	\$3.60	\$482.40	\$2.23	\$298.82	\$13.04	\$1,747.36
	2N	2N	HMA Pavement 3 LT 58-28 S, 2 1/4-Inch	TON	275	\$77.00	\$21,175.00	\$82.35	\$22,646.25	\$87.01	\$23,927.75
	3N	3N	HMA Pavement 4 LT 58-28 S, 1 3/4-Inch	TON	205	\$82.00	\$16,810.00	\$81.95	\$16,799.75	\$89.90	\$18,429.50
	4N	4N	HMA Pavement 4 LT 58-28 S, 2 1/2-Inch Driveway Aprons	TON	1.5	\$300.00	\$450.00	\$550.00	\$825.00	\$350.00	\$525.00
Airport Program Alternate Bid O: Resurfacing Taxiway "C"							<b>\$20,357.00</b>		<b>\$23,581.70</b>		<b>\$69,084.00</b>
	1O	1O	MS-2 Tack Coat	GAL	70	\$3.60	\$252.00	\$2.23	\$156.10	\$25.20	\$1,764.00
	2O	2O	HMA Pavement 3 LT 58-28 S, 2 1/4-Inch	TON	143	\$74.00	\$10,582.00	\$95.50	\$13,656.50	\$265.00	\$37,895.00
	3O	3O	HMA Pavement 4 LT 58-28 S, 1 3/4-Inch	TON	107	\$89.00	\$9,523.00	\$91.30	\$9,769.10	\$275.00	\$29,425.00
Base Bid Total:							<b>\$1,180,749.35</b>		<b>\$1,201,353.46</b>		<b>\$1,415,811.00</b>

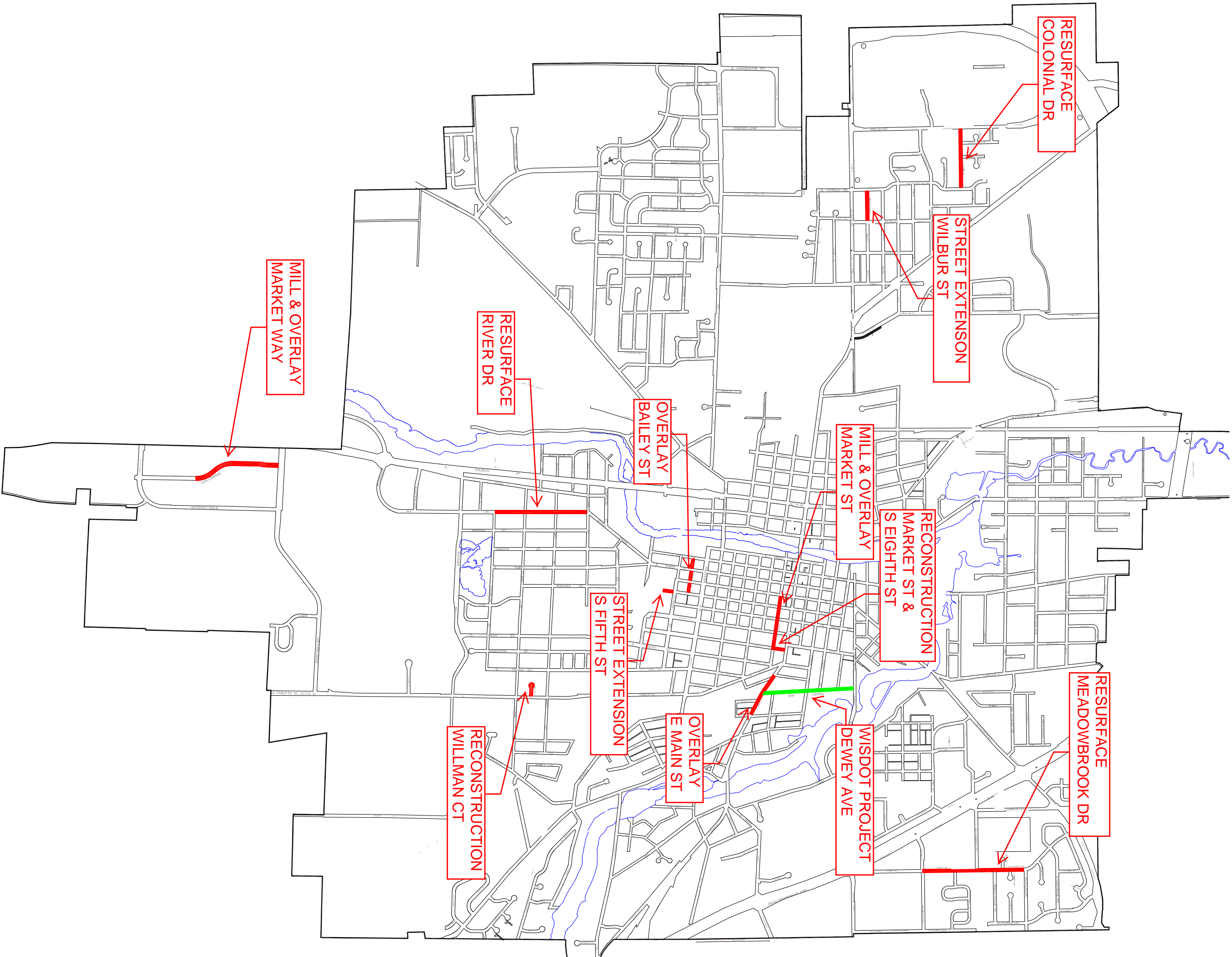



Andrew Beyer, P.E.  
920.262.4050

Maureen McBroom, ENV SP  
920.206-4264

Nathan Williams  
920-262-4052

Ritchie [Section 4, Item J]  
920.262.4034

Christopher Newberry  
920-390-

Administrative Assistant  
Wanda Fredrick 920.262.4060

MEMO

TO: Chairperson Arnett and Commission Members  
FROM: Andrew M. Beyer, P.E.  
DATE: February 19, 2026  
RE: Public Works Commission Meeting of February 24, 2026

Review and take possible action: Award LRIP 2026/2027 Bituminous Surfacing Project-2026 Market Way Contract #10-26 Base Bid A to Wolf Paving Co., Inc. for \$209,919.33.

Background

The Engineering Division publicly opened bids for the LRIP 2026/2027 Bituminous Surfacing Project-2026 Market Way Contract on February 12, 2026. Bid work includes milling the existing asphaltic surface, paving a leveling course, placing a paving interlayer fabric, bituminous surfacing, pavement marking, and traffic control on Market Way from Air Park Drive, southerly 1700 feet. Three bids were received. The Engineering Division is recommending awarding the following Base Bid to the low bidder, Wolf Paving Co., Inc.:

Base Bid A: Mill and Overlay: \$209,919.33

Total cost to perform the proposed work is \$209,919.33 from funding account #05-58-11-69, Annual Street Reserve.

Attached is the bid tab. Work being awarded is within the approved 2026 budget.

Enclosed:

- Bid Tab



**LRIP 2026/2027 Bituminous Surfacing Project 2026 Market Way (#9980156)**

**Owner: City of Watertown**

**Solicitor: Watertown WI, City of**

**02/12/2026 11:00 AM CST**

Section Title	Line Item	Item Code	Item Description	UofM	Quantity	Wolf Paving		Payne & Dolan, Inc.		Kartechner Brothers LLC	
						Unit Price	Extension	Unit Price	Extension	Unit Price	Extension
<b>Base Bid A: Mill and Overlay</b>							<b>\$209,919.33</b>		<b>\$214,323.75</b>		<b>\$247,057.24</b>
	1A	1A	Removing Asphaltic Surface Milling, 2 1/2-Inch	SY	9154	\$2.00	\$18,308.00	\$2.40	\$21,969.60	\$1.39	\$12,724.06
	2A	2A	HMA Pavement 4 LT 58-28 S Leveling Course	TON	526	\$80.00	\$42,080.00	\$74.55	\$39,213.30	\$82.64	\$43,468.64
	3A	3A	Tack Coat	GAL	641	\$3.50	\$2,243.50	\$2.25	\$1,442.25	\$4.78	\$3,063.98
	4A	4A	Geotextile Pavement Interlayer	SY	9154	\$5.27	\$48,241.58	\$5.75	\$52,635.50	\$9.45	\$86,505.30
	5A	5A	HMA Pavement 4 LT 58-28 S Surface Course	TON	1144	\$69.00	\$78,936.00	\$68.75	\$78,650.00	\$75.81	\$86,726.64
	6A	6A	Mobilization, Bonds, Insurance	LS	1	\$9,000.00	\$9,000.00	\$7,500.00	\$7,500.00	\$3,764.91	\$3,764.91
	7A	7A	Traffic Control	LS	1	\$5,200.00	\$5,200.00	\$6,800.00	\$6,800.00	\$2,160.00	\$2,160.00
	8A	8A	Marking Line Epoxy 6-Inch	LF	3745	\$1.45	\$5,430.25	\$1.50	\$5,617.50	\$2.27	\$8,501.15
	9A	9A	Marking Stop Line Epoxy 24-Inch	LF	24	\$20.00	\$480.00	\$20.65	\$495.60	\$5.94	\$142.56
<b>Base Bid Total:</b>							<b>\$209,919.33</b>		<b>\$214,323.75</b>		<b>\$247,057.24</b>