



AGENDA FOR PARKS AND RECREATION COMMISSION

A Parks and Recreation Commission meeting will be held on
Monday, August 05, 2024 at 5:45 PM
in the Recreation Station locate at **316 Arthur St Tomah WI 54660.**

Call to Order - Roll Call

Approval of the Minutes

June 2024 Minutes

Agenda Items

1. Winnebago Park Self Service Kayak Rental
- [2..](#) Fireman's Park Playground Replacement
- [3..](#) National Fitness Grant
4. Program Report

Adjourn

NOTICE: It is possible that a quorum of members of other governmental bodies of the municipality may be in attendance at the above-stated meeting to gather information. No action will be taken by any governmental body at the above-stated meeting other than the governmental body specifically referred to above in this notice. Please note that, upon reasonable notice, efforts will be made to accommodate the needs of disabled individuals through appropriate aids and services. For additional information or to request this service, contact Becki Weyer, City Clerk, at 819 Superior Avenue, Tomah, WI 54660.

MEETING MINUTES - CITY OF TOMAH

The City of Tomah **Parks & Recreation Commission (PRC)** met on Monday June 24, 2024 at 5:45p.m. in Recreation Station, Arthur St. location. The meeting notice was posted at City Hall in compliance with the provisions of Section 19.84 Wisconsin Statutes.

Call to order and roll call; present: Dir. Joe Protz, Oak Moser, Dustin Powell, DeDe Nelson, Josephine Piper, Dean Peterson, Donna Evans, Shirley Galstad-Roh

The following members were absent: Travis Scholze

Others in attendance: Jeff Cram, Tina Thompson

1. Act on Minutes of Mar 4, 2024, regular meeting. Motion by Peterson, second by Nelson, to accept the minutes of the Apr 24, 2024, regular meeting. Motion approved.
2. Request the use of cell tower fees for pavement and sidewalk at Recreation Station: Dir Protz recommended use of funds from the Cell Tower Fees account for repair and paving of the parking and sidewalk areas at Recreation Station, up to \$35,000. The account currently is at \$75,875 and collects monthly deposits. Rec Station has been actively used and is experiencing rentals. The funds would be for the material, labor provided by Public Works dept. Motion by Moser, second by Peterson, to approve use of Cell Tower Fees up to \$35,000 for the pavement and sidewalk work at Recreation Station. Motion carried.
3. Discussion on Tomah Aquatic Center: Dir Protz reviewed the current condition of the Aquatic Center and its' extensive use this season. Currently the two large water slides are not functional, there remain some leaks underground and other concerns. This season over 300 people are enrolled in swim lessons and the Center is experience heavy use. Dir Protz is planning to contact entities that may be provide proposals to evaluate the current condition and suggest necessary repairs, maintenance, improvements in infrastructure, etc... that may ensure continued function and use of the Aquatic Center. No action taken.
4. Tomah Parks and Recreation Program Report: Dir Protz reviewed the monthly Program report.
5. Discussed any affairs and business of the Tomah Parks and Recreation Department. None presented.

The Meeting was adjourned at 6:21PM. Next regular meeting to be held Monday, July 24, 2024, @ 5:45PM, at Recreation Station, Arthur St.

Respectfully Submitted: Oak Moser, June 26, 2024.

COMMISSION MEETING REPORT

Agenda Item: Winnebago Park Self Service Kayak Rental Program

Summary and Background Information:
(appropriate documentation attached)-

Director Protz would like to discuss the potential of a Kayak Rental Program at Winnebago Park. The project could be a partnership with the Lake Committee. The program is managed by www.rent.fum which provides full-service maintenance, equipment replacement, customer support and more. The City will provide site and initial funding. More information will be provided at the meeting.

Recommendation:
Discuss and/or act on Self Service Kayak Rental at Winnebago Park and Lake Tomah

Joe Protz
Joe Protz, Director

8-1-2024
Date



COLOR KEY

- RED
- BLACK
- GRANITE
- RED/WHITE



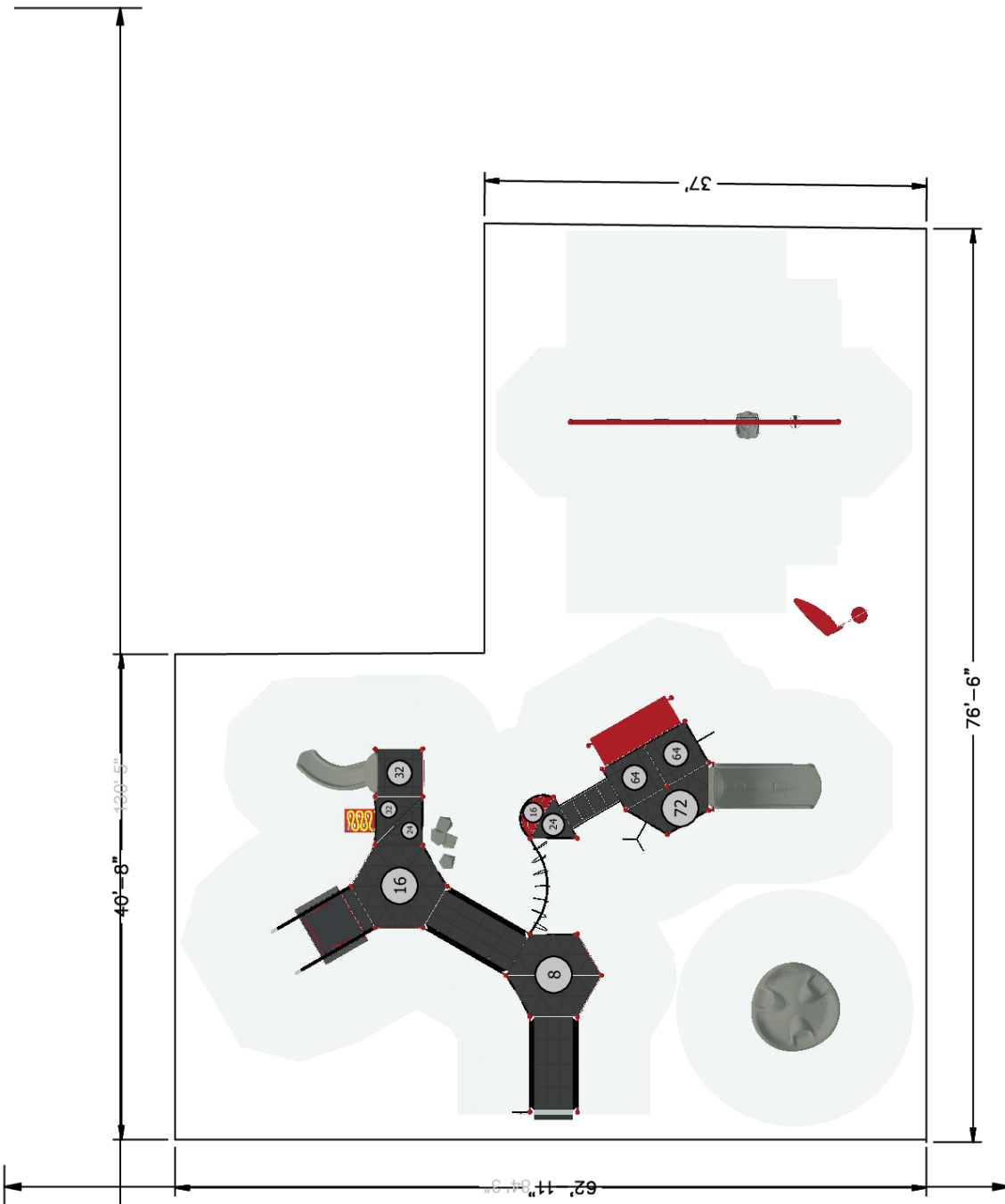

AREA: 3,890 sqft



NOTE: ALTHOUGH ALL ATTEMPTS HAVE BEEN MADE TO PROVIDE AN ACCURATE SITE IT MAY NOT TRULY REPRESENT THE AREA WHERE THIS STRUCTURE IS TO BE PLACED.

SERIES Nucleus | Intensity | Burke Basics

GROUP: Structure | Freestanding

DESIGNED FOR AGES:
5 to 12

Tomah - Fireman's Park
Tomah, WI 54660



SITE PLAN VIEW

02/05/2024

Lee Recreation, LLC
142-178428-2

Designer: Kristin La Cross

OVERALL BOUNDING OF USE ZONES

**The space requirements shown here are to ASTM standards. Requirements for other standards may be different.
Area: 10983.5 sq.ft.
Perimeter: 429.3 ft.
STRUCTURE SIZE: 3"x130' 5"
POST SIZE(S):

PLAYGROUND ACCESSIBILITY (Provided/Required)

TOTAL ELEVATED EVENTS	TRANSFER ACCESSIBLE ELEMENTS	RAMP ACCESSIBLE ELEMENTS	GROUND EVENTS	TYPES OF GROUND EVENTS
21	7 / 0	5 / 0	11 / 4	5 / 3

The use and layout of play components identified in this plan conform to the CPSC guidelines. U.S. CPSC recommends the separation of age groups in playground layouts.

Item 6.

Warning: Accessible safety surfacing material is required beneath and around this equipment that is compliant with ASTM, CPSC, and ADAAG requirements.



DATE: February 16, 2024

TO: City of Tomah
Fireman's Park
819 Superior Ave
Tomah, WI 54660

FROM: Pat Groom
RE: **Playground Proposal #142-178428-2**

BCI BURKE "Play That Moves You"
Playground Proposal #142-178428-2
21 Play Events for an estimated 163 users

1-#NUCLEUS Nucleus Modular Structure; 5-12 Years Old. \$98,387.00

DECKS: 1-Triangle, 3-Square, 2-Hexagonal, 1-Half Hexagon, 1-Crescent
RAMPS: 1-ADA Entrance Ramp 8' Long w/ Guardrails, 1-ADA Ramp 8' Long w/ Guardrails
SLIDES: Monaco Slide @ 32" Deck Ht., Contour Slide @ 72" Deck Ht.
CLIMBERS: Fire Hose Climber, Atom Climber
PLAY/ACTIVITY PANELS: 1-Custom General Store Front, 3-In-A-Row Panel, Hide-the-Numbers,
Passenger Side Door Panel, Truck Front w/ Custom Name Panel, Full Custom Curved Panel,
Bee Accessible Reach Panel, Car Accessible Reach Panel, Spinner Crescent Panel

UPPER BODY: Straight Overhead

MOTION: Innova Rocker

BALANCE/CLIMBING/SOCIAL: Eko Solo and Eko Tri

1-#560-2579 Volta Inclusive Spinner \$ 7,751.00

1-#580-1369 Firehouse Discovery Station \$ 3,863.00

1-#550-0201 2-Bay Single Post Swing Assembly \$ 4,617.00
Includes: 2 Belt Seats, 1-Freedom Seat, 1-Tot Seat

Subtotal Equipment \$114,618.00
Project Discount (\$ 17,190.00)
Installation/Assembly \$ 34,505.00
Surfacing 3,915 ft² \$ 93,960.00
Freight \$ 1,000.00
TOTAL \$226,893.00

SURFACING NOTE

Playground Grass Ultra includes: Playground Turf, Sand Infill, Synthetic Perimeter Boards, up to 5" limestone and 2" Safety Foam Pro.

Quote Accepted by: _____ Date: _____

Terms: Net 20

Marking of Private Lines, Site Preparation, Concrete Curb and Site Restoration is the responsibility of the customer.

Lead time: 10-12 Weeks Upon Receipt of Order

Quote Effective: **Until 03-01-2024**

COMMISSION MEETING REPORT

Agenda Item: Fireman's Park Playground Replacement

Summary and Background Information:
(appropriate documentation attached)-

Director Protz would like to discuss the need for replacement of Fireman's Park Playground.

Recommendation:
Discuss and/or act on fundraising for new Playground Equipment at Fireman's Park.

Joe Protz
Joe Protz, Director

8-1-2024
Date

COMMISSION MEETING REPORT

Agenda Item: National Fitness Campaign Grant

Summary and Background Information:
(appropriate documentation attached)-

Director Protz would like to discuss the National Fitness Grant campaign and get the Park Boards feedback on the program and grant possibility. <https://nationalfitnesscampaign.com/watch>

Recommendation:

Joe Protz
Joe Protz, Director

8-1-2024
Date

Other Parks

- Maintenance on equipment and buildings
- Park clean ups, bathrooms are open with high usage, and mowing
- Gillett Park Comfort Station concern with loitering.
- Busy Park Shelter season with rentals
- Assisted with set up and clean up for Squirrel Fest at Winnebago Park.
- Disc Golf Course baskets have been installed by Fireman's Park continue to work on t-boxes and working on a fall event.

RECREATION PROGRAMS

- T-Ball finished up on July 10th with 83 participants
- Youth Tennis continues with 54 participants
- Adult Softball continues with 9 teams
- Youth Sports programs can be found on City of Tomah website.
- Create N Play classes continue at Recreation Station
- Pre-School open Gym will begin in August at Recreation Station.
- Working on Fall Activities

AQUATIC CENTER

- Pool Opened on June 11th
- Swim Lessons begin on June 17th. Over 300 participants in Swim Lessons.
- Passed annual Inspection.

RECREATION PARK

- June 9th Sheep Show, June 10 Circus, June 20-23 Tractor Pull, June 29 Quinceanera.
- July 11-14 Warrior and Warlords event, July 20 Wedding, July 24-28 Fair.
- August 3 Wedding, August 6 National Night Out, August 13 Election, August 23 Feed My Starving Children.
- Sept. 7 wedding, Sept 13-14 Rotary Fundraiser, Sept 21 wedding.
- General upkeep and maintenance on buildings
- Worked with Monroe County Ag Society for set up and clean up for Monroe County Fair.
- Construction on going for the Ice Center Addition.

Joe Protz

**Joe Protz
Director Tomah Parks and Recreation**