



CITY OF SWEET HOME CITY COUNCIL AGENDA

April 27, 2021, 6:30 PM
Sweet Home City Hall, 3225 Main Street
Sweet Home, OR 97386

WIFI Passcode: guestwifi

PLEASE silence all cell phones – Anyone who wishes to speak, please sign in.

Mission Statement

The City of Sweet Home will work to build an economically strong community with an efficient and effective local government that will provide infrastructure and essential services to the citizens we serve. As efficient stewards of the valuable assets available, we will be responsive to the community while planning and preparing for the future.

Meeting Information

The City Council will hold a Regular City Council meeting at 6:30 p.m. in the City Council Chambers at City Hall, 3225 Main Street. In order to protect residents, staff, and elected officials due to the novel COVID-19 virus, individuals attending public meetings in person will be limited to the first six people, required to maintain appropriate social distancing, (6-ft.) and be free of symptoms related to COVID-19. The City of Sweet Home City Council is streaming the meeting via the Microsoft Teams platform and asks the public to consider this option. There will be opportunity for public input via the live stream. To view the City Council meeting live, online visit live.sweethomeor.gov. If you don't have access to the internet you can call in to 541-367-5128 and you'll be asked to choose option #1 to be logged in to the call. Meeting ID: 226 531 982#

This video stream and call in options are allowed under Council Rules, meet the requirements for Oregon public meeting law, and has been approved by the Mayor as Chairperson of the meeting.

Cell phones should not be used in the Council Chambers by city staff or Council during this meeting for any reason, including text messages, emails, or phone calls. If a member of the public needs to utilize their cell phone for a call, please exit the Council Chambers.

Call to Order and Pledge of Allegiance

Roll Call

Consent Agenda:

- a) [Request for Council Action – Reappointment to the Budget Committee – Hamlin & Dix \(pg. 3\)](#)

Approval of Minutes:

- a) [2021-03-13 City Council Minutes \(pg. 9\)](#)

Recognition of Visitors and Hearing of Petitions:

- a) [If I Were Mayor Contest \(pg. 14\)](#)
- b) [Public Comment re: Oregon Jamboree \(pg. 15\)](#)

Old Business:

The location of the meeting is accessible to the disabled. If you have a disability that requires accommodation, advanced notice is requested by notifying the City Manager's Office at 541-367-8969.

New Business:

- a) [Proclamation Mental Health Month - May 2021 \(pg. 16\)](#)
- b) [Request for Proposal for Integrator of Record Service \(pg. 17\)](#)
- c) [Request for Council Action - 2021 Overlay Project Contract Approval \(pg. 52\)](#)
- d) [Request for Council Action - 2021 Overlay Project Phase 2 Bid Posting \(pg. 95\)](#)
- e) [Request for Council Action – Transportation Program Operation Agreement \(pg. 140\)](#)

Ordinance Bills

Request for Council Action and First Reading of Ordinance Bills
Second Reading of Ordinance Bills
Third Reading of Ordinance Bills (Roll Call Vote Required)

Reports of Committees:

Ad Hoc Committee on Health
Administrative and Finance/Property
Area Commission on Transportation
Chamber of Commerce
Charter Review Committee
Council of Governments
Legislative Committee
Library Advisory Board
Park and Tree Committee
Solid Waste Advisory Council
Youth Advisory Council

Reports of City Officials:

Mayor's Report
City Manager's Report

Department Director's Reports (2nd meeting of the Month)

Finance Director
Police Chief
a) [Police Department Monthly Report \(pg. 144\)](#)
City Attorney

Council Business for Good of the Order

Adjournment



REQUEST FOR COUNCIL ACTION

Title: Request for Council Action – Reappointment to the Budget Committee – Hamlin & Dix

Preferred Agenda: April 27, 2021

Submitted By: Julie Fisher, Administrative Assistant

Reviewed By: Ray Towry, City Manager

Type of Action: Resolution ____ Motion x Roll Call ____ Other ____

Relevant Code/Policy: [ORS 294.336 SHMC 2.10](#)

Towards Council Goal: Goal ##2 Develop transparency in all communication. Efficient and effective local government.

Attachments: Budget Committee Application – Kenneth Hamlin

Purpose of this RCA:

Council Appointment to the Budget Committee

Background/Context:

Kenneth Hamlin has served on the Budget Committee since May 1, 2018. His three-year term has expired. Kenneth is asking for reappointment to the Budget Committee.

Derek Dix has served on the Budget Committee since March 27, 2018. His three-year term has also expired. Derek is asking for reappointment to the Budget Committee.

The Challenge/Problem:

State Law (ORS 294.336) mandates a budget committee for all Oregon local governments that consists of Council and an equal number of citizen voters. The City of Sweet Home has three citizen voter vacancies on the Budget Committee with the budget process to start in May.

Stakeholders:

- City of Sweet Home Staff – Staff benefits by having full committees that provide direction and recommendations that are consistent with law.
- City of Sweet Home Management - Management is more effective and efficient with clear, updated, best practices for policy as recommended by committees.
- Sweet Home Residents – Residents and taxpayers essentially pay the price when policies lead to inefficient operations or practices.

Issues and Financial Impacts:

None Known

Elements of a Stable Solution:

Ensuring citizen and stakeholder involvement in the preparation and adoption of a Budget that is directed towards achievement of goals within the constraints of the available resources.

Options:

1. *Do Nothing.*
2. *Seek Additional Applicants*
3. *Make a Motion* to appoint Kenneth Hamlin to the City of Sweet Home Budget Committee with a three-year term to expire Dec 31, 2024.
4. *Make a Motion to appoint Derek Dix to the City of Sweet Home Budget Committee with a three-year term to expire Dec 31, 2024*

Recommendation:

Staff Recommends Option 3 & 4: It is recommended to Make a Motion to appoint Kenneth Hamlin and Derek Dix to the City of Sweet Home Budget Committee with a term to expire Dec 31, 2024.



CITY MANAGER'S OFFICE

1140 12th Avenue
Sweet Home, OR 97386
541-367-8969 541-367-5113 FAX
jfisher@ci.sweet-home.or.us

BOARD/COMMITTEE/COMMISSION APPLICATION

Applicant Information (Please type/print clearly):

Name: Kenneth (Kenny) Hamlin

Permanent Address: 1650 11th Ave., Sweet Home

Mailing Address: _____

Contact Phone Number: 541-409-1599

E-Mail Address: kenny.hamlin@rocketmail.com

Preferred method of contact: Mail Phone Email

Occupation: clerk Employer: Hay's Hardware

Please mark the Board, Commission or Committee in which you are interested in serving:

- Budget Committee
- Planning Commission
- Library Board
- Traffic Safety Committee
- Parks Board
- Tree Commission
- Board of Appeals
- All Hazard Mitigation Committee

Are you applying for reappointment: Yes No

If yes, how long have you served in this capacity: _____ Year(s) _____ Month(s)

1. How long have you lived in the area: 4 Year(s) 8 Month(s)

2. Please give a brief description of your experiences or training that you feel qualifies you for this particular position.

Linn County Road Department - 10 years budget creation.

Oregon Utilities Coordinating Council - 8 years

Board of Directors - One Call Center - Budget Committee

3. List current involvement in other community groups and/or activities.

none

4. What special contribution do you feel you can make to the group/position you are applying for?

Experience in creating and revising budgets.

RESIDENCY:

The following applies for appointments that require residency and elector status:

I, Kenny Hamlin, certify that I currently reside within the corporate limits of the City of Sweet Home and am an eligible elector as defined by ORS 246.012(5). I further acknowledge that should either my residency or my eligibility as an elector change I will notify the City of Sweet Home immediately.

CRIMINAL HISTORY BACKGROUND CHECK (CCH):

A Criminal History Check (CCH) may be performed as part of the City of Sweet Home appointment process for City Boards, Committees, and Commissions. I acknowledge that a refusal to allow the CCH to be performed, when required, will cause my application to no longer be considered.

PUBLIC DISCLOSURE:

The City sometimes receives requests for contact information for members serving on City boards, commissions and committees. As an appointed public body volunteer serving the City of Sweet Home, the information provided on this application is considered public record.

My signature acknowledges that the information I have provided on the application is true and complete to the best of my knowledge and I understand that a CCH may be performed, when required, and that the information provided on this application is considered public record.

Kenny Hamlin
Signature

4-13-21
~~4-17-18~~
Date of Signature



CITY MANAGER'S OFFICE

1140 12th Avenue
Sweet Home, OR 97386
541-367-8969 541-367-5113
FAX
HYPERLINK
"mailto:Jfisher@ci.sweet-home.or.us"
"mailto:Jfisher@ci.sweet-home.or.us"

BOARD/COMMITTEE/COMMISSION APPLICATION

Applicant Information (Please type/print clearly):

Name: Derek D. Dix

Permanent Address: 908 Alder St. Sweet Home, OR 97386

Mailing Address: 908 Alder St. Sweet Home, OR 97386

Contact Phone Number: (503)453-5263

E-Mail Address: ddix5262012@gmail.com

Preferred method of contact: Mail Phone Email

Occupation: Warehouse Team Member Employer: Lowe'r RDC

Please mark the Board, Commission or Committee in which you are interested in serving:

- Budget Committee
- Planning Commission
- Library Board
- Traffic Safety Committee
- Parks Board
- Tree Commission
- Board of Appeals
- All Hazard Mitigation Committee

Are you applying for reappointment: Yes No

If yes, how long have you served in this capacity: Year(s) Month(s)

1. How long have you lived in the area: 4 Year(s) 4 Month(s)

2. Please give a brief description of your experiences or training that you feel qualifies you for this particular position.

I have been on staff in several non-profits, where I was on a team that was responsible for determining how we spent our money, setting up systems for how the organization was going to function, and then helping to present, train, and equip people to implement those plans and structures.

3. List current involvement in other community groups and/or activities.

I currently serve in several different capacities. I volunteer with the Fun at Sanky Park evenings in the summer, as well as the community Life Skills For Littles on Wednesday nights, where we teach kids in the Sweet Home community different life skills.

4. What special contribution do you feel you can make to the group/position you are applying for?

I have experience working with non-profits, which means that budgets are usually small. I have served on planning teams where I have been a part of a team that plans, develops and oversees budgets, develops spending plans, presents those budgets, and even helps to keep the non-profit up and running.

I feel that I bring a unique aspect to this committee, because I have experience in many different areas, and I bring a unique perspective that keeps the focus on those we represent, and doing what is best for the organization (Sweet Home), and the people we represent (citizens). I have the experience and track record of doing so with dignity, respect, and with integrity.

RESIDENCY:

The following applies for appointments that require residency and elector status:

I, Derek D. Dix, certify that I currently reside within the corporate limits of the City of Sweet Home and am an eligible elector as defined by ORS 246.012(5). I further acknowledge that should either my residency or my eligibility as an elector change I will notify the City of Sweet Home immediately.

CRIMINAL HISTORY BACKGROUND CHECK (CCH):

A Criminal History Check (CCH) may be performed as part of the City of Sweet Home appointment process for City Boards, Committees, and Commissions. I acknowledge that a refusal to allow the CCH to be performed, when required, will cause my application to no longer be considered.

PUBLIC DISCLOSURE:

The City sometimes receives requests for contact information for members serving on City boards, commissions and committees. As an appointed public body volunteer serving the City of Sweet Home, the information provided on this application is considered public record.

My signature acknowledges that the information I have provided on the application is true and complete to the best of my knowledge and I understand that a CCH may be performed, when required, and that the information provided on this application is considered public record.

Derek D. Dix
Signature

Date of Signature 033/21/21



CITY OF SWEET HOME CITY COUNCIL MINUTES

April 13, 2021, 6:30 PM
Sweet Home City Hall, 3225 Main Street
Sweet Home, OR 97386

WIFI Passcode: guestwifi

PLEASE silence all cell phones – Anyone who wishes to speak, please sign in.

Mission Statement

The City of Sweet Home will work to build an economically strong community with an efficient and effective local government that will provide infrastructure and essential services to the citizens we serve. As efficient stewards of the valuable assets available, we will be responsive to the community while planning and preparing for the future.

Meeting Information

The City Council will hold a Regular City Council meeting at 6:30 p.m. in the City Council Chambers at City Hall, 3225 Main Street. Individuals attending public meetings in person will be required to maintain appropriate social distancing, (6-ft.) and be free of symptoms related to COVID-19. The City of Sweet Home City Council is streaming the meeting via the Microsoft Teams platform and asks the public to consider this option. There will be opportunity for public input via the live stream. To view the City Council meeting live, online visit live.sweethomeor.gov. If you don't have access to the internet you can call in to 541-367-5128 and you'll be asked to choose option #1 to be logged in to the call. ID: 473 954 605#

This video stream and call in options are allowed under Council Rules, meet the requirements for Oregon public meeting law, and has been approved by the Mayor as Chairperson of the meeting. All votes may be conducted by Roll Call Vote.

Cell phones should not be used in the Council Chambers by the public, city staff or Council during this meeting for any reason, including text messages, emails, or phone calls. If someone needs to utilize their cell phone, please exit the Council Chambers.

Call to Order and Pledge of Allegiance

The meeting was called to order at 6:30 PM.

Roll Call

PRESENT

Mayor Greg Mahler
President Pro Tem Diane Gerson
Councilor Dave Trask
Councilor Lisa Gourley
Councilor Susan Coleman
Councilor Angelita Sanchez
Councilor Dylan Richards

STAFF

City Manager Ray Towry
Communications Specialist Lagea Mull
Finance Director Brandon Neish

The location of the meeting is accessible to the disabled. If you have a disability that requires accommodation, advanced notice is requested by notifying the City Manager's Office at 541-367-8969.

Public Works Director Greg Springman
Police Chief Jeff Lynn
Community and Economic Development Director Blair Larsen
City Attorney Robert Snyder
Administrative Assistant Julie Fisher

MEDIA
Benny Westcott, The New Era

Consent Agenda:

Motion to approve the Consent Agenda made by Councilor Coleman, Seconded by President Pro Tem Gerson.

Voting Yea: Mayor Mahler, President Pro Tem Gerson, Councilor Trask, Councilor Gourley, Councilor Coleman, Councilor Sanchez, Councilor Richards

Approval of Minutes:

- a) 2021-03-23 City Council Minutes (pg. 3)

Recognition of Visitors and Hearing of Petitions:

None

Old Business:

- a) Request for Council Action - 2021 Salary Adjustments for Non-Represented and AFSCME Employees (pg. 8)

City Manager Towry introduced the request to review salaries that were frozen at the beginning of COVID-19 due to uncertainty related to City financing. To avoid possible staff layoffs, management offered to give up their COLAs. AFSCME employees offered the same and agreed to receive the same as the Management Team for the year. The Council agreed to review the COLAs when the City could determine it was prudent financially to do so. In addition, a Captain's position was added to the Police Department and an Information Technologies Services Manager. Both positions are a cost neutral position and should not have a negative effect on the budget.

Finance Director Neish explained the methodology of how the salaries are set to the comparable Cities using their median salaries as a comparison and removing 5% for the middle step. Overall, Sweet Home salaries are less than the average comparable city. Finance Director reviewed the budgetary impacts of a COLA increase based upon a retro of 3% of January 2021. Finance Director Neish explained as of today, the only fund that would need an adjustment to cover the personnel cost would be the Wastewater Fund.

Motion made to approve Resolution No. 12 for 2021 with increases retroactive to December 16, 2020 made by Councilor Coleman, Seconded by Councilor Gourley.

Voting Yea: Mayor Mahler, President Pro Tem Gerson, Councilor Trask, Councilor Gourley, Councilor Coleman, Councilor Sanchez, Councilor Richards

New Business:

- a) Mayor's Appointment of a Council Liaison to the Library Advisory Board
Mayor Mahler appointed Councilor Susan Coleman to the Library Advisory Board as a Council Liaison.
- b) Request for Council Action – Transient Lodging Tax (TLT) IGA (pg. 37)

City Manager Towry explained the request for the Transient Lodging Tax Agreement with Linn County, stating the City collects TLS Tax for the County and in return keeps a portion as a collection fee.

Motion made to approve the IGA with Linn County for the Collection of Transient Lodging Tax by Councilor Gourley, Seconded by Councilor Coleman.

Voting Yea: Mayor Mahler, President Pro Tem Gerson, Councilor Trask, Councilor Gourley, Councilor Coleman, Councilor Sanchez, Councilor Richards

c) Discussion Only - American Rescue Plan Act Funding Allocation (pg. 46)

City Manager Towry explained the American Rescue Plan allocation is COVID relief funds limited to specific uses such as infrastructure. Staff asked for direction on how Council would choose to utilize the funding for preparation of the Budget. The Council discussed options. Consensus of the Council included earning interest thru saving, reimbursing the street maintenance fund, tackle broadband issues that would ultimately large and small businesses and households, especially those working from home. In addition, using funds for the water and wastewater projects.

d) Water Utility & Storm Water Utility Rate Discussion (pg. 48)

Finance Director Neish introduced the discussion on utility rates and explained staff is only looking for direction and is not asking Council to make any decisions tonight. Staff is requesting priorities of the Council, reviewing outstanding projects in water and stormwater that have been identified as important for operations. Finance Director Neish outlined the projects, completion dates, project costs, and available funding. City staff is actively seeking additional opportunities for funding such as grants for any projects.

There were questions from Council.

Finance Director Neish addressed the stormwater budget and lack of revenue in that fund for any additional repairs or projects within that system. Finance Director Neish stated his recommendation is to focus the funding and attention to the Stormwater System beginning with a Stormwater Master Plan that could only be funded with a stormwater rate increase.

Ordinance Bills

Request for Council Action and First Reading of Ordinance Bills

None

Second Reading of Ordinance Bills

None

Third Reading of Ordinance Bills (Roll Call Vote Required)

None

Reports of Committees:

Ad Hoc Committee on Health

Councilor Gourley reported on the upcoming report by Western University on April 19th.

Administrative and Finance/Property

Area Commission on Transportation

Chamber of Commerce

Charter Review Committee

Council of Governments

Legislative Committee

Library Advisory Board

Park and Tree Committee

Councilor Trask reported on the concrete upgrades at Sankey Park.

Solid Waste Advisory Council

Youth Advisory Council

Reports of City Officials:

Mayor's Report

Mayor Mahler

City Manager's Report

City Manager Ray Towry thanked the City Council for their discussion earlier during the meeting.

City Manager Towry reported staff received a Special Events application for the Oregon Jamboree event this summer. Staff is currently reviewing the application and working with the Jamboree.

The Library Services Director recruitment update was presented to the Council.

Samaritan Hospital will be holding a mass vaccination clinic on Saturday, with a second vaccination date on May 8th. Partners include Sweet Home Boys and Girls Club, the Sweet Home Fire and Ambulance District, The Linn Shuttle and Sweet Home Rotary.

Budget season is upon us, the first Budget meeting is Tuesday April 20th at 6pm for Budget presentation and message.

A Willow Street informational meeting will be held at City Hall for discussion. No decisions will be made during this meeting.

City Manager Towry reported the Executive Team will be in Portland for a training event April 14-16, 2021.

Department Director's Reports (1st meeting of the Month)

Library Services Director

- a) Statistics by Type of Circulation (pg. 51)
- b) Statistics by User (pg. 52)

Community and Economic Development Director

- a) CEDD Monthly Report for March, 2021 (pg. 53)
A written report was included in the packet.

Public Works Director

- a) Public Works Monthly Report of Activities - March 2021 (pg. 58)
A written report was included in the packet.

City Attorney

None

Council Business for Good of the Order

Councilor Gerson reported on new art in City Hall.

Finance Director Neish stated 33 accounts are scheduled for turn off tomorrow.

Adjournment

The meeting adjourned at 8:36 PM.

Mayor

ATTEST:

City Manager – Ex Officio City Recorder

IF I WAS MAYOR

Mini Golf

- Family Fun
- Attracts tourists
- Provides more jobs



CLOTHING STORE NOW OPEN

- We need a local place to purchase clothes
- Provides more jobs

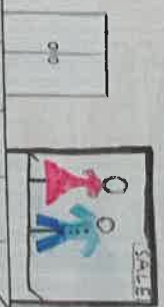

Urgent Care

- Provides more jobs
- We need a local urgent care

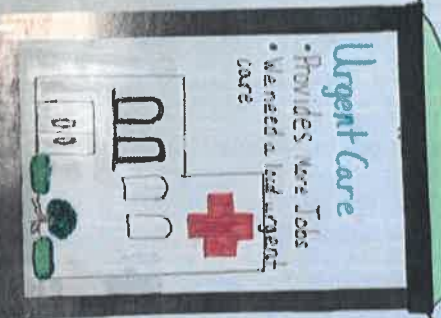

Community Garden

- Provides fresh fruit and vegetables
- Brings people together
- Bring beauty

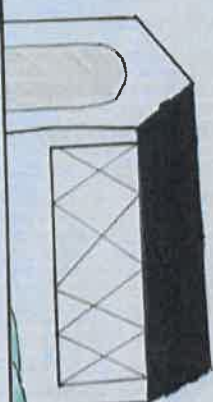

Build More Homes

- Brings more tax money
- Provides homes for people

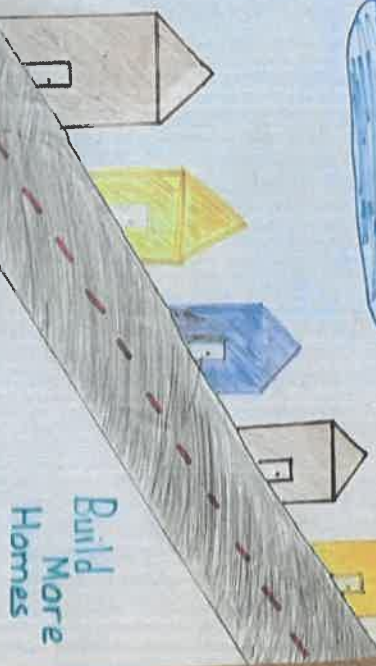

Natalie Salzman

Subject: comments for city manager/council on Oregon Jamboree
Date: Wednesday, April 21, 2021 at 4:19:07 PM Pacific Daylight Time
From: maryjane hildreth
To: Julie Fisher

Julie--please pass along this email to the City Manager and City Council. Thanks very much.

Dear Sweet Home City Manager and City Council:

I recently read in the New Era that the Director of the Oregon Jamboree, Robert Shamek, plans on having a scaled-down Oregon Jamboree this year.

The Director intends to bring thousands of out-of-towners to Sweet Home whose COVID status is entirely unknown. These visitors may be unwilling to wear masks or practice social distancing, especially in a mega party atmosphere. Those of us who walk to Safeway for our groceries know how difficult it is to keep distance when there's a crowd on Sweet Home's Highway 20 sidewalks.

Such a plan ignores the welfare of Sweet Home residents, particularly the most vulnerable (the elderly and those with preexisting conditions), and particularly when the event is held in a residential neighborhood (Sankey family Park).

Furthermore, with new variants of the COVID virus appearing on a regular basis, no one knows how effective current vaccines and protocols will be this August.

In conclusion, losing the life of one vulnerable Sweet Home resident is not worth whatever the amount of money the Oregon Jamboree may bring in. Please protect the citizens and taxpayers of Sweet Home by not having the Jamboree this year.

Sincerely, Mary Jane Hildreth phone: 541-367-8648 or 541-409-4760



May 2021 Mental Health Month Proclamation

WHEREAS, mental health is essential to everyone's overall health and well-being; and

WHEREAS, all Americans experience times of difficulty and stress in their lives; and

WHEREAS, promotion and prevention are effective ways to reduce the burden of mental health conditions; and

WHEREAS, there is a strong body of research that support user-friendly tools that all Americans can access to better handle challenges, and protect their health and well-being; and

WHEREAS, mental health conditions are real and prevalent in our nation; and

WHEREAS, with effective treatment, those individuals with mental health conditions can recover and lead full, productive lives; and

WHEREAS, each business, school, government agency, faith-based organization, health care provider, veteran's groups and citizen has a responsibility to promote mental wellness and support prevention efforts; and

WHEREAS, the COVID-19 pandemic has had profound impacts on the mental health of people of all ages and now more than ever it is critical to reduce the stigma around mental health struggles that commonly prevents individuals from seeking help. By limiting media consumption, staying connected with loved ones and staying active we can maintain our mental health as we try to protect our physical health; and

WHEREAS, the Linn County Mental Health Advisory Board is emphasizing that there is no health without mental health by being involved with Public Service Announcements, Health Fairs, public speakers and various trainings regarding mental health issues;

THEREFORE, I Greg Mahler do hereby proclaim May 2021 as Mental Health Month in Sweet Home. As the Mayor, I also call upon the citizens, governmental agencies, public and private institutions, businesses and schools in Sweet Home to recommit our community to increasing awareness and understanding of mental health, the steps our citizens can take to protect their mental health, and the need for appropriate and accessible services for all people with mental health conditions.

PROCLAIMED this 27th day of April 2021

Mayor

ATTEST:

City Manager – Ex Officio City Recorder



REQUEST FOR COUNCIL ACTION

Title: Request for Proposal for Integrator of Record Service

Preferred Agenda: April 27, 2021

Submitted By: Trish Rice, Engineering Tech 2
Greg Springman, Public Works Director

Reviewed By: Ray Towry, City Manager

Type of Action: Resolution ____ Motion X Roll Call ____ Other ____

Relevant Code/Policy: NA

Towards Council Goal: 2.6: Employ sound technology to maximize efficiency

Attachments: RFP for Integrator of Record Service
Contract document for Integrator of Record Service

Purpose of this RCA:

Staff is requesting authorization to post a Request for Proposals (RFP) to solicit an Integrator of Record for our water and sewer systems.

Background/Context:

The City does not currently have an Integrator of Record. Instrument integration has been individually procured on a project-by-project basis. This piecemeal history has complicated/contributed to many operational issues in the Water Treatment Plant and the distribution system which results in a great deal of staff time being spent on tasks that should be automated. The level of technology requires programming and other specialized knowledge, therefore the City desires to evaluate the consultant market to provide holistic integration services.

The Integrator of Record will provide maintenance/repair/emergency support services for our water and sewer control systems, assist the City with repairs and functionality improvements to the Water Treatment Plant and the distribution system, help us make sure that the new systems at the Wastewater Treatment Plant get integrated to our satisfaction, ensure all City facilities have compatible systems, and assist staff with identifying and planning for long-range capital projects of our water and sewer control systems.

With the upcoming in-house treatment plant operations and the WWTP upgrades project, this is a crucial time to bring on an Integrator of Record to resolve current issues and reduce future issues, and is a critical step to ensuring success on multiple projects.

The proposed duration of a new contract is 3 years with the option to extend by additional 3-year terms.

The Challenge/Problem:

How do we work with stakeholders to maintain city operations at the voter's expected level of service within budget restraints and being fiscally responsible?

Stakeholders:

- City Residents. Residents are the customers who deserve good service with the highest return on their tax and fees investment we can provide, and who trust the City to maintain their infrastructure systems at a high level of service.
- Council Members. Council members are the voice of the citizens we serve. Each member of this group is interested in providing the best service possible at the lowest possible cost. They must balance leadership with representation.
- Public Works Department Staff. Staff currently spend time doing tasks manually which should be automated. Staff will benefit from the expertise of an Integrator who can resolve many existing operational issues in our water system and provide maintenance & support services for the system programming and instruments which will at times be beyond our staff expertise. With the upcoming in-house treatment plant operations and the WWTP upgrades project, this is a crucial time to bring on an Integrator of Record to resolve current issues and reduce future issues, and is a critical step to ensuring success on multiple projects.
- Management Team. Comprised of five department heads, each with a responsibility to the citizens and Mayor to run their day-to-day operations as efficiently as possible.

Issues and Financial Impacts:

Public Works Budget – The City is using a qualifications based selection (QBS) process for personal service contracts in accordance with ORS 279C.120(b) and the City's *Contract Review Board Rules of Procedure*, Section 11. As a result, selection of the most qualified candidate will be made without regard to the price of the services. Only after selection of the most qualified candidate will the City and selected candidate enter into contract negotiations for the price of the services.

Contracts for Integration services are typically based on an hourly rate. There is money budgeted to pay for professional services.

Elements of a Stable Solution:

Ability to resolve operational issues within the City's utility treatment and distribution facilities and provide for efficient processes by ongoing maintenance.

Options:

1. Do Nothing. This will delay the completion of needed repairs and improvements at the Water Treatment Plant. Staff will spend a great deal of time on tasks that should be automated. Integration services will continue to be procured on a case-by-case basis.
2. Authorize the solicitation of an Integrator of Record by the posting of this RFP. Posting the solicitation through the City website, local media, and the Daily Journal of Commerce

will provide the broadest possible reach for potential proposers. Staff will rank responses and conduct negotiations with the highest-ranked proposer, then return to Council to authorize the proposed contract.

3. Review the RFP and suggest revisions. Staff will revise the RFP to address Council's areas of concern and present a new draft to Council at a later date.

Recommendation:

Staff recommends Option 2, Authorize the solicitation of an Integrator of Record by the posting of this RFP as presented. This is the best option to remedy our existing operational issues and provide for the success of our treatment plant projects into the future.



City of Sweet Home, Oregon

Request for Proposals Integrator of Record Service

Closes 4:00 pm, May 26, 2021

Table of Contents

- 1. General Information**..... 3
 - 1.1. Introduction..... 3
 - 1.2. Background & Purpose 3
 - 1.3. Selection Schedule..... 4
 - 1.4. Pre-Proposal Submission Walkthrough..... 5
- 2. Scope of Services** 5
- 3. Proposal Instructions** 6
 - 3.1. Proposal Submittal and Due Date..... 6
 - 3.2. Inquiries 6
 - 3.3. Minimum Qualifications 7
 - 3.4. Proposal Format 7
 - 3.5. Proposal Contents 7
 - 3.6. Reservation of Rights..... 9
 - 3.7. Protests..... 10
 - 3.8. Public Records 10
 - 3.9. Costs 10
- 4. Proposal Evaluation** 11
 - 4.1. Evaluation Criteria..... 11
 - 4.2. Selection..... 11
 - 4.3. Contract 12

City of Sweet Home, Oregon Request for Proposals Integrator of Record Service

1. General Information

1.1. Introduction

The City of Sweet Home (City) is soliciting proposals for an Integrator of Record (Integrator) to provide water and wastewater control system and instrumentation integration services as an independent contractor to the City. Services typically conducted by the Integrator include, but are not necessarily limited to the items listed in Section 2 of this RFP. Work shall be provided to City on an as-needed basis, as authorized by the City Manager, Public Works Director, or Utilities Manager.

This RFP, issued in accordance with the provisions of the laws including statutes, ordinances, resolutions, and rules, of the State of Oregon and the City of Sweet Home, invites qualified firms (Proposers) to submit their Proposals to provide the services described.

1.2. Background & Purpose

General

The City of Sweet Home is an Oregon municipal corporation with city limits covering approximately 6 square miles. The population of the City is approximately 9,225. The City is located in Linn County, 25 miles east of I-5, and is the third largest city in the county. The City Council consists of the Mayor and six council members elected from the city at large. The Council acts as the local contract review board for the City. The City operates under a City Manager form of government.

The City has an annual expenditure budget of over \$14.3 million with revenue from a variety of sources. The funding is derived primarily from property tax support, fees, grants and contracts.

Through the Public Works Department, the City owns and operates various utility systems and infrastructure that serve the residents including the water system and the wastewater system.

The City does not currently have an Integrator of Record. Integration services have been individually procured on a project-by-project basis. The City desires to evaluate the consultant market to provide this service.

The City's goal is *"Do the most good, for the most people, for the longest period of time."* To that end the City's objective with this RFP is a successful partnership with an Integrator who will support the City's financial and operational long-term interests.

Infrastructure

The City owns and operates a number of public facilities including the following:

- 6 MGD Water treatment plant (Trident HS package filters, expandable to 10MGD).
- Water storage reservoirs (5), booster pump stations (2), and distribution system (54 miles of pipe).
- Wastewater collection system (49 miles of gravity pipe, no lift stations).
- 6 MGD Wastewater treatment plant (activated sludge). The City is in design for major plant upgrades to 12MGD which includes full automation of the upgraded plant.

The City draws surface water from Foster Reservoir. Current demand varies seasonally 1-2 MGD. Raw water is conveyed by gravity from Foster Dam to the WTP site on 47th Avenue, where it is pumped into the treatment building. Finished water is then pumped directly from the plant's clearwell into the distribution system. (There are no transmission mains from the plant to the reservoirs.) The five reservoirs are located at 3 sites around the south and west edges of the distribution system.

Direct pumping of the finished water into the distribution system causes water hammer with each on/off cycle. The plant's backwash system also draws water from the distribution system which also causes hammer and low delivery pressures during backwash. The City is in design for finished water pump VFDs and a backwash pump from the clearwell to correct these functional issues. Integrating these improvements is a high priority.

The City also desires to recover staff time by restoring the plant's automated functions. The streaming current monitors, sludge recirculation system, turbidimeters, fluoride, and Siemens panel each have functionality issues (some due to end-of-life and some due to incomplete integration). The SCADA system is suspect for inaccuracies and needs to be thoroughly vetted.

The Wastewater Treatment Plant is located on Pleasant Valley Rd. It has no SCADA and very limited automation. There is an HMI that tracks flow, chlorine residual, and some alarms. The City is currently in design for major plant improvements which will replace most treatment equipment and provide full automation. Construction is anticipated for 2022 and 2023. The selected Integrator will be part of the City's design review team and may be tasked with providing integration service for the improvements. The 60% design package is viewable on the City website at <https://www.sweethomeor.gov/publicworks/project/wwtp-improvement-project>.

1.3. Selection Schedule

The City anticipates the following general timeline for its selection process. The City reserves the right to change this schedule.

RFP Advertised
Proposal Due Date

April 28, 2021
4:00 pm, May 26, 2021

Invitation to Interview (if needed)	June 4, 2021
Begin negotiations with selected Proposer	June 21, 2021
Award Contract	July 13, 2021

1.4. Pre-Proposal Submission Walkthrough

There will be no scheduled pre-proposal submission walkthrough. Applicants can schedule one before the submittal date.

2. Scope of Services

- Serve as the City's Integrator of Record.
- Troubleshoot issues with City facilities and make recommendations for improvements.
- Update or replace any existing programming that is not functioning as intended.
- Perform ongoing routine maintenance and repairs on the existing control system and instrumentation and affected components.
- Design and integrate any control systems and instrumentation required for future expansion of the water and wastewater systems.
- Provide emergency support services.
- Work with architects, engineers and contractors as needed concerning public improvements.
- Serve as the City's representative as requested during the instrument/component selection, design review, plan approval, construction management, and project closeout phases of any capital project, development or planning project prepared by others and submitted to the City for approval. Provide written recommendations from a control systems and instrumentation perspective when requested.
- To be determined at the City's discretion, provide integration services for the Wastewater Treatment Plant Improvement Project.
- In addition to the general and recurring activities listed above, there may be ad hoc duties including verbal communications with the Mayor, City Council, City Manager, or authorized department heads and City employees in elements of prudent administration of the city's infrastructure systems.
- Subconsultants may be used, subject to written approval by the City, on design projects or where supplemental expertise is desired.

The City intends to undertake a number of projects over the next few years. These projects may include, but are not limited to:

- Water Treatment Plant repairs & functionality improvements.
- Wastewater Treatment Plant Improvement Project.
- Review water distribution system controls & prioritize needed improvements.
- Update of system master plans.

The Integrator reports directly to the Utilities Manager. Much of the work occurs via telephone conferences and e-mail. Inquiries from the general public and/or press are outside the purview

of the Integrator. Any and all inquiries for the Integrator's time shall be channeled through the Utilities Manager, Public Works Director, or the City Manager, who must authorize such request prior to the Integrator taking any action.

The Integrator may be directed to undertake specific projects for the City that have a finite scope of work, are relatively large in scale, or for any other reason the City wishes to assign the work on a task-basis to the Integrator. For such projects, the Integrator shall provide a work order upon written request from the City. The work order shall include a detailed proposal and scope of work, schedule and cost proposal.

3. Proposal Instructions

3.1. Proposal Submittal and Due Date

Proposals shall be submitted in a sealed envelope clearly marked: "Confidential: City of Sweet Home City Integrator of Record Proposal". Proposals shall meet the requirements set forth in Sections 3.4 Proposal Format, and 3.5 Proposal Contents.

Proposals shall be submitted by **4:00 p.m. on May 26, 2021** to:

Greg Springman
Public Works Director
1400 24th Ave
Sweet Home, OR 97386

The City of Sweet Home assumes no responsibility for delayed or undelivered mail or express packages. Proposals which are not received by the above specified time and date will not be considered. Faxed or emailed proposals will be rejected as non-responsive.

3.2. Inquiries

Steven Haney, Utilities Manager shall act as the facilitator for this proposal process. Questions concerning this RFP should be submitted in writing to:

Steven Haney
Utilities Manager
1400 24th Ave
Sweet Home, OR 97386
Email: shaney@sweethomeor.gov

Oral instructions or information concerning the RFP or the project given out by elected officials, employees, agents or representatives of the City of Sweet Home to prospective Proposers shall not bind the City of Sweet Home and shall not be relied upon.

3.3. Minimum Qualifications

Proposers must meet the following minimum qualifications to be evaluated:

- 5 years of experience providing Water and Wastewater integration and support services.
- Good legal standing in Oregon, and in home state if other than Oregon. (No bankruptcy, fraud, or illegal activities for the last 10 years.)
- Ability to provide the integration work needed by the City to the standards required by the City, County and State.
- Ability to furnish insurance coverage as specified in Section 7 of the attached contract form.

3.4. Proposal Format

Proposers shall provide three (3) hard copies and one (1) digital copy in .PDF format on a USB storage drive of the proposal in a sealed envelope clearly marked: "Confidential: City of Sweet Home City Integrator of Record Proposal".

If your proposal contains proprietary information protected under Section 3.8 of this RFP, please provide an additional redacted digital copy on the USB storage drive.

Proposals, including attachments, shall not exceed thirty (30) standard size (8 ½" x 11") pages, minimum 11-point font. For the purpose of demonstrating workflows or timelines in a legible manner, Proposers may use up to two larger sheets of paper not to exceed 11" x 17". If such use is made, it must be for legibility purposes only and will be considered part of the page count.

3.5. Proposal Contents

Please include the following sections in your proposal:

Cover Letter (limited to 2 pages)

An introductory letter shall be prepared by each Proposer and included as the first page of the proposal. The letter should express the Proposer's interest in the project and summarize any key qualifications or other relevant information. The letter shall be signed by an officer of the company with the authority to commit to contractual obligations on behalf of the company.

The cover letter must include:

- Date
- RFP name
- Proposer's name
- Tax identification number
- Contact person
- Telephone number
- Email address
- Complete mailing and street address

- A description of the firm or organization (corporation, partnership, etc) that will serve as the contracting party
- Identify proposed subcontractors, if applicable.
- Include a statement confirming that the Proposer meets the minimum qualifications stated in Section 3.3.
- Identify COBID ownership status and/or employment practices regarding COBID businesses, if applicable.
- Written affirmation that the firm has a policy of nondiscrimination in employment because of race, age, color, sex, religion, national origin, mental or physical handicap, political affiliation, marital status or other protected class, and has a drug-free workplace policy.
- An explanation of any potential or actual conflicts of interest within the jurisdictional boundaries of the City. Conflict of interest is defined for purposes of this RFP and any resulting contract as proposer's provision of services to any private property owner or developer within the City's jurisdictional boundaries.

Project Approach

Describe the Proposer's project management techniques. Describe the overall project approach for identifying and performing necessary control system and instrumentation repairs and/or improvements and for providing ongoing maintenance and support services. Information concerning the design and current state of the facilities should be provided and convey a clear understanding of the City's existing facilities. Multiple aspects of the project approach should be addressed such as design/hardware, software/platform, installation, maintenance, training, and ease of operator use. Demonstrate understanding of municipal long-term capital planning & budgeting to accomplish projects in phases as budget becomes available.

Technical Expertise & Qualifications

Address proposer's familiarity with operations, construction and maintenance of the City's current systems. Describe Proposer's expertise in the following areas:

- Water treatment and distribution facilities.
- Activated sludge wastewater treatment facilities.
- SCADA, PLC, and HMI systems.
- Programming and integration of chemical feed pumps, variable frequency drives, and process instruments.
- Public finance and infrastructure financing.

Provide a current résumé for the individual who will serve as the Integrator project lead and of professional persons who will assist the project lead in performing the work. Include description of qualifications, skills, and responsibilities, and any relevant licenses or certifications. The City is interested in professionals with experience serving small governmental entities and especially serving cities comparable in size to Sweet Home.

Provide a list of the tasks, responsibilities, and qualifications of any subconsultants proposed to be used on a routine basis.

Similar Experience and Past Performance

Provide a description of similar previous work demonstrating quality of work, ability to meet schedules, ability to provide emergency support, cost control, contract administration, and the ability to maintain good long-term business relationships. Provide a list of at least five (5) clients similar in size and character to Sweet Home's facilities. For each project provide the following information:

- Project Title/Name
- Name and address of client
- Client contact person and contact information
- Summary of project scope and services provided
- Duration of service to client

Support Proximity & Availability to the City of Sweet Home

Describe the availability of personnel to the City of Sweet Home to respond for repairs, general maintenance, and emergencies. Detail the proximity of personnel or offices that will be providing on-site services, the approximate response time, and the availability and hours of support provided over the telephone.

Ancillary Support Services Provided

Describe any ancillary support services the Proposer typically offers or may offer through existing subcontractor relationships. Examples of such services could include:

- Electrical Engineering services
- Licensed Electrician services
- Development of system one line diagrams
- Providing UL listed cabinets
- Provide mobile device access to system information
- Programming, adjusting operations, and/or servicing backup power generation

3.6. Reservation of Rights

The City reserves the right to: 1) seek clarifications of each proposal; 2) negotiate a final contract that is in the best interest of the City and the public; 3) reject any or all proposals; 4) cancel this RFP at any time if doing so would be in the public interest, as determined by City in its sole discretion; 5) award the contract to any proposer based on the evaluation criteria set forth in this RFP; 6) waive minor informalities contained in any proposal, when, in the City's sole judgment, it is in the City's best interest to do so; and 7) request any additional information City deems reasonably necessary to allow City to evaluate, rank and select the most qualified proposer to perform the services described in this RFP.

3.7. Protests

Proposers are directed to the protest procedures contained in Public Contracting Rule OAR 137-048-0240.

Protests of Solicitation

Proposers are directed to the protest procedures contained in OAR 137-048-0240. Proposers may submit a written protest of anything contained in an RFP and may request a change to any provision, specification or Contract term contained in an RFP, no later than seven (7) calendar days prior to the date Proposals are due. Each protest and request for change must include the reasons for the protest or request, and any proposed changes to the RFP provisions, specifications or Contract terms.

Protests of Contract Award

Proposers are directed to the protest procedures contained in OAR 137-048-0240. A Proposer who claims to have been adversely affected or aggrieved by the selection of the highest ranked Proposer may submit a written protest of the selection to the Contracting Agency no later than seven (7) calendar days after the date of the selection notice. A Proposer submitting a protest must claim that the protesting Proposer is the highest ranked Proposer because the proposals of all higher ranked Proposers failed to meet the requirements of the RFP or because the higher ranked Proposers otherwise are not qualified to perform the Services described in the RFP.

3.8. Public Records

All proposals submitted are the property of the City of Sweet Home, thus subject to disclosure pursuant to the public records law, as qualified by ORS 279C.107. Accordingly, proposals received and opened shall not be available for public inspection until after City's notice of intent to award this contract is issued. Thereafter, except for information marked "Proprietary", all documents received by City shall be available for public disclosure. The City will attempt to maintain the confidentiality of materials marked "Proprietary" to the extent permitted under the Oregon Public Records law. Marking all, or substantially all, or your proposal as "Proprietary" is not permitted and may be grounds for the City considering your proposal nonresponsive, at the City's sole discretion. If your proposal contains proprietary information protected under this section, please provide an additional redacted digital copy on the USB storage drive.

3.9. Costs

Proposers responding to this RFP do so solely at their own expense.

4. Proposal Evaluation

4.1. Evaluation Criteria

In evaluating the proposal, the City will utilize the requirements outlined in this section to identify the contractor best qualified to perform the services.

Completeness & Responsiveness (all must be yes)

- Timeliness of submittal
- Satisfies minimum qualifications
- Satisfies content & format requirements

Scoring Criteria

Proposals meeting the above Completeness & Responsiveness requirements will be evaluated by the City using the following criteria:

(20%) Specialized experience, capabilities and technical competence, which the prospective consultant may demonstrate with the prospective consultant's proposed approach and methodology to meet the project requirements.

(20%) Resources committed to perform the services and the proportion of the time that the prospective consultant's staff would spend to perform services for the contracting agency, including time for specialized services, within the applicable time limits.

(15%) Record of past performance, including but not limited to price and cost data from previous projects, quality of work, ability to meet schedules, cost control and contract administration.

(2%) Ownership status and employment practices regarding disadvantaged business enterprises, minority-owned businesses, woman-owned businesses, businesses that service-disabled veterans own, emerging small businesses or historically underutilized businesses. (COBID businesses.)

(25%) Availability to the project locale.

(10%) Familiarity with the project locale.

(8%) Proposed project management techniques.

4.2. Selection

The City is using a qualifications based selection (QBS) process for personal service contracts in accordance with ORS 279C.120(b) and the City's Contract Review Board Rules of Procedure, Section 11. As a result, selection of the most qualified candidate will be made

without regard to the price of the services. Only after selection of the most qualified candidate will the City and selected candidate enter into contract negotiations for the price of the services.

Each member of the evaluation committee shall complete an evaluation sheet ranking each qualified proposer against the weighted criteria set forth in Section 4.1 of this RFP. Completed evaluations shall be combined and tallied. The City reserves the right to interview one or more of the highest ranked candidates. Upon completion of its evaluation process, results of the evaluation will be posted to the RFP listing on the City website and will be emailed to the primary contact identified in each proposal, and the City will begin negotiating a contract with the highest ranking candidate. The City shall direct negotiations toward obtaining written agreement on the Integrator's performance obligations, a payment methodology that is fair and reasonable to the City, and any other provisions the City believes to be in the City's best interest to negotiate.

If the City and the selected candidate are unable for any reason to negotiate a contract at a compensation level that is reasonable and fair to the City, the City shall, either orally or in writing, formally terminate negotiations with the selected candidate. The City may then negotiate with the next most qualified candidate. The negotiation process may continue in this manner through successive candidates until an agreement is reached or the City terminates this RFP.

Upon reaching agreement, the notice of intent to award will be posted and the contract will be presented to City Council for approval. If City Council approves the award of the contract as presented, then the agreement will be executed.

It is the desire of the City to have a contract in place no later than July 31, 2021.

4.3. Contract

The City desires to enter into a professional services agreement in the form attached, which includes all services necessary for this position, whether or not the services are specifically outlined in this RFP.

The selected proposer will be expected to sign the attached written agreement, which will incorporate this RFP and awardee's proposal. Any open terms in the attached contract will be completed, based upon awardee's proposal. Negotiations shall be limited to cost and any other terms the City chooses to negotiate, in City's sole discretion.

The City anticipates payment for services on an hourly basis. However, the City will also consider alternative proposals. The City reserves the right to negotiate a compensation package that is fair and reasonable to the City, as determined solely by City.

It is anticipated that the City of Sweet Home will enter into a three (3) year agreement, which thereafter may be extended upon written consent of both parties for additional three (3) year terms.

Any contract requires that awardee will comply with all applicable federal and state laws, rules and regulations.

The City of Sweet Home is an Equal Opportunity/Affirmative Action Employer.
Women, Minorities and Disabled Persons are encouraged to apply.

This RFP is issued in accordance with the provisions of the laws including statutes, ordinances, resolutions, and rules, of the State of Oregon and the City of Sweet Home. Authorized & approved for posting by the City Council and the City Manager. Staff can amend the RFP and contract form to meet the best interests of the City with the approval of the City Manager.

THIS SOLICITATION IS NOT AN IMPLIED CONTRACT AND MAY BE MODIFIED OR REVOKED WITHOUT NOTICE.

**City of Sweet Home
Personal Services Contract for
City Integrator of Record Services**

This Contract is by and between the City of Sweet Home (“City”) and _____ (“Integrator”) for the performance of utility control system and instrumentation integration services for City, on an as needed basis.

A. RECITALS

City has conducted a formal solicitation for proposals from engineering firms pursuant to Public Contracting law.

Integrator submitted its proposal, having examined the Request for Proposals (RFP), and was chosen as the most highly qualified Integrator, best suited to meet City’s needs pursuant to the RFP criteria.

City has awarded the contract to Integrator.

B. CONTRACT EXHIBITS

The following exhibits are hereby incorporated by reference into this Contract:

- Exhibit A – Scope of Work
- Exhibit B – Oregon Personal Services Public Contracting Code Requirements
- Exhibit C – Request for Proposal
- Exhibit D – Integrator’s Proposal
- Exhibit E – Integrator’s Schedule of Rates and Charges

C. AGREEMENT

1. Term

The term of this Contract shall be from its execution to June 30, 2024, for an initial three (3) year term. Thereafter, it may be extended for additional three (3) year terms upon written consent of both parties. Such extension(s) will consider adjustments to Integrator’s schedule of charges attached within Exhibit E to this Agreement.

2. Scope of Work

Integrator shall provide all services and deliver all materials as specified in the attached Exhibits A, C and D, which are hereby incorporated into this Contract by this reference, and as may be described by future addenda to this Contract.

3. Compensation

3.1 Compensation. For the services described and performed by Integrator, the City agrees to pay, and the Integrator agrees to accept, compensation in accordance with the Schedule of Rates and Charges, attached within Exhibit E.

3.2 Invoices. Invoices for services of Integrator shall be billed to the City in summary form, itemized by projects and/or work tasks, on or about the first day of each month for all services performed through the last day of the previous month. Reimbursable expenses shall be itemized and backup invoices provided if required by City.

3.3 Payments.

- a. City will review Integrator's invoice and within ten (10) days of receipt notify Integrator in writing if there is a disagreement or dispute with the invoice. If there are no such disputes with the invoice, City shall pay the invoice amount in full within thirty (30) days of invoice date.

- b. If City fails to make any payment due Integrator for services and expenses within thirty (30) days of the date on Integrator's invoice therefore, late fees will be added to amounts due Integrator at the rate of 1.0 percent per month from original invoice date. Invoices in dispute are not subject to such late fees until such time as they are no longer in dispute. In addition, Integrator may, after giving seven (7) days written notice to City, suspend services under this Contract until Integrator has been paid in full all amounts due for services, expenses, and charges, except any invoices in dispute.

4. Contractor Is an Independent Contractor

Integrator shall be an independent contractor for all purposes and shall be entitled to no compensation other than the compensation provided for under this Contract. While City reserves the right to set various schedules and evaluate the quality of Integrator's completed work, City cannot and will not control the means and manner of Integrator's performance. Integrator is responsible for determining the appropriate means and manner of performing work. Integrator is responsible for all federal and state taxes applicable to compensation and payment paid to Integrator under the Contract and will not have any amounts withheld by City to cover Integrator's tax obligations. Integrator is not eligible for any City fringe benefit plans.

5. Notices

All notices provided for hereunder shall be in writing and shall be deemed to be duly served on the date of delivery if delivered in person, when receipt of transmission is generated by the transmitting facsimile machine if delivered by facsimile transmission, on the day after deposit if delivered by overnight courier, or three days after deposit if delivered by placing in the U.S. mail, first-class, postage prepaid. Any notice delivered by facsimile transmission shall be followed by a hard copy. All notices shall be addressed as follows:

City:	Public Works Department City of Sweet Home 1400 24 th Avenue Sweet Home, OR 97386	Phone: (541) 367-6359 Fax: (541) 367-7592
-------	---	--

Integrator: _____

Phone: _____
Fax: _____

6. Indemnification

Integrator shall indemnify and hold harmless City and its representatives, officers, directors, and employees from any loss or claim made by third parties to the extent arising directly or indirectly from Integrator's negligent performance and/or fault of Integrator, its employees, representatives, or subcontractors. If the loss or claim is caused by the joint concurrent negligence or other fault of City and Integrator, the loss or claim shall be borne by each in proportion to the degree of negligence or other fault attributable to each.

For claims based upon professional negligence, Consultant's obligation to indemnify indemnitees for defense costs (as defined) is not immediate and shall be satisfied at the time of any settlement or judgment as to Consultant's indemnity obligations under this Agreement.

7. Insurance Requirements

7.1 During the term of this Contract, Integrator shall maintain, at its own expense, the following types of insurance in the following amounts:

- a. Commercial General Liability insurance, including coverage for premises operations, independent contractors, protected products, completed operations, contractual liability, personal injury, and broad form for property damage (including coverage for explosion, collapse, and underground hazards, if applicable):
 - \$2,000,000 – each occurrence (bodily injury)
 - \$2,000,000 – general aggregate
 - \$2,000,000 – property damage, contractual, etc.
 - \$2,000,000 – umbrella liability coverageCoverage shall also include contractual liability coverage for the indemnity provided under this contract.
- b. Automobile Liability insurance limit shall not be less than \$1,000,000 combined single limit per accident.
- c. Workers' Compensation and employer's liability insurance per ORS Chapter 656. The employer's liability limit shall not be less than \$1,000,000 per occurrence.
- d. Errors and Omissions insurance covering Integrator's liability arising out of negligent acts, errors or omissions in its performance of work or services under this Contract. Such policy will have a combined single limit of not less than \$2,000,000 per each claim, incident or occurrence for the term of the Project. Such policy will be on a claims made basis and will have an extended claims reporting period of five (5) years after final completion.

- e. The limits required in this Section 7.1 may be met with a combination of underlying and umbrella coverage.

7.2 Except as required in 7.1(d) above, if any of the above required insurance is arranged on a "claims made" basis, "tail" coverage will be required at final completion or termination of this Contract for a duration of two (2) years.

7.3 Policies shall provide that City, its council, officers, representatives, employees, and agents will be included as an additional insured with respect to the coverages required in Section 7.1(a) and a waiver of subrogation against them shall be obtained for all coverages.

7.4 All coverages under Section 7.1 shall be primary over any insurance City may carry on its own.

7.5 City shall be solely responsible for any loss, damage or destruction to its own property, equipment, and materials used in conjunction with the work or services under this Contract.

7.6 All policies of insurance shall be issued by good, responsible companies, with a rating reasonably acceptable to City and that are qualified to do business in the state of Oregon.

7.7 Integrator shall furnish City with certificates of insurance evidencing all required coverages prior to commencing any work or services under this Contract. If requested by City, Integrator shall furnish City with executed copies of such policies of insurance. Integrator shall furnish City with at least 30 days' written notice of cancellation of, or any modification to, the required insurance coverages. Failure to maintain any required insurance coverages in the minimum required amounts shall constitute a material breach of this Contract and shall be grounds for immediate termination of this Contract.

7.8 All liability insurance, except for Workers' Compensation, Professional Liability, and Network Security and Privacy Liability (if applicable), required under this Contract must include an additional insured endorsement with the certificate of insurance specifying the City of Sweet Home, its officers, employees and agents as Additional Insureds, including additional insured status with respect to liability arising out of ongoing operations and completed operations, but only with respect to Contractor's activities to be performed under this Contract. Coverage shall be primary and non-contributory with any other insurance and self-insurance. The Additional Insured endorsement with respect to liability arising out of your ongoing operations must be on ISO Form CG 20 10 07 04 or equivalent and the Additional Insured endorsement with respect to completed operations must be on ISO form CG 20 37 04 13 or equivalent and attached to Certificate of Insurance.

8. Workers' Compensation

8.1 Integrator, its subcontractors, if any, and all employers working under this Contract are subject employers under the Oregon Workers' Compensation Law and shall comply

with ORS 656.017, which requires them to provide workers' compensation coverage for all subject workers.

8.2 Integrator warrants that all persons engaged in Contract work and subject to the Oregon Workers' Compensation Law are covered by a workers' compensation plan or insurance policy that fully complies with Oregon law. Integrator shall indemnify City for any liability incurred by City as a result of Integrator's breach of the warranty under this paragraph.

9. Hours of Employment

Integrator shall comply with all applicable state and federal laws regarding employment.

10. Assignments and Subcontractors

Integrator may not assign or subcontract any of its responsibilities under this Contract without City's prior written consent. Integrator's assigning or subcontracting of any of its responsibilities under the Contract without City's consent shall constitute a material breach of this Contract. Regardless of any assignment or subcontract, Integrator shall remain liable for all of its obligations under this Contract.

11. Labor and Material

Integrator shall provide and pay for all labor, materials, equipment, tools, water, heat, utilities, transportation, and other facilities and services necessary for the proper execution and completion of all Contract work, all at no cost to City other than the compensation provided in this Contract.

12. Ownership of Work and Documents

All work performed by Integrator and compensated by City pursuant to this Contract shall be the property of City upon full compensation for that work performed or document produced to Integrator, and it is agreed by the parties that such documents are works made for hire. Integrator hereby conveys, transfers and grants to City all rights of reproduction and the copyright to all such documents. City shall not be limited in any way in its use of the Documents and Data at any time, provided that any such use not within the purposes intended by this Agreement shall be at City's sole risk.

13. Termination for Convenience

13.1 This Contract may be terminated by mutual consent of the parties upon written notice. In addition, City may terminate all or part of this Contract upon determining that termination is in the best interest of City by giving seven (7) days' prior written notice of intent to terminate, without waiving any claims or remedies it may have against Integrator. Upon termination under this paragraph, Integrator shall be entitled to payment in accordance with the terms of this Contract for Contract work completed and accepted before termination less previous amounts paid and any claim(s) City has against Integrator. Pursuant to this paragraph, Integrator shall submit an itemized invoice for all unreimbursed Contract work completed before termination and all Contract closeout costs actually incurred by Integrator. City shall not be liable for any costs invoiced later

than thirty (30) days after termination unless Integrator can show good cause beyond its control for the delay.

13.2 City may unilaterally order Integrator to suspend all or part of the services under this Contract. If City suspends certain services under this Contract and later orders Integrator to resume those services, Integrator will be entitled to reimbursements for the costs actually and reasonably incurred, if any, in re-starting the suspended services.

14. Termination for Cause

City may terminate this Contract effective upon delivery of written notice to Integrator, or at such later date as may be established by City, under any of the following conditions:

14.1 If City funding is not obtained and continued at levels sufficient to allow for purchases of the indicated quantity of services. The Contract may be modified to accommodate a reduction in funds.

14.2 If federal or state regulations or guidelines are modified, changed, or interpreted in such a way that the services are no longer allowable or appropriate for purchase under this Contract or are no longer eligible for the funding proposed for payments authorized by this Contract.

14.3 If any license or certificate required by law or regulation to be held by Integrator to provide the services required by this Contract is for any reason denied, revoked, or not renewed.

15. Termination for Default

Either City or Integrator may terminate this Contract in the event of a breach of the Contract by the other. Prior to such termination, the party seeking termination shall give to the other party written notice of the breach and intent to terminate. If the party committing the breach has not entirely cured the breach within fifteen (15) days of the date of the notice, then the party giving the notice may terminate the Contract at any time thereafter by giving a written notice of termination.

If Integrator fails to perform in the manner called for in this Contract or if Integrator fails to comply with any other provisions of the Contract, City may terminate this Contract for default. Termination shall be effected by serving a notice of termination on Integrator setting forth the manner in which Integrator is in default. Integrator shall be paid the Contract price only for services performed in accordance with the manner of performance as set forth in this Contract.

16. Remedies

In the event of breach of this Contract the parties shall have the following remedies:

16.1 If terminated under paragraph 15 by City due to a breach by Integrator, City may complete the work either itself, by agreement with another contractor, or by a combination thereof. If the cost of completing the work exceeds the remaining unpaid balance of the total compensation provided under this Contract, then Integrator shall pay to City the amount of the reasonable excess.

16.2 In addition to the above remedies for a breach by Integrator, City also shall be entitled to any other equitable and legal remedies that are available.

16.3 If City breaches this Contract, Integrator's remedy shall be limited to termination of the Contract and receipt of Contract payments to which Integrator is entitled.

16.4 City shall not be liable for any indirect, incidental, consequential, or special damages under the Contract or any damages arising solely from terminating the Contract in accordance with its terms.

16.5 Upon receiving a notice of termination, and except as otherwise directed in writing by City, Integrator shall immediately cease all activities related to the services and work under this Contract. As directed by City, Integrator shall, upon termination, deliver to City all then existing work product that, if the Contract had been completed, would be required to be delivered to City.

17. Nondiscrimination

During the term of this Contract, Integrator shall not discriminate against any employee or applicant for employment on the basis of any protected class as defined in ORS279A.112(b).

18. Governing Law; Jurisdiction; Venue

This Contract shall be governed by and construed in accordance with the laws of the state of Oregon without regard to principles of conflicts of law. Any claim, action, suit or proceeding (collectively "Claim") between City and Integrator that arises from or relates to this Contract which results in litigation shall be brought and conducted solely and exclusively within the Circuit Court of Linn County for the state of Oregon; provided, however, if a Claim must be brought in a federal forum, then it shall be brought and conducted solely and exclusively within the United States District Court for the District of Oregon. INTEGRATOR BY EXECUTION OF THIS CONTRACT, HEREBY CONSENTS TO THE IN PERSONAM JURISDICTION OF SAID COURTS. Nothing herein shall be construed as a waiver of City's protections under the Oregon Tort Claims Act.

19. Compliance with Laws and Regulations

Integrator shall comply with all federal, state and local laws, regulations, executive orders and ordinances applicable to the services under this Contract. Without limiting the generality of the foregoing, Integrator expressly agrees to comply with: (i) ORS 659a.142; (ii) all regulations and administrative rules established pursuant to the foregoing laws; and (iii) City's performance under this Contract is conditioned upon Integrator's compliance with all applicable provisions of the Oregon Public Contracting Code, as more particularly set forth in Exhibit B and incorporated herein by this reference. Integrator, its sub-consultants and all employers providing work, labor or materials under this Contract are subject employers under the Oregon workers' compensation law and shall comply with ORS 656.017, which requires them to provide Oregon workers' compensation coverage that satisfies Oregon law for all their subject workers. Integrator shall adhere to all safety standards and regulations established by City for work performed on its premises or under its auspices.

20. Experience, Capabilities and Resources

By execution of this Contract, the Integrator agrees that:

Integrator is an experienced integration firm having the skill, legal capacity, and professional ability necessary to perform all the services required under this Contract to design or administer any work within the scope and complexity contemplated by this Contract.

Integrator has the capabilities and resources necessary to perform the obligations of this Contract.

Integrator is familiar with all current laws, rules, and regulations which are applicable to the design and construction of work which may fall within the scope of this Contract, and that all drawings, specifications, and other documents prepared by Integrator shall be prepared in a manner consistent with the professional skill and care ordinarily provided by firms practicing in the same or similar locality under the same or similar circumstances (herein the "Standard of Care") and shall exercise the Standard of Care in complying with applicable and non-conflicting laws, rules, and regulations.

21. Drawings, Specifications and Other Documents

Integrator hereby agrees that it will, in a manner consistent with its standard of care defined in above in Section 20, prepare all drawings, specifications, and other documents pursuant to this Contract so that they are complete and that any project, if constructed in accordance with the intent established by such drawings, specifications, and other documents, shall be structurally sound and a complete and properly functioning facility.

22. Errors and Omissions

Integrator shall be responsible for correcting any errors or omissions in the drawings, specifications, and/or other documents which deviate from the standard of care set forth in Section 21. Integrator shall correct at no additional cost to City any and all such errors and omissions in the drawings, specifications, and other documents prepared by Integrator or its sub-consultants. Integrator further agrees to assist City in resolving problems relating to any project designs or specified materials that are caused by deviations from the Standard of Care

23. Contract Performance

Integrator shall at all times carry on the services diligently, without delay and punctually fulfill all requirements herein. Integrator shall not be liable for delays that are beyond Integrator's control. Contract expiration shall not extinguish, prejudice, or limit either party's right to enforce this Contract with respect to any breach of Integrator's warranties or a default or defect in performance by Integrator that has not been cured.

24. Access to Records

For not less than three (3) years after the Contract expiration and for the purpose of making audit, examination, excerpts, and transcripts, City, and its duly authorized representatives shall have access to Integrator's books, documents, papers, and records that are pertinent to this Contract. If, for any reason, any part of this Contract, or any resulting construction contract(s) is involved in litigation, Integrator shall retain all pertinent records for not less than three years or until all litigation is resolved, whichever is longer. Integrator shall provide full access to these records to City, and City's duly authorized representatives in preparation for and during litigation.

25. Representations and Warranties

Integrator represents and warrants to City that (1) Integrator has the power and authority to enter into and perform this Contract, (2) when executed and delivered, this Contract shall be a valid and binding obligation of Integrator enforceable in accordance with its terms, (3) Integrator shall, at all times during the term of this Contract, be duly licensed to perform the services, and if there is no licensing requirement for the profession or services, be duly qualified and competent, (4) the services under this Contract shall be performed in accordance with the professional skill, care and standards ordinarily used by professionals performing similar services under similar conditions. No other warranties are expressed or implied in this Agreement.

26. City Obligations

26.1 City shall provide full information in a timely manner regarding requirements for and limitations on projects and work tasks. With regard to subcontractor liens, City shall furnish to Integrator, within fifteen (15) days after receipt of a written request, information necessary and relevant for Integrator to evaluate, give notice of, or enforce lien.

26.2 City shall establish and update, if necessary, overall project budgets, including consulting and construction costs.

26.3 City shall furnish the services of consultants, when such services are requested by Integrator, reasonably required by the scope of a project, and agreed to by City.

26.4 City shall furnish all testing as required by law or the contract documents.

26.5 City shall furnish all legal accounting, auditing and insurance services as necessary for projects to meet the City's needs and interests, after Integrator has performed requisite project management and oversight duties.

26.6 City shall provide prompt written notice to Integrator if City becomes aware of any fault or defect in a project, including any errors, omissions or inconsistencies in Integrator's design or performance under the contract.

26.7 City shall pay Integrator in accordance with paragraph 3 and Exhibit E of this Contract, upon receipt of Integrator's submission of monthly invoices, and satisfactory progress and performance made in accordance with the scope of work. Payments shall reflect work completed, or progress made on a project to date, on a pro rata basis.

26.8 City shall report the total amount of all payments to Integrator, including any expenses, in accordance with federal Internal Revenue Service and State of Oregon Department of Revenue regulations.

26.9 City shall guarantee access to, and make all provisions for Integrator to enter upon public and private property necessary for performance of the Scope of Work over which City exercises control.

26.10 Extra work or work on contingency tasks is not permitted unless authorized by the City in writing. Failure of Integrator to secure written authorization for extra work shall constitute a waiver of all rights to an adjustment in the Agreement price or Agreement time.

27. Arbitration

All claims, disputes, and other matters in question between the City and Integrator arising out of, or relating to this Contract, including rescission, reformation, enforcement, or the breach thereof except for claims which may have been waived by the making or acceptance of final payment, may be decided by binding arbitration in City's sole discretion, in accordance with Uniform Oregon Arbitration Act ORS 36.600 et seq. and any additional rules mutually agreed to by both parties. If the parties cannot agree on rules within ten (10) days after the notice of demand, the presiding judge of the Linn County Circuit Court will establish rules to govern the arbitration. The City shall have the sole discretion as to whether or not dispute will be decided by arbitration rather than through the court process.

A claim by Integrator arising out of, or relating to this Contract must be made in writing and delivered to the City Manager not less than 30 days after the date of the occurrence giving rise to the claim. Failure to file a claim with the City Manager within 30 days of the date of the occurrence that gave rise to the claim shall constitute a waiver of the claim. A claim filed with the City Manager will be considered by the City Council at the Council's next regularly scheduled meeting. At that meeting the Council will render a written decision approving or denying the claim. If the claim is denied by the Council, the Integrator may file a written request for arbitration with the City Manager. No demand for arbitration shall be effective until the City Council has rendered a written decision denying the underlying claim. No demand for arbitration shall be made later than thirty (30) days after the date on which the City has rendered a written decision on the underlying claim. The failure to demand arbitration within said 30 days shall result in the City Council's decision being binding upon the City and Integrator.

Notice of demand for arbitration shall be filed in writing with the other party to the agreement. The demand for arbitration shall be made within the 30-day period specified above. The City, if not the party demanding arbitration, has the option of allowing the matter to proceed with binding arbitration or by written notice within five (5) days after receipt of a demand for arbitration, to reject arbitration and require the Integrator to proceed through the courts for relief. If arbitration is followed, the parties agree that the award rendered by the arbitrators will be final, judgment may be entered upon it in any court having jurisdiction thereof, and will not be subject to modifications or appeal except to the extent permitted by Oregon law.

28. Attorney Fees

If suit, action or arbitration is brought either directly or indirectly to rescind, reform, interpret or enforce the terms of this contract to the extent due to the negligent performance of the Integrator's employees, representatives or subcontractors, the prevailing party shall recover and the losing party hereby agrees to pay reasonable attorney's fees incurred in such proceeding, in both the trial and appellate courts, as well as the costs and disbursements. Further, if it becomes necessary for City to incur the services of an attorney to enforce any provision of this contract without initiating litigation, Integrator agrees to pay City's attorney's fees so incurred. Such costs and fees shall bear interest at the maximum legal rate from the date incurred until the date paid by losing party.

29. Successors and Assigns

The provisions of this Contract shall be binding upon and shall inure to the benefit of the parties hereto, and their respective successors and assigns.

30. Limitation of Liabilities

City shall not be liable for (i) any indirect, incidental, consequential, or special damages under the Contract or (ii) any damages of any sort arising solely from the termination of this Contract in accordance with its terms. Integrator shall not be liable for any consequential damages under this Contract.

31. Foreign Contractor

If Integrator is not domiciled in or registered to do business in the state of Oregon, Integrator shall promptly provide to the Oregon Department of Revenue and the Secretary of State Corporation Division all information required by those agencies relative to this Contract. Integrator shall demonstrate its legal capacity to perform the work under this Contract in the state of Oregon prior to entering into this Contract.

32. Confidentiality

Integrator shall maintain the confidentiality of any of City's information that has been so marked as confidential, unless withholding such information would violate the law, create the risk of significant harm to the public or prevent Integrator from establishing a claim or defense in an adjudicatory proceeding. Integrator shall require similar agreements from City's and/or Integrator's sub-consultants to maintain the confidentiality of information of City.

33. Force Majeure

Integrator shall not be deemed in default hereof nor liable for damages arising from its failure to perform its duties or obligations hereunder if such is due to causes beyond its reasonable control, including, but not limited to, acts of God, acts of civil or military authorities, fires, floods, windstorms, earthquakes, strikes or other labor disturbances, civil commotion or war, epidemics, pandemics, declared states of emergency, closing or reduction of force by the contractors or governmental permit reviewing entities, the enactment of governmental actions which cause delays or limit travel..

34. Waivers

No waiver by City of any provision of this Contract shall be deemed to be a waiver of any other provision hereof or of any subsequent breach by Integrator of the same or any other provision. City's consent to or approval of any act by Integrator requiring City's consent or approval shall not be deemed to render unnecessary the obtaining of City's consent to or approval of any subsequent act by Integrator, whether or not similar to the act so consented to or approved.

35. Severability

Any provision of this Contract which shall prove to be invalid, void or illegal shall in no way affect, impair or invalidate any other provision hereof, and such remaining provisions shall remain in full force and effect.

36. Survival

All provisions of this Agreement that would reasonably be expected to survive the termination of this Agreement will do so.

37. Headings

The captions contained in this Contract are for convenience only and shall not be considered in the construction or interpretation of any provision hereof.

38. Integration and Modification

This Contract, including the attached exhibits referenced in Section B, contains the entire agreement between the parties regarding the matters referenced herein and supersedes all prior written or oral discussions or agreements regarding the matters addressed by this Contract. Any modifications or amendments to this Contract will only be effective when made in writing and signed by authorized parties for each party to this Contract.

39. Authority

The representatives signing on behalf of the parties certify that they are duly authorized by the party for which they sign to make this Contract.

40. Certificate of Compliance with Oregon Tax Laws

By executing this Contract, Integrator certifies under penalty of perjury that Integrator is, to the best of Integrator's knowledge, not in violation of any Oregon tax laws described in ORS 305.385(6) and (7).

41. Time is of the Essence

Time is of the essence under this Contract.

CITY OF SWEET HOME

By: _____

Name: Ray Towry

Title: City Manager

Date: _____

Authorized & Approved by the City Council.
City Manager approves contract.

Approved as to form.

By: _____

Name: Robert Snyder

Title: City Attorney

Date: _____

INTEGRATOR

By: _____

Authorized Signature

Name: _____

Title: _____

Date: _____

Exhibit A

Scope of Work

SERVICES AND RESPONSIBILITY OF INTEGRATOR

1. Instrumentation, Controls, Supervisory Control and Data Acquisition (SCADA) / Human Machine Interface (HMI), Industrial Network, Wireless Network, and Security Systems Design and Programming. Work will be subject to consulting review/modifications as required or as requested by the City.
2. Technical Writing, Drafting, and Documentation to obtain approvals from the appropriate agencies.
3. Assist the City Engineer, or other City Contracted Consultant(s), with the design of instrumentation, controls, and SCADA/HMI systems as requested for City projects.
4. Installation, construction, and startup of new City instrumentation, controls, networking, security, and SCADA/HMI systems as requested by the City.
5. Perform new installations and modify existing electrical systems in City owned facilities as necessary to install instrumentation, controls, networking, security, and SCADA/HMI systems as requested by the City.
6. Perform repairs, modifications, and other tasks as required by the City to maintain functionality of the instrumentation, SCADA/HMI, Industrial Network, Wireless Network, and Security Systems. This includes after hours and emergency callouts.
7. Perform submittal reviews of new equipment and instrumentation to ensure compatibility with existing City systems.
8. Perform life cycle cost analysis, Capital Projects cost projections, and other budgetary forecasting as requested by the City.

Exhibit B

Oregon Public Contracting Requirements

ORS CHAPTERS 279B AND 279C REQUIREMENTS

(1) Consultant shall pay promptly, as due, all persons supplying labor or materials for the prosecution of the work provided for in the contract, and shall be responsible for such payment of all persons supplying such labor or material to any Subcontractor.

(2) Consultant shall promptly pay all contributions or amounts due the Industrial Accident Fund from such Consultant or Subcontractor incurred in the performance of the contract.

(3) Consultant shall not permit any lien or claim to be filed or prosecuted against the City on account of any labor or material furnished and agrees to assume responsibility for satisfaction of any such lien so filed or prosecuted.

(4) Consultant and any Subcontractor shall pay to the Department of Revenue all sums withheld from employees pursuant to ORS 316.617.

(5) If Consultant fails, neglects or refuses to make prompt payment of any claim for labor or materials furnished to the Consultant or a Subcontractor by any person in connection with the contract as such claim becomes due, the City may pay such claim to the persons furnishing the labor or material and charge the amount of payment against funds due or to become due Consultant by reason of the contract. The payment of a claim in the manner authorized hereby shall not relieve the Consultant or his surety from his or its obligation with respect to any unpaid claim. If the City is unable to determine the validity of any claim for labor or material furnished, the City may withhold from any current payment due Consultant an amount equal to said claim until its validity is determined and the claim, if valid, is paid.

(6) Consultant shall promptly, as due, make payment to any person, copartnership, association, or corporation, furnishing medical, surgical and hospital care or other needed care and attention, incident to sickness or injury, to employees of such Consultant, of all sums which the Consultant agrees to pay for such services and all monies and sums which the Consultant collected or deducted from the wages of employees pursuant to any law, contract or agreement for the purpose of providing or paying for such service.

(7) Consultant shall pay Consultant's employees who work under the public contract at least time and a half for all overtime the employees work in excess of 40 hours in any one week, except for employees under a personal services public contract who are excluded under ORS 653.010 to 653.261 or under 29 U.S.C. 201 to 209 from receiving overtime.

(8) The Consultant must give notice to employees who work on this contract in writing, either at the time of hire or before commencement of work on the contract, or by posting a notice in a location frequented by employees, of the number of hours per day and the days per week that the employees may be required to work.

(9) All subject employers working under the Consultant are either employers that will comply with ORS 656.017, or employers that are exempt under ORS 656.126.

(10) All sums due the State Unemployment Compensation Fund from the Consultant or any Subcontractor in connection with the performance of the contract shall be promptly so paid.

(11) The contract may be canceled at the election of City for any willful failure on the part of Consultant to faithfully perform the contract according to its terms.

(12) Consultant certifies compliance with all applicable Oregon tax laws, in accordance with ORS 305.385.

(13) Consultant certifies that it has not discriminated against minorities, women or emerging small business enterprises in obtaining any required subcontractors.

Exhibit C
Request for Proposals

Exhibit D
Integrator's Proposal

Exhibit E

Integrator's Schedule of Rates and Charges



REQUEST FOR COUNCIL ACTION

Title: 2021 Overlay Project Contract Approval

Preferred Agenda: April 27, 2021

Submitted By: Trish Rice, Engineering Tech 2
Greg Springman, Public Works Director

Reviewed By: Ray Towry, City Manager

Type of Action: Resolution ____ Motion ____ Roll Call X Other ____

Relevant Code/Policy: n/a

Towards Council Goal: Goal 1.1c Develop specific steps for implementation of the adopted infrastructure master plans (streets)

Attachments: 2021 Overlay Project bid tabulation
Contingency calculation
Bid documents and addendum

Purpose of this RCA:

Staff requests authorization to execute the contract for the 2021 Overlay Project.

Background/Context:

On March 23, 2021 City Council authorized posting a bid solicitation for the 2021 Overlay Project. The engineer's estimate was \$264,138.50. Staff issued one addendum in response to contractor questions. The bids closed April 20 and we received 4 bids. North Santiam Paving Co. is the low bidder at \$194,174. Staff is very pleased that the bids are so much lower than expected because no schedule trimming will be necessary.

The Challenge/Problem:

How do we make efficient use of limited funds to complete needed streets projects?

Stakeholders:

- Sweet Home Residents – Residents deserve well-maintained City infrastructure that meets their needs and improves their quality of life.
- Sweet Home City Council – The City Council has a goal to provide viable and sustainable infrastructure that serves development and improves residents' quality of life.
- Sweet Home City Staff – City Staff have an interest in completing projects that empower them to meet the Council's goals and which reduce staff time spent repairing poor quality streets.

Issues and Financial Impacts:

North Santiam Paving Co. bid \$194,174. There is still \$242,327.94 available in local funds for overlay projects. There is also \$600k+ available in ODOT exchange funds. The fund exchange IGA has been executed much more quickly than expected and we may begin drawing from it at any time. Staff intends to draw fund exchange money for this project and re-budget the local funds into the new fiscal year.

Staff discovered some minor changes are necessary due to some conditions that we missed in plan review. These will need to be addressed out of the project contingency, thus requiring a larger-than-usual contingency percentage. The changes are summarized in the attached contingency calculation spreadsheet.

Factoring in these changes brings the anticipated cost to \$229,096. This is still much lower than the engineer's estimate and within budget. Staff checked to see if the changes would result in a different low bidder based on the unit prices for each schedule, and North Santiam is still the lowest bidder at the anticipated new quantities.

Staff requests authorization for a contingency up to a total project not-to-exceed amount of \$260,000 (similar to the engineer's estimate). Although on paper this is a 34% contingency, since we now anticipate an actual cost around \$229k the actual effective contingency will be 13.5%. That's within the usual recommended contingency of 10-15% for most Public Works projects. There are available budgeted funds for Materials and Services which can cover the contingency within the current year's approved budget, if needed.

Elements of a Stable Solution:

A stable solution will provide efficient completion of needed street maintenance and improvements.

Options:

1. Option 1 – Reject all bids and cancel the project. The project will remain in the CIP. The unspent overlay funds will go into the ending fund balance and be available for re-budgeting.
2. Option 2 – Execute the contract and approve the requested contingency. Staff will execute the contract and give the contractor notice to proceed.
3. Option 3 – Execute the contract and remove schedules. Council may remove schedules from this contract and add them to future projects. This option is not recommended since the bids came in much lower than expected.
4. Option 4 – Execute the contract with a different contingency. Council may choose to provide more or less contingency funds for the project, which will affect staff's ability to adapt to changes discovered during construction. Decreasing the contingency is not recommended.
5. Option 5 – Cancel the solicitation and combine this project with the next paving project. As discussed at the March 23 Council session, the project was split into two phases to accommodate funding availability, due to the uncertainty about when the ODOT fund exchange IGA would be executed. The IGA was executed much more quickly than expected so those funds are available to us now. Council may choose to re-combine the paving work into a single project. This option will delay project completion. We are also unlikely to get such low prices a second time.

Recommendation:

Staff recommends Option 2 – Motion to allow staff to execute the FY 2021 Overlay Program Project contract as presented.

			North Santiam		Eugene Sand		Knife River**		Wildish**		
ITEM DESCRIPTION WITH BID UNIT PRICE	UNIT	APPROX. Q	UNIT PRICE	TOTAL AMOU	UNIT PRICE	TOTAL AMOU	UNIT PRICE	TOTAL AMOU	UNIT PRICE	TOTAL AMOUNT	
Bid Schedule A. Kalmia St and 45th, 46th, 47th Aves											
1	Mobilization, Cleanup, Traffic & Erosion Control	LS	1	LUMP SUM	\$ 22,500.00	LUMP SUM	\$ 98,200.00	LUMP SUM	\$ 50,900.00	LUMP SUM	\$ 53,000.00
2	Tack Coat	SY	6,650	\$ 0.10	\$ 665.00	\$ 0.30	\$ 1,995.00	\$ 0.58	\$ 3,857.00	\$ 0.40	\$ 2,660.00
3	Level 2, 1/2" ACP Mixture	TON	795	\$ 95.00	\$ 75,525.00	\$ 95.00	\$ 75,525.00	\$ 82.90	\$ 65,905.50	\$ 115.00	\$ 91,425.00
Schedule A subtotal					\$ 98,690.00	*note	\$ 175,720.00		\$ 120,662.50		\$ 147,085.00
Bid Schedule B. Harding St from Mountain View Rd to 27th Ave, and 23rd Ave											
4	Tack Coat	SY	3,255	\$ 0.10	\$ 325.50	\$ 0.30	\$ 976.50	\$ 0.58	\$ 1,887.90	\$ 0.40	\$ 1,302.00
5	Level 2, 1/2" ACP Mixture	TON	395	\$ 96.00	\$ 37,920.00	\$ 105.00	\$ 41,475.00	\$ 82.90	\$ 32,745.50	\$ 115.00	\$ 45,425.00
Schedule B subtotal					\$ 38,245.50		\$ 42,451.50		\$ 34,633.40		\$ 46,727.00
Bid Schedule C. Juniper St. from 32nd Ct to 35th Ave, and 32nd Ct											
6	Tack Coat	SY	2,530	\$ 0.10	\$ 253.00	\$ 0.30	\$ 759.00	\$ 0.58	\$ 1,467.40	\$ 0.40	\$ 1,012.00
7	Level 2, 1/2" ACP Mixture	TON	320	\$ 106.00	\$ 33,920.00	\$ 106.00	\$ 33,920.00	\$ 82.90	\$ 26,528.00	\$ 115.00	\$ 36,800.00
Schedule C subtotal					\$ 34,173.00		\$ 34,679.00		\$ 27,995.40		\$ 37,812.00
Bid Schedule D. Grape Street and Grape Loop											
8	Tack Coat	SY	1,855	\$ 0.10	\$ 185.50	\$ 0.30	\$ 556.50	\$ 0.58	\$ 1,075.90	\$ 0.40	\$ 742.00
9	Level 2, 1/2" ACP Mixture	TON	220	\$ 104.00	\$ 22,880.00	\$ 118.00	\$ 25,960.00	\$ 82.90	\$ 18,238.00	\$ 115.00	\$ 25,300.00
Schedule D subtotal					\$ 23,065.50		\$ 26,516.50		\$ 19,313.90		\$ 26,042.00
Total Bid Project Cost, Schedules A through D					\$ 194,174.00	*note	\$ 279,367.00		\$ 202,605.20		\$ 257,666.00

*submitted bid form has a math error & indicates \$125,720 for Sch A and \$229,367 total.

**Knife River and Wildish bids were missing the addendum.

CONTINGENCY CALCULATION WITH UPDATED QUANTITIES

				North Santiam		Eugene Sand		Knife River**		Wildish**	
ITEM DESCRIPTION WITH BID UNIT PRICE	UNIT	APPROX. QUANTITY	UNIT PRICE	TOTAL AMOUNT	UNIT PRICE	TOTAL AMOUNT	UNIT PRICE	TOTAL AMOUNT	UNIT PRICE	TOTAL AMOUNT	
Bid Schedule A. Kalmia St and 45th, 46th, 47th Aves											
<i>Deep repair sections need to be 4" thick. Estimate one block of Kalmia (+11,200 sf x another 2").</i>											
1	Mobilization, Cleanup, Traffic & Erosion Control	LS	1	LUMP SUM \$ 22,500.00	LUMP SUM \$ 98,200.00	LUMP SUM \$ 50,900.00	LUMP SUM \$ 53,000.00				
2	Tack Coat	SY	8,020	\$ 0.10 \$ 802.00	\$ 0.30 \$ 2,406.00	\$ 0.58 \$ 4,651.60	\$ 0.40 \$ 3,208.00				
3	Level 2, 1/2" ACP Mixture	TON	945	\$ 95.00 \$ 89,775.00	\$ 95.00 \$ 89,775.00	\$ 82.90 \$ 78,340.50	\$ 115.00 \$ 108,675.00				
Schedule A subtotal				\$ 113,077.00	*note \$ 190,381.00	\$ 133,892.10	\$ 164,883.00				
Bid Schedule B. Harding St from Mountain View Rd to 27th Ave, and 23rd Ave											
<i>Removing 23rd Ave (-4,160 sf) and Harding St west of 23rd (-4,400 sf) in anticipation of new subdivision construction.</i>											
4	Tack Coat	SY	2,210	\$ 0.10 \$ 221.00	\$ 0.30 \$ 663.00	\$ 0.58 \$ 1,281.80	\$ 0.40 \$ 884.00				
5	Level 2, 1/2" ACP Mixture	TON	280	\$ 96.00 \$ 26,880.00	\$ 105.00 \$ 29,400.00	\$ 82.90 \$ 23,212.00	\$ 115.00 \$ 32,200.00				
Schedule B subtotal				\$ 27,101.00	\$ 30,063.00	\$ 24,493.80	\$ 33,084.00				
Bid Schedule C. Juniper St. from 32nd Ct to 35th Ave, and 32nd Ct											
<i>Deep repair sections of Juniper St need to be 4" thick. Estimate 1.5x qty on Juniper St (+7,700 sf x another 2").</i>											
6	Tack Coat	SY	3,470	\$ 0.10 \$ 347.00	\$ 0.30 \$ 1,041.00	\$ 0.58 \$ 2,012.60	\$ 0.40 \$ 1,388.00				
7	Level 2, 1/2" ACP Mixture	TON	420	\$ 106.00 \$ 44,520.00	\$ 106.00 \$ 44,520.00	\$ 82.90 \$ 34,818.00	\$ 115.00 \$ 48,300.00				
Schedule C subtotal				\$ 44,867.00	\$ 45,561.00	\$ 36,830.60	\$ 49,688.00				
Bid Schedule D. Grape Street and Grape Loop											
<i>Grape Loop requires 4", not 2". Doubling quantity.</i>											
8	Tack Coat	SY	3,710	\$ 0.10 \$ 371.00	\$ 0.30 \$ 1,113.00	\$ 0.58 \$ 2,151.80	\$ 0.40 \$ 1,484.00				
9	Level 2, 1/2" ACP Mixture	TON	420	\$ 104.00 \$ 43,680.00	\$ 118.00 \$ 49,560.00	\$ 82.90 \$ 34,818.00	\$ 115.00 \$ 48,300.00				
Schedule D subtotal				\$ 44,051.00	\$ 50,673.00	\$ 36,969.80	\$ 49,784.00				
Total Bid Project Cost, Schedules A through D				\$ 229,096.00	\$ 316,678.00	\$ 232,186.30	\$ 297,439.00				

^still the lowest bidder after revisions

**Knife River and Wildish bids were missing the addendum.

CONTRACT DOCUMENT

FOR CONSTRUCTION OF

**CITY OF SWEET HOME
FY 2021 Overlay Program Project**

Department of Public Works, Engineering Division
1400 24th Avenue
Phone 541-818-8037

March 24, 2021

TABLE OF CONTENTS

TABLE OF CONTENTS 2

INSTRUCTIONS TO BIDDERS..... 3

BID..... 4

CONTRACT 7

BID BOND..... 9

PAYMENT BOND..... 10

PERFORMANCE BOND 13

FIRST-TIER SUBCONTRACTOR DISCLOSURE FORM 16

BID FORM..... 17

PREVAILING WAGE for PUBLIC WORKS CONTRACTS..... 18

PAYMENT OF MEDICAL CARE AND PROVIDING WORKERS’ COMPENSATION 18

PUBLIC WORKS BOND..... 19

RECIPROCAL PREFERENCE LAW 19

PROJECT DRAWINGS (SEPARATE ATTACHMENT) 20

SPECIAL PROVISIONS I 21

SPECIAL PROVISIONS II 27

INSTRUCTIONS TO BIDDERS

Sealed bids for the **FY 2021 Overlay Program Project** will be received on behalf of the City of Sweet Home by Greg Springman at 1400 24th Avenue, Sweet Home, OR 97386 until bid closing time of **2:00 PM local time on Tuesday, April 20, 2021**. Bids will be held but not opened until **4:00 PM** (the submittal deadline for the “First-Tier Subcontractor Disclosure Form”). The outside of the Bid envelopes shall be clearly marked **FY 2021 Overlay Program Project** and show (1) the Bidder’s name, (2) the Bid Opening time and date and (3) the Bidders CCB license number, and shall be delivered to the City of Sweet Home by or before the above listed bid closing time.

The City will require that for projects greater than \$100,000, the “First-Tier Subcontractor Disclosure Form” as contained in the bidding documents, be submitted with the bid documents in a separate sealed envelope by the Bid Closing or within two working hours of the Bid Closing, not later than **4:00 PM local time Tuesday, April 20, 2021**. The envelope shall be clearly marked “**Disclosure Form for FY 2021 Overlay Program Project**”, and shall include (1) Bidders name, and (2) the submittal time and date deadline. Bidders who fail to submit the required disclosure will be considered non-responsive. Immediately following the disclosure deadline, the bids shall be opened and publicly read. **Submittals by Facsimile or Electronic Data Interchange (EDI) will not be accepted.**

Contract specifications, and plan sets – in PDF file format –, may be obtained from the Bids and RFPs menu off the Government on the City of Sweet Home website at <https://www.sweethomeor.gov/rfps>. Questions about the project elements may be directed to Trish Rice, Engineering Technician, Sweet Home Public Works, 1400 24th Avenue, Sweet Home, Oregon, 97386, contact by phone at 541-818-8037, or email price@sweethomeor.gov.

Each bidder must possess or have access to the 2021 Oregon Standard Specifications for Construction. These are available online at: https://www.oregon.gov/ODOT/Business/Pages/Standard_Specifications.aspx

No bid shall be received or considered unless the bidder is registered with the Construction Contractors Board for construction projects or licensed with the Landscape Contractors Board for landscaping projects.

Bidders Checklist: All prospective bidders must include the following:

- Each bid must contain a statement as to whether the Bidder is a resident Bidder, as defined in ORS 279C.365. In determining the lowest responsible bidder, the City of Sweet Home will, for the purpose of awarding the Contract, add a percentage increase on the bid of a nonresident bidder equal to the percentage, if any, of the preference given to that bidder in the state in which the bidder resides.
- All bids shall contain a statement declaring that the Bidder agrees to comply with the provisions of ORS 279C.800 to 279C.870 regarding payment of prevailing wages and the Bureau of Labor and industries fee.
- The project bid document set, with names and corporate information of the bidder, schedule of prices completely filled out, additional addendum items if any; however, project drawings do not need to be included.
- The First-Tier Subcontractor Disclosure Form as noted above.
- Each bid must contain Surety and Bond information.
- A 10% bid bond, certified check, or cashier’s check shall accompany each bid on all projects and shall be forfeited if the bidder fails to enter into a Contract with the City of Sweet Home within ten (10) days after the date of the Notice of Award.

The City may reject any bid not in compliance with all prescribed public procedures and requirements, and may reject for good cause any and all submittals upon a finding of the City that it is in the best interest to do so, as determined solely by the City.

BID

To the Honorable Mayor and City Council
City of Sweet Home, Oregon 97386

BIDDER'S DECLARATION AND UNDERSTANDING

The undersigned Bidder declares that the Contract Documents for the construction of the proposed improvement have been carefully examined; that the site has been personally inspected; that the Bidder is satisfied as to the quantities of materials, items of equipment and conditions or work involved including the fact that the description of the quantities of work and materials as included herein is brief and is intended only to indicate the general nature of such items and to identify the said quantities with the detailed requirements of the Contract Documents; and that the bid is made according to the provisions and under the terms of the Contract Documents, which documents are hereby made a part of this bid. The bidder has received and considered the following Addenda to specifications, if any, of revisions and/or additions to the plans;

No. _____ to No. _____, inclusive; Plan Revision Sht. No. _____; Plan Addition Sht. No. _____.

The minimum bid submittal requirement for this project shall include this Bid form and schedule(s) of prices, bid bond as required, first-tier subcontractor form and all other required attachments. All Contract Documents are included in this Bid by reference, whether attached or not.

The Bidder further declares that the only persons or parties interested in this bid are those named herein: that this bid is in all respects fair and without fraud: that it is made without collusion with any official of the City of Sweet Home, and that the bid is made without any connection or collusion with any person making another bid on this Contract.

The Bidder further declares that the provisions required by the Oregon Revised Statutes ORS 279C.800 relating to Prevailing Wage Rates shall be included in and made a part of the Contract. The Bidder further declares that all applicable sections relating to Public Contracts as set forth in ORS 279A to 279C have been complied with in making this bid, and, as required, shall be made a part of the Contract Documents as completely as if the same were fully set forth herein.

The Bidder further declares that they are registered, or shall become registered if awarded a contract, with the Construction Contractor's Board, and possess such additional licenses and certifications as required by law for the performance of the Work proposed herein as required by OAR 812.

The Bidder further agrees that its own judgment has been exercised regarding the interpretation of subsurface information and all data, which it believes pertinent from the Engineer, Owner, and other sources in arriving at these conclusions, have been utilized.

CONTRACT EXECUTION, BONDS AND CERTIFICATES OF INSURANCE

The Bidder agrees that if this bid is accepted, a Contract with the City of Sweet Home, Oregon, will be executed within ten (10) days after the date of the Notice of Award, in the form of Contract annexed hereto, and will at that time, deliver to the City of Sweet Home the Performance and Payment Bond required by Subsection 00130.4 of the Oregon Standard Specifications for Construction (as revised), the certificates of insurance as specified in these documents, and will, to the extent of this bid, furnish all machinery, tools, apparatus, and other means of construction and do the work and furnish all of the materials necessary to complete the work in the manner, in the time, and according to the methods as specified or shown in the Contract Documents.

It is the intent of the City of Sweet Home to award the Contract to the lowest responsible Bidder, provided the Bid has been submitted in accordance with the requirements of the Contract Documents and does not exceed the funds available. The City of Sweet Home shall have the right to waive informalities or irregularities in a Bid received and to accept the Bid which, in the City of Sweet Home's judgment, is in the City of Sweet Home's own best interest. In submitting this Bid, it is understood that the City of Sweet Home reserves the right to accept or reject in part or in whole, any and all bids received, to adjust the scope of the work within reasonable limits, to postpone award for a reasonable time, or award to the selected firm or contractor any subsequent engineering design and construction services contract, part or in whole, for recommended capital projects as allowed by law. The RFB does not commit the City of Sweet Home to pay any costs incurred to prepare a bid.

BIDDING, CONSTRUCTION, AND COMPLETION DATES

Sealed bids will be received at the City of Sweet Home Public Works Department at 1400 24th Avenue
until 2:00pm on Tuesday, April 20, 2021 (Time & Date)
with 1st Tier Subcontractor Disclosure Forms until
4:00pm on Tuesday, April 20, 2021 (Time & Date)

The Bidder agrees to begin work within 10 calendar days after the date of the Notice to Proceed issued on or near;
May 3rd, 2021 (Date)

and, to complete the construction, in all respects by;
November 12, 2021 (Date)

Completion schedule – if not defined to certain date above – shall be set per #s of days as follows:
(Days)

Calendar days that inclement weather or adverse site conditions preclude normal construction activities shall be considered exempt.

RETAINAGE

To ensure the proper performance of the Contract, the City shall retain five (5%) of the amount of each progress payment until final completion and acceptance of all work covered by this contract.

LIQUIDATED DAMAGES

In the event the Bidder is awarded the Contract and shall fail to complete the work within the time stated above or extended time agreed upon, as more particularly set forth in the Contract Documents, liquidated damages, if required as specified in the Special Provisions I portion of this contract documents, shall be paid to the City of Sweet Home, Oregon, as provided under Subsection 00180.85 of the Oregon Standard Specifications.

BID BOND

Accompanying this bid is a certified check, cashier’s check or Bidder’s Bond in the sum of

Dollars & Cents (\$ _____), (10% of total contract price)
according to the General Requirements of the Contract Documents which is to be forfeited as liquidated damages, if, in the event that this bid is accepted, and the Bidder shall fail to execute the Contract and furnish satisfactory Performance and Payment Bond under the conditions and within the time specified in the Contract Documents; otherwise said check or bond is to be returned to the Bidder.

SURETY

If the Bidder is awarded a construction Contract on this bid, the Surety which will provide the Performance and Payment Bond will be:

(Name)
(Address)
(City, State)

LUMP SUM OR UNIT PRICE WORK, MANNER of PAYMENT

The Bidder further proposes to accept as full payment for the work proposed herein the amounts computed under the provisions of the Contract Documents and based on the following lump sum or unit price amounts, it being expressly understood that the unit prices are independent of the exact quantities involved. The Bidder agrees that the lump sum prices and the unit prices represent a true measure of the labor and materials required to perform the work, including all allowances for overhead and profit for each type and unit of work called for in these Contract Documents. The amounts shall be shown in both words and figures. In the case of a discrepancy, the amount shown in words shall govern.

BIDDER

The name of the Bidder submitting this bid is:

_____ (Name)
 _____ (Address)
 _____ (City, State, Zip)
 _____ (Telephone)
 _____ (Email)
 _____ (Federal Tax ID No)
 _____ (Construction Contractor Board No)
 _____ (Workers' Comp Ins. Co.)
 _____ (Workers' Comp Policy/Binder No)

The above Bidder's name and address is the address to which all communications concerned with this bid and with the Contract shall be sent.

In accordance with ORS 279C.365, Bidder hereby declares that it (circle correct designation) **is / is not** a resident Bidder. If the bidder is non-resident, indicate ___5___ % preference of your state resident bidders.

In accordance with ORS 279C.800 to 279C.870, Bidder hereby declares that it complies with provisions for labor, materials, Industrial Accident Fund, liens, withholding taxes, and employee drug testing.

The names of the principal officers of the corporation submitting this bid, or of the partnership, or of all persons interested in this bid as principals, are as follows:

_____	_____
_____	_____
_____	_____

If Sole Proprietor of Partnership: IN WITNESS hereto the undersigned has set his/her hand this _____ day of _____, 20____.

_____ (Signature of Bidder)
 _____ (Title)

If Corporation: IN WITNESS WHEREOF the undersigned corporation has caused this instrument to be executed and its seal affixed by its duly authorized officers this _____ day of _____, 20____.

_____ (Name of Corporation)
 _____ (By)
 _____ (Title)
 _____ (Attest)

Secretary (Mandatory Signature)



(SEAL)

CONTRACT

THIS CONTRACT, made between the CITY OF SWEET HOME, a municipal corporation, hereinafter called "Owner" and _____, hereinafter called "Contractor".

WITNESSETH:

The Contractor, in consideration of the sums to be paid and other covenants herein contained, agrees to perform and complete the work herein described and to furnish all necessary machinery, tools, apparatus, equipment, supplies, materials, and labor and perform all work in accordance with the 2021 Oregon Standard Specifications for Construction, the Special Specifications bound herewith, and in accordance with such alterations or modifications of the same as may be made by the City, and according to such directions as may from time to time be made or given by the Engineer under the authority and within the meaning and purpose of this Contract. This agreement shall be binding upon the heirs, executors, administrators, successors, and assigns of the Contractor.

The applicable Drawings, the Oregon Standard Specifications for Construction, the Special Specifications, and the Schedule of Contract Prices bound herewith are hereby specifically referred to and by reference made a part hereof, and shall by such reference have the same force and effect as though all of the same were fully inserted herein.

The Contractor shall faithfully complete and perform all of the obligations of this Contract, and in particular, shall promptly, as due, make payment of all just debts and obligations incurred in the performance of said Contract and shall not permit any lien or claim to be filed or prosecuted against the City.

The Contractor, its subcontractors, if any, and all employers working under this Contract are subject employers under the Oregon Workers' Compensation Law and shall comply with ORS 656.017, which requires them to provide workers' compensation coverage for all their subject workers.

The Contractor agrees to protect, indemnify, and hold harmless the Owner, its officers, agents, and employees harmless against any and all loss, claims, or suits (including costs and attorney's fees) for or on account of injury to or death of persons, damage to, or destruction of property belonging to either the Owner or others occurring by reason of the act or neglect of the Contractor, Contractor's employees, or agents (including subcontractors) in connection with the performance of this Contract.

It is expressly understood that this Contract shall be governed by the laws of the State of Oregon. The statutes of the State of Oregon for public works contracts, specifically but not exclusively ORS 279C, as amended or superseded, including the latest additions and revisions, are incorporated by reference as part of the contract documents, and the party contracting with the Owner hereby covenants and agrees to comply with all of the obligations and conditions applicable to public contracts pursuant to ORS 279C as though each obligation or condition were set forth fully herein. In addition, if the contract identified above calls for a public improvement as that term is defined by ORS 279A.010, the party contracting with the Owner further agrees to comply with all obligations and conditions applicable to public contracts for public improvements pursuant to ORS 279C as though each obligation or condition were set forth fully herein.

The Contractor further declares by the signing of this Contract that all the provisions required by ORS 279A to 279C relating to Public Contracts, Purchasing, and Prevailing Wage Rates for work performed under the Contract with the Owner are made part of this Contract as completely as if the same were fully set forth herein.

In consideration of the faithful performance of all of the obligations herein set out and in consideration of the faithful performance of this Contract, the Owner agrees to pay to the Contractor the amount earned, as determined from the actual quantities of work performed and prices and other basis of payment specified, taking into consideration any amounts that may be deductible, under the terms of the Contract.

The Contractor agrees to complete the work within the time specified herein and to accept as full payment hereunder the amounts computed as determined by the Contract Documents and based on the said bid.

Said improvements shall be completed by the date specified in said Contract Documents and if not so completed, unless said time for completion is extended, as provided in the Contract Documents, or if extended, if the same is not completed within the time extended, the City will be caused to incur liquidated damages as specified in the
FY 2021 Overlay Program Project

Contract Documents. Liquidated damages shall be retained out of any monies due or to become due under this agreement.

Payments shall be made as provided in the Contract Documents.

Should suit or action be undertaken to enforce any of the terms of this agreement or to seek damages for its breach, the prevailing party shall be entitled to an award of its reasonable attorney fees, including those incurred on appeal.

IN WITNESS WHEREOF the parties hereto have executed or caused to be executed by their duly authorized officials, the Contract and affixed their respective official seals.

CONTRACTOR:

**OWNER:
CITY OF SWEET HOME, OREGON:**

APPROVED AS TO FORM:

City Attorney

DATE: _____

DATE: _____

By: _____

By: _____
Public Works Director

Title: _____

By: _____
City Manager

By: _____

Title: _____
(Note: Signatures of two officers are required for a corporation.)

Corporation Tax No. (if incorporated)

Social Security No. (if individual)

BID BOND

DATE. _____

BOND NO. _____.

AMOUNT OF BID: _____ (\$).

KNOW ALL MEN BY THESE PRESENTS, that we

(Name of Contractor)

as Principal, hereinafter called the PRINCIPAL, and

(Name of Surety)

a corporation duly organized under the laws of the State of _____ having its principal place of business at _____, in the State of _____, and authorized to do business in the State of Oregon, as SURETY, hereinafter called the Surety, are held firmly and bound unto the City of Sweet Home, Oregon, as Obligee, hereinafter called the OBLIGEE, in the sum of

_____ Dollars & Cents (\$ _____), *(10% of total contract price)*

for the payment of which sum well and truly to be made, the said Principal and the said Surety, bind ourselves, our heirs, executors, administrators, successors, and assigns, jointly and severally, firmly by these presents.

THE CONDITION OF THIS BOND IS SUCH THAT:

WHEREAS, the PRINCIPAL is herewith submitting his or its Bid for _____, said Bid, by reference thereto, being hereby made a part hereof.

NOW, THEREFORE, if the Obligee shall accept the bid of the Principal and the Principal shall enter into a Contract with the Obligee in accordance with the terms of such bid, and give such bond or bonds as may be specified in the bidding or Contracts Documents with good and sufficient surety for the faithful performance of such Contract and for the prompt payment of labor and materials furnished in the prosecution thereof, or on the event of the failure of the Principal to enter such Contract and give such bond or bonds, if the Principal shall pay to the Obligee the difference not to exceed the penalty hereof between the amount specified in said bid and such larger amount for which the Obligee may in good faith contract with another party to perform the Work covered by said bid, then this obligation shall be null and void, otherwise to remain in full force and effect.

A certified copy of the agent's power-of-attorney must be attached hereto.

Signed and sealed this _____ day of _____, 20____

PRINCIPAL

SURETY

By: _____

By: _____

Title: _____

Title: _____

IMPORTANT: Surety companies executing BONDS must appear on the Treasury Department's most current list (Circular 570 as amended) and be authorized to transact business in the state where the project is located.

PAYMENT BOND

DATE. _____

BOND NO. _____

TOTAL BID AMOUNT: _____

KNOW ALL MEN BY THESE PRESENTS, that we

(Name of Contractor)

as CONTRACTOR (Principal), and

(Name of Surety)

a corporation, duly organized to do a general surety business in the State of Oregon as SURETY, jointly and severally, bind ourselves, our heirs, executors, administrators, successors, and assigns firmly in the sum of

_____ Dollars & Cents (\$ _____), *(total contract price)*

to the Owner for the payment of labor, materials, and equipment furnished for the use in the performance of the Contract, which is incorporated herein by reference. The Contractor and Surety, jointly and severally, agree that this Bond shall be deemed amended automatically and immediately, without formal and separate amendments, hereto, upon amendment to the Contract not increasing the Contract Price more than twenty five percent (25%). The term "amendment wherever used in this Bond, and whether referring to this Bond, the Contract, or the loan documents, shall include any alteration, extension, or modification of any character whatsoever.

With respect to the Owner, this obligation shall be null and void if the Contractor: 1) promptly makes payment, directly or indirectly, for all sums due Claimants, and 2) defends, indemnifies and holds harmless the Owner from claims, demands, liens or suits by any person or entity whose claim, demand, lien or suit is for the payment of labor, materials, or equipment furnished for use in the performance of the Contract.

With respect to Claimants, this obligation shall be null and void if the contractor promptly makes payment, directly or indirectly, for all sums due.

A Claimant is defined as persons claiming to have supplied labor or materials, for the prosecution of the work provided for in the Construction Contract, including any person having a direct contractual relationship with the Contractor furnishing the Bond or direct contractual relationship with any subcontractor, or an assignee of such person, or a person claiming monies due to the State Accident Insurance Fund Corporation, State Department of Unemployment Trust Fund, or the Department of Revenue, in connection with the performance of the Construction contract, has a right of action on the Contractor's Board as provided in ORS 279C.380 only if: 1) the person or the assignee of the person has not been paid in full; and 2) the person gives written notice of claim, as prescribed in ORS 279C.605, to the Contractor and the Secretary of State, in the Construction Contract with a state agency, or the clerk or auditor if the public body is other than a state agency.

The intent of this Bond shall be to include without limitation, the terms 'labor, materials or equipment, that part of water, gas, power, light, heat, oil. Gasoline, telephone service or rental equipment used in the Contract, architectural and engineering services required for performance of the work of the Contractor, and all other items for which a mechanic's lien may be asserted in the jurisdiction where the labor, materials or equipment were furnished.

The Contractor and Surety hereby jointly and severally agree with the Owner that every Claimant, who has not paid in full before the expiration of a period of one hundred twenty (120) days after the date on which the last of such Claimant's work or labor was done or performed, or materials were furnished by such Claimant, for which claim is made, may have a right of action on this Bond. The Owner shall not be liable for the payment of any costs or

expenses including attorneys' fees which the Owner may incur in connection with its defense of any such right of action.

No suit or action shall be commence on this Bond by any Claimant: 1) Unless claimant shall have given written notice to the Contractor and the Secretary of State, if the Contractor with a state agency, or the clerk or auditor of the public body which let the Contract if the public body is other than a state agency, within one hundred twenty (120) days after such Claimant did or performed the last of the work or labor, or furnished the last of the materials for which said claim is made, stating with substantial accuracy the amount claimed and the name of the party to whom the materials were furnished, or for whom the work or labor was done or performed. Such notice shall be served by mailing the same by registered mail or certified mail, postage prepaid, or hand delivered in an envelope addressed to the Contractor, and such other entity who is to receive notice, at any place where that party maintains an office, conducts business, or at its residence, or delivered to that location. 2) After the expiration of two (2) years from the date on which the Claimant last performed labor, materials or equipment. Any limitation embodied in this Bond, which is prohibited by any law controlling the project, shall be deemed to be amended so as to be equal to the minimum period of limitation permitted by law.

When the Claimant has satisfied the conditions of the above, the Surety shall promptly and at the Surety's expense take the following actions: 1) Send an answer to the Claimant, with a copy to the Owner, within forty-five (45) days after receipt of the claim, stating the amount that are undisputed and the basis for challenging any amount that are disputed. 2) pay or arrange for payment of any undisputed amounts.

The Surety's total obligation shall not exceed the amount of the bond and any amendment thereto as outlined above, and the amount of this Bond shall be credited for any payments made in good faith by Surety.

Amounts owed by the Owner to the Contractor under the Contract shall be used for the performance of the Contract and to satisfy claims, if any, under any Construction Performance Bond. By the Contractor furnishing and the Owner accepting this Bond, they agree that all funds earned by the Contractor in the performance of the Contract are dedicated to satisfy obligations of the Contractor and Surety under this Bond, subject to the Owner's priority to use the funds for the completion of the work.

The Surety shall not be liable to the Owner, Claimants or others for obligation of the contractor that are unrelated to the Contract. The Owner shall not be liable for payment of any costs or expenses of any Claimant under this Bond, and shall have under this Bond no obligations to make payments to, give notices on behalf of, otherwise have obligations to Claimants under this Bond.

The Surety hereby waives notice of any change, including changes of time, to the Construction Contract or to related subcontracts, purchase orders and to other obligations.

When this Bond has been furnished to comply with a statutory or other legal requirement in the location where the construction was to be performed, any provision in this Bond conflicting with said statutory or legal requirement shall be deemed deleted herefrom and provisions conforming to such statutory or other legal requirements shall be deemed incorporated herein. The intent is that this Bond shall be construed as a statutory bond and not as a common law bond.

Upon request by any person or entity appearing to be a potential beneficiary of this Bond, the Contractor shall promptly furnish a copy of this Bond or shall permit a copy to be made.

Definitions: 1) Construction Contract; The agreement between the Owner and the Contractor identified on the signature page, including all contract Documents and changes thereto.

IN WITNESS THEREOF, the parties hereto have caused this bond to be executed this _____ day of _____, 20____.

(Corporate Seal)

Principal

Title:

Street/City Address

(Corporate Seal)

Surety

Title:

Street/City Address

(Corporate Seal)

Surety Witness:

Title:

Street/City Address

City of Sweet Home, 1400 24th Avenue, Sweet Home OR 97386 *(Owner)*

FY 2021 Overlay Program Project *(Project)*

None *(Bond Modifications)*

PERFORMANCE BOND

DATE. _____

BOND NO. _____

TOTAL BID AMOUNT: _____

KNOW ALL MEN BY THESE PRESENTS, that we

(Name of Contractor)

as CONTRACTOR (Principal), and

(Name of Surety)

a corporation, duly organized to do a general surety business in the State of Oregon as SURETY, jointly and severally, bind ourselves, our heirs, executors, administrators, successors, and assigns firmly in the sum of

_____ Dollars & Cents (\$ _____), *(total contract price)*

to the Owner for the performance of the Construction Contract and any extension thereof, and during the twelve (12) month guaranty period which contract, extension and guaranty are incorporated herein by reference.

If the Contractor performs the Construction Contract, the Surety and the Contractor shall have no obligation under this Bond, except to participate in conferences as provided in the following paragraph.

If there is no Owner Default, the Surety's obligation under this Bond shall arise after: 1) The Owner has notified the Contractor and the Surety at its address described on the signature page herein, that the Owner is considering declaring the contractor Default and has requested and attempted to arrange a conference with the Contractor and the Surety to be held no later than fifteen (15) days after receipt of such notice to discuss methods of performing the Construction Contract. If the Owner, the Contractor and Surety agree, the Contractor shall be allowed a reasonable time to perform the Construction Contract, but such an agreement shall not waive the Owner's right, if any subsequently to declare a Contractor Default; and 2) The Owner has declared a Contractor Default and formally terminated the Contractor's right to complete the contract. Such Contractor Default shall not be declared earlier than twenty (20) days after the Contractor and the Surety have received notice as provided in the above paragraph; and 3) The Owner has agreed to pay the Balance of the Contract Price to the Surety in accordance with the terms of the Construction Contract or to a contractor selected to perform the construction contract in accordance with the terms of the contract with the Owner.

When the Owner has satisfied the conditions of the above paragraph, the Surety shall promptly and at the Surety's expense take one of the following actions: 1) Arrange for the Contractor with consent of the Owner, to perform and complete the Construction Contract; or 2) Undertake to perform and complete the Construction Contract itself, through its agents or through independent contractors, which agents or independent contractors shall be acceptable to the Owner; or obtain bids or negotiated proposals from qualified contractors acceptable to the Owner for a contract for performance and completion of the Construction Contract, arrange for a contract to be prepared for execution by the Owner and the contractor selected with the Owner's concurrence, to be secured with performance and payment bonds executed by a qualified surety equivalent to the bonds issued on the Construction Contract, and pay to the Owner the amount of damages as described in the following paragraph in excess of the Balance of the Contract Price incurred by the Owner resulting from the Contractor's default; or 4) Waive its right to perform and complete, arrange for completion, or obtain a new contractor and with reasonable promptness under the circumstances: 4a) After investigation, determine the amount for which it may be liable to the Owner and, as soon as practicable after the amount is determined, tender payment therefore to the Owner; or 4b) Deny liability in whole or in part and notify the Owner citing reasons therefore.

If the Surety does not proceed as provided in the above paragraph with reasonable promptness, the Surety shall be deemed to be in default on this Bond fifteen (15) days after receipt of an additional written notice from the Owner to the Surety demanding that the Surety perform its obligations under this Bond, and the Owner shall be entitled to

enforce any remedy available to the Owner. If the Surety proceeds as provided in the above paragraph, and the Owner refuses the payment tendered or the Surety has denied liability, in whole or in part, without further notice the Owner shall be entitled to enforce any remedy available to the Owner.

After the Owner has terminated the Contractor's right to complete the Construction Contract, and if the Surety elects to act under the second above paragraph, then the responsibilities of the Surety to the Owner shall not be greater than those of the Contractor under the Construction Contract, and the responsibilities of the Owner to the Surety shall not be greater than those of the Owner under the Construction Contract. To the limit of the amount of this Bond, but subject to commitment by the Owner of the Balance of the Contract Price to mitigation of costs and damages on the Construction Contract, the Surety is obligated without duplication for: 1) The responsibilities of the Contractor for correction of defective work and completion of the Construction Contract; 2) Additional legal, design professional and delay costs resulting from the Contractor's Default, and resulting from the actions or failure to act of the Surety under the second above paragraph; and 3) Liquidated damages, or if no liquidated damages are specified in the Construction Contract, actual damages caused by delayed performance or non-performance of the Contractor.

Any proceeding, legal or equitable, under this Bond may be instituted in any court of competent jurisdiction in the location in which the work or part of the work is located and shall be instituted with two (2) years after Contractor Default or within two (2) years after the Contractor ceased working or within two (2) years after the Surety refuses or fails to perform its obligations under this Bond, whichever occurs first. If the provisions of this Paragraph are void or prohibited by law, the minimum period of limitation available to sureties as a defense in the jurisdiction of the suit shall be applicable.

The Surety shall not be liable to the Owner or others for obligation of the Contractor that are unrelated to the Construction Contract, and the Balance of the Contract Price shall not be reduced or set off on account of any such unrelated obligations. No right of action shall accrue on this Bond to any person or entity other than the Owner or its heirs, executors, administrators or successors.

The Surety hereby waives notice of any change, including changes of time, to the Construction Contract or to related subcontracts, purchase orders and to other obligations.

Notice to the Surety, the Owner or the Contractor shall be mailed by certified or registered mail or delivered to the address shown on the signature page.

When this Bond has been furnished to comply with a statutory or other legal requirement in the location where the construction was to be performed, any provision in this Bond conflicting with said statutory or legal requirement shall be deemed deleted herefrom and provisions conforming to such statutory or other legal requirements shall be deemed incorporated herein. The intent is that this Bond shall be construed as a statutory bond and not as a common law bond.

Definitions: 1) Balance of the Contract Price; The total amount payable by the Owner to the Contractor under the Construction Contract after all proper adjustments have been made, including allowance to the Contractor of any amounts received or to be received by the Owner in settlement of insurance or other claims for damages to which the Contractor is entitled, reduced by all valid and proper payments made to or on behalf of the Contractor under the Construction Contract.

2) Construction Contract; The agreement between the Owner and the Contractor identified on the signature page, including all contract Documents and changes thereto.

3) Contractor Default; Failure of the contractor, which has neither been remedied nor waived, to perform or otherwise to comply with the terms of the Construction contract.

4) Owner Default; Failure of the Owner, which has neither been remedied nor waived, to pay the Contractor as required by the Construction contract or to perform and complete or comply with the other terms thereof.

IN WITNESS THEREOF, the parties hereto have caused this bond to be executed this _____ day of _____, 20____.

(Corporate Seal)

Principal

Title:

Street/City Address

(Corporate Seal)

Surety

Title:

Street/City Address

(Corporate Seal)

Surety Witness:

Title:

Street/City Address

City of Sweet Home, 1400 24th Avenue, Sweet Home OR 97386 *(Owner)*

FY 2021 Overlay Program Project *(Project)*

None *(Bond Modifications)*

FIRST-TIER SUBCONTRACTOR DISCLOSURE FORM

Project Name: **FY 2021 Overlay Program Project**

Bid Closing Date & Time: Tuesday, April 20, 2021, 2:00 PM.

Bid Open Time: Tuesday, April 20, 2021, 4:00 PM.

Disclosure Due Date & Time: Tuesday, April 20, 2021, 4:00 PM.

Bid total greater than \$100,000? _____ (Yes / No, if No, subcontractor information is not required).

If the bidder will not be using any subcontractors that are subject to the above disclosure requirements, the Bidder is required to indicate "NONE" on this form.

Bidders are required to disclose information about certain first-tier subcontractors when the contract value for a Public Improvement is greater than \$100,000, see ORS 279C.370. Specifically, when the contract amount of a first-tier subcontractor furnishing labor or labor and materials would be greater than or equal to: (i) 5% of the project Bid, but at least \$15,000 whichever is greater; or (ii) \$350,000 regardless of the percentage of the total project bid, the Bidder must disclose the following information about that subcontractor either in its Bid submission, or within two hours after Bid Closing:

- The name of each subcontractor, and
- The category of work to be performed, and
- The dollar value of the subcontract.

Compliance with the disclosure and submittal requirements outlined herein and in ORS 279C.370 and its amendments is a matter of Responsiveness. Bids that are submitted by the Bid Closing Time, but for which the disclosure submittal has not been made by the specified deadline, are not Responsive and shall not be considered for Contract award.

Subcontractor's Name	Category of Work	Dollar Value of Subcontract

Use additional sheets of this page if necessary.

Submitted by: _____ (Bidder & Contact Name), _____ (Phone #).

BID FORM

	ITEM DESCRIPTION WITH BID UNIT PRICE	UNIT	APPROX. QUANTITY	UNIT PRICE	TOTAL AMOUNT
Bid Schedule A. Kalmia St and 45th, 46th, 47th Aves					
1	Mobilization, Cleanup, Traffic & Erosion Control	LS	1	LUMP SUM	
2	Tack Coat	SY	6,650		
3	Level 2, 1/2" ACP Mixture	TON	795		
	Total Bid Project Cost, Schedule A				\$

Bid Schedule B. Harding St from Mountain View Rd to 27th Ave, and 23rd Ave					
4	Tack Coat	SY	3,255		
5	Level 2, 1/2" ACP Mixture	TON	395		
	Total Bid Project Cost, Schedule B				\$

Bid Schedule C. Juniper St. from 32nd Ct to 35th Ave, and 32nd Ct					
6	Tack Coat	SY	2,530		
7	Level 2, 1/2" ACP Mixture	TON	320		
	Total Bid Project Cost, Schedule C				\$

Bid Schedule D. Grape Street and Grape Loop					
8	Tack Coat	SY	1,855		
9	Level 2, 1/2" ACP Mixture	TON	220		
	Total Bid Project Cost, Schedule D				\$

	Total Bid Project Cost Schedule A through D				
--	--	--	--	--	--

PREVAILING WAGE for PUBLIC WORKS CONTRACTS

OREGON BOLI SPECIFICATIONS

All the provisions required by ORS 279C.800 through ORS 279C.870 relating to the payment of prevailing wage rates for work performed under the Contract with the City of Sweet Home shall be complied with.

Each worker in each trade or occupation employed in the performance of this contract either by the contractor, subcontractor, or other person doing or contracting to do, or contracting for the whole or any part of the work on this contract, must be paid not less than the applicable state prevailing rate of wage in accordance with ORS 279C.838 and 279C.840.

Each year the Oregon Bureau of Labor and Industries (BOLI) publishes two rates publications (and amendments to both) that are available by calling 971-673-0839 or online at the BOLI website at:
<https://www.oregon.gov/boli/employers/Pages/prevailing-wage-rates.aspx>

Prevailing wage rates that apply to this contract are the **January 1, 2021, Prevailing Wage Rates for Public Works Contracts** in Oregon and the **October 1, 2020, PWR Apprenticeship Rates**.

Only Oregon BOLI Prevailing Wage Rates apply to this project. **FY 2021 Overlay Program Project** does not use federal funds and does not require Davis-Bacon rates.

If the contractor fails to pay for any labor or services, the City can pay for this labor or services and withhold these amounts from payments due the contractor. ORS 279C.520; OAR 839-025-0020(2)(b).

The contractor shall pay daily, weekly, weekend and holiday overtime as required in ORS 279C.540.

The contractor shall give written notice to the workers of the number of hours per day and days per week they may be required to work. ORS 279C.520(2); OAR 839-025-0020(2)(c)

Contractors and subcontractors are required to prepare weekly certified payroll reports and statements and submit them to the City by the fifth business day of each month (ORS 279C.845; OAR 839-025-0010). Contractor payment will be withheld until the City is in receipt of these certified weekly payroll reports. Information submitted on certified statements may be used only to ensure compliance with the provisions of ORS 279C.800 through ORS 279C.870.

Contractors and subcontractors which are on BOLI's List of PWR Contractors Ineligible to Receive Public Works Contracts, as well as any firm, corporation, partnership or association in which the contractor or subcontractor has a financial interest, are ineligible to receive public works contracts until removed from the list. The current version of the list is available on the BOLI website at:
<https://www.oregon.gov/boli/employers/Pages/pwr-ineligible-contractors.aspx>

PAYMENT OF MEDICAL CARE AND PROVIDING WORKERS' COMPENSATION

Oregon BOLI Law ORS 279C.530

The contractor shall make prompt payment for all medical services for which the contractor has agreed to pay, and for all amounts for which the contractor collects or deducts from the worker's wages. ORS 279C.530; OAR 839-025-0020(2)(d)

All subject employers working under this Contract shall comply with ORS 656.017 and provide the required Workers' Compensation coverage, unless such employers are exempt under ORS 656.126. Contractor shall ensure that each of its subcontractors complies with these requirements.

PUBLIC WORKS BOND

Oregon Public Contracting Law

In addition to the required payment bond and performance bond, unless exempt under ORS 279C.836 (7), (8), or (9), the contractor and every subcontractor is required to file a \$30,000 Public Works Bond with the Construction Contractor's Board before starting work on the project, to be used exclusively for unpaid wages determined to be due by BOLI.

The contractor shall include in every subcontract a provision requiring the subcontractor to have said Public Works Bond filed with the Construction Contractor's Board before starting work on the project, unless the subcontractor is exempt. The contractor is required to verify that subcontractors, unless exempt, have filed a public works bond before permitting a subcontractor to start work on a project.

The Statutory Public Works Bond form is available from BOLI upon request or may be downloaded from <https://www.oregon.gov/boli/employers/Documents/public-works-bond.pdf>.

RECIPROCAL PREFERENCE LAW

Oregon's Reciprocal Preference Law

Oregon's reciprocal preference law, ORS 279A.120, requires public contracting agencies, in determining the lowest responsible bidder, to add a percent increase to each out-of-state bidder's bid price which is equal to the percent of preference given to local bidders in the bidder's home state. For example, if the low bidder is from a state that grants a 10 percent preference to its own in-state bidders, the Oregon agency must add 10 percent to that bidder's price when evaluating the bid.

OAR 125-246-0310: Reciprocal Preferences.

- (1) When evaluating offers according to OAR 125-247-0255 through 125-247-0260, 125-249-0390 or 125-249-0640 through 125-249-0660, Authorized Agencies must add a percentage increase to the Offer of a Nonresident Offeror equal to the percentage, if any, of the preference that would be given to that Offeror in the state in which the Offeror resides. An Authorized Agency may rely on the list maintained by the Department according to ORS 279A.120(4) to determine:
 - (a) Whether the Nonresident Offeror's state gives preference to in-state Offerors; and if so,
 - (b) The amount of such preference (Percentage).
- (2) Authorized Agencies must add a percentage to the Offer that matches the Percentage described in Section (1) before determining Tie-Offerors in accordance with OAR 125-246-0300.

The National Association of Procurement Officials (NASPO) has gathered information on preference laws of all states. See <https://www.naspo.org/research-innovation/state/OR> for more details. This list is for your use in making contract awards under Oregon's reciprocal preference law. If you are in need of any assistance in the application of this law, please call or contact the State Procurement Office:

State of Oregon
Department of Administrative Services
State Procurement Office
1225 Ferry Street SE, U-140,
Salem, OR 97301-4285.
Tel: 503-378-4642.

PROJECT DRAWINGS (SEPARATE ATTACHMENT)
CONSTRUCTION DETAILS

See Attached.

SPECIAL PROVISIONS I

GENERAL REQUIREMENTS AND INFORMATION

The Oregon Standard Specifications for Construction (as revised), American Public Works Association (APWA) and American Water Works Association (AWWA) Standard Specifications, and ADA Accessibility Guidelines for Buildings and Facilities (ADAAG), etc. as applicable, are the Construction Specifications for this project. Other sections of the Oregon Standard Specifications may also apply and their omission as a direct reference herein does not relieve the Contractor from those standards. The cost of other items not specifically called for in the bid will be considered incidental to the Project and no additional payments will be made.

The General Requirements and Information references, as provided in the Special Provisions I are general in nature, those descriptions and references in the Technical Specification portion of the Special Provision II section are related more specifically to the particulars of the Project.

NOTE: All codes, standards, workmanship, material testing, general items, products, execution, special provisions, measurement and payments etc., are well documented in the Specifications noted above, and are NOT repeated here, but are included herein in whole or in part as reference and shall be applicable.

DESCRIPTION NARRATIVE OF WORK

The project work is the AC Paving Overlay and application of tack coat of various city streets as noted in the schedule listing below.

Schedule A is the placement of 795 Tons of Level 2 Asphalt Concrete Paving for both roadways and driveways, and the pretreatment of 6,650 square yards of road surface on the Streets of Kalmia Street, 45th Avenue, 46th Avenue, and 47th Avenue.

Schedule B is the placement of 190 Tons of Level 2 Asphalt Concrete Paving for both roadways and driveways, and the pretreatment of 3,255 square yards of road surface on the on the Streets of Harding Street and 23rd Avenue.

Schedule C is the placement of 320 Tons of Level 2 Asphalt Concrete Paving for both roadways and driveways, and the pretreatment of 2,530 square yards of road surface on the Streets of Juniper Street and 32nd Court.

Schedule D is the placement of 220 Tons of Level 2 Asphalt Concrete Paving for both roadways and driveways, and the pretreatment of 1,855 square yards of road surface on the Streets of Grape Street and Grape Loop.

TIME AND PLACE OF RECEIVING BIDS

Sealed bids will be received at the City of Sweet Home Public Works Department at 1400 24th Avenue, Sweet Home, Oregon, at which time as noted in the bid documents, the sealed bids will be publicly opened and read. Bids submitted after the specified time will not be received or opened.

The City of Sweet Home reserves the right to accept the bids and award a contract to the lowest responsible bidder; to postpone the acceptance of the Bid and the award of the contract for a period not to exceed thirty (30) calendar day; or to reject any and all bids received and further advertise the project for bids. The City of Sweet Home may reject any bid not in compliance with all prescribed public bidding procedures and requirements, and may reject for good cause any or all bids upon a finding of the City that it is in the public interest to do so.

The City of Sweet Home reserves the right to accept all, or any component in part, any Bid Schedule (e.g. A, B,...) grouped bid items, or individual bid items as noted in the specifications.

CONSTRUCTION SCHEDULE

The work, as described in these Plans and Specifications, is to begin no earlier than that approved by City Council and noted in the Notice to Proceed. Following the Award of Contract, and prior to issuance of the Notice to Proceed, a Pre-Construction meeting will be held, at which the Contractor shall submit a written Work Schedule, Traffic Control Schedule, Erosion Control Plan, or other documents to the Engineer. The Work Schedule shall specify the project work days to be utilized within the allowable completion time. Failure to complete the work within the completion time prescribed shall be considered cause for assessing liquidated damages, as set forth in Paragraph "LIQUIDATED DAMAGES" of these Special Provisions.

The construction schedule, as approved by the Engineer, will be an integral part of the Contract and will establish interim contract completion dates for the various activities. "Day" used throughout the Contract, unless otherwise stated, means "calendar day". Should any activity not be completed within five (5) days after the stated scheduled date, the Engineer shall have the right to order the Contractor to expedite completion of the activity by whatever means the Engineer deems appropriate and necessary without additional compensation to the Contractor.

It is expressly understood, and agreed, that failure by the Engineer to exercise the option to either order the Contractor to expedite an activity, or to expedite the activity by other means, shall not be considered precedent setting for any other activities.

TYPE OF BID

The Bid for the work is to be submitted on a unit price basis as called for in the Bid. The estimate of quantities of work to be done as tabulated in the Bid, and although stated with as much accuracy as possible, is approximate only, and is assumed solely for the convenience of the Contractor while assembling the Bid.

BASIS OF AWARD

Award, if made, will be to a lowest responsible bidder (as defined by O.R.S.) for any combination of schedules as stated above which is determined by the City to be in the City's best interest to award.

PERMITS

The contractor shall be responsible for acquiring any permits necessary for the completion of the work, i.e. fill & grade, water & wastewater plumbing, stormwater, or building construction on private property.

INCIDENTAL ITEMS

It is the intent of these documents that the bid items listed in the Bid shall provide full and complete payment for this project, as described in the Plan and Specifications. Payment for any incidental items, whether noted on the Plans and Specifications or not, which are necessary for the completion of the project as designed, but not listed explicitly as or with a bid item, shall be considered to have been included with the Bid.

PREQUALIFICATION

Prequalification is not required for this project.

When they occur if stated in the Instructions to Bidders, statements on standard ODOT or AGC Form 40 forms must be received by the City of Sweet Home on the date stated. Prequalification shall state the bidder's experience in handling work of this type and magnitude, availability of equipment and supervisory personnel, giving references on previous similar projects, etc. Bids that are submitted by Contractors that have not prequalified will be considered non-responsive, and the bid will not be opened. Faxed Prequalification statements will not be accepted.

UTILITIES

The utilities shown on the Plans are located to the best degree possible from the information available, but are not guaranteed to be either accurate or complete. The existence of existing utility conflicts, not indicated on the Plans, shall not be the basis of extra work claims except that the cost of extra materials actually required to perform the work, and incorporated into the work, may be submitted for reimbursement in accordance with the General Conditions. The decision of the Engineer, as to the validity of such claims, shall be final. IN ACCORDANCE WITH ORS 757.542 TO 757.562 inclusive, it shall be the responsibility of the Contractor to notify all utility companies and organizations of his intention to begin construction. The Contractor alone shall be responsible for protecting all utilities and replacing utilities damaged by the Contractor during construction.

LIMITATION / SUBMISSION REQUIREMENTS

The City of Sweet Home reserves the right to:

- Accept or reject any or all bids received as a result of the RFB,
- Negotiate with qualified Bidders, as allowed by law.
- Cancel any RFB, in part or in whole, if it is determined to be in the best interest of the City to do so,
- Award to the selected firm or contractor any subsequent engineering design and construction services contract, part or in whole, for recommended capital projects,
- The RFB does not commit the City of Sweet Home to pay any costs incurred to prepare a bid.

SAFETY REQUIREMENTS

The Contractor shall have the sole responsibility for complying with the requirements of the Oregon Occupational Safety and Health Code, particularly Division 3, OAR 437-003, "Construction". Failure of the Contractor to comply with specific requirements shall be the Contractor's liability. No liability for safety violations will be assumed by the Engineer, City, or other involved parties. The Contractor shall comply with all Federal, State, County and City regulations.

PROTECTION OF FACILITIES

The Contractor shall make provisions for protection of all work during the period of construction, and shall repair or replace any facilities damaged by flood, fire, vandalism, neglect, or other means prior to acceptance of the completed facility by the Owner.

INSPECTION/ENGINEER

The term Inspector, Engineer, or the authorized representative of the Owner, for the purposes of approving materials and workmanship, shall be the City of Sweet Home.

SPECIFICATIONS

The Contractor shall perform all work in conformance with the construction drawings, special provisions and in compliance with the Oregon Standard Specifications for Construction (as revised) as if said specifications were bound herewith, or as they may be modified by the Special Provisions herein.

PROJECT WARRANTY

In addition to other specific warranties required by these Specifications, all work, including material and workmanship supplied by the Contractor shall be warranted to be free of defect for one (1) year from the date the written Final Acceptance by the City of Sweet Home. The Contractor also agrees to hold the City harmless from claims of any kind arising from damage due to said defects. The Contractor shall make all repairs, and replacements promptly upon receipt of written orders for same from the Owner. If the Contractor fails to make the repairs and replacements promptly, the Owner may do the Work, and the Contractor and his surety shall be liable for the cost thereof.

TEMPORARY PROTECTION AND DIRECTION OF TRAFFIC

This shall include all temporary protection and direction of traffic per Oregon Standard Specifications for Construction, ODOT specifications, and as shown on the drawings or as stated herein. Traffic Control shall be per current edition of the Manual on Uniform Traffic Control Devices (MUTCD).

Traffic control devices which are expected to be in place for the duration of the project may be shown on the drawings. The Contractor shall provide such other traffic control devices as may be required at locations where construction is of short duration (i.e., street intersections and access to private property).

Adequate warning protection will be required for pedestrians, residents, and any material stored in a staging area in the right-of-way, or roadway. Night time protection with lighted barricades may be required. Emergency vehicles must have access or have access provided when needed.

A traffic control plan shall be submitted to the Engineer for review and approval. Following approval, the plan SHALL BE ADHERED TO AT ALL TIMES. The Contractor may find it necessary to consider various traffic control options for different stages of construction. Limited street closure to through traffic will not be allowed on this project. The Contractor must submit and receive approval from the Engineer **prior** to any modifications to the approved plan. If, in the opinion of the Engineer, the Contractor fails to comply with the drawings or the approved traffic control plan, or fails to protect the public safety, in addition to other penalties as described in the Standard Construction Specification, payment for this item shall be reduced at the discretion of the Engineer.

The Contractor shall furnish the Engineer with the name and phone number of a responsible person with authority to ensure that the provisions of the plan are complied with, particularly with regard to 24 hour availability to provide a one (1) hour response to problems. The Contractor shall, at all times, protect access to private property.

Access for all residents must be maintained at all times, provide 48 hour written notice to the residents when specific driveways may be out of use. Maintaining access at all times to adjoining properties shall be incidental to the Contract and no extra payment shall be made for work relating to maintaining access, including temporary rock or asphalt necessary for the convenience and safety of the public.

EROSION CONTROL

As required per DSL, COE, DEQ, and any other National permits. All construction activities shall conform to City NPDES permit and Stormwater Control Best Management Practices.

Erosion control measures shall protect excessive sediment runoff into catchbasins or ditch channels located at or near the work areas. Material deposits in excess must be removed by the contractor. The City of Sweet Home will not provide removal. This will include control of runoff from any areas used for staging when or if the staging area is in a portion of the street right-of-way.

FINAL CLEANUP

Final cleanup of all work sites or staging areas shall remove construction materials, equipment, debris, and dirt or gravel from all surfaces, as well as from catch basins and storm drains, that may have been impacted by construction activities. This may also include periodic street sweeping regularly since there are local residents within the work zone.

LIQUIDATED DAMAGES

Liquidated Damages will **not** be necessary on this project.

On projects if they were to occur, and would be as noted in the Instructions to Bidders, liquidated damages would be assessed as described in Section 00180.85 of the Oregon Standard Specifications for Construction. Liquidated damages shall apply against the Contractor and accrue to the Owner at the rate of Two Hundred Dollars (\$200) per day per Schedule for each and every day that the project remains uncompleted beyond the time period outlined in the Construction Schedule.

BONDING REQUIREMENTS

A performance bond and payment bond in the amount of 100% of the contract price shall be furnished to the City of Sweet Home upon executing the contract.

A warranty bond for one year is required from the date of the acceptance by the City. The City of Sweet Home shall be named on the bond as the project Owner.

QUALITY CONTROL TESTING

The Owner reserves the right to perform any testing as may be required to determine compliance with the specifications. Costs for such testing shall be the Owner's responsibility unless testing indicates noncompliance. Costs for such testing indicating noncompliance shall be borne by the Contractor. Noncomplying Work shall be corrected and testing will be repeated until the Work complies with the specifications. Contractor shall pay any costs for retesting non-complying Work.

The Contractor shall cooperate in every respect with the activities of the testing agency.

PROPERTY PIN AND SURVEY/GPS MONUMENT PROTECTION

All property pins adjacent to and within the work area shall be protected from disturbance. If property corners are disturbed during the course of the work, and are not specifically referenced in the Bid Tabulations as requiring setting or resetting, they shall be replaced by a licensed surveyor at the Contractor's expense.

The care and protection, and replacement of damaged or dislodged property monumentation shall also apply to all City and Linn County Survey Markers, GPS Monuments, DLC Corner Monuments, and other position control points.

PRE-BID MEETING

A Pre-Bid meeting will not be required on this project.

PRE-CONSTRUCTION MEETING

A Pre-Construction meeting will be required on this project after the bidder award. When it occurs as noted in the Instructions to Bidders, the meeting will be located at the Public Works Department, and scheduled to take place anytime within ten (10) working days following the Notice of Award. Weather and or other construction scheduling issues may modify this time frame. The Construction Contract and the Notice to Proceed will generally be issued at the meeting.

RETAINAGE

To ensure the proper performance of the Contract, the Owner shall retain five (5%) of the amount of each progress payment until final completion and acceptance of all work covered by this contract.

WAGES AND SALARIES

Attention of Contractors is particularly called to the requirements concerning wages to be paid to certain categories and classifications of employees.

DISPOSAL OF EXCESS MATERIAL

All excess trench excavation, existing sidewalk or curb, and other materials designated to be removed under the contract shall be disposed of off site at the Contractor's expense and in a legal manner. Fill permits, stating Contractor provided quantity, transportation carrier, and fill destination, if within the City Limits, shall be acquired by the City as needed.

PAYMENT

The contractor shall accept the compensation as full payment for furnishing all materials, labor, tools, and equipment necessary to complete the work. Compensation shall include loss or damage arising from the nature of the work or action of the elements, or any unforeseen difficulties, which may be encountered during the prosecution of the work.

The quantities listed in the bid schedule do not govern final payment. Payments to the contractor will be made only for the actual quantities of the work performed and for the quantities of work performed as extra work or under supplemental agreement. When items of work are not listed in the bid schedule, the work shall be considered incidental and no separate payment shall be paid.

If the contract cost is determined wholly or in part, on a lump-sum basis, Engineer may use unit prices bid by Contractor in making progress estimates on the work. In case said unit prices do not, in the opinion of the Engineer, truly represent actual relative costs of different parts of work, a percentage of the unit price may be used in making progress estimates.

END OF GENERAL REQUIREMENTS AND INFORMATION

SPECIAL PROVISIONS II
TECHNICAL SPECIFICATIONS

The Oregon Standard Specifications for Construction (as revised), American Public Works Association (APWA) and American Water Works Association (AWWA) Standard Specifications, and ADA Accessibility Guidelines for Buildings and Facilities (ADAAG), etc. as applicable, are the Construction Specifications for this project. Other sections of the Oregon Standard Specifications may also apply and their omission as a direct reference herein does not relieve the Contractor from those standards. The cost of other items not specifically called for in the bid will be considered incidental to the Project and no additional payments will be made.

The General Requirements and Information references, as provided in the Special Provisions I are general in nature, those descriptions and references in the Technical Specification portion of the Special Provision II section are related more specifically to the particulars of the Project. The cost of other items not specifically called for in the Bidder's Bid will be considered incidental to the Project and no additional payments will be made.

NOTE: All codes, standards, workmanship, material type, material testing, general items, products, execution, special provisions, measurement and payments etc. related to the items noted below, are well documented in the Standard Specifications 00100 through 03010 and are NOT repeated here, but are included herein by reference.

Notification to immediately adjacent corner residents shall be made in writing by the contractor 48 hours in advance of the work. Notification shall state Project Name, Contractor Company Name, contact and phone, City Contact and Phone, the date of the work scheduled and a request to keep parked vehicles out of the corner area. Adequate warning protection will be required for pedestrians, residents, and any material stored in a staging area in the right-of-way, or roadway. Access for all residents must be maintained at all times, provide 48 hour written notice to the residents when specific driveways may be impacted.

Following this section is a map(s) showing the project work site location in Sweet Home.

Bid Items.

BID ITEM NO. 1 – Mobilization, Cleanup, Staking, Traffic & Erosion Control.

This item shall include all mobilization and final cleanup within the project area. This will also include periodic street sweeping and to provide final cleanup of all work sites or staging areas to remove construction materials, equipment, debris, and dirt or gravel from all surfaces, as well as from catch basins and storm drains, that may have been impacted by construction activities, since there are local residents within the work zone. This includes any staging area required.

This item shall include all Work Zone Traffic Control required by the City of Sweet Home, OHSA MUTCD, and Oregon Department of Transportation Standards. This bid item shall be considered full pay for all labor, materials, and equipment required to plan for, coordinate, sign, flag, detour, or direct traffic impacted by this project in accordance with Section 00225 of the ODOT Standard Specifications. A general traffic control plan shall be submitted – and approved – to the City prior to the beginning of work.

Adequate warning protection will be required for any material stored in a staging area in the right-of-way, or along the longitudinal cut drop off running lengthwise on the roadway. Night time protection of stored materials with lighted barricades may be required. This will include control of runoff from any areas used for staging when or if the staging area is a portion of the street right-of-way. Material deposits in excess must be removed by the contractor. The City of Sweet Home will not provide removal.

Access for all residents must be maintained at all times, provide written notice to the resident when specific driveways may be out of use. Emergency vehicles must have access or have access provided when needed.

This item shall include erosion control measures to protect runoff into catchbasins or drainage ditches located on the local streets where the work will be performed. Bio-Filter bags or other forms of sediment barriers may be used.

BID ITEM No. 2, 4, 6, 8. – Tack Coat.

This per square yard bid item is for tack coat on all roadways per Oregon Standard Section 00730. Application rate shall be 0.08 gal/square yard. Tack Coat shall only be applied to clean dry surfaces, all loose material should be removed prior to application.

This material is for the roadway travel lane areas only, it is not necessary to use on driveway aprons. Tack coat shall be measured and paid by square yard of roadway surface.

BID ITEM NO. 3, 5, 7, 9. – Level 2, 1/2” ACP Mixture.

This per Ton bid item shall include the wearing course lift of 2” thick, Level 2 Asphalt Concrete Pavement per Oregon Standard Section 00744. It shall be used for all roadway areas, driveway areas, and work area shoulder excavations and infills. For driveway aprons, pave the first 3 feet of the driveway or per City direction. Existing driveways of asphalt or concrete will be paved per City direction. This bid item includes edge widening lifts and pre-level applications necessary for the primary overlay lift. City and Contractor to verify locations.

Level 2, 1/2” ACP Mixture shall be paid by the ton and measured by the load ticket.

END OF GENERAL TECHNICAL REQUIREMENTS

CITY OF SWEET HOME

LINN COUNTY, OREGON



2021 PAVEMENT OVERLAY PROJECT

PROJECT NO. 2817-003
MARCH 10, 2021

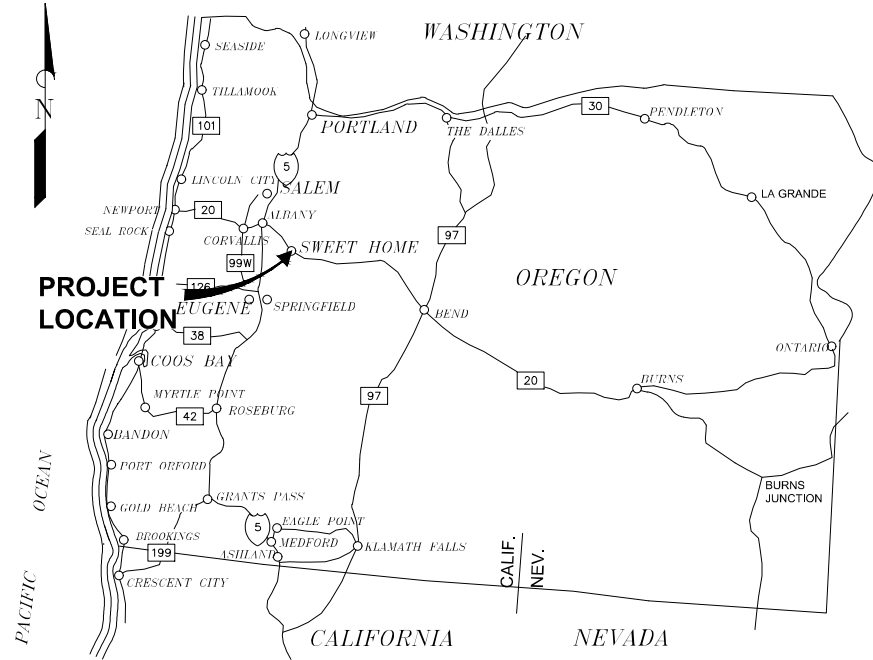

LOCATION MAP

LEGEND EXISTING

- CATCH BASIN
- MANHOLE
- VALVE CAN (WATER, GAS etc...)
- PROPERTY LINE/ROW

LEGEND NEW

- DRIVEWAY TRANSITION AREA
- OVERLAY OVERLAY
- OVERLAY TRANSITION AREA

GENERAL NOTES

- OREGON LAW REQUIRES YOU TO FOLLOW THE RULES ADOPTED BY THE OREGON UTILITY NOTIFICATION CENTER. THOSE RULES ARE SET FORTH IN OAR 952-001-0010 THROUGH 952-001-0090 AND ORS 757.542 THROUGH ORS 757.562 AND ORS 757.993. YOU MAY OBTAIN COPIES OF THE RULES FROM THE CENTER BY CALLING (503) 246-1987.
- THE CONTRACTOR SHALL CONTACT 'ONE CALL' FOR UTILITY LOCATES PRIOR TO EXCAVATION OR START OF CONSTRUCTION. (1-800-332-2344)
- THE OVERHEAD ELECTRICAL DISTRIBUTION SYSTEMS ARE NOT SPECIFICALLY INDICATED ON THE DRAWINGS BUT DO EXIST ALONG THE PAVING IMPROVEMENT ROUTES.
- THE EXISTING VALVE BOXES AND MANHOLES MAY NOT BE SPECIFICALLY INDICATED ON THE DRAWINGS BUT DO EXIST ALONG THE PAVING IMPROVEMENT ROUTES. CONTRACTOR SHALL LOCATE PRIOR TO THE START OF CONSTRUCTION AND PROTECT AS REQ'D FOR A COMPLETED PAVING IMPROVEMENT PROJECT.
- ALL MATERIALS AND WORK SHALL BE AS SPECIFIED AND CONFORM TO THE LATEST EDITION OF THE OREGON STANDARD SPECIFICATIONS (OSS) FOR CONSTRUCTION AND THE AMERICAN PUBLIC WORKS ASSOCIATION (APWA).

SHEET INDEX

SHEET NO.	SHEET TITLE
G1	COVER SHEET, INDEX, LEGEND, LOCATION, & VICINITY MAP
A	KALMIA ST, 45TH, 46TH, 47TH AVE
B	HARDING ST & 23RD AVE
C	JUNIPER ST & 32ND CT
D	GRAPE LOOP
D1	TYPICAL STREET SECTIONS
D2	TRANSITION DETAILS

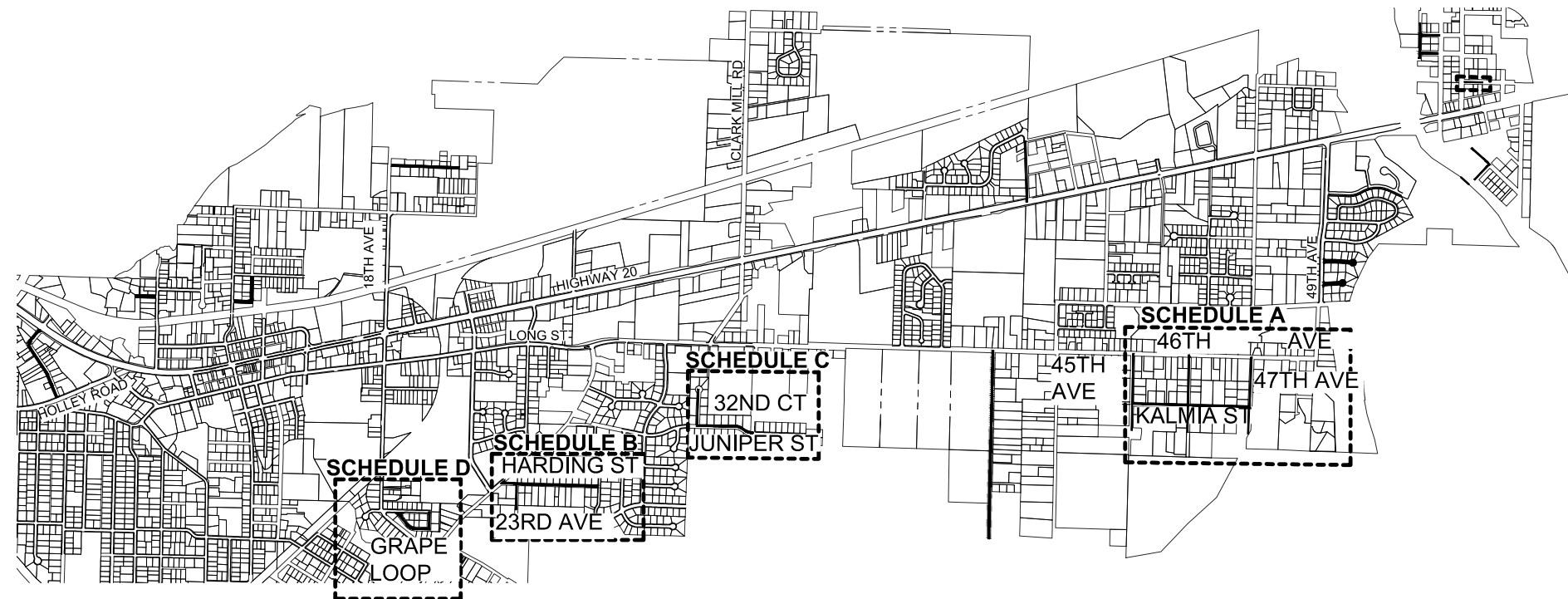

VICINITY MAP
NOT TO SCALE



RENEWS: 06/30/2022

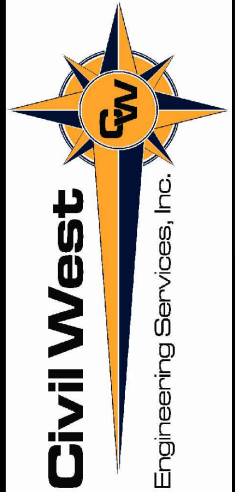

213 Water Ave. NW, Suite 100
Albany, Oregon 97321
541-266-8601
www.civilwest.com

REV.	DATE	DESCRIPTION	BY

Designed By:	ERM	Drawn By:	ERM	Checked By:	MDW
Project No.:	2817-003				

CITY OF SWEET HOME
LINN COUNTY, OREGON

2021 PAVEMENT OVERLAY PROJECT

COVER SHEET, INDEX, LEGEND,
LOCATION, + VICINITY MAP

DATE: MARCH 10, 2021

DATE: 3/12/21 FILE: C:\CW_Projects\2817 Sweet Home\2817-003 2021 Pavement Overlay\04 Final Design\Drawings\DWG\Overlays.dwg

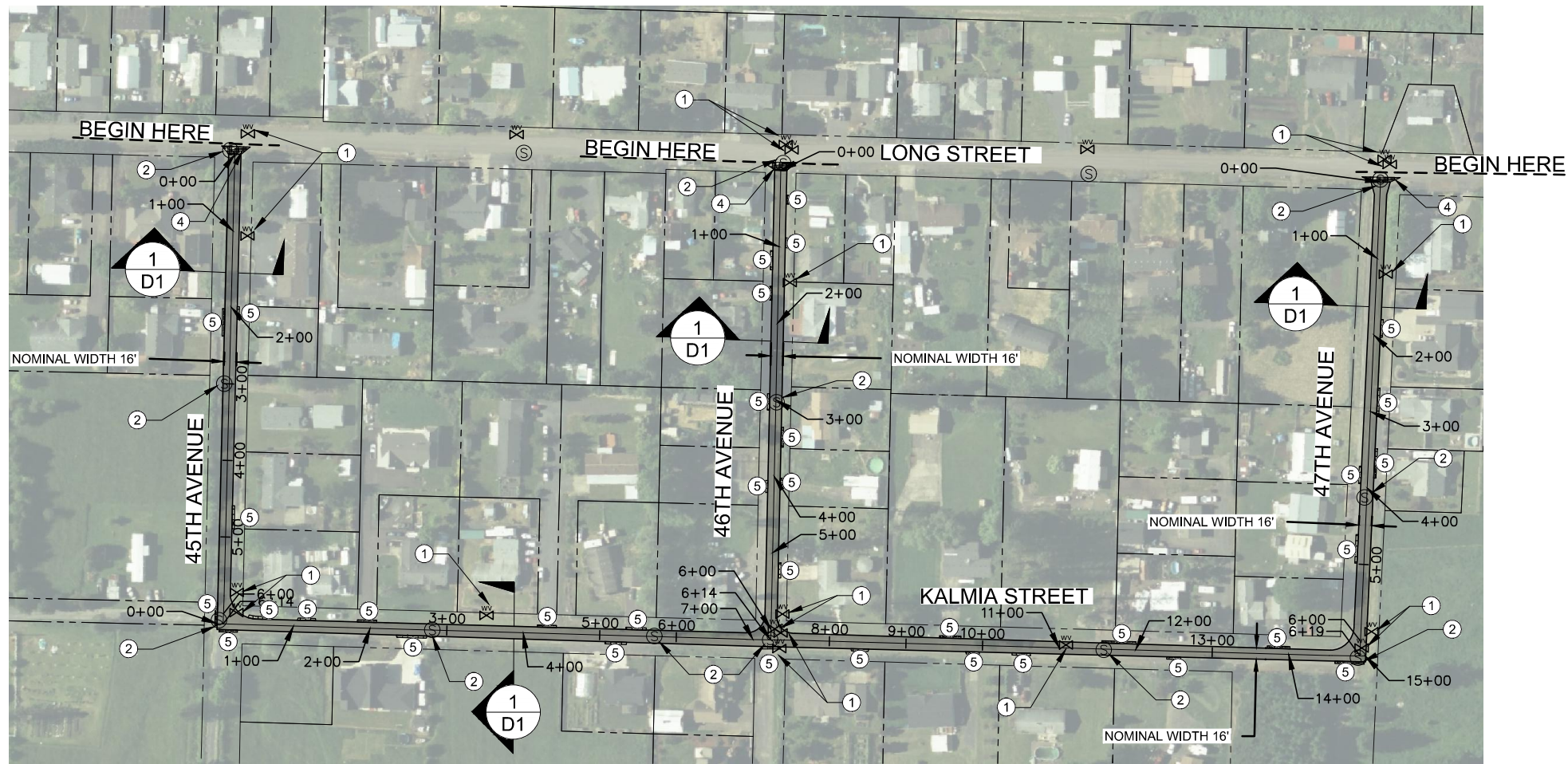

KEYED NOTES	
①	VALVE CAN PROTECTION TYPICAL
②	MANHOLE PROTECTION TYPICAL
③	STORM DRAIN GRATE PROTECTION TYPICAL
④	OVERLAY TRANSITION, SEE DETAIL 1 SHEET D2
⑤	DRIVEWAY APRON, SEE DETAIL 2 SHEET D2

SHEET NOTES:

- BEGIN AND END OF CONSTRUCTION SHALL BE TAPERED TO MATCH EXISTING PAVEMENT.
- EXISTING SEWER AND STORM DRAIN MANHOLES; VALVE CANS; AND ALL OTHER UTILITIES ALONG ROAD IMPROVEMENT AREA AS INDICATED ON THE PLANS ARE TO BE VERIFIED IN FIELD AND SHALL BE PROTECTED IN PLACE OR REPAIRED TO PRE-CONSTRUCTION CONDITION OR BETTER BY CONTRACTOR. ADDITIONAL UTILITIES MAY EXIST AT THE SITES.
- CONTRACTOR TO MAINTAIN ONE LANE OF TRAFFIC OPEN AT ALL TIMES DURING COURSE OF CONSTRUCTION.
- CONTRACTOR TO PROVIDE A CLEAN TRANSITION BETWEEN NEW IMPROVEMENTS AND EXISTING SITE SURFACES. CONTRACTOR SHALL PAY SPECIAL ATTENTION TO TRANSITIONS AT CROSS STREETS AND DRIVEWAYS.
- ALL CROSS STREETS AND DRIVEWAYS ARE IDENTIFIED AT THE APPROXIMATE LOCATIONS. ACTUAL WIDTH OF DRIVEWAYS AND CROSS STREETS MAY VARY. CONTRACTOR SHALL FIELD VERIFY.
- OTHER PAVEMENT MARKINGS SUCH AS STOP BARS, CROSS WALKS ETC. AS INDICATED ON THE PLANS SHALL BE FIELD VERIFIED AND SHALL BE REPLACED BY THE CONTRACTOR AFTER COMPLETION OF OVERLAY RESURFACING. ADDITIONAL PAVEMENT MARKINGS MAY EXIST AT THE SITES.
- AS NECESSARY, NEW 1"-0 GRAVEL SHOULDER MATERIAL SHALL BE A CLEAN ROCK MATERIAL FROM CITY APPROVED SOURCE. SHAPE AND BLEND TO EXISTING SURFACES AS REQUIRED TO PROVIDE A SMOOTH TRANSITION TO EXISTING GRADES.
- OVERLAYED SURFACE SHALL BE CURED AND OPEN TO TRAFFIC BY 5:00 PM EACH DAY

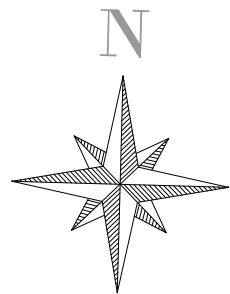

KALMIA ST, 45TH, 46TH, 47TH AVE

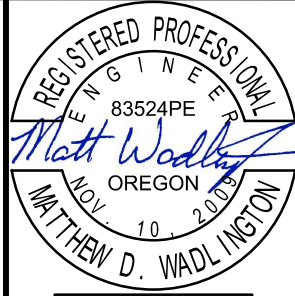
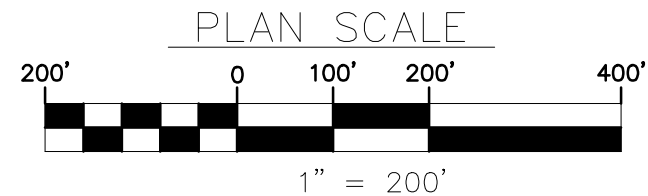

Civil West
Engineering Services, Inc.

213 Water Ave. NW, Suite 100
Albany, Oregon 97321

541-266-8601
www.civilwest.com

REV.	DATE	DESCRIPTION	BY

Designed By: ERM	Drawn By: ERM	Checked By: MDW
Project No: 2817-403		

DATE: MARCH 10, 2021

CITY OF SWEET HOME
LINN COUNTY, OREGON

2021 PAVEMENT OVERLAY PROJECT

KALMIA ST, 45TH, 46TH, 47TH AVE

Sheet No: A

Date: MARCH 10, 2021

DATE: 3/12/21 FILE: C:\CW_Projects\2817_Sweet Home\2817-003 2021 Pavement Overlay\04 Final Design\Drawings\DWG\Overlays.dwg



1
B

HARDING ST & 23RD AVE

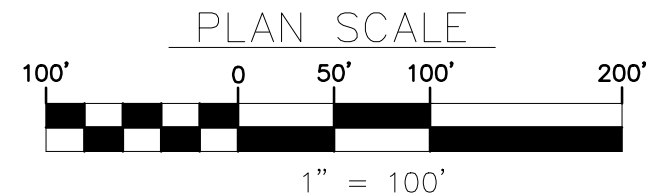

SHEET NOTES:

1. BEGIN AND END OF CONSTRUCTION SHALL BE TAPERED TO MATCH EXISTING PAVEMENT.
2. EXISTING SEWER AND STORM DRAIN MANHOLES; VALVE CANS; AND ALL OTHER UTILITIES ALONG ROAD IMPROVEMENT AREA AS INDICATED ON THE PLANS ARE TO BE VERIFIED IN FIELD AND SHALL BE PROTECTED IN PLACE OR REPAIRED TO PRE-CONSTRUCTION CONDITION OR BETTER BY CONTRACTOR. ADDITIONAL UTILITIES MAY EXIST AT THE SITES.
3. CONTRACTOR TO MAINTAIN ONE LANE OF TRAFFIC OPEN AT ALL TIMES DURING COURSE OF CONSTRUCTION.
4. CONTRACTOR TO PROVIDE A CLEAN TRANSITION BETWEEN NEW IMPROVEMENTS AND EXISTING SITE SURFACES. CONTRACTOR SHALL PAY SPECIAL ATTENTION TO TRANSITIONS AT CROSS STREETS AND DRIVEWAYS.
5. ALL CROSS STREETS AND DRIVEWAYS ARE IDENTIFIED AT THE APPROXIMATE LOCATIONS. ACTUAL WIDTH OF DRIVEWAYS AND CROSS STREETS MAY VARY. CONTRACTOR SHALL FIELD VERIFY.
6. OTHER PAVEMENT MARKINGS SUCH AS STOP BARS, CROSS WALKS ETC. AS INDICATED ON THE PLANS SHALL BE FIELD VERIFIED AND SHALL BE REPLACED BY THE CONTRACTOR AFTER COMPLETION OF OVERLAY RESURFACING. ADDITIONAL PAVEMENT MARKINGS MAY EXIST AT THE SITES.
7. AS NECESSARY, NEW 1"-0 GRAVEL SHOULDER MATERIAL SHALL BE A CLEAN ROCK MATERIAL FROM CITY APPROVED SOURCE. SHAPE AND BLEND TO EXISTING SURFACES AS REQUIRED TO PROVIDE A SMOOTH TRANSITION TO EXISTING GRADES.
8. OVERLAYED SURFACE SHALL BE CURED AND OPEN TO TRAFFIC BY 5:00 PM EACH DAY

KEYED NOTES	
①	VALVE CAN PROTECTION TYPICAL
②	MANHOLE PROTECTION TYPICAL
③	STORM DRAIN GRATE PROTECTION TYPICAL
④	OVERLAY TRANSITION, SEE DETAIL 1 SHEET D2
⑤	DRIVEWAY APRON, SEE DETAIL 2 SHEET D2

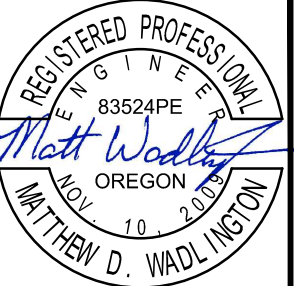

RENEWS: 06/30/2022



541-266-8601
www.civilwest.com
213 Water Ave. NW, Suite 100
Albany, Oregon 97321

REV.	DATE	DESCRIPTION	BY

Designed By:	ERM	Drawn By:	ERM	Checked By:	MDW
Project No:		2817-403			

DATE: MARCH 10, 2021

CITY OF SWEET HOME
LINN COUNTY, OREGON

2021 PAVEMENT OVERLAY PROJECT

HARDING ST + 23RD AVE

Date: **MARCH 10, 2021**

Sheet No: **B**

DATE: 3/12/21 FILE: C:\CW_Projects\2817-Sweet Home\2817-003 2021 Pavement Overlay\Drawings\Drawings\Overlay.dwg

SHEET NOTES:

1. BEGIN AND END OF CONSTRUCTION SHALL BE TAPERED TO MATCH EXISTING PAVEMENT.
2. EXISTING SEWER AND STORM DRAIN MANHOLES; VALVE CANS; AND ALL OTHER UTILITIES ALONG ROAD IMPROVEMENT AREA AS INDICATED ON THE PLANS ARE TO BE VERIFIED IN FIELD AND SHALL BE PROTECTED IN PLACE OR REPAIRED TO PRE-CONSTRUCTION CONDITION OR BETTER BY CONTRACTOR. ADDITIONAL UTILITIES MAY EXIST AT THE SITES.
3. CONTRACTOR TO MAINTAIN ONE LANE OF TRAFFIC OPEN AT ALL TIMES DURING COURSE OF CONSTRUCTION.
4. CONTRACTOR TO PROVIDE A CLEAN TRANSITION BETWEEN NEW IMPROVEMENTS AND EXISTING SITE SURFACES. CONTRACTOR SHALL PAY SPECIAL ATTENTION TO TRANSITIONS AT CROSS STREETS AND DRIVEWAYS.
5. ALL CROSS STREETS AND DRIVEWAYS ARE IDENTIFIED AT THE APPROXIMATE LOCATIONS. ACTUAL WIDTH OF DRIVEWAYS AND CROSS STREETS MAY VARY. CONTRACTOR SHALL FIELD VERIFY.
6. OTHER PAVEMENT MARKINGS SUCH AS STOP BARS, CROSS WALKS ETC. AS INDICATED ON THE PLANS SHALL BE FIELD VERIFIED AND SHALL BE REPLACED BY THE CONTRACTOR AFTER COMPLETION OF OVERLAY RESURFACING. ADDITIONAL PAVEMENT MARKINGS MAY EXIST AT THE SITES.
7. AS NECESSARY, NEW 1'-0" GRAVEL SHOULDER MATERIAL SHALL BE A CLEAN ROCK MATERIAL FROM CITY APPROVED SOURCE. SHAPE AND BLEND TO EXISTING SURFACES AS REQUIRED TO PROVIDE A SMOOTH TRANSITION TO EXISTING GRADES.
8. OVERLAYED SURFACE SHALL BE CURED AND OPEN TO TRAFFIC BY 5:00 PM EACH DAY

KEYED NOTES	
①	VALVE CAN PROTECTION TYPICAL
②	MANHOLE PROTECTION TYPICAL
③	STORM DRAIN GRATE PROTECTION TYPICAL
④	OVERLAY TRANSITION, SEE DETAIL 1 SHEET D2
⑤	DRIVEWAY APRON, SEE DETAIL 2 SHEET D2



①
C

JUNIPER ST & 32ND CT

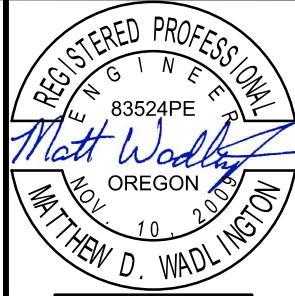
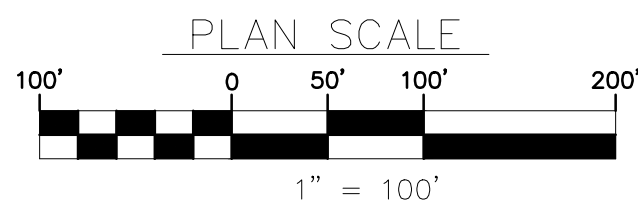

Civil West
Engineering Services, Inc.

213 Water Ave. NW, Suite 100
Albany, Oregon 97321

541-266-8601
www.civilwest.com

REV.	DATE	DESCRIPTION	BY

Designed By: ERM
 Drawn By: ERM
 Checked By: MDW
 Project No: 2817-403

CITY OF SWEET HOME
LINN COUNTY, OREGON

2021 PAVEMENT OVERLAY PROJECT

JUNIPER ST + 32ND CT

Date: **MARCH 10, 2021**

DATE: 3/12/21 FILE: C:\CW_Projects\2817_Sweet Home\2817-003_2021 Pavement Overlay\Drawings\DWG\Overlays.dwg



SHEET NOTES:

1. BEGIN AND END OF CONSTRUCTION SHALL BE TAPERED TO MATCH EXISTING PAVEMENT.
2. EXISTING SEWER AND STORM DRAIN MANHOLES; VALVE CANS; AND ALL OTHER UTILITIES ALONG ROAD IMPROVEMENT AREA AS INDICATED ON THE PLANS ARE TO BE VERIFIED IN FIELD AND SHALL BE PROTECTED IN PLACE OR REPAIRED TO PRE-CONSTRUCTION CONDITION OR BETTER BY CONTRACTOR. ADDITIONAL UTILITIES MAY EXIST AT THE SITES.
3. CONTRACTOR TO MAINTAIN ONE LANE OF TRAFFIC OPEN AT ALL TIMES DURING COURSE OF CONSTRUCTION.
4. CONTRACTOR TO PROVIDE A CLEAN TRANSITION BETWEEN NEW IMPROVEMENTS AND EXISTING SITE SURFACES. CONTRACTOR SHALL PAY SPECIAL ATTENTION TO TRANSITIONS AT CROSS STREETS AND DRIVEWAYS.
5. ALL CROSS STREETS AND DRIVEWAYS ARE IDENTIFIED AT THE APPROXIMATE LOCATIONS. ACTUAL WIDTH OF DRIVEWAYS AND CROSS STREETS MAY VARY. CONTRACTOR SHALL FIELD VERIFY.
6. OTHER PAVEMENT MARKINGS SUCH AS STOP BARS, CROSS WALKS ETC. AS INDICATED ON THE PLANS SHALL BE FIELD VERIFIED AND SHALL BE REPLACED BY THE CONTRACTOR AFTER COMPLETION OF OVERLAY RESURFACING. ADDITIONAL PAVEMENT MARKINGS MAY EXIST AT THE SITES.
7. AS NECESSARY, NEW 1"Ø GRAVEL SHOULDER MATERIAL SHALL BE A CLEAN ROCK MATERIAL FROM CITY APPROVED SOURCE. SHAPE AND BLEND TO EXISTING SURFACES AS REQUIRED TO PROVIDE A SMOOTH TRANSITION TO EXISTING GRADES.
8. OVERLAYED SURFACE SHALL BE CURED AND OPEN TO TRAFFIC BY 5:00 PM EACH DAY

KEYED NOTES	
①	VALVE CAN PROTECTION TYPICAL
②	MANHOLE PROTECTION TYPICAL
③	STORM DRAIN GRATE PROTECTION TYPICAL
④	OVERLAY TRANSITION, SEE DETAIL 1 SHEET D2
⑤	DRIVEWAY APRON, SEE DETAIL 2 SHEET D2

1
D

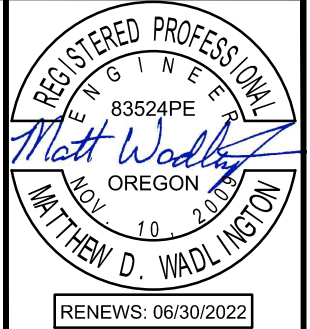
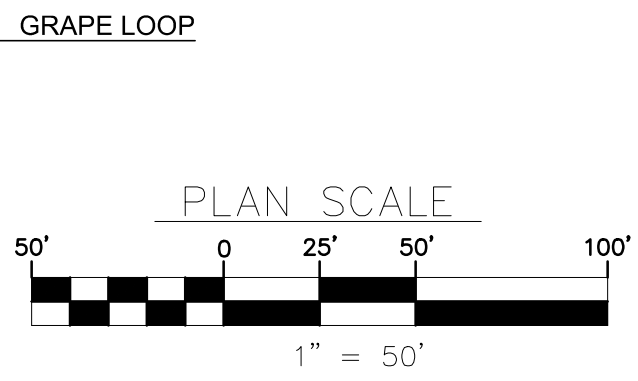
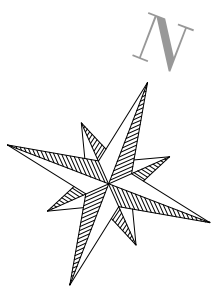

Civil West
Engineering Services, Inc.

213 Water Ave. NW, Suite 100
Albany, Oregon 97321

541-266-8601
www.civilwest.com

REV.	DATE	DESCRIPTION	BY

Designed By:	ERM	Drawn By:	ERM	Checked By:	MDW
Project No:	2817-403				

DATE: MARCH 10, 2021

CITY OF SWEET HOME
LINN COUNTY, OREGON

2021 PAVEMENT OVERLAY PROJECT

GRAPE LOOP

Date: **MARCH 10, 2021**

Sheet No: **D**

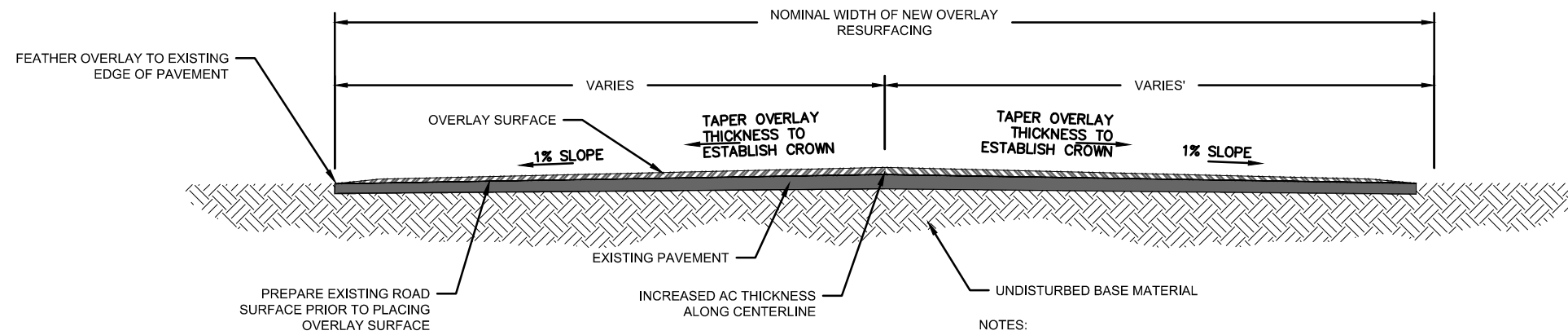

- NOTES:
1. NOMINAL DEPTH OF AC OVERLAY SHALL BE 2"
 2. AC PAVEMENT SHALL BE A LEVEL 2-1/2 DENSE HMAC
 3. MINIMUM CROSS SLOPE OF 1%

1
D1
TYPICAL STREET SECTION
NOT TO SCALE

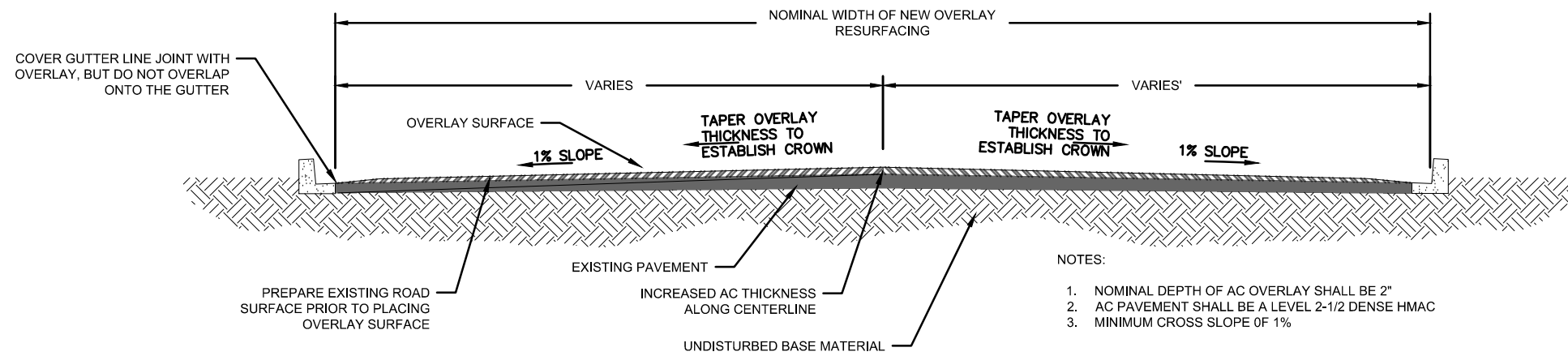

- NOTES:
1. NOMINAL DEPTH OF AC OVERLAY SHALL BE 2"
 2. AC PAVEMENT SHALL BE A LEVEL 2-1/2 DENSE HMAC
 3. MINIMUM CROSS SLOPE OF 1%

2
D1
CURB & GUTTER TYPICAL SECTION
NOT TO SCALE

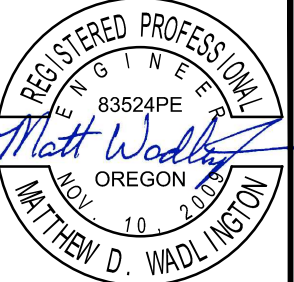

541-266-8601
www.civilwest.com
213 Water Ave. NW, Suite 100
Albany, Oregon 97321

REV.	DATE	DESCRIPTION	BY

Designed By: ERM
Drawn By: ERM
Checked By: MDW
Project No: 2817-403

DATE: MARCH 10, 2021

CITY OF SWEET HOME
LINN COUNTY, OREGON
2021 PAVEMENT OVERLAY PROJECT
TYPICAL STREET SECTIONS

Date: **MARCH 10, 2021**
Sheet No: **D1**

DATE: 3/12/21 FILE: C:\CW_Projects\2817 Sweet Home\2817-003 2021 Pavement Overlay\04 Final Design\Drawings\DWG\Overlays.dwg

DATE: 3/12/21 FILE: C:\CW_Projects\2817 Sweet Home\2817-003 2021 Pavement Overlay\Drawings\Drawings\Overlays.dwg

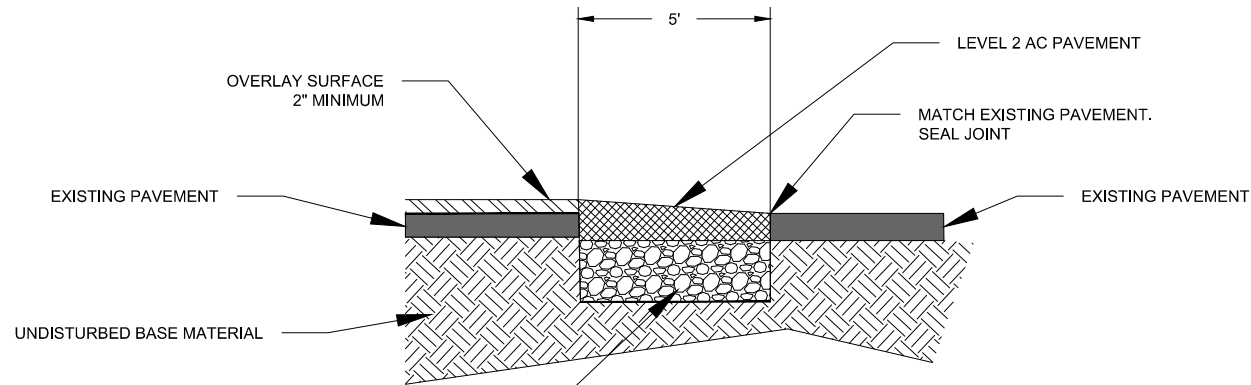

EXCAVATION AND BACKFILL TO BE COMPLETED BY CITY PRIOR TO PAVING. NOT INCLUDED IN CONTRACT.

NOTES:

1. NOMINAL DEPTH OF AC OVERLAY SHALL BE 2"
2. AC PAVEMENT SHALL BE A LEVEL 2-1/2 DENSE HMAC
3. CROSS SLOPE TO MATCH EXISTING PAVEMENT CROSS SLOPE

1
D2

OVERLAY TRANSITION DETAIL

NOT TO SCALE

CONCRETE DRIVEWAY TRANSITION

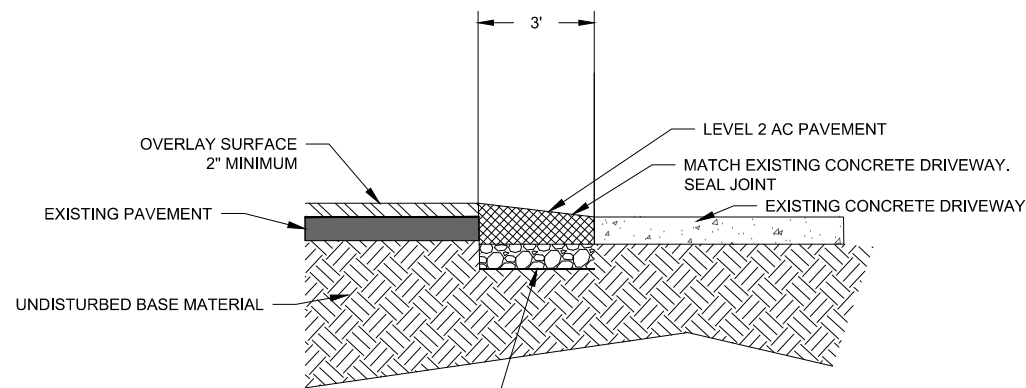

SAWCUTTING, EXCAVATION AND BACKFILL TO BE COMPLETED BY CITY PRIOR TO PAVING. NOT INCLUDED IN CONTRACT.

NOTES:

1. NOMINAL DEPTH OF AC OVERLAY SHALL BE 2"
2. AC PAVEMENT SHALL BE A LEVEL 2-1/2 DENSE HMAC
3. CROSS SLOPE TO MATCH EXISTING DRIVEWAY CROSS SLOPE

GRAVEL DRIVEWAY TRANSITION

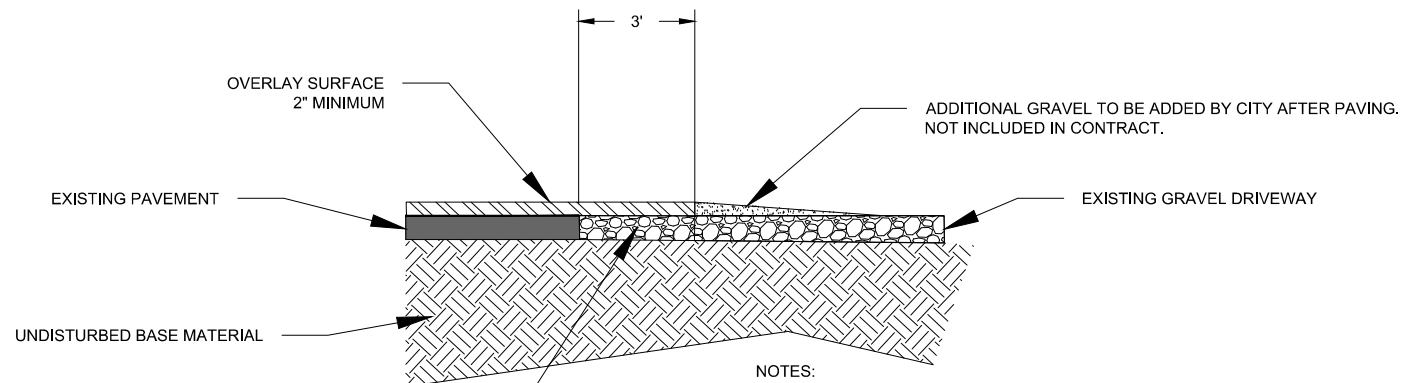

NOTES:

1. NOMINAL DEPTH OF AC OVERLAY SHALL BE 2"
2. AC PAVEMENT SHALL BE A LEVEL 2-1/2 DENSE HMAC
3. CROSS SLOPE TO MATCH EXISTING PAVEMENT CROSS SLOPE

COMPACT DRIVEWAY BENEATH OVERLAY

2
D2

DRIVEWAY TRANSITION DETAILS

NOT TO SCALE

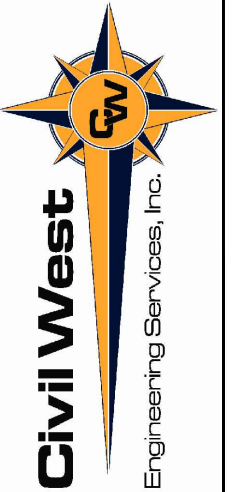

541-266-8601
www.civilwest.com
213 Water Ave. NW, Suite 100
Albany, Oregon 97321

REV.	DATE	DESCRIPTION	BY

Designed By: ERM
Drawn By: ERM
Checked By: MDW
Project No: 2817-403

DATE: MARCH 10, 2021

CITY OF SWEET HOME LINN COUNTY, OREGON
2021 PAVEMENT OVERLAY PROJECT
TRANSITION DETAILS

Sheet No: D2
Date: MARCH 10, 2021

CITY OF SWEET HOME
ITB: FY 2021 Overlay Program Project
ADDENDUM #1
April 19, 2021

SECTION 1: PURPOSE

The purpose of this addendum is to answer contractor questions and clarify bid items. Plan sheet D2 is hereby revised as described in Section 2 below.

SECTION 2: REVISIONS

New language is indicated by **bold underlined** font, deleted language is indicated by ~~strikethrough~~ font.

2.1 Plan sheet D2, detail 1 "Overlay Transition Detail" is revised as follows.

~~Excavation and backfill to be completed by City prior to paving. Not included in contract.~~
Contractor to provide excavation and backfill prior to paving.

SECTION 3: CONTRACTOR Q&A

Q1: Assuming all shoulder rocking for edge of pavement and driveways required for the project will be by the City since there is not a bid item. Please confirm.

Answer: Yes, the City will provide shoulder and driveway surface transition rock.

Q2: Assuming all preparation for the driveways and tie locations are by the City. Please confirm.

Answer: For driveways, the City will perform sawcutting, excavation and backfill for concrete driveway transitions as per sheet D2, detail 2. The Contractor will provide day-of preparation such as tack coat, etc. For overlay transitions, sheet D2, detail 1 is revised as described in Section 2 above. The contractor will perform all preparation of overlay transitions.

Q3: Does the contractor need to figure on placing a base life of asphalt in the tie transitions at road ends and driveways prior to top life.

Answer: Yes, transitions will be 2 lifts typical.

Q4: Will the City be sweeping the streets for the overlay prior to the contractor starting the project.

Answer: Yes, the City intends to sweep prior to overlay.

Q5: The plan notes mentions “Other pavement markings such as stop bars, crosswalks etc as indicated on the plans shall be replaced by the contractor.” I do not see any indication on the plans of any striping. Assuming there is none required of the contractor since none are mentioned and there is no bid item. Please confirm.

Answer: Correct, there are no pavement markings in this project.

Q6: Bid item number 1 description says “Staking.” What items are supposed to be staked? Please be specific on what is expected for staking.

Answer: No staking is anticipated for this project.

Q7: Bid item numbers 3, 5, 7, 9 description says the bid item includes edge widening lifts and prelevel applications. Where is that work occurring, on what sections, and how much?

Answer: Prelevel application is required for all streets except Grape Loop which is gravel. The City will grade Grape Loop prior to paving. Edge widening lifts are anticipated to be minimal, as needed to repair decayed road edges and to maintain uniform nominal width.

Q8: On Grape Street there is shown a “deep repair by City.” Is the contractor going to be required to pave that area? If so how deep will the pavement be, in how many lifts, and will there be any preparation work required by the contractor?

Answer: Yes, paving the deep repair area is part of Schedule D. The deep repair section is 4” deep in two lifts. The City will perform the repair up to and including compaction. The contractor will perform day-of-paving preparation such as tack coat, etc.

Q9: As far as utility adjustments (valve cans & manholes), the plans call for protection in place but do not mention adjusting the grade. Are contractors required to raise the existing utilities to match the new asphalt overlay surface?

Answer: Yes, utilities are required to be raised to the new grade. The City will provide manhole riser rings. The City will bust out water valve lids so that the contractor can adjust them.

DATE: 3/12/21 FILE: C:\CW_Projects\2817 Sweet Home\2817-003 2021 Pavement Overlay\Drawings\DWG\Overlays.dwg

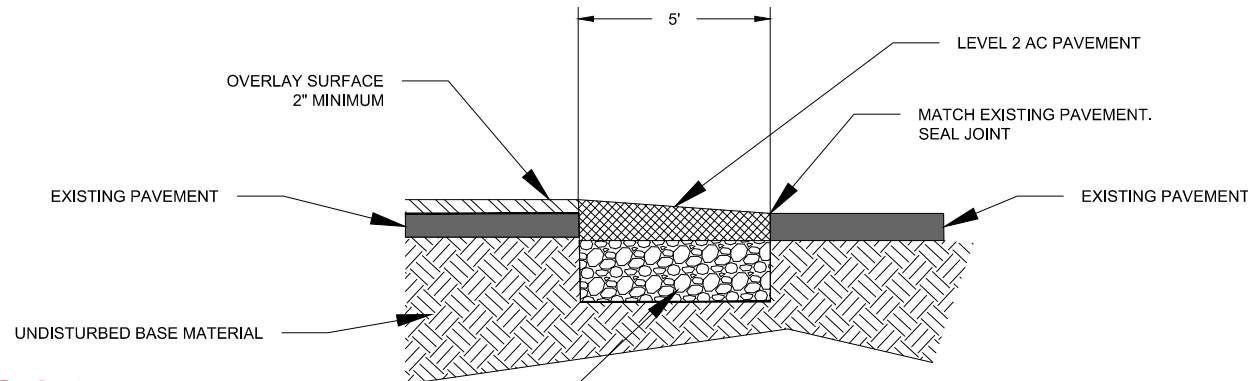

EXCAVATION AND BACKFILL TO BE COMPLETED BY CITY PRIOR TO PAVING. NOT INCLUDED IN CONTRACT.
8" DEPTH TYPICAL.
CONTRACTOR TO PROVIDE EXCAVATION AND BACKFILL PRIOR TO PAVING.

- NOTES:
1. NOMINAL DEPTH OF AC OVERLAY SHALL BE 2"
 2. AC PAVEMENT SHALL BE A LEVEL 2-1/2 DENSE HMAC
 3. CROSS SLOPE TO MATCH EXISTING PAVEMENT CROSS SLOPE

1
D2
OVERLAY TRANSITION DETAIL
 NOT TO SCALE

CONCRETE DRIVEWAY TRANSITION

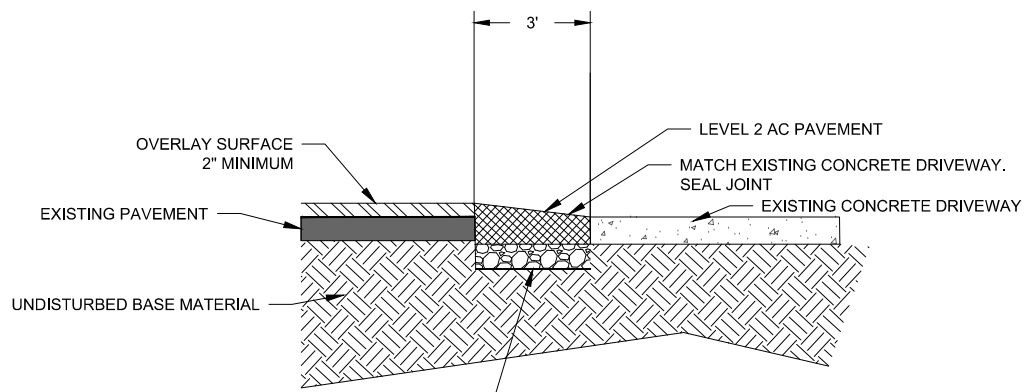

SAWCUTTING, EXCAVATION AND BACKFILL TO BE COMPLETED BY CITY PRIOR TO PAVING. NOT INCLUDED IN CONTRACT.

- NOTES:
1. NOMINAL DEPTH OF AC OVERLAY SHALL BE 2"
 2. AC PAVEMENT SHALL BE A LEVEL 2-1/2 DENSE HMAC
 3. CROSS SLOPE TO MATCH EXISTING DRIVEWAY CROSS SLOPE

GRAVEL DRIVEWAY TRANSITION

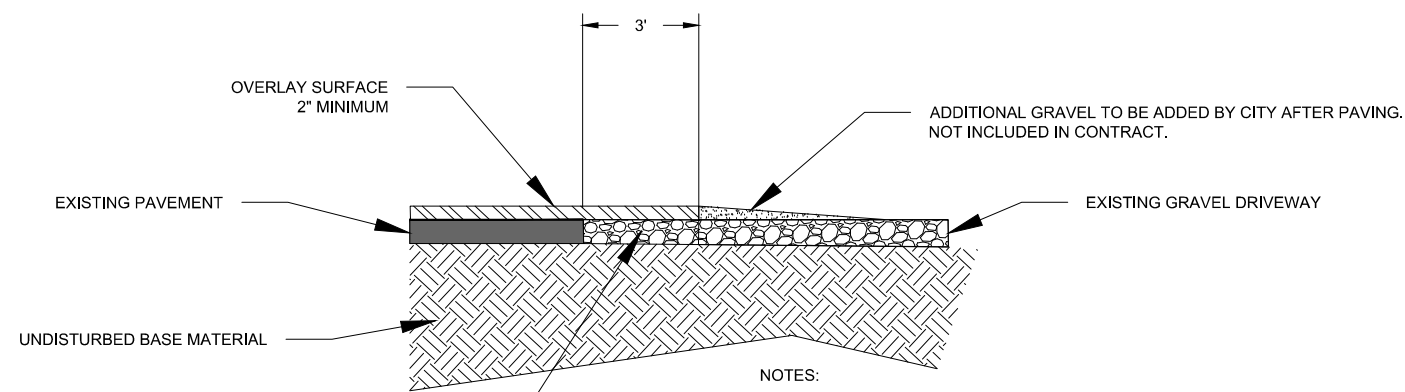

- NOTES:
1. NOMINAL DEPTH OF AC OVERLAY SHALL BE 2"
 2. AC PAVEMENT SHALL BE A LEVEL 2-1/2 DENSE HMAC
 3. CROSS SLOPE TO MATCH EXISTING PAVEMENT CROSS SLOPE

COMPACT DRIVEWAY BENEATH OVERLAY

2
D2
DRIVEWAY TRANSITION DETAILS
 NOT TO SCALE

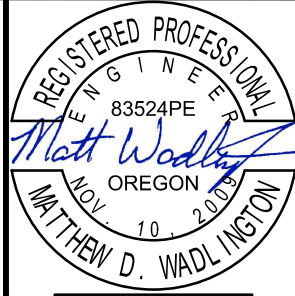

Civil West
 Engineering Services, Inc.
 213 Water Ave. NW, Suite 100
 Albany, Oregon 97321
 541-266-8601
 www.civilwest.com

REV.	DATE	DESCRIPTION	BY	PR	MDW
1	4-19-21	Detail 1 text revised.			

Designed By: ERM
 Drawn By: ERM
 Checked By: MDW
 Project No: 2817-403

CITY OF SWEET HOME
 LINN COUNTY, OREGON

2021 PAVEMENT OVERLAY PROJECT

TRANSITION DETAILS

D2
 MARCH 10, 2021



REQUEST FOR COUNCIL ACTION

Title: 2021 Overlay Project Phase 2 Bid Posting

Preferred Agenda: April 27, 2021

Submitted By: Trish Rice, Engineering Tech 2
Greg Springman, Public Works Director

Reviewed By: Ray Towry, City Manager

Type of Action: Resolution ____ Motion X Roll Call ____ Other ____

Relevant Code/Policy: n/a

Towards Council Goal: Goal 1.1c Develop specific steps for implementation of the adopted infrastructure master plans (streets)

Attachments: 2021 Overlay Project Phase 2 bid documents

Purpose of this RCA:

Staff requests authorization to solicit bids for the 2021 Overlay Project Phase 2.

Background/Context:

On March 23 Council approved the concept of doing this season's street overlays in two phases. Phase 2 is ready to bid. The engineer's estimate is \$362,844. These streets were selected because they don't require utilities and have minimal ancillary work, thus maximizing the paving that can get done. Work will begin after July 1, 2021.

Schedule	Location	Estimate
	Mobilization	\$60,474.00
E	4th Ave North of Holley Rd	\$33,110.00
F	42nd Ave South of Long St	\$56,450.00
G	Locust St and 54th Ave	\$24,147.50
H	Larch St and Locust St off 49th	\$43,197.50
I	Poplar St and Osage St between 52nd between and 53rd Ave, and 52nd Ave	\$54,730.00
J	Vine St off of 18th	\$28,022.50
K	Poplar St west of 9th Ave	\$16,050.00
L	13th Ave and Osage St	\$37,837.50
M	Nandina St between 54th & 56th	\$8,825.00
Total Bid Estimate		\$362,844.00

The Challenge/Problem:

How do we make efficient use of limited funds to complete needed streets projects?

Stakeholders:

- Sweet Home Residents – Residents deserve well-maintained City infrastructure that meets their needs and improves their quality of life.
- Sweet Home City Council – The City Council has a goal to provide viable and sustainable infrastructure that serves development and improves residents’ quality of life.
- Sweet Home City Staff – City Staff have an interest in completing projects that empower them to meet the Council’s goals and which reduce staff time spent repairing poor quality streets.

Issues and Financial Impacts:

The engineer’s estimate for Phase 2 is \$362,844. Staff is budgeting \$600k in FY2021-2022 for overlay projects. Phase 2 will be paid for out of the ODOT fund exchange money (approx. \$625k available).

Elements of a Stable Solution:

A stable solution will provide efficient completion of needed street maintenance and improvements.

Options:

1. Option 1 – Do Nothing. The project will remain in the CIP. The unspent overlay funds will go into the ending fund balance and be available for re-budgeting.
2. Option 2 – Post the solicitation as presented. Staff will post the solicitation. The results will be brought to Council for awarding the contract.
3. Option 3 – Post the solicitation with minor revisions. Staff will make minor changes to the plans or contract as directed by Council, then post the solicitation.
4. Option 4 – Make major revisions to the solicitation. Staff will make major changes to the plans or contract as directed by Council, then bring the bid package back to Council for approval prior to posting the solicitation. This will delay the project by at least few weeks.

Recommendation:

Staff recommends Option 2 – Motion to allow staff to post the 2021 Overlay Project Phase 2 Bid solicitation as presented.

CITY OF SWEET HOME

LINN COUNTY, OREGON



2021 PAVEMENT OVERLAY PROJECT

PH. 2

PROJECT NO. 2817-003
APRIL 21, 2021

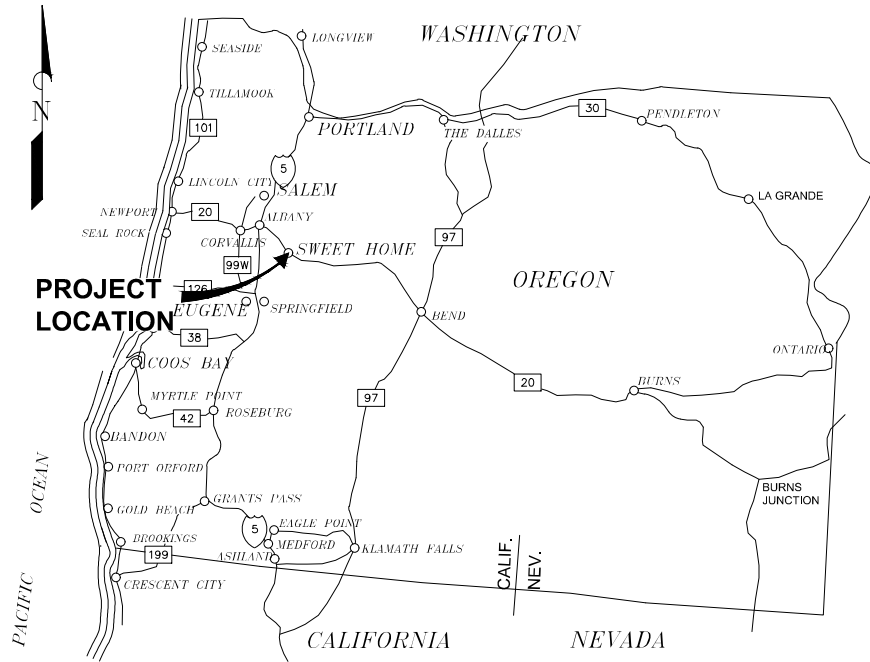
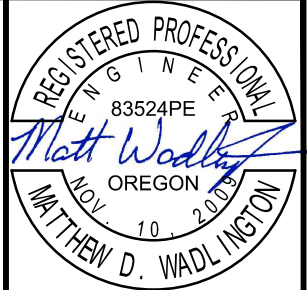

LOCATION MAP

LEGEND EXISTING

- CATCH BASIN
- MANHOLE
- VALVE CAN (WATER, GAS etc...)
- PROPERTY LINE/ROW

LEGEND NEW

- DRIVEWAY TRANSITION AREA
- OVERLAY OVERLAY
- OVERLAY TRANSITION AREA

GENERAL NOTES

- OREGON LAW REQUIRES YOU TO FOLLOW THE RULES ADOPTED BY THE OREGON UTILITY NOTIFICATION CENTER. THOSE RULES ARE SET FORTH IN OAR 952-001-0010 THROUGH 952-001-0090 AND ORS 757.542 THROUGH ORS 757.562 AND ORS 757.993. YOU MAY OBTAIN COPIES OF THE RULES FROM THE CENTER BY CALLING (503) 246-1987.
- THE CONTRACTOR SHALL CONTACT 'ONE CALL' FOR UTILITY LOCATES PRIOR TO EXCAVATION OR START OF CONSTRUCTION. (1-800-332-2344)
- THE OVERHEAD ELECTRICAL DISTRIBUTION SYSTEMS ARE NOT SPECIFICALLY INDICATED ON THE DRAWINGS BUT DO EXIST ALONG THE PAVING IMPROVEMENT ROUTES.
- THE EXISTING VALVE BOXES AND MANHOLES MAY NOT BE SPECIFICALLY INDICATED ON THE DRAWINGS BUT DO EXIST ALONG THE PAVING IMPROVEMENT ROUTES. CONTRACTOR SHALL LOCATE PRIOR TO THE START OF CONSTRUCTION AND PROTECT AS REQ'D FOR A COMPLETED PAVING IMPROVEMENT PROJECT.
- ALL MATERIALS AND WORK SHALL BE AS SPECIFIED AND CONFORM TO THE LATEST EDITION OF THE OREGON STANDARD SPECIFICATIONS (OSS) FOR CONSTRUCTION AND THE AMERICAN PUBLIC WORKS ASSOCIATION (APWA).

PRELIMINARY - NOT FOR CONSTRUCTION

SHEET INDEX

SHEET NO.	SHEET TITLE
G1	COVER SHEET, INDEX, LEGEND, LOCATION, & VICINITY MAP
E	4TH AVE NORTH OF HOLLEY RD
F	42ND SOUTH OF LONG ST
G	LOCUST ST & 54TH AVE
H	LARCH ST & LOCUST ST
I	52ND AVE & OSAGE ST & POPLAR ST
J	VINE ST
K	POPLAR ST
L	13TH AVE & OSAGE
M	NANDINA ST & 56TH AVE
D1	TYPICAL STREET SECTIONS
D2	TRANSITION DETAILS

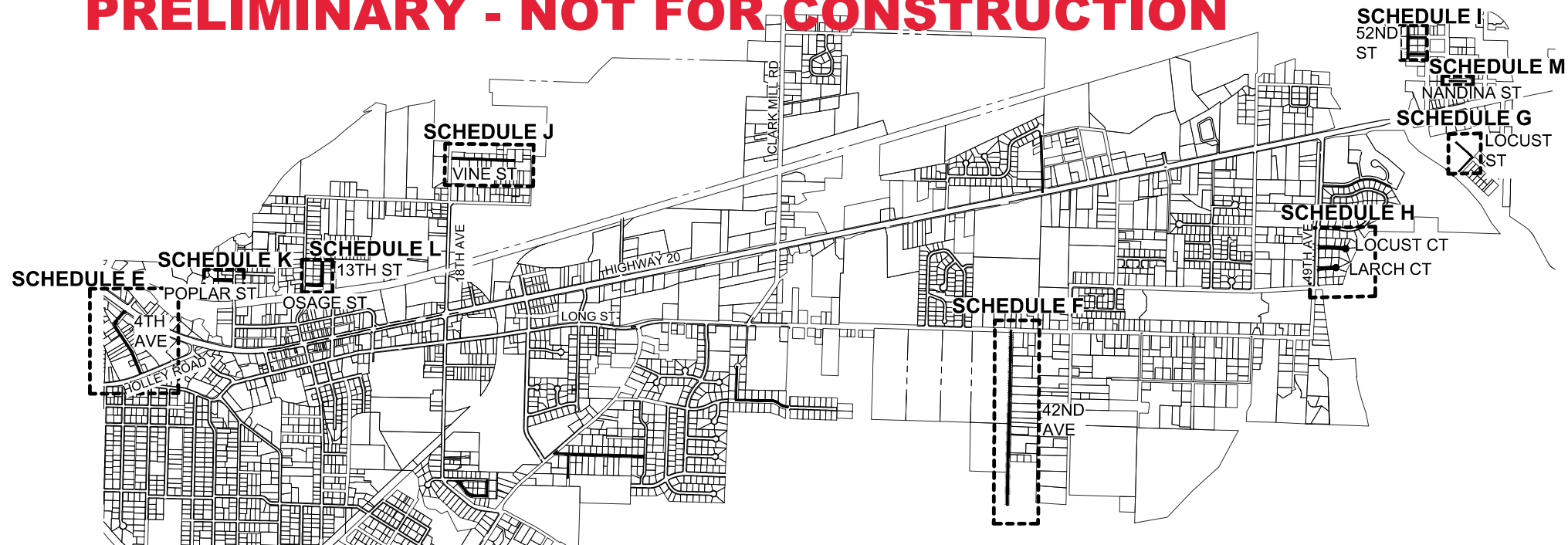

VICINITY MAP
NOT TO SCALE

Civil West
Engineering Services, Inc.
541-266-8601
www.civilwest.com
200 Ferry St.
Albany, Oregon 97321

REV.	DATE	DESCRIPTION	BY

Designed By:	ERM	Drawn By:	ERM	Checked By:	MDW
Project No:	2817-003				

CITY OF SWEET HOME
LINN COUNTY, OREGON

2021 PAVEMENT OVERLAY PROJECT PH. 2

COVER SHEET, INDEX, LEGEND, LOCATION, + VICINITY MAP

DATE:4/21/21 FILE:C:\CW_Projects\2817 Sweet Home\2817-003 2021 Pavement Overlay\04 Final Design\Drawings\DWG\Overlays.dwg

DATE:4/21/21 FILE:C:\CW_Projects\2817 Sweet Home\2817-003 2021 Pavement Overlay\04 Final Design\Drawings\Drawings\Overlays.dwg

KEYED NOTES	
①	VALVE CAN PROTECT IN PLACE, RAISE AS NECESSARY
②	MANHOLE PROTECT IN PLACE, RAISE AS NECESSARY
③	STORM DRAIN CATCH BASIN PROTECTION TYPICAL.
④	OVERLAY TRANSITION, SEE DETAIL 1 SHEET D2
⑤	DRIVEWAY APRON, SEE DETAIL 2 SHEET D2

SHEET NOTES:

- BEGIN AND END OF CONSTRUCTION SHALL BE TAPERED TO MATCH EXISTING PAVEMENT.
- EXISTING SEWER AND STORM DRAIN MANHOLES; VALVE CANS; AND ALL OTHER UTILITIES ALONG ROAD IMPROVEMENT AREA AS INDICATED ON THE PLANS ARE TO BE VERIFIED IN FIELD AND SHALL BE PROTECTED IN PLACE OR REPAIRED TO PRE-CONSTRUCTION CONDITION OR BETTER BY CONTRACTOR. ADDITIONAL UTILITIES MAY EXIST AT THE SITES.
- CONTRACTOR TO MAINTAIN EXISTING UTILITIES TO REMAIN TO EXIST ON ASPHALT SURFACE.
- CONTRACTOR TO MAINTAIN ONE LANE OF TRAFFIC OPEN AT ALL TIMES DURING COURSE OF CONSTRUCTION.
- CONTRACTOR TO PROVIDE A CLEAN TRANSITION BETWEEN NEW IMPROVEMENTS AND EXISTING SITE SURFACES. CONTRACTOR SHALL PAY SPECIAL ATTENTION TO TRANSITIONS AT CROSS STREETS AND DRIVEWAYS.
- ALL CROSS STREETS AND DRIVEWAYS ARE IDENTIFIED AT THE APPROXIMATE LOCATIONS. ACTUAL WIDTH OF DRIVEWAYS AND CROSS STREETS MAY VARY. CONTRACTOR SHALL FIELD VERIFY.
- PAVEMENT MARKINGS SUCH AS STOP BARS, CROSS WALKS ETC. SHALL BE FIELD VERIFIED AND SHALL BE REPLACED BY THE CONTRACTOR AFTER COMPLETION OF OVERLAY RESURFACING. ADDITIONAL PAVEMENT MARKINGS MAY EXIST AT THE SITES.
- OVERLAYED SURFACE SHALL BE CURED AND OPEN TO TRAFFIC BY 5:00 PM EACH DAY.
- ANY NECESSARY SIDEWALK AND PEDESTRIAN RAMP WORK WILL BE COMPLETED UNDER A SEPARATE PROJECT.

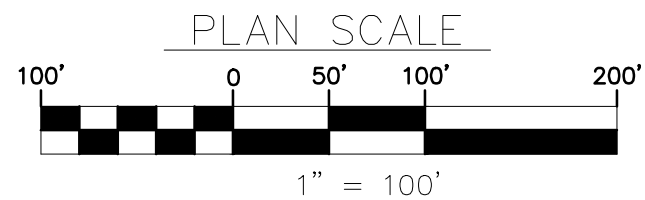

1
E

4TH AVE NORTH OF HOLLEY RD

PRELIMINARY



541-266-8601
www.civilwest.com

200 Ferry St.
Albany, Oregon 97321

REV.	DATE	DESCRIPTION	BY

Designed By:	ERM	Drawn By:	ERM	Checked By:	MDW
Project No:		2817-403			

CITY OF SWEET HOME
LINN COUNTY, OREGON

2021 PAVEMENT OVERLAY PROJECT PH. 2

4TH AVE NORTH OF HOLLEY RD

Date: APRIL 21, 2021

PRELIMINARY

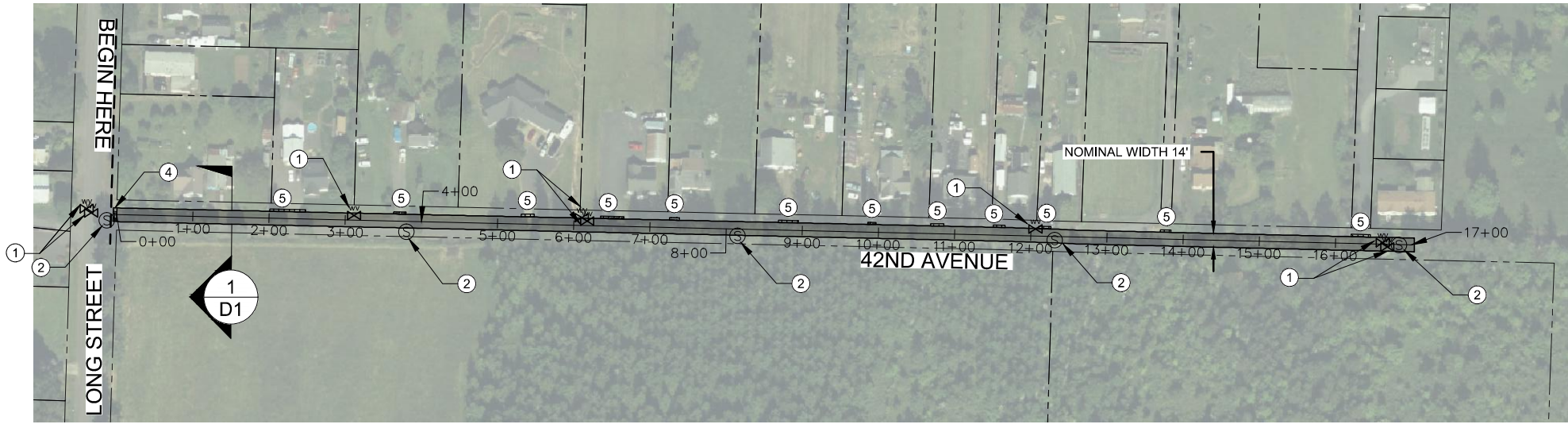

1
F

42ND SOUTH OF LONG ST

SHEET NOTES:

1. BEGIN AND END OF CONSTRUCTION SHALL BE TAPERED TO MATCH EXISTING PAVEMENT.
2. EXISTING SEWER AND STORM DRAIN MANHOLES; VALVE CANS; AND ALL OTHER UTILITIES ALONG ROAD IMPROVEMENT AREA AS INDICATED ON THE PLANS ARE TO BE VERIFIED IN FIELD AND SHALL BE PROTECTED IN PLACE OR REPAIRED TO PRE-CONSTRUCTION CONDITION OR BETTER BY CONTRACTOR. ADDITIONAL UTILITIES MAY EXIST AT THE SITES.
3. CONTRACTOR TO RAISE EXISTING UTILITIES TO MATCH NEW ASPHALT SURFACE.
4. CONTRACTOR TO MAINTAIN ONE LANE OF TRAFFIC OPEN AT ALL TIMES DURING COURSE OF CONSTRUCTION.
5. CONTRACTOR TO PROVIDE A CLEAN TRANSITION BETWEEN NEW IMPROVEMENTS AND EXISTING SITE SURFACES. CONTRACTOR SHALL PAY SPECIAL ATTENTION TO TRANSITIONS AT CROSS STREETS AND DRIVEWAYS.
6. ALL CROSS STREETS AND DRIVEWAYS ARE IDENTIFIED AT THE APPROXIMATE LOCATIONS. ACTUAL WIDTH OF DRIVEWAYS AND CROSS STREETS MAY VARY. CONTRACTOR SHALL FIELD VERIFY.
7. PAVEMENT MARKINGS SUCH AS STOP BARS, CROSS WALKS ETC. SHALL BE FIELD VERIFIED AND SHALL BE REPLACED BY THE CONTRACTOR AFTER COMPLETION OF OVERLAY RESURFACING. ADDITIONAL PAVEMENT MARKINGS MAY EXIST AT THE SITES.
8. OVERLAYED SURFACE SHALL BE CURED AND OPEN TO TRAFFIC BY 5:00 PM EACH DAY.
9. ANY NECESSARY SIDEWALK AND PEDESTRIAN RAMP WORK WILL BE COMPLETED UNDER A SEPARATE PROJECT.

PRELIMINARY - NOT FOR CONSTRUCTION

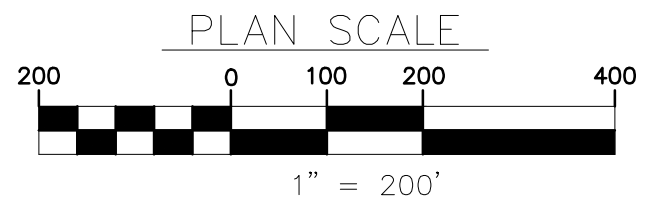
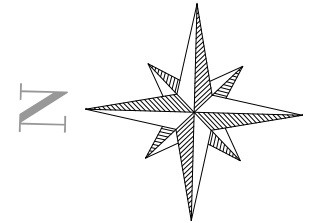

KEYED NOTES	
①	VALVE CAN PROTECT IN PLACE, RAISE AS NECESSARY
②	MANHOLE PROTECT IN PLACE, RAISE AS NECESSARY
③	STORM DRAIN GRATE PROTECTION TYPICAL
④	OVERLAY TRANSITION, SEE DETAIL 1 SHEET D2
⑤	DRIVEWAY APRON, SEE DETAIL 2 SHEET D2



Civil West
Engineering Services, Inc.
200 Ferry St.
Albany, Oregon 97321
541-266-8601
www.civilwest.com

REV.	DATE	DESCRIPTION	BY

Designed By: ERM	Drawn By: ERM	Checked By: MDW
Project No: 2817-403		

CITY OF SWEET HOME
LINN COUNTY, OREGON

2021 PAVEMENT OVERLAY PROJECT PH. 2

42ND SOUTH OF LONG ST

Date: **APRIL 21, 2021**

DATE:4/21/21 FILE:C:\CW_Projects\2817-Sweet Home\2817-003-2021 Pavement Overlay\04 Final Design\Drawings\DWG\Overlays.dwg

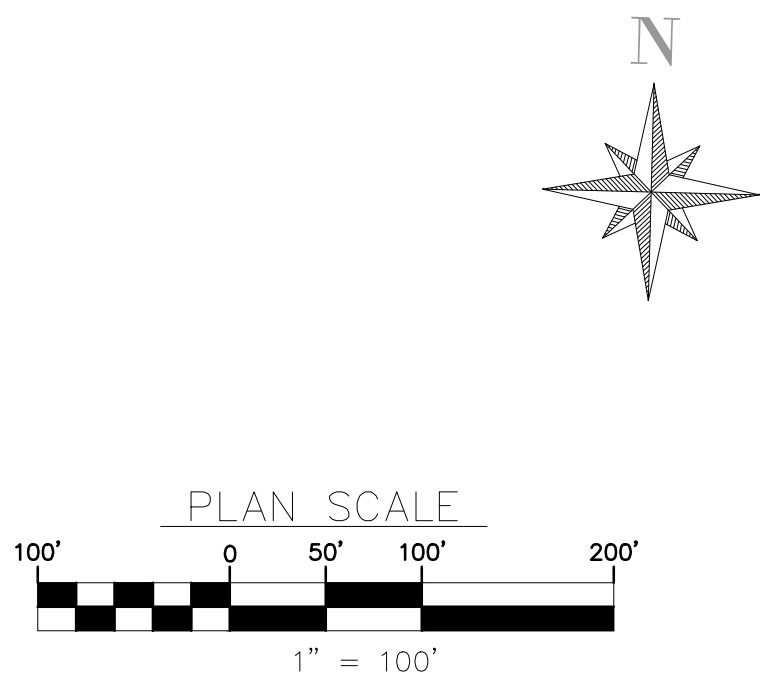

PRELIMINARY - NOT FOR CONSTRUCTION

- SHEET NOTES:**
1. BEGIN AND END OF CONSTRUCTION SHALL BE TAPERED TO MATCH EXISTING PAVEMENT.
 2. EXISTING SEWER AND STORM DRAIN MANHOLES; VALVE CANS; AND ALL OTHER UTILITIES ALONG ROAD IMPROVEMENT AREA AS INDICATED ON THE PLANS ARE TO BE VERIFIED IN FIELD AND SHALL BE PROTECTED IN PLACE OR REPAIRED TO PRE-CONSTRUCTION CONDITION OR BETTER BY CONTRACTOR. ADDITIONAL UTILITIES MAY EXIST AT THE SITES.
 3. CONTRACTOR TO RAISE EXISTING UTILITIES TO MATCH NEW ASPHALT SURFACE.
 4. CONTRACTOR TO MAINTAIN ONE LANE OF TRAFFIC OPEN AT ALL TIMES DURING COURSE OF CONSTRUCTION.
 5. CONTRACTOR TO PROVIDE A CLEAN TRANSITION BETWEEN NEW IMPROVEMENTS AND EXISTING SITE SURFACES. CONTRACTOR SHALL PAY SPECIAL ATTENTION TO TRANSITIONS AT CROSS STREETS AND DRIVEWAYS.
 6. ALL CROSS STREETS AND DRIVEWAYS ARE IDENTIFIED AT THE APPROXIMATE LOCATIONS. ACTUAL WIDTH OF DRIVEWAYS AND CROSS STREETS MAY VARY. CONTRACTOR SHALL FIELD VERIFY.
 7. PAVEMENT MARKINGS SUCH AS STOP BARS, CROSS WALKS ETC. SHALL BE FIELD VERIFIED AND SHALL BE REPLACED BY THE CONTRACTOR AFTER COMPLETION OF OVERLAY RESURFACING. ADDITIONAL PAVEMENT MARKINGS MAY EXIST AT THE SITES.
 8. OVERLAYED SURFACE SHALL BE CURED AND OPEN TO TRAFFIC BY 5:00 PM EACH DAY.
 9. ANY NECESSARY SIDEWALK AND PEDESTRIAN RAMP WORK WILL BE COMPLETED UNDER A SEPARATE PROJECT.

	KEYED NOTES
①	VALVE CAN PROTECT IN PLACE, RAISE AS NECESSARY
②	MANHOLE PROTECT IN PLACE, RAISE AS NECESSARY
③	STORM DRAIN GRATE PROTECTION TYPICAL
④	OVERLAY TRANSITION, SEE DETAIL 1 SHEET D2
⑤	DRIVEWAY APRON, SEE DETAIL 2 SHEET D2

PRELIMINARY



541-266-8601
www.civilwest.com

200 Ferry St.
Albany, Oregon 97321

REV.	DATE	DESCRIPTION	BY

Designed By: ERM	Drawn By: ERM	Checked By: MDW
Project No: 2817-403		

CITY OF SWEET HOME
LINN COUNTY, OREGON

2021 PAVEMENT OVERLAY PROJECT PH. 2

LOCUST ST + 54TH AVE

Date: **APRIL 21, 2021**

Page 100

DATE: 4/21/21 FILE: C:\CW_Projects\2817 Sweet Home\2817-003 2021 Pavement Overlay\04 Final Design\Drawings\DWG\Overlays.dwg

PRELIMINARY



200 Ferry St.
Albany, Oregon 97321
541-266-8601
www.civilwest.com

REV.	DATE	DESCRIPTION	BY

Designed By: ERM	Drawn By: ERM	Checked By: MDW
Project No: 2817-403		

CITY OF SWEET HOME
LINN COUNTY, OREGON

2021 PAVEMENT OVERLAY PROJECT PH. 2

LARCH ST + LOCUST ST

Date: **APRIL 21, 2021**

- SHEET NOTES:
- BEGIN AND END OF CONSTRUCTION SHALL BE TAPERED TO MATCH EXISTING PAVEMENT.
 - EXISTING SEWER AND STORM DRAIN MANHOLES; VALVE CANS; AND ALL OTHER UTILITIES ALONG ROAD IMPROVEMENT AREA AS INDICATED ON THE PLANS ARE TO BE VERIFIED IN FIELD AND SHALL BE PROTECTED IN PLACE OR REPAIRED TO PRE-CONSTRUCTION CONDITION OR BETTER BY CONTRACTOR. ADDITIONAL UTILITIES MAY EXIST AT THE SITES.
 - CONTRACTOR TO RAISE EXISTING UTILITIES TO MATCH NEW ASPHALT SURFACE.
 - CONTRACTOR TO MAINTAIN ONE LANE OF TRAFFIC OPEN AT ALL TIMES DURING COURSE OF CONSTRUCTION.
 - CONTRACTOR TO PROVIDE A CLEAN TRANSITION BETWEEN NEW IMPROVEMENTS AND EXISTING SITE SURFACES. CONTRACTOR SHALL PAY SPECIAL ATTENTION TO TRANSITIONS AT CROSS STREETS AND DRIVEWAYS.
 - ALL CROSS STREETS AND DRIVEWAYS ARE IDENTIFIED AT THE APPROXIMATE LOCATIONS. ACTUAL WIDTH OF DRIVEWAYS AND CROSS STREETS MAY VARY. CONTRACTOR SHALL FIELD VERIFY.
 - PAVEMENT MARKINGS SUCH AS STOP BARS, CROSS WALKS ETC. SHALL BE FIELD VERIFIED AND SHALL BE REPLACED BY THE CONTRACTOR AFTER COMPLETION OF OVERLAY RESURFACING. ADDITIONAL PAVEMENT MARKINGS MAY EXIST AT THE SITES.
 - OVERLAYED SURFACE SHALL BE CURED AND OPEN TO TRAFFIC BY 5:00 PM EACH DAY.
 - ANY NECESSARY SIDEWALK AND PEDESTRIAN RAMP WORK WILL BE COMPLETED UNDER A SEPARATE PROJECT.

KEYED NOTES	
①	VALVE CAN PROTECT IN PLACE, RAISE AS NECESSARY
②	MANHOLE PROTECT IN PLACE, RAISE AS NECESSARY
③	STORM DRAIN GRATE PROTECTION TYPICAL
④	OVERLAY TRANSITION, SEE DETAIL 1 SHEET D2
⑤	DRIVEWAY APRON, SEE DETAIL 2 SHEET D2

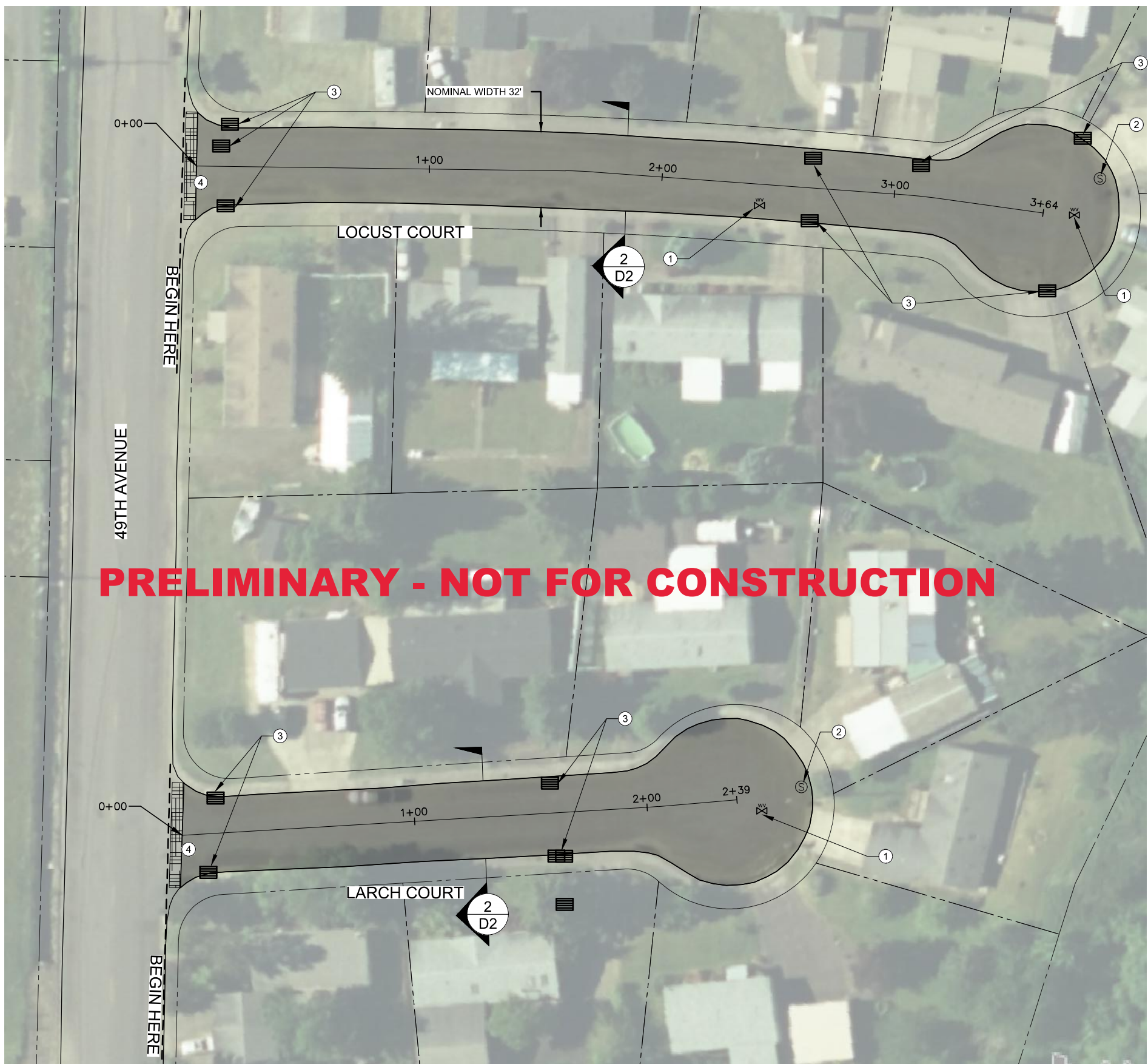

PRELIMINARY - NOT FOR CONSTRUCTION

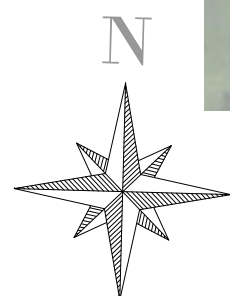

LARCH ST & LOCUST ST

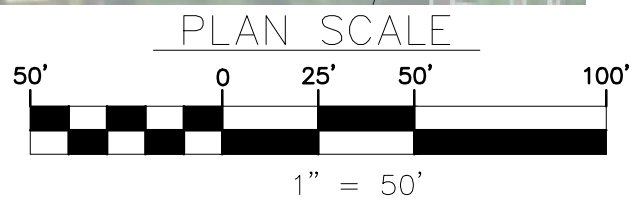

DATE:4/21/21 FILE:C:\CW_Projects\2817-003 2021 Pavement Overlay\04 Final Design\Drawings\DWG\Overlays.dwg

DATE:4/21/21 FILE:C:\CW_Projects\2817 Sweet Home\2817-003 2021 Pavement Overlay\04 Final Design\Drawings\Drawings\Overlays.dwg

SHEET NOTES:

1. BEGIN AND END OF CONSTRUCTION SHALL BE TAPERED TO MATCH EXISTING PAVEMENT.
2. EXISTING SEWER AND STORM DRAIN MANHOLES; VALVE CANS; AND ALL OTHER UTILITIES ALONG ROAD IMPROVEMENT AREA AS INDICATED ON THE PLANS ARE TO BE VERIFIED IN FIELD AND SHALL BE PROTECTED IN PLACE OR REPAIRED TO PRE-CONSTRUCTION CONDITION OR BETTER BY CONTRACTOR. ADDITIONAL UTILITIES MAY EXIST AT THE SITES.
3. CONTRACTOR TO RAISE EXISTING UTILITIES TO MATCH NEW ASPHALT SURFACE.
4. CONTRACTOR TO MAINTAIN ONE LANE OF TRAFFIC OPEN AT ALL TIMES DURING COURSE OF CONSTRUCTION.
5. CONTRACTOR TO PROVIDE A CLEAN TRANSITION BETWEEN NEW IMPROVEMENTS AND EXISTING SITE SURFACES. CONTRACTOR SHALL PAY SPECIAL ATTENTION TO TRANSITIONS AT CROSS STREETS AND DRIVEWAYS.
6. ALL CROSS STREETS AND DRIVEWAYS ARE IDENTIFIED AT THE APPROXIMATE LOCATIONS. ACTUAL WIDTH OF DRIVEWAYS AND CROSS STREETS MAY VARY. CONTRACTOR SHALL FIELD VERIFY.
7. PAVEMENT MARKINGS SUCH AS STOP BARS, CROSS WALKS ETC. SHALL BE FIELD VERIFIED AND SHALL BE REPLACED BY THE CONTRACTOR AFTER COMPLETION OF OVERLAY RESURFACING. ADDITIONAL PAVEMENT MARKINGS MAY EXIST AT THE SITES.
8. OVERLAYED SURFACE SHALL BE CURED AND OPEN TO TRAFFIC BY 5:00 PM EACH DAY.
9. ANY NECESSARY SIDEWALK AND PEDESTRIAN RAMP WORK WILL BE COMPLETED UNDER A SEPARATE PROJECT.

KEYED NOTES	
①	VALVE CAN PROTECT IN PLACE, RAISE AS NECESSARY
②	MANHOLE PROTECT IN PLACE, RAISE AS NECESSARY
③	STORM DRAIN GRATE PROTECTION TYPICAL
④	OVERLAY TRANSITION, SEE DETAIL 1 SHEET D2
⑤	DRIVEWAY APRON, SEE DETAIL 2 SHEET D2

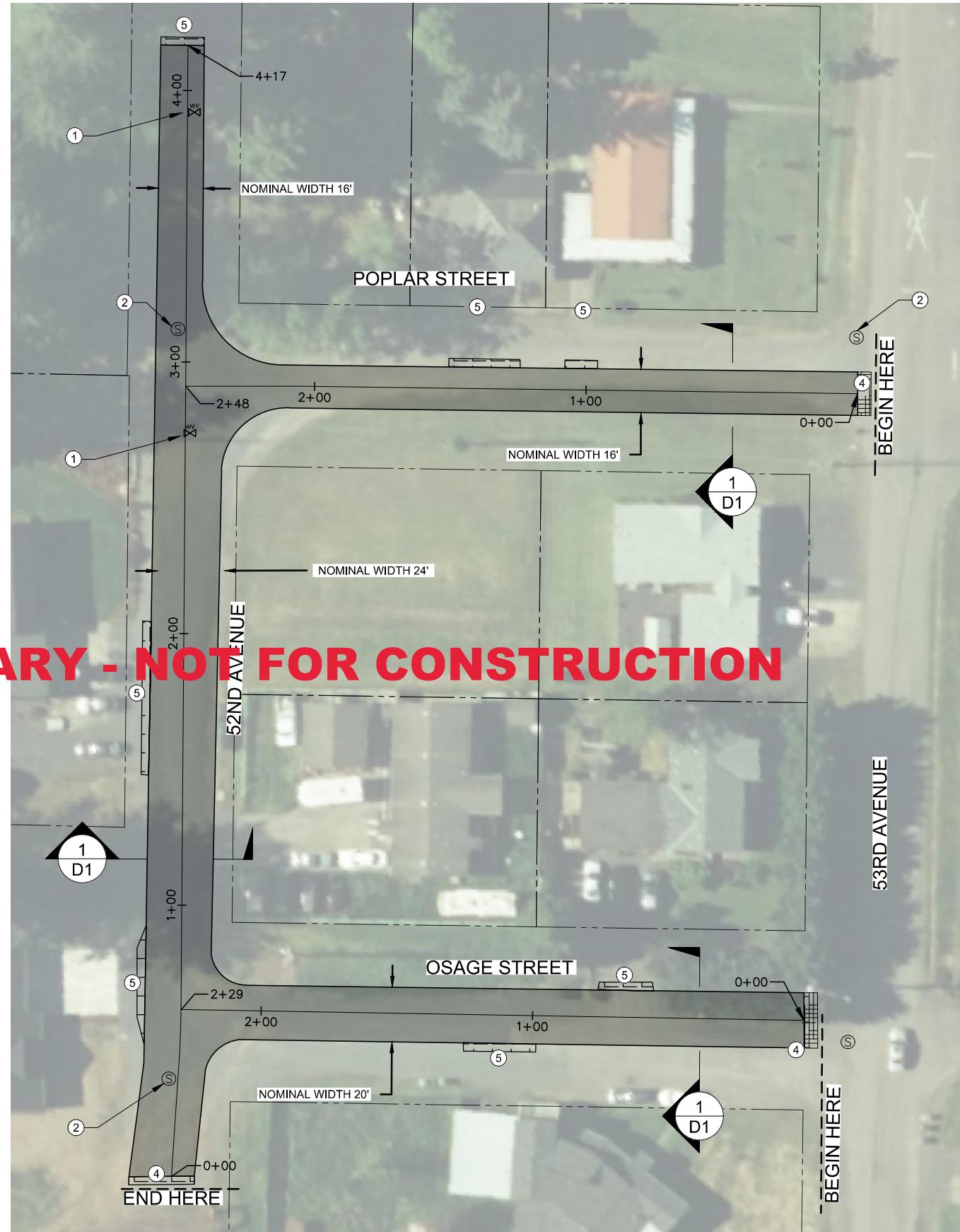
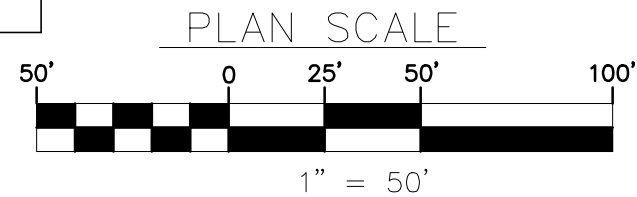

①
1
52ND AVE & OSAGE ST & POPLAR ST

PRELIMINARY

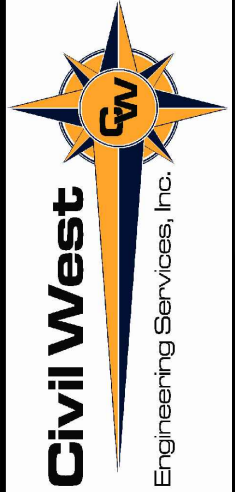

541-266-8601
www.civilwest.com
200 Ferry St.
Albany, Oregon 97321

REV.	DATE	DESCRIPTION	BY

Designed By:	ERM	Drawn By:	ERM	Checked By:	MDW
Project No:	2817-403				

CITY OF SWEET HOME
LINN COUNTY, OREGON

2021 PAVEMENT OVERLAY PROJECT PH. 2

52ND AVE + OSAGE ST + POPLAR ST

Date: APRIL 21, 2021

PRELIMINARY



541-266-8601
www.civilwest.com

200 Ferry St.
Albany, Oregon 97321

REV.	DATE	DESCRIPTION	BY

Designed By:	ERM	Drawn By:	ERM	Checked By:	MDW
Project No:	2817-403				

CITY OF SWEET HOME
LINN COUNTY, OREGON

2021 PAVEMENT OVERLAY PROJECT PH. 2

VINE ST

Date: APRIL 21, 2021

SHEET NOTES:

- BEGIN AND END OF CONSTRUCTION SHALL BE TAPERED TO MATCH EXISTING PAVEMENT.
- EXISTING SEWER AND STORM DRAIN MANHOLES; VALVE CANS; AND ALL OTHER UTILITIES ALONG ROAD IMPROVEMENT AREA AS INDICATED ON THE PLANS ARE TO BE VERIFIED IN FIELD AND SHALL BE PROTECTED IN PLACE OR REPAIRED TO PRE-CONSTRUCTION CONDITION OR BETTER BY CONTRACTOR. ADDITIONAL UTILITIES MAY EXIST AT THE SITES.
- CONTRACTOR TO RAISE EXISTING UTILITIES TO MATCH NEW ASPHALT SURFACE.
- CONTRACTOR TO MAINTAIN ONE LANE OF TRAFFIC OPEN AT ALL TIMES DURING COURSE OF CONSTRUCTION.
- CONTRACTOR TO PROVIDE A CLEAN TRANSITION BETWEEN NEW IMPROVEMENTS AND EXISTING SITE SURFACES. CONTRACTOR SHALL PAY SPECIAL ATTENTION TO TRANSITIONS AT CROSS STREETS AND DRIVEWAYS.
- ALL CROSS STREETS AND DRIVEWAYS ARE IDENTIFIED AT THE APPROXIMATE LOCATIONS. ACTUAL WIDTH OF DRIVEWAYS AND CROSS STREETS MAY VARY. CONTRACTOR SHALL FIELD VERIFY.
- PAVEMENT MARKINGS SUCH AS STOP BARS, CROSS WALKS ETC. SHALL BE FIELD VERIFIED AND SHALL BE REPLACED BY THE CONTRACTOR AFTER COMPLETION OF OVERLAY RESURFACING. ADDITIONAL PAVEMENT MARKINGS MAY EXIST AT THE SITES.
- OVERLAYED SURFACE SHALL BE CURED AND OPEN TO TRAFFIC BY 5:00 PM EACH DAY.
- ANY NECESSARY SIDEWALK AND PEDESTRIAN RAMP WORK WILL BE COMPLETED UNDER A SEPARATE PROJECT.

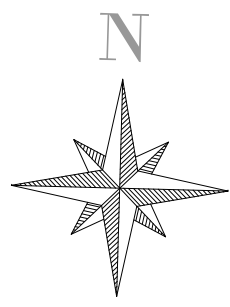
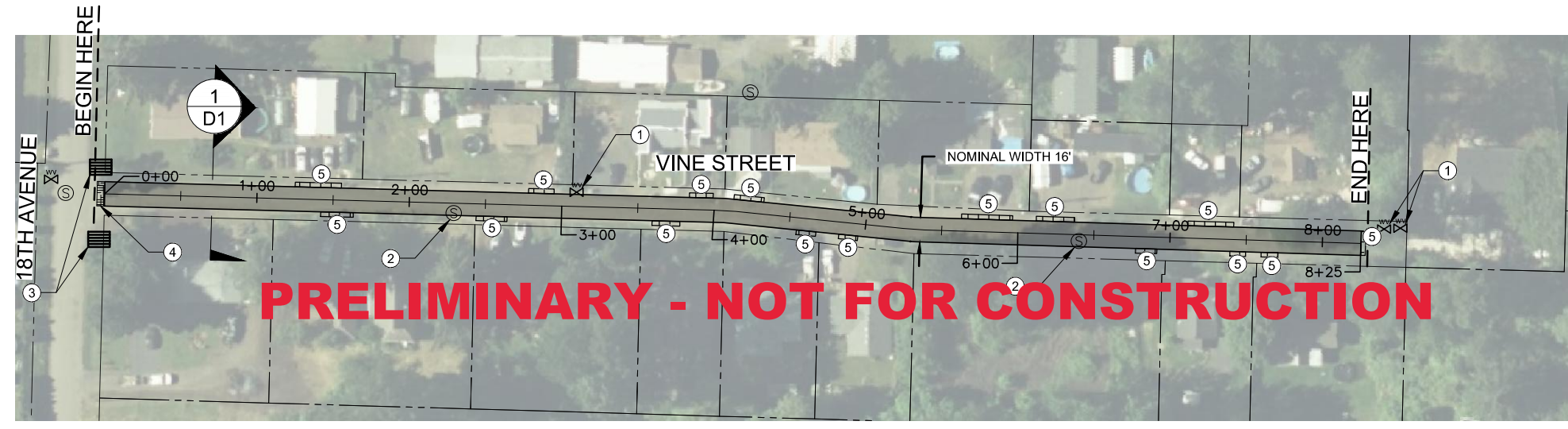

1
J

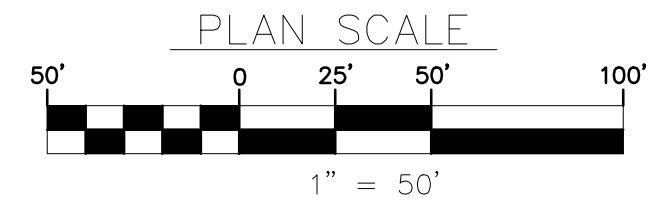

KEYED NOTES	
①	VALVE CAN PROTECT IN PLACE, RAISE AS NECESSARY
②	MANHOLE PROTECT IN PLACE, RAISE AS NECESSARY
③	STORM DRAIN GRATE PROTECTION TYPICAL
④	OVERLAY TRANSITION, SEE DETAIL 1 SHEET D2
⑤	DRIVEWAY APRON, SEE DETAIL 2 SHEET D2

DATE:4/21/21 FILE:C:\CW_Projects\2817 Sweet Home\2817-003 2021 Pavement Overlay\04 Final Design\Drawings\DWG\Overlays.dwg

DATE: 4/21/21 FILE: C:\CW_Projects\2817-Sweet Home\2817-003 2021 Pavement Overlay\04 Final Design\Drawings\DWG\Overlays.dwg

SHEET NOTES:

- BEGIN AND END OF CONSTRUCTION SHALL BE TAPERED TO MATCH EXISTING PAVEMENT.
- EXISTING SEWER AND STORM DRAIN MANHOLES; VALVE CANS; AND ALL OTHER UTILITIES ALONG ROAD IMPROVEMENT AREA AS INDICATED ON THE PLANS ARE TO BE VERIFIED IN FIELD AND SHALL BE PROTECTED IN PLACE OR REPAIRED TO PRE-CONSTRUCTION CONDITION OR BETTER BY CONTRACTOR. ADDITIONAL UTILITIES MAY EXIST AT THE SITES.
- CONTRACTOR TO RAISE EXISTING UTILITIES TO MATCH NEW ASPHALT SURFACE.
- CONTRACTOR TO MAINTAIN ONE LANE OF TRAFFIC OPEN AT ALL TIMES DURING COURSE OF CONSTRUCTION.
- CONTRACTOR TO PROVIDE A CLEAN TRANSITION BETWEEN NEW IMPROVEMENTS AND EXISTING SITE SURFACES. CONTRACTOR SHALL PAY SPECIAL ATTENTION TO TRANSITIONS AT CROSS STREETS AND DRIVEWAYS.
- ALL CROSS STREETS AND DRIVEWAYS ARE IDENTIFIED AT THE APPROXIMATE LOCATIONS. ACTUAL WIDTH OF DRIVEWAYS AND CROSS STREETS MAY VARY. CONTRACTOR SHALL FIELD VERIFY.
- PAVEMENT MARKINGS SUCH AS STOP BARS, CROSS WALKS ETC. SHALL BE FIELD VERIFIED AND SHALL BE REPLACED BY THE CONTRACTOR AFTER COMPLETION OF OVERLAY RESURFACING. ADDITIONAL PAVEMENT MARKINGS MAY EXIST AT THE SITES.
- OVERLAYED SURFACE SHALL BE CURED AND OPEN TO TRAFFIC BY 5:00 PM EACH DAY.
- ANY NECESSARY SIDEWALK AND PEDESTRIAN RAMP WORK WILL BE COMPLETED UNDER A SEPARATE PROJECT.

KEYED NOTES	
①	VALVE CAN PROTECT IN PLACE, RAISE AS NECESSARY
②	MANHOLE PROTECT IN PLACE, RAISE AS NECESSARY
③	STORM DRAIN GRATE PROTECTION TYPICAL
④	OVERLAY TRANSITION, SEE DETAIL 1 SHEET D2
⑤	DRIVEWAY APRON, SEE DETAIL 2 SHEET D2

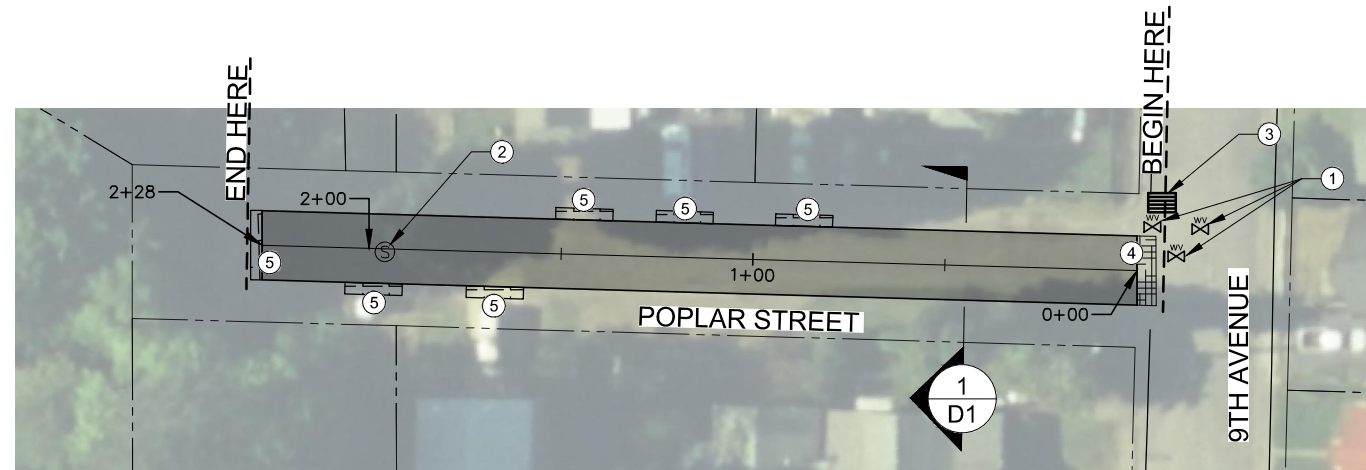

PRELIMINARY - NOT FOR CONSTRUCTION

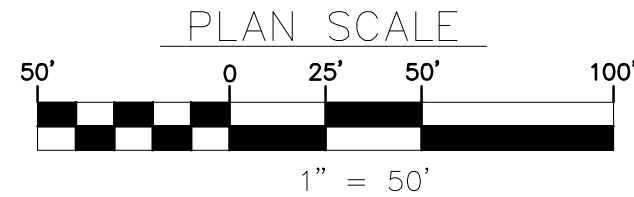
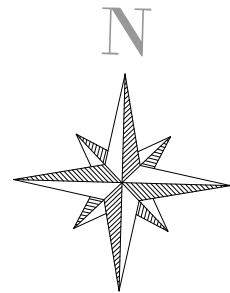

PRELIMINARY



541-266-8601
www.civilwest.com
200 Ferry St.
Albany, Oregon 97321

REV.	DATE	DESCRIPTION	BY

Designed By: ERM	Drawn By: ERM	Checked By: MDW
Project No: 2817-403		

CITY OF SWEET HOME
LINN COUNTY, OREGON

2021 PAVEMENT OVERLAY PROJECT PH. 2

POPLAR ST

Date: **APRIL 21, 2021**

Sheet No: **K**

DATE: 4/21/21 FILE: C:\CW_Projects\2817-003 2021 Pavement Overlay\04 Final Design\Drawings\DWG\Overlays.dwg

SHEET NOTES:

1. BEGIN AND END OF CONSTRUCTION SHALL BE TAPERED TO MATCH EXISTING PAVEMENT.
2. EXISTING SEWER AND STORM DRAIN MANHOLES; VALVE CANS; AND ALL OTHER UTILITIES ALONG ROAD IMPROVEMENT AREA AS INDICATED ON THE PLANS ARE TO BE VERIFIED IN FIELD AND SHALL BE PROTECTED IN PLACE OR REPAIRED TO PRE-CONSTRUCTION CONDITION OR BETTER BY CONTRACTOR. ADDITIONAL UTILITIES MAY EXIST AT THE SITES.
3. CONTRACTOR TO RAISE EXISTING UTILITIES TO MATCH NEW ASPHALT SURFACE.
4. CONTRACTOR TO MAINTAIN ONE LANE OF TRAFFIC OPEN AT ALL TIMES DURING COURSE OF CONSTRUCTION.
5. CONTRACTOR TO PROVIDE A CLEAN TRANSITION BETWEEN NEW IMPROVEMENTS AND EXISTING SITE SURFACES. CONTRACTOR SHALL PAY SPECIAL ATTENTION TO TRANSITIONS AT CROSS STREETS AND DRIVEWAYS.
6. ALL CROSS STREETS AND DRIVEWAYS ARE IDENTIFIED AT THE APPROXIMATE LOCATIONS. ACTUAL WIDTH OF DRIVEWAYS AND CROSS STREETS MAY VARY. CONTRACTOR SHALL FIELD VERIFY.
7. PAVEMENT MARKINGS SUCH AS STOP BARS, CROSS WALKS ETC. SHALL BE FIELD VERIFIED AND SHALL BE REPLACED BY THE CONTRACTOR AFTER COMPLETION OF OVERLAY RESURFACING. ADDITIONAL PAVEMENT MARKINGS MAY EXIST AT THE SITES.
8. OVERLAYED SURFACE SHALL BE CURED AND OPEN TO TRAFFIC BY 5:00 PM EACH DAY.
9. ANY NECESSARY SIDEWALK AND PEDESTRIAN RAMP WORK WILL BE COMPLETED UNDER A SEPARATE PROJECT.

KEYED NOTES	
①	VALVE CAN PROTECT IN PLACE, RAISE AS NECESSARY
②	MANHOLE PROTECT IN PLACE, RAISE AS NECESSARY
③	STORM DRAIN GRATE PROTECTION TYPICAL
④	OVERLAY TRANSITION, SEE DETAIL 1 SHEET D2
⑤	DRIVEWAY APRON, SEE DETAIL 2 SHEET D2

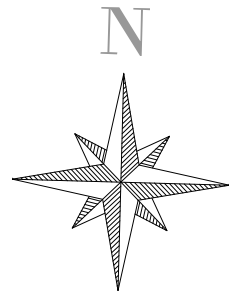
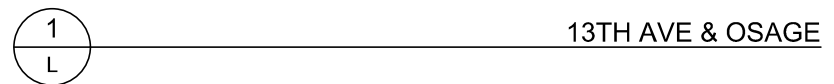
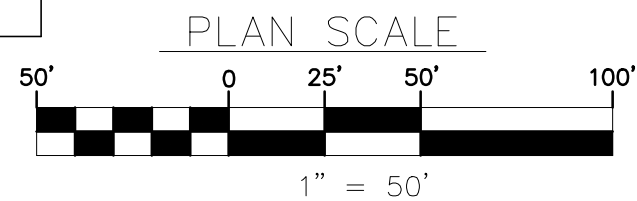

PRELIMINARY



200 Ferry St.
Albany, Oregon 97321
541-266-8601
www.civilwest.com

REV.	DATE	DESCRIPTION	BY

Designed By: ERM	Drawn By: ERM	Checked By: MDW
Project No: 2817-403		

CITY OF SWEET HOME
LINN COUNTY, OREGON

2021 PAVEMENT OVERLAY PROJECT PH. 2

13TH AVE + OSAGE

Date: **APRIL 21, 2021**

PRELIMINARY



541-266-8601
www.civilwest.com

200 Ferry St.
Albany, Oregon 97321

SHEET NOTES:

- BEGIN AND END OF CONSTRUCTION SHALL BE TAPERED TO MATCH EXISTING PAVEMENT.
- EXISTING SEWER AND STORM DRAIN MANHOLES; VALVE CANS; AND ALL OTHER UTILITIES ALONG ROAD IMPROVEMENT AREA AS INDICATED ON THE PLANS ARE TO BE VERIFIED IN FIELD AND SHALL BE PROTECTED IN PLACE OR REPAIRED TO PRE-CONSTRUCTION CONDITION OR BETTER BY CONTRACTOR. ADDITIONAL UTILITIES MAY EXIST AT THE SITES.
- CONTRACTOR TO RAISE EXISTING UTILITIES TO MATCH NEW ASPHALT SURFACE.
- CONTRACTOR TO MAINTAIN ONE LANE OF TRAFFIC OPEN AT ALL TIMES DURING COURSE OF CONSTRUCTION.
- CONTRACTOR TO PROVIDE A CLEAN TRANSITION BETWEEN NEW IMPROVEMENTS AND EXISTING SITE SURFACES. CONTRACTOR SHALL PAY SPECIAL ATTENTION TO TRANSITIONS AT CROSS STREETS AND DRIVEWAYS.
- ALL CROSS STREETS AND DRIVEWAYS ARE IDENTIFIED AT THE APPROXIMATE LOCATIONS. ACTUAL WIDTH OF DRIVEWAYS AND CROSS STREETS MAY VARY. CONTRACTOR SHALL FIELD VERIFY.
- PAVEMENT MARKINGS SUCH AS STOP BARS, CROSS WALKS ETC. SHALL BE FIELD VERIFIED AND SHALL BE REPLACED BY THE CONTRACTOR AFTER COMPLETION OF OVERLAY RESURFACING. ADDITIONAL PAVEMENT MARKINGS MAY EXIST AT THE SITES.
- OVERLAYED SURFACE SHALL BE CURED AND OPEN TO TRAFFIC BY 5:00 PM EACH DAY.
- ANY NECESSARY SIDEWALK AND PEDESTRIAN RAMP WORK WILL BE COMPLETED UNDER A SEPARATE PROJECT.



PRELIMINARY - NOT FOR CONSTRUCTION



NANDINA ST & 56TH AVE

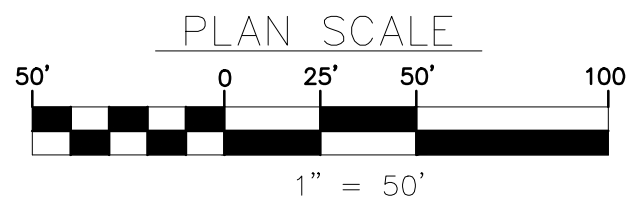

KEYED NOTES	
①	VALVE CAN PROTECT IN PLACE, RAISE AS NECESSARY
②	MANHOLE PROTECT IN PLACE, RAISE AS NECESSARY
③	STORM DRAIN GRATE PROTECTION TYPICAL
④	OVERLAY TRANSITION, SEE DETAIL 1 SHEET D2
⑤	DRIVEWAY APRON, SEE DETAIL 2 SHEET D2

REV.	DATE	DESCRIPTION	BY

Designed By: ERM	Drawn By: ERM	Checked By: MDW
Project No: 2817-403		

CITY OF SWEET HOME
LINN COUNTY, OREGON

2021 PAVEMENT OVERLAY PROJECT PH. 2

NANDINA ST + 56TH AVE

Date: APRIL 21, 2021

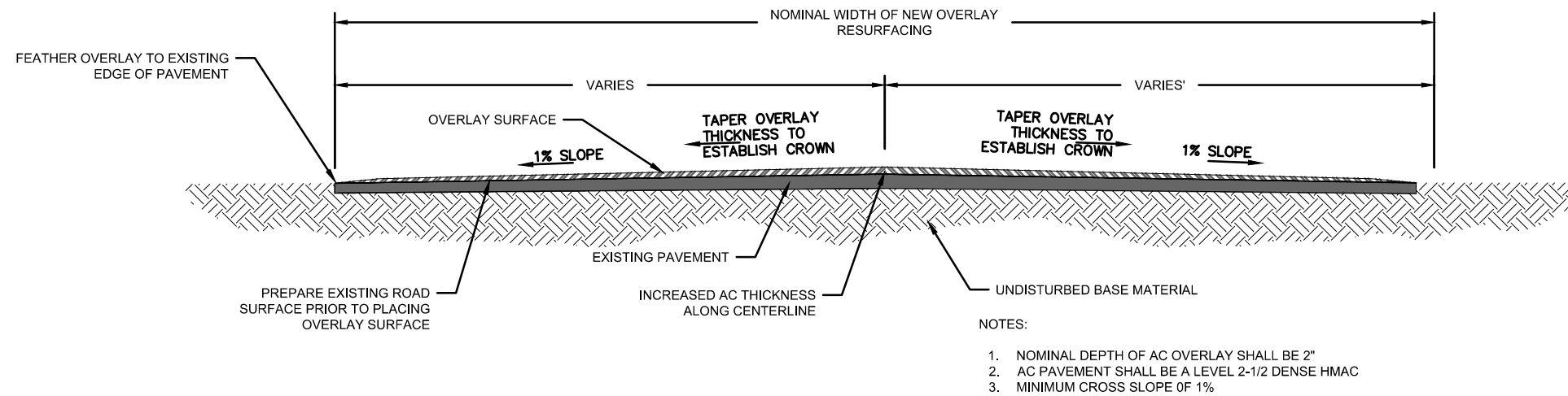

1
D1

TYPICAL STREET SECTION
NOT TO SCALE

PRELIMINARY - NOT FOR CONSTRUCTION

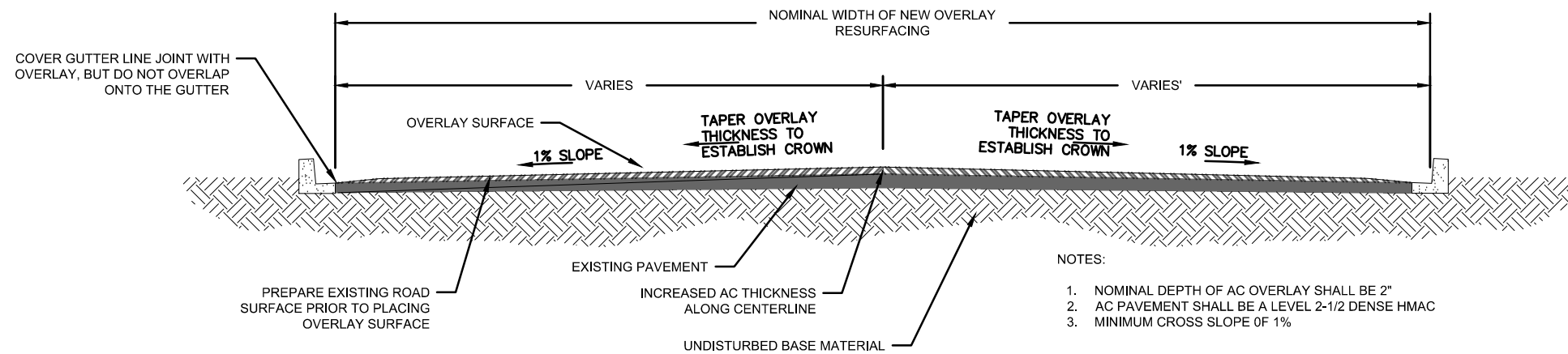

2
D1

CURB & GUTTER TYPICAL SECTION
NOT TO SCALE

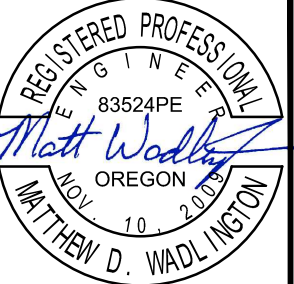

541-266-8601
www.civilwest.com
200 Ferry St.
Albany, Oregon 97321

REV.	DATE	DESCRIPTION	BY

Designed By: ERM
Drawn By: ERM
Checked By: MDW
Project No: 2817-403

CITY OF SWEET HOME
LINN COUNTY, OREGON

2021 PAVEMENT OVERLAY PROJECT PH. 2

TYPICAL STREET SECTIONS

Sheet No: D1
Date: APRIL 21, 2021

DATE: 4/21/21 FILE: C:\CW_Projects\2817 Sweet Home\2817-003 2021 Pavement Overlay\Drawings\Drawings\Overlays.dwg

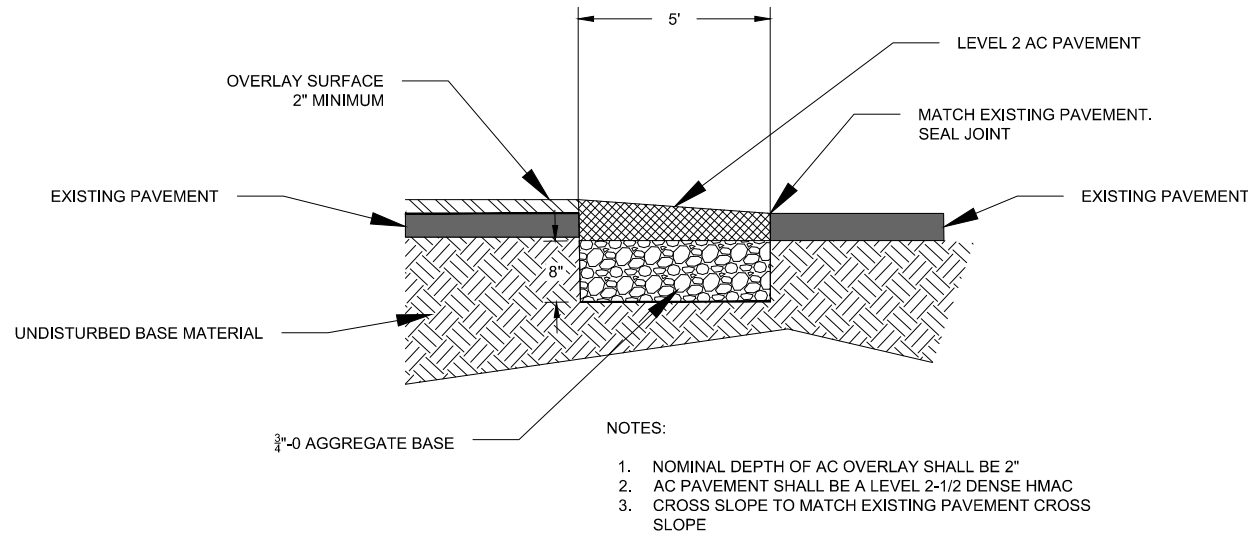

1
D2
OVERLAY TRANSITION DETAIL
NOT TO SCALE

CONCRETE DRIVEWAY TRANSITION

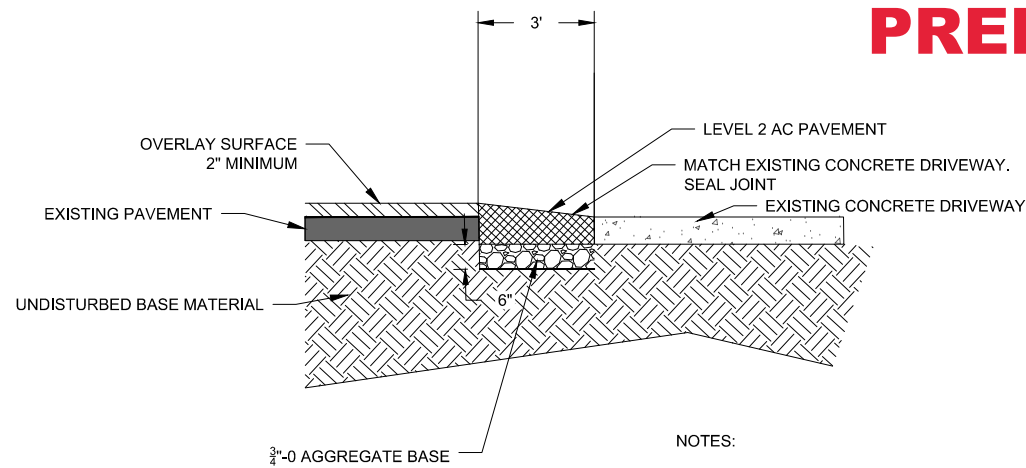

2
D2
DRIVEWAY TRANSITION DETAILS
NOT TO SCALE

GRAVEL DRIVEWAY TRANSITION

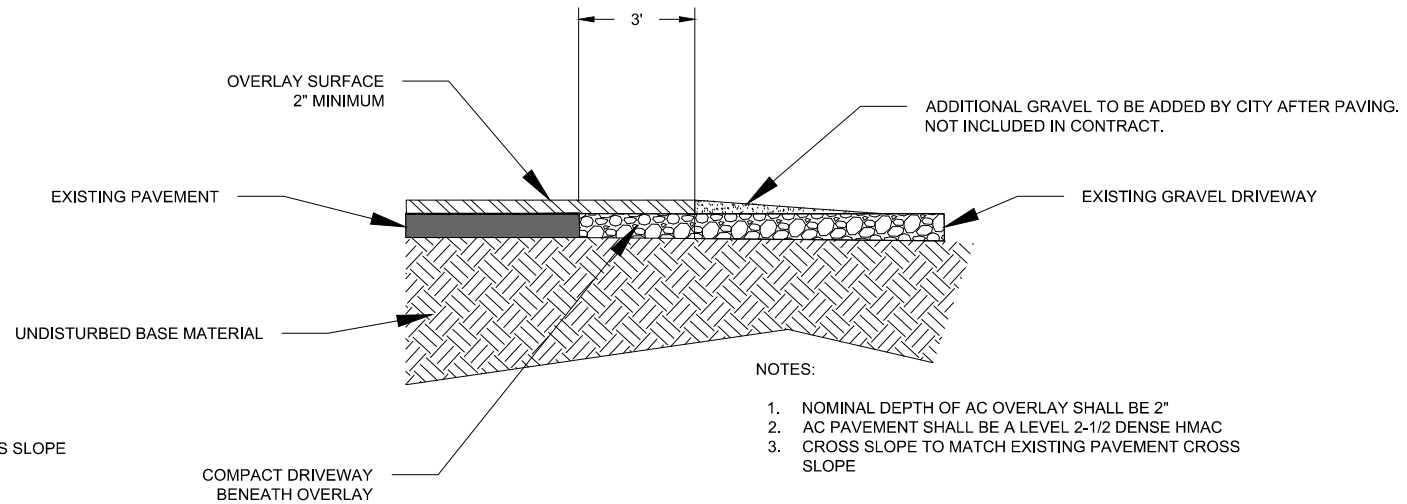

PRELIMINARY - NOT FOR CONSTRUCTION

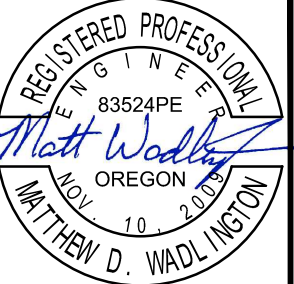

REV.	DATE	DESCRIPTION	BY

Designed By: ERM
Drawn By: ERM
Checked By: MDW
Project No: 2817-403

CITY OF SWEET HOME
LINN COUNTY, OREGON

2021 PAVEMENT OVERLAY PROJECT PH. 2

TRANSITION DETAILS

Date: APRIL 21, 2021
Sheet No: D2

CONTRACT DOCUMENT

FOR CONSTRUCTION OF

**CITY OF SWEET HOME
FY 2021 Overlay Program Project Phase 2**

Department of Public Works, Engineering Division
1400 24th Avenue
Phone 541.367.6359

April 21, 2021

TABLE OF CONTENTS

TABLE OF CONTENTS 2

INSTRUCTIONS TO BIDDERS 3

BID 4

CONTRACT 7

BID BOND 9

PAYMENT BOND 10

PERFORMANCE BOND 13

FIRST-TIER SUBCONTRACTOR DISCLOSURE FORM 16

BID FORM 17

PREVAILING WAGE for PUBLIC WORKS CONTRACTS 19

PAYMENT OF MEDICAL CARE AND PROVIDING WORKERS' COMPENSATION 20

PUBLIC WORKS BOND 20

RECIPROCAL PREFERENCE LAW 20

PROJECT DRAWINGS (SEPARATE ATTACHMENT) 22

SPECIAL PROVISIONS I 23

SPECIAL PROVISIONS II 29

INSTRUCTIONS TO BIDDERS

Sealed bids for the **FY 2021 Overlay Program Project Phase 2** will be received on behalf of the City of Sweet Home by Greg Springman at 1140 12th Avenue, Sweet Home, OR 97386 until bid closing time of **2:00 PM local time on Tuesday, May 18, 2021**. Bids will be held but not opened until **4:00 PM** (the submittal deadline for the “First-Tier Subcontractor Disclosure Form”). The outside of the Bid envelopes shall be clearly marked **FY 2021 Overlay Program Project Phase 2** and show (1) the Bidder’s name, (2) the Bid Opening time and date and (3) the Bidders CCB license number, and shall be delivered to the City of Sweet Home by or before the above listed bid closing time.

The City will require that for projects greater than \$100,000, the “First-Tier Subcontractor Disclosure Form” as contained in the bidding documents, be submitted with the bid documents in a separate sealed envelope by the Bid Closing or within two working hours of the Bid Closing, not later than **4:00 PM local time Tuesday, May 18, 2021**. The envelope shall be clearly marked “**Disclosure Form for FY 2021 Overlay Program Project Phase 2**”, and shall include (1) Bidders name, and (2) the submittal time and date deadline. Bidders who fail to submit the required disclosure will be considered non-responsive. Immediately following the disclosure deadline, the bids shall be opened and publicly read. **Submittals by Facsimile or Electronic Data Interchange (EDI) will not be accepted.**

Contract specifications, and plan sets – in PDF file format –, may be obtained from the Bids and RFPs menu off the Government on the City of Sweet Home website at <https://www.sweethomeor.gov/rfps>. Questions about the project elements may be directed to Trish Rice, Engineering Technician, Sweet Home Public Works, 1400 24th Avenue, Sweet Home, Oregon, 97386, contact by phone at 541-818-8037, or email price@sweethomeor.gov.

Each bidder must possess or have access to the 2021 Oregon Standard Specifications for Construction. These are available online at: https://www.oregon.gov/ODOT/Business/Pages/Standard_Specifications.aspx

No bid shall be received or considered unless the bidder is registered with the Construction Contractors Board for construction projects or licensed with the Landscape Contractors Board for landscaping projects.

Bidders Checklist: All prospective bidders must include the following:

- Each bid must contain a statement as to whether the Bidder is a resident Bidder, as defined in ORS 279C.365. In determining the lowest responsible bidder, the City of Sweet Home will, for the purpose of awarding the Contract, add a percentage increase on the bid of a nonresident bidder equal to the percentage, if any, of the preference given to that bidder in the state in which the bidder resides.
- All bids shall contain a statement declaring that the Bidder agrees to comply with the provisions of ORS 279C.800 to 279C.870 regarding payment of prevailing wages and the Bureau of Labor and industries fee.
- The project bid document set, with names and corporate information of the bidder, schedule of prices completely filled out, additional addendum items if any; however, project drawings do not need to be included.
- The First-Tier Subcontractor Disclosure Form as noted above.
- Each bid must contain Surety and Bond information.
- A 10% bid bond, certified check, or cashier’s check shall accompany each bid on all projects and shall be forfeited if the bidder fails to enter into a Contract with the City of Sweet Home within ten (10) days after the date of the Notice of Award.

The City may reject any bid not in compliance with all prescribed public procedures and requirements, and may reject for good cause any and all submittals upon a finding of the City that it is in the best interest to do so, as determined solely by the City.

BID

To the Honorable Mayor and City Council
City of Sweet Home, Oregon 97386

BIDDER'S DECLARATION AND UNDERSTANDING

The undersigned Bidder declares that the Contract Documents for the construction of the proposed improvement have been carefully examined; that the site has been personally inspected; that the Bidder is satisfied as to the quantities of materials, items of equipment and conditions or work involved including the fact that the description of the quantities of work and materials as included herein is brief and is intended only to indicate the general nature of such items and to identify the said quantities with the detailed requirements of the Contract Documents; and that the bid is made according to the provisions and under the terms of the Contract Documents, which documents are hereby made a part of this bid. The bidder has received and considered the following Addenda to specifications, if any, of revisions and/or additions to the plans; No. _____ to No. _____, inclusive; Plan Revision Sht. No. _____; Plan Addition Sht. No. _____.

The minimum bid submittal requirement for this project shall include this Bid form and schedule(s) of prices, bid bond as required, first-tier subcontractor form and all other required attachments. All Contract Documents are included in this Bid by reference, whether attached or not.

The Bidder further declares that the only persons or parties interested in this bid are those named herein: that this bid is in all respects fair and without fraud: that it is made without collusion with any official of the City of Sweet Home, and that the bid is made without any connection or collusion with any person making another bid on this Contract.

The Bidder further declares that the provisions required by the Oregon Revised Statutes ORS 279C.800 relating to Prevailing Wage Rates shall be included in and made a part of the Contract. The Bidder further declares that all applicable sections relating to Public Contracts as set forth in ORS 279A to 279C have been complied with in making this bid, and, as required, shall be made a part of the Contract Documents as completely as if the same were fully set forth herein.

The Bidder further declares that they are registered, or shall become registered if awarded a contract, with the Construction Contractor's Board, and possess such additional licenses and certifications as required by law for the performance of the Work proposed herein as required by OAR 812.

The Bidder further agrees that its own judgment has been exercised regarding the interpretation of subsurface information and all data, which it believes pertinent from the Engineer, Owner, and other sources in arriving at these conclusions, have been utilized.

CONTRACT EXECUTION, BONDS AND CERTIFICATES OF INSURANCE

The Bidder agrees that if this bid is accepted, a Contract with the City of Sweet Home, Oregon, will be executed within ten (10) days after the date of the Notice of Award, in the form of Contract annexed hereto, and will at that time, deliver to the City of Sweet Home the Performance and Payment Bond required by Subsection 00130.4 of the Oregon Standard Specifications for Construction (as revised), the certificates of insurance as specified in these documents, and will, to the extent of this bid, furnish all machinery, tools, apparatus, and other means of construction and do the work and furnish all of the materials necessary to complete the work in the manner, in the time, and according to the methods as specified or shown in the Contract Documents.

It is the intent of the City of Sweet Home to award the Contract to the lowest responsible Bidder, provided the Bid has been submitted in accordance with the requirements of the Contract Documents and does not exceed the funds available. The City of Sweet Home shall have the right to waive informalities or irregularities in a Bid received and to accept the Bid which, in the City of Sweet Home's judgment, is in the City of Sweet Home's own best interest. In submitting this Bid, it is understood that the City of Sweet Home reserves the right to accept or reject in part or in whole, any and all bids received, to adjust the scope of the work within reasonable limits, to postpone award for a reasonable time, or award to the selected firm or contractor any subsequent engineering design and construction services contract, part or in whole, for recommended capital projects as allowed by law. The RFB does not commit the City of Sweet Home to pay any costs incurred to prepare a bid.

BIDDING, CONSTRUCTION, AND COMPLETION DATES

Sealed bids will be received at the City of Sweet Home Public Works Department at 1140 12th Avenue until
2:00pm on Tuesday, May 18, 2021 (Time & Date)

with 1st Tier Subcontractor Disclosure Forms until
4:00pm on Tuesday, May 18, 2021 (Time & Date)

The Bidder agrees to begin work within 10 calendar days after the date of the Notice to Proceed issued on or near;
May 26, 2021 (Date)

and, to complete the construction, in all respects by;
November 12, 2021 (Date)

Completion schedule – if not defined to certain date above – shall be set per #s of days as follows:
(Days)

Calendar days that inclement weather or adverse site conditions preclude normal construction activities shall be considered exempt.

RETAINAGE

To ensure the proper performance of the Contract, the City shall retain five (5%) of the amount of each progress payment until final completion and acceptance of all work covered by this contract.

LIQUIDATED DAMAGES

In the event the Bidder is awarded the Contract and shall fail to complete the work within the time stated above or extended time agreed upon, as more particularly set forth in the Contract Documents, liquidated damages, if required as specified in the Special Provisions I portion of this contract documents, shall be paid to the City of Sweet Home, Oregon, as provided under Subsection 00180.85 of the Oregon Standard Specifications.

BID BOND

Accompanying this bid is a certified check, cashier’s check or Bidder’s Bond in the sum of

Dollars & Cents (\$ _____), (10% of total contract price)

according to the General Requirements of the Contract Documents which is to be forfeited as liquidated damages, if, in the event that this bid is accepted, and the Bidder shall fail to execute the Contract and furnish satisfactory Performance and Payment Bond under the conditions and within the time specified in the Contract Documents; otherwise said check or bond is to be returned to the Bidder.

SURETY

If the Bidder is awarded a construction Contract on this bid, the Surety which will provide the Performance and Payment Bond will be:

(Name)

(Address)

(City, State)

LUMP SUM OR UNIT PRICE WORK, MANNER of PAYMENT

The Bidder further proposes to accept as full payment for the work proposed herein the amounts computed under the provisions of the Contract Documents and based on the following lump sum or unit price amounts, it being expressly understood that the unit prices are independent of the exact quantities involved. The Bidder agrees that the lump sum prices and the unit prices represent a true measure of the labor and materials required to perform the work, including all allowances for overhead and profit for each type and unit of work called for in these Contract Documents. The amounts shall be shown in both words and figures. In the case of a discrepancy, the amount shown in words shall govern.

BIDDER

The name of the Bidder submitting this bid is:

_____ (Name)
 _____ (Address)
 _____ (City, State, Zip)
 _____ (Telephone)
 _____ (Email)
 _____ (Federal Tax ID No)
 _____ (Construction Contractor Board No)
 _____ (Workers' Comp Ins. Co.)
 _____ (Workers' Comp Policy/Binder No)

The above Bidder's name and address is the address to which all communications concerned with this bid and with the Contract shall be sent.

In accordance with ORS 279C.365, Bidder hereby declares that it (circle correct designation) **is / is not** a resident Bidder. If the bidder is non-resident, indicate _____5_____ % preference of your state resident bidders.

In accordance with ORS 279C.800 to 279C.870, Bidder hereby declares that it complies with provisions for labor, materials, Industrial Accident Fund, liens, withholding taxes, and employee drug testing.

The names of the principal officers of the corporation submitting this bid, or of the partnership, or of all persons interested in this bid as principals, are as follows:

If Sole Proprietor of Partnership: IN WITNESS hereto the undersigned has set his/her hand this _____ day of _____, 20_____.

_____ (Signature of Bidder)
 _____ (Title)

If Corporation: IN WITNESS WHEREOF the undersigned corporation has caused this instrument to be executed and its seal affixed by its duly authorized officers this _____ day of _____, 20_____.

_____ (Name of Corporation)
 _____ (By)
 _____ (Title)
 _____ (Attest)

Secretary (Mandatory Signature)



(SEAL)

CONTRACT

THIS CONTRACT, made between the CITY OF SWEET HOME, a municipal corporation, hereinafter called "Owner" and _____, hereinafter called "Contractor".

WITNESSETH:

The Contractor, in consideration of the sums to be paid and other covenants herein contained, agrees to perform and complete the work herein described and to furnish all necessary machinery, tools, apparatus, equipment, supplies, materials, and labor and perform all work in accordance with the 2021 Oregon Standard Specifications for Construction, the Special Specifications bound herewith, and in accordance with such alterations or modifications of the same as may be made by the City, and according to such directions as may from time to time be made or given by the Engineer under the authority and within the meaning and purpose of this Contract. This agreement shall be binding upon the heirs, executors, administrators, successors, and assigns of the Contractor.

The applicable Drawings, the Oregon Standard Specifications for Construction, the Special Specifications, and the Schedule of Contract Prices bound herewith are hereby specifically referred to and by reference made a part hereof, and shall by such reference have the same force and effect as though all of the same were fully inserted herein.

The Contractor shall faithfully complete and perform all of the obligations of this Contract, and in particular, shall promptly, as due, make payment of all just debts and obligations incurred in the performance of said Contract and shall not permit any lien or claim to be filed or prosecuted against the City.

The Contractor, its subcontractors, if any, and all employers working under this Contract are subject employers under the Oregon Workers' Compensation Law and shall comply with ORS 656.017, which requires them to provide workers' compensation coverage for all their subject workers.

The Contractor agrees to protect, indemnify, and hold harmless the Owner, its officers, agents, and employees harmless against any and all loss, claims, or suits (including costs and attorney's fees) for or on account of injury to or death of persons, damage to, or destruction of property belonging to either the Owner or others occurring by reason of the act or neglect of the Contractor, Contractor's employees, or agents (including subcontractors) in connection with the performance of this Contract.

It is expressly understood that this Contract shall be governed by the laws of the State of Oregon. The statutes of the State of Oregon for public works contracts, specifically but not exclusively ORS 279C, as amended or superseded, including the latest additions and revisions, are incorporated by reference as part of the contract documents, and the party contracting with the Owner hereby covenants and agrees to comply with all of the obligations and conditions applicable to public contracts pursuant to ORS 279C as though each obligation or condition were set forth fully herein. In addition, if the contract identified above calls for a public improvement as that term is defined by ORS 279A.010, the party contracting with the Owner further agrees to comply with all obligations and conditions applicable to public contracts for public improvements pursuant to ORS 279C as though each obligation or condition were set forth fully herein.

The Contractor further declares by the signing of this Contract that all the provisions required by ORS 279A to 279C relating to Public Contracts, Purchasing, and Prevailing Wage Rates for work performed under the Contract with the Owner are made part of this Contract as completely as if the same were fully set forth herein.

In consideration of the faithful performance of all of the obligations herein set out and in consideration of the faithful performance of this Contract, the Owner agrees to pay to the Contractor the amount earned, as determined from the actual quantities of work performed and prices and other basis of payment specified, taking into consideration any amounts that may be deductible, under the terms of the Contract.

The Contractor agrees to complete the work within the time specified herein and to accept as full payment hereunder the amounts computed as determined by the Contract Documents and based on the said bid.

Said improvements shall be completed by the date specified in said Contract Documents and if not so completed, unless said time for completion is extended, as provided in the Contract Documents, or if extended, if the same is not completed within the time extended, the City will be caused to incur liquidated damages as specified in the FY 2021 Overlay Program Project Phase 2

Contract Documents. Liquidated damages shall be retained out of any monies due or to become due under this agreement.

Payments shall be made as provided in the Contract Documents.

Should suit or action be undertaken to enforce any of the terms of this agreement or to seek damages for its breach, the prevailing party shall be entitled to an award of its reasonable attorney fees, including those incurred on appeal.

IN WITNESS WHEREOF the parties hereto have executed or caused to be executed by their duly authorized officials, the Contract and affixed their respective official seals.

CONTRACTOR:

**OWNER:
CITY OF SWEET HOME, OREGON:**

APPROVED AS TO FORM:

City Attorney

DATE: _____

DATE: _____

By: _____

By: _____
Public Works Director

Title: _____

By: _____
City Manager

By: _____

Title: _____
(Note: Signatures of two officers are required for a corporation.)

Corporation Tax No. (if incorporated)

Social Security No. (if individual)

BID BOND

DATE. _____

BOND NO. _____.

AMOUNT OF BID: _____ (\$).

KNOW ALL MEN BY THESE PRESENTS, that we

(Name of Contractor)

as Principal, hereinafter called the PRINCIPAL, and

(Name of Surety)

a corporation duly organized under the laws of the State of _____ having its principal place of business at _____, in the State of _____, and authorized to do business in the State of Oregon, as SURETY, hereinafter called the Surety, are held firmly and bound unto the City of Sweet Home, Oregon, as Obligee, hereinafter called the OBLIGEE, in the sum of

_____ Dollars & Cents (\$ _____), *(10% of total contract price)*

for the payment of which sum well and truly to be made, the said Principal and the said Surety, bind ourselves, our heirs, executors, administrators, successors, and assigns, jointly and severally, firmly by these presents.

THE CONDITION OF THIS BOND IS SUCH THAT:

WHEREAS, the PRINCIPAL is herewith submitting his or its Bid for _____, said Bid, by reference thereto, being hereby made a part hereof.

NOW, THEREFORE, if the Obligee shall accept the bid of the Principal and the Principal shall enter into a Contract with the Obligee in accordance with the terms of such bid, and give such bond or bonds as may be specified in the bidding or Contracts Documents with good and sufficient surety for the faithful performance of such Contract and for the prompt payment of labor and materials furnished in the prosecution thereof, or on the event of the failure of the Principal to enter such Contract and give such bond or bonds, if the Principal shall pay to the Obligee the difference not to exceed the penalty hereof between the amount specified in said bid and such larger amount for which the Obligee may in good faith contract with another party to perform the Work covered by said bid, then this obligation shall be null and void, otherwise to remain in full force and effect.

A certified copy of the agent's power-of-attorney must be attached hereto.

Signed and sealed this _____ day of _____, 20____

PRINCIPAL

SURETY

By: _____

By: _____

Title: _____

Title: _____

IMPORTANT: Surety companies executing BONDS must appear on the Treasury Department's most current list (Circular 570 as amended) and be authorized to transact business in the state where the project is located.

PAYMENT BOND

DATE. _____

BOND NO. _____

TOTAL BID AMOUNT: _____

KNOW ALL MEN BY THESE PRESENTS, that we

(Name of Contractor)

as CONTRACTOR (Principal), and

(Name of Surety)

a corporation, duly organized to do a general surety business in the State of Oregon as SURETY, jointly and severally, bind ourselves, our heirs, executors, administrators, successors, and assigns firmly in the sum of

_____ Dollars & Cents (\$ _____), *(total contract price)*

to the Owner for the payment of labor, materials, and equipment furnished for the use in the performance of the Contract, which is incorporated herein by reference. The Contractor and Surety, jointly and severally, agree that this Bond shall be deemed amended automatically and immediately, without formal and separate amendments, hereto, upon amendment to the Contract not increasing the Contract Price more than twenty five percent (25%). The term "amendment wherever used in this Bond, and whether referring to this Bond, the Contract, or the loan documents, shall include any alteration, extension, or modification of any character whatsoever.

With respect to the Owner, this obligation shall be null and void if the Contractor: 1) promptly makes payment, directly or indirectly, for all sums due Claimants, and 2) defends, indemnifies and holds harmless the Owner from claims, demands, liens or suits by any person or entity whose claim, demand, lien or suit is for the payment of labor, materials, or equipment furnished for use in the performance of the Contract.

With respect to Claimants, this obligation shall be null and void if the contractor promptly makes payment, directly or indirectly, for all sums due.

A Claimant is defined as persons claiming to have supplied labor or materials, for the prosecution of the work provided for in the Construction Contract, including any person having a direct contractual relationship with the Contractor furnishing the Bond or direct contractual relationship with any subcontractor, or an assignee of such person, or a person claiming monies due to the State Accident Insurance Fund Corporation, State Department of Unemployment Trust Fund, or the Department of Revenue, in connection with the performance of the Construction contract, has a right of action on the Contractor's Board as provided in ORS 279C.380 only if: 1) the person or the assignee of the person has not been paid in full; and 2) the person gives written notice of claim, as prescribed in ORS 279C.605, to the Contractor and the Secretary of State, in the Construction Contract with a state agency, or the clerk or auditor if the public body is other than a state agency.

The intent of this Bond shall be to include without limitation, the terms 'labor, materials or equipment, that part of water, gas, power, light, heat, oil. Gasoline, telephone service or rental equipment used in the Contract, architectural and engineering services required for performance of the work of the Contractor, and all other items for which a mechanic's lien may be asserted in the jurisdiction where the labor, materials or equipment were furnished.

The Contractor and Surety hereby jointly and severally agree with the Owner that every Claimant, who has not paid in full before the expiration of a period of one hundred twenty (120) days after the date on which the last of such Claimant's work or labor was done or performed, or materials were furnished by such Claimant, for which claim is made, may have a right of action on this Bond. The Owner shall not be liable for the payment of any costs or

expenses including attorneys' fees which the Owner may incur in connection with its defense of any such right of action.

No suit or action shall be commence on this Bond by any Claimant: 1) Unless claimant shall have given written notice to the Contractor and the Secretary of State, if the Contractor with a state agency, or the clerk or auditor of the public body which let the Contract if the public body is other than a state agency, within one hundred twenty (120) days after such Claimant did or performed the last of the work or labor, or furnished the last of the materials for which said claim is made, stating with substantial accuracy the amount claimed and the name of the party to whom the materials were furnished, or for whom the work or labor was done or performed. Such notice shall be served by mailing the same by registered mail or certified mail, postage prepaid, or hand delivered in an envelope addressed to the Contractor, and such other entity who is to receive notice, at any place where that party maintains an office, conducts business, or at its residence, or delivered to that location. 2) After the expiration of two (2) years from the date on which the Claimant last performed labor, materials or equipment. Any limitation embodied in this Bond, which is prohibited by any law controlling the project, shall be deemed to be amended so as to be equal to the minimum period of limitation permitted by law.

When the Claimant has satisfied the conditions of the above, the Surety shall promptly and at the Surety's expense take the following actions: 1) Send an answer to the Claimant, with a copy to the Owner, within forty-five (45) days after receipt of the claim, stating the amount that are undisputed and the basis for challenging any amount that are disputed. 2) pay or arrange for payment of any undisputed amounts.

The Surety's total obligation shall not exceed the amount of the bond and any amendment thereto as outlined above, and the amount of this Bond shall be credited for any payments made in good faith by Surety.

Amounts owed by the Owner to the Contractor under the Contract shall be used for the performance of the Contract and to satisfy claims, if any, under any Construction Performance Bond. By the Contractor furnishing and the Owner accepting this Bond, they agree that all funds earned by the Contractor in the performance of the Contract are dedicated to satisfy obligations of the Contractor and Surety under this Bond, subject to the Owner's priority to use the funds for the completion of the work.

The Surety shall not be liable to the Owner, Claimants or others for obligation of the contractor that are unrelated to the Contract. The Owner shall not be liable for payment of any costs or expenses of any Claimant under this Bond, and shall have under this Bond no obligations to make payments to, give notices on behalf of, otherwise have obligations to Claimants under this Bond.

The Surety hereby waives notice of any change, including changes of time, to the Construction Contract or to related subcontracts, purchase orders and to other obligations.

When this Bond has been furnished to comply with a statutory or other legal requirement in the location where the construction was to be performed, any provision in this Bond conflicting with said statutory or legal requirement shall be deemed deleted herefrom and provisions conforming to such statutory or other legal requirements shall be deemed incorporated herein. The intent is that this Bond shall be construed as a statutory bond and not as a common law bond.

Upon request by any person or entity appearing to be a potential beneficiary of this Bond, the Contractor shall promptly furnish a copy of this Bond or shall permit a copy to be made.

Definitions: 1) Construction Contract; The agreement between the Owner and the Contractor identified on the signature page, including all contract Documents and changes thereto.

IN WITNESS THEREOF, the parties hereto have caused this bond to be executed this _____ day of _____, 20_____.

(Corporate Seal)

Principal

Title:

Street/City Address

(Corporate Seal)

Surety

Title:

Street/City Address

(Corporate Seal)

Surety Witness:

Title:

Street/City Address

City of Sweet Home, 1140 12th Avenue, Sweet Home OR 97386 *(Owner)*

FY 2021 Overlay Program Project Phase 2 *(Project)*

None *(Bond Modifications)*

PERFORMANCE BOND

DATE. _____

BOND NO. _____

TOTAL BID AMOUNT: _____

KNOW ALL MEN BY THESE PRESENTS, that we

(Name of Contractor)

as CONTRACTOR (Principal), and

(Name of Surety)

a corporation, duly organized to do a general surety business in the State of Oregon as SURETY, jointly and severally, bind ourselves, our heirs, executors, administrators, successors, and assigns firmly in the sum of

_____ Dollars & Cents (\$ _____), *(total contract price)*

to the Owner for the performance of the Construction Contract and any extension thereof, and during the twelve (12) month guaranty period which contract, extension and guaranty are incorporated herein by reference.

If the Contractor performs the Construction Contract, the Surety and the Contractor shall have no obligation under this Bond, except to participate in conferences as provided in the following paragraph.

If there is no Owner Default, the Surety's obligation under this Bond shall arise after: 1) The Owner has notified the Contractor and the Surety at its address described on the signature page herein, that the Owner is considering declaring the contractor Default and has requested and attempted to arrange a conference with the Contractor and the Surety to be held no later than fifteen (15) days after receipt of such notice to discuss methods of performing the Construction Contract. If the Owner, the Contractor and Surety agree, the Contractor shall be allowed a reasonable time to perform the Construction Contract, but such an agreement shall not waive the Owner's right, if any subsequently to declare a Contractor Default; and 2) The Owner has declared a Contractor Default and formally terminated the Contractor's right to complete the contract. Such Contractor Default shall not be declared earlier than twenty (20) days after the Contractor and the Surety have received notice as provided in the above paragraph; and 3) The Owner has agreed to pay the Balance of the Contract Price to the Surety in accordance with the terms of the Construction Contract or to a contractor selected to perform the construction contract in accordance with the terms of the contract with the Owner.

When the Owner has satisfied the conditions of the above paragraph, the Surety shall promptly and at the Surety's expense take one of the following actions: 1) Arrange for the Contractor with consent of the Owner, to perform and complete the Construction Contract; or 2) Undertake to perform and complete the Construction Contract itself, through its agents or through independent contractors, which agents or independent contractors shall be acceptable to the Owner; or obtain bids or negotiated proposals from qualified contractors acceptable to the Owner for a contract for performance and completion of the Construction Contract, arrange for a contract to be prepared for execution by the Owner and the contractor selected with the Owner's concurrence, to be secured with performance and payment bonds executed by a qualified surety equivalent to the bonds issued on the Construction Contract, and pay to the Owner the amount of damages as described in the following paragraph in excess of the Balance of the Contract Price incurred by the Owner resulting from the Contractor's default; or 4) Waive its right to perform and complete, arrange for completion, or obtain a new contractor and with reasonable promptness under the circumstances: 4a) After investigation, determine the amount for which it may be liable to the Owner and, as soon as practicable after the amount is determined, tender payment therefore to the Owner; or 4b) Deny liability in whole or in part and notify the Owner citing reasons therefore.

If the Surety does not proceed as provided in the above paragraph with reasonable promptness, the Surety shall be deemed to be in default on this Bond fifteen (15) days after receipt of an additional written notice from the Owner to the Surety demanding that the Surety perform its obligations under this Bond, and the Owner shall be entitled to

enforce any remedy available to the Owner. If the Surety proceeds as provided in the above paragraph, and the Owner refuses the payment tendered or the Surety has denied liability, in whole or in part, without further notice the Owner shall be entitled to enforce any remedy available to the Owner.

After the Owner has terminated the Contractor's right to complete the Construction Contract, and if the Surety elects to act under the second above paragraph, then the responsibilities of the Surety to the Owner shall not be greater than those of the Contractor under the Construction Contract, and the responsibilities of the Owner to the Surety shall not be greater than those of the Owner under the Construction Contract. To the limit of the amount of this Bond, but subject to commitment by the Owner of the Balance of the Contract Price to mitigation of costs and damages on the Construction Contract, the Surety is obligated without duplication for: 1) The responsibilities of the Contractor for correction of defective work and completion of the Construction Contract; 2) Additional legal, design professional and delay costs resulting from the Contractor's Default, and resulting from the actions or failure to act of the Surety under the second above paragraph; and 3) Liquidated damages, or if no liquidated damages are specified in the Construction Contract, actual damages caused by delayed performance or non-performance of the Contractor.

Any proceeding, legal or equitable, under this Bond may be instituted in any court of competent jurisdiction in the location in which the work or part of the work is located and shall be instituted with two (2) years after Contractor Default or within two (2) years after the Contractor ceased working or within two (2) years after the Surety refuses or fails to perform its obligations under this Bond, whichever occurs first. If the provisions of this Paragraph are void or prohibited by law, the minimum period of limitation available to sureties as a defense in the jurisdiction of the suit shall be applicable.

The Surety shall not be liable to the Owner or others for obligation of the Contractor that are unrelated to the Construction Contract, and the Balance of the Contract Price shall not be reduced or set off on account of any such unrelated obligations. No right of action shall accrue on this Bond to any person or entity other than the Owner or its heirs, executors, administrators or successors.

The Surety hereby waives notice of any change, including changes of time, to the Construction Contract or to related subcontracts, purchase orders and to other obligations.

Notice to the Surety, the Owner or the Contractor shall be mailed by certified or registered mail or delivered to the address shown on the signature page.

When this Bond has been furnished to comply with a statutory or other legal requirement in the location where the construction was to be performed, any provision in this Bond conflicting with said statutory or legal requirement shall be deemed deleted herefrom and provisions conforming to such statutory or other legal requirements shall be deemed incorporated herein. The intent is that this Bond shall be construed as a statutory bond and not as a common law bond.

Definitions: 1) Balance of the Contract Price; The total amount payable by the Owner to the Contractor under the Construction Contract after all proper adjustments have been made, including allowance to the Contractor of any amounts received or to be received by the Owner in settlement of insurance or other claims for damages to which the Contractor is entitled, reduced by all valid and proper payments made to or on behalf of the Contractor under the Construction Contract.

2) Construction Contract; The agreement between the Owner and the Contractor identified on the signature page, including all contract Documents and changes thereto.

3) Contractor Default; Failure of the contractor, which has neither been remedied nor waived, to perform or otherwise to comply with the terms of the Construction contract.

4); Owner Default; Failure of the Owner, which has neither been remedied nor waived, to pay the Contractor as required by the Construction contract or to perform and complete or comply with the other terms thereof.

IN WITNESS THEREOF, the parties hereto have caused this bond to be executed this _____ day of _____, 20_____.

(Corporate Seal)

Principal

Title:

Street/City Address

(Corporate Seal)

Surety

Title:

Street/City Address

(Corporate Seal)

Surety Witness:

Title:

Street/City Address

City of Sweet Home, 1140 12th Avenue, Sweet Home OR 97386 *(Owner)*

FY 2021 Overlay Program Project Phase 2 *(Project)*

None *(Bond Modifications)*

FIRST-TIER SUBCONTRACTOR DISCLOSURE FORM

Project Name: **FY 2021 Overlay Program Project Phase 2**

Bid Closing Date & Time: Tuesday, May 18, 2021, 2:00 PM.

Bid Open Time: Tuesday, May 18, 2021, 4:00 PM.

Disclosure Due Date & Time: Tuesday, May 18, 2021, 4:00 PM.

Bid total greater than \$100,000? _____ (Yes / No, if No, subcontractor information is not required).

If the bidder will not be using any subcontractors that are subject to the above disclosure requirements, the Bidder is required to indicate “NONE” on this form.

Bidders are required to disclose information about certain first-tier subcontractors when the contract value for a Public Improvement is greater than \$100,000, see ORS 279C.370. Specifically, when the contract amount of a first-tier subcontractor furnishing labor or labor and materials would be greater than or equal to: (i) 5% of the project Bid, but at least \$15,000 whichever is greater; or (ii) \$350,000 regardless of the percentage of the total project bid, the Bidder must disclose the following information about that subcontractor either in its Bid submission, or within two hours after Bid Closing:

- The name of each subcontractor, and
- The category of work to be performed, and
- The dollar value of the subcontract.

Compliance with the disclosure and submittal requirements outlined herein and in ORS 279C.370 and its amendments is a matter of Responsiveness. Bids that are submitted by the Bid Closing Time, but for which the disclosure submittal has not been made by the specified deadline, are not Responsive and shall not be considered for Contract award.

Subcontractor’s Name	Category of Work	Dollar Value of Subcontract

Use additional sheets of this page if necessary.

Submitted by: _____ (Bidder & Contact Name), _____ (Phone #).

BID FORM

	ITEM DESCRIPTION WITH BID UNIT PRICE	UNIT	APPROX. QUANTITY	UNIT PRICE	TOTAL AMOUNT
Bid Schedule E. 4th Ave North of Holley Rd					
1	Mobilization, Cleanup, Traffic & Erosion Control	LS	1	LUMP SUM	
2	Road Surface Pretreatment	SY	1,890		
3	Level 2, 1/2" ACP Mixture	TON	240		
4	Sawcutting	LF	450		
5	Excavation	CY	35		
6	3/4"-0 Aggregate Base	TON	30		
7	Valve Can Raise	EA	1		
8	Manhole Raise	EA	2		
	Total Bid Project Cost, Schedule E				

Bid Schedule F. 42nd Ave South of Long St					
9	Road Surface Pretreatment	SY	3,750		
10	Level 2, 1/2" ACP Mixture	TON	430		
11	Sawcutting	LF	250		
12	Excavation	CY	20		
13	3/4"-0 Aggregate Base	TON	20		
14	Valve Can Raise	EA	6		
15	Manhole Raise	EA	4		
	Total Bid Project Cost, Schedule F				

Bid Schedule G. Locust St and 54th Ave					
16	Road Surface Pretreatment	SY	965		
17	Level 2, 1/2" ACP Mixture	TON	110		
18	Sawcutting	LF	100		
19	Excavation	CY	5		
20	3/4"-0 Aggregate Base	TON	5		
21	Valve Can Raise	EA	-		
22	Manhole Raise	EA	1		
	Total Bid Project Cost, Schedule G				

Bid Schedule H. Larch St and Locust St off 49th					
23	Road Surface Pretreatment	SY	3,115		
24	Level 2, 1/2" ACP Mixture	TON	345		
25	Sawcutting	LF	100		
26	Excavation	CY	20		
27	3/4"-0 Aggregate Base	TON	10		
28	Valve Can Raise	EA	3		
29	Manhole Raise	EA	2		
	Total Bid Project Cost, Schedule H				

Bid Schedule I. Poplar St and Osage St between 52nd between and 53rd Ave, and 52nd Ave					
30	Road Surface Pretreatment	SY	2,170		
31	Level 2, 1/2" ACP Mixture	TON	485		
32	Sawcutting	LF	300		
33	Excavation	CY	15		
34	3/4"-0 Aggregate Base	TON	15		
35	Valve Can Raise	EA	2		
36	Manhole Raise	EA	2		
0	Total Bid Project Cost, Schedule I				

Bid Schedule J. Vine St. off of 18th					
37	Road Surface Pretreatment	SY	1,615		
38	Level 2, 1/2" ACP Mixture	TON	200		
39	Sawcutting	LF	300		
40	Excavation	CY	30		
41	3/4"-0 Aggregate Base	TON	25		
42	Valve Can Raise	EA	1		
43	Manhole Raise	EA	2		
	Total Bid Project Cost, Schedule J				

Bid Schedule K. Poplar St west of 9th Ave					
44	Road Surface Pretreatment	SY	500		
45	Level 2, 1/2" ACP Mixture	TON	65		
46	Sawcutting	LF	100		
47	Excavation	CY	10		
48	3/4"-0 Aggregate Base	TON	10		
49	Valve Can Raise	EA	1		
50	Manhole Raise	EA	1		
	Total Bid Project Cost, Schedule K				

Bid Schedule L. 13th Ave and Osage St					
51	Road Surface Pretreatment	SY	1,225		
52	Level 2, 1/2" ACP Mixture	TON	160		
53	Sawcutting	LF	300		
54	Excavation	CY	30		
55	3/4"-0 Aggregate Base	TON	25		
56	Valve Can Raise	EA	1		
57	Manhole Raise	EA	1		
	Total Bid Project Cost, Schedule L				

Bid Schedule M. Nandina St between 54th & 56th					
58	Road Surface Pretreatment	SY	450		
59	Level 2, 1/2" ACP Mixture	TON	60		
60	Sawcutting	LF	100		
61	Excavation	CY	10		
62	3/4"-0 Aggregate Base	TON	10		
63	Valve Can Raise	EA	-		
64	Manhole Raise	EA	1		
	Total Bid Project Cost, Schedule M				

Total Bid Project Cost Schedule E through M					
--	--	--	--	--	--

PREVAILING WAGE for PUBLIC WORKS CONTRACTS
OREGON BOLI SPECIFICATIONS

All the provisions required by ORS 279C.800 through ORS 279C.870 relating to the payment of prevailing wage rates for work performed under the Contract with the City of Sweet Home shall be complied with.

Each worker in each trade or occupation employed in the performance of this contract either by the contractor, subcontractor, or other person doing or contracting to do, or contracting for the whole or any part of the work on this contract, must be paid not less than the applicable state prevailing rate of wage in accordance with ORS 279C.838 and 279C.840.

Each year the Oregon Bureau of Labor and Industries (BOLI) publishes two rates publications (and amendments to both) that are available by calling 971-673-0839 or online at the BOLI website at:

<https://www.oregon.gov/boli/employers/Pages/prevailing-wage-rates.aspx>

Prevailing wage rates that apply to this contract are the **January 1, 2021, Prevailing Wage Rates for Public Works Contracts** in Oregon and the **October 1, 2020, PWR Apprenticeship Rates**.

FY 2021 Overlay Program Project Phase 2 does not use federal funds and does not require Davis-Bacon rates. Only Oregon BOLI Prevailing Wage Rates apply to this project.

If the contractor fails to pay for any labor or services, the City can pay for this labor or services and withhold these amounts from payments due the contractor. ORS 279C.520; OAR 839-025-0020(2)(b).

The contractor shall pay daily, weekly, weekend and holiday overtime as required in ORS 279C.540.

The contractor shall give written notice to the workers of the number of hours per day and days per week they may be required to work. ORS 279C.520(2); OAR 839-025-0020(2)(c)

Contractors and subcontractors are required to prepare weekly certified payroll reports and statements and submit them to the City by the fifth business day of each month (ORS 279C.845; OAR 839-025-0010). Contractor payment will be withheld until the City is in receipt of these certified weekly payroll reports. Information submitted on certified statements may be used only to ensure compliance with the provisions of ORS 279C.800 through ORS 279C.870.

Contractors and subcontractors which are on BOLI's List of PWR Contractors Ineligible to Receive Public Works Contracts, as well as any firm, corporation, partnership or association in which the contractor or subcontractor has a financial interest, are ineligible to receive public works contracts until removed from the list. The current version of the list is available on the BOLI website at:

<https://www.oregon.gov/boli/employers/Pages/pwr-ineligible-contractors.aspx>

PAYMENT OF MEDICAL CARE AND PROVIDING WORKERS' COMPENSATION

Oregon BOLI Law ORS 279C.530

The contractor shall make prompt payment for all medical services for which the contractor has agreed to pay, and for all amounts for which the contractor collects or deducts from the worker's wages. ORS 279C.530; OAR 839-025-0020(2)(d)

All subject employers working under this Contract shall comply with ORS 656.017 and provide the required Workers' Compensation coverage, unless such employers are exempt under ORS 656.126. Contractor shall ensure that each of its subcontractors complies with these requirements.

PUBLIC WORKS BOND

Oregon Public Contracting Law

In addition to the required payment bond and performance bond, unless exempt under ORS 279C.836 (7), (8), or (9), the contractor and every subcontractor is required to file a \$30,000 Public Works Bond with the Construction Contractor's Board before starting work on the project, to be used exclusively for unpaid wages determined to be due by BOLI.

The contractor shall include in every subcontract a provision requiring the subcontractor to have said Public Works Bond filed with the Construction Contractor's Board before starting work on the project, unless the subcontractor is exempt. The contractor is required to verify that subcontractors, unless exempt, have filed a public works bond before permitting a subcontractor to start work on a project.

The Statutory Public Works Bond form is available from BOLI upon request or may be downloaded from <https://www.oregon.gov/boli/employers/Documents/public-works-bond.pdf>.

RECIPROCAL PREFERENCE LAW

Oregon's Reciprocal Preference Law

Oregon's reciprocal preference law, ORS 279A.120, requires public contracting agencies, in determining the lowest responsible bidder, to add a percent increase to each out-of-state bidder's bid price which is equal to the percent of preference given to local bidders in the bidder's home state. For example, if the low bidder is from a state that grants a 10 percent preference to its own in-state bidders, the Oregon agency must add 10 percent to that bidder's price when evaluating the bid.

OAR 125-246-0310: Reciprocal Preferences.

- (1) When evaluating offers according to OAR 125-247-0255 through 125-247-0260, 125-249-0390 or 125-249-0640 through 125-249-0660, Authorized Agencies must add a percentage increase to the Offer of a Nonresident Offeror equal to the percentage, if any, of the preference that would be given to that Offeror in the state in which the Offeror resides. An Authorized Agency may rely on the list maintained by the Department according to ORS 279A.120(4) to determine:
 - (a) Whether the Nonresident Offeror's state gives preference to in-state Offerors; and if so,
 - (b) The amount of such preference (Percentage).
- (2) Authorized Agencies must add a percentage to the Offer that matches the Percentage described in Section (1) before determining Tie-Offerors in accordance with OAR 125-246-0300.

The National Association of Procurement Officials (NASPO) has gathered information on preference laws of all states. See <https://www.naspo.org/research-innovation/state/OR> for more details. This list is for your use in making contract awards under Oregon's reciprocal preference law. If you are in need of any assistance in the application of this law, please call or contact the State Procurement Office:

State of Oregon
Department of Administrative Services
State Procurement Office
1225 Ferry Street SE, U-140,
Salem, OR 97301-4285.
Tel: 503-378-4642.

PROJECT DRAWINGS (SEPARATE ATTACHMENT)
CONSTRUCTION DETAILS

See Attached.

SPECIAL PROVISIONS I

GENERAL REQUIREMENTS AND INFORMATION

The Oregon Standard Specifications for Construction (as revised), American Public Works Association (APWA) and American Water Works Association (AWWA) Standard Specifications, and ADA Accessibility Guidelines for Buildings and Facilities (ADAAG), etc. as applicable, are the Construction Specifications for this project. Other sections of the Oregon Standard Specifications may also apply and their omission as a direct reference herein does not relieve the Contractor from those standards. The cost of other items not specifically called for in the bid will be considered incidental to the Project and no additional payments will be made.

The General Requirements and Information references, as provided in the Special Provisions I are general in nature, those descriptions and references in the Technical Specification portion of the Special Provision II section are related more specifically to the particulars of the Project.

NOTE: All codes, standards, workmanship, material testing, general items, products, execution, special provisions, measurement and payments etc., are well documented in the Specifications noted above, and are NOT repeated here, but are included herein in whole or in part as reference and shall be applicable.

DESCRIPTION NARRATIVE OF WORK

The project work is the AC Paving Overlay, application of tack coat, construction of transitions, and related utility work on various city streets as noted in the schedule listing below. All quantities are estimated.

Schedule E is the placement of 240 Tons of Level 2 Asphalt Concrete Paving for both roadways and driveways, the pretreatment of 1,890 square yards of road surface on the Streets of 4th Avenue. The Work includes all required sawcutting (450 linear feet), excavation (35 cubic yards), and ¾"-0 aggregate base (30 tons) to construct transitions between adjacent roads and driveways. Additionally, the Work includes raising all valve cans (1) and manhole, (2), as necessary.

Schedule F is the placement of 430 Tons of Level 2 Asphalt Concrete Paving for both roadways and the driveways, and the pretreatment of 3,750 square yards of road surface on the Streets of 42nd Avenue. The Work includes all required sawcutting (250 linear feet), excavation (20 cubic yards), and ¾"-0 aggregate base (20 tons) to construct transitions between adjacent roads and driveways. Additionally, the Work includes raising all valve cans (6) and manholes (4), as necessary.

Schedule G is the placement of 340 Tons of Level 2 Asphalt Concrete Paving for both roadways and driveways, and the pretreatment of 970 square yards of road surface on the Streets of Locust Street and 54th Avenue. The Work includes all required sawcutting (100 linear feet), excavation (20 cubic yards), and ¾"-0 aggregate base (10 tons) to construct transitions between adjacent roads and driveways. Additionally, the Work includes raising all valve cans (6) and manholes (4), as necessary.

Schedule H is the placement of 340 Tons of Level 2 Asphalt Concrete Paving for both roadways and driveways, and the pretreatment of 3,115 square yards of road surface on the Streets of Locust Street and Larch Street. The Work includes all required sawcutting (100 linear feet), excavation (10 cubic yards), and ¾"-0 aggregate base (10 tons) to construct transitions between adjacent roads and driveways. Additionally, the Work includes raising all valve cans (3) and manholes (2), as necessary.

Schedule I is the placement of 485 Tons of Level 2 Asphalt Concrete Paving for both roadways and driveways, and the pretreatment of 2,170 square yards of road surface on the Streets of Poplar Street, Osage Street, and 52nd Avenue. The Work includes all required sawcutting (300 linear feet), excavation (15 cubic yards), and ¾"-0 aggregate base (15 tons), to construct transitions between adjacent roads and driveways. Additionally, the Work includes raising all valve cans (2) and manholes (2), as necessary.

Schedule J is the placement of 200 Tons of Level 2 Asphalt Concrete Paving on roadways and driveways, and the pretreatment of 1,615 square yards of road surface on the Streets of Vine Street. The Work includes all required sawcutting (300 linear feet), excavation (30 cubic yards), and ¾"-0 aggregate base (25 tons), to construct transitions between adjacent roads and driveways. Additionally, the Work includes raising all valve cans (1) and manholes (2), as necessary.

Schedule K is the placement of 65 Tons of Level 2 Asphalt Concrete Paving on roadways and driveways, and the pretreatment of 500 square yards of road surface on the Streets of Poplar Street. The Work includes all required sawcutting (100 linear feet), excavation (10 cubic yards), and ¾”-0 aggregate base (10 tons), to construct transitions between adjacent roads and driveways. Additionally, the Work includes raising all valve cans (1), and manholes (1), as necessary.

Schedule L is the placement of 160 Tons of Level 2 Asphalt Concrete Paving on roadways and driveways, and the pretreatment of 1,225 square yards of road surface on the Streets of 13th Avenue and Osage Street. The Work includes all required sawcutting (300 linear feet), excavation (30 cubic yards), and ¾”-0 aggregate base (25 tons), to construct transitions between adjacent roads and driveways. Additionally, the Work includes raising all valve cans (1), and manholes (1), as necessary.

Schedule M is the placement of 60 Tons of Level 2 Asphalt Concrete Paving on roadways and driveways, and the pretreatment of 450 square yards of road surface on the Streets of Nandina Street. The Work includes all required sawcutting (100 linear feet), excavation (10 cubic yards), and ¾”-0 aggregate base (10 tons), to construct transitions between adjacent roads and driveways. Additionally, the Work includes raising all valve cans (1) and manholes (1) as necessary.

TIME AND PLACE OF RECEIVING BIDS

Sealed bids will be received at the City of Sweet Home Public Works Department at 1140 12th Avenue, Sweet Home, Oregon, at which time as noted in the bid documents, the sealed bids will be publicly opened and read. Bids submitted after the specified time will not be received or opened.

The City of Sweet Home reserves the right to accept the bids and award a contract to the lowest responsible bidder; to postpone the acceptance of the Bid and the award of the contract for a period not to exceed thirty (30) calendar day; or to reject any and all bids received and further advertise the project for bids. The City of Sweet Home may reject any bid not in compliance with all prescribed public bidding procedures and requirements, and may reject for good cause any or all bids upon a finding of the City that it is in the public interest to do so.

The City of Sweet Home reserves the right to accept all, or any component in part, any Bid Schedule (e.g. A, B,...) grouped bid items, or individual bid items as noted in the specifications.

CONSTRUCTION SCHEDULE

The work, as described in these Plans and Specifications, is to begin no earlier than that approved by City Council and noted in the Notice to Proceed. Following the Award of Contract, and prior to issuance of the Notice to Proceed, a Pre-Construction meeting will be held, at which the Contractor shall submit a written Work Schedule, Traffic Control Schedule, Erosion Control Plan, or other documents to the Engineer. The Work Schedule shall specify the project work days to be utilized within the allowable completion time. Failure to complete the work within the completion time prescribed shall be considered cause for assessing liquidated damages, as set forth in Paragraph “LIQUIDATED DAMAGES” of these Special Provisions.

The construction schedule, as approved by the Engineer, will be an integral part of the Contract and will establish interim contract completion dates for the various activities. “Day” used throughout the Contract, unless otherwise stated, means “calendar day”. Should any activity not be completed within five (5) days after the stated scheduled date, the Engineer shall have the right to order the Contractor to expedite completion of the activity by whatever means the Engineer deems appropriate and necessary without additional compensation to the Contractor.

It is expressly understood, and agreed, that failure by the Engineer to exercise the option to either order the Contractor to expedite an activity, or to expedite the activity by other means, shall not be considered precedent setting for any other activities.

TYPE OF BID

The Bid for the work is to be submitted on a unit price basis as called for in the Bid. The estimate of quantities of work to be done as tabulated in the Bid, and although stated with as much accuracy as possible, is approximate only, and is assumed solely for the convenience of the Contractor while assembling the Bid.

BASIS OF AWARD

Award, if made, will be to a lowest responsible bidder (as defined by O.R.S.) for any combination of schedules as stated above which is determined by the City to be in the City's best interest to award.

PERMITS

The contractor shall be responsible for acquiring any permits necessary for the completion of the work, i.e. fill & grade, water & wastewater plumbing, stormwater, or building construction on private property.

INCIDENTAL ITEMS

It is the intent of these documents that the bid items listed in the Bid shall provide full and complete payment for this project, as described in the Plan and Specifications. Payment for any incidental items, whether noted on the Plans and Specifications or not, which are necessary for the completion of the project as designed, but not listed explicitly as or with a bid item, shall be considered to have been included with the Bid.

PREQUALIFICATION

Prequalification is not required for this project.

When they occur if stated in the Instructions to Bidders, statements on standard ODOT or AGC Form 40 forms must be received by the City of Sweet Home on the date stated. Prequalification shall state the bidder's experience in handling work of this type and magnitude, availability of equipment and supervisory personnel, giving references on previous similar projects, etc. Bids that are submitted by Contractors that have not prequalified will be considered non-responsive, and the bid will not be opened. Faxed Prequalification statements will not be accepted.

UTILITIES

The utilities shown on the Plans are located to the best degree possible from the information available, but are not guaranteed to be either accurate or complete. The existence of existing utility conflicts, not indicated on the Plans, shall not be the basis of extra work claims except that the cost of extra materials actually required to perform the work, and incorporated into the work, may be submitted for reimbursement in accordance with the General Conditions. The decision of the Engineer, as to the validity of such claims, shall be final. **IN ACCORDANCE WITH ORS 757.542 TO 757.562 inclusive**, it shall be the responsibility of the Contractor to notify all utility companies and organizations of his intention to begin construction. The Contractor alone shall be responsible for protecting all utilities and replacing utilities damaged by the Contractor during construction.

LIMITATION / SUBMISSION REQUIREMENTS

The City of Sweet Home reserves the right to:

- Accept or reject any or all bids received as a result of the RFB,
- Negotiate with qualified Bidders, as allowed by law.
- Cancel any RFB, in part or in whole, if it is determined to be in the best interest of the City to do so,
- Award to the selected firm or contractor any subsequent engineering design and construction services contract, part or in whole, for recommended capital projects,
- The RFB does not commit the City of Sweet Home to pay any costs incurred to prepare a bid.

SAFETY REQUIREMENTS

The Contractor shall have the sole responsibility for complying with the requirements of the Oregon Occupational Safety and Health Code, particularly Division 3, OAR 437-003, "Construction". Failure of the Contractor to comply

with specific requirements shall be the Contractor's liability. No liability for safety violations will be assumed by the Engineer, City, or other involved parties. The Contractor shall comply with all Federal, State, County and City regulations.

PROTECTION OF FACILITIES

The Contractor shall make provisions for protection of all work during the period of construction, and shall repair or replace any facilities damaged by flood, fire, vandalism, neglect, or other means prior to acceptance of the completed facility by the Owner.

INSPECTION/ENGINEER

The term Inspector, Engineer, or the authorized representative of the Owner, for the purposes of approving materials and workmanship, shall be the City of Sweet Home.

SPECIFICATIONS

The Contractor shall perform all work in conformance with the construction drawings, special provisions and in compliance with the Oregon Standard Specifications for Construction (as revised) as if said specifications were bound herewith, or as they may be modified by the Special Provisions herein.

PROJECT WARRANTY

In addition to other specific warranties required by these Specifications, all work, including material and workmanship supplied by the Contractor shall be warranted to be free of defect for one (1) year from the date the written Final Acceptance by the City of Sweet Home. The Contractor also agrees to hold the City harmless from claims of any kind arising from damage due to said defects. The Contractor shall make all repairs, and replacements promptly upon receipt of written orders for same from the Owner. If the Contractor fails to make the repairs and replacements promptly, the Owner may do the Work, and the Contractor and his surety shall be liable for the cost thereof.

TEMPORARY PROTECTION AND DIRECTION OF TRAFFIC

This shall include all temporary protection and direction of traffic per Oregon Standard Specifications for Construction, ODOT specifications, and as shown on the drawings or as stated herein. Traffic Control shall be per current edition of the Manual on Uniform Traffic Control Devices (MUTCD).

Traffic control devices which are expected to be in place for the duration of the project may be shown on the drawings. The Contractor shall provide such other traffic control devices as may be required at locations where construction is of short duration (i.e., street intersections and access to private property).

Adequate warning protection will be required for pedestrians, residents, and any material stored in a staging area in the right-of-way, or roadway. Night time protection with lighted barricades may be required. Emergency vehicles must have access or have access provided when needed.

A traffic control plan shall be submitted to the Engineer for review and approval. Following approval, the plan SHALL BE ADHERED TO AT ALL TIMES. The Contractor may find it necessary to consider various traffic control options for different stages of construction. Limited street closure to through traffic will not be allowed on this project. The Contractor must submit and receive approval from the Engineer **prior** to any modifications to the approved plan. If, in the opinion of the Engineer, the Contractor fails to comply with the drawings or the approved traffic control plan, or fails to protect the public safety, in addition to other penalties as described in the Standard Construction Specification, payment for this item shall be reduced at the discretion of the Engineer

The Contractor shall furnish the Engineer with the name and phone number of a responsible person with authority to ensure that the provisions of the plan are complied with, particularly with regard to 24 hour availability to provide a one (1) hour response to problems. The Contractor shall, at all times, protect access to private property.

Access for all residents must be maintained at all times, provide 48 hour written notice to the residents when specific driveways may be out of use. Maintaining access at all times to adjoining properties shall be incidental to the

Contract and no extra payment shall be made for work relating to maintaining access, including temporary rock or asphalt necessary for the convenience and safety of the public.

EROSION CONTROL

As required per DSL, COE, DEQ, and any other National permits. All construction activities shall conform to City NPDES permit and Stormwater Control Best Management Practices.

Erosion control measures shall protect excessive sediment runoff into catchbasins or ditch channels located at or near the work areas. Material deposits in excess must be removed by the contractor. The City of Sweet Home will not provide removal. This will include control of runoff from any areas used for staging when or if the staging area is in a portion of the street right-of-way.

FINAL CLEANUP

Final cleanup of all work sites or staging areas shall remove construction materials, equipment, debris, and dirt or gravel from all surfaces, as well as from catch basins and storm drains, that may have been impacted by construction activities. This may also include periodic street sweeping regularly since there are local residents within the work zone.

LIQUIDATED DAMAGES

Liquidated Damages will **not** be necessary on this project.

On projects if they were to occur, and would be as noted in the Instructions to Bidders, liquidated damages would be assessed as described in Section 00180.85 of the Oregon Standard Specifications for Construction. Liquidated damages shall apply against the Contractor and accrue to the Owner at the rate of Two Hundred Dollars (\$200) per day per Schedule for each and every day that the project remains uncompleted beyond the time period outlined in the Construction Schedule.

BONDING REQUIREMENTS

A performance bond and payment bond in the amount of 100% of the contract price shall be furnished to the City of Sweet Home upon executing the contract.

A warranty bond for one year is required from the date of the acceptance by the City. The City of Sweet Home shall be named on the bond as the project Owner.

QUALITY CONTROL TESTING

The Owner reserves the right to perform any testing as may be required to determine compliance with the specifications. Costs for such testing shall be the Owner's responsibility unless testing indicates noncompliance. Costs for such testing indicating noncompliance shall be borne by the Contractor. Noncomplying Work shall be corrected and testing will be repeated until the Work complies with the specifications. Contractor shall pay any costs for retesting non-complying Work.

The Contractor shall cooperate in every respect with the activities of the testing agency.

PROPERTY PIN AND SURVEY/GPS MONUMENT PROTECTION

All property pins adjacent to and within the work area shall be protected from disturbance. If property corners are disturbed during the course of the work, and are not specifically referenced in the Bid Tabulations as requiring setting or resetting, they shall be replaced by a licensed surveyor at the Contractor's expense.

The care and protection, and replacement of damaged or dislodged property monumentation shall also apply to all City and Linn County Survey Markers, GPS Monuments, DLC Corner Monuments, and other position control points.

PRE-BID MEETING

FY 2021 Overlay Program Project Phase 2

Contract Documents
Page 27 of 31

A Pre-Bid meeting will not be required on this project.

PRE-CONSTRUCTION MEETING

A Pre-Construction meeting will be required on this project after the bidder award. When it occurs as noted in the Instructions to Bidders, the meeting will be located at City Hall, and scheduled to take place anytime within ten (10) working days following the Notice of Award. Weather and or other construction scheduling issues may modify this time frame. The Construction Contract and the Notice to Proceed will generally be issued at the meeting.

RETAINAGE

To ensure the proper performance of the Contract, the Owner shall retain five (5%) of the amount of each progress payment until final completion and acceptance of all work covered by this contract.

WAGES AND SALARIES

Attention of Contractors is particularly called to the requirements concerning wages to be paid to certain categories and classifications of employees.

DISPOSAL OF EXCESS MATERIAL

All excess trench excavation, existing sidewalk or curb, and other materials designated to be removed under the contract shall be disposed of off site at the Contractor's expense and in a legal manner. Fill permits, stating Contractor provided quantity, transportation carrier, and fill destination, if within the City Limits, shall be acquired by the City as needed.

PAYMENT

The contractor shall accept the compensation as full payment for furnishing all materials, labor, tools, and equipment necessary to complete the work. Compensation shall include loss or damage arising from the nature of the work or action of the elements, or any unforeseen difficulties, which may be encountered during the prosecution of the work.

The quantities listed in the bid schedule do not govern final payment. Payments to the contractor will be made only for the actual quantities of the work performed and for the quantities of work performed as extra work or under supplemental agreement. When items of work are not listed in the bid schedule, the work shall be considered incidental and no separate payment shall be paid.

If the contract cost is determined wholly or in part, on a lump-sum basis, Engineer may use unit prices bid by Contractor in making progress estimates on the work. In case said unit prices do not, in the opinion of the Engineer, truly represent actual relative costs of different parts of work, a percentage of the unit price may be used in making progress estimates.

END OF GENERAL REQUIREMENTS AND INFORMATION

SPECIAL PROVISIONS II

TECHNICAL SPECIFICATIONS

The Oregon Standard Specifications for Construction (as revised), American Public Works Association (APWA) and American Water Works Association (AWWA) Standard Specifications, and ADA Accessibility Guidelines for Buildings and Facilities (ADAAG), etc. as applicable, are the Construction Specifications for this project. Other sections of the Oregon Standard Specifications may also apply and their omission as a direct reference herein does not relieve the Contractor from those standards. The cost of other items not specifically called for in the bid will be considered incidental to the Project and no additional payments will be made.

The General Requirements and Information references, as provided in the Special Provisions I are general in nature, those descriptions and references in the Technical Specification portion of the Special Provision II section are related more specifically to the particulars of the Project. The cost of other items not specifically called for in the Bidder's Bid will be considered incidental to the Project and no additional payments will be made.

NOTE: All codes, standards, workmanship, material type, material testing, general items, products, execution, special provisions, measurement and payments etc. related to the items noted below, are well documented in the Standard Specifications 00100 through 03010 and are NOT repeated here, but are included herein by reference.

Notification to immediately adjacent corner residents shall be made in writing by the contractor 48 hours in advance of the work. Notification shall state Project Name, Contractor Company Name, contact and phone, City Contact and Phone, the date of the work scheduled and a request to keep parked vehicles out of the corner area. Adequate warning protection will be required for pedestrians, residents, and any material stored in a staging area in the right-of-way, or roadway. Access for all residents must be maintained at all times, provide 48 hour written notice to the residents when specific driveways may be impacted.

Following this section is a map(s) showing the project work site location in Sweet Home.

Bid Items.

BID ITEM NO. 1 – Mobilization, Cleanup, Traffic & Erosion Control.

This item shall include all mobilization and final cleanup within the project area. This will also include periodic street sweeping and to provide final cleanup of all work sites or staging areas to remove construction materials, equipment, debris, and dirt or gravel from all surfaces, as well as from catch basins and storm drains, that may have been impacted by construction activities, since there are local residents within the work zone. This includes any staging area required.

This item shall include all Work Zone Traffic Control required by the City of Sweet Home, OSHA MUTCD, and Oregon Department of Transportation Standards. This bid item shall be considered full pay for all labor, materials, and equipment required to plan for, coordinate, sign, flag, detour, or direct traffic impacted by this project in accordance with Section 00225 of the ODOT Standard Specifications. A general traffic control plan shall be submitted – and approved – to the City prior to the beginning of work.

Adequate warning protection will be required for any material stored in a staging area in the right-of-way, or along the longitudinal cut drop off running lengthwise on the roadway. Night time protection of stored materials with lighted barricades may be required. This will include control of runoff from any areas used for staging when or if the staging area is a portion of the street right-of-way. Material deposits in excess must be removed by the contractor. The City of Sweet Home will not provide removal.

Access for all residents must be maintained at all times, provide written notice to the resident when specific driveways may be out of use. Emergency vehicles must have access or have access provided when needed.

This item shall include erosion control measures to protect runoff into catchbasins or drainage ditches located on the local streets where the work will be performed. Bio-Filter bags or other forms of sediment barriers may be used.

BID ITEM No. 2, 9, 16, 23, 30, 37, 44, 51, 58. – Road Surface Pretreatment.

This per square yard bid item is for the cleaning of the road surface and application of tack coat on all roadways per Oregon Standard Section 00730. Application rate shall be 0.08 gal/square yard. Tack Coat shall only be applied to clean dry surfaces, all loose material should be removed prior to application.

This material is for the roadway travel lane areas only, it is not necessary to use on driveway aprons.

BID ITEM NO. 3, 10, 24, 38, 59. – Level 2, 1/2” ACP Mixture (2” thickness).

This per Ton bid item shall include the wearing course lift of 2” thick, Level 2 Asphalt Concrete Pavement per Oregon Standard Section 00744. It shall be used for all roadway areas, driveway areas, and work area shoulder excavations and infills. For driveway aprons, pave the first 3 feet of the driveway or per City direction. Existing driveways of asphalt or concrete will be paved per City direction. This bid item includes edge widening lifts and pre-level applications necessary for the primary overlay lift. City and Contractor to verify locations.

BID ITEM NO. 17, 31, 45, 52. – Level 2, 1/2” ACP Mixture (4” thickness).

This per Ton bid item shall include two lifts of 2” thick, Level 2 Asphalt Concrete Pavement per Oregon Standard Section 00744. It shall be used for all roadway areas, driveway areas, and work area shoulder excavations and infills. For driveway aprons, pave the first 3 feet of the driveway or per City direction. Existing driveways of asphalt or concrete will be paved per City direction. This bid item includes edge widening lifts and pre-level applications necessary for the primary overlay lift. City and Contractor to verify locations.

BID ITEM No. 4, 11, 18, 25, 32, 39, 46, 53, 60. – Sawcut Asphalt.

This linear foot bid item shall include all concrete or asphalt saw cutting necessary to separate sections to be removed. All roadway locations shall be cut in a straight line, parallel to the travel lane alignment. All driveway aprons shall be cut in a straight line, perpendicular to the travel path where possible, or as specified.

BID ITEM No. 5, 12, 19, 26, 33, 40, 47, 54, 61. – Excavation.

This cubic yard bid item shall include all materials and debris removed from the areas as necessary to perform the work. This material includes all existing concrete, roadway asphalt, base rock, gravel roadway or topsoil, and general excavation necessary for the design depth of the constructed elements. Debris shall be hauled to an approved landfill or otherwise disposed of in an approved manner. If excavated material is used as fill on a property located within the City of Sweet Home, a Fill & Grade permit will be necessary from the City Building Program office in City Hall at 1140 12th Ave (contact 541-367-7993 for information).

BID ITEM NO. 6, 13, 20, 27, 34, 41, 48, 55, 62. – 3/4” Aggregate Base.

This cubic yard bid item shall include all 3/4” -0” compacted crushed rock aggregate, for use as the aggregate base of roadways and driveways. Place as shown on Plan Set or as directed by City. Use of 1”-0” material is an acceptable alternative. Material used shall be per Oregon Standard Section 02640.

BID ITEM NO. 7, 14, 21, 28, 35, 42, 49, 56, 63. – Valve Can Adjustment.

This per unit bid item shall include all valve cans that fall within the overlay. Adjustment all cans to match new road surface elevation or as directed by City. Work shall be conducted per OSSC Section 00490.

BID ITEM NO. 8, 15, 22, 28, 36, 43, 50, 57, 64. – Manhole Rim Adjustment.

This per unit bid item shall include all manholes that fall within the overlay. Adjust all manhole rims to match new road surface elevation or as directed by City. Work shall be conducted per OSSC Section 00490.

END OF GENERAL TECHNICAL REQUIREMENTS



REQUEST FOR COUNCIL ACTION

Title: Request for Council Action – Transportation Program Operation Agreement

Preferred Agenda: April 27, 2021

Submitted By: Julie Fisher, Administrative Assistant

Reviewed By: Ray Towry, City Manager

Type of Action: Resolution ____ Motion X Roll Call ____ Other ____

Relevant Code/Policy: Sweet Home Financial Policy

Towards Council Goal: Goal 3.1 Increase access to quality healthcare services

Attachments: Transportation Program Operation Agreement

Purpose of this RCA:

The Transportation Program Operating Agreement between the City of Sweet Home and the Senior Center.

Background/Context:

The City of Sweet Home has acted as a pass thru for grant funding to the Sweet Home Senior Center. In order to receive funds, The City enters into a State of Oregon Rural and Small Urban Area Transit Assistance Program. The Transportation Program Operation Agreement specifics the terms and conditions for the receipt by the Senior Center of Transportation Program from the City.

The Challenge/Problem:

Should the City act as a pass thru to the Senior Center for a Rural and Small Urban Area Transit Assistance Program and Operating Grant?

Stakeholders:

- Sweet Home Citizens – Transportation programs impact local citizens who could not otherwise commute to work, healthcare appointments, and even shopping.

Issues and Financial Impacts:

The Senior Center is able to receive State Funding from the Rural and Small Urban Area Transit Assistance Program thru the City which acts as a pass thru.

Elements of a Stable Solution:

A viable method of funding would include grants and user fees.

Options:

1. Do Nothing
2. Approve the Transportation Program Operation Agreement between the City of Sweet Home and Senior Citizens of Sweet Home.
3. NOT Approve the Transportation Program Operation Agreement between the City of Sweet Home and Senior Citizens of Sweet Home.

Recommendation:

Staff recommends option #2: Motion to approve the Transportation Program Operation Agreement between the City of Sweet Home and Senior Citizens of Sweet Home.

Transportation Program Operation Agreement

THIS AGREEMENT is made and entered into by and between the CITY OF SWEET HOME, an Oregon municipal corporation, herein called "City" and SENIOR CITIZENS OF SWEET HOME, Inc., an Oregon nonprofit corporation, herein called "Senior Center".

WHEREAS, Senior Center is engaged in public transportation and operates an eligible transportation program as identified in the Grant Agreement between the City of Sweet Home and The State of Oregon, Oregon Department of Transportation, Public Transit Division, and

WHEREAS, City has and intends to continue to enter into a State of Oregon 5311 Rural and Small Urban Area Transit Assistance Program Operating Grant Agreements as may be awarded (herein called "Grant Agreements") by and through its Department of Transportation, Public Transit Division (herein referred to as "Division"), and

WHEREAS, this Transportation Program Operation Agreement specifies the terms and conditions for receipt by the Senior Center of Transportation Program from the City, and

WHEREAS, this Transportation Program Grant Agreement will be in full force and effect as long as the City is in receipt of funds from "Grant Agreements" and/or until June 30, 2023.

NOW, THEREFORE, in consideration of the mutual covenants herein, City and Senior Center hereby agree as follows:

City shall pay or cause to be paid from the funds received from the Division under the Grant Agreement to the Senior Center all funds that are eligible for payment under the terms of the Grant Agreement.

Senior Center shall operate its public transportation system and use the funds received in accordance with the terms of the Grant Agreement and the General Provisions, which are attached thereto and by reference incorporated therein. The records of the Senior Center pertaining thereto shall be maintained by the Senior Center and made available to City, Division, and other agencies, as provided in the General Provisions.

Senior Center is and shall act as an independent contractor in the operation of its public transportation system, and not as an agency of nor an employee of the City.

Transportation Program Operation Agreement

Page 2 of 2

Senior Center shall save and hold harmless the City and the State of Oregon, including the Oregon Transportation Commission, the Department of Transportation , Public Transit Division , and their members, officers, agents, and employees from all claims, suits, or actions of whatever nature arising out of the performance of this agreement and said Grant Agreements, except for claims arising out of the negligent acts or omissions of the City of Sweet Home or of the State of Oregon, its employees or representatives.

Senior Center shall make such reports in regard to its public transportation system as may be required by City and may be required by Division.

City shall make such reports to Division as may be required and cooperate with Division and Senior Center in the administration of the Grant Agreement.

Either party may terminate this agreement with ninety (90) days written notice.

Executed by the Senior Citizens of Sweet Home, Inc. by authority of its Board of Directors.

Executed by the City of Sweet Home by authority of its Council.

Dated this _____ day of _____, 2021

Senior Citizens of Sweet Home, Inc

City of Sweet Home

David Journey, President

Greg Mahler, Mayor

Ken Bronson, Executive Director/Finance

Ray Towry, City Manager



SWEET HOME POLICE DEPARTMENT
 CHIEF OF POLICE
 1950 Main Street
 Sweet Home, OR 97386
 (541) 367-5181 Fax (541) 367-5235

	This Month 03/31/2021	Last Month 02/28/2021	Last Year 03/31/2020	Year to Date 03/31/2021	5 Year 2020-01979
Call Volume	674	642	658	2020-01979	2040
CAD Calls	1453	1266	1286	4070	4131
ONIBR Person Crimes	16	13	7	49	40
ONIBR Person Crimes Cleared	14	10	6	38	26
ONIBR Property Crimes	33	44	45	103	124
ONIBR Property Crimes Cleared	8	16	13	29	43

Trends:

Since April of 2020 we have tried to track some of the implications that COVID-19 may have had on a variety of calls for service. We have been trying to determine what effects the current pandemic situation has on them. The calls that we are monitoring include thefts, domestic violence calls, child abuse calls (physical and sexual), suicide calls, mental health calls and burglaries. Below is a comparison of those types of calls between the first quarter of 2020 and the first quarter of 2021.

	1st Quarter 2021	1st Quarter 2020	Difference	
Domestic Violence/Dispute Calls	125	105	20	19.05%
Child Abuse(Physical/Sexual)	123	86	37	43.02%
Suicidal Calls	31	13	18	138.46%
Mental Health Calls	120	31	89	287.10%
Burglary	5	8	-3	-37.50%

Several of these calls raise significant concerns for our community. Those include the mental health calls, suicidal calls and child abuse calls for service. The calls that are listed under the mental health calls can be subjective in nature. These are the calls where the officer that is responding believes that the mental health of the person associated with the call has played a significant part in the PD having to respond. Not all of these calls result in any type of law enforcement action being taken. In order to attempt to address the increase in these calls, CSO Morgan and I have been in contact with Linn County Mental Health. Our intent is to work with Linn County Mental Health on a regular basis (ideally weekly) and attempt some additional outreach and follow-up with certain individuals that we are having repeated contacts with.

Our increased engagement with Linn County Mental Health may also help us address the increase in calls involving individuals believed to be suicidal. The same type of follow-up may benefit those individuals as well.

May is designated as Mental Health Awareness Month which is appropriate and timely for our increased calls for service associated with it. Throughout May, our hope will be to raise awareness about Mental Health and ensure that individual know that they are not alone.

The final concern regarding the pandemic's potential impact seen in our calls for service are associated with reports of child abuse. The concern is that our calls of this nature have increased 43% between the first quarter of 2021 compared to the first quarter of 2020. Not all of these cases are substantiated for any type of abuse, whether that is physical or sexual. Many involve concerns for the welfare or safety of a child and do not equate to abuse. Some encouragement can be taken from this increase. That is the simple fact that citizens are continuing to call and report potential concerns for children. Many other inferences can be made as to why the calls have increased but it is difficult to identify the exact problem.

Staffing remains an issue for our Department. We are currently in the process of filling two open police officer positions. We have several background investigations going on and are still actively recruiting other potential applicants. These positions are in addition to one other that has been filled, but the officer is still in our field training program. In essence, we are down three patrol officers.

The good news is that Officer Ean Mason has completed the DPSST Police Academy and is back at the Department training with a field training coach. Upon his graduation, Officer Mason received the Outstanding Health & Fitness Award for his Basic Police Class BP405. This award is presented to the individual who excels in the area of physical fitness. We are very proud of Ean and look forward to his continued success in his public safety career.

Person Crimes are defined as:	<u>Mar-21</u>	<u>Mar-20</u>
Assault(All)	4	4
Child Neglect	0	0
Criminal Homicide	0	0
Elder Abuse	0	0
Forcible Rape	0	0
Harassment	4	1
Menacing	2	0
Other Sex Offense	2	0
Person All Other	1	1
Strangulation	1	0
Violation Court Stalking Order	0	0
Violation Restraining Order	2	1
	<hr/>	
	16	7

Property Crimes are defined as:	<u>Mar-21</u>	<u>Mar-20</u>
Arson	0	0
Burglary	1	4
Criminal Mischief	6	5
Forgery	0	0
Fraud	6	1
Motor Vehicle Theft	0	2
Reckless Burning	0	0
Recovered Stolen	0	0
Robbery	20	33
Theft		
	<hr/>	
	33	45



Oregon

Kate Brown, Governor

Department of Public Safety Standards and Training

4190 Aumsville Hwy SE
Salem, OR 97317-8981

4/2/2021

Chief Jeffrey Lynn
Sweet Home Police Department
1950 Main Street
Sweet Home, OR 97386

Dear Chief Lynn,

I am pleased to inform you that Police Officer Ean Mason is the recipient of the Outstanding Health & Fitness Award for Basic Police Class BP405. This award is presented to the individual who excels in the area of physical fitness.

It is important that our public safety professionals attain and maintain a high level of physical fitness, which will enable them to perform their jobs of providing emergency services to others. Police Officer Mason has demonstrated an understanding of the importance of physical fitness in his chosen career and serves as a role model for other public safety professionals.

Our compliments on the award recipient's achievement and wish continued success in their public safety career.

Sincerely,

Linsay Hale

Professional Standards/Interim Training Division Director
Department of Public Safety Standards and Training
(503) 378-2427
(503) 490-1019 Cell

