



CITY COUNCIL MEETING REGULAR SESSION

Tuesday, October 24, 2023 at 5:30 PM

City Hall, 102 W. Ashley Wilson Rd, Sweeny, Texas

AGENDA

BE IT KNOWN that the City Council of the City of Sweeny will meet in **Regular Session** on **Tuesday, October 24, 2023 at 5:30 PM**, at City Hall, 102 W. Ashley Wilson Rd, Sweeny, Texas with the following agenda. Council is conducted under modified Roberts Rules of Order as approved by Resolution 102-16; July 19, 2016. In accordance with Chapter §551 of the Texas Government Code, if required, the Council may conduct an executive session on any of the agenda items provided the City Attorney is present.

CALL TO ORDER/ROLL CALL

PLEDGES & INVOCATION

EXECUTIVE SESSION

EXECUTIVE SESSION IN ACCORDANCE WITH THE TEXAS GOVERNMENT CODE SECTION 551.071, 551.072 AND 551.074

The City Council will now convene into executive session pursuant to the provision of Chapter 551 Texas Government Code, in accordance with the authority contained therein:

1. Discussion / Possible Action on Deliberations Regarding Real Property, pursuant to Section 551.072 of the Texas Government Code
2. Discussion/ Possible Action Pursuant to Section 551.071 (1) (a), Consultation with Attorney with Sweeny Economic Development Corporation

OPEN SESSION

The City Council will now adjourn Executive Session, reconvene into Open Session pursuant to the Provisions of Chapter 551 Texas Government Code and take action, if any, on item(s) discussed during Closed Executive Session.

3. Discussion/Possible Action pursuant to Executive Session item on Deliberations to Real Property, Pursuant to Section 551.072
4. Discussion/Possible Action pursuant to Executive Session item on Consultation with Attorney, Pursuant to Section 551.071 (1) (a), and the Sweeny Economic Development Corporation

CITIZENS WISHING TO ADDRESS CITY COUNCIL

This item is available for those citizens wishing to address City Council on an issue not on the agenda. Any item discussed cannot be voted on but could be considered for placement on the agenda of the next regularly scheduled meeting. Limited to three (3) minutes.

CONSENT AGENDA

All of the following items on the Consent Agenda are considered to be self-explanatory by the Council and will be enacted with one motion. There will be no separate discussion of these items unless requested by the Mayor or a Council Member; in which event, the items will be removed from the consent agenda and considered separately.

- [5.](#) Proclamation: Veterans Day, November 11, 2023
- [6.](#) Minutes: Special Session September 12, 2023, Regular Session September 19, 2023, & Special Session October 04, 2023
- [7.](#) Discussion and possible action to the Third Quarter Financial Reports for Fiscal Year 2022-2023, spanning April - June
- [8.](#) Discussion and possible action on the Fourth Quarter investment report of Fiscal Year 2022 – 2023, spanning July – September 2023

REGULAR AGENDA

- [9.](#) Discussion/ Possible action to agenda request received on cats and trash; Darlene Tipps
- [10.](#) Discussion and possible action on Fourth Quarter Updates from the Sweeny Executive Leadership Team, covering July, August, and September 2023.
- [11.](#) Discussion and possible action on staff generated request for the purchase of a new sewer jetter for use on culverts to improve and manage drainage and respond to sewer blockages.
- [12.](#) Discussion/ Possible action on proposal received by Water of Texas, Michael Claybourn Sr.
- [13.](#) Discussion/ Possible action on Sweeny EDC's Performance Agreement amendment with Cecil Joe Stark Sawmill & Logging, Inc.
- [14.](#) Discussion/ Possible action on amendment to Ordinance 130.07 and determining zone allowance; Eight-liner machines
- [15.](#) Discussion/ Possible Action to amend Ordinance Chapter 110; Peddlers and Solicitors
- [16.](#) Discussion/ Possible Action to amend Ordinance Chapter 115; Mobile Food Establishments
- [17.](#) Discussion and possible action for the fourth quarter salvage items from 2023
- [18.](#) Discussion/ Possible action on a budget amendment to the FY 2022/2023 Budget; Enterprise Fund amendment for \$50,000.00 to be used for Water Line Replacement Purposes
- [19.](#) Discussion and possible action on staff generated request to amend the Fiscal Year 2022 – 2023 budget for unanticipated expenses related to water and wastewater.

ITEMS OF COMMUNITY INTEREST

ADJOURN REGULAR SESSION

I certify that the notice and agenda of items to be considered by the Sweeny City Council on **October 24, 2023** was posted on the City Hall bulletin board on the 19th day of October, 2023, at approximately 5:00 PM.

Kaydi Smith – City Secretary

I hereby certify that this Public Notice was removed from the City Hall bulletin board on the ____ day of _____, 2023 at approximately _____ AM/ PM.

Kaydi Smith - City Secretary



**CITY OF SWEENEY
OFFICE OF THE MAYOR**

From the founding of our nation to the present day, the United States have fought against tyranny and pursued liberty. In these pursuits, the brave men and women of the U.S. military have answered the call of our nation to serve. Whether stationed overseas or at home, our country is a safer place because of their dedication.

Texas has always been willing to answer the call of Armed Forces to fight for the freedoms that our country stands for. The members of our armed forces have always taken on the task and given themselves to the duty at hand. For this, we owe all our veterans the utmost respect and should recognize the courage of our service members.

At this time, I encourage my fellow citizens to take a moment this day to recognize our veterans and honor what they have done for us.

Therefore, I, Dusty Hopkins, Mayor of Sweeny Texas, do hereby proclaim November 11, 2023, to be

Veterans Day

in Sweeny and urge the appropriate recognition whereof.

In official recognition whereof, I hereby affix my signature this the 24th day of October 2023.

Dusty Hopkins
Mayor

CITY COUNCIL MEETING SPECIAL SESSION

Tuesday, September 12, 2023 at 6:00 PM

City Hall, 102 W. Ashley Wilson Rd, Sweeny, Texas

MINUTES

BE IT KNOWN that the City Council of the City of Sweeny met in **Special Session** on **Tuesday, September 12, 2023 at 6:00 PM.** at City Hall, 102 W. Ashley Wilson Rd, Sweeny, Texas with the following agenda.

CALL TO ORDER/ROLL CALL

Mayor Hopkins called the meeting to order at 6:02 PM
Mark Morgan Jr., Reese Cook, Brian Brooks, and John Rambo were in attendance. Tim Pettigrew was absent upon roll call. Pettigrew arrived late at 6:08 p.m.

PLEDGES & INVOCATION

Pledges were led by Brian Brooks.
Invocation was given by Reese Cook.

CITIZENS WISHING TO ADDRESS CITY COUNCIL

N/A

PUBLIC HEARINGS AND ACTION ITEMS

Mayor Hopkins opened the Public Hearing at 6:03 PM. Mayor Hopkins read the Proposed Tax Rate for the Fiscal Year 2023-2024 aloud, stated below in full, during the open public hearing. (Item #1) Mayor Hopkins then read aloud the stated below item #2 on the Proposed Fiscal Year 2023-2024 Budget during the open public hearing.

- 1. Public Hearing on proposed property tax rate for the Fiscal Year 2023-2024

A tax rate of \$0.607158 per \$100 valuation has been proposed by the governing body of CITY OF SWEENY.

PROPOSED TAX RATE \$0.607158 per \$100

NO- NEW REVENUE TAX RATE \$0.516525 per \$100

VOTER-APPROVAL TAX RATE \$0.607158 per \$100

The no-new-revenue tax rate is the tax rate for the 2023 tax year that will raise the same amount of property tax revenue for CITY OF SWEENY from the same properties in both the 2022 tax year and the 2023 tax year.

The voter-approval rate is the highest tax rate that CITY OF SWEENY may adopt without holding an election to seek voter approval of the rate.

The proposed tax rate is greater than the no-new-revenue tax rate. This means that CITY OF SWEENY is proposing to increase property taxes for the 2023 tax year.

A PUBLIC HEARING ON THE PROPOSED TAX RATE WILL BE HELD ON September 12, 2023 AT 6:00PM AT Sweeny City Hall; 102 W Ashley Wilson Road, Sweeny, Texas 77480.

The proposed tax rate is not greater than the voter-approval tax rate. As a result, CITY OF SWEENY is not required to hold an election at which voters may accept or reject the proposed tax rate. However, you may express your support for or opposition to the proposed tax rate by contacting the members of the City Council of CITY OF SWEENY at their offices or by attending the public hearing mentioned above.

YOUR TAXES OWED UNDER ANY OF THE RATES MENTIONED ABOVE CAN BE CALCULATED AS FOLLOWS:

Property Tax amount= (tax rate) x (taxable value of your property) / 100

For the Proposal: Reese Cook, Brian Brooks

Against: Mark Morgan Jr.

Absent: John Rambo, Tim Pettigrew

Visit Texas.gov/PropertyTaxes to find a link to your local property tax database on which you can easily access information regarding your property taxes, including information about proposed tax rates and scheduled public hearings of each entity that taxes your property.

The 86th Texas Legislature modified the manner in which the voter-approval tax rate is calculated to limit the rate of growth of property taxes in the state.

The following table compares the taxes imposed on the average residence homestead by CITY OF SWEENY last year to the taxes proposed to be imposed on the average residence homestead by CITY OF SWEENY this year.

	2022	2023	Change
Total tax rate (per \$100 of value)	\$0.730954	\$0.607158	decrease of -0.123796, or -16.94%
Average homestead taxable value	\$150,593	\$151,363	increase of 770, or 0.51%
Tax on average homestead	\$1,100.77	\$919.01	decrease of -181.76, or -16.51%
Total tax levy on all properties	\$1,426,740	\$1,578,636	increase of 151,896, or 10.65%

For assistance with tax calculations, please contact the tax assessor for CITY OF SWEENY at (979) 864- 1320 or taxoffice@brazoriacountytx.gov, or visit <https://www.brazoriacountytx.gov/departments/tax-office> for more information.

THIS TAX RATE WILL RAISE MORE TAXES FOR MAINTENANCE AND OPERATIONS THAN LAST YEAR'S TAX RATE.

THE TAX RATE WILL EFFECTIVELY BE RAISED BY 3.50 PERCENT AND WILL RAISE TAXES FOR MAINTENANCE AND OPERATIONS ON A \$100,000 HOME BY APPROXIMATELY \$-148.96.

- 2. Public Hearing Date on the Proposed Budget for the Fiscal Year 2023-2024

This budget will raise more revenue from property taxes than last year's budget by an amount of \$151,896, which is a 10.65% increase from last year's budget, and of that amount, \$6,967 is tax revenue to be raised from new property added to the tax roll this year.

Councilman Tim Pettigrew arrived at 6:08 PM

Mayor Hopkins closed the Public Hearing at 6:10 PM. No visitors were in attendance nor comments made during the Public Hearing.

REGULAR AGENDA

3. Discussion/ Possible Action to Adopt the Proposed Budget by Ordinance for the 2023-2024 Fiscal Year, per the Texas Government Code Sec. 102.007
MUST BE A RECORD VOTE, Motion Must Be: **To approve the Fiscal Year 2023/2024 Proposed Budget (specify which one) and approving the City Ordinance adopting the municipal budget for the 2023/2024 fiscal year.**

Reese Cook moved to approve the proposed budget included in the September 12th, 2023 agenda packet as presented on pages 18-30 with the following amendments:

1. *Reallocate \$10,500 from line 50-11-6730 Vehicle Expense to line 50-11-6710 Maintenance of Water System bringing budgeted amount to \$2,500 and \$90,500 respectfully.*
2. *Reallocate \$10,500. From lines 50-21-6730 Street Department Vehicle Expense and 50-22-6730 Drainage Department Vehicle Expense each in the amounts to the lines as follows:*
 - a. *\$3,150.00 to lines 50-21-6730 Street Vehicle Expense and 50-22-6730 Drainage Vehicle Expense respectively bringing totals to \$5,650.*
 - b. *\$10,500 to line 50-24-6730 Police Vehicle Expense bringing total to \$23,000.*
 - c. *\$4,200 to line 50-28-6730 Parks/Rec Vehicle Expense bringing total to \$11,200.00.*
3. *Create a line item for Capital Improvement Projects and allocate the proposed budget savings amount of \$14,367 to this line.*

Cook stated that in other terms, take the overage from the general fund and reallocate to a capital improvements projects line item. Also, remove the Enterprise Fleet Vehicle requests and reallocate those amounts as he previously stated. Then approving the budget with the amendments proposed. City Manager agreed with the motion and reallocations. Councilman Rambo asked if by re-allocating the \$14,000 within the same budget, would this be leaving the proposed tax rate the same? City Manager Lindsay Koskiniemi stated yes. Councilman Morgan asked about the current vehicle maintenance. She stated large repairs are needed on four (4) of the public works vehicles, including transmissions and AC work. Discussion ensued on the removal of the leased vehicles and how the reallocation was suggested.

Seconded by Mark Morgan Jr.

Discussion: Councilman Brooks asked about the Maintenance of the Water System, including the significant increase, due to the amendment. Councilman Rambo asked if the expenditure increase in that line was due to Inframark. No, stated Koskiniemi, we grossly exceeded this year in the Enterprise Fund. She feels it is a much more judicious use of funds to place the funds into the Water Maintenance System. Councilman Brooks asked if we have budgeted for new vehicles? He feels we need to start budgeting for new vehicles, as we haven't in the past. Each year we need to take out an old and rotate yearly, including the Police Department vehicles, versus leasing three (3) vehicles. Koskiniemi stated we have talked about starting an equipment replacement fund for

vehicles and could use some of the \$14,000 overage for that. Currently, we have the salvaged goods allocated in that fund and it was to purchase a new sewer jetter, as previously approved. Cook stated amendments are possible if needed as funds are in the budget. Koskiniemi stated interest earnings can be utilized as well, as they are not restricted. Brooks stated he has seen the vehicles and they are horrible, but the guys also need to take care of them. Koskiniemi stated we will be starting a vehicle maintenance plan. Mark Morgan Jr. stated he seconded the motion, as it was more for having the funds allotted for reallocation. As long as we have it for later on, with better numbers, in order to go back later to make a budget amendment.

Voting FOR: Mark Morgan Jr., Reese Cook, Brian Brooks, John Rambo, Tim Pettigrew
Voting AGAINST: None
Present and NOT Voting: Mayor Dusty Hopkins
All in favor. Motion carried.

- 4. Discussion/ Possible Action to Adopt the Tax Rate and Ordinance adopting the Tax Rate for the 2023-2024 Fiscal Year
MUST BE A RECORD VOTE Motion Must Be: ***I move that the property tax rate be increased by the adoption of a tax rate of (SPECIFY RATE), which is effectively a (___ %) percent increase in the tax rate and approving the ordinance adopting the tax rate of (REPEAT RATE) per \$100 valuation for the 2023/2024 Fiscal Year.***

Voter Approved Rate	.607158 / 17.55% increase
Lesser Rate/\$0 Surplus	.592525 / 14.71% increase
No New Revenue	.516525 / % increase

Reese Cook motioned that the property tax rate be increased by the adoption of a tax rate of 0.607158, which is effectively a 17.55 % percent increase in the tax rate and approving the ordinance adopting the tax rate of 0.607158 per \$100 valuation for the 2023/2024 Fiscal Year.
Seconded by Tim Pettigrew

Discussion: Councilman Brooks stated we go thru this every year and in years past we state we want to bring in the same amount of tax revenue as the previous year. Council has to realize things go up and things aren't as cheap; gas prices, frozen wages. In the future we are going to have to have enough money for water lines changes, etc. Keeping the tax rate the same won't bring in enough to fix it. In the future, he things we should put the rate at an amount the voters would have to vote on. Council Pettigrew stated the city does not have enough money saved for emergencies. The City should make between 15-22 percent on what the budget is and we are way short. We are pulling funds to complete repairs instead of having money set aside. Brooks stated he doesn't like the way the tax rate is worded showing an increase, but yet the rate itself is dropping from last year. He thinks we need to let voters decide in the future.

Voting FOR: Mark Morgan Jr., Reese Cook, Brian Brooks, John Rambo, Tim Pettigrew
Voting AGAINST: None
Present and NOT Voting: Mayor Dusty Hopkins
All in favor. Motion carried.

ITEMS OF COMMUNITY INTEREST

Neal Bess Jr. stated that last there was a car stopped at the red light at Ashley Wilson and Main Street that appeared to be either having car troubles or a medical issue. Officer Scales was several cars behind and noticed Bess with the gentleman, unable to start the vehicle. Scales arrived and proceeded to get behind the car, pushing it out of the way with Bess, until reaching the ballpark. Bess Jr. wished to

recognize Office Scales for her caring and sharing. Bess Jr. gave Officer Scales a card of appreciation for her community service and proceeded with a photo opportunity.

Mark Morgan Jr. stated he was sorry for raising taxes.

Brian Brooks stated we need a community prayer for rain.

Mayor Hopkins stated the Sweeny Bulldogs Football team is 2 in 1. They play in Needville on Friday. Brooks stated the network that televises the games are good; shoutout to the school. Hopkins stated the community themed tailgate party was a success at the last home game against Hempstead, even with the rain and lighting. They had food trucks and approximately 250 people attend and the stands were about 75% full.

City Manager stated that National Night Out is scheduled for 10/03/2023 and Chief is actively recruiting for sponsorships. She will be requesting at the next regularly scheduled City Council meeting to reschedule the 10/03/2023 Special Meeting.

Tim Pettigrew stated he was glad to be back in Texas after a short vacation out of state.

ADJOURN REGULAR SESSION

Mayor Hopkins adjourned the meeting at 6:41 PM.

City Officials/Employees Present:

- City Manager, Lindsay Koskiniemi
- City Secretary, Kaydi Smith
- Finance Director, Karla Wilson
- Police Chief, Brad Caudle
- Project Manager, Rusty Lofton
- Gas Operator, Shae Welman

Passed and approved this _____ day of _____, 2023.

Kaydi Smith, City Secretary

CITY COUNCIL MEETING REGULAR SESSION

Item 6.

Tuesday, September 19, 2023 at 6:00 PM

City Hall, 102 W. Ashley Wilson Rd, Sweeny, Texas

MINUTES

BE IT KNOWN that the City Council of the City of Sweeny met in **Regular Session** on **Tuesday, September 19, 2023 at 6:00 PM.** at City Hall, 102 W. Ashley Wilson Rd, Sweeny, Texas with the following agenda.

CALL TO ORDER/ROLL CALL

Mayor Hopkins called the meeting to order at 6 PM.

Reese Cook, Brian Brooks, and John Rambo were present. Mark Morgan Jr. and Tim Pettigrew were absent.

PLEDGES & INVOCATION

The pledges were led by Brian Brooks.

The invocation was given by Attorney Stevenson.

Mayor Hopkins addressed Council and employees. He stated that we need to have unity. We have issues with employees video taping other employees, to council members following employees around. It doesn't build comradery. These types of things bring moral down. We need to move forward as a whole in order to fix things. He referenced the football team from prior to present and how they are now operating as a unit/team. The City must be unified and work together to bring action.

CITIZENS WISHING TO ADDRESS CITY COUNCIL

John Hessong, 105 E 5th Street in Sweeny, approached Council and stated he is here in support of Lindsay (City Manager). He knew her car allowance was taken away and wants Council to know how she has made herself available for businesses and how they work together. He thinks she trying to do good for the city and doesn't think things should be taken away from her. He wants to keep her here. Toni Kotrla, 804 Brockman, approached Council and stated she and her husband (Bob) are in support of Lindsay. She and her husband are business owners within their home. They currently do a lot of business in Colorado but wishes to stay in Sweeny. She stated Lindsay has been helping them to find a spot to place the business.

CONSENT AGENDA

1. Minutes: Special Session, September 5, 2023
*Reese Cook moved to approve. John Rambo seconded.
All in favor. Motion carried.*

REGULAR AGENDA

2. Film Friendly Certification
Representative Gabriel Ornelas, Production and Community Relations Specialist of the Texas Film Commission and Office of the Governor, congratulated the City on becoming film friendly and presented Mayor Hopkins a certificate. For a city to be designated as Film Friendly, it must meet requirements for future video production. Currently there are 175 communities within Texas that are film friendly. Ornelas stated that this process usually takes a year to complete, but Sweeny completed it in a few short months. Being certified as Film Friendly helps to keep money in Sweeny for economic development.
Photos were taken with Mayor, Council, City Manager, and Ornelas with the certificate.
3. Discussion/ Possible action on allowance of the annual SISD bonfire; Daniel Fuller, SISD Superintendent

City Manager stated this request is for the SISD's annual bonfire. However, we are currently under a burn ban and she suggests Council conditionally approve, pending the lift of the ban.

John Rambo made the motion to approve the variance to Ordinance 92.01, to allow SISD to hold the requested bonfire on October 25th, 2023, subject to an alternate date, pending the lifting of the burn ban currently in place, and following all Fire Department and Fire Marshal regulations.

Reese Cook seconded. All in favor. Motion carried.

Roger Barton, Sweeny Fire Chief, stated that SISD needs to come to the Sweeny Fire Department ahead of time with plans and the Fire Department must also pre-approve their pile.

4. Discussion/ Possible action on Waste Connections contractual CPI increase
William Holloway and a Waste Connections representative were in attendance to discuss the requested CPI and fuel increase requested, effective October 2023. Waste Connections stated that the fuel rate adjustment was not applied last year due to change in leadership. The increase last year was only for the CPI itself. This year, they are increasing for the CPI and fuel. The City is in a contract with Waste Connections until 2025 and the increase is consistent with the contract. Karla Wilson, Finance Director, asked if the fuel rate is applied per customer and to be on a separate line. Waste Connections stated they did not know how that would reflect on the City side. A cart alone would be a \$1.60 increase and billed to the City monthly. The fuel adjustment is separate and a single adjustment. Fuel rates should be reviewed every three (3) months and adjusted accordingly. The new customer rate on the city bill would be \$21.20 with the surcharge added. Councilman Rambo stated that last fall our option with Waste Connections was to raise the rate to keep services the same. Discussion was held on the fuel adjustment portion. Attorney Stevenson stated that per the contract, Waste Connections has the right to apply annual increases and/or decreases. Councilman Cook asked if we can delay this increase until January to give the City time to disperse information of the increase to our residents.
Reese Cook motioned to make the fuel rate adjustment as requested by Waste Connection with an effective January 2024 date, pending conversations of the Sweeny City Manager and Waste Connections' District Manager Zackary Ryan. John Rambo seconded.
Discussion: Brian Brooks questioned as we are approving it now but pending the rate going into effect until January. Mayor stated the contract has language for it to go up.
Reese Cook and John Rambo approved. Brian Brooks opposed. Motion carried.

5. Discussion/ Possible action to possible replat for proposal of subdivision at 908 E 2nd Street; Doug Kirk
Kaydi Smith stated that Doug Kirk approached the City with plans to develop a subdivision at the address of 908 E 2nd. He is asking for Council's consent prior to moving forward with needed engineering. If Council does not want a subdivision in the area, he does not want to waste his time or resources moving forward. Mr. Kirk was not in attendance. City Manager stated the concept presented does not work for drainage and suggests that the City enter into a developers agreement congruent with what engineering would cost for the City in order to subsidize any associated costs. Discussion ensued on Council's desire to entertain the idea of a subdivision and/or consideration to add rooftops. A motion made could be construed as an approval to move forward in which Council did not feel comfortable, noting the lack of information and attendance by the developer. Added rooftops to town is an added benefit per Cook and he is in support.
Reese Cook moved to approve. Item died for lack of second.
City Manager will reach out to Kirk and give the information expressed.

6. Discussion/ Possible action to approve the newly appointed officers of the Sweeny Beautification Committee

New Officers presented for the Beautification Committee are Ashley Rambo, President; Jenny Massey, Vice President; Joanna Rambo, Secretary; Michelle Medina, Treasurer; Wayman Hutchings, Parliamentarian.

Reese Cook moved to approve as presented. Brian Brooks seconded.

Reese Cook and Brian Brooks approved. John Rambo abstained. Motion carried.

7. Discussion/ Possible action to change signors on the Sweeny Beautification Committee bank account; Ashley Rambo
Sweeny Beautification Committee is asking to remove prior members Laurie Martinez and Abby Klutz from the Beautification bank account and to add Michelle Medina and Joanna Rambo as signors. This is a City bank account under Beautification's control.
Reese Cook stated so moved. Brian Brooks seconded.
Reese Cook and Brian Brooks approved. John Rambo abstained. Motion carried.

8. Discussion/ Possible action on process and costs of returning water softeners to service; Councilman Rambo
John Rambo stated this is about the ongoing water issues and wants to see what it will cost and the direction to pursue, with associated cost opinions for returning the water softeners to service. Reese Cook asked if agenda items #8 & #9 could be combined. All agreed.
Michael Claybourn, Water of Texas/ Water Treatment Services of Texas, addressed Council with his findings of our current system and possible options. He stated the system we currently has is oversized. He produced possible options on moving forward. City Engineer, William Huebner was in attendance to address Council's questions and add suggestions. Council needs to determine how they want to approach the issues at hand. To address the manganese, address the hardness of the water, or both. Brooks asked for the City Manager to bring out a sample of pipe recently removed from a water leak repair. He is worried about the corrosion of the City's main water lines. Previously we were blaming homeowners piping, but now feels the city's piping needs to be replaced. Brooks asked if the water is clear going into the tanks, why spend money there versus replacing pipe? To replace all piping in the ground would be millions of dollars over at least 5-8 years. It would take \$250,000.00 to replace approximately 1000 feet of pipe. Discussion continued.
Reese Cook made the motion to approve Water of Texas to continue consultation and provide estimates and timelines on the costs, materials, and installation of a manganese filtration, softening, and a combination of the two at the water plant, and additionally approve \$50,000.00 to be used at discretion to replace steel water lines in the City of Sweeny. Brian Brooks seconded. All in favor. Motion carried.

9. Discussion/ Possible action on proposal received by Water of Texas, Michael Claybourn Sr.

Combined with Agenda Item #8; see previous.

10. Discussion / Possible action on presentation for CIP initiatives; City Engineer
William Huebner, City Engineer, stated he has compiled a list of Capital Improvement Initiatives for Council consideration on the water, wastewater, gas, drainage, and streets to help create a master plan for the City's future. This would help to determine current infrastructure, capacity, and estimate for future growth. The City would be able to take this information and plan projects accordingly for the next five, ten, thirty years. Options include identifying needs, updating mapping, providing cost opinions of improvements needed, and addressing capacity needs. For additional costs, Strand could also provide GIS mapping of all utilities, create models of water, sewer, and the gas, conduct rate studies, and provide smoke testing. Timeframe on the base scope would be early next year for the report to be completed; approximately three to four

months. Any preliminary information they found would be available prior to receiving the full report.

Discussion only; no motion made.

11. Discussion/ Possible action on adding street lamps on Main/ FM 524; Councilman Rambo
Councilman Rambo stated that after sundown, there is a dark area on Main Street between 6th Street (by the Donut Shop) down to Eleanor (near Bulldog). He feels we need additional lighting for safety purposes as it helps to deter crime and the illuminations helps for aesthetics. He asked about fixing the current poles where the lights are burnt out and the process of adding lamps/street lights. City Manager stated that if the City owns the lamp, we will do maintenance. If TNMP owns the pole, we notify them to replace. Additional lights would require us to notify TxDot and TNMP. TxDot does have footage requirements between poles/foot candles.
Brian Brooks motioned to look into adding two lights and fix currently out down Main Street. John Rambo seconded. All in favor. Motion carried.
12. Discussion/ Possible action on adding signage to City owned parks; Councilman Rambo
Councilman Rambo stated the Children at Play sign on MLK is believed to be facing the wrong direction. He would like to see more signage in the area as well as signage at the Backyard Park. There are two crossings where vehicle traffic crosses with the pedestrian walking trail and would like signage posted. City Manager will be looking to correct and place signage.
Discussion only; no motion made.
13. Discussion/ Possible action on water wells on residential property; Councilman Rambo
Councilman Rambo stated there has been a lot of discussion about the current state of the water condition. The question has been posed for a water well to be drilled on resident's private property. Per our ordinance, we allow, just haven't setup a committee or a permitting process. City Manager stated the Council acting as the committee would be the easiest option and the path of least resistance. We would need to establish a permitting process, inspection process, and research all County and State requirements. In 1990, the ordinance's purpose was to prevent private wells from contaminating the public water supply per Attorney Stevenson. The permit would require depth and other factors including a well head administrator to make a determination. City Engineer, William Huebner, stated that TCEQ does has requirements, but doesn't prohibit. He stated the City has a Certificate of Convenience and Necessity and provides for a certain area. Residential wells are much less regulated and a potential source of contamination. There are requirements as to how many feet the wells must be away from sewer facilities and livestock. All drilled wells would be in generally the same aquifer containing hard water and manganese. Mayor asked how we would meter sewer going out for billing purposes. Rambo suggested affixing a flat fixed rate for sewer and cap off city water or to average the residential sewage rate.
John Rambo made a motion to get with West Columbia and see how they handle the permitting system or what their requirements entail, and to come back with information at the next meeting. Reese Cook seconded. All in favor. Motion carried.
14. Discussion/ Possible action on agenda request on "Top 10" project list for City Manager;
Councilman Cook
Councilman Cook stated that city work is never ending. This idea is for accountability for both Council and Lindsay. He wants to come up with an actionable list of items that she can work off of and get reports from. It also aids to bind the direction in which the city goes. Clear direction is requested and the list was suggested to be added to each agenda as item 1 for an update. Council discussed different items they would like to see completed. City Manager stated the City needs a new sewer jetter, which is approximately \$80,000.00, to blast culverts. Discussion

ensued over options of purchase versus renting. Council determined three items for the City Manager to start working on.

1. Water Quality- stemming from the approved previous agenda items #8 & #9
2. Work on the two (2) - six inch (6") Gorman Rups and associated piping for the wastewater plant/ RES pumps.
3. Sectioning off and delivering a map of the city for culverts and cutting weeds in/along Stevenson Slough.

Reese Cook stated so moved. (to the three (3) items listed above after repeating) Brian Brooks seconded. All in favor. Motion carried.

4. Discussion/ Possible action to cancel the October 3rd, 2023 Special City Council Meeting or reschedule to an alternate date; National Night Out
National Night Out is normally held the first Tuesday in October. Now that we are having twice monthly Council meetings, the two are in conflict. Administration is asking to either reschedule the October 3rd meeting or cancel.

Reese Cook made the motion to rescind the previous motion and go back to regular session meetings in October and cancel the October 3rd, 2023 special meeting. Seconded by John Rambo. All in favor. Motion carried.

ITEMS OF COMMUNITY INTEREST

City Manager stated that Drainage District #11 is cleaning up behind Stewarts. She has interviews tomorrow morning for the Director of Public Works position and will be bringing prospective candidates before Council at the October 17, 2023 Regular meeting.

ADJOURN REGULAR SESSION

Mayor adjourned the meeting at 8:20 PM

City Officials/Employees Present:
 City Manager, Lindsay Koskiniemi
 Finance Director, Karla Wilson
 Police Chief, Brad Caudle
 City Secretary, Kaydi Smith
 City Attorney, RC Stevenson
 City Engineer, William Huebner
 Project Manager, Rusty Lofton
 Gas Operator, Shae Welman

These minutes were passed and approved this _____ day of _____, 2023.

 Kaydi Smith, City Secretary

CITY COUNCIL MEETING SPECIAL SESSION

Item 6.

Wednesday, October 04, 2023 at 6:00 PM

City Hall, 102 W. Ashley Wilson Rd, Sweeny, Texas

MINUTES

BE IT KNOWN that the City Council of the City of Sweeny met in **Special Session** on **Wednesday, October 04, 2023 at 6:00 PM.** at City Hall, 102 W. Ashley Wilson Rd, Sweeny, Texas with the following agenda.

CALL TO ORDER/ROLL CALL

Mayor Hopkins called the meeting to order at 6:01 PM.
Mark Morgan Jr., Reese Cook, Brian Brooks, John Rambo, and Tim Pettigrew were in attendance

PLEDGES & INVOCATION

The pledges were led by Mark Morgan Jr.
The invocation was given by Mayor Hopkins.

CITIZENS WISHING TO ADDRESS CITY COUNCIL

No visitor comments.

EXECUTIVE SESSION IN ACCORDANCE WITH THE TEXAS GOVERNMENT CODE SECTION 551.071, 551.072 AND 551.074

Mayor Hopkins stated the City Council will now convene into executive session pursuant to the provision of Chapter 551 Texas Government Code, in accordance with the authority contained therein at 6:03 PM; closing the Open Session. Mayor Hopkins opened the executive session at 6:04 PM.

- 1. Deliberation / Possible action regarding personnel matters regarding the appointment, employment, evaluation, reassignment, duties, discipline, or dismissal of a public officer or employee, pursuant to Section 551.074 of the Texas Government Code. (Applicant(s) of Employment; Public Works Director)

OPEN SESSION

Mayor Hopkins stated the City Council will now adjourn Executive Session at 7:30 PM and reconvened into Open Session at 7:30 PM pursuant to the Provisions of Chapter 551 Texas Government Code and take action, if any, on item(s) discussed during Closed Executive Session.

- 2. Any Possible Action pursuant to Executive Session Item Regarding Deliberations/ Possible action to the appointment, employment, evaluation, reassignment, duties, discipline, or dismissal of a public officer or employee; Pursuant to Section 551.074 of the Texas Government Code (Applicant(s) of Employment; Public Works Director)
No Action Taken.

ITEMS OF COMMUNITY INTEREST

Mark Morgan Jr. stated National Night Out was well put together.
John Rambo stated Beautification is hosting the Main Street Cleanup this Saturday starting at the Gazebo Park.
Mayor Hopkins stated the volleyball girls won District and are 7 and 0. The football boys play Lamarque this Friday and are 3 and 2.
Tim Pettigrew asked for prayers for his family.

ADJOURN REGULAR SESSION

Mayor Hopkins adjourned the meeting at 7:42 PM

Passed and approved this _____ day of _____, 2023.
Kaydi Smith, City Secretary



AGENDA MEMO

Business of the City Council
City of Sweeny, Texas

Meeting Date	10/24/2023	Agenda Item	
Approved by City Manager		Presenter(s)	
Reviewed by City Attorney		Department	Finance
Subject	3 rd Qtr (April 2023 – June 2023) Financial Reports		
Attachments	YTD Income Statements General Fund and Enterprise Fund		
Financial Information	Expenditure Required:		N/A
	Amount Budgeted:		N/A
	Account Number:		
	Additional Appropriation Required:		
	Additional Account Number:		

Executive Summary

Recommended Action

*SWEENEY - ENTERPRISE FUND
YEAR TO DATE INCOME STATEMENT
COMPARED WITH BUDGET AND LAST YEAR
FOR THE NINE MONTHS ENDING JUNE 30, 2023

G/L ACCOUNT	Description	Current Year Actual	Current Year Budget	Variance Amount	Variance Percent
REVENUES					
20-2191	INFRASTRUCTURE	\$ 0.00	\$ 0.00	0.00	0.00
40-00-5120	GRANT REVENUE/ WATER PL	0.00	0.00	0.00	0.00
40-00-5450	TURN-ON/RECONNECT FEES	9,630.00	11,000.00	(1,370.00)	(12.45)
40-00-5460	PENALTY - LATE PAYMENTS	30,256.97	32,300.00	(2,043.03)	(6.33)
40-00-5470	CHARGED OFF ACCTS COLLE	261.00	720.00	(459.00)	(63.75)
40-00-5600	INTEREST/CUSTOMER UTILITI	3,414.47	0.00	3,414.47	0.00
40-00-5601	INTEREST ON ENTERPRISE FU	16,526.78	0.00	16,526.78	0.00
40-00-5610	INTEREST EARNINGS ON CD'S	0.00	0.00	0.00	0.00
40-00-5615	INTEREST EARNED-'78 SERIES	0.00	0.00	0.00	0.00
40-00-5616	INTEREST / TEXPOOL INFRAS	1,847.31	0.00	1,847.31	0.00
40-00-5617	INTEREST-85/95 REF 9697-001	0.00	0.00	0.00	0.00
40-00-5618	INTEREST INCOME /1601-001	0.00	0.00	0.00	0.00
40-00-5619	MISCELLANEOUS	0.00	0.00	0.00	0.00
40-00-5620	TRANSFER IN FROM SEDC	0.00	0.00	0.00	0.00
40-00-5650	MISCELLANEOUS REVENUE	0.00	0.00	0.00	0.00
40-00-5683	GAIN OR LOSS ON SALE OF AS	23,100.00	0.00	23,100.00	0.00
40-00-5692	CONTRIBUTED CAPITAL	0.00	0.00	0.00	0.00
40-00-5810	WATER SALES	529,476.30	704,000.00	(174,523.70)	(24.79)
40-00-5815	WATER SOFTENER	0.00	0.00	0.00	0.00
40-00-5816	INFRASTRUCTURE DONATIO	1,330.00	0.00	1,330.00	0.00
40-00-5820	WATER TAPS	0.00	800.00	(800.00)	(100.00)
40-00-5830	SEWER SALES	458,660.26	602,500.00	(143,839.74)	(23.87)
40-00-5840	SEWER TAPS	800.00	1,200.00	(400.00)	(33.33)
40-00-5910	GAS SALES	333,426.29	552,738.40	(219,312.11)	(39.68)
40-00-5920	GAS TAPS	0.00	800.00	(800.00)	(100.00)
40-00-5990	SEWER CAMERA/SEDC/LOAN	0.00	0.00	0.00	0.00
40-00-5991	2017-18 TRACTOR LOAN PROC	0.00	0.00	0.00	0.00
40-00-5992	2017-18 SMARTMETERS PROC	0.00	0.00	0.00	0.00
40-00-5993	2017- FEMA HURRICANE HAR	0.00	0.00	0.00	0.00
40-00-5994	2019 FEMA GRANT/ CEDAR ST	0.00	0.00	0.00	0.00
40-00-6000	TRANSFER FROM TEXPOOL	0.00	0.00	0.00	0.00
40-00-6001	TRANSFER IN FROM CO 2012	0.00	0.00	0.00	0.00
40-00-6002	TRANSFER IN FROM GENERA	12,372.92	0.00	12,372.92	0.00
40-00-6003	TRANSFER IN FROM TEXP INF	0.00	0.00	0.00	0.00
40-00-6004	TRANSFER FROM RES & REST	0.00	0.00	0.00	0.00
40-00-6005	TRANSFER FROM CAPITAL PR	0.00	0.00	0.00	0.00
40-00-6200	FUNDING FOR MINI EXCAV 20	0.00	0.00	0.00	0.00
40-00-6201	FUNDING FOR 19-20 PW TRUC	0.00	0.00	0.00	0.00
50-00-5621	TRANSFER FROM PAYROLL F	0.00	0.00	0.00	0.00
	TOTAL REVENUES	1,421,102.30	1,906,058.40	(484,956.10)	(25.44)

FOR MANAGEMENT PURPOSES ONLY

*SWEENEY - ENTERPRISE FUND
YEAR TO DATE INCOME STATEMENT
COMPARED WITH BUDGET AND LAST YEAR
FOR THE NINE MONTHS ENDING JUNE 30, 2023

G/L ACCOUNT	Description	Current Year Actual	Current Year Budget	Variance Amount	Variance Percent
COST OF SALES					
50-00-5621 (cont.)	TOTAL COST OF SALES	0.00	0.00	0.00	0.00
	GROSS PROFIT	1,421,102.30	1,906,058.40	(484,956.10)	(25.44)
EXPENSES					
50-00-6148	PAYROLL PROCESSING FEES	466.42	0.00	466.42	0.00
50-11-5470	CHARGED OFF ACCOUNTS	2,182.99	0.00	2,182.99	0.00
50-11-5811	RE-CONNECTION FEE	0.00	0.00	0.00	0.00
50-11-5820	WATER TAP/ REFUNDS	0.00	0.00	0.00	0.00
50-11-6001	CASH ADJUSTMENTS	0.00	0.00	0.00	0.00
50-11-6111	ADMIN SALARIES	55,610.04	47,975.00	7,635.04	15.91
50-11-6112	OFFICE SALARIES	71,641.65	108,424.53	(36,782.88)	(33.92)
50-11-6113	SALARIES	143,585.22	237,238.98	(93,653.76)	(39.48)
50-11-6125	OVERTIME	18,200.22	16,558.32	1,641.90	9.92
50-11-6141	FICA	22,724.83	31,915.94	(9,191.11)	(28.80)
50-11-6142	GROUP HEALTH	62,847.97	108,687.03	(45,839.06)	(42.18)
50-11-6143	WORKERS COMP	5,744.10	9,198.91	(3,454.81)	(37.56)
50-11-6144	RETIREMENT	46,048.93	64,697.58	(18,648.65)	(28.82)
50-11-6145	UNEMPLOYMENT	86.74	1,966.50	(1,879.76)	(95.59)
50-11-6146	LONGEVITY PAY	5,855.04	7,005.00	(1,149.96)	(16.42)
50-11-6147	EMPLOYEE APPREC/HOLIDAY	1,856.92	2,000.00	(143.08)	(7.15)
50-11-6240	OFFICE MACHINE SERVICE	0.00	0.00	0.00	0.00
50-11-6245	LEAD SAMPLES FOR WATER S	0.00	0.00	0.00	0.00
50-11-6250	WATER SAMPLES	556.86	7,000.00	(6,443.14)	(92.04)
50-11-6255	INSPECTION/PERMIT FEES	7,605.94	10,050.00	(2,444.06)	(24.32)
50-11-6260	ENGINEER	0.00	2,500.00	(2,500.00)	(100.00)
50-11-6271	ELECTRICITY	44,567.76	56,400.00	(11,832.24)	(20.98)
50-11-6272	TELEPHONE	5,136.52	5,100.00	36.52	0.72
50-11-6273	XEROX MAINTENANCE CONT	0.00	0.00	0.00	0.00
50-11-6274	NEXTEL RADIOS	0.00	0.00	0.00	0.00
50-11-6276	INTERNET/CABLE	0.00	0.00	0.00	0.00
50-11-6277	COMPUTER IT / BACKUP	12,259.36	10,000.00	2,259.36	22.59
50-11-6278	AQUA BEVERAGE	0.00	0.00	0.00	0.00
50-11-6310	JANITORIAL SUPPLIES	606.22	0.00	606.22	0.00
50-11-6311	OFFICE SUPPLIES	2,544.20	3,000.00	(455.80)	(15.19)
50-11-6312	POSTAGE	5,244.93	6,000.00	(755.07)	(12.58)
50-11-6313	PPE	1,248.35	1,500.00	(251.65)	(16.78)
50-11-6507	BOND PMT PRIN-'95 RE-ISSU U	0.00	0.00	0.00	0.00
50-11-6508	BOND INT-'95 RE-ISSUE UTIL R	0.00	0.00	0.00	0.00
50-11-6515	BOND PAYING AGENT FEES	0.00	0.00	0.00	0.00

FOR MANAGEMENT PURPOSES ONLY

*SWEENEY - ENTERPRISE FUND
YEAR TO DATE INCOME STATEMENT
COMPARED WITH BUDGET AND LAST YEAR
FOR THE NINE MONTHS ENDING JUNE 30, 2023

G/L ACCOUNT		Current Year	Current Year	Variance	Variance
Description		Actual	Budget	Amount	Percent
50-11-6525	1/2 RTC BUILDING	0.00	0.00	0.00	0.00
50-11-6540	TRANSFER TO DEBT SERVICE	333,748.96	500,623.19	(166,874.23)	(33.33)
50-11-6541	TRANSFER TO FUND BALANC	0.00	0.00	0.00	0.00
50-11-6542	LOAN - COMMUNITY CENTER	0.00	0.00	0.00	0.00
50-11-6543	TRANSF TO DSF - 91 CO BOND	0.00	0.00	0.00	0.00
50-11-6615	COMPUTER UPDATE/IT-EQUIP	0.00	0.00	0.00	0.00
50-11-6710	MAINTENANCE OF WATER SY	91,349.80	80,000.00	11,349.80	14.19
50-11-6711	MAINTENANCE OF SEWER SY	163,480.93	90,000.00	73,480.93	81.65
50-11-6712	MAINTENANCE OF GAS SYST	31,811.43	41,000.00	(9,188.57)	(22.41)
50-11-6713	CHEMICALS	25,156.39	58,000.00	(32,843.61)	(56.63)
50-11-6714	GAS PURCHASES	144,999.53	264,500.00	(119,500.47)	(45.18)
50-11-6715	GASOLINE, DIESEL	6,929.15	7,900.00	(970.85)	(12.29)
50-11-6716	FIRE EXTINGUISHER AUDIT	0.00	0.00	0.00	0.00
50-11-6717	HYDRANT AUDIT / REPAIR	8,000.00	10,000.00	(2,000.00)	(20.00)
50-11-6720	FREIGHT EXPENSE	0.00	0.00	0.00	0.00
50-11-6725	DUES, MEMBERSHIPS, PERIOD	2,248.90	3,000.00	(751.10)	(25.04)
50-11-6730	VEHICLE EXPENSE	7,442.51	6,000.00	1,442.51	24.04
50-11-6750	PUBLIC NOTICES	1,000.00	1,250.00	(250.00)	(20.00)
50-11-6760	UNIFORM EXPENSE	5,239.48	6,300.00	(1,060.52)	(16.83)
50-11-6770	INSURANCE-LIAB, PROP, WK	85,813.11	67,000.00	18,813.11	28.08
50-11-6771	DEPRECIATION	0.00	0.00	0.00	0.00
50-11-6775	LEASE PROPERTY-BORDER ST	0.00	0.00	0.00	0.00
50-11-6820	AUDITOR	10,000.00	13,250.00	(3,250.00)	(24.53)
50-11-6870	TRAINING	4,261.25	2,500.00	1,761.25	70.45
50-11-6880	UDS / ANNUAL SOFTWARE FE	2,303.60	5,950.00	(3,646.40)	(61.28)
50-11-6890	MISCELLANEOUS	740.38	1,000.00	(259.62)	(25.96)
50-11-6891	CITY MANAGER VEHICLE STI	1,846.20	2,400.00	(553.80)	(23.08)
50-11-6892	CITY MANAGER CELL PH. STI	277.00	360.00	(83.00)	(23.06)
50-11-6893	PW DIRECTOR CELL PHONE S	41.55	0.00	41.55	0.00
50-11-6895	DRUG SCREENING	0.00	0.00	0.00	0.00
50-11-6920	TRANSFER TO GENERAL FUN	0.00	0.00	0.00	0.00
50-11-6921	TRANSFER TO DEBT SERVICE	0.00	0.00	0.00	0.00
50-11-6922	TRANSF FROM WAT/ SEW DE	0.00	0.00	0.00	0.00
50-11-6923	TRANSFER FROM 93 CAPITAL	0.00	0.00	0.00	0.00
50-11-6924	TRANSFER FROM DIASTER CO	0.00	0.00	0.00	0.00
50-11-6925	TRANSFER FOR PROJECTS	0.00	0.00	0.00	0.00
50-11-6940	TRANSFER TO TEXP INFRAST	0.00	0.00	0.00	0.00
50-11-6941	TRANSFER TO CAPT PROJ/ 201	0.00	0.00	0.00	0.00
50-11-6942	TRANSFER TO RESERVE AND	0.00	0.00	0.00	0.00
50-11-6950	2022 JAN TRANSFER TO DIS C	0.00	0.00	0.00	0.00
50-11-8000	EMPLOYEE RECGONITION	0.00	0.00	0.00	0.00
50-11-8675	RESERVE FUND	0.00	0.00	0.00	0.00
50-30-1100	INTEREST EXP - SEWERCAM	0.00	0.00	0.00	0.00

FOR MANAGEMENT PURPOSES ONLY

*SWEENEY - ENTERPRISE FUND
YEAR TO DATE INCOME STATEMENT
COMPARED WITH BUDGET AND LAST YEAR
FOR THE NINE MONTHS ENDING JUNE 30, 2023

G/L ACCOUNT	Description	Current Year Actual	Current Year Budget	Variance Amount	Variance Percent
50-40-6600	CAPT OUTLAY / 2009 STREETS	0.00	0.00	0.00	0.00
50-40-6601	TEXPOOL INFRASTRUCTURE	0.00	0.00	0.00	0.00
50-40-6602	CAPT OUTLAY / WATER SALE	0.00	0.00	0.00	0.00
50-40-6603	CAPT OUTLAY / GAS SALES	0.00	0.00	0.00	0.00
50-40-6604	CAPT OUTLAY / SEWER	0.00	0.00	0.00	0.00
50-40-6605	CAPT. OUTLAY / CO 2011	0.00	0.00	0.00	0.00
50-40-6606	CAPT OUTLAY / CO 2012	0.00	0.00	0.00	0.00
50-40-6607	CAPT OUTLAY / WATERSOFT.	0.00	0.00	0.00	0.00
50-40-6608	CAPT OUTLAY / 2016 CO	0.00	0.00	0.00	0.00
50-40-6609	CAPT. OUTLAY - 2017 TRACTO	0.00	0.00	0.00	0.00
50-40-6610	CAPT. OUTLAY 2017 SMART M	0.00	0.00	0.00	0.00
50-40-6611	SEWER CAMERA/INTEREST	0.00	0.00	0.00	0.00
50-40-6612	SEWER CAMERA-PRINCIPAL/S	0.00	0.00	0.00	0.00
50-40-6613	CAPT. OUTLAY TEXPOOL 78 B	0.00	0.00	0.00	0.00
50-40-6620	COMPUTERS	0.00	0.00	0.00	0.00
50-40-6630	SEWER PROJECTS	0.00	0.00	0.00	0.00
50-40-6635	SEWER MACHINE LEASE PUR	0.00	0.00	0.00	0.00
50-40-6636	SEWER CAMERA - INTEREST E	0.00	0.00	0.00	0.00
50-40-6640	2007 VEHICLE PRINCIPAL	0.00	0.00	0.00	0.00
50-40-6641	2007 VEHICLE INTEREST	0.00	0.00	0.00	0.00
50-40-6642	INTEREST -- COMPASS BANK	0.00	0.00	0.00	0.00
50-40-6643	2009 BACKHOE	0.00	0.00	0.00	0.00
50-40-6645	RADIO/TELEPHONE SERVICE	0.00	0.00	0.00	0.00
50-40-6646	TRACTOR 2017 / PRINCIPAL	0.00	0.00	0.00	0.00
50-40-6647	TRACTOR 2017 / INTEREST	0.00	0.00	0.00	0.00
50-40-6650	BRINE STORAGE TANK	0.00	0.00	0.00	0.00
50-40-6651	RG-3 / SMART METERS / PRIN	34,557.73	34,557.73	0.00	0.00
50-40-6652	SMART METERS (INTEREST)	8,379.09	8,379.09	0.00	0.00
50-40-6653	MINI EXC, TRAILER, BACKHO	0.00	0.00	0.00	0.00
50-40-6654	MINI EXC, TR, ATTACH, INTER	0.00	0.00	0.00	0.00
50-40-6655	REBUILD TX GRANT/ WT PL G	0.00	0.00	0.00	0.00
50-40-6656	2019 FEMA GRANT/ CEDAR ST	0.00	0.00	0.00	0.00
50-40-6660	STAFF CAR	0.00	0.00	0.00	0.00
50-40-6661	STAFF CAR / INTEREST	0.00	0.00	0.00	0.00
50-40-6662	2013 2 NEW PUBLIC WORKS T	0.00	0.00	0.00	0.00
50-40-6663	2013 2 NEW PW TRUCKS INTE	0.00	0.00	0.00	0.00
50-40-6664	DUMP TRUCK	0.00	0.00	0.00	0.00
50-40-6665	2016 FORD F250 PANEL TRUC	0.00	0.00	0.00	0.00
50-40-6666	19-20 PW FORD F150 / PURCHA	0.00	0.00	0.00	0.00
50-40-6670	2020 FD F150 PW TRK PRINCIP	0.00	0.00	0.00	0.00
50-40-6671	2020 FD F150 PW TRK INTERES	0.00	0.00	0.00	0.00
50-40-6675	PW NEW BUILDING	0.00	0.00	0.00	0.00

FOR MANAGEMENT PURPOSES ONLY

Item 7.

*SWEENEY - ENTERPRISE FUND
 YEAR TO DATE INCOME STATEMENT
 COMPARED WITH BUDGET AND LAST YEAR
 FOR THE NINE MONTHS ENDING JUNE 30, 2023

G/L ACCOUNT	Description	Current Year Actual	Current Year Budget	Variance Amount	Variance Percent
50-40-6675 (cont. TOTAL EXPENSES		<u>1,486,248.20</u>	<u>1,941,187.80</u>	<u>(454,939.60)</u>	(23.44)
NET INCOME	\$	<u><u>(65,145.90)</u></u>	<u><u>(35,129.40)</u></u>	<u><u>(30,016.50)</u></u>	85.45

1Sweeny - General Fund
Income Statement
For the Nine Months Ending June 30, 2023

G/L Account	Description	Year to Date Actual	Year to Date Budget	YTD Variance Budget to Date	YTD % of Total
Revenues					
40-00-5000	REVENUE	\$ 0.00	\$ 0.00	0.00	0.00
40-00-5110	Ad Valorem Taxes	1,289,791.93	1,300,388.22	10,596.29	99.19
40-00-5111	Penalty & Interest- Taxes	16,732.34	26,000.00	9,267.66	64.36
40-00-5121	Franchise Tax - TX New Mexico	48,004.91	63,000.00	14,995.09	76.20
40-00-5123	Franchise Tax - Windstream	6,204.61	9,600.00	3,395.39	64.63
40-00-5124	Franchise Tax - Cable	5,062.83	5,000.00	(62.83)	101.26
40-00-5130	City Sales Tax	683,913.37	650,000.00	(33,913.37)	105.22
40-00-5135	WM- Billing GB Handling Fee	7,356.48	25,700.00	18,343.52	28.62
40-00-5210	Electrical Licenses	0.00	0.00	0.00	0.00
40-00-5220	Building Permits	32,994.09	7,500.00	(25,494.09)	439.92
40-00-5221	Manuf Home Tie-Down Inspection	0.00	0.00	0.00	0.00
40-00-5222	Manuf Home Park Permits	0.00	0.00	0.00	0.00
40-00-5230	Plumbing & Gas Permits	6,177.50	5,675.00	(502.50)	108.85
40-00-5240	Electrical Permits	3,505.00	5,500.00	1,995.00	63.73
40-00-5241	Contractors Registration	910.00	1,000.00	90.00	91.00
40-00-5242	Ambulance Registration	0.00	0.00	0.00	0.00
40-00-5243	ROW User Permits	0.00	2,400.00	2,400.00	0.00
40-00-5250	Water Well Permits	0.00	0.00	0.00	0.00
40-00-5260	Fire Marshal Inspections	300.00	800.00	500.00	37.50
40-00-5300	2017 Hurr Harvey FEMA Reimbur	0.00	0.00	0.00	0.00
40-00-5301	Tx Div Em Mgmt / COVID 19	0.00	0.00	0.00	0.00
40-00-5309	Grant Revenue	69,675.31	0.00	(69,675.31)	0.00
40-00-5310	P66 Revenue/ PD - Parks	0.00	0.00	0.00	0.00
40-00-5312	Funding for 2017 PD Explorer	0.00	0.00	0.00	0.00
40-00-5355	Tex Div Emer Mgmt / ARPA 2022	0.00	0.00	0.00	0.00
40-00-5411	Garbage Residential/Commercial	316,334.95	390,000.00	73,665.05	81.11
40-00-5412	Garbage Bag Sales	5,901.44	7,500.00	1,598.56	78.69
40-00-5413	Garbage Bag Tax	44.38	0.00	(44.38)	0.00
40-00-5415	Resid & Comm Garbage Tax	197.94	0.00	(197.94)	0.00
40-00-5420	Dog Pound Fees	345.00	600.00	255.00	57.50
40-00-5430	Culverts, Caliche Income	20.00	0.00	(20.00)	0.00
40-00-5440	Proceeds from Issuance of Debt	2,500,000.00	0.00	(2,500,000.00)	0.00
40-00-5441	Proceeds from Issuance	0.00	0.00	0.00	0.00
40-00-5511	Fines	20,086.73	31,700.00	11,613.27	63.37
40-00-5512	State Fees (10%)	11,694.55	15,000.00	3,305.45	77.96
40-00-5513	Miscellaneous	4,441.67	5,400.00	958.33	82.25
40-00-5514	School	1,000.27	0.00	(1,000.27)	0.00
40-00-5515	Income From Cty (Arrest Fees)	0.00	0.00	0.00	0.00
40-00-5516	Time Payment	776.69	1,885.00	1,108.31	41.20
40-00-5517	Municipal Court Technology	752.75	0.00	(752.75)	0.00
40-00-5518	Municipal Ct Security Bldg Fnd	904.63	0.00	(904.63)	0.00
40-00-5519	Tertiary State Tax Fund	251.80	0.00	(251.80)	0.00
40-00-5520	Collection Agency Fee	0.00	0.00	0.00	0.00

For Management Purposes Only

1Sweeny - General Fund
Income Statement
For the Nine Months Ending June 30, 2023

G/L Account	Description	Year to Date	Year to Date	YTD Variance	YTD % of Total
		Actual	Budget	Budget to Date	
40-00-5521	TCS	6,343.29	0.00	(6,343.29)	0.00
40-00-5522	Officer's Salary	0.00	0.00	0.00	0.00
40-00-5523	Local Municipal Jury Fund	17.91	0.00	(17.91)	0.00
40-00-5600	Interest Income	26,425.02	0.00	(26,425.02)	0.00
40-00-5601	Interest TexPool Sidewalk Fund	0.00	0.00	0.00	0.00
40-00-5610	Interest - CD's	259.33	1,000.00	740.67	25.93
40-00-5612	Close CD	0.00	0.00	0.00	0.00
40-00-5622	Lease - MidCoast Cable	0.00	0.00	0.00	0.00
40-00-5623	Rent - Community Center	7,730.00	9,600.00	1,870.00	80.52
40-00-5624	Damage Deposit - Comm Center	0.00	0.00	0.00	0.00
40-00-5630	Return Check Fee	210.00	300.00	90.00	70.00
40-00-5631	Rent - Chamber of Commerce	675.00	900.00	225.00	75.00
40-00-5632	Rent - Brazoria Cnty Tax Offic	1,009.04	1,500.00	490.96	67.27
40-00-5633	Rent - Sweeny EDC	675.00	900.00	225.00	75.00
40-00-5635	Emergency Management Refund	0.00	0.00	0.00	0.00
40-00-5640	Leins	337.50	0.00	(337.50)	0.00
40-00-5645	Plan Review Fees	3,432.20	0.00	(3,432.20)	0.00
40-00-5650	Miscellaneous Revenue	4,552.34	15,000.00	10,447.66	30.35
40-00-5655	TexPool Bullet Prf Vst Revenue	0.00	0.00	0.00	0.00
40-00-5656	Tap Fees	0.00	0.00	0.00	0.00
40-00-5660	Sidewalk Project	0.00	0.00	0.00	0.00
40-00-5661	Sidewalk - Garbage Fee	12,870.00	0.00	(12,870.00)	0.00
40-00-5670	L E T Reimbursement	0.00	0.00	0.00	0.00
40-00-5675	2019- P66 Grant/ Parks	0.00	0.00	0.00	0.00
40-00-5680	Grant Officer Payment	0.00	0.00	0.00	0.00
40-00-5681	Section 8 to Salaries	0.00	0.00	0.00	0.00
40-00-5682	Trnsf Street Wk Bal-99/00 Budg	0.00	0.00	0.00	0.00
40-00-5683	Sale of Assets	3,000.00	0.00	(3,000.00)	0.00
40-00-5684	Proceeds from Loan	0.00	0.00	0.00	0.00
40-00-5690	Fire Dept Donations	8,489.00	0.00	(8,489.00)	0.00
40-00-5691	GB-Disaster Contingency Fund	0.00	0.00	0.00	0.00
40-00-5692	Contributed Capital	0.00	0.00	0.00	0.00
40-00-5693	Court Tech Grant	0.00	0.00	0.00	0.00
40-00-5740	Transfer from Res & Restricted	104,372.92	0.00	(104,372.92)	0.00
40-00-5750	Transfer from Enterprise	0.00	0.00	0.00	0.00
40-00-5751	Transfer from SEDC	0.00	0.00	0.00	0.00
40-00-5752	Transfer from Community Center	0.00	0.00	0.00	0.00
40-00-5753	Trans to General FUND Bal.	0.00	0.00	0.00	0.00
40-00-5754	Transfer from Cptl Proj	2,500,000.00	0.00	(2,500,000.00)	0.00
40-00-5760	Transf from 91 CO's	0.00	0.00	0.00	0.00
40-00-5761	Transfer from CO 2012	0.00	0.00	0.00	0.00
40-00-5762	Transfer from TexP PD BPVEST	0.00	0.00	0.00	0.00
40-00-5815	Water Softener	0.00	0.00	0.00	0.00
40-00-6000	Proceeds PD Vehicle 2018/19	0.00	0.00	0.00	0.00

For Management Purposes Only

1Sweeny - General Fund
Income Statement
For the Nine Months Ending June 30, 2023

G/L Account	Description	Year to Date Actual	Year to Date Budget	YTD Variance Budget to Date	YTD % of Total
40-00-6001	Proceeds PD Vehicle 2019-20	0.00	0.00	0.00	0.00
40-00-6002	CPC Safety Grant for PD/ 2020	0.00	0.00	0.00	0.00
40-00-6003	TML - Ins Claim/ Library 2020	0.00	0.00	0.00	0.00
40-00-6004	P66 \$60K Grant	0.00	0.00	0.00	0.00
40-00-6005	P66 k-9 Grant	0.00	0.00	0.00	0.00
40-00-6006	P66 Grant	0.00	0.00	0.00	0.00
40-00-6020	CDBG-Mit-GLOW	0.00	0.00	0.00	0.00
40-00-6147	Employee Recog Contributions	200.00	0.00	(200.00)	0.00
40-00-6715	Sweeny EDC	0.00	0.00	0.00	0.00
40-50-5301	2020 - Tx Div Emer / COVID-19	0.00	0.00	0.00	0.00
40-50-5302	Police - 2013 Veh fm San Marco	10,000.00	0.00	(10,000.00)	0.00
	Total Revenues	7,723,979.72	2,583,848.22	(5,140,131.50)	298.93
Expenses					
50-20-6111	Wages - Administration	55,610.08	82,310.06	26,699.98	67.56
50-20-6114	Wages - City Clerk	43,381.23	66,713.15	23,331.92	65.03
50-20-6117		0.00	0.00	0.00	0.00
50-20-6120	Communications Phone Stipend	138.50	0.00	(138.50)	0.00
50-20-6141	FICA	18,931.87	23,075.25	4,143.38	82.04
50-20-6142	Group Health & Dental Ins	43,571.18	74,364.81	30,793.63	58.59
50-20-6143	Workers Compensation	796.30	6,140.04	5,343.74	12.97
50-20-6144	Retirement	40,567.66	46,776.39	6,208.73	86.73
50-20-6145	Unemployment	81.71	1,345.50	1,263.79	6.07
50-20-6146	Longevity Pay	6,074.96	6,285.00	210.04	96.66
50-20-6147	Employee Apprec/Holiday Party	0.00	0.00	0.00	0.00
50-20-6148	City Mgr Vehicle Stipend (1/2)	0.00	0.00	0.00	0.00
50-20-6149	City Mgr Cell Ph Stipend (1/2)	0.00	0.00	0.00	0.00
50-20-6150	Payroll Processing Fees	1,088.43	0.00	(1,088.43)	0.00
50-20-6240	Office Machine Service Policy	0.00	0.00	0.00	0.00
50-20-6250	Purdue-Brandon Leins	0.00	0.00	0.00	0.00
50-20-6270	Sales Tax Allocation to SEDC	227,971.13	0.00	(227,971.13)	0.00
50-20-6271	Electricity	3,487.83	5,500.00	2,012.17	63.42
50-20-6272	Telephone	12,530.00	14,200.00	1,670.00	88.24
50-20-6273	Xerox Maintenance Agreement	3,393.59	4,200.00	806.41	80.80
50-20-6274	Dispatching	0.00	0.00	0.00	0.00
50-20-6275	Engineer	24,783.75	5,000.00	(19,783.75)	495.68
50-20-6276	Internet/Cable	1,878.40	2,100.00	221.60	89.45
50-20-6277	Computer IT / Backup	10,982.75	10,000.00	(982.75)	109.83
50-20-6279	Plumbing Inspect	4,900.00	4,000.00	(900.00)	122.50
50-20-6280	Keese & Assoc. / Architects	1,750.00	900.00	(850.00)	194.44
50-20-6281	Consultant Fees	16,554.33	0.00	(16,554.33)	0.00
50-20-6311	Office Supplies	5,803.44	4,500.00	(1,303.44)	128.97

For Management Purposes Only

ISweeny - General Fund
Income Statement
For the Nine Months Ending June 30, 2023

G/L Account	Description	Year to Date	Year to Date	YTD Variance	YTD % of Total
		Actual	Budget	Budget to Date	
50-20-6312	Postage	1,167.34	1,350.00	182.66	86.47
50-20-6360	Brazoria Cty -Tax Coll/ Leins	1,595.60	1,700.00	104.40	93.86
50-20-6417	Flags	0.00	0.00	0.00	0.00
50-20-6418	Tap Transfers to Enterprise	0.00	0.00	0.00	0.00
50-20-6510	Bucket Truck Pymt-Principal	0.00	0.00	0.00	0.00
50-20-6511	Bucket Truck Pymt-Interest	0.00	0.00	0.00	0.00
50-20-6516	Anticipa Notes, 2004 principal	0.00	0.00	0.00	0.00
50-20-6517	Anticipat Notes, 2004 interest	0.00	0.00	0.00	0.00
50-20-6525	1/2 RTC Building	0.00	0.00	0.00	0.00
50-20-6540	1993 Bond Issue	0.00	0.00	0.00	0.00
50-20-6541	Anticipation Note-Street Repr	0.00	0.00	0.00	0.00
50-20-6542	Anticipation Note-Comm Center	0.00	0.00	0.00	0.00
50-20-6600	Sidewalk Capital Outlay	0.00	0.00	0.00	0.00
50-20-6601	Comm. Center / Capital Outlay	0.00	0.00	0.00	0.00
50-20-6602	Water Softner - Capt Outlay	0.00	0.00	0.00	0.00
50-20-6603	P66 Grant/ Parks - Capt Outlay	0.00	0.00	0.00	0.00
50-20-6604	2017 Hurr Harvey / FEMA FUNDS	0.00	0.00	0.00	0.00
50-20-6605	Refund/Damage Deposit - CCente	0.00	0.00	0.00	0.00
50-20-6607	CO 2012 / Capt Outlay	0.00	0.00	0.00	0.00
50-20-6615	Computer Update/IT-Equipment	0.00	0.00	0.00	0.00
50-20-6700	Employee Recognition	2,972.26	2,750.00	(222.26)	108.08
50-20-6705	City Apparel	0.00	0.00	0.00	0.00
50-20-6706	Community Outreach	0.00	0.00	0.00	0.00
50-20-6714	City Hall Maintenance	7,186.19	5,000.00	(2,186.19)	143.72
50-20-6715	Public Works GPS	197.55	0.00	(197.55)	0.00
50-20-6716	Connect CTY	784.70	1,569.40	784.70	50.00
50-20-6717	American Legal Publishing	2,701.84	2,000.00	(701.84)	135.09
50-20-6718	Fire Extinguisher Audit	0.00	1,300.00	1,300.00	0.00
50-20-6719	Aqua Beverage	0.00	0.00	0.00	0.00
50-20-6720	Software Annual Fee's (Sage)	0.00	0.00	0.00	0.00
50-20-6725	Dues & Membership Fees	4,002.82	4,000.00	(2.82)	100.07
50-20-6730	Vehicle Expense	62.50	1,500.00	1,437.50	4.17
50-20-6740	Election Expense	4,518.06	6,000.00	1,481.94	75.30
50-20-6750	Public Notice/Printing	2,426.94	2,500.00	73.06	97.08
50-20-6770	Insurance-Liab, Prop, Wk Comp	102,512.46	67,000.00	(35,512.46)	153.00
50-20-6800	City Manager Vehicle Stipend	1,846.20	2,400.00	553.80	76.93
50-20-6801	City Manager Cell Phon Stipend	277.00	360.00	83.00	76.94
50-20-6810	Mayor & Council	2,222.95	2,500.00	277.05	88.92
50-20-6820	Auditor	15,000.00	15,000.00	0.00	100.00
50-20-6830	Attorney Retainer	14,020.92	18,694.50	4,673.58	75.00
50-20-6850	Braz Cty Tax Appraisal Board	6,393.50	6,900.00	506.50	92.66
50-20-6860	Community Outreach	621.35	0.00	(621.35)	0.00
50-20-6880	Court Security	0.00	0.00	0.00	0.00
50-20-6890	Miscellaneous	858.90	1,000.00	141.10	85.89

For Management Purposes Only

1Sweeny - General Fund
Income Statement
For the Nine Months Ending June 30, 2023

G/L Account	Description	Year to Date Actual	Year to Date Budget	YTD Variance Budget to Date	YTD % of Total
50-20-6891	Equipment Purchases	500.00	2,500.00	2,000.00	20.00
50-20-6892	Holiday and Event Plan/Decor	3,600.58	2,500.00	(1,100.58)	144.02
50-20-6895	Drug Testing	568.50	1,500.00	931.50	37.90
	Subtotal - General Administration	700,315.30	507,434.10	(192,881.20)	138.01
50-21-6000	S T R E E T D E P T	0.00	0.00	0.00	0.00
50-21-6113	Streets - Wages	43,734.86	32,930.04	(10,804.82)	132.81
50-21-6125	Streets - Overtime	125.15	1,646.50	1,521.35	7.60
50-21-6271	Streets - Electricity	41,136.50	47,500.00	6,363.50	86.60
50-21-6411	Streets - Limestone	4,573.59	6,000.00	1,426.41	76.23
50-21-6412	Streets - Pre Mix Asphalt	10,584.74	15,500.00	4,915.26	68.29
50-21-6413	Streets - Signs & Posts	(60.06)	2,500.00	2,560.06	(2.40)
50-21-6414	Streets - Street Work	25,611.17	16,000.00	(9,611.17)	160.07
50-21-6416	Streets - Sidewalk Project	0.00	0.00	0.00	0.00
50-21-6417	Streets - Flags	972.42	700.00	(272.42)	138.92
50-21-6418	Streets - Tree Trimming	0.00	500.00	500.00	0.00
50-21-6711	Streets - Gasoline, Diesel	9,718.18	9,200.00	(518.18)	105.63
50-21-6730	Streets - Vehicle Expense	773.01	1,800.00	1,026.99	42.95
50-21-6890	Streets - Miscellaneous	340.34	1,000.00	659.66	34.03
	Subtotal - Street Department	137,509.90	135,276.54	(2,233.36)	101.65
50-22-6000	D R A I N A G E D E P T	0.00	0.00	0.00	0.00
50-22-6113	Drainage - Wages	18,535.28	20,131.23	1,595.95	92.07
50-22-6125	Drainage - Overtime	86.50	2,013.12	1,926.62	4.30
50-22-6420	Drainage- Culverts	0.00	0.00	0.00	0.00
50-22-6422	Drainage - Weed Spray	0.00	0.00	0.00	0.00
50-22-6730	Drainage - Vehicle Expense	0.00	500.00	500.00	0.00
50-22-6890	Drainage - Miscellaneous	0.00	0.00	0.00	0.00
	Subtotal - Drainage Department	18,621.78	22,644.35	4,022.57	82.24
50-23-6000	G A R B A G E D E P T	0.00	0.00	0.00	0.00
50-23-6215	Garbage - WRS	0.00	0.00	0.00	0.00
50-23-6280	Garbage - GB & Heavy Trash	293,526.99	375,000.00	81,473.01	78.27
50-23-6431	Garbage - Garbage Bags	4,222.40	4,500.00	277.60	93.83
	Subtotal - Garbage Department	297,749.39	379,500.00	81,750.61	78.46
50-24-6000	P O L I C E D E P T	0.00	0.00	0.00	0.00
50-24-6119	Pol Chief Cell Phone Stipend	443.20	0.00	(443.20)	0.00
50-24-6121	Police - Chief's Wages	55,704.72	70,953.26	15,248.54	78.51
50-24-6123	Police - Officer Wages	326,174.10	379,705.31	53,531.21	85.90

For Management Purposes Only

ISweeney - General Fund
Income Statement
For the Nine Months Ending June 30, 2023

G/L Account	Description	Year to Date	Year to Date	YTD Variance	YTD % of Total
		Actual	Budget	Budget to Date	
50-24-6124	Police - Secretary Wages	0.00	0.00	0.00	0.00
50-24-6125	Police - Overtime	28,723.46	31,316.47	2,593.01	91.72
50-24-6126	Police - Vacation Wages	0.00	0.00	0.00	0.00
50-24-6127	Police - Reserve Officer Wages	0.00	0.00	0.00	0.00
50-24-6128	Police - Grant Wages	0.00	0.00	0.00	0.00
50-24-6141	Police - FICA	31,892.11	37,332.39	5,440.28	85.43
50-24-6142	Police - Grp Health Insurance	78,941.30	102,966.66	24,025.36	76.67
50-24-6143	Police - Workers Compensation	7,710.47	19,538.20	11,827.73	39.46
50-24-6144	Police - Retirement	64,817.73	75,677.38	10,859.65	85.65
50-24-6145	Police - Unemployment	82.57	1,863.00	1,780.43	4.43
50-24-6146	Police - Longevity Pay	6,210.00	6,030.00	(180.00)	102.99
50-24-6147	Police - Professional Liab Ins	2,743.50	4,594.37	1,850.87	59.71
50-24-6225	Police - Dispatching	0.00	0.00	0.00	0.00
50-24-6240	Police - Office Mach Service	0.00	0.00	0.00	0.00
50-24-6271	Police - Electricity	3,842.88	4,200.00	357.12	91.50
50-24-6272	Police - Telephone	11,523.55	12,000.00	476.45	96.03
50-24-6276	Police - Internet	2,252.46	2,400.00	147.54	93.85
50-24-6277	Police - Computer IT	8,331.00	8,000.00	(331.00)	104.14
50-24-6311	Police - Office Supplies	2,422.19	3,000.00	577.81	80.74
50-24-6312	Police - Postage	762.86	600.00	(162.86)	127.14
50-24-6321	Police - Firing Range Supplies	141.92	2,000.00	1,858.08	7.10
50-24-6322	Police - Investigative Supply	500.81	1,700.00	1,199.19	29.46
50-24-6323	Police - Photo Supplies	0.00	0.00	0.00	0.00
50-24-6325	Police - Evidence Room Supply	2,522.51	2,700.00	177.49	93.43
50-24-6441	Police - Uniform Replacement	0.00	0.00	0.00	0.00
50-24-6442	Police - Training	4,056.15	3,700.00	(356.15)	109.63
50-24-6443	Police-Training LEOS Funds	2,095.50	0.00	(2,095.50)	0.00
50-24-6444	Police - Tires	3,342.84	0.00	(3,342.84)	0.00
50-24-6445	Police - Radio Repairs	3,060.00	1,800.00	(1,260.00)	170.00
50-24-6446	Police - Chief's Expense Acct	0.00	0.00	0.00	0.00
50-24-6449	Police - Law Library Update	0.00	0.00	0.00	0.00
50-24-6450	Police - Ticket Writers	0.00	700.00	700.00	0.00
50-24-6510	Police - Principal Axon	0.00	0.00	0.00	0.00
50-24-6511	Police - Axon Dash Cams	0.00	0.00	0.00	0.00
50-24-6610	Police - Capital Outlay	0.00	0.00	0.00	0.00
50-24-6612	Police - Cap Outlay P66 \$43K	0.00	0.00	0.00	0.00
50-24-6613	Police - TexPool / BP Vest	0.00	0.00	0.00	0.00
50-24-6614	Police - Taser Fund	0.00	5,664.00	5,664.00	0.00
50-24-6615	Computer Update/IT-Equipment	0.00	0.00	0.00	0.00
50-24-6620	Police - Computers	0.00	2,500.00	2,500.00	0.00
50-24-6621	Police - Vehicle Princip	0.00	0.00	0.00	0.00
50-24-6622	Police - Vehicle Interest	0.00	0.00	0.00	0.00
50-24-6623	Police - (2012 Chev Tahoe)	0.00	0.00	0.00	0.00
50-24-6624	Police - Vehicle/Old Staff Car	0.00	0.00	0.00	0.00

For Management Purposes Only

ISweeney - General Fund
Income Statement
For the Nine Months Ending June 30, 2023

G/L Account	Description	Year to Date Actual	Year to Date Budget	YTD Variance Budget to Date	YTD % of Total
50-24-6625	Police - Compute Software	0.00	0.00	0.00	0.00
50-24-6626	Police - (2012 Chev Tahoe) Int	0.00	0.00	0.00	0.00
50-24-6627	Police - Software Lease Int	0.00	0.00	0.00	0.00
50-24-6630	Police - Digital Camera	0.00	0.00	0.00	0.00
50-24-6632	Police - Ford Motor Credit Int	0.00	0.00	0.00	0.00
50-24-6634	Police - 2017 Fd Expl Funding	0.00	0.00	0.00	0.00
50-24-6635	Police - 2017 Ford Expl Princ	0.00	0.00	0.00	0.00
50-24-6636	Police - 2017 Fd Explor Int	0.00	0.00	0.00	0.00
50-24-6645	Police - 2019 Ford Ex Principa	0.00	0.00	0.00	0.00
50-24-6646	Police - 2019 Ford Ex Interest	0.00	0.00	0.00	0.00
50-24-6711	Police - Gasoline, Diesel	15,535.19	15,000.00	(535.19)	103.57
50-24-6714	Police - Office Maintenance	9,119.04	10,000.00	880.96	91.19
50-24-6725	Police - Membshps&Periodicals	7,802.16	6,000.00	(1,802.16)	130.04
50-24-6730	Police - Vehicle Expense	10,557.50	5,000.00	(5,557.50)	211.15
50-24-6750	Police - 2013 Veh fm San Marco	10,000.00	0.00	(10,000.00)	0.00
50-24-6760	Police - Uniform Expense	4,063.95	3,800.00	(263.95)	106.95
50-24-6777	Police - Copier Machine Lease	1,341.58	1,800.00	458.42	74.53
50-24-6792	Police - K-9 Expense	0.00	0.00	0.00	0.00
50-24-6860	Code Enforcement Compliance	575.00	0.00	(575.00)	0.00
50-24-6861	Animal Control Supplies	0.00	0.00	0.00	0.00
50-24-6865	Police - Public Serv Programs	228.35	800.00	571.65	28.54
50-24-6890	Police - Miscellaneous	715.82	2,000.00	1,284.18	35.79
50-24-6891	Police - Lab Exp Sex Assault	0.00	0.00	0.00	0.00
	Subtotal - Police Department	<u>708,236.42</u>	<u>825,341.04</u>	<u>117,104.62</u>	85.81
50-25-6000	F I R E D E P T	0.00	0.00	0.00	0.00
50-25-6116	Fire - Fire Marshal	0.00	0.00	0.00	0.00
50-25-6143	Fire - Workers Compensation	602.43	1,000.00	397.57	60.24
50-25-6146	Fire - Fire Marshal Expense	0.00	0.00	0.00	0.00
50-25-6148	Fire - State Convention	0.00	2,000.00	2,000.00	0.00
50-25-6151	Fire - Training Schools	5,286.01	14,000.00	8,713.99	37.76
50-25-6152	Fire - Pension	6,510.00	9,000.00	2,490.00	72.33
50-25-6225	Fire - Dispatching	0.00	0.00	0.00	0.00
50-25-6271	Fire - Electricity	3,650.46	3,600.00	(50.46)	101.40
50-25-6272	Fire - Telephone	1,944.58	2,400.00	455.42	81.02
50-25-6273	Fire - Internet	1,580.84	2,000.00	419.16	79.04
50-25-6274	Fire - Pagers	0.00	0.00	0.00	0.00
50-25-6311	Fire - Office Supplies	956.61	1,000.00	43.39	95.66
50-25-6340	Fire - Building Maintenance	3,514.35	6,700.00	3,185.65	52.45
50-25-6445	Fire - Radio/Pager/Repr/Replmt	2,000.00	2,000.00	0.00	100.00
50-25-6452	Fire - Member/Public Education	0.00	350.00	350.00	0.00
50-25-6453	Fire - Bunker Gear/Repr Replmt	1,275.00	5,000.00	3,725.00	25.50
50-25-6454	Fire - SCBA Repr/Inspec/Replmt	0.00	0.00	0.00	0.00

For Management Purposes Only

1Sweeny - General Fund
Income Statement
For the Nine Months Ending June 30, 2023

G/L Account	Description	Year to Date	Year to Date	YTD Variance	YTD % of Total
		Actual	Budget	Budget to Date	
50-25-6510	Fire - Principal 1st Nat Bank	4,794.41	6,539.44	1,745.03	73.32
50-25-6511	Fire - Interest 1st Nat Bank	107.19	65.39	(41.80)	163.92
50-25-6611	Fire - Capt Outlay/ Donations	0.00	812.96	812.96	0.00
50-25-6620	Fire - Training Field	0.00	0.00	0.00	0.00
50-25-6630	Fire - Building Upgrade	0.00	0.00	0.00	0.00
50-25-6635	Fire - ISO Equipment	0.00	0.00	0.00	0.00
50-25-6640	Fire - Station 2	0.00	0.00	0.00	0.00
50-25-6641	Fire - Computers	0.00	0.00	0.00	0.00
50-25-6711	Fire - Gasoline, Oil, Etc.	4,883.71	7,500.00	2,616.29	65.12
50-25-6714	Fire - Office Maintenance	408.08	500.00	91.92	81.62
50-25-6715	Fire - Fire Field Maintenance	0.00	0.00	0.00	0.00
50-25-6725	Fire - Dues, Membrshp, Periodi	1,134.00	2,500.00	1,366.00	45.36
50-25-6730	Fire - Vehicle Expense	4,477.52	5,000.00	522.48	89.55
50-25-6890	Fire - Miscellaneous	277.61	500.00	222.39	55.52
	Subtotal - Fire Department	43,402.80	72,467.79	29,064.99	59.89
50-26-6000	MUNICIPAL COURT	0.00	0.00	0.00	0.00
50-26-6131	Court - Judge's Salary	6,975.00	9,300.00	2,325.00	75.00
50-26-6132	Court- Court Clerk Salary	26,900.62	35,473.15	8,572.53	75.83
50-26-6141	Court- FICA	2,077.68	2,722.88	645.20	76.30
50-26-6142	Court- Grp Health Insurance	6,732.46	11,440.74	4,708.28	58.85
50-26-6143	Court - Workers Comp	0.00	145.93	145.93	0.00
50-26-6144	Court- Retirement	2,020.12	6,223.73	4,203.61	32.46
50-26-6145	Court- Unemployment	0.00	207.00	207.00	0.00
50-26-6146	Court- Longevity Pay	120.00	120.00	0.00	100.00
50-26-6240	Court - Office Machine Serv	0.00	0.00	0.00	0.00
50-26-6271	Court - Electricity	0.00	0.00	0.00	0.00
50-26-6272	Court - Telephone	0.00	0.00	0.00	0.00
50-26-6311	Court - Office Supplies	7.40	250.00	242.60	2.96
50-26-6312	Court - Postage	60.00	100.00	40.00	60.00
50-26-6351	Court - Forms	0.00	0.00	0.00	0.00
50-26-6352	Court - Docket Books	0.00	0.00	0.00	0.00
50-26-6461	Court - Seminar/Judge	200.00	250.00	50.00	80.00
50-26-6462	Court - Seminar/Clerk	350.00	250.00	(100.00)	140.00
50-26-6463	Court - Juror Fees	0.00	200.00	200.00	0.00
50-26-6464	Court - Attorney Retainer	3,712.50	4,950.00	1,237.50	75.00
50-26-6465	Court - State Tax	21,706.70	0.00	(21,706.70)	0.00
50-26-6466	Court - Jail Expense	0.00	1,000.00	1,000.00	0.00
50-26-6467	Court - Level II Clerk Certifi	0.00	0.00	0.00	0.00
50-26-6620	Court - Comp Update/Software	3,779.09	0.00	(3,779.09)	0.00
50-26-6630	Court - Building Renovation	0.00	0.00	0.00	0.00
50-26-6631	Court - Credit Card Set Up	0.00	0.00	0.00	0.00
50-26-6692	Court - Equipment Purchase	0.00	0.00	0.00	0.00

For Management Purposes Only

ISweeny - General Fund
Income Statement
For the Nine Months Ending June 30, 2023

G/L Account	Description	Year to Date Actual	Year to Date Budget	YTD Variance Budget to Date	YTD % of Total
50-26-6725	Court - Membrshp & Periodicals	0.00	225.00	225.00	0.00
50-26-6730	Court - Vehicle Expense	384.72	500.00	115.28	76.94
50-26-6870	Court Technology	229.99	0.00	(229.99)	0.00
50-26-6880	Court Security	0.00	0.00	0.00	0.00
50-26-6890	Court - Miscellaneous	0.00	0.00	0.00	0.00
	Subtotal - Municipal Court	75,256.28	73,358.43	(1,897.85)	102.59
50-27-6000	L I B R A R Y / C C E N T E R	155.37	0.00	(155.37)	0.00
50-27-6271	Libr/CC - Electricity	5,274.52	8,400.00	3,125.48	62.79
50-27-6272	Libr/CC - Telephone	3,721.26	4,500.00	778.74	82.69
50-27-6275	Libr/CC - Janitorial Service	7,725.00	5,100.00	(2,625.00)	151.47
50-27-6340	Libr/CC - Janitorial Supplies	387.88	500.00	112.12	77.58
50-27-6473	Libr/CC - McNaughton Book Plan	2,500.00	4,257.80	1,757.80	58.72
50-27-6625	Libr/CC - Replace Carpet	0.00	0.00	0.00	0.00
50-27-6635	Libr/CC - Replace Lights	0.00	0.00	0.00	0.00
50-27-6840	Libr/CC - Comm Center Repairs	743.72	1,200.00	456.28	61.98
50-27-6841	Libr/CC - Library Repairs	256.81	500.00	243.19	51.36
50-27-6850	Libr/CC - Capt Outlay	91,934.62	0.00	(91,934.62)	0.00
50-27-6890	Libr/CC - Miscellaneous	223.25	750.00	526.75	29.77
	Subtotal - Library/Comm. Center	112,922.43	25,207.80	(87,714.63)	447.97
50-28-6000	P A R K S D E P T	0.00	0.00	0.00	0.00
50-28-6113	Parks - Wages	59,242.82	61,118.15	1,875.33	96.93
50-28-6125	Parks - Overtime	3,110.25	6,111.82	3,001.57	50.89
50-28-6271	Parks - Electricity	9,005.61	8,500.00	(505.61)	105.95
50-28-6280	Parks - Porta Can Service	0.00	0.00	0.00	0.00
50-28-6311	Parks - Supplies	4,412.12	2,200.00	(2,212.12)	200.55
50-28-6423	Parks - Lawn Mower Repairs	60.05	0.00	(60.05)	0.00
50-28-6610	Parks - Capital Outlay	0.00	0.00	0.00	0.00
50-28-6715	Parks - Equipment Purchase	0.00	25,000.00	25,000.00	0.00
50-28-6716	Parks - Drug Testing&Physicals	0.00	0.00	0.00	0.00
50-28-6717	Parks - Maintenance of Park Eq	4,189.68	4,200.00	10.32	99.75
50-28-6730	Parks - Vehicle Expense	147.67	3,500.00	3,352.33	4.22
50-28-6890	Parks - Miscellaneous	1,105.04	900.00	(205.04)	122.78
	Subtotal - Parks Department	81,273.24	111,529.97	30,256.73	72.87
50-29-6000	H U M A N E D E P T	0.00	0.00	0.00	0.00
50-29-6005	P66 Humane Grant	0.00	0.00	0.00	0.00
50-29-6113	Humane - Wages	14,185.91	18,846.96	4,661.05	75.27
50-29-6125	Humane - Overtime	893.23	1,884.70	991.47	47.39
50-29-6318	Humane - Food & Misc Equip	808.29	500.00	(308.29)	161.66

For Management Purposes Only

ISweeney - General Fund
Income Statement
For the Nine Months Ending June 30, 2023

G/L Account	Description	Year to Date Actual	Year to Date Budget	YTD Variance Budget to Date	YTD % of Total
50-29-6481	Humane - Pound Maintenance	560.65	400.00	(160.65)	140.16
50-29-6890	Humane - Miscellaneous	55.00	100.00	45.00	55.00
	Subtotal - Humane Department	16,503.08	21,731.66	5,228.58	75.94
50-30-6000	E M E R G E N C Y M A N G M T	0.00	0.00	0.00	0.00
50-30-6113	Emerg Mngmt - Wages	0.00	0.00	0.00	0.00
50-30-6116	Emerg Mngmt - Coordinator	1,800.00	2,400.00	600.00	75.00
50-30-6141	Emerg Mngmt - FICA	0.00	0.00	0.00	0.00
50-30-6145	Emerg Mngmt - Unemployment	0.00	0.00	0.00	0.00
50-30-6148	Emerg Mngmt - Convention	0.00	1,000.00	1,000.00	0.00
50-30-6271	Emerg Mngmt - Electricity	2,552.26	3,200.00	647.74	79.76
50-30-6272	Emerg Mngmt - Telephone	824.24	4,000.00	3,175.76	20.61
50-30-6273	Emerg Mngmt - Internet	1,559.69	1,800.00	240.31	86.65
50-30-6311	Emerg Mngmt - Office Supplies	112.02	100.00	(12.02)	112.02
50-30-6312	Emerg Mngmt - Postage	0.00	100.00	100.00	0.00
50-30-6313	Emerg Mngmt - Hurricane Brouch	0.00	1,100.00	1,100.00	0.00
50-30-6492	Emerg Mngmt - Conference	0.00	0.00	0.00	0.00
50-30-6641	Emerg Mngmt - EOC Generator	0.00	0.00	0.00	0.00
	Subtotal - Emergency Management	6,848.21	13,700.00	6,851.79	49.99
50-31-6000	F I R E M A R S H A L	0.00	0.00	0.00	0.00
50-31-6116	Fire Marshal	4,500.00	6,000.00	1,500.00	75.00
50-31-6143	Workers Compensation	0.00	30.00	30.00	0.00
50-31-6146	Fire Marshal Expense	0.00	500.00	500.00	0.00
50-31-6148	State Convention	0.00	2,000.00	2,000.00	0.00
50-31-6452	Inspections, Prevention	0.00	750.00	750.00	0.00
50-31-6453	Fire Investigations	0.00	550.00	550.00	0.00
50-31-6501	Fire Marshal / Truck Interest	0.00	0.00	0.00	0.00
50-31-6502	Fire Marshall Note 1st Nat Int	0.00	0.00	0.00	0.00
50-31-6620	Computer Purchase (EOC)	0.00	1,000.00	1,000.00	0.00
50-31-6621	Fire Marshall / Truck Princ	0.00	0.00	0.00	0.00
50-31-6622	Fire Marshall Note 1st Nat Pri	0.00	0.00	0.00	0.00
50-31-6730	Vehicle Expense	0.00	1,000.00	1,000.00	0.00
	Subtotal - Fire Marshal	4,500.00	11,830.00	7,330.00	38.04
50-40-6000	S P E C I A L P R O J E C T S	0.00	0.00	0.00	0.00
50-40-6002	Debt Service Interest	0.00	0.00	0.00	0.00
50-40-6610	Equip Purchase (Bucket Truck)	0.00	0.00	0.00	0.00
50-40-6611	Spec Projects-Dispatching	0.00	0.00	0.00	0.00
50-40-6612	800 Radio System (Principal)	0.00	0.00	0.00	0.00

1Sweeny - General Fund
Income Statement
For the Nine Months Ending June 30, 2023

G/L Account	Description	Year to Date Actual	Year to Date Budget	YTD Variance Budget to Date	YTD % of Total
	Subtotal - Special Projects	<u>0.00</u>	<u>0.00</u>	<u>0.00</u>	0.00
	Total Expenses	<u>2,203,138.83</u>	<u>2,200,021.68</u>	<u>(3,117.15)</u>	100.14
	Net Income	<u>\$ 5,520,840.89</u>	<u>\$ 383,826.54</u>	<u>(5,137,014.35)</u>	1,438.37



AGENDA MEMO

Business of the City Council City of Sweeny, Texas

Meeting Date	10.24.2023	Agenda Item	
Approved by City Manager	Yes	Presenter(s)	Lindsay Koskiniemi, City Manager
Reviewed by City Attorney	No	Department	Administration / Finance
Subject	Discussion and possible action on the Fourth Quarter investment report of Fiscal Year 2022 – 2023, spanning July – September 2023		
Attachments	Q4 Investment Report		
Financial Information	Expenditure Required:	N/A	
	Amount Budgeted:	N/A	
	Account Number:		
	Additional Appropriation Required:		
	Additional Account Number:		

Executive Summary

Last year, the City Council gave staff permission to open Logic, TexStar, and TexPool Prime accounts, and staff opted to invest a large portion of the city’s account balances held in First State Bank Louise (FSBL) into the state-approved investment pools, chiefly into TexStar and Logic, as the City did not start earning interest in FSBL accounts until Fall of 2022. While FY23 presented a lot of widespread challenges related to inflation for many people, banks and investors saw a continuous incline in rising interest rates.

Last October, interest in the investment pools was paying at a rate around 3%, and by the end of September 2023, the interest rates continued to climb at 5.3% - over 5.5%.

The Fourth Quarter Investment Report is attached which includes the months of July, August, and September. Final year-end interest earnings are included in the report.

For all investments, the total collection for FY23 is \$227,697.75. Excluding interest earnings for Sweeny Economic Development Corporation, Sweeny Beautification Committee, Fire Department Donations, and Veterans Memorial Fund, the total interest earnings for FY23 total \$205,492.26. Interest rates are projected to continue to climb for the remainder of the calendar year. Financial market predictions project a slight decline in 2024 to around 4%, and closer to 3% by 2025.

Staff will continue investing practices consistent with the City’s Financial Policy and has asked why the floor rate of a quarter of one percent payable by FSBL has remained unchanged in FY23 while all other interest earnings have exceeded 5%.



AGENDA MEMO

Business of the City Council

City of Sweeny, Texas

Item 8.

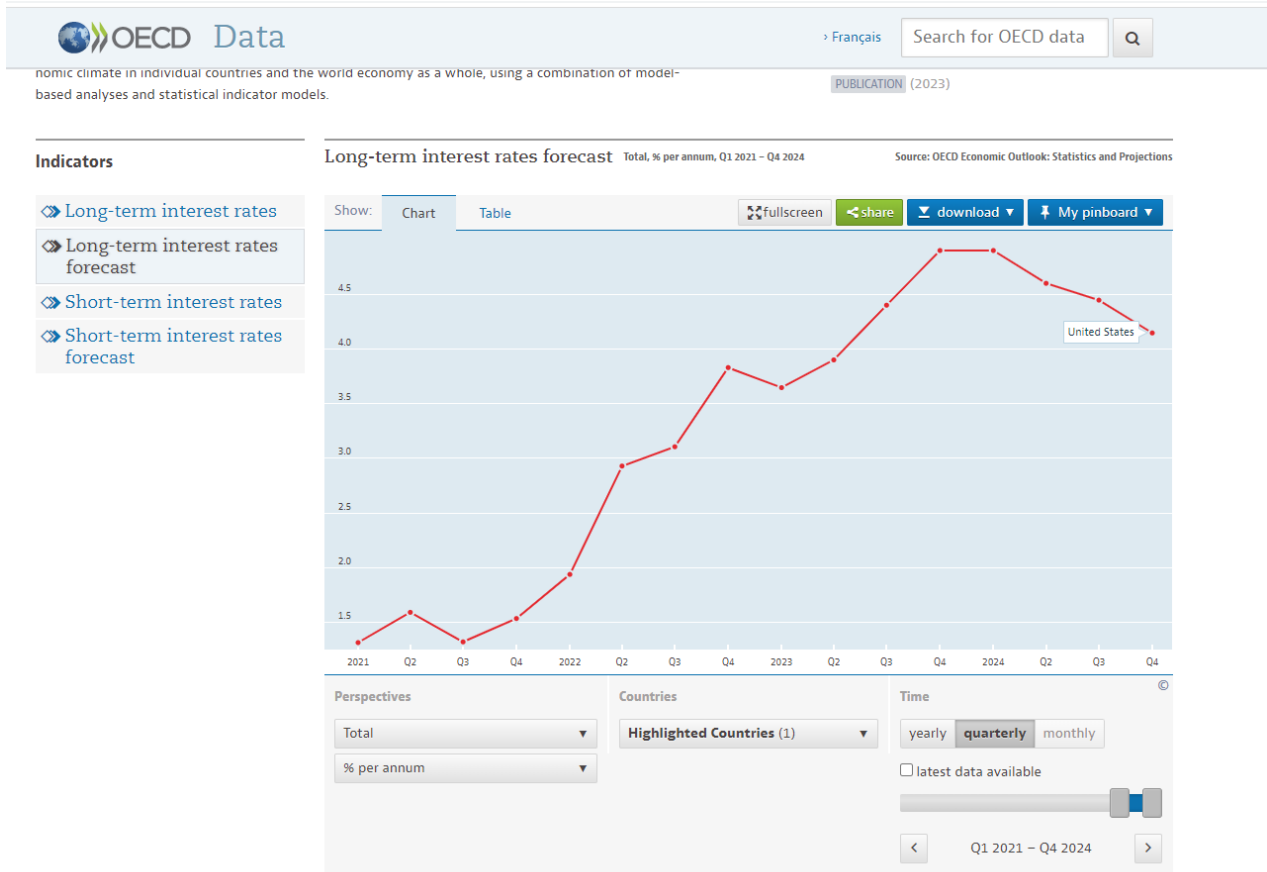

Chart made using Organisation for Economic Co-operation and Development via: <https://data.oecd.org/interest/long-term-interest-rates-forecast.htm#indicator-chart>

Recommended Action

Staff recommends the Council’s acceptance and approval of the FY23 Q4 investment report.

**CITY OF SWEENEY QUARTERLY INVESTMENT REPORT
FOURTH QUARTER OF FY23
JUL, AUG, SEP**

Item 8.

ACCOUNT NAME	ACCOUNT NUMBER	INSTITUTION	ACCOUNT TYPE	AVERAGE ACCOUNT BALANCE	AVERAGE MONTHLY INVESTMENT RATE	INTEREST EARNED
GENERAL FUND	1047264	FSBL	CHECKING	\$ 157,769.26	0.25%	98.54
VETERANS MEMORIAL PROJECT	96064528	FSBL	CHECKING	\$ 2,235.63	0.25%	1.40
TEXPOOL ACCOUNT	96120908	FSBL	CHECKING	\$ 61,067.44	0.25%	38.06
2004 CIP PROJECT FUND	2170272	FSBL	CHECKING	\$ 4,103.54	0.25%	2.60
PD NARCOTIC GRANT	17582	FSBL	CHECKING	\$ 21,063.67	0.25%	13.12
INTEREST & SINKING - GO BOND	17848	FSBL	CHECKING	\$ 172,886.97	0.25%	109.17
WATER SOFTENER	19158	FSBL	CHECKING	\$ 31,990.66	0.25%	19.94
ENTERPRISE FUND	2372566	FSBL	CHECKING	\$ 174,065.28	0.25%	108.30
PRESERVE & RESTRICTED	2385304	FSBL	CHECKING	\$ 72,556.24	0.25%	45.21
CUSTOMER UTILITY DEPOSIT HOLDINGS	5033	FSBL	CHECKING	\$ 36,779.16	0.25%	23.34
PAYROLL FUND	5066	FSBL	CHECKING	\$ 45,363.87	0.25%	28.31
BEAUTIFICATION	3038	FSBL	CHECKING	\$ 21,314.64	0.25%	13.28
POLICE FORFEITURE	96196126	FSBL	SAVINGS	\$ 11,186.84	0.15%	6.97
POLICE SEIZURE	96196134	FSBL	SAVINGS	\$ 3,092.04	0.00%	1.93
PD TRAINING	96196142	FSBL	SAVINGS	\$ 7,349.26	0.25%	4.60
SPECIAL ACCOUNT	208300048	FSBL	SAVINGS	\$ 22,050.67	0.17%	26.23
						541.00
DISASTER CONTINGENCY	208200004	TEXPOOL	INVESTMENT	\$ 226,987.15	5.2501%	3,002.76
RESERVE FUND	208200008	TEXPOOL	INVESTMENT	\$ 29,522.93	5.2501%	390.53
SWEENEY EDC	208200009	TEXPOOL	INVESTMENT	\$ 838,141.79	5.2501%	11,087.48
PAYROLL	208200010	TEXPOOL	INVESTMENT	\$ 38,951.42	5.2501%	515.29
SIDEWALK FUND	208200015	TEXPOOL	INVESTMENT	\$ 2,792,936.87	5.2501%	36,874.91
POLICE DEPT VESTS	208200017	TEXPOOL	INVESTMENT	\$ 23,318.92	5.2501%	308.48
INFRASTRUCTURE DONATION	208200018	TEXPOOL	INVESTMENT	\$ 58,742.04	5.2501%	777.14
						52,956.59
ENTERPRISE FUND	6002346001	LOGIC	INVESTMENT	\$ 590,411.94	5.4291%	8,557.34
CUSTOMER DEPOSITS	6002346003	LOGIC	INVESTMENT	\$ 103,975.14	5.4291%	1,420.31
2019 CERTIFICATES	6002346002	LOGIC	INVESTMENT	\$ 939,003.21	5.4291%	12,827.00
APRA FUNDS 2ND TRANCHE	6002346004	LOGIC	INVESTMENT	\$ 153,320.36	5.4291%	2,387.21
GENERAL FUND	6002346005	LOGIC	INVESTMENT	\$ 266,115.81	5.4291%	3,839.51
						29,031.37
2019 CERTIFICATES	201811950	TEXSTAR	INVESTMENT	\$ 457,440.77	5.2409%	6,032.53
DEBT SERVICE FUND	201810230	TEXSTAR	INVESTMENT	\$ 204,415.51	5.2409%	2,710.69
RESERVE / RESTRICTED FUNDS	201891270	TEXSTAR	INVESTMENT	\$ 113,923.24	5.2409%	1,502.42
						10,245.64

TOTAL INVESTMENT REVENUE Q4 \$ 92,774.60

INVESTMENT REV FISCAL YEAR TO DATE	
Q1	\$ 34,017.32
Q2	\$ 41,463.83
Q3	\$ 59,442.00
Q4	\$ 92,774.60
TOTAL	\$ 227,697.75
RELEASE OUTSIDE FUNDS:	
BEAUTIFICATION (FSBL)	\$ (35.56)
VETERANS MEMORIAL (FSBL)	\$ (5.60)
SWEENEY EDC (TEXPOOL)	\$ (22,116.31)
FD DONATION (FSBL)	\$ (48.02)
	\$ (22,205.49)
CITY'S EARNINGS FOR FY23	\$ 205,492.26



CITY OF SWEENEY

102 W. Ashley Wilson Rd. • PO Box 248 • Sweeny, Texas 77480 • P: (979) 548-3321 • F: (979) 548-7745

The following will be used to request an item to be placed on the agenda with the Sweeny City Council.

Personal Information:

Name: Darlene Tipps

Mailing Address: 401 E. 3rd St

Physical Address: same

Email(s): darlene.tipps@mail.com

Phone(s): 979-215-7369

Please include specific details of the item you wish to be placed on the agenda.

Cats and trash in area.

Signature: Darlene Tipps Date: 8/11/23

Requests must be received by the City Manager by close of business 10 days prior to the scheduled meeting date for placement. Administration and/or their designee reserves the right to delay the item to the following regularly scheduled meeting if it is determined that more time is needed in order to compile information specific to the request.

Once Council has acted on an agenda item; that item cannot be placed on the agenda for a period of six (6) full months. Exception is provided if three members of Council ask that the item be returned early to the agenda, or the Mayor or City Manager determines it is in the interest of the City to do so.

Received 8.11.23 10:13 AM BTA



AGENDA MEMO

Business of the City Council

City of Sweeny, Texas

Meeting Date	10.24.2023	Agenda Item	
Approved by City Manager		Presenter(s)	
Reviewed by City Attorney		Department	
Subject	Discussion/ Possible Action to Agenda Request Received on Cats and Trash; Darlene Tipps		
Attachments	Agenda Request; Minutes 03/20/2018 & 10/15/2019		
Financial Information	Expenditure Required:	-	
	Amount Budgeted:	-	
	Account Number:	-	
	Additional Appropriation Required:	-	
	Additional Account Number:	-	

Executive Summary

Agenda Request Received; See Attached

Requestor is referring to the stray cat problem and trash near her residence. Code Enforcement has been advised of the trash concern and has initiated a case.

Recommended Action

Council Discretion

**MINUTES OF A PUBLIC HEARING/ REGULAR MEETING
OF THE CITY COUNCIL
THE CITY OF SWEENY, TEXAS
TUESDAY OCTOBER 15, 2019
6:00 PM**

A regular meeting of the City Council of Sweeny, Texas, was held at City Hall on October 15, 2019 at 6:00 pm to consider the following items of business:

CALL TO ORDER

Mayor Jeff Farley
called the meeting to order at 6:00 pm.

ROLL CALL

Council Present: Position 1. Sandra Blaine; Position 2. Neal Bess Jr.; Position 3. Brian Brooks. Position 4. John Rambo. Position 5. Tim Pettigrew
Staff Present: Reatta Minshew, Interim City Manager, Kaydi Smith, City Clerk; Charlie Stevenson, City Attorney, Gene West, Dir. of Public Works and John Barnard, Chief of Police.

PLEDGE OF ALLEGIANCE

The Pledge to the American Flag
The Pledge to the Texas Flag
Led by Councilman Tim Pettigrew

INVOCATION

Invocation was given by Councilman Brian Brooks

VISITORS COMMENTS

No visitor comments made.

COMMENDATIONS

1. PRESENTATIONS

- A. Proclamation: Nurse Practitioner Week- November 11-16, 2019**
- B. Fire Department Report:** Roger Barton. Barton specified they will be conducting a fire prevention training at SES and rookie training class in the next couple of weeks.

2. CONSENT AGENDA

- A. Approval of Minutes:** September 17, 2019
- B. Bills for:** \$60,609.08

Sandra Blaine made a motion to approve the minutes and to pay the bills in the amount of \$60,609.08. Neal Bess Jr. seconded. All were in favor. Motion carried.

3. PUBLIC HEARING: N/A

4. REGULAR AGENDA

Unfinished Business

A. Discuss / Take Action on Ordinance 92.04 Ditches-Councilman Tim Pettigrew

Tim Pettigrew wanted to discuss the 92.04 and 92.05 ordinance in regards to citizens responsibilities of ditches. Wants an ordinance drawn up the citizens would be responsible up to the roadway of their property. If there is no building within 150 ft., the city would be responsible to take care the ditch area.

Tim Pettigrew made a motion to have Charlie Stevenson draft up an ordinance to approve proposed changes to ordinance 92.04. Brian Brooks seconded. Sandra Blaine and John Rambo were in favor. Neal Bess Jr. opposed. Motion carried.

New Business

A. Discuss /Take Action on Variance for Live Nativity at Christmas in the Park-Sweeny Chamber

Lil Tolley, Chamber Director, requested a variance to have live animals in the live nativity at Christmas in the Park and the Lighted Christmas Parade on December 7, 2019. She is hoping to have goats and Llamas at the least, provided by Pam Scantlin.

Neal Bess Jr. made a motion to allow live animals in the live nativity and Christmas parade on December 7, 2019. Tim Pettigrew seconded. All were in favor. Motion carried.

B. Discuss/ Take Action on Variance for Bonfire on November 14, 2019- Sweeny ISD

Terry Brown with Project Grad 2020 is requesting a variance for a bonfire November 14, 2019. He submitted a letter from SISD to the council releasing the City from liability and stated has adhered to the Fire Marshal's guidelines. The Sweeny Police Department will be assisting, Fire Chief Barton and Assistant Fire Chief Christian have been asked to assist as well. The Bonfire will take place behind the Elementary School at the kindergarten loop. Per Barton, he has requested the kids be staged upwind from the fire. Neal Bess Jr. made the motion to allow the variance for the bonfire on November 14, 2019 on behalf of Sweeny ISD Project Grad 2020. Tim Pettigrew seconded. All were in favor. Motion carried.

C. Discuss /Take Action on Rename Back Yard Park to Veterans Memorial Park-Al Lindley

Neal Bess Jr. made the motion to add a sign at the front of the park named "Veterans Memorial Park" and add a street sign at the entrance naming the road into the park "Veterans Memorial Drive". We will keep the original park sign of Backyard Park further in.

Neal Bess Jr. made a motion to approve adding a sign at the front of the park named "Veterans Memorial Park" and add a street sign at the entrance naming the road into the park "Veterans Memorial Drive". Tim Pettigrew seconded. All were in favor. Motion carried.

D. Discuss / Take Action on Complaints of Feral Cats

Discussed anonymous letters sent to city hall complaining of feral cats. Previously the council denied cats into the pound or pickup.

Brian Brooks made a motion to have our ACO pickup trapped feral cats and keep for the required amount of time and euthanize after said time is expired. Neal Bess Jr. seconded. Sandra Blaine voted no. Motion carried.

E. Discuss/ Take Action on New Position: Code Enforcement / ACO Officer

No Motion Needed. Chief Barnard discussed letting the officer use one of their older police vehicles.

F. Discuss / Take Action on House Bill #3167- Replat Property

No Motion Needed. Discussed the House Bill requiring cities must pass replats within 30 days or they will automatically be approved.

G. Discuss/ Take Action on Designate Representative & Alternate HGAC

Brian made a motion and Neal Bess Jr. seconded that Sandra Blaine be the representative for 2020. Brian Brooks made to recend the previous vote. All in favor. Motion carried.

Brian Brooks made a motion to designate John Rambo as the representative or HVAC 2020 and Tim Pettigrew as the alternate. Neal Bess Jr. seconded.

All in favor. Motion carries.

H. Discuss/ Take Action Raising Inspection Fees/Plan Review Fee

Discussed adding a plan reviewal fee and discussed options on inspections. Council asked for inspection fees to be placed back on the next months agenda for review and adjustments.

Neal Bess Jr. made the motion to add a plan reviewal fee for commercial plans at the rate of \$.20 per square foot. Tim Pettigrew seconded. All in favor. Motion carried.

I. Discuss/ Take Action on Neal Bess Jr.- Marcus Bonner

Bonner was not in attendance. No Action.

J. Discuss/ Take Action on Manholes on FM 1459- Neal Bess Jr.

Neal Bess Jr. made the motion to gather information and research hard number of costs to pursue securing rings for the manholes on FM 1459. Tim Pettigrew seconded. All in favor. Motion carried.

K. Discuss/Take Action on New Hospital Water Capacity & Sewer Capacity Needs- Neal Bess Jr.

Discussed water and sewer capacities of the city. The water plant, as of now, averages 500, 000 gallons with a max of 832, 000 gallons within 24 hours. The sewer plant, as of

now, averages 700,000 gallons a day. Low end capacity would be at 150,000 and medium capacity is at 400,000 gallons. We would be permitted for 975,000 gallons. We would be able to handle the capacity of a new proposed facility.
No Action Needed.

5. CLOSED REGULAR SESSION: 7:13 P.M.

6. OPENED EXECUTIVE SESSION: 7:15 P.M.

In Accordance with the Open Meetings Act Tex. Gov't Code §511.071, §551.072 and §551.074, to discuss:

1. City Manager Interview Process

7. CLOSED EXECUTIVE SESSION: 7:20 P.M.

8. RECONVENE TO REGULAR SESSION

1. Open Meeting Time: 7:20 P.M.

2. Action on Executive Session: None Taken

9. ITEMS OF COMMUNITY INTEREST:

10. ADJOURNMENT: 7:25 P.M.

PASSED AND APPROVED THIS 19 DAY OF November, 2019



Reatta Minshew, City Secretary

**MINUTES OF THE REGULAR MEETING
OF THE CITY COUNCIL
THE CITY OF SWEENY, TEXAS
TUESDAY MARCH 20, 2018
6:00 PM**

A regular meeting of the City Council of Sweeny, Texas, was held at City Hall on Tuesday, March 20, 2018 at 6:00 pm to consider the following items of business:

CALL TO ORDER

Mayor Dale Lemon called the meeting to order at 6:00 pm.

ROLL CALL

Council Present: Position 1. Sandra Blaine; Position 3. Brian Brooks; and Position 5. Tim Pettigrew.

Position 2. Jeff Farley and Position 4. Kay Roe were absent.

Staff Present: Cindy King, City Manager; Reatta Minshew, City Secretary, Charlie Stevenson, City Attorney and Gene West, Dir. of Public Works. John Barnard, Chief of Police was absent.

PLEDGE OF ALLEGIANCE

The Pledge to the American Flag was recited and led by Mayor Dale Lemon.
The Pledge to the Texas Flag was recited and led by Mayor Dale Lemon.

INVOCATION

Invocation was given by Keith Boyles for 1st United Methodist Church.

COMMENDATIONS

1. PRESENTATIONS

1: Proclamation: March 2018 as Fair Housing Month

A. Fire Department Report: James Christian gave the report.

2. CONSENT AGENDA

A. Approval of Minutes Feb 20, 2018.

B. Approval of Bills in the amount of \$52,202.98

Sandra Blaine made a motion to approve the consent items. Tim Pettigrew seconded. All were in favor. Motion carried.

3. PUBLIC HEARING: None

4. REGULAR AGENDA

Unfinished Business

A. Discuss / Take Action on Joint Meeting w Planning and Zoning Board of Commissioners

Ms. King stated Councilwoman Kay Roe was absent tonight and that she has asked for this item to be on the agenda.

Sandra Blaine made a motion to let this agenda item die. Tim Pettigrew seconded. All were in favor. Motion carried.

New Business

A. Discuss / Take Action on Draining the City to the River / Paul Stark

Park Stark from Shari Lane stated that the drainage ditch at Shari Lane that goes to the San Barnard River needs to be clean out. Mr. Stark stated he has been asking for a year now and he did not feel that this was his responsibility to take care of this. He was told from a city employee that Hilcorp owns this land and that Mr. Strickland will not allow the city to come on Hilcorp land and clean this ditch. Mr. Stark called Hilcorp and they stated they have no record of the City of Sweeny calling about this ditch, and that Mr. Strickland hasn't work for Hilcorp in five years. Mr. Stark stated he has lived there for 12 years and this ditch hasn't been touched by the city. Ms. King stated she had just contacted the drainage district to see if they could get this taken care of. Mr. Stark stated we needed to get in touch with Hilcorp due to their pipelines are all over this property. The council stated to have Ms. King call Hilcorp, Mr. Stark spoke to Hunter Kreneck at Hilcorp.

B. Discuss / Take Action on Engineer Portion of Strategic Planning Process

William Huebner with O'Malley Strand Associates, Inc. composed two options for the City of Sweeny for Strategic Planning. Option 1 for \$48,000.00. Services include: Site visits, staff meetings to identify known issues with water system, sanitary sewer system and gas system. Review and update current maps. Provide cost estimates for all recommended infrastructure improvements. Evaluate population projections for future growth and look at current number of customers and compare to capacities provided by existing infrastructure based on TCEQ. Option 2 for \$71,000.00. Option 2 is everything in Option 1 plus: Provide a hydraulic model analysis on the City's water distribution system, updating city's water, sewer and gas mapping. Contact natural gas utility companies to determine their interest in purchasing the gas system. Provide a hydrant coverage map to identify any gaps in existing coverage of fire hydrants.

Brian Brooks made a motion to proceed with Option 2 not to exceed \$71,000.00. Tim Pettigrew seconded. All were in favor. Motion carried.

C. Discuss / Take Action on Allow Plastic Culverts for Driveways

Ms. King stated that our policy/ ordinance states culverts must be smooth bore concrete. She stated that the city uses plastic culverts for drainage and under intersections. Mayor Lemon has had several asked about using plastic culverts for driveways. Ms. King asked the council to consider changing the ordinance to plastic culverts.

Brian Brooks made a motion to amend our policy/ ordinance to allow plastic culverts for driveways in the city limits. Sandra Blaine seconded. All were in favor. Motion carried.

D. Discuss / Take Action of Policy / City Issued Traps

Ms. King stated that we issue traps to residents to trap stray cats, racoons and opossums. Councilman Pettigrew stated he thinks this is a huge liability against the city. He has done research on trapping in city limits, two cities in Texas have had lawsuits against them over a million dollars when the animal had rabies.

Tim Pettigrew made a motion that the city changes its policy and does not issue any wildlife trap to the public. Brian Brooks seconded. All were in favor. Motion carried. Public Works Dir. Gene West asked about picking up feral cats. Mr. Pettigrew said feral cats, snakes, rodents should be the responsibility of the home owner.

E. Discuss /Take Action on Ad for Chamber Directory

Brian Brooks made a motion to purchase a quarter page ad in the amount of \$295.00. Tim Pettigrew seconded. All were in favor. Motion carried.

F. Discuss/ Take Action on Variance to Allow Alcohol in the BBQ Cook-off Section During Pride Day Festivities

Tim Pettigrew made a motion to allow alcohol in the BBQ Cook-off Section During Pride Day Festivities by City Hall or Gazebo Park. Sandra Blaine seconded. All were in favor. Motion carried.

G. Discuss / Take Action on Closing Ashley Wilson Rd During Pride Day Festivities

Brian Brooks made a motion to Close Ashley Wilson Road during Pride Day Festivities like we have done in the past. Tim Pettigrew seconded. All were in favor. Motion carried.

H. Discuss / Take Action on Closing City Hall Friday, May 4 for Pride Day.

Brian Brooks made a motion to allow City Hall to close Friday, May 4th for Pride Day. Sandra Blaine seconded. All were in favor. Motion carried.

5. CLOSED EXECUTIVE SESSION: Tim Pettigrew called for Executive Session

1. Closed Time: 6:38 pm

6. RECONVENE TO REGULAR SESSION

1. Open Meeting Time: 6:43 pm

2. Action on Executive Session: NONE

7. ITEMS OF COMMUNITY INTEREST

8. ADJOURNMENT: 6:44 pm

PASSED AND APPROVED THIS 17 DAY OF April, 2018

Reatta Minshew
Reatta Minshew, City Secretary



AGENDA MEMO

Business of the City Council City of Sweeny, Texas

Meeting Date	10.24.2023	Agenda Item	
Approved by City Manager	Yes	Presenter(s)	Sweeny Executive Leadership Team
Reviewed by City Attorney	No	Department	All
Subject	Discussion and possible action on Fourth Quarter Updates from the Sweeny Executive Leadership Team, covering July, August, and September 2023.		
Attachments	Leadership Reports		
Financial Information	Expenditure Required:	N/A	
	Amount Budgeted:	N/A	
	Account Number:		
	Additional Appropriation Required:		
	Additional Account Number:		

Executive Summary

Attached are updates from the Sweeny Executive Leadership Team for the Fourth Quarter of Fiscal Year 2022 – 2023

- Department Updates from:
 - Sweeny Police Department (including Animal Control & Code Enforcement)
 - Public Works – Utilities, Streets, Drainage, Parks, CIP / Project Management
 - Office of the City Secretary and Development Services
 - Finance and Personnel Services
 - Sweeny Fire and Rescue
 - Sweeny Economic Development Corporation
 - Office of the City Manager

Recommended Action

No recommended action.



AGENDA MEMO

Business of the City Council
City of Sweeny, Texas

Item 10.

Meeting Date	10/24/2023	Agenda Item	Quarterly Report
Approved by City Manager	L. Koskiniemi	Presenter(s)	Brad Caudle
Reviewed by City Attorney		Department	Police Department
Subject	Quarterly Report Presentation		
Attachments	Quarterly Patrol, K9, Code Enforcement and Humane Reports		
Financial Information	Expenditure Required:		N/A
	Amount Budgeted:		N/A
	Account Number:		N/A
	Additional Appropriation Required:		N/A
	Additional Account Number:		N/A

Executive Summary

Presentation of statistics and job activities for the months of July, August and September 2023

Recommended Action

N/A

SWEENY POLICE DEPARTMENT QUARTERLY REPORT

JULY-AUGUST-SEPTEMBER

2023



PRESENTED BY
Brad Caudle, Chief of Police

CALLS FOR SERVICE

The listed information shows the call for service, reports and arrests made during the last quarter. We added last year's numbers and the last quarter's numbers as a comparison.

YEAR TO YEAR

	JUL-AUG-SEP 2022	JUL-AUG-SEP 2023	DIFFERENCE	PERCENT
CALLS FOR SERVICE	651	712	61	9%
REPORTS	73	78	5	7%
ARRESTS	30	21	-9	-30%

QUARTER TO QUARTER

	APR-MAY-JUN 2023	JUL-AUG-SEP 2023	DIFFERENCE	PERCENT
CALLS FOR SERVICE	593	712	119	20%
REPORTS	93	78	-15	-16%
ARRESTS	41	21	-20	-49%

The Sweeny Police Department made 21 arrests for the quarter and 15 of them were felony arrests. Most of these felony arrests were drug cases discovered at traffic stops by subjects travelling through our city.

TRAFFIC STOPS

The listed information shows traffic stops conducted during the last quarter. We added last year's numbers and the last quarter's numbers as a comparison.

YEAR TO YEAR

	JUL-AUG-SEP 2022	JUL-AUG-SEP 2023	DIFFERENCE	PERCENT
TRAFFIC STOPS	657	386	-271	-41%
TRAFFIC WARNINGS	502	251	-251	-50%
TRAFFIC CITATIONS	155	134	-21	-14%

QUARTER TO QUARTER

	APR-MAY-JUN 2023	JUL-AUG-SEP 2023	DIFFERENCE	PERCENT
TRAFFIC STOPS	253	386	133	53%
TRAFFIC WARNINGS	174	251	77	44%
TRAFFIC CITATIONS	79	135	56	71%



Sweeny Police Department

Est. 1909 | Home of the Unknown Soldier
123 N. Oak Street | Sweeny, Texas 77480
Dispatch | 979-548-3111 | Office | 979-548-3112
Brad Caudle, Chief of Police



Item 10.

K9 Corporal M. Ferrel

3 Month Stat Sheet

07/2023- 10/2023

- Total Traffic Stops - 208
- Total arrests made - 15
- Total arrests made from traffic stops - 12
- Total DWI arrests - 1
- Total traffic narcotic arrests - 9
- Total Warrant arrests made from traffic stops - 4
- Total non-traffic arrests - 1
- Total K9 Deployments - 5
- Total K9 contributing arrests – 7 (Two for BCSO)
- Total Arrests made in a drug free zone within school hours -
- Total amount of cash seizures from narcotic arrests-
- Total number of incident reports- 17

Brad Caudle
Chief of Police



Sweeny Police Department

Est. 1909 | Home of the Unknown Soldier
123 N. Oak Street | Sweeny, Texas 77480
Dispatch | 979-548-3111 | Office | 979-548-3112
Brad Caudle, Chief of Police



Item 10.

K9 Corporal M. Ferrel

3 Month Narcotic Weight Stat Sheet

07/2023 - 10/2023

- **Methamphetamine-** 3.5 grams
- **Cocaine-** 0 grams
- **Mushrooms-** 0 grams
- **MDMA-** 3.0 grams
- **Heroin-** 0 grams
- **Marijuana-** 387.1 grams / 13.65 Ounces
- **Oxy/Fentanyl Pills-** 6.4 grams
- **Xanax Pills-** 8.8 grams
- **Amphetamine Pills-** 1.2 grams
- **LSD-** 5 Units/Strips

Brad Caudle
Chief of Police
Sweeny Police Department
Email: bbcaudle@sweenytx.gov



Sweeny Police Department

Est. 1909 | Home of the Unknown Soldier
123 N. Oak Street | Sweeny, Texas 77480
Dispatch | 979-548-3111 | Office | 979-548-3112
Brad Caudle, Chief of Police



Item 10.

Code Enforcement Quarterly Report **07/2023 – 10/2023**

Code Enforcement

Cases Started

Tall Grass- 12
Junk Yards- 0
Unsafe Structures- 2
Junk Vehicle- 1
Trash/Rubbish/Debris- 1

Total Cases- 16
Certified Letters Sent- 14

Cases Closed

Tall Grass- 12
Unsafe Structure- 2
Abandoned Sign- 0
Junk Yard- 0

Brad Caudle
Chief of Police
Sweeny Police Department
Email: bbcaudle@sweenytx.gov



Sweeny Police Department

Est. 1909 | Home of the Unknown Soldier
123 N. Oak Street | Sweeny, Texas 77480
Dispatch | 979-548-3111 | Office | 979-548-3112
Brad Caudle, Chief of Police



Quarterly Humane Report 07/2023 – 10/2023

Animal Control Officer Rodger Larsen

Dog Calls- 95
Dogs Picked up by ACO- 19
Dogs Adopted- 6
Dogs Returned to Owner(s)- 9
Dogs that went to Rescue Shelters- 5
Dogs Euthanized- 0
Dogs in Animal Shelter- consistently full, average 10 per month

Cat Calls- 0
Cats Picked up by ACO- 0
Cats Adopted- 0
Cats Returned to Owner(s)- 0
Cats that went to Rescue Shelters- 0
Cats Euthanized- 0
Cats in Animal Shelter- 0

Miscellaneous Calls- 87
Call Outs- 9
Dog Bite Report/Follow-up- 0
Animal Cruelty Case- 0

TRAINING

Brad Caudle
Chief of Police
Sweeny Police Department
Email: bbcaudle@sweenytx.gov



AGENDA MEMO

Business of the City Council
City of Sweeny, Texas

Meeting Date		Agenda Item	
Approved by City Manager		Presenter(s)	Rusty Lofton, Project Manager
Reviewed by City Attorney		Department	
Subject	Discussion and Possible action on an update on the city's special and Capital projects for the 4th Quarter of fiscal year 2022-2023		
Attachments			
Financial Information	Expenditure Required:	N/A	
	Amount Budgeted:	N/A	
	Account Number:		
	Additional Appropriation Required:		
	Additional Account Number:		

Executive Summary

- 1- Training in Freeport with Kacey Romaine to get the field hours needed to qualify for my plumbing inspection license.
- 2-Studying to take my CSI state exam waiting on TCEQ for my test date.
- 3-Library sheet rock project due to water damage .
started on 9/8/23 working to finish punchlist
cost \$4,372.50 no change orders
- 4-Sidewalk repair at 524 & AWR Damage due to water leak under sidewalk
started 10/10/23 completed 10/12/23
cost \$6,800 No change orders
- 5- 2inch water line replacement between Ave A and Ave B on Stockman st.
started 10/12/23 expected completion date 11/02/23
cost \$19,096.20 no change orders to date.

Recommended Action

water line in box





Quarterly Update July -September 2023

- **Permitting & Inspections**

Permits Issued	76
Contractors Registered	22
Total Fees Collected Permits/Reg This Quarter	\$8,363.15
Permits Closed Out/Archived	89
Inground Pools Completed	3
Licensed Inspections Completed	69
Reviews Completed	6
Replats Completed	2
Variance Requests	2
911 Addressing Completions	1
Large Scale Projects in Progress	4
Residential Homes in Progress	3

- **Communications**

CTY's Notifications Sent/Emails & FB posts regarding	12
Website Uploads/Updates/Replacements/Removals	31

- **City Secretary**

- (3)RFP's Completed Disaster Grant Admin Services, Debris Removal & EM Services, & Monitoring Services
- (2) Bid Openings; Emergency Generator – Twice/Re-opened
- GLO Postings-2
- (10) Council Meetings: Agenda/Packet Creation, Minutes Completed
- (2) Ordinances; Ordinance Research -4
- (4) Resolutions
- (4) Proclamations Generated
- (17) Public Information Requests Completed
- Budget Prep Work/Meetings; Tax Rate/Budget Postings/Publishings/State Requirements
- Prepared/updated documents for the MyGov Migration in October
- (11) General Deposits
- Updated Records Room Files as of 09/01/2023; **RCI coming week of October 23rd**

- **Municipal Court**

Tickets Processed	53
Number of Payments Received	96
Warrants Recalled	22
Warrants Issued	65
Cases Closed	58
Court Hearings Held	10



Quarterly Update July 2023 – September 2023

Finance Department

- Monthly Utility Billings/Collections/Adjustments
- Monthly Accounts Payable/Vendor registrations
- Monthly Banking/Transfers/Reconciliations/Update signatures
- Bi-monthly Payroll
- EOM TMRS Reports
- Monthly Sales and Use Tax Reports
- 23-24 Budget: tax rate adopted; 10% homestead exemption approved; budget completed and approved
- Quarter 3 Financials completed
- Quarter 4 Financials review in process – to be presented after budget amendment
- Audit preparation
- Regular and Special Council Meeting attendance

Personnel Services

- Processed Unemployment claims - 1
- Processed Workers Comp claims – 1 ongoing
- Hiring
 - New Hire Public Works 1
 - New Hire PD 3
 - Promotion Public Works 1
 - Postings for Water Plant Operator and WWTP Operator

BRAZORIA COUNTY ESD #2: Sweeny F&R

Item 10.

07/01/2023 - 09/30/2023 (92 Days)

Breakdown by Incident Category

Incident Category	# Incidents	% of Total
Fire	30	32.6%
Accident	25	27.17%
Agency Assist	16	17.39%
Canceled	7	7.6%
HazMat	6	6.52%
Utility Problem	3	3.26%
Alarm	2	2.17%
Medical	2	2.17%
Other	1	1.08%
Total	92	100%

Detailed Breakdown by Incident Type

Incident Type	# Incidents	% of Total
Accident, potential accident, other	1	1.08%
Aircraft standby	14	15.21%
Assist police or other governmental agency	16	17.39%
Brush or brush-and-grass mixture fire	8	8.69%
Building fire	2	2.17%
Citizen complaint	1	1.08%
Dispatched & canceled en route	4	4.34%
Dispatched & canceled prior to checking en route	2	2.17%
False alarm or false call, other	2	2.17%
Fire in mobile home used as fixed residence	1	1.08%
Fire, other	3	3.26%
Forest, woods or wildland fire	1	1.08%
Gas leak (natural gas or LPG)	6	6.52%
Grass fire	8	8.69%
Medical assist, assist EMS crew	2	2.17%

Incident Type	# Incidents	% of Total
Motor vehicle accident with injuries	5	5.43%
Motor vehicle accident with no injuries	3	3.26%
No incident found on arrival at dispatch address	1	1.08%
Outside equipment fire	1	1.08%
Outside rubbish, trash or waste fire	3	3.26%
Passenger vehicle fire	2	2.17%
Power line down	3	3.26%
Special outside fire, other	1	1.08%
Vehicle accident, general cleanup	2	2.17%
Total	92	100%





Executive Director's Report

The following is a general summary of my activity: July

Administration: Continue to work with Altamira in moving forward to get road and utilities extended at the Industrial Park. Helping the Chamber with billing, answering phone. Learning QuickBooks online. Will be working on a spreadsheet report to present to EDC board on all open performance agreement grants and what they are required to report and when. Continue working from home.

Networking/Meetings:

July 13 – Attend ribbon cutting ceremony for MLK Park

July 13 – Met with J & K for help on QuickBooks online

July 17 – Attend Chamber meeting

July 18 – Attend Council meeting

July 19 – Attend the Alliance Industry Update Luncheon

July 25 – Attend Bringing Back Mainstreet in Bay City

July 28 – Met with Flash Fitness and Absolute Fitness

Aug. 2 – New Teacher Breakfast and Persons interested in bringing a water park to Sweeny

Aug. 3 – Meet and Greet and ribbon cutting at CP Chem Hexene Ribbon Cutting

Aug. 4 – Met with Cecil with Stark Inc.

Aug. 7 – Attended Convocation for SISD; Monthly meeting with City Manager; Met with Tina from City of Bay City Downtown

Aug. 10 – Met with Kris and Phillip Simmons (Sweeny Legends) to talk about Block Grant and tour their progress

Aug. 11 – Met with Windy Byrd to discuss upcoming magazine

Industrial Park: Finally ready to have a groundbreaking. Trilogy waiting on deed to come back from attorney. Cecil Stark agreed to performance agreement, needs to go to council for approval on the changes.

Business Improvement/Incentive Applications/Block Grant: Dark Roast working on submitting a Performance Agreement grant; Sweeny Legends working on a Block Grant.

The following is a general summary of my activity. Aug

Administration: SGS working on Industrial Park Project. Continue helping the Chamber with billing, answering phone. Learning QuickBooks online. Still working on a spreadsheet report to present to EDC board on all open performance agreement grants and what they are required to report and when. Continue working from home. Will begin getting things organized to be moved out of the current office.

Networking/Meetings:

Aug. 24 – Groundbreaking Ceremony

Aug. 29 – Joint Meeting with Council

Sept. 5 – City Council Meeting

Sept. 7 – Site visit to the Industrial Park

Industrial Park: Groundbreaking Ceremony; 23% complete on Project.

Business Improvement/Incentive Applications/Block Grant: No new applications

The following is a general summary of my activity. Sept

Administration: SGS working on Industrial Park Project. Continue helping the Chamber with billing, agendas and minutes. Got everything moved and in storage. Working with the students on the EDC magazine. Continue working from home.

Networking/Meetings:

Sept. 11 – EDC meeting

Sept. 20 – Attended Economic Development Workshop - Angleton

Sept. 26, 27 and 28 – moved things out of the office into storage

Sept. 29 – Met with J and K to help with QuickBooks

Oct. 2 – Met with City Manager

Oct. 4 – Met with the Students about the EDC magazine

Industrial Park: As of September 30 – 66% complete on the project.

Business Improvement/Incentive Applications/Block Grant: Spoke with Elvira Alvarez, will continue to work on the front of the building. She is going through some medical issues and is aware of the February deadline to open the business.

Spoke with PT Brunner awaiting the final inspection by the Fire Marshall. They are ready to open.



AGENDA MEMO

Business of the City Council City of Sweeny, Texas

Meeting Date	10.24.2023	Agenda Item	
Approved by City Manager	Yes	Presenter(s)	Lindsay Koskiniemi
Reviewed by City Attorney	No	Department	Administration – Office of the City Manager
Subject	Discussion and possible action on the Fourth Quarter City Manager Update for Fiscal Year 2022 – 2023, spanning July, August, and September		
Attachments			
Financial Information	Expenditure Required:	N/A	
	Amount Budgeted:	N/A	
	Account Number:		
	Additional Appropriation Required:		
	Additional Account Number:		

Executive Summary

At the City Council on September 19, 2023, the Council took action to direct the City Manager to focus on key issues that include: 1) water quality, 2) repairs to the wastewater treatment plant to bring the plant into sustainable compliance, and 3) mowing within City rights-of-way to proactively manage drainage.

While not instructed as a “Top 3” focus (“Top” conveying project priority, as decided by Council majority vote), the Council directed the City Manager to research how to increase street lighting in areas that include Eleanor Street & 6th Street, possibly adding 2 more street lights near the Bulldog Café, addressing non-operational streetlights managed by TNMP along Main Street, and fixing the decorative lamp posts along Main Street that are managed by the City.

Research on water wells within the City limits was among requested tasks.

These projects, in addition to regular and non-routine duties, have received my attention as outlined below.

Water Quality:

City Manager has met with Michael Claybourn with Water of Texas and the City’s engineer (9/7/2023, 9/12/2023, 9/14/2023, and 9/29/2023; another walk of the water plant with staff, city engineer and M. Claybourn on 10/16/2023) to discuss water clarity options the City can take to reduce coloration issues related to naturally occurring metallic components within the ground water that feed into the distribution system. These options will be discussed in greater detail in a later item on this agenda with a presentation by M. Claybourn with Water of Texas.

At the September 19, 2023 City Council meeting, the Council authorized \$50,000 to be moved from Enterprise Fund balance (Budget Amendment to be discussed and formally acted on in a separate agenda item) for the provision of waterline replacement at the discretion of management’s determination of priority. The water line composed of galvanized metal held together by over a



AGENDA MEMO

Business of the City Council

City of Sweeny, Texas

dozen clamps along Stockman Street, measuring approximately 400 linear feet in length and situated in a norther-western to south-eastern direction, is in the queue for replacement. Staff obtained quotes and found the \$19k quote from Matula and Matula to be the best quote to perform the waterline replacement on Stockman. This project will begin on October 12, 2023. The City's Project Manager will provide an update to City Council at the time of the meeting on October 24, 2023.

Another high-priority line that must be replaced is the portion of the waterline along Pecan Street between 5th Street and 1st Street. This line is also composed of galvanized steel, is internally corroded, and patched together with several clamps. Staff responded to a break on this line at the intersection of 4th St. and Pecan St. in August. The repair was not fully made, and the need to replace this line is apparent. City Manager is seeking a CDBG grant through Brazoria County to replace this portion of line. The estimated cost to replace 4 blocks of waterline is around \$80,000 to \$100,000.

To complete the grant application, a total household income survey must be conducted to determine if the affected area qualifies for funding as a low-to-moderate income area. Langford Community Management Services has been requested to assist in the grant writing and application process, as staff members do not have the capacity to perform a project income household income survey.

The waterline spanning the streets of W. 6th St from Magnolia to Sycamore and from W 6th St. to 3rd St. are on track for replacement through a Mitigation grant that was conditionally awarded to Sweeny. Brazoria County sent requests for additional information that CM responded to in July 2023. This project is scheduled to be funded after January 2024 and will replace approximately one mile of 2" metal waterline with 6" PVC line to support 8 additional fire hydrants.

Staff received an auto flusher demonstration from Ferguson in September. Staff is uncertain if these are needed, although approved by City Council for purchase.

Wastewater Treatment Plant:

The sewer plant clarifiers are each fed by two pumps called return activated sludge pumps. Currently, the City remains operating on one clarifier. In April 2023, management became alerted to the fact that the sewer plant was "dead," meaning the self-sustaining ecosystem within the clarifiers was dead. In other terms, the "bugs," or, the good bacteria, was no longer alive and feeding on the bad bacteria. Staff discovered that the return pumps were not functioning, and the lines were blocked with heavy sludge. The return pumps feed the waste into the clarifiers to begin treatment. During the internal investigation at the sewer plant, we also found the chlorine contact chamber was not feeding into the system.

Clarifier 1 was de-watered and the sludge removed in May 2023. Clarifier 2 remains in the same shape and needs to be de-watered and have the sludge removed. The chlorine contact chamber feed remains non-operational. The system is currently being fed through a time-released bleach chamber. Staff has a meeting with the City engineer, Inframark, and a vendor to discuss the possibility of converting to a bleach fed system and getting away from Chlorine in the interest of cost savings and product availability. Currently compressed bleach is available through a sole source provider.

The RAS pumps to Clarifier 1 became ragged up and stopped working. We received a quote to rehab both pumps for several thousands of dollars, however, Council approved the replacement



AGENDA MEMO

Business of the City Council

City of Sweeny, Texas

of both pumps, as the broken pumps are best suited to work with head pressure because they are submersible class pumps. Alvin Contracting secured a 6” Gorman Rupp pump. The cost of the pumps and the piping work is approximately \$25k. Alvin Contracting has been paid a 50% deposit to begin work. The remainder will be paid after the work is finished. Staff is currently researching the most cost-effective solution to replacing the secondary pump on Clarifier 1, and we believe a 4” pump may work in conjunction with the new 6” pump. A 4” pump will certainly be less expensive. Staff is building a roadway along the drying beds around Clarifier 1 to access the RAS pump site in preparation for installing the new pumps.

Mowing and Drainage:

Drainage - On 9/8/2023, Public Works and City Management met with West Brazoria Drainage District #11 to discuss a request from the City to get assistance with mowing along Ashley Wilson Rd and to have the ditches dug deeper along Ashley Wilson Road near the eastern city limit and past the city’s limit near Camellia, Azalea, Forest Park Ct., and the River Oak Apartments). Staff and WBCDD also looked at the area near McKinney Street off 2nd Street at the intersection of Old Ocean Avenue.

WBCDD shared preliminary engineering plans of a culvert installation project that includes digging a deeper ditch and cutting into a tree stump along McKinney to increase drainage flow. Management made a request to the Brazoria County Engineering Department for an interlocal agreement to do the project and met with BC Engineering and WBCDD#11 on 9/29/2023. The City will purchase the material, and the County will perform the work. This project will reduce bird bathing along Old Ocean and increase the flow of run off out of the City via Avenue A.

Council approved staff to rent an industrial sewer jetter for one month. Staff rented a Kinloch jetter and has cleaned culverts throughout town with a concentration on jetting the west side. Management has created a list of all of the city streets and has divided the city into 6 zones. The 6-zone spreadsheet of city streets can be used to document sewer jetting, waterline replacement, and inventory of lines for the Lead and Copper Revision Rule which requires the composition of all city water service lines to be inventoried by 10/16/2024. Videos of the rented sewer jetter in operation will be shared in a later agenda item to discuss the possible purchase of a new sewer jetter.

Mowing - In the month of August 2023, Public Works mowed the ditch on both sides of Crosson Ct. The milkweed had grown to nearly 10 feet tall, and the job took 4 men and a full day of work to remove. After removal of the overgrowth, the area was treated with herbicide.

Mowing has been problematic for staff especially during the drought when aged water lines are subject to shifting and breaking under pressure. Water line repairs always take priority over mowing; therefore, it is easy to get behind on mowing. Areas of tall grass that adversely affect the city’s drainage include the ends of town along Ashley Wilson Rd. and areas along Stevenson Slough. Management contacted AYA Mowing and scheduled mowing in ditches along AWR not in front of residential lots (except for one enforcement mowing at an abandoned house in front of Stewart’s grocery store), along the slough from behind the car wash to behind Byrd Brothers. The areas were mowed on 10/10/2023 after the rain stopped.

Management created a city mowing map and invited vendors to submit proposals. One submittal has been received, and we intend to award a contract for mowing applying herbicide to the designated areas to the lowest bidder this month.



AGENDA MEMO

Business of the City Council

City of Sweeny, Texas

Link to mowing map:

<https://earth.google.com/earth/d/1gfSdQP6e0RQY9GWnWmHaEiOsqpmd6Le?usp=sharing>

Street Lighting:

After the September City Council meeting, the police department tagged all streetlights and decorative lamp posts along Main Street that were not working. Management coordinated with TNMP to replace burned out streetlights. 9 streetlights were replaced on 9/22/2023 by TNMP. The decorative lamp posts on Main Street are owned and managed by the City of Sweeny. The bulbs in all of the lamps were replaced in Fall of 2022. 10 lamps were replaced in September, and after replacing the bulbs, 4 remain non-operational. An electrician is currently working on assessing the wiring to give the City a quote to make the repair. The goal is to have all lampposts working in time for the holidays.

Management contacted TNMP in September to request a lighting need assessment at Eleanor St. & 6th St., around Bulldog Café, and other areas along Main Street that appear dim at night such as the area around Beals Bubbles. TNMP’s design team has received the request, and city staff is awaiting an update from TNMP.

Water Wells:

Over the summer, the City had several inquiries from the public concerning the viability of homeowners drilling water wells on their property within the City’s limits. Incorrectly, the City told the public drilling independent water wells within the city’s limits in proximity to a public water system was prohibited by TCEQ. Management contacted the Field Operations Coordinator at the Brazoria County Groundwater Conservation District who stated Texas Water Code chapter 30 under the Rule of Capture provides property owners have the right to the minerals and naturally occurring resources on their land. Cities have the option to adopt ordinances for a permitting fee, and the well is required to be at least fifty (50) feet from any septic or sewer system. To summarize, the City may adopt a permitting fee to allow for personal water wells within the City’s limits, and the property owner must adhere to the County’s well drilling regulations.

Other Items:

- Completed the Film Friendly certification.
- Met with B-Tel for pricing and scoping of City of Sweeny phone and internet service.
- Scoping possibility of finding savings on utilities and repurposing an existing building to serve as new animal shelter with TexasRebuild.
- Hurricane response and emergency management drill in August.
- Passed FY24 budget and property tax rate.
- RFP for debris management.
- RFP for emergency management generator installation at Community Center (grant funded 75/25).
- Submitted Transportation Alternatives project to TxDOT for consideration (anticipated notification in Nov 2023).
- Participated in Texas Water Development Board workshop in Huntsville (July 2023)
- Training project manager.
- Conducted a nationwide Public Works Director recruitment.



AGENDA MEMO

Business of the City Council
City of Sweeny, Texas

Recommended Action

No recommended action.



AGENDA MEMO

Business of the City Council

City of Sweeny, Texas

Meeting Date	10.24.2023	Agenda Item	
Approved by City Manager	Yes	Presenter(s)	Lindsay Koskiniemi, City Manager Rusty Lofton, Project Manager
Reviewed by City Attorney	No	Department	Public Works – Wastewater
Subject	Discussion and possible action on staff generated request for the purchase of a new sewer jetter for use on culverts to improve and manage drainage and respond to sewer blockages.		
Attachments	Quotes for new sewer jetter		
Financial Information	Expenditure Required:	TBD	
	Amount Budgeted:	\$0	
	Account Number:		
	Additional Appropriation Required:		
	Additional Account Number:		

Executive Summary

At the September City Council meeting, the Council approved a 30-day lease on a sewer jetter on a trial basis in response to staff’s request for a new jetter. The City owns a jetter that has been serviced several times and still does not work. The council instructed staff to develop a culvert cleaning schedule and to use the leased jetter for one month and report what work had been accomplished in the month to Council. Public Works employees have used the jetter consistently since the start of the lease and have cleaned dozens of culverts throughout the city and responded to sewer stops successfully without having to contact the City of Brazoria to use their equipment.

Staff divided the city into 6 sections and will dedicate 2 Public Works employees twice monthly, or more if needed to prepare for seasonal inclement weather, to cleaning culverts with the Council’s approval of a new jetter.

Staff rented a Kinloch jetter and has used it to clear drainage culverts and sewer stops since the first week of October. While we have not had the leased jetter for the full 30 days, staff is requesting Council’s approval on the purchase of a Kinloch jetter on a lease-to-own basis using \$20,000 earned from the sale of equipment / salvage and trading in the existing jetter for a \$2,000 deduction. With the down payment and trade-in on a lease-to-own payment plan, the monthly cost is estimated to be \$1676 for 4 years for the preferred Vactor model.

Staff obtained quotes from Pipe Hunter and Kinloch for various industrial sewer jettors. Project Manager, Rusty Lofton, will provide an explanation of the differences.

Recommended Action

Staff recommends approval, and if it is the Council’s pleasure to approve this request, it is further recommended to approve a budget amendment at the November meeting to move the full purchase amount into a TexPool Prime account for equipment replacement. This will allow funds set aside for monthly payments to gain the highest amount of interest as payments come due.



Presents a Proposal Summary

of the

VACTOR[®] **RAMJET**



Vactor RamJet 2040-750 Trailer

For



Morgan Taylor
Tel: 281-620-1827

PRODUCT DESCRIPTION

·Vactor Ramjet Tandem Axle trailer with 750 gallons of fresh water powered by a 74hp Hatz Tier 4 diesel engine with an output of 40 GPM at 2,000psi.

Item 11.

STANDARD FEATURES

Engine/Pump:

Hatz 74 HP Diesel Engine Tier IV

USJ 40 GPM @ 2,000 PSI

Triplex Plunger Run Dry Pump

Tier 4 Basic Control Panel

Auto Shutdown (for High Engine Temp/Low Oil Pressure)

Water Recirculation & Anti-Freeze System

Pulsation System

Shrouded Engine

Twin 375 Gallon Black Water Tank

Standard Pivot Hose Reel

3/4" x 500' Piranha Sewer Hose

Manual Hose Guide

Hydraulic Driven Hose Reel

Twin 6,000 lbs. Torsion Bar Axles

D.O.T. Approved LED Lighting

42" Aluminum Toolbox

Aluminum Rims

2 5/16" Ball Hitch

Black Rounded Fenders

10' Leader Hose

3/4" RPD 3R/1F Nozzle

3/4" RPD 6R Nozzle

Finned Nozzle Extension

3" Tiger Tail

Nozzle Rack

2 1/2" x 25' Hydrant Hose

Emergency Stop Button

Additional Features

FOOTAGE COUNTER MANUAL OPTION

FILL STORAGE HOSE RACK

KEG CULVERT CLEANING NOZZLE

1/2" ADAPTOR

150 FEET 1/2" HOSE

Product Model: Vactor RamJet 2040-750

Payment Terms: Net due Upon Delivery.

Morgan Taylor
Tel: 281-620-1827

Sourcewell Contract Price F.O.B. Sweeny, TX:	\$91,638.33
Less Trailer Jet Trade-In:	(\$2,000)
Price Net Trade In:	\$89,638.33
Down Payment:	(\$20,000)
Total Price Net Down Payment:	\$69,638.33

OPTIONAL LEASE/PURCHASE PROGRAM

TERM	ANNUAL PAYMENT	MONTHLY PAYMENT
3 Years	\$26,776.53	\$2,158.20
4 Years	\$20,789.80	\$1,675.67

Proposal Notes:

1. Prices quoted herein are firm until 10.21.23.
2. Price in accordance to Purchasing Coop Sourcewell #101221-VTR.

SIGNED BY:

Date: _____



	<u>Daily</u>	<u>Weekly</u>	<u>4 Weeks</u>
Trailer Mounted Jetter Rental Rates	\$ 315	\$ 1,575	\$ 4,725

RPO Structure Details

The Customer shall have the option to purchase the equipment listed on the rental contract after any rental payments have been made, for the selling price of: eighty nine thousand, six hundred and thirty eight (\$89,638.33) plus all amounts then owed to the Supplier.

If the customer purchases/pays for the unit outright during the first 28 days of the contract and prior to the return of the unit, KESI will apply ninety percent (90%) of the accumulated/total rental money paid against the purchase of the unit.

If the customer purchases/pays for the unit outright during the 29th to the 56th day of the contract and prior to the return of the unit, KESI will apply eighty percent (80%) of the accumulated/total rental money paid against the purchase of the unit.

If the customer purchases/pays for the unit outright during the 57th to the 84th day of the contract and prior to the return of the unit, KESI will apply seventy percent (70%) of the accumulated/total rental money paid against the purchase of the unit.

If the customer purchases/pays for the unit outright during the 85th to the 112th day of the contract and prior to the return of the unit, KESI will apply sixty-five percent (65%) of the accumulated/total rental money paid against the purchase of the unit.

If the customer purchases/pays for the unit outright between the 113th to the 168th day of the contract and prior to the return of the unit, KESI will apply sixty percent (60%) of the accumulated/total rental money paid against the purchase of the unit.

If the customer purchases/pays for the unit outright between the 169th to the 224th day of the contract and prior to the return of the unit, KESI will apply fifty percent (50%) of the accumulated/total rental money paid against the purchase of the unit.

If the customer purchases/pays for the unit outright between the 225th to the 365th day of the contract and prior to the return of the unit, KESI will apply forty percent (40%) of the accumulated/total rental money paid against the purchase of the unit.

Any implied purchase option will expire on the date of expiration of this contract, which is no more than 364 days from the start of this contract.



Presents a Proposal Summary

of the

VACTOR[®] **RAMJET**



Vactor RamJet 2040-750 Trailer Unit USJ41

For



Morgan Taylor
Tel: 281-620-1827

PRODUCT DESCRIPTION

·Vactor Ramjet Tandem Axle trailer with 750 gallons of fresh water powered by a 74hp Hatz Tier 4 diesel engine with an output of 40 GPM at 2,000psi.

Item 11.

STANDARD FEATURES

Engine/Pump:

Hatz 74 HP Diesel Engine Tier IV

USJ 40 GPM @ 2,000 PSI

Triplex Plunger Run Dry Pump

Tier 4 Basic Control Panel

Auto Shutdown (for High Engine Temp/Low Oil Pressure)

Water Recirculation & Anti-Freeze System

Pulsation System

Shrouded Engine

Twin 375 Gallon Black Water Tank

Standard Pivot Hose Reel

3/4" x 500' Piranha Sewer Hose

Manual Hose Guide

Hydraulic Driven Hose Reel

Twin 6,000 lbs. Torsion Bar Axles

D.O.T. Approved LED Lighting

42" Aluminum Toolbox

Aluminum Rims

2 5/16" Ball Hitch

Black Rounded Fenders

10' Leader Hose

3/4" RPD 3R/1F Nozzle

3/4" RPD 6R Nozzle

Finned Nozzle Extension

3" Tiger Tail

Nozzle Rack

2 1/2" x 25' Hydrant Hose

Emergency Stop Button

Additional Features

FOOTAGE COUNTER MANUAL OPTION

FILL STORAGE HOSE RACK

KEG CULVERT CLEANING NOZZLE

1/2" ADAPTOR

150 FEET 1/2" HOSE

Product Model: Vactor RamJet 2040-750

Payment Terms: Net due Upon Delivery.

Morgan Taylor
Tel: 281-620-1827

Sourcewell Contract Price F.O.B. Sweeny, TX:	\$84,904.58
Less Trailer Jet Trade-In:	(\$2,000)
Less one-month Rent to Purchase rebate:	(\$4,252)
Down Payment:	(\$20,000)
Total Price Net Down Payment:	\$58,652.58

OPTIONAL LEASE/PURCHASE PROGRAM

TERM	ANNUAL PAYMENT	MONTHLY PAYMENT
3 Years	\$22,552.42	\$1,817.73
4 Years	\$17,510.12	\$1,411.32

Proposal Notes:

1. Prices quoted herein are firm until 10.29.23.
2. Price in accordance to Purchasing Coop Sourcewell #101221-VTR.
3. The Rent to Purchase Rebate is only offered if the unit rented is the same unit being purchased.
4. The unit (USJ41) has 24.6 hours as of 9.29.23.
5. The warranty on this unit expires on 2.27.2024.

SIGNED BY:

Date: _____



	<u>Daily</u>	<u>Weekly</u>	<u>4 Weeks</u>
Trailer Mounted Jetter Rental Rates	\$ 315	\$ 1,575	\$ 4,725

RPO Structure Details

The Customer shall have the option to purchase the equipment listed on the rental contract after any rental payments have been made, for the selling price of: eighty nine thousand, six hundred and thirty eight (\$89,638.33) plus all amounts then owed to the Supplier.

If the customer purchases/pays for the unit outright during the first 28 days of the contract and prior to the return of the unit, KESI will apply ninety percent (90%) of the accumulated/total rental money paid against the purchase of the unit.

If the customer purchases/pays for the unit outright during the 29th to the 56th day of the contract and prior to the return of the unit, KESI will apply eighty percent (80%) of the accumulated/total rental money paid against the purchase of the unit.

If the customer purchases/pays for the unit outright during the 57th to the 84th day of the contract and prior to the return of the unit, KESI will apply seventy percent (70%) of the accumulated/total rental money paid against the purchase of the unit.

If the customer purchases/pays for the unit outright during the 85th to the 112th day of the contract and prior to the return of the unit, KESI will apply sixty-five percent (65%) of the accumulated/total rental money paid against the purchase of the unit.

If the customer purchases/pays for the unit outright between the 113th to the 168th day of the contract and prior to the return of the unit, KESI will apply sixty percent (60%) of the accumulated/total rental money paid against the purchase of the unit.

If the customer purchases/pays for the unit outright between the 169th to the 224th day of the contract and prior to the return of the unit, KESI will apply fifty percent (50%) of the accumulated/total rental money paid against the purchase of the unit.

If the customer purchases/pays for the unit outright between the 225th to the 365th day of the contract and prior to the return of the unit, KESI will apply forty percent (40%) of the accumulated/total rental money paid against the purchase of the unit.

Any implied purchase option will expire on the date of expiration of this contract, which is no more than 364 days from the start of this contract.



35418 Single Axle Trailer - 4,000 PSI @ 18 GPM

Item 11.

Quote Date: September 25, 2023
Customer: Sweeny Texas
Job #:
Salesman: David Mills

Due Date:
Dealer: Texas Underground
Stock #:
P.O. Number:

Part Number	Description	Quantity	Price	Total
WATER TANK				
9000-0055	300 Gallon High-Density Polyethylene	1	Std.	Std.
	400 Gallon Tank 7000 LB AXLE STD	1	\$ 1,000.00	\$ 1,000.00
9000-0103P	Single Filler Assembly	1	Std.	Std.
9000-0106	25' Fill Hose w Storage Rack	1	Std.	Std.
9000-0032P	Main Tank Water Sight Gauge(1)Std	1	Std.	Std.
9000-0092	Dual Filler Assembly		\$ 550.00	\$ -
3013-0010	Hydrant Fill Strainer		\$ 400.00	\$ -
9000-0118	2" Aux. Drain Valve- Street Side Rear		\$ 250.00	\$ -
BAFFLEBALL	Baffle Balls		\$ 700.00	\$ -
WATER PUMP				
	4,000 PSI @ 18 GPM - Giant Water Pump	1	Std.	Std.
9000-0040	Washdown System-43H with gun and 25ft hose	1	Std.	Std.
9000-0059	Air Purge	1	\$ 185.00	\$ 185.00
	Antifreeze Package		\$ 895.00	\$ -
9000-0058	Winter recirculation (not available on Jet Eye)		\$ 295.00	\$ -
9000-0060	Pulsation System		\$ 695.00	\$ -
	Pump doghouse enclosure- aluminum		\$ 1,500.00	\$ -
9000-0061	Multi-Flow Valve	1	\$ 295.00	\$ 295.00
9000-0026	25' Retractable Hand Gun Reel w 25' x 1/2" hose		\$ 1,450.00	\$ -
9000-0094	Degreaser Injection System. 5 gallon w 12 pump		\$ 2,000.00	\$ -
ENGINE				
	KOHLER 54 HP DIESEL ENGINE RATED Tier 4 Final W Clutch	1	Std.	Std.
	15 Gallon Fuel Tank	1	Std.	Std.
9000-0048	Emergency Kill	1	Std.	Std.
9000-0064	Electric Throttle Upgrade	1	Std.	Std.
	Digital Gauge Package & Tachometer Low Pressure High Temp Shutdown	1	Std.	Std.
9000-0045	Engine Shroud/ Belt Guard/ Fenders - Aluminum	1	Std.	Std.
9000-0134	Full Engine Enclosure w Access Doors - Aluminum		\$ 1,500.00	\$ -
	Fuel Gauge - Panel Mounted		\$ 198.00	\$ -
	Hydraulic Pressure Gauge		\$ 220.00	\$ -
HOSE REEL				
Single Jet Hose Reels				
9000-0133	800' x 1/2" Jet Hose Reel	1	Std.	\$ -
	1,000' x 1/2" Jet Hose Reel		\$ 800.00	\$ -
Articulating Reel Option				
9000-0316	Articulating Reel Option Hydraulic Powered Worm Gear	1	\$ 4,200.00	\$ 4,200.00
Hose Reel Accessories				
9000-0049	Standard Level Wind	1	Std.	Std.
	Double Roller Levelwind 45 Degree		\$ 295.00	\$ -
9000-0006	Manual Footage Counter		\$ 712.00	\$ -
3004-3202	Level Wind w/ Counter		\$ 830.00	\$ -
	Digital Footage Counter		\$ 3,500.00	\$ -
	Hose Reel Guard- per reel		\$ 1,500.00	\$ -
HOSE OPTIONS (per foot) Minimum 400 foot jet hose with 10 foot leader- 400, 600,800 increments				
3009-4537P	1/2" Leader hose-per foot	10	\$ 13.00	\$ 130.00
4640-08-XXX	1/2" Jet Hose per foot Piranha	600	\$ 3.34	\$ 2,004.00
3007-7001	Tiger Tail(1)Std 2"	1	Std.	Std.
	Hose Mender Kit Parker/Polyflow		\$ 1,600.00	\$ -
NOZZLE OPTIONS- Std. Hose Reel Nozzles				
7600-0084	Nozzle Rack (1)	1	Std.	Std.
3007-4014-25400	15 Degree Nozzle (1)	1	Std.	Std.
3007-4013-25400	30 Degree Nozzle (1)	1	Std.	Std.
3007-9000	Nozzle Skid Assy 6" (1)	1	Std.	Std.
ELECTRICAL OPTIONS				
	Arrowstick w Control Box & Mounting Bracket LED		\$ 2,300.00	\$ -
	Light - Strobe Flat Qty 4 ea. Corner	1	\$ 1,200.00	\$ 1,200.00
	Light - Strobe Light w/Limb Guard LED	1	\$ 450.00	\$ 450.00
	Light - Rotating Beacon Light w/Limb Guard		\$ 450.00	\$ -
9000-0011	Light - Hand Held Spot Light		\$ 250.00	\$ -
9000-0066	Light - Hand Held Spot With Reel		\$ 350.00	\$ -
	Light - Low Water Warning Light	1	\$ 205.00	\$ 205.00
9000-0030P	Light - Low Water Warning Alarm	1	\$ 120.00	\$ 120.00
	Light - Panel Light LED	1	\$ 200.00	\$ 200.00
	Light - Work Light-(Control panel) LED		\$ 200.00	\$ -
9000-0024	Light - Work Light (Engine-Pump area) LED		\$ 200.00	\$ -
9000-0024	Light - Work Light (Arrowstick DS) LED		\$ 200.00	\$ -
9000-0024	Light - Work Light (Arrowstick PS) LED		\$ 200.00	\$ -

Item 11.

Part Number	Description	Quantity	Price	Total
9000-0010	12 volt power outlet on Control Panel		\$ 120.00	\$
9000-0112	L.E.D. Upgrade Marker and Tail Lights Only	1	\$ 250.00	\$ 250.00
REMOTE CABLE PENDANT OR WIRELESS REMOTE				
9000-0002P	Remote Pendant System, with Emergency Kill, Electric Throttle, (add Electric Throttle) Reel In/ Out 25 FT Cord		\$ 3,000.00	\$ -
	Wireless Remote- Electric Throttle, Emergency Kill, Reel in/out		\$ 4,800.00	\$ -
OPTIONS BELOW AVAILABLE FOR REMOTE PENDANT OR WIRELESS REMOTE				
	Water Off/ON-Hydraulic actuator Pendant are Wireless		\$ 2,500.00	\$ -
TOOL BOX OPTIONS (Aluminum Diamond Treadplate Construction)				
7600-0661	Locking, (Drawbar) - Aluminum 52" x 26" x 15.5"	1	Std.	Std.
	Locking, DS Frame Toolbox - Aluminum 48" x 12" x 12" Side Mount		\$ 790.00	\$ -
	Locking, DS Fender Toolbox - Aluminum 36" x 9" x 12" Fold Down Door		\$ 570.00	\$ -
3004-7022	Rubber Decking EA. BOX		\$ 150.00	\$ -
ACCESSORIES				
	Garden Hose Reel 100' Capacity w/ 50' garden hose		\$ 795.00	\$ -
3007-8001	Hydrant Wrench		\$ 100.00	\$ -
3008-0511	Manhole Hook		\$ 100.00	\$ -
9000-0127	Lateral Reel Cart200' Cap. with 150' x 1/2" jet hose,ball valve, button nozzle w mounting brkt		\$ 2,300.00	\$ -
	Manhole - Lower Shoe W (4) 6' FIBERGLASS POLE SET		\$ 675.00	\$ -
8401-1401	Manhole - Upper Roller Aluminum	1	\$ 500.00	\$ 500.00
7600-0278	Traffic Cone Rack - Deck Mount		\$ 150.00	\$ -
7600-0278	Traffic Cone Rack - Reel Deck Mount		\$ 150.00	\$ -
MANUALS				
3023-0002	PipeHunter Operator's Manual CD	1	\$ 10.00	Std.
26-OMRG33324	Engine Operator's Manual CD	1	\$ 75.00	Std.
FRAME & AXLE				
	6" Frame	1	Std.	Std.
	DOT LIGHTING PACKAGE	1	Std.	Std.
	Single 6000 LB Axle W/Electric Brakes 2 5/16 Hitch 3 positions STD W 300	1	Std.	Std.
	Single 7000 LB Axle W/Electric Brakes 2 5/16 Hitch 3 positions STD W 400		Std.	Std.
3007-2012	Pintle Hitch		\$ 181.00	\$ -
9000-0139	Hydraulic Brakes (Single Axle Trailer)		\$ 2,500.00	\$ -
LINER OPTION				
	PipeHunter Speed Liner Frame & Reel	1	Std.	Std.

Color:

9000-0050(001) ~9000-0039(200) ~ 9000-0053(250) ~ 9000-0056(450)
9000-0052(600)

Quoted By: David Mills 9 25 2023

Customer Discount

Sales Tax %
Miles @ \$4.00

Ship Method:
TERMS:

Total Options:	\$ 10,539.00
Base Price:	\$ 65,500.00
Sub Total:	\$ 76,039.00
ATD Total:	\$ 3,801.95
Subtotal:	\$ 72,237.05
Sales Tax:	\$ -
Freight:	\$ -
Fees & Misc.:	
Total:	\$ 72,237.05

Notes:

PH PRICING 01-18 tb

Signing this quote confirms that you have verified the specifications and agree with the final costs. Any specification changes made after verification may alter costs. It is the dealer/customer's responsibility to ensure that the equipment ordered meets specifications and/or quotations.

Terms: TBD

Signature: _____

Date: _____



AGENDA MEMO

Business of the City Council

City of Sweeny, Texas

Meeting Date	10/24/2023	Agenda Item	
Approved by City Manager		Presenter(s)	City Manager; Lindsay Koskiniemi
Reviewed by City Attorney		Department	Administration/ Water Department
Subject	Discussion/ Possible action on proposal received by Water of Texas, Michael Claybourn Sr.		
Attachments			
Financial Information	Expenditure Required:		
	Amount Budgeted:		
	Account Number:		
	Additional Appropriation Required:		
	Additional Account Number:		

Executive Summary

Michael Claybourn, Water of Texas/ Water Treatment Services of Texas, will be presenting drafted proposal to Council as previously requested.

Recommended Action

Council Discretion

Kaydi Smith

From: Lindsay Koskiniemi
Sent: Monday, October 9, 2023 4:07 PM
To: Kaydi Smith
Subject: FW: New Water Treatment System Overview
Attachments: sweenylindsay3.pdf; sweenylindsay2.pdf; sweenylindsay1.pdf; sweenylindsay4.pdf; sweenylindsay5.pdf

From: [REDACTED]
Sent: Wednesday, September 27, 2023 10:35 AM
To: Lindsay Koskiniemi <citymanager@sweenytx.gov>
Cc: [REDACTED]
Subject: New Water Treatment System Overview

Good morning Lindsay,

Attached are several drawings of the water treatment system configurations being considered.

We are leaning hard towards recommending the 3" duplex, 600,000 grain per tank, 1,200,000 total capacity, 400 gallon per minute Clack WS-3 based system with metering, bypass, plumbing, piping, valving, installation, and commissioning.

We generally require 50%/25%/25% payment for these special order industrial systems.

50% down upon reaching an agreement on equipment and pricing. 25% upon delivery and placement of equipment. 25% upon commissioning.

The final 25% payment is due after equipment is fine-tuned, any adjustments are made, and units are running in automatic for 2 weeks, 24 hours per day, without any issues or additional adjustments needed.

Pricing also includes: 1) monthly service, for 12 consecutive months, to verify and document proper operation, and to assist your personnel with any additional questions concerning the ongoing operation of the system.

We are awaiting completion of final engineering, drawings, and pricing.

Preliminary pricing indicates that this system will be \$100k, turnkey.

If expansion is necessary within the next one to two years, a second system identical to this one could be put in place for between \$80 and \$90k, contingent upon pricing increases of course. These duplex units will require the footprint of only 1 of the existing units.

This would be a significant savings over time as opposed to attempting to rehab the existing antiquated systems.

These new systems are state of the art, reliable, dependable, much less expensive to maintain, rebuild, rebed, as opposed to the existing units.

There are a couple of more items that need to be addressed as far as flow paths and pressure and feed water to the units and back to the city system. These questions can no doubt be answered and resolved, but we want to make sure we have the all the possible questions answered before finalizing an agreement.

(P.S. The number five drawing included is actually a 24-inch unit. The unit we are proposing is a 36-in. I will forward you those drawings once that is completed)

Get [Outlook for Android](#)

TYPICAL 2" COMMERCIAL TWIN ALTERNATOR SYSTEM

TWO IDENTICAL SOFTENERS, ONLY ONE METER AND BRINE TANK, AND ONE MOTORIZED ALTERNATING VALVE (MAV).
METER IMMEDIATE REGENERATION WITH HARD WATER USED.
ONE SOFTENER ONLINE, ONE SOFTENER ON STANDBY.

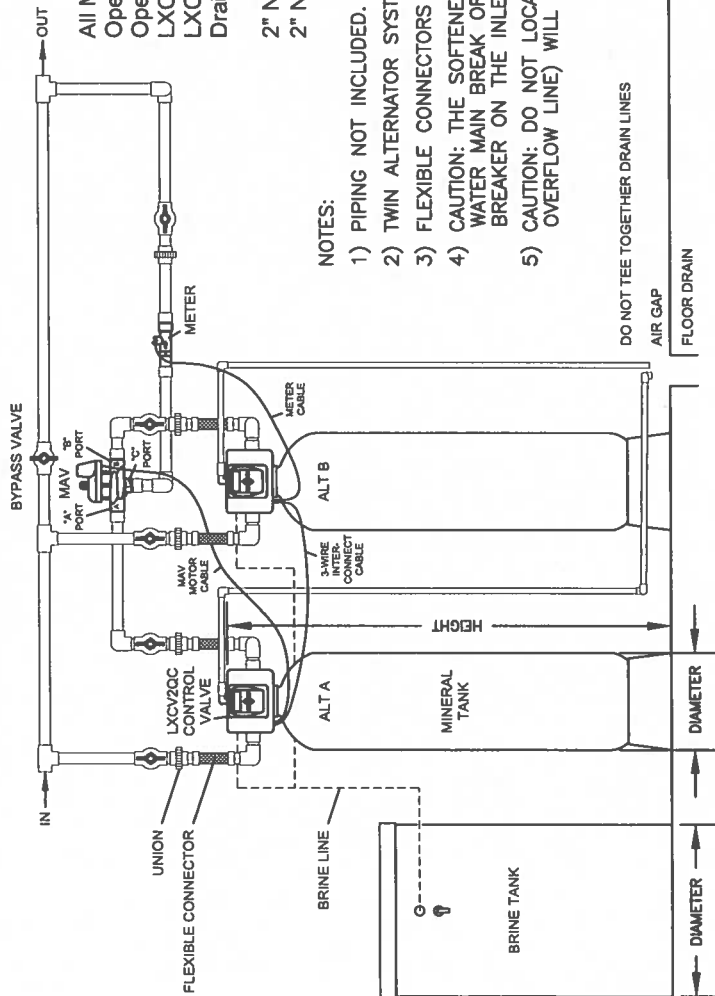

All Models:

- Operating Water Pressure Range: 20 PSI to 125 PSI.
- Operating Water Temperature Range: 40°F to 110°F.
- LXC2QC Control Valves Power Adaptors Input: 120V AC - 60 Hz.
- LXC2QC Control Valves Inlet / Outlet / Drain Port: 2" FPT / 2" FPT / 1.5" FPT.
- Drain Line Adaptor Fitting Connection Sizes: 3/4" MPT 90° Elbow for Model 7-TALX2QC-240, 1.5" FPT Straight Fitting for Models 7-TALX2QC-300 thru -1200.
- 2" NPT Meter Flow Range; Accuracy: 1.5 GPM to 150 GPM; +/- 5%.
- 2" NPT Motorized Alternating Valve: Full 2" ports; low voltage drive controlled by LXC2QC.

NOTES:

- 1) PIPING NOT INCLUDED.
- 2) TWIN ALTERNATOR SYSTEMS ARE FACTORY PRE-PROGRAMMED AND LABELED.
- 3) FLEXIBLE CONNECTORS RECOMMENDED BETWEEN THE SOFTENERS AND HARD PIPING.
- 4) CAUTION: THE SOFTENERS CANNOT BE SUBJECT TO A VACUUM DUE TO A LOSS OF PRESSURE (SUCH AS A WATER MAIN BREAK OR SUBMERSIBLE WELL PUMP CHECK VALVE FAILURE). INSTALLATION OF A VACUUM BREAKER ON THE INLET PIPING IS STRONGLY RECOMMENDED.
- 5) CAUTION: DO NOT LOCATE THE SOFTENERS WHERE THEY OR THEIR CONNECTIONS (INCLUDING DRAIN LINES AND OVERFLOW LINE) WILL EVER BE SUBJECT TO ROOM TEMPERATURES UNDER 40° F.

NOT INTENDED TO BE AN INSTALLATION DRAWING.
FOLLOW ALL LOCAL PLUMBING CODES.

7-TALX2QC SERIES TWIN ALTERNATING SOFTENER SYSTEMS SPECIFICATIONS

2" TWIN ALTERNATING SYSTEM # :	7-TALX2QC-240	7-TALX2QC-300	7-TALX2QC-360	7-TALX2QC-420	7-TALX2QC-480	7-TALX2QC-540	7-TALX2QC-600	7-TALX2QC-600	7-TALX2QC-900	7-TALX2QC-1200
SERVICE FLOW (GPM)										
Continuous @ 15 PSI Pressure Drop	48	75	72	68	77	76	75	88	97	126
Peak @ 25 PSI Pressure Drop	61	97	92	88	100	98	97	113	126	
Softener Diameter x Height (inches)	16 x 77	21 x 79	21 x 79	21 x 79	24 x 85	24 x 85	24 x 85	30 x 84	36 x 85	
Mineral Tank Size	16 x 65	21 x 62	21 x 62	21 x 62	24 x 72	24 x 72	24 x 72	30 x 72	36 x 72	
Resin per tank (cu. ft.)	4	5	6	7	8	9	10	15	20	
Brine Tank Diameter x Height (inches)	24 x 50	24 x 50	24 x 50	24 x 50	30 x 50	30 x 50	30 x 50	39 x 48	39 x 48	
Brine Tank Capacity (Lbs salt)	800	800	800	800	1250	1250	1250	2150	2150	
BACKWASH (GPM)	6.5	10	10	10	15	15	15	25	35	
EXCHANGE CAPACITY per Regeneration										
* Minimum (grains)	96,000	120,000	144,000	168,000	192,000	216,000	240,000	360,000	480,000	
Maximum (grains)	120,000	150,000	180,000	210,000	240,000	270,000	300,000	450,000	600,000	

DIMENSIONS ARE APPROXIMATE FOR ESTIMATING ONLY.
ALL DIMENSIONS ARE IN INCHES.

LANCASTER WATER TREATMENT
LANCASTER PUMP DIVISION
1340 MANHEIM PIKE LANCASTER, PA. 17601

DWG. (PART) NAME: 2" COMMERCIAL TWIN ALTERNATOR SYSTEM
DWG. (PROCESS) TYPE: GENERAL SPECIFICATIONS
DWG. (PART) NO.: 7-TALX2QC

DATE: 6-22-23
SCALE: NA
SHEET 1 OF 1
REV.:

83
THIS DRAWING IS THE PROPERTY OF C-B TOOL CO. AND IS NOT TO BE COPIED OR USED OR DISCLOSED TO OTHERS BY THE RECEIVER WITHOUT WRITTEN AUTHORIZATION BY C-B TOOL CO.

COMPONENT LIST		
ITEM NO.	DESCRIPTION	QTY.
1	MINERAL TANK: 30"x72" COMPOSITE CONSTRUCTION RATED AT 150 PSI	1
2	DISTRIBUTOR ASSEMBLY- 2" HUB AND LATERAL	1
3	GRAVEL	240 LBS.
4	RESIN	15 CU FT
5	WS3 CONTROL VALVE: METERED BRASS CONSTRUCTION 3" INLET/OUTLET 3" DRAIN	1
6	2" FPT FLOW CONTROL: 25 GPM	1
7	BRINE TANK W/LID: POLYETHYLENE CONSTRUCTION 39"x48"	1

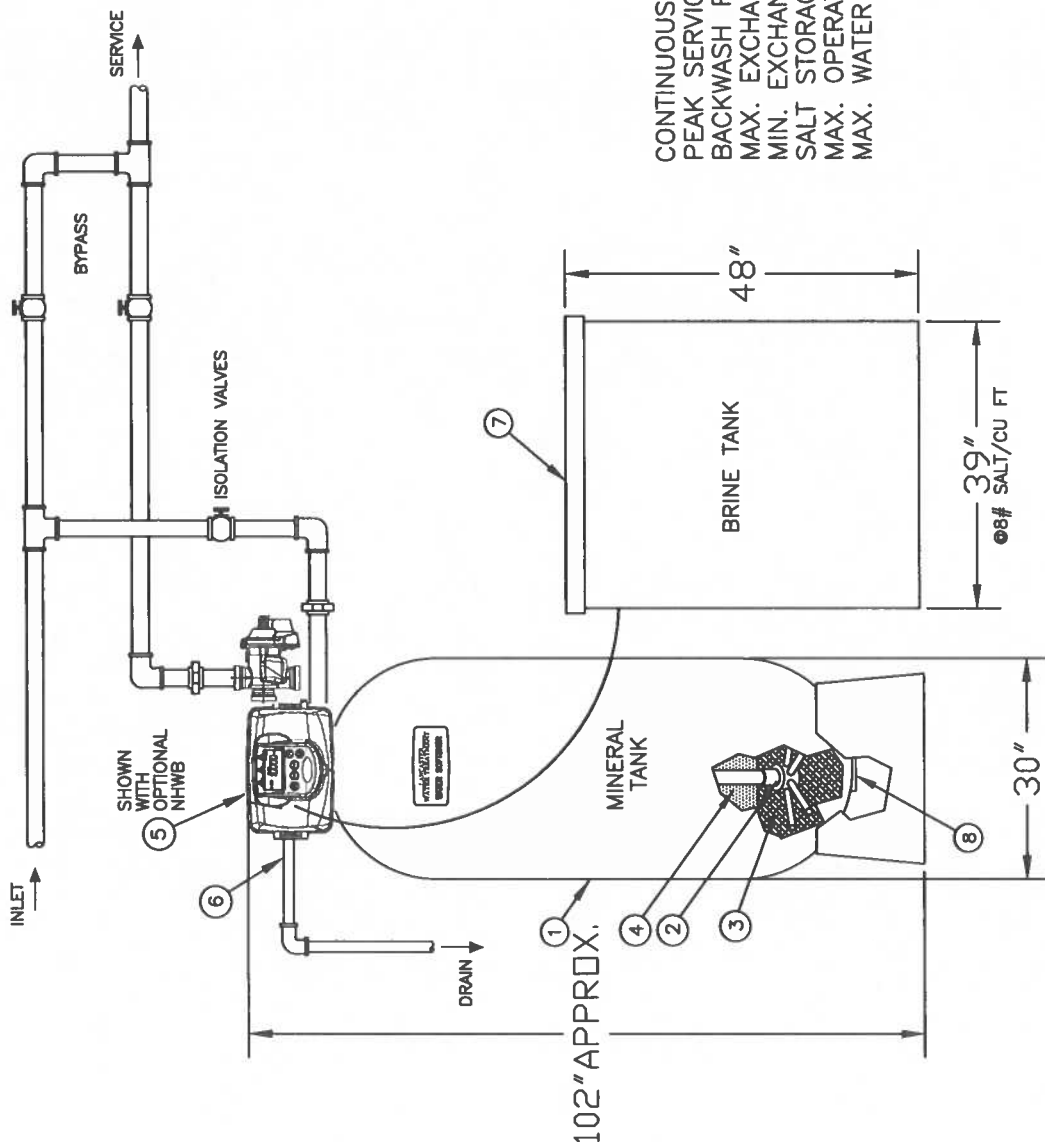

CONTINUOUS SERVICE FLOW RATE (15 PSI LOSS).....144 GPM
 PEAK SERVICE FLOW RATE (25 PSI LOSS).....186 GPM
 BACKWASH FLOW RATE.....25 GPM
 MAX. EXCHANGE CAPACITY @15# SALT/CU FT.....450,000 GR
 MIN. EXCHANGE CAPACITY @8# SALT/CU FT.....360,000 GR
 SALT STORAGE.....2150 LBS
 MAX. OPERATING TEMPERATURE.....110° F
 MAX. WATER PRESSURE.....125 PSI

Notes: This drawing is not intended to be an installation drawing. It is for reference only. Follow all local plumbing and electrical codes. Installer needs to install inlet and outlet isolation ball valves with a three valve bypass. It is recommended to have some unions in the plumbing. Brine tank not included. Operating water must be at least 25 psi during regeneration.

LANCASTER WATER TREATMENT LANCASTER PUMP DIVISION C-B TOOL COMPANY 1340 MANHEIM PIKE LANCASTER, PA. 17601	
DWG./PART/NAME	COMMERCIAL SOFTENER
MATERIAL	3" VALVE, METERED
DRAWN BY	NA
APPD BY	DLR
DATE	30JULY12
BY	B
DESCRIPTION	7-WS3-4
THIS DRAWING IS THE PROPERTY OF C-B TOOL CO. AND IS NOT TO BE COPIED OR USED OR DISCLOSED TO OTHERS BY THE RECEIVER WITHOUT WRITTEN AUTHORIZATION BY C-B TOOL CO.	SCALE NA

COMPONENT LIST		
ITEM NO.	DESCRIPTION	QTY.
1	MINERAL TANK: 24" x 65" COMPOSITE CONSTRUCTION	2
2	DISTRIBUTOR ASSEMBLY-- 3" HUB AND LATERAL	2
3	GRAVEL (total)	320 LBS.
4	RESIN (total)	16 CU FT
5	WS3H CONTROL VALVE: METERED, BRASS CONSTRUCTION 3" INLET/OUTLET 3" DRAIN	2
6	FLOW CONTROL: 15 GPM	2
7	BRINE TANK W/LID: POLYETHYLENE CONSTRUCTION 30" dia x 50" ht	1

CONTINUOUS SERVICE FLOW RATE (15 PSI LOSS).....111-222 GPM
 PEAK SERVICE FLOW RATE (25 PSI LOSS).....143-186 GPM
 BACKWASH FLOW RATE.....15 GPM
 MAX. EXCHANGE CAPACITY @15# SALT/CU FT.....256,000 GR EA TANK
 MIN. EXCHANGE CAPACITY @8# SALT/CU FT.....192,000 GR EA TANK
 SALT STORAGE.....1250 LBS
 MAX. OPERATING TEMPERATURE.....110° F
 MAX. WATER PRESSURE.....125 PSI
 MINIMUM DETECTABLE FLOW RATE.....3.5 GPM

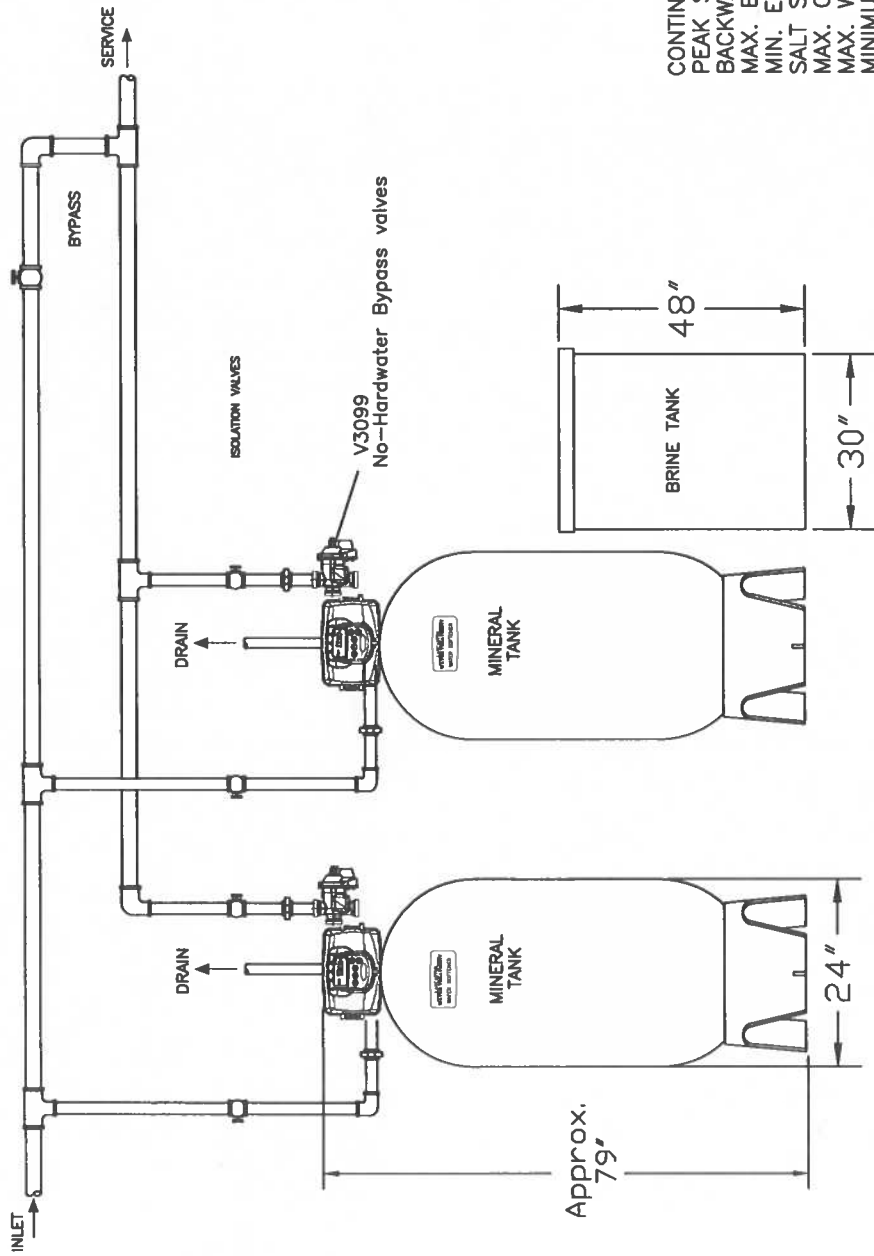

Duplex Alternating system consists of two 24" diameter x 65" height composite mineral tanks.

Notes: This drawing is not intended to be an installation drawing. It is for reference only. Follow all local plumbing and electrical codes. Installer needs to install inlet and outlet isolation ball valves with a three valve bypass. It is recommended to have some unions in the plumbing.
 8' water must be at least 25 psi during regeneration.

LANCASTER WATER TREATMENT LANCASTER PUMP DIVISION C-B TOOL COMPANY 1340 MANHEIM PIKE LANCASTER, PA. 17601	
DWG.(PART)NAME COMMERCIAL SOFTENER	Item 12.
MATERIAL 3" VALVE, METERED	
DRAWN BY APPD BY 2149	DATE 22JUN15
SIZE B	SCALE NA
	DWG.(PART)NO. 7-TAWS3

REV.	DESCRIPTION	DATE	BY
THIS DRAWING IS THE PROPERTY OF C-B TOOL CO. AND IS NOT TO BE COPIED OR USED OR DISCLOSED TO OTHERS BY THE RESENER WITHOUT WRITTEN AUTHORIZATION BY C-B TOOL CO.			

2" COMMERCIAL QUADPLEX PARALLEL PROGRESSIVE FLOW SYSTEM MODEL 7-4PPLX2QC-840

FOUR IDENTICAL SOFTENERS, EACH WITH ITS OWN METER; FOUR BRINE TANKS. METER IMMEDIATE REGENERATION USED.

ALL SOFTENERS CAN BE ONLINE FOR FOUR TIMES THE SERVICE FLOW RATE AND EXCHANGE CAPACITY OF A SINGLE SOFTENER.

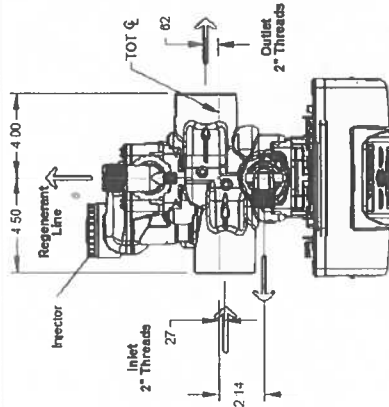

LXC2QC CONTROL VALVE TOP VIEW

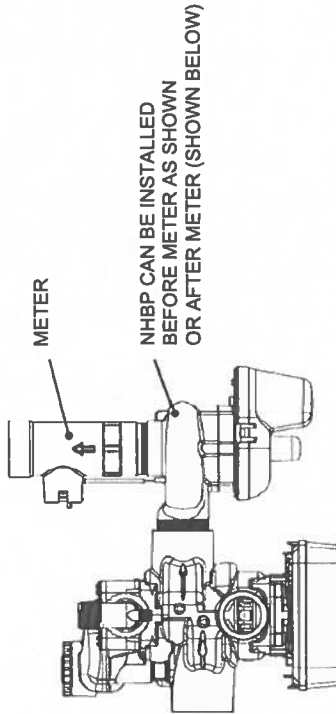

LXC2QC CONTROL VALVE TOP VIEW (NHBP) WITH NO HARD WATER BYPASS VALVE

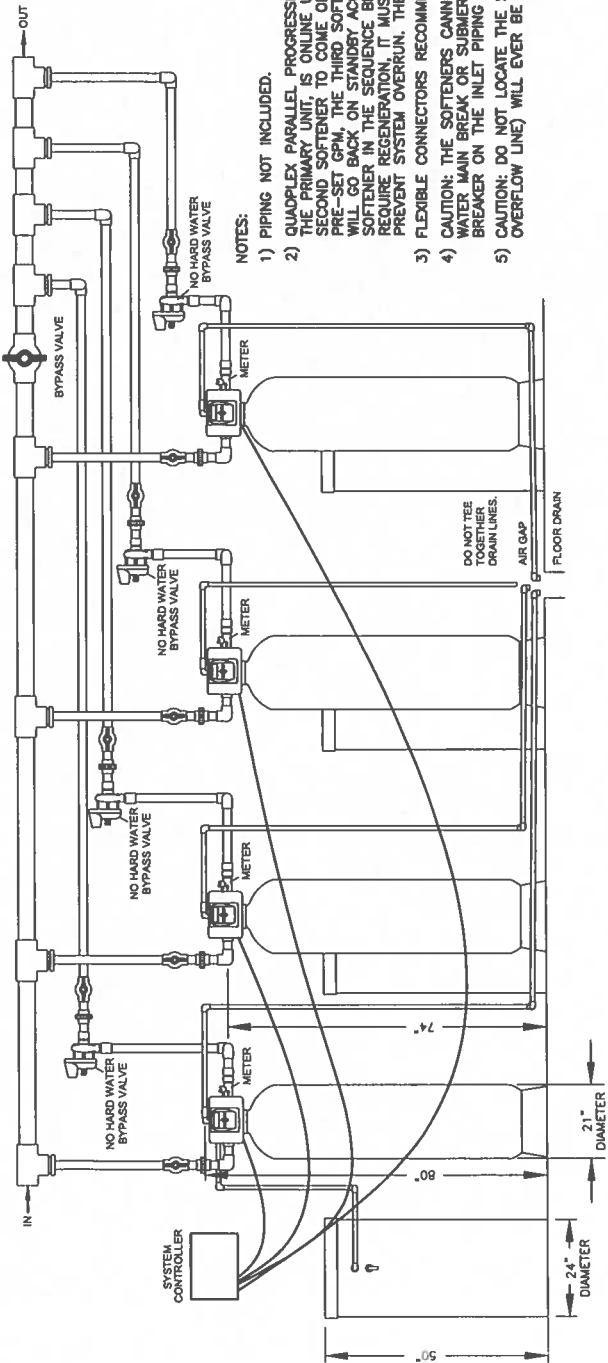

NOTES:

- 1) PIPING NOT INCLUDED.
- 2) QUADPLEX PARALLEL PROGRESSIVE SYSTEMS ARE FACTORY PRE-PROGRAMMED. ONLY ONE SOFTENER, KNOWN AS THE PRIMARY UNIT, IS ONLINE UNTIL THE SERVICE FLOW RATE INCREASES PAST A PRE-SET GPM FOR THE SECOND SOFTENER TO COME ONLINE. IF THE SECOND SOFTENER SERVICE FLOW RATE INCREASES BEYOND THE PRE-SET GPM, THE THIRD SOFTENER WILL COME ONLINE, ETC. AS THE SERVICE FLOW RATE DECREASES, SOFTENERS WILL GO BACK ON STANDBY ACCORDINGLY. WHEN THE PRIMARY UNIT GOES INTO REGENERATION, THE NEXT SOFTENER IN THE SEQUENCE BECOMES THE PRIMARY UNIT. SHOULD ANOTHER UNIT BECOME THE PRIMARY UNIT, IT WILL REQUIRE REGENERATION. IT MUST REMAIN ONLINE UNTIL THE PREVIOUS UNIT HAS BEEN FULLY REGENERATED AND/OR PREVENT SYSTEM OVERRUN. THE PRE-SET GPM UNIT ADD-POINT IS TYPICALLY 60% OF GPM @ 15 PSID.
- 3) FLEXIBLE CONNECTORS RECOMMENDED BETWEEN THE SOFTENERS AND HARD PIPING.
- 4) CAUTION: THE SOFTENERS CANNOT BE SUBJECT TO A VACUUM DUE TO A LOSS OF PRESSURE (SUCH AS A WATER MAIN BREAK OR SURVERSIBLE WELL PUMP CHECK VALVE FAILURE). INSTALLATION OF A VACUUM BREAKER ON THE INLET PIPING IS STRONGLY RECOMMENDED.
- 5) CAUTION: DO NOT LOCATE THE SOFTENERS WHERE THEY OR THEIR CONNECTIONS (INCLUDING DRAIN LINES AND OVERFLOW LINE) WILL EVER BE SUBJECT TO ROOM TEMPERATURES UNDER 40° F.

REV. DESCRIPTION DATE BY

Operating Water Pressure Range: 20 PSI to 125 PSI.
 Operating Water Temperature Range: 40°F to 110°F.
 No Plug-in DC Adaptors are required on individual valves, all connected valves will be powered by the System Controller.
 Supply Voltage (+/- 10% of Nominal) 120V AC - 60 Hz. (U.S.)
 LXC2QC Control Valves Inlet / Outlet / Drain Port: 2" FPT / 2" FPT / 1.5" FPT.
 Drain Line Adaptor Fitting Connection Size 1.5" FPT.
 LXC2QC Control Valves Distributor Pipe Pilot 2.375" OD (2" NPS).
 HDPE Lined Composite Fiberglass Filament Wound Mineral Tanks, 4" Top Opening.
 4"-8 UN QC Base Assemblies for Control Valves Top Mount.
 2" NPT Meters Flow Range: Accuracy: 1.5 GPM to 150 GPM; +/- 5%.

2" QUADPLEX PARALLEL PROGRESSIVE SYSTEM #: 7-4PPLX2QC-840	
SINGLE TANK SERVICE FLOW (GPM)	32
Continuous @ 8 PSI Pressure Drop	66
Continuous @ 15 PSI Pressure Drop	88
Peak @ 25 PSI Pressure Drop	
Softener Diameter x Height (inches)	21 x 80
Mineral Tank Size	21 x 62
Resin per tank (cu. ft.)	7
Brine Tank Diameter x Height (inches)	24 x 50
Brine Tank Capacity (Lbs salt)	800
BACKWASH (GPM)	10
EXCHANGE CAPACITY per Regeneration	
* Minimum (grains) each tank	166,000
* Maximum (grains) each tank	210,000

* Factory Setting

DIMENSIONS ARE APPROXIMATE FOR ESTIMATING ONLY.
 ALL DIMENSIONS ARE IN INCHES.
 DRAWN FOR CLARITY ONLY.

NOT INTENDED TO BE AN INSTALLATION DRAWING.
 FOLLOW ALL LOCAL PLUMBING CODES.

LANCASTER WATER GROUP

DWC (PART) NAME		2" COMMERCIAL QUADPLEX PARALLEL PROGRESSIVE SYSTEM	
LANCASTER WATER TREATMENT		FOUR WATER SOFTENERS, FOUR METERS, FOUR BRINE TANKS	
1340 MARKET PLACE		LANCASTER, PA. 17601	
DATE	5/13/21	SCALE	NA
DRAWN BY	97M/d	DWC (PART) NO.	7-4PPLX2QC-840
APP'D BY	B	SHEET	1
REV.		REV.	

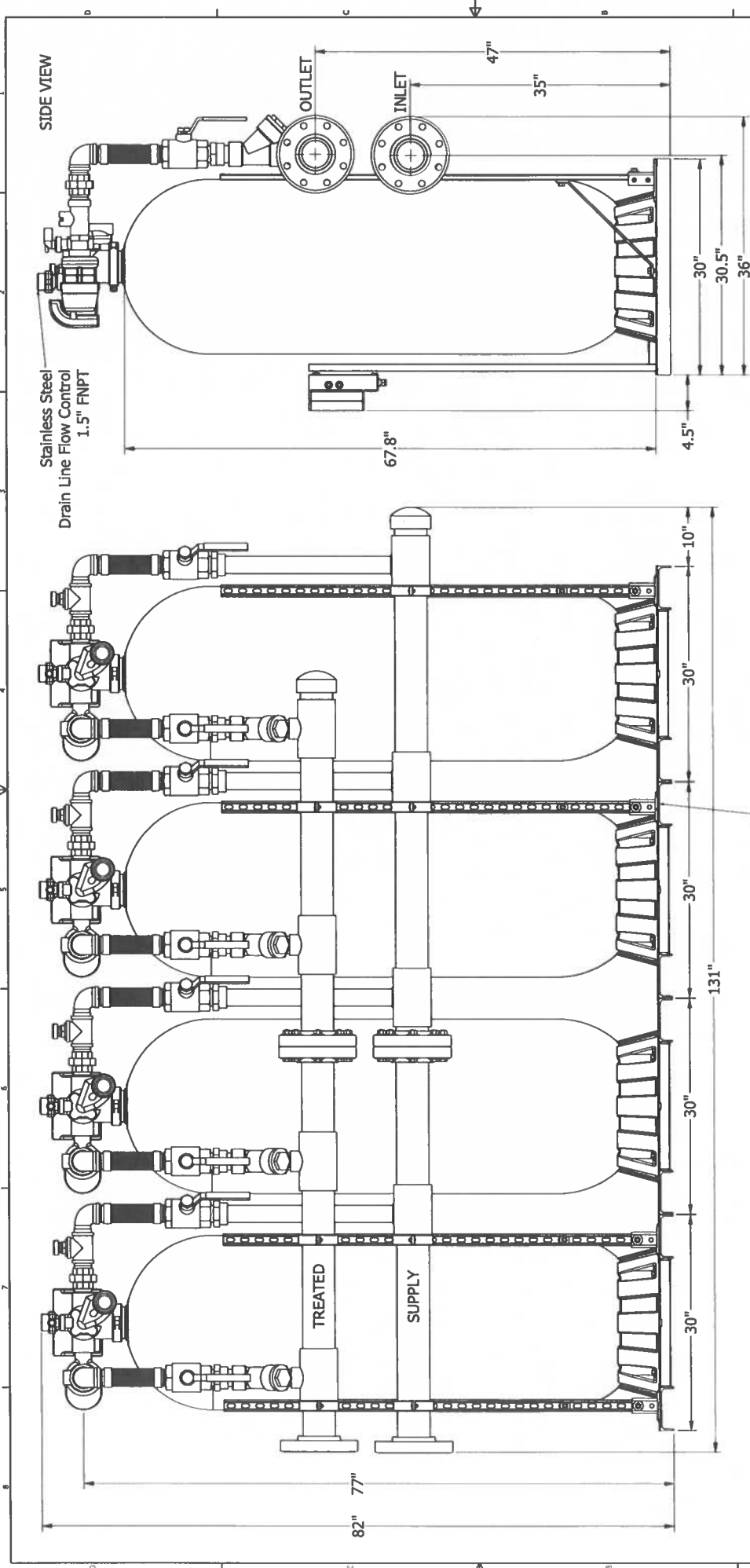

(EXCEPT AS NOTED) ALLOW DIMENSIONS TO VARY TOLERANCES		LANCASTER WATER GROUP LANCASTER PUMP LANCASTER WATER TREATMENT C&S TOOL COMPANY	
DWG. (PART) NAME	DWG. (PROCESS) TYPE	7-APPLX2QC-600, -720, -840 Dimensional	
DWG. NO. 104	MATERIAL N/A	DRAWN BY	DATE 7/20/2022
FRACTIONAL 8/164		CHK'D BY	DWG. (PART) NO.
ANGULAR 2°		DATE	7-APPLX2QC-600,
DO NOT SCALE DRAWING		SHEET 2 OF 2	-720, -840
		SCALE 1 : 1	REV.

INLET and OUTLET:
 4" PVC Van Stone Flange
 SCH 80 Female Socket-Connect

C6 x 8.2 Channel

NOTES:
 1) DIMENSIONS ARE APPROXIMATE FOR ESTIMATING ONLY
 2) QUANTITY FOUR (4) 30" X 30" BASE PLATE WELDED ASSEMBLIES ARE NOT WELDED TO EACH OTHER

Item 12.

7-4PPLX2QC-600, -720, -840
Dimensional Drawing

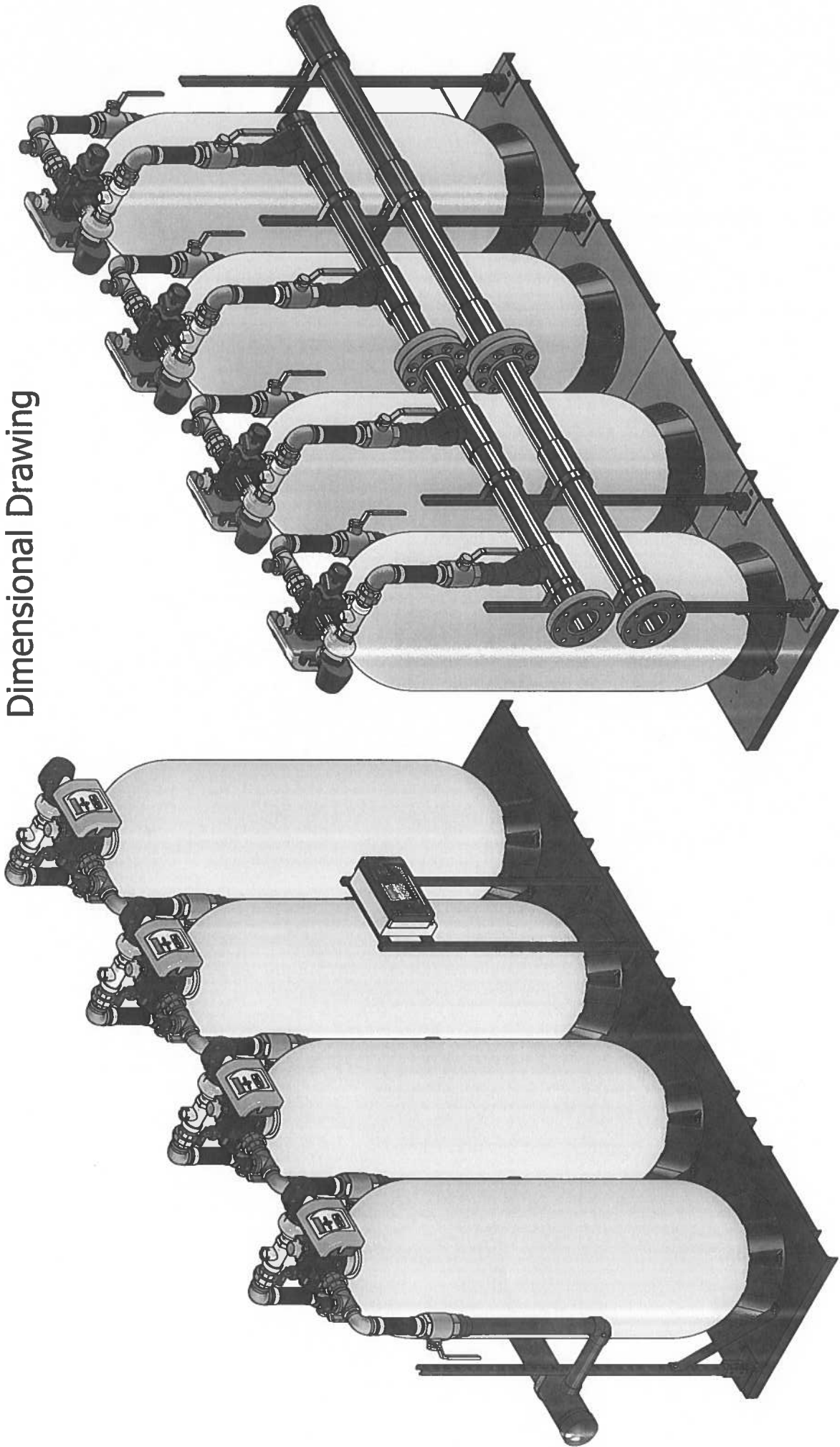



AGENDA MEMO

Business of the City Council
City of Sweeny, Texas

Meeting Date	10/24/2023	Agenda Item	
Approved by City Manager		Presenter(s)	Michelle Medina
Reviewed by City Attorney		Department	Sweeny EDC
Subject	Stark Inc. Performance Agreement		
Attachments	Business Plan and Pro Forma		
Financial Information	Expenditure Required:		
	Amount Budgeted:		
	Account Number:		
	Additional Appropriation Required:		
	Additional Account Number:		

Executive Summary

Council requested Stark Inc. provide more information prior to approving.

Recommended Action

The EDC seeks approval of performance agreement to move forward with survey and deed.



Cecil Joe Stark Logging and Sawmill Inc
DBA Stark Inc

Cecil Stark

office@starkservicesinc.com

www.starkservicesinc.com

(888) 212- DIRT

Table of Contents

1.0 Executive Summary 3

 1.1 Objectives 3

 1.2 Mission and Vision 3

 1.3 Keys to Success 3

2.0 Company Summary 4

 2.1 Company Ownership 4

3.0 Products/Services and Operations 4

 3.1 Location, Hours of Operation 4

 3.2 Products or Services 5

4.0 Market Analysis Summary 5

 4.1 Market Segmentation 5

 4.2 Industry Analysis 5

 4.3 Competition 8

 4.4 Competitive Edge 9

5.0 Strategies and Goals 9

 5.1 Marketing and Sales..... 9

6.0 Management Summary 10

7.0 Financial Requirements 10

Financial Pro Formas (attached)

Other Attachments

1.0 Executive Summary

Cecil Joe Stark Logging and Sawmill, Inc., dba Stark, Inc. is a Domestic For-Profit Corporation formed in the state of Texas by Cecil J. Stark.

Projected sales for year one after the move to the Sweeny location total \$6,000,000 building to \$7,500,000 by the third year of operation at this new location. Stark, Inc. will need to earn an average monthly revenue of \$103,813 in year one to break even. Potential sales tax collected in year one total \$495,000 building to \$618,750 in year three.

Stark Inc. is seeking \$304,000 in outside funding to supplement the owner's investment of \$76,000 cash equity injection to cover construction costs for the primary office building and retail shop. Additional improvements will be made using owner's equity.

1.1 Objectives

- Relocate operations and open the retail shop in January 2024
- Projected sales for year one after the move to the Sweeny location total \$6,000,000 building to \$7,500,000 by the third year of operation at this new location.
- Maintain a positive cash balance throughout the first 3 years of operation after relocation, maintaining a positive net worth during the first year of operation.

1.2 Mission and Vision

Stark Inc. provides professional and reliable land-clearing services to our customers. Our mission is to consistently deliver exceptional workmanship and customer service while maintaining a commitment to sustainability and environmental responsibility. We aim to be the leading provider of land-clearing services in our region.

1.3 Keys to Success

Based on company history and experience, and according to Vertical IQ industry reports, the keys to success for site prep contractors include:

- Accurate Estimates of Project Costs and Bidding. Accurate cost estimates and project bidding are critical to site prep contractors' profitability. Stark, Inc. has a long history of successful project cost estimating and has a process in place to bid successfully.
- Effective Credit and Collections. - Maintaining effective control over credit and collections can be critical to site prep contractors' profitability Stark, Inc. has a

**Cecil Joe Stark Logging and Sawmill Inc
DBA Stark Inc**

strong reputation in the industry for paying on time and collecting payments from customers. Before we start any job, we send a service agreement with the terms of the contract and we have lines of credit from local banks.

- **Managing Cash Through Swings in Demand.** - Site prep contractors must be able to manage cash through swings in business activity to be successful. Seasonality and weather conditions affect project timelines and site prep contractors' ability to perform work. Stark, Inc. maintains the pits and yard by keeping stock of the material and maintaining equipment. If we run out, we order it right away so the work is not delayed. If the weather is not to par, we try to get it to the customer as soon as we can.

2.0 Company Summary

Stark Inc. strives to offer a wide range of land-clearing services to meet the unique needs of our clients. We also provide stone for houses, lawn equipment and trailer rental for anyone. We are committed to using the latest technology and techniques to ensure the safety and efficiency of our work.

Stark Inc. helps provide transport services such as Dirt and rock delivery, which include but are not limited to, select fill, sand, clay, limestone road base, stabilized sand, crushed concrete, and firewood among many other things. We also provide site work such as land clearing, ponds, pads, driveways, and much more. The target customer base includes contractor companies, as well as small businesses and individuals. We feel that Stark Inc. can be an asset to your city by bringing in more revenue to Sweeny and bringing in more customers. It will also benefit Stark Inc. with employees and expand our business to being a retail store.

2.1 Company Ownership

Cecil Joe Stark Logging and Sawmill, Inc., dba Stark, Inc. is a Domestic For-Profit Corporation formed in the state of Texas by Cecil J. Stark.

- We have been in business since 2007 with more than 15 years of experience.
- Cecil Stark, President has been in this industry his entire life, first working at his father's business and learning about the trade.

3.0 Products and Services

Location: 149-199 Calvie Brown Rd, Sweeny TX, 77480

Our location allows us to better serve customers because we have sand pits located in Bay City, Old Ocean, Jones Creek, Angleton, and Damon.

Hours of Operation: M-F 7 am-4 pm

Products/Service offering:

Sand, clay, select fill, topsoil, limestone, crushed concrete, dozer and excavator work, land clearing, site prep, custom hauling, demolition, driveways, roads, ponds, pads, firewood, and mats.

4.0 Market Analysis Summary

Demographic forecasting for Brazoria County and the greater Houston Metro area, estimates that the population will increase over 40% during the next 10-15 years. (HGAC report 2016). The Brazosport area is a key growth area in Brazoria County, especially due to industrial expansions in the petrochemical, LNG and oil refinery industries. With anticipated population growth and increased disposable income, as measured by the value of construction, construction activity is expected to grow at an annualized rate of 1.7% over the five years to 2024.

4.1 Market Segmentation

Target Customers

- Our target customers include construction and contract companies who need trucking services or materials to their job sites. An example of these types of companies include pipeline, construction in Phillips, and CenterPoint Energy substations. Recently, Stark Inc provided services to the Byrd Ranch Substation Battery site located on FM 1459 right outside of Sweeny.
- Other target customers of Stark Inc include individuals that need site work such as land clearing, house pads, ponds, and driveways installation.

Customer Needs

- Quality: We try our best to provide the services requested by each customer in a professional and timely manner.
- Reliability: Stark Inc provides reliable services to our customers as agreed subject to weather constraints.

4.2 Industry Analysis

Site Prep Contractors

Sales for the US site prep contractors industry are forecast to grow at a 4.96% compounded annual rate from 2022 to 2027, comparable to the growth of the overall economy. According to reports from Vertical IQ, the average site preparation contractor operates out of a single location, employs 9-10 workers, and generates about \$2-3 million annually.

- The site preparation services industry consists of about 37,300 companies that employ 379,600 workers and generate about \$97 billion annually.
- The industry is fragmented; most site preparation contractors serve a limited geographical market.
- Some large general contractors, such as Granite Construction and Sterling Construction, offer site preparation services in addition to other construction services.

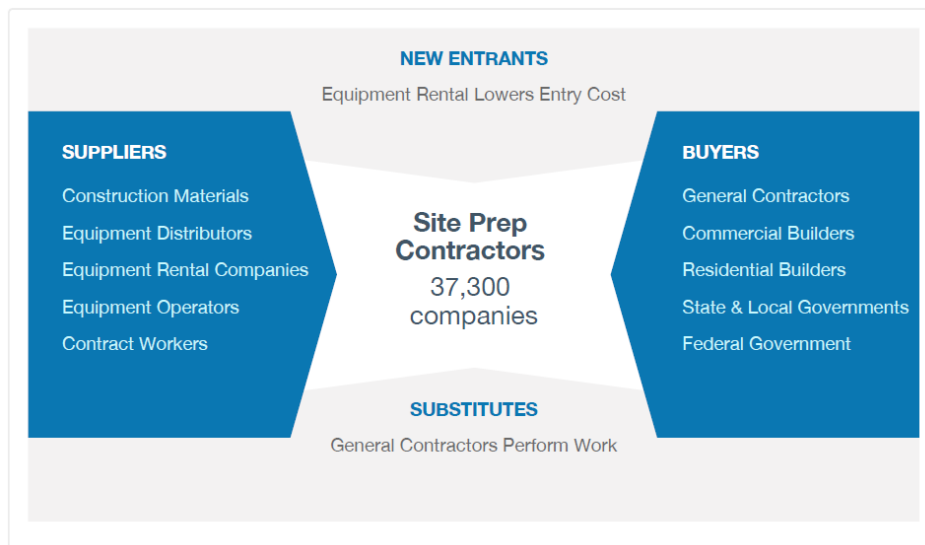

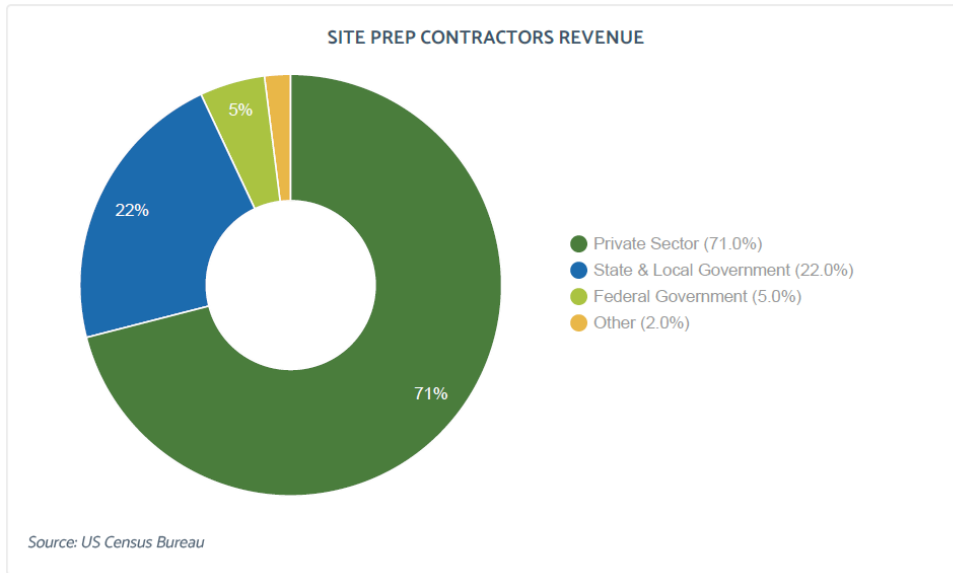

Nurseries, Garden Centers & Farm Supply

The average nursery, garden center, or farm supply retailer operates out of a single location, employs 14 workers, and generates \$3-4 million annually. Sales for the US nurseries, garden centers and farm supply retailers industry are forecast to grow at a 2.8% compounded

annual rate from 2022 to 2027, slower than the growth of the overall economy.

- The nursery, garden center, and farm supply retailing industry consists of about 9,200 companies operating 13,100 stores that employ about 130,000 workers and generate about \$35 billion annually.
- The industry is highly fragmented; the top 50 firms account for about 41% of industry sales.
- Tractor Supply is the largest farm supply retailer in the US with over 1,940 stores. Large nursery and garden centers, such as Armstrong Garden Centers and Stein Garden Centers, have multiple locations but typically operate in one or two states. Most companies are small, independent operations.

Cecil Joe Stark Logging and Sawmill Inc
DBA Stark Inc

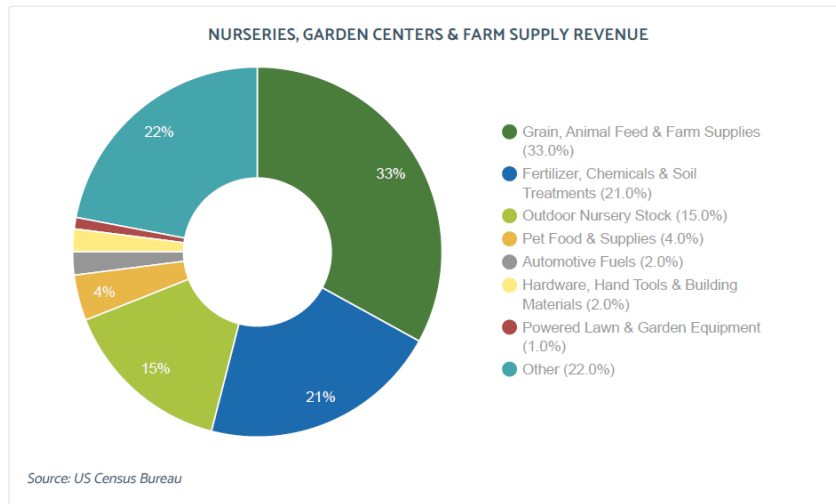
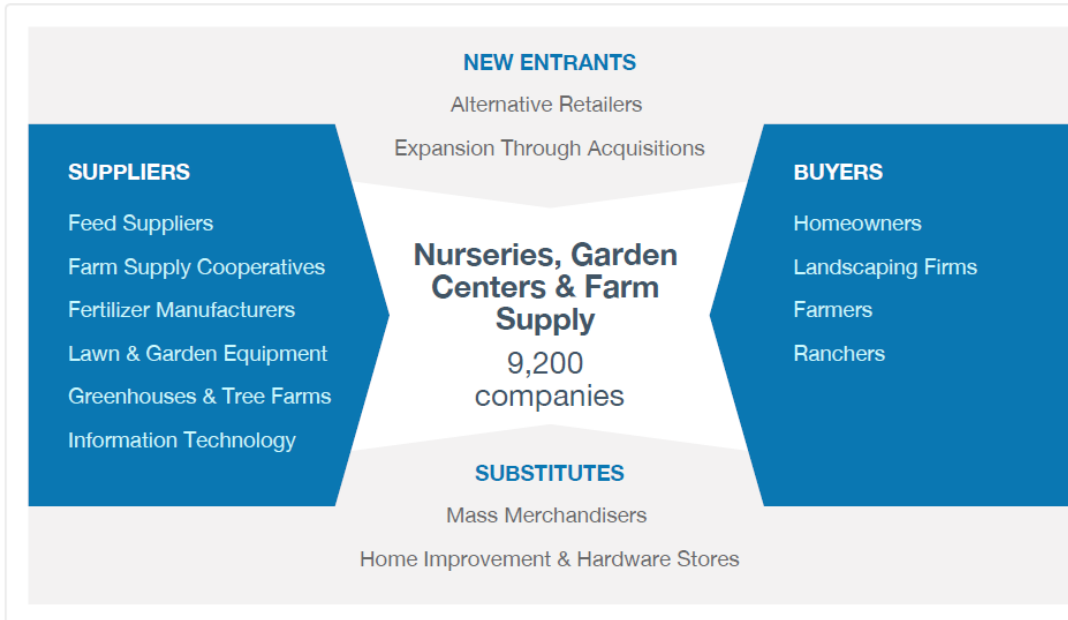

4.3 Competition

The top 3 competitors for [Business Name] include the following:

Company	Location	Pros & Cons
Vernor Material	545 County Road 227A Freeport, TX 77541 website: https://vernor.com/	Pros: they do a lot more then what we do. We also work with them. Friends with owners

		Cons: Been around a long time.
Justice Sand	19216 TX-35 Sweeny, TX 77480 Website: https://justicesandco.com/	Pros: going out of business Cons: Close to us
SRM Concrete	13510 FM 523 Angleton, TX 77515 Website: https://www.smyrnareadymix.com/	Pros: There are all around the world. Cons: There office is in TN

4.4 Competitive Edge

- Quality: We try our best to provide the services requested by each customer in a professional and timely manner.
- Reliability: Stark Inc provides reliable services to our customers as agreed subject to weather constraints.

5.0 Strategies and Goals

- **Short-Term Goals:**
 - To move closer to town and become the go-to resource for lawn and landscaping products West of the Brazos.
 - Expand the business by adding a retail storefront and more products for sale.

5.1 Marketing and Sales Summary

Dirt Delivery

Select Fill
 Sand
 Topsoil
 Common Fill
 Clay
 Black Dirt

Rock

Stabilized Material
 Limestone
 57 stone-finish rock
 Crushed Concrete
 Stone
 Asphalt Milling's
 Aggregate
 Pea Gravel
 3x5 Bull Rock

Maintenance

Mowing
 Weeding
 Ditch Cleaning

Rolloff Dumpster

20's,25's,30's,35's,40's,45's

Other services

Land Clearing
 Site Prep
 Custom Hauling
 Dozer work
 Excavator Work
 Demolition
 Driveways
 Pads
 Ponds
 Roads

Equipment Rent

Trailers
 Lawn Equipment
 Chainsaws
 Crash Trailers / Trucks

Repair

Chainsaws
 Lawn Equipment

Parts

Lawn Equipment
 Chainsaws

Firewood- Delivery/pick up.

¼ cord
 ½ a cord
 Full (1) cord
 Stacked on pallet.
 Self-Loading

5.2 Promotions Plan

Cecil Joe Stark Logging and Sawmill Inc DBA Stark Inc. will use the following tactics to attract new customers.

customers:

- Banners and Billboards: Put up billboards around town or towns.
- Classified Ads: In the school athletic books and in the newspaper.
- Online Marketing: Facebook posts and Stark Inc. website
- Support Baseball/ Softball teams around Brazoria County.
- Support Fire department/ Police station

6.0 Management Summary

Cecil Joe Stark Logging and Sawmill Inc
DBA Stark Inc

Cecil Stark, Title: Owner: Owner of Stark Inc. since 2007. Deals with pricing and what jobs Stark Inc does.

Shelly French, Office Manager: Deals with QuickBooks and billing and writing checks.

Emily Stark, Office Assistant: Does trucking payroll and filing, answer phones. Has a degree in office administration.

Daniel Stark, Trucking Supervisor: Schedules deliveries, trucking services, and provides bids.

Charles Carter, Manager: Provides bids and oversees site work at the job site.

Below is a list of advisors who will provide support to the management team:

Name	Organization	Specialization
Emily Stark	Stark Inc.	Office Manager
Shelly French	Stark Inc.	Accounting & Taxes
Jennifer Finney	Brazosport College SBDC	Business & Strategic Planning, Financial Management & Marketing

7.0 Financial Requirements

Stark Inc. is seeking \$304,000 in outside funding to supplement the owner's investment of \$76,000 cash equity injection to cover construction costs for the primary office building and retail shop. Additional improvements will be made using owner's equity.



CLIENT NAME: Cecil Stark

BUSINESS NAME: Stark, Inc.

CONSULTANT NAME: Jennifer Finney

DATE: 10/12/2023

VERSION: 1

The Small Business Development Center (SBDC) has prepared this financial statement as of the date above based on information and assumptions provided by management. Neither the SBDC nor its personnel are licensed by the State of Texas to practice public accounting and therefore express no opinion or any other form of assurance on the statement or underlying assumptions.

Stark, Inc. 0 0
Use of Funds

ASSETS		OWNER INVESTMENT
Land		
	Purchased/ Owned	-
	Improvements to Parking / Land	50,000
		50,000
Facility		
	Building	380,000
	Improvements to Building	
		380,000
Equipment		
	Office Equipment	4,000
	Production Equipment	
	Vehicles	
	Other Equipment	
	Installation	
		4,000
Furniture & Fixtures		
	Tables & Chairs	6,000
	Signage	3,000
	Installation	500
		9,500
	OTHER ASSETS	
Deposits		
Lease Deposit		
Electricity		
Telephone		
Water		
		-
Inventory		100,000
Franchise Fees		-
Cash On Hand		
Total Assets		543,500

Start Up Expenses		
Insurance		
Liability		
Fire		
Slip/Fall		
Automobile		-
		-
Advertising		
Print Advertising		400
Brochures / Business Cards		
Billboard		
Television		
Radio		
Website		
Internet		2,000
Promotion - Grand Opening		
		2,400
Licenses & Permits		
LLC		
Permits		6,200
Other		
		6,200
Professional & Legal Fees		
Attorney		
Accountant		250
Other		-
		250
Supplies		
Office		2,000
Production		
		2,000
Misc		-
Misc		-
Misc		-
Misc		-
Misc		-
Misc		-
		-
Total Start Up Expenses		10,850

Total Start-up Assets & Expenses		554,350
Investor 1	Planned Owners Investment	76,000

WorkSheet/ Input Data**Monthly Fixed Costs (excluding Interest)**

Fixed Costs	Monthly ONLY
Rent/Lease	
Electricity/ Gas	450
Telephone/ Cell/ Cable	1,000
Water/ Garbage Disposal	300
Insurance	9,500
Postage & Freight	
Office Supplies	500
Repairs & Maintenance	3,500
Owner's Salary	8,000
Wages & Salaries	26,000
Payroll Taxes	5,202
Vehicle Expense (travel, fuel, repairs - busine	17,000
Legal & Professional Fees	450
Internet	200
Advertising	800
Property Taxes (if applicable)	
Safety Equipment	100
Misc	
Misc	
Misc	
Misc	-
Misc	-
Misc	-
Misc	-
	73,002

Stark, Inc.
Sources of Capital

Start-up Expenses to Fund	10,850
Start-up Assets to Fund	543,500
Total Funding Required	<u>554,350</u>

Assets	
Non-Cash Assets from Start-up	543,500
Start-up Expenses to Fund	10,850
Cash Requirements from Start-up	-
Total Assets	<u>554,350</u>

Liabilities and Equity

Liabilities	
Loan 1	304,000
Loan 2	-
Loan 3	-
Loan 4	-
Total Liabilities	<u>304,000</u>

Owner's Capital Injection	76,000
Owner's Equity	174,350
Total Liabilities & Equity	<u>554,350</u>

Stark, Inc.

Pro-Forma Annual Income Statement

Years 1 - 3

SALES	Year 1	%	Year 2	%	Year 3	%
Stone	300,000	5%	360,000	5%	375,000	5%
Rental Equipment	240,000	4%	288,000	4%	300,000	4%
Repair	210,000	4%	252,000	4%	262,500	4%
Trailers	240,000	4%	288,000	4%	300,000	4%
Parts	210,000	4%	252,000	4%	262,500	4%
Land Clearing/Site Prep/Limestone	4,800,000	80%	5,760,000	80%	6,000,000	80%
Total Sales	6,000,000	100%	7,200,000	100%	7,500,000	100%
COST OF GOODS						
Stone	150,000	3%	180,000	3%	187,500	3%
Rental Equipment	3,600	0%	4,320	0%	4,500	0%
Repair	105,000	2%	126,000	2%	131,250	2%
Trailers	192,000	3%	230,400	3%	240,000	3%
Parts	105,000	2%	126,000	2%	131,250	2%
Land Clearing/Site Prep/Limestone	240,000	4%	288,000	4%	300,000	4%
Total Cost Of Goods Sold	795,600	13%	954,720	13%	994,500	13%
Gross Profit	5,204,400	87%	6,245,280	87%	6,505,500	87%
OPERATING EXPENSES						
Sales Tax (% of Sales)	495,000	8%	594,000	8%	618,750	8%
Merchant Account Service Fee (%Sales)	180,000	3%	216,000	3%	225,000	3%
Rent/Lease	-	0%	-	0%	-	0%
Electricity/ Gas	5,400	0%	5,508	0%	5,618	0%
Telephone/ Cell/ Cable	12,000	0%	12,240	0%	12,485	0%
Water/ Garbage Disposal	3,600	0%	3,672	0%	3,745	0%
Insurance	114,000	2%	116,280	2%	118,606	2%
Postage & Freight	-	0%	-	0%	-	0%
Office Supplies	6,000	0%	6,120	0%	6,242	0%
Repairs & Maintenance	42,000	1%	42,840	1%	43,697	1%
Owner's Salary	96,000	2%	97,920	1%	99,878	1%
Wages & Salaries	312,000	5%	318,240	4%	324,605	4%
Payroll Taxes	62,424	1%	63,672	1%	64,946	1%
Vehicle Expense (travel, fuel, repairs - busines:	204,000	3%	208,080	3%	212,242	3%
Legal & Professional Fees	5,400	0%	5,508	0%	5,618	0%
Internet	2,400	0%	2,448	0%	2,497	0%
Advertising	9,600	0%	9,792	0%	9,988	0%
Property Taxes (if applicable)	-	0%	-	0%	-	0%
Safety Equipment	1,200	0%	1,224	0%	1,248	0%
Total Operating Expenses	1,551,024	26%	1,703,544	24%	1,755,165	23%
Operating Profit (EBITDA)	3,653,376	61%	4,541,736	63%	4,750,335	63%
Depreciation	21,471	0%	21,471	0%	21,471	0%
Amortization	3,617	0%	3,617	0%	3,617	0%
EBIT	3,628,288	60%	4,516,647	63%	4,725,247	63%
Interest Expense	34,892	1%	31,150	0%	26,934	0%
Net Income before tax (EBT)	3,593,396	60%	4,485,497	62%	4,698,313	63%

Stark, Inc.Annual Pro-Forma Cash Flow
Direct Method

	Year 1	Year 2	Year 3
Beginning Cash Balance	174,350	3,768,102	8,246,396
Cash Inflows			
Cash Sales	6,000,000	7,200,000	7,500,000
Accounts Receivable Collected	-	-	-
Loan & Cash Injection	-	-	-
Total Cash Inflows	6,000,000	7,200,000	7,500,000
Cash Outflows			
Inventory Purchases	790,826	953,765	994,261
Sales Tax (% of Sales)	495,000	594,000	618,750
Merchant Account Service Fee (%Sales)	180,000	216,000	225,000
Rent/Lease	0	0	0
Electricity/ Gas	5,400	5,508	5,618
Telephone/ Cell/ Cable	12,000	12,240	12,485
Water/ Garbage Disposal	3,600	3,672	3,745
Insurance	114,000	116,280	118,606
Postage & Freight	0	0	0
Office Supplies	6,000	6,120	6,242
Repairs & Maintenance	42,000	42,840	43,697
Owner's Salary	96,000	97,920	99,878
Wages & Salaries	312,000	318,240	324,605
Payroll Taxes	62,424	63,672	64,946
Vehicle Expense (travel, fuel, repairs - busi	204,000	208,080	212,242
Legal & Professional Fees	5,400	5,508	5,618
Internet	2,400	2,448	2,497
Advertising	9,600	9,792	9,988
Property Taxes (if applicable)	0	0	0
Safety Equipment	1,200	1,224	1,248
Loan Payment	64,397	64,397	64,397
Dividends Paid	0	0	0
Total Cash Paid Out	2,406,248	2,721,707	2,813,824
Annual Net Cash Flow	3,593,752	4,478,293	4,686,176
Cumulative Net Cash Position	3,768,102	8,246,396	12,932,572

Stark, Inc.

Pro Forma Annual Balance Sheet

	After Loan	Year 1	Year 2	Year 3
Current Assets				
Cash	174,350	3,768,102	8,246,396	12,932,572
Prepaid Start-up Costs	10,850	7,233	3,617	-
Accounts Receivable	-	-	-	-
Inventory	100,000	100,000	100,000	100,000
Other Current Assets	-	-	-	-
Total Current Assets	285,200	3,875,336	8,350,012	13,032,572
Non-Current Assets				
Land	-	-	-	-
Improvements to Parking / Land	50,000	50,000	50,000	50,000
Building	380,000	380,000	380,000	380,000
Less Accumulated Depreciation	-	(19,000)	(38,000)	(57,000)
Improvements to Building	-	-	-	-
Less Accumulated Depreciation	-	-	-	-
Equipment	4,000	4,000	4,000	4,000
Less Accumulated Depreciation	-	(571)	(1,143)	(1,714)
Furniture & Fixtures	9,500	9,500	9,500	9,500
Less Accumulated Depreciation	-	(1,900)	(3,800)	(5,700)
Total Non Current Assets	443,500	422,029	400,557	379,086
Other Assets				
Deposits	-	-	-	-
Franchise Fees	-	-	-	-
Total Assets	728,700	4,297,364	8,750,569	13,411,657
Liabilities & Owners Equity				
Current Liabilities				
Accounts Payable	-	4,774	5,728	5,967
Other Current Liabilities	-	-	-	-
Current Portion of Loan 1	29,505	33,247	37,463	42,215
Total Current Liabilities	29,505	38,021	43,192	48,182
Long Term Liabilities				
Long Term Portion of Loan 1	274,495	241,248	203,785	161,570
Total Long Term Liabilities	274,495	241,248	203,785	161,570
Total Liabilities	304,000	279,269	246,976	209,752
Equity				
Planned Owners Investment	76,000	76,000	76,000	76,000
Retained Earnings	174,350	3,767,746	8,253,243	12,951,556
Owner's Equity/Capital Stock	174,350	174,350	174,350	174,350
Total Equity	424,700	4,018,096	8,503,593	13,201,906
Total Liabilities & Equity	728,700	4,297,364	8,750,569	13,411,657

	Jan-24	Feb-24	Mar-24	Apr-24	May-24	Jun-24	Jul-24	Aug-24	Sep-24	Oct-24	Nov-24	Dec-24
SALES												
Stone	30,000	30,000	27,000	30,000	36,000	39,000	30,000	27,000	15,000	15,000	12,000	9,000
Rental Equipment	24,000	24,000	21,600	24,000	28,800	31,200	24,000	21,600	12,000	12,000	9,600	7,200
Repair	21,000	21,000	18,900	21,000	25,200	27,300	21,000	18,900	10,500	10,500	8,400	6,300
Trailers	24,000	24,000	21,600	24,000	28,800	31,200	24,000	21,600	12,000	12,000	9,600	7,200
Parts	21,000	21,000	18,900	21,000	25,200	27,300	21,000	18,900	10,500	10,500	8,400	6,300
Land Clearing/Site Prep/Limestone	480,000	480,000	432,000	480,000	576,000	624,000	480,000	432,000	240,000	240,000	192,000	144,000
Total Sales	600,000	600,000	540,000	600,000	720,000	780,000	600,000	540,000	300,000	300,000	240,000	180,000
COST OF GOODS												
Stone	15,000	15,000	13,500	15,000	18,000	19,500	15,000	13,500	7,500	7,500	6,000	4,500
Rental Equipment	360	360	324	360	432	468	360	324	180	180	144	108
Repair	10,500	10,500	9,450	10,500	12,600	13,650	10,500	9,450	5,250	5,250	4,200	3,150
Trailers	19,200	19,200	17,280	19,200	23,040	24,960	19,200	17,280	9,600	9,600	7,680	5,760
Parts	10,500	10,500	9,450	10,500	12,600	13,650	10,500	9,450	5,250	5,250	4,200	3,150
Land Clearing/Site Prep/Limestone	24,000	24,000	21,600	24,000	28,800	31,200	24,000	21,600	12,000	12,000	9,600	7,200
Total Cost Of Goods Sold	79,560	79,560	71,604	79,560	95,472	103,428	79,560	71,604	39,780	39,780	31,824	23,868
Gross Profit	520,440	520,440	468,396	520,440	624,528	676,572	520,440	468,396	260,220	260,220	208,176	156,132
OPERATING EXPENSES												
Sales Tax (% of Sales)	49,500	49,500	44,550	49,500	59,400	64,350	49,500	44,550	24,750	24,750	19,800	14,850
Merchant Account Service Fee (%Sales)	18,000	18,000	16,200	18,000	21,600	23,400	18,000	16,200	9,000	9,000	7,200	5,400
Rent/Lease	-	-	-	-	-	-	-	-	-	-	-	-
Electricity/ Gas	450	450	450	450	450	450	450	450	450	450	450	450
Telephone/ Cell/ Cable	1,000	1,000	1,000	1,000	1,000	1,000	1,000	1,000	1,000	1,000	1,000	1,000
Water/ Garbage Disposal	300	300	300	300	300	300	300	300	300	300	300	300
Insurance	9,500	9,500	9,500	9,500	9,500	9,500	9,500	9,500	9,500	9,500	9,500	9,500
Postage & Freight	-	-	-	-	-	-	-	-	-	-	-	-
Office Supplies	500	500	500	500	500	500	500	500	500	500	500	500
Repairs & Maintenance	3,500	3,500	3,500	3,500	3,500	3,500	3,500	3,500	3,500	3,500	3,500	3,500
Owner's Salary	8,000	8,000	8,000	8,000	8,000	8,000	8,000	8,000	8,000	8,000	8,000	8,000
Wages & Salaries	26,000	26,000	26,000	26,000	26,000	26,000	26,000	26,000	26,000	26,000	26,000	26,000
Payroll Taxes	5,202	5,202	5,202	5,202	5,202	5,202	5,202	5,202	5,202	5,202	5,202	5,202
Vehicle Expense (travel, fuel, repairs - business only)	17,000	17,000	17,000	17,000	17,000	17,000	17,000	17,000	17,000	17,000	17,000	17,000
Legal & Professional Fees	450	450	450	450	450	450	450	450	450	450	450	450
Internet	200	200	200	200	200	200	200	200	200	200	200	200
Advertising	800	800	800	800	800	800	800	800	800	800	800	800
Property Taxes (if applicable)	-	-	-	-	-	-	-	-	-	-	-	-
Safety Equipment	100	100	100	100	100	100	100	100	100	100	100	100
Total Operating Expenses	140,502	140,502	133,752	140,502	154,002	160,752	140,502	133,752	106,752	106,752	100,002	93,252
Operating Profit (EBITDA)	379,938	379,938	334,644	379,938	470,526	515,820	379,938	334,644	153,468	153,468	108,174	62,880
Depreciation	1,789	1,789	1,789	1,789	1,789	1,789	1,789	1,789	1,789	1,789	1,789	1,789
Amortization	301	301	301	301	301	301	301	301	301	301	301	301
EBIT	377,847	377,847	332,553	377,847	468,435	513,729	377,847	332,553	151,377	151,377	106,083	60,789
Interest Expense	3,040	3,017	2,993	2,970	2,946	2,921	2,897	2,872	2,847	2,822	2,797	2,771
Net Income before tax (EBT)	374,807	374,831	329,560	374,878	465,490	510,808	374,950	329,681	148,530	148,555	103,287	58,018

	Jan-25	Feb-25	Mar-25	Apr-25	May-25	Jun-25	Jul-25	Aug-25	Sep-25	Oct-25	Nov-25	Dec-25
SALES												
Stone	36,000	36,000	32,400	36,000	43,200	46,800	36,000	32,400	18,000	18,000	14,400	10,800
Rental Equipment	28,800	28,800	25,920	28,800	34,560	37,440	28,800	25,920	14,400	14,400	11,520	8,640
Repair	25,200	25,200	22,680	25,200	30,240	32,760	25,200	22,680	12,600	12,600	10,080	7,560
Trailers	28,800	28,800	25,920	28,800	34,560	37,440	28,800	25,920	14,400	14,400	11,520	8,640
Parts	25,200	25,200	22,680	25,200	30,240	32,760	25,200	22,680	12,600	12,600	10,080	7,560
Land Clearing/Site Prep/Limestone	576,000	576,000	518,400	576,000	691,200	748,800	576,000	518,400	288,000	288,000	230,400	172,800
Total Sales	720,000	720,000	648,000	720,000	864,000	936,000	720,000	648,000	360,000	360,000	288,000	216,000
COST OF GOODS												
Stone	18,000	18,000	16,200	18,000	21,600	23,400	18,000	16,200	9,000	9,000	7,200	5,400
Rental Equipment	432	432	389	432	518	562	432	389	216	216	173	130
Repair	12,600	12,600	11,340	12,600	15,120	16,380	12,600	11,340	6,300	6,300	5,040	3,780
Trailers	23,040	23,040	20,736	23,040	27,648	29,952	23,040	20,736	11,520	11,520	9,216	6,912
Parts	12,600	12,600	11,340	12,600	15,120	16,380	12,600	11,340	6,300	6,300	5,040	3,780
Land Clearing/Site Prep/Limestone	28,800	28,800	25,920	28,800	34,560	37,440	28,800	25,920	14,400	14,400	11,520	8,640
Total Cost Of Goods Sold	95,472	95,472	85,925	95,472	114,566	124,114	95,472	85,925	47,736	47,736	38,189	28,642
Gross Profit	624,528	624,528	562,075	624,528	749,434	811,886	624,528	562,075	312,264	312,264	249,811	187,358
OPERATING EXPENSES												
Sales Tax (% of Sales)	59,400	59,400	53,460	59,400	71,280	77,220	59,400	53,460	29,700	29,700	23,760	17,820
Merchant Account Service Fee (%Sales)	21,600	21,600	19,440	21,600	25,920	28,080	21,600	19,440	10,800	10,800	8,640	6,480
Rent/Lease	-	-	-	-	-	-	-	-	-	-	-	-
Electricity/ Gas	459	459	459	459	459	459	459	459	459	459	459	459
Telephone/ Cell/ Cable	1,020	1,020	1,020	1,020	1,020	1,020	1,020	1,020	1,020	1,020	1,020	1,020
Water/ Garbage Disposal	306	306	306	306	306	306	306	306	306	306	306	306
Insurance	9,690	9,690	9,690	9,690	9,690	9,690	9,690	9,690	9,690	9,690	9,690	9,690
Postage & Freight	-	-	-	-	-	-	-	-	-	-	-	-
Office Supplies	510	510	510	510	510	510	510	510	510	510	510	510
Repairs & Maintenance	3,570	3,570	3,570	3,570	3,570	3,570	3,570	3,570	3,570	3,570	3,570	3,570
Owner's Salary	8,160	8,160	8,160	8,160	8,160	8,160	8,160	8,160	8,160	8,160	8,160	8,160
Wages & Salaries	26,520	26,520	26,520	26,520	26,520	26,520	26,520	26,520	26,520	26,520	26,520	26,520
Payroll Taxes	5,306	5,306	5,306	5,306	5,306	5,306	5,306	5,306	5,306	5,306	5,306	5,306
Vehicle Expense (travel, fuel, repairs - business only)	17,340	17,340	17,340	17,340	17,340	17,340	17,340	17,340	17,340	17,340	17,340	17,340
Legal & Professional Fees	459	459	459	459	459	459	459	459	459	459	459	459
Internet	204	204	204	204	204	204	204	204	204	204	204	204
Advertising	816	816	816	816	816	816	816	816	816	816	816	816
Property Taxes (if applicable)	-	-	-	-	-	-	-	-	-	-	-	-
Safety Equipment	102	102	102	102	102	102	102	102	102	102	102	102
Total Operating Expenses	155,462	155,462	147,362	155,462	171,662	179,762	155,462	147,362	114,962	114,962	106,862	98,762
Operating Profit (EBITDA)	469,066	469,066	414,713	469,066	577,772	632,124	469,066	414,713	197,302	197,302	142,949	88,596
Depreciation	1,789	1,789	1,789	1,789	1,789	1,789	1,789	1,789	1,789	1,789	1,789	1,789
Amortization	301	301	301	301	301	301	301	301	301	301	301	301
EBIT	466,975	466,975	412,622	466,975	575,681	630,034	466,975	412,622	195,211	195,211	140,858	86,506
Interest Expense	2,745	2,719	2,692	2,666	2,639	2,611	2,584	2,556	2,528	2,499	2,471	2,442
Net Income before tax (EBT)	464,230	464,257	409,930	464,310	573,042	627,422	464,392	410,067	192,684	192,712	138,388	84,064

	Jan-26	Feb-26	Mar-26	Apr-26	May-26	Jun-26	Jul-26	Aug-26	Sep-26	Oct-26	Nov-26	Dec-26
SALES												
Stone	37,500	37,500	33,750	37,500	45,000	48,750	37,500	33,750	18,750	18,750	15,000	11,250
Rental Equipment	30,000	30,000	27,000	30,000	36,000	39,000	30,000	27,000	15,000	15,000	12,000	9,000
Repair	26,250	26,250	23,625	26,250	31,500	34,125	26,250	23,625	13,125	13,125	10,500	7,875
Trailers	30,000	30,000	27,000	30,000	36,000	39,000	30,000	27,000	15,000	15,000	12,000	9,000
Parts	26,250	26,250	23,625	26,250	31,500	34,125	26,250	23,625	13,125	13,125	10,500	7,875
Land Clearing/Site Prep/Limestone	600,000	600,000	540,000	600,000	720,000	780,000	600,000	540,000	300,000	300,000	240,000	180,000
Total Sales	750,000	750,000	675,000	750,000	900,000	975,000	750,000	675,000	375,000	375,000	300,000	225,000
COST OF GOODS												
Stone	18,750	18,750	16,875	18,750	22,500	24,375	18,750	16,875	9,375	9,375	7,500	5,625
Rental Equipment	450	450	405	450	540	585	450	405	225	225	180	135
Repair	13,125	13,125	11,813	13,125	15,750	17,063	13,125	11,813	6,563	6,563	5,250	3,938
Trailers	24,000	24,000	21,600	24,000	28,800	31,200	24,000	21,600	12,000	12,000	9,600	7,200
Parts	13,125	13,125	11,813	13,125	15,750	17,063	13,125	11,813	6,563	6,563	5,250	3,938
Land Clearing/Site Prep/Limestone	30,000	30,000	27,000	30,000	36,000	39,000	30,000	27,000	15,000	15,000	12,000	9,000
Total Cost Of Goods Sold	99,450	99,450	89,505	99,450	119,340	129,285	99,450	89,505	49,725	49,725	39,780	29,835
Gross Profit	650,550	650,550	585,495	650,550	780,660	845,715	650,550	585,495	325,275	325,275	260,220	195,165
OPERATING EXPENSES												
Sales Tax (% of Sales)	61,875	61,875	55,688	61,875	74,250	80,438	61,875	55,688	30,938	30,938	24,750	18,563
Merchant Account Service Fee (%Sales)	22,500	22,500	20,250	22,500	27,000	29,250	22,500	20,250	11,250	11,250	9,000	6,750
Rent/Lease	-	-	-	-	-	-	-	-	-	-	-	-
Electricity/ Gas	468	468	468	468	468	468	468	468	468	468	468	468
Telephone/ Cell/ Cable	1,040	1,040	1,040	1,040	1,040	1,040	1,040	1,040	1,040	1,040	1,040	1,040
Water/ Garbage Disposal	312	312	312	312	312	312	312	312	312	312	312	312
Insurance	9,884	9,884	9,884	9,884	9,884	9,884	9,884	9,884	9,884	9,884	9,884	9,884
Postage & Freight	-	-	-	-	-	-	-	-	-	-	-	-
Office Supplies	520	520	520	520	520	520	520	520	520	520	520	520
Repairs & Maintenance	3,641	3,641	3,641	3,641	3,641	3,641	3,641	3,641	3,641	3,641	3,641	3,641
Owner's Salary	8,323	8,323	8,323	8,323	8,323	8,323	8,323	8,323	8,323	8,323	8,323	8,323
Wages & Salaries	27,050	27,050	27,050	27,050	27,050	27,050	27,050	27,050	27,050	27,050	27,050	27,050
Payroll Taxes	5,412	5,412	5,412	5,412	5,412	5,412	5,412	5,412	5,412	5,412	5,412	5,412
Vehicle Expense (travel, fuel, repairs - business only)	17,687	17,687	17,687	17,687	17,687	17,687	17,687	17,687	17,687	17,687	17,687	17,687
Legal & Professional Fees	468	468	468	468	468	468	468	468	468	468	468	468
Internet	208	208	208	208	208	208	208	208	208	208	208	208
Advertising	832	832	832	832	832	832	832	832	832	832	832	832
Property Taxes (if applicable)	-	-	-	-	-	-	-	-	-	-	-	-
Safety Equipment	104	104	104	104	104	104	104	104	104	104	104	104
Total Operating Expenses	160,326	160,326	151,889	160,326	177,201	185,639	160,326	151,889	118,139	118,139	109,701	101,264
Operating Profit (EBITDA)	490,224	490,224	433,606	490,224	603,459	660,076	490,224	433,606	207,136	207,136	150,519	93,901
Depreciation	1,789	1,789	1,789	1,789	1,789	1,789	1,789	1,789	1,789	1,789	1,789	1,789
Amortization	301	301	301	301	301	301	301	301	301	301	301	301
EBIT	488,133	488,133	431,516	488,133	601,368	657,986	488,133	431,516	205,046	205,046	148,428	91,811
Interest Expense	2,412	2,383	2,353	2,323	2,293	2,262	2,231	2,199	2,168	2,136	2,103	2,071
Net Income before tax (EBT)	485,721	485,750	429,162	485,810	599,076	655,724	485,902	429,316	202,878	202,910	146,325	89,740

Stark, Inc.
Pro-Forma Cash Flow
Direct Method

	Jan-24	Feb-24	Mar-24	Apr-24	May-24	Jun-24	Jul-24	Aug-24	Sep-24	Oct-24	Nov-24	Dec-24
Beginning Cash Balance	174,350	564,834	939,405	1,267,092	1,643,254	2,111,596	2,623,641	2,993,439	3,321,125	3,462,862	3,610,964	3,712,180
Cash Inflows												
Cash Sales	600,000	600,000	540,000	600,000	720,000	780,000	600,000	540,000	300,000	300,000	240,000	180,000
Accounts Receivable Collected	-	-	-	-	-	-	-	-	-	-	-	-
Loan & Cash Injection	-	-	-	-	-	-	-	-	-	-	-	-
Total Cash Inflows	600,000	600,000	540,000	600,000	720,000	780,000	600,000	540,000	300,000	300,000	240,000	180,000
Cash Outflows												
Inventory Purchases	63,648	79,560	73,195	77,969	92,290	101,837	84,334	73,195	46,145	39,780	33,415	25,459
Sales Tax (% of Sales)	49,500	49,500	44,550	49,500	59,400	64,350	49,500	44,550	24,750	24,750	19,800	14,850
Merchant Account Service Fee (%Sales)	18,000	18,000	16,200	18,000	21,600	23,400	18,000	16,200	9,000	9,000	7,200	5,400
Rent/Lease	-	-	-	-	-	-	-	-	-	-	-	-
Electricity/ Gas	450	450	450	450	450	450	450	450	450	450	450	450
Telephone/ Cell/ Cable	1,000	1,000	1,000	1,000	1,000	1,000	1,000	1,000	1,000	1,000	1,000	1,000
Water/ Garbage Disposal	300	300	300	300	300	300	300	300	300	300	300	300
Insurance	9,500	9,500	9,500	9,500	9,500	9,500	9,500	9,500	9,500	9,500	9,500	9,500
Postage & Freight	-	-	-	-	-	-	-	-	-	-	-	-
Office Supplies	500	500	500	500	500	500	500	500	500	500	500	500
Repairs & Maintenance	3,500	3,500	3,500	3,500	3,500	3,500	3,500	3,500	3,500	3,500	3,500	3,500
Owner's Salary	8,000	8,000	8,000	8,000	8,000	8,000	8,000	8,000	8,000	8,000	8,000	8,000
Wages & Salaries	26,000	26,000	26,000	26,000	26,000	26,000	26,000	26,000	26,000	26,000	26,000	26,000
Payroll Taxes	5,202	5,202	5,202	5,202	5,202	5,202	5,202	5,202	5,202	5,202	5,202	5,202
Vehicle Expense (travel, fuel, repairs - business only)	17,000	17,000	17,000	17,000	17,000	17,000	17,000	17,000	17,000	17,000	17,000	17,000
Legal & Professional Fees	450	450	450	450	450	450	450	450	450	450	450	450
Internet	200	200	200	200	200	200	200	200	200	200	200	200
Advertising	800	800	800	800	800	800	800	800	800	800	800	800
Property Taxes (if applicable)	-	-	-	-	-	-	-	-	-	-	-	-
Safety Equipment	100	100	100	100	100	100	100	100	100	100	100	100
Loan Payment	5,366	5,366	5,366	5,366	5,366	5,366	5,366	5,366	5,366	5,366	5,366	5,366
Dividends Paid	-	-	-	-	-	-	-	-	-	-	-	-
Total Cash Paid Out	209,516	225,428	212,314	223,837	251,658	267,955	230,202	212,314	158,263	151,898	138,784	124,078
Monthly Net Cash Flow	390,484	374,572	327,686	376,163	468,342	512,045	369,798	327,686	141,737	148,102	101,216	55,922
Cumulative Net Cash Position	564,834	939,405	1,267,092	1,643,254	2,111,596	2,623,641	2,993,439	3,321,125	3,462,862	3,610,964	3,712,180	3,768,102

Stark, Inc.
Pro Forma Monthly Balance Sheet

	Jan-24	Feb-24	Mar-24	Apr-24	May-24	Jun-24	Jul-24	Aug-24	Sep-24	Oct-24	Nov-24	Dec-24
Current Assets												
Cash	564,834	939,405	1,267,092	1,643,254	2,111,596	2,623,641	2,993,439	3,321,125	3,462,862	3,610,964	3,712,180	3,768,102
Prepaid Start-up Costs	10,549	10,247	9,946	9,644	9,343	9,042	8,740	8,439	8,138	7,836	7,535	7,233
Prepaid Expenses	-	-	-	-	-	-	-	-	-	-	-	-
Accounts Receivable	-	-	-	-	-	-	-	-	-	-	-	-
Inventory	100,000	100,000	100,000	100,000	100,000	100,000	100,000	100,000	100,000	100,000	100,000	100,000
Other Current Assets	-	-	-	-	-	-	-	-	-	-	-	-
Total Current Assets	675,382	1,049,652	1,377,037	1,752,899	2,220,939	2,732,683	3,102,179	3,429,564	3,571,000	3,718,800	3,819,715	3,875,336
Non-Current Assets												
Land	-	-	-	-	-	-	-	-	-	-	-	-
Improvements to Parking / Land	50,000	50,000	50,000	50,000	50,000	50,000	50,000	50,000	50,000	50,000	50,000	50,000
Building	378,417	376,833	375,250	373,667	372,083	370,500	368,917	367,333	365,750	364,167	362,583	361,000
Improvements to Building	-	-	-	-	-	-	-	-	-	-	-	-
Equipment	3,952	3,905	3,857	3,810	3,762	3,714	3,667	3,619	3,571	3,524	3,476	3,429
Furniture & Fixtures	9,342	9,183	9,025	8,867	8,708	8,550	8,392	8,233	8,075	7,917	7,758	7,600
Total Non Current Assets	441,711	439,921	438,132	436,343	434,554	432,764	430,975	429,186	427,396	425,607	423,818	422,029
Other Assets												
Deposits	-	-	-	-	-	-	-	-	-	-	-	-
Franchise Fees	-	-	-	-	-	-	-	-	-	-	-	-
Total Assets	1,117,093	1,489,574	1,815,169	2,189,242	2,655,493	3,165,447	3,533,154	3,858,750	3,998,396	4,144,407	4,243,533	4,297,364
Liabilities & Owners Equity												
Current Liabilities												
Accounts Payable	15,912	15,912	14,321	15,912	19,094	20,686	15,912	14,321	7,956	7,956	6,365	4,774
Other Current Liabilities	-	-	-	-	-	-	-	-	-	-	-	-
Current Portion of Loan 1	2,350	2,373	2,397	2,421	2,445	2,470	2,494	2,519	2,544	2,570	2,596	2,621
Current Portion of Loan 2	-	-	-	-	-	-	-	-	-	-	-	-
Current Portion of Loan 3	-	-	-	-	-	-	-	-	-	-	-	-
Current Portion of Loan 4	-	-	-	-	-	-	-	-	-	-	-	-
Total Current Liabilities	18,262	18,285	16,718	18,333	21,540	23,155	18,406	16,840	10,500	10,526	8,960	7,395
Long Term Liabilities												
Long Term Portion of Loan 1	299,324	296,951	294,554	292,133	289,688	287,218	284,724	282,205	279,660	277,091	274,495	271,874
Long Term Portion of Loan 2	-	-	-	-	-	-	-	-	-	-	-	-
Long Term Portion of Loan 3	-	-	-	-	-	-	-	-	-	-	-	-
Long Term Portion of Loan 4	-	-	-	-	-	-	-	-	-	-	-	-
Total Long Term Liabilities	299,324	296,951	294,554	292,133	289,688	287,218	284,724	282,205	279,660	277,091	274,495	271,874
Total Liabilities	317,586	315,236	311,271	310,466	311,227	310,373	303,130	299,045	290,161	287,616	283,455	279,269
Equity												
Planned Owners Investment	76,000	76,000	76,000	76,000	76,000	76,000	76,000	76,000	76,000	76,000	76,000	76,000
Retained Earnings	549,157	923,988	1,253,548	1,628,426	2,093,916	2,604,724	2,979,674	3,309,355	3,457,885	3,606,441	3,709,727	3,767,746
Owner's Equity/Capital Stock	174,350	174,350	174,350	174,350	174,350	174,350	174,350	174,350	174,350	174,350	174,350	174,350
Total Equity	799,507	1,174,338	1,503,898	1,878,776	2,344,266	2,855,074	3,230,024	3,559,705	3,708,235	3,856,791	3,960,077	4,018,096
Total Liabilities & Equity	1,117,093	1,489,574	1,815,169	2,189,242	2,655,493	3,165,447	3,533,154	3,858,750	3,998,396	4,144,407	4,243,533	4,297,364

Stark, Inc.
Pro-Forma Cash Flow
Direct Method

	Jan-25	Feb-25	Mar-25	Apr-25	May-25	Jun-25	Jul-25	Aug-25	Sep-25	Oct-25	Nov-25	Dec-25
Beginning Cash Balance	3,768,102	4,246,123	4,709,822	5,117,260	5,582,869	6,159,093	6,787,760	7,245,731	7,653,168	7,837,466	8,029,402	8,165,075
Cash Inflows												
Cash Sales	720,000	720,000	648,000	720,000	864,000	936,000	720,000	648,000	360,000	360,000	288,000	216,000
Accounts Receivable Collected	-	-	-	-	-	-	-	-	-	-	-	-
Loan & Cash Injection	-	-	-	-	-	-	-	-	-	-	-	-
Total Cash Inflows	720,000	720,000	648,000	720,000	864,000	936,000	720,000	648,000	360,000	360,000	288,000	216,000
Cash Outflows												
Inventory Purchases	81,151	95,472	87,834	93,563	110,748	122,204	101,200	87,834	55,374	47,736	40,098	30,551
Sales Tax (% of Sales)	59,400	59,400	53,460	59,400	71,280	77,220	59,400	53,460	29,700	29,700	23,760	17,820
Merchant Account Service Fee (%Sales)	21,600	21,600	19,440	21,600	25,920	28,080	21,600	19,440	10,800	10,800	8,640	6,480
Rent/Lease	-	-	-	-	-	-	-	-	-	-	-	-
Electricity/ Gas	459	459	459	459	459	459	459	459	459	459	459	459
Telephone/ Cell/ Cable	1,020	1020	1020	1,020	1020	1020	1,020	1020	1020	1,020	1020	1020
Water/ Garbage Disposal	306	306	306	306	306	306	306	306	306	306	306	306
Insurance	9,690	9690	9690	9,690	9690	9690	9,690	9690	9690	9,690	9690	9690
Postage & Freight	-	0	0	-	0	0	-	0	0	-	0	0
Office Supplies	510	510	510	510	510	510	510	510	510	510	510	510
Repairs & Maintenance	3,570	3570	3570	3,570	3570	3570	3,570	3570	3570	3,570	3570	3570
Owner's Salary	8,160	8,160	8,160	8,160	8,160	8,160	8,160	8,160	8,160	8,160	8,160	8,160
Wages & Salaries	26,520	26520	26520	26,520	26520	26520	26,520	26520	26520	26,520	26520	26520
Payroll Taxes	5,306	5,306	5,306	5,306	5,306	5,306	5,306	5,306	5,306	5,306	5,306	5,306
Vehicle Expense (travel, fuel, repairs - business only)	17,340	17340	17340	17,340	17340	17340	17,340	17340	17340	17,340	17340	17340
Legal & Professional Fees	459	459	459	459	459	459	459	459	459	459	459	459
Internet	204	204	204	204	204	204	204	204	204	204	204	204
Advertising	816	816	816	816	816	816	816	816	816	816	816	816
Property Taxes (if applicable)	-	0	0	-	0	0	-	0	0	-	0	0
Safety Equipment	102	102	102	102	102	102	102	102	102	102	102	102
Loan Payment	5,366	5,366	5,366	5,366	5,366	5,366	5,366	5,366	5,366	5,366	5,366	5,366
Dividends Paid	-	-	-	-	-	-	-	-	-	-	-	-
Total Cash Paid Out	241,980	256,300	240,563	254,391	287,776	307,333	262,029	240,563	175,702	168,064	152,327	134,680
Monthly Net Cash Flow	478,020	463,700	407,437	465,609	576,224	628,667	457,971	407,437	184,298	191,936	135,673	81,320
Cumulative Net Cash Position	4,246,123	4,709,822	5,117,260	5,582,869	6,159,093	6,787,760	7,245,731	7,653,168	7,837,466	8,029,402	8,165,075	8,246,396

Stark, Inc.
Pro Forma Monthly Balance Sheet

	Jan-25	Feb-25	Mar-25	Apr-25	May-25	Jun-25	Jul-25	Aug-25	Sep-25	Oct-25	Nov-25	Dec-25
Current Assets												
Cash	4,246,123	4,709,822	5,117,260	5,582,869	6,159,093	6,787,760	7,245,731	7,653,168	7,837,466	8,029,402	8,165,075	8,246,396
Prepaid Start-up Costs	6,932	6,631	6,329	6,028	5,726	5,425	5,124	4,822	4,521	4,219	3,918	3,617
Prepaid Expenses	-	-	-	-	-	-	-	-	-	-	-	-
Accounts Receivable	-	-	-	-	-	-	-	-	-	-	-	-
Inventory	100,000	100,000	100,000	100,000	100,000	100,000	100,000	100,000	100,000	100,000	100,000	100,000
Other Current Assets	-	-	-	-	-	-	-	-	-	-	-	-
Total Current Assets	4,353,055	4,816,453	5,223,589	5,688,896	6,264,819	6,893,185	7,350,855	7,757,991	7,941,987	8,133,621	8,268,993	8,350,012
Non-Current Assets												
Land	-	-	-	-	-	-	-	-	-	-	-	-
Improvements to Parking / Land	50,000	50,000	50,000	50,000	50,000	50,000	50,000	50,000	50,000	50,000	50,000	50,000
Building	359,417	357,833	356,250	354,667	353,083	351,500	349,917	348,333	346,750	345,167	343,583	342,000
Improvements to Building	-	-	-	-	-	-	-	-	-	-	-	-
Equipment	3,381	3,333	3,286	3,238	3,190	3,143	3,095	3,048	3,000	2,952	2,905	2,857
Furniture & Fixtures	7,442	7,283	7,125	6,967	6,808	6,650	6,492	6,333	6,175	6,017	5,858	5,700
Total Non Current Assets	420,239	418,450	416,661	414,871	413,082	411,293	409,504	407,714	405,925	404,136	402,346	400,557
Other Assets												
Deposits	-	-	-	-	-	-	-	-	-	-	-	-
Franchise Fees	-	-	-	-	-	-	-	-	-	-	-	-
Total Assets	4,773,294	5,234,903	5,640,249	6,103,768	6,677,901	7,304,478	7,760,358	8,165,705	8,347,912	8,537,757	8,671,339	8,750,569
Liabilities & Owners Equity												
Current Liabilities												
Accounts Payable	19,094	19,094	17,185	19,094	22,913	24,823	19,094	17,185	9,547	9,547	7,638	5,728
Other Current Liabilities	-	-	-	-	-	-	-	-	-	-	-	-
Current Portion of Loan 1	2,648	2,674	2,701	2,728	2,755	2,783	2,811	2,839	2,867	2,896	2,925	2,954
Current Portion of Loan 2	-	-	-	-	-	-	-	-	-	-	-	-
Current Portion of Loan 3	-	-	-	-	-	-	-	-	-	-	-	-
Current Portion of Loan 4	-	-	-	-	-	-	-	-	-	-	-	-
Total Current Liabilities	21,742	21,769	19,886	21,822	25,668	27,605	21,905	20,024	12,414	12,443	10,562	8,682
Long Term Liabilities												
Long Term Portion of Loan 1	269,226	266,552	263,851	261,123	258,368	255,585	252,774	249,936	247,069	244,173	241,248	238,294
Long Term Portion of Loan 2	-	-	-	-	-	-	-	-	-	-	-	-
Long Term Portion of Loan 3	-	-	-	-	-	-	-	-	-	-	-	-
Long Term Portion of Loan 4	-	-	-	-	-	-	-	-	-	-	-	-
Total Long Term Liabilities	269,226	266,552	263,851	261,123	258,368	255,585	252,774	249,936	247,069	244,173	241,248	238,294
Total Liabilities	290,968	288,320	283,737	282,945	284,036	283,190	274,679	269,959	259,483	256,616	251,811	246,976
Equity												
Planned Owners Investment	76,000	76,000	76,000	76,000	76,000	76,000	76,000	76,000	76,000	76,000	76,000	76,000
Retained Earnings	4,231,976	4,696,233	5,106,163	5,570,473	6,143,515	6,770,937	7,235,329	7,645,396	7,838,079	8,030,791	8,169,179	8,253,243
Owner's Equity/Capital Stock	174,350	174,350	174,350	174,350	174,350	174,350	174,350	174,350	174,350	174,350	174,350	174,350
Total Equity	4,482,326	4,946,583	5,356,513	5,820,823	6,393,865	7,021,287	7,485,679	7,895,746	8,088,429	8,281,141	8,419,529	8,503,593
Total Liabilities & Equity	4,773,294	5,234,903	5,640,249	6,103,768	6,677,901	7,304,478	7,760,358	8,165,705	8,347,912	8,537,757	8,671,339	8,750,569

Stark, Inc.
 Pro-Forma Cash Flow
 Direct Method

	Jan-26	Feb-26	Mar-26	Apr-26	May-26	Jun-26	Jul-26	Aug-26	Sep-26	Oct-26	Nov-26	Dec-26
Beginning Cash Balance	8,246,396	8,745,414	9,230,272	9,656,523	10,143,369	10,745,439	11,402,138	11,881,028	12,307,279	12,501,093	12,702,863	12,846,026
Cash Inflows												
Cash Sales	750,000	750,000	675,000	750,000	900,000	975,000	750,000	675,000	375,000	375,000	300,000	225,000
Accounts Receivable Collected	-	-	-	-	-	-	-	-	-	-	-	-
Loan & Cash Injection	-	-	-	-	-	-	-	-	-	-	-	-
Total Cash Inflows	750,000	750,000	675,000	750,000	900,000	975,000	750,000	675,000	375,000	375,000	300,000	225,000
Cash Outflows												
Inventory Purchases	85,288	99,450	91,494	97,461	115,362	127,296	105,417	91,494	57,681	49,725	41,769	31,824
Sales Tax (% of Sales)	61,875	61,875	55,688	61,875	74,250	80,438	61,875	55,688	30,938	30,938	24,750	18,563
Merchant Account Service Fee (%Sales)	22,500	22,500	20,250	22,500	27,000	29,250	22,500	20,250	11,250	11,250	9,000	6,750
Rent/Lease	-	-	-	-	-	-	-	-	-	-	-	-
Electricity/ Gas	468	468	468	468	468	468	468	468	468	468	468	468
Telephone/ Cell/ Cable	1,040	1,040	1,040	1,040	1,040	1,040	1,040	1,040	1,040	1,040	1,040	1,040
Water/ Garbage Disposal	312	312	312	312	312	312	312	312	312	312	312	312
Insurance	9,884	9,884	9,884	9,884	9,884	9,884	9,884	9,884	9,884	9,884	9,884	9,884
Postage & Freight	-	-	-	-	-	-	-	-	-	-	-	-
Office Supplies	520	520	520	520	520	520	520	520	520	520	520	520
Repairs & Maintenance	3,641	3,641	3,641	3,641	3,641	3,641	3,641	3,641	3,641	3,641	3,641	3,641
Owner's Salary	8,323	8,323	8,323	8,323	8,323	8,323	8,323	8,323	8,323	8,323	8,323	8,323
Wages & Salaries	27,050	27,050	27,050	27,050	27,050	27,050	27,050	27,050	27,050	27,050	27,050	27,050
Payroll Taxes	5,412	5,412	5,412	5,412	5,412	5,412	5,412	5,412	5,412	5,412	5,412	5,412
Vehicle Expense (travel, fuel, repairs - business only)	17,687	17,687	17,687	17,687	17,687	17,687	17,687	17,687	17,687	17,687	17,687	17,687
Legal & Professional Fees	468	468	468	468	468	468	468	468	468	468	468	468
Internet	208	208	208	208	208	208	208	208	208	208	208	208
Advertising	832	832	832	832	832	832	832	832	832	832	832	832
Property Taxes (if applicable)	-	-	-	-	-	-	-	-	-	-	-	-
Safety Equipment	104	104	104	104	104	104	104	104	104	104	104	104
Loan Payment	5,366	5,366	5,366	5,366	5,366	5,366	5,366	5,366	5,366	5,366	5,366	5,366
Dividends Paid	-	-	-	-	-	-	-	-	-	-	-	-
Total Cash Paid Out	250,981	265,143	248,749	263,154	297,930	318,301	271,110	248,749	181,186	173,230	156,837	138,454
Monthly Net Cash Flow	499,019	484,857	426,251	486,846	602,070	656,699	478,890	426,251	193,814	201,770	143,163	86,546
Cumulative Net Cash Position	8,745,414	9,230,272	9,656,523	10,143,369	10,745,439	11,402,138	11,881,028	12,307,279	12,501,093	12,702,863	12,846,026	12,932,572

Stark, Inc.
Pro Forma Monthly Balance Sheet

	Jan-26	Feb-26	Mar-26	Apr-26	May-26	Jun-26	Jul-26	Aug-26	Sep-26	Oct-26	Nov-26	Dec-26
Current Assets												
Cash	8,745,414	9,230,272	9,656,523	10,143,369	10,745,439	11,402,138	11,881,028	12,307,279	12,501,093	12,702,863	12,846,026	12,932,572
Prepaid Start-up Costs	3,315	3,014	2,713	2,411	2,110	1,808	1,507	1,206	904	603	301	0
Prepaid Expenses	-	-	-	-	-	-	-	-	-	-	-	-
Accounts Receivable	-	-	-	-	-	-	-	-	-	-	-	-
Inventory	100,000	100,000	100,000	100,000	100,000	100,000	100,000	100,000	100,000	100,000	100,000	100,000
Other Current Assets	-	-	-	-	-	-	-	-	-	-	-	-
Total Current Assets	8,848,730	9,333,286	9,759,235	10,245,780	10,847,549	11,503,946	11,982,535	12,408,485	12,601,997	12,803,465	12,946,327	13,032,572
Non-Current Assets												
Land	-	-	-	-	-	-	-	-	-	-	-	-
Improvements to Parking / Land	50,000	50,000	50,000	50,000	50,000	50,000	50,000	50,000	50,000	50,000	50,000	50,000
Building	340,417	338,833	337,250	335,667	334,083	332,500	330,917	329,333	327,750	326,167	324,583	323,000
Improvements to Building	-	-	-	-	-	-	-	-	-	-	-	-
Equipment	2,810	2,762	2,714	2,667	2,619	2,571	2,524	2,476	2,429	2,381	2,333	2,286
Furniture & Fixtures	5,542	5,383	5,225	5,067	4,908	4,750	4,592	4,433	4,275	4,117	3,958	3,800
Total Non Current Assets	398,768	396,979	395,189	393,400	391,611	389,821	388,032	386,243	384,454	382,664	380,875	379,086
Other Assets												
Deposits	-	-	-	-	-	-	-	-	-	-	-	-
Franchise Fees	-	-	-	-	-	-	-	-	-	-	-	-
Total Assets	9,247,498	9,730,264	10,154,424	10,639,180	11,239,160	11,893,768	12,370,567	12,794,727	12,986,451	13,186,130	13,327,202	13,411,657
Liabilities & Owners Equity												
Current Liabilities												
Accounts Payable	19,890	19,890	17,901	19,890	23,868	25,857	19,890	17,901	9,945	9,945	7,956	5,967
Other Current Liabilities	-	-	-	-	-	-	-	-	-	-	-	-
Current Portion of Loan 1	2,983	3,013	3,043	3,074	3,105	3,136	3,167	3,199	3,231	3,263	3,296	3,329
Current Portion of Loan 2	-	-	-	-	-	-	-	-	-	-	-	-
Current Portion of Loan 3	-	-	-	-	-	-	-	-	-	-	-	-
Current Portion of Loan 4	-	-	-	-	-	-	-	-	-	-	-	-
Total Current Liabilities	22,873	22,903	20,944	22,964	26,973	28,993	23,057	21,100	13,176	13,208	11,252	9,296
Long Term Liabilities												
Long Term Portion of Loan 1	235,311	232,297	229,254	226,180	223,075	219,940	216,773	213,574	210,343	207,080	203,785	200,456
Long Term Portion of Loan 2	-	-	-	-	-	-	-	-	-	-	-	-
Long Term Portion of Loan 3	-	-	-	-	-	-	-	-	-	-	-	-
Long Term Portion of Loan 4	-	-	-	-	-	-	-	-	-	-	-	-
Total Long Term Liabilities	235,311	232,297	229,254	226,180	223,075	219,940	216,773	213,574	210,343	207,080	203,785	200,456
Total Liabilities	258,184	255,201	250,198	249,144	250,048	248,932	239,830	234,674	223,519	220,288	215,036	209,752
Equity												
Planned Owners Investment	76,000	76,000	76,000	76,000	76,000	76,000	76,000	76,000	76,000	76,000	76,000	76,000
Retained Earnings	8,738,963	9,224,714	9,653,876	10,139,686	10,738,762	11,394,485	11,880,388	12,309,704	12,512,582	12,715,491	12,861,816	12,951,556
Owner's Equity/Capital Stock	174,350	174,350	174,350	174,350	174,350	174,350	174,350	174,350	174,350	174,350	174,350	174,350
Total Equity	8,989,313	9,475,064	9,904,226	10,390,036	10,989,112	11,644,835	12,130,738	12,560,054	12,762,932	12,965,841	13,112,166	13,201,906
Total Liabilities & Equity	9,247,498	9,730,264	10,154,424	10,639,180	11,239,160	11,893,768	12,370,567	12,794,727	12,986,451	13,186,130	13,327,202	13,411,657

Stark, Inc.
Revenue Projections

Revenue Projections													
Yearly Sales (\$)	\$ 6,000,000.00	YEAR 1											
Average Guest Check	\$ 500,000.00												
Seasonality		10.0%	10.0%	9.0%	10.0%	12.0%	13.0%	10.0%	9.0%	5.0%	5.0%	4.0%	3.0%
Revenue Growth (base line=100)		100%	100%	100%	100%	100%	100%	100%	100%	100%	100%	100%	100%
Daily Units (20 days)		0.06	0.06	0.05	0.06	0.07	0.08	0.06	0.05	0.03	0.03	0.02	0.02
SALES		Jan-24	Feb-24	Mar-24	Apr-24	May-24	Jun-24	Jul-24	Aug-24	Sep-24	Oct-24	Nov-24	Dec-24
Stone	5.0%	30,000	30,000	27,000	30,000	36,000	39,000	30,000	27,000	15,000	15,000	12,000	9,000
Rental Equipment	4.0%	24,000	24,000	21,600	24,000	28,800	31,200	24,000	21,600	12,000	12,000	9,600	7,200
Repair	3.5%	21,000	21,000	18,900	21,000	25,200	27,300	21,000	18,900	10,500	10,500	8,400	6,300
Trailers	4.0%	24,000	24,000	21,600	24,000	28,800	31,200	24,000	21,600	12,000	12,000	9,600	7,200
Parts	3.5%	21,000	21,000	18,900	21,000	25,200	27,300	21,000	18,900	10,500	10,500	8,400	6,300
Land Clearing/Site Prep/Limestone	80.0%	480,000	480,000	432,000	480,000	576,000	624,000	480,000	432,000	240,000	240,000	192,000	144,000
Cost of Goods Sold													
Stone	50%	15,000	15,000	13,500	15,000	18,000	19,500	15,000	13,500	7,500	7,500	6,000	4,500
Rental Equipment	2%	360	360	324	360	432	468	360	324	180	180	144	108
Repair	50%	10,500	10,500	9,450	10,500	12,600	13,650	10,500	9,450	5,250	5,250	4,200	3,150
Trailers	80%	19,200	19,200	17,280	19,200	23,040	24,960	19,200	17,280	9,600	9,600	7,680	5,760
Parts	50%	10,500	10,500	9,450	10,500	12,600	13,650	10,500	9,450	5,250	5,250	4,200	3,150
Land Clearing/Site Prep/Limestone	5%	24,000	24,000	21,600	24,000	28,800	31,200	24,000	21,600	12,000	12,000	9,600	7,200
Variables													
Inventory Repurchased (% of COGS)		100%	100%	100%	100%	100%	100%	100%	100%	100%	100%	100%	100%
Accounts Payables (% of COGS Paid in)													
0-30 days		80%	80%	80%	80%	80%	80%	80%	80%	80%	80%	80%	80%
31-60 days		20%	20%	20%	20%	20%	20%	20%	20%	20%	20%	20%	20%
61-90 days		0%	0%	0%	0%	0%	0%	0%	0%	0%	0%	0%	0%
Accounts Receivable (% of sales received in)													
0-30 days		100%	100%	100%	100%	100%	100%	100%	100%	100%	100%	100%	100%
31-60 days		0%	0%	0%	0%	0%	0%	0%	0%	0%	0%	0%	0%
61-90 days		0%	0%	0%	0%	0%	0%	0%	0%	0%	0%	0%	0%

Stark, Inc.
Revenue Projections

Revenue Projections												
YEAR 2												
Yearly Sales (\$)	Jan-25	Feb-25	Mar-25	Apr-25	May-25	Jun-25	Jul-25	Aug-25	Sep-25	Oct-25	Nov-25	Dec-25
Average Guest Check												
Seasonality	10.0%	10.0%	9.0%	10.0%	12.0%	13.0%	10.0%	9.0%	5.0%	5.0%	4.0%	3.0%
Revenue Growth (base line=100)	120%	120%	120%	120%	120%	120%	120%	120%	120%	120%	120%	120%
Daily Units (20 days)	0.07	0.07	0.06	0.07	0.09	0.09	0.07	0.06	0.04	0.04	0.03	0.02
SALES	Jan-25	Feb-25	Mar-25	Apr-25	May-25	Jun-25	Jul-25	Aug-25	Sep-25	Oct-25	Nov-25	Dec-25
Stone	36,000	36,000	32,400	36,000	43,200	46,800	36,000	32,400	18,000	18,000	14,400	10,800
Rental Equipment	28,800	28,800	25,920	28,800	34,560	37,440	28,800	25,920	14,400	14,400	11,520	8,640
Repair	25,200	25,200	22,680	25,200	30,240	32,760	25,200	22,680	12,600	12,600	10,080	7,560
Trailers	28,800	28,800	25,920	28,800	34,560	37,440	28,800	25,920	14,400	14,400	11,520	8,640
Parts	25,200	25,200	22,680	25,200	30,240	32,760	25,200	22,680	12,600	12,600	10,080	7,560
Land Clearing/Site Prep/Limestone	576,000	576,000	518,400	576,000	691,200	748,800	576,000	518,400	288,000	288,000	230,400	172,800
Cost of Goods Sold												
Stone	18,000	18,000	16,200	18,000	21,600	23,400	18,000	16,200	9,000	9,000	7,200	5,400
Rental Equipment	432	432	389	432	518	562	432	389	216	216	173	130
Repair	12,600	12,600	11,340	12,600	15,120	16,380	12,600	11,340	6,300	6,300	5,040	3,780
Trailers	23,040	23,040	20,736	23,040	27,648	29,952	23,040	20,736	11,520	11,520	9,216	6,912
Parts	12,600	12,600	11,340	12,600	15,120	16,380	12,600	11,340	6,300	6,300	5,040	3,780
Land Clearing/Site Prep/Limestone	28,800	28,800	25,920	28,800	34,560	37,440	28,800	25,920	14,400	14,400	11,520	8,640
Variables												
Inventory Repurchased (% of COGS)	100%	100%	100%	100%	100%	100%	100%	100%	100%	100%	100%	100%
Accounts Payables (% of COGS Paid in)												
0-30 days	80%	80%	80%	80%	80%	80%	80%	80%	80%	80%	80%	80%
31-60 days	20%	20%	20%	20%	20%	20%	20%	20%	20%	20%	20%	20%
61-90 days	0%	0%	0%	0%	0%	0%	0%	0%	0%	0%	0%	0%
Accounts Receivable (% of sales received in)												
0-30 days	100%	100%	100%	100%	100%	100%	100%	100%	100%	100%	100%	100%
31-60 days	0%	0%	0%	0%	0%	0%	0%	0%	0%	0%	0%	0%
61-90 days	0%	0%	0%	0%	0%	0%	0%	0%	0%	0%	0%	0%

Stark, Inc.
Revenue Projections

Revenue Projections												
YEAR 3												
Yearly Sales (\$)												
Average Guest Check												
Seasonality	10.0%	10.0%	9.0%	10.0%	12.0%	13.0%	10.0%	9.0%	5.0%	5.0%	4.0%	3.0%
Revenue Growth (base line=100)	125%	125%	125%	125%	125%	125%	125%	125%	125%	125%	125%	125%
Daily Units (20 days)	0.08	0.08	0.07	0.08	0.09	0.10	0.08	0.07	0.04	0.04	0.03	0.02
SALES	Jan-26	Feb-26	Mar-26	Apr-26	May-26	Jun-26	Jul-26	Aug-26	Sep-26	Oct-26	Nov-26	Dec-26
Stone	37,500	37,500	33,750	37,500	45,000	48,750	37,500	33,750	18,750	18,750	15,000	11,250
Rental Equipment	30,000	30,000	27,000	30,000	36,000	39,000	30,000	27,000	15,000	15,000	12,000	9,000
Repair	26,250	26,250	23,625	26,250	31,500	34,125	26,250	23,625	13,125	13,125	10,500	7,875
Trailers	30,000	30,000	27,000	30,000	36,000	39,000	30,000	27,000	15,000	15,000	12,000	9,000
Parts	26,250	26,250	23,625	26,250	31,500	34,125	26,250	23,625	13,125	13,125	10,500	7,875
Land Clearing/Site Prep/Limestone	600,000	600,000	540,000	600,000	720,000	780,000	600,000	540,000	300,000	300,000	240,000	180,000
Cost of Goods Sold												
Stone	18,750	18,750	16,875	18,750	22,500	24,375	18,750	16,875	9,375	9,375	7,500	5,625
Rental Equipment	450	450	405	450	540	585	450	405	225	225	180	135
Repair	13,125	13,125	11,813	13,125	15,750	17,063	13,125	11,813	6,563	6,563	5,250	3,938
Trailers	24,000	24,000	21,600	24,000	28,800	31,200	24,000	21,600	12,000	12,000	9,600	7,200
Parts	13,125	13,125	11,813	13,125	15,750	17,063	13,125	11,813	6,563	6,563	5,250	3,938
Land Clearing/Site Prep/Limestone	30,000	30,000	27,000	30,000	36,000	39,000	30,000	27,000	15,000	15,000	12,000	9,000
Variables												
Inventory Repurchased (% of COGS)	100%	100%	100%	100%	100%	100%	100%	100%	100%	100%	100%	100%
Accounts Payables (% of COGS Paid in)												
0-30 days	80%	80%	80%	80%	80%	80%	80%	80%	80%	80%	80%	80%
31-60 days	20%	20%	20%	20%	20%	20%	20%	20%	20%	20%	20%	20%
61-90 days	0%	0%	0%	0%	0%	0%	0%	0%	0%	0%	0%	0%
Accounts Receivable (% of sales received in)												
0-30 days	100%	100%	100%	100%	100%	100%	100%	100%	100%	100%	100%	100%
31-60 days	0%	0%	0%	0%	0%	0%	0%	0%	0%	0%	0%	0%
61-90 days	0%	0%	0%	0%	0%	0%	0%	0%	0%	0%	0%	0%

Stark, Inc.
Ratio Analysis

	First Year	Second Year	Third Year
Liquidity Ratios			
Current Ratio (current assets/current liabilities)	101.9	193.3	270.5
Quick Ratio (times)	99.3	191.0	268.4
Cost of Sales/Inventory	7.96	9.55	9.95
Sales/Working Capital	1.59	0.87	0.58
Coverage Ratios			
EBIT/Interest	103.99	145.00	175.44
(Net Profit+Depr&Amr)/ Current Portion of LTD	108.84	120.40	111.89
Debt Service Coverage Ratio (EBITDA/ debt service)	56.73	70.53	73.77
Debt-to-Income (debt service/ Gross Sales)	0.01	0.01	0.01
Leverage Ratios			
Net Fixed Assets/ Net Worth	0.11	0.05	0.03
Debt/Worth	0.07	0.03	0.02
Operating Ratios			
EBT/ Net Worth	90.30%	53.11%	35.79%
EBT/ Total Assets	84.43%	51.62%	35.23%
EBT/ Total Sales	60.47%	62.73%	62.64%
Sales/ Net Fixed Assets	14.22	17.97	19.78
Sales/Total Assets	1.40	0.82	0.56
Expense to Sales Ratio			
Depr & Amr/Sales	0.42%	0.35%	0.33%
Owners Salary/Sales	1.60%	1.36%	1.33%

Stark, Inc.**Cash Basis Break-Even**

	First Year	Second Year	Third Year
Yearly Sales	6,000,000	7,200,000	7,500,000
Variable Costs	1,470,600	1,764,720	1,838,250
Contribution Margin	4,529,400	5,435,280	5,661,750
CM Ratio	0.75	0.75	0.75
Yearly Fixed Costs			
General Operating	780,024	795,624	811,537
Loan Payment	64,397	64,397	64,397
Owner's Draw	96,000	97,920	99,878
Total Fixed Costs	940,421	957,942	975,813
Average Monthly Fixed Costs	78,368	79,828	81,318
Monthly Break-Even (sales) (includes owner's draw)	103,813	105,747	107,720
Average Monthly Sales	500,000	600,000	625,000

Depreciation Schedule

Item	Amount	Per Year	Per Month	Yrs
Building	380,000	19,000	1,583	20
Improvements to Building	-	-	-	20
Equipment	4,000	571	48	7
Furniture & Fixtures	9,500	1,900	158	5
Total	393,500	21,471	1,789	

Amortization Schedule

Item	Amount	Per Year	Per Month	Yrs
Startup Costs	10,850	3,617	301	3
Franchise Fees	-	-	-	15
Total	10,850	3,617	301	

Stark, Inc.

Financial Assumptions

Loan

- 1 An 12% interest rate on a 7 year loan is assumed.
- 2 An inflation rate of 2% is assumed.
- 3 In Year 1, the business will need to bring in an estimated \$103,813 in monthly sales to break even.
- 4 Assuming the average customer spends \$500,000 per order, the business will need approximately 1 customer per month to reach estimated sales in Year 1.

Income Statement

- 1 A 15.3% Payroll tax is assumed.
- 2 A 4% account service charge is included to represent the 75% of customers who will be paying with a credit card.
- 3 An 8.25% sales tax rate is assumed.

Sales Projections

- 1 Revenue projections are based off financial data from similar businesses.
- 2 Seasonality percentages are based on historical data
- 3 Revenue is expected to increase 120% in Year 2 and an additional 125% in Year 3.

Assets and Start-Up Costs

- 1 Assets and Start-Up Costs were determined by obtaining various quotes and estimates.

Stark, Inc.
Debt Service P& I Calculations

Loan 1		
Interest rate per period (rate/12)	0.0100	12.00% APR
Period in months (years x 12)	84	7 YRS
Monthly Loan	5366	
Loan		
item	304,000	
Fixed Loan	304,000	

1st year Current			
	Period	Principal	Interest
	1	-2326.43	-3040.00
	2	-2349.70	-3016.74
	3	-2373.19	-2993.24
	4	-2396.92	-2969.51
	5	-2420.89	-2945.54
	6	-2445.10	-2921.33
	7	-2469.55	-2896.88
	8	-2494.25	-2872.18
	9	-2519.19	-2847.24
	10	-2544.38	-2822.05
	11	-2569.83	-2796.60
	12	-2595.53	-2770.91
Total First payments		-29504.97	-34892.20

2nd year Current			
	Period	Principal	Interest
	13	-2621.48	-2744.95
	14	-2647.70	-2718.74
	15	-2674.17	-2692.26
	16	-2700.91	-2665.52
	17	-2727.92	-2638.51
	18	-2755.20	-2611.23
	19	-2782.75	-2583.68
	20	-2810.58	-2555.85
	21	-2838.69	-2527.74
	22	-2867.07	-2499.36
	23	-2895.75	-2470.69
	24	-2924.70	-2441.73
Total 2nd year payments		-33246.93	-31150.24

3rd year Current			
	Period	Principal	Interest
	25	-2953.95	-2412.48
	26	-2983.49	-2382.94
	27	-3013.32	-2353.11
	28	-3043.46	-2322.97
	29	-3073.89	-2292.54
	30	-3104.63	-2261.80
	31	-3135.68	-2230.75
	32	-3167.03	-2199.40
	33	-3198.70	-2167.73
	34	-3230.69	-2135.74
	35	-3263.00	-2103.43
	36	-3295.63	-2070.80
Total 3rd year payments		-37463.48	-26933.69

4th year Current			
	Period	Principal	Interest
	37	-3328.58	-2037.85
	38	-3361.87	-2004.56
	39	-3395.49	-1970.94
	40	-3429.44	-1936.99
	41	-3463.74	-1902.69
	42	-3498.38	-1868.05
	43	-3533.36	-1833.07
	44	-3568.69	-1797.74
	45	-3604.38	-1762.05
	46	-3640.42	-1726.01
	47	-3676.83	-1689.60
	48	-3713.60	-1652.83
Total 4th year payments		-42214.78	-22182.39

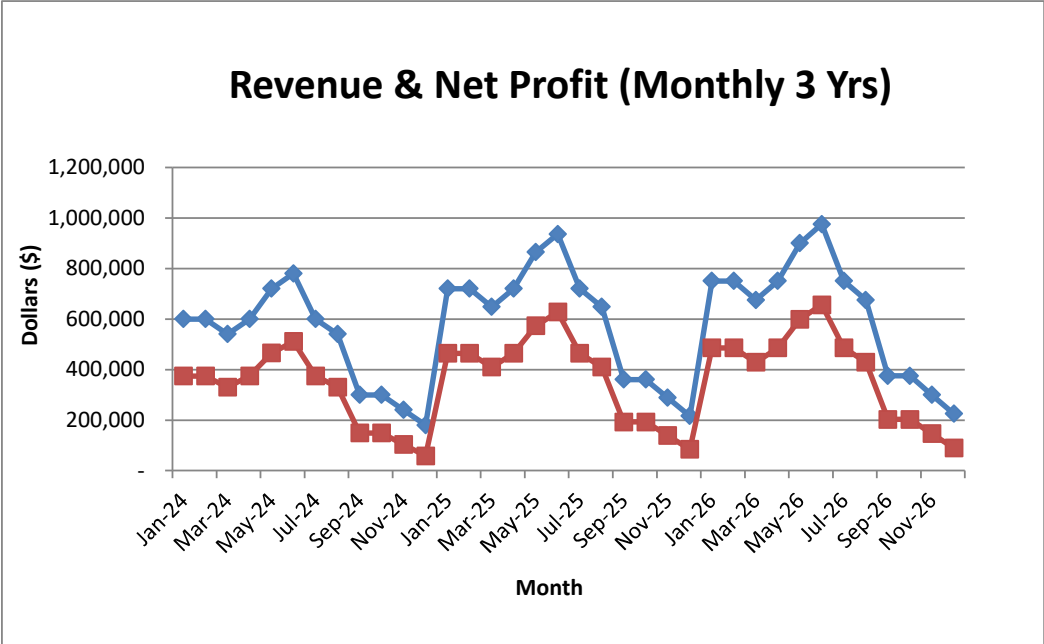
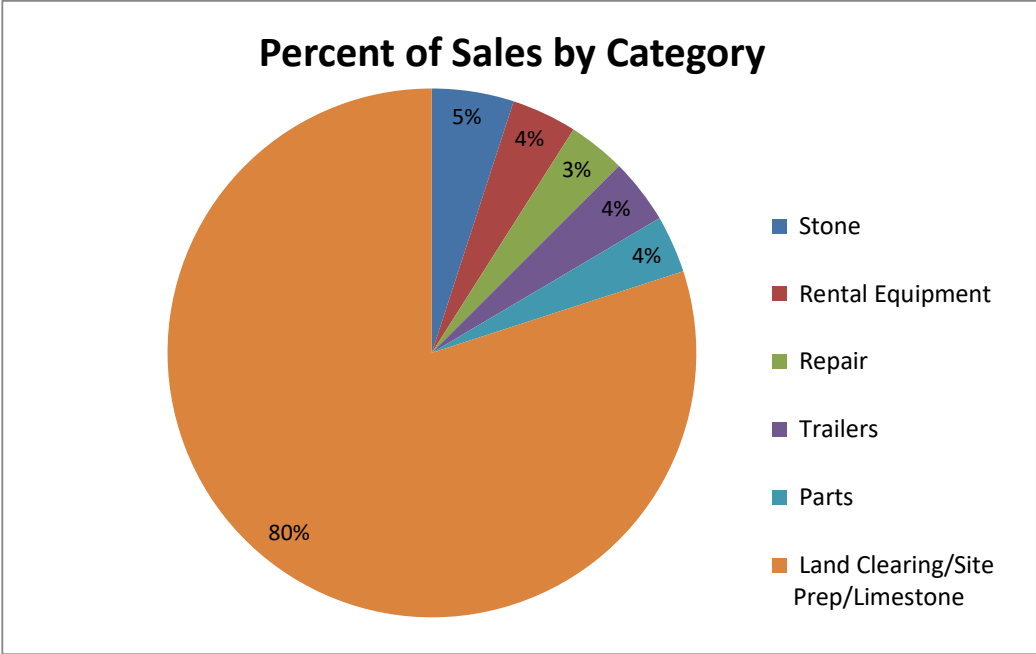

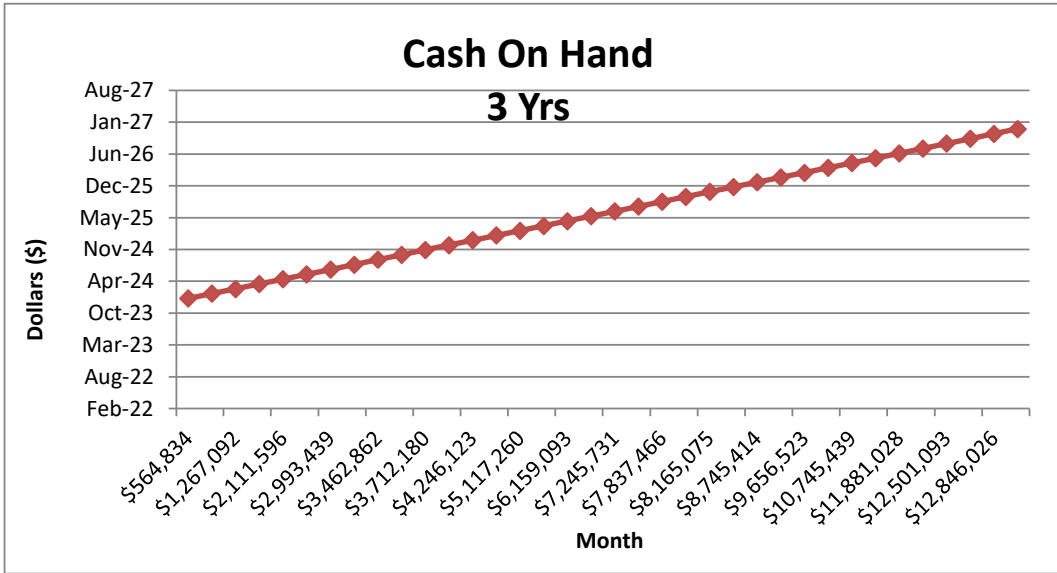
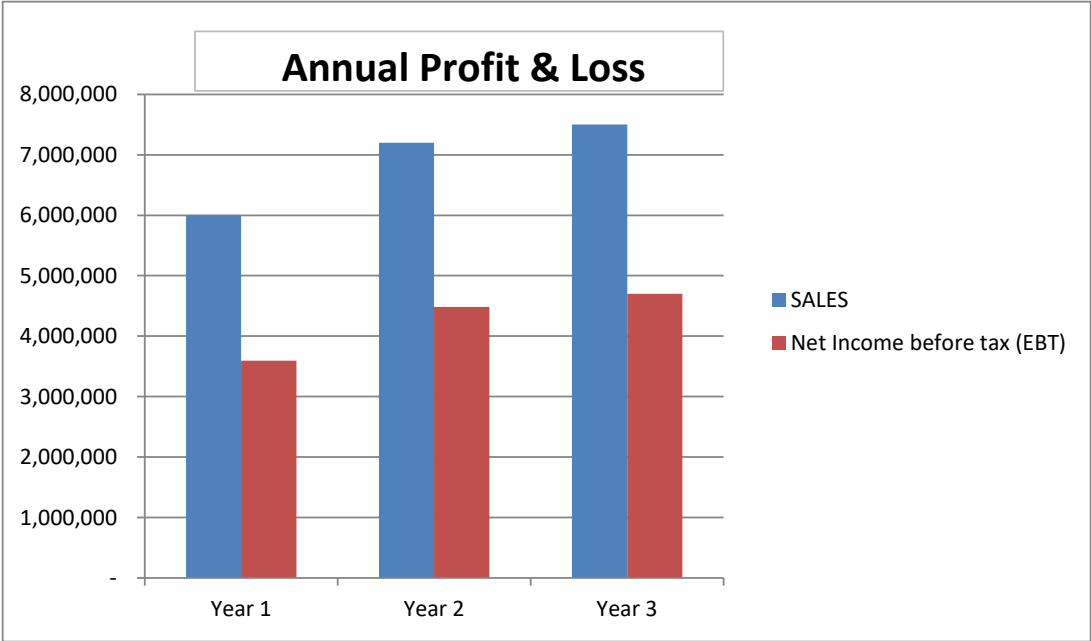

PERFORMANCE AGREEMENT

This **PERFORMANCE AGREEMENT** by and between the **SWEENEY ECONOMIC DEVELOPMENT CORPORATION**, a Texas non-profit corporation (hereinafter referred to as the “EDC”), and **CECIL JOE STARK SAWMILL & LOGGING, INC.**, a Texas corporation (hereinafter referred to as “Developer”), is made and executed on the following recitals, terms and conditions.

WHEREAS, the EDC is a Type B economic development corporation, created pursuant to Chapter 505 of the Texas Local Government Code, as amended; and

WHEREAS, Section 501.101 of the Texas Local Government Code, in pertinent part, defines the term “project” to mean “land, buildings, equipment, facilities, expenditures, targeted infrastructure, and improvements that are: (1) for the creation or retention of primary jobs; and (2) found by the board of directors to be required or suitable for the development, retention, or expansion of: (A) manufacturing and industrial facilities; (B) research and development facilities; (C) military facilities, including closed or realigned military bases; . . . (F) recycling facilities; . . . (I) distribution centers; (J) small warehouse facilities capable of serving as decentralized storage and distribution centers; (K) primary job training facilities for use by institutions of higher education; or (L) regional or national corporate headquarters facilities”; and

WHEREAS, Section 501.103 of the Texas Local Government Code, in pertinent part, defines the term “project” to mean “expenditures that are found by the board of directors to be required or suitable for infrastructure necessary to promote or develop new or expanded business enterprises, limited to: (1) streets and roads, rail spurs, water and sewer utilities, electric utilities, or gas utilities, drainage, site improvements, and related improvements; (2) telecommunications and Internet improvements . . .”; and

WHEREAS, Section 505.158 of the Texas Local Government Code provides that “[f]or a Type B corporation authorized to be created by a municipality with a population of 20,000 or less, “project” also includes the land, buildings, equipment, facilities, expenditures, targeted infrastructure, and improvements found by the corporation’s board of directors to promote new or expanded business development.” Further, the statute provides that “[a] Type B corporation may not undertake a project authorized by this section that requires an expenditure of more than \$10,000 until the governing body of the corporation’s authorizing municipality adopts a resolution authorizing the project after giving the resolution at least two separate readings”; and

WHEREAS, Section 501.158 of the Texas Local Government Code prohibits the provision of a direct incentive unless EDC enters into an Agreement with Developer providing at a minimum a schedule of additional payroll or jobs to be created or retained by EDC’s investment; a schedule of capital investments to be made as consideration for any direct incentives provided by EDC to Developer; and a provision specifying the terms and conditions upon which repayment must be made should Developer fail to meet the agreed to performance requirements specified in this Agreement; and

WHEREAS, Developer has applied to EDC for economic development assistance necessary to construct and operate a commercial office and retail establishment to be located on an 16.93 acre tract of land being out of a 67.288 acre tract being located in the Charles Breen League, Abstract No. 46 , City of Sweeny, Brazoria County, Texas (hereinafter referred to as the “Property”); and

WHEREAS, the EDC’s Board of Directors have determined the economic development assistance to be provided to Developer pursuant to this Agreement is consistent and meets the definition of “project” as that term is defined in Sections 501.101, 501.103, and 505.158 of the Texas Local Government Code; and the definition of “cost” as that term is defined by Section 501.152 of the Texas Local Government Code; and

WHEREAS, Developer agrees and understands that Section 501.073(a) of the Texas Local Government Code requires the City Council of the City of Sweeny, Texas, to approve all programs and expenditures of the EDC, and accordingly this Agreement is not effective until City Council has approved this project at a City Council meeting called and held for that purpose.

NOW, THEREFORE, for and in consideration of the agreements contained herein, and other good and valuable consideration, the receipt and sufficiency of which are hereby acknowledged, the EDC and Developer agree as follows:

SECTION 1. FINDINGS INCORPORATED.

The foregoing recitals are hereby incorporated into the body of this Agreement and shall be considered part of the mutual covenants, consideration and promises that bind the parties.

SECTION 2. TERM.

This Agreement shall be effective as of the Effective Date, as defined herein, and shall continue thereafter until **December 31, 2029**, unless terminated sooner under the provisions hereof.

SECTION 3. DEFINITIONS.

The following words shall have the following meanings when used in this Agreement.

- (a) **Act.** The word “Act” means Chapters 501 to 505 of the Texas Local Government Code, as amended.
- (b) **Agreement.** The word “Agreement” means this Performance Agreement, together with all exhibits and schedules attached to this Agreement from time to time, if any.
- (c) **Developer.** The word “Developer” means Cecil Joe Stark Sawmill & Logging, Inc., a Texas corporation, its successors and assigns, whose address for the purposes of this

Agreement is P.O. Box 1207, West Columbia, Texas 77486.

- (d) **EDC.** The term “EDC” means the Sweeny Economic Development Corporation, a Texas non-profit corporation, its successors and assigns, whose corporate address for the purposes of this Agreement is 111 W. 3rd Street, Sweeny, Texas 77480.
- (e) **Effective Date.** The words “Effective Date” mean the date of the latter to execute this Agreement by and between the Developer and the EDC.
- (f) **Event of Default.** The words “Event of Default” mean and include any of the Events of Default set forth below in the section entitled “Events of Default.”
- (g) **Full-Time Equivalent Employment Position.** The words “Full-Time Equivalent Employment Position” or “Full-Time Equivalent Employment Positions” mean and include a job requiring a minimum of One Thousand Nine Hundred Twenty (1,920) hours of work averaged over a twelve (12) month period.
- (h) **Property.** The word “Property” means the approximately 16.93 acre tract of land being out of a 67.288 acre tract being located in the Charles Breen League, Abstract No. 46, City of Sweeny, Brazoria County, Texas, and as generally depicted in *Exhibit A* of this Agreement, which is attached hereto and incorporated herein for all purposes.
- (i) **Qualified Expenditures.** The words “Qualified Expenditures” mean those expenditures consisting of the construction of an office and retail building located on the Property, as generally depicted in *Exhibit B* of this Agreement, which is attached hereto and incorporated herein for all purposes, and those expenses which meet the definition of “project” as that term is defined in Sections 501.101, 501.103, and 505.158 of the Act, and meet the definition of “cost” as that term is defined in Section 501.152 of the Act.
- (j) **Term.** The word “Term” means the term of this Agreement as specified in Section 2 of this Agreement.

SECTION 4. AFFIRMATIVE COVENANTS OF DEVELOPER.

Developer covenants and agrees with EDC that, while this Agreement is in effect, it shall comply with the following terms and conditions:

- (a) **Qualified Expenditures.** Developer covenants and agrees to commence construction of the Qualified Expenditures within 120 days of the EDC’s completion of the road and utilities leading to the Property. Further, Developer covenants and agrees to complete construction of an office and retail building within twelve (12) months of the City of Sweeny’s completion of the road and utilities leading to the Property.
- (b) **Certificate of Occupancy.** Developer covenants and agrees to obtain or cause to be

obtained within twelve (12) months of EDC's completion of the road and utilities leading to the Property, a certificate of occupancy from the City of Sweeny, Texas, for an office and retail space located on the Property.

- (c) **Operate Office and Retail Facility.** Developer covenants and agrees to maintain and operate an office and retail space located on the Property within twelve (12) months of the EDC's completion of the road and utilities leading to the Property, and during the Term of this Agreement.
- (d) **Job Creation and Retention.** Developer covenants and agrees to employ and maintain a minimum Full-Time Equivalent Employment Positions working at the Property as follows:
- (1) a minimum of **eight (8) Full-Time Equivalent Employment Positions by July 1, 2024;**
 - (2) a minimum of **ten (10) Full-Time Equivalent Employment Positions by July 1, 2025;**
 - (3) a minimum of **twelve (12) Full-Time Equivalent Employment Positions by July 1, 2026;**
 - (4) a minimum of **fourteen (14) Full-Time Equivalent Employment Positions by July 1, 2027;**
 - (5) a minimum of **sixteen (16) Full-Time Equivalent Employment Positions by July 1, 2028; and**
 - (6) a minimum of **eighteen (18) Full-Time Equivalent Employment Positions by July 1, 2028.**

Further, Developer covenants and agrees beginning on **July 1, 2024**, and during the Term of this Agreement, Developer shall deliver to EDC an annual compliance verification signed by a duly authorized representative of Developer that shall certify the number of Full-Time Equivalent Employment Positions, and shall disclose and certify the average wage for all Full-Time Equivalent Employment Positions (the "Annual Compliance Verification"). The Developer covenants and agrees beginning on **July 1, 2024**, and annually thereafter during the Term of this Agreement, there will be a total of **six (6)** Annual Compliance Verifications due and submitted to the EDC covering the Full-Time Equivalent Employment Positions created and maintained during the Term of this Agreement. All Annual Compliance Verifications shall include quarterly IRS 941 returns, or Texas Workforce Commission Employer Quarterly Reports.

- (e) **Acquisition of the Property.** Developer covenants and agrees to acquire the Property from the EDC within ninety (90) days of the Effective Date of this Agreement or consistent with the terms of a real estate sales contract executed by and between the Developer and the EDC. The Developer covenants and agrees the Property has a value of **Three Hundred Four Thousand Seven Hundred Forty and No/100 Dollars (\$304,740.00)**. Developer covenants and agrees to execute a deed of trust lien or other lien for the Property in a form acceptable to the EDC providing a first lien position to 14.093 acres of the Property, and a

second lien position to 2.00 acres of the Property at the time of closing on the Property.

- (f) **Performance Conditions.** Developer agrees to make, execute and deliver to EDC such other promissory notes, instruments, documents and other agreements as EDC or its attorneys may reasonably request to evidence this Agreement.
- (g) **Performance.** Developer agrees to perform and comply with all terms, conditions, and provisions set forth in this Agreement and in all other instruments and agreements by and between the Developer and EDC.

SECTION 5. AFFIRMATIVE COVENANTS OF EDC.

EDC covenants and agrees with Developer that, while this Agreement is in effect, it shall comply with the following terms and conditions:

- (a) **Conveyance of the Property.** The EDC covenants and agrees to convey to the Developer good and indefeasible fee simple title to the Property, free and clear of any liens or other encumbrances, by special warranty deed within ninety (90) days of the Effective Date of this Agreement or consistent with the terms of a real estate sales contract executed by and between the Developer and the EDC.
- (b) **Performance.** EDC agrees to perform and comply with all terms, conditions, and provisions set forth in this Agreement and in all other instruments and agreements by and between the Developer and EDC.

SECTION 6. CESSATION OF ADVANCES.

If the EDC has made any commitment to provide any financial assistance to Developer, whether under this Agreement or under any other agreement, the EDC shall have no obligation to advance or disburse the financial assistance if: (i) Developer becomes insolvent, files a petition in bankruptcy or similar proceedings, or is adjudged bankrupt; or (ii) an Event of Default occurs.

SECTION 7. EVENTS OF DEFAULT.

Each of the following shall constitute an Event of Default under this Agreement:

- (a) **General Event of Default.** Failure of Developer or EDC to comply with or to perform any other term, obligation, covenant or condition contained in this Agreement, or failure of Developer or EDC to comply with or to perform any other term, obligation, covenant or condition contained in any other agreement by and between Developer and EDC is an Event of Default.
- (b) **False Statements.** Any warranty, representation, or statement made or furnished to EDC by or on behalf of Developer under this Agreement that is false or misleading in any material

respect, either now or at the time made or furnished is an Event of Default.

- (c) **Insolvency.** Developer's insolvency, appointment of receiver for any part of Developer's property, any assignment for the benefit of creditors of Developer, any type of creditor workout for Developer, or the commencement of any proceeding under any bankruptcy or insolvency laws by or against Developer is an Event of Default.
- (d) **Ad Valorem Taxes.** Developer allows its ad valorem taxes owed to the City of Sweeny, Texas, to become delinquent and fails to timely and properly follow the legal procedures for protest and/or contest of such taxes and to cure such failure within thirty (30) days after written notice thereof from EDC and/or Brazoria County Central Appraisal District is an Event of Default.

SECTION 8. EFFECT OF AN EVENT OF DEFAULT.

In the event of default under Section 7 of this Agreement, the non-defaulting party shall give written notice to the other party of any default, and the defaulting party shall have thirty (30) days to cure said default. Should said default remain uncured as of the last day of the applicable cure period, and the non-defaulting party is not otherwise in default, the non-defaulting party shall have the right to immediately terminate this Agreement, enforce specific performance as appropriate or maintain a cause of action for damages caused by the event(s) of default. In the event, Developer defaults and is unable or unwilling to cure said default within the prescribed time period, the Developer covenants and agrees to immediately reconvey the Property to the EDC free and clear of all liens or other encumbrances.

SECTION 9. INDEMNIFICATION.

Developer shall indemnify, save, and hold harmless EDC, its directors, officers, agents, attorneys, and employees (collectively, the "Indemnitees") from and against: (i) any and all claims, demands, actions or causes of action that are asserted against any Indemnitee if the claim, demand, action or cause of action directly or indirectly relates to tortious interference with contract or business interference, or wrongful or negligent use of EDC's financial assistance by Developer or its agents and employees; (ii) any administrative or investigative proceeding by any governmental authority directly or indirectly related, to a claim, demand, action or cause of action in which EDC is a disinterested party; (iii) any claim, demand, action or cause of action which directly or indirectly contests or challenges the legal authority of EDC or Developer to enter into this Agreement; and (iv) any and all liabilities, losses, costs, or expenses (including reasonable attorneys' fees and disbursements) that any Indemnitee suffers or incurs as a result of any of the foregoing; provided, however, that Developer shall have no obligation under this Section to EDC with respect to any of the foregoing arising out of the gross negligence or willful misconduct of EDC or the breach by EDC of this Agreement. If any claim, demand, action or cause of action is asserted against any Indemnitee, such Indemnitee shall promptly notify Developer, but the failure to so promptly notify Developer shall not affect Developer's obligations under this Section unless

such failure materially prejudices Developer's right to participate in the contest of such claim, demand, action or cause of action, as hereinafter provided. If requested by Developer in writing, as so long as no Default or Event of Default shall have occurred and be continuing, such Indemnitee shall in good faith contest the validity, applicability and amount of such claim, demand, action or cause of action and shall permit Developer to participate in such contest. Any Indemnitee that proposes to settle or compromise any claim, demand, action, cause of action or proceeding for which Developer may be liable for payment of indemnity hereunder shall give Developer written notice of the terms of such proposed settlement or compromise reasonably in advance of settling or compromising such claim or proceeding and shall obtain Developer's concurrence thereto.

SECTION 10. MISCELLANEOUS PROVISIONS.

The following miscellaneous provisions are a part of this Agreement:

- (a) **Amendments.** This Agreement constitutes the entire understanding and agreement of the parties as to the matters set forth in this Agreement. No alteration of or amendment to this Agreement shall be effective unless given in writing and signed by the party or parties sought to be charged or bound by the alteration or amendment.
- (b) **Applicable Law and Venue.** This Agreement shall be governed by and construed in accordance with the laws of the State of Texas, and all obligations of the parties created hereunder are performable in Brazoria County, Texas. Venue for any action arising under this Agreement shall lie in the state district courts of Brazoria County, Texas.
- (c) **Assignment.** This Agreement may not be assigned without the express written consent of the other party.
- (d) **Binding Obligation.** This Agreement shall become a binding obligation on the signatories upon execution by all signatories hereto. Developer warrants and represents that the individual or individuals executing this Agreement on behalf of Developer has full authority to execute this Agreement and bind Developer to the same. EDC warrants and represents that the individual executing this Agreement on its behalf has full authority to execute this Agreement and bind it to the same.
- (e) **Caption Headings.** Caption headings in this Agreement are for convenience purposes only and are not to be used to interpret or define the provisions of the Agreement.
- (f) **Counterparts.** This Agreement may be executed in one or more counterparts, each of which shall be deemed an original and all of which shall constitute one and the same document.
- (g) **Filing.** This Agreement shall be filed in the deed records of Brazoria County, Texas. The provisions of this Agreement shall be deemed to run with the land and shall be binding on

heirs, successors and assigns of the Developer.

- (h) **Notices.** Any notice or other communication required or permitted by this Agreement (hereinafter referred to as the “Notice”) is effective when in writing and (i) personally delivered either by facsimile (with electronic information and a mailed copy to follow) or by hand or (ii) three (3) days after notice is deposited with the U.S. Postal Service, postage prepaid, certified with return receipt requested, and addressed as follows:

if to EDC: Sweeny Economic Development Corporation
111 W. 3rd Street
Sweeny, Texas 77480
Attn: Michelle Medina, Executive Director
Telephone: (979) 548-2894

if to Developer: Cecil Joe Stark Sawmill & Logging, Inc.
P.O. Box 1207
West Columbia, Texas 77486
Attn: Cecil Joe Stark, President
Telephone: _____

- (i) **Severability.** If a court of competent jurisdiction finds any provision of this Agreement to be invalid or unenforceable as to any person or circumstance, such finding shall not render that provision invalid or unenforceable as to any other persons or circumstances. If feasible, any such offending provision shall be deemed to be modified to be within the limits of enforceability or validity; however, if the offending provision cannot be so modified, it shall be stricken and all other provisions of this Agreement in all other respects shall remain valid and enforceable.
- (j) **Time is of the Essence.** Time is of the essence in the performance of this Agreement.
- (k) **Undocumented Workers.** Developer certifies that the Developer does not and will not knowingly employ an undocumented worker in accordance with Chapter 2264 of the Texas Government Code, as amended. If during the Term of this Agreement, Developer is convicted of a violation under 8 U.S.C. § 1324a(f), Developer shall repay the amount of the public subsidy provided under this Agreement plus interest, at the rate of six percent (6%), not later than the 120th day after the date the EDC notifies Developer of the violation.

[The Remainder of this Page Intentionally Left Blank]

DEVELOPER:

**CECIL JOE STARK SAWMILL
& LOGGING, INC.,**
a Texas corporation,

By: _____
Cecil Joe Stark, President

Date Signed: _____

STATE OF TEXAS §
§
COUNTY OF BRAZORIA §

This instrument was acknowledged before me on the ____ day of _____, 2023,
by Cecil Joe Stark, President of Cecil Joe Stark Sawmill & Logging, Inc., a Texas corporation, on
behalf of said Texas corporation.

Notary Public, State of Texas

Exhibit A

Legal Description and/or Depiction of the Property

PERFORMANCE AGREEMENT

This **PERFORMANCE AGREEMENT** by and between the **SWEENEY ECONOMIC DEVELOPMENT CORPORATION**, a Texas non-profit corporation (hereinafter referred to as the “EDC”), and **CECIL JOE STARK SAWMILL & LOGGING, INC.**, a Texas corporation (hereinafter referred to as “Developer”), is made and executed on the following recitals, terms and conditions.

WHEREAS, the EDC is a Type B economic development corporation, created pursuant to Chapter 505 of the Texas Local Government Code, as amended; and

WHEREAS, Section 501.101 of the Texas Local Government Code, in pertinent part, defines the term “project” to mean “land, buildings, equipment, facilities, expenditures, targeted infrastructure, and improvements that are: (1) for the creation or retention of primary jobs; and (2) found by the board of directors to be required or suitable for the development, retention, or expansion of: (A) manufacturing and industrial facilities; (B) research and development facilities; (C) military facilities, including closed or realigned military bases; . . . (F) recycling facilities; . . . (I) distribution centers; (J) small warehouse facilities capable of serving as decentralized storage and distribution centers; (K) primary job training facilities for use by institutions of higher education; or (L) regional or national corporate headquarters facilities”; and

WHEREAS, Section 501.103 of the Texas Local Government Code, in pertinent part, defines the term “project” to mean “expenditures that are found by the board of directors to be required or suitable for infrastructure necessary to promote or develop new or expanded business enterprises, limited to: (1) streets and roads, rail spurs, water and sewer utilities, electric utilities, or gas utilities, drainage, site improvements, and related improvements; (2) telecommunications and Internet improvements . . .”; and

WHEREAS, Section 505.158 of the Texas Local Government Code provides that “[f]or a Type B corporation authorized to be created by a municipality with a population of 20,000 or less, “project” also includes the land, buildings, equipment, facilities, expenditures, targeted infrastructure, and improvements found by the corporation’s board of directors to promote new or expanded business development.” Further, the statute provides that “[a] Type B corporation may not undertake a project authorized by this section that requires an expenditure of more than \$10,000 until the governing body of the corporation’s authorizing municipality adopts a resolution authorizing the project after giving the resolution at least two separate readings”; and

WHEREAS, Section 501.158 of the Texas Local Government Code prohibits the provision of a direct incentive unless EDC enters into an Agreement with Developer providing at a minimum a schedule of additional payroll or jobs to be created or retained by EDC’s investment; a schedule of capital investments to be made as consideration for any direct incentives provided by EDC to Developer; and a provision specifying the terms and conditions upon which repayment must be made should Developer fail to meet the agreed to performance requirements specified in this Agreement; and

WHEREAS, Developer has applied to EDC for economic development assistance necessary to construct and operate a commercial office and retail establishment to be located on an 16.93 acre tract of land being out of a 67.288 acre tract being located in the Charles Breen League, Abstract No. 46 , City of Sweeny, Brazoria County, Texas (hereinafter referred to as the “Property”); and

WHEREAS, the EDC’s Board of Directors have determined the economic development assistance to be provided to Developer pursuant to this Agreement is consistent and meets the definition of “project” as that term is defined in Sections 501.101, 501.103, and 505.158 of the Texas Local Government Code; and the definition of “cost” as that term is defined by Section 501.152 of the Texas Local Government Code; and

WHEREAS, Developer agrees and understands that Section 501.073(a) of the Texas Local Government Code requires the City Council of the City of Sweeny, Texas, to approve all programs and expenditures of the EDC, and accordingly this Agreement is not effective until City Council has approved this project at a City Council meeting called and held for that purpose.

NOW, THEREFORE, for and in consideration of the agreements contained herein, and other good and valuable consideration, the receipt and sufficiency of which are hereby acknowledged, the EDC and Developer agree as follows:

SECTION 1. FINDINGS INCORPORATED.

The foregoing recitals are hereby incorporated into the body of this Agreement and shall be considered part of the mutual covenants, consideration and promises that bind the parties.

SECTION 2. TERM.

This Agreement shall be effective as of the Effective Date, as defined herein, and shall continue thereafter until **December 31, 2029**, unless terminated sooner under the provisions hereof.

SECTION 3. DEFINITIONS.

The following words shall have the following meanings when used in this Agreement.

- (a) **Act.** The word “Act” means Chapters 501 to 505 of the Texas Local Government Code, as amended.
- (b) **Agreement.** The word “Agreement” means this Performance Agreement, together with all exhibits and schedules attached to this Agreement from time to time, if any.
- (c) **Developer.** The word “Developer” means Cecil Joe Stark Sawmill & Logging, Inc., a Texas corporation, its successors and assigns, whose address for the purposes of this

Agreement is P.O. Box 1207, West Columbia, Texas 77486.

- (d) **EDC.** The term “EDC” means the Sweeny Economic Development Corporation, a Texas non-profit corporation, its successors and assigns, whose corporate address for the purposes of this Agreement is 111 W. 3rd Street, Sweeny, Texas 77480.
- (e) **Effective Date.** The words “Effective Date” mean the date of the latter to execute this Agreement by and between the Developer and the EDC.
- (f) **Event of Default.** The words “Event of Default” mean and include any of the Events of Default set forth below in the section entitled “Events of Default.”
- (g) **Full-Time Equivalent Employment Position.** The words “Full-Time Equivalent Employment Position” or “Full-Time Equivalent Employment Positions” mean and include a job requiring a minimum of One Thousand Nine Hundred Twenty (1,920) hours of work averaged over a twelve (12) month period.
- (h) **Property.** The word “Property” means the approximately 16.93 acre tract of land being out of a 67.288 acre tract being located in the Charles Breen League, Abstract No. 46, City of Sweeny, Brazoria County, Texas, and as generally depicted in *Exhibit A* of this Agreement, which is attached hereto and incorporated herein for all purposes.
- (i) **Qualified Expenditures.** The words “Qualified Expenditures” mean those expenditures consisting of the construction of an office and retail building located on the Property, as generally depicted in *Exhibit B* of this Agreement, which is attached hereto and incorporated herein for all purposes, and those expenses which meet the definition of “project” as that term is defined in Sections 501.101, 501.103, and 505.158 of the Act, and meet the definition of “cost” as that term is defined in Section 501.152 of the Act.
- (j) **Term.** The word “Term” means the term of this Agreement as specified in Section 2 of this Agreement.

SECTION 4. AFFIRMATIVE COVENANTS OF DEVELOPER.

Developer covenants and agrees with EDC that, while this Agreement is in effect, it shall comply with the following terms and conditions:

- (a) **Qualified Expenditures.** Developer covenants and agrees to commence construction of the Qualified Expenditures within 120 days of the EDC’s completion of the road and utilities leading to the Property. Further, Developer covenants and agrees to complete construction of an office and retail building within twelve (12) months of the City of Sweeny’s completion of the road and utilities leading to the Property.
- (b) **Certificate of Occupancy.** Developer covenants and agrees to obtain or cause to be

obtained within twelve (12) months of EDC's completion of the road and utilities leading to the Property, a certificate of occupancy from the City of Sweeny, Texas, for an office and retail space located on the Property.

(c) **Operate Office and Retail Facility.** Developer covenants and agrees to maintain and operate an office and retail space located on the Property within twelve (12) months of the EDC's completion of the road and utilities leading to the Property, and during the Term of this Agreement.

(d) **Job Creation and Retention.** Developer covenants and agrees to employ and maintain a minimum Full-Time Equivalent Employment Positions working at the Property as follows:

- (1) a minimum of twenty-four (24) Full-Time Equivalent Employment Positions by **July 1, 2024;**
- (2) a minimum of twenty-eight (28) Full-Time Equivalent Employment Positions by **July 1, 2025;**
- (3) a minimum of thirty (30) Full-Time Equivalent Employment Positions by **July 1, 2026;**
- (4) a minimum of thirty-two (32) Full-Time Equivalent Employment Positions by **July 1, 2027;**
- (5) a minimum of thirty-four (34) Full-Time Equivalent Employment Positions by **July 1, 2028; and**
- (6) a minimum of thirty-six (36) Full-Time Equivalent Employment Positions by **July 1, 2028.**

Further, Developer covenants and agrees beginning on **July 1, 2024**, and during the Term of this Agreement, Developer shall deliver to EDC an annual compliance verification signed by a duly authorized representative of Developer that shall certify the number of Full-Time Equivalent Employment Positions, and shall disclose and certify the average wage for all Full-Time Equivalent Employment Positions (the "Annual Compliance Verification"). The Developer covenants and agrees beginning on **July 1, 2024**, and annually thereafter during the Term of this Agreement, there will be a total of **six (6)** Annual Compliance Verifications due and submitted to the EDC covering the Full-Time Equivalent Employment Positions created and maintained during the Term of this Agreement. All Annual Compliance Verifications shall include quarterly IRS 941 returns, or Texas Workforce Commission Employer Quarterly Reports.

(e) **Acquisition of the Property.** Developer covenants and agrees to acquire the Property from the EDC within ninety (90) days of the Effective Date of this Agreement or consistent with the terms of a real estate sales contract executed by and between the Developer and the EDC. The Developer covenants and agrees the Property has a value of **Three Hundred Four Thousand Seven Hundred Forty and No/100 Dollars (\$304,740.00)**. Developer covenants and agrees to execute a deed of trust lien or other lien for the Property in a form acceptable to the EDC at the time of closing on the Property.

- (f) **Performance Conditions.** Developer agrees to make, execute and deliver to EDC such other promissory notes, instruments, documents and other agreements as EDC or its attorneys may reasonably request to evidence this Agreement.
- (g) **Performance.** Developer agrees to perform and comply with all terms, conditions, and provisions set forth in this Agreement and in all other instruments and agreements by and between the Developer and EDC.

SECTION 5. AFFIRMATIVE COVENANTS OF EDC.

EDC covenants and agrees with Developer that, while this Agreement is in effect, it shall comply with the following terms and conditions:

- (a) **Conveyance of the Property.** The EDC covenants and agrees to convey to the Developer good and indefeasible fee simple title to the Property, free and clear of any liens or other encumbrances, by special warranty deed within ninety (90) days of the Effective Date of this Agreement or consistent with the terms of a real estate sales contract executed by and between the Developer and the EDC.
- (b) **Performance.** EDC agrees to perform and comply with all terms, conditions, and provisions set forth in this Agreement and in all other instruments and agreements by and between the Developer and EDC.

SECTION 6. CESSATION OF ADVANCES.

If the EDC has made any commitment to provide any financial assistance to Developer, whether under this Agreement or under any other agreement, the EDC shall have no obligation to advance or disburse the financial assistance if: (i) Developer becomes insolvent, files a petition in bankruptcy or similar proceedings, or is adjudged bankrupt; or (ii) an Event of Default occurs.

SECTION 7. EVENTS OF DEFAULT.

Each of the following shall constitute an Event of Default under this Agreement:

- (a) **General Event of Default.** Failure of Developer or EDC to comply with or to perform any other term, obligation, covenant or condition contained in this Agreement, or failure of Developer or EDC to comply with or to perform any other term, obligation, covenant or condition contained in any other agreement by and between Developer and EDC is an Event of Default.
- (b) **False Statements.** Any warranty, representation, or statement made or furnished to EDC by or on behalf of Developer under this Agreement that is false or misleading in any material respect, either now or at the time made or furnished is an Event of Default.

- (c) **Insolvency.** Developer's insolvency, appointment of receiver for any part of Developer's property, any assignment for the benefit of creditors of Developer, any type of creditor workout for Developer, or the commencement of any proceeding under any bankruptcy or insolvency laws by or against Developer is an Event of Default.
- (d) **Ad Valorem Taxes.** Developer allows its ad valorem taxes owed to the City of Sweeny, Texas, to become delinquent and fails to timely and properly follow the legal procedures for protest and/or contest of such taxes and to cure such failure within thirty (30) days after written notice thereof from EDC and/or Brazoria County Central Appraisal District is an Event of Default.

SECTION 8. EFFECT OF AN EVENT OF DEFAULT.

In the event of default under Section 7 of this Agreement, the non-defaulting party shall give written notice to the other party of any default, and the defaulting party shall have thirty (30) days to cure said default. Should said default remain uncured as of the last day of the applicable cure period, and the non-defaulting party is not otherwise in default, the non-defaulting party shall have the right to immediately terminate this Agreement, enforce specific performance as appropriate or maintain a cause of action for damages caused by the event(s) of default. In the event, Developer defaults and is unable or unwilling to cure said default within the prescribed time period, the Developer covenants and agrees to immediately reconvey the Property to the EDC free and clear of all liens or other encumbrances.

SECTION 9. INDEMNIFICATION.

Developer shall indemnify, save, and hold harmless EDC, its directors, officers, agents, attorneys, and employees (collectively, the "Indemnitees") from and against: (i) any and all claims, demands, actions or causes of action that are asserted against any Indemnitee if the claim, demand, action or cause of action directly or indirectly relates to tortious interference with contract or business interference, or wrongful or negligent use of EDC's financial assistance by Developer or its agents and employees; (ii) any administrative or investigative proceeding by any governmental authority directly or indirectly related, to a claim, demand, action or cause of action in which EDC is a disinterested party; (iii) any claim, demand, action or cause of action which directly or indirectly contests or challenges the legal authority of EDC or Developer to enter into this Agreement; and (iv) any and all liabilities, losses, costs, or expenses (including reasonable attorneys' fees and disbursements) that any Indemnitee suffers or incurs as a result of any of the foregoing; provided, however, that Developer shall have no obligation under this Section to EDC with respect to any of the foregoing arising out of the gross negligence or willful misconduct of EDC or the breach by EDC of this Agreement. If any claim, demand, action or cause of action is asserted against any Indemnitee, such Indemnitee shall promptly notify Developer, but the failure to so promptly notify Developer shall not affect Developer's obligations under this Section unless such failure materially prejudices Developer's right to participate in the contest of such

claim, demand, action or cause of action, as hereinafter provided. If requested by Developer in writing, as so long as no Default or Event of Default shall have occurred and be continuing, such Indemnatee shall in good faith contest the validity, applicability and amount of such claim, demand, action or cause of action and shall permit Developer to participate in such contest. Any Indemnatee that proposes to settle or compromise any claim, demand, action, cause of action or proceeding for which Developer may be liable for payment of indemnity hereunder shall give Developer written notice of the terms of such proposed settlement or compromise reasonably in advance of settling or compromising such claim or proceeding and shall obtain Developer's concurrence thereto.

SECTION 10. MISCELLANEOUS PROVISIONS.

The following miscellaneous provisions are a part of this Agreement:

- (a) **Amendments.** This Agreement constitutes the entire understanding and agreement of the parties as to the matters set forth in this Agreement. No alteration of or amendment to this Agreement shall be effective unless given in writing and signed by the party or parties sought to be charged or bound by the alteration or amendment.
- (b) **Applicable Law and Venue.** This Agreement shall be governed by and construed in accordance with the laws of the State of Texas, and all obligations of the parties created hereunder are performable in Brazoria County, Texas. Venue for any action arising under this Agreement shall lie in the state district courts of Brazoria County, Texas.
- (c) **Assignment.** This Agreement may not be assigned without the express written consent of the other party.
- (d) **Binding Obligation.** This Agreement shall become a binding obligation on the signatories upon execution by all signatories hereto. Developer warrants and represents that the individual or individuals executing this Agreement on behalf of Developer has full authority to execute this Agreement and bind Developer to the same. EDC warrants and represents that the individual executing this Agreement on its behalf has full authority to execute this Agreement and bind it to the same.
- (e) **Caption Headings.** Caption headings in this Agreement are for convenience purposes only and are not to be used to interpret or define the provisions of the Agreement.
- (f) **Counterparts.** This Agreement may be executed in one or more counterparts, each of which shall be deemed an original and all of which shall constitute one and the same document.
- (g) **Filing.** This Agreement shall be filed in the deed records of Brazoria County, Texas. The provisions of this Agreement shall be deemed to run with the land and shall be binding on heirs, successors and assigns of the Developer.

- (h) **Notices.** Any notice or other communication required or permitted by this Agreement (hereinafter referred to as the “Notice”) is effective when in writing and (i) personally delivered either by facsimile (with electronic information and a mailed copy to follow) or by hand or (ii) three (3) days after notice is deposited with the U.S. Postal Service, postage prepaid, certified with return receipt requested, and addressed as follows:

if to EDC: Sweeny Economic Development Corporation
111 W. 3rd Street
Sweeny, Texas 77480
Attn: Michelle Medina, Executive Director
Telephone: (979) 548-2894

if to Developer: Cecil Joe Stark Sawmill & Logging, Inc.
P.O. Box 1207
West Columbia, Texas 77486
Attn: Cecil Joe Stark, President
Telephone: _____

- (i) **Severability.** If a court of competent jurisdiction finds any provision of this Agreement to be invalid or unenforceable as to any person or circumstance, such finding shall not render that provision invalid or unenforceable as to any other persons or circumstances. If feasible, any such offending provision shall be deemed to be modified to be within the limits of enforceability or validity; however, if the offending provision cannot be so modified, it shall be stricken and all other provisions of this Agreement in all other respects shall remain valid and enforceable.
- (j) **Time is of the Essence.** Time is of the essence in the performance of this Agreement.
- (k) **Undocumented Workers.** Developer certifies that the Developer does not and will not knowingly employ an undocumented worker in accordance with Chapter 2264 of the Texas Government Code, as amended. If during the Term of this Agreement, Developer is convicted of a violation under 8 U.S.C. § 1324a(f), Developer shall repay the amount of the public subsidy provided under this Agreement plus interest, at the rate of six percent (6%), not later than the 120th day after the date the EDC notifies Developer of the violation.

[The Remainder of this Page Intentionally Left Blank]

Exhibit A

Legal Description and/or Depiction of the Property



AGENDA MEMO

Business of the City Council

City of Sweeny, Texas

Meeting Date	10/24/2023	Agenda Item	
Approved by City Manager		Presenter(s)	Administration
Reviewed by City Attorney		Department	
Subject	Discussion/ Possible action on amendment to Ordinance 130.07 and determining zone allowance; Eight-liner machines		
Attachments	COS Ordinance; City of Angleton Ordinance, City of Richwood Ordinance		
Financial Information	Expenditure Required:		
	Amount Budgeted:		
	Account Number:		
	Additional Appropriation Required:		
	Additional Account Number:		

Executive Summary

The City currently prohibits eight liner machines (game rooms). The City has been approached on the allowance and the change of ordinance.

If Council chooses to allow, a fee for permit would need to be established and updated in the master fee schedule, permitting requirements established, allowable locations and footage requirements within the zoned property, and and special provisions. Staff is proposing to allow in Light Industrial zones only, which would require a change to the Zoning Ordinance as well. This would help to restrict the number of proposed pending a zone change.

Attached are examples of ordinances where allowable; City of Angleton, City of Richwood

Recommended Action

Council Discretion : Keep current ordinance as is or amend ordinance to allow.

§ 130.07 EIGHT-LINER MACHINES PROHIBITED.

Item 14.

(A) For the purpose of this chapter, the following definitions shall apply unless the context clearly indicates or requires a different meaning.

EIGHT-LINER or **EIGHT-LINER MACHINE.** A coin-operated machine or contrivance capable of being used for games of chance, including but not limited to, a Tic-Tac-Toe eight-liner or video poker machine or other contrivance or paraphernalia, on which games of chance can be played for a consideration and which afford the player an opportunity to win a prize, gift certificate or thing of value, whether or not the prize is automatically paid by the contrivance, having a wholesale value available from a single play of the game or device once or \$5, whichever is less, but excluding the machines listed in § 2153.004 of the Texas Occupations Code.

GAME ROOM FOR EIGHT-LINERS. Any building or portion thereof, used for the exhibition or displaying of eight-liners.

(B) *Eight-liners prohibited.*

- (1) Eight-liners are prohibited within the city.
- (2) Game rooms for eight-liners are prohibited within the city.

(C) *Affirmative defense.* In any prosecution under this section, it is an affirmative defense if the owner or operator of the alleged unlawful eight-liner machines had placed or located said machines in the city on or before the date of the passage of this section.

(Ord. 105-04, passed 3-16-04; Am. Ord. 103-07, passed 3-20-07) Penalty, see § 130.99

ARTICLE V. - AMUSEMENT REDEMPTION MACHINE GAME ROOMS^[4]

Footnotes:

--- (4) ---

Editor's note— Ord. 2003-O-12E, § II, adopted Dec. 16, 2003, set out provisions intended for use as Ch. 21.2. For purposes of classification, and at the editor's discretion with the concurrence of the city, these provisions have been included in Ch. 21, as Art. V, §§ 21-151—21-156.

Sec. 21-151. - Definitions.

Amusement redemption machine game room means any business where amusement redemption machines, with the exception of excluded machines, are the primary source of income for the business.

Amusement redemption machine means:

- (1) A skill or pleasure coin-operated machine that is designed, made and adapted solely for bona fide amusement purposes, and that by operation of chance or a combination of skill and chance affords the use, in addition to any right of replay, an opportunity to receive exclusively non-cash merchandise prizes, toys, novelties, or a representation of value redeemable for those items.
- (2) Any electronic, electromechanical or mechanical contrivance designed, made and adapted solely for bona fide amusement purposes if the contrivance rewards the player exclusively with non-cash merchandise, prizes, or novelties, or a representation of value redeemable for those items, that have a wholesale value available from a single play of the game or device of not more than ten times the amount charged to lay the game or device once or \$5.00, whichever is less.

Coin-operated machine means a machine or device operated by the payment or insertion of coin or paper currency or any other consideration.

Excluded machines: An amusement redemption machine game room does not include:

- (1) A machine that awards the user non-cash merchandise prizes, toys, or novelties solely and direct from the machine, including claw, crane, or similar machines; nor
- (2) A machine from which the opportunity to receive non-cash merchandise prizes, toys, or novelties, or a representation of value redeemable for those items, varies depending upon the user's ability to throw, roll, flip, toss, hit or drop a ball or other physical object into the machine or a part thereof, including basketball, skeet ball, golf, bowling, pusher, or similar machines; nor
- (3) A machine or any device defined in V.T.C.A., Penal Code § 47.01, as a gambling device, or any activity prohibited or described in V.T.C.A., Penal Code Ch. 47.

Representation of value means cash paid under authority of sweepstakes contests as provided in the V.T.C.A., Business and Comm. Code Ch. 622, or a gift certificate or gift card that is presented to a merchant in exchange for merchandise.

(Ord. No. 2003-O-12E, § II, 12-16-03; [Ord. No. 20210413-009](#), § 2(Exh. A), 4-13-21)

Sec. 21-152. - Local initial certification fee for amusement redemption machine game room required.

Payment of fee and issuance of certificate. In order to ensure that the proposed business has adequate parking spaces and that the business complies with other requirements of the city, an owner, operator, or lessee of an amusement redemption machine game room shall be required to secure a certificate of operation by paying to the city an initial certification fee for each location as laid out in the fee schedule of the City of Angleton.

This certificate shall be issued by the city's chief building official, only upon the advance payment of the above fee and only after the city is satisfied that the business is in the proper zone, has adequate striped parking spaces (see requirements below), adequate square footage to safely house that number of machines and submission of a site plan showing the building, parking spaces, and placement of the machines.

(Ord. No. 2003-O-12E, § II, 12-16-03; Ord. No. 2008-O-6C, § IA, 6-24-08; Ord. No. [20210810-009](#), § 45, 8-10-21)

Sec. 21-153. - Local license fee for amusement redemption machine game room required.

- (a) *Payment of fee and issuance of license.* An owner, operator, or lessee of an amusement redemption machine game room shall be required to secure a license by paying to the city an annual inspection and amusement redemption machine game room license fee, per machine, as listed in the fee schedule of the City of Angleton. Upon payment of the license or renewal license and compliance with all provisions of chapter 21, article V, sections 21-151 through section 21-161, the building official shall issue a license.
- (b) *Expiration and renewal.* Annual amusement redemption machine game room licenses issued by the city shall automatically expire **on August 31** following its issuance, except as otherwise stated herein. Such permit shall automatically expire if the holder thereof sells, transfers equity, or otherwise disposes of such devices. The city shall not refund any portion of a license after the license is issued, nor shall it prorate or reduce an amount of any fee due to the city.
- (c) *Late penalty.* Upon the expiration of a license, and within 30 days thereafter, the person shall obtain a renewal in the same manner as an original license if he wishes to continue operating an amusement redemption machine game room. Failure to pay this fee within 30 days will require such person to pay an additional late fee in an amount equal to 20 percent of the fee actually due or 20 percent of the previous year's fee, whichever is greater in order to obtain reinstatement of his license; and will require the owner to reapply for a specific use permit.
- (d) *Sealing.* The city shall have the authority to seal any coin-operated machine located at any amusement redemption machine game room for which a license fee has not been secured. A fee as listed in the fee schedule of the City of Angleton will be charged for the release of any machine sealed for non-payment of said license fee.
- (e) *Posting of license.* The license shall be conspicuously posted inside the building.
- (f) *Location requirements.* Premises shall not operate within 1,000 feet of a church, school, day care or hospital. Additionally, the perimeter of the building footprint shall not be located closer than 500 feet from any residentially zoned property.
- (g) *Compliance with zoning required.* The use shall only be permitted in accordance with all applicable requirements of chapter 28, Zoning, particularly section 37.2 (§ 28-81), Use regulations (Charts), which establishes the zoning districts where the use is permitted, and section 47 (§ 28-110), Special regulations for certain types of uses.

(Ord. No. 2003-O-12E, § II, 12-16-03; Ord. No. 2004-O-8D, § 1, 8-17-04; Ord. No. 2008-O-6C, § IB, 6-24-08; Ord. No. 2011-O-4D, § 2, 4-19-11; Ord. No. 1-08-2018, § 1, 8-7-18; Ord. No. [20210810-009](#), § 46, 8-10-21)

Sec. 21-154. - Unrestricted access by law enforcement officers, code enforcement officers and agents of the City of Angleton.

It shall be the duty of any owner, manager, or employee of a game room, or other person exercising control over a game room, a portion of a game room, or an amusement redemption machine, to provide

any law enforcement officer, code enforcement officer or agent of the City of Angleton with immediate unrestricted access during business hours to all areas of the game room and to all amusement redemption machines located in the game room.

(Ord. No. 2011-O-4D, § 3, 4-19-11)

Sec. 21-155. - Inspection by law enforcement officer, code enforcement officer and agents of the City of Angleton.

- (a) Any law enforcement officer, code enforcement officer or agent of the City of Angleton may inspect a game room or an amusement redemption machine located in the City of Angleton to determine whether the game room or amusement redemption machine complies with the ordinance from which this section derives, and state law.
- (b) An owner, manager, or employee of a game room or other person who does not allow a law enforcement officer, code enforcement officer or agent of the City of Angleton to inspect a game room or amusement redemption machine commits an offense.

(Ord. No. 2011-O-4D, § 3, 4-19-11)

Sec. 21-156. - Signage required, hours of operation, ingress and egress.

- (a) A game room owner shall mark each entrance to a game room with a sign that: (1) bears the words "GAME ROOM" in six-inch or larger block letters; and (2) is legible from a distance of 25 feet.
- (b) It shall be the duty of any owner, manager, or employee of a game room, or other person exercising control over a game room or a portion of a game room, to clearly mark their hours of operation on every entrance.
- (c) All entrance doors must remain unlocked during the hours of operation.
- (d) All exit doors must comply with the International Fire Code, as amended.

(Ord. No. 2011-O-4D, § 3, 4-19-11)

Sec. 21-157. - Unobstructed view to the interior.

The entrance door of a game room shall be totally transparent to permit a clear, unobstructed view of the interior of the game room.

(Ord. No. 2011-O-4D, § 3, 4-19-11)

Sec. 21-158. - Lighting.

Lighting shall be maintained at an intensity of not less than 30 footcandle power, three feet from the floor, measured at any location in any room open to the public, which shall be operative during all hours of operation of any place of business covered under the ordinance from which this section derives.

(Ord. No. 2011-O-4D, § 3, 4-19-11)

Sec. 21-159. - Termination of license.

The city council may terminate any license to maintain and operate an amusement redemption machine game room when the licensee is in violation of any provision of this article and other ordinance of the city, or any applicable state or federal law on regulation. Such termination by the city council shall be upon the affirmative vote of a majority of the members of the city council present and voting at any regular or special meeting thereof held after at least ten days' notice sent by certified mail, return receipt requested and addressed to the licensee at the premises, specifying the particular violation or violations. Any decision of the city council thereon shall be entered upon the minutes of such meeting. Any decision of the city council thereon shall be final and may not be appealed.

(Ord. No. 2003-O-12E, § II, 12-16-03; Ord. No. 2011-O-4D, § 4, 4-19-11)

Editor's note— Section 3 of Ord. No. 2011-O-4D, added new provisions as §§ 21-154—21-158, and section 4 of Ord. No. 2011-O-4D, renumbered existing §§ 21-154—21-156 as §§ 21-159—21-161.

Sec. 21-160. - Disclaimer.

By issuing the required license, the city is not certifying the installation or use of the amusement redemption machines applying for a license, the applicant shall acknowledge that the city is not certifying or sanctioning the installation or use of such machines. By the acceptance of a license under this article, the licensee acknowledges that the installation and use of the machines which are the subject of this article may be found to violate state law. By the acceptance of a license issued under this article, the license fee paid belongs to the city and will not be refunded.

(Ord. No. 2003-O-12E, § II, 12-16-03; Ord. No. 2011-O-4D, § 4, 4-19-11)

Note— See Editor's Note under § 21-159.

Sec. 21-161. - Violation of any provision of this article constitutes a Class C misdemeanor.

Any person violating any provision of this article of the Angleton Code of Ordinances shall be guilty of a misdemeanor and upon conviction therefor shall be assessed a fine of not less than \$1.00, nor more than \$500.00; and each day such violation continues and each part of any day such violation occurs shall constitute a separate offense.

(Ord. No. 2003-O-12E, § II, 12-16-03; Ord. No. 2011-O-4D, § 4, 4-19-11)

Note— See Editor's note under § 21-159.

Secs. 21-162—21-185. - Reserved.

ARTICLE VII. AMUSEMENT REDEMPTION MACHINE GAME ROOM¹

Sec. 9-221. Definitions.

Wherever used in this article, the following terms shall have the following definitions and meanings, unless the context of the sentence in which they are used clearly indicates otherwise. When not inconsistent with the context, words used in the present tense include the future tense, words in the plural number include the singular number, and words in the single number include the plural number. The word 'shall' is always mandatory and not merely directory.

Amusement redemption machine game room shall mean any business where amusement redemption machines, with the exception of excluded machines, are the primary source of income for the business, or in which more than 25 percent of the total square feet of the building, or part thereof, which houses the business, excluding rest rooms, storage and other areas from which the public is excluded, is used as a game room for the operation of amusement redemption machines.

Amusement redemption machines means:

- (1) A skill or pleasure coin-operated machine that is designed, made or adapted solely for bona fide amusement purposes, and that by operation of chance or a combination of skill and chance affords the user, in addition to any right of replay, an opportunity to receive exclusively noncash merchandise prizes, toys, novelties, or a representation of value redeemable for those items; or
- (2) Any electronic, electro mechanical, or mechanical contrivance designed, made and adapted solely for bona fide amusement purposes if the contrivance rewards the player exclusively with noncash merchandise, prizes, or novelties, or a representation of value redeemable for those items, that have a wholesale value available from a single play of the game or device of not more than ten times the amount charged to play the game or device once or \$5.00 whichever is less.

Coin-operated machine means a machine or device operated by the payment or insertion of paper currency or any other consideration.

Excluded machines: An amusement redemption machine game room does not include:

- (1) A machine that awards the user noncash merchandise prizes, toys or novelties solely and directly from the machine, including claw, crane, or similar machines; nor
- (2) A machine from which the opportunity to receive noncash merchandise prizes, toys, or novelties, or a representation of value redeemable for those items varies depending upon the user's ability to throw, roll, flip, toss, hit or drop a ball or other physical object into the machine or part thereof, including basketball, skeet ball, golf, bowling, pusher, or similar machines; nor
- (3) A machine or any device defined in section 47.01, Penal Code, as a gambling device, or any activity prohibited or described in Chapter 47, Penal Code.

¹Editor's note(s)—Ord. No. 314A, §§ 1—4, adopted July 23, 2007, amended art. VII in its entirety to read as herein set out. Formerly, said article pertained to similar subject matter as enacted by Ord. No. 314, §§ 1—4, adopted Oct. 10, 2004. See the Code Comparative Table for a detailed analysis of inclusion.

Representation of value means cash paid under authority of sweepstakes contests as provided in the Texas Business and Commerce Code, Chapter 43(B), or a gift certificate or gift card that is presented to a merchant in exchange for merchandise.

(Ord. No. 314A, § 1, 7-23-07)

Sec. 9-222. License required.

- (a) *Payment of fee and issuance of license.* An owner, operator, or lessee of an amusement redemption machine game room shall be required to secure a license by paying to the city an annual amusement redemption game room license fee of \$2,000.00 for the first 2,000 square feet of the building, or part thereof, that houses the game room, including rest rooms, storage and other areas from which the public is excluded but which are used, in whole or in part in the operation of such business, \$1.00 for each square foot thereof over 2,000 square feet.

Each amusement machine shall have affixed to it a City of Richwood permit. This permit shall be issued with the original application. Machines shall be inspected at a minimum of three times a year and the inspection shall be conducted by the chief of police and/or the code enforcement officer. An annual inspection fee of \$50.00 per machine will help offset this cost.

Upon the payment of the required fees for the license and inspections, a license shall be issued to such owner, operator, or lessee, as the case may be, by the building official.

Owners, operators, or lessees of businesses not falling under the definition of an amusement redemption machine game room but who operate amusement redemption machines, with the exception of excluded machines, shall pay the city an annual inspection and license fee of \$250.00 per machine.

- (b) *Expiration and renewal.* Annual amusement redemption machine game room licenses issued by the city shall automatically expire on the 31st day of December in the calendar year of its issuance, except as otherwise stated herein. Such permit shall automatically expire if the holder thereof sells, transfers equity in, or otherwise disposes of such devices. The city shall not refund any portion of a license or inspection fees after the license is issued, nor shall it prorate or reduce in any amount any fee due to the city, regardless of what portion of a calendar/license year may have expired on the date on which the license is issued.
- (c) *Late penalty.* No later than 30 days following the expiration of any license under this article, the licensee shall obtain a renewal in the same manner as an original license if he wishes to continue operating an amusement redemption machine game room. Failure to pay this fee within the time period will require such person to pay an additional late fee in an amount equal to 20 percent of the fees actually due or 20 percent of the previous year's fees, whichever is greater, in order to obtain reinstatement of his license.
- (d) *Sealing.* The city shall have the authority to seal any coin-operated machine located at any amusement redemption machine game room for which a license has not been secured or which does not have the City of Richwood permit attached. A \$100.00 fee will be charged for the release of any machine sealed for nonpayment of said license or inspection fee.

On the third such time an unlicensed machine is found in operation, the amusement machine game room shall have its license to operate suspended for 30 days. On the fourth offense, the suspension will be for 40 days. In the event of a fifth such offense, the machine game room shall have its license to operate suspended for 90 days and shall pay a \$1,000.00 reinstatement fee. Any further violations will result in an immediate revocation of the amusement machine game room and the owner, operator or lessees of such business will no longer be allowed to operate a business covered by this article.

It shall be unlawful for anyone to tamper with, remove, alter, or otherwise circumvent any seal placed by the city on a coin-operated machine under the provisions of this paragraph.

- (e) *Posting of license.* This license shall be conspicuously posted inside the building.
- (f) *Restrictions, regulations, controls, and limitations.* The following restrictions, regulations, controls and limitations shall apply to all amusement redemption machine game rooms:
- (1) *Specific use permit required.* An owner, operator or lessee of an amusement redemption machine game room shall be required to secure a specific use permit from the City of Richwood. Once the above fees for the license and machines have been paid, the owner, operator or lessee may present their application to the City Council of the City of Richwood. The specific use permit automatically expires on the 31st day of December in the calendar year of its issuance except as otherwise stated herein. Such permit shall automatically expire if the holder thereof sells, transfers equity in, or otherwise disposes of such devices. The city shall not refund any portion of a license after the license is issued, nor shall it prorate or reduce in any amount any fee due to the city, regardless of what portion of a calendar/license year may have expired on the date on which the license is issued.
 - (2) *Condition of premises.* All building and fire code standards must be met. Inspection by building official and certificate of occupancy and specific use shall be obtained before license is issued.
 - (3) *Methods of conducting business.* No alcoholic beverages shall be served or allowed on premises. No activities may be conducted on the premises of the game room outside the building in which the game room is housed. No one under the age of 18 is allowed in that portion of the business in which the amusement redemption games are in operation.
 - (4) *Hours of operations.* Twenty-four hours per day, seven days a week.
 - (5) *Parking requirements.* One space per two machines, plus one space per employee per shift. Each parking space must be dedicated to use by the amusement machine game room patrons and employees for the duration of the regular hours of operations of the amusement machine game room.
 - (6) *Location requirements.* Premises shall not operate within 300 feet of a church, school, or hospital unless it was operating such location prior to October 11, 2004; and the operator of any amusement redemption machine game room at such location prior to October 11, 2004, shall have an affirmative defense in any prosecution under this chapter for operating such room at such location thereafter if a specific use permit for the use of such purposes has been issued and has not been revoked. As used herein, "church" means any facility that is owned by a religious organization and is used primarily for religious services, "school" means a private or public elementary or secondary school or day-care center, as defined in Section 42.002, Human Resources Code; and "hospital" means a place for the reception of persons sick or infirm in body or mind, and includes a clinic with separate offices for two or more health care professionals.
 - (7) *Zoning.* Amusement redemption machine game rooms can only be located in the C-1 Commercial use district as designated by color code yellow on the City of Richwood's Zoning map unless it was in operation prior to July 23, 2007; and the operator of any amusement redemption machine game room at such location prior to July 23, 2007, shall have an affirmative defense in any prosecution under this chapter for operating such room at such location thereafter if a specific use permit for the use of such purposes has not been revoked or has not expired.

(Ord. No. 314A, § 2, 7-23-07)

Sec. 9-223. Termination of license.

The city council may terminate any license to maintain and operate an amusement redemption machine game room when the licensee is in violation of any provision of this article, any applicable state or federal law on regulation of coin operated machines, any state or federal law on gaming or gambling devices or if the licensee has

had a similar license revoked in any other city. Such termination by the city council shall be upon affirmative vote of a majority of the members of the city council present and voting at any regular or special meeting thereof held after at least ten days prior to written notice sent by certified mail, return receipt requested and addressed to the licensee at the premises, specifying the particular violation or violations. Any decision of the city council thereon shall be entered upon the minutes of such meeting. Any decision of the city council thereon shall be final and nonappealable.

By issuing the required license, the city is not certifying the installation or use of the amusement redemption machines applying for a license, the applicant shall acknowledge that the city is not certifying or sanctioning the installation of such machines. By the acceptance of a license under this article, the licensee acknowledges that the installation and use of the machines which are subject to this article may be found to violate state law. By acceptance of a license issued under this article, the license fee paid belongs to the city and will not be refunded.

(Ord. No. 314A, §§ 3, 4, 7-23-07)

Secs. 9-224—9-240. Reserved.



AGENDA MEMO

Business of the City Council

City of Sweeny, Texas

Meeting Date	10/24/2023	Agenda Item	
Approved by City Manager		Presenter(s)	Kaydi Smith
Reviewed by City Attorney		Department	City Secretary/ Developmental Services
Subject	Discussion/ Possible action to amend Ordinance Chapter 110; Peddlers and Solicitors		
Attachments	Ordinance Chapter 110 amendment, 08/15/23 Minutes		
Financial Information	Expenditure Required:		
	Amount Budgeted:		
	Account Number:		
	Additional Appropriation Required:		
	Additional Account Number:		

Executive Summary

In August, the recommendation was given to Council to remove food (roadside vendors/push carts for sno cone and ice cream vendors) from Ordinance Chapter 110. Currently the ordinance is in conflict with The Texas Health and Safety Code Chapter 437 and Texas Administrative Code 229.161 due to temperature related foods.

Amendment attached is removing “food” from the definition of a peddler/ solicitor.

The food vendors consisting of roadside vendors and/or pushcarts (applying to snocone/ice cream vendors) will be established within the mobile food units ordinance.

Recommended Action

To approve the amendment to Ordinance Chapter 110, Peddlers and Solicitors.

ORDINANCE NO. _____

AN ORDINANCE OF THE CITY OF SWEENY, TEXAS, AMENDING CHAPTER 110 OF THE CODE OF ORDINANCES OF THE CITY OF SWEENY ENTITLED PEDDLERS AND SOLICITORS; AMENDING SECTION 110.02 ENTITLED DEFINITIONS BY REMOVING FOOD FROM THE DEFINITION OF PEDDLER OR SOLICITOR; PROVIDING A SAVINGS CLAUSE: PROVIDING FOR REPEAL OF CONFLICTING ORDINANCES TO THE EXTENT OF CONFLICT ONLY; AND PROVIDING THAT THIS ORDINANCE SHALL TAKE EFFECT AND BE IN FORCE AT THE DATE OF ITS PASSAGE.

BE IT ORDAINED BY THE CITY COUNCIL OF THE CITY OF SWEENY, TEXAS:

Section 1:

Section 110.02 of the Code of Ordinances of the City of Sweeny, Texas, which provides the definition of peddler or solicitor is hereby amended as follows:

“Section 110.02 PEDDLER OR SOLICITOR

For the purpose of this section, the following definitions shall apply unless the context clearly indicates or requires a different meaning.

PEDDLER OR SOLICITOR. Any person, partnership, firm or corporation going from house to house or from place to place in the city soliciting, exhibiting, selling, canvassing for or taking orders for or offering to sell or take orders for any goods, wares, merchandise, and subscriptions to magazines, publications, newspapers, photographs or services. The same shall also include any person, partnership, firm or corporations soliciting, exhibiting, selling, taking orders for or offering to sell or take orders for the goods, wares, merchandise, publications or services upon or from a truck or other vehicle whether or the streets or from any property whatever in the city,

whether public or private. Also anyone who solicits orders and, as a separate transaction, makes deliveries to purchasers as a part of a scheme or design to evade these provisions shall be deemed a peddler or solicitor. The terms PEDDLER OR SOLICITOR shall also be synonymous with itinerant merchant and transient vendor, as well as each other.”

Section 2:

All ordinances or parts of ordinances in conflict herewith are hereby repealed to the extent of the conflict only.

Section 3:

If any part of portion of this ordinance shall be determined to be invalid or unconstitutional, such invalidity or unconstitutionality shall not affect or impair any remaining portions or provisions of this ordinance.

Section 4: This ordinance shall be effective from and after the date of its passage.

PASSED AND ADOPTED this ____ day of _____, 2023.

DUSTY HOPKINS, Mayor

ATTEST:

KAYDI SMITH, City Secretary

CITY COUNCIL MEETING REGULAR SESSION

Tuesday, August 15, 2023 at 5:00 PM

City Hall, 102 W. Ashley Wilson Rd, Sweeny, Texas

MINUTES

BE IT KNOWN that the City Council of the City of Sweeny will meet in **Regular Session** on **Tuesday, August 15, 2023 at 5:00 PM.** at City Hall, 102 W. Ashley Wilson Rd, Sweeny, Texas with the following agenda.

CALL TO ORDER/ROLL CALL

Mayor Hopkins called the meeting to order at 5 P.M. and called roll. Reese Cook, Brian Brooks, and Tim Pettigrew were in attendance. Mark Morgan Jr. and John Rambo were absent.

PLEDGES & INVOCATION

EXECUTIVE SESSION IN ACCORDANCE WITH THE TEXAS GOVERNMENT CODE SECTION 551 at 5:09 P.M.

The City Council will now convene into executive session pursuant to the provision of Chapter 551 Texas Government Code, in accordance with the authority contained therein:

1. Deliberation Regarding Economic Development Negotiations, Pursuant to Section 551.087 (1) & (2) of the Texas Government Code

Mayor Hopkins Closed Executive Session at 5:54 P.M., re-opening into Regular Session at 5:55 PM.

OPEN SESSION

The City Council will now adjourn Executive Session, reconvene into Open Session pursuant to the Provisions of Chapter 551 Texas Government Code and take action, if any, on item(s) discussed during Closed Executive Session. *No action taken.*

BUDGET WORKSHOP

2. Discussion and Possible Action on the Fiscal Year 2023-2024 Budget Presentation and Discussion on the Tax Rate Adoption for FY24
Reese Cook made the motion to push Item #2 and #3 of budget workshop to the end of the agenda, after item # 22. Tim Pettigrew seconded. All were in favor. Motion Carried.
3. Discussion/ Possible Action to Determine a Date for the Public Hearing and Adoption of the FY 23/24 Tax Rate
See above item.

CITIZENS WISHING TO ADDRESS CITY COUNCIL

No visitor comments.

CONSENT AGENDA

4. Proclamation: September 11, 2023- Patriot Day
Mayor Hopkins read the proclamation aloud and signed.
5. Minutes: Special Session, August 01, 2023
Reese Cook moved to approve as presented. Tim Pettigrew seconded. All in favor. Motion carried.

REGULAR AGENDA

6. Discussion/ Possible Action on Agenda Request for Usage of the Chick Anderson/Gazebo Park; Dr. Leal
 Dr. Leal approached Council requesting to host the 16th annual Halloween in the Park. He is requesting to use the Chick Anderson Park and requesting help from the Fire Department and Police Department. He is requesting to block off streets as needed. He asked for the park to be sprayed for bugs and to use the city's porta-cans. The event will be held on October the 28th from 7—9pm. City Manager, Lindsay Koskiniemi, stated the city would help and contribute two porta-cans.
Reese Cook moved to approve as presented. Tim Pettigrew seconded. All in favor. Motion carried.
7. Discussion/ Possible Action on a Variance Request Received; 610 Walnut
 City Secretary, Kaydi Smith, gave information of requested variance to the five (5) feet setback requirement to add a screened enclosure around an existing inground swimming pool. The enclosure would be within the resident's existing privacy fence.
Reese Cook moved to approve the variance as requested. Tim Pettigrew seconded. All in favor. Motion carried.
8. Discussion/ Possible Action on Update to Inframark
 City Manager stated Inframark has been sent a fifteen (15) day notice to stop services. August 30th will be the last day with exception of the well issues that occurred over weekend.
Discussion Only, No Action
9. Discussion/ Possible Action on Water System Solution Presentation and Comprehensive Utilities Master Plan Estimate by City Engineer
 William Huebner, City Engineer, presented Council with possible options to solve current issues on the water system. First option would be to repair and upgrade the water softener system. City Manager showed a large calcium deposit removed from an ice machine at the Bulldog Café due to hardness. Michael Claybourne Sr. of Water of Texas was in attendance to talk to Council about the softener options. Second option presented by Huebner was to install an iron and manganese filter system. Third option presented was to install an iron and manganese filter and reverse osmosis filter system. Wiliam feels that a further study is needed depending on Councils direction. City Manager pointed out that the Brine system is not included in any of these proposals. It would still need to be addressed in addition to any of the above.
 Reese Cook asked to have Mr. Claybourne of Water of Texas work with Lindsay to bring back a proposal by the next meeting on Tuesday, September 5th, 2023.
Discussion Only, No Action
10. Discussion/ Possible Action on a Budget Amendment to the FY 2022/2023 Budget; Auto Flushers
 City Manager stated she is requesting a Budget amendment to be transferred in the amount of \$50,676.60 from the Enterprise Fund balance to the FY22/23 budget, account # 50-11-6710, to purchase the fifteen (15) dead end auto flushers.
Reese Cook moved to approve as presented. Tim Pettigrew seconded. All in favor. Motion carried.
11. Discussion/ Possible Action to Award and Select a Debris Removal and Emergency Services Contractor

City Manager stated that the next three (3) agenda items are in preparation of Hurricane Season and/or any disaster related events. RFP's have been advertised in preparation of establishing contractual agreements for debris removal, grant administration services, and monitoring services. To receive FEMA assistance or reimbursement, in the event of a declared disaster, these agreements must be in place prior too, and in accordance with procurement requirements. City staff reviewed and scored the proposals received. The City recommends DRC Emergency Services, LLC. as the Debris Removal and Emergency Services Contractor.

Tim Pettigrew made the motion to award DRC Emergency Services, LLC. as the Debris Removal contractor. No second was made.

Discussion: Reese Cook asked if the intent is to use DRC even if we do not meet the FEMA thresholds for reimbursement. City Manager stated we certainly could look at other options, but this would be for declared emergencies. Cook stated declared doesn't mean it will meet threshold. Cook reference the prior Hurricane Nicholas. We declared, but knew we were not going to meet the threshold. City Manager stated we are not bound to use them, but they are bound if we call for response. Reese Cook moved to approve as presented (as the second). All in favor. Motion carried.

12. Discussion/ Possible Action to Award and Select a Debris Monitoring Services Contractor and Establishing a Contract Term
After reviewing all proposals, the City is recommending Rostan Solutions as the Debris Monitoring Services Contractor. The term length of contract would need to be specified by Council.
Reese Cook moved to approve Rostan Solutions as the debris monitoring services contractor for a contract length of one year. Seconded by Tim Pettigrew. All in favor. Motion carried.
13. Discussion/ Possible Action to Award and Select a Disaster Recovery Grant Management and Administration Services Contractor
After reviewing proposals, the City is recommending Rostan Solutions, LLC as the Disaster Recovery Grant Management and Administration Services Contractor.
Reese Cook moved to approve as presented. Tim Pettigrew seconded. All in favor. Motion carried.
14. Discussion/ Possible Action to Approve a Resolution Designating an Official Newspaper
Tim Pettigrew made the motion to approve the resolution designating the Facts as the official newspaper. Reese Cook seconded. All in favor. Motion carried.
15. Discussion/ Possible Action to Adopt a Resolution Adopting Guidelines and Criteria for Granting Tax Abatements
City Manager stated the resolution and guidelines for granting tax abatements must be adopted bi-annually. This must be in place for the City to enter into any tax abatement agreements for potential economic development. The presented is currently in force, however, will need to be re-adopted due to the two-year expiration approaching.
Tim Pettigrew made the motion to adopt the resolution adopting the guidelines and criteria for granting tax abatements for the City of Sweeny. Seconded by Reese Cook. All in favor. Motion carried.
16. Discussion/Possible Action on Amending the Mobile Food Establishments Ordinance; Chapter 112
Kaydi Smith has produced suggestions of possible modifications to the Mobile Food Establishments Ordinance. Due to recent changes regulating temperature related foods, those vendors such as sno-cone vendors and push carts, must be removed from the Peddlers Ordinance. If Council still wants to regulate those vendors, they will have to be added to the

Mobile Food Establishments Ordinance. Any modifications suggested would be completed and re-presented to Council for approval.

Tim Pettigrew made the motion to establish pushcart and roadside vendors within the Mobile Food Establishments Ordinance with an annual permit fee of \$50.00. Reese Cook seconded. All in favor. Motion carried.

17. Discussion/ Possible Action to Amend the Peddlers and Solicitors Ordinance; Chapter 110
Tim Pettigrew made the motion to remove sno-cone and pushcart roadside vendors from the Peddlers and Solicitors Ordinance. Reese Cook seconded. All in favor. Motion carried.
18. Discussion/ Possible Action to Establish a Charter Review Committee
City Manager stated this was tabled from the last agenda. The preference was for all Council members to be in attendance.
Reese Cook moved to table. Tim Pettigrew seconded. All in favor. Motion carried.
19. Discussion/ Possible Action to Contractual Lease Agreement Updates; 111 W 3rd Street, City Owned Property
City Manager is requesting Council input on lease agreements for the address of 111 W 3rd Street, as lease terms are expiring at the end of September. EDC is planning to acquire an 18x40 building to place at the Industrial Park for office space. This building would be large enough to house the Sweeny Chamber. Brazoria County Tax Office would like to continue renting the office space at 111 W 3rd at the current rate. Council discussion ensued on the contractual terms and conditions.
Brian Brooks made the motion to terminate the contracts (3 entities) with a thirty (30) day notice. Tim Pettigrew seconded. Brian Brooks and Tim Pettigrew were in favor. Reese Cook opposed. Motion carried.
20. Discussion/ Possible Action on Variance Requested for Proposed Replat of 111 W 3rd Street
Roger Barton, Fire Chief, stated all property of proposed replat is city property, including the fire department. He feels it would be really good to have the EDC/Chamber building demolished and use as parking for the Fire Department. He would like to add two (2) bays to the current Fire Department building. City Manager stated there are eight (8) lots total and she is requesting to replat with the intention to sell the building of 111 W 3rd Street and place the money earned into capital projects. The replat would separate the lots as, four (4) lots for the fire department and four (4) lots for the building at 111 W 3rd. If Council wished to replat to separate the Fire Department from 111 W 3rd, there would be a variance required. Variance requested would be to the depth of the 111 W 3rd Street lot, as it falls short of the requirement. Per the Commercial C1 zoning requirements, the depth of the property is to be one hundred (100) feet.
Brian Brooks motioned to table the item. Tim Pettigrew seconded. All in favor. Motion carried.
21. Discussion/ Possible Action on the Crime Control and Prevention District's Proposed FY23/24 Budget and Proposed FY24/25 Two Year Budget Plan
Chief Caudle presented the CCPD budget to Council for FY 23/24 and FY24/25.
Reese Cook motioned to accept as proposed. Tim Pettigrew seconded. All in favor. Motion carried.
22. Discussion/ Possible Action to Appoint a Member to the Crime Control and Prevention District (CCPD)
Chief Caudle stated they received one application, John Hessong. The CCPD board has approved of the applicant at their last meeting.
Tim Pettigrew moved to approve. Reese Cook seconded. All in favor. Motion carried.

Prior to starting Budget Workshop items #2 and #3, Reese Cook moved to adjourn.

Brian Brooks made the motion to table items #2 and #3 of budget workshop. Tim Pettigrew seconded. Discussion of holding budget workshop on August 22nd was held, but no decision made. All in favor. Motion carried.

ITEMS OF COMMUNITY INTEREST

Brian Brooks stated to pray for rain.

Lindsay Koskiniemi stated that this month's BCCA meeting is at The Springs in Angleton tomorrow evening. The Industrial Park Ground Breaking Ceremony will be August 24th at 10 A.M. for the road expansion. Notice of potential quorum will be posted.

Tim Pettigrew stated the Methodist Church has a new preacher, Josh Bynam, and encouraged others to attend this Sunday.

ADJOURN REGULAR SESSION- Mayor Hopkins adjourned the meeting at 8:28 P.M.

City Officials/Staff Present:

City Manager, Lindsay Koskiniemi

Police Chief, Brad Caudle

Finance Director / Personnel Services, Karla Wilson

City Secretary/ Developmental Services, Kaydi Smith

Public Works Director/Assistant City Manager, Clarence Wittwer

Fire Chief, Roger Barton

City Engineer, William Huebner

Passed and approved this 5th day of September, 2023.

Kaydi Smith, City Secretary



AGENDA MEMO

Business of the City Council

City of Sweeny, Texas

Meeting Date	10/24/2023	Agenda Item	
Approved by City Manager		Presenter(s)	Kaydi Smith
Reviewed by City Attorney		Department	City Secretary/ Developmental Services
Subject	Discussion/ Possible Action to amend Ordinance 112; Mobile Food Establishments		
Attachments	Amended Ordinance, Minutes 08/15/2023		
Financial Information	Expenditure Required:		
	Amount Budgeted:		
	Account Number:		
	Additional Appropriation Required:		
	Additional Account Number:		

Executive Summary

In August, the recommendation was given to Council to remove the food vendors known as roadside/push carts from the Peddlers Ordinance and place them into the Mobile Food Establishments Ordinance (MFE). Temperature related foods must adhere to the The Texas Health and Safety Code, Chapter 437, and the Texas Administrative Code, 229.161.

Council moved to establish the vedors within the Mobile Food Establishments Ordinance with an annual permit fee of \$50.00.

Amendment attached is adding the pushcart and roadside vendors within the Mobile Food Establishments Ordinance for an annual permit with the fee being referenced within the City's fee schedule.

Recommended Action

To approve the amendment to Ordinance Chapter 112, Mobile Food Establishments

ORDINANCE NO. _____

AN ORDINANCE OF THE CITY OF SWEENY, TEXAS, AMENDING CHAPTER 115 OF THE CODE OF ORDINANCES OF THE CITY OF SWEENY ENTITLED MOBILE FOOD ESTABLISHMENTS; AMENDING SECTION 115.02 ENTITLED TEMPORARY FOOD ESTABLISHMENTS; REGULATING TEMPORARY FOOD ESTABLISHMENTS INCLUDING ADDING PUSH CART/ROADSIDE VENDORS; AMENDING SECTION 115.04 ESTABLISHING FEES; PROVIDING A SAVINGS CLAUSE: PROVIDING FOR REPEAL OF CONFLICTING ORDINANCES TO THE EXTENT OF CONFLICT ONLY; AND PROVIDING THAT THIS ORDINANCE SHALL TAKE EFFECT AND BE IN FORCE AT THE DATE OF ITS PASSAGE.

BE IT ORDAINED BY THE CITY COUNCIL OF THE CITY OF SWEENY, TEXAS:

Section 1:

Section 115.02 of the Code of Ordinances of the City of Sweeny, Texas, which provides for the regulation of temporary food establishments is hereby amended as follows:

Section 115.02 TEMPORARY FOOD ESTABLISHMENTS

(A) Definitions. For the purpose of this section, the following definitions shall apply unless the context clearly indicates or requires a different meaning.

TEMPORARY FOOD ESTABLISHMENT. A food establishment that operates for a temporary period of time which has a fee specified on the city’s master fee schedule, and not the annual fee specified in Section 115.01, which is payable prior to operating the temporary food establishment. Fees are not prorated, are non-refundable and subject to change. All fees are established by City Council.

(B) A temporary food establishment must obtain a temporary permit prior to setting up. An application for a temporary food establishment must be submitted seven days prior to the designated time for the permitted use.

Types of Temporary Food Establishment Permits are:

24 hour Temporary Mobile Food Establishment- 24 hour permit only. A food establishment that operates for a period of no more than 24 hours at one time and which has a day rate fee.

Push cart/Roadside Vendor Only – Annual permit. Sno-cone trucks/vendors, ice cream trucks/vendors. If push carts or roadside vendors are parking/establishing business at a location for any amount of time, Section F will apply.

(C) A permitted unit must be readily moveable as stated under the Texas Food Establishment Rules as adopted and amended under Texas Health and Safety Code Chapter 437. A Mobile Food Establishment means an operator of a vehicle mounted, self or otherwise propelled, self-contained food service operation designed to be readily moveable (including but not limited to catering trucks, trailers, push carts and roadside vendors) and used to store, prepare, display, serve or sell food that requires temperature control.

(D) No city utilities will be available.

(E) A temporary food establishment is only allowed to establish operations within a commercial, industrial or institutionally zoned area. The City Manager or his/her designee has the discretion to determine all permitted locations.

(F) Permission from the property owner of a specified location is required in a signed written statement which is to be presented at the time of the application with dates of usage specified. Any time the location is subject to change, a new permit must be issued with the new location's letter of property owner's written statement.

(G) Any application for a temporary food establishment must include a Brazoria County Environmental Health Department permit.

Section 2:

Section 115.04 of the Code of Ordinances of the City of Sweeny, Texas, which provides for fees for permanent and temporary food permits is amended and hereafter shall read as follows:

Section 115.04 FOOD PERMIT FEES

Temporary and Permanent mobile food establishments seeking a permit under the provisions of the mobile food establishment sections as provided herein shall pay an application fee as set in the City's master fee schedule. The fee shall be paid by the person desiring the permit and is payable at the time of the application.

The City, at its sole discretion, may waive fees for any City sponsored event with the request for waiver being received by the City at least sixty days prior to the event. All temporary food establishment requirements must be met per the city ordinance in order for any fees to be waived.

Section 3:

All ordinances or parts of ordinances in conflict herewith are hereby repealed to the extent of the conflict only.

Section 4:

If any part of portion of this ordinance shall be determined to be invalid or unconstitutional, such invalidity or unconstitutionality shall not affect or impair any remaining portions or provisions of this ordinance.

Section 5: This ordinance shall be effective from and after the date of its passage.

PASSED AND ADOPTED this ____ day of _____, 2023.

DUSTY HOPKINS, Mayor

ATTEST:

KAYDI SMITH, City Secretary

CITY COUNCIL MEETING REGULAR SESSION

Tuesday, August 15, 2023 at 5:00 PM

City Hall, 102 W. Ashley Wilson Rd, Sweeny, Texas

MINUTES

BE IT KNOWN that the City Council of the City of Sweeny will meet in **Regular Session** on **Tuesday, August 15, 2023 at 5:00 PM.** at City Hall, 102 W. Ashley Wilson Rd, Sweeny, Texas with the following agenda.

CALL TO ORDER/ROLL CALL

Mayor Hopkins called the meeting to order at 5 P.M. and called roll. Reese Cook, Brian Brooks, and Tim Pettigrew were in attendance. Mark Morgan Jr. and John Rambo were absent.

PLEDGES & INVOCATION

EXECUTIVE SESSION IN ACCORDANCE WITH THE TEXAS GOVERNMENT CODE SECTION 551 at 5:09 P.M.

The City Council will now convene into executive session pursuant to the provision of Chapter 551 Texas Government Code, in accordance with the authority contained therein:

1. Deliberation Regarding Economic Development Negotiations, Pursuant to Section 551.087 (1) & (2) of the Texas Government Code

Mayor Hopkins Closed Executive Session at 5:54 P.M., re-opening into Regular Session at 5:55 PM.

OPEN SESSION

The City Council will now adjourn Executive Session, reconvene into Open Session pursuant to the Provisions of Chapter 551 Texas Government Code and take action, if any, on item(s) discussed during Closed Executive Session. *No action taken.*

BUDGET WORKSHOP

2. Discussion and Possible Action on the Fiscal Year 2023-2024 Budget Presentation and Discussion on the Tax Rate Adoption for FY24
Reese Cook made the motion to push Item #2 and #3 of budget workshop to the end of the agenda, after item # 22. Tim Pettigrew seconded. All were in favor. Motion Carried.
3. Discussion/ Possible Action to Determine a Date for the Public Hearing and Adoption of the FY 23/24 Tax Rate
See above item.

CITIZENS WISHING TO ADDRESS CITY COUNCIL

No visitor comments.

CONSENT AGENDA

4. Proclamation: September 11, 2023- Patriot Day
Mayor Hopkins read the proclamation aloud and signed.
5. Minutes: Special Session, August 01, 2023
Reese Cook moved to approve as presented. Tim Pettigrew seconded. All in favor. Motion carried.

REGULAR AGENDA

6. Discussion/ Possible Action on Agenda Request for Usage of the Chick Anderson/Gazebo Park; Dr. Leal
 Dr. Leal approached Council requesting to host the 16th annual Halloween in the Park. He is requesting to use the Chick Anderson Park and requesting help from the Fire Department and Police Department. He is requesting to block off streets as needed. He asked for the park to be sprayed for bugs and to use the city's porta-cans. The event will be held on October the 28th from 7—9pm. City Manager, Lindsay Koskiniemi, stated the city would help and contribute two porta-cans.
Reese Cook moved to approve as presented. Tim Pettigrew seconded. All in favor. Motion carried.
7. Discussion/ Possible Action on a Variance Request Received; 610 Walnut
 City Secretary, Kaydi Smith, gave information of requested variance to the five (5) feet setback requirement to add a screened enclosure around an existing inground swimming pool. The enclosure would be within the resident's existing privacy fence.
Reese Cook moved to approve the variance as requested. Tim Pettigrew seconded. All in favor. Motion carried.
8. Discussion/ Possible Action on Update to Inframark
 City Manager stated Inframark has been sent a fifteen (15) day notice to stop services. August 30th will be the last day with exception of the well issues that occurred over weekend.
Discussion Only, No Action
9. Discussion/ Possible Action on Water System Solution Presentation and Comprehensive Utilities Master Plan Estimate by City Engineer
 William Huebner, City Engineer, presented Council with possible options to solve current issues on the water system. First option would be to repair and upgrade the water softener system. City Manager showed a large calcium deposit removed from an ice machine at the Bulldog Café due to hardness. Michael Claybourne Sr. of Water of Texas was in attendance to talk to Council about the softener options. Second option presented by Huebner was to install an iron and manganese filter system. Third option presented was to install an iron and manganese filter and reverse osmosis filter system. Wiliam feels that a further study is needed depending on Councils direction. City Manager pointed out that the Brine system is not included in any of these proposals. It would still need to be addressed in addition to any of the above.
 Reese Cook asked to have Mr. Claybourne of Water of Texas work with Lindsay to bring back a proposal by the next meeting on Tuesday, September 5th, 2023.
Discussion Only, No Action
10. Discussion/ Possible Action on a Budget Amendment to the FY 2022/2023 Budget; Auto Flushers
 City Manager stated she is requesting a Budget amendment to be transferred in the amount of \$50,676.60 from the Enterprise Fund balance to the FY22/23 budget, account # 50-11-6710, to purchase the fifteen (15) dead end auto flushers.
Reese Cook moved to approve as presented. Tim Pettigrew seconded. All in favor. Motion carried.
11. Discussion/ Possible Action to Award and Select a Debris Removal and Emergency Services Contractor

City Manager stated that the next three (3) agenda items are in preparation of Hurricane Season and/or any disaster related events. RFP's have been advertised in preparation of establishing contractual agreements for debris removal, grant administration services, and monitoring services. To receive FEMA assistance or reimbursement, in the event of a declared disaster, these agreements must be in place prior too, and in accordance with procurement requirements. City staff reviewed and scored the proposals received. The City recommends DRC Emergency Services, LLC. as the Debris Removal and Emergency Services Contractor.

Tim Pettigrew made the motion to award DRC Emergency Services, LLC. as the Debris Removal contractor. No second was made.

Discussion: Reese Cook asked if the intent is to use DRC even if we do not meet the FEMA thresholds for reimbursement. City Manager stated we certainly could look at other options, but this would be for declared emergencies. Cook stated declared doesn't mean it will meet threshold. Cook reference the prior Hurricane Nicholas. We declared, but knew we were not going to meet the threshold. City Manager stated we are not bound to use them, but they are bound if we call for response. Reese Cook moved to approve as presented (as the second). All in favor. Motion carried.

12. Discussion/ Possible Action to Award and Select a Debris Monitoring Services Contractor and Establishing a Contract Term
After reviewing all proposals, the City is recommending Rostan Solutions as the Debris Monitoring Services Contractor. The term length of contract would need to be specified by Council.
Reese Cook moved to approve Rostan Solutions as the debris monitoring services contractor for a contract length of one year. Seconded by Tim Pettigrew. All in favor. Motion carried.
13. Discussion/ Possible Action to Award and Select a Disaster Recovery Grant Management and Administration Services Contractor
After reviewing proposals, the City is recommending Rostan Solutions, LLC as the Disaster Recovery Grant Management and Administration Services Contractor.
Reese Cook moved to approve as presented. Tim Pettigrew seconded. All in favor. Motion carried.
14. Discussion/ Possible Action to Approve a Resolution Designating an Official Newspaper
Tim Pettigrew made the motion to approve the resolution designating the Facts as the official newspaper. Reese Cook seconded. All in favor. Motion carried.
15. Discussion/ Possible Action to Adopt a Resolution Adopting Guidelines and Criteria for Granting Tax Abatements
City Manager stated the resolution and guidelines for granting tax abatements must be adopted bi-annually. This must be in place for the City to enter into any tax abatement agreements for potential economic development. The presented is currently in force, however, will need to be re-adopted due to the two-year expiration approaching.
Tim Pettigrew made the motion to adopt the resolution adopting the guidelines and criteria for granting tax abatements for the City of Sweeny. Seconded by Reese Cook. All in favor. Motion carried.
16. Discussion/Possible Action on Amending the Mobile Food Establishments Ordinance; Chapter 112
Kaydi Smith has produced suggestions of possible modifications to the Mobile Food Establishments Ordinance. Due to recent changes regulating temperature related foods, those vendors such as sno-cone vendors and push carts, must be removed from the Peddlers Ordinance. If Council still wants to regulate those vendors, they will have to be added to the

Mobile Food Establishments Ordinance. Any modifications suggested would be completed and re-presented to Council for approval.

Tim Pettigrew made the motion to establish pushcart and roadside vendors within the Mobile Food Establishments Ordinance with an annual permit fee of \$50.00. Reese Cook seconded. All in favor. Motion carried.

17. Discussion/ Possible Action to Amend the Peddlers and Solicitors Ordinance; Chapter 110
Tim Pettigrew made the motion to remove sno-cone and pushcart roadside vendors from the Peddlers and Solicitors Ordinance. Reese Cook seconded. All in favor. Motion carried.
18. Discussion/ Possible Action to Establish a Charter Review Committee
City Manager stated this was tabled from the last agenda. The preference was for all Council members to be in attendance.
Reese Cook moved to table. Tim Pettigrew seconded. All in favor. Motion carried.
19. Discussion/ Possible Action to Contractual Lease Agreement Updates; 111 W 3rd Street, City Owned Property
City Manager is requesting Council input on lease agreements for the address of 111 W 3rd Street, as lease terms are expiring at the end of September. EDC is planning to acquire an 18x40 building to place at the Industrial Park for office space. This building would be large enough to house the Sweeny Chamber. Brazoria County Tax Office would like to continue renting the office space at 111 W 3rd at the current rate. Council discussion ensued on the contractual terms and conditions.
Brian Brooks made the motion to terminate the contracts (3 entities) with a thirty (30) day notice. Tim Pettigrew seconded. Brian Brooks and Tim Pettigrew were in favor. Reese Cook opposed. Motion carried.
20. Discussion/ Possible Action on Variance Requested for Proposed Replat of 111 W 3rd Street
Roger Barton, Fire Chief, stated all property of proposed replat is city property, including the fire department. He feels it would be really good to have the EDC/Chamber building demolished and use as parking for the Fire Department. He would like to add two (2) bays to the current Fire Department building. City Manager stated there are eight (8) lots total and she is requesting to replat with the intention to sell the building of 111 W 3rd Street and place the money earned into capital projects. The replat would separate the lots as, four (4) lots for the fire department and four (4) lots for the building at 111 W 3rd. If Council wished to replat to separate the Fire Department from 111 W 3rd, there would be a variance required. Variance requested would be to the depth of the 111 W 3rd Street lot, as it falls short of the requirement. Per the Commercial C1 zoning requirements, the depth of the property is to be one hundred (100) feet.
Brian Brooks motioned to table the item. Tim Pettigrew seconded. All in favor. Motion carried.
21. Discussion/ Possible Action on the Crime Control and Prevention District's Proposed FY23/24 Budget and Proposed FY24/25 Two Year Budget Plan
Chief Caudle presented the CCPD budget to Council for FY 23/24 and FY24/25.
Reese Cook motioned to accept as proposed. Tim Pettigrew seconded. All in favor. Motion carried.
22. Discussion/ Possible Action to Appoint a Member to the Crime Control and Prevention District (CCPD)
Chief Caudle stated they received one application, John Hessong. The CCPD board has approved of the applicant at their last meeting.
Tim Pettigrew moved to approve. Reese Cook seconded. All in favor. Motion carried.

Prior to starting Budget Workshop items #2 and #3, Reese Cook moved to adjourn.

Brian Brooks made the motion to table items #2 and #3 of budget workshop. Tim Pettigrew seconded. Discussion of holding budget workshop on August 22nd was held, but no decision made. All in favor. Motion carried.

ITEMS OF COMMUNITY INTEREST

Brian Brooks stated to pray for rain.

Lindsay Koskiniemi stated that this month's BCCA meeting is at The Springs in Angleton tomorrow evening. The Industrial Park Ground Breaking Ceremony will be August 24th at 10 A.M. for the road expansion. Notice of potential quorum will be posted.

Tim Pettigrew stated the Methodist Church has a new preacher, Josh Bynam, and encouraged others to attend this Sunday.

ADJOURN REGULAR SESSION- Mayor Hopkins adjourned the meeting at 8:28 P.M.

City Officials/Staff Present:

City Manager, Lindsay Koskiniemi

Police Chief, Brad Caudle

Finance Director / Personnel Services, Karla Wilson

City Secretary/ Developmental Services, Kaydi Smith

Public Works Director/Assistant City Manager, Clarence Wittwer

Fire Chief, Roger Barton

City Engineer, William Huebner

Passed and approved this 5th day of September, 2023.

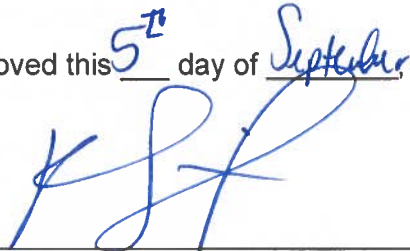

Kaydi Smith, City Secretary



AGENDA MEMO

Business of the City Council
City of Sweeny, Texas

Meeting Date	10/24/2023	Agenda Item	Salvage Items
Approved by City Manager/		Presenter(s)	Terrence Bell, Public Works Director
Reviewed by City Attorney		Department	
Subject	Discussion and possible action for the fourth quarter salvage items from 2023		
Attachments			
Financial Information	Expenditure Required:	N/A	
	Amount Budgeted:	N/A	
	Account Number:		
	Additional Appropriation Required:		
	Additional Account Number:		

Executive Summary

Recommended Action

- 1- Several old fire hydrants approximately 10. Old metal water lines. Old gates. Old water valve casings. Needs to be salvaged has been sitting up for over 8 months.
- 2- 2012 Exmark zereturn riding mower MFG.CO.IN vin #LZS801GKA7241A1 serial #316662166. Has been broken down for more than a year. been in Harvey flood has been taken to the shop. The shop requested it would cost more to fix than purchase a new one.
- 3- 2019 Troy-bilt mower. Head gasket blown unable to use.
- 4- 2011 Ford Explorer vin #1FMHK7B80BGA35846 LP 1125164. Milage 84299.6. front end damage tie rods need to be replaced front bumper is damaged. The interior is damaged due to years of poor maintenance.
- 5- 2004 Chevy Suburban vin #1GNGC26U64R231277 Vehicle does not run. Has been down for over 6 months. Interior is damaged can see exposed metal throughout vehicle. Roof vinyl ripped throughout the year.





AGENDA MEMO

Business of the City Council
City of Sweeny, Texas

Meeting Date	10/24/2023	Agenda Item	
Approved by City Manager		Presenter(s)	Brad Caudle; Police Chief
Reviewed by City Attorney		Department	Police Department
Subject	Discussion and possible action for the fourth quarter salvage items from 2023		
Attachments	Pictures (5); Letter		
Financial Information	Expenditure Required:		
	Amount Budgeted:		
	Account Number:		
	Additional Appropriation Required:		
	Additional Account Number:		

Executive Summary

2014 Chevrolet Tahoe VIN #1GNLC2E05ER204697

TXLP- 1177242

Vehicle was downed after vehicle maintenance costs exceeded the estimated value of the unit. This unit had received at least two motor replacements. Last time in the shop the cost to repair could not be justified. Precision repair was willing to except the vehicle in exchange for an outstanding balance.

Recommended Action

The image shows the interior of a vehicle, likely a Chevrolet, with a black steering wheel featuring the Chevrolet logo. The dashboard and center console are visible, showing various controls and buttons. The seats are upholstered in a grey and tan fabric. The floor is partially covered with a brown mat and some debris. The overall condition appears to be that of a used or possibly damaged vehicle.

Item 17.

178



Item 17.

179

Item 17.



180

Item 17.

181

The image shows the front end of a vehicle, possibly a truck or heavy-duty car, elevated on a metal lift. A prominent yellow hydraulic cylinder is attached to the lift's frame. The vehicle's front grille, headlights, and bumper are visible. The lift is supported by a metal frame with a horizontal bar across the front. The scene is outdoors on a paved surface.

Item 17.

182



Sweeny Police Department

Est. 1909 † Home of the Unknown Soldier
123 N. Oak Street † Sweeny, Texas 77480
Dispatch | 979-548-3111 † Office | 979-548-3112
Brad Caudle, Chief of Police



Item 17.

09/12/2022

Reatta,

Hope you're doing well. I have two requisitions that this memo is attached to. In both cases I have been asked if we can prepare a check, one for C&M Graphics for half of the quote and one for Precision Repair for parts. This request was in order for these two businesses to be able to purchase the parts/material needed to complete the projects. Both businesses have run into financial hardships due to the rising costs of material.

Precision repair – Up front check for parts in the amount of \$1,885.39 (Unit 314)

C&M Graphics - Up front check for material in the amount of \$642.50 (PD Building/Court)

The remainder balances will be paid upon completion of the work.

Thank you for any help you can give

Sincerely,

Brad Caudle

Chief of Police

Sweeny Police Department

Email: bbcaudle@sweenytx.gov



CITY OF SWEENY Purchase Requisitioning

Item 17.

102 W. Ashley Wilson Rd. • PO Box 248 • Sweeny, Texas 77480 • P: (979) 548-3321 • F: (979) 548-7745

Section I – General Information PURCHASE ORDER # BC-22-0227 (Assigned by City Manager or designate)

(A) Requisition Number: BBC-09122022 (B) Requisition Date: 09/12/2022
 (C) Expenditure Line Item: 6730 (D) Requisitioned By: B. Caudle
 (E) Total Amount of Purchase \$3,255.39 (F) Recommended Vendor: Precision Repair

Section II – HUB Contract Documentation (expenditures \$3,000.01 - \$49,999.99)

In compliance with Chapter 252.0215 of the Texas Local Government Code, the department originating this purchase requisition or the Buyer certifies that:

SELECT ONLY ONE

(G) The following Brazoria County Historically Underutilized Businesses were identified and contacted concerning this purchase

HUB #1	HUB #2

(H) No applicable Brazoria County HUBs were identified from the Comptroller of Public Accounts listing; therefore, the City is exempt from HUB contact requirements for this purchase.

(I) Purchase is exempt from HUB contact requirements because it is covered under General Exemption Number _____. (Refer to the instructions for a list of the General Exemptions)

Section III – Competitive Quotation Documentation

Competitive quotations are generally require for cooperative, emergency, sole source or single source purchases, with justifications/sole source documentation, and approval.

(J) Cooperative Purchase? Yes No PSA/Contract # _____
 (K) Sole Source? Yes No
 (L) Single Source? Yes No
 (M) Emergency Purchase? Yes No
 >If yes, City Manager authorization _____

		Quotation #1	Quotation #2	Quotation #3	Quotation #4	Quotation #5
(N)	Name of Company					
(O)	Telephone Number					
(P)	Contact Person					
(Q)	Email Address					
(R)	Total Price Quoted					
(S)	Quotation #					

(T) Justification for sole/single source, emergency purchase or recommendation of vendor other than low quote (attach additional sheets if necessary)

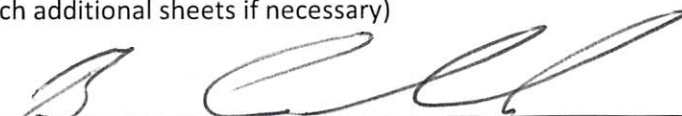

 Department/Buyer Signature

09/12/2022

 Date

PO BC-22-0227

Item 17.



PRECISION REPAIR
 105 east 5th st.
 Sweeny, TX 77480
 Phone: (361) 935-7329
 4precisionrepair@gmail.com

Sweeny PD

BRAD CAUDLE
 +1 (979) 548-3112

VIN:
Vehicle: 2014 Chevrolet Tahoe PPV 5.3L, V8, Flex, VIN 0, Des LMG, 320HP, USA

Repair Order: 000096
Created: 09/07/2022 2:05 PM
Printed:
Technician(s): John Hessong
Written by: John Hessong

License:
Fleet No.: 314
Odometer:
Customer Notes:

Engine low oil pressure

Number	Type	Part#/Op Code	Description	Quantity	Unit Price	Total Cost
1	Part		Oil pump	1.00	\$ 205.07	\$ 205.07
2	Part		Camshaft	1.00	\$ 579.64	\$ 579.64
3	Part		Lifter	2.00	\$ 89.81	\$ 179.62
4	Part		Cam bearings	1.00	\$ 62.09	\$ 62.09
5	Part		Head gasket set	1.00	\$ 449.14	\$ 449.14
6	Part		Oil pan gasket	1.00	\$ 105.07	\$ 105.07
7	Part		Timing cover gasket set	1.00	\$ 83.03	\$ 83.03
8	Part		Oil pressure sensor	1.00	\$ 106.76	\$ 106.76
9	Part		Thermostat	1.00	\$ 24.35	\$ 24.35
10	Part		Oil and filter	1.00	\$ 48.67	\$ 48.67
11	Part		Coolant	1.00	\$ 22.95	\$ 22.95
12	Part		Sealants and cleaners	1.00	\$ 19.00	\$ 19.00
13	Labor		R&l engine and replace cam bearings			\$ 1,190.00
14	Fee		Machine shop fees	1.00	\$ 180.00	\$ 180.00
Job Total:						\$ 3,255.39

Total Jobs Cost: \$ 3,255.39

Parts \$ 1,885.39
Labor \$ 1,190.00

Tax	\$ 0.00
Shop Supplies & Hazardous Materials	\$ 0.00
Fees	\$ 180.00
Grand Total	\$ 3,255.39

I hereby authorize the repair work herein set forth to be done along with the necessary materials and agree that you are not responsible for loss or damage to vehicle or articles left in vehicle. In case of fire, theft, or any other cause beyond your control or for delays caused by unavailability of parts or delays in parts shipments by the supplier or transporter. I hereby grant you and your employees permission to operate the vehicle herein described on streets, highways, or elsewhere for the purpose of testing and/or inspection.

Unless otherwise provided by law, the seller (above named entity) hereby expressly disclaims all warranties, either express or implied, including any implied warranty of merchantability or fitness of particular purpose, and neither assumes nor authorizes any other person to assume for it any liability with the sale of said products. An express mechanic's lien is hereby acknowledged on above vehicle to secure the amount or repairs thereto.

Signature: _____ Date: _____

CITY OF SWEENY

PURCHASE ORDER

PO BOX 248
 SWEENY, TEXAS 77480
 Phone: (979) 548-3321
 Fax: (979) 548-7745
 sweenytx.gov

BC-22-0227

DATE 9/12/2022

VENDOR	PURCHASING INFORMATION	
Precision Repair	Requisition:	BBC-09122022
105 E 5th St.	Funding:	#24-6730
Sweeny, Tx 77480		

ITEM #	DESCRIPTION	QTY	UNIT PRICE	TOTAL
INV# 000096	Oil Pressure Parts	1	\$1,885.39	\$1,885.39
	Labor	1	\$1,190.00	\$1,190.00
	Fees	1	\$180.00	\$180.00
TOTAL				\$3,255.39

Comments or Special Instructions

IMPORTANT:

Above Order Number must appear on all correspondence, invoices, packages and shipping papers. Notify us immediately if you are unable to ship complete order by date specified. Your acceptance of this order is your warranty to us that you are complying with the U.S. Fair Labor Standards Act of 1988, as amended, and we reserve the right to refuse merchandise not in strict accordance with this order.

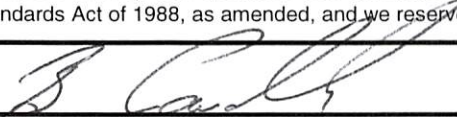

 Purchaser Signature

9/12/2022

 Date



AGENDA MEMO

Business of the City Council City of Sweeny, Texas

Meeting Date	10.24.2023	Agenda Item	
Approved by City Manager	Yes	Presenter(s)	Lindsay Koskiniemi, City Manager
Reviewed by City Attorney	No	Department	Finance and Budget
Subject	Discussion and possible action to approve a Budget Amendment for \$50,000 for the provision of waterline replacement.		
Attachments	None		
Financial Information	Expenditure Required:	\$50,000	
	Amount Budgeted:	N/A	
	Account Number:	50-11-6710	
	Additional Appropriation Required:	\$50,000	
	Additional Account Number:	From Logic Enterprise Fund investment account	

Executive Summary

At the regular City Council meeting on September 19, 2023, City Council voted on allocating \$50,000 for the provision of waterline replacement to come from investment income.

Approval of this budget amendment request will formalize the transfer of funds for use on waterline replacement.

A copy of the September 2023 statement for the Logic Enterprise Fund investment account is included.

Recommended Action

Staff recommends approval.



CITY OF SWEENY
 ATTN LINDSAY KOSKINIEMI
 102 W ASHLEY-WILSON RD
 SWEENY TX 77480

MONTHLY STATEMENT OF ACCOUNT

ACCOUNT: 6002346001

ACCOUNT NAME: ENTERPRISE FUND

STATEMENT PERIOD: 09/01/2023 - 09/30/2023

LOGIC MONTHLY SUMMARY: THE AVERAGE MONTHLY RATE WAS 5.5168%. THE AVERAGE WEIGHTED AVERAGE MATURITY WAS 39 DAYS AND THE NET ASSET VALUE FOR 9/30/23 WAS 0.999858.

MONTHLY ACTIVITY DETAIL

TRANSACTION DATE	DESCRIPTION	CONFIRMATION NUMBER	TRANSACTION AMOUNT	BALANCE
------------------	-------------	---------------------	--------------------	---------

	BEGINNING BALANCE			632,364.36
09/28/2023	WIRE WITHDRAWAL	6156599	120,000.00 -	512,364.36
09/29/2023	MONTHLY POSTING	9999888	2,812.71	515,177.07
	ENDING BALANCE			515,177.07

MONTHLY ACCOUNT SUMMARY

BEGINNING BALANCE	632,364.36
TOTAL DEPOSITS	0.00
TOTAL WITHDRAWALS	120,000.00
TOTAL INTEREST	2,812.71
ENDING BALANCE	515,177.07
AVERAGE BALANCE	620,364.36

ACTIVITY SUMMARY (YEAR-TO-DATE)

ACCOUNT NAME	DEPOSITS	WITHDRAWALS	INTEREST
ENTERPRISE FUND	150,000.00	120,000.00	20,054.84



AGENDA MEMO

Business of the City Council City of Sweeny, Texas

Meeting Date	10.24.2023	Agenda Item	
Approved by City Manager	Yes	Presenter(s)	Lindsay Koskiniemi, City Manager
Reviewed by City Attorney	No	Department	Budget / Finance
Subject	Discussion and possible action on staff generated request to amend the Fiscal Year 2022 – 2023 budget		
Attachments			
Financial Information	Expenditure Required:	N/A	
	Amount Budgeted:	\$80,000 and \$90,000	
	Account Number:	Water: 50-11-6710; Sewer: 50-11-3711	
	Additional Appropriation Required:	\$258,916.99	
	Additional Account Number:	N/A	

Executive Summary

This is a fiscal year-end budget request to adjust for overspending on water and wastewater exceptions. Since May 2023, the City has been using Inframark for licensed water and wastewater operators to run and manage both plants, treatment of water and wastewater, and compliance correspondence with TCEQ and other regulatory agencies.

The expenses requested in this budget amendment were not anticipated, therefore, these items were not intentionally budgeted. The two affected accounts include Maintenance of Water System 50-11-6710 and Maintenance of Seewer System 50-11-6711. Copies of check stubs and invoices are included in the back up. All items are numbered and correspond to their respective lead sheets.

The total amount requested to be paid from Enterprise Fund Balance for Water is \$91,728.40, and the total amount requested to be paid from Enterprise Fund Balance for Sewer is \$167,188.59, or a total amount of \$258,916.99.

One payment included in this budget amendment request is a payment to Magna Flow to de-water Clarifier 1 at the sewer plant in the amount of \$49,246.94, which can be removed from this request at Council's pleasure.

While payments have been made, a budget amendment request is appropriate to account for exceeding the budget. During the annual fiscal audit process, auditors want to see budget amendments to explain budgetary overages.

Banking and investment account balances are included.

FSBL Enterprise Fund Balance (as of 10/13/2023): \$233,948.73



AGENDA MEMO

Business of the City Council
City of Sweeny, Texas

Item 19.

FSB The First State Bank Good Afternoon, Lindsay Koskiniemi

- Home
- Messages
- Transactions
- Commercial
- Branches

[← Back to Home](#)

Enterprise Fund **2566

Last Updated: October 13, 2023 3:54 PM

\$10,535.78	\$223,948.73
Last Deposit Amount	Current Balance

[Transactions](#) [Details & Settings](#)

TexStar 2019 Certificates of Obligation investment account: Balance as of 9/30/2023: \$460,804.13

Logic Enterprise Fund investment account: Balance as of 9/30/2023: \$515,177.07

Logic 2019 Certificates of Obligation investment account: Balance as of 9/30/2023: \$946,154.90

Recommended Action

Staff recommends approval.



CITY OF SWEENEY
 ATTN LINDSAY KOSKINIEMI
 102 W ASHLEY-WILSON RD
 SWEENEY TX 77480

MONTHLY STATEMENT OF ACCOUNT

ACCOUNT: 0201811950

ACCOUNT NAME: 2019 CERTIFICATES

STATEMENT PERIOD: 09/01/2023 - 09/30/2023

TEXSTAR MONTHLY SUMMARY: THE AVERAGE MONTHLY RATE WAS 5.3105%. THE AVERAGE WEIGHTED AVERAGE MATURITY WAS 29 DAYS AND THE NET ASSET VALUE FOR 9/30/23 WAS 0.999816.

MONTHLY ACTIVITY DETAIL

TRANSACTION DATE	DESCRIPTION	CONFIRMATION NUMBER	TRANSACTION AMOUNT	BALANCE
------------------	-------------	---------------------	--------------------	---------

	BEGINNING BALANCE			458,801.56
09/29/2023	MONTHLY POSTING	9999888	2,002.57	460,804.13
	ENDING BALANCE			460,804.13

MONTHLY ACCOUNT SUMMARY

BEGINNING BALANCE	458,801.56
TOTAL DEPOSITS	0.00
TOTAL WITHDRAWALS	0.00
TOTAL INTEREST	2,002.57
ENDING BALANCE	460,804.13
AVERAGE BALANCE	458,801.56

ACTIVITY SUMMARY (YEAR-TO-DATE)

ACCOUNT NAME	DEPOSITS	WITHDRAWALS	INTEREST
2019 CERTIFICATES	0.00	62,582.29	17,869.13



CITY OF SWEENY
 ATTN LINDSAY KOSKINIEMI
 102 W ASHLEY-WILSON RD
 SWEENY TX 77480

MONTHLY STATEMENT OF ACCOUNT

ACCOUNT: 6002346001

ACCOUNT NAME: ENTERPRISE FUND

STATEMENT PERIOD: 09/01/2023 - 09/30/2023

LOGIC MONTHLY SUMMARY: THE AVERAGE MONTHLY RATE WAS 5.5168%. THE AVERAGE WEIGHTED AVERAGE MATURITY WAS 39 DAYS AND THE NET ASSET VALUE FOR 9/30/23 WAS 0.999858.

MONTHLY ACTIVITY DETAIL

TRANSACTION DATE	DESCRIPTION	CONFIRMATION NUMBER	TRANSACTION AMOUNT	BALANCE
------------------	-------------	---------------------	--------------------	---------

	BEGINNING BALANCE			632,364.36
09/28/2023	WIRE WITHDRAWAL	6156599	120,000.00 -	512,364.36
09/29/2023	MONTHLY POSTING	9999888	2,812.71	515,177.07
	ENDING BALANCE			515,177.07

MONTHLY ACCOUNT SUMMARY

BEGINNING BALANCE	632,364.36
TOTAL DEPOSITS	0.00
TOTAL WITHDRAWALS	120,000.00
TOTAL INTEREST	2,812.71
ENDING BALANCE	515,177.07
AVERAGE BALANCE	620,364.36

ACTIVITY SUMMARY (YEAR-TO-DATE)

ACCOUNT NAME	DEPOSITS	WITHDRAWALS	INTEREST
ENTERPRISE FUND	150,000.00	120,000.00	20,054.84



CITY OF SWEENY
 ATTN LINDSAY KOSKINIEMI
 102 W ASHLEY-WILSON RD
 SWEENY TX 77480

MONTHLY STATEMENT OF ACCOUNT

ACCOUNT: 6002346002

ACCOUNT NAME: 2019 CERTIFICATES

STATEMENT PERIOD: 09/01/2023 - 09/30/2023

LOGIC MONTHLY SUMMARY: THE AVERAGE MONTHLY RATE WAS 5.5168%. THE AVERAGE WEIGHTED AVERAGE MATURITY WAS 39 DAYS AND THE NET ASSET VALUE FOR 9/30/23 WAS 0.999858.

MONTHLY ACTIVITY DETAIL

TRANSACTION DATE	DESCRIPTION	CONFIRMATION NUMBER	TRANSACTION AMOUNT	BALANCE
------------------	-------------	---------------------	--------------------	---------

	BEGINNING BALANCE			941,884.04
09/29/2023	MONTHLY POSTING	9999888	4,270.86	946,154.90
	ENDING BALANCE			946,154.90

MONTHLY ACCOUNT SUMMARY

BEGINNING BALANCE	941,884.04
TOTAL DEPOSITS	0.00
TOTAL WITHDRAWALS	0.00
TOTAL INTEREST	4,270.86
ENDING BALANCE	946,154.90
AVERAGE BALANCE	941,884.04

ACTIVITY SUMMARY (YEAR-TO-DATE)

ACCOUNT NAME	DEPOSITS	WITHDRAWALS	INTEREST
2019 CERTIFICATES	0.00	100,000.00	35,852.27

*Sweeny - Enterprise Fund
General Ledger

Item 19.

For the Period From Oct 1, 2022 to Sep 30, 2023

Filter Criteria includes: 1) IDs from 50-11-6710 to 50-11-6710. Report order is by ID. Report is printed with shortened descriptions and in Detail Format.

Account ID Account Description	Date	Reference	Jrnl	Trans Description	Debit Amt	Credit Amt	Balance
50-11-6710	10/1/22			Beginning Balance			
Maintenance of Water Syst	10/3/22	93022	PJ	G&S Auto Supply Inc	88.82		
	10/4/22	812	PJ	UNIQUE WATERWO	949.00		
	10/12/22	2031	CDJ	Stewart's Food Store -	139.74		
	10/12/22	2033	CDJ	Card Service Center -	326.50		
	10/13/22	86770	PJ	Envirodyne Laboratorie		147.00	
	10/13/22	86770	PJ	Envirodyne Laboratorie	290.00		
	10/18/22	43129	PJ	RG3 Meter Company -		60.62	
	10/18/22	43129-101822	PJ	RG3 Meter Company -		12.24	
	10/24/22	2065	CDJ	Scruggs Distribution LL	2,275.00		
	10/26/22	43234	PJ	RG3 Meter Company -	60.62		
				Current Period Change	4,129.68	219.86	3,909.82
	11/1/22			Beginning Balance			3,909.82
	11/1/22	11/01/2022	PJ	Stewart's Food Store	65.18		
	11/10/22	830	PJ	UNIQUE WATERWO	2,574.63		
	11/16/22	S227502TX.0	PJ	US Underwater	3,450.00		
	11/17/22	2108	CDJ	Lowe's Home Centers I	376.05		
	11/17/22	2109	CDJ	Card Service Center -	796.73		
	11/17/22	2114	CDJ	Ferguson Waterworks #	31.78		
	11/17/22	2120	CDJ	Litzler's Feed Store - M	39.52		
	11/21/22	2108V	CDJ	Lowe's Home Centers I		376.05	
				Current Period Change	7,333.89	376.05	6,957.84
	12/1/22			Beginning Balance			10,867.66
	12/1/22	12012022 Ros	PJ	Stewart's Food Store	40.75		
	12/5/22	3000478	PJ	Scruggs Distribution LL	3,850.00		
	12/5/22	3000331	PJ	Scruggs Distribution LL	6,657.00		
	12/10/22	PHS0206500	PJ	Texas Commission On -	3,248.70		
	12/10/22	833	PJ	UNIQUE WATERWO	1,170.11		
	12/10/22	213277628-00	PJ	United Rentals	238.77		
	12/10/22	87467	PJ	Envirodyne Laboratorie	317.00		
	12/10/22	396668	PJ	McCoy's Building Supp	642.68		
	12/13/22	43588	PJ	RG3 Meter Company -	205.38		
	12/16/22	Aguirre0500	PJ	Card Service Center	8.44		
	12/21/22	Stmt 1201202	PJ	Litzler's Feed Store	262.98		
				Current Period Change	16,641.81		16,641.81
	1/1/23			Beginning Balance			27,509.47
	1/1/23	Stmt 14463	PJ	G&S Auto Supply Inc	80.70		
	1/1/23	0500 Aguirre	PJ	Card Service Center	28.53		
	1/2/23	ACCT 017 D	PJ	Litzler's Feed Store	245.05		
	1/4/23	01042023 Ros	PJ	Stewart's Food Store	366.50		
	1/4/23	97099	PJ	Reifel's Feed & Ranch -	175.00		
	1/5/23	635314	PJ	Evco Industrial Hardwa	67.98		
	1/5/23	97031284	PJ	H & E Equipment - Rep	879.61		
	1/17/23	874	PJ	UNIQUE WATERWO	2,279.29		
	1/18/23	SW0279642	PJ	ASCO - Mini Excavato	440.53		
	1/25/23	22139	PJ	Penney's Electric Co. In	1,394.36		
	1/30/23	300795	PJ	McCoy's Building Supp	47.86		
	1/30/23	300806	PJ	McCoy's Building Supp	11.99		
	1/31/23	013123	PJ	Stewart's Food Store -	40.54		
				Current Period Change	6,057.94		6,057.94
	2/1/23			Beginning Balance			33,567.41
	2/1/23	017 020123	PJ	Litzler's Feed Store	113.27		
	2/9/23	894	PJ	UNIQUE WATERWO	2,229.67		
	2/25/23	0500 Aguirre	PJ	Card Service Center	659.08		
	2/28/23	19471	PJ	Mercer Controls Inc - m	490.20		
				Current Period Change	3,492.22		3,492.22
	3/1/23			Beginning Balance			37,059.63
	3/2/23	97938	PJ	Reifel's Feed & Ranch -	300.00		
	3/2/23	017 03022023	PJ	Litzler's Feed Store - Pa	181.55		
	3/3/23	0500 Aguirre	PJ	Card Service Center	137.20		
	3/3/23	011023 03032	PJ	Donnelly Civil & Infrs	2,000.00		
	3/3/23	011023 03032	PJ	Donnelly Civil & Infrs	1,600.00		
	3/21/23	78220	PJ	Water Utility Services, I	1,000.00		
				Current Period Change	5,218.75		5,218.75
	4/1/23			Beginning Balance			42,278.38
	4/1/23	10309 040123	PJ	Stewart's Food Store	45.43		
	4/3/23	0500 Agirre 0	PJ	Card Service Center - S	31.76		
	4/3/23	017 04032023	PJ	Litzler's Feed Store	85.34		
	4/3/23	19541	PJ	Mercer Controls Inc -	440.80		

*Sweeny - Enterprise Fund
General Ledger

Item 19.

For the Period From Oct 1, 2022 to Sep 30, 2023

Filter Criteria includes: 1) IDs from 50-11-6710 to 50-11-6710. Report order is by ID. Report is printed with shortened descriptions and in Detail Format.

Account ID Account Description	Date	Reference	Jrnl	Trans Description	Debit Amt	Credit Amt	Balance
	4/3/23	19542	PJ	Mercer Controls Inc - R	876.39		
	4/3/23	19543	PJ	Mercer Controls Inc -	661.20		
	4/3/23	2344	PJ	Premium Pumps & Con	250.00		
	4/3/23	2344	PJ	Premium Pumps & Con	3,600.00		
	4/17/23	51	PJ	Texas Utilities & Envir	1,140.00		
	4/17/23	22268	PJ	Penney's Electric Co. In	1,121.85		
	4/18/23	2011-2862	PJ	Matula & Matula - Wat	2,500.00		
	4/19/23	91127	PJ	Envirodyne Laboratorie	735.00		
	4/24/23	22276	PJ	Penney's Electric Co. In	500.00		
	4/30/23	04302023	PJ	YellowRaven Backyard	730.63		
				Current Period Change	12,718.40		
	5/1/23			Beginning Balance			12,718.40
	5/1/23	939	PJ	UNIQUE WATERWO	8,639.82		54,996.78
	5/1/23	017 050123	PJ	Litzler's Feed Store	29.99		
	5/1/23	44301	PJ	RG-3 Utilities - Softwar	3,275.00		
	5/3/23	0492 Koski 05	PJ	Card Service Center - F	444.85		
	5/3/23	0500 Aguirre	PJ	Card Service Center - R	45.00		
	5/3/23	0500 Aguirre	PJ	Card Service Center -	17.47		
	5/12/23	44402	PJ	RG-3 Utilities - Hospita	3,757.60		
	5/15/23	2011-404	PJ	Matula & Matula - Rep	1,804.53		
	5/16/23	959208	PJ	Lowe's - Rotary Tool	95.02		
	5/16/23	959208	PJ	Lowe's - Padlocks	298.80		
	5/25/23	44525	PJ	RG-3 Utilities - Hospita	3,747.90		
				Current Period Change	22,155.98		
	6/1/23			Beginning Balance			22,155.98
	6/1/23	017 060123	PJ	Litzler's Feed Store	145.37		77,152.76
	6/5/23	903293/95920	PJ	Lowe's - Rotary Tool		95.02	
	6/11/23	061523	PJ	Lowe's Home Centers I	569.32		
	6/13/23	23-0418	PJ	Android Construction S	2,000.00		
	6/16/23	23026	PJ	Alvin Contracting - Em	2,650.00		
	6/22/23	1423	PJ	B&R Services	1,406.06		
	6/22/23	1425	PJ	B&R Services	1,832.12		
	6/22/23	1424	PJ	B&R Services	2,394.87		
	6/23/23	INV-Q-07082	PJ	Worldwide Power - Ge	929.32		
	6/26/23	1051	PJ	Goebel Operations, LL	2,365.00		
				Current Period Change	14,292.06	95.02	
	7/1/23			Beginning Balance			14,197.04
	7/11/23	1149551	PJ	Inframark, LLC - Water	20,554.24		91,349.80
	7/19/23	22449	PJ	Penney's Electric Co. In	250.00		
	7/19/23	22450	PJ	Penney's Electric Co. In	750.00		
	7/20/23	967	PJ	UNIQUE WATERWO	2,998.82		
	7/20/23	1906385	PJ	Waukesha-Pearce Indus	4,369.91		
	7/20/23	23-0448	PJ	Android Construction S	13,968.75		
	7/21/23	Permit 2827 0	PJ	Brazoria County Groun	400.00		
	7/21/23	Permit 2827 0	PJ	Brazoria County Groun	4,860.00		
	7/25/23	97460163	PJ	H & E Equipment - Con	121.95		
	7/28/23	750717	PJ	Andy's Tree Service - T	3,000.00		
	7/30/23	476401	PJ	Toro's Concrete - Concr	1,800.00		
				Current Period Change	53,073.67		
	8/1/23			Beginning Balance			53,073.67
	8/8/23	08/8	PJ	Litzler's Feed Store - Fit	59.16		144,423.47
	8/9/23	1150535	PJ	Inframark, LLC - Admi	416.07		
	8/9/23	1150535	PJ	Inframark, LLC - Opera	8,722.29		
	8/9/23	08/9/23	PJ	Litzler's Feed Store - Pa	230.62		
	8/10/23	23-0453	PJ	Android Construction S	4,086.40		
	8/14/23	08/14	PJ	Litzler's Feed Store - Fit	28.75		
	8/15/23	108282	PJ	Goolsby Water Well Se	4,115.00		
	8/15/23	08/15	PJ	Litzler's Feed Store - Fit	44.96		
	8/16/23	19760	PJ	Mercer Controls Inc - T	605.40		
	8/18/23	27121	PJ	SmartCover Systems -	1,728.00		
	8/21/23	8/21	PJ	Litzler's Feed Store - Pa	27.66		
	8/22/23	08/22	PJ	Litzler's Feed Store - Pa	4.49		
	8/22/23	08/22	PJ	Litzler's Feed Store - Pa	216.71		
	8/22/23	310961	PJ	McCoy's Building Supp	120.24		
	8/25/23	S237799TX.0	PJ	US Underwater - Annu	9,673.75		
	8/30/23	0406-152360	PJ	O'Reilly Automotive, In		13.05	
	8/30/23	0406-152164	PJ	O'Reilly Automotive, In	602.40		
				Current Period Change	30,681.90	13.05	
	9/1/23			Beginning Balance			30,668.85
	9/1/23	20231003-4	CDJ	Hach Company - Chlori	283.35		175,092.32

*Sweeny - Enterprise Fund
General Ledger

Item 19.

For the Period From Oct 1, 2022 to Sep 30, 2023

Filter Criteria includes: 1) IDs from 50-11-6710 to 50-11-6710. Report order is by ID. Report is printed with shortened descriptions and in Detail Format.

Account ID Account Description	Date	Reference	Jrnl	Trans Description	Debit Amt	Credit Amt	Balance
	9/11/23	1151574	PJ	Inframark, LLC - Maint	4,350.07		
	9/12/23	Kosk0492090	PJ	Card Service Center -	35.55		
	9/12/23	Kosk0492090	PJ	Card Service Center -	25.79		
	9/13/23	1590 Caudle 0	PJ	Card Service Center - S	54.47		
	9/25/23	10/02	PJ	Litzler's Feed Store - Pi	32.74		
	9/25/23	10/02	PJ	Litzler's Feed Store - Pi	24.28		
				Current Period Change	4,806.25		4,806.25
	9/30/23			Ending Balance			179,898.57

BUDGET AMENDMENT - FROM FUND BALANCE
 MAINTENANCE OF WATER SYSTEM
 50-11-6710

<u>DATE</u>	<u>BACK UP NO.</u>	<u>INVOICE NO.</u>	<u>PROVIDER</u>	<u>AMOUNT</u>	<u>NOTES / JUSTIFICATION</u>
12/5/2022	1	3000331	SCRUGGS	6,657.00	EMERGENCY BOOSTER PUMP PURCHASED AS ALT TO LOOSING H2O PSI
6/13/2023	2	23-0418	ANDROID CONTRACTING	2,000.00	ASPHALT REMOVAL FOR MAJOR LEAK ON 2ND ST.
6/16/2023	3	23026	ALVIN CONTRACTING	2,650.00	EMERGENCY REPAIR TO ELBOW ON GST 1
7/11/2023	4	1149551	INFRAMARK	20,554.24	NO LICENSED OPERATORS
7/20/2023	5	1906385	WAUKESHA-PEARCE	4,369.91	EMERGENCY WELL FIX
7/20/2023	6	23-0448	ANDROID CONSTRUCTION	13,968.75	MAJOR 2ND ST LEAK
7/28/2023	7	750717	ANDY'S TREE SERVICE	3,000.00	REGULATORY REQUIREMENT TO REMOVE VEGETATION TO AVOID CITATION
7/30/2023	8	476401	TORO'S CONCRETE	1,800.00	MAJOR LEAK ON VICTORY LN & TX AVE - CONCRETE WORK TO REPAIR SIDEWALK
8/9/2023	9	1150535	INFRAMARK - AD,IM	416.07	ADMIN
8/9/2023	10	1150535	INFRAMARK - OPS	8,722.29	WATER GEN MAIN, LAB, SAMPLINE
8/10/2023	11	23-0453	ANDROID CONSTRUCTION	4,086.40	MCKINNEY WATER LEAK
8/15/2023	12	108282	GOOLSBY WATER WELL SVE	4,115.00	EMERGENCY WORK ON WELL #5
8/25/2023	13	S237799TX	US UNDERWATER	9,673.75	INSPECTION & CLEANING TO REMOVE RESIDUAL FILTER MEDIA FROM GSTs
9/11/2023	14	1151574	INFRAMARK	4,350.07	NO LICESNED OPERATORS
9/30/2023	15	1152073	INFRAMARK	5,364.92	WATER
			AMENDMENT AMT REQUESTED		
			FROM EF BALANCE	91,728.40	
			FY23 APPROVED BUDGET	80,000.00	
			FY23 YTD AMT 9/30/2023	179,898.57	
			OVER BUDGET	(99,898.57)	

REFERENCE NO.	DESCRIPTION	INVOICE DATE	INVOICE AMOUNT	DISCOUNT TAKEN	AMOUNT PAID
3000478		12/5/22	3,850.00		3,850.00
3000364		12/5/22	3,440.00		3,440.00
3000331		12/5/22	6,657.00		6,657.00

CHECK DATE	CHECK NO.	PAYEE	DISCOUNTS TAKEN	CHECK AMOUNT
			\$13,947.00	2131

LAP53 A/P CHECK
 Rev 3/19
 104691
 10469

ITEM #	DESCRIPTION	QTY	UNIT PRICE	TOTAL
3000478*	LABOR FOR INSTALATION OF BOOSTER PUMP #3			3850
	11-6710*			
TOTAL				\$ 3,850.00

Comments or Special Instructions

①

IMPORTANT:

Above Order Number must appear on all correspondence, invoices, packages and shipping papers. Notify us immediately if you are unable to ship complete order by date specified. Your acceptance of this order is your warranty to us that you are complying with the U.S. Fair Labor Standards Act of 1988, as amended, and we reserve the right to refuse merchandise not in strict accordance with this order.

CITY OF SWEENY

PURCHASE ORDER

PO BOX 248
SWEENY, TEXAS 77480
Phone: (979) 548-3321
Fax: (979) 548-7745
sweenytx.gov

RA-193938

DATE 11/3/2022

VENDOR

SCRUGGS COMPANY

ITEM #		QTY	UNITE PRICE	175
300331*	BOOSTER PUMP FOR WATER PLANT	1		6,657.00
	Emergency - Purchased as alternative to losing water pressure according to RA.			
	11-6710*			
TOTAL				\$ 6,657.00

Comments or Special Instructions

IMPORTANT:
Above Order Number must appear on all correspondence, invoices, packages and shipping papers. Notify us immediately if you are unable to ship complete order by date specified. Your acceptance of this order is your warranty to us that you are complying with the U.S. Fair Labor Standards Act of 1988, as amended, and we reserve the right to refuse merchandise not in strict accordance with this order.



8530 Hansen Rd
Houston, TX 77075-1006
713-649-2776

INVOICE

INVOICE	
3000331	
Invoice Date	Page
10/12/2022	1 of 1
ORDER NUMBER	
1000409	

Bill To:
SWEENEY, CITY OF
PO BOX 248
Sweeny, TX 77480
USA

Ship To:
SWEENEY, CITY OF
PO BOX 248
Sweeny, TX 77480
USA

Customer ID: 11110

PO Number	Terms	Due Date	Order Date	Salesrep
Ross 2132	Net 30	11/11/2022	10/04/2022	House Account

Carrier:	
Packing #:	

Quantities			Item ID Item Description	Unit Price	Extended Price
Shipped	Remaining	UOM			

Order Note: NEW 30HP TECO VERTICAL MOTOR
460V, 1800RPM, 286TP, WPI ENCLOSURE
MODEL VH0304FP
Order Note: Attaches to P.O. 4000354

0	EA	SERVICE Field Service	6,657.00	6,657.00
---	----	--------------------------	----------	----------

Lines: 1	SUB-TOTAL:	6,657.00
	TAX:	0.00
	AMOUNT DUE:	6,657.00

REFERENCE NO.	DESCRIPTION	INVOICE DATE	INVOICE AMOUNT	DISCOUNT TAKEN	AMOUNT PAID
23-0418		6/13/23	10,000.00		10,000.00

CHECK DATE	CHECK NO.	PAYEE	DISCOUNTS TAKEN	CHECK AMOUNT
7/18/23	2382	Android Construction Services		\$10,000.00

LAP53 AP-CHECK

Rev 3/19



104691

10469

Funding-GL Acct #	DESCRIPTION	QTY	UNIT PRICE	TOTAL
GL11-6710	Asphalt removal, saw cutting and water line repair 1459/organge st	1	17,750.00	17,750.00
	<i>2nd & Orange STREETS</i>			
		56-21-644	✓	5,750.00
		50-21-6711	✓	2,000.00
		50-11-6717	✓	8,000.00
		50-11-6710	↓	2,000.00
TOTAL				\$ 17,750.00

ENTERED

Comments or Special Instructions

2

IMPORTANT:

Above Order Number must appear on all correspondence, invoices, packages and shipping papers. Notify us immediately if you are unable to ship complete order by date specified. Your acceptance of this order is your warranty to us that you are complying with the U.S. Fair Labor Standards Act of 1988, as amended, and we reserve the right to refuse merchandise not in strict accordance with this order.

REFERENCE NO.	DESCRIPTION	INVOICE DATE	INVOICE AMOUNT	DISCOUNT TAKEN	AMOUNT PAID
23-0418		6/13/23	7,750.00		7,750.00

CHECK DATE	CHECK NO.	PAYEE	DISCOUNTS TAKEN	CHECK AMOUNT
7/18/23	41004	Android Construction Services		\$7,750.00

LAP53 A/P CHECK
 Rev 3/19
 104551
 10465

Funding-GL Acct #	DESCRIPTION	QTY	UNIT PRICE	TOTAL
GL11-6710	Asphalt removal, saw cutting and water line repair 1459/orange st	1	17,750.00	17,750.00
	<i>2nd & Orange STREETS</i>			
		50-21-644	✓	5,750.00
		50-21-6711	✓	2,000.00
		50-11-6717	✓	8,000.00
		50-11-6710	↓	2,000.00
TOTAL				\$ 17,750.00

ENTERED

Comments or Special Instructions

IMPORTANT:
 Above Order Number must appear on all correspondence, invoices, packages and shipping papers. Notify us immediately if you are unable to ship complete order by date specified. Your acceptance of this order is your warranty to us that you are complying with the U.S. Fair Labor Standards Act of 1988, as amended, and we reserve the right to refuse merchandise not in strict accordance with this order.

CITY OF SWEENY

PURCHASE ORDER

PO BOX 248
 SWEENY, TEXAS 77480
 Phone: (979) 548-3321
 Fax: (979) 548-7745
 sweenytx.gov

CW061923

DATE 6/12/2023

VENDOR		PURCHASING INFORMATION	
Android Construction Services		Requisition:	
16195 S Hwy 288B			GL11-6710
Angleton, TX 77515			

Funding-GL Acct #	DESCRIPTION	QTY	UNIT PRICE	TOTAL
GL11-6710	Asphalt removal, saw cutting and water line repair 1459/organge st	1	17,750.00	17,750.00
	<i>2nd + Orange STREETS</i>			
		50-21-644	✓	5,750.00
		50-21-6711	✓	2,000.00
		50-11-6717	✓	8,000.00
		50-11-6710	↓	2,000.00
TOTAL				\$ 17,750.00

ENTERED

Comments or Special Instructions

IMPORTANT:

Above Order Number must appear on all correspondence, invoices, packages and shipping papers. Notify us immediately if you are unable to ship complete order by date specified. Your acceptance of this order is your warranty to us that you are complying with the U.S. Fair Labor Standards Act of 1988, as amended, and we reserve the right to refuse merchandise not in strict accordance with this order.

REFERENCE NO.	DESCRIPTION	INVOICE DATE	INVOICE AMOUNT	DISCOUNT TAKEN	AMOUNT PAID
23026		6/16/23	2,650.00		2,650.00

CHECK DATE	CHECK NO.	PAYEE	DISCOUNTS TAKEN	CHECK AMOUNT
7/5/23	2370	Alvin Contracting		\$2,650.0

LAP53 A/P CHECK

Rev 3/19



104691

10469

Funding-GL Acct #	DESCRIPTION	QTY	UNIT PRICE	TOTAL
GL116710	Emergency 8" elbow repair at water plant Inv# 23026	1	2,650.00	2,650.00
TOTAL				\$ 2,650.00

Comments or Special Instructions

3

IMPORTANT:

Above Order Number must appear on all correspondence, invoices, packages and shipping papers. Notify us immediately if you are unable to ship complete order by date specified. Your acceptance of this order is your warranty to us that you are complying with the U.S. Fair Labor Standards Act of 1988, as amended, and we reserve the right to refuse merchandise not in strict accordance with this order.

CITY OF SWEENY

PO BOX 248
 SWEENY, TEXAS 77480
 Phone: (979) 548-3321
 Fax: (979) 548-7745
 sweenytx.gov

PURCHASE ORDER

CW061623

DATE 6/12/2023

VENDOR		PURCHASING INFORMATION	
Alvin Contracting		Requisition:	
PO Box 2088			GL116710
Alvin, TX 77512			11-6717

Funding-GL Acct #	DESCRIPTION	QTY	UNIT PRICE	TOTAL
GL116710	Emergency 8" elbow repair at water plant Inv# 23026	1	2,650.00	2,650.00
TOTAL				\$ 2,650.00

Comments or Special Instructions

IMPORTANT:

Above Order Number must appear on all correspondence, invoices, packages and shipping papers. Notify us immediately if you are unable to ship complete order by date specified. Your acceptance of this order is your warranty to us that you are complying with the U.S. Fair Labor Standards Act of 1988, as amended, and we reserve the right to refuse merchandise not in strict accordance with this order.

INVOICE

ALVIN CONTRACTING

P.O. BOX 2088
ALVIN, TX 77612-2088
OFFICE 281-331-3618
email: alvincontracting@yahoo.com

INVOICE NO. 23026
DATE: 6/16/2023
P O NO. ~~CW061623~~
SHIP DATE: 6/7/2023
TERMS: NET 10

BILL TO: CITY OF SWEENY
102 ASLEY-WILSON RD
SWEENY, TX 77480

ATTN: CLARENCE

RE: WATER PLANT

DESCRIPTION	AMOUNT
PULLED ONE (1) 6 INCH, 90 DEGREE CAST IRON ELBOW WITH A FRACTURE	
FABRICATED NEW 6 INCH FLANGE X FLANGE ELBOW, WELDED NEW PIECE	
MATERIALS AND LABOR	2,650.00
BALANCE DUE	\$2,650.00

THANK YOU, WE APPRIATE YOUR BUSINESS

REFERENCE NO.	DESCRIPTION	INVOICE DATE	INVOICE AMOUNT	DISCOUNT TAKEN	AMOUNT PAID
1149551		7/11/23	41,459.73		41,459.73

CHECK DATE	CHECK NO.	PAYEE	DISCOUNTS TAKEN	CHECK AMOUNT
9/6/23	2450	Inframark, LLC		\$41,459.73

LAP53 A/P CHECK



104691

10469

Rev 3/19

Funding-GL Acct #	DESCRIPTION	QTY	UNIT PRICE	TOTAL
11-6711	Emergency Water and Wastewater Operations through July 8th, 2023 for emergency services contract Inv# 1149551	1	41,459.73	41,459.73
		11-6711	20,905.49	
		11-6710	20,554.24	
			<u>41,459.73</u>	
TOTAL			\$ -	\$ 41,459.73

Comments or Special Instructions

4

IMPORTANT:

Above Order Number must appear on all correspondence, invoices, packages and shipping papers. Notify us immediately if you are unable to ship complete order by date specified. Your acceptance of this order is your warranty to us that you are complying with the U.S. Fair Labor Standards Act of 1988, as amended, and we reserve the right to refuse merchandise not in strict accordance with this order.



Inframark, LLC
2002 West Grand Parkway North, Suite 100
Katy, Texas 77449
(281) 578-4200

Client ID Number	
------------------	--

Invoice Number	1149551
Invoice Date	7/11/2023
Due Date	8/10/2023

To: City of Sweeny
102 W Ashley Wilson Rd

Sweeny, TX 77480

Service Description	Total
Maintenance Services	\$41,459.73

Please Pay This Amount

Subtotal	\$41,459.73
Sales Tax	\$0.00
Total	\$41,459.73

Remit To: Inframark, LLC, P.O. Box 733778, Dallas, Texas 75373-3778

To pay by Credit Card, contact us at 281-578-4299, 9:00am - 5:30pm EST, Mon - Fri. A surcharge fee may apply

To Pay via ACH or Wire, please refer to our banking information below:

Account Name : INFRAMARK, LLC

ACH - Bank Routing Number : 111000614 / Account Number 912593196

Wire - Bank Routing Number : 021000021 / SWIFT Code : CHASUS33 / Account Number: 912593196

Please include the Project ID and the Invoice Number on the check stub of your payment.

INFRAMARK, LLC

DISTRICT : CITY OF SWEENEY

INVOICE NO. 1149551 - SUMMARY

INVOICE DATE: 7/11/2023

11 Jul 2023 12:16:32PM CST

Go Green! Think before you print.

Work Type / Sub Category	Equipment Costs	Labor Costs	Materials/Other Service Costs	Sales Tax Total	Total Costs
Maintenance, Sewer Plant					
SP1					
General Maintenance & Repairs	\$3,200.00	\$15,068.44	\$0.00	\$0.00	\$18,268.44
Maintenance	\$450.00	\$1,746.00	\$441.05	\$0.00	\$2,637.05
SP1 Total	\$3,650.00	\$16,814.44	\$441.05	\$0.00	\$20,905.49
SP Total	\$3,650.00	\$16,814.44	\$441.05	\$0.00	\$20,905.49
Maintenance, Water Plant					
WP1					
General Maintenance & Repairs	\$2,815.00	\$14,740.48	\$0.00	\$0.00	\$17,555.48
Maintenance	\$768.75	\$2,204.32	\$25.69	\$0.00	\$2,998.76
WP1 Total	\$3,583.75	\$16,944.80	\$25.69	\$0.00	\$20,554.24
WP Total	\$3,583.75	\$16,944.80	\$25.69	\$0.00	\$20,554.24
Invoice Total	\$7,233.75	\$33,759.24	\$466.74	\$0.00	\$41,459.73

INFRAMARK, LLC
 DISTRICT : CITY OF SWEENEY
 INVOICE NO. 1149551 - DETAIL
 INVOICE DATE: 7/11/2023
 11 Jul 2023 12:16:33PM CST
 Go Green! Think before you print.

Work Type / Sub Category	Date Complete	WO Number	Address	Task Details	Equipment Costs	Labor Costs	Materials/Other Service Costs	Sales Tax Total	Total Costs	B/C
Maintenance, Sewer Plant										
SP1										
General Maintenance & Repairs										
	7/10/2023	3254593	2607 Avenue A	General Repair or Maintenance of an Asset at a Sewer Treatment Plant	\$1,670.00	\$7,312.24	\$0.00	\$0.00	\$8,982.24	N
	7/10/2023	3255041	2607 Avenue A	General Repair or Maintenance of an Asset at a Sewer Treatment Plant; sewer plant weekend check in	\$75.00	\$491.06	\$0.00	\$0.00	\$566.06	N
	7/10/2023	3258670	2607 Avenue A	General Repair or Maintenance of an Asset at a Sewer Treatment Plant	\$670.00	\$3,053.46	\$0.00	\$0.00	\$3,723.46	N
	7/10/2023	3258920	2607 Avenue A	General Repair or Maintenance of an Asset at a Sewer Treatment Plant	\$150.00	\$1,047.60	\$0.00	\$0.00	\$1,197.60	N
	7/10/2023	3260029	2607 Avenue A	General Repair or Maintenance of an Asset at a Sewer Treatment Plant; Monitor chemical feed at back end of plant and pull samples as needed. Run trash pump from clarifier to aeration, moving solids back into plant. General maintenance of everyday running of sewer plant.	\$420.00	\$1,891.50	\$0.00	\$0.00	\$2,311.50	N
	7/10/2023	3261486	2607 Avenue A	General Repair or Maintenance of an Asset at a Sewer Treatment Plant; Weekend Facility check and plant operations	\$95.00	\$562.30	\$0.00	\$0.00	\$657.30	N
	7/10/2023	3264833	2607 Avenue A	General Repair or Maintenance of an Asset at a Sewer Treatment Plant	\$120.00	\$710.28	\$0.00	\$0.00	\$830.28	N
				General Maintenance & Repairs Total	\$3,200.00	\$15,068.44	\$0.00	\$0.00	\$18,268.44	
Maintenance										
	7/10/2023	3250852	2607 Avenue A	General Repair of a Sewer Treatment Plant Asset; Check over CL2 System and walk over plant with operator.	\$75.00	\$291.00	\$4.28	\$0.00	\$370.28	N

INFRAMARK, LLC

DISTRICT : CITY OF SWEENEY

INVOICE NO. 1149551 - DETAIL

INVOICE DATE: 7/11/2023

11 Jul 2023 12:16:33PM CST

Go Green! Think before you print.

Work Type / Sub Category	Date Complete	WO Number	Address	Task Details	Equipment Costs	Labor Costs	Materials/Other Service Costs	Sales Tax Total	Total Costs	B/C
	7/10/2023	3250855	2607 Avenue A	General Repair of a Sewer Treatment Plant Asset; Go over Non-potable system with operator and get parts list to make changes to non-potable system that operator is asking for.	\$375.00	\$1,455.00	\$436.76	\$0.00	\$2,266.76	N
				Maintenance Total	\$450.00	\$1,746.00	\$441.05	\$0.00	\$2,637.05	
				SP1 Total	\$3,650.00	\$16,814.44	\$441.05	\$0.00	\$20,905.49	
				SP Total	\$3,650.00	\$16,814.44	\$441.05	\$0.00	\$20,905.49	
Maintenance, Water Plant										
WP1										
General Maintenance & Repairs										
	7/10/2023	3253528	204 Peach St	General Repairs of an Asset at a Water Plant	\$1,345.00	\$7,060.67	\$0.00	\$0.00	\$8,405.67	N
	7/10/2023	3255050	204 Peach St	General Repairs of an Asset at a Water Plant; water plant weekend check in	\$85.00	\$556.54	\$0.00	\$0.00	\$641.54	N
	7/10/2023	3258712	204 Peach St	General Repairs of an Asset at a Water Plant	\$220.00	\$1,342.24	\$0.00	\$0.00	\$1,562.24	N
	7/10/2023	3258932	204 Peach St	General Repairs of an Asset at a Water Plant	\$70.00	\$488.88	\$0.00	\$0.00	\$558.88	N

INFRAMARK, LLC

DISTRICT : CITY OF SWEENEY

INVOICE NO. 1149551 - DETAIL

INVOICE DATE: 7/11/2023

11 Jul 2023 12:16:33PM CST

Go Green! Think before you print.

Work Type / Sub Category	Date Complete	WO Number	Address	Task Details	Equipment Costs	Labor Costs	Materials/Other Service Costs	Sales Tax Total	Total Costs	B/C
	7/10/2023	3259994	204 Peach St	General Repairs of an Asset at a Water Plant; Checked district residual, got residual and est booster pumps running and time. Make adjustments on chemical feed system at plant and in district.	\$310.00	\$1,353.14	\$0.00	\$0.00	\$1,663.14	N
	7/10/2023	3260014	204 Peach St	Investigate a Problem at a Water Plant; Leak at 90 degree pipe going from well to gst	\$260.00	\$1,353.15	\$0.00	\$0.00	\$1,613.15	N
	7/10/2023	3260016	204 Peach St	General Repairs of an Asset at a Water Plant; Checked district residual, got residual and est booster pumps running and time. Make adjustments on chemical feed system at plant and in district.	\$300.00	\$1,347.33	\$0.00	\$0.00	\$1,647.33	N
	7/10/2023	3260034	204 Peach St	General Repairs of an Asset at a Water Plant; Met TCEQ on site for i of water plant and distribution system	\$60.00	\$261.90	\$0.00	\$0.00	\$321.90	N
	7/10/2023	3261489	204 Peach St	General Repairs of an Asset at a Water Plant; Weekend Facility check, district residuals and plant operations	\$95.00	\$562.30	\$0.00	\$0.00	\$657.30	N
	7/10/2023	3264831	204 Peach St	General Repairs of an Asset at a Water Plant	\$70.00	\$414.33	\$0.00	\$0.00	\$484.33	N
				General Maintenance & Repairs Total	\$2,815.00	\$14,740.48	\$0.00	\$0.00	\$17,555.48	
Maintenance										
	7/10/2023	3250857	204 Peach St	General Repair of a Water Plant Asset; Check PO4 system and get info to PM pump.	\$187.50	\$517.98	\$8.56	\$0.00	\$714.04	N
	7/10/2023	3250859	204 Peach St	MTX - Chlorine/Chemical Change Out at a Facility (must verify work type); change out	\$75.00	\$291.00	\$4.28	\$0.00	\$370.28	N

INFRAMARK, LLC

DISTRICT : CITY OF SWEENEY

INVOICE NO. 1149551 - DETAIL

INVOICE DATE: 7/11/2023

11 Jul 2023 12:16:33PM CST

Go Green! Think before you print.

Work Type / Sub Category	Date Complete	WO Number	Address	Task Details	Equipment Costs	Labor Costs	Materials/Other Service Costs	Sales Tax Total	Total Costs	B/C
	7/10/2023	3250860	204 Peach St	General Repair of a Water Plant Asset; Check over CL2 System and walk over plant with operator.	\$187.50	\$430.68	\$4.28	\$0.00	\$622.46	N
	7/10/2023	3250861	204 Peach St	MTX - Chlorine/Chemical Change Out at a Facility (must verify work type); change out	\$75.00	\$151.32	\$4.28	\$0.00	\$230.60	N
	7/10/2023	3260621	204 Peach St	General Repair of a Water Plant Asset; Get parts list for quote.	\$131.25	\$437.95	\$0.00	\$0.00	\$569.20	N
	7/10/2023	3262793	204 Peach St	MTX - Chlorine/Chemical Change Out at a Facility (must verify work type); Change out cl2	\$112.50	\$375.39	\$4.28	\$0.00	\$492.17	N
				Maintenance Total	\$768.75	\$2,204.32	\$25.69	\$0.00	\$2,998.76	
				WP1 Total	\$3,583.75	\$16,944.80	\$25.69	\$0.00	\$20,554.24	
				WP Total	\$3,583.75	\$16,944.80	\$25.69	\$0.00	\$20,554.24	
				Invoice Total	\$7,233.75	\$33,759.24	\$466.74	\$0.00	\$41,459.73	

REFERENCE NO.	DESCRIPTION	INVOICE DATE	INVOICE AMOUNT	DISCOUNT TAKEN	AMOUNT PAID
1906385		7/20/23	4,369.91		4,369.91

CHECK DATE	CHECK NO.	PAYEE	DISCOUNTS TAKEN	CHECK AMOUNT
7/20/23	2398	Waukesha-Pearce Industries Inc		\$4,369.91

LAP53 A/P CHECK

Rev 3/19



104691

10469

Funding-GL Acct #	DESCRIPTION	QTY	UNIT PRICE	TOTAL
11-6710	Well #3 Generator Repairs and Parts, TCEQ Required	1	4,369.91	4,369.91
TOTAL			\$ -	\$ 4,369.91

ENTERED

Comments or Special Instructions

5

IMPORTANT:

Above Order Number must appear on all correspondence, invoices, packages and shipping papers. Notify us immediately if you are unable to ship complete order by date specified. Your acceptance of this order is your warranty to us that you are complying with the U.S. Fair Labor Standards Act of 1988, as amended, and we reserve the right to refuse merchandise not in strict accordance with this order.

CITY OF SWEENY

PURCHASE ORDER

PO BOX 248
 SWEENY, TEXAS 77480
 Phone: (979) 548-3321
 Fax: (979) 548-7745
 sweenytx.gov

CW20230611

DATE 6/11/2023

VENDOR	PURCHASING INFORMATION	
Waukesha-Pearce Industries, LLC.	Requisition:	
P.O. Box 204116		GL # 11-6710
Dallas, TX 75320-4116		

Funding-GL Acct #	DESCRIPTION	QTY	UNIT PRICE	TOTAL
11-6710	Well#3 Generator Repairs and Parts, TCEQ Required	1	4,369.91	4,369.91
ENTERED				
TOTAL			\$ -	\$ 4,369.91

Comments or Special Instructions

IMPORTANT:

Above Order Number must appear on all correspondence, invoices, packages and shipping papers. Notify us immediately if you are unable to ship complete order by date specified. Your acceptance of this order is your warranty to us that you are complying with the U.S. Fair Labor Standards Act of 1988, as amended, and we reserve the right to refuse merchandise not in strict accordance with this order.

WUKESHA-PEARCE INDUSTRIES, LLC
A PEARCE INDUSTRIES, INC. COMPANY
P.O. BOX 35068, HOUSTON TEXAS 77235-5068
PHONE (713) 723-1050

P.O.#
CW 2023,0611 - 1

STATEMENT OF ACCOUNT

Account # 203247
Date 6/2/2023
Page 1 of 1

203247
CITY OF SWEENY
P O BOX 248
SWEENY TX 77480

REMIT TO
WUKESHA-PEARCE INDUSTRIES, LLC. EXCHANGE
ACCOUNT
EXCHANGE ACCOUNT
P O BOX 204116 DALLAS, TX 75320-4116
ACH/WIRING: WELLS FARGO BANK, N.A.
ABA#: 121000248 ACCOUNT#: 4122374218

Invoice Date	Invoice	Branch	Explanation	Po#	Inv Type	Due Date	Amount Due
03/15/23	1906385	212	Service Order190418		GS	04/14/23	4,369.91
BALANCE DUE (USD):							4,369.91

CW
2023 0611 - 1

6-9-23

Current	1 - 30	31 - 60	61 - 90	91 - 120	Over 121
		4,369.91			

A service charge will be assessed equal to the lesser of 1.0% per month or the maximum rate permitted by law on all delinquent accounts, until paid in full. * The above figures are subject to errors of omission and commission.*
Please be advised that any unused credits that have aged beyond 60 days may be used against aged invoices at WPI's discretion.

REFERENCE NO.	DESCRIPTION	INVOICE DATE	INVOICE AMOUNT	DISCOUNT TAKEN	AMOUNT PAID
23-0448		7/20/23	13,968.75		13,968.75

CHECK DATE	CHECK NO.	PAYEE	DISCOUNTS TAKEN	CHECK AMOUNT
8/2/23	2403	Android Construction Services		\$13,968.75

LAP53 A/P CHECK

Rev 3/19



104691

10469

Funding-GL Acct #	DESCRIPTION	QTY	UNIT PRICE	TOTAL
11-6710	806 Windy Lane water repair	1	4,400.00	4,400.00
	Victory Ln and Texas Ave Water Leak	1	7,200.00	7,200.00
	Equipment Rental	1	2,368.75	2,368.75
TOTAL				\$ -

13,968.75

Comments or Special Instructions

6

IMPORTANT:

Above Order Number must appear on all correspondence, invoices, packages and shipping papers. Notify us immediately if you are unable to ship complete order by date specified. Your acceptance of this order is your warranty to us that you are complying with the U.S. Fair Labor Standards Act of 1988, as amended, and we reserve the right to refuse merchandise not in strict accordance with this order.

REFERENCE NO.	DESCRIPTION	INVOICE DATE	INVOICE AMOUNT	DISCOUNT TAKEN	AMOUNT PAID
750717		7/28/23	3,000.00		3,000.00

CHECK DATE	CHECK NO.	PAYEE	DISCOUNTS TAKEN	CHECK AMOUNT
8/2/23	2404	Andy's Tree Service		\$3,000.00

LAP53 A/P CHECK

Rev 3/19



104691

10469

FUNDING-GL ACCT #	DESCRIPTION	QTY	UNIT PRICE	TOTAL
11-6711	Tree removal at Water Plant per TCEQ inspection	1	3,000.00	3,000.00
TOTAL			\$ -	\$ 3,000.00

Comments or Special Instructions

7

IMPORTANT:

Above Order Number must appear on all correspondence, invoices, packages and shipping papers. Notify us immediately if you are unable to ship complete order by date specified. Your acceptance of this order is your warranty to us that you are complying with the U.S. Fair Labor Standards Act of 1988, as amended, and we reserve the right to refuse merchandise not in strict accordance with this order.

CITY OF SWEENY

PO BOX 248
 SWEENY, TEXAS 77480
 Phone: (979) 548-3321
 Fax: (979) 548-7745
 sweenytx.gov

PURCHASE ORDER

CW080123-05

DATE 8/1/2023

VENDOR	PURCHASING INFORMATION	
Andy's Tree Service	Requisition:	
P.O. Box 209		GL _____
Brazoria, TX 77422		

Funding-GL Acct #	DESCRIPTION	QTY	UNIT PRICE	TOTAL
11-6711	Tree removal at Water Plant per TCEQ inspection	1	3,000.00	3,000.00
TOTAL			\$ -	\$ 3,000.00

Comments or Special Instructions

IMPORTANT:

Above Order Number must appear on all correspondence, invoices, packages and shipping papers. Notify us immediately if you are unable to ship complete order by date specified. Your acceptance of this order is your warranty to us that you are complying with the U.S. Fair Labor Standards Act of 1988, as amended, and we reserve the right to refuse merchandise not in strict accordance with this order.

P.O.# CW080123-05

750717

Invoice

SOLD TO Andy's Tree Service		SHIP TO <i>City of Sweeny</i>	
ADDRESS P.O. Box 209		ADDRESS <i>102 W. Ashley Wilson</i>	
CITY, STATE, ZIP Brazoria, Tx 77422		CITY, STATE, ZIP <i>Sweeny Tx. 77480</i>	
CUSTOMER ORDER NO.	SOLD BY	TERMS	F.O.B.
			DATE <i>7/28/2023</i>

ORDERED	SHIPPED	DESCRIPTION	PRICE	UNIT	AMOUNT
		<i>by water tower</i>			
		<i>take down large pecan</i>			
		<i>heavy trim around tank</i>			
			<i>\$ 3000</i>		<i>.00</i>
		<i>clean up ditch</i>			
		<i>pecan st. pick up</i>			
		<i>broken limbs</i>			
		<i>506 5th st.</i>			
		<i>Pick up bundles of</i>			
		<i>brush & logs</i>			
			<i>total \$ 3000</i>		<i>.00</i>

Form 5840

08-1

REFERENCE NO.	DESCRIPTION
476401	

CHECK DATE	CHECK NO.
9/6/23	2460

FOR Karla **Urgent**

DATE 9/8/23 TIME 2:45pm

While You Were Out

M David Herrera / Patty Herrera

OF Toros Concrete TELEPHONED

PHONE 909-70301002 CAME TO SEE YOU

CELL RETURNED YOUR CALL

FAX PLEASE CALL

WILL CALL AGAIN

WANTS TO SEE YOU

Message

check payment for invoice

ck to Toro's Concrete \$1,800.00

9-8-23 Confirmed Passport 15

[Signature]

A-9711 T-3002 SIGNED [Signature]

AMOUNT PAID
1,800.00

CHECK AMOUNT
\$1,800.00

LAP53 A/P CHECK Rev 3/19

Funding-SE Acct #	DESCRIPTION	AMOUNT	TOTAL
<u>11-6710</u>	<u>Concrete on Ave</u>		
TOTAL		\$ -	\$ 1,800.00

AMOUNT	TOTAL
00.00	1,800.00
	\$ 1,800.00

Comments or Special Instructions

Note: Street repairs from major water leaks at two different locations

8

IMPORTANT:

Above Order Number must appear on all correspondence, invoices, packages and shipping papers. Notify us immediately if you are unable to ship complete order by date specified. Your acceptance of this order is your warranty to us that you are complying with the U.S. Fair Labor Standards Act of 1988, as amended, and we reserve the right to refuse merchandise not in strict accordance with this order.

Toro's Concrete

476401

Invoice

SOLD TO City of Sweeny		SHIP TO	
ADDRESS Texas & Victory Lane,		ADDRESS Sweeny, TX	
CITY, STATE, ZIP 704 Ave C.		CITY, STATE, ZIP 77480	

CUSTOMER ORDER NO.	SOLD BY	TERMS Repair Concrete	F.O.B.	DATE 7-30-23
--------------------	---------	--------------------------	--------	-----------------

ORDERED	SHIPPED	DESCRIPTION	PRICE	UNIT	AMOUNT
		* off of Texas, Victory Lane. sidewalk repair. redo the dirt work to set grade the rebar, pour concrete. rebar at 14" o.c.			\$1,800
		* 704 Ave C Repair driveway, clean out dirt from slab. tu'd rebar, dowel in. rebar at M.C. Paws Concrete.			

al Herrera 979-703-0602

09-11

Karla Wilson

From: Karla Wilson
Sent: Wednesday, August 30, 2023 9:34 AM
To: Clarence Wittwer
Subject: Re: Toros Concrete

Yes, that makes sense.

Get [Outlook for iOS](#)

From: Clarence Wittwer <cwittwer@sweenytx.gov>
Sent: Wednesday, August 30, 2023 9:33:25 AM
To: Karla Wilson <kwwilson@sweenytx.gov>
Subject: RE: Toros Concrete

I forgot to mention, not sure on the funding since all of the GL accounts are basically emptied. Also, this was street repairs but due to water line breaks so I am thinking it should be Maintenance of The Water System rather than Street Work.

From: Clarence Wittwer
Sent: Wednesday, August 30, 2023 9:32 AM
To: Karla Wilson <kwwilson@sweenytx.gov>
Subject: Toros Concrete
Importance: High

We contacted Toros and were able to get the attached invoice so I prepped a PO. Sending this via email since it is already at the 30 day mark.

Thanks

Clarence L. Wittwer
Assistant City Manager / Public Works Director
City of Sweeny





Inframark, LLC
2002 West Grand Parkway North, Suite 100
Katy, Texas 77449
(281) 578-4200

Client ID Number	
------------------	--

Invoice Number	1150535
Invoice Date	8/9/2023
Due Date	9/8/2023

To: City of Sweeny
102 W Ashley Wilson Rd

Sweeny, TX 77480

Service Description	Total
Maintenance Services	\$29,000.59

9 10

Subtotal	\$29,000.59
Sales Tax	\$0.00
Total	\$29,000.59

Please Pay This Amount

Remit To: Inframark, LLC, P.O. Box 733778, Dallas, Texas 75373-3778

To pay by Credit Card, contact us at 281-578-4299, 9:00am - 5:30pm EST, Mon - Fri. A surcharge fee may apply

To Pay via ACH or Wire, please refer to our banking information below:

Account Name : INFRAMARK, LLC

ACH - Bank Routing Number : 111000614 / Account Number 912593196

Wire - Bank Routing Number : 021000021 / SWIFT Code : CHASUS33 / Account Number: 912593196

Please include the Project ID and the Invoice Number on the check stub of your payment.

INFRAMARK, LLC

DISTRICT : CITY OF SWEENEY

INVOICE NO. 1150535 - SUMMARY

INVOICE DATE: 8/9/2023

09 Aug 2023 11:49:11PM CST

Go Green! Think before you print.

Work Type / Sub Category	Equipment Costs	Labor Costs	Materials/Other Service Costs	Sales Tax Total	Total Costs
Administrative					
Administrative Services	\$0.00	\$359.60	\$0.00	\$0.00	\$359.60
Subcontract Services	\$0.00	\$56.47	\$0.00	\$0.00	\$56.47
AD Total	\$0.00	\$416.07	\$0.00	\$0.00	\$416.07
Maintenance, Sewer Plant					
SP1					
General Maintenance & Repairs	\$2,075.00	\$10,067.23	\$0.00	\$0.00	\$12,142.23
Other Maintenance	\$0.00	\$0.00	\$7,720.00	\$0.00	\$7,720.00
SP1 Total	\$2,075.00	\$10,067.23	\$7,720.00	\$0.00	\$19,862.23
SP Total	\$2,075.00	\$10,067.23	\$7,720.00	\$0.00	\$19,862.23
Maintenance, Water Plant					
WP1					
General Maintenance & Repairs	\$1,485.00	\$7,076.29	\$0.00	\$0.00	\$8,561.29
Lab Fees or Laboratory Sampling	\$0.00	\$0.00	\$161.00	\$0.00	\$161.00
WP1 Total	\$1,485.00	\$7,076.29	\$161.00	\$0.00	\$8,722.29
WP Total	\$1,485.00	\$7,076.29	\$161.00	\$0.00	\$8,722.29
Invoice Total	\$3,560.00	\$17,559.59	\$7,881.00	\$0.00	\$29,000.59

INFRAMARK, LLC

DISTRICT : CITY OF SWEENEY

INVOICE NO. 1150535 - DETAIL

INVOICE DATE: 8/9/2023

09 Aug 2023 11:49:15PM CST

Go Green! Think before you print.

Work Type / Sub Category	Date Complete	WO Number	Address	Task Details	Equipment Costs	Labor Costs	Materials/Other Service Costs	Sales Tax Total	Total Costs	B/C
Administrative										
Administrative Services										
	6/26/2023	3294437	SWEENEY District Area	Consumer Confidence Report (CCR); Prepare and distribute the 2022 CCR.	\$0.00	\$359.60	\$0.00	\$0.00	\$359.60	N
				Administrative Services Total	\$0.00	\$359.60	\$0.00	\$0.00	\$359.60	
Subcontract Services										
	7/6/2023	3290612	SWEENEY District Area	Disinfectant Level Quarterly Operating Report; Prepare and submit the 2023 QTR2 DLQOR	\$0.00	\$56.47	\$0.00	\$0.00	\$56.47	N
				Subcontract Services Total	\$0.00	\$56.47	\$0.00	\$0.00	\$56.47	
				AD Total	\$0.00	\$416.07	\$0.00	\$0.00	\$416.07	
Maintenance, Sewer Plant										
SP1										
General Maintenance & Repairs										
	7/6/2023	3260028	2607 Avenue A	General Repair or Maintenance of an Asset at a Sewer Treatment Plant; Monitor chemical feed at back end of plant and pull samples as needed. Run trash pump from clarifier to aeration, moving solids back into plant. General maintenance of everyday running of sewer plant.	\$500.00	\$2,182.50	\$0.00	\$0.00	\$2,682.50	N

INFRAMARK, LLC

DISTRICT : CITY OF SWEENEY

INVOICE NO. 1150535 - DETAIL

INVOICE DATE: 8/9/2023

09 Aug 2023 11:49:15PM CST

Go Green! Think before you print.

Work Type / Sub Category	Date Complete	WO Number	Address	Task Details	Equipment Costs	Labor Costs	Materials/Other Service Costs	Sales Tax Total	Total Costs	B/C
	7/6/2023	3269272	2607 Avenue A	General Repair or Maintenance of an Asset at a Sewer Treatment Plant; Check in plant, monitor and adjust chemical feed. Pulled samples when needed in the proper timely manner. Monitor pump run times and flow levels of plant	\$640.00	\$3,123.59	\$0.00	\$0.00	\$3,763.59	N
	7/6/2023	3269455	2607 Avenue A	General Repair or Maintenance of an Asset at a Sewer Treatment Plant	\$215.00	\$1,374.51	\$0.00	\$0.00	\$1,589.51	N
	7/12/2023	3275830	2607 Avenue A	General Repair or Maintenance of an Asset at a Sewer Treatment Plant; Checked in plant, adjusted chemical feed and monitored trash pump and now return pump 4	\$300.00	\$1,309.50	\$0.00	\$0.00	\$1,609.50	N
	7/14/2023	3281534	2607 Avenue A	General Repair or Maintenance of an Asset at a Sewer Treatment Plant; Weekend check of plant	\$65.00	\$425.58	\$0.00	\$0.00	\$490.58	N
	7/14/2023	3281666	2607 Avenue A	General Repair or Maintenance of an Asset at a Sewer Treatment Plant; Monitor plant operations, adjusted chemicals as needed, made sure return pump was running properly	\$275.00	\$1,156.73	\$0.00	\$0.00	\$1,431.73	N
	7/17/2023	3282699	2607 Avenue A	General Repair or Maintenance of an Asset at a Sewer Treatment Plant	\$80.00	\$494.82	\$0.00	\$0.00	\$574.82	N
				General Maintenance & Repairs Total	\$2,075.00	\$10,067.23	\$0.00	\$0.00	\$12,142.23	
Other Maintenance										
	6/29/2023	3261979	2607 Avenue A	Post Sewer Treatment Plant Repair Cleanup; Clean out clarifier	\$0.00	\$0.00	\$7,720.00	\$0.00	\$7,720.00	N
				Other Maintenance Total	\$0.00	\$0.00	\$7,720.00	\$0.00	\$7,720.00	
				SP1 Total	\$2,075.00	\$10,067.23	\$7,720.00	\$0.00	\$19,862.23	
				SP Total	\$2,075.00	\$10,067.23	\$7,720.00	\$0.00	\$19,862.23	

INFRAMARK, LLC

DISTRICT : CITY OF SWEENEY

INVOICE NO. 1150535 - DETAIL

INVOICE DATE: 8/9/2023

09 Aug 2023 11:49:15PM CST

Go Green! Think before you print.

Work Type / Sub Category	Date Complete	WO Number	Address	Task Details	Equipment Costs	Labor Costs	Materials/Other Service Costs	Sales Tax Total	Total Costs	B/C
Maintenance, Water Plant										
WP1										
General Maintenance & Repairs										
	7/14/2023	3258803	204 Peach St	Flushing of a Water System; flushed trouble areas in district	\$205.00	\$915.22	\$0.00	\$0.00	\$1,120.22	N
	7/6/2023	3260012	204 Peach St	General Repairs of an Asset at a Water Plant; Checked district residual, got residual and est residual. Monitor all 3 wells . Monitor booster pumps running and time. Make adjustments on chemical feed system at plant and in district.	\$275.00	\$1,200.37	\$0.00	\$0.00	\$1,475.37	N
	7/7/2023	3269277	204 Peach St	General Repairs of an Asset at a Water Plant; Maintain water plant and well flows. Adjust chemical feeds as needed through distribution syste, and at plant	\$300.00	\$1,309.50	\$0.00	\$0.00	\$1,609.50	N
	7/6/2023	3270550	204 Peach St	General Repairs of an Asset at a Water Plant	\$125.00	\$839.31	\$0.00	\$0.00	\$964.31	N
	7/12/2023	3275833	204 Peach St	General Repairs of an Asset at a Water Plant; Checked district residual and plant residual. Monitor pump and well flow and pump times and adjusted chemical feed as needed	\$180.00	\$785.70	\$0.00	\$0.00	\$965.70	N
	7/14/2023	3281537	204 Peach St	General Repairs of an Asset at a Water Plant; Weekend check of plant and district	\$70.00	\$458.32	\$0.00	\$0.00	\$528.32	N
	7/14/2023	3281745	204 Peach St	General Repairs of an Asset at a Water Plant; Monitored plant operations and adjusted chemical as needed at plant and through district	\$260.00	\$1,134.90	\$0.00	\$0.00	\$1,394.90	N

INFRAMARK, LLC

DISTRICT : CITY OF SWEENEY

INVOICE NO. 1150535 - DETAIL

INVOICE DATE: 8/9/2023

09 Aug 2023 11:49:15PM CST

Go Green! Think before you print.

Work Type / Sub Category	Date Complete	WO Number	Address	Task Details	Equipment Costs	Labor Costs	Materials/Other Service Costs	Sales Tax Total	Total Costs	B/C
	7/17/2023	3282710	204 Peach St	General Repairs of an Asset at a Water Plant	\$70.00	\$432.97	\$0.00	\$0.00	\$502.97	N
				General Maintenance & Repairs Total	\$1,485.00	\$7,076.29	\$0.00	\$0.00	\$8,561.29	
Lab Fees or Laboratory Sampling										
	7/5/2023	3267412	204 Peach St	Purchase Laboratory Services for Water System Asset; Water Utility Services - May 2023	\$0.00	\$0.00	\$161.00	\$0.00	\$161.00	N
				Lab Fees or Laboratory Sampling Total	\$0.00	\$0.00	\$161.00	\$0.00	\$161.00	
				WP1 Total	\$1,485.00	\$7,076.29	\$161.00	\$0.00	\$8,722.29	
				WP Total	\$1,485.00	\$7,076.29	\$161.00	\$0.00	\$8,722.29	
				Invoice Total	\$3,560.00	\$17,559.59	\$7,881.00	\$0.00	\$29,000.59	

REFERENCE NO.	DESCRIPTION	INVOICE DATE	INVOICE AMOUNT	DISCOUNT TAKEN	AMOUNT PAID
23-0453		8/10/23	4,086.40		4,086.40

CHECK DATE	CHECK NO.	PAYEE	DISCOUNTS TAKEN	CHECK AMOUNT
8/14/23	2423	Android Construction Services		\$4,086.40

LAP53 A/P CHECK

Rev 3/19



104691

10469

Funding-GL Acct #	DESCRIPTION	QTY	UNIT PRICE	TOTAL
11-6710	303 N. McKinney Water Leak	1	3,000.00	3,000.00
	mobilization	1	750.00	750.00
	materials	1	336.40	336.40
TOTAL				\$ 4,086.40

Comments or Special Instructions

(11)

IMPORTANT:

Above Order Number must appear on all correspondence, invoices, packages and shipping papers. Notify us immediately if you are unable to ship complete order by date specified. Your acceptance of this order is your warranty to us that you are complying with the U.S. Fair Labor Standards Act of 1988, as amended, and we reserve the right to refuse merchandise not in strict accordance with this order.

Karla Wilson

From: Joe Gordin <jgordin@androidcs.net>
Sent: Thursday, August 10, 2023 12:26 PM
To: Pamela Vela; Accounts Payable
Cc: Rusty Lofton; Sabrina Lerma
Subject: RE: REVISED INVOICE - 23-0453 - City Of Sweeny - EMERGENCY CALL OUT - 303 N MCKINNEY
Attachments: 23-0453 -REVISED - City Of Sweeny - EMERGENCY CALL OUT - 303 N MCKINNEY.pdf

Rusty,

Attached is **REVISED Invoice # 23-0453** - City Of Sweeny - EMERGENCY CALL OUT - 303 N MCKINNEY.

Please Let me know if you have any Questions. Again, I apologize for any inconvenience.

Thanks - Pamela

Emailed to CW 8/10/23

Thank You,

Joe Gordin

Android Construction Services, LLC



Cell: 832-771-8449
Office: 713-236-0600
Fax: 713-456-2658
16195 S Hwy 288 B
Angleton, Tx 77515
jgordin@androidcs.net
www.androidcs.net

From: Pamela Vela <pvela@androidcs.net>
Sent: Tuesday, August 8, 2023 8:44 AM
To: accountspayable@sweenytx.gov
Cc: sebrinajlerma@gmail.com; Joe Gordin <jgordin@androidcs.net>; Rusty Lofton <rlofton@sweenytx.gov>
Subject: Re: INVOICE - 23-0453 - City Of Sweeny - EMERGENCY CALL OUT - 303 N MCKINNEY

Rusty,

REFERENCE NO.	DESCRIPTION	INVOICE DATE	INVOICE AMOUNT	DISCOUNT TAKEN	AMOUNT PAID
108282		8/15/23	4,115.00		4,115.00

CHECK DATE	CHECK NO.	PAYEE	DISCOUNTS TAKEN	CHECK AMOUNT
8/16/23	2447	Goolsby Water Well Service		\$4,115.00

LAP53 A/P CHECK
Rev 3/19



10469

Funding-GL Acct #	DESCRIPTION	QTY	UNIT PRICE	TOTAL
11-6710	Emergency work to get Well #5 running again New cables, hoist truck, new check valve labor and splines	1	4,115.00	4,115.00
TOTAL			\$ -	\$ 4,115.00

Comments or Special Instructions

12

IMPORTANT:

Above Order Number must appear on all correspondence, invoices, packages and shipping papers. Notify us immediately if you are unable to ship complete order by date specified. Your acceptance of this order is your warranty to us that you are complying with the U.S. Fair Labor Standards Act of 1988, as amended, and we reserve the right to refuse merchandise not in strict accordance with this order.

CITY OF SWEENY

PO BOX 248
 SWEENY, TEXAS 77480
 Phone: (979) 548-3321
 Fax: (979) 548-7745
 sweenytx.gov

PURCHASE ORDER

CW083023-08

DATE

8/30/2023

Entered

VENDOR	PURCHASING INFORMATION	
Goolsby Water Well Service, LLC	Requisition:	
20823 N. Hwy 36		
Brazoria, TX 77422		

Funding-GL Acct #	DESCRIPTION	QTY	UNIT PRICE	TOTAL
11-6710	Emergency work to get Well #5 running again New cables, hoist truck, new check valve labor and splines	1	4,115.00	4,115.00
TOTAL			\$ -	\$ 4,115.00

Comments or Special Instructions

IMPORTANT:

Above Order Number must appear on all correspondence, invoices, packages and shipping papers. Notify us immediately if you are unable to ship complete order by date specified. Your acceptance of this order is your warranty to us that you are complying with the U.S. Fair Labor Standards Act of 1988, as amended, and we reserve the right to refuse merchandise not in strict accordance with this order.

Woolsby Water Well Service, LLC
 10823 N. Hwy. 36
 Brazoria, TX 77422
 Tel. 979-798-7812

Invoice

DATE	INVOICE #
8/15/2023	108282

BILL TO
City of Sweeny P.O. Box 248 Sweeny, TX 77480

SHIP TO
Well #5 Rusty Lofton 979-665-3670

P.O. No.	DUE DATE	REP	PHONE #
	8/15/2023	RM	979-548-3321

QTY	DESCRIPTION	U/M	RATE	AMOUNT
180	#10/3 Sub Cable	ft	2.70	486.00
1	4" Ductile Iron Check Valve #7939PLG w/Break-Off Plug	ea	879.00	879.00
10	4" Splines	ea	5.00	50.00
6	Service Charge-Mobilization/Demobilization of Pump Hoist Unit & 3/4 Man Crew to Pull And Reset Pump		450.00	2,700.00

Subtotal		\$4,115.00
Sales Tax (0.0%)		\$0.00
Total		\$4,115.00
Payments/Credits		\$0.00
Balance Due		\$4,115.00

Regulated by the Texas Department of Licensing and Regulation.
 P.O. Box 12157
 Austin, Texas 78711 512-463-7880

P.O. CW 083023-08

8/21 To PW 8/22

REFERENCE NO.	DESCRIPTION	INVOICE DATE	INVOICE AMOUNT	DISCOUNT TAKEN	AMOUNT PAID
S237799TX.0041		8/25/23	9,673.75		9,673.75

CHECK DATE.	CHECK NO.	PAYEE	DISCOUNTS TAKEN	CHECK AMOUNT
9/6/23	2462	US Underwater		\$9,673.75

LAP53 A/P CHECK

Rev 3/19



104691

10469

Funding-GL Acct #	DESCRIPTION	QTY	UNIT PRICE	TOTAL
11-6710	Annual TCEQ/EPA required inspection and cleaning of Water Treatment Plant Ground Storage Tanks 1&2	1	9,673.75	9,673.75
TOTAL			\$ -	\$ 9,673.75

Comments or Special Instructions

13

IMPORTANT:

Above Order Number must appear on all correspondence, invoices, packages and shipping papers. Notify us immediately if you are unable to ship complete order by date specified. Your acceptance of this order is your warranty to us that you are complying with the U.S. Fair Labor Standards Act of 1988, as amended, and we reserve the right to refuse merchandise not in strict accordance with this order.



U.S. Underwater • 123 Sentry Drive, Mansfield, TX 76063 • P: 800-860-2178

ACH Payment to: CIBC BANK ABA: 071006486 Account No.: 2764563 FEIN: 59-3221706

Mail Payment to: Consor Engineers, LLC
14142 Denver West Pkwy., Bldg. 51, Ste. 250, Lakewood, CO 80401

City of Sweeny
PO Box 248
Sweeny, TX 77480

August 25, 2023
Invoice No: S237799TX.00 - 1

USU Project: S237799TX.00 City of Sweeny: Cleanings
PO #RA-202317

Billing Items	Amount	Previous Amount Billed	Current Amount Billed
In-Service Diver Cleaning - 420K GST W	3,825.00	0.00	3,825.00
In-Service Diver Cleaning - 420K GST E	2,975.00	0.00	2,975.00
Mob/Demob	2,873.75	0.00	2,873.75
Total Fee	9,673.75	0.00	9,673.75
Total Amount Invoiced			9,673.75
Invoice Total			<u>9,673.75</u>

Billings to Date	Current	Prior	Total	Payment Received
	9,673.75	0.00	9,673.75	0.00

P.O # CW083023-02

REFERENCE NO.	DESCRIPTION	INVOICE DATE	INVOICE AMOUNT	DISCOUNT TAKEN	AMOUNT PAID
115 1574 ✓		9/11/23	16,268.60		16,268.60 ✓

CHECK DATE	CHECK NO.	PAYEE	DISCOUNTS TAKEN	CHECK AMOUNT
9/18/23	2468	Inframark, LLC		\$16,268.60

LAP53 A/P CHECK

Rev 3/19



104691

10469

Service Description	Total
Maintenance Services	\$16,268.60

Water 11-6710 4350.07
 WWTP 11-6711 11918.53

14

Subtotal	\$16,268.60
Sales Tax	\$0.00
Total	\$16,268.60

Please Pay This Amount

Remit To: Inframark, LLC, P.O. Box 733778, Dallas, Texas 75373-3778

To pay by Credit Card, contact us at 281-578-4299, 9:00am - 5:30pm EST, Mon - Fri. A surcharge fee may apply

To Pay via ACH or Wire, please refer to our banking information below:

Account Name : INFRAMARK, LLC

ACH - Bank Routing Number : 111000614 / Account Number 912593196

Wire - Bank Routing Number : 021000021 / SWIFT Code : CHASUS33 / Account Number: 912593196

Please include the Project ID and the Invoice Number on the check stub of your payment.



Inframark, LLC
2002 West Grand Parkway North, Suite 100
Katy, Texas 77449
(281) 578-4200

Client ID Number	
------------------	--

Invoice Number	1151574
Invoice Date	9/11/2023
Due Date	10/11/2023

To: City of Sweeny
102 W Ashley Wilson Rd

Sweeny, TX 77480

Service Description	Total
Maintenance Services	\$16,268.60

14

Subtotal	\$16,268.60
Sales Tax	\$0.00
Total	\$16,268.60

Please Pay This Amount

Remit To: Inframark, LLC, P.O. Box 733778, Dallas, Texas 75373-3778

To pay by Credit Card, contact us at 281-578-4299, 9:00am - 5:30pm EST, Mon - Fri. A surcharge fee may apply

To Pay via ACH or Wire, please refer to our banking information below:

Account Name : INFRAMARK, LLC

ACH - Bank Routing Number : 111000614 / Account Number 912593196

Wire - Bank Routing Number : 021000021 / SWIFT Code : CHASUS33 / Account Number: 912593196

Please include the Project ID and the Invoice Number on the check stub of your payment.

INFRAMARK, LLC

DISTRICT : CITY OF SWEENEY

INVOICE NO. 1151574 - SUMMARY

INVOICE DATE: 9/11/2023

11 Sep 2023 09:06:17AM CST

Go Green! Think before you print.

Work Type / Sub Category	Equipment Costs	Labor Costs	Materials/Other Service Costs	Sales Tax Total	Total Costs
Maintenance, Sewer Plant					
SP1					
General Maintenance & Repairs	\$1,965.00	\$9,260.78	\$0.00	\$0.00	\$11,225.78
Lab Fees or Laboratory Sampling	\$80.00	\$349.20	\$0.00	\$0.00	\$429.20
Subcontract Services	\$0.00	\$263.55	\$0.00	\$0.00	\$263.55
SP1 Total	\$2,045.00	\$9,873.53	\$0.00	\$0.00	\$11,918.53
SP Total	\$2,045.00	\$9,873.53	\$0.00	\$0.00	\$11,918.53
Maintenance, Water					
Lab Fees or Laboratory Sampling	\$0.00	\$0.00	\$161.00	\$0.00	\$161.00
MW Total	\$0.00	\$0.00	\$161.00	\$0.00	\$161.00
Maintenance, Water Plant					
WP1					
General Maintenance & Repairs	\$710.00	\$3,479.07	\$0.00	\$0.00	\$4,189.07
WP1 Total	\$710.00	\$3,479.07	\$0.00	\$0.00	\$4,189.07
WP Total	\$710.00	\$3,479.07	\$0.00	\$0.00	\$4,189.07
Invoice Total	\$2,755.00	\$13,352.60	\$161.00	\$0.00	\$16,268.60

\$4350.07

INFRAMARK, LLC
 DISTRICT : CITY OF SWEENEY
 INVOICE NO. 1151574 - DETAIL
 INVOICE DATE: 9/11/2023
 11 Sep 2023 09:06:18AM CST
 Go Green! Think before you print.

Work Type / Sub Category	Date Complete	WO Number	Address	Task Details	Equipment Costs	Labor Costs	Materials/Other Service Costs	Sales Tax Total	Total Costs	B/C
Maintenance, Sewer Plant										
SP1										
General Maintenance & Repairs										
	7/14/2023	3276613	2607 Avenue A	General Repair or Maintenance of an Asset at a Sewer Treatment Plant	\$80.00	\$349.20	\$0.00	\$0.00	\$429.20	N
	7/24/2023	3288097	2607 Avenue A	Billable Operations at a Sewer Treatment Plant	\$90.00	\$656.84	\$0.00	\$0.00	\$746.84	N
	7/26/2023	3289703	2607 Avenue A	General Repair or Maintenance of an Asset at a Sewer Treatment Plant; Monitor plant operations, checked in lift stations	\$280.00	\$1,222.20	\$0.00	\$0.00	\$1,502.20	N
	7/31/2023	3292563	2607 Avenue A	General Repair or Maintenance of an Asset at a Sewer Treatment Plant; Pulled weekly samples, checked in plant, checked LS and monitored chemical feed and flow into plant	\$350.00	\$1,527.75	\$0.00	\$0.00	\$1,877.75	N
	7/31/2023	3297603	2607 Avenue A	General Repair or Maintenance of an Asset at a Sewer Treatment Plant; Weekend plant check	\$75.00	\$491.06	\$0.00	\$0.00	\$566.06	N
	7/31/2023	3297714	2607 Avenue A	General Repair or Maintenance of an Asset at a Sewer Treatment Plant; Check in and operate plant and sewer collection system	\$120.00	\$523.80	\$0.00	\$0.00	\$643.80	N
	8/4/2023	3299949	2607 Avenue A	General Repair or Maintenance of an Asset at a Sewer Treatment Plant; Checked in plant, monitored chemical feed and pump operations	\$180.00	\$807.53	\$0.00	\$0.00	\$987.53	N
	8/6/2023	3304768	2607 Avenue A	General Repair or Maintenance of an Asset at a Sewer Treatment Plant	\$145.00	\$896.85	\$0.00	\$0.00	\$1,041.85	N
	8/11/2023	3309844	2607 Avenue A	General Repair or Maintenance of an Asset at a Sewer Treatment Plant; Weekly plant check samples pulled and monitored chemical feed	\$255.00	\$1,200.39	\$0.00	\$0.00	\$1,455.39	N

INFRAMARK, LLC

DISTRICT : CITY OF SWEENEY

INVOICE NO. 1151574 - DETAIL

INVOICE DATE: 9/11/2023

11 Sep 2023 09:06:18AM CST

Go Green! Think before you print.

Work Type / Sub Category	Date Complete	WO Number	Address	Task Details	Equipment Costs	Labor Costs	Materials/Other Service Costs	Sales Tax Total	Total Costs	B/C
	8/21/2023	3317123	2607 Avenue A	General Repair or Maintenance of an Asset at a Sewer Treatment Plant; Weekly check of plant	\$390.00	\$1,585.16	\$0.00	\$0.00	\$1,975.16	N
				General Maintenance & Repairs Total	\$1,965.00	\$9,260.78	\$0.00	\$0.00	\$11,225.78	
Lab Fees or Laboratory Sampling										
	7/26/2023	3289693	2607 Avenue A	Purchase Laboratory Services for Sewer Treatment Plant; Pulled sample	\$80.00	\$349.20	\$0.00	\$0.00	\$429.20	N
				Lab Fees or Laboratory Sampling Total	\$80.00	\$349.20	\$0.00	\$0.00	\$429.20	
Subcontract Services										
	8/25/2023	3325983	2607 Avenue A	Misc. Filing to Environmental Agency	\$0.00	\$129.20	\$0.00	\$0.00	\$129.20	N
	8/29/2023	3329106	2607 Avenue A	Misc. Filing to Environmental Agency	\$0.00	\$134.35	\$0.00	\$0.00	\$134.35	N
				Subcontract Services Total	\$0.00	\$263.55	\$0.00	\$0.00	\$263.55	
				SP1 Total	\$2,045.00	\$9,873.53	\$0.00	\$0.00	\$11,918.53	
				SP Total	\$2,045.00	\$9,873.53	\$0.00	\$0.00	\$11,918.53	

INFRAMARK, LLC
 DISTRICT : CITY OF SWEENEY
 INVOICE NO. 1151574 - DETAIL
 INVOICE DATE: 9/11/2023

11 Sep 2023 09:06:18AM CST
 Go Green! Think before you print.

Work Type / Sub Category	Date Complete	WO Number	Address	Task Details	Equipment Costs	Labor Costs	Materials/Other Service Costs	Sales Tax Total	Total Costs	B/C
Maintenance, Water										
Lab Fees or Laboratory Sampling										
	7/28/2023	3272724	SWEENEY District Area	Purchase Laboratory Services for Water System Asset; Water Utility Services - July 2023	\$0.00	\$0.00	\$161.00	\$0.00	\$161.00	N
				Lab Fees or Laboratory Sampling Total	\$0.00	\$0.00	\$161.00	\$0.00	\$161.00	
				MW Total	\$0.00	\$0.00	\$161.00	\$0.00	\$161.00	
Maintenance, Water Plant										
WP1										
General Maintenance & Repairs										
	7/24/2023	3288101	204 Peach St	Billable Operations at a Water Plant (normal hours, after normal hours, weekends & holidays)	\$70.00	\$510.88	\$0.00	\$0.00	\$580.88	N
	7/26/2023	3289697	204 Peach St	Flushing of a Water System; flush district	\$40.00	\$174.60	\$0.00	\$0.00	\$214.60	N
	7/26/2023	3292165	204 Peach St	General Repairs of an Asset at a Water Plant; Checked in plant and monitored operation	\$205.00	\$894.82	\$0.00	\$0.00	\$1,099.82	N
	7/31/2023	3292566	204 Peach St	General Repairs of an Asset at a Water Plant; Checked in plant, checked district and plant residual	\$230.00	\$1,003.95	\$0.00	\$0.00	\$1,233.95	N
	7/31/2023	3297607	204 Peach St	General Repairs of an Asset at a Water Plant; Weekend plant check	\$80.00	\$523.80	\$0.00	\$0.00	\$603.80	N
	7/31/2023	3297717	204 Peach St	General Repairs of an Asset at a Water Plant; Check in and operate plant and sewer collection system	\$40.00	\$174.60	\$0.00	\$0.00	\$214.60	N

INFRAMARK, LLC

DISTRICT : CITY OF SWEENEY

INVOICE NO. 1151574 - DETAIL

INVOICE DATE: 9/11/2023

11 Sep 2023 09:06:18AM CST

Go Green! Think before you print.

Work Type / Sub Category	Date Complete	WO Number	Address	Task Details	Equipment Costs	Labor Costs	Materials/Other Service Costs	Sales Tax Total	Total Costs	B/C
	8/3/2023	3299731	204 Peach St	General Repairs of an Asset at a Water Plant; Daily check of water plant , checking residual in district and at water plant. Checked residual at EST and monitored flow at wells.	\$45.00	\$196.42	\$0.00	\$0.00	\$241.42	N
				General Maintenance & Repairs Total	\$710.00	\$3,479.07	\$0.00	\$0.00	\$4,189.07	
				WP1 Total	\$710.00	\$3,479.07	\$0.00	\$0.00	\$4,189.07	
				WP Total	\$710.00	\$3,479.07	\$0.00	\$0.00	\$4,189.07	
				Invoice Total	\$2,755.00	\$13,352.60	\$161.00	\$0.00	\$16,268.60	

Client:		Work Order Summary Provided to City of Sweeny - Invoice # 1151574										11 Sep 2023 09:06:19AM CST	
Type:	MW	Date Complete		Date Invoiced	Location	Asset ID	GL Code	Sub Cat	Dept	Activity Type & Comments			
WO	3272724	7/28/2023	9/11/2023	SWEENEY District Area	40400	LAB	5755	MWLAB - Purchase Laboratory Services for Water System Asset					
			Insp:	Attachments: 1	Bid Price: \$0.00				Water Utility Services - July 2023				
Materials	Mat ID:	Material Desc	Vendor Bill #	Type	Qty	Unit Cost	Unit Price	Total Price	Tax	Grand Total			
	PO	Water Utility Services	81752	164556	1.00	\$140.00	\$161.00	\$161.00	\$0.00	\$161.00			
							Materials Total	\$161.00	\$0.00	\$161.00			
Comments:	WO [3272724] Total												
	Work Type [MW] Total (Count: 1)												
								\$161.00	\$0.00	\$161.00			

Client: SWEENEY		Work Order Summary Provided to City of Sweeney - Invoice # 1151574					11 Sep 2023 09:06:19AM CST				
Type:	SP										
Comments:	7-17-23 checked in sewer plant, monitored chemical feed and return pump still running. Plant still not building solids even after return pumps are running. Checked Liftstations, Ls1,5,7 all have pumps that aren't working properly, let public works director know as well as some workers. 7-18-23. Checked in sewer plant, made sure bleach feed was good and that return pump still running, let public works director know that we needed to get plant mowed. 7-19-23. Checked in sewer plant, bleach being fed and return pump still pumping, plant not building solids, checked in all 8 lift stations in town, LS 1,5,7 still have pumps not working properly, city is aware of issue. 7-20-23. Checked residual at plant and made sure bleach feeding properly and return pump still pumping, still no solids building in plant or clarifier 1. 7-21-23 checked in plant, made sure everything was ready for the weekend, bleach flowing and return working properly.							WO [3289703] Total	\$1,502.20	\$0.00	\$1,502.20
WO	Date Complete	Date Invoiced	Location	Asset ID	GL Code	Sub Cat	Dept	Activity Type & Comments			
3292563	7/31/2023	9/11/2023	2607 Avenue A	SWEENEY- SP1	40500	GNL	5755	SPGENREP - General Repair or Maintenance of an Asset at a Sewer Treatment Plant			
		Insp:	Attachments: 0	Bid Price: \$0.00				Pulled weekly samples, checked in plant, checked LS and monitored chemical feed and flow into plant			
Labor	Emp ID:	Type	Reg Hrs	OT Hrs	Unit Price	Total Price	Tax	Grand Total			
7/24/2023	703616		5.00	0.00	\$87.30	\$436.50	\$0.00	\$436.50			
7/25/2023	703616		2.00	0.00	\$87.30	\$174.60	\$0.00	\$174.60			
7/26/2023	703616		3.50	0.00	\$87.30	\$305.55	\$0.00	\$305.55			
7/27/2023	703616		3.00	0.00	\$87.30	\$261.90	\$0.00	\$261.90			
7/28/2023	703616		4.00	0.00	\$87.30	\$349.20	\$0.00	\$349.20			
					Labor Total	\$1,527.75	\$0.00	\$1,527.75			
Equipment	Equip ID:	Equipment Desc	Reg Hrs	Unit Price	Total Price	Tax	Grand Total				
	TX121677	Utility Truck	5.00	\$20.00	\$100.00	\$0.00	\$100.00				
	TX121677	Utility Truck	2.00	\$20.00	\$40.00	\$0.00	\$40.00				
	TX121677	Utility Truck	3.50	\$20.00	\$70.00	\$0.00	\$70.00				
	TX121677	Utility Truck	3.00	\$20.00	\$60.00	\$0.00	\$60.00				

Client: SWEENY		Work Order Summary Provided to City of Sweeney - Invoice # 1151574						11 Sep 2023 09:06:19AM CST		
Type: SP	TX121677	Utility Truck				1.75	\$20.00	\$35.00	\$0.00	\$35.00
		Equipment Total					\$75.00	\$0.00	\$0.00	\$75.00
		WO [3297603] Total					\$566.06	\$0.00	\$0.00	\$566.06
WO	Date Complete	Date Invoiced	Location	Asset ID	GL Code	Sub Cat	Dept	Activity Type & Comments		
3297714	7/31/2023	9/11/2023	2607 Avenue A	SWEENY- SP1	40500	GNL	5755	SPGENREP - General Repair or Maintenance of an Asset at a Sewer Treatment Plant		
		Insp:	Attachments: 0	Bid Price: \$0.00				Check in and operate plant and sewer collection system		
Labor		Emp ID:	Type	Reg Hrs	OT Hrs	Unit Price	Total Price	Tax	Grand Total	
7/31/2023		703616		6.00	0.00	\$87.30	\$523.80	\$0.00	\$523.80	
		Labor Total					\$523.80	\$0.00	\$523.80	
Equipment		Equip ID:	Equipment Desc	Reg Hrs	Unit Price	Total Price	Tax	Grand Total		
		TX121677	Utility Truck	6.00	\$20.00	\$120.00	\$0.00	\$120.00		
		Equipment Total				\$120.00	\$0.00	\$120.00		
		WO [3297714] Total				\$643.80	\$0.00	\$643.80		
		Comments: Checked in plant, made sure return pump is running and bleach feeding, still no solids building up, pulled samples every 2 hours and filled out chain of custody. Checked all 8 lift stations in district								

Client: SWEENY		Work Order Summary Provided to City of Sweeney - Invoice # 1151574					11 Sep 2023 09:06:19AM CST		
Type:	SP								
WO	Date Complete	Date Invoiced	Location	Asset ID	GL Code	Sub Cat	Dept	Activity Type & Comments	
3299949	8/4/2023	9/11/2023	2607 Avenue A	SWEENY-SP1	40500	GNL	5755	SPGENREP - General Repair or Maintenance of an Asset at a Sewer Treatment Plant	
		Insp:	Attachments: 3	Bid Price: \$0.00				Checked in plant, monitored chemical feed and pump operations	
		<u>Emp ID:</u>	<u>Type</u>	<u>Reg Hrs</u>	<u>OT Hrs</u>	<u>Unit Price</u>	<u>Total Price</u>	<u>Tax</u>	<u>Grand Total</u>
	8/1/2023	703616		1.00	0.00	\$87.30	\$87.30	\$0.00	\$87.30
	8/2/2023	703616		3.00	0.00	\$87.30	\$261.90	\$0.00	\$261.90
	8/3/2023	703616		2.00	0.00	\$87.30	\$174.60	\$0.00	\$174.60
	8/3/2023	703616		0.00	0.50	\$130.95	\$65.48	\$0.00	\$65.48
	8/4/2023	703616		2.50	0.00	\$87.30	\$218.25	\$0.00	\$218.25
						Labor Total	\$807.53	\$0.00	\$807.53
		<u>Equip ID:</u>	<u>Equipment Desc</u>	<u>Reg Hrs</u>	<u>Unit Price</u>	<u>Total Price</u>	<u>Tax</u>	<u>Grand Total</u>	
		TX121677	Utility Truck	1.00	\$20.00	\$20.00	\$0.00	\$20.00	
		TX121677	Utility Truck	3.00	\$20.00	\$60.00	\$0.00	\$60.00	
		TX121677	Utility Truck	2.50	\$20.00	\$50.00	\$0.00	\$50.00	
		TX121677	Utility Truck	2.50	\$20.00	\$50.00	\$0.00	\$50.00	
						Equipment Total	\$180.00	\$0.00	\$180.00
						WO [3299949] Total	\$987.53	\$0.00	\$987.53
		<u>Comments:</u>	Checked in plant, please see pics in attachment						
WO	Date Complete	Date Invoiced	Location	Asset ID	GL Code	Sub Cat	Dept	Activity Type & Comments	
3304768	8/6/2023	9/11/2023	2607 Avenue A	SWEENY-SP1	40500	GNL	5755	SPGENREP - General Repair or Maintenance of an Asset at a Sewer Treatment Plant	
		Insp:	Attachments: 0	Bid Price: \$0.00					
		<u>Emp ID:</u>	<u>Type</u>	<u>Reg Hrs</u>	<u>OT Hrs</u>	<u>Unit Price</u>	<u>Total Price</u>	<u>Tax</u>	<u>Grand Total</u>
	8/5/2023	604339		0.00	3.75	\$123.70	\$463.89	\$0.00	\$463.89

Client: SWEENEY		Work Order Summary Provided to City of Sweeney - Invoice # 1151574					11 Sep 2023 09:06:19AM CST	
Type: SP	Equip ID:	Equipment Desc	Reg Hrs	Unit Price	Total Price	Tax	Grand Total	
	TX121677	Utility Truck	4.50	\$20.00	\$90.00	\$0.00	\$90.00	
	TX121677	Utility Truck	2.50	\$20.00	\$50.00	\$0.00	\$50.00	
	TX121677	Utility Truck	1.50	\$20.00	\$30.00	\$0.00	\$30.00	
	TX121677	Utility Truck	2.00	\$20.00	\$40.00	\$0.00	\$40.00	
	TX121677	Utility Truck	2.25	\$20.00	\$45.00	\$0.00	\$45.00	
				Equipment Total	\$255.00	\$0.00	\$255.00	
				WO [3309844]	\$1,455.39	\$0.00	\$1,455.39	
				Total				
Comments:	Checked in plant, ran solids, pulled samples Monday. Tuesday I purchased parts to repair bleach pump then repaired bleach pump, checked plant in and ,made sure everything stayed good. Wednesday Thursday and Friday was regular operation, did my settles, checked blanket and residual. Plant looks good, really needs to be mowed							
WO	Date Complete	Date Invoiced	Location	Asset ID	GL Code	Sub Cat	Dept	Activity Type & Comments
3317123	8/21/2023	9/11/2023	2607 Avenue A	SWEENEY- SP1	40500	GNL	5755	SPGENREP - General Repair or Maintenance of an Asset at a Sewer Treatment Plant
		Insp:	Attachments: 5		Bid Price: \$0.00			Weekly check of plant
Labor	Emp ID:	Type	Reg Hrs	OT Hrs	Unit Price	Total Price	Tax	Grand Total
8/14/2023	703616		4.50	0.00	\$87.30	\$392.85	\$0.00	\$392.85
8/15/2023	703616		2.00	0.00	\$87.30	\$174.60	\$0.00	\$174.60
8/16/2023	703616		1.50	0.00	\$87.30	\$130.95	\$0.00	\$130.95
8/16/2023	703616		0.00	0.50	\$130.95	\$65.48	\$0.00	\$65.48
8/17/2023	702914		5.25	0.00	\$60.82	\$319.30	\$0.00	\$319.30
8/17/2023	703616		3.75	0.00	\$87.30	\$327.38	\$0.00	\$327.38
8/18/2023	703616		2.00	0.00	\$87.30	\$174.60	\$0.00	\$174.60
					Labor Total	\$1,585.16	\$0.00	\$1,585.16

Client:	Work Order Summary Provided to City of Sweeny - Invoice # 1151574							11 Sep 2023 09:06:19AM CST				
Type:	SP							Unit Price	Total Price	Tax	Grand Total	
	Equipment	Equip ID:	Equipment Desc		Reg Hrs							
		TX121677	Utility Truck		4.50			\$20.00	\$90.00	\$0.00	\$90.00	
		TX121677	Utility Truck		2.00			\$20.00	\$40.00	\$0.00	\$40.00	
		TX121677	Utility Truck		2.00			\$20.00	\$40.00	\$0.00	\$40.00	
		TX121677	Utility Truck		3.75			\$20.00	\$75.00	\$0.00	\$75.00	
		TX121677	Utility Truck		2.00			\$20.00	\$40.00	\$0.00	\$40.00	
		TX121678	Utility Truck		5.25			\$20.00	\$105.00	\$0.00	\$105.00	
								Equipment Total	\$390.00	\$0.00	\$390.00	
								WO [3317123]	\$1,975.16	\$0.00	\$1,975.16	
								Total				
			Comments: 8-14-23. Took samples every 2 hours for pick up on Tuesday. 8-15-23. Nonpot pump one has leak, isolated and got pump 2 online. 8-16-23 Checked plant in, no solids in plant. 8-17-23 Met Jeff at plant and we cleaned clarifier 1. 8-18-23 checked in plant, plant is building solids again. Please see attachment									
WO	Date Complete	Date Invoiced	Location	Asset ID	GL Code	Sub Cat	Dept	Activity Type & Comments				
3325983	8/25/2023	9/11/2023	2607 Avenue A	SWEENY-SP1	40900	SUB	5004	ENVFILINGS - Misc. Filing to Environmental Agency				
		Insp:	Attachments: 0									
Labor	Emp ID:	Type	Reg Hrs	OT Hrs	Unit Price	Total Price	Tax	Grand Total				
6/21/2023	700507		1.00	0.00	\$129.20	\$129.20	\$0.00	\$129.20				
					Labor Total	\$129.20	\$0.00	\$129.20				
					WO [3325983]	\$129.20	\$0.00	\$129.20				
					Total							
			Comments: Reviewed and submitted an effluent violation report to TCEQ Region 12.									

Client: SWEENY		Work Order Summary Provided to City of Sweeny - Invoice # 1151574										11 Sep 2023 09:06:19AM CST		
Type:	SP													
WO	Date Complete	Date Invoiced	Location	Asset ID	GL Code	Sub Cat	Dept	Activity Type & Comments						
3329106	8/29/2023	9/11/2023	2607 Avenue A	SWEENY-SP1	40900	SUB	5004	ENVFILINGS - Misc. Filing to Environmental Agency						
		Insp:	Attachments: 0	Bid Price: \$0.00										
Labor	Emp ID:	Type	Reg Hrs	OT Hrs	Unit Price	Total Price	Tax	Grand Total						
7/14/2023	700507		1.00	0.00	\$134.35	\$134.35	\$0.00	\$134.35						
					Labor Total	\$134.35	\$0.00	\$134.35						
Comments:	Reviewed and submitted an effluent violation report to TCEQ Region 12.											WO [3329106] Total	\$134.35	
											Work Type [SP] Total (Count: 13)	\$11,918.53	\$0.00	\$11,918.53

Client: SWEENY		Work Order Summary Provided to City of Sweeny - Invoice # 1151574						11 Sep 2023 09:06:19AM CST	
Type:	WP								
WO	Date Complete	Date Invoiced	Location	Asset ID	GL Code	Sub Cat	Dept	Activity Type & Comments	
3288101	7/24/2023	9/11/2023	204 Peach St	SWEENY- WPI	40500	GNL	5755	WPBIOOPS - Billable Operations at a Water Plant (normal hours, after normal hours, weekends & holidays)	
		Insp:	Attachments: 0	Bid Price: \$0.00					
	<u>Labor</u>	<u>Emp ID:</u>	<u>Type</u>		<u>Reg Hrs</u>	<u>OT Hrs</u>		<u>Unit Price</u>	<u>Total Price</u>
	7/22/2023	603528	Lead Ops / Tech		0.00	1.50		\$145.97	\$218.95
	7/23/2023	603528	Lead Ops / Tech		0.00	2.00		\$145.97	\$291.93
								Labor Total	\$510.88
								Tax	\$0.00
								Grand Total	\$510.88
	<u>Equipment</u>	<u>Equip ID:</u>	<u>Equipment Desc</u>			<u>Reg Hrs</u>		<u>Unit Price</u>	<u>Total Price</u>
		TX119016	Utility Truck			1.50		\$20.00	\$30.00
		TX119016	Utility Truck			2.00		\$20.00	\$40.00
								Equipment Total	\$70.00
								Tax	\$0.00
								Grand Total	\$70.00
								WO [3288101] Total	\$580.88
								Tax	\$0.00
								Grand Total	\$580.88
WO	Date Complete	Date Invoiced	Location	Asset ID	GL Code	Sub Cat	Dept	Activity Type & Comments	
3289697	7/26/2023	9/11/2023	204 Peach St	SWEENY- WPI	40500	GNL	5755	MWFLUSH - Flushing of a Water System	
		Insp:	Attachments: 1	Bid Price: \$0.00				flush district	
	<u>Labor</u>	<u>Emp ID:</u>	<u>Type</u>		<u>Reg Hrs</u>	<u>OT Hrs</u>		<u>Unit Price</u>	<u>Total Price</u>
	7/18/2023	703616			0.50	0.00		\$87.30	\$43.65
	7/19/2023	703616			0.50	0.00		\$87.30	\$43.65
	7/20/2023	703616			1.00	0.00		\$87.30	\$87.30
								Labor Total	\$174.60
								Tax	\$0.00
								Grand Total	\$174.60

Comments: Weekend Facility check in and plant operations.

Client: SWEENEY		Work Order Summary Provided to City of Sweeney - Invoice # 1151574					11 Sep 2023 09:06:19AM CST	
Type:	WP							
<u>Equipment</u>	<u>Equip ID:</u>	<u>Equipment Desc</u>	<u>Reg Hrs</u>	<u>Unit Price</u>	<u>Total Price</u>	<u>Tax</u>	<u>Grand Total</u>	
	TX121677	Utility Truck	0.50	\$20.00	\$10.00	\$0.00	\$10.00	
	TX121677	Utility Truck	0.50	\$20.00	\$10.00	\$0.00	\$10.00	
	TX121677	Utility Truck	1.00	\$20.00	\$20.00	\$0.00	\$20.00	
		Equipment Total			\$40.00	\$0.00	\$40.00	
		Comments: 7-18-23 flushed hydrant at rural road for 30 min at about 150 gallons a minute 7-19-23 flushed hydrant at elm and third for 30 min for about 150 gal a minute 7-20-23 flushed an hour at Forrest park drive at about 200 gal a minute		WO [3289697] Total	\$214.60	\$0.00	\$214.60	
<u>WO</u>	<u>Date Complete</u>	<u>Date Invoiced</u>	<u>Location</u>	<u>Asset ID</u>	<u>GL Code</u>	<u>Sub Cat</u>	<u>Dept</u>	<u>Activity Type & Comments</u>
3292165	7/26/2023	9/11/2023	204 Peach St	SWEENEY- WP1	40500	GNL	5755	WPGENREP - General Repairs of an Asset at a Water Plant
		Insp:	Attachments: 0	Bid Price: \$0.00				Checked in plant and monitored operation
<u>Labor</u>	<u>Emp ID:</u>	<u>Type</u>	<u>Reg Hrs</u>	<u>OT Hrs</u>	<u>Unit Price</u>	<u>Total Price</u>	<u>Tax</u>	<u>Grand Total</u>
7/17/2023	703616		2.00	0.00	\$87.30	\$174.60	\$0.00	\$174.60
7/18/2023	703616		1.50	0.00	\$87.30	\$130.95	\$0.00	\$130.95
7/19/2023	703616		2.50	0.00	\$87.30	\$218.25	\$0.00	\$218.25
7/20/2023	703616		2.00	0.00	\$87.30	\$174.60	\$0.00	\$174.60
7/21/2023	703616		2.25	0.00	\$87.30	\$196.42	\$0.00	\$196.42
					Labor Total	\$894.82	\$0.00	\$894.82
<u>Equipment</u>	<u>Equip ID:</u>	<u>Equipment Desc</u>	<u>Reg Hrs</u>	<u>Unit Price</u>	<u>Total Price</u>	<u>Tax</u>	<u>Grand Total</u>	
	TX121677	Utility Truck	2.00	\$20.00	\$40.00	\$0.00	\$40.00	
	TX121677	Utility Truck	1.50	\$20.00	\$30.00	\$0.00	\$30.00	
	TX121677	Utility Truck	2.50	\$20.00	\$50.00	\$0.00	\$50.00	
	TX121677	Utility Truck	2.00	\$20.00	\$40.00	\$0.00	\$40.00	

Client: SWEENY		Work Order Summary Provided to City of Sweeny - Invoice # 1151574					11 Sep 2023 09:06:19AM CST				
Type:	WP										
	TX121677	Utility Truck			2.25		\$20.00	\$45.00	\$0.00	\$45.00	
							Equipment Total	\$205.00	\$0.00	\$205.00	
							WO [3292165] Total	\$1,099.82	\$0.00	\$1,099.82	
Comments:	7-17-23 Checked in water plant and district residual. Monitored flow in wells on and offsite. 7-18-23. Checked district residual and residual at plants, monitored well flow at plant and at offsite wells as well. 7-19-23, checked district residual as well as residual at plant and flow at wells on and offsite. 7-20-23. Checked in plant, checked district residual and residual at plant, monitored well flow at plant and at offsite well										
WO	Date Complete	Date Invoiced	Location	Asset ID	GL Code	Sub Cat	Dept	Activity Type & Comments			
3292566	7/31/2023	9/11/2023	204 Peach St	SWEENY- WPI	40500	GNL	5755	WPGENREP - General Repairs of an Asset at a Water Plant			
		Insp:	Attachments: 0	Bid Price: \$0.00				Checked in plant, checked district and plant residual			
Labor	Emp ID:	Type	Reg Hrs	OT Hrs	Unit Price	Total Price	Tax	Grand Total			
7/24/2023	703616		3.00	0.00	\$87.30	\$261.90	\$0.00	\$261.90			
7/25/2023	703616		2.00	0.00	\$87.30	\$174.60	\$0.00	\$174.60			
7/26/2023	703616		1.50	0.00	\$87.30	\$130.95	\$0.00	\$130.95			
7/27/2023	703616		3.00	0.00	\$87.30	\$261.90	\$0.00	\$261.90			
7/28/2023	703616		2.00	0.00	\$87.30	\$174.60	\$0.00	\$174.60			
					Labor Total	\$1,003.95	\$0.00	\$1,003.95			

Client: SWEENEY		Work Order Summary Provided to City of Sweeney - Invoice # 1151574					11 Sep 2023 09:06:19AM CST		
Type:	WP	Asset ID	GL Code	Sub Cat	Dept	Activity Type & Comments			
WO	3299731	8/3/2023	9/11/2023	204 Peach St	SWEENEY- WP1	40500	GNL	5755	WPGENREP - General Repairs of an Asset at a Water Plant
		Insp:	Attachments: 1		Bid Price: \$0.00				Daily check of water plant , checking residual in district and at water plant. Checked residual at Est and monitored flow at wells.
Labor	Emp ID:	Type	Reg Hrs	OT Hrs	Unit Price	Total Price	Tax	Grand Total	
8/1/2023	703616		2.25	0.00	\$87.30	\$196.42	\$0.00	\$196.42	
					Labor Total	\$196.42	\$0.00	\$196.42	
Equipment	Equip ID:	Equipment Desc	Reg Hrs		Unit Price	Total Price	Tax	Grand Total	
	TX121677	Utility Truck	2.25		\$20.00	\$45.00	\$0.00	\$45.00	
					Equipment Total	\$45.00	\$0.00	\$45.00	
Comments:	Checked in plant, monitored chemical feed, checked residual at plant, in district and at elevated. Monitor flow on wells and hours on boosters, please see attachment for daily's								
					WO [3299731] Total	\$241.42	\$0.00	\$241.42	
					Work Type [WP] Total (Count: 7)	\$4,189.07	\$0.00	\$4,189.07	
					Work Order Detail Report Total (Count: 21)	\$16,268.60	\$0.00	\$16,268.60	

Inframark, LLC		
Invoiced Backcharges		
Client:	SWEENEY	
WO #	Work Type	Address Where Work was Performed:
		Backcharged to:
Total Invoiced Backcharges		Invoice Amount
		\$0.00



Inframark, LLC
2002 West Grand Parkway North, Suite 100
Katy, Texas 77449
(281) 578-4200

Client ID Number	
------------------	--

Invoice Number	1152073
Invoice Date	10/9/2023
Due Date	11/8/2023

To: City of Sweeny
102 W Ashley Wilson Rd

Sweeny, TX 77480

Service Description	Total
Maintenance Services	\$24,411.02

15

Subtotal	\$24,411.02
Sales Tax	\$0.00
Total	\$24,411.02

Please Pay This Amount

Remit To: Inframark, LLC, P.O. Box 733778, Dallas, Texas 75373-3778

To pay by Credit Card, contact us at 281-578-4299, 9:00am - 5:30pm EST, Mon - Fri. A surcharge fee may apply

To Pay via ACH or Wire, please refer to our banking information below:

Account Name : INFRAMARK, LLC

ACH - Bank Routing Number : 111000614 / Account Number 912593196

Wire - Bank Routing Number : 021000021 / SWIFT Code : CHASUS33 / Account Number: 912593196

Please include the Project ID and the Invoice Number on the check stub of your payment.

INFRAMARK, LLC
DISTRICT : CITY OF SWEENEY
INVOICE NO. 1152073 - SUMMARY
INVOICE DATE: 10/9/2023

Work Type / Sub Category	Equipment Costs	Labor Costs	Materials/Other Service Costs	Sales Tax Total	Total Costs
Maintenance, Sewer Plant					
SP1					
General Maintenance & Repairs	\$2,375.00	\$13,334.14	\$23.48	\$0.00	\$15,732.62
Other Maintenance	\$2,040.00	\$1,096.66	\$15.82	\$0.00	\$3,152.48
SP1 Total	\$4,415.00	\$14,430.80	\$39.30	\$0.00	\$18,885.10
SP Total	\$4,415.00	\$14,430.80	\$39.30	\$0.00	\$18,885.10
Maintenance, Water					
Lab Fees or Laboratory Sampling	\$0.00	\$0.00	\$161.00	\$0.00	\$161.00
MW Total	\$0.00	\$0.00	\$161.00	\$0.00	\$161.00
Maintenance, Water Plant					
WP1					
General Maintenance & Repairs	\$815.00	\$4,385.81	\$3.11	\$0.00	\$5,203.92
Lab Fees or Laboratory Sampling	\$0.00	\$0.00	\$161.00	\$0.00	\$161.00
WP1 Total	\$815.00	\$4,385.81	\$164.11	\$0.00	\$5,364.92
WP Total	\$815.00	\$4,385.81	\$164.11	\$0.00	\$5,364.92
Invoice Total	\$5,230.00	\$18,816.61	\$364.41	\$0.00	\$24,411.02

INFRAMARK, LLC

DISTRICT : CITY OF SWEENEY

INVOICE NO. 1152073 - DETAIL

INVOICE DATE: 10/9/2023

09 Oct 2023 02:59:06PM CST

Go Green! Think before you print.

Work Type / Sub Category	Date Complete	WO Number	Address	Task Details	Equipment Costs	Labor Costs	Materials/Other Service Costs	Sales Tax Total	Total Costs	B/C
Maintenance, Sewer Plant										
SP1										
General Maintenance & Repairs										
	8/21/2023	3320086	2607 Avenue A	General Repair or Maintenance of an Asset at a Sewer Treatment Plant; Weekend plant check	\$120.00	\$785.70	\$0.00	\$0.00	\$905.70	N
	8/14/2023	3322579	2607 Avenue A	General Repair or Maintenance of an Asset at a Sewer Treatment Plant	\$145.00	\$1,058.25	\$0.00	\$0.00	\$1,203.25	N
	8/25/2023	3324477	2607 Avenue A	General Repair or Maintenance of an Asset at a Sewer Treatment Plant; Weekly plant check of sewer plant and weekly samples	\$240.00	\$1,102.16	\$0.00	\$0.00	\$1,342.16	N
	8/28/2023	3327713	2607 Avenue A	General Repair or Maintenance of an Asset at a Sewer Treatment Plant	\$155.00	\$958.71	\$0.00	\$0.00	\$1,113.71	N
	8/31/2023	3332459	2607 Avenue A	General Repair or Maintenance of an Asset at a Sewer Treatment Plant; Checked n plant, pulled samples	\$230.00	\$1,003.95	\$0.00	\$0.00	\$1,233.95	N
	9/5/2023	3333806	2607 Avenue A	General Repair or Maintenance of an Asset at a Sewer Treatment Plant; Weekend facility check in and plant operations.	\$210.00	\$1,532.64	\$0.00	\$0.00	\$1,742.64	N
	9/8/2023	3339897	2607 Avenue A	General Repair or Maintenance of an Asset at a Sewer Treatment Plant; Weekly plant check	\$50.00	\$218.25	\$0.00	\$0.00	\$268.25	N
	9/11/2023	3339904	2607 Avenue A	General Repair or Maintenance of an Asset at a Sewer Treatment Plant; Weekly plant check	\$100.00	\$480.16	\$0.00	\$0.00	\$580.16	N
	9/13/2023	3346813	2607 Avenue A	General Repair or Maintenance of an Asset at a Sewer Treatment Plant; Weekend check	\$100.00	\$654.76	\$0.00	\$0.00	\$754.76	N

INFRAMARK, LLC

DISTRICT : CITY OF SWEENEY

INVOICE NO. 1152073 - DETAIL

INVOICE DATE: 10/9/2023

09 Oct 2023 02:59:06PM CST

Go Green! Think before you print.

Work Type / Sub Category	Date Complete	WO Number	Address	Task Details	Equipment Costs	Labor Costs	Materials/Other Service Costs	Sales Tax Total	Total Costs	B/C
	9/15/2023	3346816	2607 Avenue A	General Repair or Maintenance of an Asset at a Sewer Treatment Plant; Pulled samples and checked in plant	\$215.00	\$1,625.96	\$0.00	\$0.00	\$1,840.96	N
	9/17/2023	3350694	2607 Avenue A	General Repair or Maintenance of an Asset at a Sewer Treatment Plant; Weekend plant operations	\$85.00	\$426.31	\$3.11	\$0.00	\$514.42	N
	9/25/2023	3355805	2607 Avenue A	General Repair or Maintenance of an Asset at a Sewer Treatment Plant; Weekly plant check in	\$295.00	\$1,287.68	\$0.00	\$0.00	\$1,582.68	N
	9/25/2023	3355825	2607 Avenue A	Investigate a Problem at a Sewer Treatment Plant; Had to buy parts to fix leak in bleach line	\$60.00	\$261.90	\$20.38	\$0.00	\$342.28	N
	9/26/2023	3359035	2607 Avenue A	General Repair or Maintenance of an Asset at a Sewer Treatment Plant	\$110.00	\$802.81	\$0.00	\$0.00	\$912.81	N
	10/1/2023	3366281	2607 Avenue A	General Repair or Maintenance of an Asset at a Sewer Treatment Plant; Weekly and daily part check and maintenance	\$260.00	\$1,134.90	\$0.00	\$0.00	\$1,394.90	N
				General Maintenance & Repairs Total	\$2,375.00	\$13,334.14	\$23.48	\$0.00	\$15,732.62	
Other Maintenance										
	9/18/2023	3351361	2607 Avenue A	Post Sewer Treatment Plant Repair Cleanup; Jet RAS Line & Top Clean on-site Lift station	\$2,040.00	\$1,096.66	\$15.82	\$0.00	\$3,152.48	N
				Other Maintenance Total	\$2,040.00	\$1,096.66	\$15.82	\$0.00	\$3,152.48	
				SP1 Total	\$4,415.00	\$14,430.80	\$39.30	\$0.00	\$18,885.10	
				SP Total	\$4,415.00	\$14,430.80	\$39.30	\$0.00	\$18,885.10	

INFRAMARK, LLC
DISTRICT : CITY OF SWEENEY
INVOICE NO. 1152073 - DETAIL
INVOICE DATE: 10/9/2023

Work Type / Sub Category	Date Complete	WO Number	Address	Task Details	Equipment Costs	Labor Costs	Materials/Other Service Costs	Sales Tax Total	Total Costs	B/C
Maintenance, Water										
Lab Fees or Laboratory Sampling										
	8/29/2023	3306018	SWEENEY District Area	Purchase Laboratory Services for Water System Asset; Water Utility Services - August 2023	\$0.00	\$0.00	\$161.00	\$0.00	\$161.00	N
				Lab Fees or Laboratory Sampling Total	\$0.00	\$0.00	\$161.00	\$0.00	\$161.00	
				MW Total	\$0.00	\$0.00	\$161.00	\$0.00	\$161.00	
Maintenance, Water Plant										
WP1										
General Maintenance & Repairs										
	8/31/2023	3332500	204 Peach St	General Repairs of an Asset at a Water Plant; Checked in plant and district residual	\$30.00	\$179.61	\$0.00	\$0.00	\$209.61	N
	9/5/2023	3333794	204 Peach St	General Repairs of an Asset at a Water Plant; Weekend facility check in and plant operations	\$70.00	\$510.89	\$0.00	\$0.00	\$580.89	N
	9/8/2023	3339900	204 Peach St	General Repairs of an Asset at a Water Plant; Weekly plant check	\$30.00	\$130.95	\$0.00	\$0.00	\$160.95	N
	9/12/2023	3339905	204 Peach St	General Repairs of an Asset at a Water Plant; Weekly plant check	\$120.00	\$654.75	\$0.00	\$0.00	\$774.75	N
	9/13/2023	3346812	204 Peach St	General Repairs of an Asset at a Water Plant; Weekend check	\$100.00	\$654.76	\$0.00	\$0.00	\$754.76	N
	9/15/2023	3346817	204 Peach St	General Repairs of an Asset at a Water Plant; Checked in plant and district residual	\$135.00	\$611.11	\$0.00	\$0.00	\$746.11	N
	9/17/2023	3350695	204 Peach St	General Repairs of an Asset at a Water Plant; Weekend plant operations	\$65.00	\$326.00	\$3.11	\$0.00	\$394.11	N

INFRAMARK, LLC
 DISTRICT : CITY OF SWEENEY
 INVOICE NO. 1152073 - DETAIL
 INVOICE DATE: 10/9/2023

09 Oct 2023 02:59:06PM CST
 Go Green! Think before you print.

Work Type / Sub Category	Date Complete	WO Number	Address	Task Details	Equipment Costs	Labor Costs	Materials/Other Service Costs	Sales Tax Total	Total Costs	B/C
	9/25/2023	3355823	204 Peach St	General Repairs of an Asset at a Water Plant; WP check in	\$125.00	\$545.63	\$0.00	\$0.00	\$670.63	N
	9/26/2023	3359037	204 Peach St	General Repairs of an Asset at a Water Plant	\$40.00	\$291.94	\$0.00	\$0.00	\$331.94	N
	10/1/2023	3366287	204 Peach St	General Repairs of an Asset at a Water Plant; Weekly and daily plant check , maintenance, and residual	\$100.00	\$480.17	\$0.00	\$0.00	\$580.17	N
				General Maintenance & Repairs Total	\$815.00	\$4,385.81	\$3.11	\$0.00	\$5,203.92	
Lab Fees or Laboratory Sampling										
	7/5/2023	3271182	204 Peach St	Purchase Laboratory Services for Water System Asset; Water Utility Services - June 2023	\$0.00	\$0.00	\$161.00	\$0.00	\$161.00	N
				Lab Fees or Laboratory Sampling Total	\$0.00	\$0.00	\$161.00	\$0.00	\$161.00	
				WP1 Total	\$815.00	\$4,385.81	\$164.11	\$0.00	\$5,364.92	
				WP Total	\$815.00	\$4,385.81	\$164.11	\$0.00	\$5,364.92	
				Invoice Total	\$5,230.00	\$18,816.61	\$364.41	\$0.00	\$24,411.02	

Client: SWEENEY		Work Order Summary Provided to City of Sweeney - Invoice # 1152073						09 Oct 2023 02:59:06PM CST		
Type:	MW									
WO	Date Complete	Date Invoiced	Location	Asset ID	GL Code	Sub Cat	Dept	Activity Type & Comments		
3306018	8/29/2023	10/9/2023	SWEENEY District Area		40400	LAB	5755	MWLAB - Purchase Laboratory Services for Water System Asset		
	Insp:		Attachments: 1	Bid Price:	\$0.00			Water Utility Services - August 2023		
Materials	<u>Mat ID:</u>	<u>Material Desc</u>	<u>Vendor Bill #</u>	<u>Type</u>	<u>Qty</u>	<u>Unit Cost</u>	<u>Unit Price</u>	<u>Total Price</u>	<u>Tax</u>	<u>Grand Total</u>
	PO	WATER UTILITY SERVICES	82712	166661	1.00	\$140.00	\$161.00	\$161.00	\$0.00	\$161.00
							Materials Total	\$161.00	\$0.00	\$161.00
Comments:							WO [3306018] Total	\$161.00	\$0.00	\$161.00
							Work Type [MW] Total (Count: 1)	\$161.00	\$0.00	\$161.00

Client: SWEENY		Work Order Summary Provided to City of Sweeny - Invoice # 1152073							09 Oct 2023 02:59:06PM CST		
Type:	SP										
WO	Date Complete	Date Invoiced	Location	Asset ID	GL Code	Sub Cat	Dept	Activity Type & Comments			
3320086	8/21/2023	10/9/2023	2607 Avenue A	SWEENY- SP1	40500	GNL	5755	SPGENREP - General Repair or Maintenance of an Asset at a Sewer Treatment Plant			
		Insp:	Attachments: 1	Bid Price: \$0.00				Weekend plant check			
		<u>Emp ID:</u>	<u>Type</u>		<u>Reg Hrs</u>	<u>OT Hrs</u>		<u>Unit Price</u>	<u>Total Price</u>	<u>Tax</u>	<u>Grand Total</u>
	8/19/2023	703616			0.00	3.00		\$130.95	\$392.85	\$0.00	\$392.85
	8/20/2023	703616			0.00	3.00		\$130.95	\$392.85	\$0.00	\$392.85
								Labor Total	\$785.70	\$0.00	\$785.70
		<u>Equip ID:</u>	<u>Equipment Desc</u>			<u>Reg Hrs</u>		<u>Unit Price</u>	<u>Total Price</u>	<u>Tax</u>	<u>Grand Total</u>
		TX121677	Utility Truck			3.00		\$20.00	\$60.00	\$0.00	\$60.00
		TX121677	Utility Truck			3.00		\$20.00	\$60.00	\$0.00	\$60.00
								Equipment Total	\$120.00	\$0.00	\$120.00
								WO [3320086] Total	\$905.70	\$0.00	\$905.70
		<u>Comments:</u>	Checked in Sewer plant on the weekend, made sure bleach was feeding and checked residual. Return running and plant running normal.								
WO	Date Complete	Date Invoiced	Location	Asset ID	GL Code	Sub Cat	Dept	Activity Type & Comments			
3322579	8/14/2023	10/9/2023	2607 Avenue A	SWEENY- SP1	40500	GNL	5755	SPGENREP - General Repair or Maintenance of an Asset at a Sewer Treatment Plant			
		Insp:	Attachments: 1	Bid Price: \$0.00							
		<u>Emp ID:</u>	<u>Type</u>		<u>Reg Hrs</u>	<u>OT Hrs</u>		<u>Unit Price</u>	<u>Total Price</u>	<u>Tax</u>	<u>Grand Total</u>
	8/12/2023	603528	Lead Ops / Tech		0.00	4.00		\$145.97	\$583.86	\$0.00	\$583.86
	8/13/2023	603528	Lead Ops / Tech		0.00	3.25		\$145.97	\$474.39	\$0.00	\$474.39
								Labor Total	\$1,058.25	\$0.00	\$1,058.25

Client: SWEENY		Work Order Summary Provided to City of Sweeny - Invoice # 1152073					09 Oct 2023 02:59:06PM CST	
Type:	SP							
Equipment	Equip ID:	Equipment Desc	Reg Hrs	Unit Price	Total Price	Tax	Grand Total	
	TX119016	Utility Truck	4.00	\$20.00	\$80.00	\$0.00	\$80.00	
	TX119016	Utility Truck	3.25	\$20.00	\$65.00	\$0.00	\$65.00	
		Equipment Total		\$145.00	\$145.00	\$0.00	\$145.00	
		WO [3322579] Total		\$1,203.25	\$1,203.25	\$0.00	\$1,203.25	
Comments: Weekend plant operations and facility check in								
WO	Date Complete	Date Invoiced	Location	Asset ID	GL Code	Sub Cat	Dept	
3324477	8/25/2023	10/9/2023	2607 Avenue A	SWEENY- SP1	40500	GNL	5755	
Insp:			Attachments: 3	Bid Price: \$0.00				
Weekly plant check of sewer plant and weekly samples								
Labor	Emp ID:	Type	Reg Hrs	OT Hrs	Unit Price	Total Price	Tax	
8/21/2023	703616		4.50	0.00	\$87.30	\$392.85	\$0.00	
8/22/2023	703616		1.25	0.00	\$87.30	\$109.12	\$0.00	
8/22/2023	703616		0.00	0.25	\$130.95	\$32.74	\$0.00	
8/23/2023	703616		1.50	0.00	\$87.30	\$130.95	\$0.00	
8/24/2023	703616		2.50	0.00	\$87.30	\$218.25	\$0.00	
8/25/2023	703616		2.50	0.00	\$87.30	\$218.25	\$0.00	
Labor Total					\$1,102.16	\$1,102.16	\$0.00	
Equipment	Equip ID:	Equipment Desc	Reg Hrs	Unit Price	Total Price	Tax	Grand Total	
	TX121677	Utility Truck	4.50	\$20.00	\$90.00	\$0.00	\$90.00	
	TX121677	Utility Truck	1.50	\$20.00	\$30.00	\$0.00	\$30.00	
	TX121677	Utility Truck	1.50	\$20.00	\$30.00	\$0.00	\$30.00	
	TX121677	Utility Truck	2.00	\$20.00	\$40.00	\$0.00	\$40.00	

Client: SWEENY		Work Order Summary Provided to City of Sweeny - Invoice # 1152073						09 Oct 2023 02:59:06PM CST			
Type:	SP										
	TX121677	Utility Truck			2.50			\$20.00	\$50.00	\$0.00	\$50.00
								Equipment Total	\$240.00	\$0.00	\$240.00
								WO [3324477] Total	\$1,342.16	\$0.00	\$1,342.16
		<p>Comments: Monday- came out to plant and pulled samples every two hours and combined for sampling to be picked up the next day, filled out chain of custody and left for envirodine and checked in plant. Tuesday- checked in plant , made sure do,s where good, chemical feed and residual good , plant is now building solids and looks good. Wednesday- checked in plant , made sure do,s where good, chemical feed and residual good , plant is now building solids and looks good. Thursday- checked in plant , made sure do,s where good, chemical feed and residual good , plant is now building solids and looks good. Walked plant and cleaned up walk ways and clarifier cat walks, made sure all buckets and trash were moved or throw away. Friday- upped bleach feed and got residual moving up, plant looking really good, slowly getting solids.</p>									
WO	Date Complete	Date Invoiced	Location	Asset ID	GL Code	Sub Cat	Dept	Activity Type & Comments			
3327713	8/28/2023	10/9/2023	2607 Avenue A	SWEENY- 40500 SP1	GNL		5755	SPGENREP - General Repair or Maintenance of an Asset at a Sewer Treatment Plant			
		Insp:	Attachments: 2	Bid Price: \$0.00							
		Labor	Emp ID:	Type	Reg Hrs	OT Hrs		Unit Price	Total Price	Tax	Grand Total
	8/26/2023	604339	*Operator III		0.00	4.00		\$123.70	\$494.82	\$0.00	\$494.82

Work Order Summary Provided to City of Sweeny - Invoice # 1152073											09 Oct 2023 02:59:06PM CST	
Client:	SWEENY											
Type:	SP											
8/27/2023	604339	*Operator III	0.00	3.75					\$123.70	\$463.89	\$0.00	\$463.89
Labor Total										\$958.71	\$0.00	\$958.71
Equipment	<u>Equip ID:</u>	<u>Equipment Desc</u>	<u>Reg Hrs</u>	<u>Unit Price</u>	<u>Total Price</u>	<u>Tax</u>	<u>Grand Total</u>					
	TX121680	Utility Truck	4.00	\$20.00	\$80.00	\$0.00	\$80.00					
	TX121680	Utility Truck	3.75	\$20.00	\$75.00	\$0.00	\$75.00					
Equipment Total										\$155.00	\$0.00	\$155.00
WO [3327713] Total										\$1,113.71	\$0.00	\$1,113.71
Comments: Weekend facility check in and operations.												
WO	Date Complete	Date Invoiced	Location	Asset ID	GL Code	Sub Cat	Dept	Activity Type & Comments				
3332459	8/31/2023	10/9/2023	2607 Avenue A	SWEENY- SP1	40500	GNL	5755	SPGENREP - General Repair or Maintenance of an Asset at a Sewer Treatment Plant				
	Insp:		Attachments: 0	Bid Price: \$0.00				Checked n plant, pulled samples				
Labor	<u>Emp ID:</u>	<u>Type</u>	<u>Reg Hrs</u>	<u>OT Hrs</u>	<u>Unit Price</u>	<u>Total Price</u>	<u>Tax</u>	<u>Grand Total</u>				
8/28/2023	703616		5.50	0.00	\$87.30	\$480.15	\$0.00	\$480.15				
8/29/2023	703616		2.00	0.00	\$87.30	\$174.60	\$0.00	\$174.60				
8/30/2023	703616		2.00	0.00	\$87.30	\$174.60	\$0.00	\$174.60				
8/31/2023	703616		2.00	0.00	\$87.30	\$174.60	\$0.00	\$174.60				
Labor Total										\$1,003.95	\$0.00	\$1,003.95
Equipment	<u>Equip ID:</u>	<u>Equipment Desc</u>	<u>Reg Hrs</u>	<u>Unit Price</u>	<u>Total Price</u>	<u>Tax</u>	<u>Grand Total</u>					
	TX121677	Utility Truck	5.50	\$20.00	\$110.00	\$0.00	\$110.00					
	TX121677	Utility Truck	2.00	\$20.00	\$40.00	\$0.00	\$40.00					
	TX121677	Utility Truck	2.00	\$20.00	\$40.00	\$0.00	\$40.00					

Client:	SWEENY						Work Order Summary Provided to City of Sweeny - Invoice # 1152073						09 Oct 2023 02:59:06PM CST	
Type:	SP													
	TX121677	Utility Truck				2.00					\$20.00	\$40.00	\$0.00	\$40.00
											Equipment Total	\$230.00	\$0.00	\$230.00
											WO [3332459] Total	\$1,233.95	\$0.00	\$1,233.95
	Comments: Monday- pulled samples every two hours to have ready for pick up next day, checked in plant and made sure chemical feed and effluent was good. Tuesday- checked in plant. Wednesday- checked in plant, return was thin, shut off pump and restarted and primed and got good solids moving. Thursday- checked in plant													
WO	Date Complete	Date Invoiced	Location	Asset ID	GL Code	Sub Cat	Dept	Activity Type & Comments						
3333806	9/5/2023	10/9/2023	2607 Avenue A	SWEENY- SP1	40500	GNL	5755	SPGENREP - General Repair or Maintenance of an Asset at a Sewer Treatment Plant						
		Insp:	Attachments: 2	Bid Price: \$0.00				Weekend facility check in and plant operations.						
Labor	Emp_ID:	Type	Reg_Hrs	OT_Hrs	Unit Price	Total Price	Tax	Grand Total						
9/2/2023	603528	Lead Ops / Tech	0.00	3.50	\$145.97	\$510.88	\$0.00	\$510.88						
9/3/2023	603528	Lead Ops / Tech	0.00	2.00	\$145.97	\$291.93	\$0.00	\$291.93						
9/4/2023	603528	Lead Ops / Tech	0.00	3.75	\$145.97	\$547.37	\$0.00	\$547.37						
9/4/2023	603528	Lead Ops / Tech	0.00	1.25	\$145.97	\$182.46	\$0.00	\$182.46						
					Labor Total	\$1,532.64	\$0.00	\$1,532.64						
Equipment	Equip_ID:	Equipment Desc	Reg_Hrs	OT_Hrs	Unit Price	Total Price	Tax	Grand Total						
	TX119016	Utility Truck	3.50		\$20.00	\$70.00	\$0.00	\$70.00						
	TX119016	Utility Truck	2.00		\$20.00	\$40.00	\$0.00	\$40.00						
	TX119016	Utility Truck	3.75		\$20.00	\$75.00	\$0.00	\$75.00						
	TX119016	Utility Truck	1.25		\$20.00	\$25.00	\$0.00	\$25.00						
					Equipment Total	\$210.00	\$0.00	\$210.00						
					WO [3333806] Total	\$1,742.64	\$0.00	\$1,742.64						
	Comments: Weekend & holiday facility check-in and plant operations. composite sample for 9/4													

Client: SWEENY		Work Order Summary Provided to City of Sweeny - Invoice # 1152073								09 Oct 2023 02:59:06PM CST	
Type:	SP										
	9/8/2023	703616			0.00	0.50		\$130.95	\$65.48	\$0.00	\$65.48
							Labor Total	\$480.16	\$0.00	\$0.00	\$480.16
Equipment	Equip ID:	Equipment Desc	Reg Hrs	Unit Price	Total Price	Tax	Grand Total				
	TX121677	Utility Truck	1.50	\$20.00	\$30.00	\$0.00	\$30.00				\$30.00
	TX121677	Utility Truck	1.50	\$20.00	\$30.00	\$0.00	\$30.00				\$30.00
	TX121677	Utility Truck	1.00	\$20.00	\$20.00	\$0.00	\$20.00				\$20.00
	TX121677	Utility Truck	1.00	\$20.00	\$20.00	\$0.00	\$20.00				\$20.00
				Equipment Total	\$100.00	\$0.00	\$100.00				\$100.00
				WO [3339904] Total	\$580.16	\$0.00	\$580.16				\$580.16
Comments:	Tuesday- checked residual and solids, plant looking good, checked it in. Wednesday- checked in plant, bleach feeding and return working good, plant looking good, scum trough in clarifier is clogged and LS on-site needs to be top cleaned. Thursday- checked in plant, bleach feeding . When arriving on-site noticed return pump not running. Pump 3 would not prime. Breaker tripped and unable to get it to reset. Pump 2 Scum trough clogged and on-site LS needs to be top cleaned. Let Tracy know and let Lindsey know. Friday, checked in plant and kept trying to prim return pumps.										
WO	Date Complete	Date Invoiced	Location	Asset ID	GL Code	Sub Cat	Dept	Activity Type & Comments			
3346813	9/13/2023	10/9/2023	2607 Avenue A	SWEENY- SP1	40500	GNL	5755	SPGENREP - General Repair or Maintenance of an Asset at a Sewer Treatment Plant			
		Insp:	Attachments: 0	Bid Price: \$0.00				Weekend check			
Labor	Emp ID:	Type	Reg Hrs	QT Hrs	Unit Price	Total Price	Tax	Grand Total			
	9/9/2023	703616	0.00	2.50	\$130.95	\$327.38	\$0.00	\$327.38			\$327.38
	9/10/2023	703616	0.00	2.50	\$130.95	\$327.38	\$0.00	\$327.38			\$327.38
				Labor Total	\$654.76	\$0.00	\$654.76				\$654.76

Client: SWEENY		Work Order Summary Provided to City of Sweeny - Invoice # 1152073					09 Oct 2023 02:59:06PM CST	
Type: SP	Equip ID:	Equipment Desc	Reg Hrs	Unit Price	Total Price	Tax	Grand Total	
	TX121677	Utility Truck	2.50	\$20.00	\$50.00	\$0.00	\$50.00	
	TX121677	Utility Truck	2.50	\$20.00	\$50.00	\$0.00	\$50.00	
		Equipment Total		\$100.00		\$0.00	\$100.00	
Comments:		Checked in plant on weekend, made sure chemical feeding, scum trough still clogged and return pump not working						
WO	Date Complete	Date Invoiced	Asset ID	GL Code	Sub Cat	Dept	Activity Type & Comments	
3346816	9/15/2023	10/9/2023	SWEENY- 40500 SP1	40500	GNL	5755	SPGENREP - General Repair or Maintenance of an Asset at a Sewer Treatment Plant	
		Insp:	Attachments: 0	Bid Price: \$0.00			Pulled samples and checked in plant	
Labor	Emp ID:	Type	Reg Hrs	OT Hrs	Unit Price	Total Price	Tax	
9/11/2023	703616	*Operator III	7.50	0.00	\$87.30	\$654.75	\$0.00	
9/12/2023	703616		2.25	0.00	\$87.30	\$196.42	\$0.00	
9/13/2023	703616		1.00	0.00	\$87.30	\$87.30	\$0.00	
9/13/2023	703616		0.00	0.25	\$130.95	\$32.74	\$0.00	
9/14/2023	703616		4.00	0.00	\$87.30	\$349.20	\$0.00	
9/15/2023	703616		3.50	0.00	\$87.30	\$305.55	\$0.00	
					Labor Total	\$1,625.96	\$0.00	
Equipment	Equip ID:	Equipment Desc	Reg Hrs	Unit Price	Total Price	Tax	Grand Total	
	TX121677	Utility Truck	2.25	\$20.00	\$45.00	\$0.00	\$45.00	
	TX121677	Utility Truck	1.00	\$20.00	\$20.00	\$0.00	\$20.00	
	TX121677	Utility Truck	4.00	\$20.00	\$80.00	\$0.00	\$80.00	

Client: SWEENY	Work Order Summary Provided to City of Sweeny - Invoice # 1152073					09 Oct 2023 02:59:06PM CST
Type: SP						
	TX121677	Utility Truck	3.50	\$20.00	\$70.00	\$70.00
				Equipment Total	\$215.00	\$215.00
				WO [3346816] Total	\$1,840.96	\$1,840.96
Comments:	<p>Monday- arrived at plant and chemical pump not feeding, got ahead of Hawkins and was able to meet in Sugarland and pick up new pump, came back and installed new pump and was able to get chemical feeding properly, started pulling my samples after good residual. Met BNR on site and assisted in swapping RAS pump 4 with three, they took 4 to rebuild blown motor. Tried to prime pump but was unsuccessful. Did pull all samples Tuesday- checked in plant and was able to get new pump primed but unable to get solids in return, return may be clogged, and this might of caused issue with old pump. Let Lindsey and Tracy know, Lindsey informed me that she will be scheduling a jet truck through other sources. Wednesday- checked plant, chemical feeding good, RAS pump still not working. Tried to get working, pump primed but did not come out of return. Pump got hot , turned off. Thursday- attempted to get RAS pump to pump properly again, was unsuccessful. Called Lindsey and was informed a jet trailer will be at plant Friday morning. Friday- in hooked RAS pump 4 and attempt to jet return line. Did not have proper hose, could not make all turns in line. Spoke with Lindsey and was approved to schedule inframe mark vactor truck come out Monday and jet return, and scum trough in clarifier 1 and top clean onsite lift station. Checked in lift stations in town.</p>					

WO	Date Complete	Date Invoiced	Location	Asset ID	GL Code	Sub Cat	Dept	Activity Type & Comments		
3350694	9/17/2023	10/9/2023	2607 Avenue A	SWEENY- SP1	40500	GNL	5755	SPGENREP - General Repair or Maintenance of an Asset at a Sewer Treatment Plant		
		Insp:	Attachments: 2	Bid Price: \$0.00				Weekend plant operations		
Materials	Mat ID:	Material Desc	Vendor Bill #	Type	Qty	Unit Cost	Unit Price	Total Price	Tax	Grand Total
	MS72	MISC. Photos			2.00	\$1.35	\$1.55	\$3.11	\$0.00	\$3.11
							Materials Total	\$3.11	\$0.00	\$3.11
Labor	Emp ID:	Type	Reg Hrs	OT Hrs	Unit Price	Total Price	Tax	Grand Total		
9/16/2023	700366		0.00	2.00	\$100.31	\$200.62	\$0.00	\$200.62		
9/17/2023	700366		0.00	2.25	\$100.31	\$225.69	\$0.00	\$225.69		

Equipment	Equip_ID:	Equipment_Desc	Reg_Hrs	Unit Price	Total Price	Tax	Grand Total
	TX121679	Utility Truck	2.00	\$20.00	\$40.00	\$0.00	\$40.00
	TX121679	Utility Truck	2.25	\$20.00	\$45.00	\$0.00	\$45.00
				Equipment Total	\$85.00	\$0.00	\$85.00
				WO [3350694] Total	\$514.42	\$0.00	\$514.42

Comments: Completed weekend check in. Documented data and findings...

WO	Date Complete	Date Invoiced	Location	Asset ID	GL Code	Sub Cat	Dept	Activity Type & Comments
3351361	9/18/2023	10/9/2023	2607 Avenue A	SWEENY- SP1	41400	OTHM	5060	SPPOSTCLN - Post Sewer Treatment Plant Repair Cleanup
		Insp:	Attachments: 2	Bid Price: \$0.00				Jet RAS Line & Top Clean on-site Lift station

Materials	Mat ID:	Material Desc	Vendor Bill #	Type	Qty	Unit Cost	Unit Price	Total Price	Tax	Grand Total
	MS72	MISC. Photos			2.00	\$1.35	\$1.55	\$3.11	\$0.00	\$3.11
	SA0012	Gloves - Sol-Vex - Green			3.00	\$3.69	\$4.24	\$12.72	\$0.00	\$12.72
							Materials Total	\$15.82	\$0.00	\$15.82

Labor	Emp ID:	Type	Reg_Hrs	OT_Hrs	Unit Price	Total Price	Tax	Grand Total
9/18/2023	603749		0.00	0.50	\$0.00	\$0.00	\$0.00	\$0.00
9/18/2023	704049		0.00	0.50	\$109.13	\$54.56	\$0.00	\$54.56
9/18/2023	703261		0.00	0.50	\$90.27	\$45.13	\$0.00	\$45.13
9/18/2023	603749		4.50	0.00	\$0.00	\$0.00	\$0.00	\$0.00
9/18/2023	704049		4.50	0.00	\$72.75	\$327.38	\$0.00	\$327.38
9/18/2023	703261		4.50	0.00	\$60.18	\$270.80	\$0.00	\$270.80
9/18/2023	603749		3.00	0.00	\$0.00	\$0.00	\$0.00	\$0.00
9/18/2023	703261		3.00	0.00	\$60.18	\$180.54	\$0.00	\$180.54
9/18/2023	704049		3.00	0.00	\$72.75	\$218.25	\$0.00	\$218.25
					Labor Total	\$1,096.66	\$0.00	\$1,096.66

Client: SWEENY		Work Order Summary Provided to City of Sweeny - Invoice # 1152073										09 Oct 2023 02:59:06PM CST				
Type:	SP															
Equipment	Equip ID:	Equipment Desc	Reg Hrs	Unit Price	Total Price	Tax	Grand Total									
	TX619155	Vactor Truck w/ Operator	5.00	\$220.00	\$1,100.00	\$0.00	\$1,100.00									
	TX123319	Maintenance Truck	5.00	\$35.00	\$175.00	\$0.00	\$175.00									
	TX123319	Maintenance Truck	3.00	\$35.00	\$105.00	\$0.00	\$105.00									
	TX619155N	Vactor Truck w/Operator (No Min)	3.00	\$220.00	\$660.00	\$0.00	\$660.00									
Equipment Total					\$2,040.00	\$0.00	\$2,040.00									
Comments:			Set up equipment jettted Ras line from both direction to clear line. Also jettted scum line, removed rag debris and large, graduated cylinder from line. Disposed onsite.										WO [3351361] Total	\$3,152.48	\$0.00	\$3,152.48
WO	Date Complete	Date Invoiced	Location	Asset ID	GL Code	Sub Cat	Dept	Activity Type & Comments								
3355805	9/25/2023	10/9/2023	2607 Avenue A	SWEENY- SP1	40500	GNL	5755	SPGENREP - General Repair or Maintenance of an Asset at a Sewer Treatment Plant								
		Insp:	Attachments: 0	Bid Price:	\$0.00			Weekly plant check in								
Labor	Emp ID:	Type	Reg Hrs	OT Hrs	Unit Price	Total Price	Tax	Grand Total								
	9/18/2023	703616	4.00	0.00	\$87.30	\$349.20	\$0.00	\$349.20								
	9/19/2023	703616	3.50	0.00	\$87.30	\$305.55	\$0.00	\$305.55								
	9/20/2023	703616	0.75	0.00	\$87.30	\$65.48	\$0.00	\$65.48								
	9/21/2023	703616	5.00	0.00	\$87.30	\$436.50	\$0.00	\$436.50								
	9/22/2023	703616	1.50	0.00	\$87.30	\$130.95	\$0.00	\$130.95								
Labor Total					\$1,287.68	\$0.00	\$1,287.68									
Equipment	Equip ID:	Equipment Desc	Reg Hrs	Unit Price	Total Price	Tax	Grand Total									
	TX121677	Utility Truck	4.00	\$20.00	\$80.00	\$0.00	\$80.00									
	TX121677	Utility Truck	3.50	\$20.00	\$70.00	\$0.00	\$70.00									
	TX121677	Utility Truck	0.75	\$20.00	\$15.00	\$0.00	\$15.00									

Client: SWEENY										Work Order Summary Provided to City of Sweeny - Invoice # 1152073										09 Oct 2023 02:59:06PM CST																																																																					
Type: SP																																																																																									
Equipment										Equipment_Desc										Reg_Hrs		Unit Price		Total Price		Tax		Grand Total																																																													
TX121677										Utility Truck										3.00		\$20.00		\$60.00		\$0.00		\$60.00																																																													
																						Equipment Total		\$60.00		\$0.00		\$60.00																																																													
Comments:										Met vector crew on site and jetted return line and it was fully cleared, and jetted scum trough and found obstruction in line and got it completely clear.										WO [3355825]		Total		\$342.28		\$0.00		\$342.28																																																													
WO										Date Complete										Date Invoiced										Location										Asset ID GL Code										Sub Cat										Dept										Activity Type & Comments																			
3359035										9/26/2023										10/9/2023										2607 Avenue A										SWEENY - 40500 SP1										GNL										5755										SPGENREP - General Repair or Maintenance of an Asset at a Sewer Treatment Plant																			
										Insp:										Attachments: 2										Bid Price: \$0.00																																																											
Labor										Emp ID:										Type										Reg_Hrs										OT_Hrs										Unit Price										Total Price										Tax										Grand Total									
9/23/2023										603528										Lead Ops / Tech										0.00										2.50										\$145.97										\$364.91										\$0.00										\$364.91									
9/24/2023										603528										Lead Ops / Tech										0.00										3.00										\$145.97										\$437.90										\$0.00										\$437.90									
																																								Labor Total										\$802.81										\$0.00										\$802.81																			
Equipment										Equip_ID:										Equipment_Desc										Reg_Hrs										Unit Price										Total Price										Tax										Grand Total																			
										TX121620										Utility Truck										2.50										\$20.00										\$50.00										\$0.00										\$50.00																			
										TX121620										Utility Truck										3.00										\$20.00										\$60.00										\$0.00										\$60.00																			
																																								Equipment Total										\$110.00										\$0.00										\$110.00																			
Comments:										Weekend plant check and operations										WO [3359035]										Total										\$912.81										\$0.00										\$912.81																													

Client:	SWEENY	Work Order Summary Provided to City of Sweeny - Invoice # 1152073										09 Oct 2023 02:59:06PM CST
Type:	SP											
WO	Date Complete	Date Invoiced	Location	Asset ID	GL Code	Sub Cat	Dept					Activity Type & Comments
3366281	10/1/2023	10/9/2023	2607 Avenue A	SWEENY-SP1	40500	GNL	5755					SPGENREP - General Repair or Maintenance of an Asset at a Sewer Treatment Plant
		Insp:	Attachments: 0	Bid Price: \$0.00								Weekly and daily pant check and maintenance
		<u>Emp ID:</u>	<u>Type</u>		<u>Reg Hrs</u>	<u>OT Hrs</u>		<u>Unit Price</u>	<u>Total Price</u>	<u>Tax</u>	<u>Grand Total</u>	
9/25/2023	703616			5.00	0.00		\$87.30	\$436.50	\$0.00	\$436.50	\$436.50	
9/26/2023	703616			1.50	0.00		\$87.30	\$130.95	\$0.00	\$130.95	\$130.95	
9/27/2023	703616			1.50	0.00		\$87.30	\$130.95	\$0.00	\$130.95	\$130.95	
9/28/2023	703616			1.50	0.00		\$87.30	\$130.95	\$0.00	\$130.95	\$130.95	
9/29/2023	703616			3.50	0.00		\$87.30	\$305.55	\$0.00	\$305.55	\$305.55	
							Labor Total	\$1,134.90	\$0.00	\$1,134.90		
		<u>Equip ID:</u>	<u>Equipment Desc</u>		<u>Reg Hrs</u>		<u>Unit Price</u>	<u>Total Price</u>	<u>Tax</u>	<u>Grand Total</u>		
		TX121677	Utility Truck		5.00		\$20.00	\$100.00	\$0.00	\$100.00	\$100.00	
		TX121677	Utility Truck		1.50		\$20.00	\$30.00	\$0.00	\$30.00	\$30.00	
		TX121677	Utility Truck		1.50		\$20.00	\$30.00	\$0.00	\$30.00	\$30.00	
		TX121677	Utility Truck		1.50		\$20.00	\$30.00	\$0.00	\$30.00	\$30.00	
		TX121677	Utility Truck		3.50		\$20.00	\$70.00	\$0.00	\$70.00	\$70.00	
							Equipment Total	\$260.00	\$0.00	\$260.00	\$260.00	
		Comments:	Monday-checked in plant, adjusted chemical, pulled weekly samples at plant, still need return pumps, got approval, once get in will get installed. Tuesday-checked in plant, made sure everything working properly. Wednesday-checked in plant, still need to get return pumps, plant running good, Thursday- plant checked, plant needs work. Friday- checked in plant and checked in all lift stations in town.									
							WO [3366281] Total	\$1,394.90	\$0.00	\$1,394.90	\$1,394.90	
							Work Type [SP] Total (Count: 16)	\$18,885.10	\$0.00	\$18,885.10	\$18,885.10	

Client: SWEENY		Work Order Summary Provided to City of Sweeny - Invoice # 1152073					09 Oct 2023 02:59:06PM CST	
Type:	WP							
Equipment	Equip ID:	Equipment Desc	Reg Hrs	Unit Price	Total Price	Tax	Grand Total	
	TX121677	Utility Truck	1.50	\$20.00	\$30.00	\$0.00	\$30.00	
		Equipment Total			\$30.00	\$0.00	\$30.00	
Comments:		Checked in plant, residual low, upped cl2, po4 pump not working correctly, called for quote, lead: consult with operator on issues at water plant over phone. (no truck for lead). we need to increase cl2 feed rate and make sure new cl2 bottles are delivered. i will speak with Mike G. on po4 pump issues.						
		WO [3332500] Total			\$209.61	\$0.00	\$209.61	
WO	Date Complete	Date Invoiced	Location	Asset ID	GL Code	Sub Cat	Dept	Activity Type & Comments
3333794	9/5/2023	10/9/2023	204 Peach St	SWEENY- WP1	40500	GNL	5755	WPGENREP - General Repairs of an Asset at a Water Plant
		Insp:	Attachments: 1	Bid Price: \$0.00				Weekend facility check in and plant operations
Labor	Emp ID:	Type	Reg Hrs	OT Hrs	Unit Price	Total Price	Tax	Grand Total
9/2/2023	603528	Lead Ops / Tech	0.00	1.00	\$145.97	\$145.97	\$0.00	\$145.97
9/3/2023	603528	Lead Ops / Tech	0.00	1.50	\$145.97	\$218.95	\$0.00	\$218.95
9/4/2023	603528	Lead Ops / Tech	0.00	1.00	\$145.97	\$145.97	\$0.00	\$145.97
		Labor Total				\$510.89	\$0.00	\$510.89
Equipment	Equip ID:	Equipment Desc	Reg Hrs	Unit Price	Total Price	Tax	Grand Total	
	TX119016	Utility Truck	1.00	\$20.00	\$20.00	\$0.00	\$20.00	
	TX119016	Utility Truck	1.50	\$20.00	\$30.00	\$0.00	\$30.00	

Client: SWEENY		Work Order Summary Provided to City of Sweeny - Invoice # 1152073						09 Oct 2023 02:59:06PM CST			
Type:	WP										
	9/5/2023	703616			1.00	0.00		\$87.30	\$87.30	\$0.00	\$87.30
	9/6/2023	703616			1.00	0.00		\$87.30	\$87.30	\$0.00	\$87.30
	9/7/2023	703616			2.00	0.00		\$87.30	\$174.60	\$0.00	\$174.60
	9/8/2023	703616			2.00	0.00		\$87.30	\$174.60	\$0.00	\$174.60
								Labor Total	\$654.75	\$0.00	\$654.75
		<u>Equipment</u>	<u>Equip ID:</u>	<u>Equipment Desc</u>	<u>Reg Hrs</u>	<u>Unit Price</u>	<u>Total Price</u>	<u>Tax</u>	<u>Grand Total</u>		
			TX121677	Utility Truck	1.00	\$20.00	\$20.00	\$0.00	\$20.00		\$20.00
			TX121677	Utility Truck	1.00	\$20.00	\$20.00	\$0.00	\$20.00		\$20.00
			TX121677	Utility Truck	2.00	\$20.00	\$40.00	\$0.00	\$40.00		\$40.00
			TX121677	Utility Truck	2.00	\$20.00	\$40.00	\$0.00	\$40.00		\$40.00
						Equipment Total	\$120.00	\$0.00	\$120.00		\$120.00
						WO [3339905] Total	\$774.75	\$0.00	\$774.75		\$774.75
		<u>Comments:</u>	Checked in plant during, checked in residual in district residual, residual at plant and made sure wells running properly and chemicals feeding properly								
WO	Date Complete	Date Invoiced	Location	Asset ID	GL Code	Sub Cat	Dept	Activity Type & Comments			
3346812	9/13/2023	10/9/2023	204 Peach St	SWEENY-WP1	40500	GNL	5755	WPGENREP - General Repairs of an Asset at a Water Plant			
		Insp:	Attachments: 0	Bid Price: \$0.00				Weekend check			
		<u>Labor</u>	<u>Emp ID:</u>	<u>Type</u>	<u>Reg Hrs</u>	<u>OT Hrs</u>	<u>Unit Price</u>	<u>Total Price</u>	<u>Tax</u>	<u>Grand Total</u>	
		9/9/2023	703616		0.00	2.50	\$130.95	\$327.38	\$0.00	\$327.38	
		9/10/2023	703616		0.00	2.50	\$130.95	\$327.38	\$0.00	\$327.38	
						Labor Total	\$654.76	\$0.00	\$654.76		\$654.76
		<u>Equipment</u>	<u>Equip ID:</u>	<u>Equipment Desc</u>	<u>Reg Hrs</u>	<u>Unit Price</u>	<u>Total Price</u>	<u>Tax</u>	<u>Grand Total</u>		
			TX121677	Utility Truck	2.50	\$20.00	\$50.00	\$0.00	\$50.00		\$50.00

Client: SWEENY		Work Order Summary Provided to City of Sweeny - Invoice # 1152073						09 Oct 2023 02:59:06PM CST			
Type: WP											
	TX121677	Utility Truck					2.50	\$20.00	\$50.00	\$0.00	\$50.00
								Equipment Total	\$100.00	\$0.00	\$100.00
								WO [3346812] Total	\$754.76	\$0.00	\$754.76
Comments: Checked district residual and residual in plant. Made sure plant was operating normal											
WO	Date Complete	Date Invoiced	Location	Asset ID	GL Code	Sub Cat	Dept	Activity Type & Comments			
3346817	9/15/2023	10/9/2023	204 Peach St	SWEENY- WP1	40500	GNL	5755	WPGENREP - General Repairs of an Asset at a Water Plant			
		Insp:	Attachments: 0		Bid Price: \$0.00			Checked in plant and district residual			
Labor	Emp ID:	Type	Reg Hrs	OT Hrs	Unit Price	Total Price	Tax	Grand Total			
9/11/2023	703616		0.50	0.00	\$87.30	\$43.65	\$0.00	\$43.65			
9/11/2023	703616		0.00	0.50	\$130.95	\$65.48	\$0.00	\$65.48			
9/12/2023	703616		1.00	0.00	\$87.30	\$87.30	\$0.00	\$87.30			
9/13/2023	703616		1.75	0.00	\$87.30	\$152.78	\$0.00	\$152.78			
9/14/2023	703616		1.00	0.00	\$87.30	\$87.30	\$0.00	\$87.30			
9/15/2023	703616		2.00	0.00	\$87.30	\$174.60	\$0.00	\$174.60			
					Labor Total	\$611.11	\$0.00	\$611.11			
Equipment	Equip ID:	Equipment Desc	Reg Hrs	Unit Price	Total Price	Tax	Grand Total				
	TX121677	Utility Truck	1.00	\$20.00	\$20.00	\$0.00	\$20.00				
	TX121677	Utility Truck	1.00	\$20.00	\$20.00	\$0.00	\$20.00				
	TX121677	Utility Truck	1.75	\$20.00	\$35.00	\$0.00	\$35.00				
	TX121677	Utility Truck	1.00	\$20.00	\$20.00	\$0.00	\$20.00				

Client:	SWEENY	Work Order Summary Provided to City of Sweeny - Invoice # 1152073					09 Oct 2023 02:59:06PM CST	
Type:	WP						WO [3350695]	\$394.11
Comments:		Completed weekend check in...						
WO	Date Complete	Date Invoiced	Location	Asset ID	GL Code	Sub Cat	Dept	Activity Type & Comments
3355823	9/25/2023	10/9/2023	204 Peach St	SWEENY- WP1	40500	GNL	5755	WPGENREP - General Repairs of an Asset at a Water Plant
		Insp:	Attachments: 0	Bid Price: \$0.00				WP check in
Labor	Emp ID:	Type	Reg Hrs	OT Hrs	Unit Price	Total Price	Tax	Grand Total
9/18/2023	703616		1.00	0.00	\$87.30	\$87.30	\$0.00	\$87.30
9/19/2023	703616		1.50	0.00	\$87.30	\$130.95	\$0.00	\$130.95
9/20/2023	703616		1.75	0.00	\$87.30	\$152.78	\$0.00	\$152.78
9/21/2023	703616		1.00	0.00	\$87.30	\$87.30	\$0.00	\$87.30
9/22/2023	703616		1.00	0.00	\$87.30	\$87.30	\$0.00	\$87.30
					Labor Total	\$545.63	\$0.00	\$545.63
Equipment	Equip ID:	Equipment Desc	Reg Hrs	Unit Price	Total Price	Tax	Grand Total	
	TX121677	Utility Truck	1.00	\$20.00	\$20.00	\$0.00	\$20.00	
	TX121677	Utility Truck	1.50	\$20.00	\$30.00	\$0.00	\$30.00	
	TX121677	Utility Truck	1.75	\$20.00	\$35.00	\$0.00	\$35.00	
	TX121677	Utility Truck	1.00	\$20.00	\$20.00	\$0.00	\$20.00	
	TX121677	Utility Truck	1.00	\$20.00	\$20.00	\$0.00	\$20.00	
				Equipment Total	\$125.00	\$0.00	\$125.00	
Comments:		Checked residual in district, at elevated tank, and GST at plant. Adjusted and monitored chemical feed. Monitored well flow and booster pump times.						
					WO [3355823]	\$670.63	\$0.00	\$670.63
					Total			

Inframark, LLC		
Invoiced Backcharges		
Client:	SWEENEY	
WO #	Work Type	Address Where Work was Performed:
		Backcharged to:
Total Invoiced Backcharges		Invoice Amount
		\$0.00

*Sweeny - Enterprise Fund
General Ledger

Item 19.

For the Period From Oct 1, 2022 to Sep 30, 2023

Filter Criteria includes: 1) IDs from 50-11-6711 to 50-11-6711. Report order is by ID. Report is printed with shortened descriptions and in Detail Format.

Account ID Account Description	Date	Reference	Jrnl	Trans Description	Debit Amt	Credit Amt	Balance
50-11-6711	10/1/22			Beginning Balance			
Maintenance of Sewer Syst	10/3/22	93022	PJ	G&S Auto Supply Inc	62.58		
	10/10/22	2030	CDJ	Waste Connections of T	679.79		
	10/12/22	2031	CDJ	Stewart's Food Store -	139.74		
	10/27/22	113809	PJ	HAHN Equipment Co I	1,200.00		
				Current Period Change	2,082.11		2,082.11
	11/1/22			Beginning Balance			2,082.11
	11/1/22	11/01/2022	PJ	Stewart's Food Store	65.18		
	11/9/22	2071	CDJ	Waste Connections of T	90.00		
	11/9/22	2105	CDJ	Caprice Dodds - Mainte	440.85		
	11/10/22	903445	PJ	Lakeside Equipment Co	106.06		
	11/16/22	114003	PJ	HAHN Equipment Co I	1,200.00		
	11/17/22	2109	CDJ	Card Service Center -	72.98		
	11/17/22	2112	CDJ	Penney's Electric Co. I	687.50		
	11/17/22	2119	CDJ	Brazoria County Septic	300.00		
				Current Period Change	2,962.57		2,962.57
	12/1/22			Beginning Balance			5,044.68
	12/1/22	3112286V131	PJ	Waste Connections of T	90.00		
	12/1/22	12012022 Ros	PJ	Stewart's Food Store	40.75		
	12/5/22	3000364	PJ	Scruggs Distribution LL	3,440.00		
	12/7/22	213723975-00	PJ	United Rentals	141.78		
	12/11/22	77800	PJ	Magna Flow Environme	9,640.80		
	12/11/22	21810	PJ	Penney's Electric Co. In	606.93		
	12/12/22	498074	PJ	Aqua-Zyme Services In	2,720.00		
	12/16/22	Aguirre0500	PJ	Card Service Center	18.78		
	12/21/22	Stmt 1201202	PJ	Litzler's Feed Store	19.78		
	12/29/22	0114260-IN	PJ	Underground Inc.	6,263.55		
				Current Period Change	22,982.37		22,982.37
	1/1/23			Beginning Balance			28,027.05
	1/1/23	3139233V131	PJ	Waste Connections of T	90.00		
	1/2/23	ACCT 017 D	PJ	Litzler's Feed Store	69.81		
	1/2/23	22101	PJ	Penney's Electric Co. In	312.50		
	1/4/23	01042023 Ros	PJ	Stewart's Food Store	52.70		
	1/5/23	903613	PJ	Lakeside Equipment Co	245.00		
	1/5/23	903613	PJ	Lakeside Equipment Co	722.00		
	1/5/23	635314	PJ	Evco Industrial Hardwa	67.98		
	1/11/23	0114633-IN	PJ	Underground Inc. - Jett	5,000.00		
	1/17/23	114470	PJ	HAHN Equipment Co I	1,200.00		
	1/18/23	SW0279642	PJ	ASCO - Mini Excavato	440.53		
	1/19/23	1016183	PJ	Precision Pumps Syste	1,160.00		
	1/19/23	1016184	PJ	Precision Pumps Syste	1,450.00		
	1/31/23	013123	PJ	Stewart's Food Store -	40.54		
				Current Period Change	10,851.06		10,851.06
	2/1/23			Beginning Balance			38,878.11
	2/1/23	017 020123	PJ	Litzler's Feed Store	103.95		
	2/1/23	3198711V131	PJ	Waste Connections of T	90.00		
	2/8/23	43769	PJ	Chlorinator Maint. Co.,	1,091.66		
	2/15/23	301537	PJ	McCoy's Building Supp	199.99		
	2/16/23	98927	PJ	Brazoria County Septic	4,675.00		
	2/16/23	1016786	PJ	Precision Pumps Syste	1,621.43		
	2/22/23	1016929	PJ	Precision Pumps Syste	1,740.00		
	2/23/23	98950	PJ	Brazoria County Septic	1,760.00		
	2/24/23	232328	PJ	Luyex Plumbing Co., In	4,030.00		
	2/25/23	0500 Aguirre	PJ	Card Service Center	14.69		
				Current Period Change	15,326.72		15,326.72
	3/1/23			Beginning Balance			54,204.83
	3/1/23	3231890V131	PJ	Waste Connections of T	90.00		
	3/2/23	017 03022023	PJ	Litzler's Feed Store - Pa	111.43		
	3/3/23	0500 Aguirre	PJ	Card Service Center - B	147.27		
	3/8/23	99094	PJ	Brazoria County Septic	1,540.00		
	3/9/23	99081	PJ	Brazoria County Septic	150.00		
	3/10/23	90113	PJ	Envirodyne Laboratorie	170.00		
	3/10/23	90113 031020	PJ	Envirodyne Laboratorie	120.00		
	3/13/23	0115295-IN	PJ	Underground Inc. - Jett	6,500.00		
	3/20/23	2011-2847	PJ	Matula & Matula - Rep	1,150.00		
	3/22/23	3001266	PJ	Scruggs Distribution LL	1,550.00		
	3/24/23	115070	PJ	HAHN Equipment Co I	1,200.00		
				Current Period Change	12,728.70		12,728.70
	4/1/23			Beginning Balance			66,933.53

*Sweeny - Enterprise Fund
General Ledger

Item 19.

For the Period From Oct 1, 2022 to Sep 30, 2023

Filter Criteria includes: 1) IDs from 50-11-6711 to 50-11-6711. Report order is by ID. Report is printed with shortened descriptions and in Detail Format.

Account ID Account Description	Date	Reference	Jrnl	Trans Description	Debit Amt	Credit Amt	Balance
	4/1/23	10309 040123	PJ	Stewart's Food Store	45.43		
	4/1/23	3260841V131	PJ	Waste Connections of T	90.00		
	4/3/23	0500 Agirre 0	PJ	Card Service Center - S	51.86		
	4/3/23	017 04032023	PJ	Litzler's Feed Store	24.58		
	4/7/23	115218	PJ	HAHN Equipment Co I	1,200.00		
	4/18/23	2380	PJ	Premium Pumps & Con	2,801.00		
	4/19/23	0115672-IN	PJ	Underground Inc. - Jett	5,000.00		
	4/20/23	1380	PJ	B&R Services - Steel Pl	400.00		
	4/20/23	1380	PJ	B&R Services - Cleane	2,070.00		
				Current Period Change	11,682.87		
				Beginning Balance			11,682.87
	5/1/23			Beginning Balance			78,616.40
	5/1/23	2398	PJ	Premium Pumps & Con	1,886.30		
	5/1/23	3294762V131	PJ	Waste Connections of T	90.00		
	5/1/23	99591	PJ	Brazoria County Septic	295.00		
	5/1/23	017 050123	PJ	Litzler's Feed Store	39.47		
	5/3/23	0500 Aguirre	PJ	Card Service Center - R	45.01		
	5/5/23	1018922	PJ	Precision Pumps Syste	3,259.00		
	5/9/23	91563	PJ	Envirodyne Laboratorie	290.00		
	5/15/23	2379	PJ	Premium Pumps & Con	4,132.00		
	5/16/23	959208	PJ	Lowe's - Padlocks	298.80		
	5/16/23	959208	PJ	Lowe's - Impact sockets	179.55		
	5/25/23	115685	PJ	HAHN Equipment Co I	1,200.00		
	5/31/23	May 2023	PJ	YellowRaven Backyard	793.06		
	5/31/23	81425	PJ	Magna Flow Environme	49,246.94		
				Current Period Change	61,755.13		
				Beginning Balance			61,755.13
	6/1/23			Beginning Balance			140,371.53
	6/1/23	017 060123	PJ	Litzler's Feed Store	123.93		
	6/1/23	3328447V131	PJ	Waste Connections of T	290.00		
	6/2/23	218831462-00	PJ	United Rentals - Releas	27.00		
	6/2/23	218831462-00	PJ	United Rentals - Shorin	156.00		
	6/2/23	218831462-00	PJ	United Rentals - Shorin	145.00		
	6/2/23	218831462-00	PJ	United Rentals - Cylind	196.00		
	6/2/23	218831462-00	PJ	United Rentals - Pick-u	350.00		
	6/2/23	218831462-00	PJ	United Rentals - Remov	27.00		
	6/9/23	115827	PJ	HAHN Equipment Co I	1,200.00		
	6/11/23	061523	PJ	Lowe's Home Centers I	170.90		
	6/11/23	218216436-00	PJ	United Rentals - Portabl	1,613.92		
	6/11/23	218634877-00	PJ	United Rentals - Concre	137.70		
	6/11/23	218708855-00	PJ	United Rentals - Shorin	350.00		
	6/11/23	218816196-00	PJ	United Rentals - Diesel	1,459.53		
	6/11/23	218831462-00	PJ	United Rentals - Shorin	1,179.00		
	6/11/23	219525082-00	PJ	United Rentals - Concre	402.90		
	6/23/23	INV-Q-07082	PJ	Worldwide Power - Ge	929.32		
	6/30/23	81933	PJ	Magna Flow Environme	14,351.20		
				Current Period Change	23,109.40		
				Beginning Balance			23,109.40
	7/1/23			Beginning Balance			163,480.93
	7/1/23	3357544V131	PJ	Waste Connections of T	90.00		
	7/1/23	3357544V131	PJ	Waste Connections of T	200.00		
	7/1/23	115069	PJ	HAHN Equipment Co I	1,200.00		
	7/1/23	114699	PJ	HAHN Equipment Co I	1,200.00		
	7/1/23	INV-2196	PJ	EGSW, LLC - Microsol	3,790.00		
	7/11/23	1149551	PJ	Inframark, LLC - WWT	20,905.49		
	7/17/23	3391235V131	PJ	Waste Connections of T	90.00		
	7/17/23	100323	PJ	Brazoria County Septic	570.00		
	7/18/23	116101	PJ	HAHN Equipment Co I	1,200.00		
	7/24/23	CW072423-0	PJ	J & C Plumbing - 1301	811.83		
	7/24/23	CW072423-0	PJ	Kinloch Equipment & S	1,575.00		
	7/25/23	93391	PJ	Envirodyne Laboratorie	290.00		
	7/26/23	116183	PJ	HAHN Equipment Co I	11,187.00		
	7/31/23	116215	PJ	HAHN Equipment Co I	1,152.00		
				Current Period Change	44,261.32		
				Beginning Balance			44,261.32
	8/1/23			Beginning Balance			207,742.25
	8/1/23	21217-A	PJ	Northstar Industries - T	2,450.00		
	8/1/23	2127-B	PJ	Northstar Industries - T	2,450.00		
	8/9/23	1150535	PJ	Inframark, LLC - Opera	19,862.23		
	8/9/23	08/9	PJ	Litzler's Feed Store - Pa	5.17		
	8/9/23	08/9/23	PJ	Litzler's Feed Store - Pa	178.67		
	8/15/23	3428398V131	PJ	Waste Connections of T	90.00		
	8/16/23	116359	PJ	HAHN Equipment Co I	1,200.00		
	8/21/23	94071	PJ	Envirodyne Laboratorie	405.00		

*Sweeny - Enterprise Fund
General Ledger

Item 19.

For the Period From Oct 1, 2022 to Sep 30, 2023

Filter Criteria includes: 1) IDs from 50-11-6711 to 50-11-6711. Report order is by ID. Report is printed with shortened descriptions and in Detail Format.

Account ID Account Description	Date	Reference	Jrnl	Trans Description	Debit Amt	Credit Amt	Balance
	8/30/23	0406-152164	PJ	O'Reilly Automotive, In	602.40		
				Current Period Change	27,243.47		27,243.47
	9/1/23			Beginning Balance			234,985.72
	9/11/23	1151574	PJ	Inframark, LLC - Maint	11,918.53		
	9/12/23	116538	PJ	HAHN Equipment Co I	1,200.00		
	9/13/23	1457	PJ	B&R Services - Pulled	761.25		
	9/14/23	6577728	PJ	Hawkins, Inc. - 85MJH	500.00		
	9/14/23	6577728	PJ	Hawkins, Inc. - QP500-	31.95		
	9/18/23	3461528V131	PJ	Waste Connections of T	90.00		
	9/22/23	94928	PJ	Envirodyne Laboratorie	50.00		
	9/22/23	312396	PJ	McCoy's Building Supp	64.99		
	9/27/23	09/27-1	GENJ	CC payment-Harbor Fr	1,109.54		
				Current Period Change	15,726.26		15,726.26
	9/30/23			Ending Balance			250,711.98

BUDGET AMENDMENT - FROM FUND BALANCE
 MAINTENANCE OF SEWER SYSTEM
 50-11-6711

DATE	BACK UP NO.	INVOICE NO.	PROVIDER	AMOUNT	NOTES / JUSTIFICATION
12/5/2022	1	0114260-IN	UNDERGROUND INC.	6,263.55	SEWER JETTER REPAIR
12/5/2022	2	3000364	SCRUGGS DISTRIBUTION	3,440.00	REPLACE BLOWER MOTORS 1 & 2
3/22/2023	3	3001266	SCRUGGS DISTRIBUTION	1,550.00	WORK ON RAS PUMP - BAD FEEDER
5/15/2023	4	2379	PREMIUM PUMPS & CONTROLS	4,130.00	NEW BLOWER & HORIZONTAL RIGHT SHAFT & BASE
5/1/2023	5	2398	PREMIUM PUMPS & CONTROLS	1,886.30	WORK ON RAS PUMPS
4/18/2023	6	2380	PREMIUM PUMPS & CONTROLS	2,801.00	WORK ON RAS PUMPS & REPLACE PIPING
5/31/2023	7	81425	MAGNA FLOW	49,246.94	DEWATER CLARIFYER 1 - PLANT DEAD, EMERGENCY **PAID FOR WITH 2019 CO'S**
6/30/2023	8	81933	MAGNA FLOW	14,351.20	DEWATERING, SLUDGE REMOVAL CLARIFYER 1 - PLANT DEAD , EMERGENCY
7/11/2023	9	1149551	INFRAMARK	20,905.49	WWTP OPERATIONS
7/26/2023	10	116183	HAHN EQUIPMENT	11,187.00	PUMP REPLACEMENT AT SHADY LIFT STATION
8/9/2023	11	1150535	INFRAMARK	19,862.23	WWTP OPERATIONS, GEN MAIN, REPAIRS
9/11/2023	12	1151574	INFRAMARK	11,918.53	WWTP OPERATIONS
9/11/2023	13	1457	B&R SERVICES	761.25	PULLED 2 RAS PUMPS NOT WORKING
9/30/2023	14	1152073	INFRAMARK	18,885.10	
			AMENDMENT AMT REQUESTED		
			FROM EF BALANCE	167,188.59	
			FY23 APPROVED BUDGET	90,000.00	
			FY 23 YTD AMT	250,711.98	
			OVER BUDGET	(160,711.98)	

REFERENCE NO.	DESCRIPTION	INVOICE DATE	INVOICE AMOUNT	DISCOUNT TAKEN	AMOUNT PAID
0114260-IN		12/29/22	6,263.55		6,263.55

CHECK DATE	CHECK NO.	PAYEE	DISCOUNTS TAKEN	CHECK AMOUNT
12/29/22	2161	Underground Inc.		\$6,263.55

LAP53 A/P CHECK

Rev 3/19



104691

10469

KE072522

CUSTOMER P/O

CUSTOMER P/O

Item Number	Whse	Unit	Ordered	Shipped	Back Ordered	Price	Amount
MISC PART	000	EACH	1.00	1.00	0.00	150.00	150.00
MISCELLANEOUS PART							
Fittings, Hardware, Connectors for piping, valves and hoses							
MWHR17-08	003	FT	12.00	12.00	0.00	4.22	50.64
1/2" R17 HYDRAULIC HOSE							
MISC PART	000	EACH	1.00	1.00	0.00	140.00	140.00
MISCELLANEOUS PART							
SHACKLES, BOLTS, NUTS FOR AXLE SPRINGS							
SERVICELABOR	003	EACH	5.00	5.00	0.00	125.00	625.00
SERVICE LABOR - PEARLAND SHOP							
MISC PART	000	EACH	1.00	1.00	0.00	630.00	630.00
MISCELLANEOUS PART							
ELECTRIC DRUM BRAKE KIT AND HARDWARE							
SERVICELABOR	003	EACH	5.00	5.00	0.00	125.00	625.00
SERVICE LABOR - PEARLAND SHOP							

1

ENTERED

All sales are final on electronic components. All returned items must be in new or unused condition and are subject to a minimum 25% restocking fee. To find out more information on filing a warranty claim or returning product, please call us at 800.373.1318 or email us at warranty@pipehunter.com. A warranty claim number or RMA number is required before returning product.

Net Invoice:	6,263.55
Less Discount:	0.00
Shipping/Handling:	0.00
Sales Tax:	0.00
Invoice Total:	6,263.55
Less Deposit:	0.00
Invoice Balance USD:	6,263.55

PLEASE REMIT TO THE ADDRESS AT THE TOP OF THIS FORM

Invoice

UNDERGROUND, INC.
PO BOX 2729
PEARLAND, TEXAS 77588-2729

Office 281-485-9900 or 800-373-1318
 Fax 281-485-5953

Invoice Number: 0114260-IN
Invoice Date: 12/5/2022
Order Number: 0066700
Order Date: 4/29/2022
Salesperson: 75SM
Customer Number: 02-0001301

Terms Net 30

Sold To:

SWEENEY, CITY OF
 P.O. BOX 248
 SWEENEY, TX 77480-0248

Ship To:

TEXAS UNDERGROUND INC.
 2141 CULLEN BLVD
 PEARLAND, TX 77581

Confirm To:

rdaguire@sweenytx.gov

Tracking Numbers:

Comment: KE072522

Customer P.O.	Ship VIA	F.O.B.						Check or Credit Card No.
KE072522	CUSTOMER P/U	CUSTOMER P/U						
Item Number	Whse	Unit	Ordered	Shipped	Back Ordered	Price	Amount	
MISC PART	000	EACH	1.00	1.00	0.00	150.00	150.00	
MISCELLANEOUS PART								
Fittings, Hardware, Connectors for piping, valves and hoses								
MWHIR17 08	003	FT	12.00	12.00	0.00	4.22	50.64	
1/2" R17 HYDRAULIC HOSE								
MISC PART	000	EACH	1.00	1.00	0.00	140.00	140.00	
MISCELLANEOUS PART								
SHACKLES, BOLTS, NUTS FOR AXLE SPRINGS								
SERVICELABOR	003	EACH	5.00	5.00	0.00	125.00	625.00	
SERVICE LABOR - PEARLAND SHOP								
MISC PART	000	EACH	1.00	1.00	0.00	630.00	630.00	
MISCELLANEOUS PART								
ELECTRIC DRUM BRAKE KIT AND HARDWARE								
SERVICELABOR	003	EACH	5.00	5.00	0.00	125.00	625.00	
SERVICE LABOR - PEARLAND SHOP								

All sales are final on electronic components. All returned items must be in new or unused condition and are subject to a minimum 25% restocking fee. To find out more information on filing a warranty claim or returning product, please call us at 800.373.1318 or email us at warranty@pipehunter.com. A warranty claim number or RMA number is required before returning product.

Net Invoice:	6,263.55
Less Discount:	0.00
Shipping/Handling:	0.00
Sales Tax:	0.00
Invoice Total	6,263.55
Less Deposit:	0.00
Invoice Balance USD:	6,263.55

PLEASE REMIT TO THE ADDRESS AT THE TOP OF THIS FORM

Invoice

UNDERGROUND, INC.
PO BOX 2729
PEARLAND, TEXAS 77588-2729

Office 281-485-9900 or 800-373-1318
 Fax 281-485-5953

Invoice Number: 0114260-IN
Invoice Date: 12/5/2022
Order Number: 0066700
Order Date: 4/29/2022
Salesperson: 75SM
Customer Number: 02-0001301

Terms Net 30

Sold To:

SWEENEY, CITY OF
 P.O. BOX 248
 SWEENEY, TX 77480-0248

Ship To:

TEXAS UNDERGROUND INC.
 2141 CULLEN BLVD
 PEARLAND, TX 77581

Confirm To:

rdaguirre@sweenytx.gov

Tracking Numbers: ;

Comment: KE072522

Customer P.O. KE072522 **Ship VIA** CUSTOMER P/U **F.O.B.** CUSTOMER P/U **Check or Credit Card No.**

Item Number	Whse	Unit	Ordered	Shipped	Back Ordered	Price	Amount
Customer complains of Hydraulic leaks, repair all check brakes and trailer electrical panel function no start and shorts check axles complete service, all fluids Ross Aguirre 979-482-3152 BLANK FOUND HYDRAULIC PIPE ROTTED AND LEAKING, ONE 1/2" NEW HYDRAULIC PIPE NEEDED, ADD HYDRAULIC FLUID FOUND WATER TANK DRAIN VALVE TO BE LEAKING HANDLE NEEDS REPLACEMENT FOR 3 WAY BALL VALVE BATTERY TERMINAL ENDFEAULTY. NEEDS TO BE REPLACED. FOUND BRAKE DRUMS TO BE FAULTY. RECOMMENDE REPLACEMENT.							
TRAILER PM	003	EACH	1.00	1.00	0.00	895.00	895.00
PREVENTATIVE MAINTENANCE-TRAIL							
3012-2001	003	EACH	1.00	1.00	0.00	0.00	0.00
FILTER, HYDRAULIC							
FIL-33548	003	EACH	1.00	1.00	0.00	0.00	0.00
JD FUEL FILTER / WATER SEPERAT							
FIL-57243	003	EACH	1.00	1.00	0.00	0.00	0.00
OIL FILTER J/D 4045D							
FIL-42789	003	EACH	1.00	1.00	0.00	0.00	0.00
AIR FILTER J/D 4045T							
3001-2046	003	EACH	1.00	1.00	0.00	13.01	13.01
BATTERY TERMINAL JUMPER RED							
2404-8-8	003	EACH	2.00	2.00	0.00	4.95	9.90
1/2" MJ X 1/2" MP STRAIGHT							
SERVICELABOR	003	EACH	25.00	25.00	0.00	125.00	3,125.00
SERVICE LABOR - PEARLAND SHOP							

50-11-6711

Continued

Statement

Statement Date: 12/8/2022

V 281-485-9900 or 800-373-1318
F 281-485-5953
888-2729

Customer 02-0001301
SWEENY, CITY OF
P.O. BOX 248
SWEENY, TX 77480-0248

Contact
FAX:

INVOICE DATE	INVOICE NUMBER	CustomerPONo	INVOICE AMOUNT	PAYMENT OR CREDIT AMOUNT	BALANCE
12/5/2022	0114260-IN KE072522	KE072522	6,263.55		6,263.55

Total: 6,263.55

Current	30 Days	60 Days	90 Days	120 Days	Balance Due
6,263.55	0.00	0.00	0.00	0.00	6,263.55

If you have questions concerning your account, please email AR@pipehunter.com or call 281-485-9900

REFERENCE NO.	DESCRIPTION	INVOICE DATE	INVOICE AMOUNT	DISCOUNT TAKEN	AMOUNT PAID
3000478		12/5/22	3,850.00		3,850.00
3000364		12/5/22	3,440.00		3,440.00
3000331		12/5/22	6,657.00		6,657.00

CHECK DATE	CHECK NO.	PAYEE	DISCOUNTS TAKEN	CHECK AMOUNT
			\$13,947.00	2131

LAP53 A/P CHECK
 Rev 3/19
 104691
 10469

ITEM #	DESCRIPTION	QTY	UNIT PRICE	TOTAL
3000478*	LABOR FOR INSTALATION OF BOOSTER PUMP #3			3850
	11-6710*			
TOTAL				\$ 3,850.00

Comments or Special Instructions

2

IMPORTANT:

Above Order Number must appear on all correspondence, invoices, packages and shipping papers. Notify us immediately if you are unable to ship complete order by date specified. Your acceptance of this order is your warranty to us that you are complying with the U.S. Fair Labor Standards Act of 1988, as amended, and we reserve the right to refuse merchandise not in strict accordance with this order.

CITY OF SWEENY

PURCHASE ORDER

PO BOX 248
SWEENY, TEXAS 77480
Phone: (979) 548-3321
Fax: (979) 548-7745
sweenytx.gov

RA-193942

DATE 10/25/2022

VENDOR

SCRUGGS

ITEM #		QTY	UNITE PRICE	175
3000364=	REPAIR BLOWER MOTORS	2		3440
	11-6711.			
			TOTAL	\$ 3,440.00

Comments or Special Instructions

IMPORTANT:

Above Order Number must appear on all correspondence, invoices, packages and shipping papers. Notify us immediately if you are unable to ship complete order by date specified. Your acceptance of this order is your warranty to us that you are complying with the U.S. Fair Labor Standards Act of 1988, as amended, and we reserve the right to refuse merchandise not in strict accordance with this order.



8530 Hansen Rd
Houston, TX 77075-1006
713-649-2776

INVOICE

INVOICE	
3000364	
Invoice Date	Page
10/17/2022	1 of 1
ORDER NUMBER	
1000456	

Bill To:
SWEENEY, CITY OF
PO BOX 248
Sweeny, TX 77480
USA

Ship To:
SWEENEY, CITY OF
PO BOX 248
Sweeny, TX 77480
USA

Customer ID: 11110

Number	Terms	Due Date	Order Date	Salesrep	Carrier:	Tracking #:
2152	Net 30	11/16/2022	10/13/2022	Mark Kirsopp		

Quantities				Item ID Item Description	Unit Price	Extended Price
Shipped	Remaining	UOM				

Order Note: SWEENEY WWTP- 10/12/22
LABOR TO REPLACE BLOWER MOTOR
FOR BLOWERS 1 AND 2
TECO ELECTRIC MOTOR# NP0054 5HP
1800RPM TEFC
230/460V 3PH 60HZ 184T FRAME

1	0	EA	SERVICE Field Service	3,440.00	3,440.00
---	---	----	--------------------------	----------	----------

Total Lines: 1				SUB-TOTAL:	3,440.00
				TAX:	0.00
				AMOUNT DUE:	3,440.00

REFERENCE NO.	DESCRIPTION	INVOICE DATE	INVOICE AMOUNT	DISCOUNT TAKEN	AMOUNT PAID
3001266		3/22/23	1,550.00		1,550.00

CHECK DATE	CHECK NO.	PAYEE	DISCOUNTS TAKEN	CHECK AMOUNT
4/7/23	2269	Scruggs Distribution LLC		\$1,550.00

LAP53 A/P CHECK

Rev 3/19



104691

10489

3001266*	WORK ON RES PUMPS			1550
	11-6711*			
TOTAL				\$ 1,550.00

ENTERED

Comments or Special Instructions

③

IMPORTANT:

Above Order Number must appear on all correspondence, invoices, packages and shipping papers. Notify us immediately if you are unable to ship complete order by date specified. Your acceptance of this order is your warranty to us that you are complying with the U.S. Fair Labor Standards Act of 1988, as amended, and we reserve the right to refuse merchandise not in strict accordance with this order.

INVOICE

Branch: 100 Scruggs Co
 8530 Hansen Rd
 Houston, TX 77075-1006



INVOICE	
3001266	
Invoice Date	Page
03/22/2023 15:50:31	1 of 2
ORDER NUMBER	
1001019	

713-649-2776

Bill To:
 SWEENEY, CITY OF
 PO BOX 248
 Sweeny, TX 77480
 USA

Ship To:
 SWEENEY, CITY OF
 PO BOX 248
 Sweeny, TX 77480
 USA

****DIRECT SHIPMENT****

Customer ID: 11110

PO Number	Term Description	Net Due Date	Disc Due Date	Discount Amount
Ross 2277	Net 30	04/21/2023	04/21/2023	0.00

Order Date	Pick Ticket No	Primary Salesrep Name	Taker
31/2023 08:31:18	2001245	House Account	DANIEL.GIANNELLA

Quantities					Item ID	Pricing	Unit	Extended
Ordered	Shipped	Remaining	UOM	Unit Size	Item Description	UOM	Price	Price

Order Note: SERVICE CALL - 1/10/23
 INVESTIGATE - RAS #2 FOUND BAD
 FEEDER. RAS #
 NEEDS HOA. INSTALLED HOA ON RAS 3.
 LOCATED BAD
 WIRE FOR #2. RAN TEMPORARY WIRES TO
 RUN RAS #2.
 (WILL NEED TO PROVIDE QUOTE TO
 REPAIR AND RUN
 NEW CONDUIT)
 BLACK ASSM (CONTACT BLOCK)
 30MM SELECTOR SWITCH 3 POSITION
 (HOA SWITCH)
 THHN-12-YEL-19STR-CU-500S/R

Carrier: **Tracking #:** Service Call

1	1	0	EA	1.0	SERVICE PREMIUM PUMP	EA	1,550.00	1,550.00
					Service Premium Pump	1.0000		
					Service by Premium Pump			

REFERENCE NO.	DESCRIPTION	INVOICE DATE	INVOICE AMOUNT	DISCOUNT TAKEN	AMOUNT PAID
2379		5/15/23	4,132.00		4,132.00

CHECK DATE	CHECK NO.	PAYEE	DISCOUNTS TAKEN	CHECK AMOUNT
6/3/23	2342	Premium Pumps & Controls, LLC		\$4,132.00

LAP53 A/P CHECK
Rev 3/19



HORIZONTAL RIGHT CHECK
BLOWER AT WWTP

184T Frame Adjustable Base	184T Frame Adjustable Base	1	193.00	193.00
----------------------------	----------------------------	---	--------	--------

SUBTOTAL	3,682.00
TAX	0.00
SHIPPING	450.00
TOTAL	4,132.00

BALANCE DUE **\$4,132.00**

Pay invoice

4

ENTERED

50-11-6711

PREMIUM PUMPS & CONTROLS,
LLC
1930 N Sam Houston Pkwy E Ste 211
Houston, TX 77032 US
info@premiumpumpscontrols.com
www.premiumpumpscontrols.com

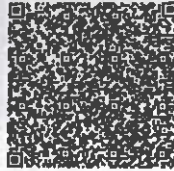

INVOICE

BILL TO
CITY OF SWEENY
102 W. ASHLEY WILSON RD.
SWEENY, TX 77480

SHIP TO
CITY OF SWEENY

INVOICE 2379
DATE 05/15/2023
TERMS Net 30
DUE DATE 06/14/2023

DATE	DESCRIPTION	QTY	RATE	AMOUNT
17351560	HIBON BLOWER - BLOWER S2H 42VN BHC STD BUILD NPT Horizontal Right Shaft BLOWER AT WWTP	1	3,489.00	3,489.00
184T Frame Adjustable Base	184T Frame Adjustable Base	1	193.00	193.00

SUBTOTAL	3,682.00
TAX	0.00
SHIPPING	450.00
TOTAL	4,132.00
BALANCE DUE	\$4,132.00

Pay invoice

ENTERED

50-11-6711

PLEASE REMIT PAYMENT TO: 8510 SILVER LURE DR,
HUMBLE, TX 77346

REFERENCE NO.	DESCRIPTION	INVOICE DATE	INVOICE AMOUNT	DISCOUNT TAKEN	AMOUNT PAID
2380		4/18/23	2,801.00		2,801.00
2398		5/1/23	1,886.30		1,886.30

CHECK DATE	CHECK NO.	PAYEE	DISCOUNTS TAKEN	CHECK AMOUNT
5/8/23	2312	Premium Pumps & Controls, LLC		\$4,687.30

LAPS3 A/P CHECK



104691

Rev 3/19

10469

2398*	WORK ON RAS PUMPS	5		1886.3
2380*	REPLACE PIPEING ON NPW PUMPS	6		2,801.00
	11-6711* ~			
TOTAL				\$ 4,687.30

Comments or Special Instructions

IMPORTANT:

Above Order Number must appear on all correspondence, invoices, packages and shipping papers. Notify us immediately if you are unable to ship complete order by date specified. Your acceptance of this order is your warranty to us that you are complying with the U.S. Fair Labor Standards Act of 1988, as amended, and we reserve the right to refuse merchandise not in strict accordance with this order.

CITY OF SWEENY

PO BOX 248
 SWEENY, TEXAS 77480
 Phone: (979) 548-3321
 Fax: (979) 548-7745
 sweenytx.gov

PURCHASE ORDER

SW-202401

DATE 5/2/2023

VENDOR

PREMIUM PUMPS

ITEM #		QTY	UNITE PRICE	175
2398*	WORK ON RAS PUMPS			1886.3
2380*	REPLACE PIPEING ON NPW PUMPS			2,801.00
	11-6711* ~			
			TOTAL	\$ 4,687.30

Comments or Special Instructions

IMPORTANT:
 Above Order Number must appear on all correspondence, invoices, packages and shipping papers. Notify us immediately if you are unable to ship complete order by date specified. Your acceptance of this order is your warranty to us that you are complying with the U.S. Fair Labor Standards Act of 1988, as amended, and we reserve the right to refuse merchandise not in strict accordance with this order.

PREMIUM PUMPS & CONTROLS,
LLC

3016 N. Loop West Houston Pkwy E Ste 211
Houston, TX 77032 US
www.premiumpumpscontrols.com
www.premiumpumpscontrols.com

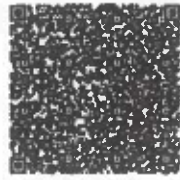

INVOICE

BILL TO
CITY OF SWEENEY
102 W. ASHLEY WILSON RD.
SWEENEY, TX 77480

SHIP TO
CITY OF SWEENEY
102 W. ASHLEY WILSON RD.
SWEENEY, TX 77480

INVOICE 2398
DATE 05/01/2023
TERMS Due on receipt
DUE DATE 05/01/2023

DATE	DESCRIPTION	QTY	RATE	AMOUNT
01/10/2023	ELECTRICIAN HOURLY RATE SERVICE CALL-1/10/23 SWEENEY INVESTIGATE - RAS #2 FOUND BAD FEEDER. RAS # NEEDS HOA. INSTALLED HOA ON RAS 3. LOCATED BAD WIRE FOR #2. RAN TEMPORARY WIRES TO RUN RAS #2.	8	185.00	1,480.00
	PARTS BLACK ASSM (CONTACT BLOCK)	1	80.80	80.80
	PARTS 30MM SELECTOR SWITCH 3 POSITION (HOA SWITCH)	1	183.00	183.00
	WIRE THHN-12-YEL-19STR-CU-500S/R	90	0.65	58.50
	CONSUMABLE CHARGE CONSUMABLE CHARGE	1	84.00	84.00

SUBTOTAL 1,886.30
TAX 0.00
TOTAL 1,886.30
BALANCE DUE **\$1,886.30**

Pay invoice

PLEASE REMIT PAYMENT TO 8510 SILVER LURE DR,
HUMBLE, TX 77346

81425 5/31/23 49,246.94 49,246.94

7/5/23 2378 Magna Flow Environmental, Inc. \$49,246.94

7



Magna Flow Environmental, Inc.

P.O. Box 60709
Houston, Texas
77205

Invoice

Date	Invoice #
5/31/2023	81425

Bill To
City of Sweeny Attn: Reatta PO Box 248 Sweeny, TX 77480

Project / Job #	P.O. No.	Terms	Rep	Location	Due Date	
57117		Net 30	CB	C/O Sweeny	7/19/2023	
Qty	Item	Description			Rate	Amount
	In	City of Sweeny				
	Out	05/22/2023				
		05/31/2023				
177,004	Dewatered Slu... Fuel Surcharge	Dewater - 177004 Gal(s) Fuel Surcharge @ 11.29%			0.25 11.29%	44,251.00 4,995.94
	Manifest	05/22/2023: 28149				
		05/24/2023: 28148				
		05/25/2023: 28122				
		05/30/2023: 28124				
		05/31/2023: 28123				
Phone #		Fax #		Balance Due \$49,246.94		
281-448-8585		281-397-7195				
Thank you for your Business!						

Please Remit To:
Magna Flow Environmental, Inc.
PO Box 4356, Dept. # 695
Houston, TX 77210-4356

U.S. Regular Gasoline Prices*(dollars per gallon)

[full history](#)  XLS

	05/15/23	05/22/23	05/29/23	Change from	
				week ago	year ago
U.S.	3.536	3.534	3.571	↑ 0.037	↓ -1.053
East Coast (PADD1)	3.397	3.381	3.427	↑ 0.046	↓ -1.120
New England (PADD1A)	3.415	3.427	3.526	↑ 0.099	↓ -1.192
Central Atlantic (PADD1B)	3.546	3.544	3.600	↑ 0.056	↓ -1.171
Lower Atlantic (PADD1C)	3.297	3.267	3.293	↑ 0.026	↓ -1.068
Midwest (PADD2)	3.440	3.469	3.484	↑ 0.015	↓ -0.973
Gulf Coast (PADD3)	3.079	3.040	3.121	↑ 0.081	↓ -1.099
Rocky Mountain (PADD4)	3.518	3.579	3.622	↑ 0.043	↓ -0.826
West Coast (PADD5)	4.519	4.514	4.534	↑ 0.020	↓ -1.025
West Coast less California	4.413	4.408	4.415	↑ 0.007	↓ -0.665

[+ See more](#)

U.S. On-Highway Diesel Fuel Prices*(dollars per gallon)

[full history](#)  XLS

	05/15/23	05/22/23	05/29/23	Change from	
				week ago	year ago
U.S.	3.897	3.883	3.855	↓ -0.028	↓ -1.684
East Coast (PADD1)	3.932	3.912	3.886	↓ -0.026	↓ -1.962
New England (PADD1A)	4.243	4.166	4.144	↓ -0.022	↓ -2.082
Central Atlantic (PADD1B)	4.238	4.198	4.190	↓ -0.008	↓ -2.035
Lower Atlantic (PADD1C)	3.787	3.780	3.747	↓ -0.033	↓ -1.805
Midwest (PADD2)	3.823	3.810	3.781	↓ -0.029	↓ -1.466
Gulf Coast (PADD3)	3.593	3.579	3.555	↓ -0.024	↓ -1.625
Rocky Mountain (PADD4)	4.089	4.088	4.077	↓ -0.011	↓ -1.417
West Coast (PADD5)	4.588	4.586	4.540	↓ -0.046	↓ -1.594
West Coast less California	4.382	4.378	4.305	↓ -0.073	↓ -1.365
California	4.825	4.825	4.810	↓ -0.015	↓ -1.732

*prices include all taxes



FUEL SURCHARGE CHART

Based on DOE Weekly On-Highway Retail Diesel Prices

<u>DOE avg \$/gallon</u>	<u>MFE Surcharge</u>	<u>DOE Avg \$/gallon</u>	<u>MFE Surcharge</u>	<u>DOE avg \$/gallon</u>	<u>MFE Surcharge</u>
\$2.00	1.00%	\$3.80	12.89%	\$5.60	23.42%
\$2.05	1.39%	\$3.85	13.21%	\$5.65	23.66%
\$2.10	1.73%	\$3.90	13.53%	\$5.70	23.90%
\$2.15	2.07%	\$3.95	13.85%	\$5.75	24.15%
\$2.20	2.41%	\$4.00	14.18%	\$5.80	24.40%
\$2.25	2.75%	\$4.05	14.51%	\$5.85	24.64%
\$2.30	3.09%	\$4.10	14.84%	\$5.90	24.88%
\$2.35	3.43%	\$4.15	15.17%	\$5.95	25.12%
\$2.40	3.77%	\$4.20	15.50%	\$6.00	25.35%
\$2.45	4.11%	\$4.25	15.82%	\$6.05	25.58%
\$2.50	4.45%	\$4.30	16.35%	\$6.10	25.81%
\$2.55	4.79%	\$4.35	16.48%	\$6.15	26.04%
\$2.60	5.13%	\$4.40	16.81%	\$6.20	26.27%
\$2.65	5.46%	\$4.45	17.15%	\$6.25	26.50%
\$2.70	5.80%	\$4.50	17.48%	\$6.30	26.75%
\$2.75	6.13%	\$4.55	17.81%	\$6.35	27.00%
\$2.80	6.47%	\$4.60	18.15%	\$6.40	27.25%
\$2.85	6.81%	\$4.65	18.47%	\$6.45	27.50%
\$2.90	7.15%	\$4.70	18.80%	\$6.50	27.75%
\$2.95	7.49%	\$4.75	19.12%	\$6.55	28.00%
\$3.00	7.83%	\$4.80	19.44%	\$6.60	28.25%
\$3.05	8.17%	\$4.85	19.76%	\$6.65	28.50%
\$3.10	8.51%	\$4.90	20.01%	\$6.70	28.75%
\$3.15	8.84%	\$4.95	20.26%	\$6.75	29.00%
\$3.20	9.18%	\$5.00	20.51%	\$6.80	29.25%
\$3.25	9.52%	\$5.05	20.76%	\$6.85	29.50%
\$3.30	9.85%	\$5.10	21.01%	\$6.90	29.75%
\$3.35	10.00%	\$5.15	21.28%	\$6.95	30.00%
\$3.40	10.33%	\$5.20	21.50%	\$7.00	30.25%
\$3.45	10.65%	\$5.25	21.74%	\$7.05	30.50%
\$3.50	10.97%	\$5.30	21.98%	\$7.10	30.75%
\$3.55	11.29%	\$5.35	22.22%	\$7.15	31.00%
\$3.60	11.61%	\$5.40	22.46%	\$7.20	31.25%
\$3.65	11.93%	\$5.45	22.70%	\$7.25	31.50%
\$3.70	12.25%	\$5.50	22.94%	\$7.30	31.75%
\$3.75	12.57%	\$5.55	23.18%	\$7.35	32.00%

REFERENCE NO.	DESCRIPTION	INVOICE DATE	INVOICE AMOUNT	DISCOUNT TAKEN	AMOUNT PAID
81933		6/30/23	14,351.20		14,351.20

CHECK DATE	CHECK NO.	PAYEE	DISCOUNTS TAKEN	CHECK AMOUNT
8/28/23	2439	Magna Flow Environmental, Inc.		\$14,351.20

LAP53 A/P CHECK  104691 10469

Funding-GL Acct #	DESCRIPTION	QTY	UNIT PRICE	TOTAL
11-6711	Dewatering at WWTP Clarifiers	1	14,351.20	14,351.20
TOTAL			\$ - -	#####

Comments or Special Instructions

8

IMPORTANT:

Above Order Number must appear on all correspondence, invoices, packages and shipping papers. Notify us immediately if you are unable to ship complete order by date specified. Your acceptance of this order is your warranty to us that you are complying with the U.S. Fair Labor Standards Act of 1988, as amended, and we reserve the right to refuse merchandise not in strict accordance with this order.



Magna Flow Environmental, Inc.

P.O. Box 60709
Houston, Texas
77205

11-6711 - Sweeney
Clarifiers

Invoice

Date	Invoice #
6/30/2023	81933

Bill To
City of Sweeny Attn: Reatta PO Box 248 Sweeny, TX 77480

Project / Job #	P.O. No.	Terms	Rep	Location	Due Date
57585		Net 30	CB	C/O Sweeny	8/13/2023
Qty	Item	Description		Rate	Amount
	In	City of Sweeny			
	Out	06/26/2023			
51,730	Dewatered Slu...	Dewater - 51730 Gal(s)		0.25	12,932.50
	Fuel Surcharge	Fuel Surcharge @ 10.97%		10.97%	1,418.70
	Manifest	06/26/2023: 28133, 28185			
Phone #	Fax #	Thank you for your Business!		Balance Due	\$14,351.20
281-448-8585	281-397-7195				

Please Remit To:
Magna Flow Environmental, Inc.
PO Box 4356, Dept. # 695
Houston, TX 77210-4356

Gasoline Prices (dollars per gallon)

full history XLS

	06/12/23	06/19/23	06/26/23	Change from	
				week ago	year ago
U.S.	3.595	3.577	3.571	↓ -0.006	↓ -1.301
East Coast (PADD1)	3.432	3.419	3.405	↓ -0.014	↓ -1.283
New England (PADD1A)	3.530	3.533	3.535	↑ 0.002	↓ -1.359
Central Atlantic (PADD1B)	3.569	3.566	3.575	↑ 0.009	↓ -1.299
Lower Atlantic (PADD1C)	3.321	3.296	3.264	↓ -0.032	↓ -1.254
Midwest (PADD2)	3.513	3.489	3.452	↓ -0.037	↓ -1.370
Gulf Coast (PADD3)	3.145	3.109	3.190	↑ 0.081	↓ -1.310
Rocky Mountain (PADD4)	3.707	3.721	3.734	↑ 0.013	↓ -1.250
West Coast (PADD5)	4.584	4.569	4.556	↓ -0.013	↓ -1.230
West Coast less California	4.448	4.437	4.452	↑ 0.015	↓ -0.945

+ See more

U.S. On-Highway Diesel Fuel Prices*(dollars per gallon)

full history XLS

	06/12/23	06/19/23	06/26/23	Change from	
				week ago	year ago
U.S.	3.794	3.815	3.801	↓ -0.014	↓ -1.982
East Coast (PADD1)	3.860	3.866	3.853	↓ -0.013	↓ -1.961
New England (PADD1A)	4.116	4.116	4.110	↓ -0.006	↓ -1.920
Central Atlantic (PADD1B)	4.137	4.126	4.102	↓ -0.024	↓ -1.956
Lower Atlantic (PADD1C)	3.732	3.745	3.735	↓ -0.010	↓ -1.964
Midwest (PADD2)	3.717	3.739	3.734	↓ -0.005	↓ -2.033
Gulf Coast (PADD3)	3.489	3.532	3.510	↓ -0.022	↓ -1.931
Rocky Mountain (PADD4)	4.013	4.032	4.022	↓ -0.010	↓ -1.748
West Coast (PADD5)	4.424	4.432	4.415	↓ -0.017	↓ -2.065
West Coast less California	4.142	4.137	4.123	↓ -0.014	↓ -2.023
California	4.750	4.773	4.751	↓ -0.022	↓ -2.112

prices include all taxes



FUEL SURCHARGE CHART

Based on DOE Weekly On-Highway Retail Diesel Prices

<u>DOE avg \$/gallon</u>	<u>MFE Surcharge</u>	<u>DOE Avg \$/gallon</u>	<u>MFE Surcharge</u>	<u>DOE avg \$/gallon</u>	<u>MFE Surcharge</u>
\$2.00	1.00%	\$3.80	12.89%	\$5.60	23.42%
\$2.05	1.39%	\$3.85	13.21%	\$5.65	23.66%
\$2.10	1.73%	\$3.90	13.53%	\$5.70	23.90%
\$2.15	2.07%	\$3.95	13.85%	\$5.75	24.15%
\$2.20	2.41%	\$4.00	14.18%	\$5.80	24.40%
\$2.25	2.75%	\$4.05	14.51%	\$5.85	24.64%
\$2.30	3.09%	\$4.10	14.84%	\$5.90	24.88%
\$2.35	3.43%	\$4.15	15.17%	\$5.95	25.12%
\$2.40	3.77%	\$4.20	15.50%	\$6.00	25.35%
\$2.45	4.11%	\$4.25	15.82%	\$6.05	25.58%
\$2.50	4.45%	\$4.30	16.35%	\$6.10	25.81%
\$2.55	4.79%	\$4.35	16.48%	\$6.15	26.04%
\$2.60	5.13%	\$4.40	16.81%	\$6.20	26.27%
\$2.65	5.46%	\$4.45	17.15%	\$6.25	26.50%
\$2.70	5.80%	\$4.50	17.48%	\$6.30	26.75%
\$2.75	6.13%	\$4.55	17.81%	\$6.35	27.00%
\$2.80	6.47%	\$4.60	18.15%	\$6.40	27.25%
\$2.85	6.81%	\$4.65	18.47%	\$6.45	27.50%
\$2.90	7.15%	\$4.70	18.80%	\$6.50	27.75%
\$2.95	7.49%	\$4.75	19.12%	\$6.55	28.00%
\$3.00	7.83%	\$4.80	19.44%	\$6.60	28.25%
\$3.05	8.17%	\$4.85	19.76%	\$6.65	28.50%
\$3.10	8.51%	\$4.90	20.01%	\$6.70	28.75%
\$3.15	8.84%	\$4.95	20.26%	\$6.75	29.00%
\$3.20	9.18%	\$5.00	20.51%	\$6.80	29.25%
\$3.25	9.52%	\$5.05	20.76%	\$6.85	29.50%
\$3.30	9.85%	\$5.10	21.01%	\$6.90	29.75%
\$3.35	10.00%	\$5.15	21.28%	\$6.95	30.00%
\$3.40	10.33%	\$5.20	21.50%	\$7.00	30.25%
\$3.45	10.65%	\$5.25	21.74%	\$7.05	30.50%
\$3.50	10.97%	\$5.30	21.98%	\$7.10	30.75%
\$3.55	11.29%	\$5.35	22.22%	\$7.15	31.00%
\$3.60	11.61%	\$5.40	22.46%	\$7.20	31.25%
\$3.65	11.93%	\$5.45	22.70%	\$7.25	31.50%
\$3.70	12.25%	\$5.50	22.94%	\$7.30	31.75%
\$3.75	12.57%	\$5.55	23.18%	\$7.35	32.00%

REFERENCE NO.	DESCRIPTION	INVOICE DATE	INVOICE AMOUNT	DISCOUNT TAKEN	AMOUNT PAID
1149551		7/11/23	41,459.73		41,459.73

CHECK DATE	CHECK NO.	PAYEE	DISCOUNTS TAKEN	CHECK AMOUNT
7/6/23	2450	Inframark, LLC		\$41,459.73

LAP53 A/P CHECK
 Rev 3/19
 104691
 10469

Funding-GL Acct #	DESCRIPTION	QTY	UNIT PRICE	TOTAL
11-6711	Emergency Water and Wastewater Operations through July 8th, 2023 for emergency services contract Inv# 1149551	1	41,459.73	41,459.73
		11-6711	20,905.49	
		11-6710	20,554.24	
			<u>41,459.73</u>	
TOTAL			\$ -	\$ 41,459.73

Comments or Special Instructions

9

IMPORTANT:

Above Order Number must appear on all correspondence, invoices, packages and shipping papers. Notify us immediately if you are unable to ship complete order by date specified. Your acceptance of this order is your warranty to us that you are complying with the U.S. Fair Labor Standards Act of 1988, as amended, and we reserve the right to refuse merchandise not in strict accordance with this order.



Inframark, LLC
2002 West Grand Parkway North, Suite 100
Katy, Texas 77449
(281) 578-4200

Client ID Number	
------------------	--

Invoice Number	1149551
Invoice Date	7/11/2023
Due Date	8/10/2023

To: City of Sweeny
102 W Ashley Wilson Rd

Sweeny, TX 77480

Service Description	Total
Maintenance Services	\$41,459.73

Subtotal	\$41,459.73
Sales Tax	\$0.00
Total	\$41,459.73

Please Pay This Amount

Remit To: Inframark, LLC, P.O. Box 733778, Dallas, Texas 75373-3778

To pay by Credit Card, contact us at 281-578-4299, 9:00am - 5:30pm EST, Mon - Fri. A surcharge fee may apply

To Pay via ACH or Wire, please refer to our banking information below:

Account Name : INFRAMARK, LLC

ACH - Bank Routing Number : 111000614 / Account Number 912593196

Wire - Bank Routing Number : 021000021 / SWIFT Code : CHASUS33 / Account Number: 912593196

Please include the Project ID and the Invoice Number on the check stub of your payment.

INFRAMARK, LLC
DISTRICT : CITY OF SWEENEY
INVOICE NO. 1149551 - SUMMARY
INVOICE DATE: 7/11/2023

11 Jul 2023 12:16:32PM CST
 Go Green! Think before you print.

Work Type / Sub Category	Equipment Costs	Labor Costs	Materials/Other Service Costs	Sales Tax Total	Total Costs
Maintenance, Sewer Plant					
SP1					
General Maintenance & Repairs	\$3,200.00	\$15,068.44	\$0.00	\$0.00	\$18,268.44
Maintenance	\$450.00	\$1,746.00	\$441.05	\$0.00	\$2,637.05
SP1 Total	\$3,650.00	\$16,814.44	\$441.05	\$0.00	\$20,905.49
SP Total	\$3,650.00	\$16,814.44	\$441.05	\$0.00	\$20,905.49
Maintenance, Water Plant					
WP1					
General Maintenance & Repairs	\$2,815.00	\$14,740.48	\$0.00	\$0.00	\$17,555.48
Maintenance	\$768.75	\$2,204.32	\$25.69	\$0.00	\$2,998.76
WP1 Total	\$3,583.75	\$16,944.80	\$25.69	\$0.00	\$20,554.24
WP Total	\$3,583.75	\$16,944.80	\$25.69	\$0.00	\$20,554.24
Invoice Total	\$7,233.75	\$33,759.24	\$466.74	\$0.00	\$41,459.73

INFRAMARK, LLC

DISTRICT : CITY OF SWEENEY

INVOICE NO. 1149551 - DETAIL

INVOICE DATE: 7/11/2023

11 Jul 2023 12:16:33PM CST

Go Green! Think before you print.

Work Type / Sub Category	Date Complete	WO Number	Address	Task Details	Equipment Costs	Labor Costs	Materials/Other Service Costs	Sales Tax Total	Total Costs	B/C
Maintenance, Sewer Plant										
SP1										
General Maintenance & Repairs										
	7/10/2023	3254593	2607 Avenue A	General Repair or Maintenance of an Asset at a Sewer Treatment Plant	\$1,670.00	\$7,312.24	\$0.00	\$0.00	\$8,982.24	N
	7/10/2023	3255041	2607 Avenue A	General Repair or Maintenance of an Asset at a Sewer Treatment Plant; sewer plant weekend check in	\$75.00	\$491.06	\$0.00	\$0.00	\$566.06	N
	7/10/2023	3258670	2607 Avenue A	General Repair or Maintenance of an Asset at a Sewer Treatment Plant	\$670.00	\$3,053.46	\$0.00	\$0.00	\$3,723.46	N
	7/10/2023	3258920	2607 Avenue A	General Repair or Maintenance of an Asset at a Sewer Treatment Plant	\$150.00	\$1,047.60	\$0.00	\$0.00	\$1,197.60	N
	7/10/2023	3260029	2607 Avenue A	General Repair or Maintenance of an Asset at a Sewer Treatment Plant; Monitor chemical feed at back end of plant and pull samples as needed. Run trash pump from clarifier to aeration, moving solids back into plant. General maintenance of everyday running of sewer plant.	\$420.00	\$1,891.50	\$0.00	\$0.00	\$2,311.50	N
	7/10/2023	3261486	2607 Avenue A	General Repair or Maintenance of an Asset at a Sewer Treatment Plant; Weekend Facility check and plant operations	\$95.00	\$562.30	\$0.00	\$0.00	\$657.30	N
	7/10/2023	3264833	2607 Avenue A	General Repair or Maintenance of an Asset at a Sewer Treatment Plant	\$120.00	\$710.28	\$0.00	\$0.00	\$830.28	N
				General Maintenance & Repairs Total	\$3,200.00	\$15,068.44	\$0.00	\$0.00	\$18,268.44	
Maintenance										
	7/10/2023	3250852	2607 Avenue A	General Repair of a Sewer Treatment Plant Asset; Check over CL2 System and walk over plant with operator.	\$75.00	\$291.00	\$4.28	\$0.00	\$370.28	N

INFRAMARK, LLC

DISTRICT : CITY OF SWEENEY

INVOICE NO. 1149551 - DETAIL

INVOICE DATE: 7/11/2023

11 Jul 2023 12:16:33PM CST

Go Green! Think before you print.

Work Type / Sub Category	Date Complete	WO Number	Address	Task Details	Equipment Costs	Labor Costs	Materials/Other Service Costs	Sales Tax Total	Total Costs	B/C
	7/10/2023	3250855	2607 Avenue A	General Repair of a Sewer Treatment Plant Asset; Go over Non-potable system with operator and get parts list to make changes to non-potable system that operator is asking for.	\$375.00	\$1,455.00	\$436.76	\$0.00	\$2,266.76	N
				Maintenance Total	\$450.00	\$1,746.00	\$441.05	\$0.00	\$2,637.05	
				SP1 Total	\$3,650.00	\$16,814.44	\$441.05	\$0.00	\$20,905.49	
				SP Total	\$3,650.00	\$16,814.44	\$441.05	\$0.00	\$20,905.49	
Maintenance, Water Plant										
WP1										
General Maintenance & Repairs										
	7/10/2023	3253528	204 Peach St	General Repairs of an Asset at a Water Plant	\$1,345.00	\$7,060.67	\$0.00	\$0.00	\$8,405.67	N
	7/10/2023	3255050	204 Peach St	General Repairs of an Asset at a Water Plant; water plant weekend check in	\$85.00	\$556.54	\$0.00	\$0.00	\$641.54	N
	7/10/2023	3258712	204 Peach St	General Repairs of an Asset at a Water Plant	\$220.00	\$1,342.24	\$0.00	\$0.00	\$1,562.24	N
	7/10/2023	3258932	204 Peach St	General Repairs of an Asset at a Water Plant	\$70.00	\$488.88	\$0.00	\$0.00	\$558.88	N

INFRAMARK, LLC

DISTRICT : CITY OF SWEENEY

INVOICE NO. 1149551 - DETAIL

INVOICE DATE: 7/11/2023

11 Jul 2023 12:16:33PM CST

Go Green! Think before you print.

Work Type / Sub Category	Date Complete	WO Number	Address	Task Details	Equipment Costs	Labor Costs	Materials/Other Service Costs	Sales Tax Total	Total Costs	B/C
	7/10/2023	3259994	204 Peach St	General Repairs of an Asset at a Water Plant; Checked district residual, got residual and est booster pumps running and time. Make adjustments on chemical feed system at plant, and in district.	\$310.00	\$1,353.14	\$0.00	\$0.00	\$1,663.14	N
	7/10/2023	3260014	204 Peach St	Investigate a Problem at a Water Plant; Leak at 90 degree pipe going from well to gst	\$260.00	\$1,353.15	\$0.00	\$0.00	\$1,613.15	N
	7/10/2023	3260016	204 Peach St	General Repairs of an Asset at a Water Plant; Checked district residual, got residual and est booster pumps running and time. Make adjustments on chemical feed system at plant, and in district.	\$300.00	\$1,347.33	\$0.00	\$0.00	\$1,647.33	N
	7/10/2023	3260034	204 Peach St	General Repairs of an Asset at a Water Plant; Met TCEQ on site for i of water plant and distribution system	\$60.00	\$261.90	\$0.00	\$0.00	\$321.90	N
	7/10/2023	3261489	204 Peach St	General Repairs of an Asset at a Water Plant; Weekend Facility check, district residuals and plant operations	\$95.00	\$562.30	\$0.00	\$0.00	\$657.30	N
	7/10/2023	3264831	204 Peach St	General Repairs of an Asset at a Water Plant	\$70.00	\$414.33	\$0.00	\$0.00	\$484.33	N
				General Maintenance & Repairs Total	\$2,815.00	\$14,740.48	\$0.00	\$0.00	\$17,555.48	
Maintenance										
	7/10/2023	3250857	204 Peach St	General Repair of a Water Plant Asset; Check PO4 system and get info to PM pump.	\$187.50	\$517.98	\$8.56	\$0.00	\$714.04	N
	7/10/2023	3250859	204 Peach St	MTX - Chlorine/Chemical Change Out at a Facility (must verify work type); change out	\$75.00	\$291.00	\$4.28	\$0.00	\$370.28	N

INFRAMARK, LLC

DISTRICT : CITY OF SWEENEY

INVOICE NO. 1149551 - DETAIL

INVOICE DATE: 7/11/2023

11 Jul 2023 12:16:33PM CST

Go Green! Think before you print.

Work Type / Sub Category	Date Complete	WO Number	Address	Task Details	Equipment Costs	Labor Costs	Materials/Other Service Costs	Sales Tax Total	Total Costs	B/C
	7/10/2023	3250860	204 Peach St	General Repair of a Water Plant Asset; Check over CL2 System and walk over plant with operator.	\$187.50	\$430.68	\$4.28	\$0.00	\$622.46	N
	7/10/2023	3250861	204 Peach St	MTX - Chlorine/Chemical Change Out at a Facility (must verify work type); change out	\$75.00	\$151.32	\$4.28	\$0.00	\$230.60	N
	7/10/2023	3260621	204 Peach St	General Repair of a Water Plant Asset; Get parts list for quote.	\$131.25	\$437.95	\$0.00	\$0.00	\$569.20	N
	7/10/2023	3262793	204 Peach St	MTX - Chlorine/Chemical Change Out at a Facility (must verify work type); Change out cl2	\$112.50	\$375.39	\$4.28	\$0.00	\$492.17	N
				Maintenance Total	\$768.75	\$2,204.32	\$25.69	\$0.00	\$2,998.76	
				WP1 Total	\$3,583.75	\$16,944.80	\$25.69	\$0.00	\$20,554.24	
				WP Total	\$3,583.75	\$16,944.80	\$25.69	\$0.00	\$20,554.24	
				Invoice Total	\$7,233.75	\$33,759.24	\$466.74	\$0.00	\$41,459.73	

REFERENCE NO.	DESCRIPTION	INVOICE DATE	INVOICE AMOUNT	DISCOUNT TAKEN	AMOUNT PAID
116183		7/26/23	11,187.00		11,187.00
116215		7/31/23	512.00 4,152.00		512.00 4,152.00
116216		7/31/23	640.00		640.00

CHECK DATE	CHECK NO.	PAYEE	DISCOUNTS TAKEN	CHECK AMOUNT
8/2/23	2409	HAHN Equipment Co Inc		\$12,339.00

LAP53 A/P CHECK

Rev 3/19

104691

10469

Funding-GL Acct #	DESCRIPTION	QTY	UNIT PRICE	TOTAL
11-6711	New 5HP Flygt Pump for Shady Ln Lift Station	1	11,187.00	11,187.00
TOTAL			\$ -	\$ 11,187.00

Comments or Special Instructions

10

IMPORTANT:

Above Order Number must appear on all correspondence, invoices, packages and shipping papers. Notify us immediately if you are unable to ship complete order by date specified. Your acceptance of this order is your warranty to us that you are complying with the U.S. Fair Labor Standards Act of 1988, as amended, and we reserve the right to refuse merchandise not in strict accordance with this order.

INVOICE

INVOICE NO.	PAGE
116183	1
INVOICE DATE	
07/26/23	



HAHN EQUIPMENT CO., INC.
 5636 KANSAS
 HOUSTON, TX 77007
 (713) 868-3255 FAX: 713-868-9725

P.O. # LK SEWER 0602202

SOLD TO

SHIP TO

CITY OF SWEENY
 accountspayable@sweenytx.gov
 102 W. ASHLEY WILSON RD.
 PO BOX 248 citymanager@sweenytx.gov
 SWEENY, TX 77480 kwwilson@sweenytx.gov
 US

CITY OF SWEENY
 SHADY LIFT STATION
 SWEENY, TX
 US

ORDER NO.	ORDER DATE	CUSTOMER NO.	LOC.	SLSMN	PURCHASE ORD. NO.	JOB NUMBER	SHIP VIA	COL/PPD
-----------	------------	--------------	------	-------	-------------------	------------	----------	---------

4923567	07/11/23	9115	01	4	LK-SEWER-06	022023	HEC SERVICE	
---------	----------	------	----	---	-------------	--------	-------------	--

QTY. ORDER/B.O.	QTY. SHIP/RETURN	ITEM NO /DESCRIPTION	UNIT PRICE	UOM DISC.	NET PRICE
-----------------	------------------	----------------------	------------	-----------	-----------

1.0000	1.0000	0031020700033		EA	
		NP463-4 5/230/3 50 FM FLS FV			
Serial No. 070-2330048					
1.0000	1.0000	O/M.		EA	
OPERATION & MAINTENANCE MANUAL					
1.0000	1.0000	00380 91 00		EA	
SLIDING BRACKET					
		1.00			
Lot No. 17	4.0000	SERVICE.		EA	
REQUESTED BY: LINDSAY					
SERVICE DATE: 07/21/2023					

COMMENTS: HEC SERVICE DN 07/21/2023 BH 07/25/2023 TERMS: 1&10DAYS/NET 30	SALE AMOUNT	11,187.00
	MISC. CHARGES	.00
	FREIGHT	.00
	SALES TAX	.00
	TOTAL	11,187.00
	AMOUNT RECEIVED	.00
	BALANCE DUE	11,187.00

HAHN EQUIPMENT Co., Inc.

5636 KANSAS • HOUSTON, TX 77007 • PHONE # 713-868-3255 • FAX # 868-9725

ATTN: Karla Wilson
COMPANY: City of Sweeny
FROM: Jason Van Alstine

QUOTE #: 19794.R-001
RE: Repair / Replace Quote - Updated Price
DATE: May 31, 2023

HAHN EQUIPMENT CO., INC. is pleased to submit to the City of Sweeny, the following proposal for pumping equipment:

OPTION A REPLACE FLYGT "N" SERIES PUMP 5 YEAR WARRANTY

QTY ONE (1) FLYGT Model NP3102, 5HP, 230V/3, 4 INCH submersible pump with HARD IRON "N" impeller 463 with 50 ft power cable

QTY ONE (1) Unit field service labor to remove pump and install new pump

TOTAL PRICE FOR ALL EQUIPMENT LISTED IN OPTION A: **\$ 11,187.00**

NOTES:

- Above pricing includes installation and freight

F.O.B.: Houston, Texas. Prices quoted good for thirty (30) days and are exclusive of any applicable taxes or duties.

SHIPMENT: Estimated delivery is 8 to 10 weeks after receipt of order

TERMS OF PAYMENT: net 30 from the date of the invoice, with approved credit

CONTRACT CONDITIONS: Conditions outlined on the Company's standard general condition form, which is enclosed with this proposal, shall apply to and constitute a part of this proposal.

Sincerely,
HAHN EQUIPMENT CO., INC.

Jason Van Alstine
Sales Representative

NOTE: Invoices will be issued upon delivery, or notification equipment is available for delivery based on delivery date below.

This proposal including terms and conditions contained within are acceptable and understood.
PLEASE SIGN AND RETURN.

AUTHORIZED SIGNATURE: 

DATE: June 02, 2023

We request this equipment available for delivery: _____

- has been a loaner since last year @ no cost to City.

Karla Wilson

From: Jason Van Alstine <jasonv@hahnequipment.com>
Sent: Wednesday, May 31, 2023 11:13 AM
To: Karla Wilson
Subject: Updated Pump Quote - Shady Lift Station
Attachments: 19794.R-001 City of Sweeny.pdf

Hi Karla,

Nice meeting you today!

As discussed attached is the updated quote for the Shady Lift Station replacement pump. We supplied a "no charge" loaner pump in September 2022 pending the order of the replacement pump. If the new pump is not purchased then we would need to charge rental fees for the loaner pump.

I also look forward to proving an educational meeting for the new Public Works Director and anyone else who would like to attend covering submersible pump, mixing, grinding and control technologies and service we provide.

Our office number is 713-868-3255, but the best way to reach me is my cell number at 281-658-9414.

Thank you!

HAHN
Equipment

Jason Van Alstine
Cell 281-658-9414
Email jasonv@hahnequipment.com
5636 Kansas
Houston TX 77007



Inframark, LLC
2002 West Grand Parkway North, Suite 100
Katy, Texas 77449
(281) 578-4200

Client ID Number	
-------------------------	--

Invoice Number	1150535
Invoice Date	8/9/2023
Due Date	9/8/2023

To: City of Sweeny
102 W Ashley Wilson Rd

Sweeny, TX 77480

Service Description	Total
Maintenance Services	\$29,000.59

Please Pay This Amount

Subtotal	\$29,000.59
Sales Tax	\$0.00
Total	\$29,000.59

Remit To: Inframark, LLC, P.O. Box 733778, Dallas, Texas 75373-3778

To pay by Credit Card, contact us at 281-578-4299, 9:00am - 5:30pm EST, Mon - Fri. A surcharge fee may apply

To Pay via ACH or Wire, please refer to our banking information below:

Account Name : INFRAMARK, LLC

ACH - Bank Routing Number : 111000614 / Account Number 912593196

Wire - Bank Routing Number : 021000021 / SWIFT Code : CHASUS33 / Account Number: 912593196

Please include the Project ID and the Invoice Number on the check stub of your payment.

INFRAMARK, LLC

DISTRICT : CITY OF SWEENEY

INVOICE NO. 1150535 - SUMMARY

INVOICE DATE: 8/9/2023

09 Aug 2023 11:49:11PM CST

Go Green! Think before you print.

Work Type / Sub Category	Equipment Costs	Labor Costs	Materials/Other Service Costs	Sales Tax Total	Total Costs
Administrative					
Administrative Services	\$0.00	\$359.60	\$0.00	\$0.00	\$359.60
Subcontract Services	\$0.00	\$56.47	\$0.00	\$0.00	\$56.47
AD Total	\$0.00	\$416.07	\$0.00	\$0.00	\$416.07
Maintenance, Sewer Plant					
SP1					
General Maintenance & Repairs	\$2,075.00	\$10,067.23	\$0.00	\$0.00	\$12,142.23
Other Maintenance	\$0.00	\$0.00	\$7,720.00	\$0.00	\$7,720.00
SP1 Total	\$2,075.00	\$10,067.23	\$7,720.00	\$0.00	\$19,862.23
SP Total	\$2,075.00	\$10,067.23	\$7,720.00	\$0.00	\$19,862.23
Maintenance, Water Plant					
WP1					
General Maintenance & Repairs	\$1,485.00	\$7,076.29	\$0.00	\$0.00	\$8,561.29
Lab Fees or Laboratory Sampling	\$0.00	\$0.00	\$161.00	\$0.00	\$161.00
WP1 Total	\$1,485.00	\$7,076.29	\$161.00	\$0.00	\$8,722.29
WP Total	\$1,485.00	\$7,076.29	\$161.00	\$0.00	\$8,722.29
Invoice Total	\$3,560.00	\$17,559.59	\$7,881.00	\$0.00	\$29,000.59

INFRAMARK, LLC

DISTRICT : CITY OF SWEENEY

INVOICE NO. 1150535 - DETAIL

INVOICE DATE: 8/9/2023

09 Aug 2023 11:49:15PM CST

Go Green! Think before you print.

Work Type / Sub Category	Date Complete	WO Number	Address	Task Details	Equipment Costs	Labor Costs	Materials/Other Service Costs	Sales Tax Total	Total Costs	B/C
Administrative										
Administrative Services										
	6/26/2023	3294437	SWEENEY District Area	Consumer Confidence Report (CCR); Prepare and distribute the 2022 CCR.	\$0.00	\$359.60	\$0.00	\$0.00	\$359.60	N
				Administrative Services Total	\$0.00	\$359.60	\$0.00	\$0.00	\$359.60	
Subcontract Services										
	7/6/2023	3290612	SWEENEY District Area	Disinfectant Level Quarterly Operating Report; Prepare and submit the 2023 QTR2 DLQOR	\$0.00	\$56.47	\$0.00	\$0.00	\$56.47	N
				Subcontract Services Total	\$0.00	\$56.47	\$0.00	\$0.00	\$56.47	
				AD Total	\$0.00	\$416.07	\$0.00	\$0.00	\$416.07	
Maintenance, Sewer Plant										
SP1										
General Maintenance & Repairs										
	7/6/2023	3260028	2607 Avenue A	General Repair or Maintenance of an Asset at a Sewer Treatment Plant; Monitor chemical feed at back end of plant and pull samples as needed. Run trash pump from clarifier to aeration, moving solids back into plant. General maintenance of everyday running of sewer plant.	\$500.00	\$2,182.50	\$0.00	\$0.00	\$2,682.50	N

INFRAMARK, LLC

DISTRICT : CITY OF SWEENEY

INVOICE NO. 1150535 - DETAIL

INVOICE DATE: 8/9/2023

09 Aug 2023 11:49:15PM CST

Go Green! Think before you print.

Work Type / Sub Category	Date Complete	WO Number	Address	Task Details	Equipment Costs	Labor Costs	Materials/Other Service Costs	Sales Tax Total	Total Costs	B/C
	7/6/2023	3269272	2607 Avenue A	General Repair or Maintenance of an Asset at a Sewer Treatment Plant; Check in plant, monitor and adjust chemical feed. Pulled samples when needed in the proper timely manner. Monitor pump run times and flow levels of plant	\$640.00	\$3,123.59	\$0.00	\$0.00	\$3,763.59	N
	7/6/2023	3269455	2607 Avenue A	General Repair or Maintenance of an Asset at a Sewer Treatment Plant	\$215.00	\$1,374.51	\$0.00	\$0.00	\$1,589.51	N
	7/12/2023	3275830	2607 Avenue A	General Repair or Maintenance of an Asset at a Sewer Treatment Plant; Checked in plant, adjusted chemical feed and monitored trash pump and now return pump 4	\$300.00	\$1,309.50	\$0.00	\$0.00	\$1,609.50	N
	7/14/2023	3281534	2607 Avenue A	General Repair or Maintenance of an Asset at a Sewer Treatment Plant; Weekend check of plant	\$65.00	\$425.58	\$0.00	\$0.00	\$490.58	N
	7/14/2023	3281666	2607 Avenue A	General Repair or Maintenance of an Asset at a Sewer Treatment Plant; Monitor plant operations, adjusted chemicals as needed, made sure return pump was running properly	\$275.00	\$1,156.73	\$0.00	\$0.00	\$1,431.73	N
	7/17/2023	3282699	2607 Avenue A	General Repair or Maintenance of an Asset at a Sewer Treatment Plant	\$80.00	\$494.82	\$0.00	\$0.00	\$574.82	N
				General Maintenance & Repairs Total	\$2,075.00	\$10,067.23	\$0.00	\$0.00	\$12,142.23	
Other Maintenance										
	6/29/2023	3261979	2607 Avenue A	Post Sewer Treatment Plant Repair Cleanup; Clean out clarifier	\$0.00	\$0.00	\$7,720.00	\$0.00	\$7,720.00	N
				Other Maintenance Total	\$0.00	\$0.00	\$7,720.00	\$0.00	\$7,720.00	
				SP1 Total	\$2,075.00	\$10,067.23	\$7,720.00	\$0.00	\$19,862.23	
				SP Total	\$2,075.00	\$10,067.23	\$7,720.00	\$0.00	\$19,862.23	

INFRAMARK, LLC

DISTRICT : CITY OF SWEENEY

INVOICE NO. 1150635 - DETAIL

INVOICE DATE: 8/9/2023

09 Aug 2023 11:49:15PM CST

Go Green! Think before you print.

Work Type / Sub Category	Date Complete	WO Number	Address	Task Details	Equipment Costs	Labor Costs	Materials/Other Service Costs	Sales Tax Total	Total Costs	B/C
Maintenance, Water Plant										
WP1										
General Maintenance & Repairs										
	7/14/2023	3258803	204 Peach St	Flushing of a Water System; flushed trouble areas in district	\$205.00	\$915.22	\$0.00	\$0.00	\$1,120.22	N
	7/6/2023	3260012	204 Peach St	General Repairs of an Asset at a Water Plant; Checked district residual, got residual and est residual. Monitor all 3 wells. Monitor booster pumps running and time. Make adjustments on chemical feed system at plant and in district.	\$275.00	\$1,200.37	\$0.00	\$0.00	\$1,475.37	N
	7/7/2023	3269277	204 Peach St	General Repairs of an Asset at a Water Plant; Maintain water plant and well flows. Adjust chemical feeds as needed through distribution syste, and at plant	\$300.00	\$1,309.50	\$0.00	\$0.00	\$1,609.50	N
	7/6/2023	3270550	204 Peach St	General Repairs of an Asset at a Water Plant	\$125.00	\$839.31	\$0.00	\$0.00	\$964.31	N
	7/12/2023	3275833	204 Peach St	General Repairs of an Asset at a Water Plant; Checked district residual and plant residual. Monitor pump and well flow and pump times and adjusted chemical feed as needed	\$180.00	\$785.70	\$0.00	\$0.00	\$965.70	N
	7/14/2023	3281537	204 Peach St	General Repairs of an Asset at a Water Plant; Weekend check of plant and district	\$70.00	\$458.32	\$0.00	\$0.00	\$528.32	N
	7/14/2023	3281745	204 Peach St	General Repairs of an Asset at a Water Plant; Monitored plant operations and adjusted chemical as needed at plant and through district	\$260.00	\$1,134.90	\$0.00	\$0.00	\$1,394.90	N

INFRAMARK, LLC

DISTRICT : CITY OF SWEENEY

INVOICE NO. 1150535 - DETAIL

INVOICE DATE: 8/9/2023

09 Aug 2023 11:49:15PM CST

Go Green! Think before you print.

Work Type / Sub Category	Date Complete	WO Number	Address	Task Details	Equipment Costs	Labor Costs	Materials/Other Service Costs	Sales Tax Total	Total Costs	B/C
	7/17/2023	3282710	204 Peach St	General Repairs of an Asset at a Water Plant	\$70.00	\$432.97	\$0.00	\$0.00	\$502.97	N
				General Maintenance & Repairs Total	\$1,485.00	\$7,076.29	\$0.00	\$0.00	\$8,561.29	
Lab Fees or Laboratory Sampling										
	7/5/2023	3267412	204 Peach St	Purchase Laboratory Services for Water System Asset; Water Utility Services - May 2023	\$0.00	\$0.00	\$161.00	\$0.00	\$161.00	N
				Lab Fees or Laboratory Sampling Total	\$0.00	\$0.00	\$161.00	\$0.00	\$161.00	
				WP1 Total	\$1,485.00	\$7,076.29	\$161.00	\$0.00	\$8,722.29	
				WP Total	\$1,485.00	\$7,076.29	\$161.00	\$0.00	\$8,722.29	
				Invoice Total	\$3,560.00	\$17,559.59	\$7,881.00	\$0.00	\$29,000.59	

REFERENCE NO.	DESCRIPTION	INVOICE DATE	INVOICE AMOUNT	DISCOUNT TAKEN	AMOUNT PAID
1151574 ✓		9/11/23	16,268.60		16,268.60 ✓

CHECK DATE	CHECK NO.	PAYEE	DISCOUNTS TAKEN	CHECK AMOUNT
9/18/23	2468	Inframark, LLC		\$16,268.60

LAP53 A/P CHECK

Rev 3/19



104691

10469

Service Description	Total
Maintenance Services	\$16,268.60

Water 11-6710 4350.07
 WWTP 11-6711 11918.53

12

Subtotal	\$16,268.60
Sales Tax	\$0.00
Total	\$16,268.60

Please Pay This Amount

Remit To: Inframark, LLC, P.O. Box 733778, Dallas, Texas 75373-3778

To pay by Credit Card, contact us at 281-578-4299, 9:00am - 5:30pm EST, Mon - Fri. A surcharge fee may apply

To Pay via ACH or Wire, please refer to our banking information below:

Account Name : INFRAMARK, LLC

ACH - Bank Routing Number : 111000614 / Account Number 912593196

Wire - Bank Routing Number : 021000021 / SWIFT Code : CHASUS33 / Account Number: 912593196

Please include the Project ID and the Invoice Number on the check stub of your payment.



Inframark, LLC
2002 West Grand Parkway North, Suite 100
Katy, Texas 77449
(281) 578-4200

Client ID Number	
------------------	--

Invoice Number	1151574
Invoice Date	9/11/2023
Due Date	10/11/2023

To: City of Sweeny
102 W Ashley Wilson Rd

Sweeny, TX 77480

Service Description	Total
Maintenance Services	\$16,268.60

Subtotal	\$16,268.60
Sales Tax	\$0.00
Total	\$16,268.60

Please Pay This Amount

Remit To: Inframark, LLC, P.O. Box 733778, Dallas, Texas 75373-3778

To pay by Credit Card, contact us at 281-578-4299, 9:00am - 5:30pm EST, Mon - Fri. A surcharge fee may apply

To Pay via ACH or Wire, please refer to our banking information below:

Account Name : INFRAMARK, LLC

ACH - Bank Routing Number : 111000614 / Account Number 912593196

Wire - Bank Routing Number : 021000021 / SWIFT Code : CHASUS33 / Account Number: 912593196

Please include the Project ID and the Invoice Number on the check stub of your payment.

INFRAMARK, LLC

DISTRICT : CITY OF SWEENEY

INVOICE NO. 1151574 - SUMMARY

INVOICE DATE: 9/11/2023

11 Sep 2023 09:06:17AM CST

Go Green! Think before you print.

Work Type / Sub Category	Equipment Costs	Labor Costs	Materials/Other Service Costs	Sales Tax Total	Total Costs
Maintenance, Sewer Plant					
SP1					
General Maintenance & Repairs	\$1,965.00	\$9,260.78	\$0.00	\$0.00	\$11,225.78
Lab Fees or Laboratory Sampling	\$80.00	\$349.20	\$0.00	\$0.00	\$429.20
Subcontract Services	\$0.00	\$263.55	\$0.00	\$0.00	\$263.55
SP1 Total	\$2,045.00	\$9,873.53	\$0.00	\$0.00	\$11,918.53
SP Total	\$2,045.00	\$9,873.53	\$0.00	\$0.00	\$11,918.53
Maintenance, Water					
Lab Fees or Laboratory Sampling	\$0.00	\$0.00	\$161.00	\$0.00	\$161.00
MW Total	\$0.00	\$0.00	\$161.00	\$0.00	\$161.00
Maintenance, Water Plant					
WP1					
General Maintenance & Repairs	\$710.00	\$3,479.07	\$0.00	\$0.00	\$4,189.07
WP1 Total	\$710.00	\$3,479.07	\$0.00	\$0.00	\$4,189.07
WP Total	\$710.00	\$3,479.07	\$0.00	\$0.00	\$4,189.07
Invoice Total	\$2,755.00	\$13,352.60	\$161.00	\$0.00	\$16,268.60

11 Sep 2023 09:06:18AM CST
Go Green! Think before you print.

INFRAMARK, LLC
DISTRICT : CITY OF SWEENEY
INVOICE NO. 1151574 - DETAIL
INVOICE DATE: 9/11/2023

Work Type / Sub Category	Date Complete	WO Number	Address	Task Details	Equipment Costs	Labor Costs	Materials/Other Service Costs	Sales Tax Total	Total Costs	B/C
Maintenance, Sewer Plant										
SP1										
General Maintenance & Repairs										
	7/14/2023	3276613	2607 Avenue A	General Repair or Maintenance of an Asset at a Sewer Treatment Plant	\$80.00	\$349.20	\$0.00	\$0.00	\$429.20	N
	7/24/2023	3288097	2607 Avenue A	Billable Operations at a Sewer Treatment Plant	\$90.00	\$656.84	\$0.00	\$0.00	\$746.84	N
	7/26/2023	3289703	2607 Avenue A	General Repair or Maintenance of an Asset at a Sewer Treatment Plant; Monitor plant operations, checked in lift stations	\$280.00	\$1,222.20	\$0.00	\$0.00	\$1,502.20	N
	7/31/2023	3292563	2607 Avenue A	General Repair or Maintenance of an Asset at a Sewer Treatment Plant; Pulled weekly samples, checked in plant, checked LS and monitored chemical feed and flow into plant	\$350.00	\$1,527.75	\$0.00	\$0.00	\$1,877.75	N
	7/31/2023	3297603	2607 Avenue A	General Repair or Maintenance of an Asset at a Sewer Treatment Plant; Weekend plant check	\$75.00	\$491.06	\$0.00	\$0.00	\$566.06	N
	7/31/2023	3297714	2607 Avenue A	General Repair or Maintenance of an Asset at a Sewer Treatment Plant; Check in and operate plant and sewer collection system	\$120.00	\$523.80	\$0.00	\$0.00	\$643.80	N
	8/4/2023	3299949	2607 Avenue A	General Repair or Maintenance of an Asset at a Sewer Treatment Plant; Checked in plant, monitored chemical feed and pump operations	\$180.00	\$807.53	\$0.00	\$0.00	\$987.53	N
	8/6/2023	3304768	2607 Avenue A	General Repair or Maintenance of an Asset at a Sewer Treatment Plant	\$145.00	\$896.85	\$0.00	\$0.00	\$1,041.85	N
	8/11/2023	3309644	2607 Avenue A	General Repair or Maintenance of an Asset at a Sewer Treatment Plant; Weekly plant check samples pulled and monitored chemical feed	\$255.00	\$1,200.39	\$0.00	\$0.00	\$1,455.39	N

INFRAMARK, LLC

DISTRICT : CITY OF SWEENEY

INVOICE NO. 1151574 - DETAIL

INVOICE DATE: 9/11/2023

11 Sep 2023 09:06:18AM CST

Go Green! Think before you print.

Work Type / Sub Category	Date Complete	WO Number	Address	Task Details	Equipment Costs	Labor Costs	Materials/Other Service Costs	Sales Tax Total	Total Costs	B/C
	8/21/2023	3317123	2607 Avenue A	General Repair or Maintenance of an Asset at a Sewer Treatment Plant; Weekly check of plant	\$390.00	\$1,585.16	\$0.00	\$0.00	\$1,975.16	N
				General Maintenance & Repairs Total	\$1,965.00	\$9,260.78	\$0.00	\$0.00	\$11,225.78	
Lab Fees or Laboratory Sampling										
	7/26/2023	3289693	2607 Avenue A	Purchase Laboratory Services for Sewer Treatment Plant; Pulled sample	\$80.00	\$349.20	\$0.00	\$0.00	\$429.20	N
				Lab Fees or Laboratory Sampling Total	\$80.00	\$349.20	\$0.00	\$0.00	\$429.20	
Subcontract Services										
	8/25/2023	3325983	2607 Avenue A	Misc. Filing to Environmental Agency	\$0.00	\$129.20	\$0.00	\$0.00	\$129.20	N
	8/29/2023	3329106	2607 Avenue A	Misc. Filing to Environmental Agency	\$0.00	\$134.35	\$0.00	\$0.00	\$134.35	N
				Subcontract Services Total	\$0.00	\$263.55	\$0.00	\$0.00	\$263.55	
				SP1 Total	\$2,045.00	\$9,873.53	\$0.00	\$0.00	\$11,918.53	
				SP Total	\$2,045.00	\$9,873.53	\$0.00	\$0.00	\$11,918.53	

11 Sep 2023 09:06:18AM CST
 Go Green! Think before you print.

INFRAMARK, LLC
 DISTRICT : CITY OF SWEENEY
 INVOICE NO. 1151574 - DETAIL
 INVOICE DATE: 9/11/2023

Work Type / Sub Category	Date Complete	WO Number	Address	Task Details	Equipment Costs	Labor Costs	Materials/Other Service Costs	Sales Tax Total	Total Costs	B/C
Maintenance, Water										
Lab Fees or Laboratory Sampling										
	7/28/2023	3272724	SWEENEY District Area	Purchase Laboratory Services for Water System Asset; Water Utility Services - July 2023	\$0.00	\$0.00	\$161.00	\$0.00	\$161.00	N
				Lab Fees or Laboratory Sampling Total	\$0.00	\$0.00	\$161.00	\$0.00	\$161.00	
				MW Total	\$0.00	\$0.00	\$161.00	\$0.00	\$161.00	
Maintenance, Water Plant										
WP1										
General Maintenance & Repairs										
	7/24/2023	3288101	204 Peach St	Billable Operations at a Water Plant (normal hours, after normal hours, weekends & holidays)	\$70.00	\$510.88	\$0.00	\$0.00	\$580.88	N
	7/26/2023	3289697	204 Peach St	Flushing of a Water System; flush district	\$40.00	\$174.60	\$0.00	\$0.00	\$214.60	N
	7/26/2023	3292165	204 Peach St	General Repairs of an Asset at a Water Plant; Checked in plant and monitored operation	\$205.00	\$894.82	\$0.00	\$0.00	\$1,099.82	N
	7/31/2023	3292566	204 Peach St	General Repairs of an Asset at a Water Plant; Checked in plant, checked district and plant residual	\$230.00	\$1,003.95	\$0.00	\$0.00	\$1,233.95	N
	7/31/2023	3297607	204 Peach St	General Repairs of an Asset at a Water Plant; Weekend plant check	\$80.00	\$523.80	\$0.00	\$0.00	\$603.80	N
	7/31/2023	3297717	204 Peach St	General Repairs of an Asset at a Water Plant; Check in and operate plant and sewer collection system	\$40.00	\$174.60	\$0.00	\$0.00	\$214.60	N

INFRAMARK, LLC

DISTRICT : CITY OF SWEENEY

INVOICE NO. 1151574 - DETAIL

INVOICE DATE: 9/11/2023

11 Sep 2023 09:06:18AM CST

Go Green! Think before you print.

Work Type / Sub Category	Date Complete	WO Number	Address	Task Details	Equipment Costs	Labor Costs	Materials/Other Service Costs	Sales Tax Total	Total Costs	B/C
	8/3/2023	3299731	204 Peach St	General Repairs of an Asset at a Water Plant; Daily check of water plant , checking residual in district and at water plant. Checked residual at EST and monitored flow at wells.	\$45.00	\$196.42	\$0.00	\$0.00	\$241.42	N
				General Maintenance & Repairs Total	\$710.00	\$3,479.07	\$0.00	\$0.00	\$4,189.07	
				WP1 Total	\$710.00	\$3,479.07	\$0.00	\$0.00	\$4,189.07	
				WP Total	\$710.00	\$3,479.07	\$0.00	\$0.00	\$4,189.07	
				Invoice Total	\$2,755.00	\$13,352.60	\$161.00	\$0.00	\$16,268.60	

Client: SWEENEY		Work Order Summary Provided to City of Sweeney - Invoice # 1151574					11 Sep 2023 09:06:19AM CST			
Type:	MW									
WO	Date Complete	Date Invoiced	Location	Asset ID	GL Code	Sub Cat	Dept	Activity Type & Comments		
3272724	7/28/2023	9/11/2023	SWEENEY District Area		40400	LAB	5755	MWLAB - Purchase Laboratory Services for Water System Asset		
	Insp:		Attachments: 1	Bid Price:	\$0.00			Water Utility Services - July 2023		
Materials	Mat ID:	Material Desc	Vendor Bill #	Type	Qty	Unit Cost	Unit Price	Total Price	Tax	Grand Total
	PO	Water Utility Services	81752	164556	1.00	\$140.00	\$161.00	\$161.00	\$0.00	\$161.00
							Materials Total	\$161.00	\$0.00	\$161.00
Comments:							WO [3272724] Total	\$161.00	\$0.00	\$161.00
							Work Type [MW] Total (Count: 1)	\$161.00	\$0.00	\$161.00

Work Order Summary Provided to City of Sweeny - Invoice # 1151574										11 Sep 2023 09:06:19AM CST	
Client:	SWEENEY										
Type:	SP										
WO	Date Complete	Date Invoiced	Location	Asset ID	GL Code	Sub Cat	Dept	Activity Type & Comments			
3276613	7/14/2023	9/11/2023	2607 Avenue A	SWEENEY-SP1	40500	GNL	5755	SPGENREP - General Repair or Maintenance of an Asset at a Sewer Treatment Plant			
		Insp:	Attachments: 0	Bid Price: \$0.00							
	Labor	<u>Emp ID:</u>	<u>Type</u>		<u>Reg Hrs</u>	<u>OT Hrs</u>		<u>Unit Price</u>	<u>Total Price</u>	<u>Tax</u>	<u>Grand Total</u>
	7/10/2023	703616	*Operator III		4.00	0.00		\$87.30	\$349.20	\$0.00	\$349.20
								Labor Total	\$349.20	\$0.00	\$349.20
	Equipment	<u>Equip ID:</u>	<u>Equipment Desc</u>					<u>Unit Price</u>	<u>Total Price</u>	<u>Tax</u>	<u>Grand Total</u>
		TX121677	Utility Truck			4.00		\$20.00	\$80.00	\$0.00	\$80.00
								Equipment Total	\$80.00	\$0.00	\$80.00
								WO [3276613] Total	\$429.20	\$0.00	\$429.20
	Comments:	checked in plant and all lift stations in town and pulled samples									
WO	Date Complete	Date Invoiced	Location	Asset ID	GL Code	Sub Cat	Dept	Activity Type & Comments			
3288097	7/24/2023	9/11/2023	2607 Avenue A	SWEENEY-SP1	40500	GNL	5755	SPBILOPS - Billable Operations at a Sewer Treatment Plant			
		Insp:	Attachments: 0	Bid Price: \$0.00							
	Labor	<u>Emp ID:</u>	<u>Type</u>		<u>Reg Hrs</u>	<u>OT Hrs</u>		<u>Unit Price</u>	<u>Total Price</u>	<u>Tax</u>	<u>Grand Total</u>
	7/22/2023	603528	Lead Ops / Tech		0.00	2.00		\$145.97	\$291.93	\$0.00	\$291.93
	7/23/2023	603528	Lead Ops / Tech		0.00	2.50		\$145.97	\$364.91	\$0.00	\$364.91
								Labor Total	\$656.84	\$0.00	\$656.84
	Equipment	<u>Equip ID:</u>	<u>Equipment Desc</u>					<u>Unit Price</u>	<u>Total Price</u>	<u>Tax</u>	<u>Grand Total</u>
		TX119016	Utility Truck			2.00		\$20.00	\$40.00	\$0.00	\$40.00

Client: SWEENY		Work Order Summary Provided to City of Sweeny - Invoice # 1151574						11 Sep 2023 09:06:19AM CST			
Type: SP											
	TX119016	Utility Truck					2.50	\$20.00	\$50.00	\$0.00	\$50.00
								Equipment Total	\$90.00	\$0.00	\$90.00
								WO [3288097] Total	\$746.84	\$0.00	\$746.84
	Comments: Weekend Facility check in and plant operations.										
WO	Date Complete	Date Invoiced	Location	Asset ID	GL Code	Sub Cat	Dept	Activity Type & Comments			
3289693	7/26/2023	9/11/2023	2607 Avenue A	SWEENY- SP1	40400	LAB	5755	SPLAB - Purchase Laboratory Services for Sewer Treatment Plant			
		Insp:	Attachments: 0	Bid Price: \$0.00				Pulled sample			
								<u>Unit Price</u>	<u>Total Price</u>	<u>Tax</u>	<u>Grand Total</u>
								\$87.30	\$349.20	\$0.00	\$349.20
								Labor Total	\$349.20	\$0.00	\$349.20
								<u>Unit Price</u>	<u>Total Price</u>	<u>Tax</u>	<u>Grand Total</u>
								\$20.00	\$80.00	\$0.00	\$80.00
								Equipment Total	\$80.00	\$0.00	\$80.00
								WO [3289693] Total	\$429.20	\$0.00	\$429.20
	Comments: Pulled samples at multiple times, to create composite sample for pick up, filled out chain of custody and left sample in fridge and paper work on outside for pick up next day										

Type:	SP	Date Complete	Date Invoiced	Location	Asset ID	GL Code	Sub Cat	Dept	Activity Type & Comments
WO	3299949	8/4/2023	9/11/2023	2607 Avenue A	SWEENEY- SP1	40500	GNL	5755	SPGENREP - General Repair or Maintenance of an Asset at a Sewer Treatment Plant
			Insp:	Attachments: 3	Bid Price: \$0.00				Checked in plant, monitored chemical feed and pump operations

Labor	Emp ID:	Type	Reg Hrs	OT Hrs	Unit Price	Total Price	Tax	Grand Total
8/1/2023	703616		1.00	0.00	\$87.30	\$87.30	\$0.00	\$87.30
8/2/2023	703616		3.00	0.00	\$87.30	\$261.90	\$0.00	\$261.90
8/3/2023	703616		2.00	0.00	\$87.30	\$174.60	\$0.00	\$174.60
8/3/2023	703616		0.00	0.50	\$130.95	\$65.48	\$0.00	\$65.48
8/4/2023	703616		2.50	0.00	\$87.30	\$218.25	\$0.00	\$218.25
Labor Total						\$807.53	\$0.00	\$807.53

Equipment	Equip ID:	Equipment Desc	Reg Hrs	Unit Price	Total Price	Tax	Grand Total
	TX121677	Utility Truck	1.00	\$20.00	\$20.00	\$0.00	\$20.00
	TX121677	Utility Truck	3.00	\$20.00	\$60.00	\$0.00	\$60.00
	TX121677	Utility Truck	2.50	\$20.00	\$50.00	\$0.00	\$50.00
	TX121677	Utility Truck	2.50	\$20.00	\$50.00	\$0.00	\$50.00
Equipment Total					\$180.00	\$0.00	\$180.00

Comments: Checked in plant, please see pics in attachment

WO	Date Complete	Date Invoiced	Location	Asset ID	GL Code	Sub Cat	Dept	Activity Type & Comments
3304768	8/6/2023	9/11/2023	2607 Avenue A	SWEENEY- SP1	40500	GNL	5755	SPGENREP - General Repair or Maintenance of an Asset at a Sewer Treatment Plant
		Insp:	Attachments: 0	Bid Price: \$0.00				

Labor	Emp ID:	Type	Reg Hrs	OT Hrs	Unit Price	Total Price	Tax	Grand Total
8/5/2023	604339		0.00	3.75	\$123.70	\$463.89	\$0.00	\$463.89
Labor Total						\$987.53	\$0.00	\$987.53

Client: SWEENY		Work Order Summary Provided to City of Sweeny - Invoice # 1151574						11 Sep 2023 09:06:19AM CST	
Type:	SP	Equip ID:	Equipment Desc	Reg Hrs	Unit Price	Total Price	Tax	Grand Total	
		TX121677	Utility Truck	4.50	\$20.00	\$90.00	\$0.00	\$90.00	
		TX121677	Utility Truck	2.50	\$20.00	\$50.00	\$0.00	\$50.00	
		TX121677	Utility Truck	1.50	\$20.00	\$30.00	\$0.00	\$30.00	
		TX121677	Utility Truck	2.00	\$20.00	\$40.00	\$0.00	\$40.00	
		TX121677	Utility Truck	2.25	\$20.00	\$45.00	\$0.00	\$45.00	
					Equipment Total	\$255.00	\$0.00	\$255.00	
					WO [3309844]	\$1,455.39	\$0.00	\$1,455.39	
					Total				
Comments: Checked in plant, ran solids, pulled samples Monday. Tuesday I purchased parts to repair bleach pump then repaired bleach pump, checked plant in and ,made sure everything stayed good. Wednesday Thursday and Friday was regular operation, did my settles, checked blanket and residual. Plant looks good, really needs to be mowed									
WO	Date Complete	Date Invoiced	Location	Asset ID	GL Code	Sub Cat	Dept	Activity Type & Comments	
3317123	8/21/2023	9/11/2023	2607 Avenue A	SWEENY- SP1	40500	GNL	5755	SPGENREP - General Repair or Maintenance of an Asset at a Sewer Treatment Plant	
		Insp:	Attachments: 5	Bid Price: \$0.00				Weekly check of plant	
Labor	Emp ID:	Type	Reg Hrs	OT Hrs	Unit Price	Total Price	Tax	Grand Total	
8/14/2023	703616		4.50	0.00	\$87.30	\$392.85	\$0.00	\$392.85	
8/15/2023	703616		2.00	0.00	\$87.30	\$174.60	\$0.00	\$174.60	
8/16/2023	703616		1.50	0.00	\$87.30	\$130.95	\$0.00	\$130.95	
8/16/2023	703616		0.00	0.50	\$130.95	\$65.48	\$0.00	\$65.48	
8/17/2023	702914		5.25	0.00	\$60.82	\$319.30	\$0.00	\$319.30	
8/17/2023	703616		3.75	0.00	\$87.30	\$327.38	\$0.00	\$327.38	
8/18/2023	703616		2.00	0.00	\$87.30	\$174.60	\$0.00	\$174.60	
					Labor Total	\$1,585.16	\$0.00	\$1,585.16	

Client: SWEENEY		Work Order Summary Provided to City of Sweeney - Invoice # 1151574					11 Sep 2023 09:06:19AM CST	
Type:	WP							
Equipment	Equip ID:	Equipment Desc	Reg Hrs	Unit Price	Total Price	Tax	Grand Total	
	TX121677	Utility Truck	0.50	\$20.00	\$10.00	\$0.00	\$10.00	
	TX121677	Utility Truck	0.50	\$20.00	\$10.00	\$0.00	\$10.00	
	TX121677	Utility Truck	1.00	\$20.00	\$20.00	\$0.00	\$20.00	
		Equipment Total			\$40.00	\$0.00	\$40.00	
Comments:		7-18-23 flushed hydrant at rural road for 30 min at about 150 gallons a minute 7-19-23 flushed hydrant at elm and third for 30 min for about 150 gal a minute 7-20-23 flushed an hour at Forrest park drive at about 200 gal a minute						
				WO [3289697]	\$214.60	\$0.00	\$214.60	
				Total				
WO	Date Complete	Date Invoiced	Location	Asset ID	GL Code	Sub Cat	Dept	Activity Type & Comments
3292165	7/26/2023	9/11/2023	204 Peach St	SWEENEY- WP1	40500	GNL	5755	WPGENREP - General Repairs of an Asset at a Water Plant
		Insp:	Attachments: 0		Bid Price: \$0.00			Checked in plant and monitored operation
Labor	Emp ID:	Type	Reg Hrs	OT Hrs	Unit Price	Total Price	Tax	Grand Total
7/17/2023	703616		2.00	0.00	\$87.30	\$174.60	\$0.00	\$174.60
7/18/2023	703616		1.50	0.00	\$87.30	\$130.95	\$0.00	\$130.95
7/19/2023	703616		2.50	0.00	\$87.30	\$218.25	\$0.00	\$218.25
7/20/2023	703616		2.00	0.00	\$87.30	\$174.60	\$0.00	\$174.60
7/21/2023	703616		2.25	0.00	\$87.30	\$196.42	\$0.00	\$196.42
					Labor Total	\$894.82	\$0.00	\$894.82
Equipment	Equip ID:	Equipment Desc	Reg Hrs	Unit Price	Total Price	Tax	Grand Total	
	TX121677	Utility Truck	2.00	\$20.00	\$40.00	\$0.00	\$40.00	
	TX121677	Utility Truck	1.50	\$20.00	\$30.00	\$0.00	\$30.00	
	TX121677	Utility Truck	2.50	\$20.00	\$50.00	\$0.00	\$50.00	
	TX121677	Utility Truck	2.00	\$20.00	\$40.00	\$0.00	\$40.00	

Client: SWEENEY		Work Order Summary Provided to City of Sweeny - Invoice # 1151574					11 Sep 2023 09:06:19AM CST			
Type:	WP									
	TX121677	Utility Truck			2.25		\$20.00	\$45.00	\$0.00	\$45.00
							Equipment Total	\$205.00	\$0.00	\$205.00
							WO [3292165] Total	\$1,099.82	\$0.00	\$1,099.82
	<p>Comments: 7-17-23 Checked in water plant and district residual. Monitored flow in wells on and offsite. 7-18-23. Checked district residual and residual at plants, monitored well flow at plant and at offsite wells as well. 7-19-23, checked district residual as well as residual at plant and flow at wells on and offsite. 7-20-23. Checked in plant, checked district residual and residual at plant, monitored well flow at plant and at offsite well</p>									
WO	Date Complete	Date Invoiced	Location	Asset ID	GL Code	Sub Cat	Dept	Activity Type & Comments		
3292566	7/31/2023	9/11/2023	204 Peach St	SWEENEY- WP1	40500	GNL	5755	WPGENREP - General Repairs of an Asset at a Water Plant		
		Insp:	Attachments: 0	Bid Price: \$0.00				Checked in plant, checked district and plant residual		
Labor	Emp ID:	Type	Reg Hrs	OT Hrs	Unit Price	Total Price	Tax	Grand Total		
7/24/2023	703616		3.00	0.00	\$87.30	\$261.90	\$0.00	\$261.90		
7/25/2023	703616		2.00	0.00	\$87.30	\$174.60	\$0.00	\$174.60		
7/26/2023	703616		1.50	0.00	\$87.30	\$130.95	\$0.00	\$130.95		
7/27/2023	703616		3.00	0.00	\$87.30	\$261.90	\$0.00	\$261.90		
7/28/2023	703616		2.00	0.00	\$87.30	\$174.60	\$0.00	\$174.60		
		Labor Total				\$1,003.95	\$0.00	\$1,003.95		

Client: SWEENY		Work Order Summary Provided to City of Sweeny - Invoice # 1151574						11 Sep 2023 09:06:19AM CST	
Type:	WP								
WO	Date Complete	Date Invoiced	Location	Asset ID	GL Code	Sub Cat	Dept	Activity Type & Comments	
3299731	8/3/2023	9/11/2023	204 Peach St	SWEENY- WP1	40500	GNL	5755	WPGENREP - General Repairs of an Asset at a Water Plant	
	Insp:	Attachments: 1		Bid Price: \$0.00				Daily check of water plant , checking residual in district and at water plant. Checked residual at Est and monitored flow at wells.	
	Labor	Emp ID:	Type		Reg Hrs	OT Hrs		Unit Price	Total Price
	8/1/2023	703616			2.25	0.00		\$87.30	\$196.42
								Labor Total	\$196.42
									\$196.42
	Equipment	Equip ID:	Equipment Desc					Unit Price	Total Price
		TX121677	Utility Truck					\$20.00	\$45.00
								Equipment Total	\$45.00
									\$45.00
	Comments:	Checked in plant, monitored chemical feed, checked residual at plant, in district and at elevated. Monitor flow on wells and hours on boosters, please see attachment for daily's							
								WO [3299731] Total	\$241.42
								Work Type [WP] Total (Count: 7)	\$4,189.07
								Work Order Detail Report Total (Count: 21)	\$16,268.60
									\$0.00
									\$0.00
									\$4,189.07
									\$16,268.60

Inframark, LLC		
Invoiced Backcharges		
Client:	SWEENY	
WO #	Work Type	Address Where Work was Performed:
		Backcharged to:
		Invoice Amount
Total Invoiced Backcharges		\$0.00

B&R Services

175 Sawyer Rd
Alvin, TX 77511
(832) 671-7132
Ben@bandrservices.co



INVOICE

BILL TO
Karla Wilson
City of Sweeny
PO Box 248
Sweeny, Texas 77480
United States

INVOICE 1457
DATE 09/13/2023
TERMS Net 30
DUE DATE 10/13/2023

LOCATION
Sweeny WWTP

DATE	ACTIVITY	DESCRIPTION	QTY	RATE	AMOUNT
09/11/2023	Services (Other)	Pulled 2 pumps. 1 pump sent for repair quote Check float valves	5:15	145.00	761.25

We appreciate your business and look forward to helping you again soon.

BALANCE DUE \$761.25

To settle your payment, you may opt to send a check or make a wire transfer.
For banking information regarding wire transfers, kindly send an email to
Ashley@bandrservices.co.

Best regards!

11-6711

13

FY 23
- Not yet Paid



Inframark, LLC
2002 West Grand Parkway North, Suite 100
Katy, Texas 77449
(281) 578-4200

Client ID Number	
------------------	--

Invoice Number	1152073
Invoice Date	10/9/2023
Due Date	11/8/2023

To: City of Sweeny
102 W Ashley Wilson Rd

Sweeny, TX 77480

Service Description	Total
Maintenance Services	\$24,411.02

*FY23
Not yet paid*

14

Please Pay This Amount

Subtotal	\$24,411.02
Sales Tax	\$0.00
Total	\$24,411.02

Remit To: Inframark, LLC, P.O. Box 733778, Dallas, Texas 75373-3778

To pay by Credit Card, contact us at 281-578-4299, 9:00am - 5:30pm EST, Mon - Fri. A surcharge fee may apply

To Pay via ACH or Wire, please refer to our banking information below:

Account Name : INFRAMARK, LLC

ACH - Bank Routing Number : 111000614 / Account Number 912593196

Wire - Bank Routing Number : 021000021 / SWIFT Code : CHASUS33 / Account Number: 912593196

Please include the Project ID and the Invoice Number on the check stub of your payment.

INFRAMARK, LLC
DISTRICT : CITY OF SWEENEY
INVOICE NO. 1152073 - SUMMARY
INVOICE DATE: 10/9/2023

Work Type / Sub Category	Equipment Costs	Labor Costs	Materials/Other Service Costs	Sales Tax Total	Total Costs
Maintenance, Sewer Plant					
SP1					
General Maintenance & Repairs	\$2,375.00	\$13,334.14	\$23.48	\$0.00	\$15,732.62
Other Maintenance	\$2,040.00	\$1,096.66	\$15.82	\$0.00	\$3,152.48
SP1 Total	\$4,415.00	\$14,430.80	\$39.30	\$0.00	\$18,885.10
SP Total	\$4,415.00	\$14,430.80	\$39.30	\$0.00	\$18,885.10
Maintenance, Water					
Lab Fees or Laboratory Sampling	\$0.00	\$0.00	\$161.00	\$0.00	\$161.00
MW Total	\$0.00	\$0.00	\$161.00	\$0.00	\$161.00
Maintenance, Water Plant					
WP1					
General Maintenance & Repairs	\$815.00	\$4,385.81	\$3.11	\$0.00	\$5,203.92
Lab Fees or Laboratory Sampling	\$0.00	\$0.00	\$161.00	\$0.00	\$161.00
WP1 Total	\$815.00	\$4,385.81	\$164.11	\$0.00	\$5,364.92
WP Total	\$815.00	\$4,385.81	\$164.11	\$0.00	\$5,364.92
Invoice Total	\$5,230.00	\$18,816.61	\$364.41	\$0.00	\$24,411.02

INFRAMARK, LLC

DISTRICT : CITY OF SWEENEY

INVOICE NO. 1152073 - DETAIL

INVOICE DATE: 10/9/2023

09 Oct 2023 02:59:06PM CST

Go Green! Think before you print.

Work Type / Sub Category	Date Complete	WO Number	Address	Task Details	Equipment Costs	Labor Costs	Materials/Other Service Costs	Sales Tax Total	Total Costs	B/C
Maintenance, Sewer Plant										
SP1										
General Maintenance & Repairs										
	8/21/2023	3320086	2607 Avenue A	General Repair or Maintenance of an Asset at a Sewer Treatment Plant; Weekend plant check	\$120.00	\$785.70	\$0.00	\$0.00	\$905.70	N
	8/14/2023	3322579	2607 Avenue A	General Repair or Maintenance of an Asset at a Sewer Treatment Plant	\$145.00	\$1,058.25	\$0.00	\$0.00	\$1,203.25	N
	8/25/2023	3324477	2607 Avenue A	General Repair or Maintenance of an Asset at a Sewer Treatment Plant; Weekly plant check of sewer plant and weekly samples	\$240.00	\$1,102.16	\$0.00	\$0.00	\$1,342.16	N
	8/28/2023	3327713	2607 Avenue A	General Repair or Maintenance of an Asset at a Sewer Treatment Plant	\$155.00	\$958.71	\$0.00	\$0.00	\$1,113.71	N
	8/31/2023	3332459	2607 Avenue A	General Repair or Maintenance of an Asset at a Sewer Treatment Plant; Checked n plant, pulled samples	\$230.00	\$1,003.95	\$0.00	\$0.00	\$1,233.95	N
	9/5/2023	3333806	2607 Avenue A	General Repair or Maintenance of an Asset at a Sewer Treatment Plant; Weekend facility check in and plant operations.	\$210.00	\$1,532.64	\$0.00	\$0.00	\$1,742.64	N
	9/8/2023	3339897	2607 Avenue A	General Repair or Maintenance of an Asset at a Sewer Treatment Plant; Weekly plant check	\$50.00	\$218.25	\$0.00	\$0.00	\$268.25	N
	9/11/2023	3339904	2607 Avenue A	General Repair or Maintenance of an Asset at a Sewer Treatment Plant; Weekly plant check	\$100.00	\$480.16	\$0.00	\$0.00	\$580.16	N
	9/13/2023	3346813	2607 Avenue A	General Repair or Maintenance of an Asset at a Sewer Treatment Plant; Weekend check	\$100.00	\$654.76	\$0.00	\$0.00	\$754.76	N

INFRAMARK, LLC

DISTRICT : CITY OF SWEENEY

INVOICE NO. 1152073 - DETAIL

INVOICE DATE: 10/9/2023

09 Oct 2023 02:59:06PM CST

Go Green! Think before you print.

Work Type / Sub Category	Date Complete	WO Number	Address	Task Details	Equipment Costs	Labor Costs	Materials/Other Service Costs	Sales Tax Total	Total Costs	B/C
	9/15/2023	3346816	2607 Avenue A	General Repair or Maintenance of an Asset at a Sewer Treatment Plant; Pulled samples and checked in plant	\$215.00	\$1,625.96	\$0.00	\$0.00	\$1,840.96	N
	9/17/2023	3350694	2607 Avenue A	General Repair or Maintenance of an Asset at a Sewer Treatment Plant; Weekend plant operations	\$85.00	\$426.31	\$3.11	\$0.00	\$514.42	N
	9/25/2023	3355805	2607 Avenue A	General Repair or Maintenance of an Asset at a Sewer Treatment Plant; Weekly plant check in	\$295.00	\$1,287.68	\$0.00	\$0.00	\$1,582.68	N
	9/25/2023	3355825	2607 Avenue A	Investigate a Problem at a Sewer Treatment Plant; Had to buy parts to fix leak in bleach line	\$60.00	\$261.90	\$20.38	\$0.00	\$342.28	N
	9/26/2023	3359035	2607 Avenue A	General Repair or Maintenance of an Asset at a Sewer Treatment Plant	\$110.00	\$802.81	\$0.00	\$0.00	\$912.81	N
	10/1/2023	3366281	2607 Avenue A	General Repair or Maintenance of an Asset at a Sewer Treatment Plant; Weekly and daily plant check and maintenance	\$260.00	\$1,134.90	\$0.00	\$0.00	\$1,394.90	N
				General Maintenance & Repairs Total	\$2,375.00	\$13,334.14	\$23.48	\$0.00	\$15,732.62	
Other Maintenance										
	9/18/2023	3351361	2607 Avenue A	Post Sewer Treatment Plant Repair Cleanup; Jet RAS Line & Top Clean on-site Lift station	\$2,040.00	\$1,096.66	\$15.82	\$0.00	\$3,152.48	N
				Other Maintenance Total	\$2,040.00	\$1,096.66	\$15.82	\$0.00	\$3,152.48	
				SP1 Total	\$4,415.00	\$14,430.80	\$39.30	\$0.00	\$18,885.10	
				SP Total	\$4,415.00	\$14,430.80	\$39.30	\$0.00	\$18,885.10	

INFRAMARK, LLC

DISTRICT : CITY OF SWEENEY

INVOICE NO. 1152073 - DETAIL

INVOICE DATE: 10/9/2023

09 Oct 2023 02:59:06PM CST

Go Green! Think before you print.

Work Type / Sub Category	Date Complete	WO Number	Address	Task Details	Equipment Costs	Labor Costs	Materials/Other Service Costs	Sales Tax Total	Total Costs	B/C
Maintenance, Water										
Lab Fees or Laboratory Sampling										
	8/29/2023	3306018	SWEENEY District Area	Purchase Laboratory Services for Water System Asset; Water Utility Services - August 2023	\$0.00	\$0.00	\$161.00	\$0.00	\$161.00	N
				Lab Fees or Laboratory Sampling Total	\$0.00	\$0.00	\$161.00	\$0.00	\$161.00	
				MW Total	\$0.00	\$0.00	\$161.00	\$0.00	\$161.00	
Maintenance, Water Plant										
WP1										
General Maintenance & Repairs										
	8/31/2023	3332500	204 Peach St	General Repairs of an Asset at a Water Plant; Checked in plant and district residual	\$30.00	\$179.61	\$0.00	\$0.00	\$209.61	N
	9/5/2023	3333794	204 Peach St	General Repairs of an Asset at a Water Plant; Weekend facility check in and plant operations	\$70.00	\$510.89	\$0.00	\$0.00	\$580.89	N
	9/8/2023	3339900	204 Peach St	General Repairs of an Asset at a Water Plant; Weekly plant check	\$30.00	\$130.95	\$0.00	\$0.00	\$160.95	N
	9/12/2023	3339905	204 Peach St	General Repairs of an Asset at a Water Plant; Weekly plant check	\$120.00	\$654.75	\$0.00	\$0.00	\$774.75	N
	9/13/2023	3346812	204 Peach St	General Repairs of an Asset at a Water Plant; Weekend check	\$100.00	\$654.76	\$0.00	\$0.00	\$754.76	N
	9/15/2023	3346817	204 Peach St	General Repairs of an Asset at a Water Plant; Checked in plant and district residual	\$135.00	\$611.11	\$0.00	\$0.00	\$746.11	N
	9/17/2023	3350695	204 Peach St	General Repairs of an Asset at a Water Plant; Weekend plant operations	\$65.00	\$326.00	\$3.11	\$0.00	\$394.11	N

INFRAMARK, LLC

DISTRICT : CITY OF SWEENEY

INVOICE NO. 1152073 - DETAIL

INVOICE DATE: 10/9/2023

09 Oct 2023 02:59:06PM CST

Go Green! Think before you print.

Work Type / Sub Category	Date Complete	WO Number	Address	Task Details	Equipment Costs	Labor Costs	Materials/Other Service Costs	Sales Tax Total	Total Costs	B/C
	9/25/2023	3355823	204 Peach St	General Repairs of an Asset at a Water Plant; WP check in	\$125.00	\$545.63	\$0.00	\$0.00	\$670.63	N
	9/26/2023	3359037	204 Peach St	General Repairs of an Asset at a Water Plant	\$40.00	\$291.94	\$0.00	\$0.00	\$331.94	N
	10/1/2023	3366287	204 Peach St	General Repairs of an Asset at a Water Plant; Weekly and daily plant check, maintenance, and residual	\$100.00	\$480.17	\$0.00	\$0.00	\$580.17	N
				General Maintenance & Repairs Total	\$815.00	\$4,385.81	\$3.11	\$0.00	\$5,203.92	
Lab Fees or Laboratory Sampling										
	7/5/2023	3271182	204 Peach St	Purchase Laboratory Services for Water System Asset: Water Utility Services - June 2023	\$0.00	\$0.00	\$161.00	\$0.00	\$161.00	N
				Lab Fees or Laboratory Sampling Total	\$0.00	\$0.00	\$161.00	\$0.00	\$161.00	
				WP1 Total	\$815.00	\$4,385.81	\$164.11	\$0.00	\$5,364.92	
				WP Total	\$815.00	\$4,385.81	\$164.11	\$0.00	\$5,364.92	
				Invoice Total	\$5,230.00	\$18,816.61	\$364.41	\$0.00	\$24,411.02	

Client: SWEENY		Work Order Summary Provided to City of Sweeny - Invoice # 1152073					09 Oct 2023 02:59:06PM CST			
Type:	SP									
WO	Date Complete	Date Invoiced	Location	Asset ID	GL Code	Sub Cat	Dept	Activity Type & Comments		
3320086	8/21/2023	10/9/2023	2607 Avenue A	SWEENY-SP1	40500	GNL	5755	SPGENREP - General Repair or Maintenance of an Asset at a Sewer Treatment Plant		
		Insp:	Attachments: 1	Bid Price: \$0.00				Weekend plant check		
		<u>Labor</u>	<u>Emp ID:</u>	<u>Type</u>	<u>Reg Hrs</u>	<u>OT Hrs</u>	<u>Unit Price</u>	<u>Total Price</u>	<u>Tax</u>	<u>Grand Total</u>
	8/19/2023	703616			0.00	3.00	\$130.95	\$392.85	\$0.00	\$392.85
	8/20/2023	703616			0.00	3.00	\$130.95	\$392.85	\$0.00	\$392.85
							Labor Total	\$785.70	\$0.00	\$785.70
		<u>Equipment</u>	<u>Equip ID:</u>	<u>Equipment Desc</u>	<u>Reg Hrs</u>		<u>Unit Price</u>	<u>Total Price</u>	<u>Tax</u>	<u>Grand Total</u>
			TX121677	Utility Truck	3.00		\$20.00	\$60.00	\$0.00	\$60.00
			TX121677	Utility Truck	3.00		\$20.00	\$60.00	\$0.00	\$60.00
							Equipment Total	\$120.00	\$0.00	\$120.00
							WO [3320086] Total	\$905.70	\$0.00	\$905.70

Comments: Checked in Sewer plant on the weekend, made sure bleach was feeding and checked residual. Return running and plant running normal.

Client: SWEENY		Work Order Summary Provided to City of Sweeny - Invoice # 1152073					09 Oct 2023 02:59:06PM CST			
Type:	SP									
WO	Date Complete	Date Invoiced	Location	Asset ID	GL Code	Sub Cat	Dept	Activity Type & Comments		
3322579	8/14/2023	10/9/2023	2607 Avenue A	SWEENY-SP1	40500	GNL	5755	SPGENREP - General Repair or Maintenance of an Asset at a Sewer Treatment Plant		
		Insp:	Attachments: 1	Bid Price: \$0.00						
		<u>Labor</u>	<u>Emp ID:</u>	<u>Type</u>	<u>Reg Hrs</u>	<u>OT Hrs</u>	<u>Unit Price</u>	<u>Total Price</u>	<u>Tax</u>	<u>Grand Total</u>
	8/12/2023	603528		Lead Ops / Tech	0.00	4.00	\$145.97	\$583.86	\$0.00	\$583.86
	8/13/2023	603528		Lead Ops / Tech	0.00	3.25	\$145.97	\$474.39	\$0.00	\$474.39
							Labor Total	\$1,058.25	\$0.00	\$1,058.25

Client: SWEENY		Work Order Summary Provided to City of Sweeny - Invoice # 1152073					09 Oct 2023 02:59:06PM CST		
Type: SP	TX121677	Utility Truck				2.50	\$20.00	\$50.00	
Equipment Total							\$240.00	\$0.00	\$240.00
WO [3324477] Total							\$1,342.16	\$0.00	\$1,342.16
<p>Comments: Monday- came out to plant and pulled samples every two hours and combined for sampling to be picked up the next day, filled out chain of custody and left for envirodine and checked in plant. Tuesday- checked in plant , made sure do,s where good, chemical feed and residual good , plant is now building solids and looks good. Wednesday- checked in plant , made sure do,s where good, chemical feed and residual good , plant is now building solids and looks good. Thursday- checked in plant , made sure do,s where good, chemical feed and residual good , plant is now building solids and looks good. Walked plant and cleaned up walk ways and clarifier cat walks, made sure all buckets and trash were moved or throw away. Friday- upped bleach feed and got residual moving up, plant looking really good, slowly getting solids.</p>									
WO	Date Complete	Date Invoiced	Location	Asset ID	GL Code	Sub Cat	Dept	Activity Type & Comments	
3327713	8/28/2023	10/9/2023	2607 Avenue A	SWEENY- SP1	40500	GNL	5755	SPGENREP - General Repair or Maintenance of an Asset at a Sewer Treatment Plant	
Labor		Insp:	Attachments: 2	Bid Price: \$0.00					
8/26/2023	Emp ID: 604339	Type	*Operator III	Reg Hrs	0.00	OT Hrs	4.00	Unit Price	\$123.70
								Total Price	\$494.82
								Tax	\$0.00
								Grand Total	\$494.82

Client: SWEENY		Work Order Summary Provided to City of Sweeny - Invoice # 1152073						09 Oct 2023 02:59:06PM CST		
Type:	SP	8/27/2023	604339	*Operator III	0.00	3.75	\$123.70	\$463.89	\$0.00	\$463.89
							Labor Total	\$958.71	\$0.00	\$958.71
Equipment		Equip ID:	Equipment Desc	Reg Hrs	Unit Price	Total Price	Tax	Grand Total		
	TX121680	Utility Truck	4.00	\$20.00	\$80.00	\$0.00	\$80.00			
	TX121680	Utility Truck	3.75	\$20.00	\$75.00	\$0.00	\$75.00			
		Equipment Total			\$155.00	\$0.00	\$155.00			
Comments:		Weekend facility check in and operations.								
		WO [3327713]		Total		\$1,113.71	\$0.00	\$1,113.71		
WO	Date Complete	Date Invoiced	Location	Asset ID	GL Code	Sub Cat	Dept	Activity Type & Comments		
3332459	8/31/2023	10/9/2023	2607 Avenue A	SWEENY- SP1	40500	GNL	5755	SPGENREP - General Repair or Maintenance of an Asset at a Sewer Treatment Plant		
	Insp:		Attachments: 0	Bid Price: \$0.00				Checked n plant, pulled samples		
Labor		Emp ID:	Type	Reg Hrs	OT Hrs	Unit Price	Total Price	Tax	Grand Total	
	8/28/2023	703616		5.50	0.00	\$87.30	\$480.15	\$0.00	\$480.15	
	8/29/2023	703616		2.00	0.00	\$87.30	\$174.60	\$0.00	\$174.60	
	8/30/2023	703616		2.00	0.00	\$87.30	\$174.60	\$0.00	\$174.60	
	8/31/2023	703616		2.00	0.00	\$87.30	\$174.60	\$0.00	\$174.60	
		Labor Total				\$1,003.95	\$0.00	\$1,003.95		
Equipment		Equip ID:	Equipment Desc	Reg Hrs	Unit Price	Total Price	Tax	Grand Total		
	TX121677	Utility Truck	5.50	\$20.00	\$110.00	\$0.00	\$110.00			
	TX121677	Utility Truck	2.00	\$20.00	\$40.00	\$0.00	\$40.00			
	TX121677	Utility Truck	2.00	\$20.00	\$40.00	\$0.00	\$40.00			

Client: SWEENEY		Work Order Summary Provided to City of Sweeney - Invoice # 1152073						09 Oct 2023 02:59:06PM CST			
Type: SP											
	TX121677	Utility Truck				2.00		\$20.00	\$40.00	\$0.00	\$40.00
	Equipment Total							\$230.00	\$0.00	\$0.00	\$230.00
	WO [3332459] Total							\$1,233.95	\$0.00	\$0.00	\$1,233.95
WO	Date Complete	Date Invoiced	Location	Asset ID	GL Code	Sub Cat	Dept	Activity Type & Comments			
3333806	9/5/2023	10/9/2023	2607 Avenue A	SWEENEY- SP1	40500	GNL	5755	SPGENREP - General Repair or Maintenance of an Asset at a Sewer Treatment Plant			
		Insp:	Attachments: 2	Bid Price: \$0.00				Weekend facility check in and plant operations.			
Labor	Emp ID:	Type	Reg Hrs	OT Hrs	Unit Price	Total Price	Tax	Grand Total			
9/2/2023	603528	Lead Ops / Tech	0.00	3.50	\$145.97	\$510.88	\$0.00	\$510.88			
9/3/2023	603528	Lead Ops / Tech	0.00	2.00	\$145.97	\$291.93	\$0.00	\$291.93			
9/4/2023	603528	Lead Ops / Tech	0.00	3.75	\$145.97	\$547.37	\$0.00	\$547.37			
9/4/2023	603528	Lead Ops / Tech	0.00	1.25	\$145.97	\$182.46	\$0.00	\$182.46			
		Labor Total				\$1,532.64	\$0.00	\$1,532.64			
Equipment	Equip ID:	Equipment Desc	Reg Hrs	Unit Price	Total Price	Tax	Grand Total				
	TX119016	Utility Truck	3.50	\$20.00	\$70.00	\$0.00	\$70.00				
	TX119016	Utility Truck	2.00	\$20.00	\$40.00	\$0.00	\$40.00				
	TX119016	Utility Truck	3.75	\$20.00	\$75.00	\$0.00	\$75.00				
	TX119016	Utility Truck	1.25	\$20.00	\$25.00	\$0.00	\$25.00				
	Equipment Total				\$210.00	\$0.00	\$210.00				
	WO [3333806] Total				\$1,742.64	\$0.00	\$1,742.64				
	Comments: Weekend & holiday facility check-in and plant operations. composite sample for 9/4										

Client: SWEENEY		Work Order Summary Provided to City of Sweeney - Invoice # 1152073					09 Oct 2023 02:59:06PM CST				
Type: SP											
	TX121677	Utility Truck			3.50		\$20.00	\$70.00	\$0.00	\$70.00	
							Equipment Total	\$215.00	\$0.00	\$215.00	
							WO [3346816] Total	\$1,840.96	\$0.00	\$1,840.96	
	<p>Comments: Monday- arrived at plant and chemical pump not feeding, got a hold of Hawkins and was able to meet in Sugarland and pick up new pump, came back and installed new pump and was able to get chemical feeding properly, started pulling my samples after good residual. Met BNR on site and assisted in swapping RAS pump 4 with three, they took 4 to rebuild blown motor. Tried to prime pump but was unsuccessful. Did pull all samples Tuesday- checked in plant and was able to get new pump primed but unable to get solids in return, return may be clogged, and this might have caused issue with old pump. Let Lindsey and Tracy know, Lindsey informed me that she will be scheduling a jet truck through other sources. Wednesday- checked plant, chemical feeding good, RAS pump still not working. Tried to get working, pump primed but did not come out of return. Pump got hot, turned off. Thursday- attempted to get RAS pump to pump properly again, was unsuccessful. Called Lindsey and was informed a jet trailer will be at plant Friday morning. Friday- in hooked RAS pump 4 and attempt to jet return line. Did not have proper hose, could not make all turns in line. Spoke with Lindsey and was approved to schedule inframe vactor truck come out Monday and jet return, and scum trough in clarifier 1 and top clean onsite lift station. Checked in lift stations in town.</p>										
WO	Date Complete	Date Invoiced	Location	Asset ID	GL Code	Sub Cat	Dept	Activity Type & Comments			
3350694	9/17/2023	10/9/2023	2607 Avenue A	SWEENEY- SP1	40500	GNL	5755	SPGENREP - General Repair or Maintenance of an Asset at a Sewer Treatment Plant			
		Insp:	Attachments: 2	Bid Price: \$0.00				Weekend plant operations			
Materials		Mat ID:	Material Desc	Vendor Bill #	Type	Qty	Unit Cost	Unit Price	Total Price	Tax	Grand Total
		MS72	MISC. Photos			2.00	\$1.35	\$1.55	\$3.11	\$0.00	\$3.11
								Materials Total	\$3.11	\$0.00	\$3.11
Labor		Emp ID:	Type	Reg Hrs	OT Hrs	Unit Price	Total Price	Tax	Grand Total		
	9/16/2023	700366		0.00	2.00	\$100.31	\$200.62	\$0.00	\$200.62		
	9/17/2023	700366		0.00	2.25	\$100.31	\$225.69	\$0.00	\$225.69		

Client: SWEENY		Work Order Summary Provided to City of Sweeny - Invoice # 1152073										09 Oct 2023 02:59:06PM CST			
Type: SP															
Equipment	<u>Equip ID:</u>	<u>Equipment Desc</u>	<u>Reg Hrs</u>	<u>Unit Price</u>	<u>Total Price</u>	<u>Tax</u>	<u>Grand Total</u>								
	TX619155	Vactor Truck w/ Operator	5.00	\$220.00	\$1,100.00	\$0.00	\$1,100.00								
	TX123319	Maintenance Truck	5.00	\$35.00	\$175.00	\$0.00	\$175.00								
	TX123319	Maintenance Truck	3.00	\$35.00	\$105.00	\$0.00	\$105.00								
	TX619155N	Vactor Truck w/Operator (No Min)	3.00	\$220.00	\$660.00	\$0.00	\$660.00								
		Equipment Total			\$2,040.00	\$0.00	\$2,040.00								
Comments:		Set up equipment jettied Ras line from both direction to clear line. Also jettied scum line, removed rag debris and large, graduated cylinder from line. Disposed onsite.										WO [3351361] Total	\$3,152.48	\$0.00	\$3,152.48
WO	Date Complete	Date Invoiced	Asset ID	GL Code	Sub Cat	Dept	Activity Type & Comments								
3355805	9/25/2023	10/9/2023	SWEENY- 40500 SP1	2607 Avenue A	GNL	5755	SPGENREP - General Repair or Maintenance of an Asset at a Sewer Treatment Plant								
		Insp:	Attachments: 0	Bid Price: \$0.00			Weekly plant check in								
Labor	<u>Emp ID:</u>	<u>Type</u>	<u>Reg Hrs</u>	<u>OT Hrs</u>	<u>Unit Price</u>	<u>Total Price</u>	<u>Tax</u>	<u>Grand Total</u>							
9/18/2023	703616		4.00	0.00	\$87.30	\$349.20	\$0.00	\$349.20							
9/19/2023	703616		3.50	0.00	\$87.30	\$305.55	\$0.00	\$305.55							
9/20/2023	703616		0.75	0.00	\$87.30	\$65.48	\$0.00	\$65.48							
9/21/2023	703616		5.00	0.00	\$87.30	\$436.50	\$0.00	\$436.50							
9/22/2023	703616		1.50	0.00	\$87.30	\$130.95	\$0.00	\$130.95							
		Labor Total				\$1,287.68	\$0.00	\$1,287.68							
Equipment	<u>Equip ID:</u>	<u>Equipment Desc</u>	<u>Reg Hrs</u>	<u>Unit Price</u>	<u>Total Price</u>	<u>Tax</u>	<u>Grand Total</u>								
	TX121677	Utility Truck	4.00	\$20.00	\$80.00	\$0.00	\$80.00								
	TX121677	Utility Truck	3.50	\$20.00	\$70.00	\$0.00	\$70.00								
	TX121677	Utility Truck	0.75	\$20.00	\$15.00	\$0.00	\$15.00								

Client: SWEENY		Work Order Summary Provided to City of Sweeny - Invoice # 1152073					09 Oct 2023 02:59:06PM CST			
Type:	SP									
	TX121677	Utility Truck			5.00		\$20.00	\$100.00	\$0.00	\$100.00
	TX121677	Utility Truck			1.50		\$20.00	\$30.00	\$0.00	\$30.00
							Equipment Total	\$295.00	\$0.00	\$295.00
							WO [3355805] Total	\$1,582.68	\$0.00	\$1,582.68
Comments:	Monday- pulled samples for sewer plant. Once return pump was re installed , I got pump primed but could not get solids through return even though pump was primed and line cleared. Pump was getting way too hot shut off and let Lindsey, Ric and Tracy know. Tuesday- tried to prime pump and get going again unsuccessfully, spoke with Lindsey and she schedule BNR to come next day to look at and give quote for new return pumps. Wednesday- met BNR on site and discussed pumps, Lindsey agreed to replace and need to get done as quick as possible, also agreed to get transducer replaced and chlorine syste, repaired. Thursday- checked in plant, still waiting for new pumps. Friday- checked in plant , still no new pumps.									
WO	Date Complete	Date Invoiced	Location	Asset ID	GL Code	Sub Cat	Dept	Activity Type & Comments		
3355825	9/25/2023	10/9/2023	2607 Avenue A	SWEENY- 40500 SP1	40500	GNL	5755	SPINVPRB - Investigate a Problem at a Sewer Treatment Plant		
		Insp:	Attachments: 2	Bid Price: \$0.00				Had to buy parts to fix leak in bleach line		
Materials	<u>Mat ID:</u>	<u>Material Desc</u>	<u>Vendor Bill #</u>	<u>Type</u>	<u>Qty</u>	<u>Unit Cost</u>	<u>Unit Price</u>	<u>Total Price</u>	<u>Tax</u>	<u>Grand Total</u>
	PCard	Litzlers Feed			1.00	\$12.47	\$14.34	\$14.34	\$0.00	\$14.34
	PCard	Home Depot			1.00	\$6.04	\$6.04	\$6.04	\$0.00	\$6.04
							Materials Total	\$20.38	\$0.00	\$20.38
Labor	<u>Emp ID:</u>	<u>Type</u>	<u>Reg Hrs</u>	<u>OT Hrs</u>	<u>Unit Price</u>	<u>Total Price</u>	<u>Tax</u>	<u>Grand Total</u>		
9/18/2023	703616		3.00	0.00	\$87.30	\$261.90	\$0.00	\$261.90		\$261.90
					Labor Total	\$261.90	\$0.00	\$261.90		\$261.90

Work Order Summary Provided to City of Sweeny - Invoice # 1152073										09 Oct 2023 02:59:06PM CST	
Client:	SWEENY										
Type:	SP										
Equipment	Equip ID:	Equipment Desc	Reg Hrs	Unit Price	Total Price	Tax	Grand Total				
	TX121677	Utility Truck	3.00	\$20.00	\$60.00	\$0.00	\$60.00				
				Equipment Total	\$60.00	\$0.00	\$60.00				
				WO [3355825] Total	\$342.28	\$0.00	\$342.28				
WO	Date Complete	Date Invoiced	Location	Asset ID	GL Code	Sub Cat	Dept	Activity Type & Comments			
3359035	9/26/2023	10/9/2023	2607 Avenue A	SWEENY- 40500 SP1	GNL	5755	SPGENREP - General Repair or Maintenance of an Asset at a Sewer Treatment Plant				
		Insp:	Attachments: 2	Bid Price: \$0.00							
Labor	Emp ID:	Type	Reg Hrs	OT Hrs	Unit Price	Total Price	Tax	Grand Total			
9/23/2023	603528	Lead Ops / Tech	0.00	2.50	\$145.97	\$364.91	\$0.00	\$364.91			
9/24/2023	603528	Lead Ops / Tech	0.00	3.00	\$145.97	\$437.90	\$0.00	\$437.90			
				Labor Total		\$802.81	\$0.00	\$802.81			
Equipment	Equip ID:	Equipment Desc	Reg Hrs	Unit Price	Total Price	Tax	Grand Total				
	TX121620	Utility Truck	2.50	\$20.00	\$50.00	\$0.00	\$50.00				
	TX121620	Utility Truck	3.00	\$20.00	\$60.00	\$0.00	\$60.00				
				Equipment Total	\$110.00	\$0.00	\$110.00				
				WO [3359035] Total	\$912.81	\$0.00	\$912.81				
				Comments:	Weekend plant check and operations						

Client: SWEENY		Work Order Summary Provided to City of Sweeny - Invoice # 1152073						09 Oct 2023 02:59:06PM CST	
Type:	WP								
9/5/2023	703616		1.00	0.00			\$87.30	\$87.30	\$87.30
9/6/2023	703616		1.00	0.00			\$87.30	\$87.30	\$87.30
9/7/2023	703616		2.00	0.00			\$87.30	\$174.60	\$174.60
9/8/2023	703616		2.00	0.00			\$87.30	\$174.60	\$174.60
Labor Total							\$654.75	\$0.00	\$654.75
Equipment	Equip ID:	Equipment Desc	Reg Hrs	Unit Price	Total Price	Tax	Grand Total		
	TX121677	Utility Truck	1.00	\$20.00	\$20.00	\$0.00	\$20.00		
	TX121677	Utility Truck	1.00	\$20.00	\$20.00	\$0.00	\$20.00		
	TX121677	Utility Truck	2.00	\$20.00	\$40.00	\$0.00	\$40.00		
	TX121677	Utility Truck	2.00	\$20.00	\$40.00	\$0.00	\$40.00		
Equipment Total							\$120.00	\$0.00	\$120.00
WO [3339905] Total							\$774.75	\$0.00	\$774.75

Comments: Checked in plant during, checked in residual in district residual, residual at plant and made sure wells running properly and chemicals feeding properly

WO	Date Complete	Date Invoiced	Location	Asset ID	GL Code	Sub Cat	Dept	Activity Type & Comments	
3346812	9/13/2023	10/9/2023	204 Peach St	SWEENY-40500 WP1	GNL	5755	WPGENREP - General Repairs of an Asset at a Water Plant		
	Insp:		Attachments: 0	Bid Price: \$0.00			Weekend check		
Labor	Emp ID:	Type	Reg Hrs	OT Hrs	Unit Price	Total Price	Tax	Grand Total	
9/9/2023	703616		0.00	2.50	\$130.95	\$327.38	\$0.00	\$327.38	
9/10/2023	703616		0.00	2.50	\$130.95	\$327.38	\$0.00	\$327.38	
Labor Total							\$654.76	\$0.00	\$654.76
Equipment	Equip ID:	Equipment Desc	Reg Hrs	Unit Price	Total Price	Tax	Grand Total		
	TX121677	Utility Truck	2.50	\$20.00	\$50.00	\$0.00	\$50.00		

Client:	SWEENY	Work Order Summary Provided to City of Sweeney - Invoice # 1152073					09 Oct 2023 02:59:06PM CST	
Type:	WP							
Comments:		Completed weekend check in...						
						WO [3350695] Total \$394.11 \$0.00 \$394.11		
WO	Date Complete	Date Invoiced	Location	Asset ID	GL Code	Sub Cat	Dept	Activity Type & Comments
3355823	9/25/2023	10/9/2023	204 Peach St	SWEENY- WP1	40500	GNL	5755	WPGENREP - General Repairs of an Asset at a Water Plant
		Insp:	Attachments: 0	Bid Price: \$0.00				WP check in
Labor	Emp ID:	Type	Reg Hrs	OT Hrs	Unit Price	Total Price	Tax	Grand Total
9/18/2023	703616		1.00	0.00	\$87.30	\$87.30	\$0.00	\$87.30
9/19/2023	703616		1.50	0.00	\$87.30	\$130.95	\$0.00	\$130.95
9/20/2023	703616		1.75	0.00	\$87.30	\$152.78	\$0.00	\$152.78
9/21/2023	703616		1.00	0.00	\$87.30	\$87.30	\$0.00	\$87.30
9/22/2023	703616		1.00	0.00	\$87.30	\$87.30	\$0.00	\$87.30
					Labor Total	\$545.63	\$0.00	\$545.63
Equipment	Equip ID:	Equipment Desc	Reg Hrs	Unit Price	Total Price	Tax	Grand Total	
	TX121677	Utility Truck	1.00	\$20.00	\$20.00	\$0.00	\$20.00	
	TX121677	Utility Truck	1.50	\$20.00	\$30.00	\$0.00	\$30.00	
	TX121677	Utility Truck	1.75	\$20.00	\$35.00	\$0.00	\$35.00	
	TX121677	Utility Truck	1.00	\$20.00	\$20.00	\$0.00	\$20.00	
	TX121677	Utility Truck	1.00	\$20.00	\$20.00	\$0.00	\$20.00	
				Equipment Total	\$125.00	\$0.00	\$125.00	
Comments:		Checked residual in district, at elevated tank, and GST at plant. Adjusted and monitored chemical feed. Monitored well flow and booster pump times.						
							WO [3355823] Total \$670.63 \$0.00 \$670.63	

Type:	WP																			
WO	Date Complete	Date Invoiced	Location	Asset ID	GL Code	Sub Cat	Dept	Activity Type & Comments												
3359037	9/26/2023	10/9/2023	204 Peach St	SWEENY- WP1 40500	40500	GNL	5755	WPGENREP - General Repairs of an Asset at a Water Plant												
		Insp:	Attachments: 1	Bid Price: \$0.00																
		<u>Emp ID:</u>	<u>Type</u>		<u>Reg Hrs</u>	<u>OT Hrs</u>		<u>Unit Price</u>	<u>Total Price</u>	<u>Tax</u>	<u>Grand Total</u>									
	9/23/2023	603528	Lead Ops / Tech		0.00	1.00		\$145.97	\$145.97	\$0.00	\$145.97									
	9/24/2023	603528	Lead Ops / Tech		0.00	1.00		\$145.97	\$145.97	\$0.00	\$145.97									
								Labor Total	\$291.94	\$0.00	\$291.94									
		<u>Equip ID:</u>	<u>Equipment Desc</u>					<u>Unit Price</u>	<u>Total Price</u>	<u>Tax</u>	<u>Grand Total</u>									
		TX121620	Utility Truck			1.00		\$20.00	\$20.00	\$0.00	\$20.00									
		TX121620	Utility Truck			1.00		\$20.00	\$20.00	\$0.00	\$20.00									
								Equipment Total	\$40.00	\$0.00	\$40.00									
								WO [3359037] Total	\$331.94	\$0.00	\$331.94									
		Comments: weekend plant check and operations																		
WO	Date Complete	Date Invoiced	Location	Asset ID	GL Code	Sub Cat	Dept	Activity Type & Comments												
3366287	10/1/2023	10/9/2023	204 Peach St	SWEENY- WP1 40500	40500	GNL	5755	WPGENREP - General Repairs of an Asset at a Water Plant												
		Insp:	Attachments: 0	Bid Price: \$0.00																
		<u>Emp ID:</u>	<u>Type</u>		<u>Reg Hrs</u>	<u>OT Hrs</u>		<u>Unit Price</u>	<u>Total Price</u>	<u>Tax</u>	<u>Grand Total</u>									
	9/25/2023	703616			1.00	0.00		\$87.30	\$87.30	\$0.00	\$87.30									
	9/26/2023	703616			0.75	0.00		\$87.30	\$65.48	\$0.00	\$65.48									
	9/26/2023	703616			0.00	0.50		\$130.95	\$65.48	\$0.00	\$65.48									
	9/27/2023	703616			0.50	0.00		\$87.30	\$43.65	\$0.00	\$43.65									
	9/27/2023	703616			0.00	0.50		\$130.95	\$65.48	\$0.00	\$65.48									
	9/28/2023	703616			0.75	0.00		\$87.30	\$65.48	\$0.00	\$65.48									

Client: SWEENY		Work Order Summary Provided to City of Sweeny - Invoice # 1152073					09 Oct 2023 02:59:06PM CST	
Type:	WP							
9/29/2023	703616		1.00	0.00	\$87.30	\$87.30	\$0.00	\$87.30
					Labor Total	\$480.17	\$0.00	\$480.17
Equipment	Equip ID:	Equipment Desc	Reg Hrs	Unit Price	Total Price	Tax	Grand Total	
	TX121677	Utility Truck	1.00	\$20.00	\$20.00	\$0.00	\$20.00	
	TX121677	Utility Truck	1.25	\$20.00	\$25.00	\$0.00	\$25.00	
	TX121677	Utility Truck	1.00	\$20.00	\$20.00	\$0.00	\$20.00	
	TX121677	Utility Truck	0.75	\$20.00	\$15.00	\$0.00	\$15.00	
	TX121677	Utility Truck	1.00	\$20.00	\$20.00	\$0.00	\$20.00	
				Equipment Total	\$100.00	\$0.00	\$100.00	
Comments:	Weekly plant check, checked residual at plant, at district and elevated. Monitored booster pump run time and well flow.					WO [3366287] Total	\$580.17	\$0.00
					Work Type [WP] Total (Count: 11)	\$5,364.92	\$0.00	\$5,364.92
					Work Order Detail Report Total (Count: 28)	\$24,411.02	\$0.00	\$24,411.02

Inframark, LLC		
Invoiced Backcharges		
Client:	SWEENEY	
WO #	Work Type	Address Where Work was Performed:
		Backcharged to:
Total Invoiced Backcharges		Invoice Amount
		\$0.00