



City Hall Council Chambers, 298 W. Washington
Tuesday, March 15, 2022 at 5:30 PM

AGENDAS

COUNCIL COMMITTEE MEETINGS

NOMINATIONS COMMITTEE

Gerald Cook, chair; LeAnn Durfey, Justin Haschke, Alan Nix

1. Downtown Lighting

FINANCE COMMITTEE

Justin Haschke, chair; Brandon Huckabee, Brady Pendleton, Ricky Thurman

2. Vehicle for New Buildings and Grounds Maintenance

PARKS AND LEISURE SERVICES COMMITTEE

Daron Trussell, chair; Justin Haschke, Alan Nix, Ricky Thurman

3. Proposed Ordinance - Chapter 97 Municipal Parks, Facilities, and Cemeteries

PERSONNEL COMMITTEE

Ricky Thurman, Chair; Gerald Cook, LeAnn Durfey, Daron Trussell

4. Review and Discuss Compensation Study and Stepped Pay Plan

SPECIAL CITY COUNCIL MEETING

CALL TO ORDER

REGULAR AGENDA

1. Consider Approval of an Expenditure for Downtown Lighting
2. Consider Approval of an Expenditure for the Purchase of a Vehicle for the Parks and Leisure Services Department

EXECUTIVE SESSION

In compliance with the provisions of the Texas Open Meetings Act, Texas Government Code Chapter 551, Subchapter D, in accordance with:

3. Section 551.074 Personnel Matters - to deliberate the appointment, employment, evaluation, reassignment, duties, discipline, or dismissal of a public officer or employee, to wit:
 1. City Manager
 2. City Attorney
 3. City Secretary

ADJOURN

In accordance with the Americans with Disabilities Act, persons who need accommodation to attend or participate in this meeting should contact City Hall at 254-918-1287 within 48 hours prior to the meeting to request such assistance.



STAFF REPORT

SUBJECT: Downtown Lighting

DEPARTMENT: Main Street

STAFF CONTACT: Julie Smith

RECOMMENDATION:

Staff recommends purchasing the eight light units for downtown.

BACKGROUND:

Staff recommends accepting the proposal for decorative street lighting for the downtown square to replace the existing, outdated and nonworking fixtures we currently have in place. Additionally, the proposed eight fixtures will accommodate banner signage with sturdy structures not presently available on the existing light poles. The turnaround for delivery of the lights is two-six months, however, the price does not include new bases and installation costs.

FISCAL IMPACT SUMMARY:

\$69,960.00

ALTERNATIVES



Proposal

DATE: February 25, 2022
TO: Stephenville Texas
ATTN: Allen Barnes
PROJECT: **Decorative Street Lighting**

We are pleased to offer the following proposal:

Manufacturer: Spring City Electrical Mfg. Co.
1 South Main Street
Spring City, PA. 19475
Phone: 610-569-4254
Prime Contact: Dan Kovalchick
Email: dkovalchick@springcity.com

SPEC-33531

Quantity: 8
24'10" Boston Downtown Assembly – Exton & Washington LED Luminaires
Standard: Decorative Site Lighting
Drawing Ref: SPEC-33531
Catalog Numbers: ALMETN-M1-LE___/EVX/2F2-___-CR3-GPLO-LACLB-FCR-CU (Luminaire)
ALMWSH-LE___/EVX/L19-___-CR3-YS29-TB-FPL-CU (Luminaire)
AWBCTB-M1-18-CU (Base)
SSHSM-G17-07.50-24.83-TN2.88-10.00-2BP-2GFWI-2SD-PF-SP-CU (Shaft)
SAROSG-1S-SD-66.36-TN2.38-6.23-CU (Roadway Arm)
AWKVNY-M1-1S-15.00-TN3.50-3.00-CU (Pedestrian Arm)
Unit Cost.....\$8,745.00

Cost Extensions:
Decorative Site Lighting (8) x 8,745.00 = **\$69,960.00**

Terms of Sale: Net 30 Days, Freight Allowed, FOB Factory

Lead times:
Shop Drawing Submission: 1 week
Materials: 10-12 weeks per shipment

Warranty:
10 Years LED Warranty

Attachments:
Drawing No. SPEC-33531



Notes:

1. A "Hold for Release" purchase or change order shall be generated for (8) units totaling \$69,960.00
2. Price includes (1) shipment to Stephenville, Texas.
3. Change orders will be accepted within (6) months of the original purchase order to increase the number of units required at the agreed upon price of \$8,745.00 each.
4. Pricing will be held for (6) months from the original purchase order date and price increases should not exceed the CPI for a (24) month period to offer Stephenville transparency on pricing moving forward.
5. Pricing does not include sales tax.

Thank You,

Daniel Kovalchick
Director of Product Development & Specification

This drawing is property of Spring City Electrical Mfg. Co. and is issued to the recipient with the understanding that it shall not be copied, duplicated, passed on to unauthorized parties, nor used for any purpose other than that for which it is specifically furnished except with Spring City's written permission.

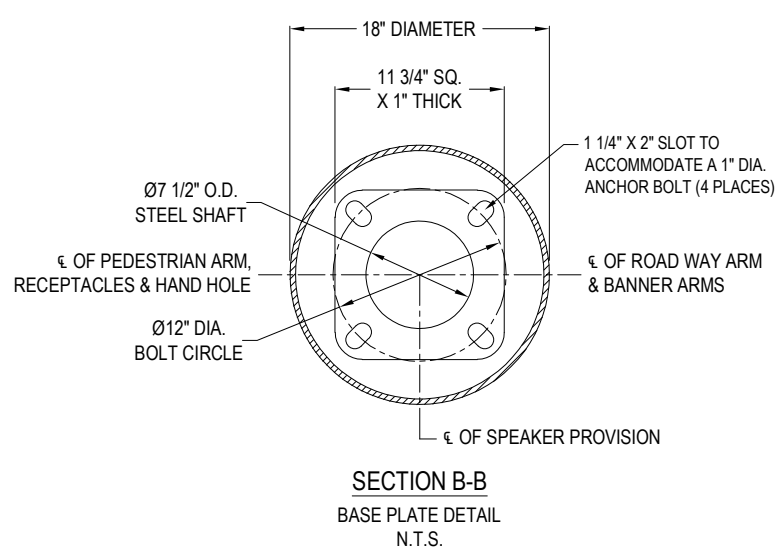
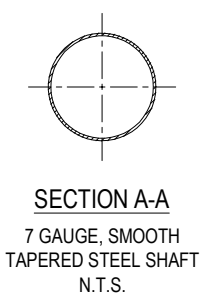
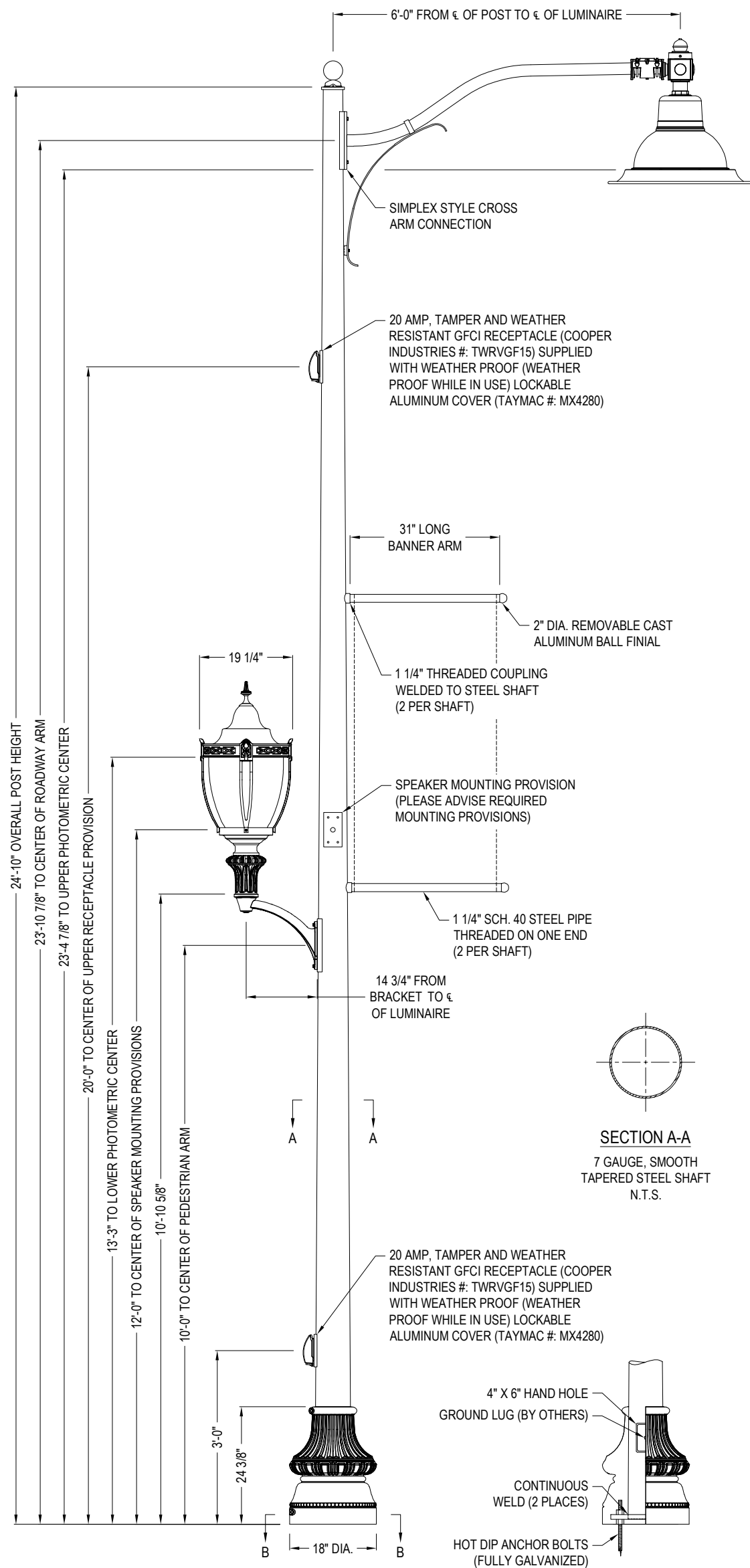

ROADWAY LUMINAIRE SPECIFICATIONS:

STYLE: EXTON
 HEIGHT: 30 1/8"
 WIDTH: 30" DIAMETER
 MATERIAL: CAST ALUMINUM ALLOY A.N.S.I. 356, PER A.S.T.M. B26-95 WITH 12 GAUGE, 1100-0 SPUN SHADE CLEAR GLASS LENS
 GLOBE: POWDER COATED - PLEASE ADVISE COLOR
 FINISH: PLEASE ADVISE DESIRED WATTAGE
 LAMPING: ELECTRICALLY WIRE AT 120-277 VOLTS
 VOLTAGE: PLEASE ADVISE DESIRED COLOR TEMPERATURE
 COLOR TEMP.: TYPE III REFRACTIVE OPTICS (ASYMMETRIC DISTRIBUTION)
 OPTICAL SYSTEM: 10KV SURGE PROTECTION
 SURGE PROTECTION: FLAIR SHADE
 MODIFIER: COLUMBIA LUMINAIRE HOLDER WITH CHARLEROI BALL FINIAL

CATALOG NO.: ALMETN-M1-LE___EVX-2F2-___CR3-GPLO-LACL-B-FCR-CU

ROADWAY CROSS ARM SPECIFICATIONS:

STYLE: OSAGE SINGLE
 HEIGHT: 36"
 WIDTH: 6'-0" FROM ϵ OF POST TO ϵ OF LUMINAIRE
 MATERIAL: STEEL PIPE WITH STEEL ORNAMENTATION
 FINISH: POWDER COATED - PLEASE ADVISE COLOR
 TENON: 2 3/8" DIA. X 6 1/4" LONG

CATALOG NO.: SAROSG-1S-SD-66-36-TN2.38-6.25-CU

PEDESTRIAN LUMINAIRE SPECIFICATIONS:

STYLE: WASHINGTON X-SERIES WITH TARBORO STRUTS
 HEIGHT: 44 1/8"
 WIDTH: 19 1/4"
 MATERIAL: CAST ALUMINUM ALLOY ANSI 356 PER A.S.T.M. B26-95
 GLOBE: CLEAR STIPPLED ACRYLIC GLOBE
 FINISH: POWDER COATED - PLEASE ADVISE COLOR
 LAMPING: PLEASE ADVISE DESIRED WATTAGE
 VOLTAGE: ELECTRICALLY WIRE AT 120-277 VOLTS
 COLOR TEMP.: PLEASE ADVISE DESIRED COLOR TEMPERATURE
 OPTICAL SYSTEM: TYPE III REFRACTIVE OPTICS (ASYMMETRIC DISTRIBUTION)
 SURGE PROTECTION: 10KV SURGE PROTECTION

CATALOG NO.: ALMWSH-LE___L19-EVX-___CR3-YS29-TB-FPL-CU

PEDESTRIAN CROSS ARM SPECIFICATIONS:

STYLE: VINEYARD
 HEIGHT: 15 3/4"
 WIDTH: 14 3/4" FROM WALL TO ϵ OF LUMINAIRE
 MATERIAL: CAST ALUMINUM ALLOY ANSI 356 PER A.S.T.M. B26-95
 FINISH: POWDER COATED - PLEASE ADVISE COLOR
 TENON: 3 1/2" DIA. X 3" HIGH (TO ACCEPT LUMINAIRE)

CATALOG NO.: AWKVNY-M1-1S-15.00-TN3.50-3.00-CU

LAMP POST SPECIFICATIONS

STYLE: BOSTON DOWNTOWN STEEL
 HEIGHT: 24'-10"
 BASE: 18" DIAMETER
 MATERIAL:
 • SHAFT: 7 GAUGE, SMOOTH TAPERED STEEL MONOTUBE CONSTRUCTION
 • BASE: TWO PIECE, (WRAP AROUND) CAST ALUMINUM ALLOY ANSI 356 PER A.S.T.M. B26-95
 FINISH: POWDER COATED - PLEASE ADVISE COLOR
 ACCESS DOOR: LOCATED IN BASE SECURED WITH TAMPER PROOF HEX SOCKET SECURITY MACHINE SCREWS
 GROUND PROVISIONS: 1/4"-20 WELDED TO INSIDE STEEL SHAFT OPPOSITE ACCESS DOOR TO COINCIDE WITH HAND HOLE TO ACCOMMODATE GROUND STUD (GROUND STUD SUPPLIED BY OTHERS)
 ANCHOR BOLTS: (4) 1" DIA. X 36" LONG X 6" HOOK (FULLY GALVANIZED WITH 2 GALVANIZED WASHERS AND 2 GALVANIZED NUTS PER BOLT)
 BOLT PROJECTION: 5" REQUIRED
 TENON: 2 7/8" DIA. X 1/2" HIGH (TO ACCEPT POST TOP FINIAL)
 MODIFIERS:
 • (2) 1 1/4" THREADED BANNER PROVISIONS
 • (2) 20 AMP GFCI RECEPTACLE WITH IN-USE COVER (SEE SECTION B-B FOR ORIENTATION)
 • (2) STEEL MOUNTING PLATES WELDED TO SHAFT FOR ARM MOUNTING
 • POLE FINIAL
 • SPEAKER MOUNTING PROVISIONS

CATALOG NO.:
 • BASE: AWBCTB-M1-18-CU
 • SHAFT: SSHSM-G17-07.50-24.83-TN2.88-10.00-2BP-2GFWI-2SD-PF-SP-CU
 • BANNER ARM: SBNUBT-1S-1.25-31.00-F02
 • ANCHOR BOLT: 136/2NW

Spring City Electrical Mfg. Co.

HALL AND MAIN STREETS - P.O. BOX 19 - SPRING CITY, PA. 19475
 PHONE (610) 948-4000 - FAX (610) 948-5577 - WWW.SPRINGCITY.COM

DESCRIPTION	THE 24'-10" CITY OF BOSTON STEEL / ALUMINUM LAMP POST WITH THE VINEYARD PEDESTRIAN ARM WITH THE WASHINGTON STYLE LED LUMINAIRE AND THE OSAGE SINGLE CROSS ARM AND THE EXTON LED LUMINAIRE		
OPPORTUNITY	CITY OF STEPHENVILLE, TX		
SCALE	DRAWN BY:	DATE	DRAWING NO.
N.T.S.	B.K.R.	02-21-2022	SPEC-33531



February 25, 2022

Sole Source

To: Allen Barnes
Stephenville Texas
City Manager

Project: Street Lighting

Re: Sole Source – Spring City Product

Spring City appreciates the opportunity to supply the Decorative LED Outdoor Lighting Standards for Stephenville Texas. As a market leading manufacturer of outdoor decorative lighting, Spring City is equipped to support the Stephenville for these critical projects with our Exton LED Symphonic Luminaires, Osage Arms, Washington X-Series and Boston Downtown Lamp Posts. The quality, performance, durability, and longevity of the Spring City product identified in drawing number SPEC-33531 sets Spring City apart from its competition. The backbone of Spring City's patented design offers a long-term advantage for the Stephenville Texas.

Stephenville Texas is very confident in the design and performance, and based on the research, and have not found a comparable product, thus a making Spring City a Sole Source Vendor for the City's light standard.

Spring City Exton Luminaire and Washington X-Series Luminaire engineered design is proprietary to Spring City, as it is covered under the following patents:

The Spring City design covered under US Patent No. 8,104,929, which states the decorative cast housing serves as the heat-sink in which the LED circuit boards are directly attached to the cast metal dome. This will allow for the highest level of heat dissipation and ensure the longest life LED product on the market. This design cannot be duplicated and provides a tremendous advantage to Stephenville.

US Patent No. 8,104,929 also covers the vertical off axis location of the LED boards in the cast metal roof, which generates the downward efficiencies necessary to replace the traditional HID sources. This feature will capture the advantages of the point source of an LED and assist in focusing the light properly on the task while eliminating wasted up-light. The Spring City Exton Luminaire's off-axis design is the only product on the market that offers this design.

Design US Patent No. 9,765,956 covers the design of the X-Series casting. This feature will capture the advantages of the point source of an LED and assist in focusing the light properly on the task while providing the highest level of heat dissipation and ensure the longest life LED product on the market. The Spring City Washington Luminaire's off-axis design is the only product on the market that offers this design.



US Provisional Patent No. 62/039093 protects the injection molded optics, which are essential in reducing the energy consumption, and limiting the total number of luminaires needed to properly illuminate walkway or roadways. These optics gather and distribute 100% of the lumens being emitted from the LED source. The combination of optics, location of the LED boards, and the cast housing offers an efficient and attractive light source that Stephenville is seeking.

Stephenville will also take advantage of the following, based on the sole source approval:

- 10 Year Manufacturer's Warranty
- Reduce Inventory Costs for Stocking Multiple Components
- Upgradeable Design to Low Energy Consumption as the Technology Increases
- Reduce Maintenance Costs with Common Components
- Limit Disposal of Material with Spring City's Upgradeable Design
- Reduce Design Costs on Evaluating or Specifying New Projects
- Product Manufactured and Assembled in United States of America

Spring City will support the project direct from our factory and will provide a convenient avenue for procurement, training and support as these luminaires are purchased, installed, and maintained.

Thank you,

Daniel Kovalchick
Director of Product Development & Specifications



STAFF REPORT

SUBJECT: Vehicle for New Buildings and Grounds Maintenance

DEPARTMENT: Parks and Leisure Services

STAFF CONTACT: Kelli Votypka

RECOMMENDATION:

Staff recommends approval to purchase vehicle from Bruner's for \$28,276.75.

BACKGROUND:

As part of the 2021-2022 Fiscal Year a new buildings and grounds maintenance section was added to parks and leisure services. This area included two new personnel along with equipment to accomplish all previously external contracted mowing and grounds maintenance. As part of the creation of this section a new pickup was proposed in the budget and \$20,000 was budgeted for this expenditure. Due to vehicle market difficulties including availability of locating vehicles the budgeted amount has not matched up with any available vehicles. Staff has worked with Bruner Fleet Sales and located a suitable pickup on the Bruner lot that can be sold as a fleet vehicle. The purchase price is \$28,276.75, resulting in \$8,276.75 over budget. Staff has only been able to locate one other available vehicle in Caldwell TX and it is in the same price range as this vehicle. There is a 3% difference.

FISCAL IMPACT SUMMARY:

\$20,000 is currently budgeted for new vehicle, another \$8,276.75 is requested.

ALTERNATIVES

- 1) Approve purchase of new pickup as presented with increased budget;
- 2) Deny approval of purchase of new pickup with increased budget.

FCA US LLC INVOICE

Item 2.

560-A

PLANT ZONE DEALER VEHICLE ID NUMBER INVOICE NO. INVOICE DT.
 WARREN 63 42839 1C6RR6FG1MS579327 M-DS1-49016480 07/20/21

SHIP BRUNER MOTORS INC

TO: PO BOX 672

STEPHENVILLE

TX 76401-

IGN KEY

TRK KEY

ACC KEY

2452-01-7M20

SOLD BRUNER MOTORS INC

TO: PO BOX 672

STEPHENVILLE

TX 76401-

SHIPPING WT. 4732

SAE HP 34.3

PAID FOR BY: GM FINANCIAL

650-021409-00

CREDIT SALE XX CASH SALE

BODY & EQUIP.	DESCRIPTION	FACTORY WHOLESALE PRICE
---------------	-------------	-------------------------

DS1L41 RAM 1500 TRADESMAN QUAD CAB 4X2
 PAR Maximum Steel Met. Clear Coat
 V9X9 Cloth 40/20/40 Bench Seat
 AEP Chrome Plus Package
 AFC Electronics Group
 AHC Trailer Tow Group
 DFT 8-Spd Auto 850RE Trans (Make)
 DMD 3.55 Rear Axle Ratio
 ERB 3.6L V6 24V VVT Engine
 TBB Full Size Spare Tire
 XMF Mopar Spray in Bedliner
 YGE 5 Additional Gallons of Gas
 2TB Customer Preferred Package 2TB
 29B Customer Preferred Package 29B
 382 DESTINATION CHARGE
 HB111000/SFP 37000

MDH #
 EP
 PP
 DR

USE DEALERCONNECT TO OBTAIN
 KEY INFORMATION

CASH DELIVERED PRICE OF UNIT		\$38,675	00
REBATE : <i>BID ASSIST.</i> #:		10,600	00
REBATE : #:			
TRADE IN MAKE: YEAR			
MODEL	BODY		
SERIAL No.			
LIC No.	MILEAGE		
A Documentary Fee is not an official fee. A Documentary Fee is not required by law, but may be charged to buyers for handling Documents and performing services relating to the closing of a sale. A Documentary Fee may not exceed \$50 for a motor vehicle contract or a reasonable amount agreed to by the parties for a heavy commercial vehicle contract. This notice is required by law.		DIFFERENCE	28,075 00
		STATE TAX	
		VEHICLE INVENTORY TAX	
		LIC. OR TRANSFER	
		TITLE	28 00
		STATE INSPECTION	23 75
		DOCUMENTARY FEE	150 00
		TOTAL	\$28,276 75
		Add Bal. Owed On Trade	
TO: Acct. #:			
TOTAL		\$28,276	75

MSRP RETAIL TOTAL 38,675.00

THIS VEHICLE IS MANUFACTURED TO MEET SPECIFIC UNITED STATES REQUIREMENTS. THIS VEHICLE IS NOT MANUFACTURED FOR SALE OR REGISTRATION OUTSIDE THE UNITED STATES.

10,600

STAFF REPORT



SUBJECT: Ordinance Chapter 97 Municipal Parks, Facilities, and Cemeteries

DEPARTMENT: Parks and Leisure Services

STAFF CONTACT: Kelli Votypka

RECOMMENDATION:

During the February 15, 2022 Committee Meeting, Chapter 97 was presented to the Parks and Leisure Services Committee. It was recommended to review the proposed section and wording on alcohol and bring back to the March committee meeting for review. Per recommendation, staff and Councilmembers Mr. Nix and Mr. Trussell met to discuss the current ordinance on alcohol and the proposed language.

Staff is recommending to repeal Ordinance Section 130.10 with the proposal of new language that reads: Alcoholic beverages are not allowed inside designated youth and adults sports fields, Splashville, Rec Hall, or Senior Citizen Center except when approved by the Director of Parks and Leisure Services.

Staff is recommending approval of the proposed ordinance in reference to alcohol.

While we were reviewing the proposed ordinance there were a few sections that needed a second look. It was determined that section **97.46 Prohibitions at the Cemetery** were duplicated rules that are provided and agreed upon when a plot is purchased.

Staff is recommending approval to removed section 97.46 Prohibitions at the Cemetery.

In Section 97.12 (E) the words "discharge firearms" is recommended to be removed along with Section 97.12 (F).

Staff is recommending to amend section 97.12 (E) and 97.12(F).

FISCAL IMPACT SUMMARY:

The fiscal impact may be an increase in revenue with additional facility rental fees which may be applied where alcohol is served.

ALTERNATIVES

If we do not allow alcohol at our facilities, residents my look at other avenues to host events.

ORDINANCE NO. 2022-O-04**AN ORDINANCE OF THE CITY OF STEPHENVILLE CREATING CHAPTER 97 OF THE CITY OF STEPHENVILLE CODE OF ORDINANCES TO BE TITLED “MUNICIPAL PARKS, FACILITIES, AND CEMETERIES” AND PROVIDING FOR AN EFFECTIVE DATE**

WHEREAS, the Parks and Leisure Services Department worked with the Parks and Recreation Advisory Board to present for consideration rules and regulations to ensure the enjoyment and safety of all city parks, facilities, and cemeteries; and

WHEREAS, the City Council of the City of Stephenville wishes to formally establish rules and regulations for the operation and use of city parkland, facilities, and cemeteries.

NOW, THEREFORE, BE IT ORDAINED BY THE CITY COUNCIL OF THE CITY OF STEPHENVILLE, TEXAS:

SECTION 1.

The Code of Ordinances of the City of Stephenville is hereby amended by the addition of the following:

**TITLE 9 - GENERAL REGULATIONS
CHAPTER 97 - MUNICIPAL PARKS, FACILITIES, AND CEMETERIES**

ARTICLE I – GENERAL PROVISIONS**Sec. 97.01 Definitions**

For the purposes of this chapter, the following words, terms and phrases shall have the meaning ascribed to them except where the context clearly indicates a different meaning:

City Parks. All parks inside the limits of the City of Stephenville that have been dedicated to the public, or leased by the City of Stephenville, including all such parks that are subsequently annexed into the city’s corporate limits. This includes both developed and undeveloped lands.

Bosque River Trail. Walking and biking trail system located along the Bosque River.

Splashville. City-owned waterpark.

Recreation Facilities. City-owned facilities such as pavilions, Recreation Center, Senior Center, gazebos, etc.

Municipal Cemeteries. West End Cemetery, East Memorial Cemetery, and Mount Olive Cemetery.

Department. The City of Stephenville Parks and Leisure Services Department.

Director. The Director of the Parks and Leisure Services Department or his/her designee.

Cemetery Supervisor. Person assigned to oversee the operations of all municipal cemeteries.

Parks and Recreation Advisory Board. An advisory board, appointed by the City Council, to advise the Council on policy matters affecting the city’s parks and recreation facilities.

Community Event. An event in the City that is open to the public in general and that enjoys widespread support from the citizens of Stephenville and surrounding areas.

Special Event. Any community event requiring a permit or involving a road closure, sale of goods or services, or charging of admissions.

Commercial Activity –An event held by any person, group, or organization, that makes or attempts to make profit, vend a service or product, receive money, or obtain goods or services as compensation from participants in activities occurring on public parkland owned and operated by the City of Stephenville, to include nonprofit training or fundraising activities, outdoor revenue generating programs, and educational groups that receive money from participants.

1. *Fundraising Activity* – a program created to seek financial support for a charity, institution, or other enterprise.
2. *Indoor/Outdoor Revenue Generating Program-* Activities/events held three or more times a month that charge a fee to generate revenue. (Ex. Sports association, Exercise training programs, etc.)
3. *Educational Program-* Program or activity to enrich educational opportunities. Can be fee based or free of charge to participants.
4. *Sports Associations, Organizations or Foundations* – any outside organized non-profit sports program not operated and staffed by the City of Stephenville.

Commercial Use Permit – written authorization from the Parks and Leisure Services Director to the applicant conducting organized educational/leisure classes at designated park sites that charge a fee to participants who desire to attend or participate in the commercial activity whether it is for profit or fundraising.

Sections 97.02 - 97.09 Reserved for future use

ARTICLE II. PARKS

Section 97.10 Public Park Hours of Operation

- (A) All public parks owned, leased, and/or managed by the city shall be closed between the hours of 11:00 p.m. and 5:00 a.m. It shall be unlawful for any person or persons to remain or be found in any area or facility outside of the designated hours that said area or facility is open to the public.
- (B) This section shall not apply to the following parks and recreation sponsored/sanctioned functions:
 1. Parks and recreation community events, sanctioned athletic events, leagues or tournaments.
 2. Any activity properly permitted through the office of the Director of Parks and Leisure Services.
 3. Permitted camping at City of Stephenville RV Park.

Section 97.11 Applicability of Local, State, and Federal Laws

- (A) All terms and provisions of the Texas Water Safety Act shall be applicable to Stephenville City Park, the Bosque River Trail, and, where applicable, to other parkland owned or leased by the City of Stephenville.
- (B) All rules and regulations promulgated by the Texas Parks and Wildlife Department pursuant to the Texas Water Safety Act shall be applicable to Stephenville City Park, the Bosque River Trail, and, where applicable, to parkland owned or leased by the City of Stephenville.
- (C) All applicable rules and regulations of the U.S. Army Corps of Engineers including Title 35, Code of Federal Regulations Chapter 111, Part 327, and any amendments or revisions thereto shall be applicable to all parklands owned or leased by the City of Stephenville.

Section 97.12 General Regulations

- (A) Children under ten (10) years of age must be accompanied by a parent, legal guardian, or person over the age of eighteen (18) years who is in a designated role of responsible care while using municipal parks or facilities.
- (B) Overnight camping in the City RV Park by persons under eighteen (18) years of age may not occur unless the individual is accompanied by parent, legal guardian, or as part of an approved, permitted group.
- (C) No person shall modify the natural conditions of topography and terrain of parkland owned by the City of Stephenville by excavating, filling, dredging, or any other means unless the city has issued a license authorizing such modification.
- (D) The city shall have the right to revoke, suspend, or refuse to reissue the permit of any individual upon the violation of rules, contract terms, regulations, standards or ordinances of the city, United States, State of Texas, or other local government entity.
- (E) No person in any park shall operate a motor-driven model airplane or drone, shoot a bow and arrow, **discharge firearms**, or hit golf balls except in an area designated for that purpose by the director.
- ~~(F) Weapons are prohibited in all city parkland in accordance with state law.~~

Section 97.13 Vehicle and traffic laws

- (A) **Traffic Regulations.** All applicable state and local vehicle and traffic laws and ordinances shall be in full force and effect in all parks.
- (B) **Speed Limit.** The speed limit in all parkland shall not exceed 10 MPH.
- (C) **Direction of traffic.** All law enforcement officers shall have the authority to limit traffic as needed in any park in order to control pedestrian and vehicular movement and park capacity in accordance with the provisions of this chapter or any other applicable laws and ordinances.

(D) **Special provisions applicable to motorcycles, motor scooters and minibikes.** The director may, in reasonable discretion and through park rules and regulations, set aside or designate areas, paths, trails, or roads in a park where operating motorcycles, motor scooters, and minibikes shall be allowed. Motorcycles, motor scooters, and mini bikes are prohibited on the Bosque River Trail.

(E) **Operating or parking vehicles**

- a. No person shall operate or park a vehicle over, through, or on any park ground except along or upon park roadways and designated parking areas as set forth in park rules and regulations.
- b. No person shall operate a non-city vehicle on city parkland between the hours of 11:00 p.m.. and 5:00 a.m. except for emergency or law enforcement purposes or in conjunction with special activities permitted by the director.
- c. No person shall park or place an inoperable motor vehicle or allow an inoperable motor vehicle to remain on city parkland for a period of more than twenty-four (24) continuous hours. Violators will be towed at owner's expense.

Section 97.14 Buildings and Other Property

No person, in any city park, shall do or cause to be done any of the following without first obtaining a permit from the director:

- (A) Mark, deface, injure, displace, remove, or tamper with any park property or any park grounds.
- (B) Construct or erect any building or structure of any kind, whether permanent or temporary.
- (C) Store or stockpile any equipment, material, or product on park property, or within any structure or compound located in a park.
- (D) Cut, gather, or remove trees or parts of trees from any park without written approval of the director.
- (E) Construct, place, or operate any pier, bulkhead, wharf, boathouse, dock, barge, building, boat ship, boat stall, fixture, or other structure or facility of any kind or character upon, in, or over the portion of the Stephenville City Park and Bosque River Trail where river water is present, or other applicable parkland, unless a permit or other appropriate written agreement has been issued by the director.
- (F) Construct or place any structure, including, but not limited to, roads, trails, signs, or landscape features, of any kind under, upon, in, or over any parkland owned or leased by the City, unless a permit or other appropriate written agreement has been issued by the director.
- (G) Items (E) and (F) above shall not apply to bulkheads, rip rap or soil conservation measures, or other facilities constructed by or on behalf of the city or USACOE (United States Army Corps of Engineers)

Section 97.15 Sanitation

No person in any park or facility shall:

- (A) Throw, discharge or otherwise place or cause to be placed in the waters of any fountain, pond, stream or other body of water in or adjacent to any park, any substance, matter of thing, liquid or solid, which will or may result in the pollution of said waters.

- (B) Dump, deposit, or leave any bottles, broken glass, ashes, paper, boxes, cans, dirt, rubbish, waste, garbage or refuse, or other trash.
- (C) Spill, pump, or otherwise discharge contaminants, pollutants, or other wastes, including, but not limited to, human or animal waste, petroleum, industrial or commercial products or by-products.
- (D) The owners and/or operators of all commercial ventures and operations shall provide on-site facilities satisfactory to the city for the collection of all trash, rubbish, and other forms of waste.

Section 97.16 Swimming

No person in any park, with the exception of Splashville, shall:

- (A) Swim, bathe, or wade in any water or waterway in or adjacent to any park, except in designated areas in accordance with the terms of this chapter and the regulations.
- (B) Swim, bathe, or wade except during those hours established for such activities.
- (C) Dive or jump from bridges or other structures which cross park waters or Bosque River Trail.

Section 97.17 Boating

- (A) No person shall bring into or operate any vessel upon any park waters.
- (B) The use of waters considered to be state waters that lay within or adjacent to city parks shall be subject to the Texas Water Safety Act, Texas Parks and Wild. Code Ann. §§ 31.001-31.142.
- (C) No person shall leave any private vessel unattended on city parkland, the Bosque River Trail, or in the portion of the Bosque River regulated by the city.

Section 97.18 Camping

- (A) No person shall camp overnight in a park or on the Bosque River Trail without first obtaining written permission from the director or his/her designee. Camping will only be allowed in designated areas.
- (B) Campers, picnickers, and all other persons shall keep their sites free of trash and litter during the period of occupancy and shall remove all personal equipment and clean their sites upon departure.
- (C) No person shall place camping equipment or other items on a campsite, nor physically occupy a campsite-overnight without payment of appropriate fees. No person shall place another person, equipment, or other items at a campsite for the purpose of reserving a campsite for future occupancy.
- (D) No person shall alter any campsite, dig or level any ground, nor construct any structure without written permission from the director.

Section 97.19 Fires

No person in any City Park or parkland shall:

- (A) Start or maintain any outdoor fire except for cooking fires. Such fires shall be started and maintained only in a stove, fireplace, barbecue pit, fire ring, or portable camp stove.
- (B) Leave any fire started or maintained unattended without first completely extinguishing the fire.
- (C) Gather or remove firewood for use on or removal from any park.
- (D) Burn any material that produces toxic fumes, including but not limited to tires, plastic, or treated wood products.
- (E) Carry onto or store gasoline or other fuels, except that which is contained in storage trucks tanks of vehicles, vessels, camping equipment, or hand portable containers designed for such purpose.

Section 97.20 Animals.

(A) General Regulations

1. No person shall abandon any animal in any park.
2. Dogs are not allowed on playing fields or spectator areas of athletic fields. Dogs specially trained to assist the disabled may be on the fields to assist their owner during programs designed for the disabled.
3. Animals and pets, except properly trained animals assisting the disabled, are prohibited in sanitary facilities such as restrooms or locker rooms.
4. Persons bringing or allowing pets in parks areas shall be responsible for proper removal and disposal of waste produced by those animals.
5. All animals and pets are prohibited in Splashville, except at special events permitted by the Director.
6. Riding horses or other animals is only allowed in areas, or on paths or trails designated by park rules and regulations. Any animal ridden in a park shall be properly restrained, ridden with due care, and shall not be allowed to go unattended. Horses, ponies, donkeys, or mules shall have successfully passed a Coggins test prior to using any park areas, paths or trails.
7. No person shall bring or allow wild or domestic animals, reptiles, bird, fish, horses, cattle or other livestock on parkland owned or leased by the City of Stephenville except in areas designated by the director.
8. Ranging, grazing, watering, or allowing livestock on parkland owned by the City of Stephenville is prohibited except when authorized by lease or license.
9. No person shall, without first obtaining permission from the director:
 - i. Capture, attempt to capture, hunt, molest, injure, trap or administer or set out any trap or harmful substance for any wild or domestic animal, reptile or bird; or
 - ii. Remove or have in possession the young, eggs, or nest of any animal, reptile, or bird.

(B) Animals prohibited in parks during activities

1. Animals, except for dogs, are prohibited in any of the parks located within the city limits during any organized special event.
2. For purposes of this section, an organized activity includes any city-sponsored activity or event, including, but not limited to, festivals, shows, or athletic events.
3. Exceptions:
 - a. Display of animals for viewing, petting zoos, or similar activities is allowed with the permission of the director.
 - b. Canine assistance for the disabled.

Section 97.21 Merchandising, Advertising, Signs, Commercial Use

No person in any park shall:

- (A) Expose or offer for sale or hire any article, thing, or service, nor station or place any stand, cart, or vehicle for the transportation, sale, or display of any article, thing, or service unless written permission has been obtained from the director.
- (B) Announce, advertise, or call the public's attention in any way to any article, thing, or service for sale or hire unless written permission has been obtained from the director.
- (C) Paste, glue, tack, or otherwise place any sign, placard, advertisement, or inscription on park property, nor erect or cause to be erected any sign on any public lands, highways, or roads adjacent to a park, unless written permission has been obtained from the director.
- (D) Provide and/or sell any food- or drink-based product to the public for free or for a fee without the provider and/or dispenser obtaining written permission from the director and having obtained all applicable health code licenses and permits.
- (E) Construct, operate, or otherwise engage in any retail or wholesale sales or commercial operation unless the city has granted a license and/or sublease for such operation.
- (F) Commercial use of public parkland is not authorized without approval from the City of Stephenville. Individuals or entities engaged with the provision and sale of goods and/or services on City of Stephenville parkland will be required to provide all necessary documentation provided by the Parks and Recreation division of the Parks and Leisure Services Department. Upon the completion of all required documentation, it is the City of Stephenville's sole discretion to approve or deny the application.
- (G) Exceptions: Any exceptions to the requirements of this section are authorized only by council approval. Upon approval, the person or organization must show and have all proper insurance and permits pertaining to their event or organization

Section 97.22 - Interference with users

- (A) No person shall prevent, disturb, or unreasonably interfere with any other persons occupying any area or participating in any lawful activity permitted within any City Park.
- (B) No person shall act in a boisterous, rowdy, disorderly manner or otherwise disturb the peace in any city park.
- (C) No person shall disrobe in public or display public nudity in any city park in accordance with State Law.
- (D) No person shall use or operate rollerblades, skates, scooters, or skateboards in and/or around concession areas, spectator seating, parking lots, and adjacent walkways during athletic events, concerts or special events.
- (E) No person shall make any use of any tobacco product (including e-cigarettes) within one hundred (100) feet of the boundaries of youth athletic fields or concessions facilities, or at organized events.

Section 97.23 Permits

(A) **Event Permit Required.** In addition to any other provision of this chapter that requires obtaining a permit prior to engaging in a given activity, no person in any City Park shall conduct, operate, present, manage, or take part in any of the following activities unless written permission has been obtained from the director prior to the start of the activity:

1. Any organized sporting event using park ballgame facilities that are designated for permit use only;
2. Any exhibit, dramatic performance, play, motion picture, radio or television broadcast, fair, circus, carnival, musical event, or any similar event;
3. Any public meeting, assembly, parade, ceremony, address, speech, political meeting, or other gathering composed of one hundred (100) or more persons;
4. Any use of any park facility by a group of persons to the exclusion of others;
5. Any use involving amplified sound;
6. Any use involving firearms or guns; or
7. Any use of parks and recreation facilities in violation of park hours of operation.

(B) Permit application procedure

1. A person seeking the issuance of a permit to conduct an activity in a park shall file an application with the director or his/her designee. The application shall state:
 - a. The name, address and telephone number of the person and organization and its officers applying for the permit;
 - i. If the use or activity is to be conducted for, on behalf of, or by any person other than the applicant, the name, address and telephone number of that person;

- b. The exact nature of the use or activity for which the permit is being sought;
 - c. The day and hours for which the permit is desired;
 - d. The specific park and portion of the park desired to be used to carry out the proposed use or activity;
 - e. An estimate of the anticipated attendance;
 - f. Any other information that the director finds to be reasonably necessary in order to determine whether to issue a permit.
2. Applications shall be filed with the director for consideration not less than thirty (30) days or more than three hundred sixty-five (365) days before the date of the proposed use or activity.
 3. The director shall evaluate the application and render a decision in accordance with Section C, below.

(C) Standards for issuance of permit; procedures

1. A permit for an activity in or use of a park shall be issued unless it is found:
 - a. That the proposed activity or use of the park will unreasonably interfere with or detract from the general public use and enjoyment of the park; or
 - b. That the proposed activity or use of the park will unreasonably interfere with or detract from the public health, safety or welfare; or
 - c. That the conduct of the proposed activity or use is reasonably likely to result in or create a clear and present danger of violence by the applicant or by others toward persons or property resulting in serious harm to the public; or
 - d. That the requested facilities have been reserved for another activity or use at the day and hour requested in the application; or
 - e. That false or misleading information is contained in the application or required information is omitted; or
 - f. That the event would violate any federal, state or municipal law; or
 - g. It is found or determined that the requested facility or park is unable to support, through physical space, infrastructure, or other factors, the proposed event or activity.
2. The director may impose reasonable conditions or restrictions on the granting of a permit, including, but not limited to, any of the following:
 - a. Restrictions on fires, fireworks, amplified sound, use of alcoholic beverages, dancing, sports, the use of animals, equipment, or vehicles, the number of persons to be present, the location of any bandstand or stage, or any other use which appears likely to create a risk to the reasonable use and enjoyment of the park property;
 - b. A refundable security deposit for the repair of any damage to Park property and/or the cost of cleanup as set in the city's fee schedule.

- c. A reasonable fee to defray the cost of furnishing adequate security forces by the city at the proposed use or activity.
 - d. Additional sanitary and refuse facilities that might be reasonably necessary, based on the use or activity for which the permit is being sought.
3. Within seven (7) days after submission of an application, the director shall apprise an applicant, in writing, of its approval or reasons for refusing a permit.
 - a. Applicants requesting removal of any conditions attached to the issuance of a permit or wishing to appeal a permit refusal shall have the right to appeal the director's decision in writing within six (6) days to the City Manager's Office. The City Manager or his/her designee shall consider the application under the standards set forth in this section and/or other reasons deemed by the City Manager to be detrimental to the use of the public parks. After review, the City Manager will sustain or overrule the director's decision.
 4. An applicant shall be bound by all ordinances fully as though the same were inserted in such person's permit.
 5. The person to whom a permit is issued shall be liable for any loss, damage, or injury to any person or property due to negligence of the person and/or organization to whom the permit was issued.
 6. The director or his/her designee shall have the authority to revoke a permit upon a finding of violation of ordinance, state or federal law, or upon the violation of any condition or restriction under which the permit was issued.
 7. Permits shall not be transferable without the written consent of the director.

(D) Posting and Exhibiting Permits

Permits required by this chapter shall be posted in the area where the activity is conducted or produced and must be shown upon the demand of any law enforcement officer or authorized City Park employee.

Section 97.24 Closed areas

Any section or part of any City Park may be declared closed to the public by the director or a law enforcement officer at any time and for any interval of time, either temporarily or at regular, stated intervals (daily or otherwise), either entirely or for certain uses, as the director or law enforcement officer shall find reasonably necessary.

Section 97.25 Naming parklands, park roads, major improvements, and facilities

- (A) The Parks and Recreation Advisory Board chairperson shall appoint a committee to be responsible for research, study, and recommendation of proposed names of parks, park roads, major improvements, facilities, or similar.
1. Recommendations for proposed names shall be presented to the Parks and Recreation Advisory Board for approval or disapproval. A resume stating the reason for the recommendation of a

name shall be submitted in writing. If the board disapproves the committee's recommendation, the matter may be referred back to the committee for further action.

- (B) The Parks and Recreation Advisory Board's recommendation for naming parklands, park roads, major improvements, or facilities shall be submitted to the city council within sixty (60) days of acquisition, construction, or completion, or at the earliest possible time thereafter. The City Council shall have the final authority for the naming of parklands, park roads, major improvements, or facilities.
- (C) The naming of park roads, major improvements, or facilities shall permit ready identification and/or geographical association by the public. The following guidelines shall be considered:
1. Outstanding and/or predominate physical characteristics of the land.
 2. Financial or real property contributions of fifty percent (50%) or more by individuals or organizations.
 3. Outstanding community leaders, living or deceased.
 4. National, state, or local historical leaders or heroes, both past and present.
 5. Predominant plant materials.
 6. Streams, rivers, lakes and creeks.
 7. Outstanding environmentalists or parks and recreation notables.
 8. No park site shall be given the same name as an existing school site or public facility except where sites abut one another.
 9. Subdivision names where parklands are adjacent to or lie within the subdivision.
- (D) Proposed names shall be kept confidential by members of the committee until they are presented to the Parks and Recreation Advisory Board, except that the proposed name may be disclosed to the individual or family of the individual that is the subject of the proposed name. An individual or relative of an individual after whom a park or recreation facility is proposed to be named shall be provided the opportunity to oppose such designation.

Section 97.26 Park Facility Rental

- (A) Facility Rentals - Individuals or groups wanting exclusive use of any Stephenville City Parks and Recreation facilities must fill out the Community / Special event application. The Exclusive Rental rate will be applied for every 24-hour period the park is rented.
1. The following facilities are available for rental:
 - a. Large Pavilion – City Park
 - b. Small Pavilion – City Park
 - c. Century Park Gazebo – City Park
 - d. Birdsong Amphitheatre – City Park

- e. Recreation Hall – City Park
 - f. Sports Complex – City Park
 - g. Senior Citizens Center
 - h. Other facilities as approved by the director or his/her designee
2. The following facilities are available for practices, tournaments, 5K runs, and other special events:
 - a. Baseball fields
 - b. Softball fields
 - c. Tennis courts
 - d. Bosque River Trail

(B) Fees for use of park facilities

1. Fees shall be approved by the city council as part of the city's fee schedule.
2. Waiving of Fees: The City of Stephenville may waive all or a portion of the fee with the recommendation of the Director of Parks and Leisure Services.
3. Any person or persons occupying park space or using such facilities where that occupancy or use requires a fee, but where said fee has not been paid, shall be considered to be trespassing.

(C) Sports Association / Organization / Foundation Facility Fees

1. These groups must meet with the Parks and Leisure Services Director and agree to terms in a written contract agreement. This contract will cover fees, policies and procedures, maintenance, and operational standards by which the City of Stephenville facilities will be utilized.
2. Individuals or entities must provide documentation of transactions for goods and/or services and proof of a current liability insurance policy naming the City of Stephenville as an additional insured party when appropriate.

(D) Refunds

1. Refundable Deposits will be processed upon inspection of parks and/or facilities by Parks and Leisure Services staff. The standard of cleanup is leaving the park and/or facilities in the same condition as it was at the time the rental period began.
2. Pavilions, Birdsong Amphitheater – no refunds will be issued for inclement weather.
3. Recreation Center – refunds will be issued if reservations are cancelled no less than seven (7) business days from event date.

Section 97.27 Insurance and Liability

- (A) The City of Stephenville and its agents disclaim all liability resulting from the exclusive use of a municipal park, its facilities and/or equipment, gazebo, and/or pavilions for events open to the public (community events, special events, or any other activity specified in these policies.)
- (B) Organizers of these public events must provide proof of insurance indemnifying the City of Stephenville against any liability arising from such exclusive use. Closed events (birthday parties, family reunions, etc.) will not require liability insurance.

- (C) The Director of Parks and Leisure Services shall have the right to waive the insurance requirement for events. The waiver will be made on a case-by-case basis. A waiver shall not be granted without adequate protection for the city, such as a sufficient indemnity agreement.
- (D) Minimum Coverage shall include: Bodily Injury coverage of at least \$100,000 per person and \$500,000 per occurrence.

Sections 97.28 – 97.39 Reserved for future use.

ARTICLE III. MUNICIPAL CEMETERIES

Section 97.40 General Rules and Operation

The Municipal Cemeteries of the City of Stephenville shall be reserved for the burial of human remains in accordance with State and Federal law. The city Manager or his/her designee shall have the authority to promulgate rules and regulations for its use and control the use of the facility in accordance with state law. Fees for services and the sale of burial plots shall be approved by the city council as part of the city's fee schedule.

Section 97.41 Burial in accordance with laws of the State of Texas

No person shall purchase or allow any cemetery lot or niche to be used for any purpose other than the burial of human remains in accordance with the laws of the State of Texas.

Section 97.42 Parking and/or driving in gardens; speed limit

- (A) No person shall use the cemetery land as a thoroughfare and the right to use automobiles or other vehicles in the cemetery is authorized solely and exclusively for transporting persons to visit burial plots.
- (B) Parking and/or driving on any gardens or grassy areas are prohibited for purposes other than those obtained from the cemetery.
- (C) The speed limit within the cemetery is ten (10) miles per hour.

Section 97.43 Possession of drugs or alcohol in cemetery

No person shall possess alcoholic beverages or illegal drugs in any Municipal Cemetery.

Section 97.44 Right of cemetery staff to enter upon lot

The cemetery supervisor shall have the right to authorize persons to enter upon or use any adjoining cemetery lot or lots to carry out duties related to interments, erection of monuments or markers, etc., without prior notice to the lot owner.

Section 97.45 Headstones

No headstones shall be installed, moved, repaired, or removed without first obtaining the approval of the Cemetery Supervisor. Temporary placeholders may be used for a period of no longer than 12 months, after which time a permanent headstone or marker shall be placed.

Section 97.46 Prohibitions

- ~~(A) Advertisements — No person shall cause a sign, notice, or advertisement of any kind to be placed or brought into the cemetery unless authorized by the cemetery supervisor and placed by cemetery employees.~~
- ~~(B) Solicitation — No person shall peddle, sell, or solicit the sale of any goods or service within municipal cemeteries.~~
- ~~(C) Decorative objects~~
- ~~1. No person shall cause decorative objects or photos to be affixed to the crypt fronts by tape or other means.~~
 - ~~2. No curbs, shrubs, landscaping, mounds, rocks or gravel, glass containers, ceramic containers or like objects shall be permitted. Such objects will be removed at the discretion of the cemetery supervisor.~~
 - ~~3. Foot markers shall be set no more than (1) inch above ground.~~
 - ~~4. Flowers shall be set to the side of the headstone; a flower receptacle will be provided if needed. Old flowers shall be removed at cemetery supervisor's discretion.~~
 - ~~5. All unauthorized items may be removed by the cemetery supervisor without notice.~~
- ~~(D) Open flames — No person shall possess or cause to be placed within a cemetery a devotional light or any open flame device.~~

ARTICLE IV. PENALTIES

Section 97.99 Penalties for Violations

Penalties for violations of this chapter are subject to the general penalty set out in 10.99 of the City of Stephenville Code of Ordinances.

SECTION 2.

Section 90.10 *Animals prohibited in parks during special activities* is hereby repealed in its entirety, as it has been incorporated into Chapter 97 *Municipal Parks, Facilities, and Cemeteries*.

SECTION 3.

Except as amended herein, the City of Stephenville ordinances shall remain in full force and effect as presently enacted and amended from time to time. To the extent of a conflict between this Ordinance and any other ordinances of the City of Stephenville as same may have existed prior to the adoption of this Ordinance, this Ordinance shall control.

SECTION 4.

If any section or part of this ordinance is held by a court of competent jurisdiction to be unconstitutional or invalid, such judgement shall not affect, impair, or invalidate the remaining provisions of this Ordinance but shall be confined in its operation to the specific section or sections that are held unconstitutional or invalid.

SECTION 5.

This ordinance shall become effective immediately upon its passage.

PASSED AND APPROVED this 1st day of March, 2022.

Doug Svien, Mayor

ATTEST:

Staci L. King, City Secretary

Reviewed by Allen L. Barnes,
City Manager

Randy Thomas, City Attorney
Approved as to form and legality

Sec. 130.15. Possession of intoxicating beverages in city recreation hall or city park prohibited.

~~It shall be unlawful for any person to have in his/her possession intoxicating beverages while that person is in the City Recreation Hall or in any of the covered pavilions in the city park.~~

(1975 Code, § 11-13; Am. Ord.. passed 5-1-1979)

Cross reference(s)—Penalty, see § 10.99Cross reference(s)—.