



**Stevensville Town Council Meeting
Agenda for
THURSDAY, FEBRUARY 25, 2021
7:00 PM
NVPL 208 Main Street**

**The Town of Stevensville live streams Town Council and board meetings
on our website at**

<http://www.townofstevensville.com/meetings>

1. Call to Order and Roll Call
2. Pledge of Allegiance
3. Public Comments (Public comment from citizens on items that are not on the agenda)
4. Approval of Minutes
 - [a.](#) October 22, 2020 Meeting Minutes
 - [b.](#) January 28, 2021 Meeting Minutes
5. Approval of Bi-Weekly Claims
 - [a.](#) Claims #16570-#16580
6. Administrative Reports
7. Guests
 - a. Chief of Police Candidates
8. Correspondence
9. Public Hearings
10. Unfinished Business
11. New Business
 - [a.](#) Discussion/Decision: Location and Future Maintenance of the Stevensville Civic Club's Splash Deck Project
 - [b.](#) Discussion/Decision: Consent to the Mayor's Appointment of Eric Paulsen as Volunteer Firefighter
 - [c.](#) Discussion/Decision: Consent to the Mayor's Appointment of Trevor Frandsen as Volunteer Firefighter
 - [d.](#) Discussion/Decision: Consent to the Mayor's Appointment of Christina Corsa as Volunteer Firefighter
12. Executive Report
13. Town Council Comments
14. Board Reports
15. Adjournment

Welcome to Stevensville Town Council Chambers

We consider it a privilege to present, and listen to, diverse views.

It is essential that we treat each other with respect.

We expect that participants will:

- ✓ Engage in active listening
- ✓ Make concise statements
- ✓ Observe any applicable time limit

We further expect that participants will refrain from disrespectful displays:

- ✗ Profanity
- ✗ Personal Attacks
- ✗ Signs
- ✗ Heckling and applause

Guidelines for Public Comment

Public Comment ensures an opportunity for citizens to meaningfully participate in the decisions of its elected officials. It is one of several ways your voice is heard by your local government. During public comment we ask that all participants respect the right of others to make their comment uninterrupted. The council's goal is to receive as much comment as time reasonably allows. All public comment should be directed to the chair (Mayor or designee). Comment made to the audience or individual council members may be ruled out of order. Public comment must remain on topic, and free from abusive language or unsupported allegations.

During any council meeting you have two opportunities to comment:

1. During the public comment period near the beginning of a meeting.
2. Before any decision-making vote of the council on an agenda item.

Comment made outside of these times may not be allowed.

Citizens wishing to speak during any public comment period should come forward to the podium and state their name and address for the record. Comment may be time limited, as determined by the chair, to allow as many people as possible to comment. Comment prior to a decision-making vote must remain on the motion before the council.

Thank you for observing these guidelines.

File Attachments for Item:

- a. October 22, 2020 Meeting Minutes

Stevensville Town Council Meeting Minutes
for THURSDAY, OCTOBER 22, 2020

1. Call to Order and Roll Call

Mayor Dewey called to meeting to order. Councilmembers Devlin, Holcomb, Michalson and Vick were present.

2. Pledge of Allegiance

3. Public Comments

No public comments.

4. Approval of Minutes

a. July 22, 2020 Meeting Minutes

b. July 23, 2020 Meeting Minutes

Mayor Dewey introduced the approval of minutes.

Councilmember Michalson: made the motion.

Councilmember Vick: 2nd.

Mayor Dewey: it has been moved by Mr. Michalson and 2nd by Mr. Vick, council discussion, public comment?

Councilmember Devlin: aye.

Councilmember Holcomb: aye.

Councilmember Michalson: aye.

Councilmember Vick: aye.

Mayor Dewey: the motion passes unanimously.

5. Approval of Bi-Weekly Claims

a. Claims #16284-16319

Mayor Dewey introduced the bi-weekly claims. Mr. Underwood sent you at least one addition this afternoon. #16284-#16324 are the claims in front of you tonight.

Councilmember Vick: I will make the motion.

Councilmember Holcomb: I will 2nd.

Mayor Dewey: it has been moved by Mr. Vick and 2nd by Ms. Holcomb. Questions? Mr. Michalson?

Councilmember Michalson: #16287, HDR 3rd Street improvements, is that for what we are going into later tonight task order. #16308 police office lease?

Mayor Dewey: that is correct, for November's lease.

Councilmember Michalson: on the minutes of July 22 on page 17 we approved this lease on the conditions.

Mayor Dewey: yep, everything is ready to go, you will see on the schedule, rent is due at the first of the month, this is the first time that the organization has to pay rent. So, we had figure how to get it into the claims. You will see the rent and the deposit and now you see the November rent. This is the new routine to get the rent check out before the council, you will always see the rent check on your last set of claims at the end of the month for the month ahead.

Councilmember Michalson: we have a written agreement, that has been drawn up?

Mayor Dewey: yes, that is why we are in the building and paying rent.

Councilmember Michalson: are you going to bring that in front of council?

Mayor Dewey: no, you approved a lease contingent on the approval the lease was not supposed to come back to council as long as it was signed off. We followed that process through the landlord signed, we signed we are all okay.

Councilmember Michalson: I have another question on #16314 MT law enforcement academy was that for a current officer or new one?

Mayor Dewey: I believe that is the tuition for Officer Guida or is that the class Officer Ellington attended.

Jenelle Berthoud: how much was it for?

Mayor Dewey: \$200.00

Jenelle Berthoud: that was for Officer Ellington.

Councilmember Michalson: 16316 fire fighter physicals? Is that new cadets? Or just ones that have to get them done?

Mayor Dewey: those are regular annual physicals. Mr. Vick?

Councilmember Vick: my question is on #16319 which is another set of physicals looks like we are getting billed again. Are those ones that we just did not get billed for.

Mayor Dewey: I don't know exactly, I will ask that question of Robert before he runs the checks, he was not able to join us this evening he had a family emergency, I don't know why those are listed separately but I can tell you that there has been some discussion between the fire department and finance on the billing that is coming from the hospital and there has been some

confusion there. So, I can't tell you exactly, but I will have him look into the double claims before the checks.

Councilmember Vick: the only reason I asked because "vasco" (clerk, unclear of the name), and Valine were already listed.

Mayor Dewey: correct they are. That just may be him caring the, the system lets you copy the names he may have not changed the names. I will look into that.

Councilmember Devlin: the date would show that it was last year.

Jenelle Berthoud: Rural sent in their bill from last year.

Mayor Dewey: as I understand it or from what Jenelle understands is, from listening in the office, this is the Rural fire district was billed for these people last year and know they are billing us. Any further comment on the claims? Public comment? Hearing none, Ms. Berthoud call for the vote.

Councilmember Devlin: aye.

Councilmember Holcomb: aye.

Councilmember Michalson: aye.

Councilmember Vick: aye.

Mayor Dewey: okay, motion passes unanimously.

6. Administrative Reports

NONE

7. Guests

NONE

8. Correspondence

NONE

9. Public Hearings

NONE

10. Unfinished Business

NONE

11. New Business

a. Discussion/Decision: HDR Task Order No. 8, Park Avenue Sewer Main Extension

Mayor Dewey: introduced new business item (a) your council communications outlines how task order 8 came to be. 1300 feet of sewer main. This is asking for engineering services. Overall project we hope to utilize sewer reserves. Stevensville Community Center will also benefit from the sewer main.

Councilmember Vick: I make a motion.

Councilmember Devlin: I 2nd.

Mayor Dewey: it has been moved by Mr. Vick and 2nd by Ms. Devlin. Questions? Mr. Michalson?

Councilmember Michalson: the cost of \$35,000 is that for this to just get it ready Brandon, HDR?

Mayor Dewey: that is correct the engineering side of this project, the construction side would be separate like with our other task orders.

Councilmember Michalson: like 3rd Street?

Mayor Dewey: correct. So, this is the engineering side and HDR takes care of the rest.

Councilmember Michalson: and we will put that out for bid?

Mayor Dewey: yes, we have to.

Councilmember Michalson: and they will bring the bids to the council?

Mayor Dewey: they have to. The council choses the bidder just like the airport projects. Just like last fall you went through three bids and chose Knife River.

Councilmember Michalson: where is this money coming from?

Mayor Dewey: sewer funds. Any further questions or discussion from council? Public comment?

Hearing no public comment Ms. Berthoud would please call for the vote.

Councilmember Devlin: aye.

Councilmember Holcomb: aye.

Councilmember Michalson: aye.

Councilmember Vick: aye.

Mayor Dewey: okay, motion passes unanimously.

b. Discussion/Decision: E. 3rd Street Re-paving update

Mayor Dewey: introduced new business (b) E 3rd Street update. In your packet you have a set of plans. Back in June you approved task order 6. Estimate in your packet is draft form and we have an updated plan for you tonight. Mayor Dewey talked the council through the packet that was provided to them this evening. Public works has requested that the water and sewer services are replaced on that street prior to re-paving (8 total). \$145,808.00 in construction costs with a

15% contingency. We will put it to bid and bring the bids back to the council. Mayor Dewey reviewed the 5th Street project with the council that was the second packet provided to the council tonight. This is the Park Ave and 5th Street area. \$56,761.00 for the project with a 15% contingency.

Councilmember Michalson: had a question about ride-a-ways on the 5th Street project. Making sure that this was not going to take from property owners' property.

Mayor Dewey: the project is all in the ride-a-ways.

Councilmember Michalson: have we run this by the school?

Mayor Dewey: I know that HDR has been in contact with the school and they have the schools plans to coordinate with the school. Any further questions from the council? Any comments from the public? With that is there any objection from council for us to move forward.

Council stated none.

c. Discussion: Conduct of Councilmember Michalson and review of relevant policies

Mayor Dewey: introduced New Business (c) a C.O.W. meeting was suggested at the last meeting and we were not able to. So, we are going to use tonight to do a workshop. It was suggested by Mr. Vick and Mr. Michalson to have this conversation to settle some tension rather than going to trial by council. I look to the council on how you want this to go tonight.

Councilmember Devlin: the findings in here speak for themselves you wanted Mr. Vick to do a council of a whole meeting so what was your intent in doing so?

Councilmember Vick: I was hoping to bring up relevant policies, see what things need to be changed to those. I was really hoping to separate these things allow us to all have a discussion with Mr. Michalson about the things that happened and have us all work together to develop a better policy plan that actually explains what could happen to one of us and really if we were going into a trial instead of a trial in the future based off some 100-year-old book we can go ahead and outline how the trial would work. Who would end of being in charge of it, who is the person that sits at the head of it, how the accused would be notified of their charges? I was just really hoping that we could all bring something to the table try to put it behind us and try to develop policies that would work better for the council, for the staff and for us this town in the future.

Councilmember Devlin: are you aware of the investigative report that was done by Johnson and Johnson Law.

Councilmember Vick: Yes.

Councilmember Devlin: did you read that?

Councilmember Vick: yes.

Councilmember Devlin: where reference were made to these policies?

Councilmember Vick: yes.

Councilmember Devlin: and now you want to change them?

Councilmember Vick: I am not saying to make a blanket change to the policy I am just saying there are some places we need some re-tooling done.

Councilmember Holcomb: I think that is what it said in that report. That somethings might need to be changed in the policies, that is what the report is saying.

Councilmember Devlin: right, but the impression I am getting is that you are wanting to change those. I am just asking for clarification on exactly what are you wanting to change what policy do you want to add or get rid of. What?

Councilmember Vick: I personally think that we need a better human resource policy as far as how councilmembers are to communicate with one and another, how councilmembers are to communicate with the public, to communicate with staff, the mayor. We don't really have any....

Mayor Dewey: you don't think the code of conduct appropriately address that?

Councilmember Vick: no.

Mayor Dewey: in what ways does it lack?

Councilmember Vick: I believe that the code of conduct is very much so lacking in that.

Mayor Dewey: what areas? What areas of that, you just stated that you want a human resource policy on how councilmembers interact with the staff and the mayor and each other and interact with the public. It happens that the code of conduct is broken into those exact sections so in what areas do those sections that appropriately address how councilmembers should interact with the mayor.

Councilmember Vick: I don't believe that the code of conduct adequately addresses the newer forms of communication such as email and social media because in a print form you can't see the emotion that a person is trying address. There are times that I have seen some of Bob's emails that he has sent and if you are going off of just reading it, it could appear that he is trying to breath down peoples necks and he is trying rush on everybody when in fact he is just asking a simple question.

Councilmember Devlin: are you suggesting that or is that what he has told you?

Councilmember Vick: it is not what he has told me, I am just saying that it is a possibility.

Councilmember Holcomb: some of the emails that I read that went to the employees to ask for information I did not see I did not read any where he was being rude with them, he was just asking for some information like I have said before we added that in here. Any councilmember can call town hall to ask for basic information without doing through the mayor we were just able to call and talk at town hall and say I am looking at this can I get a copy of this. But no where in these emails do I see where he is rude when asking. I noticed that one of them here was him asking to be put on the checking account he has always been on the checking account it has always been the mayor, the treasurer and the council president. So I don't know why that

would be in here, he just asked a simple question and he was very polite about it. Let me find it, Ms. Holcomb read the email from page 72.

Mayor Dewey: in that email Robin he is giving direction to an employee, he has no authority to give direction to an employee.

Councilmember Devlin: this has nothing about being rude or not. Under the code of conduct number four b and d it specifically outlines how you go about with staff when asking and needing materials. I know there were several times where it was said back to Mr. Michalson that the proper procedure in place to do that. That was always disregarded that is the significance of those emails, as they are not rude it shows a pattern of not following the code of conduct, that is why they are in the packet.

Councilmember Holcomb: well, then I am in agreement that we really need to, when we passed that code of conduct it wasn't gone completely through, we were sped through this and sped through this. Honestly I don't see anything wrong with a councilmember, we have been doing it for years as long as I have been at this table before that code of conduct a councilmember could call down to town hall ask for something simple without ran through the coals having to go through this person to get it that was just something we got to do.

Mayor Dewey: I am going to clarify a point because I think it is being overlooked. I don't think we are here tonight or to a degree maybe we are, the point I want to make Robin its not up to you to decide whether those emails are rude or not rude we don't get to say whether they are rude or not, the recipient of those emails gets to say how they preserved them, and you don't get to change that. I think that is the issue that we are really dealing with here, is that regardless of Mr. Michalson's intentions there is a documented history that perceive his actions a certain way and we can not change how they perceive something. Perception, we have had this issue with past councils and past employees, I remember another issue where a councilmember took issue with the actions of an employee and did so claiming merit to that and the employee to issue with that and another councilmember said it does not matter how they meant it what matters is how they perceived it, how they perceived it what trumps this and I can perceive things different than what you can and you and I don't get to say whether he was rude of not. The victim in these cases gets to say how they perceived it, you may not perceive his emails as rude, Mr. Vick and Ms. Devlin may not but the bottom line is the employee do perceive those as rude or whatever they describe. That is how we have come to, yes you are correct previous administrations have not needed to the code of conduct, previous councils have not needed the code of conduct, but the behavior became so over baring and got the town into a situation where we need to put things into place to protect employees and there property right to their job in a now hostile workplace.

Councilmember Holcomb: then I am in agreement with councilmember Vick that we really need to look through these and look through that code of conduct and maybe make some changes, I don't know where.

Mayor Dewey: so I am hearing that and I do, we are somewhat bouncing and I see Mr. Vicks point to separate we are bouncing off and on of this and I have no problem and if that councils prerogative if you want to go through the code of conduct and the council rules and what ever

policies you want to go through, we can go through those policies but what I keep hearing tonight is that we need to go through the code of conduct and change things what I am hearing is in order to dismiss the conduct that has been demonstrated to be unbecoming we are just going to change the rules and we won't have these issues anymore. We are going to get rid of the rule where it says councilmembers shouldn't miss behave let's not complain about it and then we don't have to come back to a COW meeting, that is what I am hearing. Maybe I am looking to far into it, but I don't think it is a fare we did put considerable amount of time Ms. Holcomb into the code of conduct Mr. Phillips put a great deal of work into the code of conduct and we met over this over several meeting in fact a committee was put together to go through it first before it came to council and then council met. The committee met several times, the council met the times it took and then you came to an agreement with a vote. The council agreed on it with one descending vote. And that descending vote is why we are having this conversation tonight.

Councilmember Devlin: I just want to read a couple of things out of this book, The Speed of Trust by Greenspan. Ms. Devlin read a quote from the book. So we have people that came forward some of them on multiple occasions with some issues about treatment and now we are here deciding if their feelings are valid. That is leading with the wrong impression, that is not our place to do so. When we have patterns, they are patterns you can interpret how you want, but right is still right and wrong is still wrong. I agree that before we go changing anything, we already have rules in place these have been in place since 2018 actually December 2018 there has been two years to go through this code of conduct and that wasn't right if it was rushed. Just like the purchasing policy we wait for something to happen and then we say we don't like it so let's go back and change that. It is a little late guys we have code of conduct violations that have already occurred we have to deal with those for the sake of the people that brought those to us. If we don't like how the code of conduct is written we can change it after, but you don't get to get out of your speeding ticket because you don't like what the speed zone states, you are still guilty of speeding there is a process that goes after the fact to change a speed zone. That is what we are looking at, we can agree that there may or may not be issues and that is fine, but we still have violations that is what we need to discuss first before we go and change anything on these violations.

Councilmember Vick: correct, when I was saying changing policies for starters correcting the spelling of censure. Because it is misspelled in there and that simple misspelling can make a world of difference in how you hand down a censorship. I think all we really need to have in there a better punishment section for councilmembers because the way it reads right now is that you get a piece of paper that says you have been censured. A slap on the hand that you will not do it again for the rest of the time that you are in office unless you get recalled.

Councilmember Devlin: and I agree with that, so we come up with a plan right now and try him and then punish him.

Councilmember Vick: as far as the situation with Bob is concerned any changes that make from this point forward to that any of those past actions that he is being accused of we can't just apply those new punishments to that. You can't and not have law for something, some one commits what people perceive to be a crime, you can't do that. I mean the thing with Bob, there

are sometimes when he comes across as rough, especially when the stop sign thing came up, he was just trying to inform the mayor that quite possible that stop signs should come in front of the Mayor first. When I saw that email and saw the explanation mark in the subject line it kind of through me off at first, I stopped and waited before I read the email because I had to take his intent into account.

Councilmember Devlin: so, what do you want to do with the conduct and the council and Mr. Michalson?

Councilmember Vick: I think that the best possible thing for right now I would say is that we should go past in formal censure and we should move forward. I think that the best route to go would be a censorship.

Councilmember Devlin: do you think the people in this packet would agree? Have you spoken to any of them on that?

Councilmember Vick: I have spoken to a couple of them about that.

Councilmember Devlin: because I have too. What I am hearing so I would be interested in what you are hearing, or Ms. Holcomb have you talked to any of the staff.

Councilmember Holcomb: I have not I have not actually had the chance with everything going on in my life right now, no I have not.

Councilmember Vick: I understand the concerns of the people, I understand the concerns of the staff I understand the concerns of the mayor I even understand your concerns I understand them I deeply respect that; the problem is going to trial is not in our bylaws, it is in Robert's Rules of Order, but it is not in written explicitly into our bylaws. So since right now we can't drag somebody into a trial since right now I don't know how a trial would work.

Councilmember Devlin: I did speak to an attorney I actually have spoken to an attorney and that is not true we can actually have a trial and have him removed if we choose to. We follow Robert's Rules of Order, we are full in our rights to do that.

Councilmember Vick: I still think that we should outline it ourselves.

Councilmember Devlin: just because we don't have a degree in law, you think we have the ability to do that?

Councilmember Vick: we can outline the basics of it, the people that decided how a trial was in the united states did not have degrees in law.

Councilmember Devlin: but we have resources now.

Mayor Dewey: but I think we are getting back to the changes that we are referencing in the policy, which you have in front of you today you don't have a written policy from the organization itself saying how you proceed with discipline outside of the Montana code disciplining yourselves. Your mind set may be that your hands are tied because we don't have an internal policy the very fact that a policy doesn't exist really leaves it open to the council to do whatever it wants, there is no governing body over you or court that is going to reverse your

decision a court would have to have lawful reason to reverse that you know in that vein you if you are doing what you want to do as a council lawfully I don't see any reason why that would be challenged as long as you have afforded the defendant in these allegations due process as long as he has been given his opportunity to defend himself and the council has taken whatever action is deemed necessary to do that. And then you take that as a learning experience and then you address that in your policy, that didn't work so let's try it a different way. So, you know when we developed the code of conduct, we had these allegations against the same person and we didn't have any policy on how to handle that, so the code of conduct was born from that it was a responsive measure to fix a hole. It appears on this council's discussion that it doesn't go as far as the expectations did. It met the expectations of the last council but not this council. Take that with a grain of salt, you are not beyond saying well our hands are tied and there is nothing that we can do, I think that is irresponsible. I think given the pattern of behavior that has been documented in your packet tonight and in past council packets and past documents maybe statutorily is not the right word, but you have an obligation to address this one way or another, you really do. Mr. Michalson?

Councilmember Michalson: two meetings ago we had this discussion and we decided and came to the agreement basically that we couldn't have a trial because you don't have 2/3 majority.

Councilmember Devlin: you said that.

Mayor Dewey: that was your guess.

Councilmember Michalson: that is the truth.

Councilmember Devlin: no that is what you said.

Councilmember Michalson: that is what everybody said.

Councilmember Devlin: did you ask us how we were going to vote?

Councilmember Michalson: it is pretty clear. It is pretty clear Jaime, it is going to be a two, two tie.

Councilmember Devlin: how do you know that.

Councilmember Michalson: it is clear, I can't see Robin going against me if she chooses to then I walk out I thought we were going to talk this out in a COW meeting but now we are spinning this out back around and you are dead beat on a trial.

Councilmember Devlin: I didn't say that, please don't put words in my mouth.

Councilmember Michalson: you are talking about it.

Councilmember Devlin: yes, it is on the table, it hasn't been taken off Bob, but don't put words in my mouth.

Councilmember Michalson: see? You and I just can't seem to get along, Jaime.

Mayor Dewey: I think the theme that is really I don't think the theme is to move forward with a trial Mr. Michalson, respectfully in think the theme tonight is that you need to be held

accountable for your behavior. That is as simple as it is. I think the council has to navigate how to hold you accountable.

Councilmember Michalson: 7 times Brandon? 7 times that you guys have come after me.

Councilmember Devlin: how many violations are in this packet because that is how many times you should have been held accountable. And there is more than 7, how many times have you gone after Mayor Dewey to have him recalled? We are not going there Bob, if you didn't break the rules we wouldn't be having this conversation. Like I told you before don't put this on me, this is on you. I yelled at the audience.

Councilmember Michalson: yes, you yelled at the audience. Yes, you have, you told them to shut up.

Councilmember Devlin: I told them to shut up?

Mayor Dewey: I am going to interrupt and remind folks that we do need to remain a level of respect for each other. And further this isn't a tit for tat or a he said she said situation, this is, if we want to have a committee of the whole meeting to address Ms. Delvin's rules or lack thereof then let's schedule that.

Councilmember Michalson: a committee of the whole meeting we voted 4 to 0 to do it.

Mayor Dewey: what are we doing tonight? That is what we are doing tonight this evening Mr. Michalson that was what the intent was, I don't know if you read the packet, but that was the intent of that agenda item to fulfill the committee of the whole request. It doesn't matter how many dates I throw out on a calendar I can't get the four of you in the same room except for the second and fourth Thursday of the month. And after tonight you really only have two council meetings left for the year. Because we don't meet at Thanksgiving and we don't meet at Christmas so that aside that is why you are here tonight. I apologized if that wasn't clear enough yes tonight is you committee of the whole meeting. Mr. Michalson?

Councilmember Michalson: I would like to take that part of the code of conduct out where I have to get permission to talk to staff like Robin said earlier you can't hold up government Brandon. Why should I get permission from you to get a packet from Jenelle or to talk to Robert?

Mayor Dewey: because Mr. Michalson when the rule wasn't there, we had problems with staff coming back to the mayor and saying I don't like the way Mr. Michalson interacts with me. The be born the rule, it doesn't matter how you intend it, or you perceive your actions all that matters is how the staff member perceives it. And I don't see where in your scope, we have all been through the classes I have watched Mr. Clark until I am blue in the face structure of government and where the branches lye I don't see where it is in your scope as a councilmember to send an email to finance officer telling him what to do, I don't see how that is anywhere in your scope as a councilmember as an individual.

Councilmember Michalson: (unable to understand audio) telling him?

Mayor Dewey: you told him to put you on the bank accounts.

Councilmember Michalson: I asked him, could you.

Mayor Dewey: no, could you, when you say that means do it, a person in authority says that that is exactly what it means Bob. I don't know if, we have been through this over and over again we have other, the code of conduct was born because of your behavior Mr. Michalson. So, I don't know if there is really a conclusion out of a COW meeting, your concluding that the trial would be a split vote and all for not you may be right but I am concluding I don't know if there is really a way for this body to agree with itself. I hear people time and time again; boy it would be really nice if the council and mayor in this town could get along. The reality is before the council and the mayor can really find harmony the council needs to find harmony amongst itself and that is impossible because you can't take responsibility for your actions. That is really comes down to, I spend more of my time, no we are going off track but, I am going to say it, I spend more of my time addressing results of your behavior or byproducts of that of doing the fun work of getting streets rebuilt. I mean I have slated this week and between next week I have to put 20 hours of my time Mr. Michalson in a lawsuit that resulted because of your behavior, 20 hours of my time. I don't have anyone else to do that.

Councilmember Michalson: that is pretty bad Brandon, you are accusing me of something.

Mayor Dewey: it is an accusation; it is proven in documentation. The pattern of behavior.

Councilmember Devlin: I guess I go back to the conduct of councilmember Michalson we have to deal with that before we can go in and change relevant policies.

Councilmember Vick: I said my piece earlier I put it on the table I recommended council do a sensor ship and I would even entertain a possibility of remove from the presidency seat.

Mayor Dewey: real quick, we can through suggestions out I have no objection to suggestions. I guess what I would appreciate is an action item on how we are going to move into the agenda item. You won't be able to action tonight because this was clear this was a discussion, but at your next meeting we will agendaize some result of this meeting if one comes from this. If a result is come from this, just keep that in mind I am looking for consensus from the council in order to address this on the next agenda.

Councilmember Vick: that is why I threw it on the table and pick at it and do whatever we want.

Councilmember Devlin: and I agree with you Mr. Vick that these are two separate items and treat them as such, we can't do one until we take care of one. So, I would rephrase that in the form of a motion and the first one, not a motion but a suggestion for the next agenda, that the conduct of Mr. Michalson be addresses as one. We come up with an agreement on that and then we move forward with reviewing the relevant policies. So, we would be looking at two separate meetings with items on the agenda for those.

Mayor Dewey: okay. I guess I will venture to ask than your like you stated you would like to consider an agenda item discipline, behavior as one piece and policy as another. I will ask council and it doesn't necessarily have to happen at this meeting, but I need some guidance on what you expect in meetings over the next couple of months, I was going to mention it in my executive report and have that conversation than but like I stated you are looking at a couple of

meetings left in the year and availability is getting tight availability of this room is somewhat sporadic so I would of course, I don't have a lot planned for your next two agendas but there are a few items that I would like to get going on but you know I am not planning on ramping up a bunch of things right before your Christmas break so it might be a situation where once we get into January you can really get into those policy pieces with a fresh mind set after the break that would perhaps be my recommendation that you handle the behavior get that addresses everyone agrees to follow the rules and then if you want to go in and change the rules perhaps you can consider that in the new year because of the timing. We are rapidly running out of 2020. So, bare that in mind while you agendaize things, I can certainly put both items on your agenda as standing agenda items until they are resolved so they will just keep coming up until you decide these don't need to come up anymore, at least we are touching on it at least it is in the front of your mind. Mr. Michalson?

Councilmember Michalson: this is kind of off the subject, but I am going to bring it up again, may I ask why I have to pay for documents as a councilmember. I know that you stated in your email that it took longer time and everything, but. I don't feel that a councilmember has to pay for documents.

Mayor Dewey: I think I clearly explained that in my email. That request was a specific request for emails between myself, Mr. Kellogg and Mr. Houley about Burnt Fork Enterprises. That is a very specific request Mr. Michalson and I never received a request from any other councilmember on any council stating that they were seeking those types of emails in order to carry out their duties as a councilmember. I guess I have received records requests from other councilmembers including yourself where the requests are requesting electronic records and we haven't charged for electronic records, in your case you circled general copies on your form we made the copies of your record request and we charged for the copies. Especially when an archive search is involved, we didn't necessarily charge you for the archive search fee of \$25.00 because those records were available on our electronic system but did you ask for copies and we made copies and that is why we are charging you. I don't see how that information and I think if you went through the request, if you chose to pay for it, you will find that about 80% of the emails you are copies on. So I am not sure what you were looking for in that request or if there, but it was a very specific request on who's emails you were requesting and again I don't see how they were relevant to your role as a councilmember in this organization. It looked like a witch hunt.

Councilmember Michalson: as a councilmember and a board member.

Mayor Dewey: and again, I had to explain that we are going to stay on topic, but you have not explained to me in the last several days why that is relevant to your job what is the compelling reason, I am not here to debate it tonight. We are going to stay on task and discuss behavior and not records requests.

Councilmember Michalson: I don't know, Jaime asked for a records request on my records.

Mayor Dewey: Ms. Devlin did a request on everyone's emails and we fulfilled that electronically and it wasn't a specific group of people it was just you guys. So, it wasn't the mayor or just the planning board chair or a developer, it was the whole council.

Councilmember Michalson: I thought it was just the planning and zoning board?

Mayor Dewey: no she requested emails from the town council about an issue I don't know the reasons and I don't care, it was clearly in her rights to fulfill the request she asked for electronic copies and she got electronic copies and we don't charge for electronic copies. You asked for [a]er copies, we printed paper copies we charge for paper copies.

Councilmember Michalson: I just don't think I should be charged for paper copies as a councilmember.

Mayor Dewey: you don't think that the council adopted the resolution that says we charge .25 cents for paper copies there for we charge .25 cents for paper copies. If you don't like it appeal the resolution and change the price, I don't care. I don't think it any secret that there is a little scrutiny about the mayor following policy, so I give you a break on a records request what's next? Am I going to be recalled? Back to the subject. I don't know how the council wants to proceed there have been two items placed on the agenda one addressing behavior and one addressing policy. So, I look to council if there is specific direction on where you would like to go or if this is a generic item kind of like it is listed on the agenda tonight. Discussion/decision conduct of Mr. Michalson and then it is listed review of policies we can break those apart, but what type of specificity do you want on the agenda so you want to decide that tonight you can Ms. Devlin is the one that suggested separating them on the agenda specifically so if you want to figure out amongst yourselves who is going to submit an agenda item if you want us to figure out that verbiage we can do so, I will leave it up to council otherwise if I don't hear anything I am going to take liberty with the agenda and hope for the best

Councilmember Vick: I think it is best from this point forward let's go ahead and have them split apart for the next agenda item as far as that we can call is discussion/decision on conduct violations and on the following one retooling of punishment section of code of conduct.

Mayor Dewey: I can place those on the next agenda for you, so I do have a question so that I am clear on the product of this meeting and beyond that and so others as well. You intend to discuss code of conduct violations of Mr. Michalson at the next meeting I guess from this meeting what does that conversation look like is it more a workshop conversation like we are having now or is the council intend to bring some sort of specific action forward to address that?

Councilmember Vick: I think the best way to handle it, we may as well split that into two things as well to do a workshop thing to discuss the action we are going to take, and the following agenda item would be to make the decision and bring a resolution to this.

Mayor Dewey: as I hear from that and the rest of the council can chime in, there isn't necessarily a resolution coming from this meeting and proceed to another meeting to discuss it.

Councilmember Devlin: do you want to workshop tonight we are already here?

Councilmember Vick: I guess so.

Mayor Dewey: you have 45 minutes before I kick you out.

Councilmember Devlin: we can have decision on... (phone ringing in the audience and person taking the call)

Mayor Dewey: (asked person to take their call outside.) it is the councils prerogative if they want to discuss it you can I would like to get you out of here by nine.

Councilmember Vick: I guess the best thing to do is, or the question to ask is "how do you think we should handle it?"

Councilmember Michalson; you guys are doing it. It is kind of clear what I say is not going to jive. If you guys want to move ahead, if you guys want to put an agenda item forward to discuss me that is your choice, I mean of course I am not privy to it, but that is not my place either. If you feel Dempsey and Jaime and Robin that I have been up to, if you don't feel that I can move forward and work it out I guess you have to do what you have to do. But if you think we should have a workshop here and work out our differences than we can keep spinning it along, but.

Councilmember Devlin: I am curious what you refer to as our differences on several occasions on several items in this packet I don't see anything that speaks to our differences so can you elaborate on that because I kind of get hung up on that when you say that what do you mean?

Councilmember Michalson: we have differences on how we think of things, you know. I said before I tried to be a better councilman and I meant it I can't change, a zebra cant change his stripes when he is 65 years old, I am not going to sit here and try to justify my actions you guys that is up to you guys.

Mayor Dewey: go ahead Ms. Devlin.

Councilmember Devlin: so, saying that a zebra can't change his stripes at 65 years old mean that this is what we have to look forward to for the next 3 years from you?

Councilmember Michalson: I did not say that.

Councilmember Devlin: I am asking because that is how I interpreted what you just said.

Councilmember Michalson: I am saying that I said that would try to be a better councilperson and I will try. I have made changes, if you look at those charges, a lot of them weren't even when I was on council it was when I was a citizen. Renee Christensen and all of those, I wasn't even on the council then (unclear audio) 90% of them were me and Brandon. And as far as the emails to Robert I did not know, if Robert would have come to me and said you know what I don't like the way you are writing these emails to me, I would have changed. I have been writing emails to everybody since I have been on council and I don't see where they are damaging. I am being side saddled on a lot of things as far as asking 90% of those emails were to Robert.

Councilmember Devlin: "congratulations Dempsey you have become a rubber stamp to Dewey so sad, you are the one that has to look the town in the eye I can sleep well tonight, can you?"

Councilmember Michalson: that is a (unclear audio)

Councilmember Devlin: you think that is okay?

Councilmember Michalson: yeah.

Councilmember Devlin: you think that is okay to talk to a councilmember that way?

Councilmember Michalson: have you looked at the political environment around you?

Councilmember Devlin: I am not talking about that I am talking about you.

Councilmember Michalson: yes.

Councilmember Devlin: you think it is okay to talk to somebody like that?

Councilmember Michalson: at the time, yes.

Councilmember Devlin: then we have bigger issues, and that half wants to make me defer charges currently and move forward with the trial because that sums up the answer that I need.

Councilmember Michalson: and you have already made a judgement.

Councilmember Devlin: I asked a question and you answered it.

Councilmember Michalson: you made your judgement long before you stepped in here so come on Jaime let's get real, I am going to sit here and defend myself now. You have been after me since day one. (unclear audio) I heard that you got on the council for only one reason just to get rid of me and it is pretty obvious. So yeah, it works both ways, I am not going to sit here and be Mr. Nice. Not when I am under attack for seven months, ever since I brought this contract out on this kid here, I have been attacked and attacked and attacked.

Mayor Dewey: I am going to ask a question and I am don't mean to put any one on the spot, but I am curious the statement Ms. Devlin read, and Mr. Michalson feels that it was an appropriate use of language and an appropriate way to communicate. Ms. Holcomb how do you feel about that? Are you okay with councilmembers interacting with each other that way?

Councilmember Holcomb: not in a hateful way, no.

Mayor Dewey: MS. Devlin did you have more?

Councilmember Devlin: no, I am not going to, I was going to say something, but no.

Jenelle Berthoud: Mayor?

Mayor Dewey: Ms. Berthoud.

Jenelle Berthoud: Mayor and Council can I speak to this issue coming from an employee's view.

Mayor Dewey: does the council have any objection to that?

Jenelle Berthoud: the council has no objection? So, you now before I took this position I have worked for the town since 2018 and I was the police clerk I applied for the position of town clerk and I accepted that position knowing that there were going to be some interesting days to come, with that since day one, August 3rd I was sworn in, and I have taken this job seriously everyday of it many many hours have been put in catching up on work and learning these new ways and pieces. But just in this morning I was finishing typing the minutes from the August 13, 2020 town council meeting and it reminded me of that evening and what transpired when you

Mr. Michalson allowed citizens in a sense, hopefully be involved in that meeting at your home and through that ZOOM conference we were having we were having a town council meeting and you chose to have those people at your house. You are all talking about conduct and what that looks like in that person at any point Mr. Michalson do you think what the outcome would look like by doing that? At any point do you think what it would look like and feel like to an employee, when after all those people left your home and came down to town hall, pounding on doors, yelling, pounding on the window. Myself, the mayor and finance officer where in that building during this meeting during that time. It is extremely uncomfortable to try to continue to conduct a meeting with the rest of you when we are still there trying to finish business and there is a group of people standing out front. Very very scary I waited we had to call law enforcement in law enforcement came out front they helped disperse the crowd I had a police escort across town because I did not know what the outcome of that was going to be. That is not the feeling that I want to have as your town clerk. That is why I am asking you tonight Mr. Michalson, do you think these things through? Because this is the actions of that particular night alone was very difficult to come back the next day to work. But I took an oath to be your town clerk and to continue to do my job. Very very sad.

Mayor Dewey: Mr. Michalson?

Councilmember Michalson: I did not know that night that those people were coming. I did not know, they showed up at my house. 6 f them 12 of them 20 of them, business owners and Mr. Cody got behind there and said what he said to Mr. Dewey. I didn't tell him what to say they wanted to speak, and Brandon said no and when Brandon kicked me off of the meeting, I didn't tell them to run down to town hall they just took off on their own I don't dictate what those people do.

Jenelle Berthoud: but Mr. Michalson on my side of it, it could have been stopped before the meeting even started, right? Not allowing that person to come up an speak.

Councilmember Michalson: I didn't know he was behind me if you look at the video Cody came right behind me and said what he wanted to say.

Jenelle Berthoud: I don't want to relive it; I have been typing that particular meeting now for almost five and a half hours.

Councilmember Michalson: I don't either Jenelle.

Mayor Dewey: I think what Ms. Berthoud's point might be is that you didn't come out and condone the behavior, "I am sorry that should not happen on my watch as a councilmember I am sorry that an individual in my home said those things" but based on your previous discussion with Ms. Devlin you are okay with that behavior.

Councilmember Michalson: I would of, but you kicked me out of that meeting.

Mayor Dewey: but since that meeting you have not come forward to say that this should not happen. That is part of what Ms. Berthoud is trying to say.

Jenelle Berthoud: as an employee you have to remember that it is not just that we are going to then there is more to that Mr. Michalson, there are the citizens that come in there are the

citizens that yell at us there are the citizens that scream at us we put up with that but then there comes a point that we don't want to put up with that. You and I had a discussion in regard to an email that you had sent your title to that email was embarrassment and I am going to read it it is really short. He sent it to myself, Brandon, Mr. Owens, Ms. Devlin, Mr. Vick and Ms. Holcomb. Ms. Berthoud read the email. You remember why I called you about the email what you were told by that citizen how it quickly that happened, it happened on a Friday and I received this the following Monday morning when you sent this email. Misinformation was immediately put out to our community about an event that took place at town hall and then us employees had to deal with that and relive that the conduct of who ever you talked to or whoever you told this incident to was completely blowout of proportion...

Councilmember Michalson: I didn't tell anybody.

Jenelle Berthoud: so then as an employee I have to make time to meet with the mayor to ask if I can call you to explain what happened that it was us the employees that were attacked by that person. I am seeing a pattern and it is very very discouraging as a town employee this is the pattern, I had hoped by taking this position there would be some change and it is just like, I am typing up notes from past meetings and it just like I am sitting there and yeah and am reliving that just how they had to do it. That will be it for tonight.

Mayor Dewey: part of a supervisor there is a problem here Mr. Michalson, there is a pattern of behavior and that sort of thing that I guess speaks to Jenelle's point is that we are constantly seeing employees being put into a place to defend themselves and I think that is part of the issue that we have to address regardless on how you intend this to be the employees the people that have a right to their job who diligently show up to work with the public everyday they should not have to come to work and reconsider, gosh if I talk to this individual what kind of trouble am I going to get myself into or will it get twisted and I think that has been the issue there has been inconsistencies in the telephone game that occurs between the staff members, and that is largely in point why the code of conduct was written the way that it was to channel communication through one person so that it was consistent.

Voice from the audience asked if she could speak to this.

Mayor Dewey: no, you may not we are not at public comment.

Voice from the audience, I was going to speak...

Mayor Dewey: I appreciate that, but you are not allowed to speak Ms. Rudabaugh. Yes, I am running the meeting and if you have anything else to say you can leave. I won't take disorderly conduct I just don't have the tolerance for it. This is done, back to the council's discussion. I don't know how you, a side from tweaks to policy, I don't know how you plan to address the pattern of behavior that has been demonstrated by two different ten-year and documented. I keep going back to that, this is two different ten-years with the council and the ten-year prior to that we had the same issue then you have your clerk here tonight who has 1, 2, 3, 4th clerk in three years and we are hearing the same story the other three clerks shared. When are we going to change this story you guys, Ms. Holcomb?

Councilmember Holcomb: not that I am taking this, we all need to follow this we all do. I have had attacks on me on Facebook I have seen attacks on other people you even allowed someone to personally attack me up there at that podium and did not stop it. So, if we are going to do this then we are all going to follow this. Not just one person, we are all going to have to follow this if we are going to get along. I mean I have never seen so much division and so much hatred in this town in the past three, in the past three years I have seen this it is horrible. It is horrible how people are attacking one another, and people are just okay but if we are going to do this then we all are going to do this we can't just penalize one person when we are all doing it cause like I said you personally allowed somebody to personally attack me at that podium and didn't stop it, and that is on this. So, if we are attacking one person then we all need to follow these rules and the code of conduct.

Mayor Dewey: Ms. Devlin?

Councilmember Devlin: I agree exactly with what you are saying, there have been people at that podium that have attacked all of us so going back to the issue we are talking about all of us right now, we are not talking about all of the violation of us right now. We are talking about the continued violations of Mr. Michalson we can't keep mudding the water and throwing us all in the same bucket because we are not all in that same bucket Robin.

Councilmember Holcomb: and I understand that but there have been attempts on everybody and I am sorry that you all have been going through this, but you can't blame what people have done on one person. I don't know and I wasn't there, but I think I would have aid go and charge the town hall, so you can't pin that on one person, I am sorry that you went through that, I worked at a place that I get screamed at because they think we are stealing their money. But...

Jenelle Berthoud: I think Ms. Holcomb that is why I want to make this point tonight you are right we can't continue this.

Councilmember Holcomb: no, we can't.

Jenelle Berthoud: so, make that change happen now for the rest of us and for yourselves and this town. Because you are right, we can't continue to have people stand up here and yell at us, we can't continue to do our job at town hall and have people yell at us walk down the street, go out to dinner whatever those these might be I am right there with you and I totally understand that we have to make this change now, today at some point please. You are right I don't want to continue on like that either.

Councilmember Devlin: so, it goes back to the conduct of councilmember Michalson, who I haven't heard the conversation of each of us individually and we can do that but right now we are talking about the conduct of Mr. Michalson. I am not sure if I have ever seen a time Robin where anyone was bad mouthed at this table, I have never seen it. Mr. Vick I am not aware of anytime that you did this. Nor have I received anything from anybody outside of here public, staff, saying that you overstepped your boundaries or put somebody in an uncomfortable situation. I haven't heard that. I hear that on a regular basis about Mr. Michalson I don't search for that, Mr. Michalson you talk about you and I can't work together, that is false. We have. That is totally false, but I absolutely believe in holding people accountable. 6 or 7 times not trying to

remove you I am trying to hold you accountable. If I hear the same things from both of you on your behalf or of your conduct, I would do that. Not showing up for the meeting, nothing against you I actually really like you we do a lot of things together on boards it is not personal it is a request of the people that we hear from it is called holding people accountable it is not a personal agenda it is not a business tactic it is accountability so, yeah you know there are things in here that are not followed to a "t" or the "I's" dotted and the "t's" are crossed but it is not a repeated pattern. These started in January it is not a witch hunt this is not about a recall it is not about the IT service it isn't about that. I did not join council to have somebody removed that is absurd I have other things that I can do with my time. That is absolute absurd going back to that I absolutely appreciate you saying that but I don't hear about your miss conduct, I don't hear about your misconduct I hear about your misconduct. So, what are we going to do about it? I emailed the council on a few occasions here we have an issue we don't have the opportunity to play ostrich what are we going to do? And it has escalated and here we are, what are we going to do? What are we going to do?

Mayor Dewey: maybe we can pose it this way. If we had a closed session and we had an employee just take Mr. Michalson's name out of the report and insert employees name how would you approach this? You called it as a disciplinary board, it is not something that the administration can handle, stuck the town council with the duty of handling the discipline of this employee that has behaved this way how would you address that? Because I don't think we are in a position anymore, seems like over the last hour, we have moved past whether or not the allegations are true, I think we have determined that this happened and it is not becoming and is not good conduct and that was apparent in Ms. Devlin's statement and concurrent with the council about Mr. Michalson, that is not an okay way to speak to one another. So, how would you address an employee before you that repeatedly doesn't go by the book. Just the fact that the individual sits with you at the table I don't think should really influence your moral compass on how you would address this. You should look at objectively either way.

Councilmember Vick: if it was an employee, I would follow what is in our HR policy to take action, continued behaviors could result in termination the only problem is seems that I am playing devils advocate is that a town employee does not represent half the town. And whether people like it or not Mr. Michalson was elected by 51 or 52 percent of the people of ward two. And that 51 or 52 percent have a right to have their voice heard I understand the same with the other 49 percent that voted for the other person they are just as important. But the majority that I am hearing from people is asking to and I am not saying (unclear audio) I am not saying that but that is the fear that is the perception that the entire town is getting the phone calls, emails, letters, knocks on the door that I am getting from people asking to please stop from removing him that is the majority of them there is a lesser crowd that wants blood and there is some point to some of that, that I agree with them (unclear audio), but when the majority of the people are not wanting somebody removed it wouldn't be right to remove a voice from the council that is the only reason that I am taking removal off of the table, because it is not what the majority of people want.

Mayor Dewey: it is not my intent to debate removal or not removal, but I disagree that the idea that an employee doesn't represent, an employee of this organizations represents this town more than a councilmember because they are on the front lines working and their paycheck

comes from the coffers of this organization., I will tell you right now if an employee under my administration behaved this way they would have lost their job on March 12th in the text message, on the time line that started January 10th and by March 12th they would be looking for a new job. It is that simple and I treat every employee as, and they do they represent the entire community they represent the public who doesn't even have a chance to elect them and they represent us to a lot of other communities and to a broad area, so they do represent this community and its character. And if I had an employee who represented this community and the community's character poorly, they would be gone.

Councilmember Vick: I guess I was mis-understood, when I said that an employee doesn't represent the town an employee of the town definitely represents the town just like no matter what I do I represent my employers the same of all of us in here, we all represent our employers. When I was saying the representing of the town it was the same thing you were saying there elected into their position they don't serve as a representative voice of the people, that was the point I was making.

Mayor Dewey: Ms. Devlin.

Councilmember Devlin: kind of an interesting thing led me to a thought that you said you hear from a lot of people that don't want Mr. Michalson's removal. I don't hear from people one way or the other but every time that we have had this on the agenda, we have no public comment on it. It is on the agenda again tonight and look at our audience there is nobody here giving public comment one way or the other so, who are the people that are talking to you, not talking to me possibly talking or not talking to they are not here, they are not letting their voices be heard publicly. In defense or not of Mr. Michalson. I find that very interesting there have been multiple times that it has been on the agenda and the public has not as a matter of fact one time that it was on, we were absolutely packed and not one person spoke of public comment in favor of or not so, that speaks volumes to me, volumes.

Councilmember Vick: does to me as well.

Mayor Dewey: okay, in the interest of time as I promised we want to get out of here by nine and I promise you we will. Being a quarter too we will push pause on the conversation and will agendaize it accordingly on the next agenda and you can continue how you feel necessary. If that is acceptable.

12. Executive Report

Mayor Dewey: okay I don't have anything for the executive report outside of tonight. We are going to move forward with task order number 6 get the documents and get those projects up and running. Last week some changes to, significant changes frankly to our debris pick up program this year and I realize that this has been, these changes aren't as popular as we had hoped they would be across the community I understand that we have an aging population that is not able to move debris around and those things. The office is actively putting together resources for those folks so we will make ourselves whole on that making sure that our elderly and those people that need that are being taken care of making sure that it doesn't tax our

resources that much and instead hoping to be able to bring neighbors and community members together for a good cause that is our approach in addressing those changes that we have taken away the curb side pickup of debris town wide. And instead opened a dump site at Lewis & Clark Park for one or two employees can make one run a day and get that removed instead of committing all four of our staff to seven days of cleaning up the community debris, it puts us behind in some many specs and given the short staffing that we have, keep in mind that we have a four member public works crew and an on call person to help us out, but when we have a four member public works crew one of those people leaves and that is a 25% reduction in our work force in the public works department. So, we typically run three trucks and a bob cat and when we lose a worker now we are down a truck it is not feasible to do this year it is tremendously taxing on our resources and we are taking a different approach to it and we appreciate the communities support and we will continue to find resources for these folks where we can. I think that is one piece that I would like to highlight. One other piece that I would like to highlight is that I have not heard from the Planning & Zoning Board on when they will reschedule there planning and zoning meeting on the Burnt Fork Estates and it is kind of in limbo, they had to cancel due to an outbreak of COVID-19 at the school, so I am waiting to hear from the planning board so we can get that scheduled and notices out. The phone system install is progressing, you saw a claim on your claims tonight for that and they will be here tomorrow for a sight visit as a matter of fact and then that will help them get their bearings in terms of were equipment is going and phones are going and those sorts of things. We should see that progress rather quickly when that sight visit happens. And then that will go a along ways to improving communication with the operations and customer service quiet a bit we were having some challenges with phone services over at the police department currently and this will resolve that for sure. The police department is moved in and there new office is at 102 Main and we just today finalized the construction activity over there we were waiting for a apiece of glass to come in for the customer service window and that is all in the counter top has been repaired and moved in from the old facility and that facility will be 100% ready to go, as the holidays approach you can expect it looking really sharp and then open to the public and the council for an open house, I know that we keep telling you that but want to make sure that it is buttoned up 100% before we roll that out. So, the only other consideration for you to think about is meetings unless I hear from you folks back from council and I am only planning on two more council meetings this year at least the last two years we just canceled the November, this year the November 26th meeting and the meeting in December we just canceled and paid claims out of cycle so unless I hear feedback otherwise I will agendaize paying claims out of cycle for you folks and plan on one meeting in November and in December unless we need to add a special meeting but I don't expect. Other thing that we will proceed towards that the administration will proceed with is an MOU with the library to kind of formalize our relationship with them in terms of using this room it is our best option right now in terms of space and constraints in terms of scheduling by the end of the year we would like to have something more formal with them until we find another space maybe even a community center is available for the town to use because if we can not use this space we are back to city hall and can have in person meetings with the council but we cant have the public there so you are looking at a hybrid virtual meeting and tonight that got flushed down the toilet I don't know what happened the live feed craped out on us. So keep those things in io=mind and if you have any feedback I would

love to hear it. Unless there are any questions for me that by in large ends my executive report. Ms. Holcomb?

Councilmember Holcomb: so, when we put out signs and everything do I need to put out an agenda item to get a sign put on Peterson Place saying no through traffic or dead end? No outlet, a lot of people are using that road thinking it is an outlet, a few weeks ago my husband's car got hit because they were trying to back out so I have been hearing a lot of people asking if we could get a no outlet or dead-end sign.

Mayor Dewey: yes, so, the council can approve traffic control signs and I think that has been well established. I am more than welcome to put together an agenda item on your behalf.

Councilmember Holcomb: thank you.

Mayor Dewey: any other questions before council comments?

13. Town Council Comments

Councilmember Vick: the community is really looking forward to having a dog park something similar to what Hamilton has I would like to see a project like that get going, I know it is a little bit different than my forward position on the airport board, so maybe Ms. Devlin can bring that up to and hopefully move forward with that. Another thing is and this is a comment to the public just be real careful this weekend while you are out driving supposed to get a lot of snow, so just be safe while driving. You know if you start to slip don't step on the break just let off, don't use cruise control it is wintertime in Montana.

Mayor Dewey: taking the fun out of it, the public works department is eager to put the new sander to use, it is loaded and ready to go they are just waiting for something slick to put it on. Ms. Devlin?

Councilmember Devlin: yes there is talk of a dog park maybe a couple of them maybe a pole is going to be taken to see the majority of people really want that, yeah. Comment and you don't have to answer this right now I am hoping I can get some information there is some, I don't know if I want to say upset, but that is probably the best word, as to were the stop sign is on 5th Street I think the intent was to have those stop signs on College and that one was put on 5th by that wye. If I could get some information on how that decision was made it does not seem to be working well. So if we could maybe have an agenda item to put two stop signs on College instead of one on 5th.

Mayor Dewey: we can look at that and I can get with you.

Councilmember Devlin: thank you.

Mayor Dewey: any further council comments, Mr. Michalson?

Councilmember Michalson: I would have to agree with that, that is a bad spot I have had people tell me that too it is stop and go, not a smooth flow of traffic. One other thing I would like to ask everybody to vote.

Mayor Dewey: last count shows about 50% of Stevensville’s voters have voted that was today or yesterday, we are well over our typical turn out for Stevensville, usually 40 or under. So 50% is good.

Councilmember Vick: those machines aren’t going to be ready for all of those ballots.

Mayor Dewey: are there any further council comments tonight?

14. Board Reports

None.

15. Adjournment

APPROVE:

ATTEST:

Brandon E. Dewey, Mayor

Jenelle S. Berthoud, Town Clerk

File Attachments for Item:

b. January 28, 2021 Meeting Minutes

Stevensville Town Council Meeting Minutes

THURSDAY, JANUARY 28, 2021

1. Call to Order and Roll Call

Mayor Dewey called the meeting to order. Councilmembers Ludington, Shourd and Vick were all present. Councilmember Devlin was absent

2. Pledge of Allegiance

3. Public Comments

Public comment came through via the town clerk's email. Mayor Dewey read an email from Jim Crews regarding public comment. Mayor Dewey addressed an email that had been sent to all councilmembers from Craig and Delaine Johnson.

4. Approval of Minutes

Ms. Berthoud gave an update on the meeting minutes that are outstanding. Mayor Dewey: as I am sure you are aware Jenelle has also been given the task of BFE meeting minutes.

5. Approval of Bi-Weekly Claims

a. Claims #16457-#16524

Mayor Dewey: introduced bi-weekly claims.

Councilmember Vick: made a motion

Councilmember Shourd: 2nd that.

Mayor Dewey: it has been moved by Mr. Vick and 2nd by Mr. Shourd to approve the bi-weekly claims. Discussion?

Councilmember Ludington: claim # 16515 to Ravalli County Sheriff's Department office Zuercher field opts license?

Mayor Dewey: correct the pronunciation of Zuercher. That is a special app that officers have on their phones to coordinate with the CAD system at 911.

Councilmember Ludington: so, it is an app?

Mayor Dewey: yes, it is a yearly subscription to an app. And that subscription is tied to the individual officer not to necessarily to the phone of anything so, when we have an officer, we have so many subscriptions that we purchase, and they are assigned accordingly. The fire department has the same set up. I think it is listed as anvil.

Councilmember Vick: in this format it didn't come up as annual but I remember seeing it last year.

Mayor Dewey: questions from the council on the claims? Public comment? Hearing none, Ms. Berthoud please call for the vote.

Councilmember Ludington: aye

Councilmember Shourd: aye

Councilmember Vick: aye

Mayor Dewey: the motion passes.

6. Guests

No guests.

7. Correspondence

a. Letter from Don Lorenzen dated January 10, 2021 to the city council. Mayor Dewey: introduced the letter and read it into the record.

8. Public Hearings

No public hearings.

9. Unfinished Business

a. Discussion/Decision: Police Department Staffing

Mayor Dewey: this is a carry over from your last agenda item, I am going to hand out this packet it is not included in your council packet, but we will upload it. This is from the survey, police department survey, community survey that went out after the last council meeting. I think that it was published like on the 15th of January to date we have received 194 responses to the survey and mind you when we run these, we run partial results and anybody that did not finish the survey their answers counted you will see different numbers for different questions in response and depending on what it is. In large they are pretty consistent. Just bear that in mind, that has a lot to do with why the no response column is not in some questions and short in other questions. The other reason that you will see a no response column that is pretty large for example the second page or back of the first page it says "were you satisfied with how the officer treated you" you will see no responses is 63% of the response the reason for that is the survey is programmed to skip that question if they answered no to the previous question. Because it was not relevant you would not be satisfied or dissatisfied if you haven't had any interaction with the police department. So that is primarily why those columns are larger in some of those questions. There was an algorithm response from the previous question it would skip the question. Overall, I don't think that there is anything glaring results of the survey I pretty much lines up with our gut feeling regarding the police department and where it sits. It does provide some insight into how people prioritize or show what factors into their perception of the police department and how they are viewed in terms of professionalism. You know there are some people that are not sure how they can either make a complaint or get access to a

police officer so that is something the police department would like to address of course. I think that one piece the council discussed at the last meeting was of a public safety levy and those results are at the end of your survey or at the end of your packet. These are specific questions that we included in the original survey to answer the prospect of the town council going towards a levy or considering that and so the first question was "would you support a public safety levy to assist the Stevensville Police Department" of the 194 responses 50 said yes 57 said no and 87 did not respond. Part of the rationale behind that is there are ways to, when it says no response, there are ways to do the algorithm of the survey, if they answered no to living or working in Stevensville then it did not bring up the question about the levy because we didn't think it was relevant if they didn't live or work here. We did not think it mattered to us if they supported a levy or not. On the back page you can tell there, for those that did support a levy what they were willing to pay in terms of increase of \$100,000 in property value. Mostly those folks would support \$50.00 of increase per \$100,000 of property value. The rise is where they did not respond to the question. In terms of "would they support the annexation of additional property into the town limits to increase revenue to fund" that was a pretty split response there were 51 that said yes and 40 that said no and there were 21 that did not know if they would support that or not and 34 had no responses. It gives you a little insight as to where the community sits in terms of funding its police department with a levy, you know we did not provide an opportunity, because sometimes they are difficult to consolidate and report back on, but we did not provide an opportunity for general comment, but we did see some comment through our social media channels where we posted the survey. We haven't closed the survey we would like to continue collecting responses on it all though just under 200 responses is pretty good in the short time that it has been out, and we have only done it online we would like to print some off and mail out to some people that we know don't have computer access or don't engage with us on social media. In fact, from past surveys, we can tell which quadrants of town don't respond to surveys so we will, or don't respond to our social media channels, they just don't engage with us in certain neighborhoods so we are probably going to target those neighborhoods with surveys to see if we can get some responses from those neighborhoods as well and kind of round out the data. Largely this data is coming strictly through a mass email that we sent out to every contact we had access to in our data base and then through social media posting. I know for sure that the email went out to about 650 people and that usually yields about a 30-40 % open rate those emails do, so obviously we could reach out to. we reached a pretty good berth of people through social media as well. So that is encouraging and like I said we are going to try to diversify the results a little bit, so we don't see anything one sided in terms of people that use computers and people that don't. Questions on the survey? I think that is really the large reason for having the police department staffing item on the agenda tonight. I don't think that there is anything further to discuss unless you want to discuss the survey amongst yourselves tonight. The time is yours to do as you wish.

Councilmember Shourd: we have proposed running a levy for the two positions, would it be possible to use the police officer grant for the one position and then run the levy for a single officer position.

Mayor Dewey: I think anything is possible I don't know as if we have some firm data on grant funding from COPS, in fact CARES through a monkey wrench in that where we have had a hard

time finding dates as to when those programs will be funded and when they are going to call for applications. That is a concern you know they were pretty consistent in saying these are the dates when the application deadlines and we are not seeing that. We are watching and not seeing it and it is a little bit unnerving. To us that means that there is going to be a delay if we want to fund a position through COPS.

Councilmember Shourd: just a little help in understanding how much benefit would one officer be opposed to having two officers and are they supporting themselves in the third position. Do they work in teams?

Mayor Dewey: for the town of Stevensville to provide 24/7 police coverage to have one officer all the time day and night we need 4 ½ officers and that does not account for vacation or sick leave. If somebody calls in sick that shift gets missed. Today we have three sworn officers, and then with a chief of police there would be four. We are ½ an officer short of that benchmark without counting vacation and sick leave. I think the reason for seeking five or six officers is to accommodate increased growth as, we have been trying to do this catch up game for a long time we would like to get ahead for a little bit and take a breath I think that is the rationale behind the six officer request it also helps address those deficiencies with vacation and sick leave and it would be helpful if the sixth position was not an outright patrol person, that had some investigative responsibilities as well and spent more of their time in investigations I think it is a good opportunity to provide you with an update on where we are with discussions with the Sheriffs Office. I think that is pertinent to this conversation instead at the executive report. After a lot of trying on the part of city attorney Scott Owens, very difficult time nailing down the county attorney to set up a call with him, when he did, he was late, none the less they finally got on the phone with each other which was good. The city attorney gleaned some information out of that meeting that was helpful in addressing the communication challenges between the two agencies, SPD and RCSO. And so, after that meeting Mr. Owens and I discussed the next steps and how to move forward in resolving the matter. He agreed that me sitting down with sheriff's office was a good approach with council to hear out the challenges in the mist of that there were some interactions between the sheriffs office and interactions with interim chief Ellington that I guess there was some friction between the agencies maybe some misconceptions of personalities in our agency by theirs that needed to be addressed and Mr. Ellington did a great job in addressing that with the sheriff as soon as he was made aware of those challenges he scheduled a meeting with the sheriff right away, he learned of these things on a Friday and by Monday morning he was meeting with the sheriff. The interim chief and the sheriff they met for just over two hours and nailed out a lot of the nuances and frictions that were caused between the two agencies. As it turned out despite what the letter stated and what we all in the room perceived as the letter's intent, it was expressed by the sheriff that it was not their intent to circumvent Stevensville's law enforcement and take over investigations. What came of the conversation that I had with the sheriff this week was that the sheriff's office was apparently seeking a dialog in the meeting with Stevensville's leadership and they were doing so through former Chief Marble as early as November when chief was still with us. Those requests never made it to my office and part of the conversation with the sheriff was challenged with meeting the calls for service demands 911 calls, the calls that come through the dispatch center, he was having a hard time meeting those calls for the town of Stevensville, the calls that were coming in

were taxing on his patrol resources, but he has investigative resources that can handle additional investigations and can allocate resources to assist us in getting investigations wrapped up and completed. With the idea if Stevensville PD was spending less time on investigations then maybe they could handle more of the calls for service, that was the philosophy. That was where the communication really broke down, that request was never passed into my office or to the interim chief so, you know they felt like we have to send them a letter, I think the letter was obviously stronger worded than what their intent was based on our conversation. So, as of this week now that we have flushed out all of the problems and the challenges that we have identified the sheriffs office is not taking over all felonies in Stevensville SPD is still capable and will continue to investigate felonies where it is appropriate and where there are cases like child sex crimes and even certain frauds that take a lot of tedious time those we are going to start shuffling over to the sheriffs office, they are very time consuming and there is a lot of work that needs to be done to make them prosecutable. We don't admittedly have that kind of resource to investigate and some we just can't. We have a good path forward in terms of the sheriff's department which we are relieved to have they and us both admit that communication was just not there, and it frankly was an internal break down of communication in our organization that did not help the situation and that has been addressed. I hope that kind of eases some feelings ion the community about SPD. Officer Alspaw will be released from field training on Saturday and he will start his first full shift on his own next Tuesday it has been a long time since we have had three officers on some sort of schedule for this community. Every time we take a step forward, we always take a step back, Officer Guida unfortunately is in quarantine because he was deployed to Washington D.C. through the national guard, so he has been out for a considerable a lot of time this month, the month of January we have been running on an officer and a half because Officer Alspaw is doing his field training. So, that will bring us back up and we will have coverage on Tuesday through Saturday nights with Alspaw and when Guida gets back we will have seven nights of coverage and then some day shift coverage as well, we are getting closer and closer to covering the schedule and so we are also eager to see, we have these three officers on schedule, and we kind of want to see what the results of that look like first, I can tell you statically when we talked with the sheriff they ran statistics for calls for service that come through the 911 center from the town of Stevensville, the sheriffs office is covering half of those calls for service that come through their office, so they know roughly 50% of things that come through RCSO handles the other 50% we handle. If you look at the whole picture it makes sense. If we need four and a half officers to do 100%of the time 24/7 and we are running with two officers and we are covering half of the cases that makes sense. So, you know when we get back up to full, we are going to be in a really good position and that is when we have to buckle down and look to the future and the future needs of the community as it grows because it is going to happen so quickly. Anything else.

Councilmember Ludington: I am certainly glad that it is all done, and we were able to communicate efficiently I know that it is difficult not only is our department busy, but I have looked at statistics for the sheriff's department and they get a lot of call for service every week, so I appreciate the effort that was put in between everybody.

Mayor Dewey: thank you. We acknowledged overnight that I don't think that the relationship is repaired it is still going to take some work on both of our agencies to get us in a really solid

place so we are firing on all cylinders, but we made a really giant leap this week in communication and I think we are both eager to see what a new chief of police whether that is an internal hire or an external hire regardless we are going to see what that person brings to a better collaborative environment with our CSO. I am trying to remember there was something else in regard to police staffing that I wanted to address with you folks but maybe I have already hit it. Is there anything else from council on the police staffing subject, okay I will just leave you while we continue to gather survey results and the council continues to weigh the levy question as you are aware in a workshop with the staff tomorrow on our fifth Friday workshop and a good portion of our morning is dedicated to some issues and priorities for our organization. We are going to have a very open and frank conversation about our budget where we can get more creative in as we have already discussed the general fund is paired down pretty low, but we think we can get a little tighter there. So, we are going to have that conversation in a global way and discuss if there are opportunities that we are missing in regards to revenue. Are there services that we are providing to special people, special groups of people in the community that every other taxpayer is paying for and not using and so we are going to take a look at that to see if there is a way to lesson the burden of all, be more creative there and maybe make some funding available in the budget to continue the progress in the SPD staffing dilemmas. Ready to move on? Wonderful. Is there any public comment on police staffing before we move on?

10. New Business

a. Discussion/Decision: Utility Assistance Program

Mayor Dewey: introduced new business item (a). There is a council communication in your packed this evening addressing the utility assistant program how it states there are 11 customers on that program, this month was the last month to fund or provide funding for the program. So, we would have like to have had more notice but it was one of those things that kind of snuck up on us faster than we wanted it to, so we reconciled the account and have found that the funding is depleted and so essentially before the council tonight is how do you want to continue with the program, I am not pressuring you one way or the other to make a decision tonight however it would be useful to make a decision tonight we have to run bills on Monday so we would like to know. I can tell you that the eleven customers on the program received a letter that said hey the funding has been depleted for the program and this item is on the council's agenda for this meeting and this is how you can contact your councilmembers if they suggest "X" than you can expect "Y" and we address that with them. I have not checked with Laura to see what kind of response she received if any, regardless we want the council to kind of give us some direction on how the program may move forward in fact that is the consensus.

Councilmember Vick: the first thing that I would like to see and this would not directly or this would not benefit me at all is that added to the house hold income I would like us to add permanent 100% disability for VA, because not everybody that gets 100% benefits from the VA also gets social security, it is not guaranteed. That is something that I would like to see added to this program as we do have some disabled vets that live here and are not able to work and are 100% disabled and they are having a hard time getting their bills paid and what not.

Councilmember Ludington: so, you are talking about the table that is in this document talking about age and household income.

Councilmember Vick: Correct.

Councilmember Ludington: making \$28,000 or less and receiving permanent you would also like to read and also receiving disability payment.

Councilmember Vick: at the 100% level.

Councilmember Ludington: at the 100% level.

Councilmember Vick: yes.

Councilmember Ludington: are you going to change the resolution?

Councilmember Vick: I just wanted to bounce it off first.

Mayor Dewey: if the council wants to make changes like that to the program than I think modifying that by resolution would be the way to go I think we are going to end up with it in resolution format anyway. Depending on how you proceed, you are given some latitude from previous resolutions and my review of those you are given the latitude to change the fee collection and the fee how you chose. Of course, by resolution is best practice and you can resolve, there is nothing preventing you from tonight resolving and that being ratified in the resolution, so you don't have to have the paperwork or the resolution in front of you tonight we will just take that action on the resolution when you resolve. I guess what ever changes to the program if that is your intent, we just need to know those very clearly.

Councilmember Shourd: just for clarification the original dollar fifty-two charge was because council did not know how many people were going to participate?

Mayor Dewey: correct it was a shot in the dark.

Councilmember Shourd: and then the thirty-five-cent monthly charge is to cover the eleven participants, correct?

Mayor Dewey: correct.

Councilmember Shourd: so, any additional individuals may be qualified for this program the thirty-five cents would have to increase as well.

Mayor Dewey: that is correct, that is a consideration you should take if you do reinstate a fee just so you know the fee covers the people on the program today, we rarely see it go over twelve by the time we add a participant someone has dropped off whether their income increases, or they pass away so I have never seen in my ten year the program exceed twelve participants.

Councilmember Ludington: I don't think even when it started in 2015 it went over 15, I don't think it has ever gone over the teens.

Mayor Dewey: and we have over the years tried to involve more people and there is not a ton of interest in the program by some and there are various reasons for that certainly a trust issue with the government handling your documents, you send your taxes to the government and so dropping them at city hall is a better deal. I think we are seeing less of that, last year during corona virus we extended the application deadline through July 15th and nobody really took advantage a couple one or two came in because their taxes were filed late so that is why largely we extended the deadline because we knew they weren't going to get their taxes back or their filing back so we need that for a determination and so we extended it. Somebody calls in the middle of the year we will consider their application.

Councilmember Shourd: So, if someone could do the math for me what are we looking at for the monthly charge to cover another 2-3 participants?

Mayor Dewey: if it were that easy Patrick.

Councilmember Shourd: it is just numbers.

Mayor Dewey: the challenge that we have, and I have a work sheet on my desk, the challenge that we have is what, I would encourage you to expect the worst-case scenario, because they could qualify for 25, 50 or 75%. So obviously the 25% reduction cost us less in terms of funding the program. I think you are even if you took thirty-five cents, and I know I can already tell you that number I rounded up a penny, there was a decimal in there and I rounded up a penny. So, if you took the thirty-five-cents and divided by the eleven participants it would give you a pretty good idea of what per participant costs us on the program, participants on the program are dealing with age.

Councilmember Vick: so, that is roughly (unclear audio)

Mayor Dewey: per participant you are not looking at, if you went up to forty cents you would cover a few more people and have a reserve.

Councilmember Shourd: I definitely strongly support this program.

Councilmember Vick: I will go ahead and make a motion to with utility assistance program with the change that I had discussed with the adding 100% disabled veterans that are below that household income level.

Mayor Dewey: is there a 2nd?

Councilmember Shourd: 2nd.

Mayor Dewey: it has been moved by Mr. Vick and 2nd by Mr. Shourd to continue the reduced rate program with the amendment to the program that the \$28,000 or less and receiving social security/disability payments and/or 100% disabled veteran.

Councilmember Vick: correct.

Mayor Dewey: the change we didn't clarify if you wanted to the charge reinstated in your motion.

Councilmember Vick: and reinstate the charge of thirty-five-cents.

Mayor Dewey: the motion has been amended to include to reinstate the charge for the program at a rate of thirty-five-cents.

Councilmember Shourd: just to clarify thirty-five cents covers the participants currently.

Mayor Dewey: correct.

Councilmember Shourd: we would need to increase if we had more, so we would have to have forty cents to cover any individuals in addition to the eleven.

Councilmember Ludington: I wonder if we need to break this out into two motions.

Councilmember Vick: yeah.

Councilmember Ludington: one could add the VA disability and the other to reinstate.

Mayor Dewey: okay we are going to ditch the amendment and are going to chase down continuing the program and adjusting the income bracket.

Mayor Dewey: it has been moved by Vick and 2nd by Shourd.

Councilmember Vick: you are going to hate me but there was something in the list that we would have to remove the VA benefits from income. So I make another amendment to remove VA benefits from under income in the table that was in the document created on July 15th 2019 page 22 in your packet.

Mayor Dewey: I am sorry I was reading, was that an amendment or another motion?

Councilmember Vick: it was amending the motion I made.

Mayor Dewey: is there a second to the motion.

Councilmember Shourd: 2nd.

Mayor Dewey: it has been moved by Mr. Vick and 2nd by Mr. Shourd. To amend the original motion to remove the benefits from the income criteria. Council discussion?

Councilmember Ludington: check boxes, it those receiving income from and one of them is VA benefits.

Councilmember Vick: correct that is what I was talking about.

Councilmember Ludington: you want to eliminate that from the list of incomes?

Councilmember Vick: correct.

Mayor Dewey: so I am just reviewing the program information on our website and were we identify income and the granted that it says where it says \$28,000 or less and receiving social security/disability payments right in our system the social security/disability payments still count towards your income but that is a criteria to meet in order, you have to make \$28,000 or less and check the box that you receive some sort of disability income and that social security/disability still counts towards your income. We still request that income, I don't know if you want to explicit in removing VA benefits, I think you are just adding you could be making

\$28,000 or less and receiving 100% disability VA payment isn't that what you are saying, right? But the VA payment or the VA benefit would still count towards their income.

Councilmember Vick: the disability benefit or other disability that they have?

Mayor Dewey: I think, we are not discriminating I mean we are pulling disability payments out of their income considerations so I mean that could be receiving disability social security payments and making over \$28,000 and they won't qualify for the program and that disability is counting towards their income there could be some people that ride the line where they make less than \$28,000 without their social security/disability payments but because they are getting those payments it is considered income we are counting it towards income here.

Councilmember Vick: the only reason I am bringing it up here for the 100% level is because at the 100% level they would be bringing in more than \$28,000 per year however there are some quite a few disabled veterans and I don't know the number here in our area that are able to work and that 100% level is roughly \$3200 per month which that has to pay for their housing, electricity, water and what not but it also has to pay for them some medical expenses that the VA doesn't cover and in those cases some of them have to have a vehicle that the VA won't cover for these people to be able to live a decent life and once it comes down to the end of it they sometimes have to rob Peter to pay Paul to pay your water bill.

Mayor Dewey: my concern is if you exempt VA benefits from the list are, we going to have problems because you aren't exempting social security benefits, that is my concern from that perspective. It is still income to the participant.

Councilmember Ludington: we are already not including workman's comp disability.

Councilmember Vick: right. And also, when it comes to social security/disability and someone is on it they are not able to work at all, I personally, unless Robert can explain it to me better, why would we use a disability income unless it was from like a private company annuity on this?

Robert: I am the one that validates the guys that go on the program and the program all of them are on social security and that is their sole source of income and so the only document that they come in with is that document and you are right if you do 100% VA that they would not qualify most of the people on the program have a certain income just like the VA, the VA would not put them over the top we know that. Some of what the participants have now are pretty low so, I kind of forgot your question, I am trying to I know people that are 100% disabled, and the VA covers almost all of their expenses and should and then some of the 100% VA disability person can also get or apply for social security/disability at the same time. So, I think my gut instinct, I am a 100% VA disability guy too, I think you should add that in because if you take out social security/disability or social security anybody on this program would qualify so once you have social security or social security/disability or VA disability you get are going to get 25% off of your water even though you are bringing in some sort of income some of those people on the program right now are living on \$1100 per month that is their income. So, you are talking 75% level we are giving them 75% off their water bill. And so....

Mayor Dewey: which turns out to be a credit at the 75% level and there would be a credit of \$34.00 they don't get a reduction on the bond payment. Something that we will address in

water rates when we get to that this summer. Bear that in mind it is about a \$35.00 a month reduction in their bill I do recall when the program was implemented there was a lot of discussion about what income gets included and what income doesn't get included at the council level and at the executive level and the office staff discussed at length what should and shouldn't count. Some of these benefits are being paid for their living expenses and their water and sewer bill is a part of their living expense. We are still responsible to run utilities for the community if they are receiving income to help with those expense of course if their income is less than \$28,000, they qualify.

Councilmember Ludington: they are strictly retired and receiving social security as the only benefit that is difficult to make ends meet, even if they are receiving social security and disability payments from social security or the VA sometimes it can still be difficult. Depending on what your other expense are, now that isn't really included in here, figuring out what your other expense are so.

Councilmember Vick: what about, this is something that I just pulling out of somewhere, similar to a program where at the state level, 100% VA recipients that make less than \$45,000 per year they don't pay property taxes. What about making a third bracket for people only at the 100% level, that is something that would have to be permanent and total, that is not for somebody that is receiving for individual or TDIU and things like that.

Councilmember Shourd: so, you are saying creating a third bracket that is just identifies for receiving 100% not attaching dollar amount.

Councilmember Vick: right. I would probably say a \$10,000 amount yearly and receiving their VA benefits. \$10,000 is just a number if you have a better one.

Councilmember Ludington: we have already kind of established in the original resolution they did do quite a bit of research on when they came up with the \$28,000 if you are 62 or older and you are not making \$28,000 a year no matter what type of income you have, you are eligible. If you are over 18 and making \$28,000 and receiving social security if you are receiving disability from the VA and making under \$28,000 you are eligible. Now if you are making more than \$28,000 because you have 100% VA disability to me that is a different issue that puts you above the poverty line. (unclear audio) that is what the poverty level is if you aren't making \$28,000 and have total disability from the VA

Mayor Dewey: that is a good point Paul it is household income, we have a number of customers come to us we have three and I am the disabled one and I don't make \$28,000 the water bill is in my name, give me a break. We need your household income because you have others helping you pay the bills.

Councilmember Ludington: we were purposefully trying to, retired those that were widowers that are living in a house that they have been living in for how ever long and they are living on social security and that is it at this particular time when this came about the time when the water rates got raised 40% the people were hurting so they came up with this to help some of these people out and they were finding out they were getting behind on their water bills.

Councilmember Vick: than in that case until I can spend sometime fine tuning some things to present to the council, I will rescind my motion.

Mayor Dewey: does anyone object to rescinding the motion? Groovy, we will not consider it. So,

Councilmember Ludington: I will make a motion to reinstate the utility assistance program at a rate of forty cents per month.

Councilmember Shourd: 2nd

Mayor Dewey: it has been moved by Mr. Ludington and 2nd by Mr. Shourd to reinstate the utility assistance charge at a rate of forty cents per month, council discussion? Just making sure that I am not missing anything.

Councilmember Ludington: I don't think so.

Mayor Dewey: I think we are fine I think we can make that work.

Councilmember Ludington: I think we are okay, basically resolution 409 suspended it, suspended the collection because there was too much money. We have worked things out and did not want that fund to get to big so, we suspended it and now we have spent down that surplus.

Mayor Dewey: does the council want to make that charge effective immediately? Or, because bills go out Monday and we could throw forty cents on every bill and I guess to a degree it doesn't matter when we put it on the bill, do we want to give people a heads up that there is going to be a forty cents charge on their bill and continue the program any ways I can tell you if you are collecting forty cents that is going to help us do some catch up we keep the program in place and give those people their credit on the February bill tell everyone by the way in March you are going to see forty cents on your bill that may or may not soften the blow I would like to hear on how you would like to proceed.

Councilmember Shourd: I think the heads up is good.

Mayor Dewey: so we are agreeable we will continue the program and we will give everyone their reduction on their February bill and then on their March first bill everyone will have a forty cent charge, we can do a public notice in the paper and I am sure there will be an article on this anyways we can put it on the bill Monday that says when you get this paper next month it is going to look different. Everyone is okay with that? Any public comment on reinstating the rate of forty cents? Effective March, our live stream has been down most of the meeting I grossly apologize to the community, we can do virtual meetings really well, we can do in person meetings really well but when we put the two of them together, we suck at it, I just don't know what to do. We even dedicated internet connection and ZOOM still failed us, okay. With that Ms. Berthoud call for the vote please.

Councilmember Ludington: aye

Councilmember Shourd: aye

Councilmember Vick: aye

Mayor Dewey: thank you I appreciate your indulgence on that matter.

11. Executive Report

Mayor Dewey: I have covered the law enforcement issues in the police department staffing discussion and I can tell you we held three of six interviews with police chief candidates today, Robert and I struggled with ZOOM most of the afternoon through three different ZOOM calls I think all together we spent 4 ½ hours interviewing three different candidates for the job. It has already a very interesting experience and we are very blessed and fortunate to have a really good pool that I am excited about and I am eager to get the other three under our belt next week. Following that through the rest of the process I anticipate moving forward is that the process will speed up pretty quickly that we would like to narrow down this pool from six to three or four max and then I intend to put a community panel together and that can then hold a community form with the remaining candidates. We also will get some internal interviews done with the police department staff that aren't those staff remaining that have not applied for the position and just we are trying to be as diverse as possible for what we are getting for this position because it is a key position for this community and critical so we are putting a lot of thought so when we get through the six candidates and Robert and I are able to narrow it down to a much more manageable number then we will really kick up the speed in terms of the public engagement and interaction on that so we will even go as far as, and part of that public forum is where we will give each candidate a topic to more or less present to the public on and they can give their presentation so there is some material for the interview and people get a chance to see how they present in a matter of their expertise to citizens and engage that way through questions and stuff. I don't know how; I don't know what to expect in regard to public attendance and that sort of things it will be more or less daytime type of things, but we will be adamant about some open houses and stuff as much as we can with COVID going on and whatever travel we have to accommodate. Just letting you know that is rock in and rolling. I would expect mid-February meetings will be announced and we are excited to bring in some really cool experience and knowledge to the community. In terms of meetings, we are still working to get a couple of public hearings scheduled for Burnt Fork Estates we are right on the cusp, we have contacts out to two separate facilities here in town that can facilitate large, that are not the school, we just found challenges and just didn't think we could count on school we thought safer than sorry lets just line up one of the churches we have two leads and hope to confirm. So, once we have one of those facilities confirmed and set in stone and we hope for that tomorrow and as soon as we get that we will get the public notice out in the newspaper next week and then we will get the mailing and all those things that are required so you can expect more than likely a public hearing will be set, don't let me look at January any more that was close, I think the week of the 15th we are targeting the 15th we are closed for Presidents Day one of those days following the 15th will be when you will hold a public hearing assuming we can get an answer tomorrow, if we don't get an answer tomorrow than first thing Monday morning than assume the next week just because we need fifteen days lead to get the notice in the paper ahead of the meeting so it has to be fifteen days ahead of the meeting and then all the other nonsense we have to go through. So, that will be an in person public hearing and we plan to hold one of those and then we will hold a virtual public hearing, like I said we are good at one or the other, but we are not good at both at the same time. In person public hearing will not be live streamed we are not going to virtualize it we are not going to do any of that we are just going to do an in person hearing if you want to come you come, if there are individuals that want to participate virtually then we will hold a separate public hearing we won't even get together we will hold it like we used to on ZOOM on a

separate night and we will hold a public hearing that way I imagine that one will be brief. You will run through that and then we are purposefully keeping your agendas a little lighter so you won't have a lot of business come up unless it is necessary so when you start seeing Burnt Fork Estates matters showing up on your agenda which hopefully you will be able to consider it if you get your public hearings done the week of the 15th then presumably on the 25th you could start discussing the matter in depth so I would imagine the 25th and going forward on however meetings it takes to discuss that is how we will approach it so if you have feedback, thoughts or shower thoughts or whatever you have on how we proceed with that and you want to get that in my mind before we pull the trigger on any noticing please, please let me know. We have extended an offer of employment to a public works director candidate at 5:50 and he accepted that offer so on your February 11th meeting you will see that consent item on that agenda for you folks to consent to my appointment the gentleman's name is Steve Kruse so given if you don't mind don't give any phone calls tonight and announce to the world that is the individual because the other candidates in the running obviously haven't been notified that they didn't get selected so we will get that accomplished first thing tomorrow as we can let those folks know so I imagine by Monday everybody will be notified, just to let you know that is coming down the pipe and we are excited to kind of present his qualifications for the position, Mr. Ludington and Ms. Devlin were both part of the process in selecting the public works director replacement I didn't expect to have the second interview the first round of interviews that Robert and I conducted we both kind of sat dumbfounded, we had two really strong candidates for the position and needed a little extra help and nudge to help us come to a conclusion on it and Jaime and Paul were both very helpful in that regards so we appreciate their assistance with that. That is good so we have public works good to go we will have a chief of police sooner rather than later. A position that I would really like to get filled that has been vacant since we adopted the budget in July is the community development director which fulfills the planning functions and department oversight, that has been a really hard one to fill we have received one application for that and wasn't necessarily qualified for the position, so we still wait it is very specific skill set understandably so. As you are aware staff and I meet tomorrow morning, town hall is closed, for staff development we will meet in the morning and do some internal workshopping, we have some classes lined up and some training lined up that we are implementing that is all on line where they can do their training and certifications on line and that will bridge all the way into police department and fire department so if for some reason we went back into shut downs, fire department is a good example all these firefighters that usually meet for trainings so if trainings are shut down it is very hard for them to train and practice and this new software will help resolve some of that moving forward so we are excited to implement some of that, some will happen tomorrow and we will do some other training, afternoon is set aside for council workshopping if you guys are able to attend you are welcome to if you can't we understand exceptions and obligations if you don't come it isn't that we are going to be sitting around, we can get by without you but we really want your input and engagement in the exercises in the afternoon and I think those start off at 1:00, only giving a 45 minute lunch to the clerk that only takes a 30 minute lunch.

Councilmember Vick: my associates get more than that Jenelle you can come and work for me.

Mayor Dewey: they are all given an hour and one of them either doesn't take it or takes a half hour or 45 minutes. Okay I think that largely covers the executive report unless there are any questions from council, I will turn it over to town council comments.

12. Town Council Comments

Councilmember Shourd: I just appreciate the opportunity for people having public hearing both in person and a virtually. I think that will satisfy quiet a bit of the public.

Mayor Dewey: we think that it is critical that everyone gets a vice in terms of those who wish to attend virtually and those that don't we want both of those audiences to engage if they chose to.

Councilmember Shourd: when you say in the newspaper are you referring to the Bitterroot Star or the Ravalli Republic?

Mayor Dewey: The Bitterroot Star.

Councilmember Ludington: I think there is quiet a bit out there about Burnt Fork Estates I think that there is quiet a bit of opinion out there. Jaime and I met with some members from the HOA of Creekside Residents yesterday and had a pretty informative meeting with them you guys are not going to like this, I can guarantee that, this is a lot of opposition out there and I will say the same thing in this group as I said yesterday this is the only opportunity that a group of people has and can tell another group of people what they can do with there property. I don't get to tell you what you can do with your property and you don't get to tell me this is the only opportunity we have to do that and one of those things we get to tell them and we can't just say no, we have to be able to come to some suitable arrangement in order to be able to let people to do with their property as citizens, it is their property, it belongs to them and it also happens to be in the Town of Stevensville there are rules and regulations to follow being in the town and this is our opportunity to say here are some additional things that we would like to do in order to enhance our community and not be a detriment to them. I think through the thirteen hours of planning and zoning meetings that I was in I think we got to that pretty well, there are some significate issues that go along with that and belong to the town and in my opinion they don't have anything to do with the subdivision we still have some issues out there that need to be addressed and we can address them through the conditions of the subdivision we can address them separately however you feel, conversation that I had with the mayor last night in my opinion the town has been under siege for the last four years and hasn't been able to accomplish anything and there are people out there that say that is no excuse you still should have figured it out and they are not wrong, I apologize I was part of this attempting to find the solution for eight years when I was on the council I was on the council when they approved Creekside Meadows and HDR at that time said don't worry here is the application we will turn it in we will change the place of use you know, no worries. I had no idea that DNRC would say I don't know what this is you need to start over. So that is why we are where we are today such as it is, so that being said, that is all I have to say.

Mayor Dewey: any further council comments?

Councilmember Vick: nah.

13. Board Reports

Mayor Dewey: I don't know if any boards have met have, they, no we have met since the Planning and Zoning Board didn't, we, Planning and Zoning Board report and I emailed that to you all yesterday and it is also available on the website if you have any questions for myself or the planning and zoning board chairman know

Councilmember Ludington: I can certainly answer anything on that.

Mayor Dewey: Paul is pretty critical; on that, actually ask Paul don't ask me. I will just refer to Paul. In terms of boards February sucks and it hasn't happened yet in terms of meetings we promised you all that we would get these boards together and get some workshopping done with these folks they need to be meeting we need to get things underway and the TIFT TEDD board hasn't met for over a year and maybe a year and a half, its hard. The pandemic added a whole new layer of complexities communities holding their virtual meetings with out a hitch and still getting some progress done and we are moving in that direction. Poor Jenelle and I are the only two that have the capacity to pull these things together we are really bogged down with everything else so bear with us we had a a date on the calendar and then realized we never told anyone the date existed and then we had to push the date out and then we realized that we still didn't do what we said we were going to do so now we have taken the date off the calendar have it all together on a sticky note and keep moving it until we get it done, that is where we are at with boards. Patrick?

Councilmember Shourd: could I have just a review, I just want to make sure the legal document that I received in exportay communications in regards to Burnt Fork Estates from my understanding information gathering I am not allowed to do other than what is public record is that correct.

Mayor Dewey: with anyone that has a substantial interest in the project so please don't go have lunch with the developer.

Councilmember Shourd: correct. How about having a conversation with Paul is acceptable.

Mayor Dewey: according to the legal memo that sounds like an acceptable procedure I don't see any reason, three of you should not be in the room and do that.

Councilmember Shourd: correct.

Mayor Dewey: and if you do that by accident please disclose it. That is really, you rid yourself of exportay issues when you come to a meeting and say in the last two weeks, I have these two conversations with these seven people, and they were regarding Burnt Fork Estates and leave it at that you have essentially resolved yourself of any issues.

Councilmember Shourd: okay. Just want to make sure that I am walking the line.

Councilmember Ludington: we did that because they are our constitutes, they are our ward. (unclear audio)

Councilmember Shourd: my question is more me after the meetings wanting to reach out and ask a specific question from somebody that was at the meeting and clarify if I could do that.

Mayor Dewey: you are doing your diligence with that.

Councilmember Shourd: thank you.

Mayor Dewey: I don't see why you couldn't go balls to the walls at the meeting and say I talked to Paull and he said. Okay anything else for the good of the order this evening? Very good with that we are adjourned.

14. Adjournment

APPROVE:

ATTEST:

Brandon E. Dewey, Mayor

Jenelle S. Berthoud, Town Clerk

File Attachments for Item:

a. Claims #16570-#16580

* ... Over spent expenditure

| Claim | Check | Vendor #/Name/ Invoice #/Inv Date/Description | Document \$/ Line \$ | Disc \$ | PO # | Fund Org Acct | Object Proj | Cash Account |
|--|------------|--|-------------------------|---------|------|---------------|-------------|-----------------|
| *** Claim from another period (6/20) **** | | | | | | | | |
| 16570 | 408213 | 1614 Superior Shotcrete Services, 06/06/20 Pool paint 4 gal epoxy | 516.63 516.63 | | | 1000 460450 | 230 | 101000 |
| 16571 | 98190 | 1638 Martin Lock & Key 02/16/21 Reservoir Building locks | 155.00 155.00 | | | 5210 430530 | 350 | 101000 |
| 16572 | 4237 | 1722 Local Government Serices 02/10/21 AFR Fees February Statement | 95.00 95.00* | | | 1000 410550 | 350 | 101000 |
| 16573 | 3313 | 348 Snow Mountain Electric 01/01/21 New lighting/power cord drop | 5,100.00 5,100.00* | | | 1000 420421 | 930 | 101000 |
| 16574 | 3316 | 348 Snow Mountain Electric 02/01/21 Lights for flag poles parks | 1,525.52 1,023.02 | | | 1000 460430 | 930 | 101000 |
| | 33156 | 02/01/21 IEC starter Scum Pump 2 | 352.50 | | | 5310 430640 | 360 | 101000 |
| | 3314 | 02/01/21 Install flow meter PC board we | 150.00 | | | 5210 430530 | 360 | 101000 |
| *** Claim from another period (1/21) **** | | | | | | | | |
| 16575 | 020921 | 1731 Quadient Finance USA, Inc. Water & Sewer Mailing 02/09/21 W-Postage | 400.00 200.00* | | | 5210 430510 | 311 | 101000 |
| | 020921 | 02/09/21 WW-Postage | 200.00 | | | 5310 430610 | 311 | 101000 |
| 16576 | 1200325612 | 728 HDR ENGINEERING, INC. 02/09/21 Park Ave Sewer Extension | 7,319.32 1,073.63* | | | 5310 430610 | 350 | 101000 |
| | 1200325611 | 02/09/21 Water Sys Eng Report | 3,078.49* | | | 5210 430510 | 350 | 101000 |
| | 1200325609 | 02/09/21 BFE Pre Plat Review | 2,150.84* | | | 2250 411010 | 350 | 101000 |
| | 1200325609 | 02/09/21 Pool Evaluation | 1,016.36* | | | 1000 460430 | 350 | 101000 |
| 16577 | 1692 | 1650 D.I.A.R Do It All Repair 02/22/21 fuel inspection parts 503 car | 182.82 182.82 | | | 1000 420100 | 231 | 101000 |
| 16578 | 68655 | 748 Allegra Print & Imaging 02/20/21 Admin-Env #10 Regular/Window | 359.28 64.69 | | | 1000 410550 | 210 | 101000 |
| | 68655 | 02/20/21 PD-Env #10 Regular | 17.96* | | | 1000 420100 | 210 | 101000 |
| | 68655 | 02/20/21 FD-Env # 10 Regular | 17.96* | | | 1000 420410 | 210 | 101000 |
| | 68655 | 02/20/21 BD-Env #10 Regular | 17.96 | | | 2394 420531 | 210 | 101000 |
| | 68655 | 02/20/21 Water-Env #10 Regular | 107.78 | | | 5210 430510 | 210 | 101000 |
| | 68655 | 02/20/21 Sewer-Env #10 Regular | 107.78 | | | 5310 430610 | 210 | 101000 |
| | 68655 | 02/20/21 Court- Env #10 Regular | 17.96 | | | 1000 410360 | 210 | 101000 |
| | 68655 | 02/20/21 Airport-Env #10 Regular | 7.19 | | | 5610 430300 | 210 | 101000 |

02/23/21
16:16:17

TOWN OF STEVENSVILLE
Claim Approval List
For the Accounting Period: 2/21

Page: 2 of 4
Report ID: AP100

* ... Over spent expenditure

| Claim | Check | Invoice #/Inv Date/Description | Vendor #/Name/ | Document \$/ Line \$ | Disc \$ | PO # | Fund Org Acct | Object Proj | Cash Account |
|-------|--------------|---------------------------------------|--------------------|--------------------------------|---------------|------------------------------------|-----------------|-------------|-----------------|
| 16579 | E | 1776 National League of Cities | | 175.00 | | | | | |
| | 173139 | 02/12/21 2021 Congressional City Conf | | 140.00* | | | 1000 410200 | 380 | 101000 |
| | 173139 | 02/12/21 Exe Education 2021 Package | | 35.00* | | | 1000 410200 | 380 | 101000 |
| 16580 | E | 1777 GoDaddy | | 107.88 | | | | | |
| | Feb 02/12/21 | Email and MS Software | | 35.96* | | | 1000 430100 | 312 | 101000 |
| | Feb 02/12/21 | | | 35.96* | | | 5210 430510 | 312 | 101000 |
| | Feb 02/12/21 | | | 35.96* | | | 5310 430610 | 312 | 101000 |
| | | | # of Claims | 11 | Total: | 15,936.45 | | | |
| | | | | Total Electronic Claims | 282.88 | Total Non-Electronic Claims | 15653.57 | | |

02/23/21
16:16:18

TOWN OF STEVENSVILLE
Fund Summary for Claims
For the Accounting Period: 2/21

Page: 3 of 4
Report ID: AP110

| Fund/Account | Amount |
|--------------------------------|--------------------|
| 1000 GENERAL | |
| 101000 Cash - Operating | \$8,263.36 |
| 2250 PLANNING | |
| 101000 Cash - Operating | \$2,150.84 |
| 2394 BUILDING CODE ENFORCEMENT | |
| 101000 Cash - Operating | \$17.96 |
| 5210 WATER | |
| 101000 Cash - Operating | \$3,727.23 |
| 5310 SEWER | |
| 101000 Cash - Operating | \$1,769.87 |
| 5610 AIRPORT | |
| 101000 Cash - Operating | \$7.19 |
| Total: | \$15,936.45 |

02/23/21
16:16:19

TOWN OF STEVENSVILLE
Claim Approval Signature Page
For the Accounting Period: 2 / 21

Page: 4 of 4
Report ID: AP100A

ORDERED that the Town Treasurer draw a check/warrant on the Town of Stevensville.

Council

Council

Council

Council

Mayor

Date Approved _____

File Attachments for Item:

a. Discussion/Decision: Location and Future Maintenance of the Stevensville Civic Club's Splash Deck Project



DATE: February 25, 2021

TO: Stevensville Town Council

FROM: Stevensville Civic Club

Project: Stevensville Splash Deck
Location: Lewis and Clark Park

In 2019, the Stevensville Civic Club declared the Splash Deck project to add to the Lewis and Clark Park venue and eventually an additional location at Father Ravalli Park. We checked with the Florence and Hamilton areas regarding constructions they had undertaken and operation of their facilities. We consulted with Renee Endicott, Bear Mountain Project.

After several meetings and progressive efforts for this project we have gotten to the point of presenting the project to the Town Council to ask for your approval to proceed with location and future maintenance of the Splash Deck Project addition to Lewis and Clark Park. Upon your approval, we will pursue fundraising opportunities and commitments that have already been proposed pending the Council's approval of the project.

There has been widespread support and interest and funds already committed to the project through the October Brew-fest and the Christmas parade of trees auction and private donations.

We hope that you will support the project through your approval to continue the process to completion.

Partners:

Civic Club – Organizational, communications, volunteer promotion, promotion of project, fundraising, project coordination

Project Map: Bobby Songsten , Mayor Dewey, Jennifer Heflin – Rain Deck, Project Coordinator

Budget: Rain Deck, Jennifer Heflin, Project Coordinator, Stevensville Civic Club
Funding Sources – Joan Prather and Victoria Howell
Funding: Project 59870 , Non-Profit --Victoria Howell

Grants: Joan Prather, Maureen Wali, Town of Stevensville

Park Board: Consulted and positive response. Supportive of project.

Town of Stevensville Contribution to project: Guidance, infrastructure, future maintenance, ownership. (Monetary value of participation in project.)

Available Sources Consulted: Renee Endicott, Bear Mountain Project

Size: The group with Bobby Songsten discussed 1,000-1200 sq ft for the splash deck should be adequate. We also have the area with some shaded tables and chairs which would add approximately 200-300 sq ft more for the concrete patio and the ADA ramp area. The rough area available at the park is a 60ft by 60ft square bordering the sidewalk that leads into Bear Mountain playground.

Splash Deck interested participants and consults: Bobby Sonsteng, Mayor Dewey, Joan Prather, Victoria Howell, Dempsey Vick, Cheryl Burgmeier, Maureen Wali, Toby Sannar, Jaime Devlin, Rich Marcus.

REQUEST FOR PROPOSALS
 For the
CONSTRUCTION OF A SPLASHPAD
 For
 Stevensville Civic Club, Montana

| | |
|---------------------------------|---|
| Submission Date: | September 30, 2020 – 5:00 p.m. |
| Submission Location: | Stevensville Civic Club PO Box 676 Stevensville, Montana 59870 or electronically stevsplashproject@gmail.com |
| Submission Requirements: | 1 copy of proposal marked "Lewis & Clark Park Splash Pad RFP" |
| Prepared by: | Brandon Dewey, Vice President |

1. Scope of Work -Overview

The Stevensville Civic Club is issuing this Request for Proposals (RFP) for the design, production of construction documents, and procurement of splash pad features and equipment and construction supervision of a Splash pad in Stevensville’s Lewis & Clark Park. A detailed Scope of Work and Specifications are presented later in this document.

This RFP invites companies to submit proposals describing their approach and proposed costs within the minimum criteria and scope of work set by the civic club.

Background and Objectives: Stevensville desires to expand the recreational opportunities of its residents by constructing a splash pad. Construction of a splash pad will provide a safe healthy outdoor water recreation option from late spring until early fall. This type of facility is not currently available in our parks.

The civic club intends to provide all construction services in support of the project under the direction and supervision of the proposer.

Purpose of Solicitation: The splash pad is a low maintenance, environmentally friendly project that will be available to children of all abilities and financial means. Construction of a splash pad will provide a safe, colorful and attractive playground facility for the families in the area.

The proposed splash pad will be built in Stevensville's Lewis & Clark Park. The equipment for the splash pad will be housed within a yet to be built addition to existing service buildings, or a standalone structure. The design of the specifications for the addition is part of the scope of work of the project.

2. Schedule

| | |
|----------------------------------|---------------------------|
| Request for Proposals Issued: | August 24, 2020 |
| Deadline for Responses: | September 30, 2020 5:00pm |
| Contract Award (tentative date): | October 16, 2020 |

3. Reservation of Rights, Disclaimers, Disclosures and Instructions for Proposal Submissions

The Stevensville Civic Club, at its sole discretion, reserves the following rights:

- supplement, add to, delete from and change this RFP document;
- determine which respondent, if any, shall be selected for negotiations;
- reject any or all proposals or information received pursuant to this RFP;
- supplement, amend, substitute or otherwise modify this RFP at any time;
- cancel this RFP with or without the substitution of another RFP;
- request additional data or information after the submittal date, if such data or information is considered pertinent, in the club's sole view, to aid the review and selection process; if such information is not provided in a reasonable timeframe, the proposal may be deemed non-responsive;
- conduct investigations with respect to the qualifications and experience of each respondent;
- take any action affecting the RFP or the services or facilities subject to this RFP that would be in the best interests of the club;
- require one or more respondents to supplement, clarify or provide additional information in order for the club to evaluate the RFPs submitted;
- waive any defect or technicality in any RFP received reject any portion of any submittal and/or reject all submittals, to waive any informalities or irregularities in the submittals or to re-advertise;
- accept or further negotiate cost, terms, or conditions of any proposal determined by the club to be in the best interests of the club. The club will select the proposal, which, in its sole discretion and judgment, is determined to be in the best interest of the club in accordance with lowest and best price, product quality and serviceability, bidder's qualifications and experience, responsiveness to this RFP, and any other factors the club deems relevant;
- the club may determine the qualifications and acceptability of any party or parties submitting a response to this RFP;
- the civic club, advisors and directors shall have no obligation or liability with respect to this RFP, the selection and award process contemplated hereunder, or whether any award or recommendation will be made;
- Contact information for civic club or project related to questions, comments or clarifications. Should a respondent desire to be included in written clarifications, d

comments, they should request being added to an email list: for such purposes by contacting:

Joan Prather, President
Stevensville Civic Club
PO Box 676
Stevensville, Montana 59870
406-531-8401
mikeandjoanprather@yahoo.com

Respondents shall at a minimum use the form provided. Be certain to sign the submittal. Electronic submissions are acceptable to stevishplashproject@gmail.com .

The contractor in submitting a proposal, agrees not to discriminate against any employee or applicant for employment, with respect to hire, tenure, terms, conditions or privileges of employment, or any matter directly, or indirectly related to employment, because of sex, race, color, religion, national origin, ancestry, handicap, or age, The respondent further agrees that every subcontract or order given for the supplying of this project will contain a provision requiring non discrimination in employment, as herein specified. Any breach thereof may be regarded as a material breach of the contract or purchase order awarded under this RFP.

A bidder, by submitting a proposal, represents that he has obtained any rights and licenses necessary to fulfill bidder's obligations under its proposal.

All responses, inquiries, and correspondence relating to the RFP, and all reports, charts, displays, schedules, exhibits, and other documentation produced by any vendor and submitted as part of a proposal shall be deemed the property of the Village upon opening of the proposal.

All costs incurred by a respondent in preparing and responding to this RFP are the sole responsibility of the respondent. Any recipient of this RFP who responds hereto, fully acknowledges all the provisions of Section 3 of this RFP and agrees to be bound by the terms hereof. Any response submitted pursuant to this RFP is at the sole risk and responsibility of the party submitting such response.

4. Detailed Scope of Work and Specifications

Scope of Work:

- Site familiarization visit and meeting with project managers and partners: View park site, provide input on location considerations taking into account current park activity and potential future developments, relation to utilities, access and parking, pedestrian flow, support facilities, ect., and provide project timeline. Anticipated time requirement of one-half day.
- Public Meeting Discussions: Attend one public meeting of the project committee to present design concepts, alternatives and receive input. *Anticipated time requirement of two hours.*
- Spray/Splash Park Plan: Design layout, construction budget, timeline and present to managers and partners.
- Documents and Specifications: Develop construction documents, shop drawings and specifications for accepted plan, including any above ground structures needed to accommodate park infrastructure.
- Development of material lists needed for the construction; and, procurement of non-construction related materials (such as fixtures and control equipment) at Bidder's expense. [The club will procure concrete, stone and service pipes for the project.]
- Construction: Provide oversight and technical expertise during construction of base, installation of piping, manifolds and other appurtenances, pouring of concrete base, installation of electric and control devices and the actual spray/splash features. Test and assure installation is plumb and true to line without warp or rack of frames and panels, that anchors are secure, that features are securely placed, that dissimilar metals and metal products are separated by proper coating, adjust operating parts and hardware for smooth operation, and that installation is of a workmanlike manner so that all warranties can be enforced.
- Final Review: Inspect final project with managers, develop and complete final checklist, and turnover construction, as built and operations documents. Provide staff training to ensure proper long-term operations.

Specifications:

- Drain away water system
- Dynamic sequencing control
- Low flow water conservation options
- Design must run at a maximum of 150 GPM with no more than 60% of spray features operating in normal use during sequencing. Water usage operating estimate of 85 GPM.
- Design must include interchangeable series with corresponding GPM features to allow for future design variety of the splash pad.
- Features should be a mixture of ground level fixtures and above ground fixtures.
- Splash pad size of approximately 1000 square feet, less or more based upon budgetary allowances, with provisions for expansion, provision of a dry area surrounding the pad that is a minimum of 5', provision of an adjacent spectator seating area. The spectator area may be integrated into expansion provisions by virtue of base construction, stubbed piping and slope to drain.
- Activation of entire splash park via bollard or touch pad
- Pool deck surface to be concrete, proposals should include optional cost for a padded, non-slip surface.
- Provision of a dry path through the splash pad to accommodate youth both challenged, and not, who do not wish to get wet, the ability to directly participate with others at the feature.
- Compliance with ADA standard, as well as all "pass through" features that will allow for wheelchair participation.
- Water features shall be designed to conform to all requirements of public health and state departments, WWA Considerations of Operating Safety, published by World Water Park Association, National Electric Code (NEC), and American Society of Testing of Materials (ASTM): specifications referenced herein, and applicable state and local building codes.
- The Water Feature Manufacturer shall indemnify and hold harmless the Architect/Engineer and the Owner from any and all actions caused by or related to the design, fabrication and installation of the work.
- Warranties – The Manufacturer shall supply a signed, written warranty, without monetary limitations, agreeing to repair or replace products that fail in materials or workmanship for a minimum period of five (5) years for the controller, and, twenty-five years for the play products and the manifold device.

Preferred Material Specifications are as follows (minimum specifications):

- Made in USA
- Equipment shafts, base plates and bodies: 304 stainless steel
- Anchor assemblies and bodies: 304 stainless steel
- Fasteners; stainless steel and tamperresistant
- Finish; textured, UV stabilized sealer
- Nozzles; stainless steel or machined brass

- Top plates; cast bronze
- Dynamic sequencing control, no PLC control

Bidder may propose equivalent substitutes.

5. Detailed Response Instructions

Respondents should include the following information and forms in their proposal.

Statement of Expertise:

- State experience in providing services within the scope of work; identify staff members who will be working on the project and their experience levels.
- State that the respondent is an authorized representative of the equipment manufacturer and warrant that it is licensed to do work in the jurisdiction and holds appropriate professional registrations, permits, and/or meets other requirements by authorities having jurisdiction.
- Provide three references, including a specific contact person and phone number, for projects completed that are similar in nature and scope.

Description of Approach to the Detailed Scope of Work:

- Briefly describe how your company will approach and complete the scope of work described herein.

Splash Pad Conceptual Design:

- Provide a conceptual design based upon the scope of work and specifications in this RFP.
- Provide an alternate conceptual design based upon integrating an above ground feature. If the feature is a non-typical shape or design, respondents should attempt to integrate an aspect of the village, such as historical structures or trains. The village is not interested, nor has the budget, to purchase a custom designed above ground feature.
- Discuss and identify how the design is expansion compatible.

Proposed Costs:

- Include Attachment A that details proposed costs for each phase of the scope of work. The costs of splash pad features, related materials and control mechanisms, but not concrete or service pipes, should be included under the Construction phase of the scope of work. Specify a proposed schedule for partial payments by the Civic Club.
- Include an itemized cost breakdown for the specific splash pad features, including the number of features and unit costs, and associated hardware and control mechanisms necessary for installation of the splash pad to operational status. A tentative budget, for planning purposes, of \$30,000 is available for these items.
- Identify and budget any appurtenances, such as benches, umbrellas, ect. recommended in the conceptual design.

Attachment A

SPLASH PAD COMMITTEE VISION



**Attachment B
Cost Summary**

| Scope of Work Item | Unit Cost | Units | Total Cost |
|-------------------------------------|------------------|--------------|-------------------|
| Site Familiarization | _____ | _____ | \$ _____ |
| Public Meetings Discussions | _____ | _____ | \$ _____ |
| Spray/Splash Park Plan | _____ | _____ | \$ _____ |
| Documents and Specifications | _____ | _____ | \$ _____ |
| Construction - Materials | _____ | _____ | \$ _____ |
| Construction – Oversight | _____ | _____ | \$ _____ |
| Final Review | _____ | _____ | \$ _____ |
| Total Proposal Amount | | | \$ _____ |

Company Information:

Company Name: _____

Authorized Signatory – Name Typed: _____

Authorized Signatory – Signature: _____

Title: _____

Street or Mailing Address: _____

City, State, Zip: _____

Telephone, Fax _____

Email: _____

Federal Tax ID #: _____

Date: _____



ESTIMATE #23755

RECIPIENT:

JOAN PRATHER
STEVENSVILLE CIVIC CLUB
STEVENSVILLE, MONTANA
MIKEANDJOANPRATHER@YAHOO.COM

RESPONDENT:

JENNIFER HEFLIN
OFFICE: (888) 445-7246 EXT. 721
JENNIFER@RAINDECK.COM



888-445-RAIN



info@RainDeck.com



www.RainDeck.com

Rain Deck, LLC

7319 S. Atwood, Ste. #103
 Mesa, AZ 85212
 888-445-7246
 www.raindeck.com

INVOICE: #23755

DATE: 02/16/2021

BILLING ADDRESS

Joan Prather
 Stevensville Civic Club
 Stevensville, Montana

SHIPPING ADDRESS

Joan Prather
 Stevensville Civic Club
 Stevensville, Montana

SALES REP

Jennifer Heflin
 jennifer@raindeck.com

| PRODUCT | COST | QTY | TOTAL |
|---|------------|-----|------------|
| COMMERCIAL FEATURES / STAINLESS STEEL | | | |
| RDS315-0 Rain Deck SS Dumping Bucket 2 (RDS315-0) w/ SS Footing Base (RDS399-0) GPM's: MIN 10 / TYP 15 | \$6,170.00 | × 1 | \$6,170.00 |
| RDS303-0 Rain Deck SS 60" Water Mushroom (RDS303-0) w/ SS Footing Base (RDS399-0) GPM's: MIN 10 / TYP 50 | \$5,140.00 | × 1 | \$5,140.00 |
| RDS331-0 Rain Deck SS Rain Curtain (RDS331-0) w/ SS Footing Base (RDS399-0) GPM's: MIN 5 / TYP 12.5 | \$3,873.00 | × 1 | \$3,873.00 |
| RDS356-0 Rain Deck SS Jelly Stick (RDS356-0) w/ SS Footing Base (RDS399-0) GPM's: MIN 5 / TYP 12.5 | \$2,730.00 | × 1 | \$2,730.00 |



| | | | |
|---|------------|-----|------------|
| RDS366-0 Rain Deck SS Toad (RDS366-0) w/ SS Footing Base (RDS399-0) GPM's: MIN 7 / TYP 7.5 | \$4,007.00 | × 1 | \$4,007.00 |
|---|------------|-----|------------|

GROUND SPRAYS

| | | | |
|--|----------|-----|----------|
| RD150-0 Rain Deck Commercial Jet (7.5" dia) w/ Adjustable Nozzle (RD150-0) GPM's: MIN 12 / TYP 15 | \$217.00 | × 3 | \$651.00 |
|--|----------|-----|----------|

| | | | |
|---|----------|-----|----------|
| RD155-0 Rain Deck Commercial Jet (7.5" dia) w/ Wave Jet (RD155-0) GPM's: MIN 31.5 / TYP 31.5 | \$217.00 | × 2 | \$434.00 |
|---|----------|-----|----------|

| | | | |
|---|----------|-----|----------|
| RD152-0 Rain Deck Commercial Jet (7.5" dia) w/ Spider Jet (RD152-0) GPM's: MIN 14 / TYP 17.5 | \$217.00 | × 2 | \$434.00 |
|---|----------|-----|----------|

FOOTING BASES / SPRAY PLATES

| | | | |
|---|---------|-----|----------|
| RDS399-1 Pre Cut and Tied Rebar Cages for std Footing Detail (X2) | \$41.00 | × 6 | \$246.00 |
|---|---------|-----|----------|

ACTIVATORS / TIMERS

| | | | |
|--|------------|-----|------------|
| RDS550-1 Rain Deck SS Sof-Touch™ Curved Activator w/ SS Footing Base - Post Mounted (RDS550-1) | \$3,492.00 | × 1 | \$3,492.00 |
|--|------------|-----|------------|

| | | | |
|---|----------|-----|----------|
| RD550-1 Rain Deck Sof-Touch™ Electronic Timer Box (RD550-1) | \$649.00 | × 1 | \$649.00 |
|---|----------|-----|----------|

CONTROLLERS / MANIFOLDS

| | | | |
|---|--|--|--|
| RD500-0 Rain Deck 8 Zone Multi-Program Electronic | | | |
|---|--|--|--|



| | | | |
|---|------------|-----|--------------------|
| Controller (RD500-0) | \$1,334.00 | × 1 | \$1,334.00 |
| RD507-5 RD 5 Zone Manifold - 2" Header (1.5" BALL VALVE) (RD507-5) For : (5) Above Ground Features | \$409.00 | × 1 | \$409.00 |
| RD511-0 Project Specific Splash Pad Manifold (RD511-0) 2" Pipe: w/ (7) 1" solenoids w/ flow control; Include (1) 1.5" main solenoid For: (7) Commercial Jets | \$910.00 | × 1 | \$910.00 |
| SANITATION / VALVES / FITTINGS / DRAINS & MORE | | | |
| RD428-0 16" x 16" Box Drain - 4" or 6" PVC Connection (RD428-0) | \$136.00 | × 2 | \$272.00 |
| RD428-1 16" x 16" Box Drain Strainer Basket (RD428-1) | \$60.00 | × 2 | \$120.00 |
| PLANS / PURCHASE WITH CONFIDENCE / OTHER | | | |
| RD600-0 Splash Pad Layout Plan Set (No Engineering) | \$550.00 | × 1 | \$550.00 |
| RD920-0 Custom Paint (RD920-0) Canopy: Polkadots | \$250.00 | × 1 | \$250.00 |
| ORDER SUBTOTAL: | | | \$31,671.00 |
| - SHIPPING: | | | \$1,736.52 |
| ORDER TOTAL: | | | \$33,407.52 |

GPM's: MIN 94.5 / TYP 161.5



Lewis & Clark Park
1000 Sq Ft Commercial Freshwater Splash Pad



RDS315-0
SS DUMPING BUCKET 2

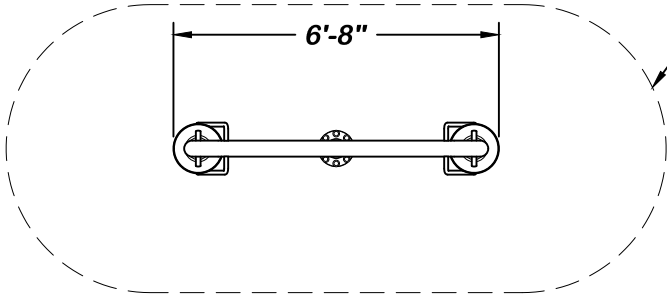

TOP VIEW

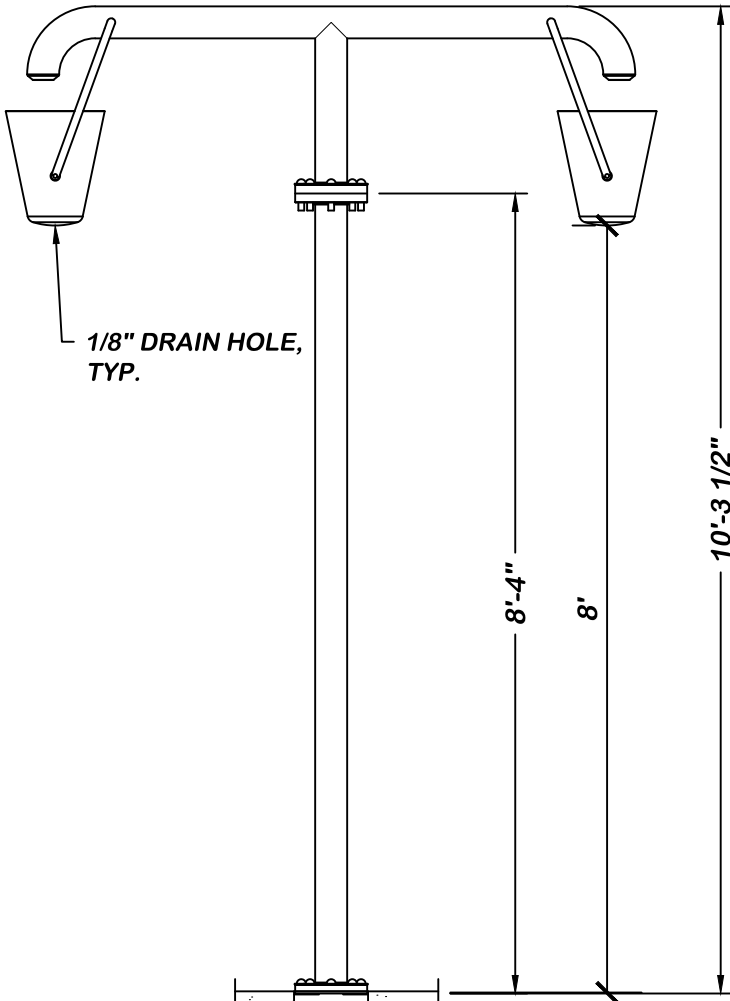
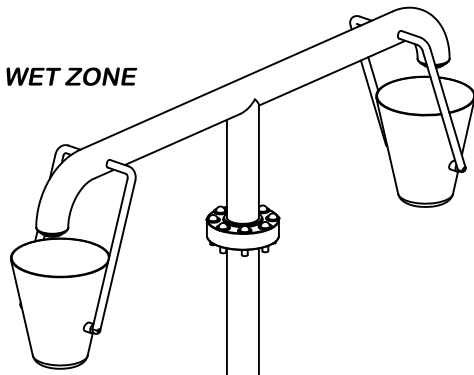

FRONT VIEW

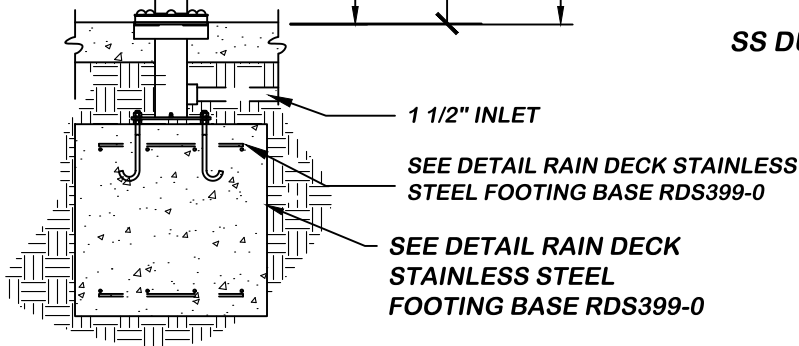

SCALE
N.T.S.

SPECIFICATIONS:

- MATERIALS: STAINLESS STEEL, ALUMINUM & FIBERGLASS
- SURFACE FINISH: POWDER COAT
- WATER PRESSURE: 3 - 5 PSI
- WATER CONSUMPTION: 10-20 GPM

SS DUMPING BUCKET 2
RDS315-0

RAINDECK
Ph. 888.445.RAIN
Fax. 866.869.3942
info@raindeck.com

THIS DRAWING IS AN INSTRUMENT OF SERVICE AND THE PROPERTY OF RAINDECK. IT IS TO BE USED ONLY FOR THE PROJECT AND SITE SPECIFICALLY IDENTIFIED HEREIN. IT IS NOT TO BE REPRODUCED, COPIED, OR TRANSMITTED IN ANY FORM OR BY ANY MEANS, ELECTRONIC OR MECHANICAL, INCLUDING PHOTOCOPYING, RECORDING, OR BY ANY INFORMATION STORAGE AND RETRIEVAL SYSTEM, WITHOUT THE WRITTEN PERMISSION OF RAINDECK. ANY UNAUTHORIZED USE OF THIS DRAWING IS PROHIBITED. RAINDECK SHALL BE RESPONSIBLE FOR THE ACCURACY OF THE INFORMATION PROVIDED HEREIN. CONTRACTORS SHALL BE RESPONSIBLE FOR VERIFYING THE INFORMATION PROVIDED HEREIN BEFORE CONSTRUCTION. RAINDECK SHALL NOT BE RESPONSIBLE FOR ANY DAMAGE TO PERSONS OR PROPERTY ARISING FROM THE USE OF THIS DRAWING. CONTRACTORS SHALL BE RESPONSIBLE FOR OBTAINING ALL NECESSARY PERMITS AND APPROVALS. CONTRACTORS SHALL BE RESPONSIBLE FOR OBTAINING ALL NECESSARY PERMITS AND APPROVALS. CONTRACTORS SHALL BE RESPONSIBLE FOR OBTAINING ALL NECESSARY PERMITS AND APPROVALS.

| REV. | DATE | BY | DESCRIPTION |
|------|------|----|-------------|
| △ | | | |
| △ | | | |
| △ | | | |
| △ | | | |
| △ | | | |

RAIN DECK
SS DUMPING BUCKET 2

SEAL

DATE

| | |
|------------------|-------------------|
| DRAWN BY RS | REVIEWED BY RV |
| DATE MAY 2017 | |
| SHEET | |

SCALE
1/2"=1'-0"

RDS303-0
SS 60" WATER MUSHROOM

RAINDECK
Ph. 888.445.RAIN
Fax. 866.869.3942
info@raindeck.com

THIS DRAWING IS AN INSTRUMENT OF SERVICE AND IS THE PROPERTY OF RAIN DECK. USE OF THIS DRAWING AND ALL REPRODUCTIONS SHALL BE LIMITED TO THE PROJECT AND SITE FOR WHICH IT WAS PREPARED AND SHALL NOT BE USED UNLESS PROPERLY SEALED AND APPROVED. PUBLICATION OF THIS DRAWING IN ANY MANNER WITHOUT THE PERMISSION OF RAIN DECK, WHERE A DRAWING, SHALL BE CONSIDERED BY SAID CONTRACTOR EXCEPT BY AGREEMENT WITH SAME CONTRACTOR.

| REV. | DATE | BY | DESCRIPTION |
|------|------|----|-------------|
| △ | | | |
| △ | | | |
| △ | | | |
| △ | | | |

RAIN DECK
SS 60" WATER MUSHROOM

| |
|------|
| SEAL |
| DATE |

| | | | |
|----------|----------|-------------|----|
| DRAWN BY | RS | REVIEWED BY | RV |
| DATE | MAY 2017 | | |
| SHEET | | | |

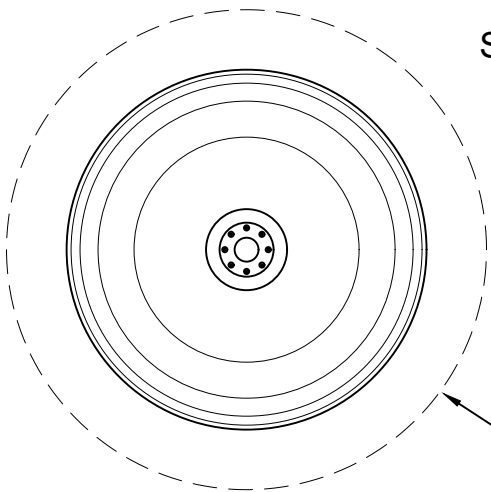

TOP VIEW

WET AREA ±9' DIAMETER

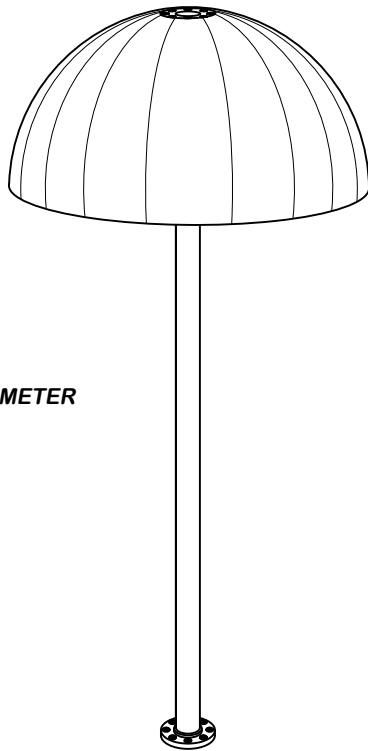

SCALE
N.T.S.

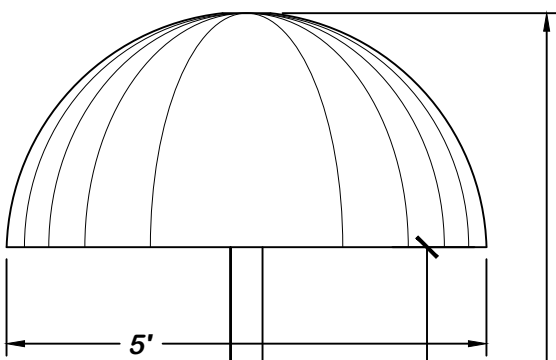

4" Ø STAINLESS STEEL

SPECIFICATIONS:

- MATERIAL: STAINLESS STEEL
- SURFACE FINISH: POWDER COAT
- WATER PRESSURE: MIN. 5 PSI
- WATER CONSUMPTION: 10-90 GPM

FIBERGLASS CANOPY
AVAILABLE IN 40" AND 60" DIA.

SS 60" WATER
MUSHROOM
RDS303-0

FINISHED GRADE

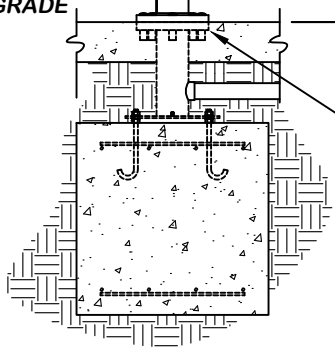

SEE DETAIL RAIN DECK
STAINLESS STEEL
FOOTING BASE RDS399-0

FRONT VIEW

SCALE
1/2"=1'-0"

RDS331-0
SS RAIN CURTAIN

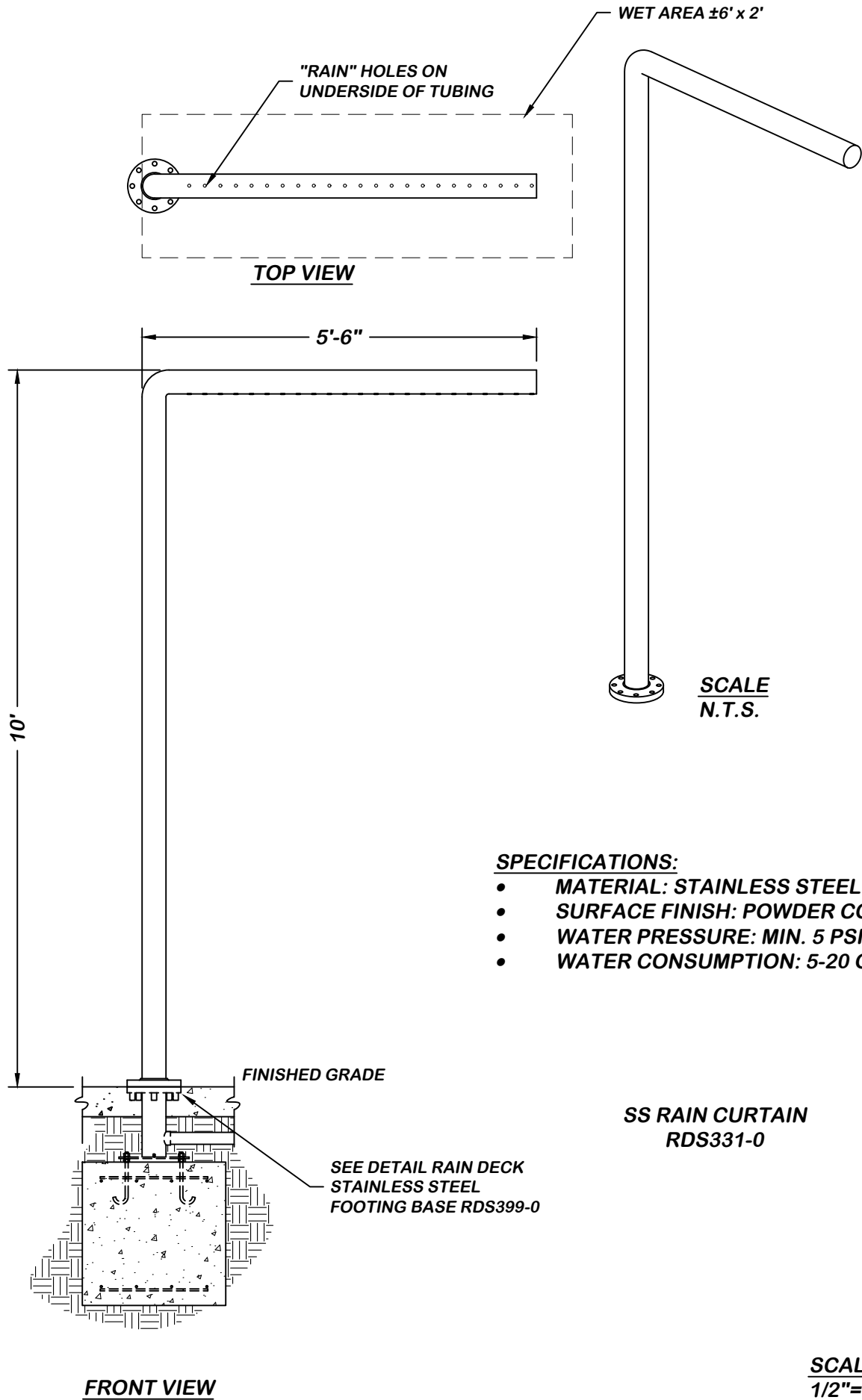

SCALE
N.T.S.

SPECIFICATIONS:

- MATERIAL: STAINLESS STEEL
- SURFACE FINISH: POWDER COAT
- WATER PRESSURE: MIN. 5 PSI
- WATER CONSUMPTION: 5-20 GPM

SS RAIN CURTAIN
RDS331-0

FRONT VIEW

SCALE
1/2"=1'-0"

RAINDECK
Ph. 888.445.RAIN
Fax. 866.869.3942
info@raindeck.com

THIS DRAWING IS AN INSTRUMENT OF SERVICE AND THE PROPERTY OF RAINDECK. IT IS TO BE USED ONLY FOR THE PROJECT AND SITE SPECIFICALLY IDENTIFIED HEREIN. IT IS NOT TO BE REPRODUCED, COPIED, REPRODUCED OR TRANSMITTED IN ANY FORM OR BY ANY MEANS, ELECTRONIC OR MECHANICAL, INCLUDING PHOTOCOPYING, RECORDING, OR BY ANY INFORMATION STORAGE AND RETRIEVAL SYSTEM, WITHOUT THE WRITTEN PERMISSION OF RAINDECK. RAINDECK ASSUMES NO LIABILITY FOR ANY DAMAGE OR LOSS OF PROFITS, BUSINESS, OR REVENUE, OR FOR ANY SPECIAL, INCIDENTAL, OR CONSEQUENTIAL DAMAGES, WHETHER IN A CONTRACT OR OTHERWISE, ARISING OUT OF OR FROM THIS DRAWING, OR FROM THE USE OF THIS DRAWING, OR FROM THE INFORMATION CONTAINED HEREIN, OR FROM THE PERFORMANCE OF ANY CONTRACT ENTERED INTO BY SAID CONTRACTOR EXCEPT BY AGREEMENT WITH SAID CONTRACTOR.

| REV. | DATE | BY | DESCRIPTION |
|------|------|----|-------------|
| △ | | | |
| △ | | | |
| △ | | | |
| △ | | | |

RAIN DECK
SS RAIN CURTAIN

SEAL

DATE

| | |
|------------------|-------------------|
| DRAWN BY RS | REVIEWED BY RV |
| DATE MAY 2017 | |
| SHEET | |
| - Page 68 - | |

RDS356-0
SS JELLY STICK

RAINDECK
Ph. 888.445.RAIN
Fax. 866.869.3942
info@raindeck.com

THIS DRAWING IS AN INSTRUMENT OF SERVICE AND THE PROPERTY OF RAINDECK. IT IS TO BE USED ONLY FOR THE PROJECT AND SITE SPECIFICALLY IDENTIFIED HEREIN. IT IS NOT TO BE REPRODUCED, COPIED, REPRODUCED OR TRANSMITTED IN ANY FORM OR BY ANY MEANS, ELECTRONIC OR MECHANICAL, INCLUDING PHOTOCOPYING, RECORDING, OR BY ANY INFORMATION STORAGE AND RETRIEVAL SYSTEM, WITHOUT THE WRITTEN PERMISSION OF RAINDECK. RAINDECK ASSUMES NO LIABILITY FOR ANY DAMAGE OR INJURY TO PERSONS OR PROPERTY CAUSED BY THE USE OF THIS DRAWING. CONTRACTOR'S NAME APPEARS ON THIS DRAWING AS A RESULT OF AN AGREEMENT WITH SAME CONTRACTOR.

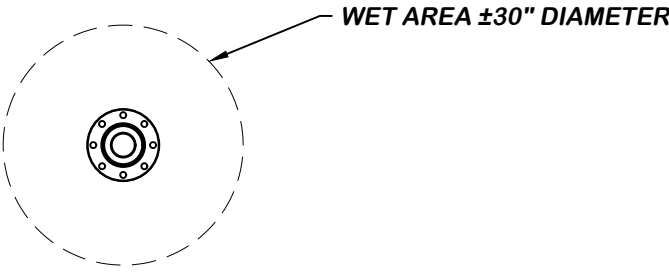

TOP VIEW

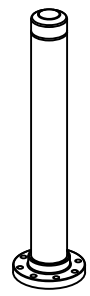

SCALE
N.T.S.

| REV. | DATE | BY | DESCRIPTION |
|------|------|----|-------------|
| △ | | | |
| △ | | | |
| △ | | | |
| △ | | | |
| △ | | | |

RAIN DECK
SS JELLY STICK

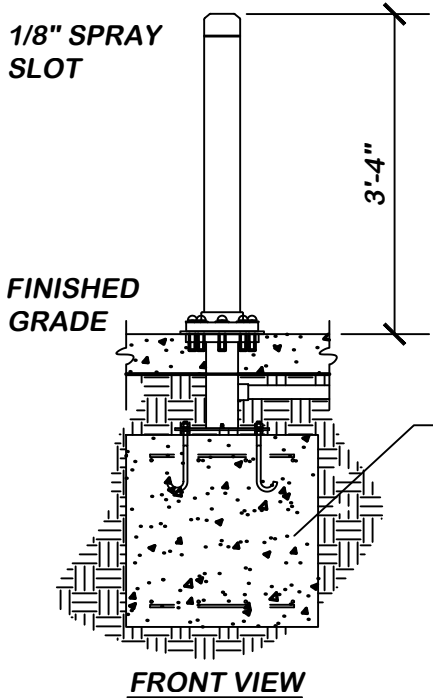

FRONT VIEW

SPECIFICATIONS:

- MATERIAL: STAINLESS STEEL
- SURFACE FINISH: POWDER COAT
- WATER PRESSURE: MIN. 5 PSI
- WATER CONSUMPTION: 5-20 GPM

JELLY STICK
RDS356-0

SCALE
1/2"=1'-0"

| |
|------|
| SEAL |
| DATE |

| | | | |
|----------|----------|-------------|----|
| DRAWN BY | RS | REVIEWED BY | RV |
| DATE | MAY 2017 | | |
| SHEET | | | |

RDS366-0
SS TOAD

RAINDECK
Ph. 888.445.4455
Fax. 866.869.3942
info@raindeck.com

THIS DRAWING IS AN INSTRUMENT OF SERVICE AND THE PROPERTY OF RAINDECK. IT IS TO BE USED ONLY FOR THE PROJECT AND SITE SPECIFICALLY IDENTIFIED HEREIN. IT IS NOT TO BE REPRODUCED, COPIED, REPRODUCED OR TRANSMITTED IN ANY FORM OR BY ANY MEANS, ELECTRONIC OR MECHANICAL, INCLUDING PHOTOCOPYING, RECORDING, OR BY ANY INFORMATION STORAGE AND RETRIEVAL SYSTEM, WITHOUT THE WRITTEN PERMISSION OF RAINDECK. WHERE A CONTRACTOR'S NAME APPEARS ON THIS DRAWING, IT IS THE PROPERTY OF SAID CONTRACTOR EXCEPT BY AGREEMENT WITH SAID CONTRACTOR.

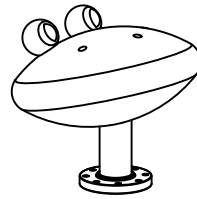
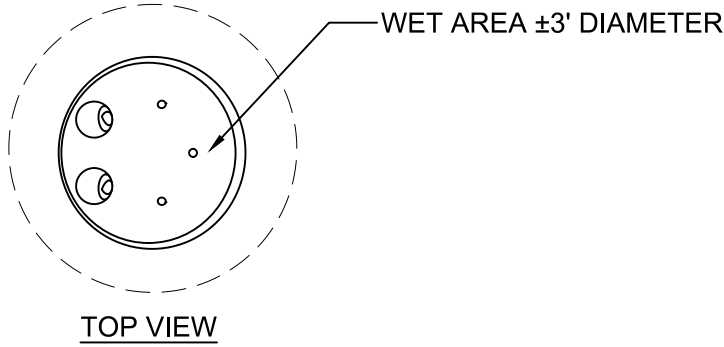

SCALE
N.T.S.

| REV. | DATE | BY | DESCRIPTION |
|------|------|----|-------------|
| △ | | | |
| △ | | | |
| △ | | | |
| △ | | | |
| △ | | | |

**RAIN DECK
SS TOAD**

SPECIFICATIONS:

- MATERIAL: STAINLESS STEEL
- SURFACE FINISH: POWDER COAT
- WATER PRESSURE: MIN. 5 PSI
- WATER CONSUMPTION: 5-20 GPM

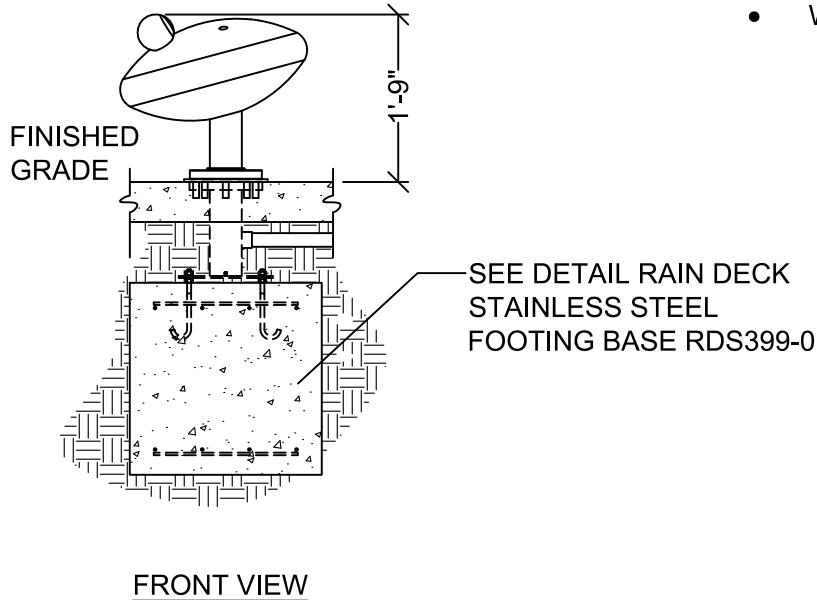

SS TOAD
RDS366-0

SEAL

DATE

| | |
|-------------------|-------------------|
| DRAWN BY RS | REVIEWED BY LB |
| DATE OCT. 2019 | |
| SHEET | |

SCALE
1/2"=1'-0"

RD150-0
LCJ ADJUSTABLE

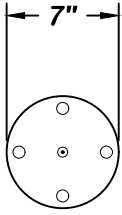

TOP VIEW

INCLUDES:

- **STAINLESS STEEL BOLTS AND GASKET**

SPECIFICATIONS:

- **MATERIAL: ANODIZED ALUMINIUM**
(AVAILABLE IN MULTIPLE COLORS)
- **EFFECTIVE WET AREA - ±5'-6' HIGH w/ A MAX. 12' THROW**
- **FLOW RATE: 4 gpm**
- **WATER PRESSURE: 3 - 5psi**

**LCJ ADJUSTABLE
RD150-0**

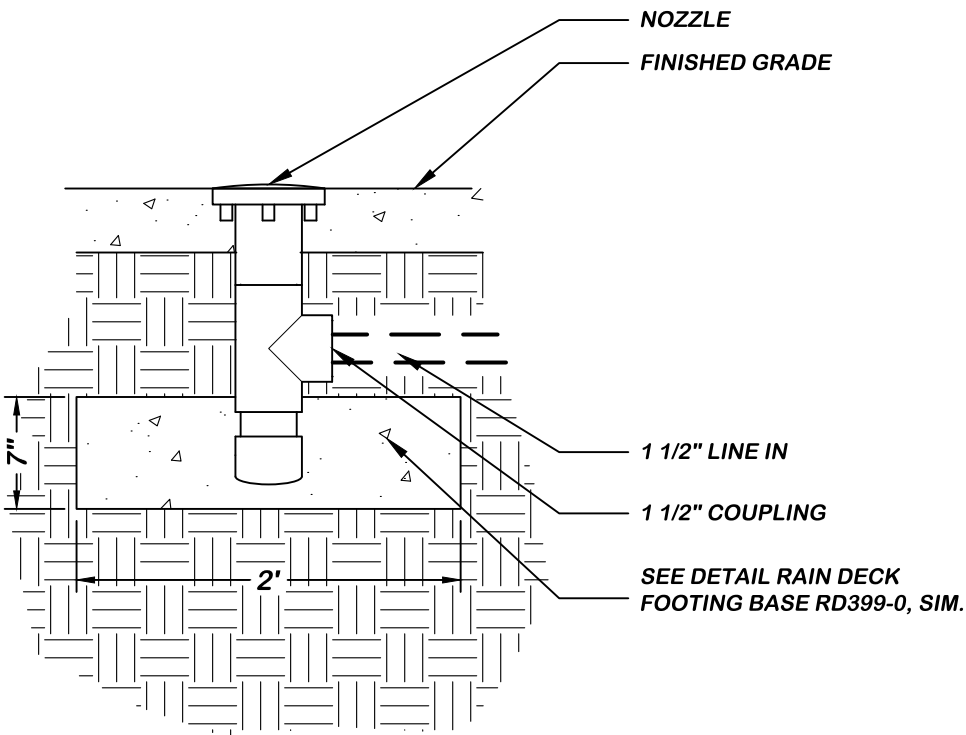

FRONT VIEW

RAINDECK
Ph. 888.445.RAIN
Fax. 866.869.3942
info@raindeck.com

THIS DRAWING IS AN INSTRUMENT OF SERVICE AND THE PROPERTY OF RAINDECK. IT IS TO BE USED ONLY FOR THE PROJECT AND SITE SPECIFICALLY IDENTIFIED HEREIN. IT IS NOT TO BE REPRODUCED OR COPIED IN ANY MANNER WITHOUT THE WRITTEN PERMISSION OF RAINDECK. ANY REPRODUCTION OR COPIING OF THIS DRAWING WITHOUT THE WRITTEN PERMISSION OF RAINDECK IS STRICTLY PROHIBITED. RAINDECK SHALL BE USED UNLESS PROPERLY SEALED AND APPROVED. PUBLICATION OF THIS DRAWING BY ANY METHOD IN WHOLE OR IN PART WITHOUT THE WRITTEN PERMISSION OF RAINDECK WHERE A CONTRACTOR'S NAME APPEARS ON THIS DRAWING SHALL BE AT THE CONTRACTOR'S RISK. RAINDECK SHALL NOT BE RESPONSIBLE FOR ANY DAMAGE TO PROPERTY OR PERSONS CAUSED BY THE USE OF THIS DRAWING WITHOUT THE WRITTEN PERMISSION OF RAINDECK. CONTRACTOR ACCEPTS BY AGREEMENT WITH SAME CONTRACTOR.

| REV. | DATE | BY | DESCRIPTION |
|------|------|----|-------------|
| △ | | | |
| △ | | | |
| △ | | | |
| △ | | | |
| △ | | | |

**RAIN DECK
LARGE COMMERCIAL JET
ADJUSTABLE NOZZLE**

SEAL

DATE

DRAWN BY: **RS** REVIEWED BY: **JW**

DATE: **MAY 2017**

SHEET

- Page 71 -

**SCALE
N.T.S**

THIS DRAWING IS AN INSTRUMENT OF SERVICE AND THE PROPERTY OF RAINDECK. IT IS TO BE USED ONLY FOR THE PROJECT AND SITE SPECIFICALLY IDENTIFIED HEREIN. IT IS NOT TO BE REPRODUCED, COPIED, REPRODUCED OR TRANSMITTED IN ANY FORM OR BY ANY MEANS, ELECTRONIC OR MECHANICAL, INCLUDING PHOTOCOPYING, RECORDING, OR BY ANY INFORMATION STORAGE AND RETRIEVAL SYSTEM, WITHOUT THE WRITTEN PERMISSION OF RAINDECK. WHERE A CONTRACTOR'S NAME APPEARS ON THIS DRAWING, IT IS THE PROPERTY OF SAID CONTRACTOR AND NOT RAINDECK. SAID CONTRACTOR ACCEPTS BY AGREEMENT WITH SAID CONTRACTOR.

| REV. | DATE | BY | DESCRIPTION |
|------|------|----|-------------|
| Δ | | | |
| Δ | | | |
| Δ | | | |
| Δ | | | |
| Δ | | | |

**RAIN DECK
 WAVE JET**

SEAL

DATE

| | |
|-------------|-------------|
| DRAWN BY | REVIEWED BY |
| QB | LB |
| DATE | |
| JUNE 2019 | |
| SHEET | |
| - Page 72 - | |

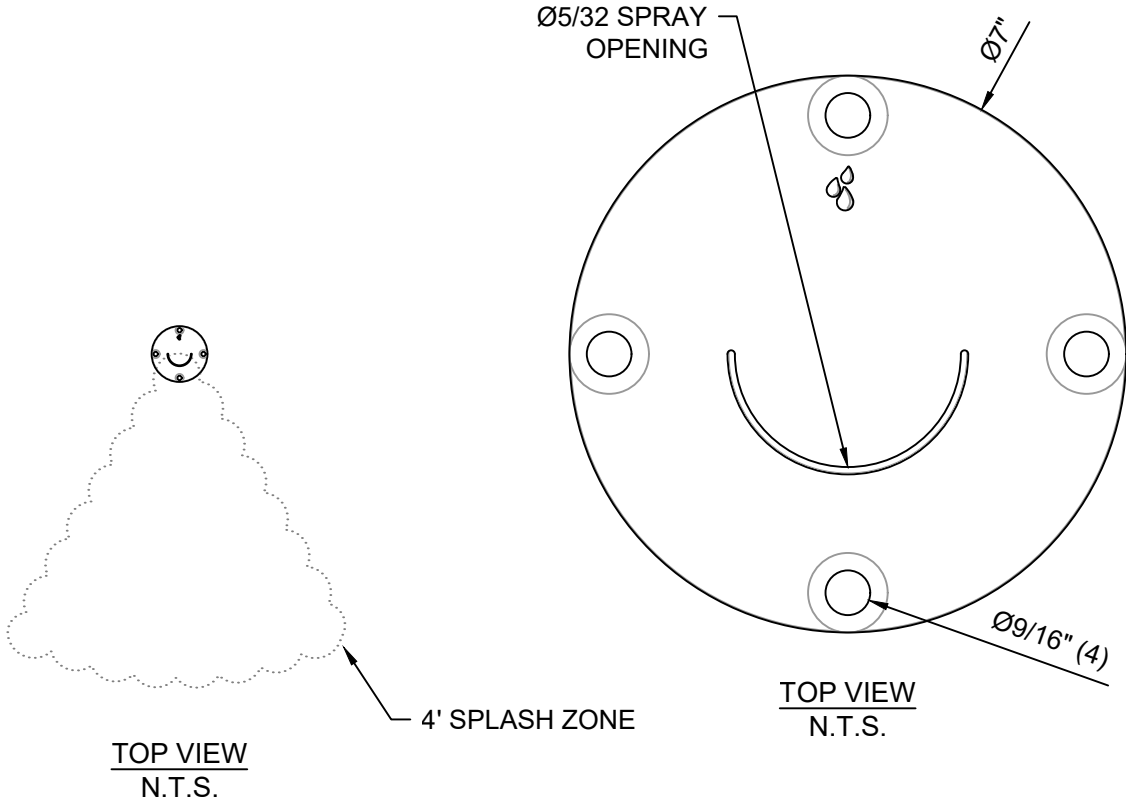

SPECIFICATIONS:

- PLATE / NOZZLE MATERIAL: ANODIZED ALUMINUM (AVAILABLE IN MULTIPLE COLORS)
- WATER PRESSURE: 1 - 5PSI
- WATER CONSUMPTION: 15.75 GPM TYP.
- EFFECTIVE WET AREA - ±4' HIGH w/ A MAX. 4' THROW

RD WAVE JET
 RD155-0

INCLUDES:

- RAIN JET HOUSING
- ADJUSTABLE PLATE w/ STAINLESS STEEL BOLTS AND GASKET

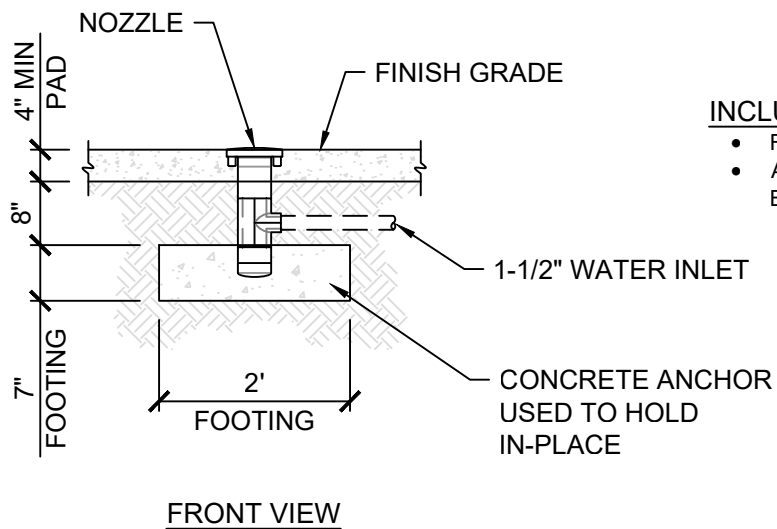

FRONT VIEW

THIS DRAWING IS AN INSTRUMENT OF SERVICE AND THE PROPERTY OF RAINDECK. IT IS TO BE USED ONLY FOR THE PROJECT AND SITE SPECIFICALLY IDENTIFIED HEREIN. IT IS NOT TO BE REPRODUCED, COPIED, REPRODUCED OR TRANSMITTED IN ANY FORM OR BY ANY MEANS, ELECTRONIC OR MECHANICAL, INCLUDING PHOTOCOPYING, RECORDING, OR BY ANY INFORMATION STORAGE AND RETRIEVAL SYSTEM, WITHOUT THE WRITTEN PERMISSION OF RAINDECK. WHERE A CONTRACTOR'S NAME APPEARS ON THIS DRAWING, IT IS THE PROPERTY OF SAID CONTRACTOR AND NOT RAINDECK. SAID CONTRACTOR ACCEPTS FULL RESPONSIBILITY FOR THE PROJECT WITH SAME CONTRACTOR.

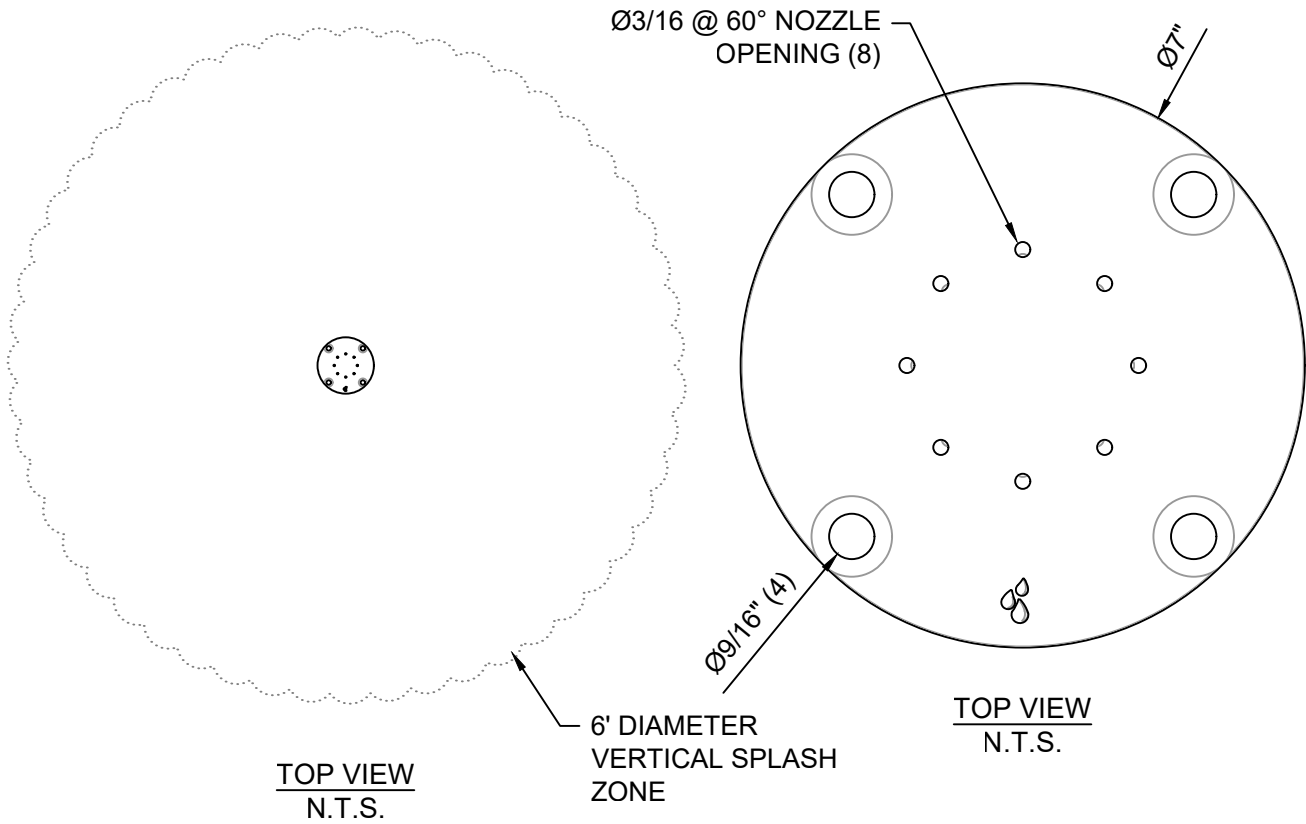

| REV. | DATE | BY | DESCRIPTION |
|------|------|----|-------------|
| Δ | | | |
| Δ | | | |
| Δ | | | |
| Δ | | | |
| Δ | | | |

- SPECIFICATIONS:**
- PLATE / NOZZLE MATERIAL: ANODIZED ALUMINUM (AVAILABLE IN MULTIPLE COLORS)
 - WATER PRESSURE: 3 - 5PSI
 - WATER CONSUMPTION: 8.75 GPM TYP (7.0 MIN / 15.0 MAX)
 - EFFECTIVE WET AREA - ±5'-6' HIGH w/ A MAX. 6' THROW

RD SPIDER JET
RD152-0

- INCLUDES:**
- RAIN JET HOUSING
 - ADJUSTABLE PLATE w/ STAINLESS STEEL BOLTS AND GASKET

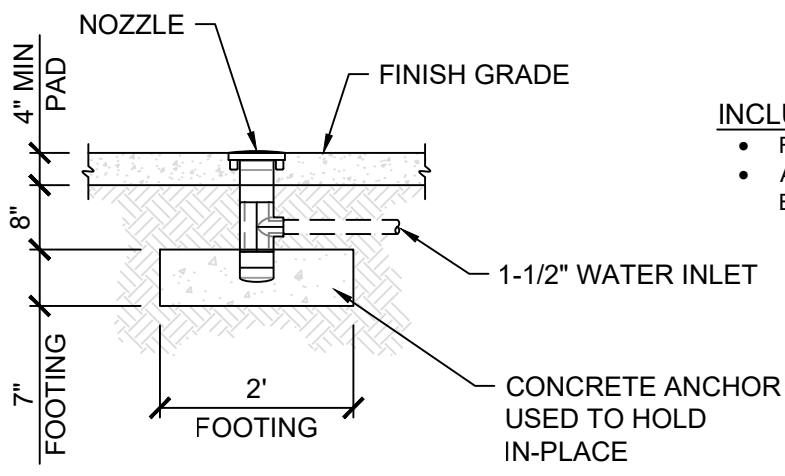

FRONT VIEW

**RAIN DECK
SPIDER JET**

SEAL

DATE

| | |
|----------|-------------|
| DRAWN BY | REVIEWED BY |
| QB | LB |
| DATE | JUNE 2019 |
| SHEET | |

RDS550-1 SS CURVED SOF-TOUCH ACTIVATOR



Ph. 888.445.4455
Fax. 866.869.3942
info@raindeck.com

THIS DRAWING IS AN INSTRUMENT OF SERVICE AND THE PROPERTY OF RAINDECK. IT IS TO BE USED ONLY FOR THE PROJECT AND SITE SPECIFICALLY IDENTIFIED HEREIN. IT IS NOT TO BE REPRODUCED, COPIED, REPRODUCED OR TRANSMITTED IN ANY FORM OR BY ANY MEANS, ELECTRONIC OR MECHANICAL, INCLUDING PHOTOCOPYING, RECORDING, OR BY ANY INFORMATION STORAGE AND RETRIEVAL SYSTEM, WITHOUT THE WRITTEN PERMISSION OF RAINDECK. WHERE A CONTRACTOR'S NAME APPEARS ON THIS DRAWING, IT IS THE PROPERTY OF THAT CONTRACTOR AND IS NOT TO BE USED FOR ANY OTHER PROJECT WITHOUT THE WRITTEN PERMISSION OF THAT CONTRACTOR. EXCEPT BY AGREEMENT WITH SAME CONTRACTOR.

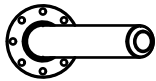

TOP VIEW

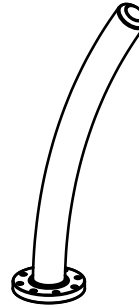

SCALE
N.T.S.

| REV. | DATE | BY | DESCRIPTION |
|------|------|----|-------------|
| △ | | | |
| △ | | | |
| △ | | | |
| △ | | | |
| △ | | | |

INCLUDES:

- SOF-TOUCH POST MOUNTED ACTIVATOR
- PROXIMITY SENSOR
- RAIN DECK SS FOOTING BASE w/ CAP
- STAINLESS STEEL BOLTS AND GASKET

SPECIFICATIONS:

- MATERIAL: STAINLESS STEEL w/ DELRIN ACTIVATOR
- SURFACE FINISH: POWDER COAT
- WIDTH: 4-1/2" O.D. SS PIPE
- HEIGHT: 40" (FROM FINISHED GRADE - CUSTOM SIZES AVAILABLE)

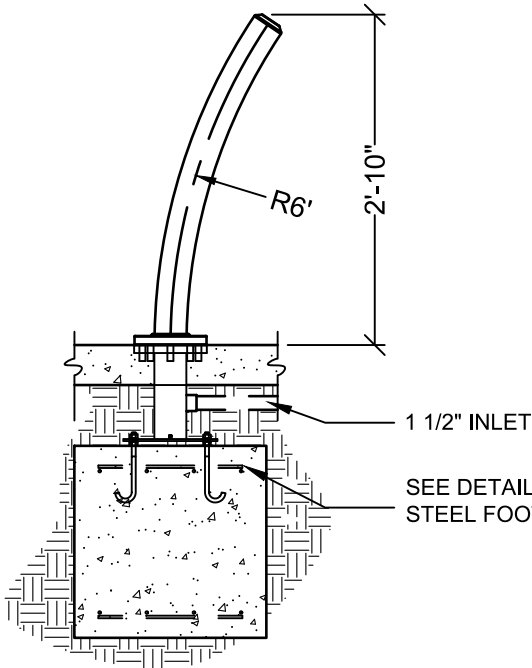

FRONT VIEW

**SS SOF-TOUCH ACTIVATOR
RDS550-1**

SCALE
1/2"=1'-0"

**RAIN DECK
SS SOF-TOUCH ACTIVATOR**

| |
|------|
| SEAL |
| DATE |

| | |
|--------------------------|--------------------------|
| DRAWN BY RS | REVIEWED BY LB |
| DATE OCT. 2020 | |
| SHEET | |
| - Page 74 - | |

RD500-0
RAIN DECK CONTROLLER

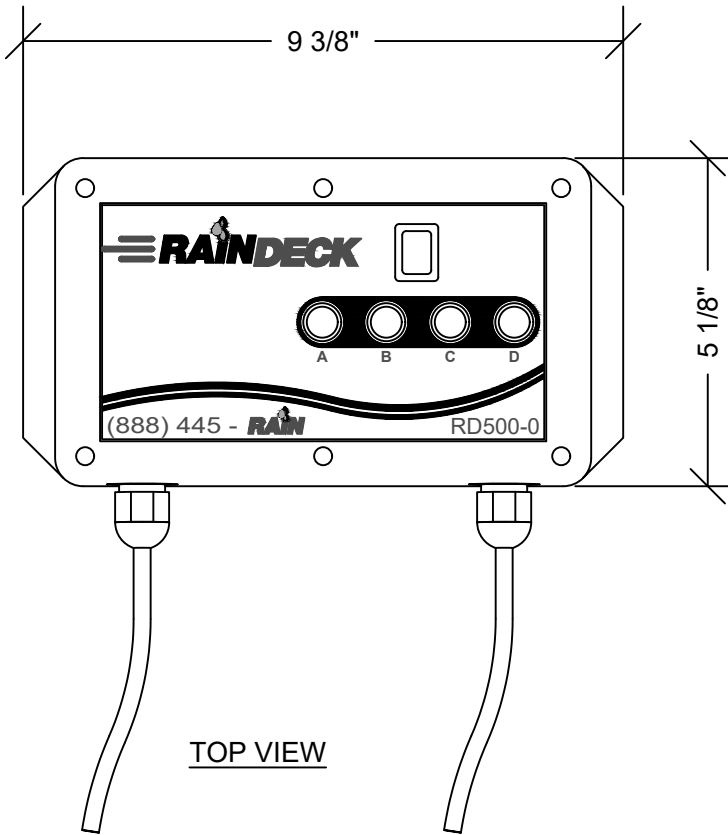

TOP VIEW

SCALE
N.T.S.

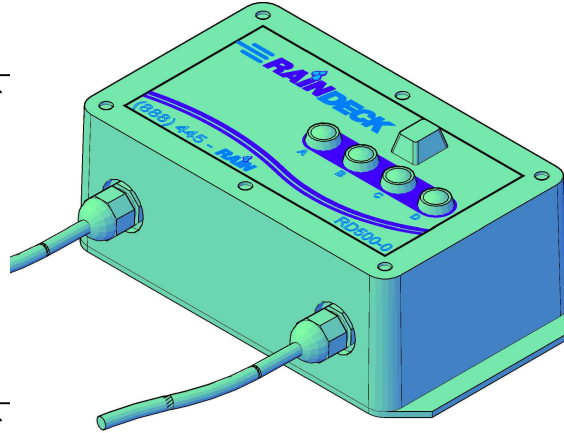

THE RAIN DECK PROPRIETARY ELECTRONIC CONTROLLER SETS THE INDUSTRY STANDARD FOR SPLASH PAD CONTROL SYSTEMS. THE RAIN DECK CONTROLLER PROVIDES THE USER WITH 4 PROGRAM SELECTIONS AND THE ABILITY TO USE WITH A FRESH WATER OR RECIRCULATION SYSTEM. THE CONTROLLER IS POWERED BY A STANDARD 100V POWER SUPPLY WITH CONNECTIONS FOR STANDARD 24VAC SOLENOID VALVES.

PROGRAMS:

- A. ONE ZONE RANDOM
- B. ONE ZONE SEQUENTIAL
- C. MULTIPLE ZONE RANDOM
- D. ALL ON

*NUMBER OF ZONES AND SPEED CYCLES CAN BE ADJUSTED ON-SITE. FOR ANY OTHER PROGRAMING QUESTIONS, PLEASE CONTACT RAIN DECK.

RAIN DECK CONTROLLER
RD500-0

RAINDECK
Ph. 888.445.RAIN
Fax. 866.869.3942
info@raindeck.com

THIS DRAWING IS AN INSTRUMENT OF SERVICE AND THE PROPERTY OF RAIN DECK. IT IS TO BE USED ONLY FOR THE PROJECT AND SITE SPECIFICALLY IDENTIFIED HEREON. IT IS NOT TO BE REPRODUCED OR COPIED IN ANY MANNER WITHOUT THE WRITTEN PERMISSION OF RAIN DECK. ANY REPRODUCTION OR COPIING WITHOUT THE WRITTEN PERMISSION OF RAIN DECK IS STRICTLY PROHIBITED. PUBLICATION OF THIS DRAWING BY ANY METHOD IN WHOLE OR IN PART WITHOUT THE WRITTEN PERMISSION OF RAIN DECK WHERE A CONTRACTOR'S NAME APPEARS ON THIS DRAWING IS STRICTLY PROHIBITED. ANY CONTRACTOR OR EXCEPT BY AGREEMENT WITH SAME CONTRACTOR.

| REV. | DATE | BY | DESCRIPTION |
|------|------|----|-------------|
| △ | | | |
| △ | | | |
| △ | | | |
| △ | | | |
| △ | | | |

RAIN DECK
RAIN DECK CONTROLLER

SEAL

DATE

| | | | |
|-------------|------------|-------------|----|
| DRAWN BY | RS | REVIEWED BY | RV |
| DATE | MARCH 2014 | | |
| SHEET | | | |
| - Page 75 - | | | |

RD428-0
16" BOX DRAIN

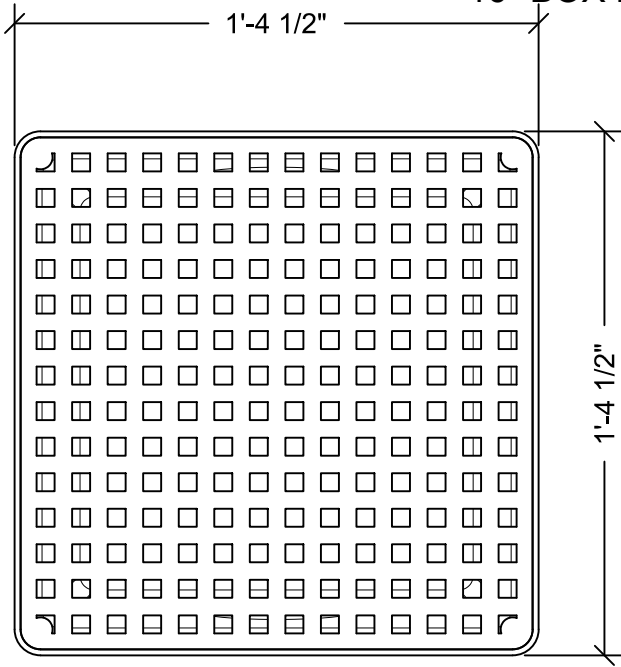

TOP VIEW

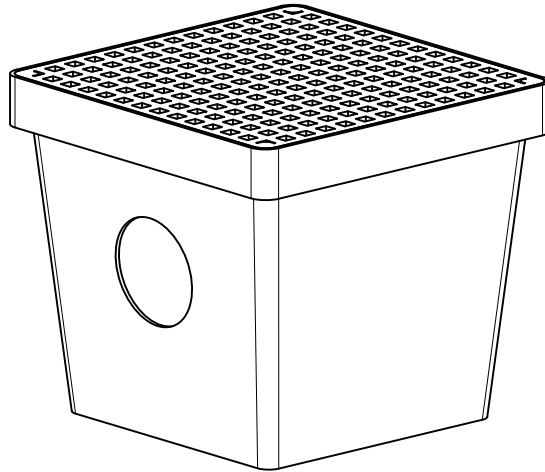

SCALE
N.T.S.

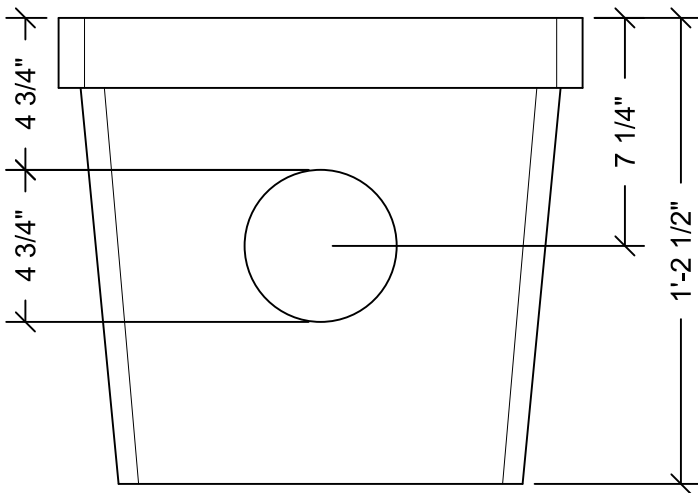

FRONT VIEW

SPECIFICATIONS:

- MATERIALS: MOLDED HIGH-DENISITY POLYETHYLENE
- ADA COMPLIANT
- AVAILABLE WITH 2, 3, OR 4-HOLE DRAIN SUMP

16" BOX DRAIN

RAINDECK
Ph. 888.445.RAIN
Fax. 866.869.3942
info@raindeck.com

THIS DRAWING IS AN INSTRUMENT OF SERVICE AND THE PROPERTY OF RAINDECK. IT IS TO BE USED ONLY FOR THE PROJECT AND SITE SPECIFICALLY IDENTIFIED HEREIN. IT IS NOT TO BE REPRODUCED, COPIED, OR REPRODUCED IN ANY MANNER WITHOUT THE WRITTEN PERMISSION OF RAINDECK. RAINDECK SHALL NOT BE LIABLE FOR ANY DAMAGES, INCLUDING CONSEQUENTIAL DAMAGES, ARISING FROM THE USE OF THIS DRAWING BY ANY METHOD IN WHOLE OR IN PART. CONTRACTOR'S NAME APPEARS ON THIS DRAWING AS A RESULT OF THE CONTRACTOR'S AGREEMENT WITH RAINDECK. CONTRACTOR ACCEPTS THIS AGREEMENT WITH SAME CONTRACTOR.

| REV. | DATE | BY | DESCRIPTION |
|------|------|----|-------------|
| △ | | | |
| △ | | | |
| △ | | | |
| △ | | | |
| △ | | | |

RAIN DECK
16" BOX DRAIN

SEAL

DATE

DRAWN BY: **RS** REVIEWED BY: **RV**

DATE: **APRIL 2014**

SHEET

- Page 76 -

Our warranty starts with our unmatched customer support. If, at any stage of your splash pad project you need support, we can help!

From installation, to winterizing, to spring start-up we offer the support you need. There is never any additional charge for any of our support services for any of our clients. **Unless otherwise stated below, Rain Deck shall warrant all products for a period of one year from the date of product shipment.**

WARRANTY

25 YEAR WARRANTY on all commercial stainless steel above ground feature pipes and welds.

25 YEAR WARRANTY on all stainless-steel footing base tubing and welds.

2 YEAR WARRANTY against peeling or fading on all finish coatings.

LIFETIME WARRANTY on all Rain Deck UHMW, PVC or Delrin spray jet housings and nozzles.

5 YEAR WARRANTY on all brass, stainless steel and aluminum housings and nozzles.

5 YEAR WARRANTY on all tanks and cisterns.

Rubber surfacing granules and binder carry a warranty on the product only. If there is a defect with the rubber granules or binder within one year of receiving the product, please contact Rain Deck. Rain Deck does NOT warranty the installation of the rubber surfacing and extends NO warranty after the rubber granules have been mixed with the binder.

On all powder coated or painted features, Rain Deck, at its discretion has the option of sending touch-up paint in lieu of replacing the feature.

Although our products should last far beyond their warranty period, should you have any warranty issues, please contact Rain Deck by calling 888- 445-RAIN, faxing 866 -869-3942 or emailing warranty@raindeck.com.





1000 SQFT COMMERCIAL FRESHWATER SPLASH PAD

STEVENSVILLE CIVIC CLUB

c/o JOAN PRATHER

STEVENSVILLE, MT

406-531-8401 / MIKEANDJOANPRATHER@YAHOO.COM

Prepared For: JENNIFER HEFLIN / RAIN DECK





P: 800-985-3031
 F: 866-869-3942
 www.SplashZone.com

Proposal

Date: February 16, 2021
Contract #: SZ-23755-2021
Customer ID:

Contract pricing valid for 30 days
Prepared by: B. Solomon for
 Jennifer Heflin/RD

Stevensville Civic Club
 c/o Joan Prather
 PO Box 676
 Stevensville, Montana 59870
 406-531-8401/ mikeandjoanprather@yahoo.com

TURN-KEY PROJECT DESCRIPTION

**APROX. 1000 SQ. FT. COMMERCIAL FRESHWATER SPLASH PAD LOCATED AT:
 LEWIS & CLARK PARK (EXACT LOCATION TBD)**

RAIN DECK SO# 23755 (SEE RAIN DECK ESTIMATED SALES ORDER ATTACHED)

Approx. 1000 square foot concrete slab (Wet Area ONLY) with minimum 4" thickness, reinforced with wire mesh or rebar, granular base and proper slope for drainage.

Complete splash pad installation including all required plumbing material, spray nozzle install, above ground feature install, labor and other misc material.

Electrical hook-up for controller(s), activator(s) and timers. Depending on local code requirements, there may be an additional cost.

Splash Zone to perform system start-up, flush all nozzles and provide operation/maintenance orientation for Client.

Client to provide site ready construction area free from debris and obstructions. Client responsible for any rough grading and demolition. Splash Zone will provide minor grading as necessary. Any haul-off is the responsibility of the client.

For Fresh water pads: The water flow on the splash pad will be limited to the size, volume and pressure of the water supplied by the client. It is the responsibility of the client to verify actual PSI and GPM's available. (Typical 2" Main Line provides between 55-127 GPM.)

Minimum electrical service for controller(s), activator(s) and timer(s) provided by others and located in an accessible location for Splash Zone to hook-up equipment.

Minimum 4" sewer stub-out to be provided by others and brought to an accessible location near splash pad.

Utility room, vault or enclosure for equipment to be provided by others, unless stated otherwise in proposal/contract.

Unless specifically stated, Payment and Performance bond are not included in this proposal; however, Splash Zone is pre-qualified to acquire at an additional cost if requested. Unless specified in writing, Splash Zone cannot guarantee an exact installation date. Projects will generally be scheduled after all required permitting is complete. This proposal is not bid with prevailing-wage unless specifically stated within this contract. Client to be named as additional insured on Splash Zone G/L policy with completed operations coverage. Unless specifically stated, all inspections, permits and permit fees are the responsibility of Client if required. Sales Tax is not included and will be billed separately if required. This proposal is subject to change based on client changes. This proposal is not a guarantee of city, county or health code requirements. Any additional governmental requirements will be at an additional charge. Client is responsible for having the splash pad site "blue staked" (free service, call 811) before construction begins.

| | | | |
|--|--|--|---------------------|
| ----- | | | |
| RAIN DECK SPLASH PAD PRODUCT SALES ORDER #23755 | | | \$33,407.52 |
| CONSTRUCTION / INSTALLATION | | | \$87,401.48 |
| SALES TAX | | | |
| TOTAL | | | \$120,809.00 |

Signed: _____ Date: _____
 Splash Zone® LLC

Accepted: _____ Date: _____
 Owner (Client)

THANK YOU FOR YOUR BUSINESS!

Payment Schedule (or as otherwise agreed upon)

| | | |
|-------------------------------------|----|-------------------|
| 20% deposit due before work begins. | \$ | 24,161.80 |
| Progress billings. | \$ | 84,566.30 |
| 10% final after client sign-off. | \$ | 12,080.90 |
| | \$ | 120,809.00 |



Agreement for Construction of Splash Pad

This Agreement for the construction of a Splash Pad ("Agreement") is between the buyer of the Splash Pad ("Client"), on the one hand, and Splash Zone, LLC ("Contractor"), on the other hand. The terms and conditions of the Agreement are set forth below.

RESPONSIBILITY OF CLIENT

Client shall provide Contractor with adequate access and a site free of debris or obstacles prior to the start of the work. Client agrees to pay to Contractor all additional costs incurred as a result of Client's failure to so provide.

Client shall be responsible to protect all trees, shrubs and other plants which Client desires to save which occupy space to be used in the construction of the splash pad.

Client agrees to assume all liability for damage to driveway, curbs, walks, shrubs, sewers, sprinkler systems, drip lines, patio, underground utility lines, fences, decomposed granite, lawn or any rerouting of irrigation water.

Contractor is not liable for any damage to any part of the splash pad caused by irrigation water, vandals, or any other persons or things not within the control of the Contractor. Any splash pad equipment or appurtenances subject to this Contract delivered to the job site are the Client's property and if removed or stolen is Client's responsibility.

It shall be the responsibility of the Client to furnish a water source and power source for the construction of the splash pad.

Contractor is not responsible for unusual soil conditions including but not limited to the following: caliche, subterranean water, floatation of splash pad due to external water, granite, or other like and unusual sub-surface conditions, mass concrete, unusually large boulders or the like. Client agrees to pay an additional sum for these additional items and/or any associated changes as an additional cost to the contract price.

Grading and drainage beyond the splash pad area is the responsibility of the Client.

Excess soil will NOT be removed and will remain on the property unless otherwise specified in writing by Client before start of excavation.

With the exception of minor grading for the splash pad, Contractor is not responsible for supplying fill dirt or providing excessive grading unless specified in the contract.

Contractor agrees to construct the splash pad diligently, but Contractor shall not be responsible for delays or damages caused by failure to perform work or furnish materials or equipment due to acts of God, conditions created by threat or of inclement weather, war, riot, or other civil disturbance, strike, government prohibition, delays caused by Client, non issuance of all required permits affecting the splash pad, availability of construction material, or other reasons beyond its control.

Requests for any changes or additions to this agreement desired by the Client shall be made in writing at a price as mutually agreed and signed by both parties and shall become part of this agreement.

Contractor shall have the right to stop work and keep the job idle if payments are not made when due.

Contractor assumes no responsibility or liability for work performed by the Client, equipment or materials supplied by the Client.

In the event the payments required hereunder are not paid in accordance with the requirements of this agreement, a credit service charge of one and one-half percent (1-1/2%) per month, which is eighteen percent (18%) corresponding annual percentage rate, will be applied from the date such payment becomes due.

In the event Contractor shall be required to employ an attorney to enforce collection of any payment required to be made by Client to Contractor under this agreement, Client agrees to pay to Contractor a reasonable amount for attorney's fees although legal action either was not instituted or not completed to judgment.

This agreement together with the signed Splash Zone Proposal constitutes the full agreement between the parties. The parties are not bound by any other statements or representations or oral expression by any agent or person purporting to act for or on behalf of either party.

Should any part on this agreement be declared invalid for any reason, such decision shall not affect the validity of any remaining portions and shall remain in force and affect as if the invalid portion had been eliminated.

Client agrees to allow Contractor to place a Splash Zone sign on Clients property during construction and use pictures of splash pad taken before, during and after construction in marketing and other material unless otherwise specified in writing.

When the splash pad is completed (surface material applied and start-up orientation) this contract shall have been completed.

LIMITED WARRANTY

MATERIALS AND WORKMANSHIP

Splash Zone LLC warrants to the original Client all labor, materials, and equipment to be free of defects for a period of two (2) years from the date the splash pad is complete, when subject to original Client's reasonable care and necessary maintenance. Upon written notice to Splash Zone LLC by the original Client within that two (2) year period, Splash Zone LLC will remedy any defect in material or workmanship without charge within a reasonable time provided the original Client has complied with all Terms of this Agreement, including payment in full.

LIMITATIONS

No warranty extends to any part of the splash pad, its equipment or appurtenances thereto which are caused by any of the following conditions or events:

1. Defects or failures caused by abuse, lack of reasonable care, lack of necessary maintenance, improper operation, vandalism, acts of God, or normal wear.
2. Damages or failures to plumbing lines, filter, motors and pumps caused by freezing.
3. Damages or failures caused by substituting or addition of equipment or service not expressly authorized which affect the operation or designed use of the splash pad.
4. Discoloration, staining, check cracks, cracks and imperfections inherit in splash pad decks and concrete products. Only cracks exceeding in width the thickness of a dime will be repaired by Contractor at no cost to the original consumer within the limited warranty period.
5. Minor high and/or low spots in the concrete or surface material which accumulate less than 1/2" inch of standing water.
6. Damages or failures caused by surface or subterranean drainage under or around said splash pad or earth fill movement, explosions, wrecking, expansive soil, and the like, and not occasioned by Contractor.
7. In some locations, expansive soil may exist. Damage caused to the splash pad as a result of expansive soil will be at the Client's expense, except for the concrete shell, shall be Contractor's expense. Client may secure at his expense an independent soil analysis to determine whether expansive soil exists in the splash pad location. Without a soil analysis, Contractor assumes no liability regarding determination of existence of expansive soil.
8. Contractor expressly denies any responsibility or liability for incidental or consequential damages arising out of or as a result of the use or ownership of the splash pad.
9. Damage by the elements or acts of God, war, civil disturbances, unusual abuse/neglect, incorrect operation or lack of care of the splash pad or equipment.

PERFORMANCE

In the event of defect in materials or workmanship within the above stated warranty period, and upon written notice to Splash Zone LLC, at 7319 S Atwood, Ste 103, Mesa, AZ 85212, by the original Client, Contractor will remedy any defect in material or workmanship without charge to the original Client with exceptions listed here within, with in a reasonable amount of time, provided the original Client has complied with all terms of this contract, including payment in full.

NOTICE

Client is entitled to a copy of this Agreement at the time it is signed. Client may cancel this agreement at any time prior to midnight of the third business day after the date of this transaction by faxing a written cancellation request to 866-869-3942. This provision is not allowed if construction of the splash pad has begun or will begin prior to the third business day.

Signed: _____
Splash Zone, LLC (Contractor)

Date: _____

Signed: _____
Client (Buyer)

Date: _____

Rain Deck, LLC

7319 S. Atwood, Ste. #103
 Mesa, AZ 85212
 888-445-7246
 www.raindeck.com

INVOICE: #23755

DATE: 02/16/2021

BILLING ADDRESS

Joan Prather
 Stevensville Civic Club
 Stevensville, Montana

SHIPPING ADDRESS

Joan Prather
 Stevensville Civic Club
 Stevensville, Montana

SALES REP

Jennifer Heflin
 jennifer@raindeck.com

| PRODUCT | COST | QTY | TOTAL |
|---|------------|-----|------------|
| COMMERCIAL FEATURES / STAINLESS STEEL | | | |
| RDS315-0 Rain Deck SS Dumping Bucket 2 (RDS315-0) w/ SS Footing Base (RDS399-0) GPM's: MIN 10 / TYP 15 | \$6,170.00 | × 1 | \$6,170.00 |
| RDS303-0 Rain Deck SS 60" Water Mushroom (RDS303-0) w/ SS Footing Base (RDS399-0) GPM's: MIN 10 / TYP 50 | \$5,140.00 | × 1 | \$5,140.00 |
| RDS331-0 Rain Deck SS Rain Curtain (RDS331-0) w/ SS Footing Base (RDS399-0) GPM's: MIN 5 / TYP 12.5 | \$3,873.00 | × 1 | \$3,873.00 |
| RDS356-0 Rain Deck SS Jelly Stick (RDS356-0) w/ SS Footing Base (RDS399-0) GPM's: MIN 5 / TYP 12.5 | \$2,730.00 | × 1 | \$2,730.00 |



| | | | |
|---|------------|-----|------------|
| RDS366-0 Rain Deck SS Toad (RDS366-0) w/ SS Footing Base (RDS399-0) GPM's: MIN 7 / TYP 7.5 | \$4,007.00 | × 1 | \$4,007.00 |
|---|------------|-----|------------|

GROUND SPRAYS

| | | | |
|--|----------|-----|----------|
| RD150-0 Rain Deck Commercial Jet (7.5" dia) w/ Adjustable Nozzle (RD150-0) GPM's: MIN 12 / TYP 15 | \$217.00 | × 3 | \$651.00 |
|--|----------|-----|----------|

| | | | |
|---|----------|-----|----------|
| RD155-0 Rain Deck Commercial Jet (7.5" dia) w/ Wave Jet (RD155-0) GPM's: MIN 31.5 / TYP 31.5 | \$217.00 | × 2 | \$434.00 |
|---|----------|-----|----------|

| | | | |
|---|----------|-----|----------|
| RD152-0 Rain Deck Commercial Jet (7.5" dia) w/ Spider Jet (RD152-0) GPM's: MIN 14 / TYP 17.5 | \$217.00 | × 2 | \$434.00 |
|---|----------|-----|----------|

FOOTING BASES / SPRAY PLATES

| | | | |
|---|---------|-----|----------|
| RDS399-1 Pre Cut and Tied Rebar Cages for std Footing Detail (X2) | \$41.00 | × 6 | \$246.00 |
|---|---------|-----|----------|

ACTIVATORS / TIMERS

| | | | |
|--|------------|-----|------------|
| RDS550-1 Rain Deck SS Sof-Touch™ Curved Activator w/ SS Footing Base - Post Mounted (RDS550-1) | \$3,492.00 | × 1 | \$3,492.00 |
|--|------------|-----|------------|

| | | | |
|---|----------|-----|----------|
| RD550-1 Rain Deck Sof-Touch™ Electronic Timer Box (RD550-1) | \$649.00 | × 1 | \$649.00 |
|---|----------|-----|----------|

CONTROLLERS / MANIFOLDS

| | | | |
|---|--|--|--|
| RD500-0 Rain Deck 8 Zone Multi-Program Electronic | | | |
|---|--|--|--|



| | | | |
|---|------------|-----|--------------------|
| Controller (RD500-0) | \$1,334.00 | × 1 | \$1,334.00 |
| <hr/> | | | |
| RD507-5 RD 5 Zone Manifold - 2" Header (1.5" BALL VALVE) (RD507-5) For : (5) Above Ground Features | \$409.00 | × 1 | \$409.00 |
| <hr/> | | | |
| RD511-0 Project Specific Splash Pad Manifold (RD511-0) 2" Pipe: w/ (7) 1" solenoids w/ flow control; Include (1) 1.5" main solenoid For: (7) Commercial Jets | \$910.00 | × 1 | \$910.00 |
| <hr/> | | | |
| SANITATION / VALVES / FITTINGS / DRAINS & MORE | | | |
| <hr/> | | | |
| RD428-0 16" x 16" Box Drain - 4" or 6" PVC Connection (RD428-0) | \$136.00 | × 2 | \$272.00 |
| <hr/> | | | |
| RD428-1 16" x 16" Box Drain Strainer Basket (RD428-1) | \$60.00 | × 2 | \$120.00 |
| <hr/> | | | |
| PLANS / PURCHASE WITH CONFIDENCE / OTHER | | | |
| <hr/> | | | |
| RD600-0 Splash Pad Layout Plan Set (No Engineering) | \$550.00 | × 1 | \$550.00 |
| <hr/> | | | |
| RD920-0 Custom Paint (RD920-0) Canopy: Polkadots | \$250.00 | × 1 | \$250.00 |
| <hr/> | | | |
| ORDER SUBTOTAL: | | | \$31,671.00 |
| - SHIPPING: | | | \$1,736.52 |
| ORDER TOTAL: | | | \$33,407.52 |

GPM's: MIN 94.5 / TYP 161.5



Lewis & Clark Park
1000 Sq Ft Commercial Freshwater Splash Pad



RDS315-0
SS DUMPING BUCKET 2

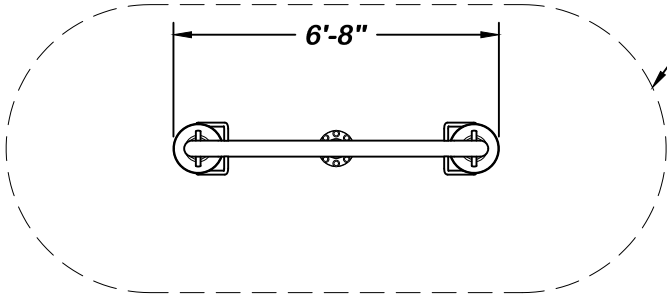

TOP VIEW

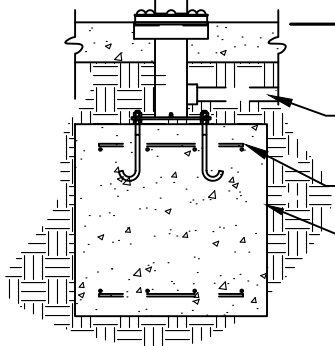
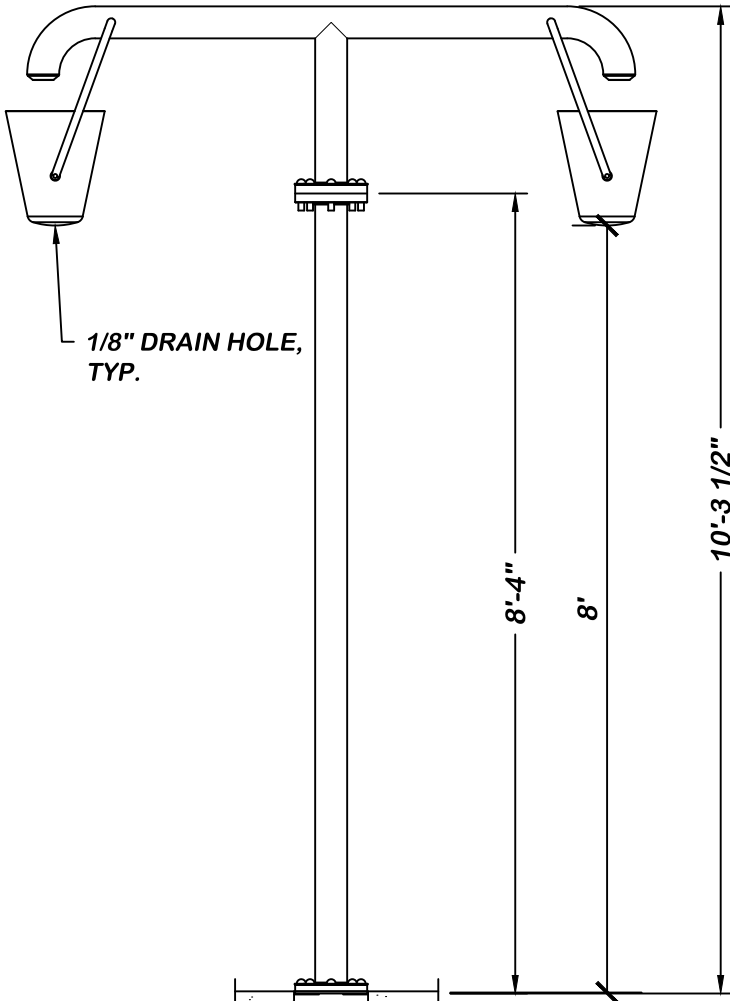
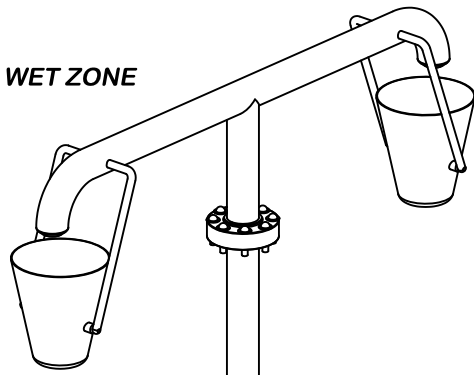

FRONT VIEW

SCALE
N.T.S.

SPECIFICATIONS:

- MATERIALS: STAINLESS STEEL, ALUMINUM & FIBERGLASS
- SURFACE FINISH: POWDER COAT
- WATER PRESSURE: 3 - 5 PSI
- WATER CONSUMPTION: 10-20 GPM

SS DUMPING BUCKET 2
RDS315-0

RAINDECK
Ph. 888.445.RAIN
Fax. 866.869.3942
info@raindeck.com

THIS DRAWING IS AN INSTRUMENT OF SERVICE AND THE PROPERTY OF RAINDECK. IT IS TO BE USED ONLY FOR THE PROJECT AND SITE SPECIFICALLY IDENTIFIED HEREIN. IT IS NOT TO BE REPRODUCED, COPIED, OR TRANSMITTED IN ANY FORM OR BY ANY MEANS, ELECTRONIC OR MECHANICAL, INCLUDING PHOTOCOPYING, RECORDING, OR BY ANY INFORMATION STORAGE AND RETRIEVAL SYSTEM, WITHOUT THE WRITTEN PERMISSION OF RAINDECK. ANY UNAUTHORIZED USE OF THIS DRAWING IS PROHIBITED. RAINDECK SHALL NOT BE LIABLE FOR ANY DAMAGES, INCLUDING CONSEQUENTIAL DAMAGES, ARISING FROM THE USE OF THIS DRAWING. CONTRACTORS NAME APPEARS ON THIS DRAWING AS A RESULT OF AN AGREEMENT WITH SAME CONTRACTOR.

| REV. | DATE | BY | DESCRIPTION |
|------|------|----|-------------|
| △ | | | |
| △ | | | |
| △ | | | |
| △ | | | |

RAIN DECK
SS DUMPING BUCKET 2

SEAL

DATE

| | |
|------------------|-------------------|
| DRAWN BY RS | REVIEWED BY RV |
| DATE MAY 2017 | |
| SHEET | |

SCALE
1/2"=1'-0"

RDS303-0
SS 60" WATER MUSHROOM

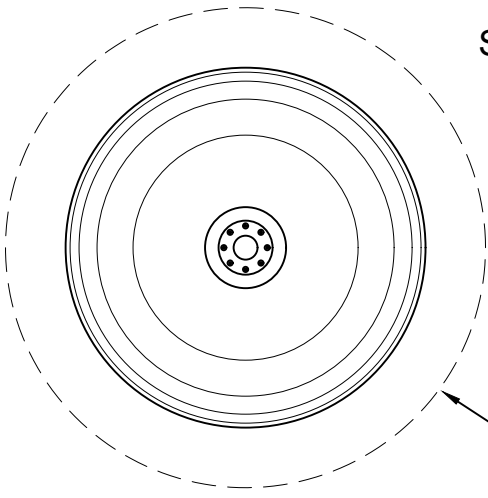

TOP VIEW

WET AREA ±9' DIAMETER

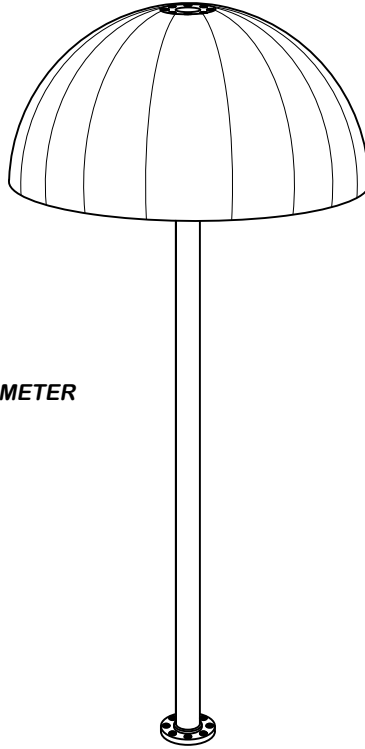

SCALE
N.T.S.

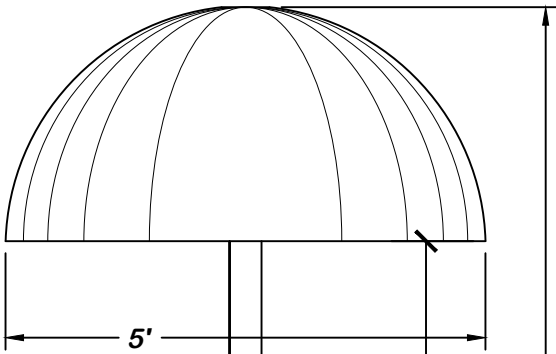

4" Ø STAINLESS STEEL

FINISHED GRADE

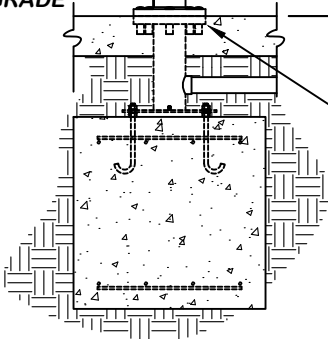

SEE DETAIL RAIN DECK
STAINLESS STEEL
FOOTING BASE RDS399-0

SPECIFICATIONS:

- MATERIAL: STAINLESS STEEL
- SURFACE FINISH: POWDER COAT
- WATER PRESSURE: MIN. 5 PSI
- WATER CONSUMPTION: 10-90 GPM

FIBERGLASS CANOPY
AVAILABLE IN 40" AND 60" DIA.

SS 60" WATER
MUSHROOM
RDS303-0

FRONT VIEW

SCALE
1/2"=1'-0"

RAINDECK
Ph. 888.445.RAIN
Fax. 866.869.3942
info@raindeck.com

THIS DRAWING IS AN INSTRUMENT OF SERVICE AND IS THE PROPERTY OF RAIN DECK. USE OF THIS DRAWING AND ALL REPRODUCTIONS SHALL BE LIMITED TO THE PROJECT AND SITE FOR WHICH IT WAS PREPARED AND SHALL NOT BE USED UNLESS PROPERLY SEALED AND APPROVED. PUBLICATION OF THIS DRAWING IN ANY MANNER WITHOUT THE PERMISSION OF RAIN DECK, WHERE A PERMITTED, SHALL BE CONSIDERED BY SAID CONTRACTOR EXCEPT BY AGREEMENT WITH SAME CONTRACTOR.

| REV. | DATE | BY | DESCRIPTION |
|------|------|----|-------------|
| △ | | | |
| △ | | | |
| △ | | | |
| △ | | | |

RAIN DECK
SS 60" WATER MUSHROOM

| |
|------|
| SEAL |
| DATE |

| | |
|------------------|-------------------|
| DRAWN BY RS | REVIEWED BY RV |
| DATE MAY 2017 | |
| SHEET | |

RDS331-0
SS RAIN CURTAIN

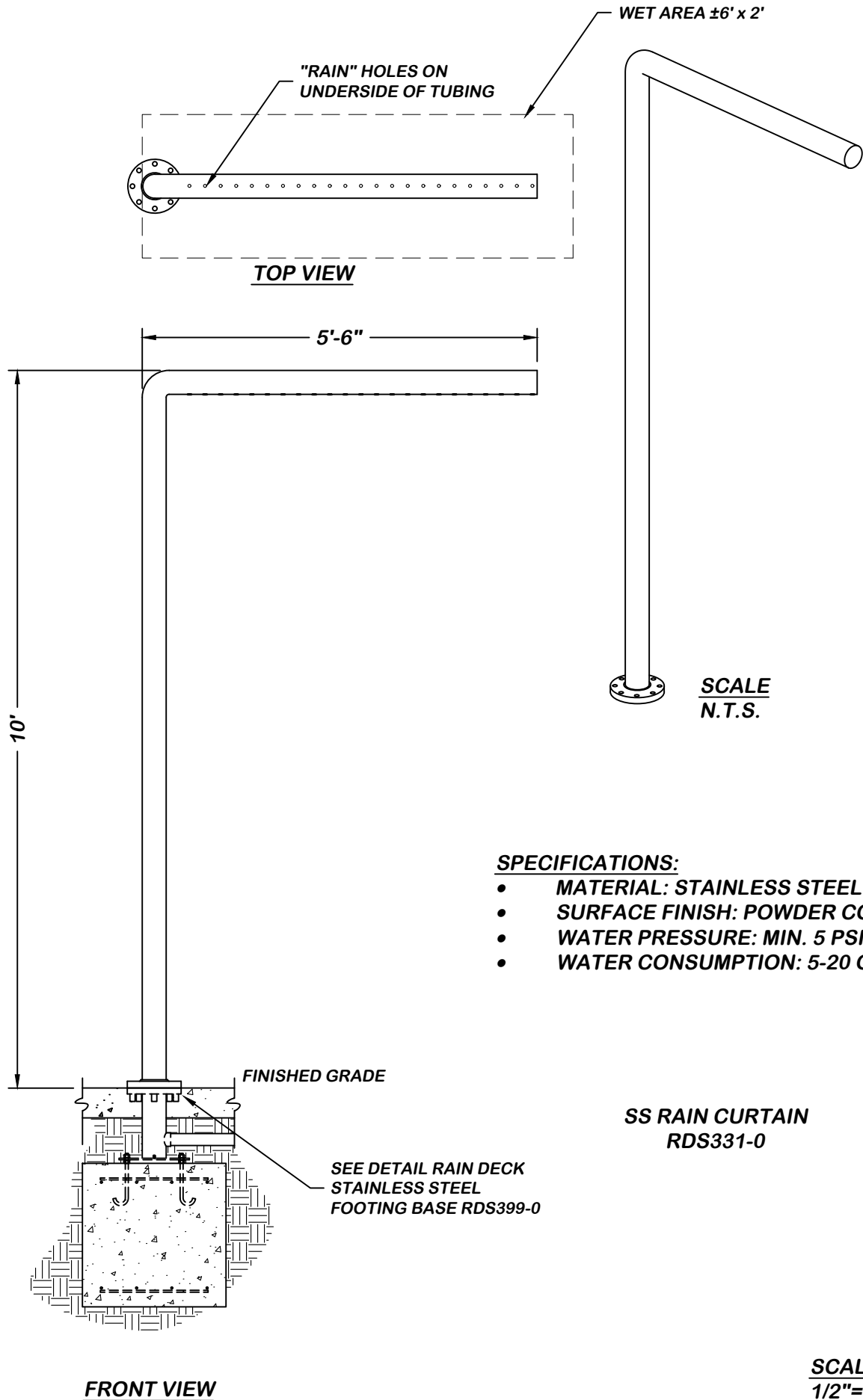

SPECIFICATIONS:

- MATERIAL: STAINLESS STEEL
- SURFACE FINISH: POWDER COAT
- WATER PRESSURE: MIN. 5 PSI
- WATER CONSUMPTION: 5-20 GPM

SS RAIN CURTAIN
RDS331-0

FRONT VIEW

SCALE
1/2"=1'-0"

RAINDECK
Ph. 888.445.RAIN
Fax. 866.869.3942
info@raindeck.com

THIS DRAWING IS AN INSTRUMENT OF SERVICE AND THE PROPERTY OF RAINDECK. IT IS TO BE USED ONLY FOR THE PROJECT AND SITE SPECIFICALLY IDENTIFIED HEREIN. ALL REPRODUCTIONS SHALL BE RESTRICTED TO THE ORIGINAL SITE FOR WHICH IT WAS DESIGNED AND BE USED UNLESS PROPERLY SEALED AND APPROVED. PUBLICATION OF THIS DRAWING BY ANY METHOD IN WHOLE OR IN PART WITHOUT THE WRITTEN PERMISSION OF RAIN DECK, WHERE A CONTRACTOR'S NAME APPEARS ON THIS DRAWING, IS STRICTLY PROHIBITED BY SAID CONTRACTOR EXCEPT BY AGREEMENT WITH SAID CONTRACTOR.

| REV. | DATE | BY | DESCRIPTION |
|------|------|----|-------------|
| △ | | | |
| △ | | | |
| △ | | | |
| △ | | | |

RAIN DECK
RAIN DECK
SS RAIN CURTAIN

SEAL

DATE

| | | | |
|----------|----------|-------------|----|
| DRAWN BY | RS | REVIEWED BY | RV |
| DATE | MAY 2017 | | |
| SHEET | | | |

- Page 87 -

RDS356-0
SS JELLY STICK

RAINDECK
Ph. 888.445.RAIN
Fax. 866.869.3942
info@raindeck.com

THIS DRAWING IS AN INSTRUMENT OF SERVICE AND THE PROPERTY OF RAINDECK. IT IS TO BE USED ONLY FOR THE PROJECT AND SITE SPECIFICALLY IDENTIFIED HEREIN. IT IS NOT TO BE REPRODUCED, COPIED, REPRODUCED OR TRANSMITTED IN ANY FORM OR BY ANY MEANS, ELECTRONIC OR MECHANICAL, INCLUDING PHOTOCOPYING, RECORDING, OR BY ANY INFORMATION STORAGE AND RETRIEVAL SYSTEM, WITHOUT THE WRITTEN PERMISSION OF RAINDECK. RAINDECK ASSUMES NO LIABILITY FOR ANY DAMAGE OR INJURY TO PERSONS OR PROPERTY CAUSED BY THE USE OF THIS DRAWING. CONTRACTORS NAME APPEARS ON THIS DRAWING AS A RESULT OF AN AGREEMENT WITH SAME CONTRACTOR.

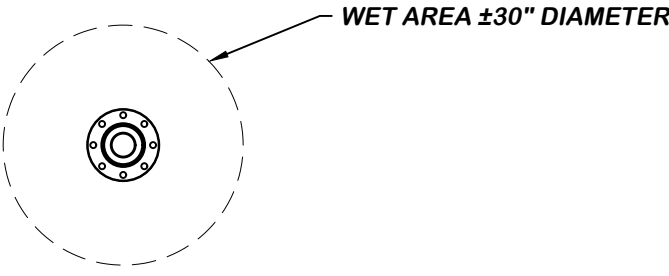

TOP VIEW

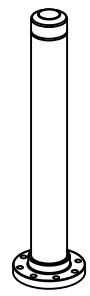

SCALE
N.T.S.

| REV. | DATE | BY | DESCRIPTION |
|------|------|----|-------------|
| △ | | | |
| △ | | | |
| △ | | | |
| △ | | | |
| △ | | | |

RAIN DECK
SS JELLY STICK

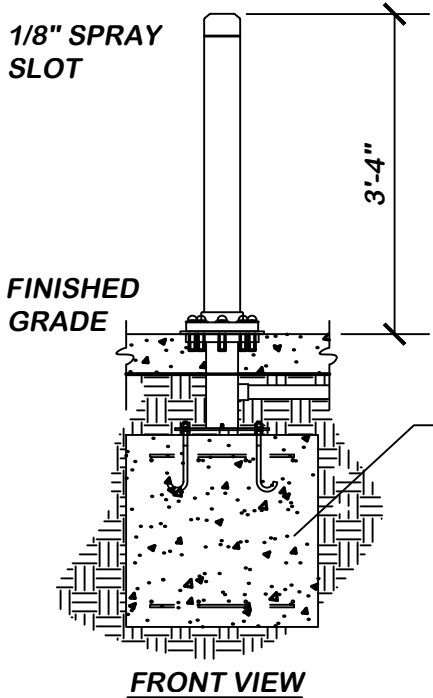

FRONT VIEW

- SPECIFICATIONS:**
- MATERIAL: STAINLESS STEEL
 - SURFACE FINISH: POWDER COAT
 - WATER PRESSURE: MIN. 5 PSI
 - WATER CONSUMPTION: 5-20 GPM

JELLY STICK
RDS356-0

SCALE
1/2"=1'-0"

| |
|------|
| SEAL |
| DATE |

| | | | |
|----------|----------|-------------|----|
| DRAWN BY | RS | REVIEWED BY | RV |
| DATE | MAY 2017 | | |
| SHEET | | | |

RDS366-0
SS TOAD



Ph. 888.445.RAIN
Fax. 866.869.3942
info@raindeck.com

THIS DRAWING IS AN INSTRUMENT OF SERVICE AND THE PROPERTY OF RAINDECK. IT IS TO BE USED ONLY FOR THE PROJECT AND SITE SPECIFICALLY IDENTIFIED HEREIN. IT IS NOT TO BE REPRODUCED, COPIED, REPRODUCED OR TRANSMITTED IN ANY FORM OR BY ANY MEANS, ELECTRONIC OR MECHANICAL, INCLUDING PHOTOCOPYING, RECORDING, OR BY ANY INFORMATION STORAGE AND RETRIEVAL SYSTEM, WITHOUT THE WRITTEN PERMISSION OF RAINDECK. WHERE A CONTRACTOR'S NAME APPEARS ON THIS DRAWING, IT IS THE PROPERTY OF SAID CONTRACTOR EXCEPT BY AGREEMENT WITH SAID CONTRACTOR.

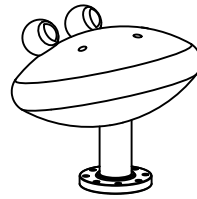
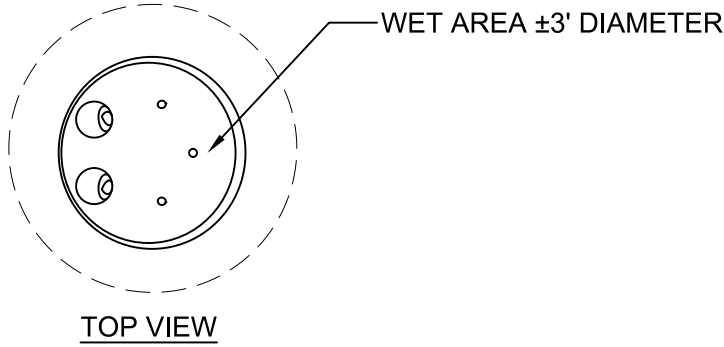

SCALE
N.T.S.

| REV. | DATE | BY | DESCRIPTION |
|------|------|----|-------------|
| △ | | | |
| △ | | | |
| △ | | | |
| △ | | | |
| △ | | | |

RAIN DECK
SS TOAD

SPECIFICATIONS:

- MATERIAL: STAINLESS STEEL
- SURFACE FINISH: POWDER COAT
- WATER PRESSURE: MIN. 5 PSI
- WATER CONSUMPTION: 5-20 GPM

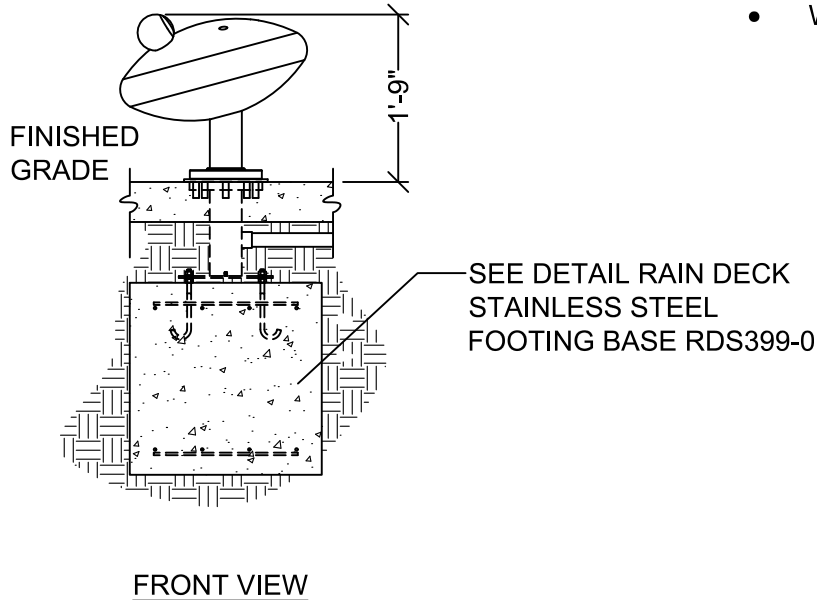

SS TOAD
RDS366-0

SEAL

DATE

| | | | |
|-------------|-----------|-------------|----|
| DRAWN BY | RS | REVIEWED BY | LB |
| DATE | OCT. 2019 | | |
| SHEET | | | |
| - Page 89 - | | | |

SCALE
1/2"=1'-0"

RD150-0
LCJ ADJUSTABLE

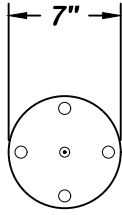

TOP VIEW

INCLUDES:

- **STAINLESS STEEL BOLTS AND GASKET**

SPECIFICATIONS:

- **MATERIAL: ANODIZED ALUMINIUM**
(AVAILABLE IN MULTIPLE COLORS)
- **EFFECTIVE WET AREA - ±5'-6' HIGH w/ A MAX.**
12' THROW
- **FLOW RATE: 4 gpm**
- **WATER PRESSURE: 3 - 5psi**

**LCJ ADJUSTABLE
RD150-0**

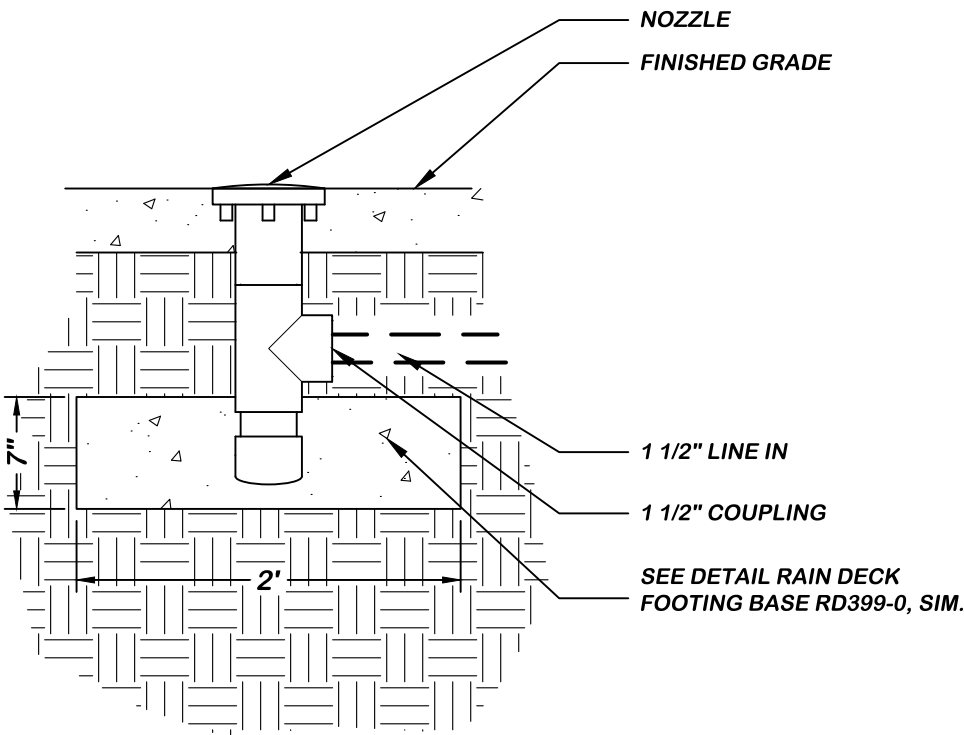

FRONT VIEW

RAINDECK
Ph. 888.445.RAIN
Fax. 866.869.3942
info@raindeck.com

THIS DRAWING IS AN INSTRUMENT OF SERVICE AND THE PROPERTY OF RAINDECK. IT IS TO BE USED ONLY FOR THE PROJECT AND SITE SPECIFICALLY IDENTIFIED HEREIN. IT IS NOT TO BE REPRODUCED, COPIED, REPRODUCED OR TRANSMITTED IN ANY FORM OR BY ANY MEANS, ELECTRONIC OR MECHANICAL, INCLUDING PHOTOCOPYING, RECORDING, OR BY ANY INFORMATION STORAGE AND RETRIEVAL SYSTEM, WITHOUT THE WRITTEN PERMISSION OF RAINDECK. WHERE A CONTRACTOR'S NAME APPEARS ON THIS DRAWING, IT IS THE PROPERTY OF SAID CONTRACTOR EXCEPT BY AGREEMENT WITH SAID CONTRACTOR.

| REV. | DATE | BY | DESCRIPTION |
|------|------|----|-------------|
| △ | | | |
| △ | | | |
| △ | | | |
| △ | | | |
| △ | | | |

**RAIN DECK
LARGE COMMERCIAL JET
ADJUSTABLE NOZZLE**

SEAL

DATE

DRAWN BY: **RS** REVIEWED BY: **JW**

DATE: **MAY 2017**

SHEET

- Page 90 -

**SCALE
N.T.S**

THIS DRAWING IS AN INSTRUMENT OF SERVICE AND THE PROPERTY OF RAINDECK. IT IS TO BE USED ONLY FOR THE PROJECT AND SITE SPECIFICALLY IDENTIFIED HEREIN. IT IS NOT TO BE REPRODUCED, COPIED, REPRODUCED OR TRANSMITTED IN ANY FORM OR BY ANY MEANS, ELECTRONIC OR MECHANICAL, INCLUDING PHOTOCOPYING, RECORDING, OR BY ANY INFORMATION STORAGE AND RETRIEVAL SYSTEM, WITHOUT THE WRITTEN PERMISSION OF RAINDECK. WHERE A CONTRACTOR'S NAME APPEARS ON THIS DRAWING, IT IS THE PROPERTY OF SAID CONTRACTOR AND NOT THE PROPERTY OF RAINDECK. SAID CONTRACTOR ACCEPTS BY AGREEMENT WITH SAID CONTRACTOR.

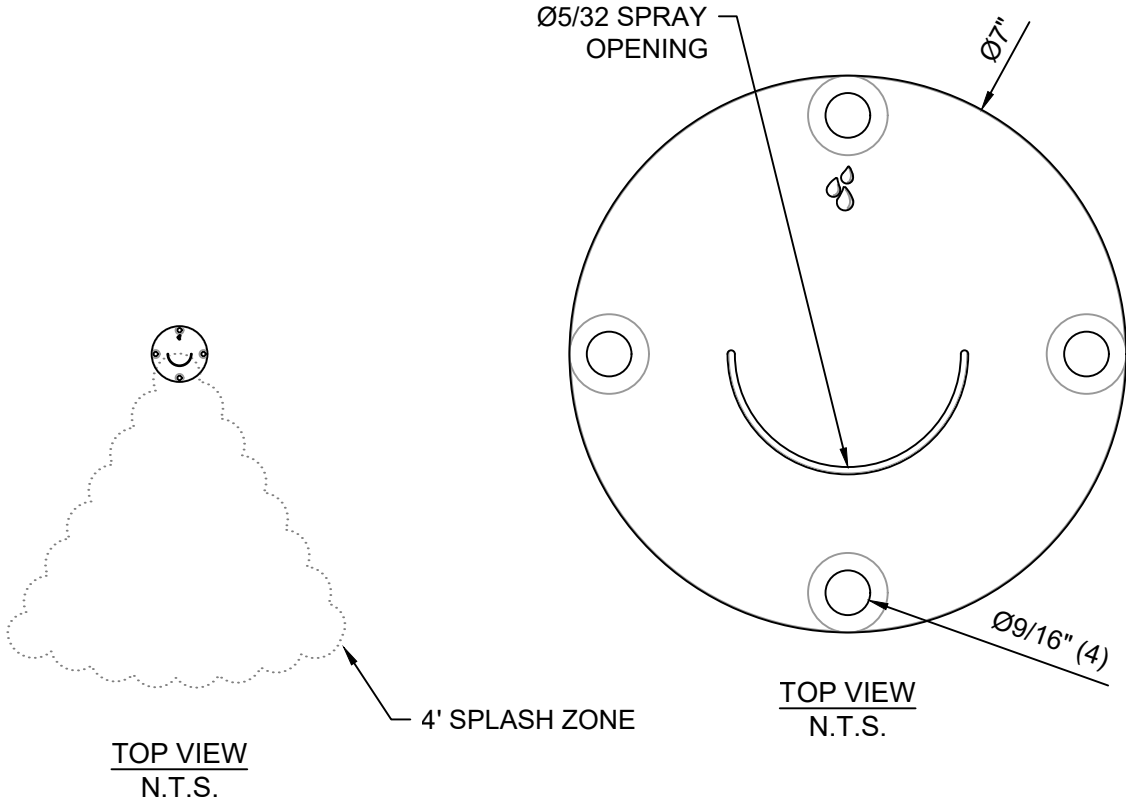

| REV. | DATE | BY | DESCRIPTION |
|------|------|----|-------------|
| Δ | | | |
| Δ | | | |
| Δ | | | |
| Δ | | | |
| Δ | | | |

SPECIFICATIONS:

- PLATE / NOZZLE MATERIAL: ANODIZED ALUMINUM (AVAILABLE IN MULTIPLE COLORS)
- WATER PRESSURE: 1 - 5PSI
- WATER CONSUMPTION: 15.75 GPM TYP.
- EFFECTIVE WET AREA - ±4' HIGH w/ A MAX. 4' THROW

RD WAVE JET
RD155-0

INCLUDES:

- RAIN JET HOUSING
- ADJUSTABLE PLATE w/ STAINLESS STEEL BOLTS AND GASKET

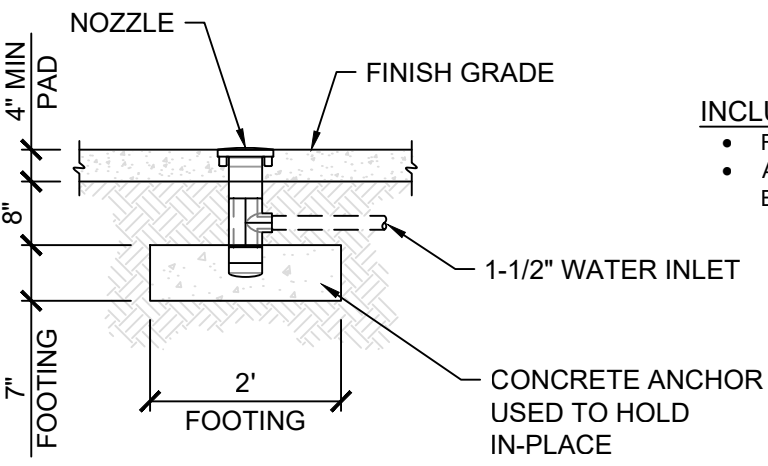

FRONT VIEW

**RAIN DECK
WAVE JET**

SEAL

DATE

| | |
|-------------|-------------|
| DRAWN BY | REVIEWED BY |
| QB | LB |
| DATE | |
| JUNE 2019 | |
| SHEET | |
| - Page 91 - | |

THIS DRAWING IS AN INSTRUMENT OF SERVICE AND THE PROPERTY OF RAINDECK. IT IS TO BE USED ONLY FOR THE PROJECT AND SITE SPECIFICALLY IDENTIFIED IN THE ORDER. IT IS NOT TO BE REPRODUCED, COPIED, REPRODUCED OR TRANSMITTED IN ANY FORM OR BY ANY MEANS, ELECTRONIC OR MECHANICAL, INCLUDING PHOTOCOPYING, RECORDING, OR BY ANY INFORMATION STORAGE AND RETRIEVAL SYSTEM, WITHOUT THE WRITTEN PERMISSION OF RAINDECK. RAINDECK ASSUMES NO LIABILITY FOR ANY DAMAGE OR INJURY TO PERSONS OR PROPERTY CAUSED BY THE USE OF THIS PRODUCT. RAINDECK SHALL NOT BE LIABLE FOR ANY DAMAGE OR INJURY TO PERSONS OR PROPERTY CAUSED BY THE USE OF THIS PRODUCT. RAINDECK SHALL NOT BE LIABLE FOR ANY DAMAGE OR INJURY TO PERSONS OR PROPERTY CAUSED BY THE USE OF THIS PRODUCT.

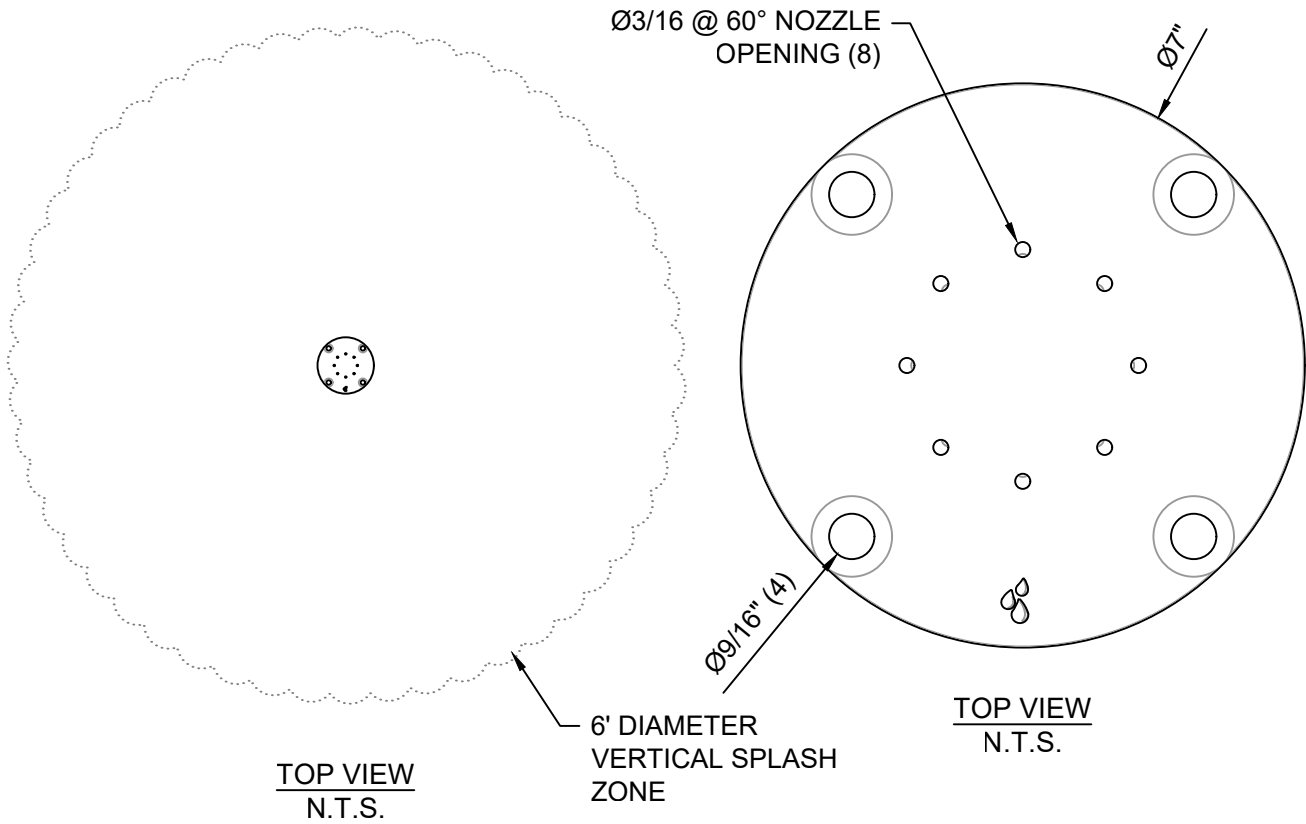

| REV. | DATE | BY | DESCRIPTION |
|------|------|----|-------------|
| Δ | | | |
| Δ | | | |
| Δ | | | |
| Δ | | | |
| Δ | | | |

- SPECIFICATIONS:**
- PLATE / NOZZLE MATERIAL: ANODIZED ALUMINUM (AVAILABLE IN MULTIPLE COLORS)
 - WATER PRESSURE: 3 - 5PSI
 - WATER CONSUMPTION: 8.75 GPM TYP (7.0 MIN / 15.0 MAX)
 - EFFECTIVE WET AREA - ±5'-6' HIGH w/ A MAX. 6' THROW

RD SPIDER JET
RD152-0

- INCLUDES:**
- RAIN JET HOUSING
 - ADJUSTABLE PLATE w/ STAINLESS STEEL BOLTS AND GASKET

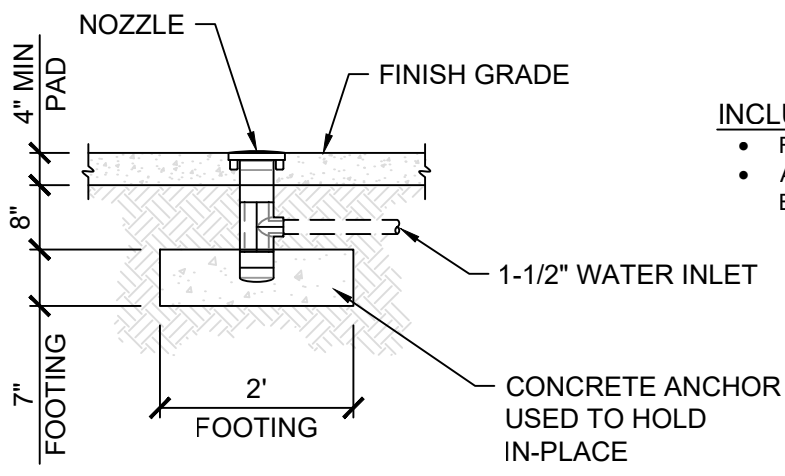

FRONT VIEW

**RAIN DECK
SPIDER JET**

SEAL

DATE

| | |
|-------------------|-------------------|
| DRAWN BY QB | REVIEWED BY LB |
| DATE JUNE 2019 | |
| SHEET | |

RDS550-1 SS CURVED SOF-TOUCH ACTIVATOR



Ph. 888.445.RAIN
Fax. 866.869.3942
info@raindeck.com

THIS DRAWING IS AN INSTRUMENT OF SERVICE AND THE PROPERTY OF RAINDECK. IT IS TO BE USED ONLY FOR THE PROJECT AND SITE SPECIFICALLY IDENTIFIED HEREIN. IT IS NOT TO BE REPRODUCED, COPIED, REPRODUCED OR TRANSMITTED IN ANY FORM OR BY ANY MEANS, ELECTRONIC OR MECHANICAL, INCLUDING PHOTOCOPYING, RECORDING, OR BY ANY INFORMATION STORAGE AND RETRIEVAL SYSTEM, WITHOUT THE WRITTEN PERMISSION OF RAINDECK. WHERE A CONTRACTOR'S NAME APPEARS ON THIS DRAWING, IT IS THE PROPERTY OF THAT CONTRACTOR AND NOT RAINDECK'S. RAINDECK ACCEPTS NO LIABILITY FOR ANY DAMAGE OR LOSS OF ANY KIND, INCLUDING CONSEQUENTIAL DAMAGES, ARISING FROM THE USE OF THIS DRAWING, WHETHER OR NOT SUCH DAMAGE OR LOSS IS CAUSED IN WHOLE OR IN PART BY THE NEGLIGENCE OF RAINDECK OR ANY OF ITS EMPLOYEES, AGENTS, OR CONTRACTORS.

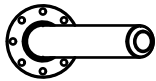

TOP VIEW



SCALE
N.T.S.

| REV. | DATE | BY | DESCRIPTION |
|------|------|----|-------------|
| △ | | | |
| △ | | | |
| △ | | | |
| △ | | | |
| △ | | | |

INCLUDES:

- SOF-TOUCH POST MOUNTED ACTIVATOR
- PROXIMITY SENSOR
- RAIN DECK SS FOOTING BASE w/ CAP
- STAINLESS STEEL BOLTS AND GASKET

SPECIFICATIONS:

- MATERIAL: STAINLESS STEEL w/ DELRIN ACTIVATOR
- SURFACE FINISH: POWDER COAT
- WIDTH: 4-1/2" O.D. SS PIPE
- HEIGHT: 40" (FROM FINISHED GRADE - CUSTOM SIZES AVAILABLE)

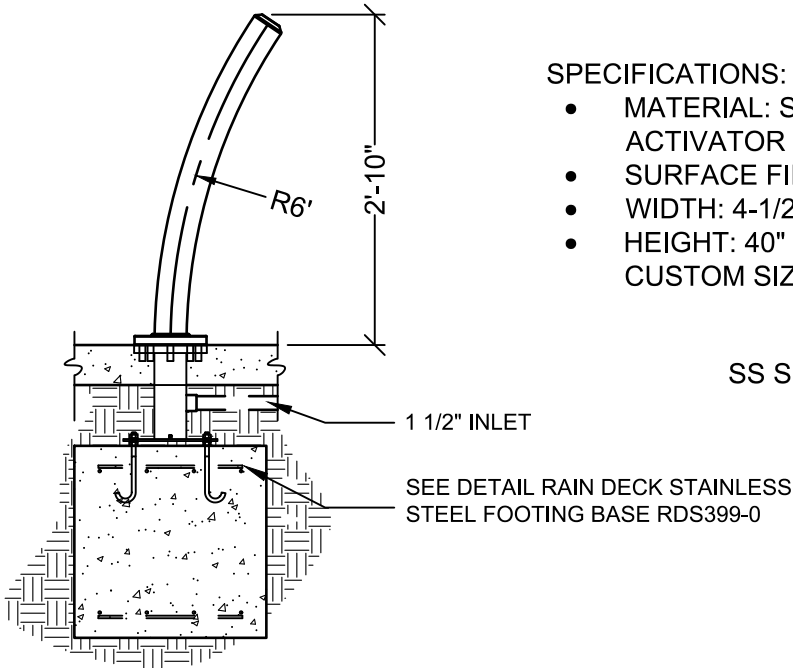

**SS SOF-TOUCH ACTIVATOR
RDS550-1**

FRONT VIEW

SCALE
1/2"=1'-0"

RAIN DECK
SS SOF-TOUCH ACTIVATOR

| | |
|------|--|
| SEAL | |
| DATE | |

| | |
|-----------------------|--------------------------|
| DRAWN BY RS | REVIEWED BY LB |
| DATE OCT. 2020 | |
| SHEET | |
| - Page 93 - | |

RD500-0
RAIN DECK CONTROLLER

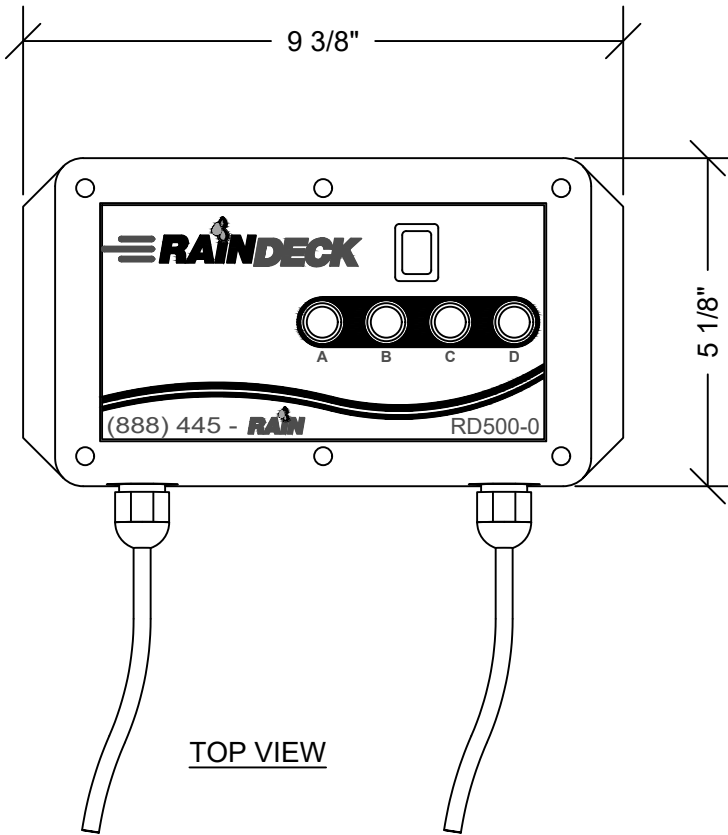

TOP VIEW

SCALE
N.T.S.

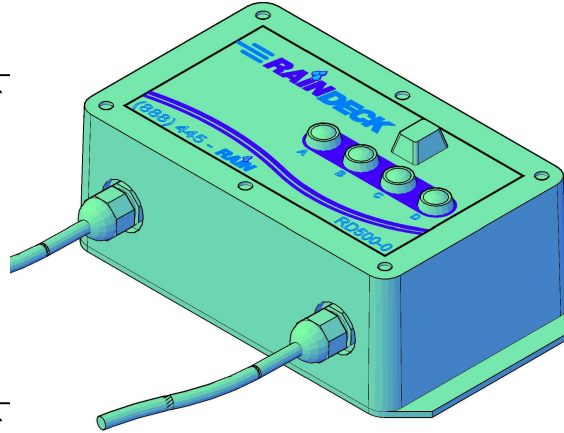

THE RAIN DECK PROPRIETARY ELECTRONIC CONTROLLER SETS THE INDUSTRY STANDARD FOR SPLASH PAD CONTROL SYSTEMS. THE RAIN DECK CONTROLLER PROVIDES THE USER WITH 4 PROGRAM SELECTIONS AND THE ABILITY TO USE WITH A FRESH WATER OR RECIRCULATION SYSTEM. THE CONTROLLER IS POWERED BY A STANDARD 100V POWER SUPPLY WITH CONNECTIONS FOR STANDARD 24VAC SOLENOID VALVES.

PROGRAMS:

- A. ONE ZONE RANDOM
- B. ONE ZONE SEQUENTIAL
- C. MULTIPLE ZONE RANDOM
- D. ALL ON

*NUMBER OF ZONES AND SPEED CYCLES CAN BE ADJUSTED ON-SITE. FOR ANY OTHER PROGRAMING QUESTIONS, PLEASE CONTACT RAIN DECK.

RAIN DECK CONTROLLER
RD500-0

RAINDECK
Ph. 888.445.RAIN
Fax. 866.869.3942
info@raindeck.com

THIS DRAWING IS AN INSTRUMENT OF SERVICE AND THE PROPERTY OF RAIN DECK. IT IS TO BE USED ONLY FOR THE PROJECT AND SITE SPECIFICALLY IDENTIFIED HEREIN. IT IS NOT TO BE REPRODUCED, COPIED, OR REPRODUCED IN ANY MANNER WITHOUT THE WRITTEN PERMISSION OF RAIN DECK. THIS DRAWING IS TO BE USED UNLESS PROPERLY SEALED AND APPROVED. PUBLICATION OF THIS DRAWING BY ANY METHOD IN WHOLE OR IN PART WITHOUT THE WRITTEN PERMISSION OF RAIN DECK WHERE A CONTRACTOR'S NAME APPEARS ON THIS DRAWING IS STRICTLY PROHIBITED. THIS DRAWING IS THE PROPERTY OF RAIN DECK. CONTRACTOR ACCEPTS BY AGREEMENT WITH SAME CONTRACTOR.

| REV. | DATE | BY | DESCRIPTION |
|------|------|----|-------------|
| △ | | | |
| △ | | | |
| △ | | | |
| △ | | | |
| △ | | | |

RAIN DECK
RAIN DECK CONTROLLER

SEAL

DATE

| | | | |
|-------------|------------|-------------|----|
| DRAWN BY | RS | REVIEWED BY | RV |
| DATE | MARCH 2014 | | |
| SHEET | | | |
| - Page 94 - | | | |

RD428-0
16" BOX DRAIN

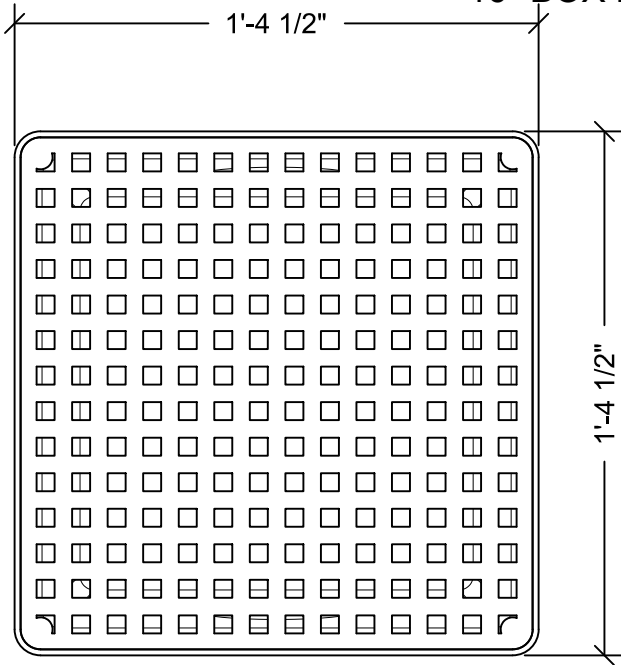

TOP VIEW

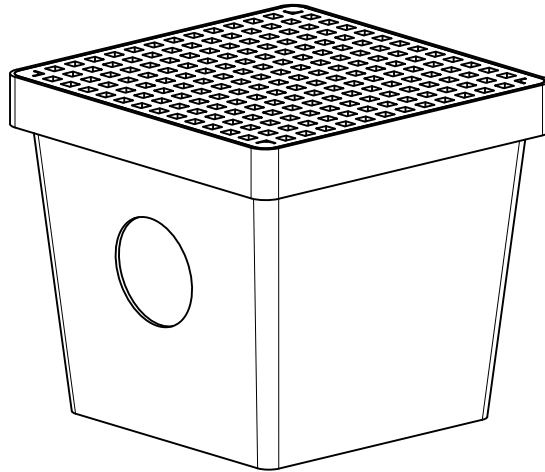

SCALE
N.T.S.

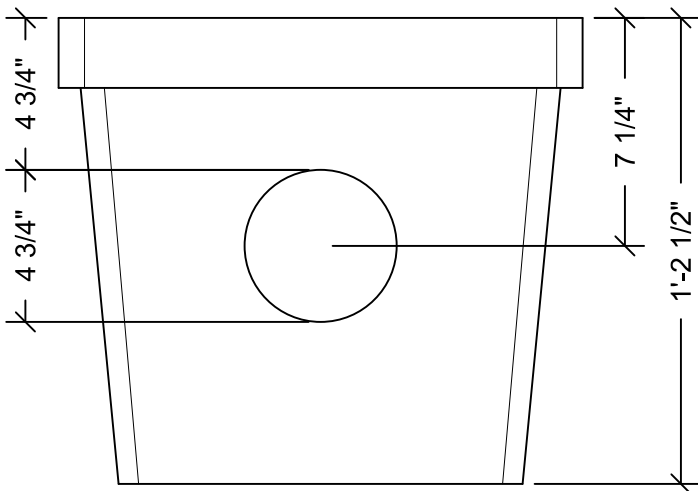

FRONT VIEW

SPECIFICATIONS:

- MATERIALS: MOLDED HIGH-DENSITY POLYETHYLENE
- ADA COMPLIANT
- AVAILABLE WITH 2, 3, OR 4-HOLE DRAIN SUMP

16" BOX DRAIN

RAINDECK
Ph. 888.445.RAIN
Fax. 866.869.3942
info@raindeck.com

THIS DRAWING IS AN INSTRUMENT OF SERVICE AND THE PROPERTY OF RAINDECK. IT IS TO BE USED ONLY FOR THE PROJECT AND SITE SPECIFICALLY IDENTIFIED HEREIN. IT IS NOT TO BE REPRODUCED, COPIED, OR REPRODUCED IN ANY MANNER WITHOUT THE WRITTEN PERMISSION OF RAINDECK. RAINDECK SHALL NOT BE LIABLE FOR ANY DAMAGE OR INJURY TO PERSONS OR PROPERTY ARISING FROM THE USE OF THIS DRAWING BY ANY METHOD IN WHOLE OR IN PART. RAINDECK'S NAME APPEARS ON THIS DRAWING AS THE DESIGNER OF RECORD. CONTRACTOR SHALL BE RESPONSIBLE FOR OBTAINING ALL NECESSARY PERMITS AND APPROVALS. CONTRACTOR SHALL BE RESPONSIBLE FOR OBTAINING ALL NECESSARY PERMITS AND APPROVALS. CONTRACTOR SHALL BE RESPONSIBLE FOR OBTAINING ALL NECESSARY PERMITS AND APPROVALS.

| REV. | DATE | BY | DESCRIPTION |
|------|------|----|-------------|
| △ | | | |
| △ | | | |
| △ | | | |
| △ | | | |
| △ | | | |

RAIN DECK
16" BOX DRAIN

SEAL

DATE

| | |
|---------------------------|--------------------------|
| DRAWN BY RS | REVIEWED BY RV |
| DATE APRIL 2014 | |
| SHEET | |
| - Page 95 - | |

Our warranty starts with our unmatched customer support. If, at any stage of your splash pad project you need support, we can help!

From installation, to winterizing, to spring start-up we offer the support you need. There is never any additional charge for any of our support services for any of our clients. **Unless otherwise stated below, Rain Deck shall warrant all products for a period of one year from the date of product shipment.**

WARRANTY

25 YEAR WARRANTY on all commercial stainless steel above ground feature pipes and welds.

25 YEAR WARRANTY on all stainless-steel footing base tubing and welds.

2 YEAR WARRANTY against peeling or fading on all finish coatings.

LIFETIME WARRANTY on all Rain Deck UHMW, PVC or Delrin spray jet housings and nozzles.

5 YEAR WARRANTY on all brass, stainless steel and aluminum housings and nozzles.

5 YEAR WARRANTY on all tanks and cisterns.

Rubber surfacing granules and binder carry a warranty on the product only. If there is a defect with the rubber granules or binder within one year of receiving the product, please contact Rain Deck. Rain Deck does NOT warranty the installation of the rubber surfacing and extends NO warranty after the rubber granules have been mixed with the binder.

On all powder coated or painted features, Rain Deck, at its discretion has the option of sending touch-up paint in lieu of replacing the feature.

Although our products should last far beyond their warranty period, should you have any warranty issues, please contact Rain Deck by calling 888- 445-RAIN, faxing 866 -869-3942 or emailing warranty@raindeck.com.





Bio of Splash Zone, LLC

Splash Zone was established in 2005 to meet the growing demands of commercial splash pad installations. In the years leading up to the formation of Splash Zone, the founders worked in the pool and construction industry supervising commercial pool projects with some of the largest pool companies in the industry. The projects ranged in scope from multi use apartment complex pools to specialty projects including the Sting Ray Bay at the Phoenix Zoo. During this time, there was an increased interest in splash pad installations; although there was not a single company that specialized in these projects. Due to the demand for commercial splash pad installations and the lack of expertise in the industry, Splash Zone, LLC was formed.

Our unique approach to splash pad installations allows us to be more versatile and more affordable. We have established a wide range of vendor relationships and have the ability to design and install splash pads that are unmatched in quality and generally offer far more water features than any competitor. Also, due to our installation experience and knowledge of splash pads, we take pride in completing every project within budget while exceeding expectations.

In the 15 years since Splash Zone was established, we have seen the industry boom. We have installed over 300 splash pads across the United States. Our projects range in size from residential splash pads with 8 spray jets to commercial splash pads with nearly every bell and whistle one can imagine. We operate with 4 crews, a designer and a professional engineer and are capable of completing large scale projects from start to finish.

At Splash Zone, we take pride in knowing that we are the industry leader in splash pad innovation and installations. We have installed more splash pads and have more experience than any other company in the country.

To protect the interest of our clients, Splash Zone carries a minimum 1 million dollar general liability policy and includes each project as an additional insured on the policy. We also come highly recommended by our bonding company and can acquire performance and payment bonds if required.

Regardless of project size, Splash Zone will make every effort to make each splash pad as unique as possible. We look forward to working with you!

For additional information, we can be reached at 800-985-3031 or you can check out our web site at www.SplashZone.com.



COMPANY APPROACH / CONTACT INFO

EQUIPMENT PROVIDER MAIN CONTACT:

Rain Deck, LLC.
Jennifer Heflin
O: 888-445-7246 x 719
E: Jennifer@raindeck.com

PRIME CONTRACTOR:

Splash Zone, LLC (AZROC 227061)
7319 S Atwood, Ste 103 Mesa, AZ 85212
O: 800-985-3031
F: 866-869-3942

DESIGN/ENGINEERING FIRM:

Splash Zone, LLC—In-House
Engineer: Ashton Avarell, P.E.
P: 800-985-3031 ext. 713

ELECTRICIAN:

Four Star Electric, LLC (ROC 257106, 257105)
Eric Boudreau
C: 480-452-9862
O: 480-567-8013
F: 602-710-1227

Splash Pad Project Superintendent: Jake Wirthlin 800-985-3031 x. 717
Splash Pad Project Coordinator: Jennifer Heflin 800-985-3031 x 719



PROJECT TEAM ORGANIZATION

Splash Zone has three primary team members to manage each commercial project. The team members assigned to this project and their responsibilities are as follows:

Project Manager – Jake Wirthlin

The project manager is responsible for the overall management of the team members. This includes making sure deadlines are met, product procurement is complete and on schedule and the project is meeting or exceeding benchmarks and deadlines. Additional responsibilities include the approval of all project bids and client interaction and communication. All communication should be directed through the Project Manager and he will be the main point of contact throughout the construction process.

Project Superintendent – Bruce Beauchamp

The project superintendent is responsible for the daily project tasks. He reports directly to the Project Manager. The Superintendent is on site daily and oversees the construction practices of our employees and subcontractors. The project superintendent is required to keep a detailed daily log of events, which is reviewed daily at 4:30pm in our management meeting. All communication with the client and the superintendent is reported daily at the management meeting to avoid communication problems and ensure that all communication is relayed to the Project Manager.

Project Coordinator – Jennifer Heflin

The Project Coordinator is responsible for ensuring that the project superintendent and manager have all the resources required to successfully complete their jobs. Once a contract is executed, the Project Coordinator begins the process of procuring the product required for the project. The Project Coordinator is also responsible for all the tasks related to general paperwork such as additional insured requirements, lien release waivers and other similar project related tasks.

The management team also meets daily to recap the daily events, plan for the following day/week, and update the client as to the project status.



SPLASH ZONE AND THE LOCAL ECONOMY

As the only company in the United States that specializes in installing Splash Pads, Splash Zone is able to competitively bid on projects across the country. One of the main concerns that often comes up is the desire of local towns and cities to use local contractors. Of course, this makes perfect sense and Splash Zone agrees that local municipalities should do what is in the best interest for their community.

We believe that by using Splash Zone, your community will receive the local impact desired for these reasons:

1. Splash zone generally offers more splash pad for less money. Our unique approach to specializing in splash pad installations allows us to be extremely efficient at what we do! Our bulk supplier purchasing allows us to be financially competitive saving the residents tax dollars and providing them with a product that they can truly enjoy.
2. Splash Zone uses local suppliers for plumbing supplies, materials, and concrete for each project in the local community. We work with local suppliers for all of our plumbing supplies, fittings and other project material during the course of construction and always order concrete from a local plant. We also rent equipment such as tractors and jackhammers within the local community if available.
3. Splash Zone uses local contractors for forming and finish work on the splash pad surface.
4. During the course of construction, Splash Zone requires the use of local lodging and dining establishments for the entire crew. This additional expense to Splash Zone goes directly back into the community and is included as part of logistics in each of our bids.
5. Splash Zone continues to donate each year to several communities we have had the pleasure of working with and we are generally eager to assist in grand opening events or other related events surrounding the start-up of a new splash pad.

Regardless of who is chosen as the successful bidder, we appreciate the opportunity to bid on this project and know your residents will enjoy the addition of a new splash pad!!

Sincerely,

The Splash Zone Team



SPLASH ZONE RECENT PROJECT HISTORY

| COMMERCIAL PROJECT NAMES | LOCATION/CONTACT INFO | YEAR COMPLETED | PROJECT BUDGET |
|---|---|--------------------------|-------------------|
| LYNNE VILLAGE HOA | PHOENIX | AZ UNDER CONTRACT | \$ 69,020 |
| CITY OF RAWLINS | RAWLINS | WY UNDER CONTRACT | \$ 110,664 |
| THE PARK AT FAIRFAX & 29TH | DENVER | CO UNDER CONTRACT | \$ 53,969 |
| CITY OF BICKNELL | BICKNELL | IN UNDER CONTRACT | \$ 103,429 |
| YMCA - PIKEVILLE | PIKEVILLE | KY UNDER CONTRACT | \$ 80,334 |
| ARROYO ROJO HOA | PHOENIX | AZ UNDER CONTRACT | \$ 69,020 |
| CITY OF BELLFLOWER | BELLFLOWER | CA IN PROGRESS | \$ 175,491 |
| WILLIS GATED COMMUNITY | CHANDLER | AZ IN PROGRESS | \$ 64,091 |
| WEST GRANITE CREEK PARK | PRESCOTT | KY IN PROGRESS | \$ 195,891 |
| GOODFELLOW AIR FORCE BASE | SAN ANGELO | TX 2020 | \$ 334,165 |
| Tyler Walter 6391 Aviation Cir., Loveland, CO 80538 | 303-485-9461 twalter@hditeam.com | | |
| PECOS APARTMENTS | PECOS CITY | TX 2020 | \$ 69,725 |
| Jovani Tarango 8900 Washington St., NE., Albuquerque, NM 87113 | 505-220-5860 jtarango@pavilionconstruction.com | | |
| MAGMA RANCH | FLORENCE | AZ 2020 | \$ 65,858 |
| Rob Arend 549 E. Barbarita Ave., Gilbert, AZ 85234 | 602-570-2808 asspruceup@gmail.com | | |
| WALKER COURT APARTMENTS | COLUMBIA | TN 2020 | \$ 109,574 |
| Nick Solima 1898 Nolensville Rd., Nashville, TN 37210 | 615-259-1516 nsolima@bacar.com | | |
| CITY OF SUMAS | SUMAS | WA 2020 | \$ 149,109 |
| Sunny Aulakh 433 Cherry St., Sumas, WA 98295 | 360-988-5711 saulakh@cityofsumas.com | | |
| CARUTHERS PARK | BELLFLOWER | CA 2020 | \$ 175,491 |
| Gustavo Anaya 10500 Flora Vista St., Bellflower, CA 90706 | 909-622-2259 gayana@reyesconstruction.com | | |
| CRISMON GATEWAY VILLAGE | MESA | AZ 2020 | \$ 19,946 |
| Greg Ringle 1845 S. Crismon Road, Mesa, AZ 85209 | 602-370-2397 jringler@derekengineering.com | | |
| BEALE AIR FORCE BASE | BEALE | CA 2020 | \$ 263,104 |
| Balfor Beatty 3340 Camp Beale Hwy, Wheatland, CA 95903 | 909-721-0948 rasurgeon@bbcgrp.com | | |
| MOUNTAIN LAKES RESORT | LYTLE CREEK | CA 2020 | \$ 577,841 |
| Jay Sullivan 277 Lytle Creek Road, Lytle Creek, CA 92358 | 909-721-0948 jays@burlingameindustries.com | | |
| MORENO VALLEY RANCH HOA | MORENO VALLEY | CA 2019 | \$ 269,390 |
| Norma Zermeno 16010 Rancho Del Lago, Moreno Valley, CA 92551 | 951-485-2020 gm@morenovalleyranch.com | | |
| BROOK HILLS PARK | WELLSBURG | VA 2019 | \$ 171,498 |
| Luke Diserio 140 Gist Lane, Wellsburg, WV 26070 | 800-223-3444 luke@amdocks.com | | |
| NORTH PARK | JEROME | ID 2019 | \$ 161,151 |
| Greg McEntarffer 300 East Main Street, Jerome, ID 83338 | 208-734-0455 greg@stanleyassociates.com | | |
| FORT DAVIS | WASHINGTON DC | DC 2019 | \$ 169,858 |
| Natarajan Satish 1400 41st Street SE, Washington DC, 20020 | 202-330-9519 nvsatish4@verizon.net | | |

| | | | | | |
|---|----------------------------------|-----------|-------------|-----------|----------------|
| CITY OF INGLEWOOD | INGLEWOOD | CA | 2019 | \$ | 205,274 |
| Juan Mata | 310-412-8750 | | | | |
| 201 South Ash Ave., Inglewood, CA 90301 | jmata@cityofinglewood.org | | | | |
| PARK WEST RETAIL | PEORIA | AZ | 2019 | \$ | 138,894 |
| Rob Kerwin | 602-750-7607 | | | | |
| 9804 West Northern Ave, Peoria, AZ 85345 | rkerwin@foursite.com | | | | |
| CITY OF SOMERTON | SOMERTON | AZ | 2018 | \$ | 164,430 |
| Sergio Davalos | 928-315-5850 | | | | |
| 143 North State Ave., Somerton, AZ 85350 | sergiodavalos@somertonaz.gov | | | | |
| BREA CENTRAL PARK #2 | BREA | CA | 2018 | \$ | 88,531 |
| Dan Ward | 714-336-0359 | | | | |
| 380 West Central Ave., Brea, CA 82821 | dward@jhrep.com | | | | |
| KIWANIS PARK | TEMPE | AZ | 2018 | \$ | 243,987 |
| Dan Pitt | 480-250-5452 | | | | |
| 6111 S. All America Way, Tempe, AZ 85283 | daniel_pitt@tempe.gov | | | | |
| BARTRAM SPRINGS | JACKSONVILLE | FL | 2018 | \$ | 140,260 |
| Jay King | 619-708-5164 | | | | |
| 475 West Town Pl., Ste 114, St. Augustine, FL 32092 | jaymesking@yahoo.com | | | | |
| BREA CENTRAL PARK #1 | BREA | CA | 2018 | \$ | 115,387 |
| Dan Ward | 714-336-0359 | | | | |
| 380 West Central Ave., Brea, CA 82821 | dward@jhrep.com | | | | |
| CORTINA HOA | QUEEN CREEK | AZ | 2018 | \$ | 93,970 |
| Kevin Bishop | 480-813-6788 | | | | |
| 633 E. Ray Rd., Ste 122, Gilbert, AZ 85142 | kevin@rcplimited.com | | | | |
| CITY OF PERRYVILLE | PERRYVILLE | MO | 2018 | \$ | 300,960 |
| Tracy Prost | 573-547-2594 | | | | |
| 215 North West Street | tracyprost@cityofperryville.com | | | | |
| VILLAS AT TUSTIN APARTMENTS | SANTA ANA | CA | 2018 | \$ | 72,480 |
| Ron Faulkner | 678-485-0566 | | | | |
| 16415 Addison Rd., Ste 575, Addison, TX 75001 | rfaulkner@capgro.net | | | | |
| LAS SENDAS | MESA | AZ | 2018 | \$ | 123,362 |
| Doug Austin | 480-357-8780 | | | | |
| 3250 N. Red Mountain | daustin@thetrailhead.org | | | | |
| CITY OF MIDDLETON | MIDDLETON | ID | 2018 | \$ | 262,410 |
| Becky Crofts | 208-585-3133 | | | | |
| 6 North Dewey Ave., Middleton, ID 83644 | bcrofts@middletoncity.com | | | | |
| PRIMROSE PRESCHOOL | SCOTTSDALE | AZ | 2018 | \$ | 49,000 |
| Mike Verlardi | 602-527-9911 | | | | |
| 10120 E Bell Rd., Scottsdale, AZ 85260 | mverlardi@primrosepv.vom | | | | |
| CROSSROADS COMMUNITY CHURCH | KOKOMO | IN | 2018 | \$ | 71,050 |
| Dick Sanburn | 765-453-4626 | | | | |
| 4254 S 00 EW, Kokomo, IN 46902 | dicksanburn@ecrossroads.org | | | | |
| CHICKAHOMINY RIVERFRONT PARK | WILLIAMSBURG | VA | 2018 | \$ | 230,000 |
| Kitty Hall | 757-253-6644 | | | | |
| 1350 John Tyler Highway, Williamsburg, VA 23185 | kitty.hall@jamescitycountyva.gov | | | | |
| SARATOGA RIDGE | PHOENIX | AZ | 2018 | \$ | 140,000 |
| Norm Schrock | 602-363-2682 | | | | |
| 1450 E Bell Rd., Phoenix, AZ 85022 | graybeardsaz@gmail.com | | | | |
| CITY OF CANON CITY | CANON CITY | CO | 2017 | \$ | 365,000 |
| Rex Brady | 719-371-2989 | | | | |
| 221 Griffen Ave., Canon City, CO 81212 | rtbrady@canoncity.org | | | | |

| | | | | | |
|---|---|-----------|-------------|-----------|----------------|
| FORT COLLINS KOA Craig Sisco 1910 Lakeside Resort Ln., Fort Collins, CO 80524 | FORT COLLINS 970-484-9880 info@fclakesidecg.com | CO | 2017 | \$ | 119,240 |
| ST. ANN'S HOME & SCHOOL John Rice 100A Haverhill St., Methuen, MA 01844 | METHUEN 978-682-5276 jrrice@stannshome.org | MA | 2017 | \$ | 123,270 |
| SACO KOA Mike Blitz 814 Portland Rd., Saco, ME 04072 | SACO 248-444-3608 mblitz@atwell-group.com | ME | 2017 | \$ | 88,880 |
| CITY OF CHESTERTON Mark O'Dell 1415 S. 23rd St., Chesterton, IN 46304 | CHESTERTON 219-728-1336 modell@chestertonin.org | IN | 2017 | \$ | 300,456 |
| CITY OF CENTRALIA Emil Pierson 539 North Pearl St., Centralia, WA 98531 | CENTRALIA 360-330-7662 e.pierson@cityofcentralia.com | WA | 2017 | \$ | 129,570 |
| BRATTONS EDGE Blair Pifer 6636 N Riverside Dr. Suite 500-A, Fort Worth, TX 76137 | AUSTIN 972-740-9914 blair@pinrocll.com | TX | 2017 | \$ | 125,970 |
| GILBERT MONTESSORI Parveen Gupta 135 s. Val Vista Dr., Mesa, AZ 85296 | GILBERT 623-414-7935 guptap4@gmail.com | AZ | 2017 | \$ | 87,530 |
| PARDEE HOMES Jay Skinner 19180 Golden Valley Rd., Santa Clarita, CA 91387 | SANTA CLARITA 310-345-4460 jay.skinner@pardeehomes.com | CA | 2017 | \$ | 169,175 |
| VICTORY WORSHIP CENTER Scott Berkey 2561 W Ruthrauff Rd., Tucson, AZ 85705 | TUCSON 520-293-6386 scottb@vwcaz.org | AZ | 2016 | \$ | 223,553 |
| WASHINGTON PARK Melissa Guerrero 15614 S Washington Ave., Compton, CA 90221 | COMPTON 213-572-0188 x201 mguerrero@lanlt.org | CA | 2016 | \$ | 135,500 |
| MADISON HEIGHTS Ben Shrunk 1110 N. Dysart Rd., Avondale, AZ 85323 | AVONDALE 480-225-4775 bshunk@gormanusa.com | AZ | 2016 | \$ | 136,803 |
| CITY OF ARGOS Jim Burroughs 10323 16th Rd., Argos IN, 46501 | ARGOS 574-281-2216 jwdjburroughs@gmail.com | IN | 2016 | \$ | 74,000 |
| CITY OF BOARDMAN Neil Livingston Front St. NE & 3rd St. N, Boardman, OR 97818 | BOARDMAN 509-293-1142 livingstonn@cityofboardman.com | OR | 2016 | \$ | 148,420 |



 **Queen Creek, Arizona**
Splash Zone, LLC



 **Chandler, Arizona**
Splash Zone, LLC

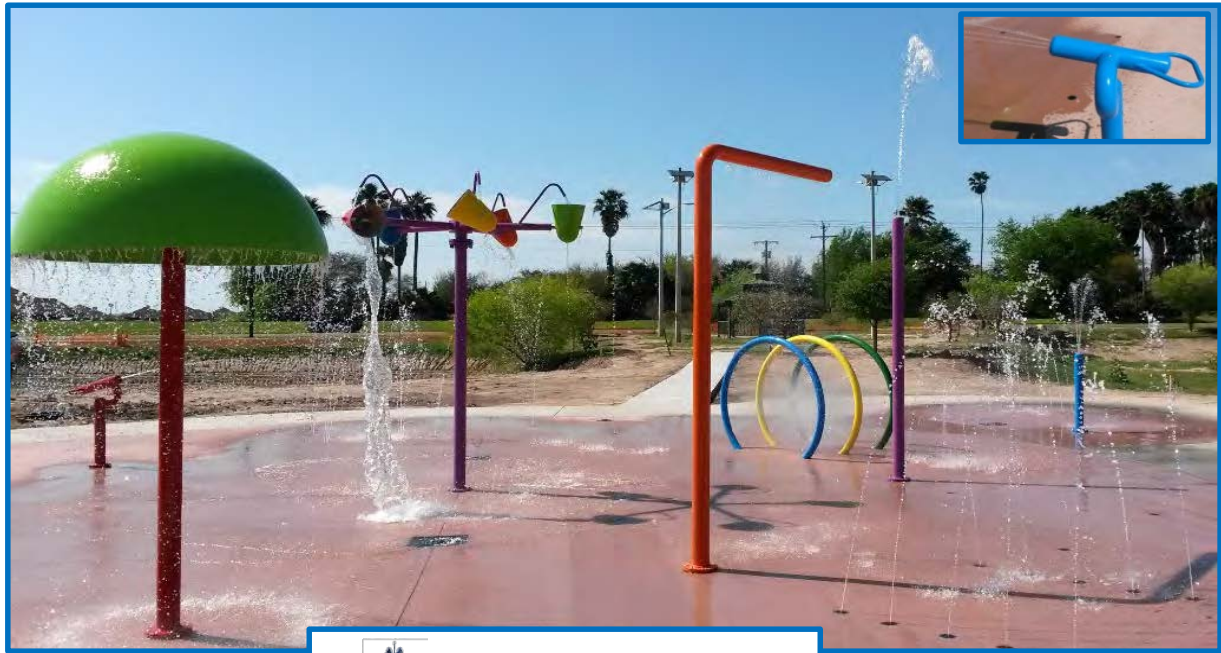

 **Edinburg, Texas**



 **Erinville, Louisiana**

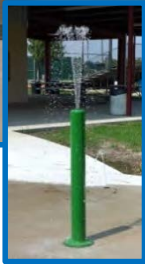



Bullhead City, Arizona



Galloway, New Jersey



Baton Rouge, Louisiana



Castle Rock, Colorado



 **Gilbert, Arizona**



 **Las Vegas, Nevada**

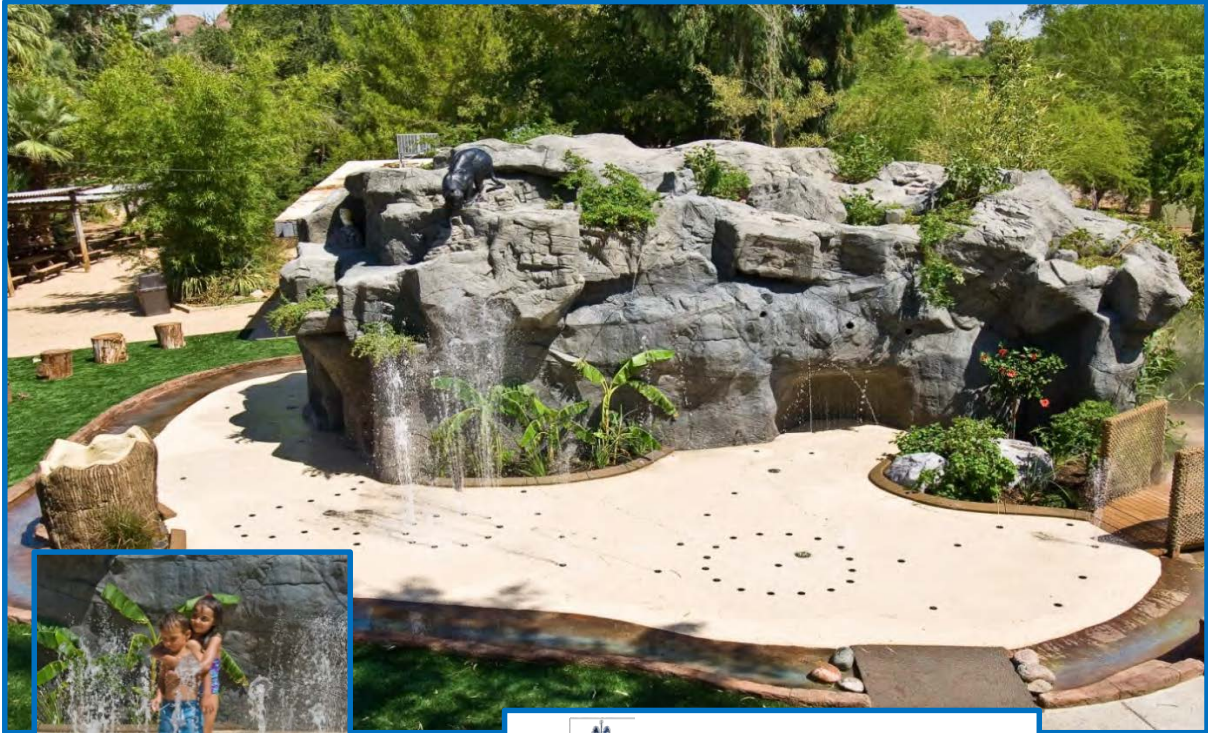

 **Phoenix, Arizona**



 **Eagle Mountain, Utah**



Calexico, California



Auburn, Alabama



 **Village of Gilberts, Illinois**
Splash Zone, LLC

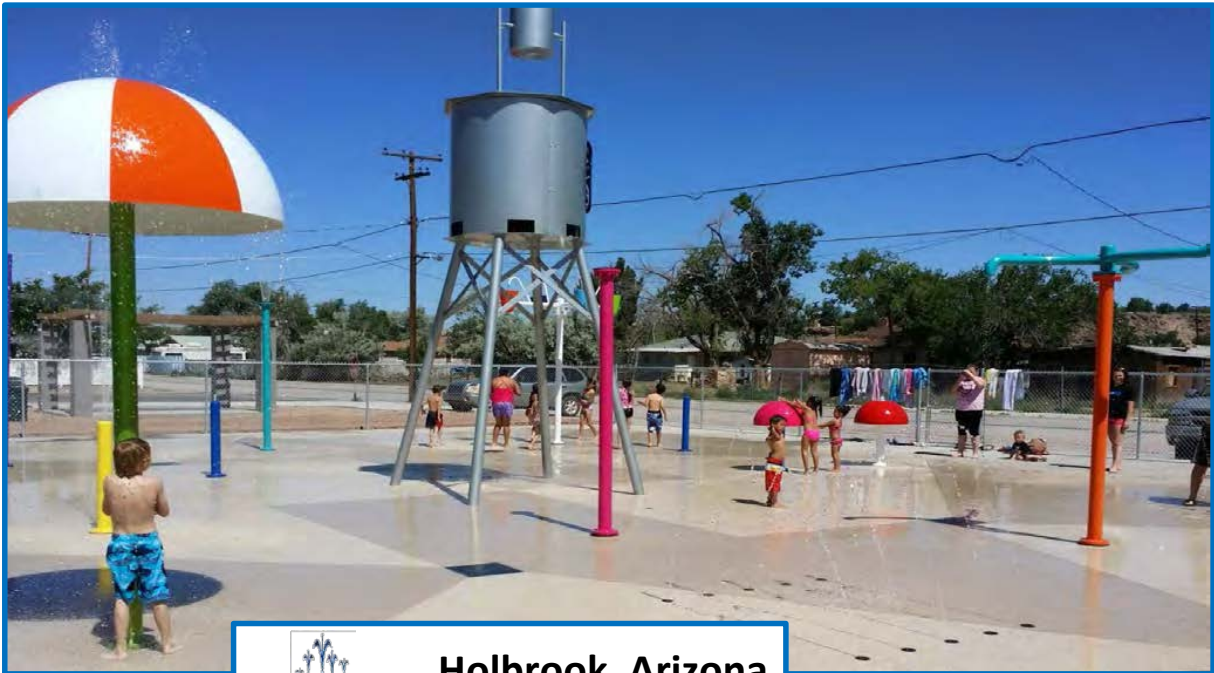

 **Holbrook, Arizona**
Splash Zone, LLC



Chesterton, Indiana

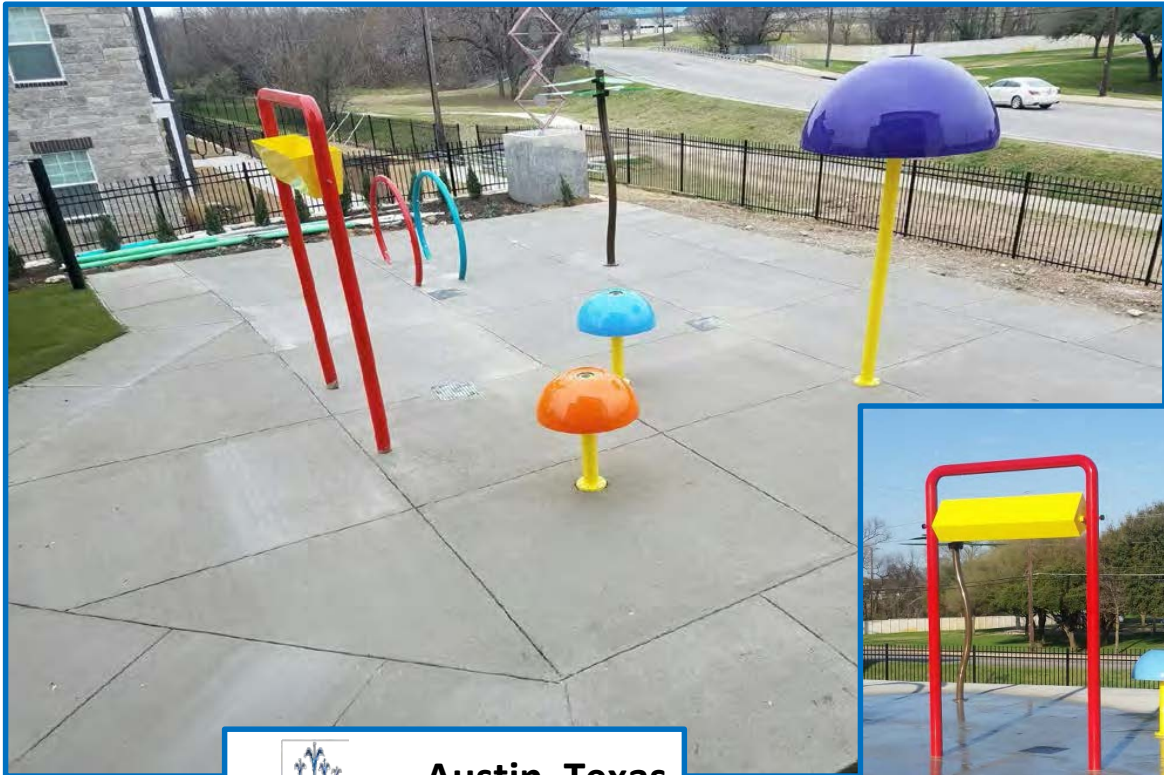

Austin, Texas



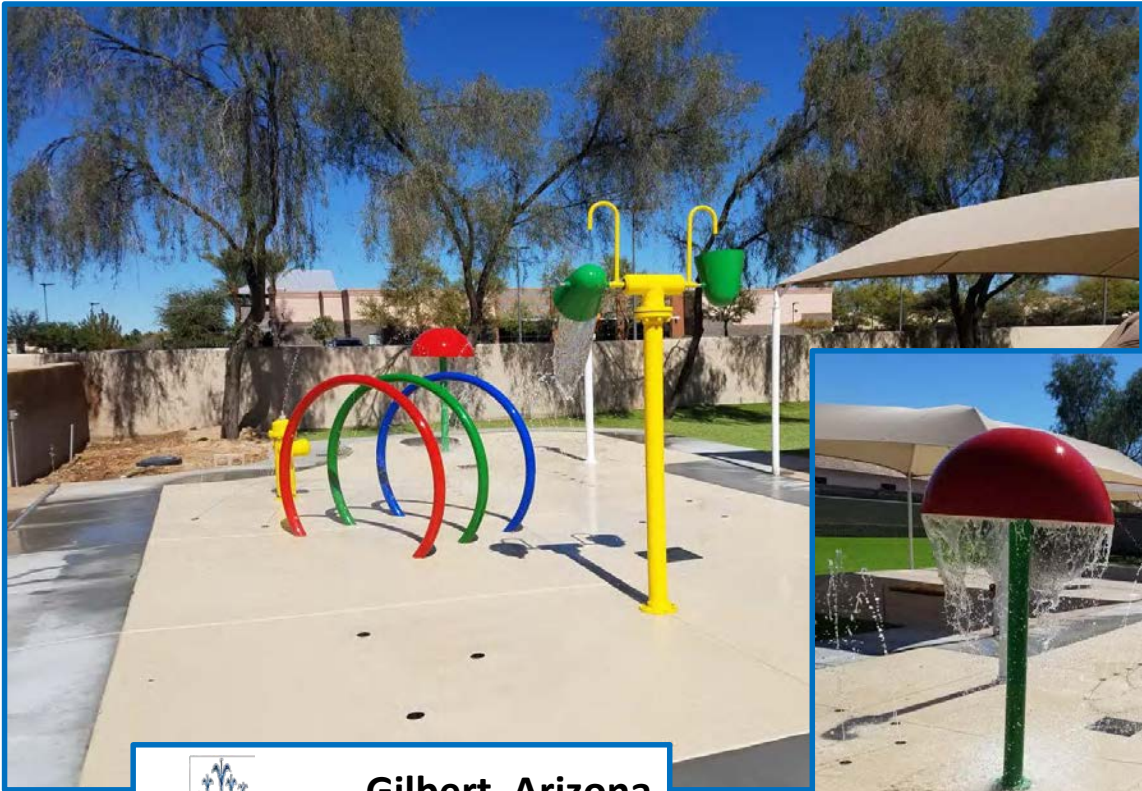

 **Gilbert, Arizona**



 **Santa Clarita, California**



**Tucson, Arizona**



**Avondale, Arizona**

2/27/2020

Re: Bonding Assurance: Splash Zone LLC
Mesa, AZ

Pre Qual Letter

To Whom it may concern:

Splash Zone is a valued bonding client of our agency. They have earned an excellent reputation both for the quality of their work as well as for completing their projects in a timely manner. They also have a seasoned and capable management team, known for their integrity in their contracting endeavors.

Splash Zone has handled all their projects in an excellent manner, with no bond claims that we are aware of.

Splash Zone has a single limit of \$1,000,000.00 and an aggregate of \$2,000,000.00. The surety is willing to entertain larger projects on a job-by-job basis.

Splash Zone is bonded by Ohio Casualty, licensed to do transact surety business in all 50 states and is a U.S. Treasury "A" rated Surety Company by A.M. Best.

This letter is not to be construed as an agreement to provide surety bonds for the any particular project but is to offer as an indication of our past experience and confidence in this firm. Their bonding company, Ohio Casualty, will consider issuance of final payment and performance bonds within the parameters mentioned heretofore. However, it reserves its right to modify its plans upon the review of the terms and conditions of any contract and contract bond forms, any underwriting information the surety deems pertinent and project financing.

Again, we highly recommend Splash Zone to you as an excellent prospective contractor. Should you have any questions, do not hesitate to contact our office.

Regards,

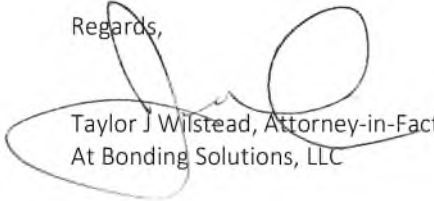

Taylor J Wilstead, Attorney-in-Fact
At Bonding Solutions, LLC



Stevensville Town Council Meeting

Agenda Item Request

To Be Submitted BEFORE Noon on the Wednesday before the Council Meeting

| | |
|---|---|
| Agenda Item Type: | New Business |
| Person Submitting the Agenda Item: | Stevensville Civic Club |
| Second Person Submitting the Agenda Item: | Joan Prather, President |
| Submitter Title: | Citizen |
| Submitter Phone: | |
| Submitter Email: | |
| Requested Council Meeting Date for Item: | 02/25/2021 |
| Agenda Topic: | Discussion/Decision: Location and Future Maintenance of the Stevensville Civic Club's Splash Deck Project |
| Backup Documents Attached? | Yes |
| If no, why not? | |
| Approved/Disapproved? | Approved |
| If Approved, Meeting Date for Consideration: | 02/25/2021 |
| Notes: | |

File Attachments for Item:

b. Discussion/Decision: Consent to the Mayor's Appointment of Eric Paulsen as Volunteer Firefighter



Stevensville Town Council Meeting

Agenda Item Request

To Be Submitted BEFORE Noon on the Wednesday before the Council Meeting

| | |
|---|--|
| Agenda Item Type: | New Business |
| Person Submitting the Agenda Item: | Chief Jeff Motley |
| Second Person Submitting the Agenda Item: | |
| Submitter Title: | Department Head |
| Submitter Phone: | |
| Submitter Email: | |
| Requested Council Meeting Date for Item: | 02/25/2021 |
| Agenda Topic: | Discussion/Decision: Consent to the Mayor's Appointment of Eric Paulsen as Volunteer Firefighter |
| Backup Documents Attached? | Yes |
| If no, why not? | |
| Approved/Disapproved? | Approved |
| If Approved, Meeting Date for Consideration: | 02/25/2021 |
| Notes: | |

File Attachments for Item:

c. Discussion/Decision: Consent to the Mayor's Appointment of Trevor Frandsen as Volunteer Firefighter



Stevensville Town Council Meeting

Agenda Item Request

To Be Submitted BEFORE Noon on the Wednesday before the Council Meeting

| | |
|---|---|
| Agenda Item Type: | New Business |
| Person Submitting the Agenda Item: | Chief Jeff Motley |
| Second Person Submitting the Agenda Item: | |
| Submitter Title: | Department Head |
| Submitter Phone: | |
| Submitter Email: | |
| Requested Council Meeting Date for Item: | 02/25/2021 |
| Agenda Topic: | Discussion/Decision: Consent to the Mayor's Appointment of Trevor Frandsen as Volunteer Firefighter |
| Backup Documents Attached? | Yes |
| If no, why not? | |
| Approved/Disapproved? | Approved |
| If Approved, Meeting Date for Consideration: | 02/25/2021 |
| Notes: | |

File Attachments for Item:

d. Discussion/Decision: Consent to the Mayor's Appointment of Christina Corsa as Volunteer Firefighter



Stevensville Town Council Meeting

Agenda Item Request

To Be Submitted BEFORE Noon on the Wednesday before the Council Meeting

| | |
|---|---|
| Agenda Item Type: | New Business |
| Person Submitting the Agenda Item: | Chief Jeff Motley |
| Second Person Submitting the Agenda Item: | |
| Submitter Title: | Department Head |
| Submitter Phone: | |
| Submitter Email: | |
| Requested Council Meeting Date for Item: | 02/25/2021 |
| Agenda Topic: | Discussion/Decision: Consent to the Mayor's Appointment of Christina Corsa as Volunteer Firefighter |
| Backup Documents Attached? | Yes |
| If no, why not? | |
| Approved/Disapproved? | Approved |
| If Approved, Meeting Date for Consideration: | 02/25/2021 |
| Notes: | |