



**Stevensville Town Council Meeting
Agenda for
THURSDAY, JUNE 22, 2023
6:00 PM
206 Buck Street, Town Hall**

1. Call to Order and Roll Call
2. Pledge of Allegiance
3. Public Comments (Public comment from citizens on items that are not on the agenda)
4. Approval of Minutes
 - [a.](#) Town Council Meeting Minutes for 05/25/2023
 - [b.](#) Town Council Meeting Minutes 06/08/2023
5. Approval of Bi-Weekly Claims
 - [a.](#) Claims #18381, #18401-#18422
6. New Business
 - [a.](#) Informational: HDR Engineer Report, Water and Wastewater Capacity
 - [b.](#) Discussion/Decision: Special Event Permit for 2023 Scarecrow Festival
 - [c.](#) Discussion/Decision: Purchasing of Water Meters

 - [d.](#) Discussion/Decision: Purchasing of a Lawn Mower
 - [e.](#) Discussion/Decision: Requesting to Publish an RFP for Street Repairs, Spring Street and Railroad Ave
 - [f.](#) Discussion/Decision: Use A2Z Personnel Services to Perform Hiring of Temporary Employees
 - [g.](#) Discussion/Decision: Stevensville Airport Board Access to Government Surplus Site
 - [h.](#) Discussion/Decision: Compensation for the Town Clerk to cover Airport Manager Duties
 - [i.](#) Discussion/Decision: Compensation for the Utility Billing Clerk for Assistance in the Finance Department
 - [j.](#) Discussion/Decision: Consent to the Mayors Appointment of Gina Crowe as the Director of Finance & HR
7. Board Reports
8. Town Council Comments
9. Executive Report
10. Adjournment

Welcome to Stevensville Town Council Chambers

We consider it a privilege to present, and listen to, diverse views.

It is essential that we treat each other with respect.

We expect that participants will:

- ✓ Engage in active listening
- ✓ Make concise statements
- ✓ Observe any applicable time limit

We further expect that participants will refrain from disrespectful displays:

- ✗ Profanity
- ✗ Personal Attacks
- ✗ Signs
- ✗ Heckling and applause

Guidelines for Public Comment

Public Comment ensures an opportunity for citizens to meaningfully participate in the decisions of its elected officials. It is one of several ways your voice is heard by your local government. During public comment we ask that all participants respect the right of others to make their comment uninterrupted. The council's goal is to receive as much comment as time reasonably allows. All public comment should be directed to the chair (Mayor or designee). Comment made to the audience or individual council members may be ruled out of order. Public comment must remain on topic, and free from abusive language or unsupported allegations.

During any council meeting you have two opportunities to comment:

1. During the public comment period near the beginning of a meeting.
2. Before any decision-making vote of the council on an agenda item.

Comment made outside of these times may not be allowed.

Citizens wishing to speak during any public comment period should come forward to the podium and state their name and address for the record. Comment may be time limited, as determined by the chair, to allow as many people as possible to comment. Comment prior to a decision-making vote must remain on the motion before the council.

Thank you for observing these guidelines.

File Attachments for Item:

- a. Town Council Meeting Minutes for 05/25/2023

Stevensville Town Council Meeting Minutes

for THURSDAY, MAY 25, 2023, 6:00 PM 206 Buck Street, Town Hall

CONDENSED MINUTES

1. Call to Order and Roll Call

Mayor called the meeting to order, Councilmembers Barker, Brown, Lowell and Michalson were all present.

2. Pledge of Allegiance

Mayor Gibson: speaking of flags, the Montana flag is up, and the US flag is on back order.

3. Public Comments (Public comment from citizens on items that are not on the agenda)

Bill Anderson, 8th Street, Stevensville. Mr. Anderson gave public comment on the update of street signs, thank you. I think that there should be a 4-way stop at 2nd and Main. Those traveling 2nd Street or leaving Cenex would agree that it is a hazard. Don't know if it is a State of Town concern.

Mayor Gibson: you are exactly right, back in August we talked with people at Montana Department of Transportation, Mr. Michalson is going to contact them again and see where we are at with traffic study.

Bill Anderson: okay so it is a state issue. It took me 15 minutes to get out at 2nd Street and Main.

Mayor Gibson: I watched yesterday the two ladies from the Genesis House almost get hit.

Bob Anderson: so, you are in the process of contacting the state department.

Mayor Gibson: I have twice, and we are going to do it again.

Councilmember Michalson: the ordinance that we passed on "J" turns. I sent that to Montana Department, and to lower the speed limit by Burnt Fork Market and we approved that. We added an amendment to this, and he told me that it was on the agenda.

Mayor Gibson: thank you, I would encourage your neighbors anyone to contact, come in tomorrow morning, and we will give you the contact information.

Lesley Tadwick: 509 Mission Street, I do have a good comment, those cemeteries look gorgeous, Steve your city guys have done a great job. I am really sad at how our town is beginning to look, I don't know what our ordinances have to say, they say that the garbage should be cleaned up and the yards should be mowed. Please come down our street, cardboard boxes and tall grasses. I ask that we clean up our town yards.

Mayor Gibson: here is where we are, there is a town ordinance, we want to take care of our own first. We will be sending letters to a number of people with the town ordinance. I just wanted to make sure that we took care of our own weeds before we told them.

4. Approval of Minutes

a. Town Council Meeting Minutes 04/27/2023

Mayor Gibson: introduced Town Council Meeting Minutes 04/27/2023

Councilmember Michalson: make a motion to approve town council meeting minutes for 04/27/2023.

Councilmember Lowell: 2nd.

Mayor Gibson: there is a motion and a 2nd. Public comment? Further discussion? Seeing none, Jenelle please take the vote.

Councilmember Barker: aye.

Councilmember Brown: aye.

Councilmember Lowell: aye.

Councilmember Michalson: aye.

Mayor Gibson: passes 4-0

5. Approval of Bi-Weekly Claims

a. Claims for April #18351, #18352, #18361-#18363, #18367, #18369

Mayor Gibson: introduced bi-weekly claims for April #18351, #18352, #18361-#18363, #18367, #18369 . Jenelle, can you explain.

Jenelle Berthoud, Town Clerk: we have been tackling multiple roles, myself and Melanie. Melanie has been doing the claims, you will see in the packet that some were posted into the month of April and then you will see some for May. So, there are two separate claims, but when you sign tonight you will sign one set of claims.

Mayor Gibson: you are well aware that we don't have a finance officer, and Robert is only here ten hours a week, so everyone is helping out. Melanie, Jenelle and Robert, thank you.

Councilmember Michalson: make a motion to approve claims for April #18351, #18352, #18361-#18363, #18367, #18369.

Councilmember Barker: 2nd.

Mayor Gibson: motion and a 2nd. Public comment? Further discussion? Jenelle, please take the vote.

Councilmember Barker: aye.

Councilmember Brown: aye.

Councilmember Lowell: aye.

Councilmember Michalson: aye.

Mayor Gibson: passes 4-0

b. Claims for May #18353,#18355-#18360, #18364, #18366, #18368

Mayor Gibson: next set of claims.

Councilmember Michalson: make a motion to approve claims for May #18353,#18355-#18360, #18364, #18366, #18368.

Councilmember Barker :2nd.

Mayor Gibson: motion and a 2nd. Public comment? Further discussion?

Councilmember Michalson: I do have one on the HDR, page 17 for \$2500.00

Mayor Gibson: what that is, the engineer had to review everything, Twin Creeks pays us back for the service.

Councilmember Michalson: I was reviewing our subdivision regulations, here we are we are paying of it.

Mayor Gibson: we pay up front and then the owner pays us back.

Jenelle Berthoud: HDR invoices us and then I send an invoice out to the developer.

Mayor Gibson: any other questions? Jenelle, please take the vote.

Councilmember Barker: aye.

Councilmember Brown: aye.

Councilmember Lowell: aye.

Councilmember Michalson: aye.

Mayor Gibson: passes 4-0

6. Public Hearings

a. Budget Amendment for FY 2022-2023

Mayor Gibson: introduced the public hearing, budget amendment for Jean Thomas funds. Update, we have some funds donated to help cover some of those costs, I spoke to Sean with the Civic Club, and they are going to step up and pay the difference.

Councilmember Barker: is that leaving anything in that fund?

Mayor Gibson: what I was told today, \$16,000?

Councilmember Barker: \$13,000-\$16,000. At the last meeting I was told.

Mayor Gibson: after this \$10,000 there should be around \$15,000 in the Jean Thomas fund.

Councilmember Barker: correct, that should be that.

7. New Business

a. Discussion/Decision: Resolution No. 518, a Resolution Amending the Fiscal Year Budget 22/23

Mayor Gibson:

Councilmember Michalson: make a motion

Councilmember Barker :2nd.

Mayor Gibson: motion and a 2nd. Public comment? Further discussion? Seeing none, Jenelle please take the vote.

Councilmember Barker: aye.

Councilmember Brown: aye.

Councilmember Lowell: aye.

Councilmember Michalson: aye.

Mayor Gibson: passes 4-0, in the executive report we will have another discussion about the pool.

b. Discussion/Decision: 2-Year Extension Request for Final Plat Filing Deadline for Twin Creeks Subdivision Phase 2

Mayor Gibson: introduced new business item b. Remind you this was originally approved some time ago and then approved by the council again, and now there is another owner. Jenelle, please correct me if I am wrong, this would be the third request.

Jenelle Berthoud: Councilmember Barker you have that in front of you. in the notes section of that agenda item, it is listed there.

Mayor Gibson: we can go to public comment, we don't need a presentation on the number of houses.

Ron Ewart: with PCI: Mark Stermites (unclear on spelling of his last name) is with us tonight and is the attorney that is representing the new owner. it has been purchased by a new owner and is preferring to take his time and come in with phases two and three all at once. He has looked at different angles to this and if for some reason the council does not approve this tonight he will still move ahead. He would start the process and whatever is not completed by January 25, 2024, would then have to go through the legal process. I have been talking with the current Twin Creeks HOA, we are working together well. These would be medium priced homes. If you give us the extension, then we can get to work on all of this.

Mayor Gibson: when we discussed this before, we don't have to and the owner does not have to, what puts us in a place is the original intent when this was approved you were going to start

digging dirt in March. I understand new owners. We had a discussion; Twin Creeks is a little different than other subdivisions. There is a \$300.00 per lot for law enforcement, which is what you agree with. And then there is utility hook ups, if this goes through what is the intent? Is it to pay as you go, because before the previous owner said that they would pay it all up front, I am more interested for the law enforcement. What is the intent on that if that goes through?

Ron Ewart: I would have to talk with Ken and Max Wolff, they are the owners of this, and they live in Colorado. I can ask them if they want to pay it all upfront.

Mayor Gibson: the only reason that I ask this is, it is not going to be my place to approve or disapprove, but especially with lots it makes it really hard to budget in the future. The last extension you were going to start in March and complete in December of 2023. We have to plan ahead, and you talked about revenue. I know that we can't say that you have to and, in some ways, it is illogical for the water and sewer hook ups. Because when this keeps getting delayed it is revenue for the town, we are in the process of starting the next budget. And it includes law enforcement and I know that it is only \$300 times the number of lots.

Ron Ewart: right around \$10,000.

Mayor Gibson: and that is a lot for Stevensville. So let us know, please.

Ron Ewart: we can postpone the meeting to next week and I am sure that he will say yes because he wants to get this going.

Mayor Gibson: the law enforcement not the utility hook ups. Council? Do you want to make a motion

Councilmember Michalson: make a motion to approve 2-Year Extension Request for Final Plat Filing Deadline for Twin Creeks Subdivision Phase 2 .

Councilmember Barker: 2nd.

Mayor Gibson: motion and a 2nd. Any public comment? Further discussion? Seeing none, Jenelle please take the vote.

Councilmember Barker: no

Councilmember Brown: abstain.

Mayor Gibson: can I ask you why.

Councilmember Brown: because I work, because what I do for a living.

Mayor Gibson: how does it with the title company, I am not saying that you can't abstain I just need.

Councilmember Brown: I feel that it is a conflict of interest for me to vote on a project that may or may not be in by office.

Mayor Gibson: alright.

Councilmember Lowell: no, because you should talk to Mr. Wolff before these decisions are made.

Councilmember Michalson: no.

Mayor Gibson: we have 3 no's and one abstain. I would say as you suggested, and we could bring this up at the next meeting and you can bring this up to the new owner and talk about the law enforcement money and that might help. Jenelle, we will put it on the next agenda, June 8th.

Jenelle Berthoud: I would need that information by May 31st at noon.

c. Discussion/Decision: Consent to the Mayors Appointment of Jessie F. Voss as a Volunteer Firefighter

Mayor Gibson: introduced new business item c. Consent to the Mayors Appointment of Jessie F. Voss as a Volunteer Firefighter

Councilmember Michalson: ,make a motion to approve the Consent to the Mayors Appointment of Jessie F. Voss as a Volunteer Firefighter

Councilmember Lowell: 2nd.

Mayor Gibson: motion and a 2nd. Further discussion?

Councilmember Michalson: regarding both of these, can we get a number from Jeff on these, we are going to need that for the budget in regards to uniforms.

Councilmember Barker: something else that we have mentioned in the past is these people that we are putting on the fire department, bring them to the council so that we can put a face to it.

Mayor Gibson: I agree 100%.

Councilmember Barker: we say yes, and it is great that they are bringing these people in but again I think that they need to be recognized through the public.

Mayor Gibson: I agree, and I will get with Chief Motley so in the future that will happen, I thought that they would be here. We have a motion and a 2nd. Jenelle, please take the vote.

Councilmember Barker: aye.

Councilmember Brown: aye.

Councilmember Lowell: aye.

Councilmember Michalson: aye.

Mayor Gibson: passes 4-0

d. Discussion/Decision: Consent to the Mayors Appointment of Erica Cochran as a Volunteer EMT

Mayor Gibson: introduced new business item d. Consent to the Mayors Appointment of Erica Cochran as a Volunteer EMT. And as Councilmember Barker brought up, I will bring that up to Chief Motley.

Councilmember Michalson: I make a motion to approve to the consent to the Mayors Appointment of Erica Cochran as a Volunteer EMT.

Councilmember Barker: 2nd

Mayor Gibson: motion and a 2nd public comment, seeing none. Any further discussion. Seeing none, Jenelle please take the vote.

Councilmember Barker: aye.

Councilmember Brown: aye.

Councilmember Lowell: aye.

Councilmember Michalson: aye.

Mayor Gibson: passes 4-0

8. Board Reports

NONE

9. Town Council Comments

Councilmember Barker: I just have some people that have concerns on the debris that were picked up May 1st -7th I guess there was a lot of misconception on what type of debris was going to be picked up they have branches and shrubberies that need to be picked up and before they could drop it off at the park. Now they are left with these types of items curb side. I myself have five bags sitting curb side that were not picked up. I don't know if we were missed again seems like we are out of sight out of mind. I was asked to bring this to the attention of town employees.

Mayor Gibson: I wish Steve Kruse had not left, we have had calls and I actually drove around it was on the water bill it was posted here we have had calls and it was on the website. It said what could be picked up.

Councilmember Barker: the people that came to me are older and I don't think that they have internet service or not.

Mayor Gibson: I will get with Mr. Kruse. I went to one place where someone had called and complained, and it was piles and piles on a tarp. That is not possible. In fact, you did not. Did you have them out by that date. If you can, let us know the people and their addresses.

Councilmember Barker: one on 2nd Street is we are noticing that people are leaving their branches piled.

Mayor Gibson: if you can give me more specific information and if it is as in your situation. We made it very clear that you had to live in town.

Councilmember Barker: this is Mrs. Detwiler. I think that is her name, she had some shrubbery that was not picked up.

Councilmember Brown: the special town council meeting on June 1st, I am leaving town and I am hoping to be back in time, but I can't guarantee.

10. Executive Report

Mayor Gibson: it is short notice will the other three of you be able to be here, what it is about is discussing the pool fees.

Jenelle Berthoud: I went back ten years, not many changes pretty stagnate.

Mayor Gibson: pretty much unchanged, Councilmember Lowell has been asking questions about the pool, it is always at a loss. Different numbers every year. The pool fees have not been raised since 2013. Everything is going up, to operate the pool and paying the lifeguards. That is one of the things that will be on there and then a discussion/decision for the town to take over the operation of the splash pad. We have a letter from the contractors, ensuring that it meets standards, when this was all done before, it is going to be another operating cost. We will have a recommendation for the pool fees, and the civic club will be here to present about the splash pad.

Councilmember Lowell: are the water guys doing the maintenance on it now, are they already doing the maintenance on the splash pad?

Mayor Gibson: I don't think that there is a lot to do at this time. They have to turn it on and then do checks every day.

Councilmember Lowell: is it going to be another big thing.

Mayor Gibson: we have gone through MMIA.

Councilmember Lowell: another question is there still money owed on it?

Mayor Gibson: not by us.

Councilmember Lowell: I don't want to accept that liability if we still owe.

Mayor Gibson: not that I know of. Good question to ask. The pothole bill has passed. We don't know how much we get but I will be calling tomorrow. There is some confusion on when we get the money and how much and then we want to put out bids for some streets. Not used for equipment no match. The ARPA grant, I am setting up a meeting with HDR and the hope is that the bids can go out in July for leaks and water storage. The water rights, a lot of objections. Ross Miller and I meet every week. One out there at this time, is Trout Unlimited. If this is all resolved, we could be looking at water court done in September. The .gov looks to be completed by July. Capacity study, same meeting with HDR next week. We have two new people, and we will be meeting to discuss.

11. Adjournment

APPROVE:

Steve Gibson, Mayor

ATTEST:

Jenelle S. Berthoud, Town Clerk

File Attachments for Item:

b. Town Council Meeting Minutes 06/08/2023

Stevensville Town Council Meeting Minutes

for THURSDAY, JUNE 08, 2023, 6:00 PM 206 Buck Street, Town Hall

CONDENSED MINUTES

1. Call to Order and Roll Call

Mayor Gibson called the meeting to order. Councilmembers Brown, Lowell and Michalson were all present. Councilmember Barker was not present.

2. Pledge of Allegiance

3. Public Comments (Public comment from citizens on items that are not on the agenda)

Leslie Tadvick: Nancy and I have a project for the summer, we would like council approval to raise funds for the pool. We are going to contact everyone that has used that pool through the years and work on donations.

Councilmember Lowell: you might want to mention that this will not affect the town, it will come to Farmers State Bank.

Leslie Tadvick: we are going to Facebook it and they can share it. It has been going on since 1956, it just needs a face lift.

Mayor Gibson: thank you, the civic club is also interested in helping out.

4. Approval of Minutes

a. Town Council Meeting Minutes for 05/11/2023

Mayor Gibson: introduced town council meeting minutes for 5/11/23.

Councilmember Michalson: approve town council meeting minutes for 5/11/23.

Councilmember Lowell: 2nd

Mayor Gibson: motion and a 2nd. Public comment? Further discussion? Seeing none, Jenelle please take the vote.

Councilmember Brown: aye.

Councilmember Lowell: aye.

Councilmember Michalson: aye.

Mayor Gibson: 3-0

b. Special Town Council Meeting Minutes for 06/01/2023

Mayor Gibson: introduced special town council meeting minutes for 6/1/23.

Councilmember Michalson: make a motion to approve special town council meeting minutes for 6/1/23.

Councilmember Lowell: 2nd

Mayor Gibson: motion and a 2nd. Further discussion. Seeing none, Jenelle please take the vote.

Councilmember Brown: aye.

Councilmember Lowell: aye.

Councilmember Michalson: aye.

Mayor Gibson: 3-0

5. Approval of Bi-Weekly Claims

a. Claims #18370-#18374, #18376-#18386

Mayor Gibson: introduced bi-weekly claims. Jenelle, you got a chance to explain. When you see Melanie, she has really stepped up to do the claims. She has done a really good job.

Councilmember Michalson: to approve #18370-#18374, #18376-#18386 and make an amendment to approve #18377-#18394

Councilmember Lowell: 2nd

Mayor Gibson: motion and a 2nd. Further discussion.

Councilmember Lowell: I don't have a problem with accepting the claims, but my concern is knowing the status of the line items, as the council we don't know if they are short, or if there is money there.

Mayor Gibson: I think Robert gave you an update to where we are with the budget. We are still under budget.

Councilmember Lowell: I guess for our own use, what we will need is an actual revenue that will show what each line item is, I just don't want to see a bunch of amendments at the end of the year if it can be handled now.

Mayor Gibson: as far as the next council meeting there, we are down a lawn mower, and water meters, and those are the only other budget amendments for this year. As far as the budget goes, we don't have a finance officer, starting next week we will be starting with the department heads and do their "wish lists".

Councilmember Brown: claim for backpack sprayers, was this for two?

Jenelle Berthoud: yes, those are for two.

Mayor Gibson: any other questions on the claims? Seeing none, Jenelle please call for the vote.

Councilmember Brown: aye.

Councilmember Lowell: aye.

Councilmember Michalson: aye.

Mayor Gibson: passes 3-0

6. Administrative Reports

Mayor Gibson: introduced administrative reports to the council.

a. Airport

b. Building Department

c. Finance

d. Fire Department

Chief Motley: report was in the packet, Chief Motley talked about the month of May stats. Six responses last night. Last month we did some training. The association is planning to put on the fourth of July fireworks show. The wall for the police department has been built and so we are cleaning up.

Councilmember Michalson: what are up to now for your roster.

Chief Motley: town roster is 16 and if you combined that with the district, I think that is around 45 to 46. If you look at active participants that number is really low.

Councilmember Lowell: you all should be commended for all of the time and work that you put in. Thank you.

e. Police Department

f. Public Works

7. Guests

NONE

8. Correspondence

NONE

9. Public Hearings

a. Rescinding Resolution No. 444

Mayor Gibson: introduced the public hearing item a. Rescinding Resolution No. 444. We asking to rescind this basically because it violates the law. It is not our intent to not have a code of conduct for elected officials. So, with that Jenelle please read the comment.

PUBLIC COMMENT

Jenelle Berthoud, Town Clerk: read a public comment from Mary Beth Egan. Her letter will be part of the minutes of this meeting.

Mayor Gibson: in defense to that person, they do not have Mr. Overstreet's comments as to why this is being done.

PUBLIC COMMENT

Vickey Motley: 318 9th Street, I also agree I do not believe that this should be rescinded, I do not know what your comments were I think that everyone needs to be held accountable.

Mayor Gibson: I agree 100% the reason that it should be rescinded is that it violates the state and federal laws.

10. Unfinished Business

a. Discussion/Decision: 2-Year Extension Request for Final Plat Filing Deadline for Twin Creeks Subdivision Phase 2

Mayor Gibson: introduced unfinished business item a. 2-Year Extension Request for Final Plat Filing Deadline for Twin Creeks Subdivision Phase 2. The owner has come forward with the \$9600.00 for law enforcement. It is to extend the final plat for phase 2 and they have provided a check for phase 2 not phase 3.

Councilmember Michalson: I make a motion to approve 2-Year Extension Request for Final Plat Filing Deadline for Twin Creeks Subdivision Phase 2.

Councilmember Lowell: 2nd

Mayor Gibson: motion and a 2nd. Public comment? Further discussion? Seeing none, Jenelle please take the vote.

Councilmember Brown: abstain

Councilmember Lowell: aye.

Councilmember Michalson: aye.

Mayor Gibson: passes 2-0 with one abstain.

11. New Business

a. Discussion/Decision: Rescinding Resolution No. 444

Mayor Gibson: introduced new business item a. Rescinding Resolution No. 444. Out intent is to have a code of conduct that follows state and federal laws, in summary it violates first amendment parts of it. Violates free speech and opens up the town for potential lawsuits. If you rescind this and go through his comments I think that you will understand why. I have asked Mr. Michalson and then if we have a finance officer to meet with me and do a new one.

Councilmember Michalson: I make a motion to rescind resolution No. 444

Councilmember Lowell: 2nd

Mayor Gibson: motion and a 2nd. Public comment? Further discussion?

Councilmember Michalson: I was on the council in 2018 when this was brought forward and I had a lot of issues with it then, some parts were good and other parts were bad, they used this to put me on trial. I fought with the previous administration to get rid of this, I brought it forth and I was shot down.

Mayor Gibson: there is another part in here where you can't speak badly of me, 24/7.

Councilmember Michalson: I agree that we need to be held accountable and the ethics that are in the MCA code are very broad.

Councilmember Brown: so, we are going to bring up a new resolution for a code of conduct. Do you have any idea when that will be.

Mayor Gibson: I need to get a finance officer, get the budget started so I can't give you an exact day.

Councilmember Brown: I was just curious.

Mayor Gibson: Jenelle, please take the vote.

Councilmember Brown: aye.

Councilmember Lowell: aye.

Councilmember Michalson: aye.

Mayor Gibson: passes 3-0

b. Discussion/Decision: Real-estate Transfer, Block 1 Lot 6 & 7, Between Mr. Brekllle to Tall Timber Flying Service

Mayor Gibson: introduced new business item b. Real-estate Transfer, Block 1 Lot 6 & 7, Between Mr. Brekllle to Tall Timber Flying Service.

Councilmember Michalson: make a motion to approve Real-estate Transfer, Block 1 Lot 6 & 7, Between Mr. Brekllle to Tall Timber Flying Service

Councilmember Brown: 2nd.

Mayor Gibson: motion and a 2nd. Public comment? Further discussion?

Councilmember Lowell: and this has been approved through the airport board. I have often wondered if all of the new people know all of the rules.

Mayor Gibson: this has been approved and then do know. And some that do not.

Councilmember Brown: this is going to be a new lease, Jenelle.

Jenelle Berthoud: yes it will.

Councilmember Brown: aye.

Councilmember Lowell: aye.

Councilmember Michalson: aye.

Mayor Gibson: passes 3-0

c. Discussion/Decision: Approval of a New Land Lease, Block 2 Lot 9 to Museum of Mountain Flying

Mayor Gibson: introduced new business item c. Approval of a New Land Lease, Block 2 Lot 9 to Museum of Mountain Flying.

Councilmember Michalson: make a motion to approve a New Land Lease, Block 2 Lot 9 to Museum of Mountain Flying.

Councilmember Lowell: 2nd.

Mayor Gibson: motion and a 2nd. Public comment? Further discussion?

Councilmember Brown: on this new lease is that the new amount?

Jenelle Berthoud: yes.

Councilmember Brown: aye.

Councilmember Lowell: aye.

Councilmember Michalson: aye.

Mayor Gibson: passes 3-0.

d. Discussion/Decision: Contract for Carpet Cleaning Services

Mayor Gibson: introduced new business item d. Contract for Carpet Cleaning Services. We do all of the cleaning here are town hall.

Councilmember Michalson: make a motion to approve carpet cleaning services.

Councilmember Brown: 2nd.

Mayor Gibson: motion and a 2nd. Any further discussion? Seeing none, Jenelle please take the vote.

Councilmember Brown: aye.

Councilmember Lowell: aye.

Councilmember Michalson: aye.

Mayor Gibson: passes 3-0.

12. Town Council Comments

NONE

13. Board Reports

NONE

14. Executive Report

Mayor Gibson: pretty close on the water rights, looks like we could be wrapped up in September. All of the objectors have pretty much gone away. the BARSSA extra money, someone is supposed to call me back next week. I think that we are going to get around \$175,000.00. would like to get bids out this summer. The ARPA grant should be getting started, the design should be done, and we hope to put the bids out in August. Budget worksheets are going out and there is a possibility and I will know tomorrow we might have a finance officer and I will let you know as soon as possible.

15. Adjournment

APPROVE:

ATTEST:

Steve Gibson, Mayor

Jenelle S. Berthoud, Town Clerk

Jenelle Berthoud

From: Mary Beth Egan <marybegan66@gmail.com>
Sent: Thursday, June 8, 2023 2:26 PM
To: Jenelle Berthoud
Subject: [EXTERNAL] Resolution No. 444

CAUTION: This email originated from outside of the organization. Do not click links or open attachments unless you recognize the sender and know the content is safe.

Dear Jenelle.

As I am unable to attend the meeting tonight, I would like to put forth my strong conviction that the above resolution not be rescinded.

Having worked in various municipal entities, these resolutions bind municipal staff and contractors to a legal code of conduct.

If we remove the right to hold our elected officials and outside contractors' accountable for their behavior, then we have opened the door to the old "*no one told me I couldn't...*" and liability will be an open ended claim.

This is in the best interest of the taxpaying public.

I am a bit concerned how this Resolution would even come up to be rescinded...on what grounds could anyone object to a forthright document mandating integrity?

I support keeping Resolution 444 intact.

Sincerely,

Mary Beth Egan
3592 Sourdough Lane
Stevensville

File Attachments for Item:

a. Claims #18381, #18401-#18422

* ... Over spent expenditure

Claim	Check	Vendor #/Name/ Invoice #/Inv Date/Description	Document \$/ Line \$	Disc \$	PO #	Fund Org Acct	Object Proj	Cash Account
*** Claim from another period (5/23) ****								
18381	E	852 CENEX FLEETCARD	1,332.79					
		263927CL 04/22/23 39 MOTLEY J	55.75			1000 420460	231	101000
		263927CL 04/22/23 11 MOTLEY T	62.18			1000 420460	231	101000
		263927CL 04/27/23 42 CORSA C	91.63			1000 420460	231	101000
		263927CL 04/13/23 43 MOTLEY T	51.05			2230 420730	231	101000
		263927CL 04/06/23 33 SOSA M	39.75			1000 420100	231	101000
		263927CL 04/25/23 33 SOSA M	70.97			1000 420100	231	101000
		263927CL 04/04/23 47 SOSA M	20.71			1000 420100	231	101000
		263927CL 04/04/23 47 SOSA M	27.04			1000 420100	231	101000
		263927CL 04/11/23 47 SOSA M	46.27			1000 420100	231	101000
		263927CL 04/01/23 41 FRANSEN T	41.15			1000 420100	231	101000
		263927CL 04/06/23 41 FRANSEN T	49.77			1000 420100	231	101000
		263927CL 04/13/23 43 MOTLEY T	38.01			1000 420100	231	101000
		263927CL 04/22/23 41 FRADSEN T	44.20			1000 420100	231	101000
		263927CL 03/31/23 5 SCHAFFER T	49.37			1000 420100	231	101000
		263927CL 04/05/23 5 SCHAFFER T	45.10			1000 420100	231	101000
		263927CL 04/13/23 5 SCHAFFER T	46.05			1000 420100	231	101000
		263927CL 04/21/23 5 SCHAFFER T	47.08			1000 420100	231	101000
		263927CL 04/04/23 17 ANDERSON C	79.49			1000 430100	231	101000
		263927CL 04/25/23 17 LASSITER S	89.06			1000 430100	231	101000
		263927CL 04/22/23 16 BIES G	60.22			1000 430100	231	101000
		263927CL 04/06/23 21 MURRAY I	73.09			1000 430100	231	101000
		263297CL 04/11/22 30 LASSITER S	59.68			1000 430100	231	101000
		263297CL 04/22/23 30 BIES G	57.22			1000 430100	231	101000
		263297CL 04/10/23 14 LASSITER S	87.95			1000 430100	231	101000
		263297CL 04/30/23	0.00			1000 430100	231	101000
18401		124 Montana League of Cities and FY 23-24 Membership Fee	1,069.61					
		ML00817 06/01/23 FY24 MEMBERSHIP FEES	1,069.61*			1000 410550	330	101000
18402		1881 Civic Plus MUNICODE PAGES CODIFICATION OF ORDIANCES	697.62					
		265077 06/09/23 MUNICODE PAGES	697.62*			1000 410550	330	101000
*** Claim from another period (5/23) ****								
18403		29 STEVENSVILLE NAPA AUTO PARTS OIL CHANGE SUPPLIES AND SWEEPER REPAIR BLOWN HYDRAULIC HOSE	39.26					
		741957 05/22/23 OIL CHANGE SUPPLIES/ DEGREASER	39.26			1000 430100	232	101000

* ... Over spent expenditure

Claim	Check	Vendor #/Name/ Invoice #/Inv Date/Description	Document \$/ Line \$	Disc \$	PO #	Fund Org Acct	Object Proj	Cash Account
18404		29 STEVENSVILLE NAPA AUTO PARTS HYDRALIC TANK CAP FOR SWEEPER	15.49					
	743836	06/02/23 BREATHER	15.49			1000 430100	232	101000
18405		20 Skagit Farmers Supply GRASS SEED	49.99					
	42427	05/09/23 GRASS SEED	25.00			1000 460430	230	101000
	42427	05/09/23 GRASS SEED	24.99			1000 460430	230	101000
18406		1754 Construct Montana, LLC BUILDING INSPECTION CONSULTATION AND PLAN REVIEW	3,669.60					
	1092	06/07/23 INSPECTION CONSULTATION	3,045.84			2394 420531	350	101000
	1092	06/07/23 PLAN REVIEW	623.76			2394 420531	350	101000
18407		228 Norco, Inc. 37856854 05/31/23 GAS CYLINDER RENTAL	12.71					
			12.71			1000 430100	231	101000
18408		1212 NewFields SUPPORT FOR WATER RIGHTS	932.50					
	000709002-	06/13/23 ENGINEERING SUPPORT	932.50			5210 430530	350	101000
18409		1918 GARDEN CITY MONUMENT NICHE BURIAL WALL ENGRAVE	125.00					
	163-23	06/01/23 INSCRIPTION NICHE	125.00			1000 430900	230	101000
18410		1862 Modern Marketing EVIDENCE TENTS W/ SCALES	481.37					
	MM12316030	06/12/23 EVIDENCE TENTS	481.37*			1000 420100	220	101000
								*** Claim from another period (4/23) ****
18411		1909 BALCO UNIFORM 73272-2 04/11/23 PATCHES	205.00					
			205.00*			1000 420100	226	101000
18412		83 KOOTENAI GARAGE 2017 EXPLORER	134.48					
	1003209	06/07/23 PARTS AND LABOR	134.48			1000 420100	232	101000
18413		858 MILLER LAW OFFICE, PLLC STEVENSVILLE WATER RIGHT MATTERS	6,565.99					
	1308	05/01/23 WATER RIGHTS FILE NO. 18013	6,565.99*			5210 430530	352	101000

* ... Over spent expenditure

Claim	Check	Vendor #/Name/ Invoice #/Inv Date/Description	Document \$/ Line \$	Disc \$	PO #	Fund Org Acct	Object Proj	Cash Account
18414		858 MILLER LAW OFFICE, PLLC	14,742.82					
		STEVENSVILLE WATER RIGHTS MATTER						
	1309	06/05/23 WATER RIGHT FILE NO 18013	14,742.82*			5210 430530	352	101000
18415		1919 NELSON TREE SERVICE	2,800.00					
		TREE REMOVAL HAZARDOUS 105 COLLEGE STREET						
	322600	06/08/23 TREE REMOVAL	2,800.00			1000 460437	350	101000
18416		201 Montana Rural Water Systems,	400.00					
		2245 02/16/23 ASSOCIATION DUES	400.00*			5210 430510	335	101000
18417		1121 a2z Supply Corp	40.00					
		ID TAGS FOR KOPSA AND FRANSEN						
	0612842	06/12/23 ID TAG FRANSEN	20.00*			1000 420100	226	101000
	0612842	06/12/23 ID TAG KOPSA	20.00*			1000 420100	226	101000
18418		1121 a2z Supply Corp	1,137.82					
		05/31/23 BODY ARMOR	931.07*			1000 420100	226	101000
		05/31/23 GUARDIAN CARRIER	206.75*			1000 420100	226	101000
18419		1711 Office Solutions & Service	108.32					
		COPY MACHINE FIRE DEPT - UPSTAIRS						
	INV115558	05/26/23 COPY MACHINE LEASE COURT	54.16			1000 410360	320	101000
	INV115558	05/26/23 COPY MACHINE LEASE FIRE	54.16			1000 410360	320	101000
18420		1841 Overstreet Law Group	1,815.00					
		05/30/23 LEGAL SERVICES	1,815.00			1000 411100	352	101000
18421		386 MONTANA RAIL LINK, INC.	100.00					
		467997 06/01/23 U/G POTABLE WATER PIPELINE	100.00*			5210 430550	340	101000
18422		1915 NORTHWEST HARDWARE	183.32					
		06056570 05/03/23 POOL	14.84*			1000 460445	230	101000
		16057918 05/08/23 PARKS	11.42			1000 430200	230	101000
		16058733 05/11/23 PARKS	7.19*			1000 430640	230	101000
		16059270 05/12/23 SEWER PLANT	14.10			5310 430640	230	101000
		16060523 05/16/23 CEMETERY	16.99			1000 460430	220	101000
		16061171 05/18/23 WATER REPAIR	20.23			5210 430550	230	101000
		16062803 05/23/23	30.07			1000 411201	360	101000
		16063458 05/25/23 STEVE	27.00*			1000 460445	230	101000
		16063707 05/26/23 VETRANS PARK	2.86			1000 460430	230	101000
		16063732 05/26/23 FOOT VALVE	7.18			1000 430100	230	101000
		16064891 05/30/23 SWEEPER	7.19			1000 430100	232	101000
		16064957 05/30/23 BIKE PATH	37.21*			1000 460437	230	101000

* ... Over spent expenditure

Claim	Check	Vendor #/Name/ Invoice #/Inv Date/Description	Document \$/ Line \$	Disc \$	PO #	Fund Org Acct	Object Proj	Cash Account
	16064959	05/30/23 BIKE PATH	-12.96*			1000 460437	230	101000
		# of Claims 23	Total: 36,658.69					
		Total Electronic Claims	1,332.79	Total Non-Electronic Claims		35325.90		

Fund/Account	Amount
1000 GENERAL	
101000 Cash - Operating	\$10,162.40
2230 AMBULANCE	
101000 Cash - Operating	\$51.05
2394 BUILDING CODE ENFORCEMENT	
101000 Cash - Operating	\$3,669.60
5210 WATER	
101000 Cash - Operating	\$22,761.54
5310 SEWER	
101000 Cash - Operating	\$14.10
Total:	\$36,658.69

06/20/23
12:08:15

TOWN OF STEVENSVILLE
Claim Approval Signature Page
For the Accounting Period: 6 / 23

Page: 6 of 6
Report ID: AP100A

ORDERED that the Director of Finance draw a check/warrant on the Town of Stevensville.

Stacie Barker, Councilmember

Bob Michalson, Councilmember

Cindy Brown, Councilmember

Nancy Lowell, Councilmember

Steve Gibson, Mayor

Date Approved _____

File Attachments for Item:

- a. Informational: HDR Engineer Report, Water and Wastewater Capacity



Stevensville Town Council Meeting

Agenda Item Request

To be submitted BEFORE Noon on the Wednesday immediately preceding the Thursday agenda publishing deadline (8-days ahead of the meeting).

Agenda Item Type:	New Business
Person Submitting the Agenda Item:	Steve Gibson
Second Person Submitting the Agenda Item:	HDR Engineering
Submitter Title:	Mayor
Submitter Phone:	
Submitter Email:	
Requested Council Meeting Date for Item:	06/22/2023
Agenda Topic:	Informational: HDR Engineer Report, Water and Wastewater Capacity
Backup Documents Attached?	Choose an item.
If no, why not?	
Approved/Disapproved?	Approved
If Approved, Meeting Date for Consideration:	06/22/2023
Notes:	

Memo

Date: Tuesday, June 06, 2023

Project: Town of Stevensville Wastewater and Water Capacity Analysis

Introduction

An assessment of the current wastewater and water infrastructure capacity was conducted for the Town of Stevensville to determine the feasibility of supplying wastewater and water infrastructure to future development.

Wastewater Treatment Infrastructure Capacity:

Design capacity, average daily flow (ADF), maximum month flow (MMF), and peak hour flow (PHF) were determined using current design data and recorded flows through 2022.

Wastewater contribution from potential development was estimated using MDEQ Circular 2 methods. The compiled data shows that there is not adequate wastewater infrastructure capacity to serve potential development. Table 1 below depicts the results from the wastewater capacity analysis.

Table 1. Wastewater Capacity Analysis

Condition	Design Capacity (MGD)	Current 2018 - 2022 Flow (MGD)	Remaining Capacity (MGD)	Remaining Capacity (EDU's)
Average Daily Flow (ADF)	0.3	0.191	0.109	472 ¹
Max Month Flow (MMF)	0.4	0.252	0.148	-
Peak Hour Flow (PHF)	1.08	-	-	-

¹ Calculated using an average daily flow of 100 gallons per person per day per MDEQ Circular 2, and 2.31 people per single family residence per the Town of Stevensville 2016 Growth Policy Update.

Water Infrastructure Capacity:

Well pumping data was examined for August 2022, and the maximum day demand was found to be August 2, 2022 with a total pumping demand of 1.4 MGD (Table 2). The water system is currently serving about 1,039 EDUs.

Table 2. Max Day Water Demand

Max Day Pumping Demand (MGD)	Firm Capacity (MGD)	Remaining Capacity (MGD)	Remaining Capacity (EDU's) ¹
1.4	1.7	0.3	437

Assumptions: 297 gpcd (max summertime use from 2021 PER) and 2.31 persons per household in Town of Stevensville Growth Plan (2016).



Summary

The wastewater treatment plant has adequate capacity to serve an additional 472 single family residences under average daily flow conditions.

The water supply system has capacity to serve an additional 437 single family residences under max day demand conditions during the irrigation season.

The water storage tank has adequate capacity to supply emergency and equalization demand for residential development, however; it does not have adequate volume to supply the desired commercial fire flow of 3,500 gallons per minute for a 3-hour duration.

File Attachments for Item:

b. Discussion/Decision: Special Event Permit for 2023 Scarecrow Festival



Stevensville Town Council Meeting

Agenda Item Request

To be submitted BEFORE Noon on the Wednesday immediately preceding the Thursday agenda publishing deadline (8-days ahead of the meeting).

Agenda Item Type:	New Business
Person Submitting the Agenda Item:	Steve Gibson
Second Person Submitting the Agenda Item:	Project 59870
Submitter Title:	Mayor
Submitter Phone:	
Submitter Email:	
Requested Council Meeting Date for Item:	06/22/2023
Agenda Topic:	Discussion/Decision: Special Event Permit for 2023 Scarecrow Festival
Backup Documents Attached?	Yes
If no, why not?	
Approved/Disapproved?	Approved
If Approved, Meeting Date for Consideration:	06/22/2023
Notes:	

TOWN OF STEVENSVILLE
APPLICATION FOR SPECIAL EVENT PERMIT

Received
5/25/23

APPLICATION DATE: April 19 23 (Must be at least 14 days prior to event)

NAME OF GROUP OR ORGANIZATION: Scarecrow Festival (Project 525870)

CONTACT PERSON: Loey Knapp TELEPHONE: 406 529 9715

ACTIVITY: Scarecrow Festival (no Brewfest)

LOCATION REQUESTING: Main Street, 3rd Street to Church, Veterans Park

DATE: Oct 6-7 STARTING TIME: 3pm Friday ENDING TIME: 9pm Friday
9am Saturday 9pm Saturday

ESTIMATED NUMBER OF PEOPLE ATTENDING: 4000

ALCOHOL USE? YES NO If yes please attach Alcohol Use Request Form

HIGHWAY OR STREET CLOSURE? YES NO If yes, please attach MDOT Street Closure Permit
Main Street From Church to 3rd Street

REQUEST FOR BONFIRE? YES NO If yes, please attach Town Burn Permit
1 at corner of Main at Rocky MT Bank

IS OVERNIGHT CAMPING REQUESTED? YES NO

DO YOU HAVE INSURANCE? YES NO

If yes please attach declaration page as proof of insurance for \$1.5 million as pursuant to Montana Statute M.C.A. 2-9-108.

WILL SECURITY BE REQUIRED? YES NO

IF YES, PLANS FOR SECURITY: _____

PLANS FOR CLEAN UP: COMMITTEE CLEANUP
Friday night / Saturday night / Sunday 2-5

FEE: \$ 315

**If the event involves less than 1,000 participants, this application will be forwarded to the Mayor for final approval. If the event involves more than 1,000 participants, this application will be considered at the first Town Council Meeting after its receipt. The contact person will be notified of the Mayor or Council's decision the following day. ** If Council approval, a representative must attend the council meeting.

File Attachments for Item:

c. Discussion/Decision: Purchasing of Water Meters



Stevensville Town Council Meeting

Agenda Item Request

To be submitted BEFORE Noon on the Wednesday immediately preceding the Thursday agenda publishing deadline (8-days ahead of the meeting).

Agenda Item Type:	New Business
Person Submitting the Agenda Item:	Steve Gibson
Second Person Submitting the Agenda Item:	Steve Kruse, Public Works Supervisor
Submitter Title:	Mayor
Submitter Phone:	
Submitter Email:	
Requested Council Meeting Date for Item:	06/22/2023
Agenda Topic:	Discussion/Decision: Purchasing of Water Meters
Backup Documents Attached?	Choose an item.
If no, why not?	
Approved/Disapproved?	Approved
If Approved, Meeting Date for Consideration:	06/22/2023
Notes:	The public works department is requesting the purchase of 140 meters at a cost of \$140.00 per meter totaling \$19,600.00.

File Attachments for Item:

d. Discussion/Decision: Purchasing of a Lawn Mower



Stevensville Town Council Meeting

Agenda Item Request

To be submitted BEFORE Noon on the Wednesday immediately preceding the Thursday agenda publishing deadline (8-days ahead of the meeting).

Agenda Item Type:	New Business
Person Submitting the Agenda Item:	Steve Gibson
Second Person Submitting the Agenda Item:	Steve Kruse, Public Works Supervisor
Submitter Title:	Mayor
Submitter Phone:	
Submitter Email:	
Requested Council Meeting Date for Item:	06/22/2023
Agenda Topic:	Discussion/Decision: Purchasing of a Lawn Mower
Backup Documents Attached?	Yes
If no, why not?	
Approved/Disapproved?	Approved
If Approved, Meeting Date for Consideration:	06/22/2023
Notes:	The public works department is requesting the purchase of a new lawn mower to replace the existing lawn mower that has passed its service life. There are bids attached to this agenda item.



No 19138

PURCHASER INFORMATION

Town of Stevensville

(Name - Print)

(Street Address)

(City, State, Zip)

Steve 406-880-5989

(Purchaser's Phone Number)

QUOTATION ORDER

BIG SKY KUBOTA, LLC

7550 Thornton Drive, Missoula, Montana 59808
(406) 542-2200 • (800) 244-4759 • Fax (406) 543-9318
E-mail: dealer@bigskykubota.com

Price prevailing at time of deliver to apply and this offer shall be subject to availability at the time the order/quote is placed.

steve@townofstevensville.com

Table with columns: QTY, MODEL #, DESCRIPTION, SERIAL #, AMOUNT. Includes trade-in equipment section and contract terms.

ACCEPTED BY: X DATE: (Authorized Signature for Dealer) Ben Arnott 6-6-23 (Salesman)

X DATE: (Purchaser's Signature)

All quotes are good for a maximum of 30 days or on availability of item quoted.

NOTICE: SEE OTHER SIDE FOR IMPORTANT INFORMATION
PURCHASER AGREES TO ALL TERMS AND CONDITIONS OF SALE SET FORTH ON THIS PAGE AND ON THE OTHER SIDE
Big Sky Kubota - White Copy • Purchaser - Yellow Copy

KUBOTA "Z-SERIES" ZERO-TURN MOWER



Kommander

Z100 Kommander SERIES

The ultimate residential zero-turn mower, the Z100 kommander series combines style, comfort and performance.



Kommander PRO

Z400 Kommander PRO SERIES

Designed for the residential user seeking high levels of comfort and convenience, and the professional user demanding superior durability and performance.



Z700 SERIES

The Z700 Series offers Kubota quality, comfort and professional performance that you can depend on.



ZG200/300 SERIES

Two compact and full size gasoline mowers that deliver versatility, efficiency, and professional performance.



KUBOTA ZERO-TURN MOWER ZD Series

Kubota's all-new ZD Series of compact and full-size zero-turn mowers have been engineered from the ground up to deliver quality, performance, comfort, and versatility.



KUBOTA TRACTOR CORPORATION

1000 Kubota Drive, Grapevine, TX 76051 Tel 888-4 KUBOTA

Visit our web site at: kubotaUSA.com

©2019 Kubota Corporation



**Kubota
Genuine Parts**
for maximum performance, durability and safety

Three premium, high-performance diesel mowers with the quality and versatility to handle a wide range of mowing jobs.

NEW
ZD SERIES



ZD1500



Top to bottom, front to back, and inside and out, Kubota's new ZD Series of zero-turn mowers are engineered for quality. Built right here in the United States, these premium mowers incorporate the best of Kubota's advanced technology in every detail and function to ensure both superior mowing performance and supreme operator comfort. No matter how you measure quality, the ZD Series delivers.

Kubota Quality



ZD1000



ZD1200

ACS Kubota PRO deck (Aerodynamic Cutting System™)

Mowing deck with smoother airflow and more powerful rotation

Improved air flow*

The airflow inside the deck has been optimized for faster, more efficient cutting and discharge by preventing clippings from clumping, sticking to the walls of the deck, and recirculating to be cut again. The improved airflow also results in reduced power consumption, increased work and fuel efficiency.



Improved work efficiency*

The improved airflow ensures better cutting efficiency. That means you can get the job done faster and with better work performance—up to 27% better.



New spindle shaft

New larger durable spindle shaft creates a better airflow inside the deck.



New clean-cut blades

The redesigned cutting blades have a new shape that improves both cutting efficiency and overall load balance, which creates a better airflow inside the deck and ensures cleaner cutting performance. These new blades also provide a longer service life so you won't need to replace them as often.

Improved fuel efficiency*

The ZD Series does more on less fuel, thanks to the ACS Kubota PRO deck's more efficient cutting performance and better fuel/horsepower balance—up to 22% better.



New flexible discharge chute

Manufactured from a flexible yet stronger material, the discharge chute has been redesigned to ensure a smoother and more uniform discharge of clippings.



Engineered for superior cutting performance and outstanding operability.

New large and bright LCD panel (ZD1200 and ZD1500 models only)

The large LCD meter—the biggest in its class—shows all of the key indicators you need to maximize cutting performance and operability, including engine oil pressure gauge, water temperature gauge, fuel level, and voltmeter. A new hour meter lets the operator know when maintenance or service is required.*



*The ZD1500 also includes an engine RPM gauge and DPF (Diesel Particulate Filter) muffler indicator and its associated control buttons. With a single glance, you know exactly how your ZD mower is performing and when it needs servicing.

New ergonomically designed control layout

For faster operation and better ergonomics, all of the mower deck controls are grouped on the right side within easy reach your right hand, letting you quickly and easily adjust the cutting height. A two-tone cutting height adjustment dial is easier to see and simplifies the setting of the cutting height.



New low profile tires

Low-profile rear tires further improve the ZD Series' stability and traction on turf. Their wide tread helps protect the turf from damage during mowing.



Outstanding stability

The ZD Series' feature a low center of gravity to help improve the weight/balance and provides stability on slopes and uneven ground. When combined with the ZD Series' long wheelbase wide, large-diameter rear tires, and fuel tanks mounted above the tires and below the seat, the result is outstanding stability on a variety of terrains.



Kubota Original Engine



Kubota diesel engines and durable transmission

With over 25 million engines produced since 1922, Kubota engines are recognized around the world for their proven quality and reliability. Powerful yet clean and quiet, the ZD Series' rugged diesel engines give you unparalleled performance, productivity, and economy. The ZD Series' dependable engines let you power through tough mowing jobs with ease and efficiency. These technically advanced engines are also environmentally friendly, thanks to excellent fuel economy, enhanced combustion efficiency, and low vibration and noise levels. These engines are paired with Kubota's original hydrostatic transmission that offers faster, smoother response under all loading conditions. Except for an occasional fluid change, the hermetically-sealed structure requires no maintenance and has no belts to change.

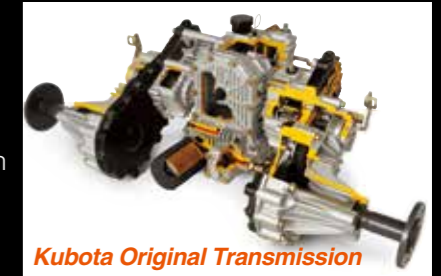

Kubota Original Transmission

*ZD1500 complies with Tier 4 regulations.

New HST levers

Redesigned HST levers not only provide more legroom, but also more settings to choose from, ensuring smoother operation, better zero-turn maneuverability, and greater job efficiency.

New damper force adjustment

Available on several Kubota mowers, this 3-position lever lets you adjust the damper force to the optimum level for your personal comfort.



Hands-free parking brake

Conveniently located on the platform, the parking brake can be easily engaged and released by pressing it with either foot while keeping both hands on the HST levers.

Hydraulic deck lift

A 2-pedal hydraulic deck lift system keeps you mowing in spite of obstacles by letting you easily raise and lower the deck with your foot.

Selectable front axle (oscillating/rigid)

Choose from two front-axle setups to optimize mowing comfort and performance: oscillating for a smooth ride, or rigid for an even cut while mowing on rough terrain.

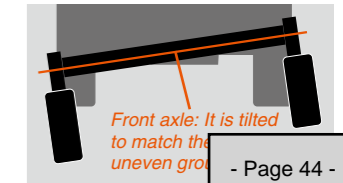

Shaft drive mower

Without drive belts, the drive shaft smoothly transfers power from the engine to the deck. Shaft drive also requires less maintenance and provides greater dependability.

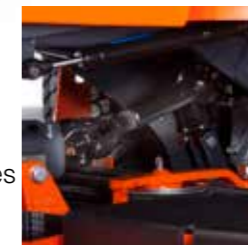

Designed to keep you comfortable and productive until the job is done

New suspension seat (ZD1000 and ZD1200 models only)

A more comfortable seat means less operator fatigue and greater productivity. With dual adjustable armrests, higher backrest, and lumbar support, the ZD Series' fully padded and reclining bucket seat ensures a high level of comfort. The seat can be adjusted up and as well as forward and backward to let operators of all body types find the perfect position that will keep you comfortable and productive all day long.



New, thicker platform mat

Thicker and more durable, the redesigned platform mat also helps reduce noise and vibration for more comfort during mowing. The mat's grip pattern was designed to make getting on and off the mower easier.



New and bigger storage box and cup holder

Store personal items as well as two beverage cups in the handy storage box and cup holder beside the seat.



New foldable ROPS*

The new ROPS is now compliant with not only OSHA standards, but also ISO standards. The ROPS conveniently folds for easier storage and transportation of the mower.

Air-ride suspension seat (ZD1500 model only)

The ZD1500 takes comfort to the next level with a new bucket seat. It features air-suspension that can be adjusted with the touch of a button for supremely soft support and gentle comfort that lasts until the job is done.



Suspension Seat Adjustment Button



Easy mower and engine access

The ZD Series is designed to keep you on the job longer between maintenance stops. When maintenance is needed, however, you can be assured of quick and easy maintenance of all the critical parts and functions. The engine hood protects the engine, yet is simple to open and offers easy access to the engine for maintenance tasks. A special maintenance hatch under the platform mat provides fast access to top of the mower deck, mower belt, gearbox case, universal joint and fuel filters.



Maintenance lift

Routine maintenance underneath the mower is quick and simple, thanks to Kubota's innovative two-pin, tilt-up maintenance lift. A simple operation raises the front of the ZD Series even with the mower deck still attached. (Standard on the ZD1500 and ZD1200, available as an option on the ZD1000.)



*The ROPS complies with Occupational Safety and Health act (OSHA) 1928.52, International Organization for Standardization (ISO) 21299.



DIESEL ENGINE ZD1000

Side discharge mower 48"/54"/60"

Versatile and reliable, the ZD1000 compact mower can handle jobs big and small.

- 19.3 HP or 21.6 HP Kubota diesel engine
- High-back deluxe suspension seat
- Full-flat operator platform with thick cushion mat
- Hands-free parking brake and hydraulic deck lift
- Selectable front axle
- Low profile drive tires



Photo shown with optional Operator Controlled Discharge Chute.



DIESEL ENGINE ZD1200

Side discharge mower 60"/72"
Rear discharge mower 60"R/72"R

With a bigger engine and wider mower deck, the ZD1200 can get the job done with speed and efficiency.

- 24.8 HP Kubota diesel engine
- High-back deluxe suspension seat
- Full-flat operator platform with a high cushion mat
- Hands-free parking brake and hydraulic deck lift
- Selectable front axle
- Semi-pneumatic(flat-free) front caster tires
- Low profile drive tires
- Maintenance lift



DIESEL ENGINE ZD1500

Side discharge mower 72"
Rear discharge mower 60"R/72"R

Built for comfort and productivity under a wide range of mowing conditions, ZD1500 is the first choice for the demanding mower operator.

- 30.8 HP Kubota diesel engine with DPF(Diesel Particular filter)
- Air-ride suspension seat
- Full-flat operator platform with a high cushion mat
- Hands-free parking brake and hydraulic deck lift
- Selectable front axle
- Semi-pneumatic(flat-free) front caster tires
- Low profile drive tires
- Maintenance lift

Optional Attachments



Hopper style grass catcher

“Catch All” hopper style grass catcher (ZD1200 only)

This hopper style grass catcher holds 11.4 bushels of clippings. The hopper is easy to remove and can be emptied while the operator remains seated.

“Catch All” 2-bag style grass catcher (ZD1000/1200 only)

This 2-bag style grass catcher holds even more, allowing the operator to mow longer between stops to empty the grass catcher. To empty it, simply unlock the lid, and the bag slides out.



Hitch kit

With optional hitch kit, the ZD can tow a trailer or cart carrier for transporting a blower, trimmer, fertilizer, or other work supplies (ZD1000/1200 only).



Operator Controlled Discharge Chute

The discharge chute cover over the grass clippings outlet can be opened and closed with single lever, letting you temporarily shut the outlet to avoid sending clippings onto flowerbeds or roads.



2-Bag style grass catcher



Mulch kit, work lights are available for selected models. See dealer for details.

Specifications

Model		ZD1011		ZD1021		ZD 1211		ZD1211L		ZD1511L		ZD1511LF														
		ZD1011-48		ZD1011-54		ZD1021-60		ZD1211-60		ZD1211R-60R		ZD1211L-72		ZD1211RL-72R		ZD1511RL-60R		ZD1511LF-72		ZD1511RLF-72R						
Engine	Model	Kubota D782-E4-ZD-3				Kubota D902-E4-ZD-2				Kubota D1105-E4-ZD-2				Kubota V1505-T-E4-ZD												
	Type	Diesel, liquid-cooled (3cyl.)										Diesel, liquid-cooled (4cyl.) with DPF and KWRS														
	Max. horsepower (Gross)*	HP	19.3@3200rpm				21.6@3200rpm				24.8@3000rpm				30.8@2500rpm											
	Total displacement	cu.in. (cc)	47.5 (778)				54.8 (898)				68.53 (1123)				91.41 (1498)											
	Starting system	Key switch																								
Dimensions	Overall length	in. (mm)	87.8 (2230)				88.8 (2255)				89.0 (2260)				93.7 (2380)				104.7 (2660)							
	Overall width	(w/ mower)	in. (mm)	61.6 (1565)		67.3 (1710)		73.8 (1875)		73.8 (1875)		63.0 (1600)		85.8 (2180)		75.2 (1910)		63.0 (1600)		85.8 (2180)		75.2 (1910)				
		(w/o mower)	in. (mm)	47.7 (1210)				55.3 (1404)				59.4 (1510)				60.6 (1540)				59.4 (1510)				60.6 (1540)		
	Overall height	(w/ ROPS upright)	in. (mm)	74.4 (1890)												78.7 (2000)										
(w/ ROPS folded)		in. (mm)	56.3 (1430)												64.6 (1640)											
Wheel base		in. (mm)	54.3 (1380)								56.7 (1440)								61.4 (1560)							
Tread	Front	in. (mm)	35.0 (890)				40.6 (1030)				41.9 (1064)				49.2 (1250)				41.9 (1064)				49.2 (1250)			
	Rear	in. (mm)	36.6 (930)				38.6 (980)								47.6 (1210)											
Tire size	Front	13 × 5.0-6 Smooth pneumatic				13 × 6.5-6 Smooth pneumatic				15 × 6.5-8, Smooth semi-pneumatic, Low profile tire																
	Rear	24 × 9.5-14, Low profile tire				24 × 12.0-14, Low profile tire				26 × 12.0-16, Low profile tire																
Weight (w/ mower)	lbs. (kg)	1296 (588)		1323 (600)		1389 (630)		1687 (765)		1720 (780)		1764 (800)		1786 (810)		1984 (900)		2006 (910)		2028 (920)						
Transmission system	2-HST w/ Gear reduction																									
Speed control	2-hand levers																									
Travel speed range	Forward	mph (km/h)	0-9.0 (0-14.5)								0-10.6 (0-17.0)															
	Reverse	mph (km/h)	0-5.0 (0-8.0)								0-5.3 (0-8.5)															
Brake type	Wet multi disks, foot applied, released																									
PTO	Type	Shaft drive																								
	Clutch type	Hydraulic independent PTO clutch with wet multi disks																								
	PTO brake	Wet single disk																								
Mower deck	Model	RCK48P-1000Z		RCK54P-1000Z		RCK60P-1000Z		RCK60P-1200Z		RCK60RP-1200Z		RCK72P-1200Z		RCK72RP-1200Z		RCK60RP-1500Z		RCK72P-1500Z		RCK72RP-1500Z						
	Mower deck type	Kubota ProDeck with ACS										Kubota ProDeck		Kubota ProDeck with ACS		Kubota ProDeck				Kubota ProDeck with ACS		Kubota ProDeck				
	Mower lift system	Hydraulic																								
	Deck depth	in. (mm)	6.0 (152)				6.0 (152.4)				5.5 (140)		6.0 (152.4)		5.5 (140)				6.0 (152.4)		5.5 (140)					
	Belt type	Multi-belt																								
	Deck steel thickness	in. (mm)	0.15 (3.8)				0.16 (4.2)						0.18 (4.5)		0.16 (4.2)				0.18 (4.5)							
	Anti-scalp roller	Rigid														Swivel										
	Cutting width of mower	in. (mm)	48 (1219)		54 (1372)		60 (1524)				72 (1829)				60 (1524)		72 (1829)									
	Number of blades	3 blades																								
	Cutting height	in. (mm)	1-5 (25-127)																							
	Mounting system of mower	Quick joint, parallel linkage																								
	Blade tip speed (max.)	FPM	17100		18200		18050		16900		18050		18000		17300		18400									
Seat	Deluxe suspension seat										Deluxe suspension seat with Reclining and lumbar support				Air-ride suspension seat with Reclining and lumbar support											
Engine stop system	Key stop																									
Fuel tank capacity	gals. (ltrs.)	6 (23)								13 (49)																
Battery	Maintenance free battery : 12 V, CCA : 430A , RC : 80 min														Maintenance free battery : 12 V, CCA : 670A , RC : 115 min											
Alternator capacity	AC Dynamo: 14 Amps @ 14 Volts														Alternator: 60Amps 12Volts											
Water temperature indicator											Standard															
Hour meter											Standard															
Fuel gauge											Standard															

*Power(HP) specifications for individual diesel engine models are rated pursuant to Society of Automobile Engineers(SAE) J1940 based on gross output testing performed in accordance with SAE J1995 without the air cleaner and muffler. Diesel engine hp will be higher than actual engine power which is affected by accessories, application, engine speed, ambient operating conditions and other factors. The gross engine horsepower information is for comparison purpose only.

Kubota Tractor Corporation reserves the right to change the stated specifications without notice. This brochure is for descriptive purposes only and reasonable efforts were used to set forth the contained information; some items shown may be optional and some products shown may not be available at all dealerships. Kubota disclaims all representations and warranties, express or implied, or any liability from the use of this brochure. For complete warranty, safety and product information, consult your local Kubota dealer and the operator's manual. Power (HP/KW) and other specifications are based on various standards or recommended practices. For your safety, Kubota strongly recommends the use of a Rollover Protective Structure (ROPS) and seat belt in almost all applications. This brochure is intended for the United States and US territories only. For information regarding Kubota products or services outside these areas, see Kubota Corporation's global web site. Kubota does not provide parts, warranty or service for any Product which is re-sold or retailed in any country other than the country for which the Product(s) were designed or manufactured.

Yellowstone Tractor

The last best place to buy a tractor

150 Be Kind Ln
Victor MT 59875

INVOICE # NO.
DATE: JUNE 9TH 2023

TO City Of Stevensville

SALESPERSON	JOB	PAYMENT TERMS	DUE DATE
		Due on receipt	

QTY	DESCRIPTION	UNIT PRICE	LINE TOTAL
1	Outlaw Renegade 61" With Perkins Diesel	\$16999.99	\$16999.99

SUBTOTAL

SALES TAX

TOTAL

THANK YOU FOR YOUR BUSINESS!

ALL PURCHASE ORDERS MUST BE MADE OUT TO (VENDOR):

RDO Equipment Co.
8571 Running W Road
Missoula, MT 59808
US

ALL PURCHASE ORDERS MUST BE SENT TO DELIVERING DEALER:

RDO Equipment Co.
8571 Running W Road
Missoula, MT 59808
406-549-4171
act-mis@rdoequipment.com

Quote Summary

Prepared For:

TOWN OF STEVENSVILLE
PO BOX 30
STEVENSVILLE, MT 59870

Delivering Dealer:

RDO Equipment Co.
Kipp Anderson
8571 Running W Road
Missoula, MT 59808
Phone: 406-549-4171
ktanderson@rdoequipment.com

Quote ID: 29010396
Created On: 08 June 2023
Last Modified On: 08 June 2023
Expiration Date: 08 July 2023

Equipment Summary	Selling Price	Qty	Extended
JOHN DEERE Z994R Diesel Commercial ZTrak Contract: Sourcewell Turf 031121-DAC (PG BT CG 23) Price Effective Date: June 7, 2023	\$ 18,624.76 X	1 =	\$ 18,624.76
JOHN DEERE Z960M ZTrak Contract: Sourcewell Turf 031121-DAC (PG BT CG 23) Price Effective Date: June 7, 2023	\$ 12,631.08 X	1 =	\$ 12,631.08
Equipment Total			\$ 31,255.84

* Includes Fees and Non-contract items

Quote Summary

Equipment Total	\$ 31,255.84
Trade In	
SubTotal	\$ 31,255.84
Est. Service Agreement Tax	\$ 0.00
Total	\$ 31,255.84
Down Payment	(0.00)
Rental Applied	(0.00)
Balance Due	\$ 31,255.84

Salesperson : X _____

Accepted By : X _____

Selling Equipment

Quote Id: 29010396 Customer Name: TOWN OF STEVENSVILLE

ALL PURCHASE ORDERS MUST BE MADE OUT TO (VENDOR):
 RDO Equipment Co.
 8571 Running W Road
 Missoula, MT 59808
 US

ALL PURCHASE ORDERS MUST BE SENT TO DELIVERING DEALER:
 RDO Equipment Co.
 8571 Running W Road
 Missoula, MT 59808
 406-549-4171
 act-mis@rdoequipment.com

JOHN DEERE Z994R Diesel Commercial ZTrak

Hours:

Stock Number:

Contract: Sourcewell Turf 031121-DAC (PG BT CG 23)

Selling Price *

Price Effective Date: June 7, 2023

\$ 18,624.76

* Price per item - includes Fees and Non-contract items

Code	Description	Qty	List Price	Discount%	Discount Amount	Contract Price	Extended Contract Price
2545TC	Z994R Diesel Commercial ZTrak	1	\$ 21,839.00	23.00	\$ 5,022.97	\$ 16,816.03	\$ 16,816.03
Standard Options - Per Unit							
001A	United States and Canada	1	\$ 0.00	23.00	\$ 0.00	\$ 0.00	\$ 0.00
1040	24x12N12 Michelin X Tweel Turf for 54 In. and 60 In. Decks	1	\$ 1,249.00	23.00	\$ 287.27	\$ 961.73	\$ 961.73
1505	60 In. 7-Iron PRO Mulch On Demand Mower Deck	1	\$ 1,100.00	23.00	\$ 253.00	\$ 847.00	\$ 847.00
2093	Fully Adjustable Suspension Seat with Armrests (24" High Back)	1	\$ 0.00	23.00	\$ 0.00	\$ 0.00	\$ 0.00
Standard Options Total			\$ 2,349.00		\$ 540.27	\$ 1,808.73	\$ 1,808.73
Value Added Services Total			\$ 0.00			\$ 0.00	\$ 0.00
Total Selling Price			\$ 24,188.00		\$ 5,563.24	\$ 18,624.76	\$ 18,624.76

JOHN DEERE Z960M ZTrak

Equipment Notes:

Hours:

Stock Number:

Selling Price *

Contract: Sourcewell Turf 031121-DAC (PG BT CG 23)

\$ 12,631.08

Price Effective Date: June 7, 2023

* Price per item - includes Fees and Non-contract items

Selling Equipment

Quote Id: 29010396 **Customer Name:** TOWN OF STEVENSVILLE

ALL PURCHASE ORDERS MUST BE MADE OUT TO (VENDOR):
 RDO Equipment Co.
 8571 Running W Road
 Missoula, MT 59808
 US

ALL PURCHASE ORDERS MUST BE SENT TO DELIVERING DEALER:
 RDO Equipment Co.
 8571 Running W Road
 Missoula, MT 59808
 406-549-4171
 act-mis@rdoequipment.com

Code	Description	Qty	List Price	Discount%	Discount Amount	Contract Price	Extended Contract Price
2233TC	Z960M ZTrak	1	\$ 15,809.00	23.00	\$ 3,636.07	\$ 12,172.93	\$ 12,172.93
Standard Options - Per Unit							
001A	United States/Canada	1	\$ 0.00	23.00	\$ 0.00	\$ 0.00	\$ 0.00
1036	24x12x12 Pneumatic Turf Tire for 54 In. and 60 In. Decks	1	\$ 0.00	23.00	\$ 0.00	\$ 0.00	\$ 0.00
1504	60 In. Side Discharge Mower Deck	1	\$ 0.00	23.00	\$ 0.00	\$ 0.00	\$ 0.00
2093	Fully Adjustable Suspension Seat with Armrests (24" High Back)	1	\$ 595.00	23.00	\$ 136.85	\$ 458.15	\$ 458.15
Standard Options Total			\$ 595.00		\$ 136.85	\$ 458.15	\$ 458.15
Value Added Services Total			\$ 0.00			\$ 0.00	\$ 0.00
Total Selling Price			\$ 16,404.00		\$ 3,772.92	\$ 12,631.08	\$ 12,631.08

Quote ID :29010396Customer Name : TOWN OF STEVENSVILLE

Product features, prices and specifications are based on published information at the time of publication and are subject to change without notice. All trademarked terms, including John Deere, the leaping deer symbol and the colors green and yellow used herein are the property of Deere & Company, unless otherwise noted. Products, product features, and other content on this site may only be accurate for products marketed and sold in North America.

Copyright ?? 1994- 2023 Deere & Company. All Rights Reserved.

File Created: 08-Jun-2023

2023 JOHN DEERE Z994R Diesel Commercial ZTrak

Key Features

Serviceability features give convenience and maximize uptime

Frequently accessed service areas such as the air cleaner, radiator screen, and oil check and fill points can be easily accessed from the open engine compartment.

An easy-to-remove rear engine service panel allows access to all engine service points for scheduled service or other maintenance work.



3-cylinder diesel engine



Access to engine service points

Base Equipment On: Z994R

The design of the Z994R makes service components like the engine oil dipstick, oil filter, and fuel filter/water separator easy to see and access:

- Large radiator coolant reservoir and fuel filter/separator reduce service requirements and increase uptime.
- A convenient fuel shutoff is provided on the filter/separator.

Quote ID :29010396Customer Name : TOWN OF STEVENSVILLE



Radiator coolant reservoir

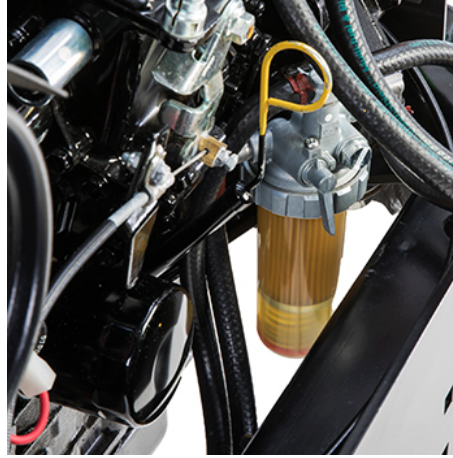

Engine oil filter, dipstick, and fuel filter/water separator

Base Equipment On: Z994R

The floor panel is easily removed, without tools, to give access to the top of the mower deck for cleaning and service.

All mower deck blade spindle grease fittings can be accessed from the top of the mower deck.

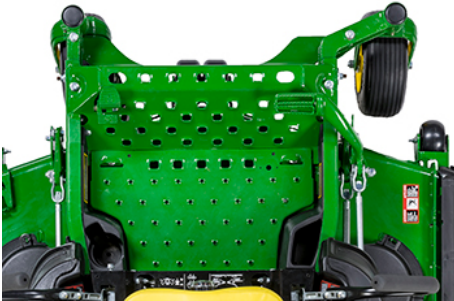

Removable floor panel



Floor panel removed for mower access (similar Z970R shown)

Base Equipment On: Z994R

Battery and transmission fluid reservoir access

The seat is locked down for operator comfort and safety, but the spring latch system is easily released to raise the seat to protect it from the elements and give access to the battery, transmission fluid reservoir, etc.

Quote ID :29010396Customer Name : TOWN OF STEVENSVILLE



Flip-up seat

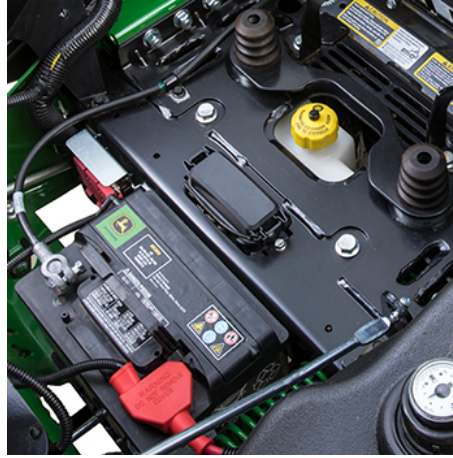

Service access with
seat in raised position

Base Equipment On: Z994R

- Maintenance free, 600 cold-cranking amp (CCA) battery is provided for fast, reliable engine starts.
- Electrical box is sealed to keep dirt and moisture out for reliability and ease of service.



Battery



Sealed fuse and relay box

Base Equipment On: Z994R

Motion-control lever and tracking adjustments

Motion-control lever adjustments include:

- Two height positions to suit the operator
- Control lever fore/aft position to suit operator size and preference
 - Slots in control levers allow forward/rearward adjustment of control arms when the bolts are loose.
- Gap between the control levers adjustment (1)
- From-the-seat tracking adjustment (2) so operators can mow straight and produce professional striping results

Quote ID :29010396Customer Name : TOWN OF STEVENSVILLE



Motion-control lever two-position height adjustment

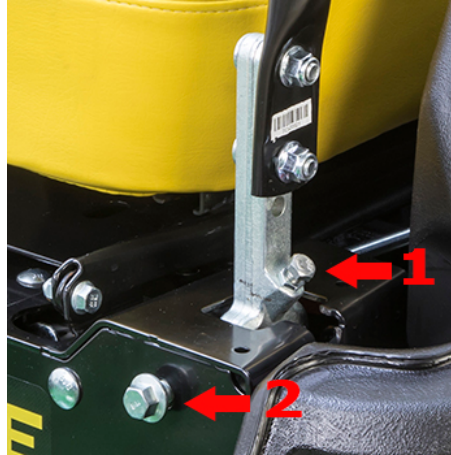

Adjustments for fore-aft position (1) and tracking (2)

Base Equipment On: Z994R

Service information and diagnostics

A digital multifunction display shows the number of hours the machine is run when the key switch is in the on position. It only counts the hours the engine is actually running. Monitoring systems to notify operators of machine status and quickly diagnose common downtime issues include:

- Glow plug monitor
- Maintenance required notification
- Low oil pressure
- Hour meter
- Coolant overheat notification
- Battery charging system
- High engine oil temperature



Service information label



Digital multi-function display

Base Equipment On: Z994R

Quote ID :29010396Customer Name : TOWN OF STEVENSVILLE

Quick response (QR) codes link to owner information web pages



QR code label

To speed access to owner information web pages, a QR code is printed onto a product identification number (PIN) label located under the right steering lever. The owner information web pages that include links to:

- Safety and how-to videos
- Operator's manuals
- Parts catalogs
- Maintenance reminder sheets
- Attachments
- Warranty statements

Base Equipment On: Z994R

Optional service jack kit and jack

The Z994R front frame member is pre-drilled to accept the optional jack kit and jack:

- The jack makes servicing the underside of the mower deck safer and easier.
- Placed in the storage position, the jack can be carried on the machine, always available for use.
- The jack will need to be removed when using front ballast that is required for a rear material collection system.



Jack kit and jack installed



Jack in storage position

Base Equipment On: Z994R

Three-year, 1500-hour bumper-to-bumper warranty

An exclusive two-year, unlimited hour/three-year, 1500-hour (whichever comes first) bumper-to-bumper warranty is standard on the Z994R. The warranty is best in the industry and puts John Deere at the forefront of commercial mowing. It is also hassle free, with one company handling all of the paperwork.

NOTE: The warranty covers 36 months or 1500 hours, whichever comes first. For the first 24 months, there is no hour limitation.

Quote ID :29010396Customer Name : TOWN OF STEVENSVILLE



Z994R ZTrak™ Mower



Z994R ZTrak Mower

Base Equipment On: Z994R

Key Features

Durable pump and wheel motor hydrostatic drive delivers speeds up to 11.4 mph (18.3 km/h)

A right-angle gearbox is used to convert power from the horizontal shaft diesel engine to vertical shaft power to operate the vehicle transmission. Cooling for the gearbox is provided by fins on the gearbox housing and a fan.

The hydrostatic drive included with the Z994R features two 13-cc (0.8-cu in.) unitized hydraulic pumps combined with commercial-grade, heavy-duty, 13-cc (0.8-cu in.) wheel motors into a single unit. The drive units feature cross porting, where the hydraulic fluid from the side doing the least work is filtered and then fed into the input of the side doing the most work. This ensures that the coolest fluid is going into the side working the hardest in order to provide the best performance during extended hillside operation in the same direction.

One pump and motor drive assembly for each wheel provides the following benefits:

- Exceptional cooling, even in high-load conditions
- Easy-to-check level and refill hydraulic oil
- Opens up access under the seat



Right angle gearbox
with cooling fins and fan

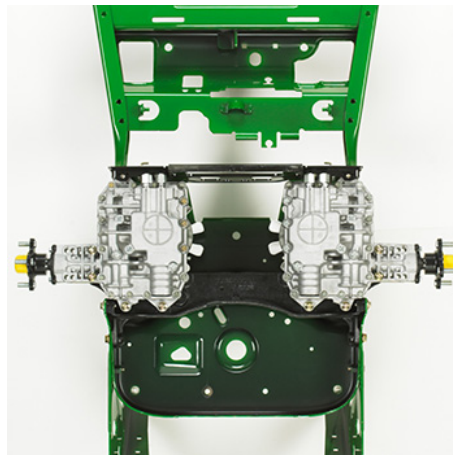

Illustration of unitized pump
and wheel motor drives

Quote ID :29010396Customer Name : TOWN OF STEVENSVILLE

Base Equipment On: Z994R

One transmission oil reservoir is used for both of the unitized transmissions.

Motion control levers are designed for operator comfort and ease of controlling vehicle speed and direction.

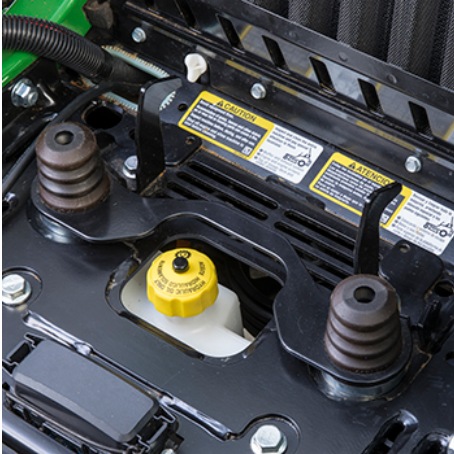

Transmission fluid tank fill cap



Motion-control levers
(shown in park position)

Base Equipment On: Z994R

Motion-control lever adjustments include:

- Two height positions to suit the operator.
- Control lever fore/aft position to suit operator size and preference.
 - Slots in control levers allow forward/rearward adjustment of control arms when the bolts are loose.
- Gap between the control levers adjustment (1).
- From-the-seat tracking adjustment (2), operators can mow straight and produce professional striping results.



Motion-control lever
height adjustment bolts

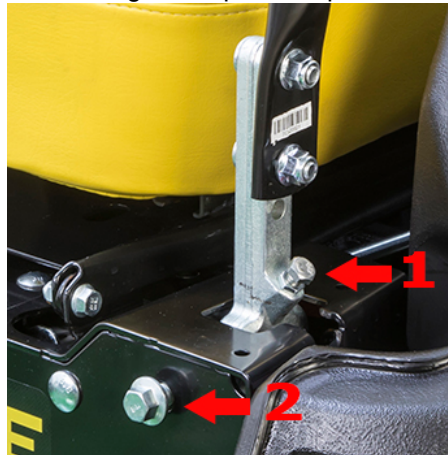

Motion-control lever gap (1)
and tracking (2) adjustments

Base Equipment On: Z994R

Key Features

Protective zone around the operator is provided by the rollover protective structure (ROPS)

Quote ID :29010396Customer Name : TOWN OF STEVENSVILLE



Z994R with 72-in. (183-cm) mower deck

The spacious operator station has been designed for comfort, visibility, and ease of use:

- Getting on and off is easy with the flat operator platform.
- Convenient-to-use controls located close to the operator are color coded and designed for easy identification and operation.

The ROPS and seat belt work in conjunction to provide a protective zone around the operator:

- It reduces the operator's risk of being crushed under the vehicle should it overturn.
- When used with the seatbelt, the ROPS can reduce the severity of injury in the event of a rollover.
- Use of the seat belt is recommended when operating with ROPS in the upright position.

Base Equipment On: Z994R

Foldable ROPS and a retractable seat belt are standard equipment:

- Position adjustment pins provide a good grip and make changing the angle of the ROPS easier.
- If operating in low clearance areas, the ROPS can be folded and secured out of the way. It can also be positioned in an intermediate position to accommodate machines equipped with a material collection system.
- Under normal operation, the ROPS should be in the up position.
- See Operator's Manual for more information on ROPS.



ROPS in upright position



ROPS in intermediate position

Base Equipment On: Z994R

Quote ID :29010396Customer Name : TOWN OF STEVENSVILLE



ROPS in down position (similar vehicle shown)

- Door height of most garages will accommodate the machine with ROPS in the full-raised position.
- Easy-fold ROPS improves the ability to store the ZTrak™ mower in structures with a lower door opening.

ROPS position	Height at top of ROPS
Full height	73 in. (185 cm)
Down	47 in. (119 cm)

Base Equipment On: Z994R

Optional Light-emitting diode (LED) work lights



LED work lights

BUC11438 LED work lights are available as a field installed attachment. BUC11438 is compatible with model year 2015 and newer (serial number 030,001-) Z900 ZTrak Mowers. All Z997R and model year 2015-2018 (serial number 030,001-070,000) gasoline powered models require AUC18778 battery jumper.

Base Equipment On: Z994R

Optional LED beacon light

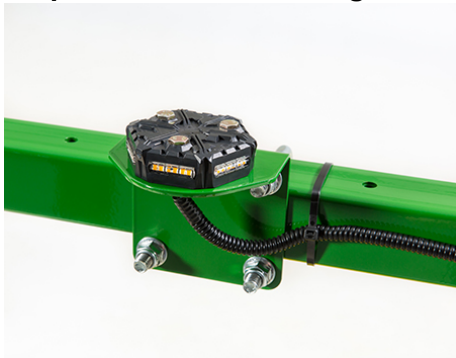

BUC11406 LED beacon light is available as a field installed attachment. The beacon light is short to avoid damage. BUC11406 is compatible with model year 2015 and newer (serial number 030,001-) Z900 ZTrak Mowers. All Z997R and model year 2015-2018 (serial number 030,001-070,000) gasoline powered models require AUC18778 battery jumper.

Quote ID :29010396 Customer Name : TOWN OF STEVENSVILLE

LED beacon light

Base Equipment On: Z994R

Key Features

Thoughtful designs and high-quality controls promote safe operation

Safety interlock systems

The Brake & Go starting system is a John Deere exclusive. This feature makes the starting process easier:

- The Brake & Go starting system is easy to understand and use.
- To start the machine, the parking brake must be engaged.
- It does not matter whether the power take-off (PTO) switch is on or off, nor does it matter if the control levers are pulled in or extended out.
 - As long as the parking brake is engaged, the machine will start. When the parking brake is applied, the control levers cannot be moved.
- Brake & Go operator-presence system returns levers to the neutral position when the brake pedal is actively engaged.



Brake & Go pedal



Motion-control levers
(shown in park position)

Base Equipment On: Z994R

Mower deck safety



60-in. (152-cm) Mower Deck

Mower safety features include:

- A high-quality deflector that meets applicable safety standards and disperses cut grass
- Spindle-sheave shielding that protects and is easy to remove without tools for cleaning and service
- A substantial welded-on metal step on the mower deck for safer operator entry and exit from the machine

Base Equipment On: Z994R

Mower decks are safety certified

Mowers decks are evaluated by the manufacturer (John Deere Turf Care) and conform to American Nation Standards Institute (ANSI) B71.4 2004 safety certification specifications for commercial turf care equipment.

Base Equipment On: Z994R

Quote ID :29010396Customer Name : TOWN OF STEVENSVILLE

Key Features

Powerful 24.7-hp (18.4-kW) diesel engine delivers superior performance and efficiency

The Z994R is powered by a 3-cylinder, liquid-cooled diesel engine with gross SAE J1995, PS 24.7 hp (18.4 kW) rated power at 3200 rpm that meets U.S. Environmental Protection Agency (EPA) Final Tier 4 emission standards:

- High-torque, low-emission diesel engine for strong performance in the toughest conditions
- Low vibration and noise levels
- Isolated with rubber mounts for a smoother operator ride
- Superior fuel economy
- High torque reserve for plenty of power and performance

Key features of the engine include:

- Economical, cast-in block cylinder design provides good cooling and long life.
- Liquid-cooled design provides more consistent operating temperatures than air-cooled.
- Fuel filter with replaceable element is provided.
- Indirect fuel injection uses a pre-combustion chamber to give the engine smooth and quiet operation.
- Full-pressure lubrication with full-flow filter lengthens engine life.
 - Engine wear reduced by ensuring proper lubrication, even when operating on hillsides or uneven terrain.
 - Oil filter helps keep oil clean for increased engine life.
- Aluminum alloy pistons with built-in steel struts are lightweight to reduce connection rod bearing loads and provide good heat-transfer characteristics.
 - Design permits tighter tolerances and neutralizes expansion of the piston, thereby reducing blow-by fuel and noise from the piston slap.
 - Higher top rings on the piston and a thinner head gasket greatly reduce the volume of unburned waste and increase combustion efficiency.
- Timing gears and injector drive gears utilize helical profile gears to help lower engine noise.
 - Gear teeth have a "roll-off" profile, giving almost no clash, no noise, and no backlash.
- Glow plugs provide quick starts in temperatures down to -18°C (0°F)
- Key start and shutoff eliminate fuel shut-off knob; electric solenoid shuts fuel supply off immediately when key is turned off.



3-cylinder diesel engine

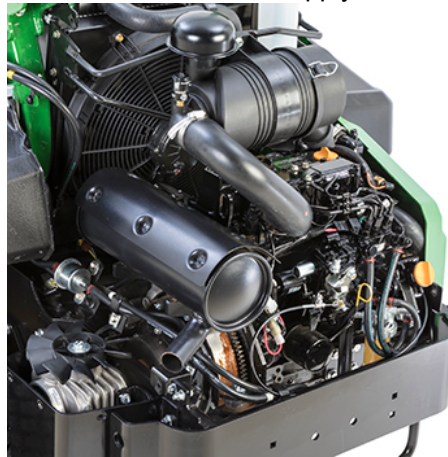

Access to engine service points

Base Equipment On: Z994R

Air cleaner with secondary safety element and restriction indicator

- Dual-element, dry-type air cleaner with safety element and air service indicator
 - Dual-element design for added engine protection and easy service
 - Completely sealed for effective cleaning
 - Ninety to 95 percent of dirt ejected before it reaches the paper element
- Air cleaner restriction indicator to let operator know when the filter needs servicing

Quote ID :29010396Customer Name : TOWN OF STEVENSVILLE

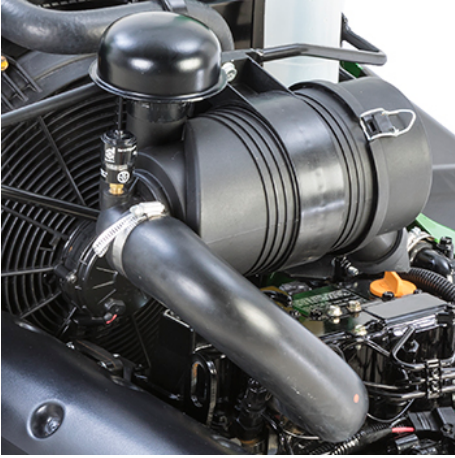

Heavy-duty air cleaner



Air cleaner restriction indicator

Base Equipment On: Z994R

Radiator

A sealed radiator compartment controls trash and debris. A cover is provided over the radiator, and a cooling fan area controls the flow of air.

Knobs on both ends of the cover hold it in place.



Radiator cover



Radiator cover knob

Base Equipment On: Z994R

An automotive-type radiator, coolant reservoir, and electric cooling fan are provided to remove heat from the engine coolant:

- The cooling fan is thermostatically controlled so it only runs when necessary.
- See-through coolant recovery tank permits the operator to check the coolant level without removing the radiator cap.

Quote ID :29010396Customer Name : TOWN OF STEVENSVILLE



Radiator shown with debris screen removed



Radiator and electric cooling fan

Base Equipment On: Z994R

A debris screen with a corrugated shape to give a large surface area covers the intake air side of the radiator to keep the radiator fins clean.

The debris screen can be easily removed for cleaning, if desired, and also for access to the radiator fins.



Radiator debris screen

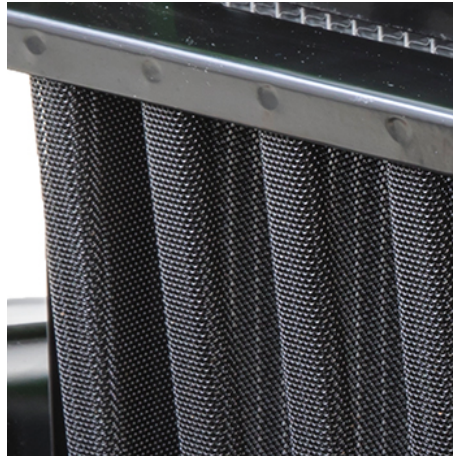

Close-up of radiator debris screen

Base Equipment On: Z994R

Fuel tank

The Z994R Diesel ZTrak™ Mower is equipped with a single 11.5-U.S. gal. (43.5-L) fuel tank that provides enough capacity to allow mowing for a full day without refueling:

- Large, angled filler neck makes for easier refueling
- Fuel cap tether is provided to secure the filler cap while refueling
- Fuel gauge is provided as standard equipment

NOTE: The fuel fill level is 1 in. (25 mm) below the bottom of the filler neck.

Quote ID :29010396Customer Name : TOWN OF STEVENSVILLE



Fuel tank and angled fuel filler cap



Diesel fuel cap and fuel gauge

Base Equipment On: Z994R

Gearbox cooling fins and fan



Cooling fins and fan for right-angle gearbox

A right-angle gearbox is used to convert power from the horizontal shaft diesel engine to vertical shaft power to operate the vehicle transmission and the mower power-take off clutch. Cooling for the gearbox is provided by fins on the gearbox housing and a fan.

Base Equipment On: Z994R

Key Features

Enhanced productivity, safety, and trim ability with a FastBack™ PRO rear-discharge mower deck

For professional landscapers and government municipalities requiring rear discharge placement of grass and debris, John Deere FastBack PRO rear-discharge mower decks deliver a commercial zero-turn mowing solution for both gas and diesel machines. Advantages of a rear-discharge mower include:

- Less chance of damage from objects being thrown from the mower deck
- Time savings with the ability to mow closely around fixed objects with either side of the deck
- A cleaner mowing experience by lessening the amount of debris that can blow onto the operator

A rear-discharge mower deck is ideally suited for:

- Schools
- Parks
- Playgrounds
- Traffic areas (city boulevards, roadsides, etc.)

Quote ID :29010396Customer Name : TOWN OF STEVENSVILLE

- Areas with long, grassy spots that need to be cut, where you are not as concerned about wide dispersal of grass (park areas, roadsides, etc.)*

**NOTE: Operators maintaining turf outside of target areas are encouraged to evaluate rear-discharge dispersion through a cut quality demonstration to ensure satisfaction.*



60-in. (152-cm) Rear-Discharge Mower Deck



72-in. (183-cm) Rear-Discharge Mower Deck

Optional Equipment On: Z930M, Z950M, Z955M EFI, Z950R, Z955R EFI, Z970R, Z994R

Compatibility

Mower deck	Z930M	Z950M	Z960M	Z950R	Z970R	Z994R
60-in. (152-cm) FastBack PRO rear-discharge	x		x	x		x
72-in. (183-cm) FastBack PRO rear-discharge		x	x		x	x

Optional Equipment On: Z930M, Z950M, Z955M EFI, Z950R, Z955R EFI, Z970R, Z994R

Commercial-quality deck design

A large volume of material can be thoroughly processed with the deep-deck design:

- Unique baffling system is designed to reduce clumping and windrowing often associated with rear-discharge mowers.
 - Efficiency is enhanced with baffles surrounding each blade to control material as it is moved to the rear.
 - Material exits the deck quickly as the baffles are lower at the rear.
 - Movement of material is controlled to minimize the likelihood that clippings are thrown onto unwanted areas.
- Less debris gets on the operator as material is directed to the rear and toward the ground.
 - Debris is kept low and directed into the turf by the flexible rear shield.

Optional Equipment On: Z930M, Z950M, Z955M EFI, Z950R, Z955R EFI, Z970R, Z994R

Level cut

The deck is suspended from and supported by the machine to provide a level cut. Mower deck wheels and rollers help smooth out the mowing job in uneven conditions and reduce the chance of scalping the lawn:

- Two wide front rollers at the center of the mower support the deck when necessary to prevent scalping.
- Wheels at all four corners protect the deck from scalping at the sides of the mower.
- Continued effectiveness results from wheels and rollers that are double captured for extra strength, which reduces the chance of damage.
- Height of rollers and wheels is adjustable to suit mowing conditions.
 - Higher setting (shown in images) are used when mowing at lower cut heights and for rougher conditions at all cut heights where you want to reduce the chance of the wheels hitting the ground.
 - Lower settings are used for higher cut heights and for helping to smooth out the mowing job.
- Mower cut height is adjustable from 1 to 5.5 in. (2.54 to 14 cm) in 0.25-in. (0.64-cm) increments from the machine operator's station.

Quote ID :29010396 Customer Name : TOWN OF STEVENSVILLE



Center deck rollers and left wheel



Right-rear deck wheel

Optional Equipment On: Z930M, Z950M, Z955M EFI, Z950R, Z955R EFI, Z970R, Z994R

Heavy-duty components for long life

These rear-discharge decks are designed to stand up to heavy-duty commercial use:

- Superior strength and durability come from a 7-gauge, 0.179-in. (4.56-mm) steel deck.
- Experience extra strength and long life with a fabricated deck design that is formed, welded, and reinforced for extra protection from damage.
- The front of the deck is protected from damage by a 1.5-in. (3.8-cm) tall by 0.5-in. (1.3-cm) thick solid steel bar welded to the mower deck for additional strength.
- Both sides of the deck have bumpers that are made from compression molded ultra-high molecular weight (UHMW) polyethylene plastic.
 - The bumpers provide great abrasion resistance to protect the machine and the property.
 - Additional strength is provided by a 0.5-in. (1.3-cm) by 0.5-in. (1.3-cm) thick solid steel bar.



Strong, reinforced deck



Right trim-side wear guard

Optional Equipment On: Z930M, Z950M, Z955M EFI, Z950R, Z955R EFI, Z970R, Z994R



Cast-iron blade-spindle housing

Extra reliability and long life are provided by cast-iron blade spindle housings:

- Ductile cast-iron material provides superior impact strength.
- Gusseted design puts reinforcement where it is needed.
- Strength of cast iron protects against damage from blade impacts.
- Chance of deck-shell damage is minimized with the 8-in. (20.3-cm) diameter housing and six mounting bolts that distribute loads and impacts.
- Ability to be reliably rebuilt is provided by use of cast iron.

Optional Equipment On: Z930M, Z950M, Z955M EFI, Z950R, Z955R EFI, Z970R, Z994R

Ease of service

Minimal service requirements increase uptime:

- Quick-release belt covers do not require tools or the removal of a ring clip; just lift one corner of the cover and rotate it slightly to remove.
 - A hole in the deck tab is provided for use of an optional ring clip for extra security, if desired.
 - This makes it quick and easy for you to clean out trash that may collect around the spindle sheave.
- There is only one belt to service.

Quote ID :29010396Customer Name : TOWN OF STEVENSVILLE



Quick-release belt cover

Optional Equipment On: Z930M, Z950M, Z955M EFI, Z950R, Z955R EFI, Z970R, Z994R

Extra convenience



Serrated-tread step

Optional Equipment On: Z930M, Z950M, Z955M EFI, Z950R, Z955R EFI, Z970R, Z994R

Key Features

Exceptional operator comfort begins with a high-quality seat and suspension



Operator comfort was a primary focus in the design of the Z994R:

- Large, open operator station and foot platform with plenty of legroom and room for multiple foot positions
- A choice of seat and suspension options to suit the operator and operating conditions
- Instruments, controls, and storage areas that are easy to see and use
- Three-position rollover protective structure (ROPS) and retractable seat belt for operator safety and convenience
- Thick seat cushion for lasting comfort, even after a full day of use
- Retractable seatbelt for convenience and ease of use
- Springs to isolate the seat base for increased ride comfort

Quote ID :29010396Customer Name : TOWN OF STEVENSVILLE

High back suspension seat

Base Equipment On: Z994R

- ComfortGlide fore/aft suspension for superior ride comfort over uneven areas
- Seat can travel up to 2 in. (50.8 mm) fore and aft to absorb bumps for a significant enhancement to ride comfort
- Ability to easily lock out if desired by the operator
- One lever for three functions
- Slide seat forward and back 3 in. (7.6 cm)
- Activate ComfortGlide fore/aft seat suspension
- Lock-out ComfortGlide fore/aft seat suspension

A spring-type locking mechanism holds the seat securely down in the operating position for operator comfort and safety, but allows quick release for tilting the seat up:

- For protection from the elements
- For access to the transmission fluid reserve tank, battery, etc.



ComfortGlide suspension
with fore/aft control



Seat easily raised with
spring-loaded latch

Base Equipment On: Z994R

Fully adjustable seat with 24-in. (61-cm) high back, armrests and ComfortGlide fore/aft suspension

The fully adjustable, 24-in. (61-cm) high-back, mechanical suspension seat with adjustable armrests includes:

- Adjustable armrests that can also be raised for operator convenience

Quote ID :29010396Customer Name : TOWN OF STEVENSVILLE



Fully adjustable suspension seat with armrests and 24-in. (61-cm) high back



Armrest adjustment

Base Equipment On: Z994R

- Suspension seat control dial for easy adjustment of suspension to suit the operator
- Adjustable lumbar support for operator preference
 - Lumbar adjustment gives extra operator comfort
 - Adjustment is especially helpful when operating the vehicle for extended periods of time
- Vibration reduction
- Seat back-angle adjustment to maximize operator comfort by using a convenient lever on the side of the seat



Mechanical suspension seat adjustment



Lumbar adjustment lever

Base Equipment On: Z994R

Quote ID :29010396Customer Name : TOWN OF STEVENSVILLE

Foot pegs

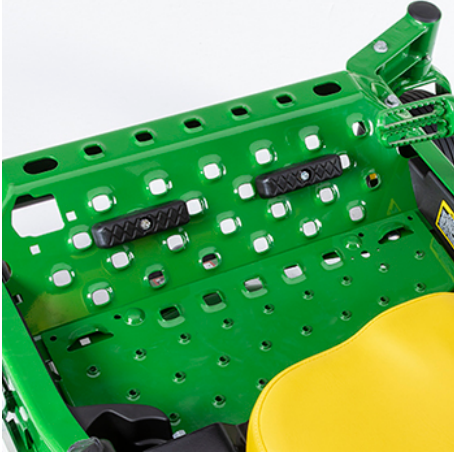

Foot pegs available
standard on R-spec Z900's

Foot pegs help provide the operator with a comfortable foot placement.

- Location and angle of foot pegs can be adjusted for individual operator comfort.

Base Equipment On: Z994R

Foot platform isolators



Foot platform isolators

Foot platform isolators provide the operator with added comfort.

- Vibration to the legs and feet is reduced.

Base Equipment On: Z994R

Onboard storage and cup holder

A convenient storage compartment and cup holder are available within easy reach of the operator.

Quote ID :29010396Customer Name : TOWN OF STEVENSVILLE



Onboard storage compartment



Cup holder

Base Equipment On: Z994R

Key Features

Heavy-duty chassis components provide strength and durability

Attractive styling incorporates a roomy and uncluttered operator platform with adjustable footrest, seat, and steering control positions for different operator preferences. Other well-thought-out features further contribute to good looks and operator comfort.

The frame is made of heavy-duty formed and welded steel for strength and reliability.



Z994R ZTrak™ Mower with optional dump-from-seat material collection system



Z994R ZTrak Mower

Base Equipment On: Z994R

Formed and welded steel frame

A strong, welded steel frame provides solid, reliable support for the machine components and operator:

Quote ID :29010396Customer Name : TOWN OF STEVENSVILLE

- Heavy-duty, 7-gauge, 0.179-in. (4.55-mm) 1.5x3-in. (38x76.2-mm) steel tubular frame for durability
- Wide-open access for maintenance and cleaning
- Rear frame provides solid support and protection for the engine



Z994R ZTrak Mower



Z994R ZTrak Mower

Base Equipment On: Z994R

Front axle and offset caster wheels



Front axle and caster wheels

Cast I-beam caster arm and spindle assemblies handle the beating and pounding professional mowers receive.

Caster wheels are offset for optimum steering and mowing performance. Benefits include better inside-corner trimming performance and less chance of between-blade striping.

Base Equipment On: Z994R

Rear bumper provides protection

A steel rear bumper provides protection for the machine.

A rear hitch can be added to the steel bumper for towing purposes. The Z994R can tow up to 400 lb (181.4 kg).

Quote ID :29010396Customer Name : TOWN OF STEVENSVILLE



Z994R rear bumper



Optional rear hitch

Base Equipment On: Z994R

Key Features

Instruments and controls are easy to find and use

The contoured dash has clean, attractive styling:

- Controls are located on the right instrument panel for convenience
- Color coded and labeled for easy identification by the operator
- Controls are logically placed and easy to reach on the right-hand control panel
- Functional design of the controls provides good appearance and a comfortable feel

Base Equipment On: Z994R

Right-hand control panel

Controls are grouped on the right console, providing one central location for key switch, engine speed control, power take-off (PTO) engagement, height-of-cut adjustment, hour meter, and engine diagnostics.

The comprehensive display tells when oil changes and other maintenance should be performed, monitors vehicle function, and helps diagnose common downtime issues:

- A service reminder feature will indicate that a general lubrication or mower/engine service interval has been reached.
- When service is required, arrows will periodically flash for two hours.
- Other features include:
 - Hour meter
 - Engine overheat warning light
 - Battery/alternator warning light
 - High transmission oil temperature warning light
 - Glow plug on indicator light
 - Maintenance needed indicator light
 - Low engine oil pressure warning light

Quote ID :29010396Customer Name : TOWN OF STEVENSVILLE



Instrument panel



Hour meter, monitoring, and diagnostic display

Base Equipment On: Z994R

Foot pedal Brake & Go starting system and mower lift

The Brake & Go starting system is a John Deere exclusive. This feature makes the starting process easier:

- The Brake & Go starting system is easy to understand and use.
- To start the machine, the parking brake must be engaged.
- It does not matter whether the PTO switch is on or off, nor does it matter if the control levers are pulled in or extended out.
 - As long as the parking brake is engaged, the machine will start. When the parking brake is applied, the control levers cannot be moved.
- Park brake engagement returns motion-control levers to the neutral position.

A foot pedal is used to raise the mower deck to adjust cut height or lock the mower deck in the transport position:

- A foot pedal is easier for many operators to use than a hand lever.
- Adjustable spring assist allows fine-tuning lift effort to the mower and the operator.

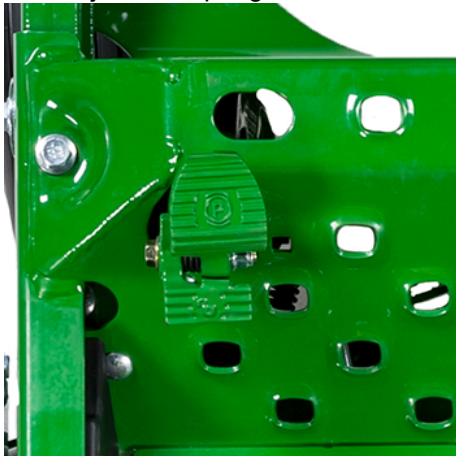

Brake & Go pedal



Mower lift pedal

Base Equipment On: Z994R

Cut-height adjustment

An easy-to-use height-of-cut adjustment lift system allows the operator to quickly adjust deck height for different mowing applications as well as transport:

- An easy-to-use cutting-height lift system allows the operator to adjust the mower deck height with no tools and minimal effort.
- The easy-to-grip knob allows operators to dial in the desired height of cut (HOC).
- Cutting height can be adjusted from approximately 1 in. to 5.5 in. (2.5 cm to 14 cm).

Quote ID :29010396Customer Name : TOWN OF STEVENSVILLE

- Rotate the knob to adjust from 1 in. to 5.5 in. (2.5 cm to 14 cm) in 0.25-in. (0.64 cm) increments.
- Each increment on the knob adjusts the HOC approximately 0.25 in. (0.64 cm).
- The deck can also be raised and locked in a transport position to provide maximum ground clearance when moving the machine from one area to another.

The transport lock function allows the deck to be locked in the transport position and returned to the previous HOC.

- Use the foot-lift pedal to lift the deck, then engage the transport lock.
- To unlock and lower the deck, simply pull up on the transport unlock knob, adjust the dial, and release the deck lift assist pedal to lower the deck to the chosen height.

This design increases productivity by allowing operators to change the cutting height without having to leave the seat.



Mower deck height adjustment knob



Transport lock knob

Base Equipment On: Z994R

Motion-control levers

Two hydrostatic control levers are designed for operator comfort and control:

- Allow the operator to select the ground speed and direction simply by moving levers forward or reverse
- Positive neutral lock position for levers provides added safety

The wide-bend, large-diameter steering levers swing out easily for entry and exit from the operator platform.



Motion-control levers in use



Motion-control levers in park position

Base Equipment On: Z994R

Motion-control lever and tracking adjustments

Motion-control lever adjustments include:

- Two height positions to suit the operator.
- Control lever fore/aft position to suit operator size and preference.

Quote ID :29010396Customer Name : TOWN OF STEVENSVILLE

- Slots in control levers allow forward/rearward adjustment of control arms when the bolts are loose.
- Gap between the control levers adjustment (1).
- From-the-seat tracking adjustment (2), operators can mow straight and produce professional striping results.



Motion-control lever height and fore/aft adjustment bolts

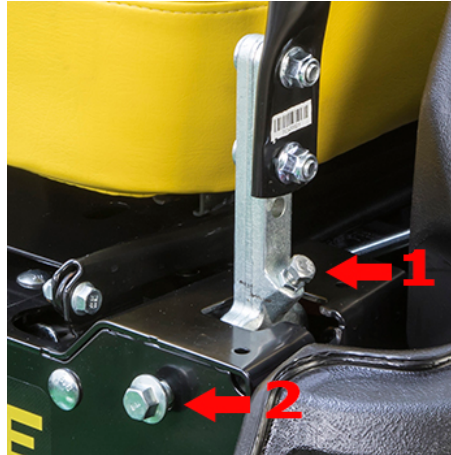

Motion-control lever gap (1) and tracking (2) adjustments

Base Equipment On: Z994R

Product Specification Details :

Manufacturer/Model John Deere Z994R (Model year 2023)

Model

Engine

Manufacturer/Model	3TNV80F
Power	Gross at 3,200 rpm, PS: 24.7 hp 18.4 kW
Displacement	77.3 cu in. 1.27 L
Cylinders	Three
Crankcase capacity	3.6 U.S. qt 3.4 L
Oil filter	Full flow, replaceable, spin-on type
Lubrication	Full pressure
Cooling	Liquid
Air cleaner	Heavy-duty canister, dry type with safety element and air-restriction indicator
Pre-cleaner	Yes

Fuel system

Fuel type	Diesel or Biodiesel (up to B20)
Fuel consumption	---
Fuel tank capacity	11.5 U.S. gal. 43.5 L
Fuel tank switch/shut-off valve	Yes

Electrical system

Charge system	75 amp
Battery voltage	12 V
Cold cranking amp	At 18 degrees C, 600 amp
Hour meter	Digital multi-function display
Operator presence starting system	Standard

Drivetrain

Transmission	Dual hydrostatic wheel drive TuffTorq heavy-duty ground drive with cross porting for improved cooling
Hydraulic pumps	---
Wheel motors	---
Travel speed	---
Forward	0-11.4

Quote ID :29010396Customer Name : TOWN OF STEVENSVILLE

Forward	0-18.3
Reverse	0-4.5
Reverse	0-7.2
Speed range	0-11.4
Speed range	0-18.3
Speed and direction control	Zero turn
Hydraulic capacity	5.9 U.S. gal. 5.6 L
Hydraulic oil cooler	Fins and fan
Filter	Internal, replaceable
Tires	
Drive wheels	24x12.00-12 4-ply turf, optional 24x12N12 Michelin Tweel turf tires
Rear tires	24x12.00-12 4-ply turf, optional 24x12N12 Michelin Tweel turf tires
Load rating	4PR
Brakes	
Dynamic braking	Twin motion control levers
Park brake	Internal wet disk integrated in the transmission
Park brake actuation	Foot brake engagement also brings steering levers to the neutral position
PTO	
Type	Electric clutch
Drive	V-belt
Mower decks	
Size	60-in. (152-cm) 7Iron™ PRO side-discharge
Deck construction	7-Iron™ PRO: 7-gauge, 0.179-in. (4.6-mm) one-piece forged steel
Discharge	---
Height-of-cut range	1-5.5 in.
Increments	0.25 in.
Increments	0.64 in.
Increments	2.54-14 cm
Increments	0.25 cm
Increments	0.64 cm
Cutting width	60, 72 in. 152, 183 cm
Blades	
Length	Varies by deck size
Thickness	0.25 in. 0.64 cm
Blade tip speed	Side discharge: approximately 16,000 fpm
Number	Three
Wheels	
Caster wheel type	Flat free
Caster wheels	13x6.5-6
Front anti-scalp rollers	LH, RH, Center
Rear anti-scalp rollers	Standard
Dimensions	
	88.6 in. 225 cm
Width	With chute down, 74, 86 in. 188, 218 cm
Height	With ROPS up 73 in. 185 cm
Weight	1,711 to 1,810 lb 776 to 821 kg
Buyer's note	
Warranty	36 months or 1500 hours, whichever comes first, no hour limitation for the first 24 months.
Key Specs	
Engine Manufacturer/model	3TNV80F
Engine power	Gross at 3,200 rpm, PS: 24.7 hp 18.4 kW 11.5 U.S. gal.

Quote ID :29010396Customer Name : TOWN OF STEVENSVILLE

Mower deck size	43.5 L 60-in. (152-cm) 7Iron™ PRO side-discharge 7Iron PRO: Approximately 16,500 fpm Dual hydrostatic wheel drive TuffTorq™ heavy-duty ground drive with cross porting for improved cooling
Speed range	0-11.4 mph 0-18.3 km/h 24x12.00-12 4-ply turf, optional 24x12-12 Michelin® Tweel® turf tires 13x5.0-6 flat free 36 months or 1500 hours, whichever comes first, no hour limitation for the first 24 months.
Operation	
Rollover protective structure (ROPS)	Yes
Slope operating limit	20 degrees (10 degrees with material collection system)
Additional information	
Date collected	15-Mar-2023

2023 JOHN DEERE Z960M ZTrak

Key Features

Extra durability and mowing performance from 7-Iron™ PRO Side-Discharge decks pressed from a single piece of steel

7-Iron PRO mower decks have demonstrated quality, performance, and durability. They deliver a high-quality cut in diverse conditions.

Key features of the 7-Iron PRO mower deck:

- Deck is forged from 7-gauge, 0.179-in. (4.6-mm) steel to minimize the number of welds and provide a smooth underside with fewer sharp corners for reduced material buildup.
- Significantly fewer welds on the deck shell to wear or break - it is forged from a single sheet of steel rather than multiple fabrications. An anti-skid step on the deck provides easy machine mounting.
- Extra reliability and long life with cast-iron blade spindle housings.
- Higher blade tip speed than many competitors - approximately 18,500 fpm (5,639 m/min) for more blade cuts per inch mowed.
- A deep-deck design of 5.5 in. (14 cm) delivers excellent airflow so material can be processed quickly and efficiently.
- The wider and higher discharge opening provides even clipping dispersal for an excellent finished appearance in all conditions.
- Quick-release belt covers do not require tools or the removal of a ring clip; just lift one corner of the cover and rotate it slightly to remove.
 - A hole in the deck tab is provided for use of an optional ring clip for extra security, if desired.
 - This makes it quick and easy for you to clean out trash that may collect around the spindle sheave.



54-in. (137-cm) 7-Iron PRO Mower Deck



72-in. (183-cm) 7-Iron PRO Mower Deck

Base Equipment On: Z920M, Z930M, Z945M EFI, Z950M, Z955M EFI, Z960M, Z930R, Z950R, Z955R EFI, Z970R

- Deck has rectangular leading deck edge reinforcement and the rounded corners of the forged deck help distribute impact stress to reduce the potential of damage when the mower contacts trees, rocks, curbs, and other fixed obstacles.
- Dual-captured front and rear anti-scalp wheels provide deck flotation over even the toughest terrain.
- Three 1-in. (2.5-cm), cold-forged spindles are heat-treated for strength without bulk and are supported by ball bearings, providing reliability and performance; spindle housings are ribbed cast iron providing both excellent strength and heat dissipation.
- The trim edge of the deck is equipped with a bumper that provides great abrasion resistance to protect the machine and the property.
- The front edge is raised above the blade plane to allow even cutting of tall grass and is reinforced with a square bar for durability. The front baffle has been redesigned to better manage airflow and control clippings.
- Three spindle grease fittings are accessible from the top.
- Blade overlap is 1.6 in. (40.6 mm), nearly 0.79 in. (20 mm) greater than previous decks, to reduce striping between blades.
- Quick-change, cutting-height adjustment.

Quote ID :29010396Customer Name : TOWN OF STEVENSVILLE



Mower rectangular leading-edge reinforcement



Dual-captured anti-scalp wheel

Base Equipment On: Z920M, Z930M, Z945M EFI, Z950M, Z955M EFI, Z960M, Z930R, Z950R, Z955R EFI, Z970R

Extra reliability and long life with cast-iron blade spindle housings

On every commercial mower deck there are three 1-in. (25-mm) spindles that are cold-forged and heat-treated for strength. Spindles are supported by precision ball bearings that provide great performance and reliability.

- Superior impact strength provided by ductile cast-iron material.
- Gusseted design puts reinforcement where it is needed.
- Strength of cast iron protects against damage from blade impacts.
- Easy access grease fittings are mounted at the top of the spindle shafts for convenience.
- Grease pressure-relief valve minimizes seal damage from overfilling with grease and keeps debris from entering housing.
- Chance of deck shell damage is minimized with the 8-in. (20.3-cm) diameter housing and six mounting bolts that distribute loads and impacts.
- Ability to be reliably rebuilt is provided by use of cast iron.



Cast-iron mower spindle



Cast-iron mower spindle

Base Equipment On: Z920M, Z930M, Z945M EFI, Z950M, Z955M EFI, Z960M, Z930R, Z950R, Z955R EFI, Z970R

7-Iron PRO mower deck

Mower deck	Z915E	Z920M	Z930M	Z950M	Z960M	Z930R	Z950R	Z970R
48-in. (122-cm) 7Iron	x	x						

Quote ID :29010396Customer Name : TOWN OF STEVENSVILLE

PRO side-discharge 54-in. (137-cm) 7Iron	x	x	x				x		
PRO side-discharge 60-in. (152-cm) 7Iron	x	x	x	x	x		x	x	x
PRO side-discharge 72-in. (183-cm) 7Iron				x	x			x	x
PRO side-discharge									

Base Equipment On: Z920M, Z930M, Z945M EFI, Z950M, Z955M EFI, Z960M, Z930R, Z950R, Z955R EFI, Z970R



The deck step safely aids the operator's entrance and egress from machine.

Mower deck step and trim-edge bumper shown on 54-in. (137-cm) mower

Base Equipment On: Z920M, Z930M, Z945M EFI, Z950M, Z955M EFI, Z960M, Z930R, Z950R, Z955R EFI, Z970R

Key Features

Heavy-duty frame provides strength and durability



The durability features of the frame are as follows:

- Heavy-duty, thick-gauge, steel channel mainframe for strength and durability
- Cast I-beam caster arms to handle the beating and pounding professional mowers receive
- Wide-open access for maintenance and cleaning

Z970R shown with optional X® Tweel®
Turf airless radial tire technology

Quote ID :29010396Customer Name : TOWN OF STEVENSVILLE

Base Equipment On: Z915E, Z920M, Z930M, Z945M EFI, Z950M, Z955M EFI, Z960M, Z930R, Z950R, Z955R EFI, Z970R

Two-piece rear bumper provides protection

A steel rear bumper provides protection for the machine. The bumper is made of two pieces, making it easy to remove and install when using a material collection system (MCS).

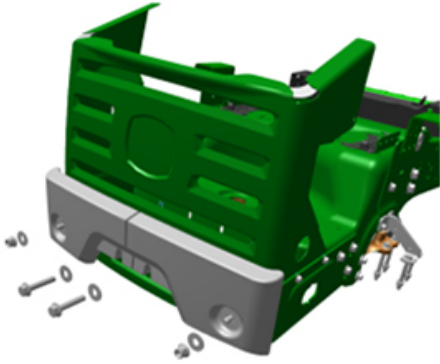

Illustration of ZTrak™
mower rear bumper

A rear hitch can be added to the steel bumper for towing purposes. ZTrak E, M, and R Series Mowers can tow up to 400 lb (181.4 kg).

Michelin, X, and Tweel are trademarks of Michelin North America, Inc.

Base Equipment On: Z915E, Z920M, Z930M, Z945M EFI, Z950M, Z955M EFI, Z960M, Z930R, Z950R, Z955R EFI, Z970R

Key Features**Powerful 31-hp (23.1-kW) commercial-grade engine delivers class-leading performance and efficiency**

The Z960M is powered by an air-cooled, vertical shaft engine:

- 31-hp (23.1-kW) gas engine

Engine features include:

- Overhead valve design
 - More horsepower and torque per cubic inch of displacement
 - Better fuel efficiency
- Full-pressure lubrication with full-flow filter
 - Reduces engine wear by ensuring proper lubrication, even when operating on hillsides or uneven terrain
 - Oil filter helps keep oil clean for increased engine life
- V-twin big block design
- Vertical shaft
- Easy-access, dual-element air filter with quick-release latch
- 15-amp alternator
- Fuel pump
- Complies with strict Environmental Protection Agency (EPA) and California Air Resources Board (CARB) emission standards without loss of horsepower or torque
- Aluminum block engines
 - Effectively dissipate heat
 - Lightweight and strong construction
 - Extend engine life due to elimination of debilitating engine temperatures
- Air-cooled engine design

Quote ID :29010396Customer Name : TOWN OF STEVENSVILLE



Z960M engine

Base Equipment On: Z960M

Air cleaner filters out dust that can damage an engine

ZTrak™ Z900 Mowers are equipped with a dual-element, canister-style air filter, easily accessible from the rear of the machine without tools.

- The filtration system pulls clean air from above the engine, in turn filtering out the dust that can damage an engine over time.
- Filters are extremely easy to change when required.
- Pre-cleaner provides more protection against contamination in dusty and dirty applications.



Engine air cleaner

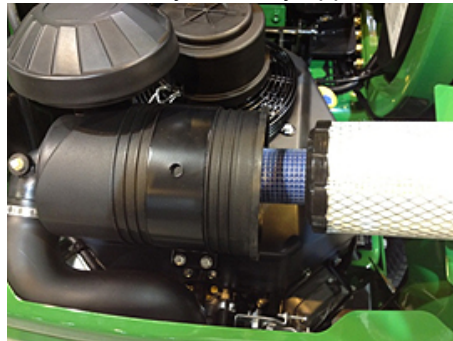

Air cleaner cover removed

Base Equipment On: Z960M

Mow all day on a single tank of fuel with efficient and easy-to-fill fuel tank

The ZTrak™ Z900 Mowers are equipped with one single-fill, top-draw fuel tank:

- 11.5-U.S. gal. (43.5-L) capacity enables operators to mow all day without refueling.
- The fuel gauge makes it quick and easy to see how much fuel is in the tank.
- Top draw provides added safety.
- A large fuel-filler neck is angled to make it easy for an operator to complete the fueling process.

Under normal conditions, load, and operation, fuel consumption for the Z900 ZTrak Mowers is 1.5 U.S. gph (5.7 L/hr) to 2.2 U.S. gph (8.3 L/hr), depending on the horsepower and conditions.

Quote ID :29010396Customer Name : TOWN OF STEVENSVILLE



Fuel tank and filler neck



Fuel filler neck

Base Equipment On: Z960M

Key Features

Durable hydrostatic drive train that delivers better cooling and provides easy access

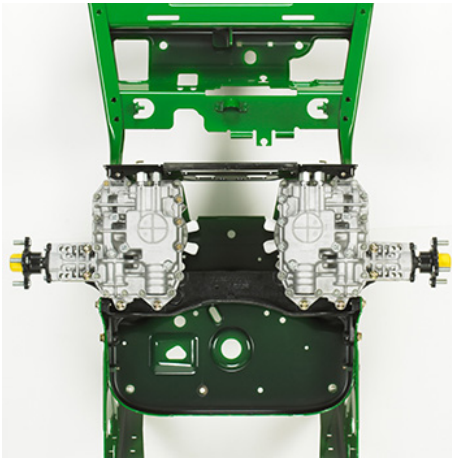

Heavy-duty ground drive

The hydrostatic drive features two 13-cc (0.8-cu in.) unitized hydraulic pumps combined with commercial-grade, heavy-duty wheel motors into a single unit.

One pump and one motor drive each wheel on the ZTrak™ E and M Series Mowers. This provides several benefits:

- Exceptional cooling in high-load conditions
- Easy-to-check level and refill hydraulic oil
- Opens up access under the seat

Base Equipment On: Z915E, Z920M, Z930M, Z945M EFI, Z950M, Z955M EFI, Z960M

Key Features

Enhanced productivity, safety, and trim ability with a FastBack™ PRO rear-discharge mower deck

For professional landscapers and government municipalities requiring rear discharge placement of grass and debris, John Deere FastBack PRO rear-discharge mower decks deliver a commercial zero-turn mowing solution for both gas and diesel machines. Advantages of a rear-discharge mower include:

- Less chance of damage from objects being thrown from the mower deck
- Time savings with the ability to mow closely around fixed objects with either side of the deck
- A cleaner mowing experience by lessening the amount of debris that can blow onto the operator

A rear-discharge mower deck is ideally suited for:

- Schools
- Parks

Quote ID :29010396Customer Name : TOWN OF STEVENSVILLE

- Playgrounds
- Traffic areas (city boulevards, roadsides, etc.)
- Areas with long, grassy spots that need to be cut, where you are not as concerned about wide dispersal of grass (park areas, roadsides, etc.)*

*NOTE: Operators maintaining turf outside of target areas are encouraged to evaluate rear-discharge dispersion through a cut quality demonstration to ensure satisfaction.



60-in. (152-cm) Rear-Discharge Mower Deck



72-in. (183-cm) Rear-Discharge Mower Deck

Optional Equipment On: Z930M, Z950M, Z955M EFI, Z950R, Z955R EFI, Z970R, Z994R

Compatibility

Mower deck	Z930M	Z950M	Z960M	Z950R	Z970R	Z994R
60-in. (152-cm) FastBack PRO rear-discharge	x		x	x		x
72-in. (183-cm) FastBack PRO rear-discharge		x	x		x	x

Optional Equipment On: Z930M, Z950M, Z955M EFI, Z950R, Z955R EFI, Z970R, Z994R

Commercial-quality deck design

A large volume of material can be thoroughly processed with the deep-deck design:

- Unique baffling system is designed to reduce clumping and windrowing often associated with rear-discharge mowers.
 - Efficiency is enhanced with baffles surrounding each blade to control material as it is moved to the rear.
 - Material exits the deck quickly as the baffles are lower at the rear.
 - Movement of material is controlled to minimize the likelihood that clippings are thrown onto unwanted areas.
- Less debris gets on the operator as material is directed to the rear and toward the ground.
 - Debris is kept low and directed into the turf by the flexible rear shield.

Optional Equipment On: Z930M, Z950M, Z955M EFI, Z950R, Z955R EFI, Z970R, Z994R

Level cut

The deck is suspended from and supported by the machine to provide a level cut. Mower deck wheels and rollers help smooth out the mowing job in uneven conditions and reduce the chance of scalping the lawn:

- Two wide front rollers at the center of the mower support the deck when necessary to prevent scalping.
- Wheels at all four corners protect the deck from scalping at the sides of the mower.
- Continued effectiveness results from wheels and rollers that are double captured for extra strength, which reduces the chance of damage.
- Height of rollers and wheels is adjustable to suit mowing conditions.
 - Higher setting (shown in images) are used when mowing at lower cut heights and for rougher conditions at all cut heights where you want to reduce the chance of the wheels hitting the ground.
 - Lower settings are used for higher cut heights and for helping to smooth out the mowing job.
- Mower cut height is adjustable from 1 to 5.5 in. (2.54 to 14 cm) in 0.25-in. (0.64-cm) increments from the machine operator's station.

Quote ID :29010396 Customer Name : TOWN OF STEVENSVILLE



Center deck rollers and left wheel



Right-rear deck wheel

Optional Equipment On: Z930M, Z950M, Z955M EFI, Z950R, Z955R EFI, Z970R, Z994R

Heavy-duty components for long life

These rear-discharge decks are designed to stand up to heavy-duty commercial use:

- Superior strength and durability come from a 7-gauge, 0.179-in. (4.56-mm) steel deck.
- Experience extra strength and long life with a fabricated deck design that is formed, welded, and reinforced for extra protection from damage.
- The front of the deck is protected from damage by a 1.5-in. (3.8-cm) tall by 0.5-in. (1.3-cm) thick solid steel bar welded to the mower deck for additional strength.
- Both sides of the deck have bumpers that are made from compression molded ultra-high molecular weight (UHMW) polyethylene plastic.
 - The bumpers provide great abrasion resistance to protect the machine and the property.
 - Additional strength is provided by a 0.5-in. (1.3-cm) by 0.5-in. (1.3-cm) thick solid steel bar.



Strong, reinforced deck



Right trim-side wear guard

Optional Equipment On: Z930M, Z950M, Z955M EFI, Z950R, Z955R EFI, Z970R, Z994R



Cast-iron blade-spindle housing

Extra reliability and long life are provided by cast-iron blade spindle housings:

- Ductile cast-iron material provides superior impact strength.
- Gusseted design puts reinforcement where it is needed.
- Strength of cast iron protects against damage from blade impacts.
- Chance of deck-shell damage is minimized with the 8-in. (20.3-cm) diameter housing and six mounting bolts that distribute loads and impacts.
- Ability to be reliably rebuilt is provided by use of cast iron.

Optional Equipment On: Z930M, Z950M, Z955M EFI, Z950R, Z955R EFI, Z970R, Z994R

Ease of service

Minimal service requirements increase uptime:

- Quick-release belt covers do not require tools or the removal of a ring clip; just lift one corner of the cover and rotate it slightly to remove.
 - A hole in the deck tab is provided for use of an optional ring clip for extra security, if desired.
 - This makes it quick and easy for you to clean out trash that may collect around the spindle sheave.
- There is only one belt to service.

Quote ID :29010396Customer Name : TOWN OF STEVENSVILLE



Quick-release belt cover

Optional Equipment On: Z930M, Z950M, Z955M EFI, Z950R, Z955R EFI, Z970R, Z994R

Extra convenience

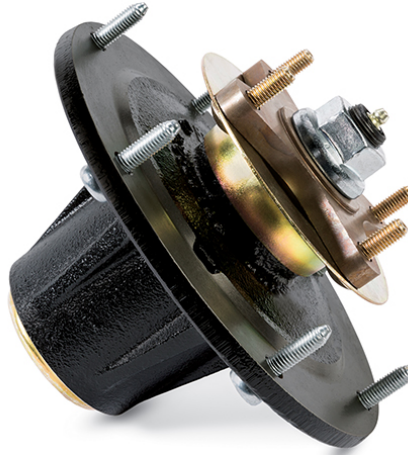

Cast-iron spindle housing assembly



Serrated-tread step

Optional Equipment On: Z930M, Z950M, Z955M EFI, Z950R, Z955R EFI, Z970R, Z994R

Extra convenience and security are provided by a serrated surface that is welded to the top left corner of the deck, providing additional traction when entering and exiting the operator station.

Key Features

Protective zone around the operator is provided by the rollover protective structure (ROPS)



The spacious operator station has been designed for comfort, visibility, and ease of use:

- Getting on and off is easy with the flat operator platform.
- Convenient-to-use controls located close to the operator are color coded and designed for easy identification and operation.

The ROPS and seat belt work in conjunction to provide a protective zone around the operator:

- It reduces the operator's risk of being crushed under the vehicle should it overturn.
- When used with the seatbelt, the ROPS can reduce the severity of injury in the event of a rollover.
- Use of the seat belt is recommended when operating with ROPS in the upright position.

Quote ID :29010396Customer Name : TOWN OF STEVENSVILLE

Z930R with 54-in. (137-cm) Mower Deck

Base Equipment On: Z915E, Z920M, Z925M EFI, Z930M, Z945M EFI, Z950M, Z955M EFI, Z960M, Z930R, Z950R, Z970R



ROPS in upright position

Foldable ROPS and retractable seat belt are standard equipment:

- Position adjustment pins provide a good grip and make changing the angle of the ROPS easier.
- The ROPS can be pinned in an intermediate position to accommodate machines equipped with a material collection system.
- Under normal operation, the ROPS should be in the upright position.
- See Operator's Manual for more information on ROPS.
- Door height of most garages will accommodate the machine with ROPS in the raised position.
 - Easy-fold ROPS improves the ability to store the ZTrak™ mower in structures with a lower door opening.

ROPS position	Height at top of ROPS
Upright	73 in. (185 cm)
Down	47 in. (119 cm)

Base Equipment On: Z915E, Z920M, Z925M EFI, Z930M, Z945M EFI, Z950M, Z955M EFI, Z960M, Z930R, Z950R, Z970R

Optional light-emitting diode (LED) work lights



LED work lights

BUC11438 LED work lights are available as a field installed attachment. BUC11438 is compatible with model year 2015 and newer (serial number 030,001-) Z900 ZTrak Mowers. All Z997R and model year 2015-2018 (serial number 030,001-070,000) gasoline powered models require AUC18778 battery jumper.

Base Equipment On: Z915E, Z920M, Z925M EFI, Z930M, Z945M EFI, Z950M, Z955M EFI, Z960M, Z930R, Z950R, Z970R

Quote ID :29010396Customer Name : TOWN OF STEVENSVILLE

Optional LED beacon light



LED beacon light

BUC11406 LED beacon light is available as a field installed attachment. The beacon light is short to avoid damage. BUC11406 is compatible with model year 2015 and newer (serial number 030,001-) Z900 ZTrak Mowers. All Z997R and model year 2015-2018 (serial number 030,001-070,000) gasoline powered models require AUC18778 battery jumper.

Base Equipment On: Z915E, Z920M, Z925M EFI, Z930M, Z945M EFI, Z950M, Z955M EFI, Z960M, Z930R, Z950R, Z970R

Key Features

Three-year, bumper-to-bumper warranty



Z960M ZTrak™ Mower



Z930R ZTrak Mower

Base Equipment On: Z915E, Z920M, Z930M, Z945M EFI, Z950M, Z955M EFI, Z960M, Z930R, Z950R, Z955R EFI, Z970R

E and M Series 3-year, 1200-hour bumper-to-bumper warranty

An exclusive 2-year, unlimited hour/3-year, 1200-hour (whichever comes first) bumper-to-bumper warranty is standard for all John Deere E and M Series Mowers. The warranty is best in its class and places John Deere at the forefront of commercial mowing. It is also hassle free, with one company handling all of the paperwork.

NOTE: 36 months or 1200 hours, whichever comes first. For the first 24 months, there is no hour limitation.

Base Equipment On: Z915E, Z920M, Z930M, Z945M EFI, Z950M, Z955M EFI, Z960M, Z930R, Z950R, Z955R EFI, Z970R

R Series 3-year, 1500-hour bumper-to-bumper warranty

An exclusive 2-year, unlimited hour/3-year, 1500-hour (whichever comes first) bumper-to-bumper warranty is standard on all John Deere R Series mowers. The warranty is best in the industry and puts John Deere at the forefront of commercial mowing. It is also hassle free, with one company handling all of the paperwork.

Quote ID :29010396Customer Name : TOWN OF STEVENSVILLE

NOTE: 36 months or 1500 hours, whichever comes first. For the first 24 months, there is no hour limitation.

Base Equipment On: Z915E, Z920M, Z930M, Z945M EFI, Z950M, Z955M EFI, Z960M, Z930R, Z950R, Z955R EFI, Z970R

Mower decks are safety certified

Mowers decks are evaluated by the manufacturer (John Deere Turf Care) and conform to American National Standards Institute (ANSI) B71.4 2004 safety certification specifications for commercial turf care equipment.

54-in. (137-cm) 7-Iron PRO Mower Deck

Base Equipment On: Z915E, Z920M, Z930M, Z945M EFI, Z950M, Z955M EFI, Z960M, Z930R, Z950R, Z955R EFI, Z970R

Key Features**Mower is easy to service with many accessible components**

Z970R left front view

The design of the Z900 Series makes many service components reachable and easily accessible from the ground.

- Large, open engine compartment at the rear of the machine provides convenient servicing and ensures the engine heat is directed away from the operator.

Base Equipment On: Z915E, Z920M, Z930M, Z945M EFI, Z950M, Z955M EFI, Z960M, Z930R, Z950R, Z955R EFI, Z970R



Flip-up foot panel

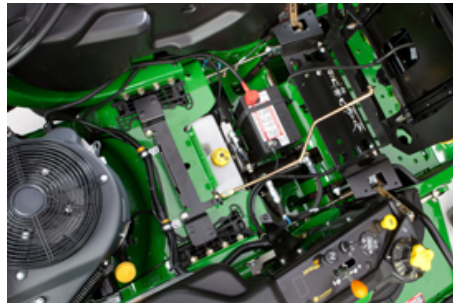

Flip-up seat

Base Equipment On: Z915E, Z920M, Z930M, Z945M EFI, Z950M, Z955M EFI, Z960M, Z930R, Z950R, Z955R EFI, Z970R

Quote ID :29010396Customer Name : TOWN OF STEVENSVILLE

Onboard maintenance chart



Maintenance chart

All ZTrak™ Mowers come with an onboard maintenance chart that is conveniently located inside the right-hand console. The service interval chart gives necessary service intervals.

Base Equipment On: Z915E, Z920M, Z930M, Z945M EFI, Z950M, Z955M EFI, Z960M, Z930R, Z950R, Z955R EFI, Z970R

Quick response (QR) codes link to owner information web pages



QR code label

To speed access to owner information web pages, a QR code is printed onto a product identification number (PIN) label located near the onboard storage. The owner information web pages that include links to:

- Safety and how-to videos
- Operator's manuals
- Parts catalogs
- Maintenance reminder sheets
- Attachments
- Warranty statements

Base Equipment On: Z915E, Z920M, Z930M, Z945M EFI, Z950M, Z955M EFI, Z960M, Z930R, Z950R, Z955R EFI, Z970R

Diagnostics

The hour meter shows the number of hours the machine is run when the key switch is in the on position. It only counts the hours the engine is actually running. Machine diagnostics are the first step of a monitoring system to help operators quickly diagnose common downtime issues. A trouble code light is included on the hour meter.

Use of the hour meter and service interval chart helps determine when the machine will need service.



Hour meter (M Series pictured)



Diagnostic chart

Quote ID :29010396 Customer Name : TOWN OF STEVENSVILLE

Base Equipment On: Z915E, Z920M, Z930M, Z945M EFI, Z950M, Z955M EFI, Z960M, Z930R, Z950R, Z955R EFI, Z970R

Product Specification Details :

Manufacturer Z960M (Model year 2023)

Model

Engine

Manufacturer/Model	FX921V
Power	Gross at 3,600 rpm 31 hp 23.1 kW
Displacement	61 cu in. 999 cc
Cylinders	Two
Crankcase capacity	With filter, 2 U.S. qt 1.9 L
Oil filter	Full flow, replaceable
Lubrication	Full pressure
Cooling	Air
Air cleaner	Heavy-duty canister type with safety element
Pre-cleaner	Yes

Fuel system

Fuel type	Gasoline
Fuel consumption	Under normal conditions, load, operation, and dependent on loads and operating conditions 1.1-1.9 U.S. gal./hr 4.2-7.2 L/hr
Fuel tank capacity	11.5 U.S. gal. 43.5 L
Fuel tank switch/shut-off valve	Yes

Electrical system

Charge system	20 amp
Battery voltage	12 V
Cold cranking amp	300 amp
Hour meter	Standard, digital
Operator presence starting system	Brake-N-Go (hand)

Drivetrain

Transmission	Hydrostatic
Hydraulic pumps	---
Wheel motors	Tuff Torq heavy-duty integrated piston wheel motor
Speed and direction control	Twin levers
Hydraulic capacity	5.9 U.S. qt 5.6 L
Filter	Internal, replaceable

Tires

Drive wheels	24x12-12
Rear tires	---
Load rating	4 PR

Brakes

Dynamic braking	Twin levers
Park brake	Internal wet disk integrated in the transmission
Park brake actuation	Hand brake

PTO

Type	Electro-magnetic, 225 lb-ft 305 Nm
Drive	V-belt

Mower decks

Size	60-in. (152-cm) 7Iron™ PRO side-discharge
Deck construction	7-Iron™ PRO: 7-gauge, 0.179-in. (4.6-mm) one-piece forged steel
Discharge	---
Height-of-cut range	1-5.5 in.
Increments	0.25 in.

Quote ID :29010396 Customer Name : TOWN OF STEVENSVILLE

Increments	0.64 in. 2.54-14 cm
Increments	0.25 cm
Increments	0.64 cm
Cutting width	60, 72 in. 152, 183 cm
Blades	
Length	Varies by deck size
Thickness	0.25 in. 0.64 cm
Blade tip speed	7Iron PRO: Approximately 18,500 fpm
Number	Three
Wheels	
Caster wheel type	Flat free
Caster wheels	13x6.5-6
Front anti-scalp rollers	RH, center, LH
Rear anti-scalp rollers	Standard
Dimensions	
	84 in. 213 cm
Width	With chute down, 74, 86 in. 188, 218 cm
Height	With ROPS up, 73 in. 185 cm
Weight	1,304 to 1,412 lb 591 to 640 kg
Buyer's note	
Warranty	36 months or 1200 hours, whichever comes first
Key Specs	
Engine Manufacturer/model	FX921V
Engine power	Gross at 3,600 rpm 31 hp 23.1 kW 11.5 U.S. gal. 43.5 L/hr
Mower deck size	60-in. (152-cm) 7Iron™ PRO side-discharge 7Iron PRO: Approximately 18,500 fpm Hydrostatic
Speed range	0-10 mph 0-16.1 km/h 24x12-12 13x6.5-6 36 months or 1200 hours, whichever comes first
Operation	
Rollover protective structure (ROPS)	Yes
Slope operating limit	20 degrees (10 degrees with material collection system installed)
Additional information	
Date collected	15-Mar-2023

MONTANA SAWS LLC

3779 Eastside Hiway
 STEVENSVILLE, MT 59870
 777-2197
 Owner: Justin Nobl

Customer's Order No. _____ Date 6-7 2023
 Name _____
 Address Quote Town of Steu
 Phone: _____

SOLD BY	CASH	C.O.D.	CHARGE	ON ACCT.	MDSE. RETD.	PAID OUT
---------	------	--------	--------	----------	-------------	----------

QUAN.	DESCRIPTION	PRICE	AMOUNT
	Toro 72028 60" \$31,110.00 Diesel Rear Discharge	22,399.20	
	Toro 72027 Diesel 60" \$29,888.00	21818.24	
	Toro 72980 60" 37hp Gas \$22,336.00	16100.00	
	Bid assist Prices		

All claims and returned goods MUST be accompanied by this bill.

Received By _____ TAX _____
 TOTAL _____



Thank you

File Attachments for Item:

e. Discussion/Decision: Requesting to Publish an RFP for Street Repairs, Spring Street and Railroad Ave



Stevensville Town Council Meeting

Agenda Item Request

To be submitted BEFORE Noon on the Wednesday immediately preceding the Thursday agenda publishing deadline (8-days ahead of the meeting).

Agenda Item Type:	New Business
Person Submitting the Agenda Item:	Steve Gibson
Second Person Submitting the Agenda Item:	Steve Kruse, Public Works Supervisor
Submitter Title:	Mayor
Submitter Phone:	
Submitter Email:	
Requested Council Meeting Date for Item:	06/22/2023
Agenda Topic:	Discussion/Decision: Requesting to Publish an RFP for Street Repairs, Spring Street and Railroad Ave
Backup Documents Attached?	Choose an item.
If no, why not?	
Approved/Disapproved?	Approved
If Approved, Meeting Date for Consideration:	06/22/2023
Notes:	With the passage of Senate Bill 536, the Town of Stevensville will be receiving one time funds for street repairs.

File Attachments for Item:

f. Discussion/Decision: Use A2Z Personnel Services to Perform Hiring of Temporary Employees



Stevensville Town Council Meeting

Agenda Item Request

To be submitted BEFORE Noon on the Wednesday immediately preceding the Thursday agenda publishing deadline (8-days ahead of the meeting).

Agenda Item Type:	New Business
Person Submitting the Agenda Item:	Steve Gibson
Second Person Submitting the Agenda Item:	Steve Kruse, Public Works Supervisor
Submitter Title:	Mayor
Submitter Phone:	
Submitter Email:	
Requested Council Meeting Date for Item:	06/22/2023
Agenda Topic:	Discussion/Decision: Use A2Z Personnel Services to Perform Hiring of Temporary Employees
Backup Documents Attached?	Choose an item.
If no, why not?	
Approved/Disapproved?	Approved
If Approved, Meeting Date for Consideration:	06/22/2023
Notes:	



Client Agreement

The Following are the terms/conditions for A2Z Personnel-Hamilton, Inc. (hereafter referred to as A2Z Personnel) supplying employee(s) to Client:

- A2Z Personnel's insurance does not cover physical loss or damage of machinery, equipment or materials while in the care, custody or control of an A2Z Personnel employee.
- Client accepts full responsibility for bodily injury, property damage, fire, theft, collision or public liability claims arising out of the operation of a licensed motor vehicle for the client by an A2Z Personnel employee.
- Client indemnifies A2Z Personnel and A2Z Personnel's employees for injuries incurred by client's employees in the course of their employment, losses resulting from work performed by A2Z Personnel's employees in a reasonable manner and/ or as instructed by client, and losses resulting from willful misconduct, intentional or negligent acts by client or client's employees except for losses covered by A2Z Personnel's Worker Compensation Insurance.
- Client agrees to not entrust an A2Z Personnel employee with unattended premises or any part thereof, or with the care, custody or control of cash, negotiables or other valuables without prior permission of A2Z Personnel and then only when the A2Z Personnel employee's specific duties necessitate such activities. Client also agrees to lock up any valuables and/ or money if an A2Z Personnel employee is unattended.
- Client agrees to furnish A2Z Personnel's employees with a suitable place to work which complies with all laws and ordinances related to occupational health and safety.
- Client agrees to notify A2Z Personnel of any change(s) in the duties of an A2Z Personnel employee from those originally described to A2Z Personnel.
- Client agrees that for a period of 120 days after the last day for which hours are reported to A2Z Personnel, utilization of this employee will be through A2Z Personnel. Client agrees to notify A2Z Personnel immediately if they re-utilize this A2Z Personnel employee during the above stated 120 day period.
- If client desires to transfer this A2Z Personnel employee to their payroll, client will notify A2Z Personnel immediately. The employee will remain on A2Z Personnel's payroll for 520 hours (3 months) unless client agrees to pay a transfer charge to A2Z Personnel of \$1500.00.
- Client agrees that all A2Z Personnel invoices will be emailed to the Client email provided in this agreement.
- Client agrees to pay charges for the hours approved by client to A2Z Personnel within seven (7) days of the invoice date and client agrees to pay the charges evidenced by the time card.
- A2Z Personnel reserves the right to assess interest charges of 1 ½% per month (18% per annum) on any charges remaining unpaid 15 days after invoice date (unless otherwise specified by state law).
- Client agrees A2Z Personnel is entitled to all reasonable collection fees, attorney fees and any other expenses, incurred in the collection of all charges on this client's account (s).
- Client agrees that if the Client job position requires a pre-employment background check or drug test, the Client will not allow an employee provided by A2Z Personnel to begin working until the background check or drug test results have been received by A2Z Personnel and communicated to the Client.



Client Agreement - p.2

By signing, client agrees to and accepts the above terms and conditions and agrees that, upon employing the services of A2Z Personnel, client should adhere to the above referenced conditions. A facsimile or electronically scanned copy of this Agreement may be signed by the parties and signatures may be signed by the parties and signatures may be transmitted by facsimile or email, which shall be deemed original signatures.

CLIENT:
Signature: _____
Date: _____

A2Z PERSONNEL:
Signature: _____
Date: _____

CLIENT INFORMATION:

Company Name: _____

Owner (s) Name: _____

Physical Address: _____ City/State/Zip _____

Billing Address: _____ City/St/Zip _____

Invoice Delivery (please check one): Mail Email

Email Address: _____

Phone Number: _____ Cell: _____ Fax: _____

Social Security #: _____ Federal Employer ID #: _____

Bank Reference: _____

Credit Reference: _____

Credit Reference: _____

By signing on page 3, client gives permission for A2Z Personnel to check the above references and agrees to release from liability any person(s) giving A2Z Personnel such Reference. A facsimile or electronically scanned copy of this document may be signed by the parties and signature



Client Agreement - p.3

PERSONAL GUARANTEE

In consideration of A2Z Personnel-Hamilton, Inc. (A2Z Personnel), providing its employees to perform services for _____ (name of business), hereafter "Client", the undersigned personally guarantees the payment of all charges owing from Client to A2Z Personnel, on demand, and the undersigned further personally guarantees payment of all late fees, interest, attorneys' fees and any and all collection costs in connection with the charges owing from Client to A2Z Personnel, and all costs and expenses, including attorney's fees, incurred by A2Z Personnel in connection with the enforcement of this Personal Guarantee. The undersigned further accepts all of the terms and conditions of the Agreement between Client and A2Z Personnel, a copy of which Agreement is attached to this Personal Guarantee, including charges of interest at a rate of 1 ½ % per month, compounded monthly, on any charges remaining unpaid 15 days after the invoice date, and including payment of all reasonable collection fees, attorney fees, and any other expenses incurred in the collection of such charges, and personally guarantees payment of the same. A facsimile or electronically scanned copy of this Personal Guarantee may be signed by the Personal Guarantor and said signature may be transmitted by facsimile or email, which shall be deemed an original signature.

Client Signature: _____ Printed Name: _____

Title: _____ Date: _____



Client Newsletter

Sign up for A2Z’s digital newsletter delivered right to your email inbox!
Receive notices about New Programs, Special Events, Office Schedule Changes and more!
Follow along for updates to Federal and State Employment Law.

Yes! I would like to receive A2Z’s Newsletter!

My email address is: _____

No, I would not like to receive the monthly newsletter.

Print Name: _____

Signature: _____ Date: _____

File Attachments for Item:

g. Discussion/Decision: Stevensville Airport Board Access to Government Surplus Site



Stevensville Town Council Meeting

Agenda Item Request

To be submitted BEFORE Noon on the Wednesday immediately preceding the Thursday agenda publishing deadline (8-days ahead of the meeting).

Agenda Item Type:	New Business
Person Submitting the Agenda Item:	Dustin Wood
Second Person Submitting the Agenda Item:	Rich Perry
Submitter Title:	Airport Board Members
Submitter Phone:	406-531-7297
Submitter Email:	Dustin@ACSR.net
Requested Council Meeting Date for Item:	6/22/2023
Agenda Topic:	Discussion/Decision: Stevensville Airport Board Access to Government Surplus Site
Backup Documents Attached?	No
If no, why not?	See website: https://gsaccess.gov/
Approved/Disapproved?	Approved by Mayor Gibson
If Approved, Meeting Date for Consideration:	06/22/2023
Notes:	Set up access and assign/approve 2 individuals from the airport board and 1 town employee to move forward with acquiring equipment when it becomes available through government surplus at little to no cost to the airport. Dollar amount/limits need to be determined for freight and delivery costs.

File Attachments for Item:

h. Discussion/Decision: Compensation for the Town Clerk to cover Airport Manager Duties



Stevensville Town Council Meeting

Agenda Item Request

To be submitted BEFORE Noon on the Wednesday immediately preceding the Thursday agenda publishing deadline (8-days ahead of the meeting).

Agenda Item Type:	New Business
Person Submitting the Agenda Item:	Steve Gibson
Second Person Submitting the Agenda Item:	
Submitter Title:	Mayor
Submitter Phone:	
Submitter Email:	
Requested Council Meeting Date for Item:	06/22/2023
Agenda Topic:	Discussion/Decision: Compensation for the Town Clerk to cover Airport Manager Duties
Backup Documents Attached?	Choose an item.
If no, why not?	
Approved/Disapproved?	Approved
If Approved, Meeting Date for Consideration:	06/22/2023
Notes:	June 12, 2023, the airport manager resigned and the town clerk, Jenelle Berthoud is filling in until the position is filled. Requesting \$1.00 per hour compensation starting June 12, 2023.

File Attachments for Item:

i. Discussion/Decision: Compensation for the Utility Billing Clerk for Assistance in the Finance Department



Stevensville Town Council Meeting

Agenda Item Request

To be submitted BEFORE Noon on the Wednesday immediately preceding the Thursday agenda publishing deadline (8-days ahead of the meeting).

Agenda Item Type:	New Business
Person Submitting the Agenda Item:	Steve Gibson
Second Person Submitting the Agenda Item:	
Submitter Title:	Mayor
Submitter Phone:	
Submitter Email:	
Requested Council Meeting Date for Item:	06/22/2023
Agenda Topic:	Discussion/Decision: Compensation for the Utility Billing Clerk for Assistance in the Finance Department
Backup Documents Attached?	Choose an item.
If no, why not?	
Approved/Disapproved?	Approved
If Approved, Meeting Date for Consideration:	06/22/2023
Notes:	April 28, 2023, the finance officer position was in need of assistance with paying the claims. Utility billing clerk, Melanie Sawyer, has been filling in. Requesting \$0.25 per hour compensation for the months of May and June 2023.

File Attachments for Item:

j. Discussion/Decision: Consent to the Mayors Appointment of Gina Crowe as the Director of Finance & HR



Stevensville Town Council Meeting

Agenda Item Request

To be submitted BEFORE Noon on the Wednesday immediately preceding the Thursday agenda publishing deadline (8-days ahead of the meeting).

Agenda Item Type:	New Business
Person Submitting the Agenda Item:	Steve Gibson
Second Person Submitting the Agenda Item:	
Submitter Title:	Mayor
Submitter Phone:	
Submitter Email:	
Requested Council Meeting Date for Item:	06/22/2023
Agenda Topic:	Discussion/Decision: Consent to the Mayors Appointment of Gina Crowe as the Director of Finance & HR
Backup Documents Attached?	Choose an item.
If no, why not?	
Approved/Disapproved?	Approved
If Approved, Meeting Date for Consideration:	06/22/2023
Notes:	