



ARCHITECTURAL REVIEW COMMITTEE

Thursday, April 11, 2024, at 5:30 PM
Santaquin City Hall Building
110 S. Center Street, Santaquin, UT 84655

MEETINGS HELD IN PERSON

The public is invited to participate as outlined below:

- **In Person** – Meetings are held in the Administrative Conference Room at City Hall

ADA NOTICE

If you are planning to attend this Public Meeting and due to a disability need assistance in understanding or participating in the meeting, please notify the City Office ten or more hours in advance and we will, within reason, provide what assistance may be required.

AGENDA

NEW BUSINESS

1. Quick Quack Car Wash

The Architectural Review Committee will review a commercial site plan for a proposed car wash located at approximately 78 N. 500 E.

2. Silver Oaks Subdivision

The Architectural Review Committee will review a request from the developer of the Silver Oaks Subdivision for fencing around the subdivision located at approximately 590 W Main Street.

MEETING MINUTES APPROVAL

3. November 8, 2023

ADJOURNMENT

CERTIFICATE OF MAILING/POSTING

The undersigned duly appointed City Recorder for the municipality of Santaquin City hereby certifies that a copy of the foregoing Notice and Agenda may be found at www.santaquin.org, in three physical locations (Santaquin City Hall, Zions Bank, Santaquin Post Office), and on the State of Utah's Public Notice Website, <https://www.utah.gov/pmn/index.html>. A copy of the notice may also be requested by calling (801)754-1904.

BY:

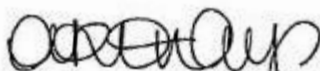

Amalie R. Ottley, City Recorder

EXTERIOR FINISH SCHEDULE

LABEL	MATERIAL	COLOR / MANUFACTURER
CMU-1	SPLIT-FACE CMU	INTEGRAL COLOR (DARK GREY) TO MATCH SW 7089 'IRON ORE'
CMU-2	SMOOTH FACE CMU	INTEGRAL COLOR (LIGHT GREY) TO MATCH SW 7655 'STAMPED CONCRETE'
S-1	STUCCO	MATCH SW 6755 'STARBOARD' (GREEN)
S-2	STUCCO	MATCH SW 6902 Decisive Yellow
S-3	CEMENTITIOUS FIBER BOARD	MATCH SW 7004 'SNOWBOUND' (WHITE)
P-1	PAINT	SW 6755 'STARBOARD' (GREEN)
P-2	PAINT	SW 6902 Decisive Yellow
P-3	PAINT	SW 7025 'BACKDROP' (DARK GREY)
M-1	STANDING SEAM ROOFING	MATCH SW 6755 'STARBOARD' (GREEN)

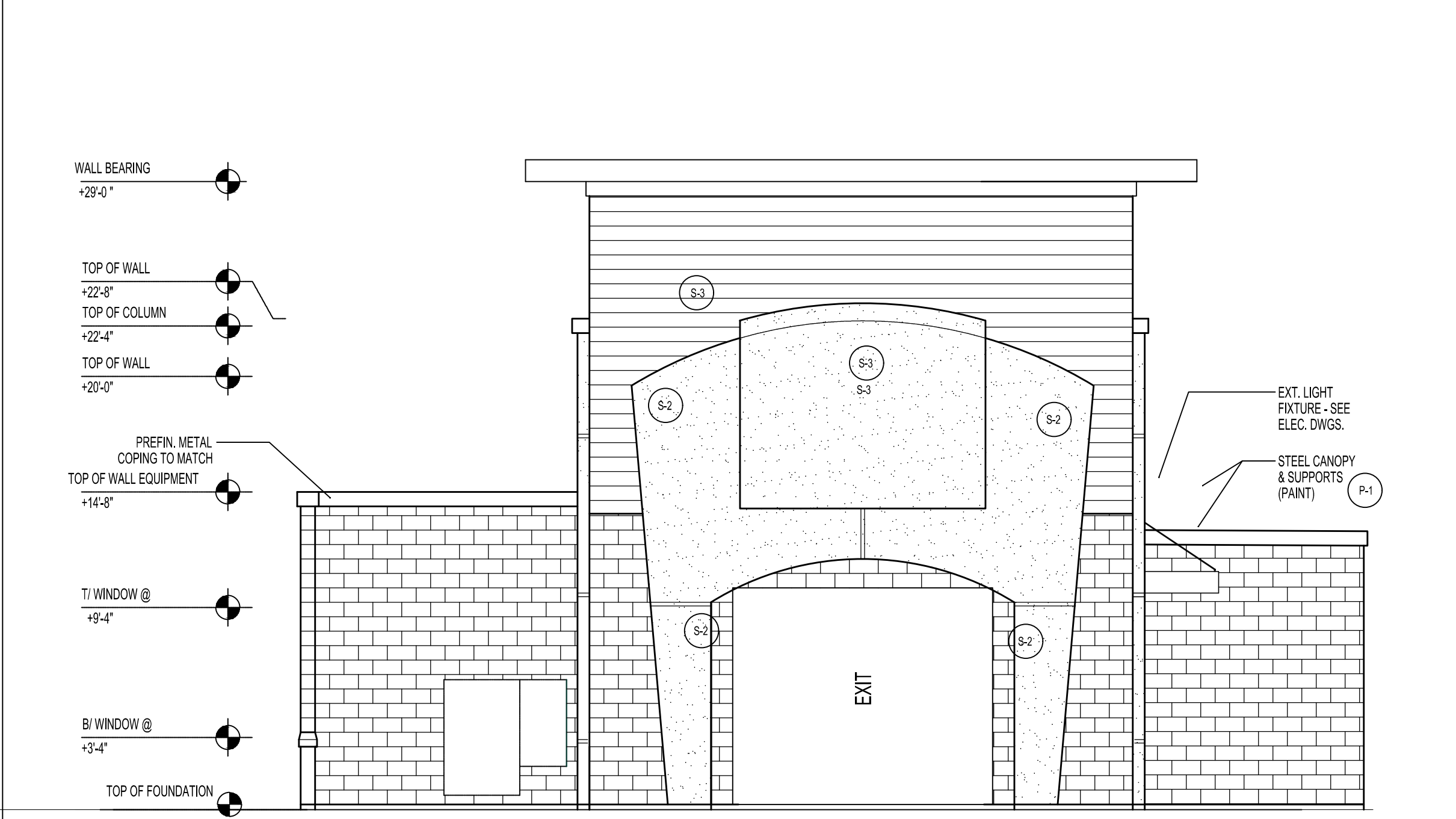
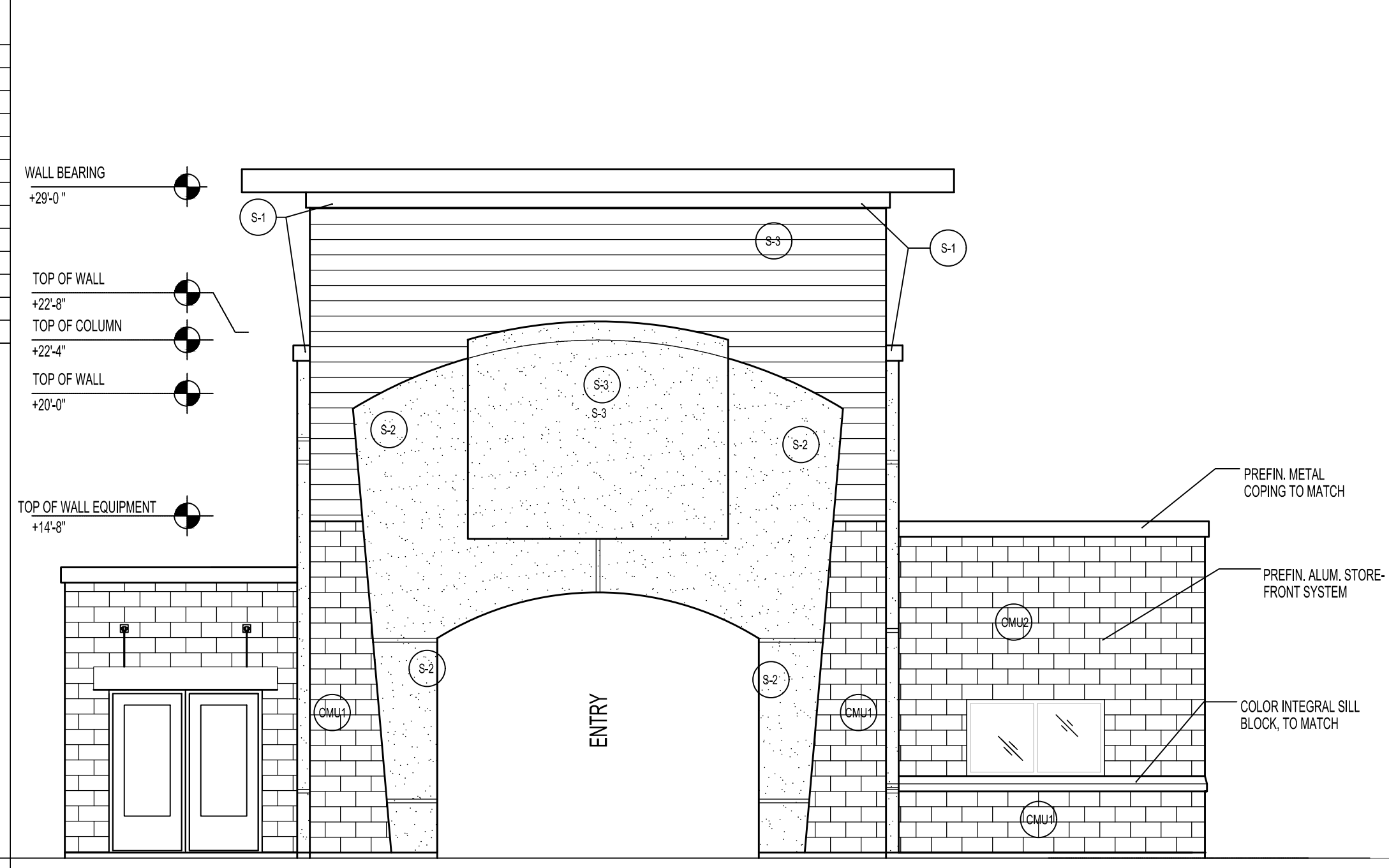

PROJECT NOTES

EXTERIOR BUILDING SUMMARY
 EAST SIDE ELEVATION 2,900 S.F.
 WEST SIDE ELEVATION 2,900 S.F.
 ENTRY 1,100 S.F.
 EXIT 1,100 S.F.
 TOTAL ELEVATIONS SQUARE FOOTAGE 8,000

FINISH SCHEDULE - EXTERIOR ELEVATIONS		8,000 TOTAL S.F.	
CEMENTITIOUS FIBER BOARD	2,500 S.F.	31.0%	
STUCCO	1,150 S.F.	14.5%	
CMU SPLIT FACE	1,440 S.F.	18%	
CMU SMOOTH FACE	1,200 S.F.	15%	
METAL FASCIA AND AWNINGS	695 S.F.	9%	
DOORS	485 S.F.	6%	
WINDOWS	530 S.F.	6.5%	
TOTAL	8,000 S.F.	100%	

PRIMARY MATERIALS	4,635 S.F.	
CMU SPLIT FACE, CEMENTITIOUS FIBER BOARD, METAL FASCIA AND AWNINGS		
SECONDARY MATERIAL	2,350 S.F.	
STUCCO, SMOOTH FACE BLOCK		
DOORS AND WINDOWS	1,015 S.F.	

TOTAL S.F. MINUS DOORS AND WINDOWS	6,985 S.F.	
PERCENTAGE OF PRIMARY MATERIAL	4,635 S.F.	66%
PERCENTAGE OF SECONDARY MATERIAL	2,350 S.F.	34%

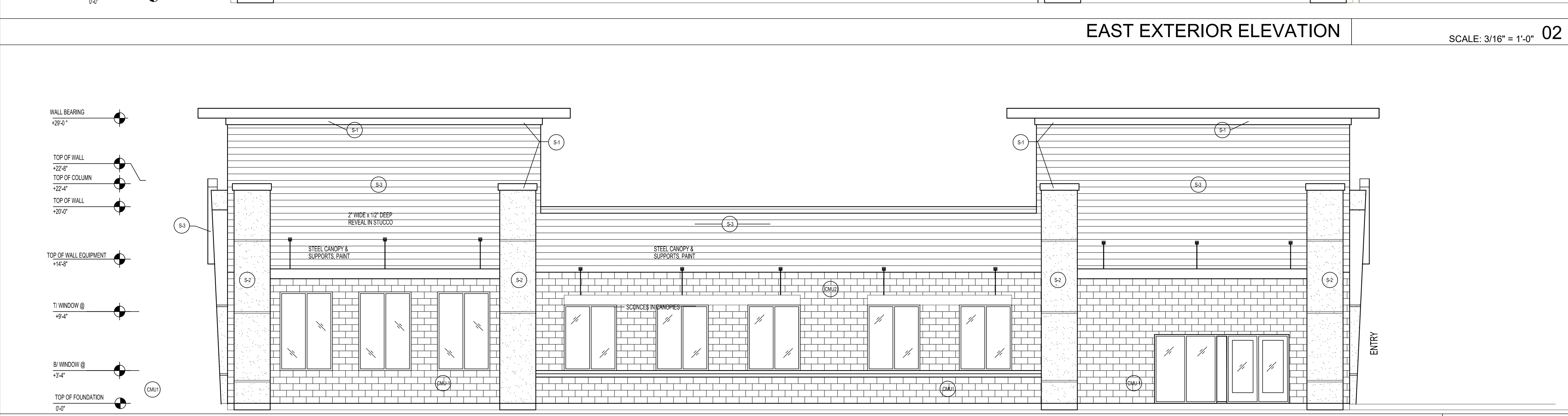
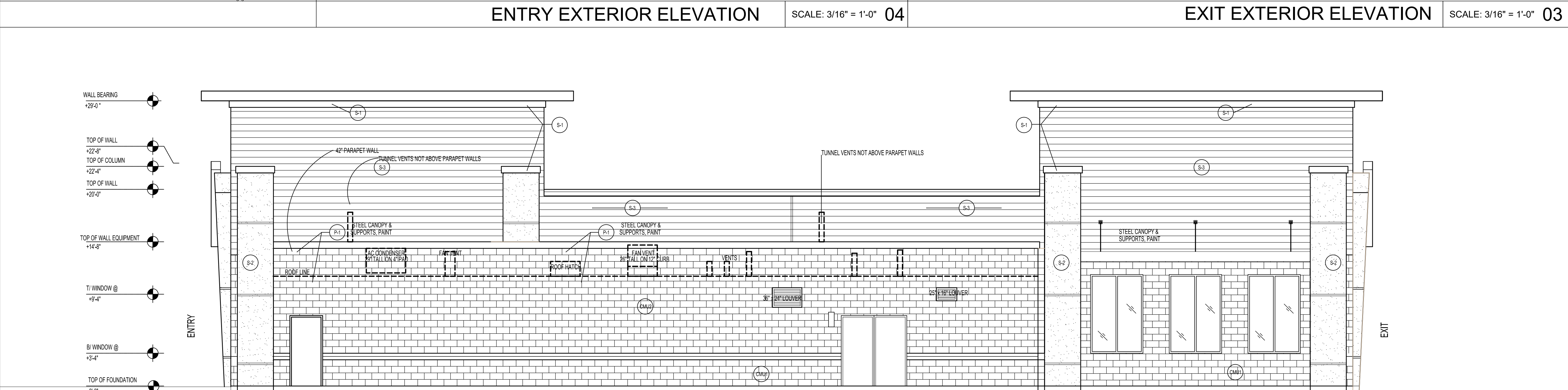

PROJECT TITLE

Quick Quack Car Wash
Santaquin

DAIN & ASSOCIATES
 ARCHITECTURE | DESIGN | PROJECT MANAGEMENT
 JAMES A. DAIN ARCHITECT
 PHONE (801) 228-5800

DATE: March 2024

REVISIONS:

A200	
------	--

EXTERIOR FINISH SCHEDULE		
LABEL	MATERIAL	COLOR / MANUFACTURER
CMU-1	SPLIT-FACE CMU	INTEGRAL COLOR (DARK GREY) TO MATCH SW 7089 'IRON ORE'
CMU-2	SMOOTH-FACE CMU	INTEGRAL COLOR (LIGHT GREY) TO MATCH SW 7655 'STAMPED CONCRETE'
S-1	STUCCO	MATCH SW 6755 'STARBOARD' (GREEN)
S-2	STUCCO	MATCH SW 6902 Decisive Yellow
S-3	CEMENTITIOUS FIBER BOARD	MATCH SW 7004 'SNOWBOUND' (WHITE)
P-1	PAINT	SW 6755 'STARBOARD' (GREEN)
P-2	PAINT	SW 6902 Decisive Yellow
P-3	PAINT	SW 7025 'BACKDROP' (DARK GREY)
M-1	STANDING SEAM ROOFING	MATCH SW 6755 'STARBOARD' (GREEN)

PROJECT NOTES		
EXTERIOR BUILDING SUMMARY EAST SIDE ELEVATION 2,900 S.F. WEST SIDE ELEVATION 2,900 S.F. ENTRY 1,100 S.F. EXIT 1,100 S.F. TOTAL ELEVATIONS SQUARE FOOTAGE 8,000		
FINISH SCHEDULE - EXTERIOR ELEVATIONS		8,000 TOTAL S.F.
CEMENTITIOUS FIBER BOARD	2,500 S.F.	31.0%
STUCCO	1,150 S.F.	14.5%
CMU SPLIT FACE	1,440 S.F.	18%
CMU SMOOTH FACE	1,200 S.F.	15%
METAL FASCIA AND AWNINGS	695 S.F.	9%
DOORS	485 S.F.	6%
WINDOWS	530 S.F.	6.5%
TOTAL		8,000 S.F. 100%
PRIMARY MATERIALS		4,635 S.F.
CMU SPLIT FACE, CEMENTITIOUS FIBER BOARD, METAL FASCIA AND AWNINGS		
SECONDARY MATERIAL		2,350 S.F.
STUCCO, SMOOTH FACE BLOCK		
DOORS AND WINDOWS		1,015 S.F.
TOTAL S.F. MINUS DOORS AND WINDOWS	6,985 S.F.	
PERCENTAGE OF PRIMARY MATERIAL	4,635 S.F.	66%
PERCENTAGE OF SECONDARY MATERIAL	2,350 S.F.	34%

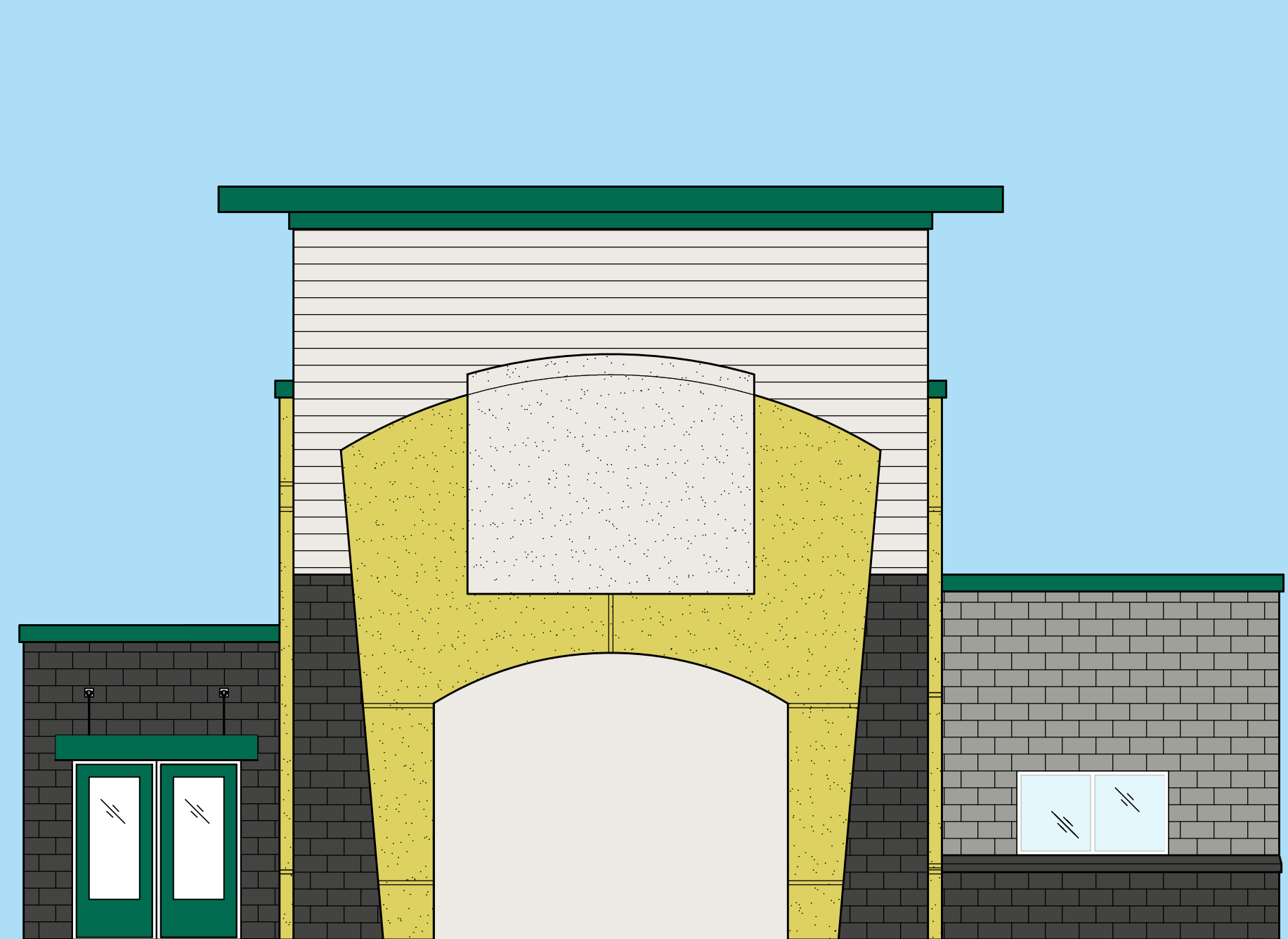

ENTRY EXTERIOR ELEVATION

SCALE: 3/16" = 1'-0" 04

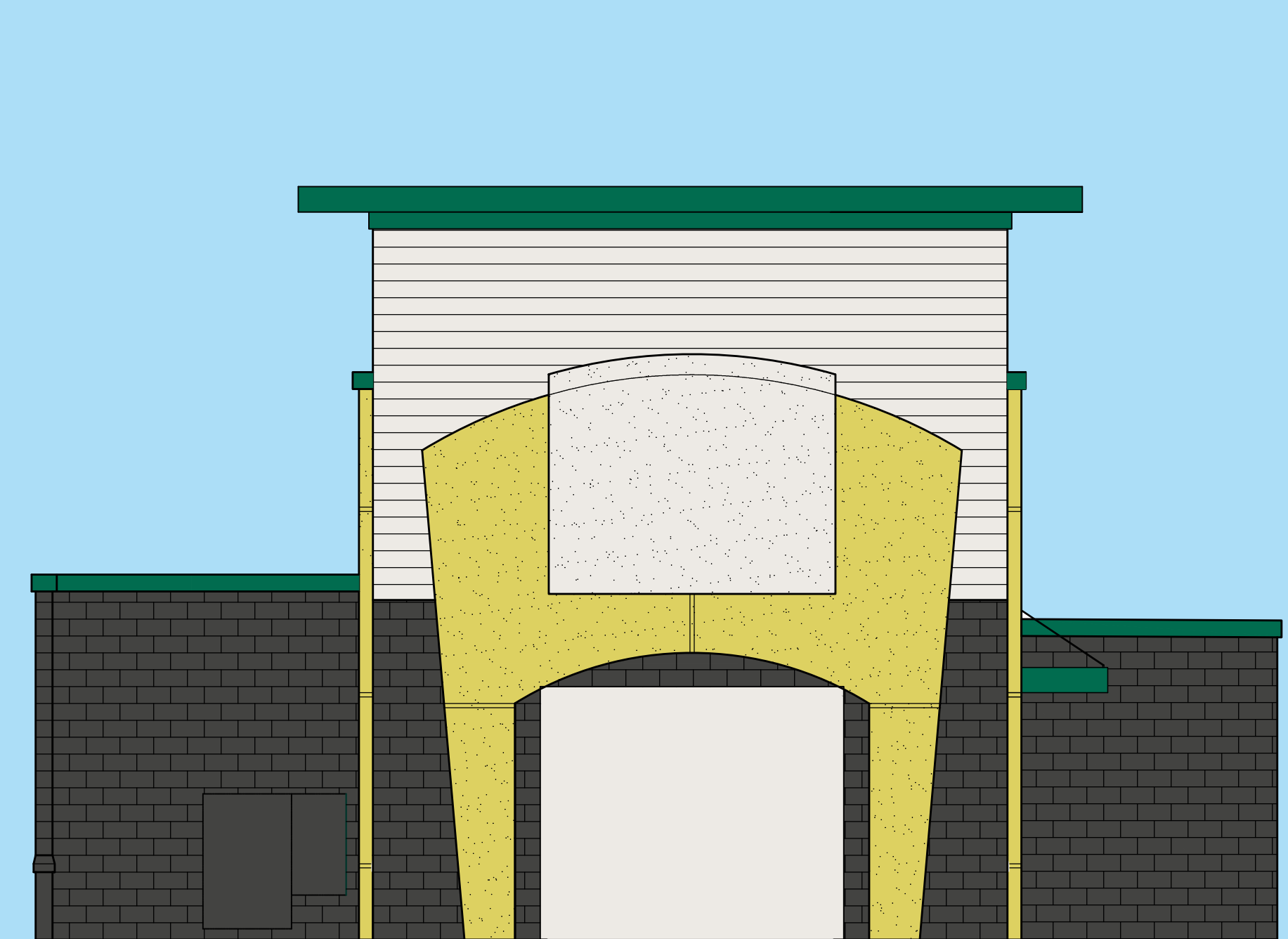

EXIT EXTERIOR ELEVATION

SCALE: 3/16" = 1'-0" 03

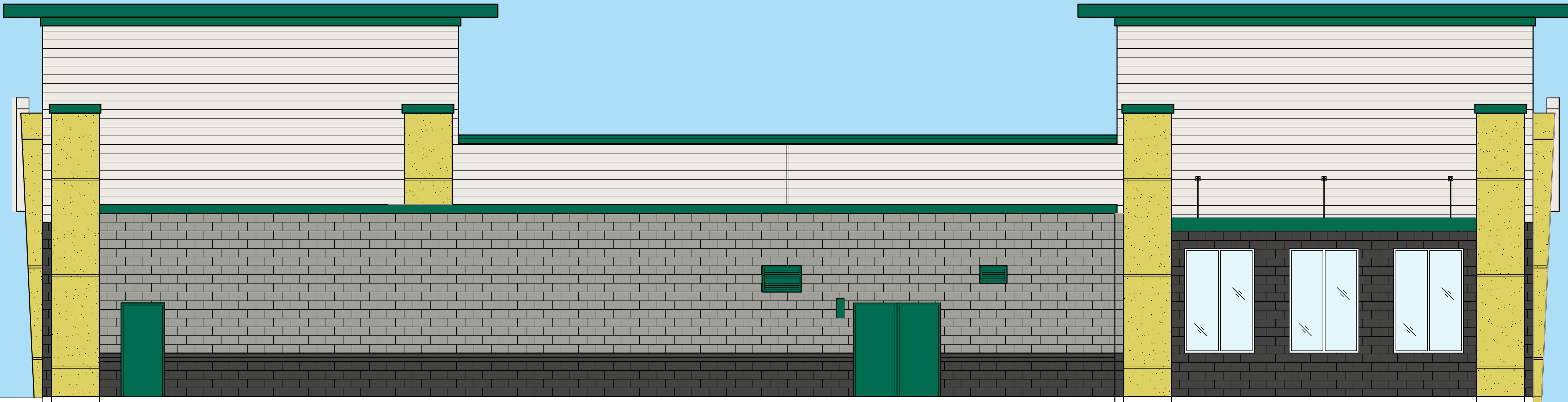

EAST EXTERIOR ELEVATION

SCALE: 3/16" = 1'-0" 02

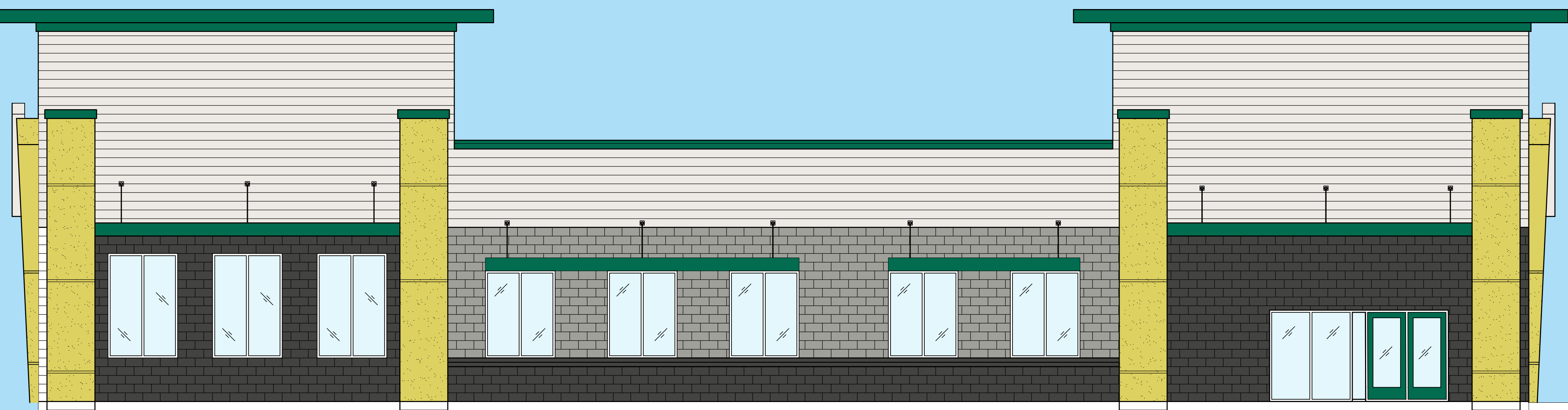

WEST EXTERIOR ELEVATION

SCALE: 3/16" = 1'-0" 01

Blank space for notes or revisions.

PROJECT TITLE
Quick Quack Car Wash
Santaquin



DATE:	March 2024	A200
REVISIONS:		

PROJECT NOTES

ALL EXTERIOR WALL TO BE FILLED WITH PERLITE INSULATION

Service counters 36 maximum height. Also areas used for check writing must have an area that is no more than 34 inches maximum in height. Work service counters 28-34 inches maximum in height ANSI 904.4.2 & 904.4.3 (Front Reception Counters and Breakroom)

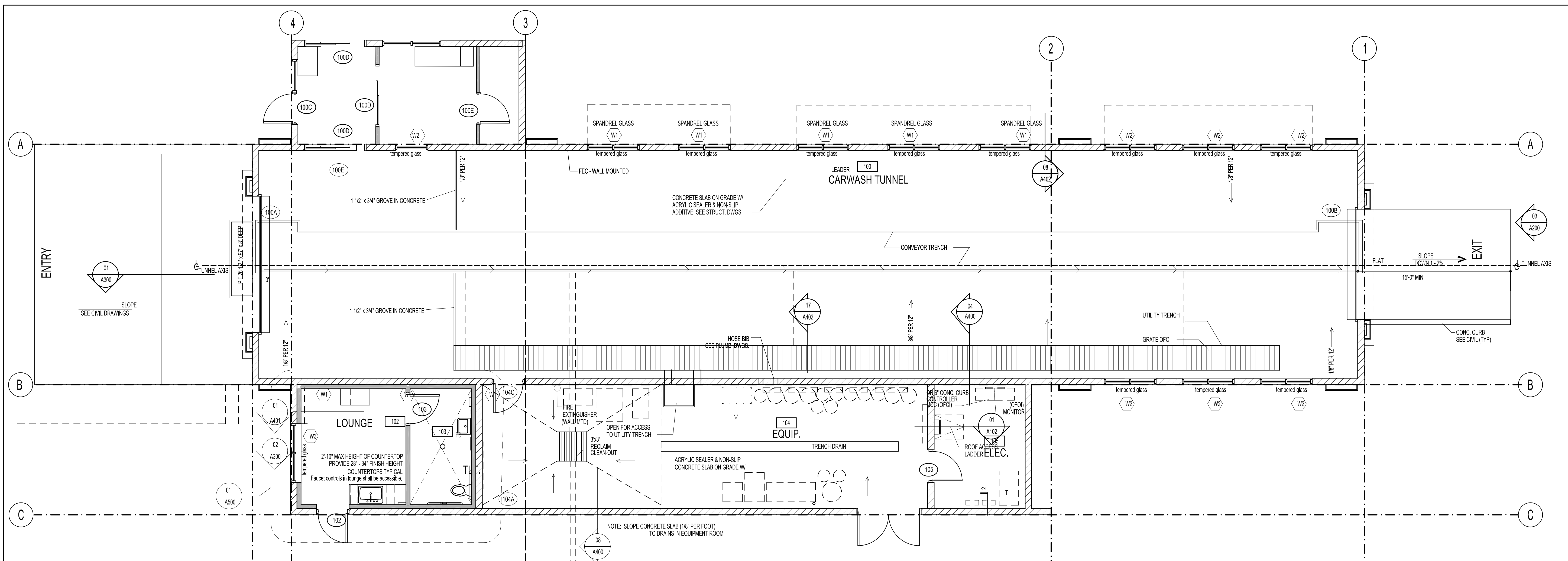

ANNOTATION FLOOR PLAN SCALE: 3/16" = 1'-0" 02

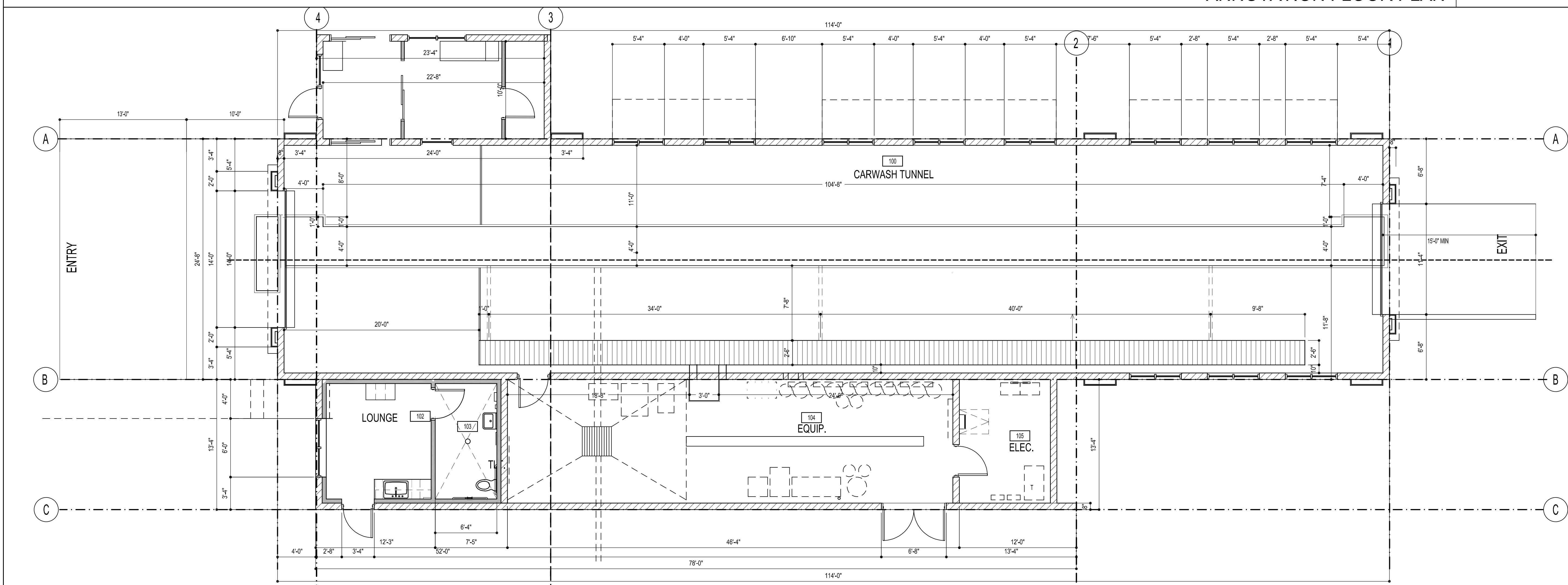

DIMENSION FLOOR PLAN SCALE: 3/16" = 1'-0" 01

PROJECT TITLE
Quick Quack Car Wash
Santaquin

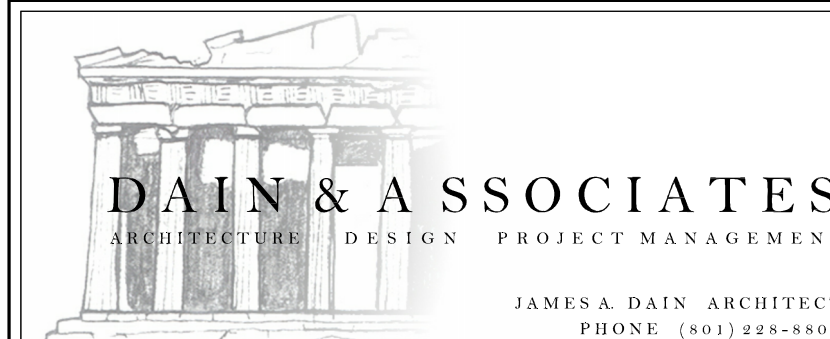

DATE: March 2024
REVISIONS:

A100

QUICK QUACK SANTAQUIN 500 EAST

SANTAQUIN, UT

VICINITY MAP



NOT TO SCALE

INDEX

- G-0 Cover Sheet
- C-1 Site Plan
- C-2 Grading Plan
- C-3 Drainage Plan
- C-4 Utility Plan
- C-5 Details
- C-6 Utility Details
- C-7 Stormwater Pollution Prevention Plan
- C-8 SWPPP Details
- L-1 Landscape Plan
- Photometric Plan

PROJECT ENGINEER:
 LARVIN POLLOCK
 ELEVATE ENGINEERING
 2208 WEST 700 SOUTH
 SPRINGVILLE, UT 84663
 (801) 718-5993
 LARVIN@ELEVATEENG.COM

DEVELOPER:
 RUSS NELSON
 LONESTAR BUILDERS
 2208 WEST 700 SOUTH
 SPRINGVILLE, UT 84663
 (435) 757-0400
 RUSS.NELSON@LONESTARBUILDERSINC.COM

SITE DATA

LOT AREA: 58,811 SF (1.35 ACRES)
 BUILDING AREA: 4,081 SF ± 6.9%
 PAVEMENT AREA: 37,507 SF ± 63.8%
 LANDSCAPE AREA: 17,223 SF ± 29.3%

ZONING: C-1 (GENERAL COMMERCIAL)
CONDITIONAL USE
 PARCEL ID#: 517170008

NOTE: THE DEVELOPER AND THE GENERAL CONTRACTOR UNDERSTAND THAT IT IS HIS/HER RESPONSIBILITY TO ENSURE THAT ALL IMPROVEMENTS INSTALLED WITHIN THIS DEVELOPMENT ARE CONSTRUCTED IN FULL COMPLIANCE WITH ALL STATE AND SANTAQUIN CITY CODES, ORDINANCES AND STANDARDS. THESE PLANS ARE NOT ALL INCLUSIVE OF ALL MINIMUM CODES, ORDINANCES AND STANDARDS. THIS FACT DOES NOT RELIEVE THE DEVELOPER OR GENERAL CONTRACTOR FROM FULL COMPLIANCE WITH ALL MINIMUM STATE AND SANTAQUIN CITY CODES, ORDINANCES AND STANDARDS.

NOTE: ALL RECOMMENDATIONS MADE IN A PERTINENT GEOTECHNICAL REPORT/STUDY SHALL BE FOLLOWED EXPLICITLY DURING CONSTRUCTION OF BUILDINGS AND SITE IMPROVEMENTS.

LEGEND & ABBREVIATION TABLE

R.O.W./PROPERTY LINE		EXISTING CURB AND GUTTER	
EASEMENT LINE		PROPOSED CURB AND GUTTER	
CENTER LINE		INVERT ELEVATION	I.E.
PROPOSED TRAIL		TOP BACK CURB	TBC
PROPOSED WATER LINE		TOP ASPHALT	TA
PROPOSED PRESSURIZED IRRIGATION		TOP OF GRATE	TOG
PROPOSED GROUND WATER DRAIN		FINISHED GRADE	FG
PROPOSED SEWER LINE		TOP OF CONCRETE	TC
PROPOSED STORM DRAIN LINE		HIGH WATER ELEVATION	HWE
EXISTING SEWER LINE		CATCH BASIN	
EXISTING WATER LINE		SURFACE FLOW DIRECTION	
EXISTING STORM DRAIN LINE		PROPOSED STREET LIGHT	
EXISTING CONTOUR		STORM DRAIN MANHOLE	
FINISHED CONTOUR		SANITARY SEWER MANHOLE	
		PROPOSED WATER VALVE	

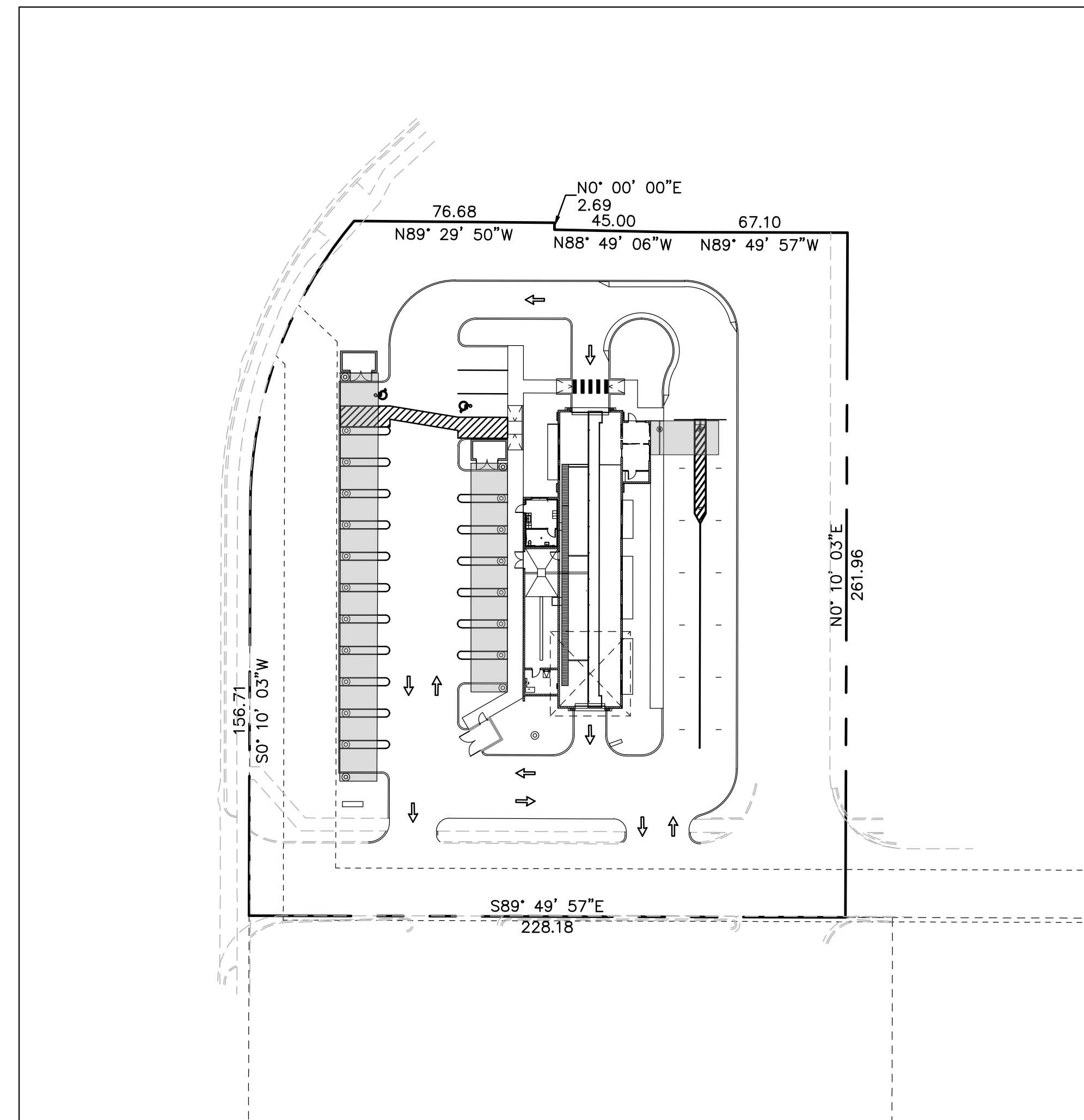

SITE MAP
 1" = 40'

NO.	REVISIONS	BY	DATE

ELEVATE ENGINEERING
 2208 WEST 700 SOUTH
 SPRINGVILLE, UT 84663
 PHONE: (801) 718-5993
 larvin@elevateeng.com

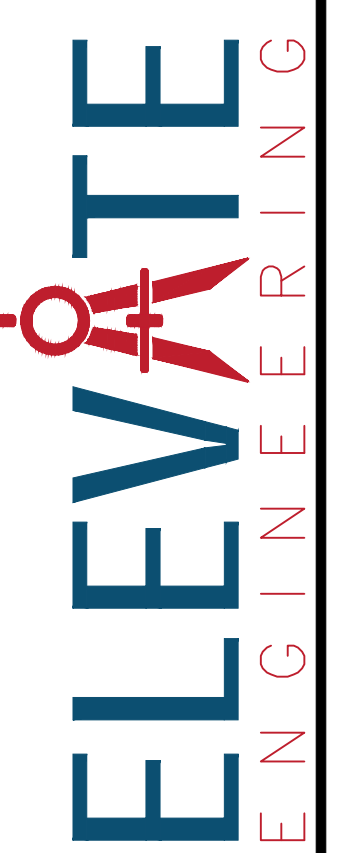

QUICK QUACK SANTAQUIN 500 EAST
 COVER SHEET
 78 N 500 E, SANTAQUIN UT 84665

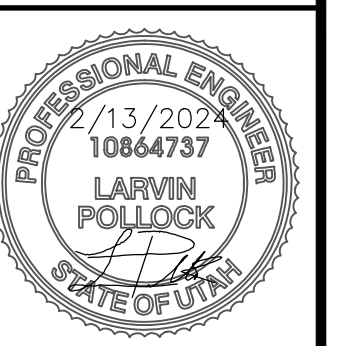

SHEET:
G-0
 DATE:
 Feb 13, 2024

PROJECT ENGINEER:
 LARVIN POLLOCK
 ELEVATE ENGINEERING
 2208 WEST 700 SOUTH
 SPRINGVILLE, UT 84663
 (801) 718-5993
 LARVIN@ELEVATEENG.COM

LEGEND

LOT LINES (PROPERTY)	---
EXISTING CURB AND GUTTER	=====
PROPOSED CURB AND GUTTER	=====
STRIPING	=====
BUILDING SETBACK	-----
LANDSCAPE SETBACK	-----
EXISTING BUILDING	-----
EXISTING FENCE	----- x -----
TOP BACK OF CURB	TBC
FINISHED FLOOR ELEVATION	FFE
LANDSCAPE AREA	[Pattern]
CONCRETE AREA	[Pattern]
CANOPY	[Pattern]

SITE DATA

LOT AREA:	58,811	SF (1.35 ACRES)
BUILDING AREA:	4,081	SF ± 6.9%
PAVEMENT AREA:	37,507	SF ± 63.8%
LANDSCAPE AREA:	17,223	SF ± 29.3%

ZONING: C-1 (GENERAL COMMERCIAL)
 CONDITIONAL USE
 PARCEL ID#: 517170008



BUILDING DATA

CONSTRUCTION TYPE: V-B
 SPRINKLERS: NO
 SETBACKS:
 FRONT=10 FEET
 REAR=10 FEET
 SIDE=10 FEET

PARKING TABULATION

REQUIRED:	5 STALLS PER 1,000 SF
PROVIDED:	3 STALLS
	1 ADA STALL
VACUUM STALLS:	19 STALLS
TUNNEL LENGTH:	114 FEET
STACKING:	14 STALLS

- NOTES:**
- 1 PROPOSED 5' SIDEWALK PER DRAWING NO. CG5. SEE SHEET C-5 FOR DETAILS.
 - 2 ALL HANDICAP STALLS AND RAMPS TO BE INSTALLED PER DRAWING NO. CG1. SEE SHEET C-5 FOR DETAILS.
 - 3 PROPOSED CURB & GUTTER TYPE E PER DRAWING NO. CG4. SEE SHEET C-5 FOR DETAILS.
 - 4 PROPOSED CURB TYPE P PER DRAWING NO. CG4. SEE SHEET C-5 FOR DETAILS.
 - 5 CONSTRUCT VACUUM ENCLOSURE WITH CONCRETE PAD AND APRON. INSTALL OWNER PROVIDED VACUUM EQUIPMENT, UNDERGROUND TRUNK LINES, PIPING, ETC. COORDINATE WITH ARCHITECTURAL PLANS.
 - 6 PAINT 4" SOLID YELLOW PAINT STRIPE AS SHOWN (TYPICAL).
 - 7 INSTALL OWNER PROVIDED "TOMMY BALL" PLANTERS/GARBAGE RECEPTACLE (TYPICAL). COORDINATE WITH ARCHITECTURAL PLANS FOR DETAILS.
 - 8 INSTALL OWNER PROVIDED PAY STATIONS WITH CANOPY. COORDINATE WITH ARCHITECTURAL PLANS FOR DETAILS.
 - 9 INSTALL OWNER PROVIDED GATES AND LOOP DETECTION SYSTEM. COORDINATE TIMING OF INSTALLATION PRIOR TO CONSTRUCTION OF PAVEMENT. SEE ARCHITECTURAL PLANS FOR DETAILS.
 - 10 PROPOSED DUMPSTER LOCATION. SEE SHEET C-5 FOR DETAILS.



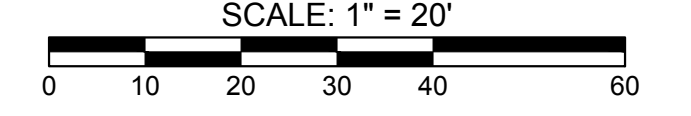

SCALE: 1" = 20'

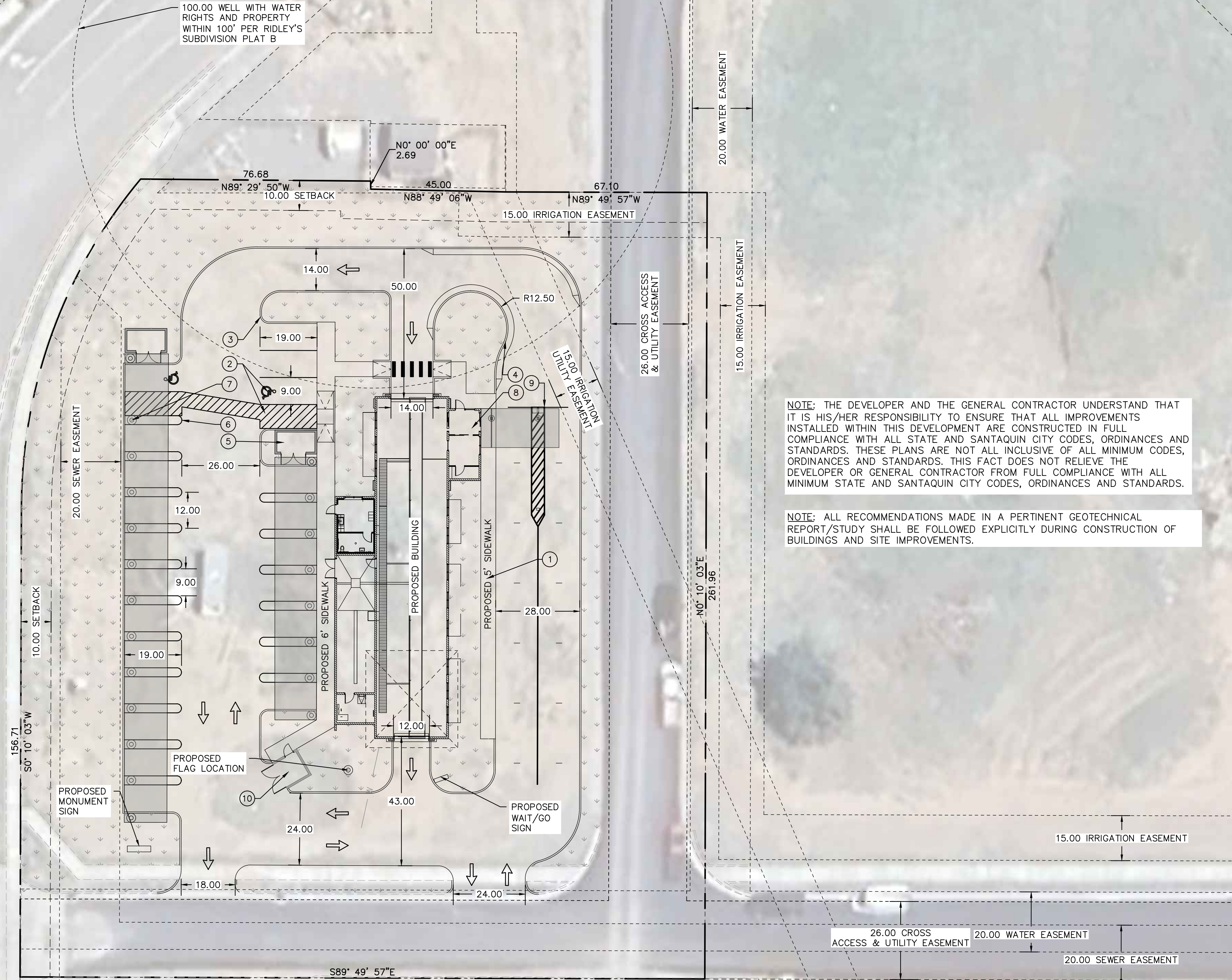

NOTE: THE DEVELOPER AND THE GENERAL CONTRACTOR UNDERSTAND THAT IT IS HIS/HER RESPONSIBILITY TO ENSURE THAT ALL IMPROVEMENTS INSTALLED WITHIN THIS DEVELOPMENT ARE CONSTRUCTED IN FULL COMPLIANCE WITH ALL STATE AND SANTAQUIN CITY CODES, ORDINANCES AND STANDARDS. THESE PLANS ARE NOT ALL INCLUSIVE OF ALL MINIMUM CODES, ORDINANCES AND STANDARDS. THIS FACT DOES NOT RELIEVE THE DEVELOPER OR GENERAL CONTRACTOR FROM FULL COMPLIANCE WITH ALL MINIMUM STATE AND SANTAQUIN CITY CODES, ORDINANCES AND STANDARDS.

NOTE: ALL RECOMMENDATIONS MADE IN A PERTINENT GEOTECHNICAL REPORT/STUDY SHALL BE FOLLOWED EXPLICITLY DURING CONSTRUCTION OF BUILDINGS AND SITE IMPROVEMENTS.

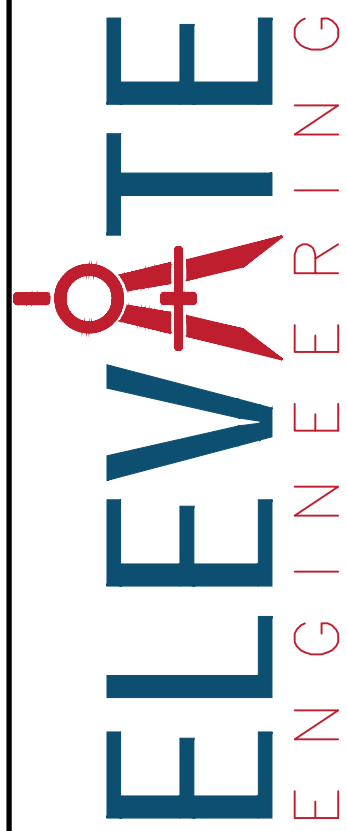
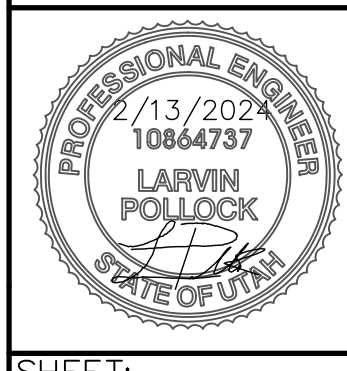

- GENERAL NOTES:**
1. CONTRACTOR TO NOTIFY BLUE STAKES PRIOR TO CONSTRUCTION
 2. CONTRACTOR TO VERIFY LOCATION AND ELEVATION OF ALL EXISTING UTILITY LINES AND STRUCTURES PRIOR TO CONSTRUCTION
 3. ALL PROPOSED WATER LINES TO HAVE A MINIMUM OF 5' OF COVER
 4. ALL SEWER, WATER AND STORM DRAIN PIPES SHALL BE BACKFILLED WITH SELECT GRANULAR FILL AS PER CITY STANDARDS.
 5. ANY OFF SITE DAMAGE TO EXISTING ASPHALT, CURB & GUTTER, LANDSCAPING AND ALL UTILITIES TO BE REPLACED IN KIND.
 6. SEE UTILITY PLAN FOR CONSTRUCTION OF SEWER AND WATER LINES.
 7. ALL WORK TO BE ACCORDING TO CITY STANDARDS.

	<p>QUICK QUACK SANTAQUIN 500 EAST SITE PLAN 78 N 500 E, SANTAQUIN UT 84665</p>
	<p>SHEET: C-1 DATE: Feb 13, 2024</p>

LEGEND

LOT LINES (PROPERTY)	---
EXISTING CURB AND GUTTER	====
PROPOSED CURB AND GUTTER	=====
PROPOSED STORM DRAIN LINE	—SD—SD—SD—
EXISTING STORM DRAIN LINE	- -SD - -SD - -SD - -SD -
GRADE BREAK	---GRADE BREAK---
FINISH GRADE CONTOUR LINES	---4960---
EXISTING GRADE CONTOUR LINES	---(4960)---
FINISH GRADE SLOPE	SLOPE
GRADE BREAK	GB
INVERT ELEVATION	IE
TOP OF GRATE	TOG
TOP OF ASPHALT	TA
TOP BACK OF CURB	TBC
EXISTING	EX
FINISHED GRADE	FG
FINISHED FLOOR ELEVATION	FFE
BACK OF SIDEWALK	BOW
EDGE OF ASPHALT	EOA
TOP OF FOUNDATION	TOF

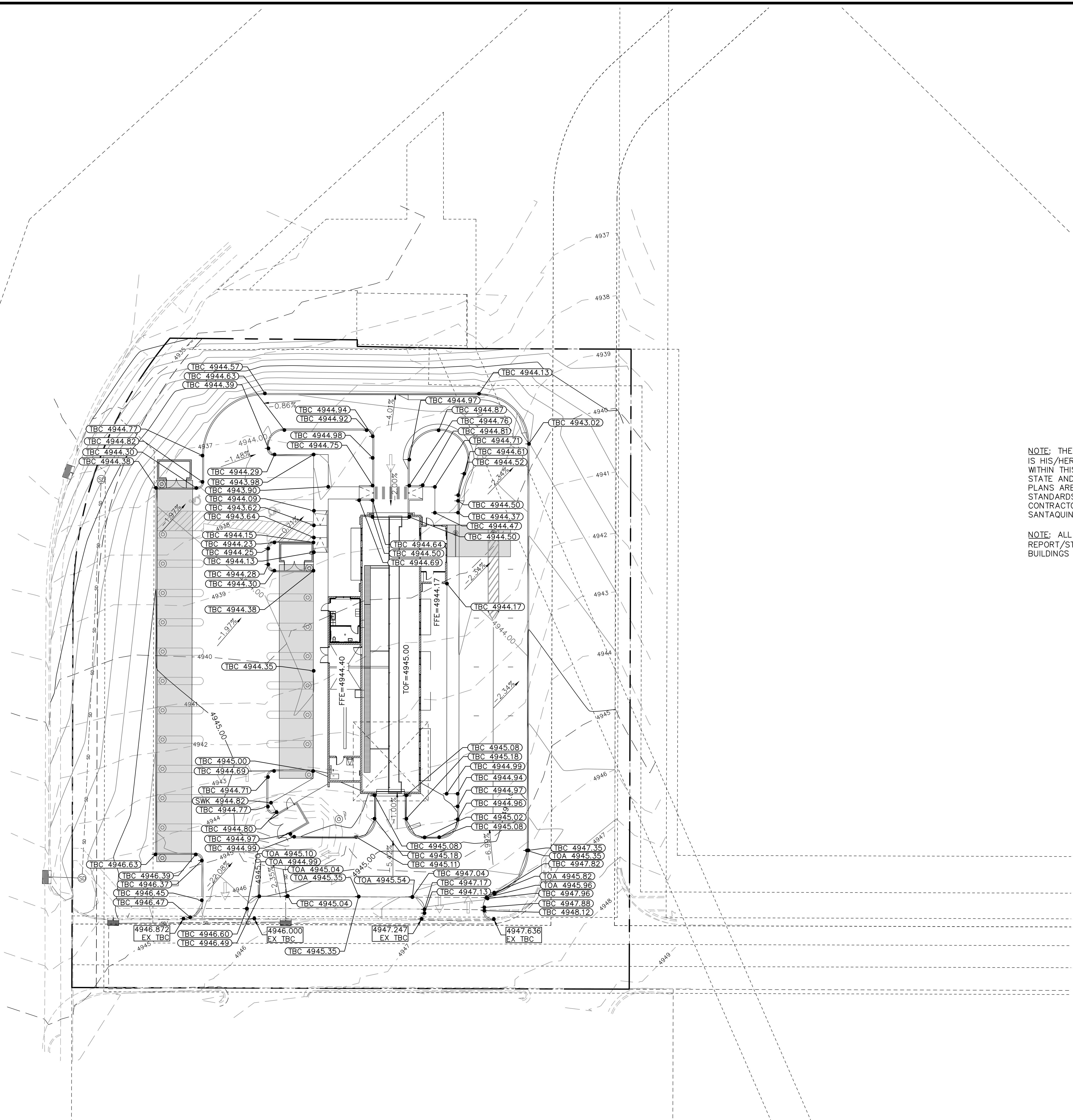

NOTE: THE DEVELOPER AND THE GENERAL CONTRACTOR UNDERSTAND THAT IT IS HIS/HER RESPONSIBILITY TO ENSURE THAT ALL IMPROVEMENTS INSTALLED WITHIN THIS DEVELOPMENT ARE CONSTRUCTED IN FULL COMPLIANCE WITH ALL STATE AND SANTAQUIN CITY CODES, ORDINANCES AND STANDARDS. THESE PLANS ARE NOT ALL INCLUSIVE OF ALL MINIMUM CODES, ORDINANCES AND STANDARDS. THIS FACT DOES NOT RELIEVE THE DEVELOPER OR GENERAL CONTRACTOR FROM FULL COMPLIANCE WITH ALL MINIMUM STATE AND SANTAQUIN CITY CODES, ORDINANCES AND STANDARDS.

NOTE: ALL RECOMMENDATIONS MADE IN A PERTINENT GEOTECHNICAL REPORT/STUDY SHALL BE FOLLOWED EXPLICITLY DURING CONSTRUCTION OF BUILDINGS AND SITE IMPROVEMENTS.

NO.	REVISIONS	BY	DATE

ELEVATE ENGINEERING
 2208 WEST 700 SOUTH
 SPRINGVILLE, UT 84663
 PHONE: (801) 718-5993
 info@elevateeng.com

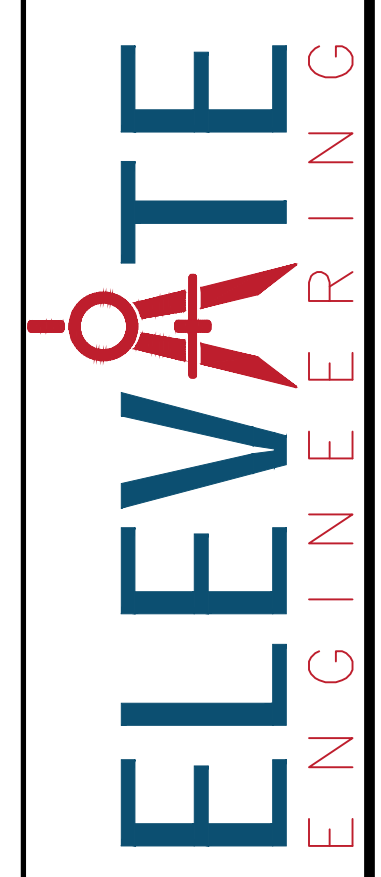

QUICK QUACK SANTAQUIN 500 EAST
 GRADING PLAN
 78 N 500 E, SANTAQUIN UT 84655

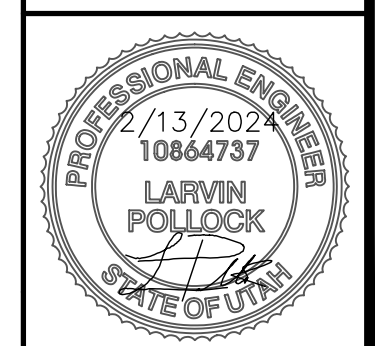

SHEET:
C-2
 DATE:
 Feb 13, 2024

CALL BEFORE YOU DIG!
 800-4-A-DIG
 BLUE STAKES 1 800 882 6711

SCALE: 1" = 20'

LEGEND

LOT LINES (PROPERTY)	---
EXISTING CURB AND GUTTER	====
PROPOSED CURB AND GUTTER	=====
PROPOSED STORM DRAIN LINE	---SD---SD---SD---
EXISTING STORM DRAIN LINE	-SD-SD-SD-
GRADE BREAK	---GRADE BREAK---
FINISH GRADE CONTOUR LINES	---4960---
EXISTING GRADE CONTOUR LINES	---(4960)---
DRAINAGE FLOW ARROWS	→
GRADE BREAK	GB
INVERT ELEVATION	IE
TOP OF GRATE	TOG
TOP OF ASPHALT	TA
TOP BACK OF CURB	TBC
EXISTING	EX
FINISHED GRADE	FG
FINISHED FLOOR ELEVATION	FFE
BACK OF SIDEWALK	BOW
EDGE OF ASPHALT	EOA
TOP OF FOUNDATION	TOF

- DESIGN NOTES:**
- INSTALL CURB INLET BOX PER APWA 315. SEE SHEET C-6 FOR DETAILS. RIM=4943.47 IE=4940.42
 - INSTALL CURB INLET BOX PER APWA 315. SEE SHEET C-6 FOR DETAILS. RIM=4942.52 IE=4939.52
 - INSTALL 12" ADS PIPE @ 0.50% MINIMUM SLOPE
 - INSTALL 28'X95' RTANK SYSTEM FOR 10,613 CF OF STORM WATER STORAGE CAPACITY. TOP OF TANK EL=4944.53 BOTTOM OF TANK EL=4939.17
 - INSTALL 6" PVC PIPE TO CONNECT TO ONSITE STORM NETWORK.
 - ALL RETAINING WALLS TO BE ENGINEERED AND CONSTRUCTED BY OTHERS

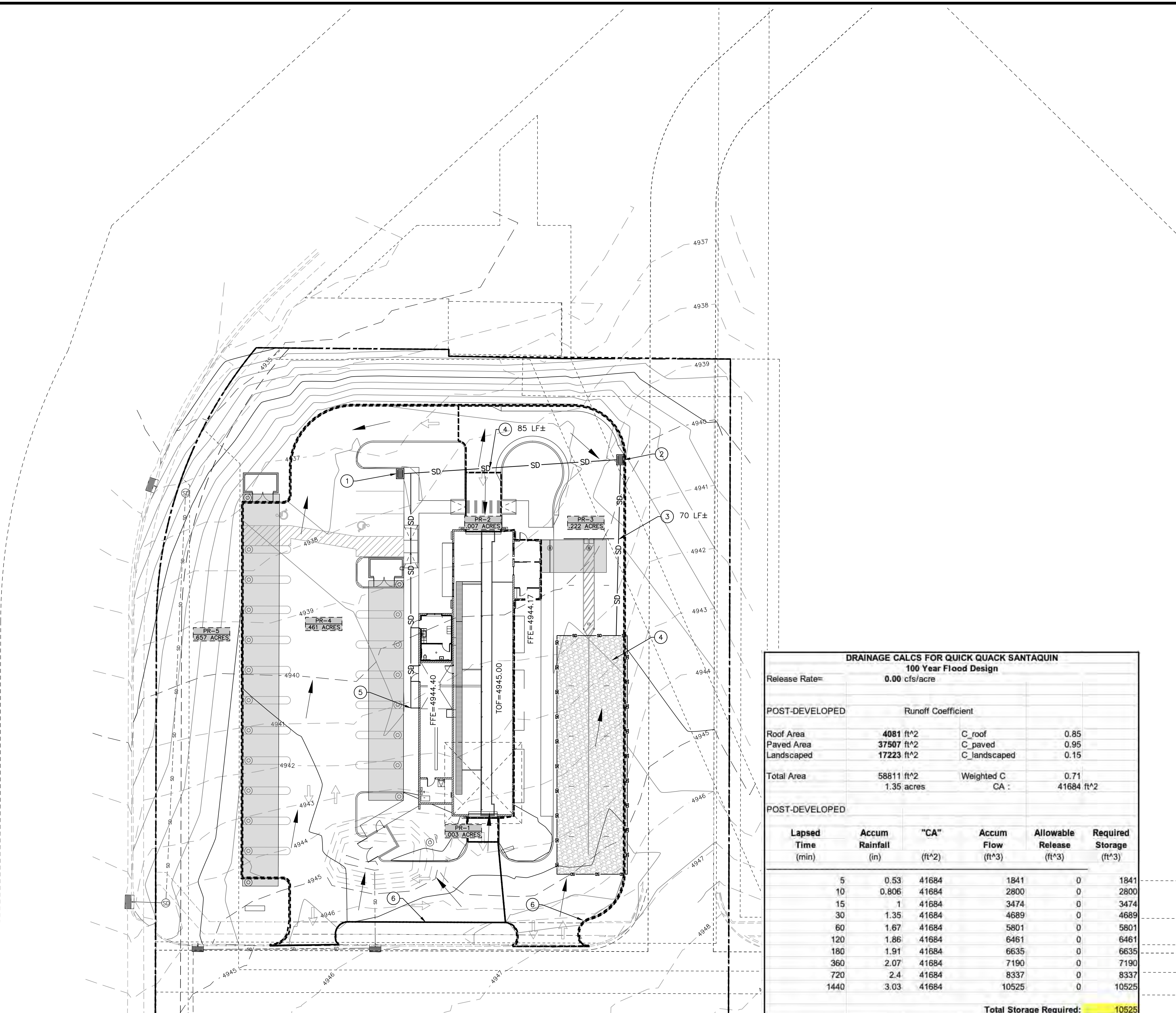

DRAINAGE CALCS FOR QUICK QUACK SANTAQUIN
100 Year Flood Design

Release Rate= 0.00 cfs/acre

POST-DEVELOPED			
Runoff Coefficient			
Roof Area	4081 ft ²	C _{roof}	0.85
Paved Area	37507 ft ²	C _{paved}	0.95
Landscaped	17223 ft ²	C _{landscaped}	0.15
Total Area	58811 ft ²	Weighted C	0.71
	1.35 acres	CA	41684 ft ²

POST-DEVELOPED					
Lapsed Time (min)	Accum Rainfall (in)	"CA" (ft ²)	Accum Flow (ft ³)	Allowable Release (ft ³)	Required Storage (ft ³)
5	0.53	41684	1841	0	1841
10	0.806	41684	2800	0	2800
15	1	41684	3474	0	3474
30	1.35	41684	4689	0	4689
60	1.67	41684	5801	0	5801
120	1.86	41684	6461	0	6461
180	1.91	41684	6635	0	6635
360	2.07	41684	7190	0	7190
720	2.4	41684	8337	0	8337
1440	3.03	41684	10525	0	10525
Total Storage Required:				10525	

VOLUME PROVIDED IN R-TANK

28'X95' R-Tank Area (ft ²)	Void Ratio	Depth (ft)	Volume/LF (ft ³)/LF	Total Volume (ft ³)
2660	0.95	4.2	2527.00	10613.40
Total Individual R-TANK Volume=				10613
Number of R-TANK Systems				1
Total Volume Provided Within R-TANK Systems				10613

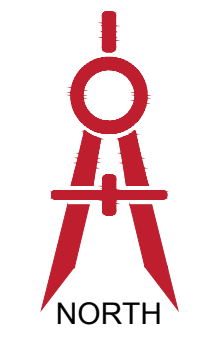
SCALE: 1" = 20'

0 10 20 30 40 60

NO.	REVISIONS	BY	DATE

ELEVATE ENGINEERING
 2208 WEST 700 SOUTH
 SPRINGVILLE, UT 84663
 PHONE: (801) 718-5993
 info@elevateeng.com

ELEVATE ENGINEERING

QUICK QUACK SANTAQUIN 500 EAST
 DRAINAGE PLAN
 78 N 500 E, SANTAQUIN UT 84655

PROFESSIONAL ENGINEER
 2/13/2024
 10864737
 LARVIN POLLOCK
 STATE OF UTAH

SHEET: **C-3**
 DATE: Feb 13, 2024

NO.	REVISIONS	BY	DATE

ELEVATE ENGINEERING
 2208 WEST 700 SOUTH
 SPRINGVILLE, UT 84663
 PHONE: (801) 718-5993
 elevateng.com

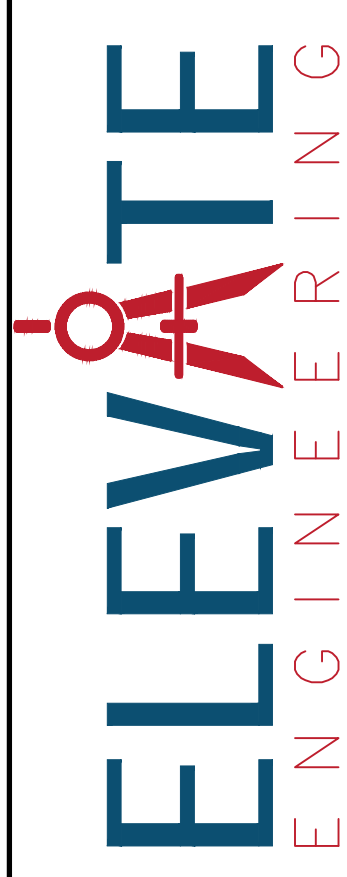

QUICK QUACK SANTAQUIN 500 EAST
 UTILITY PLAN
 78 N 500 E, SANTAQUIN UT 84655

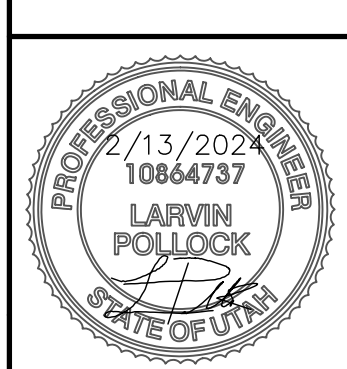

SHEET: C-4
 DATE: Feb 13, 2024

LEGEND

PROPERTY/ROW LINE	---
EXISTING CURB AND GUTTER	====
PROPOSED CURB AND GUTTER	====
PROPOSED STORM DRAIN LINE	---SD---SD---SD---
EXISTING STORM DRAIN LINE	---SD---SD---SD---
PROPOSED SEWER LINE	---SS---SS---SS---
EXISTING SEWER LINE	---SS---SS---SS---
PROPOSED WATER LINE	---W---W---W---
EXISTING WATER LINE	---W---W---W---
INVERT ELEVATION	IE
EXISTING	EX
FINISHED GRADE	FG
FINISHED FLOOR ELEVATION	FFE
TOP OF FOUNDATION	TOF

DESIGN NOTES:

- ① CONNECT TO EXISTING WATER LATERAL PER CITY STANDARDS.
- ② EXISTING 2" WATER METER.
- ③ INSTALL 2" POLY WATER LINE PER CITY STANDARDS.
- ④ END ALL UTILITIES 5' FROM BUILDING, SEE PLUMBING PLANS FOR CONTINUATION.
- ⑤ CONNECT TO EXISTING SEWER MAIN PER APWA PLAN 431. SEE SHEET C-5 FOR DETAILS. CONTRACTOR TO VERIFY LOCATION AND ELEVATION PRIOR TO ANY CONSTRUCTION.
- ⑥ INSTALL 4" Ø PVC SDR-35 SEWER PIPE AT 2% MIN. SLOPE.
- ⑦ INSTALL 6" Ø PVC SDR-35 SEWER PIPE AT 1% MIN. SLOPE.
- ⑧ INSTALL 6" CLEANOUT.
- ⑨ INSTALL 48" SANITARY SEWER SAMPLING MANHOLE PER APWA PLAN 411. SEE SHEET C-5 FOR DETAILS.
RIM=4944.72
IE IN=4937.82
IE OUT= 4937.74
- ⑩ INSTALL 1500 GAL. GREASE INTERCEPTOR/RECLAIM TANKS. INSTALL 3' OF 6" Ø PVC SDR-35 SEWER PIPE AT 1% MIN. SLOPE BETWEEN TANKS. COORDINATE WITH PLUMBING PLANS FOR DETAILS.

GENERAL NOTES:

1. CONTRACTOR TO NOTIFY BLUE STAKES PRIOR TO CONSTRUCTION.
2. CONTRACTOR TO VERIFY LOCATION AND ELEVATION OF ALL EXISTING UTILITY LINES AND STRUCTURES PRIOR TO CONSTRUCTION.
3. ALL PROPOSED WATER LINES TO HAVE A MINIMUM OF 5' OF COVER.
4. ALL SEWER, WATER AND STORM DRAIN PIPES SHALL BE BACKFILLED WITH SELECT GRANULAR FILL AS PER CITY STANDARDS.
5. ANY OFF SITE DAMAGE TO EXISTING ASPHALT, CURB & GUTTER, LANDSCAPING AND ALL UTILITIES TO BE REPLACED IN KIND.
6. SEE GRADING AND DRAINAGE PLAN FOR CONSTRUCTION OF SEWER AND WATER LINES.
7. ALL WORK TO BE ACCORDING TO CITY STANDARDS.

NOTE: THE DEVELOPER AND THE GENERAL CONTRACTOR UNDERSTAND THAT IT IS HIS/HER RESPONSIBILITY TO ENSURE THAT ALL IMPROVEMENTS INSTALLED WITHIN THIS DEVELOPMENT ARE CONSTRUCTED IN FULL COMPLIANCE WITH ALL STATE AND SANTAQUIN CITY CODES, ORDINANCES AND STANDARDS. THESE PLANS ARE NOT ALL INCLUSIVE OF ALL MINIMUM CODES, ORDINANCES AND STANDARDS. THIS FACT DOES NOT RELIEVE THE DEVELOPER OR GENERAL CONTRACTOR FROM FULL COMPLIANCE WITH ALL MINIMUM STATE AND SANTAQUIN CITY CODES, ORDINANCES AND STANDARDS.

NOTE: ALL RECOMMENDATIONS MADE IN A PERTINENT GEOTECHNICAL REPORT/STUDY SHALL BE FOLLOWED EXPLICITLY DURING CONSTRUCTION OF BUILDINGS AND SITE IMPROVEMENTS.

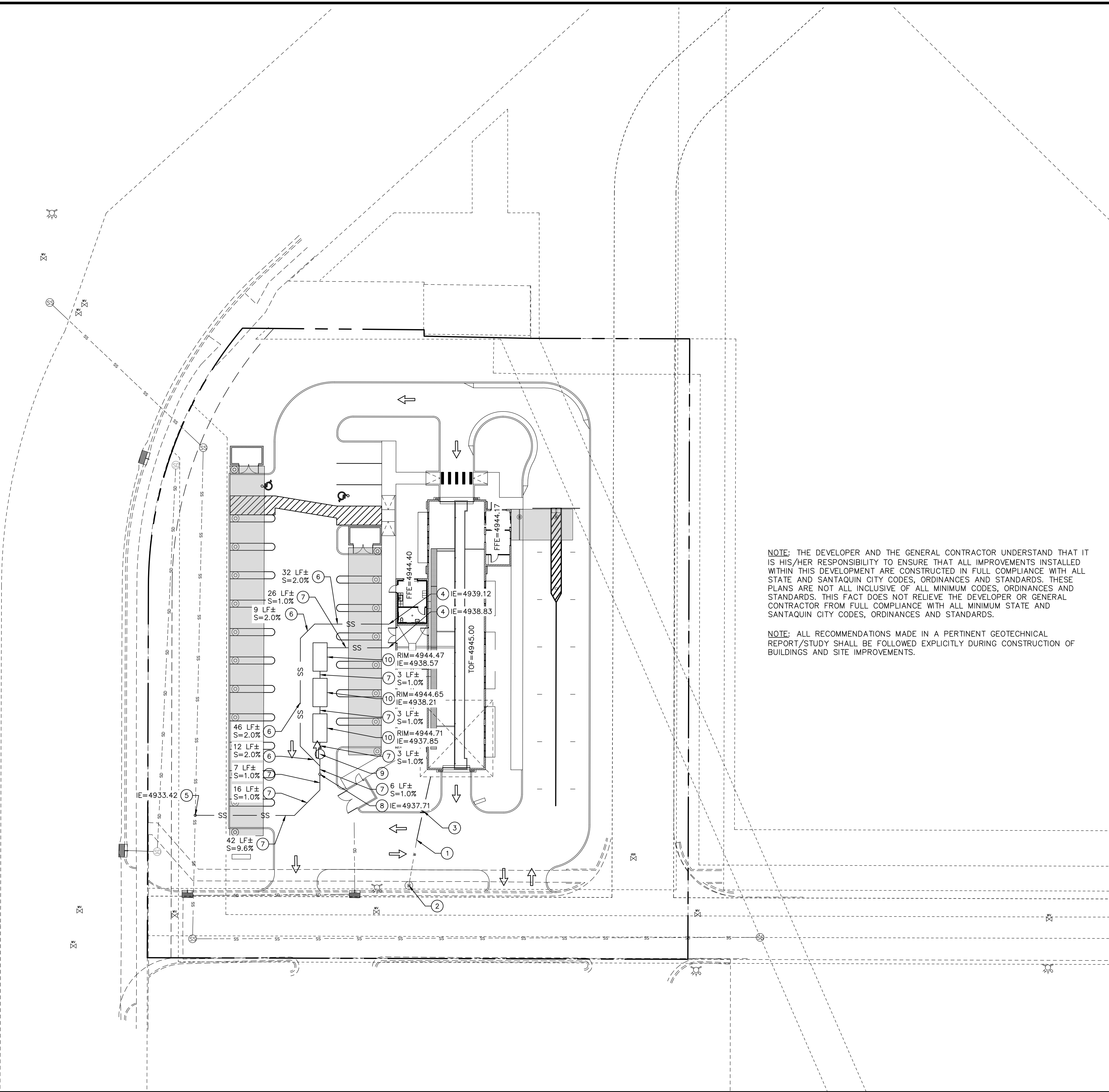

SCALE: 1" = 20'
 0 10 20 30 40 60

CALL BEFORE YOU DIG
 800 485 5711

NORTH

NO.	REVISIONS	BY	DATE

DESIGNER: JM
PROJECT ENGINEER: LP

ELEVATE ENGINEERING
2208 WEST 700 SOUTH
SPRINGVILLE, UT 84603
PHONE: (435) 731-5983
levateengineering.com

ELEVATE ENGINEERING
QUICK QUACK SANTAQUIN 500 EAST
STANDARD DETAILS
78 N 500 E, SANTAQUIN UT 84655

PROFESSIONAL ENGINEER
2/13/2024
10864737
LARVIN POLLOCK
STATE OF UTAH

SHEET: C-5
DATE: Feb 13, 2024

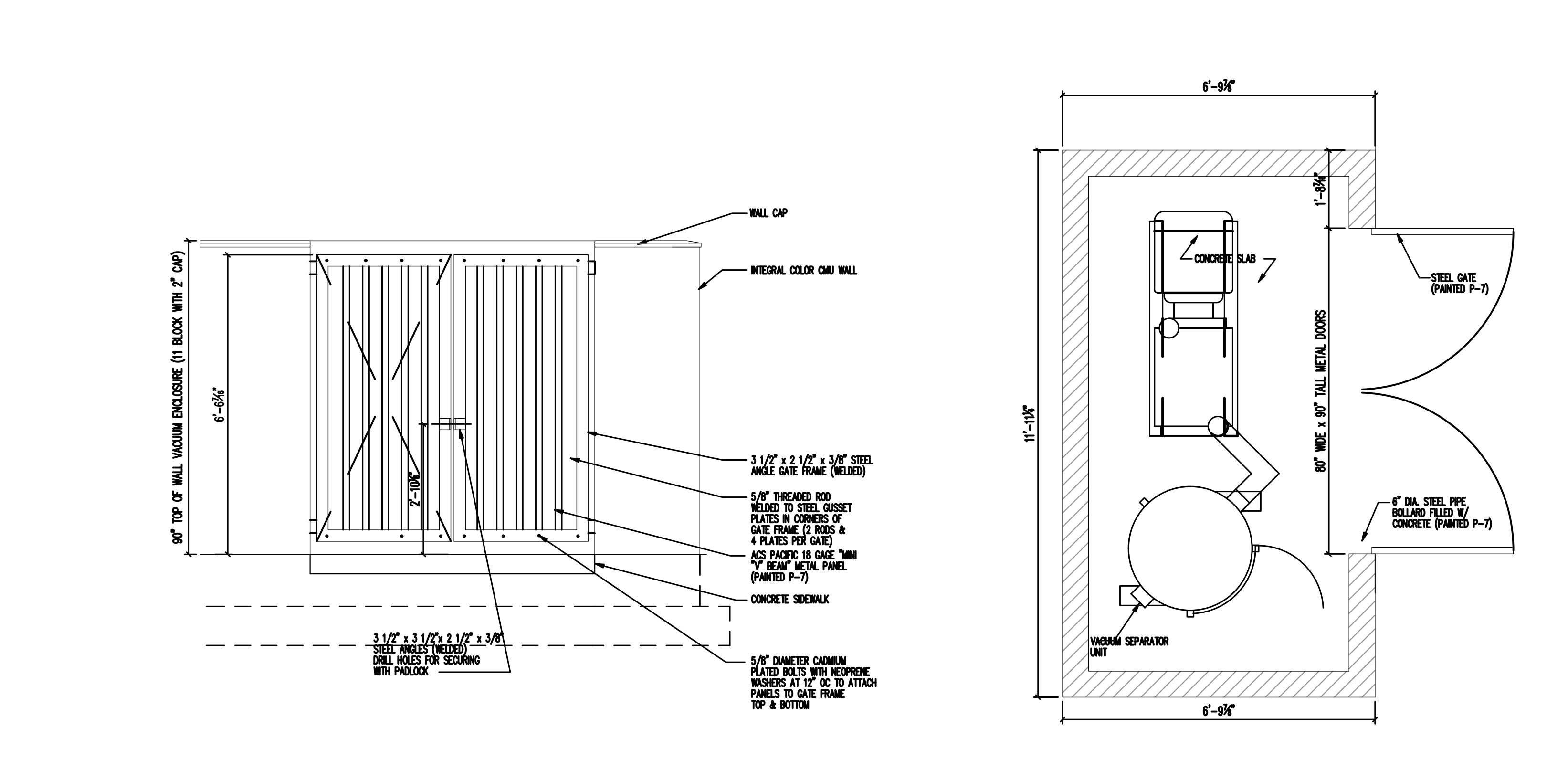
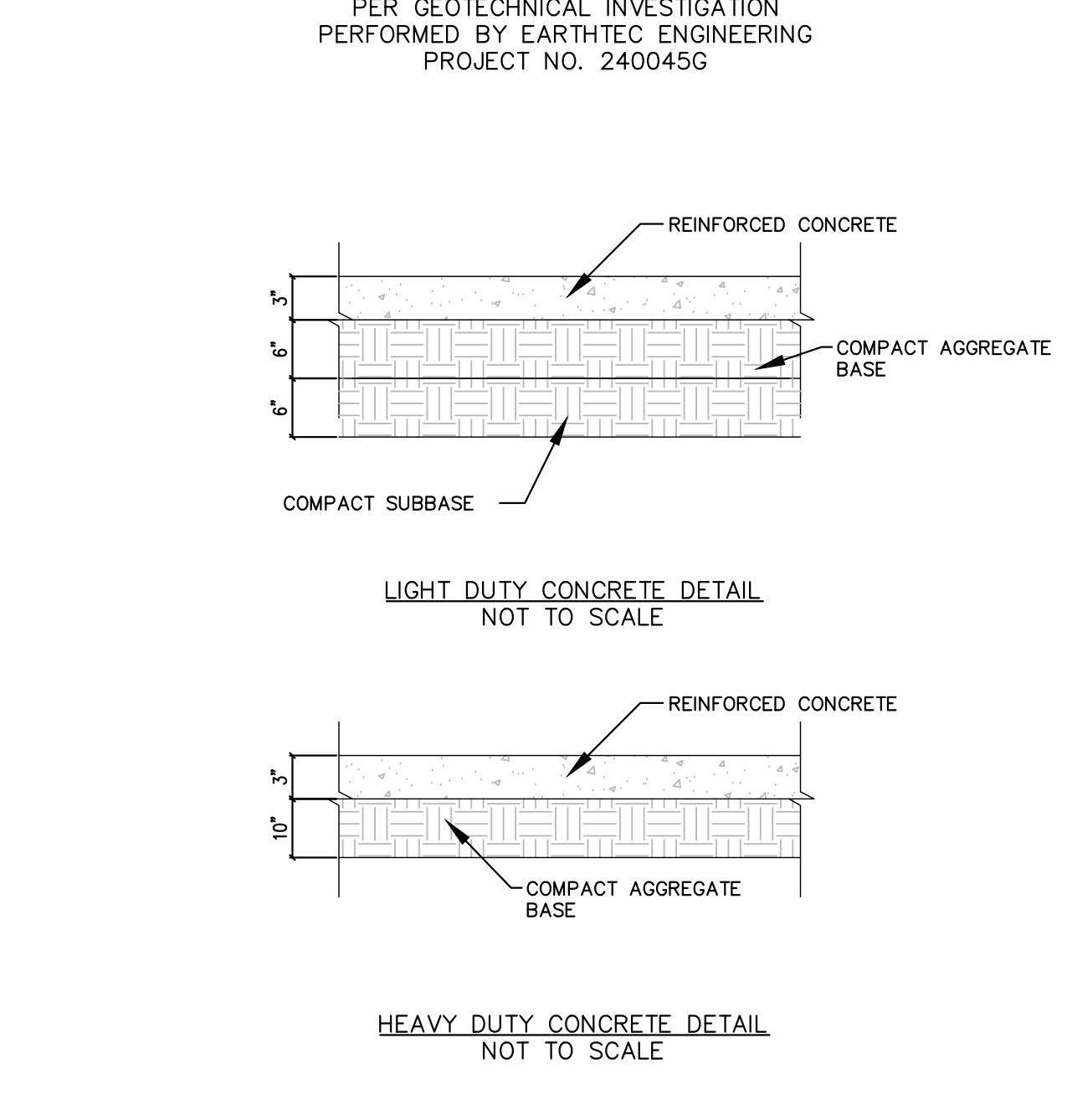
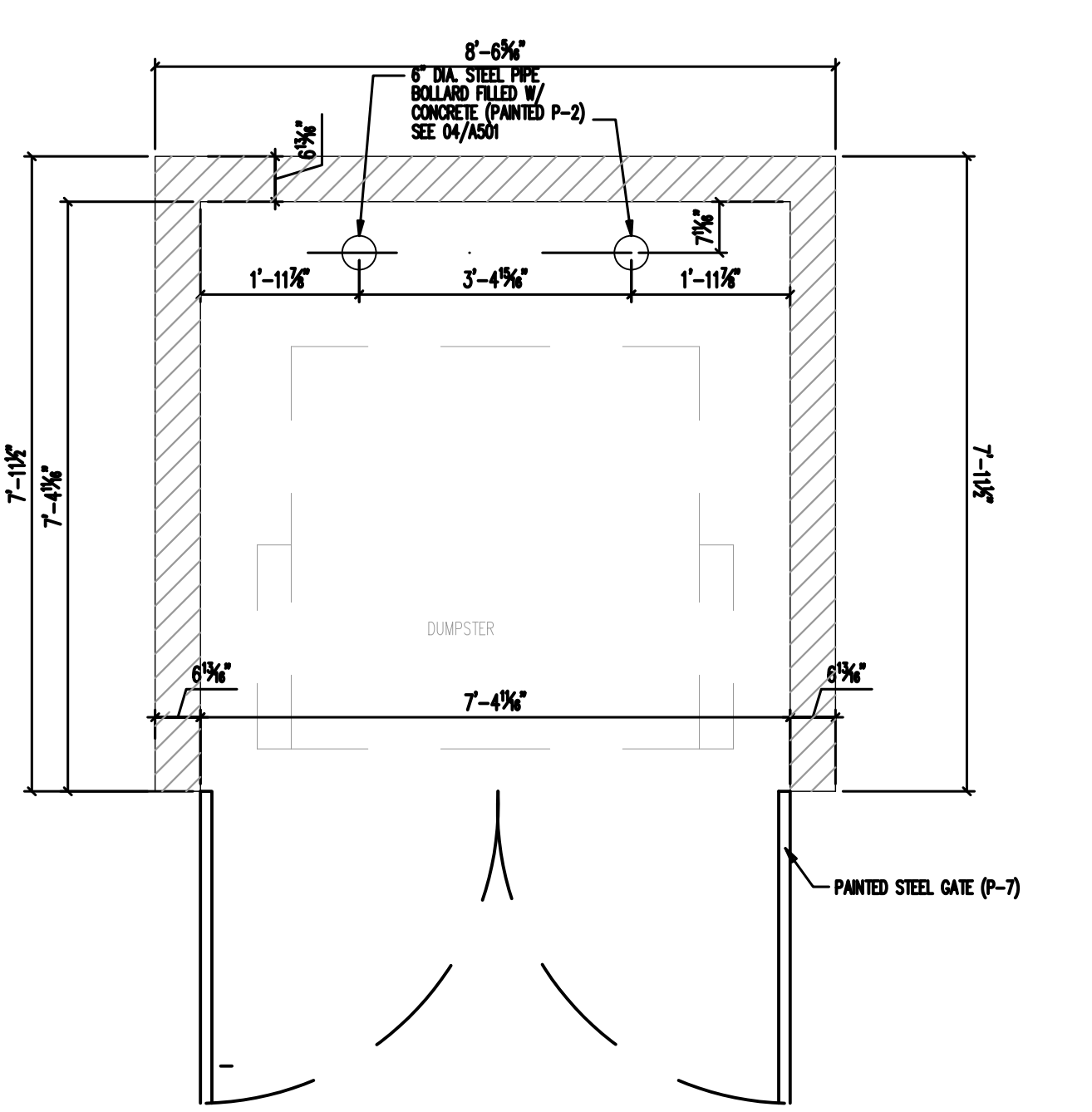
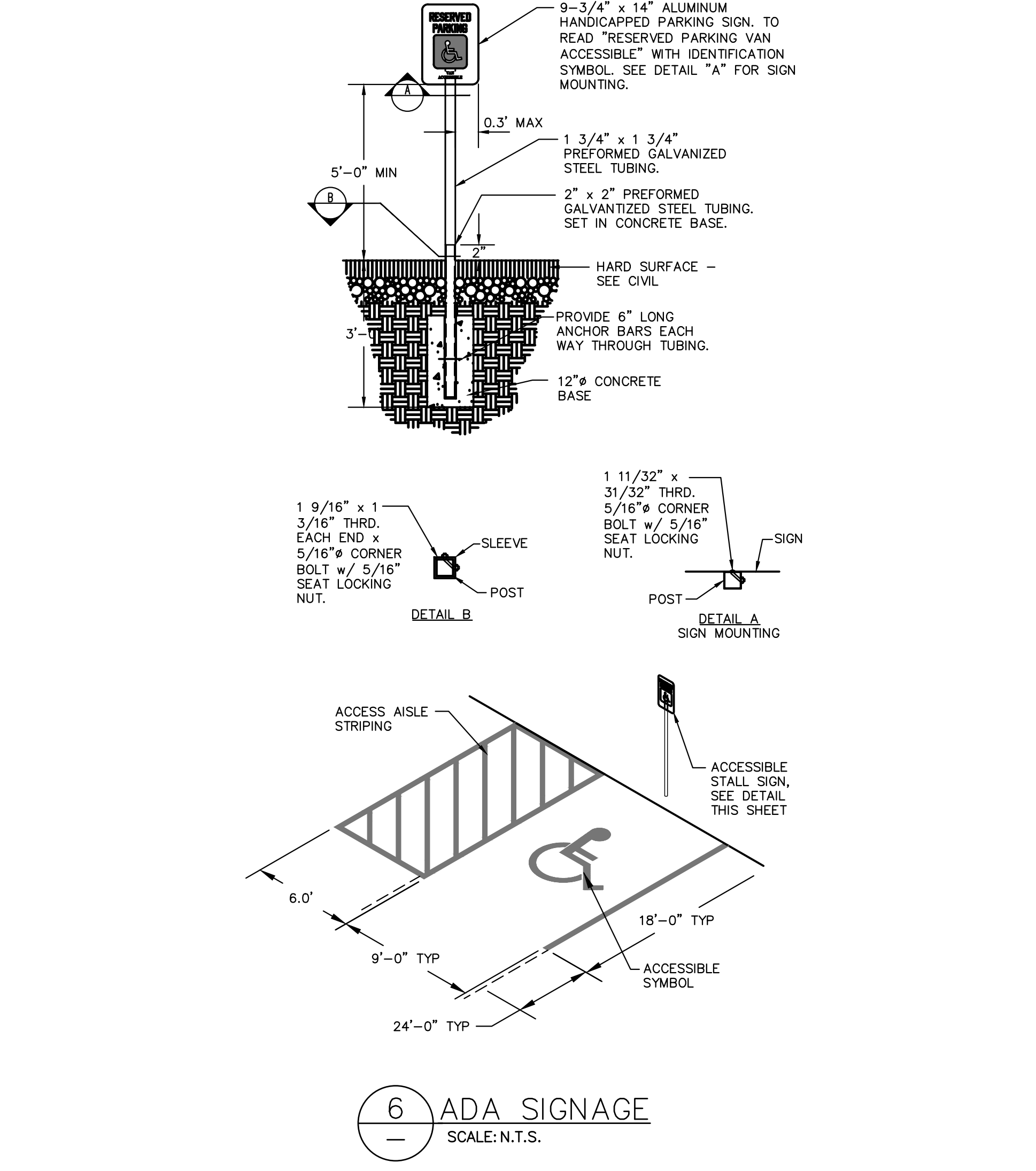
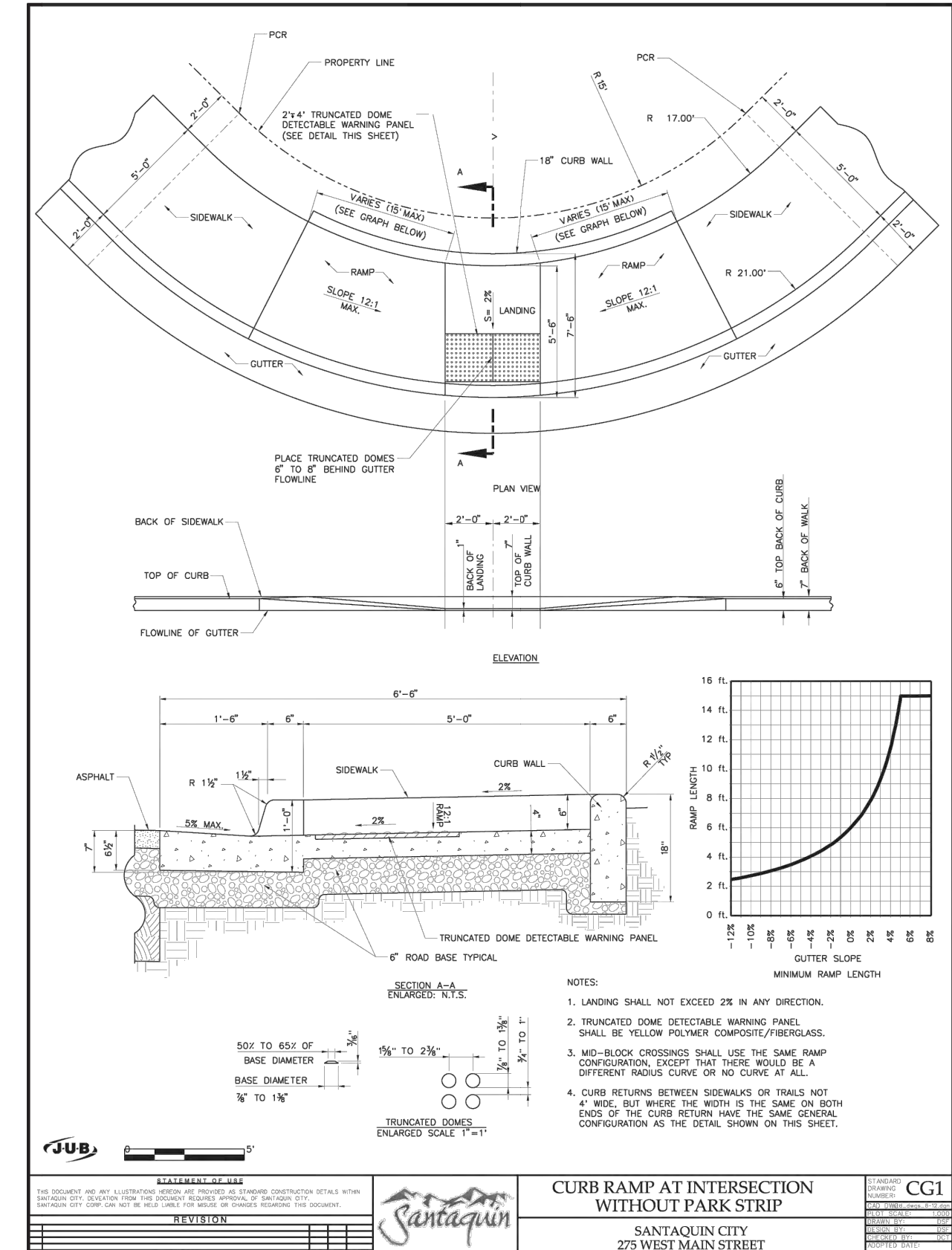
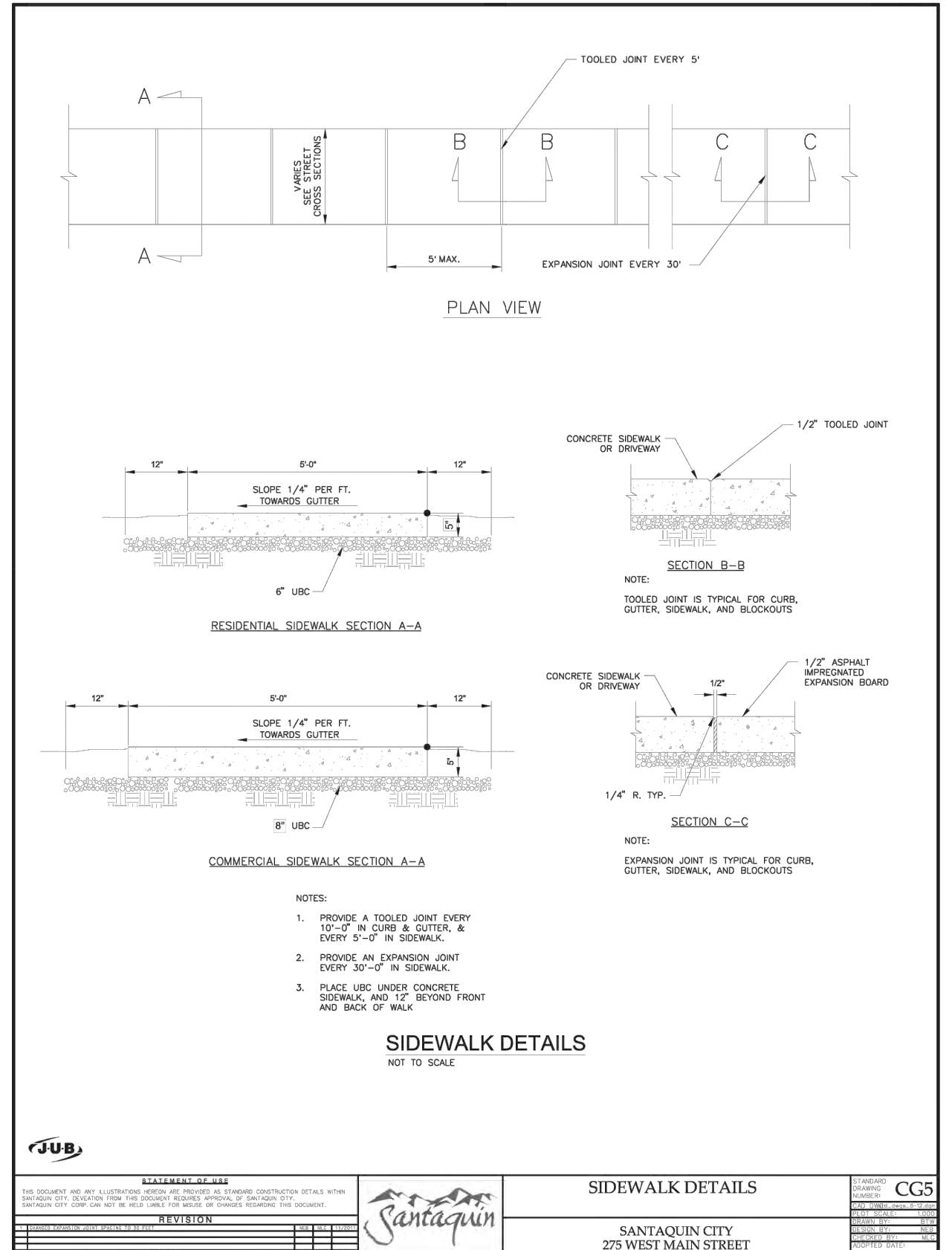
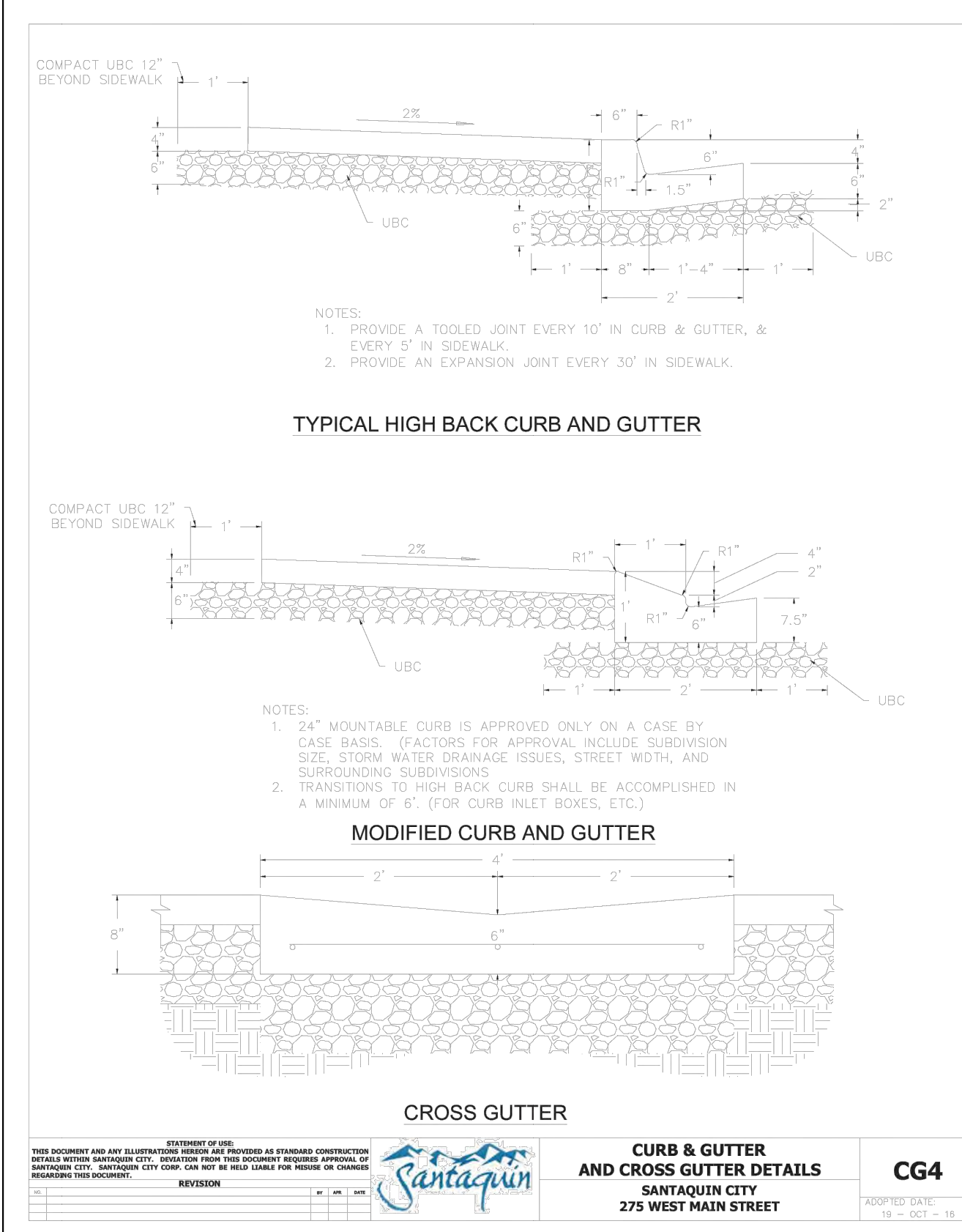

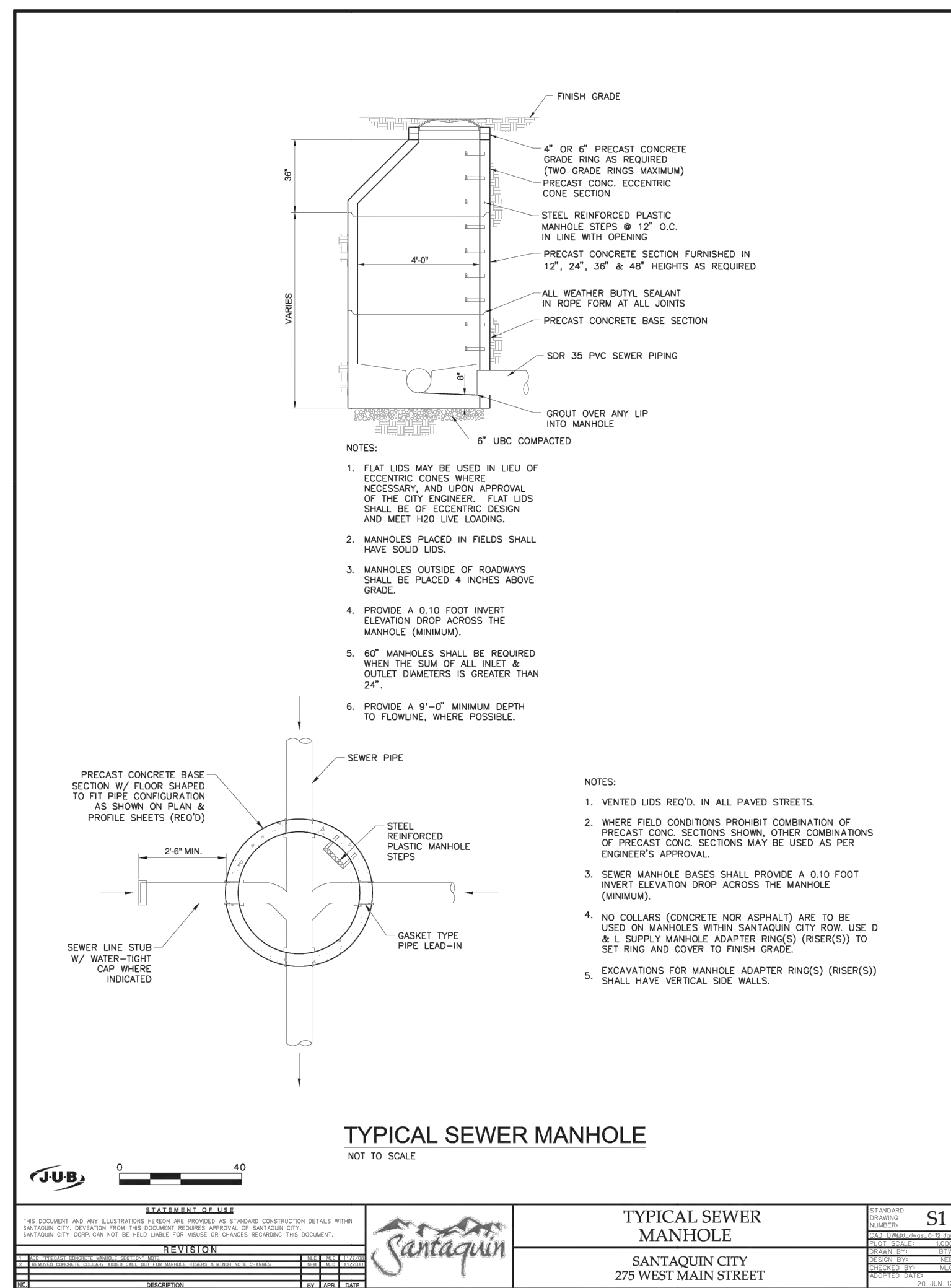

SANTAQUIN CITY 275 WEST MAIN STREET		S1
REVISION		
DATE		

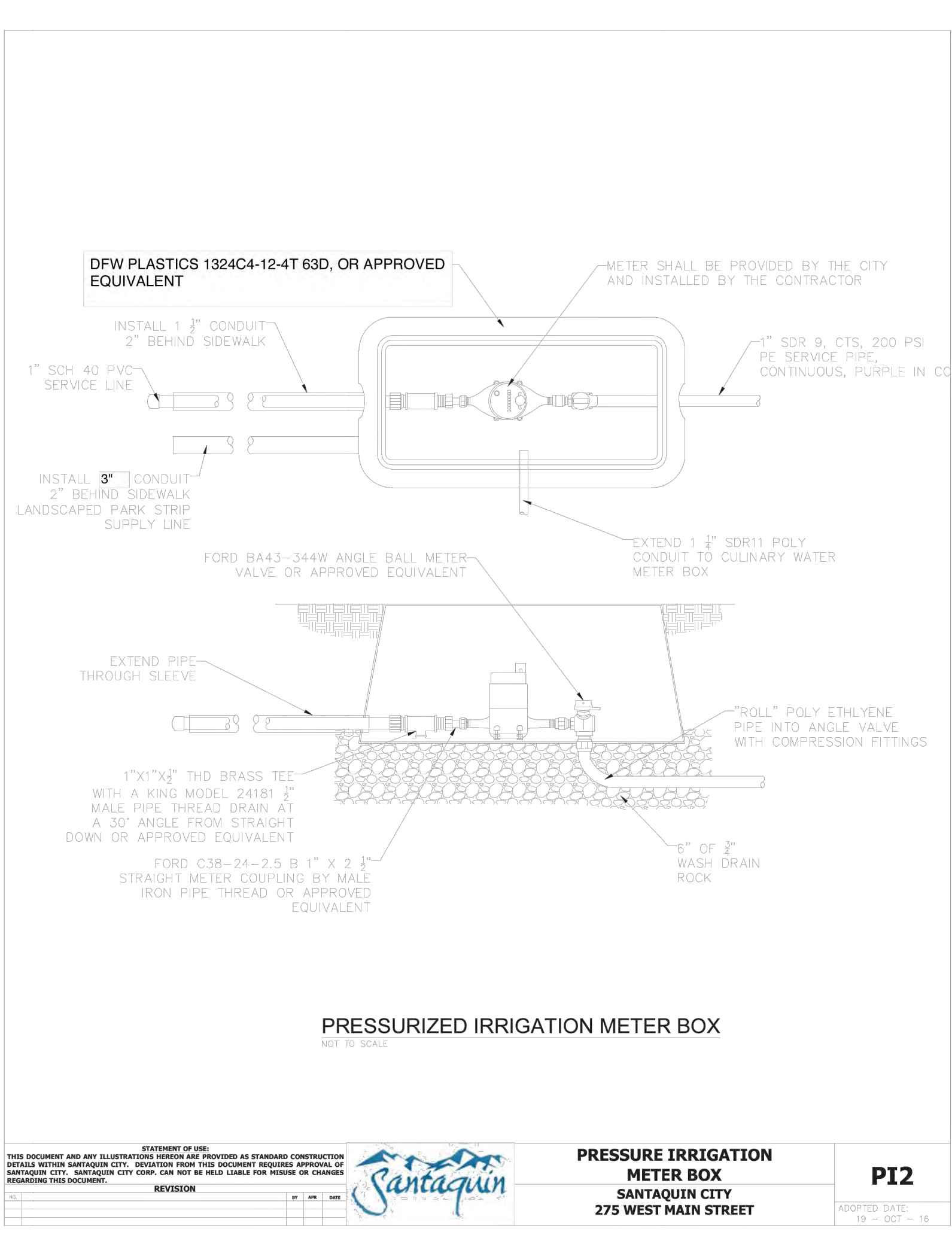

SANTAQUIN CITY 275 WEST MAIN STREET		PI2
REVISION		
DATE		

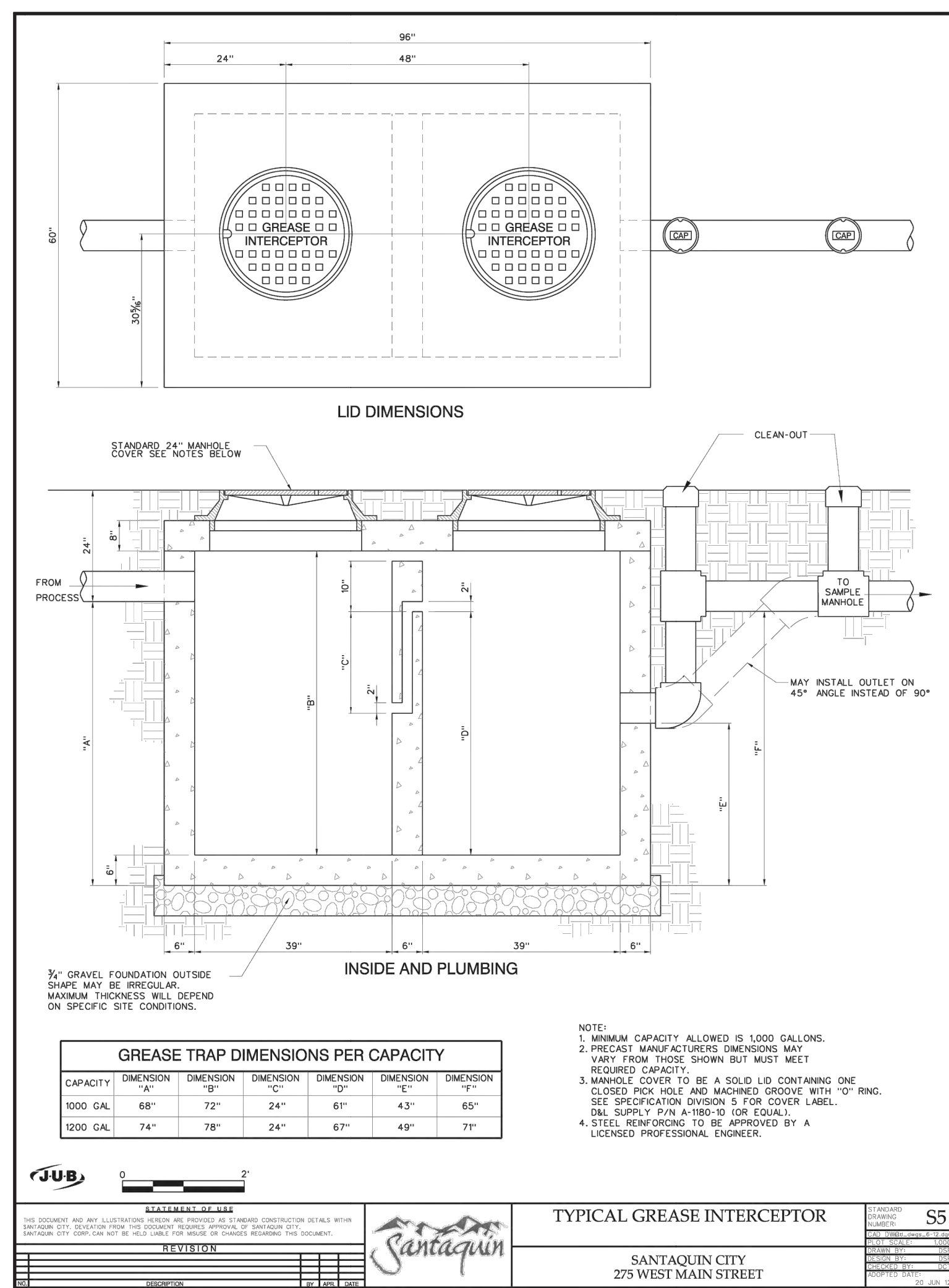

SANTAQUIN CITY 275 WEST MAIN STREET		S5
REVISION		
DATE		

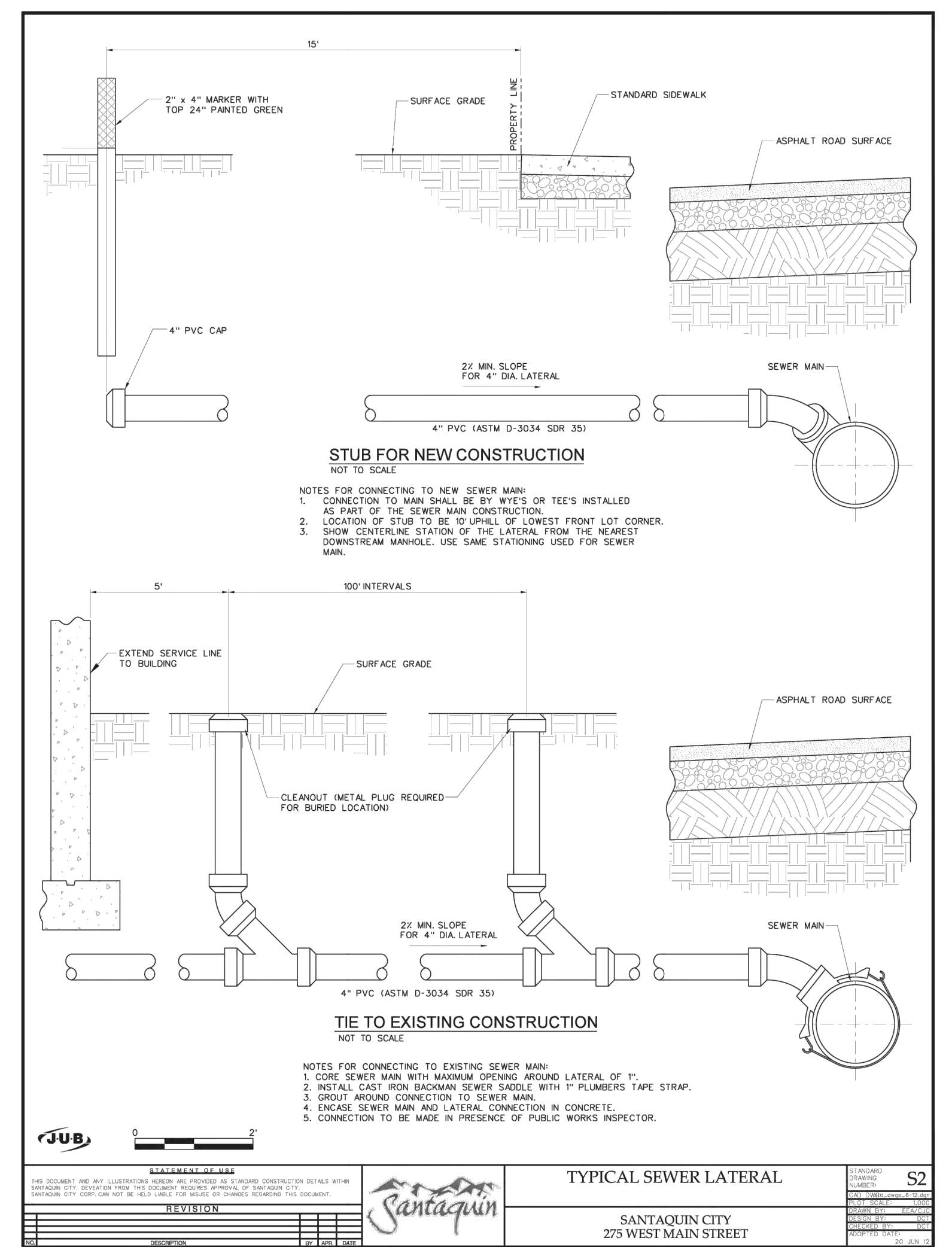

SANTAQUIN CITY 275 WEST MAIN STREET		S2
REVISION		
DATE		

NO.	REVISIONS	BY	DATE

ELEVATE ENGINEERING
2208 WEST 700 SOUTH
SPRINGVILLE, UT 84603
PHONE: 801-770-5985
lev@elevateeng.com

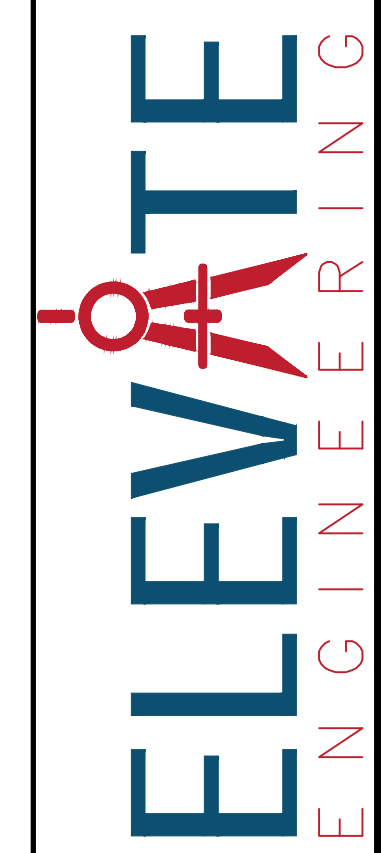

QUICK QUACK SANTAQUIN 500 EAST
UTILITY DETAILS
78 N 500 E, SANTAQUIN UT 84655

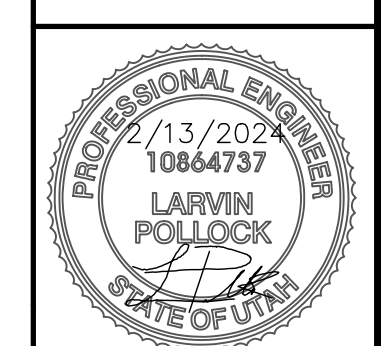

SHEET: C-6
DATE: Feb 13, 2024

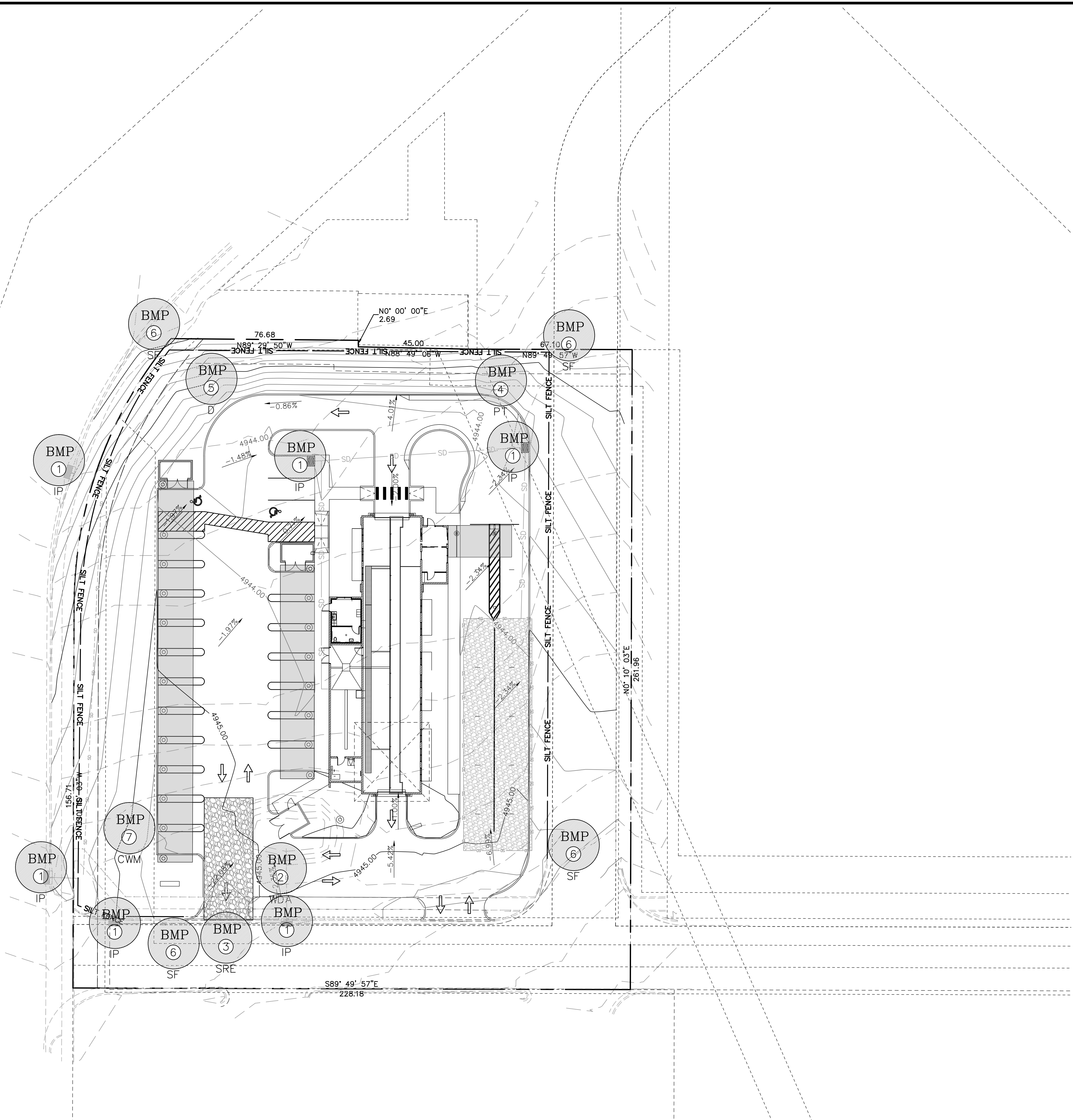

LEGEND

PROPERTY/ROW LINE	---
EXISTING CURB AND GUTTER	====
PROPOSED CURB AND GUTTER	=====
PROPOSED STORM DRAIN LINE	—SD—SD—SD—
EXISTING STORM DRAIN LINE	--SD--SD--SD--
EXISTING SEWER LINE	--SS--SS--SS--
EXISTING WATER LINE	--W--W--W--
EXISTING CONTOUR LINE	-(-2732)-
FINISHED CONTOUR LINE	-21.00-
EXISTING FENCE	-x-
SILT FENCE	-SILT FENCE-
CLEAN OUT BOX	□
BEST MANAGEMENT PRACTICE SEE BEST MANAGEMENT PRACTICE INDEX AND SHEET C-8 FOR DETAILS	

- NOTES**
- DURING CONSTRUCTION
- ALL EROSION CONTROL BEST MANAGEMENT PRACTICES SHALL BE INSPECTED AND MAINTAINED REGULARLY (ONCE A WEEK) AND AFTER EVERY STORM EVENT
 - LAND DISTURBANCE SHALL BE KEPT TO MINIMUM TO CONTROL RUNOFF FROM THE SITE
 - LIMIT LAND CLEARING AND RESTORE ALL GRADING AS SOON AS POSSIBLE
 - STAGED SEEDING TO RE-VEGETATE CUT AND FILL SLOPES AS THE WORK IS IN PROGRESS
 - AT ALL TIMES DURING CONSTRUCTION, THE CONTRACTOR SHALL BE RESPONSIBLE FOR PREVENTING AND CONTROLLING EROSION DUE TO WIND AND OTHER EROSION
 - MAINTENANCE OF STREET: STREETS TO BE KEPT CLEAN AND FREE FROM DEBRIS.
 - CONTRACTOR SHALL PROVIDE DUST CONTROL MEASURES AT ALL TIMES DURING CONSTRUCTION.
 - A COPY OF THE STORM WATER POLLUTION PREVENTION PLAN SHALL BE KEPT ON THE SITE DURING ALL CONSTRUCTION ACTIVITY

BEST MANAGEMENT PRACTICE INDEX

1	IP	INLET PROTECTION
2	WDA	EQUIPMENT AND VEHICLE WASH DOWN AREA
3	SRE	STABILIZED ROADWAY ENTRANCE
4	PT	PORTABLE TOILET
5	D	DUMPSTER LOCATION
6	SF	SILT FENCE
7	CWM	CONCRETE WASTE MANAGEMENT

ADDITIONAL BMP's TO BE ONSITE:

- SPILL CLEANUP
- VEHICLE & EQUIPMENT FUELING

SEE SHEET C-8 FOR BMP DETAILS

SCALE: 1" = 20'

<p>NO. _____</p> <p>REVISIONS _____</p> <p>BY _____</p> <p>DATE _____</p>	<p>PROJECT ENGINEER: LP</p> <p>DESIGNER: JM</p>
<p>ELEVATE ENGINEERING</p> <p>2208 WEST 700 SOUTH SPRINGVILLE, UT 84663 PHONE: (801) 748-5993 elevateeng.com</p>	
<p>QUICK QUACK SANTAQUIN 500 EAST</p> <p>SWPPP PLAN</p> <p>78 N 500 E, SANTAQUIN UT 84655</p>	
<p>PROFESSIONAL ENGINEER</p> <p>1/13/2024</p> <p>10864737</p> <p>LARVIN POLLOCK</p> <p>STATE OF UTAH</p>	
<p>SHEET: C-7</p> <p>DATE: Feb 13, 2024</p>	

NARRATIVE: THIS PLAN MAY BE USED FOR THE CONSTRUCTION OF A STORM WATER BEST MANAGEMENT PRACTICE (BMP). IT IS NOT INCLUSIVE OF ALL PRACTICES AVAILABLE AND IS ONLY SPECIFIC TO THE CONSTRUCTION OF THIS TYPE. MAINTENANCE OF THIS TYPE OF INSTALLATION IS IMPORTANT AND SHOULD BE CONTINUOUSLY MONITORED BY THE CONTRACTOR AND ENGINEER. DETAILS SHOWN HERE HIGHLIGHT IMPORTANT PARTS OF CONSTRUCTION, AND SHOULD BE MODIFIED AS NEEDED.

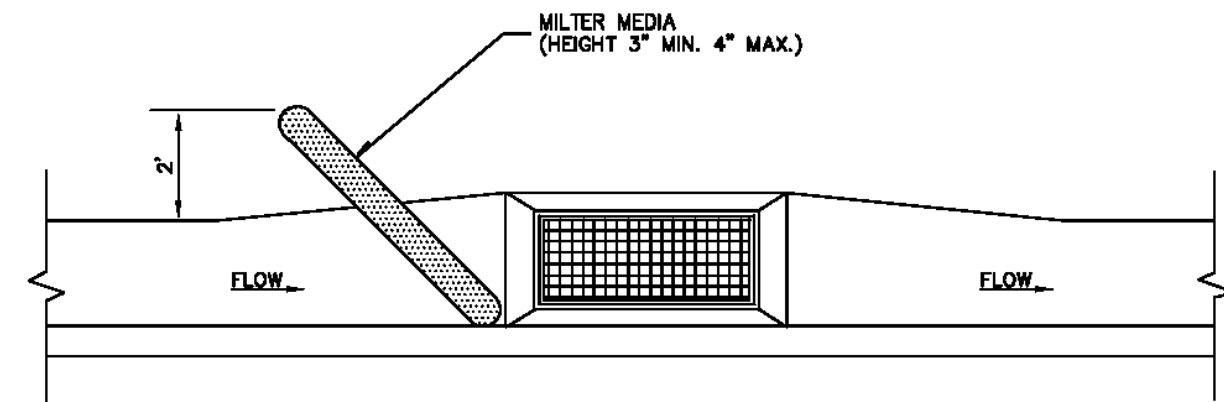

ON-GRADE INLET PROTECTION DETAIL

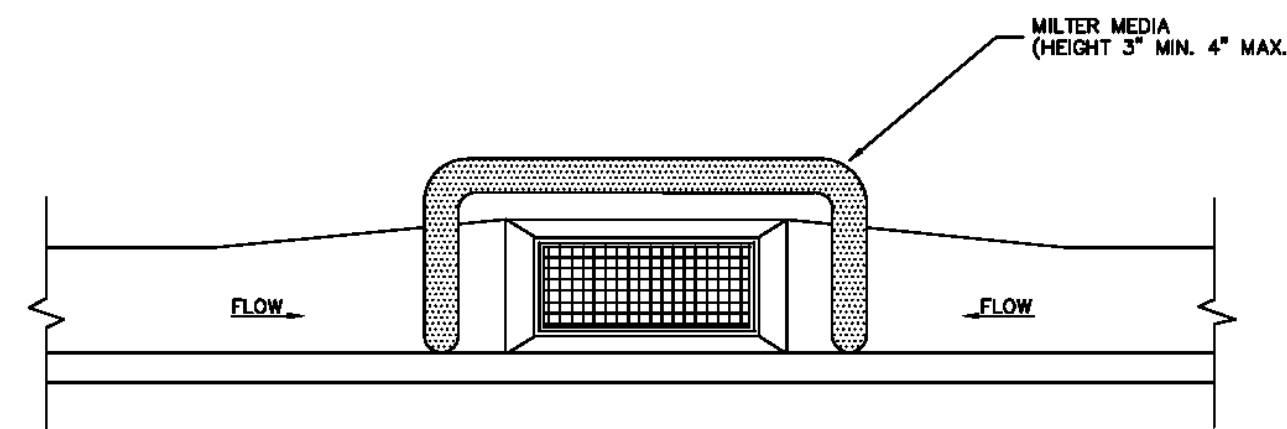

DROP INLET PROTECTION DETAIL

Inlet protection - gravel sock

Plan No. **124**

September 2006 11 Drawing 1 of 3

Inlet protection - gravel sock

1. DESCRIPTION: Placement of gravel sock on grade upstream of, or in front of storm drain inlets to filter or pond water runoff
2. APPLICATION: At inlets in paved or unpaved areas where up gradient area is to be disturbed by construction activities.
3. INSTALLATION/APPLICATION CRITERIA: Refer to APWA Section 01 57 00.
 - A. On-grade inlet protection:
 1. On-grade inlet protection should be used when completely blocking a storm drain inlet box would result in forcing water further downstream would cause flooding or other undesirable results.
 2. Prepare filter media (gravel sock, straw waddle, or other approved media) in accordance with manufacturer's recommendations.
 3. Install filter media just upstream of the inlet box.
 4. Filter media shall butt tightly against the face of the curb and angle at approximately a 45 degree angle away from the curb to trap runoff between the media and the curb.
 5. Excessive flows will flow either over or around the filter media and into the inlet box.
 6. Expect ponding behind the filter media.
 - B. Drop inlet protection:
 1. Drop inlet protection should be used at low points in the curb and when diverting flows further downstream will not cause undesirable results.
 2. Prepare filter media (gravel sock, straw waddle, or other approved media) in accordance with manufacturer's recommendations.
 3. Install filter media around the entire perimeter of the inlet grate.
 4. Filter media shall butt tightly against the face of the curb on both sides of the inlet grate.
 5. Excessive flows will either flow around the media or over the top and into the inlet box.
 6. Expect ponding around the inlet box.
4. MAINTENANCE:
 - A. Inspect inlet protection after every large storm event and at a minimum of once monthly.
 - B. Remove sediment accumulated when it reaches 2 inches in depth.
 - C. Replace filter medium when damage has occurred or when medium is no longer functioning as intended.

10

NARRATIVE: THIS PLAN MAY BE USED FOR THE CONSTRUCTION OF A STORM WATER BEST MANAGEMENT PRACTICE (BMP). IT IS NOT INCLUSIVE OF ALL PRACTICES AVAILABLE AND IS ONLY SPECIFIC TO THE CONSTRUCTION OF THIS TYPE. MAINTENANCE OF THIS TYPE OF INSTALLATION IS IMPORTANT AND SHOULD BE CONTINUOUSLY MONITORED BY THE CONTRACTOR AND ENGINEER. DETAILS SHOWN HERE HIGHLIGHT IMPORTANT PARTS OF CONSTRUCTION, AND SHOULD BE MODIFIED AS NEEDED.

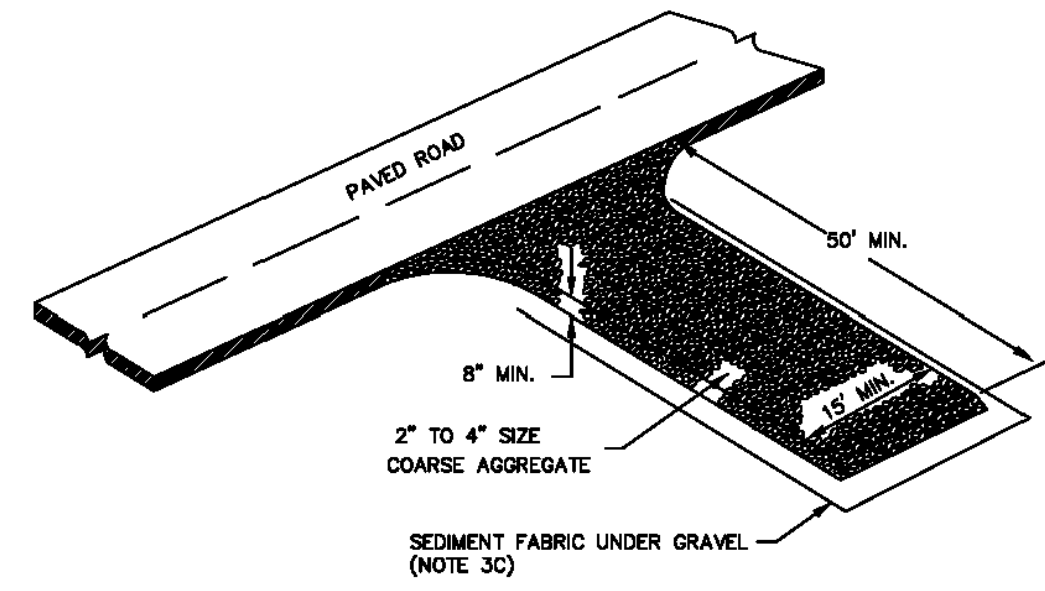

Stabilized roadway entrance

Plan No. **126**

February 2006 19

Stabilized roadway entrance

1. DESCRIPTION: A temporary stabilized pad of gravel for controlling equipment and construction vehicle access to the site.
2. APPLICATION: At any site where vehicles and equipment enter the public right of way.
3. INSTALLATION/APPLICATION CRITERIA: Refer to APWA Section 01 57 00.
 - A. Clear and grub area and grade to provide maximum slope of 1 percent away from paved roadway.
 - B. Compact subgrade.
 - C. Place filter fabric under stone if desired (recommended for entrance area that remains more than 3 months).
4. MAINTENANCE:
 - A. Requires periodic top dressing with additional stones.
 - B. Prevent tracking or flow of mud into the public right-of-way.
 - C. Periodic top dressing with 2 inches stone may be required, as conditions demand, and repair any structures used to trap sediments.
 - D. Inspect daily for loss of gravel or sediment buildup.
 - E. Inspect adjacent areas for sediment deposit and install additional controls as necessary.
 - F. Expand stabilized area as required to accommodate activities.

18

NARRATIVE: THIS PLAN MAY BE USED FOR THE CONSTRUCTION OF A STORM WATER BEST MANAGEMENT PRACTICE (BMP). IT IS NOT INCLUSIVE OF ALL PRACTICES AVAILABLE AND IS ONLY SPECIFIC TO THE CONSTRUCTION OF THIS TYPE. MAINTENANCE OF THIS TYPE OF INSTALLATION IS IMPORTANT AND SHOULD BE CONTINUOUSLY MONITORED BY THE CONTRACTOR AND ENGINEER. DETAILS SHOWN HERE HIGHLIGHT IMPORTANT PARTS OF CONSTRUCTION, AND SHOULD BE MODIFIED AS NEEDED.

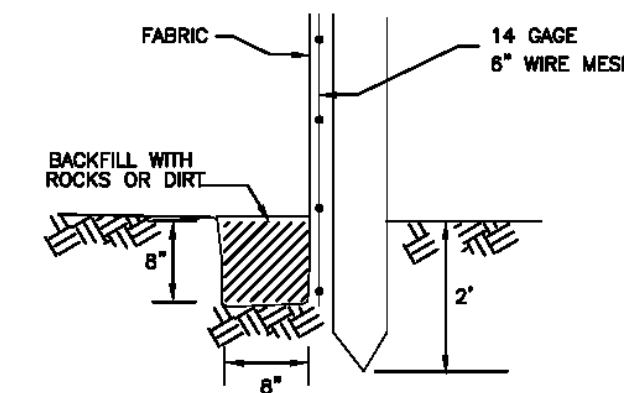
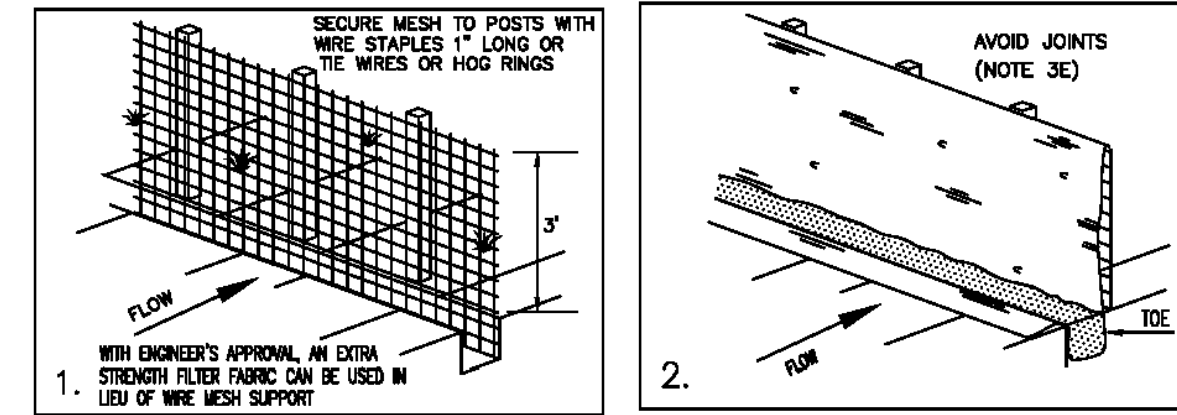

TOE DETAIL

Silt fence

Plan No. **122**

February 2006 7

Silt fence

1. DESCRIPTION: A temporary sediment barrier consisting of a filter fabric stretched across and attached to supporting posts and entrenched.
2. APPLICATION: To intercept sediment from disturbed areas of limited extent.
 - A. Perimeter Control: Place barrier at down gradient limits of disturbance.
 - B. Sediment Barrier: Place barrier at toe of slope or soil stockpile.
 - C. Protection of Existing Waterways: Place barrier at top of stream bank.
 - D. Inlet Protection.
3. INSTALLATION/APPLICATION CRITERIA: Refer to APWA Section 01 57 00.
 - A. Synthetic filter fabric shall be a pervious sheet of propylene, nylon, polyester, or polyethylene yarn. Synthetic filter fabric shall contain ultraviolet ray inhibitors and stabilizers to provide a minimum of 6 months of expected usable construction life at a temperature range of 0 deg. F. to 120 deg. F.
 - B. Burlap shall be 10 ounces per square yard of fabric.
 - C. Posts for silt fences shall be either 2" x 4" diameter wood, or 1.33 pounds per linear foot steel with a minimum length of 5 feet. Steel posts shall have projections for fastening wire to them.
 - D. The fabric is cut on site to desired width, unrolled, and draped over the barrier. The fabric toe is secured with rocks or dirt. The fabric is secured to the mesh with twin, staples or similar devices.
 - E. When attaching two silt fences together, place the end post of the second fence inside the end post of the first fence. Rotate both posts at least 180 degrees on a clockwise direction to create a tight seal with the filter fabric. Drive both posts into the ground and bury the flap.
 - F. When used to control sediments from a steep slope, silt fences should be placed away from the toe of the slope for increased holding capacity.
4. MAINTENANCE:
 - A. Inspected immediately after each rainfall and at least daily during prolonged rainfall.
 - B. Should the fabric on a silt fence or filter barrier decompose or become ineffective before the end of the expected usable life and the barrier still be necessary, the fabric shall be replaced promptly.
 - C. Sediment deposits should be removed after each storm event. They must be removed when deposits reach approximately one-half the height of the barrier.
 - D. Re-anchor fence as necessary to prevent shortcutting.
 - E. Inspect for runoff bypassing ends of barriers or undercutting barriers.

6

NARRATIVE: THIS PLAN MAY BE USED FOR THE CONSTRUCTION OF A STORM WATER BEST MANAGEMENT PRACTICE (BMP). IT IS NOT INCLUSIVE OF ALL PRACTICES AVAILABLE AND IS ONLY SPECIFIC TO THE CONSTRUCTION OF THIS TYPE. MAINTENANCE OF THIS TYPE OF INSTALLATION IS IMPORTANT AND SHOULD BE CONTINUOUSLY MONITORED BY THE CONTRACTOR AND ENGINEER. DETAILS SHOWN HERE HIGHLIGHT IMPORTANT PARTS OF CONSTRUCTION, AND SHOULD BE MODIFIED AS NEEDED.

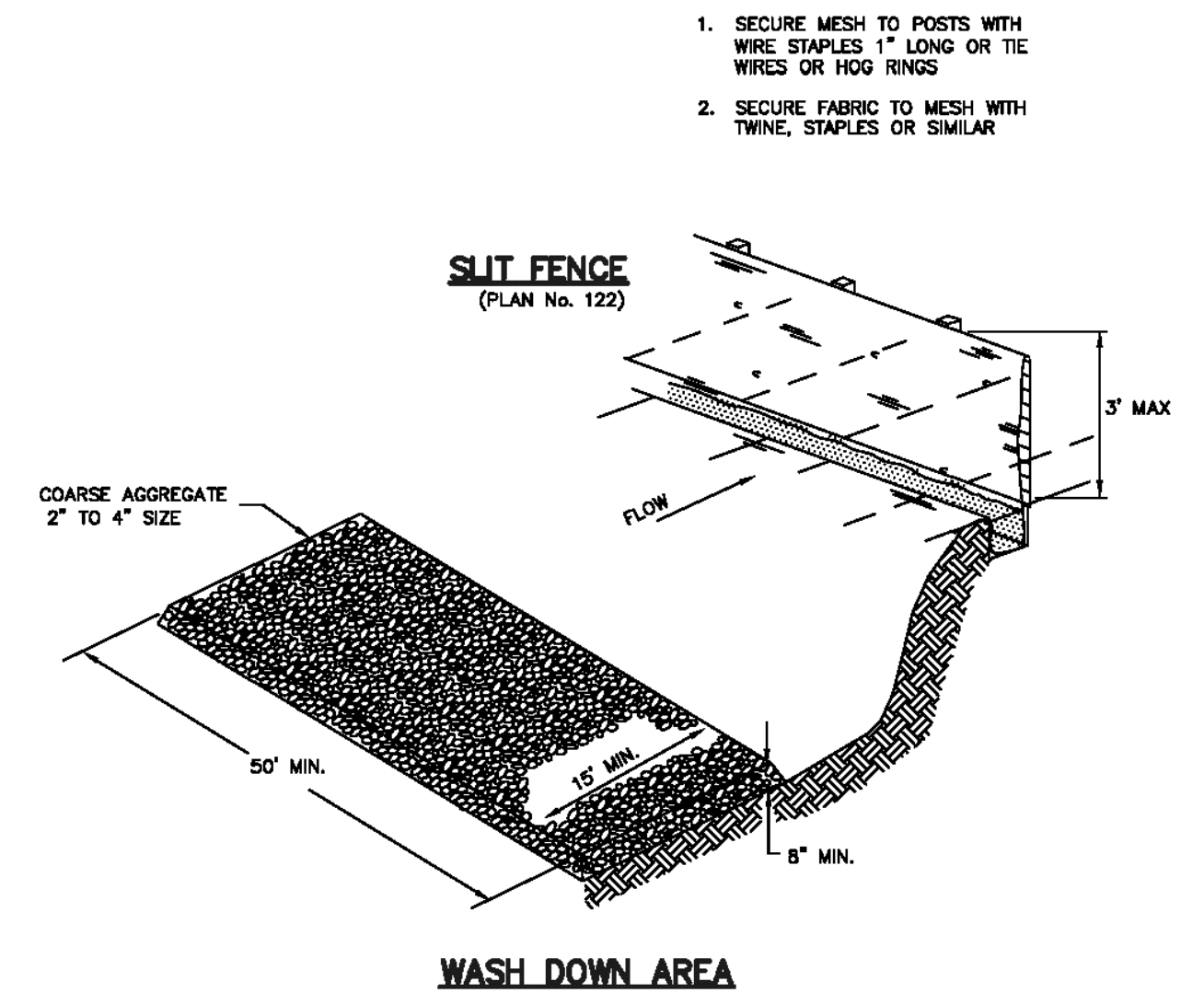

Equipment and vehicle wash down area

Plan No. **125**

February 2006 17

Equipment and vehicle wash down area

1. DESCRIPTION: A temporary stabilized pad of gravel for general washing of equipment and construction vehicles.
2. APPLICATION: At any site where regular washing of vehicles and equipment will occur. May also be used as a filling point for water trucks limiting erosion caused by overflow or spillage of water.
3. INSTALLATION/APPLICATION CRITERIA: Refer to APWA Section 01 57 00.
 - A. Clear and grub area and grade to provide maximum slope of 1 percent away from paved roadway.
 - B. Compact subgrade.
 - C. Place filter fabric under wash down area if desired (recommended for wash area that remains more than 3 months).
 - D. Install silt fence down gradient (see Plan No. 122)
4. MAINTENANCE:
 - A. Requires periodic top dressing with additional stones.
 - B. Solely used to control sediment in wash water. Cannot be utilized for washing equipment or vehicles that may cause contamination of runoff (such as fertilizer equipment or concrete equipment).
 - C. The wash area shall be maintained in a condition that will prevent tracking or flow of mud onto public rights-of-way.
 - D. Periodic top dressing with 2 inch stone may be required, as conditions demand, and repair any structures used to trap sediments.
 - E. Inspect daily for loss of gravel or sediment buildup.
 - F. Inspect adjacent area for sediment deposit and install additional controls as necessary.
 - G. Expand stabilized area as required to accommodate activities.
 - H. Maintain silt fence as outlined in Plan No. 122.

16

NO.	REVISIONS	BY	DATE

ELEVATE ENGINEERING
2208 WEST 700 SOUTH
SPRINGVILLE, UT 84663
PHONE: (801) 718-5993
larvin@elevateeng.com

ELEVATE
ENGINEERING

QUICK QUACK SANTAQUIN 500 EAST
SWPPP DETAILS
78 N 500 E, SANTAQUIN UT 84655

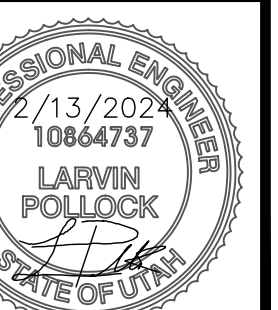

SHEET:
C-8
DATE:
Feb 13, 2024

Plant List (TREES)

Quan.	Symbol	Botanical Name	Common Name	Size	Remarks
3		<i>Crataegus crus-galli</i>	Cockspur Hawthorn	2" Caliper 8'-10" Height	Full Head Crown Straight Trunk
3		<i>Koeleruteria p.</i> 'Golden Candle'	Golden Rain Tree	2" Caliper 8'-10" Height	Full Head Crown Straight Trunk
1		<i>Pinus leucodermis heidreichii</i>	Dwarf Boenian Pine	6'-8" Height B & B	Full Throughout Specimen
2		<i>Syringa reticulata</i> 'Ivory Silk'	Japanese Tree Lilac	2" Caliper 8'-10" Height	Full Head Crown Straight Trunk
8		<i>Zelcova serrata</i> 'Musashino'	Musashino Zelcova	2" Caliper 10'-12" Height	Full Head Crown Straight Trunk

Plant List (SHRUBS)

Quan.	Symbol	Botanical Name	Common Name	Size	Remarks
9		<i>Berberis thund.</i> 'Crimson Pygmy'	Crimson Pygmy Barberry	5 Gallon	15"-18" Height
9		<i>Ligustrum x. vicaryi</i>	Golden Privet	5 Gallon	18"-24" Height
1		<i>Physocarpus o.</i> 'Summer Wine'	Summer Wine Ninebark	5 Gallon	24"-30" Height
13		<i>Prunus besseyi</i> 'Paunese Buttes'	Paunese Buttes Sandcherry	5 Gallon	18"-24" Spread
6		<i>Rhus typhina</i> 'Baltiger'	Tiger Eye's Sumac	5 Gallon	24"-30" Height
11		<i>Rosa</i> 'Knock Out Red'	Knock Out Red Rose	5 Gallon	18"-24" Height
2		<i>Spiraea bumalda</i> 'Goldmound'	Goldmound Spiraea	5 Gallon	15"-18" Height
18		<i>Spiraea japonica</i> 'Neon Flash'	Neon Flash Spiraea	5 Gallon	15"-18" Height
3		<i>Syringa vulgaris</i>	Common Lilac	5 Gallon	24"-30" Height
6		<i>Yucca filam.</i> 'Golden Sword'	Golden Sword Yucca	5 Gallon	15"-18" Height

Plant List (ORNAMENTAL GRASSES)

Quan.	Symbol	Botanical Name	Common Name	Size	Remarks
12		<i>Calamagrostis a.</i> 'Avalanche'	Avalanche Feather Grass	5 Gallon	18"-24" Height
12		<i>Calamagrostis a.</i> 'Foerster'	Foerster Feather Grass	5 Gallon	18"-24" Height
2		<i>Miscanthus sinensis</i> 'Gracillimus'	Maiden Grass	5 Gallon	24"-30" Height
28		<i>Pennisetum alopec.</i> 'Hamein'	Hamein Fountain Grass	5 Gallon	15"-18" Height

Plant List (PERENNIALS)

Quan.	Symbol	Botanical Name	Common Name	Size	Remarks
12		<i>Hemerocallis</i> 'Stella d'Oro'	Stella d'Oro Day Lily	1 Gallon	Full Can
30		<i>Lavandula</i> 'Hidcote Blue'	Blue Lavender	1 Gallon	Full Can
40		<i>Salvia</i> 'East Friesland'	East Friesland Sage	1 Gallon	Full Can

Planting Notes

- All lawn and shrub areas shall receive a 4 inch depth of topsoil. If topsoil is not available at the site, it must be imported from an approved local source. All topsoil shall be of a sandy loam consistency. Provide a chemical analysis of all topsoil for approval.
- Prior to placement of topsoil, all subgrade areas shall be loosened by scarifying the soil to a depth of 6 inches, by the use of mechanical means, in order to create a transition layer between existing and new soils.
- All plant material holes shall be dug twice the diameter of the rootball and 6 inches deeper. Excavated material shall be removed from the site.
- Plant backfill mixture shall be composed of 3 parts topsoil to 1 part humus additive (Soil Pep/or equal), and shall be rotary mixed on-site prior to installation.
- Plant fertilizer shall be 'Agriform' brand 21 gram tablets used as per manufacturers recommendations.
- Upon completion of planting operations, all shrub pits and tree wells shall receive a 4 inch depth of shredded bark mulch to cover. The overall shrub beds themselves (beyond plant wells) shall receive a 4" depth of decorative stone surfacing over Pro-5 weed barrier fabric.
- In decorative stone beds, cut the fabric from around the water well of each plant, then apply fine ground bark inside water well. The remainder of the planter bed shall receive the depth of decorative stone.
- Landscape maintenance shall be required for a period through the second mowing of the lawn (if used) and shall include weeding, pruning and one fertilization.
- The contractor shall comply with all warranties and guarantees set forth by the Owner, and in no case shall that period be less than two years following the date of completion and final acceptance.

General Notes

- All bidding landscape contractors shall have a minimum of 5 years experience in the installation of commercial landscape and irrigation projects, and be able to supply the necessary staff to perform all tasks associated with these drawings, and in a professional and timely manner.
- The landscape contractor, at all times, shall have personnel on-site experienced in being able to interpret the drawings correctly, and accurately measure the design layout using the specified scale.
- The contractor shall verify the exact location of all existing and proposed utilities, and all site conditions prior to beginning work. The contractor shall coordinate his work with the project manager and all other contractors working on the site.
- The finish grade of all planting areas shall be smooth, even and consistent, free of any humps, depressions or other grading irregularities. The finish grade of all landscape areas shall be graded consistently 1/2" below all walks, curbs, etc.
- The contractor shall provide all materials, labor and equipment required for the proper completion of all landscape work as specified and shown on the drawings.
- All plant materials shall be approved prior to planting. The Owner/Landscape Architect has the right to reject any and all plant material not conforming to the specifications.
- The contractor shall plant all plants per the planting details, stakes/guy as shown. The top of the rootballs shall be planted flush with the finish grade.

Sub-Grade Requirements

- LAWN AREAS:** Six (6) inches below finish grade. This will allow for the installation of a four inch depth of topsoil, along with the sodding material, leaving it slightly below finish grade.
- SHRUB AREAS:** Eight (8) inches below finish grade. This will allow for the installation of a four inch depth of topsoil, along with a four inch depth of bark mulch or decorative stone, leaving it slightly below finish grade and concrete areas.
- ROCK ONLY AREAS:** Seven (7) inches below finish grade. This will allow for the installation of a six inch depth of decorative stone over the weed barrier fabric, leaving it slightly below finish grade and concrete areas.
- SUB-GRADE COORDINATION:** The Landscape contractor shall meet early on in the construction process with the site grading contractor, in order to ensure that all sub-grades, prior to final topsoil placement, are provided. Any discrepancies or questions shall be discussed and resolved at that time. Landscape operations shall not begin until the specified sub-grade elevations have been provided.

Legend

Symbol	Description	Remarks
	Landscape Boulder / 3'-4' Min. Size / Individually Placed	Boulder Type And Color Shall Be From Nearest Local Source, Blonde-Tan Colored Quartzite, Block Edges (Not Rounded).
	4" x 6" Extruded Concrete Mowstrip / Natural Color	Install In Straight True Lines And Uniform Curves, 4 Between All Lawn And Shrub Areas. Compact Sub-grade To 90% Prior To Installation.
	New Lawn Area / Water Conservative Mixture	Install In Areas Shown Over A 4 Inch Depth Of Import Topsoil. Top Of Lawn To Be 1 Inch Below Finish Grade Of Concrete Surfaces.
	Rock ONLY Area / Cobble / 4" Minus Size / "Nepht Gray"	Install In Areas Shown To A Depth Of 6 Inches Over "Dewitt" Brand Weed Barrier Fabric. Provide Pre-emergent Herbicide Application.
	New Shrub - Rock Area / 2" Min. Size / Grayish Color	Install In Areas Shown To A Depth Of 4 Inches Over "Dewitt" Brand Weed Barrier Fabric. Provide Pre-emergent Herbicide Application.
	New Shrub - Rock Area / 1" Min. Size / Earthtone Color	Install In Areas Shown To A Depth Of 4 Inches Over "Dewitt" Brand Weed Barrier Fabric. Provide Pre-emergent Herbicide Application.

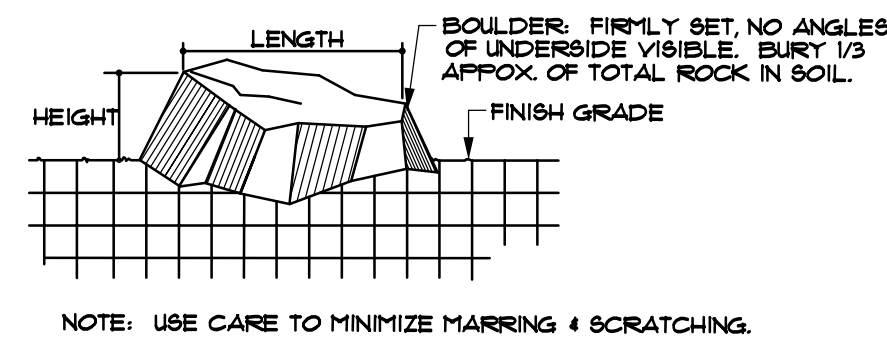

1 Decorative Boulder
L-1 N.T.S.

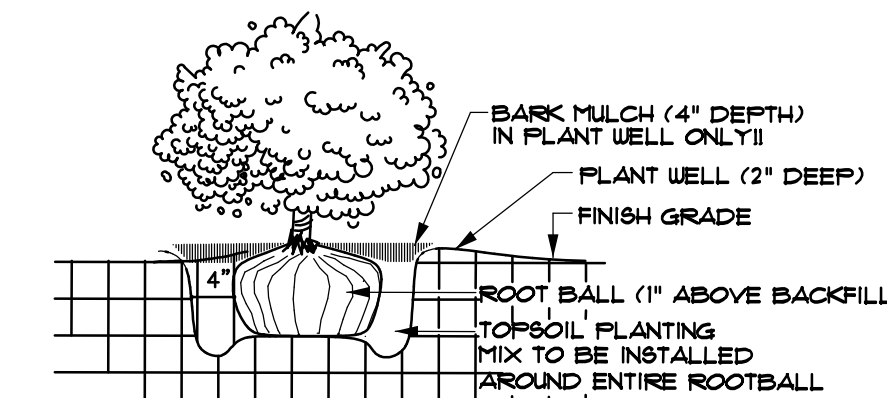

2 Shrub Planting
L-1 N.T.S.

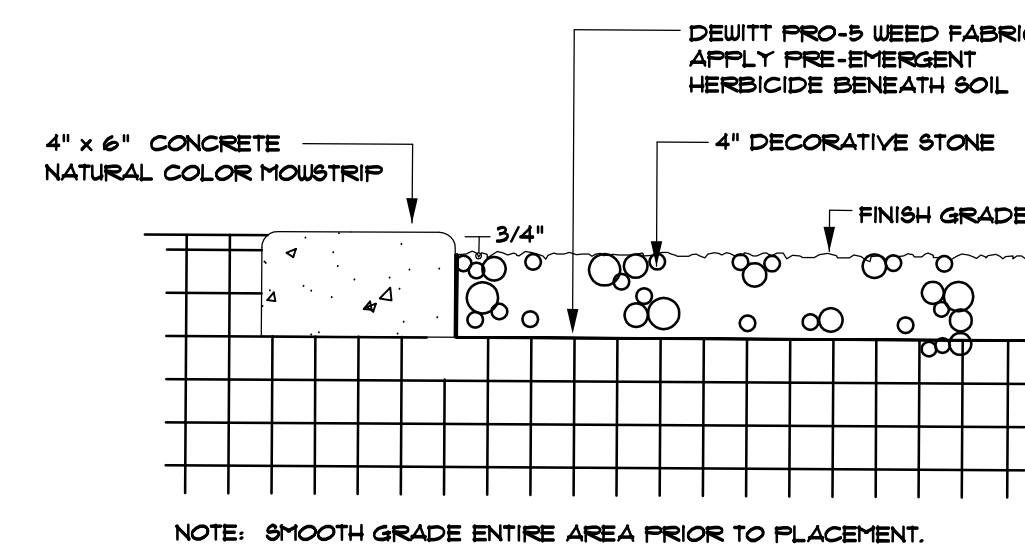

3 Mowstrip - Stone Mulch
L-1 N.T.S.

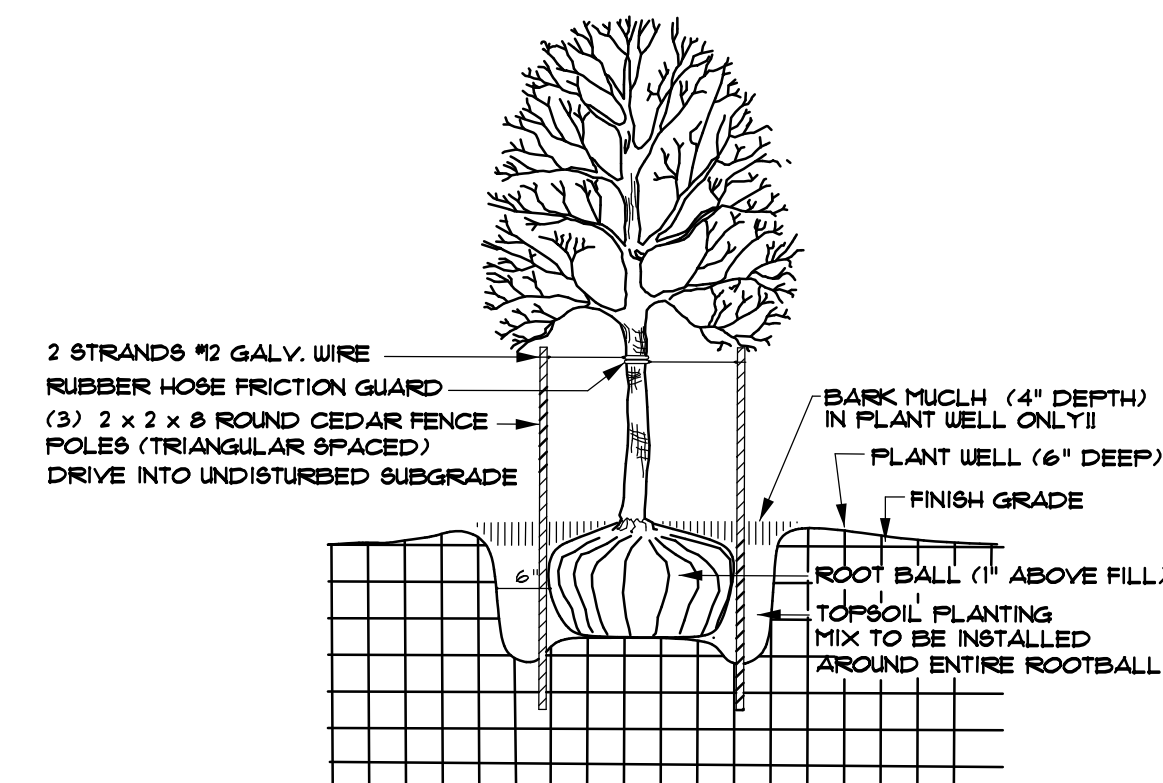

4 Tree Planting
L-1 N.T.S.



Scale In Feet: 1/16"=1'-0"

Landscape Architect

RDL Design Company, Inc.
1020 East Yale Avenue
Salt Lake City, Utah 84105
Phone: 801-641-3114
Email: raldesign@comcast.net

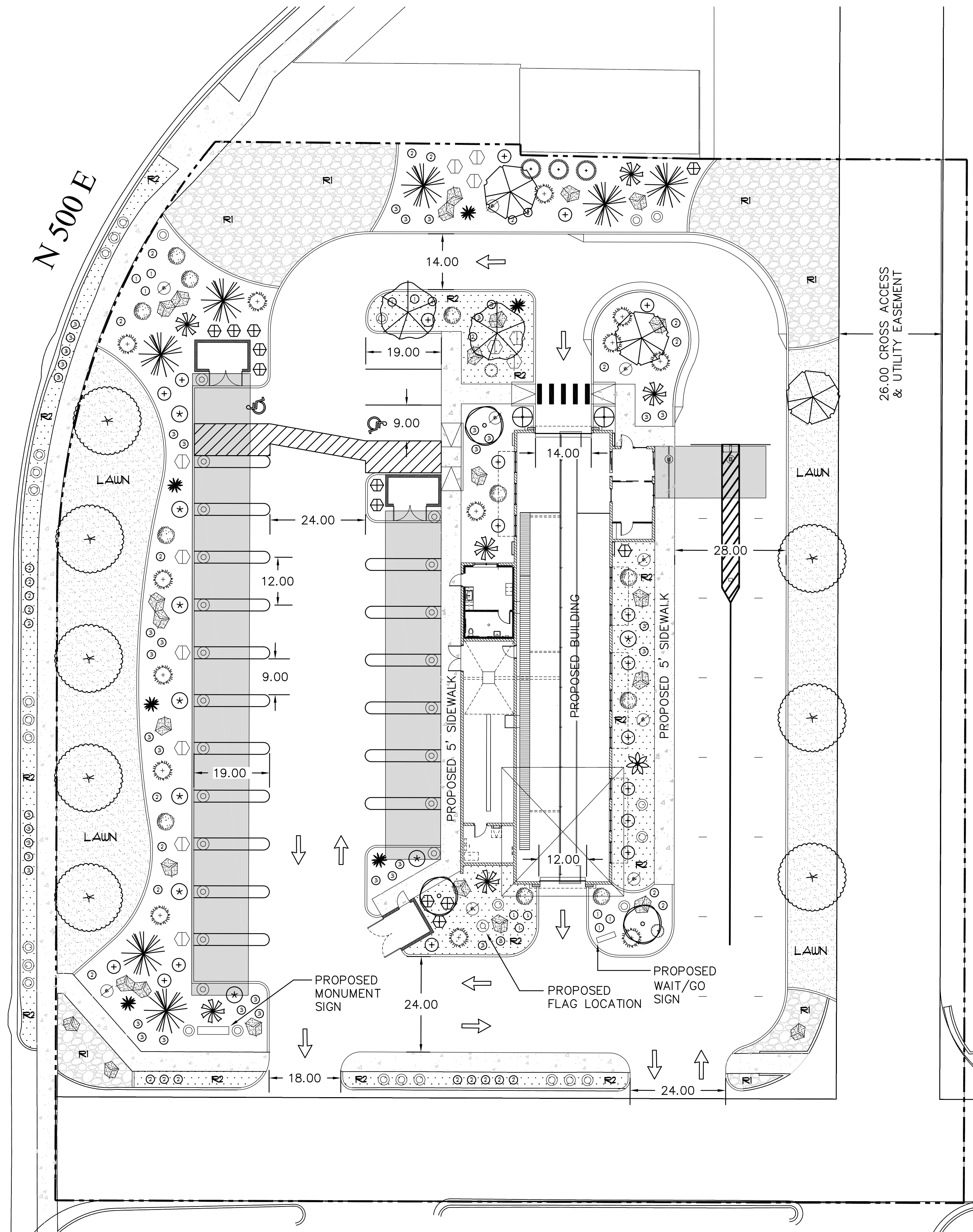

ELEVATE ENGINEERING
492 WEST 1200 NORTH
SPRINGVILLE, UT 84663
PHONE: (801) 718-5993
info@elevateeng.com

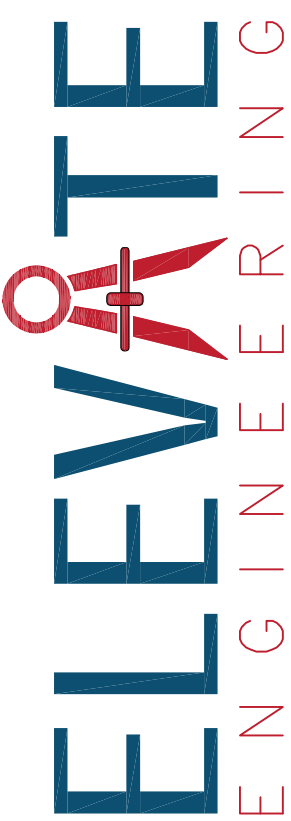

QUICK QUACK - SANTAQUIN MACEY'S
LANDSCAPE PLAN
78 N. 500 E. SANTAQUIN, UT 84665



SHEET:
L-1
DATE: 01-10-2024

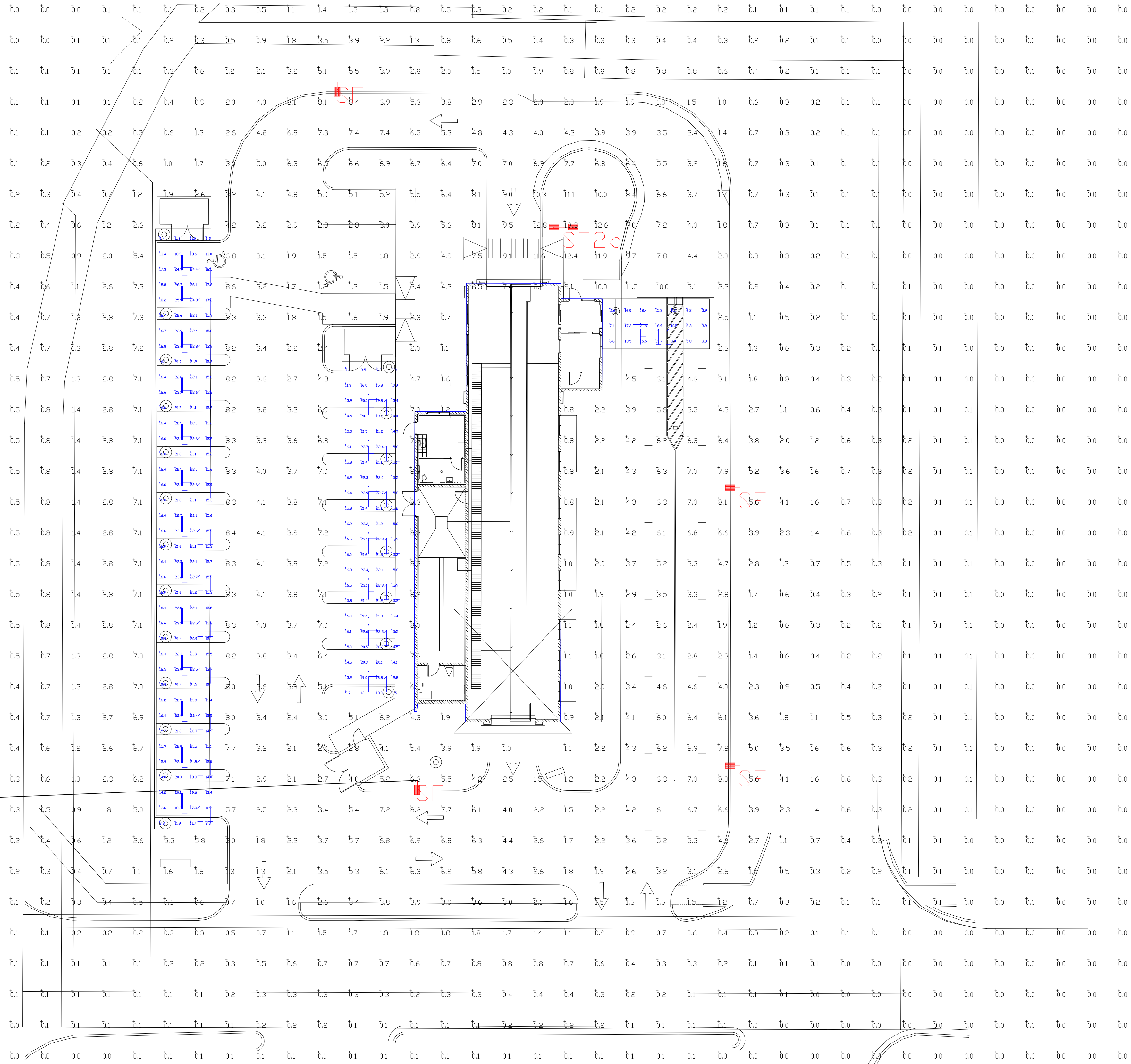

Pole to be used for flag pole light

Calculation Summary							
Label	CalcType	Units	Avg	Max	Min	Avg/Min	Max/Min
PAY CANOPY	Illuminance	Fc	11.12	20.9	3.8	2.93	5.50
VACUUM CANOPY 1	Illuminance	Fc	17.38	23.1	6.9	2.52	3.35
VACUUM CANOPY 2	Illuminance	Fc	18.47	26.7	8.3	2.23	3.22
PAVED AREA	Illuminance	Fc	4.74	12.8	1.0	4.74	12.80

NOTE: STANDARD 120-277v UNLESS OTHERWISE SPECIFIED

PHOTOMETRIC EVALUATION
NOT FOR CONSTRUCTION

Based on the information provided, all dimensions and luminaire locations shown represent recommended positions. The engineer and/or architect must determine the applicability of the layout to existing or future field conditions.

This lighting plan represents illumination levels calculated from laboratory data taken under controlled conditions in accordance with The Illuminating Engineering Society (IES) approved methods. Actual performance of any manufacturer's luminaires may vary due to changes in electrical voltage, tolerance in lamps/LED's and other variable field conditions. Calculations do not include obstructions such as buildings, curbs, landscaping, or any other architectural elements unless noted. Fixture nomenclature noted does not include mounting hardware or poles. This drawing is for photometric evaluation purposes only and should not be used as a construction document or as a final document for ordering product.

Luminaire Schedule									
Symbol	Qty	Label	Arrangement	Description	Mounting Height	LLD	LLF	Arr. Lum. Lumens	Arr. Watts
	21	F11	SINGLE	VT3204HUNV50 (FIXTURE SUPPLIED BY HERMITAGE)	12'	1.000	1.000	6778	51.95
	4	SF	SINGLE	MRS-LED-18L-SIL-FT-50-70CRI-SINGLE	16' POLE+2' BASE	1.000	1.000	16890	135
	1	SF2b	D180°	MRS-LED-18L-SIL-FT-50-70CRI-D180	16' POLE+2' BASE	1.000	1.000	33780	270

Total Project Watts_1
Total Watts = 1900.95

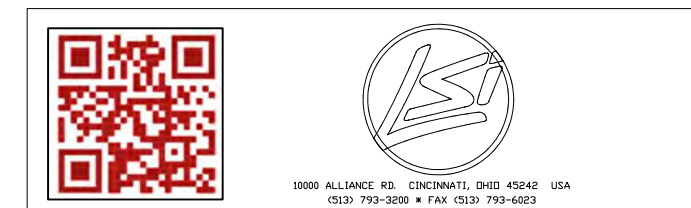

LIGHTING PROPOSAL LD-159445

QUICK GLUCK
78 N 500 E
SANTAGUITA

SCALE: 1"=16'







Architectural Review Committee Meeting Minutes

November 8, 2023

ARC Members in Attendance: Assistant City Manager Jason Bond, Committee Member Ron Jones, Committee Member Kylie Lance

Others in Attendance: Kirk & Kim Hunsaker, Tom Lundberg and Ryan Fairchild representatives for O'Reilly's Auto Parts attended the meeting via Zoom.

City Council Representative Art Adcock was excused from the meeting.

Mr. Bond called the meeting to order at 5:40 p.m.

O'Reilly's Auto Parts Architectural Review

Assistant Manager Bond presented the plans and design boards submitted to the City by O'Reilly's Auto Parts and indicated that all plans meet the objective architectural requirements. The storefront of the building will face Main Street. Committee members discussed the coloring of the brick for the outside of the building. Currently, the brick is a red/orange color. Committee members asked that the brick be changed to a more neutral/brown color. Committee Member Lance inquired about the lighting on all elevations of the building. The applicant indicated that they could add lighting to all sides of the building to match the current front lights. Committee members discussed the height requirement for buildings on Main Street, pointing out that the minimum height requirement for buildings in the Main Street Commercial Zone is 25 feet and the maximum height requirement is 60 feet. The O'Reilly's building is proposed to be a height of 25 feet, meeting the minimum height requirement. Kirk & Kim Hunsaker both expressed their approval of the building and renderings. Committee Member Jones pointed out that the building will be the first thing you see when traveling east into the City and asked if the wainscotting could be raised on the building. Members of the committee also discussed what materials will be used for the awning and other parts of the building.

Motion: Kylie Lance made a motion to approve the O'Reilly's plan as proposed with the following conditions:

- Similar goose-neck lighting fixtures be added to the two sides of the building that don't have lights, to be placed on the pillars as shown on the elevation plan.
- Brick wainscotting be raised.
- Change the color of the brick to a more red-brown color.

Ron Jones seconded the motion.

Kylie Lance	Yes
Ron Jones	Yes
Jason Bond	Yes
Art Adcock	Absent

The motion passed unanimously.

Meeting Minutes Approval

May 31, 2023

Motion: Committee Member Ron Jones motioned to approve the minutes from the May 31, 2023 meeting.

Motion seconded by Committee Member Kylie Lance

Jason Bond	Yes
Art Adcock	Absent
Ron Jones	Yes
Kylie Lance	Yes

Adjournment:

Committee Member Ron Jones motioned to adjourn at 6:04 p.m.

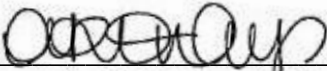

Amalie R. Ottley, City Recorder

DRAFT