



# MAY MONTHLY MEETING

Tuesday, May 16, 2023 at 6:00 PM

RUTH TOWN HALL

---

## AGENDA

**CALL TO ORDER**

**INVOCATION**

**ROLL CALL**

**AGENDA ADOPTION**

**GUEST SPEAKERS**

**COMMUNITY FORUM**

**APPROVAL OF LAST MEETING'S MINUTES**

**OLD BUSINESS**

1. Ruthridge Entrance. Amie will update the board on efforts thus far
2. Trail Lighting and Cameras -Status update for the board
3. Christmas light repairs and revamps -Brief status update for the board.
4. Insurance for Outdoor Gym equipment -Amie has some information, hopefully more to come before the meeting.
5. Town Hall Roofing Estimates -Amie has procured several quotes, see attached for one quotes information

**COMMITTEE REPORTS**

6. Financial Reports circulated prior will be reviewed.

**NEW BUSINESS**

7. Alicia Morgan has a request of utilizing Town Property for a Yard Sale.
8. Mike Sheridan interested in buying this piece of property from the Town. Amie will share the details.
9. BRWA Board -See attached for David's reappointment
10. Budget Workshop -Need to schedule budget workshop meeting before end of month or extra one for June. Amie will circulate documents and proposals prior for review so meeting can be expeditious.

**ADJOURNMENT**

*In accordance with the Americans with Disabilities Act, persons who need accommodation to attend or participate in this meeting should contact Town Hall at (828) 287-7943 within 48 hours prior to the meeting to request such assistance.*

## Roof quote

From: joseph shubin <josephmshubin@gmail.com>

Sent: Tue, May 2, 2023 at 12:40 pm

To: ahanaway@townofruthnc.gov

---

199 Northview  
Ruth Town Hall

Apply 29 gauge metal with vapor barrier  
Includes all necessary trim, pipe boots, caulking etc  
Apply EPDM on back lower room  
Clean up disposal of all waste  
\$16,400

Joseph Shubin of Shubin Brothers Roofing  
828-748-4797



Item 5.

# Precise Aerial Roof Measurement Report

Prepared For You by RCB Roofing



199 northview-Dorsey, Rutherfordton, NC 28139

## METAL- RESIDENTIAL ROOF REPORT

APR 18, 2023

We can help you with  
All Your Roofing Needs  
Residential + Commercial

**AMIE HANAWAY**

199 northview-Dorsey  
Rutherfordton, NC  
28139

470-355-1500

# INTRODUCTION

Hi

Thank you for the opportunity to serve you. Please find your estimate below along with upgrade options for potential improvements to your project, if applicable.

The following estimate is for:

1. Remove and disposal of old materials
2. Supply and install new materials
3. Clean up of entire work area (all nails and other materials)
4. Clean all gutters (if roof is done)
5. Your own dedicated Production Scheduling team
6. All employees are WCB and COR certified
7. We are Licensed to work in your geographical region
8. Audit of all work completed by Quality Control Officer
9. 5-year Workmanship Warranty on complete projects - (Full Roof Replacement)

We don't want you to be personally liable should a worker happen to get injured therefore we maintain current WCB for all employees and crews.

We carry two million liability insurance. As well, we have mandatory safety training for our staff to ensure safe practices always.

Once the job is complete, complete an additional full inspection on your home to ensure we did everything correct and up to our strict standards and site is spotless.

If you have any questions, please give me a call. We always want to provide the best value to our clients. If we are outside your budget, please let me know and we will do our best to work within that.

Best,

# INSPECTION

IPM Mon Apr 17 100%  
 jobimbus-files.s3.amazonaws.com

Waste Calculation Table							
Waste %	0%	10%	12%	15%	17%	20%	22%
Area (sq ft)	5,284	5812.4	5918.1	6076.6	6182.3	6340.8	6446.5
Squares	52.8	58.1	59.2	60.8	61.8	63.4	64.5

This table shows the total roof area and squares (rounded up to the nearest decimal) based upon different waste percentages. The waste factor is subject to the complexity of the roof, individual roofing techniques and your experience. Please consider this when calculating appropriate waste percentages. Note that only roof area is included in these waste calculations. Additional materials needed for ridge, hip, valley, and starter lengths are not included.

Penetrations	1-2	3-5	6-10	11	12				
Area (sq ft)	0.3	1	2.2	4.3	5.2				
Perimeter (ft)	2	4	6	8.8	10				

Any measured penetration smaller than 3.0x3.0 Feet may need field verification. Accuracy is not guaranteed. The total penetration area is not subtracted from the total roof area.

### All Structures Totals



Total Roof Facets = 5  
 Total Penetrations = 12

### Lengths, Areas and Pitches

- Ridges = 108 ft (2 Ridges)
- Hips = 0 ft (0 Hips)
- Valleys = 19 ft (2 Valleys)
- Rakes = 143 ft (8 Rakes)
- Eaves/Starter = 193 ft (7 Eaves)
- Drip Edge (Eaves + Rakes) = 336 ft (15 Lengths)
- Parapet Walls = 0 (0 Lengths)
- Flashing = 0 ft (0 Lengths)
- Step Flashing = 5 ft (4 Lengths)
- Total Penetrations Area = 25 sq ft
- Total Roof Area Less Penetrations = 5,259 sq ft
- Total Penetrations Perimeter = 65 ft
- Predominant Pitch = 6/12
- Total Area (All Pitches) = 5,284 sq ft**

### Property Location

Longitude = -81.9437783  
 Latitude = 35.3865951

### Notes

This was ordered as a commercial property. There were no changes to the structure in the past four years.







# WARRANTY



This document warrants that should a defect in workmanship, related to the work completed by RCB Roofing, occur within 10 years of the project, RCB Roofing will complete repairs within the original project's scope of work at no charge to the customer. This warranty does not cover normal wear and tear, hail damage, wind damage, sun damage, intentional or accidental damage by any person, or acts of God that may or may not merit an insurance claim. This warranty only applies to portions of the project in which RCB Roofing fully replaced any existing products, and does not cover repairs or service done to another contractor's work. Defects in the building materials used to complete work do not fall under the scope of this workmanship warranty; any building products installed will instead be covered by the product's original manufacturer warranty.

\*Manufacturer's Warranty detailed in separate document.

**Customer:** \_\_\_\_\_

**Project Address:** \_\_\_\_\_

**Date Project Completed:** \_\_\_\_\_

Thank you again for choosing RCB Roofing to complete work on your property. We trust you had a great customer experience!



# ADVANTAGE-LOK II®



Your Roof. For Life!  
On Time and Complete!™



Contact your sales representative for more information.

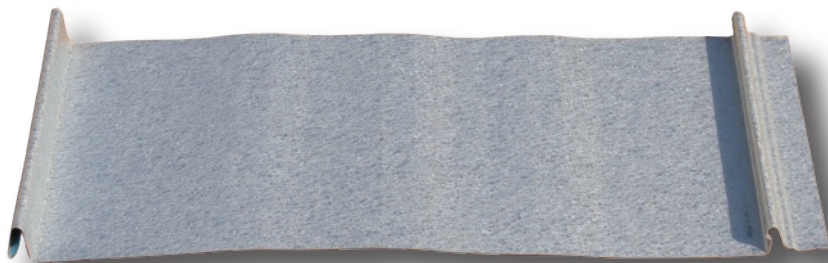

## Description

Standing seam roofing panels have been used on traditional and contemporary homes for more than a century. Their clean, graceful lines have been an enduring favorite on a wide range of architecture. Advantage-Lok II is a premium standing seam panel that was designed with low profile ribs to increase strength and wind resistance. This product utilizes a high-strength snap locking system and installs in the same manner as our original Advantage-Lok panels. It's a perfect choice for up-scale residential and commercial applications in severe weather areas.

## Specifications

- Standing seam concealed fastener panel for roof applications
- Snap locking ribs
- Screw flange installation
- 3:12 minimum recommended roof pitch
- Suitable for solid decking

## Substrates and Coatings

- 26 and 24 gauge high strength steel
- 0.032" aluminum
- Anti-corrosion AZ50 Galvalume coating for painted and AZ55 for unpainted steel
- 26 ga available in 45 Year and Lifetime Siliconized Modified Polyester Paint System
- 24 ga and aluminum available in PVDF (Kynar 500 or Hylar 5000) Paint System

## Finish Options

- PVDF (Kynar®) and Siliconized Modified Polyester Paints Available
- Energy Star Certified Colors Available
- Unpainted Galvalume®

## Approvals and Certifications

- Metal Construction Association Certified
- Miami-Dade Approved
- Florida Building Code Approved
- Energy Star Certified
- Highest UL Ratings for Wind Uplift, Fire and Impact Resistance
- No Coastal Set Back



## PANEL DETAILS

### Rib Locking Detail

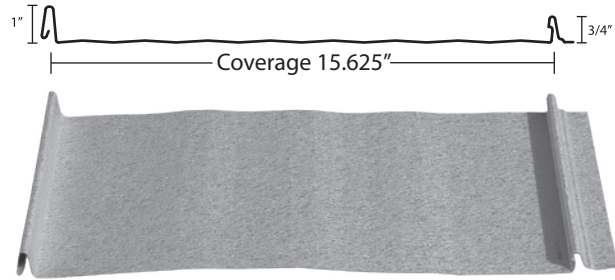

## CERTIFICATIONS & TESTING

- UL 790 Fire Resistance Class A
- UL 2218 Impact Resistance Class 4
- UL 580 Uplift UL Class 90 Construction #529
- UL 1897 Uplift Test for Roof Covering
- Texas Department of Insurance Approval #156
- Miami-Dade County NOA Compliant

## INSTALLATION

Advantage-Lok II is a snap locking standing seam panel that's easy to install and ideal for residential and commercial applications. Panels are installed by fastening the male panel leg screw flange to the substrate with pancake head screws. The female panel rib is simply snapped over the male leg which locks it into place and conceals the fasteners. Advantage-Lok II should be installed over solid decking with a minimum recommended roof pitch of 3:12.

### Installation Detail

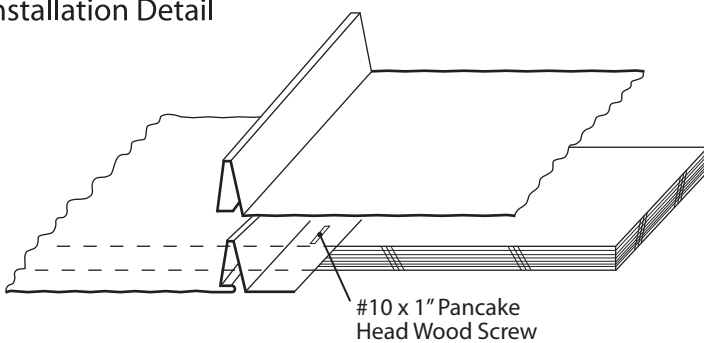

**BEFORE BEGINNING INSTALLATION OF THIS PRODUCT, CHECK LOCAL BUILDING CODES.**

\*\* For more information, call (888) MTL-ROOF or visit our website at [www.unioncorrugating.com](http://www.unioncorrugating.com) \*\*

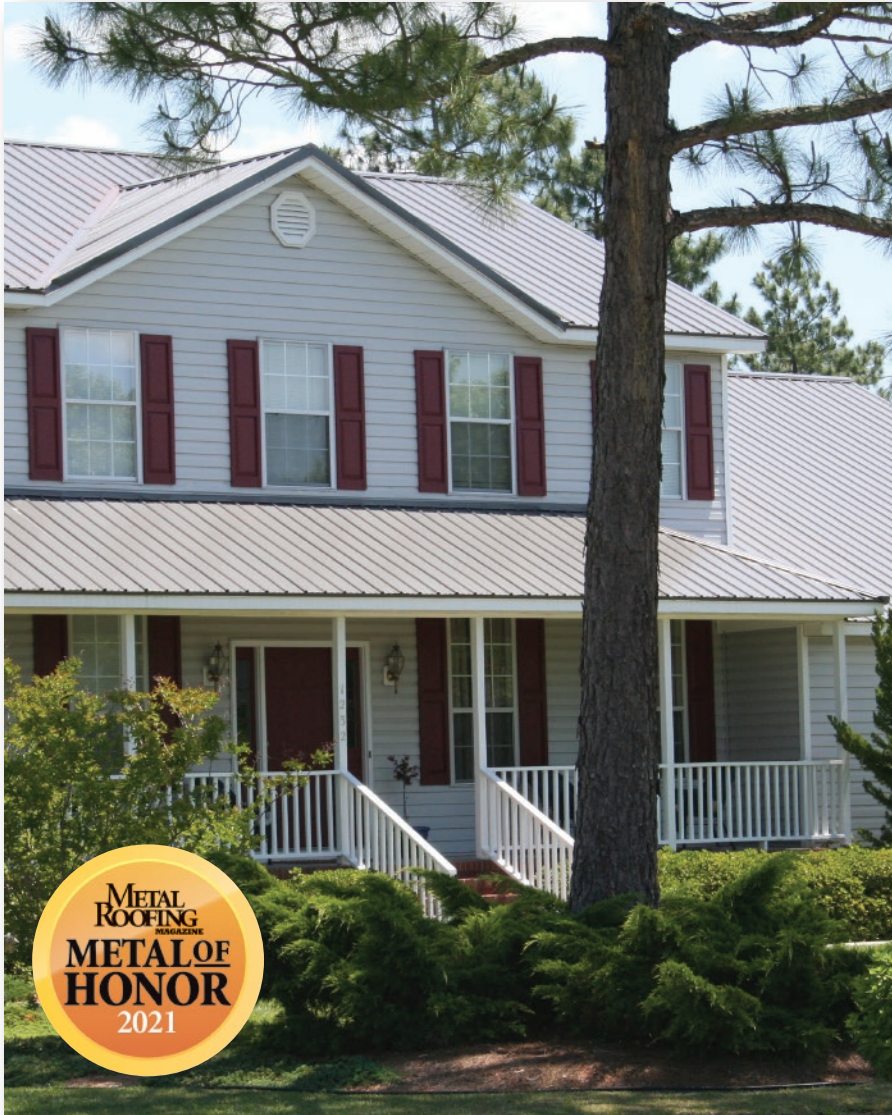

Contact your sales representative for more information.

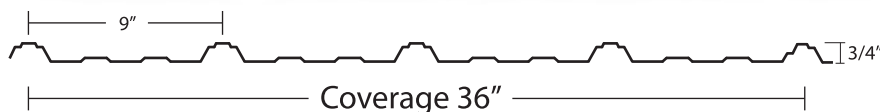
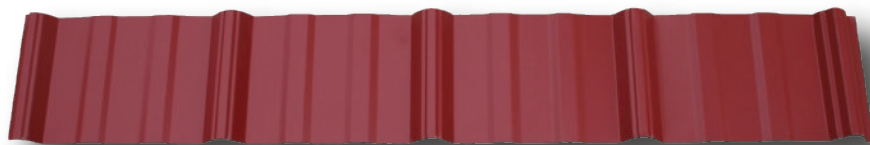

## Description

An industry leader in strength and durability, this popular and versatile panel features classic looks and is used in a wide range of applications including residential, commercial, and post-frame installations. MasterRib was designed with extra-wide ribs to increase strength and ease in handling and installation. In addition, the oversized anti-siphoning channel on the underlap rib provides superior water shedding capacity in the presence of extreme wind and rain loads.

## Specifications

- Exposed fastener panel for roof and wall applications
- 3:12 minimum recommended roof pitch
- Suitable for solid deck or open framing

## Substrates and Coatings

- 29 and 26 gauge high strength steel
- Anti-corrosion AZ50 Galvalume coating for painted and AZ55 for unpainted steel.
- 45 Year and Lifetime Siliconized Modified Polyester Paint System

## Finish Options

- 20 Paint Colors
- Energy Star Certified Color Available
- Unpainted Galvalume
- Unpainted Galvanized

## Approvals and Certifications

- Metal Construction Association Certified
- Miami-Dade Approved for Wind Uplift
- Florida Building Code Approved
- Energy Star Certified
- Texas Department of Insurance Approved
- Highest UL Ratings for Wind Uplift, Fire and Impact Resistance
- No Coastal Set Back

### CERTIFICATIONS & TESTING

- UL 580 Class 90 Wind Uplift Construction #584
- UL 790 Fire Resistance Class A
- UL 2218 Impact Resistance Class A
- Texas Department of Insurance Approval #116
- Metal Construction Association (MCA) Certified
- Miami Dade County NOA Compliant

### ALLOWABLE UNIFORM LOADS PER SQUARE FOOT

Maximum purlin spacing for roof 2' on center and maximum girt spacing for sidewall 3' on center. Place fasteners in the pan of panel for best results. (Three spans or more)

SPAN (INCHES)	LIVE LOAD (lb/ft <sup>2</sup> )						WIND LOAD (lb/ft <sup>2</sup> )					
	18"	24"	30"	36"	48"	54"	18"	24"	30"	36"	48"	54"
29 Gauge	199	112	71	49	28	22	211	118	76	52	29	23
26 Gauge	268	150	96	67	37	29	276	155	99	69	38	30

#### NOTES:

1. Theoretical allowable loads are based on section properties and allowables calculated in accordance with 2001 AISI Specifications.
2. Theoretical allowable loads are based on three or more uniform spans.
3. For roof panels, deduct self weight for actual 'live load' capacity of the panel.
4. These loads are for panel strength. Frames, purlins, decks and fasteners must be designed to resist all loads imposed on the panel.
5. Check local building codes if panel testing is required.

### RECOMMENDED FASTENING PATTERN FOR 1-1/2" SCREWS

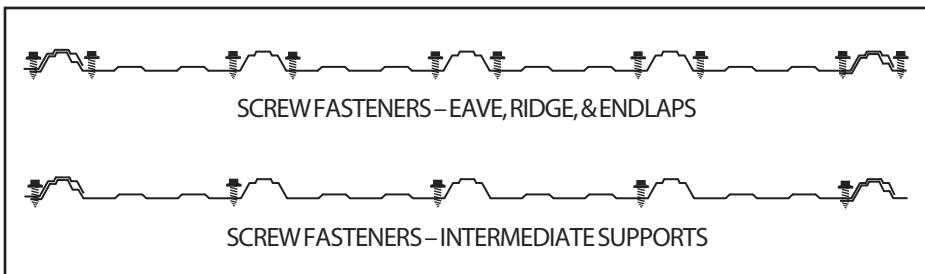

### PANEL OVERLAP

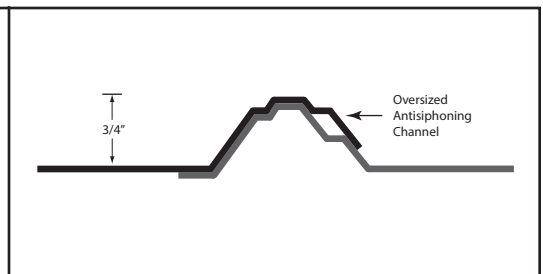

### STORAGE

If the panels are not to be used immediately, store inside in a well ventilated and dry location. Condensation or other moisture can form between the sheets during storage, causing white rust or water stains, which detract from the appearance of the product, and may effect the product's useful life. Trapped moisture between sheets of painted metal can cause white rust to form underneath the paint. This can cause the paint to flake off of the panel immediately or several years later. To prevent white rust and staining, the following precautions should be taken:

1. Break the shipping bands on the metal and wipe the sheets dry.
2. Store metal on end or on an incline of at least 8" with support bands underneath to prevent sagging.
3. Fan sheets slightly at the bottom to allow for air circulation.
4. Keep the sheets off of the ground with an insulator such as wood.

Any outdoor storage is at the customer's own risk. If outdoor storage cannot be avoided, protect the metal using a canvas cover or waterproof paper. Never cover the metal with plastic as this will cause condensation to form.

### BEFORE BEGINNING INSTALLATION OF THIS PRODUCT, READ OUR INSTALLATION INSTRUCTIONS

\*\* For more information, call (888) MTL-ROOF or visit our website at [www.unioncorrugating.com](http://www.unioncorrugating.com) \*\*



# 25 YEAR LIMITED GALVALUME® WARRANTY

Union Corrugating Company warrants that its hot-dipped aluminum-zinc alloy-coated Galvalume® and Galvalume Plus® sheet steel with a coating weight of AZ50 sold for use as unpainted steel building panels erected within the continental United States, Alaska, Hawaii, Canada or the Caribbean, and exposed to normal atmospheric conditions, WILL NOT rupture, fail structurally, or perforate due to corrosion within a period of 20 years and 6 months after shipment from our mill. For a coating weight of AZ55, this period is extended to 25 years and 6 months.

This warranty **DOES NOT APPLY** to sheets exposed at any time to corrosive or aggressive atmospheric conditions, including, **BUT NOT LIMITED TO**:

1. areas subject to salt water marine atmospheres or to constant spraying of either salt or fresh water.
2. areas subject to fallout or exposure to corrosive chemicals, fumes, ash, cement dust, animal waste or its decomposition by-products, carbon black, or fallout from copper, lead, nickel or silver mining or refining operations.
3. areas subject to water run-off from lead or copper flashings or piping or areas in contact with lead or copper.
4. conditions/circumstances where corrosive fumes or condensates are generated or released inside the building.

This warranty **DOES NOT APPLY** in the event of:

1. bends less than 2T inside bend diameter for sheet thicknesses 0.030" and thinner, and less than 4T for sheet thicknesses greater than 0.030"
2. roof or sections of the roof flatter than 1/4:12 slope.
3. mechanical, chemical, or other damage sustained during shipment, storage, forming, fabrication, or during or after erection.
4. forming which incorporates severe reverse bending or which subjects the metallic coating to alternate compression and tension.
5. failure to provide free drainage of water, including, but not limited to, internal condensation, from overlaps and from all other surfaces of the sheets or panels.
6. failure to remove debris from overlaps and from all other surface of the sheets or panels.
7. damage caused to the metallic coating by improper forming (including, but not limited to, roll forming, press braking or embossing) or scouring or cleaning procedures.
8. deterioration of the panels caused by contact with green or wet or pressure-treated lumber, or wet storage stain caused by water damage or condensation.
9. presence of damp insulation, soil, vegetation or other corrosive materials in contact with or in close proximity to the sheets or panels.
10. deterioration to the panels caused by directly or indirectly by panel contact with fasteners or by overdriving the fasteners so as to damage the panel. Selection of suitable long-lasting fasteners to be used with Galvalume® and Galvalume Plus® panels rests solely with the Buyer. Fasteners are to be electrically insulated from the panel surface (e.g., with elastomeric grommets) to prevent dissimilar metal contact.
11. failures caused by acts of God, falling objects, external forces, explosions, fires, riots, civil commotions, acts of war or radiation.

This warranty shall be subject to the stipulations, limitations, and conditions hereinafter set forth:

1. This warranty shall be interpreted and enforced in accordance with the laws of the state of Maryland, USA, without regard to principles regarding conflicts of law, the courts of which State shall have exclusive jurisdiction and venue over the enforcement of this warranty. There is excluded from this warranty the application of the United Nations Convention on Contracts for the International Sale of Goods.
2. This warranty is contingent on the proper maintenance of the building, which maintenance is to be provided by the building owner.
3. Seller's liability for breach of this warranty and/or for the failure of material to conform, **whether due to Seller's negligent acts or omissions or otherwise**, shall be limited exclusively to the cost of either repairing nonconforming panels, or at Seller's sole option, of furnishing (FOB Seller's plant) sufficient sheet product to enable Buyer to fabricate replacement panels for the nonconforming panels.
4. Seller will be responsible for replacement of material only. Seller shall not in any event be liable for the cost of the labor expended by others on any nonconforming material or for any special, indirect or consequential damages to anyone caused by nonconforming material.
5. This warranty also applies to the material repaired or used to replace the nonconforming material, but only for the unexpired portion of the warranty period applicable to the original material.
6. Buyer shall promptly inspect the material and use reasonable care to protect any rejected material until Seller has time to conduct its own inspection and make or direct disposition.
7. In order for Seller to honor any claim on material shipped, Buyer must promptly document the claim with identification of material, date of installation, Seller's order number, coil number, invoice number and date of shipment and must give Seller a reasonable opportunity to inspect the material claimed to be nonconforming.
8. Except to the extent provided under applicable law, (a) Seller extends this warranty solely to the Buyer; and (b) this warranty is non-transferable and non-assignable.
9. Seller reserves the right to terminate this warranty at any time (except as to orders already accepted) upon the giving of written notice thereof.

**SELLER MAKES NO GUARANTEES OR WARRANTIES, EITHER EXPRESSED OR IMPLIED, BEYOND THE DESCRIPTION ON THE FACE HEREOF, AND ALL OTHER WARRANTIES, INCLUDING, WITHOUT LIMITATION, WARRANTIES OF FITNESS FOR PARTICULAR PURPOSE AND MERCHANTABILITY, ARE HEREBY EXCLUDED; AND SELLER SHALL HAVE NO OTHER LIABILITY WITH RESPECT TO ANY OTHER GUARANTEES OR WARRANTIES.**



Your Roof. For Life!  
On Time and Complete!™

# Residential/Post Frame Color Chart Item 5.

- SMP<sup>✓</sup> Paint System
- 29 & 26 Gauge Galvalume<sup>®</sup> Steel Substrate
- 45-Year Industry Leading, Written Warranty on Painted Products with No Coastal Set Back

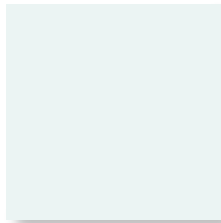

**Arctic White\***  
TSR† = 63%

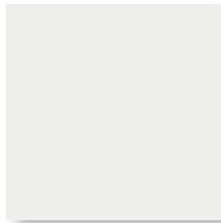

**White**  
TSR = 46%

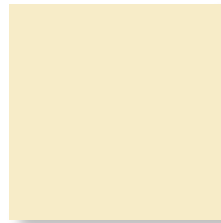

**Ivory**  
TSR = 58%

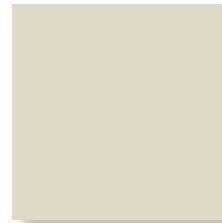

**Light Stone**  
TSR = 51%

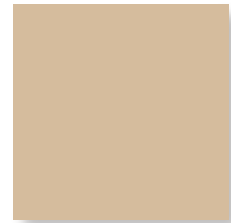

**Sahara Tan**  
TSR = 36%

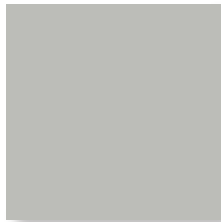

**Pearl Gray**  
TSR = 35%



**Cocoa Brown**  
TSR = 29%



**Burnished Slate**  
TSR = 32%



**Light Brown**  
TSR = 36%

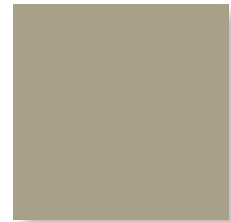

**Clay**  
TSR = 32%



**Charcoal Gray**  
TSR = 31%



**Black**  
TSR = 25%



**Patriot Red**  
TSR = 36%



**Barn Red**  
TSR = 32%



**Burgundy**  
TSR = 25%

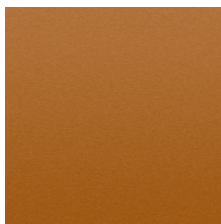

**Copper Metallic ‡**  
TSR = 46%



**Gallery Blue**  
TSR = 25%



**Royal Blue**  
TSR = 31%



**Evergreen**  
TSR = 26%



**Marine Green**  
TSR = 30%

## Non-Painted



**Acrylic Coated Galvalume**  
TSR = 55%



Denotes Energy Star™ certified high reflectance color which can reduce cooling costs.



Union utilizes the most advanced Siliconized Modified Polyester paint system in the industry, based on Akzo Nobel's Ceram-A-Star 1050 technology.

**Note:** Colors shown have been matched as accurately as possible to actual finish. For exact color match, please request a metal color sample. Availability of colors and materials is subject to change. Most panels are available in bare galvanized or bare galvalume.

† TSR = Total Solar Reflectance. An Energy Star™ certified color must meet the following TSR requirements: 25% initial, 15% after 3 years of exposure testing.

‡ Premium color. To ensure proper color match, orders for metallic colors should be placed so that they come from the same batch.

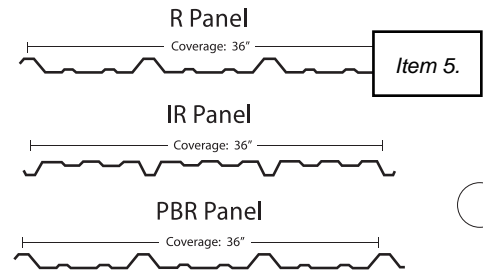
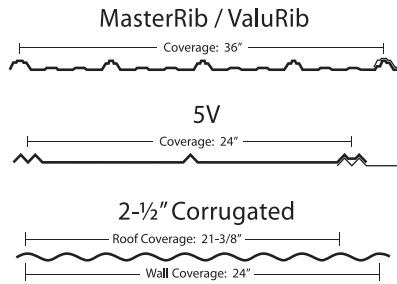
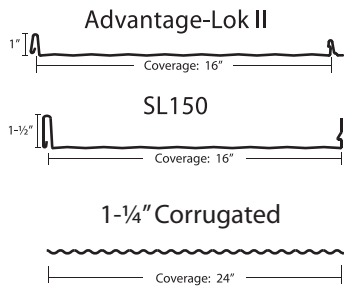

PANEL	GAUGE	COLOR																				
		Arctic White*	Barn Red	Black	Burgundy	Burnished Slate	Charcoal Grey	Clay	Cocoa Brown	Copper Metallic	Evergreen	Gallery Blue	Ivory	Light Brown	Light Stone	Marine Green	Patriot Red	Pearl Gray	Royal Blue	Sahara Tan	White	Acrylic Coated Galvalume
Advantage Lok II	26	•	•	•	•	•	•	•	•	•	•	•	•	•	•	•	•	•	•	•	•	•
SL150	26	•	•	•	•	•	•	•	•	•	•	•	•	•	•	•	•	•	•	•	•	•
MasterRib	29	•	•	•	•	•	•	•	•	•	•	•	•	•	•	•	•	•	•	•	•	•
MasterRib	26	•	•	•	•	•	•	•	•	•	•	•	•	•	•	•	•	•	•	•	•	•
<sup>s</sup> ValuRib	29	•																				
5V	29		•							•											•	•
5V	26	•				•				•	•				•	•				•	•	•
1-1/4" Corrugated	29																					•
2-1/2" Corrugated	29		•							•											•	•
2-1/2" Corrugated	26	•				•				•	•				•	•				•	•	•
R Panel	26	•	•		•	•	•		•	•	•	•		•	•	•	•	•	•	•	•	•
IR Panel	26	•	•		•	•	•		•	•	•	•		•	•	•	•	•	•	•	•	•
PBR Panel	26		•			•	•		•	•	•		•	•			•	•	•	•	•	•

\*ValuRib is only offered in Arctic White at the following locations: Yukon, Janesville, Dayton and Scranton. Please see a Union Sales Representative for additional information.

<sup>s</sup>ValuRib colors are not Energy Star certified. Copper is a metallic paint with higher cost than SMP.

## PERFORMANCE DATA

COLOR	INITIAL SOLAR REFLECTANCE	3YR. TOTAL SOLAR REFLECTANCE	INITIAL THERMAL EMITTANCE	SOLAR REFLECTANCE INDEX
Arctic White	0.65	0.63	0.87	78
Barn Red	0.32	0.32	0.87	33
Black	0.25	0.25	0.85	24
Burgundy	0.25	0.25	0.87	24
Burnished Slate	0.31	0.32	0.88	32
Charcoal Gray	0.30	0.31	0.88	31
Clay	0.33	0.32	0.87	35
Cocoa Brown	0.28	0.29	0.89	29
Copper Metallic	0.46	0.46	0.86	52
Evergreen	0.26	0.26	0.88	26
Gallery Blue	0.25	0.25	0.87	24
Ivory	0.60	0.58	0.87	71
Light Brown	0.35	0.36	0.88	38
Light Stone	0.52	0.51	0.87	60
Marine Green	0.30	0.30	0.87	31
Patriot Red	0.35	0.36	0.88	38
Pearl Gray	0.37	0.35	0.87	40
Royal Bue	0.30	0.31	0.87	31
Sahara Tan	0.36	0.36	0.87	39
White	0.56	0.46	0.87	66
Acrylic Coated Galvalume	0.67	0.55	0.14	56

### ENERGY STAR Requirements

Initial Solar Reflectivity  
 Steep Slope Roofs (>2:12) ≥ 0.25  
 Low Slope Roofs (≤2:12) ≥ 0.65  
 3 Year Solar Reflectivity  
 Steep Slope Roofs (>2:12) = 0.15  
 Low Slope Roofs (≤2:12) = 0.50

### LEED 2.2 Requirements

Solar Reflectance Index (SRI)  
 Steep Slope Roofs = ≥29  
 Low Slope Roofs = ≥78

## Plant Locations:

### Corporate Headquarters\*\*

701 S. King St.  
 Fayetteville, NC 28301  
 888-685-7663

### Vicksburg, MS

1463 Interplex Circle  
 Ceres Industrial Complex  
 Vicksburg, MS 39183  
 888-661-0577

### Morrison, TN\*\*

7747 Manchester Hwy.  
 Morrison, TN 37357  
 931-668-4393

### Dayton, OH

625 N. Third St.  
 Tipp City, OH 45371  
 877-615-9812

### Tifton, GA

3365 US Hwy 41 S.  
 Tifton, GA 31794  
 800-962-9131

### Oklahoma City, OK\*

600 N. Sara Rd. Ste B  
 Yukon, OK 73099  
 866-373-5286

### Orange, VA

12435 James Madison Hwy.  
 Orange, VA 22690  
 800-762-6785

### Scranton, PA\*

100 Keystone Industrial  
 Park Road  
 Suite 2B  
 Dunmore, PA 18512  
 866-695-6455

### Ocala, FL\*\*

490 Oak Rd.  
 Ocala, FL 34472  
 800-331-3584

### Janesville, WI\*\*

3920 Kennedy Rd.  
 Janesville, WI 53545  
 608-563-3226

**Note:** Colors shown have been matched as accurately as possible to actual finish. For exact color match, please request a metal color sample. Availability of colors and materials is subject to change. Most panels are available in bare galvanized or bare galvalume.

# ADVANTAGE LOK II

## Description

Remove existing roofing system and install Union Corrugating Advantage LOK II Standing Seam Metal Roof System

High Temperature Ice+Water Barrier (on all eaves, valleys, and protrusions)

Synthetic Underlayment - adds a second layer of protection over your entire roof.

Fasteners

Metal Hip and Ridge Caps

Ridge venting - the most efficient way to help heat exhaust from your attic

Disposal Bin - rental and disposal fees for all waste from job  
(up to 35 SQ)

**Quote subtotal** \$62,700.00

**Total** \$62,700.00



# MASTERRIB

## Description

Remove existing roofing system and install Union Corrugated MasterRib 4x8 Sheet Metal

High Temp Ice+Water Barrier (on all eaves, valleys, and protrusions)

Synthetic Underlayment - adds a second layer of protection over your entire roof

TRI-BUILT 1-1/4" to 4" Hard Pipe Flashing Black

Fasteners

Metal Hip and Ridge Caps

Ridge venting - the most efficient way to help heat exhaust from your attic

Disposal Bin - rental and disposal fees for all waste from job  
(up to 35 SQ)

**Quote subtotal** \$43,200.00

**Total** \$43,200.00

# AUTHORIZATION PAGE

- Advantage LOK II \$62,700.00
- MasterRib \$43,200.00

**Name:** Amie Hanaway

**Address:** 199 northview-Dorsey, Rutherfordton, NC

Description	Qty	Unit price	Line total
<input type="checkbox"/>			

## Customer Comments / Notes

Amie Hanaway: \_\_\_\_\_

Date: \_\_\_\_\_

# TERMS AND CONDITIONS

You may cancel this contract from the day you enter into the contract until 7 days after you receive a copy of the contract. You do not need a reason to cancel. If you do not receive the goods or services within 30 days of the date stated in the contract, you may cancel this contract within one year of the contract date. You lose that right if you accept delivery after the 30 days. There are other grounds for extended cancellation. For more information, you may contact your provincial/territorial consumer affairs office. If you cancel this contract, the seller has 15 days to refund your money and any trade-in, or the cash value of the trade-in. You must then return the goods. To cancel, you must give notice of cancellation at the address in this contract. You must give notice of cancellation by a method that will allow you to prove that you gave notice, including registered mail, fax or by personal delivery.

**I understand that if roof rot is discovered during tear-off COMPANY NAME reserves the right to replace sheathing and bill me up to \$200 in addition to the estimated cost below without notifying me in advance. COMPANY NAME will call me for authorization if wood replacement will exceed \$200.**

I understand that I must remove items from the interior walls of my home that may be damaged or fall due to vibrations from the loading/installation of shingles on to my roof (if applicable), or installation of siding. COMPANY NAME is not liable for such damages.

I understand that minor stucco damage may result when the roof is torn off areas where stucco meets my roof's surface, especially where improperly applied. COMPANY NAME is not liable for repairing said damage.

I understand that any warranty for material used during the project is provided by the material manufacturer. Unless agreed upon otherwise, COMPANY NAME provides a 5-year Workmanship Warranty on portions of the project in which COMPANY NAME fully replaced any existing products. Roofing workmanship warranties will be reduced to one year when home owners have requested that full synthetic underlayment not be installed. Full warranty details available by request.

I understand that, unless agreed upon. This does not apply to products, some of which may deteriorate more rapidly (ie. sealants) and should be inspected on a regular basis, and am not responsible for material shortage and have no claim to material surpluses.

I certify that I am the registered owner of the above project property, or have the legal permission to authorize COMPANY NAME to perform the work as stated and agree to pay the total project price.

I understand that any insurance claims are subject to the specific terms and conditions outlined by my insurance company, and may be subject to insurance company approval.

I understand that payment in full is due upon completion of work as stated in contract. All invoices not paid in full after 15 days will be subject to a 2% per month interest charge.

I understand that approval of my estimate is subject to customer credit approval by COMPANY NAME.

I agree that COMPANY NAME may access my credit bureau report(s), trade references, and other credit information prior to granting credit approval.

BE IT ORDAINED by the Governing Board of the Town of Ruth, North Carolina, the following amendment is made to the annual budget ordinance for the fiscal year ending June 30, 2023:

Section 1: As follows

<u>Revenues</u>	Increase	Decrease	
10-399-00 Appropriated Fund Balance	\$100.00	\$0.00	
<b>Total</b>	<b>\$100.00</b>	<b>\$0.00</b>	<b>\$100.00</b>

Section 2: To amend the General Fund, the appropriations are to be changed as follows:

<u>Expenses</u>	Increase	Decrease	
10-410-15 Maint/Repair-Bldg&Ground	\$348.00		
10-410-16 Maint/Repair-Equipment		\$348.00	
10-560-25 Town Hall Mowing & Beautification	\$100.00		
	<b>\$448.00</b>	<b>\$348.00</b>	<b>\$100.00</b>

Section 3: Copies of this budget amendment shall be furnished to the Clerk of the Governing Board, the Budget Officer, and the Finance Officer for their direction. Adopted this 16th day of May 2023

Notes for Amendment to the Budget Ordinance:

1 This assumes that for budgeting purpose, the city used an estimated collection rate in line with the amount established by state law [G.S. 159-13(b)(6)] and that the un-amended collection rate is equal to or less than the allowable limit.

2 Many revenues are not fully collected until June 30. To revise estimates mid-year requires careful analysis to ensure that revenue estimates will not be overestimated. Most revenue amendmets are for new revenues; however, these are not new revenues.

Type	Disp Acct	Budget	YTD	Variance	Pr	Item 6.
Type: Revenues						
Revenues	10-282-01 Late List Penalty Current	\$0.00	\$22.07	\$22.07		0.00%
Revenues	10-282-02 Late List Penalty Prior	\$0.00	\$5.78	\$5.78		0.00%
Revenues	10-300-00 Revenues	\$0.00	\$0.00	\$0.00		0.00%
Revenues	10-301-00 Current Taxes	\$124,896.55	\$96,749.22	(\$28,147.33)		77.46%
Revenues	10-301-01 Taxes - Prior Years	\$0.00	\$174.52	\$174.52		0.00%
Revenues	10-329-00 Interest Earned on Invest	\$2,350.00	\$2,265.85	(\$84.15)		96.42%
Revenues	10-329-01 Interest Earned Powell Bill	\$0.00	\$42.92	\$42.92		0.00%
Revenues	10-335-00 Miscellaneous Revenues	\$0.00	\$0.00	\$0.00		0.00%
Revenues	10-336-00 Current Personal Auto Taxes	\$8,777.43	\$6,394.05	(\$2,383.38)		72.85%
Revenues	10-336-01 Personal Auto Prior Years	\$0.00	(\$8.62)	(\$8.62)		0.00%
Revenues	10-337-00 NC Franchise Tax	\$0.00	\$0.00	\$0.00		0.00%
Revenues	10-343-00 Powell Bill Allocation	\$13,500.00	\$13,283.49	(\$216.51)		98.40%
Revenues	10-367-02 Sales & Use Tax Dist	\$43,000.00	\$40,642.50	(\$2,357.50)		94.52%
Revenues	10-367-03 NC Franchise & Utility TD	\$11,500.00	\$11,036.21	(\$463.79)		95.97%
Revenues	10-367-04 Solid Waste Disposal Tax Dist.	\$351.00	\$203.84	(\$147.16)		58.07%
Revenues	10-380-01 Sign Permit Payment	\$0.00	\$485.05	\$485.05		0.00%
Revenues	10-399-00 Appro.Fund Balance	\$25,140.99	\$0.00	(\$25,140.99)		0.00%
Revenues	10-399-01 Current Landfill Fees	\$23,400.00	\$21,658.38	(\$1,741.62)		92.56%
Revenues	10-399-02 Landfill Fees Prior	\$0.00	\$4.48	\$4.48		0.00%
Revenues	10-399-51 ARP Funding	\$0.00	\$65,811.02	\$65,811.02		0.00%
		\$252,915.97	\$258,770.76	\$5,854.79		102%
Type: Expenses						
Expenses	10-400-00 Expenses	\$0.00	\$0.00	\$0.00		0.00%
Expenses	10-409-00 NC Sales Tax	\$2,623.84	\$2,465.64	\$158.20		93.97%
Expenses	10-409-01 Sales Tax Other	\$260.00	\$251.26	\$8.74		96.64%
Expenses	10-409-02 S/H Freight	\$2,160.00	\$1,799.50	\$360.50		83.31%
Expenses	10-410-00 Mayor's Salary	\$775.00	\$645.90	\$129.10		83.34%
Expenses	10-410-01 Commissioner's Salary	\$1,292.00	\$1,076.60	\$215.40		83.33%
Expenses	10-410-02 Tax Collection & Clerk Ex	\$23,000.00	\$19,666.70	\$3,333.30		85.51%
Expenses	10-410-03 Legal	\$6,000.00	\$2,740.00	\$3,260.00		45.67%
Expenses	10-410-04 Professional Services	\$11,000.00	\$10,950.78	\$49.22		99.55%
Expenses	10-410-10 Election Expense	\$0.00	\$0.00	\$0.00		0.00%
Expenses	10-410-11 Town Employee Education	\$5,000.00	\$0.00	\$5,000.00		0.00%
Expenses	10-410-13 Utilities/CityHall/Mall	\$3,000.00	\$2,484.51	\$515.49		82.82%
Expenses	10-410-15 Maint/Repairs-Bldg&Ground	\$8,652.00	\$6,642.00	\$2,010.00		76.77%
Expenses	10-410-16 Maint/Repair-Equipment	\$8,448.00	\$8,796.00	(\$348.00)		104.12%
Expenses	10-410-26 Advertising	\$700.00	\$390.00	\$310.00		%

Type	Disp Acct	Budget	YTD	Variance	Pr	Item 6.
Expenses	10-410-33 Dept. Materials & Supplies	\$1,500.00	\$1,043.22	\$456.78		69.55%
Expenses	10-410-53 Dues & Subscriptions	\$18,450.00	\$17,363.74	\$1,086.26		94.11%
Expenses	10-410-54 Insurance & Bonds	\$3,719.00	\$3,719.00	\$0.00		100.00%
Expenses	10-410-58 Christmas Decorations	\$36,000.00	\$28,745.52	\$7,254.48		79.85%
Expenses	10-410-59 Downtown Beautification	\$200.00	\$0.00	\$200.00		0.00%
Expenses	10-410-60 Town Hall Furnishings	\$1,740.00	\$1,736.80	\$3.20		99.82%
Expenses	10-410-70 Town Grounds	\$1,000.00	\$1,000.00	\$0.00		100.00%
Expenses	10-410-76 Captial Outlay-Technology	\$0.00	\$0.00	\$0.00		0.00%
Expenses	10-420-01 CARES Expenditure account	\$0.00	\$0.00	\$0.00		0.00%
Expenses	10-510-71 Capital Outlay Land	\$0.00	\$0.00	\$0.00		0.00%
Expenses	10-510-72 Capital Outlay Building	\$0.00	\$0.00	\$0.00		0.00%
Expenses	10-510-73 Capital Outlay Other Imp	\$24,000.00	\$0.00	\$24,000.00		0.00%
Expenses	10-510-74 Capital Outlay Equipment	\$0.00	\$0.00	\$0.00		0.00%
Expenses	10-510-75 Capital Outlay Technology	\$1,000.00	\$0.00	\$1,000.00		0.00%
Expenses	10-530-00 Fire Department	\$0.00	\$0.00	\$0.00		0.00%
Expenses	10-530-45 FireDept.Contr.Serv-Calls	\$49,279.29	\$49,279.29	\$0.00		100.00%
Expenses	10-530-46 Tree Removal	\$0.00	\$0.00	\$0.00		0.00%
Expenses	10-560-00 Street Department	\$0.00	\$0.00	\$0.00		0.00%
Expenses	10-560-13 Utilities-Street Lights	\$7,500.00	\$7,282.13	\$217.87		97.10%
Expenses	10-560-14 Utilities-Signal Lights	\$50.00	\$35.22	\$14.78		70.44%
Expenses	10-560-15 Maint/Rep-Existing Street	\$5,000.00	\$3,825.00	\$1,175.00		76.50%
Expenses	10-560-16 Snow & Ice Removal	\$2,000.00	\$0.00	\$2,000.00		0.00%
Expenses	10-560-17 Traffic Control	\$0.00	\$0.00	\$0.00		0.00%
Expenses	10-560-18 Drainage & Storm Sewer	\$0.00	\$0.00	\$0.00		0.00%
Expenses	10-560-19 Curb & Gutter	\$0.00	\$0.00	\$0.00		0.00%
Expenses	10-560-20 Bikeways	\$1,500.00	\$1,125.00	\$375.00		75.00%
Expenses	10-560-21 Sidewalks	\$0.00	\$0.00	\$0.00		0.00%
Expenses	10-560-22 Greenways	\$500.00	\$0.00	\$500.00		0.00%
Expenses	10-560-25 Town Hall Mowing & beautification	\$587.00	\$587.00	\$0.00		100.00%
Expenses	10-560-33 Dept. Materials & Supplie	\$0.00	\$0.00	\$0.00		0.00%
Expenses	10-560-45 Contr.Serv.-FireHydrants	\$0.00	\$0.00	\$0.00		0.00%
Expenses	10-580-00 Sanitation Department	\$0.00	\$0.00	\$0.00		0.00%
Expenses	10-580-33 Sanitation-Dept.Mat.&Supp	\$0.00	\$0.00	\$0.00		0.00%
Expenses	10-580-45 Garbage Contracted Serciv	\$16,779.84	\$13,935.46	\$2,844.38		83.05%
Expenses	10-580-46 RCSW Landfill Fees	\$9,200.00	\$7,065.70	\$2,134.30		76.80%
		\$252,915.97	\$194,651.97	\$58,264.00		77%

May 10, 2023

Amy Goode Hanaway  
Town Clerk, Town of Ruth  
PO Box 791  
Rutherfordton, NC 28139

Re: Board Member Appointment – BRWA  
David Guy

Dear Mrs. Hanaway:

In accordance with Article II, Section 2 of the BRWA Bylaws, the above referenced Board Member's term expires on June 30, 2023, and either a re-appointment of Mr. Guy or a successor is required to be appointed by your governing body for a three (3) year term, July 1, 2023 to June 30, 2026. The appointment is not required to be an elected official. Please schedule this appointment at an appropriate council meeting so the member may be sworn in at the BRWA meeting set for July 25, 2023.

Once the Appointment is official, please send notification in the form of a letter or a copy of the meeting minutes. My email is [mhunnicutt@ncbrwa.com](mailto:mhunnicutt@ncbrwa.com).

Respectfully submitted,

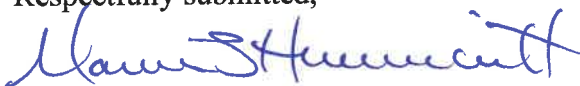

Maria S. Hunnicutt  
Secretary to the Board

cc: David Guy