



**CITY OF ROLLINGWOOD
PARK COMMISSION MEETING
AGENDA**

Tuesday, April 14, 2026

Notice is hereby given that the Park Commission of the City of Rollingwood, Texas will hold a meeting, open to the public, in the Municipal Building at 403 Nixon Drive in Rollingwood, Texas on April 14, 2026 at 12:00 PM. Members of the public and the Park Commission may participate in the meeting virtually, as long as a quorum of the Park Commission and the presiding officer are physically present at the Municipal Building, in accordance with the Texas Open Meetings Act. The public may watch this meeting live and have the opportunity to comment via audio devices at the link below. The public may also participate in this meeting by dialing one of the toll-free numbers below and entering the meeting ID and Passcode.

Link: <https://us02web.zoom.us/j/5307372193?pwd=QmNUbmZBQ1lwUINjNmK5RnJreIRFUT09>

Toll-Free Numbers: (833) 548-0276 or (833) 548-0282

Meeting ID: 530 737 2193

Password: 9fryms

The public will be permitted to offer public comments via their audio devices when logged in to the meeting or telephonically by calling in as provided by the agenda and as permitted by the presiding officer during the meeting. If a member of the public is having difficulties accessing the public meeting, they can contact the city at citysecretary@rollingwoodtx.gov. Written questions or comments may be submitted up to two hours before the meeting. A video recording of the meeting will be made and will be posted to the City’s website and available to the public in accordance with the Texas Public Information Act upon written request.

CALL PARK COMMISSION MEETING TO ORDER

- 1. Roll Call

PUBLIC COMMENTS

Citizens wishing to address the Park Commission for items not on the agenda will be received at this time. Please limit comments to 3 minutes. In accordance with the Open Meetings Act, the Park Commission is restricted from discussing or taking action on items not listed on the agenda.

Citizens who wish to address the Park Commission with regard to matters on the agenda will be received at the time the item is considered.

CONSENT AGENDA

CONSENT AGENDA

All Consent Agenda items listed are considered to be routine by the Park Commission and may be enacted by one (1) motion. There will be no separate discussion of Consent Agenda items unless a Board Member has requested that the item be discussed, in which case the item will be removed from the Consent Agenda and considered in its normal sequence on the Regular Agenda.

2. Discussion and possible action on the minutes from the March 24, 2026 Special Park Commission meeting

REGULAR AGENDA

3. Update from Western Hills Little League and Western Hills Girls Softball
4. Update from Western Hills Athletic Club
5. Discussion, update, and possible action regarding the Rollingwood Park Design Group meeting
6. Discussion and possible action regarding recommendations to City Council for a dog off leash area
7. Discussion and possible action on east driveway entrance improvements and parking area improvements in Rollingwood Park
8. Discussion and possible action on treatment solutions for mosquitos in the lower park area
9. Discussion, and possible action to improve Friends of Rollingwood Park online presence and fundraising

DEPARTMENT REPORTS

All reports are posted to inform the public. No discussion or action will take place on items not on the regular or consent agenda.

10. Park Commission Financials through March 30, 2026
11. Quarterly Rollingwood Police Department Park Report

ADJOURNMENT OF MEETING

CERTIFICATION OF POSTING

I hereby certify that the above Notice of Meeting was posted on the bulletin board at the Rollingwood Municipal Building, in Rollingwood, Texas and to the City website at www.rollingwoodtx.gov prior to 5:00 p.m. on April 8, 2026.

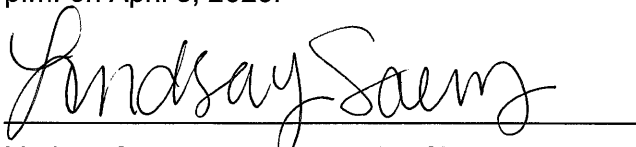

Lindsay Saenz, Assistant to the City Administrator

The Park Commission will announce that it will go into executive session, if necessary, to deliberate any matter listed on this agenda for which an exception to open meetings requirements permits such closed deliberation, including but not limited to consultation with the city's attorney(s) pursuant to Texas Government Code section 551.071, as announced at the time of the closed session.

Consultation with legal counsel pursuant to section 551.071 of the Texas Government Code;
discussion of personnel matters pursuant to section 551.074 of the Texas Government Code;
real estate acquisition pursuant to section 551.072 of the Texas Government Code;
prospective gifts pursuant to section 551.073 of the Texas Government Code;
security personnel and device pursuant to section 551.076 of the Texas Government Code;
and/or economic development pursuant to section 551.087 of the Texas Government Code.
Action, if any, will be taken in open session.



**CITY OF ROLLINGWOOD
SPECIAL PARK COMMISSION MEETING
MINUTES**

Tuesday, March 24, 2026

The Park Commission of the City of Rollingwood, Texas, held a meeting, open to the public, in the Municipal Building at 403 Nixon Drive in Rollingwood, Texas, on March 24, 2026, at 12:00 PM. Members of the public and the Park Commission were able to participate in the meeting virtually, as long as a quorum of the Park Commission and the presiding officer were physically present at the Municipal Building, in accordance with the Texas Open Meetings Act. A video recording of the meeting was made and will be posted to the City’s website and available to the public in accordance with the Texas Public Information Act upon written request.

CALL PARK COMMISSION MEETING TO ORDER

- 1. Roll Call

Chair Melissa Morrow called the meeting to order at 12:03 p.m.

Present Members: Chair Melissa Morrow, Victoria Johnson, Mary Elizabeth Cofer, Laurie Mills, and Diana Wallace

Also Present: Councilmember Kevin Glasheen, Councilmember Kevin Schell, City Administrator Alun Thomas, Assistant to the City Administrator Lindsay Saenz, and Development Services Manager Nikki Stautzenberger

PUBLIC COMMENTS

There were no public comments.

CONSENT AGENDA

- 2. Discussion and possible action on the minutes from the **February 10, 2026** Park Commission meeting

Victoria Johnson moved to approve the Consent Agenda. Mary Elizabeth Cofer seconded the motion. The motion carried with 5 in favor and 0 against.

REGULAR AGENDA

- 3. Discussion and possible action to have two park commission members sign up to conduct the park walk-through on April 17th

Park Commission Members Mary Elizabeth Cofer and Diana Wallace signed up for the April 17, 2026, park walk-through.

- 4. Update from Western Hills Little League and Western Hills Girls Softball

Chair Melissa Morrow stated that practices and games are currently underway.

- 5. Discussion and possible action regarding trash cleanup concerns related to organized sporting activities at the park

The Commission discussed the importance of maintaining cleanliness in the area and encouraged members of the public to pick up litter when observed. Western Hills Girls Softball representative Steve Franke reported that coaches will be contacted and that improvements to cleanup practices will be implemented moving forward.

- 6. Discussion, update, and possible action regarding the Rollingwood Park Design Group meeting
- 7. Discussion and possible action regarding recommendations to City Council for a dog off leash area

Curt Arnette of Sitio Design Austin presented three design options for the park. Version A proposes a 0.5-acre layout with a trail located along the north side. Version B expands the space to 0.55 acres and includes a trail on the north side, as well as an additional trail that separates the off-leash area from the fields. Version C outlines a 0.6-acre design featuring a trail on the north side and a walkway that runs through both the fields and the off-leash area.

Councilmember Glasheen said that, following the last meeting, he considered the proposal that had previously been discussed by the Park Commission to make the fence between Fields 1 & 2 and Fields 3 & 4. If that fence is moved in by 17 feet, it would add a lot of land (almost 1/10th of an acre) to Fields 3 & 4. He also noted that the 0.6-acre off-leash area would represent approximately 20% of the green space at the park.

Councilmember Schell agreed that the movable fence would add a lot of room for Fields 3 & 4, and he felt that the end users of the ball fields might not have their needs met by not being present at the meeting. He expressed his preference for not having a walking trail between the playing fields and the off-leash area.

Chairperson Melissa Morrow said that Steve Franke, from the Western Hills Little League, has provided the Park Commission with their practice and game schedule. That schedule shows that the current field usage of:

- Field 1 is being used 23.5 hours per week
- Field 2 is being used 16 hours per week
- Field 3 is being used 8 hours per week
- Field 4 is being used 13 hours per week
- Field 5 is being used 11 hours per week

Chairperson Morrow said based on the data, only three fields would accommodate the total number of hours of overall field usage, and said that the real discussion needs to be how big fields 3 & 4 would need to be following the addition of an off-leash area.

Chairperson Morrow summarized the item so far, noting that the Commission's consensus was not to include a walking trail between the playing fields and the off-leash area, and to incorporate trees into the design. Alex Robinette, resident at 2500 Hatley Drive, said that trees near the playing fields could pose a risk for baseball and softball players. Casey Hoffman, resident at 2800 Hatley Drive, said that he is a strong supporter of the 0.6-acre off-leash area, and asked what would happen to the dog memorial bricks that are currently present at the park. Mr. Arnette said that the bricks would be moved to a different location.

Commissioners Mary Elizabeth Cofer and Diana Wallis said that they could not see recommending an off-leash area of less than 0.6-acres, noting the current number of dogs at the park and the social aspect of many of the people using the off-leash area. The Commission discussed the impact of changing the off-leash area's size, and agreed with a recommendation from Councilmember Glasheen to consider forming an ad hoc subcommittee of current off-leash area users to obtain their input on the proposal. The Commission also discussed the possible formation of the "Rollingwood Canine Club", membership in which would be priced differently for Rollingwood residents and non-residents, and would grant access to the off-leash area. The members of the Commission generally agreed with the concept of the "Rollingwood Canine Club".

Mr. Franke said that he was opposed to having the fence between Fields 1 & 2 and Fields 3 & 4 moved 17 feet, saying that it would make the latter two fields unacceptably small, as proposed.

Alex Robinette lamented the slow pace of the Park's Commission formulation of a recommendation for City Council regarding the off-leash area, and encouraged the Commission to expedite its work so that Council can more quickly consider the recommendation or recommendations. Councilmember Glasheen agreed that a shorter timeframe would be helpful, but said that construction would likely take place in the fall. Chairperson Morrow said that she wanted to ensure that the process was open to the public, allow more public comment, and that any recommendation to Council was carefully thought-through and actually ready for Council to deliberate and take action on.

Mary Elizabeth Cofer motioned to ask Curt Arnette to prepare, in time for City Council's April 15, 2026 meeting, the same three drawings as presented today (the 0.5-acre, 0.55-acre, and 0.6-acre designs), but to eliminate the trail that passes between the ballfields and the off-leash area, remove the trees from in the off-leash area near the ballfields (but note that they are possible items for inclusion), and to move the trees to the outside of the off-leash area, and to provide water fountains for the dogs. Diana Wallace seconded the motion. The motion carried with 5 in favor and 0 against.

Ahead of the next Park Commission meeting, Chairperson Morrow said that she'd like to have a draft of the off-leash area user rules and a "Rollingwood Canine Club" framework. The Commission agreed that the drafts should not be assigned to staff, as the work might be too great of an administrative burden.

- 8. Discussion, update, and possible action on east driveway entrance improvements and parking area improvements in Rollingwood Park

Chair Melissa Morrow stated that she, Curt Arnette, and Robert Dial of Dial Development Services, Ltd., discussed potential pricing and next steps to move forward. Mr. Arnette presented his drawings, which included an embellished entry to the parking lot, along with greenery and fences.

- 9. Discussion and possible action on treatment solutions for mosquitoes in the lower park area

This item was not discussed.

- 10. Discussion and possible action to suggest possible improvements to Friends of Rollingwood Park

The Park Commission discussed adding an online link to the City’s website to make it easier for residents to donate. Chair Melissa Morrow stated that she is meeting with Jeff Marx, resident at 2516 Timberline Drive, to discuss easier ways to donate.

- 11. Discussion regarding Quarterly Park Walk Through report from Public Works

This item was not discussed.

DEPARTMENT REPORTS

All reports are posted to inform the public. No discussion or action will take place on items not on the regular or consent agenda.

- 12. Park Commission Financials through February 30, 2026

ADJOURNMENT OF MEETING

The meeting was adjourned at 1:34 p.m.

Minutes adopted on the 14th day of April, 2026.

Melissa Morrow, Chair

ATTEST:

Lindsay Saenz, Assistant to the City Administrator

AGENDA ITEM SUMMARY SHEET

City of Rollingwood

Meeting Date: April 14, 2026

Submitted By:

Staff

Agenda Item:

Update from Western Hills Little League and Western Hills Girls Softball

Description:

This agenda item is included on the Park Commission's agenda for informational purposes only. It allows both Western Hills Little League and Western Hills Girls Softball to provide the Commission with updates on their activities.

Action Requested:

No action.

Fiscal Impacts:

n/a

Attachments:

n/a

AGENDA ITEM SUMMARY SHEET

City of Rollingwood

Meeting Date: April 14, 2026

Submitted By:

Staff

Agenda Item:

Update from Western Hills Athletic Club

Description:

The Waves summer swim team season starts April 20. Austin Country Club is requesting to join our swim program for 18-24 months while they renovate their pool; they have a small team and would provide two coaches. The board is awaiting more information about their coaches and program before making a decision. The updated completion date for the pool deck project is now April 10. The recent delays have been due to new soil survey results, which necessitated different footings. The native area of the WHAC property that is adjacent to the city's park property and heretofore was outside of the WHAC fence: the board is looking into options to extend the fence to the WHAC property line and clear underbrush and dead trees in parallel with the current construction.

Action Requested:

No action is requested or permitted for this item

Fiscal Impacts:

No fiscal impact is expected from this item

Attachments:

None

AGENDA ITEM SUMMARY SHEET

City of Rollingwood

Meeting Date: April 14, 2026

Submitted By:

Staff

Agenda Item:

Discussion, update, and possible action regarding the Rollingwood Park Design Group meeting

Description:

This item is intended to provide an update from the April 9, 2026, Rollingwood Park Design Group meeting.

Action Requested:

No action.

Fiscal Impacts:

n/a

Attachments:

n/a

AGENDA ITEM SUMMARY SHEET

City of Rollingwood

Meeting Date: April 14, 2026

Submitted By:

Staff

Agenda Item:

Discussion and possible action regarding recommendations to City Council for a dog off leash area

Description:

The Rollingwood Park Design Group held a meeting on April 9, 2026, to discuss potential ideas for a dog-off-leash area in Rollingwood Park.

This item allows the Park Commission to review proposed designs for an off-leash dog area from Landscape Architect Curt Arnette of Sitio Design and propose a recommendation to City Council.

Action Requested:

Discuss and consider a recommendation to City Council regarding an off-leash dog area design.

Fiscal Impacts:

The fiscal impact from this item depends upon the Commission's recommendation and City Council's decision.

Attachments:

- Version A
- Version B
- Version C

Dog Park Version 'A'

.5 Acres

* Softball Field - shifted south 30', west 10'

* One field eliminated

1 acre = 43,560 sf
.5 acre = 21,780 sf
.55 acre = 23,958 sf
.6 acre = 26,136 sf

KEY

- Dog Park Area - 21,790 sf (.5 ac)
- Play Field Area - 33,186 sf (.76 ac)
- Proposed Planting Areas (Additional Butterfly Gardens)
- Proposed Dog Fencing
- Proposed Dog Park entrance
- Proposed Shade Tree
- Existing Ball Field Fencing
- Proposed Ball Field Fencing to accommodate proposed parking area
- Proposed Ball Field Fencing to accommodate proposed Dog Park
- Proposed Guardrail

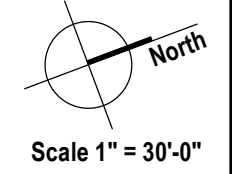

sitiodesign
 curt arnette, asa
 landscape architect
 6114 ginilla lane
 austin, texas 78739
 512.415.2097
 sitiodesigngroup@yahoo.com
 sitiodesign.com
 April 7, 2026

Dog Park Version 'B'

.55 Acres

* Softball Field - shifted south 45', west 10'

* One field eliminated

1 acre = 43,560 sf
.5 acre = 21,780 sf
.55 acre = 23,958 sf
.6 acre = 26,136 sf

KEY

- Dog Park Area - 24,140 sf (.55 ac)
- Play Field Area - 30,890 sf (.71 ac)
- Proposed Planting Areas (Additional Butterfly Gardens)
- Proposed Dog Fencing
- Proposed Dog Park entrance
- Proposed Shade Tree
- Existing Ball Field Fencing
- Proposed Ball Field Fencing to accommodate proposed parking area
- Proposed Ball Field Fencing to accommodate proposed Dog Park
- Proposed Guardrail

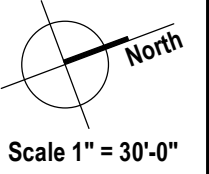

sitiodesign
 curt arnette, asa
 landscape architect
 6114 ginilla lane
 austin, texas 78739
 512.415.2097
 sitiodesigngroup@yahoo.com
 sitiodesign.com

April 7, 2026



Landscape Development Plan for the
Rollingwood Park
 Rollingwood Drive, Rollingwood, TX 78746

ProgressSet
 Not For Construction

Date: 4/09/2026

Revised:

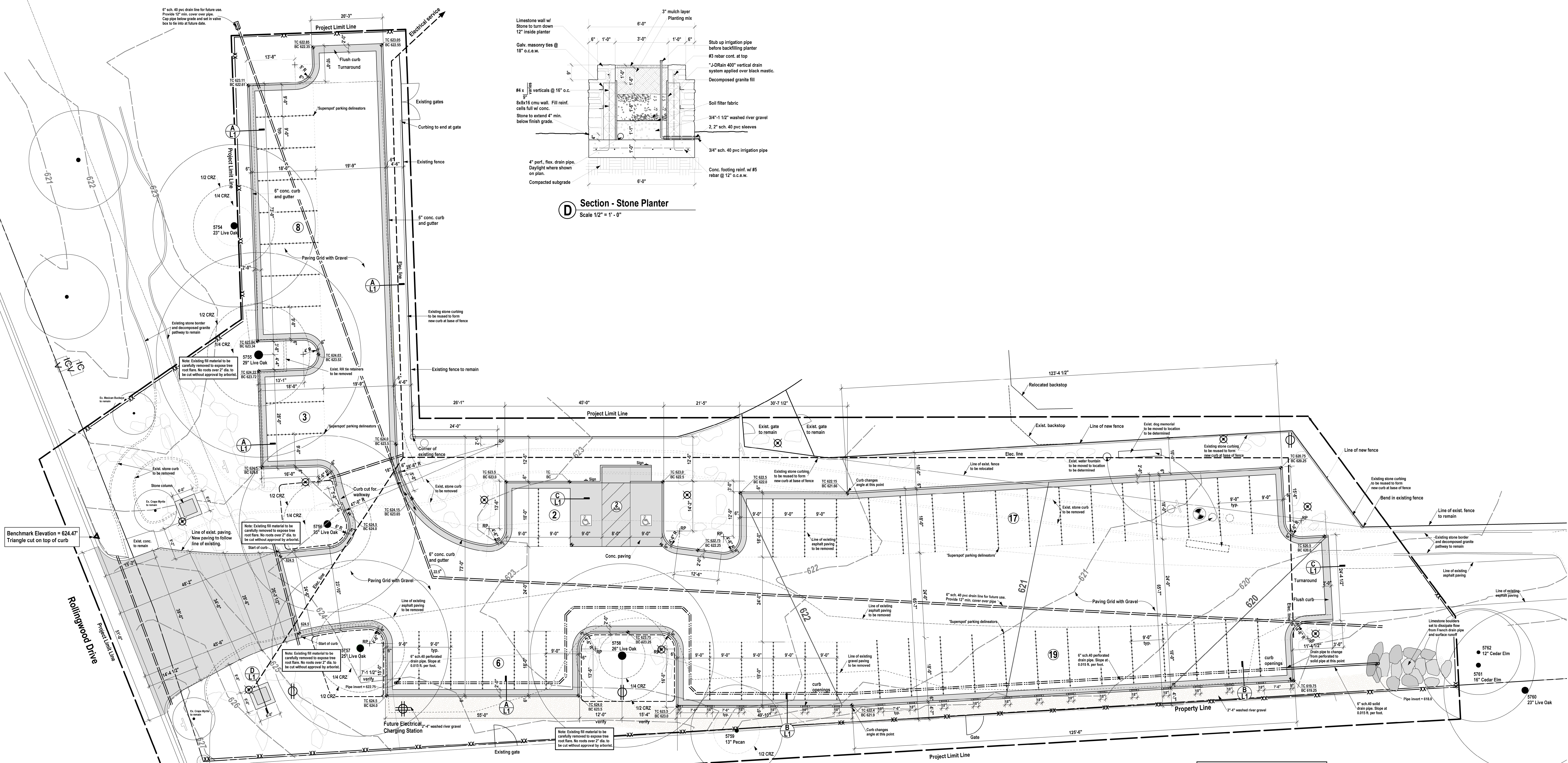
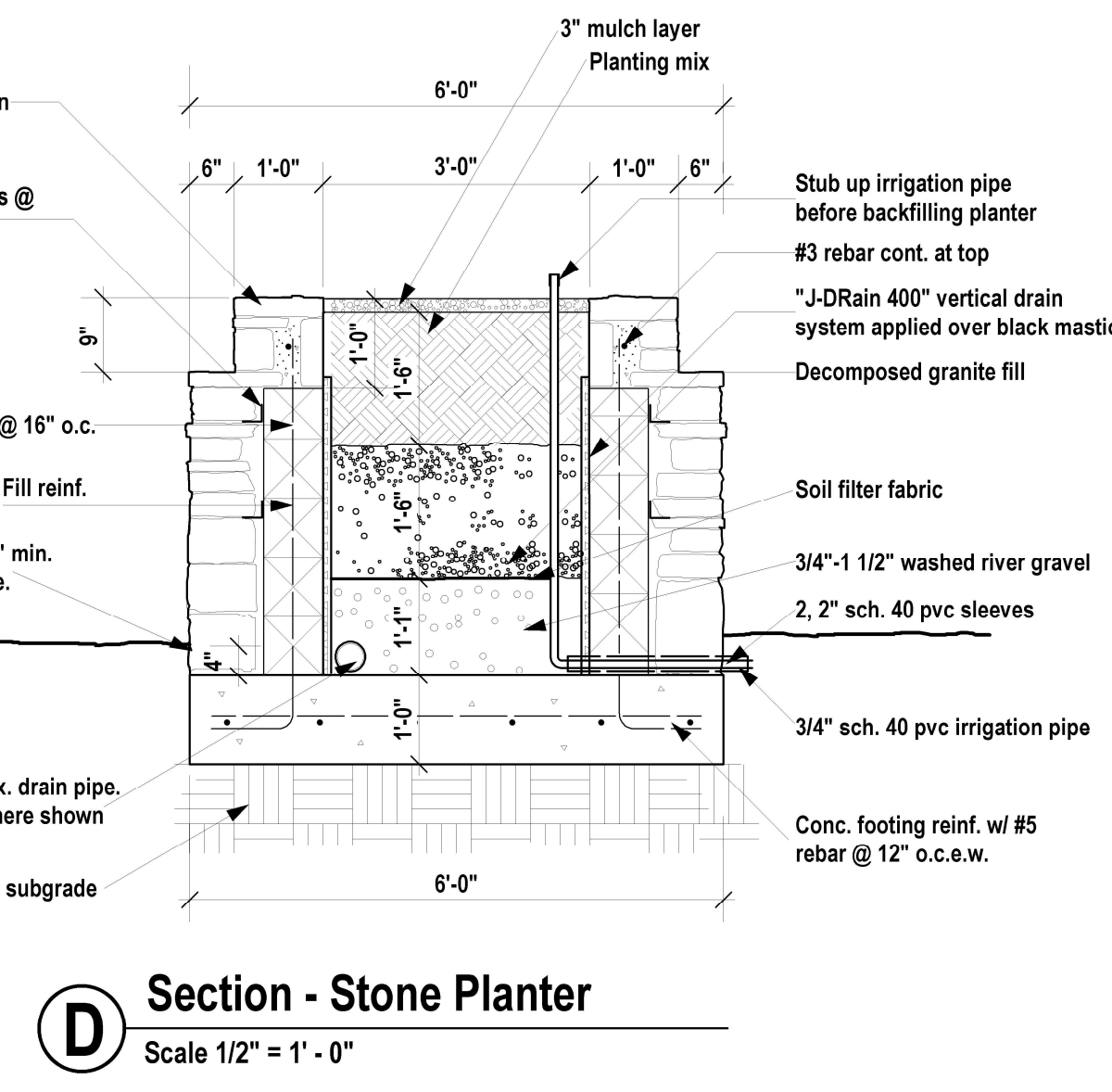
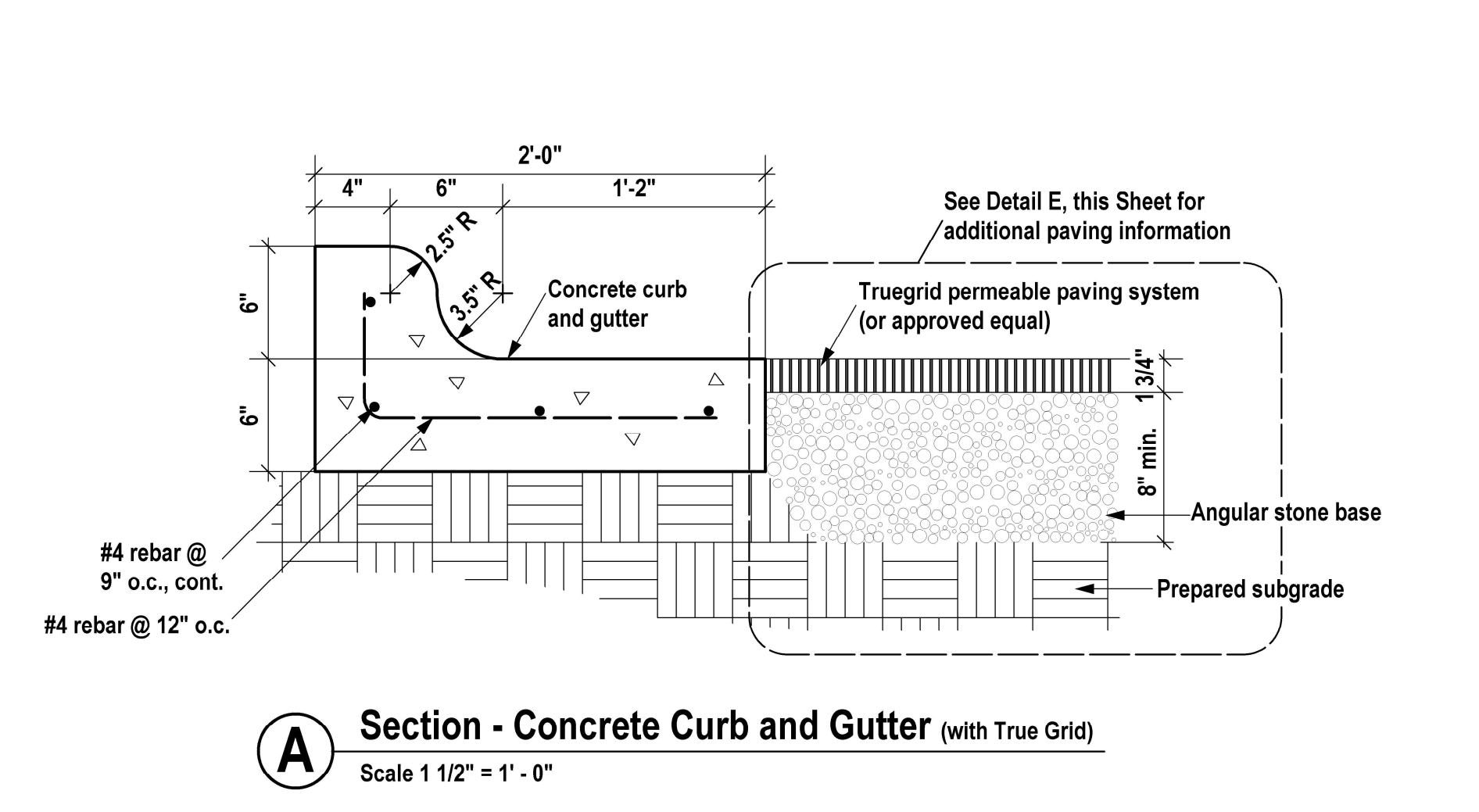
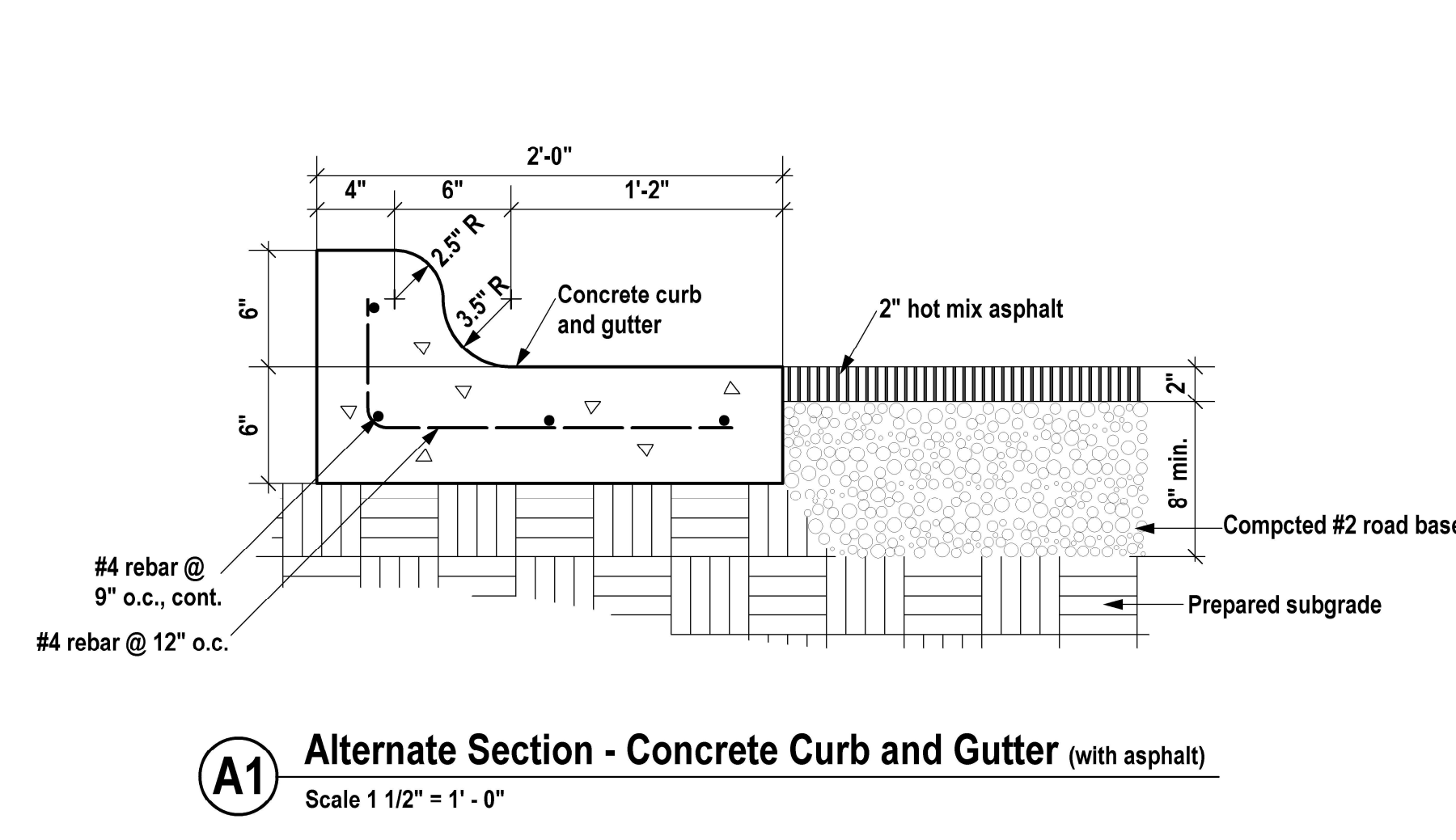
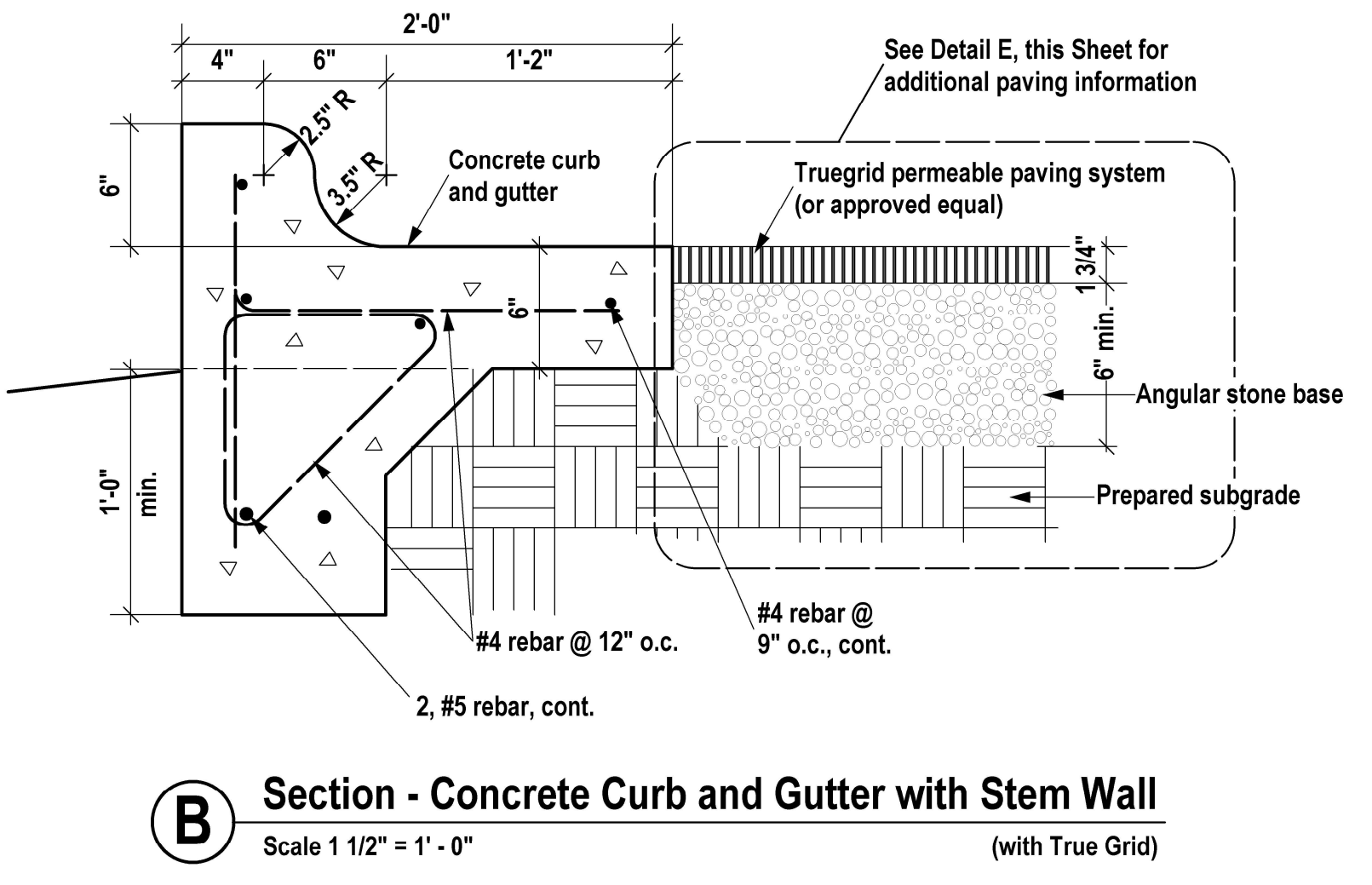
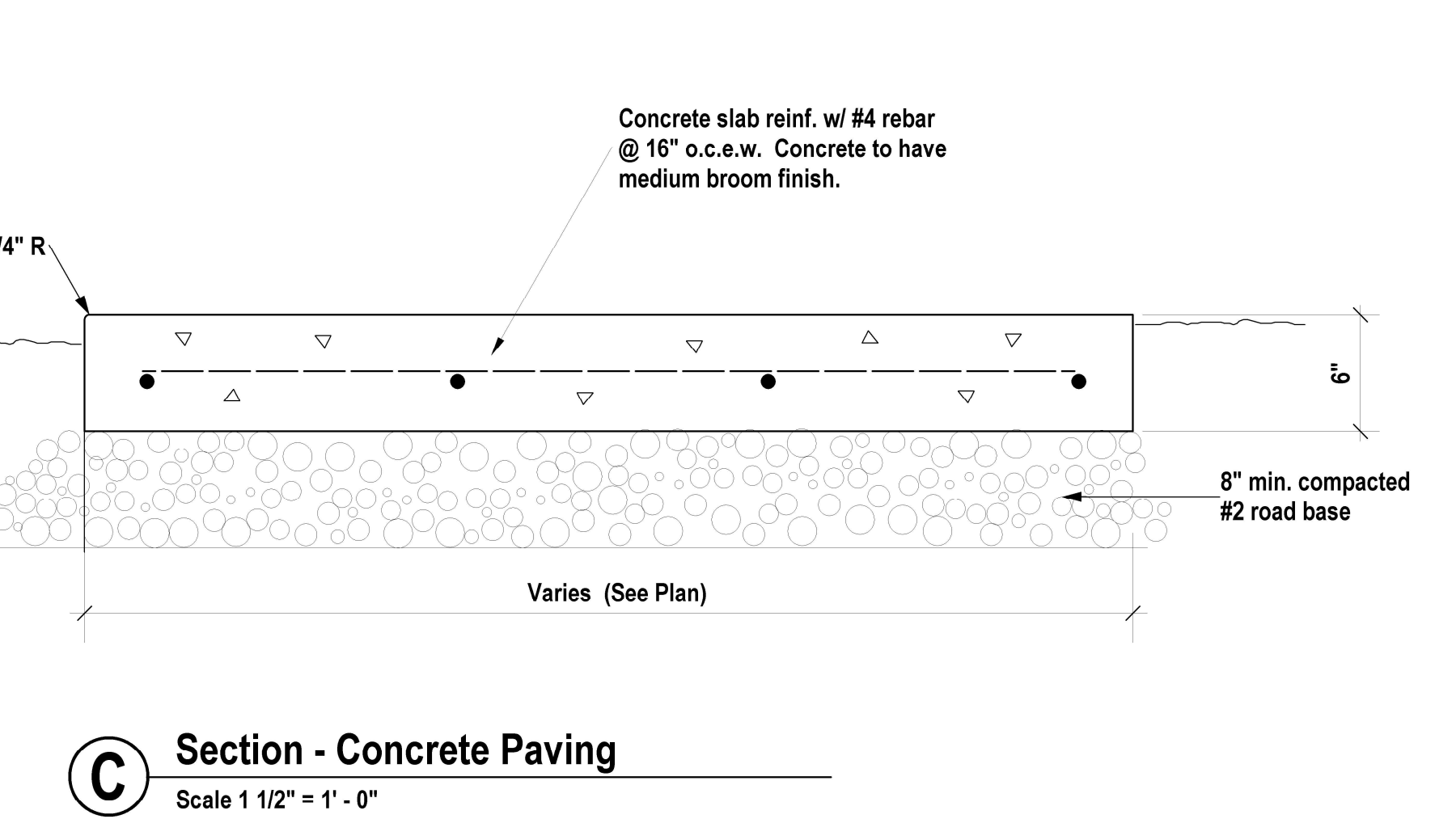

Legend

- 624.0' Proposed Finish Grade Elevation
- BC Bottom of Curb Elevation
- TC Top of Curb Elevation
- TW Top of Wall Elevation
- Detail Sheet No.
- 627 Existing Contour Elevation
- 622 Proposed Contour Elevation
- 2, 4" Sch. 40 PVC Sleeves
- XX Silt Fence Location
- Location of Tree Protection Fencing
- Landscape lighting locations
- Electrical outlet locations
- Future Electrical Charging Station

Hardscape Plan
 Scale 1" = 10'-0"

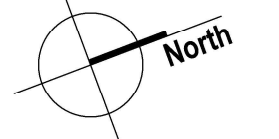

ROLLINGWOOD DRIVE (EXISTING SETBACK LINE)

Plant List

Key	Common Name	Botanical Name	Size	Height	Spread	Remarks	O.C.	Qty.
ABN	American Beechberry	Zelkova americana	5 gal	24'-28"	20'-24"		42'	4
AGA	Agave	Mahonia trifoliolata	10 gal	30'-36"	30'-36"		42'	24
BMF	Blue Mistleflower	Eupatorium coelestinum	1 gal	10'-12"	8"		24"	16
BUR	Bur Oak	Quercus macrocarpa	300 gal	14'-15'	7'-8"	8' cal. s&f full sym canopy	/	3
CHQ	Chinquapin Oak	Quercus muhlenbergii	300 gal	14'-15'	7'-8"	8' cal. s&f full sym canopy	/	3
CRV	Tangerine Beauty Crossvine	Bignonia capreolata 'Tangerine Beauty'	5 gal	30' spread		attach to fence	/	7
DNL	Baby's Breath Willow	Chipsas biparis 'Baby's Breath'	24" tree	6'-7"	3'-4"	multi-trunk	/	1
FLA	Flame Acanthus	Arisaema quadrifidum var. white	1 gal	12'-15'	10'-12"		36"	24
FRO	Frogfruit	Phyla nodiflora	1 gal	1'-2"	8"		30"	14
GAU	Butterfly Gaura	Deinothera lindheimeri	1 gal	10'-12"	8"	white flowering	24"	11
GCM	Gulf Coast Muley	Muhlenbergia capillaris	1 gal	10'-12"	8"		36"	22
GGA	Green Globe Agave	Agave sp. Green Globe	10 gal	15'-18"	12'-15"	full & symmetrical	/	7
GYU	Young Willow Hesperis	Hesperis matronalis sp. changii	10 gal	30'-36"	18'-20"	full & symmetrical	4' min	13
HCS	Heavenly Cloud Sage	Leucophyllum sp. 'Heavenly Cloud'	5 gal	18'-24"	18'-24"		48"	4
INL	Inland Sea Oats	Chamathum setosum	1 gal	12'-15'	8"		24"	85
KID	Texas Kidneywood	Erytharitia texana	5 gal	30'-36"	12'-15'		/	8
LBS	Lutea Bluestem	Schizanthium scoparium	1 gal	15'-18"	8"		30"	19
LMG	Lindheimer's Muhlenberg	Muhlenbergia lindheimeri	1 gal	10'-12"	8"		42"	26
MHO	Mexican Hornsuckle	Jasione spicosa	1 gal	10'-12"	8"		30"	24
MPL	Mexican Plum	Prunus mexicana	30 gal	30'-42"	30'-36"	4" caliper	/	1
MTL	Texas Mountain Laurel	Sophora secundiflora	30 gal	3'-4"	24'-30"	multi-trunk	/	18
MTR	Montgomery Oak	Quercus polymorpha	300 gal	14'-15'	7'-8"	8' cal. s&f full sym canopy	/	3
PAV	Rock Rose	Parsonsia lasiocarpa	1 gal	12'-15'	10'-12"	full	36"	15
PN	Pine Mistle	Muhlenbergia diffusa	1 gal	10'-12"	8"		42"	39
PTL	Purple Trailing Lantana	Lantana montevidensis	1 gal	3'-4"	5'-6"		30"	18
REB	Texas Redbud	Cercis canadensis var. texensis	30 gal	30'-42"	30'-36"	4" caliper	/	2
RBV	Rusty Blackhaw Viburnum	Viburnum rufidulum	30 gal	5'-6"	30'-36"	4" total cal., multi-trunk	/	3
RLD	Roughleaf Dogwood	Cornus drummondii	30 gal	5'-6"	30'-36"	4" total cal., multi-trunk	/	7
RYU	Red Yucca	Hesperaloe parviflora	10 gal	18'-24"	18'-24"		42"	26
SAR	San Antonio Rose Sage	Leucophyllum sp. 'San Antonio Rose'	5 gal	18'-24"	18'-18"		48"	4
SLG	Silabovleaf Goldeneye	Viguiera stenolepis	5 gal	18'-24"	18'-24"		30"	16
SPP	Snowless Pinyon Pear	Quercus sp.	5 gal	12'-15'	12'-15'		/	15
TPE	Texas Persimmon	Diospyros texana	30 gal	5'-6"	30'-36"	4" total cal., multi-trunk	/	3
TUC	Big Momma/Turk's Cap	Malvastrum drummondii 'Big Momma'	1 gal	12'-14"	5'-6"		36"	17
WAF	White Mistleflower	Eupatorium havanense	5 gal	18'-24"	18'-24"		36"	9
WST	Waxy Clematis	Clematis texensis	1 gal	4'-6"	4'-6"		30"	26
YAU	Yule of Houston Yucca	Yucca umbellata 'Yule of Houston'	30 gal	5'-6"	30'-36"	4" total cal., multi-trunk	48"	26
ZEX	Orange Zinnia	Zinnia mexicana	1 gal	8'-10"	8'-10"		24"	24

Landscape Notes

Familiarization with Jobsite: Landscape contractors should thoroughly familiarize themselves with the working area as it relates to the Construction Documents prior to the commencement of any construction activity and notify the Landscape Architect where discrepancies are encountered. Contractor to verify the location of underground utilities prior to any excavation. Landscape contractor to be responsible for repairing any damage to existing hardscape, underground electrical and existing irrigation to remain.

Protection of Existing Vegetation: Existing trees scheduled to remain should be protected from injury or damage to roots, trunks, or branches by placing tree protection fencing in areas shown on plan. Damaged trees or vegetation to be repaired immediately in a manner acceptable to the Landscape Architect. Immediately damaged trees or shrubs must be replaced with ones of similar size and shape at the expense of the Contractor. A value to be determined in accordance with the tree evaluation formula as described in "A Guide to the Professional Evaluation of Landscape Trees, Specimen Shrubs and Evergreens", published by the International Society of Arboriculture.

Treatment of Existing Weeds: Existing stands of bermudagrass, johnsongrass, nutgrass, and noxious weeds to be treated with herbicide before construction begins. Nutgrass to be treated with "Image" or "Marsang". Other weeds to be treated with "Fusatec", "Roundup", or equal herbicide. Use care not to overapply onto existing vegetation to remain. Treatment shall be in strict accordance with manufacturer's specifications and shall be accomplished to allow sufficient time for a complete kill prior to starting any soil preparation.

Grading and Earthwork: Contractor to ensure positive drainage. Planting mix to be added to fill any depression that may not exceed 200mm. Planting mix to be added to all soil settlement. Minimize the addition of planting mix under drip line of existing trees. Final grading to be approved by Landscape Architect.

Decomposed Granite Area: Granite path to receive a 3 1/2" layer of decomposed granite after compaction. Granite to be wetted and compacted with a plate compactor to achieve a smooth and even surface free from undulations.

Planting Mix: Planting mix to be "Thunder Dirt" as applied by Geo Growers, 12002-B Hwy 290 West, Austin TX 78737 (512) 892-2722. Planting mix substitutions to be approved by Landscape Architect prior to delivery to site.

Plant Material: Plants shall be healthy, vigorous, bushy, well-branched, unbroken, of normal habit of growth for the species, and shall be free from disease, insects, larvae and injury. All plant material shall be specimen quality from the best available sources, equal to or exceeding the measurements specified on the plant list. Contact Landscape Architect for possible plant sources. Landscape Architect may reject any plant material not meeting the minimum requirements. Any plant substitutions must be approved by Landscape Architect. Landscape Contractor to warrant plant material to remain alive and in vigorous condition for a period of one (1) year after completion and acceptance of entire project. Replace, in accordance with the plans and specifications, all plants that are dead or, as determined by Landscape Architect, are in an unhealthy or unsightly condition, and have lost their natural shape due to dead branches, or other causes due to the Contractor's negligence. The cost of such replacement(s) is at the Contractor's expense. Warrant all replacement plants for one year after installation.

Shrub Bed Layout: Carefully and accurately layout planting beds as they relate to known points in the field such as existing trees or building features. Notify Landscape Architect if problems are encountered in laying out beds or if dimensions are needed. Final bed layout and plant layout to be approved by Landscape Architect before planting occurs.

Planting: Planting shall be performed only by experienced workers familiar with planting procedures under the supervision of a qualified supervisor. Loose plants as indicated or as approved in the field after staking by the Contractor. If obstructions are encountered that are not shown on the plans, do not proceed with planting operations until alternate plant locations have been selected by the Landscape Architect. Excavate circular plant pits with sloped sides twice the diameter of the root ball. Pits to be no deeper than the depth of the root system. Place 1/2 to 1 cup of Gardenville 6-2-2 Soil Food or approved equal in the soil of white backfilling. Top of rootball to be 1" minimum above surrounding grade with backfill sloping up to rootball. Set plants upright, plants, and loose to give the best appearance or relationship to each other or adjacent structure.

Mulch: Mulch types are indicated on the plan. Hold back mulch from base of plants.

M1 areas: M1 areas to receive a 3" minimum layer of shaded native hardwood mulch. Hold back mulch from trunk of plant. Source to be approved by Landscape Architect.

Irrigation: Landscape Contractor to be responsible for coordinating with Irrigation Contractor. Irrigation contractor to be licensed in the state of Texas. Irrigation system to be automatically controlled with a multi-program controller equipped with a rain sensor. All new ornamental grasses, perennials, shrubs and trees to be irrigated with drip emitters. Each plant to have a minimum of one emitter, size of emitter to be determined based on each plant's watering needs. Irrigation Contractor to make final adjustments after planting is finished. No trenching to be allowed in critical root zone of existing trees to remain. Irrigation contractor to provide an as-built drawing showing water meter, doublecheck backflow preventer, valve locations, mainline location, sprinkler head layout and flood bubbles. Irrigation contractor to also provide a reduced scale drawing showing irrigation zones. A copy of this plan to be laminated and posted by the contractor.

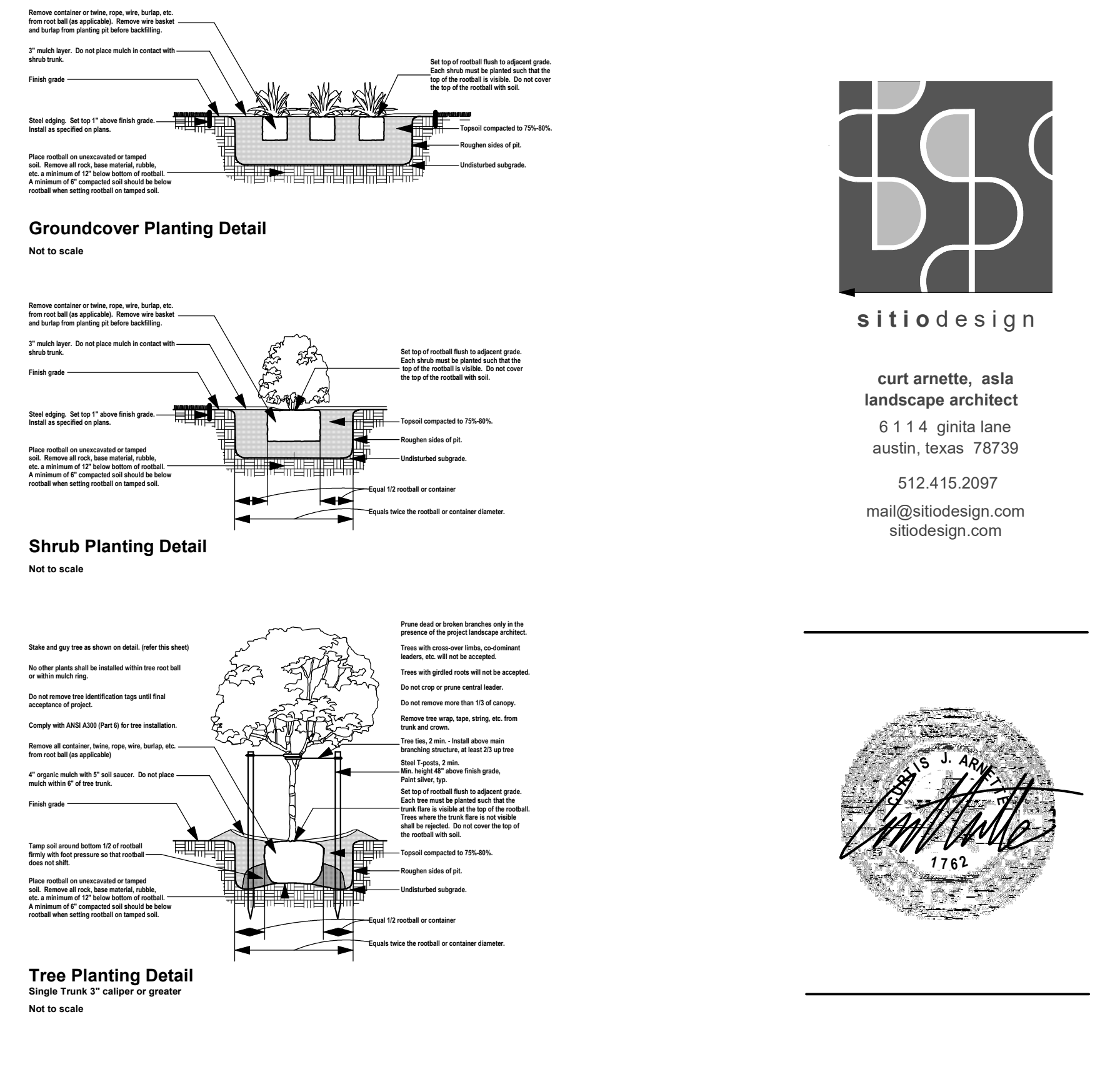

sitiodesign
 curt arnette, asia
 landscape architect
 6114 grilla lane
 austin, texas 78739
 512.415.2097
 mail@sitiodesign.com
 sitiodesign.com

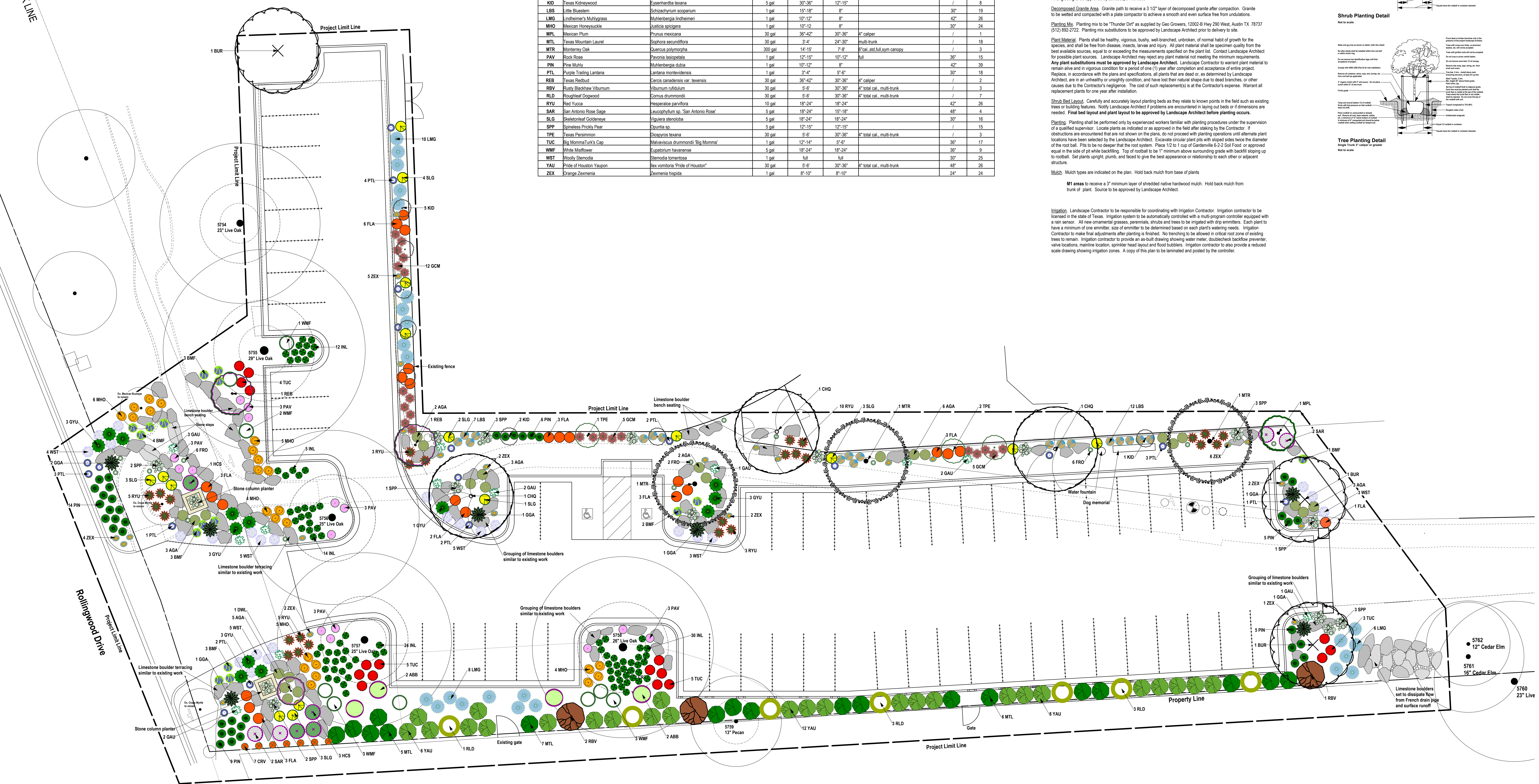

Landscape Development Plan for the
Rollingwood Park
 Rollingwood Drive, TX 78746

ProgressSet
 Not For Construction

Date: 4/09/2026
 Revised:

Planting Plan
 Scale 1" = 10'-0"

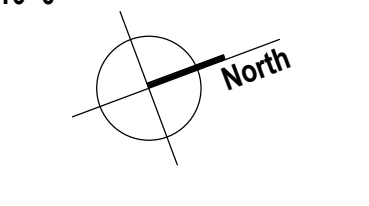

**PREAMBLE**

All of the materials used in making the Grasspave2 product are non-biodegradable plastics. As such they can be described as having an “indefinite lifespan”. From a practical standpoint, we know that plastic pipe materials have been used in the ground for at least 45 years and are still functioning.

Our plastic materials will not directly harm or help the vegetation grown within the Grasspave2 structure from a horticultural standpoint. The purpose of the structure is to minimize soil compaction, which allows the plant root system to function properly.

Grasspave2 can be exposed to sunlight, if topdressing is not maintained, and UV light from the sun can break down the chemical structure of the plastic. We have added carbon black (a UV inhibitor) to our product (made from recycled HDPE) to inhibit UV degradation. However, we will not be held responsible for long term effects of UV due to poor maintenance.

WARRANTY

Invisible Structures, Inc. warrants to its purchasers that all materials furnished by it will be free from defects in materials and/or workmanship. This warranty shall be extended for the lifetime of the installation, provided the installation was executed according to the technical specifications. In the unlikely event that a Grasspave2 part needs replacing, all defective materials shall be refurbished after inspection by our company showing the materials have failed under this warranty and providing a written claim is presented to us with proof of purchase. Under this warranty, we agree to refurbish the defective materials at no charge, excluding re-installation costs. This in lieu of all other warranties expressed or implied and is the sole warranty extended by us. Our liability under this warranty is limited to the refurbishing of materials and does not include any responsibility for consequential or other damages of any nature.

**PREAMBLE**

All of the materials used in making the Gravelpave2 product are non-biodegradable plastics. However, when plastics are exposed to sunlight and Ultra Violet (UV) light, plastic can become “photodegradable”. We incorporate use of UV inhibitors in our colorants to minimize damage done from UV light, and expect our product to have a useful lifespan of 40 years, depending upon sunlight exposure conditions.

The purpose of the structure is to stabilize gravel surfaces and “contain” the gravel for greater surface strength, durability, ease of maintenance and elimination of pot-holes.

WARRANTY

Invisible Structures, Inc. warrants to its purchasers that all materials furnished by it will be free from defects in materials and/or workmanship. This warranty shall be extended for the lifetime of the installation, provided the installation was executed according to the technical specifications. In the unlikely event that a Gravelpave2 part needs replacing, all defective materials shall be refurbished after inspection by our company showing the materials have failed under this warranty and providing a written claim is presented to us with proof of purchase. Under this warranty, we agree to refurbish the defective materials at no charge, excluding re-installation costs. This in lieu of all other warranties expressed or implied and is the sole warranty extended by us. Our liability under this warranty is limited to the refurbishing of materials and does not include any responsibility for consequential or other damages of any nature.

 Outlook

Fwd: RFQ: Grasspave2 & Gravelpave2 - City of Rollingwood, TX

From Alexandra Robinette <[REDACTED]>**Date** Mon 4/6/2026 11:23 AM**To** Lindsay Saenz <lisaenz@rollingwoodtx.gov>**Cc** Melissa Morrow <[REDACTED]>; Alun Thomas <athomas@rollingwoodtx.gov> 2 attachments (197 KB)

GP2Warranty24.pdf; GV2Warranty24.pdf;

Hi Lindsay,

Could you please distribute this information to Council and Parks Commission.

Thank you,
Alex

Begin forwarded message:

From: Cody Rollins <cody@mkmsales.com>**Subject:** RE: RFQ: Grasspave2 & Gravelpave2 - City of Rollingwood, TX**Date:** April 6, 2026 at 9:38:02 AM CDT**To:** Alexandra Robinette <[REDACTED]>**Cc:** Brook Brown <bbrown@rollingwoodtx.gov>, Melissa Morrow

<[REDACTED]>, Curt Arnette <sitiodesigngroup@yahoo.com>,

Shea Kent <shea@mkmsales.com>

Alex,

Grasspave2 / Gravelpave2 have a lifetime warranty and the material itself will long out last either concrete or asphalt as far as the product is concerned. We have some 40 year old installations that have the original grasspave2. Since the ring on grid structure itself will last a lifetime, you have to compare the entire system as a whole.

Asphalt requires resurfacing from time to time – maybe every 15 or 20 years (shorter or longer depending on varying factors)

Concrete will require touchups at some point – maybe every 25 years (shorter or longer depending on varying factors)

Grasspave2 / Gravelpave2 – the system is buried, so unless there is damage from misuse, or unless you have a base course failure (like potholes below the grasspave2/gravelpave2 system) you won't have to do anything to the Grasspave2/Gravelpave2 grid itself. If a pothole does occur, no special machin

(like with asphalt) is required. Simply repair the base course below and replace the grid and infill.

For Grasspave2: you will have lawn maintenance just like any lawn. Mow, irrigate, fertilize, weed treat – just like any other landscape area on the property. If there is a mowing crew already taking care of landscaping areas of the property – add this to the list.

For Gravelpave2: using the right sized gravel and not overfilling the rings, the gravel will stay locked in place very well. While not frequent, you may occasionally be required to broom some of the top layer of gravel back over the tops of the rings in some of the higher traffic areas (like the entrance from the road). This is not a task that requires skilled labor, simply brushing of some gravel. If the tops of the rings are exposed, the system is still functioning. It is not a cause for concern or anything as it can still be driven on and function as intended.

Let me know what other questions you have. I am happy to provide additional information on porosity, base course recommendations, installation history, or anything else.

Best regards,

MKM Sales, Inc.

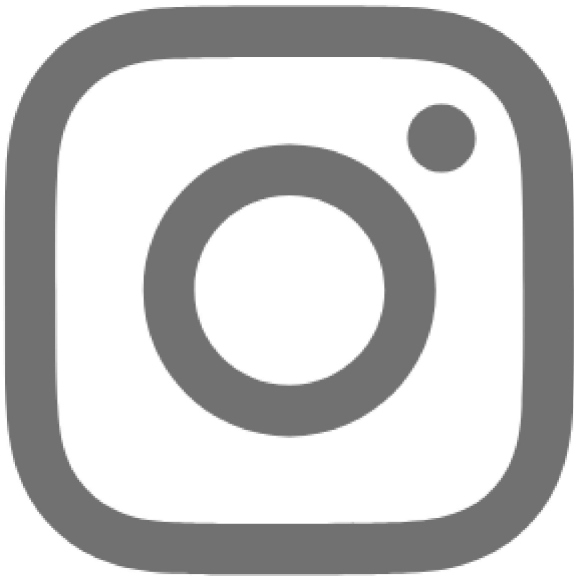

From: Alexandra Robinette <[REDACTED]>
Sent: Sunday, April 5, 2026 2:39 PM
To: Cody Rollins <cody@mkmsales.com>
Cc: Brook Brown <bbrown@rollingwoodtx.gov>; Melissa Morrow
<[REDACTED]>; Curt Arnette <sitiodesigngroup@yahoo.com>
Subject: Re: RFQ: Grasspave2 & Gravelpave2 - City of Rollingwood, TX

Hi Cody,

The RW council is taking into considering various paving options, including the Grass/Gravelpave product. Would you be able to provide some additional details regarding the life expectancy of this product versus asphalt or concrete.

Thank you!
Alex

Rollingwood Park Parking Lot Initial Cost Estimate (4/14/2026)

Excavation and hauloff (14" avg. below existing grade) – 750 cy x \$35/cy = \$26,250

Concrete curb and gutter – 1,075 lf x 35/lf = \$37,625

Concrete flatwork (driveway approach and ADA parking area) - 2,160 sf (240 sy) x \$100 sy = \$24,000

6" sch.40 pvc drain pipe – 320 lf x \$40/lf = \$12,800

6" sch. 40 pvc drain pipe (to be tied into at a later date) – 435 lf x \$40/lf = \$17,400

Paving Alternate 'A' – True Grid Pro Plus – 8" layer angular stone base, 2" layer finish gravel - 17,400 sf x \$9.25/ sf = \$160,950

Paving Alternate 'B' – 8" compacted #2 road base, 2" layer hot mix asphalt - 17,400 sf x \$3.50/ sf = \$60,900.

Paving Alternate 'C' – 5" reinforced concrete slab, 2" sand bed - 17,400 sf (1,933 sy) x \$100/ sy = \$193,333.

Tree Care Pre- and Post-Construction and Tree Protection - \$19,470

Rollingwood Dog Area Initial Cost Estimate (based on .55 acre option)

Excavation and hauloff (8" avg. below existing grade) – 540 cy x \$35/cy = \$18,900

Cedar post and wire mesh fence – 700 lf x \$15/lf = \$10,500

Items not priced:

Silt fencing installation

Limestone boulders

Masonry columns

Decomposed granite trail

Soil installation

Plant installation

Irrigation

Low voltage lighting



ENDLESS GRAVEL FILL OPTIONS

855) 355-GRID | TRUEGRIDPAVER.COM | FOXBLOCKS.COM

TRUEGRID Catalog V4.0

TRUEGRID
FOX BLOCKS

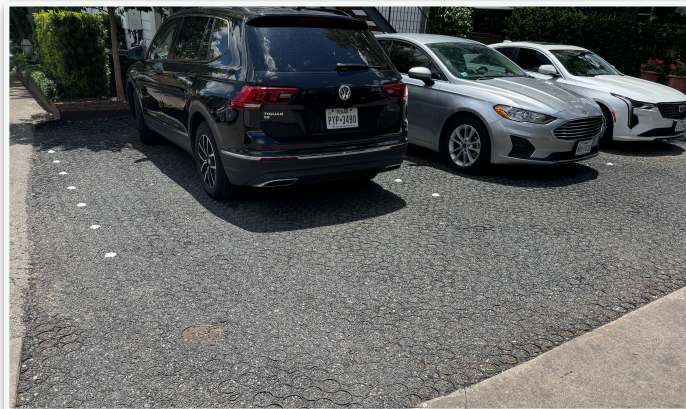
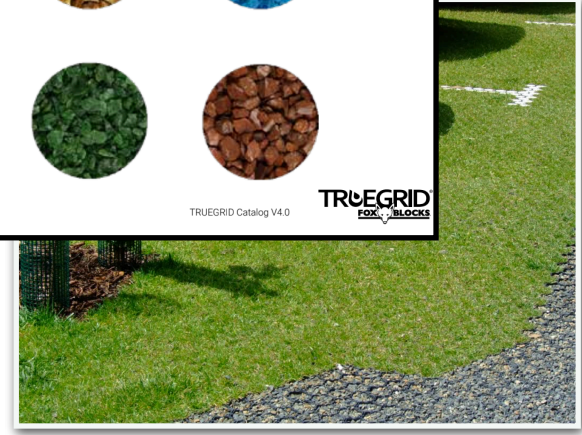

ROLLINGWOOD DR. EAST PARK ENTRY - CONCEPTS



Expanded pollinator garden



Nature Play



Picnic areas

AGENDA ITEM SUMMARY SHEET

City of Rollingwood

Meeting Date: April 14, 2026

Submitted By:

Staff

Agenda Item:

Discussion and possible action on treatment solutions for mosquitos in the lower park area

Description:

Park Commission member Sean Downing requested to discuss mosquito treatment and possible solutions.

Currently, the Public Works team treats mosquitos by using mosquito tablets to kill mosquito larvae in standing water when needed.

Action Requested:

To discuss and consider possible improvements for mosquito treatment in the lower park.

Fiscal Impacts:

Fiscal impact depends on any action made by the Commission.

Attachments:

- Sean Downing - Barefoot Mosquito Quote
- Sean Downing - Justice Pest Control Mosquito Quote

Congratulations on choosing the best pest service!!

Please review the following agreement and then sign. You will receive a copy via email for your records.
Thanks!



Serving major metropolitan areas in Texas and Oklahoma

* Call: (888)-277-2899 * Text: (512)-877-5106 * sales@barefootmosquito.com

Customer Information

Name: Sean

Phone: (512) 970-7364

Address: 401 Nixon Drive

Email Address: sdowning@gmail.com

Gate Code: _____

Service Info

Location #: 600731

Initial Date: _____

Sold By: Guy Conrad

Service Plan(s)

Service Name: Service Frequency: Initial Cost:	Recurring Cost:	Billing Frequency:
Mosquito Control as needed/evry 3 wks \$275.00	\$275.00 after each service	
\$	\$	
\$	\$	
Initial Cost Sub Total: \$	\$	

Prices listed do not include tax. Tax is based off office location and will be added when billed.

Notes

As needed until March. 80-90% reduction warranty

Barefoot Mosquito & Pest Control

Mosquito Control Agreement

Here is a summary of our Terms & Conditions.

You can read the full article, along with our consumer information sheet at <https://www.barefootmosquito.com/terms-of-service/> (<https://www.barefootmosquito.com/terms-of-service/>)

- Pest Control plans have a 12 month agreement, and have an Early Termination fee if canceled early.
- Mosquito Control is scheduled every 21 days, with the exception of the first 2 treatments which are 14 days apart.
- We treat exterior every time for Pest Control, and interior by appointment or request. If live pests come back between our visits, let us know and we can come back out. Many pests are covered, some are not, and some coverages are available separately or as add-ons.
- Services continue until canceled by the client.
- After the 3rd Mosquito treatment, if biting mosquitoes return soon (within 10 days) after service, let us know as soon as possible and we'll be able to retreat.
- Services happen on a schedule that is pre-approved by the client, who is not required to be present for most visits. We'll send notice before service, and we sometimes use yard signs.
- Invoices are charged automatically following services unless on a monthly billing plan. Delinquent invoices can incur late charges, up to and including a collections fee. Service rates may change annually. Payment is due upon receipt if not on Autopay.
- We make use of your hose/spigot. Products we use can harm fish, so clients must take precautions before service. Rodent control products can be harmful, but are used responsibly. Elements of our Mosquito Control service are scented and could be unpleasant for some, but most people like it.

Terms and Conditions

Express Consent for Text Marketing

For your benefit, Barefoot uses text messages for Service Reminders and 'on-the-way' announcements from our technicians. However, there are other beneficial text message communication we offer that you first need to agree to before receiving. By agreeing to text marketing, you are agreeing to receive Informational and Promotional text messages from us. You're also expressly consenting to receive such messages using an automated dialing system, which just means that we're sending such messages as a group. Importantly, you acknowledge that your consent is never a condition of purchasing any of our products or services. Standard messaging rates may apply. Of course, you may opt-out of receiving text messages at any time just by replying STOP to any message you receive, or by contacting our customer service team.

Re-Treatment Guarantee for Pest Control Services

Covered pests include, but aren't limited to, common ants and roaches, scorpions, silverfish, common beetles, centipedes, millipedes, most spiders, earwigs, and most other non-flying structural insects.

Pest Control plans are built around preventative exterior visits being done at regular intervals, which in turn enables an ongoing Re-Treatment Guarantee. In the event that live targeted pests indicated above reappear on the property, upon the client's request Barefoot Mosquito & Pest Control will retreat the property at no additional charge - providing that the client

has corrected any conducive conditions for pests on their property, the client's service schedule has been maintained, and the account balance is in good standing.

Barefoot Mosquito & Pest Control agrees to apply material/s to reduce the presence of pests in accordance with the Terms and Conditions of this agreement. All materials used will comply with Federal, State, and County regulations.

The Pest Control Re-Treatment Guarantee does not include: bees, birds, ornamental pests (a category of exterior pests which includes webworms and aphids), German cockroaches, bed bugs, cicada-killer wasps, Leaf Cutter and tawny crazy ants. Fleas, and wood-destroying insects (such as termites, carpenter ants, and borer beetles) are also not included, but they can be inspected, quoted, and treated separately.

Rodents are guaranteed only in certain plans that were sold to include Rodents. Other mammals in the wildlife pest category, such as gophers, raccoons, opossums, and squirrels, are excluded.

Service Guarantee for Mosquito Control

We agree to apply material to reduce mosquitoes and/or general pests in accordance with the terms and conditions of this agreement. All materials used will comply with Federal, State, and County regulations.

Once three mosquito services have been completed, and while on a continual service cycle of 21 days or less, in the event that mosquitoes re-infest the property, we will treat the exterior at no additional charge with a Booster service. Request for re-treatment must be given within 10 days of a completed service. This is provided that the customer has corrected all the conducive conditions for mosquitoes on their property, the customer's service schedule is maintained, and the customer balance is current. Although the service aggressively targets mosquitoes, it is scientifically impossible to eradicate 100% of mosquitoes on a property, and as such, a 100% guarantee is not possible.

Renewal And Cancellation

After the agreed number of services have been completed, services shall continue on their normal interval unless the client cancels by telephone. If you are unable to use a telephone to call us, we can accept an email in certain cases. It is the client's responsibility to alert Barefoot Mosquito & Pest Control of any change in address. Active Mosquito Control services will be notified by email about seasonal service pauses and restarts. Seasonal changes do not require restart confirmation from the client.

Pest Control services canceled prior to the completion of the agreement incur a \$99.99 cancellation fee. Cancellation of one service arrangement or setup is not tantamount to cancellation of others - for example, ending Mosquito service does not thereby end your Pest service.

Barefoot Mosquito & Pest Control

Mosquito Control Agreement

Terms and Conditions, cont'd

Payment

Accounts will have a method of payment recorded on file and set up for automatic payments, and will be charged within a reasonable time following service. Accounts not operating with payment on file (known as traditional billing) will be subject to a per-invoice surcharge of \$5.

A financial charge of 1.5% per month (18% per annum) will be added to past-due accounts. There is a \$25 return charge for all declined payments. No service will be rendered on accounts past due by 60 days or more. Accounts due past by 90 days or more are subject to cancellation and turnover to a third-party collections agency.

The company reserves the right to change service rates. Periodic rate changes may happen on an annual basis, while Corrective rate changes may occur at any time. Corrective rate changes exist to account for developments in the nature of service or the location to be treated.

It may become necessary that an account in arrears be submitted to a third-party collections agency. In this event, the account will be assessed a fee equal to 43% of its closing balance.

Scheduling

The individual signing below claims that they have ownership or capacity to approve service at this location. This agreement includes the above number of services. (Mosquito only): By default, Mosquito Control services are scheduled on a 2 week cycle for the first 2 treatments, and then the services move to a 3 week cycle. These intervals are set, and changes to one service day will not affect subsequent service dates. (Pest only): Pest Control services are scheduled every second or every third month, but are not required to occur exactly 60 or 90 days apart, respectively. Separate services (Flea & Tick, Termite, etc.) may be combined and performed at the same time for consolidation purposes. The client approves all work performed on and around the property as complete.

The company reserves the right to schedule services up to 5 days before or after the service timetable, due to weather or other required scheduling needs. Services will be performed notwithstanding the client's presence at the time of the technician's arrival. The arrival time may fall at any point throughout daylight hours unless previously scheduled with the client.

Prior to the day of service, notice will be sent to registered email addresses on file for the location. Service notices may be sent to additional registered email addresses, such as those of adjacent properties with expressed health concerns, solely to alert them of upcoming service nearby. These notices will never contain information that is financial in nature. If the client requires a different method of notice, they must establish that need in advance with the company so that it may best be accommodated.

Where it is permitted, the company may make use of yard signs to alert the client and nearby owners that the property is under the company's service. This signage is not meant to be permanent, and will be displayed on a rotating basis. If you do not want a sign placed in your yard, just let the office know.

Communication

Barefoot Mosquito & Pest Control may send occasional text messages or emails for appointment reminders and promotions. By providing your name and number, you consent to receive messages from this company. To opt-out reply STOP at any moment. Msg & Data rates may apply.

Liability

In the course of conducting service at a location, it may be necessary for Barefoot Mosquito and Pest technicians to use the water source on premises. Technicians will exercise caution to use only as much water as is necessary for service(s). Technicians will return hoses and adapters to the state they were in upon arrival. Barefoot Mosquito & Pest Control is not responsible for any structural damage, property loss, or personal loss caused by the service. Barefoot Mosquito & Pest Control shall not be responsible for any loss due to health issues that arise from mosquitoes, general pests, or from the service application should such occur. The products the company uses can be fatal to aquatic organisms. If client has fish or any aquatic wildlife living on the outside of their property, they must ensure the ponds, tanks, etc. are fully covered by a tarp prior to service commencing and leave on for one hour after service is complete. Barefoot Mosquito & Pest Control is not responsible for any loss of fish or other aquatic wildlife due to the service.

In the course of treating and preventing problems with mice and/or rats, it may be necessary to employ rodenticide. Though it is administered in a controlled way, the rodenticide that will be used can be harmful to children, pets and wildlife. The client agrees to use the highest degree of care in and about their property so that no children, pets or wildlife shall come in contact with the rodenticide, just as the company agrees to use the highest care in filling, placing, and securing this product. The client agrees to release Barefoot Mosquito & Pest Control from liability and to indemnify and hold Barefoot Mosquito & Pest Control, its officers, agents, contractors and employees harmless from any claims for property damage, personal injury or illness as a result of the application of rodenticide. (Mosquito Only): All materials have an odor that may be detected for 24-36 hours after the product is applied. If you or anyone living in the vicinity of your property is sensitive to essential oils or pesticides, Barefoot Mosquito & Pest Control recommends you seek advice from a physician or veterinarian prior to commencing treatment.

Barefoot Mosquito & Pest Control

Mosquito Control Agreement

Licensed and Regulated by:

Texas Depart. of Agriculture

P.O. Box 12847

Austin, TX 78711-2847

Phone: (866) 918-4481

Fax: (888) 232-2567

Austin - TPCL 0743689 - 4509 Freidrich Ln, STE 109, Austin, TX 78744

Houston - TPCL 0932216 - 6961 Brookhollow W Dr, Houston, TX 77040

Marble Falls/Kingsland - TPCL 0953856 - 103 South Avenue South, Marble Falls, TX 78654

San Antonio - TPCL 0931097 - 338 Breesport Street, San Antonio, TX 78216

Dallas - TPCL 0933481 - 14286 Gillis Road, Suite A, Dallas, TX 75244

Consumer Information Sheet

Required by the TDA Structural Pest Control Service

The structural pest control industry is regulated by the Texas Department of Agriculture (TDA), Structural Pest Control Service (SPCS), PO Box 12847, Austin, TX 78711-2847. TDA licenses the businesses, certified applicators and technicians who perform structural pest control work. Certified applicators and technicians must pass a written examination in order to receive their licenses.

Pesticides must be registered with the United States Environmental Protection Agency (EPA) and TDA before they may be used in Texas. EPA registration is not a finding of product safety. Pesticides are designed to kill or control pests. Your risk of harm depends on the degree of your exposure and or individual susceptibility.

Specific health and safety information varies between pesticides and types of exposures and is available on the label information or MSDS sheet, which can be supplied to you upon request from the licensed applicator. Take precautions when a treatment has been performed to avoid exposure to vulnerable individuals. Pesticides maybe harmful if swallowed, inhaled, or absorbed through the skin. Avoid breathing dust or spray mist and any unnecessary contact with treated services. If you desire specific information on precautions, refer to the pesticide label. The law requires that the application procedures

specified on the label be followed. If you have questions about the application, contact the business or person making the application. If you suspect a violation of the law regarding structural pest control, contact the SPCS. In case of a health emergency, seek immediate medical attention. Pest Control signs must be posted prior to treatment in many instances. The signs should be posted in an area of common access at least 48 hours prior to treatment. The information sign will allow you to contact someone and tell you what pesticide is being used.

If you are contracting for pest-control services due to a home solicitation, you have the right to cancel the contract within 72 hours. You may exercise this right by notifying the pest control company that you do not wish to receive their service. For general information on pesticides, contact the national pesticide information center 1-800-858-7378. For information concerning structural pest control laws, contact the Structural Pest Control Service at: (512) 305-8250 or 866-918-4481.

For information concerning the formulation and registration of pesticides, contact the TDA pesticide registration at (512) 463- 7476 or 800-835-5832.

For non-emergency health information relating to pesticides, contact Texas Department of State Health Services (512) 458- 7111.

Reduced Impact Service

In order to minimize the reliance on pesticides and reduce pest populations, a Reduced Impact Pest Control operator may recommend that you consider the sanitation or physical alteration of your workplace or residence. It is your responsibility to follow these recommendations. Your pest control operator may or may not offer these services upon request. A proper inspection will provide the information necessary for you to choose the method of pest control which best suits your situation. Many past problems can be solved without using pesticides.

This reduced impact service will include an inspection report and treatment recommendations. You should review these and keep a copy for your records. Your cooperation of all of the recommendations made by your service provider is essential to reduce the impact service program.

Pesticides may be used in a responsible and professional manner and I reduce the impact pest-control service. If you do not want specific pesticides used or any pesticides used at all, you must notice in writing on the contract prior to the initiation of the service. If any specific pesticide or class of pesticides or not excluded, it may be used by the provider.

POISON CONTROL CENTER - Statewide: (800) 222-1222

Barefoot Mosquito & Pest Control

Mosquito Control Agreement

By signing below, you opt-in to receive SMS and/or MMS messages and emails from Barefoot Mosquito & Pest Control about new services, promotions, and updates. You understand that your consent is not a condition of receiving services and that you may withdraw your consent at any time by contacting us at (512) 402-7121 or service@barefootmosquito.com. For SMS and/or MMS messages, you can reply with "STOP" or "OPT-OUT". For SMS and/or MMS, messages & data rates may apply. For email, you may unsubscribe at any time.

This agreement is for an initial period of 12 month(s).

Sign above

I have read and agree to the terms and conditions of this agreement including any additional terms and disclosures listed above. I confirm that my email address is entered correctly and agree to receive my agreement, additional disclosures, and future account notifications electronically.

Clear

Sign Agreement

Powered by



(<https://www.FieldRoutes.com>)

**Barefoot Mosquito & Pest
Control - Austin**

PO Box 8199

Carol Stream, IL 60197-8199

(512) 402-7121

<http://www.barefootmosquito.com>

Congratulations on choosing the best pest service!!

Please review the following agreement and then sign. You will receive a copy via email for your records.
Thanks!

Justice Pest Services
PO BOX 340010
Lakeway, TX 78734
(512) 261-2465 | info@justicepestservices.com
License #: 0708820

Service Agreement



Service Address

Sean Downing
4820 Rollingwood Dr
West Lake Hills, TX 78746
Rollingwood

Customer Information

sdowning@gmail.com
(512) 970-7364 |

Notes:

Included Insects



MOSQUITO

SEASONAL SERVICE MARCH - NOVEMBER



The effectiveness of the treatment should be apparent immediately. Allow product to dry before enjoying your yard. Keep pets up while technician administers treatment. You should expect a drastic reduction of mosquito activity around your home. If you are still experiencing a large amount of activity, call us!



You can help us keep the mosquitoes at bay by ensuring that all standing water has been removed from around your home! Mosquitoes lay their eggs in water where the larvae develop so it is important to empty containers, flower pots, pool covers, etc after a rainstorm or irrigation system activity. Water in bird baths and pet dishes should be changed regularly. Maintain your yard by keeping foliage and landscaping groomed.

MOSQUITO PROGRAM DESCRIPTION

The Mosquito Program includes a seasonal treatment for mosquitoes. Service is performed approximately every 3 weeks between April and October and is intended to be a mosquito suppression service. This service is guaranteed should the customer see a surge in mosquito population in between the regularly scheduled visits, please contact our office for immediate service. The Mosquito Program involves initial and subsequent treatments to achieve a reduction in the mosquito population around the covered premises. Justice Pest Services will render preventative treatments and warrant their service in between treatments as long as the customer's payments are current. Customer agrees to keep gutters maintained and free of debris. The customer will grant Justice Pest Services reasonable access to the premises for the purpose of rendering the service contracted for. The customer warrants full cooperation with Justice Pest Services during the term of this agreement and agrees to maintain the structure free from any factors contributing to infestation, such as standing water (other than swimming pools, fishponds, or landscaping ponds/pools), used tires, or any other man-made item or artifact that could conceivably retain water. NOTE: Mosquitoes are a disease vector. Justice Pest Services does not imply nor warrant that persons or animals at the covered premises will not be bitten by mosquitoes, and we strongly urge that precautions be taken by individuals to help reduce the opportunity for mosquitoes to bite. This agreement will renew annually when mosquito season begins and continue through the remainder of the season unless the company is notified by the customer.

Mosquito 21 Days Subscription

Mar '26

(S)375.00

Apr '26

2x(S)275.00ea

May '26

(S)275.00

Jun '26

2x(S)275.00ea

Jul '26

(S)275.00

Aug '26

2x(S)275.00ea
Sep '26

(S)275.00
Oct '26

2x(S)275.00ea
Nov '26

(S)275.00
Dec '26

Jan '27

Feb '27

Initial Service / Warranties

Initial Quote:

\$375.00

Initial Discount:

(\$0.00)

Sub Total:

\$375.00

Tax (8.25%):

\$30.94

Initial Total:

\$405.94

Recurring Services

Service Charge(monthly recurring):

\$275.00

Tax (8.25%):

\$22.69

Recurring Total:

\$297.69

Either party may cancel this transaction anytime. Customer may cancel by giving written notice of cancellation to Justice Pest Services. If for any reason, at any time, the contract is cancelled before its completion, and the initial service has been performed, customer agrees to pay the full initial service charge. Upon completion of this agreement treatments will continue at the same frequency until cancelled by the customer.

CUSTOMER OBLIGATION: This agreement will become effective upon full payment for the Initial Treatment for the above accepted service. Continuation of the agreement is subject to payment in full of the monthly payment amount. Monthly payments are due on the first of each month. Customers signing up for auto pay by putting a form of payment (credit card, debit card, or eCheck) on file to be drafted the first of each month. The agreement will automatically renew until

canceled by the customer. By signing this agreement, you opt-in to multiple forms of communication including but not limited to phone calls, text messaging and emails.

Billing Info

Sean Downing
4820 Rollingwood Dr
West Lake Hills, TX 78746

Payment Information

Sean Downing

I authorize Justice Pest Services to automatically bill my debit/credit card now for the full amount indicated above.

This agreement is for an initial period of 12 month(s).

Sign above

I have read and agree to the terms and conditions of this agreement including any additional terms and disclosures listed above. I confirm that my email address is entered correctly and agree to receive my agreement, additional disclosures, and future account notifications electronically. (Enter initials in box)

Clear

Sign Agreement

AGENDA ITEM SUMMARY SHEET

City of Rollingwood

Meeting Date: April 14, 2026

Submitted By:

Staff

Agenda Item:

Discussion and possible action on treatment solutions for mosquitos in the lower park area

Description:

Park Commission member Sean Downing requested to discuss mosquito treatment and possible solutions.

Currently, the Public Works team treats mosquitos by using mosquito tablets to kill mosquito larvae in standing water when needed.

Action Requested:

To discuss and consider possible improvements for mosquito treatment in the lower park.

Fiscal Impacts:

Fiscal impact depends on any action made by the Commission.

Attachments:

- Sean Downing - Barefoot Mosquito Quote
- Sean Downing - Justice Pest Control Mosquito Quote

11-12-2025 11:00 AM

CITY OF ROLLINGWOOD
REVENUE & EXPENSE REPORT (UNAUDITED)
AS OF: OCTOBER 31ST, 2025

100-GENERAL FUND
PARK DEPARTMENT

08.33% OF

DEPARTMENTAL EXPENDITURES	CURRENT BUDGET	CURRENT PERIOD	YEAR TO DATE ACTUAL	% OF BUDGET
<u>PERSONNEL</u>				
100-5-55-5000 SALARY	40,849.00	2,949.71	2,949.71	7.22
100-5-55-5002 HOLIDAY COMPENSATION	0.00	0.00	0.00	0.00
100-5-55-5006 OVERTIME/PLANNED OVERTIME	0.00	0.00	0.00	0.00
100-5-55-5007 STIPENDS/CERTIFICATIONS	1,300.00	38.24	38.24	2.94
100-5-55-5009 RETIREMENT PAYOUT RESERVE	0.00	0.00	0.00	0.00
100-5-55-5010 TRAINING	2,800.00	0.00	0.00	0.00
100-5-55-5020 HEALTH INSURANCE	3,200.00	1,757.78	1,757.78	54.93
100-5-55-5030 WORKERS COMP INSURANCE	950.00	751.36	751.36	79.09
100-5-55-5035 SOCIAL SECURITY/MEDICARE	3,224.00	228.58	228.58	7.09
100-5-55-5040 UNEMPLOYMENT COMP INSUR	47.00	0.76	0.76	1.62
100-5-55-5050 TX MUNICIPAL RETIREMENT SYS	5,585.00	418.39	418.39	7.49
100-5-55-5060 STORM RELATED PAYROLL	0.00	0.00	0.00	0.00
TOTAL PERSONNEL	57,955.00	6,144.82	6,144.82	10.60
<u>SUPPLIES & OPERATION EXP</u>				
100-5-55-5101 FAX / COPIER	0.00	0.00	0.00	0.00
100-5-55-5103 PRINTING & REPRODUCTION	250.00	0.00	0.00	0.00
100-5-55-5110 POSTAGE	0.00	0.00	0.00	0.00
100-5-55-5114 COVID-19	0.00	0.00	0.00	0.00
100-5-55-5115 STORM RELATED EXPENSES	0.00	0.00	0.00	0.00
100-5-55-5120 SUBSCRIPTIONS & MEMBERSHIPS	0.00	0.00	0.00	0.00
100-5-55-5125 TRAVEL	0.00	0.00	0.00	0.00
100-5-55-5130 UTILITIES	12,000.00	2,732.94	2,732.94	22.77
100-5-55-5140 TELEPHONE	0.00	0.00	0.00	0.00
100-5-55-5145 UNIFORMS & ACCESSORIES	1,000.00	0.00	0.00	0.00
100-5-55-5157 RECORDS MANAGEMENT	0.00	0.00	0.00	0.00
100-5-55-5158 OFFICE SUPPLIES	200.00	0.00	0.00	0.00
100-5-55-5159 CITY EVENT SUPPLIES	500.00	0.00	0.00	0.00
100-5-55-5164 EQUIPMENT MAINT & REPAIRS	1,500.00	0.00	0.00	0.00
100-5-55-5171 EQUIPMENT	3,000.00	0.00	0.00	0.00
100-5-55-5172 SAFETY EQUIPMENT	300.00	0.00	0.00	0.00
100-5-55-5190 MATERIALS	10,500.00	15.68	15.68	0.15
100-5-55-5191 MAINTENANCE	6,000.00	0.00	0.00	0.00
100-5-55-5195 VEHICLE OPERATIONS	3,000.00	0.00	0.00	0.00
100-5-55-5196 VEHICLE MAINT & REPAIRS	1,000.00	0.00	0.00	0.00
100-5-55-5198 FIELDHOUSE SUP & MAINT-JANITOR	9,000.00	420.00	420.00	4.67
TOTAL SUPPLIES & OPERATION EXP	48,250.00	3,168.62	3,168.62	6.57
<u>CONTRACTUAL SERVICES</u>				
100-5-55-5255 VEHICLE INSURANCE	500.00	584.94	584.94	116.99 (
100-5-55-5270 ENGINEERING SERVICES	0.00	0.00	0.00	0.00
TOTAL CONTRACTUAL SERVICES	500.00	584.94	584.94	116.99 (
<u>MISCELLANEOUS OTHER EXP</u>				
100-5-55-5300 COMPUTER SOFTWARE & SUPPORT	1,215.00	58.36	58.36	4.80
100-5-55-5350 TOOLS/EQUIPMENT & REPAIR	950.00	0.00	0.00	0.00
TOTAL MISCELLANEOUS OTHER EXP	2,165.00	58.36	58.36	2.70

11-12-2025 11:00 AM

CITY OF ROLLINGWOOD
REVENUE & EXPENSE REPORT (UNAUDITED)
AS OF: OCTOBER 31ST, 2025

100-GENERAL FUND
PARK DEPARTMENT

08.33% OF

DEPARTMENTAL EXPENDITURES	CURRENT BUDGET	CURRENT PERIOD	YEAR TO DATE ACTUAL	% OF BUDGET
<u>CAPITAL OUTLAY</u>				
100-5-55-5414 COMPUTERS	500.00	0.00	0.00	0.00
100-5-55-5455 IMPROV TO EXISTING PARK ASSETS	5,000.00	2,400.00	2,400.00	48.00
100-5-55-5456 PLANTS FOR PARK AND ENTRANCES	2,000.00	0.00	0.00	0.00
100-5-55-5490 PUBLIC WORKS LOAN PAYABLE	0.00	0.00	0.00	0.00
100-5-55-5494 VEH FIN NOTE - DEBT SERVICE	2,445.00	0.00	0.00	0.00
100-5-55-5495 NEW VEHICLE & OUTFITTING	0.00	0.00	0.00	0.00
TOTAL CAPITAL OUTLAY	9,945.00	2,400.00	2,400.00	24.13
<u>OTHER NON-DEPARTMENTAL</u>				
100-5-55-5512 PLAYGROUND MULCH & MAINT	8,000.00	0.00	0.00	0.00
100-5-55-5515 MAINTENANCE BUILDING	0.00	0.00	0.00	0.00
TOTAL OTHER NON-DEPARTMENTAL	8,000.00	0.00	0.00	0.00
TOTAL PARK DEPARTMENT	126,815.00	12,356.74	12,356.74	9.74



Quarterly Park Report **January 1, 2026-March 31, 2026**

February 19, 2026, 4:42pm Assist Complainant, Upper Park Baseball field. A resident wanted to report to police a father and son hitting baseballs onto their property and Rollingwood Drive. I spoke with the father, he apologized and said they would use the batting cage next time.

March 1, 2026, 11:34pm. Officer Bishop was patrolling the Rollingwood Municipal Park and observed a Chevy Suburban that was parked inside the park parking lot. Texas license plate did not return to the vehicle. Officer ran the vehicle-by-vehicle identification number, and it returned to an address in Rollingwood.

March 11, 2026, 3:16pm Collision leaving the scene, vehicle parked at the upper park was struck, other party did not leave information. Case # R2503-00005.



THE CITY OF ROLLINGWOOD POLICE DEPARTMENT

Phone (512) 328-1900

403 Nixon Drive, Rollingwood, TX 78746-5512

www.rollingwoodtx.gov