



**AGENDA**  
**CITY OF ROCHELLE**  
**PLANNING & ZONING COMMISSION**  
**MEETING**

**Monday, June 01, 2026 at 6:00 PM**

**City of Rochelle Council Chambers—420 North 6th Street, Rochelle, IL 61068**

---

- I. **CALL TO ORDER:**
- II. **ROLL CALL:**
- III. **APPROVE/ACCEPT MINUTES:**
  - [1.](#) Planning & Zoning Commission Meeting Minutes 03-02-2026
- IV. **PUBLIC COMMENTARY:**
- V. **COMMISSIONER COMMENTS:**
- VI. **BUSINESS ITEMS:**
  - [1.](#) PZC-02-26 Petition of Wheatland Tube, LLC for a proposed Variance of Code for a fabric covered hoop structure for the property located at 1600 Ritchie Court. (Public Hearing and Action).
- VII. **DISCUSSION ITEMS:**
- VIII. **ADJOURNMENT:**

Anyone interested in participating in public commentary remotely should contact Michelle Knight at [mknight@rochelleil.us](mailto:mknight@rochelleil.us) or call 815-562-8717 to make arrangements.



**MINUTES**  
**CITY OF ROCHELLE**  
**PLANNING & ZONING COMMISSION**

**Monday, March 02, 2026 at 6:00 PM**

**City of Rochelle Council Chambers—420 North 6th Street, Rochelle, IL 61068**

- I. **CALL TO ORDER:** The meeting was called to order at 6:00 p.m.
- II. **ROLL CALL:** Present were Commissioners Colwill, Hickey, Myers, Bowerman, Charnock and Wolter. Absent: McKibben. Non-voting Commissioners present were: Barber and Tenggren. Also present were Michelle Knight, Michelle Pease and City Attorney Dominic Lanzito.
- III. **APPROVE/ACCEPT MINUTES:** Hickey moved, seconded by Bowerman, **"I move the minutes of the December 1, 2025 Planning and Zoning Commission meeting as presented be approved."** Ayes: Colwill, Hickey, Myers, Bowerman, Charnock and Wolter. Naves: None. Motion carried 6-0.

IV. **PUBLIC COMMENTARY:** None

V. **COMMISSIONER COMMENTS:** None

VI. **BUSINESS ITEMS: PZC-01-26 Petition of Eugene Judge for a proposed Special Use for a car wash in a PUD zoning district for the property located at 25-18-378-002.** Pease stated that a notice was published in the paper and property owners were notified. Motion made by Bowerman, seconded by Charnock, **"I move the Planning and Zoning Commission open the Public Hearing regarding the proposed special use for a car wash in a PUD for the property located at parcel 25-18-378-002."** Ayes: Colwill, Hickey, Myers, Bowerman, Charnock and Wolter. Naves: None. Motion carried 6-0. Chairman Wolter requested public testimony be sworn for those who were speaking. The petitioner is seeking a proposed special use permit for a car wash. The subject property is zoned PUD, Planned Unit Development and is located at parcel #25-18-378-002. This parcel is a vacant lot, is .91 acres and is located next to 450 Coronado Drive.

Article VII – Planned Unit Developments Sec. 110-251 – Objectives. The PUD, as a subdivision of land, is intended to encourage improved design in the development of land by providing relief from traditional zoning requirements which may cause undue hardship or complication for desirable but unconventional development, and to establish standards and procedures for the issuance of a special use permit (section 110-31, special uses) for a PUD in order to achieve the following objectives:

- 1. To stimulate creative approaches to residential, commercial and industrial development of land.
- 2. To provide for more efficient use of land.
- 3. To preserve or enhance natural features and provide open space areas.

Sec. 110-252. - Modification of district regulations.

Sec. 110-253. - General standards and criteria for PUDs.

Sec. 110-254. - Permitted uses and density.

Staff is presenting the special use for a car wash in a PUD located at parcel 25-18-378-002. Motion made by Bowerman, seconded by Hickey, **"I move the Planning and Zoning Commission close the Public Hearing."** Ayes: Colwill, Hickey, Myers, Bowerman, Charnock and Wolter. Naves: None. Motion carried 6-0.

**Findings:**

- 1. Is the proposed use allowed in the proposed zoning district, but only with a special use permit?  
Yes: 6 No: \_\_\_\_\_
- 2. Is the proposed use detrimental or dangerous to public health?  
Yes: \_\_\_\_\_ No: 6
- 3. Will the proposed use impair property value in the neighborhood?  
Yes: \_\_\_\_\_ No: 6
- 4. Will the proposed use impede the normal development of the surrounding properties?  
Yes: \_\_\_\_\_ No: 6
- 5. Will the proposed use:
  - (a) impair light and air to adjacent property;
  - (b) congest public streets;

- (c) increase the risk of fire;
- (d) substantially diminish property values within the vicinity; or
- (e) endanger the public health?

Yes: \_\_\_\_\_ No: 6

Based on the findings above, the Planning and Zoning Commission hereby recommends to the Rochelle City Council that the Petitioner be granted a special use permit for the proposed use at the Subject Property, without conditions other than the other applicable requirements of the Rochelle Municipal Code. Motion made by Charnock, seconded by Bowerman, **“I move the Planning and Zoning Commission recommend to the City Council that it Approve the proposed special use for a car wash in a PUD for the property located at parcel 25-18-378-002, based on the report of findings.”** Ayes: Colwill, Hickey, Myers, Bowerman, Charnock and Wolter. Nays: None. Motion carried 6-0.

**VII. DISCUSSION ITEMS:** None

**VIII. ADJOURNMENT:** Motion made by Colwill, seconded by Charnock, **“I move to adjourn the regularly scheduled meeting of the Planning and Zoning Commission of March 2, 2026.”** Motion carried by voice vote 6-0. The Planning and Zoning Commission adjourned at 6:13 p.m.

Michelle Knight  
Community Development Specialist



**PLANNING & ZONING COMMISSION  
REPORT OF FINDINGS**

**Date: June 1, 2026**  
**Case No.: PZC-02-26**  
**Applicant: Wheatland Tube LLC**  
**Address: 1600 Ritchie Court, Rochelle, IL Parcel # 25-32-201-001**

**Narrative:**

The petitioner is seeking a variance of Section 104.11 of the 2021 International Building Code as amended and adopted by the City of Rochelle. Section 104.11 of the 2021 IBC reads as follows: “[A] **104.11 Alternative materials, design and methods of construction and equipment.** The provisions of this code are not intended to prevent the installation of any material or to prohibit any design or method of construction not specifically prescribed by this code, provided that any such alternative has been approved. An alternative material design method of construction shall be approved when the Building Official finds that the proposed alternative meets all of the following:

1. The alternative material, design or method of construction is satisfactory and complies with the intended provisions of this code,
2. The material, method or work offered is, for the purpose intended, not less than the equivalent of that prescribed in this code as it pertains to the following:
  - 2.1. Quality.
  - 2.2. Strength
  - 2.3. Effectiveness.
  - 2.4. Fire Resistance.
  - 2.5. Durability.
  - 2.6. Safety.

Where the alternative material, design or method of construction is not approved, the Building Official shall respond in writing, stating the reasons why the alternative was not approved.” The variance request is to replace “the Building Official” as it appears in Section 104.11 with “the City Council”. The purpose for request for a variance is to allow the petitioner to construct a proposed 33,000 square foot fabric-covered hoop structure. The fully enclosed structure will be forty-eight (48) feet tall, one hundred ten (110) feet wide, and two hundred ninety one and one half foot (291.5) long. The intended use of the proposed fabric building is a drive-through loading area for trucks to load finished goods. The operation runs 24 hours a day, 7 days a week, with approximately 50 employees working in this area across 3 shifts. The property is zoned I2, General Industry and is 34.9 acres.

**Sec. 110-29. – Variances.**

(a) *Intent and purpose.* A variance is a grant of relief to a property owner from the literal requirements of the zoning ordinance, where literal enforcement would cause undue hardship. Additionally, a variance is intended to provide relief where the requirements of the zoning ordinance render the land difficult to use because of some unique physical attribute of the property itself, or some other factor unique to the property for which the variance is requested.



**PLANNING & ZONING COMMISSION  
REPORT OF FINDINGS**

A variance is not intended merely to remove an inconvenience or financial burden that the requirements of the zoning ordinance may impose on a property owner in general.

A variance is not intended to allow the establishment of a use that is not otherwise allowed in a zoning district or that would change the zoning district classification of any or all of the affected property, and should not be granted where a special use permit or an amendment to the official zoning map would be more appropriate.

*(f) Standards for a granting a variance.* The planning and zoning commission shall not recommend, and the city council shall not grant, a variance from the regulations of the zoning ordinance unless it makes findings based on evidence presented to it in each specific case that:

- (1) The variance is in harmony with the general purpose and intent of the zoning ordinance;
- (2) The plight of the owner is due to unique circumstances (65 ILCS 5/11-13-4) and thus strict enforcement of the zoning ordinance would result in practical difficulties, or impose exceptional hardships, due to the special and unusual conditions that are not generally found on other properties in the same zoning district;
- (3) The property cannot yield a reasonable return if permitted only under the conditions allowed by the zoning ordinance; and
- (4) The variance, if granted, will not alter the essential character of the locality, and will not be a substantial detriment to adjacent property.

*(g) Burden of proof.* In each case of a requested variance, the applicant must satisfy the proof that the proposed variance meets the standards of subsection (f) of this section, even if there is no testimony or other evidence opposing or rebutting the requested variance.

The petitioner explains their practical difficulties or exceptional hardships by stating: “If the proposed 33,000 square foot structure adhered to the strict application of the codes referenced, the structure would then significantly hinder the facility’s ability to grow, shrink, and adapt to the frequently changing needs of the operation of the facility. A structure conforming to a traditional prescriptive construction type as defined in Section 602 of the IBC would result in an unwise allocation of very limited resources given the intended use of the proposed fabric-covered hoop structure. The fabric-covered hoop building adheres to the requirements set forth by section 104.11 of the IBC for alternative materials, design and methods of construction and equipment therefore a hardship is created if the proposed building were required to adhere to strict application of the reference sections even though the building meets the required design standards. Practical difficulties that would be experienced from strict application of the referenced codes include vastly increased facility downtime due to construction duration and material lead times.”

The petitioner provided structural design which met the required 30 pound snow load, anchoring and additional requirements set forth by the code.

After a duly noticed public hearing, the City of Rochelle Planning & Zoning Commission will consider all the relevant evidence presented at said hearing on June 1, 2026.



PLANNING & ZONING COMMISSION
REPORT OF FINDINGS

Staff recommends:

Staff is presenting the variance request for a fabric-covered hoop structure located at 1600 Ritchie Court.

Findings:

- 1. Is the proposed variance in harmony with the general purpose and intent of the zoning ordinance?
2. The plight of the owner is due to unique circumstances and thus strict enforcement of the zoning ordinance would result in practical difficulties, or impose exceptional hardships, due to the special and unusual conditions that are not generally found on other properties in the same zoning district?
3. The property cannot yield a reasonable return if permitted only under the conditions allowed by the zoning ordinance?
4. Is the proposed variance detrimental or dangerous to public health?
5. Will the proposed variance impair property value in the neighborhood?
6. Will the proposed variance impede the normal development of the surrounding properties?
7. Will the proposed variance: (a) impair light and air to adjacent property; (b) congest public streets; (c) increase the risk of fire; (d) substantially diminish property values within the vicinity; or (e) endanger the public health?

Recommendation:

Based on the findings above, the Planning and Zoning Commission hereby recommends to the Rochelle City Council that:

That the Petitioner be granted a variance for the Subject Property, without conditions other than the other applicable requirements of the Rochelle Municipal Code.



**PLANNING & ZONING COMMISSION  
REPORT OF FINDINGS**

\_\_\_\_\_ That the Petitioner be granted a variance for the Subject Property, with the following conditions attached thereto, in addition to the requirements of the Rochelle Municipal Code:

---

---

\_\_\_\_\_ That the Petitioner be denied a variance for the Subject Property. If Findings 1-3 are all affirmative, and Findings 4-7 are all negative, the Planning and Zoning Commission explains as follows:

---

---

---

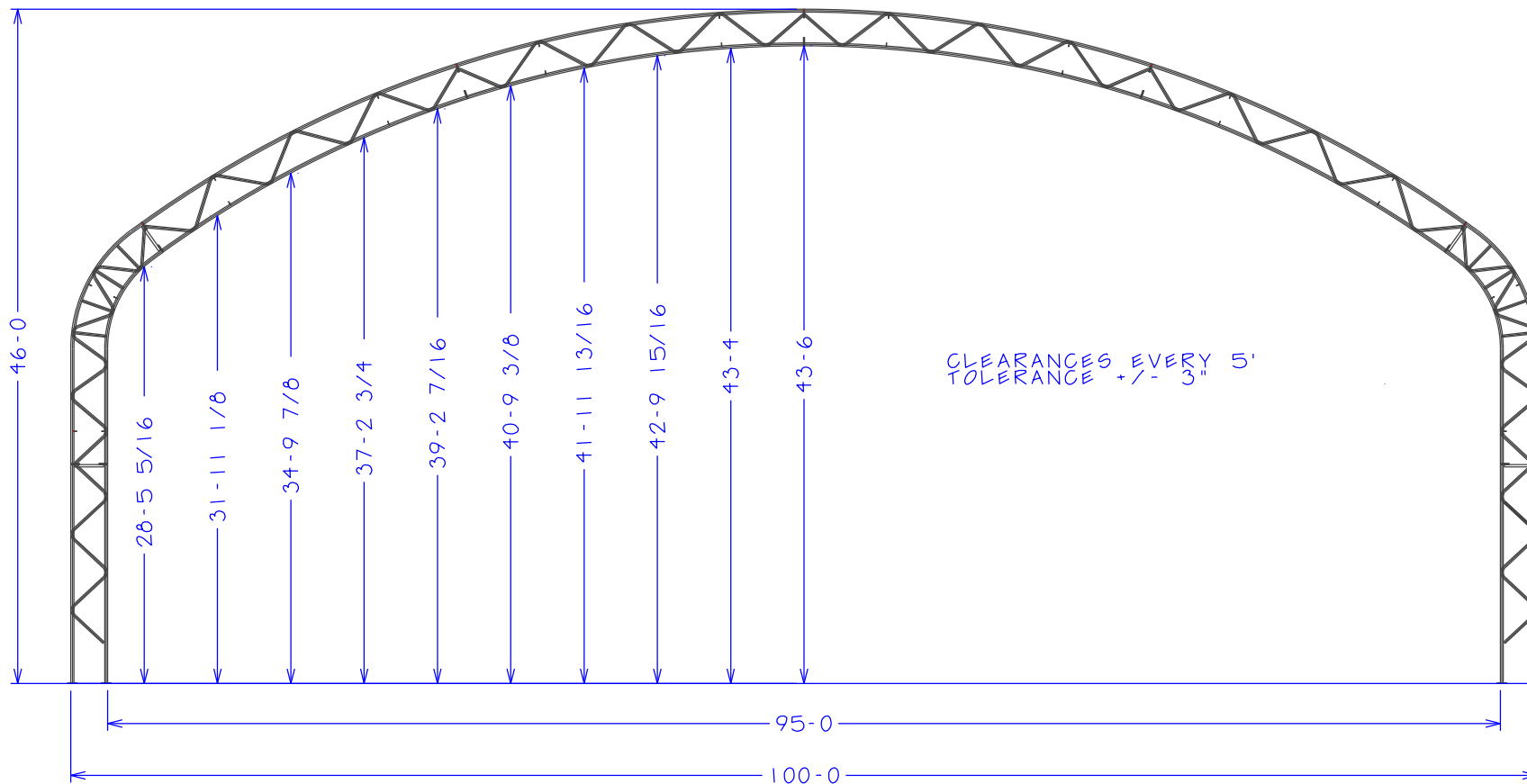

DRAWN BY: ADRIAN PETERS
DATE:
VIEW:
REQUESTED BY:
ENGINEER:

BIG TOP SHELTER  
100 X 46



3255 N. US 19  
PERRY, FLORIDA 32347  
PHONE 1-800-277-8677  
FAX (850)584-7713  
E-MAIL:  
sales@bigtopshelters.com

\*ALL INFORMATION IS PROPERTY OF BIG TOP MANUFACTURING

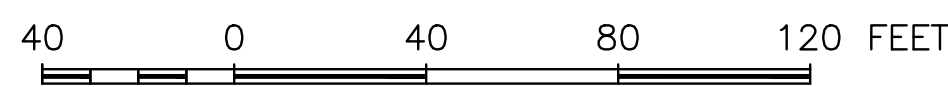
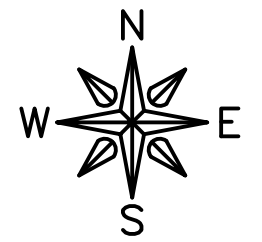
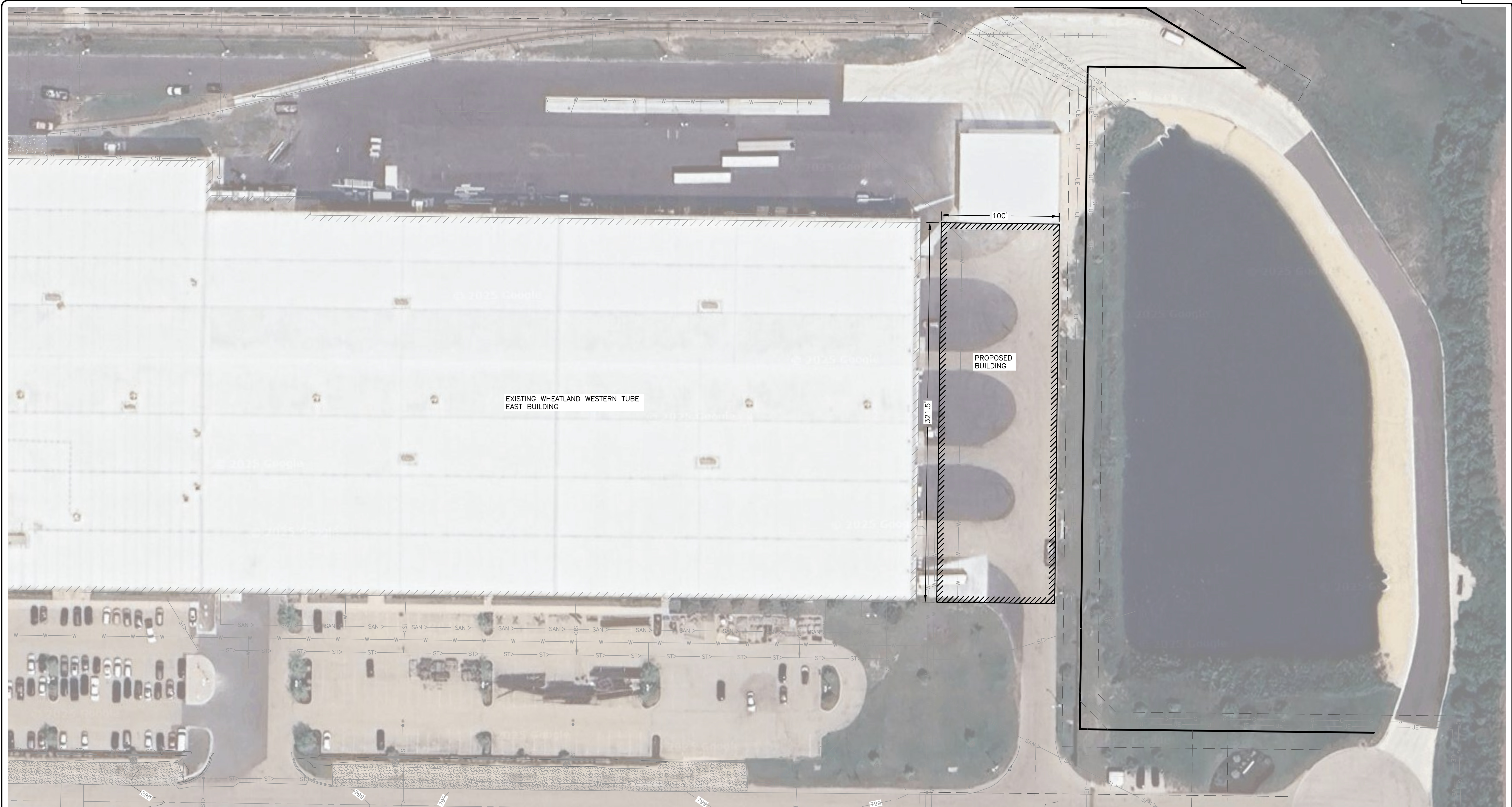

**FEHR GRAHAM**  
 ENGINEERING & ENVIRONMENTAL  
 ILLINOIS DESIGN FIRM NO. 184-003525  
 © 2026 FEHR GRAHAM

ILLINOIS  
 IOWA  
 WISCONSIN

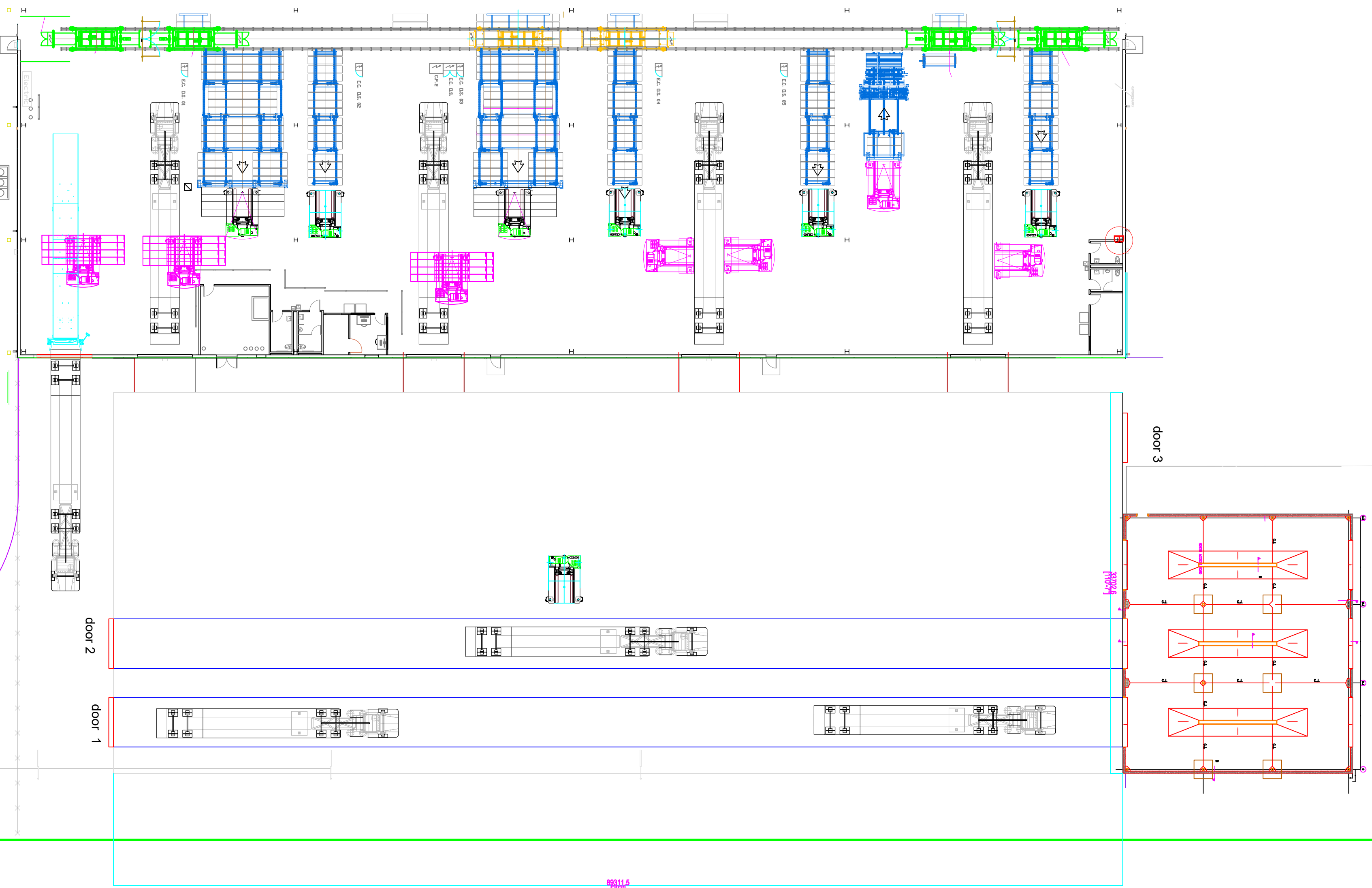

SECURITY OFFICE



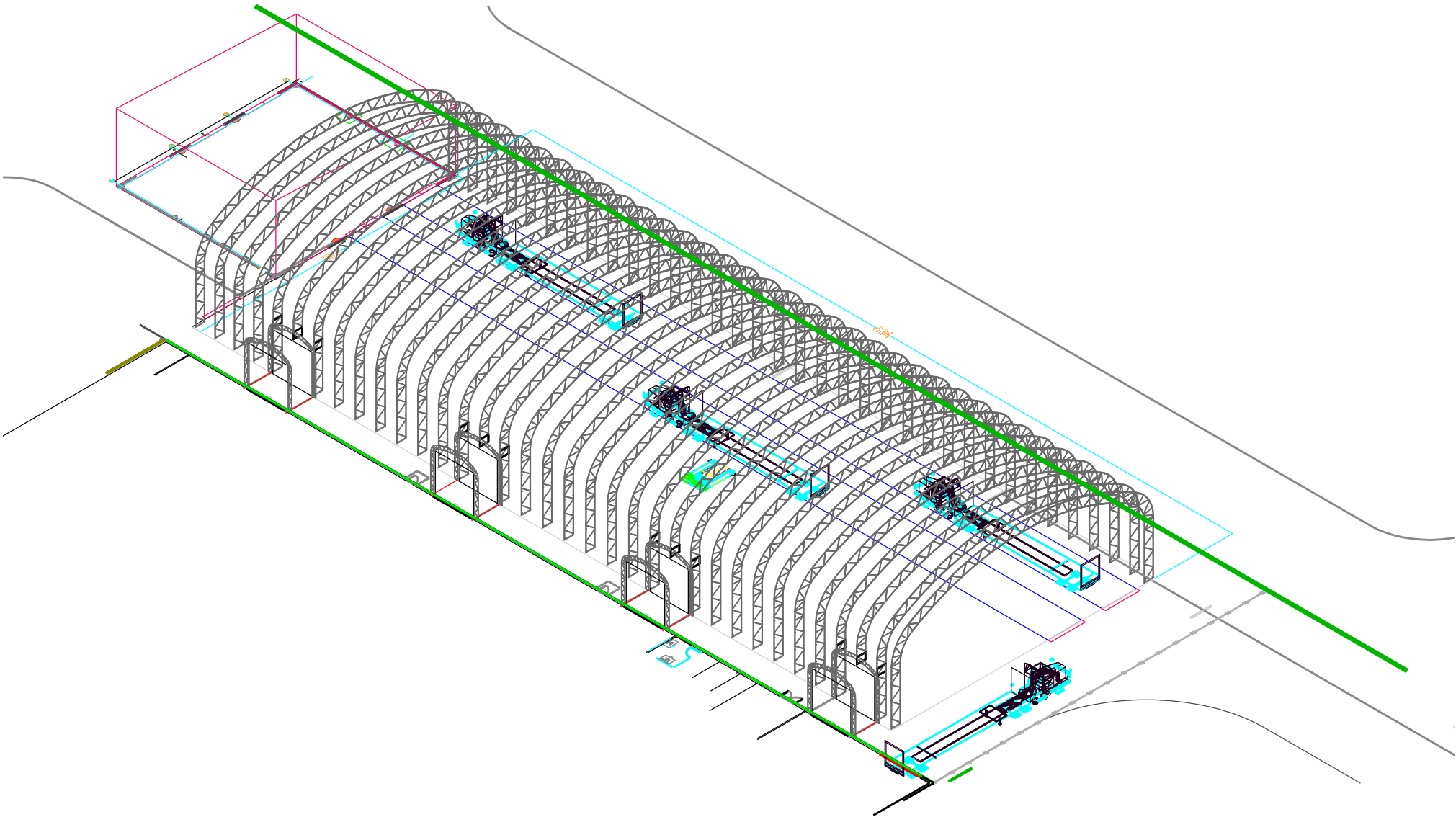

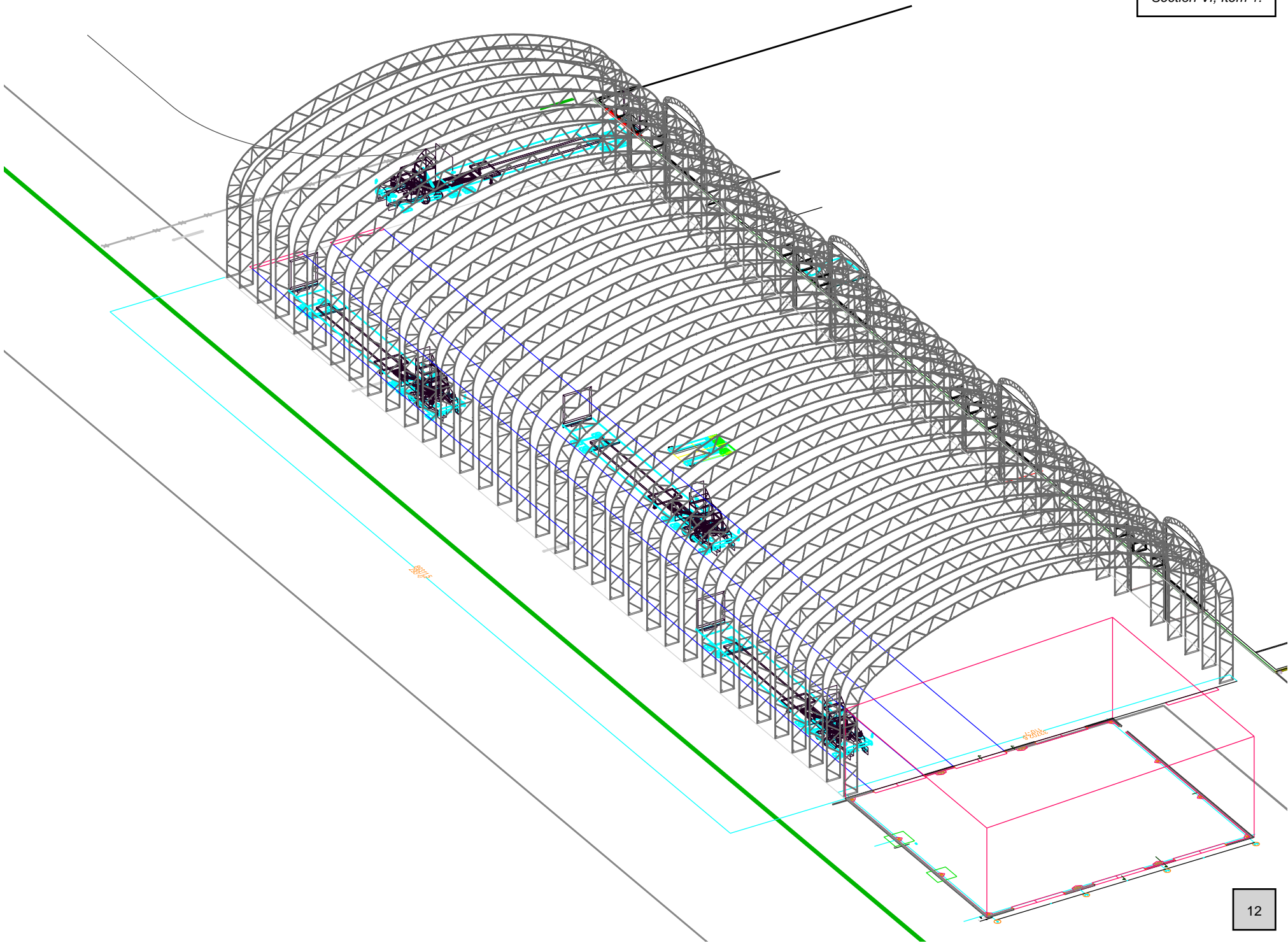

Greenbrier Rail Service 162x350x64  
Kennewick, WA

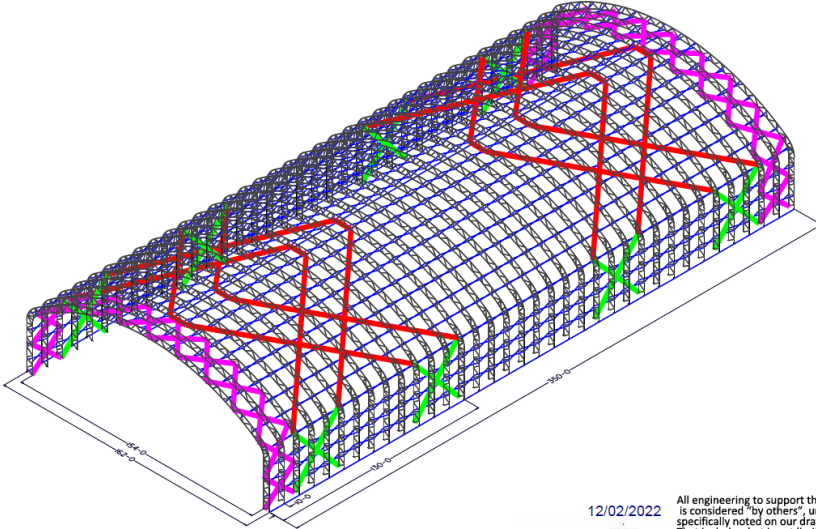

**CABLE BRACING ISOMETRIC VIEW**

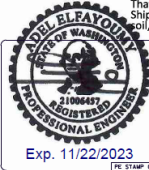
 BIG TOP MANUFACTURING INC. 3255 US HWY 19 NORTH PERRY, FL 32347 Ph: (850) 584 - 7786	CLIENT: Greenbrier Rail Services SIZE: 162 x 350 x 64 LOCATION: Kennewick, WA	NOTES: PROJECT: 222-206 DATE: 4/8/ Four Chord HEIGHT: 10 FT	12/02/2022 	All engineering to support the structure is considered "by others", unless specifically noted on our drawings. That includes, but is not limited to, Shipping containers, concrete, soil, asphalt, custom support steel, etc.
	DESIGNER: Joy C. DRAWN BY: Luke S. APPROVED BY: Aaron	DATE: 11/15/2022	ENGINEERING FILE: S-5 *ALL INFORMATION IS PROPERTY OF BIG TOP MANUFACTURING INC.	

**A. GENERAL REQUIREMENT:**

- Furnish all labor, materials, and equipment necessary to complete the work shown or inferred by these drawings.
- Where construction details are not shown or noted for any part of the work, such details shall be the same as for similar work shown on the drawings.
- Notes and details on the drawings take precedence over the general notes and typical details in case of conflict.
- Locate and protect underground or concealed conduit, plumbing or other utilities where new work is being performed.
- The contract drawings and specifications represent the finished structure and do not indicate methods, procedures or sequence of construction. The contractor shall take necessary precautions to maintain and insure the integrity of the new and any existing structures during construction. The design stresses shall not be exceeded during construction based on the age of each element. Neither the owner nor Architect/Engineer will enforce safety measure regulations. Installation Contractor shall design, construct and maintain all safety devices, including shoring and bracing for the new and any existing structures and shall be solely responsible for conforming to all local, state and federal safety and health standards, laws and regulations.
- Obtain prior written approval for any changes to the drawings.
- The contractor shall review and compare the structural drawings with all other Construction Documents, such as Architectural, Mechanical and Electrical drawings, specifications, etc. Do not scale drawings. The contractor shall verify dimensions, elevations and all information. Report, in writing, any inconsistencies, errors, or omissions to the Architect/Engineer of record before proceeding with the work.
- All existing constructions are shown schematic only. Installation Contractor is responsible to verify actual conditions and allow for them in his bid. Notify the Architect/Engineer, in writing, in case of any discrepancy between actual conditions and what is shown on the structural drawings before proceeding with the work.
- See Architectural, Mechanical, Electrical and other drawings for embedded items.
- All communication shall be in writing. No verbal communications, decisions, instructions or approvals shall be valid.
- Adequate drainage path must be provided to drain water away from the perimeter of the building.

**B. CODE AND LOADS:**

1. All material and construction work for this project shall conform to 2018 International Building Code. The International Building Code Parameters are:

- Roof Dead Load = 2 PSF
- Ground Snow Load = 20 PSF
- Roof Snow Load = 16.8 PSF (Govers)
- Roof Live Load = 5 PSF
- Seismic Occupancy Category = II
- R, Response Modification Coefficient = 1
- Ultimate Wind Speed, V3g = 110 mph, Exposure = C, Category II



**C. HOT-ROLLED STEEL:**

- Tube Frames shall be manufactured from A500 In-line galvanized steel with the following properties:
  - Yield strength: 50,000 psi (rectangular); 55,000 psi (round)
  - Tensile Strength: 55,000 psi (rectangular); 60,000 psi (round)
- The In-line galvanized steel tube meet the ASTM A-107/A & ASTM A107M - 08 Standard Specification for In-line galvanized coating.

**D. FOUNDATION DESIGN:**

- Concrete pad/foundation design/check to support the truss reactions/loads was not included in the scope of services.
- Any foundations shown on the drawings, are approximate and need to be verified/checked based on the local site conditions and local soil properties by a licensed Engineer hired by the Contractor/Builder or Owner of this shelter.
- See S-0A if the foundation is soil anchoring.

  
**PSE Consulting Engineers, Inc.**  
 www.structure1.com  
 Klamath Falls Office  
 250 Main  
 Klamath Falls, Oregon  
 97603  
 Phone: (541) 850-6300  
 Fax: (541) 850-6233  
 info@structure1.com

 BIG TOP MANUFACTURING INC. 3255 US HWY 19 NORTH PERRY, FL 32347 Ph: (850) 584 - 7786	CLIENT: Greenbrier Rail Services SIZE: 162 x 350 x 64 LOCATION: Kennewick, WA	NOTES: PROJECT: 222-206 DATE: 4/8/ Four Chord HEIGHT: 10 FT	12/02/2022 	All engineering to support the structure is considered "by others", unless specifically noted on our drawings. That includes, but is not limited to, Shipping containers, concrete, soil, asphalt, custom support steel, etc.
	DESIGNER: Joy C. DRAWN BY: Luke S. APPROVED BY: Aaron	DATE: 11/15/2022	ENGINEERING FILE: S-0 *ALL INFORMATION IS PROPERTY OF BIG TOP MANUFACTURING INC.	

Bechtel Manufacturing and Technology 106x280x46  
 New Albany, OH

INDEX OF DRAWINGS	
DRAWING NUMBER	DRAWING TITLE
0	COVER SHEET & DRAWING INDEX
02	FRAME - CLEARANCES
S3.03A	FRAME - SECTION CONNECTION DETAILS
S4.0A	FRAME - LATERAL BRACING DETAILS
55	FRAME - ISOMETRIC VIEW
56	FRAME - CABLE BRACING PLAN VIEW
57	FRAME - CABLE BRACING ELEVATION VIEW
58	FRAME - CABLE BRACING CONNECTION DETAILS
S9.0A	FRAME - FOOTPRINT AND ANCHOR DETAILS
59	FRAMING - FRAMING ATTACHMENT DETAILS
S10A/S10B	END PANEL - LAYOUT AND DETAILS

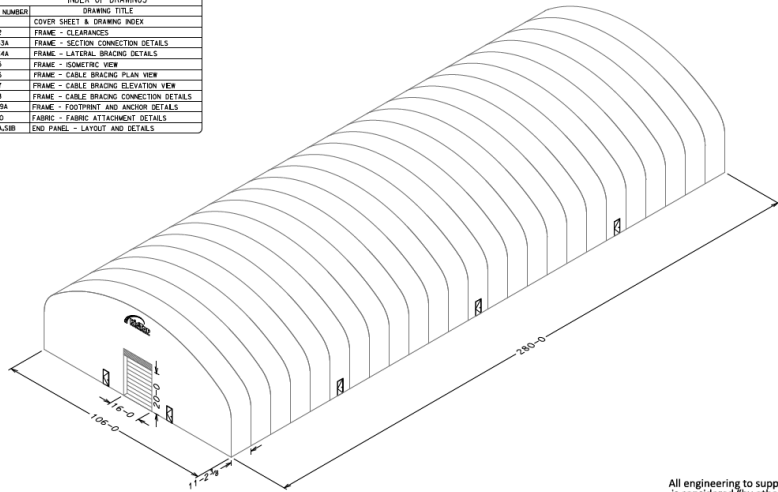

COVER SHEET & INDEX

All engineering to support the structure is considered "by others", unless specifically noted on our drawings. That includes, but is not limited to, shipping containers, concrete, soil, asphalt, custom support steel, etc.

<p>BIG TOP MANUFACTURING LLC                  3255 US HWY 19 NORTH                  PERRY, FL 32347                  PH: (850) 584 - 7786</p>	BECTHEL PROJECT: 106 X 280 X 46 LOCATION: NEW ALBANY, OH CONTRACTOR: JAY C. DRAWN BY: HUNTER A. DATE: 05/07/2025	NOTES: NUMBER: 225-099 HEIGHT: 36' FOUR-CHORD WIDTH: 11.2 FT		ENGINEERING S-1 ALL INFORMATION IS PROPERTY OF BIG TOP MANUFACTURING LLC
	PREPARED BY: [Signature] DATE: 05/07/2025			

**A. GENERAL REQUIREMENT:**

- Furnish all labor, materials, and equipment necessary to complete the work shown or inferred by these drawings.
- Where construction details are not shown or noted for any part of the work, such details shall be the same as for similar work shown on the drawings.
- Notes and details on the drawings take precedence over the general notes and typical details in case of conflict.
- Locate and protect underground or concealed conduit, plumbing or other utilities where new work is being performed.
- The contract drawings and specifications represent the finished structure and do not indicate methods, procedures or sequence of construction. The contractor shall take necessary precautions to maintain and insure the integrity of the new and any existing structures during construction. The design stresses shall not be exceeded during construction based on the age of each element. Neither the owner nor Architect/Engineer will enforce safety measure regulations. Installation Contractor shall design, construct and maintain all safety devices, including shoring and bracing for the new and any existing structures and shall be solely responsible for conforming to all local, state and federal safety and health standards, laws and regulations.
- Obtain prior written approval for any changes to the drawings.
- The contractor shall review and compare the structural drawings with all other Construction Documents, such as Architectural, Mechanical and Electrical drawings, specifications, etc. Do not scale drawings. The contractor shall verify dimensions, elevations and all information. Report, in writing, any inconsistencies, errors, or omissions to the Architect/Engineer of record before proceeding with the work.
- All existing constructions are shown schematic only. Installation Contractor is responsible to verify actual conditions and allow for them in his bid. Notify the Architect/Engineer, in writing, in case of any discrepancy between actual conditions and what is shown on the structural drawings before proceeding with the work.
- See Architectural, Mechanical, Electrical and other drawings for embedded items.
- All communication shall be in writing. No verbal communications, decisions, instructions or approvals shall be valid.
- Adequate drainage path must be provided to drain water away from the perimeter of the building.

**B. CODE AND LOADS:**

- All material and construction work for this project shall conform to the 2024 Ohio Building Code (OBC 2024) along with Amendments by the Local Authority Having Jurisdiction. The Building Code Parameters are:
  - a. Roof Dead Load = 9 PSF
  - b. Ground Snow Load = 25 PSF
  - c. Roof Snow Load = 16.8 PSF (FLAT)
  - d. Roof Live Load = 9 PSF
  - e. Seismic Occupancy Category = I
  - f. R. Response Modification Coefficient = 3.0
  - g. Ultimate Wind Speed, V<sub>3</sub> = 110 mph, Exposure = C, Category 1
  - h. Thermal Factor: Ct = 1.2

**C. HOT-ROLLED STEEL:**

- Tube Frames shall be manufactured from A500 in-line galvanized steel with the following properties:
  - a. Yield strength: 50,000 psi (rectangular); 55,000 psi (round)
  - b. Tensile Strength: 55,000 psi (rectangular); 60,000 psi (round)
  - c. The in-line galvanized steel tube meet the ASTM A-1057A & ASTM A1057M - 08 Standard Specification for in-line galvanized coating.

**D. FOUNDATION DESIGN:**

- Concrete pad/foundation design/check to support the truss reactions/loads was not included in the scope of services.
- Any foundations shown on the drawings, are approximate and need to be verified/checked based on the local site conditions and local soil properties by a licensed Engineer hired by the Contractor/Builder or Owner of this shelter.

All engineering to support the structure is considered "by others", unless specifically noted on our drawings. That includes, but is not limited to, shipping containers, concrete, soil, asphalt, custom support steel, etc.

<p>BIG TOP MANUFACTURING LLC                  3255 US HWY 19 NORTH                  PERRY, FL 32347                  PH: (850) 584 - 7786</p>	BECTHEL PROJECT: 106 X 280 X 46 LOCATION: NEW ALBANY, OH CONTRACTOR: JAY C. DRAWN BY: HUNTER A. DATE: 05/07/2025	NOTES: NUMBER: 225-099 HEIGHT: 36' FOUR-CHORD WIDTH: 11.2 FT		ENGINEERING S-0 ALL INFORMATION IS PROPERTY OF BIG TOP MANUFACTURING LLC
	PREPARED BY: [Signature] DATE: 05/07/2025			

Michels 162x300x41  
Port Washington, WI

INDEX OF DRAWINGS	
DRAWING NUMBER	DRAWING TITLE
S1	COVER SHEET & DRAWING INDEX
S2	FRAME - CLEARANCES
S3, S3A	FRAME - SECTION CONNECTION DETAILS
S4, S4A	FRAME - LATERAL BRACING DETAILS
S5	FRAME - ISOMETRIC VIEW
S6	FRAME - CABLE BRACING PLAN VIEW
S7	FRAME - CABLE BRACING ELEVATION VIEW
S8	FRAME - CABLE BRACING CONNECTION DETAILS
S15, S15A	FRAME - FOOTPRINT AND ANCHOR DETAILS
S20	FABRIC - FABRIC ATTACHMENT DETAILS
S25A, S25B	END PANEL - LAYOUT AND DETAILS

**COVER SHEET & INDEX**

<p><b>BIG TOP MANUFACTURING LLC</b> 3255 US HWY 19 NORTH PERRY, FL 32347 PH: (850) 584 - 7786</p>	<p><b>OWNER:</b> MICHEL'S 162 X 300 X 41 PORT WASHINGTON, WI <b>DESIGNER:</b> JAY C. <b>DATE:</b> 11/13/2025 <b>DESIGNED BY:</b> C. NEIDHART</p>	<p><b>NOTES:</b> PROJECT: 225-283 SHEETS: 48" FOUR-CHORD SCALE: 1/2" = 1'-0" FT</p>	<p><b>ENGINEERING</b> NAME: S-1 *ALL INFORMATION IS PROPERTY OF BIG TOP MANUFACTURING LLC</p>
	<p><b>PROFESSIONAL ENGINEER</b> NAME: KAMR KAMR 43284 KLAMATH FALLS, OREGON Exp: 07/31/26</p>	<p>11-25-25 All engineering to support the structure is considered "by others", unless specifically noted on our drawings. This includes, but is not limited to, shipping containers, concrete, soil, asphalt, custom support steel, etc.</p>	

**A. GENERAL REQUIREMENT:**

- Furnish all labor, materials, and equipment necessary to complete the work shown or inferred by these drawings.
- Where construction details are not shown or noted for any part of the work, such details shall be the same as for similar work shown on the drawings.
- Notes and details on the drawings take precedence over the general notes and typical details in case of conflict.
- Locate and protect underground or concealed conduit, plumbing or other utilities where new work is being performed.
- The contract drawings and specifications represent the finished structure and do not indicate methods, procedures or sequence of construction. The contractor shall take necessary precautions to maintain and insure the integrity of the new and any existing structures during construction. The design stresses shall not be exceeded during construction based on the age of each element. Neither the owner nor Architect/Engineer will enforce safety measure regulations. Installation Contractor shall design, construct and maintain all safety devices, including shoring and bracing for the new and any existing structures and shall be solely responsible for conforming to all local, state and federal safety and health standards, laws and regulations.
- Obtain prior written approval for any changes to the drawings.
- The contractor shall review and compare the structural drawings with all other Construction Documents, such as Architectural, Mechanical and Electrical drawings, specifications, etc. Do not scale drawings. The contractor shall verify dimensions, elevations and all information. Report, in writing, any inconsistencies, errors, or omissions to the Architect/Engineer of record before proceeding with the work.
- All existing constructions are shown schematic only. Installation Contractor is responsible to verify actual conditions and allow for them in his bid. Notify the Architect/Engineer, in writing, in case of any discrepancy between actual conditions and what is shown on the structural drawings before proceeding with the work.
- See Architectural, Mechanical, Electrical and other drawings for embedded items.
- All communication shall be in writing. No verbal communications, decisions, instructions or approvals shall be valid.
- Adequate drainage path must be provided to drain water away from the perimeter of the building.

**B. CODE AND LOADS:**

- All material and construction work for this project shall conform to the 2018 Wisconsin Building Code based on the 2015 International Building Code (IBC 2015) along with Amendments by the Local Authority Having Jurisdiction. The International Building Code Parameters are:
  - Roof Dead Load = 5 PSF
  - Ground Snow Load = 30 PSF
  - Roof Snow Load = 21 PSF (FLAT), C = 1.0
  - Roof Live Load = 5 PSF
  - Seismic Occupancy Category = II
  - R. Response Modification Coefficient = 3.0
  - Ultimate Wind Speed, V<sub>3g</sub> = 115 mph, Exposure = C, Category II

**C. HOT-ROLLED STEEL:**

- Tube Frames shall be manufactured from A500 in-line galvanized steel with the following properties:
  - Yield strength: 50,000 psi (rectangular); 55,000 psi (round)
  - Tensile Strength: 55,000 psi (rectangular); 60,000 psi (round)
  - The in-line galvanized steel tube meet the ASTM A-1057A & ASTM A1057M - 08 Standard Specification for in-line galvanized coating.

See pages 29 and 132 for un-factored reactions.

**D. FOUNDATION DESIGN:**

- Concrete pad/foundation design/check to support the truss reactions/loads was not included in the scope of services.
- Any foundations shown on the drawings, are approximate and need to be verified/checked based on the local site conditions and local soil properties by a licensed Engineer hired by the Contractor/Builder or Owner of this shelter.

<p><b>BIG TOP MANUFACTURING LLC</b> 3255 US HWY 19 NORTH PERRY, FL 32347 PH: (850) 584 - 7786</p>	<p><b>OWNER:</b> MICHEL'S 162 X 300 X 41 PORT WASHINGTON, WI <b>DESIGNER:</b> JAY C. <b>DATE:</b> 11/13/2025 <b>DESIGNED BY:</b> C. NEIDHART</p>	<p><b>NOTES:</b> PROJECT: 225-283 SHEETS: 48" FOUR-CHORD SCALE: 1/2" = 1'-0" FT</p>	<p><b>ENGINEERING</b> NAME: S-0 *ALL INFORMATION IS PROPERTY OF BIG TOP MANUFACTURING LLC</p>
	<p><b>PROFESSIONAL ENGINEER</b> NAME: KAMR KAMR 43284 KLAMATH FALLS, OREGON Exp: 07/31/26</p>	<p>11-25-25 All engineering to support the structure is considered "by others", unless specifically noted on our drawings. This includes, but is not limited to, shipping containers, concrete, soil, asphalt, custom support steel, etc.</p>	

Sigma Defense 162x140x54  
 Yokota, Japan

INDEX OF DRAWINGS	
DRAWING NUMBER	DRAWING TITLE
S1	COVER SHEET & DRAWING INDEX
S2	FRAME - CLEARANCES
S3.3A	FRAME - SECTION CONNECTION DETAILS
S4.5A	FRAME - LATERAL BRACING DETAILS
S5	FRAME - ISOMETRIC VIEW
S6	FRAME - CABLE BRACING PLAN VIEW
S7	FRAME - CABLE BRACING ELEVATION VIEW
S8	FRAME - CABLE BRACING CONNECTION DETAILS
S3.5A	FRAME - FOOTPRINT AND ANCHOR DETAILS
S9	FABRIC - FABRIC ATTACHMENT DETAILS

**COVER SHEET & INDEX**

**BIG TOP MANUFACTURING LLC**  
 3255 US HWY 19 NORTH  
 PERRY, FL 32347  
 PH: (850) 584 - 7786

**SIGMA DEFENSE**  
 162 X 140 X 54  
 SECTION: YOKOTA, JP  
 DRAWN BY: HUNTER A.  
 DATE: 07/24/2025

**NOTES:**

PROJECT: 225-153  
 NAME: 48' FOUR-CHORD  
 ID: FT  
 FILE:  
 FILE:

Digitally signed by **Ildefonso Gonzalez**  
 Date: 2025.08.06 07:44:28 -05'00'

ENGINEERING  
**S-1**  
 \*ALL INFORMATION IS PROPERTY OF  
 BIG TOP MANUFACTURING LLC

All engineering to support the structure is considered "by others", unless specifically noted on our drawings. That includes, but is not limited to, Shipping containers, concrete, soil, asphalt, custom support steel, etc.

**A. GENERAL REQUIREMENT:**

- Furnish all labor, materials, and equipment necessary to complete the work shown or inferred by these drawings.
- Where construction details are not shown or noted for any part of the work, such details shall be the same as for similar work shown on the drawings.
- Notes and details on the drawings take precedence over the general notes and typical details in case of conflict.
- Locate and protect underground or concealed conduit, plumbing or other utilities where new work is being performed.
- The contract drawings and specifications represent the finished structure and do not indicate methods, procedures or sequence of construction. The design stresses shall not be exceeded during construction based on the age of each element. Neither the owner nor Architect/Engineer will enforce safety measure regulations. Installation Contractor shall design, construct and maintain all safety devices, including shoring and bracing for the new and any existing structures and shall be solely responsible for conforming to all local, state and federal safety and health standards, laws and regulations.
- Obtain prior written approval for any changes to the drawings.
- The contractor shall review and compare the structural drawings with all other Construction Documents, such as Architectural, Mechanical and Electrical drawings, specifications, etc. Do not scale drawings. The contractor shall verify dimensions, elevations and all information. Report, in writing, any inconsistencies, errors, or omissions to the Architect/Engineer of record before proceeding with the work.
- All existing constructions are shown schematic only. Installation Contractor is responsible to verify actual conditions and allow for them in his bid. Notify the Architect/Engineer, in writing, in case of any discrepancy between actual conditions and what is shown on the structural drawings before proceeding with the work.
- See Architectural, Mechanical, Electrical and other drawings for embedded items.
- All communication shall be in writing. No verbal communications, decisions, instructions or approvals shall be valid.
- Adequate drainage path must be provided to drain water away from the perimeter of the building.

**B. CODE AND LOADS:**

- All material and construction work for this project shall conform to UFC 3-301-01, based on the 2024 International Building Code (IBC 2024), along with Amendments by the Local Authority Having Jurisdiction. The International Building Code Parameters are:
  - a. Roof Dead Load = 5 PSF
  - b. Ground Snow Load = 21 PSF
  - c. Roof Snow Load = 17.6 PSF (FLAT)
  - d. Roof Live Load = 5 PSF
  - e. Seismic Occupancy Category = II
  - f. R. Response Modification Coefficient = 3.0
  - g. Ultimate Wind Speed, V3g = 146 mph, Exposure = C, Category II

**C. HOT-ROLLED STEEL:**

- Tube Frames shall be manufactured from A500 In-line galvanized steel with the following properties:
  - a. Yield strength: 50,000 psi (rectangular); 55,000 psi (round)
  - b. Tensile Strength: 55,000 psi (rectangular); 60,000 psi (round)
  - c. The in-line galvanized steel tube meet the ASTM A-1057A & ASTM A1057M - 08 Standard Specification for in-line galvanized coating.

**D. FOUNDATION DESIGN:**

- Concrete pad/foundation design/check to support the truss reactions/loads was not included in the scope of services.
- Any foundations shown on the drawings, are approximate and need to be verified/checked based on the local site conditions and local soil properties by a licensed Engineer hired by the Contractor/Builder or Owner of this shelter.

**BIG TOP MANUFACTURING LLC**  
 3255 US HWY 19 NORTH  
 PERRY, FL 32347  
 PH: (850) 584 - 7786

**SIGMA DEFENSE**  
 162 X 140 X 54  
 SECTION: YOKOTA, JP  
 DRAWN BY: HUNTER A.  
 DATE: 07/24/2025

**NOTES:**

PROJECT: 225-153  
 NAME: 48' FOUR-CHORD  
 ID: FT  
 FILE:  
 FILE:

Digitally signed by **Ildefonso Gonzalez**  
 Date: 2025.08.06 07:44:18 -05'00'

ENGINEERING  
**S-0**  
 \*ALL INFORMATION IS PROPERTY OF  
 BIG TOP MANUFACTURING LLC



All engineering to support the structure is considered "by others", unless specifically noted on our drawings. That includes, but is not limited to, Shipping containers, concrete, soil, asphalt, custom support steel, etc.

Tesla, Inc 100 x 230 x 35  
Fremont, CA

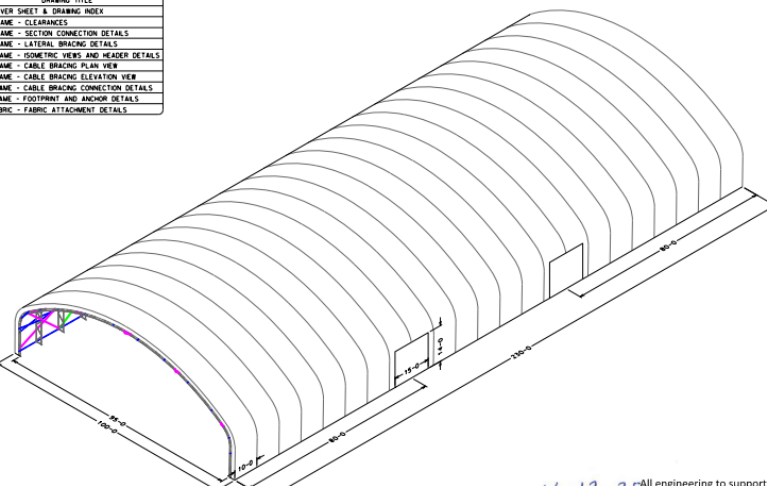
INDEX OF DRAWINGS	
DRAWING NUMBER	DRAWING TITLE
SI	COVER SHEET & DRAWING INDEX
S2	FRAME - CLEARANCES
S3,S3A	FRAME - SECTION CONNECTION DETAILS
S4,S4A	FRAME - LATERAL BRACING DETAILS
S5,S5A,S5B	FRAME - SOMEWHAT VIEWS AND HEADER DETAILS
S6	FRAME - CABLE BRACING PLAN VIEW
S7	FRAME - CABLE BRACING ELEVATION VIEW
S8	FRAME - CABLE BRACING CONNECTION DETAILS
S9,S9A,S9B	FRAME - FOOTPRINT AND ANCHOR DETAILS
S10	FABRIC - FABRIC ATTACHMENT DETAILS



**COVER SHEET & INDEX**

 BIG TOP MANUFACTURING LLC 3255 US HWY 19 NORTH PERRY, FL 32347 PH: (850) 584 - 7786	PROJECT: PRODUCTION TEMP. STR. SIZE: 100 X 230 X 35 LOCATION: FREMONT, CA DRAWING NO: 678-521-6201 DRAWN BY: HUNTER A. CHECKED BY: THOMAS H. DATE: 11/12/2025 CUSTOMER: CHARLES C. MARTO	NOTES: REVISION: F25-0065 DESCRIPTION: 30' FOUR-CHORD UNIT: ID FT	11-13-25 	ENGINEERING NO: S-1 *ALL INFORMATION IS PROPERTY OF BIG TOP MANUFACTURING LLC
	ALL engineering to support the structure is considered "by others", unless specifically noted on our drawings. That includes, but is not limited to, shipping containers, concrete, asphalt, custom support steel, etc.			

**A. GENERAL REQUIREMENT:**

- Furnish all labor, materials, and equipment necessary to complete the work shown or inferred by these drawings.
- Where construction details are not shown or noted for any part of the work, such details shall be the same as for similar work shown on the drawings.
- Notes and details on the drawings take precedence over the general notes and typical details in case of conflict.
- Locate and protect underground or concealed conduit, plumbing or other utilities where new work is being performed.
- The contract drawings and specifications represent the finished structure and do not indicate methods, procedures or sequence of construction. The contractor shall take necessary precautions to maintain and insure the integrity of the new and any existing structures during construction. The design stresses shall not be exceeded during construction based on the age of each element. Neither the owner nor Architect/Engineer will enforce safety measure regulations. Installation Contractor shall design, construct and maintain all safety devices, including shoring and bracing for the new and any existing structures and shall be solely responsible for conforming to all local, state and federal safety and health standards, laws and regulations.
- Obtain prior written approval for any changes to the drawings.
- The contractor shall review and compare the structural drawings with all other Construction Documents, such as Architectural, Mechanical and Electrical drawings, specifications, etc. Do not scale drawings. The contractor shall verify dimensions, elevations and all information. Report, in writing, any inconsistencies, errors, or omissions to the Architect/Engineer of record before proceeding with the work.
- All existing structures are shown schematic only. Installation Contractor is responsible to verify actual conditions and allow for them in his bid. Notify the Architect/Engineer, in writing, in case of any discrepancy between actual conditions and what is shown on the structural drawings before proceeding with the work.
- See Architectural, Mechanical, Electrical and other drawings for embedded items.
- All communications shall be in writing. No verbal communications, decisions, instructions or approvals shall be valid.
- Adequate drainage path must be provided to drain water away from the perimeter of the building.

**B. CODE AND LOADS:**

1. All material and construction work for this project shall conform to 2022 California Building Code (CBC 2022) based on the 2021 International Building Code (IBC 21) along with Amendments by the Local Authority Having Jurisdiction. The International Building Code Parameters are:

- a. Roof Dead Load = 1 PSF
- b. Ground Snow Load = 0 PSF
- c. Roof Snow Load = 0 PSF (FLAT)
- d. Roof Live Load = 5 PSF
- e. Seismic Occupancy Category = II
- f. R. Response Modification Coefficient = 1.0
- g. Ultimate Wind Speed, Vg = 95 mph. Exposure = C, Category III

SEISMIC DESIGN CRITERIA  
ALL DEFICIT VALUES PER ASCE 7-16

Ss : 2.39  
S1 : 0.54  
S2 : 1.57  
T1 : 1.2  
F0 : 1.2  
I0 : 1.0  
I1 : 1.0  
C1 : 1.438

FOUNDATION SUPPORTED IN REFERENCE TO GEOTECHNICAL REPORT BSK NO. G25001389

See pages 32 to 39 for un-factored reactions.



**C. HOT-ROLLED STEEL:**

- Tube Frames shall be manufactured from A500 in-line galvanized steel with the following properties:
  - a. Yield strength: 50,000 psi (rectangular); 55,000 psi (round)
  - b. Tensile Strength: 55,000 psi (rectangular); 60,000 psi (round)
  - c. The in-line galvanized steel tube meet the ASTM A-1057A & ASTM A1057M - 08 Standard Specification for in-line galvanized coating.

**D. FOUNDATION DESIGN:**

- Concrete pad/foundation design/check to support the truss reactions/loads was not included in the scope of services.
- Any foundations shown on the drawings, are approximate and need to be verified/checked based on the local site conditions and local soil properties by a licensed Engineer hired by the Contractor/Builder or Owner of this shelter. It is Tesla's responsibility to confirm that Big Top's interpretation and shelter design meet these requirements.

11-13-25  
All engineering to support the structure is considered "by others", unless specifically noted on our drawings. That includes, but is not limited to, shipping containers, concrete, asphalt, custom support steel, etc.

 BIG TOP MANUFACTURING LLC 3255 US HWY 19 NORTH PERRY, FL 32347 PH: (850) 584 - 7786	PROJECT: PRODUCTION TEMP. STR. SIZE: 100 X 230 X 35 LOCATION: FREMONT, CA DRAWING NO: 678-521-6201 DRAWN BY: HUNTER A. CHECKED BY: THOMAS H. DATE: 11/12/2025 CUSTOMER: CHARLES C. MARTO	NOTES: REVISION: F25-0065 DESCRIPTION: 30' FOUR-CHORD UNIT: ID FT	11-13-25 	ENGINEERING NO: S-0 *ALL INFORMATION IS PROPERTY OF BIG TOP MANUFACTURING LLC
	ALL engineering to support the structure is considered "by others", unless specifically noted on our drawings. That includes, but is not limited to, shipping containers, concrete, asphalt, custom support steel, etc.			

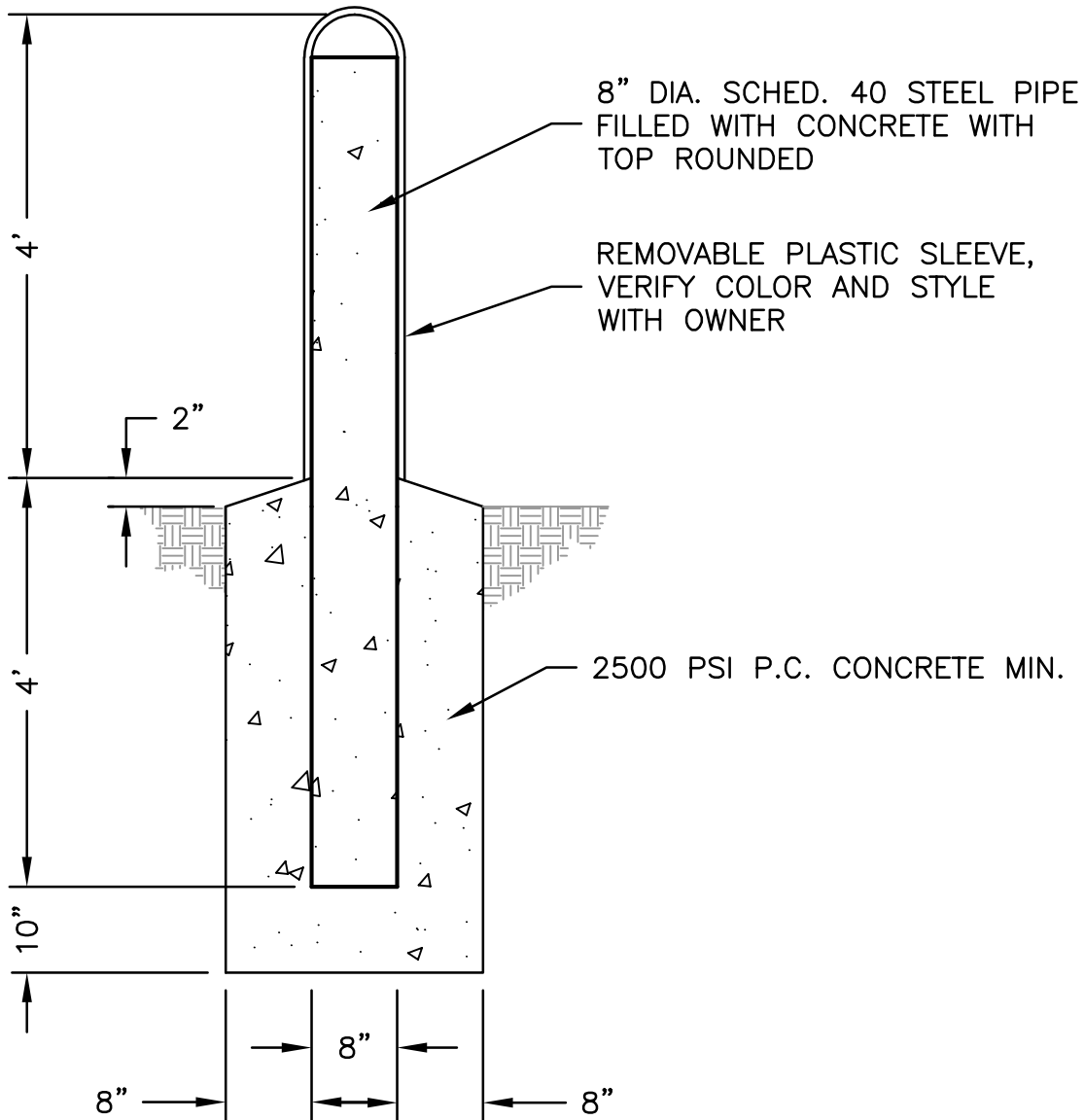

**8" BOLLARD DETAIL**  
N.T.S.





---

# STRUCTURAL ENGINEERING CALCULATIONS

PROJECT: 110 x 291.5 x 48 Zekelman Industries

PROJECT LOCATION: 1600 Ritchie Court  
Rochelle, IL 61068

PROJECT NUMBER: Big Top 226-093

DATE: 4/14/2026

**A. GENERAL REQUIREMENT:**

1. Furnish all labor, materials, and equipment necessary to complete the work shown or inferred by these drawings.
2. Where construction details are not shown or noted for any part of the work, such details shall be the same as for similar work shown on the drawings.
3. Notes and details on the drawings take precedence over the general notes and typical details in case of conflict.
4. Locate and protect underground or concealed conduit, plumbing or other utilities where new work is being performed.
5. The contract drawings and specifications represent the finished structure and do not indicate methods, procedures or sequence of construction. The contractor shall take necessary precautions to maintain and insure the integrity of the new and any existing structures during construction. The design stresses shall not be exceeded during construction based on the age of each element. Neither the owner nor Architect/Engineer will enforce safety measure regulations. Installation Contractor shall design, construct and maintain all safety devices, including shoring and bracing for the new and any existing structures and shall be solely responsible for conforming to all local, state and federal safety and health standards, laws and regulations.
6. Obtain prior written approval for any changes to the drawings.
7. The contractor shall review and compare the structural drawings with all other Construction Documents, such as Architectural, Mechanical and Electrical drawings, specifications, etc. Do not scale drawings. The contractor shall verify dimensions, elevations and all information. Report, in writing, any inconsistencies, errors, or omissions to the Architect/Engineer of record before proceeding with the work.
8. All existing constructions are shown schematic only. Installation Contractor is responsible to verify actual conditions and allow for them in his bid. Notify the Architect/Engineer, in writing, in case of any discrepancy between actual conditions and what is shown on the structural drawings before proceeding with the work.
9. See Architectural, Mechanical, Electrical and other drawings for embedded items.
10. All communication shall be in writing. No verbal communications, decisions, instructions or approvals shall be valid.
11. Adequate drainage path must be provided to drain water away from the perimeter of the building.

**B. CODE AND LOADS:**

1. All material and construction work for this project shall conform to the 2021 International Building Code (IBC 2021) along with Amendments by the Local Authority Having Jurisdiction. The International Building Code Parameters are:
  - a. Roof Dead Load = 2 PSF
  - b. Ground Snow Load = 30 PSF
  - c. Roof Snow Load = 25.2 PSF (FLAT)
  - d. Roof Live Load = 5 PSF
  - e. Seismic Occupancy Category = II
  - f. R, Response Modification Coefficient = 3.0
  - g. Ultimate Wind Speed, V3g = 110 mph, Exposure = C, Category II
  - h. Collateral Load = 3 PSF

**C. HOT-ROLLED STEEL:**

1. Tube Frames shall be manufactured from A500 in-line galvanized steel with the following properties:
  - a. Yield strength: 50,000 psi (rectangular); 55,000 psi (round)
  - b. Tensile Strength: 55,000 psi (rectangular); 60,000 psi (round)
  - c. The in-line galvanized steel tube meet the ASTM A-1057A & ASTM A1057M - 08 Standard Specification for in-line galvanized coating.

See pages 33-36, 295 for un-factored reactions.

**D. FOUNDATION DESIGN:**

1. Concrete pad/foundation design/check to support the truss reactions/loads was not included in the scope of services.
2. Any foundations shown on the drawings, are approximate and need to be verified/checked based on the local site conditions and local soil properties by a licensed Engineer hired by the Contractor/Builder or Owner of this shelter.
3. For soil anchor applications, see page S-0.1 for additional requirements.

ALL INFORMATION IS PROPERTY OF BIG TOP MANUFACTURING LLC  BIG TOP MANUFACTURING LLC 3255 US HWY 19 NORTH PERRY, FL 32347 PH: (850) 584 - 7786	CUSTOMER: ZEKELMAN INDUSTRIES	SHEET DESCRIPTION: GENERAL NOTES		
	STRUCTURE SIZE: 110 X 291.5 X 48	LOCATION: ROCHELLE, IL		
	TRUSS STYLE: 48" FOUR-CHORD	DRAWN BY: G. ANDREWS	SALES REPRESENTATIVE: THOMAS H.	
	PROJECT NO: 226-093	DATE: 04/14/2026	ISSUE: REV 0	SHEET NO: S-0

NOT FOR  
CONSTRUCTION

22  
STAMP ONLY

**D. FOUNDATION DESIGN CONTINUED:**

4. For soil anchor applications, as an alternative to item 2 on sheet S-0, the following approximate method could be used.
  - a. Number of soil anchors shown on the plans assumed that the soil anchor's ultimate capacity is 1200 lbs minimum, which shall be verified by site test results.
  - b. Pull out strength varies based on the local soil type and shall be verified by local soil tests at the site.
  - c. The tables below should be used as a guide only and subject to results of anchor pull test at the site.
  - d. Perform soil anchor tests to verify the above value for the soil type. A minimum of four tests shall be conducted to verify the assumed capacity above.
  - e. Use an approved method to obtain the values for the site:
    - (i) Dynamometer to obtain uplift by pulling out the anchors with a forklift
    - (ii) Hydraulic Pump
  - f. Pull out strength shall be measured at a maximum deflection/letup of 1/2 inch.
  - g. The tests shall be performed by a third party approved testing agency. In absence of a third party approved testing agency, the tests shall be performed in the presence of at least two of the following representatives and the results thereafter shall be signed by them upon completion of the tests.
    - (i) Big Top Manufacturing representative
    - (ii) Customer representative
    - (iii) Installation representative
  - h. If the test results are less than the above value, do not install the anchors and contact the Engineer of Record immediately, both by telephone and in writing.
  - i. If the test results are equal to or more than the above value, install the soil anchors as shown on the plans.
  - j. Results of the tests shall be submitted to both the Engineer of Record and to the Engineering Manager of Big Top Manufacturing LLC
  - k. The Owner and/or the Installation Contractor shall assume all responsibilities for the accuracy of the test results when using this method.

**Soil Anchor Installation Guideline**

Soil Type	Anchor Capacity (lbs)
Soft/Medium Sandy	600
Medium/Sandy Grass Top	1000
Medium/Sandy Soil Gray	1200
Medium/Sandy with Asphalt Top	1800
Medium Soil with Limerock and Asphalt	2000
Caliche	2500
Medium Dense Soil - Dry	3000
Medium Dense Soil with Asphalt Top	3500
Hard Clay	5500
Hard Clay with Aspalt Top	6000

Time to Set Anchor (min)	Pull Out Strength (lbs)
<1	0
1-3	0
4-6	600-1100
7-9	1100-1800
10-15	1800-2500
>15	2500-3500

Time to Set Anchor (min)	Pull Out Strength (lbs)
<1	0
1-3	600-1100
4-6	1100-1800
7-9	1800-2500
10-15	2500-3500
>15	>3500

② **Soil Anchor Capacity Based on Time to Set Anchor w/ 60lb Breaker**  
Scale: N.T.S.

③ **Soil Anchor Capacity Based on Time to Set Anchor w/ 90lb Breaker**  
Scale: N.T.S.

① **Soil Anchor Capacity Based on Soil Type**  
Scale: N.T.S.

NOT FOR CONSTRUCTION

 ALL INFORMATION IS PROPERTY OF BIG TOP MANUFACTURING LLC BIG TOP MANUFACTURING LLC 3255 US HWY 19 NORTH PERRY, FL 32347 PH: (850) 584 - 7786	CUSTOMER: ZEKELMAN INDUSTRIES	SHEET DESCRIPTION: SOIL ANCHOR NOTES		
	STRUCTURE SIZE: 110 X 291.5 X 48	LOCATION: ROCHELLE, IL		
	TRUSS STYLE: 48" FOUR-CHORD	DRAWN BY: G. ANDREWS	SALES REPRESENTATIVE: THOMAS H.	
	PROJECT NO: 226-093	DATE: 04/14/2026	ISSUE: REV 0	SHEET NO: S-0.1

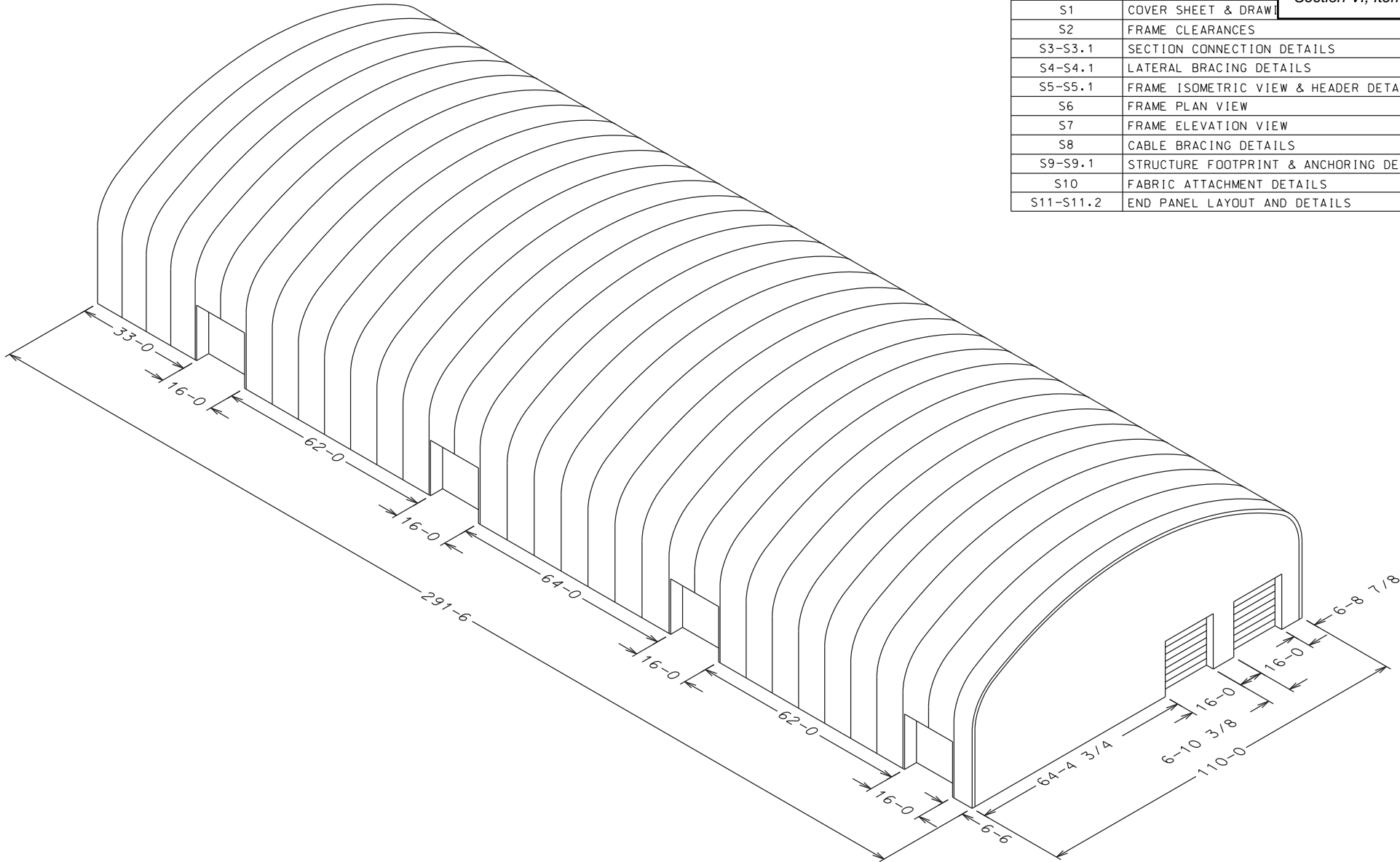

INDEX	
DRAWING NO.	DESCRIPTION
S1	COVER SHEET & DRAWING INDEX
S2	FRAME CLEARANCES
S3-S3.1	SECTION CONNECTION DETAILS
S4-S4.1	LATERAL BRACING DETAILS
S5-S5.1	FRAME ISOMETRIC VIEW & HEADER DETAILS
S6	FRAME PLAN VIEW
S7	FRAME ELEVATION VIEW
S8	CABLE BRACING DETAILS
S9-S9.1	STRUCTURE FOOTPRINT & ANCHORING DETAILS
S10	FABRIC ATTACHMENT DETAILS
S11-S11.2	END PANEL LAYOUT AND DETAILS

Section VI, Item 1.

NOT FOR  
CONSTRUCTION

ALL INFORMATION IS PROPERTY  
OF BIG TOP MANUFACTURING LLC



BIG TOP MANUFACTURING LLC  
3255 US HWY 19 NORTH  
PERRY, FL 32347  
PH: (850) 584 - 7786

CUSTOMER: ZEKELMAN INDUSTRIES
STRUCTURE SIZE: 110 X 291.5 X 48
TRUSS STYLE: 48" FOUR-CHORD
PROJECT NO: 226-093

SHEET DESCRIPTION: COVER SHEET & DRAWING INDEX	
LOCATION: ROCHELLE, IL	
DRAWN BY: G. ANDREWS	SALES REPRESENTATIVE: THOMAS H.
DATE: 04/14/2026	ISSUE: REV 0
SHEET NO: S-1	

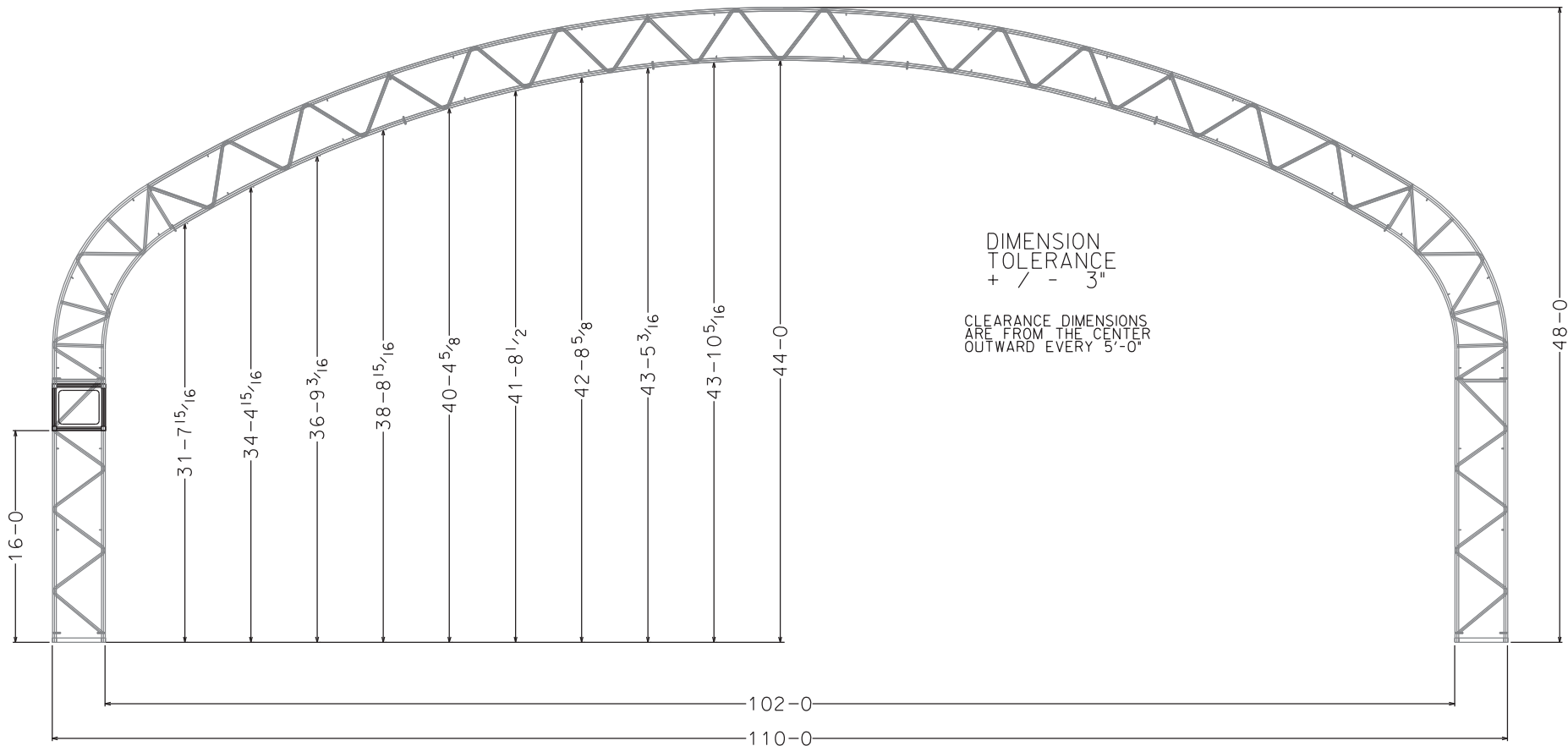

NOT FOR  
CONSTRUCTION

ALL INFORMATION IS PROPERTY  
OF BIG TOP MANUFACTURING LLC



BIG TOP MANUFACTURING LLC  
3255 US HWY 19 NORTH  
PERRY, FL 32347  
PH: (850) 584 - 7786

CUSTOMER: ZEKELMAN INDUSTRIES
STRUCTURE SIZE: 110 X 291.5 X 48
TRUSS STYLE: 48" FOUR-CHORD
PROJECT NO: 226-093

SHEET DESCRIPTION: FRAME CLEARANCES	
LOCATION: ROCHELLE, IL	
DRAWN BY: G. ANDREWS	SALES REPRESENTATIVE: THOMAS H.
DATE: 04/14/2026	ISSUE: REV 0
SHEET NO: S-2	

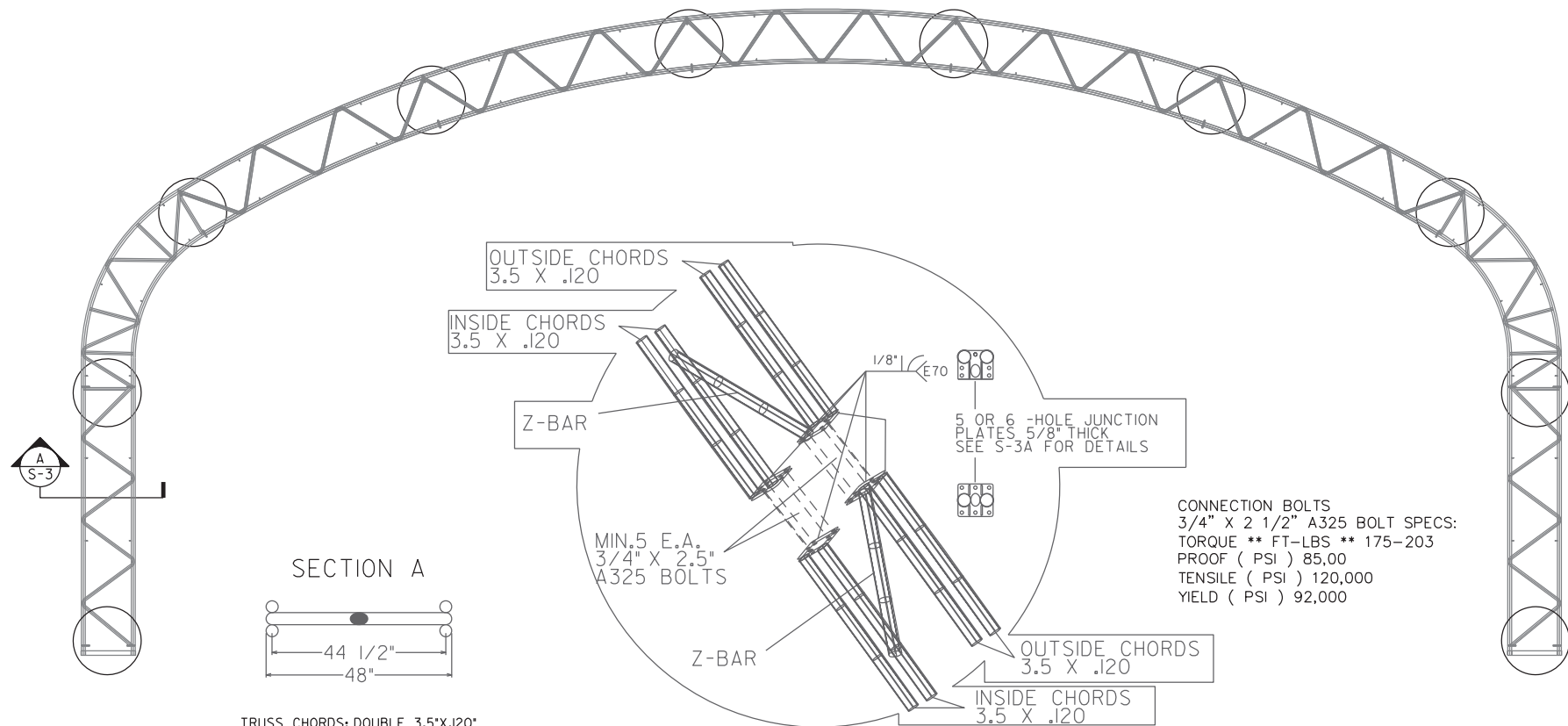

CONNECTION BOLTS  
 3/4" X 2 1/2" A325 BOLT SPECS:  
 TORQUE \*\* FT-LBS \*\* 175-203  
 PROOF ( PSI ) 85,00  
 TENSILE ( PSI ) 120,000  
 YIELD ( PSI ) 92,000

SECTION A

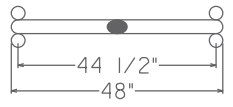

TRUSS CHORDS: DOUBLE 3.5"X.120"  
 YIELD: 55,000 PSI (ROUND)  
 TENSILE: 60,000 PSI (ROUND)  
 Z-BAR: 2.375" X 0.120  
 YIELD: 55,000 PSI (ROUND)  
 TENSILE: 60,000 PSI (ROUND)

NOT FOR  
 CONSTRUCTION

ALL INFORMATION IS PROPERTY  
 OF BIG TOP MANUFACTURING LLC



BIG TOP MANUFACTURING LLC  
 3255 US HWY 19 NORTH  
 PERRY, FL 32347  
 PH: (850) 584 - 7786

CUSTOMER: ZEKELMAN INDUSTRIES
STRUCTURE SIZE: 110 X 291.5 X 48
TRUSS STYLE: 48" FOUR-CHORD
PROJECT NO: 226-093

SHEET DESCRIPTION: SECTION CONNECTION DETAILS	
LOCATION: ROCHELLE, IL	
DRAWN BY: G. ANDREWS	SALES REPRESENTATIVE: THOMAS H.
DATE: 04/14/2026	ISSUE: REV 0
	SHEET NO: S-3

NOTE: SEE S5 FOR PURLIN LOCATIONS.

LEGEND	
□	RI <b>Section VI, Item 1.</b>
△	PURLIN
○	X-BRACE

SEE S-4.1 FOR DETAILS

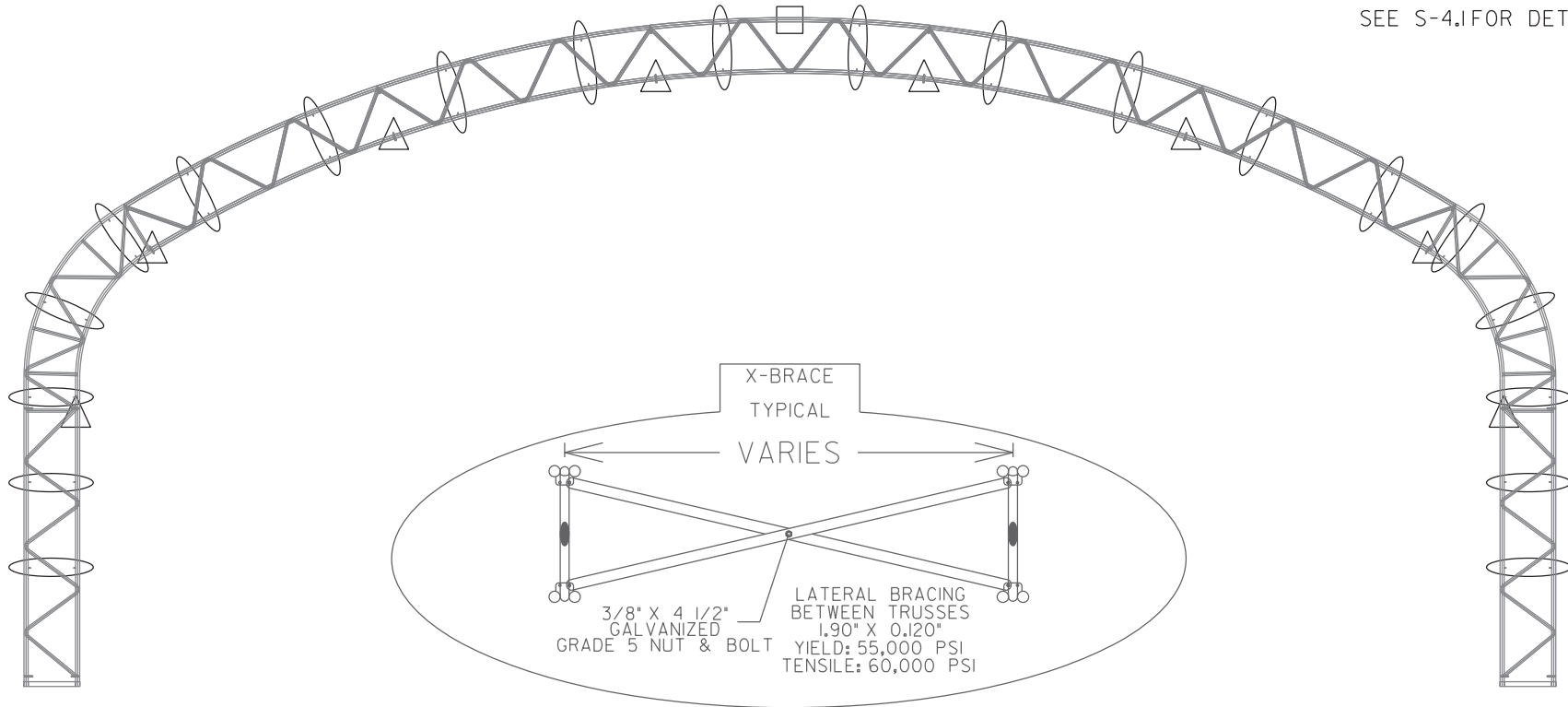

NOT FOR  
CONSTRUCTION

ALL INFORMATION IS PROPERTY  
OF BIG TOP MANUFACTURING LLC



**BIG TOP**  
BIG TOP MANUFACTURING LLC  
3255 US HWY 19 NORTH  
PERRY, FL 32347  
PH: (850) 584 - 7786

CUSTOMER: ZEKELMAN INDUSTRIES
STRUCTURE SIZE: 110 X 291.5 X 48
TRUSS STYLE: 48" FOUR-CHORD
PROJECT NO: 226-093

SHEET DESCRIPTION: LATERAL BRACING LOCATIONS	
LOCATION: ROCHELLE, IL	
DRAWN BY: G. ANDREWS	SALES REPRESENTATIVE: THOMAS H.
DATE: 04/14/2026	ISSUE: REV 0
SHEET NO: S-4	

NOTE:  
5/8" PLATE THICKNESS  
A572 GR. 50 STEEL

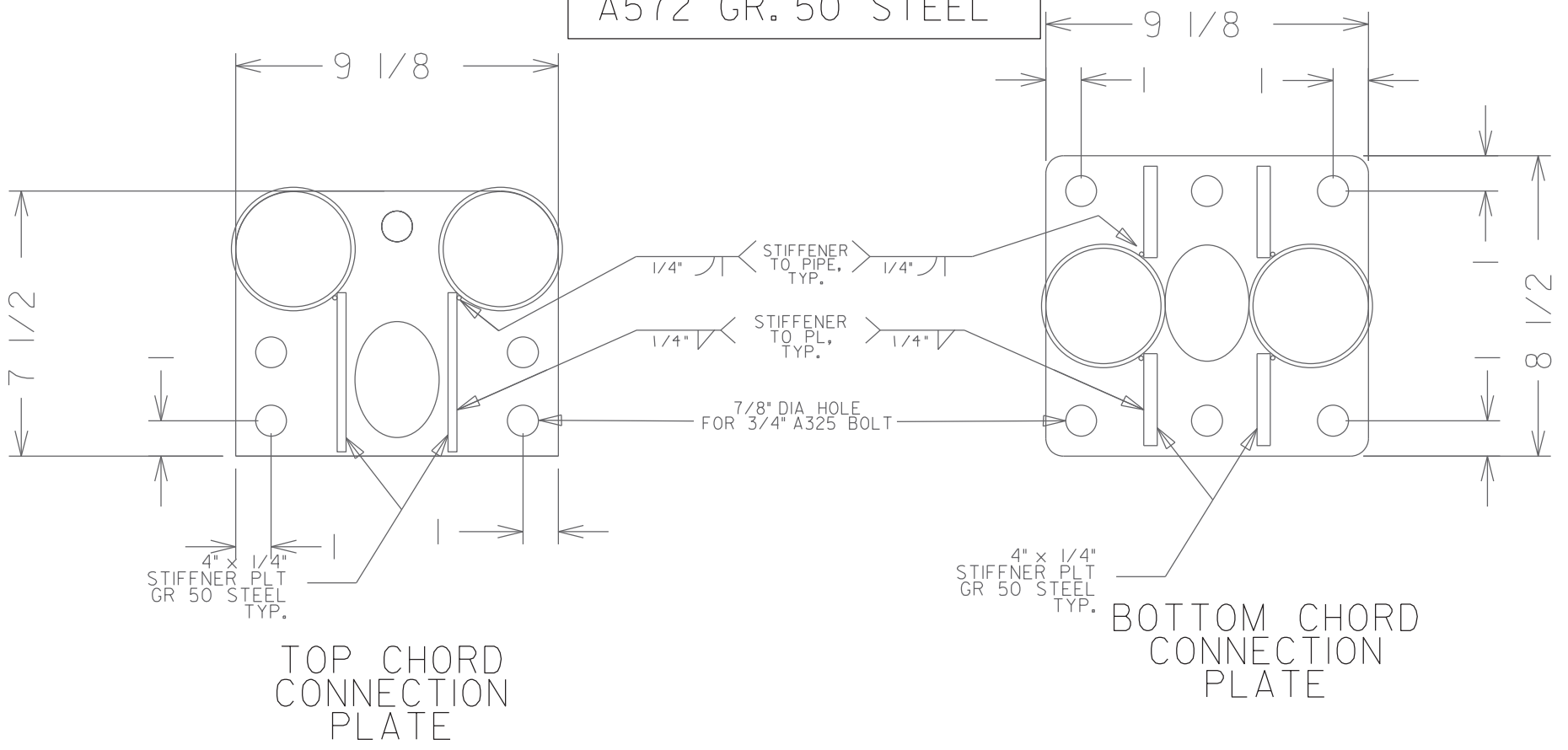

TOP CHORD  
CONNECTION  
PLATE

BOTTOM CHORD  
CONNECTION  
PLATE

NOT FOR  
CONSTRUCTION

ALL INFORMATION IS PROPERTY  
OF BIG TOP MANUFACTURING LLC



BIG TOP MANUFACTURING LLC  
3255 US HWY 19 NORTH  
PERRY, FL 32347  
PH: (850) 584 - 7786

CUSTOMER: ZEKELMAN INDUSTRIES
STRUCTURE SIZE: 110 X 291.5 X 48
TRUSS STYLE: 48" FOUR-CHORD
PROJECT NO: 226-093

SHEET DESCRIPTION: SECTION CONNECTION DETAILS	
LOCATION: ROCHELLE, IL	
DRAWN BY: G. ANDREWS	SALES REPRESENTATIVE: THOMAS H.
DATE: 04/14/2026	ISSUE: REV 0
SHEET NO: S-3.1	

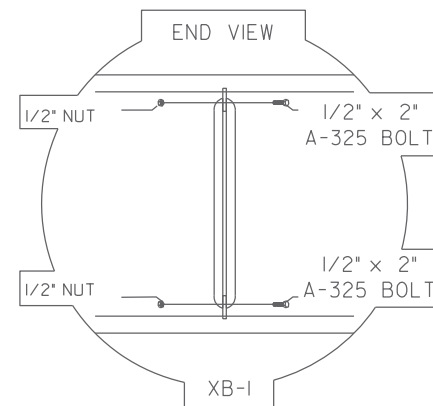
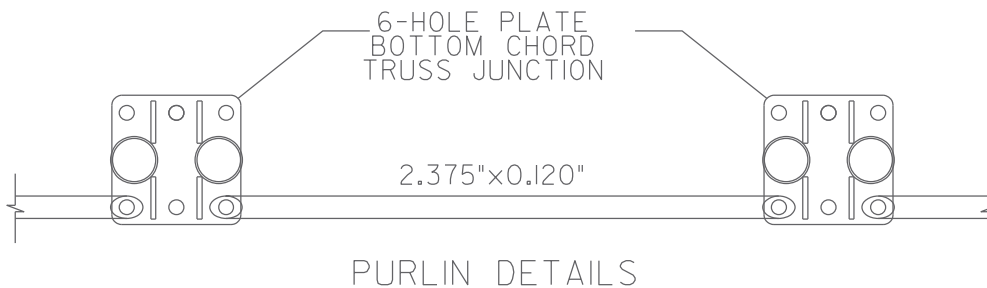
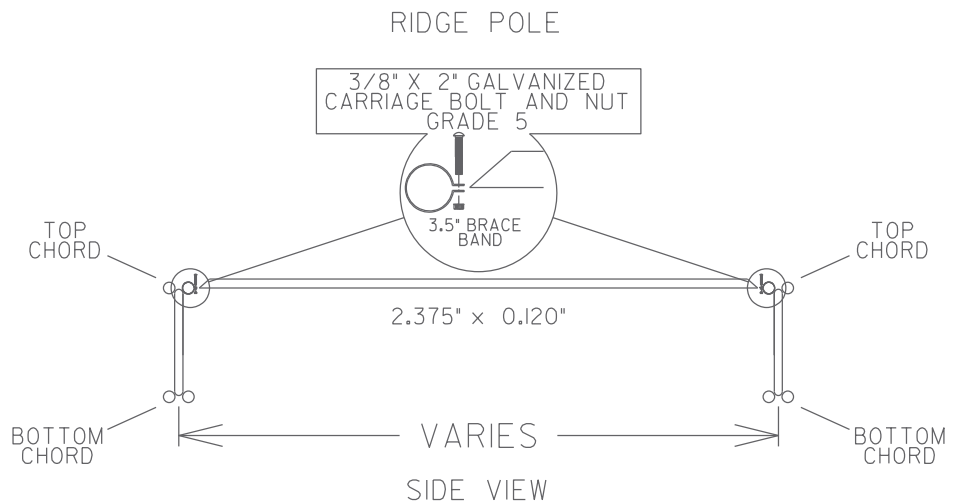
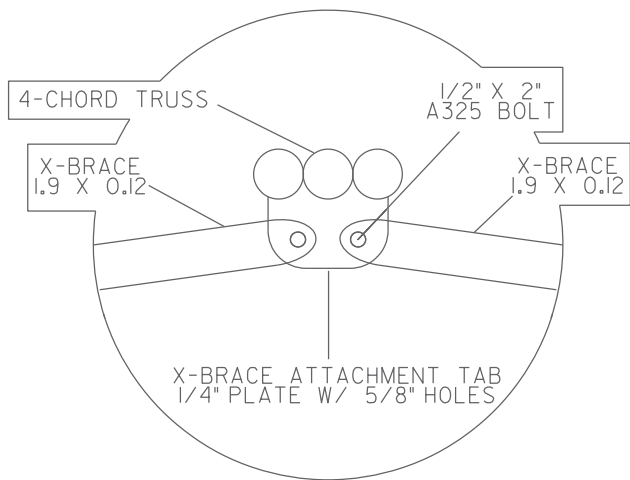

NOT FOR  
CONSTRUCTION

ALL INFORMATION IS PROPERTY  
OF BIG TOP MANUFACTURING LLC

BIG TOP MANUFACTURING LLC  
3255 US HWY 19 NORTH  
PERRY, FL 32347  
PH: (850) 584 - 7786

CUSTOMER: ZEKELMAN INDUSTRIES
STRUCTURE SIZE: 110 X 291.5 X 48
TRUSS STYLE: 48" FOUR-CHORD
PROJECT NO: 226-093

SHEET DESCRIPTION: LATERAL BRACING DETAILS	
LOCATION: ROCHELLE, IL	
DRAWN BY: G. ANDREWS	SALES REPRESENTATIVE: THOMAS H.
DATE: 04/14/2026	ISSUE: REV 0
SHEET NO: S-4.1	

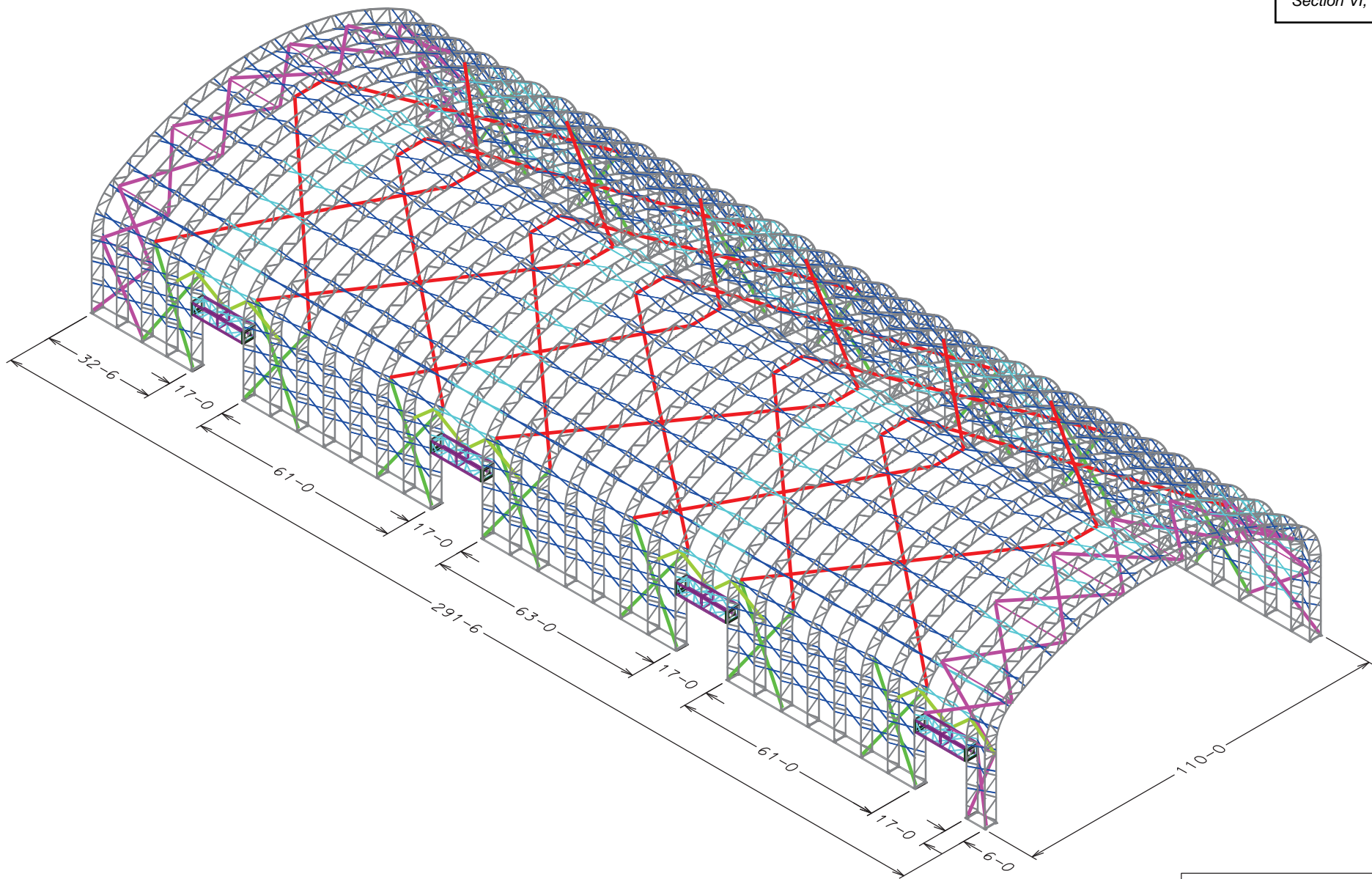

NOT FOR  
CONSTRUCTION

ALL INFORMATION IS PROPERTY  
OF BIG TOP MANUFACTURING LLC



**BIGTOP**  
BIG TOP MANUFACTURING LLC  
3255 US HWY 19 NORTH  
PERRY, FL 32347  
PH: (850) 584 - 7786

CUSTOMER: ZEKELMAN INDUSTRIES
STRUCTURE SIZE: 110 X 291.5 X 48
TRUSS STYLE: 48" FOUR-CHORD
PROJECT NO: 226-093

SHEET DESCRIPTION: CABLE BRACING ISOMETRIC VIEW	
LOCATION: ROCHELLE, IL	
DRAWN BY: G. ANDREWS	SALES REPRESENTATIVE: THOMAS H.
DATE: 04/14/2026	ISSUE: REV 0
SHEET NO: S-5	

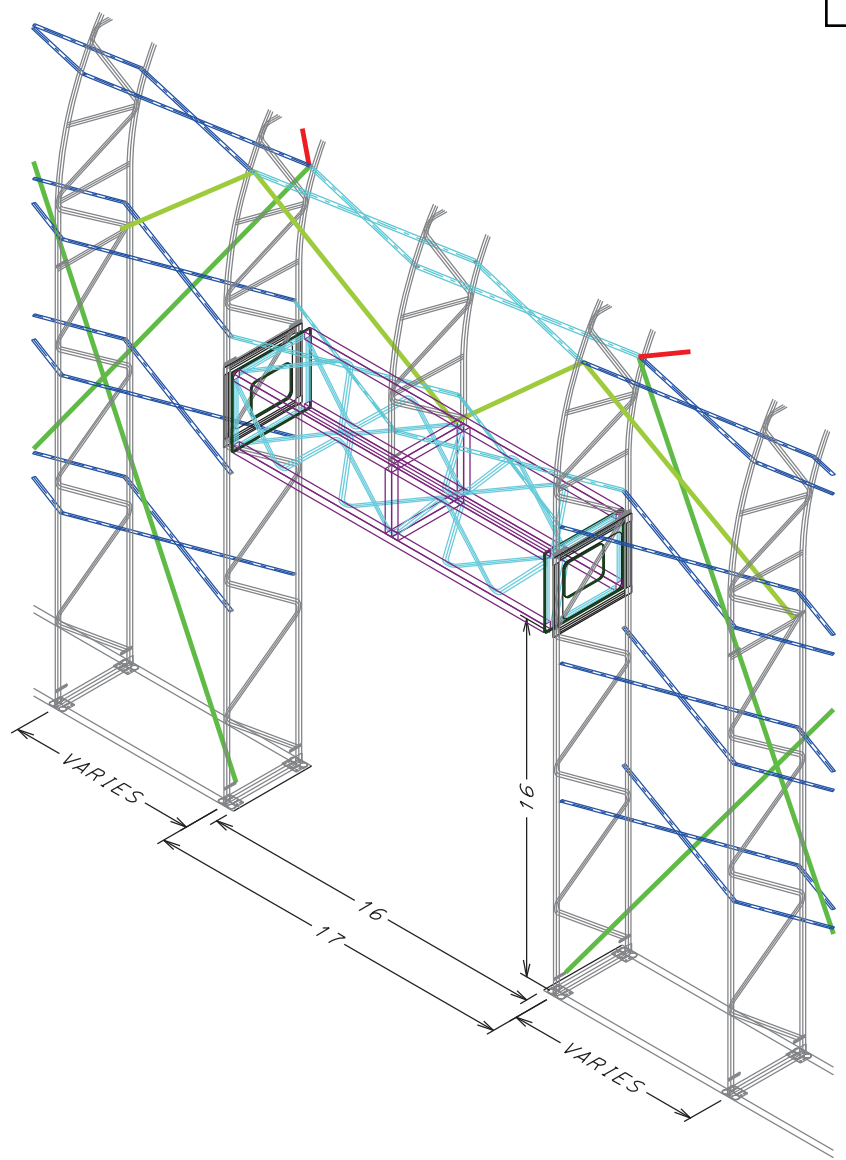
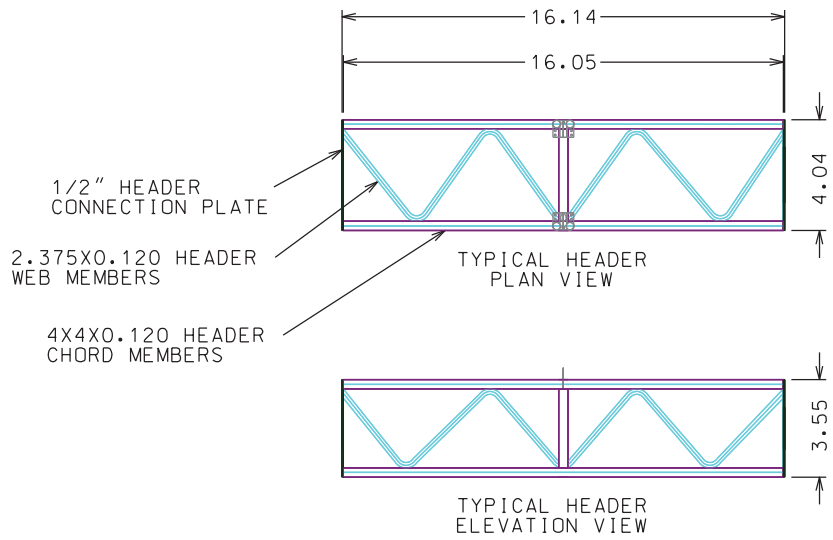

NOT FOR CONSTRUCTION





ALL INFORMATION IS PROPERTY OF BIG TOP MANUFACTURING LLC

BIG TOP MANUFACTURING LLC  
3255 US HWY 19 NORTH  
PERRY, FL 32347  
PH: (850) 584 - 7786

CUSTOMER: ZEKELMAN INDUSTRIES
STRUCTURE SIZE: 110 X 291.5 X 48
TRUSS STYLE: 48" FOUR-CHORD
PROJECT NO: 226-093

SHEET DESCRIPTION: HEADER DETAILS	
LOCATION: ROCHELLE, IL	
DRAWN BY: G. ANDREWS	SALES REPRESENTATIVE: THOMAS H.
DATE: 04/14/2026	ISSUE: REV 0
SHEET NO: S-5.1	

Section VI, Item 1.

	
	CW-2
	TB-1
	TB-2

SEE S-8 FOR DETAILS

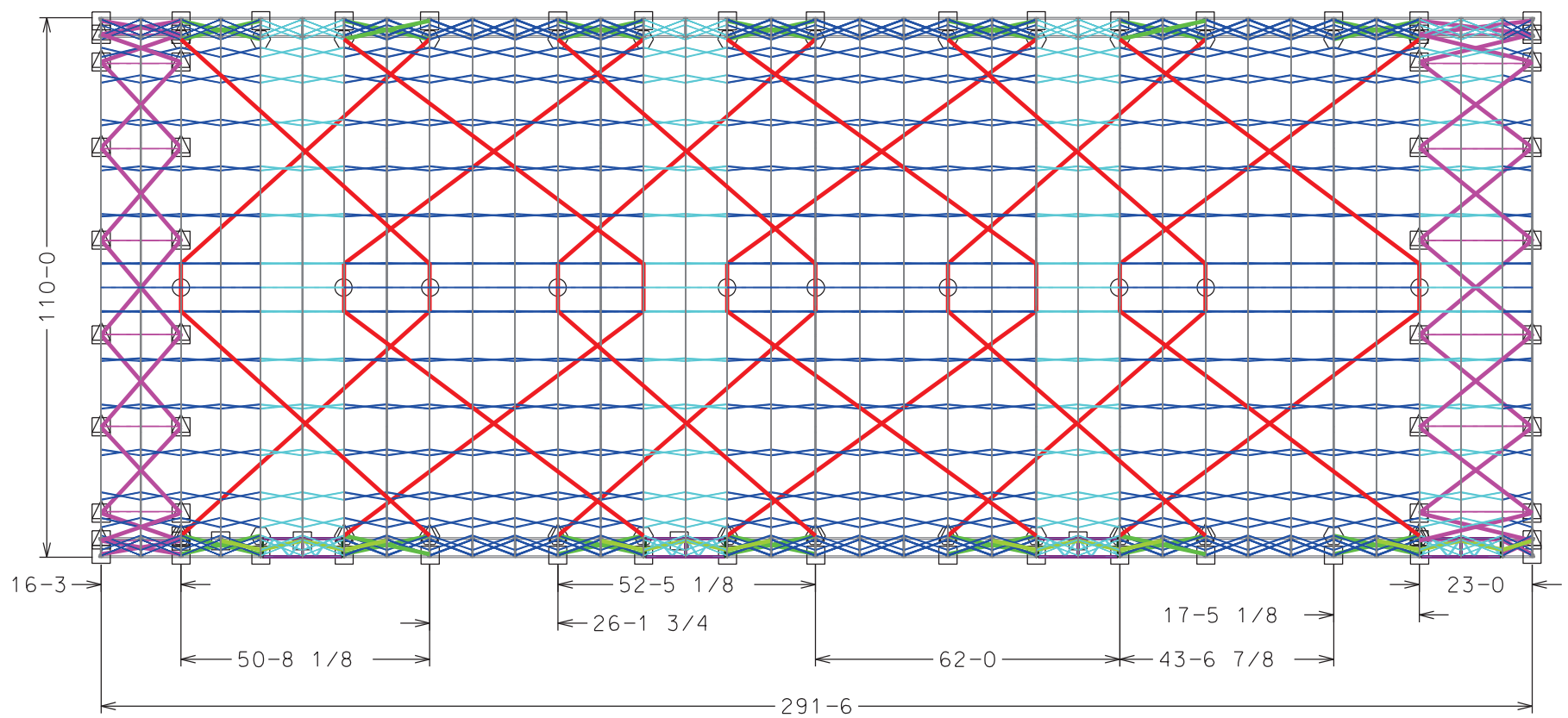

NOT FOR  
CONSTRUCTION



ALL INFORMATION IS PROPERTY  
OF BIG TOP MANUFACTURING LLC



BIG TOP MANUFACTURING LLC  
3255 US HWY 19 NORTH  
PERRY, FL 32347  
PH: (850) 584 - 7786

CUSTOMER: ZEKELMAN INDUSTRIES
STRUCTURE SIZE: 110 X 291.5 X 48
TRUSS STYLE: 48" FOUR-CHORD
PROJECT NO: 226-093

SHEET DESCRIPTION: CABLE BRACING PLAN VIEW	
LOCATION: ROCHELLE, IL	
DRAWN BY: G. ANDREWS	SALES REPRESENTATIVE: THOMAS H.
DATE: 04/14/2026	ISSUE: REV 0
	SHEET NO: S-6

SECTION	
Section VI, Item 1.	
	CW-2
	TB-1
	TB-2

SEE S-8 FOR DETAILS

ADDITIONAL HEADER SAFETY CABLE(S)

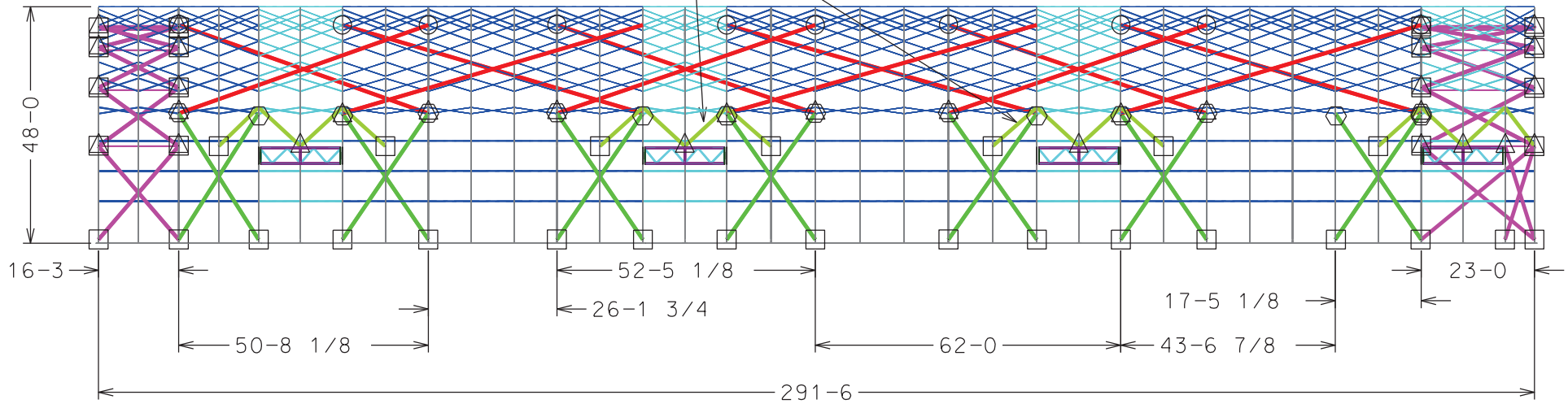

NOT FOR  
CONSTRUCTION

ALL INFORMATION IS PROPERTY  
OF BIG TOP MANUFACTURING LLC



BIG TOP MANUFACTURING LLC  
3255 US HWY 19 NORTH  
PERRY, FL 32347  
PH: (850) 584 - 7786

CUSTOMER: ZEKELMAN INDUSTRIES
STRUCTURE SIZE: 110 X 291.5 X 48
TRUSS STYLE: 48" FOUR-CHORD
PROJECT NO: 226-093

SHEET DESCRIPTION: CABLE BRACING ELEVATION VIEW	
LOCATION: ROCHELLE, IL	
DRAWN BY: G. ANDREWS	SALES REPRESENTATIVE: THOMAS H.
DATE: 04/14/2026	ISSUE: REV 0
SHEET NO: S-7	

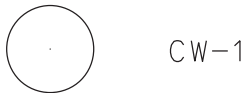

CW-1

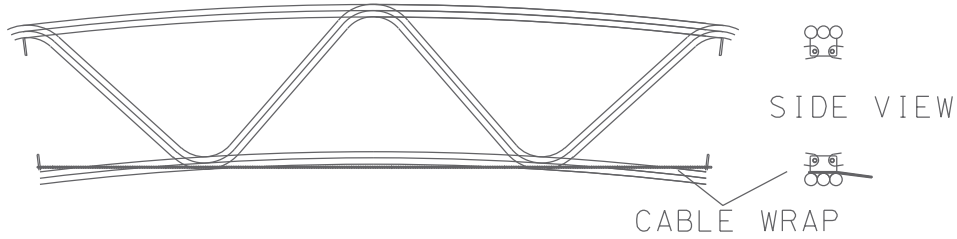

3/8" - 7x19 GAC CABLE  
7.2 TONS BREAKING STRENGTH



TB-1

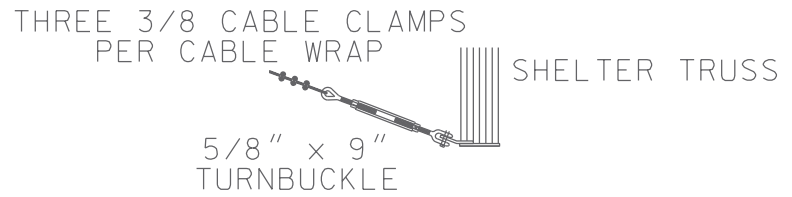

5/8 " x 9" EYE/JAW TURNBUCKLE  
3,500 LBS. WORKING LOAD LIMIT

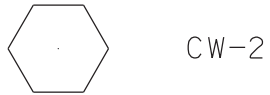

CW-2

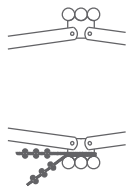

THREE 3/8 CABLE CLAMPS  
PER CABLE WRAP



TB-2

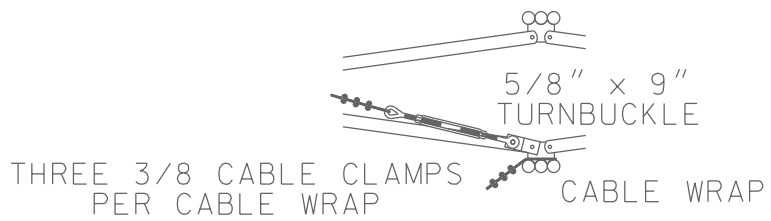

THREE 3/8 CABLE CLAMPS  
PER CABLE WRAP

NOT FOR  
CONSTRUCTION

ALL INFORMATION IS PROPERTY  
OF BIG TOP MANUFACTURING LLC

BIG TOP MANUFACTURING LLC  
3255 US HWY 19 NORTH  
PERRY, FL 32347  
PH: (850) 584 - 7786

CUSTOMER:	ZEKELMAN INDUSTRIES
STRUCTURE SIZE:	110 X 291.5 X 48
TRUSS STYLE:	48" FOUR-CHORD
PROJECT NO:	226-093

SHEET DESCRIPTION:		CABLE BRACING DETAILS	
LOCATION:		ROCHELLE, IL	
DRAWN BY:	G. ANDREWS	SALES REPRESENTATIVE:	THOMAS H.
DATE:	04/14/2026	ISSUE:	REV 0
		SHEET NO:	S-8

Section VI, Item 1.

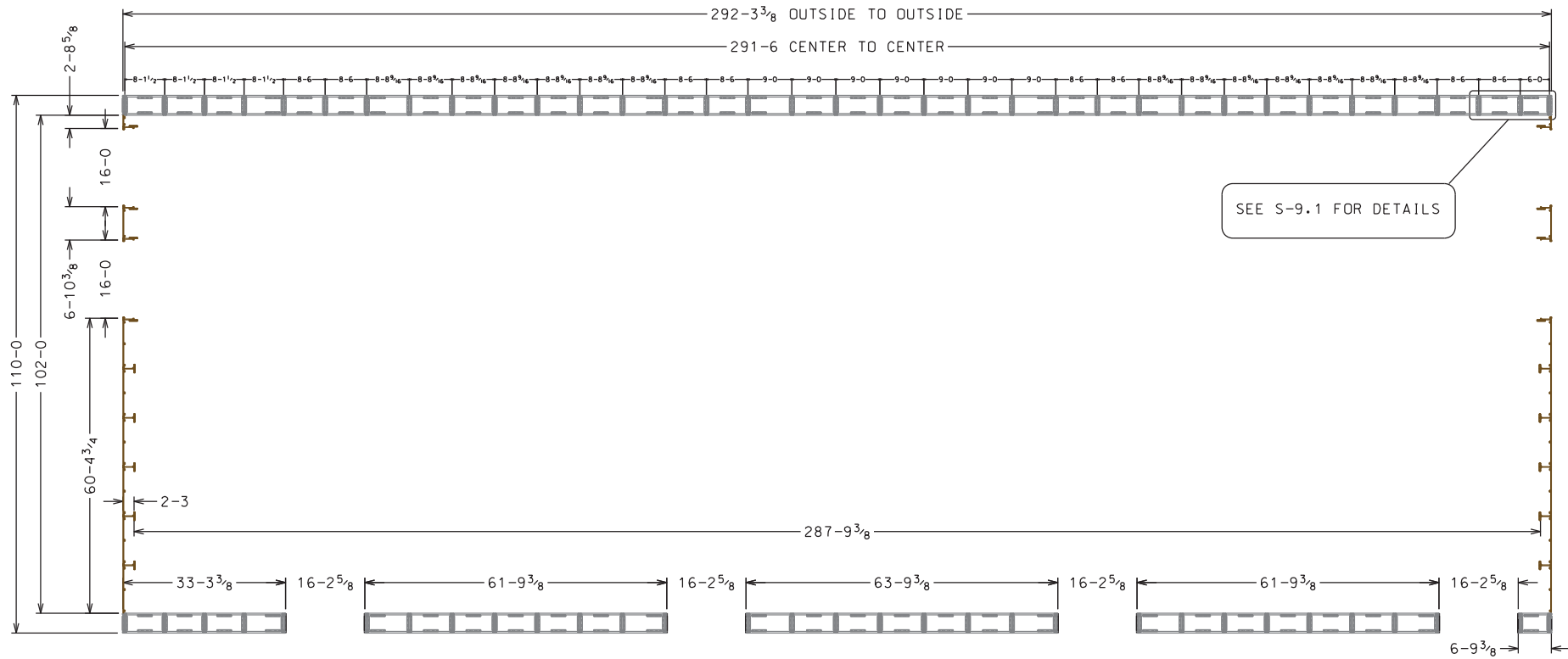

NOT FOR  
CONSTRUCTION

ALL INFORMATION IS PROPERTY  
OF BIG TOP MANUFACTURING LLC



BIG TOP MANUFACTURING LLC  
3255 US HWY 19 NORTH  
PERRY, FL 32347  
PH: (850) 584 - 7786

CUSTOMER: ZEKELMAN INDUSTRIES
STRUCTURE SIZE: 110 X 291.5 X 48
TRUSS STYLE: 48" FOUR-CHORD
PROJECT NO: 226-093

SHEET DESCRIPTION: SHELTER FOOTPRINT	
LOCATION: ROCHELLE, IL	
DRAWN BY: G. ANDREWS	SALES REPRESENTATIVE: THOMAS H.
DATE: 04/14/2026	ISSUE: REV 0
SHEET NO: S-9	

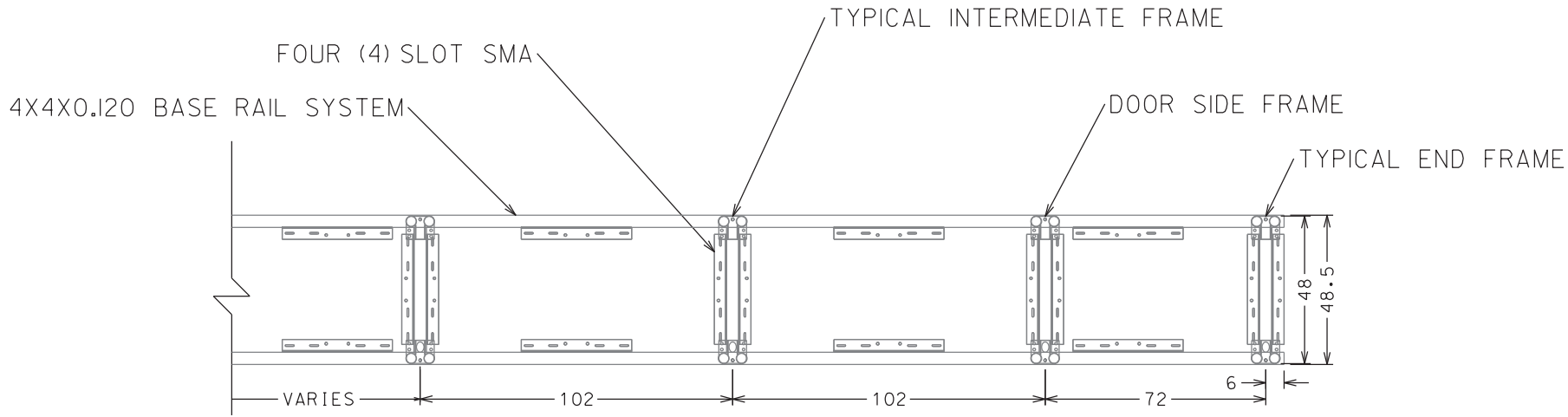

4X4X3/8X36 SOIL MODIFICATION ANGLE (SMA)

40" SOIL ANCHOR FOUR (4) PLACES

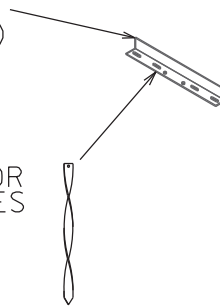

NOT FOR CONSTRUCTION

<p>ALL INFORMATION IS PROPERTY OF BIG TOP MANUFACTURING LLC</p>  <p>BIG TOP MANUFACTURING LLC 3255 US HWY 19 NORTH PERRY, FL 32347 PH: (850) 584 - 7786</p>	<p>CUSTOMER: ZEKELMAN INDUSTRIES</p>	<p>SHEET DESCRIPTION: BASE ANCHOR DETAILS</p>		
	<p>STRUCTURE SIZE: 110 X 291.5 X 48</p>	<p>LOCATION: ROCHELLE, IL</p>		
	<p>TRUSS STYLE: 48" FOUR-CHORD</p>	<p>DRAWN BY: G. ANDREWS</p>	<p>SALES REPRESENTATIVE: THOMAS H.</p>	
	<p>PROJECT NO: 226-093</p>	<p>DATE: 04/14/2026</p>	<p>ISSUE: REV 0</p>	<p>SHEET NO: S-9.1</p>

# 48" FOUR-CHORD

FABRIC

Section VI, Item 1.

COLOR

2218 WHITE

WEIGHT

22 OZ

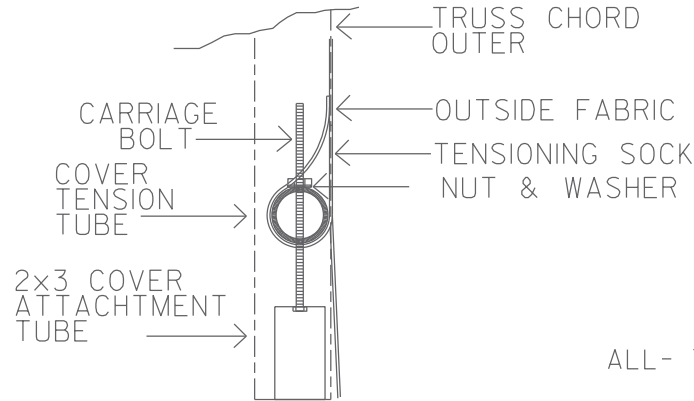

VIEW C

ALL-THREAD COVER TENSIONING ALONG SIDE  
(INSIDE LOOKING OUT)

SHELTER COVER

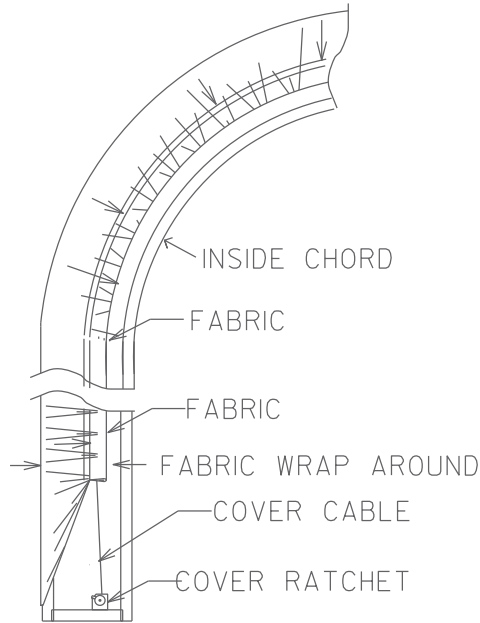

COVER TENSIONING FRAME END  
(LOOKING OUTSIDE IN)

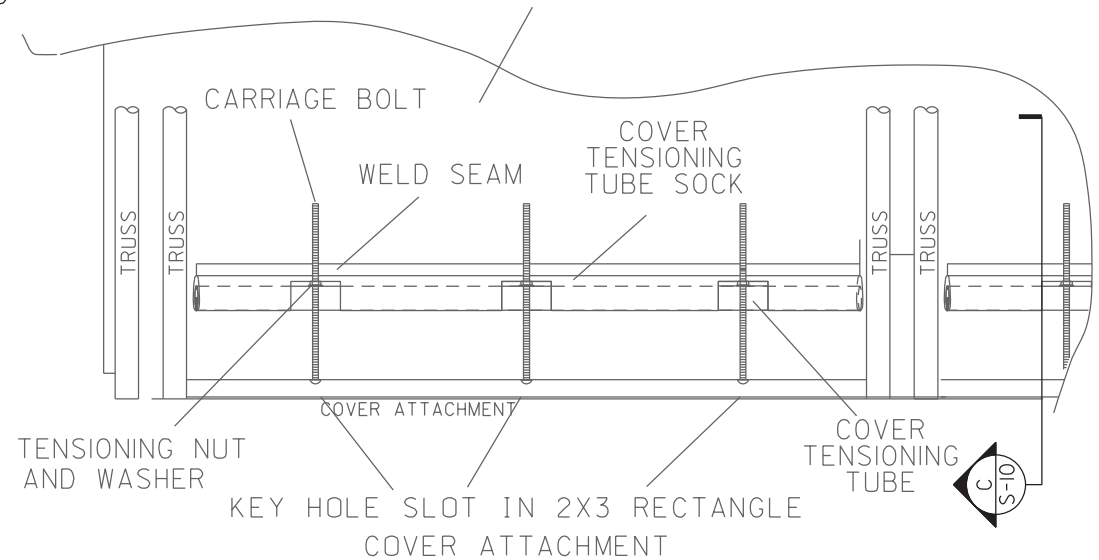

NOT FOR  
CONSTRUCTION

ALL INFORMATION IS PROPERTY  
OF BIG TOP MANUFACTURING LLC

BIG TOP MANUFACTURING LLC  
3255 US HWY 19 NORTH  
PERRY, FL 32347  
PH: (850) 584 - 7786

CUSTOMER:	ZEKELMAN INDUSTRIES
STRUCTURE SIZE:	110 X 291.5 X 48
TRUSS STYLE:	48" FOUR-CHORD
PROJECT NO:	226-093

SHEET DESCRIPTION:		FABRIC ATTACHMENT DETAILS	
LOCATION:		ROCHELLE, IL	
DRAWN BY:	G. ANDREWS	SALES REPRESENTATIVE:	THOMAS H.
DATE:	04/14/2026	ISSUE:	REV 0
		SHEET NO:	S-10

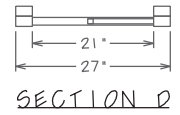
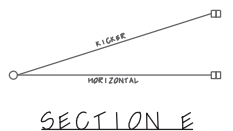
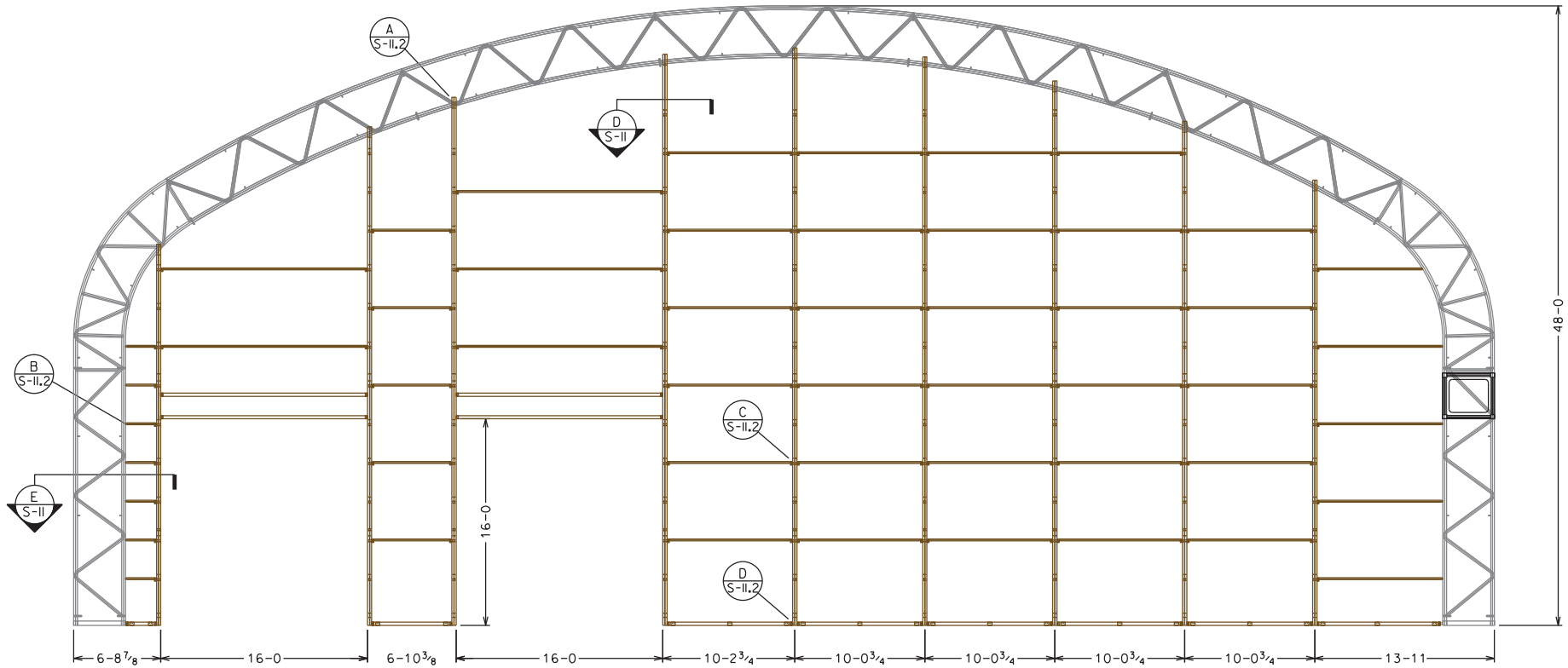

TRUSS CHORD DOUBLE 2 X 3" X 0.065"  
 50,000 PSI YIELD  
 55,000 PSI TENSILE  
 HORIZONTAL BRACE 1.75 X 1.75" X 0.065"  
 50,000 PSI YIELD  
 55,000 PSI TENSILE  
 DIAGONAL BRACE 1.5 X 1.5" X 0.065"  
 50,000 PSI YIELD  
 55,000 PSI TENSILE

NOT FOR  
 CONSTRUCTION

ALL INFORMATION IS PROPERTY  
 OF BIG TOP MANUFACTURING LLC

BIG TOP MANUFACTURING LLC  
 3255 US HWY 19 NORTH  
 PERRY, FL 32347  
 PH: (850) 584 - 7786

CUSTOMER: ZEKELMAN INDUSTRIES
STRUCTURE SIZE: 110 X 291.5 X 48
TRUSS STYLE: 48" FOUR-CHORD
PROJECT NO: 226-093

SHEET DESCRIPTION: END PANEL 1 - LAYOUT	
LOCATION: ROCHELLE, IL	
DRAWN BY: G. ANDREWS	SALES REPRESENTATIVE: THOMAS H.
DATE: 04/14/2026	ISSUE: REV 0
SHEET NO: S-11	

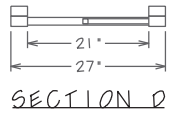
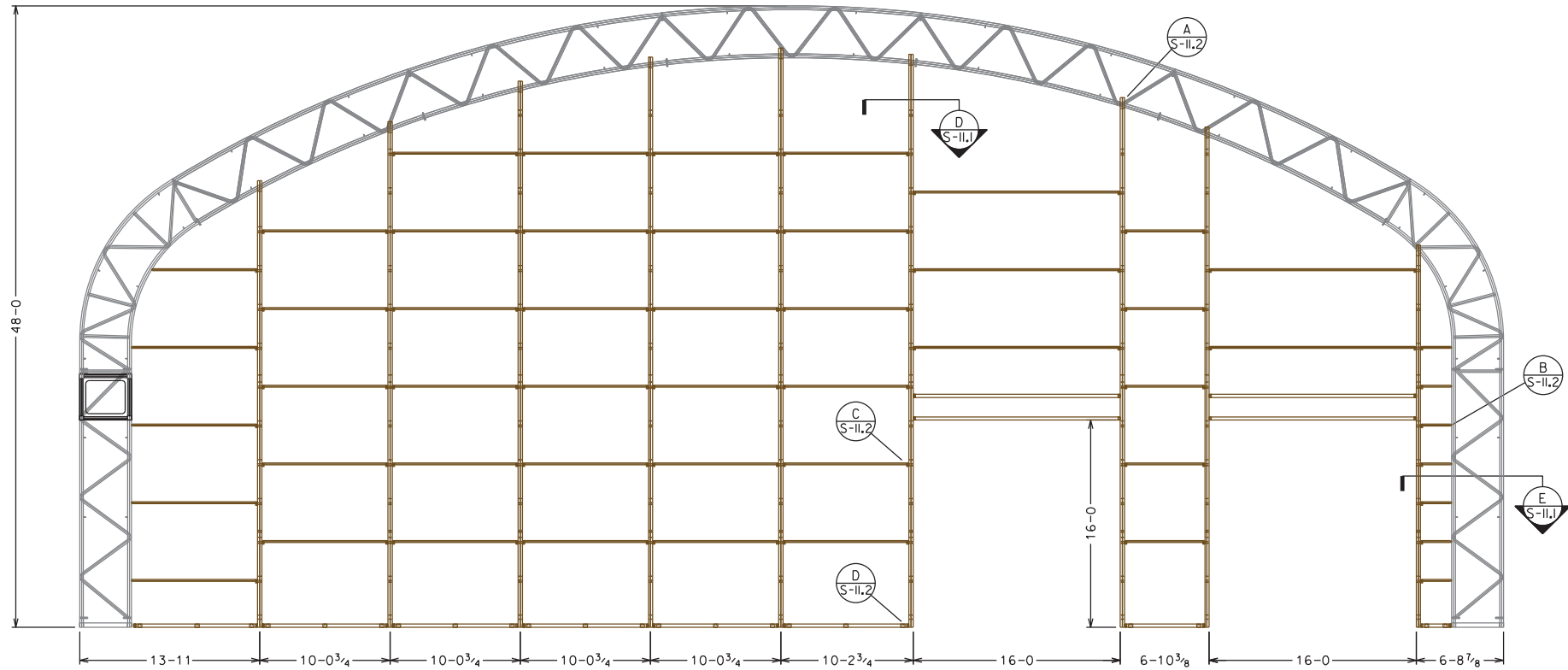

TRUSS CHORD DOUBLE 2 X 3" X 0.085"  
 50,000 PSI YIELD  
 55,000 PSI TENSILE  
 HORIZONTAL BRACE 1.75 X 1.75" X 0.085"  
 50,000 PSI YIELD  
 55,000 PSI TENSILE  
 DIAGONAL BRACE 1.5 X 1.5" X 0.065"  
 50,000 PSI YIELD  
 55,000 PSI TENSILE

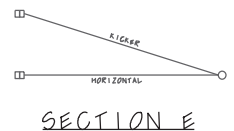

ALL INFORMATION IS PROPERTY OF BIG TOP MANUFACTURING LLC

BIG TOP MANUFACTURING LLC  
 3255 US HWY 19 NORTH  
 PERRY, FL 32347  
 PH: (850) 584 - 7786

CUSTOMER: ZEKELMAN INDUSTRIES
STRUCTURE SIZE: 110 X 291.5 X 48
TRUSS STYLE: 48" FOUR-CHORD
PROJECT NO: 226-093

SHEET DESCRIPTION: END PANEL 2 - LAYOUT	
LOCATION: ROCHELLE, IL	
DRAWN BY: G. ANDREWS	SALES REPRESENTATIVE: THOMAS H.
DATE: 04/14/2026	ISSUE: REV 0
SHEET NO: S-11.1	

NOT FOR CONSTRUCTION

39

STAMP ONLY

DETAIL A  
VERTICAL TRUSS TOP

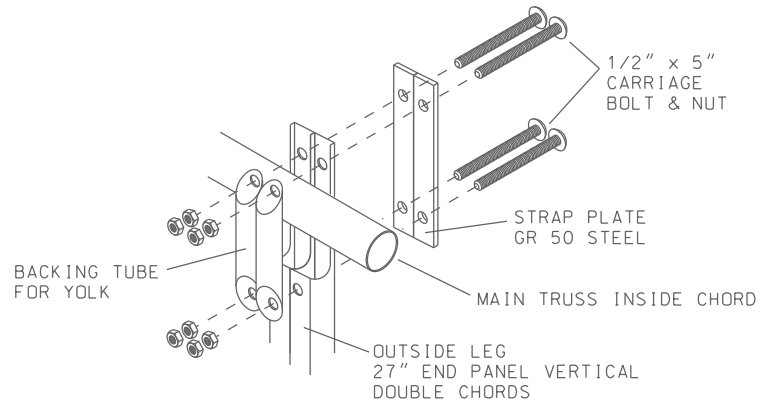

DETAIL B  
BRACE BAND DETAIL

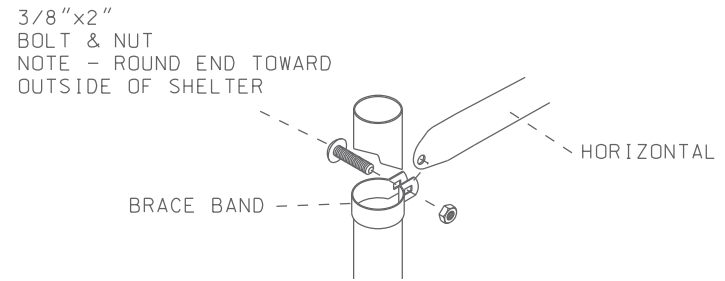

DETAIL C

HORIZONTAL TO END PANEL VERTICAL DETAIL

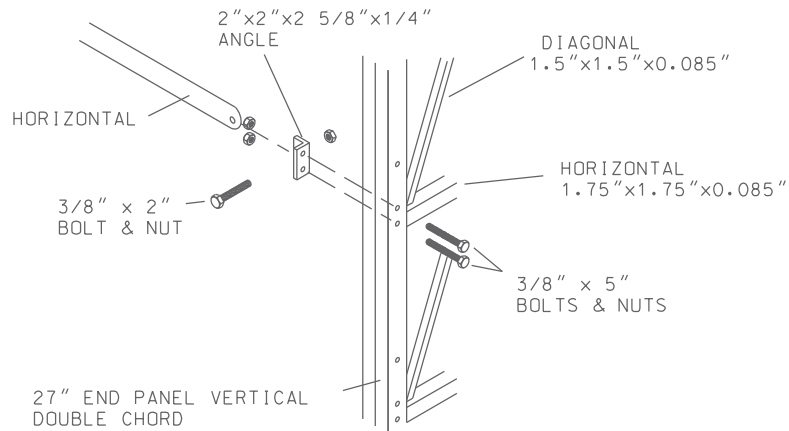

DETAIL D  
VERTICAL TRUSS BASE DETAIL

NOTE: ALL ANGLES ARE BOLTED USING 3/8" X 3" BOLTS AND NUTS. ENSURE THE THREADS ARE ALL FACING THE INSIDE OF THE SHELTER.

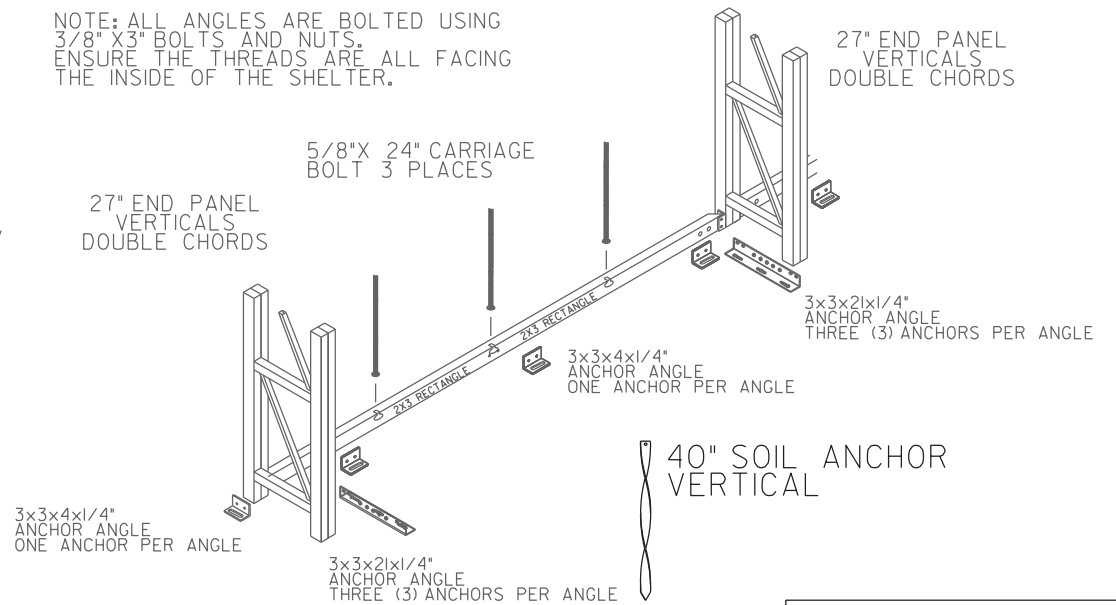

NOT FOR  
CONSTRUCTION

ALL INFORMATION IS PROPERTY OF BIG TOP MANUFACTURING LLC

BIG TOP MANUFACTURING LLC  
 3255 US HWY 19 NORTH  
 PERRY, FL 32347  
 PH: (850) 584 - 7786

CUSTOMER:	ZEKELMAN INDUSTRIES
STRUCTURE SIZE:	110 X 291.5 X 48
TRUSS STYLE:	48" FOUR-CHORD
PROJECT NO:	226-093

SHEET DESCRIPTION:	
END PANEL - DETAILS	
LOCATION:	
ROCHELLE, IL	
DRAWN BY:	SALES REPRESENTATIVE:
G. ANDREWS	THOMAS H.
DATE:	ISSUE:
04/14/2026	REV 0
SHEET NO:	
S-11.2	