



RIO DELL CITY COUNCIL AGENDA
REGULAR MEETING - 6:00 PM
TUESDAY, SEPTEMBER 5, 2023
City Council Chambers
675 Wildwood Avenue, Rio Dell

Welcome - Copies of this agenda, staff reports and other material available to the City Council are available at the City Clerk's office in City Hall, 675 Wildwood Avenue and available on the City's website at cityofriodell.ca.gov. Your City Government welcomes your interest and hopes you will attend and participate in Rio Dell City Council meetings often.

**SPECIAL PUBLIC HEALTH EMERGENCY ALTERNATIONS TO MEETING FORMAT
CORONAVIRUS (COVID 19)**

Effective immediately, the City of Rio Dell will reopen City Council meetings held in City Hall Council Chambers to in-person attendance by the public. The public may also attend these meeting virtually through Zoom. The meetings will also be viewable via livestreaming through our partners at Access Humboldt via their YouTube channel or Suddenlink channels on Cable TV.

Public Comment by Email:

In balancing the health risks associated with COVID-19 and need to conduct government in an open and transparent manner, public comment on agenda items can be submitted via email at publiccomment@cityofriodell.ca.gov. Please note the agenda item the comment is directed to (example: Public Comments for items not on the agenda) and **email no later than one-hour prior to the start of the Council meeting**. Your comments will be read out loud, for up to three minutes.

Meeting can be viewed on Access Humboldt's website at <https://www.accesshumboldt.net>. Suddenlink Channels 10, 11 & 12 or Access Humboldt's YouTube Channel at <https://www.youtube.com/user/accesshumboldt>.

Zoom Public Comment:

When the Mayor announces the agenda item that you wish to comment on, call the conference line and turn off your TV or live stream. Please call the toll-free number **1-888-475-4499**, enter meeting **ID 987 154 0944** and press star (*) 9 on your phone – this will raise your hand. You will continue to hear the meeting on the call. When it is time for public comment on the item you wish to speak on, the Clerk will unmute your phone. You will hear a prompt that will indicate your phone is unmuted. Please state your name and begin your comment. You will have 3 minutes to comment.

A. CALL TO ORDER

B. ROLL CALL

C. PLEDGE OF ALLEGIANCE

D. CEREMONIAL MATTERS

1. 2023/0905.01 - Introduction and Swearing in of Police Officer Agustin Sierra
2. 2023/0905.02 - Proclamation Acknowledging and Thanking Jeffrey Conner, John Beauchaine, Crystal Landry, Ryan Hill, Whitney Timm, and Luke Bernthal for the investigation and prosecution of two separate cases of sexual abuse of a minor

E. PUBLIC PRESENTATIONS

This time is for persons who wish to address the Council on any matter not on this agenda and over which the Council has jurisdiction. As such, a dialogue with the Council or staff is not allowed under the Ralph M. Brown Act. Items requiring Council action not listed on this agenda may be placed on the next regular agenda for consideration if the Council directs, unless a finding is made by at least 2/3 of the Council that the item came up after the agenda was posted and is of an urgency nature requiring immediate action. Please limit comments to a maximum of 3 minutes.

F. CONSENT CALENDAR

The Consent Calendar adopting the printed recommended Council action will be enacted with one vote. The Mayor will first ask the staff, the public, and the Councilmembers if there is anyone who wishes to address any matter on the Consent Calendar. The matters removed from the Consent Calendar will be considered individually following action on the remaining consent calendar items.

- [1.](#) 2023/0905.03 - Approve Minutes of the August 15, 2023 Regular **(ACTION)** - Pg. #4
- [2.](#) 2023/0905.04 - Approve Appointment of Ania Laniewski to the Nuisance Advisory Committee **(ACTION)** - Pg. #9
- [3.](#) 2023/0905.05 - Adopt Resolution No. 1591-2023 Amending the Master Fee Schedule establishing the penalties for violations of regulations concerning the standing, stopping, and parking of motor vehicles within the City of Rio Dell **(ACTION)** - Pg. #13
- [4.](#) 2023/0905.06 - Authorize the Mayor to sign correspondence related to ACA 13 **(ACTION)** - Pg. #17

G. ITEMS REMOVED FROM THE CONSENT CALENDAR

H. REPORTS/STAFF COMMUNICATIONS

- [1.](#) 2023/0905.07 - City Manager/Staff Update **(RECEIVE & FILE)** - Pg. #21

I. SPECIAL PRESENTATIONS/STUDY SESSIONS

- [1.](#) 2023/0905.08 - Presentation – SB 1383 Related to Short Lived Climate Pollution and Organic Waste - *Pg. #28*
- [2.](#) 2023/0902.09 - Presentation - Tobacco Retail Licensing -*Pg. #41*

J. SPECIAL CALL ITEMS/COMMUNITY AFFAIRS/PUBLIC HEARINGS

- [1.](#) 2023/0905.10 - Authorize City Manager to finalize and issue Request for Proposal (RFP) for Gateway Outdoor Exercise Equipment (**DISCUSSION/POSSIBLE ACTION**) - *Pg. #47*

K. ORDINANCES/SPECIAL RESOLUTIONS/PUBLIC HEARINGS

L. COUNCIL REPORTS/COMMUNICATIONS

M. ADJOURNMENT

*The next regular City Council meeting is scheduled for
Tuesday, September 19, 2023 at **6:00 PM.***

**RIO DELL CITY COUNCIL
REGULAR MEETING MINUTES
AUGUST 15, 2023**

The regular meeting of the Rio Dell City Council was called to order at 6:30 p.m. by Mayor Garnes.

ROLL CALL: Present: Mayor Garnes, Mayor Pro Tem Carter, Councilmembers Orr, and Wilson

Absent: Councilmember Woodall (excused)

Others Present: City Manager Knopp, Finance Director Sanborn, Wastewater Superintendent Taylor, Water/Roadways Superintendent Jensen, Senior Fiscal Assistant Maciel, and City Clerk

Absent: Community Development Director Caldwell (attended remotely) and Chief of Police Allen

PUBLIC PRESENTATIONS

Mayor Garnes invited public comment on non-agenda matters. No public comment was received.

CONSENT CALENDAR

Mayor Garnes asked if any council member, staff or member of the public would like to remove any item from the consent calendar for a separate discussion. No items were removed.

A motion was made by Carter/Orr to approve the consent calendar including the following items:

- 1) Approve Minutes of the August 1, 2023 Regular Meeting;
- 2) Authorize Finance Director to sign and submit the City's Annual Regional Surface Transportation Program (RSTP) Claim for FY 2022-23;
- 3) Approve the transfer of City monies to the Local Agency Investment Fund (LAIF);
- 4) Adopt Resolution No. 1587-2023 Designating a Voting Delegate and Alternate for the League of California Cities 2023 Annual Conference;
- 5) Adopt Resolution 1588-2023 Adopting FY 2023-24 Master Fee Schedule rescinding Resolution No. 1362-2017;
- 6) Adopt Resolution No. 1589-2023 Approving Revised Billable Rates for staff time for FY 2023-24;
- 7) Approve purchase of two Sodium Hypochlorite Storage Tanks and Accessories; and
- 8) Receive and File the Check Register for July.

Motion carried 4-0.

AUGUST 15, 2023 MINUTES
Page 2**REPORTS/STAFF COMMUNICATIONS**City Manager/Staff Update

City Manager Knopp provided highlights of the staff update and said that this morning staff and Mayor Garnes met with Cal Fire, Department of General Services and Senator McGuire regarding the CalFire property. He said that it was a good meeting and some issues were cleared up regarding the availability of City water and sewer services. The previous report indicated that they would connect to a septic system and use well water which was erroneous information. He said that CalFire will not be responding to the City's request for shared use of the parcel until after they develop a plan for the development of the CalFire facility. He extended thanks to Senator McGuire for his involvement and participation in the meeting.

He also reminded everyone that beginning with the next regularly scheduled meeting on September 5, 2023, meetings will begin at 6:00 p.m. rather than 6:30 p.m.

SPECIAL CALL ITEMS/COMMUNITY AFFAIRS/PUBLIC HEARINGSAuthorize the City Manager to finalize and issue the Request for Proposals (RFP's) for the Gateway Landscape Improvements

City Manager Knopp provided a staff report and said that the City was awarded nearly \$200,000 for the Gateway Enhancement Project through the Clean California Grant Program. The two components of the project include a 3-piece outdoor exercise station, and landscaping including upgrade of the irrigation system and the installation of 123 trees. He noted that this item only covers the landscaping portion of the grant project; the exercise station will return to the Council at the next meeting for separate action to finalize that portion of the RFP.

He reviewed the Bid Schedule for the Gateway Landscaping and said that in working with the Gateway AdHoc Committee members (Mayor Garnes and Mayor Pro Tem Carter), the recommendation was to plant flowering Cherry trees in the median and along the sidewalk area. The plan will include 99 new trees although there were 123 trees identified in the original plan. The reason for the reduction is that there is one less median with the removal of the median in front of Root 101, and the committee recommended preserving some of the existing trees.

City Manager Knopp explained that replacing the median grass with turf is not allowed under the terms of the grant, and turf is extremely expensive so that is no longer an option for the project. He commented that installation of a new sprinkler system will be more water efficient. He said at the end of the medians, the idea is to have a cluster of trees which will need to be selected later.

AUGUST 15, 2023 MINUTES
Page 3

Councilmember Wilson asked if the new landscaping will have any effect on the flag pole holes.

City Manager Knopp explained that it is his understanding that the design of the flag pole holders is flawed in that water gets in holes from the irrigation system and the wood flag poles get wet and expand, expressing the need for a modified design. Since this is not covered under the grant, the city will work with the Chamber of Commerce to come up with a solution for the flag poles.

Councilmember Orr asked if the 5 x 5-foot excavation for the trees is the entire median area.

City Manager Knopp explained that the width between the median and the curb is about 9 feet.

Mayor Pro Tem Carter indicated that the Chamber of Commerce has struggled with the flag poles as well as getting volunteers to help put the flags up and take them down. She said that apparently the flag poles don't fit properly in the holes which makes it difficult. She said as liaison to the Chamber, she would talk to the members and try to come up with a plan.

She added that regarding the median, she can't wait to see a tunnel of beautiful flowering trees through town.

Mayor Garnes called for public comment on the issue.

Jonathan Brodeur suggested drilling a ½-inch hole in the bottom of the flag pole holders to let the water drain.

Mayor Pro Tem Carter invited Jonathan to attend the next Chamber meeting.

Motion was made by Carter/Orr authorizing the City Manager to finalize and issue the Request for Proposals (RFP's) for the Gateway Landscape Improvements. Motion carried 4-0.

COUNCIL REPORTS/COMMUNICATIONS

Mayor Pro Tem Carter commented on the success of this year's Wildwood Days events and said that the number kudos is beyond measure. There was a great community turnout and said the Fire Department did a great job with everything including the amazing fireworks show. She said that as she watched the fireworks show she felt so much pride in the City and felt grateful to live here.

She said that she attended a Chamber of Commerce meeting on August 4th with the topic of discussion being Wildwood Days, and said that she also attended a Beautification, Walkability and Pride Committee meeting on August 11th with a recap of the Community

AUGUST 15, 2023 MINUTES**Page 4**

Clean-Up Day. She thanked the Community Resource Center staff and volunteers for participating.

She said that she attended the Gateway AdHoc Committee meeting and announced that she would be attending a Cal Cities divisional meeting in Fortuna on Friday, August 18th.

Councilmember Orr reported that he would be attending an HCAOG meeting on Thursday and regarding Wildwood Days, he was unable to participate in the activities because he had soccer tournaments out of town. However; based on the number of cars parked in front of his house before and after, it must have been a good turnout. He said that he appreciated the clean-up efforts after the event as they did a fantastic job.

Councilmember Wilson said that he thought that this year's Wildwood Days was phenomenal and the event seemed well-organized.

He reported that he attended an HWMA meeting last week and hoped to have the new director come to a council meeting soon to talk about AB 1383 which he said is a mess and something the State or the local jurisdictions are not ready for.

Mayor Garnes also commented on the success of Wildwood Days and said that she presented the three young men with Certificates of Appreciation for volunteering after the earthquakes and they seemed very grateful. She pointed out that Supervisors Bohn and Bushnell were here from start to finish with Supervisor Bohn doing a great job as auctioneer at the Fireman's Barbeque on Sunday. She agreed that the fireworks were phenomenal, there was a great turnout and a fun weekend for the community.

She reported that she attended an HTA meeting for Councilmember Woodall where they discussed the Micro Transit System where anyone (not just dial-a-ride people) can find the schedule and jump on at any one of the stops.

She said that she will also be attending the Cal Cities meeting on Friday in Fortuna from 3:00- 5:00 with a reception following, and invited everyone to attend.

City Manager Knopp announced that there would be a free tire disposal drop off event at the school on Saturday, August 19th from 10:00-2:00 and reminded everyone that the tires must be off the rims.

Mayor Garnes reminded everyone that beginning with the next regular meeting on September 5, 2023, the regular meetings will begin at 6:00 rather than 6:30.

ADJOURNMENT

A motion was made by Carter/Orr to adjourn the meeting at 7:00 p.m. to the September 5, 2023 regular meeting. Motion carried 4-0.

AUGUST 15, 2023 MINUTES
Page 5

Debra Garnes, Mayor

Attest:

Karen Dunham, City Clerk



*675 Wildwood Avenue
Rio Dell, CA 95562*

TO: Rio Dell City Council
THROUGH: Kyle Knopp, City Manager
FROM: Karen Dunham, City Clerk
DATE: September 5, 2023
SUBJECT: Nuisance Advisory Committee Appointment

RECOMMENDATION

Approve the appointment of Ania Laniewski as a third public member of the Nuisance Advisory Committee.

BACKGROUND AND DISCUSSION

The Nuisance Advisory Committee consists of up to two (2) members of the City Council, the City Manager, the Community Development Director, the Chief of Police, and at least two (2) and not more than four (4) members of the public.

There are currently two public members on the committee. This appointment will fill the public member position recently vacated by Alonzo Bradford.

A Notice of Vacancy was posted with the deadline for submittal of applications, August 30, 2023. The only application received was from Ania Laniewski, who also serves on the Beautification, Walkability, and Pride Committee.

ATTACHMENTS: Application for Committee/Board
Notice of Vacancy



675 Wildwood Avenue
Rio Dell, CA 95562
(707) 764-3532

APPLICATION FOR COMMISSION/BOARD

NAME Ania Laniewski DATE August 30, 2023
ADDRESS 775 Pacific Avenue HOME PHONE 941-726-6176
Rio Dell, CA 95562 BUSINESS PHONE _____

I AM INTERESTED IN SERVING ON THE FOLLOWING BOARD/COMMISSION:

Nuisance Advisory Committee

OCCUPATION Administrative and Business Development Consultant

HOW LONG HAVE YOU LIVED IN RIO DELL? 2+ years

PROFESSIONAL AND/OR COMMUNITY ACTIVITIES _____

ADDITIONAL PERTINENT INFORMATION/REFERENCES _____

EDUCATION BA Accounting/Business Administration

Please answer the following two questions:

1) Why are you interested in serving on this board/commission?

I care about a healthy and thriving community. I would welcome an opportunity to serve to that end.

2) What special talents/experience/education do you possess that will be useful in this position?

Administrative skills, business development skills, large event planning and execution, previous Community Association Manager license in Florida, resource and human resource management skills.

Note: A Resume may be attached

Return form to the City of Rio Dell at 675 Wildwood Ave., Rio Dell, CA 95562

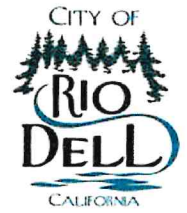

PUBLIC NOTICE NUISANCE ADVISORY COMMITTEE NOTICE OF VACANCY

NOTICE IS HEREBY GIVEN, that one (1) vacancy exists on the following committee:

NUISANCE ADVISORY COMMITTEE

The City of Rio Dell is seeking applications from members of the public who wish to be considered to fill the existing vacancy. The Committee meets on the third Wednesday of each month at 3:00 p.m.

Applications may be obtained at and returned to:

City of Rio Dell
Karen Dunham, City Clerk
675 Wildwood Ave.
Rio Dell, CA 95562

Applications must be received by **5:00 P.M. Thursday, August 30, 2023**. The new Commission appointment will be at the **September 5, 2023**, regular City Council meeting. Further information may be obtained by contacting the City Clerk at 764-3532 or at dunhamk@cityofriodell.ca.gov.

Karen Dunham, City Clerk



675 Wildwood Avenue
Rio Dell, CA 95562-1597
(707) 764-5642

For Meeting of: September 5, 2023

Consent Item; Public Hearing Item

To: City Council
From: Greg Allen, Chief of Police
Through: Kyle Knopp, City Manager
Date: August 23, 2023
Subject: Adoption of Penalty Schedule for Parking Violations

Recommendation:

That the City Council adopt Resolution 1591-2023 establishing a new penalty schedule for parking violations.

Background and Discussion

The Police Department needs to order new parking violation citations. California Vehicle Code Section 40203.5 requires that local authorities standardize their penalties to the extent possible throughout their county. The Department has polled the other jurisdictions within Humboldt County that issue parking citations and has determined that the schedule in use when its parking citations were last printed is no longer consistent with the other agencies. Consequently, the Department is proposing the adoption of a new schedule of penalties as contained in Resolution 1591-2023. This will allow the printing of new citations that are consistent with the Vehicle Code.

Attachments

Resolution 1591-2023 including the attached Exhibit A



RESOLUTION NO. 1591-2023

A RESOLUTION OF THE CITY COUNCIL OF THE CITY OF RIO DELL ESTABLISHING THE PENALTIES FOR VIOLATIONS OF REGULATIONS CONCERNING THE STANDING, STOPPING, AND PARKING OF MOTOR VEHICLES WITHIN THE CITY OF RIO DELL AND AMENDING THE MASTER FEE SCHEDULE

WHEREAS, the City of Rio Dell, California (“City”) is a municipal corporation duly organized under the constitution and laws of the State of California; and

WHEREAS, Chapter Nine of Division Eleven of the California Vehicle Code gives the authority to Local Authorities to establish regulations governing the Stopping, Standing, and Parking of motor vehicles within the Local Authority’s jurisdiction; and

WHEREAS, The City of Rio Dell is a Local Authority; and

WHEREAS, The City of Rio Dell has adopted ordinances that govern the Stopping, Standing, and Parking of motor vehicles within the city; and

WHEREAS, Chapter One of Division Thirteen of the California Vehicle Code gives the authority to a Local Authority’s governing body to establish a schedule of penalties for violations related to the Stopping, Standing, and Parking of motor vehicles; and

WHEREAS, Section 40203.5 of the California Vehicle Code also directs governing bodies to standardize the schedule of penalties to the extent possible within the county; and

WHEREAS, The governing body of the City of Rio Dell is the Rio Dell City Council; and

WHEREAS, The Rio Dell Police Department has polled the other jurisdictions within Humboldt County as to their penalty schedule for violations of regulations dealing with the Stopping, Standing, and Parking of motor vehicles; and

WHEREAS, The Rio Dell Police Department has proposed a penalty schedule for violations of regulations dealing with the Stopping, Standing, or Parking of motor vehicles within the City of Rio Dell that is standardized to the extent possible with the other jurisdictions in Humboldt County and is attached to this Resolution as *Exhibit A*

NOW, THEREFORE, BE IT RESOLVED that the City Council approves and adopts the proposed penalty schedule for violations of regulations dealing with the Stopping, Standing, and Parking of Motor Vehicles within the City of Rio Dell, attached to this Resolution as *Exhibit A*.

AYES:
NOES:
ABSENT:
ABSTAIN:

Debra Garnes, Mayor

ATTEST:

I, Karen Dunham, City Clerk for the City of Rio Dell, State of California, hereby certify the above and the foregoing to be a full, true, and correct copy of Resolution No. 1591-2023 adopted by the City Council of the City of Rio Dell on September 5, 2023.

Karen Dunham, City Clerk, City of Rio Dell



RESOLUTION NO. 1591-2023

Exhibit A – Schedule of Penalties

Code	Description	Penalty
RDMC 10.05.630-650	Exceeding timed parking limit	\$35
RDMC 10.05.680	Parking outside of a marked parking spot	\$35
VC 21458(a)	Parking in violation of colored curb	\$35
VC 22500(a)	Parking in an intersection	\$45
VC 22500(b)	Parking on or in a crosswalk	\$45
VC 22500(e)	Parking in front of a driveway	\$45
VC 22500(f)	Parking on sidewalk	\$45
VC 22500(i)	Parking in a bus stop	\$50
VC 22502(a)	Parking more than 18" from right curb	\$45
VC 22505(b)	Parking in area posted as No Parking	\$45
VC 22507.8(a)	Parking in marked disabled spot without placard/plate	\$330
VC 22514	Parking within 15' of a fire hydrant	\$50
VC 22522	Parking within 3' of a disabled person sidewalk ramp	\$330
	Parking in violation of other Vehicle Code sections	\$45



*Rio Dell City Hall
675 Wildwood Avenue
Rio Dell, CA 95562
(707) 764-3532
cityofriodell.ca.gov*

September 5, 2023

TO: Rio Dell City Council

FROM: Kyle Knopp, City Manager

SUBJECT: Authorize the Mayor to Sign Correspondence Related to ACA 13

IT IS RECOMMENDED THAT THE CITY COUNCIL:

Authorize the Mayor to sign the attached correspondence, or take no action.

BACKGROUND AND DISCUSSION

Under current law, a simple majority may vote to require a supermajority voter approval for future action, even without the corresponding level of support. This framework has given disproportionate power to a small number of voters: Little more than one-third of voters can prevent laws that a majority of voters agree upon. At the local level, this has made it difficult to pass revenue measures dedicated to critical services, such as homelessness and housing, fire, public safety, and roads.

What does ACA 13 specifically do?

- ACA 13 protects local government revenue streams and individual cities' ability to deliver critical services to residents.
- ACA 13 would require any initiative constitutional amendment to conform with any increased voter threshold that it seeks to impose on future ballot measures.
 - For example, if an initiative constitutional amendment seeks to place a two-thirds vote threshold on a specific item, that initiative would need to pass with a two-thirds vote.

Talking points:

Protects Local Government Revenue Streams

- Existing voter threshold requirements have made it difficult to pass local revenue measures dedicated to critical services, such as homelessness and housing, fire, public safety, and roads.
- From 2001-2018, city revenue measures with a two-thirds vote requirement have enjoyed only a 51% passage rate, compared to a 70% passage rate of all local revenue measures over the same period.
- The status quo has prevented cities from providing desperately needed services.

What ACA 13 Does NOT Do

- Opponents of ACA 13 argue that it is an attack on Prop. 13 and other voter-approved taxpayer protections. This is false.
 - Prop.13 was passed by voters in 1978 and is still in effect, just like other voter-approved measures that passed previously. ACA 13 is not retroactive and will not do anything to change or undo Prop. 13.
- Opponents of ACA 13 argue it takes the power to raise new taxes away from the people and into the hands of the Legislature. This is false.
 - The current citizens initiative process, as interpreted by the courts, permits a majority vote for questions posed to the voters. ACA 13 protects the majority vote and the ability for voters to weigh in on critical issues. ACA 13 will not change the requirement that the Legislature achieve a two-thirds vote when considering new revenues.
- Opponents of ACA 13 argue that it would affect measures requiring a two-thirds vote. Therefore, it should also have the same level of voter support. This is not applicable.
 - ACA 13 proposes that future measures proposing “greater than a majority” be met with the same level of voter support. Consistent with existing language in the Constitution, it is appropriate for greater than a majority (50% + 1) of voters to approve ACA 13.

///

Rio Dell City Hall
675 Wildwood Avenue
Rio Dell, CA 95562
(707) 764-3532
cityofriodell.ca.gov



September 5, 2023

The Honorable Jim Wood
State Capitol
P.O. Box 942849
Sacramento, CA 94249-0002

RE: ACA 13 (Ward) Voting Thresholds
Notice of SUPPORT *(As Amended 8/17/2023)*

Dear Assembly Member Wood:

The City of Rio Dell supports ACA 13 (Ward), which would require any constitutional amendment proposed by an initiative that increases a vote requirement for future measures to be approved by the same proportion of voters. The measure would also preserve the right of cities to place advisory questions asking voters their opinions on the ballot.

Under current law, a simple majority of voters (50% + 1 vote) may vote to require a supermajority (for example, 66%) voter approval for future action. This framework has given disproportionate power to a small number of voters: Little more than one-third of voters can prevent the enactment of laws that a majority of voters agree upon.

At the local level, this has made it unnecessarily difficult to pass revenue measures dedicated to critical services, such as homelessness and housing, fire, public safety, and roads. For example, from 2001-2018, city revenue measures with a two-thirds vote requirement have enjoyed only a 51% passage rate, compared to a 70% passage rate of all local revenue measures over the same period. The status quo has prevented cities from providing desperately needed services.

ACA 13 addresses this issue by simply requiring any initiative that enhances a voter requirement to pass by that same voter requirement. ACA 13 is a fair, good government proposal that protects the principles of democracy and majority rule.

For these reasons, the City of Rio Dell supports ACA 13.

Sincerely,

Debra L. Garnes
Mayor
City of Rio Dell

cc. Senator Mike McGuire
Sara Sanders, League of California Cities
Meg Desmond, League of California Cities, cityletters@cacities.org



Staff Highlights – 2023-09-05

City Council

City Manager

Applied for two additional grants to support the Rio Dell Gateway Project as discussed in tonight's related agenda item.

Attended interviews with HWMA for the Organics Recycling processor RFP.

Last week's Northcoast Journal contained an article regarding the recovery from the 2022 Earthquakes.

Attended a Small Cities Organized Risk Effort (SCORE) Board of Directors meeting.

Attended a Redwood Region RISE meeting which is in a planning phase for economic resiliency funding in Del Norte, Humboldt, Mendocino and Lake Counties.

Attended a meeting with Water Board staff to discuss brownfields in Rio Dell.

City Clerk

Processed Nineteen (19) Building Permit Applications:

66-88 Columbus St. – Re-Roof Residence(s)
470 Fourth Ave. – Sewer Cleanout
296 Center St. – Re-Roof Residence
233 Cherry Lane – Re-Roof Residence
140 River St. – Earthquake Repairs
300 A. Center St. – 3 Windows & Misc. Earthquake Repairs
297 First Ave. – Sewer Cleanout
371-375 Wildwood Ave. – Windows & Siding
20 Belleview Ave. – Re-Roof Residence
106 Painter St. – 13 Windows
390 - Third Ave. – Foundation Repair
1017 Riverside Dr. – Replace Windows
121 S. Cherry Lane – Replace Waterline
423 Painter St. – 2 Sewer Cleanouts
156 Grayland Heights Dr. – Replace Gas Furnace with Heat Pump & AC
150 Butcher St. – 200 Amp Service Panel Upgrade
268 Ogle Ave. Apts. A & B – Earthquake Damage Repairs
150 Butcher St. – PV Solar



390 Monument Road – Re-Roof Residence

Processed Two (2) Business License Applications:
Keller Construction – General Contractor – 250 Stream St.
Scurfield Solar & Heating – Non-Resident Contractor

Processed One (1) Encroachment Permit Application:
Dennis Katri/DCI Builders – Installation of new water/sewer service at 278 Belleview

Misc.

Submitted Bureau of Census Statistics Employment Report for August

Submitted CHF/CIRB Building Permit Report for August

Attended a Beautification, Walkability & Pride Committee meeting on 8/11/23

Prepared a Draft Farmer’s Market Interest Survey for the Beautification Committee

Attended a SCORE/Alliant AAATraq Demo Re: ADA Website Compliance

Attended PACE Board Meeting on August 23, 2023 (Employee Medical)

Submitted LAWCX Renewal Survey for SCORE

Attended a Beautification, Walkability, and Pride Committee meeting on 8/25/23

Submitted City Hall Building Valuation Update to SCORE/Alliant

Submitted Address Verification Letter for 245, 245 ½, & 229 Berkeley St.

Submitted U.S. Department of Commerce Building/Zoning Report for August

Submitted Substitution of Trustee and Full Reconveyance forms for CDBG loan

Attended a Website Compliance Demo on 8/31

City Attorney

Human Resources, Risk & Training

Finance Department

Submitted Claim for Item #3 – Building Inspection costs post-earthquake to CalOES

Met with Caltrans reps and provided signed and approved Project Authorization requests for Earthquake Road damage

Created CRRSAA Allocation Request Form / Finance Letter for Rio Dell Road Work



Established Grant Management Budget for prospective HMGP Solar Array project

Met with GHD to discuss the extent and scope of work for earthquake-damaged areas.

Attended monthly Redwood Region RISE (Resilient, Inclusive, Sustainable Economy) webinar- a Community Economic Resilience Fund (CERF) initiative in California. The initiative aims to create a regenerative, inclusive, and sustainable economy.

Coding revenues received from the County

Completed LAIF transfer – updated City/State documents

Submitted RSTP Claim to County

Prepared and submitted an invoice for Clean Ca sponsored Tire Recycling Event

City website enhancement meetings with staff and vendors

Working to update the City of Rio Dell Agency QAP Renewal per Caltrans guidelines with GHD

Work on PES (preliminary environmental study) to determine the types of technical studies needed for Caltrans road damage projects due to earthquake

Assist cannabis businesses' with tax questions

Assist City Engineers to continue to work on Rio Dell Pedestrian Connectivity Project

Provide updates to CleanCA reps updating progress on grants

Public Works Water

Repaired leak by 85 East Bridge St

Repaired leak on 220 Cherry Ln

Replaced 200 Ft of 2-inch water pipe on North St

Replaced water service line on 529 Third Ave

Work on water leaks at old part of Wastewater treatment Plant

Monthly report to SWRCB

Monthly drought report to SWRCB SAFER Clearinghouse



Preparation for Infiltration Gallery 6" Pump replacement

Work on Water treatment plant analyzers

Work on equipment – maintenance

Public Works Wastewater

Scheduling CAT for generator start up at Fern St. Lift station.

Installed plant #2 water (service water) at plant.

Continuing Chloramine trial Run. Tested effluent is meeting permit limits.

Submitted first quarter progress report to state for MMP Compliance project.

Routine Sewer collection system cleaning.

Repairs to Belt press and Dryer.

Scheduling Biosolids annual testing.

Contacting neighbor for Right of entry to properties for Biological and Historic surveys. Painter st upsizing project.

Routine Plant maintenance.

Wet weather preparation.

Public Works Streets, Buildings and Grounds

Repaired sinkhole in front of 313 Orchard St

Cleared Old ranch Rd of brush to expose water line

Mowed North and South Gateway

Cold Patched Belleview from prior water leak

Mowed City Hall, Memorial, Blue Star and Davis Park

General Roadside mowing

Public Works City Engineer

Public Works Capital Projects



Police Department

The Department had the following statistics for the period of August 9 to August 29, 2023. The summation of Calls for Service may be greater than the total as multiple officers can now be assigned to the same call for service. There may also be administrative calls for service that are not documented below.

Officer	Calls for Service	Reports	Arrests
Allen	15	2	0
Conner	3	0	0
Beauchaine	47	3	0
Landry	72	9	7
Burns	59	6	2
Johnson	46	4	0
House	63	8	4
Fielder	14	0	0
Clark	31	1	N/A
Totals	285	33	13
Averages	13.6 per day	11.0 per week	4.3 per week
2022 Yearly Average	14.1 per day	12.7 per week	5.7 per week

Calls for Service at 355 Center Street

Type	Date	Time	Location	Primary Unit	Case #
CITIZEN	08/15/2023	21:27:51	355 CENTER ST	6S1	
RECK	08/20/2023	16:15:24	355 CENTER ST	6S2	
FOOT	08/22/2023	22:29:36	355 CENTER ST	R619	

CITIZEN – Citizen contact

RECK – Reckless driving

FOOT – Foot patrol

6S1 – Sergeant John Beauchaine

6S2 – Corporal Crystal Landry

R619 – Officer Aimee House

During the period of August 9 to August 29, 2023, there were sixteen calls for service relating to animal control. Two dogs were taken to Miranda's rescue. Two additional dogs were turned over to the Sheriff's Department as they were placed under citizen's arrest in that agency's jurisdiction.

Chief Allen recently taught a block of Crisis Intervention to law enforcement and service providers in Del Norte County. CIT is a community partnership of law enforcement, mental health, and addiction professionals, and other partners to improve community response to mental health crisis. Humboldt County will be offering this 40 hr. course in October of 2023.



Chief Allen then boarded a plane to Detroit with several members of the Humboldt County Crisis Intervention Team and attended the National Conference for CIT.

Officer Russell "Conan" Johnson's last work day with the Department was August 28, 2023.

Agustin Sierra has been hired as a Police Officer and will begin on September 5, 2023.

Another candidate is expected to be hired shortly as we are expecting another officer to resign and take the same position at Arcata PD.

Officer Aimee House has completed approximately two-thirds of her field training and will soon be able to patrol by herself.

Two cases from 2021 have worked their way through the court system. One suspect was found guilty of 6 felony charges including two counts of continuous sexual abuse of a child against different victims. This defendant faces a maximum sentence of 15 years to life. In the other case, the defendant recently pled guilty to numerous sexual assault charges and faces a maximum of 55 years in prison. These two cases were investigated by Former Chief of Police J. Conner, Sgt Beauchaine, and Corporal Landry with additional assistance from the Humboldt County District Attorney's Office, Victim Witness and Northcoast Rape Crisis.

On August 22, 2023, Sergeant Beauchaine and Officer House responded to an argument at an apartment complex. They learned that a couple who live in the County had come to Rio Dell in order to confront a person that they believe stole some of their property. When the alleged thief denied and taking their property and was therefore, unable to return it, the male half of the couple broke out the rear window of the alleged thief's car. He then poured gasoline in and on the car and threatened to light it on fire if his property was not returned. It was at this point that the officers arrived and the man making the threats walked off. The officers spoke with his girlfriend and with the alleged thief. They then watched as the girlfriend parked at the gas station. A few moments later, her partner climbed into her truck. The officers were able to take him into custody without further incident. He was booked into the jail for vandalism and making criminal threats.

Community Development Department

Meeting with Mayor City Manager, Senator McGuire CalFire and DGS Team regarding Humboldt Del Norte Unit Headquarters.

Gas inspection and final inspection for new foundation 169 Belleview Ave

Final foundation inspection 745 Ireland Unit D.

Rough electrical and plumbing inspection, interior framing inspection 745 Ireland Unit A.

Review CalFire/DGS RFQ responses.



Attend Nuisance Committee meeting.

Roof inspections 565 Gunnerson.

Prepare Kim Jones Plan Check Agreement and route to all. Send Plans to BPR.

Roof inspections 20 Belleview Ave.

Mediation meeting with owners/contractor 11281 Blue Slide Road.

Review ownership property status of 129 and 255 Belleview Ave. Discuss 255 Belleview with Heidi Bauer of the RWQCB.

Forward plans for preliminary review 132 Wildwood Avenue (laundromat).

Continue work on Rental Housing Inspection program.

Respond to a complaint regarding the removal of potential asbestos roof shingle at 510 Painter Street. Conduct site visit, work being done by certified company, Infinity Abatement out of Redding. Meet Lloyd Green with the NCAQMD on-site.

Inspection siding repair 1010 Pine Street.

Email to Mark Teague (Placeworks) regarding help with obtaining a Prohousing designation.

Inspection 390 Third Ave – Foundation improvements.

Attend two day Energy Code webinar regarding single-family requirements.

Solar Plan check 150 Butcher, corrections needed.

Correspondence w/Blue Star gas regarding new propane tank. Required setbacks.
Inspection 168 Ogle Avenue, unit C, earthquake repairs.

Zoom meeting with the RWQCB regarding 255 Wildwood Avenue.

Roof Inspections 510 Painter Street

New 200 amp electrical panel inspection 150 Butcher Street.

Inspection 390 Monument, Roof replacement with no Permit.

Window replacement inspection 1017 Riverside Drive, verify U factor.

Intergovernmental



*Rio Dell City Hall
675 Wildwood Avenue
Rio Dell, CA 95562
(707) 764-3532
cityofriodell.ca.gov*

September 5, 2023

TO: Rio Dell City Council

FROM: Kyle Knopp, City Manager

SUBJECT: Presentation on SB 1383 Related to Short Lived Climate Pollution and Organic Waste

IT IS RECOMMENDED THAT THE CITY COUNCIL:

Receive a presentation and provide direction, if any.

BACKGROUND AND DISCUSSION

Mr. Eric Keller-Heckman, the Director of the Humboldt Waste Management Authority (HWMA), will give a presentation and be available for questions on the organics waste law and its implementation. The City of Rio Dell is a member of HWMA and CalRecycle is the State regulatory agency related to these matters. Attached is the powerpoint presentation.

///



SB1383 OVERVIEW AND THE PATH TO COMPLIANCE



Presented to Rio Dell City Council.
September 5, 2023

Presentation Overview

CA Legislative Building
Blocks

Local Organics Diversion
Services & Efforts

Where are we on the path
to compliance

2

Legislative Building Blocks

1989	AB 939	Mandates reduction of wastes landfilled and established integrated framework for program implementation, solid waste planning and landfill management
2011	AB 341	“Mandatory Commercial Recycling” requires jurisdictions to implement <u>commercial recycling programs</u>
2014	AB 1826	“Mandatory Commercial Organics Recycling” requires jurisdictions to implement an organic waste recycling program to divert <u>organic waste generated by businesses</u>
2016	SB 1383	Short Lived Climate Pollutant Reduction Act requires jurisdictions to implement curbside collection and processing of organic, amongst other requirements

SB 1383 Regulatory Milestones

January 1, 2020

State to achieve 50% organics reduction thru AB 1826 commercial diversion compliance activities

***2014 Baseline**

January 1, 2022

Jurisdictions must have organics recycling program in place

Enforceable regulations take effect

Jurisdictions must implement ordinance and other enforcement mechanisms

January 1, 2024

Jurisdictions must take progressive enforcement actions against non-compliant regulated entities:

- Generators
- Haulers
- Processers

January 1, 2025

State to recover a minimum of 20% of disposed edible food for human consumption

State to achieve 75% reduction in organics disposal (2014 Baseline)

HWMA Processing Facility expected to come online in 2024.

Member Agency Franchise agreements currently in negotiations

**AB 341 & AB 1826
Implementation Drove
Commercial
Implementation &
Compliance**

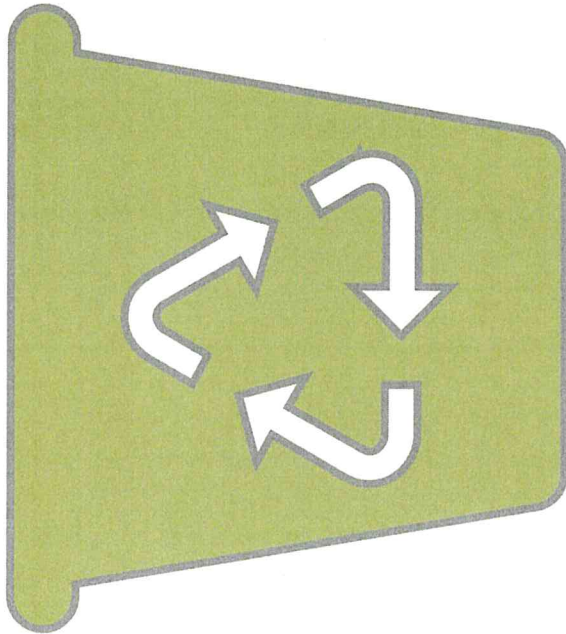

Local Organics Diversion Services and Efforts

6

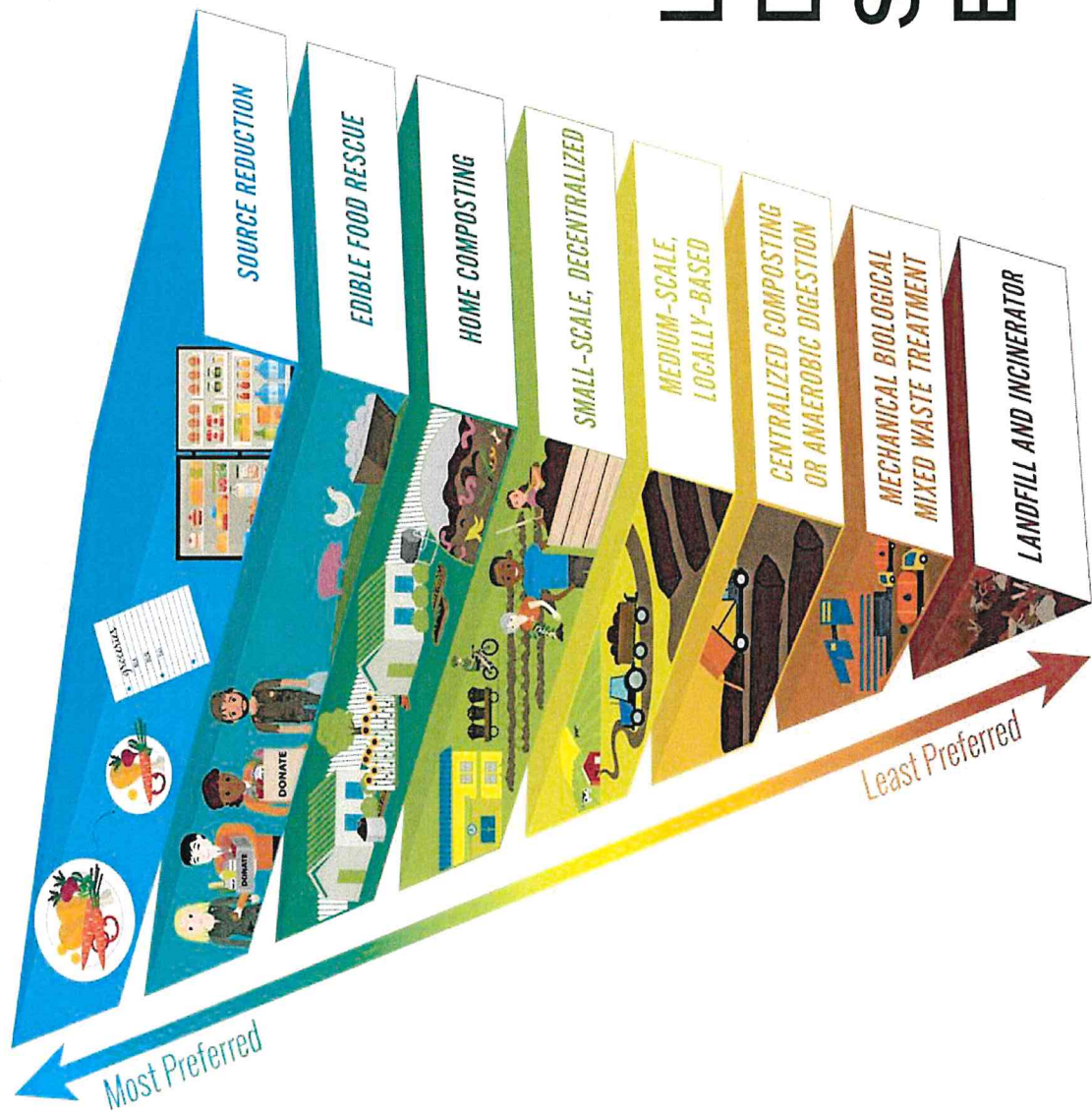

Organics Diversion Efforts to Date



Food Waste Diversion Pilot Program 2012-14

- ❖ HWMA, Eureka & HSU
- ❖ 60 Commercial Participants
- ❖ Training & Education
- ❖ Contaminant Removal
- ❖ Processing by Cold Creek Compost
- ❖ Eureka City Council opted not to proceed

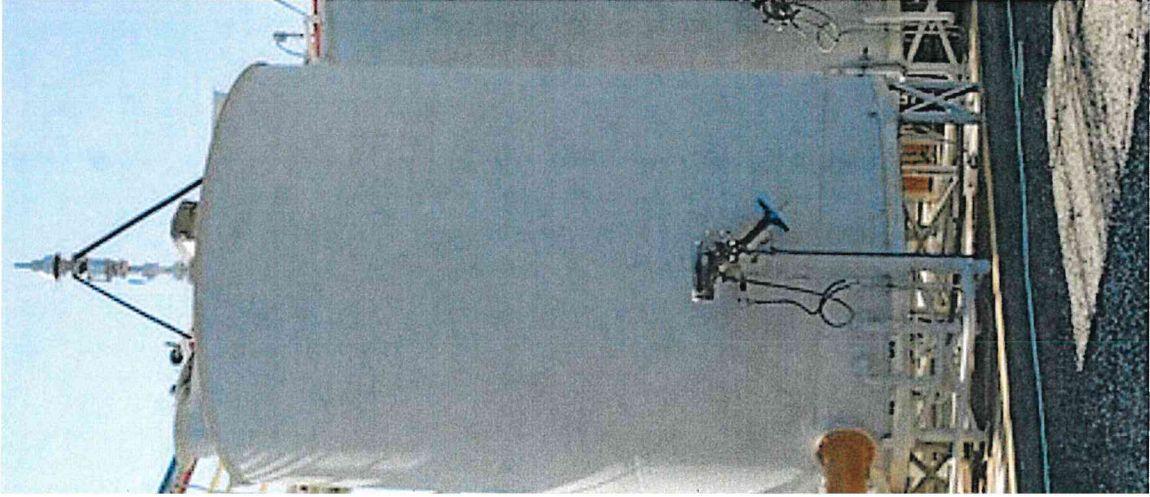

Regional Anaerobic Digestion Facility

- ❖ Concurrent with Food Waste Pilot Project
- ❖ HWMA Secured Consulting Engineer
- ❖ Secured Site & Performed Environmental Review
- ❖ HWMA Request for Proposals & Evaluated Proposals
- ❖ Lack of Material Commitment by Jurisdictions

HWMA was unable to move forward with design, financing or permitting to construct

Other Related Efforts

HWMA Waste Characterization Study 2020-21

HWMA contracted with Cascadia Inc. to perform a Waste Characterization Study to determine material composition disposed by residents of HWMA's Member Agencies.

This included evaluating those edible foods that could potentially be recoverable for future recovery program development.

Proposed Organics Processing Timeline

- 1. Amend & Approve JPA
Approved July 2023
- 2. Facility Modifications
Ongoing
- 3. Complete Ordinance Amendments
Completed
- 5. Negotiate & Approve Franchise Collection Amendments
Truck and bin order/delivery time is projected to be 2024
- 7. Rate Development
01. 02. 03.
- Recommend Phased Implementation
Commercial Generators
Residential Self-Haul

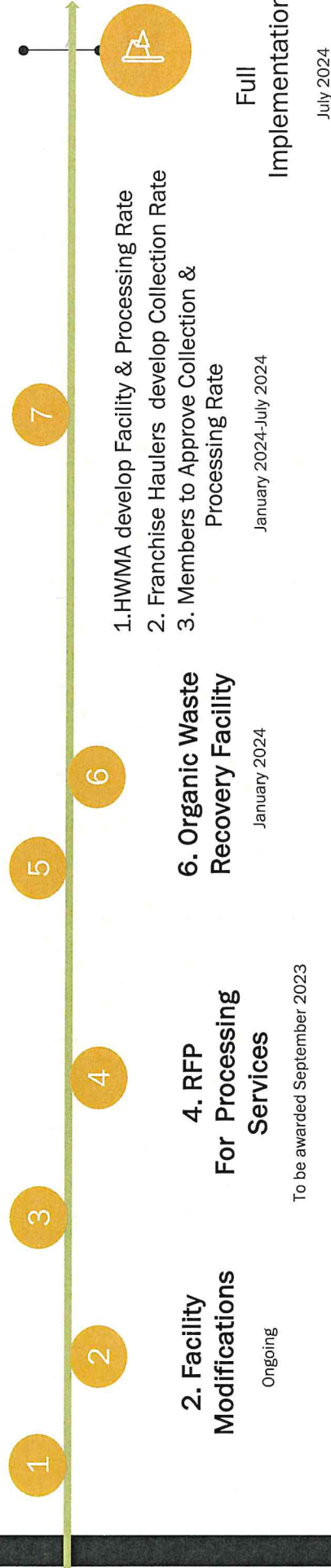

SLCP regulations
November 2020

Department of Resources
Recycling and Recovery



Short-lived Climate Pollutants (SLCP): Organic
Waste Reductions

1
2
3
4
5
6
7
8
9
10
11
12
13
14
15
16
17
18
19
20
21
22
23

California Code of Regulations
Title 14, Division 7, Chapter 3
Article 6.0. Transfer/Processing Operations and Facilities Regulatory Requirements
Section 17402. Definitions
(a) For the purposes of these articles:
1. For the purposes of these articles:
2. For the purposes of these articles:
3. For the purposes of these articles:
4. For the purposes of these articles:
5. For the purposes of these articles:
6. For the purposes of these articles:
7. For the purposes of these articles:
8. For the purposes of these articles:
9. For the purposes of these articles:
10. For the purposes of these articles:
11. For the purposes of these articles:
12. For the purposes of these articles:
13. For the purposes of these articles:
14. For the purposes of these articles:
15. For the purposes of these articles:
16. For the purposes of these articles:
17. For the purposes of these articles:
18. For the purposes of these articles:
19. For the purposes of these articles:
20. For the purposes of these articles:
21. For the purposes of these articles:
22. For the purposes of these articles:

24
25
26
27
28
29
30
31
32
33
34
35
36
37

General Provisions
Section 18981.1. Scope of Chapter.
(a) This chapter establishes the regulatory requirements for jurisdictions, generators, haulers, solid waste facilities, and other entities to achieve the organic waste disposal reduction targets codified in Section 39730.6 of the Health and Safety Code and Chapter 13.1 of Division 30 of the Public Resources Code.
Authority cited: Public Resources Code Sections 40502, 43020, 43021, and 42652.5. Reference: Public Resources Code Sections 40002, 42652.5, 42654, and Health and Safety Code Section 39730.6.
Section 18981.2. Implementation Requirement on Jurisdictions.
(a) By January 1, 2022, a jurisdiction shall adopt enforceable ordinance(s), or similarly enforceable mechanisms that are consistent with the requirements of this chapter, to mandate that organic waste generators, haulers, and other entities subject to the requirements of this chapter that are subject to the jurisdiction's authority comply with the requirements of this chapter.
(b) A jurisdiction may designate a public or private entity to fulfill its responsibilities under this chapter. A designation shall be made through any one or more of the following:
(1) Contracts with haulers or other private entities; or
(2) Agreements such as MOUs with other jurisdictions, entities, regional agencies as defined in Public Resources Code Section 40181, or other government entities.
(c) Notwithstanding Subdivision (b) of this section, a jurisdiction shall remain ultimately responsible for compliance with the requirements of this chapter.
(d) Nothing in this chapter authorizes a jurisdiction to delegate its authority to impose civil penalties, or to maintain an action to impose civil penalties, to a private entity.
(e) If a jurisdiction designates another entity as allowed in Subdivision (b) of this section, the jurisdiction shall include copies of all agreements and contracts in the Implementation Record required by Section 18995.2.
(f) Nothing in this section authorizes a jurisdiction to require a public or private entity to fulfill its obligations under this chapter without designating the entity through a mechanism authorized in Subdivision (b) of this Section.
Authority cited: Public Resources Code Sections 40502, 43020, 43021, and 42652.5. Reference: Public Resources Code Sections 42652.5, 42654, and Health and Safety Code Section 39730.6.

Elected Official Guidance tools:

<https://calrecycle.ca.gov/organics/slcp/electedofficials/>

Final SB 1383 Regulations approved November 2020

<https://calrecycle.ca.gov/organics/slcp/>

This document is for informational purposes only. It is not intended to be used as a legal document. For more information, please contact the Department of Resources at (916) 227-2300.

Questions





*Rio Dell City Hall
675 Wildwood Avenue
Rio Dell, CA 95562
(707) 764-3532
cityofriodell.ca.gov*

September 5, 2023

TO: Rio Dell City Council
FROM: Kyle Knopp, City Manager
SUBJECT: Presentation on Tobacco Retail Licensing

IT IS RECOMMENDED THAT THE CITY COUNCIL:

Receive a presentation and provide direction to staff, if any.

BACKGROUND AND DISCUSSION

Elaine Hogan and Caitlin Gillings from the Humboldt County Department of Health and Human Services will provide a presentation on Tobacco Retail Licensing (TRL) and options for the City to adopt a TRL if the Council so chooses to pursue one.

///

Tobacco Retail Licensing

Rio Dell City Council Meeting,
September 5, 2023

Presenters:
Elaine Hogan, Program Services Coordinator
Caitlin Giddings, Health Education Specialist II



1

What is a TRL ordinance?

Self-funded policy option for local governments to reduce the availability of tobacco for youth in the community and enforce local, state and federal tobacco laws.

2



Why are we talking about a TRL ordinance?

- Humboldt County passed a TRL ordinance in May 2023.
- Tobacco use is the **number one** cause of preventable death in California.
- **219** cities and counties in California have passed tobacco retail licensing (TRL) ordinances to stop youth from using tobacco.
- There is no local enforcement structure or long-term funding that allows for local control over tobacco sales.



3

What's happening in Humboldt & Rio Dell?

 <p>34%</p>	 <p>17%</p>	 <p>48%</p>
<p>In Humboldt County, tobacco smoking causes or contributes to 34% of all deaths.</p>	<p>17% of Rio Dell 7th graders have "ever used" vape products.</p>	<p>48% of Rio Dell's 8th graders report it is "fairly" or "very easy" to obtain vape (e-cigarette) products.</p>

4

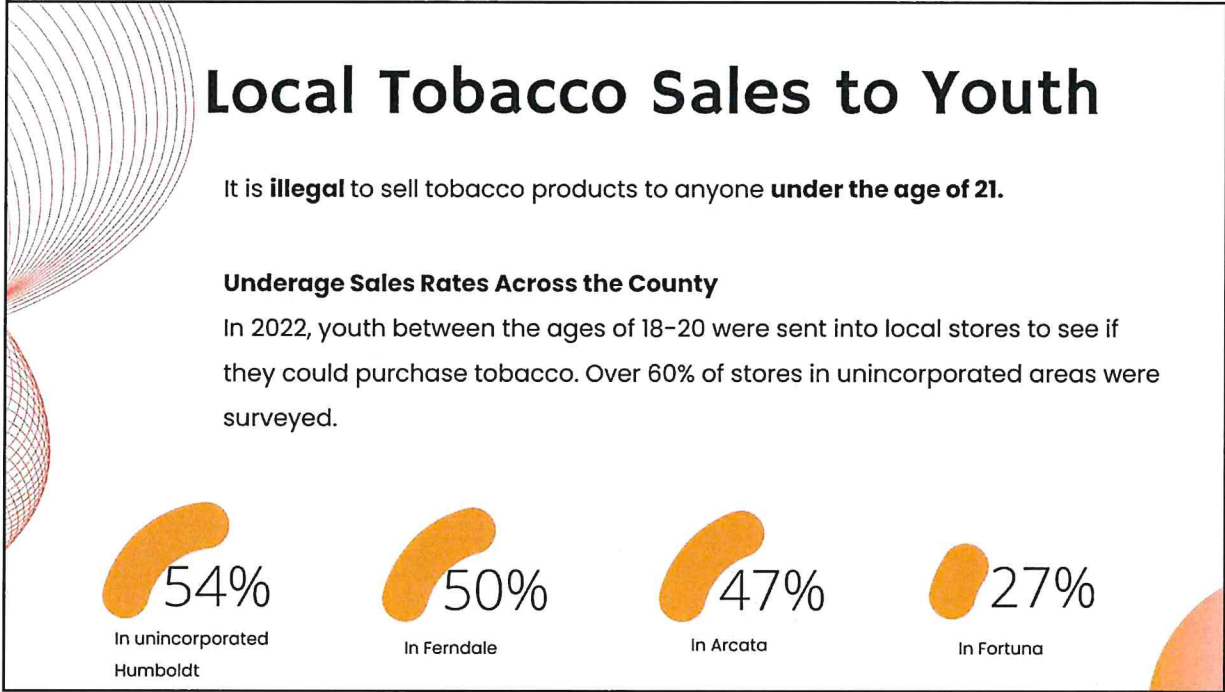

5

Humboldt County TRL Ordinance

- Requires a **valid tobacco retailer's license** to be obtained annually, valid for 1 year.
- Flavored tobacco product sales are **prohibited**.
- **Prohibits** pharmacies, mobile vendors, licensed cannabis businesses and self-service displays from licensure.
- **Prohibits** tobacco products or advertisements within five feet of candy, snacks or non-alcoholic beverages. This decreases youth exposure to tobacco products.

Photo from a Humboldt County store illustrating the proximity of tobacco advertising/products to candy and snacks.

6

Humboldt County TRL Ordinance

- **Prohibits** tobacco coupons, discounts, samples or promotional items.
- **No new licenses** will be issued if the business is located within **500 feet** of a youth-oriented facility, such as a school, park, library or recreation center; or within **500 feet** of an existing tobacco retailer.
- A tobacco retail license has **limited transferability**, if all conditions are met, to only: a parent, child, spouse or domestic partner. This means that tobacco retailer density will slowly decrease over many years, creating a healthier community.

7

Licensing, Enforcement & Appeals

Services offered by DHHS Public Health, Division of Environmental Health

- Licensing:
 - Processing tobacco retail licensing applications
 - Fee payment
 - Pre-Permitting Inspection
- Enforcement
 - Random and/or complaint-driven inspections
 - Issuance of notices of violation & citations
 - Remediation oversight
- Appeals
 - Administrative hearings
 - Issuance of final decisions



8

Contacts for Assistance with TRL

Mario Kalson, Director of the Division of Environmental Health, DHHS Public Health Branch

- To discuss your city's options for contracting with the county for TRL permitting and enforcement:



ENVHEALTH@co.humboldt.ca.us

707-445-6215

Community Partners

- For TRL education and technical assistance:

Amber Wier, NorCal 4 Health: awier@healthcollaborative.org

Jay Macedo, Communities Addressing Nicotine: JayMacedoConsulting@gmail.com

Jay McCubrey, Tobacco-Free North Coast: jay.tfnc@gmail.com

Stephanie Porrazzo, RISE: sporrazzo@healthcollaborative.org





9

Thank you



Two store displays of flavored tobacco products in Humboldt County, seen in August 2023.





10



*Rio Dell City Hall
675 Wildwood Avenue
Rio Dell, CA 95562
(707) 764-3532
cityofriodell.ca.gov*

September 5, 2023

TO: Rio Dell City Council
FROM: Kyle Knopp, City Manager
SUBJECT: Discussion and Possible Action Regarding Issuance of Request for Proposal for Gateway Outdoor Exercise Equipment

IT IS RECOMMENDED THAT THE CITY COUNCIL:

Provide direction to staff and authorize the City Manager to finalize and issue the RFP.

BACKGROUND AND DISCUSSION

The City was previously awarded \$197,870 for the Gateway Enhancement project through the Clean California Program. Deliverables for the project include a 3-piece outdoor exercise station, upgrading the Gateway’s irrigation system and the installation of 123 trees.

This item covers the exercise station.

The Ad Hoc Committee of Mayor Garnes and Mayor Pro Tem Carter have selected the following four pieces of outdoor equipment:

- Hand Cyler - \$4,253
- Squat Press - \$7,791
- Pull Up bars - \$3,308
- Ab Crunch - \$ 3,214

With the associated anchoring poles, the total equipment cost is \$20,750. The City plans to buy the equipment directly and have it installed separately. If the budget does not allow for four units, the Squat Press can be eliminated. Also, the City Manager has applied for two grants to help supplement the project. A \$5,000 grant from PG&E the city is likely to be awarded. Also, a \$20,750 grant application was submitted to Coast Central Credit Union for the equipment purchase. The City will know if that grant is awarded by the end of October.

The City is also working with Greenway Partners to develop the site plan for ADA accessibility and compliance with fall zones. At the time of publication we do not have the final designs but

they are expected soon. Staff is recommending that the Council review the attached documents and authorize the City Manager to issue an RFP once the design schematic is finalized.

Attached are images of the proposed equipment and layout for the north side of Memorial Park.

///



Ab Crunch



Hand Cycler



Pull Up and Dip



Squat Press

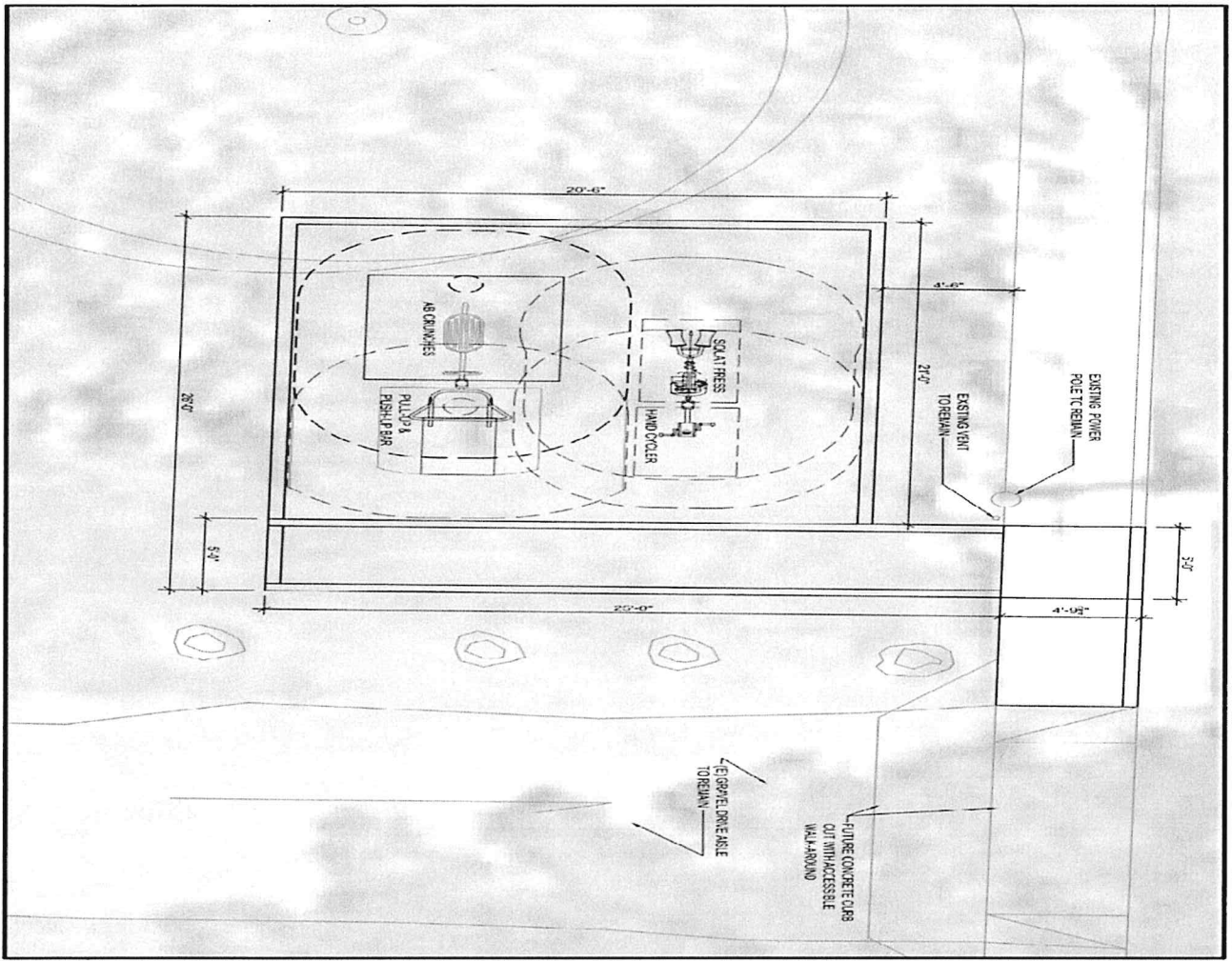



SAFETY NOTE
Choose a protective surfacing material that has a Critical Height Value of at least the height of the Highest Accessible Part/Fall Height of the adjacent equipment. (Ref. ASTM F3101.)

19350200

DETAIL RESISTANCE ASSEMBLY ATTACHMENT

Refer To The HealthBeat Post
Installation Document

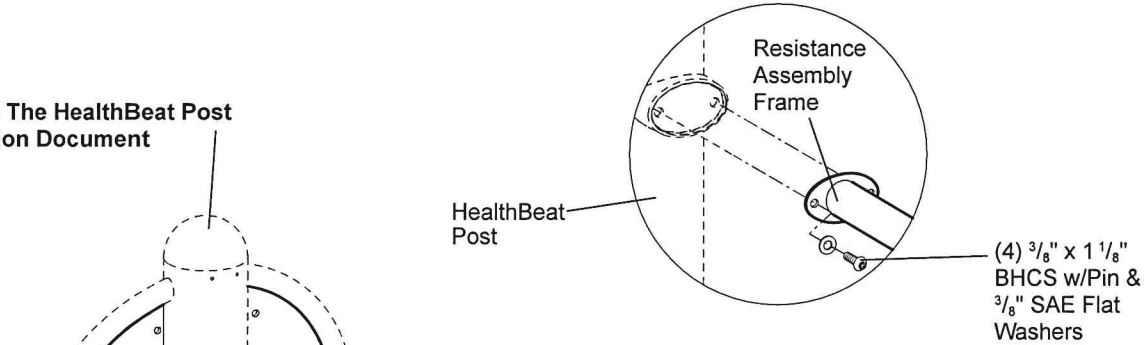

DETAIL ARM ATTACHMENT

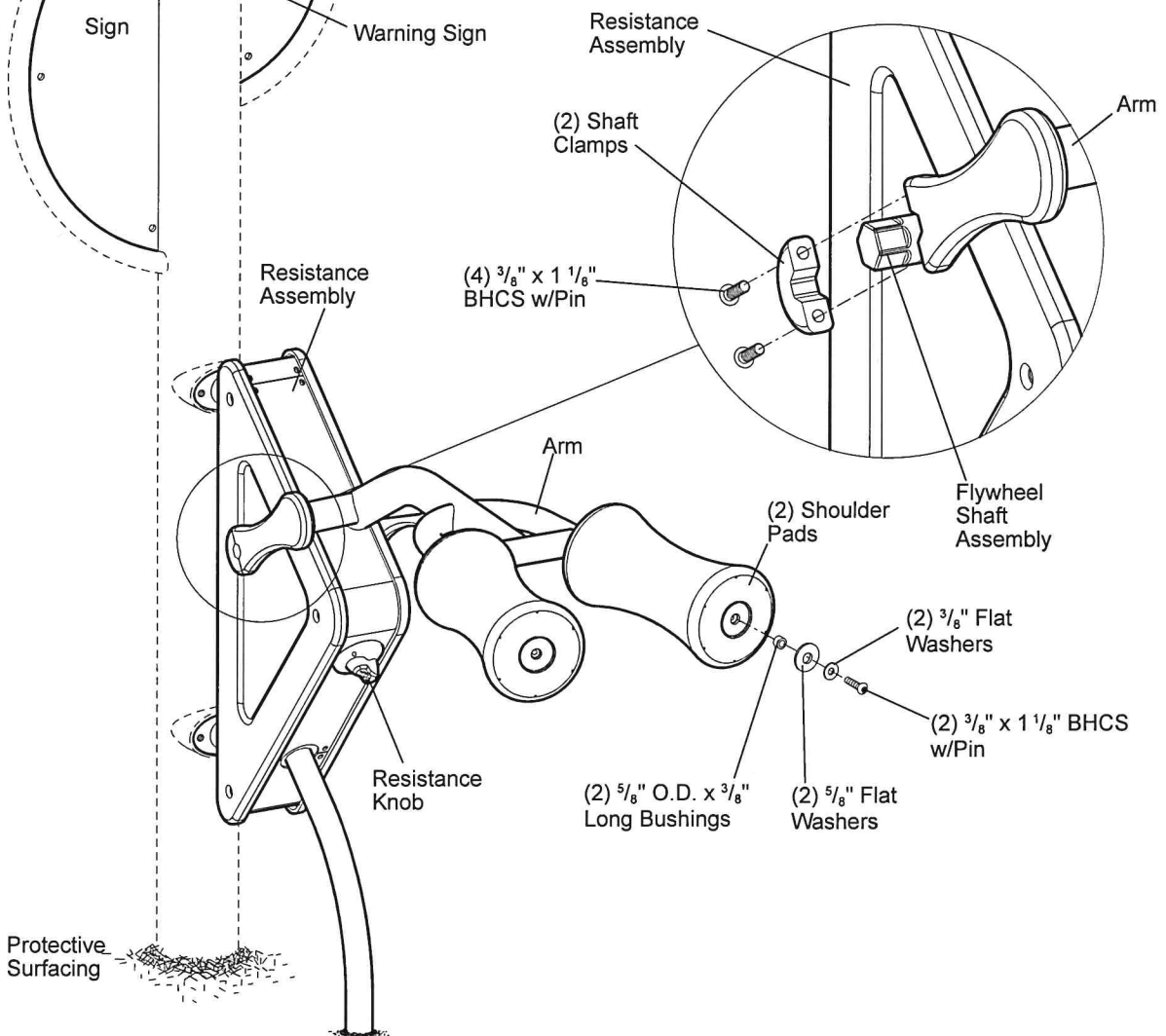

HealthBeat®

192461 Squat Press

Sheet 1 of 3



SAFETY NOTE
 Choose a protective surfacing material that has a Critical Height Value of at least the height of the Highest Accessible Part/Fall Height of the adjacent equipment. (Ref. ASTM F3101.)

19350100

Refer To The HealthBeat Post Installation Document

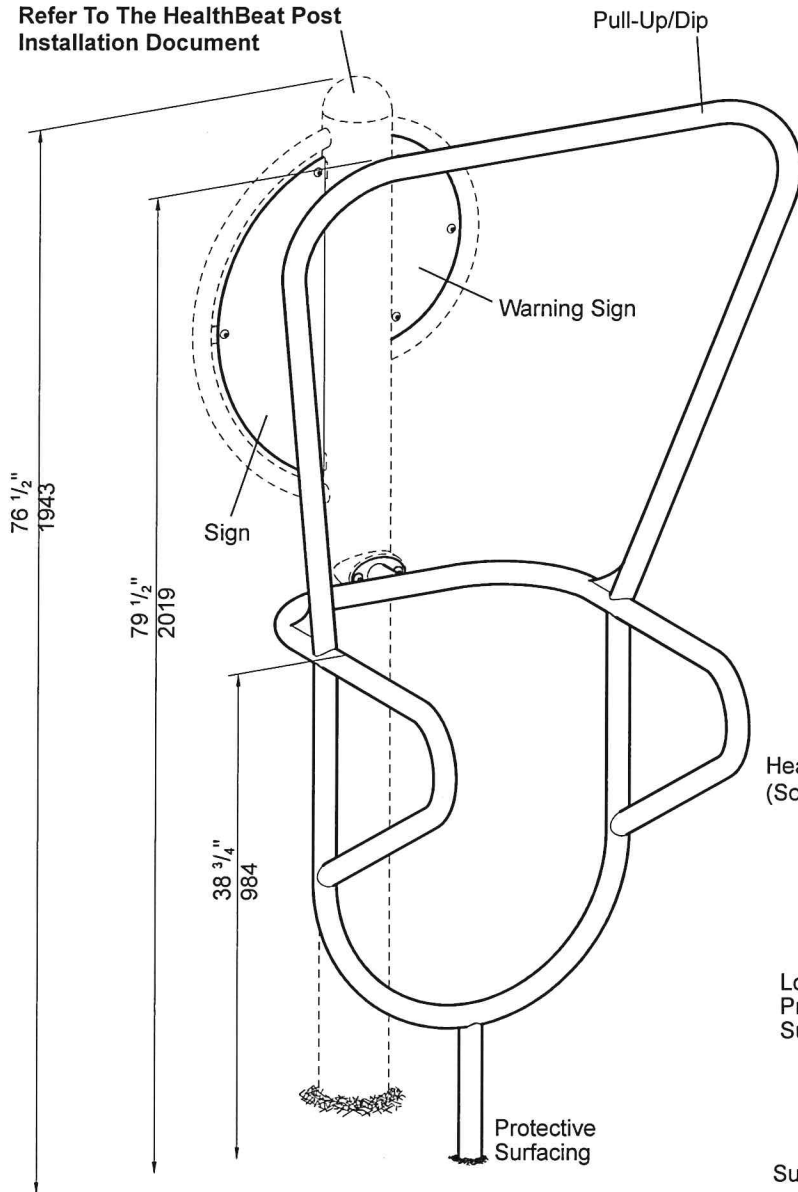

DETAIL PLAN VIEW

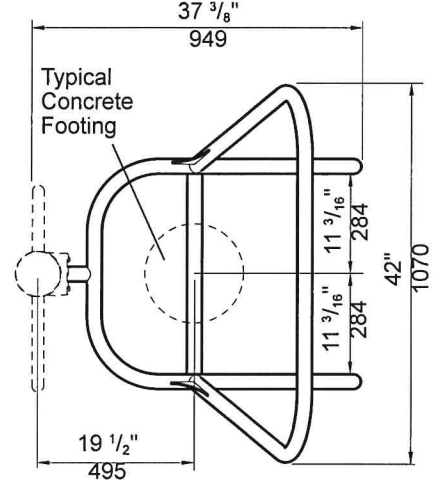

DETAIL PULL-UP/DIP ATTACHMENT

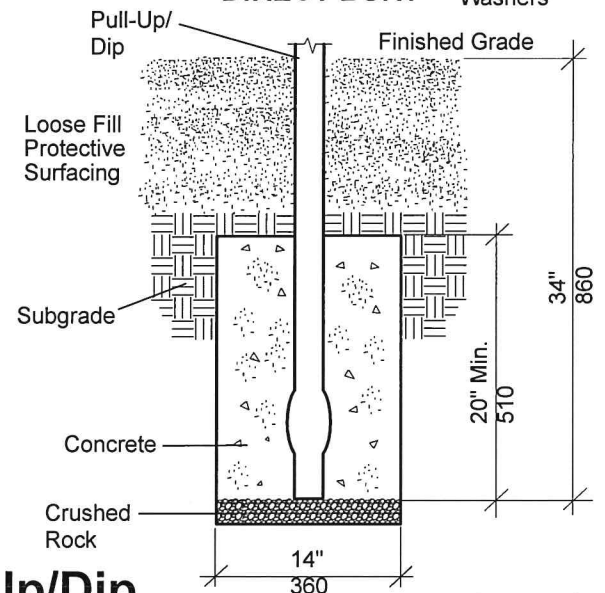
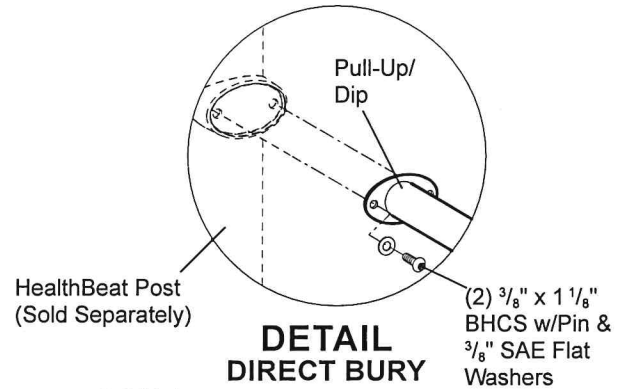

HealthBeat®

192460 Pull-Up/Dip

Sheet 1 of 2



SAFETY NOTE
Choose a protective surfacing material that has a Critical Height Value of at least the height of the Highest Accessible Part/Fall Height of the adjacent equipment. (Ref. ASTM F3101.)

19349200

Refer To The HealthBeat Post Installation Document

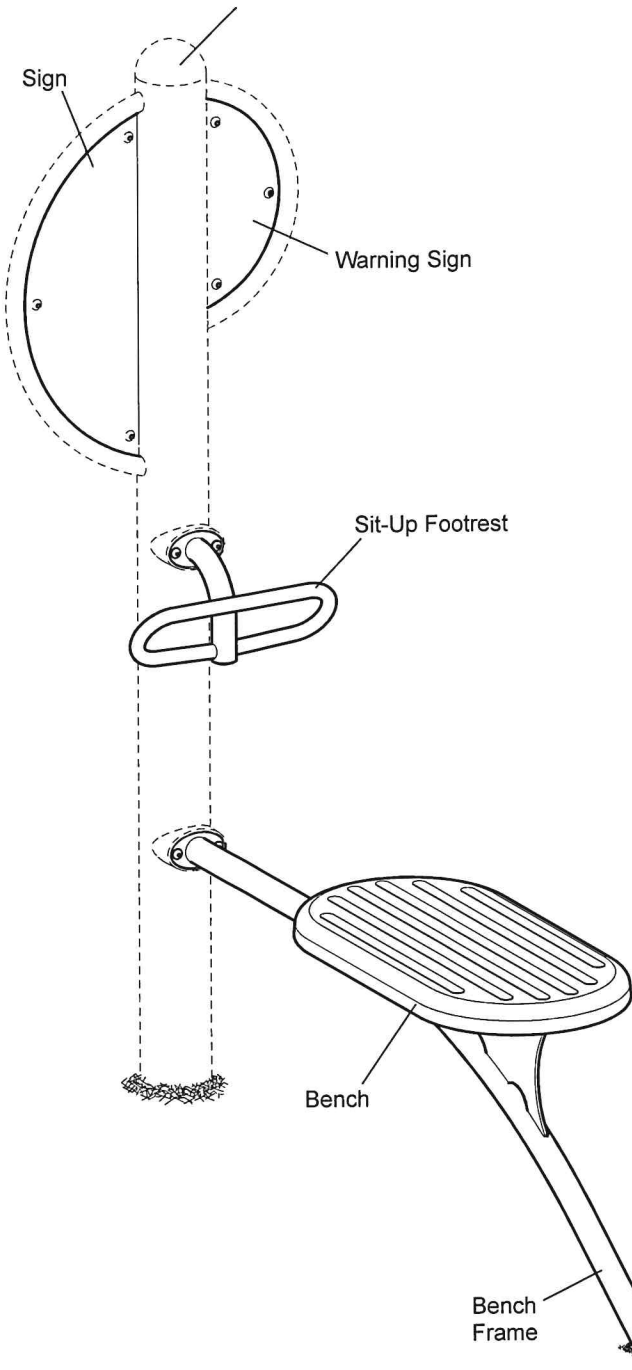

DETAIL BENCH ATTACHMENT

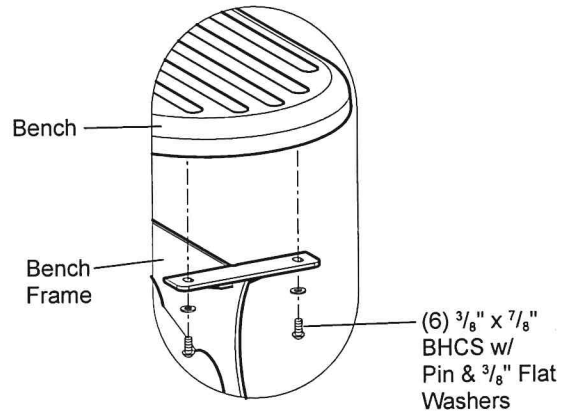

DETAIL BENCH FRAME/FOOT REST ATTACHMENT

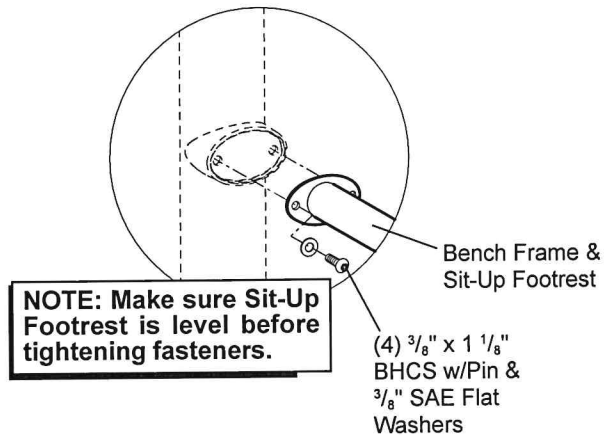



SAFETY NOTE
Choose a protective surfacing material that has a Critical Height Value of at least the height of the Highest Accessible Part/Fall Height of the adjacent equipment. (Ref. ASTM F3101.)

20593900

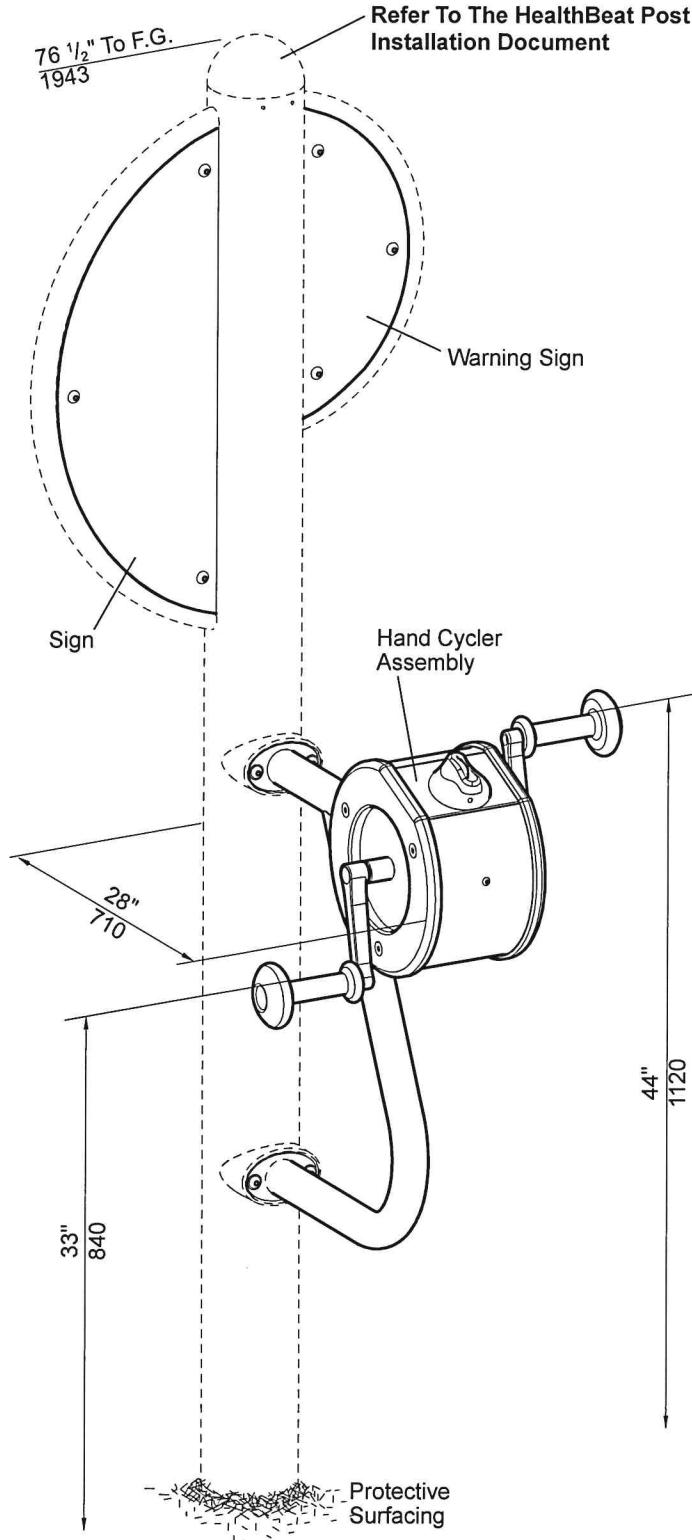

**DETAIL
HAND CYCLER ASSEMBLY
ATTACHMENT**

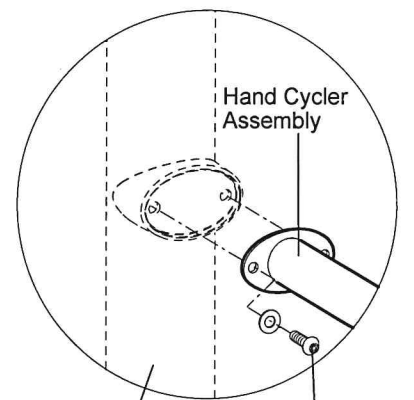

Refer To The HealthBeat Post Installation Document

(4) 3/8" x 1 1/8" BHCS w/Pin & 3/8" SAE Flat Washers

HealthBeat®

205938 Hand Cycler

Sheet 1 of 2