



OFFICIAL PUBLIC NOTICE

MEETING OF THE COMMON COUNCIL

TUESDAY, APRIL 21, 2026 AT 6:30 PM

COUNCIL ROOM, MUNICIPAL BUILDING, 450 S. MAIN ST., RICHLAND CENTER, WI 53581 & VIRTUALLY

TEAMS: bit.ly/RCTeamsMeeting

AGENDA

CALL TO ORDER *Pledge of Allegiance; Roll Call for the meeting, determine whether a quorum is present; determine whether the meeting has been properly noticed.*

APPROVAL OF AGENDA

APPROVAL OF MINUTES *Entertain a motion to waive the reading of the minutes of the last meeting in lieu of printed copies and approve said minutes or correct and approve said minutes.*

- [1.](#) March 30, 2026 Meeting Minutes

RESOLUTION HONORING OUTGOING ELECTED OFFICIALS

- [2.](#) RESOLUTION NO. 2026-05

DEPARTMENT HEAD REPORTS

MAYOR AND ALDERPERSONS REPORTS AND AGENDA ITEM REQUESTS

TREASURER'S REPORT

- [3.](#) Treasurer's Report
- [4.](#) Utility Treasurer's Report

PAYMENT OF BILLS

- [5.](#) Bills for Approval

ITEMS FOR DISCUSSION AND POSSIBLE ACTION

- [6.](#) Adoption of Council Rules, Committee Structure, and Code of Ethics
- [7.](#) Ordinance 2026-05: An Ordinance Dissolving the City Tourism Department And the Tourism Commission
- [8.](#) Tourism Services Agreement

ANNUAL DESIGNATIONS

- [9.](#) Resolution #2026-06, A Resolution Designating Signers on City Bank Accounts
- [10.](#) Resolution #2026-07, A Resolution Designating Public Depositories

APPOINTMENT & CONFIRMATION *Committees, Commissions and Boards*

11. Announcement of Alderperson District 1 (Wards 1, 2, and 3) Vacancy
12. Nominate & Elect Council President
13. Appoint and Confirm City Attorney
14. Appoint and Confirm City Assessor
15. Appoint and Confirm City Forester
16. Appoint and Confirm Emergency Government Coordinator
17. Designate and Confirm Official Newspaper
18. Nominate & Elect Two Council Representatives to the Utility Commission
19. Appointment and Confirmation of Committee, Commission, and Board Members

FINANCE COMMITTEE RECOMMENDATIONS FOR ACTION

- [20.](#) Authorize Payment for 2026 Fireworks
- [21.](#) Purchase of IPC CT50 Walk-Behind Floor Scrubber
- [22.](#) Mill Street Transverse Grate Repair Project
- [23.](#) Valley View Drive Street Project with City Utilities

PUBLIC SAFETY COMMITTEE RECOMMENDATIONS FOR ACTION

- [24.](#) Approval of License(s), if any.
 - 1. SW Partners dba Richland Rejuvenates, Temporary "Class B" Picnic License for May 9, 2026 at the City Auditorium, 182 N Central Avenue.

PUBLIC COMMENT *No Council action will be taken on any matter originating under this item.*

ADJOURNMENT

Posted this 17th day of April, 2026 by 6:30 PM.
Copy to the official newspaper the Richland Observer.

PLEASE NOTE: That upon reasonable notice, a minimum of 24 hours in advance, efforts will be made to accommodate the needs of disabled individuals through appropriate aids and services. For additional information or to request this service contact Ashley Oliphant, City Administrator at 450 S. Main St., Richland Center, WI. 53581 or call 608-647-3466. Notice is hereby given that the council members who are not members of this committee may attend this meeting so as to constitute a quorum of the city council. Any such council member attendance will be for information gathering, discussion, and/or related purposes and will not result in the direct decision making by the city council at the committee meeting. The City of Richland Center is an equal opportunity employer, provider, and lender.



SPECIAL MEETING

MONDAY, MARCH 30, 2026 AT 7:00 PM

COUNCIL ROOM, MUNICIPAL BUILDING, 450 S. MAIN ST., RICHLAND CENTER, WI 53581 & VIRTUALLY

MINUTES

CALL TO ORDER CALL TO ORDER: The meeting was called to order by Mayor Coppernoll at 7:00 PM. Alderpersons present: Ron Fruit, Karin Tepley, Tom McCarthy, Rachel Schultz, Melony Walters, Douglas Martyniuk, and Steve Downs. Absent: Ryan Cairns.

Others Present: Ashley Oliphant, City Administrator; Misty Molzof, City Clerk/Treasurer; Jasen Glasbrenner, Economic Development/Director of Public Works; Darcy Perkins, Municipal Services Specialist; Scott Gald, Utilities Superintendent; Billy Jones, Police Chief; Attorney Michael Windle and Greg (Vierbicher) were virtual; Media: Nova Video representative, WRCO, The Richland Observer; and members of the public.

APPROVAL OF AGENDA: *Motion by Schultz, second by Walters to approve the agenda as presented. Motion passed unanimously 7-0.*

Molzof confirmed the meeting was properly noticed on Friday, March 27, 2026, by 4:30 pm.

APPROVAL OF MINUTES *Motion by Tepley, second by Downs to waive the reading of the minutes of the March 3, 2026, regular meeting and the March 16, 2026, special meeting in lieu of printed copies and approve said minutes. Motion passed unanimously 7-0.*

PLANNING COMMISSION RECOMMENDATIONS FOR ACTION: (Coppernoll)

Conditional Use Permit Application of Brent and Alyssa Gaffney to construct a private garage/accessory building exceeding 3,000 sq. ft. of floor area at 23936 Cty Hwy AA (Tax Parcel 022-0934-2000).

Motion by Fruit, second by Tepley to approve the Conditional Use Permit Application of Brent and Alyssa Gaffney to construct a private garage/accessory building exceeding 3,000 sq. ft. of floor area at 23936 Cty Hwy AA (Tax Parcel 022-0934-2000) as recommended by the Plan Commission. Upon roll call vote, all members present voted aye, motion passed unanimously 7-0.

Conditional Use Application of Brad Wagner to allow tire sales and auto repairs at 780 N Orange Street (Tax Parcel 276-1651-1000).

Motion by Fruit, second by Downs to approve the Conditional Use Application of Brad Wagner to allow tire sales and auto repairs at 780 N Orange Street (Tax Parcel 276-1651-1000) as recommended by the Plan Commission. Upon roll call vote, all members present voted aye, motion passed unanimously 7-0.

Land Division by Certified Survey Map (CSM) Application of Enke Properties, LLC for creation of an eight-duplex housing development

Motion by Downs, second by Tepley to approve the Land Division by Certified Survey Map (CSM) of Enke Properties, LLC for the creation of an eight-duplex housing development as recommended by the Plan Commission. Upon roll call vote, all members present voted aye, motion passed unanimously 7-0.

Public Hearing for Rezoning Application of Enke Properties, LLC for creation of an eight-duplex housing development.

Mayor Coppernoll opened the public hearing at approximately 7:10 pm.

Alan Matteson, 1097 Valley View Drive addressed information presented in support of the rezoning of Stori Field, including population decline, housing needs, available units, and census data. He noted discrepancies in the data and suggested the Council require stone or brick accents on the buildings similar to those on 4th Street and other similarly sized buildings in the City.

Deb McCoy, 665 Chestnut Street , expressed concern that the CSM dividing the land does not reflect information she previously received, including promised land for a sledding hill, larger green space, and safe walking areas.

Mike Grindemann, 548 Stori Drive, expressed concern that the petition dated 12/2/2025 was not heard by elected officials, alleged violations of state statutes, emphasized the need for affordable owner-occupied housing, and opposed changing the property from R-1 to PUD. He also suggested the City explore Habitat for Humanity housing as a more beneficial option.

Barbara Klipp, 590 E 3rd Street, expressed agreement with prior comments made during the public hearing. She questioned the need for additional housing in light of population decline, stated the City missed opportunities to redevelop existing vacant buildings, and expressed concern about the loss of green space. She further noted that rental properties may result in transient tenants and questioned the potential impact on police, schools, and the community, stating that changes to a neighborhood’s focus can affect the entire City.

Motion by Tepley, second by Schultz to close the public hearing at approximately 7:22 pm. Motion passed unanimously 7-0.

Ordinance #2026-04, Rezoning of Tax Parcel #276-1664-1000 to Planned Unit Development, Enke Properties, LLC for creation of an eight-duplex housing development.

Motion by Walters, second by Tepley to adopt Ordinance 2026-04 rezoning Tax Parcel 276-1664-1000 to Planned Unit Development (PUD) for the development of the Stori Field property as outlined by the General Development Plan (GDP) as recommended by the Plan Commission. Upon roll call vote, all members present voted aye, motion passed unanimously 7-0.

Specific Implementation Plan for Stori Field Planned Unit Development (PUD).

Motion by Walters, second by Downs to approve the Specific Implementation Plan (SIP), as submitted, for the Stori Field Development. Upon roll call vote, all members present voted aye, motion passed unanimously 7-0.

PUBLIC WORKS RECOMMENDATIONS FOR ACTION: (FRUIT)

Agreement for Annual Contracted Mowing Services

Motion by Fruit, second by McCarthy to approve execution of a 2026 Contracted Mowing Services Agreement with the lowest responsible bidder, Gary’s Lawn Care LLC as recommended by the Public Works Board. Upon roll call vote, all members present voted aye, motion passed unanimously 7-0.

Fruit explained there has been extensive discussion, research, and planning regarding mowing services due to 2025 being an abnormally wet year requiring additional mowing, a shortage of staff, and failing equipment. In 2025, one bid was received and awarded to Gary’s Lawn Care, LLC; however, concerns were raised due to a familial relationship with a City employee. For 2026, the City solicited bids and received seven submissions, each providing pricing for two options. Gary’s Lawn Care, LLC was the lowest responsible bidder, and the Public Works Board recommended awarding the contract accordingly, with funds to be allocated from the part-time employee expense budget line item.

Agreement for Warning System Annual Inspection and Preventative Maintenance

Motion by Fruit, second by Schultz to approve the execution of a 4-Year Agreement for Warning System Annual Inspection & Biennial Preventative Maintenance with Sheboygan Warning Systems, LLC at a cost not to exceed \$12,500.00 as recommended by the Public Works Board. Upon roll call vote, all members present voted aye, motion passed unanimously 7-0.

Fruit stated that two bids were received, with Sheboygan Warning Systems, LLC providing the more favorable pricing structure and strong references.

ITEMS FOR DISCUSSION AND ACTION

Property Use Agreement with Lydia’s House.

Motion by Schultz, second by Tepley to authorize the City Administrator and City Attorney to negotiate contract terms and return the agreement to the Council for final approval. Upon roll call vote, all members present voted aye; motion passed unanimously 7-0.

Administrator Ashley Oliphant stated the agreement remains in process and has not been executed. Lydia’s House has requested continued use of the property at no cost, consistent with prior use, but also requested reimbursement from the City for maintenance and repair costs, which is not consistent with the Council’s prior direction. Additionally, terms of the original 1979 HUD grant have not been located, and the City is awaiting assistance from HUD.

Attorney Michael Windle stated that several concerns have been discussed with Lydia’s House representatives; some have been resolved, while others are not in the City’s best interest.

Michelle Elfers, President of Lydia’s House, stated the property was previously owned by SWCAP, which transferred ownership to the City via quit claim deed without the City’s knowledge. She noted Lydia’s House ceased operations at that time due to lack of an agreement and is now being asked to operate without one. She explained the building is older and may require major repairs such as roofing or HVAC replacement, which exceed Lydia’s House annual budget of \$39,000. Lydia’s House has already incurred approximately \$2,000 in utility expenses for an unoccupied facility and cannot continue operations without an agreement. Elfers indicated she has researched applicable federal regulations under CDBG; however, resolution requires locating the 1979 agreement. Lydia’s House is requesting reimbursement for major expenses upon any future sale of the property and inclusion of provisions addressing current residents in the event of a sale.

Proposed Updates to City Governance Framework, including Council Rules, Elected Official Code of Conduct, and Committee/Commission/Board Structure.

Tepley reported that she, Walters, and Attorney Windle have been meeting to review and revise Council rules, committee and board structures, and governance framework. No formal action was required. Walters requested Council members review the proposed changes, which include eliminating redundancies across multiple committees addressing the same items.

PUBLIC COMMENT *No Council action will be taken on any matter originating under this item.*

Deb McCoy, 665 Chestnut Street read a letter from Susan Stori regarding recent Council action on the Stori Field property, expressing concern that development is proceeding based on broken promises.

Alan Matteson, 1097 Valley View Drive, expressed appreciation for those serving and the time committed to their roles. He raised concerns regarding the contract with Accurate Appraisal not reflecting what was communicated at the time of Council approval and questioned why the City was paying taxes on the Hill Country Rental property purchased in 2024, which he believed should be tax-exempt.

ADJOURNMENT: *Motion by Tepley, second by Walters to adjourn at approximately 8:26 pm. Motion passed unanimously 7-0.*

Meeting adjourned at approximately 8:26 pm.

Respectfully submitted,

Misty D. Molzof, City Clerk/Treasurer

**CITY OF RICHLAND CENTER
RESOLUTION NO. 2026-05**

A RESOLUTION HONORING AND RECOGNIZING THE OUTSTANDING SERVICE OF MAYOR TODD COPPERNOLL, ALDERPERSON RON FRUIT, AND ALDERPERSON TOM McCARTHY

WHEREAS, the City of Richland Center is proud to recognize individuals who have dedicated themselves to public service and the betterment of their community; and

IN HONOR OF MAYOR TODD COPPERNOLL

WHEREAS, Todd Coppernoll served as Mayor of the City of Richland Center from 2020 to 2026, leading the City through a period of growth and change with dedication, vision, and an unwavering commitment to the public good; and

WHEREAS, Mayor Coppernoll faithfully served on numerous boards and committees on behalf of the City, including the Fire Board, the Joint Ambulance Committee, the Planning Commission, and the Board of Review, contributing his time, expertise, and judgment to each body; and

WHEREAS, Mayor Coppernoll was recognized throughout the region as an exceptional public speaker who eloquently and passionately championed the City of Richland Center, highlighting its many strengths, assets, and opportunities at every occasion; and

WHEREAS, Mayor Coppernoll pursued economic development for the City with tireless energy and genuine passion, working diligently to attract investment, support local businesses, and expand opportunities for all residents; and

WHEREAS, Mayor Coppernoll's leadership, civic pride, and gracious service have left an enduring and positive mark upon the City of Richland Center and its residents;

IN HONOR OF ALDERPERSON RON FRUIT

WHEREAS, Ron Fruit served as Alderperson for District 1 of the City of Richland Center from 2023 to 2026, bringing to the Council a thoughtful voice, measured judgment, and a consistent commitment to acting in the best interests of the City and its residents; and

WHEREAS, Alderperson Fruit served diligently on numerous boards and committees, including the Public Works Committee, the Public Safety Committee, the Tourism Commission, and the Tree Board, bringing the same care and deliberateness to each role; and

WHEREAS, Alderperson Fruit also served as a greeter for City elections, warmly welcoming residents to participate in the democratic process and making the City's polling places more inviting and accessible for all; and

WHEREAS, Alderperson Fruit was widely admired by colleagues and constituents alike for his wisdom, his calm and measured approach to governance, and his steadfast advocacy for the welfare of the entire City;

IN HONOR OF ALDERPERSON TOM McCARTHY

WHEREAS, Tom McCarthy served as Alderperson for District 2 of the City of Richland Center from 2022 to 2026, providing the Common Council with quiet, steady, and principled leadership throughout his tenure; and

WHEREAS, Alderperson McCarthy served faithfully on the Personnel Committee, the Fire Board, and the Board of Review, offering his careful judgment and deliberate perspective in service of the City and its employees; and

WHEREAS, Alderperson McCarthy exemplified the very best of public service through his measured approach, his thoughtful participation, and his commitment to doing what was right for the City and the residents of District 2;

NOW, THEREFORE, BE IT RESOLVED

by the Common Council of the City of Richland Center, Wisconsin, assembled in Annual Reorganization Meeting, as follows:

SECTION 1. The Common Council hereby expresses its profound and sincere gratitude to Mayor Todd Coppernoll for his six years of inspired and devoted service as Mayor, his exceptional

leadership, his eloquent representation of the City, and his passionate pursuit of economic prosperity for all residents of Richland Center.

SECTION 2. The Common Council hereby expresses its heartfelt appreciation to Alderperson Ron Fruit for three years of wise, thoughtful, and measured service to the residents of District 1 and the City as a whole, and for his warm hospitality and community spirit as an election greeter.

SECTION 3. The Common Council hereby expresses its deep appreciation to Alderperson Tom McCarthy for four years of discerning, principled, and steadfast service to the residents of District 2 and the entire City of Richland Center.

SECTION 4. The Common Council expresses its sincere appreciation to Mayor Todd Coppernoll, Alderperson Ron Fruit, and Alderperson Tom McCarthy for their years of dedicated public service. Each brought a distinct voice and genuine commitment to this body — and to the residents they represented. Richland Center is better for their service.

SECTION 5. The City Clerk is directed to prepare copies of this Resolution and to transmit one to each honoree as a token of the Council's esteem and the community's gratitude.

ADOPTED by the Common Council of the City of Richland Center, Wisconsin, on the 21st day of April, 2026.

Karin Tepley, Mayor

ATTEST:

Misty Molzof, Deputy Clerk

CITY OF RICHLAND CENTER - AGENDA ITEM DATA SHEET

Item 3.

Agenda Item: City Treasurer's Report

Committee Review: N/A

Meeting Date: Finance & Council – April 21, 2026

Presented by: Misty Molzof, Treasurer

Recommended Action Items:

1. Approve Payment of Bills in the amount of \$1,010,168.27, of which \$13,751.11 are Greater Richland Tourism Bills.

Items included:

1. Treasurer's Report for period ending February 28, 2026 – "Cash Balances" Report
 - a. Beginning Balance - \$14,330,738.03
 - b. Total monthly receipts - \$943,413.99: includes **total interest earned of \$42,976.42**
 - c. Total monthly Disbursements - \$702,741.72
 - d. Ending Balance - \$14,571,410.30
2. Treasurer's Report for period ending March 31, 2026 – "Cash Balances"
 - a. Beginning Balance - \$14,571,410.30
 - b. Total monthly receipts - \$310,009.17: includes **total interest earned of \$26,309.54**
 - c. Total monthly Disbursements - \$3,283,914.29
 - d. Ending Balance - \$11,597,505.18
3. Balance Sheet & Revenue & Expense Statements – Will be provided at the May Regular Meeting.
4. What else have we been doing in the Clerk/Treasurer's Office:
 - a. Accounting
 - i. Reconcile Accounts Receivable
 - ii. Reconciling Year-To-Date Budget Numbers
 - iii. Working on 2026 through March and keeping up with day-to-day accounting work.
 - iv. CDBG – Possible Closing and Requirements by State
 - v. Filing annual reports due on or before April 30th
 - b. Election – April 7, 2026
 - i. Compliments and positive comments from poll workers and citizens on how well the election went, the setup and layout of the polling place, and the efficiencies that were created.
 - ii. A few interested people in working elections in the future
 - iii. Total Ballots Cast on Election Day – 1,127
 1. In-Person Voters – 918
 2. Absentee Voters / Ballots Returned – 209
 - a. Total Ballots Requested – 236 (26 Unreturned Ballots)
 - b. In-Person / In-Office Absentee Voters – 38
 - c. Care Facility / Special Voting Deputy Served Absentee Voters – 41
 - d. Mailed Ballots – 157
 - i. Envelopes, Labels, & Ballot - \$1.50/each
 - ii. Postage on Return Ballot - \$0.78/Each
 - iii. Postage on Mailed Ballot - \$1.07/Each
 - iv. Total cost of materials & postage for Absentee Ballots - \$3.35/each - **\$525.95**
 - c. License Renewals – June 2026 Council Agenda for Approval - Annual Licenses Expire June 30, 2026.
 - d. Addressing – changing and adding new addresses – coordination with County Emergency Services, and Post Office required.
 - e. Zoning – Spring is here and there has been a lot happening in the Zoning Department.

Election Participation in All Elections From 2018 through 2026:

Date	Total	Absentee	In-Person
4/7/2026	1127	209	918
4/1/2025	1515	380	1135
11/5/2024	2449	747	1702
8/13/2024	959	216	743
4/2/2024	1092	202	890
4/4/2023	1259	273	986
2/21/2023	667	158	509
11/8/2022	1855	390	1465
8/9/2022	953	243	710
4/5/2022	649	153	496
4/16/2021	905	280	625
2/16/2021	287	169	118
11/30/2020	2314	1286	1028
8/11/2020	779	442	337
4/7/2020	1197	875	322
2/18/2020	502	74	428
4/2/2019	809	105	704
11/6/2018	1870	282	1588
8/14/2018	681	82	599

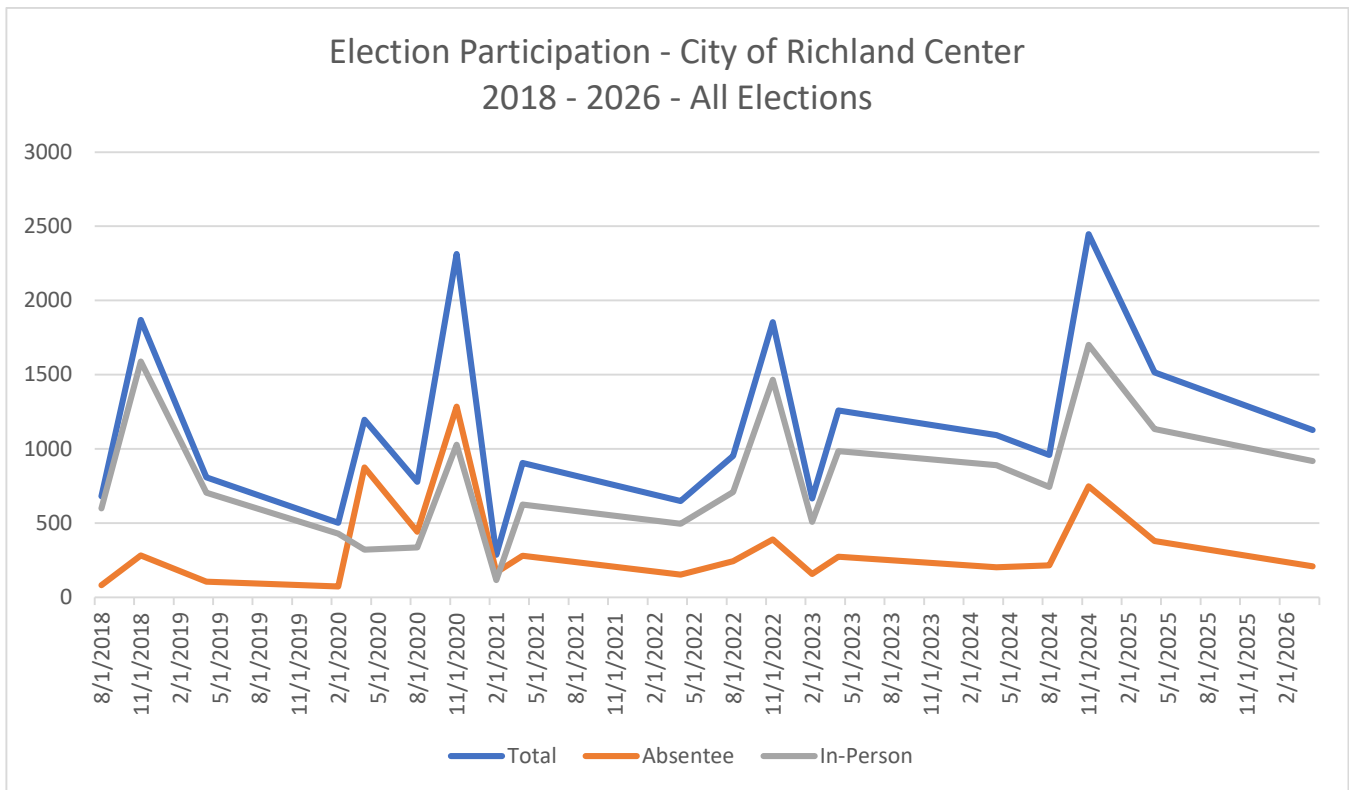

Election Participation in just the April Spring Elections from 2019 through 2026:

Date	Total	Absentee	In-Person
4/7/2026	1127	209	918
4/1/2025	1515	380	1135
4/2/2024	1092	202	890
4/4/2023	1259	273	986
4/5/2022	649	153	496
4/16/2021	905	280	625
4/7/2020	1197	875	322
4/2/2019	809	105	704

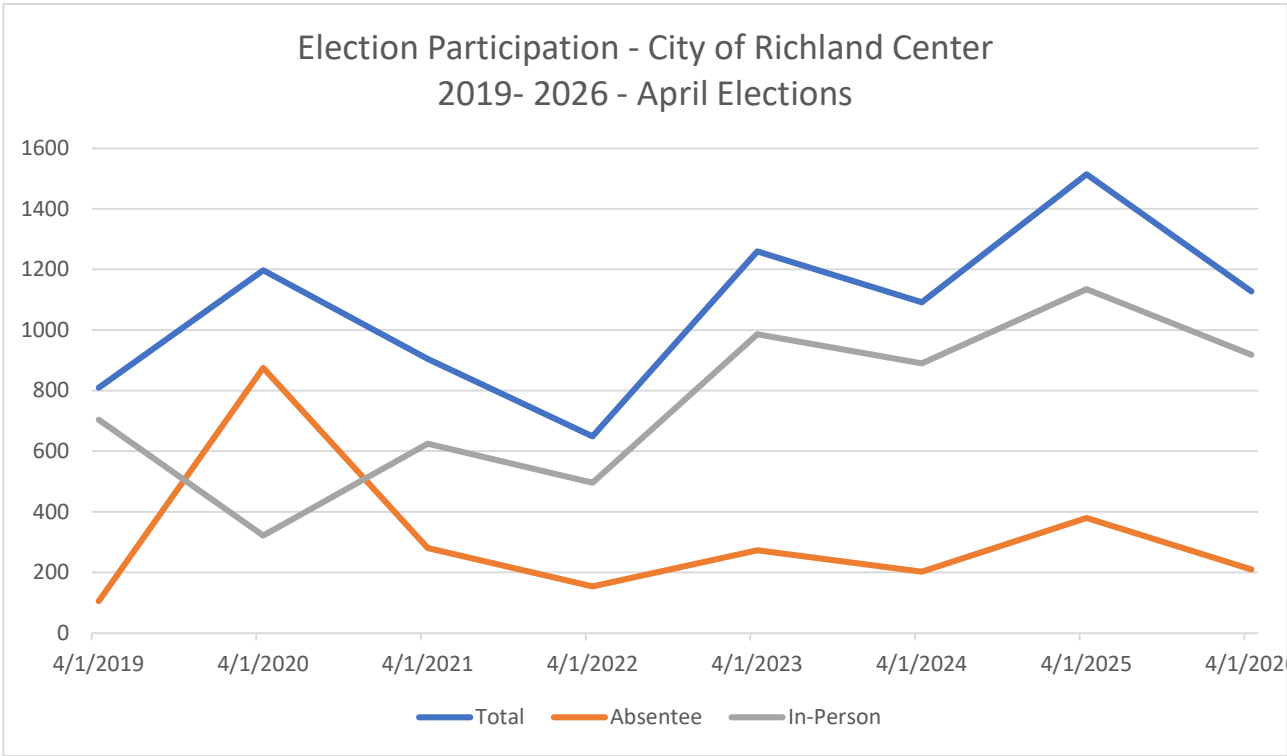

CITY OF RICHLAND CENTER - TREASURER'S REPORT

2/28/2026

Item 3.

FUNDS	Int Rate	BEG/MO BAL	Transfers In/(Out) Between Accounts			DISBURSEMENTS	END/MO BAL
			RECEIPTS				
City General Unassigned:	2.96%	\$ 323,603.62	\$ 444,251.42	\$ 2,738,712.52	\$ 619,507.60	\$ 2,887,059.96	
State Investments #1 Unassigned	3.69%	\$ 4,539,406.31	\$ 12,855.22			\$ 4,552,261.53	
Property Tax Account (partial unassigned)	2.96%	\$ 3,066,754.30	\$ 294,635.26	\$ (2,738,712.52)		\$ 622,677.04	
#2 Landfill long term care (for landfill issues)	3.69%	\$ 673,062.46	\$ 1,906.06			\$ 674,968.52	
#3 TIF-Panorama Estates (TIF 6)	3.69%	\$ 285,407.61	\$ 808.25			\$ 286,215.86	
#6 TIF 2-5 (only #4)	3.69%	\$ 155,346.01	\$ 439.93			\$ 155,785.94	
RLF Business Savings	0.50%	\$ 177,264.75	\$ 36.42	\$ (177,264.75)	\$ 10.00	\$ 26.42	
RLF Business Checking	0%	\$ 1,669.45		\$ 177,264.75		\$ 178,934.20	
RESTRICTED FUNDS: (by outside entity)		\$ -					
CDBG Housing RLF	2.96%	\$ 178,882.13	\$ 412.36			\$ 179,294.49	
Landfill Long Term Care CD to 2045	2.48%	\$ 320,243.09				\$ 320,243.09	
Landfill Long Term Care CD to 2045	2.48%	\$ 308,732.96				\$ 308,732.96	
Library Checking	2.96%	\$ 223,109.33	\$ 143,362.74		\$ 41,169.48	\$ 325,302.59	
Room Tax	2.96%	\$ 27,326.35	\$ 818.87		\$ 23,451.98	\$ 4,693.24	
Greater Richland Tourism	2.96%	\$ 31,785.85	\$ 24,563.01		\$ 18,351.66	\$ 37,997.20	
Redevelopment Authority	2.96%	\$ 75,503.61	\$ 174.06			\$ 75,677.67	
#5 Renew RC Loan Program-Affordable Hous	4.39%	\$ 876,087.39	\$ 2,481.01			\$ 878,568.40	
Renew RC Loan Program-Checking	2.96%	\$ 80,754.29	\$ 186.15			\$ 80,940.44	
COMMITTED: (by resolution of the Council)		\$ -					
#4 Projects committed	3.69%	\$ 2,672,283.17	\$ 7,567.68			\$ 2,679,850.85	
ASSIGNED: (for specific use, not assigned)		\$ -					
Cemetery CDs	2.34% & 3.21%	\$ 5,044.90	\$ 1.98			\$ 5,046.88	
Centennial Committee	2.96%	\$ 2,971.23	\$ 6.85			\$ 2,978.08	
Canine Fund	0%	\$ 50,187.93	\$ 1,500.00		\$ 251.00	\$ 51,436.93	
Park/Rec/Comm Center	2.96%	\$ 12,362.86	\$ 28.50			\$ 12,391.36	
Aquatic Center	3.69%	\$ 242,948.43	\$ 688.01			\$ 243,636.44	
Total Interest Earned in Current Month			\$ 36,286.21	\$ -			
LOANS						2/28/2026	
Loans:		Total Debt 4/30/2025	2025 Principle	Loan Term End		Balance	
Richland County Bank (2%)		\$ -	\$ -	Paid off 2024		\$ -	
WPPI (no interest)		\$ (3,794.58)	\$ 5,059.44	10/28/2027		\$ (4,216.20)	
State Trust Fund Loan - Panorama Est TIF 6 (3.5%)		\$ -	\$ -	Paid off 2021		\$ -	
Bonding - Panorama Estates TIF 6 (1.8%)		\$ 600,000.00	\$ 52,075.00	4/1/2037		\$ 600,000.00 As of 10/1/2025	
CFB Haseltine 389,390/Westside Dr 362,610 (2.73%)		\$ 352,000.00	\$ 67,117.10	4/1/2028		\$ 352,000.00 As of 10/1/2025	
Aquatic Center Bonding (20 Years)		\$ 3,145,000.00	\$ 301,600.00	8/1/2038		\$ 3,145,000.00 As of 8/1/2025	
		\$ 4,093,205.42	\$ 425,851.54			\$ 4,092,783.80	
Debt Capacity - WI Department of Revenue - 2024						\$ 20,792,625.00	
			% of Total Debt Capacity used			20%	
			65% Recommended Maximum			\$ 13,515,206.25	
			Amt Avail to Reach 65%			\$ 9,422,422.45	
		\$ 14,330,738.03	\$ 936,723.78	\$ -	\$ 702,741.72	\$ 14,564,720.09	
		Beg Bal	Receipts	Transfer	Expenditures	End Bal	
						Net Increase / (Decrease) in Funds Available \$ 233,982.06	

CITY OF RICHLAND CENTER - TREASURER'S REPORT

Item 3.

3/31/2026

FUNDS	Int Rate	BEG/MO BAL	Transfers In/(Out) Between Accounts		
			RECEIPTS	DISBURSEMENTS	
City General Unassigned:	2.96%	\$ 2,887,059.96	\$ 262,563.34	\$ 622,577.04	\$ 3,248,627.72
#1 State Investments - Unassigned	3.69%	\$ 4,552,261.53	\$ 20,626.70		
Property Tax Account (partial unassigned)	2.96%	\$ 622,677.04	\$ 151.72	\$ (622,577.04)	
#2 Landfill long term care (for landfill issues)	3.69%	\$ 674,968.52	\$ 2,113.52		
#3 TIF-Panorama Estates (TIF 6)	3.69%	\$ 286,215.86	\$ 896.22		
#6 TIF 2-5 (only #4)	3.69%	\$ 155,785.94	\$ 487.81		
RLF Business Savings	0.50%	\$ 26.42	\$ 10.00	\$ (36.42)	
RLF Business Checking	0%	\$ 178,934.20		\$ 36.42	
RESTRICTED FUNDS: (by outside entity)		\$ -			
CDBG Housing RLF	2.96%	\$ 179,294.49	\$ 3,410.14		
Landfill Long Term Care CD to 2045	2.48%	\$ 326,006.41			
Landfill Long Term Care CD to 2045	1.40%	\$ 309,659.85			
Library Checking	2.96%	\$ 325,302.59	\$ 6,085.75		\$ 34,589.84
Room Tax	2.96%	\$ 4,693.24	\$ 1,126.81		
Greater Richland Tourism	2.96%	\$ 37,997.20	\$ 98.14		\$ 458.71
Redevelopment Authority	2.96%	\$ 75,677.67	\$ 189.89		
#5 Renew RC Loan Program-Affordable Housing	4.39%	\$ 878,568.40	\$ 2,751.04		
Renew RC Loan Program-Checking	2.96%	\$ 80,940.44	\$ 203.11		
COMMITTED: (by resolution of the Council)		\$ -			
#4 Projects committed	3.69%	\$ 2,679,850.85	\$ 8,391.37		
ASSIGNED: (for specific use, not assigned)		\$ -			
Cemetery CDs	2.34% & 3.21%	\$ 5,046.88	\$ 2.16		
Centennial Committee	2.96%	\$ 2,978.08	\$ 7.47		
Canine Fund	0%	\$ 51,436.93	\$ 100.00		\$ 238.02
Park/Rec/Comm Center	2.96%	\$ 12,391.36	\$ 31.09		
#8 - Aquatic Center	3.69%	\$ 243,636.44	\$ 762.89		
Total Interest Earned in Current Month			\$ 26,309.54	\$ -	
LOANS					4/1/2026
Loans:		Total Debt 3/31/2026	2026 Principle	Loan Term End	Balance
Richland County Bank (2%)		\$ -	\$ -	Paid off 2024	\$ -
WPPI (no interest)		\$ 8,010.38	\$ 421.62	10/28/2027	\$ 7,588.76
State Trust Fund Loan - Panorama Est TIF 6 (3.5%)		\$ -	\$ -	Paid off 2021	\$ -
Bonding - Panorama Estates TIF 6 (1.8%)		\$ 600,000.00	\$ 52,075.00	4/1/2037	\$ 600,000.00
CFB Haseltine 389,390/Westside Dr \$752,000(2.73%)		\$ 348,587.50	\$ 102,000.00	4/1/2028	\$ 246,587.50
Aquatic Center Bonding (20 Years)		\$ 3,145,000.00	\$ 205,000.00	8/1/2038	\$ 2,940,000.00
		\$ 4,101,597.88	\$ 359,496.62		\$ 3,794,176.26
Debt Capacity - WI Department of Revenue - 2024					\$ 20,792,625.00
				% of Total Debt Capacity used	18%
				65% Recommended Maximum	\$ 13,515,206.25
				Amt Avail to Reach 65%	\$ 9,721,029.99
		\$ 14,571,410.30	\$ 310,009.17	\$ -	\$ 3,283,914.29
		Beg Bal	Receipts	Transfer	Expenditures
				Net Increase / (Decrease) in Funds Available	

City of Richland Center - Finance Committee Council Payment Approval Report - April 21, 2026
Invoices Approved by Dept Head Entered into System between March 4, 2026 April 21, 2026

Item 5.

Vendor Name	Inv Date	Description	Amount	Vendor Total	Date Paid	Comm/Board	Date Approved
ABT SWAYNE LAW LLC	3/3/2026	Legal: RDA - Use Funds from RDA Account	\$ 1,785.00		3/4/2026		
TOTAL	ABT SWAYNE LAW LLC			\$ 1,785.00			
Accurate Appraisal LLC	3/1/2026	Accurate Appraisal - Mo Assessment Services - March 2026	\$ 3,750.00		4/9/2026		
TOTAL	Accurate Appraisal LLC			\$ 3,750.00			
AFLAC		Payroll Deductions: Employee Contribution Only					
TOTAL	AFLAC			\$ 525.42			
ALL AMERICAN DO IT CENTER	3/3/2026	PW/B&G: Parks Footbridge Repair - BLDG-PROP/MAINT/REPAIRS	\$ 117.51		3/26/2026		
ALL AMERICAN DO IT CENTER	3/5/2026	PW/B&G: Meyer Building Repair - BLDG-PROP/MAINT/REPAIRS	\$ 55.34		3/26/2026	Public Works	3/19/2026
ALL AMERICAN DO IT CENTER	3/6/2026	PW/B&G: Parks Footbridge Repair - BLDG-PROP/MAINT/REPAIRS	\$ 44.07		3/26/2026	Public Works	3/19/2026
ALL AMERICAN DO IT CENTER	4/20/2026	PW/B&G: Community Garden Repairs - BLDG-PROP/MAINT/REPAIRS	\$ 39.72				
ALL AMERICAN DO IT CENTER	4/20/2026	PW/B&G: Community Garden Repairs - BLDG-PROP/MAINT/REPAIRS	\$ 66.91				
ALL AMERICAN DO IT CENTER	4/15/2026	PW/Street: Truck 59 Side Box Boards - STREETS/TRUCK REPAIR	\$ 33.38				
TOTAL	ALL AMERICAN DO IT CENTER			\$ 356.93			
ALLIANT ENERGY/WPL		Various City Locations / Natural Gas				Public Works	3/19/2026
ALLIANT ENERGY/WPL	4/16/2026	PW/Streets: Street Lts 14-Walmart	\$ 16.65				
TOTAL	ALLIANT ENERGY/WPL			\$ 987.93			
AMAZON CAPITAL SERVICES	3/4/2026	PW/B&G: Office Supplies - BLDG-PROP/SUPPLIES	\$ 7.30		3/26/2026	Public Works	3/19/2026
AMAZON CAPITAL SERVICES	3/4/2026	PW/Street: Office Supplies - GARAGE/OFFICE SUPPLIES	\$ 7.29		3/26/2026	Public Works	3/19/2026
AMAZON CAPITAL SERVICES	3/13/2026	PW/B&G: City Hall Water Fountain Filters - BLDG-PROP/MAINT/REPAIRS	\$ 263.98		3/26/2026	Public Works	3/19/2026
AMAZON CAPITAL SERVICES	3/2/2026	Police: label maker, air wedge bag pump	\$ 53.44		3/26/2026		
AMAZON CAPITAL SERVICES	3/4/2026	PW/B&G: PD Lock Repair - BLDG-PROP/MAINT/REPAIRS	\$ 75.98		3/26/2026	Public Works	3/19/2026
AMAZON CAPITAL SERVICES	3/4/2026	PW/B&G: Shop Toolbox - BLDG-PROP/SUPPLIES	\$ 175.98		3/26/2026	Public Works	3/19/2026
AMAZON CAPITAL SERVICES	3/9/2026	PW/B&G: CC Floor Scrubber Hose - BLDG-PROP/EQUIP MAINT-REPAIR	\$ 25.99		3/26/2026	Public Works	3/19/2026
AMAZON CAPITAL SERVICES	3/4/2026	City Hall: Postage Ink for Meter	\$ 56.67		3/26/2026		
AMAZON CAPITAL SERVICES	3/24/2026	PW/Landfill: TACTACAM - Defend 360 Cellular Security Camera - LANDFILL/SUPPLIES	\$ 166.59		4/16/2026		
AMAZON CAPITAL SERVICES	3/27/2026	PW/B&G: Dog Waste Station Refill Roll Bags - BLDG-PROP/SUPPLIES	\$ 86.99		4/16/2026		
AMAZON CAPITAL SERVICES	4/13/2026	CC/SC: WAC Supplies, Maint & Repair, and CC Supplies	\$ 396.55				
AMAZON CAPITAL SERVICES	4/13/2026	CC/SC: WAC Supplies, Maint & Repair, and CC Supplies	\$ 102.38				
AMAZON CAPITAL SERVICES	4/13/2026	CC/SC: WAC Supplies, Maint & Repair, and CC Supplies	\$ 311.62				
AMAZON CAPITAL SERVICES	3/27/2026	PW: Robotic Mower Parts, Sanding Discs	\$ 57.98				
AMAZON CAPITAL SERVICES	4/17/2026	PW/B&G: OSHA-Compliant First Aid Kit - BLDG-PROP/SUPPLIES	\$ 20.19				
AMAZON CAPITAL SERVICES	4/17/2026	PW/Street: OSHA-Compliant First Aid Kit - STREETS GARAGE/SUPPLIES	\$ 20.19				
AMAZON CAPITAL SERVICES	4/17/2026	PW/B&G: City Hall Acrylic Dome Mirror - BLDG-PROP/MAINT/REPAIRS	\$ 45.99				
TOTAL	AMAZON CAPITAL SERVICES			\$ 1,875.11			
American Heritage Life Insurance Company	3/11/2026	SUPPLEMENTAL INSURANCE ALLSTATEPOSTTAX Pay Period: 03/06/2026	\$ 146.93		4/16/2026		
American Heritage Life Insurance Company	3/11/2026	SUPPLEMENTAL INSURANCE ALLSTATEPOSTTAX Pay Period: 03/06/2026	\$ 146.93		4/16/2026		
American Heritage Life Insurance Company	3/26/2026	SUPPLEMENTAL INSURANCE ALLSTATEPOSTTAX Pay Period: 03/20/2026	\$ 146.93				
American Heritage Life Insurance Company	4/10/2026	SUPPLEMENTAL INSURANCE ALLSTATEPOSTTAX Pay Period: 04/03/2026	\$ 146.93				
American Heritage Life Insurance Company		Payroll: Employee Contribution Only					

City of Richland Center - Finance Committee Council Payment Approval Report - April 21, 2026
Invoices Approved by Dept Head Entered into System between March 4, 2026 April 21, 2026

Item 5.

Vendor Name	Inv Date	Description	Amount	Vendor Total	Date Paid	Comm/Board	Date Approved
<i>TOTAL</i>	<i>American Heritage Life Insurance Company</i>			\$ 587.72			
ARROW ENERGY	3/20/2026	PW/Airport: 2026 110LL Fuel Purchase - AIRPORT/AVIATION FUEL	\$ 7,502.59		3/26/2026		
<i>TOTAL</i>	<i>ARROW ENERGY</i>			\$ 7,502.59			
ASSURITY LIFE INSURANCE COMPANY		Payrol: Employee Contribution Only					
<i>TOTAL</i>	<i>ASSURITY LIFE INSURANCE COMPANY</i>			\$ 369.79			
AUTO VALUE PARTS STORES	2/27/2026	PW/Street: Truck #61 Repair - STREETS/TRUCK REPAIR	\$ 21.98		4/2/2026		
AUTO VALUE PARTS STORES	3/18/2026	PW/Street: Truck #61 Repair - STREETS/TRUCK REPAIR	\$ 8.68		4/2/2026		
<i>TOTAL</i>	<i>AUTO VALUE PARTS STORES</i>			\$ 30.66			
AUTO ZONE	3/18/2026	Police: Squad Car	\$ 18.74		4/2/2026		
AUTO ZONE	3/27/2026	Police: Squad Car Oil	\$ 16.64		4/2/2026		
<i>TOTAL</i>	<i>AUTO ZONE</i>			\$ 35.38			
BADGER WELDING SUPPLY, INC	2/28/2026	PW/Street: Monthly Cylinder Rental - STREETS GARAGE/SUPPLIES	\$ 35.00		3/17/2026	Public Works	3/19/2026
BADGER WELDING SUPPLY, INC	3/31/2026	PW/Street: Monthly Cylinder Rental - STREETS GARAGE/SUPPLIES	\$ 38.75		4/16/2026		
<i>TOTAL</i>	<i>BADGER WELDING SUPPLY, INC</i>			\$ 73.75			
BAYCOM INC	2/19/2026	POLICE: Priority Equipment	\$ 147.90		3/26/2026		
<i>TOTAL</i>	<i>BAYCOM INC</i>			\$ 147.90			
BFI Waste Services	2/28/2026	PW/Refuse: Garbage & Recycling Services	\$ 2,080.43		3/17/2026	Public Works	3/19/2026
BFI Waste Services	2/28/2026	PW/Refuse: Transfer Station	\$ 889.92		3/26/2026		
BFI Waste Services	2/28/2026	PW/Refuse: Recycling Services - Mar 2026	\$ 5,706.85		3/26/2026		
BFI Waste Services	2/28/2026	PW/Refuse: Garbage Services - Mar 2026	\$ 16,808.60		3/26/2026		
BFI Waste Services	2/28/2026	Landfill: 26.52 Tons + 5 Roll-Off Dumps	\$ (2,080.43)		4/16/2026		
BFI Waste Services	2/28/2026	Landfill: 26.52 Tons + 5 Roll-Off Dumps	\$ 2,074.03		4/16/2026		
BFI Waste Services	3/31/2026	PW/Refuse: Landfill Roll Offs & Tonnage (54.04)	\$ 5,125.58		4/16/2026		
BFI Waste Services	3/31/2026	PW/Refuse: Garbage & Recycling Services	\$ 5,706.85				
BFI Waste Services	3/31/2026	PW/Refuse: Garbage & Recycling Services	\$ 889.82				
BFI Waste Services	3/31/2026	PW/Refuse: Garbage & Recycling Services	\$ 16,808.60				
BFI Waste Services	4/15/2026	PW/Refuse: Landfill Roll Offs & Tonnage (22.26)	\$ 1,846.77				
<i>TOTAL</i>	<i>BFI Waste Services</i>			\$ 55,857.02			
BINDL TIRE & AUTO, LTD	2/2/2026	PW/B&G: Skid Steer Tire Repair - BLDG-PROP/EQUIP MAINT-REPAIR	\$ 52.50		3/17/2026	Public Works	3/19/2026
<i>TOTAL</i>	<i>BINDL TIRE & AUTO, LTD</i>			\$ 52.50			
CATALIS TAX & CAMA	3/5/2026	Office: Property Tax Software Annual License through Richland County	\$ 1,203.09		3/26/2026		
<i>TOTAL</i>	<i>CATALIS TAX & CAMA</i>			\$ 1,203.09			
<i>TOTAL</i>	<i>Champion Health Payroll: Benefit Plan - EE & ER Portion</i>			\$ 570.00			
CHITWOOD'S ELECTRIC REPA	2/17/2026	PW/Street: Band Saw Motor Repair - STREETS/EQUIPMENT REPAIR	\$ 156.36		4/9/2026		
<i>TOTAL</i>	<i>CHITWOOD'S ELECTRIC REPA</i>			\$ 156.36			
CHROME FIREWORKS AND DIS	3/10/2026	CC?SC: Fireworks 1st Installment	\$ 7,500.00		3/26/2026		
CHROME FIREWORKS AND DIS	3/13/2026	CC/SC: Fireworks 2nd Installment	\$ 9,500.00		3/26/2026		

City of Richland Center - Finance Committee Council Payment Approval Report - April 21, 2026
Invoices Approved by Dept Head Entered into System between March 4, 2026 April 21, 2026

Item 5.

Vendor Name	Inv Date	Description	Amount	Vendor Total	Date Paid	Comm/Board	Date Approved
<i>TOTAL</i>	<i>CHROME FIREWORKS AND DIS</i>			\$ 17,000.00			
CIVICPLUS LLC	6/29/2026	Software: Annual Subscription	\$ 3,045.00				
<i>TOTAL</i>	<i>CIVICPLUS LLC</i>			\$ 3,045.00			
COMMUNITY CENTER Refund - Haven Carley	3/12/2026	CC/SC: Refund for Gym & Kitchen due to Weather	\$ 135.00		4/2/2026		
<i>TOTAL</i>	<i>COMMUNITY CENTER Refund - Haven Carley</i>			\$ 135.00			
COMMUNITY FIRST BANK	3/16/2026	Haseltine / Westside Dr Principle Loan Payment	\$ 102,000.00		4/2/2026		
COMMUNITY FIRST BANK	3/16/2026	Haseltine / Westside Dr Interest Loan Payment	\$ 4,758.22		4/2/2026		
<i>TOTAL</i>	<i>COMMUNITY FIRST BANK</i>			\$ 106,758.22			
<i>TOTAL</i>	<i>Delta Dental</i>	<i>Payroll: Employee Contribution Only</i>		\$ 845.78			
DEPT OF WORKFORCE DEVELO	4/1/2026	Personnel: Unemployment Due for Emp on PR Drawing UI	\$ 50.00		4/9/2026		
<i>TOTAL</i>	<i>DEPT OF WORKFORCE DEVELO</i>			\$ 50.00			
ELIFEGUARD, INC	4/13/2026	Parks & Rec: Woodman Aquatic Center Supplies	\$ 1,361.67				
ELIFEGUARD, INC	4/13/2026	Parks & Rec: Woodman Aquatic Center Supplies - Did not receive items	\$ (89.95)				
<i>TOTAL</i>	<i>ELIFEGUARD, INC</i>			\$ 1,271.72			
EMERGENCY SERVICE MARKETING CORP., INC	3/27/2026	Police: IAR Yearly Subscription	\$ 305.00		4/2/2026		
<i>TOTAL</i>	<i>EMERGENCY SERVICE MARKETING CORP., INC</i>			\$ 305.00			
FERRELLGAS	2/2/2026	PW/Airport: Airport Heat - AIRPORT/HEAT	\$ 845.38		4/9/2026		
<i>TOTAL</i>	<i>FERRELLGAS</i>			\$ 845.38			
FILLBACK FORD, INC	3/11/2026	POLICE: 2025 Duragno Oil Change	\$ 84.35		4/2/2026		
<i>TOTAL</i>	<i>FILLBACK FORD, INC</i>			\$ 84.35			
<i>TOTAL</i>	<i>FRONTIER</i>	<i>Airport, Police, and Landfill Telephone / Internet Service</i>		\$ 596.18			
GENERAL COMMUNICATIONS,	2/11/2026	POLICE: Repeater move to Richland Center Tower	\$ 10,314.47		3/17/2026		
<i>TOTAL</i>	<i>GENERAL COMMUNICATIONS,</i>			\$ 10,314.47			
<i>TOTAL</i>	<i>GENUINE TELECOM</i>	<i>City Wide - Phones & Fax Machines / Numbers</i>		\$ 1,693.24			
HAAS, ADAM	3/9/2026	PW/CC/SC: Recreation Program Referee	\$ 120.00		3/17/2026	Park Board	3/23/2026
HAAS, ADAM	3/22/2026	PW/CC/SC: Recreation Program Referee	\$ 40.00		4/2/2026		
<i>TOTAL</i>	<i>HAAS, ADAM</i>			\$ 160.00			
HALLETT, LARRY	3/9/2026	Parks: referee	\$ 120.00		3/17/2026	Park Board	3/23/2026
<i>TOTAL</i>	<i>HALLETT, LARRY</i>			\$ 120.00			
HOLIDAY WHOLESale	4/16/2026	CC/SC: WSRC Supplies - Coffee	\$ 167.35				
<i>TOTAL</i>	<i>HOLIDAY WHOLESale</i>			\$ 167.35			
Innovative Public Advisors	3/3/2026	Admin/Econ Dev: Operational Structure of the Symons Recreational Complex Planning Services (IPG Funded)	\$ 31,000.00		3/26/2026		
<i>TOTAL</i>	<i>Innovative Public Advisors</i>			\$ 31,000.00			
INTERNAL REVENUE SERVICE		941 Deposits - Federal & Fica Withholding & ER Share					
<i>TOTAL</i>	<i>INTERNAL REVENUE SERVICE</i>			\$ 52,545.79			
IWMTV	2/28/2026	Tourism: Streaming TV Advertising	\$ 2,499.98		4/2/2026		
IWMTV	3/31/2026	Tourism: Streaming TV Advertising	\$ 1,500.00		4/16/2026		

City of Richland Center - Finance Committee Council Payment Approval Report - April 21, 2026
Invoices Approved by Dept Head Entered into System between March 4, 2026 April 21, 2026

Item 5.

Vendor Name	Inv Date	Description	Amount	Vendor Total	Date Paid	Comm/Board	Date Approved
IWMTV	3/31/2026	Tourism: Streaming TV Advertising	\$ 2,250.00		4/16/2026		
IWMTV - WMTV 15	1/31/2026	Tourism: Streaming TV - Greater Richland Area Tourism	\$ 2,499.98				
TOTAL	IWMTV			\$ 8,749.96			
KOELSCH, BEN	3/15/2026	Elected: Sponsor of Government Mtgs on You Tube - 1 Council, 1 Co Board, 1 Utility, 1 Hwy 14 Public Mtg	\$ 966.87		4/2/2026		
KOELSCH, BEN	4/15/2026	Elected: Sponsor of Government Mtgs on You Tube-1 Council, 2 Co Exec/Finance, 1 Util Commission	\$ 966.87				
TOTAL	KOELSCH, BEN			\$ 1,933.74			
L & M SALVAGE	3/4/2026	PW/Street: Snow Removal Equipment Repair - Roadways Equipment Repair	\$ 80.00		3/26/2026	Public Works	3/19/2026
TOTAL	L & M SALVAGE			\$ 80.00			
LAMAR COMPANIES	3/16/2026	Admin/City office: Hwy 14 digital sign	\$ 500.00		3/26/2026		
LAMAR COMPANIES	4/13/2026	Admin/City office: Hwy 14 digital sign	\$ 500.00				
TOTAL	LAMAR COMPANIES			\$ 1,000.00			
Manning, Gary A	4/8/2026	Zoning: Demo House at 695 N Chestnut Street - Approved 2025	\$ 18,800.00		4/16/2026		
TOTAL	Manning, Gary A			\$ 18,800.00			
METCO, INC	3/10/2026	PW/Airport: March 2026 Monthly Airport Inspection	\$ 100.00		3/17/2026	Public Works	3/19/2026
METCO, INC	3/25/2026	PW/Airport: Airport Fuel Pump Maintenance - AIRPORT/MAINT-REPAIRS	\$ 1,019.40		4/2/2026		
METCO, INC	4/14/2026	PW/Airport: April 2026 Monthly Airport Inspection	\$ 100.00		4/16/2026		
TOTAL	METCO, INC			\$ 1,219.40			
MetLife		Payroll: Vision Ins EE Paid					
TOTAL	MetLife			\$ 506.54			
Milwaukee Magazine	2/25/2026	Tourism: Subscriptions	\$ 900.00		4/2/2026		
TOTAL	Milwaukee Magazine			\$ 900.00			
NAPA AUTO PARTS	3/16/2026	PW/Street: Windshield Wiper - STREETS/TRUCK REPAIR	\$ 34.34		4/16/2026		
TOTAL	NAPA AUTO PARTS			\$ 34.34			
NATURE'S WAY PORTABLE UNITS	3/31/2026	PW/B&G: Parks Portable Units	\$ 194.00		4/2/2026		
NATURE'S WAY PORTABLE UNITS	3/31/2026	PW/Landfill: Landfill Portable Units	\$ 184.00		4/2/2026		
TOTAL	NATURE'S WAY PORTABLE UNITS			\$ 378.00			
PEAK SOFTWARE SYSTEMS	4/2/2026	CC/SC: Sportsman Software - 12 Month - Good thru 4/3/2027-Discount if paid by 5/2/26	\$ (62.10)				
PEAK SOFTWARE SYSTEMS	4/2/2026	CC/SC: Sportsman Software - 12 Month - Good thru 4/3/2027	\$ 2,070.00				
TOTAL	PEAK SOFTWARE SYSTEMS			\$ 2,007.90			
Pitney Bowes		Postage & Cost of Meter - Split Across City					
TOTAL	PITNEY BOWES GLOBAL			\$ 1,139.94			
Police Department Restitution / Refunds	4/13/2026	Police: Betty & Robert Sykora Refund of Parking Citation - Handicap Parking	\$ 50.00				
TOTAL	Police Department Restitution / Refunds			\$ 50.00			
PREMIER CO-OP	2/28/2026	PW/B&G: BLDG-PROP/GASOLINE	\$ 479.74		3/17/2026	Public Works	3/19/2026
PREMIER CO-OP	2/28/2026	PW/Street: STREETS/GASOLINE	\$ 1,103.89		3/17/2026	Public Works	3/19/2026
PREMIER CO-OP	3/31/2026	PW/Street: STREETS/GASOLINE	\$ 1,917.66				
PREMIER CO-OP	3/31/2026	PW/B&G: BLDG-PROP/GASOLINE	\$ 768.06				
TOTAL	PREMIER CO-OP			\$ 4,269.35			

City of Richland Center - Finance Committee Council Payment Approval Report - April 21, 2026
Invoices Approved by Dept Head Entered into System between March 4, 2026 April 21, 2026

Item 5.

Vendor Name	Inv Date	Description	Amount	Vendor Total	Date Paid	Comm/Board	Date Approved
R C TRUCK & AUTO	12/22/2025	PW/Street: Emergency Purchase 1999 International 4900 - ROADWAYS/TRUCK REPAIR	\$ 4,348.74		3/26/2026	Public Works	3/19/2026
R C TRUCK & AUTO	3/13/2026	PW/Street: 1999 International 4900 Repair - STREETS/TRUCK REPAIR	\$ 2,132.33		4/16/2026		
TOTAL	R C TRUCK & AUTO			\$ 6,481.07			
RHYME BUSINESS PRODUCTS-DALLAS	3/2/2026	Police Dept: Copier Lease	\$ 202.94		3/17/2026		
RHYME BUSINESS PRODUCTS-DALLAS	3/4/2026	City Office: Copier Lease Payment Agreement #018-1709590-000	\$ 472.58		3/26/2026		
RHYME BUSINESS PRODUCTS-DALLAS	3/26/2026	CC/SC: Copier Lease	\$ 189.84		4/2/2026		
RHYME BUSINESS PRODUCTS-DALLAS	3/23/2026	Tourism: Copier Lease	\$ 44.00		4/2/2026		
RHYME BUSINESS PRODUCTS-DALLAS	3/31/2026	Police Dept: Copier Lease	\$ 202.94		4/9/2026		
RHYME BUSINESS PRODUCTS-DALLAS	4/1/2026	Office: Copier Lease	\$ 472.58		4/9/2026		
RHYME BUSINESS PRODUCTS-DALLAS	4/1/2026	Office: Copier Lease - Overage	\$ 147.47		4/9/2026		
TOTAL	RHYME BUSINESS PRODUCTS-DALLAS			\$ 1,732.35			
RICHLAND CENTER POLICE PROFESSIONAL	3/11/2026	UNION DUES POLICE UNION DUES Pay Period: 03/06/2026	\$ 250.00		3/26/2026		
RICHLAND CENTER POLICE PROFESSIONAL	3/26/2026	UNION DUES POLICE UNION DUES Pay Period: 03/20/2026	\$ 250.00		3/26/2026		
RICHLAND CENTER POLICE PROFESSIONAL	4/10/2026	UNION DUES POLICE UNION DUES Pay Period: 04/03/2026	\$ 250.00				
TOTAL	RICHLAND CENTER POLICE PROFESSIONAL			\$ 750.00			
CITY UTILITIES	2/11/2026	City: Firewall End/Point Monthly	\$ 161.66		3/26/2026	Public Works	3/19/2026
CITY UTILITIES	2/11/2026	PW/B&G: Generator Maintenance	\$ 451.26		3/26/2026	Public Works	3/19/2026
RICHLAND CENTER UTILITIE	4/16/2026	Insurance: Workman Comp Audit Refund - 2025 - Utility Share	\$ 730.90			Public Works	3/19/2026
City Utilities - Monthly Bills		2 Months Bills - Split Across City / Buildings / Departments	\$ 41,906.17			Public Works	3/19/2026
TOTAL	CITY UTILITIES			\$ 43,249.99			
RICHLAND COUNTY TREASURER	3/3/2026	Property Taxes: Bernadette Maglish-276-1635-4100-Pd Via online portal to City	\$ 1,268.95		3/4/2026		
RICHLAND COUNTY TREASURER	3/2/2026	Taxes: 2025 MFL Payment (2026 Budget Year, 2025 Tax Year)	\$ 138.55		3/17/2026		
TOTAL	RICHLAND COUNTY TREASURER			\$ 1,407.50			
RICHLAND ELECTRIC CO-OP	3/3/2026	Public Works: ACCT #667401-FLOODWARNING	\$ 43.50		3/17/2026	Public Works	3/19/2026
RICHLAND ELECTRIC CO-OP	4/2/2026	PW/Parks: RC Flood Control	\$ 47.63		4/16/2026		
TOTAL	RICHLAND ELECTRIC CO-OP			\$ 91.13			
RICHLAND FIRE DISTRICT	2/27/2026	Incident #226024,02-27-2026, Lisa Ermilio, Accident	\$ 600.00		4/2/2026		
RICHLAND FIRE DISTRICT	2/28/2026	Incident #226025, 02-28-2026, Aiden Xavier Lemmons, Accident	\$ 612.00		4/2/2026		
RICHLAND FIRE DISTRICT	2/23/2026	Incident #226021, 02/23/2026, Isaah M Foges, Accident Sheldon St	\$ 612.00		4/2/2026		
RICHLAND FIRE DISTRICT	3/29/2026	Incident #226041, 03/29/2026, Michael Byrnes, Vehicle Fire	\$ 600.00				
TOTAL	RICHLAND FIRE DISTRICT			\$ 2,424.00			
RICHLAND OBSERVER	2/12/2026	Elected: Plan Commission PUD Hearing Notice	\$ 86.36		3/26/2026		

City of Richland Center - Finance Committee Council Payment Approval Report - April 21, 2026
Invoices Approved by Dept Head Entered into System between March 4, 2026 April 21, 2026

Item 5.

Vendor Name	Inv Date	Description	Amount	Vendor Total	Date Paid	Comm/Board	Date Approved
RICHLAND OBSERVER	2/12/2026	Elected: Ordinance #2026-2 (2/12/2026)	\$ 66.73		3/26/2026		
RICHLAND OBSERVER	2/12/2026	Elected: Ordinance #2026-1 (02/12/2026)	\$ 70.65		3/26/2026		
RICHLAND OBSERVER	2/12/2026	Elected: Zoning Notice - Class 2 - 2/12 & 2/19/2026	\$ 211.96		3/26/2026		
RICHLAND OBSERVER	2/26/2026	Elected: November 4, 2025 Meeting Minutes	\$ 375.96		3/26/2026		
RICHLAND OBSERVER	2/26/2026	Elected: November 10, 2025 Meeting Minutes	\$ 34.71		3/26/2026		
RICHLAND OBSERVER	2/26/2026	Elected: November 10, 2025 Meeting Minutes	\$ 52.06		3/26/2026		
RICHLAND OBSERVER	2/26/2026	Elected: December 2, 2025 Meeting Minutes	\$ 283.42		3/26/2026		
RICHLAND OBSERVER	2/26/2026	Elected: January 6, 2026 Meeting Minutes	\$ 209.67		3/26/2026		
RICHLAND OBSERVER	3/19/2026	Elected: Joint Plan Published 3/12 & 3/19/2026	\$ 235.50				
RICHLAND OBSERVER	3/12/2026	Elected: February 3, 2026 Meeting Minutes Published 3/12/2026	\$ 270.41				
RICHLAND OBSERVER	3/26/2026	Elections: Voting Test of Equipment - Published 3/26/2026	\$ 31.40				
RICHLAND OBSERVER	3/12/2026	Elected: Ordinance #2026-03 Published 03/12/2026	\$ 67.73				
RICHLAND OBSERVER	3/5/2026	Elections: Absentee Ballot Notice 3/5/2026	\$ 176.63				
RICHLAND OBSERVER	3/31/2026	Parks & Rec: Help Wanted Seasonal Job Ads	\$ 124.20				
TOTAL	RICHLAND OBSERVER			\$ 2,297.39			
RJB VIDEO LLC	3/26/2026	GREATER RICHLAND TOURISM - VIDEO PRODUCTION	\$ 450.00		4/2/2026		
TOTAL	RJB VIDEO LLC			\$ 450.00			
RUNNING, INC	2/10/2026	Taxi: Shared Ride Taxi Service - Jan 2026 882.67 Hours	\$ 34,053.41		3/26/2026		
RUNNING, INC	2/10/2026	Taxi: Shared Ride Taxi Service - Jan 2026 Fare Revenue	\$ (8,623.50)		3/26/2026		
RUNNING, INC	3/12/2026	Taxi: Shared Ride Taxi Service - 784.85 Hours Feb 2026	\$ 30,279.51		3/26/2026		
RUNNING, INC	3/12/2026	Taxi: Shared Ride Taxi Service - Feb 2026 Fare Revenue	\$ (6,368.50)		3/26/2026		
RUNNING, INC	4/7/2026	Taxi: Shared Ride Taxi Service - March Service	\$ 31,884.44		4/16/2026		
RUNNING, INC	4/7/2026	Taxi: Shared Ride Taxi Service - March Fare Revenues	\$ (6,766.00)		4/16/2026		
TOTAL	RUNNING, INC			\$ 74,459.36			
SCHILLING SUPPLY COMPANY	3/3/2026	PW/Airport: Cleaning Supplies, Soap - AIRPORT/SUPPLIES	\$ 111.99		3/17/2026	Public Works	3/19/2026
SCHILLING SUPPLY COMPANY	3/31/2026	PW/B&G: Paper & Cleaning Products for Restrooms/Breakrooms - BLDG-PROP/SUPPLIES	\$ 1,431.25		4/2/2026		
SCHILLING SUPPLY COMPANY	3/31/2026	PW/Street: Oil Dry - GARAGE/SUPPLIES	\$ 47.10		4/2/2026		
SCHILLING SUPPLY COMPANY	4/16/2026	PW/B&G: Paper & Cleaning Products for Restrooms/Breakrooms	\$ 448.61				
TOTAL	SCHILLING SUPPLY COMPANY			\$ 2,038.95			
SECURIAN FINANCIAL GROUP, INC		Payroll: Life Insurance - May 2026 - EE & ER Portions					
TOTAL	SECURIAN FINANCIAL GROUP, INC			\$ 3,074.87			
SEXTONVILLE WATERWORKS	4/7/2026	PW/Airport: Water and Sewer Charges	\$ 163.67		4/16/2026		
TOTAL	SEXTONVILLE WATERWORKS			\$ 163.67			
SHOPPING NEWS, INC	3/17/2026	Parks & Rec: Summer Help Job Ads Ref. 467765	\$ 230.00		4/16/2026		

City of Richland Center - Finance Committee Council Payment Approval Report - April 21, 2026
Invoices Approved by Dept Head Entered into System between March 4, 2026 April 21, 2026

Item 5.

Vendor Name	Inv Date	Description	Amount	Vendor Total	Date Paid	Comm/Board	Date Approved
<i>TOTAL</i>	<i>SHOPPING NEWS, INC</i>			\$ 230.00			
SIMPSON'S TRACTOR, INC	2/17/2026	PW/B&G: Bobcat Repair - BLDG-PROP/EQUIP MAINT-REPAIR	\$ 938.00		3/17/2026	Public Works	3/19/2026
<i>TOTAL</i>	<i>SIMPSON'S TRACTOR, INC</i>			\$ 938.00			
Sit & Git Portables, LLC	4/6/2026	PW/B&G: Parks Portable Units	\$ 860.00		4/16/2026		
<i>TOTAL</i>	<i>Sit & Git Portables, LLC</i>			\$ 860.00			
SLEEPY HOLLOW	4/1/2026	PW/Street: 2018 Chevrolet Silverado K350 Repair - STREETS/TRUCK REPAIR	\$ 2,672.45		4/16/2026		
SLEEPY HOLLOW	4/15/2026	PW/Street: Truck Tire Sensor Repair - STREETS/TRUCK REPAIR	\$ 280.65				
<i>TOTAL</i>	<i>SLEEPY HOLLOW</i>			\$ 2,953.10			
SUNSET LAW ENFORCEMENT	3/5/2026	POLICE: ammunition	\$ 2,726.12		3/26/2026		
<i>TOTAL</i>	<i>SUNSET LAW ENFORCEMENT</i>			\$ 2,726.12			
TC AUTOWORKS LLC	2/25/2026	Police: coolant leak (2020 Dodge Durango Pursuit	\$ 145.10		3/17/2026		
TC AUTOWORKS LLC	4/17/2026	Police: 2022 Ram Oil Change	\$ 55.92				
<i>TOTAL</i>	<i>TC AUTOWORKS LLC</i>			\$ 201.02			
Tools of Marketing, Inc	2/28/2026	Tourism: Marketing/Giveaway Items	\$ 555.98		4/2/2026		
<i>TOTAL</i>	<i>Tools of Marketing, Inc</i>			\$ 555.98			
U S CELLULAR	3/10/2026	PW: Floodplain Telephone	\$ 81.62		3/26/2026		
U S CELLULAR	2/18/2026	PW/office: DPW Cell	\$ 56.20		3/25/2026		
U S CELLULAR	2/18/2026	PW/Streets: Streets Cell	\$ 7.15		3/25/2026		
U S CELLULAR	2/18/2026	Admin/city office: Clerk/Treas Cell	\$ 59.11		3/25/2026		
U S CELLULAR	2/18/2026	Admin/city office: Mayor Cell	\$ 56.20		3/25/2026		
U S CELLULAR	2/18/2026	PW/Cemetery: Tess Cell	\$ 59.11		3/25/2026		
U S CELLULAR	2/18/2026	PW/CC/SC: Mieden Cell	\$ 56.20		3/25/2026		
U S CELLULAR	2/18/2026	Admin/city office: DPW Cell	\$ (9.77)		3/25/2026		
U S CELLULAR	2/18/2026	PW/Streets: Streets Cell	\$ (1.24)		3/25/2026		
U S CELLULAR	2/18/2026	Admin/city office: Clerk/Treas Cell	\$ (10.27)		3/25/2026		
U S CELLULAR	2/18/2026	Admin/city office: Mayor Cell	\$ (9.77)		3/25/2026		
U S CELLULAR	2/18/2026	PW/Cemetery: Tess Cell	\$ (10.27)		3/25/2026		
U S CELLULAR	2/18/2026	PW/CC/SC: Mieden Cell	\$ (9.77)		3/25/2026		
U S CELLULAR	3/18/2026	PW/CC/SC: Mieden Cell	\$ (8.31)				
U S CELLULAR	3/18/2026	PW/office: DPW Cell	\$ 56.20				
U S CELLULAR	3/18/2026	Admin/city office: DPW Cell	\$ (8.31)				
U S CELLULAR	3/18/2026	Admin/city office: Mayor Cell	\$ 56.20				
U S CELLULAR	3/18/2026	PW/CC/SC: Mieden Cell	\$ 56.20				
U S CELLULAR	3/18/2026	Admin/city office: Clerk/Treas Cell	\$ (8.74)				
U S CELLULAR	3/18/2026	Admin/city office: Clerk/Treas Cell	\$ 59.11				

City of Richland Center - Finance Committee Council Payment Approval Report - April 21, 2026
Invoices Approved by Dept Head Entered into System between March 4, 2026 April 21, 2026

Item 5.

Vendor Name	Inv Date	Description	Amount	Vendor Total	Date Paid	Comm/Board	Date Approved
U S CELLULAR	3/18/2026	PW/Cemetery: Tess Cell	\$ 59.11				
U S CELLULAR	3/18/2026	PW/Streets: Streets Cell	\$ 26.08				
U S CELLULAR	3/18/2026	PW/Cemetery: Tess Cell	\$ (8.74)				
U S CELLULAR	3/18/2026	Admin/city office: Mayor Cell	\$ (8.31)				
U S CELLULAR	3/18/2026	PW/Streets: Streets Cell	\$ (3.85)				
TOTAL	U S CELLULAR			\$ 591.14			
US BANK	2/6/2026	City Hall: Envelopes Pre-Stamped	\$ 488.50		3/11/2026		
US BANK	2/19/2026	City Hall: Subscription for Graphics, Social Media, Etc.	\$ 149.90		3/11/2026		
US BANK	3/25/2026	PW/Landfill: Closure Signage - LANDFILL/SUPPLIES	\$ 123.09		4/8/2026		
US BANK	3/2/2026	Office: Postage Certified Mail to County Treasurer	\$ 9.70		4/8/2026		
US BANK	3/3/2026	CC / SC - WSRC Supplies	\$ 272.71		4/8/2026		
US BANK	3/4/2026	Office: Postage Certified Mail to County Treasurer	\$ 12.98		4/8/2026		
US BANK	3/25/2026	Police: Office Supplies	\$ 55.54				
US BANK	3/26/2026	Police: Training - Officer Deneen 4/10/2026	\$ 60.00				
US BANK	4/7/2026	Elections: Food and Treats for Poll Workers	\$ 318.49				
US BANK	4/6/2026	Elections: Food and Treats for Poll Workers	\$ 125.78				
US BANK	3/5/2026	PW/Airport: Testing - AIRPORT/AVIATION FUEL	\$ 5.36		4/8/2026		
US BANK	2/27/2026	PW/Street: Tool Boxes, etc. - STREETS GARAGE/TOOLS	\$ 163.53		4/8/2026		
US BANK	2/26/2026	PW/Street: STREETS/GASOLINE	\$ 78.00		4/8/2026		
US BANK	3/30/2026	PW/Landfill: Closure Camera Subscription - LANDFILL/SUPPLIES	\$ 175.00				
US BANK	3/30/2026	PW/Landfill: Closure Cameras Cloud Subscription - LANDFILL/SUPPLIES	\$ 9.00				
US BANK	2/25/2026	CC/SC: WSRC Supplies at Dollar Tree - Inv Entered \$30 Short	\$ 30.00		4/8/2026		
US BANK	3/24/2026	PW/Landfill: Closing Banner - LANDFILL/SUPPLIES - Sales Tax Chrged	\$ 6.77		4/8/2026		
US BANK	3/24/2026	PW/Landfill: Closing Banner - LANDFILL/SUPPLIES - Sales Tax Credited	\$ (6.77)				
US BANK	4/8/2026	CC/SC: WSRC Supplies at Dollar Tree	\$ 108.50				
US BANK	4/13/2026	Police: Motel Pilla Training	\$ 420.00				
US BANK	4/14/2026	Police: Meals Pilla Training	\$ 9.48				
US BANK	4/14/2026	Police: Pilla Training - Meals	\$ 9.48				
US BANK	4/13/2026	Police: Meals Pilla Training	\$ 22.12				
US BANK	4/16/2026	Police: Meals Pilla Training	\$ 16.80				
TOTAL	US BANK			\$ 2,663.96			
VERIZON	2/21/2026	Police: Phone	\$ 592.83		3/17/2026		
VERIZON WIRELESS	3/21/2026	POLICE: Cell Phones	\$ 1,185.66		4/2/2026		
TOTAL	VERIZON			\$ 1,778.49			
VIERBICHER ASSOCIATES, INC	3/9/2026	Admin/Econ Dev: HUD Grant Administration 250923	\$ 512.50		3/26/2026		
TOTAL	VIERBICHER ASSOCIATES, INC			\$ 512.50			
VISA	2/20/2026	Tourism: Booth Rental at Convention	\$ 775.00		3/24/2026		

City of Richland Center - Finance Committee Council Payment Approval Report - April 21, 2026
Invoices Approved by Dept Head Entered into System between March 4, 2026 April 21, 2026

Item 5.

Vendor Name	Inv Date	Description	Amount	Vendor Total	Date Paid	Comm/Board	Date Approved
VISA	2/18/2026	Tourism: DFI Registration GRT Corporation	\$ 35.00		3/24/2026		
VISA	1/31/2026	Tourism: Meta Ads Promotions	\$ 25.05		3/24/2026		
VISA	2/9/2026	Tourism: Meta Ads Promotions	\$ 24.59		3/24/2026		
VISA	2/6/2026	Tourism: Food for Rest. Video	\$ 26.97		3/24/2026		
VISA	2/3/2026	Tourism: .com Domain Registration	\$ 170.46		3/24/2026		
VISA	2/20/2026	Tourism: Postage	\$ 23.64		3/24/2026		
VISA	3/25/2026	Tourism: Postage	\$ 85.87				
VISA	3/16/2026	Tourism: Liberty Station - Lunch at Conference	\$ 35.37				
VISA	3/17/2026	Tourism: Baird Center Parking at Conference	\$ 21.58				
VISA	3/16/2026	Tourism: Alliant Energy Center - Lunch at Conference	\$ 17.67				
VISA	3/17/2026	Tourism: Starbucks Breakfast during Conference	\$ 15.56				
VISA	3/20/2026	Tourism: Alliant Energy - Parking at Conference	\$ 10.00				
VISA	3/26/2026	Tourism: RJB Video	\$ 450.00				
VISA	3/18/2026	Tourism: Lunch at Conference	\$ 18.42				
VISA	3/17/2026	Tourism: Ambassador Hotel - Dinner at Conference	\$ 21.20				
VISA	1/31/2026	Tourism: Online Ads - Facebook	\$ 49.95		3/24/2026		
VISA	3/13/2026	Tourism: Papvero - Lunch for CanoeCopia	\$ 102.89				
VISA	3/7/2026	Tourism: Subscription for Canva	\$ 119.40				
VISA	3/3/2026	Tourism: Alliant Energy - Booth Setup CanoeCopia	\$ 225.01				
VISA	3/3/2026	Tourism: QR Code Generator Pro	\$ 191.88				
VISA	2/22/2026	Tourism: Postage (No Receipt)	\$ 23.64				
VISA	2/22/2026	Tourism: CanoeCopia Exhibitor Booth - 10X10	\$ 775.00				
VISA	2/18/2026	Tourism: Dept of Financial Institution Office Support	\$ 35.00				
VISA	2/9/2026	Tourism: Promotion of http://GreaterRichland Tourism.com	\$ 24.59				
VISA	2/8/2026	Tourism: TST Nates - Video Development (No Receipt)	\$ 26.97				
VISA	2/3/2026	Tourism: Renewal of Domain	\$ 170.46				
TOTAL	VISA			\$ 3,501.17			
WALSH'S ACE HARDWARE	3/5/2026	PW/B&G: Meyer Building Repair - BLDG-PROP/MAINT/REPAIRS	\$ 32.38		3/17/2026	Public Works	3/19/2026
WALSH'S ACE HARDWARE	2/24/2026	PW/Street: Endloader 625K Maintenance - ROADWAYS/TRUCK REPAIR	\$ (3.36)		3/26/2026	Public Works	3/19/2026
WALSH'S ACE HARDWARE	3/3/2026	PW/Street: Batteries - STREETS GARAGE/SUPPLIES	\$ 16.99		3/26/2026	Public Works	3/19/2026
WALSH'S ACE HARDWARE	3/4/2026	PW/Street: Sand Disc Kit - STREETS GARAGE/TOOLS	\$ 9.09		3/26/2026	Public Works	3/19/2026
WALSH'S ACE HARDWARE	3/4/2026	PW/B&G: CC Repairs - BLDG-PROP/MAINT/REPAIRS	\$ 36.33		3/26/2026	Public Works	3/19/2026
WALSH'S ACE HARDWARE	3/5/2026	PW/B&G: Zero Turn Brackets - BLDG-PROP/SUPPLIES	\$ 38.08		3/26/2026	Public Works	3/19/2026
WALSH'S ACE HARDWARE	3/5/2026	PW/B&G: Trimmer Line BLDG-PROP/WEED CONTROL	\$ 28.08		3/26/2026	Public Works	3/19/2026
WALSH'S ACE HARDWARE	3/6/2026	PW/Street: Sand Disc Kit - STREETS GARAGE/TOOLS	\$ 8.64		3/26/2026	Public Works	3/19/2026
WALSH'S ACE HARDWARE	3/6/2026	PW/B&G: Zero Turn Brackets - BLDG-PROP/MAINT/REPAIRS	\$ 11.26		3/26/2026	Public Works	3/19/2026
WALSH'S ACE HARDWARE	3/12/2026	PW/B&G: Padlocks, Cylinder - BLDG-PROP/SUPPLIES	\$ 23.59		3/26/2026		
WALSH'S ACE HARDWARE	3/13/2026	PW/Street: Concrete Sand Mix - STREETS/SUPPLIES	\$ 37.53		4/2/2026		
WALSH'S ACE HARDWARE	3/23/2026	PW/B&G: Pool Misc Fasteners - Aquatic Center Building /Prop Maint Repair	\$ 7.18		4/2/2026		
WALSH'S ACE HARDWARE	3/5/2026	PW/B&G: Zero Turn Brackets - BLDG-PROP/SUPPLIES Overpaid by \$10.00	\$ (10.00)		4/2/2026		
WALSH'S ACE HARDWARE	3/5/2026	Chk 105949					
WALSH'S ACE HARDWARE	3/5/2026	PW/B&G: Trimmer Line BLDG-PROP/WEED CONTROL Overpaid by \$4.11	\$ (4.11)		4/2/2026		
WALSH'S ACE HARDWARE	3/5/2026	Chk 105949					

City of Richland Center - Finance Committee Council Payment Approval Report - April 21, 2026
Invoices Approved by Dept Head Entered into System between March 4, 2026 April 21, 2026

Item 5.

Vendor Name	Inv Date	Description	Amount	Vendor Total	Date Paid	Comm/Board	Date Approved
WALSH'S ACE HARDWARE	4/1/2026	PW/B&G: Dike Light Repair - BLDG-PROP/MAINT/REPAIRS	\$ 28.49		4/9/2026		
WALSH'S ACE HARDWARE	3/9/2026	PW/B&G: Park Bench Repair - BLDG-PROP/MAINT/REPAIRS	\$ 33.64		4/16/2026	Public Works	3/19/2026
WALSH'S ACE HARDWARE	3/13/2026	PW/B&G: Pool Misc Fasteners - Aquatic Center Building /Prop Maint Repair	\$ 4.25		4/16/2026		
WALSH'S ACE HARDWARE	3/25/2026	PW/Street: Barricade Light Batteries - SIGNS/SUPPLIES (MARKING, ETC)	\$ 16.99		4/16/2026		
WALSH'S ACE HARDWARE	3/25/2026	PW/B&G: PD Repair Misc. Fasteners - BLDG-PROP/MAINT/REPAIRS	\$ 9.25		4/16/2026		
WALSH'S ACE HARDWARE	3/25/2026	PW/Street: Adhesive; Rekey - STREETS GARAGE/BLDNG REP & MAI	\$ 69.45		4/16/2026		
WALSH'S ACE HARDWARE	3/30/2026	PW/Airport: Aero1200 Install - AIRPORT/MAINT-REPAIRS	\$ 31.02		4/16/2026		
WALSH'S ACE HARDWARE	3/30/2026	PW/Airport: Aero1200 Install - AIRPORT/MAINT-REPAIRS	\$ 15.28		4/16/2026		
WALSH'S ACE HARDWARE	3/31/2026	PW/Airport: Aero1200 Install - AIRPORT/MAINT-REPAIRS	\$ 18.76		4/16/2026		
WALSH'S ACE HARDWARE	4/6/2026	PW/Street: Misc Fasteners - STREETS GARAGE/SUPPLIES	\$ 22.13		4/16/2026		
WALSH'S ACE HARDWARE	1/12/2026	PW/B&G: City Hall Toilet Repair - BLDG-PROP/MAINT/REPAIRS	\$ 2.71		4/16/2026		
WALSH'S ACE HARDWARE	1/15/2026	PW/B&G: Cylinder Refill - BLDG-PROP/SUPPLIES	\$ 134.47		4/16/2026		
WALSH'S ACE HARDWARE	1/27/2026	PW/B&G: Truck Batteries (2) - BLDG-PROP/EQUIP MAINT-REPAIR	\$ 327.33		4/16/2026		
WALSH'S ACE HARDWARE	2/13/2026	PW/B&G: Parks Bench Paint - BLDG-PROP/SUPPLIES	\$ 35.27		4/16/2026		
WALSH'S ACE HARDWARE	2/13/2026	PW/B&G: Backpack Leaf Blower - BLDG-PROP/EQUIPMENT	\$ 599.99		4/16/2026		
WALSH'S ACE HARDWARE	2/25/2026	PW/B&G: Truck Battery (1) - BLDG-PROP/EQUIP MAINT-REPAIR	\$ 350.00		4/16/2026		
WALSH'S ACE HARDWARE	3/3/2026	PW/B&G: Parks Wood Screws - BLDG-PROP/SUPPLIES	\$ 2.03		4/16/2026		
WALSH'S ACE HARDWARE	3/10/2026	PW/B&G: Parks Bench Paint - BLDG-PROP/SUPPLIES	\$ 33.64		4/16/2026		
WALSH'S ACE HARDWARE	3/10/2026	PW/Street: Mailbox Replacement - SNOW RMVL/SUPPLIES	\$ 32.61		4/16/2026		
WALSH'S ACE HARDWARE	3/27/2026	PW/B&G: Parks Spray Paint - BLDG-PROP/SUPPLIES	\$ 28.02		4/16/2026		
WALSH'S ACE HARDWARE	3/30/2026	PW/B&G: Spackle, Caulk - BLDG-PROP/MAINT/REPAIRS	\$ 8.05		4/16/2026		
WALSH'S ACE HARDWARE	4/14/2026	PW/B&G: Nylon Rope - BLDG-PROP/SUPPLIES	\$ 112.83				
WALSH'S ACE HARDWARE	4/16/2026	PW/B&G: Parks Shelter Repairs - BLDG-PROP/MAINT/REPAIRS	\$ 54.99				
WALSH'S ACE HARDWARE	4/17/2026	PW/B&G: Misc. Fasteners - BLDG-PROP/SUPPLIES	\$ 5.92				
WALSH'S ACE HARDWARE	4/13/2026	Zoning: Higby Property Demo Silt Fence - ZONING/MISC EXP	\$ 79.98				
TOTAL	WALSH'S ACE HARDWARE			\$ 2,288.78			
WARCO	3/2/2026	CC/SC: Warco Diamond Jo Trip 03/26/2026	\$ 1,395.00		3/17/2026		
TOTAL	WARCO			\$ 1,395.00			
WE ENERGIES	3/10/2026	Airport: Ct Hwy B hanger	\$ 102.72		3/26/2026	Public Works	3/19/2026
WE ENERGIES	3/9/2026	397 W Seminary - RR Museum	\$ 177.91		3/26/2026		
WE ENERGIES	3/9/2026	1055 N Orange Pool	\$ 23.80		3/26/2026		
WE ENERGIES	3/9/2026	1055 N Orange Concessions	\$ 9.24		3/26/2026		
WE ENERGIES	3/9/2026	1050 N Orange CC/SC	\$ 657.64		3/26/2026		
WE ENERGIES	3/9/2026	450 S Main / Muni Bldng	\$ 483.58		3/26/2026		
WE ENERGIES	3/9/2026	1300 N Park Cemetery Garage	\$ 105.65		3/26/2026		
WE ENERGIES	3/9/2026	950 N Orange - Krouskop Warming	\$ 193.39		3/26/2026		
WE ENERGIES	3/9/2026	141 W Robb Road	\$ 1,205.64		3/26/2026		
WE ENERGIES	3/9/2026	1100 N Jefferson Parks Dept Garage	\$ 209.43		3/26/2026		
TOTAL	WE ENERGIES			\$ 3,169.00			
WEGNER AUTO SERVICE	3/16/2026	PW/Street: Peterbilt Tow - STREETS/EQUIPMENT RENTAL	\$ 450.00		3/30/2026		
TOTAL	WEGNER AUTO SERVICE			\$ 450.00			
WERTZ PLUMBING & HEATING	3/4/2026	PW/B&G: Meyer Building Pump Repair - BLDG-PROP/MAINT/REPAIRS	\$ 525.11		3/26/2026		

City of Richland Center - Finance Committee Council Payment Approval Report - April 21, 2026

Item 5.

Invoices Approved by Dept Head Entered into System between March 4, 2026 April 21, 2026

Vendor Name	Inv Date	Description	Amount	Vendor Total	Date Paid	Comm/Board	Date Approved
<i>TOTAL</i>	<i>WERTZ PLUMBING & HEATING</i>			\$ 525.11			
WEX BANK	3/31/2026	POLICE: Vehicle Fuel	\$ 2,597.35		4/9/2026		
<i>TOTAL</i>	<i>WEX BANK</i>			\$ 2,597.35			
WI CRISIS NEGOTIATORS ASSN	3/12/2026	Police: Spring conf registration (Moe)	\$ 75.00		3/17/2026		
<i>TOTAL</i>	<i>WI CRISIS NEGOTIATORS ASSN</i>			\$ 75.00			
<i>TOTAL</i>	<i>WI Deferred Compensation</i>			\$ 3,033.78			
WI Dept of Administration	4/13/2026	City Office: Close RLF Act at CFB - Move \$ to St Pool - Better Interest Rate	\$ 173,970.62		4/16/2026		
<i>TOTAL</i>	<i>WI Dept of Administration</i>			\$ 173,970.62			
WI Dept of EE Trust Funds	3/4/2026	Payroll: Health & Basic Dental Insurance - April 2026	\$ 39,069.46		3/20/2026		
WI Dept of EE Trust Funds	3/4/2026	Payroll: Health & Basic Dental Insurance - April 2026	\$ 67,423.26		3/20/2026		
WI Dept of EE Trust Funds	3/4/2026	Payroll: Health & Basic Dental Insurance - April 2026	\$ 818.68		3/20/2026		
WI Dept of EE Trust Funds	2/28/2026	Payroll: WRS - Utility Portion & Rounding_02-2026	\$ 15,753.68		3/30/2026		
WI Dept of EE Trust Funds	2/28/2026	Payroll: WRS - Utility Portion & Rounding_02-2026	\$ 0.06		3/30/2026		
WI Dept of EE Trust Funds	3/11/2026	WRS WRS RETIREMENT Pay Period: 03/06/2026	\$ 3,049.95		4/15/2026		
WI Dept of EE Trust Funds	3/11/2026	WRS WRS RETIREMENT Pay Period: 03/06/2026	\$ 3,049.95		4/15/2026		
WI Dept of EE Trust Funds	3/11/2026	WRS PROTECTIVE W/ SS Employee Pay Period: 03/06/2026	\$ 2,580.36		4/15/2026		
WI Dept of EE Trust Funds	3/11/2026	WRS PROTECTIVE W/ SS Employee Pay Period: 03/06/2026	\$ 5,304.09		4/15/2026		
WI Dept of EE Trust Funds	3/11/2026	WRS WRS Additional Pay Period: 03/06/2026	\$ 20.00		4/15/2026		
WI Dept of EE Trust Funds	3/26/2026	WRS WRS RETIREMENT Pay Period: 03/20/2026	\$ 3,007.83		4/15/2026		
WI Dept of EE Trust Funds	3/26/2026	WRS WRS RETIREMENT Pay Period: 03/20/2026	\$ 3,007.83		4/15/2026		
WI Dept of EE Trust Funds	3/26/2026	WRS PROTECTIVE W/ SS Employee Pay Period: 03/20/2026	\$ 2,555.04		4/15/2026		
WI Dept of EE Trust Funds	3/26/2026	WRS PROTECTIVE W/ SS Employee Pay Period: 03/20/2026	\$ 5,252.41		4/15/2026		
WI Dept of EE Trust Funds	3/26/2026	WRS WRS Additional Pay Period: 03/20/2026	\$ 20.00		4/15/2026		
WI Dept of EE Trust Funds	4/10/2026	WRS WRS RETIREMENT Pay Period: 04/03/2026	\$ 2,930.56				
WI Dept of EE Trust Funds	4/10/2026	WRS WRS RETIREMENT Pay Period: 04/03/2026	\$ 2,930.56				
WI Dept of EE Trust Funds	4/10/2026	WRS WRS Additional Pay Period: 04/03/2026	\$ 20.00				
WI Dept of EE Trust Funds	4/10/2026	WRS PROTECTIVE W/ SS Employee Pay Period: 04/03/2026	\$ 2,888.52				
WI Dept of EE Trust Funds	4/10/2026	WRS PROTECTIVE W/ SS Employee Pay Period: 04/03/2026	\$ 5,937.48				
WI Dept of EE Trust Funds	4/15/2026	Payroll: Health & Basic Dental Insurance - May 2026	\$ 39,069.46		4/20/2026		
WI Dept of EE Trust Funds	4/15/2026	Payroll: Health & Basic Dental Insurance - May 2026	\$ 61,954.46		4/20/2026		
WI Dept of EE Trust Funds	4/15/2026	Payroll: Health & Basic Dental Insurance - May 2026	\$ 818.68		4/20/2026		
WI Dept of EE Trust Funds	4/15/2026	Payroll: WRS - Utility Portion & Rounding_03-2026	\$ 15,720.72		4/15/2026		
WI Dept of EE Trust Funds	4/15/2026	Payroll: WRS - Utility Portion & Rounding_03-2026	\$ (0.32)		4/15/2026		
<i>TOTAL</i>	<i>WI Dept of EE Trust Funds</i>			\$ 283,182.72			
WI DEPT OF JUSTICE	3/30/2026	Police: Training - Jared Wilson	\$ 700.00		4/9/2026		
WI DEPT OF JUSTICE-CRIME	4/1/2026	Police: Background Checks	\$ 7.00		4/16/2026		
<i>TOTAL</i>	<i>WI DEPT OF JUSTICE</i>			\$ 707.00			
WI DEPT OF MILITARY AFFAIRS	4/1/2026	Police: Annual LESO Enrollment Fee	\$ 400.00		4/9/2026		
<i>TOTAL</i>	<i>WI DEPT OF MILITARY AFFAIRS</i>			\$ 400.00			
WI DEPT OF REVENUE	3/11/2026	SWT TAXES STATE WITHHOLDING TAX Pay Period: 03/06/2026	\$ 3,055.50		3/30/2026		
WI DEPT OF REVENUE	3/26/2026	SWT TAXES STATE WITHHOLDING TAX Pay Period: 03/20/2026	\$ 3,002.24		4/14/2026		
WI DEPT OF REVENUE	4/10/2026	SWT TAXES STATE WITHHOLDING TAX Pay Period: 04/03/2026	\$ 3,228.48		4/30/2026		
WI DEPT OF REVENUE-AV FUEL	3/4/2026	Aviation Fuel Tax	\$ 10.86		3/20/2026	Public Works	3/19/2026
WI DEPT OF REVENUE-AV FUEL	4/13/2026	Aviation Fuel Tax - April 2026	\$ 6.42		4/20/2026		
<i>TOTAL</i>	<i>WI DEPT OF REVENUE</i>			\$ 9,303.50			

City of Richland Center - Finance Committee Council Payment Approval Report - April 21, 2026
Invoices Approved by Dept Head Entered into System between March 4, 2026 April 21, 2026

Item 5.

Vendor Name	Inv Date	Description	Amount	Vendor Total	Date Paid	Comm/Board	Date Approved
WI DEPT OF TRANSPORTATIO	3/26/2026	Police: Use of Suspending & Refusing Suspension Vehicle Registrations	\$ 300.00		4/2/2026		
TOTAL	WI DEPT OF TRANSPORTATIO			\$ 300.00			
WICONNECT WIRELESS LLC	4/1/2026	Airport Internet Service 3Mb/s Download	\$ 59.99		4/9/2026		
TOTAL	WICONNECT WIRELESS LLC			\$ 59.99			
Wild Honey Collective LLC	3/30/2026	Admin/Econ Dev: WEDC Grant Funding - 3rd (Final) Draw Request Paid Out	\$ 27,252.78		4/1/2026		
TOTAL	Wild Honey Collective LLC			\$ 27,252.78			
WIL-KIL PEST CONTROL	2/28/2026	PW/Refuse: pest control landfill	\$ 67.38		3/17/2026	Public Works	3/19/2026
WIL-KIL PEST CONTROL	2/28/2026	PW/CC/SC: pest control community center	\$ 81.56		3/17/2026		
WIL-KIL PEST CONTROL	2/28/2026	PW/CC/SC: pest control Meyer Shelter	\$ 73.44		3/17/2026	Public Works	3/19/2026
WIL-KIL PEST CONTROL	2/28/2026	PW/Admin: Municipal Building Pest Control	\$ 73.44		3/17/2026	Public Works	3/19/2026
WIL-KIL PEST CONTROL	3/31/2026	Admin/city office: pest control municipal bldg	\$ 73.44				
WIL-KIL PEST CONTROL	3/31/2026	PW/Refuse: pest control landfill	\$ 67.38				
WIL-KIL PEST CONTROL	3/31/2026	PW/CC/SC: pest control community center	\$ 81.56				
TOTAL	WIL-KIL PEST CONTROL			\$ 518.20			
WOODMAN, TIM	3/30/2026	PW/B&G: PD Garage Door Repair - BLDG-PROP/MAINT/REPAIRS	\$ 541.58		4/16/2026		
TOTAL	WOODMAN, TIM			\$ 541.58			
WORKSITE SOLUTIONS	3/11/2026	COMBINED INSURANCE Pay Period: 03/06/2026	\$ 23.35		3/26/2026		
WORKSITE SOLUTIONS	3/26/2026	COMBINED INSURANCE Pay Period: 03/20/2026	\$ 23.35		3/26/2026		
WORKSITE SOLUTIONS	4/10/2026	COMBINED INSURANCE Pay Period: 04/03/2026	\$ 23.35				
TOTAL	WORKSITE SOLUTIONS			\$ 70.05			
FRONTIER	4/9/2026	PW/Airport: 608-647-4237 Phone Line	\$ 149.24				
FRONTIER	4/9/2026	PW/Airport: 608-383-0969 Phone Line	\$ 149.24				
TOTAL	FRONTIER			\$ 298.48			
Yes Equipment & Services, Inc.	4/15/2026	REPAIR	\$ 23.77				
TOTAL	Yes Equipment & Services, Inc.			\$ 23.77			
TOTAL BILLS PRESENTED FOR APPROVAL:				\$ 1,010,168.27			
			Tourism Fund	\$ 13,751.11			
			General Fund	\$ 996,417.16			

The bills presented on this day (excluding any Library Fund invoices) having been referred to the Finance and Budget Committee and said committee having duly investigated and audited these bills, hereby make the following recommendation:

THAT THE CITY BILLS PRESENTED ON THIS DAY BE PAID, WITH THE FOLLOWING ADJUSTMENTS AND/OR EXCEPTIONS:

Dated: _____

Filed in the office of the City Clerk/Treasurer

CODE OF CONDUCT FOR ELECTED OFFICIALS

The intent of this Code is to provide guidelines for the elected members of City government as they interact with each other and with members of the public. While acknowledging an individual's right to expression, the Council feels that elected officials must be held to a higher standard of behavior, and therefore violation of this Code may be construed as inefficiency, neglect of duty, official misconduct, and/or malfeasance in office, depending on the nature and severity of the offense.

The provisions of this Code apply to all elected officers of the City of Richland Center, regardless of the use of the term "Council Member" or other titles throughout.

Official Statements by Council Members

- The Mayor and/or City Administrator are authorized to make official statements on behalf of the City, and the Council President is authorized to make official statements on behalf of the Council.
- No Council Member other than the Council President is authorized to make any official statement or comment on behalf of the City or Council.
- If a Council Member makes a statement or comment, the Council Member shall ensure such statement or comment contains language indicating the statement or comment reflects the personal views of the Council Member and not the views of the City or Council.

Council Member Rules of Conduct

Each Council Member shall:

- (A) Uphold the Oath of Office and faithfully and impartially discharge the duties of a Council Member to the best of their ability;
- (B) Adhere to the ordinances and policies adopted by the Council intended to apply to Council Members;
- (C) Act in the best interests of City government at all times;
- (D) Refrain from conduct which a reasonable person would deem unethical, offensive or otherwise contrary to community values;
- (E) Be responsive to the needs of the community;
- (F) Represent the interest of constituents by attending and participating in meetings; adequately prepare for meetings and observe the rules of decorum and these Council Rules at meetings; and conduct City government business in a manner consistent with law and refrain from discussions surrounding City business outside the appropriate meetings and channels of communication.
- (G) Council Member Conduct at Meetings. In addition to the rules of decorum in RONR, Council Members shall, at all meetings of the City Council or a Committee, conduct themselves and dress in a professional and respectful manner. Council Member comments should be directed to the presiding officer and not to any individual Council Member, City employee or member of the public. All comments must be respectful, courteous, appropriate and germane to the topic under discussion. Any inappropriate conduct will be recognized and addressed by the presiding officer.

The presiding officer of a Council or Committee meeting shall have the power to direct a Council Member's removal from a meeting.

(H) Council Member Conduct Outside Meetings. In addition to the proceeding provisions, Council Members shall adhere to the following.

1. Council Members shall at all times exhibit professional and courteous behavior when interacting with the City Administrator and City employees. Council Members shall be mindful that in their interactions with City employees they represent said employees' employer, and act accordingly.
2. Council Members shall refrain from requesting that a City employee perform a task or function without first obtaining the appropriate authorization. Matters relating to official City business should be addressed through the Administrator or the appropriate Committee, Board or Commission.

(I) As elected representatives, Council Members receive complaints from constituents, including City employees and the general public. Council Members shall refer complaints and/or concerns regarding the management and operation of City government to the appropriate step within the chain of command (Department Head and/or City Administrator). Outside of the chain of command, Council Members shall refrain from reviewing or discussing the merits of such complaints or concerns until the matter has been submitted to the chain of command and reported by that authority to the Board or Committee. However, Council Members shall be entitled to reasonable updates or other information so as to respond to the reporter. Council Members may make referrals to the appropriate party in the chain of command if determined to be the best way to resolve the matter.

Procedure for Enforcement

(A) If the Council Rules are violated during a meeting of a Board, Committee, Other Board or Commission, the presiding officer of the meeting shall have all powers under these Rules to immediately bring a Council Member's conduct into conformity with the Council Rules. If appropriate, the Board Chair or other presiding officer of the meeting may report a violation of the Council Rules to law enforcement for purposes of taking appropriate action, which may include (without limitation) removal of the offending Council Member from a meeting and/or issuing a citation for disorderly conduct or other violations, as appropriate. In addition, the presiding officer of the meeting shall refer the matter to the Council to determine what, if any, further sanction is warranted. The Council Member who is alleged to have violated the Council Rules shall be provided an opportunity to address the Council prior to final determination and disposition.

(B) The Council may, in its discretion, impose one or more of the following sanctions:

1. Private reprimand, a confidential record of which shall be kept by the City Clerk;
2. Censure without a formal Resolution of the Council;
3. Censure with a formal Resolution of the Council;
4. Removal from position of Committee Chair;
5. Removal from Committee; and
6. Referral to Council and the City Attorney to determine if cause exists to remove the Council Member from office.

If the Council determines cause (defined as inefficiency, neglect of duty, official misconduct or malfeasance in office) exists to remove the Council Member from office, the Council is authorized to appoint agents to (a) conduct any further and other investigation as may be necessary; (b) prepare verified charges seeking the Council Member's removal from office; and (c) prosecute the Council Member's removal from office. Any such proceedings shall comply with Wis. Stats. Chap. 17.

RULES OF THE COMMON COUNCIL

Updated [DATE]

Table of Contents

[AWAITING FINAL REVISION]

SECTION 1: PURPOSE AND DEFINITIONS

1.01 Purpose

The Common Council of the City of Richland Center (referred to as the “City Council” or “Council”) recognizes and understands the importance of City government, and the programs and services it provides, to the citizens of Richland Center. The City Council further recognizes citizens’ rightful expectation that the financial resources provided to the City through tax levy and other sources be invested in a wise and deliberate matter. Therefore, in recognition of these principles, the City Council hereby adopts the following Rules of the Common Council (referred to as “Council Rules” or “Rules”) in order to promote orderly and efficient rules of governance for the City Council and all City-related governmental bodies.

1.02 Interpretation

These Council Rules are not intended to, and shall not, supersede any requirements or provisions in the Wisconsin Statutes. In the event of any conflict between the Wisconsin Statutes and these Council Rules, the Wisconsin Statutes shall take precedence. The latest version of Robert’s Rules of Order shall govern in all circumstances not otherwise addressed by law or these Rules.

1.03 Committees, Commissions and Boards

As used in this document, references to “Committees” shall also refer to other commissions and boards unless such reference creates an absurd or impossible interpretation.

SECTION 2 CITY COUNCIL ORGANIZATION

2.01 Constitution of the Common Council and Quorum

The Common Council shall consist of the Mayor and alderpersons. Two-thirds of all seated members of the Council, excluding the Mayor, shall constitute a quorum.

2.02 City Council Meetings

The period of time between the organizational meetings in Section 2.02(A) hereof shall constitute a session of the City Council, and any business pending and upon which the Council has not acted prior to the close of a session can no longer be acted upon without being reintroduced.

(A) The Organizational Meeting. On the third Tuesday in April, after each Spring general election at which the Mayor and/or alderpersons are elected for full terms, the City Council will meet and shall:

1. Organize and transact general business;
2. Elect a Council President, by majority vote of all Council Members, to perform the duties set forth in Section 3.03;

3. Conduct appointments to committees, commissions and boards, such appointments being made by the Mayor and subject to confirmation of the Council unless otherwise specified;

Persons nominated for Council President are allowed 10 minutes to speak and answer questions. Voting shall take place by written secret ballot and the City Clerk and City Attorney shall serve as ballot clerks. A majority of votes of the Council Members present shall be necessary to elect the Council President.

(B) Regular Meetings. The City Council shall meet for the purpose of transacting general business at half past six o'clock (6:30PM/1830) on the first Tuesday of each month unless otherwise decided upon by the Council.

(C) Special Meetings. Special meetings of the City Council may be called upon written notice from the Mayor, provided to the alderpersons in a manner likely to give each notice of the meeting, provided at least six (6) hours prior to said meeting. The notice shall specify the time, place and purpose of the meeting. Attendance at such a meeting shall constitute a waiver of any defect of notice.

A special meeting may also be called if two alderpersons consent in writing to a meeting. Such written consent must be filed with the City Clerk before the commencement of the meeting. Notice of such meeting shall be provided to the Mayor by means likely to give notice of such meeting.

Notwithstanding the above, any special meeting of the Council must conform to laws governing public notice and open meetings.

2.03 Code of Conduct

The City Council may adopt and amend a code of conduct. Any code so adopted shall be appended to these Rules and incorporated herein by reference.

2.03 Agenda Responsibilities for the Council, Committees, Commissions and Boards

(A) The City Clerk is responsible for the contents of the agenda for any City Council meeting except for a special meeting called by the alderpersons. The Clerk shall add to the agenda all items recommended for consideration by the various committees, commissions and boards as well as those recommended by the Mayor. If circumstances preclude an item from being considered by a committee prior to its consideration at a Council meeting, the Mayor, Council President or the Chair of the relevant committee may authorize its inclusion on the agenda. Consultation should be made with the City Attorney prior to the inclusion of any closed sessions items.

- (B) Any individual member of the Council desiring an item to be placed on the agenda for a Council meeting shall make a motion during the Future Agenda

Items portion of the agenda at a City Council meeting to have an item placed on the agenda for the next meeting. The Council may vote to refer said matter to committee (with the Council President determining the appropriate committee), approve the item's addition to the next meeting's agenda, or to deny the motion.

(C) The Committee Chair shall serve as the presiding officer of their Committee meeting. Department heads, in consultation with the City Clerk and the Chair, are responsible for the preparation of all Committee meeting agendas. In the event there is no department head, the Clerk or designated member of the body will be assigned this responsibility.

(E) A Committee may request another Committee to attend a future meeting of the requesting body. In such an event, each Committee shall prepare an agenda for the joint meeting in the usual manner.

(F) In the first meeting of a Committee following the Organizational Meeting, the Committee shall adopt dates and times for regular Committee meetings and shall make every attempt to schedule such meetings prior to the regular City Council meetings and with due regard to the meeting dates and times of other Committees. Committees shall also elect Chairs (and other officers, as necessary) from amongst their members at this first meeting.

(G) The City Clerk, in consultation with the presiding officer of the relevant body, is responsible for providing notice of every meeting of the City Council and its subunits by posting the agenda in compliance with Wisconsin's Open Meetings Law, Wis. Stat. § 19.81, et seq.

(H) The City Clerk shall make every effort to distribute the agenda to all City Council Members, the City Administrator, and the City Attorney, in addition to any other interested persons, by the end of day on the Thursday immediately preceding a regular City Council meeting, but under no circumstances later than the end of day on that Friday. Any Committee or Council Member responsible for submitting materials (resolutions, ordinances, ordinance amendments, reports, etc.) for inclusion in the meeting packet shall provide the materials to the City Clerk no later than the end of the business day on the Tuesday preceding the week of the regular meeting. The agenda and meeting packets shall be delivered in electronic format to the recipient's City email address unless a recipient requests a hard copy of the materials. The requirements of this Section 2.03(D) may be waived, in whole or in part, by the Mayor, Council President, or Committee Chair in their discretion.

2.04 Electronic Communications

The City shall provide every Council Member with a City email address. Use of email for communications is strongly encouraged for all Council Members. All Council Members shall utilize their City email address for City business and shall not conduct City business on any other email address. Texting among members of the Council may be used for scheduling purposes only,

and may still be subject to release under public records laws.

2.05 Committees of the City Council and Other Boards and Commissions – Creation and Existence

(A) Standing Committees. The City Council shall establish the standing committees (referred to as “Standing Committees”), designated on Appendix A to these Council Rules as may from time to time be amended. Standing Committees are regular committees of the City Council, shall have the authority, power, duties and responsibilities as set forth in Appendix A and shall operate according to the procedures set forth in Appendix A. Committees shall elect officers from among their members at their first meeting after their creation.

(B) Advisory Committees. The City Council may establish advisory committees, whose purpose shall be to review matters of a specific nature and provide reports and recommendations to the Council or a standing committee. Advisory committees are not decision-making bodies. Appointment of citizen members to an advisory committee may be considered to maximize the efficacy of these bodies.

(C) Ad Hoc Committees. The City Council may form ad hoc committees (referred to as “Ad Hoc Committees”) from time to time by resolution or action of the City Council. Any resolution or action creating an Ad Hoc Committee shall specify the name of the committee, the committee’s purpose, the number of members of the committee, the appointing authority for committee membership, the duration of the committee and the committee’s reporting relationship. Unless otherwise defined, the appointing authority shall be the Mayor subject to confirmation by the Council. Appendix A will be updated by May 1 in even-numbered years to reflect current Ad Hoc Committees and particulars surrounding each particular Ad Hoc Committee’s operations. In these Council Rules, Ad Hoc Committees and Standing Committees are together referred to as “Committees.” An Ad Hoc Committee shall elect a Chair from among its members at its first meeting after its creation.

(D) Other Boards and Commissions. The City may be associated with certain Other Boards and Commissions (referred to as “Other Boards and Commissions”). Appendix A will be updated from time to time to reflect current Other Boards and Commissions and particulars surrounding operations.

(E) Residency. Unless otherwise required by law, a candidate need not be a resident of the City to be considered for appointment to a Committee, Commission or Board. However, the Council the residency of a candidate may be used as a factor when considering their confirmation.

(F) Council President Consideration for Quorum. The Council President may serve as a member, with full rights and privileges, of any Committee, Commission, or Board if there is not otherwise a quorum present at a given meeting.

2.06 Committee and Other Boards and Commissions Appointments and Removals

(A) At the time of the Organizational Meeting, or as otherwise required by law or circumstances, the Mayor shall appoint members of committees, subject to confirmation by the City Council.

(B) At the first meeting of each committee following the Organizational Meeting, each committee shall elect from among its members a Chair.

(C) The Mayor or Council President may recommend the removal of any member of any Committee, at any time and for any reason, to the City Council and the City Council may make such removal. The Mayor or Council President may recommend the removal of the designation as Chair of any Committee, at any time for any reason, and the City Council may make such removal.

2.07 City Council Member Compensation

(A) Compensation of Members. The Council shall have the right to ordain the compensation of its members and the members of Other Boards, Committees and Commissions, but no change to said compensation shall be effective in the same session in which it is passed.

(B) Expense Reimbursement. Council Members shall be reimbursed for expenses in the amounts, and according to the regulations and procedures, established by the Council from time to time. If no such regulations are established specific to the Council, the Council shall follow the regulations and procedures for reimbursement found in the Employee Handbook.

2.08 Meeting Minutes

(A) City Council Meetings. The City Clerk is responsible for the preparation of minutes for all meetings of the City Council. The City Clerk may use a personal recording device to record any open session portion of a meeting for purposes of verifying the accuracy of the proceedings. The City Clerk shall destroy any recording not sooner than ninety (90) days after approval of the minutes of the meeting at which the recording is taken. The City Clerk shall not record any closed session of a City Council meeting. A draft form of the minutes of meetings shall be included in the meeting packet distributed prior to City Council meetings as specified in Section 2.03(D).

(B) Committee, Other Council and Commission Meetings. The City Clerk or their designee is responsible for taking and recording the minutes of any meeting of the Committee. All draft minutes shall be filed with the City Clerk's office no later than fourteen (14) days after the meeting to which the draft minutes apply and shall be in a format approved by the City Clerk.

2.9 City Council Meeting Seating Arrangements

Except as provided herein, City Council Members shall be seated in order by district number. The Mayor shall sit at the designated head of the room. The City Administrator, City Clerk and City Attorney shall each be seated as designated by the Mayor. There shall be a designated area for members of the public and members of the press. The Mayor may alter the seating arrangements to meet the needs of individual Council Members or members of the public.

2.10 Post-Election Procedures

(A) Within 7 days after City Council Members are elected in the Spring general election, the City Clerk shall distribute orientation materials to all persons elected to the City Council, including a copy of these Rules.

(B) Council Members interested in nomination for the position of Council President are encouraged to indicate their interest in the positions on the Council President candidate answers form. In addition, such Council Members are encouraged to answer two additional questions:

- *Why do you want to serve as Council President?*
- *What do you feel are the strengths and weaknesses you would bring to the role of Council President?*

All Council Members shall also complete a Committee/Board/Commission Preference form. The City Clerk will create and distribute these forms to all City Council Members-elect in advance of the Organizational Meeting.

(C) All Council Members must complete the Wisconsin League of Municipalities “Local Government Basics Training” prior to becoming eligible for appointment to any committee, commission, or board. Another course, training, or equivalent experience may be substituted for this training at the discretion of the Council President.

2.11 Council Relationship with the City Administrator, Department Heads and City Employees

The City Council serves as the legislative body in City government. As such, the City Council’s role is to enact policy. To implement the policy the City Council establishes, the City Council shall appoint a person as the City Administrator. The Administrator shall perform all duties and have such authority as specified in the Position Description, these Council Rules and as otherwise may be authorized and directed by the City Council from time to time. Department Heads are responsible, and shall report, to the Administrator. City Council Members desiring information or a report from a Department Head or other City staff shall request such information or report either in the context of a City Council or Committee meeting or from the Administrator.

The Administrator shall serve as a non-voting, *ex officio* member of all Committees, Commissions and Boards.

2.12 Vacancies in Office of City Council Member

(A) Vacancies – How Caused. Vacancies in the office of alderperson or Mayor shall be determined according to Wis. Stat. § 17.03.

(B) Vacancies – How Filled. Vacancies in the office of alderperson or Mayor may be filled, pursuant to Wis. Stat. § 17.23(1), by a majority vote of the Council. Vacancies shall be announced at the first Council meeting following their creation, and the vacancy shall be filled at the subsequent Council meeting. If circumstances require the appointment occur sooner, the Council may waive this requirement by a three-fourths (3/4) vote.

2.14 Official Statements by Council Members

No Council Members other than the Mayor or Council President is authorized to make any official statement or comment on behalf of the City Council. If a Council Member makes a statement or comment, the Council Member shall ensure such statement or comment contains language indicating the statement or comment reflects the personal views of the Council Member and not the views of the City Council.

2.15 Closed Session at Committee Meetings – Attendance

In accordance with Wis. Stat. § 19.89, and unless otherwise provided by law, no Council Member may be excluded from any meeting of the Council. However, a Committee may exclude a Council Member that is not a member of the Committee from a closed session portion of a meeting upon a three-fourths (3/4) majority vote of the Committee members present. No individual may attend a closed session by remote means unless approved to do so by the presiding officer.

SECTION 3 CITY COUNCIL OFFICERS

3.01 Presiding Officer

(A) The Mayor shall act as the presiding officer at all meetings of the City Council. In the absence of the Mayor, the Council President shall act as presiding officer, but shall retain their vote while so serving and do not cast a vote in the event of a tie. If both the Mayor and the Council President are absent, the Clerk shall call the Council to order and thereupon the Council shall elect a *pro tempore* presiding officer.

(B) The presiding officer shall decide all questions of order.

(C) The presiding officer may at any time request or permit a person other than a Council Member to address the Council. Such an address shall be for the purpose of explaining, clarifying or otherwise assisting the Council in evaluating

the merits or legality of the matter under consideration.

(D) It shall be the duty of the presiding officer to preserve decorum, and if any member shall transgress these Rules, the presiding officer or any member may call to order, in which case the member called to order shall immediately sit and be silent unless permitted by the presiding officer to explain.

(E) The presiding officer shall have the right to order the ejection of any person who shall persistently speak out of order or otherwise act so as to disrupt a meeting of the Council. If appropriate, the presiding officer may report a violation of these Rules to law enforcement for purposes of taking appropriate action, which may include (without limitation), removal of the offending person and/or issuing a citation for disorderly conduct or other appropriate charge.

(F) Any decision of the presiding officer may be appealed by a Council Member to the Council as a whole using the following procedure: within a reasonable time after the decision of the presiding officer is made, the appellant shall state their disagreement and demand a determination by the Council as to whether the decision of the presiding officer shall stand or be reversed. The matter will then be voted upon without debate. No action of the presiding officer shall be reversed unless two-thirds (2/3) of Council Members present shall vote for such reversal.

Whether an appeal is made within a reasonable time is a decision made by the presiding officer, subject to the same rights of appeal as above. An appeal of the officer's decision on whether the time is reasonable must be made within the same meeting as the decision itself.

3.02 Mayor

(A) The Mayor shall have all the powers, duties and responsibilities granted to the position pursuant to Wis. Stat. § 62.09(8). The Council may define the Mayor's responsibilities so long as such definition does not unlawfully interfere with the exercise of the Mayor's statutory authorities.

(B) The Mayor shall have the power to veto all acts of Council, except where it is expressly or by necessary implication otherwise provided by Wisconsin Statutes. All acts of the Council shall be submitted to the Mayor by the Clerk and shall be in force upon approval evidenced by the Mayor's signature, or upon failing to approve or disapprove within five (5) days, which fact shall be certified thereon by the Clerk. If the Mayor disapproves of an act of the Council, the Mayor's objections shall be filed with the Clerk, who shall present them to the Council at its next meeting. A two-thirds (2/3) vote of all of the members of the Council shall then make the act effective notwithstanding the objections of the Mayor.

(C) The Mayor shall serve as the spokesperson for the City and is authorized to comment to the public or press on any matter of City business provided any such comments are consistent with the City's policies or expressed positions.

(D) The Mayor shall have the power to order the attendance of any absentee Council Member at a meeting of the City Council.

(E) The Mayor may not serve as a member of a Committee for the purposes of creating a quorum.

3.03 Council President

(A) The Council President shall perform all duties as specified in these Council Rules. In addition, the Council President shall perform such other duties as the City Council may authorize from time to time. The Council President may serve as a member, with full rights and privileges, of any Committee if there is otherwise not a quorum at any Committee meeting.

(B) The Council President shall serve as the spokesperson for the City Council and is authorized to comment to the public or press on any matter of City business provided any such comments are consistent with the City Council’s policies or expressed positions.

(C) In the event of a vacancy in the position of Council President, the City Council shall hold an election for the position according to the procedure set forth in Section 2.02(A)2.

3.03 Chairs of Committees.

The Chair of a Committee shall preside at Committee meetings. If the Chair is also an elected representative, they shall serve as the spokesperson on behalf of the Committee in City Council meetings.

SECTION 4 RULES OF PROCEDURE

4.01 Parliamentary Authority

The latest edition of *Robert’s Rules of Order, Newly Revised* (“RONR”) shall govern the proceedings at all meetings of the City Council and the Committees. The City Attorney or their designee shall serve as parliamentarian for all such meetings and shall consult with the presiding officer on all questions of parliamentary procedure.

4.02 Committee of the Whole

The City Council may convene as the committee of the whole at the call of the Mayor or Council President provided the public is provided notice of any such meeting in accordance with Wisconsin’s Open Meetings Law, Wis. Stat. § 19.81, et seq.

4.03 Remote Attendance at Meetings

(A) Remote Attendance at Meetings. Council Members shall make every attempt to attend City Council and Committee meetings in-person. A Council Member authorized under these Council Rules to attend a meeting by remote communication (telephonic or videoconference technology) shall be considered present for a meeting with full rights to participate and vote. Any Council Member attending a Council or Committee meeting remotely shall be encouraged to keep their camera on for the entirety of their attendance if attending by video, and shall be excused from any closed session part of a meeting unless granted permission to remain in the meeting by the presiding officer or Committee Chair. No person may serve as presiding officer of a City Council meeting if the person is attending the meeting by remote communication unless the entire meeting is held by remote communication as provided in Section 4.03(B).

(B) Fully Remote Meetings. If in-person meetings are not advised or not possible due to an emergency situation, as declared by the appropriate authority under Wis. Stat. Chap. 323 or otherwise determined by the Mayor or Council President, meetings of the City Council and Committees may be conducted via teleconference, video conference or other such methods, provided that members of the public can access the meeting in accordance with Wis. Stat. § 19.89, Wisconsin's Open Meetings Law.

4.04 Order of Business

(A) City Council Meetings.

The order of business for all meetings of the City Council shall be as follows:

1. Call to Order
2. Roll Call
3. Pledge of Allegiance
4. Verification of Open Meetings Law Compliance
5. Approve Agenda
6. Approve Minutes of Previous Meeting(s)
7. Public Comment
8. Special Orders of Business/Recognitions
9. Public Hearings
10. Resolutions
11. Ordinances and Ordinance Amendments
12. Reports
 - a. Reports of Committees, Commissions and Boards
 - b. Administrator's Report
 - c. Reports of other Department Heads
13. Correspondence
14. Future Agenda Items
15. Closed Session (if any)
16. Adjourn

The order of business may be changed by the Mayor or by majority vote of the Council. When preparing the agenda for the meeting, where no business is contemplated on an item on this order of business, the item can be omitted.

(B) Committee Meetings.

The order of business for all meetings of Committees shall be as follows:

1. Call to Order
2. Roll Call
3. Verification of Open Meetings Law Compliance
4. Approve Agenda
5. Approve Minutes from Previous Meeting(s)
6. Public Comment
7. Public Hearing
8. Reports
9. Contract Approvals
10. Resolutions
11. Ordinances and Ordinance Amendments
12. Correspondence
13. Future Agenda Items
14. Closed Session (if any)
15. Adjourn

The order of business may be changed by the committee or other Council and commission chair or by majority vote of the committee or other Council and commission. When preparing the agenda for the meeting, where no business is contemplated on an item on this order of business, the item can be omitted.

(C) Approval of Minutes. There is no requirement that minutes of a previous meeting be read unless requested by a majority of the City Council or Committee.

(D) Consideration of Resolutions. There is no requirement that resolutions introduced at a meeting be read, unless requested by the Council President or a majority of the City Council or Committee, provided such resolution(s) is made available to the Council or Committee members prior to the meeting.

4.05 Personal Electronic Devices

(A) City Council Members. All City Council Members shall silence their mobile phones and all other personal electronic devices during a meeting of the City Council and of any Committee on which the Council Member serves, except those provided to them for the purposes of conducting City business. Such devices may not be used during any such meeting except in the event of an emergency or with permission of the presiding officer of the meeting. This Section 4.05(A) does not preclude the recording of open session portions of any meeting by any person.

(B) Other Meeting Attendees. All other meeting attendees shall silence their mobile phones and other personal electronic devices during a meeting of the City Council and of any Committee. This Section 4.05(B) does not preclude the recording of open session portions of any meeting by any person.

4.06 Recognition, Debate and Voting at City Council Meetings

(A) Recognition. A Council Member must be recognized by the presiding officer prior to speaking and shall do so by rising or raising a hand. The presiding officer is responsible for determining recognition and the order thereof.

(B) Debate. Each Council Member shall be entitled to speak on any matter pending before the Council and open for discussion. Any member may move to limit or extend the floor time of any speaker and such motion shall require two-thirds (2/3) vote and is not debatable. Discussion and comments should be directed to the presiding officer and not to any individual Council Member, City staff or member of the public. All Council Member comments shall be germane to the business currently pending before the Council. Council Members shall maintain and exercise proper decorum at all times when discussing any matter before the Council.

(C) Voting. Unless roll call or secret ballot voting is required by the Wisconsin Statutes or these Council Rules, when a question is put to the City Council, the presiding officer shall conduct a voice vote by asking for those in favor and those opposed. When conducting roll call votes, the City Clerk shall call the roll in numeric order according to supervisory district and each succeeding roll call vote at the same meeting shall start with the next succeeding name that completed the last preceding roll call vote.

(D) Abstention. All City Council Members are expected to represent their constituents and fully participate in meetings of the City Council, including voting. Nonetheless, there are recognized circumstances where participation in discussion, voting, or both would be inappropriate. A Council Member may abstain from participating in discussion, voting or both. When a Council Member abstains, the presiding officer shall provide the Council Member with the opportunity to explain the reason for the abstention and, if a reason is provided, the City Clerk shall record the reason in the meeting minutes.

(E) With the exception of subsection (D), this Section 4.06 does not apply to Committee meetings. Unless otherwise required by the Wisconsin Statutes or these Council Rules, Committee meeting procedure shall be governed by RONR 49:21, *Procedure in Small Councils*.

4.07 Public Decorum and Comment

(A) Rules of Decorum. All attendees at City Council and Committee meetings are expected to maintain appropriate decorum during the meeting. Talking,

shouting, outbursts, clapping and similar gestures are prohibited. Any attendee may be requested to cease any activities, including the use of signs, banners or displays, that unduly disrupt a meeting consistent with applicable law. Citizens in the audience are not to audibly respond to comments being made during a meeting or to make demonstrations either in support of or in opposition to a speaker or idea. The Chair of the meeting is responsible for enforcing meeting decorum.

(B) Rules for Public Comment. The following rules apply to all periods of public comment at City Council and Committee meetings:

1. Any person who wishes to address the City Council during the “Public Comment” portion of the agenda must provide their name and address prior to beginning comment. A form may be provided by the Council for this purpose.
2. A commenter may not speak longer than three (3) minutes and may only speak once per meeting. Time may not be transferred from one speaker to another.
4. Comments should be directed to the Council as a whole and not addressed to individual Council Members.
5. Commenters shall refrain from asking questions of the Council or any individual Council Member.
6. Commenters should be courteous in their language, avoid personalized remarks and refrain from comments that are rude, obscene, profane, personally attacking, and which demonstrate a lack of respect for others.
7. The presiding officer reserves the right to terminate an individual’s public comments if these rules are violated. As well, the presiding officer has the authority to rule speakers out of order and may call a short recess in disorderly situations.

(C) Public Participation at Meetings. Unless specifically requested by the presiding officer of a meeting, members of the public are not allowed to participate in any meeting. No Council Member or member of a Committee may cede time during discussion of a pending question to a member of the public. This Section 4.07(C) shall not be construed to prohibit City staff from providing information and reports to the City Council or a Committee consistent with the meeting agenda or practice of the City Council or Committee.

(D) Council Member Participation at Committee Meetings of Which They Are Not a Member. Subject to Section 2.15, Council Members, including the Mayor, are allowed to attend any meeting of a Committee. No Council Member, including the Mayor, may speak at a Committee meeting except during public comment or

upon permission of the Chair of the Committee.

4.08 Reconsideration

Any City Council Member on the prevailing side of any question determined by the City Council may make a motion to reconsider the question at the same or next succeeding meeting. When the City Council is equally divided on any question before it, the question shall be considered lost, but in that case any City Council Member present at the meeting where the question was considered may move for reconsideration at the same or next succeeding meeting.

4.09 Resolutions – Form and Introduction

(A) Form of Resolutions. A Council Member may request the assistance of administration and staff, together with the City Attorney, in drafting any proposed Resolution provided, however, the identity of the Council Member shall not be confidential. Resolutions shall be in form approved by the City Clerk and City Attorney. In addition to any other form requirements, all proposed Resolutions shall include the following:

1. A space for a fiscal note. The City Administrator or designee is responsible for reviewing the financial impact of any proposed Resolution and providing any comments relating to such financial impact, if requested to do so.
2. A space for a legal note. The City Attorney or designee is responsible for reviewing whether the proposed Resolution is within the scope of the City's authority and otherwise providing any comments relating to the legal impact of the proposed Resolution, if requested to do so.
3. A space indicating the identity of the Committee(s) that considered the proposed Resolution, the date of the Committee(s) meeting at which such consideration occurred, the official action of the Committee(s) on the proposed Resolution and the votes of the Committee(s) members relative to the proposed Resolution.

(B) Introduction of Resolutions. A Resolution may be proposed by an individual Council Member or by a Committee.

1. Resolutions Proposed by an individual Council Member. If a Resolution is proposed by an individual Council Member, prior to any action by the Council on the proposed Resolution, the Council President shall refer the proposed Resolution to the appropriate Committee. The City Council may, from time to time, request a report from the presiding officer as to referral of proposed Resolutions. The Committee(s) to which a proposed Resolution is referred shall file the official action on any proposed Resolution

with the City Clerk as soon as practicable following the meeting at which such official action occurred, and the act of filing shall serve as a request that the proposed Resolution be placed on the agenda for the next City Council meeting. The requirements of this Section 4.09(B)1 may be waived, in whole or in part, by the presiding officer in their discretion.

2. Resolutions Proposed by a Committee. A Committee may propose a Resolution. Any Committee that recommends City Council adoption of a Resolution proposed by the Committee shall file the official action on the proposed Resolution with the City Clerk as soon as practicable following the meeting at which such official action occurred, and the act of filing shall serve as a request that the proposed Resolution be placed on the agenda for the next City Council meeting.

4.10 Suspension of and Amendment to Rules

(A) Suspension of Rules. Any rule in these Rules may be suspended by two-thirds (2/3) vote provided any such suspension does not cause a violation of the Wisconsin Statutes.

(B) Amendment to Rules. The City Council may amend these Rules by two-thirds (2/3) vote of the Council Members provided any proposed amendment is provided in writing to all Council Members in the meeting packet distributed by the City Clerk under Rule 2.03(D). Appendix A relating to committees may be amended at any time by majority vote.

APPENDIX A – COMMITTEES, BOARDS AND COMMISSIONS

Updated [DATE]

This Appendix A is created and updated pursuant to Section X.XX of the Council Rules. Committees are intended as policy-making bodies, determining the broad outlines and principles governing administration of their area of concern.

As used in this Appendix, “Committees” shall refer to all committees, commissions, boards, or other, similar bodies, unless otherwise specified.

I. RULES GOVERNING ALL COMMITTEES

- A. Unless otherwise specified in statute, herein, or in another valid authority appointments to committees shall be by appointment of the Mayor, subject to confirmation by the Council.
- B. No individual may serve more than three consecutive terms as the chair of a given committee.
- C. Committee proceedings shall be governed by the newest edition of Robert’s Rules of Order.

II. STANDING COMMITTEES

Standing committees are intended to be permanent. The Council may delegate to them certain decision-making authority. These Committees will handle the regular business of the City, each with distinct areas of authority.

GENERAL GOVERNMENT COMMITTEE

This Committee shall have jurisdiction over matters that affect the entire city, including legal matters, governance of the Council itself, and citywide policies and procedures.

- A. The Chairs of the Budget, Public Works, and Personnel Committees shall comprise the General Government Committee. Each Chair may name a designee to serve on this Committee in their stead, and shall do so if serving as the Chair of more than one of the constituent Committees.
- B. Reviews and revises the Council Rules when called upon to do so, but no less than biennially and with the goal of completing any revisions prior to the swearing-in of new Council Members.
- C. May Provides direction to the City Attorney in matters pertaining to legal services and shall solicit receive advice from the City Attorney.
- D. Monitors the actual vs. proposed annual budget in funds managed by the City Administrator, Common Council, Clerk, City Attorney, Zoning, and Treasurer Departments on a minimum quarterly basis.

- E. Provides oversight and advice (i.e., policy-making determining the broad outlines and principles governing administration) regarding issues that arise out of the offices of the City Administrator, City Clerk, City Attorney, Zoning Administrator and Treasurer.
- F. Unless delegated to other officers of the City, the committee, together with such professional assistance as may be provided by the City Administrator, shall represent the City in collective bargaining and all other situations and procedures covered by Wis. Stat. § 111.70, including the applications and interpretation of all collective bargaining agreements. The Common Council shall have authority to approve or reject any and all agreements of any employee bargaining units.
- G. Consider all claims made against the City and, if allowed under statute, dispose of any claim or otherwise make a recommendation to the Common Council as to how to dispose of each such claim.
- H. Provides oversight and advice regarding technology needs of all City departments.
- I. Provides oversight and advice over the City Administrator's recommendations for property, liability, and workers' compensation policies.
- J. Provides oversight and advice regarding all security matters relating to all buildings and grounds owned and/or utilized by the City.

BUDGET COMMITTEE

This Committee shall conduct oversight of the City's financial matters, including revenues and expenditures, and shall work with appropriate officials to develop and monitor the annual budget.

- A. The Budget Committee shall consist of three Alderpersons.
- B. Provides oversight and advice regarding all financial matters of the Common Council for the purpose of keeping expenditures under control and within the budget adopted by the Common Council, the Treasurer's recommendations for investment monies, and financial audits by outside auditors.
- C. Prepare the annual budget for submission to the Common Council.
- D. Handle all matters relating to debt service issues.
- E. Make fund transfers between budget lines within the budgets of individual departments or committees in the annual City budget within the authority granted in Wis. Stat. § 65.90(5).
- F. Provides oversight and advice regarding the amount of bonds of various City officers and employees.
- G. Act as the Audit Committee, providing oversight and advice regarding reports on all expense vouchers for members of the Common Council and the various departments of the City.

PERSONNEL COMMITTEE

This Committee shall conduct oversight of the City's personnel matters, including personnel policies, hearing employee grievances, and monitoring the City Administrator's performance as Chief Personnel Officer.

- A. The Personnel Committee shall consist of three Alderpersons.

- B. Review proposed modifications and updates to the City's Personnel Policies, including any recommended deviations therefrom. Following review, the Committee shall make such recommendations to the Common Council as it determines appropriate.
- C. Provides oversight and advice regarding the performance of the City Administrator, including providing any performance review established by policy.
- D. The committee shall from time to time provide oversight and advice regarding Job Analysis and Evaluations and a study of the organizational chart, and if a change in any of the above is recommended, said recommendation shall be submitted to the Common Council for action.
- E. Provides oversight and advice over the City Administrator's recommendations for employees' health insurance policies.

PLANNING COMMITTEE

This committee will create, monitor, and apply the City's Master Plan and other such documents, as well as serving as the City's zoning authority.

- A. Operates pursuant to the relevant provisions of Wis. Stat. § 62.23, as they may be from time to time amended.
- B. Acts as the Zoning Committee as follows:
 1. Provides oversight and advice over the City Zoning Ordinance and Land Division Ordinances in cooperation with the City Attorney.
 2. May grant conditional use permits according to the terms of the City Zoning Ordinance, subject to appeal to the Zoning Board of Appeals.
 3. Make recommendations to the Common Council in all matters relating to exclusive agricultural zoning as provided in Wis. Stat. Chapter 91, if an appropriate ordinance is adopted.

PUBLIC SAFETY STANDING COMMITTEE

This committee will oversee those services which provide for the health and safety of the City's residents, as well as providing priorities and guidance in the prioritization of enforcement actions by the City's various departments.

- A. The Public Safety Committee shall consist of three Alderpersons, with preference given to those who also serve on the Fire Board, Public Works Committee, and/or the governing bodies of other emergency or public safety services.
- B. Monitors the actual vs. proposed annual budget in funds managed by the Richland Center Police Department and Emergency Manager.
- C. To audit all bills for expenditures within the police department.
- D. Provides oversight and advice regarding service and maintenance of all departmental equipment.
- E. Present to the Council any suggestions the Committee may have concerning law enforcement and other duties required by the police department.
- F. Provides oversight and advice regarding matters pertaining to the operation of the police radio system.

- G. Provides oversight and advice regarding the security and maintenance and rental (if applicable) of the City's radio towers and the accompanying building and surrounding fenced grounds.
- H. Provides oversight and advice regarding the operation of the City's 911 emergency telephone response system.
- I. Develop and recommend to the Council for adoption an emergency management plan compatible with the state plan as required under Wis. Stat. § 32.14(b)(1).

PUBLIC WORKS STANDING COMMITTEE

This committee shall provide oversight of the use, maintenance, and management of the City's properties, including all buildings, cemeteries, grounds, parks, and other facilities.

- A. Monitors the actual vs. proposed annual budget in funds managed by the Public Works and Parks Departments on a minimum quarterly basis.
- B. Provides oversight and advice regarding the operation, maintenance and janitor service of all City buildings not specifically assigned by the Wisconsin Statutes, or by action of the Council, to other agencies or departments in the City.
- C. Provides oversight and advice regarding a perpetual inventory of the real estate and buildings owned by the City.
- D. Provides oversight and advice regarding utilization and repair policies of all public lands, buildings, recreation sites, access sites inclusive of all short-term public holdings of the City not specifically assigned by the Wisconsin Statutes, or by action of the Council, to other bodies, agencies or departments of the City
- E. Provides oversight and advice an annual inspection of inventories and buildings so they can establish policies related thereto.
- F. When appropriate, effect the appraisal of real property to be sold by the City.
- G. Review and make the final decision on requests by citizens and citizen groups to use major portions of City grounds.

UTILITY COMMISSION

This commission shall serve as described in Wis. Stat. § 66.0805, under the general control and supervision of the Common Council, to operate the City's public utilities in coordination with other City departments.

- A. The Commission shall be a quasi-independent body, but ultimately subject to the authority of the Council.
- B. The Commission may adopt its own bylaws governing its proceedings.
- C. The Commission shall operate the Utilities as a department of the City, subject to the ordinances adopted by the Council governing said operations.
- D. The Commission shall collaborate in its efforts with the appropriate City personnel for the purposes of planning and development.
 - a. Such collaboration shall include, but is not limited to, coordination and sharing of equipment, labor, and other resources with other City departments.

LIBRARY BOARD

This commission shall serve as described in Wis. Stat. ch. 43, to operate the City’s public library.

- A. The Library Board may adopt its own bylaws governing its proceedings.
- B. The Library Board shall present its proposed budget in a timely manner to allow for proper consideration and approval by the Council.

III. ADVISORY COMMITTEES

Committees intended to be permanent, but not decision-making bodies.

HISTORICAL PRESERVATION SOCIETY

IV. AD HOC COMMITTEES

Committees intended to be temporary, typically with specialized fields of focus.

[RULES COMMITTEE]

Placed here as an example of an ad hoc committee, this committee formulated the Rules before you.]

V. OTHER BOARDS AND COMMISSIONS

Bodies with representation by the City, but not necessarily under the authority of the Council.

FIRE BOARD

The governing body of the Richland Fire Department, this body was created through an agreement between the City and the Rural Fire District when the two organizations merged their resources.

- A. Fire Board operations are governed by contract.

CITY OF RICHLAND CENTER, WISCONSIN

Richland County

Dissolving the Board of Park Commissioners and Establishing a Friends of the Parks Organization

A Code-Specific Guide for City Leadership

Prepared with reference to Chapters 50, 701, 702, 703 and 704 of the City Code

2026

1. Purpose of This Guide

This guide is intended to help the Richland Center Common Council, City Administrator, and City Attorney plan and execute a two-phase transition: first, the orderly dissolution of the Board of Park Commissioners through coordinated ordinance action; and second, the subsequent establishment of a community-led Friends of the Parks nonprofit organization.

These are sequential steps, not simultaneous ones. The Park Board will be dissolved first. After that process is complete and park governance is operating cleanly under the new structure, interested community members — acting independently of city government — may organize a Friends group as a community partner.

This document is grounded in Richland Center's city code. It identifies every cross-chapter ordinance amendment required, explains how park functions will be reassigned within city government, and provides a frank analysis of why the Park Board model no longer serves this city's needs.

Two-Phase Sequence

- Phase 1 (City action): Amend Chapters 50, 701, 702, and 704 to dissolve the Park Board and reassign all of its functions within city government. The Park Board is dissolved. Its functions do not disappear — they are reassigned.
- Phase 2 (Community action): After dissolution is complete, community members independently organize a Friends of the Parks nonprofit. The city is a supportive partner but does not lead or control this effort.
- The phases do not overlap. The Park Board will not be retained as a transitional body.

2. Why the Board of Park Commissioners No Longer Serves Richland Center

The Council is in a strong position to make this change, and the reasons for doing so are grounded in sound governance, not convenience or cost-cutting. The Park Board, as it has operated for many years, has drifted from the role envisioned by state statute and has become, in several meaningful ways, a structural obstacle to effective city management. What follows is an honest accounting of those concerns — offered with appreciation for the individuals who have served and with the goal of building a structure that works better for the parks and the community alike.

2a. The Board Has Operated as an Operational Authority, Not a Policy Body

Wisconsin Statute § 27.08 envisions a park board as a governing and planning body — one that sets direction, acquires and develops park land, and ensures parks serve the long-term public interest. In practice, Richland Center's Park Board has focused primarily on day-to-day operational matters: maintenance schedules, facility use, and routine program decisions that are more appropriately handled at the staff level.

A seven-member appointed board meeting in formal session — subject to the Open Meetings Law, requiring a quorum, generating minutes — to address operational details is a structural mismatch. It adds administrative overhead and process friction without adding governance value. The same decisions made by trained staff under the authority of a professional administrator are faster, more consistent, and more clearly accountable.

2b. A Structural Conflict with Administrator-Form Governance

Under *Chapter 701.01(b)*, the Park Board directly supervises the Parks and Grounds Director. In a mayor-council city without a professional administrator, this arrangement has logic. But Richland Center operates under an administrator form of government, in which operational supervision is properly and intentionally the domain of the City Administrator. Having an appointed citizen board with direct supervisory authority over a department director creates a dual-reporting structure that undermines both the administrator's management authority and the Parks Director's ability to operate with unified, clear direction.

This tension is not hypothetical — it is the kind of structural conflict that has led many similarly situated Wisconsin cities to move away from empowered park boards. The administrator form of government is specifically designed to unify operational management. Maintaining a statutory body with independent supervisory authority over a department runs counter to that design. One of them, inevitably, is operating outside its proper lane.

2c. The City Is Not Seeking Additional Park Land

One of the core statutory purposes of a Board of Park Commissioners under Wis. Stat. § 27.08 is to acquire, develop, and expand the municipal park system. Richland Center already manages an extensive inventory of public recreation land relative to its size: Krouskop Park with

the Community/Senior Center, Strickland Park, West Side Community Park, North Side Park, North Lake Park, North Park West, Wedgewood North and South Parks, Miner Hill Park, North Park East, Summit Park, the Occooch Learning Center, the unnamed park west of the Pine River, trails on both riverbanks, a Frisbee golf area, and additional property at the old Community Center site — all enumerated in Chapter 701.02.

The city is not in a financial or strategic position to pursue additional park land acquisition in the foreseeable future. This means the Park Board's most substantive statutory function has, as a practical matter, ceased to exist. What remains is operational management and permitting — functions that belong in the hands of city staff and the Council's committee structure, not in an independent board.

2d. The Park Fund Has Not Been Used for Its Intended Purpose

Chapter 50.10 grants the Park Board independent authority to spend the Park Fund — money received through subscriptions and gifts — at the Board's discretion, without Council approval. (Ch. 50.10(1)) This authority was designed to enable a proactive board to attract community donations and supplement the park budget with privately raised funds. That has not happened. The Park Board has not conducted meaningful fundraising. The Park Fund has not become a vehicle for community investment in the parks.

This is not primarily a criticism of individual board members. It reflects a structural reality: governmental boards are poorly positioned to raise private money. Donors give to causes they feel personally connected to, and they give through organizations they can see making a visible difference. A Friends of the Parks nonprofit — nimble, community-driven, and unencumbered by the formalities of public governance — is far better suited to this function. The Park Board holding dormant fundraising authority it does not use is not a reason to preserve that structure; it is a reason to transfer the function to an entity that can actually exercise it effectively.

2e. Stagnation Through Long Tenure

Several current Park Board members have served for a decade or more. Long service can reflect real dedication, and the Council should honor that sincerely. But an appointed body on which the same members serve for ten, fifteen, or twenty years — with five-year renewable terms — is a body that has become self-perpetuating rather than self-renewing. Fresh perspectives may not easily enter the room. New community demographics, new ideas about what parks can and should be, and new community priorities are harder to surface when membership has been stable for a generation.

This is not about any individual. It is about what happens to any institution — in government or anywhere else — when the same people shape its priorities for too long without rotation. A Friends of the Parks organization, structured from the beginning with meaningful term limits and a culture of leadership development, can avoid this entirely. It is an opportunity to build something that stays fresh.

2f. The Right Tool for the Right Job

None of this diminishes the importance of Richland Center's parks or the community's investment in them. The argument is precisely the opposite: because parks matter, they *deserve* governance structures that actually work. The Park Board model made sense when cities needed a semi-autonomous body to actively expand and develop their park systems. That season, for Richland Center, has passed.

What the parks need now is efficient operational management under the City Administrator, clear permit authority vested in an identifiable body, and an energized community organization that can raise funds, recruit volunteers, and advocate for the parks in ways a governmental board never can. Dissolving the Park Board and establishing a Friends organization delivers exactly that combination.

A Note of Respect for Current Members

- This is a structural decision about governance design, not an evaluation of any individual's performance or commitment.
- The Council should acknowledge the service of current board members genuinely and directly. A formal resolution of thanks, adopted at the same meeting as the dissolution ordinance, is appropriate.
- Current Park Board members are among the strongest candidates to become founding leaders of the Friends of the Parks organization. They know the parks, they care about them, and they should be actively encouraged to carry that commitment forward in this new form.

3. What the Board of Park Commissioners Currently Does Under City Code

Before any ordinance action, every legal function the Park Board holds must be identified and affirmatively reassigned. None of these functions disappear with dissolution — they must each be transferred to a new authority within city government.

3a. General Governing Authority — Chapters 50 and 701

Chapter 50.01 (*Ord. 2016-1*) vests the Park Board with general government, management, control, improvement, and care of all city parks, parkways, and pleasure drives. Chapter 701.01(a) extends all powers and duties under Wis. Stat. § 27.08. The Council retains the right to supersede by ordinance or resolution under Wis. Stat. § 62.11(5) — and that is precisely the authority it will exercise here.

3b. Direct Personnel Supervision — Chapter 701.01(b)

The Park Board directly supervises the Parks and Grounds Director (now called Parks & Recreation Director), who in turn oversees all park employees and daily operations. (*Ch. 701.01(b)*) Hiring, firing, and extraordinary discipline are reserved to the Council. After dissolution, this supervisory role reverts cleanly to the City Administrator.

3c. Independent Financial Authority — Chapter 50.10

The Park Board may spend Park Fund money (gifts and subscriptions) without Council approval (*Ch. 50.10(1)*) and must submit a budget estimate to the Council by September 1 and a full annual financial and inventory report by the end of March each year. (*Ch. 50.09*)

3d. Permit-Issuing Authority — Chapter 701

This is the most operationally critical function and the most consequential gap that dissolution will create without amendment. Chapter 701 names the Board of Park Commissioners — also referred to in that chapter as the 'Parks and Grounds Commission' — as the permit-issuing authority for the following activities. No fallback authority currently exists in the code:

Permitted Activity	Current Authorizing Body in Ch. 701
Advertising / signage in parks	Board of Park Commissioners — Ch. 701.03(1)(a)
Sound amplification in parks	Board of Park Commissioners — Ch. 701.03(1)(b)
Vehicles on park walkways / non-road areas	Board of Park Commissioners — Ch. 701.03(9)(a)
Snowmobile trail designation	Parks Board — Ch. 701.03(9)(b)
Parking in non-standard areas	Parks and Grounds Commission — Ch. 701.03(10)
Sale of merchandise or services in parks	Parks and Grounds Commission — Ch. 701.03(6)
Camping in parks	Parks and Grounds Commission — Ch. 701.03(7)
Swimming facility use and fees	Parks and Grounds Commission — Ch. 701.03(11)
Alcohol in parks (picnic license)	Common Council or Parks and Grounds Commission — Ch. 701.04(2)

3e. Cemetery Coordination — Chapter 702

Under *Chapter 702.02(2)*, the Public Works Committee of the Common Council oversees the city cemeteries in coordination with the Board of Park Commissioners. Burial fees are set jointly. (*Ch. 702.03(2)*) After dissolution, Chapter 702 must be amended to remove the Park Board’s role and vest the cemetery coordination function entirely in the Public Works Committee or the City Administrator.

3f. Intergovernmental Appointment — Chapter 50.02(2)

One Park Board seat belongs to a Richland County Board member, appointed by the County Board Chair for a two-year term. (*Ch. 50.02(2)*) Dissolution terminates this intergovernmental appointment. The County Board Chair should receive written notice before action is taken.

3g. Chapter 704 Boundary Definition

Chapter 704 defines the Public Works Committee's jurisdiction as all city properties "*other than those properties assigned to the Park Board under chap. 701.*" (Ch. 704.01(2)) Dissolving the Park Board without amending Chapter 704 would cause parks to silently fall under the Public Works Committee's catch-all at Ch. 704.02(p). The Council must decide whether that is the intended structure and amend the chapter explicitly.

4. Functions That Must Stay in City Government

A Friends of the Parks organization is a private nonprofit. It has no governmental authority. The following functions currently held by the Park Board must be reassigned to a city body — not to the Friends group under any circumstances:

Cannot Be Delegated to a Friends Group

- Issuing park permits (advertising, sound amplification, vehicles, merchandise, camping, swimming fees, and alcohol licenses)
- Supervising the Parks and Grounds Director and park employees
- Setting burial fees for city cemeteries
- Receiving, holding, or expending the Park Fund — this is public money held by the City Clerk/Treasurer
- Submitting the annual park budget estimate and annual financial/inventory report to the Common Council
- Any exercise of authority under Wis. Stat. Ch. 27.08

5. Reassigning Park Board Functions After Dissolution

The Council may reassign Park Board functions to the Public Works Committee as significant overlap already exists.

Recommended Reassignment: Public Works Committee Absorbs Park Oversight

Amend Chapters 701, 702, and 704 to extend the Public Works Committee's authority to include parks. Chapter 704's catch-all at Ch. 704.02(p) would naturally absorb parks under this approach, but should be made explicit.

- **Pros:** Consolidates all city property oversight in one committee; significant overlap currently exists; minimal new structure; straightforward to implement
- **Cons:** Parks are a distinct public-facing civic function from utility and infrastructure management; combining them risks parks becoming secondary in a committee focused on heavier operational concerns; no dedicated park voice or community focus at the committee level

Recommended Approach: Staff Permit Delegation

The most important operational change is to delegate routine permitting authority to the City Administrator or Parks & Recreation Director by ordinance. The vast majority of park permit requests involve predictable, low-stakes decisions: events, signage, temporary vehicle access, alcohol licenses, and similar matters. These should not require a committee meeting. Staff-level permit authority with defined parameters is standard practice in Wisconsin cities of Richland Center’s size and is fully consistent with the administrator form of governance.

Significant policy-level decisions like permanent infrastructure, fee schedules, and major commercial events would come to the full Council and/or the Public Works Committee. But the routine work of keeping parks open and active should be handled at the administrative level, efficiently and without delay.

6. Ordinance Amendments Required for Dissolution

The following chapters must be amended as a coordinated package. The City Attorney should prepare all of them together and present them for a single vote to avoid creating internal code inconsistencies.

Chapter	Current Park Board Reference	Required Amendment
Ch. 50	Establishes the Board of Park Commissioners in its entirety: composition, terms, officers, quorum, powers, budget process, and finance authority	Repeal Chapter 50 in full; assign all residual functions (budget reporting, Park Fund oversight) to the City Administrator and Common Council by ordinance
Ch. 701	Vests Park management in the Park Board (Ch. 701.01); names the Board and 'Parks and Grounds Commission' as permit authority throughout Ch. 701.03 and Ch. 701.04; provides for direct Park Board supervision of the Parks Director	Amend Ch. 701.01 to vest management in the Council and operations in the City Administrator; amend all permit provisions to name the City Administrator, Parks & Recreation Director, or Public Works Committee; standardize terminology throughout
Ch. 702	Public Works Committee coordinates cemetery operations with the Park Board (Ch. 702.02(2)); both jointly set burial fees (Ch. 702.03(2))	Remove all Park Board references; vest cemetery coordination and fee-setting in the Public Works Committee alone or in the City Administrator under Public Works Committee oversight
Ch. 704	Public Works Committee jurisdiction defined as all city properties other than those assigned to the Park Board (Ch. 704.01(2)); parks are currently excluded from the Public Works Committee domain	Amend Ch. 704.01(2) to reflect the new park governance model; do not rely on the catch-all at Ch. 704.02(p) — make the assignment explicit

Note on 'Parks and Grounds Commission' Language in Chapter 701

- Chapter 701 inconsistently uses both 'Board of Park Commissioners' and 'Parks and Grounds Commission' as the permit-issuing authority. These appear to be the same entity referred to by different names within the same chapter.
- The amendment to Chapter 701 should eliminate both names and replace them throughout with the single successor authority — whether that is the City Administrator, Parks & Recreation Director, or Public Works Committee.
- The City Attorney should confirm there is no separately established 'Parks and Grounds Commission' distinct from the Park Board.

7. The Park Fund — Disposition Before Dissolution

Under *Chapter 50.10(1)*, the City Clerk/Treasurer holds the Park Fund — money received through subscriptions and gifts — in a separate account under the Park Board’s authority. Before dissolution, the Council must formally address what happens to any balance in this fund.

Appropriate options include:

- Transfer the balance to the city’s general park operations budget
- Establish a new city-held parks capital fund under Council or Administrator oversight, preserving donor intent
- A combination: retain a parks-designated city account with spending authority vested in the City Administrator subject to Council approval under normal appropriations rules

Park Fund Is Public Money

- The Park Fund balance belongs to the city. Any transfer to a future Friends group would be a public expenditure requiring Council authorization.
- If the Council wishes to provide the Friends group with seed funding as a gesture of support, it may do so by separate resolution — but this should be a deliberate, documented decision, not an automatic transfer.
- Going forward, private donations intended for city parks should be directed to a city-held account for proper public accounting.

8. Phase 1 Dissolution Timeline

This timeline covers Phase 1 only. The Friends group formation is Phase 2, a separate and subsequent community process.

Months 1-2	Legal audit and Council decision City Attorney audits all Park Board references across Chapters 50, 701, 702, and 704. Council votes to proceed with dissolution. City Administrator documents the
-------------------	--

Months 2-3	<p>current Park Fund balance. County Board Chair notified in writing of intended dissolution of the intergovernmental seat.</p> <p>Draft ordinance package</p> <p>City Attorney prepares coordinated amendments to Chapters 50, 701, 702, and 704. Council selects governance model. Scope of staff-level permit delegation determined. Draft reviewed internally.</p>
Month 3	<p>Public process</p> <p>Ordinance package introduced at a Council meeting. Public notice issued. Formal public hearing conducted. Current Park Board members individually notified by Mayor or Council President before the public announcement.</p>
Month 4	<p>Passage and notification</p> <p>Council votes on ordinance package. Resolution of thanks for Park Board members adopted at the same meeting. City code updated and published. City Administrator assumes operational authority over park staff. Parks & Recreation Director assumes delegated permit authority under new Ch. 701 provisions.</p>
Month 4+	<p>Dissolution complete</p> <p>All park functions operating under new governance structure. Park Fund disposition completed by Council resolution. Cemetery ordinance operating without Park Board reference. New committee or Public Works Committee schedules first park review session.</p>

9. Phase 2: Establishing a Friends of the Parks Organization

After the Park Board is dissolved and park governance is operating cleanly under the new structure, interested community members may organize a nonprofit Friends of the Parks. This is a community initiative, not a city project. The founding energy and leadership must come from private citizens, not from city hall.

The city’s role in Phase 2 is to be an informed, communicative partner: sharing information about park needs and priorities, providing a designated city liaison, and formalizing the relationship through a Memorandum of Understanding once the group is established. City officials should not hold officer positions in the Friends group, fund its startup operations, or direct its activities.

What the Friends Group Can and Cannot Do

Friends Group CAN Do	Friends Group CANNOT Do
Raise private funds through donations, events, memberships, and grants	Issue park permits of any kind
Apply for grants not available to municipal governments (e.g., DNR Stewardship)	Supervise city employees

Organize volunteers for park maintenance and beautification (with city approval)	Hold or administer the Park Fund or any city account
Advocate publicly for the parks budget at Council budget sessions	Make binding decisions about park use, access, or programming
Propose capital improvements to the Council or City Administrator	Act as a formal city advisory board without a separate Council ordinance
Host events in parks (with a city permit, same as any other organization)	Represent the city or county in any governmental capacity
Build a donor base and durable civic investment in the parks	Spend public money or bind the city to any obligation

Formation Steps

Step 1	<p>Recruit founding members</p> <p>Identify 5-10 committed community volunteers. Former Park Board members are strong candidates and should be actively encouraged to lead this effort. Also consider parents active in park programs, local business owners, and civic group members. City officials may participate as private citizens but should not dominate early leadership.</p>
Step 2	<p>Name and bylaws</p> <p>Choose a name (e.g., 'Friends of Richland Center Parks'). Draft bylaws with term limits, succession provisions, officer roles, voting procedures, and meeting requirements. Build renewal mechanisms in from the beginning. Templates at wnonprofit.org.</p>
Step 3	<p>Incorporate in Wisconsin</p> <p>File Articles of Incorporation with the Wisconsin DFI (wdfi.org). Fee: \$35 online. Creates the legal entity.</p>
Step 4	<p>Federal EIN</p> <p>Obtain an Employer Identification Number at irs.gov. Free. Required to open a bank account.</p>
Step 5	<p>IRS 501(c)(3) status</p> <p>File Form 1023-EZ (for groups with projected revenue under \$50,000/year; fee: \$275; typically 2-4 weeks to approval). This enables tax-deductible donations and access to most grant programs.</p>
Step 6	<p>Bank account</p> <p>Open at a local bank. Require dual signatures on checks above a set threshold. Elect a treasurer with relevant financial background.</p>
Step 7	<p>DATCP registration</p> <p>Register with Wisconsin DATCP as a charitable organization soliciting public donations (datcp.wi.gov). Annual renewal required.</p>

Step 8	<p>MOU with the city</p> <p>Work with the City Administrator to draft a Memorandum of Understanding defining volunteer access, project approval, permit requirements, insurance, and the city liaison relationship. Present to the Common Council for approval.</p>
---------------	--

10. Memorandum of Understanding: City and Friends Group

Once the Friends group has been organized and has obtained 501(c)(3) status, the city and the Friends group should execute a formal MOU approved by the Common Council. This document protects both parties and establishes clear mutual expectations.

MOU Topic	What to Address
Volunteer access to parks	When and how volunteers may enter park facilities; who supervises them on-site; signed liability waivers required before any volunteer work begins
Project approval	How the Friends group proposes physical improvements; who approves before work begins; whether city procurement rules apply to donated labor or materials on city property
Donated funds and capital improvements	How donations reach the city (direct gift vs. Friends paying contractors); whether Council must formally accept donated capital improvements; documentation requirements
City in-kind support	What the city may provide (equipment loans, waste disposal, meeting space); what it will not provide; no expectation of cash subsidy
Permit requirements	Confirmation that the Friends group must obtain city permits for events and activities in parks, the same as any other organization — no exemptions
City liaison	Named city contact (Parks & Recreation Director); liaison attends Friends meetings as a resource, not a voting member; defined channel for project requests and questions
Insurance	Whether city liability insurance covers Friends volunteer activities; if not, the Friends group must carry its own general liability policy
Financial reporting	Friends group provides an annual financial summary to the city liaison; transparency as a foundation for the relationship
Term and exit	Duration of MOU (typically 1-3 years, renewable); how either party may exit with notice; what happens if the Friends group becomes inactive or dissolves

11. Risk Management

Risk	Why It Is Specific to Richland Center	Mitigation
Permit-issuing vacuum	Ch. 701 names the Park Board as the permit authority for 9+ activity types with no fallback provision in the current code	Do not dissolve the Park Board until Ch. 701 is amended and the new permit authority is designated and operational; this is the single most important sequencing requirement
Cemetery fee-setting gap	Ch. 702 requires joint Park Board and Public Works Committee involvement in setting burial fees	Amend Ch. 702 before dissolution; vest fee-setting in the Public Works Committee alone or in the City Administrator under Public Works Committee oversight
County relationship disruption	The County Board Chair holds a formal appointment to the Park Board; dissolution terminates this without County input	Notify County Board Chair in writing at least 60 days before the dissolution vote; acknowledge the County's historical role; invite the County to informally support the future Friends group
Park Fund disposition	The Park Fund is public money whose governance authority disappears with the Park Board; its status after dissolution is undefined without Council action	Council must pass a resolution addressing the Park Fund before or concurrent with dissolution; document the disposition clearly
Ch. 704 catch-all ambiguity	Dissolving the Park Board without amending Ch. 704 causes parks to silently fall under the Public Works Committee via the catch-all at Ch. 704.02(p)	Amend Ch. 704 explicitly with the intended park oversight structure; do not rely on implied jurisdiction for a deliberate governance decision
Community perception	The Park Board has a long history and visible presence; residents may misread dissolution as the city abandoning its parks	Lead with strong public messaging; maintain or increase the parks operational budget; be clear that oversight and permit authority remain in city government; recognize outgoing members publicly
Friends group sustainability	Small volunteer nonprofits are vulnerable to founder departure; organizations built around one champion often stall when that person steps back	Require succession planning in bylaws from day one; city liaison should actively support leadership development; Friends group should broaden its board and donor base in its first year

12. Communicating the Transition to the Public

This transition will attract attention. The parks are visible, the Park Board has a long history, and any change to park governance will prompt questions. A clear, proactive, and honest communication plan is essential — not to manage the narrative, but to give residents the full picture.

Core Messages

- The city's commitment to its parks is unchanged. City staff will continue to operate and maintain all park facilities at the same level of service.
- The Park Board's governmental functions are not disappearing — they are being reassigned within city government to bodies that are better aligned with how the city is structured.
- The Park Board structure, while well-intentioned, no longer fits how the city is governed or what the parks actually need right now.
- A Friends of the Parks nonprofit can do things for the parks that a governmental board simply cannot: raise private funds, attract grants, recruit volunteers, and build genuine civic energy around the parks.
- The parks budget is not being reduced. The Friends group supplements city investment; it is not a substitute for it.

Recommended Communication Steps

1. Notify current Park Board members individually and directly before any public announcement. They should not hear about this from Rants and Chats.
2. Notify the Richland County Board Chair in writing about the dissolution of the intergovernmental seat.
3. Announce the Council's intent at a public meeting before ordinances are introduced. Explain the reasoning plainly and invite questions from the public.
4. Publish a clear explanation in the Richland Observer and through city social media channels.
5. At the meeting where the dissolution ordinance passes, adopt a concurrent resolution thanking each Park Board member by name.
6. Issue a follow-up public statement after dissolution identifying which city body holds park permitting and oversight, so residents know where to go.
7. When the community organizes a Friends group, recognize them at a Council meeting as a positive civic development.

13. Final Checklist

Phase 1: City Government — Before and During Dissolution

- City Attorney has audited Chapters 50, 701, 702, and 704 for all Park Board and Parks and Grounds Commission references
- Council has selected governance model (Parks Committee of the Council vs. Public Works Committee extension)
- Scope of staff-level permit delegation determined and documented for Ch. 701 amendments
- Ordinance package amending Chapters 50, 701, 702, and 704 drafted, reviewed, and introduced
- Park Fund balance documented; Council resolution on disposition drafted
- County Board Chair notified in writing (minimum 60 days before Council vote)
- Current Park Board members individually notified before public announcement

- Public hearing on ordinance package conducted
- Resolution of thanks for Park Board members prepared
- Ordinance package passed and resolution of thanks adopted at the same meeting
- City code updated and published
- City Administrator assumes park personnel supervision; Parks Director assumes delegated permit authority
- Park Fund disposition completed by separate Council resolution

Phase 2: Friends Group Formation (Community-Led, Post-Dissolution)

- Founding members recruited from community (minimum 5-7; majority not city employees or elected officials)
- Name chosen and checked for conflicts
- Bylaws drafted and adopted — must include term limits and succession provisions
- Articles of Incorporation filed with Wisconsin DFI (\$35 online at wdfi.org)
- Federal EIN obtained from IRS (free, at irs.gov)
- IRS Form 1023-EZ filed for 501(c)(3) status (\$275 fee)
- Bank account opened; dual-signature requirement on checks above set threshold
- Wisconsin DATCP charitable organization registration completed
- MOU with city negotiated and approved by Common Council
- Annual compliance calendar established (990-N filing, DATCP renewal, DFI annual report, MOU review)

14. Key Resources

Resource	Contact / Use
Wisconsin Nonprofit Association	wnonprofit.org — bylaws templates, board governance guides, nonprofit startup resources
Wisconsin DFI (Incorporation)	wdfi.org — Articles of Incorporation online, \$35; annual report requirement (\$10/year)
IRS Form 1023-EZ	pay.gov — 501(c)(3) application for groups projecting revenue under \$50,000/year; \$275 fee
Wisconsin DATCP	datcp.wi.gov — charitable organization registration; required for any group soliciting public donations
Wisconsin DNR Stewardship Grants	dnr.wi.gov/topic/Stewardship — outdoor recreation capital grants; city is typically the applicant with Friends as community partner
Southwest Wisconsin Community Foundation	swwcf.org — serves Crawford, Iowa, Richland, and Vernon counties; well-suited to local park improvement projects

USDA Rural Development — Wisconsin	rd.usda.gov/wi — Community Facilities grants for smaller municipalities
Wis. Stat. Ch. 27.08	Full statutory text governing municipal park board authority; governs scope of Park Board powers and dissolution implications
Wis. Stat. Ch. 62.11(5)	Council’s plenary authority to supersede the Park Board by ordinance or resolution — the direct legal basis for dissolution

City of Richland Center, Wisconsin

This guide is a working document prepared to inform Council deliberations.

DRAFT

**CITY OF RICHLAND CENTER
ORDINANCE NO. 2026 - 05**

AN ORDINANCE DISSOLVING THE CITY TOURISM DEPARTMENT AND THE TOURISM COMMISSION

WHEREAS, the City of Richland Center (the "City") is a fourth-class city duly organized and existing under the laws of the State of Wisconsin, including Chapter 62 of the Wisconsin Statutes; and

WHEREAS, the City has established a Tourism Department as an administrative unit of City government responsible for functions relating to tourism promotion and tourism development within the City; and

WHEREAS, the City has also established a Tourism Commission to assist in the oversight and direction of tourism-related activities and room tax expenditures; and

WHEREAS, the Common Council has reviewed the City's current tourism governance structure and has determined, in the exercise of its legislative discretion, that the Tourism Department and the Tourism Commission no longer serve a necessary municipal function and that their continued operation is not required by state law or by the City's municipal code; and

WHEREAS, Wis. Stat. § 66.0615(1m)(b)1. expressly provides that a single municipality imposing a room tax "may" create a tourism commission, and the use of permissive language confirms that maintenance of a tourism commission is not a statutory obligation for a municipality acting alone; and

WHEREAS, the Common Council finds that the orderly dissolution of the City Tourism Department and the City Tourism Commission, with appropriate transition provisions for personnel, records, assets, and pending obligations, is in the best interest of the City of Richland Center.

NOW, THEREFORE, THE COMMON COUNCIL OF THE CITY OF RICHLAND CENTER, RICHLAND COUNTY, WISCONSIN, DOES ORDAIN AS FOLLOWS:

Section 1. *Dissolution of the City Tourism Department.* Effective May 1, 2026, the City of Richland Center Tourism Department is hereby dissolved and abolished as an administrative department of City government. All functions, duties, and responsibilities previously assigned to the Tourism Department are hereby terminated, except as necessary to fulfill existing obligations as provided in Section 4 of this Ordinance.

Section 2. *Dissolution of the City Tourism Commission.* Effective May 1, 2026, the City of Richland Center Tourism Commission is hereby dissolved and abolished. All terms of office of current members of the Tourism Commission shall terminate on such date. The dissolution of the Tourism Commission shall not affect the City's authority or obligation to collect room tax pursuant to Wis. Stat. § 66.0615, nor shall it affect the City's obligation to expend the required percentage of room tax revenues on tourism promotion and tourism development as required by law.

Section 3. *Amendment of the Municipal Code.* All provisions of the Code of Ordinances shall be removed or amended that reference, establish, or prescribe the duties of the Tourism Department or the Tourism Commission, consistent with the dissolution effected by this Ordinance.

Section 4. *Transition Provisions.* The City Administrator is authorized and directed to take all steps necessary and appropriate to effectuate an orderly transition, including: (a) the reassignment, transfer, or separation of any City employees or contracted personnel previously employed in or assigned to the Tourism Department, consistent with applicable employment law and City personnel policy; (b) the

transfer, archiving, or disposition of all records, files, data, equipment, and other assets previously held or used by the Tourism Department or the Tourism Commission; and (c) the fulfillment and termination of any outstanding vendor contracts, service agreements, or other obligations previously entered into on behalf of the Tourism Department or Tourism Commission, subject to the terms of those agreements and applicable law.

Section 5. Room Tax Authority Unaffected. Nothing in this Ordinance shall be construed to repeal, limit, or otherwise affect the City's authority to impose, collect, and administer a room tax pursuant to Wis. Stat. § 66.0615, or the City's obligation to expend room tax revenues in accordance with that statute. The Common Council retains full authority over the collection and direction of room tax revenues following the dissolution of the Tourism Department and Tourism Commission.

Section 6. Savings Clause. The dissolution of the City Tourism Department and City Tourism Commission shall not impair or affect: (a) any civil or contractual liability incurred by the City, the Tourism Department, or the Tourism Commission prior to the effective date of this Ordinance; (b) any pending administrative or legal proceedings to which the Tourism Department or Tourism Commission is a party; or (c) any right or obligation of any person arising under any contract or agreement entered into with the Tourism Department or Tourism Commission prior to the effective date of this Ordinance. Any such liabilities, proceedings, rights, and obligations shall be assumed by and transferred to the City of Richland Center and administered by the appropriate City officer as directed by the City Administrator.

Section 7. Severability. If any provision of this Ordinance or its application to any person or circumstance is held to be invalid or unconstitutional by a court of competent jurisdiction, such invalidity shall not affect the remaining provisions of this Ordinance, which shall continue in full force and effect.

Section 8. Effective Date. This Ordinance shall take effect on May 1, 2026, following passage and publication as required by law.

ADOPTED by the Common Council of the City of Richland Center, on this 21st day of April, 2026, by the following vote: AYES:_____, NOS:_____

CITY OF RICHLAND CENTER
RICHLAND COUNTY, WISCONSIN

Karin Tepley, Mayor
Attest:

Misty D. Molzof, Deputy Clerk

CERTIFICATE OF PUBLICATION

I, Misty D. Molzof, Deputy Clerk of the City of Richland Center, Richland County, Wisconsin, hereby certify that the foregoing Ordinance No. 2026-05 was published in the Richland Observer, a newspaper of general circulation in the City, on _____, 2026, as required by Wis. Stat. § 62.11(4).

Deputy Clerk

Agenda Item: Tourism Services Agreement

Meeting Date: Council on 4/21/2026

Requested by: Ashley Oliphant, City Administrator

Background: Wisconsin Stat. § 66.0615 requires municipalities to forward at least 70% of room tax revenues to a qualified tourism entity for tourism promotion and development. The Greater Richland Tourism Corporation ("GRTC") is a newly organized Wisconsin nonprofit that meets those qualifications and will serve as the City's designated tourism entity.

The proposed two-year Tourism Services Agreement establishes the terms for forwarding room tax revenues to GRTC, along with performance standards and accountability measures. The City will also make the Visitor Center/Railroad Depot at 397 W. Seminary Street available to GRTC at no rental cost; GRTC is responsible for utilities.

Key Agreement Terms:

Term	Detail
Initial Term	Two (2) years, effective May 1, 2026; auto-renews in one-year increments
Room Tax Forwarding	70% of quarterly collections, paid within 45 days of quarter-end
Required Events	Dairy Days & Rodeo Parade; Canyon of Lights Parade
Reporting — Quarterly	Written report to City Clerk within 30 days of each quarter-end
Reporting — Annual	Comprehensive Annual Report by Mar 31; in-person Council presentation by Jul 30
Marketing Plan	Preliminary plan by September 1; final plan by November 1 of each year
Insurance	\$1M/\$2M general liability; statutory workers' comp; City named as add'l insured
Audit Rights	City may audit GRTC financial records with 10-business-day advance written notice
Termination	30-day written notice with opportunity to cure; 90-day written notice by either party

Department Recommendation: To execute the Tourism Services Agreement as presented.

Financial Impact: No change in cost to the City. 70% of total room tax collected will now be forwarded to GRTC rather than to the City's Tourism Commission. The City will make the Visitor Center/Railroad Depot (397 W. Seminary St.) available to GRTC at no rental cost; GRTC is responsible for utilities.

Funding Source: 70% of room tax revenues collected each quarter will be forwarded to GRTC within 45 days following quarter-end. No general fund appropriation is required to execute this Agreement.

Suggested Action:

FINANCE: Motion to recommend Council approval of the Tourism Services Agreement between the City of Richland Center and the Greater Richland Tourism Corporation, effective May 1, 2026, and to authorize the execution of the Agreement.

COUNCIL: Motion to approve the Tourism Services Agreement between the City of Richland Center and the Greater Richland Tourism Corporation, effective May 1, 2026, and to authorize the execution of the Agreement.

Attachments: Tourism Services Agreement

TOURISM SERVICES AGREEMENT

BETWEEN THE CITY OF RICHLAND CENTER, WISCONSIN AND THE GREATER RICHLAND TOURISM CORPORATION

Effective Date: May 1, 2026

RECITALS

WHEREAS, the City of Richland Center, Wisconsin ("City") is authorized under Wis. Stat. § 66.0615 to impose a room tax on the furnishing of rooms by lodging operators within the City; and

WHEREAS, Wisconsin law requires that at least seventy percent (70%) of room tax revenues collected by a municipality shall be forwarded to a qualified tourism entity for use in tourism promotion and tourism development; and

WHEREAS, the Greater Richland Tourism Corporation ("GRTC") is a Wisconsin nonprofit corporation newly organized to serve as the tourism entity for the City of Richland Center, and meets the applicable requirements of Wis. Stat. § 66.0615(1)(f) as a nonprofit organization that spends at least 51 percent of its revenues on tourism promotion and tourism development and provides destination marketing staff and services for the tourism industry; and

WHEREAS, the City and GRTC desire to enter into this Agreement to set forth the terms under which room tax revenues will be forwarded to GRTC and to establish clear expectations, performance standards, and accountability measures;

NOW, THEREFORE, in consideration of the mutual promises contained herein, the parties agree as follows:

SECTION 1 — PARTIES AND STATUTORY BASIS

1.1 Parties. This Agreement is between the City of Richland Center, a Wisconsin municipal corporation ("City"), and the Greater Richland Tourism Corporation, a Wisconsin nonprofit corporation ("GRTC").

1.2 Statutory Authority. This Agreement is entered into pursuant to Wis. Stat. § 66.0615, which authorizes municipalities to impose a room tax and requires that a designated portion be forwarded to a tourism entity for tourism promotion and tourism development.

1.3 Tourism Entity Status. GRTC represents and warrants that it qualifies as a "tourism entity" within the meaning of Wis. Stat. § 66.0615(1)(f) as a nonprofit organization that spends at least 51 percent of its revenues on tourism promotion and tourism development and provides destination marketing staff and services. GRTC shall maintain this status throughout the term of this Agreement and shall promptly notify the City if its qualification status changes.

SECTION 2 — TERM

2.1 Initial Term. This Agreement shall be effective as of the date last signed below and shall continue for an initial term of two (2) years, unless earlier terminated as provided herein.

2.2 Renewal. This Agreement shall automatically renew for successive one-year terms unless either party provides written notice of non-renewal at least sixty (60) days before the end of the then-current term.

2.3 Annual Review. The City Council shall review GRTC's performance annually in conjunction with the Annual Report described in Section 6 and may adjust funding levels or terms for any renewal term by written amendment.

SECTION 3 — ROOM TAX FUNDING

3.1 Forwarding of Funds. The City shall forward to GRTC seventy percent (70%) of the room tax revenues collected each quarter, consistent with the requirements of Wis. Stat. § 66.0615(1m)(d).

3.2 Payment Schedule. The City shall forward funds to GRTC within forty-five (45) days following the end of each calendar quarter (i.e., by May 15, August 15, November 15, and February 15). Each payment shall be accompanied by a written statement showing the total room tax collected for the quarter and the amount forwarded.

3.3 Eligible Uses. GRTC shall use room tax revenues received under this Agreement solely for tourism promotion and tourism development, as those terms are defined in Wis. Stat. § 66.0615(1). Eligible uses include, but are not limited to:

- Marketing and advertising designed to attract overnight visitors to the Richland Center area;
- Development and distribution of visitor guides, maps, digital content, and promotional materials;
- Support for tourism-related events, festivals, and activities that generate overnight stays;
- Visitor information services and staffing;
- Tourism research, data collection, and strategic planning;
- Partnerships with regional, state, and national tourism organizations.

3.4 Prohibited Uses. Room tax revenues shall not be used for:

- Construction or development of a lodging facility (Wis. Stat. § 66.0615(1m)(d)5.);
- General operating expenses of GRTC that are unrelated to tourism promotion and development;
- Political contributions or lobbying activities;
- Personal benefit to officers, directors, or employees beyond reasonable compensation for services rendered.

3.5 Fund Accounting. Room tax revenues received under this Agreement need not be held in a separate bank account but shall be accounted for in a dedicated fund within GRTC's financial records, kept distinct from all other GRTC revenues and expenditures. GRTC may pool room tax funds with other operating cash for banking purposes, provided that its books and records clearly track the receipt, balance, and expenditure of room tax funds at all times and that such tracking is reflected in all quarterly and annual reports submitted to the City.

SECTION 4 — SCOPE OF SERVICES AND PERFORMANCE EXPECTATIONS

4.1 Core Services. GRTC shall perform the following services in support of tourism promotion and development within the City of Richland Center and the greater Richland County area:

(a) Destination Marketing. Develop and implement an annual marketing plan promoting Richland Center as a visitor destination, including digital marketing, social media, print, and cooperative advertising with state and regional partners such as Wisconsin Department of Tourism.

(b) Visitor Services. Maintain accessible visitor information services, which may include a visitor center, website, and telephone/email inquiry response, providing timely and accurate information to prospective visitors.

(c) Event Support. Actively support and help develop tourism-generating events and activities that attract overnight visitors and increase room tax revenue. GRTC shall specifically provide promotional and organizational support for the following community events: Dairy Days and Rodeo Parade, and Canyon of Lights Parade. Support for these named events is a required obligation under this Agreement and shall be reflected in each annual marketing plan. To the extent that participation in or support of these named events requires event liability insurance coverage, the City shall provide or arrange for such coverage through its municipal insurance program; GRTC shall cooperate with the City's insurer as reasonably requested and shall provide advance notice to the City Clerk of any GRTC-organized activities associated with these events so that appropriate coverage can be confirmed.

(d) Stakeholder Coordination. Collaborate with local lodging operators, restaurants, retailers, and other tourism-related businesses to strengthen the overall visitor experience.

(e) Annual Marketing Plan. By September 1 of each year, GRTC shall submit to the City a written preliminary marketing and operational plan for the upcoming year, including a proposed budget and priority initiatives. The preliminary plan is intended to inform the City's annual budget deliberations. By November 1 of each year, GRTC shall submit a final marketing and operational plan and budget for the upcoming year, incorporating any feedback received from the City following submission of the preliminary plan. The final plan and budget shall govern GRTC's operations and expenditures for the upcoming year and shall serve as the performance baseline against which GRTC's activities are measured in quarterly and annual reports.

4.2 Performance Measures. GRTC shall track and report the following metrics to the City at minimum:

Performance Metric	Description / Benchmark
Room Tax Revenue Trend	Track total room tax collected by the City year-over-year; GRTC efforts should support stable or growing revenue.
Visitor Inquiries	Track volume of visitor inquiries received via all channels (phone, email, web, walk-in) annually.
Website & Digital Engagement	Report annual website visits, social media reach/followers, and digital ad impressions.
Events Supported	Number and estimated attendance of tourism-generating events supported or co-sponsored.
Marketing Expenditures	Document that at least 51% of GRTC total revenues are spent on tourism promotion and development, as required by statute.
Media & PR Value	Track earned media coverage and estimated publicity value for Richland Center.
Partner Collaborations	Number of active partnerships with state, regional, or local tourism organizations.

4.3 Annual Marketing Plan Submission. GRTC shall submit a written annual marketing and operational plan to the City no later than September 1 of each year for the following calendar year. The plan shall include a proposed budget, priority initiatives, and intended performance benchmarks for the coming year.

SECTION 5 — GOVERNANCE AND FINANCIAL MANAGEMENT

5.1 Nonprofit Status. GRTC shall maintain its status as a Wisconsin nonprofit corporation and its federal tax-exempt status throughout the term of this Agreement.

5.2 Board Composition. GRTC's board of directors shall include representation from the lodging industry and the broader business community of Richland Center. GRTC shall notify the City of any material change in board membership within thirty (30) days.

5.3 Conflict of Interest. GRTC shall adopt and maintain a conflict-of-interest policy applicable to its officers and directors and shall make it available to the City upon request.

5.4 Financial Controls. GRTC shall maintain books and records consistent with generally accepted accounting principles. GRTC shall retain all financial records related to room tax expenditures for a minimum of seven (7) years.

5.5 Audit Rights. The City reserves the right, upon reasonable advance written notice of not less than ten (10) business days, to audit or inspect any financial records, accounts, or documentation of GRTC relating to the receipt and expenditure of room tax revenues under this Agreement. GRTC shall cooperate fully with any such audit.

SECTION 6 — REPORTING REQUIREMENTS

6.1 Quarterly Written Reports

GRTC shall submit a written Quarterly Report to the City Clerk within thirty (30) days following the end of each calendar quarter (by April 30, July 31, October 31, and January 31). Each Quarterly Report shall include:

- A financial summary showing all room tax funds received and all expenditures made during the quarter, categorized by type of activity;
- A narrative summary of tourism promotion activities and initiatives undertaken during the quarter;
- Progress on performance metrics identified in Section 4.2;
- Any significant partnerships, events, or media placements;
- Any issues, concerns, or anticipated changes to programs or staffing.

6.2 Annual Written Report

GRTC shall submit a comprehensive Annual Report to the City Clerk no later than March 31 of each year covering the prior calendar year. The Annual Report shall include:

- A complete financial statement showing all revenues and expenditures, with documentation that at least 51% of total revenues were spent on tourism promotion and development;
- A year-end summary of all performance metrics from Section 4.2;
- Accomplishments, challenges, and lessons learned;
- A copy of any independent financial review or audit conducted;
- The proposed annual marketing plan for the current year (if not already submitted under Section 4.3).

6.3 Annual In-Person Presentation

GRTC's executive director (or designated representative) and at least one board member shall appear in person before the City Council or a designated City committee at least once per year — no later than July 30 — to present the Annual Report and respond to questions. The City may schedule this presentation at any regular or special City Council meeting. The presentation shall include at minimum:

- A summary of the prior year's activities, expenditures, and accomplishments;
- Performance metric results compared to prior year and to the annual plan;
- Goals and budget overview for the current year;

- An open question-and-answer period for Council members.

6.4 Special Reports

The City may request additional written or oral reports from GRTC on specific topics or expenditures at any time, and GRTC shall respond within fifteen (15) business days of such a request.

SECTION 7 — CITY OVERSIGHT AND COMPLIANCE

7.1 Compliance with Wis. Stat. § 66.0615. The parties acknowledge that this Agreement is intended to satisfy the City's obligations under Wis. Stat. § 66.0615(1m)(d) to forward the required percentage of room tax revenues to a qualified tourism entity. GRTC's performance under this Agreement must remain consistent with the requirements of that statute.

7.2 City Liaison. The City Clerk (or designee) shall serve as the primary City liaison to GRTC, and shall be responsible for receiving reports, facilitating communication, and bringing compliance matters to the City Council's attention.

7.3 Annual Funding Review. The City Council shall review GRTC's performance, annual report, and funding level on an annual basis. Funding may be adjusted for subsequent periods by resolution, subject to the 70% minimum required by state law.

7.4 Corrective Action. If the City determines that GRTC has not complied with the terms of this Agreement or with Wis. Stat. § 66.0615, the City shall provide written notice specifying the deficiency. GRTC shall have thirty (30) days to cure the deficiency or submit a written corrective action plan. Failure to cure may result in suspension of funding or termination under Section 9.

SECTION 8 — BRANDING AND CITY ACKNOWLEDGMENT

8.1 City Acknowledgment. In all significant marketing materials, publications, and campaigns funded in whole or in part by City room tax revenues, GRTC shall include a statement acknowledging that funding is provided by the City of Richland Center room tax. The specific form of acknowledgment is subject to agreement of the parties and need not be prominent but should be present.

8.2 Use of City Name. GRTC shall not use the City's official seal or represent itself as an agency of the City without prior written consent.

SECTION 9 — TERMINATION

9.1 Termination for Cause. Either party may terminate this Agreement for material breach by the other party upon thirty (30) days' written notice, provided that the breaching party has failed to cure the breach within the notice period.

9.2 Termination for Convenience. Either party may terminate this Agreement without cause upon ninety (90) days' written notice to the other party.

9.3 Loss of Qualifying Status. This Agreement shall terminate automatically if GRTC ceases to qualify as a tourism entity under Wis. Stat. § 66.0615(1)(f), unless the City waives this requirement in writing within thirty (30) days of receiving notice of the disqualifying change.

9.4 Effect of Termination. Upon termination, GRTC shall promptly return to the City any unspent room tax funds held in its dedicated account. Any funds already committed or expended for eligible purposes prior to the termination date shall not be subject to recapture.

SECTION 10 — GENERAL PROVISIONS

10.1 Independent Contractor Status. GRTC is an independent contractor and not an agent, employee, or department of the City. GRTC shall operate independently and maintain control over its own methods and means of performing the services described in this Agreement. Nothing in this Agreement shall be construed to create an employment relationship, partnership, or joint venture between the parties. GRTC is responsible for its own federal, state, and local tax obligations, including IRS Form 1099 reporting requirements.

10.2 Indemnification. The parties shall mutually indemnify and hold harmless each other, including their respective officials, officers, employees, and agents, from and against any claims, damages, losses, or expenses (including reasonable attorneys' fees) arising out of or resulting from the indemnifying party's negligent or wrongful acts or omissions in the performance of or failure to perform obligations under this Agreement, to the extent permitted by law.

10.3 Insurance. GRTC shall obtain and maintain, at its own expense, throughout the term of this Agreement the following minimum insurance coverage, consistent with the City of Richland Center Independent Contractors Policy (adopted August 5, 2025):

- **General Liability Insurance:** \$1,000,000 per occurrence and \$2,000,000 aggregate, covering bodily injury, property damage, and personal injury;
- **Workers' Compensation Insurance:** Statutory limits as required by Wisconsin law, with Employer's liability coverage of at least \$500,000 per accident for bodily injury or disease.

Certificates of insurance shall name the City of Richland Center as an additional insured and shall include a waiver of subrogation in favor of the City. GRTC's insurance company shall have no right to seek recovery from the City, its agents, employees, or insurers for any loss or damage arising from GRTC's performance of this Agreement to the extent such loss is covered by GRTC's insurance policies. GRTC shall provide updated certificates of insurance to the City Clerk upon request and upon any policy renewal. The City Administrator may require higher limits or additional coverage for high-risk or specialized activities.

10.3a Dispute Resolution. Disputes arising under this Agreement shall be resolved through mediation before either party initiates legal action. The cost of mediation shall be shared equally by both parties unless otherwise agreed during the mediation process.

10.4 Visitor Center / Railroad Depot. The City agrees to make available to GRTC the use of the City's Visitor Center/Railroad Depot facility located at 397 W. Seminary Street, Richland Center for the purpose of conducting GRTC's tourism operations and visitor services, at no rental cost to GRTC. GRTC shall be solely responsible for all utility costs associated with its occupancy and use of the facility, including but not limited to water, sewer, heat, electric, telephone, and internet services. The parties shall enter into a separate facility use agreement or license if necessary to address the specific terms of occupancy, maintenance responsibilities, and permitted uses. GRTC's use of the facility is a privilege contingent upon continued performance under this Agreement, and the City reserves the right to revoke access upon thirty (30) days' written notice or immediately upon termination of this Agreement.

Notwithstanding the foregoing, the parties recognize that GRTC is a newly formed organization during the initial two-year term of this Agreement and that utility costs at the Facility may present a financial burden that impairs GRTC's ability to carry out its tourism promotion and development obligations. If during the initial two-year term GRTC determines that utility expenses are materially impeding its ability to fulfill those obligations, GRTC may submit a written request to the City for financial assistance with utility costs. Any such request shall include documentation of the utility expenses incurred and an explanation of the operational impact. The City Council shall

consider the request at its next regularly scheduled meeting and may, in its sole discretion, provide supplemental financial assistance for utility expenses by separate resolution. Nothing in this paragraph creates an obligation on the part of the City to provide such assistance, and any assistance approved shall not be construed as a modification of GRTC's ongoing utility obligations under this Agreement or the Facility License Agreement.

10.5 Amendment. This Agreement may be amended only by a written instrument signed by authorized representatives of both parties.

10.6 Entire Agreement. This Agreement constitutes the entire agreement between the parties with respect to the subject matter hereof and supersedes all prior discussions, representations, and agreements.

10.7 Governing Law. This Agreement shall be governed by and construed in accordance with the laws of the State of Wisconsin. Any dispute arising under this Agreement shall be resolved in the courts of Richland County, Wisconsin, following the mediation process described in Section 10.3a.

10.8 Severability. If any provision of this Agreement is found to be invalid or unenforceable, the remaining provisions shall continue in full force and effect.

10.9 Notices. All notices under this Agreement shall be in writing and delivered by first-class mail, email with confirmation, or personal delivery to:

City of Richland Center
Attn: City Administrator
450 S Main St, Richland Center, WI 53581

Greater Richland Tourism Corporation
Attn: Executive Director
397 W. Seminary Street, Richland Center, WI 53581

SIGNATURES

IN WITNESS WHEREOF, the parties have executed this Agreement as of the date last written below.

CITY OF RICHLAND CENTER

GREATER RICHLAND TOURISM CORPORATION

Karin Tepley, Mayor

Authorized Representative / Board President

Karin Tepley
Printed Name

Printed Name

May 1, 2026
Date

Title

City Clerk (Attestation)

Date

— END OF AGREEMENT —

**CITY OF RICHLAND CENTER
RESOLUTION 2026-06**

A RESOLUTION DESIGNATING SIGNERS ON CITY BANK ACCOUNTS

WHEREAS, in the course of the City of Richland Center’s (“City”) business, it establishes relationships with various banks for the purposes including, but not limited to depository of City funds, borrowing money, or making payments on bonds issued by the City; and

WHEREAS, banks with whom the City does business normally require a City Resolution designating which City officials are authorized to open bank accounts and to execute checks and other orders for payments of City funds; and

WHEREAS, the City desires to designate certain City Officials to open bank accounts and execute checks and other orders for payment of City funds; and

NOW, THEREFORE BE IT RESOLVED, by the Common Council of the City of Richland Center, Richland County, Wisconsin, resolves as follows:

1. As used in this Resolution, the term “Bank” shall mean any financial institution with whom, pursuant to this Resolution, the City establishes a banking relationship.
2. The City’s Administrator and Financial Officer are hereby authorized to open or cause to be opened one or more accounts with a Bank on such terms, conditions, and agreements as the Bank may now or hereafter require and to make any other agreements deemed advisable in regard to any of the foregoing.
3. That checks, or other orders for payment, transfer, or withdrawal of any of the funds or other property of the City on deposit with a Bank shall be binding on the City when signed, manually or by use of a facsimile or mechanical signature or otherwise authorized, by any two of the of the individuals listed below as Authorized Signers, and the Bank is hereby authorized to pay and charge to the account of the City any such checks, drafts, or other orders so signed or otherwise authorized, including those payable to the individual order of the same person or persons signing otherwise authorizing the same and including also those payable to the Bank or to any other person for application, or which are actually applied to the payment of any such indebtedness owing the Bank from the persons who signed such checks, drafts, or other withdrawal orders or otherwise authorized such withdrawals. In particular, and not in limitation of foregoing, such persons may authorize payment, transfer, or withdrawal by oral or telephonic directions to the Bank complying with such rules and regulations relating to such authorization as the Bank may communicate to the City from time to time.
4. That City’s Mayor or Administrator will certify to a Bank the names and signatures (either actual or any form or forms of facsimile or mechanical signatures adopted by the person authorized to sign) of the Authorized Signers listed below and shall from time to time hereafter, upon a change in the facts so certified, immediately certify to the Bank the names and signatures (actual or facsimile) of the persons then authorized to sign or act. The Bank shall be fully protected in relying on such certificates and on the obligation of the certifying officer (set forth above) to immediately certify

**CITY OF RICHLAND CENTER
RESOLUTION 2026-06**

the Bank any change in any facts so certified, and the Bank shall be indemnified and saved harmless by the City from any claims, demands, expenses, loss or damage resulting from or growing out of honoring or relying on the signature of other authority (whether or not properly used and, in the case of any facsimile signature, regardless of when or by whom or by what means such signature may have been made or affixed) of any officer or person whose name and signature was so certified, or refusing to honor any signature or authority not so certified.

5. That the holders of the following positions with the City are authorized to sign or act on behalf of the City (“Authorized Signers”):

Mayor (Highest Elected Official)
City Administrator
Financial Officer
Treasurer
Clerk

ADOPTED by the Common Council of the City of Richland Center on this 21st day of April, 2026, by the following vote: AYES: _____, NOS: _____

CITY OF RICHLAND CENTER
RICHLAND COUNTY, WISCONSIN

Karin Tepley, Mayor

Attest:

Misty D. Molzof, Deputy Clerk

**CITY OF RICHLAND CENTER
RESOLUTION 2026-07**

A RESOLUTION DESIGNATING PUBLIC DEPOSITORIES AND AUTHORIZING WITHDRAWAL OF CITY MONIES

WHEREAS, in the course of the City of Richland Center’s (“City”) business, it establishes relationships with various banks for the purposes including, but not limited to depository of City funds, borrowing money, or making payments on bonds issued by the City; and

NOW, THEREFORE BE IT RESOLVED, by the Common Council of the City of Richland Center, Richland County, Wisconsin, that the following qualified public depositories under Chapter 34 of the Wisconsin Statutes shall be and are hereby designated as public depositories for all public moneys coming into the hands of the City Treasurer:

- The Peoples Community Bank
- Local Government Investment Pool
- Community First Bank
- Richland County Bank
- Royal Bank
- Westby Coop Credit Union

BE IT FURTHER RESOLVED, that the withdrawal or disbursement from any one of the above shall be made in accordance with Section 66.0607 of the Wisconsin Statutes; with all order checks signed by two people as designated in A Resolution Designating Signers on City Bank Accounts; and

BE IT FURTHER RESOLVED, that in lieu of one personal signature, one facsimile signature may be affixed on such order checks; and

BE IT FURTHER RESOLVED, that the Common Council authorizes the investment of public moneys, within the terms established by law acting to the best of his ability to ensure the safety of these funds; and

ADOPTED by the Common Council of the City of Richland Center on this 21st day of April, 2026, by the following vote: AYES:_____, NOS:_____

CITY OF RICHLAND CENTER
RICHLAND COUNTY, WISCONSIN

Karin Tepley, Mayor

Attest:

Misty D. Molzof, Deputy Clerk



PO Box 44186 ☆ Madison, WI ☆ 53744
608.732.4545 ☆ chromefireworks@gmail.com
www.chromefireworks.com

Sponsor

*City of Richland Center
450 S Main Street
Richland Center, WI 53581*

2026 CONTRACT

This contract entered into this 2nd day of September 2025, engages the services of Chrome Fireworks & Displays, LLC, hereinafter referred to as "Chrome", to produce and perform a pyrotechnic display on behalf of Sponsor under the following terms:

1. The date of the display will be Sat June 27, 2026. In case of inclement weather, the display will be rescheduled for Sun 6/28. Chrome will have complete authority to cancel the display if, in the reasonable opinion of Chrome, the health, safety, and well-being of the pyrotechnicians, spectators or property would be jeopardized by proceeding with the display including inclement weather or imminent threat thereof.
2. The cost of the display will be \$ 17,000. Upon signing this Contract, Sponsor will pay an initial payment to Chrome in the amount of \$ 7,500 due in January '26. The remaining balance will be paid within 10 days of the display. A late fee of 1.5% per month shall apply to any unpaid balance remaining beyond a 10-day period. Should a cancellation occur once crew is enroute or onsite, the cost of insurance, labor and any non-reusable items will be billed or deducted from the deposit, minimum 50% of budget amount. If Chrome and Sponsor agree to cancel and event, likely due to display date weather issues, and a nearby reschedule date cannot be obtained, the Sponsor agrees to reimburse Chrome for incurred expenses including insurance at 15% of the budget amount plus any permit fees and other costs incurred by Chrome for the Sponsor's display.
3. Sponsor will procure and furnish a suitable location for the fireworks display with adequate distances from audience, roof tops, flammable materials and other hazards in compliance with NFPA 1123 guidelines - including a minimum spectator set back of at least 500 feet at all points from the largest diameter mortars. Sponsor will secure all police, fire, local and state permits, and shall arrange for all security bonds if required by law for the location of the display. Sponsor will furnish all necessary police, fire and other appropriate protection necessary for proper crowd control and protection, automobile parking, and supervision in clearing of debris after the display. Sponsor will be solely responsible for keeping all unauthorized persons out of the display firing area and behind the safety zone lines.
4. Chrome reserves the right to make substitutions as to the amount, size and description of fireworks as is reasonably necessary to address site, weather, health, supply availability and safety concerns should they arise.
5. **Prior Cancellation:** Should the fireworks display(s) agreed upon in this Contract be cancelled by the Client prior to the fireworks display date, shall result in liquidated damages payable to Chrome Fireworks from the Sponsor for an amount equal to 40% of the Contract price plus any and all other related costs incurred by the Display Operator in resolving matters related to failure of Client to fulfill this Contract, including but not limited court costs, attorney fees, litigation expenses, witness fees/expenses, travel expenses and similar costs), prejudgment interest, post judgment interest, fees, and expenses incurred by the Display Operator.

6. **Bad weather and Shoot Trailers:** In event of worsening weather conditions at the planned showtime, Chrome will need flexibility on shoot times, earlier or later depending on weather conditions. Chrome often provides electronic & shoot trailer shows for utmost performance of the firework show. The downfall of these electronic setups is that they CANNOT be dismantled. The show will need to be fired or secured/ stored until the nearby rain date. It is very hazardous and potentially fatal to our crews to dismantle this type of display. Chrome needs flexibility of the Sponsor to shoot the show or adequately secure the setup until the rain date.

7. **Setup:** Chrome will provide qualified pyrotechnicians who will deliver, set-up, execute, dismantle and cleanup the pyrotechnic display. In some cases, the crew shall arrive the night prior to the event to begin setup.

8. **Clean Up & Searches:** The pyrotechnicians shall conduct an after-display search of the grounds in an effort to locate and dispose of any unexploded fireworks. The search shall be reasonably dictated by such elements including, but not limited to terrain, ground cover, weather conditions and time of completion of display. Chrome pyrotechnicians will provide reasonable cleanup for the site immediately following the display. All equipment, firework packaging, and larger debris will be removed to the best of the crew's ability before leaving the display area. Sponsor shall provide a nearby dumpster or other adequate space for boxes, spent cakes and refuse after the display.

After our cleanup pieces of paper, cardboard, multi-shot cake inserts and fuse casing will remain but should disappear with weather, time and/or lawn mowing.

9. Chrome will conduct a reasonable search of the display area before departure, in an attempt to locate any damages or unexploded shells. Sponsor acknowledges that an early morning search of the area is of utmost importance, or as soon as reasonably possible following the display. This search is to locate anything abnormal including site damage or unexploded fireworks that might not have been spotted by Chrome in the night. In the event that Sponsor discovers any unexploded fireworks, Sponsor will immediately contact Chrome and Chrome shall be responsible for removing said fireworks as soon as possible after receipt of such notice. **Please notify Jim Krueger via cell phone 608-732-4545. If you have a cell # for your crew lead they may be notified in addition.**

10. \$5,000,000 Insurance: Unless otherwise agreed, Chrome shall provide General Liability and Property Damage Insurance for the fireworks display in the amount of \$5,000,000 naming the Sponsor as an additional insured party. The current industry standard is \$1,000,000 of such coverage. A certificate evidencing liability insurance shall be provided to Sponsor before the display. Sponsor will notify Chrome of any additional insureds prior to issuing the insurance certificate.

The additional insured coverage shall be written on a primary and noncontributory basis and include a waiver of subrogation. The sponsor and landowner along with other entities and individuals listed on the certificate of insurance shall be deemed an additional insured per this contract. No additional written agreement is needed for endorsement.

Chrome is also covered with \$5,000,000 of MCS-90 Transportation insurance which is compliant with Dept. of Transportation interstate regulations.

The pyrotechnicians on site are covered with a \$500,000 Workers Comp insurance policy, proof of all insurances are readily available by request.

11. Chrome shall take all steps reasonably anticipated to safeguard spectators and Sponsor's property. Should any losses occur which Sponsor believes are the result of Chrome's firework display, Sponsor will immediately notify Chrome of the nature of the loss and the date on which the loss occurred. Said notice shall be in writing and provide as much detail as possible regarding the extent of the loss (including clear pictures) as this process will be required by the insurance adjustors.

12. In the event of fire, accident, flood, act of God or other causes beyond the control of Chrome which prevent Chrome from performing under this contract, other than inclement weather, both parties agree to terminate this contract and all performance requirements and damages resulting therefrom.

13. The Sponsor will pay to Chrome pay all costs (including but not limited to court costs, attorney fees, litigation expenses, witness fees/expenses, travel expenses and similar costs), prejudgment interest, post judgment interest, fees, expenses, and all damages incurred by the Chrome through enforcing this contract.

14. The Sponsor agrees to indemnify, hold harmless and defend Display Operator and employees from any and all claims brought against the Display Operator for any and all accidents, incidents or allegations not directly related to the Display Operator’s agreed upon contractual duties and obligations, aka: any other liabilities arising from sponsor’s event.

Chrome will provide the General Liability insurance certificate to Sponsor for the purpose of insuring Chrome’s risk in performing contracted duties involving the fireworks display. However, Chrome will be indemnified and held harmless for the remainder of the Sponsor’s event or issues arising as result of the event. This includes but is not limited to the event’s activities, other contractors, vendors, traffic issues, and members of general public, audience and/or any other matters beyond the direct control, scope, and duty of Chrome’s contract.

15. This Contract will be construed by laws of the state of Wisconsin. If any provision of this agreement is deemed unenforceable by any court of competent jurisdiction, the remaining provisions hereof shall remain in full force and effect.

16. This Contract constitutes the entire agreement between the parties hereto and supersedes all prior and contemporaneous agreements, understanding, negotiations and discussions, either oral or executed in writing by the parties to be bound thereby. Chrome reserves the right to transfer the contract at which time the duties and liability would also be transferred in entirety, indemnifying and holding harmless Chrome. The waiver of any provisions of this Contract will not constitute a waiver of any other provision of this contract.

17. The party signing this document on behalf of Sponsor warrants and represents that (s)he is solely authorized to enter into this agreement on behalf of the Sponsor.

ADDITIONAL PROVISIONS:

X _____
Sponsor – signature

X Todd Coppernoll, Mayor
Print name and title

CHROME FIREWORKS AND DISPLAYS, LLC:



James Krueger - owner

Agenda Item: Consider approval of contract with Chrome Fireworks & Displays, LLC for City Fireworks for June 27, 2026.

Committee Review: Park Board

Meeting Date: July 28th, 2025

Requested by: Jodi Mieden- Recreation Director

Background: For 2026, the industry may see a sizable increase in cost given the 2025 tariffs and trade issues with China; this increased costs on both imported fireworks and shipping expenses. Many fireworks are in production or arrived this past spring with tariffs already paid. Most don't realize professional grade fireworks are often acquired a year in advance. Chrome is offering limited 2026 contracts on a first-come first-served basis until their pre-tariff fireworks are committed. There will be some additional expenses, however, the bulk of your firework show can be tariff free (30-45% less cost). Deposits aren't necessary now, that can wait until early 2026, just a signed contract is needed to secure the stock and pricing.

Department Recommendation:

Approve Chrome Fireworks & Displays, LLC contract for 2026 to lock in pre-tariff stock pricing.

Committee Recommendation:

Financial Impact: \$17,000.00

Funding Source: Community Center Fireworks 10-55200-220

Budget: 17,000.00

Requested Action:

PARK BOARD: Motion to recommend to the Finance Committee to approve contract with Chrome Fireworks & Displays, LLC for City Fireworks for June 27, 2026.

FINANCE: Motion to recommend to the Council to approve contract with Chrome Fireworks & Displays, LLC for City Fireworks for June 27, 2026.

COUNCIL: Motion to approve contract with Chrome Fireworks & Displays, LLC for City Fireworks for June 27, 2026.

Attachment(s):

- 2026 contract with Chrome Fireworks and Displays, LLC
- Permit for Fireworks Form



**P.O. Box 44186
Madison, WI 53744**

**Phone: (608) 732-4545
chrome fireworks@gmail.com
www.chromefireworks.com**

PERMIT TO POSSESS AND DISPLAY FIREWORKS

To whom it may concern, Greetings!

The local authority having jurisdiction grants Chrome Fireworks and Displays, LLC right to exhibit display fireworks for the following event:

State: Wisconsin

County: Richland

Fireworks Event: Thunder in the Hills

Event Sponsor: City of Richland Center

Date of Display: June 27, 2026

Rain Date: June 28, 2026

Fireworks Location: North Park

Approx. Display Start Time; Subject to Change with Weather: 10PM

SHERIFF, FIRE DEPARTMENT CHIEF
OR TOWN CHAIRMAN:

Signature of Official Issuing Permit

Scott Gald, Chief - Richland Center Fire Department
Print Name and Title of Official Issuing Permit

(Email or send a copy of this permit to Chrome Fireworks at least one month prior to display)

(Keep a copy of this permit for Sponsor's records)

Agenda Item: Purchase of IPC CT50 Walk-Behind Floor Scrubber

Requested & Presented by: Darcy Perkins, MSS

Meeting Date: Finance Committee and Common Council on 04-21-2026

Committee Review: Due to the recent sale of existing equipment, there is a time constraint on this purchase to avoid a gap in operational capabilities. As a result, this item is being brought directly to Finance and Council. Staff have had ongoing discussions with the Public Works Committee regarding the strategy of selling older equipment with the intent of replacing it with more efficient, modern units, and the Committee has been fully supportive of this approach.

Background: The Public Works Department is proposing the purchase of an IPC CT50 walk-behind floor scrubber to support cleaning operations at the Community Center. The CT50 is a durable, high-productivity unit with a 20" cleaning path, 13-gallon tank capacity, and approximately 2.5-hour runtime, designed for efficient large-area floor maintenance. This purchase replaces recently sold equipment and ensures continued operational efficiency. The unit is expected to improve cleaning effectiveness, reduce manual labor, and provide reliable, consistent performance across facilities.

Department Recommendation: Staff recommend authorizing the purchase of an IPC CT50 walk-behind floor scrubber.

Financial Impact: ~\$3,800.00

Funding Source: Revenue from sale of surplus equipment; year-to-date balance: ~\$8,891.00

Requested Action:

FINANCE: Motion to recommend to the Common Council the approval of the purchase of an IPC CT50 walk-behind floor scrubber using funds from proceeds from the sale of surplus City equipment.

COUNCIL: Motion to approve the purchase of an IPC CT50 walk-behind floor scrubber using funds from proceeds from the sale of City equipment.



IPC

BY TENNANT COMPANY

AUTOMATIC SCRUBBERS - WALK BEHIND

CT50

The CT50 is a cost-effective, highly productive, and durable walk behind scrubber that will meet a wide range of floor care needs. With intuitive controls, precision engineered squeegee assembly, and straightforward operation, achieving a clean floor is as simple as turning a key.

MAX PRODUCTIVITY

21,000
ft²/h

BATTERY RUNNING TIME

2.5 h

KEY SPECS

13 gal
20"
brush drive



CERTIFICATIONS



GREEN CLEANING EFFICIENCY

BATTERIES AND BATTERY CHARGER INCLUDED

MOST FREQUENT USE



INNOVATIONS



SPECS



SOLUTION LEVEL INDICATOR



EASY TO USE CONTROL PANEL



QUICK CONNECT BRUSH HEAD

TECHNICAL DATA

		CT50 BRUSH DRIVE
Code		BRUSH DRIVE
PERFORMANCE		
Max theoretical productivity	ft ² / h-m ²	21,000/ 1,750 m ²
Cleaning path	in/ mm	20 in/ 500 mm
Squeegee width	in/mm	28 in/ 700 mm
Solution recovery	gal/l	13/13 gal / 50/50 l
Max running time	min	150
Voltage	V-Ah	24V (2x12) agm
Installed power	W	550
Max speed	mph/kph	2.2 mph/ 3.5 kph
Brush pressure	lbs/kg	55 lbs / 25 kg
Weight	lbs/kg	243 lb 110 kg
Dimension (LxWxH)	in	48 x 28 x 30 in

STANDARD ACCESSORIES

		CT50 BRUSH DRIVE
BRUSHES		
PPL MEDIUM		SPPV01332
SQUEEGEE BLADES		
LATEX FRONT BLADE		MPVR06287 - 815mm
LATEX REAR BLADE		MPVR06288 - 715mm

ACCESSORIES

STANDARD PPL



PAD DRIVER



SOFT NATURAL BRUSTLE



SOFT PPL BRUSH



TYNEX BRUSH



SPLASH GUARD



SQUEEGEE BLADES

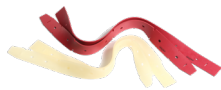

AGENDA ITEM DATA SHEET

Agenda Item: Mill Street Transverse Grate Repair Project

Meeting Dates: Finance and Council on 4/21/2026

Requested by: Jasen Glasbrenner, Director of Public Works

Committee Review: The Public Works Committee was bypassed due to urgency and safety concerns.

Background: The transverse grate located at the intersection of Mill and Main Streets is a drainage structure spanning the roadway that captures and conveys stormwater into the storm sewer system. Upon recent inspection, the grate and storm channel has been found to be deteriorated and in need of repair. Structural wear to the grate system and concrete structure has reduced its capacity to effectively manage stormwater while allowing long term safe passage of vehicle traffic.

Repair of the system would extend its life by approximately 5 to 10 years at an estimated cost of \$20,000 to \$30,000. Full replacement involves removal, excavation, storm sewer modifications, and installation of new collection basins at an estimated cost of \$80,000. Full replacement would have a life expectancy of 30+ years.



Department Recommendation: The Public Works Department recommends authorizing funding for the full replacement of the transverse grate and storm water system at a cost of approximately \$80,000 as soon as possible.

Financial Impact: Estimated repair cost of \$80,000

Funding Source: Pool 4 – Street Projects. Current balance of \$317,232.78

Requested Action:

FINANCE: Motion to recommend to Council to authorize an expenditure approximately \$80,000 from Pool 4 – Street Projects for the replacement of the Mill Street transverse grate and storm water system and to authorize the Director of Public Works to solicit quotes and award the contract to the lowest responsible bidder in accordance with Wis. Stat. § 62.15.

COUNCIL: Motion to authorize an expenditure of approximately \$80,000 from Pool 4 – Street Projects for the replacement of the Mill Street transverse grate and storm water system and to authorize the Director of Public Works to solicit quotes and award the contract to the lowest responsible bidder in accordance with Wis. Stat. § 62.15.

Attachments: MSA Estimate, MSA Preliminary Plan



N MAIN STREET

MILL STREET

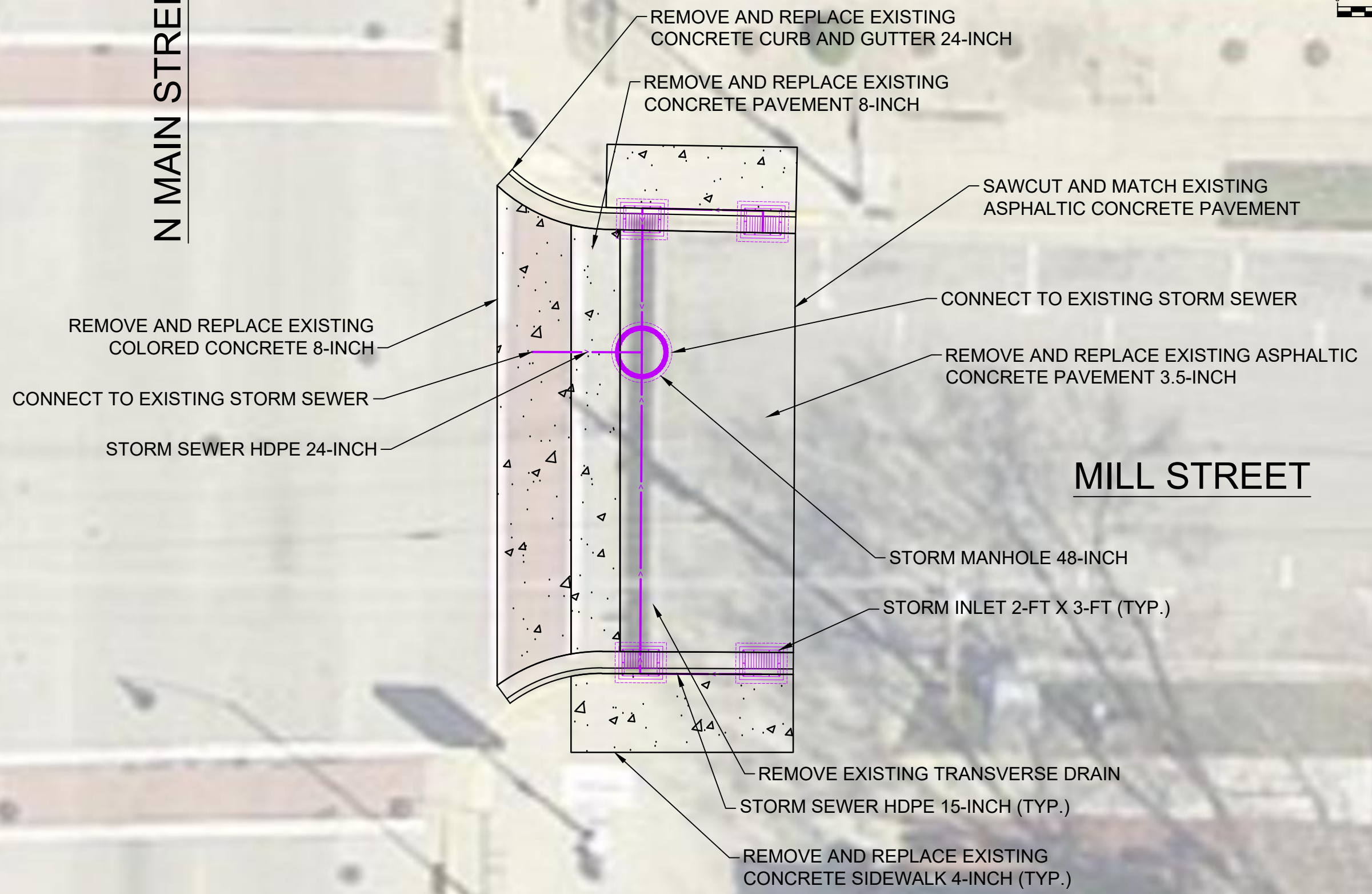

PROJECT DATE:	NO.	DATE	REVISION	BY:
DRAWN BY: ZA	-	-	-	-
DESIGNED BY: Init	-	-	-	-
CHECKED BY: AZ	-	-	-	-

MSA ENGINEERING | ARCHITECTURE | SURVEYING
 FUNDING | PLANNING | ENVIRONMENTAL
 1230 South Boulevard, Baraboo WI 53913
 (608) 356-2771 www.msa-ps.com
© MSA Professional Services, Inc.

MILL STREET DRAINAGE IMPROVEMENTS
 CITY OF RICHLAND CENTER
 RICHLAND COUNTY, WISCONSIN

PRELIMINARY PLAN VIEW

PLOT DATE: 4/20/2026 3:18 PM, G:\00\00013\00013098\CADD\Construction Documents\Exhibits\2026.04.20 Preliminary Estimate.dwg

BUDGETARY ESTIMATE OF PROBABLE COSTS

MILL STREET DRAINAGE IMPROVEMENTS

RICHLAND CENTER, WI

DATE: 4/20/2026

ESTIMATE YEAR: 2026

MSA PROJECT #: 00013098

CONSTRUCTION YEAR: 2026

Project Description:

REmove existing trench drain at the eastern side of Mill Street and Church Street and replace with inlets and associated restoration.

ITEM NO.	DESCRIPTION	QUANTITY	UNIT	UNIT PRICE	TOTAL PRICE
1	Mobilization, Bonds, & Insurance	1	LS	\$6,000.00	\$ 6,000.00
2	Traffic Control	1	LS	\$1,500.00	\$ 1,500.00
3	Erosion Control	1	LS	\$1,000.00	\$ 1,000.00
4	Remove Asphaltic Pavement	70	SY	\$3.00	\$ 210.00
5	Remove Concrete Pavement	80	SY	\$15.00	\$ 1,200.00
6	Remove Existing Transverse Drain	1	EA	\$5,000.00	\$ 5,000.00
7	Excavation Below Subgrade (EBS)	15	CY	\$50.00	\$ 750.00
8	Dense Graded Base 1-1/4-inch	59	TON	\$25.00	\$ 1,475.00
9	Breaker Run	99	TON	\$30.00	\$ 2,970.00
10	Asphaltic Concrete Pavement 3-1/2 Inch	15	TON	\$95.00	\$ 1,425.00
11	Concrete Curb & Gutter 24-Inch, Spot Repair	55	LF	\$40.00	\$ 2,200.00
12	Concrete Pavement 8-Inch	175	SF	\$15.00	\$ 2,625.00
13	Concrete Pavement 8-Inch, Colored	280	SF	\$25.00	\$ 7,000.00
14	Concrete Pavement 4-Inch	245	SF	\$8.00	\$ 1,960.00
15	Storm Manhole 48-Inch	1	EA	\$4,200.00	\$ 4,200.00
16	Storm Inlet 2-Ft x 3-Ft	4	EA	\$3,500.00	\$ 14,000.00
17	Storm Sewer HDPE 24-Inch	10	LF	\$100.00	\$ 1,000.00
18	Storm Sewer HDPE 15-Inch	65	LF	\$65.00	\$ 4,225.00
19	Connect to Existing Storm Sewer	2	EA	\$1,500.00	\$ 3,000.00
ESTIMATED CONSTRUCTION SUBTOTAL					\$ 61,740.00
Contingency 15%					\$ 9,260.00
ESTIMATED CONSTRUCTION COST (2026)					\$ 71,000.00
Engineering					\$ 8,500.00
TOTAL ESTIMATED PROJECT COST:					\$ 79,500.00

Disclaimers & Assumptions

- 1 This estimate of probable cost is approximate. Actual construction bids may vary significantly from this estimate due to timing of bids, construction schedule restraints, labor rate increases, material increases, or other factors beyond the control of the estimator.
- 2 Estimate based on unit prices observed in 2024, 2025, & 2026.
- 3 Pavement marking by City.

Agenda Item: Valley View Drive Street Project with City Utilities

Meeting Dates: Utility Commission on 4/8/2026, Finance and Council on 4/21/2026

Requested by: Jasen Glasbrenner, Director of Public Works

Background: City Utilities has approved and is proceeding with the replacement of the aging water main along Valley View Drive, Stori Drive, and Chestnut Street. Four bids were received on April 7, 2026; G-Pro Excavating LLC was the low bidder at **\$913,955** for all work. The City has an opportunity to partner with City Utilities as has been done in the past. This would allow the City to address the street, curb, gutter, and storm sewer portions of the project under the same contract lowering projects costs for both entities.

The pavement, curb, and gutter along these streets are in dire condition and are well overdue for replacement. The City did not plan for this work in the 2026 budget, but the opportunity to complete it under an already-bid, already-mobilized contract is one the City will not have again at this price.

- **Lower cost:** Shared mobilization and traffic control with the City Utilities project eliminates large cost drivers of a standalone street project.
- **One disruption:** Residents face construction once, not twice. Combining all work into a single season avoids a second round of road closures in a future year.
- **Protects the new infrastructure:** Resurfacing over the new water main at the time of installation is best practice.
- **Declining does not defer the need:** The road must be rebuilt. Waiting means higher costs, a separate bid process, and another year of deterioration.

PROJECT COSTS		
Item	Utility Cost	City Cost
Base Bid - Valley View Drive	\$424,285	\$15,523
Alt A: Chestnut Street and Stori Drive	\$114,619	\$2,100
Alt B: Pulverize & Re-Surface Valley View Drive	\$72,848	\$104,412
Alt C: Pulverize & Re-Surface Stori Drive and Chestnut Street	\$30,423	\$15,092
Alt D: Valley View Drive Storm Sewer	\$0	\$34,186
Total Construction (Base + Alternates, A, B, C & D)	\$642,175	\$171,314
Construction Engineering and Administration	\$45,556	\$11,389
Total Construction Cost	\$687,731	\$182,703
Contingency	\$34,818	\$8,704
TOTAL PROJECT	\$722,548	\$191,407

Financial Impact: City’s Portion of the total project cost is \$191,407

Funding Source: Because this project was unplanned it was not included in the 2026 budget. However, the following financing options are available:

- **Pool 4 – Street Projects:** Approximately \$317,232.78 is available in this fund, making it a straightforward option requiring no borrowing. However, nearly depleting this reserve would significantly limit the City's capacity to fund future street projects and would result in a loss of interest earnings on those funds.
- **Borrow from City Utilities:** City Utilities has offered to finance the City's share at a negotiated interest rate over an agreed repayment term. This option preserves the Street Projects fund balance and, importantly, debt payments on intergovernmental borrowing can be levied outside of the City's statutory levy limit.
- **Local bank loan:** The City could finance its share through a local financial institution at prevailing municipal rates. While this option also allows debt payments to be levied outside the levy limit, it will likely carry a higher interest rate than borrowing from City Utilities and will require a more involved procurement process.

Estimated Tax Levy Impact

Based on \$191,500 at 4% interest | City 2025 TID-Out Equalized Value: \$462,222,800

Loan Term	Annual Debt Service	Levy per \$1,000 EV	Est. Annual Tax (\$250,000 Home)	Est. Monthly Impact
10 Years	\$23,610	\$0.051	\$12.77	\$1.06
15 Years	\$17,224	\$0.037	\$9.32	\$0.78
20 Years	\$14,091	\$0.031	\$7.62	\$0.64

Requested Action:

FINANCE: Motion to recommend Council approval of the City’s participation in the 2026 Valley View Drive project in partnership with City Utilities, authorizing the City's share of project costs in an amount not to exceed \$191,500 for the Base Bid and all Alternates and to recommend that the City finance its share through:

(Select one)

- a) Pool 4 – Street Projects, or
- b) An intergovernmental loan from City Utilities at a negotiated interest rate and repayment term, or
- c) A local bank loan at prevailing municipal rates

and further recommending that the City Administrator and Treasurer be authorized to negotiate and execute the necessary financing documents consistent with the option selected.

COUNCIL: Motion to approve the City’s participation in the 2026 Valley View Drive project in partnership with City Utilities, authorizing the City's share of project costs in an amount not to exceed \$191,500 for the Base Bid and all Alternates and to recommend that the City finance its share through:

(Select one)

- a) Pool 4 – Street Projects, or
- b) An intergovernmental loan from City Utilities at a negotiated interest rate and repayment term, or
- c) A local bank loan at prevailing municipal rates

and further recommending that the City Administrator and Treasurer be authorized to negotiate and execute the necessary financing documents consistent with the option selected.

Attachments

- Bid Tabulation
- G-Pro Excavating LLC Bid Allocation – MSA Professional Services
- Project Plan Set – MSA Professional Services, Project No. 11137052

CITY UTILITIES OF RICHLAND CENTER -2026 VALLEY VIEW DRIVE WATER MAIN REPLACEMENT (#10095170)
 Owner: Richland Center City Utilities
 Solicitor: MSA Professional Services, Inc - CORP HQ - Baraboo
 04/07/2026 02:00 PM CDT

Section Title	Line Item	Item Description	UoM	Quantity	G-Pro Excavating LLC		Allen Steele Co Inc		A-1 Excavating LLC		Gerke Excavating Inc.	
					Unit Price	Extension	Unit Price	Extension	Unit Price	Extension	Unit Price	Extension
Base Bid: Valley View Drive						\$509,345.00		\$547,730.80		\$572,007.00		\$604,556.10
	1	Mobilization	LS	1	\$25,150.00	\$25,150.00	\$29,000.00	\$29,000.00	\$50,050.00	\$50,050.00	\$16,684.30	\$16,684.30
	2	Traffic Control	LS	1	\$6,250.00	\$6,250.00	\$5,000.00	\$5,000.00	\$15,000.00	\$15,000.00	\$5,748.75	\$5,748.75
	3	Erosion Control	LS	1	\$5,000.00	\$5,000.00	\$5,000.00	\$5,000.00	\$1,500.00	\$1,500.00	\$2,218.00	\$2,218.00
	4	Erosion Control, Rock Check	TON	150	\$18.00	\$2,700.00	\$36.00	\$5,400.00	\$30.00	\$4,500.00	\$26.40	\$3,960.00
	5	Erosion Control, Sediment Log	LF	150	\$25.00	\$3,750.00	\$16.00	\$2,400.00	\$10.00	\$1,500.00	\$7.95	\$1,192.50
	6	Turf Restoration	LS	1	\$12,500.00	\$12,500.00	\$16,350.00	\$16,350.00	\$4,000.00	\$4,000.00	\$14,793.05	\$14,793.05
	7	Imported Granular Backfill	CY	320	\$20.00	\$6,400.00	\$25.00	\$8,000.00	\$1.00	\$320.00	\$36.45	\$11,664.00
	8	Asphaltic Pavement Removal	SY	1100	\$6.10	\$6,710.00	\$6.24	\$6,864.00	\$20.00	\$22,000.00	\$6.75	\$7,425.00
	9	Dense Graded Base 1-1/4-Inch	TON	750	\$20.00	\$15,000.00	\$29.11	\$21,832.50	\$30.00	\$22,500.00	\$19.55	\$14,662.50
	10	Asphaltic Concrete Pavement 4-Inch	TON	245	\$193.00	\$47,285.00	\$212.30	\$52,013.50	\$345.00	\$84,525.00	\$304.60	\$74,627.00
	11	Asphaltic Concrete Pavement 2-Inch	TON	5	\$245.00	\$1,225.00	\$269.50	\$1,347.50	\$355.00	\$1,775.00	\$267.20	\$1,336.00
	12	Concrete Curb & Gutter 24-Inch, Restoration	LF	600	\$38.00	\$22,800.00	\$46.80	\$28,080.00	\$66.00	\$39,600.00	\$43.45	\$26,070.00
	13	Concrete Driveway 6-Inch	SF	2450	\$6.00	\$14,700.00	\$7.39	\$18,105.50	\$11.00	\$26,950.00	\$7.00	\$17,150.00
	14	6-Inch C.I. To 8-Inch HDPE WM, Pipe Burst	LF	1516	\$75.00	\$113,700.00	\$84.10	\$127,495.60	\$57.00	\$86,412.00	\$90.00	\$136,440.00
	15	8-Inch PVC C900 WM, Open Cut	LF	65	\$100.00	\$6,500.00	\$66.49	\$3,671.85	\$92.00	\$5,980.00	\$81.70	\$5,310.50
	16	6-Inch PVC C900 WM, Open Cut	LF	40	\$95.00	\$3,800.00	\$49.07	\$1,962.80	\$83.00	\$3,320.00	\$118.35	\$4,734.00
	17	8-Inch Valve & Box	EA	7	\$3,553.00	\$24,871.00	\$3,965.00	\$27,755.00	\$5,000.00	\$35,000.00	\$3,390.85	\$23,735.95
	18	6-Inch Valve & Box	EA	4	\$2,371.00	\$9,484.00	\$2,599.00	\$10,396.00	\$4,300.00	\$17,200.00	\$2,294.00	\$9,176.00
	19	8-Inch x 8-Inch Tee	EA	2	\$903.00	\$1,806.00	\$1,709.25	\$3,418.50	\$2,300.00	\$4,600.00	\$1,012.90	\$2,025.80
	20	8-Inch x 6-Inch Tee	EA	3	\$670.00	\$2,010.00	\$2,291.75	\$6,875.25	\$2,300.00	\$6,900.00	\$803.40	\$2,410.20
	21	8-Inch Bend	EA	2	\$782.00	\$1,564.00	\$1,906.50	\$3,813.00	\$1,800.00	\$3,600.00	\$902.60	\$1,805.20
	22	8-Inch x 6-Inch Reducer	EA	2	\$450.00	\$900.00	\$954.75	\$1,909.50	\$1,800.00	\$3,600.00	\$566.05	\$1,132.10
	23	8-Inch Plug	EA	2	\$300.00	\$600.00	\$792.00	\$1,584.00	\$700.00	\$1,400.00	\$464.25	\$928.50
	24	6-Inch Plug	EA	2	\$250.00	\$500.00	\$724.00	\$1,448.00	\$600.00	\$1,200.00	\$389.20	\$778.40
	25	Connect to Existing Water Main	EA	1	\$3,000.00	\$3,000.00	\$1,996.00	\$1,996.00	\$2,500.00	\$2,500.00	\$1,497.60	\$1,497.60
	26	Remove and Salvage Hydrant	EA	3	\$1,000.00	\$3,000.00	\$1,858.00	\$5,574.00	\$800.00	\$2,400.00	\$1,054.40	\$3,163.20
	27	Fire Hydrant (7.5 ft Bury)	EA	4	\$6,746.00	\$26,984.00	\$7,091.00	\$28,364.00	\$8,000.00	\$32,000.00	\$7,367.30	\$29,469.20
	28	1-Inch Saddle, Corp, Curb Stop & Box	EA	31	\$1,321.00	\$40,951.00	\$1,603.00	\$49,693.00	\$1,400.00	\$43,400.00	\$3,783.35	\$117,283.85
	29	1-Inch Water Service	LF	670	\$16.00	\$10,720.00	\$8.27	\$25,640.90	\$28.00	\$18,760.00	\$50.55	\$33,868.50
	30	2-Inch Saddle, Corp, Curb Stop & Box	EA	1	\$2,250.00	\$2,250.00	\$2,376.00	\$2,376.00	\$2,400.00	\$2,400.00	\$5,633.45	\$5,633.45
	31	2-Inch Water Service	LF	195	\$65.00	\$12,675.00	\$39.12	\$7,628.40	\$57.00	\$11,115.00	\$52.45	\$10,227.75
	32	Temporary Water Service	EA	32	\$2,330.00	\$74,560.00	\$1,148.00	\$36,736.00	\$500.00	\$16,000.00	\$543.90	\$17,404.80
Alternate A: Chestnut Street and Stori Drive						\$144,824.00		\$176,681.99		\$167,385.00		\$170,086.20
	A1	Traffic Control and Bonds	LS	1	\$4,600.00	\$4,600.00	\$6,400.00	\$6,400.00	\$11,000.00	\$11,000.00	\$8,651.25	\$8,651.25
	A2	Turf Restoration	LS	1	\$2,000.00	\$2,000.00	\$2,064.00	\$2,064.00	\$500.00	\$500.00	\$5,815.95	\$5,815.95
	A3	Asphalt Pavement Removal	SY	410	\$10.00	\$4,100.00	\$6.24	\$2,558.40	\$20.00	\$8,200.00	\$4.15	\$1,701.50
	A4	Dense Graded Base 1-1/4-Inch	TON	280	\$20.00	\$5,600.00	\$29.11	\$8,150.80	\$30.00	\$8,400.00	\$19.55	\$5,474.00
	A5	Asphaltic Concrete Pavement 4-Inch	TON	95	\$193.00	\$18,335.00	\$212.30	\$20,168.50	\$270.00	\$25,650.00	\$256.70	\$24,386.50
	A6	Concrete Curb & Gutter 24-Inch, Restoration	LF	210	\$37.00	\$7,770.00	\$45.70	\$9,597.00	\$69.00	\$14,490.00	\$42.90	\$9,009.00
	A7	Concrete Sidewalk 4-Inch	SF	265	\$6.00	\$1,590.00	\$7.60	\$2,014.00	\$11.00	\$2,915.00	\$7.95	\$2,106.75
	A8	Concrete Driveway 6-Inch	SF	730	\$6.00	\$4,380.00	\$7.63	\$5,569.90	\$12.00	\$8,760.00	\$9.40	\$6,862.00
	A9	6-Inch C.I. To 8-Inch HDPE WM, Pipe Burst	LF	425	\$75.00	\$31,875.00	\$119.91	\$50,961.75	\$60.00	\$25,500.00	\$71.10	\$30,217.50
	A10	6-Inch PVC C900 WM, Open Cut	LF	10	\$95.00	\$950.00	\$49.07	\$490.70	\$110.00	\$1,100.00	\$130.40	\$1,304.00
	A11	8-Inch PVC C900 WM, Open Cut	LF	8	\$100.00	\$800.00	\$66.93	\$455.44	\$120.00	\$960.00	\$181.80	\$1,454.40
	A12	6-Inch Valve & Box	EA	1	\$2,371.00	\$2,371.00	\$2,599.00	\$2,599.00	\$4,300.00	\$4,300.00	\$2,298.75	\$2,298.75
	A13	8-Inch Valve & Box	EA	1	\$3,553.00	\$3,553.00	\$4,349.00	\$4,349.00	\$5,100.00	\$5,100.00	\$3,461.50	\$3,461.50
	A14	8-Inch x 6-Inch Tee	EA	1	\$670.00	\$670.00	\$2,192.00	\$2,192.00	\$3,200.00	\$3,200.00	\$1,142.30	\$1,142.30
	A15	8-Inch Bend	EA	3	\$782.00	\$2,346.00	\$1,461.00	\$4,383.00	\$1,200.00	\$3,600.00	\$776.85	\$2,330.55
	A16	Connect to Existing Water Main	EA	2	\$3,000.00	\$6,000.00	\$2,060.00	\$4,120.00	\$1,600.00	\$3,200.00	\$1,370.50	\$2,741.00
	A17	Remove and Salvage Hydrant	EA	1	\$1,000.00	\$1,000.00	\$1,909.00	\$1,909.00	\$800.00	\$800.00	\$1,057.55	\$1,057.55
	A18	Fire Hydrant	EA	1	\$6,746.00	\$6,746.00	\$7,091.00	\$7,091.00	\$8,000.00	\$8,000.00	\$6,838.35	\$6,838.35
	A19	1-Inch Saddle, Corp, Curb Stop & Box	EA	6	\$1,521.00	\$9,126.00	\$1,662.00	\$9,972.00	\$1,400.00	\$8,400.00	\$3,783.40	\$22,700.40
	A20	1-Inch Water Service	LF	215	\$16.00	\$3,440.00	\$37.46	\$8,053.90	\$40.00	\$8,600.00	\$50.55	\$10,868.25
	A21	2-Inch Saddle, Corp, Curb Stop & Box	EA	1	\$2,250.00	\$2,250.00	\$2,371.00	\$2,371.00	\$2,000.00	\$2,000.00	\$5,633.45	\$5,633.45
	A22	2-Inch Water Service	LF	30	\$50.00	\$1,500.00	\$40.52	\$1,215.60	\$57.00	\$1,710.00	\$52.55	\$1,576.50
	A23	Valve Manhole, Water Service	EA	1	\$7,512.00	\$7,512.00	\$7,403.00	\$7,403.00	\$7,500.00	\$7,500.00	\$7,827.75	\$7,827.75
	A24	Temporary Water Service	EA	7	\$2,330.00	\$16,310.00	\$1,799.00	\$12,593.00	\$500.00	\$3,500.00	\$661.00	\$4,627.00
Alternate B: Pulverize & Re-Surface Valley View Drive						\$177,260.00		\$194,365.40		\$230,040.00		\$204,519.45
	B1	Pulverize Existing Asphaltic Pavement	SY	5660	\$3.00	\$16,980.00	\$3.69	\$20,885.40	\$3.00	\$16,980.00	\$2.45	\$13,867.00
	B2	Asphaltic Concrete Pavement 3-Inch	TON	980	\$81.00	\$79,380.00	\$88.55	\$86,779.00	\$112.00	\$109,760.00	\$107.95	\$105,791.00
	B3	Load, Haul and Stockpile Excess Millings	CY	350	\$15.00	\$5,250.00	\$7.50	\$2,625.00	\$20.00	\$7,000.00	\$9.90	\$3,465.00
	B4	Curb Removal and Replacement, Inclusive	LF	3200	\$22.00	\$70,400.00	\$24.90	\$79,680.00	\$29.00	\$92,800.00	\$24.25	\$77,600.00
	B5	Storm Water Curb Casting	EA	7	\$750.00	\$5,250.00	\$628.00	\$4,396.00	\$500.00	\$3,500.00	\$542.35	\$3,796.45
Alternate C: Pulverize & Re-Surface Stori Drive and Chestnut Street						\$45,515.00		\$49,536.25		\$63,760.00		\$56,138.25
	C1	Pulverize Existing Asphaltic Pavement	SY	1400	\$3.40	\$4,760.00	\$3.93	\$5,502.00	\$3.00	\$4,200.00	\$3.80	\$5,320.00
	C2	Asphaltic Concrete Pavement 3-Inch	TON	245	\$81.00	\$19,845.00	\$88.55	\$21,694.75	\$120.00	\$29,400.00	\$114.90	\$28,150.50
	C3	Load, Haul and Stockpile Excess Millings	CY	140	\$15.00	\$2,100.00	\$7.50	\$1,050.00	\$20.00	\$2,800.00	\$10.15	\$1,421.00
	C4	Curb Removal and Replacement, Inclusive	LF	855	\$22.00	\$18,810.00	\$24.90	\$21,289.50	\$32.00	\$27,360.00	\$24.85	\$21,246.75
Alternate D: Valley View Drive Storm Sewer						\$34,186.00		\$36,767.60		\$43,780.00		\$35,580.55
	D1	Storm Sewer Inlet, 2x3-Foot	EA	3	\$3,437.00	\$10,311.00	\$3,875.00	\$11,625.00	\$4,500.00	\$13,500.00	\$4,109.15	\$12,327.45
	D2	Storm Inlet Manhole, 48-Inch	EA	1	\$4,175.00	\$4,175.00	\$4,583.00	\$4,583.00	\$5,000.00	\$5,000.00	\$4,116.75	\$4,116.75
	D3	15-Inch Storm Sewer, HDPE	LF	180	\$65.00	\$11,700.00	\$46.47	\$8,364.60	\$66.00	\$11,880.00	\$50.80	\$9,144.00
	D4	Connect to Existing Storm Structure	LS	1	\$3,000.00	\$3,000.00	\$1,675.00	\$1,675.00	\$3,400.00	\$3,400.00	\$1,225.05	\$1,225.05
	D5	Storm Structure Restoration	LS	1	\$5,000.00	\$5,000.00	\$10,520.00	\$10,520.00	\$10,000.00	\$10,000.00	\$8,767.30	\$8,767.30
Alternate E: Supplemental Items						\$43.00		\$115.92		\$105.00		\$91.70
	E1	Trenchless 1-Inch Water Service Installation	LF	1	\$15.00	\$15.00	\$81.12	\$81.12	\$50.00	\$50.00	\$51.20	\$51.20
	E2	Curb Removal and Replacement, Machine Pour	LF	1	\$28.00	\$28.00	\$34.80	\$34.80	\$55.00	\$55.00	\$40.50	\$40.50

CITY UTILITIES OF RICHLAND CENTER -2026 VALLEY VIEW DRIVE WATER MAIN REPLACEMENT (#11137052)

Owner: Richland Center City Utilities

Solicitor: MSA Professional Services, Inc - CORP HQ - Baraboo

04/07/2026 02:00 PM CDT

Section Title	Line Item	Item Description	UofM	Original Bid			Proposed Adjustment			Proposed Allocation			
				Quantity	Unit Price	Extension	Quantity	Unit Price	Extension	Water		City	
Base Bid: Valley View Drive													
	1	Mobilization	LS	1	\$25,150.00	\$25,150.00	1	\$25,150.00	\$25,150.00	80%	\$20,120.00	20%	\$5,030.00
	2	Traffic Control	LS	1	\$6,250.00	\$6,250.00	1	\$6,250.00	\$6,250.00	80%	\$5,000.00	20%	\$1,250.00
	3	Erosion Control	LS	1	\$5,000.00	\$5,000.00	1	\$5,000.00	\$5,000.00	80%	\$4,000.00	20%	\$1,000.00
	4	Erosion Control, Rock Check	TON	150	\$18.00	\$2,700.00	150	\$18.00	\$2,700.00	80%	\$2,160.00	20%	\$540.00
	5	Erosion Control, Sediment Log	LF	150	\$25.00	\$3,750.00	150	\$25.00	\$3,750.00	80%	\$3,000.00	20%	\$750.00
	6	Turf Restoration	LS	1	\$12,500.00	\$12,500.00	1	\$12,500.00	\$12,500.00	1	\$12,500.00		\$0.00
	7	Imported Granular Backfill	CY	320	\$20.00	\$6,400.00	320	\$20.00	\$6,400.00	320	\$6,400.00		\$0.00
	8	Asphaltic Pavement Removal	SY	1100	\$6.10	\$6,710.00	85	\$6.10	\$518.50	50	\$305.00	35	\$213.50
	9	Dense Graded Base 1-1/4-Inch	TON	750	\$20.00	\$15,000.00	750	\$20.00	\$15,000.00	750	\$15,000.00		\$0.00
	10	Asphaltic Concrete Pavement 4-Inch	TON	245	\$193.00	\$47,285.00	0	\$193.00	\$0.00	0	\$0.00		\$0.00
	11	Asphaltic Concrete Pavement 2-Inch	TON	5	\$245.00	\$1,225.00	9	\$245.00	\$2,205.00	5	\$1,225.00	4	\$980.00
	12	Concrete Curb & Cutter 24-Inch, Restoration	LF	600	\$38.00	\$22,800.00	0	\$38.00	\$0.00	0	\$0.00		\$0.00
	13	Concrete Driveway 6-Inch	SF	2450	\$6.00	\$14,700.00	3410	\$6.00	\$20,460.00	2450	\$14,700.00	960	\$5,760.00
	14	6-Inch C.I. To 8-Inch HDPE WM, Pipe Burst	LF	1516	\$75.00	\$113,700.00	1516	\$75.00	\$113,700.00	1516	\$113,700.00		\$0.00
	15	8-Inch PVC C900 WM, Open Cut	LF	65	\$100.00	\$6,500.00	65	\$100.00	\$6,500.00	65	\$6,500.00		\$0.00
	16	6-Inch PVC C900 WM, Open Cut	LF	40	\$95.00	\$3,800.00	40	\$95.00	\$3,800.00	40	\$3,800.00		\$0.00
	17	8-Inch Valve & Box	EA	7	\$3,553.00	\$24,871.00	7	\$3,553.00	\$24,871.00	7	\$24,871.00		\$0.00
	18	6-Inch Valve & Box	EA	4	\$2,371.00	\$9,484.00	4	\$2,371.00	\$9,484.00	4	\$9,484.00		\$0.00
	19	8-Inch x 8-Inch Tee	EA	2	\$903.00	\$1,806.00	2	\$903.00	\$1,806.00	2	\$1,806.00		\$0.00
	20	8-Inch x 6-Inch Tee	EA	3	\$670.00	\$2,010.00	3	\$670.00	\$2,010.00	3	\$2,010.00		\$0.00
	21	8-Inch Bend	EA	2	\$782.00	\$1,564.00	2	\$782.00	\$1,564.00	2	\$1,564.00		\$0.00
	22	8-Inch x 6-Inch Reducer	EA	2	\$450.00	\$900.00	2	\$450.00	\$900.00	2	\$900.00		\$0.00
	23	8-Inch Plug	EA	2	\$300.00	\$600.00	2	\$300.00	\$600.00	2	\$600.00		\$0.00
	24	6-Inch Plug	EA	2	\$250.00	\$500.00	2	\$250.00	\$500.00	2	\$500.00		\$0.00
	25	Connect to Existing Water Main	EA	1	\$3,000.00	\$3,000.00	1	\$3,000.00	\$3,000.00	1	\$3,000.00		\$0.00
	26	Remove and Salvage Hydrant	EA	3	\$1,000.00	\$3,000.00	3	\$1,000.00	\$3,000.00	3	\$3,000.00		\$0.00
	27	Fire Hydrant (7.5 ft Bury)	EA	4	\$6,746.00	\$26,984.00	4	\$6,746.00	\$26,984.00	4	\$26,984.00		\$0.00
	28	1-Inch Saddle, Corp, Curb Stop & Box	EA	31	\$1,321.00	\$40,951.00	31	\$1,321.00	\$40,951.00	31	\$40,951.00		\$0.00
	29	1-Inch Water Service	LF	670	\$16.00	\$10,720.00	670	\$16.00	\$10,720.00	670	\$10,720.00		\$0.00
	30	2-Inch Saddle, Corp, Curb Stop & Box	EA	1	\$2,250.00	\$2,250.00	1	\$2,250.00	\$2,250.00	1	\$2,250.00		\$0.00
	31	2-Inch Water Service	LF	195	\$65.00	\$12,675.00	195	\$65.00	\$12,675.00	195	\$12,675.00		\$0.00
	32	Temporary Water Service	EA	32	\$2,330.00	\$74,560.00	32	\$2,330.00	\$74,560.00	32	\$74,560.00		\$0.00
Total Base Bid:						\$509,345.00			\$439,808.50	96%	\$424,285.00	4%	\$15,523.50
Alternate A: Chestnut Street and Stori Drive													
	A1	Traffic Control and Bonds	LS	1	\$4,600.00	\$4,600.00	1	\$4,600.00	\$4,600.00	1	\$4,600.00		\$0.00
	A2	Turf Restoration	LS	1	\$2,000.00	\$2,000.00	1	\$2,000.00	\$2,000.00	1	\$2,000.00		\$0.00
	A3	Asphalt Pavement Removal	SY	410	\$10.00	\$4,100.00	0	\$10.00	\$0.00	0	\$0.00		\$0.00
	A4	Dense Graded Base 1-1/4-Inch	TON	280	\$20.00	\$5,600.00	280	\$20.00	\$5,600.00	280	\$5,600.00		\$0.00
	A5	Asphaltic Concrete Pavement 4-Inch	TON	95	\$193.00	\$18,335.00	0	\$193.00	\$0.00	0	\$0.00		\$0.00
	A6	Concrete Curb & Gutter 24-Inch, Restoration	LF	210	\$37.00	\$7,770.00	0	\$37.00	\$0.00	0	\$0.00		\$0.00
	A7	Concrete Sidewalk 4-Inch	SF	265	\$6.00	\$1,590.00	415	\$6.00	\$2,490.00	265	\$1,590.00	150	\$900.00
	A8	Concrete Driveway 6-Inch	SF	730	\$6.00	\$4,380.00	930	\$6.00	\$5,580.00	730	\$4,380.00	200	\$1,200.00
	A9	6-Inch C.I. To 8-Inch HDPE WM, Pipe Burst	LF	425	\$75.00	\$31,875.00	425	\$75.00	\$31,875.00	425	\$31,875.00		\$0.00
	A10	6-Inch PVC C900 WM, Open Cut	LF	10	\$95.00	\$950.00	10	\$95.00	\$950.00	10	\$950.00		\$0.00
	A11	8-Inch PVC C900 WM, Open Cut	LF	8	\$100.00	\$800.00	8	\$100.00	\$800.00	8	\$800.00		\$0.00
	A12	6-Inch Valve & Box	EA	1	\$2,371.00	\$2,371.00	1	\$2,371.00	\$2,371.00	1	\$2,371.00		\$0.00
	A13	8-Inch Valve & Box	EA	1	\$3,553.00	\$3,553.00	1	\$3,553.00	\$3,553.00	1	\$3,553.00		\$0.00
	A14	8-Inch x 6-Inch Tee	EA	1	\$670.00	\$670.00	1	\$670.00	\$670.00	1	\$670.00		\$0.00
	A15	8-Inch Bend	EA	3	\$782.00	\$2,346.00	3	\$782.00	\$2,346.00	3	\$2,346.00		\$0.00
	A16	Connect to Existing Water Main	EA	2	\$3,000.00	\$6,000.00	2	\$3,000.00	\$6,000.00	2	\$6,000.00		\$0.00
	A17	Remove and Salvage Hydrant	EA	1	\$1,000.00	\$1,000.00	1	\$1,000.00	\$1,000.00	1	\$1,000.00		\$0.00
	A18	Fire Hydrant	EA	1	\$6,746.00	\$6,746.00	1	\$6,746.00	\$6,746.00	1	\$6,746.00		\$0.00
	A19	1-Inch Saddle, Corp, Curb Stop & Box	EA	6	\$1,521.00	\$9,126.00	6	\$1,521.00	\$9,126.00	6	\$9,126.00		\$0.00
	A20	1-Inch Water Service	LF	215	\$16.00	\$3,440.00	215	\$16.00	\$3,440.00	215	\$3,440.00		\$0.00
	A21	2-Inch Saddle, Corp, Curb Stop & Box	EA	1	\$2,250.00	\$2,250.00	1	\$2,250.00	\$2,250.00	1	\$2,250.00		\$0.00
	A22	2-Inch Water Service	LF	30	\$50.00	\$1,500.00	30	\$50.00	\$1,500.00	30	\$1,500.00		\$0.00
	A23	Valve Manhole, Water Service	EA	1	\$7,512.00	\$7,512.00	1	\$7,512.00	\$7,512.00	1	\$7,512.00		\$0.00
	A24	Temporary Water Service	EA	7	\$2,330.00	\$16,310.00	7	\$2,330.00	\$16,310.00	7	\$16,310.00		\$0.00
Total Alternate A:						\$144,824.00			\$116,719.00	98%	\$114,619.00	2%	\$2,100.00
Alternate B: Pulverize & Re-Surface Valley View Drive													
	B1	Pulverize Existing Asphaltic Pavement	SY	5660	\$3.00	\$16,980.00	5660	\$3.00	\$16,980.00	24%	\$4,100.00	76%	\$12,880.00
	B2	Asphaltic Concrete Pavement 3-Inch	TON	980	\$81.00	\$79,380.00	980	\$81.00	\$79,380.00	60%	\$47,628.00	40%	\$31,752.00
	B3	Load, Haul and Stockpile Excess Millings	CY	350	\$15.00	\$5,250.00	350	\$15.00	\$5,250.00	0	\$0.00	350	\$5,250.00
	B4	Curb Removal and Replacement, Inclusive	LF	3200	\$22.00	\$70,400.00	3200	\$22.00	\$70,400.00	30%	\$21,120.00	70%	\$49,280.00
	B5	Storm Water Curb Casting	EA	7	\$750.00	\$5,250.00	7	\$750.00	\$5,250.00		\$0.00	7	\$5,250.00
Total Alternate B:						\$177,260.00			\$177,260.00	41%	\$72,848.00	59%	\$104,412.00
Alternate C: Pulverize & Re-Surface Stori Drive and Chestnut Street													
	C1	Pulverize Existing Asphaltic Pavement	SY	1400	\$3.40	\$4,760.00	1400	\$3.40	\$4,760.00	85%	\$4,046.00	15%	\$714.00
	C2	Asphaltic Concrete Pavement 3-Inch	TON	245	\$81.00	\$19,845.00	245	\$81.00	\$19,845.00	95%	\$18,852.75	5%	\$992.25
	C3	Load, Haul and Stockpile Excess Millings	CY	140	\$15.00	\$2,100.00	140	\$15.00	\$2,100.00	0	\$0.00	140	\$2,100.00
	C4	Curb Removal and Replacement, Inclusive	LF	855	\$22.00	\$18,810.00	855	\$22.00	\$18,810.00	40%	\$7,524.00	60%	\$11,286.00
Total Alternate C:						\$45,515.00			\$45,515.00	67%	\$30,422.75	33%	\$15,092.25
Alternate D: Valley View Drive Storm Sewer													
	D1	Storm Sewer Inlet, 2x3-Foot	EA	3	\$3,437.00	\$10,311.00	3	\$3,437.00	\$10,311.00		\$0.00	3	\$10,311.00
	D2	Storm Inlet Manhole, 48-Inch	EA	1	\$4,175.00	\$4,175.00	1	\$4,175.00	\$4,175.00		\$0.00	1	\$4,175.00
	D3	15-inch Storm Sewer, HDPE	LF	180	\$65.00	\$11,700.00	180	\$65.00	\$11,700.00		\$0.00	180	\$11,700.00
	D4	Connect to Existing Storm Structure	LS	1	\$3,000.00	\$3,000.00	1	\$3,000.00	\$3,000.00		\$0.00	1	\$3,000.00
	D5	Storm Structure Restoration	LS	1	\$5,000.00	\$5,000.00	1	\$5,000.00	\$5,000.00		\$0.00	1	\$5,000.00
Total Alternate D:						\$34,186.00			\$34,186.00	0%	\$0.00	100%	\$34,186.00
Total Construction (Base Bid + Alternates A, B, C & D):						\$911,130.00			\$813,488.50	79%	\$642,174.75	21%	\$171,313.75
Construction Engineering and Administration (~7%):									\$56,945.00	80%	\$45,556.00	20%	\$11,389.00
Total Construction Cost:									\$870,433.50	79%	\$687,730.75	21%	\$182,702.75
Contingency (~5%):									\$43,522.00	80%	\$34,817.60	20%	\$8,704.40
Total Project:									\$913,955.50		\$ 722,548.35		\$ 191,407.15

2026 VALLEY VIEW DRIVE WATER MAIN REPLACEMENT

CITY OF RICHLAND CENTER RICHLAND COUNTY, WISCONSIN

SHEET INDEX

G - GENERAL SHEETS	
G1	TITLE SHEET
G2	EROSION CONTROL DETAILS
G3-G4	DETAILS
G5	TRAFFIC CONTROL PLAN
P - PLAN AND PROFILE SHEETS	
P1-P3	PLAN AND PROFILE - BASE BID - VALLEY VIEW DRIVE
P4	PLAN AND PROFILE - BASE BID - 1100 WATER SERVICE
P5	PLAN AND PROFILE - ALTERNATE A - STORI DRIVE

LEGEND

	EXISTING WATER MAIN
	EXISTING WATER MAIN, VALVE & HYDRANT
	EXISTING WATER SERVICE & CURB STOP
	PROPOSED WATER MAIN, VALVE, & HYDRANT
	PROPOSED WATER SERVICE & CURB STOP
	EXISTING SANITARY SEWER & MANHOLE
	PROPOSED SANITARY SEWER & MANHOLE
	EXISTING FORCEMAIN
	EXISTING STORM SEWER & INLET
	PROPOSED STORM SEWER & INLET
	PROPOSED STORM SEWER & MANHOLE
	BURIED ELECTRIC
	BURIED GAS & VALVE
	BURIED CABLE TELEVISION
	BURIED TELEPHONE
	BURIED FIBER OPTICS
	OVERHEAD UTILITY
	RAILROAD TRACKS
	EXISTING CURB & GUTTER
	PROPOSED CURB & GUTTER
	EXISTING SIDEWALK
	PROPOSED SIDEWALK
	EXISTING CULVERT PIPE
	PROPOSED CULVERT PIPE
	FENCE LINE
	DRAINAGE ARROW
	SILT FENCE
	RIGHT-OF-WAY
	BASELINE
	PROPERTY LINE
	TREE LINE
	BENCHMARK
	IRON PIPE
	IRON ROD
	CONTROL POINT
	UTILITY POLE & GUY
	SOIL BORING
	LIGHT POLE
	PEDESTAL
	STREET SIGN
	MAILBOX
	FLAGPOLE
	TREE - DECIDUOUS
	TREE - CONIFEROUS
	TREE TO BE REMOVED

UTILITIES

GAS:
 WE ENERGIES
 315 WILLIAM STREET
 WATERTOWN, WI 53094
 ATTN: ADAM MARING
 PHONE: (800) 261-5325

TV:
 CHARTER COMMUNICATIONS
 2701 DANIELS STREET
 MADISON, WI 53718
 ATTN: STEVE HEGGIE
 PHONE: (608) 274-3822, EXT. 6687

TELEPHONE:
 FRONTIER COMMUNICATIONS
 451 BRIADWAY DRIVE
 SUN PRAIRIE, WI 53590
 ATTN: CHRIS BLUMER
 PHONE: (608) 622-3807
 EMAIL: CHRISTOPHER.BLUMER@FTR.COM

GENUINE TELECOM
 1027 NORTH JEFFERSON STREET
 RICHLAND CENTER, WI 53581
 ATTN: BRANDON KINNEY
 PHONE: (608) 647-2345

SEWER, WATER & ELECTRICAL:
 RICHLAND CENTER CITY UTILITIES
 P.O. BOX 312
 RICHLAND CENTER, WI 53581
 ATTN: SCOTT GALD (ELECTRICAL)
 PHONE: (608) 604-6456
 ATTN: STEVE KRUEGER (WATER)
 PHONE: (608) 604-1048
 ATTN: TODD FISCHER (WASTE WATER)
 PHONE: (608) 604-4917

RICHLAND CENTER STREET DEPARTMENT
 450 SOUTH MAIN STREET
 RICHLAND CENTER, WI 53581
 ATTN: JASEN GLASSBRENNER, DPW
 PHONE: (608) 475-0766

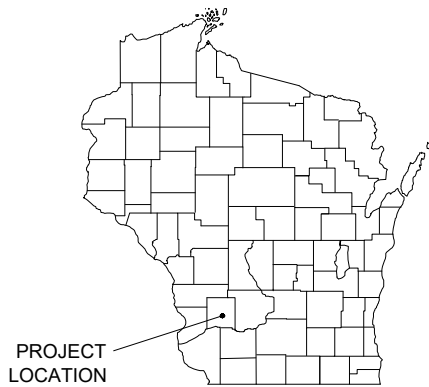

LOCATION MAP
NOT TO SCALE

DIGGERS HOTLINE

Dial **811** or (800) 242-8511

www.DiggersHotline.com

NOTE:
 UTILITY LOCATIONS SHOWN ON PLANS ARE APPROXIMATE AND CONTRACTOR SHALL HAVE APPROPRIATE UTILITY MARK EXACT LOCATIONS PRIOR TO CONSTRUCTION.

PROJECT DATE:	DRAWN BY:	NO.	DATE	REVISION	BY:
	DRK				
	DESIGNED BY:	Init			
	CHECKED BY:	Init			

MSA ENGINEERING | ARCHITECTURE | SURVEYING
 FUNDING | PLANNING | ENVIRONMENTAL
 1230 South Boulevard, Baraboo WI 53913
 (608) 356-2771 www.msa-ps.com
© MSA Professional Services, Inc.

2026 VALLEY VIEW DRIVE WATER MAIN REPLACEMENT
 RICHLAND CENTER CITY UTILITIES
 RICHLAND COUNTY, WISCONSIN

TITLE SHEET

**CONSTRUCTION SITE
EROSION CONTROL REQUIREMENTS**

- SECTION NR216.46 OF WISCONSIN STATE ADMINISTRATIVE CODE IDENTIFIES REQUIREMENTS FOR CONSTRUCTION SITE AND POST-CONSTRUCTION EROSION CONTROL. IT IS THE INTENT OF THESE PLANS TO SATISFY THESE REQUIREMENTS. THE METHODS AND STRUCTURES USED TO CONTROL EROSION SHALL BE THE RESPONSIBILITY OF THE CONTRACTOR. CONTRACTOR SHALL IMPLEMENT AN APPROPRIATE MEANS OF CONTROLLING EROSION DURING SITE OPERATION AND UNTIL THE VEGETATION IS RE-ESTABLISHED. ADJUSTMENTS TO THE CONTROL SYSTEM SHALL BE MADE AS REQUIRED.
- ALL WORK SHALL BE IN ACCORDANCE WITH THE LATEST EDITION OF THE WISCONSIN DNR'S CONSERVATION PRACTICE STANDARDS. THESE STANDARDS ARE PERIODICALLY UPDATED AND IT IS THE CONTRACTOR'S RESPONSIBILITY TO OBTAIN AND REFERENCE THE MOST RECENTLY RELEASED STANDARD.
- THIS INFORMATION IS ONLY ONE PART OF THE OVERALL EROSION CONTROL REQUIREMENTS. ADDITIONAL REQUIREMENTS MAY ALSO BE SHOWN ON THE CONTRACT DRAWINGS AND IN THE ACCOMPANYING SPECIFICATIONS.
- ADDITIONAL EROSION CONTROL MEASURES, AS REQUESTED IN WRITING BY THE STATE OR LOCAL INSPECTORS, OR THE OWNER'S ENGINEER, SHALL BE INSTALLED WITHIN 24 HOURS.
- THE AREA OF EROSION EXPOSED TO THE ELEMENTS BY GRUBBING, EXCAVATION, TRENCHING, BORROW AND FILL OPERATIONS AT ANY ONE TIME SHALL BE MINIMIZED TO THE MAXIMUM EXTENT PRACTICABLE. FOR ANY DISTURBED AREA THAT REMAINS INACTIVE FOR GREATER THAN 7 WORKING DAYS, OR WHERE GRADING WORK EXTENDS BEYOND THE PERMANENT SEEDING DEADLINES, THE SITE MUST BE TREATED WITH TEMPORARY STABILIZATION MEASURES SUCH AS SOIL TREATMENT, TEMPORARY SEEDING AND/OR MULCHING. ALL DISTURBED AREAS SHALL BE TREATED WITH PERMANENT STABILIZATION MEASURES WITHIN 3 WORKING DAYS OF FINAL GRADING.
- ALL EROSION CONTROL MEASURES AND STRUCTURES SERVING THE SITE MUST BE INSPECTED AT LEAST WEEKLY OR WITHIN 24 HOURS OF THE TIME 0.5 INCHES OF RAIN HAS OCCURRED. ALL NECESSARY REPAIR AND MAINTENANCE WILL BE DONE AT THIS INSPECTION TIME.
- ALL EROSION CONTROL DEVICES AND/OR STRUCTURES SHALL BE PROPERLY INSTALLED PRIOR TO CLEARING AND GRUBBING OPERATIONS WITHIN THEIR RESPECTIVE DRAINAGE AREAS. THESE SHALL BE PROPERLY MAINTAINED FOR MAXIMUM EFFECTIVENESS UNTIL VEGETATION IS RE-ESTABLISHED.
- ALL EROSION CONTROL DEVICES SHALL BE PROPERLY INSTALLED PRIOR TO ANY SOIL DISTURBANCE.
- ANY SLOPES STEEPER THAN 3H:1V SHALL BE STAKED WITH EROSION CONTROL FABRIC UNLESS INDICATED ON THE PLAN.
- ALL WASTE AND UNUSED BUILDING MATERIALS (INCLUDING GARBAGE, DEBRIS, CLEANING WASTES, WASTEWATER, TOXIC MATERIALS, OR HAZARDOUS MATERIALS) SHALL BE PROPERLY DISPOSED OF AND NOT ALLOWED TO BE CARRIED OFF-SITE BY RUNOFF OR WIND.
- WIND EROSION SHALL BE KEPT TO A MINIMUM DURING CONSTRUCTION. WATERING, MULCH, OR A TACKING AGENT MAY BE REQUIRED TO PROTECT NEARBY RESIDENCES AND WATER RESOURCES.
- CHANNELIZED RUNOFF ENTERING THE PROJECT SITE FROM ADJOINING LANDS SHALL BE DIVERTED THROUGH NATURALLY OR ARTIFICIALLY EROSION-RESISTANT CONVEYANCES. IF CHANNELIZED RUNOFF CANNOT BE DIVERTED, SITE BEST MANAGEMENT PRACTICES MUST ACCOUNT FOR THE ADDITIONAL FLOW RATES AND EROSION POTENTIAL THAT SUCH RUNOFF PRESENTS.
- THE CONTRACTOR SHALL TAKE ALL POSSIBLE PRECAUTIONS TO PREVENT SOILS FROM BEING TRACKED ONTO PUBLIC OR PRIVATE ROADWAYS. PAVED SURFACES ADJACENT TO CONSTRUCTION SITE VEHICLE ACCESS SHALL BE SWEEPED AND/OR SCRAPED (NOT FLUSHED) PERIODICALLY TO REMOVE SOIL, DIRT, AND/OR DUST.
- EROSION CONTROLS SHALL BE INSTALLED ON THE DOWNSTREAM SIDE OF TEMPORARY STOCKPILES. ANY SOIL STOCKPILE THAT REMAINS FOR MORE THAN 7 DAYS SHALL BE COVERED OR TREATED WITH STABILIZATION PRACTICES SUCH AS TEMPORARY OR PERMANENT SEEDING AND MULCHING. ALL STOCK PILES SHALL BE PLACED AT LEAST 75 FEET FROM STREAMS OR WETLANDS.
- ADDITIONAL EROSION CONTROL FOR UTILITY CONSTRUCTION (STORM SEWER, SANITARY SEWER, WATER MAIN, ETC.) SHALL INCLUDE THE FOLLOWING:
 - PLACE EXCAVATED TRENCH MATERIAL ON THE HIGH SIDE OF THE TRENCH.
 - BACKFILL, COMPACT, AND STABILIZE THE TRENCH IMMEDIATELY AFTER PIPE CONSTRUCTION.
 - DISCHARGE OF TRENCH WATER OR DEWATERING EFFLUENT MUST BE PROPERLY TREATED TO REMOVE SEDIMENT IN ACCORDANCE WITH THE WDNR CONSERVATION PRACTICE STANDARD 1061 - DEWATERING OR A SUBSEQUENT WDNR DEWATERING STANDARD PRIOR TO DISCHARGE INTO A STORM SEWER, DITCH, DRAINAGEWAY, OR WETLAND OR LAKE.
- ALL DRAINAGE CULVERTS, STORM DRAIN INLETS, MANHOLES, OR ANY OTHER EXISTING STRUCTURES THAT COULD BE DAMAGED BY SEDIMENTATION SHALL BE PROTECTED ACCORDING TO THE VARIOUS METHODS PROVIDED IN THE PRINTED CONSERVATION PRACTICE STANDARDS.
- ANY SOIL EROSION THAT OCCURS AFTER FINAL GRADING AND/OR STABILIZATION MUST BE REPAIRED AND THE STABILIZATION WORK REDONE.
- THE FIRST SIX WEEKS AFTER INITIAL STABILIZATION, ALL NEWLY SEEDED AND MULCHED AREAS SHALL WATERED WHENEVER 7 DAYS ELAPSE WITHOUT A RAIN EVENT.
- WHEN THE DISTURBED AREA HAS BEEN STABILIZED BY PERMANENT VEGETATION OR OTHER MEANS, TEMPORARY BMP'S SUCH AS SILT FENCES, STRAW BALES, AND SEDIMENT TRAPS SHALL BE REMOVED AND THESE AREAS STABILIZED.
- ALL TEMPORARY BEST MANAGEMENT PRACTICES SHALL BE MAINTAINED UNTIL THE SITE IS STABILIZED.
- ALL DISTURBED AREAS SHALL BE PERMANENTLY STABILIZED WITH SEED AND MULCH UNLESS OTHERWISE SPECIFIED. A MINIMUM OF FOUR INCHES OF TOPSOIL SHALL BE APPLIED TO ALL AREAS TO BE SEEDED OR SODDED.

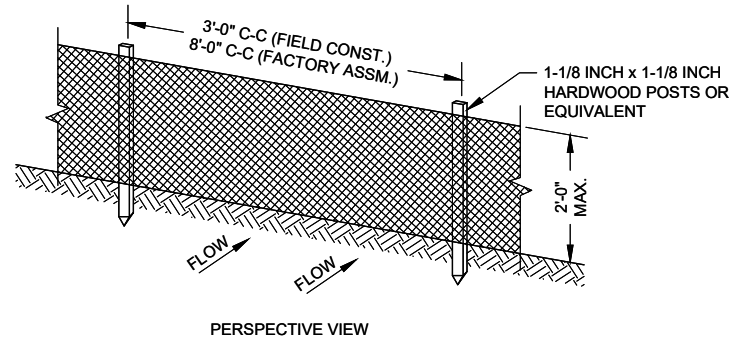
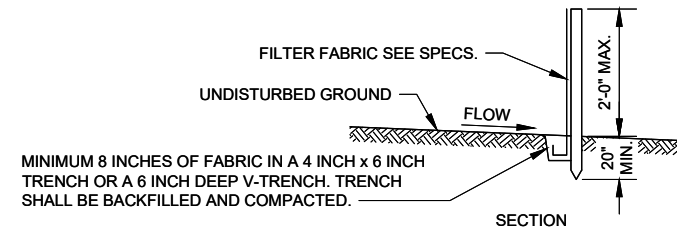

GENERAL NOTES:

- ENDS OF FENCE SHALL BE TURNED UPSLOPE 1 TO 2 FEET IN ELEVATION TO PREVENT FLANKING.
- STAPLE FABRIC WITH 1/2 INCH (MINIMUM) STAPLES TO THE UPSLOPE SIDE OF THE POSTS.
- WHEN TWO SECTIONS OF FILTER FABRIC ADJOIN EACH OTHER THEY SHALL BE OVERLAPPED BY SIX INCHES AND FOLDED.

TYPICAL SILT FENCE INSTALLATION AT SITE PERIMETER DETAIL
NO SCALE

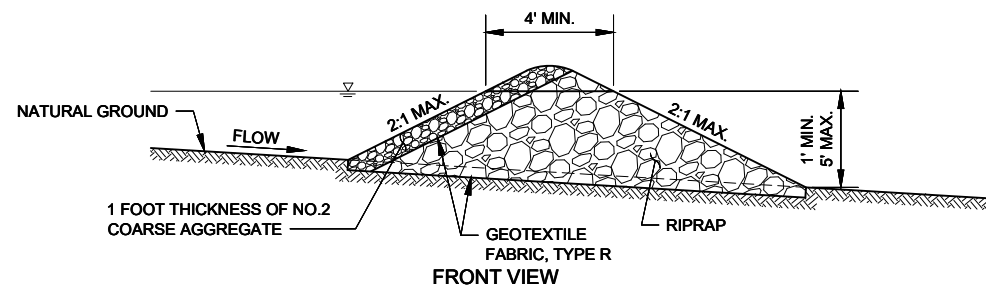

GENERAL NOTES:

- DETAILS OF CONSTRUCTION, MATERIALS AND WORKMANSHIP NOT SHOWN ON THIS DRAWING SHALL CONFORM TO THE PERTINENT REQUIREMENTS OF THE SPECIFICATIONS AND THE "WISCONSIN CONSTRUCTION SITE BEST MANAGEMENT PRACTICE HANDBOOK".

ROCK CHECK DETAIL
NO SCALE

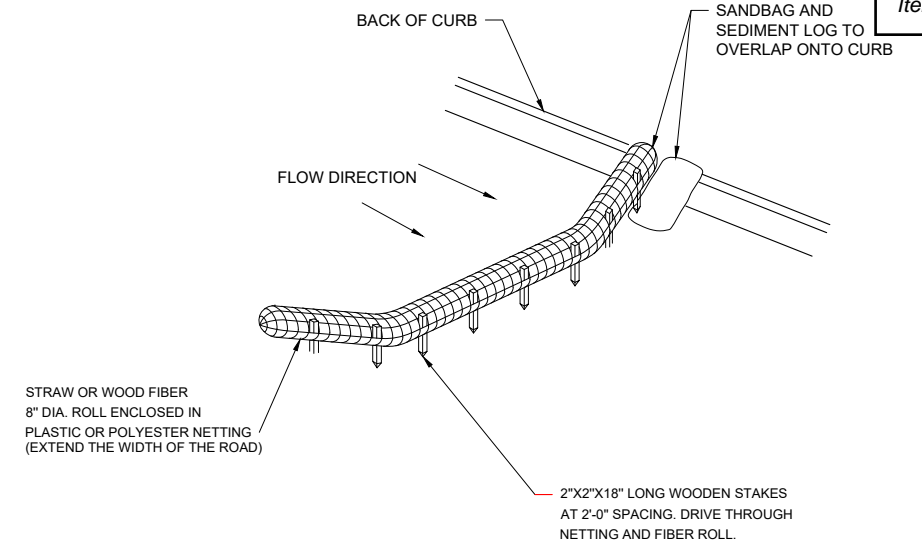

SEDIMENT LOG DETAIL
SCALE: NONE

GENERAL NOTES:

- SEDIMENT LOGS SHALL BE STAKED FOR ADDITIONAL STABILITY WHERE PAVEMENT IS REMOVED.
- PROVIDE ADDITIONAL SAND BAGS WHERE PAVEMENT IS IN TACT
- SEDIMENT LOGS SHALL ONLY BE REMOVED IF THEY INTERFERE WITH UTILITY INSTALLATION, AND SHALL BE REINSTALLED AFTER THE UTILITY WORK IS COMPLETED.

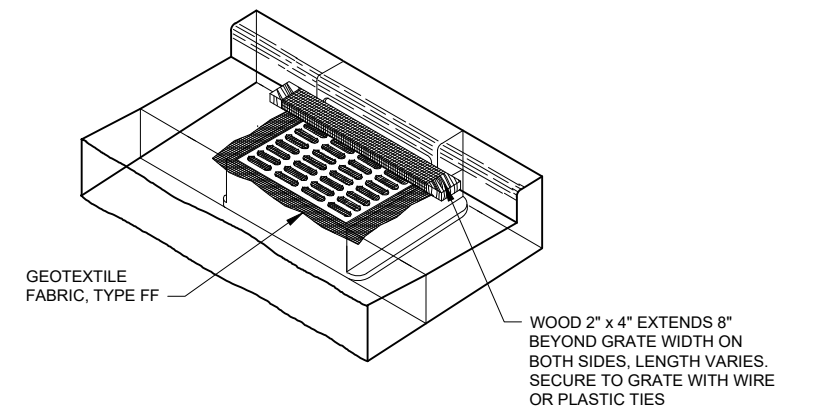

INSTALLATION NOTES:

- TRIM EXCESS FABRIC IN THE FLOW LINE TO WITHIN 3" OF THE GRATE. THE CONTRACTOR SHALL DEMONSTRATE A METHOD OF MAINTENANCE, USING A SEWN FLAP, HAND HOLDS OR OTHER METHOD TO PREVENT ACCUMULATED SEDIMENT FROM ENTERING THE INLET.

INLET PROTECTION, TYPE C
NO SCALE

PROJECT DATE:	DRAWN BY:	NO.	DATE	REVISION	BY:
3/20/2026 10:43 AM, G:\1111137051\CADD\Construction Documents\11137052 Details.dwg	DRK				
	DESIGNED BY: Init				
	CHECKED BY: Init				



ENGINEERING | ARCHITECTURE | SURVEYING
FUNDING | PLANNING | ENVIRONMENTAL
1230 South Boulevard, Baraboo WI 53913
(608) 356-2771 www.msa-ps.com
© MSA Professional Services, Inc.

2026 VALLEY VIEW DRIVE WATER MAIN REPLACEMENT
RICHLAND CENTER CITY UTILITIES
RICHLAND COUNTY, WISCONSIN

EROSION CONTROL DETAILS

Item 23.

PROJECT NO. 1113705
SHEET 97
G2

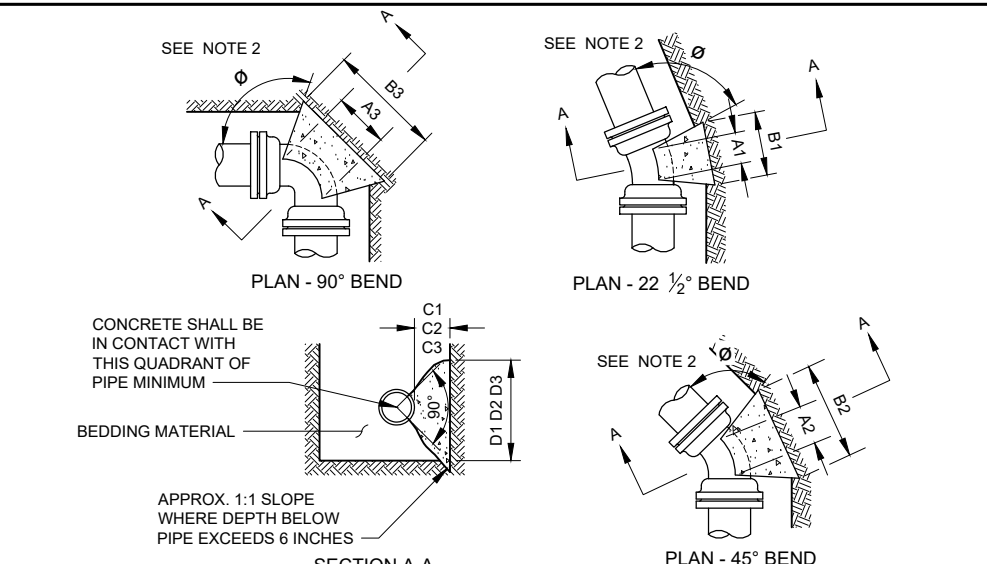
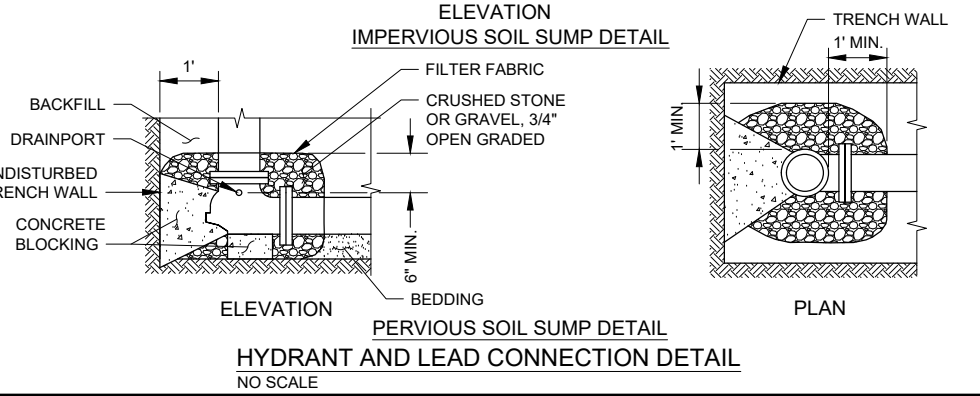
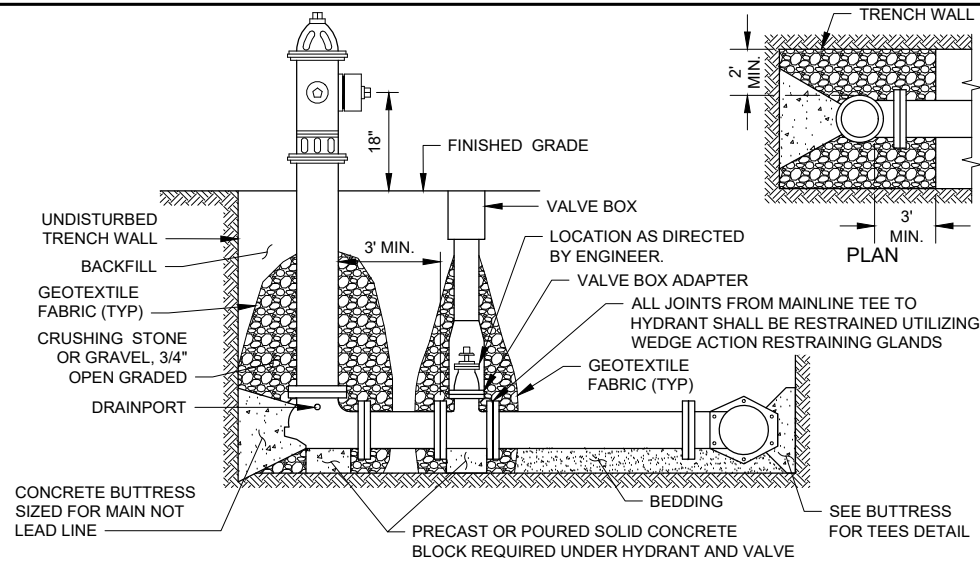

NOTES:

- DIMENSIONS IN TABLE ARE BASED ON A WATER PRESSURE OF 150 P.S.I. AND AN EARTH RESISTANCE OF 2 TONS PER SQ. FT. INFORM THE ENGINEER IF PRESSURES EXCEED 150 PSI, OR ON-SITE SOIL DOES NOT MEET THIS CONDITION.
- DIMENSION C1 C2 C3 SHOULD BE LARGE ENOUGH TO MAKE ANGLE Ø EQUAL TO OR LARGER THAN 45°.
- DIMENSION A1 A2 A3 SHOULD BE AS LARGE AS POSSIBLE WITHOUT INTERFERING WITH THE MECHANICAL JOINT.
- BUTTRESS TO BE POURED AGAINST FIRM UNDISTURBED SOIL, OR DISTURBED SOIL COMPACTED TO 95% OF MODIFIED PROCTOR DENSITY, ASTM D1557.
- ALL BUTTRESSED FITTINGS SHALL BE WRAPPED IN POLYETHYLENE.
- CONCRETE SHALL HAVE A MINIMUM 7-DAY COMPRESSIVE STRENGTH OF 2000 PSI.
- IN ADDITION TO BUTTRESSES, ALL JOINTS SURROUNDING BENDS SHALL BE RESTRAINED WITH WEDGE ACTION RESTRAINING GLANDS.

BUTTRESS DIMENSIONS

PIPE SIZE	22 1/2° BENDS		45° BENDS		90° BENDS	
	B1	D1	B2	D2	B3	D3
6"	1'-0"	1'-0"	1'-0"	1'-0"	1'-4"	1'-2"
8"	1'-0"	1'-0"	1'-4"	1'-2"	1'-10"	1'-6"
10"	1'-2"	1'-2"	1'-7"	1'-7"	2'-3"	1'-10"
12"	1'-4"	1'-4"	1'-10"	1'-10"	2'-8"	2'-3"
16"	1'-10"	1'-8"	2'-6"	2'-4"	3'-10"	2'-10"
20"	2'-4"	2'-0"	3'-3"	2'-10"	5'-0"	3'-4"
24"	2'-10"	2'-4"	4'-0"	3'-3"	6'-4"	3'-10"

BUTTRESS FOR BENDS DETAIL
NO SCALE

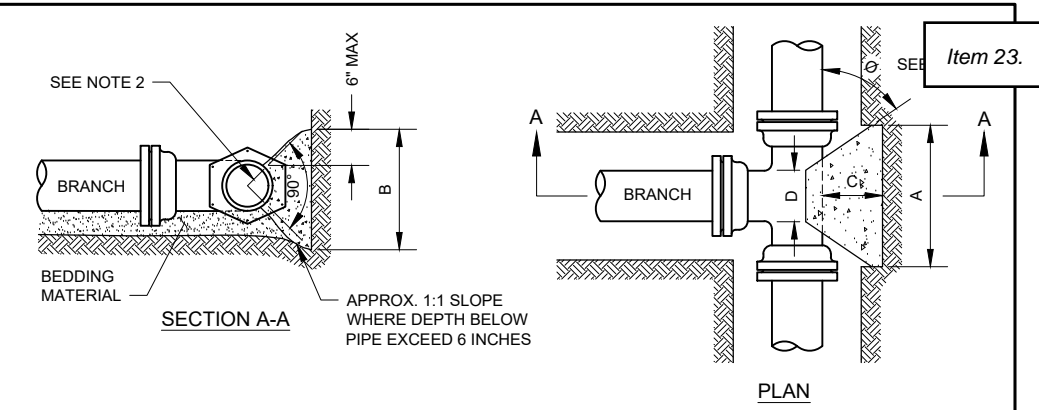

NOTES:

- DIMENSION 'C' SHOULD BE LARGE ENOUGH TO MAKE ANGLE Ø GREATER THAN OR EQUAL TO 45°.
- CONCRETE SHOULD BEAR ON THIS QUADRANT OF PIPE AT A MINIMUM.
- DIMENSION 'D' SHOULD BE AS LARGE AS POSSIBLE BUT CONCRETE SHOULD NOT INTERFERE WITH MECHANICAL JOINTS.
- BUTTRESS DIMENSIONS ARE BASED ON A SOIL RESISTANCE OF TWO TONS PER SQ. FT. AND A WATER PRESSURE OF 150 PSI. INFORM THE ENGINEER IF ON-SITE SOIL DOES NOT MEET THIS CONDITION OR PRESSURES EXCEED 150 PSI.
- BUTTRESS TO BE PLACED AGAINST FIRM UNDISTURBED SOIL, OR DISTURBED SOIL COMPACTED TO 95% OF MODIFIED PROCTOR DENSITY, ASTM D1557.
- CONCRETE SHALL HAVE A MINIMUM 7-DAY COMPRESSIVE STRENGTH OF 2000 PSI.
- ALL POURED BUTTRESSED FITTINGS SHALL BE WRAPPED IN POLYETHYLENE.
- IN ADDITION TO BUTTRESSES, ALL JOINTS SURROUNDING TEES SHALL BE RESTRAINED WITH WEDGE ACTION RESTRAINING GLANDS.

BUTTRESS DIMENSIONS

DIA.	A	B	C	D
6"	1'-3"	1'-0"		
8"	1'-6"	1'-4"		
10"	1'-10"	1'-8"	SEE NOTE NO. 1	SEE NOTE NO. 3
12"	2'-3"	2'-0"		
16"	3'-2"	2'-6"		
20"	4'-0"	3'-0"		
24"	5'-3"	3'-4"		

DIA. = BRANCH DIAMETER

BUTTRESS FOR TEES DETAIL
NO SCALE

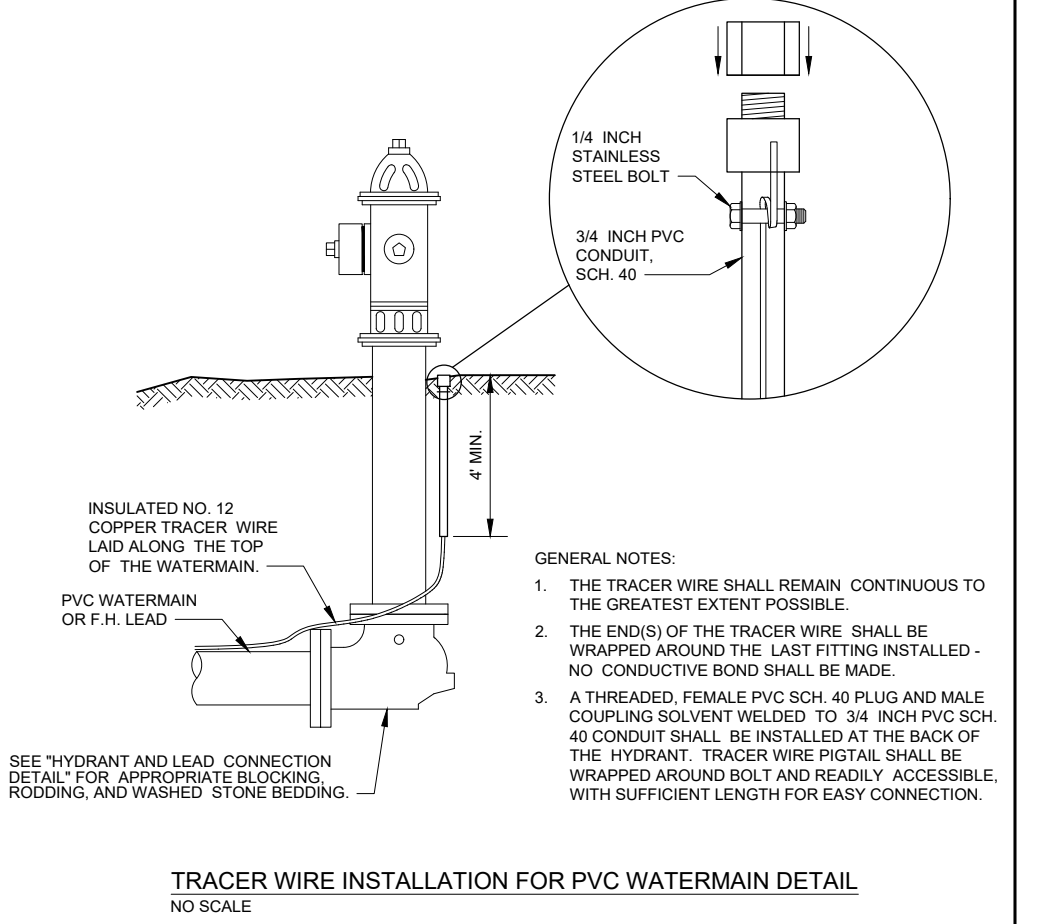
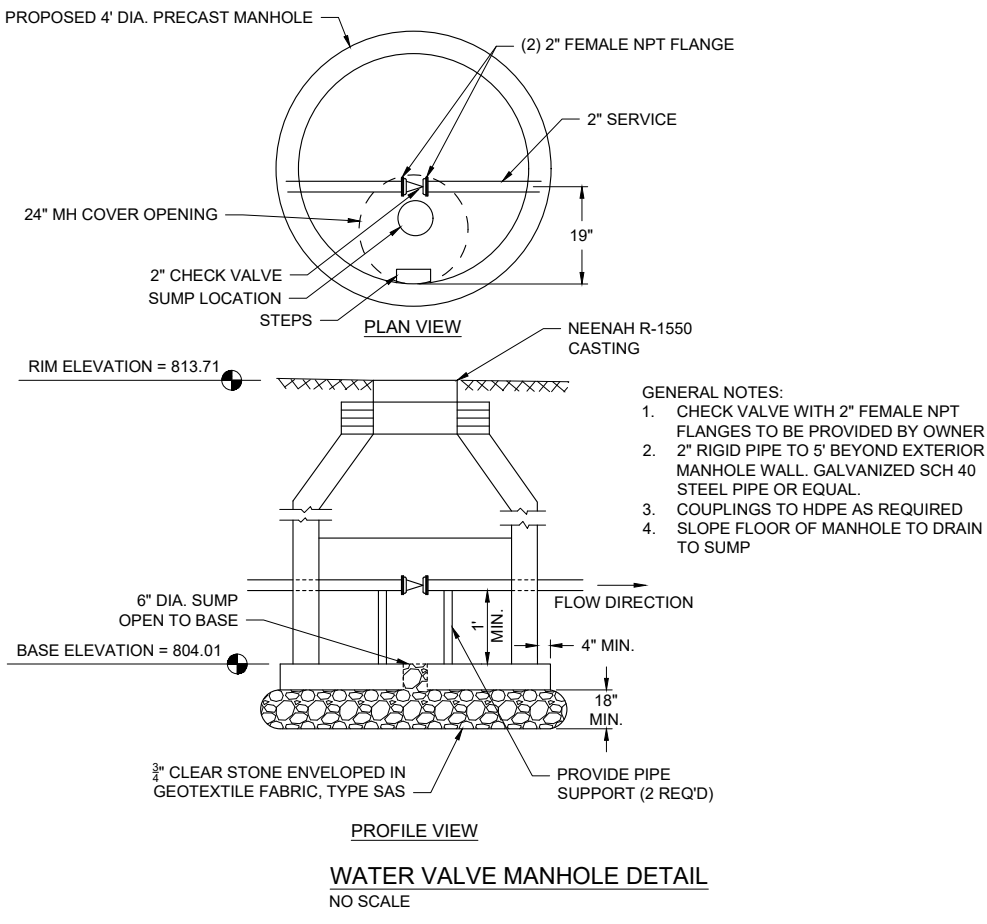
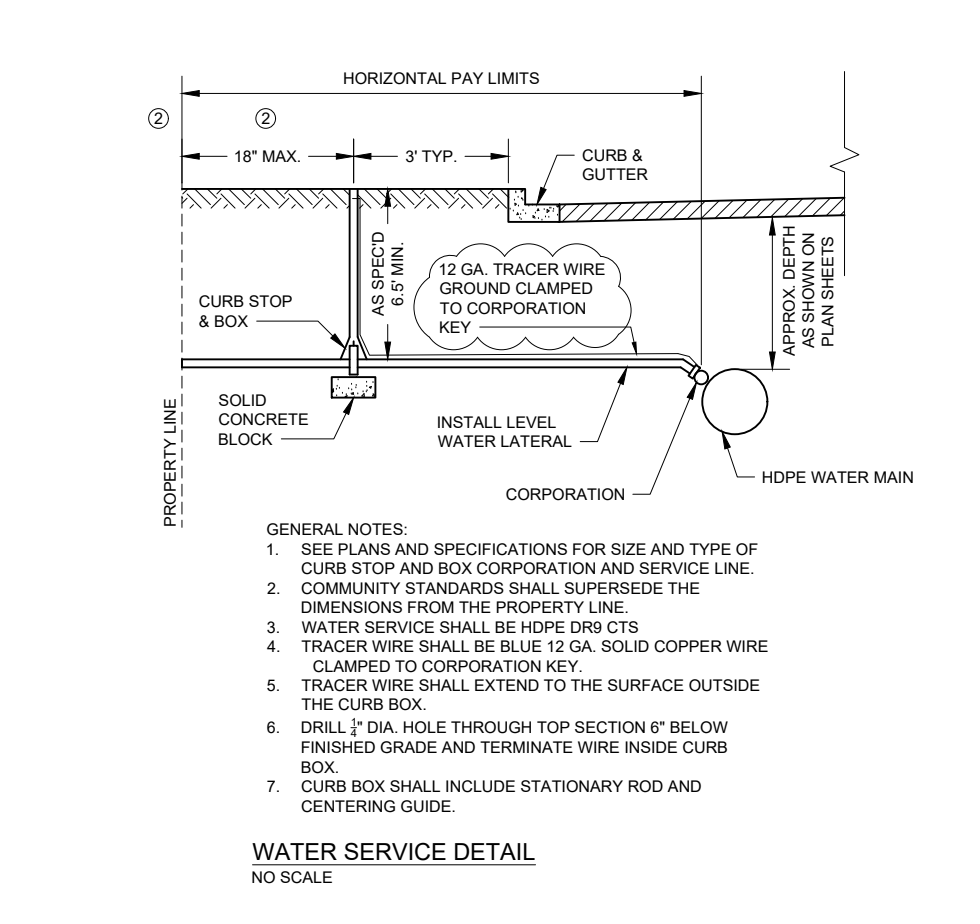

PROJECT DATE:	DRAWN BY:	NO.	DATE	REVISION	BY:
	DRK				
	INIT				
	INIT				

PLOT DATE: 3/20/2026 10:43 AM, G:\11111137\11137051\CADD\Construction Documents\11137052 Details.dwg



ENGINEERING | ARCHITECTURE | SURVEYING
FUNDING | PLANNING | ENVIRONMENTAL
1230 South Boulevard, Baraboo WI 53913
(608) 356-2771 www.msa-ps.com
© MSA Professional Services, Inc.

2026 VALLEY VIEW DRIVE WATER MAIN REPLACEMENT
RICHLAND CENTER CITY UTILITIES
RICHLAND COUNTY, WISCONSIN

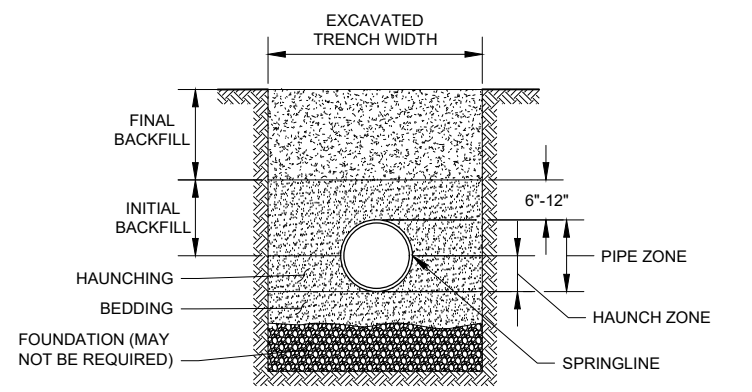

- GENERAL NOTES:
1. DETAILS OF CONSTRUCTION NOT SHOWN ON THIS DRAWING SHALL CONFORM TO ASTM D2321.
 2. CLASS II EMBEDMENT MATERIAL SHALL BE CLEAN, COARSE-GRAINED SOILS WITH LITTLE TO NO FINES. NO PARTICLES LARGER THAN 1 1/2 -INCHES SHALL BE USED IN THE PIPE EMBEDMENT.
 3. WHERE HYDRAULIC GRADIENT EXISTS USE A WELL-GRADED MIXTURE TO MINIMIZE MIGRATION OF FINES FROM ADJACENT SOIL.
 4. CLASS II MATERIAL IS SUITABLE AS A FOUNDATION AND FOR REPLACING OVER- EXCAVATED AND UNSTABLE TRENCH BOTTOM. INSTALL AND COMPACT IN 6-INCH MAXIMUM LAYERS.
 5. INSTALL AND COMPACT BEDDING IN 6-INCH MAXIMUM LAYERS. LEVEL FINAL GRADE BY HAND. MINIMUM DEPTH 4 INCH (6 INCH IN ROCK CUTS.)
 6. INSTALL AND COMPACT HAUNCHING IN 6-INCH MAXIMUM LAYERS. WORK IN AROUND PIPE BY HAND TO PROVIDE UNIFORM SUPPORT.
 7. INSTALL AND COMPACT INITIAL BACKFILL TO A MINIMUM OF 6 INCH ABOVE PIPE CROWN.
 8. EMBEDMENT COMPACTION:
MINIMUM DENSITY 85% STANDARD PROCTOR. USE HAND TAMPERS OR VIBRATORY COMPACTORS.
 10. EMBEDMENT INCLUDES BEDDING, HAUNCHING, AND INITIAL BACKFILL.

CLASS II - FLEXIBLE PIPE EMBEDMENT DETAIL
NO SCALE

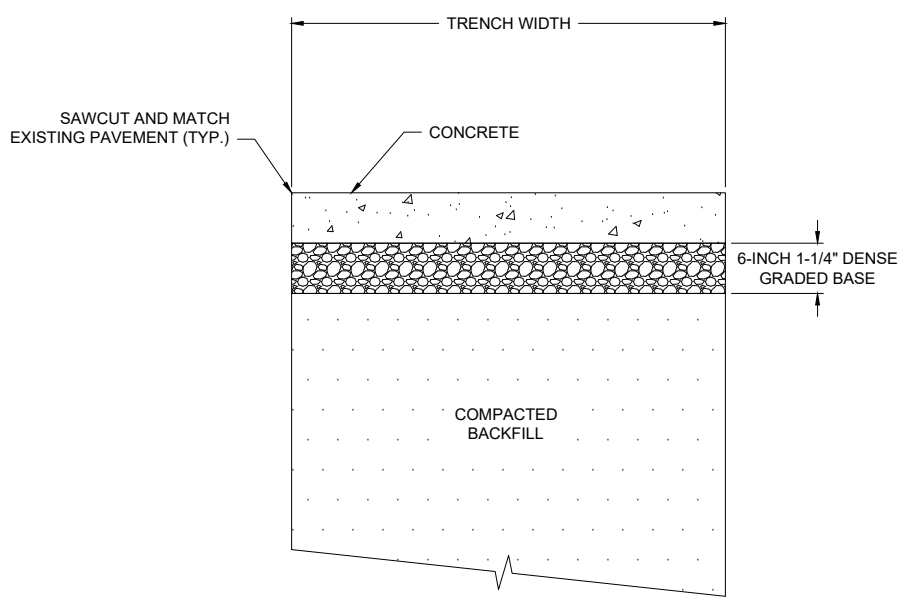

- GENERAL NOTES:
1. PLAN QUANTITY BASED ON ASSUMED 6-INCH THICKNESS FOR DRIVEWAYS AND 4-INCH THICKNESS FOR SIDEWALKS
 2. CONTRACTOR TO MATCH EXISTING CONCRETE THICKNESS

CONCRETE DRIVEWAY AND SIDEWALK RESTORATION DETAIL
NO SCALE

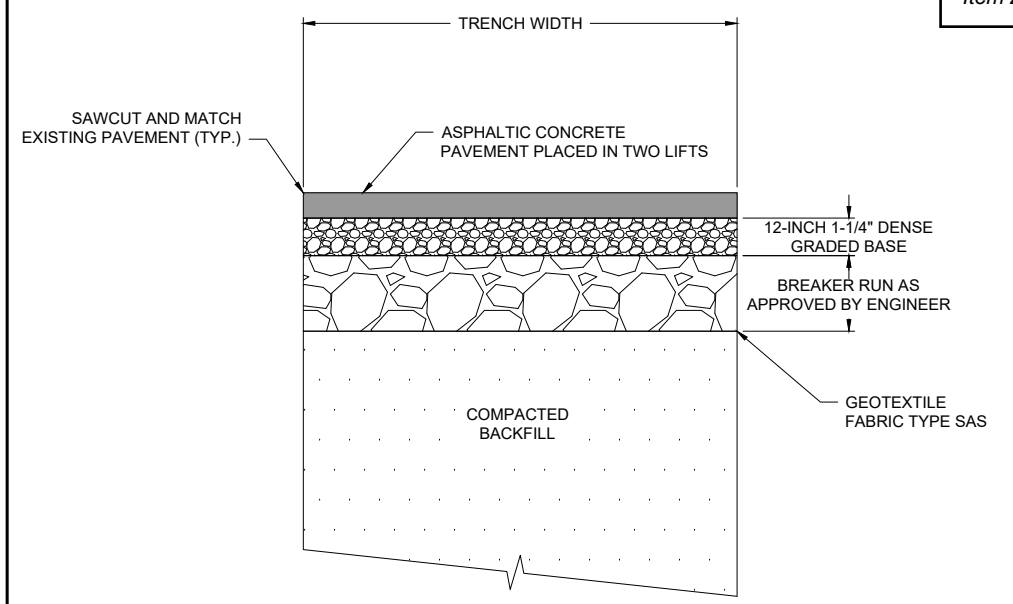

- GENERAL NOTES:
1. PLAN QUANTITY BASED ON ASSUMED 4-INCH THICKNESS FOR ROADWAYS AND 2-INCH THICKNESS FOR DRIVEWAYS
 2. CONTRACTOR TO MATCH EXISTING ASPHALT THICKNESS
 3. ASPHALTIC CONCRETE PAVEMENT MIX SHALL BE 4 MT 58-28S

ASPHALTIC CONCRETE PAVEMENT RESTORATION DETAIL
NO SCALE

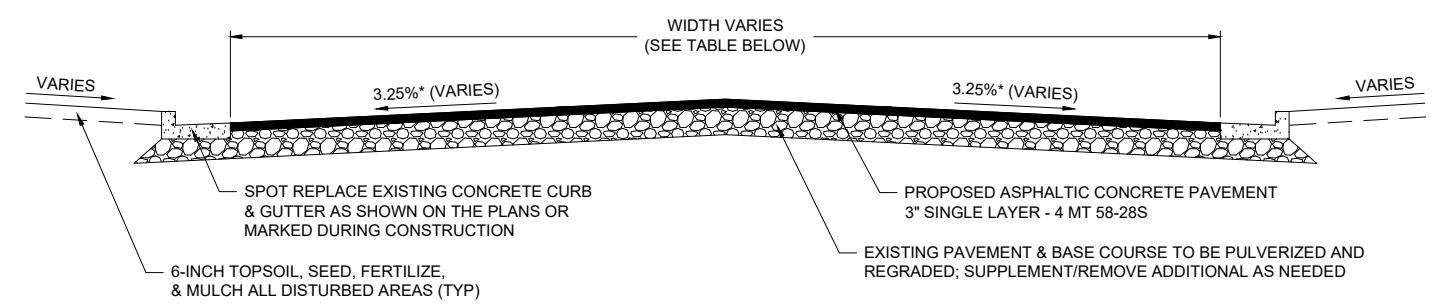

*GRADE TO BE DETERMINED IN FIELD AND ADJUSTED TO MAXIMIZE USE OF PULVERIZED MATERIALS

- GENERAL NOTES:
1. THIS TYPICAL SECTION IS TO BE USED IF ALTERNATE C IS SELECTED IN LIEU OF ROADWAY PATCHES
 2. RED TOP CROWN OR CENTERLINE GRADE TO BE DETERMINED IN FIELD AND ADJUSTED TO MAXIMIZE USE OF PULVERIZED MATERIALS

TYPICAL SECTION - ALTERNATE BID
STORI DRIVE (STA 1+20 - STA 4+10)
CHESTNUT STREET (STA 4+50 - STA 5+50)
VALLEY VIEW DRIVE (STA 6+20 - STA 19+25)

NOT TO SCALE

ROAD WIDTHS	
ROAD	A
STORI DRIVE	27'
CHESTNUT STREET	33'
VALLEY VIEW DRIVE	32'

PROJECT DATE:	DRAWN BY:	NO.	DATE	REVISION	BY:
	DRK				
	Init				
	Init				

MSA ENGINEERING | ARCHITECTURE | SURVEYING
FUNDING | PLANNING | ENVIRONMENTAL
1230 South Boulevard, Baraboo WI 53913
(608) 356-2771 www.msa-ps.com
© MSA Professional Services, Inc.

2026 VALLEY VIEW DRIVE WATER MAIN REPLACEMENT
RICHLAND CENTER CITY UTILITIES
RICHLAND COUNTY, WISCONSIN

DETAILS
PROJECT NO. 1113704
SHEET G4



NOTES:

- ONE LANE OF TRAFFIC SHALL REMAIN OPEN AT ALL TIMES DURING CONSTRUCTION.
- CONSTRUCTION OF TEMPORARY BYPASS LANES SHALL BE COORDINATED WITH AFFECTED RESIDENTS AND APPROVED BY OWNER AND/OR ENGINEER.
- ALL EXCAVATIONS SHALL BE RESTORED WITH AGGREGATE BASE AND OPENED TO TRAFFIC OVER NIGHTS, HOLIDAYS, AND WEEKENDS.
- THE EXACT NUMBER, LOCATION, AND SPACING OF ALL SIGNS AND BARRICADES SHALL BE ADJUSTED TO FIT FIELD CONDITIONS AS APPROVED BY THE ENGINEER.
- BARRICADES THAT MUST BE MOVED FOR A WORK OPERATION SHALL BE IMMEDIATELY RE-ESTABLISHED UPON COMPLETION OF THE OPERATION, OR FOR CONTINUING OPERATIONS, AT THE END OF EACH WORKING DAY.
- ALL TYPE III BARRICADES SHALL BE PROVIDED WITH TYPE "A" LOW - INTENSITY FLASHING WARNING LIGHTS AND BE VISIBLE ON BOTH SIDES.
- ALL TYPE III BARRICADES SHALL HAVE RAILS REFLECTORIZED ON BOTH FACES. STRIPES SHALL BE PROPERLY SLOPED DOWN TOWARD THE TRAFFIC SIDE.
- TRAFFIC CONTROL DEVICES NOT SHOWN TO SCALE. CONTRACTOR SHALL PROVIDE ALL TRAFFIC CONTROL DEVICES AND FLAGGING REQUIRED TO PROTECT THE WORK ZONE(S).
- SIGNS THAT WILL BE IN PLACE LESS THAN 7 CONTINUOUS DAYS AND NIGHTS MAY BE MOUNTED ON PORTABLE SUPPORTS.
- TRAFFIC CONTROL DEVICES AND PLACEMENT SHALL CONFORM TO MUTCD STANDARDS.

LEGEND

- ←→ TRAFFIC DIRECTION
- ⊥ SIGN ON TEMPORARY SUPPORT
- ⊥ TYPE III BARRICADE
- ⊥ TYPE III BARRICADE WITH SIGN
- ▨ WORK ZONE
- TRAFFIC CONTROL DRUMS
- ① ROAD WORK AHEAD (W20-1)
- ② ONE LANE ROAD AHEAD (W20-4)
- ③ LANE CLOSURE



PROJECT DATE:	NO.	DATE	REVISION	BY:
DRAWN BY: DRK	-	-	-	-
DESIGNED BY: Init	-	-	-	-
CHECKED BY: Init	-	-	-	-

MSA
 ENGINEERING | ARCHITECTURE | SURVEYING
 FUNDING | PLANNING | ENVIRONMENTAL
 1230 South Boulevard, Baraboo WI 53913
 (608) 356-2771 www.msa-ps.com
© MSA Professional Services, Inc.

2026 VALLEY VIEW DRIVE WATER MAIN REPLACEMENT
 RICHLAND CENTER CITY UTILITIES
 RICHLAND COUNTY, WISCONSIN

TRAFFIC CONTROL PLAN

PLOT DATE: 3/20/2026 10:43 AM, G:\1111137\11137051\CADD\Construction Documents\11137052 Traffic Control Plan.dwg

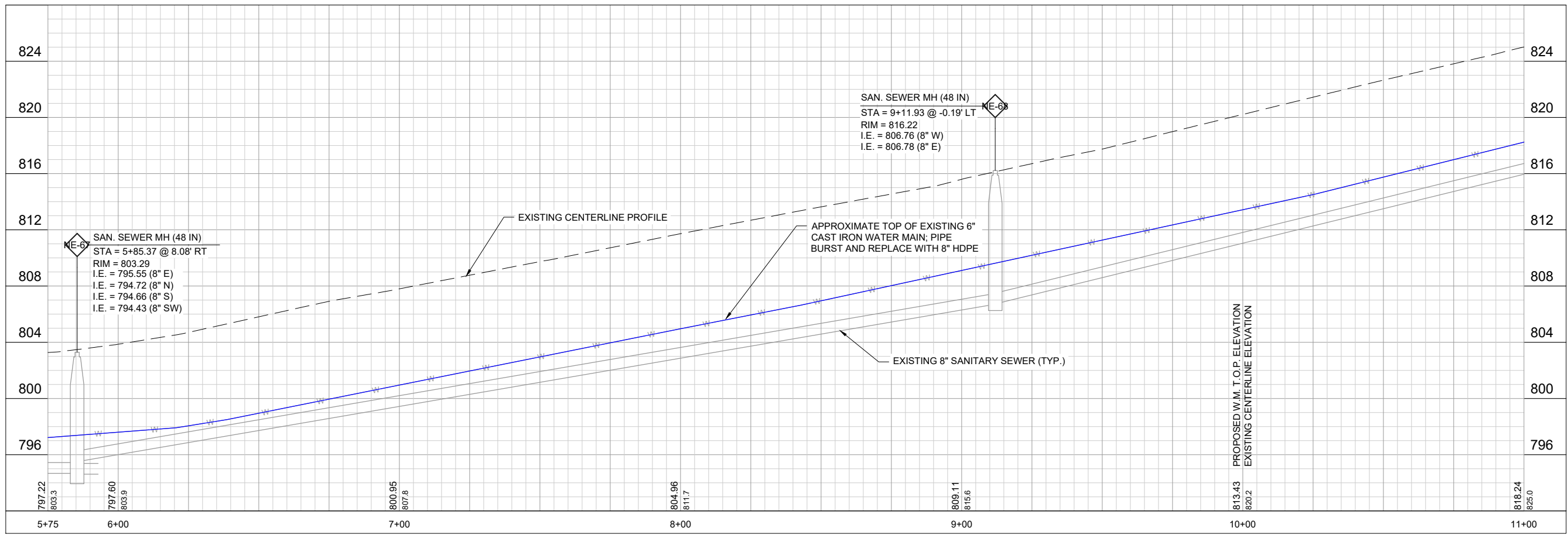
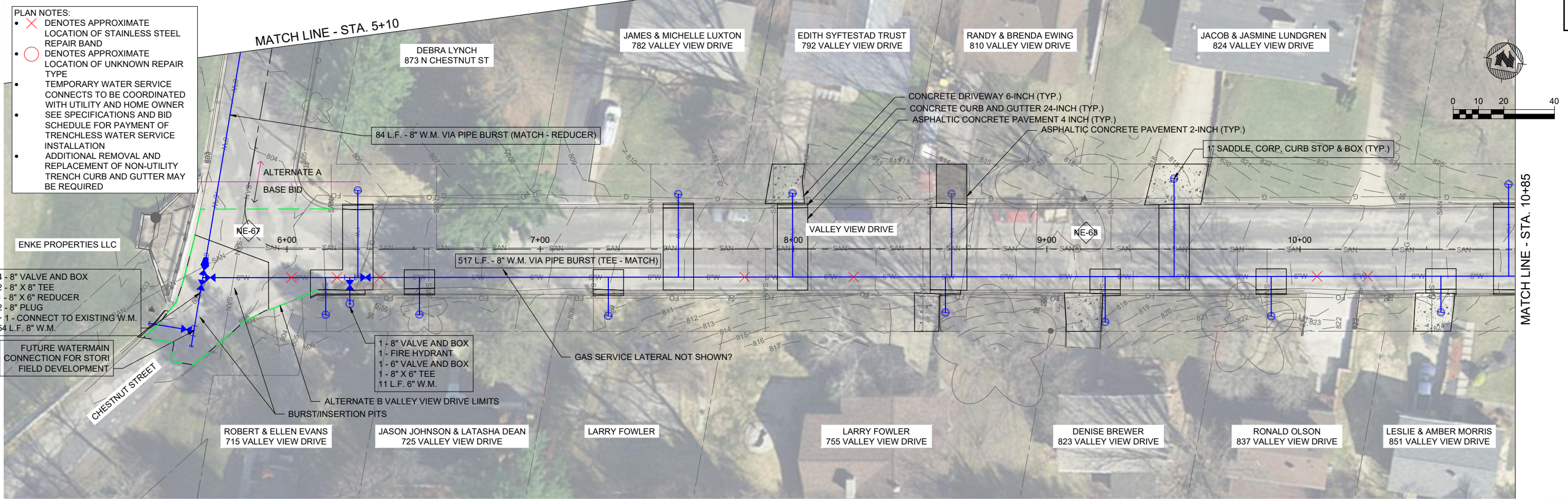

PROJECT DATE:	DRAWN BY:	NO.	DATE	REVISION	BY:
	DRK				
	Init				
	Init				

MSA
 ENGINEERING | ARCHITECTURE | SURVEYING
 FUNDING | PLANNING | ENVIRONMENTAL
 1230 South Boulevard, Baraboo WI 53913
 (608) 356-2771 www.msa-ps.com
 © MSA Professional Services, Inc.

2026 VALLEY VIEW DRIVE WATER MAIN REPLACEMENT
 RICHLAND CENTER CITY UTILITIES
 RICHLAND COUNTY, WISCONSIN

PLAN AND PROFILE - BASE BID - VALLEY VIEW DRIVE

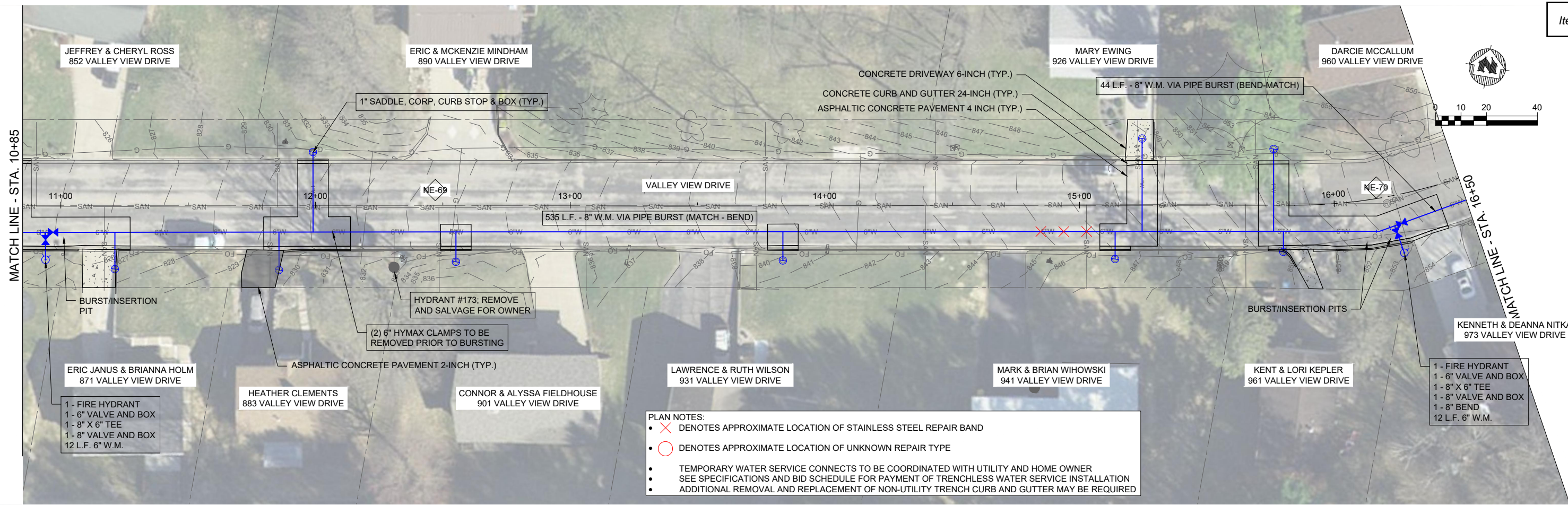

PLAN NOTES:

- X DENOTES APPROXIMATE LOCATION OF STAINLESS STEEL REPAIR BAND
- O DENOTES APPROXIMATE LOCATION OF UNKNOWN REPAIR TYPE
- TEMPORARY WATER SERVICE CONNECTS TO BE COORDINATED WITH UTILITY AND HOME OWNER
SEE SPECIFICATIONS AND BID SCHEDULE FOR PAYMENT OF TRENCHLESS WATER SERVICE INSTALLATION
- ADDITIONAL REMOVAL AND REPLACEMENT OF NON-UTILITY TRENCH CURB AND GUTTER MAY BE REQUIRED

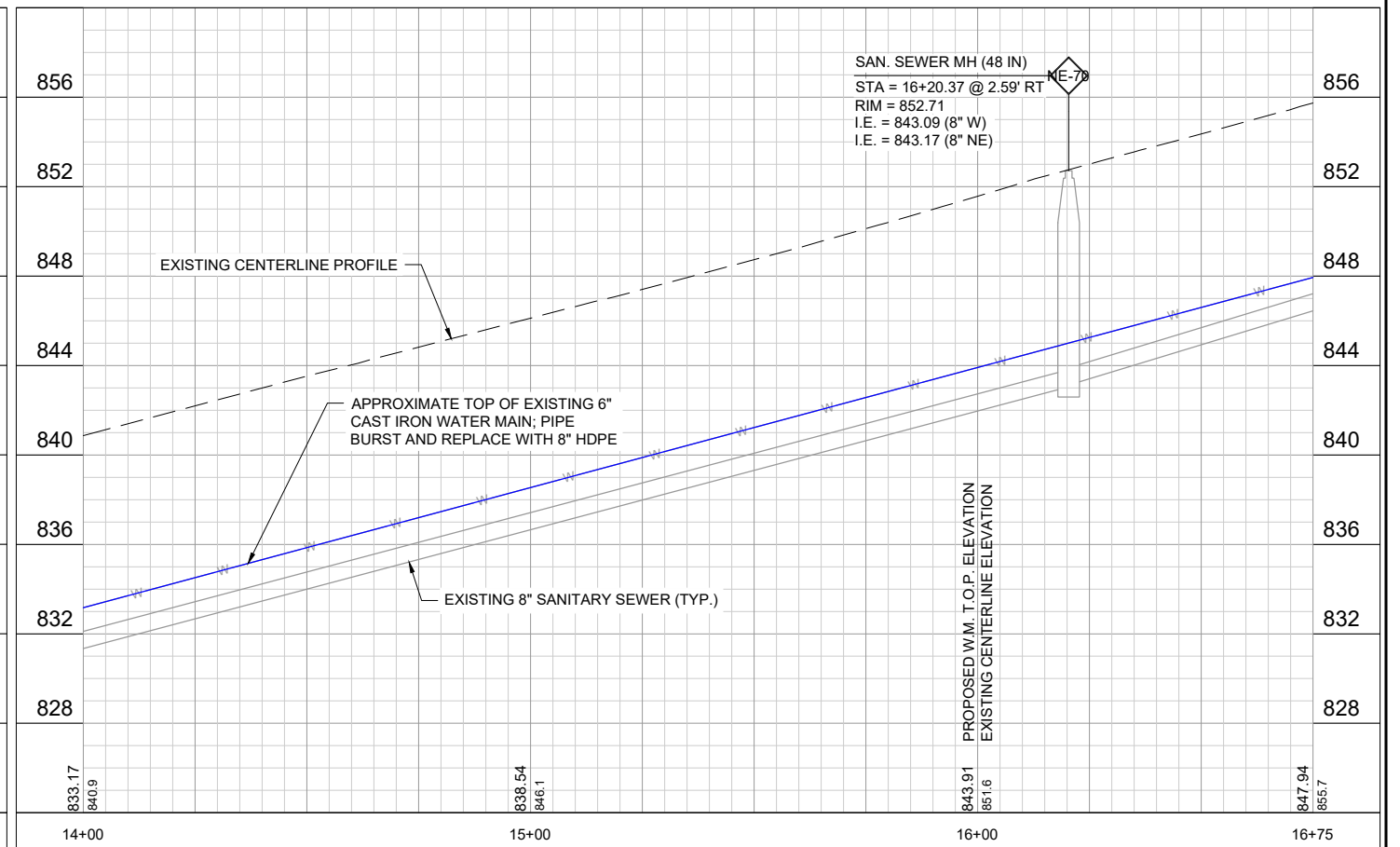
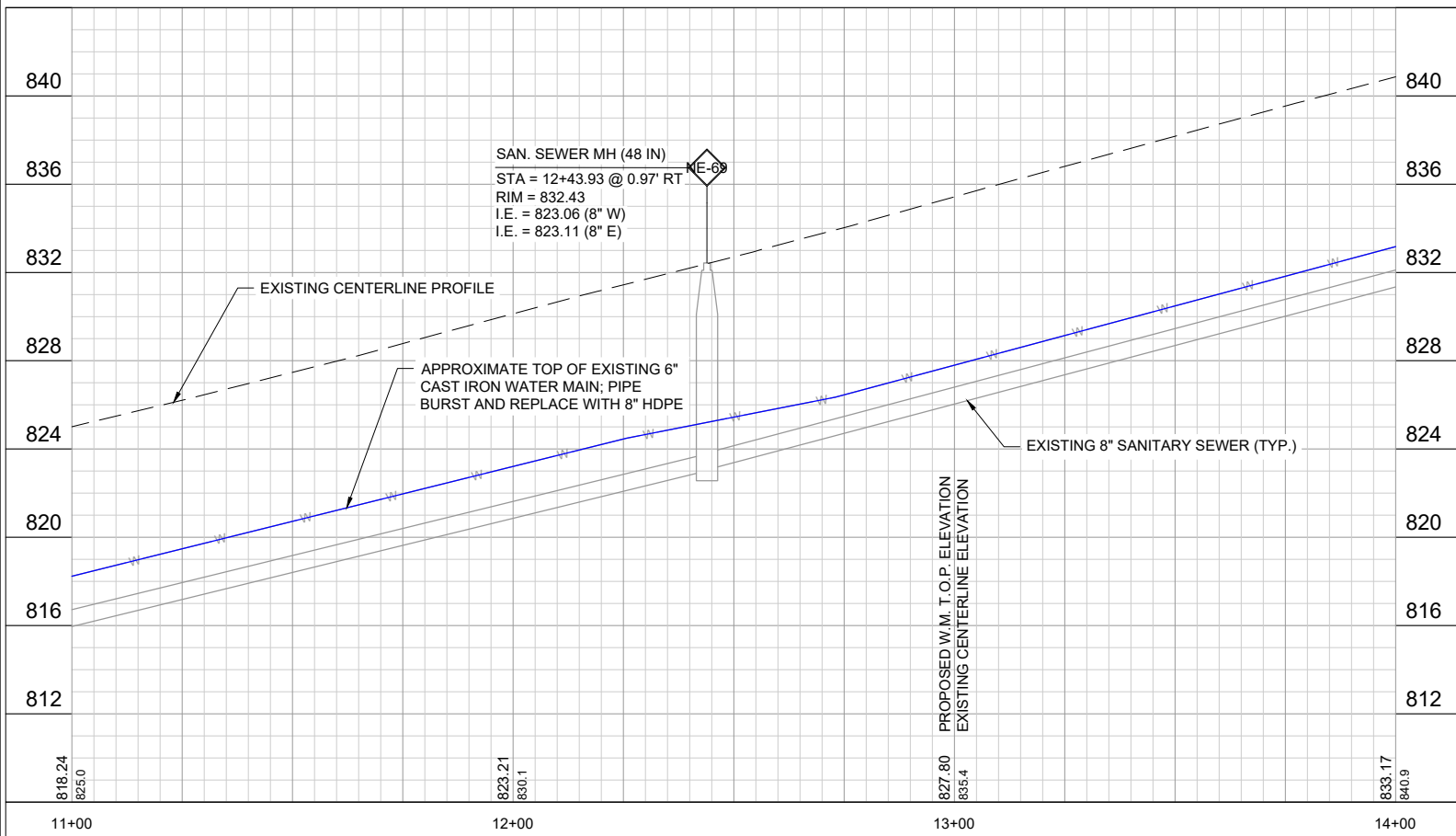

PROJECT DATE:	DRAWN BY:	NO.	DATE	REVISION	BY:
	DRK				
	Init				
	Init				

MSA ENGINEERING | ARCHITECTURE | SURVEYING
 FUNDING | PLANNING | ENVIRONMENTAL
 1230 South Boulevard, Baraboo WI 53913
 (608) 356-2771 www.msa-ps.com
 © MSA Professional Services, Inc.

2026 VALLEY VIEW DRIVE WATER MAIN REPLACEMENT
 RICHLAND CENTER CITY UTILITIES
 RICHLAND COUNTY, WISCONSIN

PLAN AND PROFILE - BASE BID - VALLEY VIEW DRIVE

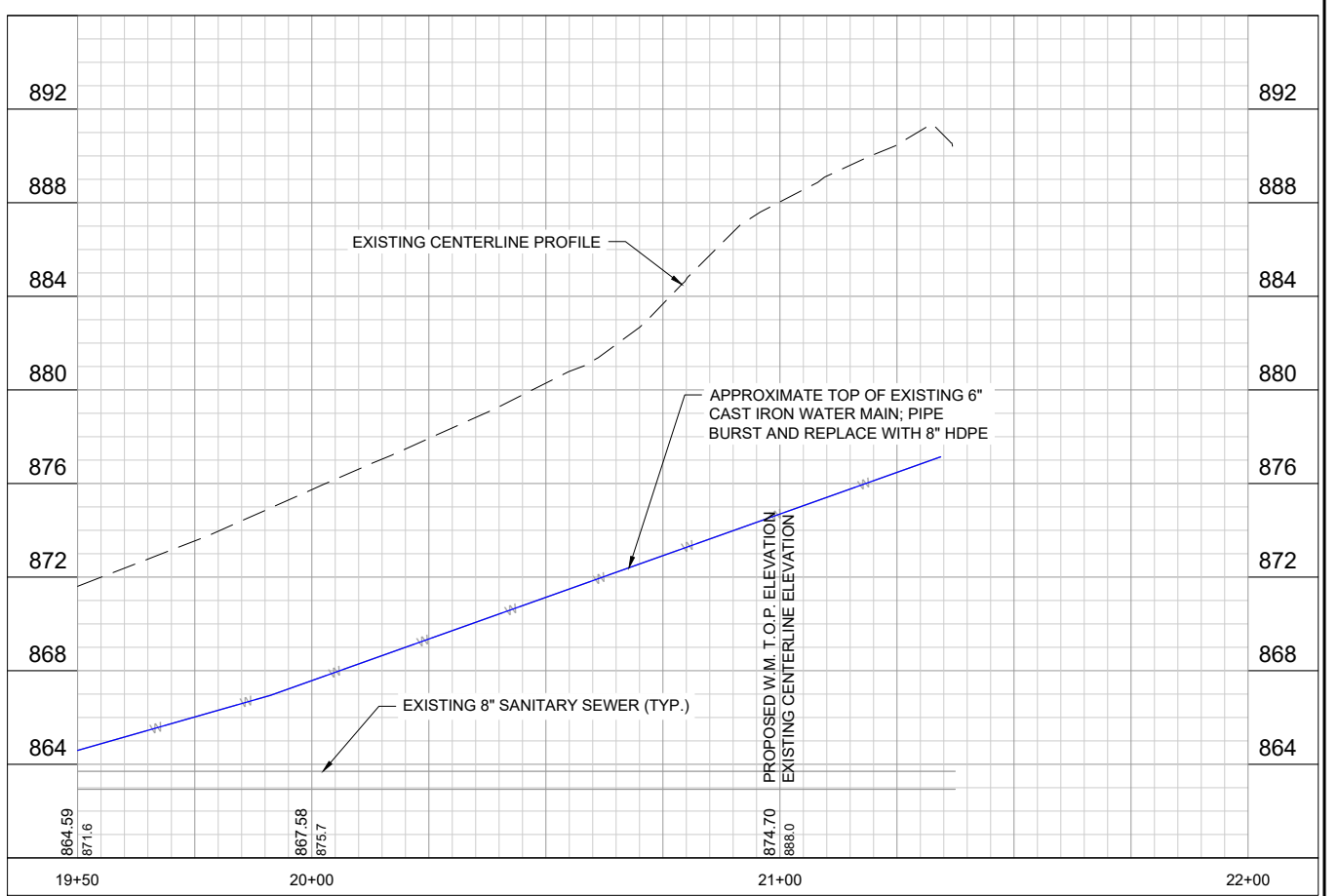
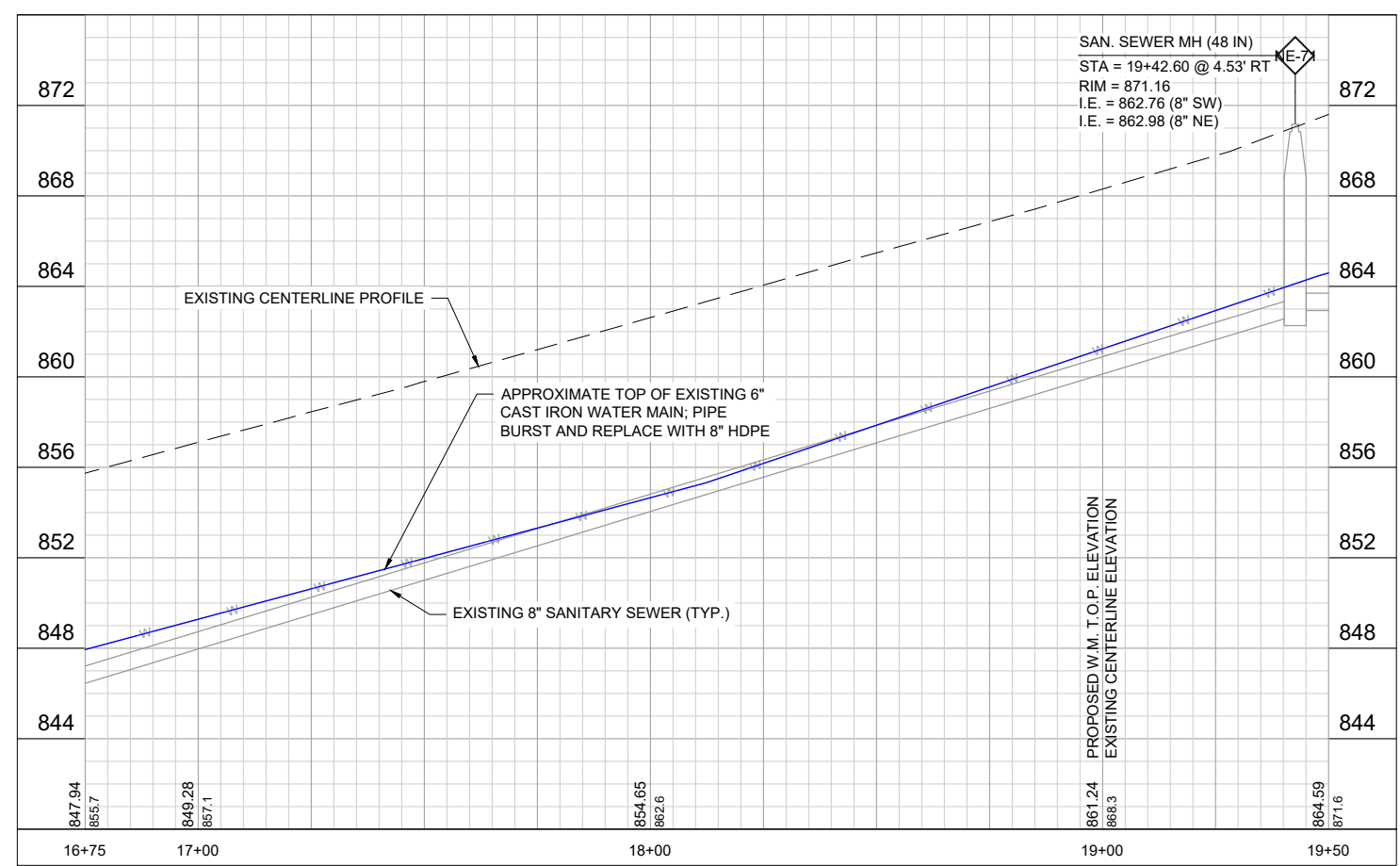
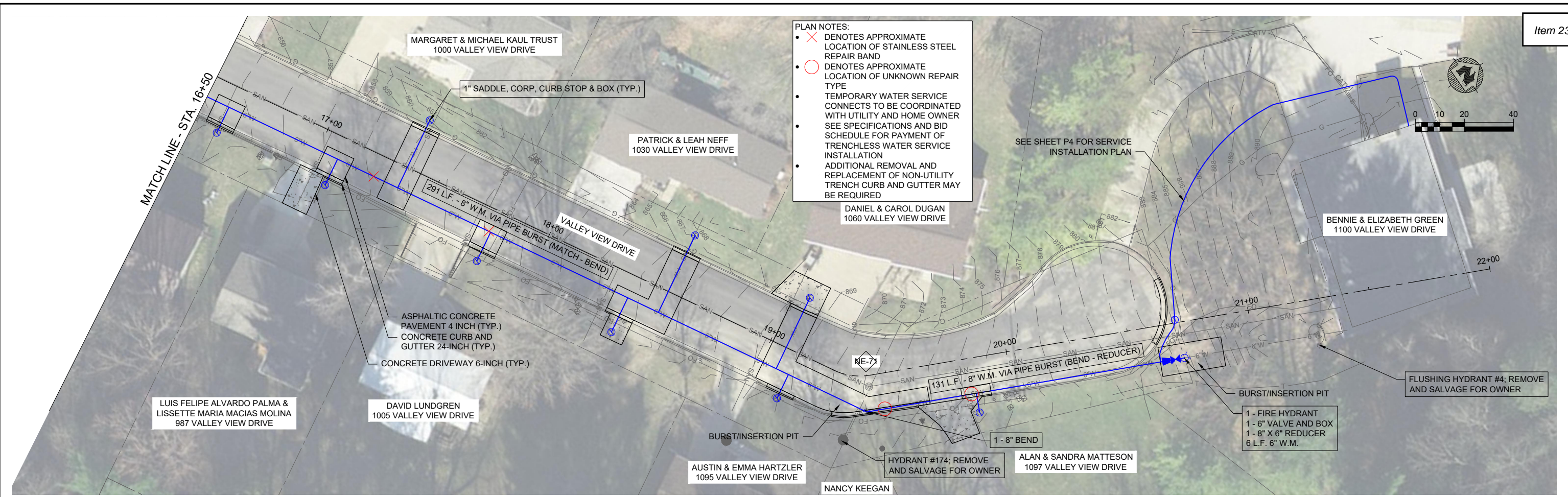

PROJECT DATE:	DRAWN BY:	NO.	DATE	REVISION	BY:
	DRK				
	Init				
	Init				

MSA
 ENGINEERING | ARCHITECTURE | SURVEYING
 FUNDING | PLANNING | ENVIRONMENTAL
 1230 South Boulevard, Baraboo WI 53913
 (608) 356-2771 www.msa-ps.com
 © MSA Professional Services, Inc.

2026 VALLEY VIEW DRIVE WATER MAIN REPLACEMENT
 RICHLAND CENTER CITY UTILITIES
 RICHLAND COUNTY, WISCONSIN

PLAN AND PROFILE - BASE BID - VALLEY VIEW DRIVE

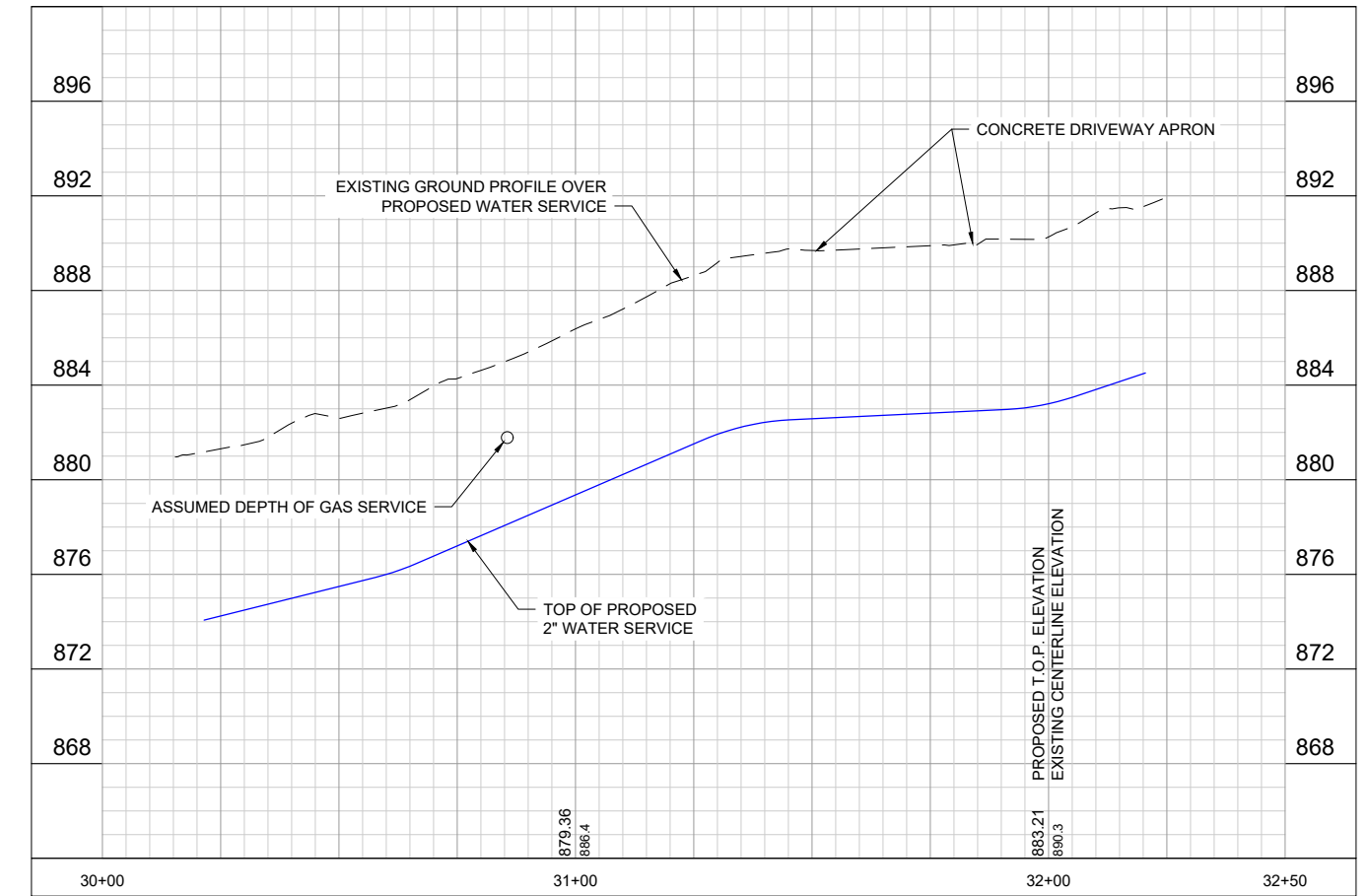
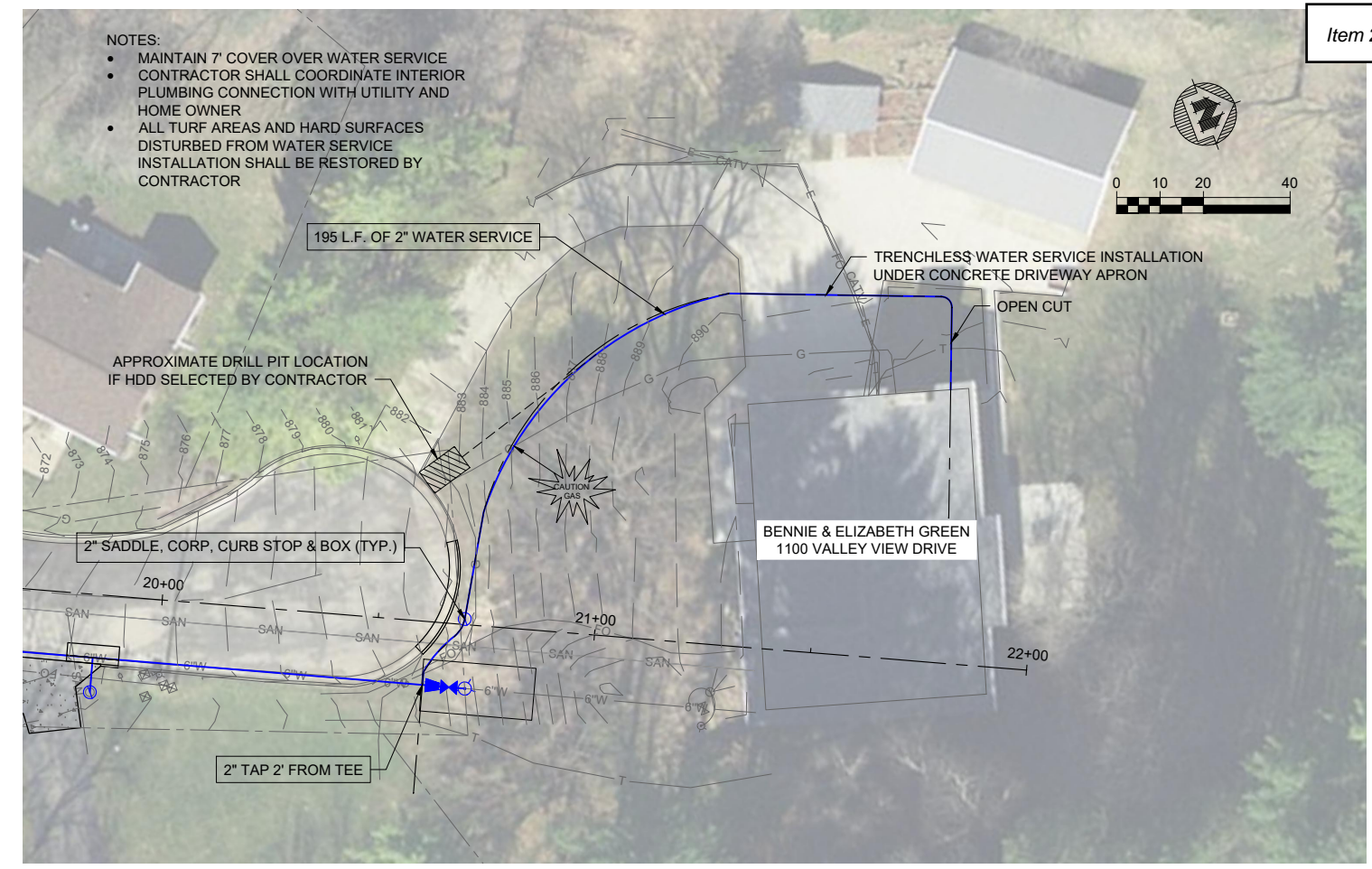

PROJECT DATE:	NO.	DATE	REVISION	BY:
DRAWN BY: DRK	-	-	-	-
DESIGNED BY: Init	-	-	-	-
CHECKED BY: Init	-	-	-	-

PLOT DATE: 3/20/2026 10:44 AM, G:\11111137\11137051\CADD\Construction Documents\11137052 Plan and Profile - 1100 Valley View Drive Service.dwg

MSA ENGINEERING | ARCHITECTURE | SURVEYING
 FUNDING | PLANNING | ENVIRONMENTAL
 1230 South Boulevard, Baraboo WI 53913
 (608) 356-2771 www.msa-ps.com
 © MSA Professional Services, Inc.

2026 VALLEY VIEW DRIVE WATER MAIN REPLACEMENT
 RICHLAND CENTER CITY UTILITIES
 RICHLAND COUNTY, WISCONSIN

PLAN AND PROFILE - BASE BID - 1100 WATER SERVICE

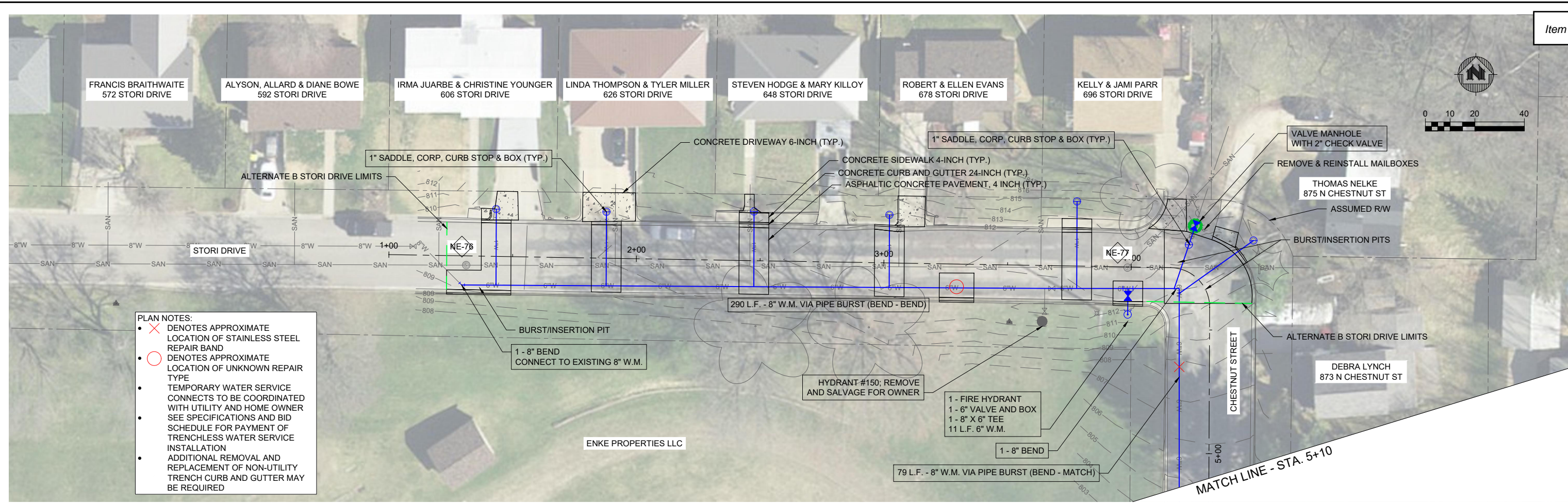

- PLAN NOTES:**
- DENOTES APPROXIMATE LOCATION OF STAINLESS STEEL REPAIR BAND
 - DENOTES APPROXIMATE LOCATION OF UNKNOWN REPAIR TYPE
 - TEMPORARY WATER SERVICE CONNECTS TO BE COORDINATED WITH UTILITY AND HOME OWNER SEE SPECIFICATIONS AND BID SCHEDULE FOR PAYMENT OF TRENCHLESS WATER SERVICE INSTALLATION
 - ADDITIONAL REMOVAL AND REPLACEMENT OF NON-UTILITY TRENCH CURB AND GUTTER MAY BE REQUIRED

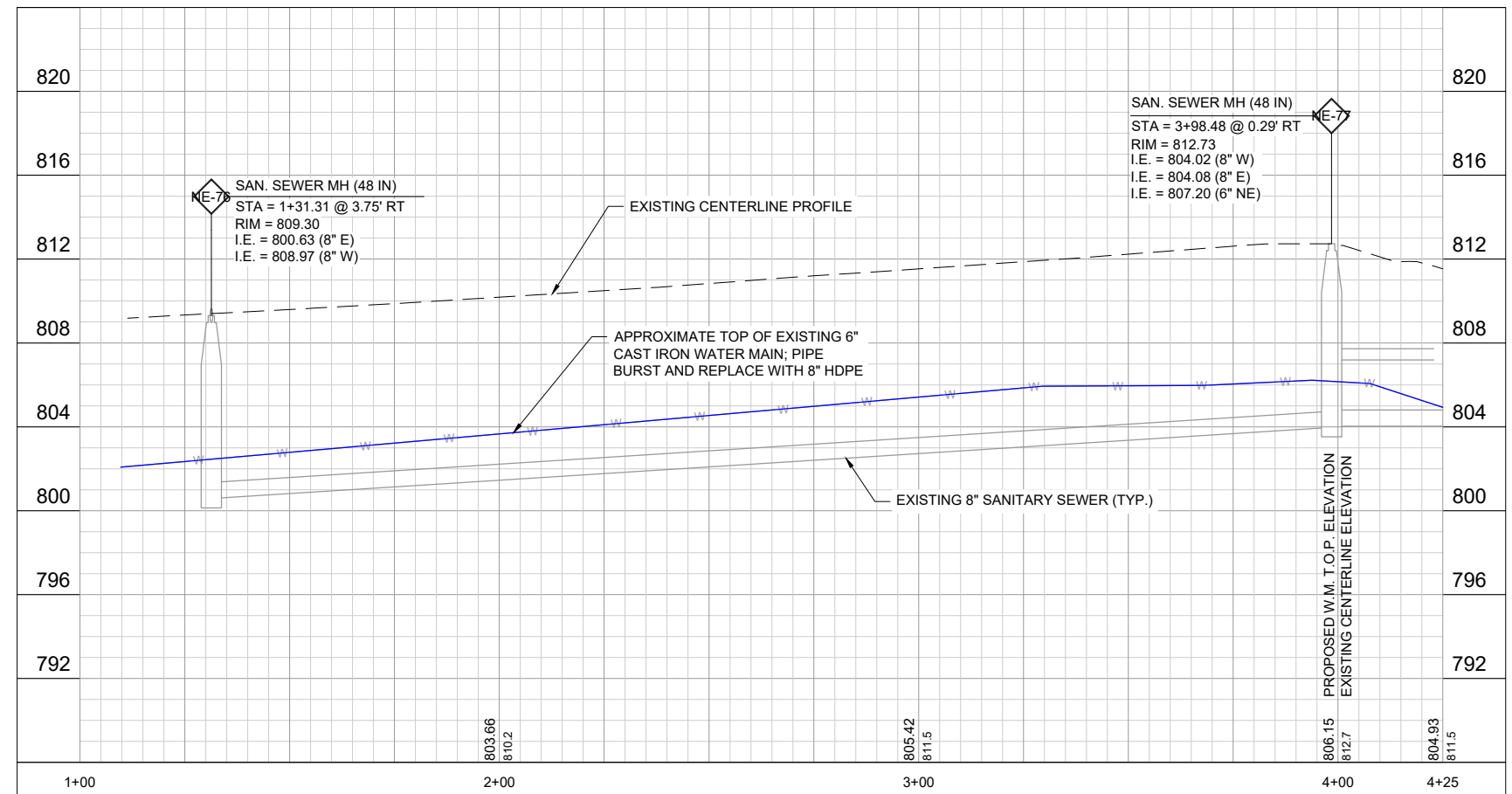

PROJECT DATE:	DESIGNED BY:	CHECKED BY:	NO.	DATE	REVISION	BY:
3/20/2026 10:44 AM, G:\1111137\11137051\CADD\Construction Documents\11137052 Plan and Profile - Valley View.dwg	DRK	Init	-	-	-	-

MSA ENGINEERING | ARCHITECTURE | SURVEYING
 FUNDING | PLANNING | ENVIRONMENTAL
 1230 South Boulevard, Baraboo WI 53913
 (608) 356-2771 www.msa-ps.com
 © MSA Professional Services, Inc.

2026 VALLEY VIEW DRIVE WATER MAIN REPLACEMENT
 RICHLAND CENTER CITY UTILITIES
 RICHLAND COUNTY, WISCONSIN

PLAN AND PROFILE - ALTERNATE A - STORI DRIVE

APPLICATION FOR TEMPORARY CLASS "B"/"CLASS B" RETAILER'S LICENSE

Item 24.

See Additional Information on reverse side. Contact the municipal clerk if you have questions.

FEE \$ 10.00

Application Date: 03/27/2026

Town Village City of Richland Center County of Richland

The named organization applies for: (check appropriate box(es).)

- A Temporary Class "B" license to sell fermented malt beverages at picnics or similar gatherings under s. 125.26(6), Wis. Stats.
A Temporary "Class B" license to sell wine at picnics or similar gatherings under s. 125.51(10), Wis. Stats.

at the premises described below during a special event beginning 05/09/2026 and ending 05/09/2026 and agrees to comply with all laws, resolutions, ordinances and regulations (state, federal or local) affecting the sale of fermented malt beverages and/or wine if the license is granted.

1. ORGANIZATION (check appropriate box) Bona fide Club Church Lodge/Society Veteran's Organization Fair Association

(a) Name SW Partners dba Richland Rejuvenates

(b) Address 1313 W Seminary St. PO BOX 651 Richland Center WI 53581 (Street) Town Village City

(c) Date organized 03/03/2016

(d) If corporation, give date of incorporation 03/04/2016

(e) If the named organization is not required to hold a Wisconsin seller's permit pursuant to s. 77.54 (7m), Wis. Stats., check this box: [X]

(f) Names and addresses of all officers:

President Michael Breininger

Vice President Kent Adsit

Secretary Liz Perkins

Treasurer Michael Cosgrove

(g) Name and address of manager or person in charge of affair: Michael Cosgrove

2. LOCATION OF PREMISES WHERE BEER AND/OR WINE WILL BE SOLD:

(a) Street number 182 N Central Avenue City Auditorium

(b) Lot Block

(c) Do premises occupy all or part of building? All interior only top 2 floors

(d) If part of building, describe fully all premises covered under this application, which floor or floors, or room or rooms, license is to cover:

3. NAME OF EVENT

(a) List name of the event Concert "High Mileage"

(b) Dates of event May 9th 2026 6pm to 11p

DECLARATION

The Officer(s) of the organization, individually and together, declare under penalties of law that the information provided in this application is true and correct to the best of their knowledge and belief.

SWPartners dba Richland Rejuvenates (Name of Organization)

Officer Michael Cosgrove 03-27-26 (Signature/date)

Officer (Signature/date)

Officer (Signature/date)

Officer (Signature/date)

Date Filed with Clerk

Date Reported to Council or Board

Date Granted by Council

License No.