



Location: City Hall – Council Chambers
Date: April 28, 2020
Time: 6:30 PM

City Council Meeting Agenda

Mayor Steve Uffelman, Council Members Jason Beebe, Janet Hutchison, Patricia Jungmann, Gail Merritt, Jeff Papke, Teresa Rodriguez and City Manager Steve Forrester

This meeting will be open to the public by telephonic communications due to commitment to eliminate the exposure and spread of COVID-19. This meeting can be attended by calling 346-248-7799 Meeting ID 947 5839 2608. Please visit our website for additional meeting information.

Call to Order

Flag Salute

Additions to Agenda

Consent Agenda

- [1.](#) Regular Meeting Brief 4-14-2020
- [2.](#) The Beer Trailer Liquor License
- [3.](#) Shut Up -N- Drink Liquor License Application

Visitors, Appearances and Requests

4. St. Charles Hospital / Crook County Health Department
- [5.](#) Streetscape Plan Design - Third Street - Ben Weber, Sera Design - Josh Smith

Council Business

- [6.](#) Reading of a Proclamation - Older Americans Month - Mayor Uffelman
7. Sale of Real Property - Baldwin Industrial Park (**PUBLIC HEARING**) - Eric Klann / Jered Reid
- [8.](#) COVID-19 - Local Business Assistance Grant - Steve Forrester

Staff Reports and Requests

9. City Manager's Report - Steve Forrester

Committee Reports

10. COVID - 19 Update / Discussion - Mayor Uffelman

Ordinances



Resolutions

- [11.](#) Resolution No. 1434 - Extending State of Emergency - Steve Forrester / Jered Reid
- [12.](#) Resolution No. 1435 - Declaring Prineville Policies During COVID-19 - Steve Forrester / Jered Reid
- [13.](#) Resolution No. 1436 - Approving Personal Services Agreement with Dowl - Eric Klann
- [14.](#) Resolution No. 1437 -Second Amendment to Easement Agreement with County - Eric Klann

Visitors, Appearances and Requests

Adjourn

Agenda items maybe added or removed as necessary after publication deadline



CITY OF PRINEVILLE
Regular Meeting Brief
387 NE Third Street – Prineville, OR 97754
541.447.5627 ph 541-447-5628 fax

Full Meeting Recordings Available at:
<http://cityofprineville.com/meetings/>

City Council Meeting Brief
April 14, 2020

Council Members Present:

Gail Merritt

Teresa Rodriguez

Janet Hutchison

Steve Uffelman

Patricia Jungmann

Jason Beebe

Jeff Papke

Council Members Absent

None.

Additions to the Agenda

Item No. 7 under Resolution has been removed.

Consent Agenda

1. Regular Meeting Brief 3-24-2020
2. Special Meeting Brief 4-7-2020

Councilor Hutchison explained that her call dropped and she was unable to vote for the last two votes on March 24, 2020.

Councilor Merritt made a motion to approve the Consent Agenda as amended. Motion seconded. No discussion on motion, motion carried.

Visitors, Appearances and Requests:

Public Appearances

Mayor read a public comment received from Karen Hahn Curci regarding her concern of the shutdown of local businesses into the record.

3. Third Street Access Plan Update – Mike Darling – ODOT

Mike Darling, explained that he last visited with council on February 25, 2020 about things coming down the pike. He is back to remind everyone where we are in the process. The notice on methodology went out certified mail, and comments were received. Mr. Darling explained

that they will put comments into methodology and go from there and look at each approach, as well as many other scenarios in the strategy and will come back to council with that. ODOT is interested in comments and suggestions as part of process to go through for strategy.

Councilor Hutchison had questions regarding comments received and if it was positive. Mr. Darling replied that one was they were confused on the process. There were good comments and suggestions regarding making it more normal and less governmental and nothing real negative.

Mayor Uffelman talked about access restrictions. Mr. Darling stated that would not necessarily be the case, and referred back to criteria. Looking at each property, what permits say, and what is happening as traffic moves through.

Discussions continued regarding bicycle access/traveling, time frame, hoping for Access Strategy Management plan by late summer, project area, improvements at Combs Flat Road and Lynn Boulevard, if anything can be done about Knowledge Street at Third Street, and number of accesses already permitted.

Mr. Darling stated he will be circling back with Council in about a month.

Council Business

4. Consideration of a Proclamation – Older Americans Month – Councilor Merritt

Councilor Merritt provided the background information. Councilor Merritt explained that we have a large number of over 65 population, adding that the Council on Aging has a lot of services for our seniors and feels it would be a good thing to do.

No comments or concerns.

Council agreed to read the proclamation at the April 28th Council meeting.

5. Consideration of the Sale of Real Property – Eric Klann

Eric Klann, City Engineer wanted to get input from Council on property the city owns, and provided a short history on the property including the city putting in utilities. This is the one remaining city owned property in the industrial park. Mr. Klann went through a power point presentation and explained the city has an interested buyer recently. Jered Reid, City Attorney explained the Oregon Revised Statute and public hearing required if council is interested in selling.

Mayor Uffelman talked about people who have looked at over the years for various purposes, and no one made an offer.

Jered summarized the process for the recommended motion to approve moving forward.

Councilor Rodriguez made a motion to approve public hearing to move forward with sale. Motion seconded. Discussion on reference to the recommended motion.

Councilor Rodriguez made a motion to withdraw first motion. Motion seconded to withdraw.

Councilor Rodriguez made a motion that it is convenient to sell real property identified as Map No. 1515-12B, Tax Lot 001700, on SW Cessna Drive, Prineville, Oregon, and that a public hearing be scheduled and appropriately noticed. Motion seconded. No discussion on motion. All in favor, motion carried.

There were discussions about the public hearing procedure since we are conducting meetings by telephone. Mr. Reid explained the legal process for a public hearing and methods of making comments. It would require written comments and the submitter would have to disclose name and address to be considered for the record.

Staff Reports and Requests:

6. COVID – 19 Update / Discussion – Mayor Uffelman

Discussions included: concern that not enough people are being tested; hearing of people having all the symptoms but can't get tested unless admitted to hospital; snowbirds coming back from hotspots with possibly bringing back the virus, and recommendations to self-quarantine for 14 days; parks and national parks should have plenty of room to meet social distancing in the larger outdoor recreation areas and should be open; not knowing what the magic answer is to people's concerns; decisions should be based on science, not on feelings and how to balance that; recognizing that not every decision is going to be perfect; this being a mess for many small businesses.

Mayor Uffelman asked Council what at the local level should be done.

Discussions continued regarding this being taken up at the state level; how to speed up the opening of businesses; how we can help businesses that will go under; what is the definition of essential; looking at each business individually with actual safety protocol that they have developed to be open; available testing concerns and asking St. Charles CEO attend our next meeting.

7. Manager's Report

Steve Forrester, City Manager reported: City projects are continuing under social distancing guidelines and provided a summary of those projects that will be part of the Mayor's Message this Friday.

Mr. Forrester continued with talking about a financial bridge on a local level and has been working with local leaders to form a COVID-19 taskforce. The Task Force will be forwarding a recommendation and asking council for funding. We talked with Liz, and there is funding that

we can repurpose from other typical funding in budget that isn't getting spent right now. Be looking for that in the future, and will bring back to council.

There were no questions.

Committee Reports

There were no reports.

Ordinances:

None.

Resolutions:

None.

Visitors Appearances and Requests:

There were no other written comments submitted to enter into the record.

Adjourn

Councilor Rodriguez made a motion to adjourn the meeting. Motion seconded. No discussion on motion. All in favor, motion carried.

Meeting adjourned at 7:25 P.M.

Motions and Outcomes:

Motion:	Outcome	Beebe	Hutchison	Jungmann	Merritt	Papke	Rodriguez	Uffelman
Consent Agenda as Amended	PASSED	Y	Y	Y	Y	Y	Y	Y
That it is Convenient to Sell Real Property Identified as Map No. 1515-12B, Tax Lot 001700, on SW Cessna Drive, Prineville, Oregon, and That a Public Hearing be Scheduled and Appropriately Noticed	PASSED	Y	Y	Y	Y	Y	Y	Y
Adjourn Meeting	PASSED	Y	Y	Y	Y	Y	Y	Y

Public Records Disclosure

Under the Oregon public records law, all documents referred to in this session are available at the City’s website. www.cityofprineville.com. An electronic copy of the meeting packet is available for download at www.cityofprineville.com/packets. A full recording of this meeting is available at www.cityofprineville.com/meetings



LIQUOR LICENSE APPLICATION

1. Application. **Do not include** any OLCC fees with your application packet (the license fee will be collected at a later time). Application is being made for:

License Applied For:	CITY AND COUNTY USE ONLY
<input type="checkbox"/> Brewery 1st Location	Date application received and/or date stamp: Name of City or County: _____ Recommends this license be: <input type="checkbox"/> Granted <input type="checkbox"/> Denied By: _____ Date: _____
<input type="checkbox"/> Brewery 2nd Location	
<input type="checkbox"/> Brewery 3rd Location	
<input type="checkbox"/> Brewery-Public House 1st Location	
<input type="checkbox"/> Brewery-Public House 2nd Location	
<input type="checkbox"/> Brewery-Public House 3rd Location	
<input type="checkbox"/> Distillery	
<input type="checkbox"/> Full On-Premises, Commercial	
<input type="checkbox"/> Full On-Premises, Caterer	
<input type="checkbox"/> Full On-Premises, Passenger Carrier	
<input type="checkbox"/> Full On-Premises, Other Public Location	
<input type="checkbox"/> Full On-Premises, For Profit Private Club	
<input type="checkbox"/> Full On-Premises, Nonprofit Private Club	
<input type="checkbox"/> Grower Sales Privilege 1st Location	
<input type="checkbox"/> Grower Sales Privilege 2nd Location	
<input type="checkbox"/> Grower Sales Privilege 3rd Location	
<input type="checkbox"/> Limited On-Premises	OLCC USE ONLY Date application received: <u>3-24-20</u> By: <u>[Signature]</u> License Action(s): <u>Alpnu</u> <div style="text-align: right;"> RECEIVED OREGON LIQUOR CONTROL COMMISSION MAR 27 2020 SALEM REGIONAL OFFICE </div>
<input checked="" type="checkbox"/> Off-Premises	
<input type="checkbox"/> Off-Premises with Fuel Pumps	
<input type="checkbox"/> Warehouse	
<input type="checkbox"/> Wholesale Malt Beverage & Wine	
<input type="checkbox"/> Winery 1st Location	
<input type="checkbox"/> Winery 2nd Location	
<input type="checkbox"/> Winery 3rd Location	
<input type="checkbox"/> Winery 4th Location	
<input type="checkbox"/> Winery 5th Location	

2. Identify the applicant(s) applying for the license(s). ENTITY (example: corporation or LLC) or INDIVIDUAL(S) applying for the license(s):

The Beer Trailer LLC

(Applicant #1)

(Applicant #2)

(Applicant #3)

(Applicant #4)

3. Trade Name of the Business (Name Customers Will See)

The Beer Trailer

4. Business Address (Number and Street Address of the Location that will have the liquor license)

2959 SW High Desert Drive

City Prineville	County Crook	Zip Code 97754
--------------------	-----------------	-------------------



LIQUOR LICENSE APPLICATION

5. Trade Name of the Business (Name Customers Will See) The Beer Trailer			
6. Does the business address currently have an OLCC liquor license? <input checked="" type="checkbox"/> YES <input type="checkbox"/> NO			
7. Does the business address currently have an OLCC marijuana license? <input type="checkbox"/> YES <input checked="" type="checkbox"/> NO			
8. Mailing Address/PO Box, Number, Street, Rural Route (where the OLCC will send your mail) 2959 SW High Desert Drive			
City Prineville	State Oregon	Zip Code 97754	
9. Phone Number of the Business Location 541-815-0168		10. Email Contact for this Application [REDACTED]	
11. Contact Person for this Application Sean Ryan		Phone Number 541-815-0168	
Contact Person's Mailing Address (if different)	City	State	Zip Code

Please note that liquor license applications are public records. A copy of the application will be posted on the OLCC website for a period of several weeks.

I understand that marijuana (such as use, consumption, ingestion, inhalation, samples, give-away, sale, etc.) is **prohibited** on the licensed premises.

I attest that all answers on all forms, documents, and information provided to the OLCC are true and complete.

Applicant Signature(s)

- Each individual person listed as an applicant must sign the application.
- If an applicant is an entity, such as a corporation or LLC, at least one person who is authorized to sign for the entity must sign the application.
- A person with the authority to sign on behalf of the applicant (such as the applicant's attorney or a person with power of attorney) may sign the application. If a person other than an applicant signs the application, please provide proof of signature authority.

(Applicant#1)

(Applicant #2)

(Applicant#3)

(Applicant #4)



OREGON LIQUOR CONTROL COMMISSION
INDIVIDUAL HISTORY FORM

1. Name: (LAST) <u>RYAN</u> (FIRST) <u>SEAN</u> (MIDDLE) <u>MICHAEL</u>		
2. Other Names Used (Maiden, Etc.):		
3. Do you have a Social Security Number (SSN) issued by the U.S. Social Security Administration? <input checked="" type="checkbox"/> Yes <input type="checkbox"/> No If yes, please provide your SSN: [REDACTED]		
<p>SOCIAL SECURITY NUMBER DISCLOSURE: As part of your application for an initial or renewal license, Federal and State laws require you to provide your Social Security Number (SSN) to the Oregon Liquor Control Commission (OLCC) for child support enforcement purposes (42 USC § 666(a)(13) & ORS 25.785). If you are an applicant or licensee and fail to provide your SSN, the OLCC may refuse to process your application. Your SSN will be used only for child support enforcement purposes unless you indicate below.</p> <p>Based on our authority under ORS 471.311 and OAR 845-005-0312(6), we are requesting your voluntary consent to use your SSN for the following administrative purposes only: to match your license application to your Alcohol Server Education records (where applicable), and to ensure your identity for criminal records checks. OLCC will not deny you any rights, benefits or privileges otherwise provided by law if you do not consent to use of your SSN for these administrative purposes (5 USC § 552(a)).</p> <p>Do you voluntarily consent to the OLCC's use of your SSN as just described? <input checked="" type="checkbox"/> Yes <input type="checkbox"/> No</p>		
4. Date of Birth (MM/DD/YYYY): <u>05/27</u> [REDACTED]	5. Contact Phone: <u>541-815-0148</u>	
6. Driver License or State ID #: [REDACTED]	7. State: <u>OREGON</u>	
8. Residence Address: [REDACTED] <u>PRINEVILLE, OR 97754</u>		
9. Mailing Address (if different): <u>2959 S.W. HIGH DESERT DRIVE, PRINEVILLE, OR 97754</u>		
10. E-Mail (optional): [REDACTED]	<u>OS/DMV</u> Search Completed	
11. Do you have a spouse or domestic partner? <input type="checkbox"/> Yes <input checked="" type="checkbox"/> No If yes, list his/her full name: <u>30 2020</u>		
12. If yes to #11, will this person be involved in the management of, or have control over the business? <input checked="" type="checkbox"/> No <input type="checkbox"/> Yes		
13. In the past 10 years, have you been convicted ("convicted" includes paying a fine) in Oregon or another U.S. state of driving a car with a suspended driver license or driving a car with no insurance? <input checked="" type="checkbox"/> No <input type="checkbox"/> Yes (Please include explanation below) <input type="checkbox"/> Unsure (Please include explanation below) <u>INITIALS: NO CONVICTIONS</u>		
14. In the past 10 years, have you been convicted ("convicted" includes paying a fine) in Oregon or another U.S. state of a FELONY ? <input checked="" type="checkbox"/> No <input type="checkbox"/> Yes (Please include explanation below) <input type="checkbox"/> Unsure (Please include explanation below)		
15. Have you ever been in a drug or alcohol diversion program in Oregon or another U.S. state? A diversion program is where you are required, usually by the court or another government agency, to complete certain requirements in place of being convicted of a drug or alcohol-related offense. <input checked="" type="checkbox"/> No <input type="checkbox"/> Yes (Please include explanation below) <input type="checkbox"/> Unsure (Please include explanation below)		

16. Do you, or any legal entity that you are a part of, **currently hold** or **have previously held** a liquor license or a recreational marijuana license in Oregon or another U.S. state? (Note: alcohol service permits and marijuana worker permits are not liquor licenses).

No Yes (Please include explanation below) Unsure (Please include explanation below)

THE BEER TRAILER L.L.C.
License # 297291

17. Have you, or any legal entity that you are a part of, **ever** had an application for a license, permit, or certificate **denied or cancelled** by the OLCC or any other governmental agency in the U.S.?

No Yes (Please include explanation below) Unsure (Please include explanation below)

18. Are you applying for a Full On-Premises, Limited On-Premises, Off-Premises, or Brewery-Public House license?

No Please skip questions 19 & 20. Go directly to question 21.

Yes Please answer questions 19, 20, and 21.

19. Do you or will you have any ownership interest in a business that manufactures, wholesales, or distributes alcohol in Oregon or another U.S. state?

No Yes (Please include explanation below) Unsure (Please include explanation below)

20. Does or will an alcohol manufacturer, wholesaler, or distributor in Oregon or another U.S. state have any ownership interest in your business?

No Yes (Please include explanation below) Unsure (Please include explanation below)

21. Do you currently have, or will you have, any ownership interest in any business in Oregon with a Full On-Premises, Limited On-Premises, Off-Premises, or Brewery-Public House license?

No Yes (Please include explanation below) Unsure (Please include explanation below)

THE BEER TRAILER LLC
License # 297291

You must sign your own form. Another person, like your attorney or a person with power of attorney, may not sign your form. I affirm that my answers are true and complete. I understand the OLCC will use the above information to check my records, including but not limited to, criminal history. I understand that if my answers are not true and complete, the OLCC may deny my license application.

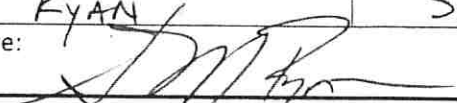
Name: (LAST) RYAN	(FIRST) SEAN	(MIDDLE) MICHAEL
Signature: 		Date: 08/27/2020



OREGON LIQUOR CONTROL COMMISSION
INDIVIDUAL HISTORY FORM

1. Name: (LAST) <u>RYAN</u>	(FIRST) <u>DAVID</u>	(MIDDLE) <u>MICHAEL</u>
2. Other Names Used (Maiden, Etc.): <u>N/A</u>		
3. Do you have a Social Security Number (SSN) issued by the U.S. Social Security Administration? <input checked="" type="checkbox"/> Yes <input type="checkbox"/> No If yes, please provide your SSN: [REDACTED]		
<p>SOCIAL SECURITY NUMBER DISCLOSURE: As part of your application for an initial or renewal license, Federal and State laws require you to provide your Social Security Number (SSN) to the Oregon Liquor Control Commission (OLCC) for child support enforcement purposes (42 USC § 666(a)(13) & ORS 25.785). If you are an applicant or licensee and fail to provide your SSN, the OLCC may refuse to process your application. Your SSN will be used only for child support enforcement purposes unless you indicate below.</p> <p>Based on our authority under ORS 471.311 and OAR 845-005-0312(6), we are requesting your voluntary consent to use your SSN for the following administrative purposes only: to match your license application to your Alcohol Server Education records (where applicable), and to ensure your identity for criminal records checks. OLCC will not deny you any rights, benefits or privileges otherwise provided by law if you do not consent to use of your SSN for these administrative purposes (5 USC § 552(a).</p> <p>Do you voluntarily consent to the OLCC's use of your SSN as just described? <input checked="" type="checkbox"/> Yes <input type="checkbox"/> No</p>		
4. Date of Birth (MM/DD/YYYY): <u>08 / 30 / [REDACTED]</u>	5. Contact Phone: <u>541- [REDACTED]</u>	
6. Driver License or State ID #: <u>[REDACTED]</u>	7. State: <u>OREGON</u>	
8. Residence Address: <u>[REDACTED]</u>	<div style="text-align: center;"> <p>OSP/DMV</p> <p>Search Completed</p> <p>PRINEVILLE, OR 97754</p> <p>MAR 30 2020</p> </div>	
9. Mailing Address (if different): <u>[REDACTED]</u>		
10. E-Mail (optional): <u>[REDACTED]</u>		
11. Do you have a spouse or domestic partner? <input type="checkbox"/> Yes <input checked="" type="checkbox"/> No If yes, list his/her full name: <u>INITIALS: [REDACTED]</u>		
12. If yes to #11, will this person be involved in the management of, or have control over the business? <input type="checkbox"/> No <input type="checkbox"/> Yes		
13. In the past 10 years, have you been convicted ("convicted" includes paying a fine) in Oregon or another U.S. state of driving a car with a suspended driver license or driving a car with no insurance? <input checked="" type="checkbox"/> No <input type="checkbox"/> Yes (Please include explanation below) <input type="checkbox"/> Unsure (Please include explanation below)		
14. In the past 10 years, have you been convicted ("convicted" includes paying a fine) in Oregon or another U.S. state of a FELONY ? <input checked="" type="checkbox"/> No <input type="checkbox"/> Yes (Please include explanation below) <input type="checkbox"/> Unsure (Please include explanation below)		
15. Have you ever been in a drug or alcohol diversion program in Oregon or another U.S. state? A diversion program is where you are required, usually by the court or another government agency, to complete certain requirements in place of being convicted of a drug or alcohol-related offense. <input checked="" type="checkbox"/> No <input type="checkbox"/> Yes (Please include explanation below) <input type="checkbox"/> Unsure (Please include explanation below)		

16. Do you, or any legal entity that you are a part of, **currently hold** or **have previously held** a liquor license or a recreational marijuana license in Oregon or another U.S. state? (Note: alcohol service permits and marijuana worker permits are not liquor licenses).

No Yes (Please include explanation below) Unsure (Please include explanation below)

THE BEER TRAILER # 297291

17. Have you, or any legal entity that you are a part of, **ever** had an application for a license, permit, or certificate **denied or cancelled** by the OLCC or any other governmental agency in the U.S.?

No Yes (Please include explanation below) Unsure (Please include explanation below)

18. Are you applying for a Full On-Premises, Limited On-Premises, Off-Premises, or Brewery-Public House license?

No Please skip questions 19 & 20. Go directly to question 21.
 Yes Please answer questions 19, 20, and 21.

19. Do you or will you have any ownership interest in a business that manufactures, wholesales, or distributes alcohol in Oregon or another U.S. state?

No Yes (Please include explanation below) Unsure (Please include explanation below)

20. Does or will an alcohol manufacturer, wholesaler, or distributor in Oregon or another U.S. state have any ownership interest in your business?

No Yes (Please include explanation below) Unsure (Please include explanation below)

21. Do you currently have, or will you have, any ownership interest in any business in Oregon with a Full On-Premises, Limited On-Premises, Off-Premises, or Brewery-Public House license?

No Yes (Please include explanation below) Unsure (Please include explanation below)

THE BEER TRAILER LLC # 297291

You must sign your own form. Another person, like your attorney or a person with power of attorney, may not sign your form. I affirm that my answers are true and complete. I understand the OLCC will use the above information to check my records, including but not limited to, criminal history. I understand that if my answers are not true and complete, the OLCC may deny my license application.

Name: (LAST)

RYAN

(FIRST)

DAVID

(MIDDLE)

MICHAEL

Signature:

Michael Ryan

Date:

3/27/20



Oregon Liquor Control Commission

SAME-DAY DELIVERY OF MALT BEVERAGES, WINE, OR CIDER FOR OREGON LICENSEES

"Same-day delivery" means you cause a resident of Oregon to receive malt beverages, wine, or cider on the same day you receive the order from the customer.

Applicant Name (entity or individuals): The Beer Trailer LLC			
Trade Name of Business: The Beer Trailer			
Premises Location Address: 2959 SW High Desert Drive		City Prineville	State Oregon
Email(s): 59villager@gmail.com		Zip	Phone:
<input checked="" type="checkbox"/> I have an Oregon OFF-PREMISES SALES license and I'm applying to make same-day delivery of: <ul style="list-style-type: none"> <input checked="" type="checkbox"/> Malt Beverages <input checked="" type="checkbox"/> Wine and/or Cider 			
<input type="checkbox"/> I have an Oregon BREWERY license and I'm applying to make same-day delivery of: <ul style="list-style-type: none"> <input type="checkbox"/> Malt Beverages <input type="checkbox"/> Wine and/or Cider 			
<input type="checkbox"/> I have an Oregon BREWERY PUBLIC-HOUSE license and I'm applying to make same-day delivery of: <ul style="list-style-type: none"> <input type="checkbox"/> Malt Beverages <input type="checkbox"/> Wine and/or Cider 			
<input type="checkbox"/> I have an Oregon GROWER SALES PRIVILEGE license and I'm applying to make same-day delivery of only wine or cider where all of the fruit or grapes used to make the wine or cider are grown in Oregon under my control.			
<input type="checkbox"/> I have an Oregon WINERY license with a valid TTB <u>Producer and Blender Basic Permit</u> and I'm applying to make same-day delivery of: <ul style="list-style-type: none"> <input type="checkbox"/> Malt Beverages <input type="checkbox"/> Wine and/or Cider 			
<input type="checkbox"/> I have an Oregon WINERY license with a valid TTB <u>Wholesaler Basic Permit</u> and I'm applying to make same-day delivery of: <ul style="list-style-type: none"> <input type="checkbox"/> Malt Beverages <input type="checkbox"/> Wine and/or Cider brands under my control 			

I understand I may make same-day deliveries of malt beverages, wine, or cider to an Oregon resident only as allowed by OAR 845-006-0392 and 845-006-0396.

I certify that I have read and will follow OAR 845-006-0392 and 845-006-0396. I affirm that I am authorized to sign this application on behalf of the applicant.

Print Name SEAN M. RYAN

Signature [Handwritten Signature]

Date 3-24-2020

Return to: OLCC, PO Box 22297, Milwaukie, OR, 97269
Phone: 503-872-5123 Fax: 503-872-5018

OLCC USE ONLY	
License Number	
Approved by <u>[Handwritten Signature]</u>	Date <u>3-30-20</u>



OREGON LIQUOR CONTROL COMMISSION

LIQUOR LICENSE APPLICATION

1. Application. Do not include any OLCC fees with your application packet (the license fee will be collected at a later time). Application is being made for:

License Applied For:	CITY AND COUNTY USE ONLY
<input type="checkbox"/> Brewery 1st Location	Date application received and/or date stamp:
<input type="checkbox"/> Brewery 2nd Location	
<input type="checkbox"/> Brewery 3rd Location	Name of City or County:
<input type="checkbox"/> Brewery-Public House 1st Location	
<input type="checkbox"/> Brewery-Public House 2nd Location	Recommends this license be:
<input type="checkbox"/> Brewery-Public House 3rd Location	
<input type="checkbox"/> Distillery	<input type="checkbox"/> Granted <input type="checkbox"/> Denied
<input type="checkbox"/> Full On-Premises, Commercial	By: _____
<input type="checkbox"/> Full On-Premises, Caterer	
<input type="checkbox"/> Full On-Premises, Passenger Carrier	Date: _____
<input checked="" type="checkbox"/> Full On-Premises, Other Public Location	
<input type="checkbox"/> Full On-Premises, For Profit Private Club	<p style="text-align: center;">OLCC USE ONLY</p> Date application received: _____ 4/8/2020
<input type="checkbox"/> Full On-Premises, Nonprofit Private Club	
<input type="checkbox"/> Grower Sales Privilege 1st Location	By: <u>Utterberg</u> RECEIVED
<input type="checkbox"/> Grower Sales Privilege 2nd Location	
<input type="checkbox"/> Grower Sales Privilege 3rd Location	License Action(s): <u>N/O</u> APR 08 2020
<input checked="" type="checkbox"/> Limited On-Premises <u>per applicant 4/8/20</u> UT	
<input type="checkbox"/> Off-Premises	Oregon Liquor Control Commission Bend, Oregon
<input type="checkbox"/> Off-Premises with Fuel Pumps	
<input type="checkbox"/> Warehouse	
<input type="checkbox"/> Wholesale Malt Beverage & Wine	
<input type="checkbox"/> Winery 1st Location	
<input type="checkbox"/> Winery 2nd Location	
<input type="checkbox"/> Winery 3rd Location	
<input type="checkbox"/> Winery 4th Location	
<input type="checkbox"/> Winery 5th Location	

2. Identify the applicant(s) applying for the license(s). ENTITY (example: corporation or LLC) or INDIVIDUAL(S) applying for the license(s):

Rita Rhoden
(Applicant #1)

James Kinsey
(Applicant #2)

(Applicant #3)

(Applicant #4)

3. Trade Name of the Business (Name Customers Will See)
Shut UP-N-Drink

4. Business Address (Number and Street Address of the Location that will have the liquor license)
1500 NE 3rd St

City <u>Prineville</u>	County <u>Crater</u>	Zip Code <u>97754</u>
---------------------------	-------------------------	--------------------------



LIQUOR LICENSE APPLICATION

5. Trade Name of the Business (Name Customers Will See) <i>Shut UP-N-Drink</i>			
6. Does the business address currently have an OLCC liquor license? <input type="checkbox"/> YES <input checked="" type="checkbox"/> NO			
7. Does the business address currently have an OLCC marijuana license? <input type="checkbox"/> YES <input checked="" type="checkbox"/> NO			
8. Mailing Address/PO Box, Number, Street, Rural Route (where the OLCC will send your mail) [REDACTED]			
City <i>Prineville</i>	State <i>oregon</i>	Zip Code <i>97754</i>	
9. Phone Number of the Business Location <i>541-[REDACTED]</i>		10. Email Contact for this Application	
11. Contact Person for this Application <i>Rita Rhoden</i>		Phone Number <i>541-[REDACTED]</i>	
Contact Person's Mailing Address (if different)	City <i>prineville</i>	State <i>OR</i>	Zip Code <i>97754</i>

Please note that liquor license applications are public records. A copy of the application will be posted on the OLCC website for a period of several weeks.

I understand that marijuana (such as use, consumption, ingestion, inhalation, samples, give-away, sale, etc.) is **prohibited** on the licensed premises.

I attest that all answers on all forms, documents, and information provided to the OLCC are true and complete.

Applicant Signature(s)

- Each individual person listed as an applicant must sign the application.
- If an applicant is an entity, such as a corporation or LLC, at least one person who is authorized to sign for the entity must sign the application.
- A person with the authority to sign on behalf of the applicant (such as the applicant's attorney or a person with power of attorney) may sign the application. If a person other than an applicant signs the application, please provide proof of signature authority.

Rita Rhoden

(Applicant#1)

[Signature]

(Applicant#2)

(Applicant#3)

(Applicant#4)



OREGON LIQUOR CONTROL COMMISSION
INDIVIDUAL HISTORY FORM

1. Name: (LAST) <u>Kinsey</u>	(FIRST) <u>James</u>	(MIDDLE) <u>Kenneth</u>
2. Other Names Used (Maiden, Etc.):		
3. Do you have a Social Security Number (SSN) issued by the U.S. Social Security Administration? <input checked="" type="checkbox"/> Yes <input type="checkbox"/> No If yes, please provide your SSN: [REDACTED]		
<p>SOCIAL SECURITY NUMBER DISCLOSURE: As part of your application for an initial or renewal license, Federal and State laws require you to provide your Social Security Number (SSN) to the Oregon Liquor Control Commission (OLCC) for child support enforcement purposes (42 USC § 666(a)(13) & ORS 25.785). If you are an applicant or licensee and fail to provide your SSN, the OLCC may refuse to process your application. Your SSN will be used only for child support enforcement purposes unless you indicate below.</p> <p>Based on our authority under ORS 471.311 and OAR 845-005-0312(6), we are requesting your voluntary consent to use your SSN for the following administrative purposes only: to match your license application to your Alcohol Server Education records (where applicable), and to ensure your identity for criminal records checks. OLCC will not deny you any rights, benefits or privileges otherwise provided by law if you do not consent to use of your SSN for these administrative purposes (5 USC § 552(a).</p> <p>Do you voluntarily consent to the OLCC's use of your SSN as just described? <input checked="" type="checkbox"/> Yes <input type="checkbox"/> No</p>		
4. Date of Birth (MM/DD/YYYY): <u>4/26/1974</u>	[REDACTED]	Contact Phone: <u>541</u> - [REDACTED]
6. Driver License or State ID #:	[REDACTED]	7. State: <u>Oregon</u>
8. Residence Address:	[REDACTED]	<u>Prineville OR 97754</u>
9. Mailing Address (if different):		
10. E-Mail (optional): [REDACTED] @ gmail.com		
11. Do you have a spouse or domestic partner? <input checked="" type="checkbox"/> Yes <input type="checkbox"/> No If yes, list his/her full name: <u>Rita Rhoden</u>		
12. If yes to #11, will this person be involved in the management of, or have control over the business? <input type="checkbox"/> No <input checked="" type="checkbox"/> Yes		
13. In the past 10 years, have you been <u>convicted</u> ("convicted" includes paying a fine) in Oregon or another U.S. state of driving a car with a suspended driver license or driving a car with no insurance? <input checked="" type="checkbox"/> No <input type="checkbox"/> Yes (Please include explanation below) <input type="checkbox"/> Unsure (Please include explanation below)		
14. In the past 10 years, have you been <u>convicted</u> ("convicted" includes paying a fine) in Oregon or another U.S. state of a <u>FELONY</u> ? <input checked="" type="checkbox"/> No <input type="checkbox"/> Yes (Please include explanation below) <input type="checkbox"/> Unsure (Please include explanation below)		
[REDACTED]		

16. Do you, or any legal entity that you are a part of, currently hold or have previously held a liquor license or a recreational marijuana license in Oregon or another U.S. state? (Note: alcohol service permits and marijuana worker permits are not liquor licenses).
 No Yes (Please include explanation below) Unsure (Please include explanation below)

17. Have you, or any legal entity that you are a part of, ever had an application for a license, permit, or certificate denied or cancelled by the OLCC or any other governmental agency in the U.S.?
 No Yes (Please include explanation below) Unsure (Please include explanation below)

18. Are you applying for a Full On-Premises, Limited On-Premises, Off-Premises, or Brewery-Public House license?
 No Please skip questions 19 & 20. Go directly to question 21.
 Yes Please answer questions 19, 20, and 21.

19. Do you or will you have any ownership interest in a business that manufactures, wholesales, or distributes alcohol in Oregon or another U.S. state?
 No Yes (Please include explanation below) Unsure (Please include explanation below)

20. Does or will an alcohol manufacturer, wholesaler, or distributor in Oregon or another U.S. state have any ownership interest in your business?
 No Yes (Please include explanation below) Unsure (Please include explanation below)

21. Do you currently have, or will you have, any ownership interest in any business in Oregon with a Full On-Premises, Limited On-Premises, Off-Premises, or Brewery-Public House license?
 No Yes (Please include explanation below) Unsure (Please include explanation below)

You must sign your own form. Another person, like your attorney or a person with power of attorney, may not sign your form. I affirm that my answers are true and complete. I understand the OLCC will use the above information to check my records, including but not limited to, criminal history. I understand that if my answers are not true and complete, the OLCC may deny my license application.

Name: (LAST) <i>Kinsey</i>	(FIRST) <i>James</i>	(MIDDLE) <i>Kenneth</i>
Signature: <i>[Handwritten Signature]</i>		Date: <i>4-7-20</i>



OREGON LIQUOR CONTROL COMMISSION
INDIVIDUAL HISTORY FORM

1. Name: (LAST) Rhoden | (FIRST) Rita | (MIDDLE) lea

2. Other Names Used (Maiden, Etc.): Rita lea mcdellan

3. Do you have a Social Security Number (SSN) issued by the U.S. Social Security Administration?
 Yes No If yes, please provide your SSN: [REDACTED]

SOCIAL SECURITY NUMBER DISCLOSURE: As part of your application for an initial or renewal license, Federal and State laws require you to provide your Social Security Number (SSN) to the Oregon Liquor Control Commission (OLCC) for child support enforcement purposes (42 USC § 666(a)(13) & ORS 25.785). If you are an applicant or licensee and fail to provide your SSN, the OLCC may refuse to process your application. Your SSN will be used only for child support enforcement purposes unless you indicate below.

Based on our authority under ORS 471.311 and OAR 845-005-0312(6), we are requesting your voluntary consent to use your SSN for the following administrative purposes only: to match your license application to your Alcohol Server Education records (where applicable), and to ensure your identity for criminal records checks. OLCC will not deny you any rights, benefits or privileges otherwise provided by law if you do not consent to use of your SSN for these administrative purposes (5 USC § 552(a).

Do you voluntarily consent to the OLCC's use of your SSN as just described? Yes No

4. Date of Birth (MM/DD/YYYY): 01/27/1981 5. Contact Phone: 541-[REDACTED]

6. Driver License or State ID #: [REDACTED] 7. State: oregon

8. Residence Address: [REDACTED] Lane Prineville OR 97752

9. Mailing Address (if different): [REDACTED]

10. E-Mail (optional):

11. Do you have a spouse or domestic partner? Yes No
If yes, list his/her full name:

12. If yes to #11, will this person be involved in the management of, or have control over the business?
 No Yes James Kinsey

13. In the past 10 years, have you been **convicted** ("convicted" includes paying a fine) in Oregon or another U.S. state of driving a car with a suspended driver license or driving a car with no insurance?
 No Yes (Please include explanation below) Unsure (Please include explanation below)

14. In the past 10 years, have you been **convicted** ("convicted" includes paying a fine) in Oregon or another U.S. state of a **FELONY**?
 No Yes (Please include explanation below) Unsure (Please include explanation below)

15. Have you ever been in a drug or alcohol **diversion program** in Oregon or another U.S. state? A diversion program is where you are required, usually by the court or another government agency, to complete certain requirements in place of being convicted of a drug or alcohol-related offense.
 No Yes (Please include explanation below) Unsure (Please include explanation below)

16. Do you, or any legal entity that you are a part of, **currently hold** or **have previously held** a liquor license or a recreational marijuana license in Oregon or another U.S. state? (Note: alcohol service permits and marijuana worker permits are not liquor licenses).

No Yes (Please include explanation below) Unsure (Please include explanation below)

17. Have you, or any legal entity that you are a part of, **ever** had an application for a license, permit, or certificate **denied or cancelled** by the OLCC or any other governmental agency in the U.S.?

No Yes (Please include explanation below) Unsure (Please include explanation below)

18. Are you applying for a Full On-Premises, Limited On-Premises, Off-Premises, or Brewery-Public House license?

No Please skip questions 19 & 20. Go directly to question 21.
 Yes Please answer questions 19, 20, and 21.

19. Do you or will you have any ownership interest in a business that manufactures, wholesales, or distributes alcohol in Oregon or another U.S. state?

No Yes (Please include explanation below) Unsure (Please include explanation below)

20. Does or will an alcohol manufacturer, wholesaler, or distributor in Oregon or another U.S. state have any ownership interest in your business?

No Yes (Please include explanation below) Unsure (Please include explanation below)

21. Do you currently have, or will you have, any ownership interest in any business in Oregon with a Full On-Premises, Limited On-Premises, Off-Premises, or Brewery-Public House license?

No Yes (Please include explanation below) Unsure (Please include explanation below)

You must sign your own form. Another person, like your attorney or a person with power of attorney, may not sign your form. I affirm that my answers are true and complete. I understand the OLCC will use the above information to check my records, including but not limited to, criminal history. I understand that if my answers are not true and complete, the OLCC may deny my license application.

Name: (LAST) <i>Rhodens</i>	(FIRST) <i>Rita</i>	(MIDDLE) <i>Lee</i>
Signature: <i>Rita J Rhoden</i>		Date: <i>3/30/20</i>



OREGON LIQUOR CONTROL COMMISSION BUSINESS INFORMATION

Please Print or Type

Applicant Name: Rita Rhoder James Kinsey Phone: 3/30/20

Trade Name (dba): Shut Up - N - Drink

Business Location Address: 1500 NE 3rd St

City: Prineville OR ZIP Code: 97754

DAYS AND HOURS OF OPERATION

Business Hours:

Sunday	12	to	9
Monday	11	to	11
Tuesday	11	to	11
Wednesday	11	to	11
Thursday	11	to	11
Friday	11	to	11
Saturday	11	to	11

Outdoor Area Hours:

Sunday	12	to	9
Monday	11	to	11
Tuesday	11	to	11
Wednesday	11	to	11
Thursday	11	to	11
Friday	11	to	11
Saturday	11	to	11

The outdoor area is used for:

- Food service Hours: 5 am to 11 pm
- Alcohol service Hours: 11 am to 11 pm
- Enclosed, how _____

The exterior area is adequately viewed and/or supervised by Service Permittees.

(Investigator's Initials)

Seasonal Variations: Yes No If yes, explain: _____

ENTERTAINMENT

Check all that apply:

- Live Music
- Recorded Music
- DJ Music
- Dancing
- Nude Entertainers
- Karaoke
- Coin-operated Games
- Video Lottery Machines
- Social Gaming
- Pool Tables
- Other: _____

DAYS & HOURS OF LIVE OR DJ MUSIC

Sunday	12	to	9
Monday	11	to	11
Tuesday	11	to	11
Wednesday	11	to	11
Thursday	11	to	11
Friday	11	to	11
Saturday	11	to	11

SEATING COUNT

Restaurant: _____ Outdoor: 50

Lounge: _____ Other (explain): _____

Banquet: _____ Total Seating: _____

OLCC USE ONLY

Investigator Verified Seating: _____ (Y) _____ (N)

Investigator Initials: _____

Date: _____

I understand if my answers are not true and complete, the OLCC may deny my license application.

Applicant Signature: Rita Rhoder Date: 3/30/20

1-800-452-OLCC (6522)
www.oregon.gov/olcc

STREETSCAPE CONCEPT RECOMMENDATION

US 26 / THIRD STREET PRINEVILLE, OR

APRIL 28, 2020

PROJECT GOALS

1. Modernize infrastructure

- **Traffic signals and traffic communication**
- **Correct ADA non-compliance areas**
- **Implement pedestrian & bicycle improvements**

2. Integrate safety improvements

- **US 26 / 3rd St. Corridor (walkways, crosswalks, bikeways, signals, signs, operations)**
- **OR 380 / Combs Flat & Lynn (short and long term)**

3. Implement streetscape improvements

- **Sidewalk enhancements**
- **Pedestrian-scale lighting & landscaping**
- **Pedestrian amenities (street furniture & fixtures)**

4. Improve the storm drainage system

- **Better manage seasonal / storm flooding**

WHAT'S THE BIG PICTURE?

- **Improve multi-modal connectivity**
- **Promote accessibility to Downtown destinations where people want to spend time**
- **Evaluate comprehensive street safety & operational improvements**
- **Create strong placemaking & character-building that unifies Third Street**
- **Implement various technical fixes, including ADA improvements, stormwater infrastructure, and signal upgrades.**
- **Implement streetscape improvements identified in the 2017 “Third Street Redevelopment Plan”**

KEY EVALUATION FACTORS

- **Consistency with recent projects and design direction**
- **Supports multi-modal connectivity**
- **A signature look for Prineville**
- **Cost and phasing**
- **Maintenance and durability**
- **Flexibility of elements and support for varied streetscape layout options**
- **Technical needs (i.e. luminance)**
- **Compatibility with downtown businesses and properties**
- **Safety and sightlines**



THE IMPACT OF STREETSCAPES

Streetscape improvements can help create a more walkable, safe, and business-supporting district. Projects create a more unified look and feel for an area, provide places to gather and socialize, and improve the environmental health of a street. The following are several streetscape project examples.

BEFORE: BROADALBIN STREET (ALBANY, OR)



- **Unmarked street pavement encourages speeding and disjointed parking**
- **Unattractive sidewalk discourages foot traffic to businesses**
- **Lack of stormwater facilities creates polluted runoff to the nearby river**



IMPROVED: BROADALBIN STREET (ALBANY, OR)

TREES

STREETLIGHT

BENCH

PAVER BLOCK

MOVABLE PLANTERS

STORMWATER PLANTER

BIKE RACK

BEFORE: CASCADE AVE. (SISTERS, OR)



- **Narrow sidewalks with gaps makes walking unsafe and unappealing**
- **Poorly marked and long crosswalks – especially hazardous with freight trucks**
- **A vehicle-dominated street doesn't support the “Western” town theme**

IMPROVED: CASCADE AVE. (SISTERS, OR)

LAMP AND
BANNER POLE

TREE
CLUSTER

WAYFINDING
SIGN

TRASH
CAN

ENHANCED
CROSSING

BUILT-IN
BENCH

PAVER BLOCK

LANDSCAPE

DECORATIVE PAD



RECOMMENDED STREETSCAPE FOR THE DOWNTOWN CORE

- **A streetscape concept to make Prineville's downtown safer and more inviting**
- **Improves crosswalks, sidewalk conditions, and ADA access around downtown**
- **Uses furnishings, materials, and plants to create a cohesive public realm**

PROJECT AREA

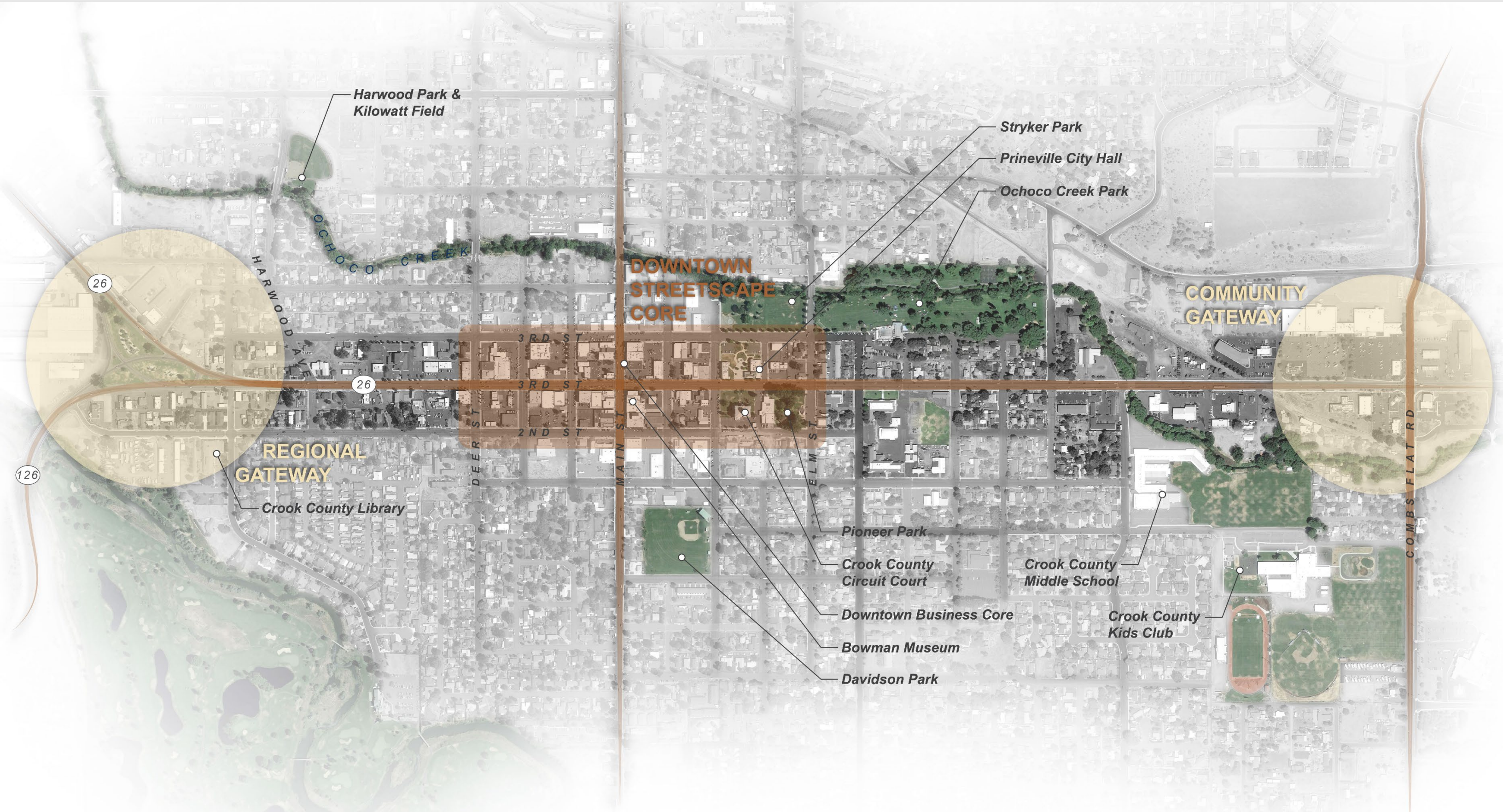

Harwood Park & Kilowatt Field

Stryker Park

Prineville City Hall

Ochocho Creek Park

**DOWNTOWN
STREETSCAPE
CORE**

**COMMUNITY
GATEWAY**

**REGIONAL
GATEWAY**

Crook County Library

Pioneer Park

Crook County
Circuit Court

Crook County
Middle School

Downtown Business Core

Crook County
Kids Club

Bowman Museum

Davidson Park



EXISTING CROSS-SECTION

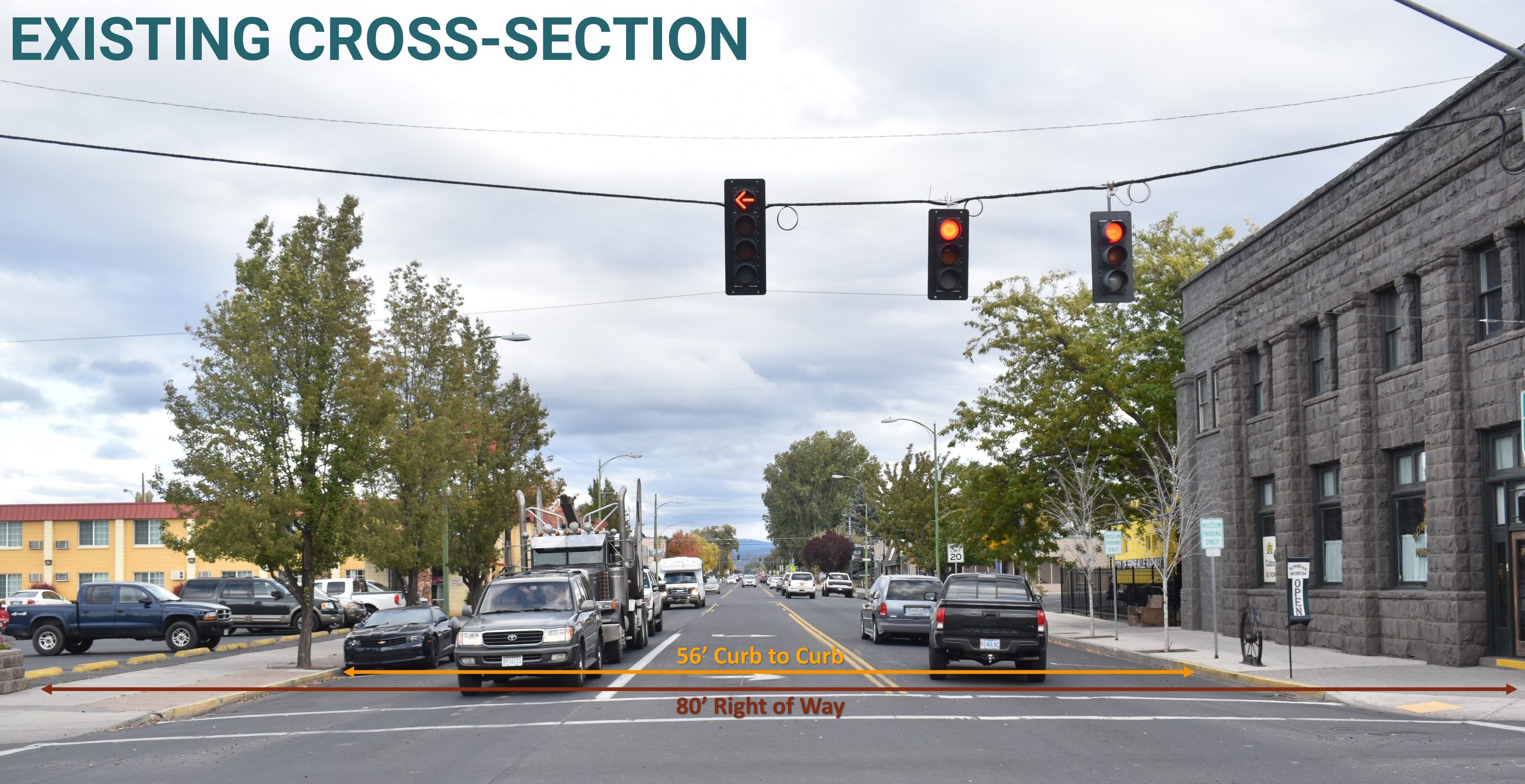

- **Street recommendations work within the existing ROW and street width**
- **Ensures turn movements at key locations and long freight, RV, and trailer travel**
- **Fine-tunes the streetscape to fit with local businesses and access needs**

PROPOSED CROSS-SECTION – MID-BLOCK

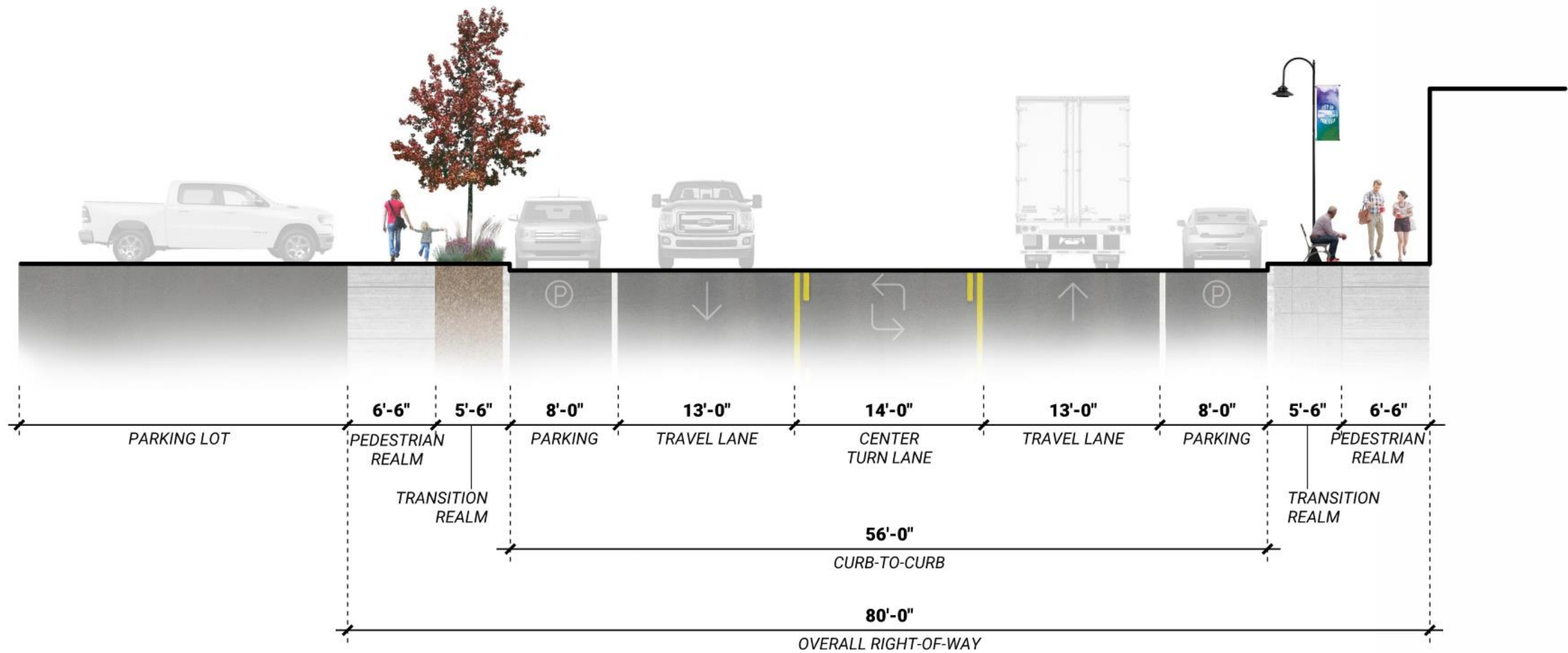

PROPOSED CROSS-SECTION – AT CORNERS

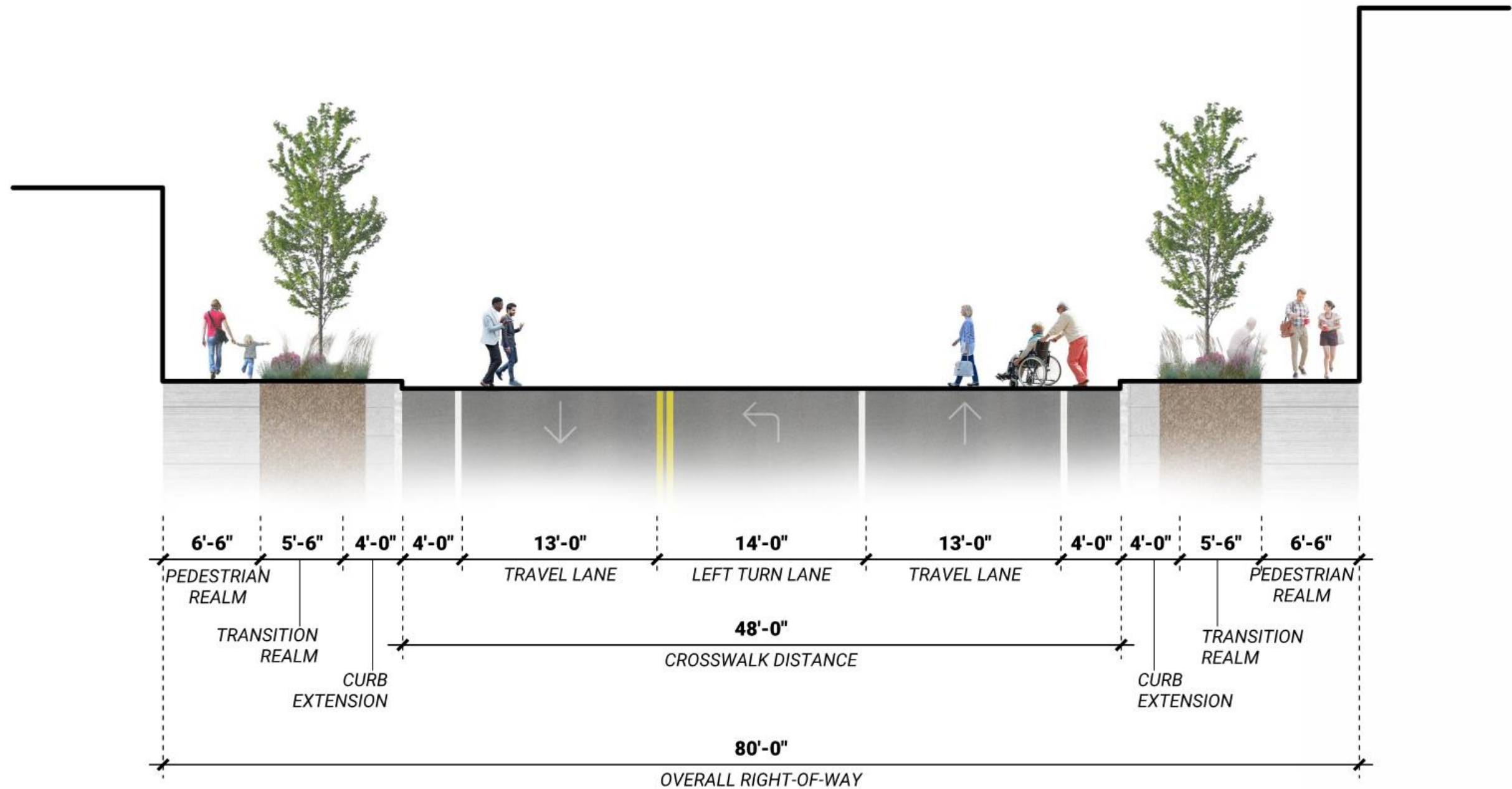

ILLUSTRATION OF 3RD AND MAIN INTERSECTION

4' CURB EXTENSIONS
WITH BASALT PAVER
MATERIAL TREATMENT

CLUSTERED TREES
IN TREE GRATES

SIDEWALK BENCH
STREET LIGHTS

CURB EXTENSION
PLANTER

ADA-COMPLIANT
CROSSING RAMPS

TRAFFIC SIGNAL / LIGHT POLES
FIT IN CURB-EXTENSION AREA



36

*ADA ramp locations and design is subject to ongoing refinement and finalization.

TRUCK TURN ANALYSIS

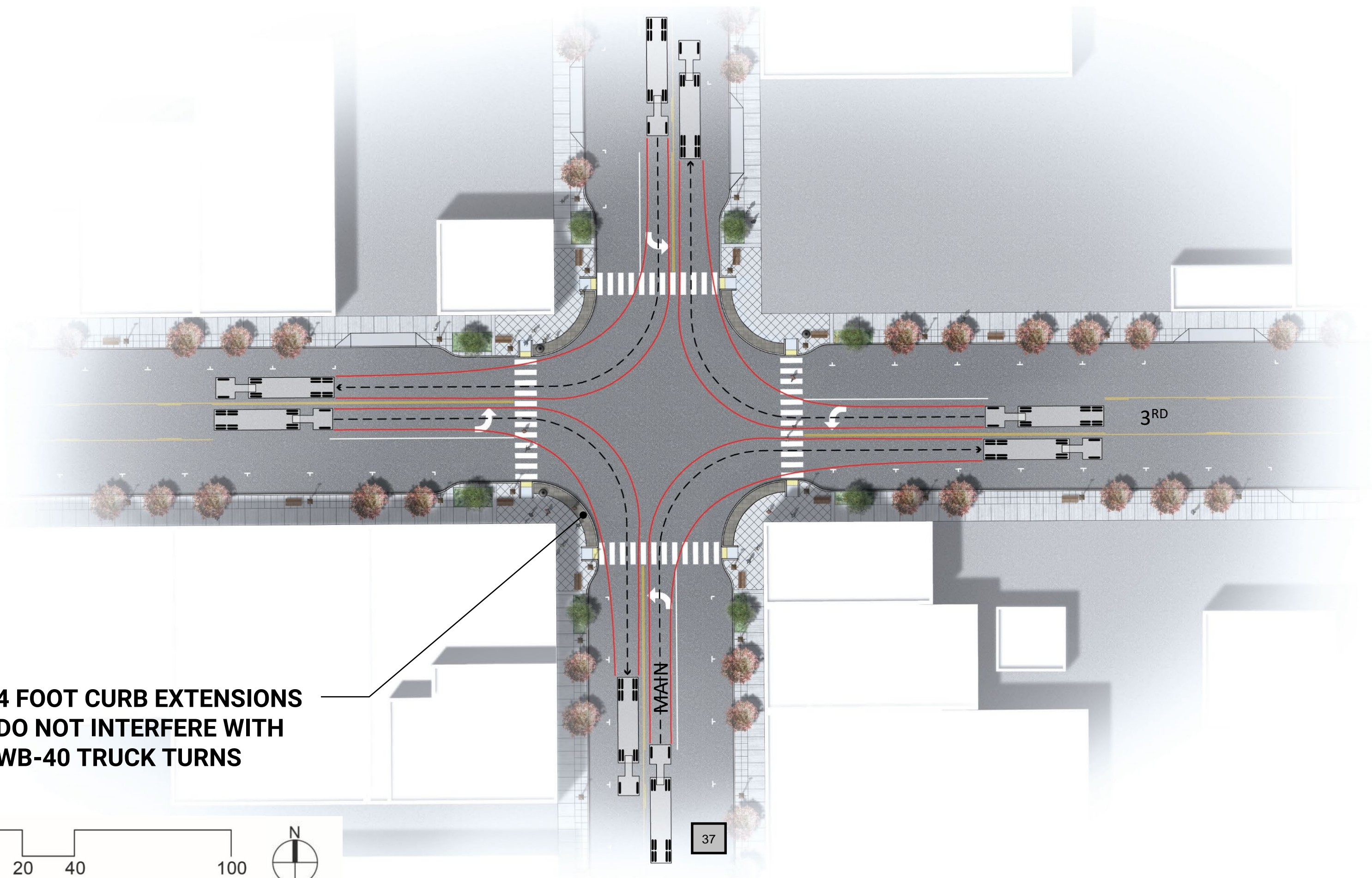

**4 FOOT CURB EXTENSIONS
DO NOT INTERFERE WITH
WB-40 TRUCK TURNS**



CURB MODIFICATIONS

**ADDITIONAL CURB EXTENSION
AREA FITS ADA RAMPS,
LIGHTS,
SIGNALS, LANDSCAPE,
BENCHES,
AND OTHER SAFETY AND DESIGN
IMPROVEMENTS**

EXISTING CURB

**PROPOSED NEW CURB RADIUS
POINT IS NO FURTHER THAN**

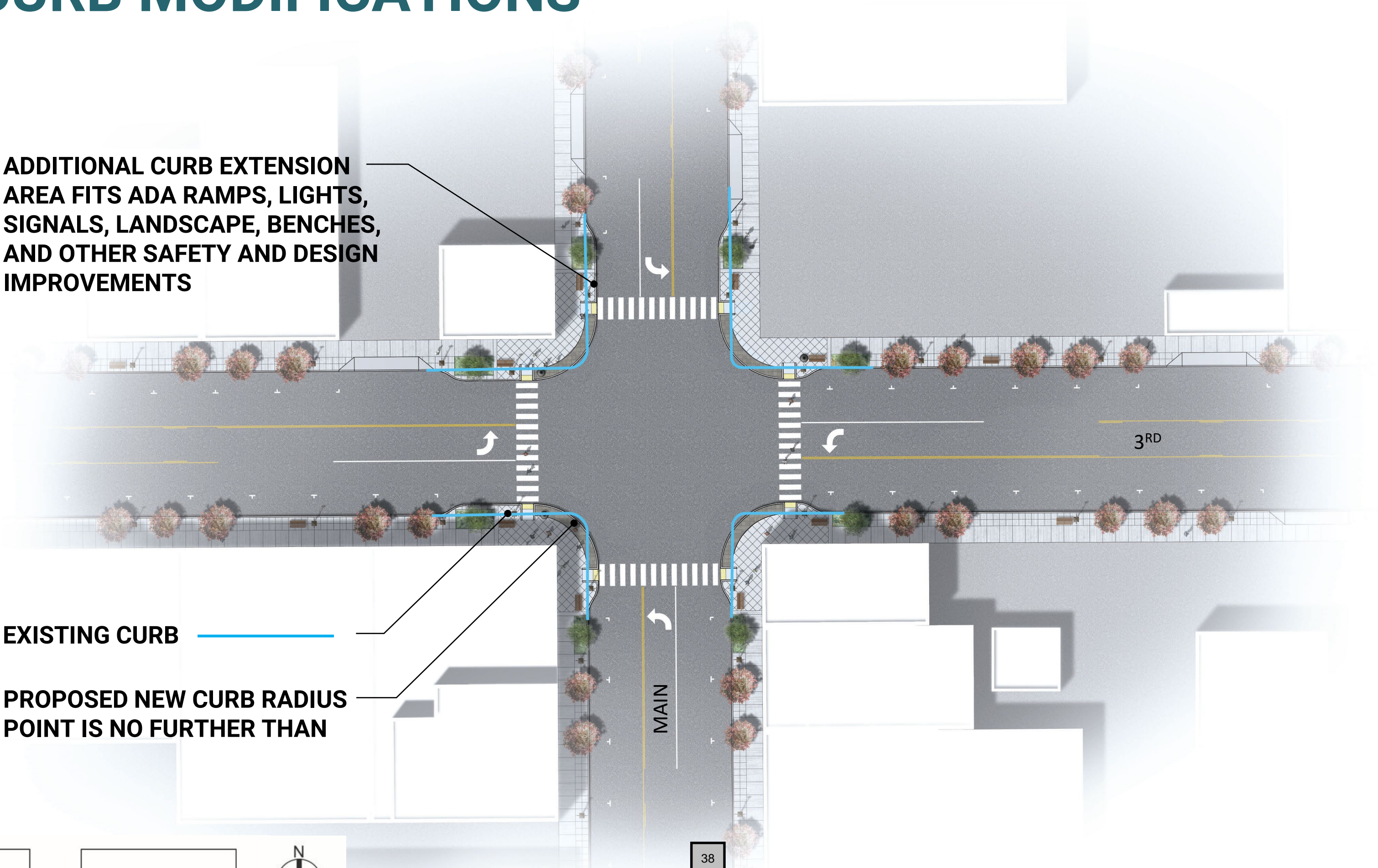

ILLUSTRATION OF CURB EXTENSION IMPROVEMENTS



FURNISHINGS AND PLANTINGS

- Recommendations for a consistent family of benches, lights, and furnishings
- Trees, plants, and grasses selectively used to enhance the street ecology
- Opportunities for custom and artistic streetscape pieces for a unique feel

RECOMMENDED FURNISHING AND MATERIALS



BENCH

Manufacturer: Tournesol Siteworks
 Model: Plaza Bench
 Finish: Black powdercoat
 Note: Center arm option available



BIKE RACK (CITY STANDARD)

Manufacturer: Dero
 Model: Hitch Rack
 Finish: Black powdercoat (also available with PVC dip)



TRASH RECEPTACLE

Manufacturer: Tournesol
 Model: Plaza Trash Recepticle with Hood (PZ-075D-30)
 Size: 35 Gallon; 36.5"H x 25"DIA
 Finish: Black powdercoat



ADA TACTILE PAVERS - PLASTIC

Manufacturer: Armor Tile
 Model: Tactile Warning Pad
 Size: 36"x36" shown (24"x48" available)
 Color: Yellow



LIGHT POLE

Manufacturer: Sternberg Lighting
 Model: Decatur Base 12' Tapered Smooth Shaft / R2
 Arm / 1527 Omega (LED) Lamp / DBA Banner Arm
 Finish: Black powdercoat



TREE GRATE

Manufacturer: Neenah Foundry
 Model: R-8710
 Finish: Black



CURB EXTENSION ACCENT STONE

Manufacturer: Various
 Model: Basalt Paver Blocks
 Finish: Grey



SEASONAL, MOVABLE PLANTER BOXES

Manufacturer: Tournesol
 Model: Rectangle 48"x18"x24"
 Finish: Wood (stock or local Douglas Fir or Ponderosa Pine), custom metal, or custom stone (Basalt)

ARTISTIC BIKE RACK PROGRAMS (OPTIONAL)

POTENTIAL CITY "MAIN STREET" ARTS PROGRAM

- Custom commissioned artistic bike racks supported by local businesses, arts organizations, or civic groups
- Example programs in other cities are shown below



WAGON WHEEL
Prineville, OR



HORSE RACK AT CITY HALL
Whitehorse, Yukon, Canada



BRANDED RACK
Milwaukee, WI
Business Improvement District funding

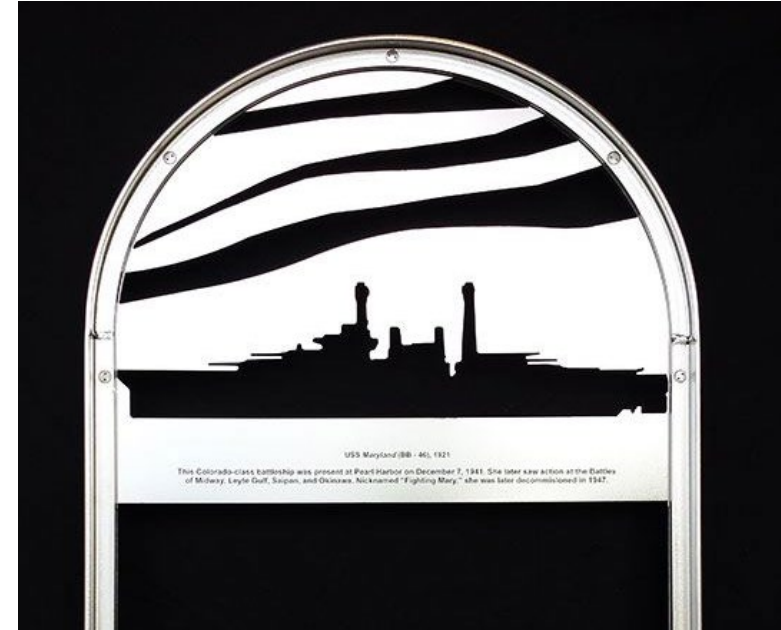

BRANDED RACK
Annapolis, MD
City of Annapolis, Maryland DOT, Anne Arundel County, MainStreets Annapolis Program



ART RACKS
Portland, OR
Bureau of Transportation permitting



PLANT PALETTE – STREET TREES

PRIMARY STREET TREE



AUTUMN BLAZE RED MAPLE*
Acer x freemanii 'Autumn Blaze'
 Height: 40-50', Spread: 30-40'

ACCENT TREES: IN CORNER PLANTER LOCATIONS



GREENSPIRE LITTLELEAF LINDEN*
Tilia cordata 'Greenspire'
 Height: 30-40', Spread: 20-30'



SERVICEBERRY
Amelanchier
 Height: 20-25', Spread: 10-15'



EUROPEAN HORNBEAM
Carpinus betulus 'Fastigiata'
 Height: 40-60', Spread: 30-40'

*= City of Prineville approved street tree

 = Native

 = Attracts wildlife

 = Fire resistant

PLANT PALETTE – SHRUBS

- For use in built-in curb extension planters and seasonal, movable planter boxes



ADAM'S NEEDLE YUCCA
Yucca filamentosa



BITTERBRUSH
Purshia tridentata



BLUE MIST SPIRAEA
Caryopteris x clandonensis 'Blue Mist'



CREeping OREGON GRAPE
Mahonia repens



GRAY RABBITBRUSH
Chrysothamnus nauseosus



GREENLEAF MANZANITA
Arctostaphylos patula



GRO-LOW SUMAC
Rhus aromatica



SAGEBRUSH
Artemisia tridentata



- = Native
- = Attracts wildlife
- = Fire resistant

PLANT PALETTE – GRASSES

- For use in built-in curb extension planters and seasonal, movable planter boxes



BLUE IDAHO FESCUE
Festuca idahoensis 'Siskiyou Blue'



DWARF FOUNTAIN GRASS
Pennisetum alopecuroides 'Hamelin'



HEAVY METAL SWITCHGRASS
Panicum virgatum 'Heavy Metal'

 = Native

 = Attracts wildlife

 = Fire resistant

PLANT PALETTE – PERENNIALS/GROUNDCOVER

- For use in built-in curb extension planters and seasonal, movable planter boxes



BEARBERRY
Arctostaphylos uva-ursi



DELPHINIUM
Delphinium spp.

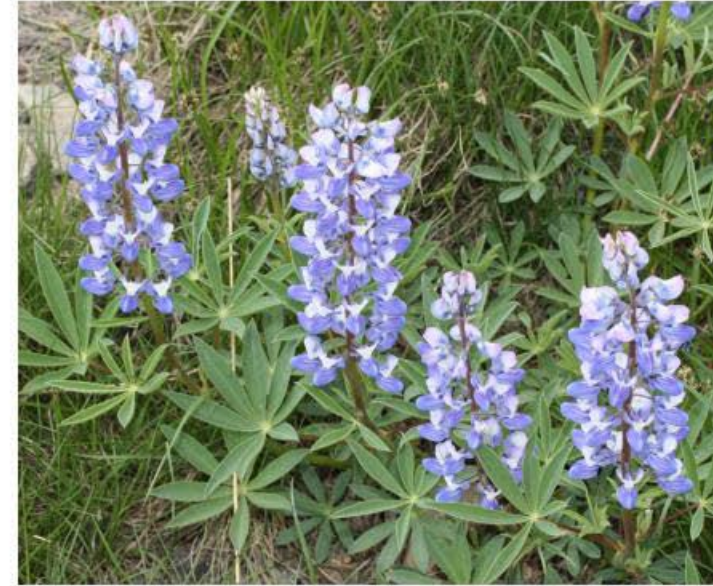

LUPINE
Lupinus spp.



MOUNT ATLAS DAISY
Anacyclus depressus



SAGE
Salvia nemorosa



WESTERN YARROW
Achillea millefolium var. occidentalis



WOOLLY THYME
Thymus pseudolanuginosus



 = Native

 = Attracts wildlife

 = Fire resistant

TRUCK TURN ANALYSIS

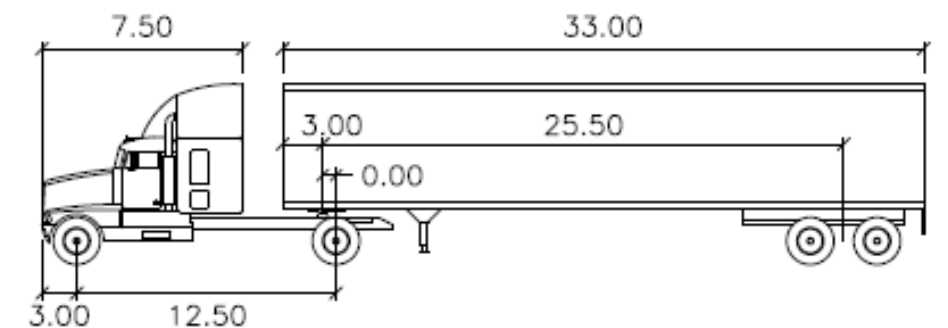
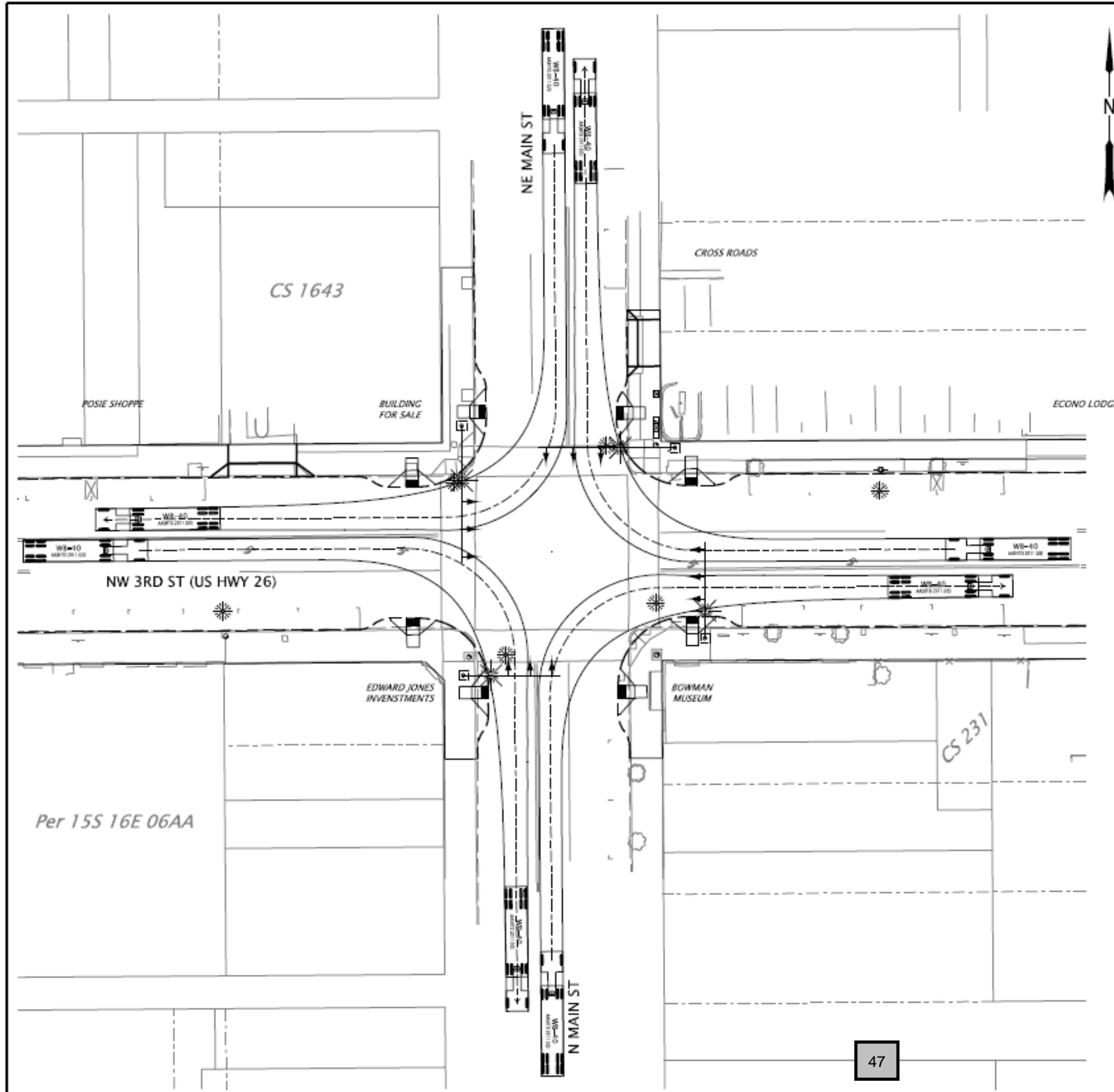

WB-40	feet		
Tractor Width	: 8.00	Lock to Lock Time	: 6.0
Trailer Width	: 8.00	Steering Angle	: 20.3
Tractor Track	: 8.00	Articulating Angle	: 70.0
Trailer Track	: 8.00		

OREGON DEPARTMENT OF TRANSPORTATION 	
US26; Meadow Lakes Ave. - Combs Flat Rd. (Prineville) Signs, Signals, Sidewalk/Crosswalk and ADA Improvements HIGHWAY NO. 41 CROOK COUNTY	
Design	Review
Draft	Check
N MAIN ST: PROP. CURRENT DESIGN	
SHEET NO. 2D	

KEY EVALUATION FACTORS

- **Consistency with recent projects and design direction**
- **Supports multi-modal connectivity**
- **A signature look for Prineville**
- **Cost and phasing**
- **Maintenance and durability**
- **Flexibility of elements and support for varied streetscape layout options**
- **Technical needs (i.e. luminance)**
- **Compatibility with downtown businesses and properties**
- **Safety and sightlines**

CONTACT INFORMATION:

Ben Austin
bena@hhpr.com

Ben Weber
benw@seradesign.com

Proclamation

Older Americans Month 2020

WHEREAS, Central Oregon includes a growing number of older Americans who enrich our community through their diverse life experiences; and

WHEREAS, the City of Prineville and the Council on Aging of Central Oregon are committed to strengthening our community by connecting with and supporting older adults, their families, and caregivers and acknowledging their many valuable contributions to society; and

WHEREAS, the City of Prineville and the Council on Aging of Central Oregon recognize the importance of bringing together all generations and engaging in activities that promote physical, mental, and emotional well-being for the benefit of all; and

WHEREAS, the City of Prineville and the Council on Aging of Central Oregon can enhance the lives of older Americans in our community by:

- promoting home- and community-based services that support independent living;
- involving older adults in community events and other activities; and
- providing opportunities for older adults to work, volunteer, learn, lead, and mentor.

NOW, THEREFORE, BE IT PROCLAIMED, that on this day, April 28, 2020, I Stephen P. Uffelman, Mayor of the City of Prineville, do hereby recognize May 2020 to be Older Americans Month. We urge every resident to take time during this month to recognize older adults and the people who serve them as essential and valuable members of our community.

IN WITNESS THEREOF, I have hereunto set my hand and caused to be affixed the seal of the City of Prineville on this 28th day of April, 2020.



Stephen P. Uffelman, Mayor



STAFF REPORT

MEETING DATE: 4/28/2020

PREPARED BY: Casey Kaiser

SECTION: Council Business

DEPARTMENT: Planning

CITY GOAL: Position the City for the Future

SUBJECT: COVID-19 Local Emergency Business Grant funds requests - \$10,000 requested

REASON FOR CONSIDERATION: See Attached

BACKGROUND: See Attached

FISCAL IMPACT: \$10,000.00 See Attached

RECOMMENDATION:

Staff recommends contributing \$10,000 to the local COVID-19 Emergency Business Assistance grant pool. These funds should be delivered to the Prineville-Crook County Chamber of Commerce who is the administrator of the grant program on behalf of the task force.



Community Development Department

387 NE Third Street – Prineville, OR 97754

Staff Report

April 28th, 2020

City of Prineville City Council Meeting

Staff: **Casey Kaiser**
Department: **Planning/Community Development**
Subject: **Funding Local COVID-19 Business Assistance Grant Program**

Council Action:

Consider contributing \$10,000 to the grant funding pool for the Crook County COVID-19 Business Assistance grant program developed and implemented by the local COVID-19 Business Task Force.

Background:

In March the City of Prineville joined several other organizations in Crook County to form a local COVID-19 Business Assistance Task Force. The task force was formed around the immediate need to help local companies adversely impacted by the COVID-19 pandemic and the associated government mandated changes to operations.

City Manager Steve Forrester and Planning Dept. staff member Casey Kaiser along with Mayor Steve Uffelman engaged with the task force early in the process to identify what resources the City could potentially contribute in order to help preserve the stability of the local business community.

The current member organizations of the task force and their representatives on the working group include:

- Prineville Crook County Chamber of Commerce – Kim Daniels
- Facebook – William Marks
- City of Prineville – Casey Kaiser
- Crook County – Seth Crawford
- Prineville Downtown Association – Bryan Iverson
- Prineville Economic Development – Kelsey Lucas, Craig Hunt
- Representative Vikki Breese Iverson – Bryan Iverson

The task force initially conducted a survey of local businesses to identify some of their most critical needs resulting from the Coronavirus and the corresponding mandated closure or change in service requirements. Providing the business community with technical assistance in accessing state and federal resources, and offering direct financial assistance through a local grant program were identified as the two most critical areas of need.

On April 7th both technical assistance and a local grant program had been developed by the task force and were made available to the local business community. The grant program currently offers up to \$2,500 in grant funds to help cover payroll expenses and/or fixed



Community Development Department

387 NE Third Street – Prineville, OR 97754

operations costs for our most vulnerable businesses. The technical assistance is being offered by the staff of the Prineville Chamber of Commerce.

The grant funding pool is currently made up of funds contributed by Facebook, the Prineville Chamber of Commerce, the Prineville Downtown Association, and Crook County.

Within the first week of offering the grant to the public over 90 applications were received. By the time this staff report is released the number will likely be over 150. On April 20th the task force approved the first round of grants, effectively delivering approximately \$170,000 directly to businesses in Crook County. More applications continue to be received and indicators show there are more local businesses that can benefit from the grant.

Additional funds are needed to continue to meet the emergent needs of Prineville's business community. These funds help ensure that more of our businesses are able remain open, or re-open. Therefore the task force is requesting a \$10,000 contribution to the grant fund from the City of Prineville.

Liz has indicated there are several options for sourcing the funds that would not adversely impact the current City budget.

Below is a link to the online grant application and the grant information page located on the Chamber of Commerce website.

<https://prinevillechamber.com/coronavirus/#grant>

Staff Comments/Recommendations:

The business community in Crook County has been dramatically impacted by the current Coronavirus pandemic and the related government mandated restrictions on their operations. Many of our local businesses have been forced to significantly scale back operations and some have been ordered to close completely for an indefinite period of time. While some federal and state aid for the business community is being offered, there are local businesses that need additional financial help or simply do not qualify for other resources currently available.

Staff recommends contributing \$10,000 to the local COVID-19 Emergency Business Assistance grant pool. These funds should be delivered to the Prineville-Crook County Chamber of Commerce who is the administrator of the grant program on behalf of the task force.

**RESOLUTION NO. 1434
CITY OF PRINEVILLE, OREGON**

**A RESOLUTION EXTENDING THE LOCAL STATE OF EMERGENCY AS A RESULT
OF COVID-19 PANDEMIC**

Whereas, COVID-19 was declared a pandemic by the World Health Organization on March 11, 2020; and

Whereas, COVID-19 are a group of viruses that can cause respiratory disease, with the potential to cause serious illness or loss of life for individuals with underlying health conditions; and

Whereas, COVID-19 requires a significant amount of resources at the local level to keep the public and community informed and as safe as possible; and

Whereas, on March 8, 2020, Oregon Governor Kate Brown declared a state of emergency due to the COVID-19 outbreak in Oregon (Executive Order 20-03), finding that COVID-19 has created a threat to public health and safety, and constitutes a statewide emergency under ORS 401.025(1); and

Whereas, on March 13, 2020, the President of the United States, Donald J. Trump, declared the COVID-19 outbreak a national emergency; and

Whereas, on March 13, 2020, the Crook County Court declared a state of emergency relating to COVID-19 in Crook County, Oregon; and

Whereas, on March 13, 2020, the City Council of Prineville declared a state of emergency as a result of the COVID-19 pandemic per Resolution 1429; and

Whereas, on March 17, 2020, Governor Brown issued Executive Order 20-07 prohibiting on-premises consumption of food or drink and gatherings of more than 25 people; and

Whereas, on March 23, 2020, Governor Brown issued Executive Order 20-12, “Stay-Home, Save Lives,” which prohibited non-essential social and recreational gatherings of individuals outside of a home or place of residence regardless of size, if a distance of six feet between individuals cannot be maintained; and

Whereas, on April 7, 2020, the City Council of Prineville continued the State of Emergency as a result of the COVID-19 pandemic per Resolution 1433, which is set to expire on April 30, 2020 at 11:59 p.m.; and

Whereas, the unknown duration of the COVID-19 pandemic will have significant financial impact to the community; and

Whereas, pursuant to ORS 401.309(1), the governing body of a city may declare, by ordinance or resolution, that a state of emergency exists within the city; and

Whereas, pursuant to Prineville City Code 31.05, the City of Prineville City Council may declare a state of emergency and may redirect city funds for emergency use or order such other measures as are found to be immediately necessary for the protection of life and/or property.

NOW, THEREFORE, the City of Prineville resolves and declares the following:

1. A State of Emergency continues to exist in the City of Prineville (City), encompassing all of the areas within city limits.
2. That the City and its officials shall continue to be authorized to take such actions and issue such orders as are determined to be necessary to protect the public and property and to efficiently conduct activities that minimize or mitigate the effect of the emergency as described in Prineville City Code 31.05,
3. The City shall continue to take all necessary steps authorized by law to coordinate response and recovery from this emergency, including, but not limited to, requesting assistance and potential reimbursements from the State of Oregon and the appropriate federal agencies.
4. That emergency procurements of goods and services are authorized pursuant to ORS 279B.080, ORS 279C.335(6), Prineville City Code 31.05, and all other applicable rules.
5. This Resolution and Declaration is effective immediately and shall remain in effect until May 31, 2020 at 11:59 p.m. unless sooner superseded.

Approved by the City Council this ____ day of April, 2020.

Stephen P. Uffelman, Mayor

ATTEST:

Lisa Morgan, City Recorder

**RESOLUTION NO. 1435
CITY OF PRINEVILLE, OREGON**

**A RESOLUTION DECLARING PRINEVILLE POLICIES DURING THE COVID-19
PANDEMIC**

Whereas, COVID-19 was declared a pandemic by the World Health Organization on March 11, 2020; and

Whereas, COVID-19 are a group of viruses that can cause respiratory disease, with the potential to cause serious illness or loss of life for individuals with underlying health conditions; and

Whereas, COVID-19 requires a significant amount of resources at the local level to keep the public and community informed and as safe as possible; and

Whereas, on March 8, 2020, Oregon Governor Kate Brown declared a state of emergency due to the COVID-19 outbreak in Oregon (Executive Order 20-03), finding that COVID-19 has created a threat to public health and safety, and constitutes a statewide emergency under ORS 401.025(1); and

Whereas, on March 13, 2020, the President of the United States, Donald J. Trump, declared the COVID-19 outbreak a national emergency; and

Whereas, on March 13, 2020, the Crook County Court declared a state of emergency relating to COVID-19 in Crook County, Oregon; and

Whereas, on March 13, 2020, the City Council of Prineville declared a state of emergency as a result of the COVID-19 pandemic per Resolution 1429; and

Whereas, on March 17, 2020, Governor Brown issued Executive Order 20-07 prohibiting on-premises consumption of food or drink and gatherings of more than 25 people; and

Whereas, on March 23, 2020, Governor Brown issued Executive Order 20-12, “Stay-Home, Save Lives,” which prohibited non-essential social and recreational gatherings of individuals outside of a home or place of residence regardless of size, if a distance of six feet between individuals cannot be maintained; and

Whereas, on March 24, 2020, per Resolution 1430, the City Council ratified City Manager’s Administrative Order dated March 16, 2020 regarding the City’s policies and responses to the COVID-19 pandemic, some of which require updated; and

Whereas, an Emergency continues to exist, which requires the City taking such actions and issue such orders as are determined to be necessary to protect the public and property and to

efficiently conduct activities that minimize or mitigate the effect of the emergency as described in Prineville City Code 31.05.

NOW, THEREFORE, the City of Prineville resolves and declares the following:

1. To protect the health and safety of City employees, with input from the City Human Resource Department, IT, legal, and other City department heads, the City Manager is authorized to continue to develop emergency policies and guidance on the use of sick leave, vacation leave, telecommuting, meeting protocol, identification of essential and non-essential staff for ongoing presence at City facilities, and other policies that will be in effect for the duration of the emergency.
2. To eliminate the exposure to and spread of COVID-19, and in support of state and federal guidelines for social distancing, the City of Prineville is canceling all standing advisory committee meetings and activities.
4. To eliminate the exposure to and spread of COVID-19, and in support of state and federal guidelines for social distancing, City Hall shall be closed to the general public. Citizens may call City Hall at 541.447.5627 for any governmental needs. Citizens may pay utility bills by utilization of the drop box behind City Hall, over the phone at 541.447.5627, by mail, or through the City's website at <https://www.cityofprineville.com/>.
5. To eliminate the exposure to and spread of COVID-19, and in support of state and federal guidelines for social distancing, the Prineville Police Department lobby will be closed to the general public. Citizens may call the Prineville Police Department at 541.447.4168.
6. To eliminate the exposure to and spread of COVID-19, and in support of state and federal guidelines for social distancing, all non-emergency service calls by Prineville Police shall be handled by telephone.
7. To eliminate the exposure to and spread of COVID-19, and in support of state and federal guidelines for social distancing, the City of Prineville project-based meetings shall be done telephonically and/or by live feed. If the meeting is unable to be conducted telephonically and/or by live feed, then the meeting shall be cancelled.
8. City Council meetings shall be conducted telephonically and by simultaneous video transmission on the City's Facebook page. Citizens shall be provided a phone number to listen to the Council Meeting and are encouraged to utilize Facebook.
9. Other than public hearings, which shall be governed by Oregon Executive Order 20-16, public comment shall be limited to written comments provided to City Council by mail at City of Prineville, ATTN: Lisa Morgan, 387 NE Third Street, Prineville, Oregon 97754, or by email at cityhall@cityofprineville.com. Any written comments must be received no later than 4:00 p.m. on the date of the scheduled Council meeting and must include the sender's name and address to be officially read into the record.

10. The City will not send shut-off notices or shut off water for non-payment of unpaid water bills while this emergency is in place. Any late fees caused as a result of the emergency shall be eligible for a future credit.

11. All permitted special events of more than 10 persons are cancelled during this emergency.

12. This Order shall be effective so long as a Local State of Emergency regarding the COVID-19 pandemic is in existence.

Approved by the City Council this ____ day of April, 2020.

Stephen P. Uffelman, Mayor

ATTEST:

Lisa Morgan, City Recorder

**RESOLUTION NO. 1436
CITY OF PRINEVILLE, OREGON**

**A RESOLUTION APPROVING A PERSONAL SERVICES AGREEMENT WITH
DOWL, LLC. PROVIDE PERSONAL SERVICES FOR ENGINEERING SERVICES
REGARDING TRANSPORTATION DESIGN**

Whereas, the City of Prineville (“City”) requires a transportation design for the 3rd Street/US 26 Corridor with emphasis on conceptual and final designs with cost estimates for Combs Flat Road to Main Street and Main Street to Lamonta Street.

Whereas, City requires engineering services to complete the aforementioned services.

Whereas, City’s Council serves as the Local Contract Review Board for the City and pursuant to City Resolution 1266 Section 8(C), may award personal services contracts according to specific criteria that are applicable to the services provided.

Whereas, Engineering services are considered personal services pursuant to City Resolution 1266.

Whereas, DOWL, LLC. has provided the attached material marked as Exhibit A and incorporated herein.

Whereas, City Council finds that DOWL, LLC, meets the following applicable criteria as set out in City Resolution 1266, Section 8(C): (1) total costs to the City for delivery of services; (2) expertise of the contractor in the required area of specialty; (3) references regarding prior work done by the Contractor; (4) capacity and capability to perform the work, including any specialized services within the time limitations for the work; (5) educational and professional records; (6) availability to perform the assignment and familiarity with the area in which the specific work is located; (7) timeliness of delivery of service; (8) experience in working with the City; and (9) knowledge of City’s needs and desires related to the contract.

Now, Therefore, the City of Prineville Resolves as follows:

1. That the City Council, serving in its role as the Local Contract Review Board for the City, hereby approves the City entering into a personal services contract with DOWL, LLC, to provide engineering services related to the City’s transportation design regarding the 3rd Street/US 26 corridor and authorizes the City Manager to execute, on behalf of the City, such contract and any other related documents.

Approved by the City Council this ____ day of April, 2020.

Stephen P. Uffelman, Mayor

ATTEST:

Lisa Morgan, City Recorder

City of Prineville
Direct Award Criteria

(1) Total costs to the City for delivery of services; **\$133,038.00**

(2) Expertise of the contractor in the required area of specialty.

Established in 1962, DOWL has been performing engineering services for decades, with transportation and related services forming the cornerstone of our business throughout our history. We have performed numerous major transportation improvements projects in the Pacific Northwest, including the current, \$30 million Murphy Road Corridor project in Bend.

(3) References regarding prior work done by the Contractor.

Mike Tiller

Facilities Director
Bend-La Pine Schools
541.355.4702
mike.tiller@bend.k12.or.us
Projects: Caldera High School, North Star Elementary

Garrett Sabourin, PE

Project Engineer
City of Bend
541.323.8596
gsabourin@bendoregon.gov
Project: Murphy Road Corridor Improvements

Rory Rowan

Project Engineer
City of Bend
541.388.5575
rrowan@bendoregon.gov
Project: Neighborhood Greenways, Phases II-III

(4) Capacity and capability to perform the work, including any specialized services within the time limitations for the work.

DOWL's transportation-related capabilities include road and highway alternatives analysis and design, survey, geotechnical engineering, hydrology, heavy utilities, traffic engineering, lighting and signage design, landscape architecture, public involvement, 3D/4D modeling, and more. We anticipate having ample capacity to address this work from the City. Furthermore, as evidenced by our work on the City of Bend's Murphy Road Corridor (where we produced multiple GMPs for major roadway improvements in less than a year), we are adept at performing work under compressed time schedules and complying with State of Oregon and federal guidelines.

(5) Educational and professional records.

	Steve Hannas, PE, PLS	Justin Mason, PE	Jim Albin, PE
Years of Professional Experience	31	16	20
Years with DOWL	6	6	6
Education	Bachelor of Science, Civil Engineering Technology, Oregon Institute of Technology; Associate of Applied Science, Surveying, Oregon Institute of Technology;	Bachelor of Science, Civil Engineering, Oregon Institute of Technology	Bachelor of Science, Civil Engineering, Oregon State University

	Associate of Applied Science, Spokane Community College		
Professional Registration/Certification	Professional Engineer: Oregon #18080 Professional Land Surveyor: Oregon #47021	Professional Engineer: Oregon #72574	Professional Engineer: Oregon #77683

	Scott Little, PE	Adam Conway, PE	Ryan Stephens, PE
Years of Professional Experience	9	21	10
Years with DOWL	4	4	8
Education	Bachelor of Science, Civil Engineering, Oregon State University; Bachelor of Arts, Civil Engineering, Oregon State University	Bachelor of Science, Civil Engineering, Texas Tech University	Bachelor of Science, Civil and Environmental Engineering, Brigham Young University; Master of Science Civil and Environmental Engineering, Brigham Young University
Professional Registration/Certification	Professional Engineer Oregon #83845 Oregon Department of Transportation (ODOT) Certified General Inspector #49710 ODOT Traffic Signal Inspector #49710	Professional Engineer: Oregon #89724	Professional Engineer: Oregon #93763

	Brian Coursen, PLS	Ron Hand	Lynn Bruno, PLS
Years of Professional Experience	13	27	32
Years with DOWL	1	5	6
Education	Bachelor of Science, Geomatics Engineering, California State University - Fresno	Bachelor of Arts, Outdoor Education, Syracuse University, NY	Master of Business Administration, Concordia University; Bachelor of Science, Surveying, Oregon Institute of Technology
Professional Registration/Certification	Professional Land Surveyor: Oregon #86998PLS		Professional Land Surveyor: Oregon #02335

(6) Availability to perform the assignment and familiarity with the area in which the specific work is located.

DOWL anticipates having ample capacity to devote to this project in the next 18 months. Over the previous two years, we have been developing preliminary designs and alternatives for the bypass project, giving us extensive familiarity with project issues and challenges, allowing us to hit the ground running for the City.

(7) Timeliness of delivery of service.

As previously stated, DOWL is adept with techniques aimed at compressing schedule, including fast-track design, and with value engineering concepts that reduce costs while maintaining quality.

(8) Experience in working with the City.

DOWL's team has performed numerous projects for the City of Prineville and with the City, including:

- Ochoco Creek Trail
- IronHorse
- OR Highway 126 Corridor Facility Plan
- Highway 26/Stafford Inn to Robberson Ford Access
- Combs Flat Road
- Stormwater Master Plan
- Ochoco Lumber Mill/Parcel 1 Highway 26 Frontage
- 3rd Street Drainage Basin Update

(9) Knowledge of City's needs and desires related to the contract.

Six highways converge into the 3rd Street/US 26 corridor in the center of Prineville. This area is surrounded by the greatest concentration of homes and businesses in the city. DOWL helped to explore an option to create an alternative route to allow users to bypass the highway corridor, to alleviate congestion downtown and to delay the need for a major capital project to improve the carrying capacity of the existing corridor. The Combs Flat Road north to Peters Road and westward link to Lamonta Road provides a secondary access to a substantial developable portion of the city.

Additionally, DOWL is aware that the City is seeking projects that are "shovel-ready" in anticipation of future stimulus funding released by the US federal government.

**RESOLUTION NO. 1437
CITY OF PRINEVILLE, OREGON**

**A RESOLUTION APPROVING A SECOND AMENDMENT TO AGREEMENT FOR
TEMPORARY EASEMENT**

Whereas, the City of Prineville (“City”) and Crook County (“County”) entered into an Agreement for Temporary Easement on or about January 8, 2020, recorded in the official records of Crook County, Oregon, as document number 2020-297627 (“Easement”).

Whereas, The City and County entered into a First Amendment to Agreement for Temporary Easement on or about March 11, 2020, recorded in the official records of Crook County, Oregon, as document number 2020-298894 (“Amendment”).

Whereas, The City wishes to drill one (1) additional test well on the Property indicated on the Easement to determine if the test well has the potential to serve as a municipal production well and wishes to gain access to Property in order to facilitate the same.

Whereas, The City wishes to abandon the Test Well identified as Millican 6.

Whereas, County is willing to allow access to City to drill one (1) additional test well on County’s Property and, if City desires, grant City a perpetual, exclusive easement to use the portion of the property for municipal production well purposes.

Whereas, City staff and County have negotiated a Second Amendment to Agreement for Temporary Easement (“Agreement”); and

Whereas, City staff believes it is in the best interest of the City to approve and execute this Agreement.

NOW, THEREFORE, the City of Prineville resolves that the Agreement between the City and County attached hereto is approved and the Mayor and City Manager are authorized and directed to sign the Agreement.

Approved by the City Council this ____ day of April, 2020.

Stephen P. Uffelman, Mayor

ATTEST:

Lisa Morgan, City Recorder

After Recording Return to:
Jered Reid
545 Seventh Street
Prineville, OR 97754

**SECOND AMENDMENT TO
AGREEMENT FOR TEMPORARY EASEMENT**

THIS SECOND AMENDMENT TO AGREEMENT FOR TEMPORARY EASEMENT (“Second Amendment”) is entered into as of the date last written below, by and between **Crook County**, a political subdivision of the State of Oregon, of 300 NE Third Street, Room 10, Prineville, Oregon 97754 (hereafter “County”) and the **City of Prineville**, an Oregon municipal corporation, of 387 NE Third Street, Prineville, Oregon 97754, its successors and assigns, (hereafter “City” or “Grantee”). County and City shall collectively be referred to as the “Parties” and individually as a “Party.”

RECITALS:

- A. The Parties entered into an Agreement for Temporary Easement on or about January 8, 2020, recorded in the official records of Crook County, Oregon, as document number 2020-297627 (“Easement”).
- B. The Parties entered into a First Amendment to Agreement for Temporary Easement on or about March 11, 2020, recorded in the official records of Crook County, Oregon, as document number 2020-298894 (“Amendment”).
- B. The City wishes to drill one (1) additional test well on the Property indicated on the Easement to determine if the test well has the potential to serve as a municipal production well and wishes to gain access to Property in order to facilitate the same.
- C. The City wishes to abandon the Test Well identified as Millican 6.
- D. County is willing to allow access to City to drill one (1) additional test well on Property and, if City desires, grant City a perpetual, exclusive easement to use the portion of the property for municipal production well purposes.
- E. The Parties desire to amend the Temporary Easement.

NOW, THEREFORE, City and County, for valuable consideration the receipt and sufficiency of which is hereby acknowledged, consent, and agree to amend the Easement as follows:

1. County grants to City, including its employees, agents, invitees, and contractors, access to the Property for the purposes of drilling a test well, pump testing the well for water quantity, and testing the water produced from the well for quality. City, their employees, agents, invitees, and contractors have authority to dig a 20-foot by 20-foot by 4-foot-deep area around the test well to support the drilling and testing operations described above.

2. The additional Well shall be identified as Millican 8, the location of which is identified on Exhibit 1, attached hereto and incorporated herewith.

3. City shall have 550 days, i.e. more or less 1.5 years, after the date of this Second Amendment (“Test Period”) to complete the drilling and testing operations of the test well and to determine if City will develop a test well into a permanent municipal production well.

4. If City determines it will not use any test well as a municipal well, any disturbance to the Property caused by City and/or its employees, agents, invitees, and contractors shall be returned to essentially its original condition at City’s expense. This will include abandoning the test well in accordance with Oregon state rules and regulations.

5. If City desires to use the test well as a permanent municipal well, the following shall apply:

a. City shall give notice to County within the Test Period that City intends to use the well as a permanent municipal well.

b. County shall provide City a permanent easement to the City to allow City to access the property for municipal well purposes, which shall include, but is not limited to drilling and developing a municipal water production well or wells, construction of a well house or well houses, construction of security fence on the perimeter of the easements, or any of them, and maintaining and repairing the wells, fences, and associated plumbing and electrical connections, and the well house or houses. The form of the permanent easement will be substantially similar to the template referenced in Easement Exhibit 2.

c. Upon execution of the Easement, City shall pay to County the sum of \$32,000.00 per acre of the Easement.

6. The Easements provided to Millican, Millican 3, and Millican 6 are hereby revoked.

7. This Second Amendment shall be binding on the successors and assigns of the parties.

8. Except as specifically amended hereby, all terms and conditions of the Easement and Amendment shall remain in full force and effect. In the event of any conflict between the terms and conditions of this Second Amendment and the terms and conditions of the Easement and Amendment, the terms and conditions of this Second Amendment shall control.

9. This Second Amendment may be executed in multiple counterparts, each of which will be considered to be an original.

Crook County

By: _____
Seth Crawford, County Judge

By: _____
Brian Barney, Commissioner

By: _____
Jerry Brummer, Commissioner

STATE OF OREGON)
) ss.
County of Crook)

Personally appeared the above-named **Seth Crawford, County Judge, Brian Barney, Commissioner, and Jerry Brummer, Commissioner**, for Crook County and acknowledged the foregoing instrument to be their voluntary act and deed on behalf of Crook County this _____ day of _____, 2020.

Notary Public for Oregon
My Commission Expires: _____

City of Prineville

By: _____
Steve Forrester, City Manager

By: _____
Stephen P. Uffelman, Mayor

STATE OF OREGON)
) ss.
County of Crook)

Personally appeared the above-named **Steve Forrester, City Manager, and Stephen P. Uffelman, Mayor**, for the City of Prineville and acknowledged the foregoing instrument to be their voluntary act and deed on behalf of the City this _____ day of _____, 20__.

Notary Public for Oregon
My Commission Expires: _____

— water_pipe
wells
○ Test Holes
P production



Disclaimer: CROOK COUNTY MAKES NO WARRANTY OF ANY KIND, EXPRESSED OR IMPLIED, INCLUDING ANY WARRANTY OF MERCHANTABILITY, FITNESS FOR A PARTICULAR PURPOSE, OR ANY OTHER MATTER. THE COUNTY IS NOT RESPONSIBLE FOR POSSIBLE ERRORS, OMISSIONS, MISUSE, OR MISINTERPRETATION. COUNTY DIGITAL INFORMATION IS PREPARED FOR REFERENCE PURPOSES ONLY AND SHOULD NOT BE USED, AND IS NOT INTENDED FOR, SURVEY OR ENGINEERING PURPOSES OR THE AUTHORITATIVE AND/OR PRECISE LOCATION OF BOUNDARIES, FIXED HUMAN WORKS, AND/OR THE SHAPE AND CONTOUR OF THE EARTH. NO REPRESENTATION IS MADE CONCERNING THE LEGAL STATUS OF ANY APPARENT ROUTE OF ACCESS IDENTIFIED IN DIGITAL OR HARD COPY MAPPING OF GEOSPATIAL INFORMATION OR DATA. DATA FROM THE CROOK COUNTY ASSESSOR'S OFFICE MAY NOT BE CURRENT. DATA IS UPDATED AS SCHEDULES AND RESOURCES PERMIT. PLEASE NOTIFY CROOK COUNTY GIS OF ANY ERRORS (541) 416-3930.

