

Agenda

City Council Meeting
20 Second Avenue SW, Oelwein
6:00 PM

March 23, 2026
Oelwein, Iowa

Mayor: Brett DeVore

Mayor Pro Tem: Matt Weber

Council Members: Tony Cannon, Anthony Ricchio, Lynda Payne, Jason Gearhart, Renee Cantrell

Pledge of Allegiance

Call to Order

Roll Call

Additions or Deletions

Employee Recognition

- A. Recognition of years of service awards for the fire and police departments.

Citizens Public Comments - See Guidelines for Public Comments Below

- B. Public Comment Policy.

Consent Agenda

- 1. Consideration of a motion approving the March 9, 2026 minutes.
- 2. Claims resolution in the amount of \$427,408.46.
- 3. Consideration of a motion approving the Class "C" Retail Alcohol License for the Columbus Club.
- 4. Consideration of a motion approving the Class "B" Retail Alcohol License for Kwik Star #665.
- 5. Consideration of a resolution authorizing temporary closure of public ways or grounds for Oelwein Fire Fighters Foundation.
- 6. Consideration of a resolution authorizing temporary closure of public ways or grounds for Pony Express.
- 7. Consideration of a resolution approves pay application no. 6 in the amount of \$407,043.42 to Taylor Construction for the 10th St. Bridge Project.
- 8. Consideration of a resolution approving an expense reimbursement number five in the amount of \$43,746.57 for the Oelwein RISE Day Habilitation Center Improvements Project.

Ordinances

- 9. Consideration of an ordinance amending, Chapter 6, Article IV, Oelwein Airport Board, Section 6-103 Meeting and Minutes of the Code of Ordinances of the City of Oelwein, Iowa. - Second Reading.

- [10.](#) Consideration of an ordinance amending Chapter 19 – Animal and Fowl - Sections 19-0.5 through 19-39 Related to Animal and Fowl. - First Reading.

Resolutions

- [11.](#) Consideration of a resolution scheduling a public hearing for the proposed City Budget for the Fiscal Year 2027 (2026-2027) for April 13, 2026 at 6:00 PM at the Oelwein City Council Chambers.
- [12.](#) Consideration of a resolution approving city property use and street closures for the Oelwein Fire Convention September 2027 and 2028.
- [13.](#) Consideration of a resolution formally awarding Downtown Property Forgivable Loans for building improvements provided by Tax Increment Financing.
- [14.](#) Consideration of a resolution amending the Oelwein Fee Schedule.
- [15.](#) Consideration of a resolution amending the Oelwein Salary Schedule.
- [16.](#) Consideration of a resolution approving an updated project cost for the 2026 Airport Paving Project.

Motions

- [17.](#) Consideration of a motion to approve the recommendation from the Planning, Finance, Enterprise and Economic Development Committee on the Hotel Motel request from the Fayette County Agricultural Society.
- [18.](#) Consideration of a motion to approve the recommendation from the Planning, Finance, Enterprise and Economic Development Committee on the Hotel Motel request for the Big O Weekend.
- [19.](#) Consideration of a motion to approve a special event application for the Oelwein Christian Church Easter Egg Hunt.

Committee Reports

- [20.](#) Report from Payne on the Library Board meeting minutes.

Council Updates

Mayor's Report

City Attorney's Report

- [A.](#) City Attorney.

City Administrator's Report

- [B.](#) City Administrator.

Adjournment

In compliance with the Americans with Disabilities Act, those requiring accommodation for Council meetings should notify the City Clerk's Office at least 24 hours prior to the meeting at 319-283-5440



Public Comment Policy
Oelwein Guidelines for Public Participation during City Council Meetings
Adopted by Council Resolution 5495-2023

1. Regular City Council Meetings “Public Comments” on non-agenda items.
 - a. The first opportunity for public comment is listed on the agenda as “Public Comments”. This time is set aside for the public to address the City Council on issues not scheduled on the agenda. It is not to be confused with a public hearing, which is a formal proceeding conducted for the purpose of discussing a specific topic, such as the city budget.
 - b. Anyone wishing to address the City Council must adhere to the following “Rules of Procedure and Decorum”:
 - i. Be recognized by the Mayor or Mayor Pro Tem.
 - ii. State their name and address.
 - iii. Speak from the podium in a civil, non-argumentative and respectful manner.
 - iv. Whenever a group wishes to address the City Council on the same subject, the Mayor may request that a spokesperson be chosen by the group to avoid significant repetitive comments. Follow up comments by others that are similarly minded, should be limited to acknowledging their agreement with the comments made by the spokesperson or any other prior speaker, and not merely repeating previously made comments.
 - v. Each person wishing to speak during the public comment period shall be given three (3) minutes to share their comments.
 - vi. Speakers will be required to speak into the microphone, speak clearly and succinctly, to ensure all in attendance, in person or virtually, can clearly hear and understand what is being said.
 - vii. All remarks shall be directed to the Mayor and City Council as a body rather than to the Mayor, any particular Councilmember, or any member of the staff or audience.
 - viii. If the speaker intends to share any documents the City Council during their comments, a copy must also be provided to the City Clerk. If the speaker is reading a “statement” to the Council, it is requested that a copy of the “statement” be provided to the City Clerk so as to have a clear and accurate record of what was said.
 - ix. Speakers shall refrain from the use of profanity; language likely to incite violence or outbursts from the audience; language that is disruptive to the orderly process of the meeting; engaging in conversations with individual council members; making comments of a personal nature regarding others; shouting, yelling or screaming.
 - x. Speakers shall not continue to address the City Council once they have left the podium and will at no point address or engage in conversation with the Mayor, Council, or staff from their seat.
 - c. Other matters relevant to the Public Comment section reference topics not on the Agenda.
 - i. Should the Mayor or Council request clarifications from the speaker the Mayor, in the Mayor’s sole discretion, may provide additional time to the speaker.



- ii. The Mayor or Mayor Pro Tem, in the sole discretion of the Mayor or Mayor Pro Tem in the absence of the Mayor, may provide additional time or reduce time allowed any speaker and/or make other allowances or judgements deemed appropriate under the circumstances, in the Mayor’s capacity as the presiding official.
- iii. In many cases, the speaker will be directed to meet with staff outside of the meeting to further discuss, obtain answers to questions, to resolve the issue, and/or to discuss next steps.
- iv. Other than asking a question to clarify a statement made by the speaker, Council members shall refrain from entering into a dialogue with the speaker. This portion of the agenda is not intended for a discussion or debate between the City Council and the speaker and should not be used for that purpose. Iowa Code requires public notice of all items to be considered/debated to be posted at least twenty-four (24) hours in advance of the meeting. Therefore, Council discussion or debate on a topic brought up in the public comment section would be a violation of Iowa Code.
- v. The Mayor is responsible for maintaining order and decorum and will not allow the speaker, or any other person in attendance, to make personal attacks or inflammatory comments and will, when appropriate, direct any person violating any of the rules set forth herein to be quiet, to sit down and/or return to their seat as appropriate. Failure to comply with directives of the Mayor may result in the person being asked to leave the meeting or removed from the meeting. The Mayor may call for a break or recess to allow the speaker to leave or be removed from the meeting.

2. City Council Meetings “Public Comments” on Agenda Items during the meeting

- a. The City Council meeting is designed for the City Council to discuss and make decisions on the various issues on the agenda. The procedure for introduction, consideration, and action on agenda items is as follows:
 - i. Each agenda item is introduced by the Mayor
 - ii. The Mayor asks for a staff presentation or clarification of any relevant staff report.
 - iii. If dealing with an issue tied to an applicant, the Mayor may ask for comments from the applicant.
 - iv. The Mayor will then request whether any person in attendance wished to comment on the agenda item.
 - v. After the cessation of Council debate and any other comments as appropriate, the Mayor will call for a motion and second.
 - vi. Once a motion has been made and seconded, no additional comments will be received from the public, only City Council debate, with staff input as appropriate, will occur from this point forward.
- b. The rules for addressing the City Council at the designated time during this portion of the meeting are:
 - i. The speaker must be recognized by the Mayor.
 - ii. The speaker must speak from the podium and must provide their name and address for the record.



- iii. At no time will members of the public be allowed to enter into the City Council discussion from their seat. Upon recognition by the Mayor, a person may only be allowed to speak at the podium during the City Council discussion so long as the Mayor finds the comments to be germane, necessary and/or helpful to the City Council.
 - iv. No speaker will be allowed to speak more than once on any agenda item unless clarification is requested by the City Council and permission granted by the Mayor.
 - v. When an agenda includes a “Public Hearing”, any comments from the Public will only be received during the Public Hearing, not after the Public Hearing during consideration of any action item tied to the Public Hearing discussion.
 - vi. All rules set forth above in the “Public Comments” on non-agenda items section of this Policy, unless specifically excepted by the provisions of this section, shall by this reference be applicable to Public Comments on agenda items.
3. Public Hearings
- a. When an item under consideration requires a public hearing by statute, the Mayor will open and facilitate the public hearing. Public comments will be received in the same manner, and subject to, all provisions described and set forth under Paragraph 2 of this Policy.
 - b. Reasonable limitations on the number of speakers and time allowed to speak may be imposed by the Mayor in order to keep the meeting moving.
 - c. Public hearings are held to gather data and opinions from the public to assist and facilitate the decision-making process.
 - d. All rules set forth above in the “Public Comments” on non-agenda items section of this Policy, unless specifically excepted by the provisions of this section, shall by this reference be applicable to Public Comments on agenda items..
4. Public Comments at Council Workshops / Work Sessions.
- a. The committee chair runs the work session. The purpose of work sessions is to allow staff to present material and for the Council to have time to discuss and consider issues in greater detail before taking action.
 - b. Public Comments:
 - i. Because the Workshop/Work Session is designed for discussion among the members of the City Council and staff, public comment is not warranted. A member of the audience may only speak should the chair recognizes a member of the public or interested party or if a Council member requests that a member of the public be recognized. If so recognized, the same rules of decorum as listed for Council meetings apply, and the chair may impose any and all other restrictions deemed appropriate in the sole discretion of the chair.
 - c. All rules set forth above in the “Public Comments” on non-agenda items section of this Policy, unless specifically excepted by the provisions of this section, shall by this reference be applicable to Public Comments on agenda items.
5. Rules of Decorum for the Audience during Council Meetings and Work Sessions
- a. Meeting attendees (the audience):



- i. Will refrain from commenting, clapping, shouting, booing, or other inappropriate and/or disruptive behavior.
 - ii. Will refrain from private conversations during meetings.
 - iii. Should not address Council members in individual conversation or make comments to individual Council members.
6. Contacting City Council Members outside of Meetings
 - a. You may contact your City Council member at any time. Their contact information is on the City's website (<https://www.cityfoelwein.org>) at the button marked Government then City Council. Phone numbers may be provided City Hall should permission be given by the elected official.



Minutes

City Council Meeting
20 Second Avenue SW, Oelwein
March 09, 2026 - 6:00 PM

Pledge of Allegiance

Call to Order Mayor DeVore called the meeting to order at 6:00 PM

Roll Call **Present:** Weber, Payne, Cantrell, Cannon, Gearhart, Ricchio (via speaker phone)
Also Present: City Administrator Mulfinger, Wedemeier, Guest Councilmember Ron Williams

Additions or Deletions

A motion was made by Weber, seconded by Gearhart to adopt the agenda as presented.

All aye. Motion carried.

Consent Agenda

1. Consideration of a motion approving the February 23, 2026 minutes.
2. Consideration of a motion approving an amendment to the Class "C" Retail Alcohol License (LC) for Clete and Connie's.

A motion was made by Weber, seconded by Payne to adopt the consent agenda.

All aye. Motion carried.

Ordinances

3. Consideration of an ordinance amending, Chapter 6, Article IV, Oelwein Airport Board, Section 6-103 Meeting and Minutes of the Code of Ordinances of the City of Oelwein, Iowa. - First Reading.

A motion was made by Weber, seconded by Gearhart to approve the first reading of an ordinance amending Chapter 6, Article IV, Oelwein Airport Board, Section 6-103 Meeting and Minutes of the Code of Ordinances of the City of Oelwein, Iowa.

Ayes: Weber, Payne, Cantrell, Cannon, Gearhart, Ricchio

Nays: None Motion carried.

4. Consideration of a motion to waive the second and third readings for an ordinance amending Appendix A, Article II – Zoning District Section 202.4, 203.4, 202.3(8) and 203.3(8).

A motion was made by Weber, seconded by Cantrell to waive the second and third readings for an ordinance amending Appendix A, Article II – Zoning District Section 202.4, 203.4, 202.3 (8) and 203.3 (8).

All aye. Motion carried.

5. Consideration of an ordinance amending Appendix A, Article II – Zoning District Section 202.4, 203.4, 202.3(8) and 203.3(8). - First and Final Reading.

A motion was made by Weber, seconded by Payne to approve Ordinance No. 1225 on the first and final reading.

Ayes: Weber, Payne, Cantrell, Cannon, Gearhart, Ricchio

Nays: None Motion carried.

- 6. Consideration of a motion to waive the second and third readings for an ordinance amending the Oelwein Zoning Ordinance to reclassify real estate commonly known as 204 8th Ave SW, 208 8th Ave SW, 201 9th Ave SW, and Parcel ID 1820435019 Oelwein, Fayette County, Iowa from R-1 To R-2 Residential.

A motion was made by Weber, seconded by Cantrell to waive the second and third reading for an ordinance amending the Oelwein Zoning Ordinance to reclassify real estate commonly known as 204 8th Ave SW, 208 8th Ave SW, 201 9th Ave SW, and Parcel ID 1820435019 Oelwein, Fayette County, Iowa from R-1 to R-2 Residential. All aye. Motion carried.

- 7. Consideration of an ordinance amending the Oelwein Zoning Ordinance to reclassify real estate commonly known as 204 8th Ave SW, 208 8th Ave SW, 201 9th Ave SW, and Parcel ID 1820435019 Oelwein, Fayette County, Iowa from R-1 To R-2 Residential. - First and Final Reading.

A motion was made by Weber, seconded by Cantrell to approve Ordinance No. 1226 on the first and final reading.

Ayes: Weber, Payne, Cantrell, Cannon, Gearhart, Ricchio

Nays: None

Motion carried.

Resolutions

- 8. Consideration of a resolution approving the 2026 Housing Tax Abatement Applications.

A motion was made by Weber, seconded by Cantrell to approve Resolution No. 5872-2026.

Ayes: Weber, Payne, Cantrell, Cannon, Gearhart, Ricchio

Nays: None

Motion carried.

Motions

- 9. Consideration of a motion approving direction from the Planning, Finance, Enterprise, and Economic Development on the Hotel Motel request of \$2,500.00 to Williams Center for the Arts.

A motion was made by Weber, seconded by Cantrell to approve the recommendation from the Planning, Finance, Enterprise and Economic Development Committee on the Hotel Motel funding request of \$2,500.00 to Williams Center for the Arts.

All aye.

Motion carried.

Mayor's Report

Mayor DeVore stated he will be emailing council information from the Iowa State Extension office regarding tax bills.

City Administrator's Report

City Administrator Mulfinger informed council Nick Humpal with the Iowa Department of Transportation will be attending a work session on May 11th regarding Highway 150 issues.

Mulfinger informed council he attended the Local Leadership Day in Des Moines and was able to meet with Chad Ingles discussing upcoming tax issues.

Adjournment

A motion was made by Cantrell, seconded by Weber to adjourn the meeting at 6:19 PM.

All aye.

Motion carried.

Brett DeVore, Mayor

ATTEST:

Dylan Mulfinger, City Administrator

I, Dylan Mulfinger, City Administrator in and for the City of Oelwein, Iowa do hereby certify that the above and foregoing is a true accounting of the Council Proceedings held March 09, 2026 and copy of said proceedings was furnished to the Register March 11, 2026.

Dylan Mulfinger, City Administrator

Fund	Beg Balance	Revenue	Expense	Transfers	Fund Balance	BANK BAL
001 General	949,348.80	99,112.76	244,491.53	(916.67)	803,053.36	
051 County Emergency Management	15,221.75	235.44	8,064.48	-	7,392.71	
110 Road Use Tax	660,188.73	53,768.81	44,559.99	-	669,397.55	
112 Trust and Agency	715,762.67	15,535.86	83,431.85	-	647,866.68	
113 Flex Spending	1,415.73	1,645.50	822.75	-	2,238.48	2,238.48
119 Emergency	-	-	-	-	-	
120 Sidewalks Repaired/Replaced Dwtm	125,000.00	-	-	-	125,000.00	
121 Sales Tax	516,639.78	59,787.37	-	-	576,427.15	
122 Hotel/Motel Tax	72,559.46	3,589.54	3,474.39	-	72,674.61	
123 Gas-Electric Franchise Fee	182,417.99	187,180.94	5,500.00	(21,295.00)	342,803.93	
124 Library Bequest	373,823.24	2,362.01	557.54	-	375,627.71	
126 Downtown TIF	287,972.62	102.44	-	-	288,075.06	
127 Industrial Park TIF	-	-	-	-	-	
128 Ind Park SubFund TIF East Penn	912,791.70	2,134.21	-	-	914,925.91	
132 DARE	-	-	-	-	-	
136 Trees Forever	4,607.11	-	-	-	4,607.11	
146 Oelwein Housing Revolving Loan Fund	114,337.32	241.41	-	-	114,578.73	
160 Econ Dev (\$12,500 Wellness Res)	(172,422.18)	-	20,771.36	-	(193,193.54)	
161 IRP Revolving Loan	377,862.91	12,951.16	1,636.81	-	389,177.26	390,814.07
162 Downtown Business Grants	151,516.29	-	25,000.00	-	126,516.29	
167 Oelwein Volunteer Fire Dept	14,506.93	-	1,900.00	916.67	13,523.60	
177 Forfeit Assets	1,689.66	-	799.10	-	890.56	
200 Debt Service	773,599.49	9,608.67	-	21,295.00	804,503.16	
201 Water Bondsinking	288,097.64	639.97	-	29,287.00	318,024.61	
202 Sewer Bondsinking	554,302.73	1,224.57	-	62,235.00	617,762.30	
205 Special Assessments	31,292.00	-	-	-	31,292.00	
282 CDBG Housing Rehab	-	-	-	-	-	
287 2020 GO Bond	6,846.67	-	-	-	6,846.67	
301 HMGP 4483 GRANT	-	-	-	-	-	
302 Oelwein Housing Teardown	784.50	-	-	-	784.50	
305 Airport Grant	(40,641.16)	-	5,520.48	-	(46,161.64)	
307 Tri Park Trail Extensions	789,117.40	-	9,924.75	-	779,192.65	
310 Plaza Park Expansion (OCAD Project)	-	-	-	-	-	
314 Dry Run Creek Flooding	(189,993.77)	-	-	-	(189,993.77)	
360 Cares Act NE Sewer Replacement	-	-	-	-	-	
385 Water Main Rpl 1 Av NE 5 & 12 Av SE	5,679.97	-	-	-	5,679.97	
387 '23-24 HMA Paving Imp 1st 12th SF Evnt	232,156.75	-	-	-	232,156.75	
388 2024 GO Bond Const 10th St Bridge	1,040,367.32	3,583.29	121,581.48	-	922,369.13	
393 2022 GO Bond Construction City Hall	24,354.64	-	1,919.20	-	22,435.44	
397 Railroad Grant-Viaduct	18,271.76	-	-	-	18,271.76	
501 Cemetery Perp Care	300,492.56	240.27	-	-	300,732.83	3,732.83
600 Water (2016D Reserve \$67,000)	901,512.17	157,309.32	74,448.97	(64,287.00)	920,085.52	
601 Water Infrastructure Fee	511,231.56	24.15	5,045.73	35,000.00	541,209.98	
620 Customer Water Deposits	143,321.96	2,585.10	1,509.82	-	144,397.24	
640 Fuel	8,997.13	2,808.85	-	-	11,805.98	
670 Landfill	199,735.65	49,648.81	31,923.80	-	217,460.66	
671 Recycling	50,848.79	6,183.08	81.47	-	56,950.40	
672 ROW Trees Utility Fee	32,215.78	7,867.57	343.35	-	39,740.00	
680 Wellness Center	(22,396.13)	18,239.10	16,070.02	-	(20,227.05)	
700 Sewer/Waste Treatment	1,579,816.21	184,172.57	62,623.86	(97,235.00)	1,604,129.92	
701 Sewer Infrastructure Fee	662,240.43	6.70	-	35,000.00	697,247.13	
706 Reed Bed Exp - EQ Liner	(32,611.95)	-	-	-	(32,611.95)	
	13,174,880.61	882,789.47	772,002.73		13,285,667.35	

Fidelity 999-1003 and Community 999-1004 Money Market Accounts 2,320,262.97
 CD'S Fidelity 999-1113, Community 999-1114 Cemetery 501-1001 9,047,000.00
 Fidelity IRP 999-1001/Flex 999-1002/Cem Perp Bank Ckng 501-1002 395,148.57
 Unapplied Accounts Receivable -
 Balance Checking Account 999-1000 1,523,255.81
 Payroll Liabilities -

13,285,667.35 **13,285,667.35**

Signature:  Date: 3/5/26

2/1/2026

2/28/2026

1/31/2026

revenue	expense	transfer in	transfer out	
001-___-4	001-___-6	001-___-49	001-___-69	-
051-___-4	051-___-6	051-___-49	051-___-69	0.00
110-___-4	110-___-6	110-___-49	110-___-69	0.00
112-___-4	112-___-6	112-___-49	112-___-69	(0.00)
113-___-4	113-___-6	113-___-49	113-___-69	-
119-___-4	119-___-6	119-___-49	119-___-69	-
120-___-4	120-___-6	120-___-49	120-___-69	-
121-___-4	121-___-6	121-___-49	121-___-69	-
122-___-4	122-___-6	122-___-49	122-___-69	-
123-___-4	123-___-6	123-___-49	123-___-69	-
124-___-4	124-___-6	124-___-49	124-___-69	-
126-___-4	126-___-6	126-___-49	126-___-69	(0.00)
127-___-4	127-___-6	127-___-49	127-___-69	-
128-___-4	128-___-6	128-___-49	128-___-69	(0.00)
132-___-4	132-___-6	132-___-49	132-___-69	-
136-___-4	136-___-6	136-___-49	136-___-69	-
146-___-4	146-___-6	146-___-49	146-___-69	-
160-___-4	160-___-6	160-___-49	160-___-69	-
161-___-4	161-___-6	161-___-49	161-___-69	-
162-___-4	162-___-6	162-___-49	162-___-69	-
167-___-4	167-___-6	167-___-49	167-___-69	(916.67)
177-___-4	177-___-6	177-___-49	177-___-69	-
200-___-4	200-___-6	200-___-49	200-___-69	(21,295.00)
201-___-4	201-___-6	201-___-49	201-___-69	(29,287.00)
202-___-4	202-___-6	202-___-49	202-___-69	(62,235.00)
205-___-4	205-___-6	205-___-49	205-___-69	-
282-___-4	282-___-6	282-___-49	282-___-69	-
287-___-4	287-___-6	287-___-49	287-___-69	-
301-___-4	301-___-6	301-___-49	301-___-69	-
302-___-4	302-___-6	302-___-49	302-___-69	-
305-___-4	305-___-6	305-___-49	305-___-69	-
307-___-4	307-___-6	307-___-49	307-___-69	-
310-___-4	310-___-6	310-___-49	310-___-69	-
314-___-4	314-___-6	314-___-49	314-___-69	-
360-___-4	360-___-6	360-___-49	360-___-69	-
385-___-4	385-___-6	385-___-49	385-___-69	-
387-___-4	387-___-6	387-___-49	387-___-69	-
388-___-4	388-___-6	388-___-49	388-___-69	-
393-___-4	393-___-6	393-___-49	393-___-69	-
397-___-4	397-___-6	397-___-49	397-___-69	-
501-___-4	501-___-6	501-___-49	501-___-69	-
600-___-4	600-___-6	600-___-49	600-___-69	-
601-___-4	601-___-6	601-___-49	601-___-69	(35,000.00)
620-___-4	620-___-6	620-___-49	620-___-69	-
640-___-4	640-___-6	640-___-49	640-___-69	-
670-___-4	670-___-6	670-___-49	670-___-69	-
671-___-4	671-___-6	671-___-49	671-___-69	-
672-___-4	672-___-6	672-___-49	672-___-69	-
680-___-4	680-___-6	680-___-49	680-___-69	-
700-___-4	700-___-6	700-___-49	700-___-69	-
701-___-4	701-___-6	701-___-49	701-___-69	(35,000.00)
706-___-4	706-___-6	706-___-49	706-___-69	-
				(183,733.67)

Item 2.

	1,523,255.81	9991000 Checking	Revenue check - should equal transfers
	0.00	9991111 Utility	
	0.00	9991112 Accounts Receivable	
001-1301	0.00	0012120 payroll liabilities	
	0.00	___-2020 accounts payable	
	1,523,255.81	- Ckg Bal to match	
		Col I Line 62	

City of Oelwein

February 2026 Receipts

General \$99,112.76; Cnty Emrgncy Mngmnt \$235.44; RUT \$53,768.81; Trust & Agency \$15,535.86; Flex Spending \$1,645.50; Sales Tax \$59,787.37; Hotel/ Motel Tax \$3,589.54; Gas/Elecric Franchise Fee \$187,180.94; Library Bequest \$2,362.01; Dwntwn TIF \$102.44; Ind Prk SubFund TIF-East Penn \$2,134.21; Housing RLF \$241.41; IRP Revolving Loan \$12,951.16; Debt Servce \$9,608.67; Water Bondsinking \$639.97; Sewer Bondsinking \$1,224.57; 2024 GO Bond Constrct 10th ST Brdg \$3,583.29; Cemetery Perp Care \$240.27; Water \$157,309.32; Water Infrastructure \$24.15; Water Deposits \$2,585.10; Fuel \$2,808.85; Landfill \$49,648.81; Recycling \$6,183.08; ROW Trees Utility Fee \$7,867.57; Wellness Center \$18,239.10; Sewer/Waste Treatment \$184,172.57; Sewer Infrastructure Fee \$6.70; TOTAL \$882,789.47

X _____

Dylan Mulfinger, City Administrator

I certify the council has approved these expenditures.

Report Criteria:

- Detail report.
- Invoices with totals above \$0.00 included.
- Paid and unpaid invoices included.

Vendor Name	Invoice Number	Description	Invoice Date	Net Invoice Amount	Amount Paid
001-1100-61810 UNIFORM					
ELAN FINANCIAL SERVICES	85878437	Dispatch Uniform Shirts	02/09/2026	763.30	763.30
Total 001-1100-61810 UNIFORM:				763.30	763.30
001-1100-61990 EMPLOYEE PERSONNEL EXPENSE					
ELAN FINANCIAL SERVICES	020226	Monitoring Services Feb	02/27/2026	44.40	44.40
ELAN FINANCIAL SERVICES	02262026	Monitoring Services	02/27/2026	10.69	10.69
ELAN FINANCIAL SERVICES	1358-7318	Police Officer Ad	03/02/2026	199.00	199.00
ELAN FINANCIAL SERVICES	32203945	Annual Engagement Items	02/27/2026	697.31	697.31
GO LAW ENFORCEMENT LLC	KPEMXFMO-0	Officer ad	03/02/2026	120.00	.00
Total 001-1100-61990 EMPLOYEE PERSONNEL EXPENSE:				1,071.40	951.40
001-1100-63100 BUILDING					
ELAN FINANCIAL SERVICES	114-2639375-4	Wall storage accessories - Armory	02/12/2026	125.99	125.99
ELAN FINANCIAL SERVICES	114-2657839-4	Wall storage - Armory	02/12/2026	206.97	206.97
ELAN FINANCIAL SERVICES	459417487-00	Replace break room appliance	02/23/2026	409.09	409.09
Total 001-1100-63100 BUILDING:				742.05	742.05
001-1100-63310 VEHICLE					
ADVANCED AUTOMOTIVE INC	12226	car 1 oil	03/04/2026	88.75	.00
O'REILLY AUTOMOTIVE STORE	0390-163401	car 3wiper blades	02/20/2026	22.94	.00
WEX BANK	110978419	FUEL PURCHASES	02/28/2026	1,282.56	1,282.56
Total 001-1100-63310 VEHICLE:				1,394.25	1,282.56
001-1100-63730 COMMUNICATIONS					
MEDIACOM COMMUNICATIONS	0003535 2026	PHONE/INTERNET SERVICE	03/16/2026	238.00-	.00
NUWAVE COMMUNICATIONS IN	152186	PHONE SERVICE	03/01/2026	200.17	200.17
Total 001-1100-63730 COMMUNICATIONS:				37.83-	200.17
001-1100-63810 UTILITIES					
ALLIANT ENERGY	4830253977 20	ELECTRIC SERVICE	03/05/2026	247.86	247.86
ALLIANT ENERGY	6455490000 20	ELECTRIC SERVICE	03/12/2026	21.17	.00
EAGLE POINT ENERGY 5 LLC	OELWEIN 89	ELECTRIC SERVICE	02/28/2026	949.91	949.91
Total 001-1100-63810 UTILITIES:				1,218.94	1,197.77
001-1100-64090 JANITORIAL					
ACE HARDWARE	B177650	ice melt	02/23/2026	29.97	.00
ELAN FINANCIAL SERVICES	114-3055482-1	ice melt	02/23/2026	174.88	174.88
ELAN FINANCIAL SERVICES	114-7955386-6	Ice melt spreader	02/23/2026	56.99	56.99
Total 001-1100-64090 JANITORIAL:				261.84	231.87
001-1100-64300 IMPOUND VEHICLE EXPENSES					
MIDWEST COLLISION CENTER I	7257	26-000433 towing	02/28/2026	125.00	.00

Vendor Name	Invoice Number	Description	Invoice Date	Net Invoice Amount	Amount Paid
Total 001-1100-64300 IMPOUND VEHICLE EXPENSES:				125.00	.00
001-1100-64910 TELETYPE CONTRACT					
IA DEPT OF PUBLIC SAFETY	3120	JAN-MAR TELETYPE BILLING	03/13/2026	1,799.52	.00
Total 001-1100-64910 TELETYPE CONTRACT:				1,799.52	.00
001-1100-64950 CONTRACTS					
HORAN CLEANING LLC	1832	MONTHLY PD CLEANING - FEB	03/04/2026	390.41	.00
Total 001-1100-64950 CONTRACTS:				390.41	.00
001-1100-65071 TOBACCO PREVENTION					
ELAN FINANCIAL SERVICES	32203945	Annual Engagement Items	02/27/2026	199.00	199.00
Total 001-1100-65071 TOBACCO PREVENTION:				199.00	199.00
001-1100-65102 INVESTIGATION					
ELAN FINANCIAL SERVICES	111-1363958-0	Digital Evidence SSD	02/19/2026	399.99	399.99
ELAN FINANCIAL SERVICES	111-2535581-5	Digital Evidence Lockable Cart	02/19/2026	399.97	399.97
ELAN FINANCIAL SERVICES	111-7521861-8	Digital Evidence Charger	02/19/2026	89.99	89.99
US CELLULAR	453072630 202	CAMERA	03/02/2026	20.59	20.59
Total 001-1100-65102 INVESTIGATION:				910.54	910.54
001-1100-65130 COMPUTER SUPPLIES					
ELAN FINANCIAL SERVICES	BBY01-807142	Replace Computer that failed	02/04/2026	1,373.98	1,373.98
Total 001-1100-65130 COMPUTER SUPPLIES:				1,373.98	1,373.98
001-1500-61990 EMPLOYEE PERSONNEL EXPENSE					
COVENANT OCCUPATIONAL M	86781	fire physical/Schultz	02/16/2026	393.00	393.00
ELAN FINANCIAL SERVICES	020226	Monitoring Services Feb	02/27/2026	44.40	44.40
Total 001-1500-61990 EMPLOYEE PERSONNEL EXPENSE:				437.40	437.40
001-1500-63310 VEHICLE					
ARNOLD MOTOR SUPPLY LLP	09NV149409	Fuel stabilizer 774	01/27/2026	7.99	.00
WEX BANK	110978419	FUEL PURCHASES	02/28/2026	284.53	284.53
Total 001-1500-63310 VEHICLE:				292.52	284.53
001-1500-63730 COMMUNICATIONS					
NUWAVE COMMUNICATIONS IN	152186	PHONE SERVICE	03/01/2026	19.37	19.37
Total 001-1500-63730 COMMUNICATIONS:				19.37	19.37
001-1500-63810 UTILITIES					
ALLIANT ENERGY	0106966292 20	ELECTRIC SERVICE	02/25/2026	42.57	42.57
ALLIANT ENERGY	4830253977 20	ELECTRIC SERVICE	03/05/2026	24.22	24.22
ALLIANT ENERGY	6455490000 20	ELECTRIC SERVICE	03/12/2026	219.33	.00
ALLIANT ENERGY	8600344075 20	ELECTRIC SERVICE	02/18/2026	26.26	26.26
ALLIANT ENERGY	9707011000 20	GAS SERVICE	02/12/2026	1,109.40	1,109.40
EAGLE POINT ENERGY 5 LLC	OELWEIN 89	ELECTRIC SERVICE	02/28/2026	80.10	80.10

Vendor Name	Invoice Number	Description	Invoice Date	Net Invoice Amount	Amount Paid
Total 001-1500-63810 UTILITIES:				1,501.88	1,282.55
001-1500-64950 CONTRACTS					
HORAN CLEANING LLC	1832	MONTHLY FD CLEANING - FEB	03/04/2026	97.60	.00
Total 001-1500-64950 CONTRACTS:				97.60	.00
001-1500-65041 EQUIPMENT					
ARNOLD MOTOR SUPPLY LLP	09NV149263	spark plug chain saw	01/26/2026	3.36	.00
ELAN FINANCIAL SERVICES	114-6211369-3	AED Batteries	02/11/2026	68.85	68.85
Total 001-1500-65041 EQUIPMENT:				72.21	68.85
001-1500-65060 OFFICE SUPPLIES					
ELAN FINANCIAL SERVICES	113-7018792-8	flash drives	03/03/2026	29.44	29.44
Total 001-1500-65060 OFFICE SUPPLIES:				29.44	29.44
001-1700-63310 VEHICLE					
ARNOLD MOTOR SUPPLY LLP	09CR018428	CORE EXCHANGE - EQUINOX	03/10/2026	40.00-	.00
ARNOLD MOTOR SUPPLY LLP	09NV151990	BRAKES - EQUINOX	03/09/2026	141.05	.00
ARNOLD MOTOR SUPPLY LLP	09NV152052	BRAKE HYD HOSE - EQUINOX	03/10/2026	33.43	.00
OELWEIN FUEL FUND	2028 02 28	FUEL FEB 01 TO FEB 28	02/28/2026	59.58	.00
Total 001-1700-63310 VEHICLE:				194.06	.00
001-1700-63730 COMMUNICATIONS					
NUWAVE COMMUNICATIONS IN	152186	PHONE SERVICE	03/01/2026	19.37	19.37
Total 001-1700-63730 COMMUNICATIONS:				19.37	19.37
001-1700-63750 CELLULAR/PAGING					
US CELLULAR	453072630 202	CELLPHONE SERVICE	03/02/2026	57.27	57.27
US CELLULAR	453072630 202	TABLET	03/02/2026	24.79	24.79
US CELLULAR	453072630 202	CELLPHONE SERVICE	03/02/2026	26.14	26.14
US CELLULAR	453072630 202	TABLET	03/02/2026	39.78	39.78
US CELLULAR	453072630 202	CELLPHONE SERVICE	03/02/2026	52.27	52.27
Total 001-1700-63750 CELLULAR/PAGING:				200.25	200.25
001-1700-65060 OFFICE SUPPLIES					
ELAN FINANCIAL SERVICES	8557 DM 2026	ADOBE - MONTHLY SUBSCRIPT	03/03/2026	25.43	25.43
Total 001-1700-65060 OFFICE SUPPLIES:				25.43	25.43
001-2510-64110 LEGAL EXPENSE					
LYNCH DALLAS PC	150213-00800	LEGAL/PROFESSIONAL FEES -	03/12/2026	3,657.50	.00
Total 001-2510-64110 LEGAL EXPENSE:				3,657.50	.00
001-2510-64992 DISPOSAL EXPENSE					
FAYETTE COUNTY SOLID WAST	2026 02 28	DISPOSAL FEES - ABATEMENT	02/28/2026	208.80	.00
MIDWEST COLLISION CENTER I	7267	TOW FOR 210 4th ave SE	03/04/2026	145.00	.00
Total 001-2510-64992 DISPOSAL EXPENSE:				353.80	.00

Vendor Name	Invoice Number	Description	Invoice Date	Net Invoice Amount	Amount Paid
001-2800-63100 BUILDING					
MODERN BUILDING PRODUCT	151040	Ceiling tiles for airport building	02/24/2026	209.92	.00
Total 001-2800-63100 BUILDING:				209.92	.00
001-2800-63730 COMMUNICATIONS					
AUREON COMMUNICATIONS	789004155 202	AIRPORT PHONE SERVICE	03/01/2026	82.52	82.52
ORAN MUTUAL TELEPHONE C	0000000770 20	AIRPORT INTERNET SERVICE	03/01/2026	55.95	55.95
Total 001-2800-63730 COMMUNICATIONS:				138.47	138.47
001-2800-63810 UTILITIES					
ALLIANT ENERGY	6455490000 20	ELECTRIC SERVICE	03/12/2026	194.62	.00
EAGLE POINT ENERGY 5 LLC	OELWEIN 89	ELECTRIC SERVICE	02/28/2026	248.71	248.71
Total 001-2800-63810 UTILITIES:				443.33	248.71
001-2800-64950 CONTRACTS					
HORAN CLEANING LLC	1832	MONTHLY AIRPORT CLEANING	03/04/2026	140.00	.00
Total 001-2800-64950 CONTRACTS:				140.00	.00
001-2800-65065 FUEL PROCESSING FEES					
FIDELITY BANK & TRUST	2026 02 28	AIRPORT FUEL FEES - PCI COM	02/28/2026	35.00	35.00
FIDELITY BANK & TRUST	2026 02 28	AIRPORT FUEL PROCESSING F	02/28/2026	20.12	20.12
Total 001-2800-65065 FUEL PROCESSING FEES:				55.12	55.12
001-4100-63100 BUILDING					
BLACKHAWK AUTOMATIC SPRI	127690	QUARTERLY INSPECTION	02/13/2026	165.00	.00
HAWKEYE ALARM & SIGNAL CO	104941	ANNUAL ALARM MONITORING	02/11/2026	600.00	.00
HOMETOWN PEST CONTROL	118416	PEST CONTROL	03/10/2026	80.00	.00
KENS ELECTRIC	67590321	REPAIR LIGHTING	02/18/2026	362.27	.00
PLUMB SUPPLY COMPANY	101481206.001	TOILET REPAIR	02/16/2026	10.29	.00
Total 001-4100-63100 BUILDING:				1,217.56	.00
001-4100-63730 COMMUNICATIONS					
CENTURYLINK	503191595032	LIBRARY PHONE SERVICE	02/24/2026	118.10	118.10
Total 001-4100-63730 COMMUNICATIONS:				118.10	118.10
001-4100-63810 UTILITIES					
ALLIANT ENERGY	599879032026	ELECTRIC & GAS	02/18/2026	3,343.04	3,343.04
EAGLE POINT ENERGY 5 LLC	OELWEIN 89	ELECTRIC SERVICE	02/28/2026	498.47	498.47
Total 001-4100-63810 UTILITIES:				3,841.51	3,841.51
001-4100-64090 JANITORIAL					
QUILL.COM	47862264	TOWELS	02/19/2026	26.03	.00
Total 001-4100-64090 JANITORIAL:				26.03	.00
001-4100-64950 CONTRACTS					
MIDWEST JANITORIAL SERVIC	259469	JANITORIAL	03/06/2026	1,480.00	.00

Vendor Name	Invoice Number	Description	Invoice Date	Net Invoice Amount	Amount Paid
Total 001-4100-64950 CONTRACTS:				1,480.00	.00
001-4100-65060 OFFICE SUPPLIES					
UNIQUE MANAGEMENT	6152063	COLLECTION SERVICE	03/01/2026	34.95	.00
Total 001-4100-65060 OFFICE SUPPLIES:				34.95	.00
001-4100-65077 PASSPORT EXPENSES					
SUSAN MACKEN	20260314	PASSPORTS	03/11/2026	107.55	.00
Total 001-4100-65077 PASSPORT EXPENSES:				107.55	.00
001-4100-65220 BOOKS,FILM,CD'S,ETC					
FOOD NETWORK MAGAZINE	20260314	MAGAZINE SUBSCRIPTION	03/01/2026	39.97	.00
INGRAM LIBRARY SERVICES LL	94370014	BOOKS	03/09/2026	1,247.66	.00
LIBRARY IDEAS LLC	124167	BOOKS	02/19/2026	207.72	.00
PEOPLE MAGAZINE	20260314	MAGAZINE	03/01/2026	138.00	.00
TASTE OF HOME	20260314	MAGAZINE RENEWAL	03/01/2026	27.82	.00
Total 001-4100-65220 BOOKS,FILM,CD'S,ETC:				1,661.17	.00
001-4300-61990 EMPLOYEE PERSONNEL EXPENSE					
JOHN DEERE FINANCIAL F.S.B.	3291425	Supervisor Boots	02/24/2026	80.00	80.00
Total 001-4300-61990 EMPLOYEE PERSONNEL EXPENSE:				80.00	80.00
001-4300-63200 BUILDING					
ACE HARDWARE	a349132	Door bolt	02/26/2026	8.99	.00
KAY PARK RECREATION CORP	207249	Memorial Bench	02/26/2026	1,229.70	.00
Total 001-4300-63200 BUILDING:				1,238.69	.00
001-4300-63310 VEHICLE					
OELWEIN FUEL FUND	2028 02 28	FUEL FEB 01 TO FEB 28	02/28/2026	141.88	.00
Total 001-4300-63310 VEHICLE:				141.88	.00
001-4300-63730 COMMUNICATIONS					
NUWAVE COMMUNICATIONS IN	152186	PHONE SERVICE	03/01/2026	6.46	6.46
US CELLULAR	453072630 202	CELLPHONE SERVICE	03/02/2026	56.26	56.26
Total 001-4300-63730 COMMUNICATIONS:				62.72	62.72
001-4300-63810 UTILITIES					
ALLIANT ENERGY	0106966292 20	ELECTRIC SERVICE	02/25/2026	108.27	108.27
ALLIANT ENERGY	6455490000 20	ELECTRIC SERVICE	03/12/2026	174.35	.00
ALLIANT ENERGY	6455490000 20	ELECTRIC SERVICE	03/12/2026	284.33	.00
ALLIANT ENERGY	9707011000 20	GAS SERVICE	02/12/2026	215.40	215.40
Total 001-4300-63810 UTILITIES:				782.35	323.67
001-4300-65041 EQUIPMENT					
JOHN DEERE FINANCIAL F.S.B.	p20829	Bearing	02/24/2026	36.79	36.79
OELWEIN FUEL FUND	2028 02 28	FUEL FEB 01 TO FEB 28	02/28/2026	55.16	.00

Vendor Name	Invoice Number	Description	Invoice Date	Net Invoice Amount	Amount Paid
Total 001-4300-65041 EQUIPMENT:				91.95	36.79
001-4300-65060 OFFICE SUPPLIES					
ELAN FINANCIAL SERVICES	112-1060624-4	Ink	02/27/2026	136.78	136.78
Total 001-4300-65060 OFFICE SUPPLIES:				136.78	136.78
001-4300-65065 PROCESSING FEES					
FIDELITY BANK & TRUST	2026 03 10	ACH FEES FORTE	03/10/2026	1.66	.00
FIDELITY BANK & TRUST	2026 03 10	PROCESSING FEES - FORTE C	03/10/2026	5.14	.00
Total 001-4300-65065 PROCESSING FEES:				6.80	.00
001-4300-65070 SUPPLIES					
ACE HARDWARE	a348988	Sawsall blades	02/24/2026	5.99	.00
ACE HARDWARE	A349060	screws	02/25/2026	18.98	.00
ELAN FINANCIAL SERVICES	8557 DM 2026	ADOBE - MONTHLY SUBSCRIPT	03/03/2026	25.43	25.43
Total 001-4300-65070 SUPPLIES:				50.40	25.43
001-4320-63730 COMMUNICATIONS					
US CELLULAR	453072630 202	INTERNET - CAMPGROUND	03/02/2026	74.79	74.79
Total 001-4320-63730 COMMUNICATIONS:				74.79	74.79
001-4320-63810 UTILITIES					
ALLIANT ENERGY	8600344075 20	ELECTRIC SERVICE	02/18/2026	63.51	63.51
Total 001-4320-63810 UTILITIES:				63.51	63.51
001-4320-65065 PROCESSING FEES					
FIDELITY BANK & TRUST	2026 03 10	ACH FEES FORTE	03/10/2026	1.67	.00
Total 001-4320-65065 PROCESSING FEES:				1.67	.00
001-4400-63810 UTILITIES					
ALLIANT ENERGY	8600344075 20	ELECTRIC SERVICE	02/18/2026	21.17	21.17
Total 001-4400-63810 UTILITIES:				21.17	21.17
001-4410-63100 BUILDING					
ELAN FINANCIAL SERVICES	112-3567623-9	ADA Lift battery	02/11/2026	352.03	352.03
Total 001-4410-63100 BUILDING:				352.03	352.03
001-4410-63730 COMMUNICATIONS					
NUWAVE COMMUNICATIONS IN	152186	PHONE SERVICE	03/01/2026	12.91	12.91
Total 001-4410-63730 COMMUNICATIONS:				12.91	12.91
001-4410-63810 UTILITIES					
ALLIANT ENERGY	6455490000 20	ELECTRIC SERVICE	03/12/2026	66.00	.00
Total 001-4410-63810 UTILITIES:				66.00	.00

Vendor Name	Invoice Number	Description	Invoice Date	Net Invoice Amount	Amount Paid
001-4410-64180 SALES TAX - ADMISSIONS					
TREASURER STATE OF IOWA	1-33-000974 2	FEBRUARY SALES TAX	02/28/2026	11.45	.00
Total 001-4410-64180 SALES TAX - ADMISSIONS:				11.45	.00
001-4410-65065 PROCESSING FEES					
FIDELITY BANK & TRUST	2026 03 10	ACH FEES FORTE	03/10/2026	1.67	.00
FIDELITY BANK & TRUST	2026 03 10	PROCESSING FEES - FORTE C	03/10/2026	7.00	.00
Total 001-4410-65065 PROCESSING FEES:				8.67	.00
001-4500-63310 VEHICLE					
AVALON TIRE	1-50616	plow seal	02/11/2026	67.98	67.98
OELWEIN FUEL FUND	2028 02 28	FUEL FEB 01 TO FEB 28	02/28/2026	118.70	.00
Total 001-4500-63310 VEHICLE:				186.68	67.98
001-4500-63730 COMMUNICATIONS					
MEDIACOM COMMUNICATIONS	0003535 2026	PHONE/INTERNET SERVICE	03/16/2026	46.31	.00
Total 001-4500-63730 COMMUNICATIONS:				46.31	.00
001-4500-63810 UTILITIES					
ALLIANT ENERGY	6455490000 20	ELECTRIC SERVICE	03/12/2026	163.01	.00
EAGLE POINT ENERGY 5 LLC	OELWEIN 89	ELECTRIC SERVICE	02/28/2026	71.27	71.27
Total 001-4500-63810 UTILITIES:				234.28	71.27
001-4500-65041 EQUIPMENT					
OELWEIN FUEL FUND	2028 02 28	FUEL FEB 01 TO FEB 28	02/28/2026	16.93	.00
Total 001-4500-65041 EQUIPMENT:				16.93	.00
001-6200-61990 EMPLOYEE PERSONNEL EXPENSE					
IMFOA	2026 02 26	SPRING 2026 IMFOA CONF RE	02/26/2026	66.66	66.66
IMFOA	2026 02 27	ANNUAL MEMBERSHIP 2026-27	02/27/2026	16.66	16.66
IMFOA	2026 02 27 - 1	SPRING 2026 IMFOA CONF RE	02/27/2026	66.66	66.66
IOWA EMPLOYMENT CONFERE	6269	IA EMPLOYMENT CONF - BARB	02/26/2026	170.00	170.00
Total 001-6200-61990 EMPLOYEE PERSONNEL EXPENSE:				319.98	319.98
001-6200-63100 BUILDING					
DYLAN MULFINGER	2026 02 26	MICHAELS - FRAMING RAGBRA	02/26/2026	239.99	239.99
Total 001-6200-63100 BUILDING:				239.99	239.99
001-6200-63310 VEHICLE					
ARNOLD MOTOR SUPPLY LLP	09NV151353	WIPERS/ICE SCRAPER	02/27/2026	61.11	.00
OELWEIN FUEL FUND	2028 02 28	FUEL FEB 01 TO FEB 28	02/28/2026	28.60	.00
Total 001-6200-63310 VEHICLE:				89.71	.00
001-6200-63730 COMMUNICATIONS					
AT&T MOBILITY LLC	287315354942	FIRSTNET INTERNET SERVICE	02/28/2026	10.44	10.44
MEDIACOM COMMUNICATIONS	0003535 2026	PHONE/INTERNET SERVICE	03/16/2026	48.56-	.00
NUWAVE COMMUNICATIONS IN	152186	PHONE SERVICE	03/01/2026	12.92	12.92
US CELLULAR	453072630 202	CELLPHONE SERVICE	03/02/2026	52.27	52.27

Vendor Name	Invoice Number	Description	Invoice Date	Net Invoice Amount	Amount Paid
Total 001-6200-63730 COMMUNICATIONS:				27.07	75.63
001-6200-63810 UTILITIES					
ALLIANT ENERGY	6455490000 20	ELECTRIC SERVICE	03/12/2026	94.00	.00
ALLIANT ENERGY	8482421000 20	ELECTRIC SERVICE - CAR CHA	03/05/2026	13.53	13.53
ALLIANT ENERGY	9707011000 20	GAS SERVICE	02/12/2026	351.17	351.17
EAGLE POINT ENERGY 5 LLC	OELWEIN 89	ELECTRIC SERVICE	02/28/2026	34.33	34.33
Total 001-6200-63810 UTILITIES:				493.03	399.03
001-6200-64090 JANITORIAL					
HORAN CLEANING LLC	1832	MONTHLY CITY HALL CLEANIN	03/04/2026	133.33	.00
Total 001-6200-64090 JANITORIAL:				133.33	.00
001-6200-64110 LEGAL EXPENSE					
LYNCH DALLAS PC	150213-00500	LEGAL/PROFESSIONAL FEES -	03/12/2026	79.50	.00
LYNCH DALLAS PC	150213-00600	LEGAL/PROFESSIONAL FEES -	03/12/2026	144.00	.00
LYNCH DALLAS PC	150213-00900	LEGAL/PROFESSIONAL FEES -	03/12/2026	18.00	.00
LYNCH DALLAS PC	150213-01000	LEGAL/PROFESSIONAL FEES -	03/12/2026	160.50	.00
Total 001-6200-64110 LEGAL EXPENSE:				402.00	.00
001-6200-64140 LEGAL PUBLICATION					
OELWEIN PUBLISHING CO	304365494	JANUARY 26 MINUTES	02/03/2026	64.79	.00
OELWEIN PUBLISHING CO	304368134	FEBRUARY 9 MINUTES	02/18/2026	43.55	.00
OELWEIN PUBLISHING CO	304370088	FEBRUARY CLAIMS	02/27/2026	79.65	.00
OELWEIN PUBLISHING CO	304370089	JANUARY RECEIPTS	02/27/2026	7.97	.00
OELWEIN PUBLISHING CO	304370090	FEBRUARY 23 MINUTES	02/27/2026	43.55	.00
Total 001-6200-64140 LEGAL PUBLICATION:				239.51	.00
001-6200-64950 CONTRACTS					
CIVICPLUS, LLC	360531	WEB OPEN PLATFORM MAINT/	03/01/2026	1,010.62	.00
Total 001-6200-64950 CONTRACTS:				1,010.62	.00
001-6200-65060 OFFICE SUPPLIES					
ACE HARDWARE	A348080	CLEANING SUPPLIES/GLUE	02/11/2026	22.63	.00
BARB RIGDON	2026 03 02	REIMBURE - CALCULATOR	03/02/2026	56.71	56.71
COPY SYSTEMS INC	IN594838	COPIER MAINT SUPPORT	03/10/2026	13.90	.00
ELAN FINANCIAL SERVICES	8557 DM 2026	ADOBE - MONTHLY SUBSCRIPT	03/03/2026	42.38	42.38
OFFICE TOWNE INC	131133	COLOR TONERS/THERMAL PAP	03/05/2026	169.79	.00
OFFICE TOWNE INC	131157	DRUM - BROTHER PRINTER	03/12/2026	61.17	.00
OFFICE TOWNE INC	131159	CHAIRMAT	03/12/2026	23.33	.00
SPECTRA ASSOCIATES INC	45061-E	MINUTE BOOKS QTY 6 /A-Z TAB	12/29/2025	295.20	295.20
Total 001-6200-65060 OFFICE SUPPLIES:				685.11	394.29
051-1300-64131 EMERGENCY MANAGEMENT					
FAYETTE CO TREASURER	EMA 2026 02 2	1ST HALF EMA FUND 2025-2026	02/23/2026	8,064.48	8,064.48
Total 051-1300-64131 EMERGENCY MANAGEMENT:				8,064.48	8,064.48
110-2100-61990 EMPLOYEE PERSONNEL EXPENSE					
JIM SPENCE	124643	Boot Reimbursement	02/28/2026	200.00	200.00

Vendor Name	Invoice Number	Description	Invoice Date	Net Invoice Amount	Amount Paid
JOHN DEERE FINANCIAL F.S.B.	3290622	Employee Pants	02/20/2026	37.99	37.99
Total 110-2100-61990 EMPLOYEE PERSONNEL EXPENSE:				237.99	237.99
110-2100-63100 BUILDING					
ELAN FINANCIAL SERVICES	112-2131955-7	Hose reel for hotsy washer	02/11/2026	224.69	224.69
Total 110-2100-63100 BUILDING:				224.69	224.69
110-2100-63310 VEHICLE					
OELWEIN FUEL FUND	2028 02 28	FUEL FEB 01 TO FEB 28	02/28/2026	1,240.61	.00
Total 110-2100-63310 VEHICLE:				1,240.61	.00
110-2100-63730 COMMUNICATIONS					
NUWAVE COMMUNICATIONS IN	152186	PHONE SERVICE	03/01/2026	6.46	6.46
US CELLULAR	453072630 202	CELLPHONE SERVICE	03/02/2026	65.32	65.32
Total 110-2100-63730 COMMUNICATIONS:				71.78	71.78
110-2100-63810 UTILITIES					
ALLIANT ENERGY	6455490000 20	ELECTRIC SERVICE	03/12/2026	60.88	.00
ALLIANT ENERGY	6455490000 20	ELECTRIC SERVICE	03/12/2026	284.33	.00
ALLIANT ENERGY	9707011000 20	GAS SERVICE	02/12/2026	1,421.45	1,421.45
Total 110-2100-63810 UTILITIES:				1,766.66	1,421.45
110-2100-65041 EQUIPMENT					
ARNOLD MOTOR SUPPLY LLP	09NV151148	Parts for Volvo Grader	02/25/2026	67.09	.00
ARNOLD MOTOR SUPPLY LLP	09NV151481	Filters for johnston sweeper	03/02/2026	38.80	.00
ARNOLD MOTOR SUPPLY LLP	09NV151593	Wiper blades for Johnston Sweep	03/03/2026	23.84	.00
ARNOLD MOTOR SUPPLY LLP	09NV151859	Filters for Elgin Sweeper	03/06/2026	74.64	.00
ARNOLD MOTOR SUPPLY LLP	09NV151911	Hydraulic Filter for Elgin Sweeper	03/06/2026	42.52	.00
DONS TRUCK SALES INC	545369	Water pump for truck 73	02/20/2026	359.46	.00
DONS TRUCK SALES INC	545380	Hydraulic Reservoir Cap for truck 7	02/23/2026	38.97	.00
ELAN FINANCIAL SERVICES	23346282	UST tank renewal	02/25/2026	134.79	134.79
JOHN DEERE FINANCIAL F.S.B.	P20612	Hydarulic hose for truck #74	02/19/2026	153.56	153.56
MODERN BUILDING PRODUCT	150088	Side Boards for dump trucks	12/05/2025	96.19	.00
OELWEIN FUEL FUND	2028 02 28	FUEL FEB 01 TO FEB 28	02/28/2026	369.69	.00
RECALL AUTO PARTS LLC	15571	Strobe lights for truck #74	02/23/2026	88.52	.00
THOMAS ELECTRIC MOTOR SE	67618	Solenoid for Johnston Sweeper	03/02/2026	32.35	.00
Total 110-2100-65041 EQUIPMENT:				1,520.42	288.35
110-2100-65060 OFFICE SUPPLIES					
COPY SYSTEMS INC	IN594838	COPIER MAINT SUPPORT	03/10/2026	13.91	.00
ELAN FINANCIAL SERVICES	8557 DM 2026	ADOBE - MONTHLY SUBSCRIPT	03/03/2026	50.86	50.86
SPECTRA ASSOCIATES INC	45061-E	MINUTE BOOKS QTY 6 /A-Z TAB	12/29/2025	295.20	295.20
Total 110-2100-65060 OFFICE SUPPLIES:				359.97	346.06
110-2100-65070 SUPPLIES					
JOHN DEERE FINANCIAL F.S.B.	3287662	Floor dry for street shop	02/09/2026	67.96	67.96
JOHN DEERE FINANCIAL F.S.B.	3289976	Paint for street shop	02/18/2026	27.96	27.96
JOHN DEERE FINANCIAL F.S.B.	3290013	Bar and chain oil	02/18/2026	13.98	13.98
JOHN DEERE FINANCIAL F.S.B.	3290283	Metric QD set	02/19/2026	16.79	16.79
JOHN DEERE FINANCIAL F.S.B.	3290622	Cordless ratchet for shop	02/20/2026	99.99	99.99

Vendor Name	Invoice Number	Description	Invoice Date	Net Invoice Amount	Amount Paid
JOHN DEERE FINANCIAL F.S.B.	3291428	Supplies for street shop	02/24/2026	65.95	65.95
JOHN DEERE FINANCIAL F.S.B.	3293904	Welding supplies for street shop	03/05/2026	140.44	140.44
JOHN DEERE FINANCIAL F.S.B.	P20419	Chain saw chain	02/16/2026	41.99	41.99
SUPERIOR WELDING SUPPLY	1142880	Welding gas	02/24/2026	159.04	.00
Total 110-2100-65070 SUPPLIES:				634.10	475.06
110-2100-67990 CAPITAL OUTLAY					
BAUMLER IMPLEMENTS INC	12881	Bush hog mower CIP	02/23/2026	30,500.00	.00
Total 110-2100-67990 CAPITAL OUTLAY:				30,500.00	.00
110-2300-63810 UTILITIES					
ALLIANT ENERGY	0106966292 20	ELECTRIC SERVICE	02/25/2026	358.75	358.75
ALLIANT ENERGY	0106966292 20	ELECTRIC SERVICE	02/25/2026	8,091.70	8,091.70
ALLIANT ENERGY	4830253977 20	ELECTRIC SERVICE	03/05/2026	54.45	54.45
ALLIANT ENERGY	6455490000 20	ELECTRIC SERVICE	03/12/2026	421.04	.00
Total 110-2300-63810 UTILITIES:				8,925.94	8,504.90
110-2400-63810 UTILITIES					
ALLIANT ENERGY	4830253977 20	ELECTRIC SERVICE	03/05/2026	158.12	158.12
ALLIANT ENERGY	6455490000 20	ELECTRIC SERVICE	03/12/2026	69.20	.00
Total 110-2400-63810 UTILITIES:				227.32	158.12
112-3820-61840 CLAIMS-SIDE FUND					
ADVANTAGE ADMINISTRATORS	17586	SELF FUND MEDICAL INS	02/23/2026	121.80	121.80
ADVANTAGE ADMINISTRATORS	2026 02 20	FEB 20 MEDICAL CLAIMS	02/20/2026	3,332.29	3,332.29
ADVANTAGE ADMINISTRATORS	2026 02 27	FEB 27 MEDICAL CLAIMS	02/27/2026	236.61	236.61
ADVANTAGE ADMINISTRATORS	2026 03 06	MAR 06 MEDICAL CLAIMS	03/06/2026	3,672.69	3,672.69
ADVANTAGE ADMINISTRATORS	2026 03 13	MAR 13 MEDICAL CLAIMS	03/13/2026	414.95	414.95
Total 112-3820-61840 CLAIMS-SIDE FUND:				7,778.34	7,778.34
112-3830-61500 MEDICAL-HEALTH					
COVENANT OCCUPATIONAL M	86901	CONSORTIUM FEE 2/25 EMPLO	02/16/2026	16.07	.00
Total 112-3830-61500 MEDICAL-HEALTH:				16.07	.00
112-3830-61840 CLAIMS-SIDE FUND					
ADVANTAGE ADMINISTRATORS	17586	SELF FUND MEDICAL INS	02/23/2026	30.45	30.45
ADVANTAGE ADMINISTRATORS	2026 02 27	FEB 27 MEDICAL CLAIMS	02/27/2026	35.00	35.00
ADVANTAGE ADMINISTRATORS	2026 03 06	MAR 06 MEDICAL CLAIMS	03/06/2026	18.11	18.11
Total 112-3830-61840 CLAIMS-SIDE FUND:				83.56	83.56
112-3840-61500 MEDICAL-HEALTH					
COVENANT OCCUPATIONAL M	86901	CONSORTIUM FEE 2/25 EMPLO	02/16/2026	10.71	.00
Total 112-3840-61500 MEDICAL-HEALTH:				10.71	.00
112-3840-61840 CLAIMS-SIDE FUND					
ADVANTAGE ADMINISTRATORS	17586	SELF FUND MEDICAL INS	02/23/2026	43.50	43.50
ADVANTAGE ADMINISTRATORS	2026 02 20	FEB 20 MEDICAL CLAIMS - LIBR	02/20/2026	70.00	70.00
ADVANTAGE ADMINISTRATORS	2026 03 06	MAR 06 MEDICAL CLAIMS	03/06/2026	35.00	35.00
ADVANTAGE ADMINISTRATORS	2026 03 06	MAR 06 MEDICAL CLAIMS - LIB	03/06/2026	35.00	35.00

Vendor Name	Invoice Number	Description	Invoice Date	Net Invoice Amount	Amount Paid
ADVANTAGE ADMINISTRATORS	2026 03 13	MAR 13 MEDICAL CLAIMS - LIB	03/13/2026	133.43	133.43
Total 112-3840-61840 CLAIMS-SIDE FUND:				316.93	316.93
112-3860-61840 CLAIMS-SIDE FUND Q HRA FEE					
ADVANTAGE ADMINISTRATORS	17586	SELF FUND MEDICAL INS	02/23/2026	26.10	26.10
ADVANTAGE ADMINISTRATORS	2026 02 20	FEB 20 MEDICAL CLAIMS	02/20/2026	1,828.82	1,828.82
ADVANTAGE ADMINISTRATORS	2026 02 27	FEB 27 MEDICAL CLAIMS	02/27/2026	1,168.50	1,168.50
ADVANTAGE ADMINISTRATORS	2026 03 06	MAR 06 MEDICAL CLAIMS	03/06/2026	126.26	126.26
ADVANTAGE ADMINISTRATORS	2026 03 13	MAR 13 MEDICAL CLAIMS	03/13/2026	86.82	86.82
Total 112-3860-61840 CLAIMS-SIDE FUND Q HRA FEE:				3,236.50	3,236.50
113-3900-61840 FLEX SPENDING					
ADVANTAGE ADMINISTRATORS	2026 02 27 FL	PAYROLL DEDUCTION FLEX SP	02/27/2026	822.75	.00
ADVANTAGE ADMINISTRATORS	2026 03 13 FL	PAYROLL DEDUCTION FLEX SP	03/13/2026	822.75	.00
Total 113-3900-61840 FLEX SPENDING:				1,645.50	.00
122-5210-64132 TOURISM					
OELWEIN COLISEUM BALLROO	2026 02	CONTRIBUTION - MILITARY DA	02/27/2026	800.00	800.00
OELWEIN COLISEUM BALLROO	2026 02 12	CONTRIBUTION - RICHIE LEE V	02/27/2026	1,500.00	1,500.00
Total 122-5210-64132 TOURISM:				2,300.00	2,300.00
123-4410-67990 PARK CAPITAL					
ADEN RABER	1448	RR Shelter Ceiling	02/20/2026	5,500.00	5,500.00
Total 123-4410-67990 PARK CAPITAL:				5,500.00	5,500.00
123-5250-67242 POOL CAPITAL					
ELAN FINANCIAL SERVICES	pwc-92129	Drinking fountains	02/13/2026	2,100.99	2,100.99
Total 123-5250-67242 POOL CAPITAL:				2,100.99	2,100.99
124-4100-65070 SUPPLIES					
QUILL.COM	47862264	TONER	02/19/2026	223.19	.00
Total 124-4100-65070 SUPPLIES:				223.19	.00
160-1710-63310 VEHICLE					
OELWEIN FUEL FUND	2028 02 28	FUEL FEB 01 TO FEB 28	02/28/2026	65.79	.00
Total 160-1710-63310 VEHICLE:				65.79	.00
160-1710-63750 CELLULAR/PAGING					
US CELLULAR	453072630 202	CELLPHONE SERVICE	03/02/2026	26.14	26.14
US CELLULAR	453072630 202	TABLET	03/02/2026	39.78	39.78
Total 160-1710-63750 CELLULAR/PAGING:				65.92	65.92
160-1710-65060 OFFICE SUPPLIES					
OELWEIN PUBLISHING CO	304368351	PN - SPECIAL ASSESSMENT - A	02/19/2026	63.73	.00
Total 160-1710-65060 OFFICE SUPPLIES:				63.73	.00

Vendor Name	Invoice Number	Description	Invoice Date	Net Invoice Amount	Amount Paid
160-5200-63730 COMMUNICATIONS					
AT&T MOBILITY LLC	287315354942	FIRSTNET INTERNET SERVICE	02/28/2026	10.44	10.44
MEDIACOM COMMUNICATIONS	0003535 2026	PHONE/INTERNET SERVICE	03/16/2026	48.56-	.00
NUWAVE COMMUNICATIONS IN	152186	PHONE SERVICE	03/01/2026	12.91	12.91
Total 160-5200-63730 COMMUNICATIONS:				25.21-	23.35
160-5200-64110 LEGAL EXPENSE					
LYNCH DALLAS PC	150213-00500	LEGAL/PROFESSIONAL FEES -	03/12/2026	53.00	.00
LYNCH DALLAS PC	150213-00600	LEGAL/PROFESSIONAL FEES -	03/12/2026	96.00	.00
LYNCH DALLAS PC	150213-00900	LEGAL/PROFESSIONAL FEES -	03/12/2026	12.00	.00
LYNCH DALLAS PC	150213-01000	LEGAL/PROFESSIONAL FEES -	03/12/2026	107.00	.00
Total 160-5200-64110 LEGAL EXPENSE:				268.00	.00
160-5200-64133 TOURISM					
ALLIANT ENERGY	6464321877 20	ELECTRIC SERVICE	03/06/2026	23.56	23.56
ALLIANT ENERGY	8100421000 20	ELECTRIC SERVICE	03/06/2026	23.56	23.56
Total 160-5200-64133 TOURISM:				47.12	47.12
160-5200-64140 LEGAL PUBLICATION					
OELWEIN PUBLISHING CO	304365494	JANUARY 26 MINUTES	02/03/2026	21.60	.00
OELWEIN PUBLISHING CO	304368134	FEBRUARY 9 MINUTES	02/18/2026	14.52	.00
OELWEIN PUBLISHING CO	304368135	PH - SALE OF PROPERTY - 502	02/18/2026	27.74	.00
OELWEIN PUBLISHING CO	304368136	PH - SALE OF PROPERTY - 111	02/18/2026	29.51	.00
OELWEIN PUBLISHING CO	304370088	FEBRUARY CLAIMS	02/27/2026	26.55	.00
OELWEIN PUBLISHING CO	304370089	JANUARY RECEIPTS	02/27/2026	2.66	.00
OELWEIN PUBLISHING CO	304370090	FEBRUARY 23 MINUTES	02/27/2026	14.52	.00
Total 160-5200-64140 LEGAL PUBLICATION:				137.10	.00
160-5200-64904 JUNK HOUSE REMOVAL					
FAYETTE CO TREASURER	1821155010 20	PROPERTY TAXES - 501 W CHA	03/11/2026	505.00	505.00
Total 160-5200-64904 JUNK HOUSE REMOVAL:				505.00	505.00
160-5200-64908 OELWEIN FESTIVAL					
ELAN FINANCIAL SERVICES	1489	EVEN EVENTS - TENT/TABLES/	02/17/2026	403.41	403.41
HOWL USA LLC	3901 D	50% DOWN - EVENT 7/10 BIG O	03/03/2026	2,500.00	2,500.00
Total 160-5200-64908 OELWEIN FESTIVAL:				2,903.41	2,903.41
160-5200-64950 CONTRACTS					
FEHR GRAHAM ENGINEERING	138199	PROJECT 25-2061 PARKING LO	02/20/2026	4,576.00	.00
Total 160-5200-64950 CONTRACTS:				4,576.00	.00
160-5200-65060 OFFICE SUPPLIES					
COPY SYSTEMS INC	IN594838	COPIER MAINT SUPPORT	03/10/2026	13.90	.00
SPECTRA ASSOCIATES INC	45061-E	MINUTE BOOKS QTY 6 /A-Z TAB	12/29/2025	295.20	295.20
Total 160-5200-65060 OFFICE SUPPLIES:				309.10	295.20
161-5225-64030 ADMINISTRATIVE COSTS					
UPPER EXPLORERLAND	FY26274	FEBRUARY 2026 ADMIN COSTS	02/28/2026	2,316.63	.00

Vendor Name	Invoice Number	Description	Invoice Date	Net Invoice Amount	Amount Paid
Total 161-5225-64030 ADMINISTRATIVE COSTS:				2,316.63	.00
161-5225-64907 REVOLVING FUNDS DISBURSED					
THORP'S AUTO & REPAIR LLC	2026 03 05 IR	LOAN PROCEEDS	03/05/2026	40,000.00	.00
Total 161-5225-64907 REVOLVING FUNDS DISBURSED:				40,000.00	.00
200-7100-68015 2020 GO BOND					
UMB BANK NA	1040887	2020 BONDS SERVICE FEES	03/07/2026	600.00	.00
Total 200-7100-68015 2020 GO BOND:				600.00	.00
305-2800-64950 CONTRACTS					
AECOM TECHNICAL SERVICES	2001121641	PROJECT 60777499 OLZ T-HAN	03/11/2026	1,521.11	.00
Total 305-2800-64950 CONTRACTS:				1,521.11	.00
388-7550-64070 CONTRACTS, ENGINEERING					
ORIGIN DESIGN CO	82995	PROJECT 23036 10TH ST BRID	02/26/2026	40,645.86	.00
Total 388-7550-64070 CONTRACTS, ENGINEERING:				40,645.86	.00
388-7550-67850 CONSTRUCTION					
TAYLOR CONSTRUCTION INC	2026 02 06	PAYMENT REQ # 5 10TH ST BRI	02/23/2026	99,574.69	99,574.69
Total 388-7550-67850 CONSTRUCTION:				99,574.69	99,574.69
393-7509-67850 CONSTRUCTION					
ACE HARDWARE	A348708	GLUE FOR TILES	02/19/2026	15.98	.00
ACE HARDWARE	A349152	PAINT/JNT CMPND/ROLLER/BR	02/26/2026	112.90	.00
ACE HARDWARE	A349260	TEXTURE SPRAY/FASTGRAB	02/27/2026	65.87	.00
ACE HARDWARE	A349527	PAINT BRUSH	03/03/2026	4.99	.00
ACE HARDWARE	B177736	SCREWS - PARTITION FRONT	02/25/2026	13.99	.00
ACE HARDWARE	B177788	JOINT COMPOUND/SCRAPPER/	02/26/2026	23.57	.00
ACE HARDWARE	B177793	OUTLET SUPPLIES	02/26/2026	112.91	.00
ACE HARDWARE	B177844	VINYL BASE BOARDS/CAULK	02/27/2026	42.52	.00
ACE HARDWARE	B177851	INTERNET JACK/SUPPLIES	02/27/2026	66.56	.00
ACE HARDWARE	B177862	WIRE/SUPPLIES	02/27/2026	147.33	.00
ACE HARDWARE	B177864	TEXTURE SPRAY	02/27/2026	21.99	.00
ACE HARDWARE	B178057	RETURNED VINYL BASE BOAR	03/03/2026	37.90-	.00
JOHN DEERE FINANCIAL F.S.B.	3293027	PAINT BRUSH/TOWEL/PAINT TR	03/02/2026	7.71	7.71
K-LOG INC	26-337375-1	RECEPTION STATION - PARTITI	03/02/2026	7,766.16	.00
STEVE'S CONSTRUCTION	2026 02 27	SHELVES - MATERIAL & LABOR	02/27/2026	390.00	.00
Total 393-7509-67850 CONSTRUCTION:				8,754.58	7.71
600-6200-61840 CLAIMS-SIDE FUND					
ADVANTAGE ADMINISTRATORS	17586	SELF FUND MEDICAL INS	02/23/2026	47.85	47.85
ADVANTAGE ADMINISTRATORS	2026 02 20	FEB 20 MEDICAL CLAIMS	02/20/2026	35.00	35.00
ADVANTAGE ADMINISTRATORS	2026 02 27	FEB 27 MEDICAL CLAIMS	02/27/2026	584.24	584.24
ADVANTAGE ADMINISTRATORS	2026 03 06	MAR 06 MEDICAL CLAIMS	03/06/2026	127.77	127.77
ADVANTAGE ADMINISTRATORS	2026 03 13	MAR 13 MEDICAL CLAIMS	03/13/2026	43.41	43.41
Total 600-6200-61840 CLAIMS-SIDE FUND:				838.27	838.27

Vendor Name	Invoice Number	Description	Invoice Date	Net Invoice Amount	Amount Paid
600-6200-61990 EMPLOYEE PERSONNEL EXPENSE					
IAMU	34579	2026-27 WATER MEMBER DUES	03/05/2026	1,159.00	.00
IMFOA	2026 02 26	SPRING 2026 IMFOA CONF RE	02/26/2026	66.67	66.67
IMFOA	2026 02 27	ANNUAL MEMBERSHIP 2026-27	02/27/2026	16.67	16.67
IMFOA	2026 02 27 - 1	SPRING 2026 IMFOA CONF RE	02/27/2026	66.67	66.67
IOWA EMPLOYMENT CONFERE	6269	IA EMPLOYMENT CONF - BARB	02/26/2026	170.00	170.00
Total 600-6200-61990 EMPLOYEE PERSONNEL EXPENSE:				1,479.01	320.01
600-6200-63100 BUILDING					
DYLAN MULFINGER	2026 02 26	MICHAELS - FRAMING RAGBRA	02/26/2026	239.99	239.99
Total 600-6200-63100 BUILDING:				239.99	239.99
600-6200-63730 COMMUNICATIONS					
AT&T MOBILITY LLC	287315354942	FIRSTNET INTERNET SERVICE	02/28/2026	10.44	10.44
MEDIACOM COMMUNICATIONS	0003535 2026	PHONE/INTERNET SERVICE	03/16/2026	96.90	.00
MEDIACOM COMMUNICATIONS	0003535 2026	PHONE/INTERNET SERVICE	03/16/2026	48.56-	.00
NUWAVE COMMUNICATIONS IN	152186	PHONE SERVICE	03/01/2026	12.92	12.92
Total 600-6200-63730 COMMUNICATIONS:				71.70	23.36
600-6200-63810 UTILITIES					
ALLIANT ENERGY	6455490000 20	ELECTRIC SERVICE	03/12/2026	156.67	.00
ALLIANT ENERGY	8482421000 20	ELECTRIC SERVICE - CAR CHA	03/05/2026	13.53	13.53
ALLIANT ENERGY	9707011000 20	GAS SERVICE	02/12/2026	263.37	263.37
EAGLE POINT ENERGY 5 LLC	OELWEIN 89	ELECTRIC SERVICE	02/28/2026	57.22	57.22
Total 600-6200-63810 UTILITIES:				490.79	334.12
600-6200-64090 JANITORIAL					
HORAN CLEANING LLC	1832	MONTHLY CITY HALL CLEANIN	03/04/2026	133.33	.00
Total 600-6200-64090 JANITORIAL:				133.33	.00
600-6200-64110 LEGAL EXPENSE					
LYNCH DALLAS PC	150213-00500	LEGAL/PROFESSIONAL FEES -	03/12/2026	66.25	.00
LYNCH DALLAS PC	150213-00600	LEGAL/PROFESSIONAL FEES -	03/12/2026	120.00	.00
LYNCH DALLAS PC	150213-00900	LEGAL/PROFESSIONAL FEES -	03/12/2026	15.00	.00
LYNCH DALLAS PC	150213-01000	LEGAL/PROFESSIONAL FEES -	03/12/2026	133.75	.00
Total 600-6200-64110 LEGAL EXPENSE:				335.00	.00
600-6200-64140 LEGAL PUBLICATION					
OELWEIN PUBLISHING CO	304365494	JANUARY 26 MINUTES	02/03/2026	28.79	.00
OELWEIN PUBLISHING CO	304368134	FEBRUARY 9 MINUTES	02/18/2026	19.35	.00
OELWEIN PUBLISHING CO	304370088	FEBRUARY CLAIMS	02/27/2026	35.40	.00
OELWEIN PUBLISHING CO	304370089	JANUARY RECEIPTS	02/27/2026	3.54	.00
OELWEIN PUBLISHING CO	304370090	FEBRUARY 23 MINUTES	02/27/2026	19.35	.00
Total 600-6200-64140 LEGAL PUBLICATION:				106.43	.00
600-6200-64182 WATER EXCISE TAX					
TREASURER STATE OF IOWA	1-33-809659 2	FEBRUARY WET TAX	02/28/2026	7,864.03	.00
Total 600-6200-64182 WATER EXCISE TAX:				7,864.03	.00

Vendor Name	Invoice Number	Description	Invoice Date	Net Invoice Amount	Amount Paid
600-6200-64950 CONTRACTS					
CIVICPLUS, LLC	360531	WEB OPEN PLATFORM MAINT/	03/01/2026	1,010.62	.00
Total 600-6200-64950 CONTRACTS:				1,010.62	.00
600-6200-65060 OFFICE SUPPLIES					
ACE HARDWARE	A348080	CLEANING SUPPLIES/GLUE	02/11/2026	22.64	.00
BARB RIGDON	2026 03 02	REIMBURE - CALCULATOR	03/02/2026	56.71	56.71
COPY SYSTEMS INC	IN594838	COPIER MAINT SUPPORT	03/10/2026	13.91	.00
ELAN FINANCIAL SERVICES	8557 DM 2026	ADOBE - MONTHLY SUBSCRIPT	03/03/2026	42.38	42.38
FIDELITY BANK & TRUST	2026 03 03	PSN MONTHLY FEE-CR CARD/D	03/03/2026	27.45	.00
OFFICE TOWNE INC	131133	COLOR TONERS/THERMAL PAP	03/05/2026	169.80	.00
OFFICE TOWNE INC	131157	DRUM - BROTHER PRINTER	03/12/2026	61.18	.00
OFFICE TOWNE INC	131159	CHAIRMAT	03/12/2026	23.33	.00
SPECTRA ASSOCIATES INC	45061-E	MINUTE BOOKS QTY 6 /A-Z TAB	12/29/2025	295.20	295.20
U S POST OFFICE	2026 02 27	MARCH WATER BILL POSTAGE	02/27/2026	346.25	346.25
Total 600-6200-65060 OFFICE SUPPLIES:				1,058.85	740.54
600-8100-61990 EMPLOYEE PERSONNEL EXPENSE					
COVENANT OCCUPATIONAL M	86901	CONSORTIUM FEE 2/25 EMPLO	02/16/2026	32.15	.00
Total 600-8100-61990 EMPLOYEE PERSONNEL EXPENSE:				32.15	.00
600-8100-63100 BUILDING					
JOHN DEERE FINANCIAL F.S.B.	3288642	Dewalt vacuum and batteries for o	02/13/2026	329.98	329.98
Total 600-8100-63100 BUILDING:				329.98	329.98
600-8100-63310 VEHICLE					
JOHN DEERE FINANCIAL F.S.B.	3293148	cleaning supplies for vehicle	03/02/2026	8.48	8.48
OELWEIN FUEL FUND	2028 02 28	FUEL FEB 01 TO FEB 28	02/28/2026	61.86	.00
OELWEIN FUEL FUND	2028 02 28	FUEL FEB 01 TO FEB 28	02/28/2026	69.91	.00
Total 600-8100-63310 VEHICLE:				140.25	8.48
600-8100-63730 COMMUNICATIONS					
MEDIACOM COMMUNICATIONS	0003535 2026	PHONE/INTERNET SERVICE	03/16/2026	174.99	.00
NUWAVE COMMUNICATIONS IN	152186	PHONE SERVICE	03/01/2026	25.83	25.83
US CELLULAR	453072630 202	CELLPHONE SERVICE	03/02/2026	35.46	35.46
US CELLULAR	453072630 202	TABLET	03/02/2026	24.79	24.79
US CELLULAR	453072630 202	CELLPHONE SERVICE	03/02/2026	37.65	37.65
Total 600-8100-63730 COMMUNICATIONS:				298.72	123.73
600-8100-63810 UTILITIES					
ALLIANT ENERGY	4830253977 20	ELECTRIC SERVICE	03/05/2026	5,857.55	5,857.55
ALLIANT ENERGY	6455490000 20	ELECTRIC SERVICE	03/12/2026	213.25	.00
ALLIANT ENERGY	6455490000 20	ELECTRIC SERVICE	03/12/2026	3,412.59	.00
ALLIANT ENERGY	9707011000 20	GAS SERVICE	02/12/2026	444.47	444.47
Total 600-8100-63810 UTILITIES:				9,927.86	6,302.02
600-8100-64920 ONE CALL					
IOWA ONE CALL	279739	ONE CALLS	02/27/2026	33.30	.00

Vendor Name	Invoice Number	Description	Invoice Date	Net Invoice Amount	Amount Paid
Total 600-8100-64920 ONE CALL:				33.30	.00
600-8100-65041 EQUIPMENT					
OELWEIN FUEL FUND	2028 02 28	FUEL FEB 01 TO FEB 28	02/28/2026	9.64	.00
Total 600-8100-65041 EQUIPMENT:				9.64	.00
600-8100-65060 OFFICE SUPPLIES					
ELAN FINANCIAL SERVICES	112-5452969-9	Desk chair mat	02/02/2026	75.20	75.20
Total 600-8100-65060 OFFICE SUPPLIES:				75.20	75.20
600-8100-65070 SUPPLIES					
ACE HARDWARE	A347534	Toolbox for water truck	02/03/2026	115.99	.00
ACE HARDWARE	A347552	Return toolbox for water truck	02/03/2026	115.99-	.00
ACE HARDWARE	A347553	Toolbox for water truck	02/03/2026	93.98	.00
ACE HARDWARE	A348929	PVC for 50 well	02/23/2026	12.99	.00
ACE HARDWARE	B177270	Frost bleeder valve for residents h	02/13/2026	10.99	.00
ACE HARDWARE	B177499	Coupling and nipple	02/18/2026	16.95	.00
ACE HARDWARE	B177699	Lysol, garbage bags and white out	02/24/2026	35.92	.00
ELAN FINANCIAL SERVICES	112-2804782-3	Frost probe for locating	02/04/2026	141.51	141.51
EUROFINS ENVIRONMENT TES	3100169130	WATER SAMPLES	02/27/2026	159.84	.00
EUROFINS ENVIRONMENT TES	3100169186	WATER SAMPLES	02/27/2026	119.88	.00
JOHN DEERE FINANCIAL F.S.B.	3288144	Weatherpack wire nuts	02/11/2026	5.39	5.39
JOHN DEERE FINANCIAL F.S.B.	3288482	Car charger for water tablet	02/12/2026	15.99	15.99
JOHN DEERE FINANCIAL F.S.B.	3292003	Dewalt Oscillating Tool	02/26/2026	99.99	99.99
JOHN DEERE FINANCIAL F.S.B.	3293102	Materials to make ground rod	03/02/2026	27.27	27.27
USABLUBOOK	INV00979007	water supplies	03/03/2026	614.59	.00
Total 600-8100-65070 SUPPLIES:				1,355.29	290.15
601-8110-64070 CONTRACTS,ENGINEERS					
FEHR GRAHAM ENGINEERING	138198	PROJECT 25-905 2026 WATER	02/20/2026	1,446.50	.00
Total 601-8110-64070 CONTRACTS,ENGINEERS:				1,446.50	.00
601-8110-64950 CONTRACTS					
UPPER EXPLORERLAND	FY26281	JANUARY 2026 CDBG WATER #	02/28/2026	894.97	.00
Total 601-8110-64950 CONTRACTS:				894.97	.00
670-8400-65060 OFFICE SUPPLIES					
U S POST OFFICE	2026 02 27	MARCH WATER BILL POSTAGE	02/27/2026	162.94	162.94
Total 670-8400-65060 OFFICE SUPPLIES:				162.94	162.94
670-8420-64950 SINGLE HAULER CONTRACT					
KLUESNER SANITATION LLC	179351	BULK ITEM STICKERS - QTY 20	03/02/2026	3,800.00	.00
KLUESNER SANITATION LLC	180436	monthly garbage & recycling picku	03/02/2026	31,512.69	.00
Total 670-8420-64950 SINGLE HAULER CONTRACT:				35,312.69	.00
671-8410-65060 OFFICE SUPPLIES					
U S POST OFFICE	2026 02 27	MARCH WATER BILL POSTAGE	02/27/2026	81.47	81.47

Vendor Name	Invoice Number	Description	Invoice Date	Net Invoice Amount	Amount Paid
Total 671-8410-65060 OFFICE SUPPLIES:				81.47	81.47
672-4310-65041 EQUIPMENT					
EDWARD R GINGERICH	3394-4	chainsaw chains	02/23/2026	104.86	.00
Total 672-4310-65041 EQUIPMENT:				104.86	.00
680-8220-64090 JANITORIAL					
OELWEIN COMM SCHOOLS	2026 02 28	FEBRUARY WELLNESS CUSTO	02/28/2026	1,908.48	.00
Total 680-8220-64090 JANITORIAL:				1,908.48	.00
680-8220-64180 SALES TAX					
TREASURER STATE OF IOWA	1-33-000974 2	FEBRUARY SALES TAX	02/28/2026	1,096.58	.00
Total 680-8220-64180 SALES TAX:				1,096.58	.00
680-8220-64950 CONTRACTS					
OELWEIN COMM SCHOOLS	2026 02 28	FEBRUARY WELLNESS EXPEN	02/28/2026	10,218.35	.00
Total 680-8220-64950 CONTRACTS:				10,218.35	.00
680-8220-65065 PROCESSING FEES					
FIDELITY BANK & TRUST	2026 03 10	ACH FEES FORTE	03/10/2026	5.00	.00
FIDELITY BANK & TRUST	2026 03 10	PROCESSING FEES - FORTE C	03/10/2026	491.78	.00
Total 680-8220-65065 PROCESSING FEES:				496.78	.00
680-8220-65070 SUPPLIES					
COPY SYSTEMS INC	IN594138	COPIER MAINT SUPPORT	03/02/2026	53.96	.00
OELWEIN COMM SCHOOLS	2026 02 28 SU	WWC GENERAL SUPPLIES	02/28/2026	3,434.18	.00
Total 680-8220-65070 SUPPLIES:				3,488.14	.00
700-6200-61840 CLAIMS-SIDE FUND					
ADVANTAGE ADMINISTRATORS	17586	SELF FUND MEDICAL INS	02/23/2026	34.80	34.80
ADVANTAGE ADMINISTRATORS	2026 02 20	FEB 20 MEDICAL CLAIMS	02/20/2026	1,822.38	1,822.38
ADVANTAGE ADMINISTRATORS	2026 02 27	FEB 27 MEDICAL CLAIMS	02/27/2026	584.25	584.25
ADVANTAGE ADMINISTRATORS	2026 03 06	MAR 06 MEDICAL CLAIMS	03/06/2026	123.35	123.35
ADVANTAGE ADMINISTRATORS	2026 03 13	MAR 13 MEDICAL CLAIMS	03/13/2026	84.85	84.85
Total 700-6200-61840 CLAIMS-SIDE FUND:				2,649.63	2,649.63
700-6200-61990 EMPLOYEE PERSONNEL EXPENSE					
IMFOA	2026 02 26	SPRING 2026 IMFOA CONF RE	02/26/2026	66.67	66.67
IMFOA	2026 02 27	ANNUAL MEMBERSHIP 2026-27	02/27/2026	16.67	16.67
IMFOA	2026 02 27 - 1	SPRING 2026 IMFOA CONF RE	02/27/2026	66.67	66.67
IOWA EMPLOYMENT CONFERE	6269	IA EMPLOYMENT CONF - BARB	02/26/2026	170.00	170.00
Total 700-6200-61990 EMPLOYEE PERSONNEL EXPENSE:				320.01	320.01
700-6200-63100 BUILDING					
DYLAN MULFINGER	2026 02 26	MICHAELS - FRAMING RAGBRA	02/26/2026	240.00	240.00
Total 700-6200-63100 BUILDING:				240.00	240.00

Vendor Name	Invoice Number	Description	Invoice Date	Net Invoice Amount	Amount Paid
700-6200-63730 COMMUNICATIONS					
AT&T MOBILITY LLC	287315354942	FIRSTNET INTERNET SERVICE	02/28/2026	10.45	10.45
MEDIACOM COMMUNICATIONS	0003535 2026	PHONE/INTERNET SERVICE	03/16/2026	48.57-	.00
NUWAVE COMMUNICATIONS IN	152186	PHONE SERVICE	03/01/2026	12.91	12.91
Total 700-6200-63730 COMMUNICATIONS:				25.21-	23.36
700-6200-63810 UTILITIES					
ALLIANT ENERGY	6455490000 20	ELECTRIC SERVICE	03/12/2026	156.68	.00
ALLIANT ENERGY	8482421000 20	ELECTRIC SERVICE - CAR CHA	03/05/2026	13.54	13.54
ALLIANT ENERGY	9707011000 20	GAS SERVICE	02/12/2026	263.37	263.37
EAGLE POINT ENERGY 5 LLC	OELWEIN 89	ELECTRIC SERVICE	02/28/2026	57.21	57.21
Total 700-6200-63810 UTILITIES:				490.80	334.12
700-6200-64090 JANITORIAL					
HORAN CLEANING LLC	1832	MONTHLY CITY HALL CLEANIN	03/04/2026	133.34	.00
Total 700-6200-64090 JANITORIAL:				133.34	.00
700-6200-64110 LEGAL EXPENSE					
LYNCH DALLAS PC	150213-00500	LEGAL/PROFESSIONAL FEES -	03/12/2026	66.25	.00
LYNCH DALLAS PC	150213-00600	LEGAL/PROFESSIONAL FEES -	03/12/2026	120.00	.00
LYNCH DALLAS PC	150213-00900	LEGAL/PROFESSIONAL FEES -	03/12/2026	15.00	.00
LYNCH DALLAS PC	150213-01000	LEGAL/PROFESSIONAL FEES -	03/12/2026	133.75	.00
Total 700-6200-64110 LEGAL EXPENSE:				335.00	.00
700-6200-64140 LEGAL PUBLICATION					
OELWEIN PUBLISHING CO	304365494	JANUARY 26 MINUTES	02/03/2026	28.79	.00
OELWEIN PUBLISHING CO	304368134	FEBRUARY 9 MINUTES	02/18/2026	19.35	.00
OELWEIN PUBLISHING CO	304370088	FEBRUARY CLAIMS	02/27/2026	35.41	.00
OELWEIN PUBLISHING CO	304370089	JANUARY RECEIPTS	02/27/2026	3.54	.00
OELWEIN PUBLISHING CO	304370090	FEBRUARY 23 MINUTES	02/27/2026	19.35	.00
Total 700-6200-64140 LEGAL PUBLICATION:				106.44	.00
700-6200-64180 SALES TAX					
TREASURER STATE OF IOWA	1-33-000974 2	FEBRUARY SALES TAX	02/28/2026	2,111.49	.00
Total 700-6200-64180 SALES TAX:				2,111.49	.00
700-6200-64950 CONTRACTS					
CIVICPLUS, LLC	360531	WEB OPEN PLATFORM MAINT/	03/01/2026	1,010.63	.00
Total 700-6200-64950 CONTRACTS:				1,010.63	.00
700-6200-65060 OFFICE SUPPLIES					
ACE HARDWARE	A348080	CLEANING SUPPLIES/GLUE	02/11/2026	22.64	.00
BARB RIGDON	2026 03 02	REIMBURE - CALCULATOR	03/02/2026	56.71	56.71
COPY SYSTEMS INC	IN594838	COPIER MAINT SUPPORT	03/10/2026	13.91	.00
ELAN FINANCIAL SERVICES	8557 DM 2026	ADOBE - MONTHLY SUBSCRIPT	03/03/2026	42.39	42.39
FIDELITY BANK & TRUST	2026 03 03	PSN MONTHLY FEE-CR CARD/D	03/03/2026	27.45	.00
OFFICE TOWNE INC	131133	COLOR TONERS/THERMAL PAP	03/05/2026	169.80	.00
OFFICE TOWNE INC	131157	DRUM - BROTHER PRINTER	03/12/2026	61.18	.00
OFFICE TOWNE INC	131159	CHAIRMAT	03/12/2026	23.34	.00
SPECTRA ASSOCIATES INC	45061-E	MINUTE BOOKS QTY 6 /A-Z TAB	12/29/2025	295.20	295.20

Vendor Name	Invoice Number	Description	Invoice Date	Net Invoice Amount	Amount Paid
U S POST OFFICE	2026 02 27	MARCH WATER BILL POSTAGE	02/27/2026	427.71	427.71
Total 700-6200-65060 OFFICE SUPPLIES:				1,140.33	822.01
700-8310-63310 VEHICLE					
OELWEIN FUEL FUND	2028 02 28	FUEL FEB 01 TO FEB 28	02/28/2026	61.87	.00
Total 700-8310-63310 VEHICLE:				61.87	.00
700-8310-63810 UTILITIES					
ALLIANT ENERGY	0106966292 20	ELECTRIC SERVICE	02/25/2026	619.76	619.76
ALLIANT ENERGY	6455490000 20	ELECTRIC SERVICE	03/12/2026	71.08	.00
ALLIANT ENERGY	6455490000 20	ELECTRIC SERVICE	03/12/2026	76.89	.00
ALLIANT ENERGY	9707011000 20	GAS SERVICE	02/12/2026	148.16	148.16
Total 700-8310-63810 UTILITIES:				915.89	767.92
700-8310-64920 ONE CALL					
IOWA ONE CALL	279739	ONE CALLS	02/27/2026	33.30	.00
Total 700-8310-64920 ONE CALL:				33.30	.00
700-8310-65041 EQUIPMENT					
GLASCO UV LLC	18724	Spring UV set up	02/18/2026	2,474.69	.00
Total 700-8310-65041 EQUIPMENT:				2,474.69	.00
700-8500-61990 EMPLOYEE PERSONNEL EXPENSE					
COVENANT OCCUPATIONAL M	86901	CONSORTIUM FEE 2/25 EMPLO	02/16/2026	16.07	.00
KAMERSON BENNETT	705080	Meal reimbursement-class	03/04/2026	12.58	12.58
Total 700-8500-61990 EMPLOYEE PERSONNEL EXPENSE:				28.65	12.58
700-8500-63310 VEHICLE					
KAMERSON BENNETT	779052	Fuel for city truck-reimbursement	03/03/2026	56.16	56.16
KENS ELECTRIC	68091310	Electrical supplies for power shutd	03/11/2026	164.22	.00
OELWEIN FUEL FUND	2028 02 28	FUEL FEB 01 TO FEB 28	02/28/2026	15.32	.00
Total 700-8500-63310 VEHICLE:				235.70	56.16
700-8500-63730 COMMUNICATIONS					
MEDIACOM COMMUNICATIONS	0003535 2026	PHONE/INTERNET SERVICE	03/16/2026	303.25	.00
NUWAVE COMMUNICATIONS IN	152186	PHONE SERVICE	03/01/2026	12.91	12.91
US CELLULAR	453072630 202	CELLPHONE SERVICE	03/02/2026	37.67	37.67
Total 700-8500-63730 COMMUNICATIONS:				353.83	50.58
700-8500-63810 UTILITIES					
ALLIANT ENERGY	6455490000 20	ELECTRIC SERVICE	03/12/2026	7,676.96	.00
ALLIANT ENERGY	9707011000 20	GAS SERVICE	02/12/2026	646.19	646.19
Total 700-8500-63810 UTILITIES:				8,323.15	646.19
700-8500-65041 EQUIPMENT					
JOHN DEERE FINANCIAL F.S.B.	3294123	Grease zerk for WPCP	03/06/2026	1.79	1.79
SIGMA CONTROLS INC	34920	TRANSDUCER REBUILT	03/03/2026	619.38	.00
USABLUBOOK	INV00987999	Pipe for non-pot pumps	03/11/2026	290.96	.00

Vendor Name	Invoice Number	Description	Invoice Date	Net Invoice Amount	Amount Paid
WBC MECHANICAL	66613	Main Lift Boiler	02/20/2026	173.78	.00
Total 700-8500-65041 EQUIPMENT:				1,085.91	1.79
700-8500-65070 SUPPLIES					
EUROFINS ENVIRONMENT TES	3100169110	WASTEWATER SAMPLES	02/27/2026	757.08	.00
FAREWAY STORES INC	283727	Water and Ice for WPCP lab	02/09/2026	57.63	.00
NCL OF WISCONSIN INC	531851	Lab Supplies	02/12/2026	303.57	.00
STAR EQUIPMENT LTD	70948901	Bypass pump for WPCP Transfer	03/12/2026	1,231.20	.00
Total 700-8500-65070 SUPPLIES:				2,349.48	.00
706-8315-64030 ADMINISTRATIVE COSTS					
DORSEY & WHITNEY LLP	2026 02 24	LEGAL SERVICES - SRF LOAN	02/24/2026	6,500.00	.00
Total 706-8315-64030 ADMINISTRATIVE COSTS:				6,500.00	.00
Grand Totals:				425,146.94	177,705.92

Dated: _____

Mayor: _____

City Council: _____

City Recorder: _____

Report Criteria:

- Detail report.
- Invoices with totals above \$0.00 included.
- Paid and unpaid invoices included.

Check Number	Check Issue Date	Payee	Amount
64877	03/11/2026	BROOK HEADINGTON	150.15
64878	03/11/2026	KASSANDRA HARE	150.54
64879	03/11/2026	KATHRYN HILTON	143.64
64880	03/11/2026	SANDRA GRAF	145.85
64881	03/19/2026	OELWEIN USBC	1,671.34
Grand Totals:			<u>2,261.52</u>

RESOLUTION NO. _____-2026

A RESOLUTION AUTHORIZING TEMPORARY CLOSURE OF PUBLIC WAYS OR GROUNDS FOR OELWEIN FIRE FIGHTERS' FOUNDATION.

WHEREAS, Iowa Code Section 364. 12 (2) states that " a city shall keep all public grounds, streets, sidewalks, alleys, bridges, culverts, overpasses, underpasses, grade crossing separations and approaches, public ways, squares, and commons open, in repair, and free from nuisance, with the following exceptions "; and

WHEREAS, Iowa Code Section 364. 12 (2) (a) states that "Public ways and grounds may be temporarily closed by resolution "; and

WHEREAS, Oelwein Fire Fighters Foundation have requested temporarily closure of streets and parks for the following events, locations and times:

NOW, THEREFORE, BE IT RESOLVED by the City Council of Oelwein, Iowa that

Event	Location of Street Closures	Date & Time
Oelwein Fire Department 3 rd Annual BBQ Competition	100 block of South Frederick Avenue and the adjacent alleys	April 25, 2026 7:00 A.M. – 6:00 P.M.

Oelwein Fire Fighters Foundation organizers are authorized to temporarily close the aforementioned requested streets and park.

Passed and approved this 23rd day of March, 2026

Brett DeVore, Mayor

It was moved by _____ and seconded by _____ that the Resolution as read be adopted, and upon roll call there were:

AYES NAYS ABSENT ABSTAIN

Attest:

Weber
Payne
Cantrell
Cannon
Gearhart
Ricchio

Dylan Mulfinger, City Administrator

Recorded April 15, 2025.



Oelwein Fire Department
200 West Charles St
Oelwein, IA 50662



Oelwein Fire Fighters Foundation
Oelwein, IA 50662

Item 5.

To the Honorable Mayor and Members of the Oelwein City Council,

I am writing to respectfully request temporary no on-street parking and closure of South Frederick Ave between 1st Street SW and the entrance to the parking lot by Jon's Barber (see page 2) on Saturday April 25th from 700 hrs until 1800 hrs (7am – 6pm).

The purpose of this request is to allow for us to host our Annual BBQ Cookoff Contest. I also request city barricades for this event. Closing this section of the road during the requested time will help ensure the safety of contestants and attending public.

Thank you for considering this request.

Sincerely,

Kyle Randall

Oelwein Fire Fighters Foundation Secretary



Oelwein Fire Department
200 West Charles St
Oelwein, IA 50662



Item 5.

Oelwein Fire Fighters Foundation
Oelwein, IA 50662



RESOLUTION NO. _____-2026

A RESOLUTION AUTHORIZING TEMPORARY CLOSURE OF PUBLIC WAYS OR GROUNDS FOR PONY EXPRESS

WHEREAS, Iowa Code Section 364. 12 (2) states that " a city shall keep all public grounds, streets, sidewalks, alleys, bridges, culverts, overpasses, underpasses, grade crossing separations and approaches, public ways, squares, and commons open, in repair, and free from nuisance, with the following exceptions "; and

WHEREAS, Iowa Code Section 364. 12 (2) (a) states that "Public ways and grounds may be temporarily closed by resolution "; and

WHEREAS, Pony Express organizers have requested temporarily closure of streets and parks for the following events, locations and times:

Event	Location of Street Closures	Date & Time
Pony Express	Charles street to south Fredrick avenue then left to South Fredrick Avenue to 2nd street then 2nd street to 2nd avenue then 2nd avenue back to the trailers	April 3, 2026 9:30 A.M. – 12:00 P.M.

NOW, THEREFORE, BE IT RESOLVED by the City Council of Oelwein, Iowa that

Pony Express organizers are authorized to temporarily close the aforementioned requested streets.

Passed and approved this 23rd day of March, 2026

Brett DeVore, Mayor

Attest:

Dylan Mulfinger, City Administrator

It was moved by _____ and seconded by _____ that the Resolution as read be adopted, and upon roll call there were:

AYES NAYS ABSENT ABSTAIN

- Weber
- Payne
- Cantrell
- Cannon
- Gearhart
- Ricchio

Kaylonna McKee

From: Karissa Meitner <14kmeitner14@gmail.com>
Sent: Thursday, March 5, 2026 10:14 PM
To: Kaylonna McKee
Subject: Fwd: Pony Express 4.3.26

You don't often get email from 14kmeitner14@gmail.com. [Learn why this is important](#)

https://youtu.be/q6it2T5rWhw?si=Xvd8fCj_ZsCG-7Hj

Part One: Money Collection of donations

Oelwein money collectors

Corner of charles and fredrick from 830 to 1130 AM or whatever times you can do is fine but closer towards ending at 1130 AM to noon and starting at 9:30 AM even to is fine or whatever you guys can do- Oelwein FFA? Just asked waiting to confirm vs. NFV FFA West Union

Part 2. Date: Friday April 3rd, 2026 Route 5 Ride CONTACT 563-422-8814 IF INTERESTED

Where to meet at: Oelwein behind dentist office if okay in the huge parking lot

Time: 11:30 AM to 12:00 PM

What: Horse Parade to represent pony express

Route: Oelwein 1130 to noon start

Parking: behind share dentist if get permission in big parking lot

Route:

1. Charles street to south Fredrick avenue
2. Turn left South Fredrick Avenue to 2nd street
3. 2nd street to 2nd avenue
4. 2nd avenue back to the trailers

RESOLUTION NO. _____-2026

RESOLUTION APPROVING PAY APPLICATION NO. 6 IN THE AMOUNT OF \$407,043.42 TO TAYLOR CONSTRUCTION FOR THE 10TH ST. BRIDGE PROJECT

WHEREAS, the city is using bond dollars and state bridge funds to pay for the 10th St Bridge; and

WHEREAS, this is pay application number 6 for the project; and

WHEREAS, all work on the project has been satisfactory as of this pay application; and

WHEREAS, the amount of Pay Application 6 is \$407,043.42;

NOW, THEREFORE, BE IT RESOLVED by the city council of Oelwein, Iowa approves pay application no. 6 in the amount of \$407,043.42 to Taylor Construction for the 10th St. Bridge Project

Passed and approved by the City Council of the City of Oelwein, Iowa this 23rd day of March, 2026.

Brett DeVore, Mayor

It was moved by _____ and seconded by _____ that the Resolution as read be adopted, and upon roll call there were:

AYES NAYS ABSENT ABSTAIN

Attest:

- Ricchio
- Weber
- Payne
- Cantrell
- Cannon
- Gearhart

Dylan Mulfinger, City Administrator

Recorded March 24, 2026

City of Oelwein - Iowa

Detailed Payment

33-5657-614-A

Description BRM-5657(614)--8N-33, Letting Date- August 19, 2025
Payment Number 6
Pay Period 02/07/2026 to 03/06/2026
Prime Contractor TAYLOR CONSTRUCTION, INC.
7314 COLUMBUS
NEW VIENNA
Payment Status Pending
Awarded Project Amount \$1,416,351.70
Authorized Amount \$1,419,447.45

Line Number	Item ID	Unit	Unit Price	Authorized Quantity	Current Paid Quantity	Previous Paid Quantity	Total Quantity Paid To Date	Total Quantity Placed To Date	Current Payment Amount	Total Amount Paid To Date
Section: 0001 - BRM-5657(614)--8N-33, ITEMS FOR A 239'-0 X 32'-0 SKEW PRETENSTIONED PRESTRESSED CONCRETE BEAM BRIDGE										
0010	2101-0850001	ACRE	\$7,500.000	0.720	0.000	0.720	0.720	0.720	\$0.00	\$5,400.00
CLEARING AND GRUBBING										
0020	2102-2710070	CY	\$6.500	295.000	0.000	0.000	0.000	0.000	\$0.00	\$0.00
EXCAVATION, CLASS 10, ROADWAY AND BORROW										

Line Number	Item ID	Unit	Unit Price	Authorized Quantity	Current Paid Quantity	Previous Paid Quantity	Total Quantity Paid To Date	Total Quantity Placed To Date	Current Payment Amount	Total Amount Paid To Date
0030	2104-2713020	CY	\$6.000	4,107.000	500.000	3,025.000	3,525.000	3,525.000	\$3,000.00	\$21,150.00
EXCAVATION, CLASS 13, CHANNEL										
0040	2105-8425015	CY	\$7.000	241.000	0.000	0.000	0.000	0.000	\$0.00	\$0.00
TOPSOIL, STRIP, SALVAGE AND SPREAD										
0050	2115-0100000	CY	\$34.750	85.000	0.000	0.000	0.000	0.000	\$0.00	\$0.00
MODIFIED SUBBASE										
0060	2121-7425010	TON	\$21.000	55.000	0.000	0.000	0.000	0.000	\$0.00	\$0.00
GRANULAR SHOULDERS, TYPE A										
0070	2301-0685550	SY	\$263.000	154.200	0.000	0.000	0.000	0.000	\$0.00	\$0.00
BRIDGE APPROACH PAVEMENT, AS PER PLAN										
0080	2301-1033080	SY	\$83.000	268.000	0.000	0.000	0.000	0.000	\$0.00	\$0.00
STANDARD OR SLIP FORM PORTLAND CEMENT CONCRETE PAVEMENT, CLASS C, CLASS 3 DURABILITY, 8 IN.										
0090	2315-8275025	TON	\$21.000	42.000	0.000	0.000	0.000	0.000	\$0.00	\$0.00
SURFACING, DRIVEWAY, CLASS A CRUSHED STONE										
0100	2401-6745625	LS	\$25,000.000	1.000	0.000	1.000	1.000	1.000	\$0.00	\$25,000.00
REMOVAL OF EXISTING BRIDGE										
0110	2402-2720000	CY	\$45.000	121.800	0.000	121.800	121.800	121.800	\$0.00	\$5,481.00
EXCAVATION, CLASS 20										
0120	2402-2721000	CY	\$65.000	106.000	0.000	106.000	106.000	106.000	\$0.00	\$6,890.00
EXCAVATION, CLASS 21										

Line Number	Item ID	Unit	Unit Price	Authorized Quantity	Current Paid Quantity	Previous Paid Quantity	Total Quantity Paid To Date	Total Quantity Placed To Date	Current Payment Amount	Total Amount Paid To Date
0130	2403-0100010	CY	\$821.000	495.000	18.900	111.800	130.700	130.700	\$15,516.90	\$107,304.70
STRUCTURAL CONCRETE (BRIDGE)										
0140	2404-7775005	LB	\$1.100	128,331.000	2,582.000	17,449.000	20,031.000	20,031.000	\$2,840.20	\$22,034.10
REINFORCING STEEL, EPOXY COATED										
0150	2407-0562870	EACH	\$15,000.000	10.000	10.000	0.000	10.000	10.000	\$150,000.00	\$150,000.00
BEAMS, PRETENSIONED PRESTRESSED CONCRETE, BTB70										
0160	2407-0562895	EACH	\$25,000.000	5.000	5.000	0.000	5.000	5.000	\$125,000.00	\$125,000.00
BEAMS, PRETENSIONED PRESTRESSED CONCRETE, BTB95										
0170	2408-7800000	LB	\$5.000	5,787.200	4,683.200	0.000	4,683.200	4,683.200	\$23,416.00	\$23,416.00
STRUCTURAL STEEL										
0180	2414-6424110	LF	\$115.000	476.000	0.000	0.000	0.000	0.000	\$0.00	\$0.00
CONCRETE BARRIER RAILING										
0190	2414-6460000	LF	\$235.000	261.600	0.000	0.000	0.000	0.000	\$0.00	\$0.00
ORNAMENTAL METAL RAILING										
0200	2417-0225024	EACH	\$500.000	1.000	0.000	0.000	0.000	0.000	\$0.00	\$0.00
APRONS, METAL, 24 IN. DIA.										
0210	2417-1040024	LF	\$65.000	28.000	0.000	0.000	0.000	0.000	\$0.00	\$0.00
CULVERT, CORRUGATED METAL ENTRANCE PIPE, 24 IN. DIA.										
0220	2501-0201057	LF	\$60.000	1,096.000	0.000	1,096.000	1,096.000	1,096.000	\$0.00	\$65,760.00
PILES, STEEL, HP 10 X 57										

Line Number	Item ID	Unit	Unit Price	Authorized Quantity	Current Paid Quantity	Previous Paid Quantity	Total Quantity Paid To Date	Total Quantity Placed To Date	Current Payment Amount	Total Amount Paid To Date
0230	2501-6335010	LF	\$50.000	183.200	0.000	195.750	195.750	195.750	\$0.00	\$9,787.50
PREBORED HOLES										
0240	2505-4008120	LF	\$5.000	106.000	0.000	106.000	106.000	106.000	\$0.00	\$530.00
REMOVAL OF STEEL BEAM GUARDRAIL										
0250	2507-3250005	SY	\$3.500	1,310.000	578.670	488.440	1,067.110	1,067.110	\$2,025.35	\$3,734.89
ENGINEERING FABRIC										
0260	2507-6800061	TON	\$31.000	1,250.000	540.000	347.810	887.810	887.810	\$16,740.00	\$27,522.11
REVTMENT, CLASS E										
0270	2510-6745850	SY	\$10.000	529.000	0.000	219.800	219.800	219.800	\$0.00	\$2,198.00
REMOVAL OF PAVEMENT										
0280	2515-2475006	SY	\$81.000	56.000	0.000	0.000	0.000	0.000	\$0.00	\$0.00
DRIVEWAY, P.C. CONCRETE, 6 IN.										
0290	2524-6765010	EACH	\$300.000	1.000	0.000	0.000	0.000	0.000	\$0.00	\$0.00
REMOVE AND REINSTALL SIGN AS PER PLAN										
0300	2528-2518000	EACH	\$100.000	4.000	0.000	2.000	2.000	2.000	\$0.00	\$200.00
SAFETY CLOSURE										
0310	2528-8445110	LS	\$3,940.000	1.000	0.180	0.220	0.400	0.400	\$709.20	\$1,576.00
TRAFFIC CONTROL										
0320	2533-4980005	LS	\$150,000.000	1.000	0.527	0.473	1.000	1.000	\$79,050.00	\$150,000.00
MOBILIZATION										

Line Number	Item ID	Unit	Unit Price	Authorized Quantity	Current Paid Quantity	Previous Paid Quantity	Total Quantity Paid To Date	Total Quantity Placed To Date	Current Payment Amount	Total Amount Paid To Date
0330	2599-9999005	EACH	\$200.000	4.000	0.000	0.000	0.000	0.000	\$0.00	\$0.00
('EACH' ITEM): 34 TO 38 CONCRETE BARRIER TRANSITION SECTION, MODIFIED										
0340	2599-9999005	EACH	\$2,100.000	4.000	0.000	0.000	0.000	0.000	\$0.00	\$0.00
('EACH' ITEM): CONCRETE BARRIER, APPROACH, MODIFIED, 16 FT										
0350	2599-9999005	EACH	\$5,000.000	1.000	0.000	0.000	0.000	0.000	\$0.00	\$0.00
('EACH' ITEM): REMOVE AND REINSTALL EXISTING FLAP GATE, 24										
0360	2599-9999009	LF	\$50.000	24.000	0.000	24.830	24.830	24.830	\$0.00	\$1,241.50
('LINEAR FEET' ITEM): CORING ROCK SOCKET										
0370	2601-2634100	ACRE	\$500.000	1.000	0.000	0.000	0.000	0.000	\$0.00	\$0.00
MULCHING										
0380	2601-2636043	ACRE	\$3,000.000	0.500	0.000	0.000	0.000	0.000	\$0.00	\$0.00
SEEDING AND FERTILIZING (RURAL)										
0390	2601-2642100	ACRE	\$500.000	0.500	0.000	0.000	0.000	0.000	\$0.00	\$0.00
STABILIZING CROP - SEEDING AND FERTILIZING										
0400	2601-2700020	SF	\$20.000	240.000	0.000	0.000	0.000	0.000	\$0.00	\$0.00
TRANSITION MAT										
0410	2602-0000020	LF	\$2.500	450.000	0.000	0.000	0.000	0.000	\$0.00	\$0.00
SILT FENCE										
0420	2602-0000071	LF	\$0.010	450.000	0.000	0.000	0.000	0.000	\$0.00	\$0.00
REMOVAL OF SILT FENCE OR SILT FENCE FOR DITCH CHECKS										

Line Number	Item ID	Unit	Unit Price	Authorized Quantity	Current Paid Quantity	Previous Paid Quantity	Total Quantity Paid To Date	Total Quantity Placed To Date	Current Payment Amount	Total Amount Paid To Date
0430	2602-0000101	LF	\$0.010	225.000	0.000	0.000	0.000	0.000	\$0.00	\$0.00
MAINTENANCE OF SILT FENCE OR SILT FENCE FOR DITCH CHECK										
0440	2602-0000309	LF	\$2.150	575.000	0.000	0.000	0.000	388.000	\$0.00	\$0.00
PERIMETER AND SLOPE SEDIMENT CONTROL DEVICE, 9 IN. DIA.										
0450	2602-0000351	LF	\$0.010	575.000	0.000	0.000	0.000	0.000	\$0.00	\$0.00
REMOVAL OF PERIMETER AND SLOPE OR DITCH CHECK SEDIMENT CONTROL DEVICE										
8000	8000-0000000	None	\$0.000	0.000	0.000	0.000	0.000	0.000	\$0.00	\$0.00
PLACEHOLDER ONLY (DO NOT USE)										
8010	6100-2501010	EACH	\$600.000	2.000	0.000	2.000	2.000	2.000	\$0.00	\$1,200.00
{EXTRA WORK} SPLICE STEEL H-PILES (PRE-ESTABLISHED PRICE)										
8020	2501-0201042	LF	\$53.390	25.000	25.000	0.000	25.000	25.000	\$1,334.75	\$1,334.75
PILES, STEEL, HP 10 X 42										
Section Totals:									\$419,632.40	\$756,760.55
Total Payments:									\$419,632.40	\$756,760.55

Time Charges

Time Limit	Original Deadline	Authorized Deadline	Charges This Period	Damages This Period	Days Completed To Date	Days Remaining To Date	Damages To Date
Working Days, Late Start Date - 04/27/2026, Liquidated Damage Rate - 1,000	100.0 Days	100.0 Days	0.0 Days	\$0.00	0.0 Days	100.0 Days	\$0.00
Total Damages:							\$0.00

Summary

Current Approved Work:	\$419,632.40
Current Stockpile Advancement:	\$0.00
Current Stockpile Recovery:	\$0.00
Current Retainage:	\$12,588.98
Current Retainage Released:	\$0.00
Current Liquidated Damages:	\$0.00
Current Adjustment:	\$0.00
Current Payment:	\$407,043.42
Previous Payment:	\$99,574.69

Approved Work To Date:	\$756,760.55
Stockpile Advancement To Date:	\$0.00
Stockpile Recovery To Date:	\$0.00
Retainage To Date:	\$22,702.82
Retainage Released To Date:	\$0.00
Liquidated Damages To Date:	\$0.00
Adjustments To Date:	\$0.00
Payments To Date:	\$734,057.73
Previous Payments To Date:	\$327,014.31

Funding Details

33-5657-614-A-CAT-2 NON-PARTICIPATING:	\$0.00
33-5657-614-CAT-1 33-5657-614-CAT-1 33-5657-614-A:	\$419,632.40
Current Payment:	\$419,632.40

33-5657-614-A-CAT-2 NON-PARTICIPATING To Date:	\$0.00
33-5657-614-CAT-1 33-5657-614-CAT-1 33-5657-614-A To Date:	\$756,760.55
Payments To Date:	\$756,760.55

RESOLUTION NO. _____-2026

RESOLUTION APPROVING PROJECT EXPENSE REIMBURSEMENTS NUMBER FIVE IN THE AMOUNT OF \$43,746.57 FOR THE OELWEIN RISE DAY HABILITATION CENTER IMPROVEMENTS PROJECT

WHEREAS, the City of Oelwein is the official grant recipient for the Oelwein RISE Day Habilitation Center Improvements Project; and

WHEREAS, RISE will provide reimbursement requests based on expenses from their project; and

WHEREAS, the city will receive grant reimbursements from the state of Iowa CDBG grant and in turn provide a check to RISE for their project; and

WHEREAS, the following expenses were created in reimbursement number five:

INVOICE #	PAYEE	INVOICE DATE	INVOICE AMOUNT	CDBG SHARE	LOCAL SHARE
Pay App #4	Matt Construction, Inc. (RISE paid)	11/30/2025	\$47,997.67	\$41,729.17	\$6,268.50
1178743	Oelwein Publishing (RISE paid)	12/10/2025	\$22.43	\$19.50	\$2.93
FY26210	Upper Explorerland Regional Planning Commission (CITY paid)	11/30/2025	\$742.54	\$742.54	\$ -
FY26231	Upper Explorerland Regional Planning Commission (CITY paid)	12/31/2025	\$1,255.36	\$ 1,255.36	\$ -

Now, therefore, be it resolved by the City Council of Oelwein, Iowa expense reimbursements number five in the amount of \$43,746.57 for the Oelwein RISE Day Habilitation Center Improvements Project

Passed and approved this 23rd day of March, 2026.

Brett DeVore, Mayor

Attest:

Dylan Mulfinger, City Administrator

It was moved by _____ and seconded by _____ that the Resolution as read be adopted, and upon roll call there were:

AYES NAYS ABSENT ABSTAIN

- Ricchio
- Weber
- Lenz
- Cantrell
- Seeders
- Payne

STATE OF IOWA

GAX Item 8.

BUDGET FY	General Accounting Expenditure		DOCUMENT NUMBER
2026	DATE 3/23/2026	ACCTG PERIOD (mm/yy) 11/30/2025 - 12/31/2025	5

VENDOR CODE	AGENCY NAME	
VENDOR NAME AND ADDRESS City of Oelwein 20 2nd Avenue SW Oelwein, IA 50662	BILL TO ADDRESS (ORDERING AGENCY) Iowa Economic Development Authority 1963 Bell Avenue, Suite 200 Des Moines, Iowa 50315	SHIP TO ADDRESS

TERMS	FOB	ORDER APPROVED BY	GOODS RECEIVED/SERVICES PERFORMED
			DATE INITIALS
QUANTITY		VENDOR'S INVOICE NUMBER	
		5	

ORDERED	RECEIVED	UNIT OF MEASURE	DESCRIPTION	UNIT PRICE	TOTAL PRICE
			Request for Payment under CDBG Contract Number: 24-CF-002 Report Number: 5		43,747.00

DOCUMENT TOTAL **43,747.00**

CLAIMANT'S CERTIFICATION I CERTIFY THAT THE ITEMS FOR WHICH PAYMENT IS CLAIMED WERE FURNISHED FOR STATE BUSINESS UNDER THE AUTHORITY OF THE LAW AND THAT THE CHARGES ARE REASONABLE, PROPER, AND CORRECT, AND NO PART OF THIS CLAIM HAS BEEN PAID. DATE 3/23/2026 TITLE Mayor	AGENCY CERTIFICATION I CERTIFY THAT THE ABOVE EXPENSE WERE INCURRED AND THE AMOUNTS ARE CORRECT AND SHOULD BE PAID FROM THE FUNDS APPROPRIATED BY: CODE OR CHAPTER SECTION(S)
CLAIMANT'S SIGNATURE	AUTHORIZED SIGNATURE

THE FOLLOWING FIELDS ARE FOR STATE ACCOUNTING USE ONLY

DOC TYPE (GAX) GAX	DOC NUMBER 5	DOC DATE	ACCTG PRD	BUDGET FY 2026	ACTION NEW/MOD	PO SHIP INSTR	GAX TYPE 1	INT IND	INT SELLER FUND	INT SELLER AGCY
------------------------------	------------------------	----------	-----------	--------------------------	----------------	---------------	----------------------	---------	-----------------	-----------------

VENDOR CODE 2130037	ADDR OVERRIDE	F/A INDICATOR	LEFT IND Y	TEXT -po's only (Y/N)	TEXT (po's only)
-------------------------------	---------------	---------------	----------------------	-----------------------	------------------

REF DOC TYPE	REF DOC NUMBER	REF DOC LINE	COM LN	VEND INVOICE # 5	COMMODITY CODE	GS CONTRACT
--------------	----------------	--------------	--------	----------------------------	----------------	-------------

LINE	FUND	AGCY	ORG	SUB ORG	ACTV	FUNC	OBJT	SUB OBJT	JOB NUMBER	REP CAT	QUANTITY / UNITS	I/D	DESCRIPTION	AMOUNT	I/D	P/F
01	0340	269	4610	24			4125							43,747.00		
02																
03																
04																
05																
06																
07																

DOCUMENT TOTAL **43,747.00**

Ordinance No. 1227

AN ORDINANCE AMENDING, CHAPTER 6, ARTICLE IV, OELWEIN AIRPORT BOARD, SECTION 6-103 MEETING AND MINUTES OF THE CODE OF ORDINANCES OF THE CITY OF OELWEIN, IOWA

BE IT ORDAINED by the City Council of the City of Oelwein, Iowa, as follows:

Section 1. That the General Ordinances of the City of Oelwein adopted July 1, 2012, with subsequent amendments, be amended by amending the following from Section 6-103:

Sec. 6-103. - Meeting and minutes.

The board shall hold at least one public meeting ~~each month~~ *every other month or as needed*, at such times and places as the board shall establish.

Section 2. That all Ordinances or parts thereof in conflict herewith be and the same are hereby repealed.

First reading -	March 9, 2026
Second reading -	March 23, 2026
Third reading -	April 13, 2026

Passed and adopted by the City Council of the City of Oelwein, Iowa, this day of April 13, 2026.

Brett DeVore, Mayor

Attest:

Dylan Mulfinger, City Administrator

Recorded April 14, 2026.

First Reading on: March 9, 2026. It was moved by Weber and seconded by Gearhart that the Ordinance as read be adopted, and upon roll call there were:

	AYES	NAYS	ABSENT	ABSTAIN
Weber	x			
Payne	x			
Cantrell	x			
Cannon	x			
Gearhart	x			
Ricchio	x			

Second Reading on March 23, 2026. It was moved by _____ and seconded _____ that the Ordinance as read be adopted, and upon roll call there were:

	AYES	NAYS	ABSENT	ABSTAIN
Weber				
Payne				
Cantrell				
Cannon				
Gearhart				
Ricchio				

Third Reading on April 13, 2026. It was moved by _____ and seconded by _____ that the Ordinance as read be adopted, and upon roll call there were:

	AYES	NAYS	ABSENT	ABSTAIN
Weber				
Payne				
Cantrell				
Cannon				
Gearhart				
Ricchio				

Ordinance No. 1228

AN ORDINANCE AMENDING CHAPTER 19 – ANIMAL AND FOWL -
SECTIONS 19-0.5 THROUGH 19-39 RELATED TO ANIMAL AND FOWL

BE IT ORDAINED by the City Council of the City of Oelwein, Iowa, as follows:

SECTION 1. Chapter 19, Sections 19-0.5 through 19-39 of the Code of Ordinances of the City of Oelwein, Iowa, shall be deleted in their entirety, and replaced as follows:

Sec. 19-1. - Definitions.

For use in this Chapter, the following terms are defined:

- a. *Adequate shelter* means any shelter that allows for a cat or dog to be protected from the outside weather elements, ensures that they have room to move around, and clean dry bedding.
- b. *Animal* means all non-human species, avian, reptile or mammal.
- c. *At Large* means any licensed or unlicensed dog or cat found off the premises of their owner and not under the control of a competent person, restrained within a motor vehicle, housed in a veterinary hospital or kennel.
- d. *Cats* means both male and female animals of the feline species, whether altered or not.
- e. *Chicken* means a female or hen domesticated gallinaceous bird (*Gallus gallus domesticus*) used as a source of eggs and meat, sometimes referred to as 'Fowl'.
- f. *Dogs* means both male and female animals of the canine species, whether altered or not.
- g. *Domestic animal* means only a dog or a cat.
- h. *Enclosure* means a fence or kennel structure of at least six feet in height, forming or causing an enclosure suitable to prevent the entry of young children, and suitable to confine a vicious dog. Such enclosure shall be securely enclosed and locked and designed with secure sides, top and bottom and shall be designed to prevent the animal from escaping from the enclosure. Any gates or access to the enclosure shall be self-closing and equipped with a keyed or combination locking device. Any Enclosure shall be built to be fully compliant with the City of Oelwein fence regulations
- i. *Fowl* means a female or hen domesticated gallinaceous bird (*Gallus gallus domesticus*) used as a source of eggs and meat, sometimes referred to as 'Chicken'.
- j. *Impounded* means taken into custody by the animal control officer.
Persons means a natural person or any legal entity, including but not limited to, a corporation, firm, partnership or trust.
- k. *Owner* means any person or persons, firm, association or corporation owning, keeping, sheltering or harboring a Domestic Animal.
- l. *Person(s)* means a natural person or legal entity.
- m. *Police Chief* means the Chief of Police or the chief's authorized designee.
- n. *Vicious Animal* means:
 1. Any Animal which when unprovoked, in a vicious or terrorizing manner approaches any Person or Domestic Animal in in a manner determined to be aggressive, vicious, or in a terrorizing manner, in any public place,

including but not limited to public rights of way, streets, sidewalks, parks or other public grounds or ways; or

2. Any Animal with a known propensity, tendency or disposition to attack unprovoked, to cause injury or to otherwise endanger the safety of Persons or Domestic Animals, including but not limited to an Animal that has previously attacked or bitten any Person or Domestic Animal, including those where the Person who owns, possesses or harbors said Animal should know of said propensity, tendency or disposition.
 3. Any Animal which bites, inflicts injury, assaults or otherwise attacks a Person or Domestic Animal without provocation on public or private property; or
 4. Any Animal that has been trained and/or is harbored in part for the purpose of fighting.
- o. Vicious Animal Exception* means any Animal otherwise fitting the definition of a Vicious Animal, based upon the Animal causing injury to a Person or Domestic Animal, where the injury was sustained while said Person or Domestic Animal was committing a willful trespass or other tort upon premises occupied by the Owner of the Animal, or was teasing, tormenting, abusing or assaulting the Animal or was committing or attempting to commit a crime. No Animal may be declared vicious if the Animal was protecting or defending a human being within the immediate vicinity of the Animal from an unjustified attack or assault.

Sec. 19-2. - Animals on Sidewalks.

It shall be unlawful for any Person to drive, lead or ride any Animal, other than Domestic Animals, upon any sidewalk. No Animal shall be leashed or restrained in a fixed location in a manner which allows access to the sidewalk by the Animal. Dogs must be kept on a leash when not on private property.

Sec. 19-3. - Bothersome animals.

It is unlawful for a Person to possess within the city limits of the City of Oelwein, bothersome animals such as bees, cattle, horses, goats, swine, sheep, fowl, excluding hen chickens if possessed in accordance with the City Code, and further excluding fowl kept in bird cages as a pet inside the principal dwelling as defined by Chapter 25 of the City Code, with allowable pets to never include chicken, geese, duck, and other common domestic or state protected birds, donkey, alpaca, buffalo, llama, any other domesticated livestock, or feral cats. The possession of bothersome animals within the city limits shall only be allowed for educational purposes on public school property.

1. Gerbils, hamsters, guinea pigs, rabbits, mice, exotic birds, snakes, insects, lizards, and other similar animals that are customarily sold at commercially operated pet stores and maintained as household pets in an enclosure inside a principal or accessory structure are not considered a bothersome animal, but may be excluded under other provisions of the city Code of Ordinances.

Sec. 19-4. - Running at large.

It shall be unlawful to permit any Animal, including but not limited to fowl, to run at large, whether licensed or unlicensed.

Sec. 19-5. - Actions of Animals constituting a nuisance.

1. It shall be unlawful for an Owner of a Animal to allow or permit the Animal to pass upon the private property of another, public property, or right of way, in a manner that damages, soils with feces, unless the feces are immediately collected by the Owner, or to otherwise unreasonably interfere with the use of the property by said Owner or members of the public, in the case of public property or right of way.
2. It shall be unlawful for an owner of an Animal to allow or permit such Animal to cause serious annoyance or disturbance to any Person(s) by frequent and habitual howling, yelping, barking or otherwise; or by running after or chasing Persons, bicycles, automobiles or other vehicles.

Sec. 19-6. - Fowl on premises of another.

1. It shall be unlawful for any Person to take possession and control of any fowl that may enter upon their property. In the event fowl enter upon the property of any Person, not the owner of said fowl, said Person shall immediately contact the Oelwein Police department who shall attempt to collect said fowl and remove them from said Property.

Sec. 19-7. – Impoundment – Generally - Quarantine.

1. Any animal found running at large, found staked, or tied out to graze contrary to the provisions of this chapter will be impounded and turned over to a private kennel or placed in other available suitable housing, with the Owner of the Animal to be solely responsible for all costs associated with the kenneling, placement, feeding, care, and impoundment, including fees tied to necessary medical care, vaccines where appropriate and legally required, of the Animal, with all sums to be due and payable prior to the release of the Animal to the Owner. Any Animal not claimed by the Owner in accordance with the rules of the kennel or other facility where the Animal has been placed within seven (7) days of placement, shall forfeit the right to said Animal, and said Animal shall be sold or humanely destroyed in the discretion of the Police Chief. The Owner shall be responsible for costs of destruction.
 - a. Owners of licensed Domestic Animals shall be notified within two days that upon payment of costs of impoundment, cost of food and care, and costs of vaccination if vaccination is required, the Domestic Animal will be returned to the Owner upon proper identification and proof of ownership. If the impounded licensed Domestic Animal is not recovered by its' Owner within seven (7) days after notice, the Domestic Animal shall be disposed of in a humane manner as directed by the Police Chief.
 - b. Owners of unlicensed Domestic Animals, if determinable, shall be notified within two days of said determination, that upon payment of licensing fees required by City Code, costs of impoundment, cost of food and care, and costs of vaccination if vaccination is required, the Domestic Animal will be returned to the Owner upon proper identification and proof of ownership. If the impounded Domestic Animal is not recovered by its' Owner within seven days after notice, or within fourteen (14) days from the date of impoundment if the Owner has not been identified, the Domestic Animal shall be disposed of in a humane manner as directed by the Police Chief.
2. When the Police Chief receives information that any Person or Domestic Animal has been bitten by an Animal, that any Animal is suspected of having rabies or

other disease communicable to humans or other Domestic Animal, or said Animal otherwise meets the definition of a Vicious Animal or Bothersome Animal as defined in this Code of Ordinances, then:

- a. Licensed animals with written certification of current rabies vaccination shall be ordered confined for such period of time as directed by the Police Chief necessary to determine whether the Animal possesses any communicable disease. Upon determination by the Police Chief that the Owner is not confining the Animal as directed, the animal may be impounded.
 - b. Unlicensed or unvaccinated animals may be immediately apprehended and impounded by the police department, and turned over to a private kennel or placed in other available suitable housing for such period of time as directed by the Police Chief necessary to determine whether the Animal possesses any communicable disease, with the Owner of the Animal to be solely responsible for all costs associated with the kenneling, placement, feeding, care, and impoundment, including fees tied to necessary medical care, vaccines where appropriate and legally required, of the Animal, with all sums to be due and payable prior to the release of the Animal to the Owner. Any Animal not claimed by the Owner in accordance with the rules of the kennel or other facility where the Animal has been placed within seven (7) days of placement, shall forfeit the right to said Animal, and said Animal shall be sold or humanely destroyed in the discretion of the Police Chief. The Owner shall be responsible for costs of destruction.
3. Any animal found to be in violation of any provision of this Chapter may be impounded by the Police Department, and delivered to any private kennel or placed in other available suitable housing.
 4. The failure of any Person harboring, keeping, or possessing any Animal to produce said Animal to the Police Chief upon direction to do so shall be punishable as a municipal infraction citation.
 5. Impounded Animals shall be held for seven (7) days, after which they may be recovered by the owner upon proper identification, payment of any solely responsible for all costs associated with the kenneling, placement, feeding, care, and impoundment, including fees tied to necessary medical care, vaccines where appropriate and legally required. When an Animal has been impounded under Section 19-7(2)(a), the seven (7) day period shall be extended until such time that it has been determined that the Animal does not possess any communicable disease.
 6. Impounded Animals that are not claimed within three (3) days' written notice, shall be considered abandoned and thereafter disposed of in a humane manner, including sale in accordance with Section 19-9, as directed by the Police Chief.
 - a. The failure of an Owner to claim an Animal impounded hereunder shall in no way relieve the Owner or responsibility for all costs associated with the kenneling, placement, feeding, care, and impoundment, including fees tied to necessary medical care, vaccines where appropriate and legally required, and/or to disposal of the Animal.

Sec. 19-8. Release of Animals.

1. Animals impounded and/or quarantined may be released to the Owner, only after payment of all fees and costs as required under Section 19-7, as follows:
 - a. Release to possession of the Owner without conditions.
 - b. Release to possession of the Owner with such conditions, terms and requirements, related to the release and continued possession of the Animal in the City limits, as directed by the Police Chief, deemed reasonably necessary and appropriate to ensure public safety including, but not limited to any one or more of the following:
 1. To keep the Animal confined to the Owner's property in an Enclosure or by any other means approved by the Police Chief.
 2. To require the Owner to identify the Animal by means of a special blaze orange collar.
 3. To keep the Animal securely muzzled, leashed, and under control of a Person 18 years of age or older who is physically capable of restraining the Animal when outside of any Enclosure, and to keep the dog or animal on the owner's property at all times.
 4. To require the Owner to inform by any means necessary, the postmaster, utility companies, meter readers, or other Persons who routinely come on the property of the Owner that a Vicious Animal is on the property, and to continually notify said Persons in the event of a move by Owner to another property within the City.
 5. To require the Owner to prove financial responsibility for any injury or damage which may be caused by the Animal by providing proof of insurance in the following amounts: \$5,000.00 no fault medical coverage and \$200,000.00 liability coverage, with confirmation from the insurer that the Animal in question is not excluded from coverage under the policy.
 6. To require the owner to acknowledge any conditions in writing and to further acknowledge that any violation of the conditions will result in the immediate impoundment of the Animal, without the possibility of the Animal being returned to the Owner.

Sec. 19-9. - Sale.

All impounded Animals or Fowl may be sold to the highest bidder for cash, upon giving three days' notice of the date and time of such sale by one publication in one newspaper published in the City of Oelwein, which sale shall not be less than three nor more than five days after the date of service of such notice.

Sec. 19-10. – Keeping or Harboring a Vicious animals.

1. It shall be unlawful for any Person to keep or harbor a Vicious Animal within the City limits of the City of Oelwein, unless the Vicious Animal is kept or harbored under one of the following circumstances:
 - a. On private property for the protection of person or property, provided that such Animal is located within an Enclosure or restrained by a leash of no longer than three feet (3') of a significant strength, muzzled, and

under the control of a Person of legal age capable of controlling and maintaining possession of the Animal.

- b. Used by a law enforcement or military agency
- 2. No Person shall own or harbor any Animal for the purpose of fighting, or train, torment, badger, bait or use any Animal for the purpose of causing or encouraging said Animal to unprovoked attacks upon Persons or Domestic Animals.
- 3. No Person shall possess any Vicious Animal with intent to sell or attempt to sell, breed, or buy or attempt to buy, within the City.
- 4. Enforcement of this section may be accomplished in any manner authorized by law, including an action to abate public nuisance.

Sec. 19-11. - Owner's duty.

- 1. It shall be the duty of the Owner of any Animal which has bitten or attacked a Person, or of any Person having knowledge of such bite or attack, to report the bite or attack to the Police Chief within 24 hours of the bite or attack.
- 2. Any Person required to report a bite or attack under Paragraph 1 who fails to do so may be charged with a municipal infraction.

Sec. 19-12. - Fowl on residential property.

- 1. Chicken on residential property shall abide by the following:
 - a. Be kept in an Enclosure which is fully enclosed on all sides and top.
 - 1. Four square feet of space minimum provided per chicken.
 - 2. Enclosures must be in rear yard and may occupy a max of 100 square feet of ground space.
 - 3. Enclosures shall be maintained to be aesthetically and structurally sound; and be made of weather-resistant materials.
- 2. A maximum of ten Chickens shall be allowed on a property.
- 3. Roosters are prohibited.
- 4. Enclosures must be kept in a clean, dry, odor-free, neat and sanitary condition at all times. Odors from chickens, chicken manure or other Chicken related substances shall not be perceptible beyond the boundaries of the property.
- 5. Chickens shall be provided with access to feed and clean water. The feed and water shall be unavailable to rodents, wild birds, and predators.
- 6. No Person shall keep Chickens inside a single-family dwelling unit, multi family dwelling unit(s) or rental unit.
- 7. No Chickens are allowed to run at large.
- 8. Noise from Chickens shall not be loud enough beyond the boundaries of the Owner's property to disturb any Person(s) of reasonable sensitivity.

Sec. 19-13. – Possession of Dogs and Cats - Limitations.

- 1. It shall be unlawful for more than a combined total of four cats and/or dogs to be kept, sheltered or harbored in one residential living unit, or on one non-residential use parcel of property. This restriction shall not apply to:
 - a. Kennels, pet shops, veterinary clinics or animal grooming in properly zoned zoning districts.
 - b. The off-spring produced by any Domestic Animal, permitted herein, may be maintained at or in a residential dwelling with the parent animal for a period not to exceed ten weeks after birth.

- c. An annual special permit may be granted for the keeping, sheltering or harboring of AKC recognized breeds, in numbers which exceed the limitation of this chapter, upon prior written application to the Police Chief on a form furnished by the City of Oelwein, payment as set by the City's fee schedule, non-refundable inspection fee, and a determination by the Police Chief that the applicant has the demonstrable ability to provide each animal, appropriate for the particular breed, the following:
 1. Proper food and water;
 2. Proper grooming and cleaning;
 3. Adequate veterinary care, including: Immunizations, parasite control and preventative health care;
 4. Adequate shelter that meets the following standards:
 - a. Is structurally sound, weather proof and properly ventilated with access to shade from direct sunlight and escape from exposure in inclement weather;
 - b. Sufficient space pursuant to most recent published standards of the AKC for the breed(s) sheltered with adequate freedom of movement and to allow postural and social adjustment which is maintained so as not to constitute a nuisance;
 5. Otherwise in compliance with the Oelwein City Code.
 6. All Animal shall be properly licensed in compliance with City Code licensing requirements.
 7. Non-compliance with this exception shall warrant immediate revocation of the annual special permit and the applicant shall not qualify for a special permit for a period of 24 months from revocation.
2. All structures, pens, kennels or yards wherein said animals are confined clean and devoid of vermin and free of odors arising from feces. Feces shall be collected, removed and placed in an air tight receptacle until disposed of in a sanitary manner.
3. No Domestic Animal may be enclosed or fenced in the front yard of a residential dwelling and all permitted Enclosures shall be located at a minimum of 15 feet from a neighboring residential dwelling. No Domestic Animal shall be staked on bare ground in the front or side yard of a residential dwelling.
4. No Domestic Animal shall be left outside unattended for more than 30 minutes when the ambient or wind chill temperature is below -20 F or when the head index exceeds 105 F as determined by any city official. This code does not apply if adequate shelter is provided for the Animal.

Sec. 19-14. - Vicious Animal Designation.

1. In the event the Police Chief has declared any Animal to be a Vicious Animal, the Police Chief shall notify, in writing, by personal service or certified mail, the Owner of the Animal, that said Animal has been declared a vicious animal. The written notice shall include:
 - a. Description of the Animal, to the extent possible;

- b. A description of the facts leading to the determination that the Animal is a Vicious Animal;
- c. Explanation that within five (5) days, exclusive of Saturday, Sundays and City or State recognized holidays, from the service of notice, that the Owner of the Animal shall:
 - 1. License the Animal with the City, and follow all other requirement of Sec. 19-15 of this Chapter of the Code of Ordinances; or
 - 2. Permanently remove the Animal from the City limits, providing evidence of said removal to the satisfaction of the Police Chief; or
 - 3. Destroy the Animal in an expeditious and humane manner, and submit evidence of said destruction to the satisfaction of the Police Chief; and
 - 4. Explanation that if a Vicious Animal has not been registered, removed or destroyed within five (5) days, exclusive of Saturday, Sundays and City or State recognized holidays, from the service of notice, that the Police Chief will impound the Animal, and all costs of impoundment, including necessary shots and/or medical care, or costs of destruction, shall be assessed against the Owner.
- d. Explanation that Owner shall maintain the Animal in an Enclosure from the delivery of the Vicious Animal declaration notice, until taking action under subsection three (3) above, and/or during an appeal of the Vicious Animal declaration as described in subsection 19.14(1)(e) below.
 - 1. No Animal declared to be a Vicious Animal shall be kept or allowed outside the dwelling of the Owner unless it is necessary for the Owner to obtain veterinary care for the Vicious Animal, to sell or give away the Vicious Animal, to comply with commands or directions of the Police Chief with respect to the Vicious Animal, or to comply with any provisions of this Chapter. In such event, the Vicious Animal shall be securely muzzled and restrained with a chain having a minimum tensile strength of 300 pounds and not exceeding three feet (3') in length, and shall be under the direct control and supervision of a Person at least eighteen (18) years of age capable of controlling the Animal.
- e. Explanation that the Owner may appeal the decision of the Police Chief by submitting a written appeal, delivered to the City Clerk's Office, located at the Oelwein City Hall, within five (5) days of delivery of the Vicious Animal notice, exclusive of Saturday, Sundays and City or State recognized holidays.
 - 1. The notice to advise the Owner that in the event an appeal is not timely submitted, that the right to appeal will be deemed waived and the decision of the Police Chief will be final, and the Animal will be conclusively presumed to be a Vicious Animal.
 - 2. The hearing on any Appeal shall be before the Police Chief.

3. The appellant (Owner) may present any evidence deemed appropriate to the Police Chief to counter the Chief's initial determination that the Animal was a Vicious Animal.
2. In the event that the Police Chief has probable cause to believe that the Animal declared to be a Vicious Animal may pose a threat of serious harm to Persons or other Animals from the declaration through any appeal period, the Police Chief may seize and impound the Animal from the declaration forward. The owner shall not be liable to the City of Oelwein for the costs and expenses of impoundment if the Animal is not thereafter found to not be a Vicious Animal.

Sec. 19-15. – Vicious Animal Licensing and other Requirements.

1. No Animal determined to be a Vicious Animal shall be licensed by the City of Oelwein, where applicable, for any licensing period commencing after the date of such determination, or shall any Vicious Animal be maintained in the City of Oelwein where licensing of such Animal is not required, unless the Owner of such Vicious Animal shall satisfy all of the following requirements:
 - a. Provide to the City Clerk or designee, proof of the procurement of liability insurance issued by an insurance company licensed to do business in the State of Iowa to the Owner, same to provide coverage for any injury or damage which may be caused by the Animal by providing proof of insurance in the following amounts: \$5,000.00 no fault medical coverage and \$200,000.00 liability coverage, with confirmation from the insurer that the Animal in question is not excluded from coverage under the policy. The required coverage shall show coverage for a period of twelve (12) months following the declaration, shall show that the premium has been fully paid, and include a provision requiring the City to be named as additional insured for the sole purpose of the City Clerk or designee to be notified by the insurance company of any cancellation, termination or expiration of the liability insurance policy.
 - b. The Owner shall display a sign on the premises where the Vicious Animal is maintained that warns the public of the presence of an animal determined to be a Vicious Animal. Said sign shall be visible and capable of being read from the public roadway, street or alleyway, adjacent to the premises.
 - c. The Owner shall sign a statement, to be maintained by the City Clerk, attesting that:
 1. The Owner will maintain and not allow the liability insurance required by this section to be cancelled, unless the Owner shall cease to possess the Animal.
 2. The Owner will continuously maintain the required Enclosure on any property where the Vicious Animal will be maintained.
 3. The Owner will notify the Police Chief immediately if a Vicious Animal is at large, unconfined, has attacked another Animal or Person, has died, was sold, or given away. If a Vicious Animal has been sold or given away the owner shall provide the Police Chief with the name, address and telephone number of the new owner.
2. The Police Chief is hereby empowered to make whatever inquiry deemed necessary to ensure compliance with the provisions of this Chapter, and to seize

and impound any Vicious Animal whose Owner fails to comply with the provisions hereof.

3. In the event an Owner refuses to surrender a Vicious Animal to the Police Chief when required, the Police Chief may apply for an Administrative Search Warrant to allow for the seizure of the Animal upon execution of the warrant.
4. The provisions hereof shall apply to all Vicious Animals located within the City limits of the City of Oelwein whether such determination was made prior to or after approval of this Ordinance or amendments hereto. Owners shall have fourteen (14) days to come into compliance with these code provisions, unless a shorter time, under the Ordinances of the City, applies, in which case the shorter term applies.

Sec. 19-16. Vicious Animal at Large.

1. In the event an Animal declared a Vicious Animal is found at large or unattended upon any property within the City, creating a hazard to life or property, such Animal may, in the sole discretion of the Police Chief or designee, be destroyed if it cannot safely be confined or captured. The City shall be under no duty to attempt to confine or capture a Vicious Animal found at large, whether previously declared such or not, nor shall it have a duty to seek to identify the owner and/or to notify the owner in advance of its destruction.

Sec. 19-17. - Penalties for violation.

1. Any Owner who maintains a Vicious Animal in violation any of the provisions of this chapter shall, upon conviction, be guilty of a municipal infraction. Each day that a violation occurs or is permitted to exist shall be considered a separate offense, with penalties to be applied per day of violation.
2. If any Vicious Animal, shall, when unprovoked, attack, assault, bite or otherwise injure any Person or other Domestic Animal or participate in an attack or , assault, where a Person is bitten or otherwise injured whether within or without the enclosure of the Owner, on or off the property of the Owner, whether on a leash and/or securely muzzled, and regardless of whether the Vicious Animal is at large or outside the control of the Owner, whether unintentionally or not, the Owner of the Vicious Animal shall be guilty of a municipal infraction. It is rebuttably presumed as a matter of law that owning, keeping or harboring a Vicious Animal in violation of this chapter is a nuisance. It shall not be necessary, in order to sustain any such action, to prove that the owner of the Vicious Animal knew that the Vicious Animal had the propensity to cause any particular damage or injury in any particular circumstance. Upon such damage or injury, the Police Chief is hereby authorized to confiscate and, after expiration of a five (5) day waiting period, exclusive of Sundays and local holidays, shall see to the destruction of said Vicious Animal. Prior to said destruction, the Owner shall be given notice and appeal rights consistent with Section 19.16(1)(e). In the event of an appeal, the destruction of the Vicious Animal shall be stayed with the animal remaining impounded, with all costs thereof to be assessed to and paid by the Owner, unless it is determined on appeal that the allegations supporting the impoundment and proposed destruction are unfounded and/or otherwise not sustained.

Section 3. Severability Clause. If any section, provision or part of this ordinance shall be adjudged invalid or unconstitutional, such adjudication shall not affect the validity of the ordinance as a whole or any section, provision or part thereof not adjudged invalid or unconstitutional.

Section 4. Effective Date. This ordinance shall be in effect from and after its final passage, approval, and publication as provided by law.

First reading - March 23, 2026
Second reading - April 13, 2026
Third reading - April 27, 2026

Passed and adopted by the City Council of the City of Oelwein, Iowa, this day of April 27, 2026.

Brett DeVore, Mayor

Attest:

Dylan Mulfinger, City Administrator

Recorded April 28, 2026.

First Reading on: March 23, 2026. It was moved by _____ and seconded by _____ that the Ordinance as read be adopted, and upon roll call there were:

AYES NAYS ABSENT ABSTAIN

Weber
Payne
Cantrell
Cannon
Gearhart
Ricchio

Second Reading on April 13, 2026. It was moved by _____ and seconded _____ that the Ordinance as read be adopted, and upon roll call there were:

AYES NAYS ABSENT ABSTAIN

Weber
Payne
Cantrell
Cannon
Gearhart
Ricchio

Third Reading on April 27, 2026. It was moved by _____ and seconded by _____ that the Ordinance as read be adopted, and upon roll call there were:

AYES NAYS ABSENT ABSTAIN

Weber
Payne
Cantrell
Cannon
Gearhart
Ricchio

RESOLUTION NO. _____-2026

RESOLUTION SCHEDULING A PUBLIC HEARING FOR THE PROPOSED CITY BUDGET FOR THE FISCAL YEAR 2027 (2026-2027) FOR APRIL 13, 2026 AT 6:00 PM AT THE OELWEIN CITY COUNCIL CHAMBERS

WHEREAS, the City of Oelwein is required by state law to hold a public hearing before the budget is adopted; and

WHEREAS, the City of Oelwein will hold a public hearing on the budget adoption April 13, 2026 at 6:00 PM at the Oelwein City Council Chambers 20 2nd Ave. SE, Oelwein, Iowa; and

WHEREAS, the city of Oelwein's levy is being reduced for Fiscal Year 2027 (2026-2027); and

WHEREAS, the City of Oelwein held their public hearing for the proposed Property Tax Hearing for the fiscal year 2027 (2026-2027) budget March 23 at 5:30 PM at the Oelwein City Council Chambers; and

NOW, THEREFORE, BE IT RESOLVED by the City Council of Oelwein, Iowa schedules a Public Hearing for the Proposed City Budget for the Fiscal Year 2027 (2026-2027) for April 13, 2026 at 6:00 PM at the Oelwein City Council Chambers.

Passed and approved this 23rd day of March, 2026.

Brett DeVore, Mayor

Attest:

Dylan Mulfinger, City Administrator

Recorded March 24, 2026.

It was moved by _____ and seconded by _____ that the Resolution as read be adopted, and upon roll call there were:

AYES NAYS ABSENT ABSTAIN

- Ricchio
- Weber
- Payne
- Cantrell
- Cannon
- Gearhart

RESOLUTION NO. _____-2026

RESOLUTION approving use of city property and street closures for the Oelwein Fire Convention
September 2027 and 2028

WHEREAS, Oelwein Volunteer Fire Fighter Foundation Inc will be hosting the Iowa Firefighters
Association Annual Convention in 2027 and 2028; and

WHEREAS, the following will be used at the Veterans Sports Complex

- Use of the Veterans Park Sports Complex parking lot and concession stand.
 - 40 x 60ft space reserved for a tent by the concession stand.
- ;and

WHEREAS, the bike trail will be closed from 10th St SE to the Veterans Sports complex; and

WHEREAS, 10th St. SE/Old Road traffic flow will be changed allowing traffic exclusively for the fire
convention on 10th St. SE; and

WHEREAS, the downtown will see events on each Saturday resulting in the following street
closures:

- 1st St SW from 1st Ave SW to South Frederick
- South Frederick from the Veridian Drive through to 1st St SW
- West Charles from 1st Ave SW to Frederick
- Lot D Depot parking lot
- Lot F Main Line Hub parking lot

WHEREAS, these closures will ensure a safe convention for the members and the public;

NOW, THEREFORE, BE IT RESOLVED by the city council of Oelwein, Iowa approves city property
use and street closures for the Oelwein Fire Convention September 2027 and 2028

Passed and approved by the City Council of the City of Oelwein, Iowa this 23rd day of March,
2026.

Brett DeVore, Mayor

It was moved by _____ and seconded by _____ that the Resolution as read be adopted, and upon roll call there were:

AYES NAYS ABSENT ABSTAIN

Attest:

Dylan Mulfinger, City Administrator

Ricchio
Weber
Payne
Cantrell
Cannon
Gearhart

Recorded March 24, 2026

REGISTRATION

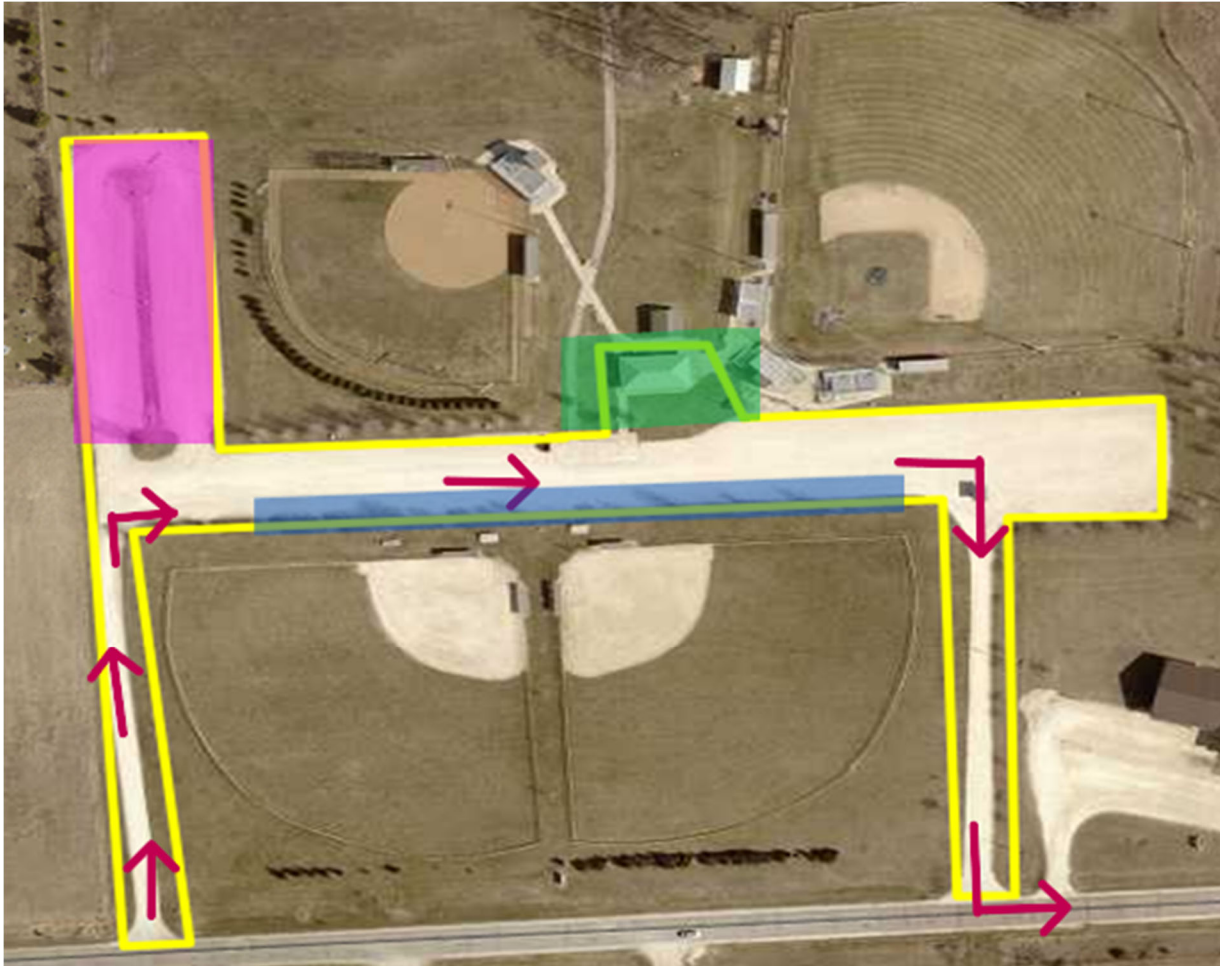

Campers will enter in from the west entrance and proceed through the parking lot as shown. They will exit the east entrance when finished. The concession stand will be used as well as erecting a tent. Inside the tent will be an area multiple people can sign in or register. Also, campers can fill their on-board water tanks. This will be used from Wednesday until Saturday.

MAP KEY

GREEN – Registration area. This is where the tent would also need to be set up.

PINK – Overflow. If needed we can stage campers there as they come in.

BLUE – Water Fill area for campers to fill on board water tanks.

CAMPGROUND



The Campground will be constructed on OCAD's property between Old Road and 14th Street Se. This area will be where participants will camp, attend entertainment and eat 2 catered meals. A power grid system will be designed and installed on this site. Alliant will run the power to the property line and a secondary company will be needed to install the power grid. After the 2028 convention, this will all be removed and returned to OCAD in the original condition. With the bike trail running through the middle of the property, this is why it would need closed to maintain safety and security of the event. The bike trail will have 1 designated crossing point (shown by blue box icon) to access the far west piece of property. The remaining bike trail will be closed off to keep golf carts and vehicles off. It is requested that the bike trail be closed from 10th Street to the sports complex. The entire border of the campground will be fenced off. The entrance will be staffed keeping anyone not registered for the event out. This is a security factor. (The entrance is marked with a star.) Committee members will also do random roaming patrols of the border to ensure compliance

Traffic Flow

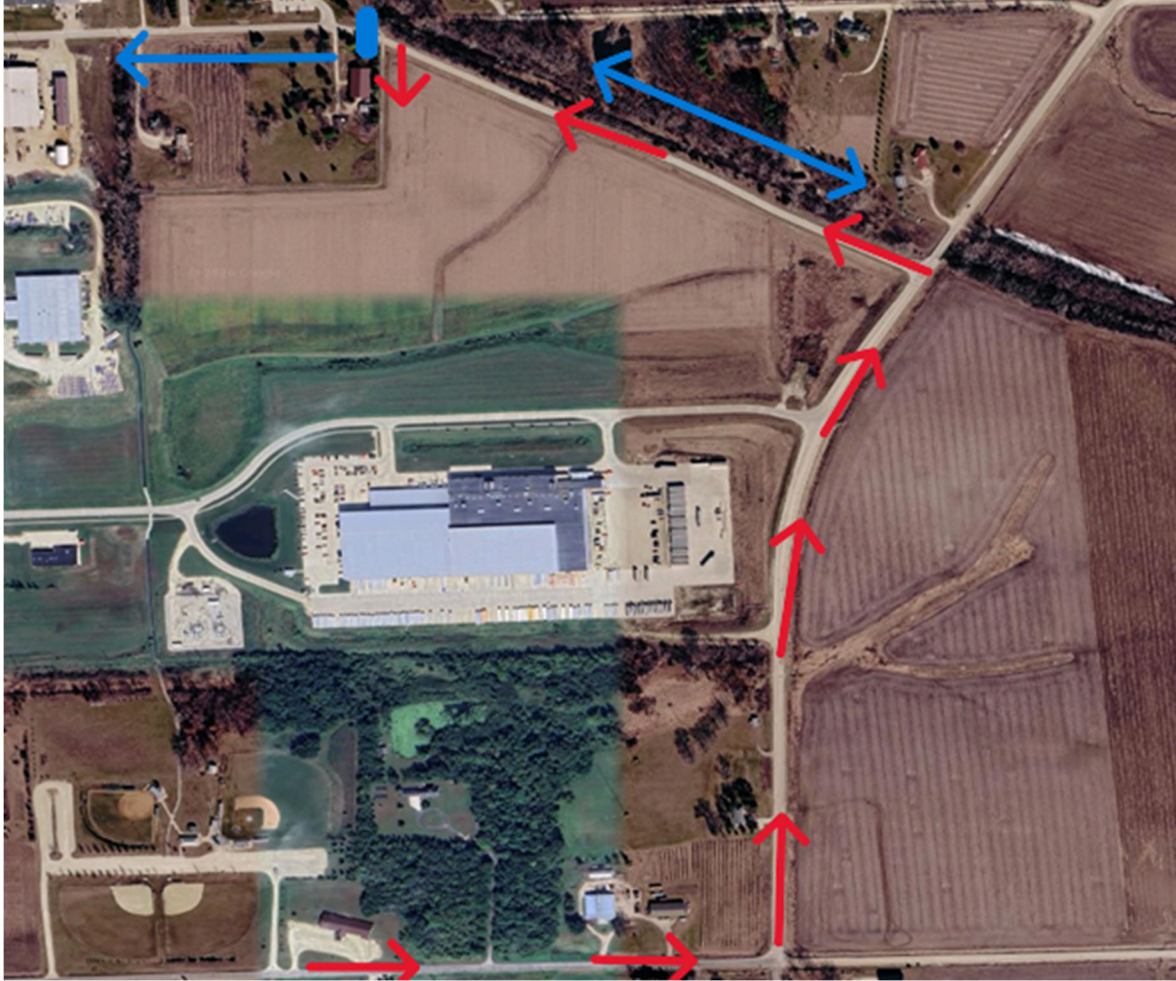

The red arrows show how campers will come from the complex. This keeps campers from utilizing 14th St Se. This avoids and disruption to East Penn's operations. The blue arrows are the requested traffic flow change for the week of convention. Signage will be requested at a later date. The blue block is the point of traffic flow change.

CONTEST AREA



This area would be used on the Saturday of Convention for State Contest. This is a general area. Finalized plans would be presented to the council in the future. There are several contests that will be held during the day. IFA representatives will visit Oelwein a few months in advance to access the roadway conditions. By holding this event downtown, it will shut traffic down however, will be a great increase of foot traffic to the businesses and restaurants as event goers will patronize them. Also, it should be noted that in previous experience, the citizens of town will also come and spectate drawing more patrons into these businesses. It should also be noted that Non-profit groups and a few food trucks may set up near this event. This is still a work in progress however.

RESOLUTION NO. _____-2026

RESOLUTION AWARDING DOWNTOWN PROPERTIES FORGIVABLE LOANS FOR BUILDING IMPROVEMENTS PROVIDED BY TAX INCREMENT FINANCING

WHEREAS, the City of Oelwein allocates \$75,000 annually from the downtown Tax Increment Financing (TIF) district; and

WHEREAS, the city can allocate \$100,000 in 2026 from remining funds which were unused in previous years; and

WHEREAS, the applications are rated and evaluated by the Oelwein Housing Committee and a recommendation of awards are provided to City Council; and

WHEREAS, the following awards shall be made in 2026:

Last Name	Location	Amount Awarded
Farrand	14 N. Frederick	\$20,000
Lawson	24 S. Frederick	\$20,000
Moore	104 1 st Street SW	\$10,000
Mullen	9 S. Fredrick	\$10,000
Ottesen	21 E. Charles	\$17,000
Tylee	26 S. Frederick	\$23,000

WHEREAS, property owners will have one year from receiving funding to complete their improvements; and

WHEREAS, the City of Oelwein will monitor progress of the project and will have a lien on each property to ensure that funds are paid back if the project is not complete; and

NOW, THEREFORE, BE IT RESOLVED by the City Council of Oelwein, Iowa formally awards Downtown Property Forgivable Loans for Building Improvements Provided by Tax Increment Financing.

Passed and approved this 23rd day of March, 2026.

Brett DeVore, Mayor

Attest:

Dylan Mulfinger, City Administrator

Recorded March 24, 2026

It was moved by _____ and seconded by _____ that the Resolution as read be adopted, and upon roll call there were:

AYES NAYS ABSENT ABSTAIN

Weber
Payne
Cantrell
Cannon
Gearhart
Ricchio

RESOLUTION NO. _____-2026

RESOLUTION AMENDING THE OELWEIN FEE SCHEDULE

WHEREAS, the city has a fee schedule that it reviewed annually; and

WHEREAS, the amendments focus on parks, aquatic center, and cemetery; and

WHEREAS, cost of operations continue to increase for each department and these increases are justified;

NOW, THEREFORE, BE IT RESOLVED by the city council of Oelwein, Iowa amends the Oelwein Fee Schedule.

Passed and approved by the City Council of the City of Oelwein, Iowa this 23rd day of March, 2026.

Brett DeVore, Mayor

It was moved by _____ and seconded by _____ that the Resolution as read be adopted, and upon roll call there were:

AYES NAYS ABSENT ABSTAIN

- Ricchio
- Weber
- Payne
- Cantrell
- Cannon
- Gearhart

Attest:

Dylan Mulfinger, City Administrator

Recorded March 24, 2026

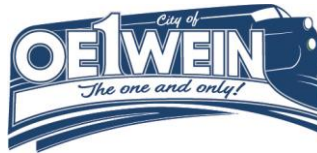

Oelwein Fee Schedule
 Approved by Resolution No. _____-2026
 March 23, 2026

City Hall		
Description	Detail	Amount
Research	Conducting Research for Public	Staff time calculated to the quarter hour at \$30.00 per hour
Open Records Request	Labor	Staff time calculated to the quarter hour at \$30.00 per hour
Special Session Council Meeting	Request for a special council meeting by an outside organization	\$50 per council member and \$50 administration fee
Administrative Collection Fee	Any unpaid debt sent to the Iowa Income Offset Program will include a collection fee	\$25.00
Administrative Lien Fee	Any unpaid debt sent to the county shall add a fee to the property lien	\$25.00
Copies		\$1.00
Color Copies		\$2.00
Photo Copy		\$0.25 per page
Cigarette Permit		\$75.00
Peddler Permit		\$35.00
Bank Return Fees		\$30.00
Notary Service	Resident	N/C
	Non-Resident	\$10.00
Video/Audio Tape Copy		\$25.00
Food Truck Permit	One Day	\$10.00
	One Week	\$25.00
	One Month	\$100.00
	One Year	\$150.00
Food Truck Electricity	Per Occurrence	\$10.00
Sidewalk Café/Parklet Permit	One Year	\$25.00

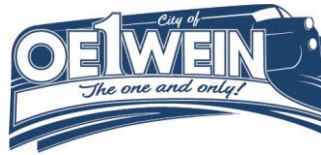

Oelwein Fee Schedule
 Approved by Resolution No. _____-2026
 March 23, 2026

Police		
Description	Detail	Amount
Alarm responses determined to be false	first & second in 12 month period	No Charge
	3rd false alarm in 12 month period	\$50.00
	4th & subsequent with 12 months	\$75.00
Delivery of public crime or accident reports		
	Reports	\$15.00
	Copy of audio or video	\$25.00
	Copy of computer disc evidence	\$25.00
	Duplicate copy of digital photos	\$10.00 per page
Fingerprinting		\$15.00
Subpoena and Warrant Return	Mileage reflects IRS standard mileage	\$35.00 – 1 mile min. plus \$.50 per copy
Service of Court Order (ie. Writ or No Contact Order)	Mileage reflects IRS standard mileage	\$35.00 – 1 mile min. plus \$.50 per copy
Service of Court Order (ie. Writ or No Contact Order)	Mileage reflects IRS standard mileage	\$35.00 – 1 mile min. plus \$.50 per copy
	Replacement Tag	\$1.00
	Delinquent License (add'l)	\$5.00
	Animal Impound Fee	\$20.00
Bicycle	Tag	\$3.00
	Replacement Tag	\$1.00
Parking Tickets	Parking Ticket	\$25.00
	Handicap Parking Ticket	\$200.00
Vehicle	Impound Fee	\$75.00
	Storage	\$25.00/day
Officer Present for Abatement Clean-up	Court ordered clean-up	\$150.00/hour
Police Officer traffic control	Fire or disaster traffic control	\$50.00/hour
Police vehicle traffic control	Fire or disaster traffic control	\$75.00/hour
Expert Witness Fee	Officers subpoena for testimony for a non-criminal	\$150.00/hour two hour minimum

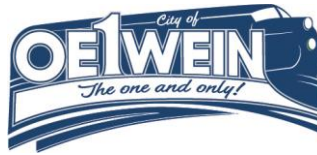

Oelwein Fee Schedule
 Approved by Resolution No. _____-2026
 March 23, 2026

	court hearing (ie. divorce hearing, civil suit etc..)	
Fireworks	Permit Fee (Selling)	\$100.00
Fireworks	Annual Inspection (Selling)	\$200.00
Display Permit	Providing a show	\$200.00

Animal License by Dog Type (American Kennel Club Breeds by size, mixed breed based on weight)	License Fee for spayed/neutered and chipped dog	License Fee for spayed/neutered dog	License fee for dog
Giant – 75 plus pounds	\$10.00	\$25.00	\$50.00
Large – 55-85 pounds	\$10.00	\$25.00	\$50.00
Medium – 35-65 pounds	\$10.00	\$20.00	\$40.00
Small – 7-35 pounds	\$10.00	\$20.00	\$40.00
Toy – 2-9 pounds	\$10.00	\$20.00	\$40.00

Fire Department		
Description	Detail	Amount
Residential Fire Service Fee		\$500
Commercial-Industrial Fire Service Fee		\$750
Motor Vehicle Accident Response		\$250
Motor Vehicle Accident Response with Extrication		\$500
Personnel	Firefighter	\$25.00 per hour
Incident Report		\$10.00
Burning Permit	Outside of open burning	\$25.00
Damaged Equipment		Billed at replacement cost
Equipment Cleaning		Billed at parts and labor cost
False Alarms		First and second in 12 months no charge Third \$50.00 Fourth and Proceeding \$75.00
Lockouts	Home and Business.	\$100.00 non-emergency
Burning Complaint	First and second no charge	Third \$50.00 Fourth and Proceeding \$75.00
Carbon Monoxide		\$45.00



Oelwein Fee Schedule
 Approved by Resolution No. _____-2026
 March 23, 2026

Community Development		
Description	Detail	Amount
Official Present for abatement clean-up	Court ordered clean-up inspection	\$150.00/hour
Preliminary Plat Fee		\$50.00
Final Plat		\$100.00
Re-Zoning		\$75.00
Board of Adjustment	Variance Request	\$75.00
Building Permit	See attached	<i>Addendum A</i>
Temporary Structure	Permit	\$35.00
Lot Mowing	Per Hour, minimum one hour	\$150.00
Snow Removal	Per Hour, minimum one hour	\$150.00
Late Permit Fee	Failure to pull and pay a permit	Doubles the permit fee with a minimum of \$100.00
Stop Work Order	Stopping work because of no permit	\$25.00
Rental Permit single family housing	Annual	\$85.00
Multi-family housing structure	Annual	\$85.00
Multi-family housing additional number of units		\$25.00
Initial Inspection		\$0.00
2 nd Inspection	60 days after initial inspection	Pass \$0.00 Fail \$100.00
3 rd Inspection	15 days after 2 nd inspection Failure of a third inspection results in the pulling of the occupancy permit and being placed on the habitual violator list. The property cannot be rented for six months.	Pass \$0.00 Fail \$250.00
Occupancy Renewal Inspection	6 months after last failed inspection	\$100.00
No show inspection		\$100.00



Oelwein Fee Schedule
 Approved by Resolution No. _____-2026
 March 23, 2026

1 st Reschedule	Only allowed before 2 nd inspection 15 day maximum	\$25.00
2 nd Reschedule	Only allowed before 2 nd inspection 15 day maximum	\$100.00
1 st Complaint Insp - If founded complaint		\$25.00
2 nd Complaint Insp - If founded complaint		\$50.00
3 rd or more Complaint Insp - If founded complaint		\$75.00
Failure to Register Rental Unit	Per day (Maximum \$300)	\$10.00
Appeal		\$100.00
Vacant Residential	Annual	\$25
Vacant Commercial	Annual	\$50
Vacant Industrial	Annual	\$100
Failure to Register Vacant Unit	Per Day (Maximum \$300)	\$10.00
Vacant Building 1 st Inspection		\$0.00
Vacant Building 2 nd Inspection		Pass \$0.00 Fail \$250.00
Vacant Building 3 rd Inspection and any subsequent inspections		Pass \$0.00 Fail \$350.00

Airport		
Description	Detail	Amount
Airport Hanger (East)	Month Rental	\$70.00
Airport Hanger (West)	Month Rental	\$75.00
Airport Hanger (new)	Month Rental	\$95.00
Community Hanger	Month Rental	\$160.00
Courtesy Car		



Oelwein Fee Schedule
 Approved by Resolution No. _____-2026
 March 23, 2026

Library (Set by Library Board)		
Description	Detail	Amount
Replacement Library Card		\$2.00
Out-of-State Library Card		\$20.00 Annually
Lost item	Retail	Cost of replacement
Lost magazine		Cover Price or \$5.00
Repair damaged item		\$2.00
Return check		\$30.00
Research	postage and copy costs	Cost of consumables
Interlibrary Loan postage fee		\$3.00
Earbuds		\$2.00
Laminating		\$0.50 per sheet
Black and White copies	per page	\$0.20
Color copies	per page	\$0.50
Fax transmission	first page	\$0.50
Fax receiving	first page	\$0.20
Unattended child/in need of caregiver	after library is closed; per minute	\$1.00
Unpaid overdue items submit to Collections	total cost of items minimum of \$25	\$13.00
Public Photocopies on Rite Price copier	per page	\$0.20
Passport Acceptance Facility	per application	Set by the Department of State
Passport Photo	per application	\$15.00



Oelwein Fee Schedule
 Approved by Resolution No. _____-2026
 March 23, 2026

Parks			
Description	Detail	Amount	
Campground			
Tent Site	Primitive	\$20.00-max stay 4 consecutive days	
	Supplementar y to RV site	\$10.00	
61 & Under	30 Amp sites— Daily	\$25.00	Proposed Sites 1-13 & 21-42
	30 Amp sites— Weekly	\$100.00	61 & Under
	30 Amp sites— Monthly (30 Days)	\$320.00	Daily \$35.00
61 & Under	50 Amp sites— Daily	\$30.00	Weekly \$135.00
	50 Amp sites— Weekly	\$130.00	Monthly \$350.00
	50 Amp sites— Monthly (30 Days)	\$345.00	Seniors 62+
Sr. 62+	30 Amp sites— Daily	\$20.00	Daily \$25.00
	30 Amp sites— Weekly	\$95.00	Weekly \$125.00
	30 Amp sites— Monthly (30 Days)	\$305	Monthly \$340.00
	50 Amp sites— Daily	\$25.00	Cash Pay Sites 14-20
	50 Amp sites— Weekly	\$120.00	Daily - \$40.00
	50 Amp sites— Monthly (30 Days)	\$335.00	Weekly \$140.00
Kayak/Paddleboard	One Hour Per Kayak/PB	\$10.00	Monthly - \$355.00
	Four Hours Per Kayak	\$35.00	



Oelwein Fee Schedule
 Approved by Resolution No. _____-2026
 March 23, 2026

	Two or more for four hours per kayak	\$30.00	
Box of Wood		\$5.00	
Shelter Rental	Capacity 60-100	\$30.00	\$40.00
Shelter Rental (Railroad shelter at City Park and new shelter at Platt's Park)	Capacity 200	\$30.00	
Memorial Benches	Grey Stone with Plaque	\$2,000.00	
Field Rentals			\$500 per season + cost of supplies



Oelwein Fee Schedule
 Approved by Resolution No. _____-2026
 March 23, 2026

Recreation		
Description	Detail	Amount
Flag Football	1st-4th grade	\$25.00
Volleyball	3rd-6th grade	\$25.00
Basketball	Kindergarten-6th grade	\$25.00
Dodgeball	1st-6th	\$20.00
Soccer	Kindergarten-6th grade	\$25.00
Little League		
Blast ball	3 & 4 year olds	\$20.00
T-ball	Kindergarten	\$25.00
Baseball/Softball	1st-4th grade Local	\$30.00
Baseball/Softball	3rd-7th Travel	\$50.00
Diamond Rental Fee	Diamond Prep per game	\$40.00
Tennis	1st-8th	\$25.00
Organizations <20		\$1,000.00
Organizations >20		\$1,500.00
Adult Sports		
Women's Volleyball	Per Team	\$60.00
Coed Volleyball	Per Team	\$60.00
Women's Softball	Per Team	\$200.00
Coed Softball	Per Team	\$200.00
Men's Softball	Per Team	\$225.00
Adult Tennis	Per Individual	\$15.00
Adult Disc Golf	Per Individual	\$15.00

Aquatic Center (Pool)			
Description	Detail	Amount	Proposed
American Red Cross / Learn-to-Swim Classes		\$35.00	\$40.00
Private Lessons		\$60.00	
Passes (2026)			
-	Single Pass 18+	\$70.00	



Oelwein Fee Schedule

Approved by Resolution No. _____-2026

March 23, 2026

	Child season Pass 7-17	\$40.00	
	Nanny Pass	\$60.00	\$70.00
Season Pass 1 member (under 6)		\$40.00	\$50.00
Season Pass 1 member age 6 and over		\$85.00	\$100.00
Season Pass 2 members		\$140.00	\$150.00
Season Pass 3 members		\$160.00	\$175.00
Season Pass 4 members		\$180.00	\$200.00
Season Pass 5 members		\$200.00	\$225.00
Season Pass 6 members		\$220.00	\$250.00
Season Pass 7-10 members		\$240.00	\$275.00
10-Punch Card for Person 6 or Older		\$50.00	\$60.00
10 punch card for person 5 or younger		\$20.00	
Daily Admissions:	Everyone	\$5.00	\$6.00
Swim Team	Part time – Fairbank/Dunkerton	\$5.00	
	Full time kids	\$10.00	
	Concession rental per use	\$30.00	
Facility Reservations:			
Pool Party Prices – Including Water Slide			
1 Hour Pool Party		\$200.00	\$250.00
2 Hour Pool Party		\$275.00	\$350.00



Oelwein Fee Schedule
 Approved by Resolution No. _____-2026
 March 23, 2026

Cemetery			
Description	Detail	Amount	Proposed
Grave Openings			
Regular Season			
Grave Opening	Weekday opening (Apr 1-Nov 30)	\$1,200.00	
Grave Opening	Infant grave (Apr 1-Nov 30)	\$500.00	
Grave Opening	Holidays/Saturdays (Apr 1-Nov 30)	\$1,300.00	
Grave Opening	After hours (Apr 1-Nov 30)	\$1,300.00	
Cremation Opening	Cremation (Apr 1-Nov 30)	\$600.00	
Cremation Opening	Holidays/Sat. cremation (Apr 1-Nov 30) After Hours	\$700.00	
Cold Weather Season			
Grave Opening	Weekday opening (Dec 1 –March 30)	\$1,400.00	
Grave Opening	Infant grave (Dec 1 – March 30)	\$600.00	
Grave Opening	Holidays/Saturdays (Dec 1 –March 30)	\$1,700.00	
Grave Opening	After hours (Dec 1 – March 30)	\$1,700.00	
Cremation Opening	Cremation (Dec 1 – March 30)	\$700.00	
Cremation Opening	Holidays/Sat. cremation (Dec 1 – March 30) After Hours	\$800.00	
Continuation on Weekdays	Any continuation of services keeping city crews after 3:30 PM (All Year)	\$150.00 per hour	\$200.00 per hour
Late Notice Fee for all Burials		\$500.00	



Oelwein Fee Schedule
 Approved by Resolution No. _____-2026
 March 23, 2026

Grave Spaces			
Grave Space	Regular space	\$600.00	
	Memorial section	\$350.00	
	Baby lot	\$300.00	
Interment Certificate	(formerly "Deed")	\$50.00	
State Audit Fee		\$10.00	
Exchange Grave Spaces		\$100.00	\$200.00
Foundations			
Foundations	Per running ft. (\$100 min)	\$90.00	\$95.00
Foundations (Veterans)	Per running ft. - 4' max	\$45.00	\$50.00
Foundation Removal	\$15 per foot	\$15	
Disinterment / Reinterment			
Disinterment of a casket		\$1,400.00	\$3,000.00
Reinterment of a casket		\$1,400.00	\$3,000.00
Disinterment of a cremation vault		\$1,200.00	\$3,000.00
Reinterment of a cremation vault		\$1,200.00	\$3,000.00
Disinterment of a baby casket		\$1,000.00	\$3,000.00
Reinterment of a baby casket		\$1,000.00	\$3,000.00

Forestry		
Description	Detail	Amount
Tree Removal Permit	City approved, licensed contractor removal	\$0
Tree Trimming Permit	City approved, licensed contractor trimming	\$0
Tree Removal Fine	Removal of City tree without City permission	Based on judgement
Yard Waste Site whole tree charge	Cost of taking an entire tree from private property	See policy



Oelwein Fee Schedule

Approved by Resolution No. _____-2026
March 23, 2026

Utilities		
Description	Detail	Current
Penalty for Unpaid Bills	Penalty for bills not paid by the 15 th of the month	10% of the unpaid balance
Labor only		\$150.00
Labor 1 EE and Equipment 1 unit	Assistance on jobs and work within city limits	\$200.00 per hour
Labor 1 EE and Equipment 1 unit	Assist on jobs and work within city limits OT rate	\$300.00 per hour
Labor 1 EE and Equipment 1 unit	Assistance on jobs and work outside city limits	\$250.00 per hour
Labor 1 EE and Equipment 1 unit	Assist on jobs and work outside city limits OT rate	\$350 per hour
Labor 1 EE	Additional staff member assist on jobs in city	\$30 per hour
Labor 1 EE	Additional staff member assist on jobs in city OT Rate	\$45 per hour
Disconnect Notice	Door Tag Posting	\$50.00
Water Off/On	Per Trip	\$20.00
Meter	Install or Remove	\$20.00
Excessive Trip Fee	No person is present for the turn on or meter install	\$50.00
Trip Data or Sample Collection - Industry	Per Trip	\$25.00
Denial of External Register Installation	Per Trip	\$25.00
Deposit	Any person w/out 3 yrs. established service	\$150.00
Deposit	Any person not in good standing	\$300.00
Meter Accuracy Test		\$75.00
Fire Sprinkler Test	Witness or Conduct by Business	\$75.00
Call Out per hour	Carry through from regular hrs.	\$40.00
Call Out per hour	After hours, 2 hr. minimum	\$80.00
Industrial Surcharge	Reporting for DNR	\$35.00 monthly
Lab Testing	Charge for each test completed	Cost of test if shipped out
Lock Box	In addition to service charge	\$1.00 per Day



Oelwein Fee Schedule
 Approved by Resolution No. _____-2026
 March 23, 2026

Discharge Request	Charge for processing and researching discharge	\$250 flat fee
Temporary Construction Meter 5/8" Service Line	Deposit	\$300.00
Temporary Construction Meter Hydrant set, small 5/8"	Deposit	\$500.00
Temporary Construction Meter Hydrant set, large 2"	Deposit	\$5,000.00
Frost Plates/Meters are updated as price and/or Labor Fees Increase		
Surcharges		\$0.45 cents per pound BOD \$0.26 cents per pound TSS \$2.50 cents per pound TKN
Mailbox Replacement		\$55.00
Use of barricades & signs & labor	Accident / private incident / emergencies	\$4 per day
Use of cones & labor	Accident / private incident / emergencies	\$3 per day

Single Hauler		
Description	Detail	Amount
Trash Pickup	April 2023-2024 Monthly	\$12.26
	April 2024-2025 Monthly	\$12.26
	April 2025-2026 Monthly	\$12.51
	April 2026-2027 Monthly	\$13.36
	April 2027-2028 Monthly	\$14.21
Admin Fee	Monthly	\$1.25
Container Exchange	One Time Charge	\$50
Container Replacement Fee	One Time Charge	\$100
Assisted/Elderly/Disabled Pickup		No additional fee
Bulk Item	Each item	\$20

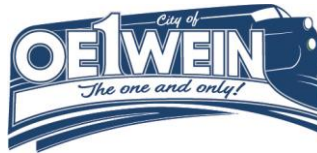

Oelwein Fee Schedule
 Approved by Resolution No. _____-2026
 March 23, 2026

Extra Bag Sticker	Each Sticker	\$2
Unpaid Bills	Penalty for bills not paid by the 15 th of the month	10% of the balance

Wellness Center		
Description	Detail	Amount
Single Membership	12 Month	\$216.00
Couple	12 Month	\$300.00
Family (3 or 4)	12 Month	\$360.00
(5 plus)	12 Month	\$90.00 per person
Student Membership	12 Month High School Gr 9-12	\$120.00
24 Hour Access	Upon Membership Included in all memberships	\$5.00
Personal Training Member	1 session 1 person	\$30.00
	8 session 1 person	\$184.00
Day Pass	Adult	\$8.00
Day Pass	K-12	\$5.00
Gym Rental	2-hour Party (ie Birthday)	\$50.00
	4+ Hr Tournament Rental	\$150.00
	Practice Gym Rental	\$25.00
24 Hour Fob	Replacement	\$20.00



Oelwein Fee Schedule
 Approved by Resolution No. _____-2026
 March 23, 2026

Addendum A

BUILDING PERMIT FEE SCHEDULE

TOTAL VALUATION	FEE
\$1 to \$500	\$20
\$501 to \$2,000	\$20 for the first \$500; plus \$2 for each additional \$100 or fraction thereof, up to and including \$2,000
\$2,001 to \$40,000	\$50 for the first \$2,000; plus \$9 for each additional \$1,000 or fraction thereof, up to and including \$40,000
\$40,001 to \$100,000	\$392 for the first \$40,000; plus \$6 for each additional \$1,000 or fraction thereof, up to and including \$100,000
\$100,000 to \$500,000	\$752 for the first \$100,000; plus \$4.50 for each additional \$1,000 or fraction thereof, up to and including \$500,000
\$500,001 to \$1,000,000	\$2,552 for the first \$500,000; plus \$3.50 for each additional \$1,000 or fraction thereof, up to and including \$1,000,000
\$1,000,001 to \$5,000,000	\$4,302 for the first \$1,000,000; plus \$2 for each additional \$1,000 or fraction thereof, up to and including \$5,000,000
\$5,000,001 and over	\$14,302 for the first \$5,000,000; plus \$1 for each additional \$1,000 or fraction thereof

RESOLUTION NO. _____-2026

RESOLUTION AMENDING THE SALARY SCHEDULE

WHEREAS, the city council approved a three-year plan for salaries, and this is the last year of the three-year plan; and

WHEREAS, the need to amend the salaries come as changes have been made to the aquatic center; and

WHEREAS, changes to the aquatic center will help retain, attract, and recruit new employees each season; and

WHEREAS, all other salaries remain on the four percent increase except for the union/former union police department employees;

NOW, THEREFORE, BE IT RESOLVED by the city council of Oelwein, Iowa amends the Oelwein Salary Schedule.

Passed and approved by the City Council of the City of Oelwein, Iowa this 23rd day of March, 2026.

Brett DeVore, Mayor

It was moved by _____ and seconded by _____ that the Resolution as read be adopted, and upon roll call there were:

AYES NAYS ABSENT ABSTAIN

Attest:

- Ricchio
- Weber
- Payne
- Cantrell
- Cannon
- Gearhart

Dylan Mulfinger, City Administrator

Recorded March 24, 2026



Pool Wages Difference

PARKS / CEMETERY / TRAILS / AQUATICS / CAMPGROUND

Guards

Current rates	Start \$10.30	4065 hours	\$41,869.50
Proposed rate	Start \$12.00	4065 hours	<u>\$48,780.00</u>
		Difference	\$6,910.50

3% Increases	Second Season \$12.36	Third Season \$12.73	Fourth Season \$13.11
--------------	--------------------------	-------------------------	--------------------------

Front Desk/Concessions

Current rates	Start \$8.24	1418 hours	\$11,684.32
Proposed rate	Start \$10.00	1418 hours	<u>\$14,180.00</u>
		Difference	\$2,495.68

3% Increases	Second Season \$10.25	Third Season \$10.55	Fourth Season \$10.86
--------------	--------------------------	-------------------------	--------------------------

Managers

Manager

Current rate	Start \$15.00	620 hours	\$9,864.20	Currently \$15.91
Proposed	Start \$18.00	620 hours	<u>\$11,160.00</u>	
		Difference	\$1,295.80	

3% Increases	Second Season \$18.79	Third Season \$19.35	Fourth Season \$19.93
--------------	--------------------------	-------------------------	--------------------------

Assistant

Current rate	Start \$12.36	520 hours	\$6,427.20
Proposed	Start \$14.50	520 hours	<u>\$7,540.00</u>
		Difference	\$1,112.80

3% Increases	Second Season \$14.93	Third Season \$15.37	Fourth Season \$15.83
--------------	--------------------------	-------------------------	--------------------------

\$11,814.78

Purchase all chemicals through CIP 123-5250-67242

Move \$13,000 to Salary 001-4410-60100

Keep \$2,000 in Supply 001-4410-65070

Wage Comparables

	<u>Manager</u>	<u>Guard</u>	<u>Front Desk</u>
Monticello	\$11,278 \$18.19 @620 hrs	\$12.25	\$10.25
Charles City	\$13.50	\$10.20	\$8.90
Vinton	\$5-\$6k	\$12.00	\$12.00
Waukon	\$18.00	\$13.00	\$13.00
Sumner	\$17.25	\$11.00	NA
New Hampton	\$16.00	\$12.00	\$9.00
Independence	\$14-17	\$10.50-13	\$9-11
Oelwein	<u>\$15.00</u>	<u>\$10.30</u>	<u>\$8.24</u>
Averages	\$16.32	\$11.54	\$10.23

Local Employer starting wages

McDonalds	\$11.00
Fareway	\$14.00
Dollar Fresh	\$12.00
Casey's	\$12.00
Kwik Star	\$15.00

Fiscal Year 2027

Increased by 4% per Resolution No. 5684-2024

Aquatic Center							Proposed			
		Start	Second Season	Third Season	Fourth Season	Start	Second Season	Third Season	Fourth Season	
Manager	Hourly	\$15.00	\$15.45	\$15.91	\$16.78	\$18.00	\$18.79	\$19.35	\$19.93	
Assistant Manager	Hourly	\$12.36	\$12.73	\$13.11	\$13.50	\$14.50	\$14.93	\$15.37	\$15.83	
Lifeguard	Hourly	\$10.30	\$10.61	\$10.93	\$11.26	\$12.00	\$12.36	\$12.73	\$13.11	
Front Desk & Maintenance	Hourly	\$8.24	\$8.49	\$8.74	\$9.00	\$10.00	\$10.25	\$10.55	\$10.86	
Concession Manager	Hourly	\$12.36	\$12.73	\$13.11	\$13.50	-	-	-	-	
Private Lessons with Water Safety Instructor		Additional \$.50								
Season End Stipend for All Hours Worked*		Additional \$.25								

*Must work the entire regular season to earn the season end stipend.

RESOLUTION NO. _____-2026

RESOLUTION APPROVING AN UPDATED PROJECT COST FOR THE 2026 AIRPORT PAVING PROJECT

WHEREAS, the city council approved an airport paving project at \$401,000.00; and

WHEREAS, the current conditions of the pavement will not support an asphalt overlay as intended; and

WHEREAS, the new project calls for removal and paving of the taxi lanes with asphalt; and

WHEREAS, the new cost is \$489,575.00; and

WHEREAS, this project is in line with the city’s goals of maintaining the airport, but not adding any new liabilities at the airport; and

WHEREAS, the Pavement Design - OLZ Rehabilitate T-Hangar Taxi Lanes (FAA AIP 3-19-0067-017) should be completed in FY2026; and

NOW, THEREFORE, BE IT RESOLVED by the city council of Oelwein, Iowa approves an updated project cost for the 2026 Airport Paving Project.

Passed and approved by the City Council of the City of Oelwein, Iowa this 23rd day of March, 2026.

Brett DeVore, Mayor

It was moved by _____ and seconded by _____ that the Resolution as read be adopted, and upon roll call there were:

AYES NAYS ABSENT ABSTAIN

Attest:

Ricchio
Weber
Payne
Cantrell
Cannon
Gearhart

Dylan Mulfinger, City Administrator

Recorded March 24, 2026



To: Mayor and City Council
From: Dylan Mulfinger, City Administrator
Subject: Pavement Design Report - OLZ Rehabilitate T-Hangar Taxi Lanes (FAA AIP 3-19-0067-017)
Date: 3/23/2026

After a core sample was completed at the airport, it was determined by our engineer team AECOM an asphalt overlay was not feasible for the taxi lane improvement. The city council now must vote to change the scope and price of the project.

Original Cost: \$401,000

City Share at 10 Percent: \$40,100

This project was budgeted for in the FY2027 budget year.

New Cost: \$489,575

City Share at Five Percent: \$24,478.75

After a meeting last week, it was determined that the city still had dollars left at the five percent matching rate and not at the usual ten percent as part of the Airport Improvement Program (AIP). The five percent matching rate is part of the Infrastructure Investment and Jobs Act (IIJA).

FEDERAL AVIATION ADMINISTRATION

CAPITAL IMPROVEMENT PROGRAM (CIP)
AIRPORTS DIVISION - CENTRAL REGION

CIP DATA Item 16.

Original Project

SEE INSTRUCTIONS TO COMPLETE THIS INFORMATION			
Airport Name, LOCID, City, State:	Oelwein Municipal Airport, OLZ, Oelwein, IA		
AIP Project Type:	Pavement Rehabilitation – Hangar Area		
Local Priority:	1 - Very High	Fed. Share (AIP):	\$ 380,950
FFY Requested:	2026	Fed. Share (IIJA):	\$Click here to enter text.
NEPA Determination:	Click here to enter text	State Share:	\$Click here to enter text.
Provide Detailed Project Scope and Justification Below. You must attach a sketch/drawing (on a separate sheet) that clearly identifies the scope of the project.	Local Share:		\$20,050
	Total Project Cost:		\$ 401,000

Project will include reconstruction of the existing asphalt section of taxiway pavement and repair/replace concrete panels for taxiway and hangar approach pavements in the west general aviation hangar area. The 2022 Pavement Evaluation Study showed that the PCI values for the asphalt pavements in this area were in the low 40's while the concrete pavements were in the 60's.

Oelwein Municipal Airport – Pavement Management Report (2022)

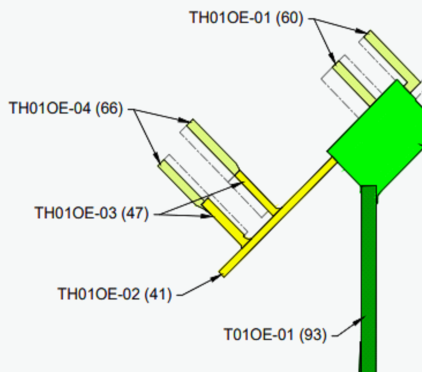

SPONSOR SIGNATURE BLOCK

Signature:		Date:	12/19/2025
Printed Name:	Dylan Mulfinger	Title:	City Administrator
Phone Number:	(319) 283-5440	Email:	DMulfinger@cityfoelwein.org

Oelwein Municipal Airport
 ACIP Data Sheet Cost Estimate
 Pavement Rehabilitation - Hangar Area
 December 18, 2025

Original Project

Item	Unit	Quantity	Unit Price	Total
Mobilization and Safety	LS	1	\$ 30,000.00	\$ 30,000.00
PCC Removals	SYD	400	\$ 50.00	\$ 20,000.00
PCC Replacement	SYD	400	\$ 225.00	\$ 90,000.00
Pavement Removal	SYD	2600	\$ 15.00	\$ 39,000.00
Unclassified Excavation	CYD	1800	\$ 30.00	\$ 54,000.00
Aggregate Base Course	CYD	450	\$ 50.00	\$ 22,500.00
Asphalt Pavement	TONS	700	\$ 150.00	\$ 105,000.00
Joint Sealing PCC Pavement	LFT	2500	\$ 3.00	\$ 7,500.00
Subdrain	LFT	1000	\$ 10.00	\$ 10,000.00
Engineering, Legal, Administration				\$ 53,000.00

TOTAL **\$ 401,000.00**

RECONSTRUCT T-HANGAR TAXILANES
 FLEXIBLE PAVEMENT RECONSTRUCTION
 OELWEIN MUNICIPAL AIRPORT
 CITY OF OELWEIN, IOWA
 FAA AIP PROJECT NO. 3-19-0067-016
 AECOM PROJECT NO. 60777499

New Proposed Price

March 16, 2026

ITEM No.	SPECIFICATION SECTION	ITEM DESCRIPTION	UNIT	ESTIMATED QUANTITY	ESTIMATED UNIT PRICE	ESTIMATED AMOUNT
1	P-100	MOBILIZATION AND DEMOBILIZATION	LS	1.0	\$ 53,000.00	\$ 53,000.00
2	P-101	PAVEMENT REMOVAL	SYD	2,900.0	\$ 15.00	\$ 43,500.00
3	P-152	UNCLASSIFIED EXCAVATION	CY	3,300.0	\$ 15.00	\$ 49,500.00
4	P-154	FROST PROTECTION COURSE	CY	1,900.0	\$ 35.00	\$ 66,500.00
5	P-208	SUBBASE COURSE - 6"	CY	620.0	\$ 40.00	\$ 24,800.00
6	PLANS	GEOGRID	SYD	4,400.0	\$ 5.00	\$ 22,000.00
7	P-156	INSTALLATION AND REMOVAL OF SEDIMENT LOGS	LF	1,100.0	\$ 5.00	\$ 5,500.00
8	P-403	HOT MIX ASPHALT (HMA) - 4"	TON	750.0	\$ 110.00	\$ 82,500.00
9	P-501	PORTLAND CEMENT CONCRETE (PCC) PAVEMENT - 5"	SYD	580.0	\$ 60.00	\$ 34,800.00
10	P-602	BITUMINOUS PRIME COAT	GAL	1,100.0	\$ 7.00	\$ 7,700.00
11	P-603	BITUMINOUS TACK COAT	GAL	300.0	\$ 7.00	\$ 2,100.00
12	D-705	SUBDRAIN - 4"	LF	1,100.0	\$ 25.00	\$ 27,500.00
13	D-705	SUBDRAIN CLEANOUTS	EA	10.0	\$ 1,600.00	\$ 16,000.00
14	D-701	RCP - 12"	LF	115.0	\$ 90.00	\$ 10,350.00
15	D-701	FLARED END SECTIONS	EA	4.0	\$ 2,500.00	\$ 10,000.00
16	P-605	PCC PAVEMENT JOINT RESEALING	LF	870.0	\$ 5.00	\$ 4,350.00
17	P-605	CRACK ROUTING AND SEALING	LF	250.0	\$ 8.00	\$ 2,000.00
18	P-620	REFLECTIVE MARKING, YELLOW	SF	550.0	\$ 4.50	\$ 2,475.00
19	P-620	NON-REFLECTIVE MARKING, BLACK	SF	1,050.0	\$ 4.00	\$ 4,200.00
20	L-110	4-INCH SPLIT DUCT - CONCRETE ENCASED	LF	500.0	\$ 25.00	\$ 12,500.00
21	T-901	SEEDING	AC	0.30	\$ 1,800.00	\$ 540.00
22	T-908	MULCHING	AC	0.30	\$ 3,200.00	\$ 960.00
23	T-905	TOPSOILING (OBTAINED ON-SITE)	CY	80.0	\$ 85.00	\$ 6,800.00
TOTAL ESTIMATE OF PROBABLE CONSTRUCTION COST:						\$ 489,575.00

Hotel Motel FY 2026

Past Fiscal Year

Fund 122 balance 6/30/2025 \$ 36,971.38
 (June '25 pmt \$5693.46 didn't have 49% taken out)

Current Fiscal Year

Estimated Revenue 2025 70,000.00
 less Revenue to General Fund 49% (34,300.00)
 less Revenue to Trails (to trans 6-2021) (10,000.00)
FY 2025-26 available for tourism awards \$ 25,700.00

Treasurer's Report Fund 122

Month End Balance History

July 49,718.15
 August 56,966.36
 September 64,351.30
 October 72,016.06
 November 56,655.91
 December 69,935.93
 January 72,559.46
 February 72,674.61
 March
 April
 May
 June

Revenue Rec'd Tracking (s/b \$65,000)

July '25 9,956.97
 August '25 7,248.21
 September '25 7,384.94
 October '25 7,664.76
 November '25 -
 December '25 13,280.02
 January '26 4,123.53
 February '26 3,589.54
 March '26
 April '26
 May '26
 June '26 \$ 53,247.97

Project	Date Requested	Amount Requested	Council Award Date	Amount Awarded	Date Paid	Amount paid	*Remaining Balance	Special Instructions
Williams Center - Reba McEntire Tribute	6/1/2025	1500	6/9/2025	1,500	11/12/2025	1,500.00		
Williams Center - Spirit of Christmas	9/1/2025	1500	9/22/2025	1,500	1/9/2026	1,500.00		
Grand Theatre - HVAC system	9/1/2025	9779.33	9/22/2025	5,291.15	11/25/2025	5,291.15		
Oelwein Coliseum	10/22/2025	9369	10/27/2025	9,369	2/27/2026	9,369.00		
Williams Center - Billy Joel Tribute	1/1/2026	2500	1/26/2026	2,500				
Oelwein USBC - 2026 Tournament	1/1/2026	4600	1/26/2026	4,600	2/9/2026	2,844.99	1,755.01	
Oelwein Coliseum	2/1/2026	2500	2/13/2026	1,500	2/27/2026	1,500.00		
Williams Center - Alabama Tribute	3/1/2026	2500	3/9/2026	2,500				
				Total	\$	28,760.15		

\$ 33,911.23 Available to award



**CITY OF OELWEIN
HOTEL AND MOTEL TAX FUNDING APPLICATION
(TOURISM)**

Application Deadlines

September 1 • December 1 • March 1 • June 1

Applications must be received by 5:00 p.m. on the deadline date. All areas of the applications must be completed and typed. Each applicant will be afforded the opportunity to attend a brief question and answer session with the Advisory Board.

Organization Name:

Contact Name:

Mailing Address:

City, State, Zip:

Phone: **Email Address:**

Date of Project:

Total Project Cost: \$

Total Requested from Hotel/Motel Tax Funds: \$

Please indicate which category you are applying for funds:

- Category 1 - Primary
- Category 2 - Community Culture and Education
- Category 3 - Community Recreation and Events
- Category 4 - New and Emerging Organization and Events

Project Identification

I. What is the title of your project?

2026 Fayette County Fair Free Carnival for All Fayette County Children

Provide a brief description of your project. Attach additional pages, if needed.

In recent years, the Fayette County Fair has relied on support from Fayette County communities to sponsor the Carnival. This allows the Fayette County Ag Society to keep the fair free to all for parking, entry, and rides. In doing so, the fair can provide a family friendly atmosphere for all Fayette County residents that is free of charge and affordable family entertainment.

See City of Oelwein Letter of Support Attached As Well

2. Hotel and Motel Tax Funds must be used to fund projects that promote and/or expand tourism activity in Oelwein. How will your project help to realize this goal?

The Fayette County Fair brings in roughly 20,000 people throughout the week. Many of these people are not from Oelwein or Fayette County. Bringing them to the fair provides an opportunity for all communities to further promote themselves. Additionally, many, if not all of the hotel rooms in the county are often booked by non-locals who are in the area to visit the fair. Finally, the fair partners with many Oelwein businesses to promote their industries.

3. Project Evaluation:

Projected number of adults the project will reach 20,000

Projected number of youth the project will reach 4,000

Geographic area of draw

Fayette County, Clayton County, Bremer County, Winneshiek County, Buchanan County, Delaware County, Allamakee County, Black Hawk County, Chickasaw County

Volunteers:

Number of volunteers 100

Number of volunteer hours 5,000

Attendance of event previous year(s) 25,000

Day opens to public or performance(s)

Tuesday, July 21st, 2026 through Saturday, July 25th, 2026

4. Project Budget:

Please provide a project budget and schedule of completion including all expenses. If desired, the project budget may be attached to the application. If exact costs are not known please attach estimates to the application, which should be identified as such.

\$38,000 - Carnival Rental Fee
Carnival Dates: July 21-July 25, 2026

List sources of matching funds obtained below. Funding requests are eligible for up to 100% funding, but priority will be given to projects with additional sources of funding, including in-kind donations.

City of West Union \$10,000

Is this application “seed money” for a new project? If yes, please explain.

No

Is this application for the expansion of an existing project/program? If yes, please explain.

No

Have you ever received Hotel/Motel Tax Funding from the City of Oelwein in the past?

Yes: No: (check one)

If you answered yes, please answer the following: (attach additional pages, if needed)

Amount of Funding: \$ 5,000

Date of Funding: 2023

Reporting

Projects or Events Under \$500

- Funds can be provided up front to the organization
- A short memo to the city at the conclusion of the event describing the impact the event had on the community
- Receipts proving the hotel motel funds were used properly

Projects or events \$500-\$2000

- A budget and event plan must be provided with the application
- Funds can be provided up front to the organization
- A memo to the city at the conclusion of the event describing the impact the event had on the community
- Receipts proving the hotel motel funds were used properly

Projects or events over \$2000

- A budget and event plan must be provided with the application
- Funds can be provided up front to the organization
- A memo to the city at the conclusion of the event describing the impact the event had on the community
- Memo should include why/if the event made a profit and how that profit will be used
- Receipts proving the hotel motel funds were used properly

Assurances

Applicants hereby agree and acknowledge that:

If they are awarded funds, they will conduct their operations in accordance with Title VI and the Civil Rights Act of 1964, as amended, and the Rehabilitation Act of 1973, as amended, which prohibits discrimination against any employee, applicant for employment, or any person participating in a sponsored program on the basis of race, creed, color, national origin, religion, sex, age, or physical or mental disability, and require compensation for employment at no less than minimum wage requirements, and will provide safe and sanitary working conditions;

They will comply with the Americans with Disabilities Act;

They will comply with all other applicable State and federal laws, rules, ordinances, regulations, and orders;

They will expend funds, received as a result of this application, solely on the described project and programs included within the grant application documents within the fiscal year from which the grant is disbursed;

If they are awarded funds, applicants will include in all appropriate promotions, publicity, advertising, and in printed material the following credit line as applicable:

- This project was partially supported by a Hotel-Motel Tax Fund grant from the City of Oelwein.
- Our operations are partially supported by a Hotel-Motel Tax Fund grant from the City of Oelwein.
- Our operations are and this project was partially supported by a Hotel-Motel Tax Fund grant from the City of Oelwein.

The filing of this application has been approved by the legally authorizing body of the applicant, if applicable;

The facts, figures and information contained in this application including all attachments, are true and

correct;

Failure to comply with the administrative rules for this program will result in the forfeiture of funds allocated based upon this application grant;

All records of the grantee relating to this grant application are available during reasonable business hours to the City or their authorized representative upon request;

All records of the grantee related to this grant will be maintained for a period of three years following the date the final grant payment is made;

All grantees acknowledge that the source of the grant it is requesting from the City comes from the hotel and motel tax applicable in the City of Oelwein as contemplated by Iowa Code Chapter 422A (2007). The grantee specifically acknowledges the limited use that can be made of hotel and motel tax revenues and assures the City of Oelwein that the grant will be used only for allowable purposes as specifically set forth in Iowa Code Chapter 422A (2) (4) (2007). The grantee additionally and specifically acknowledges and assures the City of Oelwein that it will not use the grant for any purpose, which would be improper pursuant to this law. Furthermore, the grantee warrants that should it use the grant for any purpose not allowed by Iowa Code Section 422A (2)(4)(2007) that it will reimburse, in full, the City of Oelwein the entire amount of the grant;

All grantees acknowledge and assure the City of Oelwein that all grant funds received shall be segregated from other funds maintained by the grantee, until used for the proper purposes as described herein. The sums will be deposited into a segregated, identifiable checking account;

All grantees expressly acknowledge and assure the City of Oelwein that none of the sums received hereunder shall be used for "political purposes" as contemplated by Chapter 56 of the Code of Iowa (2007).

Cost Reimbursement

- A complete project budget and schedule of completion must be included with the application.
- Applicants must have accurate estimates included with the project budget.
- Applicants are eligible for up to 100% funding and funds will be distributed upon approval of the City of Oelwein City Council.
- Funds will be paid only to the applicant, not to contractors or vendors.
- Upon completion of the project, the applicant must submit documentation of expenses and a project recap **within 60 days to City Hall.**
- Any funds that are not expended or are found to be outside the scope of the grant made by the Funding Advisory Board must be reimbursed/returned, by the applicant, to the City of Oelwein
- **Failure to comply with the aforementioned rules will prohibit the applicant from applying for funds for one year.**

Please sign and date this application. Your signature on the back of this page certifies that you have read and understand all of the guidelines for this funding program. You further understand that you will be required to submit a summary of expenses at the end of the project and that if any funds are not expended or are found to be outside the scope of the grant made by the City Council you will be **required to reimburse/return** these funds to the City of Oelwein.

Erin Fink - Treasurer

02/24/26

Recipient

Date

Recipient

Date

RESOLUTION NO. 5619-2024

RESOLUTION APPROVING HOTEL/MOTEL TAX FUNDING TOURISM PROGRAM GUIDELINES

WHEREAS, the city of Oelwein needs to update the Hotel/Motel Tax Funding Tourism Program Guidelines; and

WHEREAS, the city only wants to partner with nonprofits; and

WHEREAS, this update will ensure recipients of hotel motel funding follow strict rules which come from using public dollars; and

WHEREAS, the city wants to support activities which enhance the community;

NOW, THEREFORE, BE IT RESOLVED by the City Council of Oelwein, Iowa approves the Hotel/Motel Tax Funding Tourism Program Guidelines

Passed and approved this 12 day of August, 2024.



Brett DeVore, Mayor

It was moved by Lenz and seconded by Weber that the Resolution as read be adopted, and upon roll call there were:

	AYES	NAYS	ABSENT	ABSTAIN
Ricchio	x			
Weber	x			
Lenz	x			
Garrigus	x			
Seeders	x			
Payne	x			

Attest:

Dylan Mulfinger, City Administrator

Recorded August 13, 2024.



**City Of Oelwein
Hotel/Motel Tax Funding
Tourism Program Guidelines
Adopted by Resolution 5619-2024**

Purpose

The City of Oelwein is offering grant funds for tourism through projects presented to them by nonprofits. These grant funds are made possible through the hotel/motel tax funds received by the City of Oelwein. By law, 50 percent of these funds must be spent on ventures that promote area tourism. The city will only provide funding to a nonprofit organization, or an event partnering with a nonprofit organization

Application and Project Deadlines

Applications will be accepted four times per year and must be received by 4300 p.m. on the deadlines provided below. If deadline falls on a weekend or holiday the deadline shall be 4:30 P.M. on the last working day prior to:

- September 1
- December 1
- March 1
- June 1

The Planning, Finance, Enterprise and Economic Development Committee (PFEED) will meet the first part of January, April, July and October at the Oelwein City Hall Council Room. Each applicant will be afforded the opportunity to attend a brief question and answer session with the PFEED. Applicants need not be available during the committee’s review of an application. All applications recommended for approval by PFEED are subject to approval of the Oelwein City Council, which meets on the second and fourth Monday of every month. Applicants will be notified of application approval/denial by mail.

Application Requirements

- All applications must be typed.
- All areas of the application must be completed.
- Emailed applications are encouraged

Eligible Projects

Eligible applicants include non-profit organizations whose project has a beneficial impact on the community of Oelwein. PFEED encourages creative projects that enhance the lives of residents of Oelwein or promotes tourism in the community. This program supports projects that include but are not limited to:

- Developing and/or expanding tourism programs or facilities.
- Building partnerships and cooperative efforts among tourism providers.
- Enhancing and initiating efforts to attract visitors to the community.

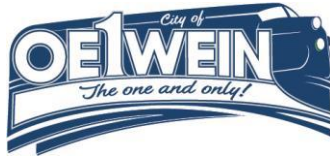

Eligibility and Allocation Procedures

Preference will be given to 501c(3) entities as recognized by the Internal Revenue Code of the United States.

All recommendations on allocations shall be subject to City Council approval. Final action on the allocation recommendations and City Council determinations shall be made as a part of the annual budget process.

PFEED will review all four categories. The city council will vote to determine allocation amounts. All meetings will adhere to Iowa’s open meeting law.

Category 1:

Primary:

Applicants are City-owned and operated facilities housing activity that is primarily recreational, cultural, destination marketing or entertainment oriented; the Williams Center for Performing Arts; the Williams Wellness Center; the Veterans Memorial Sports Complex; City commissions dealing with activity that is primarily recreational, cultural, destination marketing or entertainment oriented; and other organizations, programs, events or venues deemed by Council to be of community-wide importance that are not included as line items in the City budget. Debt payments incurred by the City for community organizations or city facilities that provide recreational, cultural, destination marketing or entertainment oriented activities will be the first items funded with Hotel-Motel allocations. In addition, the City may set aside hotel-motel funding for recreational, cultural, community events, or other allocations deemed appropriate by the City Council.

Category 2:

Community Culture and Education:

Applicants are educational, cultural, and entertainment-oriented entities that are mission-driven and improve the overall quality of life in Oelwein. Organizations should have 501 (c)(3) status under the Internal Revenue Code. Applicants should have regular hours open to the public or a regular series of events open to the public.

Category 3:

Community Recreation and Events:

Applicants are community recreational and event-oriented entities particularly for recreation activities, annual events or limited time events which illustrate a positive impact on the quality of life. Organizations that are 501(c)(3) will be given preference.

Category 4:

New and Emerging Organizations and Events.

Applicants are limited to a total of three successive annual applications for a new or emerging organization or event. The program or event shall show uniqueness, fulfill an unmet need or program, and have a positive impact on the quality of life. Organizations should be 501(c)(3) or have applied for such status to be eligible in this category.



Ineligible Projects/Components

- Projects with full funding already in place.
- Projects that do not have a beneficial impact on Oelwein.
- Funds should not become recurring operational expenses.
- Funds may not be used as an individual fundraiser or a donation.
- Funds may not pass through to other projects or organization.
- Non Oelwein events

Cost Reimbursement

- A complete project budget and schedule of completion must be included with the application.
- Applicants must have accurate estimates included with the project budget.
- Applicants are eligible for up to 100% funding and funds will be distributed upon approval of the City of Oelwein City Council.
- Funds will be paid only to the applicant, not to contractors or vendors.
- Upon completion of the project, the applicant must submit documentation of expenses and a project recap within 60 days to City Hall.
- Any funds that are not expended or are found to be outside the scope of the grant made by PFEED must be reimbursed/returned, by the applicant, to the City of Oelwein within 60 days.
- Failure to comply with the aforementioned rules will prohibit the applicant from applying for funds for one year.

Review/Evaluation Criteria (Tourism)

Projects will be evaluated using certain criteria including but not limited to:

- Potential number of guests to be generated by the project.
- Number of people the project will reach.
- Financial need of the project.
- Percentage of project funding being requested.
- “Seed money” to start a new project or expand an existing project.
- Quality of the project.
- The likelihood that the project will achieve stated goals.

Megan Baumgartner
Fayette Co. Fair Queen Contest Coordinator
Fayette Co. Fair Concert Committee Chair
221 Park Ave
Arlington, IA 50606

February 23, 2026

Dear Members of the Oelwein City Council:

I apologize for not being in attendance this evening due to helping judge NE Sub-District FFA at Starmont. On behalf of the Fayette County Fair Board, we respectfully request your consideration of a financial contribution to support the carnival at the upcoming Fayette County Fair held from July 21st-25th located at 504 S Vine St, West Union, IA 52175.

The support of our local towns truly serves as the backbone of our ability to offer carnival rides and activities to fairgoers from across Fayette County, including families from Oelwein. We have also had great representation from Oelwein the last few years. In 2022, Abigail Patrick was crowned the Fayette Co. Fair Queen. In 2024, we had four ladies from Oelwein run for the Fair Queen Contest. More recently, Jenna Bahe is hosting a line dancing night this Saturday, February 28th from 7:30-11:00 PM at the Dance Pavilion. It is fantastic to see so much involvement and leadership from one of our largest communities in the county.

It is because of community support like yours, we are able to provide opportunities for children and families to make lasting memories enjoying rides at no cost, rather than requiring the purchase of tickets or a wristband. Not to mention, the fair also attracts many other neighboring communities with free parking and free gate admission.

The Fayette County Fair is a cornerstone event that brings together residents from all communities in our county, promotes local agriculture, advertises our small towns that make us great, and provides affordable family entertainment. We are grateful that other towns throughout the county have already committed their support, and we hope you will consider joining them in making this experience accessible and enjoyable for all.

Thank you for your time, continued leadership, and thoughtful consideration of this request. We truly appreciate your commitment to supporting events that strengthen our community.

Warmest Regards,



Megan Baumgartner
Fayette Co. Fair Queen Contest Coordinator
fayettecoiafairqueen@gmail.com
Fayette Co. Fair Concert Committee Chair
sponsorship@fayettecoiafair.com
(563) 380-2057



To: Mayor and City Council
From: Dylan Mulfinger, City Administrator
Subject: Big O Request
Date: 3/23/2026

The celebration in Oelwein has a colorful history. Several groups have stepped up to take on the challenge with some being more successful than others. While the city council in December of 2025 did not move forward with the idea of supporting the event, a new council in January of 2026 decided it was needed. The event is taking place July 10 and 11. Music and loads of fun for families.

The committee is requesting \$10,000 in hotel motel tax. The city council should also anticipate an annual request moving forward as the event will, for the time be, associated with the city and city staff. The goal this year is to throw an incredible event then pass the leadership to Kami LeComte.

The anticipated expense are:

Expense	
Band Fri	\$5,000
Band Sat	\$5,000
Tent	\$2,753
Drinks	\$5,000
Inflatables	\$5,000
Carnival	\$2,500
Parade Prizes	\$350
Fence	
Fireworks	\$5,000
Chalk	\$500
Dance Party	\$648
Scavenger	\$300
Toilets	\$1,000
Garbage	\$1,000
Shirts	
	\$34,051

Anticipated Revenues:

Funding	
RAG \$	\$15,000
Hotel Motel	\$10,000
Donations	\$10,000
Sponsor	\$5,000
	\$40,000



CITY OF OELWEIN

SPECIAL EVENT APPLICATION

Prior to completing this application, please review the special event policy.

Initial Information (Please Print)

Name of Event: Oelwein Christian Church - Easter Egg Hunt
Date of Event: April 5, 2026
Starting Time: 12 PM Ending Time: 1 PM Setup Time: 8 AM

If the event is more than one day, please list additional dates and times below. If more room is needed, please attach a separate piece of paper listing additional dates and times. Posted park hours are 7AM to one hour past sundown.

Day 2: -
Day 3: -
Day 4: -

Rain Date Information

Date of Event: - Location: -
Starting Time: - Ending Time: - Setup Time: -

Contact Information

Contact Person #1: Julia Robinson
Phone Number: (515) 971-7986 E-mail: julia@oelweinchurch.com
Contact Person #2: Hayden Robinson
Phone Number: (319) 509-9260 E-mail: hayden@oelweinchurch.com

Type of Event:

- Ceremony
- Race Event
- Other Community Egg Hunt
- Company Activity
- Fundraiser
- Bike Event
- Cultural Event

Event Description and Purpose: Oelwein Christian Church would like to host a 5000 egg hunt on Easter for the kids in the community (ages 1-year-old - 5th grade) - free + open to all families

Anticipated Number of guests/participants: Unsure. If the weather is good, could be very high. At least 150+ people (children + adults).

Location

Name of park and general area North side of Oelwein City Park - including the "old" playground, road that loops, + all green space throughout

Map attached: YES NO

Shelter(s) Reserved: YES* NO

*If yes, paid: YES NO

Additional Structures

Do you plan on having additional structures put in place? YES NO

Only eggs

*Additional structures include but are not limited to: inflatables, tents, amusement rides

**If yes, please provide the following information for each type of structure, attached additional information to this application as needed:

Name of Company: _____ Type of Structure: _____
Contact Person: _____ Phone: _____

Name of Company: _____ Type of Structure: _____
Contact Person: _____ Phone: _____

Name of Company: _____ Type of Structure: _____
Contact Person: _____ Phone: _____

Restroom Facilities

Do you plan on having portable toilets put in place? Yes* No

*If yes, please provide the following information:

Name of Company: _____
Contact Person: _____ Phone: _____
Number of Units: _____ Drop-Off date: _____ Pickup Date: _____

Amplification

Do you plan to provide other types of non-amplified entertainment? YES* NO

*If yes, describe: _____

Do you plan to provide other types of amplified entertainment? YES* NO

*If yes, do you acknowledge the city's noise control Ordinance?

YES NO

Electrical Needs

Each park shelter has electricity available in varying degrees. If further information is needed, please contact the parks department at 319-348-4047. If additional electrical is needed, please utilize your own generator.

Street/Alley Closures

If required for a special event, a listing of requested street or alley closures must be listed.

Street or Alley to be closed	Beginning Point	Ending Point	Date(s)	Hours of Closure
#1 Roadways on the N. side of city park	Where cars turn into the N. side of the park from S. Frederick		4/5/2026	8 AM - 1 PM
#2 Small road/trail that is parallel to S. Frederick	South end of this trail		4/5/2026	8 AM - 1 PM

Use Of Certain Motorized Vehicles

Please indicate if any of the vehicles from the list below may be used during the special event. Please also indicate quantity and model of vehicles. If approved, these vehicles may be used are subject to an Auto Liability limit no less than \$1,000,000.

NA

- ATV (All Terrain Vehicles)

- Golf Carts

- Off-Road Utility Vehicles

- Snowmobiles

Additional Information

- 1. Do you plan to have pets and/or livestock? Yes No
 If so, please list how many, the type(s), was provisions have been made for care, containment, and waste removal of animal(s):

_____ Contact Person: _____ Phone: _____

- a. Do you acknowledge pets must be leashed at all times YES NO
- 2. Do you plan to use a generator? YES* NO

If yes, explain the power source it is being used for: _____

- 3. Will grills or propane stoves, etc. be used? YES* NO

*If yes, do you acknowledge the person conducting this activity is responsible for providing appropriate safety equipment (i.e. fire extinguishers, etc.) Open burning and/or fires are prohibited. All used and unused charcoal are to be removed at the conclusion of the event.

- 4. Do you or any of your guests plan to serve/sell alcoholic beverages? YES* NO

*If yes, you will need to apply for your permit with the Iowa Alcoholic Beverage Division for this location and allow time for the approval at a regular city council meeting.

Please attach a copy of your license

- 5. Explain your plan for leftover refuse & garbage removal as all city parks are carry-in, carry-out:

We will place some large trash bins + dispose in OCC dumpster. If any

 Contact Person (if pertinent): _____ Phone: _____

Failure to clean up after your event could result in denial of future special event applications and \$150 cleaning bill may be assessed.

eggs are not claimed, we will pick them up.

- 6. The City of Oelwein has 2 large portable picnic tables with total seating for 40 people and 4 wheelchairs. If you want to rent these tables and are a non-profit, contact City Hall at 319-283-5440.

Any other special provisions or concerns pertaining to your activity which have not been addressed on this application: _____

Due to the large number of children + families we hope
will attend, having a police officer present from 11:45 AM
to about 12:30 PM (when all eggs have been found)
would be wonderful

Please read and initial your understanding of the following:

- JK 1.) No organization or person receiving a permit for use for the use of City property may discriminate on the basis of sex, sexual orientation, gender, identity, religion, color, race, age, ancestry or national origin.
- JK 2.) This authorization is only applicable for the area and time duration as suggested by this application.
- JK 3.) This authorization may be terminated by the City of Oelwein.
- JK 4.) No refunds will be issued with the exception of extreme conditions and/or circumstances. All refund requests must be in writing and include photos. Requests must be within 5 days of the permitted event.
- JK 5.) The organization or person must provide (at their expense) all equipment, including extra tables and portable restrooms.
- JK 6.) Your non-refundable application fee must be received by City Hall in full before your application can be processed and/or your date and location can be reserved. Applications are processed on a first come, first paid basis.
- JK 7.) Applicants are allowed to make changes to a reservation only once. Anything after, will consist of filling out another application and paying an additional application fee. Any changes must be submitted in writing by the applicant.
- JK 8.) Incomplete applications cannot be processed and will be returned.
- JK 9.) Applicants shall indemnify and hold harmless the city and its officers, directors, agents, employees and volunteers from and against claims, damages, losses and expenses, including but not limited to attorneys' fees, arising out of or resulting from the negligence or misconduct of applicant in connection with the special event.

I have read the Special Event Policy and have completed the Special Event Application. I understand the conditions under which it is issued and agree to comply with these conditions for this event.

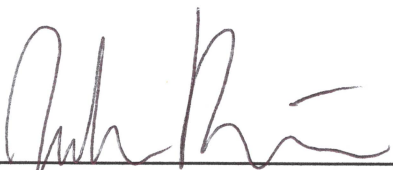
Applicant's Signature

3/10/2026
Date

Julia Robinson
Print Applicant's Name

Oelwein Christian Church
Organization (if applicable)

FOR INTERNAL USE ONLY

Department Review

All affected departments are to review the application and provide written comments for the City Clerk/Treasurer to compile and submit to the City Council and applicant prior to the City Council meeting where the event will be up for consideration.

Department	Comments attached (Yes/No/NA)	Additional Fees (Other than listed below)
Police		
Fire		
Public Works		
Parks		
Recreation		
Chamber		
Total		\$

Requirement Checklist

Requirement	Date Received/Action Taken
Application Submittal Date	3-13-24
Map Submitted	YES
Certificate of Insurance Submitted	
Liquor License	N/A
Liquor Liability Coverage	N/A
Department(s) Reviewed	
Council Reviewed	
Council Approval	
Permit Issued	
Deposit Received	25.00
Event Costs Paid	3-13-24

Fees Checklist – as listed in City’s Fee Schedule

Fee	Amount
Application Fee	paid \$25.00
Park Shelter	\$30.00
Depot Park Rental	\$75.00

Additional fees may be applied city property is damaged and/or if additional cleaning is required. Please refer to the policy for additional information.

Oelwein Christian Church - Easter Egg Hunt at City Park - April 5, 2026

Area used for OCC Egg Hunt:

- North section of City Park (the playground, loop, and green spaces throughout) that borders the Oelwein Christian Church property

Barricades Requested (to prevent cars from driving around the North side of City Park while children are running around)

- #1 - Road entrance to the North side of city park (where the old playground is located)
- #2 - Block off road/trail that is parallel to S Frederick Ave

Note: The church will start placing eggs as early as 8 AM on April 5th, so having the barricades set-up before then would be awesome. They could then be removed by 1 PM (or the church can set them aside next to the bathrooms once the children are done).



The Oelwein Public Library Board of Trustees met on Wednesday, March 11, 2026, at 5:00 p.m. at the Oelwein Public Library.

Present: Mars, Franzen, Kerns, Macken

Absent: VanDenHul, Ingersoll, Payne

Kerns called the meeting to order at 5:04

Agenda Approved: Franzen made a motion to approve the agenda. Seconded by Mars. Motion carried.

Minutes Approved: Mars made a motion to approve the minutes. Seconded by Franzen. Motion carried.

Correspondence and communications: There were no correspondences.

Trustee Training: Recruit New Trustees-

Develop a list of potential board members to fill vacancies ensuring the list reflects:

- Diversity in representation
- A variety of occupations and knowledge bases
- Participation in community groups and organizations
- Library users and non-users

Director's Report:

- Staff are in the process of hiring a replacement part-time librarian. The board suggested using Facebook ads if needed.
- Staff will be attending a class on Website Compliance. A new federal rule will require state and local government websites (including public library websites) to comply with accessibility standards to ensure web content is accessible to people with disabilities.
- The repairs to the atrium are completed.
- Midwest Janitorial has assigned a new custodian to clean the library as the former custodian was doing substandard work. The new person is doing a good job.
- Staff will have a display at the Diversity Night on March 31 at the event center.
- The Daughters of the American Revolution genealogy program will be April 8 at 6:00 p.m.
- The Norma Jean Warner Trust is distributing \$941.69 to all public libraries in Iowa with a population below 7,000. The funds will be distributed to the Oelwein Library Foundation.

Friends' Report: The next meeting is March 16.

Bills Approved: Mars made a motion to approve the list of bills. Seconded by Franzen. Motion carried.

Grounds Maintenance -The Parks Department will be taking care of the mowing and grounds maintenance. The Lot line item in the library's budget will be transferred to the Parks Department.

Flagpole - The plants around the flagpole have become scraggly. Parks staff suggested filling the space with pavers to match the reading garden. This would also better accommodate raising and lowering the flag, especially under wet conditions. An estimate from Stewartscape is \$4,362.76 for pavers that match the Reading Garden. A Holland Paver block like the banding in the city sidewalks would be \$3,960.96. Kerns will ask if Connie Kerns and Jake Blitsch would like to maintain or improve the area around the flagpole.

Iowa Adventure Pass – This program is available to Iowa public libraries. Libraries can buy season passes to various museums and zoos for patrons to use once per season. Season passes cost anywhere from \$100 to \$550. In addition, there is an annual website platform fee of \$250. The director will ask if the Friends of the Library would like to sponsor this program.

3-D Printer- Information was presented to the board on 3-D printers. The printer would be available for patrons to create objects for a fee or for staff to create reading incentives. The Bambu P1S would cost \$549 with the AMS Combo and the P2S, the updated version, would cost \$800 with the AMS Combo. Filament and tools are additional costs. Franzen made a motion to purchase the P2S and additional tools using Enrich Iowa funds. Seconded by Mars. Motion carried.

Foundation Board Member Recommendation – Janice Minton has been recommended to serve on the Library Foundation Board. Franzen made a motion to approve the appointment of Janice Minton to the Library Foundation Board. Seconded by Mars. Motion carried.

Policy Review: Staff and Board Member's Considerations

Mars made a motion to approve the following revisions to the policy:

Remove Fax Usage since long distance charges are inclusive in the monthly phone bill.

Add printer usage with copier and add color printing charges for \$0.25 per page.

Remove computer usage print charges as these charges are part of the copier and printer charges.

Seconded by Franzen. Motion carried.

Adjournment: Franzen made a motion to adjourn at 6:33.

Respectfully submitted,
Susan Macken

The next meeting will be Wednesday, April 15 at 5:00 p.m.

IN ACCOUNT WITH
 LYNCH DALLAS LEGAL
 PO BOX 2457
 CEDAR RAPIDS, IA 52406-2457
 TELEPHONE 319-365-9101
 FEDERAL ID: 42-1378496

Item A.

City of Oelwein
 Dylan Mulfinger
 send via email

Page: 1
 March 12, 2026
 Account No: 150213-00500P
 Statement No: 227380

General Matters

Professional Services

		Hours	
02/13/2026	MDB Finalize and file SRK Appearance and Praecepte post attorney review (.3).	0.30	
02/16/2026	MDB Follow up with SRK re any information provided by client to use for garnishment (.2).	0.20	
02/23/2026	DMM Review correspondence from City re: public records request and draft follow-up (.2).	0.20	
02/24/2026	DMM Follow-up and review correspondence re: records request (.2).	0.20	
03/04/2026	MDB Attention to file and information provided re collection efforts (writ of execution in hand, but not collectable to date until bank information or employer information obtained) (.2). Research any collectable or garnishable assets re writ of execution enforcement (.5).	0.70	
	Current Services Rendered	1.60	230.00

Recapitulation

<u>Lawyer Hrs</u>	<u>Hours</u>	<u>Rate</u>	<u>Total</u>
DANIEL M MORGAN	0.40	\$200.00	\$80.00
MICHELLE D BARNES (Paralegal)	1.20	125.00	150.00

Expenses

02/13/2026	Filing Fee - Iowa Judicial Branch	35.00
	Total Expenses	35.00
	Total Current Services and Expenses	265.00
	Previous Balance	\$809.60

City of Oelwein

General Matters

Ma Item A. : 2
26
Account No: 150213-00500P
Statement No: 227380

Payments

02/27/2026	Payment on Account - Thank You	-809.60
	BALANCE DUE	<u>\$265.00</u>

**PLEASE MAKE CHECKS PAYABLE TO:
LYNCH DALLAS LEGAL**

PAYMENTS RECEIVED AFTER STATEMENT DATE
WILL APPEAR ON YOUR NEXT MONTH'S BILL.
PLEASE INCLUDE ACCOUNT NUMBER ON YOUR
CHECK OR RETURN A COPY OF YOUR BILL.

IN ACCOUNT WITH
 LYNCH DALLAS LEGAL
 PO BOX 2457
 CEDAR RAPIDS, IA 52406-2457
 TELEPHONE 319-365-9101
 FEDERAL ID: 42-1378496

Item A.

City of Oelwein
 Dylan Mulfinger
 send via email

Page: 1
 March 12, 2026
 Account No: 150213-00600P
 Statement No: 227381

Real Estate

Professional Services

		Hours	
02/17/2026	DDH Review easement agreement, return to City Admin. (5); review resolutions approving sales of R.E. reference 502 E. Charles and 111 5th Ave. SW (.3). Review proposed easement agreement with fiber company, provide feedback (.5).	1.30	
03/02/2026	DDH Review and amend where appropriate documents related to the transfer of city owned real estate, 502 E. Charles, 111 5th Ave. SW, and 201 9th Ave. SW, return to staff with comments and mark ups (1.1).	1.10	
	Current Services Rendered	2.40	480.00

Recapitulation

<u>Lawyer Hrs</u>	<u>Hours</u>	<u>Rate</u>	<u>Total</u>
DOUGLAS D HERMAN	2.40	\$200.00	\$480.00

Total Current Services and Expenses	480.00
Previous Balance	\$321.01

Payments

02/27/2026	Payment on Account - Thank You	-321.01
------------	--------------------------------	---------

BALANCE DUE \$480.00

**PLEASE MAKE CHECKS PAYABLE TO:
 LYNCH DALLAS LEGAL**

PAYMENTS RECEIVED AFTER STATEMENT DATE
 WILL APPEAR ON YOUR NEXT MONTH'S BILL.
 PLEASE INCLUDE ACCOUNT NUMBER ON YOUR
 CHECK OR RETURN A COPY OF YOUR BILL.

City of Oelwein
Dylan Mulfinger
send via email

Page: 1
March 12, 2026
Account No: 150213-00800P
Statement No: 227382

Nuisance/Code Enforcement

Professional Services

		Hours
02/11/2026	DDH Review email from Treasurer, update assessment notice, return to staff with directions, next steps, etc. (.3).	0.30
02/12/2026	DDH Review email from Building Official, review calendar, review dates, and reply (.1).	0.10
02/13/2026	DMM Review photos re: 982 1st Ave SW, identify exhibits and witnesses (.5). Prepare SRK for coverage (.1).	0.60
02/13/2026	RMR Prepare exhibits and exhibit list for trial re: 982 1st Ave. SW (2.8 but 1.8 @ no charge).	2.80
02/13/2026	MDB Attention to exhibit preparation re 982 1st Ave SW (.4)	0.40
02/16/2026	DMM Follow-up on exhibits and coordinate coverage with SRK re: 982 1st Ave SW (.4 but .2 @ no charge).	0.40
02/16/2026	SRK Prepare for trial re 982 1st Ave SW, including reviewing file, proposed exhibits, and drafting trial outline (.6).	0.60
02/17/2026	DMM Follow-up with SRK re: 982 1st Ave SW (.2).	0.20
02/17/2026	RMR Review/revise proposed orders for judgment for 982 1st Ave SW and file same with the court (.4 but .2 @ no charge).	0.40
02/17/2026	SRK Travel to/from Oelwein for trial re 982 1st Ave SW (2.2). Attend trial for 982 1st Ave SW and additional pre-trial conference for other MI matter (.4). Revise proposed stipulated orders after court hearing to be submitted and approved by judge re 982 1st Ave SW (.3). Prep for trial re 982 1st Ave SW (.3).	3.20
02/18/2026	DMM Review orders re: 982 1st Ave SW and draft follow-up to Code Enforcement (.1).	0.10
02/19/2026	DMM Prepare exhibits and notebooks for C.P. Properties trial on 3/3/26 (1.3).	1.30

Nuisance/Code Enforcement

		Hours	
02/23/2026	DMM Review exhibits for 811 1st Ave NE and overall templates for other C.P. exhibits (.3). Review exhibits re: 141 2nd Ave NW (.1). Review exhibits for 407 Frederick Ave (.1). Review and revise exhibits re: 720 S Frederick (.1). Review exhibits re: 827 1st Ave NE (.1). Review exhibits re: 205 4th Ave NE (.1). Review exhibits re: 15 2nd Street NW (.1). Review exhibits re: 11 2nd St NW (.1). Review exhibits re: 107 7th Ave NW (.1). Review exhibits re: 319 2nd Ave NW (.1).	1.20	
02/23/2026	KAB Prepare Witness and Exhibit List, label exhibits for trial and e-file same with court re: 811 1st Ave NE (.4). Prepare Witness and Exhibit List, label exhibits for trial and e-file same with court re: 141 2nd Ave NW (.3). Prepare Witness and Exhibit List, label exhibits for trial and e-file same with court re: 407 N. Frederick Ave (.3). Prepare Witness and Exhibit List, label exhibits for trial and e-file same with court re: 827 1st Ave NE (.3). Prepare Witness and Exhibit List, label exhibits for trial and e-file same with court re: 205 4th Ave NE (.3). Prepare Witness and Exhibit List, label exhibits for trial and e-file same with court re: 15 2nd Street NW (.3). Prepare Witness and Exhibit List, label exhibits for trial and e-file same with court re: 11 2nd Street NW (.3). Prepare Witness and Exhibit List, label exhibits for trial and e-file same with court re: 107 7th Ave NW (.3). Prepare Witness and Exhibit List, label exhibits for trial and e-file same with court re: 319 2nd Ave NW (.3). Prepare Witness and Exhibit List, label exhibits for trial and e-file same with court re: 221 2nd Ave SE (.3). Prepare Witness and Exhibit List, label exhibits for trial and e-file same with court re: 229 4th Ave SE (.3).	3.40	
02/24/2026	DMM Review exhibits re: 319 2nd Ave NW (.1). Review exhibits re: 221 2nd Ave SE (.1). Review exhibits re: 229 4th Ave SE (.1).	0.30	
02/24/2026	KAB Prepare trial notebooks for all 12 Purdy Property trials on 3/3/26 (3.9).	3.90	
02/27/2026	DMM Brief follow-up with City in preparation for trial on 3.3.26 re: C.P. properties (.1).	0.10	
03/02/2026	DMM Telephone call from Building Official re: C.P. properties (.2). Review correspondence re: 107 9th Ave SE (.1). Review City follow-up and attachment re: 107 9th Ave SE and response from opposing counsel (.2).	0.50	
03/03/2026	DMM Compile notes and outline re: C.P. properties for trial on 3.3.26 (.7). Travel to Oelwein (1.0). Meet with Building Official, settlement negotiations with Attorney Woods and Defendant (1.0). Travel from Oelwein (1.0). Draft proposed order and send to Attorney Woods (.8).	4.50	
	Current Services Rendered	24.30	3,657.50

Recapitulation

<u>Lawyer Hrs</u>	<u>Hours</u>	<u>Rate</u>	<u>Total</u>
DANIEL M MORGAN	0.20	\$0.00	\$0.00
DANIEL M MORGAN	9.00	200.00	1,800.00
ROZIE M REYNOLDS (Legal Assistant)	2.00	0.00	0.00
ROZIE M REYNOLDS (Legal Assistant)	1.20	125.00	150.00

City of Oelwein

Nuisance/Code Enforcement

Ma Item A. : 3
26

Account No: 150213-00800P
Statement No: 227382

<u>Lawyer Hrs</u>	<u>Hours</u>	<u>Rate</u>	<u>Total</u>
MICHELLE D BARNES (Paralegal)	0.40	125.00	50.00
SAMANTHA R KUNTZ (Associate)	3.80	175.00	665.00
DOUGLAS D HERMAN	0.40	200.00	80.00
KIM A BROWN (Legal Assistant)	7.30	125.00	912.50

Total Current Services and Expenses 3,657.50

Previous Balance \$1,967.44

Payments

02/27/2026 Payment on Account - Thank You -1,967.44

BALANCE DUE \$3,657.50

**PLEASE MAKE CHECKS PAYABLE TO:
LYNCH DALLAS LEGAL**

PAYMENTS RECEIVED AFTER STATEMENT DATE
WILL APPEAR ON YOUR NEXT MONTH'S BILL.
PLEASE INCLUDE ACCOUNT NUMBER ON YOUR
CHECK OR RETURN A COPY OF YOUR BILL.

City of Oelwein
Dylan Mulfinger
send via email

Page: 1
March 12, 2026
Account No: 150213-01000P
Statement No: 227384

Prosecutions

Professional Services

		Hours
02/09/2026	DMM Follow-up on B.K. outstanding fees and coordinate collection actions with SRK (.2).	0.20
02/11/2026	DMM Coordinate collection activities with SRK and MDB (.2).	0.20
02/11/2026	MDB Attention to email communications with DMM/SRK re Praecipe to be prepared and review file re same (.2). Prepare Praecipe/Request for Writ of Execution for Garnishment (.4).	0.60
02/11/2026	SRK Confer w/ DMM re set up of collection efforts against defendant (.1).	0.10
02/12/2026	MDB Update Praecip calculations for judgment and finalize same for SRK/DMM review (.1).	0.10
02/13/2026	DMM Review and provide feedback on judgment collection remedies and draft follow-up to City (.3 @ no charge).	0.30
02/13/2026	SRK Review and provide feedback on judgment collection draft documents (.2). Follow up with City regarding banking and employment information of defendant for judgment collection efforts (.1).	0.30
02/17/2026	DMM Review citation re: smoking for R.L., draft motion and order re: no state charging authority (.3).	0.30
02/17/2026	KAB Review Order Setting Hearing on new prosecution case and calendar same (.1).	0.10
02/18/2026	DMM Follow-up on state prosecution matter (.1).	0.10
02/23/2026	RMR File Motion and Order to Withdraw with the court re: improper state charge (.1).	0.10
02/23/2026	DDH Review criminal prosecution application to withdraw and order, ok filing by KAB (.1).	0.10

Prosecutions

		Hours	
02/23/2026	KAB Prepare Motion to Withdraw and Order granting same re: state charge matter (.2).	0.20	
02/27/2026	DMM Draft motion and order to withdraw re: improper state charge assigned to City Attorney (.2 @ no charge). Follow-up on motion to withdraw (.1 @ no charge).	0.30	
03/04/2026	DMM Follow-up re: collection status for B.K. (.1).	0.10	
03/04/2026	SRK Email communication with DMM re judgment collection efforts, and follow up with City Administrator and Police Chief re the same (.1). Review email from Police Chief re Defendant information for purposes of judgment collection and look into possible ways to collect based on that information (.3).	0.40	
03/05/2026	DMM Follow-up with MBD and SRK re: B.K. collections and background (.2).	0.20	
03/05/2026	SRK Confer w/ MDB and DMM re possible judgment collection efforts (.1).	0.10	
	Current Services Rendered	3.80	535.00

Recapitulation

<u>Lawyer Hrs</u>	<u>Hours</u>	<u>Rate</u>	<u>Total</u>
DANIEL M MORGAN	0.60	\$0.00	\$0.00
DANIEL M MORGAN	1.10	200.00	220.00
ROZIE M REYNOLDS (Legal Assistant)	0.10	125.00	12.50
MICHELLE D BARNES (Paralegal)	0.70	125.00	87.50
SAMANTHA R KUNTZ (Associate)	0.90	175.00	157.50
DOUGLAS D HERMAN	0.10	200.00	20.00
KIM A BROWN (Legal Assistant)	0.30	125.00	37.50

Total Current Services and Expenses 535.00

Previous Balance \$40.00

Payments

02/27/2026 Payment on Account - Thank You -40.00

BALANCE DUE **\$535.00**

**PLEASE MAKE CHECKS PAYABLE TO:
 LYNCH DALLAS LEGAL**

PAYMENTS RECEIVED AFTER STATEMENT DATE
 WILL APPEAR ON YOUR NEXT MONTH'S BILL.
 PLEASE INCLUDE ACCOUNT NUMBER ON YOUR
 CHECK OR RETURN A COPY OF YOUR BILL.



To: Mayor and City Council
From: Dylan Mulfinger, City Administrator
Subject: Agenda Memo
Date: 3/23/2026

Consent Agenda

- 1. Consideration of a motion approving the March 9, 2026 minutes.
- 2. Claims resolution in the amount of \$427,408.46.
- 3. Consideration of a motion approving the Class "C" Retail Alcohol License for the Columbus Club.
- 4. Consideration of a motion approving the Class "B" Retail Alcohol License for Kwik Star #665.
- 5. Consideration of a resolution authorizing temporary closure of public ways or grounds for Oelwein Fire Fighters Foundation.
 - 1. This BBQ event is in its third year. The city had no issues last year with the event. The City Administrator recommends approving the resolution.
- 6. Consideration on a resolution authorizing temporary closure of public ways or grounds for Pony Express.
 - 1. This is an annual request. The city has no current or former issues with the Pony Express. The City Administrator recommends approving the resolution.
- 7. Consideration of a resolution approving Pay Application No. 6 in the amount of \$407,043.42 to Taylor Construction for the 10th St. Bridge Project.
 - 1. Work on the bridge project has been going well. Pouring the deck will be coming soon. The City Administrator recommends approving the resolution.
- 8. Consideration of a resolution approving an expense reimbursement number five in the amount of \$43,746.57 for the Oelwein RISE Day Habilitation Center Improvements Project.
 - 1. This project is coming near the end. RISE is almost done and will be able to move back into their updated facility. The City Administrator recommends approving the resolution.

Ordinances

- 9. Consideration of an ordinance amending, Chapter 6, Article IV, Oelwein Airport Board, Section 6-103 Meeting and Minutes of the Code of Ordinances of the City of Oelwein, Iowa. - Second Reading.
 - 1. The Airport board voted to move to meetings every other month. This code allows for the move and will also allow them to meet as needed. The recent changes at the airport with the city now overseeing all operations has reduced oversight needs of the airport board. The City Administrator recommends approving the second reading.



- 10. Consideration of an ordinance amending Chapter 19 – Animal and Fowl - Sections 19-0.5 through 19-39 Related to Animal and Fowl. - First Reading.
 - 1. The goal has been to move appeals away from the city council. This ensures the appeal is not a large event at the council chambers and the city council is not the judge and jury. The new process sends the appeal to the police chief. The City Administrator recommends approving the first reading.

Resolutions

- 11. Consideration of a resolution scheduling a Public Hearing for the Proposed City Budget for the Fiscal Year 2027 (2026-2027) for April 13, 2026 at 6:00 PM at the Oelwein City Council Chambers.
 - 1. This public hearing is required by Iowa Code. The City Administrator recommends approving the resolution.
- 12. Consideration of a resolution authorizing temporary closure of public ways or grounds for Oelwein Fire Fighters Foundation.
 - 1. The city council was shown the plans for this convention at the March 23 work session. The volunteers are well organized, and their ability to throw a top-notch convention is certain. The City Administrator recommends approving the resolution.
- 13. Consideration of a resolution formally awarding Downtown Property Forgivable Loans for building improvements provided by Tax Increment Financing.
 - 1. This funding has been increased this year because of additional dollars coming in from the downtown fund. The fund also had a carry over of \$10,000 as one loan was turned down last year. These are scored by the OCAD housing committee. After that, a recommendation is made to the city council. These projects will help six buildings in the downtown. The City Administrator recommends approving the resolution.
- 14. Consideration of a resolution amending the Oelwein Fee Schedule.
 - 1. It is a goal each year to update fees. This year the changes are in parks, aquatics, and cemetery. These changes are already recommended by the parks and recreation board. Having an updated and annually reviewed fee schedule is important for the city. The City Administrator recommends approving the resolution.
- 15. Consideration of a resolution amending the Oelwein Salary Schedule
 - 1. This is the last of a three-year four percent increase for most city employees. The reason for the amendment is to increase aquatic wages. Discussions at the staff level determined a change was needed. The City Administrator recommends approving the resolution.
- 16. Consideration of a resolution approving an updated project cost for the 2026 Airport Paving Project.
 - 1. The airport paving project was supposed to be an asphalt overlay. After core samples of the current pavement were taking, a full rebuild has been recommended. The city council has this project still within budget



because of the 95 to 5 federal match. The City Administrator recommends approving the resolution.

Motions

17. Consideration of a motion to approve the recommendation from the Planning, Finance, Enterprise and Economic Development Committee on the Hotel Motel request from the Fayette County Agricultural Society.
 1. The city has a long history of funding the fair. The funding stopped once the city determined the fair was cash flowing.
18. Consideration of a motion to approve the recommendation from the Planning, Finance, Enterprise and Economic Development Committee on the Hotel Motel request for the Big O Weekend.
 1. This new event will be a big hit in town. The event name is already being made fun of so you know it will be good.
19. Consideration of a motion to approve a special event application for the Oelwein Christian Church Easter Egg Hunt.
 1. This event happened last year with no issues. The City Administrator recommends approving the motion.