



Agenda

City Council Meeting

Oelwein Community Plaza, 25 West Charles, Oelwein

6:00 PM

March 22, 2021
Oelwein, Iowa

Mayor: Brett DeVore

Mayor Pro Tem: Warren Fisk

Council Members: Matt Weber, Renee Cantrell, Tom Stewart, Lynda Payne, Karen Seeders

Pledge of Allegiance

Call to Order

Roll Call

Additions or Deletions

Citizens Public Comments - See Guidelines for Public Comments Below

Consent Agenda

- [1.](#) Consideration of a motion approving March 8, 2021 Council Minutes
- [2.](#) Claims Resolution in the amount of \$486,327.01
- [3.](#) Consideration of a new Class 'E' Liquor and Sunday Sales permit for H & S Store LLC dba Super Mart
- [4.](#) Consideration of a new Cigarette Permit for H & S Store LLC dba Super Mart

Resolutions

- [5.](#) Consideration of a Resolution finally approving and confirming plans, specifications, form of contract and estimate of cost for the Oelwein 2021 Water Main Improvements Project
- [6.](#) Consideration of a Resolution awarding contract for the Oelwein 2021 Water Main Improvements Project
- [7.](#) Consideration of a Resolution approving contract and performance and/or payment bonds for the Oelwein 2021 Water Main Improvements Project
- [8.](#) Consideration of a Resolution Directing the Sale of the City's Interest in 17 5th Avenue SE, Oelwein, Fayette County, Iowa
- [9.](#) Consideration of a Resolution Reinstating Online Fees for Utility Bill Payments
- [10.](#) Consideration of a Resolution Establishing Collective Bargaining and Nonunion Salaries for City Employees

Motions

- [11.](#) Consideration of a motion to set a Public Hearing for April 12, 2021 at 6:00 P.M. on Notice of Intent to apply for financial assistance with the USDA Rural Development for Oelwein Police Department Heating and Cooling System and Oelwein Fire Department Aerial Fire Truck Apparatus
- [12.](#) Consideration of a motion approving an amendment for engineering services in the amount of \$9000.00 for Oelwein Industrial Park 3rd Addition Utility Improvements
- [13.](#) Consideration of a motion to purchase Replacement Dump Box in the amount of \$19,610.00
- [14.](#) Consideration of a motion to purchase skid steer in the amount of \$68,361.76
- [15.](#) Consideration of a motion to purchase dump truck and snow plow equipment in the amount of \$136,715.00
- [16.](#) Consideration of a motion to purchase wheel loader in the amount of \$131,500.00
- [17.](#) Consideration of a motion to purchase snow blower attachment and heavy duty pallet fork in the amount of \$7,172.72

[18.](#) Consideration of a recommendation from Planning, Finance, Enterprise and Economic Development re: Williams Center for the Arts Hotel/Motel Funding Application

19. Consideration of a motion to set date for Spring Clean Up

Committee Reports

[20.](#) Report from Cantrell on March Park and Recreation Commission meeting

[21.](#) Report from Payne on March Library Board meeting

Council Updates

Mayor's Report

City Attorney's Report

City Administrator's Report

[A.](#) City Administrators Report

Adjournment

[ii.](#) Additional Information

In compliance with the Americans with Disabilities Act, those requiring accommodation for Council meetings should notify the City Clerk's Office at least 24 hours prior to the meeting at 319-283-5440



Minutes

Council Meeting

Oelwein Community Plaza, 25 W Charles

March 08, 2021 - 6:00 PM

Pledge of Allegiance

Call to Order by Mayor DeVore at 6:00 P.M.

Roll Call Present: Weber, Cantrell, Stewart, Payne, Seeders, Fisk
 Also Present: Mulfinger, Rigdon
 Absent: Dillon

Additions or Deletions

A motion was made by Cantrell, seconded by Weber to adopt the Agenda as amended. All voted aye.

Citizens Public Comments - See Guidelines for Public Comments Below

Jean Kane, 1311 E Charles St spoke on 2 items regarding Fayette Co Outer Road project and city assessments.

1. Not to assess residents the full portion of the City's 45% because of the high traffic on the road.
2. Photos were provided showing the gravel and a mix placed on the shoulders in the city limits when city was told it would be dirt shoulders. The rock/mix excessive and caused a terrible mess in the right of way.

Council discussed not approving project completion but was confident the city would address and correct this issue. Council was concerned we may lose our bargaining power if we approve the project but the City could withhold payments to the county.

Regarding the 5-year payback for the City agreed portion of funds for county project. Joel Fantz, Fayette County Engineer, will be contacted regarding the gravel shoulder, if no cooperation, then escalated to Fayette County Supervisors

Consent Agenda

1. Consideration of a motion approving February 22, 2021 Council Minutes
2. Consideration of a motion to approve the minutes of the March 1, 2021 Special Council meeting
3. Consideration of motion of approving Class 'C' Liquor License renewal for Clete and Connie's
4. Consideration of a motion to approve a Class 'C' Liquor License, Outdoor Service and Sunday Sales Renewal for Oelwein Columbus Club, Inc.

A motion was made by Cantrell, seconded by Fisk to adopt the Consent Agenda. All voted aye.

Motion Carried

Public Hearing

5. Public Hearing on Fiscal Year 2022 Budget

Mayor DeVore opened the public hearing. No oral or written comments were received. The mayor closed the public hearing.

6. Public Hearing on the Proposed Disposal by Sale of the City's interest in 412 1st Avenue NE

Mayor DeVore opened the public hearing. No oral or written comments were received. The mayor closed the public hearing.

7. Public Hearing on Proposed Plans, Specifications, Form of Contract and Estimate of Cost for the Oelwein 2021 Water Main Improvements Project

Mayor DeVore opened the public hearing. No oral or written comments were received. The mayor closed the public hearing.

Resolutions

8. Consideration of a Resolution adopting Fiscal Year 2022 Budget

A motion was made by Weber, seconded by Fisk to adopt Resolution No. 5257-2021.

Ayes: Weber, Cantrell, Stewart, Payne, Seeders, Fisk
Nays: None

Motion Carried

Mulfinger stated budget adoption includes hiring one full time police officer and one full time code enforcement officer.

- 9. Consideration of a Resolution Accepting Work Covering the Outer Road & 6th Street NE HMA Improvements Project

A motion was made by Fisk, seconded by Stewart to adopt Resolution No. 5258-2021.

Ayes: Weber, Cantrell, Stewart, Payne, Seeders, Fisk
Nays: None

Motion Carried

Mulfinger stated the County will maintain the road agreement with the City.

- 10. Consideration of a Resolution Adopting Final Assessment Schedule for the Outer Road & 6th Street NE HMA Improvements Project and Amending, Confirming and Levying the Assessments

A motion was made by Weber, seconded by Stewart to adopt Resolution No. 5259-2021

Ayes: Weber, Stewart, Payne, Seeders
Nays: Fisk, Cantrell

Motion Carried

Fisk wanted a discount for Outer Rd assessments because of the heavy traffic on that road vs the assessment rate for Wings East project in which only local property owners drive on that road.

- 11. Consideration of a Resolution Directing the sale of the City's interest in 122 3rd Avenue NW, Oelwein, Fayette County, Iowa

A motion was made by Seeders, seconded by Fisk to adopt Resolution No. 5260-2021.

Ayes: Weber, Cantrell, Stewart, Payne, Seeders, Fisk
Nays: None

Motion Carried

Council provided clarification to Nita Willie of 130 3rd Ave NW that she pays for the back taxes plus transfer fees

- 12. Consideration of a Resolution Directing the Sale of the City's Interest in 412 1st Avenue NE, Oelwein, Fayette County, Iowa

A motion was made by Seeders, seconded by Cantrell to adopt Resolution No. 5261-2021

Ayes: Weber, Cantrell, Stewart, Payne, Seeders, Fisk
Nays: None

Motion Carried

Council provided clarification to Mary Bender of 416 1st Ave NE that she can apply for tear down assistance from the City. She must pay back taxes and transfer fees.

Motions

- 13. Consideration of a motion updating the Oelwein Intermediary Relending Program

A motion was made by Weber, seconded by Cantrell for updating the Oelwein Intermediary Relending Program. All voted aye.

Motion Carried

- 14. Consideration of a motion to approve Change Order No. 2 to Lodge Construction for Wings East Pavement Improvements Project

A motion was made by Weber, seconded by Fisk to approve the change order. All voted aye.

Motion Carried

- 15. Consideration of a motion to award Oelwein 2021 Water Main Improvements Project to Summers Enterprise in the amount of \$1,057,488.83

A motion was made by Payne, seconded by Stewart to approve the 201 Water Main Improvements. All voted aye.

Motion Carried

- 16. Consideration of a recommendation from Planning, Finance, Enterprise and Economic Development Committee re: Hotel Motel Funding Application from Williams Center for the Arts in the amount of \$1,500.00

Failed for lack of motion based on Planning, Finance, Enterprise and Economic Development committee’s recommendation to collect additional information regarding verification of applicant numbers.

3

- 17. Consideration of a motion to take action on a snow removal appeal from Matt Properties, LLC

A motion was made by Fisk, seconded by Weber to deny the snow removal appeal. All voted aye.

Motion Carried

Committee Reports

Stewart presented to council the minutes which can be found here:

<http://www.cityofuelwein.org/government/agendas-and-minutes.html>

Council Updates

Mayor's Report

- A. Consideration of the reappointment of Kyle Scheel and Jeff Milks to the Tree Board
- B. Consideration of a motion to appoint Karen Seeders to Regional Housing Authority Board

A motion was made by Weber, seconded by Fisk to approve the reappointments. All voted aye.

Motion Carried

City Administrator’s Report

Mulfinger let council know that the annual evaluation of the city administrator will take place April 19. Mulfinger will send out evaluations and the council will provide them to the Mayor. The Mayor will work with a committee to determine the final direction for the administrator based on the council feedback.

Mulfinger let council know that meetings will start to slow down now that the budget is passed. Mulfinger said that staff has everything in place and projects will start. While it may seem like less will come to council, Mulfinger assured council that it will be a busy summer.

Adjournment

A motion was made by Cantrell, seconded by Weber to adjourn at 6:50 P.M. All voted aye.

Motion Carried

Brett DeVore, Mayor

ATTEST:

Dylan Mulfinger, City Administrator

I, Dylan Mulfinger, City Administrator in and for the City of Oelwein, Iowa do hereby certify that the above and foregoing is a true accounting of the Council Proceedings held March 08, 2021 and copy of said proceedings was furnished to the Register March 11, 2021.

Dylan Mulfinger, City Administrator

Report Criteria:

Detail report.
Invoices with totals above \$0.00 included.
Paid and unpaid invoices included.

| Vendor Name | Invoice Number | Description | Invoice Date | Net Invoice Amount | Amount Paid |
|--|----------------|----------------------------|--------------|-----------------------|-------------|
| 001-1100-61810 UNIFORM | | | | | |
| CARDMEMBER SERVICES | 8023 JL 2021 0 | BLAUER MFG - BODY CAMERA/ | 03/04/2021 | 341.80 | 341.80 |
| GALLS LLC | 17711854 | WINTER GLOVES - OFFICERS | 02/22/2021 | 121.07 | .00 |
| GALLS LLC | 1773213 | WINTER GLOVES - OFFICERS | 02/24/2021 | 48.43 | .00 |
| GALLS LLC | 17743818 | WINTER GLOVES - OFFICERS | 02/25/2021 | 121.09 | .00 |
| Total 001-1100-61810 UNIFORM: | | | | 632.39 | 341.80 |
| 001-1100-61990 EMPLOYEE PERSONNEL EXPENSE | | | | | |
| CARDMEMBER SERVICES | 8023 JL 2021 0 | FBI LEEDA - MEMBERSHIP | 03/04/2021 | 50.00 | 50.00 |
| CARDMEMBER SERVICES | 8023 JL 2021 0 | WALDORF UNIVERSITY - CONT' | 03/04/2021 | 1,066.50 | 1,066.50 |
| CARDMEMBER SERVICES | 8023 JL 2021 0 | AMAZON - DRUG TESTING KITS | 03/04/2021 | 76.99 | 76.99 |
| GALLS LLC | 17673957 | DEPT & COMM AWARDS | 02/17/2021 | 436.00 | .00 |
| GALLS LLC | 17682758 | DEPT & COMM AWARDS | 02/18/2021 | 180.39 | .00 |
| PRIORITY DISPATCH CORP | SIN266810 | COURSE TRAINING & CERT R. | 10/14/2020 | 365.00 | .00 |
| Total 001-1100-61990 EMPLOYEE PERSONNEL EXPENSE: | | | | 2,174.88 | 1,193.49 |
| 001-1100-63100 BUILDING | | | | | |
| CARDMEMBER SERVICES | 8023 JL 2021 0 | US FLAGS - AMERICAN FLAG | 03/04/2021 | 140.12 | 140.12 |
| Total 001-1100-63100 BUILDING: | | | | 140.12 | 140.12 |
| 001-1100-63310 VEHICLE | | | | | |
| ADVANCED AUTOMOTIVE INC | 61460 | CAR 9 REPAIRS | 02/09/2021 | 106.80 | 106.80 |
| ADVANCED AUTOMOTIVE INC | 61600 | CAR 9 SERVICED | 03/02/2021 | 31.45 | .00 |
| ADVANCED AUTOMOTIVE INC | 61607 | CAR 6 SERVICED | 03/03/2021 | 34.58 | .00 |
| ADVANCED AUTOMOTIVE INC | 61629 | CAR 6 REPAIRS | 03/05/2021 | 185.06 | .00 |
| CARDMEMBER SERVICES | 8023 JL 2021 0 | AMAZON - JUMP STARTER BOX | 03/04/2021 | 162.63 | 162.63 |
| WEX BANK | 70526944 | FUEL PURCHASES | 02/28/2021 | 1,422.59 | 1,422.59 |
| Total 001-1100-63310 VEHICLE: | | | | 1,943.11 | 1,692.02 |
| 001-1100-63730 COMMUNICATIONS | | | | | |
| MEDIACOM COMMUNICATIONS | 0003535 2021 | PHONE/INTERNET SERVICE | 02/16/2021 | 350.23 | 350.23 |
| MEDIACOM COMMUNICATIONS | 0003535 2021 | PHONE/INTERNET SERVICE | 03/16/2021 | 350.23 | .00 |
| Total 001-1100-63730 COMMUNICATIONS: | | | | 700.46 | 350.23 |
| 001-1100-63750 CELLULAR/PAGING | | | | | |
| AT&T MOBILITY LLC | 287289189784 | CAR AIR CARDS | 02/19/2021 | 412.70 | 412.70 |
| US CELLULAR | 453072630 202 | CELLPHONE SERVICE | 03/02/2021 | 60.01 | .00 |
| Total 001-1100-63750 CELLULAR/PAGING: | | | | 472.71 | 412.70 |
| 001-1100-63810 UTILITIES | | | | | |
| ALLIANT ENERGY | 4830253977 20 | ELECTRIC SERVICE | 03/08/2021 | 1,968.94 | .00 |
| ALLIANT ENERGY | 6455490000 20 | ELECTRIC SERVICE | 02/11/2021 | 19.07 | 19.07 |
| EAGLE POINT ENERGY 5 LLC | OELWEIN 29 | ELECTRIC SERVICE | 03/03/2021 | 295.77 | 295.77 |
| OELWEIN CITY WATER | 2021 03 01 | WATER/SEWER SERVICE | 03/01/2021 | 49.71 | 49.71 |

| Vendor Name | Invoice Number | Description | Invoice Date | Net Invoice Amount | Amount Paid |
|--|----------------|------------------------------|--------------|-----------------------|-------------|
| Total 001-1100-63810 UTILITIES: | | | | 2,333.49 | 364.55 |
| 001-1100-64080 INSURANCE CLAIMS | | | | | |
| ACE HARDWARE | B72232 | HEATERS | 02/21/2021 | 449.94 | .00 |
| LUMBER RIDGE HOME SOURC | B67045 | HEATERS | 02/20/2021 | 527.60 | .00 |
| LUMBER RIDGE HOME SOURC | B67048 | RETURNED HEATER | 02/20/2021 | 71.03- | .00 |
| Total 001-1100-64080 INSURANCE CLAIMS: | | | | 906.51 | .00 |
| 001-1100-64300 IMPOUND VEHICLE EXPENSES | | | | | |
| MIDWEST COLLISION CENTER I | 4134 | TOW IMPOUND | 02/26/2021 | 60.00 | .00 |
| MIDWEST COLLISION CENTER I | 4135 | TOW IMPOUND | 02/26/2021 | 80.00 | .00 |
| MIDWEST COLLISION CENTER I | 4136 | TOW IMPOUND | 02/26/2021 | 80.00 | .00 |
| Total 001-1100-64300 IMPOUND VEHICLE EXPENSES: | | | | 220.00 | .00 |
| 001-1100-64950 CONTRACTS | | | | | |
| COPY SYSTEMS INC | IN404547 | COPIER MAINT SUPPORT | 03/04/2021 | 40.17 | .00 |
| Total 001-1100-64950 CONTRACTS: | | | | 40.17 | .00 |
| 001-1100-65041 EQUIPMENT | | | | | |
| KIESLER POLICE SUPPLY INC | IN158995 | RIFLE AMMUNITION | 02/16/2021 | 604.00 | .00 |
| LUMBER RIDGE HOME SOURC | A132960 | SNOW PUSHER/SHOVEL | 02/04/2021 | 107.98 | .00 |
| PI VARIABLES INC | 4445T | FLARES | 01/22/2021 | 1,225.00 | 1,225.00 |
| Total 001-1100-65041 EQUIPMENT: | | | | 1,936.98 | 1,225.00 |
| 001-1100-65060 OFFICE SUPPLIES | | | | | |
| CARDMEMBER SERVICES | 0060 BR 2021 | USPS - POSTAGE COBRA MAILI | 03/04/2021 | 2.50 | 2.50 |
| LUMBER RIDGE HOME SOURC | A133122 | UPS SHIPPING - RETURN | 02/09/2021 | 16.02 | .00 |
| NAFCO INC | 44995 | PARKING TICKETS | 03/02/2021 | 750.00 | .00 |
| Total 001-1100-65060 OFFICE SUPPLIES: | | | | 768.52 | 2.50 |
| 001-1100-65102 INVESTIGATION | | | | | |
| US CELLULAR | 453072630 202 | CAMERA | 03/02/2021 | 8.24 | .00 |
| US CELLULAR | 453072630 202 | CAMERA | 03/02/2021 | 8.24 | .00 |
| Total 001-1100-65102 INVESTIGATION: | | | | 16.48 | .00 |
| 001-1220-64950 CONTRACTS | | | | | |
| STATE OF IOWA | 2021 02 18 | NOV 13 2020 - JAN 26 2021 MA | 02/18/2021 | 4,694.49 | 4,694.49 |
| Total 001-1220-64950 CONTRACTS: | | | | 4,694.49 | 4,694.49 |
| 001-1500-61990 EMPLOYEE PERSONNEL EXPENSE | | | | | |
| EMSLRC | 32836 | BLS HEALTHCARE PROVIDER | 02/26/2021 | 127.50 | .00 |
| FIRE SERVICE TRAINING BURE | 211216 | CERT FEES HAZMAT - T THRON | 02/17/2021 | 50.00 | .00 |
| FIRE SERVICE TRAINING BURE | 211216 | CERT FEES FF1 - T THRONDSO | 02/17/2021 | 100.00 | .00 |
| Total 001-1500-61990 EMPLOYEE PERSONNEL EXPENSE: | | | | 277.50 | .00 |
| 001-1500-63100 BUILDING | | | | | |
| ACE HARDWARE | A200731 | FOAM BRUSHES/PAINT | 02/21/2021 | 17.99 | .00 |
| ACE HARDWARE | A200735 | BRUSHES | 02/21/2021 | 21.78 | .00 |

| Vendor Name | Invoice Number | Description | Invoice Date | Net Invoice Amount | Amount Paid |
|--|----------------|-----------------------------|--------------|-----------------------|-------------|
| ACE HARDWARE | B71918 | PAINT/GREAT STUFF | 02/13/2021 | 31.58 | .00 |
| ACE HARDWARE | B72126 | SPRAY PAINT | 02/18/2021 | 18.36 | .00 |
| ACE HARDWARE | B72150 | COUPLING/VALVE | 02/19/2021 | 18.48 | .00 |
| ACE HARDWARE | B72556 | CABLE CONNECTOR | 02/27/2021 | 7.08 | .00 |
| JOHN DEERE FINANCIAL F.S.B. | 2712559 | FITTINGS/COUPLING/PVC PIPE | 03/02/2021 | 34.84 | 34.84 |
| KENS ELECTRIC | 305009 | INSULATED FLEX DUCT | 02/18/2021 | 57.89 | .00 |
| LUMBER RIDGE HOME SOURC | B66887 | PAINT/COVERS/FRAME | 02/13/2021 | 432.55 | .00 |
| LUMBER RIDGE HOME SOURC | B66903 | PAINT | 02/13/2021 | 115.59 | .00 |
| LUMBER RIDGE HOME SOURC | B67029 | PAINT | 02/19/2021 | 13.22 | .00 |
| LUMBER RIDGE HOME SOURC | B67177 | CAB CLAMP CONNECTOR/CAB | 02/26/2021 | 59.20 | .00 |
| LUMBER RIDGE HOME SOURC | B67191 | CABLE | 02/27/2021 | 63.47 | .00 |
| Total 001-1500-63100 BUILDING: | | | | 892.03 | 34.84 |
| 001-1500-63310 VEHICLE | | | | | |
| HEARTSMART | 1813171 | AED FACILITY DECALS | 12/16/2020 | 27.81 | .00 |
| KENS ELECTRIC | 305141 | INSULATED FLEX DUCT | 03/03/2021 | 57.89 | .00 |
| TOYNE INC | IN0012001 | SHELF W/TURTLE TILE | 01/08/2021 | 2,516.86 | .00 |
| Total 001-1500-63310 VEHICLE: | | | | 2,602.56 | .00 |
| 001-1500-63730 COMMUNICATIONS | | | | | |
| MEDIACOM COMMUNICATIONS | 0003535 2021 | PHONE/INTERNET SERVICE | 02/16/2021 | 189.11 | 189.11 |
| MEDIACOM COMMUNICATIONS | 0003535 2021 | PHONE/INTERNET SERVICE | 03/16/2021 | 213.47 | .00 |
| Total 001-1500-63730 COMMUNICATIONS: | | | | 402.58 | 189.11 |
| 001-1500-63810 UTILITIES | | | | | |
| ALLIANT ENERGY | 0106966292 20 | ELECTRIC SERVICE | 02/24/2021 | 43.76 | 43.76 |
| ALLIANT ENERGY | 4830253977 20 | ELECTRIC SERVICE | 03/08/2021 | 20.43 | .00 |
| ALLIANT ENERGY | 6455490000 20 | ELECTRIC SERVICE | 02/11/2021 | 183.65 | 183.65 |
| ALLIANT ENERGY | 8600344075 20 | ELECTRIC SERVICE | 02/18/2021 | 24.40 | 24.40 |
| EAGLE POINT ENERGY 5 LLC | OELWEIN 29 | ELECTRIC SERVICE | 03/03/2021 | 12.79 | 12.79 |
| OELWEIN CITY WATER | 2021 03 01 | WATER/SEWER SERVICE | 03/01/2021 | 79.31 | 79.31 |
| Total 001-1500-63810 UTILITIES: | | | | 364.34 | 343.91 |
| 001-1500-65041 EQUIPMENT | | | | | |
| AMERICAN TEST CENTER INC | 2210412 | ANNUAL SAFETY INSPECTION | 02/16/2021 | 944.00 | .00 |
| Total 001-1500-65041 EQUIPMENT: | | | | 944.00 | .00 |
| 001-1700-61990 EMPLOYEE PERSONNEL EXPENSE | | | | | |
| CARDMEMBER SERVICES | 3357 JS 2021 | INT'L CODE COUNCIL - MEMBE | 03/04/2021 | 145.00 | 145.00 |
| Total 001-1700-61990 EMPLOYEE PERSONNEL EXPENSE: | | | | 145.00 | 145.00 |
| 001-1700-63750 CELLULAR/PAGING | | | | | |
| US CELLULAR | 453072630 202 | CELLPHONE SERVICE | 03/02/2021 | 66.66 | .00 |
| US CELLULAR | 453072630 202 | CELLPHONE SERVICE | 03/02/2021 | 25.83 | .00 |
| US CELLULAR | 453072630 202 | CELLPHONE SERVICE | 03/02/2021 | 71.88 | .00 |
| Total 001-1700-63750 CELLULAR/PAGING: | | | | 164.37 | .00 |
| 001-1700-64950 CONTRACTS | | | | | |
| ONLINE SOLUTIONS LLC | 4070 | 2021-2022 ANNUAL BILLING CI | 03/15/2021 | 2,700.00 | .00 |

| Vendor Name | Invoice Number | Description | Invoice Date | Net Invoice Amount | Amount Paid |
|--|----------------|--------------------------|--------------|-----------------------|-------------|
| Total 001-1700-64950 CONTRACTS: | | | | 2,700.00 | .00 |
| 001-1700-65041 EQUIPMENT | | | | | |
| ACE HARDWARE | A200163 | FLASHLIGHT/VOLT DETECTOR | 02/11/2021 | 59.98 | .00 |
| Total 001-1700-65041 EQUIPMENT: | | | | 59.98 | .00 |
| 001-1700-65060 OFFICE SUPPLIES | | | | | |
| BERGANKDV TECHNOLOGY & | CW101561 | OFFICE 365 | 02/05/2021 | 24.75 | 24.75 |
| BERGANKDV TECHNOLOGY & | CW101561 | PREMIUM OFFICE 365 | 02/05/2021 | 37.50 | 37.50 |
| STOREY KENWORTHY CORP | PINV877206 | TONER CRTDGS | 02/09/2021 | 238.36 | .00 |
| Total 001-1700-65060 OFFICE SUPPLIES: | | | | 300.61 | 62.25 |
| 001-2510-64110 LEGAL EXPENSE | | | | | |
| DILLON LAW PC | 8013 | FEBRUARY LEGAL SERVICE - | 03/03/2021 | 70.52 | .00 |
| Total 001-2510-64110 LEGAL EXPENSE: | | | | 70.52 | .00 |
| 001-2800-63100 BUILDING | | | | | |
| BLUEGLOBES LLC | OLZ-54989 | COUPLINGS/LENS | 03/12/2021 | 457.34 | .00 |
| Total 001-2800-63100 BUILDING: | | | | 457.34 | .00 |
| 001-2800-63730 COMMUNICATIONS | | | | | |
| AUREON COMMUNICATIONS | 0789004155 20 | AIRPORT PHONE SERVICE | 03/01/2021 | 31.82 | 31.82 |
| COMMUNITY DIGITAL WIRELES | 0510000374 20 | AIRPORT INTERNET SERVICE | 03/01/2021 | 43.95 | 43.95 |
| Total 001-2800-63730 COMMUNICATIONS: | | | | 75.77 | 75.77 |
| 001-2800-63810 UTILITIES | | | | | |
| ALLIANT ENERGY | 6455490000 20 | ELECTRIC SERVICE | 02/11/2021 | 364.13 | 364.13 |
| BLACKHAWK WASTE DISPOSAL | 04-210985 202 | GARBAGE PICKUP | 03/01/2021 | 28.00 | .00 |
| EAGLE POINT ENERGY 5 LLC | OELWEIN 29 | ELECTRIC SERVICE | 03/03/2021 | 141.43 | 141.43 |
| Total 001-2800-63810 UTILITIES: | | | | 533.56 | 505.56 |
| 001-2800-64950 CONTRACTS | | | | | |
| TEGELER AVIATION LLC | 2021 03 01 | MARCH FBO FEE | 03/01/2021 | 2,883.34 | .00 |
| Total 001-2800-64950 CONTRACTS: | | | | 2,883.34 | .00 |
| 001-2810-64181 PROPERTY TAXES | | | | | |
| FAYETTE CO TREASURER | 2021 03 01 | PROPERTY TAXES AIPORT | 03/01/2021 | 2,413.00 | .00 |
| Total 001-2810-64181 PROPERTY TAXES: | | | | 2,413.00 | .00 |
| 001-4100-61990 EMPLOYEE PERSONNEL EXPENSE | | | | | |
| IOWA LIBRARY ASSOCIATION | 2021 03 16 | ANNUAL MEMBERSHIP RENEW | 03/16/2021 | 130.00 | .00 |
| Total 001-4100-61990 EMPLOYEE PERSONNEL EXPENSE: | | | | 130.00 | .00 |
| 001-4100-63100 BUILDING | | | | | |
| PLUMB SUPPLY COMPANY | 7179139 | FURNACE FILTERS | 02/22/2021 | 144.12 | .00 |

| Vendor Name | Invoice Number | Description | Invoice Date | Net Invoice Amount | Amount Paid |
|---|----------------|--------------------------|--------------|--------------------|-------------|
| Total 001-4100-63100 BUILDING: | | | | 144.12 | .00 |
| 001-4100-63730 COMMUNICATIONS | | | | | |
| WINDSTREAM | 73571909 | LIBRARY PHONE SERVICE | 03/01/2021 | 80.02 | 80.02 |
| Total 001-4100-63730 COMMUNICATIONS: | | | | 80.02 | 80.02 |
| 001-4100-63810 UTILITIES | | | | | |
| ALLIANT ENERGY | 5998790000 20 | LIBRARY ELECTRIC SERVICE | 02/19/2021 | 3,282.61 | 3,282.61 |
| ALLIANT ENERGY | 5998790000 20 | LIBRARY GAS SERVICE | 02/19/2021 | 33.53 | 33.53 |
| EAGLE POINT ENERGY 5 LLC | OELWEIN 29 | ELECTRIC SERVICE | 03/03/2021 | 117.17 | 117.17 |
| OELWEIN CITY WATER | 2021 03 01 | WATER/SEWER SERVICE | 03/01/2021 | 43.56 | 43.56 |
| Total 001-4100-63810 UTILITIES: | | | | 3,476.87 | 3,476.87 |
| 001-4100-64090 JANITORIAL | | | | | |
| JOHN DEERE FINANCIAL F.S.B. | 2710321 | JANITORIAL SUPPLIES | 02/20/2021 | 73.65 | 73.65 |
| STOREY KENWORTHY CORP | PINV879854 | PAPER TOWELS | 02/18/2021 | 23.89 | .00 |
| Total 001-4100-64090 JANITORIAL: | | | | 97.54 | 73.65 |
| 001-4100-64092 MOWING SAUR LOT | | | | | |
| SCHMITT CLEANING SERVICES | 2291 | SNOW REMOVAL | 03/01/2021 | 224.00 | .00 |
| Total 001-4100-64092 MOWING SAUR LOT: | | | | 224.00 | .00 |
| 001-4100-64950 CONTRACTS | | | | | |
| SCHMITT CLEANING SERVICES | 2291 | CUSTODIAL SERVICES | 03/01/2021 | 1,104.29 | .00 |
| Total 001-4100-64950 CONTRACTS: | | | | 1,104.29 | .00 |
| 001-4100-65060 OFFICE SUPPLIES | | | | | |
| QUILL.COM | 15099444 | INK | 03/05/2021 | 293.78 | .00 |
| UNIQUE MANAGEMENT | 599862 | COLLECTION SERVICE | 03/01/2021 | 53.70 | .00 |
| Total 001-4100-65060 OFFICE SUPPLIES: | | | | 347.48 | .00 |
| 001-4100-65072 BOOKS - ENRICH IOWA | | | | | |
| FAREWAY STORES INC | 726688 730267 | SUPPLIES - TAKE & MAKE | 03/11/2021 | 18.88 | .00 |
| iREAD | 191281 | T-SHIRT | 02/26/2021 | 15.55 | .00 |
| POPULAR MECHANICS | 0090268954 20 | MAGAZINE SUBS RENEWAL | 03/16/2021 | 36.38 | .00 |
| Total 001-4100-65072 BOOKS - ENRICH IOWA: | | | | 70.81 | .00 |
| 001-4100-65220 BOOKS,FILM,CD'S,ETC | | | | | |
| BAKER & TAYLOR | L5050572 2021 | BOOKS | 02/28/2021 | 324.20 | .00 |
| BAKER & TAYLOR | L5050572 2021 | JUVENILE BOOKS | 02/28/2021 | 138.83 | .00 |
| BOY'S LIFE | 2021 03 16 | MAGAZINE SUBSCRIPTION | 03/16/2021 | 15.00 | .00 |
| CARDMEMBER SERVICES | 8198 SM 2021 | AMAXON - MOVIES | 03/04/2021 | 106.75 | 106.75 |
| SATURDAY EVENING POST | 2021 03 16 | MAG SUB RENEWAL | 03/16/2021 | 15.00 | .00 |
| Total 001-4100-65220 BOOKS,FILM,CD'S,ETC: | | | | 599.78 | 106.75 |
| 001-4300-63200 BUILDING | | | | | |
| FAYETTE CO TREASURER | 2021 03 01 | PROPERTY TAXES SPORTS CO | 03/01/2021 | 94.00 | .00 |
| KAY PARK RECREATION CORP | 191294 | MEMORIAL BENCH -HENDERS | 02/23/2021 | 882.00 | .00 |

| Vendor Name | Invoice Number | Description | Invoice Date | Net Invoice Amount | Amount Paid |
|--|----------------|---------------------------|--------------|-----------------------|-------------|
| KAY PARK RECREATION CORP | 191296 | MEMORIAL BENCH - SCHULZ | 02/23/2021 | 912.00 | .00 |
| Total 001-4300-63200 BUILDING: | | | | 1,888.00 | .00 |
| 001-4300-63210 TRAILS MAINTENANCE | | | | | |
| TRAFX RESEARCH LTD | MOU 2021 03 | MOU TRAILS | 03/01/2021 | 1,543.75 | 1,543.75 |
| Total 001-4300-63210 TRAILS MAINTENANCE: | | | | 1,543.75 | 1,543.75 |
| 001-4300-63730 COMMUNICATIONS | | | | | |
| AUREON COMMUNICATIONS | 0789004155 20 | PARKS PHONE SERVICE | 03/01/2021 | 101.74 | 101.74 |
| OELWEIN PUBLISHING CO | 303468511--30 | HELP WANTED ADS | 02/01/2021 | 41.75 | .00 |
| US CELLULAR | 453072630 202 | CELLPHONE SERVICE | 03/02/2021 | 76.97 | .00 |
| Total 001-4300-63730 COMMUNICATIONS: | | | | 220.46 | 101.74 |
| 001-4300-63810 UTILITIES | | | | | |
| ALLIANT ENERGY | 0106966292 20 | ELECTRIC SERVICE | 02/24/2021 | 118.37 | 118.37 |
| ALLIANT ENERGY | 6455490000 20 | ELECTRIC SERVICE | 02/11/2021 | 153.65 | 153.65 |
| ALLIANT ENERGY | 6455490000 20 | ELECTRIC SERVICE | 02/11/2021 | 221.63 | 221.63 |
| OELWEIN CITY WATER | 2021 03 01 | WATER/SEWER SERVICE | 03/01/2021 | 34.32 | 34.32 |
| Total 001-4300-63810 UTILITIES: | | | | 527.97 | 527.97 |
| 001-4300-65060 OFFICE SUPPLIES | | | | | |
| STOREY KENWORTHY CORP | PINV875290 | PAPER/BINDERS/INK CRTDG | 02/02/2021 | 29.18 | .00 |
| Total 001-4300-65060 OFFICE SUPPLIES: | | | | 29.18 | .00 |
| 001-4300-65070 SUPPLIES | | | | | |
| ACE HARDWARE | A200400 | BLACK TAPE/DUCT TAPE/DROP | 02/16/2021 | 26.16 | .00 |
| ACE HARDWARE | A200573 | FASTENERS | 02/19/2021 | 35.16 | .00 |
| ACE HARDWARE | B71809 | BUSHINGS/ADAPTER | 02/11/2021 | 25.35 | .00 |
| AMERICAN TEST CENTER INC | 2210411 | ANNUAL SAFETY INSPECTION | 02/16/2021 | 125.00 | .00 |
| CARDMEMBER SERVICES | 9480 JJ 2021 0 | AMAZON - YELLOW MARKING F | 03/04/2021 | 31.52 | 31.52 |
| CARDMEMBER SERVICES | 9480 JJ 2021 0 | AMAZON - PIPE MARKERS | 03/04/2021 | 7.88 | 7.88 |
| FAYETTE COUNTY SOLID WAST | 138892 | DISPOSED - PALLETS | 03/10/2021 | 118.20 | .00 |
| JOHN DEERE FINANCIAL F.S.B. | 2712843 | GREASE/NUTS & BOLTS | 03/04/2021 | 32.07 | 32.07 |
| JOHN DEERE FINANCIAL F.S.B. | 2713938 | TRASH CAN/GRASS SEED/SIDE | 03/08/2021 | 255.67 | 255.67 |
| JOHN DEERE FINANCIAL F.S.B. | P03145 | ROLLER CHAIN | 02/23/2021 | 33.34 | 33.34 |
| LUMBER RIDGE HOME SOURC | A133174 | TREATED LUMBER 2 X 10 | 02/10/2021 | 97.39 | .00 |
| LUMBER RIDGE HOME SOURC | D3274 | SINK/FAUCET | 02/03/2021 | 346.13 | .00 |
| O'REILLY AUTOMOTIVE STORE | 0390-377088 | ACTIVATOR/THINNER/CUT OFF | 02/19/2021 | 133.44 | .00 |
| O'REILLY AUTOMOTIVE STORE | 0390-377399 | QT-P/S FLUIDS | 02/22/2021 | 7.98 | .00 |
| USABLUBOOK | 519089 | PROBE | 03/02/2021 | 98.05 | .00 |
| Total 001-4300-65070 SUPPLIES: | | | | 1,373.34 | 360.48 |
| 001-4320-63810 UTILITIES | | | | | |
| ALLIANT ENERGY | 8600344075 20 | ELECTRIC SERVICE | 02/18/2021 | 65.10 | 65.10 |
| Total 001-4320-63810 UTILITIES: | | | | 65.10 | 65.10 |
| 001-4320-65060 OFFICE SUPPLIES | | | | | |
| STOREY KENWORTHY CORP | PINV875290 | PAPER/BINDERS/INK CRTDG | 02/02/2021 | 29.18 | .00 |

| Vendor Name | Invoice Number | Description | Invoice Date | Net Invoice Amount | Amount Paid |
|---------------------------------------|----------------|---------------------------|--------------|-----------------------|-------------|
| Total 001-4320-65060 OFFICE SUPPLIES: | | | | 29.18 | .00 |
| 001-4320-65070 SUPPLIES | | | | | |
| OELWEIN PUBLISHING CO | 303468511--30 | HELP WANTED ADS | 02/01/2021 | 41.77 | .00 |
| Total 001-4320-65070 SUPPLIES: | | | | 41.77 | .00 |
| 001-4400-63730 COMMUNICATIONS | | | | | |
| US CELLULAR | 453072630 202 | CELLPHONE SERVICE | 03/02/2021 | 46.03 | .00 |
| Total 001-4400-63730 COMMUNICATIONS: | | | | 46.03 | .00 |
| 001-4400-63810 UTILITIES | | | | | |
| ALLIANT ENERGY | 8600344075 20 | ELECTRIC SERVICE | 02/18/2021 | 19.73 | 19.73 |
| Total 001-4400-63810 UTILITIES: | | | | 19.73 | 19.73 |
| 001-4400-65220 ADULT SOFTBALL | | | | | |
| TREASURER STATE OF IOWA | 1-33-000974 2 | FEBRUARY SALES TAX | 02/28/2021 | 12.00 | 12.00 |
| Total 001-4400-65220 ADULT SOFTBALL: | | | | 12.00 | 12.00 |
| 001-4400-65240 BASKETBALL | | | | | |
| CARDMEMBER SERVICES | 3397 JR 2021 | AMAZON - BASKETBALLS | 03/04/2021 | 43.79 | 43.79 |
| TREASURER STATE OF IOWA | 1-33-000974 2 | FEBRUARY SALES TAX | 02/28/2021 | 40.00 | 40.00 |
| Total 001-4400-65240 BASKETBALL: | | | | 83.79 | 83.79 |
| 001-4400-65270 LITTLE LEAGUE | | | | | |
| CARDMEMBER SERVICES | 3397 JR 2021 | AMAZON - SOFTBALL PITCHIN | 03/04/2021 | 240.75 | 240.75 |
| Total 001-4400-65270 LITTLE LEAGUE: | | | | 240.75 | 240.75 |
| 001-4400-65290 SOCCER | | | | | |
| TREASURER STATE OF IOWA | 1-33-000974 2 | FEBRUARY SALES TAX | 02/28/2021 | 39.00 | 39.00 |
| Total 001-4400-65290 SOCCER: | | | | 39.00 | 39.00 |
| 001-4400-65380 DODGEBALL | | | | | |
| TREASURER STATE OF IOWA | 1-33-000974 2 | FEBRUARY SALES TAX | 02/28/2021 | 44.00 | 44.00 |
| Total 001-4400-65380 DODGEBALL: | | | | 44.00 | 44.00 |
| 001-4410-63730 COMMUNICATIONS | | | | | |
| OELWEIN PUBLISHING CO | 303468511--30 | HELP WANTED ADS | 02/01/2021 | 41.75 | .00 |
| Total 001-4410-63730 COMMUNICATIONS: | | | | 41.75 | .00 |
| 001-4410-63810 UTILITIES | | | | | |
| ALLIANT ENERGY | 6455490000 20 | ELECTRIC SERVICE | 02/11/2021 | 19.73 | 19.73 |
| Total 001-4410-63810 UTILITIES: | | | | 19.73 | 19.73 |
| 001-4410-65060 OFFICE SUPPLIES | | | | | |
| STOREY KENWORTHY CORP | PINV875290 | PAPER/BINDERS/INK CRTDG | 02/02/2021 | 29.18 | .00 |

| Vendor Name | Invoice Number | Description | Invoice Date | Net Invoice Amount | Amount Paid |
|---------------------------------------|----------------|---------------------------|--------------|--------------------|-------------|
| Total 001-4410-65060 OFFICE SUPPLIES: | | | | 29.18 | .00 |
| 001-4410-65070 SUPPLIES | | | | | |
| CARDMEMBER SERVICES | 9480 JJ 2021 0 | AMAZON - TAP | 03/04/2021 | 23.55 | 23.55 |
| CARDMEMBER SERVICES | 9480 JJ 2021 0 | HALOGEN SUPPLY - WATER TE | 03/04/2021 | 291.92 | 291.92 |
| CARDMEMBER SERVICES | 9480 JJ 2021 0 | AMAZON - KEY CABINET/CABL | 03/04/2021 | 174.88 | 174.88 |
| Total 001-4410-65070 SUPPLIES: | | | | 490.35 | 490.35 |
| 001-4500-63730 COMMUNICATIONS | | | | | |
| MEDIACOM COMMUNICATIONS | 0003535 2021 | PHONE/INTERNET SERVICE | 02/16/2021 | 45.06 | 45.06 |
| MEDIACOM COMMUNICATIONS | 0003535 2021 | PHONE/INTERNET SERVICE | 03/16/2021 | 45.06 | .00 |
| OELWEIN PUBLISHING CO | 303468511--30 | HELP WANTED ADS | 02/01/2021 | 41.75 | .00 |
| Total 001-4500-63730 COMMUNICATIONS: | | | | 131.87 | 45.06 |
| 001-4500-63810 UTILITIES | | | | | |
| ALLIANT ENERGY | 4830253977 20 | ELECTRIC SERVICE | 03/08/2021 | 20.22 | .00 |
| ALLIANT ENERGY | 6455490000 20 | ELECTRIC SERVICE | 02/11/2021 | 401.54 | 401.54 |
| EAGLE POINT ENERGY 5 LLC | OELWEIN 29 | ELECTRIC SERVICE | 03/03/2021 | 21.56 | 21.56 |
| OELWEIN CITY WATER | 2021 03 01 | WATER/SEWER SERVICE | 03/01/2021 | 16.85 | 16.85 |
| Total 001-4500-63810 UTILITIES: | | | | 460.17 | 439.95 |
| 001-4500-65041 EQUIPMENT | | | | | |
| JOHN DEERE FINANCIAL F.S.B. | 2710970 | METAL WHEEL/NUTS & BOLTS | 02/24/2021 | 6.97 | 6.97 |
| JOHN DEERE FINANCIAL F.S.B. | P03187 | BOLTS | 02/24/2021 | 7.37 | 7.37 |
| Total 001-4500-65041 EQUIPMENT: | | | | 14.34 | 14.34 |
| 001-4500-65060 OFFICE SUPPLIES | | | | | |
| STOREY KENWORTHY CORP | PINV875290 | PAPER/BINDERS/INK CRTDG | 02/02/2021 | 29.18 | .00 |
| Total 001-4500-65060 OFFICE SUPPLIES: | | | | 29.18 | .00 |
| 001-4500-65070 SUPPLIES | | | | | |
| ACE HARDWARE | B71287 | COUPLING/ELBOW/PRIMER | 02/01/2021 | 13.09 | .00 |
| USABLUBOOK | 518825 | PROBE | 03/02/2021 | 182.34 | .00 |
| Total 001-4500-65070 SUPPLIES: | | | | 195.43 | .00 |
| 001-6200-63100 BUILDING | | | | | |
| AUTO XTRAS | 20996 | SIGNS/LOGOS/TINT WINDOW | 02/24/2021 | 290.16 | .00 |
| KERNS COMPANY INC | 139446 | FLAG | 02/18/2021 | 180.50 | .00 |
| KERNS COMPANY INC | 139447 | FLAG POLES/BASES | 02/11/2021 | 205.50 | .00 |
| Total 001-6200-63100 BUILDING: | | | | 676.16 | .00 |
| 001-6200-63730 COMMUNICATIONS | | | | | |
| MEDIACOM COMMUNICATIONS | 0003535 2021 | PHONE/INTERNET SERVICE | 02/16/2021 | 66.04 | 66.04 |
| MEDIACOM COMMUNICATIONS | 0003535 2021 | PHONE/INTERNET SERVICE | 03/16/2021 | 66.04 | .00 |
| US CELLULAR | 453072630 202 | CELLPHONE SERVICE/ROUTER | 03/02/2021 | 95.42 | .00 |
| Total 001-6200-63730 COMMUNICATIONS: | | | | 227.50 | 66.04 |

| Vendor Name | Invoice Number | Description | Invoice Date | Net Invoice Amount | Amount Paid |
|--|----------------|-----------------------------|--------------|-----------------------|-------------|
| 001-6200-63810 UTILITIES | | | | | |
| ALLIANT ENERGY | 6455490000 20 | ELECTRIC SERVICE | 02/11/2021 | 78.71 | 78.71 |
| EAGLE POINT ENERGY 5 LLC | OELWEIN 29 | ELECTRIC SERVICE | 03/03/2021 | 5.48 | 5.48 |
| OELWEIN CITY WATER | 2021 03 01 | WATER/SEWER SERVICE | 03/01/2021 | 44.48 | 44.48 |
| Total 001-6200-63810 UTILITIES: | | | | 128.67 | 128.67 |
| 001-6200-64110 LEGAL EXPENSE | | | | | |
| LYNCH DALLAS PC | 180808 | LEGAL/PROFESSIONAL FEES | 02/24/2021 | 528.50 | .00 |
| Total 001-6200-64110 LEGAL EXPENSE: | | | | 528.50 | .00 |
| 001-6200-64140 LEGAL PUBLICATION | | | | | |
| OELWEIN PUBLISHING CO | 303468637 | JANUARY CLAIMS | 02/02/2021 | 87.55 | .00 |
| OELWEIN PUBLISHING CO | 303470354 | FEB 8 MINUTES | 02/13/2021 | 45.94 | .00 |
| OELWEIN PUBLISHING CO | 303473825 | PH PROPOSED BUDGET | 02/24/2021 | 134.77 | .00 |
| OELWEIN PUBLISHING CO | 303477540 | FEBRUARY CLAIMS | 02/27/2021 | 72.41 | .00 |
| OELWEIN PUBLISHING CO | 303477541 | FEB 22 MINUTES & JAN RECEIP | 02/27/2021 | 56.03 | .00 |
| Total 001-6200-64140 LEGAL PUBLICATION: | | | | 396.70 | .00 |
| 001-6200-64950 CONTRACTS | | | | | |
| BERGANKDV TECHNOLOGY & | CW102370 | DISPATCH TRANSITION | 02/26/2021 | 123.75 | .00 |
| OELWEIN COMMUNITY PLAZA F | 2021 02 26 | PLAZA - COUNCIL MEETINGS 2/ | 02/26/2021 | 66.66 | .00 |
| Total 001-6200-64950 CONTRACTS: | | | | 190.41 | .00 |
| 001-6200-65060 OFFICE SUPPLIES | | | | | |
| BERGANKDV TECHNOLOGY & | CW101561 | OFFICE 365 | 02/05/2021 | 13.75 | 13.75 |
| BERGANKDV TECHNOLOGY & | CW101561 | PREMIUM OFFICE 365 | 02/05/2021 | 33.33 | 33.33 |
| BERGANKDV TECHNOLOGY & | CW101561 | HOSTED EXCHANGE | 02/05/2021 | 26.66 | 26.66 |
| BERGANKDV TECHNOLOGY & | CW101718 | WEBROOT | 02/05/2021 | 37.33 | 37.33 |
| BERGANKDV TECHNOLOGY & | CW102007 | EMAIL SECURITY | 02/05/2021 | 38.00 | 38.00 |
| CARDMEMBER SERVICES | 8557 DM 2021 | ADOBE - MONTHLY SUB | 03/04/2021 | 27.73 | 27.73 |
| COPY SYSTEMS INC | IN404675 | COPIER MAINT SUPPORT | 03/05/2021 | 13.89 | .00 |
| OELWEIN PUBLISHING CO | 0180375 2021 | SUBSCRIPTION RENEWAL | 03/05/2021 | 43.99 | 43.99 |
| QUADIENT LEASING USA INC | N8772698 | FEB - APR POSTAGE METER LE | 03/12/2021 | 81.71 | .00 |
| STOREY KENWORTHY CORP | PINV877886 | PAPER LEGAL 8.5 X 14 | 02/11/2021 | 5.51 | .00 |
| STOREY KENWORTHY CORP | PINV878507 | DOOR TAGS | 02/15/2021 | 132.66 | .00 |
| Total 001-6200-65060 OFFICE SUPPLIES: | | | | 454.56 | 220.79 |
| 001-6600-64080 INSURANCE-LIABILITY | | | | | |
| VOGEL INSURANCE AGENCY | 7176 | ANNUAL INS PREMIUM - PUBLI | 03/17/2021 | 43,807.00 | .00 |
| VOGEL INSURANCE AGENCY | 7176 | ANNUAL INS PREMIUM - STREE | 03/17/2021 | 43,702.00 | .00 |
| VOGEL INSURANCE AGENCY | 7176 | ANNUAL INS PREMIUM - LIBRA | 03/17/2021 | 37,020.00 | .00 |
| VOGEL INSURANCE AGENCY | 7176 | ANNUAL INS PREMIUM - ADMIN | 03/17/2021 | 22,195.00 | .00 |
| Total 001-6600-64080 INSURANCE-LIABILITY: | | | | 146,724.00 | .00 |
| 110-2100-61990 EMPLOYEE PERSONNEL EXPENSE | | | | | |
| JOHN DEERE FINANCIAL F.S.B. | 2711494 | SWEATSHIRT - S CHERRIER 20 | 02/26/2021 | 69.99 | 69.99 |
| Total 110-2100-61990 EMPLOYEE PERSONNEL EXPENSE: | | | | 69.99 | 69.99 |
| 110-2100-63200 SNOW SUPPLIES | | | | | |
| CARGILL INCORPORATED | 2906078776 | DEICER SALT | 03/10/2021 | 1,754.70 | .00 |

| Vendor Name | Invoice Number | Description | Invoice Date | Net Invoice Amount | Amount Paid |
|--------------------------------------|----------------|--------------------------|--------------|-----------------------|-------------|
| CARGILL INCORPORATED | 2906078777 | DEICER SALT | 03/10/2021 | 1,913.33 | .00 |
| Total 110-2100-63200 SNOW SUPPLIES: | | | | 3,668.03 | .00 |
| 110-2100-63730 COMMUNICATIONS | | | | | |
| MEDIACOM COMMUNICATIONS | 0003535 2021 | PHONE/INTERNET SERVICE | 02/16/2021 | 45.06 | 45.06 |
| MEDIACOM COMMUNICATIONS | 0003535 2021 | PHONE/INTERNET SERVICE | 03/16/2021 | 45.06 | .00 |
| MEDIACOM COMMUNICATIONS | 00116348 2021 | STREETS INTERNET SERVICE | 02/28/2021 | 74.49 | 74.49 |
| US CELLULAR | 453072630 202 | CELLPHONE SERVICE | 03/02/2021 | 40.02 | .00 |
| Total 110-2100-63730 COMMUNICATIONS: | | | | 204.63 | 119.55 |
| 110-2100-63810 UTILITIES | | | | | |
| ALLIANT ENERGY | 6455490000 20 | ELECTRIC SERVICE | 02/11/2021 | 19.21 | 19.21 |
| ALLIANT ENERGY | 6455490000 20 | ELECTRIC SERVICE | 02/11/2021 | 221.63 | 221.63 |
| OELWEIN CITY WATER | 2021 03 01 | WATER/SEWER SERVICE | 03/01/2021 | 44.61 | 44.61 |
| Total 110-2100-63810 UTILITIES: | | | | 285.45 | 285.45 |
| 110-2100-65041 EQUIPMENT | | | | | |
| ACE HARDWARE | B72402 | DRILL BIT | 02/24/2021 | 22.99 | .00 |
| ICE MANUFACTURING INC | 1077 | PLAT 5/8" | 03/11/2021 | 445.50 | .00 |
| MACQUEEN EQUIPMENT | P12163 | SHEAR PINS | 02/01/2021 | 163.73 | .00 |
| Total 110-2100-65041 EQUIPMENT: | | | | 632.22 | .00 |
| 110-2100-65070 SUPPLIES | | | | | |
| ACE HARDWARE | B72340 | SUPERGLUE/HOOK/EYE BOLT/ | 02/23/2021 | 22.38 | .00 |
| AMERICAN TEST CENTER INC | 2210410 | ANNUAL SAFETY INSPECTION | 02/16/2021 | 125.00 | .00 |
| BARRON MOTOR SUPPLY | 220023 | OIL FILTER | 03/04/2021 | 4.97 | .00 |
| BARRON MOTOR SUPPLY | 220031 | TOWELS | 03/04/2021 | 49.99 | .00 |
| BARRON MOTOR SUPPLY | 220037 | OIL | 03/04/2021 | 7.20 | .00 |
| DONS TRUCK SALES INC | 525393 | FILTERS - BOOM TRUCK | 03/03/2021 | 53.15 | .00 |
| ICE MANUFACTURING INC | 1068 | PLAT 3/16" | 02/12/2021 | 29.94 | .00 |
| JOHN DEERE FINANCIAL F.S.B. | 2709330 | SOFTNER SALT | 02/17/2021 | 24.95 | 24.95 |
| JOHN DEERE FINANCIAL F.S.B. | 2709822 | FEBREZE/LUBE/GREASE/SPAD | 02/19/2021 | 59.10 | 59.10 |
| MARTIN EQUIPMENT OF ILLINO | 541444 | BULB/CAP | 02/13/2021 | 68.20 | .00 |
| MULGREW OIL CO | 929868 | OIL/DEF | 02/12/2021 | 520.60 | 520.60 |
| SUPERIOR WELDING SUPPLY | 254569 | OXYGEN | 02/02/2021 | 49.48 | .00 |
| SUPERIOR WELDING SUPPLY | 254614 | ARGON | 03/02/2021 | 77.11 | .00 |
| Total 110-2100-65070 SUPPLIES: | | | | 1,092.07 | 604.65 |
| 110-2300-63810 UTILITIES | | | | | |
| ALLIANT ENERGY | 0106966292 20 | ELECTRIC SERVICE | 02/24/2021 | 348.21 | 348.21 |
| ALLIANT ENERGY | 0106966292 20 | ELECTRIC SERVICE | 02/24/2021 | 7,922.05 | 7,922.05 |
| ALLIANT ENERGY | 4830253977 20 | ELECTRIC SERVICE | 03/08/2021 | 50.36 | .00 |
| ALLIANT ENERGY | 6455490000 20 | ELECTRIC SERVICE | 02/11/2021 | 514.48 | 514.48 |
| Total 110-2300-63810 UTILITIES: | | | | 8,835.10 | 8,784.74 |
| 110-2400-63810 UTILITIES | | | | | |
| ALLIANT ENERGY | 4830253977 20 | ELECTRIC SERVICE | 03/08/2021 | 112.62 | .00 |
| ALLIANT ENERGY | 6455490000 20 | ELECTRIC SERVICE | 02/11/2021 | 74.60 | 74.60 |
| Total 110-2400-63810 UTILITIES: | | | | 187.22 | 74.60 |

| Vendor Name | Invoice Number | Description | Invoice Date | Net Invoice Amount | Amount Paid |
|--|----------------|---------------------------|--------------|-----------------------|-------------|
| 112-3820-61500 MEDICAL-HEALTH | | | | | |
| UNUM LIFE INSURANCE CO O | 0618207-0015 | LIFE INSURANCE PREMIUM | 03/12/2021 | 92.88 | .00 |
| Total 112-3820-61500 MEDICAL-HEALTH: | | | | 92.88 | .00 |
| 112-3820-61840 CLAIMS-SIDE FUND | | | | | |
| ADVANTAGE ADMINISTRATORS | 2021 02 19 | FEBRUARY 19 MEDICAL CLAIM | 02/19/2021 | 56.36 | 56.36 |
| ADVANTAGE ADMINISTRATORS | 2021 02 26-1 | FEBRUARY 26 MEDICAL CLAIM | 02/26/2021 | 100.09 | 100.09 |
| ADVANTAGE ADMINISTRATORS | 2021 03 05 | MARCH 05 MEDICAL CLAIMS | 03/05/2021 | 99.02 | 99.02 |
| ADVANTAGE ADMINISTRATORS | 2021 03 12 | MARCH 12 MEDICAL CLAIMS | 03/12/2021 | 56.91 | 56.91 |
| ADVANTAGE ADMINISTRATORS | 4359 | SELF FUND MEDICAL INS | 02/19/2021 | 139.20 | 139.20 |
| Total 112-3820-61840 CLAIMS-SIDE FUND: | | | | 451.58 | 451.58 |
| 112-3830-61500 MEDICAL-HEALTH | | | | | |
| COVENANT OCCUPATIONAL M | 55687 | CONSORTIUM FEE 2-25 EMPLO | 02/12/2021 | 16.07 | 16.07 |
| UNUM LIFE INSURANCE CO O | 0618207-0015 | LIFE INSURANCE PREMIUM | 03/12/2021 | 25.48 | .00 |
| Total 112-3830-61500 MEDICAL-HEALTH: | | | | 41.55 | 16.07 |
| 112-3830-61840 CLAIMS-SIDE FUND | | | | | |
| ADVANTAGE ADMINISTRATORS | 2021 02 19 | FEBRUARY 19 MEDICAL CLAIM | 02/19/2021 | 19.80 | 19.80 |
| ADVANTAGE ADMINISTRATORS | 2021 03 05 | MARCH 05 MEDICAL CLAIMS | 03/05/2021 | 3.10 | 3.10 |
| ADVANTAGE ADMINISTRATORS | 4359 | SELF FUND MEDICAL INS | 02/19/2021 | 17.40 | 17.40 |
| Total 112-3830-61840 CLAIMS-SIDE FUND: | | | | 40.30 | 40.30 |
| 112-3840-61500 MEDICAL-HEALTH | | | | | |
| COVENANT OCCUPATIONAL M | 55687 | CONSORTIUM FEE 2-25 EMPLO | 02/12/2021 | 10.71 | 10.71 |
| UNUM LIFE INSURANCE CO O | 0618207-0015 | LIFE INSURANCE PREMIUM | 03/12/2021 | 30.07 | .00 |
| Total 112-3840-61500 MEDICAL-HEALTH: | | | | 40.78 | 10.71 |
| 112-3840-61840 CLAIMS-SIDE FUND | | | | | |
| ADVANTAGE ADMINISTRATORS | 2021 02 19 | FEBRUARY 19 MEDICAL CLAIM | 02/19/2021 | 44.31 | 44.31 |
| ADVANTAGE ADMINISTRATORS | 2021 02 26-1 | FEBRUARY 26 MEDICAL CLAIM | 02/26/2021 | 66.74 | 66.74 |
| ADVANTAGE ADMINISTRATORS | 2021 03 05 | MARCH 05 MEDICAL CLAIMS | 03/05/2021 | 116.75 | 116.75 |
| ADVANTAGE ADMINISTRATORS | 2021 03 12 | MARCH 12 MEDICAL CLAIMS | 03/12/2021 | 53.90 | 53.90 |
| ADVANTAGE ADMINISTRATORS | 4359 | SELF FUND MEDICAL INS | 02/19/2021 | 34.80 | 34.80 |
| Total 112-3840-61840 CLAIMS-SIDE FUND: | | | | 316.50 | 316.50 |
| 112-3860-61500 MEDICAL-HEALTH | | | | | |
| UNUM LIFE INSURANCE CO O | 0618207-0015 | LIFE INSURANCE PREMIUM | 03/12/2021 | 18.22 | .00 |
| Total 112-3860-61500 MEDICAL-HEALTH: | | | | 18.22 | .00 |
| 112-3860-61830 FLEX BENEFITS Q ADM FEE ALL EE | | | | | |
| ADVANTAGE ADMINISTRATORS | PLAN # 608 20 | QUARTERLY ADMIN FEE - 2ND | 03/10/2021 | 152.70 | 152.70 |
| Total 112-3860-61830 FLEX BENEFITS Q ADM FEE ALL EE: | | | | 152.70 | 152.70 |
| 112-3860-61840 CLAIMS-SIDE FUND Q HRA FEE | | | | | |
| ADVANTAGE ADMINISTRATORS | 2021 03 12 | MARCH 12 MEDICAL CLAIMS | 03/12/2021 | 5.85 | 5.85 |
| ADVANTAGE ADMINISTRATORS | 4359 | SELF FUND MEDICAL INS | 02/19/2021 | 26.10 | 26.10 |

| Vendor Name | Invoice Number | Description | Invoice Date | Net Invoice Amount | Amount Paid |
|--|----------------|------------------------------|--------------|-----------------------|-------------|
| Total 112-3860-61840 CLAIMS-SIDE FUND Q HRA FEE: | | | | 31.95 | 31.95 |
| 112-3860-64990 EMPLOYEE BENEFITS CONSULTING | | | | | |
| TASC | IN1983608 | ACA EMP REPORTING ADM FE | 03/01/2021 | 65.40 | 65.40 |
| Total 112-3860-64990 EMPLOYEE BENEFITS CONSULTING: | | | | 65.40 | 65.40 |
| 113-3900-61840 FLEX SPENDING | | | | | |
| ADVANTAGE ADMINISTRATORS | 2021 02 26 | PAYROLL DEDUCTION FLEX SP | 02/26/2021 | 933.12 | 933.12 |
| ADVANTAGE ADMINISTRATORS | 2021 02 26 | PAYROLL DEDUCTION FLEX SP | 02/26/2021 | 933.12 | 933.12 |
| Total 113-3900-61840 FLEX SPENDING: | | | | 1,866.24 | 1,866.24 |
| 123-1100-67990 CAPITAL OUTLAY | | | | | |
| AXON ENTERPRISE INC | SI-1709936 | TASERS | 01/14/2021 | 2,432.00 | 2,432.00 |
| KENS ELECTRIC | 304749 | SERVICE CALL - INSTALL PH LI | 02/03/2021 | 436.14 | 436.14 |
| Total 123-1100-67990 CAPITAL OUTLAY: | | | | 2,868.14 | 2,868.14 |
| 123-4410-67990 CAPITAL OUTLAY | | | | | |
| BODENSTEINER IMPLEMENT C | E02645 | 2021 JD HD 60 BROOM | 02/19/2021 | 4,200.00 | 4,200.00 |
| LIME ENERGY SERVICES CO | 479120-IN | SAVE INSTALLMENT | 03/01/2021 | 132.45 | 132.45 |
| Total 123-4410-67990 CAPITAL OUTLAY: | | | | 4,332.45 | 4,332.45 |
| 123-5250-65041 FIRE CAPITAL | | | | | |
| DANKO EMERGENCY EQUIPME | 115208 | CYLINDERS | 02/25/2021 | 4,930.00 | .00 |
| Total 123-5250-65041 FIRE CAPITAL: | | | | 4,930.00 | .00 |
| 123-5250-67240 CEMETERY CAPITAL | | | | | |
| ED STIVERS FORD INC | F01839 | 2020 FORD F350 - CEMETERY | 01/05/2021 | 42,998.00 | 42,998.00 |
| Total 123-5250-67240 CEMETERY CAPITAL: | | | | 42,998.00 | 42,998.00 |
| 123-5250-67280 ADMINISTRATION CAPITAL | | | | | |
| CARDMEMBER SERVICES | 0060 BR 2021 | WAYFAIR - WALL MOUNT RACK | 03/04/2021 | 128.39 | 128.39 |
| KENS ELECTRIC | 304811 | SERVICE CALL - FINISHED UP | 02/22/2021 | 4,405.65 | .00 |
| LUMBER RIDGE HOME SOURC | B66939 | BATTERY/CONNECTOR/COVER | 02/16/2021 | 34.43 | .00 |
| LUMBER RIDGE HOME SOURC | B66962 | OUTLET | 02/16/2021 | 8.27 | .00 |
| STEVE'S CONSTRUCTION | 2021 03 01 A | CITY HALL RENO - WALLS TEXT | 03/01/2021 | 4,338.46 | 4,338.46 |
| STEVE'S CONSTRUCTION | 2021 03 01 B | CITY HALL RENO - BRICK WALL | 03/01/2021 | 2,200.63 | 2,200.63 |
| STEVE'S CONSTRUCTION | 2021 03 01 C | NEW OFFICE - INSULATE/DRYW | 03/01/2021 | 1,916.05 | 1,916.05 |
| Total 123-5250-67280 ADMINISTRATION CAPITAL: | | | | 13,031.88 | 8,583.53 |
| 123-5250-67701 LIBRARY CAPITAL | | | | | |
| KIRK GROSS COMPANY | 20400 | HUSH POD | 02/17/2021 | 16,812.50 | .00 |
| LIME ENERGY SERVICES CO | 64629 | SAVE INSTALLMENT | 03/01/2021 | 244.66 | 244.66 |
| Total 123-5250-67701 LIBRARY CAPITAL: | | | | 17,057.16 | 244.66 |
| 160-1710-63750 CELLULAR/PAGING | | | | | |
| US CELLULAR | 453072630 202 | CELLPHONE SERVICE | 03/02/2021 | 31.67 | .00 |
| US CELLULAR | 453072630 202 | CELLPHONE SERVICE | 03/02/2021 | 25.83 | .00 |

| Vendor Name | Invoice Number | Description | Invoice Date | Net Invoice Amount | Amount Paid |
|---|----------------|------------------------------|--------------|-----------------------|-------------|
| Total 160-1710-63750 CELLULAR/PAGING: | | | | 57.50 | .00 |
| 160-1710-64950 CONTRACTS | | | | | |
| ONLINE SOLUTIONS LLC | 4070 | 2021-2022 ANNUAL BILLING CI | 03/15/2021 | 2,700.00 | .00 |
| Total 160-1710-64950 CONTRACTS: | | | | 2,700.00 | .00 |
| 160-1710-65060 OFFICE SUPPLIES | | | | | |
| STOREY KENWORTHY CORP | PINV877206 | TONER CRTDGS | 02/09/2021 | 238.35 | .00 |
| STOREY KENWORTHY CORP | PINV878523 | BLANK DOOR TAGS | 02/15/2021 | 445.00 | .00 |
| Total 160-1710-65060 OFFICE SUPPLIES: | | | | 683.35 | .00 |
| 160-5030-67901 HOMES FOR IOWA | | | | | |
| ALLIANT ENERGY | 1199211000 20 | ELEC/GAS SERVICE 318 7TH S | 03/03/2021 | 87.13 | 87.13 |
| KENS ELECTRIC | 304981 | INSTALL DUCT RUN - 318 7TH S | 02/23/2021 | 760.00 | .00 |
| Total 160-5030-67901 HOMES FOR IOWA: | | | | 847.13 | 87.13 |
| 160-5200-63730 COMMUNICATIONS | | | | | |
| MEDIACOM COMMUNICATIONS | 0003535 2021 | PHONE/INTERNET SERVICE | 02/16/2021 | 66.04 | 66.04 |
| MEDIACOM COMMUNICATIONS | 0003535 2021 | PHONE/INTERNET SERVICE | 03/16/2021 | 66.04 | .00 |
| Total 160-5200-63730 COMMUNICATIONS: | | | | 132.08 | 66.04 |
| 160-5200-64133 TOURISM | | | | | |
| ALLIANT ENERGY | 8100421000 20 | ELECTRIC SERVICE | 03/08/2021 | 23.42 | 23.42 |
| Total 160-5200-64133 TOURISM: | | | | 23.42 | 23.42 |
| 160-5200-64139 OCAD DUES | | | | | |
| OELWEIN CHAMBER & AREA D | 2021 03 02 | 3RD QTR CONTRIBUTION | 03/02/2021 | 12,500.00 | .00 |
| Total 160-5200-64139 OCAD DUES: | | | | 12,500.00 | .00 |
| 160-5200-64140 LEGAL PUBLICATION | | | | | |
| OELWEIN PUBLISHING CO | 303468637 | JANUARY CLAIMS | 02/02/2021 | 29.18 | .00 |
| OELWEIN PUBLISHING CO | 303470278 | PN SELL PROPERTY 322 N FRE | 02/12/2021 | 16.62 | .00 |
| OELWEIN PUBLISHING CO | 303470354 | FEB 8 MINUTES | 02/13/2021 | 15.31 | .00 |
| OELWEIN PUBLISHING CO | 303474691 | PN SELL PROPERTY 412 1ST A | 02/26/2021 | 10.55 | .00 |
| OELWEIN PUBLISHING CO | 303477540 | FEBRUARY CLAIMS | 02/27/2021 | 24.14 | .00 |
| OELWEIN PUBLISHING CO | 303477541 | FEB 22 MINUTES & JAN RECEIP | 02/27/2021 | 18.68 | .00 |
| Total 160-5200-64140 LEGAL PUBLICATION: | | | | 114.48 | .00 |
| 160-5200-64181 PROPERTY TAXES-MISC | | | | | |
| FAYETTE CO TREASURER | 2021 03 01 | PROPERTY TAXES DAN FORSY | 03/01/2021 | 117.00 | .00 |
| FAYETTE CO TREASURER | 2021 03 01 | PROPERTY TAXES FAUST | 03/01/2021 | 81.00 | .00 |
| Total 160-5200-64181 PROPERTY TAXES-MISC: | | | | 198.00 | .00 |
| 160-5200-64904 JUNK HOUSE REMOVAL | | | | | |
| FAYETTE CO TREASURER | 1821427017 20 | PROPERTY TAXES 416 E CHAR | 02/24/2021 | 1,102.00 | 1,102.00 |
| FAYETTE CO TREASURER | 1828127006 20 | PROPERTY TAXES 620 3RD AV | 02/24/2021 | 747.00 | 747.00 |
| FAYETTE CO TREASURER | 2021 03 02 | PROPERTY TAXES 11 12TH AVE | 03/02/2021 | 50.00 | .00 |
| FAYETTE CO TREASURER | 2021 03 02 | PROPERTY TAXES 20 2ND AVE | 03/02/2021 | 55.00 | .00 |

| Vendor Name | Invoice Number | Description | Invoice Date | Net Invoice Amount | Amount Paid |
|--|----------------|------------------------------|--------------|-----------------------|-------------|
| FAYETTE CO TREASURER | 2021 03 02 | PROPERTY TAXES 24 2ND AVE | 03/02/2021 | 43.00 | .00 |
| FAYETTE CO TREASURER | 2021 03 02 | PROPERTY TAXES 318 7TH ST | 03/02/2021 | 125.00 | .00 |
| FAYETTE CO TREASURER | 2021 03 02 | PROPERTY TAXES 815 4TH AVE | 03/02/2021 | 433.00 | .00 |
| FAYETTE COUNTY SOLID WAST | 138665 | DISPOSAL FEES - OLD CHAMB | 02/25/2021 | 87.00 | .00 |
| FAYETTE COUNTY SOLID WAST | 138690 | DISPOSAL FEES - OLD CHAMB | 02/26/2021 | 66.60 | .00 |
| FAYETTE COUNTY SOLID WAST | 138800 | DISPOSAL FEES - OLD CHAMB | 03/04/2021 | 78.00 | .00 |
| FAYETTE COUNTY SOLID WAST | 138819 | DISPOSAL FEES - OLD CHAMB | 03/05/2021 | 53.40 | .00 |
| Total 160-5200-64904 JUNK HOUSE REMOVAL: | | | | 2,840.00 | 1,849.00 |
| 160-5200-65060 OFFICE SUPPLIES | | | | | |
| COPY SYSTEMS INC | IN404675 | COPIER MAINT SUPPORT | 03/05/2021 | 13.89 | .00 |
| OELWEIN PUBLISHING CO | 0180375 2021 | SUBSCRIPTION RENEWAL | 03/05/2021 | 44.00 | 44.00 |
| QUADIENT LEASING USA INC | N8772698 | FEB - APR POSTAGE METER LE | 03/12/2021 | 81.71 | .00 |
| Total 160-5200-65060 OFFICE SUPPLIES: | | | | 139.60 | 44.00 |
| 160-5240-64990 OELWEIN ELEVATOR | | | | | |
| FAYETTE CO TREASURER | 2021 03 01 | PROPERTY TAXES OELWEIN EL | 03/01/2021 | 117.00 | .00 |
| Total 160-5240-64990 OELWEIN ELEVATOR: | | | | 117.00 | .00 |
| 161-5225-64030 ADMINISTRATIVE COSTS | | | | | |
| UPPER EXPLORERLAND | FY21169 | FEB 2021 ADMIN COSTS IRP | 02/28/2021 | 1,764.32 | .00 |
| Total 161-5225-64030 ADMINISTRATIVE COSTS: | | | | 1,764.32 | .00 |
| 307-4300-67850 CONSTRUCTION | | | | | |
| OELWEIN PUBLISHING CO | 303473727 | PH TRAIL IMPROVEMENTS | 02/23/2021 | 31.10 | .00 |
| Total 307-4300-67850 CONSTRUCTION: | | | | 31.10 | .00 |
| 385-8125-64070 CONTRACTS, ENGINEERS | | | | | |
| FOX ENGINEERING ASSOCIATE | 47500 | OEL 2020 WATER MAIN REPLA | 02/28/2021 | 14,770.02 | .00 |
| UPPER EXPLORERLAND | FY21175 | CDBG - WATER/SEWER #19-WS | 02/28/2021 | 3,365.30 | .00 |
| Total 385-8125-64070 CONTRACTS, ENGINEERS: | | | | 18,135.32 | .00 |
| 385-8125-65030 ADMINISTRATIVE COSTS | | | | | |
| OELWEIN PUBLISHING CO | 303470279 | PH INVITATION TO BID - WATER | 02/12/2021 | 96.48 | .00 |
| OELWEIN PUBLISHING CO | 303472517 | PH '21 WATER MAIN IMP | 02/18/2021 | 22.69 | .00 |
| Total 385-8125-65030 ADMINISTRATIVE COSTS: | | | | 119.17 | .00 |
| 386-8120-64070 CONTRACTS,ENGINEERS | | | | | |
| FOX ENGINEERING ASSOCIATE | 47463 | OEL WELL & DISINFECTION IMP | 02/28/2021 | 2,042.50 | .00 |
| Total 386-8120-64070 CONTRACTS,ENGINEERS: | | | | 2,042.50 | .00 |
| 386-8120-67850 CONSTRUCTION | | | | | |
| PORTZEN CONSTRUCTION INC | 17 | PAY # 17 DISINFECTION/42 WE | 02/18/2021 | 48,064.75 | 48,064.75 |
| Total 386-8120-67850 CONSTRUCTION: | | | | 48,064.75 | 48,064.75 |
| 387-7560-64070 CONTRACTS, ENGINEERING | | | | | |
| FOX ENGINEERING ASSOCIATE | 47495 | WINGS EAST PAVING IMP | 02/28/2021 | 1,202.00 | .00 |

| Vendor Name | Invoice Number | Description | Invoice Date | Net Invoice Amount | Amount Paid |
|--|----------------|-----------------------------|--------------|-----------------------|-------------|
| Total 387-7560-64070 CONTRACTS, ENGINEERING: | | | | 1,202.00 | .00 |
| 600-6200-61500 MEDICAL-HEALTH | | | | | |
| UNUM LIFE INSURANCE CO O | 0618207-0015 | LIFE INSURANCE PREMIUM | 03/12/2021 | 31.85 | .00 |
| Total 600-6200-61500 MEDICAL-HEALTH: | | | | 31.85 | .00 |
| 600-6200-61840 CLAIMS-SIDE FUND | | | | | |
| ADVANTAGE ADMINISTRATORS | 2021 02 19 | FEBRUARY 19 MEDICAL CLAIM | 02/19/2021 | 994.12 | 994.12 |
| ADVANTAGE ADMINISTRATORS | 2021 02 26-1 | FEBRUARY 26 MEDICAL CLAIM | 02/26/2021 | 114.44 | 114.44 |
| ADVANTAGE ADMINISTRATORS | 2021 03 05 | MARCH 05 MEDICAL CLAIMS | 03/05/2021 | 58.69 | 58.69 |
| ADVANTAGE ADMINISTRATORS | 2021 03 12 | MARCH 12 MEDICAL CLAIMS | 03/12/2021 | 250.53 | 250.53 |
| ADVANTAGE ADMINISTRATORS | 4359 | SELF FUND MEDICAL INS | 02/19/2021 | 52.20 | 52.20 |
| Total 600-6200-61840 CLAIMS-SIDE FUND: | | | | 1,469.98 | 1,469.98 |
| 600-6200-63100 BUILDING | | | | | |
| AUTO XTRAS | 20996 | SIGNS/LOGOS/TINT WINDOW | 02/24/2021 | 290.17 | .00 |
| Total 600-6200-63100 BUILDING: | | | | 290.17 | .00 |
| 600-6200-63730 COMMUNICATIONS | | | | | |
| MEDIACOM COMMUNICATIONS | 0003535 2021 | PHONE/INTERNET SERVICE | 02/16/2021 | 96.90 | 96.90 |
| MEDIACOM COMMUNICATIONS | 0003535 2021 | PHONE/INTERNET SERVICE | 02/16/2021 | 66.03 | 66.03 |
| MEDIACOM COMMUNICATIONS | 0003535 2021 | PHONE/INTERNET SERVICE | 03/16/2021 | 96.90 | .00 |
| MEDIACOM COMMUNICATIONS | 0003535 2021 | PHONE/INTERNET SERVICE | 03/16/2021 | 66.03 | .00 |
| US CELLULAR | 453072630 202 | CELLPHONE SERVICE/ROUTER | 03/02/2021 | 71.56 | .00 |
| Total 600-6200-63730 COMMUNICATIONS: | | | | 397.42 | 162.93 |
| 600-6200-63810 UTILITIES | | | | | |
| ALLIANT ENERGY | 6455490000 20 | ELECTRIC SERVICE | 02/11/2021 | 131.17 | 131.17 |
| EAGLE POINT ENERGY 5 LLC | OELWEIN 29 | ELECTRIC SERVICE | 03/03/2021 | 9.13 | 9.13 |
| OELWEIN CITY WATER | 2021 03 01 | WATER/SEWER SERVICE | 03/01/2021 | 33.36 | 33.36 |
| Total 600-6200-63810 UTILITIES: | | | | 173.66 | 173.66 |
| 600-6200-64080 INSURANCE-LIABILITY | | | | | |
| VOGEL INSURANCE AGENCY | 7176 | ANNUAL INS PREMIUM - WATE | 03/17/2021 | 17,716.00 | .00 |
| Total 600-6200-64080 INSURANCE-LIABILITY: | | | | 17,716.00 | .00 |
| 600-6200-64110 LEGAL EXPENSE | | | | | |
| LYNCH DALLAS PC | 180808 | LEGAL/PROFESSIONAL FEES | 02/24/2021 | 528.50 | .00 |
| Total 600-6200-64110 LEGAL EXPENSE: | | | | 528.50 | .00 |
| 600-6200-64140 LEGAL PUBLICATION | | | | | |
| OELWEIN PUBLISHING CO | 303468637 | JANUARY CLAIMS | 02/02/2021 | 38.91 | .00 |
| OELWEIN PUBLISHING CO | 303470354 | FEB 8 MINUTES | 02/13/2021 | 20.42 | .00 |
| OELWEIN PUBLISHING CO | 303477540 | FEBRUARY CLAIMS | 02/27/2021 | 32.18 | .00 |
| OELWEIN PUBLISHING CO | 303477541 | FEB 22 MINUTES & JAN RECEIP | 02/27/2021 | 24.90 | .00 |
| Total 600-6200-64140 LEGAL PUBLICATION: | | | | 116.41 | .00 |

| Vendor Name | Invoice Number | Description | Invoice Date | Net Invoice Amount | Amount Paid |
|--|----------------|-----------------------------|--------------|-----------------------|-------------|
| 600-6200-64182 WATER EXCISE TAX | | | | | |
| TREASURER STATE OF IOWA | 1-33-809659 2 | FEBRUARY WET TAX | 02/28/2021 | 4,248.00 | 4,248.00 |
| Total 600-6200-64182 WATER EXCISE TAX: | | | | 4,248.00 | 4,248.00 |
| 600-6200-64950 CONTRACTS | | | | | |
| BERGANKDV TECHNOLOGY & | CW102370 | DISPATCH TRANSITION | 02/26/2021 | 123.75 | .00 |
| OELWEIN COMMUNITY PLAZA F | 2021 02 26 | PLAZA - COUNCIL MEETINGS 2/ | 02/26/2021 | 66.67 | .00 |
| Total 600-6200-64950 CONTRACTS: | | | | 190.42 | .00 |
| 600-6200-65060 OFFICE SUPPLIES | | | | | |
| BERGANKDV TECHNOLOGY & | CW101561 | OFFICE 365 | 02/05/2021 | 13.75 | 13.75 |
| BERGANKDV TECHNOLOGY & | CW101561 | PREMIUM OFFICE 365 | 02/05/2021 | 33.33 | 33.33 |
| BERGANKDV TECHNOLOGY & | CW101561 | HOSTED EXCHANGE | 02/05/2021 | 26.67 | 26.67 |
| BERGANKDV TECHNOLOGY & | CW101718 | WEBROOT | 02/05/2021 | 37.33 | 37.33 |
| BERGANKDV TECHNOLOGY & | CW102007 | EMAIL SECURITY | 02/05/2021 | 38.00 | 38.00 |
| CARDMEMBER SERVICES | 8557 DM 2021 | ADOBE - MONTHLY SUB | 03/04/2021 | 27.74 | 27.74 |
| COPY SYSTEMS INC | IN404675 | COPIER MAINT SUPPORT | 03/05/2021 | 13.89 | .00 |
| FIDELITY BANK & TRUST | 2021 02 26 | PSN MONTHLY FEE-CR CARD/D | 02/26/2021 | 27.45 | 27.45 |
| FIDELITY BANK & TRUST | 2021 02 26 | PSN PROCESSING FEES COVI | 02/26/2021 | 668.55 | 668.55 |
| OELWEIN PUBLISHING CO | 0180375 2021 | SUBSCRIPTION RENEWAL | 03/05/2021 | 44.00 | 44.00 |
| QUADIANT LEASING USA INC | N8772698 | FEB - APR POSTAGE METER LE | 03/12/2021 | 81.71 | .00 |
| STOREY KENWORTHY CORP | PINV877886 | PAPER LEGAL 8.5 X 14 | 02/11/2021 | 5.51 | .00 |
| STOREY KENWORTHY CORP | PINV878507 | DOOR TAGS | 02/15/2021 | 132.67 | .00 |
| U S POST OFFICE | 2021 02 26 | MARCH WATER BILLS POSTAG | 02/26/2021 | 238.00 | 238.00 |
| Total 600-6200-65060 OFFICE SUPPLIES: | | | | 1,388.60 | 1,154.82 |
| 600-8100-61990 EMPLOYEE PERSONNEL EXPENSE | | | | | |
| COVENANT OCCUPATIONAL M | 55687 | CONSORTIUM FEE 2-25 EMPLO | 02/12/2021 | 32.15 | 32.15 |
| JOHN DEERE FINANCIAL F.S.B. | 2710859 | SWEATSHIRT - H DOUDNEY 20 | 02/23/2021 | 69.99 | 69.99 |
| Total 600-8100-61990 EMPLOYEE PERSONNEL EXPENSE: | | | | 102.14 | 102.14 |
| 600-8100-63730 COMMUNICATIONS | | | | | |
| MEDIACOM COMMUNICATIONS | 0003535 2021 | PHONE/INTERNET SERVICE | 02/16/2021 | 190.00 | 190.00 |
| MEDIACOM COMMUNICATIONS | 0003535 2021 | PHONE/INTERNET SERVICE | 03/16/2021 | 190.00 | .00 |
| US CELLULAR | 453072630 202 | CELLPHONE SERVICE | 03/02/2021 | 46.02 | .00 |
| US CELLULAR | 453072630 202 | CELLPHONE SERVICE | 03/02/2021 | 20.01 | .00 |
| Total 600-8100-63730 COMMUNICATIONS: | | | | 446.03 | 190.00 |
| 600-8100-63810 UTILITIES | | | | | |
| ALLIANT ENERGY | 4830253977 20 | ELECTRIC SERVICE | 03/08/2021 | 4,626.02 | .00 |
| ALLIANT ENERGY | 6455490000 20 | ELECTRIC SERVICE | 02/11/2021 | 166.23 | 166.23 |
| ALLIANT ENERGY | 6455490000 20 | ELECTRIC SERVICE | 02/11/2021 | 655.18 | 655.18 |
| OELWEIN CITY WATER | 2021 03 01 | WATER/SEWER SERVICE | 03/01/2021 | 69.92 | 69.92 |
| Total 600-8100-63810 UTILITIES: | | | | 5,517.35 | 891.33 |
| 600-8100-65041 EQUIPMENT | | | | | |
| ACE HARDWARE | A200585 | AIR PLUG/AIR COUPLER/NIPPL | 02/19/2021 | 18.27 | .00 |
| BARRON MOTOR SUPPLY | 219666 | SWITCH | 02/18/2021 | 29.61 | .00 |
| DONS TRUCK SALES INC | 525400 | HYD COUPLER ENDS - BREAKE | 03/03/2021 | 75.05 | .00 |
| JOHN DEERE FINANCIAL F.S.B. | 2712328 | LOCKPINS | 03/02/2021 | 5.07 | 5.07 |

| Vendor Name | Invoice Number | Description | Invoice Date | Net Invoice Amount | Amount Paid |
|---|----------------|-----------------------------|--------------|-----------------------|-------------|
| Total 600-8100-65041 EQUIPMENT: | | | | 128.00 | 5.07 |
| 600-8100-65060 OFFICE SUPPLIES | | | | | |
| CARDMEMBER SERVICES | 0201 VK 2021 | STAPLES - WEBCAM | 03/04/2021 | 74.89 | 74.89 |
| Total 600-8100-65060 OFFICE SUPPLIES: | | | | 74.89 | 74.89 |
| 600-8100-65070 SUPPLIES | | | | | |
| ACE HARDWARE | B72112 | EXCHANGE LP TANK | 02/18/2021 | 19.99 | .00 |
| ACE HARDWARE | B72335 | ICEMAKER KIT/DRILL BIT | 02/23/2021 | 22.98 | .00 |
| BARRON MOTOR SUPPLY | 219814 | NOX-ICE | 02/24/2021 | 2.90 | .00 |
| HAWKINS INC | 4873064 | AZONE | 02/02/2021 | 1,369.50 | .00 |
| JOHN DEERE FINANCIAL F.S.B. | 2709681 | BELT | 02/18/2021 | 4.34 | 4.34 |
| JOHN DEERE FINANCIAL F.S.B. | 2712415 | COUPLERS/TILE | 03/02/2021 | 32.50 | 32.50 |
| MULGREW OIL CO | 940174 | OIL | 03/05/2021 | 429.00 | .00 |
| TESTAMERICA LABORATORIES | 3100041329 | WATER SAMPLES | 02/19/2021 | 609.00 | .00 |
| USBLUEBOOK | 519007 | TESTING SUPPLIES | 03/02/2021 | 265.67 | .00 |
| UTILITY EQUIPMENT CO | 30059917-000 | SS REPAIR CLAMPS | 02/26/2021 | 578.66 | .00 |
| UTILITY EQUIPMENT CO | 30059917-001 | REPAIR CLAMP | 03/03/2021 | 98.40 | .00 |
| UTILITY EQUIPMENT CO | 30059960-000 | SS REPAIR CLAMPS/CURB BOX | 03/11/2021 | 1,295.35 | .00 |
| UTILITY EQUIPMENT CO | 30059979-000 | 24" VB BOTTOM/26" VB TOP/4" | 03/11/2021 | 395.70 | .00 |
| UTILITY EQUIPMENT CO | 30059995-000 | REPAIR CLAMPS | 03/15/2021 | 540.79 | .00 |
| Total 600-8100-65070 SUPPLIES: | | | | 5,664.78 | 36.84 |
| 600-8100-67855 WATER PROJECTS | | | | | |
| FOX ENGINEERING ASSOCIATE | 47498 | 200320A OEL NE SANITARY SE | 02/28/2021 | 1,650.00 | .00 |
| Total 600-8100-67855 WATER PROJECTS: | | | | 1,650.00 | .00 |
| 670-8400-65060 OFFICE SUPPLIES | | | | | |
| U S POST OFFICE | 2021 02 26 | MARCH WATER BILLS POSTAG | 02/26/2021 | 112.00 | 112.00 |
| Total 670-8400-65060 OFFICE SUPPLIES: | | | | 112.00 | 112.00 |
| 671-8410-65060 OFFICE SUPPLIES | | | | | |
| U S POST OFFICE | 2021 02 26 | MARCH WATER BILLS POSTAG | 02/26/2021 | 56.00 | 56.00 |
| Total 671-8410-65060 OFFICE SUPPLIES: | | | | 56.00 | 56.00 |
| 680-8220-63730 COMMUNICATIONS | | | | | |
| CARDMEMBER SERVICES | 3397 JR 2021 | YES! MUSIC - MONTHLY SUB | 03/04/2021 | 8.94 | 8.94 |
| Total 680-8220-63730 COMMUNICATIONS: | | | | 8.94 | 8.94 |
| 680-8220-63810 UTILITIES | | | | | |
| SECURITY EQUIPMENT INC | 615526 | SERVICE AGREEMENT | 01/13/2021 | 270.00 | 270.00 |
| Total 680-8220-63810 UTILITIES: | | | | 270.00 | 270.00 |
| 680-8220-64080 INSURANCE-LIABILITY | | | | | |
| VOGEL INSURANCE AGENCY | 7176 | ANNUAL INS PREMIUM - WELL | 03/17/2021 | 3,274.00 | .00 |
| Total 680-8220-64080 INSURANCE-LIABILITY: | | | | 3,274.00 | .00 |

| Vendor Name | Invoice Number | Description | Invoice Date | Net Invoice Amount | Amount Paid |
|---|----------------|---------------------------|--------------|-----------------------|-------------|
| 680-8220-64180 SALES TAX | | | | | |
| TREASURER STATE OF IOWA | 1-33-000974 2 | FEBRUARY SALES TAX | 02/28/2021 | 620.00 | 620.00 |
| Total 680-8220-64180 SALES TAX: | | | | 620.00 | 620.00 |
| 680-8220-65041 EQUIPMENT | | | | | |
| CARDMEMBER SERVICES | 3397 JR 2021 | AMAZON - TAPE | 03/04/2021 | 9.30 | 9.30 |
| CARDMEMBER SERVICES | 3397 JR 2021 | AMAZON - TAPE | 03/04/2021 | 9.12 | 9.12 |
| PUSH PEDAL PULL INC | 301477 | PREVENTATIVE MAINT | 02/11/2021 | 187.50 | 187.50 |
| Total 680-8220-65041 EQUIPMENT: | | | | 205.92 | 205.92 |
| 680-8220-65060 OFFICE SUPPLIES | | | | | |
| FIDELITY BANK & TRUST | 2021 02 26 | WELLNESS CENTER MERCHAN | 02/26/2021 | 131.36 | 131.36 |
| FIDELITY BANK & TRUST | 2021 02 26 | WELLNESS TSYS FEES-ACH BI | 02/26/2021 | 110.00 | 110.00 |
| FIDELITY BANK & TRUST | 2021 02 26 | WELLNESS BANKCARD FEES | 02/26/2021 | 152.73 | 152.73 |
| FIDELITY BANK & TRUST | 2021 02 26-1 | WELLNESS CLUB SYSTEMS DU | 02/26/2021 | 133.95 | 133.95 |
| STOREY KENWORTHY CORP | PINV877723 | POSTCARDS | 02/11/2021 | 216.20 | .00 |
| Total 680-8220-65060 OFFICE SUPPLIES: | | | | 744.24 | 528.04 |
| 680-8220-65070 SUPPLIES | | | | | |
| COPY SYSTEMS INC | IN404581 | COPIER MAINT SUPPORT | 03/04/2021 | 47.72 | .00 |
| FAREWAY STORES INC | 119679 | LAUNDRY DET/TISSUES | 02/12/2021 | 13.96 | .00 |
| Total 680-8220-65070 SUPPLIES: | | | | 61.68 | .00 |
| 680-8220-65350 AFTER SCHOOL PROGRAMS | | | | | |
| FAREWAY STORES INC | 118048 | SNACKS | 02/03/2021 | 13.98 | .00 |
| FAREWAY STORES INC | 119441 | SNACKS/JUICE | 02/11/2021 | 31.15 | .00 |
| Total 680-8220-65350 AFTER SCHOOL PROGRAMS: | | | | 45.13 | .00 |
| 700-6200-61500 MEDICAL-HEALTH | | | | | |
| UNUM LIFE INSURANCE CO O | 0618207-0015 | LIFE INSURANCE PREMIUM | 03/12/2021 | 37.33 | .00 |
| Total 700-6200-61500 MEDICAL-HEALTH: | | | | 37.33 | .00 |
| 700-6200-61840 CLAIMS-SIDE FUND | | | | | |
| ADVANTAGE ADMINISTRATORS | 2021 02 19 | FEBRUARY 19 MEDICAL CLAIM | 02/19/2021 | 1,138.58 | 1,138.58 |
| ADVANTAGE ADMINISTRATORS | 2021 02 26-1 | FEBRUARY 26 MEDICAL CLAIM | 02/26/2021 | 94.43 | 94.43 |
| ADVANTAGE ADMINISTRATORS | 2021 03 05 | MARCH 05 MEDICAL CLAIMS | 03/05/2021 | 45.94 | 45.94 |
| ADVANTAGE ADMINISTRATORS | 2021 03 12 | MARCH 12 MEDICAL CLAIMS | 03/12/2021 | 2.92 | 2.92 |
| ADVANTAGE ADMINISTRATORS | 4359 | SELF FUND MEDICAL INS | 02/19/2021 | 26.10 | 26.10 |
| Total 700-6200-61840 CLAIMS-SIDE FUND: | | | | 1,307.97 | 1,307.97 |
| 700-6200-63100 BUILDING | | | | | |
| AUTO XTRAS | 20996 | SIGNS/LOGOS/TINT WINDOW | 02/24/2021 | 290.17 | .00 |
| Total 700-6200-63100 BUILDING: | | | | 290.17 | .00 |
| 700-6200-63730 COMMUNICATIONS | | | | | |
| MEDIACOM COMMUNICATIONS | 0003535 2021 | PHONE/INTERNET SERVICE | 02/16/2021 | 66.03 | 66.03 |
| MEDIACOM COMMUNICATIONS | 0003535 2021 | PHONE/INTERNET SERVICE | 03/16/2021 | 66.03 | .00 |
| US CELLULAR | 453072630 202 | CELLPHONE SERVICE/ROUTER | 03/02/2021 | 71.56 | .00 |

| Vendor Name | Invoice Number | Description | Invoice Date | Net Invoice Amount | Amount Paid |
|---|----------------|-----------------------------|--------------|-----------------------|-------------|
| Total 700-6200-63730 COMMUNICATIONS: | | | | 203.62 | 66.03 |
| 700-6200-63810 UTILITIES | | | | | |
| ALLIANT ENERGY | 6455490000 20 | ELECTRIC SERVICE | 02/11/2021 | 131.17 | 131.17 |
| EAGLE POINT ENERGY 5 LLC | OELWEIN 29 | ELECTRIC SERVICE | 03/03/2021 | 9.13 | 9.13 |
| OELWEIN CITY WATER | 2021 03 01 | WATER/SEWER SERVICE | 03/01/2021 | 33.36 | 33.36 |
| Total 700-6200-63810 UTILITIES: | | | | 173.66 | 173.66 |
| 700-6200-64080 INSURANCE-LIABILITY | | | | | |
| VOGEL INSURANCE AGENCY | 7176 | ANNUAL INS PREMIUM - SEWE | 03/17/2021 | 23,093.00 | .00 |
| Total 700-6200-64080 INSURANCE-LIABILITY: | | | | 23,093.00 | .00 |
| 700-6200-64110 LEGAL EXPENSE | | | | | |
| LYNCH DALLAS PC | 180808 | LEGAL/PROFESSIONAL FEES | 02/24/2021 | 528.50 | .00 |
| Total 700-6200-64110 LEGAL EXPENSE: | | | | 528.50 | .00 |
| 700-6200-64140 LEGAL PUBLICATION | | | | | |
| OELWEIN PUBLISHING CO | 303468637 | JANUARY CLAIMS | 02/02/2021 | 38.91 | .00 |
| OELWEIN PUBLISHING CO | 303470354 | FEB 8 MINUTES | 02/13/2021 | 20.41 | .00 |
| OELWEIN PUBLISHING CO | 303477540 | FEBRUARY CLAIMS | 02/27/2021 | 32.19 | .00 |
| OELWEIN PUBLISHING CO | 303477541 | FEB 22 MINUTES & JAN RECEIP | 02/27/2021 | 24.89 | .00 |
| Total 700-6200-64140 LEGAL PUBLICATION: | | | | 116.40 | .00 |
| 700-6200-64180 SALES TAX | | | | | |
| TREASURER STATE OF IOWA | 1-33-000974 2 | FEBRUARY SALES TAX | 02/28/2021 | 1,561.00 | 1,561.00 |
| Total 700-6200-64180 SALES TAX: | | | | 1,561.00 | 1,561.00 |
| 700-6200-64950 CONTRACTS | | | | | |
| BERGANKDV TECHNOLOGY & | CW102370 | DISPATCH TRANSITION | 02/26/2021 | 123.75 | .00 |
| OELWEIN COMMUNITY PLAZA F | 2021 02 26 | PLAZA - COUNCIL MEETINGS 2/ | 02/26/2021 | 66.67 | .00 |
| Total 700-6200-64950 CONTRACTS: | | | | 190.42 | .00 |
| 700-6200-65060 OFFICE SUPPLIES | | | | | |
| BERGANKDV TECHNOLOGY & | CW101561 | OFFICE 365 | 02/05/2021 | 13.75 | 13.75 |
| BERGANKDV TECHNOLOGY & | CW101561 | PREMIUM OFFICE 365 | 02/05/2021 | 33.34 | 33.34 |
| BERGANKDV TECHNOLOGY & | CW101561 | HOSTED EXCHANGE | 02/05/2021 | 26.67 | 26.67 |
| BERGANKDV TECHNOLOGY & | CW101718 | WEBROOT | 02/05/2021 | 37.34 | 37.34 |
| BERGANKDV TECHNOLOGY & | CW102007 | EMAIL SECURITY | 02/05/2021 | 38.00 | 38.00 |
| CARDMEMBER SERVICES | 8557 DM 2021 | ADOBE - MONTHLY SUB | 03/04/2021 | 27.74 | 27.74 |
| COPY SYSTEMS INC | IN404675 | COPIER MAINT SUPPORT | 03/05/2021 | 13.90 | .00 |
| FIDELITY BANK & TRUST | 2021 02 26 | PSN MONTHLY FEE-CR CARD/D | 02/26/2021 | 27.45 | 27.45 |
| FIDELITY BANK & TRUST | 2021 02 26 | PSN PROCESSING FEES COVI | 02/26/2021 | 668.56 | 668.56 |
| OELWEIN PUBLISHING CO | 0180375 2021 | SUBSCRIPTION RENEWAL | 03/05/2021 | 44.00 | 44.00 |
| QUADIENT LEASING USA INC | N8772698 | FEB - APR POSTAGE METER LE | 03/12/2021 | 81.72 | .00 |
| STOREY KENWORTHY CORP | PINV877886 | PAPER LEGAL 8.5 X 14 | 02/11/2021 | 5.51 | .00 |
| STOREY KENWORTHY CORP | PINV878507 | DOOR TAGS | 02/15/2021 | 132.67 | .00 |
| U S POST OFFICE | 2021 02 26 | MARCH WATER BILLS POSTAG | 02/26/2021 | 294.00 | 294.00 |
| Total 700-6200-65060 OFFICE SUPPLIES: | | | | 1,444.65 | 1,210.85 |

| Vendor Name | Invoice Number | Description | Invoice Date | Net Invoice Amount | Amount Paid |
|--|----------------|----------------------------|--------------|-----------------------|-------------|
| 700-8310-61990 EMPLOYEE PERSONNEL EXPENSE | | | | | |
| TINDELL SHOES INC | 20813504 | BOOTS J RECHKEMMER | 03/15/2021 | 144.46 | .00 |
| Total 700-8310-61990 EMPLOYEE PERSONNEL EXPENSE: | | | | 144.46 | .00 |
| 700-8310-63810 UTILITIES | | | | | |
| ALLIANT ENERGY | 0106966292 20 | ELECTRIC SERVICE | 02/24/2021 | 442.01 | 442.01 |
| ALLIANT ENERGY | 6455490000 20 | ELECTRIC SERVICE | 02/11/2021 | 55.41 | 55.41 |
| ALLIANT ENERGY | 6455490000 20 | ELECTRIC SERVICE | 02/11/2021 | 34.30 | 34.30 |
| Total 700-8310-63810 UTILITIES: | | | | 531.72 | 531.72 |
| 700-8310-65041 EQUIPMENT | | | | | |
| USABLUBOOK | 522026 | ROTO FLOATS | 03/04/2021 | 162.53 | .00 |
| Total 700-8310-65041 EQUIPMENT: | | | | 162.53 | .00 |
| 700-8310-65070 SUPPLIES | | | | | |
| JOHN DEERE FINANCIAL F.S.B. | 2713926 | SAW BLADE | 03/08/2021 | 54.99 | 54.99 |
| USABLUBOOK | 527882 | O2 SENSOR GAS ALERT MAX | 03/10/2021 | 183.48 | .00 |
| UTILITY EQUIPMENT CO | 30060000-000 | EJ FRAME ONLY/AGS EJ GASK | 03/15/2021 | 403.16 | .00 |
| UTILITY EQUIPMENT CO | 30060002-000 | LADTECH HDPE RISERS | 03/15/2021 | 50.84 | .00 |
| Total 700-8310-65070 SUPPLIES: | | | | 692.47 | 54.99 |
| 700-8500-61990 EMPLOYEE PERSONNEL EXPENSE | | | | | |
| COVENANT OCCUPATIONAL M | 55687 | CONSORTIUM FEE 2-25 EMPLO | 02/12/2021 | 16.07 | 16.07 |
| JOHN DEERE FINANCIAL F.S.B. | 2709155 | JACKET/BIBS/STEEL TOE | 02/16/2021 | 232.97 | 232.97 |
| TINDELL SHOES INC | 20808157 | BOOTS M ROGERS | 03/15/2021 | 161.46 | .00 |
| Total 700-8500-61990 EMPLOYEE PERSONNEL EXPENSE: | | | | 410.50 | 249.04 |
| 700-8500-63730 COMMUNICATIONS | | | | | |
| MEDIACOM COMMUNICATIONS | 0003535 2021 | PHONE/INTERNET SERVICE | 02/16/2021 | 142.01 | 142.01 |
| MEDIACOM COMMUNICATIONS | 0003535 2021 | PHONE/INTERNET SERVICE | 03/16/2021 | 142.01 | .00 |
| US CELLULAR | 453072630 202 | CELLPHONE SERVICE | 03/02/2021 | 40.02 | .00 |
| US CELLULAR | 453072630 202 | CELLPHONE SERVICE | 03/02/2021 | 20.02 | .00 |
| Total 700-8500-63730 COMMUNICATIONS: | | | | 344.06 | 142.01 |
| 700-8500-63810 UTILITIES | | | | | |
| ALLIANT ENERGY | 6455490000 20 | ELECTRIC SERVICE | 02/11/2021 | 5,984.12 | 5,984.12 |
| OELWEIN CITY WATER | 2021 03 01 | WATER/SEWER SERVICE | 03/01/2021 | 36.82 | 36.82 |
| OELWEIN CITY WATER | 2021 03 01 | WATER/SEWER SERVICE | 03/01/2021 | 121.40 | 121.40 |
| Total 700-8500-63810 UTILITIES: | | | | 6,142.34 | 6,142.34 |
| 700-8500-65041 EQUIPMENT | | | | | |
| KENS ELECTRIC | 304614 | SERVICE CALL - GEO REPAIR | 01/18/2021 | 1,548.99 | .00 |
| KENS ELECTRIC | 304924 | CONTACTOR | 02/12/2021 | 17.76 | .00 |
| USABLUBOOK | 522026 | ROTO FLOATS | 03/04/2021 | 162.52 | .00 |
| UTILITY EQUIPMENT CO | 30059982-000 | PVC PIPE/6" PVC FLEX CPLG | 03/11/2021 | 173.14 | .00 |
| Total 700-8500-65041 EQUIPMENT: | | | | 1,902.41 | .00 |
| 700-8500-65070 SUPPLIES | | | | | |
| FAREWAY STORES INC | 2425 | ICE/DISTILLED WATER/SUPPLI | 02/02/2021 | 46.44 | .00 |

| Vendor Name | Invoice Number | Description | Invoice Date | Net Invoice Amount | Amount Paid |
|-----------------------------------|----------------|-----------------------------|--------------|--------------------|-------------|
| LUMBER RIDGE HOME SOURC | B66698 | UPS SHIPPING - TEST AMERIC | 02/04/2021 | 17.97 | .00 |
| TESTAMERICA LABORATORIES | 3100041328 | WASTEWATER SAMPLES | 02/19/2021 | 1,790.25 | .00 |
| Total 700-8500-65070 SUPPLIES: | | | | 1,854.66 | .00 |
| 706-8315-64070 ENGINEERING | | | | | |
| FOX ENGINEERING ASSOCIATE | 47537 | OEL IND PARK 3RD ADD UTIL I | 02/28/2021 | 9,000.00 | .00 |
| Total 706-8315-64070 ENGINEERING: | | | | 9,000.00 | .00 |
| Grand Totals: | | | | 486,170.41 | 163,775.59 |

Dated: _____

Mayor: _____

City Council: _____

City Recorder: _____

Report Criteria:

- Detail report.
- Invoices with totals above \$0.00 included.
- Paid and unpaid invoices included.

Report Criteria:
Summary report

| Check Number | Date | Payee | Amount |
|---------------|------------|-----------------------------------|---------------|
| 56542 | 02/24/2021 | BETTY BURKHALTER | 60.00 |
| 56543 | 02/24/2021 | LUMBER RIDGE HOME SOURCE | 20.00 |
| 56549 | 03/03/2021 | MATT WEBER | 29.66 |
| 56550 | 03/03/2021 | VIRGINIA SCHOENENBERGER | 25.00 |
| 56551 | 03/03/2021 | ARDELLE WINSTON OR TIFFANI MASSEY | 21.94 |
| Grand Totals: | | | <u>156.60</u> |

Applicant License Application ()

Item 3.

| | | | |
|--------------------------------|----------------------------|----------------|---|
| Name of Applicant: | <u>H&S STORE LLC</u> | | |
| Name of Business (DBA): | <u>SUPER MART</u> | | |
| Address of Premises: | <u>701 S FREDERICK AVE</u> | | |
| City | <u>Oelwein</u> | County: | <u>Fayette</u> Zip: <u>50662</u> |
| Business | <u>(319) 830-2729</u> | | |
| Mailing | <u>701 S FREDERICK AVE</u> | | |
| City | <u>Oelwein</u> | State | <u>IA</u> Zip: <u>50662</u> |

Contact Person

| | | | |
|---------------|-----------------------|--------------|--------------------------------|
| Name | <u>WALEED PARVEZ</u> | | |
| Phone: | <u>(319) 830-2729</u> | Email | <u>MIDWESTLLC786@GMAIL.COM</u> |

Classification Class E Liquor License (LE)

Term:12 months

Effective Date: 03/30/2021

Expiration Date: 01/01/1900

Privileges:

- Class B Wine Permit
- Class C Beer Permit (Carryout Beer)
- Class E Liquor License (LE)
- Sunday Sales

Status of Business

| | | | |
|-----------------------------|----------------------------------|----------------------------|-------------------|
| BusinessType: | <u>Limited Liability Company</u> | | |
| Corporate ID Number: | <u>XXXXXXXXXX</u> | Federal Employer ID | <u>XXXXXXXXXX</u> |

Ownership

nadeem islam

First Name: nadeem **Last Name:** islam
City: ASBURY **State:** Iowa **Zip:** 52002
Position: OWNER
% of Ownership: 50.00% **U.S. Citizen:** Yes

WALEED PARVEZ

First Name: WALEED **Last Name:** PARVEZ
City: CEDAR FALLS **State:** Iowa **Zip:** 50613
Position: OWNER
% of Ownership: 50.00% **U.S. Citizen:** No

Insurance Company Information

Insurance Company: Auto Owners Insurance Company

Item 3.

Policy Effective Date: 03/30/2021

Policy Expiration 01/01/1900

Bond Effective 2

Dram Cancel Date:

Outdoor Service Effective

Outdoor Service Expiration

Temp Transfer Effective

Temp Transfer Expiration Date:

Instructions on the reverse side

For period (MM/DD/YYYY) 03 / 31 / 2021 through June 30, 2021

I/we apply for a retail permit to sell cigarettes, tobacco, alternative nicotine, or vapor products:

Business Information:

Trade Name/DBA H&S STORE LLC
Physical Location Address 701 S Frederick Ave City Oelwein ZIP 50662
Mailing Address 4215 DAINA DRIVE City EDGEMOUNT State IA ZIP 50613
Business Phone Number 319-830-2729

Legal Ownership Information:

Type of Ownership: Sole Proprietor Partnership Corporation LLC LLP
Name of sole proprietor, partnership, corporation, LLC, or LLP _____
Mailing Address 4215 DAINA DRIVE City EDGEMOUNT State IA ZIP 50613
Phone Number 319-830-2729 Fax Number 563-556-2934 Email Midwest LLC 286@gmail.com

Retail Information:

Types of Sales: Over-the-counter Vending machine
Do you make delivery sales of alternative nicotine or vapor products? (See Instructions) Yes No
Types of Products Sold: (Check all that apply)
Cigarettes Tobacco Alternative Nicotine Products Vapor Products

Type of Establishment: (Select the option that best describes the establishment)

Alternative nicotine/vapor store Bar Convenience store/gas station Drug store
Grocery store Hotel/motel Liquor store Restaurant Tobacco store
Has vending machine that assembles cigarettes Other _____

If application is approved and permit granted, I/we do hereby bind ourselves to a faithful observance of the laws governing the sale of cigarettes, tobacco, alternative nicotine, and vapor products.

Signature of Owner(s), Partner(s), or Corporate Official(s)

Name (please print) Nadaem ISLAM Name (please print) Wakeed Parvez
Signature [Signature] Signature [Signature]
Date 03-08-2021 Date 03/08/21

Send this completed application and the applicable fee to your local jurisdiction. If you have any questions contact your city clerk (within city limits) or your county auditor (outside city limits).

FOR CITY CLERK/COUNTY AUDITOR ONLY – MUST BE COMPLETE

- Fill in the amount paid for the permit: _____
- Fill in the date the permit was approved by the council or board: _____
- Fill in the permit number issued by the city/county: _____
- Fill in the name of the city or county issuing the permit: _____
- New Renewal

Send completed/approved application to Iowa Alcoholic Beverages Division within 30 days of issuance. Make sure the information on the application is complete and accurate. A copy of the permit does not need to be sent; only the application is required. It is preferred that applications are sent via email, as this allows for a receipt confirmation to be sent to the local authority.

- Email: iapledge@iowaabd.com
- Fax: 515-281-7375

RESOLUTION NO. ____

Resolution finally approving and confirming plans, specifications, form of contract and estimate of cost for the Oelwein 2021 Water Main Improvements

WHEREAS, the City Council of the City of Oelwein, Iowa, has heretofore given approval to the plans, specifications, form of contract and estimate of cost (the "Contract Documents") for the proposed Oelwein 2021 Water Main Improvements (the "Project"), as described in the notice of hearing on the Contract Documents for the Project; and

WHEREAS, a hearing has been held on the Contract Documents on March 8, 2021;

NOW, THEREFORE, Be It Resolved by the City Council of the City of Oelwein, Iowa, as follows:

Section 1. The Contract Documents referred to in the preamble hereof are hereby finally approved, and the prior action of the Council giving preliminary approval is hereby finally confirmed, and the Project, as provided for in the Contract Documents, is necessary and desirable.

Section 2. All resolutions or parts of resolutions in conflict herewith are hereby repealed to the extent of such conflict.

Passed and approved March 22, 2021.

Mayor

Attest:

City Clerk

RESOLUTION NO. ____

Resolution awarding contract for the Oelwein 2021 Water Main Improvements

WHEREAS, pursuant to notice duly posted in the manner and form prescribed by resolution of the City Council of the City of Oelwein, Iowa, and as required by law, bids and proposals were received by this Council for the Oelwein 2021 Water Main Improvements(the “Project”); and

WHEREAS, all of the said bids and proposals have been carefully considered, and it is necessary and advisable that provision be made for the award of the contract for the Project;

NOW, THEREFORE, Be It Resolved by the City Council of the City of Oelwein, Iowa, as follows:

Section 1. The bid for the Project submitted by the following contractor is fully responsive to the plans and specifications for the Project, is heretofore approved by the Council, and is the lowest responsible bid received, such bid being as follows:

| <u>Name and Address of Contractor</u> | <u>Amount of Bid</u> |
|---|----------------------|
| Summers Enterprise, Inc 1776 Buchanan Delaware Ave Masonville, IA 50654 | \$1,057,488.83 |

Section 2. The contract for the Project is hereby awarded to such contractor at the total estimated cost set out above, the final settlement to be made on the basis of the unit prices therein set out and the actual final quantities of each class of materials furnished, the said contract to be subject to the terms of the aforementioned resolution, the notice of hearing and letting, the plans and specifications and the terms of the bidder’s written proposal.

Section 3. The Mayor and City Clerk are hereby authorized and ordered to enter into a written contract with said contractor for the Project, said contract not to be binding until approved by resolution of this Council.

Section 4. The amount of the contractor’s performance and/or payment bonds is hereby fixed and determined to be 100% of the amount of the contract.

Section 5. All resolutions or parts of resolutions in conflict herewith are hereby repealed to the extent of such conflict.

Passed and approved March 22, 2021.

Mayor

Attest:

City Clerk

RESOLUTION NO. ____

Resolution approving contract and performance and/or payment bonds for the Oelwein 2021 Water Main Improvements

WHEREAS, the City Council of the City of Oelwein, Iowa, has heretofore awarded a contract for the Oelwein 2021 Water Main Improvements and fixed the amount of the performance and/or payment bonds to be furnished by such contractor, and instructed and authorized the Mayor and City Clerk to execute the said contract on behalf of the City, subject to the approval of the Council; and

WHEREAS, the said contract has been duly signed by the contractor and by the Mayor and City Clerk, and upon examination by this Council the same appears to be in proper form; and

WHEREAS, the contractor has filed satisfactory performance and/or payment bonds in the required amount;

NOW, THEREFORE, Be It Resolved by the City Council of the City of Oelwein, Iowa, as follows:

Section 1. The contract and performance and/or payment bonds referred to above are hereby approved and declared to be binding upon the parties thereto.

Section 2. All resolutions or parts of resolutions in conflict herewith are hereby repealed to the extent of such conflict.

Passed and approved _____, 2021.

Mayor

Attest:

City Clerk

RESOLUTION NO. _____

RESOLUTION DIRECTING THE SALE OF THE CITY'S INTEREST IN 17 5TH AVENUE SE, OELWEIN, FAYETTE COUNTY, IOWA

WHEREAS, the City is desirous of selling the real estate described herein.

WHEREAS, the City Council has set forth its proposal to sell its interest in the above described real estate and has published notice of the date, time and place of a public hearing thereon; and

WHEREAS, said public hearing was held and the City Council believes it is in the best interest of the City to sell the above described real estate on the terms and conditions set forth below;

BE IT RESOLVED by the Council of the city of Oelwein, Iowa, as follows:

Section 1. On behalf of the City, the Mayor shall contract to sell and shall convey by Quit Claim Deed the following described real estate:

17 5TH AVENUE SE LEGALLY DESCRIBED AS LOT 38, BLOCK 3, OELWEINS 4TH ADDITION, FAYETTE COUNTY, IOWA

To: Jeffrey T. Schuler

For the sum of \$704.00 and other valuable consideration.

Section 2. The City Administrator shall co-sign such contracts and deeds. The Deed shall be delivered thirty days after the date of this Resolution, unless an appeal on this action has been made to District Court. Action on this Resolution shall be final upon the purchaser of the Deed giving evidence to the Clerk that the Deed has been recorded, and such facts to be noted on the official record of this Resolution.

Section 3. This resolution shall be in effect upon its passage and approval as provided by law.

Passed and adopted by the City Council of the City of Oelwein, Iowa, this 22nd day of March, 2021.

Brett DeVore, Mayor

It was moved by _____ and seconded by _____ that the Resolution as read be adopted, and upon roll call there were:
AYES NAYS ABSENT ABSTAIN

M Weber
Stewart
Cantrell
Seeders
Fisk
Payne

Attest:

Dylan Mulfinger, City Administrator

Recorded _____, 2021.

City Administrator



March 17, 2021

MEMO: RE: 17 5th Ave SE

Jeff Schuler is the only party interested in this lot for \$704.

NOTES

Rec'd 3/16/21

Item 8.

I Jeff Schuler am paying
the Amount of \$1704.00 to the
City of Odwein for the land
at 175th AVES. E.

Jeff Schuler

17 5th Ave SE

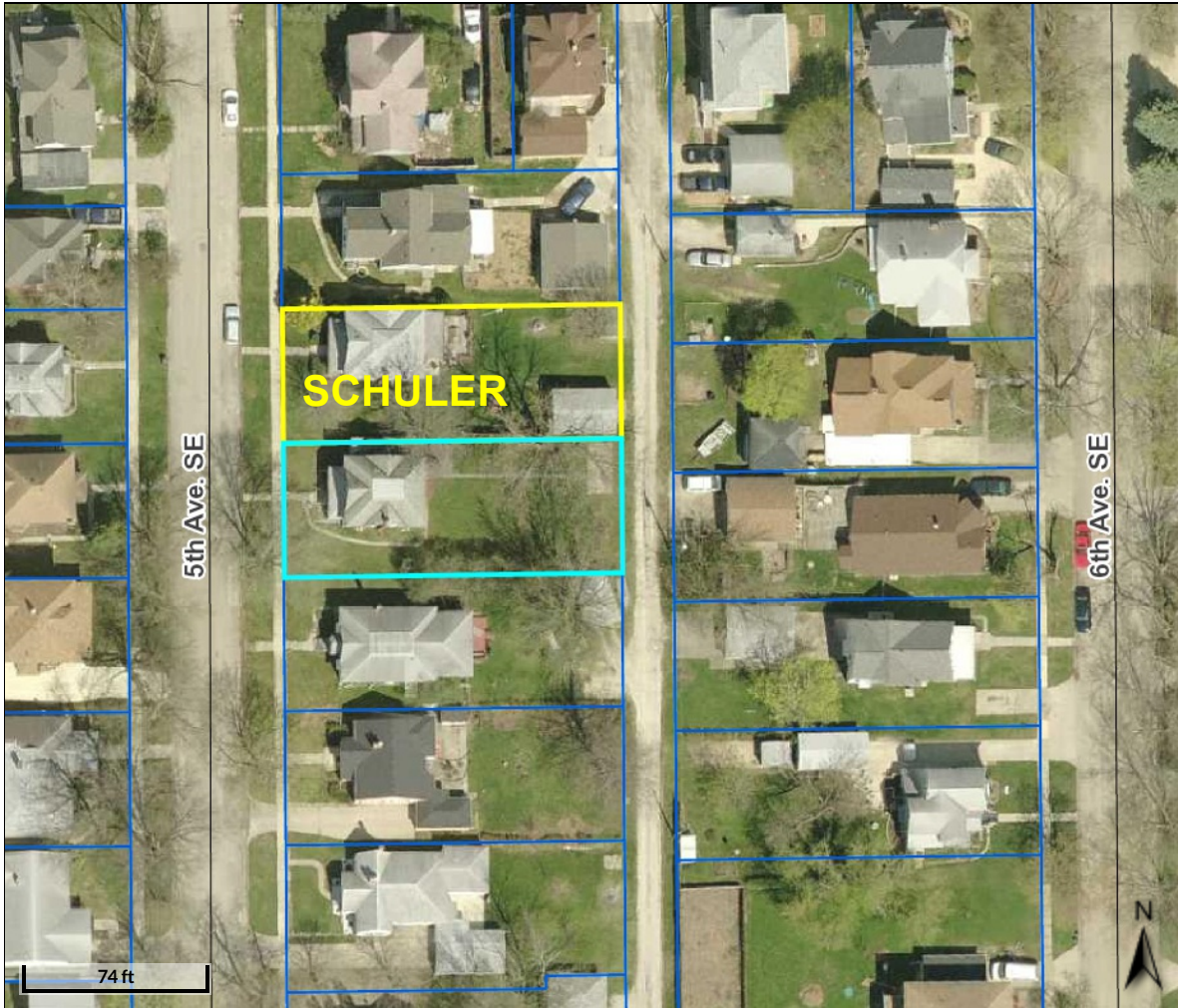

Overview

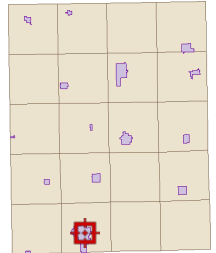

Legend

-  Corporate Limits
-  Parcels
- Major Highways**
 -  County Highway
 -  Federal Highway
 -  State Highway
 -  Roads

| | | | | | |
|------------------------------|--|---------------------|-----|----------------------|--------------------------|
| Parcel ID | 1821428005 | Alternate ID | n/a | Owner Address | Oelwein, City Of |
| Sec/Twp/Rng | 21-91-9 | Class | R | | City Hall 20 2nd Ave. SW |
| Property Address | 17 5TH AVE. SE | Acreage | n/a | | Oelwein, IA 50662- |
| | OELWEIN | | | | |
| District | OELWEIN OELWEIN INC | | | | |
| Brief Tax Description | LOT 37 BLK 3 | | | | |
| | OELWEIN 4TH ADD | | | | |
| | <i>(Note: Not to be used on legal documents)</i> | | | | |

Disclaimer: Fayette County, the Fayette County Assessor and their employees make every effort to produce and publish the most current and accurate information possible. The maps included in this website do not represent a survey and are compiled from official records, including plats, surveys, recorded deeds, and contracts, and only contain information required for government purposes. See the recorded documents for more detailed legal information. Data is provided in "as is" condition. No warranties, expressed or implied, are provided for the data herein, its use or its interpretation. Fayette County and its employees assume no responsibility for the consequences of inappropriate uses or interpretations of the data. Any person that relies on any information obtained from this site does so at his or her own risk. All critical information should be independently verified. If you have questions about this site please contact the Assessor's Office at (563) 422-3397.

Date created: 3/17/2021
 Last Data Uploaded: 3/17/2021 2:53:40 AM

Developed by 

RESOLUTION NO. _____

Resolution Reinstating Online Fees for Utility Bill Payments

WHEREAS, the city of Oelwein suspended online fee for customers in April of 2020 because of the pandemic and the shutting down of City Hall and:

WHEREAS, City Hall will be open to the public starting April of 2021 resulting in all options to pay the utility be being available and;

WHEREAS, it is recommended to council to reinstate fees starting with the bill in April of 2021 for the online payments and stop having them be absorbed by the city and;

THEREFORE, BE IT RESOLVED by the City Council of the City of Oelwein, Iowa Does Hereby Reinstating Online Fees for Utility Bill Payments:

Passed and approved by the City Council of the City of Oelwein, Iowa this 22 day of March 2021.

Brett DeVore, Mayor

It was moved by _____ and seconded by _____ that the Resolution as read be adopted, and upon roll call there were:

AYES NAYS ABSENT ABSTAIN

Weber
Seeders
Cantrell
Payne
Fisk
Stewart

Attest:

Dylan Mulfinger, City Administrator

Recorded _____, 2021.

City Administrator

RESOLUTION NO. _____

RESOLUTION ESTABLISHING COLLECTIVE BARGAINING AND NONUNION SALARIES FOR CITY EMPLOYEES

Be it resolved by the City Council of the City of Oelwein, Iowa that the following salary schedule is hereby adopted and effective with Pay Period Date Beginning June 20, 2021.

SECTION 1.

City Hall

| | Monthly Salary | Hourly |
|-------------------------------------|----------------|---------------------|
| City Administrator | \$9,288.46 | |
| City Clerk/Treasurer (deputy clerk) | \$6,862.42 | |
| Secretary | | \$21.53- \$25.08 |
| Union | | |
| Clerk | | |
| Start | | \$18.82 |
| 6 Months | | \$19.20 |
| 12 Months | | \$19.58 |
| 18 Months | | \$19.96 |
| 24 Months | | \$20.37 |
| Clerk 1 | | |
| Start | | \$19.90 |
| 6 Months | | |
| 12 Months | | |
| 18 Months | | \$21.11 |
| 24 Months | | \$21.54 |
| Clerk 2 | | |
| Start | | \$20.99 |
| 6 Months | | |
| 12 Months | | |
| 18 Months | | \$22.27 |
| 24 Months | | \$22.66 |

Police Department

| | Monthly Salary | Hourly |
|---|----------------|--------|
| Police Chief | \$8,894.00 | |
| Police Captain less than two years | \$7,070.81 | |
| Police Captain more than two years | \$7,289.50 | |
| Police 1 st Lieutenant less than two years | \$5,582.90 | |
| Police 1 st Lieutenant more than two years | \$5,738.33 | |
| Police 2 nd Lieutenant less than two years | \$5,274.43 | |
| Police 2 nd Lieutenant more than two years | \$5,429.05 | |
| Police Clerical | | |

| | | |
|--------------------------------|-------------------------|---------------------|
| Police Matron | | \$7.85 |
| Administrative Assistant | | \$21.53- \$25.08 |
| Clerical | | |
| Start | | \$18.82 |
| 6 Months | | \$19.20 |
| 12 Months | | \$19.58 |
| 18 Months | | \$19.96 |
| 24 Months | | \$20.37 |
| Union | | |
| Patrolman | | |
| Start | | \$23.11 |
| 12 Months | | \$25.33 |
| 18 Months | | \$25.96 |
| 24 Months | | \$26.53 |
| Police Part Time Certified | 12-month Patrolman Rate | \$25.33-26.53 |
| Police Part Time Non-Certified | | \$19.06-23.75 |

Building and Inspections

| | Monthly Salary | Hourly |
|--------------------------------|----------------|-----------------|
| Zoning Admin/Building Official | \$5,418.38 | |
| Building Inspector | | \$22.63 |
| Code Enforcement Officer | | \$19.23-\$22.63 |
| Administrative Assistant | | |
| Start | | \$18.82 |
| 6 Months | | \$19.20 |
| 12 Months | | \$19.58 |
| 18 Months | | \$19.96 |
| 24 Months | | \$20.37 |

Fire Department

| | Monthly Salary | Hourly |
|-------------|----------------|---------|
| Firefighter | | \$22.40 |

Volunteer Fire Department

| | Payment |
|--------------------------|------------------|
| Volunteer Equipment Fund | \$916.67 monthly |
| Fire Chief | \$250 monthly |

Parks and Recreation

| | Monthly Salary | Hourly |
|----------------------|----------------|---------|
| Parks Superintendent | \$5,423.16 | |
| Parks Lead | | |
| Start | | \$19.61 |

| | | |
|--------------------------------|---|-----------------|
| 6 months | | \$21.34 |
| 12 months | | \$22.09 |
| 18 months | | \$23.75 |
| Campground Host | \$135.00 per week (Includes Camping Fees) | |
| Seasonal, Part-time, Temporary | | \$8.45-12.88 |
| Umpire with partner | | \$15 (per game) |
| Umpire without partner | | \$20 (per game) |
| Referee | | \$7.25-\$8.42 |
| Tennis Instructor | | \$7.25-\$8.42 |

Aquatic Center

| | | |
|--|--|------------------|
| Manager | | \$10.00 – 16.00 |
| Assistant Manager | | \$ 9.00 – 11.52 |
| Lifeguard | | \$7.65-8.74 |
| Front Desk and Maintenance | | \$7.65-8.09 |
| Concession Manager | | \$7.65-9.37 |
| Private Lessons with Water Safety Instructor | | Additional \$.50 |
| Season End Stipend for all hours worked* | | Additional \$.10 |
| Head Guard | | Additional \$.50 |

*Must work the entire regular season to earn the season end Stipend.

Utilities

| | Monthly Salary | Hourly |
|------------------------|----------------|--------|
| Utility Superintendent | \$8,720.45 | |
| Utility Lead | | 29.03 |
| Wastewater Lead | | 28.69 |
| Union | | |
| Laborer | | |
| Start | | 19.61 |
| 6 Months | | 21.34 |
| 12 Months | | 22.09 |
| 18 Months | | 23.75 |
| Grade I | | |
| Start | | 21.31 |
| 6 Months | | 22.17 |
| 12 Months | | 22.92 |
| 18 Months | | 24.64 |
| Grade II | | |
| Start | | 21.61 |
| 6 Months | | 22.51 |
| 12 Months | | 23.21 |
| 18 Months | | 25.03 |

| | | |
|--------------------------|--|------------------|
| Grade III | | |
| Start | | 22.69 |
| 6 Months | | 23.40 |
| 12 Months | | 24.22 |
| 18 Months | | 25.61 |
| Grade IV | | |
| Start | | 23.81 |
| 6 Months | | 24.53 |
| 12 Months | | 25.36 |
| 18 Months | | 26.79 |
| Lead Man | | Additional \$.75 |
| Summer Help | | \$11.11-12.88 |
| Administrative Assistant | | |
| Start | | \$18.82 |
| 6 Months | | \$19.20 |
| 12 Months | | \$19.58 |
| 18 Months | | \$19.96 |
| 24 Months | | \$20.37 |

Library (As approved by the Library Board)

| | Monthly Salary | Hourly |
|--------------------|----------------|----------------|
| Director | \$6,180.72 | |
| Assistant Director | | \$18.33 |
| Outreach Librarian | | \$17.94 |
| Part-Time | | \$7.25-\$14.11 |
| Pages | | \$7.25-\$7.65 |

SECTION 2. The longevity pay for regular full-time employees, except where otherwise provided for by contract, will be granted in addition to the salaries listed in Section 1. The total listed for longevity is not to be cumulative.

| | |
|-----------------------|----------------|
| Service over 3 years | \$ 49.90 Month |
| Service over 5 years | \$ 60.98 Month |
| Service over 10 years | \$ 72.08 Month |
| Service over 15 years | \$ 83.16 Month |
| Service over 20 years | \$ 94.26 Month |
| Service over 25 years | \$105.34 Month |
| Service over 30 years | \$116.42 Month |

SECTION 4. Fulltime non-union personnel electing medical insurance coverage shall contribute toward premiums as outlined below.

| Beginning Date | Single Coverage | Family Coverage |
|----------------|-----------------|-----------------|
| July 1, 2021 | \$95.06 | \$173.94 |

SECTION 5. Fulltime Union personnel electing medical insurance coverage shall contribute toward premiums as outlined below for each Union.

| | | |
|----------------|-----------------|-----------------|
| Police | | |
| Beginning Date | Single Coverage | Family Coverage |
| July 1, 2021 | \$95.06 | \$173.94 |
| Public Works | | |
| Beginning Date | Single Coverage | Family Coverage |
| July 1, 2021 | \$95.06 | \$173.94 |

SECTION 6. All fulltime employees shall receive a paid membership (single or family) in the Williams Wellness Center including a 24-hour access key. One key per family, extra keys at the full annual rate of \$60.00. Oelwein Volunteer Fire Department members will receive a paid single membership to the Williams Wellness Center. Oelwein Police Reserve Officers will receive a paid single membership to the Williams Wellness Center following a one-year probationary period.

SECTION 7. An employee who takes on the Safety Official role appointed by the City Administrator receives an additional \$0.25 an hour annually. When the employee is no longer the safety official, the \$0.25 is taken away.

SECTION 8. An employee who takes on the Deputy Clerk role appointed by the City Clerk/Treasurer receives an additional \$1.00 an hour annually. When the employee become certified as a City Clerk, they will receive \$1.50 additional pay.

Section 9. The City will assist and pay for training for utility employees interested in obtaining grade certifications. The city will pay the highest-grade levels acquired by the employee.

SECTION 10. Passed and adopted by the City Council of the City of Oelwein, Iowa this _____ day of _____, 2021.

BRETT DEVORE, MAYOR

ATTEST:

DYLAN MULFINGER, CITY ADMINISTRATOR

Recorded this _____, 2021.

DYLAN MULFINGER, CITY ADMINISTRATOR

DATE: March 15, 2021

TO: **Dylan Mulfinger**
City Administrator
20 Second Avenue SW
Oelwein, IA 50662

RE: **Oelwein Industrial Park 3rd Addition Utility Improvements – Status Report**
FOX Ref No. 8686-15B.correspondance

DELIVERY: Mail

ITEMS: Invoice

COMMENTS:

The construction project has been closed and final completion accepted by the city. FOX has submitted the amendment to our engineering services agreement for reimbursement of additional construction administration fees. This invoice is for payment for these services.

Please review and let me know if you have any questions.



Lance Aldrich, P.E.



414 South 17th Street, Ste 107
 Ames, IA 50010
 515-233-0000

City of Oelwein
 20 2nd Avenue SW
 Oelwein, IA 50662
 Dylan Mulfinger

Invoice number 47537
 Date 02/28/2021

Project **868615B Oelwein Industrial Park 3rd
 Addition - Utility Improvements**

Professional Services for the Period of 1/31/2021 to 2/27/2021

Invoice Breakdown:
 Sewer:\$0.00
 Water: \$0.00

Lump Sum Phases

| Description | Contract Amount | Percent Complete | Prior Billed | Total Billed | Current Billed |
|--|-------------------|------------------|------------------|-------------------|-----------------|
| Preliminary Design | 19,400.00 | 100.00 | 19,400.00 | 19,400.00 | 0.00 |
| Final Design | 36,000.00 | 100.00 | 36,000.00 | 36,000.00 | 0.00 |
| Bidding Phase Services | 5,500.00 | 100.00 | 5,500.00 | 5,500.00 | 0.00 |
| Bidding Documents (Quest CDN + 10 sets @ \$50) | 700.00 | 100.00 | 700.00 | 700.00 | 0.00 |
| Construction Administration | 31,500.00 | 100.00 | 22,500.00 | 31,500.00 | 9,000.00 |
| Record Drawings | 4,000.00 | 100.00 | 4,000.00 | 4,000.00 | 0.00 |
| Construction Staking | 9,000.00 | 100.00 | 9,000.00 | 9,000.00 | 0.00 |
| Total | 106,100.00 | 100.00 | 97,100.00 | 106,100.00 | 9,000.00 |

Invoice total \$9,000.00

Approved by: 

Late Payment Charge: 15% per annum beginning 30 days from above date

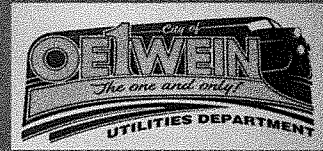

Memo

To: Honorable Mayor & City Council,

From: Utility Superintendent Victor Kane

CC: City Administrator Dylan Mulfinger

Reference: Replacement Dump Box

Date: 03/18/21

Greetings,

We have received a quote from Dons' Trucks on the replacement dump box for the Tandem. They are the Henderson representative and for ease of install they are located in Fairbank thus one quote provided. Due to the age of this vehicle the two options quoted will not be needed. I recommend that we go with Dons' trucks quote of \$19,610 installed.

Thank you for your time.

Victor Kane

From the Desk of
Oelwein Utility Superintendent Victor Kane



Don's Truck Sales

Tel: 319.635.2751
Fax: 319.635.2231

102 1st Street South
Fairbank, IA 50629



Item 13.

www.donstrucksales.com
trucks@donstrucksales.com

www.customclassictrailer.com
trailers@customclassictrailer.com

March 17, 2021

City of Oelwein
Oelwein, Iowa

Replacement Dump Body Quote:

16' Henderson Mark E-ti Dump Body
Mild Steel
36" Sides
Front Telescopic Hoist -74-156 Cylinder
7 ga. Floor
10 ga. Sides and Head
Single Side Brace
Sloped Top Rail
7 ga. Tailgate
Single Tailgate Brace
Air Tailgate Release
One Rear Light Hole
LED Light Kit
Greasable Rear Hinge
16"x78" Cab Shield
Oil
Paint One Color – White or Black
Labor to Remove Old Body & Install New Body

Price **\$ 19,610.00**

(Does not include any Hoses that need to be replaced)

Options:

1) 201 Stainless Steel Body ILO Painted Mild Steel Add: \$ 3,405.00

2) Mailhot Trunion Mounted Hoist ILO 74-156 Hoist Add: \$ 875.00
This is a Nitrited Cylinder ILO Chromed Cylinder

Give me a call with any questions.

Gene Carpenter



Memo

To: Honorable Mayor & City Council,

From: Utility Superintendent Victor Kane

CC: City Administrator Dylan Mulfinger

Reference: New Skid Steer

Date: 03/18/21

Greetings,

We have received 2 quotes for the purchase of a new skid steer.

Bryan Heavy Equipment Inc. quoted a Bobcat brand for \$53,048.52.

Bodensteiner Implement Co. quoted a John Deere brand for \$56,000.00.

We only quoted the Bobcat hydraulic breaker, root grapple and snow blade attachments from Bryan Heavy Equipment. This was to keep them interchangeable between the new and the old machine.

Quote total for the three is \$15,313.24

The Bobcat works with all the current attachments. The John Deere has its own periphery system.

Thus, it would require a purchase of an electronic control box converter to use with bobcat

attachments. Then our accessories including the old Bobcat would need switched to work with the

John Deere setup. Otherwise, to switch the John Deere may void the warranty. Do to these issue and

the pricing difference I recommend purchasing the Bobcat and attachments from Bryan Heavy

Equipment for a total cost of \$68,361.76.

Thank you for your time.

Victor Kane

From the Desk of
Oelwein Utility Superintendent Victor Kane



Bobcat

Item 14.

Product Quotation

Quotation Number: HMM-25337v1

Date: 2021-02-16 12:49:31

| | | |
|---|--|--|
| Customer Name/Address: | Bobcat Delivering Dealer | ORDER TO BE PLACED WITH: Contract Holder/Manufacturer |
| CITY OF OELWEIN 270057 20 2nd Ave Oelwein, IA 50662 | Bryan Heavy Equipment Inc., Oelwein, IA 101 COUNTY LINE RD OELWEIN IA 50662 Phone: 319-283-2345 Fax: 319-283-4567 | Clark Equipment Co dba Bobcat Company 250 E Beaton Dr, PO Box 6000 West Fargo, ND 58078 Phone: 701-241-8719 Fax: 701-280-7860 Contact: Heather Messmer Heather.Messmer@doosan.com |

| Description | Part No | Qty | Price Ea. | Total |
|---|--|-----|-------------|---------------------|
| S770 T4 Bobcat Skid-Steer Loader 92 HP Turbo Tier 4 Diesel Engine Air Intake Heater (Automatically Activated) Auxiliary Hydraulics: Variable Flow Backup Alarm Bob-Tach Bobcat Interlock Control System (BICS) Controls: Bobcat Standard Engine/Hydraulic Systems Shutdown Horn Instrumentation: Engine Temp and Fuel Gauges, Hourmeter, RPM and Warning Lights | M0283 | 1 | \$42,238.70 | \$42,238.70 |
| | Lift Arm Support Lift Path: Vertical Lights, Front & Rear Operator Cab | | | |
| | <ul style="list-style-type: none"> Includes: Adjustable Suspension Seat, Top & Rear Windows, Parking Brake, Seat Bar, Seat Belt Roll Over Protective Structure (ROPS) meets SAE-J1040 & ISO 3471 Falling Object Protective Structure (FOPS) meets SAE-J1043 & ISO 3449, Level I; (Level II is available through Bobcat Parts) | | | |
| | Tires: 12-16.5 12 PR Bobcat Heavy Duty Warranty: 2 years, or 2000 hours whichever occurs first | | | |
| P68 Performance Package Power Bob-Tach 7-Pin Attachment Control Kit High Flow | M0283-P06-P68 | 1 | \$4,461.10 | \$4,461.10 |
| | 2-Speed Hydraulic Bucket Positioning Automatic Ride Control | | | |
| C37 Comfort Package Enclosed Cab with AC/Heat Sound Reduction Cab Accessories Package | M0283-P07-C37 | 1 | \$4,504.50 | \$4,504.50 |
| | Deluxe Instrument Panel with Keyless Start Radio Heated Cloth Air Ride Suspension Seat | | | |
| Selectable Joystick Controls (SJC) | M0283-R01-C04 | 1 | \$661.50 | \$661.50 |
| Telematics US | M0283-R51-C02 | 1 | \$0.00 | \$0.00 |
| 80" Heavy Duty Bucket | 7272681 | 1 | \$931.00 | \$931.00 |
| --- Bolt-On Cutting Edge, 80" | 6718008 | 1 | \$251.72 | \$251.72 |
| Total of Items Quoted | | | | \$53,048.52 |
| Dealer Assembly Charges | | | | \$37.50 |
| Trade-in 2009 Bobcat S130 | | | | (\$3,000.00) |
| Quote Total - US dollars | | | | \$50,086.02 |

Notes:

ORDER ACCEPTED BY:

SIGNATURE

DATED

PRINT NAME AND TITLE

PURCHASE ORDER #

SHIP TO ADDRESS: _____

BILL TO ADDRESS (if different than Ship To): _____

****Prices per the Iowa State Contract #MA 005 – 17312D***

****Terms Net 30 Days. Credit cards accepted.***

****FOB Destination within the 48 Contiguous States.***

****Delivery: 60 to 90 days from ARO.***

****Please include a Tax Exempt Certificate with order placed.***

****TID# 38-0425350***

****Orders Must be Placed With: Clark Equipment dba Bobcat Company, Govt Sales, 250 E Beaton Drive, PO Box 6000, West Fargo, ND 58078.***

Prices & Specifications are subject to change. Please call before placing an order. Applies to factory ordered units only.





Product Quotation

Quotation Number: HMM-25338

Date: 2021-02-16 11:26:54

| | | |
|---|--|---|
| Customer Name/Address: | Bobcat Delivering Dealer | ORDER TO BE PLACED WITH: Contract Holder/Manufacturer |
| CITY OF OELWEIN 270057 20 2nd Ave Oelwein, IA 50662 | Bryan Heavy Equipment Inc., Oelwein, IA 101 COUNTY LINE RD OELWEIN IA 50662 Phone: 319-283-2345 Fax: 319-283-4567 | Clark Equipment Co dba Bobcat Company 250 E Beaton Dr, PO Box 6000 West Fargo, ND 58078 Phone: 701-241-8719 Fax: 701-280-7860 Contact: Heather Messmer Heather.Messmer@doosan.com |

| Description | Part No | Qty | Price Ea. | Total |
|--|---------|-----|------------|------------|
| HB1180 Hydraulic Breaker with Nail Point | 7115923 | 1 | \$8,091.72 | \$8,091.72 |
| --- X-Change Mounting Cap - HB1180/HB1380/NB170 | 7117325 | 1 | \$433.96 | \$433.96 |
| --- Hose Kit - Breakers - Ldr | 7114764 | 1 | \$160.36 | \$160.36 |
| --- Loader Mounting Frame, HB1180/HB2380 | 7115937 | 1 | \$598.88 | \$598.88 |
| 82" Root Grapple | 7168338 | 1 | \$3,046.84 | \$3,046.84 |
| 86" Snow Blade - Heavy Duty | 7207861 | 1 | \$2,981.48 | \$2,981.48 |

| | |
|---------------------------------|--------------------|
| Total of Items Quoted | \$15,313.24 |
| Dealer Assembly Charges | \$0.00 |
| Quote Total - US dollars | \$15,313.24 |

Notes:

**Prices per the Iowa State Contract #MA 005 – 17312D*
**Terms Net 30 Days. Credit cards accepted.*
**FOB Destination within the 48 Contiguous States.*
**Delivery: 60 to 90 days from ARO.*
**Please include a Tax Exempt Certificate with order placed.*
**TID# 38-0425350*
**Orders Must be Placed With: Clark Equipment dba Bobcat Company, Govt Sales, 250 E Beaton Drive, PO Box 6000, West Fargo, ND 58078.*

Prices & Specifications are subject to change. Please call before placing an order. Applies to factory ordered units only.

ORDER ACCEPTED BY:

SIGNATURE

DATED

PRINT NAME AND TITLE

PURCHASE ORDER #

SHIP TO ADDRESS: _____

BILL TO ADDRESS (if different than Ship To): _____

Quote Summary

Prepared For:
 OELWEIN CITY OF
 20 2ND AVE SW
 OELWEIN, IA 50662
 jletzring@cityofoelwein.org

Prepared By:
 Bryan Rau
 Bodensteiner Implement Co.
 1900 S Frederick Avenue
 Oelwein, IA 50662
 Phone: 319-283-4371
 Mobile: 563-920-0111
 raub@bodimp.com

Price includes delivery to Oelwein shop.

Quote Id: 23688342
Created On: 17 February 2021
Last Modified On: 18 February 2021
Expiration Date: 26 March 2021

| Equipment Summary | Selling Price | Qty | Extended |
|----------------------------|----------------|-----|--------------|
| JOHN DEERE 332G SKID STEER | \$ 56,000.00 X | 1 = | \$ 56,000.00 |

Equipment Total **\$ 56,000.00**

| Trade In Summary | Qty | Each | Extended |
|-----------------------|-----|--------------|--------------|
| 2007 BOBCAT S130 | 1 | \$ 13,500.00 | \$ 13,500.00 |
| PayOff | | | \$ 0.00 |
| Total Trade Allowance | | | \$ 13,500.00 |

Trade In Total **\$ 13,500.00**

Quote Summary

| | |
|----------------------------|---------------------|
| Equipment Total | \$ 56,000.00 |
| Trade In | \$ (13,500.00) |
| Document Fees | \$ 0.00 |
| Registration Fees DNR | \$ 0.00 |
| SubTotal | \$ 42,500.00 |
| Est. Service Agreement Tax | \$ 0.00 |
| Total | \$ 42,500.00 |
| Down Payment | (0.00) |
| Rental Applied | (0.00) |
| Balance Due | \$ 42,500.00 |



Selling Equipment

Quote Id: 23688342

Customer: OELWEIN CITY OF

JOHN DEERE 332G SKID STEER

Hours:

Stock Number:

| Code | Description | Qty |
|-------|-----------------|-----|
| 0BD2T | 332G SKID STEER | 1 |

Standard Options - Per Unit

| | | |
|------|--|---|
| 0770 | Cab/Heat/AC, Power QT, Hi Flow, SL & RC, 2Spd, LED Lights, Rev Fan, Chrome, Heat Seat, Radio | 1 |
| 0953 | ISO-H Switchable Controls and EH Joystick Performance Package | 1 |
| 1501 | English Operator's Manual and Decals | 1 |
| 1741 | Less JDLink | 1 |
| 2320 | 14x17.5 14 PR Titan HD2000-II | 1 |
| 4001 | 2-Inch Seat Belt with Shoulder Harness | 1 |
| 6006 | Air Suspension Seat (Cloth with Heat) | 1 |
| 8042 | Rear View Camera | 1 |
| 8050 | Cold Start Package | 1 |
| 8060 | Engine Air Precleaner | 1 |
| 8380 | Footrest with Floormat | 1 |
| 9062 | 84 in. HD Construction Bucket (21.0 cu. ft.) with Edge | 1 |

Other Charges

| | |
|---------|---|
| Freight | 1 |
| Setup | 1 |



Trade In

Quote Id: 23688342

Customer: OELWEIN CITY OF

2007 BOBCAT S130

Machine Details

| Description | Net Trade Value |
|------------------|-----------------|
| 2007 BOBCAT S130 | \$ 13,500.00 |

Your Trade In Description

Additional Options

| | |
|--------------------|------|
| Hour Meter Reading | 2500 |
|--------------------|------|

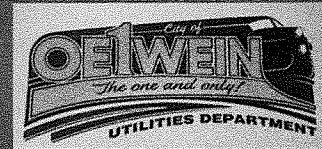

Memo

To: Honorable Mayor & City Council,

From: Utility Superintendent Victor Kane

CC: City Administrator Dylan Mulfinger

Reference: New Dump Truck & Snow Plow Equipment

Date: 03/18/21

Greetings,

We have received quotes on a 2022 dump truck from Dons Trucks and Thompson Truck & Trailer.

Thompson quoted an International with Henderson accessories. Base bid of \$117,250.00. We recommend adding Option 1, 2 & 3, on the Henderson package, for an additional \$10,875.00. Bringing the total quote to \$136,715.00. The estimated delivery is November 2021.

Dons Truck Sales quoted a Freightliner with Henderson accessories. Base Bid of \$128,485.00. We recommend adding the 201 Stainless Steel option for an additional \$2,850.00. After receiving the quote, we were informed to add \$2,500 due to a delivery issue I will explain later. Bringing the total quote to \$133,835.00. The estimated delivery sometime in 2023.

Currently Dons is unable to place orders for a Freightliner. They were informed on 3/16/2021 that all Freightliner 108SD trucks are on hold until further notice. That at such time as they are released to be ordered, a new concession will have to be applied for and the truck will be repriced as a 2023 model. It is the dealerships best estimate that the \$2,500.00 will cover the price increase once they can order it.

The difference between quotes is \$2,880.00 using the "estimated" increase. Dons Truck is now quoting a 2023 for less than Thompsons 2022. However, they are uncertain of delivery date (some time in 2022) and what the associated cost will actually be. I would recommend to purchase from Thompson Truck for \$136,715.00.

Thank you for your time.
Victor Kane

From the Desk of
Oelwein Utility Superintendent Victor Kane



Don's Truck Sales



Tel: 319.635.2751
Fax: 319.635.2231

102 1st Street South
Fairbank, IA 50629

www.donstrucksales.com
trucks@donstrucksales.com

www.customclassictrailer.com
trailers@customclassictrailer.com

March 3, 2021

City of Oelwein
20 Second Ave. SW
Oelwein, IA 50662

Mayor and City Council:

Below is the bid price on a new snow plow truck and equipment. Please let me know if you have any questions.

Sincerely,

Gene Carpenter

| | |
|-------------------------------|---------------|
| 2022 Freightliner 108SD with | \$ 128,485.00 |
| 11' Dump Body | |
| Load Sensing Hydraulic System | |
| 11' Reversible Snow Plow | |
| 8' Wing Plow | |
| Tailgate Sander | |

| | |
|--|-----------------|
| Option: | |
| 11' Dump Body – 201 Stainless Steel ILO Mild Steel | Add \$ 2,850.00 |

From: Gene Carpenter <Gene.C@donstrucksales.com>

Sent: Wednesday, March 17, 2021 4:44 PM

To: Herb Doudney <HDoudney@cityoffoelwein.org>

Subject: New Truck Quote

Herb:

We were informed today that all Freightliner 108SD trucks like the one we have bid you are on hold until further notice. At such time as they are released to be ordered, a new concession will have to be applied for and the truck will be repriced as a 2023 model. At that time, we will have to revise our quote to you with new pricing. Historically a model year increase is around \$1200 so if the government concession remains the same with an expected equipment price increase, I am hoping to keep the price increase for your unit under \$2500.

I am very sorry to have to give you this news but I wanted to inform you ASAP. Feel free to give me a call with any questions.

Sincerely

Gene Carpenter



Don's Truck Sales

Tel: 319.635.2751
Fax: 319.635.2231

102 1st Street South
Fairbank, IA 50629



Item 15.

www.donstrucksales.com
trucks@donstrucksales.com

www.customclassictrailer.com
trailers@customclassictrailer.com

March 3, 2021

City of Oelwein
20 Second Ave. SW
Oelwein, IA 50662

Truck Equipment Bid:

Dump Body:

11' Henderson Mark E-SA Dump Body
Mild Steel
UB-8-21 DA Hoist
3/16" AR-400 Floor
24" Sides, 32" Tailgate
10" I-Beam Long Sills
10 ga. Sides and Head
Single Weld-on Side Brace

Option: 201 Stainless Steel Body

7 ga Tailgate
Two Horizontal Tailgate Braces
Air Tailgate Release – Air Brake Chamber Type
16" x 78" Cab Shield – Mild Steel
LED Light Kit – Stop/Turn/Tail Lights
Rear LED Strobe Lights
Front Whelen L31 Strobe Light
Poly Quarter Fenders ahead of Rear Tires
Mud Flaps behind Rear Tires
Back-up Alarm
Painted Woodlawn Green

Option: 201 SS

Option: No Paint

Hydraulics

Force America FASD45 Load Sensing Pump
Constant Mesh PTO w/ Pressure Lube Hose
Spicer Driveline
V20LS-4-K4-4-4-4-NR Hydraulic Valve
Morse Cable Controls w/ Joy Stick on Plow Lift and Angle
30 Gallon Reservoir w/ 10 Micron Filter
2" Brass Ball Shut Off Valve
Sander Valve W/ On-Off Handle
Wing Lock
High Pressure Hoses, Fittings, Quick Couplers

Snow Plow:

Henderson RSP-11-36 Snow Plow
Integral Shield w/ 12" Rubber Deflector
Level Lift Design
Two External Compressor Trip Springs
Five Position Adjustable Spring Tension
Side Markers
UQH – 30.5" LoPro Truck Hitch
3"x10" DA Lift Cylinder
UQH – 30.5" Plow Portion Hitch
Frame to Hitch Mounting Kit
Plow Lights
Stainless Steel Hood Mounted Light Brackets

Wing:

Henderson Mid Mount Wing
8' Cutting Edge
27" Moldboard Height
8" Front Mast Lift
Front Cross Tubes and Cheek Plates
Single Push Arm

Tailgate Sander:

Henderson TGS-II Sander - 201SS
6" Auger – Direct Drive
Poly Spinner
Hoses, Fittings, Quick Couplers
Sander Light

Truck Minimum Specifications

| | Deviation |
|--|----------------|
| 2022 Model Year | _____ |
| Models Acceptable – Freightliner 108SD, or Equivalent | _____ |
| Wheelbase – 162" | _____ |
| Cab-to-Axle – 96" | _____ |
| Must be compliant with body manufacturer requirements. | _____ |
| Engine – In Line 6 Cylinder Diesel, Minimum of 300 HP And 860 ft/lb of Torque, Sleeved Motor | _____ |
| Batteries – Two Group 31, 12 Volt, 2000 CCA Battery Box mounted behind Cab on Driver's side | _____ |
| Extended Life Coolant | _____ |
| Fuel /Water Separator with Hand Primer & Heater | _____ |
| RH Outboard Under Step Horizontal ATD with Cab Mounted Vertical Pipe, Turn out on Exhaust Pipe 6 Gallon DEF Tank, LH Back of Cab | _____ _____ |
| Maximum Height 9'8" | _____ |
| Coolant Filter | _____ |
| Engine Block Heater – 1000 Watt | _____ |
| Allison 3500 RDS Automatic Transmission – 6 speed Push Button Controls, Synthetic Fluid | _____ |
| Front Axle – 16,000# | _____ |
| Rear Axle – 23,000# Single Speed | _____ |
| Front Springs – 16,000# Flat Leaf, No Taper Leaf Allowed | _____ |
| Rear Springs – 23,000# Multi-Leaf with Aux. Leaf Spring Helper | _____ |
| Brakes – Air w/18.0 CFM Air Compressor | _____ |
| Front – 16.5" x 6" Cam | _____ |
| Rear – 16.5" x 7" Cam | _____ |
| Front and Rear Brake Dust Shields | _____ |
| Automatic Slack Adjusters | _____ |
| Air Brake Dryer w/spin-on Cartridge | _____ |

- Petcock Drain Valves on All Air Tanks _____
- Power Steering – TAS-85 Gear Type _____
- Driver Controlled Differential Lock _____
- Frame – Single Channel _____
Minimum of 16.9 SM, 120,000 PSI, 2,028,000 RBM
- 24" Integral Front Frame Extension _____
No Add-on Extensions Allowed
- LH 60 Gallon Aluminum Fuel Tank – Under Cab _____
- Front Tires – 315/80/22.5-20 ply _____
- Rear Tires – 11R x 22.5 14 Ply Mud and Snow _____
- Front and Rear Wheels – 22.5 x 9.00 ISO Steel Disc Rear Wheels - 8.25"
- Fiberglas Tilting Hood _____
- Radiator Mounted Grille – Bright Finish _____
Wide enough to tip over Snow Plow Frame
- West Coast Bright Finish Heated Mirrors/8" Convex Mirrors _____102"
Wide Mirror Brackets
- Heater/Defroster w/Plumbing Shut-off _____
- Hi-Back Air Ride Driver's Seat, Air Lumbar w/vinyl covering _____
- Non-Suspension Passenger Seat w/vinyl covering _____
- Dash Mounted Air Restriction Gauge _____
- AM/FM/WB Radio w/Cowl Mounted Antenna Blue Tooth capable _____
- Self Canceling Turn Signals _____
- Color – School Bus Yellow _____
- Factory Plow Light Harness and Cab Switch _____
- Front Mounted Plow Lights _____
- Vehicle Interface Wiring Connection at end of Frame _____
- Electric Windows _____
- Cruise Control _____

Equipment Specifications

Dump Body:

- 11' Henderson Mark E Crossmember less Dump Body
 - 8" I-Beam Long Sills
 - 4" Structural Channel Subframe
 - 10 Gauge Sides and Head sheet
 - 24" Sides w/Single Side Brace
 - 32" 7 gauge. Tailgate w/Two Tailgate Braces
 - 3/16" AR-400 Floor
 - 1.5" Stainless Steel Rear Hinge Pins
 - Greaseless Composite Bushing on Hinge Pins

10" I-Beam Long Sills

UB-7-17 Underbody Hoist
Double Acting Cylinder

16" x 78" Cab Shield

Cab Shield Maximum Height 9'8"

Air Tailgate Release – Brake Chamber Style

Rear Corner Post Stop/Turn/Tail Lights

Rear Corner Post LED Strobe Lights

Front LED Strobe Light

Poly Quarter Fenders ahead of Rear Tires

Mud Flaps behind Rear Tires

Painted Forest or Woodlawn Green

Back-up Alarm

Option: 2015S Dump Body with Above Spec's

Hydraulics:

4.6 CID Force America Load Sensing Pump

Constant Mesh PTO off of 3500 RDS Trans.

High Pressure Lube Hose for PTO

1310 Spicer Driveline from PTO to Pump

Gresen V20-4-K4-4-NR Valve Body
Double Acting Hoist Section
Double Acting with Float for Front Plow Lift
Double Acting Plow Angle

Morse Cable Controls – Stainless Steel Cables
Single Axis for Hoist
Joy Stick for Plow Lift and Angle

30 Gallon Reservoir w/Sight Gauge, Internal Baffle
In-Tank Filter – 10 Micron, Brass Ball Shut-off

Manual Dual Flow Control Valve in Cab For Tailgate Sander

All High-Pressure Hoses, Fittings, Quick Couplers for
Hoist, Front Plow, Tailgate Sander

Snow Plow:

Henderson RSP-11-36 Snow Plow
11' Moldboard – 36" High
Power Reversing Cylinders
Reversing Cylinders to set Above Circle Frame
Snow Plow Marker

Integral Shield with 12" Rubber Deflector

One Piece Rolled Moldboard w/Eight 1/2" x 3 1/2" Ribs

Level Lift Design with Plow in any Position

Two External Trip Springs
Three Position Adjustment on Moldboard

Five Position Adjustable Trip Spring Collars

Low Profile Truck Hitch – Hood of Truck must Tilt Over Plow Hitch

Universal Quick Hitch Style Hitch on Plow and Truck _____

3" x 10" DA Lift Cylinder _____

Lift Arm and Cylinder to fold Flat in Front when Not in Use _____

OPTIONAL

Tailgate Sander:

201 Stainless Steel Tailgate Sander _____

7 gauge 201SS Trough and Rear Panel _____

1/4" 201SS End Plates _____

Bottom Trough hinged for auger cleanout _____

201SS Trough Cover w/201SS Hinge Rod and Handle _____

6" Diameter Bi-Directional Auger with 3/8" Flighting _____

Auger supported by 1 1/4" diameter Shaft _____

304SS Anti-Flow Shield over Discharge Hole _____

Hydraulic Auger Motor to be High Torque, Low Speed
18.7 C.I.R. Char-lynn _____

18" Poly Spinner Disc _____

201SS Stationary Shield mounted in front of spinner to
Protect truck undercarriage _____

Spreader Mounting Brackets to have 201SS Pins removable
Without use of tools _____

Non-Stainless-Steel parts to be painted Aluminum _____

High Pressure Hoses, Fittings, Quick Couplers _____

Rear Sander Light with Cab Switch _____

Mid Mount Wing:

Moldboard 10-GA Grade 50

Cutting edge ½"x6"x8'

Length of moldboard 8'

Height of moldboard 27"

Single HD Push Arm with Spring Cushion & Shear Pin

7" Mechanical Float

Stored at an Angle against side of Body

Prepared for:
 Dylan Mulfinger
 City of Oelwein
 20 2ND AVE SW

 OELWEIN, IA 50662
 Phone: 319-283-1197

Prepared by:
 Gene Carpenter
 TRUCK CENTER COMPANIES
 101 PLAZA DRIVE
 ELK RUN HEIGHTS, IA 50707
 Phone:

S P E C I F I C A T I O N P R O P O S A L

| Data Code | Description | Weight Front | Weight Rear | Retail Price |
|------------------------------|---|-----------------|----------------|--------------|
| Price Level | | | | |
| PRL-24D | SD PRL-24D (EFF:01/19/21) | | | STD |
| Data Version | | | | |
| DRL-005 | SPECPRO21 DATA RELEASE VER 005 | | | N/C |
| Vehicle Configuration | | | | |
| 001-176 | 108SD CONVENTIONAL CHASSIS | 6,829 | 3,748 | \$123,710.00 |
| 004-222 | 2022 MODEL YEAR SPECIFIED | | | N/C |
| 002-004 | SET BACK AXLE - TRUCK | | | STD |
| 019-002 | STRAIGHT TRUCK PROVISION | | | STD |
| 003-001 | LH PRIMARY STEERING LOCATION | | | STD |
| General Service | | | | |
| AA1-002 | TRUCK CONFIGURATION | | | STD |
| AA6-002 | DOMICILED, USA (EXCLUDING CALIFORNIA AND CARB OPT-IN STATES) | | | STD |
| A85-010 | UTILITY/REPAIR/MAINTENANCE SERVICE | | | N/C |
| A84-1GM | GOVERNMENT BUSINESS SEGMENT | | | N/C |
| AA4-010 | DIRT/SAND/ROCK COMMODITY | | | N/C |
| AA5-002 | TERRAIN/DUTY: 100% (ALL) OF THE TIME, IN TRANSIT, IS SPENT ON PAVED ROADS | | | STD |
| AB1-008 | MAXIMUM 8% EXPECTED GRADE | | | STD |
| AB5-001 | SMOOTH CONCRETE OR ASPHALT PAVEMENT - MOST SEVERE IN-TRANSIT (BETWEEN SITES) ROAD SURFACE | | | STD |
| 995-1A0 | FREIGHTLINER SD VOCATIONAL WARRANTY | | | STD |
| A66-99D | EXPECTED FRONT AXLE(S) LOAD : 16000.0 lbs | | | |
| A68-99D | EXPECTED REAR DRIVE AXLE(S) LOAD : 23000.0 lbs | | | |
| A63-99D | EXPECTED GROSS VEHICLE WEIGHT CAPACITY : 39000.0 lbs | | | |



Prepared for:
 Dylan Mulfinger
 City of Oelwein
 20 2ND AVE SW

 OELWEIN, IA 50662
 Phone: 319-283-1197

Prepared by:
 Gene Carpenter
 TRUCK CENTER COMPANIES
 101 PLAZA DRIVE
 ELK RUN HEIGHTS, IA 50707
 Phone:

| Data Code | Description | Weight Front | Weight Rear | Retail Price |
|------------------------------|---|--------------|-------------|--------------|
| Truck Service | | | | |
| AA3-018 | FRONT PLOW/END DUMP BODY | | | N/C |
| AF3-1W0 | HENDERSON | | | N/C |
| Engine | | | | |
| 101-3BN | CUM L9 300 HP @ 2200 RPM; 2200 GOV RPM, 860 LB-FT @ 1200 RPM | | | \$1,517.00 |
| Electronic Parameters | | | | |
| 79A-075 | 75 MPH ROAD SPEED LIMIT | | | N/C |
| 79B-000 | CRUISE CONTROL SPEED LIMIT SAME AS ROAD SPEED LIMIT | | | N/C |
| 79M-001 | PTO MODE BRAKE OVERRIDE - SERVICE BRAKE APPLIED | | | N/C |
| 79S-001 | PTO MODE CANCEL VEHICLE SPEED - 5 MPH | | | N/C |
| 79U-007 | PTO GOVERNOR RAMP RATE - 250 RPM PER SECOND | | | N/C |
| 80G-002 | PTO MINIMUM RPM - 700 | | | N/C |
| 80J-002 | REGEN INHIBIT SPEED THRESHOLD - 5 MPH | | | N/C |
| Engine Equipment | | | | |
| 99C-021 | 2016 ONBOARD DIAGNOSTICS/2010 EPA/CARB/GHG21 CONFIGURATION | | | STD |
| 99D-010 | NO 2008 CARB EMISSION CERTIFICATION | | | N/C |
| 13E-001 | STANDARD OIL PAN | | | STD |
| 105-001 | ENGINE MOUNTED OIL CHECK AND FILL | | | STD |
| 014-099 | SIDE OF HOOD AIR INTAKE WITH FIREWALL MOUNTED DONALDSON AIR CLEANER | | | STD |
| 124-1D7 | DR 12V 160 AMP 28-SI QUADRAMOUNT PAD ALTERNATOR WITH REMOTE BATTERY VOLT SENSE | | | STD |
| 292-235 | (2) DTNA GENUINE, FLOODED STARTING, MIN 2000CCA, 370RC, THREADED STUD BATTERIES | | | STD |
| 290-017 | BATTERY BOX FRAME MOUNTED | | | STD |
| 281-001 | STANDARD BATTERY JUMPERS | | | STD |
| 282-003 | SINGLE BATTERY BOX FRAME MOUNTED LH SIDE BACK OF CAB | | | STD |
| 291-017 | WIRE GROUND RETURN FOR BATTERY CABLES WITH ADDITIONAL FRAME GROUND RETURN | | | STD |
| 289-001 | NON-POLISHED BATTERY BOX COVER | | | STD |
| 107-032 | CUMMINS TURBOCHARGED 18.7 CFM AIR COMPRESSOR WITH INTERNAL SAFETY VALVE | | | STD |
| 152-041 | ELECTRONIC ENGINE INTEGRAL SHUTDOWN PROTECTION SYSTEM | | | STD |



Prepared for:
Dylan Mulfinger
City of Oelwein
20 2ND AVE SW

OELWEIN, IA 50662
Phone: 319-283-1197

Prepared by:
Gene Carpenter
TRUCK CENTER COMPANIES
101 PLAZA DRIVE
ELK RUN HEIGHTS, IA 50707
Phone:

| Data Code | Description | Weight Front | Weight Rear | Retail Price |
|-----------|--|-----------------|----------------|--------------|
| 128-076 | CUMMINS ENGINE INTEGRAL BRAKE WITH VARIABLE GEOMETRY TURBO ON/OFF | 20 | | STD |
| 016-1C2 | RH OUTBOARD UNDER STEP MOUNTED HORIZONTAL AFTERTREATMENT SYSTEM ASSEMBLY WITH RH B-PILLAR MOUNTED VERTICAL TAILPIPE | 30 | 25 | \$816.00 |
| 28F-002 | ENGINE AFTERTREATMENT DEVICE, AUTOMATIC OVER THE ROAD REGENERATION AND DASH MOUNTED REGENERATION REQUEST SWITCH | | | STD |
| 239-026 | 10 FOOT 06 INCH (126 INCH+0/-5.9 INCH) EXHAUST SYSTEM HEIGHT | | | (\$3.00) |
| 237-1CR | RH CURVED VERTICAL TAILPIPE B-PILLAR MOUNTED ROUTED FROM STEP | | | N/C |
| 23U-001 | 6 GALLON DIESEL EXHAUST FLUID TANK | -35 | -10 | N/C |
| 30N-003 | 100 PERCENT DIESEL EXHAUST FLUID FILL | | | (\$17.00) |
| 23Y-001 | STANDARD DIESEL EXHAUST FLUID PUMP MOUNTING | | | STD |
| 43X-002 | LH MEDIUM DUTY STANDARD DIESEL EXHAUST FLUID TANK LOCATION | | | STD |
| 43Y-001 | STANDARD DIESEL EXHAUST FLUID TANK CAP | | | STD |
| 242-011 | ALUMINUM AFTERTREATMENT DEVICE/MUFFLER/TAILOPIPE SHIELD(S) | | | N/C |
| 273-018 | HORTON DRIVEMASTER ADVANTAGE ON/OFF FAN DRIVE | | | STD |
| 276-001 | AUTOMATIC FAN CONTROL WITHOUT DASH SWITCH, NON ENGINE MOUNTED | | | STD |
| 110-003 | CUMMINS SPIN ON FUEL FILTER | | | STD |
| 118-008 | COMBINATION FULL FLOW/BYPASS OIL FILTER | | | STD |
| 120-009 | FLEETGUARD PLAIN COOLANT FILTER | | | \$122.00 |
| 266-104 | 1115 SQUARE INCH ALUMINUM RADIATOR | | | STD |
| 103-039 | ANTIFREEZE TO -34F, OAT (NITRITE AND SILICATE FREE) EXTENDED LIFE COOLANT | | | STD |
| 171-007 | GATES BLUE STRIPE COOLANT HOSES OR EQUIVALENT | | | STD |
| 172-001 | CONSTANT TENSION HOSE CLAMPS FOR COOLANT HOSES | | | STD |
| 270-016 | RADIATOR DRAIN VALVE | | | STD |
| 138-011 | PHILLIPS-TEMRO 1000 WATT/115 VOLT BLOCK HEATER | 4 | | \$92.00 |
| 140-053 | BLACK PLASTIC ENGINE HEATER RECEPTACLE MOUNTED UNDER LH DOOR | | | N/C |
| 132-004 | ELECTRIC GRID AIR INTAKE WARMER | | | STD |
| 155-058 | DELCO 12V 38MT HD STARTER WITH INTEGRATED MAGNETIC SWITCH | | | STD |

Prepared for:
 Dylan Mulfinger
 City of Oelwein
 20 2ND AVE SW

OELWEIN, IA 50662
 Phone: 319-283-1197

Prepared by:
 Gene Carpenter
 TRUCK CENTER COMPANIES
 101 PLAZA DRIVE
 ELK RUN HEIGHTS, IA 50707
 Phone:

| Data Code | Description | Weight Front | Weight Rear | Retail Price |
|-------------------------------|---|--------------|-------------|--------------|
| Transmission | | | | |
| 342-584 | ALLISON 3500 RDS AUTOMATIC TRANSMISSION WITH PTO PROVISION | | | (\$75.00) |
| Transmission Equipment | | | | |
| 343-339 | ALLISON VOCATIONAL PACKAGE 223 - AVAILABLE ON 3000/4000 PRODUCT FAMILIES WITH VOCATIONAL MODELS RDS, HS, MH AND TRV | | | STD |
| 84B-012 | ALLISON VOCATIONAL RATING FOR ON/OFF HIGHWAY APPLICATIONS AVAILABLE WITH ALL PRODUCT FAMILIES | | | N/C |
| 84C-023 | PRIMARY MODE GEARS, LOWEST GEAR 1, START GEAR 1, HIGHEST GEAR 6, AVAILABLE FOR 3000/4000 PRODUCT FAMILIES ONLY | | | STD |
| 84D-023 | SECONDARY MODE GEARS, LOWEST GEAR 1, START GEAR 1, HIGHEST GEAR 6, AVAILABLE FOR 3000/4000 PRODUCT FAMILIES ONLY | | | STD |
| 84E-017 | S5 PERFORMANCE LIMITING PRIMARY SHIFT SCHEDULE, AVAILABLE FOR 3000/4000 PRODUCT FAMILIES ONLY | | | N/C |
| 84F-016 | S5 PERFORMANCE LIMITING SECONDARY SHIFT SCHEDULE, AVAILABLE FOR 3000/4000 PRODUCT FAMILIES ONLY | | | N/C |
| 84G-005 | 1500 RPM PRIMARY MODE SHIFT SPEED | | | N/C |
| 84H-005 | 1500 RPM SECONDARY MODE SHIFT SPEED | | | N/C |
| 84N-200 | FUEL SENSE 2.0 DISABLED - PERFORMANCE - TABLE BASED | | | STD |
| 84U-000 | DRIVER SWITCH INPUT - DEFAULT - NO SWITCHES | | | STD |
| 84V-001 | DIRECTION CHANGE ENABLED WITH MULTIPLEXED SERVICE BRAKES - ALLISON 5TH GEN TRANSMISSIONS | | | STD |
| 353-066 | VEHICLE INTERFACE WIRING CONNECTOR WITH BLUNT CUTS, AT END OF FRAME | | | \$62.00 |
| 362-823 | CUSTOMER INSTALLED CHELSEA 280 SERIES PTO | | | N/C |
| 363-001 | PTO MOUNTING, LH SIDE OF MAIN TRANSMISSION | | | N/C |
| 341-018 | MAGNETIC PLUGS, ENGINE DRAIN, TRANSMISSION DRAIN, AXLE(S) FILL AND DRAIN | | | STD |
| 345-003 | PUSH BUTTON ELECTRONIC SHIFT CONTROL, DASH MOUNTED | | | STD |
| 97G-004 | TRANSMISSION PROGNOSTICS - ENABLED 2013 | | | STD |
| 370-015 | WATER TO OIL TRANSMISSION COOLER, IN RADIATOR END TANK | | | STD |



Prepared for:
 Dylan Mulfinger
 City of Oelwein
 20 2ND AVE SW

 OELWEIN, IA 50662
 Phone: 319-283-1197

Prepared by:
 Gene Carpenter
 TRUCK CENTER COMPANIES
 101 PLAZA DRIVE
 ELK RUN HEIGHTS, IA 50707
 Phone:

| Data Code | Description | Weight Front | Weight Rear | Retail Price |
|---------------------------------|---|--------------|-------------|--------------|
| 346-003 | TRANSMISSION OIL CHECK AND FILL WITH ELECTRONIC OIL LEVEL CHECK | | | STD |
| 35T-001 | SYNTHETIC TRANSMISSION FLUID (TES-295 COMPLIANT) | | | STD |
| Front Axle and Equipment | | | | |
| 400-1A9 | DETROIT DA-F-16.0-5 16,000# FL1 71.0 KPI/3.74 DROP SINGLE FRONT AXLE | 190 | | \$1,865.00 |
| 402-030 | MERITOR 16.5X6 Q+ CAST SPIDER CAM FRONT BRAKES, DOUBLE ANCHOR, FABRICATED SHOES | 10 | | N/C |
| 403-002 | NON-ASBESTOS FRONT BRAKE LINING | | | STD |
| 419-001 | CAST IRON OUTBOARD FRONT BRAKE DRUMS | | | STD |
| 427-001 | FRONT BRAKE DUST SHIELDS | 5 | | \$102.00 |
| 409-006 | FRONT OIL SEALS | | | STD |
| 408-001 | VENTED FRONT HUB CAPS WITH WINDOW, CENTER AND SIDE PLUGS - OIL | | | STD |
| 416-022 | STANDARD SPINDLE NUTS FOR ALL AXLES | | | STD |
| 405-002 | MERITOR AUTOMATIC FRONT SLACK ADJUSTERS | | | STD |
| 406-001 | STANDARD KING PIN BUSHINGS | | | STD |
| 536-012 | TRW TAS-85 POWER STEERING | 40 | | N/C |
| 539-003 | POWER STEERING PUMP | | | STD |
| 534-015 | 2 QUART SEE THROUGH POWER STEERING RESERVOIR | | | STD |
| 40T-001 | MINERAL SAE 80/90 FRONT AXLE LUBE | | | STD |
| Front Suspension | | | | |
| 620-004 | 16,000# FLAT LEAF FRONT SUSPENSION | 260 | | \$689.00 |
| 619-004 | GRAPHITE BRONZE BUSHINGS WITH SEALS - FRONT SUSPENSION | | | N/C |
| 62G-998 | NO FRONT SUSPENSION OPTIONS | | | STD |
| 410-998 | NO FRONT SHOCK ABSORBERS | -30 | | N/C |
| Rear Axle and Equipment | | | | |
| 420-037 | RS-23-161 23,000# R-SERIES SINGLE REAR AXLE | | 174 | \$807.00 |
| 421-614 | 6.14 REAR AXLE RATIO | | | N/C |
| 424-001 | IRON REAR AXLE CARRIER WITH STANDARD AXLE HOUSING | | | STD |
| 386-073 | MXL 17T MERITOR EXTENDED LUBE MAIN DRIVELINE WITH HALF ROUND YOKES | 20 | 20 | STD |
| 452-001 | DRIVER CONTROLLED TRACTION DIFFERENTIAL - SINGLE REAR AXLE | | 20 | \$734.00 |



Prepared for:
 Dylan Mulfinger
 City of Oelwein
 20 2ND AVE SW

OELWEIN, IA 50662
 Phone: 319-283-1197

Prepared by:
 Gene Carpenter
 TRUCK CENTER COMPANIES
 101 PLAZA DRIVE
 ELK RUN HEIGHTS, IA 50707
 Phone:

| Data Code | Description | Weight Front | Weight Rear | Retail Price |
|------------------------|---|--------------|-------------|--------------|
| 878-018 | (1) DRIVER CONTROLLED DIFFERENTIAL LOCK REAR VALVE FOR SINGLE DRIVE AXLE | | | N/C |
| 87B-004 | BLINKING LAMP WITH EACH MODE SWITCH, DIFFERENTIAL UNLOCK WITH IGNITION OFF, ACTIVE <5 MPH | | | N/C |
| 423-020 | MERITOR 16.5X7 Q+ CAST SPIDER CAM REAR BRAKES, DOUBLE ANCHOR, FABRICATED SHOES | | | STD |
| 433-002 | NON-ASBESTOS REAR BRAKE LINING | | | STD |
| 434-011 | BRAKE CAMS AND CHAMBERS ON FORWARD SIDE OF DRIVE AXLE(S) | | | N/C |
| 451-001 | CAST IRON OUTBOARD REAR BRAKE DRUMS | | | STD |
| 425-002 | REAR BRAKE DUST SHIELDS | | 5 | \$65.00 |
| 440-006 | REAR OIL SEALS | | | STD |
| 426-100 | WABCO TRISTOP D LONGSTROKE 1-DRIVE AXLE SPRING PARKING CHAMBERS | | | STD |
| 428-002 | MERITOR AUTOMATIC REAR SLACK ADJUSTERS | | | STD |
| 41T-002 | CURRENT AVAILABLE SYNTHETIC 75W-90 REAR AXLE LUBE | | | STD |
| 42T-001 | STANDARD REAR AXLE BREATHER(S) | | | STD |
| Rear Suspension | | | | |
| 622-1MJ | 23,000# 52 INCH VARIABLE RATE MULTI-LEAF SPRING REAR SUSPENSION WITH LEAF SPRING HELPER | | 30 | (\$6.00) |
| 621-001 | SPRING SUSPENSION - NO AXLE SPACERS | | | N/C |
| 431-001 | STANDARD AXLE SEATS IN AXLE CLAMP GROUP | | | STD |
| Brake System | | | | |
| 490-100 | WABCO 4S/4M ABS | | | STD |
| 871-001 | REINFORCED NYLON, FABRIC BRAID AND WIRE BRAID CHASSIS AIR LINES | | | STD |
| 904-001 | FIBER BRAID PARKING BRAKE HOSE | | | STD |
| 412-001 | STANDARD BRAKE SYSTEM VALVES | | | STD |
| 46D-002 | STANDARD AIR SYSTEM PRESSURE PROTECTION SYSTEM | | | STD |
| 413-002 | STD U.S. FRONT BRAKE VALVE | | | STD |
| 432-003 | RELAY VALVE WITH 5-8 PSI CRACK PRESSURE, NO REAR PROPORTIONING VALVE | | | STD |
| 480-088 | WABCO SYSTEM SAVER HP WITH INTEGRAL AIR GOVERNOR AND HEATER | | | STD |
| 479-015 | AIR DRYER FRAME MOUNTED | | | STD |



Prepared for:
 Dylan Mulfinger
 City of Oelwein
 20 2ND AVE SW

 OELWEIN, IA 50662
 Phone: 319-283-1197

Prepared by:
 Gene Carpenter
 TRUCK CENTER COMPANIES
 101 PLAZA DRIVE
 ELK RUN HEIGHTS, IA 50707
 Phone:

| Data Code | Description | Weight Front | Weight Rear | Retail Price |
|------------------------------|--|--------------|-------------|--------------|
| 460-090 | STEEL AIR BRAKE RESERVOIRS, NO TRIPLE OR TORPEDO TANKS | | | N/C |
| 477-011 | PETCOCK DRAIN VALVES ON ALL AIR TANK(S) | | | (\$3.00) |
| Trailer Connections | | | | |
| 335-004 | UPGRADED CHASSIS MULTIPLEXING UNIT | | | STD |
| Wheelbase & Frame | | | | |
| 545-412 | 4125MM (162 INCH) WHEELBASE | | | N/C |
| 546-101 | 11/32X3-1/2X10-15/16 INCH STEEL FRAME (8.73MMX277.8MM/0.344X10.94 INCH) 120KSI | 90 | | \$314.00 |
| 548-803 | BODY COMPANY INSTALLED ADDITIONAL FRONT FRAME REINFORCEMENT FOR SNOW PLOW | | | N/C |
| 552-030 | 1600MM (63 INCH) REAR FRAME OVERHANG | | | STD |
| 55W-006 | FRAME OVERHANG RANGE: 61 INCH TO 70 INCH | | | N/C |
| 549-002 | 24 INCH INTEGRAL FRONT FRAME EXTENSION | 115 | -20 | \$4.00 |
| AC8-99D | CALC'D BACK OF CAB TO REAR SUSP C/L (CA) : 96.85 in | | | |
| AE8-99D | CALCULATED EFFECTIVE BACK OF CAB TO REAR SUSPENSION C/L (CA) : 93.85 in | | | |
| AE4-99D | CALC'D FRAME LENGTH - OVERALL : 290.55 | | | |
| FSS-0LH | CALCULATED FRAME SPACE LH SIDE : 39.96 in | | | N/C |
| FSS-0RH | CALCULATED FRAME SPACE RH SIDE : 124.8 in | | | N/C |
| AM6-99D | CALC'D SPACE AVAILABLE FOR DECKPLATE : 90.45 in | | | |
| 553-001 | SQUARE END OF FRAME | | | STD |
| 550-001 | FRONT CLOSING CROSSMEMBER | | | STD |
| 559-003 | LIGHTWEIGHT HEAVY DUTY ALUMINUM ENGINE CROSSMEMBER | -12 | | \$50.00 |
| 562-001 | STANDARD MIDSHIP #1 CROSSMEMBER(S) | | | STD |
| 572-001 | STANDARD REARMOST CROSSMEMBER | | | STD |
| 565-001 | STANDARD SUSPENSION CROSSMEMBER | | | STD |
| Chassis Equipment | | | | |
| 556-1E5 | 14 INCH PAINTED STEEL BUMPER | 20 | | STD |
| 574-001 | BUMPER MOUNTING FOR SINGLE LICENSE PLATE | | | STD |
| 551-007 | GRADE 8 THREADED HEX HEADED FRAME FASTENERS | | | STD |
| Fuel Tanks | | | | |
| 204-151 | 60 GALLON/227 LITER ALUMINUM FUEL TANK - LH | | | STD |



Prepared for:
 Dylan Mulfinger
 City of Oelwein
 20 2ND AVE SW

 OELWEIN, IA 50662
 Phone: 319-283-1197

Prepared by:
 Gene Carpenter
 TRUCK CENTER COMPANIES
 101 PLAZA DRIVE
 ELK RUN HEIGHTS, IA 50707
 Phone:

| Data Code | Description | Weight Front | Weight Rear | Retail Price |
|---------------------|--|--------------|-------------|--------------|
| 218-006 | 25 INCH DIAMETER FUEL TANK(S) | | | STD |
| 215-005 | PLAIN ALUMINUM/PAINTED STEEL FUEL/HYDRAULIC TANK(S) WITH PAINTED BANDS | | | STD |
| 212-007 | FUEL TANK(S) FORWARD | | | STD |
| 664-001 | PLAIN STEP FINISH | | | STD |
| 205-001 | FUEL TANK CAP(S) | | | STD |
| 122-1J1 | DETROIT FUEL/WATER SEPARATOR WITH WATER IN FUEL SENSOR, HAND PRIMER AND 12 VOLT PREHEATER" | -5 | | \$51.00 |
| 216-020 | EQUIFLO INBOARD FUEL SYSTEM | | | STD |
| 202-016 | HIGH TEMPERATURE REINFORCED NYLON FUEL LINE | | | STD |
| Tires | | | | |
| 093-1RJ | MICHELIN X WORKS Z 315/80R22.5 20 PLY RADIAL FRONT TIRES | 100 | | \$474.00 |
| 094-2EU | HANKOOK DH06 11R22.5 14 PLY RADIAL REAR TIRES | | 64 | (\$824.00) |
| Hubs | | | | |
| 418-060 | CONMET PRESET PLUS PREMIUM IRON FRONT HUBS | | | STD |
| 450-060 | CONMET PRESET PLUS PREMIUM IRON REAR HUBS | | | STD |
| Wheels | | | | |
| 502-433 | ACCURIDE 29039 22.5X9.00 10-HUB PILOT 5.25 INSET 5-HAND STEEL DISC FRONT WHEELS | 66 | | \$204.00 |
| 505-545 | MAXION WHEELS 90260 22.5X8.25 10-HUB PILOT 2-HAND HD STEEL DISC REAR WHEELS | | 80 | (\$32.00) |
| Cab Exterior | | | | |
| 829-1A5 | 108 INCH BBC FLAT ROOF ALUMINUM CONVENTIONAL CAB | | | STD |
| 650-008 | AIR CAB MOUNTING | | | STD |
| 648-002 | NONREMOVABLE BUGSCREEN MOUNTED BEHIND GRILLE | | | STD |
| 667-037 | SHORT FENDER WITH MUDFLAP | | | \$141.00 |
| 754-017 | BOLT-ON MOLDED FLEXIBLE FENDER EXTENSIONS | 10 | | \$115.00 |
| 678-001 | LH AND RH GRAB HANDLES | | | STD |
| 645-002 | BRIGHT FINISH RADIATOR SHELL/HOOD BEZEL | | | \$253.00 |
| 646-042 | STATIONARY BLACK GRILLE WITH BRIGHT ACCENTS | | | \$88.00 |
| 65X-003 | CHROME HOOD MOUNTED AIR INTAKE GRILLE | | | \$15.00 |



Prepared for:
 Dylan Mulfinger
 City of Oelwein
 20 2ND AVE SW

 OELWEIN, IA 50662
 Phone: 319-283-1197

Prepared by:
 Gene Carpenter
 TRUCK CENTER COMPANIES
 101 PLAZA DRIVE
 ELK RUN HEIGHTS, IA 50707
 Phone:

| Data Code | Description | Weight Front | Weight Rear | Retail Price |
|---------------------|---|--------------|-------------|--------------|
| 644-004 | FIBERGLASS HOOD | | | STD |
| 727-1AH | SINGLE 14 INCH ROUND POLISHED AIR HORN ROOF MOUNTED | | | STD |
| 726-001 | SINGLE ELECTRIC HORN | | | STD |
| 728-001 | SINGLE HORN SHIELD | | | STD |
| 657-001 | DOOR LOCKS AND IGNITION SWITCH KEYED THE SAME | | | STD |
| 78G-002 | KEY QUANTITY OF 2 | | | STD |
| 575-001 | REAR LICENSE PLATE MOUNT END OF FRAME | | | STD |
| 312-067 | HALOGEN COMPOSITE HEADLAMPS WITH BRIGHT BEZELS | | | N/C |
| 302-001 | (5) AMBER MARKER LIGHTS | | | STD |
| 294-001 | INTEGRAL STOP/TAIL/BACKUP LIGHTS | | | STD |
| 300-015 | STANDARD FRONT TURN SIGNAL LAMPS | | | STD |
| 744-1BM | DUAL WEST COAST BRIGHT FINISH HEATED MIRRORS | | | \$140.00 |
| 797-001 | DOOR MOUNTED MIRRORS | | | STD |
| 796-001 | 102 INCH EQUIPMENT WIDTH | | | STD |
| 743-204 | LH AND RH 8 INCH BRIGHT FINISH CONVEX MIRRORS MOUNTED UNDER PRIMARY MIRRORS | | | N/C |
| 729-001 | STANDARD SIDE/REAR REFLECTORS | | | STD |
| 768-043 | 63X14 INCH TINTED REAR WINDOW | | | STD |
| 661-004 | TINTED DOOR GLASS LH AND RH WITH TINTED OPERATING WING WINDOWS | | | STD |
| 654-027 | RH AND LH ELECTRIC POWERED WINDOWS, PASSENGER SWITCHES ON DOOR(S) | 4 | | \$218.00 |
| 663-013 | 1-PIECE SOLAR GREEN GLASS WINDSHIELD | | | STD |
| 659-007 | 8 LITER (2 GAL) WINDSHIELD WASHER RESERVOIR, CAB MOUNTED, WITHOUT FLUID LEVEL INDICATOR | | | STD |
| Cab Interior | | | | |
| 707-1AK | OPAL GRAY VINYL INTERIOR | | | STD |
| 706-013 | MOLDED PLASTIC DOOR PANEL | | | STD |
| 708-013 | MOLDED PLASTIC DOOR PANEL | | | STD |
| 772-006 | BLACK MATS WITH SINGLE INSULATION | | | STD |
| 785-004 | DASH MOUNTED ASH TRAY(S) WITHOUT LIGHTER | | | STD |
| 691-008 | FORWARD ROOF MOUNTED CONSOLE WITH UPPER STORAGE COMPARTMENTS WITHOUT NETTING | | | STD |
| 694-010 | IN DASH STORAGE BIN | | | STD |
| 742-007 | (2) CUP HOLDERS LH AND RH DASH | | | STD |



Prepared for:
Dylan Mulfinger
City of Oelwein
20 2ND AVE SW

OELWEIN, IA 50662
Phone: 319-283-1197

Prepared by:
Gene Carpenter
TRUCK CENTER COMPANIES
101 PLAZA DRIVE
ELK RUN HEIGHTS, IA 50707
Phone:

| Data Code | Description | Weight Front | Weight Rear | Retail Price |
|-----------|--|-----------------|----------------|--------------|
| 680-006 | GRAY/CHARCOAL FLAT DASH | | | STD |
| 860-004 | SMART SWITCH EXPANSION MODULE | | | \$196.00 |
| 700-002 | HEATER, DEFROSTER AND AIR CONDITIONER | | | STD |
| 701-001 | STANDARD HVAC DUCTING | | | STD |
| 703-005 | MAIN HVAC CONTROLS WITH RECIRCULATION SWITCH | | | STD |
| 170-019 | STANDARD HEATER PLUMBING WITH BALL SHUTOFF VALVES | | | \$37.00 |
| 130-041 | VALEO HEAVY DUTY A/C REFRIGERANT COMPRESSOR | | | STD |
| 702-002 | BINARY CONTROL, R-134A | | | STD |
| 739-033 | STANDARD INSULATION | | | STD |
| 285-013 | SOLID-STATE CIRCUIT PROTECTION AND FUSES | | | STD |
| 280-007 | 12V NEGATIVE GROUND ELECTRICAL SYSTEM | | | STD |
| 324-014 | DOME LIGHT WITH 3-WAY SWITCH ACTIVATED BY LH AND RH DOORS | | | STD |
| 655-005 | LH AND RH ELECTRIC DOOR LOCKS | | | \$36.00 |
| 284-023 | (1) 12 VOLT POWER SUPPLY IN DASH | | | STD |
| 756-1D9 | PREMIUM HIGH BACK AIR SUSPENSION DRIVER SEAT WITH 3 CHAMBER AIR LUMBAR, INTEGRATED CUSHION EXTENSION, FORWARD AND REAR CUSHION TILT, ADJUSTABLE SHOCK ABSORBER | 70 | | \$414.00 |
| 760-1DC | BASIC HIGH BACK NON SUSPENSION PASSENGER SEAT | | | STD |
| 711-004 | LH AND RH INTEGRAL DOOR PANEL ARMRESTS | | | STD |
| 758-036 | VINYL WITH VINYL INSERT DRIVER SEAT | | | STD |
| 761-036 | VINYL WITH VINYL INSERT PASSENGER SEAT | | | STD |
| 763-101 | BLACK SEAT BELTS | | | STD |
| 532-001 | FIXED STEERING COLUMN | | | STD |
| 540-015 | 4-SPOKE 18 INCH (450MM) STEERING WHEEL | | | STD |
| 765-002 | DRIVER AND PASSENGER INTERIOR SUN VISORS | | | STD |

Instruments & Controls

| | | | | |
|---------|--|--|--|-----|
| 732-004 | GRAY DRIVER INSTRUMENT PANEL | | | STD |
| 734-004 | GRAY CENTER INSTRUMENT PANEL | | | STD |
| 870-001 | BLACK GAUGE BEZELS | | | STD |
| 486-001 | LOW AIR PRESSURE INDICATOR LIGHT AND AUDIBLE ALARM | | | STD |
| 840-002 | 2 INCH PRIMARY AND SECONDARY AIR PRESSURE GAUGES | | | STD |



Prepared for:
 Dylan Mulfinger
 City of Oelwein
 20 2ND AVE SW

 OELWEIN, IA 50662
 Phone: 319-283-1197

Prepared by:
 Gene Carpenter
 TRUCK CENTER COMPANIES
 101 PLAZA DRIVE
 ELK RUN HEIGHTS, IA 50707
 Phone:

| Data Code | Description | Weight Front | Weight Rear | Retail Price |
|-----------|---|--------------|-------------|--------------|
| 198-003 | DASH MOUNTED AIR RESTRICTION INDICATOR WITH GRADUATIONS | | | \$25.00 |
| 149-013 | ELECTRONIC CRUISE CONTROL WITH SWITCHES IN LH SWITCH PANEL | | | STD |
| 156-007 | KEY OPERATED IGNITION SWITCH AND INTEGRAL START POSITION; 4 POSITION OFF/RUN/START/ACCESSORY | | | STD |
| 811-042 | ICU3S, 132X48 DISPLAY WITH DIAGNOSTICS, 28 LED WARNING LAMPS AND DATA LINKED | | | STD |
| 160-038 | HEAVY DUTY ONBOARD DIAGNOSTICS INTERFACE CONNECTOR LOCATED BELOW LH DASH | | | STD |
| 844-001 | 2 INCH ELECTRIC FUEL GAUGE | | | STD |
| 148-003 | PROGRAMMABLE RPM CONTROL - ELECTRONIC ENGINE | | | STD |
| 856-001 | ELECTRICAL ENGINE COOLANT TEMPERATURE GAUGE | | | STD |
| 864-001 | 2 INCH TRANSMISSION OIL TEMPERATURE GAUGE | | | STD |
| 830-017 | ENGINE AND TRIP HOUR METERS INTEGRAL WITHIN DRIVER DISPLAY | | | STD |
| 372-051 | CUSTOMER FURNISHED AND INSTALLED PTO CONTROLS | | | N/C |
| 852-002 | ELECTRIC ENGINE OIL PRESSURE GAUGE | | | STD |
| 746-115 | AM/FM/WB WORLD TUNER RADIO WITH BLUETOOTH AND USB AND AUXILIARY INPUTS, J1939 | 10 | | \$490.00 |
| 747-001 | DASH MOUNTED RADIO | | | N/C |
| 750-002 | (2) RADIO SPEAKERS IN CAB | | | N/C |
| 753-001 | AM/FM ANTENNA MOUNTED ON FORWARD LH ROOF | | | \$23.00 |
| 810-027 | ELECTRONIC MPH SPEEDOMETER WITH SECONDARY KPH SCALE, WITHOUT ODOMETER | | | STD |
| 817-001 | STANDARD VEHICLE SPEED SENSOR | | | STD |
| 812-001 | ELECTRONIC 3000 RPM TACHOMETER | | | STD |
| 162-002 | IGNITION SWITCH CONTROLLED ENGINE STOP | | | STD |
| 836-015 | DIGITAL VOLTAGE DISPLAY INTEGRAL WITH DRIVER DISPLAY | | | STD |
| 660-008 | SINGLE ELECTRIC WINDSHIELD WIPER MOTOR WITH DELAY | | | STD |
| 304-038 | MARKER LIGHT SWITCH INTEGRAL WITH HEADLIGHT SWITCH AND SINGLE CONNECTOR AND SWITCH FOR CUSTOMER FURNISHED SNOW PLOW LIGHTS, LOW BEAMS OFF WITH HIGH BEAMS | | | \$178.00 |



Prepared for:
 Dylan Mulfinger
 City of Oelwein
 20 2ND AVE SW

 OELWEIN, IA 50662
 Phone: 319-283-1197

Prepared by:
 Gene Carpenter
 TRUCK CENTER COMPANIES
 101 PLAZA DRIVE
 ELK RUN HEIGHTS, IA 50707
 Phone:

| Data Code | Description | Weight Front | Weight Rear | Retail Price |
|--------------------------------------|--|--------------|-------------|--------------|
| 882-009 | ONE VALVE PARKING BRAKE SYSTEM WITH WARNING INDICATOR | | | STD |
| 299-013 | SELF CANCELING TURN SIGNAL SWITCH WITH DIMMER, WASHER/WIPER AND HAZARD IN HANDLE | | | STD |
| 298-039 | INTEGRAL ELECTRONIC TURN SIGNAL FLASHER WITH HAZARD LAMPS OVERRIDING STOP LAMPS | | | STD |
| Design | | | | |
| 065-000 | PAINT: ONE SOLID COLOR | | | STD |
| Color | | | | |
| 980-6H9 | CAB COLOR A: L3258EY SEMI YELLOW ELITE EY | | | N/C |
| 986-020 | BLACK, HIGH SOLIDS POLYURETHANE CHASSIS PAINT | | | STD |
| 962-972 | POWDER WHITE (N0006EA) FRONT WHEELS/RIMS (PKWHT21, TKWHT21, W, TW) | | | STD |
| 966-972 | POWDER WHITE (N0006EA) REAR WHEELS/RIMS (PKWHT21, TKWHT21, W, TW) | | | STD |
| 964-020 | STANDARD BLACK BUMPER PAINT | | | STD |
| 963-003 | STANDARD E COAT/UNDERCOATING | | | STD |
| Certification / Compliance | | | | |
| 996-001 | U.S. FMVSS CERTIFICATION, EXCEPT SALES CABS AND GLIDER KITS | | | STD |
| Raw Performance Data | | | | |
| AE8-99D | CALCULATED EFFECTIVE BACK OF CAB TO REAR SUSPENSION C/L (CA) : 93.85 in | | | |
| AM6-99D | CALC'D SPACE AVAILABLE FOR DECKPLATE : 90.45 in | | | |
| Sales Programs | | | | |
| NO SALES PROGRAMS HAVE BEEN SELECTED | | | | |

T O T A L V E H I C L E S U M M A R Y

Adjusted List Price

Adjusted List Price ** \$133,087.00

Weight Summary



Prepared for:
Dylan Mulfinger
City of Oelwein
20 2ND AVE SW

OELWEIN, IA 50662
Phone: 319-283-1197

Prepared by:
Gene Carpenter
TRUCK CENTER COMPANIES
101 PLAZA DRIVE
ELK RUN HEIGHTS, IA 50707
Phone:

| | Weight Front | Weight Rear | Total Weight |
|---------------------------------|-----------------|-----------------|------------------|
| Factory Weight [†] | 7811 lbs | 4136 lbs | 11947 lbs |
| Total Weight[†] | 7811 lbs | 4136 lbs | 11947 lbs |

ITEMS NOT INCLUDED IN ADJUSTED LIST PRICE

Other Factory Charges

| | | |
|---------|-------------------------------|------------|
| PMV-021 | GHG21 ENHANCEMENT PRICE | \$510.00 |
| RAG-020 | CUMMINS TARIFF CHARGE - \$205 | \$205.00 |
| P73-2FT | STANDARD DESTINATION CHARGE | \$2,200.00 |

(+) Weights shown are estimates only.

If weight is critical, contact Customer Application Engineering.

(**) Prices shown do not include taxes, fees, etc... "Net Equipment Selling Price" is located on the Quotation Details Proposal Report.

(***) All cost increases for major components (Engines, Transmissions, Axles, Front and Rear Tires) and government mandated requirements, tariffs, and raw material surcharges will be passed through and added to factory invoices.





HV507 SFA

Sales Proposal For:
City of Oelwein

Presented By:
Thompson Truck & Trailer

INTERNATIONAL®

March 16, 2021

Prepared For:
 City of Oelwein
 Dylan Mulfinger
 20 2nd Ave. SW
 Oelwein, IA 50662-2247
 (319)283 - 5440
 Reference ID: N/A

Presented By:
 Thompson Truck & Trailer
 Matt Moore
 2740 6TH ST SW
 CEDAR RAPIDS IA 52404 -
 (319)364-2491

Thank you for the opportunity to provide you with the following quotation on a new International truck. I am sure the following detailed specification will meet your operational requirements, and I look forward to serving your business needs.

Model Profile
2022 HV507 SFA (HV507)

| | |
|----------------------------------|---|
| AXLE CONFIG: | 4X2 |
| APPLICATION: | Front Plow and Wing with Spreader |
| MISSION: | Requested GVWR: 39000. Calc. GVWR: 39000 Calc. Start / Grade Ability: 39.68% / 2.48% @ 55 MPH Calc. Geared Speed: 73.5 MPH |
| DIMENSION: | Wheelbase: 171.00, CA: 96.00, Axle to Frame: 63.00 |
| ENGINE, DIESEL: | {Cummins L9 300} EPA 2021, 300HP @ 2200 RPM, 860 lb-ft Torque @ 1200 RPM, 2200 RPM Governed Speed, 300 Peak HP (Max) |
| TRANSMISSION, AUTOMATIC: | {Allison 3500 RDS} 5th Generation Controls, Wide Ratio, 6-Speed with Double Overdrive, with PTO Provision, Less Retarder, Includes Oil Level Sensor, with 80,000-lb GVW and GCW Max, On/Off Highway |
| CLUTCH: | Omit Item (Clutch & Control) |
| AXLE, FRONT NON-DRIVING: | {Meritor MFS-16-143A} Wide Track, I-Beam Type, 16,000-lb Capacity |
| AXLE, REAR, SINGLE: | {Meritor RS-23-160} Single Reduction, 23,000-lb Capacity, Driver Controlled Locking Differential, 200 Wheel Ends Gear Ratio: 5.63 |
| CAB: | Conventional, Day Cab |
| TIRE, FRONT: | (2) 315/80R22.5 Load Range L M843 (BRIDGESTONE), 480 rev/mile, 65 MPH, All-Position |
| TIRE, REAR: | (4) 11R22.5 Load Range G HDL2 DL (CONTINENTAL), 491 rev/mile, 75 MPH, Drive |
| SUSPENSION, REAR, SINGLE: | 23,500-lb Capacity, Vari-Rate Springs, with 4500-lb Capacity Auxiliary Rubber Springs |
| PAINT: | Cab schematic 100WK Location 1: 4421, School Bus Yellow (Std) Chassis schematic N/A |

| <u>Code</u> | <u>Description</u> |
|-------------|---|
| HV50700 | Base Chassis, Model HV507 SFA with 171.00 Wheelbase, 96.00 CA, and 63.00 Axle to Frame. |
| 1570 | TOW HOOK, FRONT (2) Frame Mounted |
| 1ANA | AXLE CONFIGURATION {Navistar} 4x2 |
| | <u>Notes</u> : Pricing may change if axle configuration is changed. |
| 1CAJ | FRAME RAILS Heat Treated Alloy Steel (120,000 PSI Yield); 10.866" x 3.622" x 0.437" (276.0mm x 92.0mm x 11.1mm); 456.0" (11582mm) Maximum OAL |
| 1LLA | BUMPER, FRONT Swept Back, Steel, Heavy Duty |
| 1MEJ | FRAME, SPECIAL EFFECTS Dimple on Left and Right Top Flange of Frame Rail to Reference Rear Axle Centerline |
| 1UAM | FRAME EXTENSION, FRONT Integral; 27" In Front of Grille |
| 1WEV | WHEELBASE RANGE 146" (370cm) Through and Including 195" (495cm) |
| 2ARU | AXLE, FRONT NON-DRIVING {Meritor MFS-16-143A} Wide Track, I-Beam Type, 16,000-lb Capacity |
| 3ACP | SUSPENSION, FRONT, SPRING Multileaf, Shackle Type, 16,000-lb Capacity, Less Shock Absorbers |
| 4091 | BRAKE SYSTEM, AIR Dual System for Straight Truck Applications |
| | <u>Includes</u> : BRAKE LINES Color and Size Coded Nylon : DRAIN VALVE Twist-Type : GAUGE, AIR PRESSURE (2) Air 1 and Air 2 Gauges; Located in Instrument Cluster : PARKING BRAKE CONTROL Yellow Knob, Located on Instrument Panel : PARKING BRAKE VALVE For Truck : QUICK RELEASE VALVE On Rear Axle for Spring Brake Release: 1 for 4x2, 2 for 6x4 : SPRING BRAKE MODULATOR VALVE R-7 for 4x2, SR-7 with relay valve for 6x4/8x6 |
| 4732 | DRAIN VALVE {Berg} with Pull Chain, for Air Tank |
| 4AZA | AIR BRAKE ABS {Bendix AntiLock Brake System} 4-Channel (4 Sensor/4 Modulator) Full Vehicle Wheel Control System |
| 4EBS | AIR DRYER {Bendix AD-9} with Heater |
| 4EXU | BRAKE CHAMBERS, REAR AXLE {Bendix EverSure} 30/30 SqIn Spring Brake |
| 4EXV | BRAKE CHAMBERS, FRONT AXLE {Bendix} 24 SqIn |
| 4LAG | SLACK ADJUSTERS, FRONT {Gunite} Automatic |
| 4LGG | SLACK ADJUSTERS, REAR {Gunite} Automatic |
| 4SPA | AIR COMPRESSOR {Cummins} 18.7 CFM |
| 4VKC | AIR DRYER LOCATION Mounted Inside Left Rail, Back of Cab |
| 4VKJ | AIR TANK LOCATION (2) Mounted Under Battery Box, Outside Left Rail, Back of Cab, Perpendicular to Rail |
| 4WBX | DUST SHIELDS, FRONT BRAKE for Air Cam Brakes |
| 4WDM | DUST SHIELDS, REAR BRAKE for Air Cam Brakes |
| 4XDL | BRAKES, FRONT {Bendix Spicer ES-165-6X} Air S-Cam Type, Heavy Duty Fabricated Spider, Fabricated Shoe, Single Anchor Pin, Size 16.5" X 6", 23,000-lb Capacity |
| 4XDM | BRAKES, REAR {Bendix Spicer ES-165-7X} Air S-Cam Type, Heavy Duty Fabricated Spider, Fabricated Shoe, Single Anchor Pin, Size 16.5" X 7", 23,000-lb Capacity per Axle |

INTERNATIONAL®

Vehicle Specifications
2022 HV507 SFA (HV507)

March 16, 2021

| <u>Code</u> | <u>Description</u> |
|-------------|---|
| 5708 | STEERING COLUMN Tilting |
| 5CAW | STEERING WHEEL 4-Spoke; 18" Dia., Black |
| 5PSL | STEERING GEAR {Sheppard M110} Power |
| 6DGB | DRIVELINE SYSTEM {Dana Spicer} SPL140, for 4x2/6x2 |
| 7BEV | AFTERTREATMENT COVER Steel, Black |
| 7BLW | EXHAUST SYSTEM Horizontal Aftertreatment System, Frame Mounted Right Side Under Cab, for Single Vertical Tail Pipe, Frame Mounted Right Side Back of Cab |
| 7WAZ | TAIL PIPE (1) Turnback Type |
| 7WCM | EXHAUST HEIGHT 8' 10" |
| 7WDN | MUFFLER/TAIL PIPE GUARD (1) Aluminum |
| 8000 | ELECTRICAL SYSTEM 12-Volt, Standard Equipment |
| | <u>Includes</u> |
| | : DATA LINK CONNECTOR For Vehicle Programming and Diagnostics In Cab |
| | : HAZARD SWITCH Push On/Push Off, Located on Instrument Panel to Right of Steering Wheel |
| | : HEADLIGHT DIMMER SWITCH Integral with Turn Signal Lever |
| | : PARKING LIGHT Integral with Front Turn Signal and Rear Tail Light |
| | : STARTER SWITCH Electric, Key Operated |
| | : STOP, TURN, TAIL & B/U LIGHTS Dual, Rear, Combination with Reflector |
| | : TURN SIGNAL SWITCH Self-Cancelling for Trucks, Manual Cancelling for Tractors, with Lane Change Feature |
| | : WINDSHIELD WIPER SWITCH 2-Speed with Wash and Intermittent Feature (5 Pre-Set Delays), Integral with Turn Signal Lever |
| | : WINDSHIELD WIPERS Single Motor, Electric, Cowl Mounted |
| | : WIRING, CHASSIS Color Coded and Continuously Numbered |
| 8518 | CIGAR LIGHTER Includes Ash Cup |
| 8GXD | ALTERNATOR {Leece-Neville AV1160P2013} Brush Type, 12 Volt, 160 Amp Capacity, Pad Mount, with Remote Sense |
| 8HAA | BODY BUILDER WIRING To Rear of Frame, with Stop, Tail, Turn, and Marker Lights Circuits, Ignition Controlled Auxiliary Feed and Ground, Less Trailer Socket |
| 8MJU | BATTERY SYSTEM {Fleetrite} Maintenance-Free, (3) 12-Volt 2850CCA Total, Top Threaded Stud |
| 8RMV | SPEAKERS (2) 6.5" Dual Cone Mounted in Doors |
| 8RPS | RADIO AM/FM/WB/Clock/Bluetooth/USB Input/Auxiliary Input |
| 8THJ | AUXILIARY HARNESS 3.0' for Auxiliary Front Head Lights and Turn Signals for Front Plow Applications |
| 8VAY | HORN, ELECTRIC Disc Style |
| 8VUL | BATTERY BOX Steel, with Plastic Cover, 18" Wide, 2-4 Battery Capacity, Mounted Left Side Back of Cab |
| 8WBW | JUMP START STUD Remote Mounted |
| 8WPH | CLEARANCE/MARKER LIGHTS (5) {Truck Lite} Amber LED Lights, Flush Mounted on Cab or Sunshade |
| 8WWJ | INDICATOR, LOW COOLANT LEVEL with Audible Alarm |
| 8WXG | STARTING MOTOR {Mitsubishi Electric Automotive America 105P} 12-Volt, with Soft-Start |
| 8XAH | CIRCUIT BREAKERS Manual-Reset (Main Panel) SAE Type III with Trip Indicators, Replaces All Fuses |
| 8XGT | TURN SIGNALS, FRONT Includes LED Side Turn Lights Mounted on Fender |

INTERNATIONAL®

Vehicle Specifications
2022 HV507 SFA (HV507)

March 16, 2021

| <u>Code</u> | <u>Description</u> |
|--------------------|---|
| 8XHN | HORN, AIR Single Trumpet, Black, with Lanyard Pull Cord |
| 9AAB | LOGOS EXTERIOR Model Badges |
| 9AAE | LOGOS EXTERIOR, ENGINE Badges |
| 9HBM | GRILLE Stationary, Chrome |
| 9WBC | FRONT END Tilting, Fiberglass, with Three Piece Construction, for WorkStar/HV |
| 10060 | PAINT SCHEMATIC, PT-1 Single Color, Design 100 |
| | <u>Includes</u> : PAINT SCHEMATIC ID LETTERS "WK" |
| 10761 | PAINT TYPE Base Coat/Clear Coat, 1-2 Tone |
| 11001 | CLUTCH Omit Item (Clutch & Control) |
| 12703 | ANTI-FREEZE Red, Extended Life Coolant; To -40 Degrees F/ -40 Degrees C, Freeze Protection |
| 12849 | BLOCK HEATER, ENGINE 120V/1000W, for Cummins ISB/B6.7/ISL/L9 Engines |
| | <u>Includes</u> : BLOCK HEATER SOCKET Receptacle Type; Mounted below Drivers Door |
| 12ESL | ENGINE, DIESEL {Cummins L9 300} EPA 2021, 300HP @ 2200 RPM, 860 lb-ft Torque @ 1200 RPM, 2200 RPM Governed Speed, 300 Peak HP (Max) |
| 12THT | FAN DRIVE {Horton Drivemaster} Two-Speed Type, Direct Drive, with Residual Torque Device for Disengaged Fan Speed |
| | <u>Includes</u> : FAN Nylon |
| 12UWZ | RADIATOR Aluminum, Cross Flow, Front to Back System, 1228 SqIn, with 1167 SqIn Charge Air Cooler, Includes In-Tank Oil Cooler |
| | <u>Includes</u> : DEAERATION SYSTEM with Surge Tank : HOSE CLAMPS, RADIATOR HOSES Gates Shrink Band Type; Thermoplastic Coolant Hose Clamps : RADIATOR HOSES Premium, Rubber |
| 12VAG | AIR CLEANER Single Element, with Integral Snow Valve and In-Cab Control |
| 12VHR | FEDERAL EMISSIONS {Cummins L9} EPA, OBD and GHG Certified for Calendar Year 2021 |
| 12VXU | THROTTLE, HAND CONTROL Engine Speed Control for PTO; Electronic, Stationary Pre-Set, Two Speed Settings; Mounted on Steering Wheel |
| 12WZE | EMISSION COMPLIANCE Federal, Does Not Comply with California Clean Air Idle Regulations |
| 12XBM | ENGINE CONTROL, REMOTE MOUNTED Provision for; Includes Wiring for Body Builder Installation of PTO Controls and Starter Lockout, with Ignition Switch Control, for Cummins B6.7 and L9 Engines |
| 13AVL | TRANSMISSION, AUTOMATIC {Allison 3500 RDS} 5th Generation Controls, Wide Ratio, 6-Speed with Double Overdrive, with PTO Provision, Less Retarder, Includes Oil Level Sensor, with 80,000-lb GVW and GCW Max, On/Off Highway |
| 13WET | TRANSMISSION SHIFT CONTROL Column Mounted Stalk Shifter, Not for Use with Allison 1000 & 2000 Series Transmission |
| 13WLP | TRANSMISSION OIL Synthetic; 29 thru 42 Pints |
| 13WUC | ALLISON SPARE INPUT/OUTPUT for Rugged Duty Series (RDS) and Regional Haul Series (RHS), General Purpose Trucks, Construction, Package Number 223 |

INTERNATIONAL®**Vehicle Specifications
2022 HV507 SFA (HV507)****March 16, 2021**

| Code | Description |
|-------------|--|
| 13WVV | NEUTRAL AT STOP Allison Transmission Shifts to Neutral When Service Brake is Depressed and Vehicle is at Stop; Remains in Neutral Until Service Brake is Released |
| 13WYU | SHIFT CONTROL PARAMETERS {Allison} 3000 or 4000 Series Transmissions, Performance Programming |
| 13XAL | PTO LOCATION Customer Intends to Install PTO at Left Side of Transmission |
| 14ARB | AXLE, REAR, SINGLE {Meritor RS-23-160} Single Reduction, 23,000-lb Capacity, Driver Controlled Locking Differential, 200 Wheel Ends . Gear Ratio: 5.63 |
| 14VAH | SUSPENSION, REAR, SINGLE 23,500-lb Capacity, Vari-Rate Springs, with 4500-lb Capacity Auxiliary Rubber Springs |
| 15LNS | FUEL/WATER SEPARATOR {Racor 400 Series} 12 VDC Electric Heater, Includes Pre-Heater, with Primer Pump, Includes Water-in-Fuel Sensor, Mounted on Engine |
| 15SGG | FUEL TANK Top Draw, Non-Polished Aluminum, D-Style, 19" Tank Depth, 70 US Gal (265L), Mounted Left Side, Under Cab |
| 15WDG | DEF TANK 7 US Gal (26L) Capacity, Frame Mounted Outside Left Rail, Under Cab |
| 16030 | CAB Conventional, Day Cab |
| 16BAL | HEATER |
| 16GDC | GAUGE CLUSTER Base Level; English with English Speedometer and Tachometer, for Air Brake Chassis, Includes Engine Coolant Temperature, Primary and Secondary Air Pressure, Fuel and DEF Gauges, Oil Pressure Gauge, Includes 3 Inch Monochromatic Text Display |
| 16HHE | GAUGE, AIR CLEANER RESTRICTION {Filter-Minder} with Black Bezel, Mounted in Instrument Panel |
| 16HKT | IP CLUSTER DISPLAY On Board Diagnostics Display of Fault Codes in Gauge Cluster |
| 16JNT | SEAT, DRIVER {National 2000} Air Suspension, High Back with Integral Headrest, Vinyl, Isolator, 1 Chamber Lumbar, with 2 Position Front Cushion Adjust, -3 to +14 Degree Angle Back Adjust |
| 16SMN | SEAT, PASSENGER {National} Non Suspension, High Back, Fixed Back, Integral Headrest, Vinyl |
| 16SNP | MIRRORS (2) C-Loop, Power Adjust, Heated, Black Heads and Arms, 7.5" x 14" Flat Glass, Includes 7.5" x 7" Convex Mirrors, for 102" Load Width |
| | Notes : Mirror Dimensions are Rounded to the Nearest 0.5" |
| 16VKB | CAB INTERIOR TRIM Classic, for Day Cab |
| | Includes : CONSOLE, OVERHEAD Molded Plastic with Dual Storage Pockets, Retainer Nets and CB Radio Pocket; Located Above Driver and Passenger : DOME LIGHT, CAB Door Activated and Push On-Off at Light Lens, Timed Theater Dimming, Integral to Overhead Console, Center Mounted : SUN VISOR (2) Padded Vinyl; 2 Moveable (Front-to-Side) Primary Visors, Driver Side with Toll Ticket Strap |
| 16WBY | ARM REST, RIGHT, DRIVER SEAT |
| 16WJU | WINDOW, POWER (2) and Power Door Locks, Left and Right Doors, Includes Express Down Feature |
| 16WSK | CAB REAR SUSPENSION Air Bag Type |
| 16XJN | INSTRUMENT PANEL Flat Panel |
| 16ZBT | ACCESS, CAB Steel, Driver & Passenger Sides, Two Steps per Door, for use with Day Cab and Extended Cab |
| 27DUL | WHEELS, FRONT {Accuride 29300} DISC; 22.5x9.00 Rims, Powder Coat Steel, 5-Hand Hole, 10-Stud, 285.75mm BC, Hub-Piloted, Flanged Nut, with Steel Hubs |

INTERNATIONAL®**Vehicle Specifications
2022 HV507 SFA (HV507)****March 16, 2021**

| <u>Code</u> | <u>Description</u> |
|--------------------------|--|
| 28DUK | WHEELS, REAR {Accuride 29169} DUAL DISC; 22.5x8.25 Rims, Powder Coat Steel, 5-Hand Hole, 10-Stud, 285.75mm BC, Hub-Piloted, Flanged Nut, with .472" Thick Increased Capacity Disc and Steel Hubs |
| 7372135417 | (4) TIRE, REAR 11R22.5 Load Range G HDL2 DL (CONTINENTAL), 491 rev/mile, 75 MPH, Drive |
| 7762549052 | (2) TIRE, FRONT 315/80R22.5 Load Range L M843 (BRIDGESTONE), 480 rev/mile, 65 MPH, All-Position |
| Services Section: | |
| 40128 | WARRANTY Standard for HV507, HV50B, HV607 Models, Effective with Vehicles Built July 1, 2017 or Later, CTS-2025A |
| 1 | BODY SPEC PER HENDERSON |

INTERNATIONAL®

Financial Summary
2022 HV507 SFA (HV507)

March 16, 2021

| <u>Description</u> | <u>(US DOLLAR)</u> | <u>Price</u> |
|---|--------------------|---------------|
| Factory List Prices: | | |
| Product Items | \$127,374.00 | |
| Service Items | \$0.00 | |
| Total Factory List Price Including Options: | | \$127,374.00 |
| Freight | \$2,350.00 | |
| Total Freight: | | \$2,350.00 |
| Total Factory List Price Including Freight: | | \$129,724.00 |
| Less Customer Allowance: | | (\$55,436.00) |
| Total Vehicle Price: | | \$74,288.00 |
| Total Body/Allied Equipment: | | \$42,962.00 |
| Total Sale Price: | | \$117,250.00 |
| Total Per Vehicle Sales Price: | | \$117,250.00 |
| Net Sales Price: | | \$117,250.00 |

136,715 55 box sand wings

Please feel free to contact me regarding these specifications should your interests or needs change. I am confident you will be pleased with the quality and service of an International vehicle.

Approved by Seller:

Accepted by Purchaser:

Official Title and Date

Firm or Business Name

Authorized Signature

Authorized Signature and Date

This proposal is not binding upon the seller without Seller's Authorized Signature

Official Title and Date

The TOPS FET calculation is an estimate for reference purposes only. The seller or retailer is responsible for calculating and reporting/paying appropriate FET to the IRS.

The limited warranties applicable to the vehicles described herein are Navistar, Inc.'s standard printed warranties which are incorporated herein by reference and to which you have been provided a copy and hereby agree to their terms and conditions.



HENDERSON

PRODUCTS, INC.

916 S 10TH ST
MANCHESTER, IA 52057
PHONE: 563-927-7000
FAX: 563-927-7001

CUSTOMER QUOTE

Item 15.

Page 1
Quote #146225
Rev #35

To: THOMPSON TRUCK & TRAILER INC
Attn: MATT MOORE
Quote Date: 2/26/2021
Valid Until: 3/28/2021

Quoted By: Ryan Burkle
Phone: 563-927-2828
Cell: 515-689-2578
Fax: 563-927-2521
Email: rburkle@hendersonproducts.com

Quoted:

CITY OF OELWEIN IA Henderson Equipment Package: 11'x24in Mark E Dump Body,
11'x36in RSP Plow, Force America Hydraulics with Install. SEE SPEC
COMPLIANCE FOR ADDITIONAL DETAILS

Henderson Products is pleased to present the following quote. Please contact us if you have any questions.

MARKE SA Dump Body

BODY LENGTH: 11ft BODY LENGTH
SIDE STYLE: STRAIGHT SIDES
SIDE HEIGHT (FROM FLOOR): 24" SIDE HEIGHT
REAR BODY PROFILE: STANDARD STRAIGHT VERTICAL GATE
REAR CORNER POSTS: REAR BOLSTERS 8" ABOVE SIDES
BOARD POCKETS: 2" WIDE BOARD POCKETS
HOIST TYPE: 8/21 UNDERBODY HOIST W/ SUBFRM
HOIST CYLINDER/MODEL: UB 8/21 CYLINDER, CLASS 60, 22.1 TON LIFT CAPACITY
UB HOIST BUSHINGS: GREASELESS BUSHINGS
HYDRAULIC PUMP: PUMP SUPPLIED WITH HYDRAULIC PACKAGE
CYLINDER CRADLE STYLE: STANDARD HOIST CRADLE
INSTALL SUBFRAME AND/OR CYLINDER: SHIP LOOSE - DEALER TO INSTALL
EXTRA BODY PROP: NO EXTRA BODY PROP
HYDRAULIC RESERVOIR: RESERVOIR SUPPLIED WITH HYDRAULICS PACKAGE
FLOOR MATERIAL: 3/16" AR400 FLOOR
FLOOR TO SIDE RADIUS: 5" RADIUS FLOOR TO SIDE
LONGSILL MATERIAL: 10" I-BEAM LONGSILLS (STANDARD SKIP WELD)
SIDES/HEADSHEET MATERIAL: 10GA GRADE 50 SIDES/HEAD
SIDE BRACING TYPE: SINGLE WELD-ON INTERMEDIATE SIDE BRACE
SIDE BRACE MATERIAL: 10GA GRADE 50 SIDE BRACING
TOP RAIL STYLE: FLAT (2" FLAT, THEN SLOPED)
CONTOURED FRONT CORNER POSTS: NO FRONT CORNER POSTS
REAR CORNER POST MATERIAL: 10GA GRADE 50 REAR CORNER POSTS
TAILGATE STYLE: STANDARD TAILGATE
TAILGATE SHEET MATERIAL: 7GA GRADE 50 TAILGATE SHEET
TAILGATE BRACING: DOUBLE HORIZONTAL TAILGATE BRACING
TAILGATE BRACE MATERIAL: 10GA GRADE 50 TAILGATE BRACING
TAILGATE TOP PIVOT HARDWARE: 1-1/4" PINS, 1" PLATES, NON-GREASABLE
TAILGATE LATCH TYPE: AIR PANCAKE TAILGATE RELEASE, SS BUSHINGS
TAILGATE RELEASE VALVE: NO TAILGATE RELEASE VALVE
TAILGATE PIN LANYARDS: NO TAILGATE PIVOT PIN LANYARDS
TAILGATE LIFT LOOP: TAILGATE LIFT LOOP, D-RING, CENTER OUTSIDE (MILD)
LATCH JAWS: LOWER TG LATCH JAWS, NON-GREASABLE





HENDERSON

PRODUCTS, INC.

916 S 10TH ST
MANCHESTER, IA 52057
PHONE: 563-927-7000
FAX: 563-927-7001

CUSTOMER QUOTE

Item 15.

Page 2
Quote #146225
Rev #35

COAL CHUTE: NO COAL CHUTE
REAR FACE LIGHT HOLES: (2) OBOURND LIGHT HOLES, EA BOLSTER REAR FACE
REAR SIDE MARKER LIGHT HOLE: STD 2.5" SIDE MARKER LIGHT HOLES
EXTERIOR LIGHT BOXES INSTALLED: NO EXTERIOR LIGHT BOXES
LIGHTING PACKAGE: NO OEM LIGHTING PACKAGE
BODY HINGE CONSTRUCTION: STD SUBFRAME INTEGRAL HINGE
BODY HINGE TYPE: GREASELESS COMPOSITE BUSHING HINGE BLOCKS (I)
BODY HINGE PAINT: YES, REAR HINGE PAINTED @ FACTORY
PAINT PREPARATION: NO PRIME-RAW STEEL FINISH (MILD OR AR BODIES ONLY)
CABSHIELD STYLE: STANDARD WELD ON CABSHIELD
CABSHIELD MATERIAL: 10GA W/ 7GA END PLATES (GRADE 50)
CABSHIELD SIZE: 16" X 78" CABSHIELD (1/4 CAB)
CABSHIELD MOUNTED LIGHT HOLES: NO CABSHIELD LIGHT HOLES
INSTALL CABSHIELD: CABSHIELD SHIPPED LOOSE, DEALER TO INSTALL
ASPHALT LIP: NO ASPHALT LIP
WALK RAILS: NO WALKRAILS ON LOWER RUBRAILS
TARP RAILS: NO TARP RAILS
SIDE LADDERS: (NO) SIDE LADDER
STEP(S): NO STEP(S)
GRAB HANDLES: NO GRAB HANDLES
SIDEBOARDS: NO SLOPED SIDEBOARDS
Show Options: Show Options
RUBBER MOUNTING PADS: NO RUBBER MOUNTING PADS
VIBRATOR MOUNTING PAD: NO VIBRATOR MOUNTING PAD
REAR APRON FILLER PLATE (FOR TGS SANDER): REAR APRON FILLER PLATE FOR TGS
INSTALL TGS SPREADER: NO TGS INSTALL
HEATED BODY: NO HEATED BODY OPTION
CRADLE MOUNT TOOLBOX: NO TRIANGULAR CRDL MOUNT TOOLBOX (SLOPED HEAD P2P ONLY)
TOOLBOX (BODY INTEGRAL): NO INTEGRAL BODY TOOLBOX

Reversible snow plow

Plow Length: 11' length
Moldboard Trip: Full trip with 2 external compression springs
Pushframe Type: Standard Circle Frame with Top Mount Cylinders
Moldboard Height: 36" height
Moldboard Shield: Integral shield
Moldboard Sheet Material: 10 GA GR50 steel (standard)
Adjustable Trip Spring: Five position adjustable trip spring preload
Hydraulic Cylinders: 3" x 1 1/2" x 10" reversing nitrided cylinders
Paint: Henderson Orange
12" Rubber Deflector: Yes, w/ SS Backer
Install Rubber Deflector: Yes
36" Plastic Side Markers, Pair: Yes
Parking Jack, Screw Adjustable: Yes
Cutting Edge: Std 5/8" x 8" One Piece AASHTO punch
Hitch, Plow Portion: Quick hitch
Plow portion hitch width: 30.5"





HENDERSON

PRODUCTS, INC.

916 S 10TH ST
MANCHESTER, IA 52057
PHONE: 563-927-7000
FAX: 563-927-7001

CUSTOMER QUOTE

Item 15.

Page 3
Quote #146225
Rev #35

Plow Portion Installed on Plow: **Yes**
Hitch, Truck Portion: **See HPH or HCH for Truck portion hitch**
Custom Option Fields: **Note Custom Details Below**
Option 1 Description: **156037 low pro quick hitch w/ 3x2x10in lift cyl**
Option 2 Description:
Option 3 Description:
Option 4 Description:
Option 5 Description:
Option 6 Description:

Installation Workup

Facility: **IDC-IA**
Chassis Delivery To Henderson: **Truck Dealer/Customer Delivers**
Completed Truck Delivery Method: **Henderson Delivers (100 miles or less)**
Chassis Make: **International**
Chassis Model Yr: **2022**
Chassis Model: **HV Series**
Front Frame Ext?: **Yes**
Frnt Frame Ext Type: **Full**
Pump Location: **Transmission Mount Pump**
Transmission Type: **Automatic**
Transmission Model: **Allison Transmission**

Hitch Type: **Low Profile or Manual Tilt Type Hitch**
Mount Type: **Cheek Plate Mount Kit (Select type below)**
Mount Kit Model (Req'd): **Quick HCH Low Pro/MT Ck Plt Kit (No Wng, 34" w Full Frame)**
Front Bumper: **Fabricated Channel Bumper (2pc design) (MFG Material)**

Front Plow Type: **Standard Henderson Plow**
Plow Markers (Front Plow): **IDC Install of fact supplied markers, sales to order w/ unit**
Rubber Deflector Install: **Supplied/Installed @ Factory, sales to order w/ unit**
Plow Jack Install: **MFG Supl'd jack (loose), IDC instl'd, sales order with unit**

Dump Body Type: **Mark E Single Axle**
Floor Length: **(11') floor length**
Hoist Type: **Underbody Hoist with Subframe**
Cylinder Type: **Double Acting**
Body Material (Sides/ends): **Painted Steel Type Body Material**
Tailgate Release Type: **IDC supplied Electric over air valve**
Pressure Protection Valve: **Direct to air tank valve (Int & Mack ONLY)**
Cabshield Install: **Supl'd by fact, welded to body @ IDC, sales to order w/ unit**

Body Spec Notes:





HENDERSON

PRODUCTS, INC.

916 S 10TH ST
MANCHESTER, IA 52057
PHONE: 563-927-7000
FAX: 563-927-7001

CUSTOMER QUOTE Item 15.

Page 4
Quote #146225
Rev #35

Chassis Accessories: **Yes (SELECT RELATED OPTIONS BELOW)**

Mudflaps (Rear): **Swinging w/Logo**
Mudflap Type (Rear): **36" Swinging, SS (with LOGO)**
Fenders: **Front Quarter Fenders, Poly (standard)**
Pintle Plate: **None (Cover Plate Only)**
Pintle Hook: **Not Required**
Truck Wash: **Complete Truck Wash/Clean/Vac 1**
Warranty: **Standard 1 Year Warranty**
Inspection: **Walk-around meeting only**
Training: **Yes, Training Required**
Install Touch-up: **Basic Installation Touch-Up**

Electrical: **Yes (SELECT RELATED OPTIONS BELOW)**

Power Distribution Panel: **Power Distribution Panel**
Misc Electrical Supplies: **Req'd Misc Elect Supplies**
Plow Lights: **Plow Lts, Hella 220, HALO, Except Frtlnr/Mack/Pbilt (PAIR)**
Plow Light Brackets: **Plow Lt Brckts, SS, Mnt to Fact Hood Mnt Mirror, INTL, Pair**
Cab Beacon: **LED Mini Ltbar, 201SS Stationary Mntng Brkct, Top Mnt**
Rear Dump Bolster (S/T/T): **LED S/T/T/BU, MK3, Grote harness light kit**
Rear Dump Bolster Strobes: **6" LED Oval Strobes, Amber, 1 PR, (order holes w/unit)**
Back up alarm: **Backup Alarm, 97db**
Backbone & Wire Standoffs: **10' Backbone (For SA)**

Electrical Spec Notes:

Hydraulics: **Full Hydraulic Package**

Hyd Supplier: **Force America (Select Pkg Below)**
Hyd Supplier (Spec): **QT001-1206274-1**
Controls Type: **Cable Controls**
Cable Qty: **3 Functions**
PTO Type: **Included in Hydraulics Package**
Reservoir Type: **Supplied With Hydraulics**
Valve Enclosure Type: **Not Required**
Low Oil Shut Down: **Yes, included in Hyd Pkg**
Low Oil Indicator: **Yes, included in Hyd Pkg**
Quick Coupler Upgrade: **Standard Quick Couplers**
Hyd Options 1: **Install valve under dump body behind cab**

Hydraulics Notes:

Force America Hydraulic system. See spec compliance pages for additional details

IDC Paint Location: **IDC-IA**

Body Paint Type: **Powder Paint**
Powdercoat Paint (Body): **12' MKE/3, All from charts non-metal, Blast, Prim, Paint**
Paint Code & Color (from color charts): **Forest or Woodlawn Green to Match existing bodies**





HENDERSON

PRODUCTS, INC.

916 S 10TH ST
MANCHESTER, IA 52057
PHONE: 563-927-7000
FAX: 563-927-7001

CUSTOMER QUOTE

Item 15.

Page 5
Quote #146225
Rev #35

Single Package: \$42,962.00
Package(s) : 1
Total: \$42,962.00

Signed: _____ Date: _____

Quote notes:

Lead Time: 4 Months for equipment. Install to take place 60-90 days after receipt of chassis and all equipment

Additional Options to consider. Please "X" to include with package:

___1) 10GA 201 Stainless steel sides and headsheets, and 7GA 201 Stainless tailgate for dump body ILO of GR50 steel. Includes all 201 stainless steel bracing, corner posts, and cabshield. Floor will remain 3/16in AR400, and longsills will remain 10in I-beams
ADD \$4,090.00

___2) Include and install Henderson 201 Stainless Steel Tailgate spreader per City of Oelwein spec
ADD \$4,500.00

___3) Include and install Henderson Mid-Mount wing system per City of Oelwein spec. Includes hydraulics and controls to operate wing installed on chassis, and (1) LED work light to illuminate wing when deployed
ADD \$10,875.00

TOTAL WITH OPTIONS = _____





Memo

To: Honorable Mayor & City Council,

From: Utility Superintendent Victor Kane

CC: City Administrator Dylan Mulfinger

Reference: Wheel Loader

Date: 03/18/21

Greetings,

We have received 3 quotes for the purchase of a new wheel loader and three attachments. A 4 in 1 bucket, grapple bucket and a lite material bucket.

Martian Equipment quoted a 2021 John Deere brand with attachments for \$147,950.00.

Titian Machinery quoted a 2021 Case brand with attachments for \$135,780.00.

Housby Heavy Equipment quoted a 2021 VOLVO brand with attachments for \$131,500.00.

I would recommend purchasing the wheel loader and attachments from Housby Heavy Equipment quoted a for \$131,500.00.

Thank you for your time.

Victor Kane

From the Desk of
Oelwein Utility Superintendent Victor Kane

February 18, 2021

Oelwein, City of
Oelwein, IA



NEW CASE 621G Z-Bar (qte 701464785)

- 28,000 lbs Class Machine
- 172 Gross HP (152 net) Tier 4 Final FPT (Case) Engine
- SCR-ONLY Emissions system (NO EGR, NO DPF, NO REGEN)
- Outboard Planetaries & Multi-disk wet brakes (service brakes)
- Standard Z-Bar Loader Configuration
- 4 speed Transmission
- Limited-Slip Axles (front & back)
- Enhanced Cab Comfort Package
 - Air Suspended Seat
 - Heated seat
 - Sound Suppression package
 - Sun Shade
 - Extra left side interior mirror
 - Seat drawer
 - 24V lighter
 - Am/FM/BT Radio
- Enhanced Visibility Package
 - Right & Left heated exterior mirror
 - LED headlights w/Hi/Low beam
 - 4 front & 2 rear LED work lights
 - Rear view camera
- Joystick loader control
- 1 Aux Function hydraulics
- Michelin 20.5R25 SnoPlus tires on 3 pc rim
- Hydraulic coupler - ACS Standard (best for tool carrier configuration)
- ACS Compatible 4-in-1 multi-function bucket
- ACS Compatible 5 yrd Light Material Bucket
- ACS Compatible Scrap Grapple (open sides)
- Cold Weather Package
 - Heavy duty batteries (2 x 950 CCA)
 - Low-temp Hytran Ultra hydraulic oil
 - grid heater
 - DEF line insulating blanket
 - heated fuel filter/water separator
- Ride control
- ProCare (3 yrs, 2000 hrs -- warranty and maintenance filters & fluids)

\$ 187,480

Options

5-speed Transmission
with Lockup Torque Converter, Includes PowerInch
progressive de-clutch
+ \$ 2,455

Diff-Lock Front Axle
Open Rear
+ \$ 1,772

High-Debris Cooling System
+ \$ 635

2nd Aux Hydraulic Circuit
+ \$ 715

Full Fenders
+ \$ 610

Tire Pressure Monitor System
+ \$ 828

Skid Plate & Transmission
Guard
+ \$ 552

Trade Current 621E

\$ - 51,700

NET BALANCE AFTER TRADE

\$ 135,780

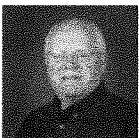

Bruce Rempe, Field Marketer
Titan Machinery - Center Point, IA
bruce.rempe@titanmachinery.com
319-213-4120 texts are welcome

This quote is good for 30 days.
The right to fix any honest errors is reserved.
Payments are estimated only.

February 18, 2021

Oelwein, City of
Oelwein, IA



\$ 196,352

Options

5-speed Transmission
with Lockup Torque Converter, Includes PowerInch progressive de-clutch
+ \$ 2,455

Diff-Lock Front Axle
Open Rear
+ \$ 1,772

High-Debris Cooling System
+ \$ 635

2nd Aux Hydraulic Circuit
+ \$ 715

Full Fenders
+ \$ 610

Tire Pressure Monitor System
+ \$ 828

Skid Plate & Transmission
Guard
+ \$ 552

| | |
|---|---|
| <p>NEW CASE 621G XT (qte 701464813)</p> <ul style="list-style-type: none"> • 29,000 lbs Class Machine • 172 Gross HP (162 net peak) Tier 4 Final FPT (Case) Engine • SCR-ONLY Emissions system (NO EGR, NO DPF, NO REGEN) • Outboard Planetaries & Multi-disk wet brakes (service brakes) • Parallel Lift Loader configuration (tool carrier) <ul style="list-style-type: none"> ○ Mechanical Self-level ○ Better Roll-back -- load retainage ○ Higher forward visibility • 4 speed Transmission • Limited-Slip Axles (front & back) • Enhanced Cab Comfort Package <ul style="list-style-type: none"> ○ Air Suspended Seat ○ Heated seat ○ Sound Suppression package ○ Sun Shade ○ Extra left side interior mirror ○ Seat drawer ○ 24V lighter ○ Am/FM/BT Radio • Enhanced Visibility Package <ul style="list-style-type: none"> ○ Right & Left heated exterior mirror ○ LED headlights w/Hi/Low beam ○ 4 front & 2 rear LED work lights ○ Rear view camera • Joystick loader control • 1 Aux Function hydraulics • Michelin 20.5R25 SnoPlus tires on 3 pc rim • Hydraulic coupler - ACS Standard (best for tool carrier configuration) • ACS Compatible 4-in-1 multi-function bucket • ACS Compatible 5 yrd Light Material Bucket • ACS Compatible Scrap Grapple (open sides) • Cold Weather Package <ul style="list-style-type: none"> ○ Heavy duty batteries (2 x 950 CCA) ○ Low-temp Hytran Ultra hydraulic oil ○ grid heater ○ DEF line insulating blanket ○ heated fuel filter/water separator • Ride control • ProCare (3 yrs, 2000 hrs -- warranty and maintenance filters & fluids) | <p>\$ 196,352</p> <p>Options</p> <p>5-speed Transmission with Lockup Torque Converter, Includes PowerInch progressive de-clutch + \$ 2,455</p> <p>Diff-Lock Front Axle Open Rear + \$ 1,772</p> <p>High-Debris Cooling System + \$ 635</p> <p>2nd Aux Hydraulic Circuit + \$ 715</p> <p>Full Fenders + \$ 610</p> <p>Tire Pressure Monitor System + \$ 828</p> <p>Skid Plate & Transmission Guard + \$ 552</p> |
| <p>Trade Current 621E</p> | <p>\$ - 51,700</p> |
| <p>NET BALANCE AFTER TRADE</p> | <p>\$ 144,652</p> |



Bruce Rempe, Field Marketer
Titan Machinery - Center Point, IA
bruce.rempe@titanmachinery.com
319-213-4120 texts are welcome

This quote is good for 30 days.
The right to fix any honest errors is reserved.
Payments are estimated only.

Light and durable wheel loader bucket constructed of high strength steel. These hard working buckets are designed to re-handle materials up to 2,200 pounds per cubic yard such as loose ash, dry loam, solid waste, cereals/wheat, salt, gypsum, wood chips, snow and leaves under 'normal/light conditions.

Drilled to accept ACS reversible bolt-on edges. Available in either pin-on or coupler-equipped configurations (please specify when ordering).

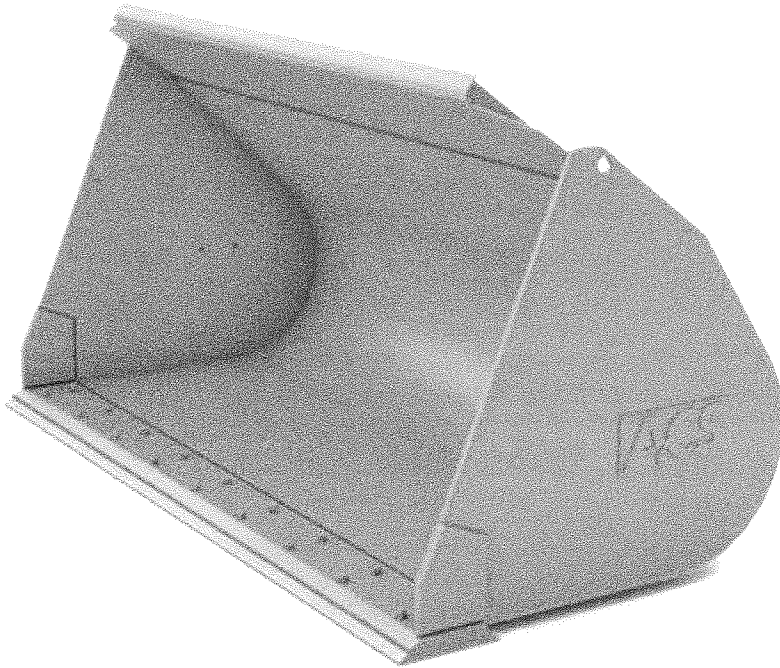



WHEEL LOADER BUCKETS

Item 16.

Selection, Innovation, Performance

Your One-Stop Shop
for Hydraulic Tools
and Attachments

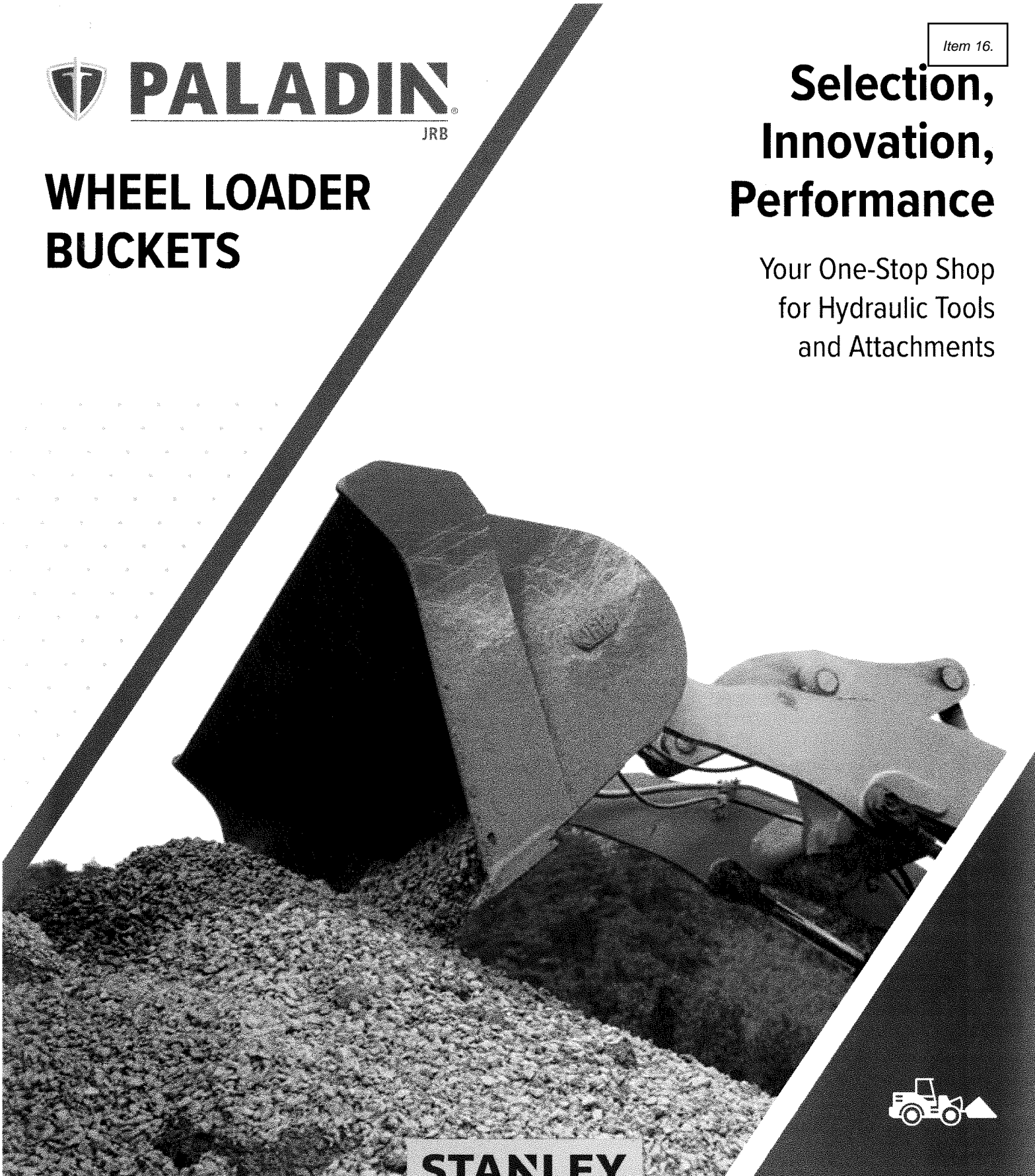

STANLEY
Infrastructure

INDUSTRIAL TOOLS & ATTACHMENTS

▼ PALADIN. STANLEY. LABOUNTY. ⚙️ PENGU

WHY SHOULD YOU BUY A JRB® LOADER BUCKET?

Exceptional Performance

- JRB® buckets allow for max fill capacities and material retention, so that you can get the most out of your bucket and the loader.

Designed for Your Loader

- Buckets have been optimized to fit your specific loader model to optimize productivity and to use common wear parts.

Buckets for Every Need

- JRB's loader bucket offering covers a wide range of applications. These buckets have been designed to...



GENERAL PURPOSE

The **JRB General Purpose (GP)** bucket is an ideal attachment to handle a variety of materials and loading tasks on the job site.

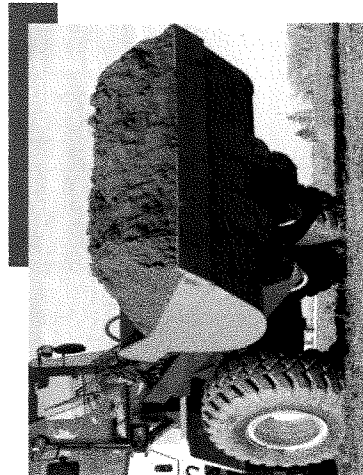
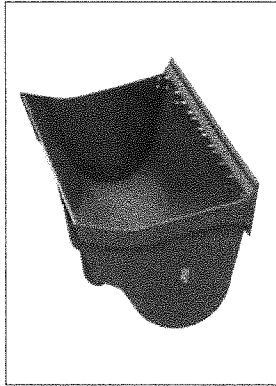

OPTIMIZED FIT

Designed specifically for the design of excavator attachments for a firm fit.



SLOPED BOTTOM

Allows for max. fill and improves dump angle by 5°.

GENERAL PURPOSE CURVED

The **JRB General Purpose Curved (GPC)** bucket builds upon the GP bucket with curved sides and other features to keep spillage to a minimum for a more productive job site.

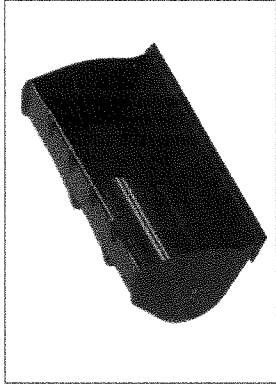

IMPROVED MATERIAL RETENTION

Curved sides and spill guard traps returned material (reverses).



OPTIMIZED FIT

Designed specifically for the design of excavator attachments for a firm fit.



SLOPED BOTTOM

Allows for max. fill and improves dump angle by 5°.

Level Indicator to help operator with bucket placement.

Spill Guard

Curved Side Cutters to minimize spillage from loaded loads.

AVAILABLE IN THE FOLLOWING LOADER SIZES

100 200 300 500 600 700 800 900

AVAILABLE IN THE FOLLOWING LOADER SIZES

200 300 500 600 700 800 900

LIGHT MATERIAL

The **JRB Light Material (LM)** bucket is perfect for picking up and transferring lighter weight materials such as mulch, coal, etc.

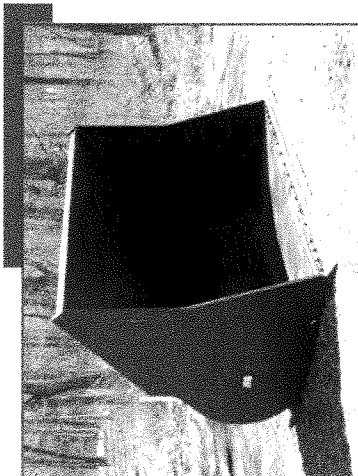
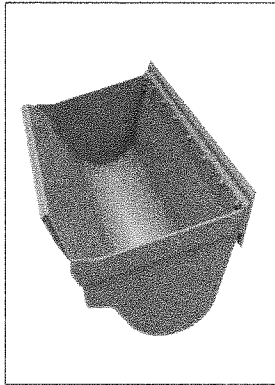

OPTIMIZED FIT

Designed specifically for the dig change excavator's attachments for a tight fit.



LIGHT WEIGHT CONSTRUCTION

Bucket weight is optimized to provide great capacity.



DOUBLE FLOOR BOTTOM

Provides greater strength and durability.



OPTIMIZED FIT

Designed specifically for the designed excavator's attachments for a tight fit.

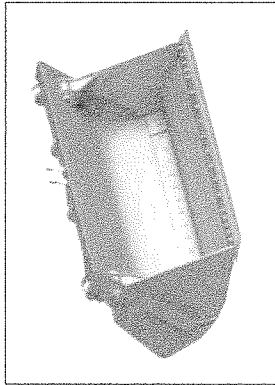

The **JRB Multi-Purpose (MP)** bucket provides a versatile loader tool that can handle excavating, gripping, loading and top dumping.

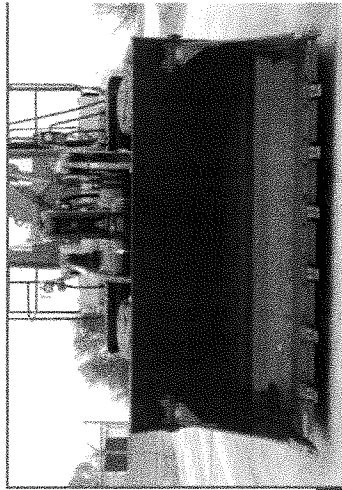

MULTI-PURPOSE

AVAILABLE IN THE FOLLOWING LOADER SIZES

| | | | | | | | |
|-----|-----|-----|-----|-----|-----|-----|-----|
| 100 | 200 | 300 | 500 | 600 | 700 | 800 | 900 |
|-----|-----|-----|-----|-----|-----|-----|-----|

AVAILABLE IN THE FOLLOWING LOADER SIZES

| | | | | | | | |
|-----|-----|-----|-----|-----|-----|-----|-----|
| 100 | 200 | 300 | 500 | 600 | 700 | 800 | 900 |
|-----|-----|-----|-----|-----|-----|-----|-----|

HIGH LIFT, ROLLOUT

The **JRB High Lift, Rollout** buckets are ideal for use in feed truck loading, transfer stations, or anywhere increased dump height and accurate load placement is required.

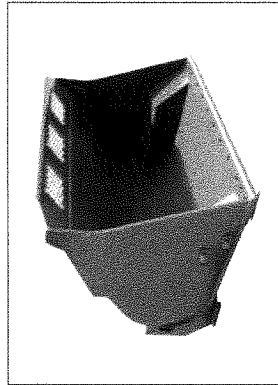

INCREASED STABILITY

Dual cushioned cylinders on the outer bucket edge prevent twisting.



INCREASED DUMP HEIGHT

Lead (16") tall rollers with ease, will up to 89% greater dump height.



PLACEMENT FLEXIBILITY

92° dump angle provides maximum load placement flexibility.

GRAPPLE

The **JRB Grapple** buckets are designed to work in land clearing and trash handling applications.

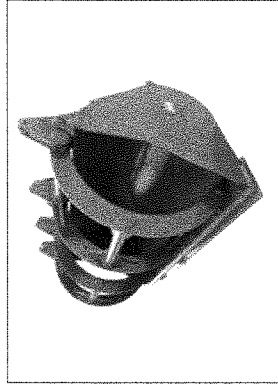

INDEPENDENT OPERATION

Grapple arms allow flexibility to climb uneven loads.



CONFIGURABLE

Full, Half and Quarter size profiles available to handle a variety of loads.



OPTIMIZED FIT

Designed specifically for the digger/digger excavator's attachments for a firm fit.

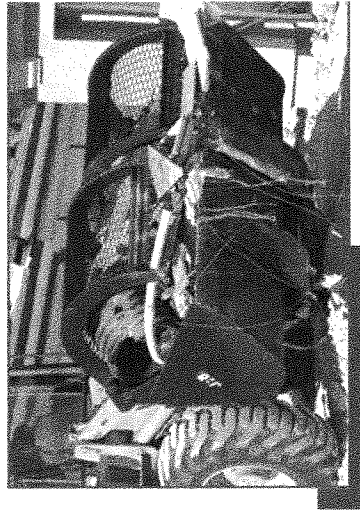

AVAILABLE IN THE FOLLOWING LOADER SIZES

| | | | | | |
|-----|-----|-----|-----|-----|-----|
| 100 | 200 | 300 | 500 | 600 | 700 |
|-----|-----|-----|-----|-----|-----|

AVAILABLE IN THE FOLLOWING LOADER SIZES

| | | | | | |
|-----|-----|-----|-----|-----|-----|
| 100 | 200 | 300 | 500 | 600 | 700 |
|-----|-----|-----|-----|-----|-----|

BUCKETS TO FIT YOUR UNIQUE NEEDS

Side Dump

Ideal for operating in confined, hard to maneuver areas. The buckets allow material to be discharged to one side at a 45° angle.

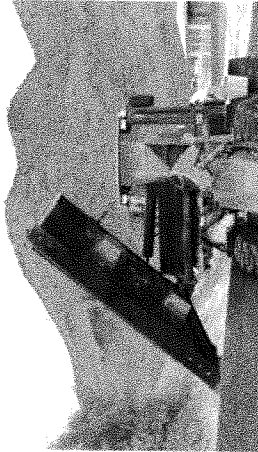

Refuse

Specifically designed to use in landfills and transfer stations. The bucket is available in Pushing and Loading styles.

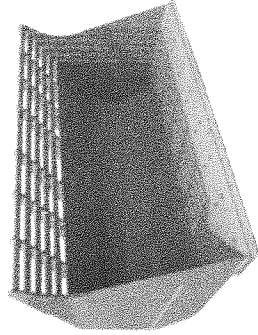

Rock

Ideal for operating in more severe loading and digging applications. A range of wear, tooth, and edge options are available to meet your specific needs.

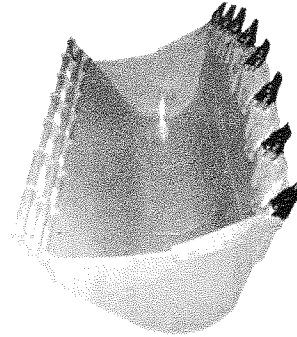

PALADIN OFFERS A FULL RANGE OF LOADER ATTACHMENTS

Forks

Tackle through material handling jobs with JRB Forks

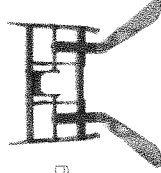

Couplers

Increase the versatility of your loader with one of JRB's hydraulic couplers.

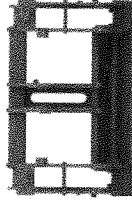

Rakes

Clear debris and brush with JRB's loader rakes.

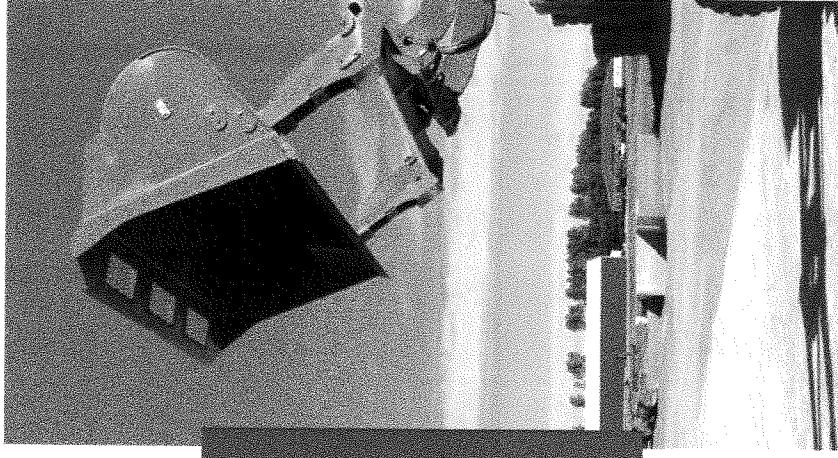

and More...

Delivering specialized solutions to enhance your loaders, CustomWorks® can help standard machines tackle the most rugged applications. CustomWorks® can modify your newly purchased or current equipment at one of four convenient locations, or ship the necessary parts and kits directly to the dealership.

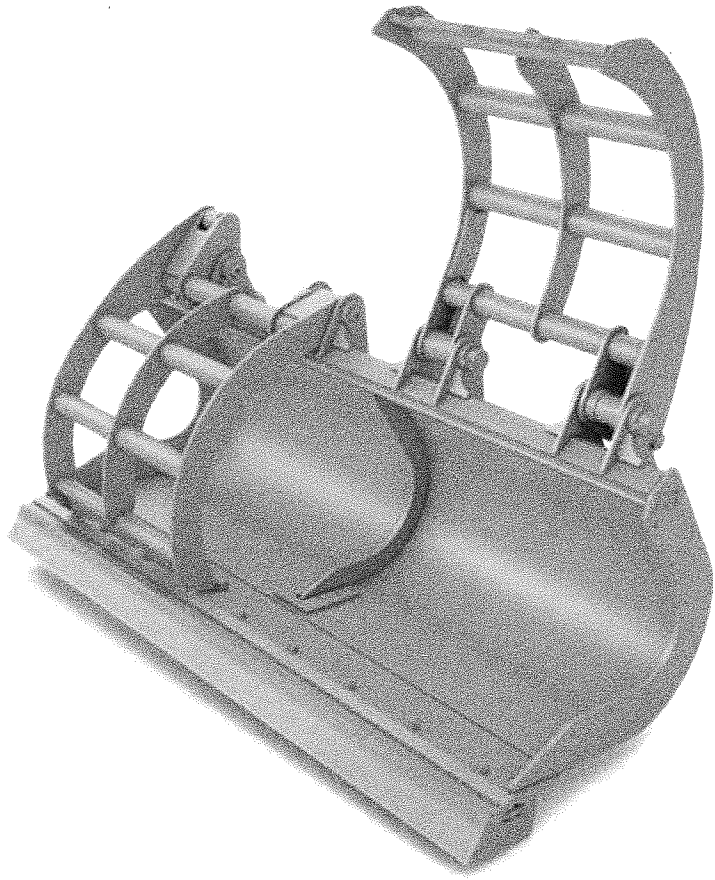



Martin Equipment
 9173 E. Tamarack Dr
 Dubuque, IA 52003

| | |
|---|--|
| Quote Issued To : CITY OF OELWEIN 20 SECOND AVENUE SW OELWEIN , IA , 50662 319-283-5440 | QUOTATION Quote # : 8003999 Issue Date : 2/12/2021 Expire Date : 3/14/2021 Est Delivery : 5/13/2021 FOB : DUBUQUE |
| Quote Issued By : Ramler, Shawn | |

ITEMS LISTED FOR SALE

| Item # | Year | Make | Model | Serial # | Hours | List Price | Sale Price |
|--------|------|------|-------|----------|-------|------------|------------|
| | 2021 | JD | 544 | (TBD) | 0 | 274,693.00 | 189,950.00 |

- 544 P WHEEL LOADER
- English Decals and Manuals
- Agriculture Material Handling Configuration
- John Deere PowerTech Engine
- Automatic Reversing Hydraulic Fan
- Engine Air Intake System with Centrifugal Precleaner
- Flat Black Curved Stack
- Standard Fuel Filter with Water Separator and Standard Fuel Fill
- Engine Block Heater
- Environmental Drains and Sampling Ports
- Engine Compartment Light
- 140 amp Alternator
- 8 Amp Converter
- Premium LED Work and Drive Lights
- 5-Speed Powershift Transmission with Lock-up Torque Converter
- High Traction - Front & Rear Hydraulically Locking Differential Axles
- Automatic Differential Lock
- Axle Oil Cooling and Filtration
- Standard Z-BAR
- Joystick Controls
- Three Function Hydraulics
- Hydrau Hydraulic Fluid
- Ride Control
- Standard Cab
- Cab with Air A/C Charge
- Deluxe Seat, Cloth with Air Suspension
- 7 inch Monitor
- Standard Exterior Mirrors
- Standard Radio
- Rear Camera
- LED Strobe Beacon with Left Beacon Bracket
- Left Side Steps Only
- Powered Cab Fresh Air Pre-Cleaner
- Steering Wheel Only
- No Payload Scale without Cycle Counter
- JDLINK Ultimate 5 Year Subscription
- Standard Front Fenders
- Hydraulic Coupler - JRB 416 Pattern
- No Bucket
- No Bucket Edge or Teeth
- No Fork Frame
- No Tines
- Rear Hitch and Counterweight
- Transmission and Bottom Guards

Total: 189,950.00

TRADE ALLOWANCES

| TIV # | Year | Make | Model | Serial # | Trade Allowance |
|---------------------------------|------|------|-------|----------|------------------|
| 211230 | 2011 | CASE | 621E | 211230 | 42000.00 |
| Total Trade Allowances : | | | | | 42,000.00 |

ADDITIONAL ITEMS

| Description | Taxable | Price | Tax | Total |
|---|-------------|-------|-----|-------|
| GEM- 2.75 YD. 4 IN 1 BUCKET, WITH JRB 416 HOOK UP AND BOLT ON CUTTING EDGE | | 0.00 | 0 | 0.00 |
| GEM-3.25 GRAPPLE BUCKET HALF OPEN SIDES, JRB 416 HOOK UP, BOLT ON CUTTING EDGE | | 0.00 | 0 | 0.00 |
| GEM- 5.0 YD. LITE MATERIAL BUCKET, WITH JRB 416 HOOK UP AND BOLT ON CUTTING EDGE. | | 0.00 | 0 | 0.00 |
| Total of Additional Items : | 0.00 | | | |

Notes

2021 544 JOHN DEERE WHEEL LOADER, MACHINE WILL BE ORDERED, COMES WITH ALL THE ABOVE OPTIONS AND MORE WITH 3 DIFFERENT BUCKETS, AND MICHELINS SNO PRO 20.5 R25 TIRES IN THE DEAL! EXTENDED POWER TRAIN / HYDS. 60/ 5000 ALSO IN THE DEAL! BUCKETS LISTED BELOW, ALL IN DEAL ALSO!

QUOTE SUMMARY

| | |
|--------------------------------------|-------------------|
| Total Sale Price : | 189,950.00 |
| Less Trade Allowance : | 42,000.00 |
| Additional Taxable Items : | 0.00 |
| Subtotal: | 147,950.00 |
| Sales Tax : | 0.00 |
| Additional Nontaxable Items : | 0.00 |
| Total : | 147,950.00 |

Acceptance Signature: _____ **Date:** _____

All quotations contingent upon strikes, delays, and conditions beyond our control. Prices subject to change with or without notice.
All prices are subject to expiration of any current sales programs and incentives.



HOUSBY HEAVY EQUIPMENT

Item 16.

City of Oelwein
Oelwein, Iowa

Date: 2/23/2021

Quote

2021 Volvo L60H Wheel Loader, New Machine Ordered

| | | |
|-----------------------------------|-------------------------------------|--------------------------------------|
| Volvo D6H Tier 4 Final Engine | 20.5R25 L2 Michelin Snow Plus Tires | Heated and Electric Rear View Mirror |
| Deluxe Cab with Heat and AC | 120V Engine Block Heater | Slow Moving Vehicle Sign |
| Air Suspension Heated Seat | Rear Axle Limited Slip | Front Aux Hydraulics |
| Ride Control | AM-FM, Bluetooth/USB/Aux | Logging Counterweight |
| Lifetime Frame Warranty | Dual Front and Rear Halogen Lights | 3.25 Grapple Brush Bucket |
| Four Year Care Track Subscription | Rear View Camera | 2.75 4in 1 Bucket With Edges |
| Std Fenders and MudFlaps | Single Lever Control | 5 Yard Light Material Bucket W/Edge |
| Standard Speed Fan | Volvo High Vis Coupler | |

Machine Warranty:

Machine has One Year Full Machine warranty with an additional 48 Month, 5,000 total hour powertrain, hydraulics and components warranty. Warranty coverage details attached.

Price: \$183,000.00

Trade: \$51,500.00

Diff: \$131,500.00

Thank you for the opportunity to quote this equipment to you.

Delivery 90 to 120 Days.

DES MOINES LOCATIONS

SALES 4747 NE 14th Street, Des Moines, IA 50313 | 515-266-2666

PARTS & SERVICE 4410 SE Four Mile Dr, Ankeny, IA 50021 | 515-964-2762

CEDAR RAPIDS 3145 16th Ave SW, Cedar Rapids, IA 52404 | 319-365-9155

HOUSBY.COM



106

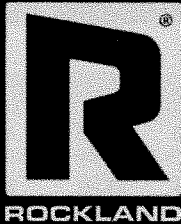

CLAMP BUCKETS

**EFFICIENTLY LOAD BULKY MATERIAL
TWO MODELS FOR EVERY APPLICATION**

Get a real grip on difficult loads!

Rockland GPC and LBC Clamp Buckets handle large bulky loads that are often impossible to load using a conventional bucket. Clamp Buckets have wide rugged dual clamps to get a firm grip on brush, scrap, demolition debris and other hard to handle materials. They really speed up the loading process and out-produce conventional buckets many times over. The small extra investment for hydraulic clamps quickly pays off on the job.

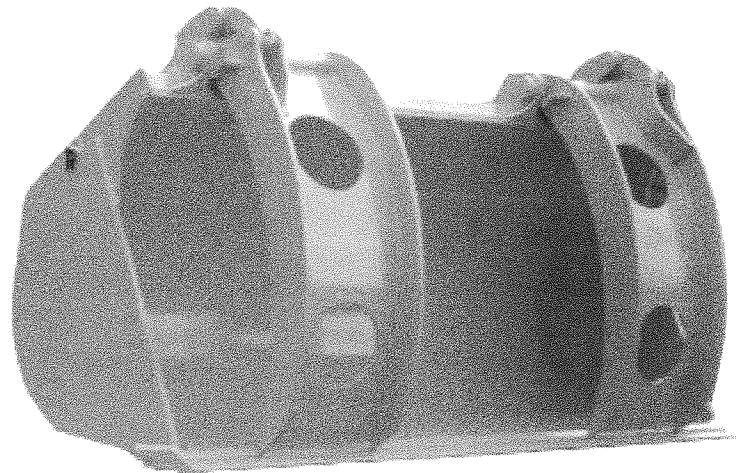

Both the GPC and the LBC are the productive combination of a standard Rockland bucket with a heavy-duty spillguard designed to support two wide hydraulic clamps. The special heavy-duty spillguard will stand up under years of dual cylinder hydraulic clamping forces. Each clamp is independently powered by its own hydraulic cylinder to get a firm grip on any load.

Bucket Selection Guide

| |
|--|
| LBC = For material less than 1500 lbs. per cubic yard |
| GPC = For material 1500 - 2700 lbs. per cubic yard |

Heavy-duty high pressure hydraulic cylinders feature induction hardened chrome plated rods, oversize pins, heat-treated bushings, and high-pressure hydraulic hoses. Each Clamp Bucket comes complete with hoses that connect to standard OEM hydraulics.

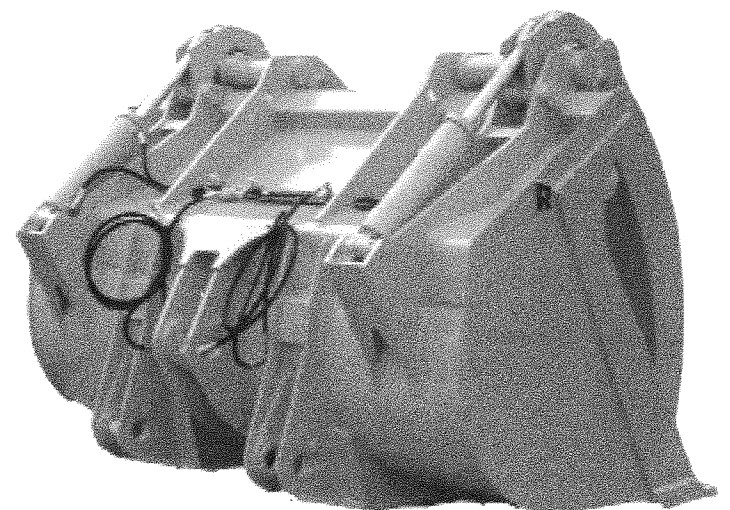

Clamp width is proportional to bucket width. Special clamps are available for unique applications. The clamps and bucket are built from weight saving, high-strength alloy steels. Bolt-on cutting edges are standard, rubber bolt-on edges and teeth of your choice are optional. Custom clamps and bucket profiles are available.

Get a firm grip on productivity with Rockland Clamp Buckets.

CLAMP BUCKETS CAN DOUBLE PRODUCTIVITY

Item 16.

GPC Clamp Buckets

| Category | 5 | | 10 | | 20 | | 30 | | 40 | | 50 | |
|-----------------------------|--------------------|---------------------|---------------------|---------------------|---------------------|---------------------|---------------------|--------------------|---------------------|---------------------|---------------------|---------------------|
| Capacity (Yd ³) | 1 0.76 | 1.25 0.96 | 1.25 0.96 | 1.5 1.15 | 2 1.53 | 2.25 1.72 | 2.5 1.91 | 3 2.29 | 3.5 2.68 | 3.75 2.87 | 4.25 3.25 | 4.5 3.44 |
| Width (") | 90 2286 | 96 2438 | 96 2438 | 100 2540 | 96 2438 | 100 2540 | 106 2692 | 106 2692 | 108 2743 | 108 2743 | 120 3048 | 126 3200 |
| Clamp Width (") | 16 406 | 16 406 | 16 406 | 18 457 | 16 406 | 18 457 | 18 457 | 18 457 | 18 457 | 18 457 | 20 508 | 20 508 |
| Weight (lbs) | 1880 853 | 2160 980 | 2210 1002 | 2400 1089 | 2775 1259 | 3175 1440 | 3775 1712 | 4125 457 | 4590 2082 | 4760 2159 | 6190 2808 | 6500 2948 |

| Category | 60 | | 70 | | 80 | | 90 | |
|-----------------------------|---------------------|---------------------|---------------------|---------------------|---------------------|---------------------|----------------------|----------------------|
| Capacity (Yd ³) | 5 3.82 | 5.5 4.21 | 6 4.59 | 6.5 4.97 | 7 5.35 | 7.5 5.73 | 8 6.12 | 9 6.88 |
| Width (") | 126 3200 | 136 3454 | 136 3454 | 136 3454 | 148 3759 | 148 3759 | 156 3962 | 156 3962 |
| Clamp Width (") | 20 508 | 24 610 | 24 610 | 24 610 | 24 610 | 24 610 | 28 711 | 28 711 |
| Weight (lbs) | 6750 1667 | 7100 3221 | 8000 3629 | 8200 3720 | 9075 4116 | 9540 4327 | 10265 4656 | 11550 5239 |

LBC Clamp Buckets

| Category | 5 | | 10 | | 20 | | 30 | | 40 | | 50 | |
|-----------------------------|---------------------|---------------------|---------------------|---------------------|---------------------|---------------------|---------------------|---------------------|---------------------|---------------------|---------------------|---------------------|
| Capacity (Yd ³) | 2 1.53 | 2.25 1.72 | 2.25 1.72 | 2.5 1.91 | 3.5 2.68 | 3.75 2.87 | 4 3.06 | 4.25 3.25 | 4.5 3.44 | 5 3.82 | 6 4.59 | 7 5.35 |
| Width (") | 90 2286 | 96 2438 | 96 2438 | 96 2438 | 96 2438 | 100 2540 | 106 2692 | 108 2743 | 112 2845 | 120 3048 | 126 3200 | 136 3454 |
| Clamp Width (") | 16 406 | 16 406 | 16 406 | 16 406 | 18 457 | 18 457 | 18 457 | 18 457 | 20 508 | 20 508 | 20 508 | 24 610 |
| Weight (lbs) | 2300 1043 | 2425 1100 | 2500 1134 | 2600 1179 | 3900 1769 | 4200 1905 | 4350 1973 | 4500 2041 | 4700 2132 | 5000 2268 | 6470 2935 | 7020 3184 |

| Category | 60 | | 70 | | 80 | | 90 | |
|-----------------------------|---------------------|---------------------|---------------------|---------------------|----------------------|----------------------|----------------------|----------------------|
| Capacity (Yd ³) | 8 6.12 | 9 6.88 | 10 7.65 | 11 8.41 | 12 9.17 | 13 9.94 | 14 10.70 | 15 11.47 |
| Width (") | 144 3658 | 144 3658 | 158 4013 | 158 4013 | 158 4013 | 158 4013 | 168 4267 | 168 4267 |
| Clamp Width (") | 24 610 | 24 610 | 28 711 | 28 711 | 28 711 | 28 711 | 30 762 | 30 762 |
| Weight (lbs) | 7600 3447 | 8500 3856 | 8700 3946 | 9030 4096 | 10000 4536 | 10235 4643 | 11775 5341 | 12275 5568 |

(mm/kg)

Specifications subject to change without notice.

INSTALLATION INFORMATION

Clamp buckets mount in place of the standard bucket using factory pins or coupler brackets. The loader must be equipped with a three-spool valve and boom arm piping. Clamp buckets come complete with jumper hoses to connect to standard boom arm piping.

WARRANTY

Rockland GPC and LBC Clamp Buckets are guaranteed against failure due to defective design, materials, or workmanship for a period of two years or 4,000 hours.



Distributed by:

ROCKLAND MANUFACTURING CO.

P.O. Box 5

Bedford, PA 15522

800-458-3773

www.rocklandmfg.com



LIGHT MATERIAL BUCKETS

MAXIMIZE YOUR MACHINE'S CAPABILITIES
ON EVERY PASS!

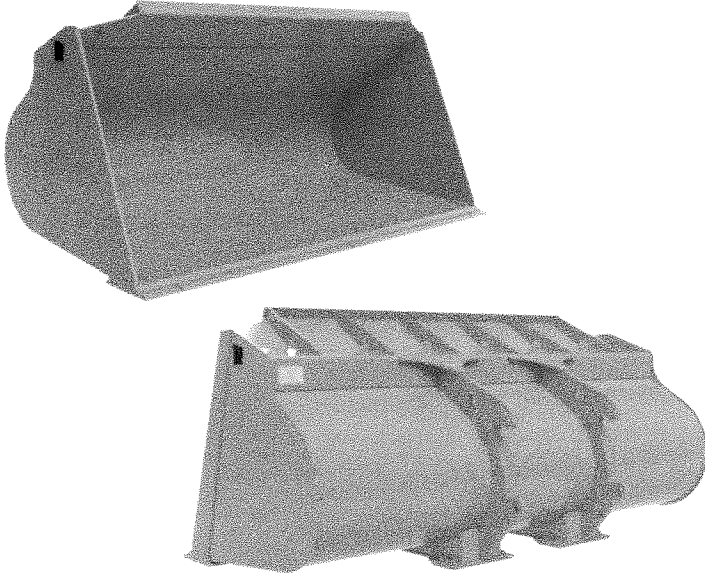

PERFECT FOR MULCH, WOOD CHIPS, DRY TOPSOIL, FERTILIZER, AND LIVESTOCK FEED APPLICATIONS

- Move as much as your machine can handle, every time
- Slope-bottom design and replaceable wear plates extend bucket life
- Lightweight, high-strength alloy steel construction delivers years of dependable performance
- Equipped with reversible bolt-on cutting edges
- Backed by our no-hassle, no-nonsense 2 year warranty!

Specifications*

RECOMMENDED CAPACITY RANGES (CU. YD.)

MACHINE STRAIGHT TIP LOAD (LBS.)

| | Up to 2.5 | 2.5-4 | 4-5 | 5-6 | 6-7 | 7-8 | 8-10 | 10-11 | 11-14 | 14-15 | 15-18 | 18-20 |
|---------------|-----------|-------|-----|-----|-----|-----|------|-------|-------|-------|-------|-------|
| Up to 8,600 | █ | | | | | | | | | | | |
| 8,601-12,800 | █ | █ | | | | | | | | | | |
| 12,801-16,700 | | █ | █ | | | | | | | | | |
| 16,701-23,800 | | | █ | █ | | | | | | | | |
| 23,801-27,000 | | | █ | █ | █ | | | | | | | |
| 27,001-34,000 | | | | █ | █ | █ | █ | | | | | |
| 34,001-42,500 | | | | | | | █ | █ | | | | |
| 42,501-54,000 | | | | | | | | █ | █ | █ | | |
| 54,001-64,000 | | | | | | | | | | █ | █ | |
| 64,001-79,000 | | | | | | | | | | █ | █ | █ |

Proudly Made in USA

*Specifications subject to change without notice

WARRANTY Rockland Light Material Buckets are guaranteed against failure due to defective design, materials, or workmanship for a period of two years or 4,000 hours.

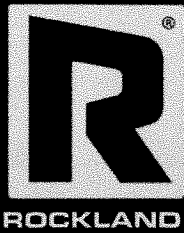

MULTI-PURPOSE BUCKETS

TWO MODELS FOR EVERY APPLICATION

Item 16.

VERSATILE

Need to be able to grip, grab, pull and lift? Need to grade, doze, or dig and load? If so, your machine deserves a Rockland Multi-Purpose Bucket. These buckets are designed to perform and built to last. They deliver true versatility without changing attachments.

The MP is ideal for utility work and general contractors.

TWO MODELS FOR EVERY APPLICATION

It excavates, loads, and clears land—virtually whatever the job may require.

The MP-L was designed specifically for trash transfer stations. Its ability to crush, pick, sort, and doze really increases trash handling efficiency.

BUILT TO LAST

Both models are built to last in the Rockland tradition. Heavy-duty clams, oversize pivots, and hard alloy wear strips guarantee years of dependable service. Hydraulics are the heart of any multi-purpose bucket and Rockland hydraulics are first-class. High pressure cylinders with special heat-treated, hard chrome-plated rods deliver dependability—year after year. All moldboards are reinforced with box sections and equipped with bolt-on cutting edges and replaceable end bits. Clams can be equipped with bolt-on cutting edges or the teeth of your choice.

This all adds up to versatility, productivity, and dependability. If you are thinking Multi-Purpose buckets, specify Rockland. You will be glad you did!

MP MULTI-PURPOSE

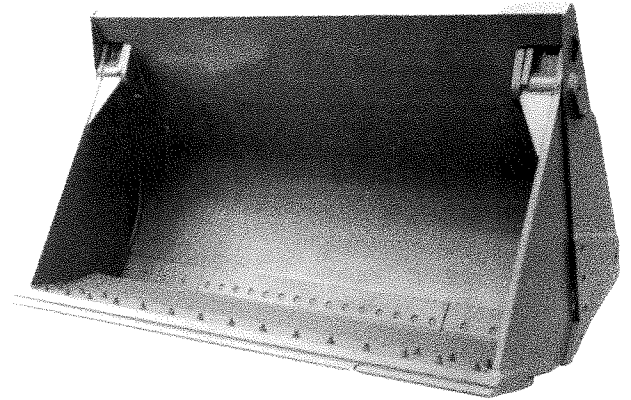

Rockland MP Buckets are ideal for utility work and general contractors.

MP-L TRASH HANDLING

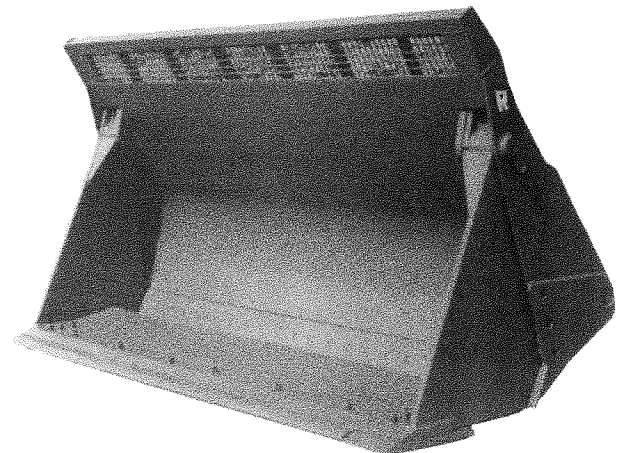

Transfer station operators appreciate the versatility of the Rockland MP-L because of the way it really speeds trash handling.

SPECIFICATIONS

Item 16.

MP MULTI-PURPOSE

WHEEL LOADER

| MACHINE CLASS | 5,10 | | 10 | | 10 | | 10,20 | | 20,30 | | 20,30 | | 30,40 | | 40 | | 40,50 | |
|----------------------------------|------|------|------|------|-------|------|-------|------|-------|------|-------|------|-------|------|------|------|-------|------|
| CAPACITY (Yd³) | 1 | .76 | 1.25 | .96 | 1.375 | 1.05 | 1.5 | 1.15 | 1.75 | 1.34 | 2 | 1.53 | 2.25 | 1.72 | 2.5 | 1.91 | 2.75 | 2.1 |
| OAW (") | 88 | 2235 | 89 | 2261 | 95 | 2413 | 95 | 2413 | 96 | 2438 | 96 | 2438 | 100 | 2540 | 106 | 2692 | 106 | 2692 |
| CEW (") | 86.5 | 2197 | 87.5 | 2223 | 93.5 | 2375 | 93 | 2362 | 94 | 2388 | 94 | 2388 | 98 | 2489 | 104 | 2642 | 104 | 2642 |
| WEIGHT (lbs.) | 1735 | 787 | 2045 | 928 | 2145 | 973 | 2360 | 1071 | 3060 | 1388 | 3260 | 1479 | 3600 | 1633 | 3790 | 1719 | 4190 | 1901 |

| MACHINE CLASS | 50 | | 50 | | 50,60 | | 60 | | 60 | | 60,70 | | 70 | | 70 | | 80 | |
|----------------------------------|------|------|------|------|-------|------|------|------|------|------|-------|------|------|------|------|------|------|------|
| CAPACITY (Yd³) | 3 | 2.29 | 3.25 | 2.48 | 3.5 | 2.68 | 3.75 | 2.87 | 4 | 3.06 | 4.25 | 3.25 | 4.5 | 3.44 | 4.75 | 3.63 | 5 | 3.82 |
| OAW (") | 116 | 2946 | 116 | 2946 | 122 | 3099 | 126 | 3200 | 132 | 3353 | 135 | 3429 | 144 | 3658 | 144 | 3658 | 144 | 3658 |
| CEW (") | 114 | 2896 | 114 | 2896 | 120 | 3048 | 124 | 3150 | 130 | 3302 | 133 | 3378 | 142 | 3607 | 142 | 3607 | 142 | 3607 |
| WEIGHT (lbs.) | 4500 | 2041 | 4900 | 2223 | 5380 | 2440 | 5480 | 2486 | 5680 | 2576 | 6110 | 2772 | 7275 | 3300 | 7775 | 3527 | 8575 | 3890 |

(mm/kg)

Specifications subject to change without notice.

CRAWLER LOADER

| MACHINE CLASS | 10 | | 10,20 | | 20 | | 20,30 | | 30 | | 30,40 | | 40 | | 40,50 | | 50 | |
|----------------------------------|------|------|-------|------|-------|------|-------|------|------|------|-------|------|------|------|-------|------|------|------|
| CAPACITY (Yd³) | 1 | 0.76 | 1.25 | 0.96 | 1.375 | 1.05 | 1.5 | 1.15 | 1.75 | 1.34 | 2 | 1.53 | 2.25 | 1.72 | 2.5 | 1.91 | 2.75 | 2.1 |
| OAW (") | 76 | 1930 | 80 | 2032 | 84 | 2134 | 84 | 2134 | 90 | 2286 | 92 | 2337 | 96 | 2438 | 100 | 2540 | 100 | 2540 |
| CEW (") | 74 | 1880 | 78 | 1981 | 82 | 2083 | 82 | 2083 | 88 | 2235 | 90 | 2286 | 94 | 2388 | 98 | 2489 | 98 | 2489 |
| WEIGHT (lbs.) | 1765 | 801 | 2395 | 1086 | 2595 | 1177 | 2795 | 1268 | 3360 | 1524 | 3615 | 1640 | 3855 | 1749 | 4300 | 1950 | 4655 | 2112 |

| MACHINE CLASS | 50,60 | | 60 | | 60 | |
|----------------------------------|-------|------|------|------|------|------|
| CAPACITY (Yd³) | 3 | 2.29 | 3.25 | 2.48 | 3.5 | 2.68 |
| OAW (") | 106 | 2692 | 106 | 2692 | 110 | 2794 |
| CEW (") | 104 | 2642 | 104 | 2642 | 108 | 2743 |
| WEIGHT (lbs.) | 5320 | 2413 | 5620 | 2549 | 6720 | 3048 |

(mm/kg)

Specifications subject to change without notice.

MP-L TRASH HANDLING

MP-L Trash Handling Bucket capacity should be determined by the weight of the material usually handled and the operating capacity of the loader. Often a bucket larger than the standard multi-purpose bucket can be used to maximize productivity.

| MACHINE CLASS | 10 | | 20 | | 20 | | 30 | | 30 | | 40 | | 40 | | 50 | | 50 | | 60 | |
|----------------------------------|------|------|------|------|------|------|------|------|------|------|------|------|------|------|------|------|------|------|------|------|
| CAPACITY (Yd³) | 2.75 | 2.1 | 2.75 | 2.1 | 4 | 3.06 | 4 | 3.06 | 5 | 3.82 | 5 | 3.82 | 6.75 | 5.16 | 6.75 | 5.16 | 7.75 | 5.93 | 7.75 | 5.93 |
| OAW (") | 96 | 2438 | 96 | 2438 | 106 | 2692 | 106 | 2692 | 106 | 2692 | 106 | 2692 | 120 | 3048 | 120 | 3048 | 130 | 3302 | 130 | 3302 |
| CEW (") | 94 | 2388 | 94 | 2388 | 104 | 2642 | 104 | 2642 | 104 | 2642 | 104 | 2642 | 118 | 2997 | 118 | 2997 | 128 | 3251 | 128 | 3251 |
| WEIGHT (lbs.) | 3295 | 1495 | 3760 | 1706 | 4090 | 1855 | 4490 | 2037 | 4900 | 2223 | 5465 | 2479 | 6000 | 2722 | 6380 | 2894 | 6755 | 3064 | 7530 | 3416 |

(mm/kg)

Specifications subject to change without notice.

INSTALLATION INFORMATION

Rockland MP buckets mount in place of the standard bucket using factory pins or specified coupler brackets. The loader must be equipped with a three-spool valve and boom arm piping. MP buckets come complete with jumper hoses to connect to standard boom arm piping.

WARRANTY

Rockland Multi-Purpose Buckets are guaranteed against failure due to defective design, workmanship or materials for a period of two years or 4000 hours.



Distributed by:

ROCKLAND MANUFACTURING CO.
P O BOX 5 **BEDFORD, PA 15522**
800-458-3773 **www.rocklandmfg.com**

| EXTENDED SERVICE PROTECTION PLAN | |
|---|--|
| MASTER PARTS SCHEDULE | |
| VOLVO CONSTRUCTION EQUIPMENT | |
| COMPACT WHEEL LOADER / WHEEL LOADER | |
| NEW AND USED EQUIPMENT | |
| <p><i>This plan provides coverage for the components listed below when a failure occurs due to a defect in material or workmanship, and may provide coverage for additional components not listed when the damage is caused by or resulting from a covered failure of a listed component.</i></p> | |
| ENGINE ONLY COVERAGE | |
| <p>The components listed below are covered under Engine Only coverage:</p> | |
| <p>ENGINE and all internal lubricated components within</p> <p>Accessory Gears Camshaft Camshaft Bearings Camshaft Drive Gear Connecting Rods & Bearings Crankshaft Bearings & Gear Crankshaft Including Front And Rear Crankshaft Seals Cylinder Heads/ Head Gaskets Cylinder Liners Engine Block Engine Oil Cooler Engine Speed Controls, Linkages, and Cables Engine Mounted Filter Mount Flywheel, Ring Gear Front And Rear Engine Covers And Seals Front Damper Fuel Lines Fuel Pumps Oil Filler Tube Oil Lines Oil Pan And Gasket Oil Pump</p> | <p>Pistons & Rings Pressure/Temperature Sensors & Sending Units Pulleys Rocker Arm Assembly Thermostat Timing Gears Valve Cover And Gasket Water Pumps Wiring Harness (internal)</p> |
| <p>Engine Components Covered After Emission Warranty</p> <p>Actuator Turbocharger Crank Case Ventilation Oil Separator And Pipes Before Separator EGR Cooler, Mixer, Flowmeter, Valve, pipes & Mixer Engine Wire Harness: (Circuits Related To Emission Warrantable Components) Engine Control Module (ECM) Emission Sensors: (Circuits Related To Emission Warrantable Components) Intake and Exhaust Manifolds and Gaskets Turbocharger Unit Injectors Charge Air Cooler, Hoses, Air Pipes & C-Clamps Emission After Treatment System as Detailed by Volvo Emission Warranty</p> | |
| <p><i>This plan excludes coverage for any failure to any component caused by or resulting from the failure of a component not listed as a covered component, including any resulting damage to a listed component. See the Terms and Conditions document for complete plan details.</i></p> | |
| POWERTRAIN COVERAGE | |
| <p>The components listed below, plus those listed below Engine Only Coverage, are covered under Powertrain Coverage:</p> | |
| <p>POWER TRANSMISSION</p> <p>Drive Axles, Front & Rear, including the Cooling Pump Dropbox Hydraulic Motor, Travelling Hydraulic Pump, Travelling Hydraulic Transmission Hydraulic Transmission Pump Hydraulic Transmission Control Valve Hydraulic Transmission Solenoid Valve Internal Wiring Harness Propeller Shaft</p> | <p>Propeller Shaft Bearing Propeller Shaft Mounting Pump Drive Transmission/Axle/Drop Box Sensors and Sending Units Torque converter, including the pump Transmission ECU</p> |
| <p>BRAKES</p> <p>Brake Discs, excluding normal wear Parking brake</p> | |
| <p><i>This plan excludes coverage for any failure to any component caused by or resulting from the failure of a component not listed as a covered component, including any resulting damage to a listed component. See the Terms and Conditions document for complete plan details.</i></p> | |
| POWERTRAIN + HYDRAULICS COVERAGE | |
| <p>The components listed below, plus those listed below Engine Only and Powertrain Coverages, are covered under Powertrain + Hydraulics Coverage:</p> | |
| <p>ENGINE</p> <p>Hydraulic Motor, cooling system Hydraulic Pump, cooling system</p> <p>STEERING SYSTEM</p> <p>Steering cylinder Steering pump Steering valves</p> | <p>HYDRAULIC SYSTEM & SPECIAL FUNCTIONS</p> <p>Hydraulic cylinders Main hydraulic pump Servo pump Servo valves Solenoid valves Valves, main hydraulics</p> |
| <p><i>This plan excludes coverage for any failure to any component caused by or resulting from the failure of a component not listed as a covered component, including any resulting damage to a listed component. See the Terms and Conditions document for complete plan details.</i></p> | |

| | |
|--|--|
| EXTENDED SERVICE PROTECTION PLAN | |
| MASTER PARTS SCHEDULE | |
| VOLVO CONSTRUCTION EQUIPMENT | |
| COMPACT WHEEL LOADER / WHEEL LOADER | |
| NEW AND USED EQUIPMENT | |
| <i>This plan provides coverage for the components listed below when a failure occurs due to a defect in material or workmanship, and may provide coverage for additional components not listed when the damage is caused by or resulting from a covered failure of a listed component.</i> | |
| POWERTRAIN + HYDRAULICS + COMPONENTS COVERAGE | |
| The components listed below, plus those listed below Engine Only, Powertrain and Powertrain + Hydraulics Coverages, are covered under Powertrain + Hydraulics + Components Coverage: | |
| ENGINE | BRAKES |
| Cooling Fan Thermostat | Brake cooling pump |
| ELECTRICAL SYSTEM | Brake pumps |
| Alternator | Brake valves |
| Circuit board | |
| VECU1 and Instrument ECU | FRAME |
| Display Unit | Rear axle mounting |
| Starter motor | |
| <i>This plan excludes coverage for any failure to any component caused by or resulting from the failure of a component not listed as a covered component, including any resulting damage to a listed component. See the Terms and Conditions document for complete plan details.</i> | |
| PREMIER COVERAGE | |
| The components listed below, plus those listed below Engine Only, Powertrain, Powertrain + Hydraulics and Powertrain + Hydraulics + Components Coverages, are covered under Premier Coverage: | |
| ENGINE | TRANSMISSION / AXLES / HYDROSTATICS |
| Air Filter Housing | Control Rods |
| Air Intake Hose | External Oil Lines |
| Engine Mounts And Supports | Filler Tubes (Transmission) |
| Fuel Tank | Pneumatic Valves |
| Mufflers | Pneumatic Dryer |
| Radiator | Transmission Oil Cooler |
| Water Piping | |
| Remote Mounted Oil Filter | ELECTRICAL (FACTORY INSTALLED) |
| | Caretrack ECU |
| | Electric Motors |
| FACTORY INSTALLED HEAT AND AIR CONDITIONING | Electronic Joysticks |
| Accumulator | Gauges |
| Clutch | Horn |
| Compressor | Indicators |
| Condenser | Instruments |
| Dryer | Radios (Factory installed only) |
| Evaporator | Sensors |
| Expansion Valve | Solenoid Valves |
| Heater Core | Switches |
| Hoses | VECU II |
| Pulley | Voltage Regulator |
| Seals & Gaskets | Wiring Harnesses |
| Temperature Control Programmers and Valves | Wiring Harnesses Exclusions |
| |Rubbing, Chafing, Loose Or Corroded Connections |
| STRUCTURAL | HYDRAULICS |
| Articulation Joint | Accumulators |
| Engine Frame | Hydraulic Cylinders |
| Rear Frame | Hydraulic Hoses and Piping |
| | Hydraulic Motors |
| CAB | Hydraulic Oil Coolers |
| Cab Frame | Hydraulic Pumps |
| Cab Mounts | Hydraulic Reservoir |
| Gas Struts | Hydraulic Valves |
| Seat Frame and Suspension | Pressure Reducing Valves |
| Steering Column | Unloading Valves |
| <i>This plan excludes coverage for any failure to any component caused by or resulting from the failure of a component not listed as a covered component, including any resulting damage to a listed component. See the Terms and Conditions document for complete plan details.</i> | |

MEMORANDUM

TO: Mayor Brett DeVore – Oelwein City Council - City Administrator Dylan Mulfinger

SUBJECT: Equipment Upgrade

With the street department, purchasing new equipment the parks department is looking forward to an equipment trade. If the parks department receives the A300 Bobcat, Bryan Const. has offer \$3,000 in trade for the current cemetery skid loader. We believe it is in the Cities best interest to sell the S130 bobcat and take the proceeds to purchase a snow blower attachment to utilize on our ever-growing trail system. In addition, purchase a set of 48” forks to be left at the cemetery to leave cribbing on a pallet, which would save the employees loading and off-loading cribbing on the dump truck every burial. It is our recommendation to stick with the Bobcat brand with Bryan Heavy Equipment, as both the Bobcat snow blower and forks are lower cost as well than the Deere equipment.





PARKS / CEMETERY / AQUATICS / CAMPGROUND / TRAILS

Park and Recreation

www.oelwein.fun

Bobcat SBX240 Snow blower – 84”

Hydraulics

Hydraulic Flow Required Min: 35 gal/min (132.5 l/min) | Required Max: 42 gal/min (159 l/min)

Dimensions

Length 44.4 in (1128 mm)

Width 86.5 in (2197 mm)

Height 65.5 in (1664 mm) | Intake: 33.8 in (859 mm)

Dimensions Steel Cutting Edge: .5x4.0 in. (13x102mm) | Fan Diameter: 24 in (610 mm) | Auger Diameter: 18.5 in (470 mm) | Discharge Chute Angle: 270° | Throw Distance: Up to 45 feet (13.7 M)

Weights

Weight Operating: 1105 lb (501 kg)

Features

Discharge Type Chute: Hydraulically Controlled

John Deere SB84H Snow blower - 84”

Key Features

- Two-stage hydraulic blower
- Simplified direct-drive hydraulic motor design
- Skid shoes adjust easily
- Deflector make it easy to direct the snow

Flow Rate 114-159 lpm (30-42 gpm)

Cutting Width 2134 mm (84 in.)

Cutting Height 914 mm (36 in.)

Bryan Heavy Equipment -SBX240 \$6,400.72

Bodensteiner John Deere - SB84H \$11,500.00



PARKS / CEMETERY / AQUATICS / CAMPGROUND / TRAILS

Park and Recreation www.oelwein.fun

**Bryan Heavy Equipment - 48" 4k Heavy Duty Pallet Fork frame and teeth
\$772.00**

**Bodensteiner John Deere - 48" 4k Heavy Duty Pallet Fork frame and teeth
\$897.00**

Joshua Johnson MA
Oelwein Park Superintendent



February 26, 2021

To the City Council:

Enclosed is a request for \$1500 from the Hotel-Motel Tax to use for continuing expenses toward reopening the Williams Center for the Arts. The need for these funds is because of the closure of the Center due to Covid 19.

I will be submitting a financial report from January-March in late March, 2021.

Sincerely

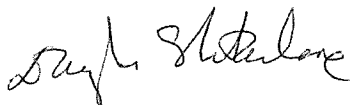
A handwritten signature in black ink, appearing to read "Douglas McFarlane". The signature is written in a cursive style with a large initial "D".

Douglas McFarlane,
Director – Williams Center for the Arts
Oelwein, IA

**CITY OF OELWEIN
HOTEL AND MOTEL TAX FUNDING APPLICATION
(TOURISM, COMMUNITY CULTURE AND EDUCATION,
AND COMMUNITY RECREATION AND EVENTS)**

Application Deadlines
September 1 – December 1
March 1 – June 1

Applications must be received by 5:00 p.m. on the deadline date. All areas of the applications must be completed and typed. Each application will be afforded the opportunity to attend a brief question and answer session with the Advisory Board.

Organization Name: Williams Center for the Arts
(Williams Center, INC.)

Contact Name: Douglas E. McFarlane, Executive Director

Mailing Address: P. O. Box 636

City, State, and Zip: Oelwein, IA 50662-0636

Phone: 319-283-6616 **FAX:** 319-283-4497

Email Address: dmcfarlane@oelwein.k12.ia.us

Total Project Cost: \$10,800

Amount requested from the Hotel/Motel Tax Funds is \$1500.

Please indicate which category you are applying for funds:

- Primary
- Community Culture and Education
- Community Recreation and Events
- New and Emerging Organization and Events

Please sign and date this application. Your signature below certifies that you have read and understand the guidelines for this funding program. You further understand that you will be required to submit a summary of expenses at the end of the project and if any funds are not expended or are found to be outside the scope of the grant made by the City Council you will be required to reimburse/return these funds to the City of Oelwein.

Applicant:

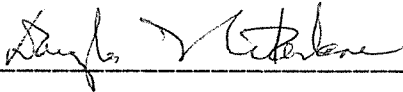
By  February 26, 2021

Douglas E. McFarlane
(Printed name)

**CITY OF OELWEIN
HOTEL/MOTEL TAX FUNDING APPLICATIONM
(Tourism, Community Culture and Education, and Community Recreation and
Events.)**

Project Identification:

1. What is the title of your project?

Continuing financial support associated with reopening the Williams Center for the Arts

2. Provide a brief description of your project. Attach Additional pages if needed.

This project is designed to help in the continued process of reopening Williams Center for the Arts. The Center is hoping to reopen for the presentation of shows in the fall of 2021. The funds being requested are needed to help pay for the operational expenses that include retainers for the five projected shows. The projected shows to be presented in the 2021-2022 season include The Boy Band (retainer has been paid), Shades of Bubl , Abbamania, Simply Queen, and the Highway Men- a tribute to Willie, Waylon and Cash. Each of these requires an upfront retainer of \$1,000. Other operating expenses include salaries, payments to Oelwein Community School District toward utilities and custodial services, printing, advertising, artist's fee, lighting, and other expenses.

The closure of the Center due to the Covid 19 pandemic resulted in the Williams Center for the Arts canceling the remainder of the 2019-2020 and the entire 2020-2021 concert seasons. The loss of revenue for this period of time was over \$100,000. Funding sources such as ticket sales and sponsorships dried up.

3. Hotel and Motel Tax Funds must be used to fund projects that promote and/or expand tourism activity in Oelwein. How will your project help to realize this goal?

The Williams Center for the Arts has been one of the top destinations of choice for the arts in the five county areas of northeast Iowa, consisting of Fayette, Allamakee, Clayton Winneshiek, and Buchanan Counties. Almost 1/3 of our audiences have come from communities other than Oelwein. We have had concert attendees from over 40 area communities, including patrons from include: Spencer, IA, Des Moines, IA, Minneapolis, MN, Rochester, MN, Galena, IL, Dubuque, IA, as well as the Oelwein area.

Without the continued help of start up funds to help reopen the Center there is the possibility of reduction of availability.

This entire proposal is based on the future situation in which the Covid 19 virus can be contained, and reopening slated for August of 2021 is still dependent on the safety of all participants.

To reopen the Williams Center for the Arts, funds will be needed regardless of the time frame of the actual opening.

People coming to Oelwein for programs at the Williams Center for the Arts not only come to the programs but also spend money with our local businesses such as eating establishments, convenience stores and motel/hotels.

During a normal concert year, the Williams Center for the Arts has spent almost \$10,000 in hotel costs at the Oelwein Cornerstone Inn and Suites. An additional \$1350 was spent for artist meals and hospitality. Sound for all nine events would total \$7,500, professional lighting \$2500 and advertisement for the season is about \$5,900,

An itemized listing of expenses is found at the end of this grant application.

Project Evaluation:

A. Targeted Population

1.) Hotel/Motel guests generated by this project.

a. Number of guests.

In years prior to this projected reopening, the number of guests generated by this project is over 100 persons. This includes the performers as well as members of the audience needing housing.

b. How will hotel/motel guests be tracked?

We ask for information from the Super 8 Hotel, the Parkview Motel and the Cornerstone Inn and Suites as to the number of rooms used and how many guests were housed in those rooms per evening.

2.) Number of adults this project will reach.

As a result of this reopening project, the projected number of visitors to the Williams Center will be dictated by the extent of the protocols. Those protocols include:

*Wearing of masks at all times by members of the audience

*Social distancing

*No more than 300 persons in the auditorium at a time.

(The hope is that this number may be raised.)

It could be as high as 775 per event depending on how Covid 19 affects our community and surrounding area.

Total number of persons using the Williams Center for the Arts has been 75,000 in past years. It is realized that this number will probably not be achieved immediately. Groups that have used the center have included the Williams Center for the Arts Artist Series, City of Oelwein, Mercy One Hospital, NICC use, school use, district and state music associations, the State of Iowa, and the Federal Government. The usage of the Center by outside groups will depend on Covid 19.

The Williams Center for the Arts has provided residents with special needs the opportunity to attend the events at the center. Groups with special needs using the Williams Center for the Arts include: Mercy One Living Plus, the two Alternative Living Homes in Oelwein, Full Circle Services, Grandview Nursing Home, Oelwein Care Nursing Home, and the ABCM facilities in Independence, IA. These residents are admitted to the Artist Series event at a greatly reduced ticket price. Because of Covid 19, these entities may not be able to return coming to the Center immediately.

3.) Number of youth the project will reach.

This project prepares the center for usage. As has been Center policy, all Oelwein Community School District School students (K-12. are admitted at no charge.

C. Volunteers

1.) Number of volunteers

When the Center can reopen, it is anticipated there will be about 25 volunteers per event.

2.) Number of volunteer hours.

We anticipated volunteers would be contributing 50 hours to the reopening process.

D. Attendance of event previous year(s)

The total number of visitors to the Williams Center for the Arts has been approximately 75,000 persons. (This includes the Williams Center for the Arts Artist Series, North East Iowa Honor Bands and Honor Choirs, Pre-All State High School Vocal Workshop, Programs and Concerts from the Oelwein Community Schools, Gallagher-Bluedorn children's plays, and various Community usages, as well as the State of Iowa, and the Federal Government.

E. Day open to the public or performances(s)?

The Center officials anticipate that the reopening of the center programs will be August, 2021. Of course, this is contingent on the status of the Covid 19 virus. At this time we project that ticket sales for the first event will go on sale in June 2021.

4. Project Budget:

A. Please provide a project budget and schedule of completion including all expenses. If desired, the project budget may be attached to the application. If

exact costs are not known please attach estimates to the application, which should be identified as such.

Cost estimates are Included at the conclusion of this grant request. Date of cost completion is anticipated to be June30, 2021. These funds are needed to keep the Williams Center going regardless of the status of the Covid 19 virus.

B. List sources of matching funds obtained below. Funding requests are eligible up to 100% funding, but priority will be given to projects with additional sources of funding, including in-kind donations.

Matching funds:

*For this project of reopening the Greater Oelwein Charitable Foundation and the *Northeast Iowa Charitable Foundation will assist.

*We continue to search for grants to assist us in the reopening process.

*The Williams Center for the Arts is hoping for a \$1,500 from this City Hotel/Motel Tax to help reopen the Williams Center for the Arts

C. Is this application “seed money” for a new? Project? If yes, Please explain.

No

D. Is this application for the expansion of an existing project/program? If yes, please explain.

This application, if approved allows for the preparation to resume normal operation.

E. Have you ever received Hotel/Motel funding? From the City of Oelwein in the past?

Yes: X No: _____

If you answered yes, please answer the following: (attach additional pages if needed)

Amount of Funding: The Williams Center Artist Series has received \$4,000 each year in the past. This amount was raised to \$6,000 recently. We are hoping for a \$1,500 grant for this particular event.

Completion Date is: June 20, 2021.

The final report for this grant will be filed soon as all bills have been submitted and paid.

It should be noted that the center has not had any usual income since March of 2020. Normal sources of income have included, Season Memberships, Event Ticket Sales and Sponsorships. Although the City Hotel/Motel Tax. Approved a \$1500 grant for "The Boy Band Night," the concert will be rescheduled in the upcoming concert series.

TOTAL BUDGET FOR: Reopening the Williams Center: Concert year 2021-2022

Salaries for the Director and Tech Director: \$21,000
Utilities: \$6,000
Advances for "Performers in the Artist Series" - \$4000
Performance fees: \$56,000
Advertising - \$5,900
Sound and Light: \$10,000
Miscellaneous: \$10,000

Total Projected Costs: \$112,900



Minutes

Park & Rec Meeting
 Oelwein Fire Department
 March 16th, 2021 - 5:15 PM

Park and Recreation

www.oelwein.fun

Call to Order: 5:18 by Gearhart

Roll Call: Burkhart, Cantrell, Gearhart, Johnson, Jorgensen, Meska, Milks, Stasi, Stewart, Taylor

Attending: Burkhart, Cantrell, Gearhart, Johnson, Jorgensen, Stasi

Absent: Milks, Taylor

Approval of Minutes

- Consideration of a motion approving the minutes of the January 18th, 2021 meeting
- | | | | |
|---------|-----------|-------------------|---------|
| Motion: | Jorgensen | 2 nd : | Stewart |
| Aye: | All | Nay: | None |

Park and Recreation Master Plan

- 1-5 years

Johnson started out the discussion by going through the different areas that he brought to the meeting. Johnson explained that these are areas the need the quickest maintenance on them and invited the board to suggest changes and add as needed. Gearhart agreed that the City should continue to make sure the pool is in great working condition as it is a great asset to the community. Meska talked about the bocce ball court at Red Gate being updating. Discussion went on how the board would really like to see cabins built at the campground. The opportunity to bring in people to utilize the cabins would be a year round proposal and would bring people to the community.

Gearhart stated that the rec program could use some changes, as he would like to see more participation. Gearhart stated that coaches meetings could be more organized for everyone. Gearhart would like to see a layout of what goals are expected out of a participant in a season and have more structure with practices. Jorgensen agreed that more structure to practices would benefit the program and that they had someone complete this years ago for the program. Stewart stated that if they had structured plans then they would not have each coach coming up with their own plans for each team. Stasi stated that he has been interested in coaching soccer but was unsure about expectations. Gearhart stated the varsity high school coaches should be brought in and meet with the park and rec board to offer their assistance.

Recreation Report

Burkhart stated that they finished coed volleyball and will be hosting their tournament this weekend. Itty-bitty basketball where split up this year with girls and boy separate due to COVID. Burkhart stated that they sent basketballs home with the participants instead of shirts this season. Burkhart talked about 3-6th dodgeball and soccer program starting. Little league registration were sent out and are due on the 17th of this month. Burkhart stated that the rec program is still looking for coaches and umpires for various programs, and is working on adult softball schedules. Burkhart stated that starting in April they would be relaxing mask mandates requiring when enter the building and can remove when get to their station. Easer and Burkhart are teaching BLS classes. Burkhart stated that they had 192 kids apply for grant assistance for programs last year and expect those numbers to increase this year. Cantrell asked if registrations are online and Burkhart stated that they are not at this time. Burkhart stated that they will be training new personnel at the wellness center and that fitness classes are filling up as attendance is picking up with more people being vaccinated.

Tree Board Update

Johnson stated that they held their monthly meeting last week at the park shop. Kyle Scheel and Jeff Milks where reappointed to the board by council for another three year term. The board interviewed an applicant for the empty position that Tom Fick is vacating. Johnson stated that the board received the Tree City Award for 2020 for the City of Oelwein. Johnson also stated that they received the Trees Forever grant again this year. The award was for the full \$5,000 to purchase trees to be planted in the street boulevard, as energy saving benefits are a requirement of this grant. Johnson stated that this amount usually purchases around 50-55 trees that he gets competitive quotes from the two closest tree nursery's, Manskes corner market and Cannons in Westgate. Johnson stated that he included a link for citizens to use on their website if they are interested in have a tree planted in front of their property with this grant.

Trails Update

Johnson stated that they held their monthly meeting last week at the park shop to review their progress. Johnson stated that he was able to secure a donation this month for \$1,000 from Dave Sondrol for trails. Johnson stated that he also talked with Michelle McBride with BCHC and was able to secure a donation of \$1,000 per year for the next 5 years for trails. Johnson said that they received their annual contribution from the Northeast Iowa Charitable Foundation for the \$250,000 last week. Johnson stated that they wrote a grant proposal to the Well mark Foundation and received over 20 letters from the community in support of the proposal. Johnson stated that there have been numerous citizens tell them that they really appreciate the department clearing the snow off the trails this winter season.

- **Segment 1** - Johnson stated that they received bids from several contractors on the segment one project, as he displayed the bid amounts to the board. Johnson stated that they timed the bidding very well and received some very good quotes for this project. Johnson provided pictures of the trail segments and the bid amounts received. Johnson reviewed with the board that this segment would create a trailhead at 2nd St. NW until they can get an easement from Iowa Northern Railroad.

- SF 420 – Johnson stated that he has enlisted the assistance of Larry Murphy to help with proposing a bill in Des Moines changing the wording of state code. This change in code will satisfy any concerns that INR has about giving the City an easement for the trail section to the viaduct. Johnson stated that this bill has passed the senate transportation committee and hit the senate floor last week. The bill has similar wording in which they used for RAGBRAI when they had issues of liability with counties banning the event due to lawsuits. Johnson stated that he received a call from Andrea Bolton, the Trails and Greenways Director with the Iowa Natural Heritage Foundation concerning our trails bill. Bolton stated that this bill would benefit so many communities throughout the state for future trail developments.
- **Segment 2** – Johnson showed the board maps of segment 2 with what he has been working with on easements. Johnson discussed the retaining wall on the west side of the viaduct that needs to be addressed. Johnson discussed different options traversing the trail through Woodlawn Cemetery as well and showed them a bridge possibility if he can find the funding.

Parks/Cemetery Report

Johnson stated that they met with Jennifer Dillon the new FFA instructor and took the hanging baskets for the kids to start planting the flowers for downtown. Johnson stated that the new tables for the aquatic center arrived and have been assembled which was part of the bond project. Johnson stated that Jay has prepped the doors for the campground shower house and Wings Park storage area for install when the employees return. Johnson stated that they have been clearing sidewalks for delinquent homes for community development. Johnson stated that they are working on an equipment trade with the streets getting their skid loader. This will enable the employees to use all the attachments without having to borrow their skid loader all the time. Johnson stated that they are working on a proposal to sell the old cemetery loader that only has slow gear and cannot use any attachments by utilizing that money for attachments. One would be a snow blower attachment for the skid loader to properly clean trails in the winter and the other would be a set of forks for the cemetery to use. Johnson said that Upper Iowa called about their appreciation day and will be sending down a group to help with some painting projects. Johnson stated that they received a brush that they can utilize on their tractor to clean the trail instead of taking the skid loader on the trails. Perkins picked up a pair of memorial benches that will be installed this spring. Perkins also grabbed the anchors for the new basketball hoops that they will be installing at Wings Park in the old tennis courts. Johnson stated that the dam was been put back the first week in March as planned and the lake is full once again. Johnson stated that they have had eight full burials this year thus far at Woodlawn Cemetery. Johnson stated that the contractors are eager to get working on the bathroom/shelter at Red Gate Park as soon as possible. Johnson said that on Wednesday he would be attending a zoom meeting with the Upper explorer land Commission. Weather pending the parks and cemetery employees will be called in soon to get started on projects for the season. Johnson stated that Perkins and he started removal of the fencing at the pool to make way for the new trail section. Johnson stated that he called in the cemetery crew to clean out the old chamber building near the log cabin. The City is hoping to sell this building and wanted it cleaned out as the previous owner left their belongings all over the inside and basement.

Johnson and Perkins also exchanged the lights in the pump room at the aquatic facility to LED lighting, which will help tremendously as the room has been dim in the past. Johnson said all the lights in the large shower building and the parking lot lights were converted to LED last season. Work on lighting and returning some of the palm leaves on the tiki hut that have blown off with strong winds was completed. Jay has been checking drainage areas to make sure they are clear with the snow melting. Jay reinstalled the bike fixit station at Wings Park that was damaged last fall. The main drain plug on the pool filter that rusted through last season was replaced after we tapped the threads, as the filter replacement project is our high priority for this department.

Johnson stated that the following larger projects are planned this season with the parks department.

- ❖ Disc golf course install
- ❖ Diamond 3 infield fencing
- ❖ Website work
- ❖ Finish shelter/sidewalk at Platt Park
- ❖ Remove old well houses at City Park
- ❖ Drinking fountains install
- ❖ Replace campground shower house doors
- ❖ Diamond 1 building work
- ❖ Arching sign for entrance at Woodlawn
- ❖ Memorial benches install
- ❖ Take new tables to aquatic center
- ❖ Wings door replacement
- ❖ WIFI install campground
- ❖ Playground equip install Red Gate
- ❖ Trail work/easements
- ❖ Electrical project at City Park
- ❖ Bathroom/shelter project at Red Gate
- ❖ Replace decking on old bridge
- ❖ Grant work
- ❖ Pool shelter install
- ❖ Motor/Pump replacement at pool
- ❖ Block signs at Woodlawn
- ❖ Surveillance system at pool
- ❖ Install basketball hoops at Wings
- ❖ Upgrade new controller at pool

Board Member Updates: None

Adjournment: 6:28pm

Next Meeting: April 19th 2021

The Oelwein Public Library Board of Trustees held its regular board meeting on Tuesday March 16, 2021 at 5:00 p.m. at the library.

Present: Ingersoll, Gilson, Kerns, Berryman, Payne, and Macken

Absent: Mars

Vice-president Kerns called the meeting to order at 5:02 p.m.

Gilson made a motion to approve the agenda and the minutes. Seconded by Berryman. Motion carried.

Correspondences: none

Trustee Training: The board reviewed the standard on providing access to digitized local collections. The Oelwein Daily Register is microfilmed and digitized. Currently, the newspapers are digitized up to 2016.

Director's Report:

- **Building Leaks Project:** The city administrator is pursuing a project manager to investigate and resolve the building roof leaks.
- **Seuss books:** Some titles of the Dr. Seuss books will no longer be published. Some because of content and some because of poor sales. This decision by the publisher has caused the resale of some of these books to dramatically increase. Persons have been inquiring if the library is going to withdraw these books from the collection and, if so, they would like to buy them. Therefore, these particular titles have been temporarily removed from the shelves until the market softens.
- **Library Page:** Jeff Hughes has submitted his resignation. His last day is March 18. Staff are in the process of filling this position.
- **Story Walk:** The Fayette County Library Association is interested in writing a grant for CARES funds that would cover the cost of a county-wide story walk. The grant funds would purchase permanent signage holders and two years' worth of story books to rotate around the county throughout the year. Each library would have a kiosk with a map of the location of all the story walks. Each library would be responsible for installing and maintaining the holders. If the grant is approved, the story walk needs to be installed by June 30.

Friend's Report:

- The curbside delivery chocolate fest will be March 26-27 during library hours.

Bills were reviewed. Gilson made a motion to approve the bills. Seconded by Ingersoll. Motion carried.

Library Services and Hours were discussed. Staff have the opportunity to get their COVID vaccinations in the upcoming weeks. After staff are fully vaccinated or have been given the opportunity to be fully vaccinated, more services will be available. Currently, services and precautionary measures will remain the same.

The **Gifts and Donations policy** was reviewed. Gilson made a motion to accept the policy as reviewed. Seconded by Ingersoll. Motion carried.

Berryman made a motion to adjourn at 5:45 p.m. The next meeting will be held on April 13.

Respectfully submitted,

Susan Macken



To: Mayor and City Council

From: Dylan Mulfinger

Subject: Administrator's Council Agenda Memo

Date: 03/22/2021

Consent Agenda

1. Consideration of a motion approving March 8, 2021 Council Minutes
2. Claims Resolution in the amount of \$486,327.01
3. Consideration of a new Class 'E' Liquor and Sunday Sales permit for H & S Store LLC dba Super Mart
4. Consideration of a new Cigarette Permit for H & S Store LLC dba Super Mart

Resolutions

5. Consideration of a Resolution finally approving and confirming plans, specifications, form of contract and estimate of cost for the Oelwein 2021 Water Main Improvements Project
 1. Council will now approve the plans for the Water Infrastructure project. Council accepted the bid last meeting. The City Administrator recommends approving the resolution.
6. Consideration of a Resolution awarding contract for the Oelwein 2021 Water Main Improvements Project
 1. Council will now enter into an agreement with Summer for the Water Infrastructure project. Council accepted the bid last meeting. The City Administrator recommends approving the resolution.
7. Consideration of a Resolution approving contract and performance and/or payment bonds for the Oelwein 2021 Water Main Improvements Project
 1. Council will now approve the bonds for the Water Infrastructure project. Council accepted the bid last meeting. The City Administrator recommends approving the resolution.
8. Consideration of a Resolution Directing the Sale of the City's Interest in 17 5th Avenue SE, Oelwein, Fayette County, Iowa
 1. This property owner will expand their 50-foot lot with another 50 foot lot. The City Administrator recommends approving the resolution.
9. Consideration of a Resolution Reinstating Online Fees for Utility Bill Payments
 1. The City suspended electronic transition fees on the utility bills because city hall was closed to the public. City Hall will open in April. The City Administrator recommends approving the resolution.
10. Consideration of a Resolution Establishing Collective Bargaining and Nonunion Salaries for City Employees



1. The City Administrator is tasked with setting wages and salaries for staff. Police Union is negotiated along with public works and is on year four of a five-year contract. Both contracts are set for three percent in 2021-2022. Hourly employees are at a three percent increase in the resolution presented. Department heads are negotiated with the City Administrator and based on performance reviews. No wages are over four percent for the year 2021-2022. The City Administrator is set at three percent and can be adjusted during the evaluation process. The City Administrator recommends approving the resolution.

Motions

11. Consideration of a motion to set a Public Hearing for April 12, 2021 at 6:00 P.M. on Notice of Intent to apply for financial assistance with the USDA Rural Development for Oelwein Police Department Heating and Cooling System and Oelwein Fire Department Aerial Fire Truck Apparatus
 1. The City is working toward a grant to repair the heating and cooling system for the Police Station. This public hearing starts the process for the grant.
12. Consideration of a motion approving an amendment for engineering services in the amount of \$9000.00 for Oelwein Industrial Park 3rd Addition Utility Improvements
 1. This is the final payment for work on the industrial park. This closes out the project. The City Administrator recommends approving the payment.
13. Consideration of a motion to purchase Replacement Dump Box in the amount of \$19,610.00
 1. This item has been discussed in work sessions with council. Vic Kane has provided the recommendation and bids. The City Administrator recommends approving the purchase.
14. Consideration of a motion to purchase skid steer in the amount of \$68,361.76
 1. This item has been discussed in work sessions with council. Vic Kane has provided the recommendation and bids. The City Administrator recommends approving the purchase.
15. Consideration of a motion to purchase dump truck and snow plow equipment in the amount of \$136,715.00
 1. This item has been discussed in work sessions with council. Vic Kane has provided the recommendation and bids. The City Administrator recommends approving the purchase.
16. Consideration of a motion to purchase wheel loader in the amount of \$131,500.00
 1. This item has been discussed in work sessions with council. Vic Kane has provided the recommendation and bids. The City Administrator recommends approving the purchase.
17. Consideration of a motion to purchase snow blower attachment and heavy duty pallet fork in the amount of \$7,172.72
 1. The Parks department would add two pieces of equipment to help at parks and cemetery. Funds for this unbudgeted item would come from selling the parks skid loader. Josh Johnson has provided a



recommendation. The City Administrator recommends approving the purchase.

18. Consideration of a recommendation from Planning, Finance, Enterprise and Economic Development re: Williams Center for the Arts Hotel/Motel Funding Application
19. Consideration of a motion to set date for Spring Clean Up
 1. The City Administrator recommends using the ticket system this year as 253 \$5.00 bulk item stickers were sold last year. In 2019 the spring cleanup brought in 179 people. In 2019 we had 20 open nuisance abatements for trash and none of them used the spring cleanup.



Street Department
February 2021

Department News

Snow plowing and hauling

Monthly Activities

Safety Meeting, Street Sweeping, Push up brush & leaf piles.
Record Underground Storage Tank "UST" information. "City Fuel Station"

Nonscheduled Work Performed

Dug 0 Graves. 0 Tree removals.
Clear storm sewer intakes
Plow snow Haul snow
Assist water Department with water main breaks

Scheduled Work Performed

Filling potholes
Perform routine maintenance on Equipment.
Repairing Street Sweepers

Up Coming Projects



Water & Sewer Collection Department Monthly Report
February 2021

Department News

Monthly Activities

Pumped **17,813,000** gallons of water from the wells.
 Completed **29** work orders from City Hall.
 Performed **10** locates marking location of city water, sewer, storm sewers and electrical.
 Collected **0** water meter readings from walking routes.
 Delivered **20** red door tags giving the final notice of impending shut down of services.
 Shut down **6** services for nonpayment.
 Took **8** Bacteria tests of the water system – All passed.
 Monthly safety check lists and departmental safety meeting completed.
 Responded to **4** sewer backup call. **3** homeowner and **1** City sewer surcharge issues.
 Daily water rounds consisting of chlorine residual testing, well and lift station checks.

Nonscheduled Work Performed

Dig and repair curb stop 800 Block 2nd Street NW.
 Dig and repair main break 600 Block 7th Ave NE.
 Dig and repair main break Hillside West.
 Dig and repair curb stop 10 Block 2nd Street NW.
 Dig and repair main break 3rd Ave NE.
 Thaw frozen water service 200 Block 5th Ave NE.
 Thaw frozen water service 700 Block 1st Street NE.
 Plow snow.
 Haul snow.

Scheduled Work Performed

Equipment maintenance.
 Meter changes.

Up Coming Projects

42 well completion



PARKS MONTHLY REPORT, FEBRUARY 2021
PARKS / CEMETERY / AQUATICS / CAMPGROUND / TRAILS

Park and Recreation **www.oelwein.fun**

This month in the park department, we have been completing our daily disinfecting of areas and cleaning the downtown every morning. The new tables for the aquatic center arrived this month, as Jay will assemble them and take to the facility. I talked with Jennifer Dillon who has taken over the FFA program this past year about the hanging flowers for downtown. Jay and I will take the baskets up to the school when they are ready so they can go through them and replace some of the older baskets. We came in on Sunday after the snow was finished and did our sidewalks, trails and cemetery responsibilities. The guys completed 10 more sidewalks for homeowners that neglected to take care of their sidewalks after this past snow. I have been ordering our CIP items this year so that they will be here ready to go for installation when the employees come back. I contacted Blake Gamm with the county to see when they can assist the City with their seed drill, putting in another prairie planting at Platt Park this season. The trails committee met the second Tuesday as we are finishing the Wellmark grant and have been receiving letters of support to go along with our proposal.

Jay is prepping the new doors for paint that are going on the campground shower house and at Wings storage. Delinquent sidewalks were completed for community development people. Trail Segment 1 is out for bid and have had several contractors download the plans for this project, which will hopefully result in many competitive bids. The bidding concludes on February 19th and we will present results to council for contractor approval. At Woodlawn, we had a full burial for Geilenfeld funeral home on Tuesday. We are looking at trade with the street department skid loader and selling the 09' S130 cemetery skid loader with 2124 hours on it which we could roughly get around 7k for trade in. The snow and cold weather continues as Friday we had blizzard conditions all day, which drifted in the north end of Woodlawn that we finished clearing out on Monday. I have been in contact with Buchanan County Health Center and they are planning to make a sizeable donation towards our trail project for the next five years.

Jay painted the shower house doors for the campground this past week. I submitted a grant intent letter to Alliant Energy for possible trail money. On Tuesday, I submitted our trails grant to the Wellmark Foundation in which we received over 20 letters of support from community members. I accepted a thousand dollar check from Dave Sondrol this week for a trail donation. This Friday will be the final day for taking bids on Segment one trail. I received a call from Andrea Bolton with the Iowa Natural Heritage Foundation. Andrea was inquiring/excited about our bill we have in Des Moines to change state law for trails that will help many communities with future trail systems. We prepared at full burial on Monday morning in subzero temperatures for a Tuesday burial. I had a call from Upper Iowa University, as they are looking for projects for their Day of Caring that they had to forego last spring. We have painting projects in City Park and Platt Park for them to paint, tables, shelters, signs and benches. Jay and I have been assembling the new tables for the aquatic center that will go in the concession area and in the new shelter this spring.

Jay and I finished assembling the new tables for the aquatic center, which is a bond project. This month we received the brush for the 730 tractor so we can brush the trails, which is a CIP item. Jay made a run to Janesville to pick up two memorial benches that were donated to the City. One bench is for Bob Henderson that will go to the complex and the other is for Roger Schulz that will be placed in Plaza Park. Jay is working on fabricating new rings for the elevated guard chairs at the pool to accept the new umbrellas that we received \$5,000 through a grant from the RJ McElroy Trust. Jay swung by Scheels and picked up the anchors for the new basketball hoops we will be putting in at Wings Park that is a CIP item. Jay did some snow removal for

PARKS / CEMETERY / AQUATICS / CAMPGROUND / TRAILS

Park and Recreation www.oelwein.fun

delinquent sidewalks this week. We have received many compliments recently for clearing the trails of snow this winter season, and for clearing trailhead areas for parking. We also received a call this week from a citizen thanking us for keep the cemetery plowed so they could walk there this winter. Friday the 19th, we held a zoom meeting with contractors accepting bids for trail segment 1 for construction this season.

Aquatics tables delivered



Downtown hanging baskets



Trails

Grant work



Campground doors

Delinquent sidewalks

Picnic table painting

Trail clearing



Burials

Skidloader trade

Trail donation

CIP item





PARKS / CEMETERY / AQUATICS / CAMPGROUND / TRAILS

Park and Recreation

www.oelwein.fun

Painted doors



Grant work

Burial



FAD

Aquatics tables



Alliant Energy™



UPPER IOWA UNIVERSITY



Iowa Natural Heritage Foundation

Aquatic tables



Trail brush



Memorial benches



Umbrellas



BB anchors



Trail bids



Snow removal





PARKS / CEMETERY / AQUATICS / CAMPGROUND / TRAILS

Park and Recreation

www.oelwein.fun

Daily Activities

www.oelwein.fun

- ❖ Sanitizing shop and equipment
- ❖ Pick up garbage downtown
- ❖ Checking/maintaining parks, cemeteries
- ❖ Maintenance on equipment
- ❖ Order supplies for all departments
- ❖ Safety meetings
- ❖ 3 full burials
- ❖ Meet with contractors

Progress on Projects

www.oelwein.fun

- ❖ Website work
- ❖ Finish ordering CIP items
- ❖ Trail work/easements/grants
- ❖ Continuing education classes
- ❖ Equipment maintenance finished
- ❖ Work on Park and Rec master plan
- ❖ Secured \$6,000 in trails donations
- ❖ Picked up memorial benches and basketball hoop anchors
- ❖ Took hanging baskets to FFA
- ❖ Received quotes on trail segment 1

Next Month and Future Projects

www.oelwein.fun

- ❖ Disc golf course install
- ❖ Diamond 3 fencing
- ❖ Website work
- ❖ Finish shelter/sidewalk at Platt Park
- ❖ Remove old well houses at City Park
- ❖ Drinking fountains install
- ❖ Replace campground doors
- ❖ Diamond 1 building work
- ❖ Arching sign for entrance at Woodlawn
- ❖ Memorial benches install
- ❖ Take new tables to aquatic center
- ❖ Wings door replacement
- ❖ WIFI install campground
- ❖ Playground equip install Red Gate
- ❖ Trail work/easements
- ❖ Electrical project at City Park
- ❖ Bathroom/shelter project at Red Gate
- ❖ Replace decking on old bridge
- ❖ Grant work
- ❖ Pool shelter install
- ❖ Motor/Pump replacement at pool
- ❖ Block signs at Woodlawn
- ❖ Surveillance system at pool
- ❖ Install basketball hoops at Wings

Joshua Johnson MA
Oelwein Park Superintendent



Friends of the Library Drive Through Chocolate Fest March 26-27



Pick up a box of delicious, homemade

chocolates during the annual Friends of the Library Chocolate Fest. Pre-order and pre-pay on the Friends Facebook page or call the library at 283-1515 to get your name on the sign-up sheet. The cost of a box of chocolates is \$10.

Contact FOLLibrary@yahoo.com with any questions.

Online Book Club



Join the Oelwein Library Book Club to discuss *Catch and Kill* by Ronan

Farrow. Members will meet online on Wednesday, March 31st at 10:00 a.m. If interested, contact Deann at dfox@oelwein.lib.ia.us with your email address or watch our Facebook page for the link to the meeting. The book is available on Bridges and Hoopla or by checkout at the library.

March Take & Make Kit



Does the thought of the Chocolate Fest make you hungry for chocolate? This month's take home kit is "Brownie in a

Mug." The recipe and dry ingredients are all ready to take home. Just add water and oil, pop it in a mug to microwave, and enjoy!

Presidential Trivia

Hear ye, hear ye! This is the last call to get your name in the drawing for \$10 in Oelwein Bucks! Go to the Oelwein Public Library website to complete all three of the Presidential Trivia Challenges by March 15 to have your name entered in the drawing.



Online Story Time

- Watch weekly activity videos on the library Facebook page with Miss Katie.
- Pick a theme and watch past videos on the Oelwein Public Library YouTube page.
- Listen to celebrities read a favorite picture book on the library's Storyline Online page.

Storyline Online

The Oelwein Public Library Board of Trustees will meet on Tuesday, March 16, 2021 at 5:00 p.m. at the Oelwein Public Library.

AGENDA

- Roll Call**
- Agenda Approved**
- Minutes Approved**
- Correspondence and communications –**
- Trustee Training –** Library Access – Digitized Collection
- Director’s Report –** Building Project Manager, Seuss books, Library Page,
- Friend’s Report –** Chocolate Fest March 26-27
- Bills Approved –**
- Unfinished Business**
- Library Services and Hours - April
- New Business**
- Policy Review – Gifts and Donations
- Adjournment**

February Statistics

| | | |
|---|-------------------------|--|
| Circulation: | Computer Use: | Reference Questions: |
| 21 February: 2,752 | 21 February: 192 | 21 February: 430 |
| <i>20 February: 5,287</i> | <i>20 February: 582</i> | <i>20 February: 585</i> |
| Attendance: | New Patrons: | Program Attendance: Website Visits: |
| 21 February: (1,132) Sunday(40) | 21 February: 19 | 21 February: 12 |
| <i>20 February: (3,192) Sunday(129)</i> | <i>20 February: 22</i> | <i>20 February: 235</i> |

| | | |
|----------------------|-------------------------------|------------------------------|
| Acquisitions: | BRIDGES Downloads: 345 | HOOPLA Downloads: 108 |
| Books 52 | eBooks: 239 | eBooks: 39 |
| Movies 6 | Audio: 92 | Audio: 34 |
| | eMagazines: 14 | Movies: 17 |
| | | Comics: 2 |
| | | Music: 6 |
| | | TV: 10 |

46. (NEW) The library provides access to digitized local collections. To meet the standard, the library can either digitize the collection or contract with another entity that has digitized the collection. Examples include:

- ❖ Local newspapers
- ❖ Photographic collections
- ❖ Cemetery records

Gifts and Donations
 August 10, 2006
 Revised 1/21/10, 11/10/10
 Reviewed 4/12/12, 11/17/15, 11/13/18, 03/16/21

The Oelwein Public Library encourages individuals and organizations to support library services through gifts, donations, and memorials. The library will maintain an active development program through the Oelwein Public Library Foundation, which operates exclusively for the benefit of the Oelwein Public Library.

[Iowa Code §392.5 and Oelwein Municipal Code §3.134 (10)]

Gift Funds:

- Funds received from gifts, memorials, cash, and securities are directed either to the Oelwein Public Library or the Oelwein Public Library Foundation as requested by the donor.
- Unspecified donations will automatically be deferred to the Foundation.
- Donations will be used for the public benefit of the library service as approved by the library board of trustees.
- Funds designated for materials will be purchased in accordance with the materials selection policy. Suggestions for subject areas or other areas of interest are welcome.
- The Oelwein Public Library, in cooperation with the Oelwein Public Library Foundation, will make an effort to inform potential donors of the options for donations and the possible tax credits for endowment donations under the Endow Iowa Tax Credit Program.

Real Property:

- Gifts and bequests of real property are accepted upon approval of such gift by the library board of trustees.
- Trustees may require appraisal, title opinion, boundary survey, environmental assessment, or other professional evaluations at the expense of the donor prior to acceptance of real estate.

Works of Art and Other Personal Property of Value:

- Works of art or other personal property of value (e.g. collectibles) received as a gift or bequest may be accepted by the library board of trustees.
- The donor is responsible for an appraisal when an art work, collectible, or other personal item is donated to the library to obtain a tax benefit.
- Such works of art and other personal property of value may either be retained as property of the library or liquidated for cash funds, at the discretion of the library board of trustees.
- A good faith effort will be made to return works of art or other property of value to the donor if the library withdraws the item from the collection.

Books and Other Media:

- The library accepts the donation of books and contemporary media formats.
- Items will be added to the collection in accordance with the materials selection policy of the Oelwein Public Library.

- Once donated, items become the property of the Oelwein Public Library and may be added to the collection; donated to other libraries or non-profit agencies; sold through the Friends of the Oelwein Public Library for the benefit of the library; or discarded.
- Donated items will not be returned to the donor and the library will not accept any item that is not an outright gift.
- The library reserves the right to decide when a gift added to the collection must be withdrawn.
- The library will provide a receipt of the donated items but will not set a fair market or appraised value to any item. If items are donated to obtain a tax benefit, it is the donor's responsibility to establish such value.

Acceptance of gifts:

- Acceptance of any gift, including cash, securities, real or personal property, will be determined by the library board based on their suitability to the purposes and needs of the library, laws and regulations that govern the ownership of the gift, and the library's ability to meet the requirements, if any, associated with the donation.
- The library board reserves the right to refuse or reject any gift.
- The library will not accept gifts which would require or cause the library to act in violation of established policies forbidding discrimination, particularly on the grounds of age, sex, sexual orientation, religion, physical or mental disabilities, race, ethnicity, or national origin.

Donor Recognition:

- Materials purchased with bequests, memorial, or honorary contributions will be identified with special donor plates whenever possible.
- At the request of the donor, notification of memorial or honorary contributions will be sent to the family of the person being recognized.
- Recognition of monetary and accepted items in excess of \$500 in value will be made at a centrally designated area of the library.
- Upon request, the library board will honor requests to refrain from acknowledging a donor in conformance to applicable state laws on confidentiality. [*Iowa Code §22.7. 52 a (5)*]

Gifts to Employees:

- The Oelwein Public Library employees are subject to the gift law outlined in the provisions of the Iowa Gift Act. [*Senate File 480*]
- The Oelwein Public Library employees and their family members shall accept no gift of value exceeding \$2.99. [*City of Oelwein Personnel Policy Manual, Gift Policy 7.11*]



PARKS / CEMETERY / AQUATICS / CAMPGROUND / TRAILS

TREE BOARD MINUTES
WEDNESDAY MARCH 10TH 2021
PARK BUILDING @ 5:30, 500 7TH AVE SW

1. Roll Call – Ron Lenth, Joshua Johnson, Kyle Scheel, Jeff Milks, Bill Brownell

2. Absent – Ron Lenth

3. Call to Order 5:20pm

4. Guest – Robby McKeeman

Robby discussed his application with the tree board for becoming a member.

5. Downtown Tree Trimming

Johnson discussed his appreciation with the board with their help on trimming the trees in the downtown streetscape last fall.

6. Trees Forever Planting

The board discussed their tree planting last fall in which they planted 53 trees in the street boulevards with the assistance of the Branching Out grant.

7. Old Business - None

8. New Business

Johnson notified the board that the City has received the Tree City award for 2020. Johnson also told the board that the City is receiving the Trees Forever/Alliant Energy – Branching Out grant for the maximum amount of \$5000 for 2021.

9. Adjourn - 6:11pm

10. Next Meeting – April 5th, 2021



Community Development Department Monthly Abatement/Code Enforcement Report

February 2021

Total Reported Properties

February was calmer than January with 14 new cases. Of these, 10 were abatements (sanitation, rodents/animals, vehicles, some of which also had code enforcement issues) and the other 4 were code enforcement (structure related such as collapsing porches, missing siding, dilapidated garages, etc.). Three cases were closed.

Online vs Staff Generated Activities

Of the 14 new cases, 7 were staff generated with the remaining 7 being complaints submitted online or called in.

Progress on Cases

Of the 14 cases, three were closed with the remaining 11 in progress awaiting delivery of the Certified Mail, responses from homeowners, compliance actions to be performed, or progress being made but not yet completed.

Next Month and Future Enforcement

As the snow continues to melt, it will expose further abatement needs and we will continue enforcement.



Minutes

Airport Board

Oelwein Community Plaza, 25 West Charles Streets

March 04, 2021 - 6:30 PM

CALL TO ORDER by Chairman Bryan at 6:30 P.M.

ROLL CALL Present: Bryan, Woodraska, Nations, Bagge, Tuchscherer
Also Present: City Administrator Mulfinger, Council Liaison Stewart, FBO Tegeler

APPROVAL OF MINUTES

1. Consideration of a motion to approve the minutes of the October 1, 2020 meeting

A motion was made by Nations, seconded by Bagge to approve the minutes of the October 1, 2020 meeting. All voted aye.

Motion Carried

EXPENSE REVIEW

2. Review of Revenue and Expense Reports

The Board reviewed the monthly expense and revenue reports.

CITY ADMINISTRATOR’S REPORT

Mulfinger gave the following updates:

Crack Sealing will be done with Cares Act money

Gas Pump Card Readers and related equipment is scheduled for Spring, 2021

There is one year remaining on the agricultural land lease. It will be terminated September 1.

Discussion was held on activities to promote the Airport. It was suggested to invite the City Council to the Airport. The Young Eagles program will be held August 21st.

OLD BUSINESS

NEW BUSINESS

SCHEDULE NEXT MEETING DATE

The next meeting was scheduled for April 15, 2021 ay 6:30 P.M. at the Airport

ADJOURNMENT

A motion was made by Woodraska, seconded by Tuchscherer to adjourn at 7:00 P.M.