

**Mayor**  
John K. Handeland

**Manager**  
Glenn Steckman

**Deputy Clerk**  
Jeremy Jacobson



**Nome Common Council**  
Scot Henderson  
Mark Johnson  
Adam Martinson  
Maggie Miller  
Cameron Piscoya  
M. Sigvanna Tapqaq

**NOME COMMON COUNCIL**  
**WORK SESSION & REGULAR MEETING AGENDA**  
MONDAY, FEBRUARY 26, 2024 at 5:30 PM / 7:00 PM  
COUNCIL CHAMBERS IN CITY HALL

102 Division St. ▪ P.O. Box 281 ▪ Nome, Alaska 99762 ▪ Phone (907) 443-6663 ▪ Fax (907) 443-5345

---

WORK SESSION - 5:30PM

- [A.](#) Discussion of Personal Property Exemption on Commercial Aircraft,

**PAGE 4**

ROLL CALL

APPROVAL OF AGENDA

APPROVAL OF MINUTES

- [A.](#) July 24, 2023 Nome Common Council Regular Meeting Minutes,

**PAGE 5**

- [B.](#) August 14, 2023 Nome Common Council Regular Meeting Minutes,

**PAGE 9**

- [C.](#) August 28, 2023 Nome Common Council Regular Meeting Minutes,

**PAGE 14**

- [D.](#) February 12, 2024 Nome Common Council Work Session & Regular Meeting Minutes,

**PAGE 19**

COMMUNICATIONS

- [A.](#) Letter of January 7, 2024 from Mark Synnott to Nome Common Council re: Tax Bill on SV Polar Sun,

**PAGE 26**

- [B.](#) Letter of February 12, 2024 from Nome Local Emergency Planning Committee to Nome Area Legislature,

**PAGE 32**

- [C.](#) Letter of February 22, 2024 from AMCO to City of Nome re: Beverage Dispensary License Renewal Application Notice,

**PAGE 35**

- [D.](#) Email of February 16, 2024 from William Crockett to Glenn Steckman re Letter for Print to the Nome Community,

**PAGE 36**

CITIZEN'S COMMENTS

NEW BUSINESS

- [A.](#) O-24-03-01 An Ordinance Adopting the Port of Nome Tariff No. 16.4 to Replace All Existing Tariffs of The Port of Nome, **FIRST READING/DISCUSSION,**  
**PAGE 38**
- [B.](#) O-24-03-02 An Ordinance Amending the City of Nome FY 2024 General Fund Municipal Budget, **FIRST READING/DISCUSSION,**  
**PAGE 69**
- [C.](#) O-24-03-03 An Ordinance Amending the City of Nome FY 2024 School Debt Service Fund Budget, **FIRST READING/DISCUSSION,**  
**PAGE 105**
- [D.](#) O-24-03-04 An Ordinance Amending the City of Nome FY 2024 Special Revenue Fund Budget, **FIRST READING/DISCUSSION,**  
**PAGE 108**
- [E.](#) O-24-03-05 An Ordinance Amending the City of Nome FY 2024 Capital Projects Fund Budget, **FIRST READING/DISCUSSION,**  
**PAGE 114**
- [E.](#) O-24-03-06 An Ordinance Amending the City of Nome FY 2024 Construction Capital Projects Fund Budget, **FIRST READING/DISCUSSION,**  
**PAGE 117**
- [G.](#) O-24-03-07 An Ordinance Amending the City of Nome FY 2024 Port of Nome Fund Budget, **FIRST READING/DISCUSSION,**  
**PAGE 119**
- [H.](#) O-24-03-08 An Ordinance Amending the City of Nome FY 2024 Port of Nome Capital Projects Fund Budget, **FIRST READING/DISCUSSION,**  
**PAGE 130**
- [I.](#) R-24-02-06 A Resolution Authorizing the City of Nome to Apply For and Participate In the USDOT Raise Discretionary Grant Program For the Funding of the Snake River Moorage Facility Project,  
**PAGE 133**
- [I.](#) R-24-02-07 A Resolution Authorizing the City of Nome to Apply For and Participate In the USDOT Raise Discretionary Grant Program For the Funding of the Port of Nome Local Service Facilities Design & Engineering - Phases II & III,  
**PAGE 137**
- [K.](#) R-24-02-08 A Resolution Setting the Dates for the 2024 Board of Equalization,  
**PAGE 142**
- [L.](#) R-24-02-09 A Resolution Approving an Employment Agreement Between the City of Nome and Daniel Grimmer for Provision of City Clerk Services,  
**PAGE 143**

- [M.](#) R-24-02-10 A Resolution Awarding a Contract for the Supply and Installation of Automatic Garage Doors at the Nome Volunteer Fire Department Fire Hall,

**PAGE 148**

- [N.](#) R-24-02-11 A Resolution Rejecting All Bids For the Nome Public Schools - ADA and Security Upgrades Project,

**PAGE 164**

UTILITY MANAGER'S REPORT

- A. Activity Report: February 13 - February 23, 2024,

**VERBAL**

CITY MANAGER'S REPORT

- [A.](#) Activity Report: February 13 - February 23, 2024,

**PAGE 166**

- [B.](#) February 2024 Port Director Report / Capital Projects Update,

**PAGE 174**

- [C.](#) January 18, 2024, Nome Port Commission Regular Meeting Minutes,

**PAGE 177**

CITIZEN'S COMMENTS

COUNCIL MEMBER'S COMMENTS

MAYOR'S COMMENTS AND REPORT

- A. Activity Report: February 13 - February 23, 2024,

**VERBAL**

EXECUTIVE SESSION

- A. Discussion of Contractual and Personnel Matters the Immediate Knowledge of Which Could Have Adverse Effects on City of Nome Finances,

**VERBAL**

ADJOURNMENT

the formula: time x frequency x property value

example: an aircraft is on the ground for 45 minutes. this is .03.13 % of a day.

that aircraft lands in nome every day of the year (we will exclude Christmas) frequency is then "1"

the aircraft has a value of \$21M

the calculation:  $.0313 \times 1 \times \$21M = \$656,250$ - assessed value

for mill rate calculation divide  $656,250/1000 = 656.25$  x mill rate 10.5 = \$6,690.63 tax.



**Mayor**  
John K. Handeland

**Manager**  
Glenn Steckman

**Deputy Clerk**  
Jeremy Jacobson



**Nome Common Council** Item A.  
Scot Henderson  
Mark Johnson  
Adam Martinson  
Doug Johnson  
Cameron Piscoya  
M. Sigvanna Tapqaq

**NOME COMMON COUNCIL  
REGULAR MEETING MINUTES  
MONDAY, JULY 24, 2023 at 7:00 PM  
COUNCIL CHAMBERS IN CITY HALL**

102 Division St. ▪ P.O. Box 281 . Nome, Alaska 99762 . Phone (907) 443-6663 . Fax (907) 443-5345

---

**ROLL CALL AT 7:04PM**

Members Present: Scot Henderson; Mark Johnson; Cameron Piscoya; M. Sigvanna Tapqaq (virtual)

Members Absent: Doug Johnson (excused); Adam Martinson(excused)

Also Present: John K. Handeland, Mayor; Glenn Steckman, City Manager; Jeremy Jacobson, Deputy City Clerk; William Crockett, Acting NPD Chief, Sergeant Le; Investigator Nguyen; Thomas Simonsson, NJUS Field Superintendent; Officer Chelsea Griffin, NPD; Officer Leighton McNabb, NPD

In the audience: Diana Haecker, Nome Nugget Newspaper; Anna Lionas, Nome Nugget Newspaper; Andrew Lee; Jo Cappeto, USDA; Theresa Johnson, USDA RPN; Jennifer Rachels, USDA RPN

**APPROVAL OF AGENDA**

A motion was made by C. M. Johnson and seconded by C. Henderson to approve the agenda.

Discussion:

- Mayor Handeland advised that City Manager request for item (B) *R-23-07-03 Resolution approving an employment agreement between the City of Nome and Joy Baker to serve as a Project Manager for the Arctic Port for the City of Nome* be stricken from this evening for further discussion.

A motion was made by C. M. Johnson and seconded by C. Henderson to approve agenda as amended.

At the roll call: C. M. Johnson; C. Piscoya; C. Tapqaq; C. Henderson

Aye:

Nay:

Abstain:

The motion **CARRIED**.

**OATH OF OFFICE**

- Swearing in of Officer Chelsea Griffin and Officer Leighton McNabb by Mayor Handeland.

**COMMUNICATIONS**

- None

### **PRESENTATION BY RURAL PARTNERS NETWORK**

- Rural Partners Network is an all-of-government program that helps rural communities find resources and funding to create jobs, build infrastructure, and support long-term economic stability on their own terms. They will be in town for the next week to learn about the different needs of Nome and the surrounding area.
- Mayor Handeland welcomed Rural Partners Network team to Nome. He expressed that often times various local organization are unable to utilize government funds and programs due to the strenuous documentation process. It would be hugely beneficial if Rural Partners is able to be a liaison and provide administrative assistance/guidance to these organizations.

### **CITIZEN'S COMMENTS**

- None given

### **NEW BUSINESS**

- A. R-23-07-02 A Resolution approving an employment agreement between the City of Nome and Cheryl Thompson for the position of Museum Director.

A motion was made by C. Henderson and seconded by C. Piscoya to adopt R-23-07-02.

#### Discussion:

- Manager Steckman requested support for this resolution. Cheryl comes with experience and understanding of our collections having worked at the museum as an assistant for many years. She is also well rooted in the history and community of Nome.

At the roll call:

Aye: C. Piscoya; C. Tapqaq; C. Henderson; C. M. Johnson

Nay:

Abstain:

The motion **CARRIED**.

### **UTILITY MANAGER'S REPORT**

- A. Activity Report: July 10 – July 21, 2023.  
Thomas Simonson, NJUS Field Superintendent
  - Ken is out doing upgrades to the waterlines in preparation of pressurization of the moonlight waterline.
  - Equipment issues are being addressed with the sewage lagoons.

### **CITY MANAGER'S REPORT**

- A. Activity Report: July 10 – July 21, 2023.
  - The Police Report and the Recreation Report will be presented in the next packet.

- National Night Out (a nationwide program to have the community interact with the first responders) will be held at the Rec Center from 5pm to 8pm.
- 3D Housing paperwork is being signed.
- There will be a voluntary reduction of alcohol hours by Quickstop and Hanson's, and potentially AC.
- Statistically the volume of assault calls has declined from last year. There has been an increase in calls from the Courts for delivery of judicial court documents.
  - o Chief Crockett explained that previously the Court Service Officer provided service to the Courts and the judge (subpoena service). Currently the burden has shifted from the State to the City due to State staffing issues.

### **CITIZEN'S COMMENTS**

- Andrew Le expressed that Cheryl is coming onboard as Museum Director.

### **COUNCIL MEMBER'S COMMENTS**

- Council Member Mark Johnson also reiterated Cheryl being a great fit for the Museum. He also welcomed to the new reporter as well as Mr. Simonsson to the Utilities.
- Council Member Adam Martinson gave appreciation for everyone who assisted with the New Year's Eve firework show.
- Council Member Cameron Piscoya: No comments.
- Council Member Sigvanna Tapqaq: No comments.
- Council Member Henderson stated he was glad to see two new police officers join the city and inquired about their certification process. He also agreed that Cheryl is a great fit for the Museum.

### **MAYOR'S COMMENTS AND REPORT**

- A. Activity Report: July 10 – July 21, 2023.
  - Mayor Handeland expressed excitement for the arrival of the first cruise ship.
  - He discussed the memorial service for Sandra Maderas. The archives of the Nugget are filled with her articles. Sandra did a great job ensuring our history and activities were well documented.

### **EXECUTIVE SESSION**

- A. Discussion of Personnel, Legal, and Financial Matters the Immediate Knowledge of Which May Have Adverse Impacts on City of Nome Finances.

A motion was made by C. Henderson and seconded by C. M. Johnson to enter into executive session to discuss Personnel, Legal, and Financial Matters the Immediate Knowledge of Which May Have Adverse Impacts on City of Nome Finances.

The Council entered executive session at 7:38pm.

The Council came out of executive session 8:02PM.

**ADJOURNMENT**

Hearing no objections, the Council adjourned at 8:03PM.

**APPROVED** and **SIGNED** this 26<sup>th</sup> day of February 2024.

\_\_\_\_\_  
**JOHN K. HANDELAND**  
Mayor

**ATTEST:**

\_\_\_\_\_  
**Jeremy Jacobson**  
Deputy Clerk

**Mayor**  
John K. Handeland

**Manager**  
Glenn Steckman

**Deputy Clerk**  
Jeremy Jacobson



**Nome Common Council** Item B.  
Scot Henderson  
Doug Johnson  
Mark Johnson  
Adam Martinson  
Cameron Piscoya  
M. Sigvanna Tapqaq

**NOME COMMON COUNCIL**  
**REGULAR MEETING MINUTES**  
MONDAY, AUGUST 14, 2023 at 7:00 PM  
COUNCIL CHAMBERS IN CITY HALL

102 Division St. ▪ P.O. Box 281 ▪ Nome, Alaska 99762 ▪ Phone (907) 443-6663 ▪ Fax (907) 443-5345

---

**ROLL CALL**

Members Present: Scot Henderson; Mark Johnson; Adam Martinson; Cameron Piscoya; Sigvanna Tapqaq (Telephonic)

Members Absent: Doug Johnson (excused); Youth Rep. Kellie Miller (excused)

Also Present: John K. Handeland, Mayor; Glenn Steckman, City Manager; Jeremy Jacobson, Deputy Clerk; Joy Baker, Port Director; Ken Morton, NJUS Assistant Manager; Thomas Simonsson, NJUS Plant Operations Manager

In the audience: Diana Haecker, The Nome Nugget Newspaper; Anna Lionas, The Nome Nugget Newspaper

**APPROVAL OF AGENDA**

A motion was made by C. M. Johnson and seconded by C. Martinson to approve the agenda as presented.

At the roll call:

Aye: C. M. Johnson; C. Martinson; C. Piscoya; C. Tapqaq; C. Henderson

Nay:

Abstain:

The motion **CARRIED**.

**COMMUNICATIONS**

- A. Email Chain between Clerk Hammond & City Manager William Glenn re: Seppala House.
- B. July 29, 2023 NSHC PSA: Harmful Algal Bloom (HAB) Advisory.
- C. E-mail of August 4, 2023 from AMCO to City of Nome re: Arctic Native Brotherhood Club Liquor License Renewal Notice.
- D. E-mail of August 10, 2023 from AMCO to City of Nome re: Nome Grown LLC Limited Marijuana Cultivation Facility License Renewal Notice.
- E. E-mail of August 11, 2023 from AMCO to City of Nome re: Nome Grown LLC Retail Marijuana Store License Renewal Notice.
- F. Letter from DOA: USACE - AK District to Port of Nome.
  - Mayor Handeland clarified Corps of Engineers are working on the PPA partnership between the CORPS and the City of Nome on the requirement for providing man camp property by the local sponsor.

- Manager Steckman confirmed that the City is out soliciting.
- Mayor Handeland reiterated that if the City goes out to lease the property, it is 100% on our side of the ledger with no credit from the Corps.
- Joy Baker, Port Director clarified the Corps requested 4 acres, that it have power, and reasonable access to water and sewer if possible. It is an option to lease at the City's expense. The contractor is responsible for utilities and upkeep of property.
- C. Henderson inquired if the property will be within city limits and be taxable considering the Corps' request to be within 3 miles from port operations.
- Mayor Handeland explained that we are obligated to provide this property, regardless of city limit restrictions.

### **CITIZEN'S COMMENTS**

- None given

### **NEW BUSINESS**

- A. O-23-08-01 An Ordinance Authorizing Sale to AK DOT&PF of Parcels Adjacent to Seppala Drive for Road Projects, **FIRST READING/DISCUSSION.**

A motion was made by C. Henderson and seconded by C. Piscoya to advance O-23-08-01.

Discussion:

- Manager Steckman confirmed that this was a parcel that was forgotten during the original discussion.

At the roll call:

Aye: C. M. Johnson; C. Martinson; C. Piscoya; C. Tapqaq; C. Henderson

Nay:

Abstain:

The motion **CARRIED.**

- B. R-23-08-01 A Resolution Authorizing The Sale of Seven Unserviceable Rifles From the Nome Police Department's Armory.

A motion was made by C. Martinson and seconded by C. M. Johnson to adopt R-23-08-01.

Discussion:

- C. M. Johnson wanted to know what made the firearms unserviceable.
- Manager Steckman confirmed that these are almost 20 year old firearms that are not being used. NPD is in the process of updating their firearms inventory and cleaning out the armory.

At the roll call:

Aye: C. Martinson; C. Piscoya; C. Tapqaq; C. Henderson; C. Johnson

Nay:

Abstain:

The motion **CARRIED**.

- C. R-23-08-02 A Resolution Designating Charles "Chip" Leeper As Acting City Manager for August 30, 2023 to September 6, 2023.

A motion was made by C. Martinson and seconded by C. Henderson to adopt R-23-08-02.

At the roll call:

Aye: C. Piscoya; C. Tapqaq; C. Henderson; C. M. Johnson; C. Martinson

Nay:

Abstain:

The motion **CARRIED**.

### **UTILITY MANAGER'S REPORT**

- A. Activity Report: July 22 - August 11, 2023.  
Ken Morton, NJUS Assistant Manager
- Sewer lagoon is showing issues that will need to be addressed soon.
  - Fuel: Delivery is anticipated at the end of the month.
  - The battery project has been pushed to spring 2024
  - The State will be constructing Seppala Drive next summer and will assist with the replacement of the Seppala waterline.
  - C. M. Johnson inquired about movement towards micro-nuclear energy. Ken Morton confirmed conversations are still being had and no decisions have been made.
    - o Mayor Handeland advised that Westinghouse will likely be the manufacturer and will be invited up to provide information.

### **CITY MANAGER'S REPORT**

- A. Activity Report: July 22 - August 11, 2023.
- The City has hosted a variety of guests the last few weeks, most recently the 3D Housing Construction team. The Military will be in for a training program on the use of 3D computers in summer 2024. We recommend they offer training to the youth of City of Nome and introduce and connect them with the National Guard.
  - C. Henderson inquired into the NVAD staff shortage and legislative priorities regarding the youth center.
    - o Manager Steckman clarified that there is substantial concern on juvenile housing due to safety concerns, lack of parole staffing, and adequate youth facilities at Anvil Mountain Correctional Center.
  - Mayor Handeland addressed citizen's concerns for the lack of patrolling from NPD.
- B. Port & Capital Projects Update - August, 2023.
- Port Commision will meet on Wednesday to look at drafts for an RFP to do a Tarif studies and ananalysis, as well as an update to the Strategic Development Plan.
  - The Corps is 98-99% on design. We should be 100% by the end of the month.
  - Uncertain if FEMA will grant approval for harbor work before the end of the season.
  - Bristol Engineers should provide updates on Cape Nome Jetty repair within 4 to 6 weeks. The jetty is unusable by marine traffic until repairs are done.

- C. Finance Quarterly Report: FY23 Draft report.
- C. Henderson inquired if the City is still estimated to have a reduced deficit than previously budgeted.
- D. NPD 2<sup>nd</sup> Quarter 2023 Report.

**CITIZEN'S COMMENTS**

- None given.

**COUNCIL MEMBER'S COMMENTS**

- Council Member Tapqaq: No comments.
- Council Member Henderson acknowledged Mayor Handeland's idea to use National Guard Armory facilities for youth detention center purposes, when need.
- Council Member M. Johnson: No comments.
- Council Member Martinson: No comments.
- Council Member Piscoya: No comments.

**MAYOR'S COMMENTS AND REPORT**

- A. Activity Report: July 22 - August 11, 2023.
- Met with Department of Defense.
  - Met with Lieutenant Governor Nancy Dahlstrom visiting with DOA.
  - Met Dan Graham, Duog Smith, and Larry Peterson to discuss future housing needs.

**EXECUTIVE SESSION**

- A. Discussion of Legal Matters the Immediate Knowledge of Which May have Adverse Impacts in City of Nome Finances.

A motion was made by C. M. Johnson and seconded by C. Henderson to enter into executive session to discuss Legal Matters the Immediate Knowledge of Which May have Adverse Impacts in City of Nome Finances.

The Council entered executive session at 8:10pm .

The Council came out of executive session 8:55PM.

**ADJOURNMENT**

Hearing no objections, the Council adjourned at 8:56PM.

**APPROVED and SIGNED** this 26<sup>th</sup> day of February 2024.



---

**JOHN K. HANDELAND**  
**Mayor**

**ATTEST:**

---

**Jeremy Jacobson**  
**Deputy Clerk**

**Mayor**  
John K. Handeland

**Manager**  
Glenn Steckman

**Deputy Clerk**  
Jeremy Jacobson



**Nome Common Council** Item C.  
Scot Henderson  
Doug Johnson  
Mark Johnson  
Adam Martinson  
Cameron Piscoya  
M. Sigvanna Tapqaq

**NOME COMMON COUNCIL  
REGULAR MEETING MINUTES  
MONDAY, AUGUST 28, 2023 at 7:00 PM  
COUNCIL CHAMBERS IN CITY HALL**

102 Division St. ▪ P.O. Box 281 . Nome, Alaska 99762 . Phone (907) 443-6663 . Fax (907) 443-5345

---

**ROLL CALL AT 7:05PM**

Members Present: Scot Henderson; Doug Johnson (virtual); Mark Johnson; Adam Martinson; Sigvanna Tapqaq

Members Absent: Cameron Piscoya (excused)

Also Present: John K. Handeland, Mayor; Glenn Steckman, City Manager; Jeremy Jacobson, Deputy City Clerk; Joy Baker, Port Director; Thomas Simonsson, NJUS

In the audience: Anna Lionas, Nome Nugget Newspaper; Diana Haecker, Nome Nugget Newspaper

**APPROVAL OF AGENDA**

A motion was made by C. Henderson and seconded by C. Martinson to approve the agenda as presented.

At the roll call:

Aye: C. D. Johnson; C. M. Johnson; C. Martinson; C. Tapqaq; C. Henderson

Nay:

Abstain:

The motion **CARRIED**.

**COMMUNICATIONS**

A. Letter of August 14, 2023 from Lynden Inc. to City of Nome re: Tax Forgiveness.

B. Letter of August 16, 2023 from Mark Synnott to City of Nome re: Tax Forgiveness.

A motion was made by C. Henderson and seconded by C. M. Johnson to grant tax forgiveness as requested by Lynden and Mr. Synnott.

At the roll call:

Aye: C. D. Johnson; C. M. Johnson; C. Martinson; C. Tapqaq; C. Henderson

Nay:

Abstain:

The motion **CARRIED**.

- C. Letter of August 15, 2023 from Greg Smith/Nome Grown LLC to Nome Common Council re: Code Amendment.
- Manager Steckman advised that Greg Smith withdrew the request.
- D. E-mail of August 15, 2023 from Nome Community Center Inc. to City of Nome re: FY 2023 - Year End Report.
- E. Letter of August 22, 2023 from ADEC to City of Nome re: July 27, 2023 Inspection of Nome Beam Rd. Class II Landfill, Nome Inert Waste Monofill, and Nome Center Creek Closed Class II Landfill.
- Manager Steckman acknowledged Aaron Cooper for his efforts out at Beam Road Landfill.
- F. E-mail of August 16, 2023 from AKDOT&PF: Yvonne Adams to Nome Common Council re: 2024-2027 Draft Stip Public Comment: Nome, AK.
- Mayor Handeland suggested trying to get Greg Kruschek Avenue on the list for possible the next STIP project.
  - Manager Steckman confirmed that work on Seppala will proceed next year and Steadman (not on this list) is scheduled for the year after that. Will follow up on whether the projects listed in the draft fully funded or planned funding. Some projects were delayed due to the port funding.

### **CITIZEN'S COMMENTS**

- None given.

### **UNFINISHED BUSINESS**

- A. R-23-07-03 A Resolution Approving an Employment Agreement Between the City of Nome and Joy Baker to Serve as A Project Manager for the Arctic Port for the City of Nome.

A motion was made by C. M. Johnson and seconded by C. Henderson to adopt R-23-07-03.

#### Discussion:

- Manager Steckman fully recommend resolution. Her deadline is May 1<sup>st</sup>. Should we be unable to legally extend Joy's contract we will seek a project manager by Fall 2023 to repair for her absence.

At the roll call:

Aye: C. Martinson; C. Tapqaq; C. Henderson; C. D. Johnson; C. M. Johnson

Nay:

Abstain:

The motion **CARRIED**.

### **NEW BUSINESS**

- A. R-23-08-03 A Resolution Authorizing Application, Approval & Acceptance of A Loan from The Alaska Department of Environmental Conservation Alaska Drinking Water Fund to Provide Loan Financing for Improvements to Community Water System Infrastructure

A motion was made by C. Henderson and seconded by C. Martinson to adopt R-23-08-03.

Discussion:

- Mayor Handeland explained that this outlines the replacement of the water utilities within the State streets as they are being redone. Confirmed additional 2.7 million needs in funding with a continuance of 1.5% interest rate. Mayor recommended approval.

At the roll call:

Aye: C. Tapqaq; C. Henderson; C. D. Johnson; C. M. Johnson; C. Martinson

Nay:

Abstain:

The motion **CARRIED**.

**UTILITY MANAGER'S REPORT**

A. Activity Report: August 12 – August 24, 2023.

Thomas Simonsson, NJUS Field Superintendent

- Water sewer enhancement project, moonlight wells, well house is complete.
- The lagoon project parts are expected early September.
- NSHC sanitary service construction on anticipation of Solar farm project.
- 1 year extension of NJUS labor contract.
- C. M. Johnson inquired on the location of the solar farm, near banner farm. 1 megawatt capacity, harvesting energy in the summer while windmill farm has slowed in production, offsetting diesel generators usage.

**CITY MANAGER'S REPORT**

A. Activity Report: August 12 - August 24, 2023.

- USACE in town to view the seawall. An expected report in 2-3 weeks, measurements were taken, however there is an annual inspection of the seawall.
- The city has many open positions currently.
- C. Henderson inquired into the post office service and the city's post office box on tax notifications for proper delivery.
- Mayor Handeland noted some of the NJUS feedback had received properly addressed mail still not delivered.
- C. M. Johnson inquired into the recently laid gravel near 4th Avenue, the size of rocks, and usage of a roller to smooth out gravel.

**CITIZEN'S COMMENTS**

- None given.

**COUNCIL MEMBER'S COMMENTS**

- Council Member Tapqaq - no comment.
- Council Member Henderson - no comment.

- Council Member D. Johnson - no comment.
- Council Member M. Johnson - no comment.
- Council Member Martinson gave sentiments to the recent passing of resident Stan Anderson.

### **MAYOR'S COMMENTS AND REPORT**

- A. Activity Report: August 12 - August 24, 2023
  - He seconded C. Martinson's sentiment on the passing of Stan Anderson.
  - NORAD will be here soon to investigate logistics and the community's resources prior to.
- B. Appointment of Kirsten Timbers to Public Safety Advisory Commission Seat "C."

A motion was made by C. Henderson and seconded by C. Martinson to appoint Kirsten Timbers to Public Safety Advisory Commission Seat "C."

At the roll call:

Aye: C. Henderson; C. D. Johnson; C. M. Johnson; C. Martinson; C. Tapqaq

Nay:

Abstain:

The motion **CARRIED**.

### **EXECUTIVE SESSION**

- A. Discussion of Personnel Matters the Immediate Knowledge of Which Could Have Adverse Impacts on City of Nome Finances.

A motion was made by C. Henderson and seconded by C. Martinson to enter into executive session.

The Council entered executive session at 7:40pm.

The Council came out of executive session 8:00pm.

### **ADJOURNMENT**

Hearing no objections, the Council adjourned at 8:01pm.

**APPROVED and SIGNED** this 26<sup>th</sup> day of February 2024.

---

**JOHN K. HANDELAND**

**Mayor**

Page 4 of 5

**ATTEST:**

---

**Jeremy Jacobson**  
**Deputy Clerk**

**Mayor**  
John K. Handeland

**Manager**  
Glenn Steckman

**Deputy Clerk**  
Brad Soske

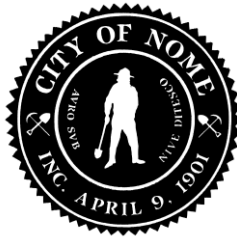

**Nome Common Council** Item D.  
Scot Henderson  
Mark Johnson  
Adam Martinson  
Maggie Miller  
Cameron Piscoya  
M. Sigvanna Tapqaq

**NOME COMMON COUNCIL**  
**WORK SESSION & REGULAR MEETING MINUTES**  
MONDAY, FEBRUARY 12, 2024 AT 5:15PM/7:00PM  
COUNCIL CHAMBERS IN CITY HALL

102 Division St. ▪ P.O. Box 281 ▪ Nome, Alaska 99762 ▪ Phone (907) 443-6663 ▪ Fax (907) 443-5345

---

**WORK SESSION at 5:15PM**

- A. Discussion of Personal Property Tax Commercial Aviation and Landing Tax
- B. Review of State Legislative Priorities

**ROLL CALL at 7:12PM**

Members Present: Scot Henderson; Mark Johnson; M. Sigvanna Tapqaq (telephonic); Maggie Miller; Cameron Piscoya

Members Absent: Adam Martinson (excused); Luke Hansen (excused)

Also Present: John K. Handeland, Mayor; Glenn Steckman, City Manager; Brad Soske, Deputy City Clerk; Thomas Simonsson, NJUS Plant Operations Manager; Angie Nguyen, Executive Assistant; Bryant Hammond, Project Manager; Joy Baker, Port Director (virtual); Nickie Crowe, Finance Director (virtual), Wade Harrison, Admin Sargent (virtual); Arne Erickson, City Assessor (teleconference)

In the Audience: Ken Hughes, Diana Haecker, Nome Nugget Newspaper

**APPROVAL OF AGENDA**

A motion was made by C. Henderson and seconded by C. Piscoya to approve the agenda.

At the roll call:

Aye: C. Johnson; C. Piscoya; C. Tapqaq, C. Miller, C. Henderson

Nay:

Abstain:

The motion to amend **CARRIED**.

**APPROVAL OF MINUTES**

- A. September 25, 2023 Nome Common Council Regular Meeting Minutes
- B. October 24, 2023 Nome Common Council Regular Meeting Minutes

A motion was made C. Piscoya and seconded by C. Henderson to approve the September 25, 2023 Nome Common Council Regular

Meeting Minutes and October 24, 2023 Nome Common Council Regular Meeting Minutes.

At the roll call:

Aye: C. Piscoya; C. Topqaq; C. Miller; C. Henderson; C. Johnson

Nay:

Abstain:

The motion **CARRIED**.

### **COMMUNICATIONS**

- A. E-mail of January 7, 2024 from Mark Synnott to Nome Common Council re: Tax Bill on SV Polar Sun.
- B. Letter of January 16, 2024 from DCCED to Manager Steckman re: Population Determination for FY 2025 DCCED Financial Assistance Programs.
- C. Letter of January 22, 2024 from Village of Solomon to City of Nome Leadership re: Annual Event Raising Awareness for Missing & Murdered Indigenous Women & Girls Day.
- D. Arctic Business Journal Article of February 1, 2024 entitled *Red Sea Disruptions Could be Avoided in Future by Arctic Shipping, Which May Trouble Ecosystems*.

### **CITIZEN'S COMMENTS**

- Ken Hughes shared his gratitude for council and acknowledged the difficulty of making decisions on the countless important subjects that are continuously presented to them. However, he expressed his concerns regarding Executive Session and the lack of transparency in the verbiage on the agenda and motion to enter Executive Session. He read aloud a section of the Open Meetings Act and requested that moving forward a more thorough and specific motion to enter into Executive Session is made; with a council vote and without going into details.
- Wade Harrison noted that he saw the Resolution to hire Will Crockett as Chief of Police and shared his enthusiasm for the appointment as both an employee of the Police Department and a citizen of Nome.

### **NEW BUSINESS**

- A. R-24-02-02 A Resolution Designating Charles "Chip" Leeper as Acting City Manager for March 1st through 10th 2024.

A motion was made by C. Henderson and seconded by C. Piscoya to adopt R-24-02-02.

At the roll call:

Aye: C. Topqaq; C. Miller; C. Henderson; C. Johnson; C. Piscoya

Nay:

Abstain:

The motion **CARRIED**.



- B. R-24-02-03 A Resolution Approving an Employment Agreement Between the City of Nome and William Crockett for the Position of Chief of Police.

A motion was made by C. Henderson and seconded by C. Piscoya to adopt R-24-02-03.

At the roll call:

Aye: C. Miller; C. Henderson; C. Johnson; C. Piscoya; C. Topqaq

Nay:

Abstain:

The motion **CARRIED**.

- C. R-24-02-04 A Resolution Approving an Employment Agreement Between the City of Nome and Cynthia Gray for the Position of Human Resources Manager.

A motion was made by C. Henderson and seconded by C. Piscoya to adopt R-24-02-04.

At the roll call:

Aye: C. Henderson; C. Johnson; C. Piscoya; C. Topqaq; C. Miller

Nay:

Abstain:

The motion **CARRIED**.

- D. R-24-02-05 A Resolution Endorsing Projects for the City of Nome's 2024 State Legislative Priorities.

A motion was made by C. Johnson and seconded by C. Henderson to adopt R-24-02-05.

A motion was made by C. Henderson and seconded by C. Johnson to amend R-24-02-05 with changes to Priority 5 to read instead "A Local Culturally Relevant In-Patient Treatment Facility for Alcoholic and Substance Abuse," and addition of Priority #2 (with license on verbiage) "Funding for Rural Public Safety Awareness of Missing and Murdered Indigenous Peoples Through Local Initiatives and Programs."

At the roll call:

Aye: C. Piscoya; C. Topqaq; C. Miller; C. Henderson; C. Johnson

Nay:

Abstain:

The motion to amend **CARRIED**.

Returning to the main motion.

Discussion:

- C. Johnson sought clarity on Priority #8 Covered Multi-Use Recreational Structure. He inquired if the structure is a cover or an enclosed structure. Based on his conversation with local residents there is a concern regarding snow drift and winds in the area.
- C. Miller requested to replace the phrasing “substance abuse” to “substance misuse” as a descriptor and title to Priority #5.

At the roll call:

Aye: C. Johnson; C. Piscoya; C. Topqaq; C. Miller; C. Henderson

Nay:

Abstain:

The motion **CARRIED**.

### **UTILITY MANAGER'S REPORT**

A. Activity Report: January 30 - February 9, 2024.

Thomas Simonsson, NJUS Plant Operations Manager

- Line crew is working on sound systems around town to prepare for upcoming events such as Iron Dog and Iditarod.
- Wilson Bourdon is retiring after many years of service to NJUS. His dedication and skills have been instrumental in the operations of NJUS. Currently looking to fill the position so the new person can shadow and learn from Wilson.
- Public Meeting at the Mini Convention tomorrow (Wednesday February 13, 2024) to discuss the water and sewer master plan from 4-7pm. Anyone and everyone is invited to come and share their insight and experience.
- Note that the two lower utility lines on the streets do not belong to NJUS. If there is an issue and anyone calls in, please advise them that those lines belong to GCI.
- C. Piscoya inquired about adding NJUS projects into the Sanitation Deficiency System.
- C. Piscoya inquired about NJUS Meeting Packets and Minutes as it was not posted on NJUS website.
  - o Thomas clarified that they are not posted online however, a copy can easily be sent via email or printed if a call is made to the NJUS office.

### **CITY MANAGER'S REPORT**

A. Activity Report: January 30 - February 9, 2024.

- Thomas Simonsson has been assisting City Hall with updating the sound system inside Council Chambers in preparations for upcoming events.
- The siren has arrived in Nome. The new one is stronger and will be installed by the snow dump.
- Bering View Housing has 9 vacant units but lack the staff to bring units back online.
- Iron Dog will be on the 19<sup>th</sup>, 20<sup>th</sup>, and 21<sup>st</sup> of this month. Ramps are being installed near Subways in preparation. The parking lot across from City Hall will also be prepped by Public Works for snow machine parking and display.
- Currently interviewing City Clerks and anticipates presentation to Council by next meeting.
- Historic Preservation Plan has been modified after meeting with different Local Native Organization for input and will be presented to Council in the near future.
  - o C. Henderson inquired if the plan will be submitted to the Planning Committee first or directly to Council. Shared his concerns about bypassing policy.

- Manager Steckman stated this was up to Council. If Council wishes to present it to Planning Committee first then it will be.
  - C. Johnson suggested having a joint meeting with the Planning Committee.
  - C. Henderson requested to have the \$500,000 personal property tax be broken down by industry for the next work session.
  - Manager Steckman informed Council that Meeting Minutes are currently being worked on and four will be provided in the next meeting.
  - C. Johnson acknowledged Mr. Hughes' comments regarding transparency for Executive Session.
  - As of now the City of Nome is and will continue to run the Ambulance Department for the City due to lack of contract agreement with Norton Sound Health Corporation. NSHC is requesting an on-call fire fighter and police officer be available to assist on calls should the ambulance team need assistance. We do not have an on-call fire fighter nor has police ever been guaranteed to be readily available for medical calls even in the current operations. We are currently also in communication with the State to acquire a Medical Director. If we are unable to attain one then NSHC offered their Medical Director for \$15,000 a month. City lawyer will be on teleconference to provide further details in Executive Session.
    - C. Piscoya inquired if the lack a Medical Director would affect future revenue from Medicaid.
  - Nickie Crowe addressed concerns regarding vacancies within the Finance Department. She updated Council on new hires and advised of a hold on hiring to conduct a needs assessment within Finance.
- B. Finance Department - FY24 2Q
- C. Johnson inquired why some funds have encumbered numbers and some don't.
  - C. Henderson inquired if there is any anticipation for any major differences in budget.

### **CITIZEN'S COMMENTS**

- None given.

### **COUNCIL MEMBER'S COMMENTS**

- Council Member Henderson praised Nickie on the new hires, the needs assessment within the department, and the mid-year report. He thanked Glenn for filling the important positions of Police Chief and HR Manager, two vital rolls within the organization. C. Henderson also thanked Mayor Handeland on his appointment of the two Advisory Board Members, however he agreed with C. Piscoya's concerns regarding long term vacancies.
- Council Member Johnson inquired on the City's status of an outdoor basketball court. He also thanked Nickie's update on the staffing within finance. He expressed reassurance in knowing the vacant positions within City Hall are being filled and potential new hires down the line.
- Council Member Piscoya expressed concerns for the vacant seats in city committees and inquired if it is possible to amend our ordinance to have Council appoint someone to a vacant seat after a certain time frame.
- Council Member Tapqaq: No comments.
- Council Member Miller inquired about the City's status on getting a strategic plan and if there is an economic plan for the port.

**MAYOR'S COMMENTS AND REPORT**

- A. Activity Report: January 30 - February 9, 2024.
- Mayor Handeland shared his gratitude to Rose Reale-Gray for her service to the city. During her time with the Ambulance Department she helped save many lives and impacted the lives of many more here in Nome.
  - Mayor Handeland advised he met with the Nugget Inn Owners along with Manager Steckman and Building Inspector Cliff McHenry to review and discuss processes. The owners are hopeful they will be open by Iditarod.

**EXECUTIVE SESSION**

- Discussion of Contractual and Personnel Matters the Immediate Knowledge of Which Could Have Adverse Effects on City of Nome Finances

A motion was made by C. Johnson and seconded by C. Henderson to enter into Executive Session to discuss contractual and personnel matters the immediate knowledge of which could have adverse effects on City of Nome finances and specifically to discuss the ambulance contract with the hospital.

## Discussion:

- C. Piscoya inquired if he should stay for Executive Session since he had previously declared a conflict of interest in previous discussions and votes.

At the roll call:

Aye: C. Henderson; C. Johnson; C. Piscoya; C. Topqaq; C. Miller

Nay:

Abstain:

The motion **CARRIED**.

The Council entered executive session at 7:22pm.

The Council came out of executive session 9:06pm.

**ADJOURNMENT**

Hearing no objections, the Council adjourned at 9:07pm.

**APPROVED** and **SIGNED** this 26<sup>th</sup> day of February 2024.

\_\_\_\_\_  
**JOHN K. HANDELAND**  
 Mayor

**ATTEST:**

---

**Brad Soske**  
**Deputy Clerk**

# Arctic Passage: Sailing the Edge of Alaska – Part I

by [Ben Spiess](#) | Nov 7, 2022 | [Adventure](#), [Cover Story](#), [Sailing](#)

The Polar Sun, a 47-foot cutter-rigged, bluewater sail boat

I got a call from my old friend Mark Synnott in late August. Mark was in the middle of sailing the Arctic Northwest Passage from Maine through to Nome.

Could I join him in Tuktoyaktuk, Northwest Territories in a week? He needed crew for the last leg of his voyage – from Northwest Territories to Nome. I hedged. Busy at work, I said. He persisted in a text: “It’s gonna be epic.”

I’ve lived in Alaska for awhile. But, the Northwest Territories? It’s the most-deserted part of a lonely region. And Tuktoyaktuk? Never even heard of it.

Mark Synnott

Mark is a sponsored North Face athlete with a deserved reputation for stellar mountaineering feats and well-executed expeditions all over the globe. He’s turned to the sea in recent years, and his Northwest Passage expedition proved a magnet for big sponsors.

He sailed from Portland, Maine in June. National Geographic, Disney, and his book publisher were all on board. The 47-foot Polar Sun – a cutter-rigged, bluewater sail boat – had been re-fit for the Arctic. Renan Ozturk, another famous climber and photographer joined. North Sails donated a custom suit of red sails. The boat was stuffed with sponsored clothing and food – everything from vitamins and energy drinks to free sweaters from a company in Norway. Mark’s reputation for success coupled with a combined on-board Instagram following in excess of 1 million proved persuasive.

A confirmed Instagram-addict, I’d followed the Polar Sun north to Greenland then west into the maze of island and ice which is the heart of the Northwest Passage. Posts from Mark and Renan were a panoply of ice, smiles, blue sky and sunshine coupled with wry tales of life aboard.

Ben Zartman, first mate

In mid-August, the mood changed.

At the crux of the Passage, the ice trapped the Polar Sun for 10 harrowing days in Pasley Bay. A 47-foot boat is a solid thing underfoot, but it's a bath toy in the ice. They were pushed on shore, grounded, flexed between ice floes, lost (then recovered) an anchor, and very nearly wrecked. Mark was scheming to freeze the boat in place for the winter when the ice relaxed and they escaped, firing the engine through an open lead and dragging the keel across the bottom into deep water.

A few days later in Cambridge Bay, two crew abruptly left and flew south. Mark and Ben Zartman – his sole remaining crew – explored stopping then and there.

Dave Thoreson, Northwest Passage veteran

It could work – they could weld together a cradle out of scrap steel then haul the boat onto the beach with a front-end loader. Mark spent two days bolting around town trying to piece together a plan. No ramp. Not enough power. No one to look after the boat. Finally, a local offered to buy the boat for \$25,000. Mark could just take the money and leave. No way, Mark said. Stymied, he and Ben plunged westward alone for Tuktoyaktuk.

After leaving Cambridge Bay, Mark canvassed his contacts for two fresh crew to join the boat. From the Northwest Territories to Nome is almost 1,500 miles of open ocean.

I don't know how many calls Mark made, but first and foremost he needed experience. He found it in Dave Thoreson. Dave is a veteran of two Northwest Passage trips and thousands of miles of bluewater sailing. He also happens to be one of the world's fine human beings – direct, sensible, cheerful, and fun. Over the next two weeks, he also proved his ocean experience.

Mark and Dave studying the weather

With Dave committed, Mark needed one more body, preferably a person he knew, and someone with at least some salt-water experience. Meeting the minimum criteria plus being in Alaska already, I got the call. “You can just get a direct flight from Anchorage to Tuk, right?” he asked.

The scale of the Arctic escapes even those who are there.

In a private jet, a trip from Anchorage to Tuktoyaktuk would be a straight shot. In reality, it involves seven flights and 36-hours of travel, capped by a bone-rattling, two-hour taxi ride across the tundra.

Tuktoyaktuk, Northwest Territories

By the time Dave and I joined the boat on the dock in Tuktoyaktuk, Mark and Ben were almost 100 days into the voyage. They were all smiles at seeing some fresh faces. But, the fatigue and anxiety was apparent.

At times, a sense of foreboding pervades September in the Arctic – the sky, sea and land are all grey alike. It was late fall with the cold coming down and the pack ice behind.

Mark seemed worn down – by decisions, by the departure of his crew, the ice, the ocean, the increasing cold. There could be no better mate than Ben-Wah. Ben is a professional rigger with deep experience, cooking ability, quirky humor, incisive opinions, and bullet proof optimism. But it was apparent both were ready for some new blood and Polar Sun needed shot of enthusiasm.

The Beaufort Sea

**SAILING SPECIAL: This is the first of a 4-part series written and photographed by Ben Spiess of Anchorage.**



January 7, 2024

City of Nome Common Council  
PO Box 281  
Nome, Alaska 99762

Dear Nome Common Council,

My name is Mark Synnott and I'm the owner of a 47-foot sailboat called Polar Sun which spent the winter of 2022/2023 on the hard in Nome. I came to Nome from Maine via the Northwest Passage during the summer of 2022. It was an eventful voyage and I was most thankful to make it to your wonderful community, where I was lucky to meet Rolland Trowbridge, who managed to get us out of the water. I also communicated extensively with the harbor master.

One subject which never came up is that I would be charged property tax for keeping my boat in Nome over the winter. I got there so late in the season that there was no way to continue on, especially since all of my crew had left, so I would have stayed anyway. But nonetheless, I was caught off guard by the property tax bill. As soon as it arrived I called the town clerk and pointed out that the tax bill referenced Polar Sun as a "commercial vessel," which it is not. (Please see the attached Coast Guard certificate of documentation which list my vessel's operation endorsements of "recreation" only.) I was told by this person that it didn't matter and there was no way I could get out of the tax bill. At no point was I told that it was possible to appeal.

The original tax bill I received from the city of Nome listed only a physical address of 102 Division St. I sent a check to this address and it was eventually returned saying the address didn't work. I incurred penalties for late payment, and I wrote back to ask that these late penalties should be removed since it wasn't my fault I was given the wrong address.

I had been waiting to hear back with a decision on this and after months with no response, I called the tax office. This time I spoke with a man named Jeremy Jacobson who informed me that I was required to submit a property declaration to confirm that my boat was moved out of Nome in July 2023. This declaration form includes instructions where it lists exemptions to those required to pay property taxes in Nome. Here is the relevant section:



nomes.

**DO NOT REPORT** automobiles, snow machines, ATVs boats & motors and trailers held for personal and/or subsistence use.

- C) **NO LONGER IN BUSINESS.** See Section A on reverse side of this form.
- D) **IN BUSINESS BUT NO PERSONAL/BUSINESS PROPERTY TO REPORT** See Section B on reverse side of this form.
- E) **EXEMPTIONS.** (NCO 17.20.020): 1) Household furniture and personal effects of members of a household, 2) all aircraft, 3) snowmachines, ATVs, boats/motor and trailers held for personal and/or subsistence use and, 4) business inventories held for resale in the normal course of business of a seller as defined by NCO 17.10.180 and who is issued a City sales tax certificate.

I was surprised to see that "boats held for personal use" are supposed to be exempt from property tax. Since I was just passing through Nome, and my boat is used for personal and recreational use—NOT COMMERCIAL (as you classified my vessel)— I believe that I have been charged property tax in error.

My tax bill has been paid in full, including penalties, and I believe that based on your own statutes that I am owed a refund.

As such, I would appreciate it if you would please review this matter.

Thanks for your consideration and with my best regards,

Mark Synnott

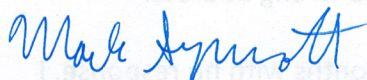

SV Polar Sun  
PO Box 72  
Jackson, NH 03846

[mark@marksynnott.com](mailto:mark@marksynnott.com)

603-986-9607





# UNITED STATES OF AMERICA

DEPARTMENT OF HOMELAND SECURITY  
UNITED STATES COAST GUARD



NATIONAL VESSEL DOCUMENTATION CENTER

## CERTIFICATE OF DOCUMENTATION

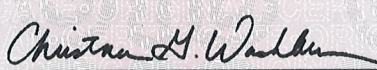
VESSEL NAME POLAR SUN		OFFICIAL NUMBER 657328	IMO OR OTHER NUMBER QSC477270382	YEAR COMPLETED 1982	
HAILING PORT PORTLAND ME		HULL MATERIAL FRP (FIBERGLASS)		MECHANICAL PROPULSION YES	
GROSS TONNAGE 23 GRT	NET TONNAGE 21 NRT	LENGTH 43.2	BREADTH 14.3	DEPTH 6.6	
PLACE BUILT KAOHSIUNG TAIWAN					
OWNERS MARK SYNNOTT HAMPTON SYNNOTT			OPERATIONAL ENDORSEMENTS RECREATION		
MANAGING OWNER MARK SYNNOTT 6 IRON MOUNTAIN RD PO BOX 72 JACKSON NH 03846					
RESTRICTIONS NO COASTWISE - FOREIGN BUILT; NO FISHERY - FOREIGN BUILT					
ENTITLEMENTS NONE					
REMARKS NONE					
ISSUE DATE DECEMBER 21, 2021		 DIRECTOR, NATIONAL VESSEL DOCUMENTATION CENTER			
THIS CERTIFICATE EXPIRES DECEMBER 31, 2026					



COPYBAR CAPTURED ANTI-FRAUD PROTECTION

8523585418





## NOME LOCAL EMERGENCY PLANNING COMMITTEE

PO Box 1506  
Nome, AK 99762  
907.443.8521

Senator Donny Olson  
Senator Loki Tobin  
Representative Neal Foster  
State Emergency Response Commission  
Local Emergency Planning Committee Association

February 12, 2024

Honorable Madams and Sirs,

The purpose of this correspondence is to emphasize the need for funding the Local Emergency Planning Committees (LEPC) especially in smaller communities.

As a general rule LEPC's in smaller communities have no funding and are run by volunteers, yet the LEPC's have enormous responsibilities. The LEPC's are expected to complete the following:

- 1: Notify all local organizations that have Hazardous Materials within reporting thresholds to complete Tier II reporting as required by the Emergency Planning and Community Right-to-Know act (EPCRA) also known as Title III of the Superfund Amendments and Reauthorization Act (1)
- 2: Write and review Emergency Operation Plans for Hazardous materials incidents, review all Emergency Operations Plans of all hazard incidents for all organizations within the jurisdiction.
- 3: Write and review the Hazard Mitigation Plan(s) for the local jurisdiction(s).

- 4: Write the Emergency Evacuation Plan(s) for the local jurisdiction.
- 5: Write and exercise Table Top Exercises within the local Jurisdiction.
- 6: Write and exercise Full Scale Exercises within the Jurisdiction
- 7: Have a minimum of four meeting annually.
- 8: Encourage training for Incident Command Systems for all responders and community leadership.
- 9: Encourage training for all managers and responders in the National Incident Management System (NIMS).

Incidents include:

- Terrorism both Domestic and International
- War Related Disasters
- Hazardous Material Events
- Nuclear Accidents
- Aircraft Accidents
- Wildland and Urban Fires
- Floods
- Earthquakes
- Hurricanes
- Tornadoes
- Typhoons
- Fall Sea Storms
- Search and Rescue events

All of this in the smaller communities is expected to be done by volunteers.

In larger communities and boroughs with the State of Alaska there are paid departments that are paid employees, while the funding helped I don't think it was critical to have for their ability to operate.

Please note that LEPC's are not operational organization but planning organizations. This can be overlooked as a lot of LEPC members have Roles in the Emergency Operations Center or as responders with representing their various organizations but that is not the same as planning. In the biannual meeting of the Local Emergency Planning Committee Association (LEPCA) as the LEPC's round table briefing about what the LEPC's have been doing a common theme is that since funding has ceased

from DHS-EM in fiscal year 2020 is that the LEPC's have been rebuilding, or trying to get more members in attendance.

In closing I think funding the LEPC's is critical to the citizens of the State of Alaska, I would recommend that a Legislative appropriation be considered.

Thank you

Thomas Vaden  
Nome LEPC Chair



Paul Kosto  
Nome LEPC Vice Chair



*(1) Congress passed the Emergency Planning and Community Right-to-Know Act (EPCRA), also known as Title III of the Superfund Amendments and Reauthorization Act (SARA), in 1986. EPCRA establishes requirements for businesses and for federal, state, and local governments regarding emergency planning and community right-to-know (CRTK) reporting for hazardous chemicals. The CRTK provision in EPCRA helped increase awareness about the presence of chemicals in their communities and releases of these chemicals into the environment. The Alaska State Legislature also enacted CRTK laws consistent with federal law. As a result, Alaskan communities, working with industry, are better able to protect public health and the environment. Alaska Congress enacted EPCRA regulations to benefit communities. Two main goals of this law are to: • Provide a basis for each community to develop and tailor a chemical emergency planning and response program to suit the community's needs, and • Provide the public with a right-to-know attitude to identify, quantify, locate, and determine the physical and chemical properties of hazardous substances in the community.*



THE STATE  
of ALASKA  
GOVERNOR MIKE DUNLEAVY

Department of Commerce, Community,  
and Economic Development

ALCOHOL & MARIJUANA CONTROL OFFICE  
550 West 7<sup>th</sup> Avenue, Suite 1600  
Anchorage, AK 99501  
Main: 907.269.0350

February 22, 2024

City of Nome

[bhammond@nomealaska.org](mailto:bhammond@nomealaska.org)

[clerksoffice@nomealaska.org](mailto:clerksoffice@nomealaska.org)

**Re: Notice of 2024/2025 Alcoholic Beverage License Renewal Application**

144	Board of Trade Saloon	Beverage Dispensary	Nome	Unorganized Borough	211 Front Street
-----	-----------------------	---------------------	------	---------------------	------------------

We have received completed renewal applications for the above listed licenses within your jurisdiction. This is the notice required under AS 04.11.480.

A local governing body may protest the issuance, renewal, relocation, or transfer to another person of a license with one or more endorsement, or issuance of an endorsement by sending the director and the applicant a protest and the reasons for the protest in a clear and concise statement within 60 days of the date of the notice of filing of the application. A protest received after the 60-day period may not be accepted by the board, and no event may a protest cause the board to reconsider an approved renewal, relocation, or transfer.

To protest any application(s) referenced above, please submit your written protest for each within 60 days to AMCO and provide proof of service upon the applicant and proof that the applicant has had reasonable opportunity to defend the application before the meeting of the local governing body.

Sincerely,

Joan M. Wilson, Director

[amco.localgovernmentonly@alaska.gov](mailto:amco.localgovernmentonly@alaska.gov)

**Glenn Steckman**

---

**From:** William Crockett  
**Sent:** Friday, February 16, 2024 12:19 PM  
**To:** Glenn Steckman  
**Subject:** FW: Letter for print to the Nome Community

**From:** Crockett, Ashly H (LAW) <ashly.crockett@alaska.gov>  
**Sent:** Wednesday, February 14, 2024 5:28 PM  
**To:** William Crockett <WCrockett@nomealaska.org>  
**Subject:** FW: Letter for print to the Nome Community

This sender is trusted.

Chief Crockett –

The victim's family in the Tyler Shold homicide case asked me to forward this to you and the City. Could you please share this with your office? And either pass it on to Glenn and City Counsel, or let me know the best email addresses?

It meant so much to the family for your officers and paramedics to attend the sentencing hearing. Thank you SO much for the strong show of support. It really made a huge difference.

Best,  
 Ashly

Ashly H. Crockett  
 Assistant District Attorney  
 Nome, Alaska 907.443.2296

**From:** Tavia Barr <[Tavia@Reagan.com](mailto:Tavia@Reagan.com)>  
**Sent:** Wednesday, February 14, 2024 5:02 PM  
**To:** [diana@nomenugget.com](mailto:diana@nomenugget.com)  
**Cc:** Crockett, Ashly H (LAW) <[ashly.crockett@alaska.gov](mailto:ashly.crockett@alaska.gov)>  
**Subject:** Letter for print to the Nome Community

You don't often get email from [tavia@reagan.com](mailto:tavia@reagan.com). [Learn why this is important](#)

**CAUTION:** This email originated from outside the State of Alaska mail system. Do not click links or open attachments unless you recognize the sender and know the content is safe.

To the Nome, Alaska Community:

We are tormented with the events that transpired on January 8, 2020. There is no escaping, undoing, nor forgetting. It's a reality that we must confront and compartmentalize within ourselves; conjuring guilt, regret, sadness, and anger; but then, we ultimately dwell on the delight that Anna brought to us. We are thankful and grateful that God gave her to us, if only for a very short while. February 6, 2024, was a difficult day, too. The State of Alaska can not adequately administer justice to satisfy our



desire to feel better; even though convicted murderer Tyler Shold is serving jail time for taking the life of our dear and darling (precious and irreplaceable) Anna Matoomealook. We have forever been robbed.

Judge DiBenedetto handed down a sentence coinciding with the agreement between the Public Defender and District Attorney. We asked for more, but understand that our legal system is plagued with ridiculous case law that ties the hands of judges. Judge DiBenedetto indicated that he believed that the crime was cruel and unconscionable deserving a tougher penalty, but, they are often appealed and he didn't want us to go through this again. Thank you, Judge DiBenedetto, for your wisdom and understanding of what we have lost; and, for recognizing that the whole demographic of Native women experiences the highest rape and murder incidents of any group.

The Matoomealook and Barr families deepest and sincere thanks goes to Assistant District Attorney Ashly Crockett, and Paralegal Specialist Luella Iyatunguk for their kindness, patience and true interest in our thoughts and feelings. Through investigation, the attorneys and judge knew Tyler Shold, but almost nothing about our darling Anna. D.A. Crockett's consistent encouragement and interest in her story made Anna real to all involved.

Years ago Nome Police Department bad actors left an indelible scar on the community causing much mistrust. When we arrived to attend the sentencing hearing, this was not the case. Chief William Crockett exhibited caring and thoughtful leadership which encouraged many Nome Police Department personnel to be present in the courtroom in support of our family and to represent the community of Nome to us. We thank each and every one in attendance: Investigator Vincent Nguyen, Administrative Sergeant Wade Harrison, Adult Probation Officer Gail Smithhisler (who commented that this was the most difficult report she has ever had to write,) Officers: Alex Le, Chelsea Griffin, Nathan Bryson, Dylan Howard, Advocate Sharon Sparks, Administrative Assistant Kelly Corns, Angie Nguyen and other Nome City officials.

We also extend a special thank you to the Medics who responded to the scene of Anna's murder and worked to revive her. One quick hug doesn't adequately convey our heartfelt gratitude to EMS Hunter Bellamy and EMS Rose Reale. This worst type of call to answer took courage and diligence, to your already emotionally difficult job, and is commendable.

Godspeed and our prayers for the Nome officials who are bringing restoration to your community. We pray that Nome finds healing and peace with God. This was a tragedy that effects everyone.

Romans 12:19 *"Dearly beloved, avenge not yourselves, but rather give place unto wrath: for it is written, Vengeance is mine; I will repay, saith the Lord."* God have mercy on the soul of Tyler Shold.

With all sincerity,  
The family of Anna Matoomealook

Scott Barr  
907-691-8388  
Tavia Barr  
907-414-8163  
[Tavia@Reagan.com](mailto:Tavia@Reagan.com)

PO Box 926  
Barrow, Alaska 99723

1<sup>st</sup> Reading: February 26, 2024

2<sup>nd</sup> Reading: March 25, 2024

**Presented by:**

City Manager

**Action Taken:**

Yes \_\_\_\_\_

No \_\_\_\_\_

Abstain \_\_\_\_\_

**CITY OF NOME, ALASKA  
ORDINANCE NO. O-24-03-01**

**AN ORDINANCE ADOPTING THE PORT OF NOME TARIFF NO. 16.4  
TO REPLACE ALL EXISTING TARIFFS OF THE PORT OF NOME**

**IT IS HEREBY ORDAINED** by the Nome Common Council as follows:

**SECTION 1.**

This is a non-Code ordinance.

**SECTION 2.**

The Port of Nome Tariff No. 16.4 attached hereto is hereby adopted in its entirety to replace all existing tariffs of the Port of Nome.

**SECTION 3.**

The Port of Nome Tariff No. 16.4 shall be effective upon adoption and publication.

**APPROVED** and **SIGNED** the 25<sup>th</sup> day of March, 2024.

\_\_\_\_\_  
**JOHN K. HANDELAND**

Mayor

**ATTEST:**

\_\_\_\_\_  
**JEREMY JACOBSON**

Deputy City Clerk

# Memo

TO: Mayor John Handeland & Nome Common Council  
 FROM: Jim West, Jr. – Chairman, Nome Port Commission *JW2*  
 THRU: Glenn Steckman - City Manager  
 DATE: 02/21/2024  
 RE: Recommending City Council Adopt Port of Nome Tariff No. 16.4 Rules & Regulations

---

The following motion was passed by the Nome Port Commission at a Regular Meeting on Thursday February 15, 2024.

1. Moved by **C. McCann**, and seconded by **C. McLarty**, the following motion be approved as written:
  - **MOTION:** Approval of all revisions and rates presented in Port of Nome Tariff No. 16.3, as amended, and recommending Nome Common Council adopt these revisions as Port of Nome Tariff No. 16.4 Rules & Regulations, replacing all existing tariffs.

**AT THE ROLL CALL:**

Ayes: McCann, Sheffield, McLarty, Smithhisler, Lean, West  
 Nays:  
 Abstain:

The motion **CARRIED**.

---

Discussion on this motion reflected in the DRAFT minutes from Feb 15, 2024 Regular Meeting.



# PORT OF NOME TARIFF RULES AND REGULATIONS

**TARIFF NO. 16.43**  
(~~AMENDED JANUARY 1, 2023~~)

ADOPTED: ~~February 28th, 2022~~

Ordinance No: O-~~22-02-07~~

CITY/PORT OF NOME  
P.O. BOX 281  
NOME, ALASKA 99762

PH. (907) 443-6619  
FAX (907) 443-5473  
PORT@NOMEALASKA.ORG

**TABLE OF CONTENTS**

	PAGE
CHAPTER 1 GENERAL PROVISIONS	4
01.010 Legal Effect .....	4
01.020 Port Use Constitutes Tariff Acceptance .....	4
01.030 Notice .....	4
01.040 Hold Harmless and Indemnification.....	4
01.050 Facility Use and Bonding .....	5
01.055 Snake River Area .....	5
01.060 Compliance with Law .....	6
01.070 Housekeeping and Safety .....	7
01.075 Care in the Performance of Operations .....	8
01.080 Used Oil Handling .....	9
01.090 Facility Security and Access .....	9
01.100 Maneuvering and Navigation .....	9
01.110 Closed Season.....	10
 CHAPTER 2 BERTHING	 10
02.010 Permission Required .....	10
02.020 Preferential Berthing .....	11
02.030 Alteration or Revocation of Berthing Assignments .....	11
02.040 Reassignment or Return to Berth.....	11
02.050 Orders of Alteration, Revocation or Reassignment of Berthing .....	11
02.060 Securing Vessels.....	12
02.070 Floating Dock .....	12
02.080 Vessel Condition .....	12
02.085 Repairs and Maintenance .....	13
02.090 Barge Ramp Use .....	13
 CHAPTER 3 CARGO HANDLING	 13
03.010 Permission Required .....	13
03.020 Manifests and Cargo Information .....	14
03.030 Port Equipment and Services .....	14
03.040 Right to Refuse Cargo .....	15
03.050 Petroleum Products and Hazardous Substance .....	15
03.060 Risk of Damage .....	17
03.070 Removal or Transfer of Cargo .....	17
03.080 Over-Side Petroleum Products Transfers .....	17
 CHAPTER 4 TERMINAL STORAGE	 17
04.010 Permission Required.....	17
04.020 Termination of Storage .....	18
04.030 Fixtures and Improvements.....	18
 CHAPTER 5 SCHEDULE OF CHARGES AND TERMS OF PAYMENT	 19
05.010 Dockage Rates.....	19
05.020 Wharfage Rates .....	21
05.030 Terminal Storage Rates.....	22
05.035 Amenities & Other Charges.....	22
05.040 Free Time .....	23

05.050 Negotiable Rates ..... 23  
 05.060 Terms of Payment ..... 23  
 05.070 Interest Accrued..... 24  
 05.080 Additional Legal Remedies ..... 24  
 05.090 Annual Adjustment of Rates and Charges ..... 24

CHAPTER 6 DEFINITIONS ..... 24

06.005 Barge Ramp..... 24  
 06.010 Berthing..... 24  
 06.020 Cargo ..... 24  
 06.030 Cargo Handling Areas ..... 24  
 06.040 Cargo Handling Equipment ..... 24  
 06.045 Cargo Handling Permittee ..... 24  
 06.047 Causeway City Dock..... 24  
 06.050 Company Gear and Equipment..... 24  
 06.060 Dockage..... 24  
 06.070 Dock-Side..... 25  
 06.080 Empty Containers ..... 25  
 06.085 Free-Time..... 25  
 06.090 Harbormaster ..... 25  
 06.092 Home-Ported Vessel..... 25  
 06.095 Idle Vessel ..... 25  
 06.100 Inner Harbor..... 25  
 06.105 Inter-Facility Transfers..... 25  
 06.107 Length Over All (LOA) ..... 25  
 06.108 Nuisance Property ..... 25  
 06.110 Over-Side Cargo or Fuel ..... 25  
 06.120 Over Stow..... 25  
 06.130 Port Director..... 25  
 06.140 Port of Nome ..... 26  
 06.150 Port of Nome Facilities..... 26  
 06.155 Production Film Crews ..... 26  
 06.160 Rafting ..... 26  
 06.162 Retail Marine Fuel Sale ..... 26  
 06.165 Roadstead ..... 26  
 06.170 Ship's Gear or Stores..... 26  
 06.173 Small Boat Harbor..... 26  
 06.175 Snake River Area ..... 26  
 06.178 Support Vessel ..... 26  
 06.179 Third Party ..... 26  
 06.180 Through Cargo ..... 27  
 06.190 Vessel..... 27  
 06.195 Wharfage ..... 27  
 06.200 Working Stow..... 27  
 APPENDIX A - RULES AND REGULATIONS..... A1  
 APPENDIX B - PORT FACILITY LAYOUT MAP..... B1  
 APPENDIX C – DOCKING PERMIT RATE SCHEDULE..... C1

## **CHAPTER 1**

### **GENERAL PROVISIONS**

#### **01.010 Legal Effect:**

(a) These tariff regulations, published online at [www.nomealaska.org](http://www.nomealaska.org), constitute notice to all persons and entities that these rules, regulations, rates and charges apply to all traffic and activities at the Port of Nome without further specific notice or quotation or other arrangement.

(b) In addition to this Port and Harbor Tariff, the public, shippers, consignees and carriers using the Port of Nome should consult and be aware that the City of Nome Code of Ordinances, including, but not limited to, Chapter 10 (Health, Safety & Welfare), Chapter 15 (Public Utilities & Services), and Chapter 13 (Ports & Harbors) all as amended apply and govern where not specifically provided otherwise in this tariff. Also, the City reserves the right to adopt specific tariffs governing particular marine-related facilities operated by the Port of Nome.

(c) The rules, regulations, rates and charges described in this tariff shall be effective immediately upon being published electronically. For the convenience of port users this tariff is posted on the Internet at [www.nomealaska.org](http://www.nomealaska.org).

#### **01.020 Port Use Constitutes Tariff Acceptance:**

USERS ARE HEREBY ADVISED THAT ANY AND ALL USES OF THE PORT OF NOME CONSTITUTE ACCEPTANCE OF ALL RESPONSIBILITY, LIABILITY AND WAIVERS CONTAINED IN THESE TARIFF REGULATIONS. Any person, entity or vessel enjoying the beneficial use of the premises, facilities, equipment or services of the Port of Nome is deemed to have thereby accepted all of the terms, conditions, rates, liabilities and indemnifications of these tariff regulations, and is deemed to have thereby agreed to all limitations and waivers contained in these tariff regulations.

#### **01.030 Notice:**

All legal notices, inquiries, requests for information and applications to the Port of Nome shall be addressed and delivered to:

**PORT DIRECTOR  
CITY OF NOME  
P.O. BOX 281  
102 DIVISION ST.  
NOME, AK 99762  
[port@nomealaska.org](mailto:port@nomealaska.org)**

#### **01.040 Hold Harmless and Indemnification:**

Each and every vessel, permittee, carrier, shipper, agent and other user of the Port of Nome hereby agrees to hold harmless and to indemnify the City of Nome, its employees and agents from and against any and all claims, liabilities and damages, including actual attorney fees, arising from or caused by an act or omission of the same port user, its employees, agents or assigns.

Rates in this Tariff do NOT include insurance of any kind. All companies and persons engaged in the business of trucking, storing, and/or shipping, fuel, general cargo, gravel, and equipment, providing haulout services, vessel repairs and/or any type of labor services anywhere on Port of Nome property shall have on file with the Port a current certificate of liability insurance in the amount of \$1,000,000.00 (one Million dollars) naming the Port as a certificate holder and additionally insured before they are allowed to work within the facility, and listing all equipment and vehicles owned by the company or person that are being used at the port facility and are covered by the policy. Companies, persons, and operators required to file a certificate under this paragraph are also subject to restrictions in Section 01.050(d) and (e) of this Tariff. It is the responsibility of the insured to provide renewal certificates to the Port Director prior to the policy expiration.

**01.050 Facility Use and Bonding:**

(a) Each and every permittee, carrier, shipper, agent or other port user covenants and agrees to maintain in good condition and safeguard all structures and improvements in the Port of Nome. The Port Director may at any time order any port user to additionally post a bond and/or create a cash escrow account protecting the Port of Nome from and against any and all liability and damage caused by or resulting from an act or omission of that port user and/or to ensure collection of incurred fees or charges.

(b) All permittees, carriers, shippers, agents, or other users of the Port of Nome hereby covenant and agree to repair and restore any and all damage that the port user may cause to the submerged lands, causeway, breakwaters revetment, marine headers, floating docks, ramps or other facilities of the Port of Nome, reasonable wear and tear excepted.

(c) Each vessel owner/operator must maintain a local and emergency contact name, phone number and valid winter and summer mailing addresses on file with the Harbormaster's office at all times. It is the vessel owner's responsibility to update this information as needed and to notify the Port Director if the vessel may be left unattended. All unattended vessels are required to have a caretaker who is responsible for monitoring the vessel. Each caretaker must have current contact information on file with the Harbormaster's office. Anytime a vessel is transferred or conveyed to a new owner, both the seller and buyer shall contact the Harbormaster's office within three (3) business days of the transaction and provide all information necessary on the transfer.

(d) All users with vessels over 20 feet in length must provide proof of liability insurance. Vessels using the Belmont Beach and Snake River exclusively for the purposes of sport and/or subsistence fishing and hunting are exempt from this insurance requirement. Vessels using the Small Boat Harbor exclusively for the purposes of sport and/or subsistence fishing and hunting prior to June 15<sup>th</sup> or after October 15<sup>th</sup> are also exempt from the insurance requirement. This exemption does not apply to any vessels on charter or operating for hire. The Port Director has sole authority to determine whether a vessel is exempt under this subsection.

(e) Any entity required to have a current insurance certificate on file with the Port who fails to provide a current certificate after a written or oral request from the Port Director, shall be considered a trespasser on Port property and subject to one or more of the following actions: 1) summary eviction; 2) issuance of a stop work order by the Port Director, his or her designee, or any Public Safety officer; 3) daily fines of \$300 for each day of operation without the required certificate; 4) future denial of use of the Port of Nome; and/or 5) additional fees and penalties as set out in this Tariff.

**01.055 Snake River area:**

(a) Vessels drawing less than 20 inches of water, including support vessels, may only moor in the Snake River area, and may not dock anywhere else in the Harbor unless specifically allowed by the Port Director or Harbormaster.

(b) Support vessels may not remain attached to main vessels, or dock in the Small Boat Harbor unless approved by the Port Director. All users must keep mooring areas alongside their vessels clear of obstructions to allow for other vessels to raft.

(c) Any vessel, regardless of size, may apply to the Harbormaster for a Snake River permit, which shall be issued in his or her discretion, subject to availability and compliance with use restrictions. The Port Director and Harbormaster may also require or permit vessels to use the Snake River area at his or her discretion.

(d) All provisions of this tariff, the rules and regulations, and other Port policies apply equally to vessels and users of the Snake River area.

(e) Users should exercise due care when anchoring along the bank or in the mudflats. All moorage is undertaken at the user's own risk. The Port is not responsible for any damage to persons or property on Port property, including the Snake River area, the Belmont Beach launch, and all other facilities.

(f) Vessels must be properly anchored and secured. Vessel owners should monitor or check their vessels frequently in order to ensure compliance with this section, especially during high wind and surge.



(g) No sewage or waste may be disposed of anywhere in the Port Facility, except in authorized disposal containers provided.

**01.060 Compliance with Law:**

(a) All persons entering or using the Port of Nome agree to comply with all rules, regulations, ordinances, statutes and laws applicable to the activities and circumstances.

(b) Open containers and/or consumption of alcohol will not be permitted on any parts of the Port of Nome premises. Persons found in violation of this rule will be asked to leave the premises immediately, will be reported to the local and State authorities, and may be denied future access to and the use of the Port and its facilities. Consumption of alcohol onboard a vessel that is underway will be reported to the United States Coast Guard for necessary action.

(c) Any person whose conduct while on Port of Nome property is in violation of law or this tariff may be refused further access to the Port in addition to any other fine or penalty imposed by law,. Any vessel located within the Port of Nome upon which any conduct occurs that is in violation of the law or this tariff, may be refused future access to the Port. Any person who refuses or repeatedly refuses to obey a direct order of the Harbormaster or Port Director may be subject to fine under Section 01.060(d) of this tariff and **permanently** denied access to the facility. The Port Director shall have full discretion to take the appropriate action to enforce the rules contained in this tariff and other municipal, state, and federal laws, up to and including permanent denial of access to the Port and Port facilities and/or impounding and disposing of the vessel.

(d) Any person or vessel or vessel owner or operator who violates any provision of this tariff or the rules and regulations of the Port of Nome shall be subject to a civil fine in an amount of \$500 for the first violation, \$750 for the second violation, and \$950 for subsequent violation, plus any surcharge required to be imposed by AS 12.55.039. In cases of continuing violations, each day during which a violation continues shall be considered a separate offense.

(e) The amount of fines assessed shall be added to any invoice for services issued by the Port Director. If an invoice would not otherwise be issued, a fine may be imposed by civil action.

(f) A person who disputes whether a fine has been properly added to an invoice shall have the right to request in writing an informal administrative hearing with the Port Director within thirty (30) business days of the date of receipt of the invoice. The Port Director shall schedule the informal administrative hearing within thirty (30) business days of receipt of the request for the hearing, and shall issue a written decision regarding the matters discussed at the hearing no later than ten (10) business days after the day of the hearing. Any person aggrieved by said written decision may appeal the matter to the Nome City Council no later than thirty (30) business days after receipt of said written decision. The Mayor shall outline reasonable procedures for appeals to the Nome City Council. The decision of the Nome City Council shall be final and may be appealed to the Superior Court for the State of Alaska, Second Judicial District.

(g) Any vessel that has incurred an unpaid account or fine, or that is owned or operated by a person who has incurred an unpaid account or fine may, in the sole discretion of the Port Director, be denied use of the Port until such time as the fine has been paid in full. Any user who facilitates or assists a person with an unpaid fine in using Port facilities when the person is banned from using Port facilities, or in an effort to avoid such a ban or fine from being imposed, enforced, or collected, may likewise be denied use of the Port for up to ten (10) days or until the fine is paid, at the sole discretion of the Port Director.

(h) The Port Director, Harbormaster, their designees, and employees shall at all times have the right to refuse the use of any port or harbor facility by any person, equipment materials or vessel, or to remove any vessel or, person or cargo at any time from any port, or harbor facility. This right shall be reserved at all times to the Port of Nome without responsibility for demurrage, loss or damage when:

(1) previous arrangements for berthing, space, receiving or unloading have not been made with the Port Director; or

(2) the vessel is deemed unstable, a fire hazard, or threat to the environment and may pose risk to life or property; or

(3) the value of the vessel, in the opinion of the Port Director, is less than the probable service and other charges accruing or likely to accrue for its use of the city dock or terminal, or harbor facility; or

(4) during periods of congestion or in cases of emergency, in the judgment of the Port Director, the circumstances are likely to prevent the city docks or terminal, or harbor facilities, or any portion of them from providing customary services to the public.

For vessels that may be hazardous or become a menace to other vessels, their occupants, or city facilities, the Port Director may require an operator or owner of a vessel to furnish evidence that there is currently in effect liability insurance in an amount satisfactory to the City by filing a certificate of insurance or other satisfactory evidence signed by an agent or officer of the insurance company and stating the effectiveness and expiration date thereof. Upon demand of such proof of coverage, the operator or owner shall be subject to the penalties set forth in Section 01.050(e) of this tariff.

~~(i) The Port Director shall at all times have the right to impound a vessel for failure to pay required fees or obey other provisions of this tariff.~~

~~\_\_\_\_\_ (1) The Port Director and/or Harbormaster is authorized to impound or move any vessel in or on the Harbor, terminal, or dock facilities if the vessel is in violation of any provisions of this tariff; or any vessel whose owner or operator has not paid any fee or charge due to the City for the vessel by the due date of such fee or charge and such fee or charge is **thirty (30) calendar days past due**; or any vessel which is unsafe and whose owner or operator has failed to remove it after notice. The Harbormaster may impound a vessel by immobilizing it or removing or having it removed from the water and placed in City or commercial storage with all expenses and risk of haul-out and storage to be borne by the owner of such vessel.~~

~~\_\_\_\_\_ (2) The owner or operator of any vessel impounded by the City shall be subject to and liable for all costs incurred by the City by reason of impounding or removal, as well as all costs associated with collecting unpaid fees or charges, including all reasonable and actual attorney's fees.~~

~~\_\_\_\_\_ (3) In addition to the rights described in this section, the Port Director and/or Harbormaster may immobilize, impound, or seize any personal property located on Port property, including machinery, containers, trailers, gear, tools, and equipment of any kind, in order to secure payment of unpaid fees, accounts, or fines. If the personal property is not redeemed by complete payment of the account, it may be sold as surplus property and the proceeds applied to the delinquent account.~~

~~\_\_\_\_\_ (j) Any vessel that is deemed delinquent, derelict, or abandoned as defined in NGO 12.30.010 and which is located within the boundaries of the Port of Nome may be impounded and moved and disposed of in accordance with the procedures outlined in NGO 12.30.010 --080.~~

~~\_\_\_\_\_ (k) Any equipment or cargo that is deemed delinquent, derelict or abandoned within the boundaries of the Port of Nome shall cause a written notice to be sent to the owner of record via certified mail. If no response is received within thirty (30) business days, the cargo and/or equipment shall become the property of the Port of Nome and may be disposed of immediately. All costs associated with the handling of such items will be billed to the owner on a time-and-materials basis.~~

**01.070 Housekeeping and Safety:**

(a) All persons entering or using Port of Nome property are required to maintain the same in an orderly and clean manner. If any user of Port of Nome property does not leave areas of the Port used by the user in an orderly and clean condition, the Port Director shall order the work necessary to return the area to an orderly and clean condition and the user shall be responsible for all charges for said work. Users shall be responsible for all charges associated with cleanup, including disposal of hazardous or non-hazardous materials and storage of non-disposable items and materials. Such items and materials will be kept at the user's expense for no more than sixty (60) business days and then disposed of in a manner deemed appropriate by the Port Director, with costs of disposal also chargeable to the user. Users may be allowed to obtain a dockside vessel work area immediately adjacent to their vessel for a limited period of time, at the discretion of the Port Director. Dock face walkways must be kept clear at all times for safe access.

(b) No smoking shall be allowed on any Port of Nome premises where posted. Safety and warning signs shall be observed and adhered to at all times by all persons within the Port of Nome.

(c) Per NCO 10.30.020, unattended animals are prohibited. No animal may run loose within the Port and Harbor facilities. All vessels arriving into Nome with animals onboard must contact the local Animal Control Officer (through the Harbormaster or Nome Police Department) for a visual assessment of the animal and current vaccination records, prior to the animal being allowed to leave the vessel. Non-aggressive animals, in compliance with this section and NCO Chapter 10.30 will be permitted on the dock or a vessel, but must remain properly restrained or leashed at all times while in the port area. Violators will be reported to the Nome Police Department, and loose animals captured and impounded by the Animal Control Officer.

(d) All persons utilizing underwater divers anywhere inside the Port of Nome and/or Small Boat Harbor, are required to notify the Harbormaster's office of the scheduled dive activity and display the "Diver Down Flag" on the vessel mast for the entire duration of the dive. The Harbormaster's office must be notified once the operation is complete and all divers are out of the water.

(e) At the Port Director's discretion, the Port Director shall at all times have the right to immediately remove any hazardous vessel, or any vessel containing hazardous cargo, or one containing cargo, which by its nature, is liable to damage other vessels, or other cargo, or harbor or port facilities. The vessel may be removed from its location to any other location and all expenses and risk of loss or damage shall be charged to the account of the owner, shipper, vessel or consignee.

(f) No person shall cause or allow to occur any nuisance property, as defined by Section 06.108, in or on Port of Nome Facilities. ~~The Harbormaster may take immediate possession of and/or remove such nuisance property.~~

#### 01.071 Impound of Vessels and Personal Property

~~(a) The Harbormaster shall at all times have the right to impound, in accordance with NCO 12.30.010-12.30.030, any vessel in or on the Harbor, terminal, or dock facilities if the vessel is in violation of any provisions of this tariff; or any vessel whose owner or operator has not paid any fee or charge due to the City for the vessel by the due date of such fee or charge and such fee or charge is **thirty (30) calendar days past due**, or any vessel which is unsafe and whose owner or operator has failed to remove it after notice. The Harbormaster may impound a vessel by immobilizing it or removing or having it removed from the water and placed in City or commercial storage.~~

~~(b) The Harbormaster may impound nuisance property by impounding it in place, immobilizing it, removing or having it removed and placed in City or commercial storage. For impound pursuant to this subsection, the Harbormaster shall give notice of the impound as required by this section. The notice shall describe the property, the owner of record, if any, the location of the impounded property, provide a summary or the basis or reason for impound, and give notice of the right to appeal the impound, and that the impounded property is subject to disposal without further notice to the putative owner or operative if not redeemed within 30 days.~~

~~(1) Nuisance property shall be subject to impound if not removed, or written permission from the Harbormaster for such placement or storage is not received, within 48 hours of placement on port property. Written notice shall be placed on the property to the extent practicable.~~

~~(2) In the event property impounded under this section remains impounded for 30 days and impound charges and fees remain unpaid, the Harbormaster may sell the property at public auction to the highest and best bidder. Such sale shall be conducted pursuant to a procedure generally similar to that set forth in Nome Code of Ordinances Chapter 2.12 for sale of abandoned property, and, in addition to the notice requirements of Chapter 2.12, shall post notice in the Harbormaster's office as well as one other conspicuous place in the port; provided that if impounded property is reasonably believed by the Harbormaster to have a market value of less than \$250, the Harbormaster shall make reasonable effort to give notice of the impoundment to the owner and post notices in the Harbormaster's office and at least one other conspicuous place in the port, if not redeemed within 30 days, the Harbormaster may destroy, retain for a public purpose, donate, or sell the property as he or she deems fit.~~

(2) Written notice shall be mailed, return receipt requested, to the owner of record at the most current address provided by the owner or, absent such address, to an address for the owner contained in the public records of the city or state.

(3) In the event that the owner of impounded property cannot be identified, the harbormaster shall post the impound notice in the harbormaster's office and in city hall and shall cause the notice to be printed in a newspaper of general circulation within the city once each week for four consecutive weeks.

(c) In addition to the rights described in this section, the Port Director and/or Harbormaster may immobilize, impound, or seize any personal property located on Port property, including machinery, containers, trailers, gear, tools, and equipment of any kind, in order to secure payment of unpaid fees, accounts, or fines.

(d) The owner of impounded property, including a vessel, shall have the right to request in writing an informal administrative hearing with the Port Director within thirty (30) days of the notice of impound. The Port Director shall schedule the informal administrative hearing within thirty (30) days of receipt of the request for the hearing, and shall issue a written decision regarding the matters discussed at the hearing no later than ten (10) business days after the day of the hearing. The decision of the Port Director may be appealed as follows:

(1) For an impounded vessel, an owner or operator may, appeal the Nome common council by giving written notice to the Port Director hand delivered or postmarked within thirty days of receipt of the Port Director's decision.

(2) For all other property, the decision of the Port Director shall be final and may be appealed, as an administrative appeal, to the Superior Court for the State of Alaska, Second Judicial District within thirty days of receipt of the Port Director's decision.

(3) Failure to timely exercise the appeal rights set forth in this section shall constitute waiver of all right to appeal the Port Director's decision.

(e) In the event property impounded under this section remains impounded for 30 days and impound charges and fees remain unpaid, the Harbormaster may sell the property at public auction to the highest and best bidder. Such sale shall be conducted pursuant to a procedure generally similar to that set forth in Nome Code of Ordinances Chapter 2.12 for sale of abandoned property, and, in addition to the notice requirements of Chapter 2.12, shall post notice in the Harbormaster's office as well as one other conspicuous place in the port; provided that if impounded property is reasonably believed by the Harbormaster to have a market value of less than \$250, the Harbormaster shall make reasonable effort to give notice of the impoundment to the owner and post notices in the Harbormaster's office and at least one other conspicuous place in the port, if not redeemed within 30 days, the Harbormaster may destroy, retain for a public purpose, donate, or sell the property as he or she deems fit. The owner or operator of any nuisance property or vessel impounded by the City shall be subject to and liable for all costs incurred by the City by reason of impounding or removal, as well as all costs associated with collecting unpaid fees or charges, including all reasonable and actual attorney's fees incurred by the City in connection with impound, removal or collection. The City shall not be liable to any owner for any damage to or loss of impounded property except to the extent caused by willful misconduct of an officer, employee, or agent of the City. The owner or operator of any nuisance property or vessel impounded assumes all risk associated with impound.

(f) The City shall have a possessory lien upon all impounded property for all amounts due under this tariff and a storage lien in accordance with AS 34.35.220 for reasonable charges for the labor, care, and attention on or for impounded property. The City may record a notice of any such lien.

#### **01.072 Disposal of Impounded Property**

(a) Without limiting any other rights of the City of harbormaster provided by this tariff, the Nome Code of Ordinances, or Alaska law, the harbormaster may dispose of impounded property in accordance with this section.

(b) The harbormaster may dispose of impounded property if the property has not been redeemed within 30 days of the notice of impound. The 30 days to redeem the property shall be tolled by appeal of the impound pending resolution of that appeal.

(c) If impounded property is reasonably believed by the Harbormaster to have a market value of less than \$500 and the impound is not appealed nor the property redeemed within 30 days of such notice, the Harbormaster may destroy, retain for a public purpose, donate, or sell the property as he or she deems fit.

(d) Except as otherwise provided in this section, disposal of impounded property shall be by sealed bid or public outcry auction. Notice of the auction shall be posted in city hall and the harbormaster's office and shall be published in a newspaper of general circulation within the city once each week for four consecutive weeks. The auction notice shall identify the property to be sold, the date the property was impounded, and the owner, if known, as well as any other information the harbormaster may include. The public auction or deadline for submission of sealed bids shall not be less than thirty days after the notice of public auction is first published. Not less than thirty days prior to the public auction or deadline for submitting sealed bids, the harbormaster shall mail notice of the auction to any person with a lien or security interest of record in the property to be sold, with a notice that the party may redeem the impounded property upon payment of all amounts due at any time prior to the auction or deadline for bid opening. Any notice required by this tariff for impounding property may be given concurrently with the posting and publication of the auction notice, provided that no impounded property may be sold until the periods to appeal the impound and redeem the property have expired.

(e) Proceeds from the sale of impounded property shall first be used to reimburse the city for all costs associated with impounding, storage and selling of the vessel; remaining funds shall be paid to holders of any liens recognized under federal or state law, provided such lien holders request payment from the city, in writing, within sixty days from the date of the vessel's sale. Sale proceeds shall then be applied to amounts owed to the City for any charges, fines, or debts not already discharged. The remaining balance, if any, shall be returned to the property owner, provided that the owner makes such a request in writing, within sixty days from the date of sale and provided that the owner provides satisfactory proof of ownership to the port director. If any funds remain from the sale of a vessel, the funds shall be turned over to the city treasury after the sixty-day period.

(f) Any property for which no bid or offer is received shall be deemed to have a market value of \$1 and, the Harbormaster may destroy, retain for a public purpose, donate, or sell the property as he or she deems fit.

#### **01.075 CARE IN THE PERFORMANCE OF OPERATIONS:**

(a) Third party employees shall exercise care in the performance of their operations in order to prevent injury to, or death of, any person and damage to, or destruction, or loss of property, whether of the Port, of the third party, of the vessel being loaded/unloaded, or of another party.

(b) When cargo/freight is in an elevated position, such as suspended from a crane hook, a safety line should be attached to the load and handled by a Safety Watch person to prevent spillage, or unplanned descent, which has the capability to produce injury, or death. In all cases, the Safety Watch should ensure that individuals are prevented from walking under a raised load and remain clear of cargo/freight operations.

(c) Safety helmets (hard hats) and safety vests are required when working cargo, gravel and equipment on, or at, Port of Nome facilities. The use of steel-toed shoes/boots is strongly recommended.

(d) Any third party operating at the Port of Nome shall take all necessary safety and fire precautions, and comply with recognized commercial and marine safety practices, procedures, and regulations.

#### **01.080 Used Oil Handling:**

(a) Used oil in increments of five (5) gallons or less from small vessels (less than 75 feet) will be accepted free of charge when disposed of properly by Port users in the specified containment bin located in the Small Boat Harbor facility. Used sorbents and filters are collected in a tote near the containment bin in reasonable quantities for incineration. Please contact the Harbormaster's office regarding larger quantities.

(b) Used oil from any source other than small vessels or in quantities greater than five (5) gallons will be accepted by the port for a fee (designated in Section 05.035 of this tariff). Port users shall contact the Port Director to arrange for a place where such used oil will be accepted.



(c) Any unpermitted disposal or abandoning of used oil in the Port of Nome will subject the person disposing of or abandoning the used oil, the vessel from which the used oil originated, and the owner of the vessel from which the used oil originated, to the fine established by this tariff. Glycol, solvents or any other non-petroleum based product disposal shall not be permitted.

**01.090 Facility Security and Access:**

(a) All persons within the Port of Nome must comply with any security signage and barricades defining restricted or secured areas and controlled access points. Specific regulations regarding the handling of cargo and fuel and access within these areas are outlined in the Port of Nome's USCG approved Facility Security Plan. As of February 12, 2009, all personnel needing access to restricted or secure areas within the facility during regulated operations will be required to present their Transportation Worker's Identification Credentials (TWIC) and have a valid reason for entry. **Cargo and fuel shore-side operators will operate under the Port's Security Plan and be responsible for controlling access to the restricted and secure areas during their respective operations.** No unauthorized personnel (including customers of shore-side operators) will be allowed in the restricted and secure areas, unless specifically authorized by the Port Director or Harbormaster. Failing to comply with any of these requirements may result in the imposition of the fines set forth in Section 1.060 of this tariff, and removal of the operator from the Port's Security Plan. Operators removed from the Port's Security Plan shall not operate at the facility until a stand-alone company security plan, approved by the USCG, is submitted to the Port. Regulated cargo and fuel vessels will maintain security watch whenever remaining dockside without actively conducting any cargo operations. The Port of Nome will provide access control to these areas during all passenger and foreign-flagged vessel operations.

(b) All foreign-flagged and/or passengers vessels requiring active port security under MTSA will be charged one security fee for each 12 hour period of security (shift), providing the over-time labor hours do not exceed 6 total hours during the 12 hour shift. For security shifts exceeding 6 hours of over-time, labor hours will be billed per the rate and type identified in Chapter 5, Section 05.035(a)8 of this tariff. All shift hours classified as Holiday Time will be billed per the rates in Section 05.035 (a) 8 of this tariff.

(c) All film, video and/or photography production companies are required to complete a license application, pay the application fee, and receive an approved license prior to any production operations commencing on Port facilities. This licensing requirement applies to commercial entities only, and not private photographs or video

(d) Users are hereby notified that surveillance cameras may be operating at any time within the Port of Nome facility. To the fullest extent allowed by law and subject to the Public Records Act, recorded video shall be reviewed only by authorized personnel. Users requesting access to review footage must submit a public records request form to the City Clerk.

**01.100 Maneuvering and Navigation:**

(a) All vessels traveling in and out of the Nome Port and Harbor will be required to have at least one fully operational marine VHF radio on board at all times, and must monitor VHF Marine channel 16 when maneuvering within the navigation channel into or out of the port or harbor entrances. All vessel operators, regardless of size, must adhere to standard rules of navigation at all times, and grant the right of way to larger vessels that are underway in an approach or departure. Vessels larger than 75 feet in length are required to give security calls before entering or departing the navigation channel.

(b) The narrow 500' wide breakwater entrance and large waves, strong winds and currents challenge safe transits to and from the Port of Nome. The Port of Nome has accordingly prescribed navigation safety parameters to enhance maritime safety. All vessels seeking access to port facilities shall comply with the written navigation safety directives as provided by the Harbormaster.

(c) All vessels operating within the Small Boat Harbor and navigation channel shall do so in a safe manner so as not to cause a wake, wash or wave action which will cause damage or endanger any other vessels or occupants. Vessels shall travel at a speed no faster than 5 mph while in the Small Boat Harbor or portion of the navigation channel that extends from the Inner Harbor to the southern limits of the armored slopes of the Small Boat Harbor entrance. Violators of this section will be subject to fines as defined in Section 01.060(d) of this tariff.

(d) Fish nets that extend across or below the water's surface may not be used or deployed in or around any portion of the facility between the entrance to the Port at the breakwaters, through the entire outer and inner harbor, and extending to 300 feet above the Snake River Bridge.

(e) The Port of Nome currently hosts an active National Oceanic and Atmospheric Administration (NOAA) tidal station located at the Causeway City Dock. Station information can be found through a link on the Port & Harbor page of the City of Nome website at [www.nomealaska.org](http://www.nomealaska.org).

**01.110 Closed Season:**

(a) The Port of Nome facilities are considered closed from November 1<sup>st</sup> until ice-free in the spring. Activities within the Port may not be carried out during the closed season without prior authorization by the Port Director. The Port Director shall have sole discretion to determine whether the user requesting access shall be allowed to use the Port under such circumstances. Users should submit cost estimates and work plans when seeking approval to conduct operations during the closed season. The Port Director shall evaluate any request to use the Port during the iced-in months according to the cost and burden the facilities may reasonably be expected to incur by approving the request, in comparison with its overall value to the community, the Port and City of Nome.

(b) If the operation is approved, all reasonable charges incurred by the Port of Nome over and above the typical summer season expenses for a similar operation will be the responsibility of the user. The rate may be negotiated or based on actual incurred costs, as determined by the Port Director. Any damage to the Port of Nome during these winter operations will also be the responsibility of the user and/or company conducting the operation.

## **CHAPTER 2 BERTHING**

**02.010 Permission Required:**

(a) Prior to any non-home-ported/transient vessel mooring, anchoring, or berthing within the Port of Nome, they shall first receive approval for a berth assignment from the Port Director. Written berthing applications must be submitted for all vessels requiring use of the Causeway facility and all cargo vessels requiring use of the Small Boat Harbor, at least 7 days in advance of the requested day of use. When a vessel requesting use of the Causeway facility requires the stand-by of emergency services or security services, such as vessels loading or unloading hazardous materials and passenger vessels, written requests for the specific services shall be submitted no less than five days in advance of the requested date of use. Vessels arriving at the Port of Nome without prior notification will be granted dockside access only after all scheduled traffic has completed operations or an open berth is available and sufficient time exists for operations to be completed prior to the arrival of the next scheduled vessel.

(b) All berthing assignments approved by the Port Director shall be granted on a first-in-time basis of receipt of berthing requests, provided however that preferential berthing requests shall be granted in accordance with the procedures described in Section 02.020 of this tariff below, and emergency berthing may be granted at any time at the discretion of the Port Director.

(c) Docking permits are available to Homeported vessels only, provided the Port of Nome is given notification of vessel's initial arrival or launch, and a docking permit defining a particular period (weekly, monthly or seasonal) is issued by the Port of Nome for the vessel. It is the responsibility of the vessel owner/operator to obtain renewals for expired docking permits. Users choosing not to obtain a docking permit will pay dockage at the full daily rate identified under Section 05.010, with all tariff rules and stipulations in effect.

(d) At the discretion of the Port Director or his/her designee, docking permit holders operating out of the Inner Harbor may be **temporarily** allowed to occupy a Causeway dock for the purposes of refueling, repairs or other short-term operational activities. Docking permit holders operating out of the Outer Harbor shall be allowed to **reserve space** at a Causeway dock for the same aforementioned purposes, but such occupancy and use shall be in accordance with any restrictions or limitations set by the Port Director and shall not interfere with or delay previously scheduled vessel traffic at the Causeway.

(e) All docking permit holders must sign and file with the Harbormaster's office a Dock Use Agreement stipulating compliance with harbor rules, including the use requirements set forth in Section 01.050 of this tariff, and file the required paperwork and/or fee under the applicable provisions of Section 01.050(d) of this tariff. Users who cannot provide proof of coverage are subject to additional fees and may be denied use of the Port.

(e) All berthing and docking permits assigned shall apply to a specific vessel at a specific location (or area) for a specific period of time, and are non-transferable, non-refundable, conditional permits, revocable without notice or claim, except as otherwise provided in these tariff regulations.

**02.020 Preferential Berthing:**

(a) The Port Director shall review and consider all written requests for preferential berthing, for specific dates and times, received by the Port of Nome based on the date received. Preferential berthing permits shall be based on a 24-hour period constituting one day.

(b) If two or more applicants apply for preferential berthing for the same time and location, the Port Director shall convene an informal telephonic or personal conference with representatives of all conflicting applicants, and shall attempt to obtain a good faith accommodation that minimizes costs or damages to all of the conflicting applicants. If the Port Director is unsuccessful in obtaining a consensus accommodation among conflicting applicants, then the Port Director shall arrange and execute a fair and impartial drawing of lots to determine which conflicting applicant shall receive the preferential berthing reservation.

(c) No holdover rights are derived from the award of preferential berthing. A vessel delayed in arrival to its reserved, preferential berthing, or a vessel choosing to hold over beyond the term of its preferential berthing, shall be accommodated only during the period of its original preferential berthing reservation, and shall be treated as any other application on a first-in-time basis for any holdover berthing time. Delays resulting from inclement weather will be handled on a case-by-case basis as determined by the Port Director or Harbormaster.

**02.030 Alteration or Revocation of Berthing Assignments:**

The Port Director may, at his or her sole discretion, alter or revoke any and all berthing assignments whenever he or she determines that such an alteration or revocation is necessary to prevent illegal activities, to prevent damage to the Port of Nome, to avoid undue delay in port operations, to avoid unsafe congestion in the port, to avoid grossly excessive operational costs to the Port of Nome or to other users of the Port of Nome, to prevent further accumulation of charges on an already outstanding account, or to accommodate emergencies, the public health, safety and welfare.

**02.040 Reassignment or Return to Berth:**

Whenever the revocation of a berthing assignment is not caused by culpable acts or omissions of any person associated with the permittee of the berthed vessel, the Port Director shall make all reasonable effort to assign another berth to the vessel if a satisfactory alternative is available. Whenever the revocation of a berthing assignment is not caused by culpable acts or omissions of any person associated with the permittee of the berthed vessel, the Port Director shall make all reasonable effort to return the vessel to the original berth as soon as possible, provided however that no decision to return the vessel to its original berth shall result in interference with other berthing reservations existing at the time of the revocation.

**02.050 Orders of Alteration, Revocation or Reassignment of Berthing:**

The Port Director may require or cause any vessel's berthing assignment to be changed or reassigned to facilitate access and efficiency in the Port, or if the Port Director determines that doing so is in the best interest of the public health, safety, or welfare. Any and all orders from the Port Director demanding the alteration, revocation or reassignment of berthing arrangements for a vessel shall be delivered to the vessel orally or in writing, or to the permittee if the vessel is not in the Port of Nome, The vessel shall comply fully with the Order no later than four (4) hours after the time of receipt of the Order, provided, however, that the Port Director can require compliance within a shorter time if an emergency so requires.

**02.060 Securing Vessels:**

(a) All vessels berthing in the Port of Nome shall be moored, anchored and secured in a safe manner according to generally accepted practices of seamanship. All vessels lying at a wharf, pier, causeway, revetment, dock, floats, other improvements or alongside another vessel shall be secured with head and stern lines to mooring bits, bollards or cleats. **Any securing of lines to scupper holes, tires, chains or ladders is not permitted.** All methods of securing a vessel and all rigging of a vessel in the Port of Nome shall be subject to inspection and approval by the Port Director at any time. Orders of the Port Director to change or improve vessel security or rigging shall be executed by the permittee immediately. Each vessel owner or operator is responsible for checking and re-securing all lines, anchors, and rigging in use by his or her vessel during all weather conditions.



(b) The Port Director may require vessels to raft on the floats and sheet pile docks during periods of heavy traffic and/or bad weather. If so ordered, all vessels shall comply immediately. Volunteer rafting of like-owned or buddy vessels are encouraged. No vessel, owner, agent, etc. has the right to refuse outside berthing if it has been authorized by the Port Director or their designee. Vessels tied to the outside of a vessel already tied to any part of the dock facilities (rafting), will adhere to the same Tariff Rules and Regulations as any vessel tied to the dock, and are subject to the same charges as if moored directly to the dock. When rafted vessels are moved to allow for departure of another vessel, the remaining vessel will be securely re-tied in the manner described above. Users are required to maximize the use of all sheet pile and floating dock space by mooring as close to neighboring vessels as is safe under the circumstances.

(c) Every vessel secured to a structure, or lying alongside another vessel berthed at the Causeway facility within the Port of Nome shall, from sunset to sunrise, be equipped with stable access secured in a manner subject to inspection and approval by the Port Director at any time. Every gangway shall be brightly illuminated between sunset and sunrise, and shall be monitored by the vessel watch. Any vessel over 75 feet in length moored, and all vessels at anchor within the Port of Nome shall be sufficiently illuminated between sunset and sunrise so as to not compromise navigational safety.

(d) All vessels moored in the Port of Nome shall always and continuously, **without fail**, maintain on board the vessel such crew members as are necessary to care for the vessel and to move the vessel immediately on emergency order of the Port Director. Skiffs and other small craft in the Small Boat Harbor and Snake River may be exempt from this requirement if the Port Director approves of an alternative method of ensuring that a vessel can be contacted and the vessel relocated without delay in the event of an emergency.

(e) Failure to comply with these regulations may result in the imposition of the fines set forth in Section 1.060 of this tariff against the person violating this provision, the owner and operator of the improperly secured vessel, and the improperly secured vessel, all of whom shall be jointly and severally responsible for payment of all fines assessed. In addition to the fine assessed, the vessel, vessel owner, and vessel operator may be denied use of Port facilities.

#### **02.070 Floating Dock:**

The floating docks are provided for vessels that are 40 feet and under in length unless otherwise allowed by the Port Director. All moorage on the floating docks is on a first-come-first-served basis, as space permits. Rafting is required during periods of heavy traffic and/or bad weather, provided that this does not cause a safety or navigation hazard. When rafted vessels are moved, they will be securely re-tied. The floating docks and ramp areas shall not be used for storage of any kind and shall be kept entirely clear and tidy of all gear, supplies and debris by its users. Storage is available on the uplands near the floats on arrangement with the Harbormaster's office.

#### **02.080 Vessel Condition:**

All vessels moored in the Small Boat Harbor and Snake River must be in a functional status, unless actively conducting repairs dockside with the consent of the Port Director. At least once in each 30-calendar-day period during the ice-free season, all vessels must leave the Small Boat Harbor under their own power, travel at least half (½) mile outside the Port, and return under their own power unless the Port Director has provided written exemption for a vessel undergoing long-term repair. Any vessel that does not or cannot do so will be deemed "inoperable." Any vessel deemed inoperable for a period exceeding 15 calendar days, may seek authorization for one (1) extension of no more than 15 calendar days to allow repairs to continue dockside. After 30 calendar days of being inoperable, the vessel must be removed from the harbor until such time as it is deemed functional again and authorized to be moored within the facility.

#### **02.085 Repairs and Maintenance:**

When work is performed on tugs, boats, barges, or other types of maritime vessels while they are in temporary storage or moored at the dock, the area where the work is being performed must be cleaned up and reasonably consolidated at the end of each working day. Failure to clean up after the work is performed could result in the owner/operator being assessed a clean-up fee plus being denied future storage and moorage privileges. Tarpaulins, or some form of heavy-duty material must be placed under the section of the hull being scraped, or worked on, so as to preclude any of the residue being left on the land where the craft is located. Owners/operators shall be responsible for disposal of any debris, or residue, and for restoring the ground base to original condition when work is completed. Users performing maintenance and repairs with wheeled equipment that can be moved immediately upon order of the Harbormaster are authorized to occupy port property at no charge for a maximum of one week to conduct the work.

Upon conclusion of that week, the Harbormaster may approve up to one additional week at his or her discretion, provided there is sufficient justification.

**02.090 Barge Ramp Use:**

(a) Use of the Barge Ramp in the Small Boat Harbor must be scheduled to prevent vessel conflicts. Vessels under twenty-five (25) feet will be exempt from this requirement, provided that the operation requiring use of the ramp occurs in less than **twenty (20) minutes**. Vessel trailers are subject to inspection by the Port Director and required to be adequately constructed to support the length and weight of the vessel. Launching operations must likewise be conducted in a safe and reasonable manner. Operations deemed unsafe by port staff will cease immediately until alternative methods or equipment are obtained. Users are responsible for any damage resulting from use, and are required to clean up ramp after vessel launch or haulout. Before launching or hauling out any vessel over 50 ft in length, a written Haul Out/Launch Plan must be filed with the Harbormaster for the Harbormaster's review. If the Harbormaster does not object to the plan within 3 days of filing, the vessel may be hauled out in accordance with the filed plan. Violation of this section will subject users to fines set forth in Section 01.060(d) of this tariff.

(b) Haul-out and launch plans shall be prepared to minimize interference with other users and ensure the safety of all users and property.

### **CHAPTER 3** **CARGO HANDLING**

**03.010 Permission Required:**

(a) All movement and placement of cargo within the defined cargo handling areas in the Port of Nome shall occur only in compliance with the prior approval of the Port Director. No person may place or deposit cargo or other property at any location within the cargo handling areas in the Port of Nome without first obtaining this approval from the Port Director. Cargo and other property shall be off-loaded from or loaded to vessels only at specific locations as designated by the Port Director. The Port Director may establish a time by which cargo must be removed from the port cargo handling area. Failure to comply with this regulation may result in the imposition of the fines set forth in Section 1.060 of this tariff against the person violating this provision, the owner and operator of the vessel, and the vessel, all of whom shall be jointly and severally responsible for the payment of all fines assessed. In addition to the fines assessed, the vessel, vessel owner and vessel operator may be denied use of Port facilities.

(b) Fire lanes and a strip of land extending twenty (20) feet uplands from all revetments shall remain clear of any resting cargo and vehicles at all times unless special arrangements are made with the Port Director. The Port Director may allow for the temporary placement of cargo in otherwise prohibited areas for purposes of loading/unloading or authorized and active repairs. Unauthorized cargo and vehicles will be removed by the Port of Nome and all associated charges will be the responsibility of the person that deposited the unauthorized cargo, including any fines imposed pursuant to Section 1.060 of this tariff.

(c) The dock-side staging of rock, sand and/or gravel products must be made by special arrangement with the Port Director at least seventy-two (72) hours prior to the vessel's arrival. The exact staging location shall be determined by the Port Director. Specific written directives for loading/unloading all rock, sand and gravel materials are available at the Harbormaster's office and at [www.nomealaska.org](http://www.nomealaska.org). Every contractor should review the directives prior to the start of each season. Staging areas and dock facilities must be returned to their original condition by the port user within twenty (24) hours of the vessel's departure unless gravel exports continue over a prolonged period, in which case the gravel staging areas shall be returned to their original condition by a date approved in advance in writing by the Port Director. Any damage to facility or significant material loss overboard must be reported to the Port Director immediately. Continued overboard material loss that goes unreported will subject contractors to fines as outlined in Section 01.060(d) of this tariff, and the expense of retrieving overboard materials. Repeat offenses may result in the vessel and vessel owner being denied use of port facilities.

(d) Over-side cargo being discharged or loaded between vessels when one vessel is berthed at a Port of Nome facility shall be charged according to the wharfage rates identified in Section 05.020(a) for that cargo. Manifest requirements and all other rules of cargo handling shall apply in these circumstances.

(e) All cargo containers, their contents, flats and loose stow are the full responsibility of the carrier or consignee while stored anywhere on Port property. No cargo security will be provided by the Port of Nome. All cargo,

flats and loose stow MUST be removed from the face of the Causeway docks during storms to prevent damage and potential loss. It is the responsibility of the carrier or consignee to monitor the weather when using the Causeway docks, and remove any cargo or equipment prior to each storm event or at the direction of Port staff.

(f) All hazardous cargo shall be handled on a first-on, first-off basis when being loaded to or unloaded from a vessel moored at the Port of Nome. Hazardous cargo shall not be left unattended unless authorized by the Port Director.

### **03.020 Manifests and Cargo Information:**

(a) Any approved cargo handling permittee shall furnish to the Port Director a complete copy of the manifest of the vessel, including names of consignees or consignors, a detailed description of all cargo to be loaded or discharged, the weights or measurements of all cargo to be loaded or discharged at the Port of Nome, Dangerous Cargo Manifests (DCM) as required by the USCG, and such other information as the Port Director may require. The manifest must also designate the basis, weight or measurement on which the ocean cargo was assessed. **Manifests shall be provided prior to actual unloading of a vessel and within forty-eight (48) hours after loading a vessel**, except on special arrangement with the Port Director. Failure to supply this information may result in the imposition of the fines set forth in Section 1.060 of this tariff against the person violating this provision, the owner and operator of the vessel, and the vessel, all of whom shall be jointly and severally responsible for the payment of all fines assessed. In addition to the fines assessed, the vessel, vessel owner and vessel operator, may be denied use of Port facilities.

(b) The Port Director may, at his or her discretion, accept certified freight lists, mates' receipts, or copies of "boat notes" in lieu of the vessel's manifest, provided the alternative sources of information contain all of the information required for the issuance of a cargo handling permit and for the levy of wharfage charges.

(c) All charges associated with a vessel's port call will be charged on one invoice, unless a different billing arrangement has been previously approved in writing by the Port Director. All manifested commodities (cargo, fuel, equipment and gravel) will be billed to the carrier transporting the commodity, unless a different billing arrangement has been previously approved in writing by the Port Director. Charges will not be split between a vessel and any other person unless deemed warranted by the Port Director.

### **03.030 Port Equipment and Services:**

(a) The Port of Nome does not, at this time, provide stevedoring, handling, checking or other port services with the exception of monitoring inbound petroleum transfers at the Causeway City Dock header and the dispensing of potable water. Labor costs for header crew during petroleum transfers will be assessed per Section 05.035(a)(8) of this tariff. The Port of Nome may authorize an approved cargo handling permittee to monitor outbound petroleum transfers, provided all personnel participating in the transfer are first deemed qualified by the Harbormaster. Any approved cargo handling permittee shall be responsible for arranging privately any and all port services except petroleum transfers and potable water dispensing. Arrangements for conducting petroleum transfers must be made through the Port Director at least seventy-two (72) hours prior to the vessel's arrival. Failure to meet this requirement may subject the user to delays in product transfer. In the event that the user is unprepared to commence transfer after stating readiness, or delays occur that are directly related to the product carrier or recipient, the stand by rate established in Section 05.035(a)(8) of this tariff for per man per hour will be charged by the Port of Nome for port personnel until operations resume. A minimum rate of 750 GPM (gallons per minute) or 45,000 GPH (gallons per hour) must be maintained for each inbound and outbound fuel transfer or labor costs for City personnel will be charged to tank farm operator conducting transfer. A list of specific directives for conducting transfers is available at the Harbormaster's office or at [www.nomealaska.org](http://www.nomealaska.org). All tank farm operators and fuel suppliers should review the directives prior to the start of each season.

(b) All cargo handling equipment shall be properly maintained and operators of cargo handling equipment shall be properly trained, supervised and directed by the cargo handling permittee, and the same permittee shall be fully and primarily responsible and liable to the Port of Nome at all times for any and all claims, losses or damages incurred or suffered by the Port of Nome as a result of acts or omissions in conjunction with or caused by the operators or operation of cargo handling equipment. Any damages to any Port of Nome facility must be reported to the Port Director immediately.

(c) Whenever the Port Director determines that the counting or checking of cargo against appropriate documents by the cargo handling permittee is inadequate to safeguard the accurate levy of wharfage, or the health,

safety, economic interests or public welfare of the Port of Nome, the Port Director may retain at the expense of the cargo handling permittee alternative services as the case may require for counting, checking, measuring, grading, scaling, surveying, weighing, marking, segregating, sampling, or supplying accurate, necessary information.

(d) High Mast Lights must be used any time cargo, fuel, equipment and gravel operations occur on the City and Westgold Docks during periods of darkness. Vessel operators who intend to operate during dark hours must notify the Harbormaster or his/her designee prior to the vessel's arrival. Only port staff is allowed to operate the lighting controls unless the Harbormaster has specifically authorized a particular user to do so.

#### **03.040 Right to Refuse Cargo:**

(a) The Port of Nome reserves the right to refuse to permit the loading, off-loading or placement of any cargo on Port of Nome premises whenever the Port Director finds at his or her discretion:

- 1) That the shipper, consignee, carrier or cargo handling permittee has failed to make adequate arrangements for receiving, handling, storage or movement of cargo;
  - 2) That the cargo contains illegal, perishable and deteriorating, hazardous or otherwise offensive substances;
  - 3) That the cargo creates an attractive nuisance or a public nuisance;
  - 4) That the cargo value is less than the probable unpaid dockage, wharfage and terminal charges;
- or,
- 5) That the cargo is not secured in packages or containers suitable for the nature of materials, or suitable for withstanding ordinary handling incidental to transportation from the Port of Nome; or,
  - 6) That the shipper, consignee, carrier or cargo handling permittee has delinquent unpaid charges with the Port of Nome.

#### **03.050 Petroleum Products and Hazardous Substances:**

(a) Acids, gasolines, fuel oil, volatile fuels, distillates, liquid petroleum products, explosives and hazardous substances ("Petroleum Products and Hazardous Substances") shall be unloaded from or loaded to vessels only at those locations within the Port of Nome designated as suitable for such purposes by the Port Director. All Petroleum Products and Hazardous Substances loaded or unloaded as cargo shall be identified on the Dangerous Cargo Manifest (DCM) (required with submittal of overall cargo manifests in Section 03.020(a) of this tariff) and clearly marked on vessel cargo manifests, including property reporting requirements. Dock-side bulk transfer of Petroleum Product cargo is restricted to the Causeway City Dock and the Harbor East Dock only, and limited to bulk transfers between vessels, or between vessels and shore-based tanks. Marine fuel retail sales are restricted to authorized locations and limited to outbound shore-based pipeline or trucked deliveries. The Port Director may from time to time impose safety conditions and such other operating procedures as are necessary for the transfer, including retail sale, of any such materials anywhere inside the Port Facility and exceptions to these restrictions may be made at the discretion of the Port Director.

(b) Each user of the Port of Nome transferring Petroleum or Hazardous Substances to or from a vessel, other than for use and/or consumption on the vessel, shall have available and be capable of implementing an Oil Discharge Prevention and Contingency Plan (ODPCP) approved by the Alaska Department of Conservation (ADEC), Environmental Protection Agency (EPA) and United States Coast Guard (USCG) capable of fully containing damages that might otherwise be caused by an explosion, fire, contamination or pollution. No ODPCP relying solely on equipment or expertise outside the immediate Nome area at the time of the cargo handling shall be acceptable.

(c) Any person possessing or keeping Petroleum or Hazardous Substances anywhere in the Port of Nome shall do so in full compliance with the terms and conditions of all applicable Federal, State and local laws and regulations, including, the requirements of the agencies responsible for the administration of such laws and regulations including the Maritime Transportation Security Agency (MTSA), the USCG and the ADEC. Additionally, any person possessing or keeping Petroleum or Hazardous Substances anywhere in the Port of Nome shall do so in full

compliance with the terms and conditions of this tariff, Port rules, Port regulations, and standard regulatory safety conditions controlling the use, storage, and disposal of such materials.

(d) A weekly permit is required prior to initiating any hotwork (welding, cutting), sandblasting, or painting, whether on a vessel or dockside. A text or telephone call notification to the Harbormaster or his designee is required prior to commencing any such work in order to facilitate the safe and orderly operations of the port. Permit application forms are available at the Port office during regular office hours. Outside regular office hours, users must first obtain verbal authorization by contacting the Harbormaster via VHF radio or other means, which authorization shall be logged by the Harbormaster, followed by the completion of the permit application on the next regular business day at the Port office. Users who do not obtain advance approval will be subject to the imposition of fines set forth in Section 01.060(d). Any “hotwork” conducted on Port of Nome facilities must be done in compliance with USCG 33CFR126.30.

(e) Failure to notify the Port of Nome of the possession on a vessel or transferring to or from a vessel of Petroleum or Hazardous Substances in quantities greater than what is reasonably necessary for use and/or consumption on the vessel may result in the immediate confiscation and removal of the Petroleum or Hazardous Substances by the Port of Nome at user’s expense, the imposition of the fines set forth in Section 1.060 of this tariff against the person violating this provision, the owner and operator of the vessel containing the improper cargo, and any vessel containing the improper cargo, all of whom shall be jointly and severally responsible for payment of all fines assessed. In addition to the fine assessed, the vessel, vessel owner, and vessel operator may be denied use of Port facilities.

(f) A vessel engaged in the business of supplying Petroleum or Hazardous Substances may haul or lie alongside a vessel or port facility only at locations specifically designated as suitable for the loading or unloading of such cargo, and only for so long as is required to load or discharge the same cargo products unless alternative arrangements are made with the Port Director. All users handling materials described in subsection (a) will comply with the hazardous cargo handling requirements outlined in the Port of Nome’s USCG approved Facility Security Plan. Any release of Petroleum or Hazardous Substances into the waters or property of the Port of Nome facility shall be reported to the Harbormaster and federal/state agencies listed below without delay. Clean-up efforts must commence immediately. Should the responsible party not begin clean-up efforts within a timeframe deemed reasonable by the Harbormaster, port personnel will provide such services, with all materials and labor costs charged to the responsible party.

- Port & Harbor Office 907-443-6619
- Harbormaster 907-304-1906
- National Response Center 800-424-8802
- U.S. Coast Guard – Sector Anchorage 907-271-6700
- Alaska Dept. of Environmental Conservation 907-451-2121

(g) Nothing in these tariff regulations, or discretionary instructions or orders from the Port Director, shall be construed to reduce the standard of care required by the laws and regulations of any governmental entity for the safe and proper handling of Petroleum or Hazardous Substances. In each and every instance, the requirements and regulations of the Port of Nome shall be additional and supplemental to any and all rules, regulations, ordinances, statutes and laws of all other governmental entities.

(h) A red flag shall be displayed as a danger signal at the fore top mast head of the vessel while Petroleum or Hazardous Substances are being transferred in either direction between the vessel and the Port of Nome, or between vessels. Adequate signage shall be displayed as a danger signal in plain view on all hazardous cargo in staging, transshipment or laying at rest in the Port of Nome.

(i) The standby of emergency services is required during the loading or unloading of “Designated Dangerous Cargo” as defined by 33 C.F.R. 126.09 as amended, and/or any other materials the transport of which requires a permit pursuant to 33 C.F.R. 126.17, 49 C.F.R. 176.100 and/or 49 C.F.R. 176.415. Standby emergency services will also be provided upon request by the shipper. The shipper shall pay for the standby of emergency services at the rate set in Section 5 of this tariff. A minimum of five (5) business days’ notice must be provided to the Port Director of the specific date and time the stand by services are needed. Any violation of this 5-business-day notice requirement will be subject to the imposition of fines set forth in Section 01.060(d).



**03.060 Risk of Damage:**

The approval for cargo handling shall not be construed as the assumption of any responsibility by the Port of Nome for any loss or damage caused by or resulting from the receipt, delivery, handling, movement or loading of cargo, or any damage caused to cargo by third parties or by vessels berthed at the Port of Nome.

**03.070 Removal or Transfer of Cargo:**

(a) Petroleum or Hazardous Substances, volatile, toxic, explosive or otherwise dangerous cargo may in an emergency be transferred and removed by the Port Director from its staged location to a safe location within or away from the Port of Nome with all expenses and risk of loss or damage chargeable to the permittee, owner, carrier, shipper, consignee or other claimant as their interests or responsibility may appear.

(b) Cargo remaining in any staging area after the expiration of free time, and cargo shut out at the clearance of a berthed vessel, may be piled or re-piled to make space, transferred to other locations or receptacles within or away from the Port of Nome, or removed to public or private warehouses by the Port of Nome, with all expenses and risk of loss or damage attributed to the account of the permittee, owner, carrier, shipper, consignee or claimant as their interest and responsibility may appear unless special arrangements have been made with the Port Director. Any and all storage fees and all costs of removal and subsequent handling and storage shall be charged to the account of the owner of the cargo. All cargo considered abandoned under Section 01.060(k) of this tariff, shall become the property of the Port of Nome and may be disposed of immediately.

**03.080 Over-Side Petroleum Products Transfers:**

Over-side transfer of Petroleum Products is allowed only for the purpose of moving cargo between barge carriers for inbound delivery to shore or outbound delivery to coastal communities. Over-side transfer of Petroleum Products for the purposes of marine fuel retail sales is not allowed.

## **CHAPTER 4**

### **TERMINAL STORAGE**

**04.010 Permission Required:**

(a) The Port of Nome has designated certain lands and facilities for the storage of cargo prior to short-term staging dockside for purposes of loading aboard any vessel, and following the expiration of short-term free time for off-loaded cargo at the dockside staging area.

(b) **No cargo, vessel, equipment or other property shall be deposited or stored at any location within the Port of Nome without consent of the Port Director, or acquisition of a specified location.** No structure or improvement may be placed on the premises of the Port of Nome without the prior written consent of the Port Director. No hazardous substances or explosive material components may be stored at any location on Port of Nome property without the prior written consent of the Port Director. The Port Director has complete discretion to refuse any request for storage of hazardous or explosive materials.

(c) The Port Director will designate the location of open storage for cargo or a vessel on a daily, weekly, monthly, or annual basis. Users of the open storage areas for any duration of time are required to sign a Storage Use Permit (SUP) from the Port of Nome before placing cargo or a vessel in open storage. The recipient of a SUP shall comply with the rules and responsibilities outlined in the SUP. Cargo or vessels placed in the open storage area without a SUP may be removed from the Port of Nome at the expense of the person who placed the cargo or vessel and result in the imposition of the fines set forth in Section 01.060 of this tariff against the person violating this provision. In addition to the fine assessed, persons placing cargo or vessels in open storage without the necessary SUP may be denied use of Port facilities.

(d) Persons storing vessels on Port of Nome property shall use commercial grade boat stands with safety chains for all vessel types except flat bottom vessels or skiffs less than 20 feet. Twin screw engine vessels are to have boat stands under the bow for storage purposes. All vessel storage must be approved in advance by the Port Director. Permittees will be responsible for all aspects associated with the movement of vessels to and from storage and for ensuring the stability of the vessel when dry-docked. The Port of Nome accepts no responsibility for the placement and/or movement of these vessels. Vessels not properly stored, or that shift from inadequate storage

methods, must promptly be repositioned and stabilized by the owner. Vessels remaining in an unsafe stored condition will be repositioned by a private contractor hired by the Port of Nome, with all costs chargeable to the vessel owner. In addition, violators of this section will be subject to the fines set forth in Section 01.060 of this tariff.

(e) All persons are prohibited from using vessels, containers and/or structures, or vehicles on Port of Nome property as residential units. This includes vessels in storage on port property – no liveaboards on hard ground. Violations of this provision shall be subject to fines as set forth in Section 01.060 of this tariff. Repeat violations of this provision may cause the termination of storage and removal of all user's containers, cargo or equipment at user's expense.

**04.020 Termination of Storage:**

(a) The Port of Nome reserves the right to terminate storage of any and all cargo or equipment at any time following reasonable notice to the terminal storage permittee. If cargo is not removed from the Port of Nome following reasonable notice, the Port Director may cause the cargo to be removed or otherwise disposed at the expense of the terminal storage user.

(b) All storage users intending to remove stored items off Port property, so as to reduce the square footage of the area used for storage, shall notify the port office no later than the day of removal. Storage charges shall be based on the total area used for storage before and after stored items are moved through the date of occupancy. If proper notice is not given, then user will be responsible for storage charges based on the total area initially assigned from the date of commencement of the use until all stored items have been removed from Port property.

**04.030 Fixtures and Improvements:**

(a) The Port Director may negotiate in the public interest prudent terms and conditions for a permit allowing the construction or improvement of terminal storage areas for a period of time not to exceed five years, provided however that no such agreement shall favor one or more users among competitors, and no such agreement shall result in discouraging competition among shippers, carriers, terminal companies or consignees.

(b) A permit including the construction or improvement of terminal storage areas shall not be construed as the conveyance of any interest in real property by the Port of Nome. All structures and improvements to the real property shall remain the property of the Port of Nome upon termination of the terminal storage permit or property lease unless the Port Director orders the permittee to remove the structure or improvement.

(c) Any agreement for the retention of ownership of improvements by the permittee, or for the issuance of a terminal storage permit or agreement for a period in excess of five years, shall be construed as a lease of real property subject to all City of Nome ordinances governing the conveyance of an interest in real property.

## **CHAPTER 5**

### **SCHEDULE OF CHARGES AND TERMS OF PAYMENT**

**05.010 Dockage Rates:**

(a) All vessels berthing at the Port of Nome shall pay dockage as follows:

1) Any vessel permitted to anchor within the Port of Nome municipal boundaries, that is loading or unloading cargo or passengers by lighters, shall pay dockage at the daily rate assessed upon the size of the anchored vessel(s), commencing when the first lighter of the operation places the first line upon any Port of Nome facility and continuing until the last lighter is free from any Port of Nome facility. Lightering vessels will not be charged dockage during this transfer of cargo or passengers, except when the vessel that is being lightered from is docked at the Causeway facility, whether or not that vessel is actively engaged in loading or unloading.

2) A vessel permitted to beach or run aground in the tidelands or at the mean high tide line away from any Port of Nome dock or landing shall pay dockage at the daily rate assessed upon the size of that vessel or, the port may determine that any vessel beached or grounded more than thirty (30) calendar days in succession can be rescheduled as an idle vessel for purposes of dockage charges. Beached or grounded vessels will not be permitted to remain throughout the winter at the high tide line anywhere within the Port of Nome.

3) Daily dockage rates for any vessel berthed at the Port of Nome facility shall be based on a 24-hour period constituting one day and will be paid in accordance with the size of the vessel as follows:

- (A) Vessels up to 200 ft. in length..... \$1.58/ft. per day
- (B) Vessels over 200 ft. in length..... \$2.43/ft. per day
- (C) Vessels anchored within the breakwaters (outer harbor).... \$0.80/ft. per day

(D) Vessels operating out of the port & harbor during the months of June through October shall have the option to apply for a seasonal docking permit and pay at the current rate (for that size vessel) as follows:

1. INNER HARBOR:

	<u>SEASONAL *</u>
Vessels 32 ft. and under	\$1,032.79
Vessels over 32 ft. to 52 ft.	15%
Vessels over 52 ft. to 72 ft.	25%
Vessels over 72 ft. to 92 ft.	35%
Vessels over 92 ft. to 125 ft.	45%
Vessels over 125 ft. to 175 ft.	55%
Vessels over 175 ft.	65%

\*Percentages of standard daily dockage rate calculated on length of permit (see Docking Rate Permit Schedule attached as Appendix C)

4) The fee for any vessel docking in the Snake River area is one-half (1/2) of the rate applicable to the vessel under the schedule set forth in Section 05.010 (a) 3. Users must apply to the Harbormaster for a Snake River area docking permit. Snake River permit holders must comply with the Port of Nome Moorage Policy and all other rules and regulations, including all applicable provisions of this tariff. Sport fishermen and subsistence users of the Snake River area are exempt from the dockage fee.

(b) Home-ported vessels dry-docked within the Port of Nome that remain idle throughout the applicable period shall pay a flat rate identified below for the winter-season (November through May) or summer-season (June through October).

	<u>Winter</u>	<u>Summer</u>
Vessels 32 ft and under	\$ 687.22	\$ 549.77
Vessels over 32 ft to 42 ft	\$ 1,031.48	\$ 824.66
Vessels over 42 ft to 52 ft	\$ 1,374.44	\$ 1,099.55
Vessels over 52 ft to 62ft	\$ 2,061.65	\$ 1,649.32
Vessels over 62 ft to 72 ft	\$ 2,748.87	\$ 2,199.10
Vessels over 72 ft to 92 ft	\$ 3,848.42	\$ 3,023.76
Vessels over 92 ft to 125 ft	\$ 6,184.96	\$ 4,535.64
Vessels over 125 ft to 175 ft	\$ 9,895.94	\$ 7,258.33
Vessels over 175 ft	\$ 15,341.33	\$11,250.74

(c) No vessels will be permitted to freeze in at the water line within the Small Boat Harbor or Port of Nome Facilities during the winter months of November through May, except with prior written approval from the Port Director, based upon specific design requirements.

(d) No vessels will be permitted to dry dock or to be stored on the Causeway docks or along the Causeway road at any time during the year without the expressed written consent of the Port Director.

(e) Vessels using the Belmont Beach or Snake River area for the purposes of sport and/or subsistence fishing and hunting are exempt from docking fees. This exemption does not apply to improved docking facilities within the Port and Harbor.



(f) Vessels requiring shore-side assistance from the Port of Nome to secure the vessel shall be charged one line handling fee per visit. Line handling procedures shall be established by the Harbormaster and adhered to at all times. Any variation in these procedures will be implemented or approved by the Harbormaster as needed based on the individual requirements of the vessel. Notification must be made to the Port Director at least seventy-two (72) hours prior to vessel arrival that vessel is requiring assistance to moor. Specific arrival and departure times shall be provided to the Port Director at least twelve (12) hours prior to each docking. If changes or delays to scheduled arrival and departure times occur within the 12hour notice window, a stand by time per man, per hour for port personnel will be assessed by the Port of Nome, unless notice is provided to the Harbormaster at least two (2) hours prior to the vessel's arrival or departure. Line handling services performed beyond regular operating hours will be charged per man hour at the applicable rate defined in Section 05.035(a) 8 of this tariff. Regular operating hours are 8:00 am to 5:00 pm, Monday through Friday, excluding holidays.

(g) Vessels moving between different Port of Nome facility docks shall be assessed dockage based on the combined elapsed time at all locations.

(h) A single vessel when actively engaged as a tug boat, assisting and made fast outboard a vessel and working cargo, shall be accorded free dockage. A tug boat leaving its tended vessel shall have waived its right to free dockage and will be charged accordingly upon mooring to any other Port of Nome facilities, except during which time the vessel relocates to an open berth to receive fuel or water with the approval of the Port Director. All tug and barge vessels that arrive and remain in the "push" configuration, will be charged for the combined length of both tug and barge when alongside any dock or wharf structure. Barges moored on the "hip" of the barge will be assessed for the LOA (Length-Over-All) of the barge.

(i) Vessels drawing less than twenty (20) inches of water, including support vessels, may only moor in the Snake River area, and may not moor anywhere else in the Inner Harbor (unless authorized by the Port Director). The dockage rate set forth in Section 05.010(a) (4) of this tariff applies to all vessels utilizing the Snake River area unless the use is limited to vessel launching or haulout. Vessels using the area for launching and haulout purposes only are not required to pay the moorage fee. Improperly moored vessels, or vessels drawing less than twenty (20) inches of water docked in the Small Boat Harbor without permission, will be relocated at the owner's expense and assessed the appropriate fee. Repeat offenders will be fined in accordance with Section 01.060(d) of this tariff.

(j) All vessel trailers stored on Port property during the ice-free season will be stored in a location and manner as defined by the Port Director and assessed charges as set forth in Section 05.035(a) of this tariff. Parking stickers will be issued by the Harbormaster's office at the per foot rate defined in Section 05.035(a) 9 of this tariff, and must be displayed on the tongue showing the current calendar year. Trailers without stickers that are left unattended for more than seven (7) calendar days will be impounded and hauled to the City monofill at the owner's expense. Payment for original parking fees, storage and moving costs will be required to retrieve trailers.

(k) The Port of Nome search and rescue vessel "The Guardian" is available for emergency and non-emergency response at rates defined in Section 05.035(a) 10 of this tariff. In order to qualify for the lesser non-emergency rate, vessels requesting assistance must specify that the situation is a non-emergency. Failure to specify will result in assessment of the higher rate.

**05.020 Wharfage Rates:**

(a) A wharfage charge for all cargo loaded or off-loaded between any vessel and the Port of Nome shall be paid as follows:

- 1) Bulk liquid products -
  - Inbound only..... \$0.046 per gal
  - Outbound only..... \$0.030 per gal
  - Over-side only..... \$0.015 per gal\*\*
  - Inter-facility transfer..... \$0.046 per gal
  
- 2) Dry commodities, scientific equipment, ISO Tanks and company gear - (excluding rock, sand, gravel, project cargo and ship's gear)
  - Inbound/outbound..... \$15.13 per ton
  - Over-side cargo..... \$ 7.52 per ton
  - Over-stow cargo (outbound)..... \$ 7.52 per ton\*

Inter-facility transfer..... \$11.39 per ton

- 3) Rock, sand and gravel – (bulk non-bagged)
  - 50,000 tons and under..... \$ 2.52 per ton
  - 50,001-100,000 tons..... \$ 2.39 per ton
  - 100,001-200,000 tons..... \$ 2.32 per ton
  - 200,001-300,000 tons..... \$ 2.21 per ton
  - Over 300,000 tons..... \$ 2.15 per ton

(\*Over-stow rate is based on qualifying cargo in which full wharfage is being paid for inbound movement, and is destined to points beyond Nome.)

(\*\*See Section 03.050 and 03.080 for restrictions)

- 4) Project cargo in excess of 2,000 tons in one shipment for one consignee to be consumed in one project ..... 75% of published rate
- 5) Empty containers, bottles or tanks, that are non-revenue cargo, being shipped in or out for re-fill of product **only**..... No Charge
- 6) Ship’s gear, ship’s stores, and shore-side cargo handling equipment (as defined) ..... No Charge

(b) In addition to all other tariff provisions, the following charges will be assessed against vessels, their owners, agents or operators which load or discharge passengers at any Port of Nome facility:

PASSENGER FEE	FACILITY CHARGE
<del>\$51.00</del> <u>1.00</u>	<del>\$2.50</del> <u>2.00</u>
<u>\$1.25</u>	<u>\$2.25</u>
<u>\$1.50</u>	<u>\$2.50</u>

**05.030 Terminal Storage Rates:**

- (a) A terminal storage fee for all cargo and equipment stored at the Port of Nome shall be paid as follows:
  - 1) For open storage on uplands east and west of the Snake River (except Causeway)..... \$ 0.08 sq. ft. per week
  - 2) For open storage on Causeway road or docks..... \$ 0.11 sq. ft. per week
  - 3) Secured storage (palletized or exceeds 50#)..... \$23.56 per day

**05.035 Amenities & Other Charges:**

- (a) A charge for these amenities will be assessed as follows:
  - 1) Line Handling (Ships over 300') ..... \$1,832.58 per visit\*
    - Line Handling (Ships up to 300')..... \$ 916.29 per visit\*
    - (Initial tie-up and throw-off)
  - 2) Dump Truck/Refuse (Ships over 300')
    - (a) Unregulated Refuse..... \$556.91 per load\*
  - 3) Potable Water -
    - First 1000 gallons..... \$238.24 Flat Fee\*
    - 1,001 – 9,999 gallons..... \$ 0.08 per gallon
    - 10,000 gallons and above..... \$ 0.05 per gallon

4) Garbage Dumpster Fee.....	\$ 56.29 per visit
5) Security Fee (Foreign Flagged and/or Passenger Vessels.	\$2,382.36 per 12 hour Shift*
6) Used Oil.....	\$3,083.97 per 55 gal. drum* (or any portion thereof)
7) Emergency Services Stand By - (First hour).....	\$2,165.78 hour
Each additional hour	\$1,443.46 per hour
8) Personnel Labor Rates (1 hour minimum):	
a) Regular/Straight Time .....	\$115.00 per hour
b) Over Time.....	\$180.00 per hour
c) Holiday Time.....	\$288.00 per hour
d) After Hours Call Out .....	\$275.00 per hour
e) Stand by .....	\$275.00 per hour
9) Trailer Parking Fee (ice-free season) .....	See rates shown in Section 05.030(a) Storage
10) Smart Ash Burner Operation – (burning used sorbents)	\$159.70/per hour
11) Gangway or Brow Rental.....	\$198.97/day*
Rubber Tire Fendering .....	\$ <u>198.97</u> /day*
12) Vessel Assist – 28' Guardian	
After-Hours.....	\$1,191.18 Flat Rate
Regular Hours.....	\$ 349.50 Flat Rate
Plus Fuel/Oil... (1 hr minimum) ....	\$ 24.87 per hour
Plus Labor .....	See above labor rates*
18' Skiff..... (1 hr minimum)	\$39.27 per hour
13) Film License Application Fee.....	\$392.70 Flat Fee

\*Rates for these services performed beyond regular operating hours will be charged per man hour at the applicable rate defined in Section 05.035(a) 8. Regular operating hours are 8:00 am to 5:00 pm, Monday through Friday, excluding holidays.

**05.040 Free Time:**

Cargo being loaded or off-loaded in accordance with the Port of Nome tariff, may occupy assigned cargo-handling space at the berthing facility free of charges for a period of time not to exceed forty-eight hours prior to the commencement of berthing and seventy-two (72) hours following discharge of the vessel from its berth unless on special arrangement with the Port Director.

**05.050 Negotiable Rates:**

(a) The Port of Nome reserves the right to enter into negotiated agreements for the use of specific port facilities, storage space, tanks, land or other terminal facilities at rates determined by the Port Commission or Port Director.

(b) The Port of Nome reserves the right to enter into agreements with common carriers, shippers, and agents concerning rates and services, provided that such agreements shall be consistent with existing rules, regulations, statutes and laws of all governmental entities.

(c) If, in the opinion of the Port Director, any operation, use, or user of the Port is reasonably likely to require special handling, the Port Director shall have the right to charge the user additional fees to compensate the Port for actual and/or reasonable costs associated with the operation, use, or user. This may be a flat fee or a negotiated rate, depending on the circumstances. Cases requiring "special handling" shall include off-season and other operations that the Port Director believes will require substantially more resources or funds than average operations or users,

**05.060 Terms of Payment:**

(a) All dockage, wharfage, terminal storage fees and other charges assessed by the Port of Nome shall be paid at the time of use, except as provided in subsection (b) below.

(b) The Port Director may extend credit to any user of the Port of Nome who establishes a sound financial condition to the satisfaction of the Port Director. User must satisfactorily complete a credit application and provide all information necessary to determine creditworthiness. Charges assessed and levied to any such creditworthy user shall be due and payable within **thirty (30) calendar days** from the date of invoice from the Port of Nome.

(c) The creditworthy status of such a user of the Port of Nome shall terminate immediately and automatically upon failure to pay all amounts due and owing within thirty (30) calendar days of the date of invoicing. In no event shall creditworthy status attach to any user for a period of time in excess of one (1) year without additional and supplemental evidence of continuing creditworthiness that is satisfactory to the Port Director. During this time of non-creditworthiness, the user shall be required to pay all charges in full and in advance for activity conducted within the Port of Nome. Further, users in delinquent status may be denied access to the Port of Nome facilities and any cargo, gear or vessel within the Port of Nome may be held as security for payment until all unpaid charges are paid in full. At the Port Director's sole discretion and upon terms acceptable to the Port Director, including for adequate security, a user may enter into a payment agreement with the City for the purpose of satisfying debts owed for use of Port of Nome facilities, and such agreement may provide that the user shall not be considered in default or arrears if the user adheres to the terms of the agreement.

(d) No credit shall be extended to any person or entity who is delinquent in the payment of any amount due and owing to the City of Nome, the Nome Public School District, or the Nome Joint Utility System.

(e) An administration fee of 20% will be charged on all issues that require administrative services to process and handle, beyond the typical day-to-day business, such as but not limited to; known spill response incidents that require port supplies and personnel, clean up, repair or replacement of facility or infrastructure due to user neglect or damage, etc. All outstanding accounts reaching any level of collection will be assessed a 15% collection fee for balances exceeding sixty (60) calendar days beyond the payment due date, and a 20% collection fee for balances exceeding one hundred and twenty (120) calendar days. Fees will be assessed on a quarterly basis and rounded up to the nearest whole dollar. Collection fees on account balances exceeding \$1,000.00 will be capped at the applicable percentage assessed on a \$1,000.00 account balance. An NSF fee of \$35.00 will be charged on all bounced checks. All foreign and domestic banking transaction fees incurred when making payments will be the responsibility of all users and will be charged to the applicable user account.

(f) Prepaid docking permits are non-refundable. Credits for unused portions of prepaid long-term storage may be credited back to user accounts at the discretion of the Port Director. The Port will not assist any user in the sale of prepaid space.

**05.070 Interest Accrued:**

All amounts due and owing to the Port of Nome for dockage, wharfage, terminal storage fees or other charges shall accrue interest at the rate of ten and a half percent (10.5%) per annum. All costs of collection, including actual reasonable attorney and administrative fees, shall be paid by the delinquent user of the Port of Nome.

**05.080 Additional Legal Remedies:**

Nothing in these tariffs shall be construed as limiting or waiving any and all legal rights and legal remedies available to the Port of Nome in pursuit of collection of all amounts due and owing to the Port.

**05.090 Annual Adjustment of Rates and Charges:**

Commencing January 1, 2021 and each January 1 thereafter, all tariff rates and charges except the passenger fee and facility charges set by Chapter 5.020(b) shall be increased or decreased in an amount equal to the average

annual percent change in the CPI-U for Urban Alaska as published by the U.S. Bureau of Labor Statistics over the previous five calendar years. The effective date of the change in rates shall apply prospectively only and shall not increase previously paid flat rate charges for winter storage. ~~Commencing January 1, 2024 and each January 1 thereafter, the passenger fee and facility charges set by Chapter 5.020(b) shall be increased or decreased in an amount equal to the average annual percent change in the CPI-U for Urban Alaska as published by the U.S. Bureau of Labor Statistics over the previous five calendar years.~~

## **CHAPTER 6**

### **DEFINITIONS**

**06.005 Barge Ramp:**

"Barge Ramp" shall include the boat launching area off of Port Road identified as Barge Ramp in the Port of Nome aerial photograph dated August 2011 (version v. 041213) on file with the City of Nome.

**06.010 Berthing:**

"Berthing" is the act of anchoring, tying up, mooring, securing, idling, grounding, dry-docking, beaching or otherwise laying a water vessel to rest within the Port of Nome.

**06.020 Cargo:**

"Cargo" shall include all freight, merchandise, supplies, equipment, tools, fuel, and other tangible goods held for shipment or movement within the Port of Nome.

**06.030 Cargo Handling Areas:**

The "cargo handling areas" shall include all dedicated and usable right of ways, the Nome causeway, the full length of the Snake River revetment improvements including the barge ramp uplands and Small Boat Harbor property for a distance of fifty (50) feet back from that revetment along the uplands.

**06.040 Cargo Handling Equipment:**

"Cargo handling equipment" shall mean all equipment, gear and supplies transported to and/or from a vessel which is necessary for cargo handling at the Port of Nome and that: (a) is loaded or unloaded in Nome and (b) used exclusively for cargo handling at the Port of Nome. Equipment, gear and supplies that are used for cargo handling and for another purpose while offloaded in Nome are not "Cargo handling equipment".

**06.045 Cargo Handling Permittee:**

"Cargo Handling Permittee" is a person, firm or company that has been issued a permit to use the Port, and which is engaged in the business of handling cargo, equipment, fuel or gravel at the Port of Nome docks and facilities, whether in the capacity of a vessel or shore-side operator.

**06.047 Causeway City Dock:**

"Causeway City Dock" shall include the area on the southern end of the causeway identified as City Dock in the Port of Nome aerial photograph dated August 2011 (version v. 041514) on file with the City of Nome.

**06.050 Company Gear and Equipment:**

"Company Gear and Equipment" includes all equipment, gear and supplies transported to and/or from a vessel which is necessary for cargo handling at another shore-side facility or is being transported by a vessel to another location or vessel for such use, but not considered part of the transporting vessel's (ship's) gear or stores.

**06.060 Dockage:**

"Dockage" is the charge assessed to a vessel for docking at a wharf, dock, pier, float, revetment or other facility, or for mooring to a vessel so docked at a Port of Nome facility.

**06.070 Dock-Side:**

"Dock-Side" is the shore-side area of any part of the Port of Nome facilities in which vessels and/or crew may conduct working activities such as loading and unloading.

**06.080 Empty Containers:**

"Empty Containers" qualifying for free wharfage are defined as containers being loaded or unloaded that have no contents and are owned by the carrying vessel.

**06.085 Free-Time:**

"Free-Time" is the specified period of time (seventy-two (72) hours) during which cargo may occupy an assigned space on port property free of charges immediately prior to the loading or subsequent to the discharge of such cargo on or off a vessel.

**06.090 Harbormaster:**

The "Harbormaster" is the individual charged with directly supervising and facilitating all operations of the Nome Port & Harbor, including the use of uplands, facility services, and including the assessment of charges and required compliance contained within the Port of Nome Tariff Rules & Regulations; the Port Director's designee.

**06.092 Home-Ported Vessel:**

A "home-ported vessel" is a seaworthy vessel laying at rest in the Port of Nome during the immediately preceding winter months of November through May, with no delinquent charges or assessments of taxes, damages, dockage, wharfage or other port charges, which operates exclusively out of the Nome Inner and Outer Harbors during the ice-free summer season.

**06.095 Idle Vessel:**

"Idle Vessel" is defined as a vessel in lay-up status or laying at rest on hard ground within the Port of Nome facility.

**06.100 Inner Harbor:**

The "inner harbor" of the Port of Nome is the Snake River and the Bourbon Creek/Dry Creek confluence also known as the turning basin or Small Boat Harbor, including the concrete barge ramp.

**06.105 Inter-Facility Transfers:**

The movement of cargo, equipment or fuel between facilities entirely within the Port of Nome property (excluding Cape Nome). Applies only to movements between the two facilities that are not loaded onto a vessel for shipment.

**06.107 LOA or Length Over All:**

The overall length of a watercraft measured from the most forward point at the stem (bow), to the after most part of the stern of the watercraft, to include the motor.

**06.108 Nuisance Property:**

"Nuisance property" means all personal property, including but not limited to machinery, equipment, gear, appliances, furniture, materials or parts, and Ship's Gear or Stores placed or stored on Port of Nome Facilities:

- (1) ~~unless authorized by the Tariff or with the express permission of the Harbormaster, or property that;~~
- (2) ~~otherwise~~ constitutes a violation of any provision of this tariff;
- (3) ~~otherwise constitutes a~~ hazard and a hindrance to safe use of the Port of Nome;
- (4) ~~abandoned or for which no owner can be identified; and,~~
- (5) for which any tariff fees or charges relating to the property, including those owed by the property owner or operator is thirty (30) calendar days past due.-

**06.110 Over-Side Cargo or Fuel:**

"Over-Side" refers to the act of transferring cargo or fuel directly between vessels when one vessel is docked at any Port of Nome facility and the other vessel is moored alongside.

**06.120 Over Stow:**



"Over Stow" is defined as any cargo placed on the Port premises from common carrier or its agent, which is to be reloaded on a vessel and destined for discharge at another port. Over Stow charges will apply so long as no value has been added to the cargo while awaiting transshipment.

**06.130 Port Director:**

The "Port Director" is either the City Manager or such person designated by the Nome City Council or the designee of the City Manager, consistent with existing Nome Ordinances governing the Port of Nome.

**06.140 Port of Nome:**

The "Port of Nome" shall include all tide and submerged lands owned, occupied, managed, leased or administered by the City of Nome within and beyond the municipal boundaries, all parcels of real property contiguous to the mean high tide line of the Bering Sea, the Snake River and its tributaries, and all lands and navigable waters within the jurisdiction of the City of Nome.

**06.150 Port of Nome Facilities:**

"Port of Nome Facilities" includes all causeway docks, revetments, marine headers, industrial pad, barge ramp, harbor floats, east and west Small Boat Harbor docks, storage areas and tidelands of the outer harbor, Small Boat Harbor and Snake River. Unimproved beaches bordering the Bering Sea and unimproved submerged lands of the Bering Sea are not included as "facilities".

**06.155 Production Film, Video, and/or Photography Crews:**

A film, video and/or photography production crew is one or more people engaged in filming, video or digital taping, photography or recording on any medium in a commercial capacity or for profit.

**06.160 Rafting:**

When two or more boats tie alongside each other, specifically at a pier, wharf or dock.

**06.162 Retail Marine Fuel Sale:**

"Retail Marine Fuel Sale" refers to the transfer of non-cargo fuel, or fuel intended for use and/or consumption on the vessel, from a seller to a vessel.

**06.165 Roadstead:**

"Roadstead" shall include the navigable channel approach into the Port of Nome outer harbor where vessels transit in preparation for maneuvers into and away from the Causeway docks or Small Boat Harbor. No vessel shall anchor or sit idle in such a manner that obstructs the passage of any vessel transiting the approach into and out of the outer harbor.

**06.170 Ship's Gear or Stores:**

"Ship's Gear and Ship's Stores" shall include all equipment, gear and supplies being loaded to and/or from a vessel that is directly related to that vessel's cargo handling ability or part of that vessel's crew necessities.

**06.173 Small Boat Harbor:**

"Small Boat Harbor" shall include that area on the eastern entrance of the Snake River identified as Small Boat Harbor in the Port of Nome aerial photograph dated August 2011 (version v.041213) on file with the City of Nome.

**06.175 Snake River Area:**

The "Snake River area" means the area within the property of the Port of Nome designated by the Port Director/Harbormaster for use by small crafts and support vessels, located in and along the Snake River on the western side of the Port of Nome. The area extends from the corner of the MS 410 property, near the concrete launch ramp, to the armor stone at the end of Belmont Street, and up river to the City Limit boundary.

**06.178 Support Vessel:**

"Support vessel" is defined as any vessel which is used exclusively to provide assistance to another vessel by, for example, ferrying gear or persons to or from the main vessel, or to allow repairs, cleaning, and other services to occur on the main vessel.

**06.179 Third Party Employers:**

"Third Party Employers" refers to employers of all cargo, fuel, gravel, construction employees, service organization staff, vessel employees, longshoremen, stevedores, independent contractors, and all other non-City employees.

**06.180** Through Cargo:

"Through Cargo" is defined as cargo that is transported into Nome for temporary staging, while awaiting shipment to destinations beyond Nome, and billed as over stow cargo. (See 06.120 Over-Stow)

**06.190** Vessel - "Vessel" or "Vessels":

Shall mean any, ship, barge, LASH barge, SEABEE barge, tug, towboat, lighter, raft or other watercraft that is designed to float. All references to "VESSEL" or "VESSELS" in this tariff shall include, without exception, her owner, charterer, and agent.

**06.195** Wharfage:

The charge assessed against any cargo placed on any shore-side property and passing over, across, under or through the Port of Nome cargo handling facilities.

**06.200** Working Stow:

"Working Stow" is defined as any cargo not destined for the Port of Nome that has to be removed from a vessel and placed temporarily on the dock before being loaded to the same vessel from which it was removed and before any movement of vessel from the dock.

1<sup>st</sup> Reading: February 26, 2024

2<sup>nd</sup> Reading: March 25, 2024

Presented By:

City Manager/Finance Director

Action Taken:

Yes \_\_\_

No \_\_\_

Abstain \_\_\_

**CITY OF NOME, ALASKA**

**ORDINANCE NO. O-24-03-02**

**AN ORDINANCE AMENDING THE CITY OF NOME  
FY 2024 GENERAL FUND MUNICIPAL BUDGET**

**Section 1.**

This is a non-Code ordinance.

**Section 2.**

**BE IT HEREBY ORDAINED** by the Nome City Council, that the attached adjustments be made to the FY 2024 City of Nome General Fund Municipal Budget.

**APPROVED** and **SIGNED** the 25<sup>th</sup> day of March, 2024.

\_\_\_\_\_  
**JOHN K. HANDELAND**  
Mayor

**ATTEST:**

\_\_\_\_\_  
**JEREMY JACOBSON**  
Deputy City Clerk

FY2024 Proposed Budget General Fund Revenue		F21 Actuals	F22 Actuals	F23 Actuals	F24 YTD Actuals @ 1.31.24	O-23-06-01 F24 Approved Budget	Budget Adjustment	O-24-03-02 F24 Proposed Amended Budget	Budget Notes
<b>General Tax Collections</b>									
11.3310.0001	Property Tax	4,027,149.15	3,814,426.49	4,133,654.70	3,870,937.59	4,031,398.35	(126,516.60)	3,904,881.75	Taxable Base post-BOE 383,895,700 / 10.5 mills (Compared to 2022 post-BOE @ 345,218,900) (2023 Exemption 126,023; Tax Roll Change 493.50)
11.3310.0002	Personal Property Tax	547,489.22	499,295.46	545,219.84	423,726.09	484,823.17	(52.50)	484,770.67	Taxable Base post-BOE 46,168,635 / 10.5 mills (Compared to 2022 post-BOE @ 45,492,368)
11.3310.0003	Deferred Prop Tax	(9,931.36)	(48,536.85)	(49,616.02)	-	-		-	Total 2023 Tax Base \$ 430,064,335; 1 mill is approx. \$430,064.33
11.3310.0004	Prop Tax Exempt Redempt	-	-	-	-	-		-	
11.3310.0005	Sales Tax	5,902,073.32	6,086,867.12	6,633,635.93	3,655,429.50	6,800,000.00	100,000.00	6,900,000.00	
11.3310.0006	Hotel/Motel Tax	118,588.80	185,671.47	208,717.96	128,937.03	175,000.00	45,000.00	220,000.00	
11.3310.0007	Sales Tax - Other	2,919.94	6,124.33	8,368.03	4,524.66	10,000.00		10,000.00	
11.3310.0008	Sales Tax - AK Remote Sellers		426,165.16	551,217.53	251,204.66	550,000.00	50,000.00	600,000.00	
<b>Tax Penalties &amp; Interest</b>									
11.3319.0001	Real Property-Penalty	32,095.71	48,426.83	40,048.33	38,054.61	40,000.00	5,000.00	45,000.00	
11.3319.0002	Real Property-Interest	29,533.83	24,721.71	17,387.69	13,544.56	20,000.00		20,000.00	
11.3319.0003	Personal Property-Penalty	2,849.58	4,186.14	8,668.25	8,360.07	4,000.00	6,000.00	10,000.00	
11.3319.0004	Personal Property-Interest	1,561.90	1,741.16	2,386.10	3,382.06	2,000.00	2,000.00	4,000.00	
11.3319.0005	Sales Tax-Penalty	9,106.37	9,105.21	19,279.31	19,384.40	9,500.00	15,000.00	24,500.00	
11.3319.0006	Sales Tax-Interest	2,038.27	1,902.95	3,288.43	3,000.17	2,000.00	4,000.00	6,000.00	
11.3319.0007	Pers & Real Pen & Int Pr Yr	-	-	-	-	-		-	
<b>Permits Licenses &amp; Fees</b>									
11.3320.0001	Vehicle/ATV License	35,752.12	34,033.56	36,346.44	12,833.08	32,500.00	2,500.00	35,000.00	
11.3320.0002	Chauffeur License	1,200.00	675.00	700.00	300.00	600.00		600.00	
11.3320.0003	Animal License/Clinic	5,185.00	4,090.00	2,785.00	1,560.00	5,000.00	(1,000.00)	4,000.00	
11.3320.0004	Election Candidate Fees	160.00	200.00	160.00	120.00	200.00	(80.00)	120.00	
11.3320.0005	Health & Sanitation Cert	260.00	260.00	188.75	119.75	270.00		270.00	27 @ \$10
11.3320.0006	Sales Tax Collection Lcns	-	25.00	-	50.00	-	50.00	50.00	
11.3320.0007	Business Lcns: Transient, Other	300.00	1,735.00	5.00	-	1,500.00		1,500.00	
11.3320.0008	Bed Tax Collection License	15.00	30.00	58.86	45.00	30.00	30.00	60.00	
11.3320.0009	Nome Landfill Maint Fees	328,370.51	322,207.78	324,758.70	193,815.45	325,000.00		325,000.00	
11.3320.0010	Correctional Facility Permit	-	-	-	-	-		-	
11.3320.0011	Taxi Vehicle License Fee	1,600.00	600.00	1,100.00	-	1,100.00		1,100.00	6 @ \$100 Taxi, 5 @ \$100 Bus
11.3320.0012	Pull Tab Sales License	1,300.00	1,100.00	900.00	400.00	1,300.00		1,300.00	13 @ \$100
11.3320.0013	Resale Certificate	3,450.00	4,050.00	3,450.00	1,050.00	3,750.00		3,750.00	25 @ \$150
11.3320.0014	Moving, Land Use, Demo Permits	4,200.00	845.96	1,666.16	770.58	2,000.00		2,000.00	
11.3320.0015	Building Permits	37,880.91	16,801.70	26,279.60	32,334.99	4,000.00	36,000.00	40,000.00	\$600k-\$700k
11.3320.0016	Mechanical/Electric Permit	775.00	573.10	150.00	-	500.00		500.00	
11.3320.0017	Remodeling Permit	19,423.25	18,517.36	20,796.44	11,568.39	4,000.00	11,000.00	15,000.00	\$600k-\$700k
11.3320.0018	Excavation/Fill Permit	1,750.00	1,397.05	1,175.00	800.00	1,750.00		1,750.00	
11.3320.0019	Mining/Watershed Permit	-	-	-	-	-		-	
11.3320.0020	Cemetery Fees	6,500.00	7,600.00	8,700.00	3,500.00	7,000.00		7,000.00	
<b>Shared Revenue/Municipal Assistance</b>									
11.3335.0001	Dept Rev Liquor Licenses	-	19,400.00	5,850.00	-	15,000.00		15,000.00	F23 1st Half Pmt \$3,850
11.3335.0003	Dept Rev Raw Fish	-	-	-	-	-		-	
11.3335.0004	Dept Rev Amusement License	-	-	-	-	-		-	
11.3335.0005	Muni Assist - Rev Sharing	76,241.41	121,290.60	128,102.53	119,824.25	75,371.88	44,452.37	119,824.25	
11.3335.0007	St Shared Revenue-Energy\$	-	-	-	-	-		-	
11.3335.0008	Federal / State Fiscal Relief	-	-	73,927.00	-	-		-	
11.3335.0009	Empl PERS On-Behalf Relief	317,952.07	318,634.64	130,545.32	-	-		-	

FY2024 Proposed Budget General Fund Revenue		F21 Actuals	F22 Actuals	F23 Actuals	F24 YTD Actuals @ 1.31.24	O-23-06-01 F24 Approved Budget	Budget Adjustment	O-24-03-02 F24 Proposed Amended Budget	Budget Notes
11.3335.0010	Emply Relief PSR Lifelns	-	-	-	-	-		-	
11.3335.0020	Dept Ed OWL Internet	2,400.00	2,040.00	2,040.00	2,040.00	2,040.00		2,040.00	
<b>Payment in Lieu of Tax/Pilot</b>									
11.3336.0003	NW College In Lieu of Taxes	-	-	-	-	-		-	
11.3336.0004	BLM In Lieu of Tax 198Acres	-	-	-	-	-		-	
11.3336.0005	PILT Unorganized Areas	508,874.10	523,215.18	515,069.92	542,616.16	515,000.00	27,616.16	542,616.16	
11.3336.0006	Nome Joint Utility PILT	250,000.00	250,000.00	250,000.00	62,500.00	250,000.00		250,000.00	
11.3336.0007	Port of Nome PILT	72,311.85	66,767.40	66,749.40	-	61,186.95	(2,781.22)	58,405.73	Assessed Value \$5,562,450 x Mill Rate
11.3336.0008	Nome School PILT	624.62	576.58	576.58	-	528.53	(24.03)	504.50	Assessed Value \$48,048 x Mill Rate
11.3336.0009	Nome Eskimo Comm PILT	1,500.00	1,500.00	1,500.00	1,500.00	1,500.00		1,500.00	
11.3336.0010	Bering Vue PILT	22,490.15	24,140.12	15,814.31	-	24,000.00	(6,000.00)	18,000.00	
11.3336.0011	Bering Strts Reg Housing PILT	27,808.80	34,113.20	33,829.46	-	33,000.00		33,000.00	
<b>Charge for Services</b>									
11.3340.0001	Abatement/Foreclosure Fees	3,021.43	366.60	-	-	1,000.00		1,000.00	
11.3340.0002	Failure 2 Remove Snow Fee	-	-	-	-	-		-	
11.3340.0003	StAk Reimb Dog # Self Move	-	-	-	-	-		-	
11.3340.0004	Project Admin Fee	-	-	-	-	-		-	
<b>Copies, Plat, Court Fees</b>									
11.3341.0001	Maps,Copies,Apparel,Pubs	1,029.13	1,266.85	1,078.06	1,522.87	1,250.00	1,750.00	3,000.00	
11.3341.0002	Variance, Plats, Zoning,Vacant	1,250.00	775.00	325.00	950.00	1,000.00	600.00	1,600.00	
11.3341.0003	Banking/ NSF Check Fees	-	-	-	-	500.00		500.00	
11.3341.0004	Notary Fee	-	-	-	-	-		-	
11.3341.0005	Credit Card Service Fees	-	-	-	-	-		-	
11.3341.0006	Restitution	20.86	-	-	-	-		-	
11.3341.0007	Records Request Fee	-	-	-	10,641.75	-	250.00	250.00	
<b>Public Safety Special Svs</b>									
11.3342.0001	Police Services, Protective	5,250.00	250.00	60.00	-	1,500.00	(500.00)	1,000.00	
11.3342.0002	Nome Police Patches	-	-	-	-	-		-	
11.3342.0003	Prints,Photos,Reports	6,163.70	1,400.00	2,120.00	590.00	2,000.00		2,000.00	
11.3342.0004	Alarm Monitor User Fees	1,600.00	600.00	600.00	-	600.00		600.00	
11.3342.0005	Ambulance Fees/NSHC	412,293.43	248,537.94	342,219.17	194,777.45	360,000.00	(72,000.00)	288,000.00	\$103k FY22 SEMT Reimb / \$185k Amb Fees
11.3342.0006	Ambulance Accts - Contract Adj	(173,580.33)	(141,468.29)	(104,018.46)	(38,920.86)	(125,000.00)	32,500.00	(92,500.00)	
11.3342.0007	MOA Dispatch Trooper,Bldg Rent	-	-	-	-	-		-	
11.3342.0008	Sale of Police Weapons	-	-	-	-	-		-	
<b>Recreation</b>									
11.3347.0001	NRC Passes	41,701.72	68,318.77	82,491.64	49,826.43	80,000.00		80,000.00	
11.3347.0003	NRC Open Bowling	1,160.13	1,180.92	2,546.21	844.74	2,000.00		2,000.00	
11.3347.0004	NRC League Bowling	-	-	76.19	-	1,000.00		1,000.00	
11.3347.0005	NRC Shoe Rental	142.79	148.37	227.83	92.36	150.00		150.00	
11.3347.0006	NRC Admissions	15,458.53	40,903.01	59,177.85	28,836.82	42,000.00	8,000.00	50,000.00	
11.3347.0009	NRC Instructional Classes	-	-	-	-	-		-	
11.3347.0010	NRC Equipment Rent	814.51	1,882.81	6,152.43	1,623.45	4,500.00		4,500.00	
11.3347.0011	NRC Court & Gym Rental	7,829.98	34,051.58	48,614.97	28,943.14	35,000.00	12,500.00	47,500.00	
11.3347.0012	NRC Membership Fees	14,263.12	21,039.61	24,061.72	14,675.18	20,000.00	5,000.00	25,000.00	
11.3347.0013	NRC Locker Rental	1,519.54	3,040.94	3,693.54	1,529.43	6,000.00	(2,500.00)	3,500.00	
11.3347.0015	NRC Sponsor Fees	-	4,750.01	8,525.00	6,881.19	7,000.00		7,000.00	
11.3347.0016	NRC Player Fees	-	6,052.36	13,288.08	9,402.52	12,500.00		12,500.00	

FY2024 Proposed Budget General Fund Revenue		F21 Actuals	F22 Actuals	F23 Actuals	F24 YTD Actuals @ 1.31.24	O-23-06-01 F24 Approved Budget	Budget Adjustment	O-24-03-02 F24 Proposed Amended Budget	Budget Notes
11.3347.0017	NRC Youth Activity Fees	-	-	1,085.71	347.62	3,000.00		3,000.00	
11.3347.0018	NRC Resale - Food, Vending, Sp	4,351.59	12,642.69	18,686.37	11,611.63	16,000.00	2,000.00	18,000.00	
11.3347.0019	NRC Bowling Lane Rental	1,212.95	1,579.05	3,108.57	2,152.82	3,000.00		3,000.00	
11.3347.0020	NRC Bowling/Dining Fac Rental	-	5,400.00	3,300.00	-	6,000.00	(2,700.00)	3,300.00	*Original Productions is renting to film
<b>Nome Swimming Pool</b>									
11.3348.0001	Pool Passes	2,967.39	1,291.38	1,646.99	315.00	3,500.00	(2,625.00)	875.00	
11.3348.0006	Pool Admissions	409.94	6,717.78	5,791.78	-	3,500.00	(2,625.00)	875.00	
11.3348.0009	Pool Swim Programs/Lessons	-	3.80	-	-	1,750.00	(1,312.50)	437.50	
11.3348.0010	Pool Equipment Rental	106.18	388.57	295.24	-	500.00	(375.00)	125.00	
11.3348.0011	Pool Facility Rental	7,121.41	19,865.18	13,983.53	-	12,000.00	(9,000.00)	3,000.00	
11.3348.0013	Pool Locker Rental	-	442.85	314.28	-	500.00	(375.00)	125.00	
11.3348.0014	Pool Resale - Food, Equipment	726.76	1,030.61	863.81	-	1,250.00	(937.50)	312.50	
<b>Culture</b>									
11.3350.0002	Library Use Fees, Copies	-	666.62	1,000.68	515.95	1,000.00		1,000.00	
11.3350.0003	SCC Laundry Proceeds	-	-	-	-	-		-	
11.3350.0004	Museum Admissions	-	410.00	553.05	-	1,500.00		1,500.00	
11.3350.0005	Museum Concessions	-	5,179.04	5,063.87	2,567.44	5,000.00		5,000.00	
11.3350.0006	Museum Memberships	-	-	-	-	-		-	
<b>Fines &amp; Forfeitures</b>									
11.3351.0001	Police & Court Fines	1,476.20	1,871.00	656.90	775.00	2,000.00		2,000.00	
11.3351.0002	Animal Fine,Dispose,Adoption	325.00	-	150.00	100.00	500.00		500.00	
11.3351.0003	Library Fine, ILL Return Fee	-	-	-	83.92	500.00		500.00	
11.3351.0004	Bldg Mtnc Permit Fines	-	-	-	-	-		-	
<b>Investment &amp; Interest Earnings</b>									
11.3361.0003	Interest Income	20,806.24	4,811.12	194,980.83	152,013.96	280,000.00	30,000.00	310,000.00	GF Sweep \$240,000; Investment Est @ 4% \$70,000
11.3361.0004	Interest Earn Sif Ins/Eq	16,695.83	763.48	10,214.31	28,022.84	39,500.00		39,500.00	
11.3361.0005	Interest Earn Mielke	-	-	-	-	-		-	
11.3361.0006	Interest Earnings - Leases	-	28,237.16	25,909.95	-	26,000.00		26,000.00	
11.3361.0009	Interest Earn Landfill \$\$	28,590.10	4,753.33	85,243.07	62,707.02	80,000.00		80,000.00	
11.3361.0010	Interest Earn School Loan	-	-	-	-	-		-	
11.3361.0013	Interest Earn PERS Reserve	12,548.47	831.95	12,516.46	7,953.23	35,000.00		35,000.00	
<b>Building, Equipment, Land Lease Rents</b>									
11.3363.0001	Equipment Rental/Use	118,409.78	275.00	19,337.60	-	1,000.00	39,000.00	40,000.00	
11.3363.0002	GGG Building/Space Rent	-	-	-	-	-		-	
11.3363.0003	Building Rental MCC	22,018.03	8,400.75	6,355.25	6,622.44	10,000.00		10,000.00	
11.3363.0004	Gold Hill Tutit Ininat	-	-	-	-	-		-	
11.3363.0005	Building Rental Old St Joe	596.75	6,437.52	7,849.19	6,102.94	10,000.00		10,000.00	
11.3363.0008	WM Caldwell Armory Lease	1.00	1.00	1.00	-	1.00		1.00	
11.3363.0009	Nome Cablevision Lease	6,258.74	8,309.45	8,309.48	8,840.83	8,310.00		8,310.00	
11.3363.0011	Public Health Svs Lease	-	-	-	-	-		-	
11.3363.0012	FAA New Zealand Instru LS	1,806.39	1,806.39	1,806.39	1,806.39	1,806.39		1,806.39	
11.3363.0013	FAA Newton Peak Lease	125.00	125.00	125.00	125.00	125.00		125.00	
11.3363.0015	Recycle Center Royalty	-	2,495.16	-	-	-		-	
11.3363.0016	Animal Shelter Royalty	-	-	-	-	-		-	
11.3363.0017	Rent/Lease	122,049.92	121,363.44	139,308.44	76,893.96	126,500.00	8,500.00	135,000.00	\$120,500 RFB Rent, \$22,000 Officer Apartment, \$4,300 Warren PL GASB 87 (\$13,207)
<b>Donations &amp; Contributions</b>									
11.3365.0001	Donations - C McLain Museum	1,000.00	1,332.00	3,456.50	3,857.00	2,500.00	5,000.00	7,500.00	



FY2024 Proposed Budget General Fund Revenue		F21 Actuals	F22 Actuals	F23 Actuals	F24 YTD Actuals @ 1.31.24	O-23-06-01 F24 Approved Budget	Budget Adjustment	O-24-03-02 F24 Proposed Amended Budget	Budget Notes
11.3365.0002	Donations - Library	3,000.00	7,500.00	8,000.15	5,000.00	4,000.00	2,000.00	6,000.00	
11.3365.0006	Contributions NJU Lobbyist	-	-	-	-	-	-	-	
11.3365.0007	Contribution NJU Energy Consul	-	-	-	-	-	-	-	
11.3365.0008	Contrib NVFD Equip,Fireworks	-	5,000.00	400.00	-	-	-	-	
11.3365.0011	Donations-Belmont Pt Cemetery	-	100.00	-	-	-	-	-	
11.3365.0012	Donations - Parks	-	-	-	-	-	-	-	
11.3365.0013	Donations - Visitor Info Cnter	-	-	-	-	-	-	-	
11.3365.0014	Donations - Public Safety, EMS	30,811.00	30,500.00	16,736.00	2,550.00	30,000.00	(25,000.00)	5,000.00	
11.3365.0015	Donations - Clerks Office	-	-	-	-	-	-	-	
11.3365.0016	Donations - Pub Wrks Bldg	-	-	-	-	-	-	-	
11.3365.0017	Donations - Recreation Ctr	-	-	5,450.00	-	-	-	-	
11.3365.0018	Donations - Animal Shelter	-	-	-	-	-	-	-	
11.3365.0019	Donations - Clean Up	1,000.00	-	2,000.00	1,000.00	2,000.00	-	2,000.00	
11.3365.0020	Donations - PWKS Roads	-	-	-	-	-	-	-	
11.3365.0021	Donations - Pool	-	-	-	-	-	-	-	
11.3365.0022	Donations - Housing Support	-	-	20.00	-	-	-	-	
<b>Sale of General Fixed Assets</b>									
11.3392.0001	Sale of Property/Easement	46,119.73	292,960.47	155,800.00	42,400.00	-	42,400.00	42,400.00	
11.3392.0002	Sale of Equipment, Supply,Ins	-	6,500.00	-	-	-	-	-	
11.3392.0003	Sale Equipment Police	-	-	-	1,250.00	-	1,250.00	1,250.00	
11.3392.0004	Sale Equipment Rec Center	-	-	-	-	-	-	-	
<b>Transfers - Interfunds</b>									
11.3888.8810	Transfers In - Debt Service	-	-	-	-	-	-	-	
11.3888.8820	Transfers In - Other Funds	-	-	-	-	-	-	-	
<b>Proceeds from Issuance of a Lease</b>									
11.3393.0001	Proceeds: Issuance of Leases	-	48,254.17	-	-	48,500.00	-	48,500.00	GASB 87 Placeholder
11.3393.0002	Proceeds: Insurance	-	-	-	114,120.12	-	114,120.12	114,120.12	
<b>Fund Balance Appropriation</b>									
11.3999.9992	Fund Bal Approp Carry Forward	-	-	-	-	-	-	-	
11.3999.9993	Fund Bal Approp PERS Reserve	-	-	-	-	-	-	-	
11.3999.9994	Fund Bal Equip Rplc-NPD+Mayor	-	-	-	-	-	-	-	
11.3999.9995	School Constr Fund Approp	-	-	-	-	-	-	-	
11.3999.9996	Fund Bal Approp Port Loan	-	-	-	-	-	-	-	
11.3999.9997	Fund Bal Approp Landfill	-	-	-	-	-	-	-	
11.3999.9998	Fund Bal Approp Equip/Vehicle	-	-	-	-	185,000.00	172,000.00	357,000.00	
11.3999.9999	Fund Balance Appropriation	-	-	-	-	1,672,773.46	1,070,594.42	2,743,367.88	
<b>Total Revenue:</b>		<b>13,184,272.46</b>	<b>13,767,858.85</b>	<b>15,027,040.18</b>	<b>10,260,184.63</b>	<b>16,574,364.73</b>	<b>1,639,708.72</b>	<b>18,214,073.45</b>	

FY2024 Proposed Budget Amendment /F25 Proposed Budget		F21 Actuals	F22 Actuals	F23 Actuals	F24 YTD Actuals @ 1.31.24	O-23-06-01 F24 Approved Budget	Budget Adjustment	O-24-03-02 F24 Proposed Amended Budget	Budget Notes
<b>Legislative</b>									
11.6110.1101	Salaries - Mayor & Council	4,500.00	4,450.00	4,500.00	2,625.00	4,500.00		4,500.00	1 Mayor, 6 Councilmen
11.6110.1421	Health Insurance-Mayor&Council	51,390.01	50,410.78	57,950.06	36,697.35	66,792.36	(7,927.01)	58,865.35	
11.6110.1431	Life Insurance-Mayor&Council	844.92	830.13	724.28	410.96	701.28	4.23	705.51	
11.6110.1441	FICA/Medicare- Mayor & Council	344.63	340.81	344.64	201.04	344.25		344.25	
11.6110.1461	PERS - Mayor & Council	632.96	503.52	257.02	115.50	198.00		198.00	
11.6110.1471	Workers' Comp Insurance	18.00	13.82	12.82	13.05	13.05		13.05	
	<b>Subtotal Salaries &amp; Benefits:</b>	<b>57,730.52</b>	<b>56,549.06</b>	<b>63,788.82</b>	<b>40,062.90</b>	<b>72,548.94</b>	<b>(7,922.78)</b>	<b>64,626.16</b>	
11.6110.1520	Vehicle Insurance	909.00	-	-	-	-			
11.6110.1530	Property/Building Insurance	808.75	1,043.00	1,288.75	1,709.00	1,709.00		1,709.00	
11.6110.1540	Public Official Insurance/Bond	28,160.64	33,660.26	41,261.03	52,424.32	56,619.84		56,619.84	Shared Cost with Non-Dept.
11.6110.1850	Lobbying	18,750.00	21,750.00	21,250.00	37,450.00	36,250.00	1,200.00	37,450.00	LCIA \$17k x 5mo = \$85k @ 25%/ Windward \$5400k x12 mo = \$64800k @ 25%
11.6110.1870	Other Professional/Contract Sv	1,239.49	1,605.74	1,375.61	508.07	3,500.00		3,500.00	Canon \$825, Boynton \$160, PK Electric, GCSIT, ICE Help Desk \$2500.
11.6110.1930	Expense Account	-	-	-	-	500.00		500.00	Iditarod Banquet Tickets Legis 50%/Admin 50%
11.6110.1940	Advertising	198.90	306.00	1,037.00	1,531.30	1,000.00	1,000.00	2,000.00	
11.6110.2010	Communications	385.99	859.40	458.24	71.45	450.00		450.00	NJUS Phone x1 / Internet x1 - Billed quarterly
11.6110.2012	Computer Network/Hardware/Soft	2,999.34	89.22	84.00	72.06	2,000.00		2,000.00	MSDSOnline \$110, Municode,
11.6110.2020	Dues & Memberships	4,468.00	4,601.00	4,510.04	4,450.37	4,701.00		4,701.00	AML Member Dues \$4,351, Conf of Mayors \$100, NLC Affiliate Dues \$230
11.6110.2030	Travel & Training - Mayor	250.00	-	1,230.42	-	4,000.00	(2,000.00)	2,000.00	
11.6110.2031	Travel & Training - Council	800.00	650.00	4,908.61	125.00	4,000.00	(2,000.00)	2,000.00	NEO, AML Conference
11.6110.2070	Office Supplies	217.31	-	-	14.40	-		-	
11.6110.2071	Operating Supplies	1,785.88	1,388.47	1,628.83	1,282.07	1,800.00	(100.00)	1,700.00	4th of July Street Games \$500, Boynton Copy Fees \$500, Food Expenses - meetings/ws dinners
11.6110.3010	Sponsorship/Donation/Contrib	5,850.00	26,000.00	19,655.00	2,000.00	26,000.00		26,000.00	Facility Waivers, Tax Forgiveness
11.6110.4010	Gas & Oil Supplies	364.52	-	-	-	-		-	
11.6110.4020	Vehicle/Eq Parts & Supply	30.05	-	-	-	-		-	
11.6110.4030	Vehicle/Eq Maintenance	243.00	-	-	-	-		-	
11.6110.4040	Vehicle Regis & Permits	-	-	-	-	-		-	
11.6110.4050	Small Tools & Equipment	-	-	-	-	-		-	
11.6110.4060	Tools & Eq Repair & Maint	-	-	-	-	-		-	
11.6110.7001	Salaries - Legis (Bldg Mtnc)	-	-	-	-	-		-	
11.6110.7002	Salaries - Janitorial	-	-	-	-	-		-	
11.6110.7005	Building Maint Contracts	160.32	476.25	51.87	228.39	150.00	150.00	300.00	Yukon Fire Annual Fire inspection \$75 , SOA Boiler Cert \$30
11.6110.7010	Bldg Maint Materials & Supply	665.10	1,694.04	7,994.17	306.08	2,500.00	(1,500.00)	1,000.00	
11.6110.7011	Janitorial Services & Supplies	96.85	1,084.74	116.63	106.79	400.00		400.00	
11.6110.7020	Building Utilities 25%	-	-	-	-	-		-	
11.6110.7021	Utilities - Electric	4,591.69	5,534.10	6,472.80	2,698.09	6,500.00	(500.00)	6,000.00	
11.6110.7022	Utilities - Water	554.30	538.80	529.50	263.20	550.00		550.00	
11.6110.7023	Utilities - Sewer	264.19	245.55	234.36	115.38	250.00		250.00	
11.6110.7024	Utilities - Garbage	217.10	215.70	226.09	111.51	230.00		230.00	
11.6110.7025	Utilities - Heat	2,465.47	3,004.97	5,601.95	2,890.66	4,080.00	3,723.00	7,803.00	6,800 gal
11.6110.8030	Machinery & Equipment	-	-	-	-	-		-	
	<b>Total Legislative:</b>	<b>134,206.41</b>	<b>161,296.30</b>	<b>183,703.72</b>	<b>148,421.04</b>	<b>229,738.78</b>	<b>(7,949.78)</b>	<b>221,789.00</b>	

FY2024 Proposed Budget Amendment /F25 Proposed Budget Expense		General Fund		F21 Actuals	F22 Actuals	F23 Actuals	F24 YTD Actuals @ 1.31.24	O-23-06-01 F24 Approved Budget	Budget Adjustment	O-24-03-02 F24 Proposed Amended Budget	Budget Notes
<b>Administration</b>											
11.6210.1101	Salaries - City Manager, Asst City Manager	92,695.33	157,986.23	163,006.43	93,039.93	265,149.14	(80,725.21)	184,423.93	1 Manager - Exempt, 1 Asst. Manager Exempt <b>Est Start 5.1.24</b>		
11.6210.1102	Salaries - Executive Asst, HR	44,031.64	144,937.27	148,367.44	65,924.26	173,568.32	6,289.94	179,858.26	1 Exec Assistant, 1 HR Manager, 1 Project Manager		
11.6210.1103	Salaries - Finance	191,694.23	277,511.34	289,242.25	151,648.63	304,575.12	(24,985.49)	279,589.63	1 Fin Dir, 1 Asst Fin Dir, 1 Acct Tech, 1 Acct Tech Vacant- <b>Est Start 5.1.24</b> , 1 Acctg Clerk 50% Finance, 1 Acct Tech 7.5r per week - shared with EMS (20% Share with Port)		
11.6210.1201	Salaries - Overtime	20,267.93	6,095.58	3,540.65	10,951.08	5,000.00	10,000.00	15,000.00			
11.6210.1411	Accrued Personal Lv Mgr	2,753.85	2,682.00	3,211.17	4,031.74	3,738.41	5,394.66	9,133.07			
11.6210.1412	Accrued Personal Lv Admin/HR	-	-	-	-	2,181.63		2,181.63			
11.6210.1413	Accrued Personal Lv Finance	733.93	6,347.18	6,584.45	25,980.76	9,599.87	20,380.89	29,980.76			
11.6210.1421	Health Insurance - Admin	56,678.64	117,386.95	140,794.29	61,482.13	187,180.47	(61,698.33)	125,482.14			
11.6210.1431	Life Insurance - Admin	558.77	736.79	366.95	501.52	989.05	(203.32)	785.73			
11.6210.1441	FICA/Medicare - Admin	26,959.69	45,489.84	46,211.29	26,360.24	57,244.38	(4,236.00)	53,008.38			
11.6210.1461	PERS - Admin	109,420.83	165,351.43	147,354.60	70,231.55	164,624.33	(15,540.39)	149,083.94			
11.6210.1471	Workers' Comp Ins - Admin	1,010.18	1,519.84	1,780.26	2,097.67	2,170.05		2,170.05			
	<b>Subtotal Salaries &amp; Benefits:</b>	<b>546,805.02</b>	<b>926,044.45</b>	<b>950,459.78</b>	<b>512,249.51</b>	<b>1,176,020.77</b>	<b>(145,323.25)</b>	<b>1,030,697.52</b>			
11.6210.1520	Vehicle Insurance	874.00	909.00	1,737.09	957.00	957.00		957.00	2022 Ford Expedition		
11.6210.1530	Property/Building Insurance	1,617.50	2,086.00	2,577.50	3,418.00	3,418.00		3,418.00			
11.6210.1540	Public Official Insurance/Bond	750.00	750.00	750.00	750.00	750.00		750.00			
11.6210.1810	Audit/Accounting	27,471.73	29,462.54	38,595.08	31,675.00	31,700.00	-	31,700.00	Base Fee \$27925, GASB 87 & GASB 96 - Shared with Port		
11.6210.1830	Legal Services	26,819.83	27,768.67	51,676.07	40,455.58	35,000.00	35,000.00	70,000.00	*NSHC		
11.6210.1870	Other Professional/Contract Sv	13,463.83	14,588.90	18,988.77	11,292.18	20,000.00	(1,000.00)	19,000.00	Casele \$8260, Canon \$3360, Pitney Bowes \$780, LocalGov Online Sales Tax Portal Shared with Clerk \$3978, Caselle Training \$3000		
11.6210.1940	Advertising	5,309.10	7,294.35	7,197.60	3,302.98	6,000.00		6,000.00	*Increase in RFP notices		
11.6210.1950	Buildings/Land Rental	8,400.00	6,065.99	10,254.22	1,677.15	8,500.00	(1,000.00)	7,500.00	1 City Apartment 8 mo - Rent Increase Jan 1 \$1050		
11.6210.2010	Communications	6,350.34	5,179.41	5,913.72	2,230.67	6,000.00		6,000.00	Fastwyre \$1600, NJUS \$1625, AT&T Cell \$1085, GCI LD \$1200, FD Data \$480		
11.6210.2012	Computer Network/Hardware/Soft	852.36	2,936.29	6,572.02	2,807.77	1,500.00	700.00	2,200.00	Adobe Fee \$480, MSDS \$100, Zoom \$600, Hardware \$1000		
11.6210.2020	Dues & Memberships	3,108.99	808.00	2,571.37	200.00	2,500.00	350.00	2,850.00	AMMA Dues \$200, SHRM \$219, ICMA Dues \$1225, LogMeIn \$700, AGFOA \$95, GFOA \$160, PHR \$250		
11.6210.2030	Travel & Training - Admin	224.00	8,607.26	8,871.42	5,023.49	7,500.00	500.00	8,000.00			
11.6210.2031	Travel & Training - Finance	302.63	390.00	4,503.00	8,346.18	7,500.00	4,000.00	11,500.00	GFOA Cert Program, Medicare Audit Training, Excel,		
11.6210.2032	Travel & Training - HR			1,186.26	-	3,500.00	(500.00)	3,000.00	2024 OSHA Training \$2500, LinkedIn Learning \$480		
11.6210.2070	Office Supplies	3,613.93	2,761.83	1,538.42	1,825.18	2,000.00	1,000.00	3,000.00			
11.6210.2071	Operating Supplies	15,154.10	16,833.06	16,326.72	15,103.22	17,000.00	(500.00)	16,500.00	Boynton Copy Fees \$2000, Purchase Power Supplies, Safeway, Employee Holiday Gift \$11500		
11.6210.2704	Recruitment	-	-	-	-	-		-	*Not Needed		
11.6210.3010	Sponsorship/Donation/Contrib	3,207.70	5,560.44	7,316.53	920.75	6,000.00		6,000.00	Fall/Spring Clean Up		
11.6210.4010	Gas & Oil Supplies	315.33	580.85	988.25	907.60	900.00	600.00	1,500.00			
11.6210.4020	Vehicle/Eq Parts & Supply	320.44	189.08	382.64	204.45	700.00	(200.00)	500.00			
11.6210.4030	Vehicle/Eq Maintenance	211.75	-	-	-	1,000.00	(500.00)	500.00			
11.6210.4040	Vehicle Regis & Permits	10.00	10.00	10.00	-	20.00		20.00			
11.6210.4050	Small Tools & Equipment	-	-	-	-	-		-			

FY2024 Proposed Budget Amendment /F25 Proposed Budget		F21 Actuals	F22 Actuals	F23 Actuals	F24 YTD Actuals @ 1.31.24	O-23-06-01 F24 Approved Budget	Budget Adjustment	O-24-03-02 F24 Proposed Amended Budget	Budget Notes
11.6210.4060	Tools & Eq Repair & Maint	-	-	-	-	-	-	-	
11.6210.7001	Salaries - Admin (Bldg Mtnc)	-	-	-	-	-	-	-	
11.6210.7002	Salaries - Janitorial	-	-	-	-	-	-	-	
11.6210.7005	Building Maint Contracts	292.07	952.50	103.75	456.79	200.00	300.00	500.00	Yukon Fire Annual Fire inspection \$75, Labor \$325; SOA Boiler Cert \$60
11.6210.7010	Bldg Maint Materials & Supply	1,439.99	3,458.07	2,089.97	457.73	4,500.00	(2,500.00)	2,000.00	
11.6210.7011	Janitorial Services & Supplies	208.90	2,263.41	233.27	213.54	500.00		500.00	
11.6210.7020	Building Utilities 50%	-	-	-	-	-	-	-	
11.6210.7021	Utilities - Electric	9,183.43	11,068.25	12,945.70	5,396.17	12,000.00	(2,000.00)	10,000.00	
11.6210.7022	Utilities - Water	1,108.60	1,077.60	1,059.00	526.40	1,100.00		1,100.00	
11.6210.7023	Utilities - Sewer	528.41	491.16	468.90	230.70	500.00		500.00	
11.6210.7024	Utilities - Garbage	434.35	431.34	452.20	223.07	455.00		455.00	
11.6210.7025	Utilities - Heat	4,931.04	6,010.00	11,203.83	5,781.29	8,160.00	7,446.00	15,606.00	6,800 gal
11.6210.7540	Banking / Credit Card Fees	970.54	289.30	210.74	188.76	1,200.00	(450.00)	750.00	Monthly Analysis Fees, Local Gov Banking Fees
11.6210.8030	Machinery & Equipment	-	-	-	-	-	-	-	
<b>Total Administration:</b>		<b>684,279.91</b>	<b>1,084,867.75</b>	<b>1,167,183.82</b>	<b>656,821.16</b>	<b>1,367,080.77</b>	<b>(104,077.25)</b>	<b>1,263,003.52</b>	

FY2024 Proposed Budget Amendment /F25 Proposed Budget Expense		General Fund		F21 Actuals	F22 Actuals	F23 Actuals	F24 YTD Actuals @ 1.31.24	O-23-06-01 F24 Approved Budget	Budget Adjustment	O-24-03-02 F24 Proposed Amended Budget	Budget Notes
<b>Information Technology</b>											
11.6211.1103	Salaries - IT	71,160.82	25,036.73	36,355.00	21,319.66	31,780.32	3,151.34	34,931.66	Split position 30% IT shared with Police / 12% Salary/Benefits Transferred to Port		
11.6211.1201	Salaries - Overtime	4,641.44	1,328.98	1,189.17	1,471.32	1,500.00	1,000.00	2,500.00			
11.6211.1411	Accrued Personal Leave - IT	43,149.99	-	-	-	381.29		381.29			
11.6211.1421	Health Insurance - IT	4,793.44	3,568.93	8,729.16	4,979.23	7,808.04	425.19	8,233.23			
11.6211.1431	Life Insurance - IT	86.77	29.60	6.81	27.54	37.92	5.42	43.34			
11.6211.1441	FICA/Medicare - IT	9,238.60	2,044.76	2,941.81	1,743.48	2,545.94	317.58	2,863.52			
11.6211.1461	PERS - IT	21,048.36	6,764.87	9,936.01	4,902.98	7,321.67	913.30	8,234.97			
11.6211.1471	Workers' Comp Insurance - IT	212.66	275.26	86.95	96.51	96.51		96.51			
	<b>Subtotal Salaries &amp; Benefits</b>	<b>154,332.08</b>	<b>39,049.13</b>	<b>59,244.91</b>	<b>34,540.72</b>	<b>51,471.69</b>	<b>5,812.83</b>	<b>57,284.52</b>			
11.6211.1870	Other Professional/Contract Sv	120,508.76	130,235.99	136,388.34	91,047.85	145,000.00	(7,500.00)	137,500.00	GCSIT GEMS \$112602 -88% IT, Project Work		
11.6211.2010	Communications	258.95	313.11	664.55	750.93	378.00	1,835.00	2,213.00	NJUS Phone/Net \$378, ATT \$1835		
11.6211.2012	Computer Network/Hardware/Soft	33,146.29	36,341.65	30,646.40	38,970.93	36,000.00	6,000.00	42,000.00	Smartnet Renewal, Phone \$7000, Smartnet for Controller \$6173, Dell Support \$3415, Municode \$2369, \$3400, VEEAM Back up \$1000, Audio Eye \$4453, Archive Social \$2400, IT Malware \$2200, GCSIT, Firepower Support \$1510, Cisco Support \$560, Circo Essentials \$736, Phone Replacements		
11.6211.2070	Office Supplies	-	-	-	-	-	-	-			
11.6211.2071	Operating Supplies	829.33	556.12	365.06	500.00	600.00		600.00			
11.6211.8030	Machinery & Equipment	36,697.67	10,060.00	6,832.00	29,665.00	37,500.00		37,500.00	Switch Replacements, Wireless Controller \$29,665 + Contingency \$5000		
	<b>Total Information Technology:</b>	<b>345,773.08</b>	<b>216,556.00</b>	<b>234,141.26</b>	<b>195,475.43</b>	<b>270,949.69</b>	<b>6,147.83</b>	<b>277,097.52</b>			

FY2024 Proposed Budget Amendment /F25 Proposed Budget Expense		General Fund		F21 Actuals	F22 Actuals	F23 Actuals	F24 YTD Actuals @ 1.31.24	O-23-06-01 F24 Approved Budget	Budget Adjustment	O-24-03-02 F24 Proposed Amended Budget	Budget Notes
<b>City Clerk</b>											
11.6220.1101	Salaries - City Clerk	87,652.61	107,743.28	116,996.30	27,586.71	121,921.76	(54,968.05)	66,953.71	1 City Clerk - Exempt - <b>Est Start Date 2.27.24</b>		
11.6220.1102	Salaries - Deputy Clerk	49,508.54	62,729.70	68,059.71	63,642.31	71,993.76	56,177.55	128,171.31	2 Deputy Clerk		
11.6220.1103	Salaries - Clerk Staff	80,901.27	131,169.79	95,939.22	32,928.60	87,270.32	(43,126.72)	44,143.60	1 Revenue Tech moved to Deputy Clerk in Nov 23, 1 Acctg Clerk Shared with FIN		
11.6220.1201	Salaries - Overtime	6,506.07	11,213.16	5,071.03	4,971.23	7,000.00	1,000.00	8,000.00			
11.6220.1411	Accrued Personal Lv-City Clerk	527.90	-	-	-	3,259.87		3,259.87			
11.6220.1421	Health Insurance - City Clerk	44,602.53	36,458.92	57,960.65	27,547.13	57,687.62	(3,409.49)	54,278.13			
11.6220.1431	Life Insurance - City Clerk	434.24	460.00	483.00	252.08	459.54	(29.21)	430.33			
11.6220.1441	FICA/Medicare - City Clerk	16,004.52	22,590.74	21,883.98	9,878.42	22,046.22	(3,130.17)	18,916.05			
11.6220.1461	PERS - City Clerk	63,147.22	76,742.22	69,755.57	27,953.76	63,401.14	(8,582.38)	54,818.76			
11.6220.1471	Workers' Comp Ins - City Clerk	941.29	830.25	935.05	835.74	835.74		835.74			
	<b>Subtotal Salaries &amp; Benefits</b>	<b>350,226.19</b>	<b>449,938.06</b>	<b>437,084.51</b>	<b>195,595.98</b>	<b>435,875.97</b>	<b>(56,068.47)</b>	<b>379,807.50</b>			
11.6220.1530	Property/Building Insurance	808.75	1,043.00	1,288.75	1,709.00	1,709.00		1,709.00			
11.6220.1540	Public Official Insurance/Bond	750.00	750.00	750.00	750.00	750.00		750.00			
11.6220.1810	Audit/Accounting	-	-	-	-	-		-			
11.6220.1830	Legal Services	7,880.50	13,621.00	27,071.00	450.50	10,000.00	(2,000.00)	8,000.00			
11.6220.1840	Survey/Appraisal Services	42,018.00	41,923.00	32,000.00	52,423.00	49,500.00	4,923.00	54,423.00	Appraisal Co of Alaska \$26k Real Update & \$6k Personal Valuation/ Alaska Cama/MARS \$20,423, Surveyor \$2000		
11.6220.1870	Other Professional/Contract Sv	37,935.10	37,637.95	31,101.36	31,139.33	42,500.00		42,500.00	MyGov \$2520, Caselle Mo Mtncs Fees \$8260, Canon Mo Fees \$3,256, SOA Recording Fees, Pitney Bowes \$780, Duncan GIS \$20,000, Tex R US \$500, Code Publishing Inc \$1500, LocalGov Online Sales Tax Portal Shared with Admin \$3978		
11.6220.1920	Election Expenses	5,352.72	8,397.44	15,964.41	9,478.34	7,500.00	1,978.34	9,478.34	Routine Expenses		
11.6220.1940	Advertising	3,900.94	2,009.13	5,472.72	4,918.19	4,000.00	4,000.00	8,000.00	Legal Advertising for Ordinances		
11.6220.2010	Communications	1,477.84	1,160.68	1,155.91	262.80	1,200.00		1,200.00	GCI LD \$300, NIUS Phones / Internet \$900		
11.6220.2012	Computer Network/Hardware/Soft	2,516.33	3,421.15	5,313.52	2,081.98	7,500.00		7,500.00	Smartnet Renewal \$2276, ArcGIS Renewal \$506, MSDS Online \$90, Archive Social \$996, Municode, GCSIT, Filemaker \$1107.50, Deputy to Laptop with Docking Station \$2500.		
11.6220.2020	Dues & Memberships	70.00	540.00	465.00	225.00	525.00		525.00	AAMC Dues \$105, IIMC Dues \$310, Idirarod \$50		
11.6220.2030	Travel, Training & Related Cost	125.00	3,049.62	6,538.10	1,511.00	6,000.00		6,000.00	Clerk/Deputy to AAMC, Deputy & Rev Tech to PD		
11.6220.2070	Office Supplies	1,252.17	987.77	145.11	1,838.15	2,500.00		2,500.00			
11.6220.2071	Operating Supplies	11,676.64	9,586.10	3,449.40	5,252.41	10,000.00	(1,000.00)	9,000.00	Boynton Copy Fees \$2500, Purchase Power (Pitney Bowes) Postage \$4000, Chinook Printing, AC, Safeway, Notary Fees		
11.6220.2073	Resale Supplies	-	-	-	-	500.00		500.00			
11.6220.3010	Sponsorship/Donation/Contribut	-	-	-	-	-		-			



FY2024 Proposed Budget Amendment /F25 Proposed Budget Expense		General Fund		F21 Actuals	F22 Actuals	F23 Actuals	F24 YTD Actuals @ 1.31.24	O-23-06-01 F24 Approved Budget	Budget Adjustment	O-24-03-02 F24 Proposed Amended Budget	Budget Notes
11.6220.4050	Small Tools & Equipment	-	-	-	-	-	-	-	-	-	
11.6220.7001	Salaries - Clerk (Bldg Mtnc)	-	-	-	-	-	-	-	-	-	
11.6220.7002	Salaries - Janitorial	-	-	-	-	-	-	-	-	-	
11.6220.7005	Building Maint Contracts	160.32	476.25	51.88	228.39	150.00	100.00	250.00	Yukon Fire Annual Fire inspection \$50, SOA Boiler Cert \$30, PK Electric		
11.6220.7010	Bldg Maint Materials & Supply	665.10	1,694.02	1,035.80	306.09	2,500.00	(1,500.00)	1,000.00			
11.6220.7011	Janitorial Services & Supplies	96.86	1,084.75	116.63	106.79	300.00		300.00			
11.6220.7020	Building Utilities 25%	-	-	-	-	-	-	-			
11.6220.7021	Utilities - Electric	4,591.71	5,534.10	6,472.83	2,698.08	6,500.00	(1,000.00)	5,500.00			
11.6220.7022	Utilities - Water	554.30	538.80	529.50	263.20	550.00		550.00			
11.6220.7023	Utilities - Sewer	264.12	245.61	234.41	115.38	250.00		250.00			
11.6220.7024	Utilities - Garbage	217.10	215.64	226.05	111.53	230.00		230.00			
11.6220.7025	Utilities - Heat	2,465.48	3,004.99	5,601.99	2,890.61	4,080.00	3,723.00	7,803.00	6,800 gal		
11.6220.7530	Cash - Over/Short	0.95	0.80	(0.10)	-	50.00		50.00			
11.6220.7540	Banking / Credit Card Fees	-	25.00	55.00	315.88	1,000.00	(250.00)	750.00			
11.6220.8030	Machinery & Equipment	-	-	-	-	-		-			
<b>Total City Clerk:</b>		<b>475,006.12</b>	<b>586,884.86</b>	<b>582,123.78</b>	<b>314,671.63</b>	<b>595,669.97</b>	<b>(47,094.13)</b>	<b>548,575.84</b>			

FY2024 Proposed Budget Amendment /F25 Proposed Budget Expense	General Fund	F21 Actuals	F22 Actuals	F23 Actuals	F24 YTD Actuals @ 1.31.24	O-23-06-01 F24 Approved Budget	Budget Adjustment	O-24-03-02 F24 Proposed Amended Budget	Budget Notes
<b>Planning &amp; Engineering</b>									
11.6230.1101	Salaries - Building Inspector	28,778.18	43,309.45	48,552.59	30,471.09	49,878.83	5,393.26	55,272.09	Building Inspector P/T - 28 Hours per week Start 3.1.24
11.6230.1301	Stipends - Planning Commission	3,120.00	3,320.00	2,480.00	600.00	3,360.00		3,360.00	
11.6230.1411	Accrued Personal Leave - P & E	-	-	-	-	356.67		356.67	
11.6230.1421	Health Insurance - P & E	2,575.03	978.30	-	-	-		-	
11.6230.1431	Life Insurance - P & E	5.18	13.16	-	-	-		-	
11.6230.1441	FICA/Medicare - P & E	2,201.52	3,313.24	3,709.11	2,331.03	3,815.73	412.58	4,228.31	
11.6230.1461	PERS - P & E	8,674.05	13,084.78	11,865.83	6,703.62	10,973.34	1,186.50	12,159.84	
11.6230.1471	Workers' Comp Ins - P & E	2,500.10	1,561.76	2,185.10	1,815.60	1,815.60		1,815.60	
	<b>Subtotal Salaries &amp; Benefits</b>	<b>47,854.06</b>	<b>65,580.69</b>	<b>68,792.63</b>	<b>41,921.34</b>	<b>70,200.17</b>	<b>6,992.34</b>	<b>77,192.51</b>	
11.6230.1520	Vehicle Insurance	418.00	418.00	418.00	418.00	418.00		418.00	99 Chevy Suburban
11.6230.1820	Engineering/Architectural Svcs	34,929.06	40,738.21	28,603.42	40,302.10	40,000.00		40,000.00	Bristol Task Order No 1 - General Engineering Svcs
11.6230.1830	Legal Services	-	-	-	-	500.00	(500.00)	-	
11.6230.1870	Other Professional/Contract Sv	15,749.09	17,604.47	2,925.62	42,121.63	53,500.00		53,500.00	MyGov \$2,520, Canon 30% \$400, Boynton Annual Support \$160, Contractual Planner \$30,000, Grant Writer \$20,000
11.6230.1940	Advertising	229.07	1,643.50	198.90	-	1,200.00	(700.00)	500.00	Planning Commission and Public Hearing Ads
11.6230.2010	Communications	267.71	613.28	726.41	344.06	775.00		775.00	NJUS phone, net \$235, 1 Cell \$542
11.6230.2012	Computer Network/Hardware/Soft	746.12	513.42	608.19	570.62	1,000.00		1,000.00	
11.6230.2020	Dues & Memberships	748.33	342.00	486.00	116.00	875.00		875.00	NAPC \$50, ICC \$ 185, ASFPM Floodplain \$165, National Fire Protection \$475
11.6230.2030	Travel, Training & Related Cost	1,013.44	2,560.26	1,772.21	344.20	3,000.00		3,000.00	
11.6230.2070	Office Supplies	73.80	-	94.47	-	200.00		200.00	
11.6230.2071	Operating Supplies	986.51	1,334.04	603.31	659.39	1,500.00		1,500.00	Boynton Copy Fees \$250, Planning Commission Events, Code Books
11.6230.4010	Gas & Oil Supplies	804.15	328.47	355.02	-	750.00		750.00	
11.6230.4020	Vehicle/Eq Parts & Supply	-	30.93	658.06	572.86	400.00		400.00	
11.6230.4030	Vehicle/Eq Maintenance	-	-	-	-	400.00		400.00	
11.6230.4040	Vehicle Regis & Permits	-	10.00	-	-	10.00		10.00	
11.6230.4070	Demolition/Abatement	-	-	450.00	-	5,000.00	(3,000.00)	2,000.00	
	<b>Total Planning &amp; Engineering:</b>	<b>103,819.34</b>	<b>131,717.27</b>	<b>106,692.24</b>	<b>127,370.20</b>	<b>179,728.17</b>	<b>2,792.34</b>	<b>182,520.51</b>	

FY2024 Proposed Budget Amendment /F25 Proposed Budget Expense		General Fund		F21 Actuals	F22 Actuals	F23 Actuals	F24 YTD Actuals @ 1.31.24	O-23-06-01 F24 Approved Budget	Budget Adjustment	O-24-03-02 F24 Proposed Amended Budget	Budget Notes
<b>Police</b>											
11.6310.1101	Salaries - Chief of Police	67,404.25	130,472.43	163,101.80	77,461.05	142,192.43	17,660.62		159,853.05	1 Chief of Police	
11.6310.1102	Salaries - Officers	376,066.44	766,897.62	862,996.79	632,989.11	1,149,365.71	(63,075.60)	1,086,290.11	2 Sergeants, 1 Admin Sergeant, 6 Officers, 2 Trainee Officers		
11.6310.1103	Salaries - Dispatch	232,201.88	429,079.04	402,677.11	224,711.71	554,859.26	(134,579.55)	420,279.71	1 CO Supv, 1 CO III, 5 COII		
11.6310.1104	Salaries - Other Staff	119,517.84	173,542.95	197,184.71	129,467.15	244,416.49	13,301.66	257,718.15	1 Admin Asst, 1 Victim Advocate, <b>1 Victim Advocate Est Start 4.1.24</b> , 1 Evidence Custodian		
11.6310.1105	Salaries-Community Sv Officer	49,880.38	86,056.85	71,765.31	43,013.04	70,652.16	13,755.88	84,408.04	1 CSO FT + 1 CSO 10r per week		
11.6310.1106	Salaries - Investigators	127,028.69	105,130.90	102,144.46	52,880.20	105,298.72		105,298.72	1 Investigator		
11.6310.1201	Salaries - Officer Overtime	117,156.78	147,202.09	175,411.73	124,771.73	115,000.00	60,000.00	175,000.00			
11.6310.1202	Salaries - Dispatch Overtime	24,912.44	54,212.44	70,205.29	40,132.38	40,000.00	30,000.00	70,000.00			
11.6310.1411	Accrued Personal Leave - NPD	42,204.59	35,062.94	58,500.69	16,801.43	42,575.52		42,575.52			
11.6310.1421	Health Insurance - NPD	91,036.38	289,595.68	364,544.73	230,442.85	517,946.48	(106,385.63)	411,560.85			
11.6310.1431	Life Insurance - NPD	1,328.28	2,581.48	2,495.62	1,821.91	3,534.00	(336.09)	3,197.91			
11.6310.1441	FICA/Medicare - NPD	88,297.05	147,798.69	160,195.46	101,219.66	185,266.53	(3,529.37)	181,737.16			
11.6310.1461	PERS - NPD	353,395.44	502,711.81	456,851.19	270,904.69	491,288.60	(5,950.91)	485,337.69			
11.6310.1471	Workers' Comp Insurance - NPD	38,790.77	51,277.91	65,395.63	68,432.91	63,207.53	5,225.38	68,432.91			
	<b>Subtotal Salaries &amp; Benefits:</b>	<b>1,729,221.21</b>	<b>2,921,622.83</b>	<b>3,153,470.52</b>	<b>2,015,049.82</b>	<b>3,725,603.43</b>	<b>(173,913.61)</b>	<b>3,551,689.82</b>			
11.6310.1520	Vehicle Insurance	10,624.98	11,801.04	11,443.98	13,121.26	11,464.00	1,657.26	13,121.26			
11.6310.1530	Property/Building Insurance	9,898.80	12,707.11	15,366.50	20,095.44	20,095.44		20,095.44			
11.6310.1550	Liability Insurance	107,553.00	113,461.00	131,099.00	123,466.00	123,466.00		123,466.00			
11.6310.1830	Legal Services	5,113.00	9,072.00	11,453.00	15,639.50	8,000.00	17,000.00	25,000.00	Accreditation Process and Consulting		
11.6310.1870	Other Professional/Contract Sv	33,810.76	20,759.73	24,445.46	15,218.49	19,000.00		19,000.00	APsIN \$709, Crimestar \$2100, Canon \$2727, Kustom Signal Radar Recerts, GCSIT - APsIN IT work, Public Safety Comm Background checks,		
11.6310.1940	Advertising	2,360.40	1,516.40	1,714.60	1,538.51	1,500.00	1,000.00	2,500.00			
11.6310.1950	Buildings/Land Rental	4,293.42	6,066.00	4,800.00	36,600.68	5,900.00		5,900.00	City Apartment \$3600 / GASB 87 Lease Conversion -Entries in NonDept.		
11.6310.2010	Communications	17,072.71	18,225.14	18,527.85	8,687.16	19,000.00		19,000.00	Local Phone \$8850, AT&T \$4892, Internet/Phone \$4859, plus GCI LD		
11.6310.2012	Computer Network/Hardware/Soft	25,365.19	23,994.40	41,228.02	44,080.88	30,000.00	22,000.00	52,000.00	MSDS Online \$110, Smartnet Renew \$12,504, Axon Evidence Storage, Body Cams \$17,703, REVL, Accreditation Software \$6915, 4 PC Replacements \$7000, Archive Social \$996, Zoom \$200, Hardware \$6000		
11.6310.2020	Dues & Memberships	755.00	3,142.00	412.82	2,064.18	3,500.00		3,500.00	IACP Membership \$190, APOA \$475, Oregon Alliance for Accreditation \$2500		
11.6310.2030	Travel, Training & Related Cost	36,409.67	32,445.01	37,588.74	40,435.63	65,000.00	(15,000.00)	50,000.00	New Police employees will need to attend the academy in Sitka. Need to meet the training matrix in PD evaluation by Greg Russell.		
11.6310.2040	Uniform/Clothing	10,728.86	9,580.74	9,396.62	11,589.49	11,000.00	4,000.00	15,000.00	3-4 new officers - full uniforms/ballistic vests		
11.6310.2070	Office Supplies	2,724.55	3,334.56	1,661.59	2,050.87	3,000.00		3,000.00			
11.6310.2071	Operating Supplies	17,871.74	17,697.01	18,883.14	11,530.87	18,000.00	2,000.00	20,000.00	Boynton Copy Fees, Business Cards, National Night Out Event, Evidence Supplies, Foremost Promotions, Brownells, Amazon, Galls, Batteries,		

FY2024 Proposed Budget Amendment /F25 Proposed Budget Expense		General Fund		F21 Actuals	F22 Actuals	F23 Actuals	F24 YTD Actuals @ 1.31.24	O-23-06-01 F24 Approved Budget	Budget Adjustment	O-24-03-02 F24 Proposed Amended Budget	Budget Notes
11.6310.2120	Firearms & Ammunition	14,319.18	19,641.22	42,712.13	14,896.59	25,000.00	(5,000.00)	20,000.00	3 Shotguns, 1 9mm Handgun, ammo		
11.6310.2130	Impound Fee Expense	125.00	-	-	-	250.00		250.00	Towing fees for when dispatch requests a vehicle be towed		
11.6310.2140	Investigations	20,760.71	4,877.02	6,958.47	1,543.87	5,000.00		5,000.00	Evidence Postage Out, SART fees not covered by the SOA		
11.6310.2704	Recruitment	16,061.22	10,898.40	8,678.43	6,905.22	12,000.00		12,000.00	Psych Testing, Recruitment Advertising, Airfare and hotel fees, NSHC Physicals		
11.6310.4010	Gas & Oil Supplies	18,818.94	22,752.75	41,922.32	24,845.89	30,000.00	15,000.00	45,000.00	Gas & Oil for vehicles		
11.6310.4020	Vehicle/Eq Parts & Supply	18,075.28	22,940.00	16,156.61	15,362.78	23,000.00	10,000.00	33,000.00			
11.6310.4030	Vehicle/Eq Maintenance	16,532.30	16,009.20	420.44	4,838.35	16,000.00	(8,500.00)	7,500.00			
11.6310.4040	Vehicle Regis & Permits	10.00	142.00	70.00	100.00	250.00		250.00			
11.6310.4050	Small Tools & Equipment	8,350.36	19,015.81	34,373.74	-	10,000.00		10,000.00	Radar Replacement, Radios		
11.6310.4060	Tools & Equip Repair & Maint	1,967.28	89.12	308.46	380.45	500.00		500.00			
11.6310.7001	Salaries - NPD (Bldg Mtnc)	-	-	-	-	-		-			
11.6310.7002	Salaries - Janitorial	-	-	-	-	-		-			
11.6310.7005	Building Maint Contracts	12,387.07	627.80	5,300.16	5,034.45	2,500.00	2,600.00	5,100.00	Yukon Fire Annual Fire inspection \$550, SOA Boiler Cert \$175, Repairs, Trane Svs Agreement \$1610, Carpet Cleaning \$1387		
11.6310.7010	Bldg Maint Materials & Supply	5,057.16	4,405.47	9,230.68	3,932.12	10,000.00		10,000.00	Update Exterior Lights, Receptacles,		
11.6310.7011	Janitorial Services & Supplies	378.38	176.96	661.37	564.22	1,000.00		1,000.00			
11.6310.7020	Building Utilities	-	-	-	-	-		-			
11.6310.7021	Utilities - Electric 73%	41,004.33	41,287.72	45,350.17	17,098.93	42,000.00	(5,000.00)	37,000.00			
11.6310.7022	Utilities - Water 73%	2,460.01	2,435.80	2,426.28	1,212.66	2,500.00		2,500.00			
11.6310.7023	Utilities - Sewer 73%	441.65	-	-	-	500.00		500.00			
11.6310.7024	Utilities - Garbage 73%	2,194.82	2,180.00	2,285.18	1,128.12	2,300.00		2,300.00			
11.6310.7025	Utilities - Heat 73%	21,649.42	26,995.19	49,941.50	18,977.95	38,707.52		38,707.52	13,256 gal		
11.6310.8030	Machinery & Equipment	48,691.00	20,077.80	10,800.00	12,619.92	10,800.00	1,820.00	12,620.00	Taser Contract - \$ 10,800 ; Taser Lcns \$1820		
<b>Total Police:</b>		<b>2,263,087.40</b>	<b>3,419,977.23</b>	<b>3,759,087.78</b>	<b>2,490,610.30</b>	<b>4,296,836.39</b>	<b>(130,336.35)</b>	<b>4,166,500.04</b>			

FY2024 Proposed Budget Amendment /F25 Proposed Budget Expense		General Fund		F21 Actuals	F22 Actuals	F23 Actuals	F24 YTD Actuals @ 1.31.24	O-23-06-01 F24 Approved Budget	Budget Adjustment	O-24-03-02 F24 Proposed Amended Budget	Budget Notes
<b>Animal Control</b>											
11.6312.1102	Salaries - Animal Control	-	-	-	-	-	-	-	-	-	
11.6312.1201	Salaries - Overtime	-	-	-	-	-	-	-	-	-	
11.6312.1411	Accrued Personal Leave	-	-	-	-	-	-	-	-	-	
11.6312.1421	Health Insurance	-	-	-	-	-	-	-	-	-	
11.6312.1431	Life Insurance	-	-	-	-	-	-	-	-	-	
11.6312.1441	FICA/Medicare	-	-	-	-	-	-	-	-	-	
11.6312.1461	PERS	-	-	-	-	-	-	-	-	-	
11.6312.1471	Workers' Comp Insurance	-	-	-	-	-	-	-	-	-	
	<b>Subtotal Salaries &amp; Benefits</b>	-	-	-	-	-	-	-	-	-	
11.6312.1520	Vehicle Insurance	868.00	-	-	418.00	418.00	418.00	418.00		418.00	2011 Ford Expedition
11.6312.1830	Legal Services	259.00	-	-	-	-	-	-		-	
11.6312.1870	Other Professional/Contract Sv	27,983.30	29,950.34	30,137.97	16,410.00	30,000.00	30,000.00			30,000.00	
11.6312.1940	Advertising	1,938.50	-	-	122.40	1,000.00	(500.00)			500.00	
11.6312.2010	Communications	133.48	91.41	129.64	27.06	115.00				115.00	
11.6312.2012	Computer Network/Hardware/Soft	342.34	89.22	24.02	72.06	110.00				110.00	
11.6312.2030	Travel, Training & Related Cost	-	-	-	-	-				-	
11.6312.2070	Office Supplies	-	-	-	-	-				-	
11.6312.2071	Operating Supplies	6,821.26	1,617.02	774.29	665.01	2,500.00	(700.00)			1,800.00	JP Cooke Pet Lnns \$181, Revival Animal Health \$2000, Amazon Misc supplies
11.6312.4010	Gas & Oil Supplies	395.32	-	-	89.29	500.00				500.00	
11.6312.4020	Vehicle/Eq Parts & Supply	-	-	196.38	217.44	500.00				500.00	
11.6312.4030	Vehicle/Eq Maintenance	-	-	-	-	1,000.00	(500.00)			500.00	
11.6312.4040	Vehicle Regis & Permits	10.00	-	-	-	-				-	
11.6312.7001	Salaries - AC (Bldg Mtnc)	-	-	-	-	-				-	
11.6312.7010	Bldg Maint Materials & Supply	99.45	550.56	170.61	-	750.00	(250.00)			500.00	
11.6312.7011	Janitorial Services & Supplies	813.80	90.67	-	148.97	500.00				500.00	
11.6312.7020	Building Utilities	-	-	-	-	-				-	
11.6312.7021	Utilities - Electric	761.13	776.72	892.90	406.69	850.00				850.00	
11.6312.7022	Utilities - Water	-	-	-	-	-				-	
11.6312.7023	Utilities - Sewer	-	-	-	-	-				-	
11.6312.7024	Utilities - Garbage	-	-	-	-	-				-	
11.6312.7025	Utilities - Heat	481.13	715.48	1,311.86	403.08	900.00	132.75			1,032.75	225gal
11.6312.7540	Credit Card Service Fees	-	-	-	-	-				-	
11.6312.7550	Bad Debt	-	-	-	-	-				-	
11.6312.8010	Land/Building & Improvements	-	-	-	-	-				-	
11.6312.8030	Machinery & Equipment	-	6,136.67	-	-	2,500.00	(2,500.00)			-	
	<b>Total Animal Control:</b>	<b>40,906.71</b>	<b>40,018.09</b>	<b>33,637.67</b>	<b>18,980.00</b>	<b>41,643.00</b>	<b>(4,317.25)</b>			<b>37,325.75</b>	

FY2024 Proposed Budget Expense	F21 Actuals	F22 Actuals	F23 Actuals	F24 YTD Actuals @ 1.31.24	O-23-06-01 F24 Approved Budget	Budget Adjustment	O-24-03-02 F24 Proposed Amended Budget	Budget Notes
<b>Nome Volunteer Fire Department</b>								
11.6320.1101 Salaries - Fire	1,634.27	44,989.35	52,359.73	44,832.25	48,098.20	21,094.05	69,192.25	2 ESTs, 1 ESA (Split with Ambulance)
11.6320.1201 Overtime - Fire	-	3,810.37	4,079.80	9,374.34	2,500.00	12,500.00	15,000.00	
11.6320.1301 Fire Chief Stipend	4,000.00	6,000.00	6,000.00	3,500.00	6,000.00		6,000.00	
11.6320.1411 Accrued Personal Leave - Fire	-	-	-	-	498.53		498.53	
11.6320.1421 Health Insurance - Fire	-	4,990.70	9,998.20	7,479.57	8,493.23	2,384.34	10,877.57	
11.6320.1431 Life Insurance - Fire	-	67.16	117.43	83.98	86.25	32.23	118.48	
11.6320.1441 FICA/Medicare - Fire	469.27	4,192.18	4,779.67	4,414.53	4,329.76	2,110.95	6,440.71	
11.6320.1461 PERS - Fire	-	11,859.97	13,740.14	11,790.91	11,131.56	7,390.74	18,522.30	
11.6320.1471 Workers' Comp Insurance - Fire	1,801.54	2,641.12	2,958.55	3,042.13	3,042.13		3,042.13	
11.6320.1472 Special Disability Insurance	6,244.00	6,244.00	5,773.00	7,324.00	5,800.00	1,524.00	7,324.00	
<b>Subtotal Salaries &amp; Benefits:</b>	<b>14,149.08</b>	<b>84,794.85</b>	<b>99,806.52</b>	<b>91,841.71</b>	<b>89,979.66</b>	<b>47,036.31</b>	<b>137,015.97</b>	
11.6320.1520 Vehicle/Boat Insurance	18,551.00	18,551.00	18,501.79	10,530.00	10,530.00		10,530.00	
11.6320.1530 Property/Building Insurance	4,014.20	5,178.15	6,413.30	8,524.60	8,524.60		8,524.60	
11.6320.1830 Legal Services	-	517.50	450.00	-	-		-	
11.6320.1870 Other Professional/Contract Sv	3,105.45	2,230.04	3,178.00	156.85	10,000.00		10,000.00	Trainers to Nome
11.6320.1910 Volunteer Incentives	27,392.50	28,510.00	39,992.50	16,115.00	48,000.00	(18,000.00)	30,000.00	Volunteer Electricity Credits - Applied through NJUS Oct-Mar \$15,000/NVFD Mo Billings - Split Fees (1800 man hours @ \$15 = \$27,000 responders / 1200 man hours @ \$5 = \$6,000 meetings, training)
11.6320.1940 Advertising	-	-	-	-	500.00	(500.00)	-	
11.6320.2010 Communications	2,729.93	2,537.04	3,397.96	1,295.42	3,300.00		3,300.00	Fastwyre \$1050, GCI Net Svs \$1800, NJUS Phone/Net \$200, AT&T Cell Svs \$250,
11.6320.2012 Computer Network/Hardware/Soft	292.16	124.00	1,323.42	36.03	1,500.00		1,500.00	Smartnet Renew \$160,MSDS Online \$90, Radio Lcns Renewal \$1167,
11.6320.2030 Travel,Training & Related Cost	-	2,511.97	8,066.26	4,084.94	20,000.00	(5,000.00)	15,000.00	AK Fire Conf Valdez
11.6320.2040 Uniforms/Clothing	14,866.31	14,151.68	6,140.34	14,575.87	35,000.00		35,000.00	10 Sets of Turnout Gear
11.6320.2070 Office Supplies	-	-	-	-	250.00	(250.00)	-	
11.6320.2071 Operating Supplies	1,777.26	1,341.75	2,309.92	1,822.94	2,000.00	2,000.00	4,000.00	Kitchen Propane
11.6320.4010 Gas & Oil Supplies	4,040.84	2,050.28	2,517.34	705.33	4,000.00	(1,000.00)	3,000.00	
11.6320.4020 Vehicle/Boat/Eq Parts & Supply	-	-	4,144.12	3,037.16	4,000.00	2,500.00	6,500.00	
11.6320.4030 Vehicle/Boat/Eq Maintenance	-	-	6,018.95	-	10,000.00	(4,000.00)	6,000.00	
11.6320.4040 Vehicle/Boat Regis & Permits	40.00	30.00	40.00	10.00	50.00		50.00	
11.6320.4050 Small Tools & Equipment	13,883.80	7,209.64	28,672.50	20,105.00	17,500.00	4,000.00	21,500.00	Above ground main, Generator \$12,000
11.6320.4060 Tools & Eq Repair & Maint	1,120.25	372.52	10,802.15	10.90	14,000.00		14,000.00	
11.6320.7005 Building Maint Contracts	305.00	290.00	535.00	513.57	600.00		600.00	SOA DOL Boiler Cert \$60, Yukon Fire Alarm Inspect \$415, Air Compressor Inspection
11.6320.7010 Bldg Maint Materials & Supply	1,951.35	2,250.46	5,062.52	2,292.61	6,000.00		6,000.00	
11.6320.7011 Janitorial Services & Supplies	-	-	-	200.40	500.00		500.00	
11.6320.7021 Utilities - Electric	8,156.34	8,167.31	8,998.66	3,437.22	9,250.00	(1,000.00)	8,250.00	
11.6320.7022 Utilities - Water	3,099.12	3,099.12	3,099.12	1,549.56	3,100.00		3,100.00	
11.6320.7023 Utilities - Sewer	893.04	893.04	893.04	446.52	900.00		900.00	
11.6320.7024 Utilities - Garbage	2,004.28	1,990.82	2,086.90	835.01	2,100.00		2,100.00	
11.6320.7025 Utilities - Heat	14,820.59	16,828.60	20,710.15	10,999.58	20,780.00	3,065.05	23,845.05	5,195 gal
11.6320.7121 Utilities - Electric - IV	3,105.87	3,067.63	3,696.46	1,697.70	3,500.00		3,500.00	
11.6320.7122 Utilities - Water - IV	588.12	588.12	588.12	294.06	600.00		600.00	
11.6320.7123 Utilities - Sewer - IV	705.72	705.72	705.72	352.86	710.00		710.00	
11.6320.7124 Utilities - Garbage - IV	-	-	-	-	-		-	
11.6320.7125 Utilities - Heat - IV	4,513.74	5,214.38	7,863.02	2,990.58	6,964.00	1,027.19	7,991.19	1,741 gal
11.6320.8030 Machinery & Equipment	14,336.00	21,464.89	-	-	60,000.00		60,000.00	Scotpkaks
<b>Total NVFD:</b>	<b>160,441.95</b>	<b>234,670.51</b>	<b>296,013.78</b>	<b>198,461.42</b>	<b>394,138.26</b>	<b>29,878.55</b>	<b>424,016.81</b>	



FY2024 Proposed Budget Amendment /F25 Proposed Budget Expense	General Fund	F21 Actuals	F22 Actuals	F23 Actuals	F24 YTD Actuals @ 1.31.24	O-23-06-01 F24 Approved Budget	Budget Adjustment	O-24-03-02 F24 Proposed Amended Budget	Budget Notes
<b>Nome Volunteer Ambulance Department</b>									
11.6325.1101	Salaries - Ambulance	52,522.16	101,959.46	110,200.20	81,367.44	135,931.17	25,808.27	161,739.44	2 ESTs, 1 ESA PT
11.6325.1201	Salaries - Overtime	4,255.16	8,737.80	18,897.37	15,671.32	2,500.00	25,000.00	27,500.00	
11.6325.1301	Ambulance Chief Stipend	4,000.00	6,000.00	6,000.00	3,500.00	6,000.00		6,000.00	
11.6325.1411	Accrued Personal Leave - Amb	6,458.48	-	-	-	1,458.59		1,458.59	
11.6325.1421	Health Insurance - Amb	948.57	13,869.38	20,306.87	12,610.69	22,082.39	4,118.30	26,200.69	
11.6325.1431	Life Insurance - Amb	35.55	186.66	228.21	154.54	224.25	68.29	292.54	
11.6325.1441	FICA/Medicare - Amb	5,211.89	8,927.36	10,342.72	7,691.18	11,048.98	3,886.84	14,935.82	
11.6325.1461	PERS - Amb	9,539.76	30,382.61	31,442.22	18,489.04	27,313.92	8,857.12	36,171.04	
11.6325.1471	Workers' Comp Insurance - Amb	2,119.48	295.95	472.84	418.85	418.85		418.85	
	<b>Subtotal Salaries &amp; Benefits:</b>	<b>85,091.05</b>	<b>170,359.22</b>	<b>197,890.43</b>	<b>139,903.06</b>	<b>206,978.15</b>	<b>67,738.82</b>	<b>274,716.97</b>	
11.6325.1520	Vehicle/Boat Insurance	8,005.00	7,434.00	7,225.00	4,518.00	4,518.00		4,518.00	
11.6325.1530	Property/Building Insurance	3,661.20	4,699.89	5,683.50	7,432.56	7,432.56		7,432.56	
11.6325.1830	Legal Services	-	-	-	-	300.00	(300.00)	-	
11.6325.1870	Other Professional/Contract Sv	16,903.48	11,642.67	12,927.26	9,374.57	30,000.00	(10,000.00)	20,000.00	Systems Design West \$ 20k
11.6325.1910	Volunteer Incentives	43,767.50	21,015.00	17,445.00	9,490.00	40,000.00	(15,000.00)	25,000.00	Volunteer Electricity Credits - Applied through NJUS Oct-Mar \$9000 / NVAD \$30 (500 Runs = \$15,000)
11.6325.1940	Advertising	-	-	1,156.00	107.10	1,000.00		1,000.00	
11.6325.2010	Communications	1,927.03	1,981.05	5,344.70	621.68	2,050.00		2,050.00	Fastwyre \$1100, NJUS Phone/Net \$600, AT&T Cell Svs \$450
11.6325.2012	Computer Network/Hardware/Soft	608.24	8,939.38	3,886.68	2,763.47	2,700.00	300.00	3,000.00	Smartnet Renew \$124, Image Trend \$451, MSDS Online \$90, Radio Lcns Renewal \$1167, IamResponding Software \$860
11.6325.2030	Travel, Training & Related Cost	3,741.50	2,379.96	12,693.25	4,457.09	10,000.00	(4,000.00)	6,000.00	Travel to EMS Symposium ANC, FAI
11.6325.2040	Uniform/Clothing	63.72	-	2,104.23	-	500.00		500.00	
11.6325.2070	Office Supplies	155.62	56.90	18.47	-	250.00	(250.00)	-	
11.6325.2071	Operating Supplies	1,201.30	1,676.92	2,149.60	227.92	1,500.00	500.00	2,000.00	
11.6325.2072	Medical Supplies	-	-	-	-	-	5,000.00	5,000.00	
11.6325.3040	Emergency Preparedness	-	-	-	-	-		-	
11.6325.4010	Gas & Oil Supplies	3,368.02	3,170.91	4,813.95	2,207.32	4,000.00		4,000.00	
11.6325.4020	Vehicle/Boat/Eq Parts & Supply	3,814.90	1,126.05	2,934.06	4,505.45	4,000.00	2,500.00	6,500.00	
11.6325.4030	Vehicle/Boat/Eq Maintenance	5,180.50	3,862.50	-	-	8,000.00	(5,000.00)	3,000.00	
11.6325.4040	Vehicle/Boat Regis & Permits	20.00	40.00	20.00	199.00	50.00	200.00	250.00	
11.6325.4050	Small Tools & Equipment	1,723.80	2,872.07	3,395.93	7,331.45	10,000.00		10,000.00	
11.6325.4060	Tools & Eq Repair & Maint	102.64	453.01	-	-	7,500.00	(2,500.00)	5,000.00	
11.6325.7005	Building Maint Contracts	328.38	232.20	1,960.34	2,186.13	1,000.00	1,500.00	2,500.00	Trane \$1100, Yukon Fire \$250
11.6325.7010	Bldg Maint Materials & Supply	1,549.13	5,422.90	3,451.81	3,795.74	4,000.00		4,000.00	Bifold Bay Doors 1 thru 6
11.6325.7011	Janitorial Services & Supplies	237.67	-	-	19.81	250.00		250.00	
11.6325.7021	Utilities - Electric 27%	15,165.98	15,270.82	16,773.34	6,324.27	16,500.00	(2,500.00)	14,000.00	
11.6325.7022	Utilities - Water 27%	909.87	900.92	897.39	448.52	900.00		900.00	
11.6325.7023	Utilities - Sewer 27%	163.35	-	-	-	200.00		200.00	
11.6325.7024	Utilities - Garbage 27%	811.82	806.30	845.21	417.27	850.00		850.00	
11.6325.7025	Utilities - Heat 27%	8,007.30	9,984.53	18,471.55	6,296.65	14,316.48	864.95	15,181.43	12,250 gal
11.6325.7550	Bad Debt	38,640.48	18,695.05	2,122.50	2,100.50	20,000.00		20,000.00	
11.6325.8030	Machinery & Equipment	1,174.90	1,125.10	-	-	5,000.00	(5,000.00)	-	
	<b>Total NVAD:</b>	<b>246,324.38</b>	<b>294,147.35</b>	<b>324,210.20</b>	<b>214,727.56</b>	<b>403,795.19</b>	<b>34,053.77</b>	<b>437,848.96</b>	

FY2024 Proposed Budget Amendment /F25 Proposed Budget Expense		General Fund		F21 Actuals	F22 Actuals	F23 Actuals	F24 YTD Actuals @ 1.31.24	O-23-06-01 F24 Approved Budget	Budget Adjustment	O-24-03-02 F24 Proposed Amended Budget	Budget Notes
<b>Public Works</b>											
11.6330.1101	Salaries - Public Works Sup	-	-	-	-	40,031.36	27,060.80	51,558.40		51,558.40	1 Public Works Supervisor 50% Shared with Roads
11.6330.1102	Salaries - Building Maint	266,524.83	273,456.00	266,131.51	154,334.29	321,594.10	(33,357.81)	288,236.29		288,236.29	1 Bldg Mtnc I, 2 Bldg Mtnc II, 1 Laborer, 3 Summer Temp Laborer
11.6330.1105	Salaries - Custodian	-	-	46,741.52	39,820.96	94,871.14	(14,062.18)	80,808.96		80,808.96	1 FT Custodian, 2 PT 15r/20r Custodians
11.6330.1201	Salaries - Overtime	10,840.44	23,587.75	35,016.87	14,327.42	10,000.00	10,000.00	20,000.00		20,000.00	
11.6330.1411	Accrued Personal Lv- Bldg Mtnc	14,180.50	32,751.56	-	1,158.80	4,084.59		4,084.59		4,084.59	
11.6330.1421	Health Insurance - Bldg Mtnc	67,290.89	58,030.67	92,029.41	64,921.90	109,380.72	26,661.18	136,041.90		136,041.90	
11.6330.1431	Life Insurance - Bldg Mtnc	445.80	376.74	537.16	410.18	773.10	39.70	812.80		812.80	
11.6330.1441	FICA/Medicare - Bldg Mtnc	22,372.22	25,278.44	29,912.06	18,107.80	36,568.81	(2,862.63)	33,706.18		33,706.18	
11.6330.1461	PERS - Bldg Mtnc	84,118.51	79,385.38	81,995.97	47,717.99	85,094.90	64.67	85,159.57		85,159.57	
11.6330.1471	Workers' Comp Insur - Bldg Mtn	20,216.13	13,508.16	18,447.12	17,303.92	17,303.92		17,303.92		17,303.92	
	<b>Subtotal Salaries &amp; Benefits</b>	<b>485,989.32</b>	<b>506,374.70</b>	<b>610,842.98</b>	<b>385,164.06</b>	<b>731,229.68</b>	<b>(13,517.07)</b>	<b>717,712.61</b>		<b>717,712.61</b>	
11.6330.1520	Vehicle Insurance	6,113.00	4,491.00	5,068.42	5,007.00	4,989.00	18.00	5,007.00		5,007.00	2010 Ford Expedition x2, 2008 GMC Sierra, 2012 Chevy Silverado, 2012 GMC Sierra, 2017 Chevy Silverado, 2023 Cargo High Roof Van
11.6330.1530	Property/Building Insurance	178.80	230.85	283.70	376.40	376.40		376.40		376.40	
11.6330.1870	Other Professional/Contract Sv	-	3,390.40	3,950.00	4,325.00	3,950.00	375.00	4,325.00		4,325.00	Maintain X \$3,950
11.6330.1940	Advertising	940.80	1,953.30	770.10	123.13	1,500.00	(500.00)	1,000.00		1,000.00	
11.6330.2010	Communications	615.27	329.11	638.97	187.17	925.00		925.00		925.00	NJUS Net, Phone \$350, AT&T Cell \$550, GCI LD \$25
11.6330.2012	Computer Network/Hardware/Soft	342.33	569.21	3,931.50	420.51	2,500.00		2,500.00		2,500.00	Smartnet Renew \$278, MSDS Online \$90, IT Ports \$500
11.6330.2030	Travel, Training & Related Cost	-	1,416.00	813.20	-	2,000.00		2,000.00		2,000.00	
11.6330.2040	Uniform/Clothing	842.42	772.71	2,646.14	443.98	2,000.00		2,000.00		2,000.00	
11.6330.2070	Office Supplies	88.95	-	28.98	174.45	-		-		-	
11.6330.2071	Operating Supplies	1,239.44	1,730.96	1,445.84	2,060.73	2,500.00	500.00	3,000.00		3,000.00	Supplies - Safeway, AK Comm Co
11.6330.2612	Salaries - Veh R/M - Bldg Mtnc	-	-	-	-	-		-		-	
11.6330.4010	Gas & Oil Supplies	6,851.94	11,627.73	25,334.45	18,035.73	14,000.00	16,000.00	30,000.00		30,000.00	
11.6330.4020	Vehicle/Eq Parts & Supply	301.59	4,133.92	1,898.53	2,029.31	4,000.00		4,000.00		4,000.00	
11.6330.4030	Vehicle/Eq Maintenance	180.50	-	-	-	1,500.00		1,500.00		1,500.00	
11.6330.4040	Vehicle Regis & Permits	60.00	20.00	40.00	-	80.00		80.00		80.00	
11.6330.4050	Small Tools & Equipment	1,472.58	3,917.56	18,397.08	2,358.67	5,000.00		5,000.00		5,000.00	
11.6330.4060	Tools & Eq Repair & Maint	831.46	153.91	101.69	-	1,000.00		1,000.00		1,000.00	
11.6330.7010	Bldg Maint Materials & Supply	8,590.38	4,580.69	5,740.24	3,029.45	10,000.00		10,000.00		10,000.00	
11.6330.7011	Janitorial Services & Supplies	1,384.75	3,095.37	5,597.07	6,020.70	4,000.00	5,000.00	9,000.00		9,000.00	
11.6330.8030	Machinery & Equipment	-	-	-	-	-		-		-	
	<b>Total Public Works:</b>	<b>516,023.53</b>	<b>548,787.42</b>	<b>687,528.89</b>	<b>429,756.29</b>	<b>791,550.08</b>	<b>7,875.93</b>	<b>799,426.01</b>		<b>799,426.01</b>	

FY2024 Proposed Budget Amendment /F25 Proposed Budget Expense	General Fund	F21 Actuals	F22 Actuals	F23 Actuals	F24 YTD Actuals @ 1.31.24	O-23-06-01 F24 Approved Budget	Budget Adjustment	O-24-03-02 F24 Proposed Amended Budget	Budget Notes
<b>St. Joseph's Church</b>									
11.6331.1421	Health Insurance - OSJ	-	-	-	-	-	-	-	
11.6331.1431	Life Insurance - OSJ	-	-	-	-	-	-	-	
11.6331.1441	FICA/Medicare - OSJ	-	-	-	-	-	-	-	
11.6331.1461	PERS - OSJ	-	-	-	-	-	-	-	
11.6331.1471	Workers' Comp Insurance - OSJ	-	-	-	-	-	-	-	
11.6331.1530	Property/Building Insurance	4,452.00	5,597.00	6,984.00	9,002.00	9,002.00	-	9,002.00	
11.6331.1870	Other Professional/Contract Sv	-	-	-	-	-	-	-	
11.6331.1940	Advertising	-	-	-	-	-	-	-	
11.6331.2010	Communications	447.40	438.37	488.27	263.56	500.00	-	500.00	Fastwyre Local Phone \$475, GCI LD
11.6331.2012	Computer Network/Hardware/Soft	188.22	371.22	162.02	72.06	375.00	-	375.00	MSDS Online \$90, Smartnet Renew \$138
11.6331.2070	Office Supplies	-	-	-	-	-	-	-	
11.6331.2071	Operating Supplies	-	-	-	701.06	-	1,000.00	1,000.00	
11.6331.7001	Salaries - OSJ (Bldg Mtnc)	-	-	-	-	-	-	-	
11.6331.7002	Salaries - Janitorial	-	-	-	-	-	-	-	
11.6331.7005	Building Maint Contracts	70.00	-	60.00	-	-	-	-	
11.6331.7010	Bldg Maint Materials & Supply	1,503.68	1,037.06	928.68	104.08	12,000.00	(10,000.00)	2,000.00	
11.6331.7011	Janitorial Services & Supplies	304.66	269.99	106.06	353.74	500.00	-	500.00	
11.6331.7020	Utilities - OSJ	-	-	-	-	-	-	-	
11.6331.7021	Utilities - Electric	2,145.83	2,923.01	3,188.01	1,101.25	3,230.00	(730.00)	2,500.00	
11.6331.7022	Utilities - Water	909.24	909.24	909.24	454.62	910.00	-	910.00	
11.6331.7023	Utilities - Sewer	893.04	893.04	893.04	429.52	900.00	-	900.00	
11.6331.7024	Utilities - Garbage	1,737.18	1,725.48	1,808.65	893.52	1,817.00	-	1,817.00	
11.6331.7025	Utilities - Heat	6,761.54	7,838.59	9,270.01	4,766.38	10,864.00	-	10,864.00	2,716 gal / Toyo Heaters
11.6331.8030	Machinery & Equipment	-	-	-	12,906.27	-	13,376.59	13,376.59	Replacement of Destroyed Christmas Tree
<b>Total St. Joseph's Church:</b>		<b>19,412.79</b>	<b>22,003.00</b>	<b>24,797.98</b>	<b>31,048.06</b>	<b>40,098.00</b>	<b>3,646.59</b>	<b>43,744.59</b>	

FY2024 Proposed Budget Amendment /F25 Proposed Budget Expense	General Fund	F21 Actuals	F22 Actuals	F23 Actuals	F24 YTD Actuals @ 1.31.24	O-23-06-01 F24 Approved Budget	Budget Adjustment	O-24-03-02 F24 Proposed Amended Budget	Budget Notes
<b>Mini Convention Center</b>									
11.6332.1421	Health Insurance - MCC	-	-	-	-	-	-	-	
11.6332.1431	Life Insurance - MCC	-	-	-	-	-	-	-	
11.6332.1441	FICA/Medicare - MCC	-	-	-	-	-	-	-	
11.6332.1461	PERS - MCC	-	-	-	-	-	-	-	
11.6332.1471	Workers' Comp Insurance - MCC	-	-	-	-	-	-	-	
11.6332.1530	Property/Building Insurance	31,415.00	39,761.00	4,604.00	4,665.00	5,704.00		5,704.00	Flood Insurance Re-rated/AMLJIA
11.6332.1820	Engineering/Architectural Svcs	-	-	-	-	-		-	
11.6332.1870	Other Professional/Contract Sv	-	-	2,717.23	-	1,500.00	(500.00)	1,000.00	DEC \$500, GCSIT
11.6332.2010	Communications	542.65	491.90	3,886.35	258.56	6,100.00		6,100.00	Fastwyre Local Phone \$540, Fiber \$5544
11.6332.2012	Computer Network/Hardware/Soft	89.22	89.22	4,557.88	504.50	3,500.00		3,500.00	MSDS Online \$90, IT Devices Meraki Lcns \$355, TV Expansion & AV Equipment Upgrades \$3000 est
11.6332.2071	Operating Supplies	-	-	9,142.48	-	2,500.00		2,500.00	
11.6332.4050	Small Tools & Equipment	142.75	1,072.89	-	-	1,200.00		1,200.00	
11.6332.4060	Tools & Eq Repair & Maint	-	-	-	-	-		-	
11.6332.7001	Salaries - MCC (Bldg Mtnc)	-	-	-	-	-		-	
11.6332.7002	Salaries - Janitorial	-	-	-	-	-		-	
11.6332.7005	Building Maintenance Contracts	70.00	7,027.14	60.00	-	-		-	
11.6332.7010	Bldg Maint Materials & Supply	6,125.26	30,403.86	13,668.66	495.30	11,500.00		11,500.00	Finish Remodel: Cabinets & Small Appliances
11.6332.7011	Janitorial Services & Supplies	133.37	269.99	891.93	226.72	900.00		900.00	
11.6332.7020	Utilities - MCC	-	-	-	-	-		-	
11.6332.7021	Utilities - Electric	9,258.91	5,452.15	5,065.26	1,721.97	5,800.00	(1,300.00)	4,500.00	
11.6332.7022	Utilities - Water	4,921.68	2,268.08	2,094.48	979.04	2,000.00		2,000.00	
11.6332.7023	Utilities - Sewer	5,044.56	1,860.24	1,651.92	744.12	1,850.00		1,850.00	
11.6332.7024	Utilities - Garbage	2,875.95	2,195.57	3,130.39	1,544.30	3,150.00		3,150.00	
11.6332.7025	Utilities - Heat	10,871.01	13,655.88	26,856.41	8,722.90	18,928.00	2,791.88	21,719.88	4,732 gal
<b>Total Mini Convention Center:</b>		<b>71,490.36</b>	<b>104,547.92</b>	<b>78,326.99</b>	<b>19,862.41</b>	<b>64,632.00</b>	<b>991.88</b>	<b>65,623.88</b>	

FY2024 Proposed Budget Amendment /F25 Proposed Budget Expense	General Fund	F21 Actuals	F22 Actuals	F23 Actuals	F24 YTD Actuals @ 1.31.24	O-23-06-01 F24 Approved Budget	Budget Adjustment	O-24-03-02 F24 Proposed Amended Budget	Budget Notes
<b>Public Works Building</b>									
11.6334.1105	Salaries - Temporary		-	12,286.38	7,450.80	-	15,000.00	15,000.00	
11.6334.1421	Health Insurance - PWKS Bldg	-	-	-	-	-	-	-	
11.6334.1431	Life Insurance - PWKS Bldg	-	-	-	-	-	-	-	
11.6334.1441	FICA/Medicare - PWKS Bldg	-	-	939.91	570.01	-	1,147.50	1,147.50	
11.6334.1461	PERS - PWKS Bldg	-	-	-	-	-	-	-	
11.6334.1471	Workers' Comp Ins - PWKS Bldg	-	-	-	-	-	570.00	570.00	
11.6334.1530	Property/Building Insurance	2,095.00	2,701.00	3,485.61	4,711.00	4,711.00	-	4,711.00	
11.6334.1870	Other Professional/Contract Sv	-	-	5,390.00	51,406.00	-	52,000.00	52,000.00	
11.6334.2012	Computer Network/Hardware/Soft	-	-	-	-	-	-	-	
11.6334.4050	Small Tools & Equipment	-	-	-	-	5,000.00	-	5,000.00	Fire Replacement
11.6334.7001	Salaries - Public Works Bldg	-	-	-	-	-	-	-	
11.6334.7005	Building Maintenance Contracts	70.00	60.00	-	22,869.00	100.00	29,900.00	30,000.00	SOA Boiler Inspection
11.6334.7010	Bldg Maint Materials & Supply	817.45	3,379.43	7,625.03	32,424.67	3,500.00	51,500.00	55,000.00	
11.6334.7011	Janitorial Services & Supplies	-	-	-	-	-	-	-	
11.6334.7020	Utilities - Public Works Bldg	-	-	-	-	-	-	-	
11.6334.7021	Utilities - Electric	8,156.26	8,167.28	8,998.63	3,437.23	8,700.00	(700.00)	8,000.00	
11.6334.7022	Utilities - Water	909.24	909.24	909.24	454.62	910.00	-	910.00	
11.6334.7023	Utilities - Sewer	893.04	893.04	893.04	446.52	900.00	-	900.00	
11.6334.7024	Utilities - Garbage	868.55	862.68	904.33	640.63	910.00	-	910.00	
11.6334.7025	Utilities - Heat	15,699.46	27,385.30	44,577.91	14,739.01	34,000.00	5,015.00	39,015.00	8,500 gal
	<b>Total Public Works Building:</b>	<b>29,509.00</b>	<b>44,357.97</b>	<b>86,010.08</b>	<b>139,149.49</b>	<b>58,731.00</b>	<b>154,432.50</b>	<b>213,163.50</b>	

FY2024 Proposed Budget Amendment /F25 Proposed Budget		General Fund		F21 Actuals	F22 Actuals	F23 Actuals	F24 YTD Actuals @ 1.31.24	O-23-06-01 F24 Approved Budget	Budget Adjustment	O-24-03-02 F24 Proposed Amended Budget	Budget Notes
<b>Senior Citizens Building</b>											
11.6335.1421	Health Insurance - SCC	-	-	-	-	-	-	-	-	-	
11.6335.1431	Life Insurance - SCC	-	-	-	-	-	-	-	-	-	
11.6335.1441	FICA/Medicare - SCC	-	-	-	-	-	-	-	-	-	
11.6335.1461	PERS - SCC	-	-	-	-	-	-	-	-	-	
11.6335.1471	Workers' Comp Insurance - SCC	-	-	-	-	-	-	-	-	-	
11.6335.1530	Property/Building Insurance	3,527.00	4,589.00	5,823.00	7,692.00	7,692.00				7,692.00	
11.6335.1870	Other Professional/Contract Sv	-	-	-	-	-	-	-	-	-	
11.6335.2012	Computer Network/Hardware/Soft	-	-	-	-	-	-	-	-	-	
11.6335.2071	Operating Supplies	4,715.25	6,739.95	5,800.68	3,712.96	6,000.00	1,000.00			7,000.00	BFI Propane Expense
11.6335.4050	Small Tools & Equipment	-	-	-	-	-	-	-	-	-	
11.6335.7001	Salaries - SCC (Bldg Mtnc)	-	-	-	-	-	-	-	-	-	
11.6335.7002	Salaries - SCC Janitorial	-	-	-	-	-	-	-	-	-	
11.6335.7005	Building Maintenance Contracts	7,025.89	3,610.13	3,360.09	4,030.03	4,000.00	800.00			4,800.00	SCC Elev Mtnc \$2750, Yukon Fire Sprinkler, Fire Alarm Inspection \$1000, Freezer Insp, Elevator Inspection, North Star Cellular Monitoring \$600, SOA DOL Elev Inspec \$450
11.6335.7010	Bldg Maint Materials & Supply	5,414.52	2,265.40	2,538.46	1,052.55	7,000.00	(5,000.00)			2,000.00	
11.6335.7020	Utilities - SCC	-	-	-	-	-	-	-	-	-	
11.6335.7021	Utilities - Electric	12,430.09	16,702.36	18,647.91	8,008.52	18,500.00	(1,500.00)			17,000.00	
11.6335.7022	Utilities - Water	2,291.60	2,614.00	2,812.40	1,449.60	2,850.00				2,850.00	
11.6335.7023	Utilities - Sewer	1,146.00	1,532.88	1,770.96	937.56	1,800.00				1,800.00	
11.6335.7024	Utilities - Garbage	5,533.21	5,496.04	5,761.20	2,842.22	5,800.00				5,800.00	
11.6335.7025	Utilities - Heat	9,475.23	11,548.59	21,528.97	6,985.58	15,680.00	(386.12)			15,293.88	6,800 gal
11.6335.8030	Machinery & Equipment	-	-	-	-	-	-	-	-	-	
<b>Total Senior Citizens Building:</b>		<b>51,558.79</b>	<b>55,098.35</b>	<b>68,043.67</b>	<b>36,711.02</b>	<b>69,322.00</b>	<b>(5,086.12)</b>			<b>64,235.88</b>	



FY2024 Proposed Budget Amendment /F25 Proposed Budget		General Fund		F21 Actuals	F22 Actuals	F23 Actuals	F24 YTD Actuals @ 1.31.24	O-23-06-01 F24 Approved Budget	Budget Adjustment	O-24-03-02 F24 Proposed Amended Budget	Budget Notes
<b>Landfill</b>											
11.6336.1101	Salaries-Beam Road-Operators	79,099.89	72,895.61	78,641.75	48,756.81	89,082.64	(2,177.83)		86,904.81	1 Landfill Operator	
11.6336.1102	Salaries-CntrCrk-Operators	6,067.08	9,596.50	22,442.88	12,246.41	17,816.53			17,816.53		
11.6336.1201	Salaries - Overtime	2,289.54	1,439.96	9,515.95	5,044.91	6,000.00	3,500.00		9,500.00		
11.6336.1411	Accrued Personal Lv - Landfill	-	-	-	-	971.27			971.27		
11.6336.1421	Health Insurance - Landfill	10,866.05	9,408.79	16,332.18	9,401.70	13,589.16	1,474.69		15,063.85		
11.6336.1431	Life Insurance - Landfill	143.44	131.20	166.22	103.72	138.00	23.22		161.22		
11.6336.1441	FICA/Medicare - Landfill	6,690.38	6,420.80	8,435.54	5,052.69	8,636.79	101.14		8,737.93		
11.6336.1461	PERS - Landfill	23,163.35	23,118.89	27,041.17	14,457.76	24,837.82	290.87		25,128.69		
11.6336.1471	Workers' Comp Ins - Landfill	4,397.15	4,384.55	6,232.23	6,456.71	6,456.71			6,456.71		
	<b>Subtotal Salaries &amp; Benefits:</b>	<b>132,716.88</b>	<b>127,396.30</b>	<b>168,807.92</b>	<b>101,520.71</b>	<b>167,528.92</b>	<b>3,212.09</b>		<b>170,741.01</b>		
11.6336.1520	Vehicle/Eq Insurance	2,789.00	1,144.00	1,144.00	1,144.00	1,144.00			1,144.00	2010 Komatsu Dozer, 966F	
11.6336.1530	Property/Building Insurance	1,440.00	1,870.00	2,397.00	3,253.00	3,253.00			3,253.00		
11.6336.1820	Engineering/Architectural Svcs	83,151.79	76,849.25	70,526.81	80,492.83	87,500.00			87,500.00	Bristol Task Order #5 - Landfill Engineering / Groundwater Sampling/ADEC Coordination on Gas Probe Install \$7500	
11.6336.1840	Survey/Appraisal Services	13,765.00	12,815.00	11,385.00	12,745.00	15,750.00			15,750.00	SOA DEC Annual Permitting \$8250, Survey Svcs \$4500, Environmental Monitoring Water Sampling \$3000	
11.6336.1870	Other Professional/Contract Sv	7,285.34	3,132.25	3,748.75	6,284.75	2,000.00	6,500.00		8,500.00	Pederson \$700, Qtrucking Equip Hauling Fees \$500,	
11.6336.1940	Advertising	-	183.60	-	-	200.00	(200.00)		-		
11.6336.2010	Communications	447.40	438.37	488.27	231.62	500.00			500.00	Fastwyre Local Phone	
11.6336.2012	Computer Network/Hardware/Soft	-	-	-	-	-			-		
11.6336.2030	Travel,Training & Related Cost	-	-	-	-	-			-		
11.6336.2040	Clothing,Safety Gear	-	-	957.37	-	1,500.00			1,500.00		
11.6336.2071	Operating Supplies	44.00	47.38	1,280.18	758.70	1,000.00			1,000.00		
11.6336.3030	Recycling Center	-	-	-	-	-			-		
11.6336.4010	Gas & Oil Supplies	10,944.27	13,190.00	24,103.45	8,469.39	14,000.00	2,000.00		16,000.00		
11.6336.4020	Vehicle/Eq Parts & Supply	8,348.85	2,191.55	50,230.14	1,078.57	15,000.00			15,000.00		
11.6336.4030	Vehicle/Eq Maintenance	-	-	-	-	-			-		
11.6336.4040	Vehicle Regis & Permits	-	10.00	-	-	10.00			10.00		
11.6336.4050	Small Tools & Equipment	2,285.64	133.12	-	2,784.28	8,000.00			8,000.00	Can Crusher, Welder, Occupational Health	
11.6336.7001	Salaries-Bldg Mtnc CC & Beam	-	-	-	-	-			-		
11.6336.7005	Building Maintenance Contracts	140.00	-	60.00	-	140.00			140.00	SOA Boiler Certification	
11.6336.7010	Bldg Maint Materials & Supply	532.57	17,266.35	2,524.85	53.60	4,000.00			4,000.00		
11.6336.7020	Utilities - Landfill Building	-	-	-	-	-			-		
11.6336.7021	Utilities - Electric	5,059.52	6,084.81	12,437.68	7,609.39	11,500.00	3,700.00		15,200.00		
11.6336.7022	Utilities - Water	-	-	-	-	-			-		
11.6336.7023	Utilities - Sewer	-	-	-	-	-			-		
11.6336.7024	Utilities - Garbage	-	-	-	-	-			-		
11.6336.7025	Utilities - Heat	6,748.90	9,398.32	15,287.87	2,525.97	11,460.00	(4,960.00)		6,500.00	2,865 gal - Oil Burner In Service in F23	
11.6336.7500	Debt Payment	50,750.96	-	-	-	-			-		
11.6336.8030	Machinery & Equipment	-	15,389.48	13,587.79	34,950.00	25,000.00	9,950.00		34,950.00	Gas Probe Installation \$34,950	
	<b>Total Landfill:</b>	<b>326,450.12</b>	<b>287,539.78</b>	<b>378,967.08</b>	<b>263,901.81</b>	<b>369,485.92</b>	<b>20,202.09</b>		<b>389,688.01</b>		

FY2024 Proposed Budget Amendment /F25 Proposed Budget Expense	General Fund	F21 Actuals	F22 Actuals	F23 Actuals	F24 YTD Actuals @ 1.31.24	O-23-06-01 F24 Approved Budget	Budget Adjustment	O-24-03-02 F24 Proposed Amended Budget	Budget Notes
<b>Cemetery</b>									
11.6337.1101	Salaries - Morgue	14,665.03	11,911.59	9,968.08	19,517.11	20,985.12	7,750.99	28,736.11	FT Laborer May-Oct - Shared employee PWKS
11.6337.1411	Accrued Leave - Morgue	-	-	-	-	-	-	-	
11.6337.1421	Health Insurance - Morgue	591.58	757.21	926.81	4,306.06	1,076.75	4,927.96	6,004.71	
11.6337.1431	Life Insurance - Morgue	5.10	7.95	11.00	27.02	41.40	2.87	44.27	
11.6337.1441	FICA/Medicare - Morgue	1,121.91	911.24	762.57	1,493.08	1,605.36	592.95	2,198.31	
11.6337.1461	PERs - Morgue	1,368.95	844.12	2,578.29	3,841.89	4,616.73	1,705.21	6,321.94	
11.6337.1471	Workers' Comp Ins - Morgue	631.98	1,117.80	1,268.30	763.85	763.85	-	763.85	
	<b>Subtotal Salaries &amp; Benefits</b>	<b>18,384.55</b>	<b>15,549.91</b>	<b>15,515.05</b>	<b>29,949.01</b>	<b>29,949.01</b>	<b>14,979.98</b>	<b>44,069.19</b>	
11.6337.1520	Vehicle/Eq Insurance	97.00	97.00	97.00	97.00	97.00	-	97.00	2008 Kubota Mini Excavator
11.6337.1530	Property/Building Insurance	727.00	926.00	1,219.00	1,580.00	1,580.00	-	1,580.00	
11.6337.1840	Survey/Appraisal Services	-	-	-	-	-	-	-	
11.6337.1870	Other Professional/Contract Sv	130.00	-	1,200.00	450.00	1,500.00	-	1,500.00	Qtrucking Equip Hauling Fees, Canon Fees if Applicable, Arctic Refrig Prof Svcs
11.6337.1940	Advertising	-	-	-	-	-	-	-	
11.6337.2010	Communications	267.71	221.70	229.12	35.72	250.00	-	250.00	NIJUS Local Phone/Net \$250
11.6337.2012	Computer Network/Hardware/Soft	1,734.22	1,239.22	1,449.98	1,150.00	1,755.00	-	1,755.00	MSDS Online \$110, Ramaker Annual Mtnc & Cloud Hosting \$1150, Autodeck Fusion 360 \$495
11.6337.2030	Travel, Training & Related Cost	-	-	-	-	-	-	-	
11.6337.2040	Uniform/Clothing	-	-	-	-	-	-	-	
11.6337.2070	Office Supplies	-	-	-	-	-	-	-	
11.6337.2071	Operating Supplies	8.05	-	-	24.13	150.00	-	150.00	
11.6337.4010	Gas & Oil Supplies	37.17	24.46	-	8.04	100.00	-	100.00	
11.6337.4020	Vehicle/Eq Parts & Supply	563.21	618.38	1,703.20	52.23	700.00	-	700.00	
11.6337.4030	Vehicle/Eq Maintenance	-	-	-	-	-	-	-	
11.6337.4040	Vehicle Regis & Permits	10.00	-	10.00	-	10.00	-	10.00	
11.6337.4050	Small Tools & Equipment	377.89	1,610.15	-	-	1,000.00	-	1,000.00	
11.6337.4060	Tools & Eq Repair & Maint	153.00	109.21	51.83	-	400.00	-	400.00	
11.6337.4080	Road Maintenance Materials	-	5,040.00	-	-	5,000.00	-	5,000.00	Cover material for burials
11.6337.7001	Salaries - Morgue (Bldg Mtnc)	-	-	-	-	-	-	-	
11.6337.7005	Building Maintenance Contracts	305.00	-	-	-	500.00	-	500.00	Freezer Inspection
11.6337.7010	Bldg Maint Materials & Supply	853.89	897.91	107.73	4,218.00	1,200.00	4,800.00	6,000.00	
11.6337.7011	Janitorial Services & Supplies	-	-	-	0.80	-	-	-	
11.6337.7020	Utilities - Morgue Building	-	-	-	-	-	-	-	
11.6337.7021	Utilities - Electric	8,263.24	6,274.23	6,335.80	2,931.27	7,650.00	(650.00)	7,000.00	
11.6337.7022	Utilities - Water	-	-	-	-	-	-	-	
11.6337.7023	Utilities - Sewer	-	-	-	-	-	-	-	
11.6337.7024	Utilities - Garbage	-	-	-	-	-	-	-	
11.6337.7025	Utilities - Heat	864.79	1,050.00	1,853.00	1,029.76	1,356.00	480.00	1,836.00	339 gal
11.6337.7540	Credit Card Service Fees	-	-	-	-	-	-	-	
11.6337.8010	Land/Buildings & Improvements	-	-	-	-	4,000.00	-	4,000.00	Staining Morgue Exterior
11.6337.8030	Machinery & Equipment	-	7,874.56	-	2,343.90	32,000.00	(9,000.00)	23,000.00	Mower \$23000
	<b>Total Cemetery:</b>	<b>32,776.72</b>	<b>41,532.73</b>	<b>29,771.71</b>	<b>43,869.86</b>	<b>88,337.21</b>	<b>10,609.98</b>	<b>98,947.19</b>	

FY2024 Proposed Budget Amendment /F25 Proposed Budget		General Fund		F21 Actuals	F22 Actuals	F23 Actuals	F24 YTD Actuals @ 1.31.24	O-23-06-01 F24 Approved Budget	Budget Adjustment	O-24-03-02 F24 Proposed Amended Budget	Budget Notes
<b>Parks / Playgrounds / Lights</b>											
11.6338.1101	Salaries - Parks	-	-	-	-	-	-	-	-	-	
11.6338.1421	Health Insurance - Parks	-	-	-	-	-	-	-	-	-	
11.6338.1431	Life Insurance - Parks	-	-	-	-	-	-	-	-	-	
11.6338.1441	FICA/Medicare - Parks	-	-	-	-	-	-	-	-	-	
11.6338.1461	PERS - Parks	-	-	-	-	-	-	-	-	-	
11.6338.1471	Workers' Comp Ins - Parks	-	-	-	-	-	-	-	-	-	
	<b>Subtotal Salaries &amp; Benefits:</b>	-	-	-	-	-	-	-	-	-	
11.6338.1520	Vehicle Insurance	92.00	-	-	-	-	-	-	-	-	
11.6338.1820	Engineering/Architectural Svcs	-	-	-	-	-	-	-	-	-	
11.6338.1870	Other Professional/Contract Sv	2,060.31	7,596.98	1,085.00	31.29	2,000.00	(500.00)	1,500.00		SOA DEC Fees	
11.6338.1940	Advertising	-	-	-	-	-	-	-	-	-	
11.6338.2012	Computer Network/Hardware/Soft	-	-	-	-	-	-	-	-	-	
11.6338.2071	Operating Supplies	-	-	-	-	-	-	-	-	-	
11.6338.2210	City Beautification/Betterment	-	-	-	-	-	-	-	-	-	
11.6338.4010	Gas & Oil Supplies	-	193.34	-	-	300.00	-	-	-	300.00	
11.6338.4020	Vehicle/Eq Parts & Supply	-	615.58	636.59	412.95	500.00	-	-	-	500.00	
11.6338.4050	Small Tools & Equipment	-	6,805.47	-	-	4,000.00	-	-	-	4,000.00	
11.6338.4080	Road Maintenance Materials	-	-	-	-	-	-	-	-	-	
11.6338.7001	Salaries - Parks/Playgrounds	-	-	-	-	-	-	-	-	-	
11.6338.7002	Salaries - Monuments, Signs	-	-	-	-	-	-	-	-	-	
11.6338.7005	Building Maintenance Contracts	-	-	-	-	-	-	-	-	-	
11.6338.7010	Bldg Maint Materials & Supply	4,173.69	2,465.11	2,516.83	274.00	20,000.00	(18,000.00)	2,000.00			
11.6338.7020	Utilities	-	-	-	-	-	-	-	-	-	
11.6338.7021	Utilities - Electric	20,290.98	21,013.91	27,011.89	9,985.76	26,125.00	(5,125.00)	21,000.00			
11.6338.7022	Utilities - Water	-	-	-	-	-	-	-	-	-	
11.6338.7023	Utilities - Sewer	-	-	-	-	600.00	-	-	-	600.00	
11.6338.7024	Utilities - Garbage	7,448.69	7,398.54	7,755.55	3,826.06	7,795.00	-	-	-	7,795.00	
11.6338.7025	Utilities - Heat	1,806.07	2,176.17	3,895.47	1,078.43	2,800.00	-	-	-	2,800.00	700 gal
11.6338.8010	Land/Buildings & Improvements	-	-	10,324.05	-	10,000.00	-	-	-	10,000.00	Mulch for Playground
11.6338.8030	Machinery & Equipment	-	-	-	-	-	-	-	-	-	
	<b>Total Parks / Playgrounds / Lights:</b>	<b>35,871.74</b>	<b>48,265.10</b>	<b>53,225.38</b>	<b>15,608.49</b>	<b>74,120.00</b>	<b>(23,625.00)</b>	<b>50,495.00</b>			

FY2024 Proposed Budget Amendment /F25 Proposed Budget Expense		General Fund		F21 Actuals	F22 Actuals	F23 Actuals	F24 YTD Actuals @ 1.31.24	O-23-06-01 F24 Approved Budget	Budget Adjustment	O-24-03-02 F24 Proposed Amended Budget	Budget Notes
<b>Road Maintenance</b>											
11.6339.1101	Salaries - Public Works Supervisor	-	-	-	-	48,866.39	24,079.36	51,558.40	(5,236.04)	46,322.36	1 Public Works Supervisor 50% Shared with Building Maint
11.6339.1102	Salaries - Operators	227,000.41	235,580.96	296,254.26	175,317.19	296,254.26	175,317.19	326,073.53		326,073.53	1 Road Crew Foreman, 3 Equip Operators, 1 Winter Driver
11.6339.1103	Salaries - Veh Maintenance	-	-	-	-	53,563.55	43,308.88	70,600.56	4,103.32	74,703.88	1 City Mechanic
11.6339.1104	Salaries - Admin-Purchasing	-	-	-	-	-	-	34,200.00	(26,708.00)	7,492.00	1 Purchasing Manager Shared with Port May 1
11.6339.1105	Salaries - Temporary Help	41,581.92	52,245.46	26,493.75	18,476.92	26,493.75	18,476.92	35,000.00		35,000.00	
11.6339.1201	Salaries - Overtime	77,000.82	83,274.75	112,176.70	55,522.87	112,176.70	55,522.87	80,000.00	20,000.00	100,000.00	
11.6339.1411	Accrued Personal Lv-Operators	3,120.99	-	(1,345.20)	-	-	-	4,739.61		4,739.61	
11.6339.1421	Health Ins - Operators	57,635.27	50,489.89	84,258.73	59,216.75	84,258.73	59,216.75	122,758.44	(17,945.69)	104,812.75	
11.6339.1431	Life Insurance - Operators	452.95	498.42	744.54	421.85	744.54	421.85	834.07	4.38	838.45	
11.6339.1441	FICA/Medicare - Operators	26,736.42	28,490.82	41,615.61	24,227.88	41,615.61	24,227.88	45,703.59	(599.82)	45,103.77	
11.6339.1461	PERS - Operators	89,867.31	84,245.23	123,257.05	63,383.02	123,257.05	63,383.02	123,735.04	4,437.98	128,173.02	
11.6339.1471	Workers' Comp Ins - Operators	12,685.28	23,174.72	35,337.94	34,118.40	35,337.94	34,118.40	34,118.40		34,118.40	
	<b>Subtotal Salaries &amp; Benefits:</b>	<b>536,081.37</b>	<b>558,000.25</b>	<b>821,223.32</b>	<b>498,073.12</b>	<b>821,223.32</b>	<b>498,073.12</b>	<b>929,321.64</b>	<b>(21,943.87)</b>	<b>907,377.77</b>	
11.6339.1520	Vehicle Insurance	23,842.02	19,032.00	18,617.90	17,064.00	18,617.90	17,064.00	16,046.00	1,018.00	17,064.00	
11.6339.1530	Property/Building Insurance	1,143.00	1,453.00	1,996.00	2,700.00	1,996.00	2,700.00	2,700.00		2,700.00	
11.6339.1820	Engineering/Architectural Svcs	-	-	-	-	-	-	-		-	
11.6339.1840	Survey/Appraisal Services	-	-	-	-	-	-	-		-	
11.6339.1860	Snow Removal	268,377.50	293,675.50	461,978.50	381,085.00	461,978.50	381,085.00	275,000.00	175,000.00	450,000.00	
11.6339.1870	Other Professional/Contract Sv	-	4,040.40	16,910.00	4,925.00	16,910.00	4,925.00	6,000.00		6,000.00	Maintain X \$3950, Q Trucking \$1500
11.6339.1940	Advertising	1,629.15	2,798.20	1,337.90	367.20	1,337.90	367.20	2,000.00	(500.00)	1,500.00	
11.6339.2010	Communications	623.78	953.56	1,261.66	487.18	1,261.66	487.18	1,175.00		1,175.00	NJUS Phone/Net \$575, AT&T Cell \$600
11.6339.2012	Computer Network/Hardware/Soft	2,507.34	6,365.71	6,166.78	12,472.94	6,166.78	12,472.94	12,000.00	500.00	12,500.00	MSDS Online \$250, Smartnet Renewal \$400, Construction Machinery Annual Subscription for Tech Tool \$3000, Freightliner/Volvo Software for Mtn \$3000, Cat Subscription \$3000, Ford \$1000, Cummins \$1000
11.6339.2020	Dues & Memberships	-	-	-	-	-	-	-		-	
11.6339.2030	Travel, Training & Related Cost	-	876.00	-	-	-	-	5,000.00	(2,000.00)	3,000.00	
11.6339.2040	Uniform/Clothing	488.69	200.50	4,161.52	352.91	4,161.52	352.91	2,500.00	(500.00)	2,000.00	
11.6339.2070	Office Supplies	67.35	44.26	82.42	195.74	82.42	195.74	100.00		150.00	
11.6339.2071	Operating Supplies	2,399.44	10,204.10	16,377.82	5,155.41	16,377.82	5,155.41	7,000.00	500.00	7,500.00	
11.6339.4010	Gas & Oil Supplies	93,094.04	103,404.23	212,463.79	98,545.79	212,463.79	98,545.79	115,000.00	85,000.00	200,000.00	
11.6339.4020	Vehicle/Eq Parts & Supply	101,498.52	128,760.92	164,559.15	99,642.88	164,559.15	99,642.88	130,000.00	50,000.00	180,000.00	
11.6339.4030	Vehicle/Eq Maintenance	46,100.78	5,800.74	910.32	-	910.32	-	5,000.00	(2,500.00)	2,500.00	
11.6339.4040	Vehicle Regis & Permits	1,430.00	40.00	135.00	2,240.00	135.00	2,240.00	3,500.00	250.00	3,750.00	SOA DOT Summer/Winter Road Permits \$3300 , DMV Fees
11.6339.4050	Small Tools & Equipment	14,672.73	2,909.02	18,616.56	11,744.24	18,616.56	11,744.24	11,000.00	4,000.00	15,000.00	
11.6339.4060	Tools & Eq Repair & Maint	588.09	492.49	2,763.90	243.97	2,763.90	243.97	2,000.00	(500.00)	1,500.00	
11.6339.4080	Road Maintenance Materials	143,493.04	143,923.73	180,205.29	111,044.11	180,205.29	111,044.11	160,000.00		160,000.00	Gravel, Calcium Chloride and Road signs

FY2024 Proposed Budget Amendment /F25 Proposed Budget General Fund Expense		F21 Actuals	F22 Actuals	F23 Actuals	F24 YTD Actuals @ 1.31.24	O-23-06-01 F24 Approved Budget	Budget Adjustment	O-24-03-02 F24 Proposed Amended Budget	Budget Notes
11.6339.7001	Salaries GGG Bldg Maint	-	-	-	-	-	-	-	
11.6339.7005	Building Maintenance Contracts	-	60.00	60.00	60.00	100.00	-	100.00	
11.6339.7010	Bldg Maint Materials & Supply	5,019.86	4,077.85	21,147.77	3,185.22	15,000.00	-	15,000.00	
11.6339.7011	Janitorial Services & Supplies	-	266.76	310.24	105.96	500.00	-	500.00	
11.6339.7021	Utilities - Electric	32,684.74	43,719.01	21,988.37	4,525.55	35,000.00	(5,000.00)	30,000.00	Grader Greg's Garage, Heat Trace
11.6339.7022	Utilities - Water	-	-	-	-	-	-	-	
11.6339.7025	Utilities - Heat	8,594.57	8,429.90	12,771.02	6,733.61	13,500.00	270.00	13,770.00	3,000 gal
11.6339.7540	Banking/Credit Card Fees	-	-	-	-	-	-	-	
11.6339.8030	Machinery & Equipment	-	-	-	-	15,000.00	-	15,000.00	Traffic Control Project (shared with port)
<b>Total Road Maintenance:</b>		<b>1,284,336.01</b>	<b>1,339,528.13</b>	<b>1,986,045.23</b>	<b>1,260,949.83</b>	<b>1,764,442.64</b>	<b>283,744.13</b>	<b>2,048,186.77</b>	

FY2024 Proposed Budget Amendment /F25 Proposed Budget Expense		General Fund		F21 Actuals	F22 Actuals	F23 Actuals	F24 YTD Actuals @ 1.31.24	O-23-06-01 F24 Approved Budget	Budget Adjustment	O-24-03-02 F24 Proposed Amended Budget	Budget Notes
<b>Recreation</b>											
11.6410.1101	Salaries - NRC Director	75,940.45	111,525.92	113,773.73	67,653.14	115,481.17	1,783.97	117,265.14	1 Director - Exempt		
11.6410.1102	Salaries - Staff	142,581.25	159,848.41	227,167.32	124,186.71	232,981.90	3,517.81	236,499.71	1 Asst Dir, 2 F/T Attn, 3 P/T Attn		
11.6410.1103	Salaries - Staff Janitor	45,226.51	50,450.38	22,070.70	26,757.74	56,055.68	(8,159.94)	47,895.74	1 Janitor		
11.6410.1104	Salaries - Bowling Alley Staff	7,043.75	8,202.50	9,822.50	4,643.75	8,750.00		8,750.00	1 Bowling Manager P/T		
11.6410.1105	Salaries - Laborer	222.34	6,972.48	-	-	-	-	-	4 mo Laborer P/T - moved to Parks		
11.6410.1106	Salaries - Programming					71,292.00	(53,804.00)	17,488.00	1 Program Coordinator <b>Est Start 4.1.24</b>		
11.6410.1201	Salaries - Overtime	827.41	7,503.47	9,401.10	6,433.71	5,000.00	5,000.00	10,000.00			
11.6410.1411	Accrued Personal Leave - NRC	24,282.97	24,323.19	5,090.82	405.54	4,621.00		4,621.00			
11.6410.1421	Health Insurance - NRC	44,817.18	52,897.60	53,884.91	39,515.53	80,381.52	(8,697.99)	71,683.53			
11.6410.1431	Life Insurance - NRC	572.82	563.28	627.58	360.26	833.64	(218.03)	615.61			
11.6410.1441	FICA/Medicare - NRC	22,653.64	28,215.39	29,661.41	17,601.25	37,451.40	(3,921.13)	33,530.27			
11.6410.1461	PERS - NRC	76,062.81	80,571.33	85,523.78	42,997.50	98,041.68	(15,378.18)	82,663.50			
11.6410.1471	Workers' Comp Insurance - NRC	10,097.81	8,746.13	5,783.06	8,586.36	8,586.36		8,586.36			
	<b>Subtotal Salaries &amp; Benefits:</b>	<b>450,328.94</b>	<b>539,820.08</b>	<b>562,806.91</b>	<b>339,141.49</b>	<b>719,476.35</b>	<b>(79,877.49)</b>	<b>639,598.86</b>			
11.6410.1520	Vehicle Insurance	634.00	418.00	418.00	418.00	418.00		418.00	2001 Ford F250		
11.6410.1530	Property/Building Insurance	9,587.00	12,430.00	16,059.00	21,392.00	21,392.00		21,392.00			
11.6410.1870	Other Professional/Contract Sv	1,526.41	8,885.36	16,582.47	15,746.91	16,500.00	1,500.00	18,000.00	Referees - Basketball, Volleyball, Youth Softball; GCSIT Damaged Ports \$500		
11.6410.1940	Advertising	-	-	234.60	546.63	-	1,500.00	1,500.00			
11.6410.2010	Communications	4,666.18	3,868.29	7,326.48	3,315.58	7,900.00		7,900.00	Fastwyre \$1075, NJUS Phone/Internet \$900, GCI LD \$100, GCI Sports Package \$5802 (\$483.50 per mo); May Svs Start StarLink \$90 unlimited plus Dish-Basic \$800		
11.6410.2012	Computer Network/Hardware/Soft	2,722.13	-	117.30	795.02	3,500.00		3,500.00	Smartnet Renewal \$1435, MyRec Recreation Management \$1000 est, Repair Damaged Ports Hardware \$500		
11.6410.2020	Dues & Memberships	-	175.00	229.00	-	400.00		400.00	ARPA x2 \$95, NRPA \$175		
11.6410.2030	Travel, Training & Related Cost	175.00	5,434.34	5,095.21	4,520.19	6,000.00		6,000.00	NRPA, ARPA, ITC Start, PERMS Conference		
11.6410.2040	Uniform/Clothing	-	-	-	-	-		-			
11.6410.2070	Office Supplies	464.29	198.75	552.38	156.95	300.00	125.00	425.00			
11.6410.2071	Operating Supplies	2,510.27	4,175.36	5,767.84	2,479.39	6,000.00	(1,000.00)	5,000.00			
11.6410.2073	Resale Supplies	14,349.47	5,870.90	11,876.93	11,960.19	14,000.00	2,500.00	16,500.00	Vending Machine Supplies		
11.6410.2078	Youth Programs Supplies	1,587.54	681.62	5,109.16	1,839.41	1,250.00	1,250.00	2,500.00			
11.6410.3010	Sponsorship/Donations/Contrib	-	1,770.00	1,672.06	-	2,500.00	(300.00)	2,200.00	Facility Fee Waivers		
11.6410.4010	Gas & Oil Supplies	1,557.34	1,814.74	2,929.96	1,492.31	2,000.00	1,000.00	3,000.00			
11.6410.4020	Vehicle/Eq Parts & Supply	1,341.02	395.66	327.64	81.26	1,000.00		1,000.00			
11.6410.4030	Vehicle/Eq Maintenance	2,022.81	642.25	-	-	1,000.00		1,000.00			
11.6410.4040	Vehicle Regis & Permits	-	10.00	-	-	10.00		10.00			
11.6410.4050	Small Tools & Equipment	3,135.88	685.20	1,534.69	195.34	1,000.00		1,000.00			
11.6410.4060	Tools & Eq Repair & Maint	1,876.36	2,787.60	4,609.41	513.06	3,000.00	1,000.00	4,000.00	Cardio Tech Visit - Replacement Parts		



FY2024 Proposed Budget Amendment /F25 Proposed Budget Expense		General Fund		F21 Actuals	F22 Actuals	F23 Actuals	F24 YTD Actuals @ 1.31.24	O-23-06-01 F24 Approved Budget	Budget Adjustment	O-24-03-02 F24 Proposed Amended Budget	Budget Notes
11.6410.7001	Salaries - NRC (Bldg Mtn)	-	-	-	-	-	-	-	-	-	
11.6410.7002	Salaries - Janitorial	-	-	-	-	-	-	-	-	-	
11.6410.7005	Building Maintenance Contracts	3,510.21	660.00	3,554.26	933.57	4,500.00				4,500.00	Cardio Tech Visit Labor \$3000, Annual Fire Inspection Fee \$1160, SOA DOL Boiler Insp \$200, PK Electric Prof Svcs, Arctic Refrig Prof Svcs
11.6410.7010	Bldg Maint Materials & Supply	4,121.88	16,183.42	14,776.05	3,592.33	12,000.00		(2,000.00)		10,000.00	General Maintenance
11.6410.7011	Janitorial Services & Supplies	7,585.01	3,563.02	4,926.21	5,954.81	7,000.00		3,000.00		10,000.00	
11.6410.7020	Utilities	-	-	-	-	-		-		-	
11.6410.7021	Utilities - Electric	32,824.35	39,884.68	47,520.40	18,050.13	43,700.00		(3,700.00)		40,000.00	
11.6410.7022	Utilities - Water	5,153.44	6,641.44	8,216.24	5,639.52	7,250.00				7,250.00	
11.6410.7023	Utilities - Sewer	3,095.28	4,880.88	7,070.64	5,373.00	6,150.00				6,150.00	
11.6410.7024	Utilities - Garbage	7,448.69	8,721.51	4,817.19	2,368.52	5,000.00				5,000.00	
11.6410.7025	Utilities - Heat	39,904.85	44,394.45	58,611.81	20,514.78	63,636.00		5,214.00		68,850.00	15,000 gal
11.6410.7540	Credit Card Service Fees	-	-	-	-	-		-		-	
11.6410.8030	Machinery & Equipment	11,029.09	6,759.76	14,814.05	-	10,000.00		2,000.00		12,000.00	Cardio Equipment - Treadmills
<b>Total Recreation:</b>		<b>613,157.44</b>	<b>721,752.31</b>	<b>807,555.89</b>	<b>467,020.39</b>	<b>966,882.35</b>		<b>(67,788.49)</b>		<b>899,093.86</b>	

FY2024 Proposed Budget Amendment /F25 Proposed Budget		F21 Actuals	F22 Actuals	F23 Actuals	F24 YTD Actuals @ 1.31.24	O-23-06-01 F24 Approved Budget	Budget Adjustment	O-24-03-02 F24 Proposed Amended Budget	Budget Notes
<b>Swimming Pool</b>									
11.6420.1101	Salaries - Pool Mgr, Assistant	-	-	-	-	-	-	-	
11.6420.1102	Salaries - Pool Lifeguards	12,044.15	25,394.22	26,482.41	-	32,348.53	(24,261.40)	8,087.13	Lead Guard 15 hrs, Lifeguard I,II,III,
11.6420.1103	Salaries - Clerical Assistant	-	-	-	-	750.00	(562.50)	187.50	
11.6420.1201	Salaries - Overtime	-	-	-	-	-	-	-	
11.6420.1411	Accrued Personal Leave - Pool	-	-	-	-	-	-	-	
11.6420.1421	Health Insurance - Pool	-	-	-	-	-	-	-	
11.6420.1431	Life Insurance - Pool	-	-	-	-	-	-	-	
11.6420.1441	FICA/Medicare - Pool	921.37	1,942.78	2,025.96	-	2,532.04	(1,899.03)	633.01	
11.6420.1461	PERS - Pool	-	-	-	-	-	-	-	
11.6420.1471	Workers' Comp Insurance	751.59	1,177.61	1,145.32	1,204.80	1,204.80	(903.60)	301.20	
	<b>Subtotal Salaries &amp; Benefits:</b>	<b>13,717.11</b>	<b>28,514.61</b>	<b>29,653.69</b>	<b>1,204.80</b>	<b>36,835.37</b>	<b>(27,626.53)</b>	<b>9,208.84</b>	
11.6420.1530	Property/Building Insurance	-	-	-	-	-	-	-	
11.6420.1870	Other Professional/Contract Sv	342.38	-	343.84	-	2,000.00	(1,500.00)	500.00	SGS Water Sample Testing plus Freight
11.6420.1940	Advertising	-	-	-	-	-	-	-	
11.6420.2010	Communications	459.40	450.37	500.27	237.68	500.00	-	500.00	Fastwyre Local Phone
11.6420.2012	Computer Network/Hardware/Soft	253.13	-	-	-	-	-	-	
11.6420.2030	Travel, Training & Related Cost	450.02	1,528.69	2,222.50	-	2,000.00	-	2,000.00	
11.6420.2070	Office Supplies	33.36	-	-	-	100.00	(100.00)	-	
11.6420.2071	Operating Supplies	3,392.53	4,255.30	2,148.92	2,855.26	3,000.00	500.00	3,500.00	
11.6420.2073	Resale Supplies	970.84	867.54	1,002.51	-	900.00	(900.00)	-	
11.6420.4050	Small Tools & Equipment	1,771.09	12.96	-	-	500.00	-	500.00	
11.6420.4060	Tools & Eq Repair & Maint	254.33	1,007.23	-	-	500.00	-	500.00	
11.6420.7001	Salaries - Pool (Bldg Mtnc)	-	-	-	-	-	-	-	
11.6420.7002	Pool Janitorial Contract	-	-	-	-	-	-	-	
11.6420.7005	Building Maintenance Contracts	-	28,756.78	-	-	5,000.00	-	5,000.00	Plumbing
11.6420.7010	Bldg Maint Materials & Supply	15,000.00	1,570.50	5,289.04	8,240.62	5,000.00	15,000.00	20,000.00	
11.6420.7011	Janitorial Services & Supplies	-	-	-	-	-	-	-	
11.6420.7020	Swimming Pool Utilities	-	-	-	-	-	-	-	
11.6420.7021	Utilities - Electric	-	-	-	-	-	-	-	
11.6420.7022	Utilities - Water	-	-	-	-	-	-	-	
11.6420.7023	Utilities - Sewer	-	-	-	-	-	-	-	
11.6420.7025	Utilities - Heat	-	-	-	-	-	-	-	
11.6420.8030	Machinery & Equipment	15,237.00	-	2,816.13	-	2,000.00	(2,000.00)	-	
	<b>Total Swimming Pool:</b>	<b>51,881.19</b>	<b>66,963.98</b>	<b>43,976.90</b>	<b>12,538.36</b>	<b>58,335.37</b>	<b>(16,626.53)</b>	<b>41,708.84</b>	

FY2024 Proposed Budget Amendment /F25 Proposed Budget		General Fund		F21 Actuals	F22 Actuals	F23 Actuals	F24 YTD Actuals @ 1.31.24	O-23-06-01 F24 Approved Budget	Budget Adjustment	O-24-03-02 F24 Proposed Amended Budget	Budget Notes
<b>Museum</b>											
11.6510.1101	Salaries - Museum Director	86,729.96	89,475.94	33,684.57	36,302.85	85,000.00	(10,620.15)	74,379.85	1 Director		
11.6510.1102	Salaries - Museum Staff	229.82	43,962.37	71,785.27	38,097.08	76,445.20	(17,495.12)	58,950.08	1 Ed/Prog Coordinator FT, 1 FT Summer Temp <b>Est Start 6.1.24</b>		
11.6510.1103	Salaries - Museum Aide	-	-	-	-	-	-	-			
11.6510.1104	Salaries - Temporary Hire	-	1,474.12	-	1,088.64	-	2,500.00	2,500.00			
11.6510.1201	Salaries - Overtime	122.96	2,839.46	3,731.15	260.29	2,000.00	(1,000.00)	1,000.00			
11.6510.1411	Accrued Personal Lv - Museum	-	-	3,970.43	1,620.00	1,290.93	977.07	2,268.00			
11.6510.1421	Health Insurance - Museum	19,723.88	24,946.75	22,566.52	21,385.94	27,178.32	14,782.72	41,961.04			
11.6510.1431	Life Insurance - Museum	150.36	226.02	197.85	127.88	276.00	(7.77)	268.23			
11.6510.1441	FICA/Medicare - Museum	6,661.79	10,648.51	8,657.59	5,660.80	12,503.56	(1,912.14)	10,591.42			
11.6510.1461	PERS - Museum	25,923.87	39,016.81	25,563.53	15,212.26	31,388.72	(3,474.46)	27,914.26			
11.6510.1471	Workers' Comp Ins - Museum	399.57	449.15	646.40	473.99	473.99		473.99			
	<b>Subtotal Salaries &amp; Benefits:</b>	<b>139,942.21</b>	<b>213,039.13</b>	<b>170,803.31</b>	<b>120,229.73</b>	<b>236,556.72</b>	<b>(16,249.85)</b>	<b>220,306.87</b>			
11.6510.1530	Property/Building Insurance	15,378.16	18,709.04	20,704.88	24,851.12	24,851.12		24,851.12			
11.6510.1870	Other Professional/Contract Sv	20,739.06	11,200.74	5,025.25	5,925.40	12,000.00	(2,000.00)	10,000.00	SOA DEC Fees, Printing/Copyediting		
11.6510.1940	Advertising	869.20	875.20	705.20	367.20	900.00	3,100.00	4,000.00	Advertising for public programs, special exhibits, and museum events, Travel Guide Ad \$3400		
11.6510.2010	Communications	1,489.61	1,160.45	1,652.59	278.70	1,250.00		1,250.00	Fastwyre \$269, NJUS Phone/Internet \$910, GCI LD \$50		
11.6510.2012	Computer Network/Hardware/Soft	1,284.34	2,847.91	10,549.02	705.46	3,100.00	215.00	3,315.00	Smartnet Renewal \$665, MSDS Online \$110, 1 UPS \$2000, PastPerfect \$540		
11.6510.2020	Dues & Memberships	636.00	365.00	-	-	500.00		500.00	Annual memberships and participation in Museums Alaska & Alaska Historical Society; Alaska Anthropological Association, Native American Art Studies Association, American Alliance of Museums, American Anthropological Association		
11.6510.2030	Travel, Training & Related Cost	235.00	320.34	229.03	1,248.81	2,000.00	(750.00)	1,250.00	Participation in 2 annual conferences (i.e. Museums Alaska and American Alliance of Museums)		
11.6510.2070	Office Supplies	49.57	96.79	10.70	-	100.00	(100.00)	-			
11.6510.2071	Operating Supplies	1,627.83	4,004.88	733.55	1,163.74	1,500.00	500.00	2,000.00	Education Materials & Refreshments for Public Programs; exhibit lights; furniture; artifact mounts, labels; photography & video material;		
11.6510.2073	Resale Supplies	963.33	1,851.94	-	-	2,000.00		2,000.00	Gift Store		
11.6510.2703	Exhibits/Artifacts	8,766.07	9,786.15	112.73	-	8,000.00	(3,000.00)	5,000.00			
11.6510.2704	Recruitment	-	-	-	-	1,000.00	(1,000.00)	-	Advertisement for EPPC with American Alliance of Museums		
11.6510.2705	Inventory Archive	5,170.73	802.25	2,162.75	-	2,000.00		2,000.00	Archival supplies including acid-free storage boxes, photograph sleeves, nitrile gloves, acid-free folders, interlaying tissue, etc.		
11.6510.3010	Sponsorship/Donation/Contribut	-	-	-	-	-		-			
11.6510.4050	Small Tools & Equipment	-	579.27	-	-	150.00	(150.00)	-			
11.6510.4060	Tools & Eq Repair & Maint	170.27	326.56	-	-	300.00	(300.00)	-			

FY2024 Proposed Budget Amendment /F25 Proposed Budget Expense		General Fund		F21 Actuals	F22 Actuals	F23 Actuals	F24 YTD Actuals @ 1.31.24	O-23-06-01 F24 Approved Budget	Budget Adjustment	O-24-03-02 F24 Proposed Amended Budget	Budget Notes
11.6510.7001	Salaries - Museum (Bldg Mtnc)	-	-	-	-	-	-	-	-	-	
11.6510.7002	Salaries - Janitorial	-	-	-	-	-	-	-	-	-	
11.6510.7005	Building Maintenance Contracts	4,655.69	2,491.99	639.80	5,636.16	1,250.00	5,000.00	6,250.00	Annual Fire Inspection \$425, SOA DOL Boiler Inspection \$60, Yukon Fire Repair \$525, ATS AK \$220, Convirgent \$4900		
11.6510.7010	Bldg Maint Materials & Supply	4,142.48	6,612.44	2,458.67	1,670.33	7,500.00	7,500.00	7,500.00	Humidifier Canisters		
11.6510.7011	Janitorial Services & Supplies	918.32	4,616.92	-	-	800.00	800.00	800.00			
11.6510.7020	Building Utilities	-	-	-	-	-	-	-			
11.6510.7021	Utilities - Electric 56%	6,796.37	20,709.66	22,801.62	8,061.58	22,400.00	(2,400.00)	20,000.00	Current Transformer rated at incorrect multiplier: Corrected to 120 vs 40 - NJUS previously under billing		
11.6510.7022	Utilities - Water 56%	1,860.37	1,858.20	1,858.20	934.78	1,860.00	1,860.00	1,860.00			
11.6510.7023	Utilities - Sewer 56%	502.76	500.04	500.06	256.89	505.00	505.00	505.00			
11.6510.7024	Utilities - Garbage 56%	486.36	483.10	506.45	249.82	510.00	510.00	510.00			
11.6510.7025	Utilities - Heat 56%	18,853.25	19,863.80	26,149.42	13,648.43	25,462.08	3,755.66	29,217.74	11,367 gal		
11.6510.7530	Cash - Over/Short	-	-	-	-	5.00	5.00	5.00			
11.6510.7540	Credit Card Service Fees	-	9.59	11.88	10.96	10.00	5.00	15.00			
11.6510.8030	Machinery & Equipment	-	-	-	-	-	-	-			
<b>Total Museum:</b>		<b>235,536.98</b>	<b>323,111.39</b>	<b>267,615.11</b>	<b>185,239.11</b>	<b>356,509.92</b>	<b>(13,374.19)</b>	<b>343,135.73</b>			

FY2024 Proposed Budget Amendment /F25 Proposed Budget Expense		General Fund		F21 Actuals	F22 Actuals	F23 Actuals	F24 YTD Actuals @ 1.31.24	O-23-06-01 F24 Approved Budget	Budget Adjustment	O-24-03-02 F24 Proposed Amended Budget	Budget Notes
<b>Library</b>											
11.6520.1101	Salaries - Librarian	76,738.99	102,269.81	111,497.52	67,040.19	114,300.37	1,812.82	116,113.19	1 Library Director		
11.6520.1102	Salaries - Library Staff	37,860.68	50,305.41	68,833.50	39,816.99	82,558.27	(5,015.28)	77,542.99	1 Lib Asst, 1 PT Lib Clerk, 1 Lib Clerk 6 hours per week, 1 Asst Librarian Temp 120 hours		
11.6520.1103	Salaries - Library Aide	-	-	-	2,850.39	21,487.72	(6,336.33)	15,151.39	1 Lib Aide 14r, 1 Lib Aide Temp 6r per week + June, 1 PT Summer Temp		
11.6520.1201	Salaries - Overtime	-	-	1,299.36	-	1,500.00		1,500.00			
11.6520.1411	Accrued Personal Lv - Library	5,118.52	5,839.48	8,963.33	8,391.70	9,965.32	5,979.19	15,944.51			
11.6520.1421	Health Insurance - Library	32,527.82	39,052.18	52,262.39	32,433.80	55,600.80		55,600.80			
11.6520.1431	Life Insurance - Library	238.72	270.30	287.28	191.52	287.28	23.94	311.22			
11.6520.1441	FICA/Medicare - Library	9,240.39	12,027.73	14,544.87	9,010.32	16,818.25	490.03	17,308.28			
11.6520.1461	PERS - Library	39,478.04	43,315.99	40,598.99	21,297.79	41,774.48	(2,437.13)	39,337.35			
11.6520.1471	Workers' Comp Ins - Library	510.14	472.14	548.45	623.87	637.56		637.56			
	<b>Subtotal Salaries &amp; Benefits:</b>	<b>201,713.30</b>	<b>253,553.04</b>	<b>298,835.69</b>	<b>181,656.57</b>	<b>344,930.05</b>	<b>(5,482.76)</b>	<b>339,447.29</b>			
11.6520.1530	Property/Building Insurance	6,316.03	7,684.07	8,503.79	10,206.71	10,206.71		10,206.71			
11.6520.1870	Other Professional/Contract Sv	2,456.04	2,670.25	4,670.25	3,583.20	2,670.00	1,000.00	3,670.00	Canon Fees \$1252, Boynton \$168, SOA DEC \$250, M Goade Author Visit includes Presentation/workshop: hotel, airfare \$2655 offset by \$1000 donation		
11.6520.1940	Advertising	765.00	666.74	892.50	1,172.75	900.00	600.00	1,500.00	Summer Reading Program Ad, Employment Ads		
11.6520.2010	Communications	4,772.34	4,067.80	4,130.90	1,903.46	4,200.00		4,200.00	Fastwyre DSL for Public Computers \$3350, NJUS Phone/Net \$700, GCI LD \$20		
11.6520.2012	Computer Network/Hardware/Soft	2,318.34	1,451.91	904.02	705.46	3,000.00		3,000.00	Smartnet Renewal \$880, MSDS Online \$90, 1 Computer Replacements \$2000		
11.6520.2020	Dues & Memberships	335.00	100.00	100.00	424.00	325.00	100.00	425.00	Ak Library Network Dues \$100, ALA Member Fee \$224, AKLA Member Fee \$100		
11.6520.2030	Travel, Training & Related Cost	664.21	375.00	3,025.10	1,178.88	2,200.00		2,200.00	CE Conferences: AKLA, ALA		
11.6520.2050	Audio/Visual Materials	744.37	1,988.37	692.28	59.98	900.00		900.00			
11.6520.2060	Books, Periodicals & Subscript	13,001.32	20,064.57	20,080.60	14,343.94	15,000.00		15,000.00	OCLC \$3026, Brodart \$3865, AK Lib Network \$1998, Follett School Solutions \$1061, Useful \$1794, Books \$3250		
11.6520.2070	Office Supplies	1,763.65	1,864.22	1,694.00	419.18	1,800.00		1,800.00			
11.6520.2071	Operating Supplies	12,027.45	11,518.98	16,142.03	10,684.47	13,000.00	4,000.00	17,000.00	Boynton Copy Fees \$700, Youth Programming Supplies: Summer Reading Program, PreSchool Story Hour, Iditarod Events, Goade Book Giveaway \$4080 offset by \$4000 donation		
11.6520.4050	Small Tools & Equipment	-	150.00	-	-	-		-			
11.6520.4060	Tools & Eq Repair & Maint	69.93	-	-	-	-		-			
11.6520.7001	Salaries - Library (Bldg Mtnc)	-	-	-	-	-		-			
11.6520.7002	Salaries - Janitorial	-	-	-	-	-		-			
11.6520.7005	Building Maintenance Contracts	1,928.99	1,023.50	262.78	2,314.85	600.00	1,900.00	2,500.00	Yukon Fire Annual Fire Alarm Inspection \$175, SOA Boiler Certification \$30, Yukon Fire Repairs \$215, ATS AK \$90, Convergint \$1845		
11.6520.7010	Bldg Maint Materials & Supply	2,509.24	2,653.55	937.00	522.58	3,200.00		3,200.00	Humidifier Canisters		
11.6520.7011	Janitorial Services & Supplies	127.28	1,829.69	-	-	500.00		500.00			
11.6520.7020	Building Utilities	-	-	-	-	-		-			
11.6520.7021	Utilities - Electric 23%	2,791.34	8,505.75	9,364.96	3,311.01	9,200.00	(1,200.00)	8,000.00	Current Transformer rated at incorrect multiplier: Corrected to 120 vs 40 - NJUS previously under billing		
11.6520.7022	Utilities - Water 23%	764.10	763.20	763.20	383.93	775.00		775.00			
11.6520.7023	Utilities - Sewer 23%	206.40	205.44	205.44	105.52	210.00		210.00			
11.6520.7024	Utilities - Garbage 23%	199.81	198.44	208.00	102.62	210.00		210.00			
11.6520.7025	Utilities - Heat 23%	7,743.30	8,158.36	10,739.94	5,605.58	10,457.64	1,542.50	12,000.14	11,367 gal @ 23%		
11.6520.8030	Machinery & Equipment	-	-	-	-	-		-			
	<b>Total Library:</b>	<b>263,217.44</b>	<b>329,492.88</b>	<b>382,152.48</b>	<b>238,684.69</b>	<b>424,284.40</b>	<b>2,459.74</b>	<b>426,744.14</b>			

FY2024 Proposed Budget Amendment /F25 Proposed Budget Expense		General Fund		F21 Actuals	F22 Actuals	F23 Actuals	F24 YTD Actuals @ 1.31.24	O-23-06-01 F24 Approved Budget	Budget Adjustment	O-24-03-02 F24 Proposed Amended Budget	Budget Notes
<b>RFB Katirvik</b>											
11.6570.1421	Health Insurance	-	-	-	-	-	-	-	-	-	
11.6570.1431	Life Insurance	-	-	-	-	-	-	-	-	-	
11.6570.1441	FICA/Medicare	-	-	-	-	-	-	-	-	-	
11.6570.1461	PERS	-	-	-	-	-	-	-	-	-	
11.6570.1471	Workers' Comp Insurance	-	-	-	-	-	-	-	-	-	
11.6570.1530	Property/Building Insurance	5,766.81	7,015.89	7,764.33	9,319.17	9,319.17	9,319.17	9,319.17	9,319.17	9,319.17	
11.6570.1870	Other Professional/Contract Sv	492.55	708.19	241.48	31.26	500.00	500.00	500.00	500.00	500.00	
11.6570.2010	Communications	78.11	92.01	102.53	48.63	125.00	125.00	125.00	125.00	125.00	
11.6570.2071	Operating Supplies	-	-	-	-	-	-	-	-	-	
11.6570.4050	Small Tools & Equipment	-	-	-	-	-	-	-	-	-	
11.6570.7001	Salaries - RFB Kat (Bldg Mtnc)	-	-	-	-	-	-	-	-	-	
11.6570.7005	Building Maintenance Contracts	1,763.74	934.50	239.92	2,113.56	500.00	1,700.00	2,200.00	2,200.00	2,200.00	Yukon Fire Annual Fire Alarm Inspection \$250, SOA Boiler Inspection, Convergent
11.6570.7010	Bldg Maint Materials & Supply	3,651.14	2,974.17	661.74	482.02	4,500.00	4,500.00	4,500.00	4,500.00	4,500.00	Humidifier canisters
11.6570.7011	Janitorial Services & Supplies	85.56	1,670.59	-	-	400.00	400.00	400.00	400.00	400.00	
11.6570.7021	Utilities - Electric 21%	2,548.63	7,766.12	8,550.60	3,023.11	8,400.00	(1,400.00)	7,000.00	7,000.00	7,000.00	Current Transformer rated at incorrect multiplier: Corrected to 120 vs 40 - NJUS previously under billing
11.6570.7022	Utilities - Water 21%	697.65	696.84	696.84	350.55	700.00	700.00	700.00	700.00	700.00	
11.6570.7023	Utilities - Sewer 21%	188.54	187.56	187.54	96.33	200.00	200.00	200.00	200.00	200.00	
11.6570.7024	Utilities - Garbage 21%	182.38	181.14	189.88	93.69	195.00	195.00	195.00	195.00	195.00	
11.6570.7025	Utilities - Heat 21%	7,069.95	7,448.91	9,806.02	5,118.21	9,548.28	1,408.37	10,956.65	10,956.65	10,956.65	11,367 gal @ 21%
<b>Total RFB Katirvik:</b>		<b>22,525.06</b>	<b>29,675.92</b>	<b>28,440.88</b>	<b>20,676.53</b>	<b>34,387.45</b>	<b>1,708.37</b>	<b>36,095.82</b>	<b>36,095.82</b>	<b>36,095.82</b>	



FY2024 Proposed Budget Amendment /F25 Proposed Budget		General Fund		F21 Actuals	F22 Actuals	F23 Actuals	F24 YTD Actuals @ 1.31.24	O-23-06-01 F24 Approved Budget	Budget Adjustment	O-24-03-02 F24 Proposed Amended Budget	Budget Notes
<b>Visitor Center</b>											
11.6580.1421	Health Insurance - NVIC	-	-	-	-	-	-	-	-	-	
11.6580.1431	Life Insurance - NVIC	-	-	-	-	-	-	-	-	-	
11.6580.1441	FICA/Medicare - NVIC	-	-	-	-	-	-	-	-	-	
11.6580.1461	PERS - NVIC	-	-	-	-	-	-	-	-	-	
11.6580.1471	Worker's Comp Ins - NVIC	-	-	-	-	-	-	-	-	-	
11.6580.1530	Property/Building Insurance	508.00	658.00	874.00	1,167.00	1,167.00	1,167.00	1,167.00		1,167.00	
11.6580.1870	Other Professional/Contract Sv	-	-	-	-	-	-	-	-	-	
11.6580.1940	Advertising	-	-	-	-	-	-	-	-	-	
11.6580.2010	Communication	1,338.94	1,312.76	1,364.87	668.60	1,400.00	1,400.00			1,400.00	Fastwyre Local Phone, Fax
11.6580.2200	Chamber of Commerce	200,000.00	200,000.00	200,000.00	200,000.00	200,000.00	200,000.00			200,000.00	
11.6580.7001	Salaries - NVIC (Bldg Mtnc)	-	-	-	-	-	-	-	-	-	
11.6580.7005	Bldg Maintenance Contracts	450.00	-	5,930.00	-	5,000.00	(2,000.00)			3,000.00	
11.6580.7010	Bldg Mtnc Materials & Supplies	1,131.30	373.92	14,367.63	46.97	1,500.00				1,500.00	
11.6580.7011	Janitorial Services & Supplies	70.02	-	-	-	100.00				100.00	
11.6580.7020	Building Utilities	-	-	-	-	-	-	-	-	-	
11.6580.7021	Utilities - Electric	1,484.10	1,778.11	1,902.76	808.81	1,800.00				1,800.00	
11.6580.7022	Utilities - Water	1,008.24	1,008.24	1,070.24	504.12	1,010.00				1,010.00	
11.6580.7023	Utilities - Sewer	893.04	893.04	967.44	446.52	900.00				900.00	
11.6580.7024	Utilities - Garbage	868.55	862.68	904.33	446.12	910.00				910.00	
11.6580.7025	Utilities - Heat	4,035.97	5,253.91	6,899.97	2,806.48	6,932.00	(932.00)			6,000.00	1,733 gal - Toyo Heaters
11.6580.8030	Machinery & Equipment	-	12,138.17	4,320.00	2,040.45	-	2,100.00			2,100.00	
<b>Total Visitor Center:</b>		<b>211,788.16</b>	<b>224,278.83</b>	<b>238,601.24</b>	<b>208,935.07</b>	<b>220,719.00</b>	<b>(832.00)</b>			<b>219,887.00</b>	

FY2024 Proposed Budget Amendment /F25 Proposed Budget		General Fund		F21 Actuals	F22 Actuals	F23 Actuals	F24 YTD Actuals @ 1.31.24	O-23-06-01 F24 Approved Budget	Budget Adjustment	O-24-03-02 F24 Proposed Amended Budget	Budget Notes
<b>Non-Departmental</b>											
11.6700.1451	Employment Security Unemployt	561.62	6,414.32	3,896.01	(703.31)	5,000.00	(1,000.00)	4,000.00			
11.6700.1510	General Insurance	32,250.60	31,658.05	42,714.68	112,277.68	121,778.16		121,778.16			
11.6700.1870	CPC Planning Support/Energy	-	-	-	-	-		-			
11.6700.3020	School Support/Appropriation	3,000,000.00	3,000,000.00	3,150,000.00	1,711,276.96	3,200,000.00		3,200,000.00			
11.6700.4070	Residential Demolition	-	-	-	-	-		-			
11.6700.4655	Iditarod Trail Committee	-	25,000.00	25,000.00	25,000.00	25,000.00	10,000.00	35,000.00			
11.6700.4656	Being Sea Women's Group	-	-	-	-	-		-			
11.6700.4661	Nome PreSchool Association	65,000.00	65,000.00	65,000.00	-	65,000.00		65,000.00			
11.6700.4700	Boys & Girls Club	-	-	-	-	-		-			
11.6700.4701	All-Alaska Sweepstakes \$	-	-	-	-	-		-			
11.6700.4702	Nome Comm Center Food Bank	-	-	-	-	-		-			
11.6700.4703	Nome Sportsmen's Association	-	-	-	-	-		-			
11.6700.4704	NEST (Nome Emergency Shelter)	30,000.00	30,000.00	40,000.00	35,000.00	35,000.00		35,000.00			
11.6700.4705	Fireworks	2,500.00	4,999.00	4,999.00	5,039.00	5,000.00	39.00	5,039.00			
11.6700.4706	Iron Dog	-	10,000.00	12,500.00	15,000.00	12,500.00		2,500.00			
11.6700.4707	Nome Winter Sports	-	-	-	13,496.45	10,000.00	4,000.00	14,000.00			Youth Programs
11.6700.4708	Nome Community Center	-	20,000.00	20,000.00	-	20,000.00		20,000.00			
11.6700.4709	Checkpoint Youth Center	-	10,000.00	10,000.00	-	10,000.00		10,000.00			Youth Programs
11.6700.4710	Nome Public Schools	-	30,000.00	30,000.00	30,000.00	30,000.00		30,000.00			Youth Programs
11.6700.4711	PAWS of Nome	-	5,000.00	-	-	3,000.00		3,000.00			
11.6700.4712	Nome Eskimo Community	-	15,000.00	-	-	15,000.00		15,000.00			Youth Programs
11.6700.4713	Nordic Ski Program	-	5,000.00	-	-	3,000.00		3,000.00			Youth Programs
11.6700.4714	LEPC	-	600.00	4,708.00	-	5,000.00		5,000.00			
11.6700.7550	Bad Debt	19,594.56	19,508.61	64,851.84	-	20,000.00		20,000.00			
11.6700.8001	Leases - Principal	-	23,575.41	24,678.76	-	25,000.00		25,000.00			GASB 87 Lessee Entries - NPD Nanuaq
11.6700.8002	Leases - Interest	-	1,724.59	621.24	-	2,000.00		2,000.00			GASB 87 Lessee Entries - NPD Nanuaq
11.6700.8030	Capital Outlay for Leases	-	50,554.17	-	-	50,500.00		50,500.00			GASB 87 Lessee Entries - NPD Nanuaq - New Lease Agreement Placeholder
11.6700.9124	Clean Up Nome	-	-	-	-	-		-			
11.6700.9210	Land Sale/Swap/Clean/Transfer	3,267.23	211,658.95	19,518.15	11,029.19	8,768.00	10,650.00	19,418.00			Utilities @ 504 Warren Place \$15,650, Ins \$768, Maint \$3000
11.6700.9211	Vacate City-Owned Property	-	-	-	-	-		-			
11.6700.9213	Special Items	-	-	-	-	-		-			
11.6700.9491	Schl Fence, NACTEC Ins, Boiler	4,791.71	5,597.00	6,258.50	7,689.57	7,399.00	291.00	7,690.00			\$854 NACTEC Alarm & Sprinkler Inspection, \$6836 Bldg Insurance
11.6700.9492	School Other	9,880.00	-	-	-	-		-			
11.6700.9900	Budget Savings	-	-	-	-	(650,000.00)	650,000.00	-			Salary & Benefits: Grant allocations, vacancies
11.6700.9901	Budget Adjustment	-	-	-	-	(504,697.17)	504,697.17	-			Energy Savings + CM Request to Reduce by \$465,058.17k
<b>Total Non-Departmental:</b>		<b>3,167,845.72</b>	<b>3,571,290.10</b>	<b>3,524,746.18</b>	<b>1,965,105.54</b>	<b>2,524,247.99</b>	<b>1,181,177.17</b>	<b>3,705,425.16</b>			
<b>Transfers - Interfunds</b>											
11.6888.8810	Transfers Out - Debt Service	453,875.00	226,142.46	125,766.61	-	123,804.18		123,804.18			Transfer to Fund 12 - School Bond Payments Less Net Projected SOA Reimbursement
11.6888.8812	Transfers Out - PWR Rev %	-	-	97,490.42	-	70,000.00	7,500.00	77,500.00			Assigned to the purchase of a new CAT 160M
11.6888.8815	Transfers Out - Ambulance Rev	-	-	34,993.11	-	50,000.00	(50,000.00)	-			Assigned to the purchase of a new ambulance
11.6888.8818	Transfers Out - Vehicle Replacement	-	33,316.83	288,945.14	-	185,000.00	172,000.00	357,000.00			Transfer to Fund 14 - Vehicle Replacement
11.6888.8820	Transfers Out - Other Funds	314,325.00	50,682.40	311,770.60	-	459,895.00	191,594.94	651,489.94			Transfer to Fund 14 - CP - \$602,095, Transfer to Fund 13 \$45,395 for Mus/IMLS Grant Cost Share, Lib Rasmuson Cost Share \$4,000
<b>Total Transfers - Interfunds:</b>		<b>768,200.00</b>	<b>310,141.69</b>	<b>858,965.88</b>	<b>-</b>	<b>888,699.18</b>	<b>321,094.94</b>	<b>1,209,794.12</b>			
<b>Fund Balance Contribution</b>											
11.6999.9999	Contribution to Fund Balance	-	-	-	-	-	-	-			
<b>Total General Fund Expense:</b>		<b>12,155,426.35</b>	<b>14,238,502.86</b>	<b>16,231,565.82</b>	<b>9,704,595.69</b>	<b>16,574,364.73</b>	<b>1,639,708.72</b>	<b>18,214,073.45</b>			

1<sup>st</sup> Reading: February 26, 2024  
2<sup>nd</sup> Reading: March 25, 2024

**Presented By:**  
City Manager / Finance Director

**Action Taken:**  
Yes \_\_\_\_  
No \_\_\_\_  
Abstain \_\_\_\_

**CITY OF NOME, ALASKA**

**ORDINANCE NO. O-24-03-03**

**AN ORDINANCE AMENDING THE CITY OF NOME  
FY 2024 SCHOOL DEBT SERVICE FUND BUDGET**

**Section 1.**

This is a non-Code ordinance.

**Section 2.**

**BE IT HEREBY ORDAINED** by the Nome City Council, that the attached adjustments be made to the FY 2024 City of Nome School Debt Service Fund Budget.

**APPROVED** and **SIGNED** the 25<sup>th</sup> day of March, 2024.

\_\_\_\_\_  
**JOHN K. HANDELAND**  
Mayor

**ATTEST:**

\_\_\_\_\_  
**JEREMY JACOBSON**  
Deputy Clerk

FY2024 Proposed Budget School Bond Fund		F21 Actuals	F22 Actuals	F23 Actuals	F24 YTD Actuals @ 1.31.24	O-23-06-02 F24 Approved Budget	Budget Adjustment	O-24-03-03 F24 Proposed Amended Budget	Budget Notes
<b>School Bond Fund Revenue</b>									
<b>Interest Earnings</b>									
12.3361.0003	School Bond Interest Income	-	-	-	-	-	-	-	
12.3361.0004	USBank QZAB SinkFund Interest	-	-	-	-	-	-	-	
12.3361.0005	Antitrust Stlmnt QZAB 03 Bond	-	-	-	-	-	-	-	
<b>State Grants, Bonds</b>									
12.3393.0001	EED GR09-014 Roof	-	-	-	-	-	-	-	
12.3393.0005	2009-2 AMBB Proceeds Roof	-	-	-	-	-	-	-	
12.3393.0006	State Reimb School Projects	-	-	-	-	-	258,551.00	258,551.00	70% SOA Reimb ACSA Restroom Remodel
12.3393.0008	Bond Issuance, Refunding	-	-	-	-	-	-	-	
12.3393.0015	Unex Bonds,Int,Trans,Schl Blr\$	-	-	-	-	-	-	-	
12.3393.5000	AMBB 2,112 STAK Reimb 04B	-	-	-	-	-	-	-	
12.3393.5001	QZAB 1,798 StAk Reimb 03B	-	-	-	-	-	-	-	
12.3393.5002	AMBB 1,260 StAk Reimb 06B	-	-	-	-	-	-	-	
12.3393.5003	AMBB 1,180 StAk Reimb 12-2	-	36,368.81	101,284.22	89,974.15	89,974.15	-	89,974.15	
12.3393.5004	AMBB 750 StAk Reimb 2015-1 A	-	22,213.73	61,199.17	59,139.17	61,971.67	-	61,971.67	
12.3393.5005	PY Bond Reimbursements	-	-	385,141.46	-	-	-	-	
<b>Transfers - Interfunds</b>									
12.3888.8830	Transfers In - General Fund	453,875.00	226,142.46	125,766.61	-	123,804.18	-	123,804.18	
<b>Fund Balance Appropriation</b>									
12.3999.9999	Fund Balance Appropriation	-	-	-	-	370,313.00	(208,058.00)	162,255.00	
<b>Total Revenue:</b>		<b>453,875.00</b>	<b>284,725.00</b>	<b>673,391.46</b>	<b>149,113.32</b>	<b>646,063.00</b>	<b>50,493.00</b>	<b>696,556.00</b>	

FY2024 Proposed Budget School Bond Fund		F21 Actuals	F22 Actuals	F23 Actuals	F24 YTD Actuals @ 1.31.24	O-23-06-02 F24 Approved Budget	Budget Adjustment	O-24-03-03 F24 Proposed Amended Budget	Budget Notes
<b>School Bond Fund Expense</b>									
12.6149.0001	Elementary UST TNK 03-149 SPCC	-	-	-	-	-	-	-	
12.6150.0001	EED 09-014 Constr Mgmt	-	-	-	-	-	-	-	
12.6150.0003	EED 09-014 Site Investigation	-	-	-	-	-	-	-	
12.6150.0004	EED 09-014 Design Services	-	-	-	-	-	-	-	
12.6150.0005	EED 09-014 Construction	-	-	-	-	-	-	-	
12.6150.0007	EED 09-014 Admin Overhead	-	-	-	-	-	-	-	
12.6150.0009	EED 09-014 Project Contng	-	-	-	-	-	-	-	
12.6222.1101	Salaries - Administrative	-	-	-	-	-	-	-	
12.6222.1102	Salaries - Finance	-	-	-	-	-	-	-	
12.6222.1801	Professional Services	-	-	575.00	-	-	-	-	
12.6222.3031	Office, Operating Supplies	-	-	-	-	-	-	-	
12.6222.4699	Use Other Fin Sources Bond	-	-	-	-	-	-	-	
12.6222.4700	Bond Issuance, Refunding Exp	-	-	-	-	-	-	-	
12.6222.4701	2000-07 Bond Principal	-	-	-	-	-	-	-	
12.6222.4702	2000-07 GO Bond Interest Exp	-	-	-	-	-	-	-	
12.6222.4703	2004 GO Bond Principal	-	-	-	-	-	-	-	
12.6222.4704	2004 GO Bond Interest Exp	-	-	-	-	-	-	-	
12.6222.4762	2003 QZAB Bond Payment	-	-	-	-	-	-	-	
12.6222.4763	2006 Bond Principal	-	-	-	-	-	-	-	
12.6222.4764	2006 Bond Interest	-	-	-	-	-	-	-	
12.6222.4766	2009-2 Bond Principal	-	-	-	-	-	-	-	
12.6222.4767	2009-2 Bond Interest	-	-	-	-	-	-	-	
12.6222.4768	2012-2/2004B Bond Principal	125,000.00	130,000.00	140,000.00	130,000.00	130,000.00	-	130,000.00	Final Payment
12.6222.4769	2012-2/2004B Bond Interest	21,825.00	16,100.00	10,000.00	3,250.00	3,250.00	-	3,250.00	
12.6222.4770	2015-1A/2006A Bond Principal	65,000.00	70,000.00	75,000.00	80,000.00	80,000.00	-	80,000.00	Matures 10/1/25
12.6222.4771	2015-1A/2006A Bond Interest	21,125.00	17,750.00	14,125.00	6,125.00	10,250.00	-	10,250.00	
12.6222.4772	2015-1B/2009-2 Bond Principal	35,000.00	35,000.00	35,000.00	40,000.00	40,000.00	-	40,000.00	Matures 10/1/28
12.6222.4773	2015-1B/2009-2 Bond Interest	17,625.00	15,875.00	14,125.00	6,625.00	12,250.00	-	12,250.00	
12.6222.4774	2016-3/2007-1 Bond Principal	165,000.00	-	-	-	-	-	-	
12.6222.4775	2016-3/2007-1 Bond Interest	3,300.00	-	-	-	-	-	-	
12.6222.7000	School Bond Construction	-	-	-	-	-	-	-	
12.6222.7001	NES Boiler/Gym Floor Expenses	-	-	-	-	-	-	-	
12.6222.7002	Pool Expenses	-	-	-	-	-	-	-	
12.6888.8820	Transfers Out - Other Funds	182,939.01	-	152,922.23	-	370,313.00	50,493.00	420,806.00	Transfer to Fund 15
12.6888.8830	Transfers Out - General Fund	-	-	-	-	-	-	-	
12.6999.9999	Contribution to Fund Balance	-	-	-	-	-	-	-	
	<b>Total Expense:</b>	<b>636,814.01</b>	<b>284,725.00</b>	<b>441,747.23</b>	<b>266,000.00</b>	<b>646,063.00</b>	<b>50,493.00</b>	<b>696,556.00</b>	

1<sup>st</sup> Reading: February 26, 2024  
2<sup>nd</sup> Reading: March 25, 2024

**Presented By:**  
City Manager/Finance Director

**Action Taken:**  
Yes \_\_\_\_  
No \_\_\_\_  
Abstain \_\_\_\_

**CITY OF NOME, ALASKA**

**ORDINANCE NO. O-24-03-04**

**AN ORDINANCE AMENDING THE CITY OF NOME  
FY 2024 SPECIAL REVENUE FUND BUDGET**

**Section 1.**

This is a non-Code ordinance.

**Section 2.**

**BE IT HEREBY ORDAINED** by the Nome City Council, that the attached adjustments be made to the FY 2024 City of Nome Special Revenue Fund Budget.

**APPROVED** and **SIGNED** the 25<sup>th</sup> day of March, 2024.

\_\_\_\_\_  
**JOHN K. HANDELAND**  
Mayor

**ATTEST:**

\_\_\_\_\_  
**JEREMY JACOBSON**  
Deputy City Clerk

FY2024 Proposed Budget Special Revenue Fund		F21 Actuals	F22 Actuals	F23 Actuals	F24 YTD Actuals @ 1.31.24	O-23-06-03 F24 Approved Budget	Budget Adjustment	O-24-03-04 F24 Proposed Amended Budget	Budget Notes
<b>Special Revenue Fund Revenue</b>									
13.3001.0001	Clara Mielke Richards Estate	45.13	438.95	37,137.90	9,023.93	15,000.00	3,000.00	18,000.00	Est Interest @ 5.3%
13.3001.0002	Nome Library Foundation \$	-	-	-	-	-	-	-	
13.3001.0003	Alaska Coastal Mgmt 2011	-	-	-	-	-	-	-	
13.3001.0004	E911 Surcharge, Approp Fnd Bal	98,561.28	102,072.93	82,731.98	35,424.82	95,000.00	-	95,000.00	
13.3001.0005	Fed Emergency Mgmt Assist	-	-	-	-	-	-	-	
13.3001.0006	MOA DOT Law Enforce Airport	-	-	-	-	-	-	-	
13.3001.0007	Public Library Assistance	7,000.00	7,000.00	7,000.00	7,000.00	7,000.00	-	7,000.00	
13.3001.0008	SOA Grants, Tech Assist - Mus	-	10,396.00	10,656.00	-	105,015.00	-	105,015.00	IMLS Museum Cares Act Grant
13.3001.0009	Emergency Svs Nome LEPC	-	-	-	-	-	-	-	
13.3001.0010	Training, SART, Trips Reimb	107,624.00	11,476.00	7,974.00	625.00	10,000.00	-	10,000.00	AST SART Reimb
13.3001.0011	NSEDC Community Benefit Share	-	200,000.00	931,818.03	-	100,000.00	-	100,000.00	NSEDC CBS
13.3001.0012	FEMA NVFD/NVAD Training	-	-	-	-	-	-	-	
13.3001.0013	NSEDC - Pool Lessons Grant	-	-	-	-	-	-	-	
13.3001.0014	12DC405 Sprinkler/Fire Alarm	-	-	-	-	-	-	-	
13.3001.0015	Rasmuson Foundation	-	-	-	15,000.00	-	15,000.00	15,000.00	
13.3001.0016	NSEDC - CSO	-	-	-	-	-	-	-	
13.3001.0017	NSEDC - Rural Fire Protection	-	-	-	-	-	-	-	
13.3001.0018	NEC - IMLS Grant	11,744.44	8,500.00	1,500.00	-	-	-	-	
13.3001.0019	NSEDC Community Employmt Prgm	1,093.32	4,973.03	9,855.30	3,787.21	10,000.00	-	10,000.00	Awarded \$17,760: 4.1.23-12.31.23
13.3001.0020	NPD NSHC SART IHS Grant	-	-	-	-	-	-	-	
13.3001.0021	Bullet Proof Vest Partnership	-	-	-	-	-	-	-	
13.3001.0022	SOA Dept of Ed Grants - Lib	11,109.90	5,977.00	1,634.20	1,000.00	2,500.00	-	2,500.00	Continuing Education Grant
13.3001.0023	National Park Service Pass-Thr	240.00	442.50	-	-	-	-	-	
13.3001.0024	CLG Historic Preservation Grnt	11,256.00	-	-	-	-	-	-	
13.3001.0025	Highway Safety - TraCs Equip	7,864.00	-	-	-	-	-	-	
13.3001.0026	Public Safety Grant - CESF	51,993.87	-	-	-	-	-	-	
13.3001.0027	State Homeland Security(SHSP)	-	14,571.00	29,767.40	-	-	-	-	
13.3001.0028	NSEDC - Outside Entity Funding (OEF)	-	-	-	-	-	-	-	
13.3001.2011	Gala Reception, Events Contrib	-	-	-	-	-	-	-	
13.3001.4050	FEMA Storm	-	-	-	-	-	-	-	
13.3001.4051	DHS FEMA Hazard Mitigation	-	-	-	-	-	-	-	
13.3002.0001	FEMA - Disaster Recovery	161,668.07	-	14,113.20	-	1,255,202.50	(78,319.50)	1,176,883.00	
13.3003.0001	Coronavirus Relief Funds - CARES	4,662,350.25	185,094.95	-	-	-	-	-	
13.3004.0001	MOA SOA DHSS COVID-19 EOC	33,860.71	137,189.11	68,549.87	-	103,317.00	-	103,317.00	C0622-584-Q Amendment #1 \$103,317
13.3005.0001	American Rescue Plan - ARP	-	-	200,000.00	-	-	-	-	
13.3006.0001	American Rescue Plan - Non-UGLG	-	-	-	-	-	-	-	
13.3888.8830	Transfers In - General Fund	17,657.12	5,927.64	1,943.14	-	45,395.00	4,000.00	49,395.00	Mus CARES ACT Cost Share \$45,395, Lib Rasmuson Grant In-Kind Contrib \$2000, Bookcases \$2000
13.3999.9999	Fund Balance Appropriation	-	-	-	-	-	-	-	
<b>Total SRF Revenue:</b>		<b>5,184,068.09</b>	<b>694,059.11</b>	<b>1,404,681.02</b>	<b>71,860.96</b>	<b>1,748,429.50</b>	<b>(56,319.50)</b>	<b>1,692,110.00</b>	



FY2024 Proposed Budget Special Revenue Fund		F21 Actuals	F22 Actuals	F23 Actuals	F24 YTD Actuals @ 1.31.24	O-23-06-03 F24 Approved Budget	Budget Adjustment	O-24-03-04 F24 Proposed Amended Budget	Budget Notes
<b>Special Revenue Fund Expense</b>									
13.6001.0001	Clara Mielke Richards Est	12,959.19	20,000.00	-	-	15,000.00	3,000.00	18,000.00	
13.6001.0002	Nome Library Foundation \$	-	-	-	-	-	-	-	
13.6001.0003	Alaska Coastal Mgmt 2011	-	-	-	-	-	-	-	
13.6001.0004	E911 Surcharge, Approp Fnd Bal	7,193.80	21,259.85	-	-	95,000.00	-	95,000.00	
13.6001.0005	FED Emergency Mgmt Assist	-	-	-	-	-	-	-	
13.6001.0006	MOA DOT Law Enforce Airport	-	-	-	-	-	-	-	
13.6001.0007	Public Library Assistance	7,000.00	7,000.00	7,000.00	2,930.19	7,000.00	-	7,000.00	
13.6001.0008	SOA Grants, Tech Assist - Mus	-	16,323.64	10,896.99	-	150,410.00	-	150,410.00	CARES Act Grant \$105,015 Salary & Benefit Cost Share \$45,395
13.6001.0009	Emerg Svs Nome LEPC	-	-	-	-	-	-	-	
13.6001.0010	Training, SART, Trips Reimb	107,624.00	11,476.00	7,974.00	2,595.00	10,000.00	-	10,000.00	SART Expenses
13.6001.0011	NSEDC Community Benefit Share	246,629.07	24,792.21	753,196.36	63,716.97	100,000.00	-	100,000.00	
13.6001.0012	FEMA NVFD/NVAD Training	-	-	-	-	-	-	-	
13.6001.0013	NSEDC - Pool Lessons Grant	-	-	-	-	-	-	-	
13.6001.0014	12DC405 Sprinkler/Fire Alarm	-	-	-	-	-	-	-	
13.6001.0015	Rasmuson Foundation	-	-	-	-	-	19,000.00	19,000.00	Grant \$15000, In-Kind Match \$1300 + \$200 Labels + Readers \$500, Bookcases \$2000
13.6001.0016	NSEDC - CSO	-	-	-	-	-	-	-	
13.6001.0017	NSEDC - Rural Fire Protection	-	-	-	-	-	-	-	
13.6001.0018	NEC - IMLS Grant	11,744.44	8,500.00	1,500.00	-	-	-	-	
13.6001.0019	NSEDC Community Employ Prgm	1,093.32	4,973.03	9,855.30	5,203.57	10,000.00	-	10,000.00	Awarded \$17,760: 4.1.23-12.31.23
13.6001.0020	NPD NSHC SART IHS Grant	-	-	-	-	-	-	-	
13.6001.0021	Bullet Proof Vest Partnership	-	-	-	-	-	-	-	
13.6001.0022	SOA Dept of Ed Grants - Lib	12,185.70	5,977.00	1,634.20	1,575.49	2,500.00	-	2,500.00	Continuing Education Grant
13.6001.0023	National Park Service Pass-Thr	240.00	442.50	-	-	-	-	-	
13.6001.0024	CLG Historic Preservation Grnt	24,200.00	-	-	-	-	-	-	
13.6001.0025	Highway Safety - TraCs Equip	11,501.32	-	-	-	-	-	-	
13.6001.0026	Public Safety Grant - CESF	51,993.87	-	-	-	-	-	-	
13.6001.0027	State Homeland Security(SHSP)	-	14,571.00	29,767.40	-	-	-	-	
13.6001.0028	NSEDC - Outside Entity Funding (OEF)	-	-	-	-	-	-	-	
13.6001.2011	Gala Reception,Events Contrib	-	-	-	-	-	-	-	
13.6001.4050	FEMA Storm	-	-	-	-	-	-	-	
13.6001.4051	DHS FEMA Hazard Mitigation	-	-	-	-	-	-	-	
<b>Subtotal:</b>		<b>494,364.71</b>	<b>135,315.23</b>	<b>821,824.25</b>	<b>76,021.22</b>	<b>389,910.00</b>	<b>22,000.00</b>	<b>411,910.00</b>	

FY2024 Proposed Budget Special Revenue Fund		F21 Actuals	F22 Actuals	F23 Actuals	F24 YTD Actuals @ 1.31.24	O-23-06-03 F24 Approved Budget	Budget Adjustment	O-24-03-04 F24 Proposed Amended Budget	Budget Notes
<b>Special Revenue Fund - FEMA Disaster Recovery</b>									
13.6002.1101	Salaries - CAT A Debris Removal	13,882.05	-	15,812.25	4,674.03	150,000.00	(140,000.00)	10,000.00	DR-4672 FEMA Public Assistance
13.6002.1102	Salaries - Emergency Protectiv	-	-	781.76	-	-	-	-	Estimated Project Expenses
13.6002.1103	Salaries - CAT C PW	-	-	15,444.06	4,688.31	20,000.00	-	20,000.00	More info pending FEMA Project approval
13.6002.1104	Salaries - CAT D PW	-	-	-	-	-	10,000.00	10,000.00	
13.6002.1105	Salaries - CAT E PW	-	-	-	875.81	-	20,000.00	20,000.00	
13.6002.1106	Salaries - CAT G PW	-	-	-	-	-	10,000.00	10,000.00	
13.6002.1107	Salaries - Category Z	8,257.08	2,862.54	4,857.16	7,851.01	-	15,000.00	15,000.00	
13.6002.1201	Salaries OT-CAT A Debris Remv	5,654.83	-	29,269.57	7,116.37	45,000.00	(30,000.00)	15,000.00	
13.6002.1202	Salaries OT-CAT B Protect Meas	-	-	2,169.09	-	-	-	-	
13.6002.1203	Salaries OT-CAT C PW Roads	-	-	12,990.91	-	-	-	-	
13.6002.1207	Salaries OT-Cat Z	1,134.36	-	-	-	-	-	-	
13.6002.1411	Accrued Personal Leave	-	-	14,092.89	-	40,205.00	(21,505.00)	18,700.00	
13.6002.1421	Health Insurance	1,978.51	49.40	17,667.96	3,493.73	60,200.00	(32,200.00)	28,000.00	
13.6002.1431	Life Insurance	71.86	0.30	2.27	48.51	1,505.00	(802.00)	703.00	
13.6002.1441	FICA/Medicare	2,182.96	219.00	6,549.62	1,974.55	16,447.50	(8,797.50)	7,650.00	
13.6002.1451	ESC	1,567.73	-	1,912.91	-	5,095.50	(2,725.50)	2,370.00	
13.6002.1461	PERS	2,421.34	45.08	18,536.00	5,271.83	47,300.00	(25,300.00)	22,000.00	
13.6002.1471	Workers' Comp Insurance	2,275.28	-	4,731.40	-	9,449.50	(3,139.50)	6,310.00	
13.6002.1870	Professional Services	2,893.40	-	-	-	250,000.00	(250,000.00)	-	Moved to Port Fund 85
13.6002.1880	ProfSvcs-CAT A Debris Removal	-	-	59,095.87	1,400.00	80,000.00	(75,000.00)	5,000.00	
13.6002.1885	ProfSvcs-CAT E PW Buildings/Eq	-	-	6,411.65	-	-	-	-	
13.6002.2071	Operating Supplies	5,433.42	-	66.52	-	-	-	-	
13.6002.2072	Emergency Shelter Expenses	-	-	943.62	-	-	-	-	
13.6002.4000	Equipment Use	118,409.78	-	22,250.83	-	75,000.00	(35,000.00)	40,000.00	
13.6002.6000	CAT C - Roads & Bridges	-	-	16,183.71	30,043.00	150,000.00	471,150.00	621,150.00	River Street Storm Drain \$47,191 / West F Street \$86,315 & River Street Road Materials \$121,082, Submarine Beach Road \$42,560, Gold Ave & West E \$324,001
13.6002.6005	CAT D - Water	-	-	-	-	5,000.00	-	5,000.00	Seawall Materials: Cobble/Armor
13.6002.6010	CAT E - Buildings	-	-	30,809.25	24.41	300,000.00	-	300,000.00	Mini Convention Center, Visitor's Center, Garco, Equipment Repairs, Swanberg Dredge \$110,946
13.6002.6020	CAT G - Parks, Rec, Other Fac	-	-	-	3,000.00	-	20,000.00	20,000.00	East End Park Repairs
13.6002.8030	Equipment Purchases	8,144.50	-	-	-	-	-	-	
<b>FEMA Subtotal:</b>		<b>174,307.10</b>	<b>3,176.32</b>	<b>280,579.30</b>	<b>70,461.56</b>	<b>1,255,202.50</b>	<b>(78,319.50)</b>	<b>1,176,883.00</b>	

FY2024 Proposed Budget Special Revenue Fund		F21 Actuals	F22 Actuals	F23 Actuals	F24 YTD Actuals @ 1.31.24	O-23-06-03 F24 Approved Budget	Budget Adjustment	O-24-03-04 F24 Proposed Amended Budget	Budget Notes
<b>Special Revenue Fund - CARES</b>									
13.6003.1101	Salaries - Public Safety	586,171.05	9,710.67	-	-	-	-	-	
13.6003.1102	Salaries - Support Staff	195,895.76	-	-	-	-	-	-	
13.6003.1201	Overtime - Public Safety	67,724.47	-	-	-	-	-	-	
13.6003.1202	Overtime - Support Staff	44,651.78	-	-	-	-	-	-	
13.6003.1421	Health Insurance	252,440.30	2,214.03	-	-	-	-	-	
13.6003.1431	Life Insurance	1,444.63	-	-	-	-	-	-	
13.6003.1441	FICA/Medicare	68,411.28	742.87	-	-	-	-	-	
13.6003.1451	ESC	5,068.95	-	-	-	-	-	-	
13.6003.1461	PERS	188,428.27	2,136.35	-	-	-	-	-	
13.6003.1471	Workers' Comp Insurance	16,315.42	276.94	-	-	-	-	-	
13.6003.1870	Professional Services	8,110.50	1,695.00	-	-	-	-	-	
13.6003.5000	Public Health	346,978.75	25,463.24	-	-	-	-	-	
13.6003.5100	Medical	136,561.05	-	-	-	-	-	-	
13.6003.5200	Economic Support	1,541,548.16	143,955.85	-	-	-	-	-	
13.6003.5300	Telework Capabilities	270,748.99	-	-	-	-	-	-	
13.6003.5400	Food Programs / Other	19,950.89	-	-	-	-	-	-	
13.6003.5500	Distance Learning	133,600.00	-	-	-	-	-	-	
13.6003.5700	CARES Phase V-Economic Support	778,300.00	(1,100.00)	-	-	-	-	-	
13.6003.8030	Machinery & Equipment	-	-	-	-	-	-	-	
<b>CARES Subtotal:</b>		<b>4,662,350.25</b>	<b>185,094.95</b>	-	-	-	-	-	
<b>Special Revenue Fund - MOA SOA DHSS COVID-19 EOC</b>									
13.6004.1101	Salaries - COVID 19 Mitigation	7,800.77	2,814.49	-	-	-	-	-	
13.6004.1201	Salaries - Overtime	6,146.20	10,373.38	-	-	-	-	-	
13.6004.1421	Health Insurance	2,058.20	4,538.66	-	-	-	-	-	
13.6004.1431	Life Insurance	2.88	20.46	-	-	-	-	-	
13.6004.1441	FICA/Medicare	1,047.29	1,005.20	-	-	-	-	-	
13.6004.1451	ESC	324.79	312.55	-	-	-	-	-	
13.6004.1461	PERS	2,299.44	2,861.72	-	-	-	-	-	
13.6004.1471	Workers' Comp Insurance	76.52	42.73	-	-	-	-	-	
13.6004.1940	Advertising	-	18,067.60	-	-	-	-	-	
13.6004.2071	Supplies: PPE	-	19,190.42	-	-	-	-	-	
13.6004.5000	Health Equity	6,018.03	23,643.83	-	-	-	-	-	
13.6004.7020	Utilities - Airport Tent	8,086.59	29,619.22	-	-	-	-	-	
13.6004.8030	Equipment	-	24,698.85	68,549.87	27,252.78	103,317.00	-	103,317.00	NRC Kitchen \$32,816, Tables & Chairs \$59,801, Siren Replacement \$10,700
<b>MOA SOA DHSS Subtotal:</b>		<b>33,860.71</b>	<b>137,189.11</b>	<b>68,549.87</b>	<b>27,252.78</b>	<b>103,317.00</b>	-	<b>103,317.00</b>	

FY2024 Proposed Budget Special Revenue Fund		F21 Actuals	F22 Actuals	F23 Actuals	F24 YTD Actuals @ 1.31.24	O-23-06-03 F24 Approved Budget	Budget Adjustment	O-24-03-04 F24 Proposed Amended Budget	Budget Notes
<b>Special Revenue Fund - American Rescue Plan Act: ARPA</b>									
13.6005.3000	Housing Support			200,000.00	-	-		-	
<b>ARPA Subtotal:</b>			-	<b>200,000.00</b>	-	-		-	
<b>Transfers Out</b>									
13.6888.8820	Transfers Out - Other Funds		85,360.71	<b>214,639.29</b>	-	-		-	
13.6888.8830	Transfers Out - General Fund	-	-	-	-	-		-	
<b>Transfers Out Subtotal:</b>		-	<b>85,360.71</b>	<b>214,639.29</b>	-	-		-	
<b>Total SRF Expense:</b>		<b>5,364,882.77</b>	<b>546,136.32</b>	<b>1,585,592.71</b>	<b>173,735.56</b>	<b>1,748,429.50</b>	<b>(56,319.50)</b>	<b>1,692,110.00</b>	

1<sup>st</sup> Reading: February 26, 2024  
2<sup>nd</sup> Reading: March 25, 2024

**Presented By:**  
City Manager/Finance Director

**Action Taken:**  
Yes \_\_\_\_  
No \_\_\_\_  
Abstain \_\_\_\_

**CITY OF NOME, ALASKA**

**ORDINANCE NO. O-24-03-05**

**AN ORDINANCE AMENDING THE CITY OF NOME  
FY 2024 CAPITAL PROJECTS FUND BUDGET**

**Section 1.**

This is a non-Code ordinance.

**Section 2.**

**BE IT HEREBY ORDAINED** by the Nome City Council, that the attached adjustments be made to the FY 2024 City of Nome Capital Projects Fund Budget.

**APPROVED** and **SIGNED** the 25<sup>th</sup> day of March, 2024.

\_\_\_\_\_  
**JOHN K. HANDELAND**  
Mayor

**ATTEST:**

\_\_\_\_\_  
**JEREMY JACOBSON**  
Deputy City Clerk

FY2024 Proposed Budget Capital Projects Fund		F21 Actuals	F22 Actuals	F23 Actuals	F24 YTD Actuals @ 1.31.24	O-23-06-04 F24 Approved Budget	Budget Adjustment	O-24-03-05 F24 Proposed Amended Budget	Budget Notes
<b>CPF Revenue</b>									
14.3010.0001	Nome Eskimo Mtnc Roads	-	50,000.00	-	-	-	-	-	
14.3406.0001	12DC406 Richard Foster Bldg	-	-	-	-	-	-	-	
14.3501.0001	Contribution to NPS 18 Plex	25,695.00	387.50	20,300.50	-	42,000.00	(3,504.00)	38,496.00	Reimbursement from NPS
14.3601.0001	Sale of Vehicles - Replcmt Program	-	20,175.07	-	-	20,000.00	-	20,000.00	
14.3701.0002	Coronavirus Local Fiscal Recovery Fund	-	188,695.26	152,597.35	-	1,100,000.00	62,054.22	1,162,054.22	ARPA \$\$ - City Hall Heat & Vent
14.3701.0011	Contribution to SCC Fire Alarm	-	-	-	-	-	25,000.00	25,000.00	SCC Contribution
14.3888.8812	Transfer in - Net PWR Rev %	-	-	97,490.42	-	70,000.00	7,500.00	77,500.00	GF Transfer - Assign 25% General Interest to CAT 160M
14.3888.8815	Transfer In - Net Ambulance Revenue %	-	-	34,993.11	-	50,000.00	(50,000.00)	-	GF Transfer - Assign 40% to save for Ambulance
14.3888.8818	Transfer In - Vehicle Replacement Fund	-	33,316.83	288,945.14	-	185,000.00	172,000.00	357,000.00	\$277k Vehicle Replacement Funds, EMS multi purpose hose truck \$80k
14.3888.8820	Transfer In - Other Funds	-	85,360.71	14,639.29	-	-	-	-	
14.3888.8830	Transfer In - General Fund	296,667.88	44,754.76	309,827.46	-	414,500.00	187,594.94	602,094.94	Transfer from General Fund
	<b>Total CPF Revenue:</b>	<b>322,362.88</b>	<b>422,690.13</b>	<b>918,793.27</b>	<b>-</b>	<b>1,881,500.00</b>	<b>400,645.16</b>	<b>2,282,145.16</b>	
<b>CPF Expense</b>									
14.6011.0001	Nome Eskimo Mtnc Roads	-	50,000.00	-	-	-	-	-	
14.6406.0001	12DC406 Richard Foster Bldg	-	-	-	-	-	-	-	
<b>NPS 18 Plex</b>									
14.6501.1820	NPS 18 Plex - Engineering	25,695.00	387.50	20,300.50	-	42,000.00	(3,504.00)	38,496.00	Bristol Task Order #44 - Contract Amt
14.6501.2071	NPS 18 Plex - Operating	173.46	-	-	-	-	-	-	
14.6501.7020	NPS 18 Plex - Utilities	2,717.76	404.34	176.47	-	-	-	-	
14.6501.8010	NPS 18 Plex - Land/Buildings	199,277.73	-	4,135.00	-	-	-	-	
<b>Vehicle Replacement Program</b>									
14.6601.0001	Vehicle Purchase - Police	89,554.00	53,491.90	128,980.06	160,230.63	60,000.00	172,000.00	232,000.00	2023 F150 +Outfitting \$82,468, 2023 Ford Transit Van \$77,107, 1 Ford Expedition \$71,993
14.6601.0002	Vehicle Purchase - PWKS	-	-	110,027.00	-	-	-	-	
14.6601.0003	Vehicle Purchase - EMS	-	-	-	-	80,000.00	-	80,000.00	MultiPurposeHoseTruck \$80,000
14.6601.0004	Vehicle Purchase - Admin	-	-	49,938.08	-	65,000.00	-	65,000.00	1 Ford Expedition
14.6601.0005	Vehicle Purchase - Ambulance	-	-	-	-	50,000.00	(50,000.00)	-	
<b>CPF Expense Continued:</b>									
14.6701.0001	MCC Heat & Vent Upgrades	-	1,848.69	-	-	-	-	-	
14.6701.0002	NRC Heat & Vent Upgrades	-	188,695.26	152,597.35	43,854.40	-	45,000.00	45,000.00	Fire Plan Review \$10,055, RSA Engin \$27,692, Bristol \$6,125
14.6701.0003	PWKS Heat & Vent Upgrades	-	1,848.68	-	-	-	-	-	
14.6701.0004	City Hall Heat & Vent Upgrades	-	85,360.71	85,764.60	85,584.45	1,100,000.00	62,054.22	1,162,054.22	Sturgeon Electric \$1,406,400; RSA \$74,002, Bristol \$10,651 (project short \$328,999)
14.6701.0005	NRC Locker Room Upgrades	-	-	-	-	-	-	-	
14.6701.0006	Ice Rink Design & Construction	4,944.93	-	-	-	-	-	-	
14.6701.0009	NVFD Concrete Replacement	-	24,910.00	-	-	-	-	-	
14.6701.0010	City Hall Fire Alarm Upgrades	-	-	-	-	-	-	-	
14.6701.0011	SCC Fire Alarm Upgrades	-	15,743.05	77,286.98	6,855.34	-	6,855.34	6,855.34	
14.6701.0012	Morgue Upgrades	-	-	-	-	-	-	-	

FY2024 Proposed Budget Capital Projects Fund		F21 Actuals	F22 Actuals	F23 Actuals	F24 YTD Actuals @ 1.31.24	O-23-06-04 F24 Approved Budget	Budget Adjustment	O-24-03-05 F24 Proposed Amended Budget	Budget Notes
14.6701.0013	Police Camera Upgrades	-	-	86,857.00	-	-	-	-	
14.6701.0014	Equip Purchase - Public Works	-	-	27,609.17	163,953.62	35,000.00	129,956.00	164,956.00	Genie Boom Lift \$96,054, Landfill Bucket 966F \$38,000, Snow Bucket for Skid steer \$21,462, Sander \$8,440
14.6701.0015	Heavy Equipment Purchase	-	-	-	-	70,000.00	7,500.00	77,500.00	Cat 160M - Placeholder - Save toward purchase
14.6701.0016	NPD 911 & Radio Comm Sys Upgrd	-	-	42,637.53	29,260.00	-	29,260.00	29,260.00	
14.6701.0017	Camera Upgrades - Recreation Center				86,186.00	82,000.00	4,186.00	86,186.00	
14.6701.0018	OSJ Flooring				-	50,000.00		50,000.00	
14.6701.0019	Steadman Park				-	75,000.00		75,000.00	ADEC Requirement
14.6701.0020	Police Impound Storage				-	60,000.00		60,000.00	Required for Accreditation
14.6701.0021	NVFD Improvements				-	62,500.00	(14,500.00)	48,000.00	Replace 2 Bay Doors
14.6701.0022	Landfill Equipment				36,449.33	50,000.00	1,450.00	51,450.00	Side-By-Side UTV \$15,000; Mad Vac Portable Litter Vacuum \$36,450
14.6701.0023	NACTEC Upgrades				10,387.60		10,387.60	10,387.60	
14.6888.8830	Transfers Out - General Fund	-	-	-	-	-	-	-	
<b>Total CPF Expense:</b>		<b>322,362.88</b>	<b>422,690.13</b>	<b>786,309.74</b>	<b>622,761.37</b>	<b>1,881,500.00</b>	<b>400,645.16</b>	<b>2,282,145.16</b>	



1<sup>st</sup> Reading: February 26, 2024  
2<sup>nd</sup> Reading: March 25, 2024

**Presented By:**  
City Manager/Finance Director

**Action Taken:**  
Yes \_\_\_\_  
No \_\_\_\_  
Abstain \_\_\_\_

**CITY OF NOME, ALASKA**

**ORDINANCE NO. O-24-03-06**

**AN ORDINANCE AMENDING THE CITY OF NOME  
FY 2024 CONSTRUCTION CAPITAL PROJECTS FUND BUDGET**

**Section 1.**

This is a non-Code ordinance.

**Section 2.**

**BE IT HEREBY ORDAINED** by the Nome City Council, that the attached adjustments be made to the FY 2024 City of Nome Construction Capital Projects Fund Budget.

**APPROVED** and **SIGNED** the 25<sup>th</sup> day of March, 2024.

\_\_\_\_\_  
**JOHN K. HANDELAND**  
Mayor

**ATTEST:**

\_\_\_\_\_  
**JEREMY JACOBSON**  
Deputy City Clerk

FY2024 Proposed Budget School Renovation & Repairs		F21 Actuals	F22 Actuals	F23 Actuals	F24 YTD Actuals @ 1.31.24	O-23-06-05 F24 Proposed Budget	Budget Adjustment	O-24-03-06 F24 Proposed Amended Budget	Budget Notes
<b>School Renovation &amp; Repairs Revenue</b>									
15.3393.0015	Contribution,School Roof Reimb	57,334.00	5,595.17	-	-	1,910,715.00		1,910,715.00	Reimbursed by NPS
15.3393.2000	NSEDC Outside Entity Funding			100,000.00	-			-	
15.3888.8810	Transfers In - Debt Service	182,939.01	-	152,922.23	-	370,313.00	50,493.00	420,806.00	
15.3888.8820	Transfers In - Other Funds			200,000.00	-			-	
	<b>Total SRR Revenue:</b>	<b>240,273.01</b>	<b>5,595.17</b>	<b>452,922.23</b>	<b>-</b>	<b>2,281,028.00</b>	<b>50,493.00</b>	<b>2,331,521.00</b>	
<b>School Renovation &amp; Repairs Expense</b>									
15.6222.1101	Salaries - Admin/Maintenance	-	-	-	-	-		-	
15.6222.1820	Engineering/Architectural Svcs	74,293.00	4,556.25	-	-	72,398.00		72,398.00	NPS Roof Repair & Replacement Design Services: Bristol Est \$14,183, MCG \$58,215
15.6222.1870	Other Professional/Contract Sv	-	-	187.23	-	500.00		500.00	ADEC NES
15.6222.1940	Advertising	505.75	1,038.92	-	-	-		-	
15.6222.3031	Office Supplies	-	-	-	-	-		-	
15.6222.7000	School Bond Construction	165,474.26	-	-	-	1,838,317.00		1,838,317.00	NBHS Roof Repair & Replacement Construction + Project Contingency
15.6222.7001	NES Boiler/Gym Floor Expenses	-	-	-	-	-		-	
15.6222.7002	Pool Expenses	-	-	452,735.00	50,715.00	151,035.00	(58,897.00)	92,138.00	HS Pool Mechanical & Sanitation Upgrade
15.6222.7003	NPS Special Projects				48,754.77	218,778.00	109,390.00	328,168.00	ADA Entrance Security Project
15.6999.9999	Contingency	-	-	-	-	-		-	
	<b>Total SRR Expense:</b>	<b>240,273.01</b>	<b>5,595.17</b>	<b>452,922.23</b>	<b>99,469.77</b>	<b>2,281,028.00</b>	<b>50,493.00</b>	<b>2,331,521.00</b>	

1<sup>st</sup> Reading: February 26, 2024  
2<sup>nd</sup> Reading: March 25, 2024

**Presented By:**  
City Manager/Finance Director

**Action Taken:**  
Yes \_\_\_\_  
No \_\_\_\_  
Abstain \_\_\_\_

**CITY OF NOME, ALASKA**

**ORDINANCE NO. O-24-03-07**

**AN ORDINANCE AMENDING THE CITY OF NOME  
FY 2024 PORT OF NOME FUND BUDGET**

**Section 1.**

This is a non-Code ordinance.

**Section 2.**

**BE IT HEREBY ORDAINED** by the Nome City Council, that the attached adjustments be made to the FY 2024 City of Nome Port of Nome Fund Budget.

**APPROVED** and **SIGNED** the 25<sup>th</sup> day of March, 2024.

\_\_\_\_\_  
**JOHN K. HANDELAND**  
Mayor

**ATTEST:**

\_\_\_\_\_  
**JEREMY JACOBSON**  
Deputy City Clerk

FY2024 Proposed Budget Port Operating Fund		F21 Actuals	F22 Actuals	F23 Actuals	F24 YTD Actuals @ 1.31.24	O-23-06-06 F24 Approved Budget	Budget Adjustment	O-24-03-07 F24 Proposed Amended Budget	Budget Notes
<b>Port Operating Fund Revenue</b>									
<b>Causeway Facility</b>									
80.3111.2001	Causeway Dockage	91,619.29	99,217.71	75,113.48	117,826.85	95,000.00	30,000.00	125,000.00	Increased cruise ship traffic
80.3111.2002	Causeway Wharfage - Dry	251,664.21	229,428.73	346,852.49	125,304.89	300,000.00	(125,000.00)	175,000.00	1st contractor barges June 2024
80.3111.2003	Causeway Wharfage - Fuel	283,497.24	263,841.12	282,388.21	429,643.51	325,000.00	110,000.00	435,000.00	Increased deliveries to support contractors
80.3111.2004	Causeway Wharfage - Gravel	256,664.62	662,389.98	248,790.09	520,240.97	260,000.00	280,000.00	540,000.00	Brice to Shish - 50k tons
80.3111.2005	Causeway Storage Rental	9,702.81	4,002.35	14,996.74	2,965.20	18,000.00	(13,000.00)	5,000.00	Contractors storing containerized freight instead of trucking it back and forth
80.3111.2006	Causeway Utility Sales	10,762.55	9,688.43	7,183.43	12,868.73	21,000.00	(6,000.00)	15,000.00	Ship H2O Increase Cruise Ships/ Research Vessels
80.3111.2007	Causeway Misc Term Revenue	23,244.06	20,386.08	50,931.32	86,657.49	60,000.00	28,000.00	88,000.00	Increased cruise traffic - line handling & security
80.3111.2008	Leases, Rentals, Land, Bldgs	-	-	-	-	-	-	-	
80.3111.2009	Sale of Property & Assets	-	-	-	-	-	-	-	
80.3111.2010	Passenger & Facility Fees	-	-	6,044.50	8,168.00	8,000.00	6,000.00	14,000.00	Estimated 2000 PAX numbers
80.3111.2073	Resale: Spill Supplies	-	-	-	-	2,000.00	-	2,000.00	
	<b>Total Causeway Facility:</b>	<b>927,154.78</b>	<b>1,288,954.40</b>	<b>1,032,300.26</b>	<b>1,303,675.64</b>	<b>1,089,000.00</b>	<b>310,000.00</b>	<b>1,399,000.00</b>	
<b>CPV Excise Tax</b>									
80.3112.1001	CPV Excise Tax	-	-	11,155.00	-	5,000.00	-	5,000.00	Rough estimate
<b>Harbor Facility</b>									
80.3211.1001	Harbor Seasonal Dock Permit	123,269.94	138,146.71	230,676.94	14,044.89	140,000.00	(30,000.00)	110,000.00	
80.3211.2001	Harbor Dockage	58,063.76	51,951.05	76,528.92	84,994.20	82,000.00	4,000.00	86,000.00	
80.3211.2002	Harbor Wharfage - Dry	65,785.36	155,531.56	119,217.74	98,890.48	135,000.00	(15,000.00)	120,000.00	
80.3211.2003	Harbor Wharfage - Fuel	61,191.34	58,824.36	70,569.77	26,518.75	75,000.00	(25,000.00)	50,000.00	
80.3211.2004	Harbor Wharfage - Gravel	940.94	6,698.64	8,178.73	133,939.81	15,000.00	125,000.00	140,000.00	
80.3211.2005	Harbor Storage Rental	54,417.80	52,362.20	69,284.57	26,196.23	65,000.00	(20,000.00)	45,000.00	June storage
80.3211.2006	Harbor Utility Sales	5,278.14	5,948.29	8,164.90	11,556.51	7,500.00	5,000.00	12,500.00	
80.3211.2007	Harbor Misc Term Revenue	-	475.77	16,964.87	13,441.92	15,000.00	-	15,000.00	Increased Harbor Cruise Traffic Security
80.3211.2008	Leases, Rentals, Land, Bldgs	38,236.57	37,237.36	37,186.54	34,686.49	37,000.00	-	37,000.00	
80.3211.2009	Sale of Property & Assets	-	-	-	-	-	-	-	
80.3211.2010	Passenger & Facility Fees	-	-	3,321.50	5,860.00	6,000.00	500.00	6,500.00	Increased Cruise PAX numbers
80.3211.2073	Resale: Spill Supplies	-	-	1,860.00	210.00	2,000.00	-	2,000.00	
	<b>Total Harbor Facility:</b>	<b>407,183.85</b>	<b>507,175.94</b>	<b>641,954.48</b>	<b>450,339.28</b>	<b>579,500.00</b>	<b>44,500.00</b>	<b>624,000.00</b>	
<b>Cape Nome Quarry</b>									
80.3311.2001	Quarry Dockage	-	-	-	-	-	-	-	
80.3311.2002	Quarry Wharfage - Dry	-	-	-	-	-	-	-	
80.3311.2003	Quarry Wharfage - Fuel	-	-	-	-	-	-	-	
80.3311.2004	Quarry Wharfage - Gravel	-	-	-	-	-	-	-	
80.3311.2005	Quarry Storage Rental	-	-	-	-	-	-	-	
80.3311.2007	Quarry Misc Term Revenue	-	-	-	-	-	-	-	
80.3311.2008	Leases, Rentals, Land, Bldgs	-	-	-	-	-	-	-	
	<b>Total Cape Nome Quarry:</b>	<b>-</b>	<b>-</b>	<b>-</b>	<b>-</b>	<b>-</b>	<b>-</b>	<b>-</b>	
<b>Industrial Park Facility</b>									
80.3411.2001	Westside Tank Farm Rental	-	-	-	-	-	-	-	
80.3411.2005	Industrial Park Storage Rental	235,635.87	238,915.33	270,916.83	288,634.28	285,000.00	10,000.00	295,000.00	New large mining setup operations
80.3411.2008	Leases, Rentals, Land, Bldgs	222,095.45	188,359.38	181,681.09	50,044.40	140,000.00	(25,000.00)	115,000.00	
80.3411.2009	Sale of Property & Assets	-	-	-	-	-	-	-	
80.3411.2073	Resale: Spill Supplies	-	-	-	-	1,500.00	-	1,500.00	
	<b>Total Industrial Park Facility:</b>	<b>457,731.32</b>	<b>427,274.71</b>	<b>452,597.92</b>	<b>338,678.68</b>	<b>426,500.00</b>	<b>(15,000.00)</b>	<b>411,500.00</b>	

FY2024 Proposed Budget Port Operating Fund		F21 Actuals	F22 Actuals	F23 Actuals	F24 YTD Actuals @ 1.31.24	O-23-06-06 F24 Approved Budget	Budget Adjustment	O-24-03-07 F24 Proposed Amended Budget	Budget Notes
<b>Other Misc Revenue</b>									
80.3511.0001	Copies, Fax, Pubs, Film Lcns	1,395.48	1,031.06	717.07	-	1,000.00	(500.00)	500.00	
80.3511.0002	Banking / NSF Check Fee	-	-	-	-	50.00		50.00	
80.3511.0003	Credit Card Service Fees	206.90	-	-	-	-		-	
80.3511.0004	Resale-Hats,Charts,Apparel	1,266.40	1,077.60	1,473.78	806.05	2,000.00	(1,000.00)	1,000.00	
80.3511.0005	Other Port Revenue	26,844.30	7,469.04	32,301.73	39,886.19	7,500.00	27,500.00	35,000.00	FY23 Fish Business Shared Tax \$29,630; Records Request \$4,686
	<b>Total Other Misc Revenue:</b>	<b>29,713.08</b>	<b>9,577.70</b>	<b>34,492.58</b>	<b>40,692.24</b>	<b>10,550.00</b>	<b>26,000.00</b>	<b>36,550.00</b>	
<b>Interest Earnings</b>									
80.3611.2001	Interest Earnings Port Op	13,445.96	12,865.91	19,102.48	15,935.63	13,500.00	2,500.00	16,000.00	
80.3611.2002	Interest Earnings Causeway	2,564.91	1,624.15	4,458.10	3,019.37	2,500.00	1,000.00	3,500.00	
80.3611.2003	Investment Earnings	12,561.56	497.98	20,090.01	22,156.27	17,500.00	5,500.00	23,000.00	
80.3611.2004	Interest Earnings - Leases	-	27,793.30	26,580.98	-	26,600.00		26,600.00	GASB 87
	<b>Total Interest Earnings:</b>	<b>28,572.43</b>	<b>42,781.34</b>	<b>70,231.57</b>	<b>41,111.27</b>	<b>60,100.00</b>	<b>9,000.00</b>	<b>69,100.00</b>	
<b>Contributions / Other</b>									
80.3711.0001	StAK Employer On-Behalf PERS	16,367.72	(13,594.62)	10,764.62	-	15,000.00		15,000.00	
80.3711.0002	Other Contributions	-	-	-	-	2,000.00		2,000.00	
	<b>Total Contributions Other:</b>	<b>16,367.72</b>	<b>(13,594.62)</b>	<b>10,764.62</b>	<b>-</b>	<b>17,000.00</b>	<b>-</b>	<b>17,000.00</b>	
<b>Events</b>									
80.3811.0001	Conference Registration			72,540.63					
80.3811.0002	Sponsor Fee								
80.3811.0003	Exhibitor Fee								
80.3811.0004	Other								
	<b>Total Events</b>			<b>72,540.63</b>					
<b>Transfers - Interfunds</b>									
80.3888.8820	Transfers In - Other Funds	-	-	-	-	-		-	
80.3888.8830	Transfers In - General Fund	-	-	-	-	-		-	
	<b>Total Transfers - Interfunds:</b>	<b>-</b>	<b>-</b>	<b>-</b>	<b>-</b>	<b>-</b>		<b>-</b>	
	<b>Total Revenue before Fund Balance:</b>	<b>1,866,723.18</b>	<b>2,262,169.47</b>	<b>2,326,037.06</b>	<b>2,174,497.11</b>	<b>2,187,650.00</b>	<b>374,500.00</b>	<b>2,562,150.00</b>	
<b>Fund Balance Appropriation</b>									
80.3899.9997	PON Use of Fund Bal Carry Frwd		-	-	-	-		-	
80.3899.9999	Port of Nome Use Fund Balance		-	-	-	-		-	
	<b>Total Fund Balance Appropriation:</b>	<b>-</b>	<b>-</b>	<b>-</b>	<b>-</b>	<b>-</b>		<b>-</b>	
	<b>Total Port Operating Revenue</b>	<b>1,866,723.18</b>	<b>2,262,169.47</b>	<b>2,253,496.43</b>	<b>2,174,497.11</b>	<b>2,187,650.00</b>	<b>374,500.00</b>	<b>2,562,150.00</b>	

FY2024 Proposed Budget Port Operating Fund	F21 Actuals	F22 Actuals	F23 Actuals	F24 YTD Actuals @ 1.31.24	O-23-06-06 F24 Approved Budget	Budget Adjustment	O-24-03-07 F24 Proposed Amended Budget	Budget Notes
<b>Port Operating Fund Expense</b>								
<b>Causeway Facility</b>								
80.6111.1101 Salaries - Causeway Maint	1,811.71	1,962.18	1,494.10	1,185.14	2,000.00		2,000.00	
80.6111.1102 Salaries - Causeway Operations	4,456.14	4,099.92	10,782.10	8,740.80	10,000.00	5,000.00	15,000.00	
80.6111.1103 Salaries - Causeway Admin	17,062.78	19,649.94	21,414.62	8,735.30	25,863.11	(6,599.81)	19,263.30	Finance Allocation Split between Cswy & Admin
80.6111.1411 Accrued Personal Leave - Cswy	4,347.97	3,346.10	6,285.12	1,633.50	5,482.06		5,482.06	
80.6111.1421 Health Insurance - Cswy	6,198.11	6,176.78	7,848.53	3,747.53	9,572.72		9,572.72	
80.6111.1431 Life Insurance - Cswy	11.02	39.59	187.69	14.92	68.69		68.69	
80.6111.1441 FICA/Medicare - Cswy	1,786.11	1,996.86	2,577.42	1,427.52	2,896.53	2.58	2,899.11	
80.6111.1451 ESC - Causeway	551.05	157.60	289.04	207.03	897.36	(37.92)	859.44	
80.6111.1461 PERS - Cswy	7,042.33	7,299.21	8,175.64	3,972.69	8,329.88	(351.95)	7,977.93	
80.6111.1471 Workers' Comp Ins - Cswy	590.73	419.13	1,840.45	777.13	751.80	25.33	777.13	
80.6111.1481 Amortized Inflows/Outflows	-	-	-	-	-		-	
80.6111.1520 Vehicle/Boat Insurance	605.48	578.00	578.00	578.00	578.00		578.00	Guardian Boat, Tuff Boat 18C Skiff - 50% Shared with Harbor
80.6111.1530 Property/Building Insurance	33,645.00	34,236.50	37,013.84	38,366.02	40,715.22	(2,349.20)	38,366.02	
80.6111.1802 Prof Svcs - High Mast Lights	-	-	-	-	-		-	
80.6111.1803 Prof Svcs - Middle Dock	-	-	-	-	-		-	
80.6111.1804 Prof Svcs - Arctic Deep Draft	-	-	-	-	-		-	
80.6111.1810 Audit/Accounting	13,735.87	14,725.47	16,297.55	19,637.50	19,700.00		19,700.00	Base Fee % 13692, \$6000 State Compliance
80.6111.1820 Engineering/Architectural Svcs	8,365.20	(4,979.95)	8,600.00	1,000.00	30,000.00		30,000.00	Placeholder for unexpected in-house
80.6111.1830 Legal Services	-	-	-	-	5,000.00		5,000.00	Potential P3 Agreements
80.6111.1840 Survey/Appraisal Services	-	-	-	-	12,500.00		12,500.00	Potential Topo for fuel line agreements + dredging surveys
80.6111.1870 Other Professional/Contract Sv	7,912.45	15,567.32	5,874.50	-	25,000.00		25,000.00	Dredging dock berthing areas
80.6111.2010 Communications	-	-	-	-	-		-	
80.6111.2012 Computer Network/Hardware/Soft	-	-	-	-	-		-	
80.6111.2040 Uniform/Clothing	-	128.39	667.49	443.31	2,000.00		2,000.00	Rain Gear / Gloves / Boots
80.6111.2071 Operating Supplies	87.93	2,428.70	169.00	653.94	2,000.00		2,000.00	Misc. Pigs, gaskets, fittings, epoxy paint
80.6111.2073 Resale: Spill Supplies	-	-	1,928.07	-	2,500.00		2,500.00	
80.6111.4010 Gas & Oil Supplies	-	-	-	-	500.00		500.00	
80.6111.4020 Boat/Hvy Eq Parts & Supply	453.39	77.84	-	17.80	500.00	22,500.00	23,000.00	Guardian Honda 225HP Outboards x2 Replacement, \$20k each + \$3-4k shipping; split with harbor
80.6111.4030 Boat/Hvy Eq Maintenance	217.99	-	-	-	3,000.00		3,000.00	Guardian winch line replacement and deck maint.
80.6111.4040 Vehicle/Boat Regis & Permits	-	-	-	-	-		-	
80.6111.4050 Small Tools & Equipment	1,909.98	300.00	1,131.73	1,268.56	2,000.00		2,000.00	Water Trailer new hose and fittings
80.6111.4060 Tools & Eq Repair & Maint	735.15	2,482.42	141.00	-	2,000.00		2,000.00	Pigs, gaskets, fittings, drip pans
80.6111.4080 Road Maintenance Materials	-	-	15,708.33	-	25,000.00		25,000.00	3" material - Stock Piles depleted
80.6111.4090 Docks & Foundations	1,004.77	-	-	-	25,000.00		25,000.00	Repairs and/or Maintenance (damage, material loss, deterioration)
80.6111.4100 Fuel Lines Maintenance	11,745.01	3,711.17	10,445.85	59,905.80	35,000.00	39,905.80	74,905.80	Fuel Header Repair \$41,450, UT Testing \$18,456, Plan for Potential Bridge Repair Work \$15k
80.6111.7005 Building Maintenance Contracts	-	-	-	-	-		-	
80.6111.7010 Bldg Maint Materials & Supply	-	-	-	38.00	2,500.00		2,500.00	Bathroom upgrade - Door, seat, fixtures, paint
80.6111.7011 Janitorial Services & Supplies	-	-	-	-	-		-	

FY2024 Proposed Budget Port Operating Fund		F21 Actuals	F22 Actuals	F23 Actuals	F24 YTD Actuals @ 1.31.24	O-23-06-06 F24 Approved Budget	Budget Adjustment	O-24-03-07 F24 Proposed Amended Budget	Budget Notes
80.6111.7020	Causeway Utilities	-	-	-	-	-	-	-	
80.6111.7021	Utilities - Electric	1,744.25	1,741.90	3,808.22	1,377.45	3,000.00	-	3,000.00	
80.6111.7022	Utilities - Water	-	-	-	-	-	-	-	
80.6111.7023	Utilities - Sewer	1,550.00	1,750.00	1,050.00	1,400.00	1,400.00	-	1,400.00	\$350 ea x 4 pumps July, Aug, Sept, Oct
80.6111.7024	Utilities - Garbage	2,664.10	2,802.77	5,122.21	1,917.67	4,000.00	-	4,000.00	
80.6111.7025	Utilities - Heat	-	-	-	-	-	-	-	
80.6111.7026	Utilities - Resale	-	2,052.16	-	-	5,000.00	-	5,000.00	
80.6111.7510	Debt Interest Payment	148,314.34	142,539.93	136,532.49	96,949.84	135,000.00	-	135,000.00	
80.6111.7520	Depreciation	-	-	-	-	-	-	-	
80.6111.7550	Bad Debt	-	-	-	-	-	-	-	
80.6111.8030	Machinery & Equipment	-	-	-	-	15,000.00	-	15,000.00	Shared Project Traffic Control (PWKS)
<b>Total Causeway Facility:</b>		<b>278,548.86</b>	<b>265,289.93</b>	<b>305,962.99</b>	<b>253,995.45</b>	<b>464,755.37</b>	<b>58,094.83</b>	<b>522,850.20</b>	



FY2024 Proposed Budget Port Operating Fund		F21 Actuals	F22 Actuals	F23 Actuals	F24 YTD Actuals @ 1.31.24	O-23-06-06 F24 Approved Budget	Budget Adjustment	O-24-03-07 F24 Proposed Amended Budget	Budget Notes
<b>CPV Operating &amp; Maintenance</b>									
80.6112.1101	Salaries - Operations	-	-	-	-	-	-	-	
80.6112.1102	Salaries - Maintenance	-	-	-	-	-	-	-	
80.6112.1103	Salaries - Admin	-	-	-	-	-	-	-	
80.6112.1411	Accrued Annual Leave	-	-	-	-	-	-	-	
80.6112.1421	Health Insurance	-	-	-	-	-	-	-	
80.6112.1431	Life Insurance	-	-	-	-	-	-	-	
80.6112.1441	FICA/Medicare	-	-	-	-	-	-	-	
80.6112.1461	PERS	-	-	-	-	-	-	-	
80.6112.1471	Workers' Comp Insurance	-	-	-	-	-	-	-	
80.6112.1820	Engineering	-	-	-	-	-	-	-	
80.6112.1870	Professional Services	-	-	-	-	-	-	-	
80.6112.2071	Operating Supplies	-	-	4,830.61	-	5,000.00	-	5,000.00	Placeholder
80.6112.7005	Building Maintenance Contracts	-	-	-	-	-	-	-	
80.6112.7010	Materials & Supplies	-	-	-	-	-	-	-	
<b>Total CPV Op &amp; Mtnc:</b>		-	-	<b>4,830.61</b>	-	<b>5,000.00</b>	-	<b>5,000.00</b>	

FY2024 Proposed Budget Port Operating Fund		F21 Actuals	F22 Actuals	F23 Actuals	F24 YTD Actuals @ 1.31.24	O-23-06-06 F24 Approved Budget	Budget Adjustment	O-24-03-07 F24 Proposed Amended Budget	Budget Notes
<b>Harbor Facility</b>									
80.6211.1101	Salaries - Harbor	2,629.86	3,050.37	732.79	1,555.65	5,000.00		5,000.00	Road Repairs
80.6211.1411	Accrued Personal Lv - Harbor	548.20	570.42	96.05	-	935.00		935.00	
80.6211.1421	Health Insurance - Harbor	805.86	804.50	149.53	579.57	1,349.44		1,349.44	
80.6211.1431	Life Insurance - Harbor	5.13	1.45	0.36	3.10	8.30		8.30	
80.6211.1441	FICA/Medicare - Harbor	209.00	233.32	56.07	119.01	382.50		382.50	
80.6211.1451	ESC - Harbor	69.48	72.30	12.17	-	118.50		118.50	
80.6211.1461	PERS - Harbor	823.16	903.44	235.57	342.22	1,100.00		1,100.00	
80.6211.1471	Workers' Comp Ins - Harbor	197.14	170.44	372.84	302.00	302.00		302.00	
80.6211.1481	Amortized Inflows/Outflows	-	-	-	-	-		-	
80.6211.1520	Vehicle/Boat Insurance	605.47	578.00	578.00	578.00	635.80		635.80	Guardian Boat, Tuff Boat 18C Skiff - 50% Shared with Causeway
80.6211.1530	Property/Building Insurance	23,445.00	24,036.50	26,735.86	27,911.03	29,409.45	(1,498.42)	27,911.03	
80.6211.1802	Prof Svcs - Barge High Ramp	-	-	-	-	-		-	
80.6211.1803	Prof Svcs - Snake River	-	-	-	-	-		-	
80.6211.1807	Prof Svcs - Seawall Repairs	-	-	-	-	-		-	
80.6211.1820	Engineering/Architectural Svcs	628.50	1,938.25	2,112.50	500.00	20,000.00		20,000.00	Placeholder for unexpected in-house
80.6211.1870	Other Professional/Contract Sv	23,592.98	9,231.29	10,452.32	1,860.00	25,000.00		25,000.00	Survey of berthing areas, potential dredging
80.6211.2010	Communications	-	-	-	-	-		-	
80.6211.2040	Uniform/Clothing	85.77	95.62	1,715.15	193.25	2,200.00		2,200.00	PPE Split
80.6211.2071	Operating Supplies	443.96	2,054.62	485.49	849.08	6,000.00		6,000.00	Fittings, hoses
80.6211.2073	Resale: Spill Supplies	-	-	15,424.58	-	20,000.00	(5,000.00)	15,000.00	
80.6211.4010	Gas & Oil Supplies	29.48	-	-	-	500.00		500.00	
80.6211.4020	Boat/Hvy Eq Parts & Supply	478.65	77.84	-	17.80	1,000.00	22,500.00	23,500.00	Guardian Honda 225HP Outboards x2 Replacement, \$20k each + \$3-4k shipping; split with cswy
80.6211.4030	Boat/Hvy Eq Maintenance	217.99	-	-	-	2,000.00		2,000.00	Annual service and unexpected maint
80.6211.4040	Vehicle/Boat Regis & Permits	-	-	-	-	10.00		10.00	
80.6211.4050	Small Tools & Equipment	2,865.99	300.00	141.00	1,268.56	2,500.00		2,500.00	
80.6211.4080	Road Maintenance Materials	-	-	15,708.33	-	20,000.00		20,000.00	Need surfacing material, stockpile almost depleted.
80.6211.4090	Docks & Foundations	-	-	-	-	15,000.00		15,000.00	Repairs and/or Maintenance (damage, material loss, deterioration)
80.6211.4100	Fuel Lines Maintenance	-	-	-	-	1,500.00		1,500.00	
80.6211.7005	Building Maintenance Contracts	-	-	-	-	-		-	
80.6211.7010	Bldg Maint Materials & Supply	101.20	1,769.50	2,487.75	-	5,000.00		5,000.00	
80.6211.7011	Janitorial Services & Supplies	-	-	-	-	-		-	
80.6211.7020	Harbor Utilities	-	-	-	-	-		-	
80.6211.7021	Utilities - Electric	4,790.42	5,159.87	6,782.83	2,593.60	7,000.00	(500.00)	6,500.00	
80.6211.7022	Utilities - Water Meter	3,481.92	3,390.16	3,433.56	1,779.40	3,500.00		3,500.00	
80.6211.7023	Utilities - Sewer	2,443.04	2,643.04	2,293.04	3,446.52	4,000.00		4,000.00	
80.6211.7024	Utilities - Garbage	8,924.85	5,827.09	9,529.99	2,209.42	7,500.00		7,500.00	
80.6211.7025	Utilities - Heat	1,776.70	1,894.37	3,486.54	1,088.52	3,000.00		3,000.00	
80.6211.7520	Depreciation	-	-	-	-	-		-	
80.6211.7560	Payment in Lieu of Tax	18,377.45	16,984.20	16,984.20	-	15,568.85	(707.67)	14,861.18	Based on 10.5 mills (Value 1,415,350)
80.6211.8010	Land/Buildings	-	-	-	-	-		-	
80.6211.8030	Machinery & Equipment	-	-	-	-	15,000.00	(15,000.00)	-	
<b>Total Harbor Facility:</b>		<b>97,577.20</b>	<b>81,786.59</b>	<b>120,006.52</b>	<b>47,196.73</b>	<b>215,519.84</b>	<b>(206.09)</b>	<b>215,313.75</b>	

FY2024 Proposed Budget Port Operating Fund		F21 Actuals	F22 Actuals	F23 Actuals	F24 YTD Actuals @ 1.31.24	O-23-06-06 F24 Approved Budget	Budget Adjustment	O-24-03-07 F24 Proposed Amended Budget	Budget Notes
<b>Cape Nome Facility</b>									
80.6311.1101	Salaries - Cape Nome	-	-	-	-	-	-	-	
80.6311.1411	Accrued Personal Lv -Cape Nome	-	-	-	-	-	-	-	
80.6311.1421	Health Insurance - Cape Nome	-	-	-	-	-	-	-	
80.6311.1431	Life Insurance - Cape Nome	-	-	-	-	-	-	-	
80.6311.1441	FICA/Medicare - Cape Nome	-	-	-	-	-	-	-	
80.6311.1451	ESC - Cape Nome	-	-	-	-	-	-	-	
80.6311.1461	PERS - Cape Nome	-	-	-	-	-	-	-	
80.6311.1471	Workers' Comp Ins - Cape Nome	-	-	-	-	-	-	-	
80.6311.1820	Engineering/Architectural Svcs	-	-	-	15,000.00	1,000.00	14,000.00	15,000.00	
80.6311.1830	Legal Services	-	-	-	-	500.00	-	500.00	
80.6311.1870	Other Professional/Contract Sv	-	-	-	-	1,000.00	-	1,000.00	
80.6311.1940	Advertising	-	-	-	-	-	-	-	
80.6311.2010	Communications	-	-	-	-	-	-	-	
80.6311.7520	Depreciation	-	-	-	-	-	-	-	
80.6311.8020	Building/Grounds Improvements	-	-	-	-	-	-	-	
	<b>Total Cape Nome Facility:</b>	-	-	-	<b>15,000.00</b>	<b>2,500.00</b>	<b>14,000.00</b>	<b>16,500.00</b>	

FY2024 Proposed Budget Port Operating Fund	F21 Actuals	F22 Actuals	F23 Actuals	F24 YTD Actuals @ 1.31.24	O-23-06-06 F24 Approved Budget	Budget Adjustment	O-24-03-07 F24 Proposed Amended Budget	Budget Notes
<b>Industrial Park Facility</b>								
80.6411.1101		826.62	1,739.88	5,269.56	1,500.00	6,000.00	7,500.00	
80.6411.1411		154.57	-	-	280.50		280.50	
80.6411.1421		418.66	-	2,055.07	404.83	2,114.24	2,519.07	
80.6411.1431		2.53	-	13.26	2.49	14.55	17.04	
80.6411.1441		63.26	133.10	403.11	114.75	459.00	573.75	
80.6411.1451		19.59	-	-	35.55	142.20	177.75	
80.6411.1461		244.86	567.81	1,159.31	330.00	1,320.00	1,650.00	
80.6411.1471		42.77	104.40	90.60	90.60	382.65	473.25	
80.6411.1481		-	-	-	-	-	-	
80.6411.1530	1,129.00	1,460.00	1,889.00	2,580.00	2,580.00		2,580.00	
80.6411.1820	38,563.86	18,772.50	5,945.00	500.00	25,000.00		25,000.00	Permitting
80.6411.1830	-	-	-	-	-	-	-	
80.6411.1870	3,318.50	31,447.50	250.00	2,617.50	20,000.00		20,000.00	Surveys/ sampling
80.6411.1940	-	-	-	-	-	-	-	
80.6411.2071	147.66	285.72	-	-	500.00		500.00	
80.6411.2073	-	-	1,928.08	-	2,500.00		2,500.00	
80.6411.4050	396.44	299.99	141.00	63.00	1,000.00		1,000.00	
80.6411.4080	-	-	15,708.34	-	16,000.00		16,000.00	Need surfacing material, stockpile almost depleted.
80.6411.4100	21,243.10	2,944.00	10,445.85	59,905.80	30,000.00	29,905.80	59,905.80	Fueling Header Repair \$41,450, UT Testing \$18,456
80.6411.7005	-	-	-	-	-	-	-	
80.6411.7010	-	111.01	57.80	-	500.00		500.00	
80.6411.7011	-	-	-	-	-	-	-	
80.6411.7020	-	-	-	-	-	-	-	
80.6411.7021	4,207.23	4,734.30	5,744.96	2,510.49	5,000.00		5,000.00	
80.6411.7023	1,550.00	1,750.00	1,400.00	1,400.00	1,400.00		1,400.00	
80.6411.7520	-	-	-	-	-	-	-	
80.6411.7560	53,934.40	49,783.20	49,765.20	-	45,618.10	(2,073.55)	43,544.55	Based on 10.5 mills (Value 4,147,100)
80.6411.8030	11.39	-	-	-	15,000.00	(15,000.00)	-	
<b>Total Industrial Park Facility:</b>	<b>124,501.58</b>	<b>113,361.08</b>	<b>95,820.42</b>	<b>78,567.70</b>	<b>167,856.82</b>	<b>23,264.89</b>	<b>191,121.71</b>	

FY2024 Proposed Budget Port Operating Fund		F21 Actuals	F22 Actuals	F23 Actuals	F24 YTD Actuals @ 1.31.24	O-23-06-06 F24 Approved Budget	Budget Adjustment	O-24-03-07 F24 Proposed Amended Budget	Budget Notes
<b>Port Admin Office</b>									
80.6711.1101	Salaries - Port Admin	75,560.70	78,024.40	85,647.55	38,496.32	91,806.53	(43,710.21)	48,096.32	1 Port Director <b>Est Start Date 6.1.24</b>
80.6711.1102	Salaries - Port Staff	201,860.66	226,172.83	272,598.68	152,534.02	303,992.61	2,396.41	306,389.02	1 Project Manager, 1 Hrbmstr 12mo, 1 HM Asst 6 mo, 1 Purchasing Manager shared with Public Works, 1 FT Acctg Tech , 1 Temp Dockwatch, (20% Shared Cost with Finance, 12% IT)
80.6711.1201	Salaries - Overtime	7,077.97	8,939.88	10,507.71	9,956.69	7,500.00	5,000.00	12,500.00	
80.6711.1301	Stipends - Port Commission	3,280.00	3,280.00	3,360.00	840.00	3,360.00		3,360.00	
80.6711.1411	Accrued Personal Lv - Port Adm	6,649.86	4,399.03	7,987.32	3,033.65	5,402.98	51,694.47	57,097.45	
80.6711.1421	Health Insurance - Port Adm	48,368.99	48,433.84	52,713.57	33,132.34	100,954.12	(32,039.78)	68,914.34	
80.6711.1431	Life Insurance - Port Adm	315.94	364.62	626.74	241.34	655.41	(127.96)	527.45	
80.6711.1441	FICA/Medicare - Port Adm	21,794.58	23,963.77	28,153.69	15,406.28	30,852.38	(2,545.93)	28,306.45	
80.6711.1451	ESC - Port Admin	751.78	-	(144.43)	384.48	500.00		500.00	
80.6711.1461	PERS - Port Adm	80,206.96	81,414.13	76,537.76	40,068.45	83,539.88	(5,880.87)	77,659.01	
80.6711.1471	Workers' Comp Ins - Port Adm	9,944.49	4,940.54	10,434.42	7,874.22	7,827.17	47.05	7,874.22	
80.6711.1481	Amortized Inflows/Outflows	-	-	-	-	-		-	
80.6711.1520	Vehicle/Boat Insurance	3,007.00	2,447.00	2,641.00	3,132.00	3,132.00		3,132.00	2002 F350 Flatbed, 2012 GMC Sierra, 2014 F250 Crew Cab, 2013 Ford Expedition
80.6711.1530	Property/Building Insurance	498.00	647.00	800.00	1,068.00	1,068.00		1,068.00	
80.6711.1810	Audit/Accounting	13,735.87	14,725.47	20,297.53	19,637.50	18,000.00		18,000.00	Base Fee % 13962 + GASB 87 & 96
80.6711.1820	Engineering/Architectural Svcs	-	-	1,754.00	1,000.00	30,000.00		30,000.00	Onshore Renderings / Design Drawings
80.6711.1830	Legal Services	1,993.50	5,914.50	17,235.39	32,906.49	15,000.00		15,000.00	Onshore P3 Agreements
80.6711.1850	Lobbying	104,250.00	115,011.91	124,894.00	112,350.00	108,750.00		108,750.00	LCIA \$63,750 / WWS \$45,000
80.6711.1870	Other Professional/Contract Sv	28,455.44	44,315.64	35,166.23	78,820.30	115,500.00	184,500.00	300,000.00	12% GCS IT Managed Svcs \$15355, Canon, Caselle, GCSIT, Arctic Fire & Security, Grant Writing/P3 Support \$25000, Rate Study \$40,000, Onshore Development Plan \$212,000.
80.6711.1940	Advertising	2,809.20	1,961.80	1,833.20	5,970.10	1,000.00	5,000.00	6,000.00	
80.6711.1950	Buildings/Land Rental	7,200.00	4,441.00	9,604.23	6,797.16	11,700.00		11,700.00	\$900 x 6mo, \$1050 x 6 mo
80.6711.2010	Communications	3,462.17	3,445.05	3,025.99	1,530.78	4,100.00		4,100.00	
80.6711.2012	Computer Network/Hardware/Soft	3,097.23	1,286.90	8,651.41	4,773.22	7,500.00	500.00	8,000.00	Port office computer replacement
80.6711.2020	Dues & Memberships	205.00	185.00	318.99	635.00	500.00	635.00	1,135.00	
80.6711.2030	Travel, Training & Related Cost	2,320.70	12,060.55	16,152.26	2,720.15	16,500.00		16,500.00	
80.6711.2070	Office Supplies	734.73	906.03	1,410.02	570.33	1,800.00	500.00	2,300.00	
80.6711.2071	Operating Supplies	2,988.93	3,994.53	7,385.91	4,175.31	5,000.00	1,000.00	6,000.00	
80.6711.2073	Resale Supplies	4,206.81	3,287.66	5,639.54	4,736.25	8,000.00		8,000.00	Hoodies, T-shirts
80.6711.3010	Sponsorship/Donation/Contrib	-	10,500.00	-	-	2,500.00		2,500.00	
80.6711.4010	Gas & Oil Supplies	3,770.04	4,896.45	9,406.95	5,228.08	8,000.00		8,000.00	
80.6711.4020	Vehicle Parts & Supply	4,754.87	1,545.31	3,101.97	7,534.66	5,000.00	4,000.00	9,000.00	2012 GMC tow hitch / bumper
80.6711.4030	Vehicle Maintenance	180.50	-	-	-	5,000.00		5,000.00	
80.6711.4040	Vehicle/Boat Regis & Permits	10.00	40.00	10.00	-	50.00		50.00	
80.6711.7010	Bldg Maint Materials & Supply	831.15	1,600.00	1,103.45	430.37	15,000.00		15,000.00	Leaking Port Office/ bathroom upgrade/Laser 530.
80.6711.7011	Janitorial Services & Supplies	245.23	2,000.67	8.96	220.37	500.00		500.00	Laser 301 for Front Office
80.6711.7500	Debt Principal Payment	-	-	-	-	-		-	
80.6711.7510	Interest Payment	-	-	-	-	-		-	
80.6711.7520	Depreciation	-	-	-	-	-		-	
80.6711.7530	Cash - Over/Short	-	0.05	(91.00)	-	-		-	
80.6711.7540	Banking/Credit Card Fees	4.90	-	-	-	300.00		300.00	
80.6711.7550	Bad Debt	12,564.58	22,527.47	(7,309.65)	-	5,000.00		5,000.00	
80.6711.8030	Machinery & Equipment	-	-	-	-	-		-	
<b>Total Port Admin Office:</b>		<b>657,137.78</b>	<b>737,673.03</b>	<b>811,463.39</b>	<b>596,203.86</b>	<b>1,025,291.08</b>	<b>170,968.18</b>	<b>1,196,259.26</b>	

FY2024 Proposed Budget Port Operating Fund		F21 Actuals	F22 Actuals	F23 Actuals	F24 YTD Actuals @ 1.31.24	O-23-06-06 F24 Approved Budget	Budget Adjustment	O-24-03-07 F24 Proposed Amended Budget	Budget Notes
<b>Events - AAHPA Conference September 2022</b>									
80.6811.1101	Salaries - Events			-	-	-		-	
80.6811.1105	Salaries - Temporary			-	-	-		-	
80.6811.1201	Salaries - Overtime			-	-	-		-	
80.6811.1421	Health Insurance - Events			-	-	-		-	
80.6811.1431	Life Insurance - Events			-	-	-		-	
80.6811.1441	FICA/Medicare - Events			-	-	-		-	
80.6811.1461	PERS - Events			-	-	-		-	
80.6811.1471	Worker's Comp - Events			-	-	-		-	
80.6811.1870	Professional Services			6,260.00	-	-		-	
80.6811.1940	Advertising			-	-	-		-	
80.6811.2071	Operating Supplies			17,831.64	-	-		-	
80.6811.2078	Program Supplies			41,637.71	-	-		-	
80.6811.2080	Logistics			-	-	-		-	
80.6811.2085	Sponsor Expenses			5,145.68	-	-		-	
80.6811.2088	Sponsor Expenses -Scholarships			1,665.60	-	-		-	
	<b>Total Events:</b>	-	-	<b>72,540.63</b>	-	-		-	
	<b>Total Expense before Transfers</b>	<b>1,157,765.42</b>	<b>1,198,110.63</b>	<b>1,410,624.56</b>	<b>990,963.74</b>	<b>1,880,923.11</b>	<b>266,121.81</b>	<b>2,147,044.92</b>	
<b>Transfers - Interfunds</b>									
80.6888.8820	Transfers Out - Other Funds	138,022.17	2,539,227.79	566,851.93	-	306,726.89	108,378.19	415,105.08	Transfer to CPF for Non Grant Projects \$117,500 / Transfer Revenue Surplus to Capital Projects Fund \$297,605
<b>Contribution to Fund Balance</b>									
80.6999.9999	Contribution to Fund Balance	-	-	-	-	-		-	
	<b>Total Port Operating Expense</b>	<b>1,295,787.59</b>	<b>3,737,338.42</b>	<b>1,977,476.49</b>	<b>990,963.74</b>	<b>2,187,650.00</b>	<b>374,500.00</b>	<b>2,562,150.00</b>	

1<sup>st</sup> Reading: February 26, 2024  
2<sup>nd</sup> Reading: March 25, 2025

**Presented By:**  
City Manager/Finance Director

**Action Taken:**  
Yes \_\_\_\_  
No \_\_\_\_  
Abstain \_\_\_\_

**CITY OF NOME, ALASKA**

**ORDINANCE NO. O-24-03-08**

**AN ORDINANCE AMENDING THE CITY OF NOME  
FY 2024 PORT OF NOME CAPITAL PROJECTS FUND BUDGET**

**Section 1.**

This is a non-Code ordinance.

**Section 2.**

**BE IT HEREBY ORDAINED** by the Nome City Council, that the attached adjustments be made to the FY 2024 City of Nome Port of Nome Capital Projects Fund Budget.

**APPROVED** and **SIGNED** the 25<sup>th</sup> day of March, 2024.

\_\_\_\_\_  
**JOHN K. HANDELAND**  
Mayor

**ATTEST:**

\_\_\_\_\_  
**JEREMY JACOBSON**  
Deputy City Clerk

FY2024 Proposed Budget Port Capital Projects Fund	F21 Actuals	F22 Actuals	F23 Actuals	F24 YTD Actuals @ 1.31.24	O-23-06-07 F24 Proposed Budget	Budget Adjustment	O-24-03-08 F24 Proposed Amended Budget	Budget Notes	
<b>Port Grants &amp; Awards - Revenue</b>									
85.3811.0002	15-DC-112 Port Improvements	-	-	-	-	-	-		
85.3811.0003	13-GO-012 Port Design, Constr	-	-	-	-	-	-		
85.3811.0005	14-DC-108 - Port Improvements	-	-	-	-	-	-		
85.3811.0006	NSEDC Middle Dock	-	-	-	-	-	-		
85.3811.0007	EDA Causeway Middle Dock	-	0.08	-	-	-	-		
85.3811.0008	DOT 13-HG-010 Repairs, Upgrade	-	-	-	-	-	-		
85.3811.0009	FEMA Port Security Grant	-	-	-	-	-	-		
85.3811.0010	DR-4050-AK PW17 Cape Nome	-	-	-	-	-	-		
85.3811.0012	DR-4672-AK PW Disaster Assist	-	-	-	4,000,000.00	5,835,000.00	9,835,000.00	FEMA Public Assistance Program	
85.3811.0020	17-DC-005 Arctic DDP Design	40,058.10	29,443.69	-	-	-	-		
85.3811.0021	19-DC-008 Support Design ADDP	403,105.02	834,699.42	209,837.90	-	-	-		
85.3811.0023	NOAA-AOOS Weather Camera	-	-	-	-	-	-		
85.3811.0025	23-DC-005 Arctic Deep Draft	-	-	-	150,300,000.00	-	150,300,000.00	Grant Funds	
85.3811.0026	23-DC-006 Deep Draft Port	-	-	1,781,861.96	21,184.24	23,000,000.00	218,138.04	Grant True Up	
85.3811.0050	NSEDC Hbr Concrete Ramp Repair	202,629.33	97,370.67	-	-	-	-		
85.3811.7100	EDA Harbor Launch Ramp Repair	407,045.46	1,686,409.97	148,198.45	-	-	-		
85.3811.9000	Port Security Grant	-	-	-	30,000.00	(30,000.00)	-		
					-	-	-		
85.3888.8820	Transfers In - Other Funds	138,022.17	2,539,227.79	566,851.93	-	306,726.89	108,378.19	415,105.08	Transfer IN for Non Grant Projects \$117,500 / Transfer Port Op Revenue Surplus to Capital Projects Fund \$297,605
	<b>Total Port Grants &amp; Awards Rev:</b>	<b>1,190,860.08</b>	<b>5,187,151.62</b>	<b>2,706,750.24</b>	<b>177,636,726.89</b>	<b>6,131,516.23</b>	<b>183,768,243.12</b>		
<b>Port Grants &amp; Awards - Expense</b>									
85.6811.1100	DR-4050-AK PW17 Cape Nome	-	-	-	-	-	-		
85.6811.1200	DR-4672-AK PW Cape Nome	-	-	51,427.50	423,150.00	4,000,000.00	4,000,000.00	8,000,000.00	\$6.5MM Repairs, \$1.5MM Design, Inspection, CA
85.6811.1203	DR-4672-AK PW Cswy Road + 3Docks	-	-	-	-	-	1,275,000.00	1,275,000.00	
85.6811.1205	DR-4672-AK PW Inner Harbor	-	-	-	10,795.60	-	550,000.00	550,000.00	
85.6811.1207	FEMA - CAT Z	-	-	10,000.00	4,651.00	-	10,000.00	10,000.00	
85.6811.1421	Health Insurance - Port Grants	-	-	-	613.40	-	-	-	
85.6811.1431	Life Insurance - Port Grants	-	-	-	6.23	-	-	-	
85.6811.1441	FICA/Medicare - Port Grants	-	-	-	269.11	-	-	-	
85.6811.1461	PERS - Port Grants	-	-	-	773.91	-	-	-	
85.6811.2000	15-DC-112 Port Improvements	-	-	-	-	-	-	-	
85.6811.2100	19-DC-008 Support Design ADDP	898.97	530,130.04	203,350.13	-	-	-	-	
85.6811.2150	19-DC-008 Local Service Fac	-	200,000.00	-	-	-	-	-	
85.6811.2155	LSFs - Port Contribution	-	1,693,393.95	128,725.06	-	-	-	-	
85.6811.2200	17-DC-005 Arctic DDP Design	40,058.10	29,443.69	-	-	-	-	-	
85.6811.2250	ADDP - Port Contribution	-	5,470.23	-	-	-	-	-	
85.6811.2300	19DC008 Hbr CAP107 FeasStudy	402,206.05	104,569.38	6,487.77	-	-	-	-	
85.6811.2400	NOAA-AOOS Weather Camera	-	-	-	-	-	-	-	
85.6811.2500	23-DC-005 Arctic Deep Draft	-	-	-	150,300,000.00	-	150,300,000.00	150,300,000.00	Grant Funds
85.6811.2600	23-DC-006 Deep Draft Port	-	-	1,781,861.96	227,923.19	23,000,000.00	203,255.97	23,203,255.97	Grant True Up
85.6811.2601	23-DC-006 DDP PED/WIK	-	-	-	8,566.55	-	8,566.55	8,566.55	Grant True Up
85.6811.2602	23-DC-006 DDP LERRDS	-	-	-	6,315.52	-	6,315.52	6,315.52	Grant True Up
85.6811.3000	13-GO-012 Causeway Deep Water	-	-	-	-	-	-	-	
85.6811.3100	13-GO-012 Causeway Middle Dock	-	-	-	-	-	-	-	
85.6811.3200	13-GO-012 Harbor Repairs, Upgr	-	-	-	-	-	-	-	



FY2024 Proposed Budget Port Capital Projects Fund		F21 Actuals	F22 Actuals	F23 Actuals	F24 YTD Actuals @ 1.31.24	O-23-06-07 F24 Proposed Budget	Budget Adjustment	O-24-03-08 F24 Proposed Amended Budget	Budget Notes
85.6811.3300	13-GO-012 Harbor High Ramp	-	-	-	-	-	-	-	
85.6811.3400	13-GO-012 Seawall	-	-	-	-	-	-	-	
85.6811.3500	13-GO-012 Thornbush TractA Dev	-	-	-	-	-	-	-	
85.6811.5000	14-DC-108 Port Improvements	-	-	-	-	-	-	-	
85.6811.6000	NSEDC Middle Dock	-	-	-	-	-	-	-	
85.6811.7000	EDA Causeway Middle Dock	-	-	-	-	-	-	-	
85.6811.7100	EDA Harbor Launch Ramp Repair	466,288.66	2,315,870.70	33,573.09	-	-	-	-	
85.6811.7900	Harbor Launch Ramp Rpr NSEDC \$	202,629.33	97,370.67	-	-	-	-	-	
85.6811.8000	DOT 13-HG-010 Repairs, Upgrade	-	-	-	-	-	-	-	
85.6811.8001	Grant Match Port Contribution	8,074.72	14,261.12	3,246.73	-	-	-	-	
85.6811.8002	Barge Ramp Lighting Improvmts	-	-	-	-	-	-	-	
85.6811.8003	Garco Bldg Lighting Improvmts	-	-	-	-	-	-	-	
85.6811.8004	Bridge Fuel Line Replacements	-	-	-	-	-	-	-	
85.6811.8005	Concrete Barge Ramp Repairs NSEDC	-	-	-	-	-	-	-	
85.6811.8006	Port Waste Reception Facility	-	-	-	-	1,500.00	-	1,500.00	Anticipated consultant costs for grants and permit req's
85.6811.8007	Snake River Moorage Project	-	-	-	-	-	-	-	
85.6811.8008	DOT/Port Road Improvements	-	29,892.60	196,861.50	-	-	-	-	This Project is being pushed to F26/F27
85.6811.8009	WestGold Dock Emergency Repair	-	-	-	-	-	-	-	
85.6811.8010	Ramp Deadman Anchor Project	-	-	-	-	-	-	-	
85.6811.8011	Cswy Docks - Replace Anodes	46,709.15	110,000.26	-	-	-	-	-	
85.6811.8012	Fish Dock - Replace Anodes	23,995.10	56,633.30	-	-	-	-	-	
85.6811.8013	IP Fuel Line Repairs	-	-	-	-	-	-	-	
85.6811.8014	Cswy Mid & WG Dock Repairs	-	-	-	-	-	-	-	
85.6811.8015	High Mast Lights	-	-	50,330.42	-	30,000.00	-	30,000.00	Contract finalize/inspect installation - powerup connection
85.6811.8016	Thornbush IP - Drainage	-	115.60	176,975.00	-	16,000.00	-	16,000.00	in-house labor/equipment rental
85.6811.9000	Port Security Grant	-	-	-	-	30,000.00	(30,000.00)	-	Matching grant placeholder
85.6811.9500	Vehicle Purchase	-	-	-	-	70,000.00	-	70,000.00	F350 Super Cab Flatbed
85.6888.8820	Transfers Out - Other Funds	-	-	-	-	-	-	-	
85.6999.9999	Contribution to Fund Balance	-	-	-	-	189,226.89	108,378.19	297,605.08	Savings for Future Capital Needs
	<b>Total Port Grants &amp; Awards Exp:</b>	<b>1,190,860.08</b>	<b>5,187,151.54</b>	<b>2,642,839.16</b>	<b>683,064.51</b>	<b>177,636,726.89</b>	<b>6,131,516.23</b>	<b>183,768,243.12</b>	

**CITY OF NOME, ALASKA**

**RESOLUTION NO. R-24-02-06**

**A RESOLUTION AUTHORIZING THE CITY OF NOME TO APPLY FOR AND PARTICIPATE IN THE USDOT RAISE DISCRETIONARY GRANT PROGRAM FOR THE FUNDING OF THE SNAKE RIVER MOORAGE FACILITY PROJECT**

**WHEREAS**, the U.S. Department of Transportation (USDOT) administers the Rebuilding American Infrastructure with Sustainability & Equity (RAISE) Grant Program, which supports surface transportation projects necessary to facilitate direct intermodal, transfer or access into or out of a facility that will improve commodity movement throughout a region or freight network; and

**WHEREAS**, the City of Nome owns the Port & Harbor, which serves as the regional maritime hub facility for over fifty (50) western Alaska communities, transshipping fuel, cargo and gravel throughout the region during the ice-free season, serving as the critical transportation network link that enables equipment, fuel, household goods, and basic life-sustaining necessities to be delivered to the regional rural network; and

**WHEREAS**, Nome’s Inner Harbor has experienced an escalation in vessel congestion in the last ten (10) years, which has created numerous vessel incidents and significant delays in the transshipment of goods and services across the region and caused vessel overcrowding that has impacted subsistence activities; and

**WHEREAS**, the City of Nome identified the Snake River Moorage Facility as a priority projects in the Port of Nome Strategic Development Plan in an effort to increase shipping efficiencies deemed critical in the limited ice-free maritime window; and

**WHEREAS**, barge operators and the fishing industry have routinely demonstrated written project support in an effort to reduce risks of conflicts with smaller vessels that result in damage and potential crew injury, as well as exponentially increase shipping inefficiencies that cause delays in the delivery of equipment, materials and supplies that are on tight construction deadlines in the short ice-free season; and

**NOW, THEREFORE, BE IT RESOLVED** that the Nome Common Council supports application to the USDOT RAISE Grant Program with a match of up to twenty (20%) for development of the Snake River Moorage Facility Project, and agrees, subject to selection by USDOT, to enter into a grant agreement with USDOT for a RAISE Discretionary Grant.

**APPROVED** and **SIGNED** this 26<sup>th</sup> day of February, 2024.

\_\_\_\_\_  
**JOHN K. HANDELAND, Mayor**

**ATTEST:**

\_\_\_\_\_  
**JEREMY JACOBSON, Deputy Clerk**

# Memo

TO: Mayor John Handeland & Nome Common Council  
 FROM: Jim West, Chairman – Nome Port Commission *JW2*  
 THRU: Glenn Steckman - City Manager  
 DATE: 02/21/2024  
 RE: 2024 USDOT RAISE Grant Program – Snake River Moorage Design & Construction

---

The following motion was passed by the Nome Port Commission at their Regular Meeting on Thursday, February 15, 2024.

1. Moved by C. McLarty and seconded by C. Sheffield, that the following motion be approved:
  - **MOTION:** Recommend the Nome Common Council authorize making application to the 2024 USDOT RAISE Grant Program for funds to complete design and construction of the Snake River Moorage Facility.

**AT THE ROLL CALL:**

Ayes: Sheffield, McLarty, Smithhisler, West, McCann, Lean  
 Nays:  
 Abstain:

The motion **CARRIED.**

---

Discussion on this motion is reflected in the minutes of the February 15, 2024 Regular Meeting.

**PORT OF NOME  
SNAKE RIVER MOORAGE FACILITY  
GRANT FUNDING STRATEGY**

AGENCY	U.S. Department of Transportation
PROGRAM	RAISE Grants (Rebuilding American Infrastructure w/Sustainability & Equity)
DESCRIPTION	Funding Surface Transportation Projects having Significant Local/Regional Impact
FUNDING	\$1.5B Total – 50% to Rural Projects (Project Awards of \$1M Min/\$25M Max)
ELIGIBILITY	State, local & tribal governments (port infrastructure investment)
FED SHARE	Min 80% (Secretary may elect go fund up to 100% for rural projects)
DEADLINE	February 28, 2024 – 11:59 PM (Eastern)
PROJECT	PORT OF NOME – SNAKE RIVER MOORAGE FACILITY
APPLICANT	CITY OF NOME (up to 20% cost-share or \$3.3M)
\$\$ REQUEST	\$13.2M (Rural Projects can be funded up to 100% which is \$16.5M)

Primary Selection Criteria:

Safety  
Environmental Sustainability  
Quality of Life  
Mobility and Community Connectivity

Secondary Selection Criteria:

Economic Competitiveness  
State of Good Repair  
Partnerships and Collaboration  
Innovation

Program Requirements:

Climate Change and Environmental Justice Impact Consideration  
Racial Equity and Barriers to Opportunity

**PROJECT PURPOSE:**

As regional and international vessel traffic in the Bering Strait and Arctic Regions continues to increase, congestion in the Inner Harbor drives elevated safety concern for users and the Port, requiring constant coordination to ensure vessel and crew safety, minimize shipping delays and address vessel conflicts timely. Extensive efforts are undertaken to ensure a wide variety of fleet types ranging from 200-foot cargo barges to 40-foot fiberglass sailboats and 20-foot subsistence skiffs; all competing for operational space in the congestion.

As the only maritime coastal shipping hub in Western Alaska, delays in and out of the facility, caused by minimally available dock access frequently result in significant shipping delays. These delays impact delivery of fuel, equipment, building materials, household goods and basic life-sustaining necessities that must be delivered to the regional rural network during the ice-free shipping season. As Nome continues to struggle with vessel congestion and overcrowding, the region's critical transportation network link experiences reduced capacity and ability to serve the region. This escalates costs and risks for the population in Nome and across the region.

As the only protected harbor of refuge in the Bering Strait and Arctic Regions, it is very common to have a large number of vessels set course for Nome to evade an impending and often brutal Bering Sea storm. It is during

this time that the Port of Nome makes every effort to accommodate as many vessels as physically and safely possible into the protected harbor to keep mariners out of harm’s way. However, in order to continue serving this role, a secondary moorage space must be established to meet the increasing demand of the maritime industry relying on Nome’s protection and services.

The pressure of this significant operating congestion and overwhelming storm level occupancy can be relieved through the development of the Snake River basin. This location will contain sufficient shore-side infrastructure to support small dredges, subsistence vessels and sailboats with drafts less than 8 feet, and eliminate the need for accessing the Small Boat Harbor. This would allow for increased capacity for larger cargo, gravel and mining vessels to maneuver to/from the sheet pile docks and loading ramps, thereby significantly reducing the risks vessel or dock damage, crew injury, or shipping delays resulting from limited dock access and maneuverability.

**PROJECT BUDGET:**

Total ROM Estimated Snake River Moorage	\$16,500,000
Federal Funding Requested	13,200,000
City Contribution (Cash Match)	2,550,000
Potential Other Contribution	750,000
Total Funds	\$16,500,000

**REQUEST:**

Support is requested from the Nome Common Council for the Port to submit an application to the USDOT RAISE grant program to fund a minimum of 80%\* of costs to complete the Snake River Moorage Facility to expand critically needed moorage space within the inner harbor.

---

\*Secretary can choose to fund up to 100% for rural project costs.

**CITY OF NOME, ALASKA**

**RESOLUTION NO. R-24-02-07**

**A RESOLUTION AUTHORIZING THE CITY OF NOME TO APPLY FOR AND PARTICIPATE IN THE USDOT RAISE DISCRETIONARY GRANT PROGRAM FOR THE FUNDING OF THE PORT OF NOME LOCAL SERVICE FACILITIES DESIGN & ENGINEERING – PHASES II & III**

**WHEREAS**, the U.S. Department of Transportation (USDOT) administers the Rebuilding American Infrastructure with Sustainability & Equity (RAISE) Grant Program, which supports investments in the planning and/or construction of surface transportation that will have a significant local or regional impact, with at least \$75M awarded to eligible design projects, \$15M of which seeks to directly benefit areas of persistent poverty, or historically disadvantaged communities; and,

**WHEREAS**, the City of Nome owns the Port & Harbor, which serves as the regional maritime hub facility for over fifty (50) western Alaska communities, transshipping fuel, cargo and gravel throughout the region during the ice-free season, serving as the critical transportation network link that enables equipment, fuel, building supplies, and basic life-sustaining necessities to be delivered to the region’s rural network, and the only publicly-owned coastal maritime infrastructure north of the Aleutians for the refueling and resupply of Arctic vessels that has grown exponentially since 2012, as demonstrated in the port’s vessel traffic statistics; and,

**WHEREAS**, the USACE performed multiple Arctic port studies to determine the best site to serve as the first Arctic Deep Draft Port for the nation, identifying Nome as the most practical and cost-efficient location that will further facilitate resource development, search and rescue response, protection of the marine environment, and to provide a practical Arctic location for strategic defense of the country; and,

**WHEREAS**, the USACE recently completed the Nome Modifications Feasibility Study, which resulted in a Signed Chief’s Report submitted to the 116<sup>th</sup> Congress as part of the WRDA 2020 legislation, and the project was authorized through the FY2021 Omnibus Consolidations Appropriations Act; and,

**WHEREAS**, the City executed an Agreement with the USACE Alaska District for Phases II and III of a Preconstruction, Engineering & Design (PED) covering 100% the Local Service Facilities (LSF), for docks, roads and utilities, which are required to be funded by the non-federal sponsor; and,

**WHEREAS**, the City has qualified engineering firms that have just completed Phase I design of the LSF’s, and are now pursuing RAISE funds to support design of Phases II and III; and,

**NOW, THEREFORE, BE IT RESOLVED** that the Nome Common Council supports application to the USDOT RAISE Grant Program with a match of up to twenty (20) percent for the design and engineering of Phases II and III of the Local Service Facilities associated with the Arctic Deep Draft Port Modifications Project, and agrees, subject to selection by USDOT, to enter into an agreement with USDOT for a RAISE Discretionary Grant.

**APPROVED** and **SIGNED** this 26<sup>th</sup> day of February 2024.

\_\_\_\_\_  
**JOHN K. HANDELAND, Mayor**

**ATTEST:**

*Item J.*

---

**JEREMY JACOBSON, Clerk**

# Memo

TO: Mayor John Handeland & Nome Common Council  
 FROM: Jim West, Chairman – Nome Port Commission *JWz*  
 THRU: Glenn Steckman - City Manager  
 DATE: 02/21/2024  
 RE: 2024 USDOT RAISE Grant Program – Local Service Facilities Engineering and Design

---

The following motion was passed by the Nome Port Commission at their Regular Meeting on Thursday, February 15, 2024.

1. Moved by C. McLarty, and seconded by C. Sheffield, that the following motion be approved:
  - **MOTION:** Recommend the Nome Common Council authorize making application to the 2024 USDOT RAISE Grant Program for funds to complete engineering and design of the local service facilities, as part of the Army Corps’ Arctic Deep Draft Port Project construction.

**AT THE ROLL CALL:**

Ayes: Sheffield, McLarty, Smithhisler, West, McCann, Lean  
 Nays:  
 Abstain:

The motion **CARRIED.**

---

Discussion on this motion is reflected in the minutes of the February 15, 2024 Regular Meeting.



**PORT OF NOME  
LOCAL SERVICE FACILITIES DESIGN & ENGINEERING GRANT  
FUNDING STRATEGY**

AGENCY	U.S. Department of Transportation
PROGRAM	RAISE Grants (Rebuilding American Infrastructure w/Sustainability & Equity)
DESCRIPTION	Funding Surface Transportation Projects having Significant Local/Regional Impact
FUNDING	\$1.5B Total – 50% to Rural Projects (Project Awards of no Min/\$25M Max)
ELIGIBILITY	State, local & tribal governments (port infrastructure investment)
FED SHARE	Min 80% (Secretary may elect go fund up to 100% for rural projects)
DEADLINE	February 28, 2024 – 11:59:00 PM (EST)
PROJECT	PORT OF NOME LOCAL SERVICE FACILITIES DESIGN & ENGINEERING PLANNING GRANT
APPLICANT	CITY OF NOME (up to 20% cost-share or \$926K)
\$S REQUEST	\$3.704M

Primary Selection Criteria:

Safety  
Environmental Sustainability  
Quality of Life  
Mobility and Community Connectivity

Secondary Selection Criteria:

Economic Competitiveness  
State of Good Repair  
Partnerships and Collaboration  
Innovation

Program Requirements:

Climate Change and Environmental Justice Impact Consideration  
Racial Equity and Barriers to Opportunity

PORT OF NOME LOCAL SERVICE FACILITIES DESIGN & ENGINEERING – PROJECT PURPOSE:

Throughout the last 10 years, the City of Nome has worked diligently with the Corps of Engineers Alaska District to investigate demand and gauge need for enhanced maritime facilities in the Arctic. Although this effort has frequently been multi-faceted, the predominant purposes have been to prevent loss of life at sea, reduce elevated shipping costs, minimize impacts to the marine environment, and protect U.S. national security interests in Arctic waters. As more and more vessels transit this region each ice-free season, it is clear that marine shipping, research activity and resource development continue in an upward trend, with few signs of slowing down or reversing course. As the changes in climate accelerate to thin out multi-year ice, the geopolitical stage seems to change just as quickly, with more countries displaying efforts to pursue interests in the region whether or not they are anywhere close to the Arctic.

These significant changes resulted in several completed navigation studies by the USACE, the latest of which has identified Nome as the most practical and cost-effective location to develop a deep-water port in the U.S. Arctic, produced a signed Chief's Report, and received authorization from the 117<sup>th</sup>

Congress to design and construct an Arctic Deep Draft Port at Nome. The City executed a cost-share agreement with the U.S. Army Corps of Engineers (USACE) for the Preconstruction, Engineering & Design (PED) of the Port of Nome Port Modifications Project that began in July 2021. Design costs consist of all phases of both the General Navigation Features (GNF), as well as the Local Service Facilities (LSF).

Phase 1 design is now complete and the City’s cost-share funded through a combination of state and port funds. The Phase 1 solicitation package is scheduled for release by the USACE on 26 February 2024. The City is now obligated to fund 100% design/engineering of Phases II and III of the project LSF’s. These elements consist of docks, bridge, roads and utilities, and are performed parallel to the GNF efforts.

**PROJECT DESCRIPTION:**

The Project Development Team (PDT), comprised of personnel from the Alaska District, Bristol Engineering, PND Engineers, CRW Engineering, NJUS, Port Commission and Port staff, with meetings typical bi-monthly (during design) to discuss questions on project integration.

**PROJECT BUDGET:**

Total ROM Estimated LSF Design Costs	\$4,630,000
Federal Funding Requested	3,704,000
City Contribution (Cash Match)	926,000
Other Contribution	0
Total Funds	\$4,630,000

**REQUEST:**

Support is requested from the Nome Common Council for the Port to apply to the USDOT RAISE grant program to fund a minimum of 80%\* of the design costs for Phases II & III of the Local Service Facilities associated with the Nome Port Modifications Project and Arctic Port Expansion.

---

\*Secretary can choose to fund up to 100% for rural project costs.

**Presented By:**  
City Manager

**Action Taken:**  
Yes \_\_\_  
No \_\_\_  
Abstain \_\_\_

**CITY OF NOME, ALASKA**

**RESOLUTION NO. R-24-02-08**

**A RESOLUTION SETTING THE DATES FOR THE 2024 BOARD OF EQUALIZATION**

**WHEREAS**, the Nome Code of Ordinances provides that the Board of Equalization shall convene each year; and,

**WHEREAS**, the Nome Common Council will sit as the Board of Equalization to hear grievances and requests for adjustment concerning the City of Nome’s 2024 Tax Roll.

**NOW, THEREFORE, BE IT RESOLVED** by the Nome Common Council that the Board of Equalization shall convene Wednesday, May 1, 2024 at 5:30 PM in the Council Chambers of Nome City Hall and shall continue through Friday, May 3, 2024, as is necessary.

**APPROVED** and **SIGNED** this 26<sup>th</sup> day of February 2024.

\_\_\_\_\_  
**John K. Handeland,**  
Mayor

**ATTEST:**

\_\_\_\_\_  
**Jeremy Jacobson,**  
Deputy City Clerk

**Presented By:**  
City Manager

**Action Taken:**  
Yes \_\_\_  
No \_\_\_  
Abstain \_\_\_

**CITY OF NOME, ALASKA**

**RESOLUTION NO. R-24-02-09**

**A RESOLUTION APPROVING AN EMPLOYMENT AGREEMENT BETWEEN  
THE CITY OF NOME AND DANIEL GRIMMER FOR PROVISION OF CITY  
CLERK SERVICES**

**WHEREAS**, the City of Nome wishes to employ the services of Daniel Grimmer as the City Clerk of the City of Nome; and,

**WHEREAS**, Mr. Grimmer wishes to be employed as the City Clerk of the City of Nome, Alaska, under the terms and conditions recited in the accompanying Employment Agreement; and,

**WHEREAS**, the City Clerk position is considered a professional exempt position, not subject to overtime provisions of the Federal Fair Labor Standards Act and Alaska Wage and Hour Act; and,

**WHEREAS**, the City and Mr. Grimmer desire to provide for certain procedures, benefits and requirements regarding the employment of Mr. Grimmer by the City.

**NOW, THEREFORE, BE IT RESOLVED** that the Nome Common Council approves the accompanying Employment Agreement with Daniel Grimmer for the position of Nome City Clerk.

**APPROVED and SIGNED** this 26<sup>th</sup> day of February, 2024.

\_\_\_\_\_  
**JOHN K. HANDELAND, Mayor**

**ATTEST:**

\_\_\_\_\_  
**JEREMY JACOBSON, Deputy City Clerk**

**EMPLOYMENT AGREEMENT**

**Between the CITY OF NOME, ALASKA and Daniel Grimmer for the  
Position of City Clerk for the City of Nome**

---

This Agreement, effective the **27th day of February, 2024** is between the City of Nome (hereinafter referred to as "City") and **Daniel Grimmer** (hereinafter referred to as "Employee"). The City agrees to employ the Employee as the *City Clerk* under the direction of the City Manager. This agreement shall continue until **February 27, 2027**, unless terminated or extended as provided below.

In consideration of the mutual covenants and promises of the Parties hereto, the City and the Employee agree as follows:

**Section 1. MUTUAL ASSENT TO EMPLOYMENT**

The City hereby employs the Employee to perform services as the City Clerk for the City of Nome, Alaska, and Employee hereby accepts and agrees to such employment.

**Section 2. GOVERNING LAW**

Unless otherwise provided in this Agreement, this agreement and the employment of the Employee hereunder shall be subject generally to all applicable provisions of Title 29 of the Alaska Statutes and the Nome Municipal Code and all amendments thereto and judicial determinations thereof. In the case of any conflict between the provisions of Chapter 2.45 of the Nome Municipal Code and any personnel policies adopted pursuant thereto, the terms of this contract shall govern.

**Section 3. DUTIES OF CITY CLERK**

Under the direction of, and answerable to the City Manager, the Employee shall perform all duties required as described in the job description attached as Appendix A of this Agreement, and other duties as assigned.

**Section 4. EXTENT OF SERVICES**

The Employee shall devote sufficient time, attention, knowledge and skills to the interests of the City to provide for efficient, effective, accountable and credible administration and operations of the City Clerk's Office. Employee agrees not to undertake any obligations, have other business affiliations, or engage in any activities which are competitive, incompatible, adverse to, or in conflict with, the City's interests, except as provided in this Agreement or as specifically approved by the City Manager. This does not prohibit Employee from being involved with unrelated business or passive personal investments.

**Section 5. TERM OF EMPLOYMENT**

This Agreement shall be for a Term of three (3) years, from **February 27, 2024** to **February 27, 2027**, subject to termination provisions by either of the Parties as addressed in following sections of this Agreement. Upon expiration of the initial Term, the parties may, by mutual consent, extend the Employment Agreement for additional years.

**Section 6. TERMINATION OF THE EMPLOYMENT AGREEMENT**

A. The Parties agree that the City's business can only succeed if the Employee and the City Manager enjoy a working relationship based upon mutual respect, trust, and positive attitudes. Accordingly, Employee serves at the pleasure of the City Manager and is an "at will" employee of the City of Nome. The City may terminate the employment of the Employee, without cause, at any time during the term of this Agreement by directing written notice of termination to Employee by certified or registered mail, return receipt requested, or by hand delivery. In the event of termination without cause while Employee is ready, willing, and able to perform the duties of the City Clerk for the City of Nome, City shall pay Employee a sum equal to two (2) month of Employee's annual compensation. The Employee shall also be entitled to the balance of accrued personal leave to the date of termination.

8. City may terminate Employee for "just cause" based upon the performance and professional conduct of the Employee. Should City intend to terminate Employee for "just cause," Employee shall be given written notice of the reasons for the termination and an opportunity to respond in person before the City Council, in either open or executive session at Employee's sole option, prior to the effective date of the termination of employment. If the relationship is so terminated; the Employee shall not be entitled to any severance or termination pay. The Employee shall be entitled to the balance of accrued personal leave to the date of termination.

C. The Employee, for any reason or no stated reason, may terminate this Agreement upon giving thirty (30) days written notice to the City Manager. Upon receipt of notice, the City Manager may immediately terminate the relationship, or require the Employee to continue employment for a period not to exceed thirty (30) days, at the regular rate of pay from the date of receipt of notice. If the relationship is so terminated, the Employee shall not be entitled to any severance or termination pay. The Employee shall be entitled to the balance of accrued personal leave to the date of termination.



**Section 7. COMPENSATION**

- A. It is agreed and understood by the Parties that the position of **City Clerk** is an exempt position under the guidelines of the Federal Fair Labor Standards Act and the Alaska Wage and Hour Law. It is specifically understood by the Parties that no overtime compensation will accrue to the Employee or be offered or paid to the Employee.
- B. The City shall pay Employee in full payment of Employee's compensation at the annual rate of **One Hundred Thousand Dollars (\$100,000.00 for twelve (12) months** of employment. The Employee will be eligible for a salary review after six months,
- C. At the one-year anniversary of the initial salary review, and thereafter on the annual anniversary dates of employment, the City Manager shall conduct a performance evaluation. Employee may receive a salary increase after the annual evaluation, during the term of this Agreement, based upon that performance evaluation.

**Section 8. BENEFITS**

- A. The City shall provide the Employee, Employee's spouse, and dependents with health (medical, dental, vision) insurance coverage equivalent to the insurance package provided to regular City employees.
8. The City agrees that the Employee will participate in the Public Employees Retirement System (PERS).
- C. The City shall provide the Employee with a term life insurance policy in an amount of Fifty Thousand dollars (\$50,000).
- D. The City shall provide the Employee workers' compensation insurance coverage.
- E. The City will provide funding to allow the Employee to attend the AMCC conference and training to become an "accredited" city clerk.

**Section 9. LEAVE**

The Employee shall accrue 20 hours of personal leave per month (30 days per year). Any unused personal leave at the termination of employment will be paid to the Employee at the wage rate in effect at the time. Any personal leave time may not be taken unless authorized by the City Manager.

**Section 10. HOLIDAYS**

The City shall extend to the Employee all holidays awarded to regular City employees: Seven holidays and five floating holidays.

**Section 11. CITY VEHICLE**

The City shall provide, for business use of the Employee only, an existing vehicle owned by City providing for insurance, fuel and maintenance of such vehicle.

**Section 12. PERFORMANCE EVALUATIONS**

The City Manager shall conduct and present a written performance evaluation of the Employee's work annually, and emergency evaluations as deemed necessary by the City Manager to call attention to marked improvements or deterioration of the Employee's work performance.

**Section 13. ENTIRE AGREEMENT**

This instrument and identified appendices contain the entire Agreement of the Parties. It may not be changed orally, but only by agreement in writing and signed by all Parties hereto.  
Wherever approval of the City is required, it is understood that such approval will be by the City Manager of the City of Nome, Alaska.

**Section 14. CONTRACT APPROVAL**

This Agreement shall become effective after signature by the Employee and the City Manager.

---

IN WITNESS WHEREOF, the Parties have executed this Agreement as of the dates indicated

\_\_\_\_\_  
Glenn Steckman, City Manager

\_\_\_\_\_  
Date

  
Daniel Grimmer, Employee

2/21/24  
Date



Presented By:  
City Manager  
Action Taken:  
Yes \_\_\_  
No \_\_\_  
Abstain \_\_\_

**CITY OF NOME, ALASKA**

**RESOLUTION NO. R-24-02-10**

**A RESOLUTION AWARDING A CONTRACT FOR THE SUPPLY AND INSTALLATION OF  
AUTOMATIC GARAGE DOORS AT THE NOME VOLUNTEER FIRE DEPARTMENT FIRE HALL  
TO BLISS CONSTRUCTION INC.**

**WHEREAS**, the City of Nome maintains and operates a volunteer fire department; and,

**WHEREAS**, response times to emergencies involving fire need to be quick enough to protect the lives and property of the residents of Nome; and,

**WHEREAS**, two sets of doors on the fire hall are reaching their end of life and need to be replaced; and,

**WHEREAS**, the City of Nome solicited proposals to furnish and install two new automatic garage doors at the NVFD fire hall; and

**WHEREAS**, the City of Nome received two proposals prior to a public opening held at 3:00 PM on February 1, 2024; and

**WHEREAS**, the reviewal panel determined Bliss Construction’s second proposal, to furnish and install automatic garage doors at the NVFD fire hall, of \$47,506 best suited;

**NOW, THEREFORE, BE IT RESOLVED** that the Nome Common Council hereby awards to Bliss Construction Inc. the contract for supply and installation of automatic doors at the Nome Volunteer Fire Department Fire Hall.

**APPROVED** and **SIGNED** this 26<sup>th</sup> day of February, 2024.

\_\_\_\_\_  
**JOHN K. HANDELAND, Mayor**

**ATTEST:**

\_\_\_\_\_  
**JEREMY JACOBSON, Deputy City Clerk**

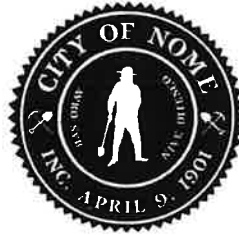

## NOTICE OF INTENT TO AWARD

---

TO: Bidders of Record

PROJECT DESCRIPTION: Request for Proposals – Furnish and Install Automatic Garage Doors at Nome Volunteer Fire Department

The City of Nome has received and opened bids for the subject RFP. Based upon careful review, the City intends to award the contract to Bliss Construction Inc. for an installed cost of \$47,506.

This staff recommendation will be heard by the Nome Common Council on Monday February 26, 2024 at their Regular Meeting at 7:00PM.

Dated this 22<sup>nd</sup> day of February, 2024

**CITY OF NOME**  
OWNER

By *Glenn Steckman*  
City Manager

Bidders of Record:

<u>Company</u>	<u>Representative</u>	<u>Contact</u>
<i>Bliss Construction Inc</i>	<i>Nicolas Bliss</i>	<i>nic@blissconstructionak.com</i>

CC: Cole Cushman, Public Works Director  
Nickie Crowe, Finance Director

City of Nome  
 Project: NVFD Garage Doors

Bid Opening: Thursday,  
~~March 9, 2023~~ 3:00 P.M.  
 2/1/24

Item M.

BIDDER NAME	DATE/TIME RECEIVED	SEALED	Enveloped Addressed and Properly Marked	Bid Form Signed in Ink and Dated	Description & Specs enclosed	TOTAL BASE BID
Bliss Construction 1	2/1/24 1050	✓	✓	✓	✓	44870
Bliss Construction 2	2/1/24 1050	✓	✓	✓	✓	47506

COC 2/1/24  
 Witness Date  
JH 2-1-24  
 Witness Date  
Kevin R. K... 2-1-2024  
 Witness Date

Attest:  
Jeremy Jacobson  
 Jeremy Jacobson, Deputy Clerk

City of Nome  
 Project: NVFD Garage Doors

Bid Opening: Thursday,  
~~March 9, 2023~~ 3:00 P.M.  
 2-1-2024

Item M.

BIDDER NAME	DATE/TIME RECEIVED	SEALED	Enveloped Addressed and Properly Marked	Bid Form Signed in Ink and Dated	Description & Specs enclosed	TOTAL BASE BID
Bliss Construction Inc	2-1-2024 10:50 AM	✓	✓	✓	✓	\$44,870.00
Bliss Construction Inc	2-1-24 - 10:50 AM	✓	✓	✓	✓	\$47,506.00

[Signature] 2-1-2024  
 Witness Date

[Signature] 2/1/24  
 Witness Date

[Signature] 2-1-2024  
 Witness Date

Attest: [Signature]  
 Jeremy Jacobson, Deputy Clerk

City of Nome  
 Project: NVFD Garage Doors

Bid Opening: Thursday,  
 February 1 - ~~March 9,~~ 2023 3:00 P.M.

Item M.

BIDDER NAME	DATE/TIME RECEIVED	SEALED	Enveloped Addressed and Properly Marked	Bid Form Signed in Ink and Dated	Description & Specs enclosed	TOTAL BASE BID
Bliss Construction Inc.	2/1/24 10:50am	YES	YES	YES	YES	\$44,870
Bliss Construction Inc	2/1/24 10:50am	YES	YES	YES	YES	47,506

Kevin Knowlton  
Chris R. Knowlton 2-1-2024  
 Witness Date

CCe 2/1/24  
 Witness Date

BJA 2-1-24  
 Witness Date

Attest:  
Jeremy Jacobson  
 Jeremy Jacobson, Deputy Clerk

Proposal Enclosed:

Furnish and Install Automatic Garage  
Doors at the Nome Volunteer Fire Department

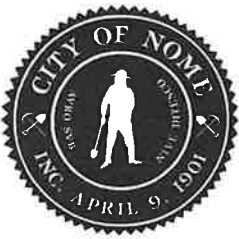

## CITY OF NOME RFP NO. 2023-05

### PUBLIC WORKS DEPARTMENT **REQUEST FOR PROPOSALS: FURNISH AND INSTALL AUTOMATIC GARAGE DOORS AT NOME VOLUNEER FIRE DEPARTMENT**

#### **1.0 INTRODUCTION**

This City of Nome (City) is seeking Proposals from qualified contractors for the replacement and installation of two out of the five doors overhead garage doors at the Nome Volunteer Fire Department. These doors are critical for the rapid deployment of fire personnel in responding to emergencies in and around the Community of Nome. The City of Nome is seeking a reliable and experienced contractor to ensure timely completion of this important project.

#### **2.0 REQUEST FOR PROPOSALS AND HOW TO RESPOND**

Those interested in responding to this RFP may do so by completing the enclosed form and submitting a description and specifications for the equipment proposed, as well as a timeline for completion of the project. The form should include sums for all various aspects of the furnishing and installation of automatic garage doors together with detailed specifications of the equipment the proposer would furnish. All responses must use the form provided. All blanks on the form must be filled in or the proposal will be deemed non-responsive. This RFP is governed by Nome Code of Ordinances Chapter 17.40.

One complete set of RFP Documents will be available for review at The Plans Room, 4831 Old Seward Hwy # 102, Anchorage, AK 99503, 907-563-2029. Another complete set will also be available for review at The Associated General Contractors of Alaska, 3750 Bonita Street, Fairbanks, AK 99701, 907-452-1809.

The deadline for submission of sealed proposal is **Thursday, February 1, 2024 at 3:00 PM** local time and shortly thereafter the proposals will be considered by an appropriate panel of City staff.

The completed proposal shall be mailed in an envelope marked **"Proposal Enclosed: Furnish and Install Automatic Garage Doors at the Nome Volunteer Fire Department"** to:

City of Nome  
P.O. Box 281  
102 Division Street  
Nome, AK 99762  
P: 907-443-6663  
F: 907-443-5345  
E: [bhammond@nomealaska.org](mailto:bhammond@nomealaska.org)

Improper or inaccurately marked envelopes shall render a proposal non-responsive. All proposals shall be subject to acceptance by the Nome Common Council at their February 12, 2024 Regular Meeting or the next date following the opening at which quorum is present.



Advertisement: December 21, 2023  
Proposal Deadline: February 1, 2024  
Award by Council: February 12, 2024  
Required Completion by: June 30, 2024

All questions regarding the content of the RFP and the proposal process shall be directed to the City's designated representative:

Public Works Director  
Cole Cushman  
P: 907-443-6642  
E:ccushman@nomealaska.org

Pricing should be consistent with NASPO standards.

### **3.0 PROJECT DESCRIPTION & MINIMUM REQUIREMENTS**

The Owner is seeking a Supplier to furnish and install two automatic garage doors at the Nome Volunteer Fire Department. Nome is a remote community with extended winters occurring between October and May. Located five blocks from the seawall and Northern Norton Sound, the Nome Volunteer Fire Hall is subject to weather extremes year-round. Vegetation surrounding Nome is scarce and the wind blows year-round, with gusts that approach hurricane strength occurring several times a year. Any doors proposed will need to function properly in elements such as extended periods of high wind, light, snow, and a marine environment. Minimum requirements are:

1. Dimensions – 12 feet 2 inches wide; 12 feet tall
2. White in color (matching the existing doors)
3. R-Factor of 10 or better
4. High-speed opening – at least 30 inches per second, preferably faster
5. One window per door
6. Self-shutting timer
7. Remote and local operation
8. Heat element on the foot pad
9. Minimum wind rating of 130 MPH; preferably 150 MPH or higher
10. Warranty





#### **4.0 DESCRIPTION AND SPECIFICATIONS OF EQUIPMENT PROPOSED**

Proposers shall include with the proposal form a complete description of the make and model proposed to be furnished, together with any additional add-ons or equipment, and provide detailed specifications for the proposed garage doors. The proposal shall identify all additional offered or applicable warranties included in the base bid.

#### **5.0 MULTIPLE PROPOSALS**

Owing to the nature of the RFP, a proposer may submit separate proposals for different models of garage doors. A proposer may submit *no more than two separate proposals*. Should a proposer elect to submit multiple proposals, each proposal must be submitted separately and must satisfy all substantive and procedural requirements of this RFP. Only one contract for the furnishing and installation of doors will be awarded.

#### **6.0 BASIS OF SELECTION AND EXECUTION OF THE SERVICES AGREEMENT**

Responsive proposals received from proposers shall be scored based on the base bid, the suitability of the garage doors proposed to be furnished, and additional warranties offered, if any. The contract shall be awarded based on the overall best value to the City.

Following evaluation and determination of the best value proposal, the City shall within 14 days of proposal opening, notify proposers of the acceptance or rejection of the proposal.

The City of Nome reserves the right to reject any and all proposals, to waive informalities, and to reject non-conforming, non-responsive, or conditional proposals.

Once notified, the selected proposer shall have 7 days to sign the Agreement for Purchase and Sale of Goods, the form of which is included with this RFP.

#### **7.0 DELIVERY & INSTALLATION**

The base bid shall include delivery to Nome and installation at the Nome Volunteer Fire Department with project completion no later than June 30, 2024. Nome is a remote community, off the North American road system. Proposers are encouraged to contact barge and air freight providers for schedules and rates prior to submitting proposals.



**BID FORM**

Company:	<u>Bliss Construction INC.</u>	Phone:	<u>907-451-8652</u>
Address:	<u>2625 Tall Spruce Rd.</u>	Fax:	<u>907-457-5022</u>
	<u>Fairbanks, AK 99709</u>	Email:	<u>nic@blissconstructionak.com</u>

Description and Specifications Enclosed



BASE BID (Required)

- |                             |                          |
|-----------------------------|--------------------------|
| • Make / Model              | <u>C.H.I. 3216/GHVFD</u> |
| • Overall Cost, installed   | <u>\$ 47,506</u>         |
| • Warranty length           | <u>1 year Standard</u>   |
| • Estimated Completion Date | <u>6/30/24</u>           |

By signing below, you acknowledge that you have received and reviewed all RFP Documents, including the form of Agreement for Purchase and Sale of Goods, and if selected by the City agree to enter into the Agreement for Purchase and Sale of Goods on the basis of your proposal for the amount bid, including the additive item if bid and elected by the City.

Date:	<u>1/30/24</u>	Title:	<u>VP</u>
Name:	<u>Nicolas Bliss</u>	Signature:	<u><i>Nicolas Bliss</i></u>

## STANDARD FEATURES

- **2 year Warranty**
- Electronic logic controller, B2 controls, timer to close, delay reverse
- Operator mounted variable frequency drive inverter
- **Soft start soft stop speed control**
- High efficiency inverter rated motor, three phase, TEFC
- Dynamic DC & solenoid activated drum type brake
- Available in **115/220V 1 phase**, 208/230V 3 phase, 460/575V 3 phase
- 50VA transformer, secondary controls fuse protected
- External radio control terminal strip
- Primary worm gear reduction in oil bath
- Adjustable friction clutch (optional)
- Emergency chain hoist for electrical cut-out switch for manual operation
- **Door speeds up to 24 inches per second**
- Three button control station open-close-stop
- #50 roller chain and sprockets on final drive
- Chain keeper
- Universal mounting
- N4/4X Micanan photo cells included for up to 45' wide door
- Shipping weight 120 lbs



**When ordering a PRO-GH operator, supply Micanan with the following information:**

- Door height
- Door width
- Type of door
- Voltage/ Phase
- Safety devices
- Door shaft diameter & door shaft key size
- Mounting (LH or RH, Bracket or Wall mount)

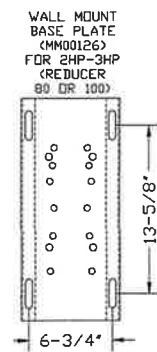
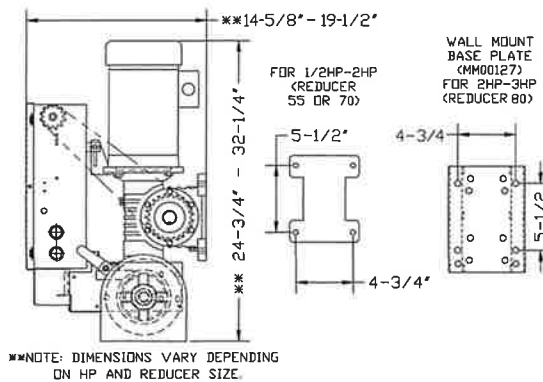
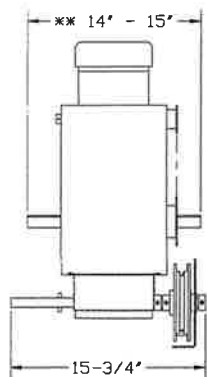

# PRO-GH VFD

## ARCHITECTURAL SHOP DRAWING

Date: \_\_\_\_\_  
 Page: \_\_\_\_\_ of \_\_\_\_\_  
 Drawing No.: \_\_\_\_\_  
 Architect/ Engineer: \_\_\_\_\_  
 Contractor: \_\_\_\_\_  
 Customer: \_\_\_\_\_

### FULL LOAD AMP RATING CHART (AMPS)

voltage	1hp	1.5hp
115, 220V, 208/230V 3-Φ, 60 HZ	3.6	5.0

\*460V, 575V available

**A** Smart logic board (monitored reversing devices supplied)

Number of Operators: \_\_\_\_\_  
 Horsepower: \_\_\_\_\_  
 Volts: \_\_\_\_\_  
 Phase: \_\_\_\_\_  
 Hertz: \_\_\_\_\_  
 Type of Door: \_\_\_\_\_  
 Door Width/ Height: \_\_\_\_\_ W x \_\_\_\_\_ H  
 Operator Nema Rating: \_\_\_\_\_  
 OPEN/ CLOSE/ STOP Control Stations: \_\_\_\_\_

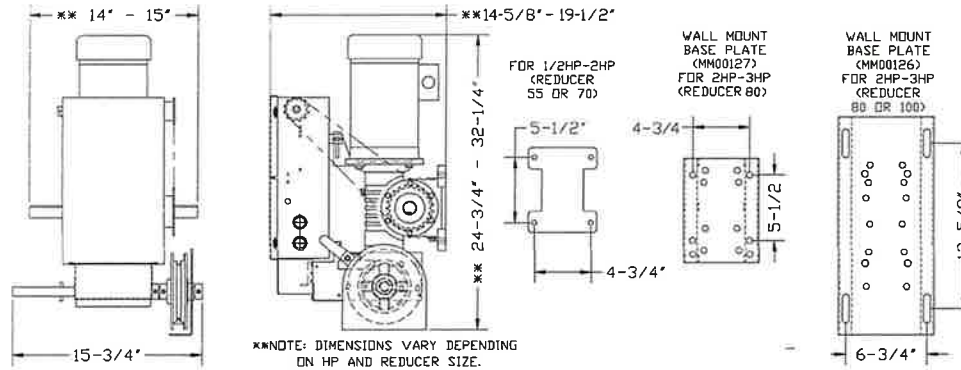

### ADDITIONAL EQUIPMENT OR OPTIONS

Liftmaster 850LM Recievers with remotes

---



---



---

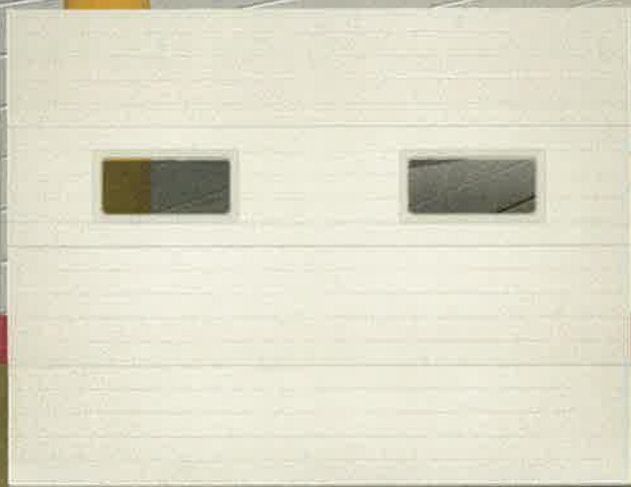

9' x 7' 3216 white with optional 24" x 12" windows

This model also available in



DURABLE.  
THERMALLY-BROKEN.



## SPECIFICATIONS, OPTIONAL FEATURES AND ACCESSORIES



### END STILES

White painted end stiles are 4" or 8" wide to accommodate double or single-end hinges



### SPRINGS

Torsion springs are helically wound with stress relieved, oil-tempered wire



### LOGOS

Showcase your brand with this unique and customized door

### OPTIONAL WINDOW DESIGNS

24" SECTION HEIGHT



24" x 6"



24" x 12"

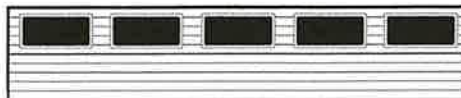

34" x 16"

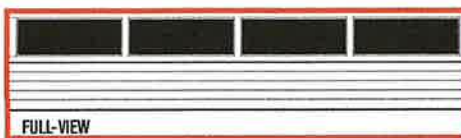

FULL-VIEW

**C.H.I.** OVERHEAD DOORS  
Item M.

WHITE

ALMOND

SANDSTONE

BROWN

GRAY

BLACK

COLOR SELECTION

Note: Refer to samples at your local C.H.I. Dealer for exact color match.



Wind chamber tested to ensure wind-load resistance, the C.H.I. Windbreaker Series and iSeries doors provide enhanced defense against the elements.

26-GAUGE **MODEL 3216**, Thermally-Broken Insulated Steel Back

### SECTIONS

- Sections are 2" thick
- Sections include a thermal break to eliminate thermal convection
- Outside skin features horizontal micro-grooves
- Concealed steel back-up plates run from top to bottom of each section for secure hardware attachment
- Bottom "U" type astragal is a standard feature
- Available with Accents logos

### TRACKS

- Tracks are 2" or 3", as specified
- Available in bracket mount, angle mount, clip angle mount, 12" radius, 15" radius, high lift, vertical lift, roof pitch, or dual track low headroom

### HARDWARE

- Package includes 14 gauge or 11 gauge hinges, as specified
- 2" or 3" short-stem or long-stem ball bearing rollers
- Heavy duty adjustable top roller brackets

### SPRINGS

- Torsion springs are helically wound with stress relieved, oil-tempered wire
- Springs are individually calibrated per door
- Counter-balance torsion shafts are galvanized for rust resistance

### INSULATION TYPE

- Foamed in place CFC free polyurethane core
- R-value - 17.54



### IECC® COMPLIANT

C.H.I. Overhead Door Model 3216 is compliant with the requirements set forth by the International Energy Conservation Code (IECC) for operable fenestrations.

VISIT YOUR DOOR PROFESSIONAL AT:

C.H.I. Overhead Doors are manufactured in Arthur, Illinois, USA.

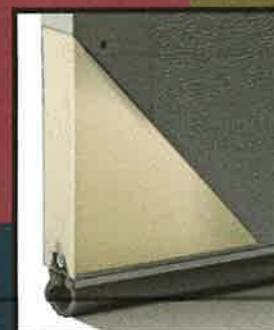

### DOOR CONSTRUCTION

This Model utilizes 26-gauge exterior and 27-gauge interior steel skins injected with CFC free urethane insulation. The thermally-broken tongue and groove section joint includes a continuous weather seal offering exceptional protection from the elements.

Model 3216 ..... R-value\* - 17.54

\*R-value testing is in accordance with ASTM C518 standards.

All information presented is based on the specifications and features available at the time of printing and is subject to change without notice.



1485 Sunrise Drive | Arthur, Illinois 61911  
tel 800 677 2650 | fax 800 738 5006

## Specification Sheet: Model 3216 Micro-Grooved Sandwich Door Urethane Core Foamed-in-Place

### Door Sections:

Section Thickness:	2"
Section Heights:	Monolithic plank sections, 18", 21" or 24" high by width of door.
Exterior Skin:	26 gauge commercial quality woodgrain textured steel with micro-grooves. Hot dipped galvanized coating, polyester primer and topcoat; available in white, almond, sandstone, brown, black, gray or RAL# powder-coating. Logo printing.
Interior Skin:	27 gauge commercial quality steel. Hot dipped galvanized coating, polyester primer and topcoat available in white or RAL# powder-coating. Logo printing.
Panel Profile:	Four evenly spaced micro-grooves per section.
Joint Design:	Tongue and groove rails with full thermal break.
Insulation:	1-7/8" CFC free urethane foamed in place to exterior and interior skins. R-Value* of 17.54, U-Value of 0.057, U-Factor** 0.19, Air Infiltration** 0.15
Reinforcement Plates:	24 gauge galvanized steel, 2-1/2" wide, full height of section.
End Caps:	20 gauge galvanized steel painted white. Full height of section.
Tracks:	2" tracks are roll-formed 17 gauge galvanized steel for doors up to 8'-0" in height. Doors over 8'-0" through 10'-0" will be 16 gauge track. Doors exceeding 10'-0" in height will be 14 gauge track. All 3" track will be 12 gauge. Tracks to be mounted with track brackets, clip mount angle or continuous jamb angle. Lower tracks are adjustable to ensure weather-tight fit. Horizontal tracks to be reinforced with angle (min 13 gauge) according to door size and weight.
Hardware:	Graduated heavy duty hinges (min 14 gauge), top fixtures (min 12 gauge) and bottom fixtures (min 13 gauge) are made of galvanized steel. Rollers have 10 ball bearings with case-hardened steel tire on a solid shaft.
Spring Counterbalance:	Oil tempered torsion springs are mounted on a cross-header shaft supported by galvanized steel ball bearing end plates and center bracket(s). Springs are custom designed for exact door weight, size and trajectory in accordance with current ANSI 102 standards for a minimum of 10,000 cycles. Counterbalance is transferred through galvanized aircraft quality cables secured to bottom of door. Springs may be custom specified for higher cycles when available.
Trussing:	Galvanized trussing provided according to door size and design.
Weather-stripping:	Double contact bottom seal and flexible gasket between sections. Optional header and jamb seals.
Locking:	Optional inside slide lock, outside center lock with automatic latch or double lock bar lock.
Window Lites:	Optional 24"x6", 24"x12" or 34"x16" lites with 1" insulated glass.
Aluminum Full-View:	Optional aluminum frame to match sizes and panel layout of steel sections. Optional field glazing, 1/8" DSB, 1/8" polycarbonate, 1/8" tempered, 1/4" tempered, 1/2" insulated glass or 1/2" tempered insulated glass.
Installation / Framing:	Torsion spring mounting pads, jamb plates, header plates and associated track system hangers shall be furnished by other than C.H.I. All installation quality and workmanship is responsibility of Contractor and is to be executed in accordance with C.H.I. installation instructions, local and state building codes and work site safety regulations.  *R-value testing is in accordance with ANSI/DASMA 163 and ASTM C518 standards **Thermal transmittance and air infiltration testing in accordance with ANSI/DASMA 105 and ASTM E283 standards   Testing details do not apply to doors with windows and/or exhaust ports



### LIMITED WARRANTY Commercial Sectional Overhead Doors

C.H.I. Overhead Doors, Inc. ("C.H.I.") warrants steel garage door sections used in commercial applications, under normal conditions, against splitting, cracking, rusting through or delaminating for a period of ten (10) years. Hardware, including springs, is warranted against defects in material or workmanship for one (1) year. All warranty periods begin with the date of manufacture. C.H.I.'s obligations are strictly limited to repair or replacement of defective parts and components during the warranty period.

This limited warranty excludes: (1) rust caused by damages or scratching; (2) damage resulting from exposure to corrosive chemicals, corrosive fumes, salt environments including coastal areas, condensation, water or fire; (3) damages caused by accident, improper use, negligent operation, improper installation, improper maintenance or normal wear; (4) delamination caused by impact; (5) shipping, installation or labor charges; (6) defects in paints or coatings used to finish door sections; (7) any product or component which is modified, altered, or not part of the original door, and (8) damages resulting from any circumstances beyond the direct control of C.H.I.

In the event of a defective component, contact the dealer the door was purchased from within fifteen (15) days from discovery of the defect. C.H.I. reserves the right to inspect all products alleged to be defective and to verify eligibility of this limited warranty.

**THIS LIMITED WARRANTY EXCLUDES ANY LOSS OR DAMAGE NOT SPECIFICALLY UNDERTAKEN HEREIN, INCLUDING, WITHOUT LIMITATION, ANY CONSEQUENTIAL OR INCIDENTAL DAMAGES, SUCH AS DEATH, INJURY, DAMAGES TO PROPERTY, OR DAMAGES ARISING FROM LOSS OF USE OF ANY PRODUCT OR FACILITY. ALL OTHER WARRANTIES, EXPRESSED OR IMPLIED, INCLUDING ANY WARRANTIES OF FITNESS FOR A PARTICULAR PURPOSE AND OF MERCHANTABILITY, ARE HEREBY EXPRESSLY EXCLUDED.**

This warranty is non-transferable.

Date: \_\_\_\_\_  
Job Name: \_\_\_\_\_



Presented By:  
City Manager  
Action Taken:  
Yes \_\_\_  
No \_\_\_  
Abstain \_\_\_

**CITY OF NOME, ALASKA**  
**RESOLUTION NO. R-24-02-11**

**A RESOLUTION REJECTING ALL BIDS FOR THE NOME PUBLIC SCHOOLS – ADA AND SECURITY UPGRADES PROJECT**

**WHEREAS**, the only bid received through the Request for Bids process exceeded the funds available to do the work, and

**WHEREAS**, the City Manager of Nome believes these bids are excessive related to the City Engineer’s estimate, and

**WHEREAS**, it is the City Manager’s recommendation that the Common Council reject the low bid of \$773,673 by Bliss Construction, Inc.

**NOW THEREFORE LET IT BE RESOLVED**, the Common Council rejects the low bid by Bliss Construction, Inc. of \$773,673

**APPROVED** and **SIGNED** this 26<sup>th</sup> day of February, 2024

\_\_\_\_\_  
**JOHN K. HANDELAND, Mayor**

**ATTEST:**

\_\_\_\_\_  
**JEREMY JACOBSON, Deputy City Clerk**

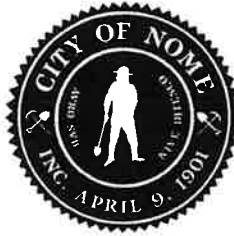

## NOTICE OF BID REJECTION

---

TO: Bidders of Record

PROJECT DESCRIPTION: NOME PUBLIC SCHOOLS – ADA AND SECURITY UPGRADES

The City of Nome has received and opened bids on February 15, 2024 for the subject project. Based on the bid tabulations (attached) the City of Nome (City) rejects all bids because all received bids exceed the allocated project budget.

Dated this 23<sup>rd</sup> day of February, 2024.

CITY OF NOME  
OWNER

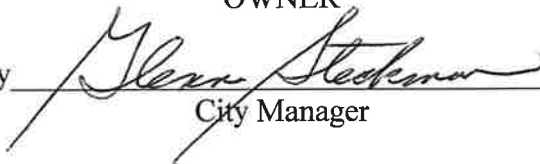
By   
City Manager

Bidders of Record:

<u>Company</u>	<u>Representative</u>	<u>Contact Fax</u>
Bliss Construction, Inc.	Carey Bliss	fax (907)457-5022

Cc: Charles Cacciola, City Attorney

TO: The Mayor and Common Council

FROM: Glenn Steckman

RE: City Manager's report

February 23, 2024

**Nugget Inn:**

City staff is assisting the owners of the inn as they seek to get the State Fire Marshal approval to reopen. The owners hope open on a phased basis to start producing revenue. Further improvements are planned for the summer when supplies are to be delivered by barge.

**Commercial property inspections:**

There have been a number of questions concerning the city's involvement with commercial building inspections. First, Cliff McHenry is not a commercial building inspector. He works with the State's Fire Marshal's Office as their eyes on the ground here in Nome. Second, he can only issue a commercial CO with the approval of the Fire Marshal's Office. Plans are accepted by the Building Inspector's Office but the plans are reviewed by the Fire Marshall's Office.

In the next round of quarterly reports from department heads, Cliff will outline how the process works.

**City Clerk:**

I am requesting approval to hire Dan Grimmer to be the new city clerk. Dan and his family reside in Nome. He worked for Norton Sound Hospital in the Behavioral Health Center and had fifteen years of senior administrative experience with them. He will bring strong process skills to the position. And, more importantly, strong customer service skills.

**Communications System:**

The bid for a new radio system came in at \$1,062,000. The price was within the parameters that our third-party designer, Federal Engineering, estimated. Because of the complexity of the project and the bid proposal, I am asking Federal Engineering to review the proposal to see if it meets Federal Engineering's specifications.

**NVFD Garage Doors:**

I am asking that the council approve the higher of two bids by Bliss Construction. The higher priced option allows for a faster opening of the garage doors to allow for a quicker response time. The price difference is \$2,636.00, The bid came in below the estimate of \$60,000.

**Emergency Siren:**

The replacement for fire damaged siren at the public works building will start February 28-March 4. However, the siren is being relocated to the snow dump off Greg Kruschek Ave. to provide better coverage for Nome. The damaged siren was forty years old.

City staff with assistance from the NVFD will review the other locations of the other sirens to see what improvements need to be done. The city received a \$10,000 to assist with this process of updating our siren system.

**ADA and Security Improvements for Nome Schools:**

The sole proposal by Bliss Construction came in at \$773,673.00. The estimated price was \$320,000. The staff recommends not approving it.

**Port Tariffs':**

The Port Commission is requesting approval of the tariff language change. I am requesting a special meeting on March 4 for second reading and hopefully approval.

**Mark Synnott Request;**

Mr. Synnott's request for personal property tax relief should be denied because he failed to follow process and it's too late to request relief according to solicitor Charles Cacciola. He was also operating his 47' boat for business purposes according to a Google search.

**The Swimming Pool:**

The pool is heated and properly operating. However, the three factory reps could not coordinate their meeting to approve and warranty the system at the end of February. Mr. Walker is working to get the reps to Nome after Iditarod but before the end of March. Mr. Leeper is communicating with the swim team families.

**Comprehensive Plan update:**

The city grant writer is submitting a funding request to the Denali Commission to assist in paying for a new comp plan. The Comprehensive Plan does not need to be dated as was the 2020 Comprehensive Plan but can be listed simply as the Nome Comprehensive and reviewed periodically and amended as needed.

**NVAD and NSHC:**

The City has signed an agreement with NSHC to receive the necessary services to allow NVAD to continue providing ambulance services. The agreement is attached to this report.

**NVAD:**

City attorney Sam Severin continues to try to reach an agreement with NSHC on management of the ground ambulance service.

**Recidivism Reduction:**

Please find attached a letter sent to the Alaska Dept of Health in support of a grant proposal by NSHC to reduce the rate of recidivism in Nome.

**Visitor Center:**

Working with the Chamber of Commerce's President, Drew McCann, a new Visitor Center Director has been hired. Shauntel Bruner-Alvanna will take over the position in March and just in time for Iditarod.

**Iditarod:**

City staff is now preparing the city for the Iditarod. Public Works staff will soon begin building the snow ramp and move the Iditarod Arch to Front Street. The Mini Convention Center will serve Iditarod HQ. OSJ will host the craft fair. The Museum and Library will be hosting events for children and visitors on snow dog sledding. The Museum will open for extended hours to provide visitors more opportunities to do things.

The Rec Center will play host to the Lonnie O'Conner Basketball Tournament and then the Iditarod banquet.

The council chambers will serve as the communications center for Iditarod. Because of this, there will be no council meeting on March 11.

Housing for Iditarod support teams and attendees remains a challenge in the community. Using the racquetball court at the Rec Center for a dorm is being considered as a last resort.

**Planning Commission:**

NJUS will make a presentation to the Planning Commission on their efforts updating NJUS' master plan and proposed future development plan for water and waste water expansion plans. These plans depend on securing grants and developers' projects having funds to extend the system to their developments.

Erin Reinders, the city planner, will discuss with the commission members on how to proceed to solicit public input on the proposed "Downtown Zoning District".

Sam Severin is developing procedures for the commission to follow on how to grant variances.

Because there have been three commissioners appointed in the last year, I have asked Erin to find a training module on how the planning process works and their roles as commission members.

**Snow Removal:**

As of February 16<sup>th</sup>, city road crews and city contractors have moved 7,200 truck loads of snow exceeding the winter of 2010-2011 at the same time.

**Iron Dog:**

With brutal weather for Iron Dog, the Public Works Building hosted 37 contestants who used the building to repair their machines for the second part of the race.

The City of Nome contributed \$2,500 to buy helmets for children who ride/operate snow machine in the city.

**Front Street Speaker System:**

Thanks to NJUS and Thomas Simonsen, the sound system works. But new microphones are being ordered to replace the partially workings mics we currently have.

**Historic Preservation Plan:**

The recommended changes from Austin Ahmasuk have been incorporated into the document. The HPP will be reviewed at the May meeting of the commission. I've requested Councilmember Tapqaq to also reviewing the HPP.

**Recreation Center:**

A five-year MOA has been signed with the City of Nome and NSHC. This allows for NSHC to use the Rec Center if there is an emergency at the hospital and the hospital needs to be evacuated. No monies will exchange hands and NSHC indemnifies the City of Nome. There is a ninety day withdraw clause.

**Behavior Health Services and NPD:**

An agreement has been signed between NPD and Behavioral Health and NSHC to provide training and education to designated NPD staff to deal with the continuing behavioral health crisis in Nome.

This level of training is not provided at the police academy and will better prepare our officers to deal with these incidents.



**NORTON SOUND  
HEALTH CORPORATION**

*Providing quality health services and promoting  
wellness within our people and environment.*

MEMORANDUM OF AGREEMENT BETWEEN THE  
CITY OF NOME  
AND  
NORTON SOUND HEALTH CORPORATION  
REGARDING USE OF NOME ELEMENTARY SCHOOL  
AS A TEMPORARY SHELTER DURING EMERGENCIES

**I. Purpose**

This Memorandum of Agreement (MOA) is between the City of Nome (the City) and Norton Sound Health Corporation (NSHC) for the purpose of providing an emergency evacuation for NSHC.

**II. MOA Regarding Use of Nome Recreation Center**

In the event of an internal or external emergency where a determination is made by NSHC that it is necessary to partially or fully evacuate the Norton Sound Regional Hospital (Hospital), The City agrees to provide the Nome Recreation Center (Facility) as a temporary shelter for NSHC patients and staff. In the event that the Hospital is unable to be reoccupied, patients will be transported to Anchorage or other site(s) as soon as can be arranged. NSHC does recognize the Facility is not a medical facility. Each of the undersigned expressly acknowledges and agrees that the activities held in the Facility pursuant to this MOA involve the risk of serious injury, death, and/or property damage.

**III. Term of MOA**

This MOA shall remain in effect for a period of five (5) years starting August 1, 2022 and ending August 1, 2027, subject to the termination provisions provided herein. The parties may review the terms of the MOA periodically as necessary and may choose to extend the term if so desired by the parties.

**IV. NSHC's Obligation**

NSHC hereby releases, waives, discharges, and covenants not to sue the City of Nome, their officers, agents, servants, lessors, employees and successors from any and all liability, claims, demands, actions, or causes of actions whatsoever of NSHC arising out of any damage, loss, or personal injury, suffered or sustained by NSHC employees and/or others who gain entry into the Facility through NSHC, while the Facility is being utilized by NSHC pursuant to this MOA.

NSHC agrees to defend, indemnify and hold harmless the City of Nome, their officers, agents, servants, employees and successors from any claims or losses brought against them by third parties for any physical injury, damage or loss to NSHC patients, staff or others who gain entry into the Facility through NSHC while the Facility is being utilized by NSHC pursuant to this MOA, to the extent of NSHC's own negligence or fault.

T. 907.443.3311 | F. 907.443.2113 | P.O. BOX 966, NOME, ALASKA 99762-0966 | [www.nortonsoundhealth.org](http://www.nortonsoundhealth.org)

BREVIG MISSION | COUNCIL | DIOMEDE | ELIM | GAMBELL | GOLOVIN | KING ISLAND | KOYUK | MARY'S IGLOO | NOME | ST. MICHAEL  
SAVOONGA | SHAKTOOLIK | SHISHIMAREF | SOLOMON | STEBBINS | TELLER | UNALAKLEET | WALES | WHITE MOUNTAIN

NSHC hereby assumes full responsibility for and risk of bodily injury, death or property damage due to the negligence or fault of NSHC while in or upon the Facility.

Each of the undersigned further expressly agrees that the foregoing release, waiver, and indemnity MOA is intended to be as broad and inclusive as is permitted by the law of the State of Alaska.

**V. Severability**

If any portion of this MOA is held invalid, it is agreed that the balance shall, notwithstanding, continue in full legal force and effect.

**VI. Amendment and Termination**

This MOA may be amended by mutual written MOA of the parties.

Either party may terminate this MOA prior to the end of the term of the MOA by providing the other party with written notice sixty (60) days in advance of such termination, except that, this MOA shall be extended beyond such termination date until use of the Facility is no longer necessary in the event the Facility is currently being utilized pursuant to this MOA at the time of termination.

**Certification**

The parties hereby affirm that both parties are in agreement to this MOA:

**NORTON SOUND HEALTH CORPORATION**



Angie Gao  
Norton Sound Health Corporation  
President/CEO

\_\_\_\_\_  
Date

**City of Nome**  
Glenn Steckmen  
Glenn Steckmen  
City of Nome Manager

7/25/23  
Date





P.O. Box 281 • Nome, Alaska 99762  
phone 907.443.6663 fax 907.443.5349

February 16, 2024

Katlyn Felkl, Grants Administrator  
Grants and Contracts, Department of Health and Social Services  
PO Box 110650  
Juneau, Alaska 99811-0650

Ms. Felkl:

On behalf of the City of Nome, please accept this letter of support for the Norton Sound Health Corporation's (NSHC) Behavioral Health Services' (BHS) application for the *Recidivism Reduction for FY25* Request for Proposals through the Department of Health and Social Services, Division of Behavioral Health.

I understand Behavioral Health Services will coordinate activities required as an Established Community Reentry Coalition to support the overall goals to:

- 1) Coordinate pre-release planning efforts for reentrants at AMCC, and
- 2) Enhance and expand access to transitional supports to reduce recidivism

Because of the high recidivism rates in our region, I strongly support reentry efforts to mitigate this issue. If awarded, I will:

- 1) Provide applicable information on resources available through the City of Nome.
- 2) Participate in meetings and trainings as applicable.
- 3) Support the efforts of the AMCC Case Manager.

I fully support Norton Sound Health Corporation's request for funding as an Established Community Reentry Coalition program.

Sincerely,

Glenn Steckman  
City Manager  
City of Nome  
907-443-6601



**NORTON SOUND  
HEALTH CORPORATION**

*Providing quality health services and promoting  
wellness within our people and environment.*

**EXTENSION OF CERTAIN MEDICAL SERVICES BY NORTON SOUND HEALTH CORPORATION FOR TEMPORARY SUPPORT OF THE NOME VOLUNTEER AMBULANCE DEPARTMENT**

On April 28, 2017 NSHC entered into a Memorandum of Agreement (MOA) to provide certain medical services to support the City of Nome's Ambulance Service (Nome Volunteer Ambulance Department).

This MOA expires on February 15, 2024, with no extension from NSHC. Therefore, all covenants, mutual promises, recitals, and agreements found therein will no longer be in effect, with the **exception of section "7: HIPAA Business Associate Agreement Requirements"**. This section remains in effect until this addendum is expired.

NSHC has no interest in extending the MOA. However, NSHC will provide certain medical services until April 1, 2024, as a limited in time assist to the City of Nome Volunteer Ambulance Department.

**This assistance will consist of the following services:**

- Provision of a Medical Director at \$1500 per month
- Medications will be provided upon request and charged to the City of Nome at retail pharmacy price.
- Supplies will be provided upon request and charged at the MCD rate to the City of Nome.

This extension of services is not an extension of the original MOA between NSHC and City of Nome.

AGREED TO AS REFLECTED BY THE SIGNATURES BELOW.

**CITY OF NOME**

**NORTON SOUND HEALTH CORPORATION**

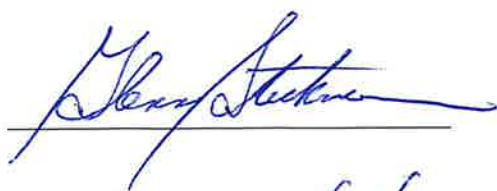



DATE SIGNED 2/14/24

DATE SIGNED 2/13/2024

T. 907.443.3311 | F. 907.443.2113 | P.O. BOX 966, NOME, ALASKA 99762-0966 | [www.nortonsoundhealth.org](http://www.nortonsoundhealth.org)



# Memo

To: Glenn Steckman – City Manager  
 From: Joy L. Baker – Project Manager *JLB*  
 CC: Mayor Handeland & Common Council; Planning Commission; Port Commission  
 Date: February 12, 2024  
 Re: Monthly Projects Update – Feb 2024

## **Administrative:**

### Tariff Rate Study:

Northern Economics (NE) is making progress on the Tariff Rate Study & Analysis, with the next draft to be presented to the Port Commission in the coming weeks. This project remains on schedule and within budget at this time, with NE indicating they have received good response from users being polled for input on the project.

### Strategic Development Plan:

Public meetings were held in Nome from 23-25 Jan 2024, to gather input from the community and port users on port development. A wide range of ideas were captured and currently being considered and incorporated into a draft plan for presenting to the Port Commission in the coming weeks. This project is also on schedule and within budget, with Phase A wrapping up soon, and Phase B to commence once that part of the budget receives authorization.

## **Causeway:**

### Arctic Deep Draft Port – Nome Modifications Pre-Construction Engineering & Design (PED):

The Alaska Corps District and Pacific Ocean Division (POD-HI) have completed their final review of the design/specs for construction of Phase 1 of the Port of Nome Modification (PONM) Project. The contracting office is finalizing the solicitation package which has just another 10-day process to complete before it will be ready for official release to bidders at the end of Feb 2024. The ceremonial signing of the Project Partnership Agreement (PPA) was performed on 25 Jan 2024 in Nome, which was the remaining official action required to allow the project to be put out to bid.

### Local Service Facilities (LSF) Design Integration:

*Upon release of the final PONM Phase 1 solicitation package, the City's design teams will remain onboard and available during the bidding process to address contractor questions, and throughout construction to provide inspection services and ensure the LSF elements are built correctly.*

### U.S. DOT Maritime Administration (MARAD) – Port Infrastructure Development Program (PIDP) Grant Pre-Award:

*The Finance Director and myself have been engaging in multiple webinars hosted by MARAD for all grant recipients to ensure a solid understanding of all pre-award submittal requirements. There are numerous layers to this new approach, all of which must be met before the \$11.25M grant agreement is executed. These funds will be used to cover a portion of the costs needed to purchase and construct the marine utilities for Phase 1 of the Port of Nome Modification Project. The City will provide matching funds in the estimated amount of \$16M, which will be sourced through eligible state funding. The exact*

*amount of the match will depend on the winning bid for the work.*

**Causeway Bridge Repairs and Sediment Removal:**

*The Corps has awarded the contract to Bristol Engineering for the repairs to the abutment and girders on the north end of the Causeway bridge. The project field work is now scheduled for early summer 2024.*

**Arctic Port Reception Facility – Solid Waste Disposal (Incinerator):**

*Additional funding opportunities are on the horizon and being evaluated for this project.*

**Harbor:**

**Inner Harbor CAP 107 Study (Deepen/Widen the Inner Basin):**

*The City continues to make monthly inquiries on the status of this project, with District reporting they are awaiting direction from Corps HQ on how to proceed. The delays on this issue have also been submitted to Alaska Delegation staff members for action. Recent information indicates there has been movement at Corps HQ on this project.*

**Snake River Moorage Facility:**

*Port staff are in the process of preparing a grant application for this project under the USDOT RAISE Program as a suitable funding vehicle to perform design and construction of this project. Applications are due on 28 Feb 2024.*

**Port Industrial Pad:**

**West Nome Tank Farm (WNTF) - Property Conveyance:**

*The USAF has just returned the final drafts of the Quit Claim Deed and Environmental Covenants that should be the last round of reviews by the City and ADEC. If all is in order, this will move the 7-acre conveyance into the signature/execution phase within the next few months.*

**Thornbush Laydown Site Development (TBS):**

*Dredge spoils from the port expansion and inner harbor project have been given clearance by two ADEC programs (Solid Waste and Contaminated Sites), to be disposed of in the undeveloped 9-acre portion of this property. The spoils will require dewatering before serving as a hardened base layer to the specified fill and surfacing to complete development of the 18-acre parcel. Port staff are currently working on pricing for fill that may be placed in 2024 to continue making progress on the laydown site.*

*Over the summer, Public Works filled depressions on the pad to maximize the usable surface before winter. This repair/prep will allow relocations of containers, dredges and equipment in 2024 for construction setup.*

**Port Rd. Improvements (ADOT Project cost-shared with City/Port):**

*This state STIP project has been postponed to approximately 2028/2029 to avoid conflicting with the heavier truck traffic during the port expansion.*

**FEMA DR4672 Merbok Recover Projects:**

**Inner Harbor Dredging – South Wall and East Ramp:**

*The City has finally received and approved Scope of Work (SOW) from FEMA on the estimate of cubic yards of sediment that remains near the south wall and east gravel ramp in the inner harbor. FEMA is processing the funding obligation for the City’s signature so work can be done in the 2024 season.*

**Cape Nome Jetty Repair:**

*PND (subcontractor to Bristol) is close to having 95% design repair drawings, specs and bid documents that will be shared with FEMA for review and input. Once completed, the bid package will be released on the street for contractors to propose on construction in the 2024 season.*

---

*Italics reflects no change in project information from previous report*

**City Manager**  
Glenn Steckman

**Project Manager**  
Joy Baker

**Harbormaster**  
Lucas Stotts



**Nome Port Commission**  
Jim West, Jr., Chairman  
Charlie Lean, Vice Chairman  
Derek McLarty  
Shane Smithhisler  
Russell Rowe  
Gay Sheffield  
Drew McCann

102 Division St. • P.O. Box 281  
Nome, Alaska 99762  
(907) 443-6619  
Fax (907) 443-5473

**NOME PORT COMMISSION  
MINUTES  
REGULAR MEETING  
JANUARY 18<sup>th</sup> 2024 @ 7 PM  
COUNCIL CHAMBERS CITY HALL**

The Regular Meeting of the Nome Port Commission was called to order at 7 pm by acting Chairman Lean at the City Hall Council Chambers.

**ROLL CALL**

Members Present: Smithhisler; Lean; Rowe; Sheffield; McLarty

Absent: West; McCann

Also Present: PM Baker (zoom); HM Stotts (zoom); Glenn Steckman; Angie Nguyen

In the audience: Megan Gannon – Nome Nugget

**APPROVAL OF AGENDA**

Chairman Lean asked for a motion to approve the agenda.

Motion to approve made by Smithhisler, seconded by Sheffield.

At the Roll Call:

Ayes: Lean; Rowe; Sheffield; McLarty; Smithhisler

Nays:

Abstain:

The motion **CARRIED**.

Discussion: none

**APPROVAL OF MINUTES**

November 16<sup>th</sup>, 2023 Regular Mtg.

Motion made by Smithhisler, seconded by Sheffield to approve the minutes as presented.

At the Roll Call:

Ayes: Rowe; Sheffield; McLarty; Smithhisler; Lean

Nays:

Abstain:

The motion **CARRIED**.

Discussion: none

**CITIZENS' COMMENTS**

- None

**COMMUNICATIONS**

- 23-12-14 – KUCB News – Fed Fisheries Managers Hold Bering Sea Pollock Steady
- 23-12-14 – KTOO News - NOAA's Arctic Report Card - Climate Change
- 23-12-22 – AAHPA 2024 Scholarship Flyer

Discussion:

- Lean commented on the Fisheries report and noted that there is a Salmon meeting starting the 19<sup>th</sup> on the US/Canadian treaty regarding Salmon. The Chinook salmon have been on the decline for 20 years and the Chum have been for about half that, with the last 4 years being most intense. Bering Seas Sockeye have been strong the last several years, except for Norton Sound. All other salmon are not doing well. Salmon are also being found in the Canadian/Arctic Slope area where they have not been observed in the past.
- Rowe commented that he has been working with some fisheries groups doing aerial studies of rivers involving climate change and fish habitat and it was very interesting.

**COMMISSIONER'S UPDATES**

- None.

**HARBORMASTER'S REPORT**

- HM Stotts gave an overview of the following;
  - FY24 2<sup>nd</sup> Qtr Report
  - AR/collections efforts overview; currently 32 port accounts past due/delinquent which port staff are working with on payment plans. Accounts that are non-responsive will be included in February/March impoundment rounds.
  - Working with folks at the UAF earthquake and Tsunami center to develop resources for Nome to educate the public and Port users on hazards and information on tsunamis and earthquakes. This will help develop better emergency management practices for the Port and City of Nome.
  - Bering Sea Gold will be filming end of January for Season 13 BSG on the Ice and ice miners will be gearing up to be out on the Ice.
  - Update on regular office work by port staff with good progress.

Discussion:

- Lean commented that the ice has not been in the best shape last week and is very treacherous this time of year, but is now starting to set up better. Stated that the commercial crab season opens February 15<sup>th</sup>.

**PROJECT MANAGER REPORT**

- PM Baker gave a brief overview of the 24-01-15 PM Monthly Projects Report
  - Have been busy with notifications on the upcoming Strategic Development Plan public meetings at Old St Joes church next week. We have consultants coming in to get input from the public. We are hoping all of the PC members can attend the of the meetings, but especially the Wednesday Work Session to encourage good discussion.
  - Stated the City recently signed the Project Partnering Agreement (PPA) with the USACE and they are working to get the Project Solicitation Package out sometime in late February.
  - Next Thursday at noon in Chambers there will be a USACE team coming to Nome for the ceremonial signing of the PPA. Council, PC, Media and others have been invited.

- Port staff are still working with FEMA on several items such as the Inner Harbor dredging to clean up sediment along the South Wall and East gravel ramp; as well as the repairs out at Cape Nome, both to be performed in the 2024 ice free season.
- Port staff are also working on potential Tariff changes which we hope to bring to you in February. We are hoping to have the 2024 Anchorage CPI adjustment, and will bring recommended PAX/Facility fees scheduled to begin in 2024. There are also some language changes on impounding equipment that the City attorney is currently drafting.

Discussion:

- Sheffield asked if we sign the PPA next week, when will the RFP be awarded?
  - PM Baker stated they are projecting a date sometime in February for the contract solicitation to go out on the street and will not be awarded until later in the summer of 2024.
- Smithhisler asked if there were any other items left for the USACE to get done for Phase 1 to start such as the Contract Labor agreement.
  - PM Baker stated, no, that should not delay anything but is something they are working on.
- McLarty asked if the bid will be awarded to the lowest bidder?
  - PM Baker stated with will be awarded to the lowest qualified bidder.

**OLD BUSINESS**

- None

**NEW BUSINESS**

- PON Tariff No. 16.3 – Recommended Revisions

Discussion:

- PM Baker stated that there are some language changes in the tariff we are looking at;
  - Page 7 has some language dealing with impounded items. Some of these do not follow standard rules for impoundment such as vessels and vehicles. They City attorney is looking into these language changes to clean this section up and streamline the process.
  - Page 21 has the section on Passenger fees and the Facility Charge for cruise ships. This section only ran from 2021 to 2023, so we need to project new rates starting 2024.
  - Page 24 has the CPI adjustment which does not need approval by the council, as it is already a part of the Tariff. We do not yet have the rate but will soon.
- WPM Baker stated that we will need the PC to look at Page 7 and 21 items and give recommendations we can then bring to the council and they get it out to the users in March.

This was tabled for next months meeting to discuss more in depth.

**CITIZENS' COMMENTS**

- None.

**COMMISSIONER'S COMMENTS**

- Sheffield commented that we recently had a 4.6 earthquake on Sunday- it was about 30 miles NE of Brevig which was felt in around Nome. Stated we did have a Polar bear with ok body condition that was found dead at Utqiagvik in October. The lab results just came back and determined the bear died from Avian Influenza. Possibly that particular bear ate a contaminated bird. There are events going on in the southern half of the Pacific Ocean (Argentina and Peru) that are causing mass mortality events for sealions and elephant seals that indicates the transmission rate may have changed. CDC is seeking more information. This coming 2024 summer, if anyone see something weird in our marine resources, they report that to Kawerak or Sea Grant so they can get the work out. Sheffield also stated UAF NWC and UAF Alaska Sea Grant are hosting the Western Alaska Interdisciplinary Science Conference 2-4 April.



- Smithhisler commented that the tariff rate study was interesting and is curious to see how much this may help port staff and the PC.
- Rowe commented that a lot of PAX fees and facility charges for other ports are posted online. It looks like several ports charge a little more than Nome, but also provide more services than Nome does. Stated that airports do a similar thing with passenger facility charges (PFC) which DOT has a cap on at \$4.50 per PAX. Airport can decide if they want to charge less than that; Anchorage charges \$3.40. Feels we should keep the term at 3 years so we not locked into something that may need to change as Nome begins to provide more services. Feels we should not increase it too much too soon.
- McLarty none.
- Lean stated that it as good to see everyone and it is good to see the upcoming public meetings.

**ADJOURNMENT**

Motion was made by Sheffield for adjournment at 7:50 pm.

**APPROVED** and **SIGNED** this 15<sup>th</sup> day of February 2024.



Jim West, Chairman

**ATTEST:**



Lucas Stotts, Harbormaster