



# NEW HAVEN ZONING BOARD OF APPEALS PUBLIC HEARING AGENDA

April 28, 2026 at 7:00 PM  
Municipal Council Room – 57775 Main Street

---

*In accordance with the Americans with Disabilities Act, reasonable accommodations can be made with advance notice by calling the Village Offices at (586) 749-5301*

**The New Haven Zoning Board of Appeals will hold a Public Hearing at 7:00 pm, at the New Haven Council Room located at 57775 Main Street.**

**1. Call to Order/Pledge/Roll Call**

**2. Approval of minutes**

A. October 28, 2025 meeting minutes

**3. Public Hearing**

A. Extra Credit Union Sign Variance for 2 signs on parcel number 26-06-27-300-023, 59010 Gratiot

**4. Adjournment**

**Meeting Agenda**

**Call to Order:**

Time: 7:00pm

**Pledge of Allegiance:**

(Completed  / Not Completed )

**Roll Call:**

- Brett Knybel ✓
- Barb Williams ✓
- Matt Benoit ✓
- Tim Sosnovske ✓

**Add Agenda Item: Appointment of Secretary**

Nominee: Brett Knybel

Motion by: \_\_\_\_\_

Second by: \_\_\_\_\_

Vote:  Yes  No

**Public Hearing**

Topic: 58717 Main Street Parcel# 26-06-33-103-034 (1) foot setback variance on Heldt side

Motion By: BARB WILLIAMS Second Motion: BRETT KNYBEL

Vote:  Yes  No

**Roll Call:**

- Brett Knybel Yes
- Barb Williams Yes
- Matt Benoit NO
- Tim Sosnovske Yes

**Adjourn Meeting**

Time: 7:12

Motion by: TIM SOSNOVSKE

Second by: BRETT KNYBEL

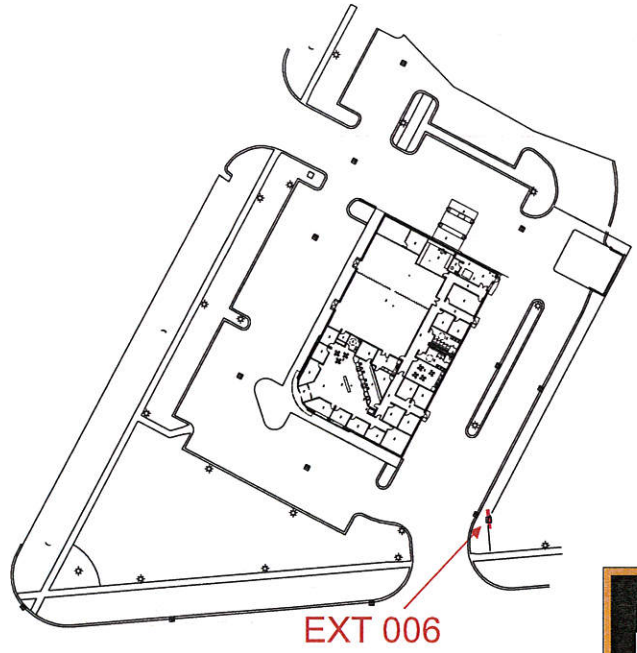

Field Measure Existing Sign for exact dimensions.

NOTE: CONCEPT ONLY. REFURBISH EXISTING SIGN. FINAL DRAWINGS TO BE SUBMITTED BY SIGNAGE VENDOR. FIELD MEASUREMENTS ESSENTIAL PRIOR TO PRODUCTION. SEE LOCAL ORDINANCES FOR FINAL SIZE.

Front & Back View

Side View

- (A) REPLACE ACRYLIC PANEL WITH NEW PANEL TO ILLUMINATE. FRAME TO BE PAINTED YELLOW TO MATCH LOGO COLOR. SIDES TO BE FINISHED BLACK
- (B) COLUMN AND PLINTH TO BE FINISHED BLACK.
- (C)
- (D)
- (E)
- (F)

GJ PERELLI COMPANY



**CUMO** DESIGNS LLC

248.432.7147 cumodesigns.com

- graphic only
  - single sided
  - double sided
  - wall mounted
  - soffit mounted
  - hanging
  - finished back
  - fixture mounted
  - floor standing
  - millwork
  - door/window
  - illuminated
  - exterior
  - bathroom
  - detail
- preliminary
- presentation
- final / bid
- revision
- 24 Feb 26
- GJP / Extra CU client
- New Haven, MI location
- New Branch proj.name
- sb drawn
- Exterior Pylon Sign item name
- EXT 006 code
- 1 of 1 sheet #

THESE DRAWINGS ARE CONSIDERED DESIGN INTENT ONLY AND ARE NOT FOR CONSTRUCTION. DO NOT SCALE DRAWINGS. FIGURED DIMENSIONS ARE FOR GUIDANCE ONLY.

EXT 006 EXISTING

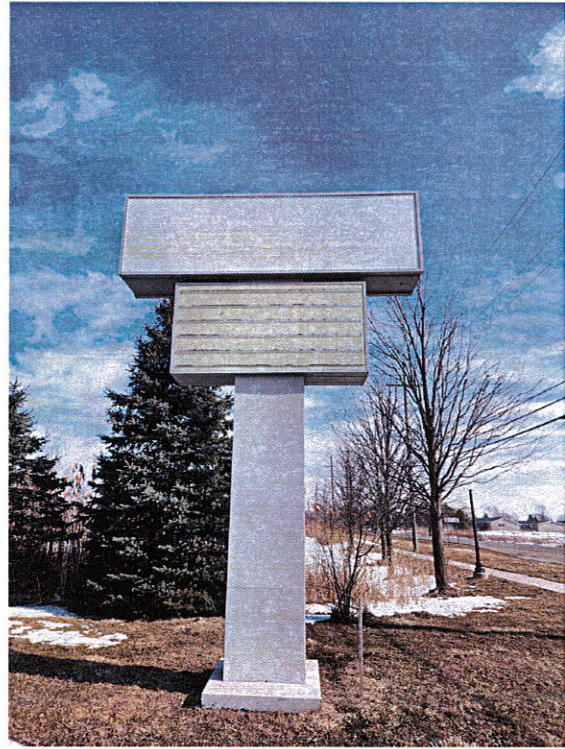

EXT 006 PROPOSED



EXT 005 EXISTING



EXT 005 PROPOSED

GJ PERELLI COMPANY



cumo DESIGNS LLC

248.432.7147 cumodesigns.com

- preliminary
- presentation
- final / bid

24 Feb 26 ● revision

GJP / Extra CU client

New Haven, MI location

New Branch proj.name

sb drawn

Exterior Pylon Sign Comparison item name

EXT 005 & EXT 006 code

1 of 1 sheet #

THESE DRAWINGS ARE CONSIDERED DESIGN INTENT ONLY AND ARE NOT FOR CONSTRUCTION. DO NOT SCALE DRAWINGS. FIGURED DIMENSIONS ARE FOR GUIDANCE ONLY.

COPYRIGHT © 2026 CUMO DESIGNS L.L.C. NO REPRODUCTION ALLOWED WITHOUT EXPRESS CONSENT OF CUMO DESIGNS L.L.C.

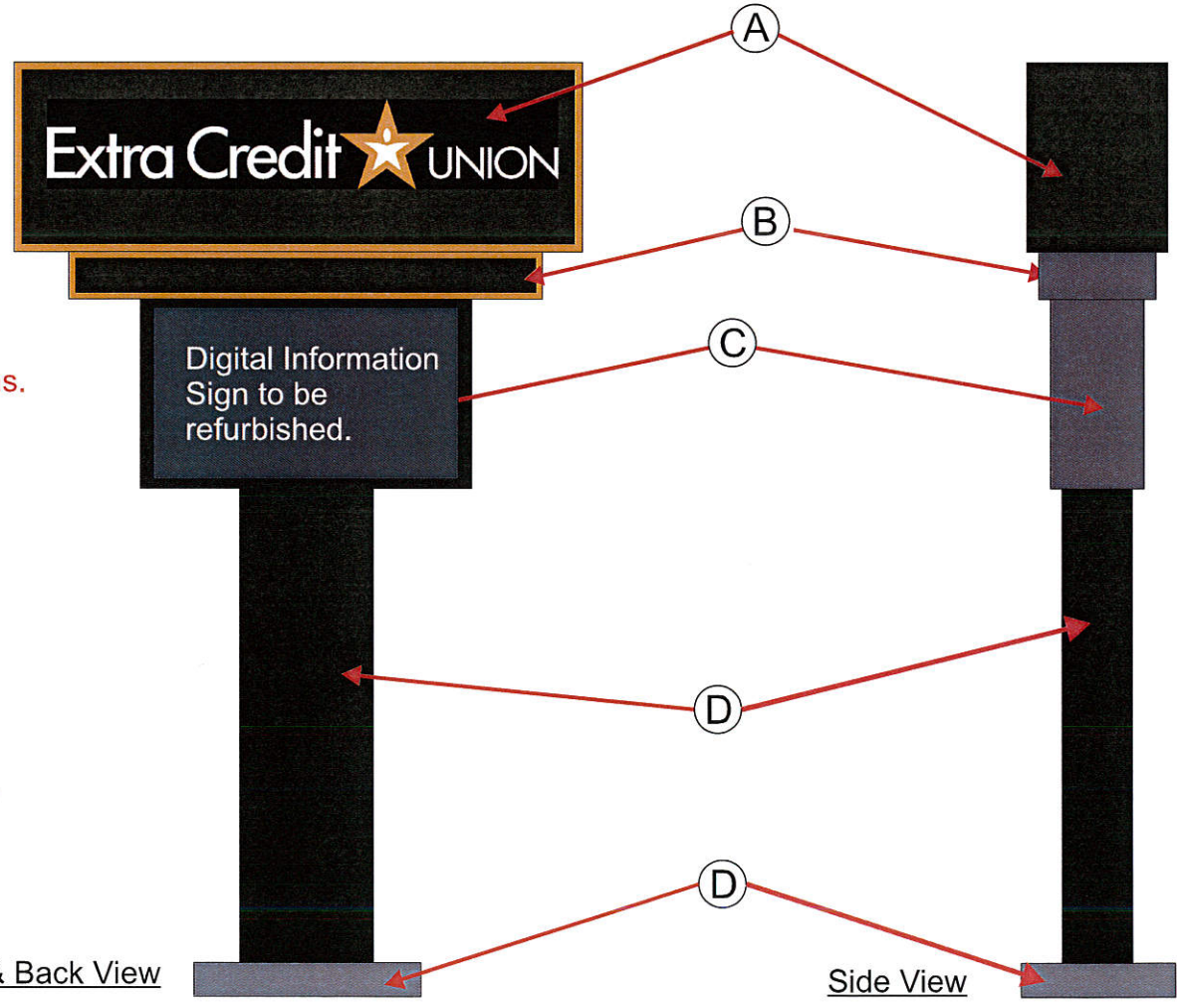
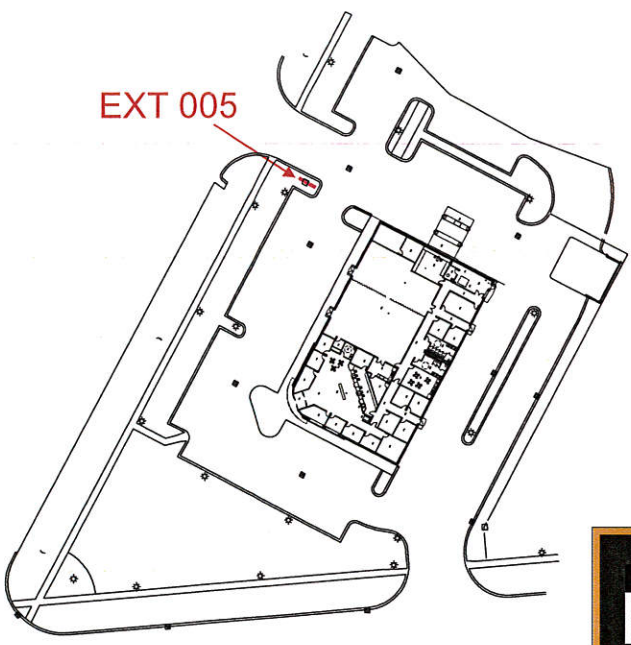

Field Measure Existing Sign for exact dimensions.

NOTE: CONCEPT ONLY. REFURBISH EXISTING SIGN. FINAL DRAWINGS TO BE SUBMITTED BY SIGNAGE VENDOR. FIELD MEASUREMENTS ESSENTIAL PRIOR TO PRODUCTION. SEE LOCAL ORDINANCES FOR FINAL SIZE.

- A** REPLACE ACRYLIC PANEL WITH NEW PANEL TO ILLUMINATE. FRAME TO BE PAINTED YELLOW TO MATCH LOGO COLOR. SIDES TO BE FINISHED BLACK
- B** REPLACE SIGN PANEL AND PAINT FRAME TO MATCH LOGO COLOR. SIDES TO BE FINISHED BLACK
- C** UPDATE DIGITAL SIGN AS NECESSARY. SIDES TO BE FINISHED BLACK
- D** COLUMN AND PLINTH TO BE FINISHED BLACK
- E**
- F**

GJ PERELLI COMPANY



**CUMO** DESIGNS LLC

248.432.7147 cumodesigns.com

- preliminary
- presentation
- final / bid
- revision

24 Feb 26

GJP / Extra CU client  
 New Haven, MI location  
 New Branch proj.name  
 sb draw  
 Exterior Pylon Sign item name  
 EXT 005 code  
 1 of 1 sheet #

- graphic only
- single sided
- double sided
- wall mounted
- soffit mounted
- hanging
- finished back
- fixture mounted
- floor standing
- millwork
- door/window
- illuminated
- exterior
- bathroom
- detail

THESE DRAWINGS ARE CONSIDERED DESIGN INTENT ONLY AND ARE NOT FOR CONSTRUCTION. DO NOT SCALE DRAWINGS. FIGURED DIMENSIONS ARE FOR GUIDANCE ONLY.