



NEW HAVEN PLANNING COMMISSION MEETING AGENDA

August 06, 2024 at 7:00 PM
Municipal Council Room – 57775 Main Street

In accordance with the Americans with Disabilities Act, reasonable accommodations can be made with advance notice by calling the Village Offices at (586) 749-5301

The New Haven Planning Commission will hold its Regular Meeting at 7:00 pm, at the New Haven Municipal Offices at 57775 Main Street.

- 1. Call to Order/Roll Call**
- 2. Public Hearing - None**
- 3. Approval of Agenda**
- 4. Public Comments on Agenda**
- 5. Approval of the Minutes**
 - A. Regular Meeting Minutes - July 8, 2024**
- 6. Communications/Correspondence/Workshop**
- 7. Old Business**
 - A. Outdoor Cafe, Dining, or Seating Ordinance**
- 8. New Business**
 - A. Morgans Auto - Preliminary Site Plan Approval**
- 9. Planner's Report**
- 10. Public Comments on Non-Agenda Items**
- 11. Call from the Table**
- 12. Adjournment**



NEW HAVEN PLANNING COMMISSION MEETING MINUTES

July 08, 2024 at 7:00 PM
Municipal Council Room – 57775 Main Street

1. Call to Order/Roll Call

Meeting called to order at 7:01 PM

PRESENT

Katie Cendrowski

Chris Dilbert

Lucy Nolan-Dilbert

Rob Pannell

Genevieve Rodzik

Craig Simms

Rachel Whitsett

2. Public Hearing

None

3. Approval of Agenda

Motion made by R. Whitsett to approve the agenda as amended, Seconded by L. Nolan-Dilbert.

Voting Yea: K. Cendrowski, C. Dilbert, L. Nolan-Dilbert, R. Pannell, G. Rodzik, C. Simms, R. Whitsett

Switch New Business & Old Business items

Remove Morgan's Auto - Final Site Plan Approval

4. Public Comments on Agenda

None

5. Approval of the Minutes

A. May 7, 2024 Regular meeting minutes

Motion made by G. Rodzik to approve the minutes from May 7, 2024 as presented, Seconded by C. Simms.

Voting Yea: K. Cendrowski, C. Dilbert, L. Nolan-Dilbert, R. Pannell, G. Rodzik, C. Simms, R. Whitsett

6. Communications/Correspondence/Workshop

None

7. Old Business

A. Outdoor Cafe, Dining, or Seating Ordinance

Look further into outdoor food preparation, bring back in August.

8. New Business

A. Crossroads Liquor Store Preliminary Site Plan

Motion made by G. Rodzik to deny the site plan approval based on reports from planning and engineering on setbacks, sidewalks, parking total number and location, in addition to any over engineering and planning comments and concerns, Seconded by R. Pannell.

Roll Call - Voting Yea: K. Cendrowski, C. Dilbert, L. Nolan-Dilbert, R. Pannell, G. Rodzik, C. Simms, R. Whitsett

Planning - Zoning is General Business Downtown

Orientation - front yard Max 10 ft - not compliant

Parking - requirement is 24, only 12 on site plan - not compliant

Dumpster - need further detail

Lighting - no plan given, need further information

Landscaping - screen/buffer strip and fence (masonry) required between residential

Signage - none given, need further information

Building on property line in back, meets requirements of zoning

Engineering

Water and sewer - OK

Paving - Compliant

Fire Hydrant at corner

Sidewalk - Needed uninterrupted and contained along Main Street and connected to building

Fire Department - plan approval given on June 13, 2024 based on fire hydrant on site

9. Planner's Report

None

10. Public Comments on Non-Agenda Items

None

11. Call from the Table

None

12. Adjournment

Motion made by R. Whitsett to adjourn at 8:26 PM, Seconded by R. Pannell.

Voting Yea: K. Cendrowski, C. Dilbert, L. Nolan-Dilbert, R. Pannell, G. Rodzik, C. Simms, R. Whitsett

§ 515-150

Outdoor Cafes, Dining, or Seating Areas.

Outdoor cafes, dining, or seating when incidental or accessory to a permitted use in the GBD (General Business Downtown) District or GB (General Business) District, may be permitted as a special land use provided the following conditions are met:

A. Outdoor cafes, dining, or seating shall be directly adjacent to, and on the same parcel as, the building or tenant space occupied by the principal use that it serves. These outdoor areas are permitted in all yards, though providing site plan application and adhering to the defined setback standards for the underlying district, and pending review and approval from public safety and engineering for compliance with all building and fire safety codes and requirements.

B. Design and Layout Criteria

(1.) Outdoor dining areas shall be separated from parking areas, public rights-of-way and other common areas by a 4 foot tall ornamental fence, in addition to landscaping or other materials acceptable to the Planning Commission, upon review and in compliance with the requirements of Village Public Safety, and in accordance with all current fire and building codes. The fence, screening, and protective barriers shall be designed in a manner that is compatible and complementary to the primary building and adjacent sites.

(2.) When adjacent to a pedestrian walk, a five-foot sidewalk width shall be maintained for pedestrian flow. Further, ingress and egress to these outdoor areas shall comply with ADA standards.

(3.) Carry-out restaurants without indoor seating shall not exceed twelve (12) seats for outdoor dining.

(4.) If alcoholic beverages are to be served, the current Liquor Control Commission Rules and Regulations shall apply. Further, all food preparation shall take place inside the establishment. Proper State, Local, and Health Department licensing and approvals from permitting jurisdictions shall be provided to the Village.

(5.) No music, intercom or other noise shall be permitted that impacts adjacent properties and violates Village noise ordinance.

C. Off-Street Parking. Outdoor dining shall be considered an incidental and accessory use and therefore not included in the parking calculation of required parking spaces under the following conditions:

(1.) The occupant load of the outdoor dining area shall not exceed thirty (30) percent of the interior customer/patron occupant load of the building or tenant space housing the principal permitted use (occupant load to be determined per the building code). If greater than thirty (30) percent, then the outdoor dining area shall be included as part of the floor area and occupant load of the principal use for the purposes of calculating the parking requirement for that use.

D. Lighting for outdoor dining areas shall be noted on the application and shall be shielded downward and away from adjacent properties and rights-of-way. All lighting shall be designed to prevent glare from negatively impacting adjacent properties or rights-of-way. See § 515-90 for specific requirements for site lighting.

E. Hours of Operation. The hours of outdoor dining operation shall be limited to the hours of 10a.m. to 10p.m., or the hours of operation of the principal use, whichever is more restrictive.

F. Temporary/Seasonal Outdoor Cafe, Dining, or Seating. The intent of this provision is to create or increase outdoor cafe, dining, or seating areas for existing restaurants and food service establishments on a temporary or seasonal basis. Temporary/Seasonal Outdoor areas are a permitted use in the GBD and GB District and may be administratively reviewed at the discretion of the Building Department Director/Official or their designee with the following guidance and design criteria:

(1.) Permit required. An annual building permit issued by the Building Department Director/Official or their designee shall be required. A restaurant must submit a permit application and all required documents (including written consent form the property owner/landlord if not the applicant), and applicable fees as determined by the Village of New Haven before the issuance of a permit.

(2.) Permit revocation. A permit may be revoked for cause by the Building Department Director/Official of their designee, if the outdoor dining is creating a nuisance, or for any other violation of law, fire and safety code, or other ordinance.

(3.) Appeals. An appeal of a permit denial or revocation shall be made to Village Council.

(4.) Dates of operation. Permitted temporary/seasonal outdoor seating may operate between April 15th and October 15th. All seating, screening, fencing, or other outdoor dining materials must be removed

and stored when outside of the permitted outdoor dining season, as defined. On-site storage shall be in accordance with building and fire code guidelines, or materials can be held at an offsite facility.

(5.) Required design and landscaping for temporary dining areas shall adhere to the design criteria as provided by this ordinance, and may be waived by the Building Department Director/Official or their designee in specific case consideration where no good purpose would come from following such criteria. Permit applications shall include a sketch plan of the seating area and location, properly scaled and dimensioned, and demonstrating the safety and design features as required by ordinance. Further, the proposed design shall be reviewed for compliance with the requirements of Village Public Safety, and in accordance with all current fire and building codes.

(6.) In the event that the outdoor area is temporarily displacing required parking spaces, up to ten (10) percent of the existing spaces for the building or tenant space housing the permitted use may be displaced to permit the outdoor dining. If the site consists of less than ten (10) total parking spaces, then only 1 parking space may be displaced for this purpose. The outdoor dining area shall be configured to provide safe separation from neighboring parking spaces and drive aisles; protective barriers, and movable planters or decorative fencing shall be used in these instances to define the outdoor dining space and to provide proper screening for the area. Further, adequate clearance for car door swing areas shall be maintained for adjacent parking spaces (Minimum: 3 feet).

"Morgan's Auto"

PART OF THE SOUTHEAST 1/4 OF SECTION 33, T.4N., R.14E.,
VILLAGE OF NEW HAVEN, MACOMB COUNTY, MICHIGAN.

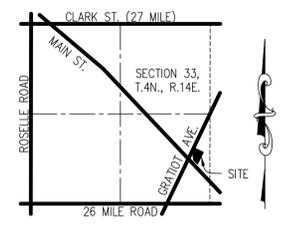
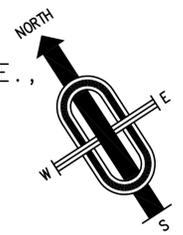

LOCATION MAP
NOT TO SCALE

LEGAL DESCRIPTION: PARCEL 03-33-430-009
PART OF SECTION 33, T.4N., R.14E., VILLAGE OF NEW HAVEN, MACOMB COUNTY, MICHIGAN, BEING MORE PARTICULARLY DESCRIBED AS COMMENCING AT THE CENTERLINE OF GRATIOT AVENUE AND NEW HAVEN ROAD; THENCE N32°38'30"E 200.0' TO THE POINT OF BEGINNING; THENCE N32°38'30"E 167.0'; THENCE S57°21'30"E 313.0'; THENCE S32°38'30"W 384.23'; THENCE N40°29'W 145.0'; THENCE N12°22'W 50.0'; THENCE N13°41'E 33.66'; THENCE N14°14'51"W 59.01'; THENCE N30°45'25"E 43.26'; THENCE N57°21'30"W 54.58'; THENCE N12°22'W 36.50' TO THE POINT OF BEGINNING, CONTAINING 2.105 ACRES. LEGAL DESCRIPTION PROVIDED FROM ASSESSING RECORDS.

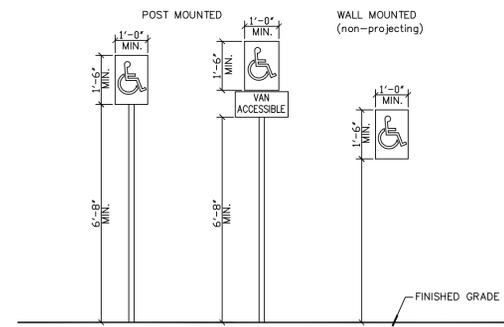

EACH ACCESSIBLE PARKING SPACE IS REQUIRED TO HAVE A SIGN. THE SIGN SHALL BE CENTERED IN THE PARKING SPACE.
VAN ACCESSIBLE PARKING SPACES SHALL BE DESIGNATED "VAN ACCESSIBLE" ON THE FACE OF THE SIGN OR SHALL HAVE AN ADDITIONAL SIGN "VAN ACCESSIBLE" MOUNTED BELOW THE REQUIRED SIGN.

ACCESSIBLE PARKING SIGNAGE
NOT TO SCALE

GENERAL NOTES:

- A PERMIT WILL BE REQUIRED FROM THE MACOMB COUNTY DEPT. OF ROADS FOR ALL WORK PERFORMED WITHIN THE NAPI DRIVE RIGHT-OF-WAY. ENTRANCE PAVEMENT REQUIREMENTS WILL BE COORDINATED WITH THE DEPT. OF ROADS DURING THE PERMITTING PROCESS.
- PROPOSED UTILITY LOCATIONS SHOWN ARE FOR PLANNING PURPOSES AND MAY BE SUBJECT TO CHANGE DURING THE ENGINEERING STAGE. MUNICIPAL UTILITIES (WATER, SANITARY, AND STORM SEWER) WILL BE BROUGHT ON SITE BY THE DEVELOPER FROM EXISTING SOURCES. PLANS WILL BE SUBMITTED TO THE SHELBY TWP DPW FOR REVIEW FOR ENGINEERING REVIEW PRIOR TO CONSTRUCTION.
- NO CONSTRUCTION ACTIVITY SHALL BE PERMITTED PRIOR TO RECEIPT OF "PERMIT TO CONSTRUCT" FROM SHELBY TWP DPW.
- ALL UNPAVED AREAS SHALL HAVE APPROPRIATE GROUND COVER. AREAS ADJACENT TO BUILDINGS AND WITHIN THE PARKING AREAS SHALL BE COVERED WITH SHREDDED BARK MULCH BEDDINGS. SOD SHALL BE USED IN THE LARGER GREENBELT AREAS ALONG THE FRONTAGE OF THE SITE, AND AROUND ALL SIDES OF THE BUILDINGS, WHERE APPROPRIATE. THE BALANCE OF THE SITE AREA THAT IS ENCLOSED BY THE FENCE WILL BE A STORAGE AREA.
- SODDED AREAS SHALL HAVE AUTOMATIC UNDERGROUND SPRINKLER SYSTEMS INSTALLED.
- THERE ARE EXISTING TREES ON THIS PROPERTY ALONG THE FRONTAGE OF THE SITE. SEE LANDSCAPE PLAN FOR TREE PROTECTION NOTES AND DETAILS.
- A PHOTOMETRIC PLAN WILL BE SUPPLIED BY OTHERS.
- SEE ARCHITECTURAL PLANS SUPPLIED BY RLA STUDIO.
- ANY PROPOSED ROOF MOUNTED MECHANICAL UNITS WILL BE PROPERLY SCREENED.
- DETENTION HAS BEEN PROVIDED BY OFFSITE IMPROVEMENTS IN THE LONGSTAFF DRAIN, WHICH IS DOWNSTREAM

PREPARED FOR:
MARK BROWN
MORGAN'S AUTO
57660 GRATIOT AVE.
NEW HAVEN, MI 48048
(586) 943-1453
MORGANSAUTO@YAHOO.COM

PREPARED BY:
COMMUNITY E.S., INC.
C/O RICHARD HODSDON, P.E. #48078
5805 24 MILE ROAD, STE. B
SHELBY TWP., MI 48316
PH: (586) 677-4081
E-MAIL: RICH@COMMUNITYENG.COM

© 2024 - COMMUNITY E.S., INC. ALL RIGHTS RESERVED. THESE PLANS AND DRAWINGS ARE OWNED BY AND THE SOLE PROPERTY OF COMMUNITY E.S., INC. ANY REPRODUCTION, COPYING, REUSE OR DISTRIBUTION OF THESE PLANS AND DRAWINGS IS STRICTLY PROHIBITED WITHOUT THE PRIOR WRITTEN CONSENT OF COMMUNITY E.S., INC.



PRELIMINARY

SITE DATA:

- EXISTING SITE INFORMATION:
PART OF PARCEL NO. 06-33-430-009
ADDRESS: 57660 GRATIOT AVE.
- ZONING: L1
- EXISTING BUILDING: 4,284 SF AUTO SERVICE
6 SERVICE BAYS
PROPOSED BARN: 3,477 SF WAREHOUSE
- PARKING:
5 SPACES MINIMUM PLUS 4 SPACES FOR EACH ADDITIONAL SERVICE BAY
5 SERVICE BAYS X 4 SPACES = 20 SPACES
25 SPACES REQUIRED
269 SPACES PROVIDED

NOTE: THE SHOP CURRENTLY HAS 6 EMPLOYEES.

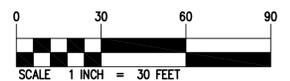

COMMUNITY E.S. CIVIL ENGINEERING & SURVEYING Civil Engineering and Surveying 5805 24 Mile Road, Suite B Shelby Twp., Michigan 48316 Telephone (586) 677-4081 www.communityeng.com		MORGAN'S AUTO PART OF SECTION 33, T.4N., R.14E., VILLAGE OF NEW HAVEN, MACOMB COUNTY, MICHIGAN.
DATE Jan. 3, 2024	SCALE 1" = 20'	
DRAWN BY R.S.H.	SHEET 1 OF 1	
CHECKED BY R.S.H.	DRAWING Z-24-152	
PRELIMINARY SITE PLAN		

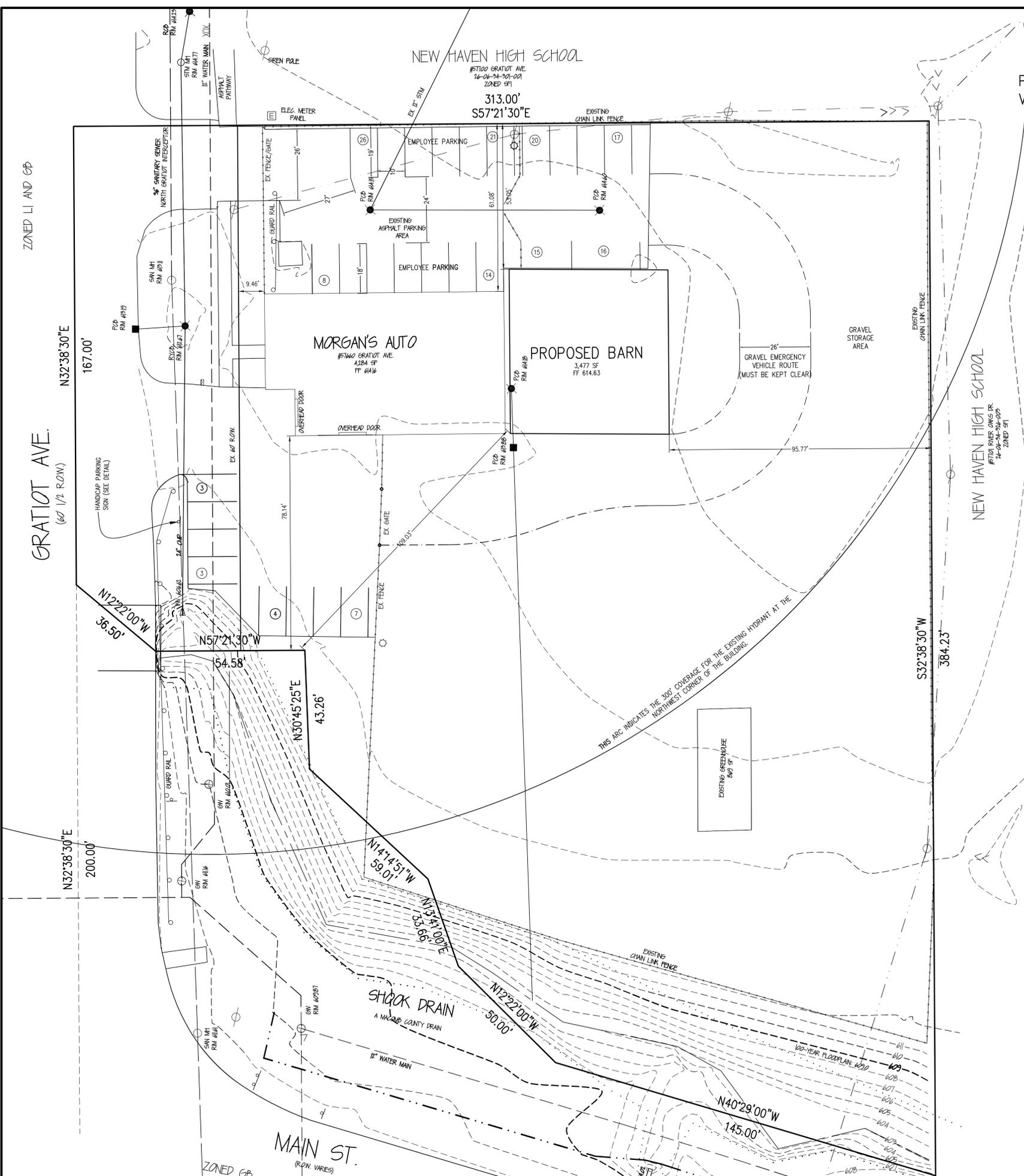

"Morgan's Auto"

PART OF THE SOUTHEAST 1/4 OF SECTION 33, T.4N., R.14E.,
VILLAGE OF NEW HAVEN, MACOMB COUNTY, MICHIGAN.

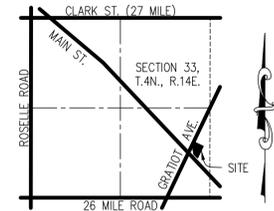

LOCATION MAP
NOT TO SCALE

LEGAL DESCRIPTION: PARCEL 03-33-430-009
PART OF SECTION 33, T.4N., R.14E., VILLAGE OF NEW HAVEN, MACOMB COUNTY, MICHIGAN, BEING MORE PARTICULARLY DESCRIBED AS COMMENCING AT THE CENTERLINE OF GRATIOT AVENUE AND NEW HAVEN ROAD; THENCE N32°38'30"E 200.0' TO THE POINT OF BEGINNING; THENCE N32°38'30"E 167.0'; THENCE S57°21'30"E 313.0'; THENCE S32°38'30"W 384.23'; THENCE N40°29'W 145.0'; THENCE N12°22'W 50.0'; THENCE N13°41'E 33.66'; THENCE N14°14'51"W 59.01'; THENCE N30°45'25"E 43.26'; THENCE N57°21'30"W 54.58'; THENCE N12°22'W 36.50' TO THE POINT OF BEGINNING.
CONTAINING 2.105 ACRES.
LEGAL DESCRIPTION PROVIDED FROM ASSESSING RECORDS.

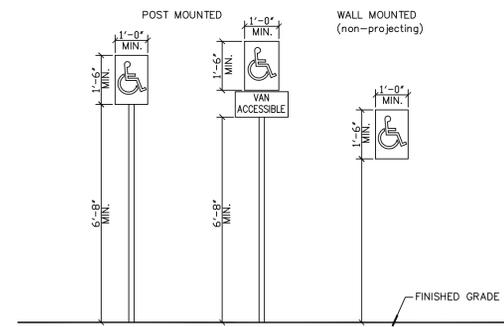

EACH ACCESSIBLE PARKING SPACE IS REQUIRED TO HAVE A SIGN. THE SIGN SHALL BE CENTERED IN THE PARKING SPACE.
VAN ACCESSIBLE PARKING SPACES SHALL BE DESIGNATED "VAN ACCESSIBLE" ON THE FACE OF THE SIGN OR SHALL HAVE AN ADDITIONAL SIGN "VAN ACCESSIBLE" MOUNTED BELOW THE REQUIRED SIGN.

ACCESSIBLE PARKING SIGNAGE
NOT TO SCALE

GENERAL NOTES:

1. A PERMIT WILL BE REQUIRED FROM THE MACOMB COUNTY DEPT. OF ROADS FOR ALL WORK PERFORMED WITHIN THE NAPI DRIVE RIGHT-OF-WAY. ENTRANCE PAVEMENT REQUIREMENTS WILL BE COORDINATED WITH THE DEPT. OF ROADS DURING THE PERMITTING PROCESS.
2. PROPOSED UTILITY LOCATIONS SHOWN ARE FOR PLANNING PURPOSES AND MAY BE SUBJECT TO CHANGE DURING THE ENGINEERING STAGE. MUNICIPAL UTILITIES (WATER, SANITARY, AND STORM SEWER) WILL BE BROUGHT ON SITE BY THE DEVELOPER FROM EXISTING SOURCES. PLANS WILL BE SUBMITTED TO THE SHELBY TWP DPW FOR REVIEW FOR ENGINEERING REVIEW PRIOR TO CONSTRUCTION.
3. NO CONSTRUCTION ACTIVITY SHALL BE PERMITTED PRIOR TO RECEIPT OF "PERMIT TO CONSTRUCT" FROM SHELBY TWP DPW.
4. ALL UNPAVED AREAS SHALL HAVE APPROPRIATE GROUND COVER. AREAS ADJACENT TO BUILDINGS AND WITHIN THE PARKING AREAS SHALL BE COVERED WITH SHREDDED BARK MULCH BEDDINGS. SOD SHALL BE USED IN THE LARGER GREENBELT AREAS ALONG THE FRONTAGE OF THE SITE, AND AROUND ALL SIDES OF THE BUILDINGS, WHERE APPROPRIATE. THE BALANCE OF THE SITE AREA THAT IS ENCLOSED BY THE FENCE WILL BE A STORAGE AREA.
5. SODDED AREAS SHALL HAVE AUTOMATIC UNDERGROUND SPRINKLER SYSTEMS INSTALLED.
6. THERE ARE EXISTING TREES ON THIS PROPERTY ALONG THE FRONTAGE OF THE SITE. SEE LANDSCAPE PLAN FOR TREE PROTECTION NOTES AND DETAILS.
7. A PHOTOMETRIC PLAN WILL BE SUPPLIED BY OTHERS.
8. SEE ARCHITECTURAL PLANS SUPPLIED BY RLA STUDIO.
9. ANY PROPOSED ROOF MOUNTED MECHANICAL UNITS WILL BE PROPERLY SCREENED.
10. DETENTION HAS BEEN PROVIDED BY OFFSITE IMPROVEMENTS IN THE LONGSTAFF DRAIN, WHICH IS DOWNSTREAM.

PRELIMINARY

SITE DATA:

1. EXISTING SITE INFORMATION:
PART OF PARCEL NO. 06-33-430-009
ADDRESS: 57660 GRATIOT AVE.
2. ZONING: L1
3. EXISTING BUILDING: 4,284 SF AUTO SERVICE
6 SERVICE BAYS
PROPOSED BARN: 3,477 SF WAREHOUSE
4. PARKING:
5 SPACES MINIMUM PLUS 4 SPACES FOR EACH ADDITIONAL SERVICE BAY
5 SERVICE BAYS X 4 SPACES = 20 SPACES
25 SPACES REQUIRED
269 SPACES PROVIDED

NOTE: THE SHOP CURRENTLY HAS 6 EMPLOYEES.

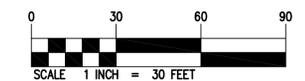

PREPARED FOR:
MARK BROWN
MORGAN'S AUTO
57660 GRATIOT AVE.
NEW HAVEN, MI 48048
(586) 943-1453
MORGANSAUTO@YAHOO.COM

PREPARED BY:
COMMUNITY E.S., INC.
C/O RICHARD HODSDON, P.E. #48078
5805 24 MILE ROAD, STE. B
SHELBY TWP., MI 48316
PH: (586) 677-4081
E-MAIL: RICH@COMMUNITYENG.COM

© 2024 - COMMUNITY E.S., INC. ALL RIGHTS RESERVED. THESE PLANS AND DRAWINGS ARE OWNED BY AND THE SOLE PROPERTY OF COMMUNITY E.S., INC. ANY REPRODUCTION, COPYING, REUSE OR DISTRIBUTION OF THESE PLANS AND DRAWINGS IS STRICTLY PROHIBITED WITHOUT THE PRIOR WRITTEN CONSENT OF COMMUNITY E.S., INC.



COMMUNITY E.S.
CIVIL ENGINEERING & SURVEYING

MORGAN'S AUTO
PART OF SECTION 33, T.4N., R.14E., VILLAGE OF NEW HAVEN, MACOMB COUNTY, MICHIGAN.

DATE Jan. 3, 2024	SCALE 1" = 20'
DRAWN BY R.S.H.	SHEET 1 OF 1
CHECKED BY R.S.H.	DRAWING Z-24-152

PRELIMINARY SITE PLAN

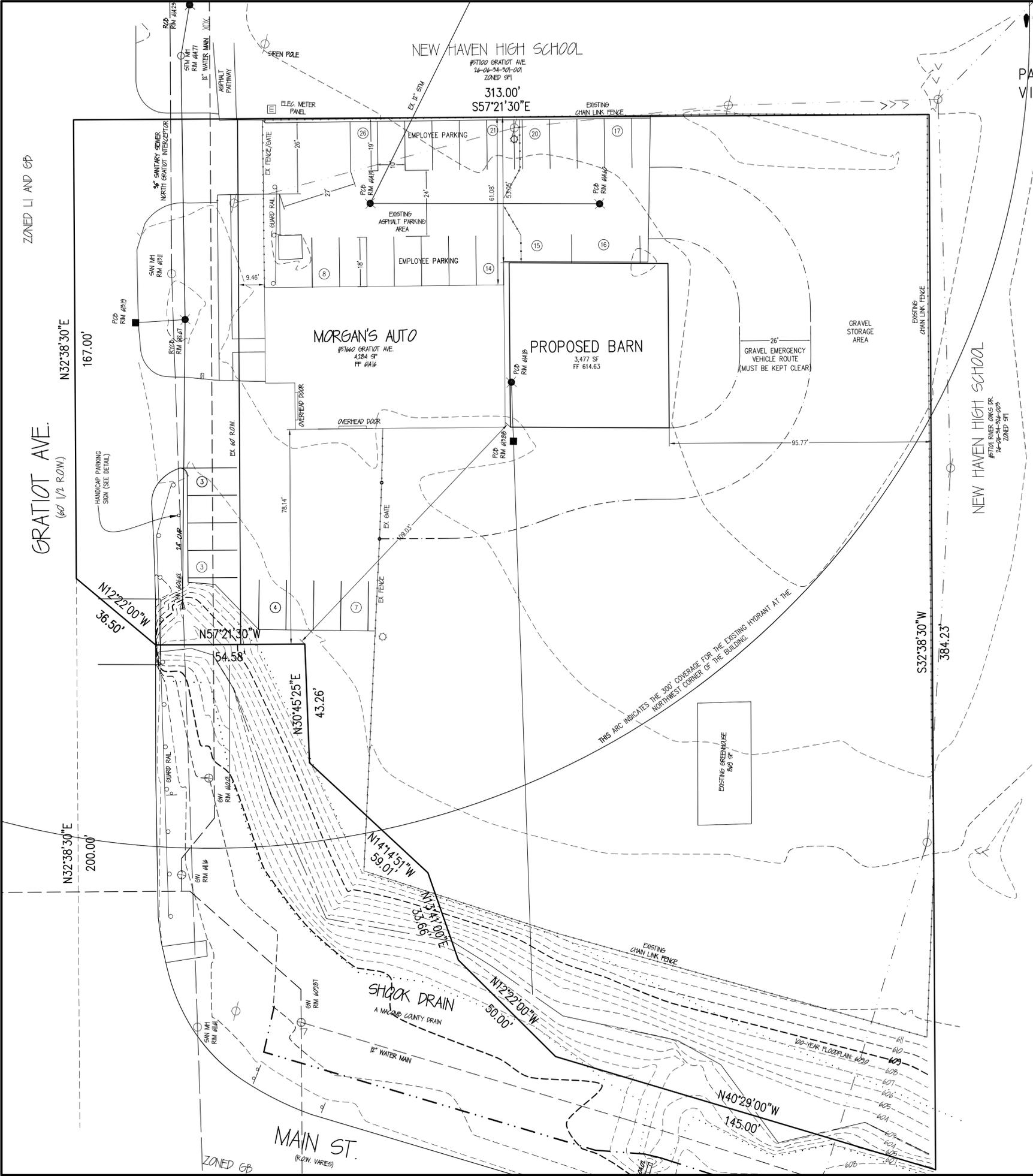

ZONED L1 AND GP

GRATIOT AVE.
(60' 1/2 ROW)

N32°38'30"E
167.00'

N32°38'30"E
200.00'

N12°22'00"W
36.50'

N57°21'30"W
54.58'

N30°45'25"E
43.26'

N14°14'51"W
59.01'

N13°41'00"E
33.66'

N12°22'00"W
50.00'

EXISTING GREENHOUSE
849 SF

THIS ARC INDICATES THE 300' COVERAGE FOR THE EXISTING HYDRANT AT THE NORTHWEST CORNER OF THE BUILDING.

MAIN ST.
(ROW VARIES)

ZONED GP

MARK BROWN NEW HAVEN, MI



Service doors and windows shown for representation only. Please confirm exact locations at time of construction.

Service doors and windows shown for representation only. Please confirm exact locations at time of construction.

MIDWEST
MINI PRINT
FILE NUMBER: EM616105

DIMENSIONS
Material views, steel views, and floor plan are not to scale.
ERRORS AND OMISSIONS
MENDOTA, INC. is unable to accept liability for any errors or omissions in excess of the original purchase price for these plans. Consequently, builders must carefully check all details and information in these drawings including dimensioning, material quantities and availability of the products specified. Any errors or omissions must show up at the request immediately to Mendota Manufacturing, 3511 White House, Eau Claire, WI 54703

ADAPTATION AND UTILIZATION OF THIS PLAN
These plans have been professionally prepared to conform to most generally accepted construction requirements throughout North America, however due to local codes, regulations, and building practices and/or because of specific site conditions, in all localities. Consequently, these drawings are not to be used as a guide for construction unless the builder has confirmed their suitability or until the drawings have been brought into conformity with all local requirements.

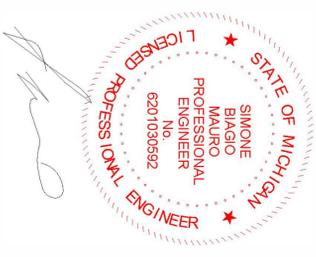

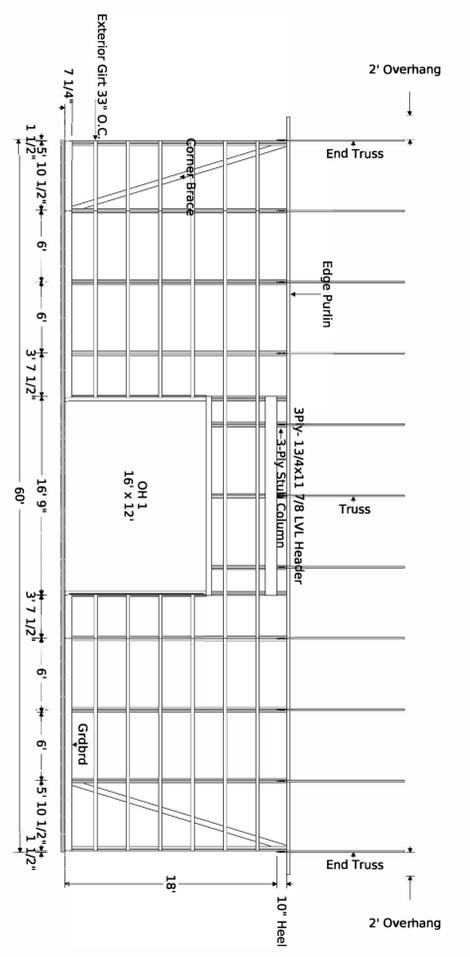

WALL 1-A-FRAMING

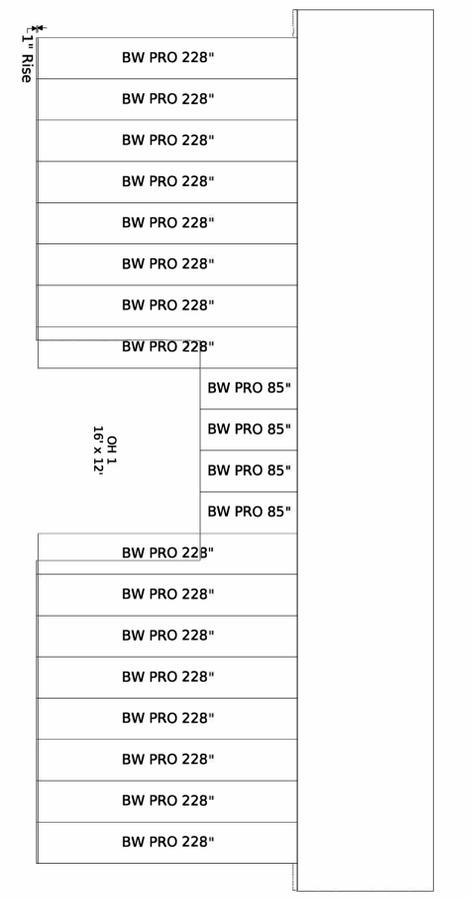

WALL 1-A-STEEL

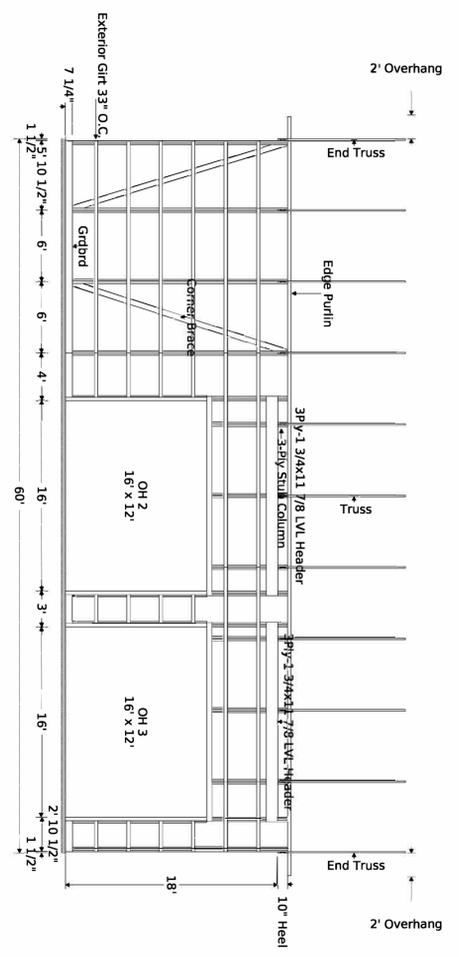

WALL 1-B-FRAMING

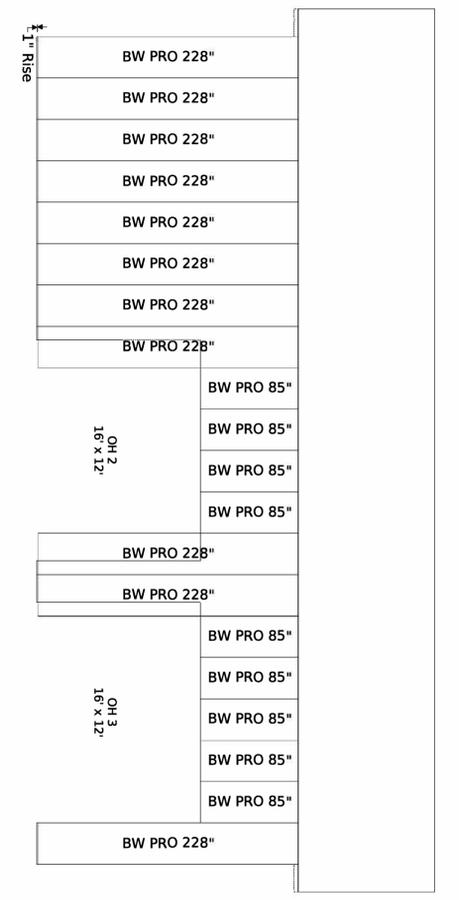

WALL 1-B-STEEL

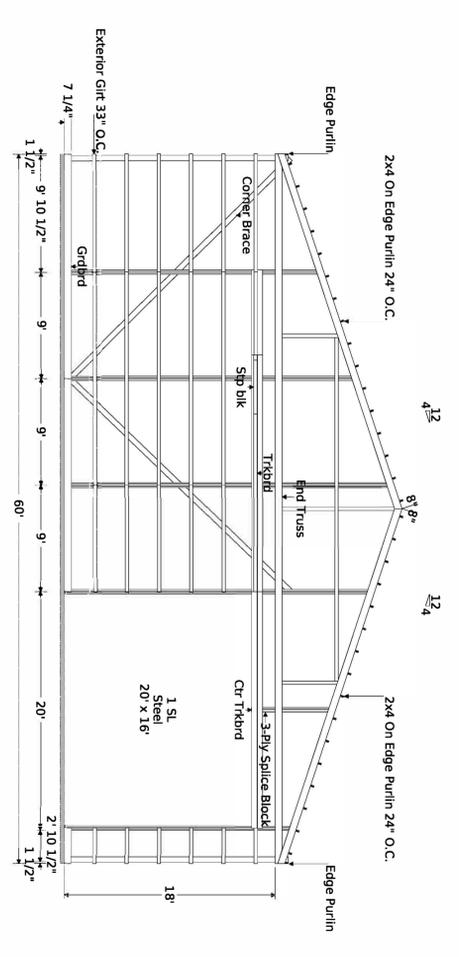

WALL 1-C-FRAMING

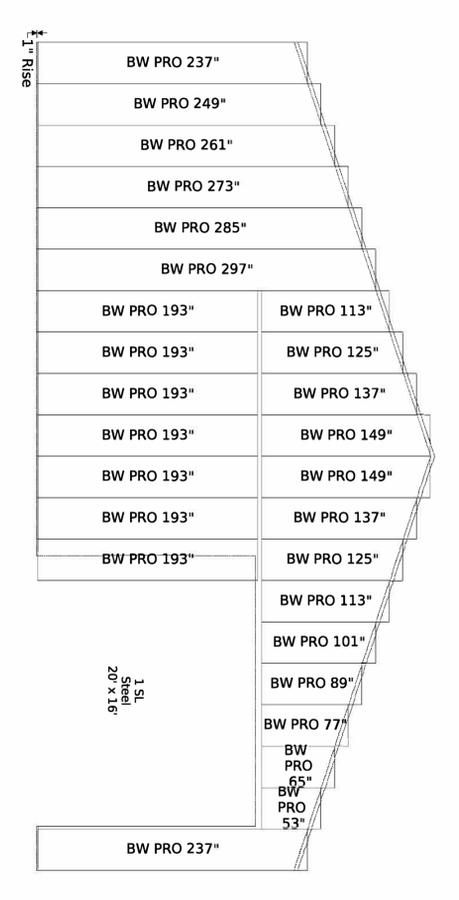

WALL 1-C-STEEL

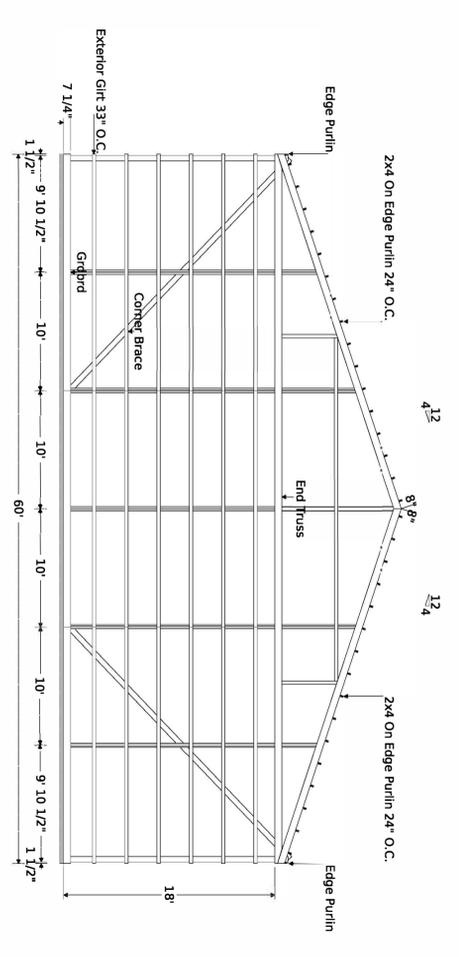

WALL 1-D-FRAMING

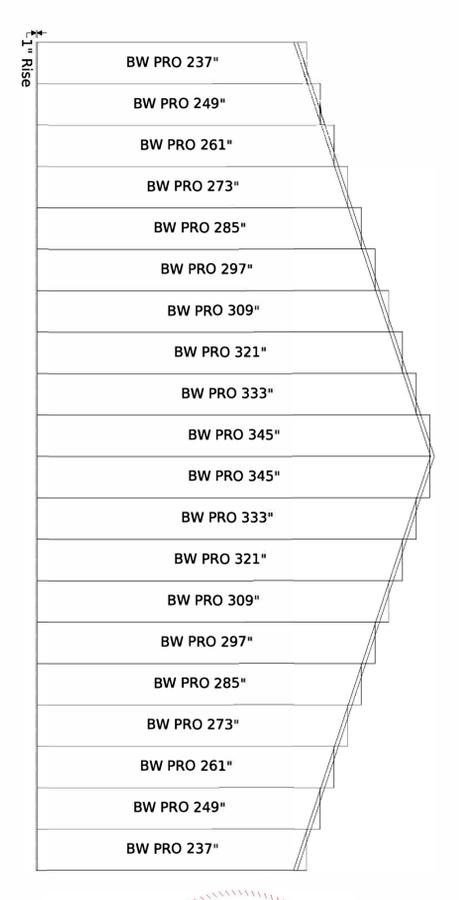

WALL 1-D-STEEL

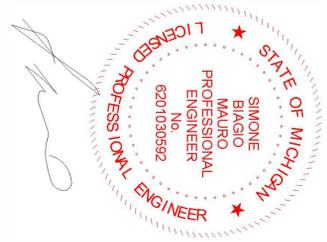





STATE OF MICHIGAN
SIMONE
BIAGIO MAURO
PROFESSIONAL
ENGINEER
No. 62010303592
LICENSED PROFESSIONAL ENGINEER



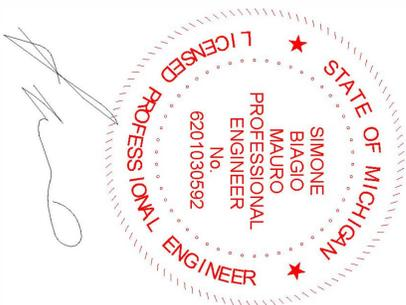
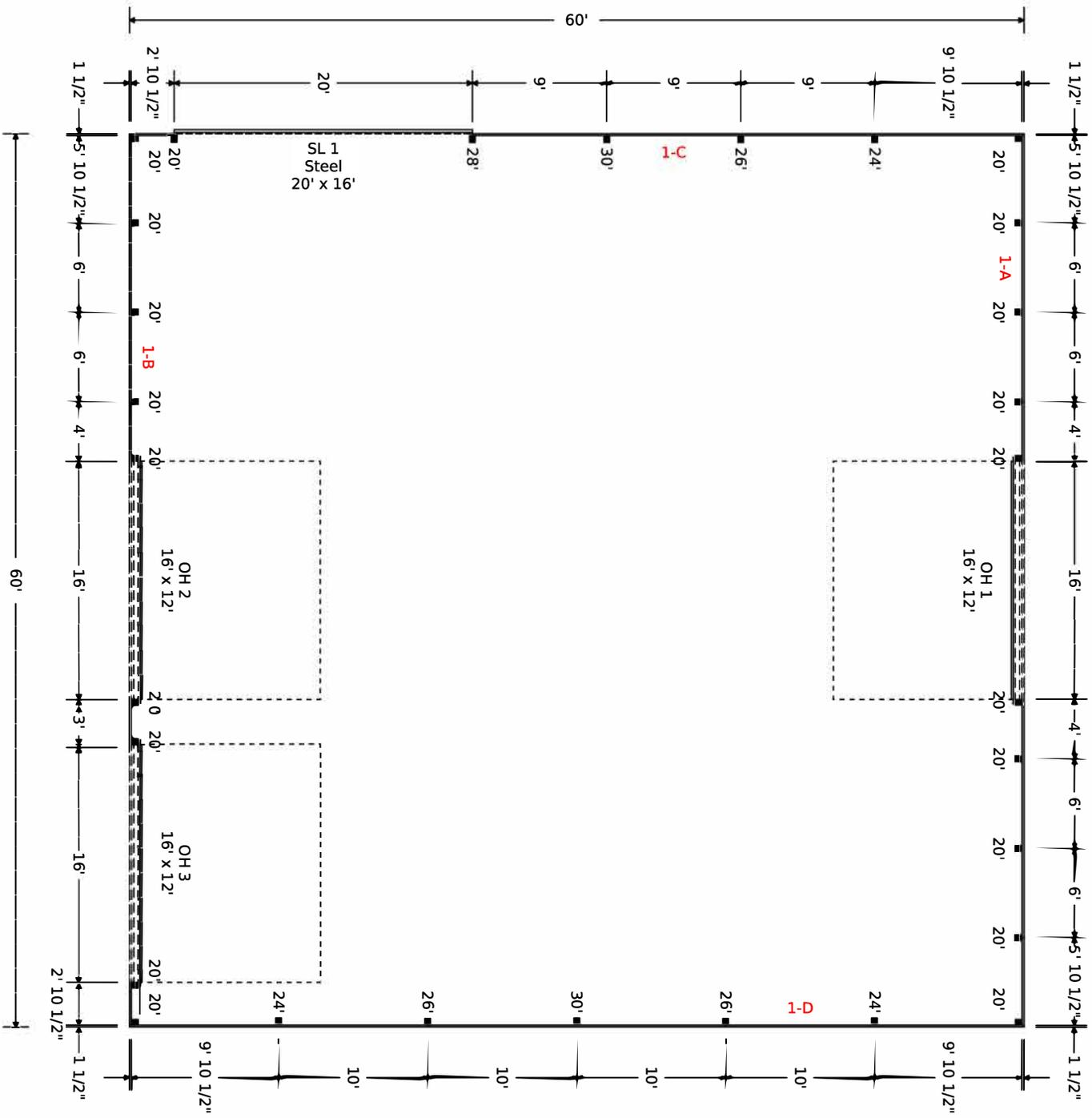

STATE OF MICHIGAN
SIMONE
BIAGIO MAURO
PROFESSIONAL
ENGINEER
No. 62010303592
LICENSED PROFESSIONAL ENGINEER

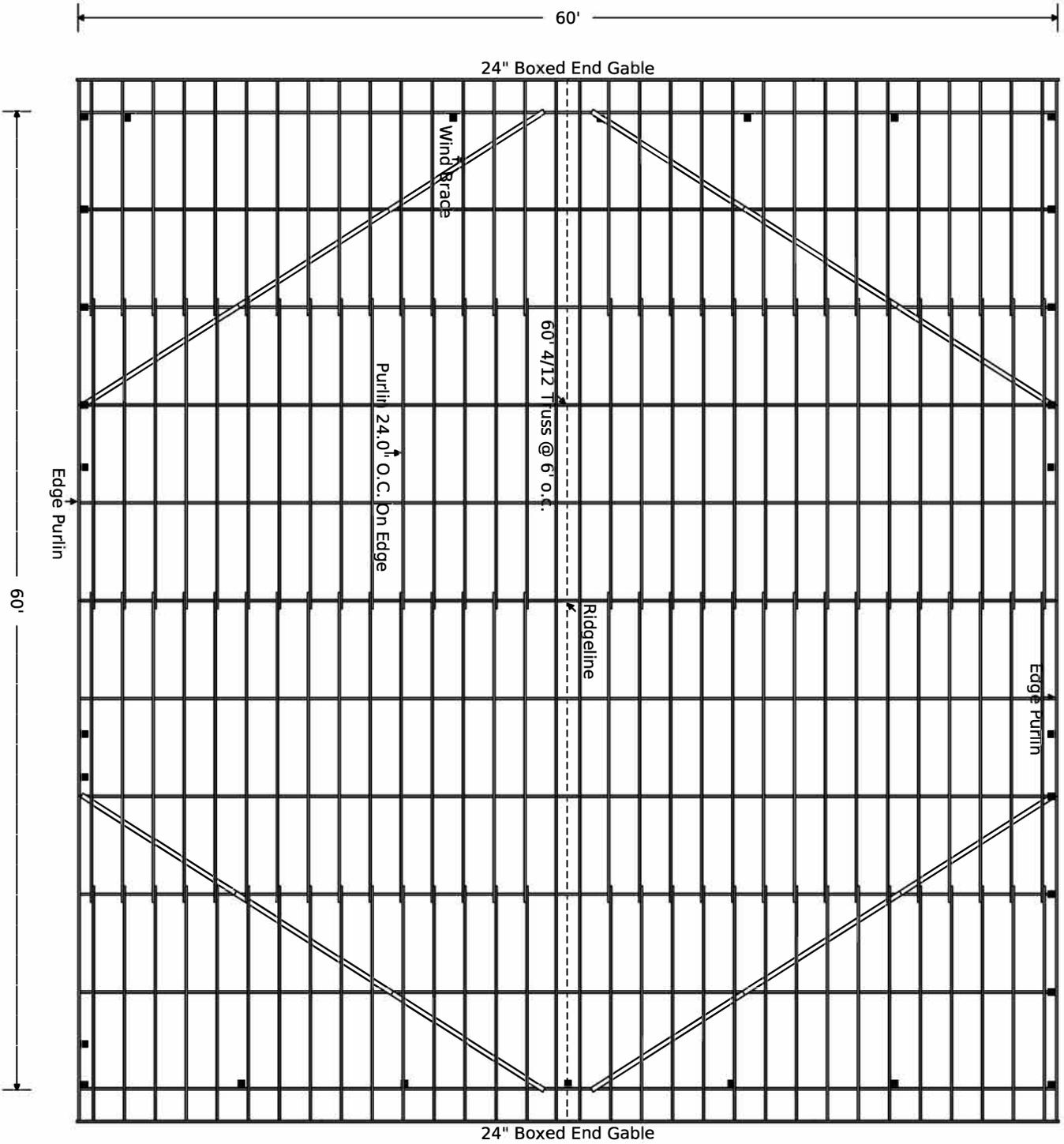
FLOOR PLAN



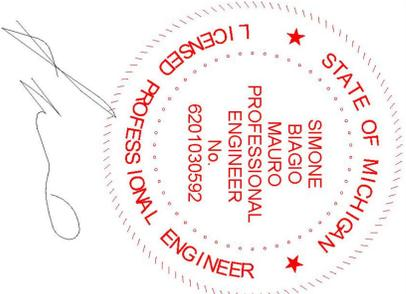

ROOF FRAMING



WALL 1-A FRAMING

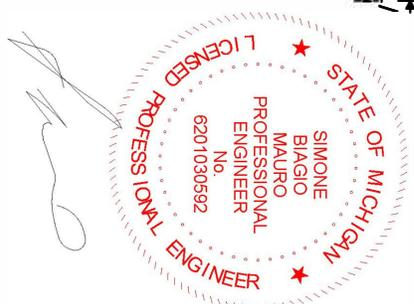
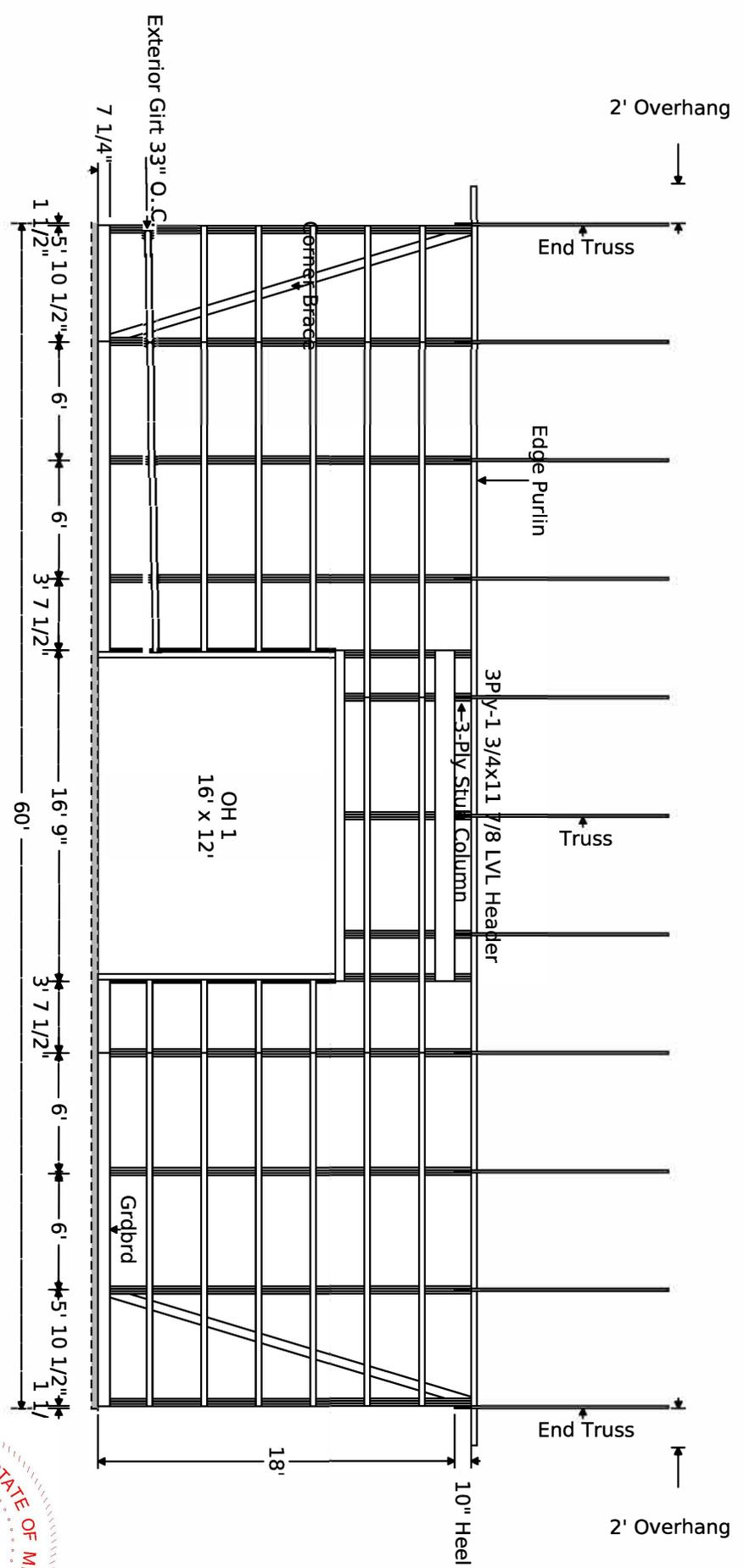

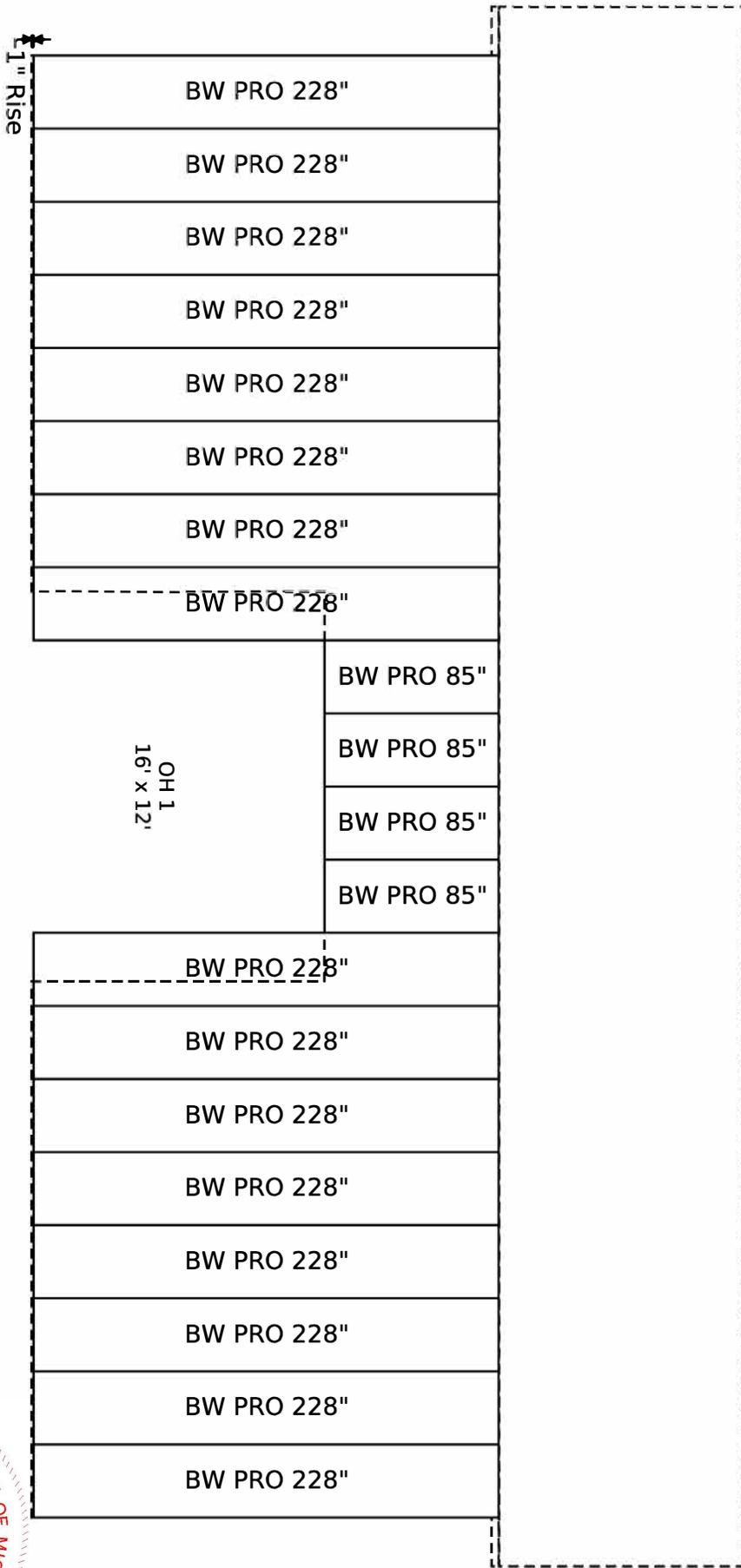

WALL 1-A STEEL

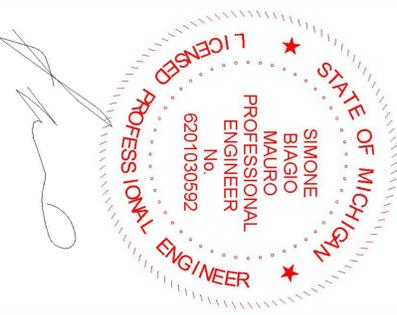

WALL 1-B FRAMING

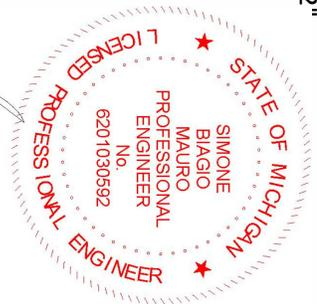
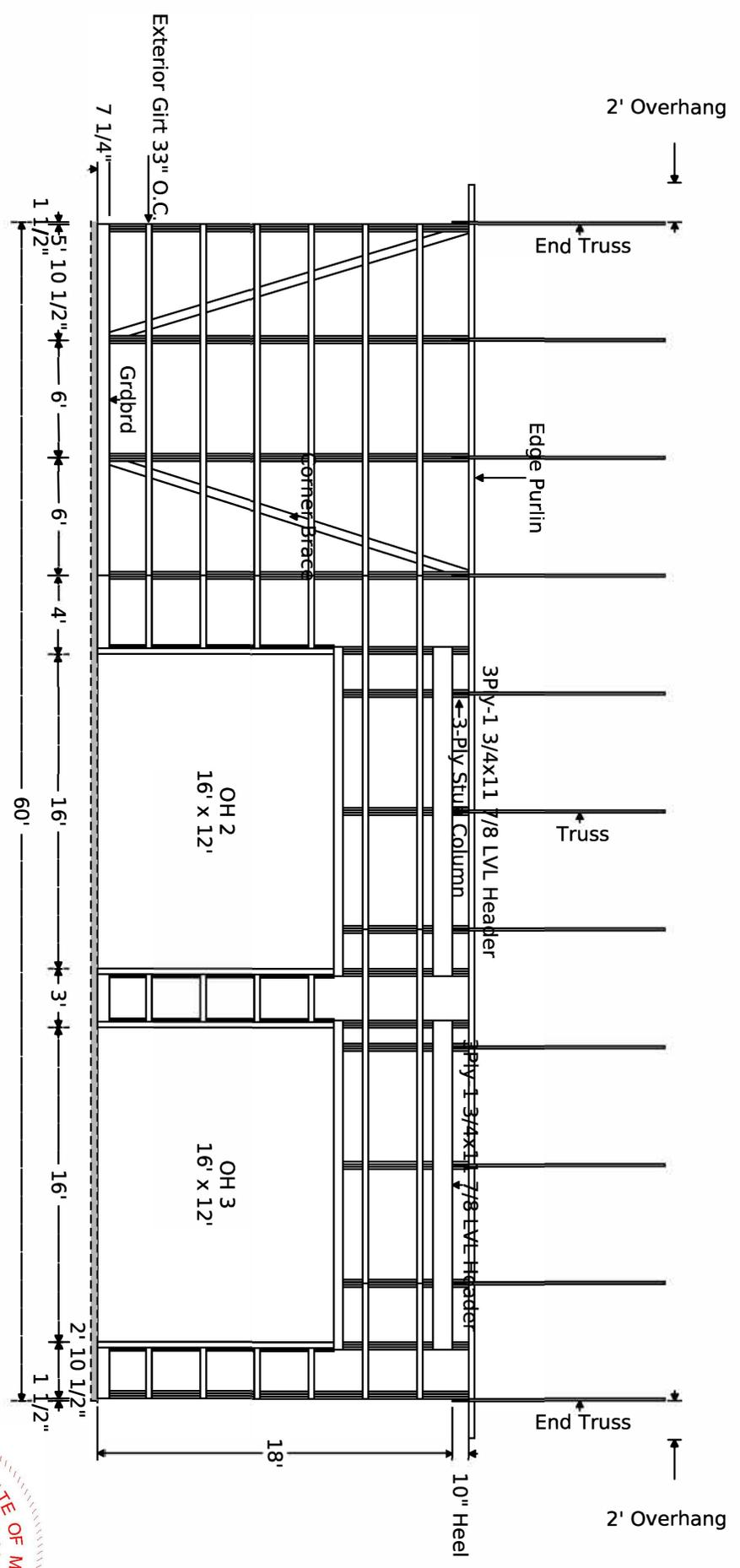

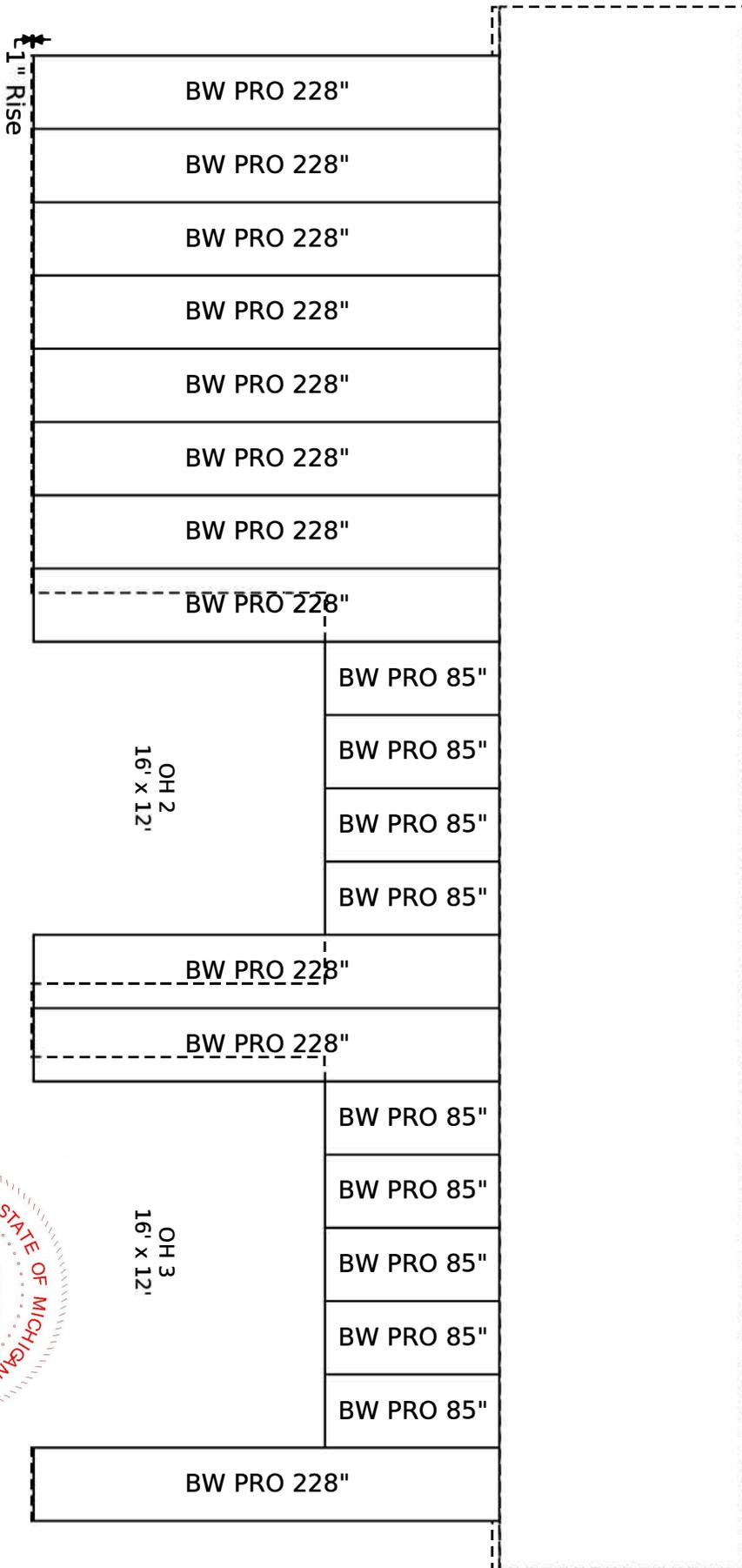

WALL 1-B STEEL

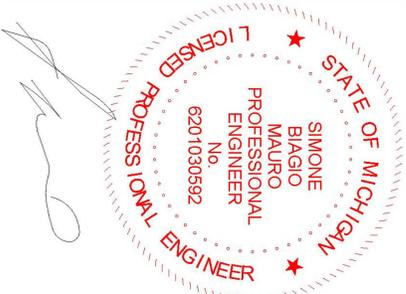

WALL 1-C FRAMING

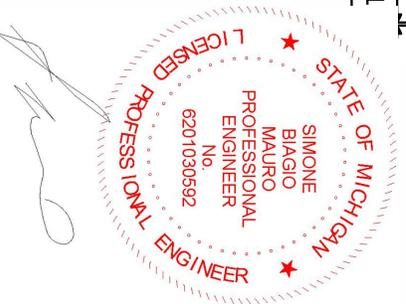
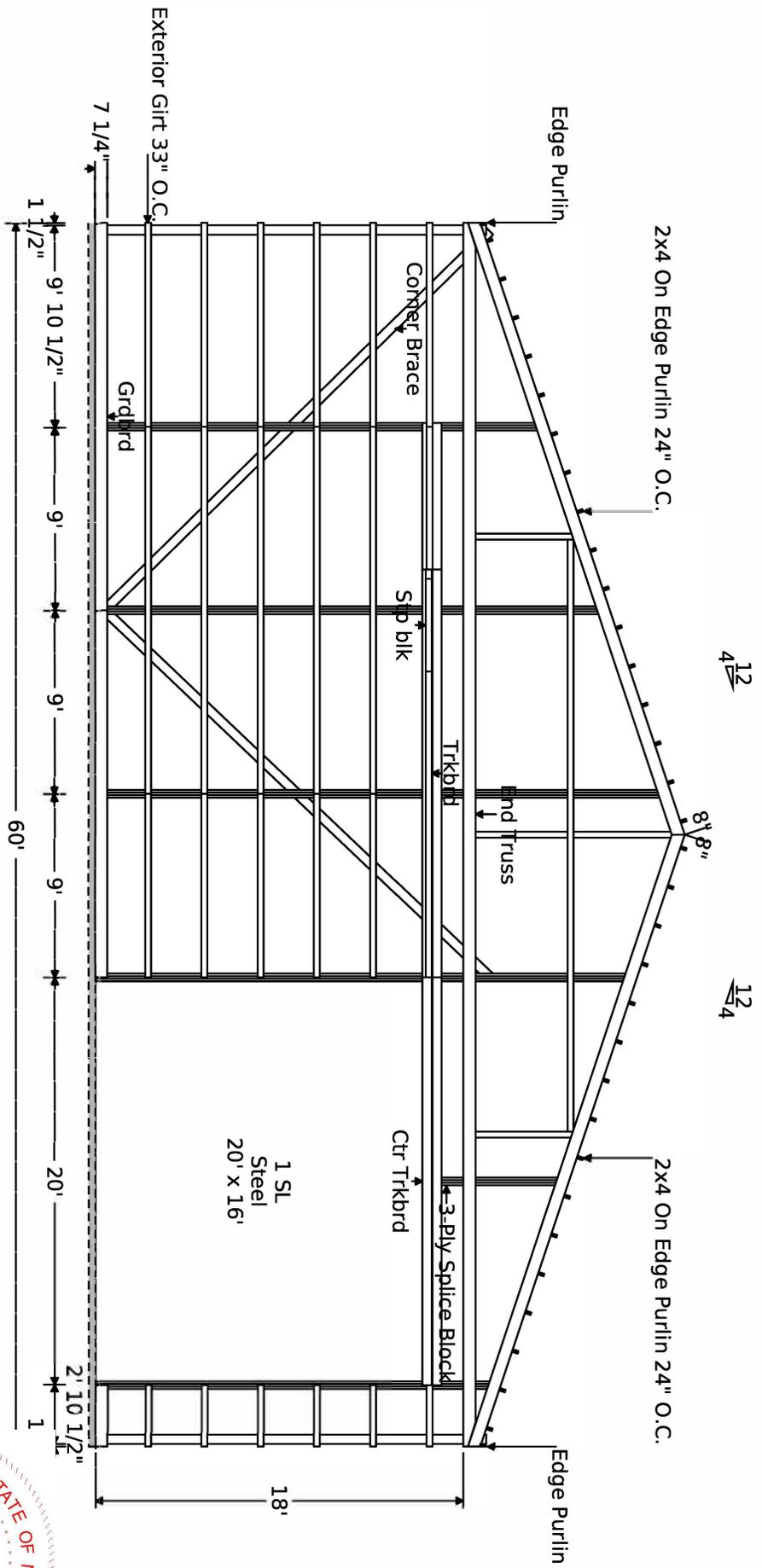

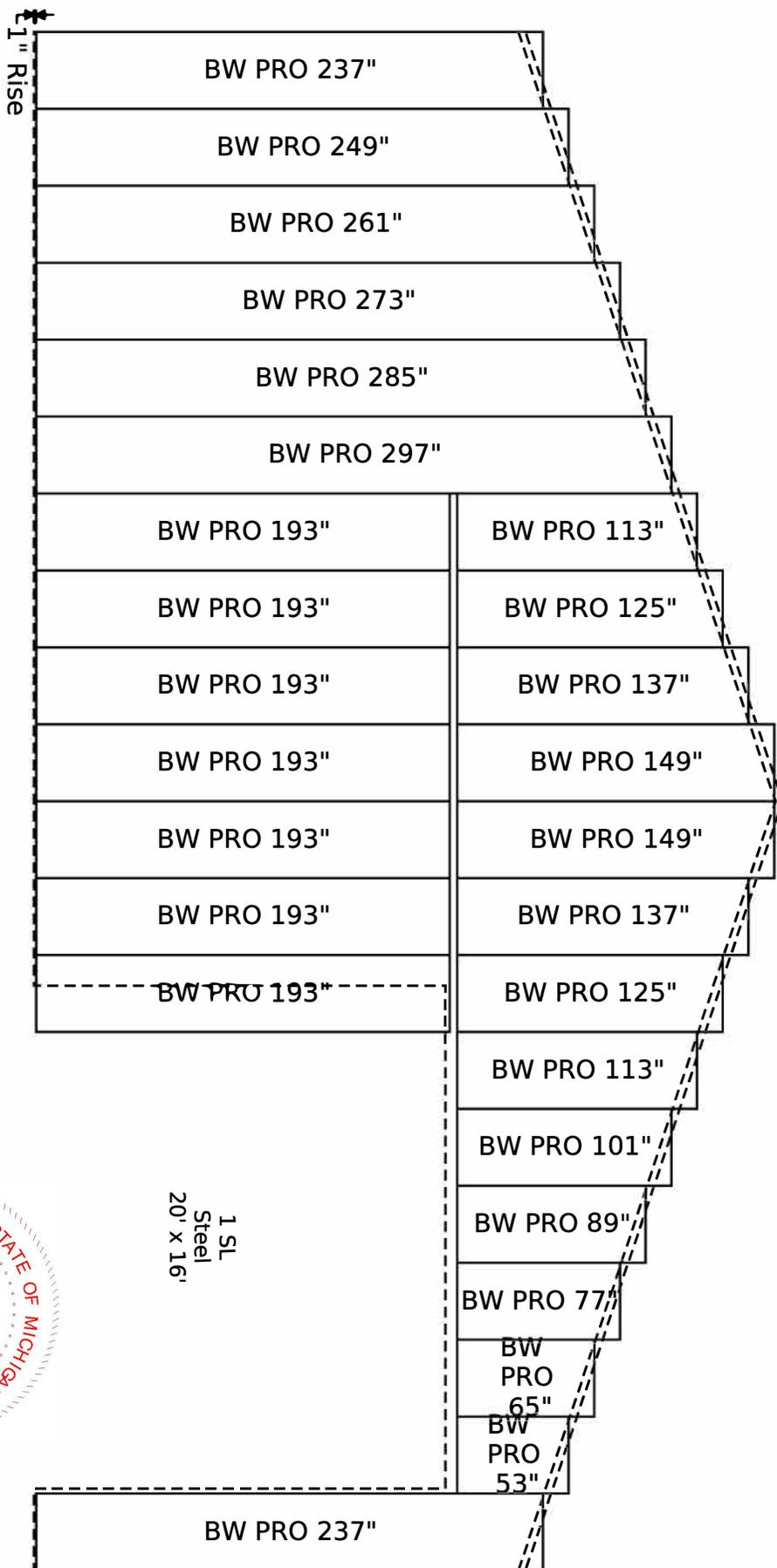

WALL 1-C STEEL

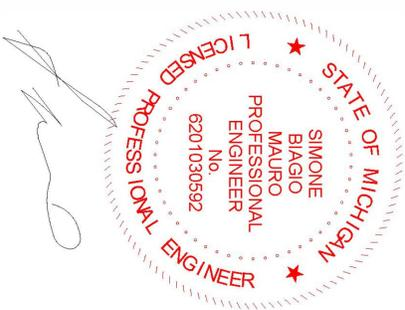

WALL 1-D FRAMING

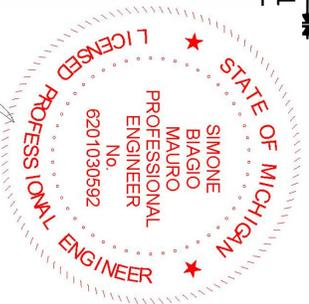
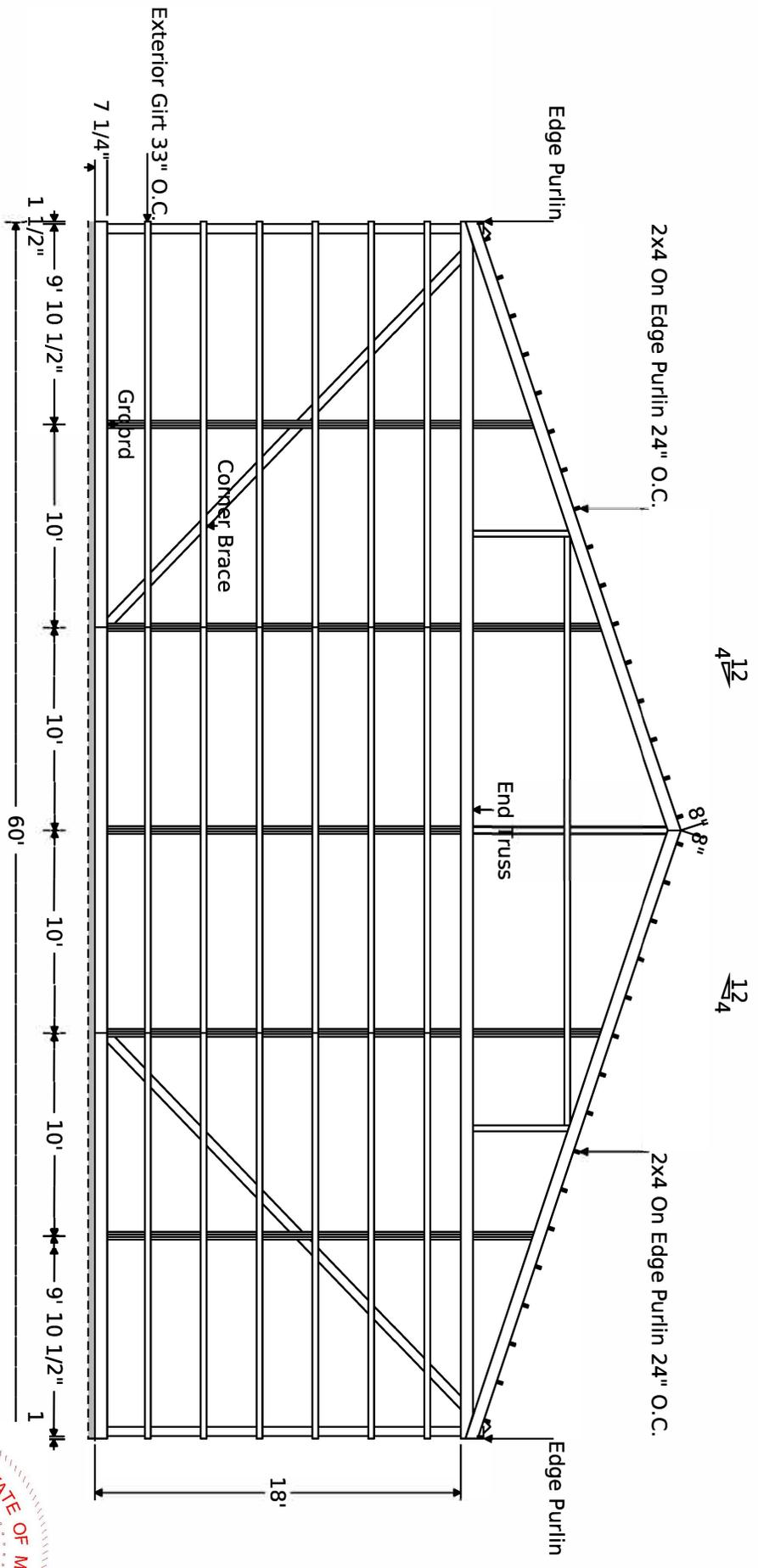

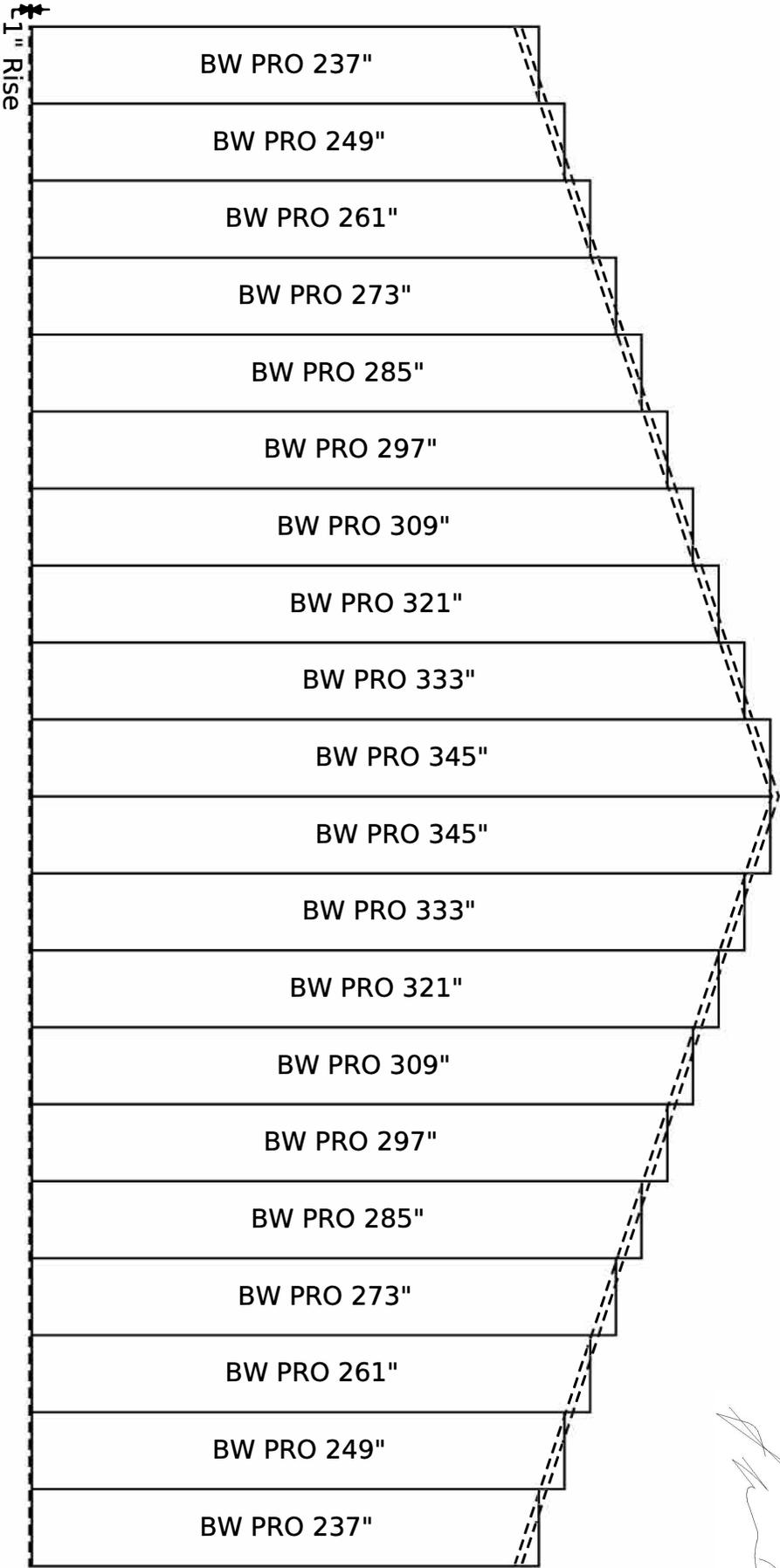

WALL 1-D STEEL

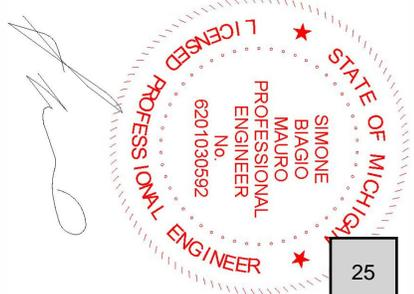

TRUSS, HEADER, AND KNEE BRACE DETAILS

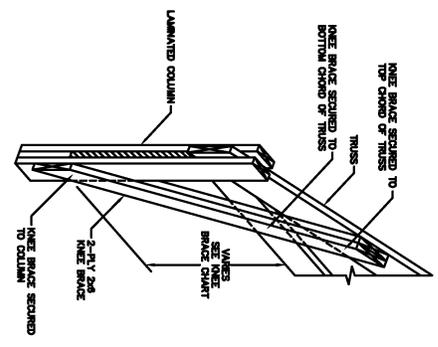
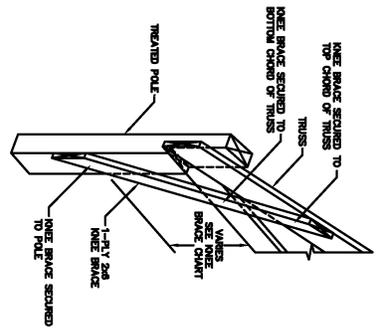
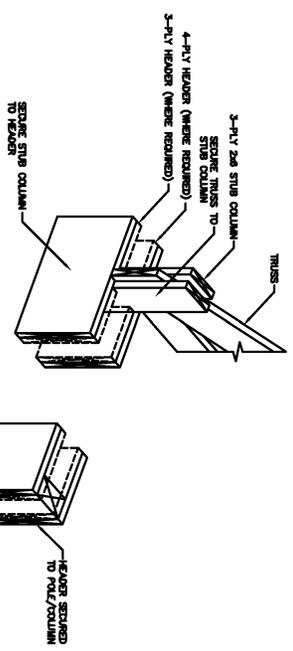
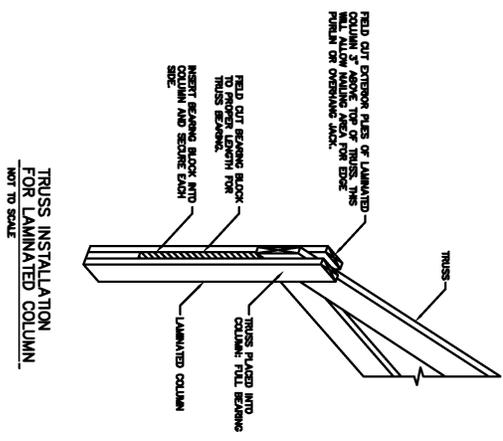
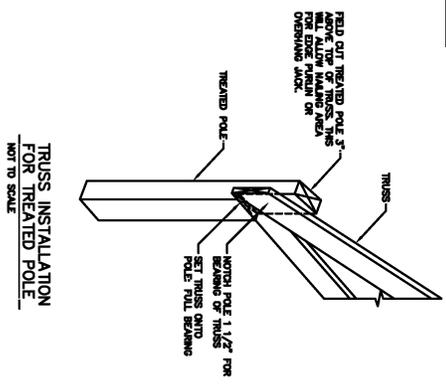

HEADER NOTCH SCHEDULE

HEADER PILES	DOMINANTIAL LAMBER
3-PLY HEADER	1-PLY FACE NAILED TO POLE AT EXTENSION & 1-PLY FACE NAILED TO POLE AT INTERIOR
3-PLY HEADER	2-PILES NOTCHED 1 1/2" AND POLE AT EXTENSION & 1-PLY FACE NAILED TO POLE AT INTERIOR
4-PLY HEADER	2-PILES NOTCHED 1 1/2" AND POLE AT EXTENSION & 2-PILES NOTCHED 1 1/2" AND POLE AT INTERIOR
HEADER PILES	LM LUMBER
3-PLY HEADER	1-PLY NOTCHED 1/4" AND POLE AT EXTENSION & 1-PLY NOTCHED 1/4" AND POLE AT INTERIOR
3-PLY HEADER	2-PILES NOTCHED 2" AND POLE AT EXTENSION & 1-PLY NOTCHED 1/4" AND POLE AT INTERIOR
4-PLY HEADER	2-PILES NOTCHED 2" AND POLE AT EXTENSION & 2-PILES NOTCHED 2" AND POLE AT INTERIOR

KNEE BRACE CHART

WALL HEIGHT	DIMENSION
8'-0"	1-2" (TRUSS TO BOTTOM OF BRACE)
9'-0"	1-6" (TRUSS TO BOTTOM OF BRACE)
10'-0"	2-0" (TRUSS TO BOTTOM OF BRACE)
11'-0"	2-6" (TRUSS TO BOTTOM OF BRACE)
12'-0"	3-0" (TRUSS TO BOTTOM OF BRACE)
13'-0"	3-6" (TRUSS TO BOTTOM OF BRACE)
14'-0"	4-0" (TRUSS TO BOTTOM OF BRACE)
15'-0"	4-6" (TRUSS TO BOTTOM OF BRACE)
16'-0"	5-0" (TRUSS TO BOTTOM OF BRACE)
17'-0"	5-6" (TRUSS TO BOTTOM OF BRACE)
18'-0"	6-0" (TRUSS TO BOTTOM OF BRACE)
19'-0"	6-6" (TRUSS TO BOTTOM OF BRACE)
20'-0"	7-0" (TRUSS TO BOTTOM OF BRACE)

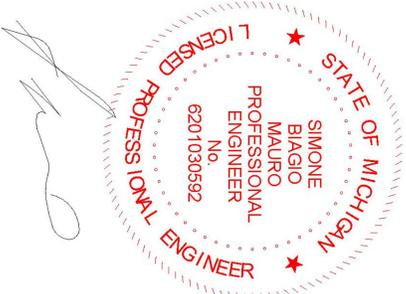

WIND AND CORNER BRACE DETAILS

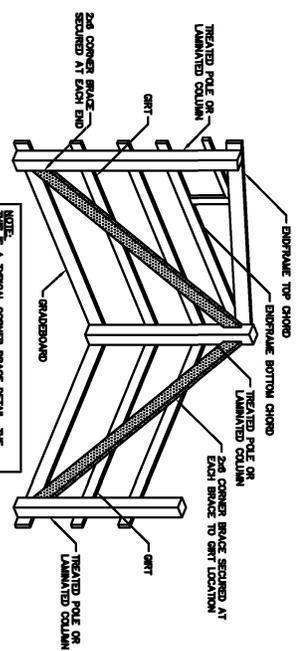
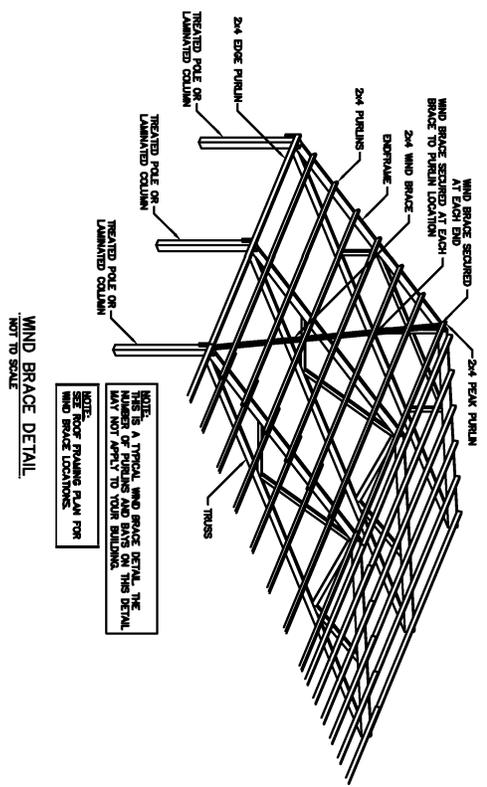

SERVICE DOOR AND WINDOW DETAILS

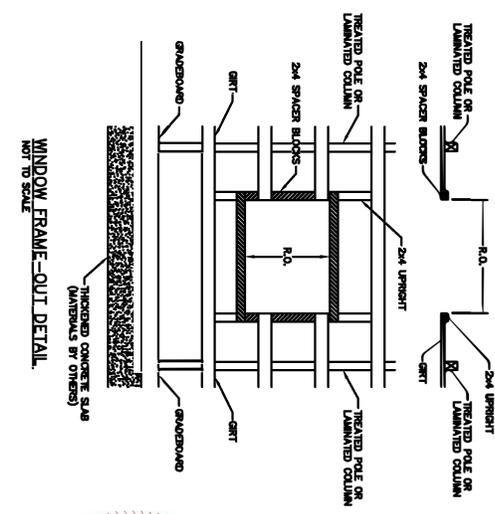
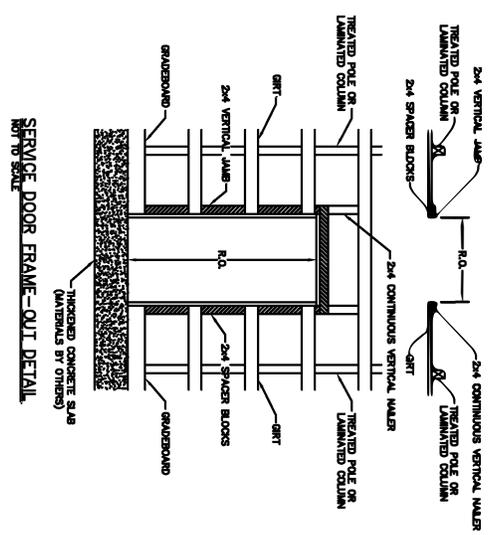

STATE OF MICHIGAN
 SIMONE
 BIAGIO MAURO
 PROFESSIONAL
 ENGINEER
 No. 6201030592
 LICENSED PROFESSIONAL ENGINEER

ENDWALL COLUMN BLOCK EXTENSION AND ENDWALL BRACE DETAILS

GENERAL COLUMN LENGTH	COLUMN LENGTH	COLUMN BLOCK EXTENSIONS				2nd FLOOR	GENERAL BRACE
		1st FLOOR	2nd FLOOR	3rd FLOOR	4th FLOOR		
18'	18'	N/A	N/A	N/A	N/A	N/A	
20'	20'	N/A	N/A	N/A	N/A	N/A	
22'	22'	N/A	N/A	N/A	N/A	N/A	
24'	24'	N/A	N/A	N/A	N/A	N/A	
26'	26'	N/A	N/A	N/A	N/A	N/A	
28'	28'	N/A	N/A	N/A	N/A	N/A	
30'	30'	N/A	N/A	N/A	N/A	N/A	
32'	32'	N/A	N/A	N/A	N/A	N/A	
34'	34'	N/A	N/A	N/A	N/A	N/A	
36'	36'	N/A	N/A	N/A	N/A	N/A	
38'	38'	N/A	N/A	N/A	N/A	N/A	
40'	40'	N/A	N/A	N/A	N/A	N/A	
42'	42'	N/A	N/A	N/A	N/A	N/A	
44'	44'	N/A	N/A	N/A	N/A	N/A	
46'	46'	N/A	N/A	N/A	N/A	N/A	
48'	48'	N/A	N/A	N/A	N/A	N/A	
50'	50'	N/A	N/A	N/A	N/A	N/A	
52'	52'	N/A	N/A	N/A	N/A	N/A	
54'	54'	N/A	N/A	N/A	N/A	N/A	
56'	56'	N/A	N/A	N/A	N/A	N/A	
58'	58'	N/A	N/A	N/A	N/A	N/A	
60'	60'	N/A	N/A	N/A	N/A	N/A	
62'	62'	N/A	N/A	N/A	N/A	N/A	
64'	64'	N/A	N/A	N/A	N/A	N/A	
66'	66'	N/A	N/A	N/A	N/A	N/A	
68'	68'	N/A	N/A	N/A	N/A	N/A	
70'	70'	N/A	N/A	N/A	N/A	N/A	
72'	72'	N/A	N/A	N/A	N/A	N/A	
74'	74'	N/A	N/A	N/A	N/A	N/A	
76'	76'	N/A	N/A	N/A	N/A	N/A	
78'	78'	N/A	N/A	N/A	N/A	N/A	
80'	80'	N/A	N/A	N/A	N/A	N/A	
82'	82'	N/A	N/A	N/A	N/A	N/A	
84'	84'	N/A	N/A	N/A	N/A	N/A	
86'	86'	N/A	N/A	N/A	N/A	N/A	
88'	88'	N/A	N/A	N/A	N/A	N/A	
90'	90'	N/A	N/A	N/A	N/A	N/A	
92'	92'	N/A	N/A	N/A	N/A	N/A	
94'	94'	N/A	N/A	N/A	N/A	N/A	
96'	96'	N/A	N/A	N/A	N/A	N/A	
98'	98'	N/A	N/A	N/A	N/A	N/A	
100'	100'	N/A	N/A	N/A	N/A	N/A	

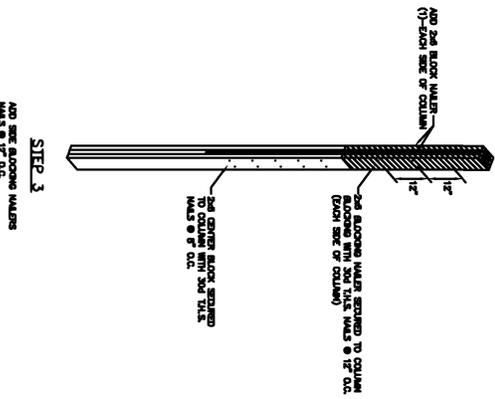
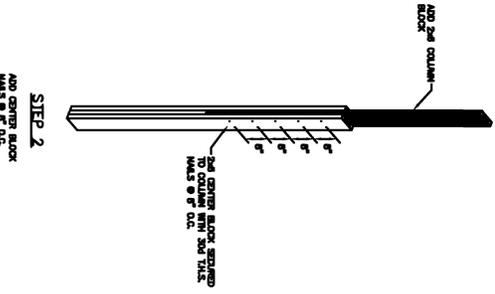
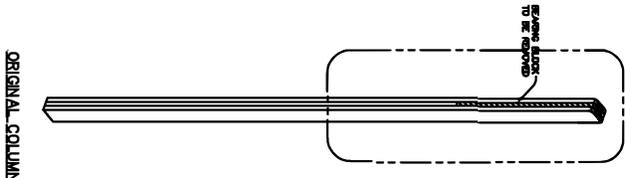
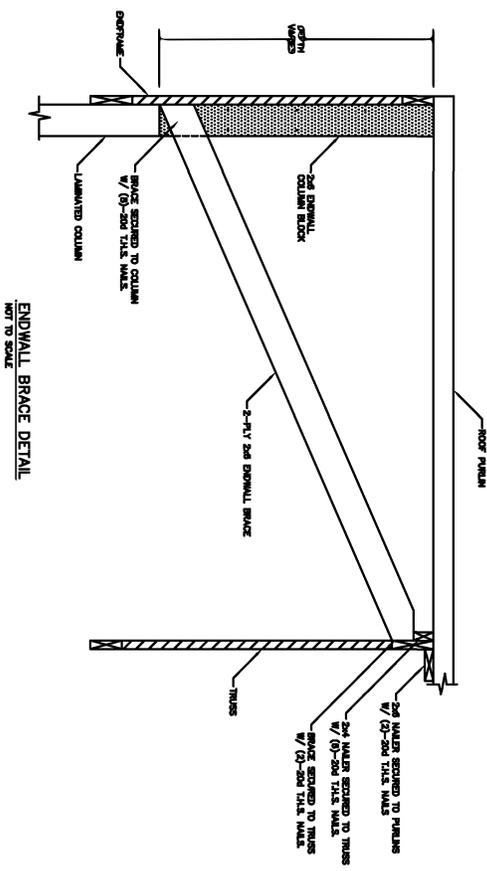

ENDWALL COLUMN BLOCK EXTENSION DETAIL

ENDWALL BRACE DETAIL
NOT TO SCALE

STATE OF MICHIGAN
 SIMONE BIAGIO MAURO
 PROFESSIONAL ENGINEER
 No. 6201030592
 LICENSED PROFESSIONAL ENGINEER

TRIM DETAILS

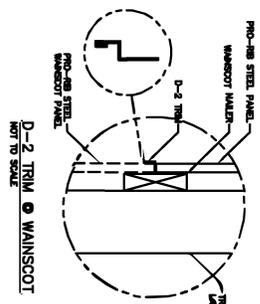

D-2 TRIM @ WAINSCOT
NOT TO SCALE

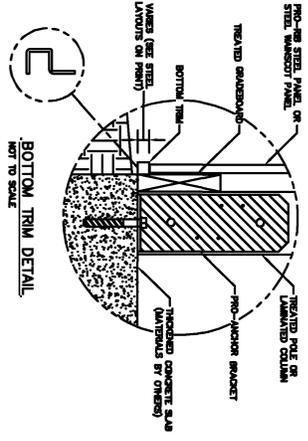

BOTTOM TRIM DETAIL
NOT TO SCALE

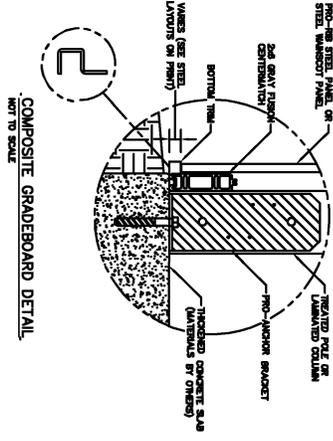

COMPOSITE GRADEBOARD DETAIL
NOT TO SCALE

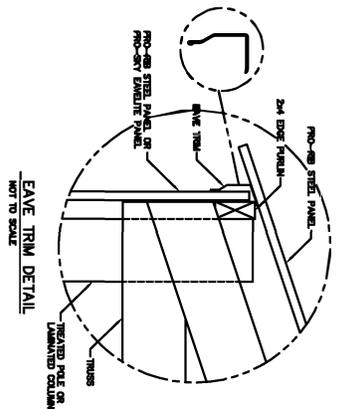

EAVE TRIM DETAIL
NOT TO SCALE

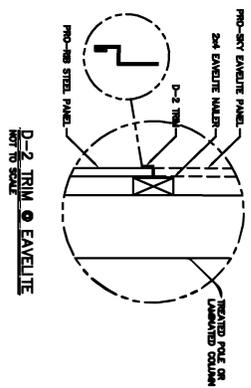

D-2 TRIM @ EAVELITE
NOT TO SCALE

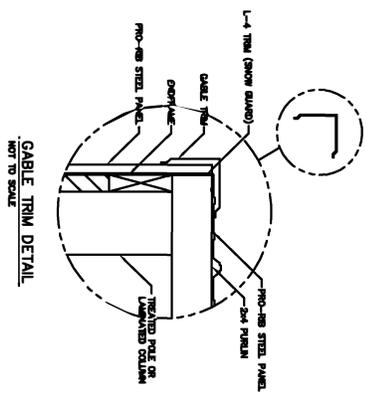

GABLE TRIM DETAIL
NOT TO SCALE

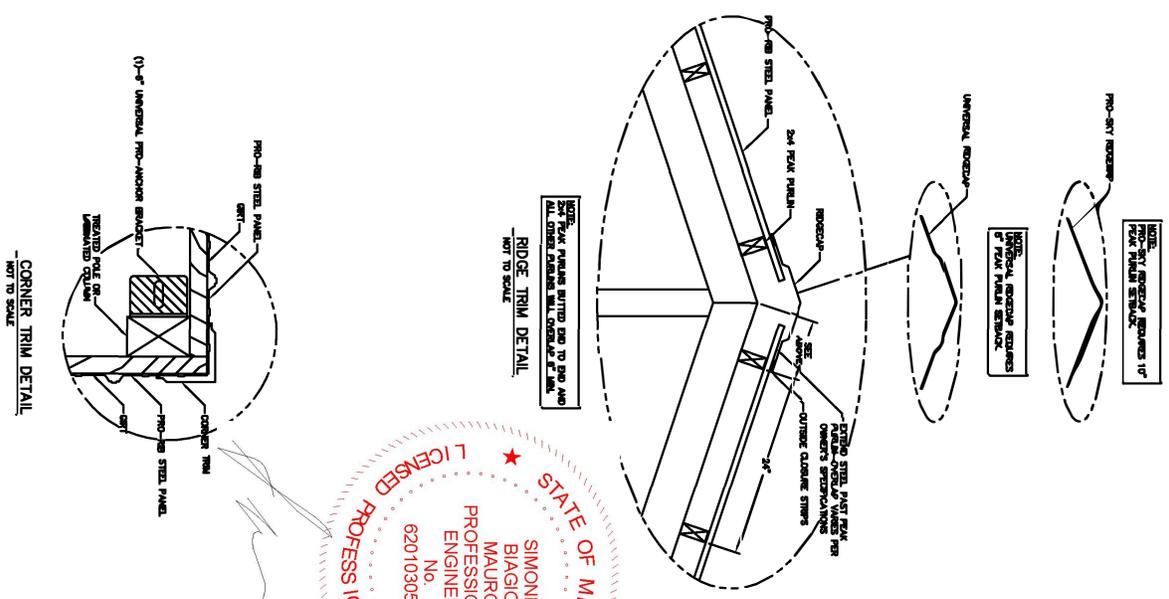

RIDGE TRIM DETAIL
NOT TO SCALE

CORNER TRIM DETAIL
NOT TO SCALE

STATE OF MICHIGAN
 SIMONE
 BIAGIO MAURO
 PROFESSIONAL
 ENGINEER
 No. 6201030592
 LICENSED PROFESSIONAL ENGINEER

OVERHANG DETAILS

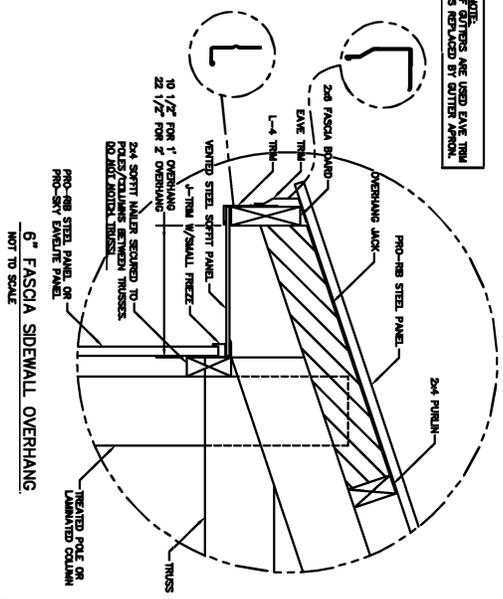
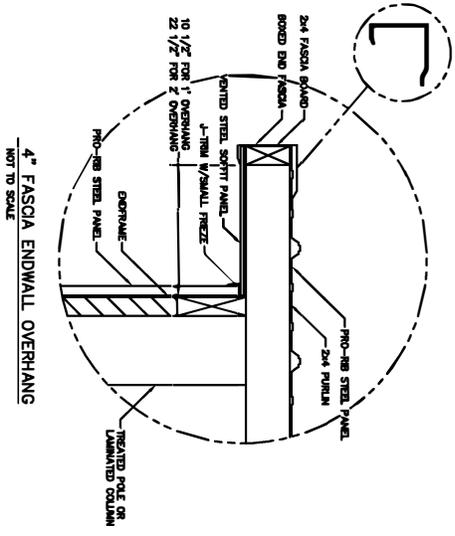
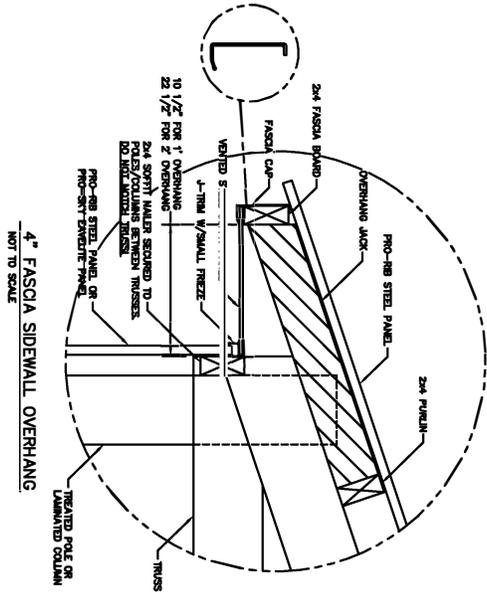

NOTE:
IF GUTTERS ARE USED EAVE TRIM
IS REPLACED BY GUTTER APPROX.

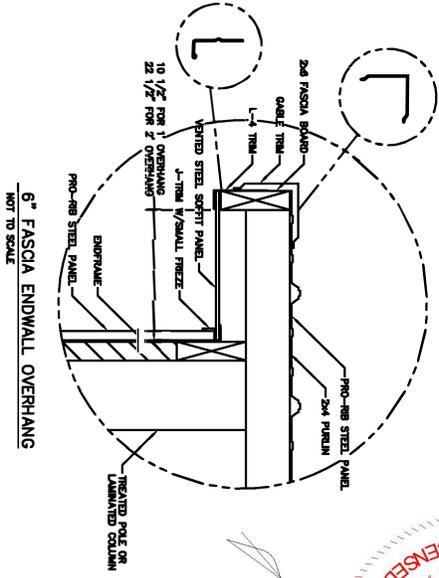

SIMONE
BIAGIO
MAURO
PROFESSIONAL
ENGINEER
No. 6201030592
STATE OF MICHIGAN
LICENSED PROFESSIONAL ENGINEER

SLIDING DOOR DETAILS

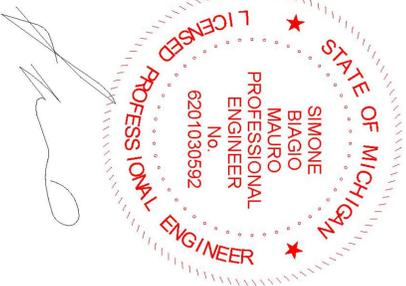
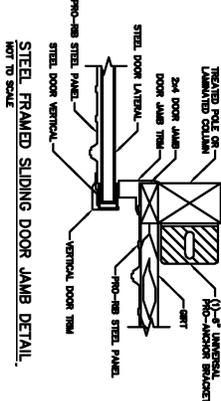
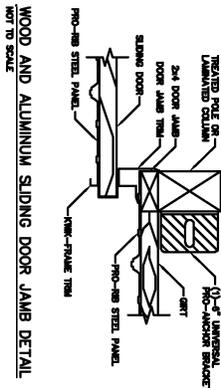
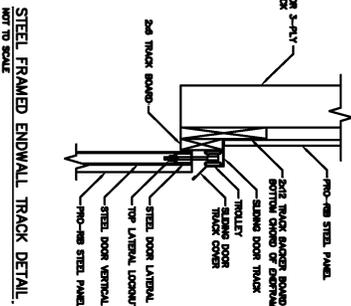
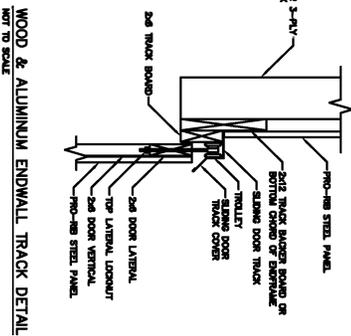
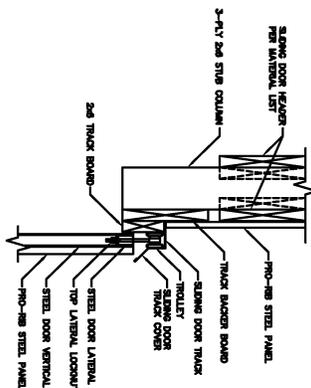
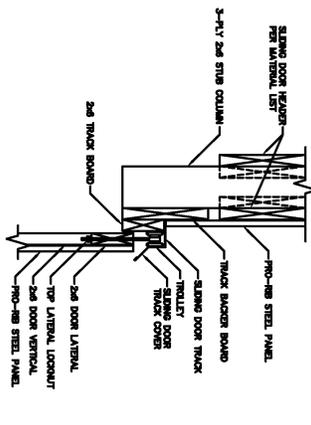
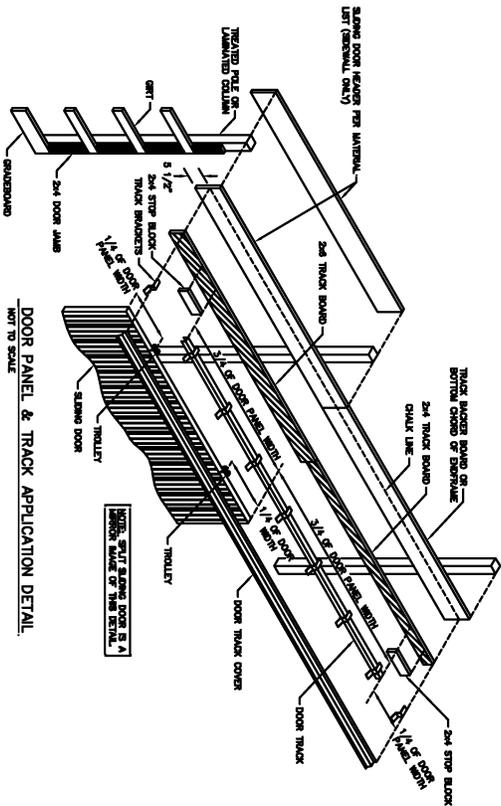

OVERHEAD DOOR DETAILS

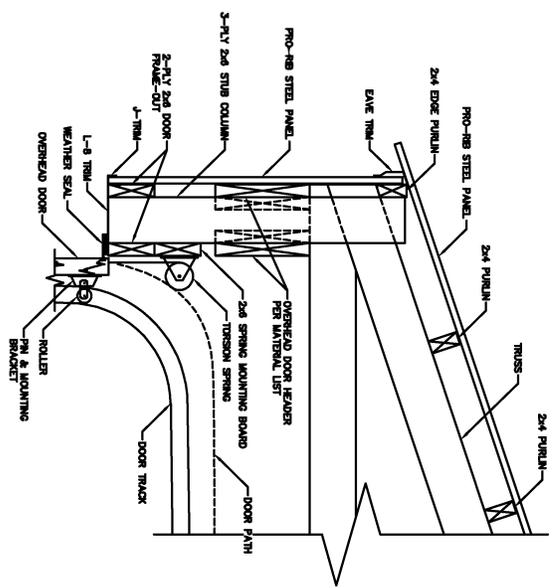

NOTE: CONTRACTOR MUST VERIFY OVERHEAD DOOR MANUFACTURER REQUIREMENTS WITH DOOR MANUFACTURER PRIOR TO STARTING CONSTRUCTION.

HEADER FRAMING SECTION THROUGH SIDEWALL
NOT TO SCALE

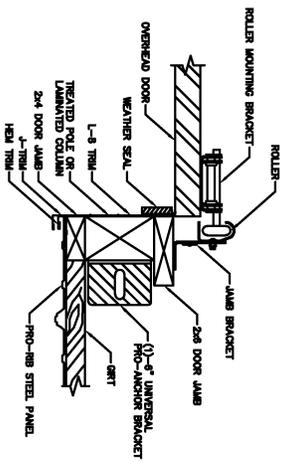

OVERHEAD DOOR JAMB DETAIL
NOTE TO SCALE

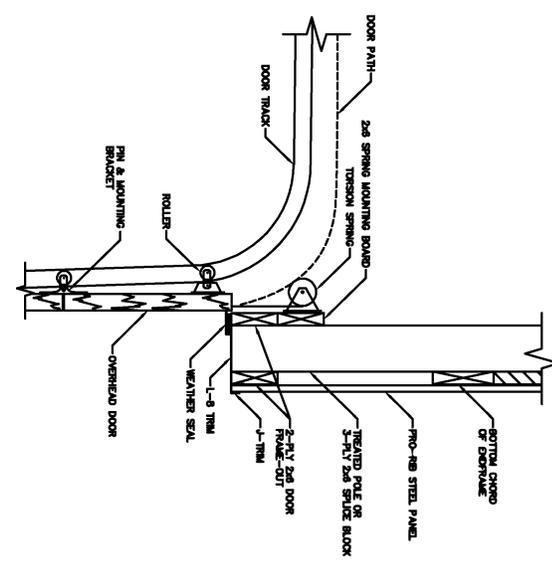

NOTE: CONTRACTOR MUST VERIFY OVERHEAD DOOR MANUFACTURER REQUIREMENTS WITH DOOR MANUFACTURER PRIOR TO STARTING CONSTRUCTION.

HEADER FRAMING SECTION THROUGH ENDWALL
NOT TO SCALE

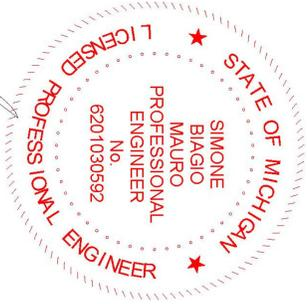

STEEL APPLICATION DETAILS

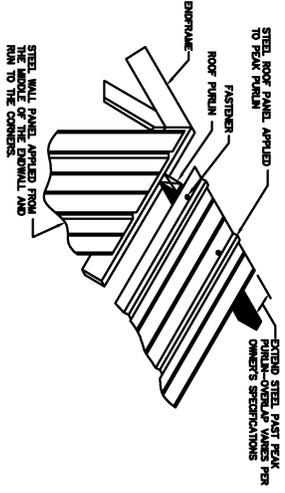

ROOF & ENDWALL STEEL APPLICATION @ GABLE PEAK

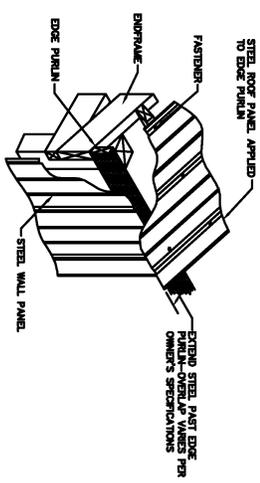

ROOF & SIDEWALL STEEL APPLICATION @ EAVE

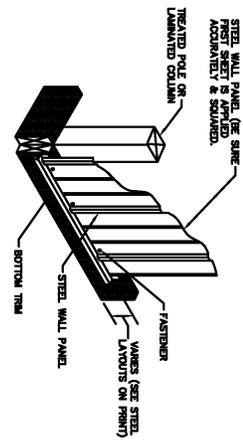

WALL STEEL APPLICATION @ GRADEBOARD

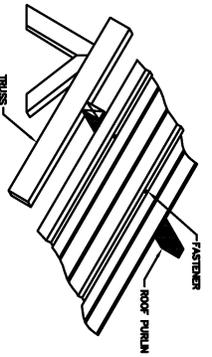

ROOF STEEL APPLICATION @ INTERMEDIATE

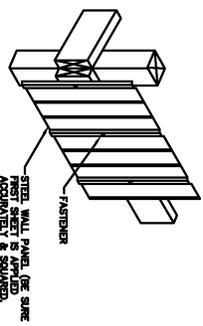

WALL STEEL APPLICATION @ INTERMEDIATE

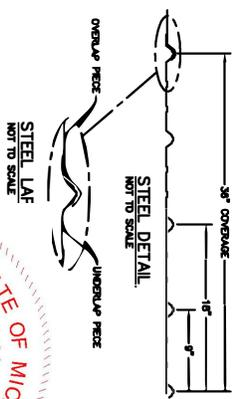

STATE OF MICHIGAN
 SIMONE
 BLAGIO
 MAURO
 PROFESSIONAL
 ENGINEER
 No. 62011030592
 LICENSED PROFESSIONAL ENGINEER

[Handwritten signature]

MARK BROWN

CHESTERFIELD

note #: 349712 Design #: 1

Design ID: 329957888416

5/30/2023

Material Allocation & Usage

SKU	Quantity	Size	Description	Color	Usage
1004546	1	4/12 60'	60' 4/12 PF Structural End, 25#GSL, 20-4-0-1, 4' 6" oc, 10" Heel		End Truss
1878309	1	4/12 60'	60' Post Frame 4/12 End Pickup /jobsite		End Truss
1878325	9	4/12 60'	60' Postframe 4/12 29#9'oc Pickup /jobsite		Truss
1104996	8	13x5x0. 25	6" Universal Bracket Hardware Includ		Opening Ancr Brckt
1104974	8	13x5x0. 25	3 Ply 6" Lam Col Anchor Hardware Includ		End Ancr Brckt
1104996	4	13x5x0. 25	6" Universal Bracket Hardware Includ		Corner Ancr Brckt
1104974	9	13x5x0. 25	3 Ply 6" Lam Col Anchor Hardware Includ		Side Ancr Brckt
1021761	1	2x6-10'	2x6-10' Stud/#2&btr Spf Const. /framing		Column Block
1021774	1	2x6-12'	2x6-12' #2&btr Spf Const./framing		Column Block
1021758	4	2x6-8'	2x6-8' Stud/#2&btr Spf Const./framing		Column Block
1105206	1	2x6-22'	3ply 2x6-22'lamm Col Syp#1 Prebuilt Column		Opening Post
1105196	7	2x6-20'	3ply 2x6-20'lamm Col Syp#1 Prebuilt Column		Opening Post
1105247	1	2x6-30'	3ply 2x6-30'lamm Col Syp#1 Mm Spliced		End Post
1105221	1	2x6-26'	3ply 2x6-26'lamm Col Syp#1 Mm Spliced		End Post
1105218	1	2x6-24'	3ply 2x6-24'lamm Col Syp#1 Mm Spliced		End Post
1105196	4	2x6-20'	3ply 2x6-20'lamm Col Syp#1 Prebuilt Column		Corner Post
1105196	9	2x6-20'	3ply 2x6-20'lamm Col Syp#1 Prebuilt Column		Side Post

105206	5	2x6-22'	3ply 2x6-22'Iam Col Syp#1 Prebuilt Column	End Post
1021790	9	2x6-16'	2x6-16' #2&btr Spf Const./framing	Stub Column
1021800	3	2x6-18'	2x6-18' #2&btr Spf Const./framing	Stub Column
1021787	1	2x6-14'	2x6-14' #2&btr Spf Const./framing	Column Block
1021790	1	2x6-16'	2x6-16' #2&btr Spf Const./framing	Column Block
1021800	1	2x6-18'	2x6-18' #2&btr Spf Const./framing	Column Block
1021127	4	2x4-12'	2x4-12' #2&btr Spf Const./framing	Edge Purlin
1021169	4	2x4-20'	2x4-20' #2&btr Spf Const./framing	Edge Purlin
1021130	8	2x4-14'	2x4-14' #2&btr Spf Const./framing	Web Lat Brace
1021169	8	2x4-20'	2x4-20' #2&btr Spf Const./framing	Web Lat Brace
1021774	18	2x6-12'	2x6-12' #2&btr Spf Const./framing	Knee Brace
1021127	1	2x4-12'	2x4-12' #2&btr Spf Const./framing	Purlin
1021143	60	2x4-16'	2x4-16' #2&btr Spf Const./framing	Purlin
1021156	2	2x4-18'	2x4-18' #2&btr Spf Const./framing	Purlin
1021169	64	2x4-20'	2x4-20' #2&btr Spf Const./framing	Purlin
1095293	1	2x8-10'	2x8-10' Cca Green Treated Cs .60	1-A Grdbrd
1095329	1	2x8-16'	2x8-16' Cca Green Treated Cs .60	1-A Grdbrd
1095332	1	2x8-18'	2x8-18' Cca Green Treated Cs .60	1-A Grdbrd
1021127	12	2x4-12'	2x4-12' #2&btr Spf Const./framing	Wind Brace
1061572	9	2x12-17'	1-3/4"x11-7/8" - 17' Lvl 1.9e	Header
1021787	8	2x6-14'	2x6-14' #2&btr Spf Const./framing	Corner Brace
1021813	4	2x6-20'	2x6-20' #2&btr Spf Const./framing	Corner Brace
1021169	18	2x4-20'	2x4-20' #2&btr Spf Const./framing	1-D Girt
1095290	1	2x8-8'	2x8-8' Cca Green Treated Cs .60	1-C Grdbrd
1095332	1	2x8-18'	2x8-18' Cca Green Treated Cs .60	1-C Grdbrd
1095345	1	2x8-20'	2x8-20' Cca Green Treated Cs .60	1-C Grdbrd
1021143	5	2x4-16'	2x4-16' #2&btr Spf Const./framing	1-A Girt
1021156	12	2x4-18'	2x4-18' #2&btr Spf Const./framing	1-A Girt
1021758	1	2x6-8'	2x6-8' Stud/#2&btr Spf Const./framing	1 Stub Spl Blk
1021790	1	2x6-16'	2x6-16' #2&btr Spf Const./framing	1 Stub Spl Blk
1021114	1	2x4-10'	2x4-10' Stud/#2&btr Spf Const./framing	1-C Girt
1021130	1	2x4-14'	2x4-14' #2&btr Spf Const./framing	1-C Girt
1021143	1	2x4-16'	2x4-16' #2&btr Spf Const./framing	1-C Girt

021156	8	2x4-18'	2x4-18' #2&btr Spf Const./framing	1-C Girt
021169	4	2x4-20'	2x4-20' #2&btr Spf Const./framing	1-C Girt
021130	10	2x4-14'	2x4-14' #2&btr Spf Const./framing	Lat Brace
1021169	10	2x4-20'	2x4-20' #2&btr Spf Const./framing	Lat Brace
1021156	12	2x4-18'	2x4-18' #2&btr Spf Const./framing	1-B Girt
1021143	1	2x4-16'	2x4-16' #2&btr Spf Const./framing	1-B Girt
1095345	3	2x8-20'	2x8-20' Cca Green Treated Cs .60	1-D Grdbrd
1095293	1	2x8-10'	2x8-10' Cca Green Treated Cs .60	1-B Grdbrd
1095332	1	2x8-18'	2x8-18' Cca Green Treated Cs .60	1-B Grdbrd
1558388	44.124	44 - 380"	Pro-rib Midnight Gray .0142bp-.0165ap	Midnight Gray Roof
1558137	0.786	2 - 149"	Pro-rib Brite White .0142bp-.0165ap	Brite White End Wall
1558137	0.723	2 - 137"	Pro-rib Brite White .0142bp-.0165ap	Brite White End Wall
1558137	0.66	2 - 125"	Pro-rib Brite White .0142bp-.0165ap	Brite White End Wall
1558137	0.596	2 - 113"	Pro-rib Brite White .0142bp-.0165ap	Brite White End Wall
1558137	0.267	1 - 101"	Pro-rib Brite White .0142bp-.0165ap	Brite White End Wall
1558137	0.235	1 - 89"	Pro-rib Brite White .0142bp-.0165ap	Brite White End Wall
1558137	0.203	1 - 77"	Pro-rib Brite White .0142bp-.0165ap	Brite White End Wall
1558137	0.172	1 - 65"	Pro-rib Brite White .0142bp-.0165ap	Brite White End Wall
1558137	0.14	1 - 53"	Pro-rib Brite White .0142bp-.0165ap	Brite White End Wall
1558137	2.502	4 - 237"	Pro-rib Brite White .0142bp-.0165ap	Brite White End Wall
1558137	2.351	3 - 297"	Pro-rib Brite White .0142bp-.0165ap	Brite White End Wall
1558137	2.256	3 - 285"	Pro-rib Brite White .0142bp-.0165ap	Brite White End Wall
1558137	2.161	3 - 273"	Pro-rib Brite White .0142bp-.0165ap	Brite White End Wall

1558137	2.066	3 - 261"	Pro-rib Brite White .0142bp-.0165ap	Brite White	End Wall
1558137	1.971	3 - 249"	Pro-rib Brite White .0142bp-.0165ap	Brite White	End Wall
1558137	3.565	7 - 193"	Pro-rib Brite White .0142bp-.0165ap	Brite White	End Wall
1558137	16.246	27 - 228"	Pro-rib Brite White .0142bp-.0165ap	Brite White	Side Wall
1558137	2.916	13 - 85"	Pro-rib Brite White .0142bp-.0165ap	Brite White	Side Wall
1558137	1.821	2 - 345"	Pro-rib Brite White .0142bp-.0165ap	Brite White	End Wall
1558137	1.758	2 - 333"	Pro-rib Brite White .0142bp-.0165ap	Brite White	End Wall
1558137	1.694	2 - 321"	Pro-rib Brite White .0142bp-.0165ap	Brite White	End Wall
1558137	1.631	2 - 309"	Pro-rib Brite White .0142bp-.0165ap	Brite White	End Wall
1563915	8	10'	10' Corner And Gable Trim Spo Colors	Midnight Gray	Corner Trim
1558425	7	10'	10' Universal Ridge Cap Spo Colors	Midnight Gray	Ridge
1564545	15	12' 3"	12' 3" Bottom Trim Spo Colors	Midnight Gray	Bottom Trim
1564639	11	12' 3"	12' 3" Eave Trim Spo Colors	Midnight Gray	Eave Trim
1564312	100	100 - 24"	16"x2' Steel Vent Soffit Color Pro-steel	Midnight Gray	Sft Panel
1564354	12	12'	12' J-trim W/ Sm Frieze Color Pro-steel	Midnight Gray	Small f&j
1021143	8	2x4-16'	2x4-16' #2&btr Spf Const./framing		End Fascia
1565641	12	14'	14' Boxed End Fascia Spo Colors	Midnight Gray	End Fascia Trim
1555062	1	1x0-10'	10' Guide Rail With Brackets		SL 1 Gdtrail
1555729	1	1x0-	Door Stop Single Door		SL 1 Dr Stp
1555745	1	1x0-	Sliding Door Jamb Stop Door Stop Track Cover Support 5-pk Special		SL 1 Jmb Stp

556265	1	1x0-	Order	SL 1 Trk Cvr Brk
555790	1	0x0-	Track Cover Support Bracket	SL 1 Trk Cvr Brk
556100	1	1x0-	Ball Bearing Trolley Hngr Special Order	SL 1 Trolley
1555761	1	1x0-	6" Heavy Duty Door Handle Galvanized	SL 1 Handle
1556168	2	1x0-	Sliding Door Latch Special Order	SL 1 Jmb Latch
4251075	1	6x6-6"	Keyed Lock Set #1024050	OH 2 Lock Set
4251075	1	6x6-6"	Keyed Lock Set #1024050	OH 3 Lock Set
4251075	1	6x6-6"	Keyed Lock Set #1024050	OH 1 Lock Set
4259119	1	16'x12'	16x12 Wht Noninrl Rib Tor C5est 12" Radi	OH 2
4259119	1	16'x12'	16x12 Wht Noninrl Rib Tor C5est 12" Radi	OH 3
4259119	1	16'x12'	16x12 Wht Noninrl Rib Tor C5est 12" Radi	OH 1
1554791	7	2x3-20'	20' Steel Door Lateral Galvanized	SL 1 Tab Lat
1554937	2	2x2-16'	16' Steel Door Vertical Galvanized	SL 1 Tab Vrt
1558137	3.528	7 - 191"	Pro-rib Brite White .0142bp-.0165ap	Brite White SL 1 Covering
4171664	3	192x2x0. 44	Pvc Garage Dr Stop Wht 7/16x2x16'	OH 2 Weatherstrip
4171664	3	192x2x0. 44	Pvc Garage Dr Stop Wht 7/16x2x16'	OH 3 Weatherstrip
4171664	3	192x2x0. 44	Pvc Garage Dr Stop Wht 7/16x2x16'	OH 1 Weatherstrip
1021143	2	2x4-16'	2x4-16' #2&btr Spf Const./framing	SL 1 Dr Jmb
1566857	2	8' 6"	8'6" L-8 Fascia Door Angle	Midnight Gray OH 1 Out. Jamb Trim
1566912	2	12'	12' L-8 Steel Fascia Color Steel	Midnight Gray OH 1 Out. Jamb Trim
1566721	3	10'	10' Hem Trim Spo Colors	Midnight Gray OH 1 Out. Hem Trim
1564545	2	12' 3"	12'3" Bottom Trim Spo Colors	Midnight Gray SL 1 Btm Trim
1021800	1	2x6-18'	2x6-18' #2&btr Spf Const./framing	Midnight OH 2 Mnt Brd

566433	1	16' 3"	16'3" J-trim Spo Colors	Gray	OH 2 Ext Hrz J Trim
566682	2	16'	16' Vertical Door Trim Spo Colors	Midnight Gray	SL 1 Vrt Dr Trm
1021813	1	2x6-20'	2x6-20' #2&btr Spf Const./framing		SL 1 Ctr Trkbrd
1021127	2	2x4-12'	2x4-12' #2&btr Spf Const./framing		OH 2 Jamb Nlr
1021127	2	2x4-12'	2x4-12' #2&btr Spf Const./framing		OH 3 Jamb Nlr
1566721	3	10'	10' Hem Trim Spo Colors	Midnight Gray	OH 2 Out. Hem Trim
1021169	1	2x4-20'	2x4-20' #2&btr Spf Const./framing		SL 1 Trkbrd
1022142	1	2x12-8'	2x12-8' #2&btr Fir Const./framing		SL 1 Trkbrd Sprt
1022207	2	2x12-20'	2x12-20' #2&btr Fir Const./framing		SL 1 Trkbrd Sprt
1021800	1	2x6-18'	2x6-18' #2&btr Spf Const./framing		OH 3 Mnt Brd
1565308	2	4x3-16'	16' Door Jamb Trim Spo Colors	Midnight Gray	SL 1 Jmb Trm
1021800	2	2x6-18'	2x6-18' #2&btr Spf Const./framing		OH 2 Frmout
1555842	4	5x6-10'	10' Track Cover Special Order	Midnight Gray	SL 1 Trk Cvr
1566404	2	12' 6"	12'6" J-trim Spo Colors	Midnight Gray	OH 1 Out. J-Trim
1021800	1	2x6-18'	2x6-18' #2&btr Spf Const./framing		OH 1 Mnt Brd
1566857	2	8' 6"	8'6" L-8 Fascia Door Angle	Midnight Gray	OH 2 Out. Jamb Trim
1566912	2	12'	12' L-8 Steel Fascia Color Steel	Midnight Gray	OH 2 Out. Jamb Trim
1566721	3	10'	10' Hem Trim Spo Colors	Midnight Gray	OH 3 Out. Hem Trim
1566404	2	12' 6"	12'6" J-trim Spo Colors	Midnight Gray	OH 2 Out. J-Trim
1566404	2	12' 6"	12'6" J-trim Spo Colors	Midnight Gray	OH 3 Out. J-Trim
1555392	2	2x3-16'	16' Sliding Door Track Special Order		SL 1 Dr Track
1566433	1	16' 3"	16'3" J-trim Spo Colors	Midnight Gray	OH 3 Ext Hrz J Trim
1021774	2	2x6-12'	2x6-12' #2&btr Spf Const./framing		OH 2 Int Jmb Nlr
1021017	1	2x4-8'	2x4-8' Premium/select Const./framing		SL 1 Stp blk
1021774	2	2x6-12'	2x6-12' #2&btr Spf Const./framing		OH 1 Int Jmb Nlr

021800	2	2x6-18'	2x6-18' #2&btr Spf Const./framing			OH 1 Frmout
021127	2	2x4-12'	2x4-12' #2&btr Spf Const./framing			OH 1 Jamb Nlr
021800	2	2x6-18'	2x6-18' #2&btr Spf Const./framing			OH 3 Frmout
1566857	2	8' 6"	8'6" L-8 Fascia Door Angle		Midnight Gray	OH 3 Out. Jamb Trim
1566912	2	12'	12' L-8 Steel Fascia Color Steel		Midnight Gray	OH 3 Out. Jamb Trim
1566433	1	16' 3"	16'3" J-trim Spo Colors		Midnight Gray	OH 1 Ext Hrz J Trim
1021774	2	2x6-12'	2x6-12' #2&btr Spf Const./framing			OH 3 Int Jmb Nlr
1558616	11	3'	Pro-rib Inside Closure Strip 4 Pack So			Intclsrstp
1558603	11	3'	Pro-rib Outside Closure Strip 4 Pack So			Extclsrstp
2301671	3	2"	2" Woodgrip Painted Screw 1lb Box		Midnight Gray	Steel - Trim Fastener
2301370	1	3"	10d Polebarn Hdg Nail 5lb Box			Fastener
2301642	1	1 1/2"	1-1/2" woodgrp Paint Screw 1lb Box		Midnight Gray	Jamb Trim Fastener
2324425	5	4"	1/2 X 4 Lag Screw 5pc 14822 Hdg			Bracket Fastener
2301613	4	1"	1" Woodgrip Painted Screw 1lb Box		Midnight Gray	Steel - Roof Fastener
2301683	2	2"	2" Woodgrip Painted Screw 20lb		Midnight Gray	Steel - Roof Fastener
2301370	4	3"	10d Polebarn Hdg Nail 5lb Box			Framing Fastener
2301464	5	6"	60d Polebarn Oil Quenched 5lb Box			Framing Fastener
2301435	6	4 1/2"	30d Polebarn Hdg Nail 5 Lb Box		Galvanized	Framing Fastener
2301435	1	4 1/2"	30d Polebarn Hdg Nail 5 Lb Box		Galvanized	Fastener
2301626	4	1"	1" Woodgrip Painted Screw 5lb Box		Brite White	Steel - Wall Fastener
2301613	4	1"	1" Woodgrip Painted Screw 1lb Box		Brite White	Steel - Wall Fastener
2301594	2	1 1/4"	Premium Trim Screw W/ Bit Spo Colors		Midnight Gray	Soffit Fastener
2290326	3	1 1/4"	6x1-1/4 Construction Scrw 1lb Phillips			Hid. Trim Fastener
2301859	3	1"	1" Self Tap Painted Screw 1lb Box		Brite White	Covering Steel - SlidingDoor Tblk Sd Fstnr

801642	1	1 1/2"	1-1/2" woodgrp Paint Screw 1lb Box	Midnight Gray	Steel - Trim Fastener
638804	1		Dap Silicone Caulk Clr #08641 9.8oz		Silicone
917998	1		Post Frame Mini-print Email Only		
1559976	2		28' Vert Steel Pallet 11-2x4-20'		Steel Pallet
1559981	2		Steel Pkg 24'1" To 32' Charge		Pallet Fee
1559971	2		16' Trim Crate Spec Order 7-2x6x16		Trim Box
1559969	2		16' Package/handling Charge		Trim Pack Fee
1911100	1		Helpful Hints Post Frame Midwest Man		Helpful Hints Booklet
1567869	1		Touch-up Paint Spo Colors	Midnight Gray	Paint
1567869	1		Touch-up Paint Spo Colors	Brite White	Paint

"Morgan's Auto"

PART OF THE SOUTHEAST 1/4 OF SECTION 33, T.4N., R.14E.,
VILLAGE OF NEW HAVEN, MACOMB COUNTY, MICHIGAN.

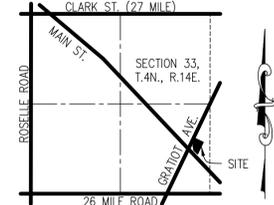

LOCATION MAP
NOT TO SCALE

ZONED LI AND GP

GRATIOT AVE.
(60' 1/2 ROW)

N32°38'30"E
167.00'

N32°38'30"E
200.00'

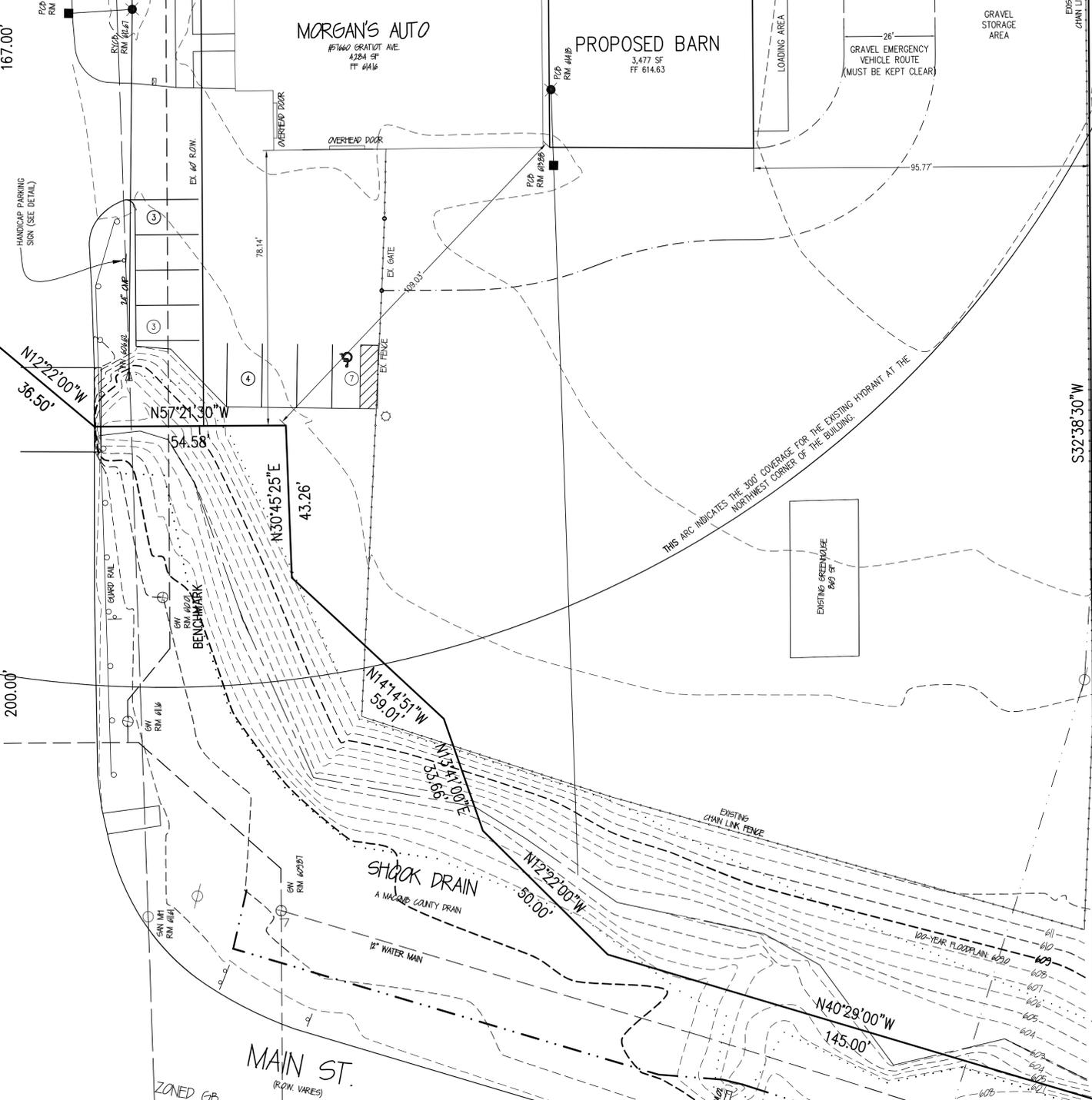

NEW HAVEN HIGH SCHOOL
#1710 RIVER CREEK DR.
14-04-34-30-00
ZONED S1

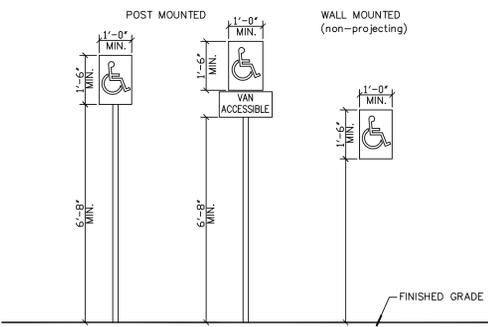

EACH ACCESSIBLE PARKING SPACE IS REQUIRED TO HAVE A SIGN. THE SIGN SHALL BE CENTERED IN THE PARKING SPACE.
VAN ACCESSIBLE PARKING SPACES SHALL BE DESIGNATED "VAN ACCESSIBLE" ON THE FACE OF THE SIGN OR SHALL HAVE AN ADDITIONAL SIGN "VAN ACCESSIBLE" MOUNTED BELOW THE REQUIRED SIGN.

ACCESSIBLE PARKING SIGNAGE
NOT TO SCALE

BENCHMARKS: NAVD 88 DATUM
1. SANITARY SEWER MANHOLE IN FRONT OF MORGAN'S AUTO #57660 GRATIOT AVE. ELEVATION: 613.11
2. A GAVE VALVE RIM ON THE EAST SIDE OF GRATIOT, JUST SOUTH OF THE SHOOK DRAIN CROSSING. ELEVATION: 610.01

LEGAL DESCRIPTION: PARCEL 03-33-430-009
PART OF SECTION 33, T.4N., R.14E., VILLAGE OF NEW HAVEN, MACOMB COUNTY, MICHIGAN. BEING MORE PARTICULARLY DESCRIBED AS COMMENCING AT THE CENTERLINE OF GRATIOT AVENUE AND NEW HAVEN ROAD; THENCE N32°38'30"E 200.0' TO THE POINT OF BEGINNING; THENCE N32°38'30"E 167.0'; THENCE S57°21'30"E 313.0'; THENCE S32°38'30"W 384.23'; THENCE N40°29'W 145.0'; THENCE N12°22'W 50.0'; THENCE N13°41'E 33.66'; THENCE N14°14'51"W 59.01'; THENCE N30°45'25"E 43.26'; THENCE N57°21'30"W 54.58'; THENCE N12°22'W 36.50' TO THE POINT OF BEGINNING. CONTAINING 2.105 ACRES. LEGAL DESCRIPTION PROVIDED FROM ASSESSING RECORDS.

- GENERAL NOTES:**
- A PERMIT WILL BE REQUIRED FROM THE MACOMB COUNTY DEPT. OF ROADS FOR ALL WORK PERFORMED WITHIN THE NAPI DRIVE RIGHT-OF-WAY. ENTRANCE PAVEMENT REQUIREMENTS WILL BE COORDINATED WITH THE DEPT. OF ROADS DURING THE PERMITTING PROCESS.
 - PROPOSED UTILITY LOCATIONS SHOWN ARE FOR PLANNING PURPOSES AND MAY BE SUBJECT TO CHANGE DURING THE ENGINEERING STAGE. MUNICIPAL UTILITIES (WATER, SANITARY, AND STORM SEWER) WILL BE BROUGHT ON SITE BY THE DEVELOPER FROM EXISTING SOURCES. PLANS WILL BE SUBMITTED TO THE SHELBY TWP DPW FOR REVIEW FOR ENGINEERING REVIEW PRIOR TO CONSTRUCTION.
 - NO CONSTRUCTION ACTIVITY SHALL BE PERMITTED PRIOR TO RECEIPT OF "PERMIT TO CONSTRUCT" FROM SHELBY TWP DPW.
 - ALL UNPAVED AREAS SHALL HAVE APPROPRIATE GROUND COVER. AREAS ADJACENT TO BUILDINGS AND WITHIN THE PARKING AREAS SHALL BE COVERED WITH SHREDDED BARK MULCH BEDDINGS. SOD SHALL BE USED IN THE LARGER GREENBELT AREAS ALONG THE FRONTAGE OF THE SITE, AND AROUND ALL SIDES OF THE BUILDINGS, WHERE APPROPRIATE. THE BALANCE OF THE SITE AREA THAT IS ENCLOSED BY THE FENCE WILL BE A STORAGE AREA.
 - SODDED AREAS SHALL HAVE AUTOMATIC UNDERGROUND SPRINKLER SYSTEMS INSTALLED.
 - THERE ARE EXISTING TREES ON THIS PROPERTY ALONG THE FRONTAGE OF THE SITE. SEE LANDSCAPE PLAN FOR TREE PROTECTION NOTES AND DETAILS.
 - A PHOTOMETRIC PLAN WILL BE SUPPLIED BY OTHERS.
 - SEE ARCHITECTURAL PLANS SUPPLIED BY RLA STUDIO.
 - ANY PROPOSED ROOF MOUNTED MECHANICAL UNITS WILL BE PROPERLY SCREENED.
 - DETENTION HAS BEEN PROVIDED BY OFFSITE IMPROVEMENTS IN THE LONGSTAFF DRAIN, WHICH IS DOWNSTREAM

PREPARED FOR:
MARK BROWN
MORGAN'S AUTO
57660 GRATIOT AVE.
NEW HAVEN, MI 48048
(586) 943-1453
MORGANSAUTO@YAHOO.COM

PREPARED BY:
COMMUNITY E.S., INC.
C/O RICHARD HODSDON P.E. #48078
5805 24 MILE ROAD, STE. B
SHELBY TWP., MI 48316
PH: (586) 677-4081
E-MAIL: RICH@COMMUNITYENG.COM



© 2024 - COMMUNITY E.S., INC. ALL RIGHTS RESERVED. THESE PLANS AND DRAWINGS ARE OWNED BY AND THE SOLE PROPERTY OF COMMUNITY E.S., INC. ANY REPRODUCTION, COPYING, REUSE OR DISTRIBUTION OF THESE PLANS AND DRAWINGS IS STRICTLY PROHIBITED WITHOUT THE PRIOR WRITTEN CONSENT OF COMMUNITY E.S., INC.



Fire Savvy Consultants
701 Woodward Heights, Suite 106
Ferndale, MI 48220
Plan Review #: 24-2-304
Reviewed by: Timothy J. Blackwood Jr.
We recommend the submittal be: **APPROVED**
Date: August 1, 2024
See letter for comments

- SITE DATA:**
- EXISTING SITE INFORMATION:
PART OF PARCEL NO. 06-33-430-009
ADDRESS: 57660 GRATIOT AVE.
 - ZONING: LI
 - EXISTING BUILDING: 4,284 SF AUTO SERVICE
6 SERVICE BAYS
PROPOSED BARN: 3,477 SF WAREHOUSE
 - PARKING:
5 SPACES MINIMUM PLUS 4 SPACES FOR EACH ADDITIONAL SERVICE BAY
5 SERVICE BAYS X 4 SPACES = 20 SPACES
25 SPACES REQUIRED
26 SPACES PROVIDED
- NOTE: THE SHOP CURRENTLY HAS 6 EMPLOYEES.

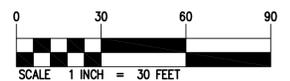

COMMUNITY E.S.
CIVIL ENGINEERING & SURVEYING

MORGAN'S AUTO
PART OF SECTION 33, T.4N., R.14E., VILLAGE OF NEW HAVEN, MACOMB COUNTY, MICHIGAN.

DATE: Jan. 3, 2024 SCALE: 1" = 20'
DRAWN BY: R.S.H. SHEET: 1 OF 3
CHECKED BY: R.S.H. DRAWING: Z-24-152

PRELIMINARY SITE PLAN