



Town of New Castle
450 W. Main Street
PO Box 90
New Castle, CO 81647

Administration Department
Phone: (970) 984-2311
Fax: (970) 984-2716
www.newcastlecolorado.org

Agenda

New Castle Town Council Regular Meeting

Tuesday, September 16, 2025, 7:00 PM

Virtual Meetings are subject to internet and technical capabilities.

To join by computer, smart phone or tablet:

<https://us02web.zoom.us/j/7096588400>

If you prefer to telephone in:

Please call: 1-346-248-7799

Meeting ID: 709 658 8400

Follow the prompts as directed. Be sure to set your phone to mute until called on

Call to Order

Pledge of Allegiance

Roll Call

Meeting Notice

Conflicts of Interest

Agenda Changes

Citizen Comments on Items not on the Agenda

-Comments are limited to three minutes-

Consultant Reports

Consultant Attorney

Consultant Engineer

Items for Consideration

A. Presentation – Riverside Middle School Support Project

B. Presentation – Colorado River Valley Economic Development Partnership (CRVEDP) – Alicia Gresley

C. Consider Resolutions TC2025-19 – A Resolution of the New Castle Town Council Supporting the Ballot Measure of the Confluence Early Childhood Education Coalition to be Decided by Voters at the November 4, 2025, Election

Consent Agenda

Items on the consent agenda are routine and non-controversial and will be approved by one motion. There will be no separate discussion of these items unless a council member or citizen requests it, in which case the item will be removed from the consent agenda.

[September 2, 2025, minutes](#)

CRS Frens, LLC dba: New Castle Liquors Liquor License Renewal

CRS Frens, LLC dba: New Castle Liquors Tasting License Application

Dillon Companies LLC dba: City Market #41 Liquor License Renewal

Kum & Go LC dba: Maverik 5050 Liquor License Renewal

Staff Reports

Town Administrator

Town Clerk

Town Treasurer

Town Planner

Public Works Director

Commission Reports

Planning & Zoning Commission

Historic Preservation Commission

Climate and Environment Commission

Senior Program

RFTA

AGNC

GCE

EAB

POSTR

Council Comments

Items for Future Council Agenda

Adjourn



Town of New Castle
450 W. Main Street
PO Box 90
New Castle, CO 81647

Administration Department
Phone: (970) 984-2311
Fax: (970) 984-2716
www.newcastlecolorado.org

Memorandum

To: Mayor & Council
From: David Reynolds
Re: Agenda Item: Riverside Middle School Project Introduction
Date: 09/16/2025

Purpose:

The purpose of this agenda item is to allow time for representatives from New Castle's Riverside Middle School to introduce an exciting new multi-use playground project to be built on school property. This project is designed to include multiple pieces of play equipment, a ball court, shade structure, and a small amphitheater with targeted use by students and the wider community. With the projects planning stage well under way, the various elements of this project including architect, civil engineering, excavation, equipment purchase, surfacing work, etc., are all being finalized so that once final financing is secured the project will be ready to go. To date the school has done a great job of managing internal fundraising and private donations and is now reaching out to explore community partnerships that may help to get this project over the finish line.

RIV Exterior Improvements

Preliminary Layout



Jeff Johnson Architectural PC

RIV Exterior Improvements

Summary

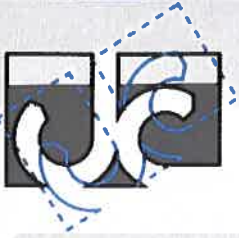

This submittal package goes over the different exercise equipment and their location on the new improvements. The renderings offers an idea as to what the new area will look like with the changes we discussed.

We have also included options for selective exercise equipment for your review. There is flexibility here. The equipment can come in a package and that is what we are showing in the renderings. Although picking items one by one may be more expensive, the equipment we are showing you is more advanced than a swing set, but designed to fit the grade level of Riverside.

We suggest you involve the community in the selection of these items (or maybe just the PTA).

The project area is large and will entail excavation and earthwork. Because this area is being improved, we are introducing elements like concrete walkways, partial retainage walls, landscape, irrigation, and outdoor lighting.

We have also introduced a narrative to the area that integrates the Viking mascot of Riverside. This includes some refined outdoor space surrounding a Viking statue. As in other instances, we would recommend soliciting a local artisan to be commissioned to design and build the statue.

RIV Exterior Improvements

Narrative

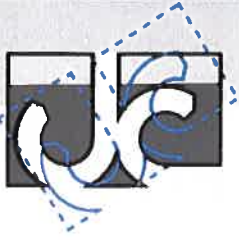

RIV Exterior Improvements

Site Plan Images

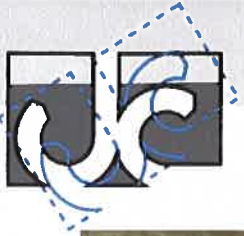

RIV Exterior Improvements

Site Plan Images



RIV Exterior Improvements

Perspective Images

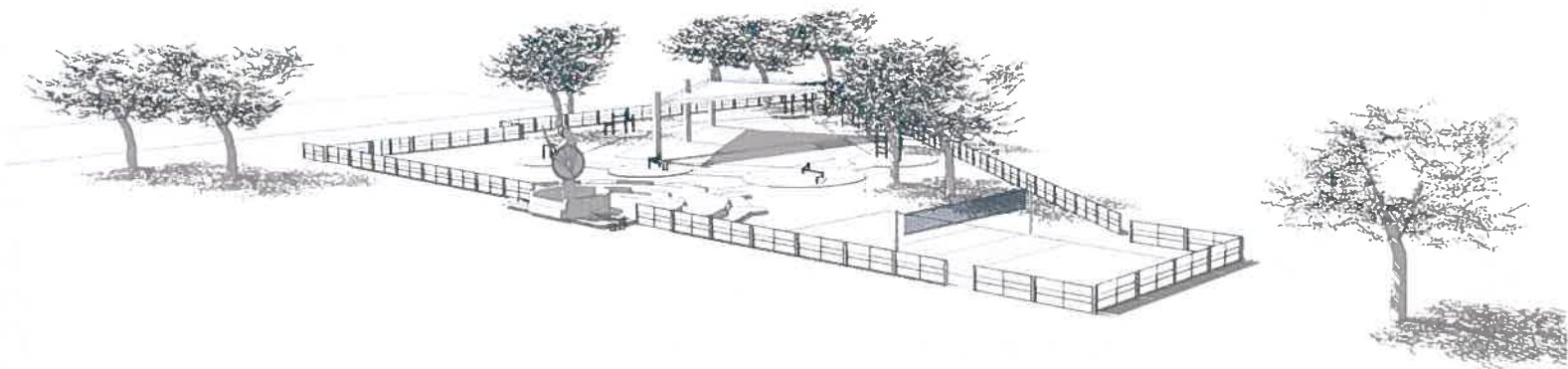
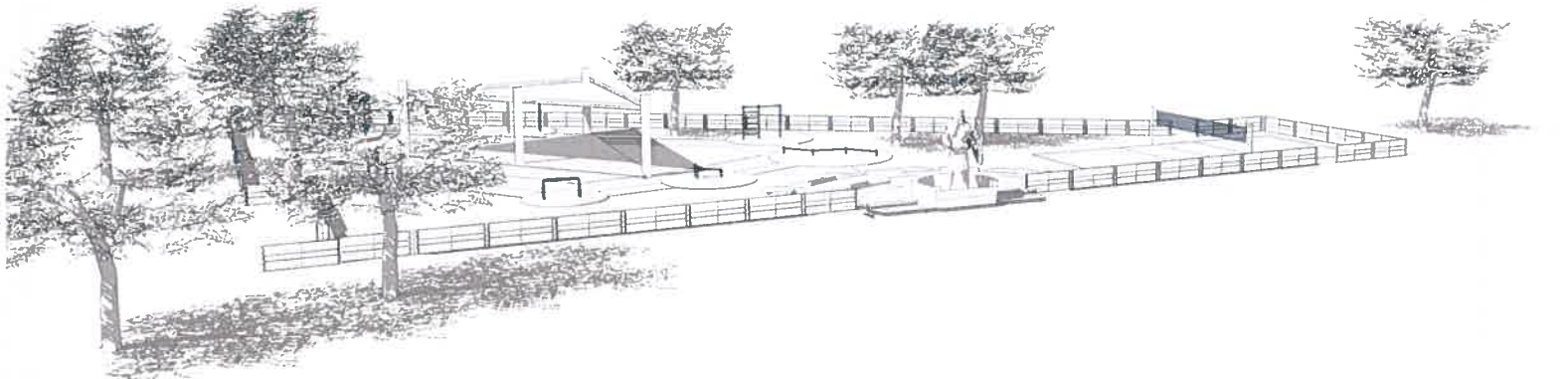
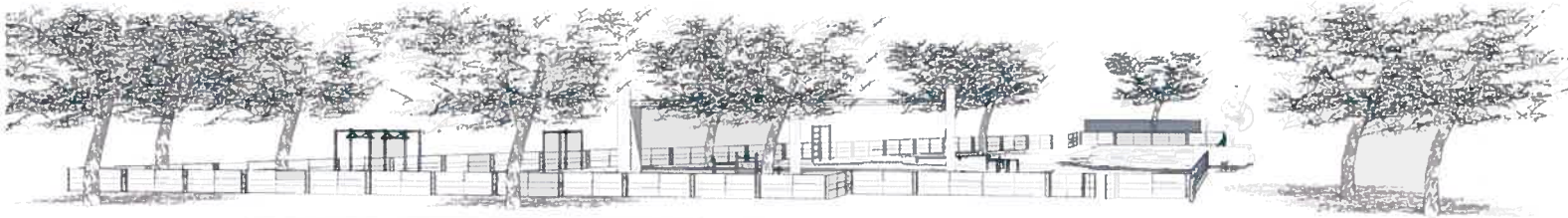

RIV Exterior Improvements

Perspective Images

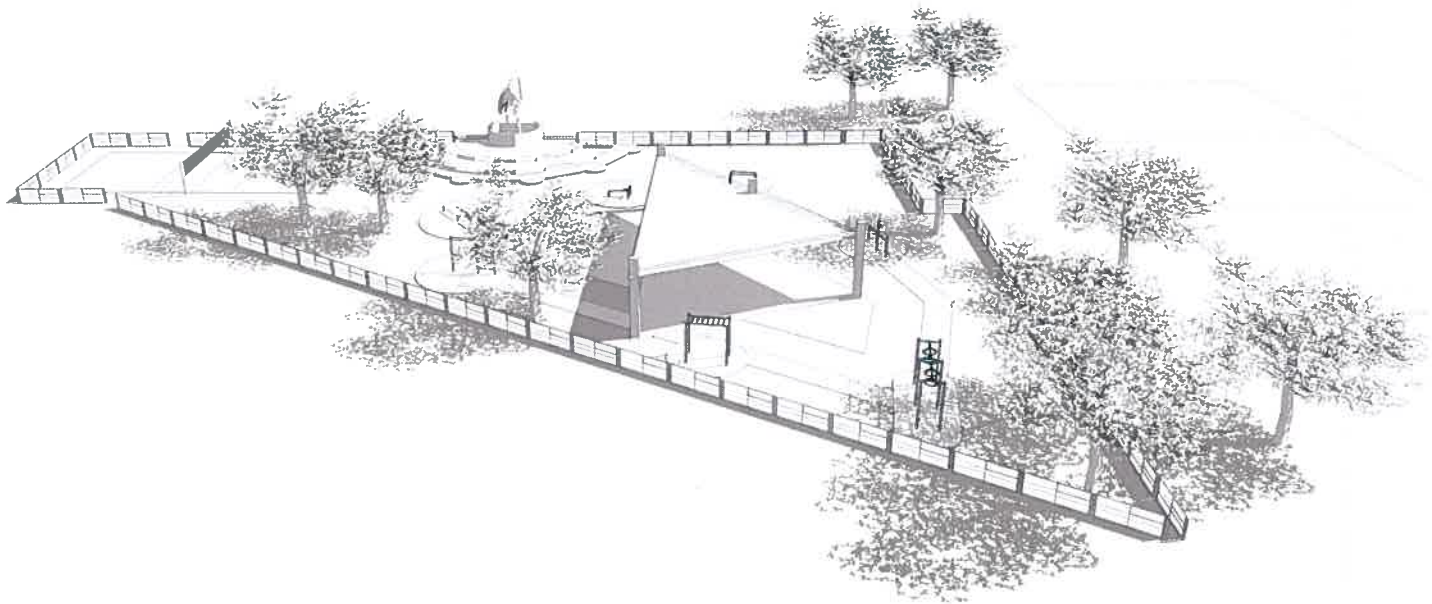
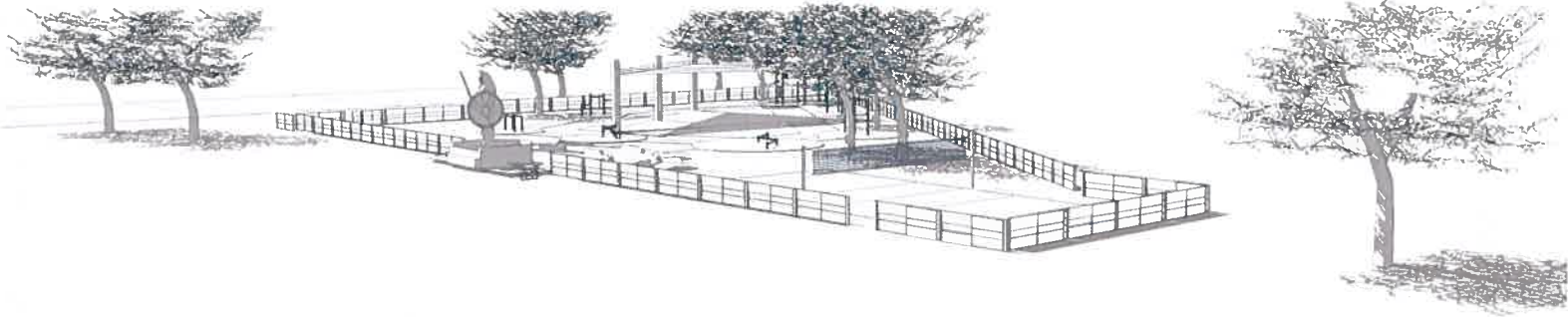
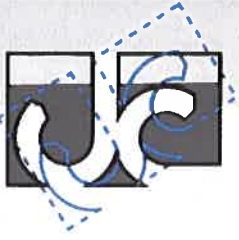

RIV Exterior Improvements

Preliminary Layout

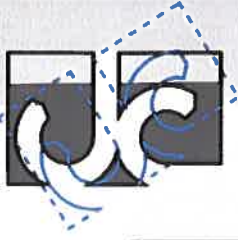

- Preferred equipment

[TerraBound Solutions Inc.](https://www.terraboundsolutions.com)
<https://www.terraboundsolutions.com/product/12-unit-course-2/>

12 Unit Course Playground System

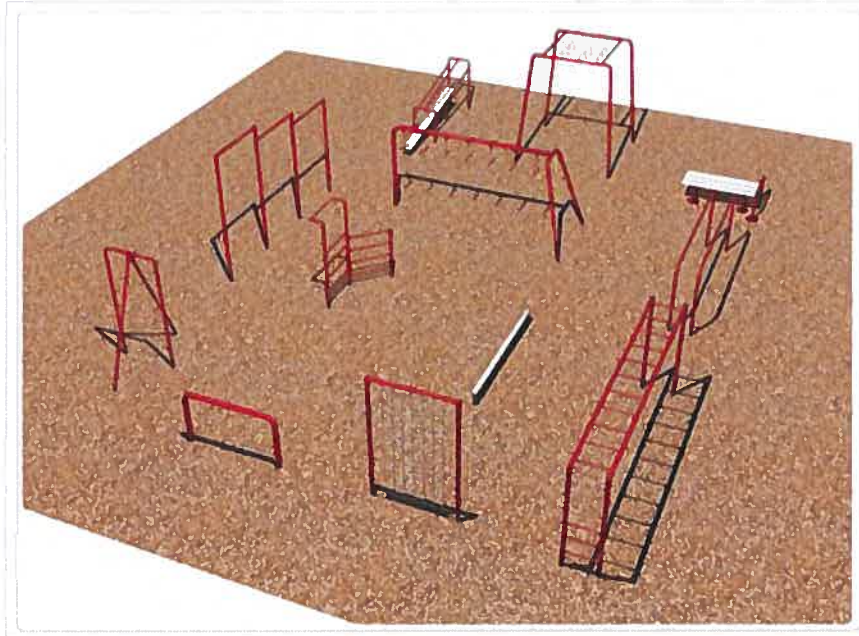

Price: \$10,641.00

SKU: 511-215

Product Page:
<https://www.terraboundsolutions.com/product/12-unit-course-2/>

Product Summary

Dimensions: 64' x 47'
Weight: 1,425 lbs.

Product Description

This 12 Unit Course features several different types of playground and fitness equipment that are guaranteed to liven up any outdoor activity area.

Installation Tips:

- Do not place equipment in an area where people walking past could be injured while the equipment is in use
- Install multiple pieces at a safe distance from other equipment – A good rule of thumb is maintaining a minimum of 8' between each unit.

Product Attributes

- Dimensions: N/A
- Weight: 1425 lbs

Export date: Fri Jan 31 17:05:11 2025 / +0000 GMT
Product data have been exported from TerraBound Solutions Inc. [<https://www.terraboundsolutions.com>]

Product Print by [WooCommerce PDF & Print](#) plugin.

Swing Frame, 4 Seat, 8 ft H

KSW924



Item no. KSW924-0910	
General Product Information	
Dimensions LxWxH	23'4"x6'0"x8'4"
Age group	2 - 12
Play capacity (users)	-
Color options	



KOMPAN Portal swings are a modern update on a traditional favorite, constructed from galvanized steel. They are configurable for the unique needs and requirements of every playground site. All Portal swings come standard in 7", 8" or 10" heights with posts made from hot dip galvanized steel. For swing seats, we offer as standard a rubber swing

seat, baby seat, or toddler swing seat for individual use, or the duo swing seat, birds nest, or you & me swing seat for multiple users. The seats are available with either hot dip galvanized chains or stainless steel chains with the option of antiwrap suspension. The modular swing system is also available in multibay configurations with 2, 3, 4 or more sections.

Swing Frame, 4 Seat, 8 ft H

KSW924



Item no. KSW924-0910	
Installation Information	
Total installation time	7.0
Excavation volume	2.2yd ³
Concrete volume	0yd ³
Footing depth (standard)	2'11"
Shipment weight	605lbs
Anchoring options	In-ground ▾
Warranty Information	
Hot dip galvanized steel	Lifetime
Movable parts	2 Years
Post	10 Years
Spare Parts Availability	10 Years

**ASTM
F1487**
compliant

Sustainability Data

KSW924

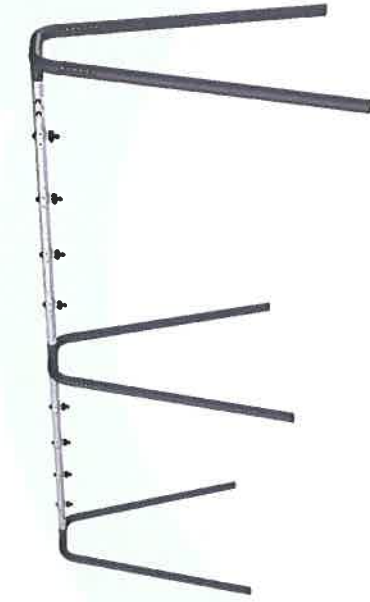

Cradle to Gate A1-A3	Total CO ₂ emission		CO ₂ e/kg		Recycled materials	
	kg CO ₂ e	670.66	kg CO ₂ e/kg	3.19	%	46.78
KSW924-0910						

The overall framework applied for these factors is the Environmental Product Declaration (EPD), which quantifies "environmental information on the life cycle of a product and enable comparisons between products fulfilling the same function" (ISO, 2006). This follows the structure and applies a Life-Cycle Assessment approach to the entire Product stage from raw material through manufacturing (A1-A3)

Kompan A/S
 C.F. Tietgens Boulevard 32C
 DK-5220 Odense SØ
 Denmark



Verification of CO₂ calculation of: Freestanding play equipment

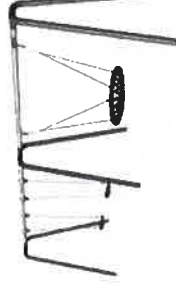

Date version no. 2023-10-05

The CO₂ calculation and data are in compliance with the principles of a carbon footprint: impact according to the GHG protocol (Greenhouse Gas Protocol), Scope 3, cradle to gate related to all individual components in the product category: "Freestanding play equipment" represented by item no. KSW92011-0910.

(Scope 3 emissions include emission sources in the upstream and downstream value chain).

Date: 30. October 2023 | Valid until: 30. October 2025

Verified by:



Julie Marie Vejsgaard Larsen, LCA & EPD Consultant

Verification based on report: Validation of CO₂ calculation of 9 categories of Kompan product line, version 1.0, prepared by: Bureau Veritas HSE, Denmark, Julie M. V. Larsen.

Publication date: 30. October 2023



By Bureau Veritas HSE
 www.bureauveritas.dk
 +45 7731 1000

Swing, 3 seat, 8 ft H, 1 Shell Seat

KSW92009



Item no. KSW92009-0910	
General Product Information	
Dimensions LxWxH	21'11" x 6'0" x 8'4"
Age group	2 - 12
Play capacity (users)	8
Color options	●

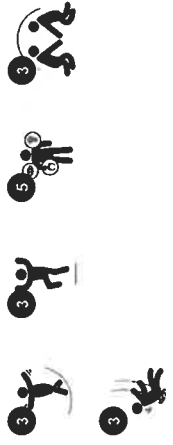

WOW! The combination of the bird's nest swing and two single seats swing is a hit: children love it, as it can be done individually and together. It facilitates lying, seated, and standing swinging, alone or together. It is a great facilitator of fun rough-and-tumble play. The seats allow for multiple users of all abilities and most ages to play day after day, for hours

and hours. Swinging, apart from being tremendous fun, trains the children's ABCs: agility, balance and coordination, as well as their spatial awareness. These motor skills are crucial to being able to judge distance and navigate traffic safely. The standing sitting, lying and standing swing activities train the arm, leg and core muscles. Jumping off builds

bone density – the majority of which is built up during the first years of life. Finally, this swing supports social skills such as taking turns and cooperation.

Swing, 3 seat, 8 ft H, 1 Shell Seat

KSW92009



Two single swing seats
Physical: balance, coordination and spatial awareness are trained when swinging. All necessary when judging distances and managing traffic safely. The swinging movement trains the arm, leg and core muscles. Social-Emotional: parallel play invites cooperation and consideration. Cognitive: cause and effect and thinking skills for younger children. Rules games for bigger children, when swinging in same or different rhythm.



Shell nest swing
Physical: balance, coordination and spatial awareness are developed. The swinging movement trains the arm, leg and core muscles, and strengthens bone density when jumping off. Social-Emotional: the spacious seat allows for many children standing, lying, seated together and is inclusive for all. Cognitive: develops cause and effect understanding, rhythm and thinking skills in younger children.

Swing, 3 seat, 8 ft H, 1 Shell Seat

KSW92009



Vertical posts of hot dip galvanized steel or powder coated on pre-galvanized steel base. Swing frame end connectors and crossbeam of hot dip galvanized steel or powder coated on hot dip galvanized steel base.



KOMPAN heavy duty designed swing hangers of stainless steel with anti-twist function. The hangers are attached to the cross beam on a welded bracket with two bolts. The bearings are embedded with silicone lubricant and needs no further lubrication.



The standard seats of KOMPAN swings is engineered for maximum safety and durability. The seat two component seat with a PP inner core and outside rubber is produced in one operation. The seats are available with swing chains of either hot dip galvanized steel or stainless steel for all swings heights.



The swing hangers are made of high quality UV-stabilized nylon (PA6) housing with integrated lifetime sealed ball bearings. The height adjustable chains are fixed by a stainless steel hook with theft proof snake-eye bolt in a turn able anti twist housing. All seats with two chain fixation are available with either standard or anti-wrap suspension.

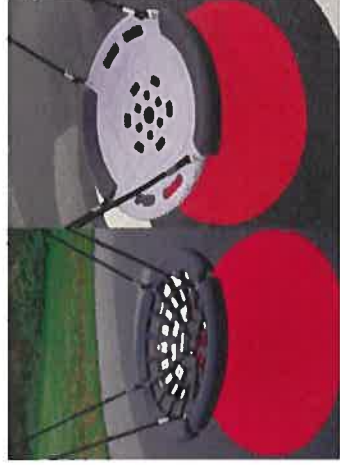

KOMPAN designed the bird's nest seats to be light in weight and in compliance with global safety standards. The soft, shock absorbent bumpers with non-slip surface makes the swing seat extremely user friendly. Choose between a rope version with reinforced PA rope or a molded PE version. Both equipped with soft rubber bumpers.

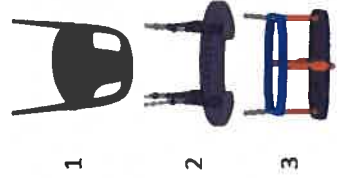

Unique designed seats for toddlers: Baby seat of rubber. Toddler seat of PUR with four chain suspension for easy movement. Cradle seat. You & Me swing seat for adult/child or children of different ages to swing together while facing each other.



Item no. KSW92009-0910	
Installation Information	
Max. fall height	7'11"
Safety surfacing area	850ft ²
Total installation time	7.0
Excavation volume	2.07yd ³
Concrete volume	0.76yd ³
Footing depth (standard)	2'11"
Shipment weight	675lbs
Anchoring options	In-ground ✓
Warranty Information	
Chains	10 Years
Spare Parts Availability	10 Years
Steel post HDG	Lifetime
Swing hangers	5 Years
Swing seat	10 Years

Elevated activities 0	Accessible elevated activities	Accessible ground level activities	Accessible ground level play types
Present	0	1	1
Required	1	1	1



Sustainability Data

KSW92009



Cradle to Gate A1-A3	Total CO ₂ emission	CO ₂ e/kg	Recycled materials
	kg CO ₂ e	kg CO ₂ e/kg	%
KSW92009-0910	764.34	3.18	44.74

The overall framework applied for these factors is the Environmental Product Declaration (EPD), which quantifies "environmental information on the life cycle of a product and enable comparisons between products fulfilling the same function" (ISO, 2006). This follows the structure and applies a Life-Cycle Assessment approach to the entire Product stage from raw material through manufacturing (A1-A3)



Kompan A/S
 C.F. Tietgens Boulevard 32C
 DK-5220 Odense SØ
 Denmark



Verification of CO₂ calculation of: Freestanding play equipment



Date version no. 2023-10-05

The CO₂ calculation and data are in compliance with the principles of a carbon footprint: impact according to the GHG protocol (Greenhouse Gas Protocol). Scope 3, cradle to gate related to all individual components in the product category: "Freestanding play equipment", represented by item no. KSW92011-0910.

(Scope 3 emissions include emission sources in the upstream and downstream value chain).

Date: 30. October 2023 | Valid until: 30. October 2025

Verified by:



Julie Marie Vejsgaard Larsen, LCA & EPD Consultant

Verification based on report: Validation of CO₂ calculation of 9 categories of Kompan product line, version 1.0, prepared by: Bureau Veritas HSE, Denmark, Julie M. V. Larsen.

Publication date: 30. October 2023



By Bureau Veritas HSE
 www.bureauveritas.dk
 +45 7731 1000

Swing, 3 seat, 8 ft H, 1 Shell Seat

KSW92009



* Max fall height | ** Total height | *** Safety surfacing area

* Max fall height | ** Total height

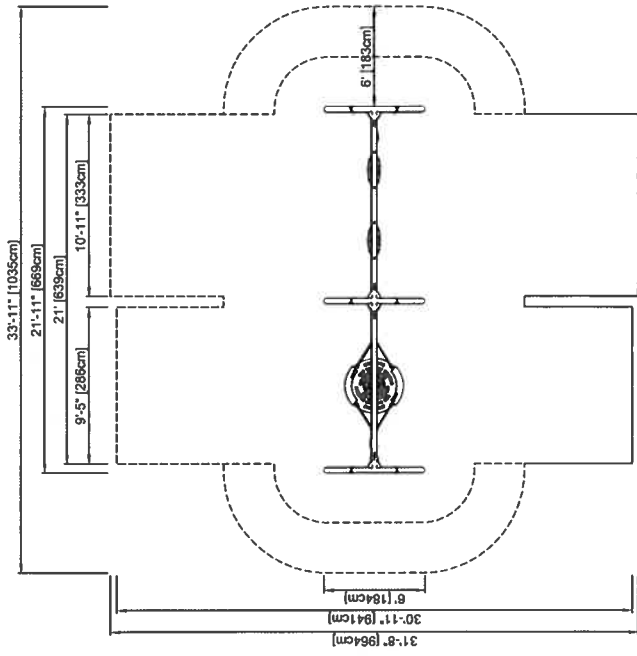

KSW92009
 **7'-11" / 241cm
 ***8'-4" / 255cm
 ***848ft² / 79m²

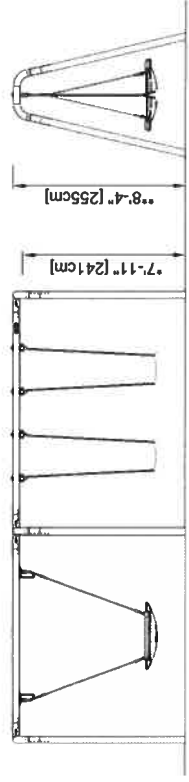

KSW92009

[Click to see TOP VIEW](#)

[Click to see SIDE VIEW](#)

Swing Seat, Stainless

SW990011



Item no. SW990011-00	
General Product Information	
Dimensions LxWxH	2'1"x0'8"x0'0"
Age group	2 - 12
Play capacity (users)	1
Color options	●

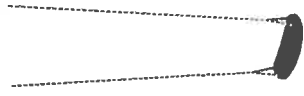
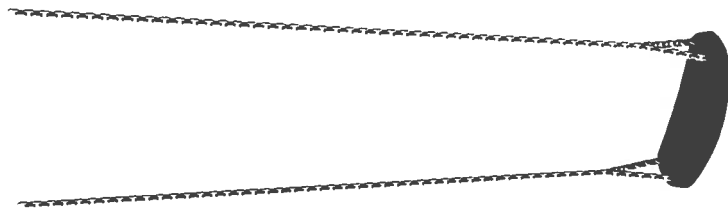

YES! The Swing is an all time playground favorite: children love swinging, individually and together. Swinging is pure thrill and joy, being swung up and down, using all the body to increase speed, or slow down. The seat is shaped with a slight curve in the middle, to facilitate the secure seat position of a wide age span. A great place to play, for all ages, for

hours and days. Swinging, apart from being great fun, trains the children's ABC: agility, balance and coordination as well as their spatial awareness. These motor skills are crucial to being able to judge distances and navigate traffic safely. Swings allows for standing sitting, lying – and not least jumping off. Apart from the motor skills training, this

trains the arm, leg and core muscles. The jumping off builds bone density – the majority of which is built up during the first years of life.

Swing Seat, Stainless

SW990011



Swing seat

Physical: balance, coordination and spatial awareness are developed when swinging. These are necessary skills for judging distances and navigating. The swinging movement trains the arm, leg and core muscles, and strengthens bone density when jumping off. **Cognitive:** cause and effect understanding and thinking skills for younger children when swinging.

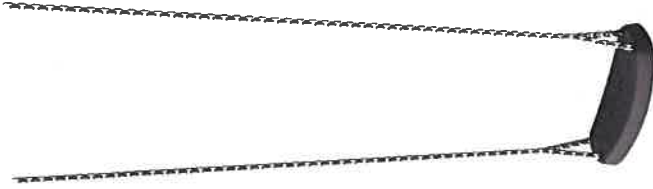

Swing Seat, Stainless

SW990011



The standard seats of KOMPAN swings is engineered for maximum safety and durability. The seat two component seat with a PP inner core and outside rubber is produced in one operation. The seats are available with swing chains of either hot dip galvanized steel or stainless steel for all swings heights.



Item no. SW990011-00	
Installation Information	
Max. fall height	7'11"
Safety surfacing area	212ft ²
Total installation time	0.1
Excavation volume	0yd ³
Concrete volume	0yd ³
Footing depth (standard)	0'0"
Shipment weight	12lbs
Anchoring options	
Warranty Information	
Chains	10 Years
Spare Parts Availability	10 Years
Swing seat	10 Years

Elevated activities 0	Accessible elevated activities	Accessible ground level activities	Accessible ground level play types
Present	0	0	0
Required	0	0	0

Sustainability Data

SW990011



Cradle to Gate A1-A3

Total CO ₂ emission	CO ₂ e/kg	Recycled materials
kg CO ₂ e	kg CO ₂ e/kg	%
21.35	4.01	31.28

SW990011-00

Kompan A/S
C.F. Tietgens Boulevard 32C
DK-5220 Odense SØ
Denmark



Verification of CO₂ calculation of: Freestanding play equipment

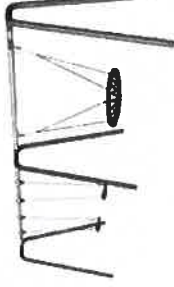

Data version no. 2023-10-05

The CO₂ calculation and data are in compliance with the principles of a carbon footprint, impact according to the GHG protocol (Greenhouse Gas Protocol), Scope 3, cradle to gate related to all individual components in the product category, "Freestanding play equipment" represented by item no. KSW92011-0910.

(Scope 3 emissions include emission sources in the upstream and downstream value chain).

Date: 30. October 2023 | **Valid until:** 30. October 2025

Verified by:



Julie Marie Vejsgaard, Larsen, LCA & EPD Consultant

Verification based on report: Validation of CO₂ calculation of 9 categories of Kompan product line, version 1.0, prepared by Bureau Veritas HSE, Denmark. Julie M. V. Larsen.

Publication date: 30. October 2023

The overall framework applied for these factors is the Environmental Product Declaration (EPD), which quantifies "environmental information on the life cycle of a product and enable comparisons between products fulfilling the same function" (ISO, 2006). This follows the structure and applies a Life-Cycle Assessment approach to the entire Product stage from raw material through manufacturing (A1-A3)



By Bureau Veritas HSE
www.bureauveritas.dk
+45 7731 1000

Swing Seat, Stainless

SW990011



* Max fall height | ** Total height | *** Safety surfacing area

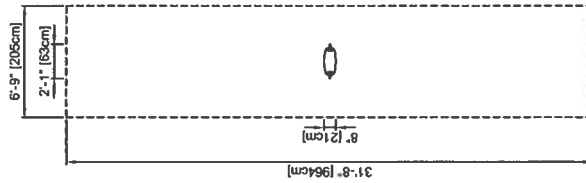

SW990011
***212ft² / 19.7m²

* Max fall height | ** Total height

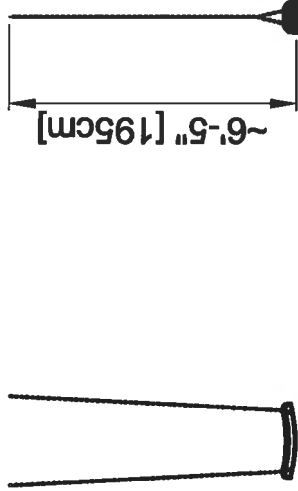

SW990011
1:100

[Click to see TOP VIEW](#)

[Click to see SIDE VIEW](#)

Balance Beam

FSW215



Post are made of 101.6 x 2mm, pre-galvanized carbon steel and powder coated, a great protection to all conditions.



The connectors are made of die-cast aluminium, specially alloyed for the outdoor environments and heavy usage. The screws attaching the connectors are stainless steel and protected by zinc washers.



The bars intended for exercises are made of hot-dip galvanized steel $\varnothing 48\text{mm}$. The diameter of these bars provide a good support when used to for push ups exercises or when doing exercises standing on the tubes.

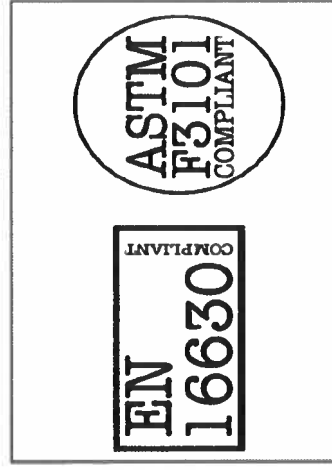

All KOMPAN fitness products are compliant with the ASTM F3101 & EN16630 Outdoor Fitness Standards. Load tests are performed as a static test by adding dynamic factors as well as safety factors to the specified load of 78kg per user. A product intended for 1 user is loaded with 420kg.



The information sign is made of a PA6 (Polyamide) and shows the most relevant exercise and a QR code. When scanned the QR code will link to an animated illustration of the exercise and offers the possibility of downloading the KOMPAN sport & fitness App, which will provide a large amount of exercises and workouts.



All decks are made of High Pressure Laminate HPL with a thickness 17.8mm and non skid surface texture according to EN 438-6. KOMPAN HPL has high wearing strength to ensure long lifetime in all climates.

Item no. FSW21500-0900	
Installation Information	
Max. fall height	1'4"
Safety surfacing area	278ft ²
Total installation time	3.7
Excavation volume	0.14yd ³
Concrete volume	0.01yd ³
Footing depth (standard)	2'11"
Shipment weight	215lbs
Anchoring options	In-ground ✓
	Surface ✓
Warranty Information	
Connectors	10 Years
EcoCore HDPE	Lifetime
Hot dip galvanized steel	Lifetime
Post	10 Years
Spare Parts Availability	10 Years

Sustainability Data

FSW215



Cradle to Gate A1-A3	Total CO ₂ emission		CO ₂ e/kg		Recycled materials	
	kg CO ₂ e	156.40	kg CO ₂ e/kg	2.29	%	53.91
FSW21500-0900						

The overall framework applied for these factors is the Environmental Product Declaration (EPD), which quantifies "environmental information on the life cycle of a product and enable comparisons between products fulfilling the same function" (ISO, 2006). This follows the structure and applies a Life-Cycle Assessment approach to the entire Product stage from raw material through manufacturing (A1-A3)



Kompan A/S
 C.F. Tietgens Boulevard 32C
 DK-5220 Odense SØ
 Denmark



Verification of CO₂ calculation of: Fitness



Data version no. 2023-10-05

The CO₂ calculation and data are in compliance with the principles of a carbon footprint impact according to the GHG protocol (Greenhouse Gas Protocol), Scope 3, cradle to gate related to all individual components in the product category "Fitness" represented by item no. FAZ10100-0900.

(Scope 3 emissions include emission sources in the upstream and downstream value chain).

Date: 30. October 2023 | **Valid until:** 30. October 2025

Verified by:



Julie Marie Vejsgaard Larsen, LCA & EPD Consultant

Verification based on report: Validation of CO₂ calculation of 9 categories of Kompan product line, version 1.0, prepared by Bureau Veritas HSE, Denmark: Julie M. V. Larsen.

Publication date: 30. October 2023



By Bureau Veritas HSE
 www.bureauveritas.dk
 +45 7731 1000

Balance Beam

FSW215



* Max fall height | ** Total height | **** Safety surfacing area

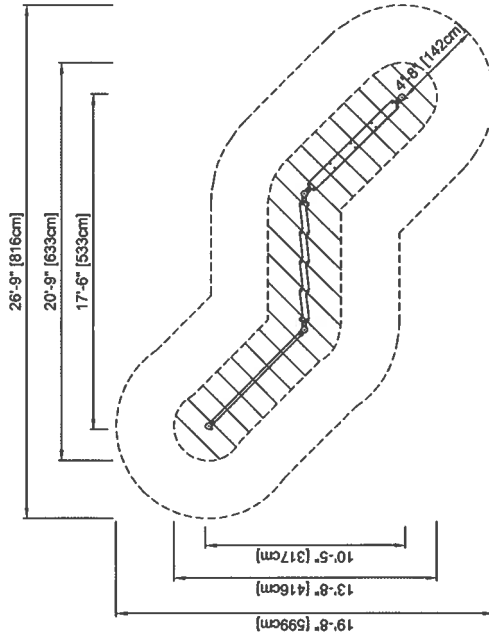

* Max fall height | ** Total height

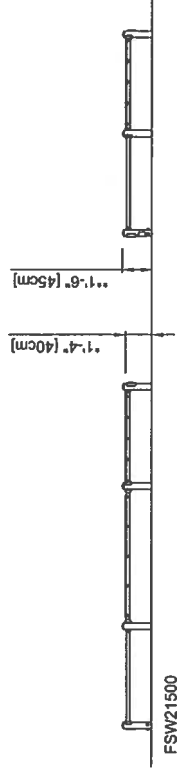

[Click to see TOP VIEW](#)

[Click to see SIDE VIEW](#)



Product Name	Nebula Mini IV
Product Number	DX-918
Size -- Length	6.00 m / 19' 8"
Size -- Width	2.50 m / 8' 2"
Size -- Height	3.07 m / 10' 1"
Shipping Weight	500 kg / 1102.3 lb
Shipping Volume	4.50 m ³ / 158.9 ft ³
Foundations	8
Concrete Volume	2.35 m ³ / 83.0 ft ³

	ASTM F-1487	CSA Z614	EN 1176
Capacity	15	15	15
Use Zone -- Length	9.80 m / 32' 2"	9.80 m / 32' 2"	10.60 m / 34' 9"
Use Zone -- Width	6.16 m / 20' 3"	6.16 m / 20' 3"	6.96 m / 22' 10"
Fall Height	2.60 m / 8' 6"	2.60 m / 8' 6"	2.60 m / 8' 6"

*Note: Concrete must be minimum 3500 PSI / 25MPa

Product Features:

SUPPORT POSTS:	This will be 5 1/2" (139.8mm) OD phosphate dipped steel tubing finished with hot dipped galvanization.
CLIMBING NETS:	These will be 20 mm diameter, polyamide (nylon) rope cable with UV protection and fire retardant solution. Each rope consists of 6 strands each containing 24 galvanized steel reinforcing strands within a polyamide sleeve, wrapped around a solid polyamide core for a total of 144 steel reinforcing strands; each end of the cable having a junction loop attached onto the cable with a finished aluminum sleeve and lined with a galvanized steel wear bar. Rope shall achieve a Class 7-8 Colourfastness rating.
BALL KNOTS:	This will be a one-piece compressed aluminum ball, compressed in place with 150,000 pounds force (667 kN) to prevent the connection from moving and causing premature cable wear.
BASIC FASTENERS:	All fasteners for component attachments are stainless steel.
FOUNDATION:	These will be 10" (250mm) square steel plates, 1/8" (3mm) thick, bolted to concrete blocks and attached to the main structure with 12" (300mm) long, 2 3/8" (60.5mm) OD steel tubing, all finished with either polyester powder coating or hot dipped galvanization.
ANCHOR BOLTS:	Mounting plates will be secured to concrete blocks with 7/8" (22mm) diameter x 20" (500mm) long "L" Anchor bolts, inserted into the wet concrete when poured.
SURFACE MOUNT:	Optionally, the product may be surface mounted utilizing 6" (150mm) long expansion bolts in place of the standard anchor bolts.
INSTALLATION:	This should be installed only by a licensed playground installer, trained and certified on the relevant playground standards in place in the region of installation, e.g., NPSI, CPSI or similar certified.

COMPLIANT WITH:

CAN/CSA-Z614-14
ASTM F-1487-11
EN-1176
CPSC Handbook for Public Playground Safety



† Where proper surfacing is used, this product meets the ADAAG guidelines for accessibility, allowing the same play possibilities for people of all abilities.



Support Post



Climbing Net - 20 mm

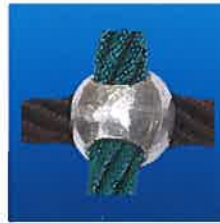

Ball Knot



Footing



Anchor Bolt



Expansion Bolt

We offer the following colour choices. 1) Other paint colours may be possible as a special order item at increased cost. 2) Biggo seats are standard Window Grey painted metal with Galvanized Chain and Blue bumper. 3) The selection of colours available for the PE Panels will vary according to supplier stock; please contact us to find out what combinations are available prior to placing your order. 4) Depending on the style of slide required, colour availability may vary; there may also be additional colour options not shown below. 5) Purple and Orange rope are available for select products only. Please consult your sales representative for confirmation.

ROPE COLOURS



PAINT COLOURS



NATURE'S AURA WOOD STAIN COLOURS

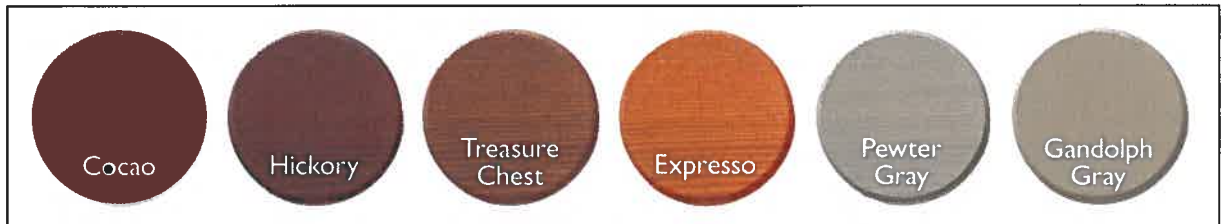

PE SLIDE COLOURS

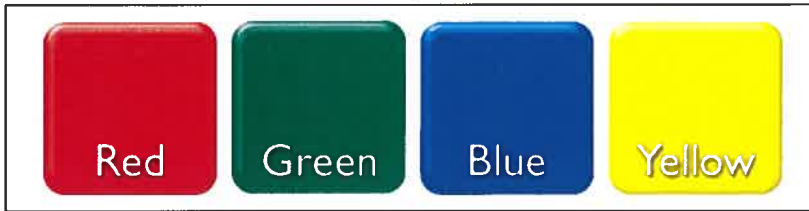

PE PANEL COLOURS

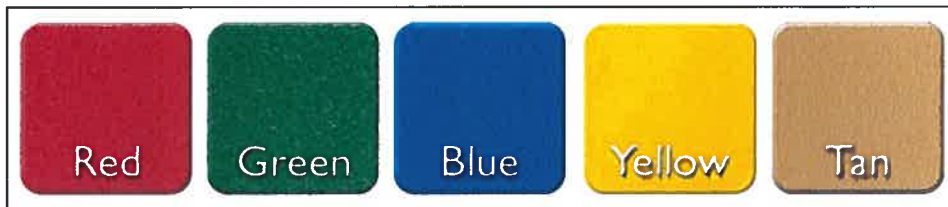

DECKING



NOTE: Actual colours of products and materials may appear slightly different than pictured. Products are subject to availability and may change without notice.



12/19/2024

Chain Ring Challenge Ladder

Brand: SportsPlay

Regular Price: **MSRP \$2,480.00**

Sale Price: **\$2,311.00**

Product Specifications:

Age Range: 5 to 12 Years Old

Equipment Weight: 325 lb

Installed Dimensions: 8 ft x 8 ft

Use Zone: 20 ft x 20 ft

Description:

The Chain Ring Ladder Fitness Course Section is designed to challenge and engage individuals in active play and physical fitness. This unique obstacle combines the fun of swinging chains with the skillful navigation of ring ladders, offering a stimulating workout that enhances coordination and agility. Its robust construction ensures durability for sustained use in outdoor environments. This piece is an excellent addition to any fitness course, encouraging users to push their limits in a fun and dynamic way.



Overhead Ladder, Wide

FSW205



Item no. FSW20501-0901	
General Product Information	
Dimensions LxWxH	7'5"x3'11"x7'10"
Age group	13+
Play capacity (users)	2
Color options	



See KOMPAN Fit App for More Information



The overhead ladder, also known as the monkey bar, may be the most famous of all obstacle course elements. The goal is to get to the other side without using your feet. This overhead ladder is wide and high to ensure anyone can hang and move freely. To make sure that everyone can reach the overhead ladder we added 4 stepping pods at different

heights. The overhead ladder has a clear instruction sign showing the basic exercise and a QR code. By clicking on the QR code users can connect to the KOMPAN Fitness App, where they will find multiple exercises and workouts at every level.

Overhead Ladder, Wide

FSW205



Post are made of 101.6 x 2mm, pre-galvanized carbon steel and powder coated, a great protection to all conditions.



The connectors are made of die-cast aluminium, specially alloyed for the outdoor environments and heavy usage. The screws attaching the connectors are stainless steel and protected by zinc washers.



Steps are made of extruded aluminium with a non-skid surface. Aluminium has high corrosion resistance and ensures durability of the product. Steps have been mounted at heights of 34,7cm and 54,7cm this creates an easy access to reach the overhead activity

Item no. FSW20501-0901	
Installation Information	
Max. fall height	7'8"
Safety surfacing area	124ft ²
Total installation time	3.5
Excavation volume	0.14yd ³
Concrete volume	0.1yd ³
Footing depth (standard)	2'11"
Shipment weight	321lbs
Anchoring options	In-ground ✓
	Surface ✓
Warranty Information	
Connectors	10 Years
Hot dip galvanized steel	Lifetime
Post	10 Years
Spare Parts Availability	10 Years

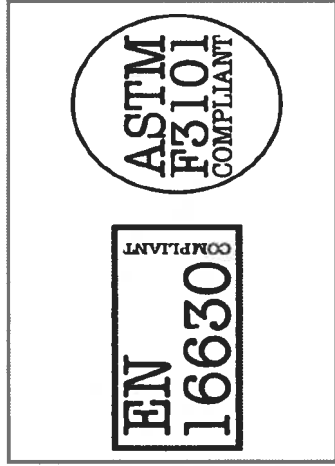

All KOMPAN fitness products are compliant with the ASTM F3101 & EN16630 Outdoor Fitness Standards. Load tests are performed as a static test by adding dynamic factors as well as safety factors to the specified load of 78kg per user. A product intended for 1 user is loaded with 420kg.



The information sign is made of a PA6 (Polyamide) and shows the most relevant exercise and a QR code. When scanned the QR code will link to an animated illustration of the exercise and offers the possibility of downloading the KOMPAN sport & fitness App, which will provide a large amount of exercises and workouts.



KOMPAN fitness products are standard available in Orange, RAL2010 and Grey, RAL7012. All other RAL colors are available on request. It will always be possible to match the surroundings or color theme!

ASTM F3101
compliant

Sustainability Data

FSW205



Cradle to Gate A1-A3	Total CO ₂ emission	CO ₂ e/kg	Recycled materials
	kg CO ₂ e	kg CO ₂ e/kg	%
FSW20501-0901	179.77	1.83	68.73

The overall framework applied for these factors is the Environmental Product Declaration (EPD), which quantifies "environmental information on the life cycle of a product and enable comparisons between products fulfilling the same function" (ISO, 2006). This follows the structure and applies a Life-Cycle Assessment approach to the entire Product stage from raw material through manufacturing (A1-A3))



Kompani A/S
C.F. Tietgens Boulevard 32C
DK-5220 Odense SØ
Denmark



Verification of CO₂ calculation of: Fitness



Data version no. 2023-10-05

The CO₂ calculation and data are in compliance with the principles of a carbon footprint, impact according to the GHG protocol (Greenhouse Gas Protocol), Scope 3, cradle to gate related to all individual components in the product category: "Fitness" represented by item no. FAZ10100-0900.

(Scope 3 emissions include emissions from sources in the upstream and downstream value chain).

Date: 30. October 2023 | Valid until: 30. October 2025

Verified by:

Julie Marie Vejsgaard Larsen, LCA & EPD Consultant

Verification based on report: Validation of CO₂ calculation of 9 categories of Kompani product line, version 1.0, prepared by Bureau Veritas HSE, Denmark: Julie M. V. Larsen.

Publication date: 30. October 2023



By Bureau Veritas HSE
www.bureauveritas.dk
+45 7731 1000

Overhead Ladder, Wide

FSW205



* Max fall height | ** Total height | *** Safety surfacing area

* Max fall height | ** Total height

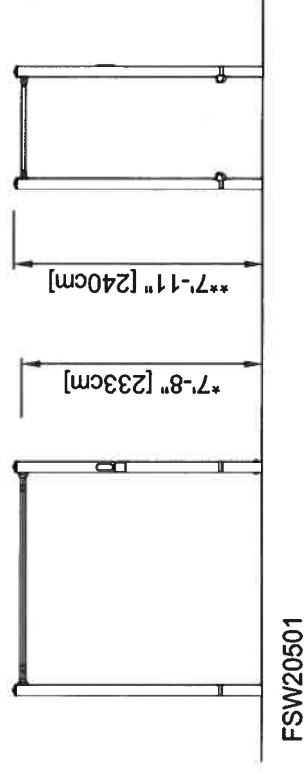
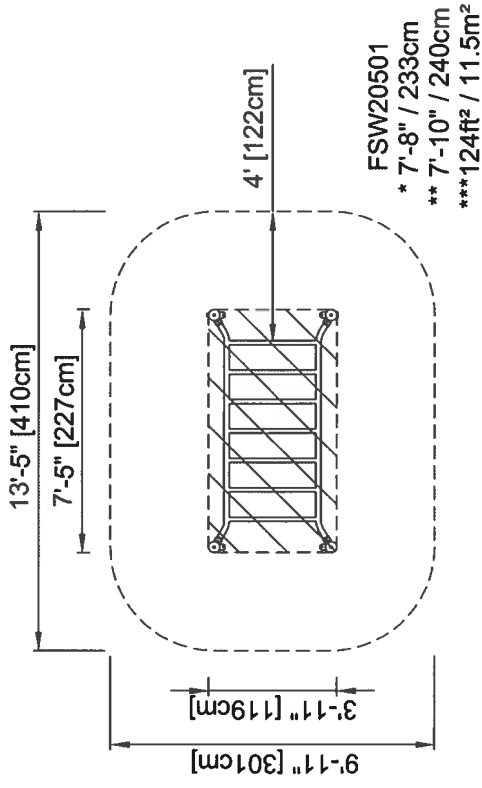

[Click to see TOP VIEW](#)

[Click to see SIDE VIEW](#)

Parallel Bars

FSW201

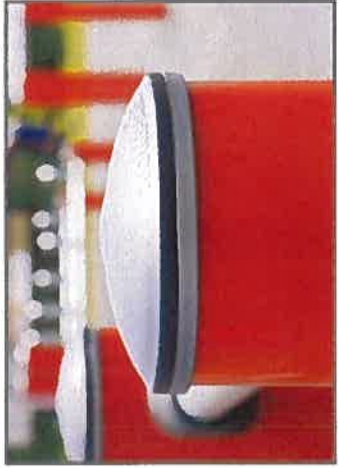

Post are made of 101.6 x 2mm, pre-galvanized carbon steel and powder coated, a great protection to all conditions.



The connectors are made of die-cast aluminium, specially alloyed for the outdoor environments and heavy usage. The screws attaching the connectors are stainless steel and protected by zinc washers.



Bars intended as grips during exercises are made of hot-dip galvanized steel ø38mm. A great diameter to support the wrist when doing dips or handstands.

Item no. FSW20100-0901	
Installation Information	
Max. fall height	3'6"
Safety surfacing area	88ft²
Total installation time	2.6
Excavation volume	0.14yd³
Concrete volume	0.1yd³
Footing depth (standard)	2'11"
Shipment weight	163lbs
Anchoring options	In-ground ✓ Surface ✓
Warranty Information	
Connectors	10 Years
Hot dip galvanized steel	Lifetime
Post	10 Years
Spare Parts Availability	10 Years

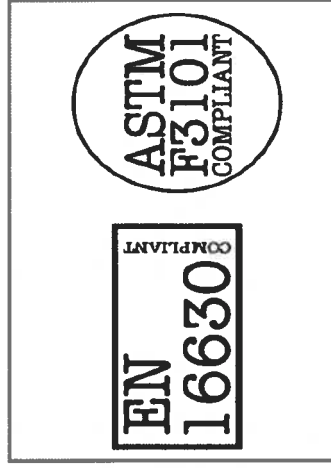

All KOMPAN fitness products are compliant with the ASTM F3101 & EN16630 Outdoor Fitness Standards. Load tests are performed as a static test by adding dynamic factors as well as safety factors to the specified load of 78kg per user. A product intended for 1 user is loaded with 420kg.



The information sign is made of a PA6 (Polyamide) and shows the most relevant exercise and a QR code. When scanned the QR code will link to an animated illustration of the exercise and offers the possibility of downloading the KOMPAN sport & fitness App, which will provide a large amount of exercises and workouts.



KOMPAN fitness products are standard available in Orange, RAL2010 and Grey, RAL7012. All other RAL colors are available on request. It will always be possible to match the surroundings or color theme!

ASTM F3101
compliant

Sustainability Data

FSW201



Cradle to Gate A1-A3	Total CO ₂ emission		CO ₂ e/kg		Recycled materials	
	kg CO ₂ e	113.80	kg CO ₂ e/kg	2.02	%	65.93
FSW20100-0901						

The overall framework applied for these factors is the Environmental Product Declaration (EPD), which quantifies "environmental information on the life cycle of a product and enable comparisons between products fulfilling the same function" (ISO, 2006). This follows the structure and applies a Life-Cycle Assessment approach to the entire Product stage from raw material through manufacturing (A1-A3)



Kompani A/S
 C.F. Tietgens Boulevard 32C
 DK-5220 Odense SØ
 Denmark



Verification of CO₂ calculation of: Fitness



Data version no. 2023-10-05
 The CO₂ calculation and data are in compliance with the principles of a carbon footprint impact according to the GHG protocol (Greenhouse Gas Protocol). Scope 3, cradle to gate related to all individual components in the product category: "Fitness" represented by item no. FAZ10100-0900.
 (Scope 3 emissions include emission sources in the upstream and downstream value chain).

Date: 30. October 2023 | Valid until: 30. October 2025
Verified by:



Julie Marie Vejsgaard Larsen, LCA & EPD Consultant

Verification based on report: Validation of CO₂ calculation of 9 categories of Kompani product line, version 1.0, prepared by Bureau Veritas HSE, Denmark: Julie M. V. Larsen.

Publication date: 30. October 2023



By Bureau Veritas HSE
 www.bureauveritas.dk
 +45 7731 1000

Parallel Bars

FSW201



* Max fall height | ** Total height | *** Safety surfacing area

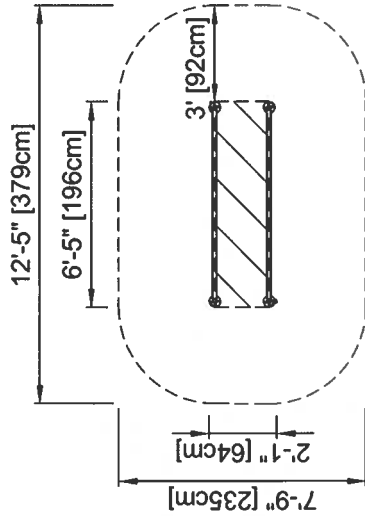

FSW20100
* 3'-6" / 107cm
** 3'-6" / 107cm
***88ft² / 8.2m²

* Max fall height | ** Total height

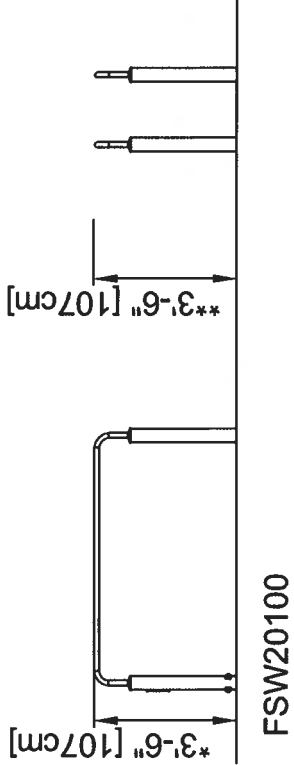

[Click to see TOP VIEW](#)

[Click to see SIDE VIEW](#)

12/19/2024

Pole Climb Challenge

Brand: SportsPlay

Regular Price: **MSRP \$680.00**

Sale Price: **\$661.00**

Features:

Your choice of Galvanized or Powder Coated finish, color choice is only needed if you choose the painted option

Materials:

Galvanized or Powder Coated finish

Product Specifications:

Age Range: 5 to 12 Years Old

Equipment Weight: 125 lb

Installed Dimensions: 4 ft x 8 ft x 8 ft

Use Zone: 16 ft x 20 ft



Description:

The Pole Climb Fitness Course Section is a thoughtfully designed outdoor playground equipment that skillfully blends entertainment with a dose of educational enrichment. This innovative piece not only challenges users physically, encouraging the development of strength and coordination, but also stimulates problem-solving skills, offering a multifaceted approach to outdoor play. Its robust design ensures durability and safety, making it a perfect addition to parks, schools, and community spaces. It's an inviting structure that promises endless hours of active fun, while subtly fostering an appreciation for physical education and outdoor activities. Its appeal lies in its ability to provide a balanced mix of fun and learning in an engaging environment.



12/19/2024

Pull Slide Challenge

Brand: SportsPlay

Regular Price: \$1,730.00

Sale Price: \$1,686.00

Features:

Your choice of Galvanized or Powder Coated finish, color choice is only needed if you choose the painted option

Materials:

Galvanized or Powder Coated finish

Product Specifications:

Age Range: 5 to 12 Years Old

Equipment Weight: 250 lb

Installed Dimensions: 2 ft x 10 ft

Use Zone: 14 ft x 22 ft



Description:

Transform your outdoor area with the Pull Slide Fitness Course Section, a brilliantly crafted playground piece that seamlessly combines fun with learning opportunities. Made from robust galvanized aluminum, it ensures durability and offers customization through eye-catching, colorful powder-coated finishes. Designed to promote active engagement, it aids in physical development and boosts social interaction among children. Featuring a mix of climbing and sliding options, it challenges yet entertains, making it an excellent addition to any play space. This equipment not only enriches the playground experience but also cultivates a sense of community, allowing children to play, grow, and learn together in a joyful and stimulating environment.

Sit Up Bench

FSW203



Item no. FSW20300-0901	
General Product Information	
Dimensions LxWxH	5'0"x2'11"x2'8"
Age group	13+
Play capacity (users)	1
Color options	



See KOMPAN Fit App for More Information



The Bench provides a perfect training for the core and lower back muscles by doing exercises such as leg lifts and sit ups. Easy grips are created to make sure anyone can do the exercise in a correct way. The durable Ekogrip® surfacing offers perfect grip, allowing the bench to be used as a jump box for performing various step and jump exercises

under all weather conditions. The Bench has a clear instruction sign showing the basic exercise and a QR code. By clicking on the QR code users can connect to the KOMPAN Fitness App, where they will find multiple exercises and workouts at every level.

Sit Up Bench

FSW203



Post are made of 101.6 x 2mm, pre-galvanized carbon steel and powder coated, a great protection to all conditions.



The connectors are made of die-cast aluminium, specially alloyed for the outdoor environments and heavy usage. The screws attaching the connectors are stainless steel and protected by zinc washers.



The surface is made of Ekogrip™ panels, consisting of 15mm polyethylene with a 3mm top-layer of thermoplastic rubber. The Ekogrip™ panels have a non-skid effect for comfortable and safe training at all weather circumstances.

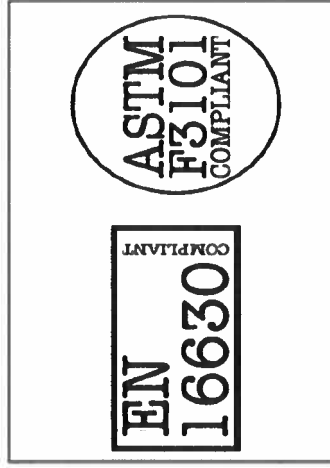

All KOMPAN fitness products are compliant with the ASTM F3101 & EN16630 Outdoor Fitness Standards. Load tests are performed as a static test by adding dynamic factors as well as safety factors to the specified load of 78kg per user. A product intended for 1 user is loaded with 420kg.



The information sign is made of a PA6 (Polyamide) and shows the most relevant exercise and a QR code. When scanned the QR code will link to an animated illustration of the exercise and offers the possibility of downloading the KOMPAN sport & fitness App, which will provide a large amount of exercises and workouts.



KOMPAN fitness products are standard available in Orange, RAL2010 and Grey, RAL7012. All other RAL colors are available on request. It will always be possible to match the surroundings or color theme!

Item no. FSW20300-0901	
Installation Information	
Max. fall height	2'1"
Safety surfacing area	110ft²
Total installation time	2.9
Excavation volume	0.14yd³
Concrete volume	0yd³
Footing depth (standard)	2'11"
Shipment weight	124lbs
Anchoring options	In-ground ✓
	Surface ✓
Warranty Information	
Connectors	10 Years
EcoCore HDPE	Lifetime
Hot dip galvanized steel	Lifetime
Post	10 Years
Spare Parts Availability	10 Years

ASTM F3101 compliant

Sustainability Data

FSW203



Cradle to Gate A1-A3

	Total CO ₂ emission	CO ₂ e/kg	Recycled materials
	kg CO ₂ e	kg CO ₂ e/kg	%
FSW20300-0901	95.74	2.44	50.48

The overall framework applied for these factors is the Environmental Product Declaration (EPD), which quantifies "environmental information on the life cycle of a product and enable comparisons between products fulfilling the same function" (ISO, 2006). This follows the structure and applies a Life-Cycle Assessment approach to the entire Product stage from raw material through manufacturing (A1-A3)



Kompan A/S
 C.F. Tietgens Boulevard 32C
 DK-5220 Odense SØ
 Denmark



Verification of CO₂ calculation of: Fitness



Data version no. 2023-10-05

The CO₂ calculation and data are in compliance with the principles of a carbon footprint impact according to the GHG protocol (Greenhouse Gas Protocol), Scope 3, cradle to gate related to all individual components in the product category "Fitness" represented by item no. FAZ10100-0900.

(Scope 3 emissions include emission sources in the upstream and downstream value chain).

Date: 30. October 2023 | Valid until: 30. October 2025

Verified by:



Julie Marie Vejsgaard Larsen, LCA & EPD Consultant

Verification based on report: Validation of CO₂ calculation of 9 categories of Kompan product line, version 1.0, prepared by Bureau Veritas HSE, Denmark: Julie M. V. Larsen.

Publication date: 30. October 2023



By Bureau Veritas HSE
 www.bureauveritas.dk
 +45 7731 1000

Sit Up Bench

FSW203



* Max fall height | ** Total height | *** Safety surfacing area

* Max fall height | ** Total height

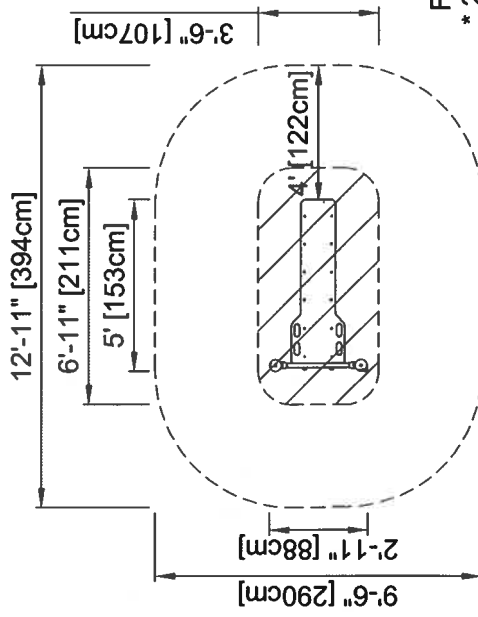

FSW20300
* 2'-1" / 63cm
** 2'-8" / 81cm
*** 110ft² / 10.2m²

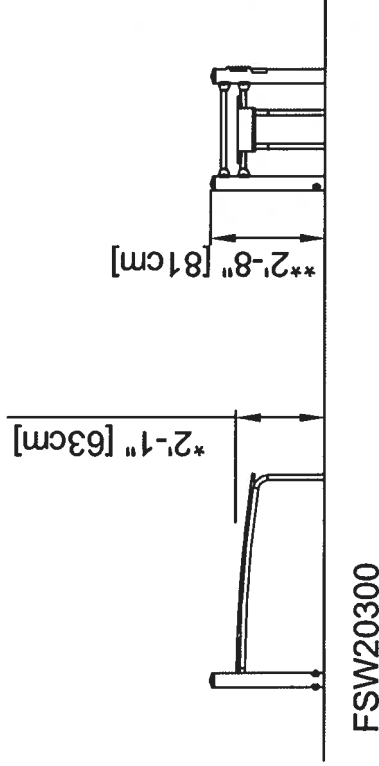

[Click to see TOP VIEW](#)

[Click to see SIDE VIEW](#)

Pull Up Station

FSW208



reaching the pull-up bar.

The Pull-Up Bar is made from solid steel and has a diameter of 1.26 inches. This is an ideal size for both men and women to have a good grip. The vertical ladder can be used like a wall, offering a spot for varied difficulty levels for handstand push-ups, Bulgarian split squats and push-ups. Additionally, the vertical ladder is perfect for stretching and offers a step up for

Item no. FSW20801-0901

General Product Information

Dimensions LxWxH 9'0"x0'5"x7'10"
Age group 13+
Play capacity (users) 2
Color options



See KOMPAN Fit App for More Information



Pull Up Station

FSW208



Post are made of 101.6 x 2mm, pre-galvanized carbon steel and powder coated, a great protection to all conditions.



The connectors are made of die-cast aluminium, specially alloyed for the outdoor environments and heavy usage. The screws attaching the connectors are stainless steel and protected by zinc washers.



All bars intended for pull ups are made of solid, $\varnothing 32\text{mm}$ x 138 m, hot dip galvanized, S235JR steel bars. This diameter gives the right grip for everyone.

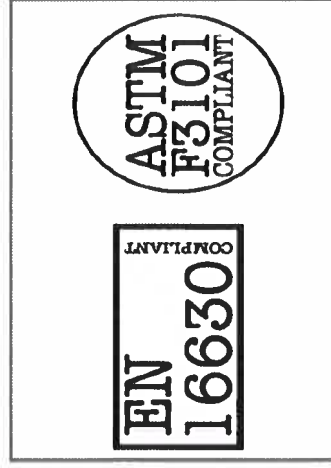

All KOMPAN fitness products are compliant with the ASTM F3101 & EN16630 Outdoor Fitness Standards. Load tests are performed as a static test by adding dynamic factors as well as safety factors to the specified load of 78kg per user. A product intended for 1 user is loaded with 420kg.



The information sign is made of a PA6 (Polyamide) and shows the most relevant exercise and a QR code. When scanned the QR code will link to an animated illustration of the exercise and offers the possibility of downloading the KOMPAN sport & fitness App, which will provide a large amount of exercises and workouts.



The pull up bar is mounted at a height of 233cm with a clean work out space underneath, next to a vertical ladder with 6 horizontal bars. The spaces in between the bars is 38cm.

Item no. FSW20801-0901	
Installation Information	
Max. fall height	7'8"
Safety surfacing area	138ft ²
Total installation time	3.2
Excavation volume	0.5yd ³
Concrete volume	0.3yd ³
Footing depth (standard)	2'11"
Shipment weight	230lbs
Anchoring options	In-ground <input checked="" type="checkbox"/>
	Surface <input checked="" type="checkbox"/>
Warranty Information	
Connectors	10 Years
Hot dip galvanized steel	Lifetime
Post	10 Years
Spare Parts Availability	10 Years

ASTM F3101 compliant

Sustainability Data

FSW208



Cradle to Gate A1-A3	Total CO ₂ emission		CO ₂ e/kg		Recycled materials	
	kg CO ₂ e	kg CO ₂ e	kg CO ₂ e/kg	kg CO ₂ e/kg	%	%
FSW20801-0901	131.11	131.11	1.88	1.88	69.14	69.14

The overall framework applied for these factors is the Environmental Product Declaration (EPD), which quantifies "environmental information on the life cycle of a product and enable comparisons between products fulfilling the same function" (ISO, 2006). This follows the structure and applies a Life-Cycle Assessment approach to the entire Product stage from raw material through manufacturing (A1-A3)



Kompani A/S
 C.F. Tietgens Boulevard 32C
 DK-5220 Odense SØ
 Denmark



Verification of CO₂ calculation of: Fitness

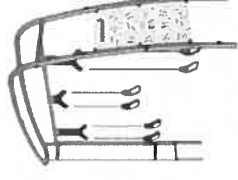

Data version no. 2023-10-05
 The CO₂ calculation and data are in compliance with the principles of a carbon footprint impact according to the GHG protocol (Greenhouse Gas Protocol), Scope 3, cradle to gate related to all individual components in the product category "Fitness" represented by item no. FAZ10100-0900.
 (Scope 3 emissions include emission sources in the upstream and downstream value chain).

Date: 30. October 2023 | Valid until: 30. October 2025

Verified by:



Julie Marie Vejsgaard Larsen, LCA & EPD Consultant

Verification based on report: Validation of CO₂ calculation of 9 categories of Kompani product line, version 1.0, prepared by Bureau Veritas HSE, Denmark: Julie M. V. Larsen.

Publication date: 30. October 2023



By Bureau Veritas HSE
 www.bureauveritas.dk
 +45 7731 1000

Pull Up Station

FSW208



* Max fall height | ** Total height | *** Safety surfacing area

* Max fall height | ** Total height

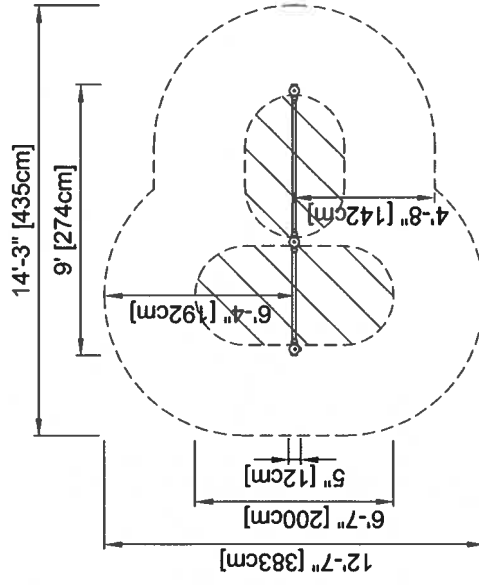

FSW20801
* 7'-8" / 233cm
** 7'-10" / 240cm
*** 138ft² / 12.8m²

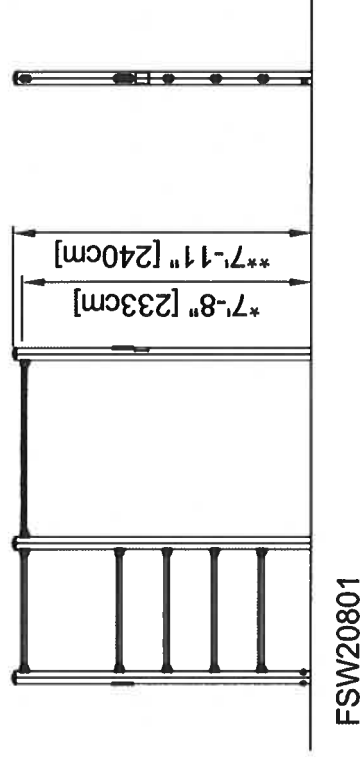

[Click to see TOP VIEW](#)

[Click to see SIDE VIEW](#)

Double Turbo Challenge

FSW21201



Item no. FSW21201-0900	
General Product Information	
Dimensions LxWxH	14'6"x3'11"x8'10"
Age group	13+
Play capacity (users)	3
Color options	



See KOMPAN Fit App for More Information

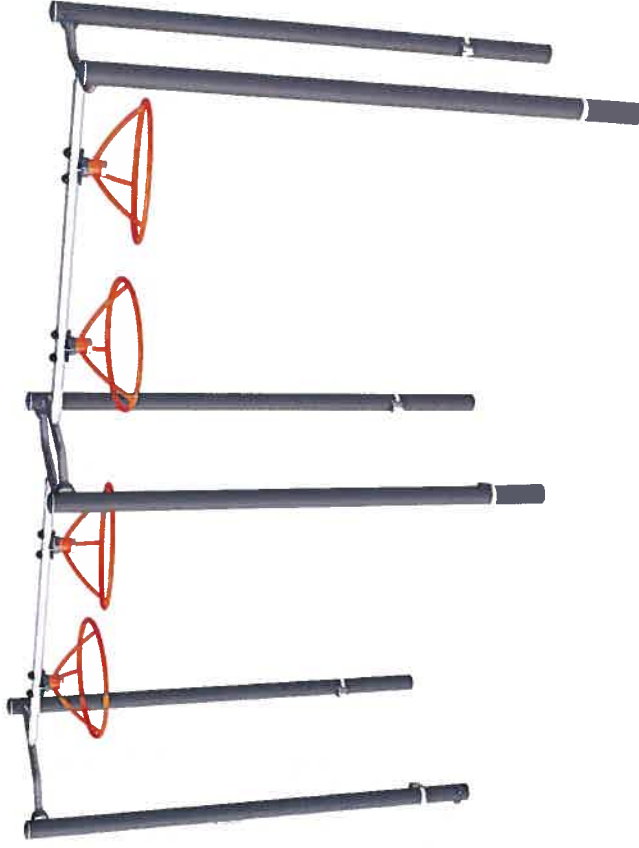

The Turbo Challenge is the most dynamic and thrilling element of all obstacle course exercises. To do the exercise in the best way, a combination of skills, timing, rhythm and cross body coordination is needed. This Turbo Challenge is wide and high to ensure anyone can hang and move freely. To make sure that everyone can reach the dynamic wheels we

added 4 stepping pods at different heights. For an optimized and direct swing the 4 four dynamic wheels have been mounted under a 5 degree angle.

Double Turbo Challenge

FSW21201



Post are made of 101.6 x 2mm, pre-galvanized carbon steel and powder coated, a great protection to all conditions.



The connectors are made of die-cast aluminium, specially alloyed for the outdoor environments and heavy usage. The screws attaching the connectors are stainless steel and protected by zinc washers.



Steps are made of extruded aluminium with a non-skid surface. Aluminium has high corrosion resistance and ensures durability of the product. Steps have been mounted at heights of 34,7cm and 54,7cm this creates an easy access to reach the overhead activity



All KOMPAN fitness products are compliant with the ASTM F3101 & EN16630 Outdoor Fitness Standards. Load tests are performed as a static test by adding dynamic factors as well as safety factors to the specified load of 78kg per user. A product intended for 1 user is loaded with 420kg.



The information sign is made of a PA6 (Polyamide) and shows the most relevant exercise and a QR code. When scanned the QR code will link to an animated illustration of the exercise and offers the possibility of downloading the KOMPAN sport & fitness App, which will provide a large amount of exercises and workouts.



KOMPAN fitness products are standard available in Orange, RAL2010 and Grey, RAL7012. All other RAL colors are available on request. It will always be possible to match the surroundings or color theme!

Item no. FSW21201-0900	
Installation Information	
Max. fall height	7'5"
Safety surfacing area	245ft²
Total installation time	5.2
Excavation volume	0.22yd³
Concrete volume	0.17yd³
Footing depth (standard)	2'11"
Shipment weight	608lbs
Anchoring options	In-ground ✓ Surface ✓
Warranty Information	
Bearing construction	5 Years
Hot dip galvanized steel	Lifetime
Post	10 Years
Spare Parts Availability	10 Years
Wheels	10 Years

**ASTM
F3101**
compliant

Sustainability Data

FSW21201

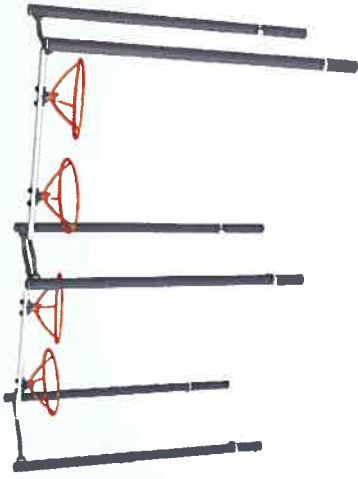

Cradle to Gate A1-A3	Total CO ₂ emission	CO ₂ e/kg	Recycled materials
	kg CO ₂ e	kg CO ₂ e/kg	%
FSW21201-0900	373.68	1.99	65.72

The overall framework applied for these factors is the Environmental Product Declaration (EPD), which quantifies "environmental information on the life cycle of a product and enable comparisons between products fulfilling the same function" (ISO, 2006). This follows the structure and applies a Life-Cycle Assessment approach to the entire Product stage from raw material through manufacturing (A1-A3)

Kompan A/S
 C.F. Tietgens Boulevard 32C
 DK-5220 Odense SØ
 Denmark



Verification of CO₂ calculation of: Fitness



Data version no. 2023-10-05

The CO₂ calculation and data are in compliance with the principles of a carbon footprint impact according to the GHG protocol (Greenhouse Gas Protocol), Scope 3, cradle to gate related to all individual components in the product category "Fitness" represented by item no. FAZ10100-0900.

(Scope 3 emissions include emission sources in the upstream and downstream value chain).

Date: 30. October 2023 | Valid until: 30. October 2025

Verified by:

Julie Marie Vejsgaard Larsen, LCA & EPD Consultant

Verification based on report: Validation of CO₂ calculation of 9 categories of Kompan product line, version 1.0, prepared by Bureau Veritas HSE, Denmark, Julie M. V. Larsen.

Publication date: 30. October 2023



By Bureau Veritas HSE
 www.bureauveritas.dk
 +45 7731 1000

Double Turbo Challenge

FSW21201



* Max fall height | ** Total height | *** Safety surfacing area

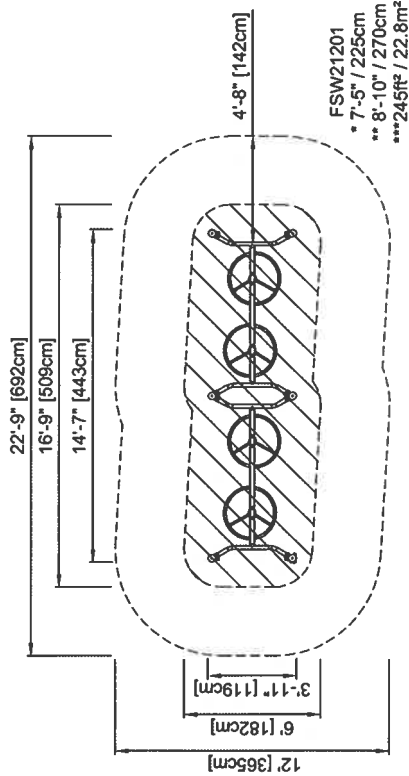

* Max fall height | ** Total height

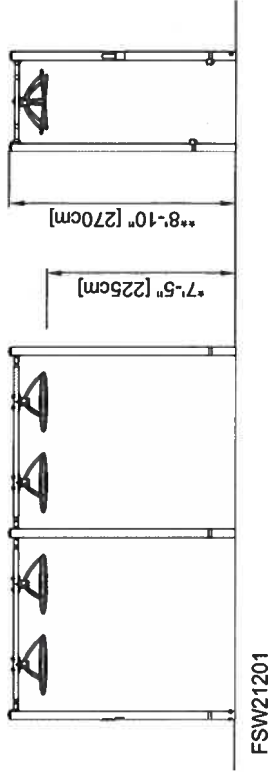

[Click to see TOP VIEW](#)

[Click to see SIDE VIEW](#)



12/19/2024

Swing Bars Challenge

Brand: SportsPlay

Regular Price: **MSRP \$1,580.00**

Sale Price: \$1,498.00

Product Specifications:

Age Range: 5 to 12 Years Old

Equipment Weight: 220 lb

Installed Dimensions: 7 ft x 8 ft x 15 ft

Use Zone: 19 ft x 27 ft



Description:

The Swing Bars Fitness Course Section is a captivating addition to any outdoor fitness or play area, blending the excitement of swinging movements with the rigorous benefits of physical exercise. This outdoor fitness apparatus is engineered to boost agility, strength, and coordination, promoting an active lifestyle in a fun and engaging manner. Its sturdy design ensures lasting durability and safety for users, making it a standout feature in community parks or playgrounds. Ideal for those seeking to incorporate playful elements into fitness routines, it epitomizes the harmonious blend of entertainment and health.

Triple Somersault Bars

PCM803



Item no. PCM803-0902	
General Product Information	
Dimensions LxWxH	10'0"x3'11"x5'7"
Age group	2 - 12
Play capacity (users)	3
Color options	●

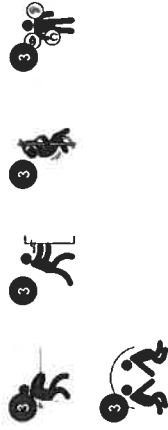

The Triple Somersault Bars are great old-school playground favorites. They are irresistible to children, and their parents, repeatedly. The Triple Somersault Bars make possible cooperation and sharing, in two varied heights. They accommodate more users and different age and ability levels. The Triple Somersault Bars cater to a range of play

activities, including hanging from your arms, swaying, and training upper body muscles. They also create space for sitting on the bars with friends, sharing, using social-emotional skills or somersaulting. Somersaulting on the Triple Somersault Bars trains children's proprioception: the awareness of where body parts are and how to coordinate movements to

fit a space. It trains the senses of space and balance, too, making the child able to navigate the surroundings securely. Last, but not least, it develops major muscles.

Triple Somersault Bars

PCM803



Somersault bar

Physical: develop balance and core when hanging from knees. Arm, leg and core muscles are developed when climbing up, somersaulting around. Balance and spatial awareness are strengthened. **Social:** Emotional: meeting, socializing and turn-taking when climbing up and down via bar.



Triple Somersault Bars

PCM803



Steel posts are galvanized inside and outside with powder coated top finish. This provides an ultimate corrosion resistance in all climates around the world.

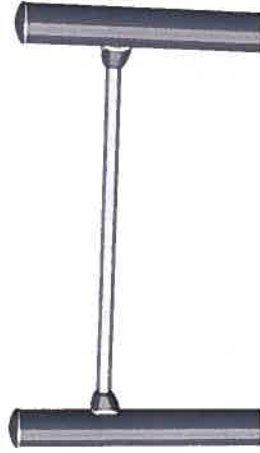

The turnbars are hot dip galvanized inside and outside with lead free zinc. The galvanization has excellent corrosion resistance in outside environments and it requires low maintenance.



Item no. PCM803-0902	
Installation Information	
Max. fall height	4'10"
Safety surfacing area	250ft ²
Total installation time	3.1
Excavation volume	0.14yd ³
Concrete volume	0.05yd ³
Footing depth (standard)	2'9"
Shipment weight	175lbs
Anchoring options	In-ground ✓ Surface ✓
Warranty Information	
Post	10 Years
Spare Parts Availability	10 Years

Elevated activities 0	Accessible elevated activities	Accessible ground level activities	Accessible ground level play types
Present	0	1	1
Required	0	1	1

**ASTM
F1487**
compliant

Sustainability Data

PCM803



Kompan A/S
 C.F. Tietgens Boulevard 32C
 DK-5220 Odense SØ
 Denmark

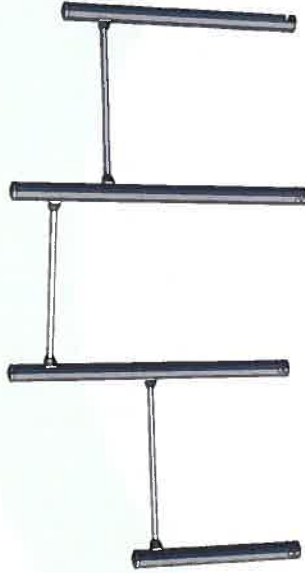

Verification of CO₂ calculation of: Freestanding play equipment



Data version no. 2023-10-05

The CO₂ calculation and data are in compliance with the principles of a carbon footprint impact according to the GHG protocol (Greenhouse Gas Protocol), Scope 3, cradle to gate related to all individual components in the product category: "Freestanding play equipment" represented by item no. GXY916012.3417.

(Scope 3 emissions include emissions from sources in the upstream and downstream value chain).

Date: 30. October 2023 | Valid until: 30. October 2025

Verified by:



Julie Marie Vejsgaard Larsen, LCA & EPD Consultant

Verification based on report: Validation of CO₂ calculation of 9 categories of Kompan product line, version 1.0, prepared by Bureau Veritas HSE, Denmark, Julie M. V. Larsen.

Publication date: 30. October 2023

The overall framework applied for these factors is the Environmental Product Declaration (EPD), which quantifies "environmental information on the life cycle of a product and enable comparisons between products fulfilling the same function" (ISO, 2006). This follows the structure and applies a Life-Cycle Assessment approach to the entire Product stage from raw material through manufacturing (A1-A3)

PCM803-0902	Cradle to Gate A1-A3		Recycled materials	
	Total CO ₂ emission kg CO ₂ e	CO ₂ e/kg kg CO ₂ e/kg	kg CO ₂ e/kg	%
	123.82	2.20	2.20	61.42

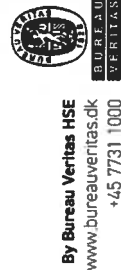

By Bureau Veritas HSE
 www.bureauveritas.dk
 +45 7731 1000

Triple Somersault Bars

PCM803



* Max fall height | ** Total height | *** Safety surfacing area

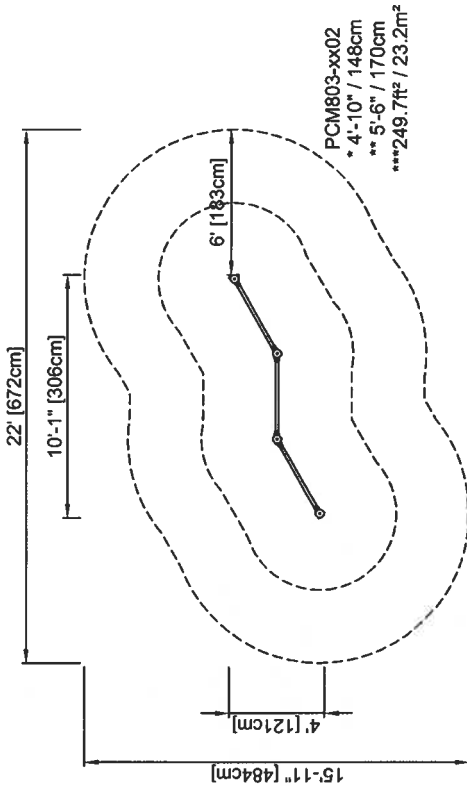

* Max fall height | ** Total height

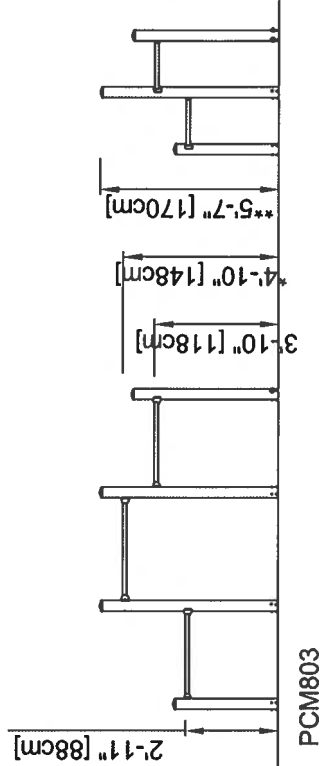

[Click to see TOP VIEW](#)

[Click to see SIDE VIEW](#)



12/19/2024

Vault Bar Challenge

Brand: SportsPlay

Regular Price: **\$560.00**

Sale Price: **\$525.00**

Product Specifications:

Age Range: 5 to 12 Years Old

Equipment Weight: 85 lb

Description:

The Vault Bar Challenge revolutionizes outdoor fitness by merging fun with educational benefits, creating an unmatched exercise experience. This robust equipment, with its durable, galvanized finish, is built to last, aiming to enhance coordination, agility, and strength in a fun-filled yet structured manner. Proudly crafted in the USA, it not only offers endless entertainment but also fosters active learning and physical advancement. Ideal for fitness courses or playgrounds, it appeals to a diverse audience looking for a mix of challenge and enjoyment. This standout product exemplifies the best in engaging and dynamic fitness solutions, making it an essential offering for those committed to promoting health, education, and fun.



RIVERSIDE MIDDLE SCHOOL PLAYGROUND GRANT PROPOSAL

PRESENTED TO TOWN OF NEW CASTLE - 9/16/2025



A group of diverse students in a gymnasium, some wearing USA-themed shirts, listening to a teacher in a white lab coat. An American flag is visible in the background.

WHO IS RIVERSIDE

466 STUDENTS

68 STAFF

7 ATHLETIC PROGRAMS

BAND

CHOIR

DRAMA

OUTDOOR EDUCATION

FAMILIES

COMMUNITY

OUR CURRENT FACILITY



 Riverside Middle School

 Kathryn Senior
Elementary School

INITIAL PROPOSAL



CURRENT PLAN IN PLACE:

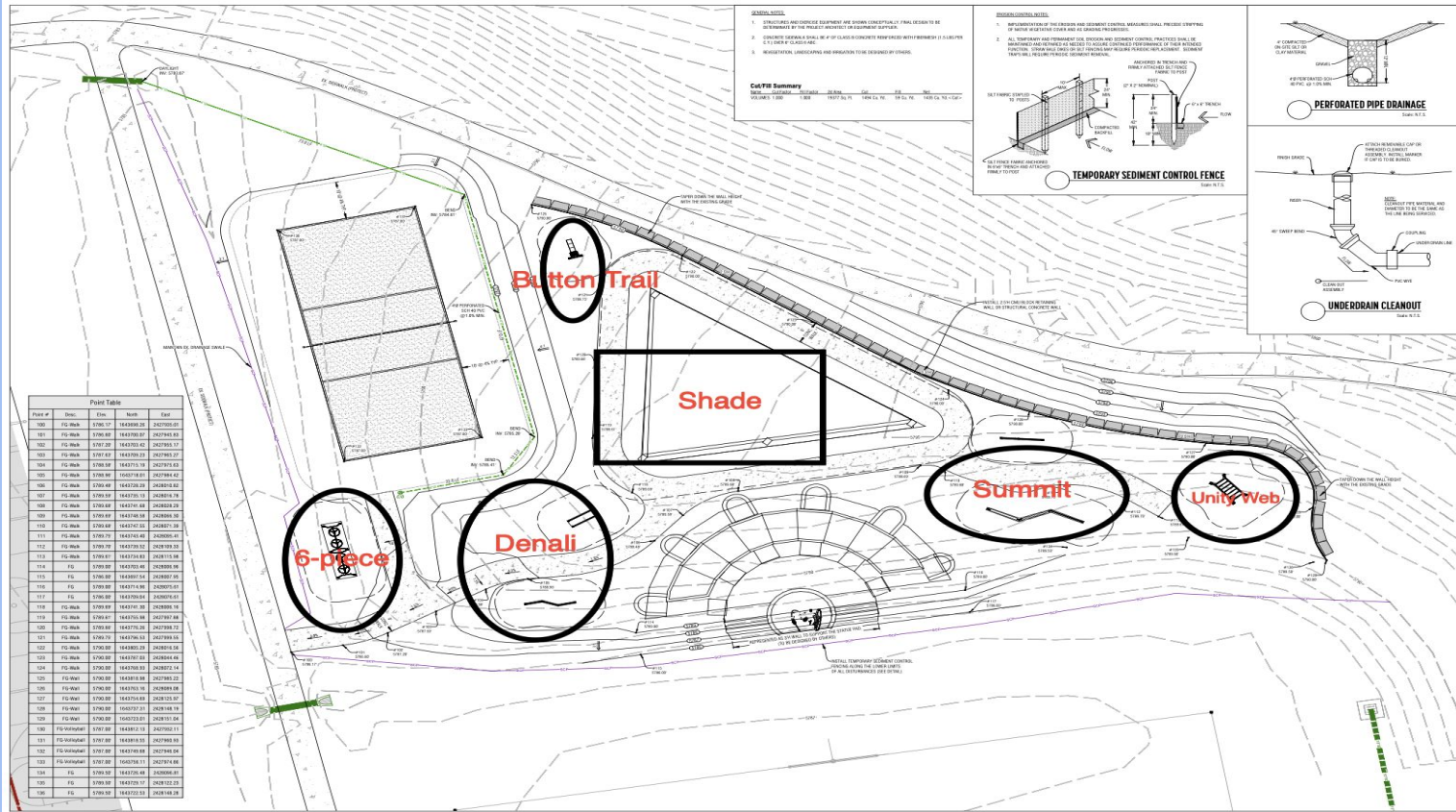

BOUNDARIES UNLIMITED INC.
 CIVIL ENGINEERING
 405 Orange Avenue, Ste. 201
 Orange, CA 92667
 (714) 962-5825
 www.bu.com

Professional Engineer
 License No. 47175
 State of California

INVESTMENT
 RIVERSIDE MIDDLE SCHOOL
 230 ALLEN AVENUE
 NEW CASTLE, CALIF. 92564
 (951) 445-1000

Prepared by: [Signature]
 Checked by: [Signature]
 Approved by: [Signature]

811
 Know what's below. Call before you dig.

Riverside Middle School Recreation Area
 Grading & Erosion Control Plan

Scale: 1" = 10'-0"

North Arrow

DATE: 10/1/2010

Project: Riverside Middle School
 Location: Riverside, CA
 Client: Riverside Unified School District

Scale: 1" = 10'-0"

DATE: 10/1/2010

Project: Riverside Middle School
 Location: Riverside, CA
 Client: Riverside Unified School District

C.1

THE GEMS

Traditional, modern, colorful, and functional

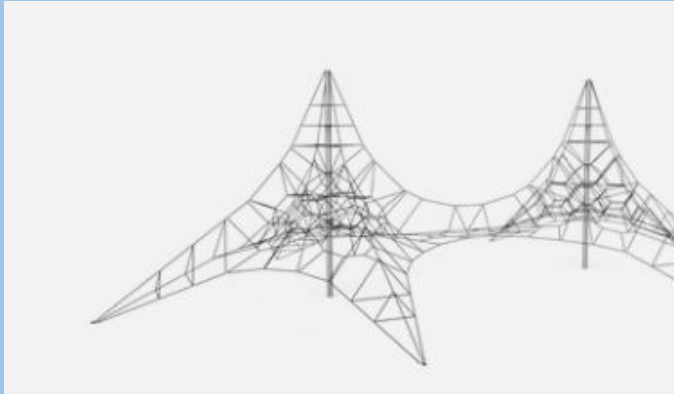

TIMELINE

Early Stages: This included the upgrade of outdoor facilities, funded by Riverside, that saw the beautification of the football facilities with 26 trees (7 more to come) to address the lack of shade and landscaping in the area.

Phase 1: By spring of 2026 all pre-planning, State approvals and vendors in place, excavation and funding secured for planned improvements

Phase 2: By fall of 2026 Volleyball court and shade structure in place and available for use by Riverside student and community members

Phase 3: By fall of 2027 all playground equipment, walkways, and landscaping complete. Statue and terraced seating planning and scheduling complete.

OUR PARTNERS:



BOUNDARIES UNLIMITED INC.



STAR
Playgrounds
stellar design and installation



Redneck Excavating Llc.

A school band performing in a gymnasium. The students are wearing dark uniforms and are seated at music stands. They are playing various instruments including saxophones, clarinets, and trumpets. The background shows a gymnasium setting with blue walls and a white door.

FUNDRAISING (RIVERSIDE'S CURRENT EFFORTS)

Mad Math-a-Thon

Riverside Family Night

The Riverside Yard Sale

Business Sponsors (signs in our gym and outside of Riverside)

Athletic Contributions

Community and Family Donations (Community install day?)

Grants

BY THE NUMBERS



Architect-\$1,920

Civil engineer-\$9,500

Excavation-\$20,000

Retaining wall-\$10,000

Playground (equipment, freight, installation)-\$175,050

Rubberized surfaces-\$15,000

Curbing-\$5,000

Statue-\$30,000

Concrete terracing-\$10,000

Landscaping-\$7,000

Total-\$276,477

Proposed total budget: \$350,000 (due to inflation and other considerations)

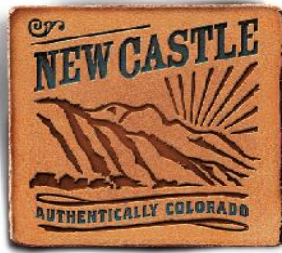

Town of New Castle
450 W. Main Street
PO Box 90
New Castle, CO 81647

Administration Department
Phone: (970) 984-2311
Fax: (970) 984-2716
www.newcastlecolorado.org

Memorandum

To: Mayor & Council
From: David Reynolds
Re: Agenda Item: Update from Colorado River Valley Economic Development Partnership (CRVEDP)
Date: 09/16/2025

The purpose of this agenda item is to receive an update from Alicia Gresley, Director of Colorado River Valley Economic Development Partnership.

Mission Statement (from the CRVEDP website)

“The Colorado River Valley Economic Development Partnership (CRVEDP) serves as an economic hub supporting coordination and partnerships to advance the economic priorities of our region. We will achieve this through being a nexus of regional information and trusted resources, assisting with workforce growth and development in the region, acting as a catalyst for innovation and action and championing projects and decisions that strengthen our regional economy.”

Launched in 2022 through the efforts of municipal managers and formally organized in 2023, CRVEDP brings together the Colorado River Valley communities of New Castle, Silt, Rifle, and Parachute/Battlement Mesa. With early guidance from the Rifle Regional Economic Development Corporation, the coalition was designed to represent the full region, identify shared priorities, and implement strategies to strengthen long-term economic vitality.

CRVEDP is structured as a public-private partnership, ensuring that government, business, and nonprofit voices all play a role in shaping initiatives and outcomes. This balance of perspectives has been key to building credibility and momentum.

Over the past two years, Alicia has not only unified local partners behind a common mission but has also actively pursued grant opportunities and forged new partnerships to expand CRVEDP’s effectiveness. Under her leadership, the coalition has gained meaningful regional recognition and has delivered tangible results for existing businesses while also creating a welcoming environment for new ventures. Alicia will provide Council with an overview of these accomplishments as well as current initiatives and future goals.

See CRVEDP website: <https://crvedp.org/>

See CRVEDP Vision Board below.

VISION BOARD

BETTER JOBS CLOSER TO HOME!

START HERE ↘

2024 – 2026 STRATEGIC PLAN

- SUPPORT GROWTH AND DEVELOPMENT OF WELL PAYING JOBS
- DATA SPECIFIC TO WESTERN GARFIELD COUNTY
- REDUCE COMMUTING TIME, GHG, STRESS, WEAR & TEAR
- INVOLVE MORE PRIVATE ECONOMIC STAKEHOLDERS
- HIRE STAFF
- BUILD IDENTITY & REGIONAL BRAND
- EDUCATE & INFORM ON ECONOMIC PROSPERITY



- PRIORITIZE NEEDS & ASPIRATIONS OF COMMUNITIES
- ENHANCE QUALITY OF LIFE FOR ALL RESIDENTS
- WORK, LIVE, PLAY IN SAME PLACE

Innovation

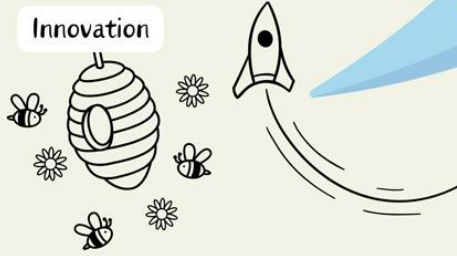

- DIVERSIFY, DIVERSIFY, DIVERSIFY!
- BUILDING FOR FUTURE GENERATIONS
- PROACTIVE NOT REACTIVE
- CIVILITY AND CANDID ABOUT THE REAL ISSUES

- WORK WITH EXISTING & NEW INDUSTRIES



Empowerment

- CONNECT STAKEHOLDERS TO RESOURCES, SUPPORT & OPPORTUNITIES
- CHAMPION THE NEEDS OF THE REGION
- GET OTHERS INVOLVED

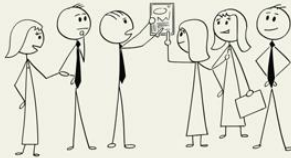

Resilience

- BUILD A SUSTAINABLE FINANCIAL MODEL
- WIN MORE GRANTS! THANKS TO CEO FOR AWARDING US THEIR EECBG GRANT!
- INVESTMENT IN OUR REGION
- MOVE AWAY FROM ECONOMIC VOLATILITY ROLLERCOASTER



Collaboration

- WE BELIEVE IN THE POWER OF WORKING TOGETHER. BY FOSTERING RELATIONSHIPS AMONG LOCAL GOVERNMENTS, BUSINESSES, INSTITUTIONS OF LEARNING AND COMMUNITY ORGANIZATIONS, WE AIM TO BUILD A COHESIVE AND UNITED REGIONAL ECONOMY.
- WE VALUE THE LESSONS LEARNED FROM OUR HISTORY AS WELL AS OUR NEIGHBORS, USING THEM TO INFORM AND GUIDE OUR STRATEGIES AND DECISIONS FOR A BETTER FUTURE.



LEARN MORE



CONTACT ALICIA GRESLEY DIRECTOR CRVEDP
INFO@CRVEDP.ORG
970-505-7391

COLORADO RIVER VALLEY ECONOMIC DEVELOPMENT PARTNERSHIP



2025 Update Town of New Ca



September 2025

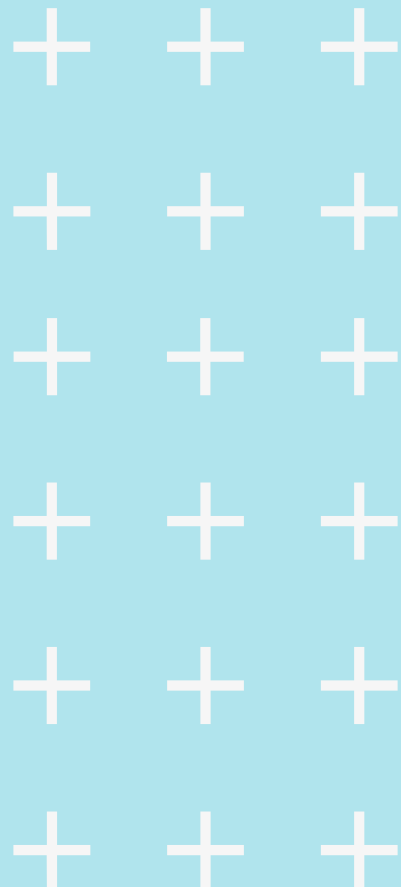

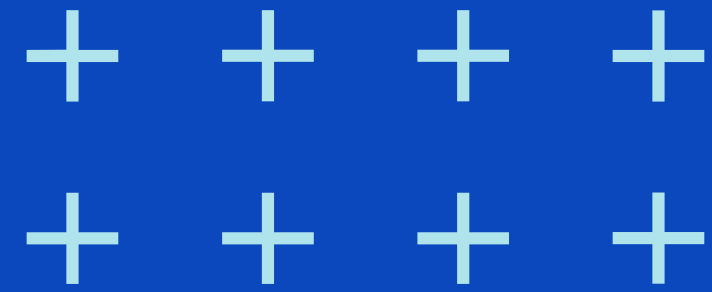

Collaborations



Innovations



Resilience

Getting a seat at the table

The CRVEDP is committed to elevating the region's presence and participation in areas that will serve to position us for success in our future

Highlights



01 Entering Phase 3 of CRV Economic Development Strategy Project, complete end of October

02 Becoming our own 501 c3

03 Won Market Study Grant, lead applicant for CPW Regional Partnership Initiative Grant

Projects = The Ripple Effect, Transportation Round Table, Hurst Leadership Initiative, Aspen Ideas Fellows, Revolving Loan Fund, StartUp Colorado Ideas Factory, Elevate Quantum, Wildfire Economic Recovery, Food Systems, Airport Business Master Plan Committee, advisory committees in region and beyond & more

04

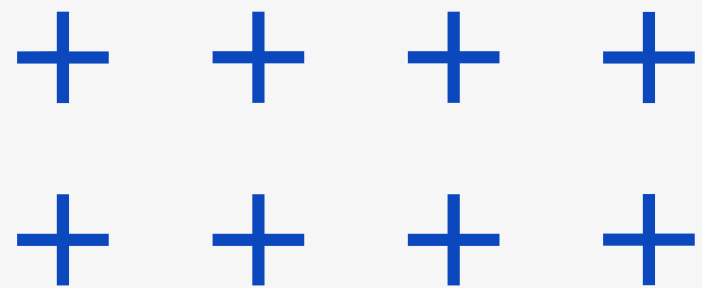

Survey Sneak Peak

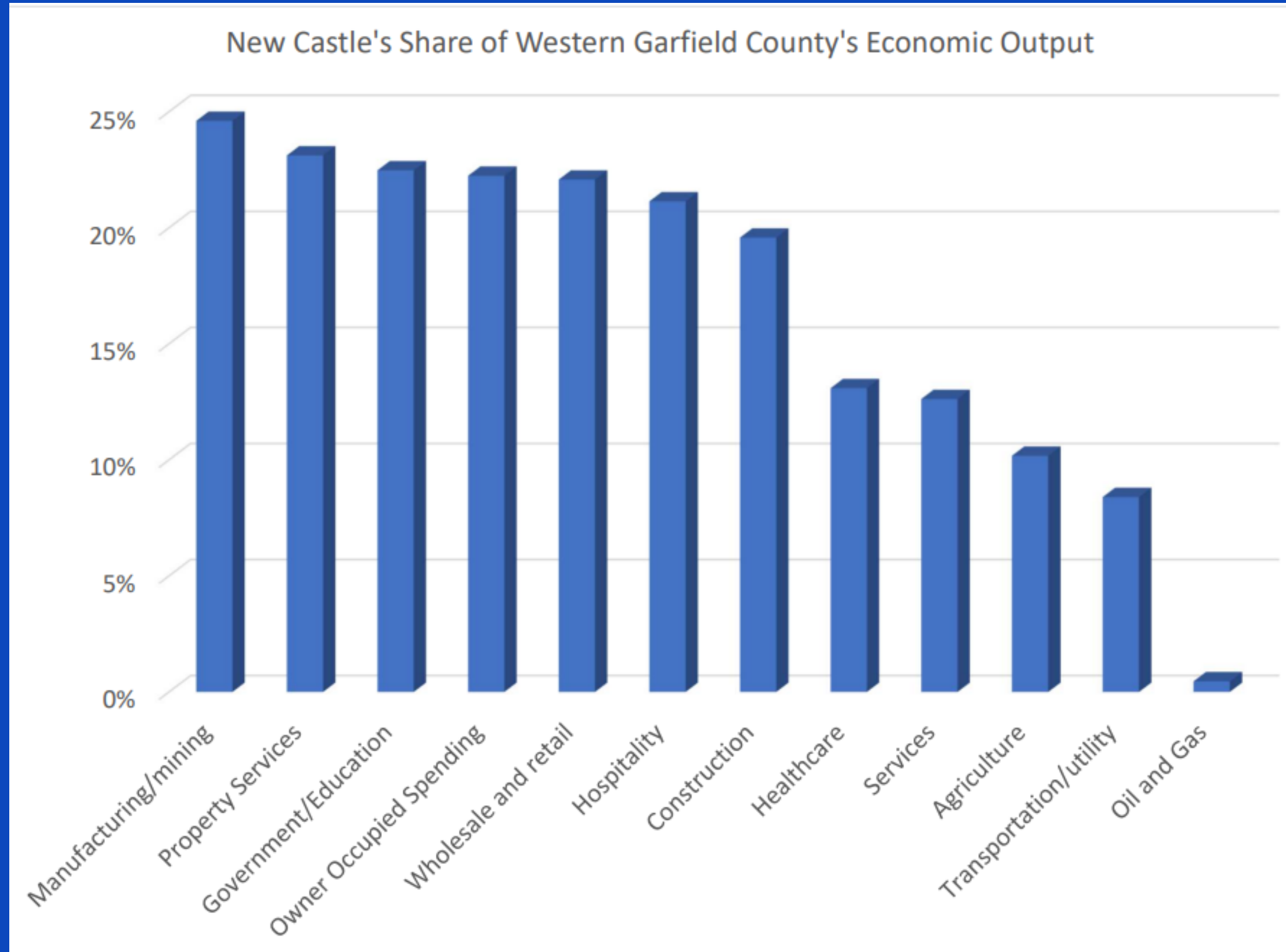

New Castle Water Use (Economic Sector)
Services
Healthcare
Transportation/utility
Wholesale and retail
Property Services
Government/Education
Manufacturing/mining
Hospitality
Construction
Owner Occupied Spending
Oil and Gas
Agriculture

- Most of New Castle’s economic sectors use relatively little water for the amount of economic value produced. For example, New Castle’s service sector uses only a little water and as a result produces \$105 million in value per year for every acre-foot of water used.
- In contrast, agriculture uses 95% of New Castle’s water (6,900 AFY) and produces only 1.3% of its economic output.
- 81657 respondents rated Outdoor Rec highest and childcare lowest



Please rate the following in your town by town (1-5 scale)					
Town	K-12 Schools	Outdoor Recreation	Healthcare	Downtown Business Vitality	Cultural

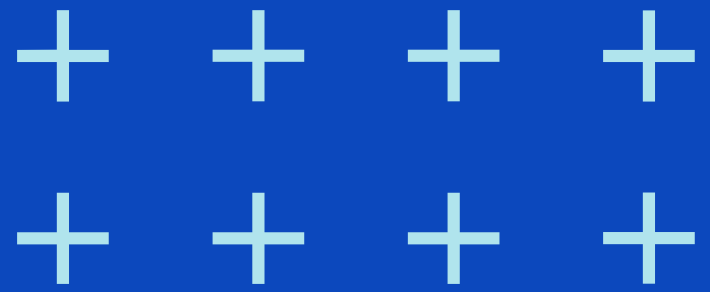

2025

Financals

March 2025 we became a Contribution Project through the Enterprise Zone; 25% tax credit for eligible contributions, 12.5% for in kind. Win!

+ \$47,500

MUNICIPAL CONTRIBUTIONS 2025
THANK YOU NEW CASTLE
\$5000!

\$11,000 additional contributions
Total operating budget to work with
\$81,500

+ \$80,000 grant rev

COLORADO ENERGY OFFICE
GRANT 2025

\$50K for Market Study grant likely will
come in late 2025 or early 2026

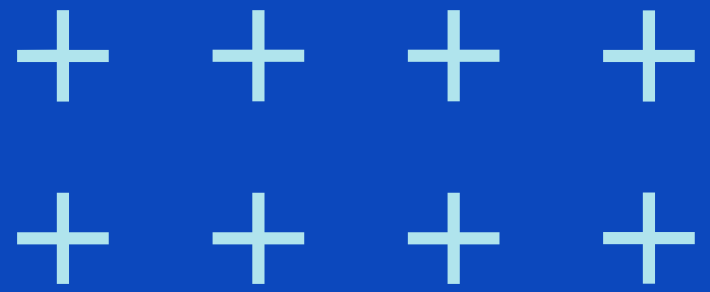

Asks

As you consider your 2026 budget, CRVEDP is requesting \$10,000 contribution from the Town. Revolving Loan Fund separate ask if Council/Town is interested for town specific loans.



LONG TERM INVESTMENT - FIND NEW REVENUES FOR TOWN



OPERATING COSTS TO KEEP EDP LIGHTS ON



ED STRATEGY IMPLEMENTATION



HUB FOR INFORMATION, RESOURCES, TOOLS



20 Years from now....?



A wise reflection from seasoned leaders: “What decision could you have made 20 years ago that would have changed everything today?”

We can’t predict the future, but we can prepare for it—by creating options, building capacity, and aligning as a region.

CRVEDP exists to do that hard, strategic work now—so 20 to 50 years from today, our communities are not just surviving, but thriving.

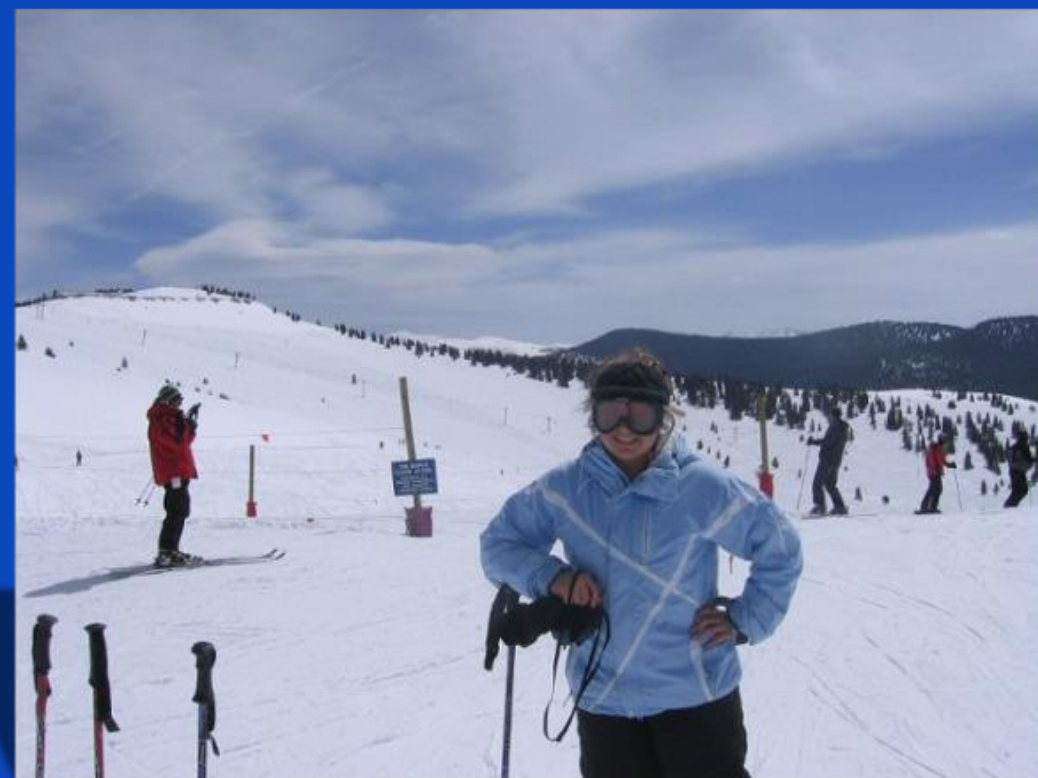

This is me, in 2005, after I made the decision to get off the train in Glenwood Springs

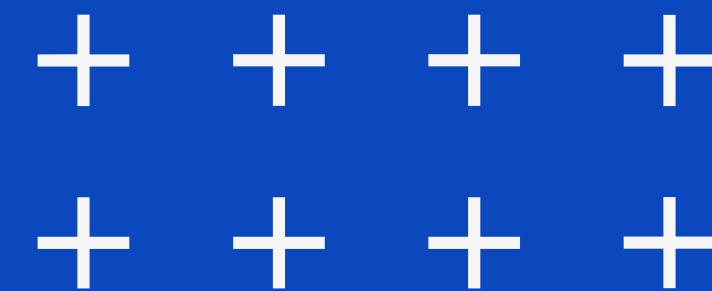



Town of New Castle
450 W. Main Street
PO Box 90
New Castle, CO 81647

Administration Department
Phone: (970) 984-2311
Fax: (970) 984-2716
www.newcastlecolorado.org

Memorandum

To: Mayor & Council

From: David Reynolds

Re: Agenda Item: Consider Resolution TC 2025-19 Supporting the Confluence Early Childhood Education (CECE), Strong Bright Future Campaign.

Date: 09/16/2025

Purpose:

The purpose of this agenda item is to Consider Resolution TC 2025-19 supporting CECE's "Strong Bright Future Campaign," and their related ballot initiative to be decided by voters on November 4, 2025.

During a regular Town Council meeting held on August 5, 2025, CECE Coalition Director Maggie Tolan Tiscornia presented the work that CECE is doing to develop a funding mechanism for Early Childhood Development Services in the area from Parachute to Aspen. During a regular Town Council meeting held on August 19, 2025, Town Council directed staff to provide a Resolution for Council consideration supporting CECE's efforts. With CECE's November 4th ballot language now finalized, staff presents Resolution TC 2025-19 for Town Council's review and consideration.

See attached Resolution TC 2025-19

See below for CECE November 4th Ballot Language:

SHALL TAXES IN THE PROPOSED CONFLUENCE EARLY CHILDHOOD DEVELOPMENT SERVICE DISTRICT BE INCREASED BY \$12.1 MILLION ANNUALLY, AND BY WHATEVER ADDITIONAL AMOUNTS MAY BE RAISED THEREAFTER, TO FUND THE DISTRICT TO REDUCE THE COST OF AND PROVIDE MORE PRESCHOOL AND CHILDCARE FOR FAMILIES IN GARFIELD, PITKIN, AND SOUTHWESTERN EAGLE COUNTIES, AND IN CONNECTION THEREWITH:

ORGANIZING THE CONFLUENCE EARLY CHILDHOOD DEVELOPMENT SERVICE DISTRICT;

AUTHORIZING THE DISTRICT TO COLLECT A .25% SALES AND USE TAX (EQUAL TO 25 CENTS ON A \$100 PURCHASE) IN GARFIELD, PITKIN, AND SOUTHWESTERN EAGLE COUNTIES EFFECTIVE IN 2026, TO FUND EARLY CHILDHOOD DEVELOPMENT SERVICES INCLUDING:

- LOWERING FAMILIES' COST OF PRESCHOOL AND CHILDCARE; AND
- EXPANDING CAPACITY OF PRESCHOOL AND CHILDCARE FACILITIES SO MORE CHILDREN CAN ATTEND; AND
- INCREASING WAGES FOR PRESCHOOL AND CHILDCARE TEACHERS AND STAFF;

WITHOUT TAXING ITEMS EXCLUDED BY STATE LAW SUCH AS GROCERIES, GAS, DIAPERS AND MEDICINE;

REQUIRING AN ANNUAL AUDIT BY AN INDEPENDENT THIRD-PARTY; AND

AUTHORIZING THE DISTRICT TO COLLECT, RETAIN AND SPEND ALL DISTRICT REVENUE AS VOTER-APPROVED REVENUE?

**TOWN OF NEW CASTLE, COLORADO
RESOLUTION NO. TC 2025-19**

A RESOLUTION OF THE NEW CASTLE TOWN COUNCIL SUPPORTING
THE BALLOT MEASURE OF THE CONFLUENCE EARLY CHILDHOOD EDUCATION
COALITION TO BE DECIDED BY VOTERS AT THE NOVEMBER 4, 2025, ELECTION

WHEREAS, the Town Council of the Town of New Castle (“Town Council”) understands the importance of early childhood care and education; and

WHEREAS, affordable and reliable childcare and preschool are essential for the healthy development of children and for working parents to thrive; and

WHEREAS, there are not enough licensed childcare spaces in our region to meet the needs of families, and costs are often out of reach; and

WHEREAS, improving access to early education supports school readiness, reduces workforce challenges for employers, and benefits the entire community; and

WHEREAS, the Confluence Early Childhood Education Coalition proposes a ballot measure to be decided by the voters at the November 4, 2025, election to create a regional, early-childhood development service district funded by a modest sales tax increase to, among other things, expand childcare and preschool access and affordability for families in Garfield County, Pitkin County, and southwestern Eagle County; and

WHEREAS, the Town Council desires to make known its support of the Confluence Early Childhood Education Coalition’s ballot measure, which stands to positively impact the health, safety, and welfare of the Town and its residents.

NOW, THEREFORE, BE IT RESOLVED BY THE NEW CASTLE TOWN COUNCIL AS FOLLOWS:

1. Recitals. The foregoing recitals are incorporated by reference as findings and determinations of the Town Council.
2. Statement of Support. By this Resolution, the Town Council hereby expresses its support for the following ballot measure being proposed by the Confluence Early Childhood Education Coalition at the November 4, 2025, election:

BALLOT ISSUE 7A

SHALL TAXES IN THE PROPOSED CONFLUENCE EARLY CHILDHOOD DEVELOPMENT SERVICE DISTRICT BE INCREASED BY \$12.1 MILLION ANNUALLY, AND BY WHATEVER ADDITIONAL AMOUNTS MAY BE RAISED THEREAFTER, TO FUND THE DISTRICT TO REDUCE THE COST OF AND PROVIDE MORE PRESCHOOL AND CHILDCARE FOR FAMILIES IN GARFIELD,

PITKIN, AND SOUTHWESTERN EAGLE COUNTIES, AND IN CONNECTION THEREWITH:

ORGANIZING THE CONFLUENCE EARLY CHILDHOOD DEVELOPMENT SERVICE DISTRICT;

AUTHORIZING THE DISTRICT TO COLLECT A .25% SALES AND USE TAX (EQUAL TO 25 CENTS ON A \$100 PURCHASE) IN GARFIELD, PITKIN, AND SOUTHWESTERN EAGLE COUNTIES EFFECTIVE IN 2026, TO FUND EARLY CHILDHOOD DEVELOPMENT SERVICES INCLUDING:

- LOWERING FAMILIES' COST OF PRESCHOOL AND CHILDCARE; AND
- EXPANDING CAPACITY OF PRESCHOOL AND CHILDCARE FACILITIES SO MORE CHILDREN CAN ATTEND; AND
- INCREASING WAGES FOR PRESCHOOL AND CHILDCARE TEACHERS AND STAFF;

WITHOUT TAXING ITEMS EXCLUDED BY STATE LAW SUCH AS GROCERIES, GAS, DIAPERS AND MEDICINE;

REQUIRING AN ANNUAL AUDIT BY AN INDEPENDENT THIRD-PARTY; AND

AUTHORIZING THE DISTRICT TO COLLECT, RETAIN AND SPEND ALL DISTRICT REVENUE AS VOTER-APPROVED REVENUE?

3. Further Action. The Town Clerk and Town Manager are hereby authorized and directed to take all necessary and appropriate action to effectuate the provisions of this Resolution, including reporting the passage of or distribution of this Resolution through established, customary means, other than paid advertising, pursuant to C.R.S. § 1-45-117(1)(b)(III)(B).

INTRODUCED, PASSED, AND ADOPTED by a vote of ___ to ___ at a regular meeting of the New Castle Town Council held on September 16, 2025.

TOWN COUNCIL OF TOWN OF NEW
CASTLE, COLORADO

Art Riddile, Mayor

ATTEST:

Mindy Andis, Town Clerk

1 **New Castle Town Council Regular Meeting**
2 **Tuesday, September 2, 2025, 7:00 PM**
3

4 **Call to Order**

5 Mayor Art Riddile called the meeting to order at 7:00 p.m.

6 **Pledge of Allegiance**

7 **Roll Call**

8 Councilor Carey
9 Councilor Mariscal
10 Councilor Hazelton
11 Mayor A. Riddile
12 Councilor Copeland
13 Councilor Leland
14 Councilor G Riddile

15
16 Absent None
17

18 Also present at the meeting were Town Clerk Mindy Andis, Administrator Dave Reynolds,
19 and members of the public.
20

21 **Meeting Notice**

22 Clerk Andis verified that her office gave notice of the meeting in accordance with
23 Resolution TC 2025-1.

24 **Conflicts of Interest**

25 There were no citizen comments
26

27 **Agenda Changes**

28 There were no agenda changes

29 **Citizen Comments on Items not on the Agenda**

30 There were no citizen comments

31 **Consultant Reports**

32 Consultant Attorney – not present
33 Consultant Engineer – not present

34 **Items for Consideration**

35 **Presentation – Western Slope Veterans Coalition – Patty Buxman**

36 Administrator Reynolds said Western Slope Veterans Coalition (WSVC) mission “is to
37 improve the quality of life for service members, veterans, and their families. Providing outreach to
38 all service persons including Veterans and their families by connecting veterans to local and
39 national agencies and veteran resources.”

40 Patty Buxman introduced herself to the council. She said she is a volunteer for the WSVC in
41 Glenwood Springs. Ms. Buxman reviewed the slideshow presentation with the council.

42 **(Exhibit A)**

43 Ms. Buxman said the coalition is a resource center and are not funded by VA. The funding comes

1 from private donors and grants. She said WSVC is able to refer to other nonprofits if WSVC is not
2 able to assist.
3 Ms. Buxman said on Friday, October 17, 2025, from 10:00am – 4:00pm at the Rifle Moose Lodge
4 will be Stand Down Day. At the event there would be VA representatives available to assist along
5 with other nonprofit organizations to assist the veterans.
6 Ms. Buxman said future project is tiny homes in Silt for unhoused veterans. WSVC are still
7 working through the approval process. She said once the WSVC has full approval, they will start
8 fund raising and breaking ground.
9 Mayor A. Riddile asked Ms. Buxman when WSVC would have a decision on the project by Silt. Ms.
10 Buxman said tonight is the Silt P&Z meeting for the Planned Unit Development presentation.
11 Mayor A. Riddile asked to be informed when Silt does make a decision and what the decision is.
12 Ms. Buxman said she would let the town know what the decision is when she finds out. Ms.
13 Buxman said all the money raised goes to the veterans.

14
15 **Presentation/Update – YouthZone**

16 Administrator Reynolds said Youth Zone operates from offices in Glenwood, Rifle, Aspen,
17 and Carbondale. Offering services that include Juvenile Diversion, CYDC Screening and
18 Monitoring, Substance Use Prevention, Mental Health Services, Life Skill Training,
19 Community Service, and Peer Support Groups, Youth Zone is sure to touch the lives of
20 youth and families in New Castle and throughout our region.
21 Administrator Reynolds introduced Lyn Williams Director of Operations for YouthZone.
22 Mr. Williams reviewed the slideshow presentation with the council. (**Exhibit B**)
23 Mayor A. Riddile said Fentanyl use has largely increased has YouthZone notices it filtering
24 down to the youth in the area. Mr. Williams said yes, if it is out in the general community
25 then the youth would have access to it. He said YouthZone has a substance group with
26 several teens at once. There is a higher success rate when counseling a group of teens vs.
27 one on one.
28 Councilor Leland asked if YouthZone has clients that would need to be rehabilitated. Mr.
29 Williams said they done. They will discover the level of need once the client has been
30 evaluated. Councilor Leland asked where the client would be referred to. Mr. Williams said
31 it depends on the extent of help and financial need.
32 Councilor Mariscal said the number of Latinos is alarming. She asked if YouthZone is
33 seeing any patterns. Mr. Williams said he didn't have an answer.
34 Councilor Carey asked if Mr. Williams knew where Coal Ridge High School fell in the list of
35 schools attended by clients. Mr. Williams said he didn't have an answer but would find
36 out.
37 Councilor Carey asked if the general public whose children are not referred to YouthZone
38 but are looking for parenting tools. Mr. Williams said YouthZone does do parent consulting
39 and can refer the parent to other organizations for help. Councilor Carey suggested have
40 resources for families available on YouthZone website.

1 Councilor Hazelton asked when YouthZone interviews the children, where are the children
2 getting the drugs from. Mr. Williams said since the legalization of Marijuana the use of it
3 has increased. He said there are parents who view the use of Marijuana not harmful, and
4 others do. Where the child gets the drugs sometimes does not come directly. He said
5 YouthZone has two main courses of how they get their information. First is by subjective
6 which is done by the interview process and the second is a quantitative the survey.
7

8 **Update/Direction Concerning 600 W. Main Street**

9 Administrator Reynolds gave a brief update on the proposed development of 600 W. Main
10 Street. The council may discuss and consider potential amendments to the Restrictive
11 Covenants recorded with the property in 2024 when it was sold by the town to private
12 individuals. Under the existing Restrictive Covenants, the property must be used in whole
13 or in part as a restaurant, the foundation must be completed within two years of
14 purchase, and the building must receive a Certificate of Occupancy within five years of
15 purchase.

16 Owner Aaron Shockley said he has completed a survey and received a soils sample of the
17 property. Mr. Shockley explained some of the issues that he has run into during the
18 process. He said the plan as to have a restaurant and a catering business in one facility
19 and would need to be one level. He said the survey revealed that the back right corner of
20 the lot to the front left of the lot has a 6 foot slope, which means the building would need
21 to be about 5 feet off of the sidewalk. He said working with the town, the building needs
22 to be street level and unfortunately would not work with the current plans. Mr. Shockley
23 said he would continue to work with Planner Paul Smith and propose other ideas. He said
24 with having an elevated building would be to have elevated seating which would be better
25 views of the Hogback and downtown. The soils sample revealed there would need to
26 remove 5 feet of soil from the entire property to build a foundation. He said that alone has
27 added a lot of unexpected cost to the project. Mr. Shockley said he is currently working
28 with two contractors. One contractor has given a cost estimate of \$500 per square foot
29 and the other is uncomfortable giving a cost estimate until Mr. Shockley has hired an
30 architect in Colorado to finalize the plans. Mr. Shockley said the building and the garage is
31 about 2800sft in total. Mr. Shockley said he doesn't have the funds for the additional
32 expenses and costs. He said this was an investment for his family's future and would need
33 to go into debt to build the project. He said he understands the contract he has with the
34 town which states he has to start construction by July 2026. Mr. Shockley said he is
35 asking for an extension because building costs are high and needs sometime to go back to
36 redesign the building. The original plan for the Rolling Fork was to build a facility to house
37 the catering business, which revolves around a garage and a commercial kitchen. Mr.
38 Shockley said he understands that it's important for the council to have a place that could
39 be open to the public. He said being a catering business he doesn't service the public very
40 much. They do New Castle Community Market, Burning Mountain Festival and music at
41 the park in Glenwood Springs. He said he continues to commit to New Castle events and

1 want to continue to have the public presence in Downtown New Castle. New Castle is
2 where Mr. Shockley said he wants to build the facility for Rolling Fork. At the current time
3 it's not feasible to include the restaurant in the plans. Mr. Shockley said it's not out of the
4 question to grow into the restaurant but right now it's not affordable to do everything at
5 once. Mr. Shockley said the town does have the opportunity to buy the property back. He
6 said he would be building a facility for Rolling Fork and want it to be in New Castle and on
7 Main Street. Mr. Shockley said he is envisioning a catering kitchen and garage constructed
8 on the property with the ability to add indoor restaurant space in the future as the
9 economy and finances allow. In the meantime, would be interested in having an outdoor
10 food court with a service area that would highlight Rolling Fork Food Truck or local
11 vendors. The commissary kitchen space would allow other food vendors to lease space for
12 prep work, ware washing, food deliveries, which would bring more opportunities to the
13 community. Would be able to use the garage space as an event space for charity events,
14 dances and private parties. Mr. Shockley said that Rolling Fork is a very successful
15 catering company and would like to utilize the property to build the catering facility and to
16 continue to grow in New Castle.

17 Councilor Hazelton asked Mr. Shockley thoughts are stilling wanting to do the facility,
18 catering and catering but not the restaurant. What is the roadblock on going that extra
19 little bit for the restaurant. Mr. Shockley said it would remove about 1800sqft of indoor
20 seating. The restaurant part of building would not be built, just the garage and the
21 kitchen.

22 Councilor Hazelton asked Mr. Shockley why he wants a building like that on Main Street.
23 Mr. Shockley said he believes he could create something to serve the public on Main
24 Street. He said it would be something similar to Down Valley Brewing. He said there could
25 also be a food truck in the front and the food truck would be open all the time. It would be
26 more affordable to have a nice patio than building a whole restaurant space.

27 Councilor Hazelton said he doesn't want to see just being a warehouse that you are
28 backing your truck into. Mr. Shockley said he understands and is asking for time to create
29 different drawings. He said he is very interested in doing a food delivery service in New
30 Castle.

31 Councilor Carey asked about the invision of the food court if it would be gravel or paved
32 where you could drop one side of the building and you could serve food year-round. Mr.
33 Shockley said ideally paved with some grass. The building was originally up against the
34 sidewalk. The garage and the kitchen space would be in the back of the property and
35 leave the entire front of property open. Then, get creative with the space to have the
36 public gather. He said he wanted the building to be more western and fit the Downtown
37 New Castle is a cost factor. Then, moving more towards a warehouse with big doors in the
38 front that would open up and possibly have some seating inside for people in the winter.

39 Councilor Copeland said she supports the idea of building in sections and thinks it's a good
40 idea.

41 Councilor Leland said from the beginning the plan was to have a commercial kitchen and a

1 garage. The restaurant would come later. He said he supports the idea of the commercial
2 kitchen and a garage with the restaurant coming later.
3 Mayor A. Riddile asked Mr. Shockley if he was asking for a one-year extension after July
4 2026. Mr. Shockley said yes, but also asking for a one-year extension on all the timelines.
5 Administrator Reynolds said the Restrictive Covenants has three parts first states: The
6 foundation of a building to be used in whole or in part as a restaurant shall be completed
7 on the property no later than two years after the date of the closing date. The second
8 states: A building to be used in whole or in part as a restaurant shall be completed and
9 receive a certificate of occupancy no later than five years after the closing date. The third
10 states: The property shall be used in whole or in part for the operation of a restaurant or
11 other food and beverage establishment open to the public for a period of at least two
12 years from the date a certificate of occupancy is issued for the property.
13 Administrator Reynolds said there are projects in New Castle that are struggling right now
14 due to the building costs and interest rates being high. He said staff is recommending
15 have the town attorney rewrite the Restrictive Covenants to extend all the timelines by
16 one year. Administrator Reynolds said the council would receive another update from Mr.
17 Shockley in a year to hear about the progress of the project.
18 Council agreed to have the town attorney rewrite the Restrictive Covenants to extend all
19 the timelines by one year.

20

21 **Consent Agenda**

22 Items on the consent agenda are routine and non-controversial and will be approved by
23 one motion. There will be no separate discussion of these items unless a council member
24 or citizen requests it, in which case the item will be removed from the consent agenda.

25

26 August 19, 2025, minutes

27 August Bills \$1,092,068.93

28 **MOTION: Mayor A. Riddile made a motion to approve the Consent Agenda.**
29 **Councilor Carey seconded the motion, and it passed unanimously.**

30

31 **Staff Reports**

32 **Town Administrator** –Administrator Reynolds reminded the council about the council
33 retreat on September 27, 2025, at the Lakota Rec Center. He said he has received some
34 ideas from council and staff. Administrator Reynolds said he has spoken with Riverside
35 Middle School Principal about the school has a project that they would like the town to
36 help with for a grant. The middle school will be presenting to the council at the next
37 council meeting about the project.

38 Administrator Reynolds asked Mayor A. Riddile to speak about Steve Rippy’s memorial
39 service. Mayor A. Riddile said he was approached by former Mayor Bill Wentzel would like
40 for staff and council to get with Becky Rippy to create a formal legacy in remembrance of
41 Steve Rippy. Mayor A. Riddile said possible renaming something and one thought was to

1 name the new roundabout after Steve Rippy. Councilor Leland said he thought it might be
2 possible to speak with the library and renaming the remaining half of the history room
3 after Steve Rippy and might be a place to store his photographs.

4 Administrator Reynolds said every councilor and mayor has their personal phone number
5 on the town's website. He would like to see if the council is still comfortable with their
6 phone numbers being on the website or would like something different. Councilor Hazelton
7 said he has a separate number that goes to his cell phone with a separate ring and a
8 separate mailbox. Might consider as a town getting additional lines with a separate
9 number for the council. If something was to happen or get out of control it wouldn't be a
10 big deal to change the phone number without having the need to change the personal
11 number. Councilor Carey agreed to have a conversation regarding the councilor's phone
12 numbers.

13 Administrator Reynolds said the town has received a thank you from the New Castle
14 Chamber of Commerce for supporting the Block Party. The town also received a thank you
15 from the Focus Kids Team which was for an outgoing grant. Also, one from Great
16 Expectation for the grant they received from the town.

17 Administrator Reynolds gave an update regarding the resolution to support the CECE
18 ballot issue. He said the town attorney wanted to see the final ballot language to put into
19 the resolution. The resolution will come before the council at the next council meeting.

20 Administrator Reynolds said it's that that time of year for reviews for the Town
21 Administrator, Treasurer and Clerk. For a couple of years, the council has talked about
22 doing a 360 review and getting input from other staff members. Administrator Reynolds
23 has spoken with both Treasurer Ehlers and Clerk Andis about the 360 reviews. After
24 speaking with them they are on board with the 360 reviews, and he is as well. The council
25 could move forward with the 360 reviews and also have department head fill them out or
26 continue with the reviews as they have been done in the past. The council agreed to move
27 forward with the 360 reviews. Administrator Reynolds said Assistant Rochelle Firth could
28 collect the reviews in a sealed envelope and get them to the Mayor or Mayor Pro Tem.
29 Administrator asked the council if they would like to spread out the reviews or have all
30 three in one meeting. The council agreed to have all three reviews in one meeting.

31 Administrator Reynolds reminded the council Burning Mountain Festival is next weekend.
32 **Town Clerk** – Clerk Andis said Deputy Samantha Sorenson has resigned and her last day
33 will be Friday, September 12, 2025. Clerk Andis said she had completed one of two CBI
34 Audits, and the state approved the audit. She is working with Police Clerk Jessica
35 Hernandez on the IT Audit for CBI and hopes to have that complete by the end of the
36 week. Clerk Andis said she did start train Deputy Sorenson on court.

37 **Town Treasurer** – not present

38 **Town Planner** – not present

39 **Public Works Director** – not present

40

41 **Commission Reports**

42 **Planning & Zoning Commission** – Councilor G. Riddile said they did meet. The owners
43 of the Walters Center had presented to the commission an amendment to the PUD. The
44 proposed plan is commercial space with highly stacked townhomes. Councilor G. Riddile

1 said R2 might be breaking ground this fall.
2 **Historic Preservation Commission** – have not met
3 **Climate and Environment Commission** – Councilor Leland said CEC awarded two
4 business grants from the bag fee. Home Town Real Estate Company received \$800. They
5 were going to shred old documents and go paperless. They also had lightbulbs and
6 computers that needed to be recycled. Salon West received \$1600. They are going to
7 create a waste diversion program to responsibly recycle materials such as hair, excess
8 color, foils, aerosol cans, plastics and more.
9 **Senior Program** – Clerk Andis said the BOCC had approved their plan to change the age
10 requirement from 65 to 70 to help increase the ridership on the Traveler. The town should
11 see that change in the MOU at the end of the year.
12 **RFTA** – have not met
13 **AGNC** – Councilor Hazelton they didn't meet but there was an Economic Summit in Rifle.
14 **GCE** – Councilor Leland said Morgan Hill had asked if she needed to present to the
15 council. The council agreed to have Ms. Morgan email her presentation and Clerk Andis
16 would put it in the council packet.
17 **EAB** – have not met
18 **POSTR** – have not met
19 **Council Comments**
20 Councilor Mariscal reminded the council of the community worship service on Sunday,
21 September 14, 2025, at 10:30am at Burning Mountain Park. Councilor Marical said she is
22 concerned about court interpretation. Administrator Reynolds and Clerk Andis explained,
23 they have had conversations with the municipal judge and prosecutor about court
24 interpreter. Both the judge and prosecutor are comfortable with who is currently
25 interpreting for the court and don't feel there is a conflict. Clerk Andis said she does have
26 a backup interpreter if needed for council meeting. Councilor G. Riddile asked if the
27 interpreter feels uncomfortable with a court case if there is someone else to interpret.
28 Clerk Andis said yes, she would call her backup interpreter to fill in.
29 Councilor Carey said she would like to have a conversation about the law regarding people
30 on e-bikes. Administrator Reynolds said he would look in it.
31 Councilor Hazelton asked about the CUP and business on County Road 335. He said there
32 are three businesses on County Road 335 that have RV storage on their property. He said
33 he has been informed there is a mechanic shop in the Livery building. Administrator
34 Reynolds said he would look into it.
35 Councilor Leland asked if Xcel Energy has gotten back to the town regarding the number
36 of power outages. Administrator Reynolds said Xcel said it was either due to high demand,
37 peak hours, work in the area, or high winds. No, formal answer was given. He said notice
38 about Steve Rippy's passing was in the current CML newsletter.
39
40 **Items for Future Council Agenda**
41 There were none.
42
43
44

1 **Adjourn**

2 **MOTION: Mayor A. Riddile made a motion to adjourn. Councilor Leland seconded**
3 **the motion and it passed unanimously.**

4
5 The meeting adjourned at 9:05 p.m.

6
7 Respectfully submitted,

8
9
10
11 _____
12 Mayor Art Riddile

13 _____
14 Town Clerk Mindy Andis, CMC

DRAFT

Submit to Local Licensing Authority

Fees Due	
Annual Renewal Application Fee	\$ 125
Renewal Fee	227.50
Storage Permit \$100 X _____	\$
Sidewalk Service Area \$75.00	\$
Additional Optional Premise Hotel & Restaurant \$100 X _____	\$
Related Facility - Campus Liquor Complex \$160.00 per facility	\$
Amount Due/Paid	\$ 352.50

Make check payable to: Colorado Department of Revenue. The State may convert your check to a one-time electronic banking transaction. Your bank account may be debited as early as the same day received by the State. If converted, your check will not be returned. If your check is rejected due to insufficient or uncollected funds, the Department may collect the payment amount directly from your banking account electronically.

Retail Liquor License Renewal Application

Please verify & update all information below

Return to city or county licensing authority by due date

* Note that the Division will not accept cash

Paid by check

Paid online

Uploaded to
MoveIt on

Date
08-29-2025

Licensee Name CRS FRENS LLC		Doing Business As Name (DBA) New Castle Liquors	
Liquor License # 03-21876	License Type Retail Liquor Store		
Sales Tax License Number 96358538-0000	Expiration Date 12-31-25	Due Date	
Business Address 820 Castle Valley BLVD STE#104			Phone Number 970-984-3707
Mailing Address 820 Castle Valley BLVD STE#104			Email
Operating Manager Rajesh Ranjtkar	Date of Birth [REDACTED]	Home Address [REDACTED]	Phone Number [REDACTED]
1. Do you have legal possession of the premises at the street address above? <input checked="" type="checkbox"/> Yes <input type="checkbox"/> No Are the premises owned or rented? <input type="checkbox"/> Owned <input checked="" type="checkbox"/> Rented* *If rented, expiration date of lease <u>June 2030</u>			
2. Are you renewing a storage permit, additional optional premises, sidewalk service area, or related facility? If yes, please see the table in the upper right hand corner and include all fees due. <input type="checkbox"/> Yes <input checked="" type="checkbox"/> No			
3a. Are you renewing a takeout and/or delivery permit? (Note: must hold a qualifying license type and be authorized for takeout and/or delivery license privileges) <input type="checkbox"/> Yes <input type="checkbox"/> No			
3b. If so, which are you renewing? <input checked="" type="checkbox"/> Delivery <input type="checkbox"/> Takeout <input type="checkbox"/> Both Takeout and Delivery			
4a. Since the date of filing of the last application, has the applicant, including its manager, partners, officer, directors, stockholders, members (LLC), managing members (LLC), or any other person with a 10% or greater financial interest in the applicant, been found in final order of a tax agency to be delinquent in the payment of any state or local taxes, penalties, or interest related to a business? <input checked="" type="checkbox"/> Yes <input type="checkbox"/> No			
4b. Since the date of filing of the last application, has the applicant, including its manager, partners, officer, directors, stockholders, members (LLC), managing members (LLC), or any other person with a 10% or greater financial interest in the applicant failed to pay any fees or surcharges imposed pursuant to section 44-3-503, C.R.S.? <input type="checkbox"/> Yes <input type="checkbox"/> No			
5. Since the date of filing of the last application, has there been any change in financial interest (new notes, loans, owners, etc.) or organizational structure (addition or deletion of officers, directors, managing members or general partners)? If yes, explain in detail and attach a listing of all liquor businesses in which these new lenders, owners (other than licensed financial institutions), officers, directors, managing members, or general partners are materially interested. <input type="checkbox"/> Yes <input type="checkbox"/> No			

6. Since the date of filing of the last application, has the applicant or any of its agents, owners, managers, partners or lenders (other than licensed financial institutions) been convicted of a crime? If yes, attach a detailed explanation. <input type="checkbox"/> Yes <input type="checkbox"/> No
7. Since the date of filing of the last application, has the applicant or any of its agents, owners, managers, partners or lenders (other than licensed financial institutions) been denied an alcohol beverage license, had an alcohol beverage license suspended or revoked, or had interest in any entity that had an alcohol beverage license denied, suspended or revoked? If yes, attach a detailed explanation. <input type="checkbox"/> Yes <input checked="" type="checkbox"/> No
8. Does the applicant or any of its agents, owners, managers, partners or lenders (other than licensed financial institutions) have a direct or indirect interest in any other Colorado liquor license, including loans to or from any licensee or interest in a loan to any licensee? If yes, attach a detailed explanation. <input type="checkbox"/> Yes <input checked="" type="checkbox"/> No

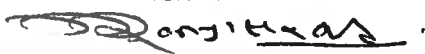
Affirmation & Consent	
I declare under penalty of perjury in the second degree that this application and all attachments are true, correct and complete to the best of my knowledge.	
Type or Print Name of Applicant/Authorized Agent of Business	Title
Rajesh Ranjitkar	Chairman
Signature	Date
	08-29-25
Report & Approval of City or County Licensing Authority	
The foregoing application has been examined and the premises, business conducted and character of the applicant are satisfactory, and we do hereby report that such license, if granted, will comply with the provisions of Title 44, Articles 4 and 3, C.R.S., and Liquor Rules.	
Therefore this application is approved.	
Local Licensing Authority For	Date
Signature	Title
	Attest



Tax Check Authorization, Waiver, and Request to Release Information

I, Rajesh Ranjitkar am signing this Tax Check Authorization, Waiver and Request to Release Information (hereinafter "Waiver") on behalf of New Castle Liquors (the "Applicant/Licensee") to permit the Colorado Department of Revenue and any other state or local taxing authority to release information and documentation that may otherwise be confidential, as provided below. If I am signing this Waiver for someone other than myself, including on behalf of a business entity, I certify that I have the authority to execute this Waiver on behalf of the Applicant/Licensee.

The Executive Director of the Colorado Department of Revenue is the State Licensing Authority, and oversees the Colorado Liquor Enforcement Division as his or her agents, clerks, and employees. The information and documentation obtained pursuant to this Waiver may be used in connection with the Applicant/Licensee's liquor license application and ongoing licensure by the state and local licensing authorities. The Colorado Liquor Code, section 44-3-101. et seq. ("Liquor Code"), and the Colorado Liquor Rules, 1 CCR 203-2 ("Liquor Rules"), require compliance with certain tax obligations, and set forth the investigative, disciplinary and licensure actions the state and local licensing authorities may take for violations of the Liquor Code and Liquor Rules, including failure to meet tax reporting and payment obligations.

The Waiver is made pursuant to section 39-21-113(4), C.R.S., and any other law, regulation, resolution or ordinance concerning the confidentiality of tax information, or any document, report or return filed in connection with state or local taxes. This Waiver shall be valid until the expiration or revocation of a license, or until both the state and local licensing authorities take final action to approve or deny any application(s) for the renewal of the license, whichever is later. Applicant/Licensee agrees to execute a new waiver for each subsequent licensing period in connection with the renewal of any license, if requested.

By signing below, Applicant/Licensee requests that the Colorado Department of Revenue and any other state or local taxing authority or agency in the possession of tax documents or information, release information and documentation to the Colorado Liquor Enforcement Division, and its duly authorized employees, to act as the Applicant's/Licensee's duly authorized representative under section 39-21-113(4), C.R.S., solely to allow the state and local licensing authorities, and their duly authorized employees, to investigate compliance with the Liquor Code and Liquor Rules. Applicant/Licensee authorizes the state and local licensing authorities, their duly authorized employees, and their legal representatives, to use the information and documentation obtained using this Waiver in any administrative or judicial action regarding the application or license.

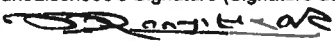
Name (Individual/Business) Rajesh Ranjitkar		Social Security Number/Tax Identification Number 	
Address 			
City New Castle		State CO	Zip 81647
Home Phone Number		Business/Work Phone Number 970-984-3707	
Printed name of person signing on behalf of the Applicant/Licensee Rajesh Ranjitkar			
Applicant/Licensee's Signature (Signature authorizing the disclosure of confidential tax information) 			Date signed 08-29-25

Privacy Act Statement

Providing your Social Security Number is voluntary and no right, benefit or privilege provided by law will be denied as a result of refusal to disclose it. § 7 of Privacy Act, 5 USCS § 552a (note).



Town of New Castle
 PO Box 90
 450 West Main Street
 New Castle, CO 81647
 970-984-2311
 Fax: 970-984-2716
www.newcastlecolorado.org

ALCOHOL BEVERAGE TASTING PERMIT APPLICATION

Applicant Name: <u>CRS FRENS LLC dbo New Castle Liquors</u>	
Address of Licensed Premises (must be Retail Liquor Store or Liquor-Licensed Drugstore): <u>820 Castle Valley Blvd Ste # 104, New Castle, CO 81647</u>	
Mailing Address:	
Phone Number: <u>970 984 3707</u>	Fax Number:
E-Mail Address: <u>crsfrensllc@gmail.com</u>	Web Site Address:

Attach the following items:

- Employees' certificates of completion of a server training program that meets the standards established by the Colorado Department of Revenue Liquor Enforcement Division.
- A written Control Plan to establish how the Licensee will conduct tastings without violating the provisions of the Colorado Revised Statutes and applicable provisions of the New Castle Municipal Code.
- A list of tasting event dates. If unsure of future dates, submit list to Town Clerk's Office at least one week prior to the event.
- \$25 permit fee. This fee is nonrefundable. If Council grants this permit, this fee would pay for a permit for one year running and expiring concurrently with the license of the retail liquor store or liquor-licensed drugstore. First-year tastings permits shall be prorated as to the permit fee based on an average of two (2) tastings events per week.

I acknowledge that if the Town grants this permit, the alcohol beverage tastings conducted under this permit shall be subject to the following limitations:

- Tastings shall be conducted only by a person who has completed a server training program that meets the standards established by the Colorado Department of Revenue Liquor Enforcement Division, and who is either a retail liquor store licensee or a liquor-licensed drugstore licensee, or an employee of a licensee, and only on a licensee's licensed premises.
- The alcohol used in tastings shall be purchased through a licensed wholesaler, licensed brew pub, or winery licensed pursuant to Colorado Revised Statute 12-47-403 at a cost that is not less than the laid-in cost of such alcohol.
- The size of an individual alcohol sample shall not exceed one ounce of malt or vinous liquor or one-half of one ounce of spirituous liquor.
- Tastings shall not exceed a total of five hours in duration per day, which need not be consecutive.

- Tastings shall be conducted only during the operating hours in which the licensee on whose premises the tastings occur is permitted to sell alcohol beverages, and in no case earlier than 11 a.m. or later than 7 p.m.
- The licensee shall prohibit patrons from leaving the licensed premises with an unconsumed sample.
- The licensee shall promptly remove all open and unconsumed alcohol beverage samples from the licensed premises or shall destroy the samples immediately following the completion of the tasting.
- The licensee shall not serve a person who is under twenty-one years of age or who is visibly intoxicated.
- The licensee shall not serve more than four individual samples to a patron during a tasting.
- Alcohol samples shall be in open containers and shall be provided to a patron free of charge.
- Tastings may occur on no more than four of the six days from a Monday to the following Saturday, not to exceed one hundred four days per year.
- No manufacturer of spirituous or vinous liquors shall induce a licensee through free goods or financial or in-kind assistance to favor the manufacturer's products being sampled at a tasting. The licensee shall bear the financial and all other responsibility for a tasting.
- The licensee shall notify the Town Clerk and the New Castle Police Department at least seven days prior to any alcohol beverage tasting event.



07/31/25

Applicant Signature

Date

Local Licensing Authority for:
Signature:
Signature (attest)

Date:
Title:
Title:

DR 8400 (02/18/24)
COLORADO DEPARTMENT OF REVENUE
 Liquor Enforcement Division
 PO BOX 17087
 Denver CO 80217-0087
 (303) 205-2300

Submit to Local Licensing Authority

CITY MARKET #41
PO BOX 305103
Nashville TN 37230-5103

Fees Due	
Annual Renewal Application Fee	\$
Renewal Fee	346.25
Storage Permit \$100 X _____	\$
Sidewalk Service Area \$75.00	\$
Additional Optional Premise Hotel & Restaurant \$100 X _____	\$
Related Facility - Campus Liquor Complex \$160.00 per facility	\$
Amount Due/Paid	\$346.25

Make check payable to: Colorado Department of Revenue. The State may convert your check to a one-time electronic banking transaction. Your bank account may be debited as early as the same day received by the State. If converted, your check will not be returned. If your check is rejected due to insufficient or uncollected funds, the Department may collect the payment amount directly from your banking account electronically.

Retail Liquor License Renewal Application

Please verify & update all information below. Return to city or county licensing authority by due date.

Note that the Division will not accept cash.

Paid by check

Uploaded to MoveIt on Date

Paid Online

Licensee Name

DILLON COMPANIES LLC

Doing Business As Name (DBA)

CITY MARKET #41

Liquor License Number

01-10779-0153

License Type

Fermented Malt Beverage and Wine (city)

Sales Tax License Number

01107790153

Expiration Date

10/29/2025

Due Date

09/14/2025

Business Address

Street Address

850 CASTLE VALLEY BOULEVARD

Phone Number

9709849715

City, State, ZIP Code

New Castle CO 81647-9441

Mailing Address

Street Address

PO BOX 305103 Attn: Business License Department

City, State, ZIP Code

Nashville TN 37230-5103

Email

business.license@kroger.com

Operating Manager

Milgjan Tellez

Date of Birth

Home Address

Street Address		Phone Number
[REDACTED]		[REDACTED]
City	State	ZIP Code
New Castle	CO	81647

1. Do you have legal possession of the premises at the street address?..... Yes No

Are the premises owned or rented? Owned Rented* *If rented, expiration date of lease

2. Are you renewing a storage permit, additional optional premises, sidewalk service area, or related facility?..... Yes No

If yes, please see the table in the upper right hand corner and include all fees due.

3. Are you renewing a takeout and/or delivery permit?..... Yes No

(Note: must hold a qualifying license type and be authorized for takeout and/or delivery license privileges) If selecting 'Yes', an additional \$11.00 is required to renew the permit.

If so, which are you renewing?..... Delivery Takeout Both Takeout and Delivery

4. Since the date of filing of the last application, has the applicant, including its manager, partners, officer, directors, stockholders, members (LLC), managing members (LLC), or any other person with a 10% or greater financial interest in the applicant, been found in final order of a tax agency to be delinquent in the payment of any state or local taxes, penalties, or interest related to a business?..... Yes No

Since the date of filing of the last application, has the applicant, including its manager, partners, officer, directors, stockholders, members (LLC), managing members (LLC), or any other person with a 10% or greater financial interest in the applicant failed to pay any fees or surcharges imposed pursuant to section 44-3-503, C.R.S.?..... Yes No

5. Since the date of filing of the last application, has there been any change in financial interest (new notes, loans, owners, etc.) or organizational structure (addition or deletion of officers, directors, managing members or general partners)?..... Yes No

If yes, explain in detail and attach a listing of all liquor businesses in which these new lenders, owners (other than licensed financial institutions), officers, directors, managing members, or general partners are materially interested.

6. Since the date of filing of the last application, has the applicant or any of its agents, owners, managers, partners or lenders (other than licensed financial institutions) been convicted of a crime? Yes No

If yes, attach a detailed explanation.

7. Since the date of filing of the last application, has the applicant or any of its agents, owners, managers, partners or lenders (other than licensed financial institutions) been denied an alcohol beverage license, had an alcohol beverage license suspended or revoked, or had interest in any entity that had an alcohol beverage license denied, suspended or revoked? Yes No

If yes, attach a detailed explanation.

8. Does the applicant or any of its agents, owners, managers, partners or lenders (other than licensed financial institutions) have a direct or indirect interest in any other Colorado liquor license, including loans to or from any licensee or interest in a loan to any licensee? Yes No

If yes, attach a detailed explanation.

Affirmation & Consent

I declare under penalty of perjury in the second degree that this application and all attachments are true, correct and complete to the best of my knowledge.

Type or Print Name of Applicant/Authorized Agent of Business

Laura Alsteen

Title

Vice President

Signature

Laura Alsteen

Date (MM/DD/YY)

8/26/2025

B9EAB5CE8ED748D...

Report & Approval of City or County Licensing Authority

The foregoing application has been examined and the premises, business conducted and character of the applicant are satisfactory, and we do hereby report that such license, if granted, will comply with the provisions of Title 44, Articles 4 and 3, C.R.S., and Liquor Rules.

Therefore this application is approved.

Local Licensing Authority For

Title

Attest

Signature

Date (MM/DD/YY)

DR 8495 (02/18/24)
COLORADO DEPARTMENT OF REVENUE
Liquor Enforcement Division
PO BOX 17087
Denver CO 80217-0087
(303) 205-2300

Tax Check Authorization, Waiver, and Request to Release Information

I, Brian Urbahns

am signing this Tax Check Authorization, Waiver and Request to Release Information (hereinafter

"Waiver") on behalf of

(the "Applicant/Licensee")

Dillon Companies, LLC

to permit the Colorado Department of Revenue and any other state or local taxing authority to release information and documentation that may otherwise be confidential, as provided below. If I am signing this Waiver for someone other than myself, including on behalf of a business entity, I certify that I have the authority to execute this Waiver on behalf of the Applicant/Licensee.

The Executive Director of the Colorado Department of Revenue is the State Licensing Authority, and oversees the Colorado Liquor Enforcement Division as his or her agents, clerks, and employees. The information and documentation obtained pursuant to this Waiver may be used in connection with the Applicant/Licensee's liquor license application and ongoing licensure by the state and local licensing authorities. The Colorado Liquor Code, section 44-3-101. et seq. ("Liquor Code"), and the Colorado Liquor Rules, 1 CCR 203-2 ("Liquor Rules"), require compliance with certain tax obligations, and set forth the investigative, disciplinary and licensure actions the state and local licensing authorities may take for violations of the Liquor Code and Liquor Rules, including failure to meet tax reporting and payment obligations.

The Waiver is made pursuant to section 39-21-113(4), C.R.S., and any other law, regulation, resolution or ordinance concerning the confidentiality of tax information, or any document, report or return filed in connection with state or local taxes. This Waiver shall be valid until the expiration or revocation of a license, or until both the state and local licensing authorities take final action to approve or deny any application(s) for the renewal of the license, whichever is later. Applicant/Licensee agrees to execute a new waiver for each subsequent licensing period in connection with the renewal of any license, if requested.

By signing below, Applicant/Licensee requests that the Colorado Department of Revenue and any other state or local taxing authority or agency in the possession of tax documents or information, release information and documentation to the Colorado Liquor Enforcement Division, and is duly authorized employees, to act as the Applicant's/Licensee's duly authorized representative under section 39-21-113(4), C.R.S., solely to allow the state and local licensing authorities, and their duly authorized employees, to investigate compliance with the Liquor Code and Liquor Rules. Applicant/Licensee authorizes the state and local licensing authorities, their duly authorized employees, and their legal representatives, to use the information and documentation obtained using this Waiver in any administrative or judicial action regarding the application or license.

Name (Individual/Business)

Dillon Companies, LLC dba City Market #41

Social Security Number/Tax Identification Number

48-0196590

Home Phone Number

970-984-9715

Business/Work Phone Number

615-232-9878

Street Address

850 Castle Valley Boulevard

City

New Castle

State

CO

ZIP Code

81647-9441

Printed name of person signing on behalf of the Applicant/Licensee

Brian Urbahns

Applicant/Licensee's Signature (Signature authorizing the disclosure of confidential tax information) Date Signed

Brian A. Urbahns

8/26/2025

D1A8044D3787417...

Privacy Act Statement

Providing your Social Security Number is voluntary and no right, benefit or privilege provided by law will be denied as a result of refusal to disclose it. § 7 of Privacy Act, 5 USCS § 552a (note).

DR 8400 (02/16/24)
COLORADO DEPARTMENT OF REVENUE
 Liquor Enforcement Division
 PO BOX 17087
 Denver CO 80217-0087
 (303) 205-2300

Submit to Local Licensing Authority

Fees Due	
Annual Renewal Application Fee	\$ 250
Renewal Fee	
Storage Permit \$100 X _____	\$
Sidewalk Service Area \$75.00	\$
Additional Optional Premise Hotel & Restaurant \$100 X _____	\$
Related Facility - Campus Liquor Complex \$160.00 per facility	\$
Amount Due/Paid	\$

Make check payable to: Colorado Department of Revenue. The State may convert your check to a one-time electronic banking transaction. Your bank account may be debited as early as the same day received by the State. If converted, your check will not be returned. If your check is rejected due to insufficient or uncollected funds, the Department may collect the payment amount directly from your banking account electronically.

Retail Liquor License Renewal Application

Please verify & update all information below. Return to city or county licensing authority by due date.

Note that the Division will not accept cash.

Paid by check

Uploaded to Movelt on Date

Paid online

Licensee Name

Doing Business As Name (DBA)

Liquor License Number

License Type

Sales Tax License Number

Expiration Date

Due Date

Business Address

Street Address

Phone Number

City

State

ZIP Code

Mailing Address

Street Address

City

State

ZIP Code

Email

Operating Manager

Jessa Ortega

Date of Birth

[Redacted]

Home Address

Street Address

[Redacted]

Phone Number

[Redacted]

City

[Redacted]

State

CO

ZIP Code

81650

1. Do you have legal possession of the premises at the street address?..... Yes No

Are the premises owned or rented?

Owned

Rented*

*If rented, expiration date of lease

11/30/2032

2. Are you renewing a storage permit, additional optional premises, sidewalk service area, or related facility?..... Yes No

If yes, please see the table in the upper right hand corner and include all fees due.

3. Are you renewing a takeout and/or delivery permit?..... Yes No

(Note: must hold a qualifying license type and be authorized for takeout and/or delivery license privileges)

If selecting 'Yes', an additional \$11.00 is required to renew the permit.

If so, which are you renewing?..... Delivery Takeout Both Takeout and Delivery

4. Since the date of filing of the last application, has the applicant, including its manager, partners, officer, directors, stockholders, members (LLC), managing members (LLC), or any other person with a 10% or greater financial interest in the applicant, been found in final order of a tax agency to be delinquent in the payment of any state or local taxes, penalties, or interest related to a business?..... Yes No

Since the date of filing of the last application, has the applicant, including its manager, partners, officer, directors, stockholders, members (LLC), managing members (LLC), or any other person with a 10% or greater financial interest in the applicant failed to pay any fees or surcharges imposed pursuant to section 44-3-503, C.R.S.?..... Yes No

5. Since the date of filing of the last application, has there been any change in financial interest (new notes, loans, owners, etc.) or organizational structure (addition or deletion of officers, directors, managing members or general partners)?..... Yes No

If yes, explain in detail and attach a listing of all liquor businesses in which these new lenders, owners (other than licensed financial institutions), officers, directors, managing members, or general partners are materially interested.

See attached master file

6. Since the date of filing of the last application, has the applicant or any of its agents, owners, managers, partners or lenders (other than licensed financial institutions) been convicted of a crime?..... Yes No
 If yes, attach a detailed explanation.

7. Since the date of filing of the last application, has the applicant or any of its agents, owners, managers, partners or lenders (other than licensed financial institutions) been denied an alcohol beverage license, had an alcohol beverage license suspended or revoked, or had interest in any entity that had an alcohol beverage license denied, suspended or revoked?..... Yes No
 If yes, attach a detailed explanation. See attached violations

8. Does the applicant or any of its agents, owners, managers, partners or lenders (other than licensed financial institutions) have a direct or indirect interest in any other Colorado liquor license, including loans to or from any licensee or interest in a loan to any licensee?..... Yes No
 If yes, attach a detailed explanation. See attached locations

Affirmation & Consent

I declare under penalty of perjury in the second degree that this application and all attachments are true, correct and complete to the best of my knowledge.

Type or Print Name of Applicant/Authorized Agent of Business

Camille Hayes

Title

Licensing Coordinator

Signature

Camille Hayes

Date (MM/DD/YY)

8/29/2025

Report & Approval of City or County Licensing Authority

The foregoing application has been examined and the premises, business conducted and character of the applicant are satisfactory, and we do hereby report that such license, if granted, will comply with the provisions of Title 44, Articles 4 and 3, C.R.S., and Liquor Rules.

Therefore this application is approved.

Local Licensing Authority For

Title

Attest

Signature

Date (MM/DD/YY)

Tax Check Authorization, Waiver, and Request to Release Information

I, Camille Hayes

am signing this Tax Check Authorization, Waiver and Request to Release Information (hereinafter "Waiver") on behalf of

(the "Applicant/Licensee")

Kum & Go LC/Maverik 5050

to permit the Colorado Department of Revenue and any other state or local taxing authority to release information and documentation that may otherwise be confidential, as provided below. If I am signing this Waiver for someone other than myself, including on behalf of a business entity, I certify that I have the authority to execute this Waiver on behalf of the Applicant/Licensee.

The Executive Director of the Colorado Department of Revenue is the State Licensing Authority, and oversees the Colorado Liquor Enforcement Division as his or her agents, clerks, and employees. The information and documentation obtained pursuant to this Waiver may be used in connection with the Applicant/Licensee's liquor license application and ongoing licensure by the state and local licensing authorities. The Colorado Liquor Code, section 44-3-101. et seq. ("Liquor Code"), and the Colorado Liquor Rules, 1 CCR 203-2 ("Liquor Rules"), require compliance with certain tax obligations, and set forth the investigative, disciplinary and licensure actions the state and local licensing authorities may take for violations of the Liquor Code and Liquor Rules, including failure to meet tax reporting and payment obligations.

The Waiver is made pursuant to section 39-21-113(4), C.R.S., and any other law, regulation, resolution or ordinance concerning the confidentiality of tax information, or any document, report or return filed in connection with state or local taxes. This Waiver shall be valid until the expiration or revocation of a license, or until both the state and local licensing authorities take final action to approve or deny any application(s) for the renewal of the license, whichever is later. Applicant/Licensee agrees to execute a new waiver for each subsequent licensing period in connection with the renewal of any license, if requested.

By signing below, Applicant/Licensee requests that the Colorado Department of Revenue and any other state or local taxing authority or agency in the possession of tax documents or information, release information and documentation to the Colorado Liquor Enforcement Division, and its duly authorized employees, to act as the Applicant's/Licensee's duly authorized representative under section 39-21-113(4), C.R.S., solely to allow the state and local licensing authorities, and their duly authorized employees, to investigate compliance with the Liquor Code and Liquor Rules. Applicant/Licensee authorizes the state and local licensing authorities, their duly authorized employees, and their legal representatives, to use the information and documentation obtained using this Waiver in any administrative or judicial action regarding the application or license.

Name (Individual/Business)

Kum & Go LC/Maverik 5050

Social Security Number/Tax Identification Number

01240424-0005

Home Phone Number

Business/Work Phone Number

515-274-7793

Street Address

801 Castle Valley Blvd

City

New Castle

State

CO

ZIP Code

81647

Printed name of person signing on behalf of the Applicant/Licensee

Camille Hayes

Applicant/Licensee's Signature (Signature authorizing the disclosure of confidential tax information)

Camille Hayes

Date Signed

8/29/2025

Privacy Act Statement

Providing your Social Security Number is voluntary and no right, benefit or privilege provided by law will be denied as a result of refusal to disclose it. § 7 of Privacy Act, 5 USCS § 552a (note).