

## **SPECIAL ORDINANCE OVERSIGHT COUNCIL COMMITTEE AGENDA**

City Hall – Second floor - Midwest City Council Conference room, 100 N. Midwest Boulevard

October 18, 2022 – 5:30 PM

A. **CALL TO ORDER.**

B. **DISCUSSION ITEMS.**

- 1.** Discussion and consideration, including any amendments, of approving the Special Ordinance Oversight Council Committee meeting minutes from October 12, 2021 and April 18, 2022.
- 2.** Discussion and consideration for adoption, including any amendments, of an ordinance amending the Midwest City Municipal Code, Chapter 2 Administration; Article II, City Council; Section 2-11, Time of regular meetings of council; and providing for a repealer, and severability.
- 3.** Discussion and consideration for adoption, including any amendments, of an ordinance amending the Midwest City Municipal Code, Chapter 2 Administration; Article II, City Council; Section 2-11, Time of regular meetings of council; and providing for a repealer, and severability.
- 4.** Discussion and consideration for adoption, including any amendments, of an ordinance amending the Midwest City Municipal Code, Chapter 13, Drainage and Flood Control, Article III, Stormwater Runoff Control, Section 13-71, Requirements relating to improvements; Section 13-73, Figures and providing for a repealer, and severability.
- 5.** Discussion and consideration for adoption, including any amendments, of an ordinance amending the Midwest City Municipal Code, Chapter 27 Nuisances; Article II, Weeds and Trash; Section 27-28, Accumulation of rubbish declared a nuisance; penalty; providing for a repealer, and severability.
- 6.** Discussion and consideration for adoption, including any amendments, of a new ordinance located in the Midwest City Municipal Code, Chapter 42, Trees; Article III, Tree Trimming, Etc.; Section 42-55, Dead Trees on Private Property; and providing for a repealer, and severability.
- 7.** Discussion of the provisions of 9-124 of the Midwest City Municipal Code, Chapter 9, Building and Building Regulations; Article IV, Electricity; Division 3 – Electricians, Section 9-124, Defective workmanship or materials.
- 8.** Discussion of the Administrative Fines contained in the Midwest City Municipal Code, Chapter 27, Nuisances; Article I, In General; Section 27-2, Declared unlawful; penalties.
- 9.** Discussion and consideration for adoption, including any possible amendment of an ordinance amending Midwest City code, Chapter 37, Streets and Sidewalks, Article III, Section 37-67, Construction of Sidewalk; and providing for repealer and severability.

C. **ADJOURNMENT.**

Notice of this Ordinance Oversight Council Committee special meeting was filed with the City Clerk of Midwest City at Least 48 hours prior to the meeting and copies of the agenda for this meeting were posted at City Hall for at least 24 hours in advance of the meeting.

**Ordinance Oversight Council Committee Minutes  
Special Meeting**

**April 18, 2021**

This meeting was held in the second floor conference room of City Hall, City of Midwest City, County of Oklahoma, State of Oklahoma.

Chairman Pat Byrne called the meeting to order at 5:00 PM with Mayor Matt Dukes and Councilmember Susan Eads.

Staff Present: City Manager Tim Lyon, City Attorney Donald Maisch, City Clerk Sara Hancock, Assistant City Manager Vaughn Sullivan, Director of Operations Ryan Rushing, Director of Communications Josh Ryan.

**DISCUSSION ITEMS.**

- 1. Discussion and consideration for adoption, including any possible amendment of, an ordinance amending the Midwest City Municipal Code, Chapter 2 Administration, Article VIII, Purchasing, Section 2-118, Bids Required, Invitation; and Providing for Repealer and Severability.**

Eads made a motion to approve the minutes, as submitted, seconded by Dukes. Voting aye: Dukes, Eads, and Byrne. Nay: none. Motion carried.

- 2. Discussion and consideration for adoption, including any amendments, of an ordinance amending the Midwest City Municipal Code, Chapter 3 Advertising, Article II, License, Sections 3-16, Required; Application; Section 3-17, Fee, 3-18, Expiration; Prorating; Transfer; Signing, Seal; Chapter 9, Buildings And Building Regulations; Article VII, Sign Regulations; Section 9-382, Definitions; and Providing For Repealer And Severability.**

Dukes made a motion to approve and submit to the full City Council, seconded by Eads. Voting aye: Dukes, Eads, and Byrne. Nay: none. Motion carried.

- 3. Discussion and consideration for adoption, including any amendments, of an ordinance amending the Midwest City Municipal Code, Chapter 9, Buildings and Building Regulations, Article II, Builder's Advisory Board, Section 9-17, Members; and providing for a repealer and severability.**

Eads made a motion to approve and submit to the full City Council, seconded by Dukes. Voting aye: Dukes, Eads, and Byrne. Nay: none. Motion carried.

- 4. Discussion and consideration for adoption, including any possible amendment, of an ordinance amending the Midwest City Municipal Code, Chapter 13, Drainage and Flood Control, Article III, Stormwater Runoff Control, Sections 13-71, Requirements relating to improvements, and Section 13-73, Figures; and Providing for Repealer and Severability.**

Eads made a motion to approve and submit to the full City Council, seconded by Dukes. Voting aye: Dukes, Eads, and Byrne. Nay: none. Motion carried.

- 5. Discussion and consideration for adoption, including any possible amendment, of an ordinance amending the Midwest City Municipal Code, Chapter 18, Garbage and Refuse, Article II, Municipal Collection and Disposal Service, Section 18-25, Container Required, Duty to Use; and providing for Repealer and Severability.**

Dukes made a motion to approve upon further review prior to submitting to the full City Council, seconded by Byrne. Voting aye: Dukes, Eads, and Byrne. Nay: none. Motion carried.

- 6. Discussion and consideration for adoption, including any amendments, of an ordinance amending the Midwest City Municipal Code, Chapter 28 Offenses - Miscellaneous, Article V, Offenses Against Public Peace, Section 28-94 out of reserve and entitling it "Offenses Against Public Peace; and providing for Repealer and Severability.**

Eads made a motion to approve and submit to the full City Council, seconded by Byrne. Voting aye: Dukes, Eads, and Byrne. Nay: none. Motion carried.

- 7. Discussion and consideration for adoption, including any amendments, of an ordinance amending the Midwest City Municipal Code, Chapter 38 Subdivision Regulations, Article VIII, Definitions, Section 38-65.120, Park Land Review Committee; and providing for a repealer and severability.**

Eads made a motion to approve and submit to the full City Council, seconded by Byrne. Voting aye: Dukes, Eads, and Byrne. Nay: none. Motion carried.

- 8. Discussion and consideration for adoption, including any amendments, of an ordinance amending the Midwest City Municipal Code: Appendix A, Zoning Regulations; Section 6, Development Review Bodies; Part 6.3, Board of Adjustment; Subpart 6.3.2, Membership; and providing for repealer, and severability.**

Eads made a motion to approve and submit to the full City Council, seconded by Byrne. Voting aye: Dukes, Eads, and Byrne. Nay: none. Motion carried.

### **FURTHER INFORMATION.**

No action was taken on these items: Discussion of appointment of Boards and Commissions; Discussion of Soft Surface Parking; Discussion of abandoned shopping carts; and Discussion of sidewalks and overlay districts.

**ADJOURNMENT.** Chairman Byrne adjourned the meeting at 5:26 PM.

Notice of this Ordinance Oversight Council Committee special meeting was filed with the City Clerk of Midwest City at Least 48 hours prior to the meeting and copies of the agenda for this meeting were posted at City Hall for at least 24 hours in advance of the meeting.

**Ordinance Oversight Council Committee Minutes  
Special Meeting**

**October 12, 2021**

This meeting was held in the second floor conference room of City Hall, City of Midwest City, County of Oklahoma, State of Oklahoma.

Chairman Pat Byrne called the meeting to order at 5:00 PM with Mayor Matt Dukes and Councilmember Susan Eads.

Staff Present: City Manager Tim Lyon, City Attorney Donald Maisch, City Clerk Sara Hancock, Assistant City Manager Vaughn Sullivan, Director of Operations Ryan Rushing, Director of Communications Josh Ryan.

**DISCUSSION ITEMS.**

- 1. Discussion and consideration for adoption, including any possible amendment of, the minutes of the July 14, 2021 special meeting.**

Eads made a motion to approve the minutes, as submitted, seconded by Dukes. Voting aye: Dukes, Eads, and Byrne. Nay: none. Motion carried.

- 2. Discussion and consideration for adoption, including any amendments, of an ordinance amending the Midwest City Municipal Code, Chapter 2, Administration, Article VIII, Purchasing, Sections 2-116 Generally and 2-125 When bidding not required; and providing for a repealer, severability and an effective date.**

Dukes made a motion to approve and submit to the full City Council, seconded by Eads. Voting aye: Dukes, Eads, and Byrne. Nay: none. Motion carried.

- 3. Discussion and consideration for adoption, including any amendments, of an ordinance amending the Midwest City Municipal Code, Chapter 5 Alcoholic Beverages, Article II, Alcoholic Beverages, Article IV, Occupation Tax, Various Sections; and providing for repealer, severability and effective date.**

Eads made a motion to approve and submit to the full City Council, seconded by Dukes. Voting aye: Dukes, Eads, and Byrne. Nay: none. Motion carried.

- 4. Discussion and consideration for adoption, including any amendments, of an ordinance amending the Midwest City Municipal Code, Chapter 7 Amusements, Article IV, Circuses and Carnivals, Sections 7-50, License; and 7-52 Insurance; providing for repealer, severability and effective date.**

Eads made a motion to approve and submit to the full City Council, seconded by Dukes. Voting aye: Dukes, Eads, and Byrne. Nay: none. Motion carried.

5. **Discussion and consideration for adoption, including any amendments, of an ordinance amending the Midwest City Municipal Code, Chapter 20, Housing Code, Article IV, Rental Property, Sections 20-204 through 20-210; and providing for repealer, severability and effective date.**

Dukes made a motion to approve upon further review prior to submitting to the full City Council, seconded by Byrne. Voting aye: Dukes, Eads, and Byrne. Nay: none. Motion carried.

6. **Discussion and consideration for adoption, including any amendments, of an ordinance amending the Midwest City Municipal Code, Chapter 20 Appendix A, Zoning Regulations, Section 8 Definitions, Paragraph 8.3, Words and Terms Defined, Subparagraphs 8.3.13 and 8.3.68; and providing for repealer, severability and an effective date.**

Eads made a motion to approve and submit to the full City Council, seconded by Byrne. Voting aye: Dukes, Eads, and Byrne. Nay: none. Motion carried.

**ADJOURNMENT.** Chairman Byrne adjourned the meeting at 5:26 PM.

---

PAT BYRNE, Chairman



**City Attorney, Donald D. Maisch**

100 N. Midwest Boulevard  
Midwest City, OK 73110  
DMaisch@midwestcityok.org  
Office: 405.739.1203  
[www.midwestcityok.org](http://www.midwestcityok.org)

**MEMORANDUM**

To: Chair and Members of the Ordinance Review Committee

From: Don Maisch City Attorney; through Sara Bana, Ward 5, City Council Member

Date: October 18, 2022

RE: Discussion and consideration for adoption, including any amendments, of an ordinance amending the Midwest City Municipal Code, Chapter 2 Administration; Article II, City Council; Section 2-11, Time of regular meetings of council; and providing for a repealer, and severability. (D. Maisch, City Attorney; through S. Bana, Ward 5, City Council Member).

---

The proposed amendment to Chapter 2 Administration; Article II, City Council; Section 2-11, Time of regular meetings of council, would change the number of meetings of the City Council to two (2) meetings a month, to give the City Council more oversight of the activities of the City Administration. The months of November and December would only have one meeting (second Tuesday of the month) due to the holidays.

Recommended approval is at the pleasure of the Ordinance Review Committee.

Respectfully submitted,

Sara Bana  
Ward 5, City Council Member

1 **ORDINANCE NO. \_\_\_\_\_**  
2

3 AN ORDINANCE AMENDING THE MIDWEST CITY MUNICIPAL CODE, CHAPTER 2  
4 ADMINISTRATION; ARTICLE II, CITY COUNCIL; SECTION 2-11, TIME OF REGULAR  
5 MEETINGS OF COUNCIL; AND PROVIDING FOR REPEALER AND SEVERABILITY.  
6

7 BE IT ORDAINED BY THE COUNCIL OF THE CITY OF MIDWEST CITY, OKLAHOMA:  
8

9 **ORDINANCE**  
10

11 **Section 1.** That the Midwest City Municipal Code, Chapter 2 Administration; Article II, City  
12 Council; Section 2-11, Time of regular meetings of council; is hereby amended to read as follows:  
13

14 **Sec. 2-11. - Time of regular meetings of council.**  
15

16 All regular meetings of the council of the city shall be held at or after 6:00 p.m., and shall  
17 be held as follows:

18 (1) ~~There shall be only one (1) regular meeting, in the months of November and~~  
19 ~~December, which meeting shall be held on the second Tuesday;~~

20 (2) ~~There shall be only one (1) regular meeting in the months of January, February,~~  
21 ~~March, April, May, July, August, September and October, which meeting shall be held on the~~  
22 ~~fourth Tuesday; and~~

23 (3) There there shall be two (2) regular meetings held in June each month, which  
24 meetings shall be held on the second and fourth Tuesday, except for the months of November  
25 and December, wherein there shall be one (1) regular meeting held on the second Tuesday of the  
26 month.  
27

28 If the date of a regular meeting falls on a holiday recognized by the city, that meeting shall be  
29 held on the next day that is not a holiday.  
30

31 **Section 2. REPEALER.** All ordinances or parts of ordinances in conflict herewith are hereby  
32 repealed.  
33

34 **Section 3. SEVERABILITY.** If any section, sentence, clause, or portion of this ordinance is for  
35 any reason held to be invalid, such decision shall not affect the validity of the remaining provisions  
36 of the ordinance.  
37

38 PASSED AND APPROVED by the Mayor and the Council of the City of Midwest City,  
39 Oklahoma, this \_\_\_\_\_ day of \_\_\_\_\_, 2022.  
40

41 **THE CITY OF MIDWEST CITY, OKLAHOMA**  
42

43  
44  
45 \_\_\_\_\_  
MATTHEW D. DUKES, II, Mayor

1  
2  
3  
4  
5  
6  
7  
8  
9  
10  
11  
12  
13

ATTEST:

\_\_\_\_\_  
SARA HANCOCK, City Clerk

Approved as to form and legality this \_\_\_\_\_ day of \_\_\_\_\_, 2022.

\_\_\_\_\_  
DONALD D. MAISCH, City Attorney



1  
2  
3  
4  
5  
6  
7  
8  
9  
10  
11  
12  
13  
14  
15  
16  
17  
18  
19  
20  
21  
22  
23  
24  
25  
26  
27  
28  
29  
30  
31  
32  
33  
34  
35  
36  
37  
38  
39  
40  
41  
42  
43  
44

**ORDINANCE NO. \_\_\_\_\_**

AN ORDINANCE AMENDING THE MIDWEST CITY MUNICIPAL CODE, CHAPTER 2 ADMINISTRATION; ARTICLE II, CITY COUNCIL; SECTION 2-11, TIME OF REGULAR MEETINGS OF COUNCIL; AND PROVIDING FOR REPEALER AND SEVERABILITY.

BE IT ORDAINED BY THE COUNCIL OF THE CITY OF MIDWEST CITY, OKLAHOMA:

**ORDINANCE**

**Section 1.** That the Midwest City Municipal Code, Chapter 2 Administration; Article II, City Council; Section 2-11, Time of regular meetings of council; is hereby amended to read as follows:

**Sec. 2-11. - Time of regular meetings of council.**

All regular meetings of the council of the city shall be held at or after 6:00 p.m., there shall be two (2) regular meetings held each month, which meetings shall be held on the second and fourth Tuesday, except for the months of November and December, wherein there shall be one (1) regular meeting held on the second Tuesday of the month.

If the date of a regular meeting falls on a holiday recognized by the city, that meeting shall be held on the next day that is not a holiday.

**Section 2.** REPEALER. All ordinances or parts of ordinances in conflict herewith are hereby repealed.

**Section 3.** SEVERABILITY. If any section, sentence, clause, or portion of this ordinance is for any reason held to be invalid, such decision shall not affect the validity of the remaining provisions of the ordinance.

PASSED AND APPROVED by the Mayor and the Council of the City of Midwest City, Oklahoma, this \_\_\_\_\_ day of \_\_\_\_\_, 2022.

**THE CITY OF MIDWEST CITY, OKLAHOMA**

\_\_\_\_\_  
MATTHEW D. DUKES, II, Mayor

ATTEST:

\_\_\_\_\_  
SARA HANCOCK, City Clerk

1  
2  
3  
4  
5  
6  
7

Approved as to form and legality this \_\_\_\_\_ day of \_\_\_\_\_, 2022.

\_\_\_\_\_  
DONALD D. MAISCH, City Attorney



**City Attorney, Donald D. Maisch**

100 N. Midwest Boulevard  
Midwest City, OK 73110  
DMaisch@midwestcityok.org  
Office: 405.739.1203  
[www.midwestcityok.org](http://www.midwestcityok.org)

**MEMORANDUM**

To: Chair and Members of the Ordinance Review Committee

From: Don Maisch, City Attorney

Date: October 18, 2022

RE: Discussion and consideration for adoption, including any amendments, of an ordinance amending the Midwest City Municipal Code, Chapter 2 Administration; Article II, City Council; Section 2-11, Time of regular meetings of council; and providing for a repealer, and severability. (D. Maisch, City Attorney).

---

The proposed amendment to Chapter 2 Administration; Article II, City Council; Section 2-11, Time of regular meetings of council, adds the month of January and May into the list of two regularly scheduled meetings for the month. Staff believes there is a need for two meetings in January due to the length of time between the December meeting and the current January meeting. Two meetings in the month of May already occur, one to discuss the draft budget with the City Council and the other as the regularly scheduled meeting.

Recommended approval is at the pleasure of the Ordinance Review Committee.

Respectfully submitted,

Donald D. Maisch  
City Attorney

1                                   **ORDINANCE NO. \_\_\_\_\_**

2  
3 AN ORDINANCE AMENDING THE MIDWEST CITY MUNICIPAL CODE, CHAPTER 2  
4 ADMINISTRATION; ARTICLE II, CITY COUNCIL; SECTION 2-11, TIME OF REGULAR  
5 MEETINGS OF COUNCIL; AND PROVIDING FOR REPEALER AND SEVERABILITY.

6  
7 BE IT ORDAINED BY THE COUNCIL OF THE CITY OF MIDWEST CITY, OKLAHOMA:

8  
9                                   **ORDINANCE**

10  
11 **Section 1.** That the Midwest City Municipal Code, Chapter 2 Administration; Article II, City  
12 Council; Section 2-11, Time of regular meetings of council; is hereby amended to read as follows:  
13

14 **Sec. 2-11. - Time of regular meetings of council.**

15  
16                   All regular meetings of the council of the city shall be held at or after 6:00 p.m., and shall  
17 be held as follows:

18           (1)       There shall be only one (1) regular meeting, in the months of November and  
19 December, which meeting shall be held on the second Tuesday;

20           (2)       There shall be only one (1) regular meeting in the months of ~~January~~, February,  
21 March, April, ~~May~~, July, August, September and October, which meeting shall be held on the  
22 fourth Tuesday; and

23           (3)       There shall be two (2) regular meetings held in January, May and June, which  
24 meetings shall be held on the second and fourth Tuesday.

25  
26 If the date of a regular meeting falls on a holiday recognized by the city, that meeting shall be  
27 held on the next day that is not a holiday.  
28

29 **Section 2. REPEALER.** All ordinances or parts of ordinances in conflict herewith are hereby  
30 repealed.

31  
32 **Section 3. SEVERABILITY.** If any section, sentence, clause, or portion of this ordinance is for  
33 any reason held to be invalid, such decision shall not affect the validity of the remaining provisions  
34 of the ordinance.

35  
36 PASSED AND APPROVED by the Mayor and the Council of the City of Midwest City,  
37 Oklahoma, this \_\_\_\_\_ day of \_\_\_\_\_, 2022.

38  
39                                   **THE CITY OF MIDWEST CITY, OKLAHOMA**

40  
41  
42                                   \_\_\_\_\_  
43 MATTHEW D. DUKES, II, Mayor

44  
45 ATTEST:

1  
2  
3  
4  
5  
6  
7  
8  
9  
10  
11

\_\_\_\_\_  
SARA HANCOCK, City Clerk

Approved as to form and legality this \_\_\_\_ day of \_\_\_\_\_, 2022.

\_\_\_\_\_  
DONALD D. MAISCH, City Attorney



1  
2  
3  
4  
5  
6  
7  
8  
9  
10  
11

\_\_\_\_\_  
SARA HANCOCK, City Clerk

Approved as to form and legality this \_\_\_\_ day of \_\_\_\_\_, 2022.

\_\_\_\_\_  
DONALD D. MAISCH, City Attorney



**City Attorney, Donald D. Maisch**

100 N. Midwest Boulevard  
Midwest City, OK 73110  
DMaisch@midwestcityok.org  
Office: 405.739.1203  
[www.midwestcityok.org](http://www.midwestcityok.org)

**MEMORANDUM**

To: Mayor and City Council

From: Don Maisch  
City Attorney

Date: October 18, 2022

RE: Discussion and consideration for adoption, including any amendments, of an ordinance amending the Midwest City Municipal Code, Chapter 13, Drainage and Flood Control, Article III, Stormwater Runoff Control, Section 13-71, Requirements relating to improvements; Section 13-73, Figures and providing for a repealer, and severability.

---

Staff discovered a conflict between Section 13-71 and Section 13-73 of the City Ordinances for the City of Midwest City. To resolve the conflict, this proposed amendment is to amend Section 13-71, so that it and Section 13-73 no longer conflict. Amendments will allow fencing to be placed immediately adjacent to the Open Paved Storm Channel as requested by the City Council when previously considered.

Recommended approval for the Ordinance Review Committee.

Respectfully submitted,

Donald D. Maisch  
City Attorney





1  
2  
3  
4  
5  
6  
7  
8  
9  
10  
11  
12  
13  
14  
15  
16  
17  
18  
19  
20  
21  
22  
23  
24  
25  
26  
27  
28  
29  
30  
31

**Section 2.** That the Midwest City Municipal Code, Chapter 13 Drainage and Flood Control, Article III, Stormwater Runoff Control, Section 13-73, Figures; is hereby amended to read as follows:

Sec. 13-73. - Figures.

[See attached document for amendments to be inserted here].

**Section 3.** REPEALER. All ordinances or parts of ordinances in conflict herewith are hereby repealed.

**Section 4.** SEVERABILITY. If any section, sentence, clause, or portion of this ordinance is for any reason held to be invalid, such decision shall not affect the validity of the remaining provisions of the ordinance.

PASSED AND APPROVED by the Mayor and the Council of the City of Midwest City, Oklahoma, this \_\_\_\_\_ day of \_\_\_\_\_, 2022.

**THE CITY OF MIDWEST CITY, OKLAHOMA**

\_\_\_\_\_  
MATTHEW D. DUKES, II, Mayor

ATTEST:

\_\_\_\_\_  
SARA HANCOCK, City Clerk

1  
2  
3  
4  
5  
6

Approved as to form and legality this \_\_\_\_\_ day of \_\_\_\_\_, 2022.

\_\_\_\_\_  
DONALD D. MAISCH, City Attorney



1 **Section 2.** That the Midwest City Municipal Code, Chapter 13 Drainage and Flood Control, Article  
2 III, Stormwater Runoff Control, Section 13-73, Figures; is hereby amended to read as follows:

3  
4 Sec. 13-73. - Figures.

5  
6 [See attached document for amendments to be inserted here].

7  
8 **Section 3.** REPEALER. All ordinances or parts of ordinances in conflict herewith are hereby  
9 repealed.

10  
11 **Section 4.** SEVERABILITY. If any section, sentence, clause, or portion of this ordinance is for  
12 any reason held to be invalid, such decision shall not affect the validity of the remaining provisions  
13 of the ordinance.

14  
15 PASSED AND APPROVED by the Mayor and the Council of the City of Midwest City,  
16 Oklahoma, this \_\_\_\_\_ day of \_\_\_\_\_, 2022.

17  
18 **THE CITY OF MIDWEST CITY, OKLAHOMA**

19  
20  
21 \_\_\_\_\_  
22 MATTHEW D. DUKES, II, Mayor

23  
24 ATTEST:

25  
26 \_\_\_\_\_  
27 SARA HANCOCK, City Clerk  
28  
29

1  
2  
3  
4  
5  
6

Approved as to form and legality this \_\_\_\_\_ day of \_\_\_\_\_, 2022.

\_\_\_\_\_  
DONALD D. MAISCH, City Attorney



**City Attorney, Donald D. Maisch**

100 N. Midwest Boulevard  
Midwest City, OK 73110  
DMaisch@midwestcityok.org  
Office: 405.739.1203  
[www.midwestcityok.org](http://www.midwestcityok.org)

**MEMORANDUM**

To: Chair and Members of the Ordinance Review Committee

From: Donald D. Maisch, City Attorney

Date: October 18, 2022

RE: Discussion and consideration for adoption, including any amendments, of an ordinance amending the Midwest City Municipal Code, Chapter 27 Nuisances; Article II, Weeds and Trash; Section 27-28, Accumulation of rubbish declared a nuisance; penalty; providing for a repealer, and severability. (M. Stroh – Director, Code Enforcement).

---

The proposed amendment to Chapter 27 Nuisances; Article II, Weeds and Trash; Section 27-28, Accumulation of rubbish declared a nuisance; penalty, will allow staff or city contractors to pick up and dispose of any and all rubbish determined to be a nuisance on private property, including any additional rubbish found, and access the cost of removal upon the land owner.

Recommended approval is at the pleasure of the Ordinance Review Committee.

Respectfully submitted,

Mike Stroh,  
Director, Code Enforcement





1 found while abating the property by removing such rubbish with the cost of such removal,  
2 including the cost for the removal of any additional rubbish found, shall to be assessed to the owner  
3 or responsible party of the property. The notice shall state that any accumulations of ~~trash or weeds~~  
4 rubbish on the owner's property occurring within six (6) months after the removal of ~~trash or weeds~~  
5 rubbish on the property pursuant to such notice may be summarily abated by the municipal  
6 governing body, unless the property owner has been issued a burn permit from the fire department;  
7 that the costs of such abatement shall be assessed against the owner; and that a lien may be imposed  
8 on the property to secure such payment, all without further prior notice to the property owner. Any  
9 chains, locks or other similar devices used to secure any portion of the property where such  
10 violation exists shall be removed by the owner and/or responsible party or, such devices will be  
11 removed by the city or their representative without liability to the city or it's representative by the  
12 owner and/or responsible party. After abatement, the city clerk shall send a statement of the cost  
13 of such abatement, including the city's administrative expenses, to the owner of the property. Until  
14 paid, such cost shall constitute a debt to the city collectible in any manner as provided under local  
15 or state laws, including the filing of a lien, or other available debt collection remedies.

16  
17 (e) In addition to abatement by removal as indicated in subsection (d) of this section, the owner  
18 or responsible party, upon conviction of creating, maintaining, permitting or allowing a nuisance  
19 upon the premises, may be fined as set out in section 1-15.

20  
21 **Section 2.** REPEALER. All ordinances or parts of ordinances in conflict herewith are hereby  
22 repealed.

23  
24 **Section 3.** SEVERABILITY. If any section, sentence, clause, or portion of this ordinance is for  
25 any reason held to be invalid, such decision shall not affect the validity of the remaining provisions  
26 of the ordinance.

27

1 PASSED AND APPROVED by the Mayor and the Council of the City of Midwest City,  
2 Oklahoma, this \_\_\_\_\_ day of \_\_\_\_\_, 2021.

3  
4 **THE CITY OF MIDWEST CITY, OKLAHOMA**

5  
6  
7 \_\_\_\_\_  
8 MATTHEW D. DUKES, II, Mayor

9  
10 ATTEST:  
11  
12  
13 \_\_\_\_\_  
14 SARA HANCOCK, City Clerk

15  
16  
17 Approved as to form and legality this \_\_\_\_\_ day of \_\_\_\_\_, 2021.

18  
19  
20 \_\_\_\_\_  
21 DONALD D. MAISCH, City Attorney



1 found while abating the property by removing such rubbish with the cost of such removal,  
2 including the cost for the removal of any additional rubbish found, shall be assessed to the owner  
3 or responsible party of the property. The notice shall state that any accumulations of rubbish on  
4 the owner's property occurring within six (6) months after the removal of rubbish on the property  
5 pursuant to such notice may be summarily abated by the municipal governing body, unless the  
6 property owner has been issued a burn permit from the fire department; that the costs of such  
7 abatement shall be assessed against the owner; and that a lien may be imposed on the property to  
8 secure such payment, all without further prior notice to the property owner. Any chains, locks or  
9 other similar devices used to secure any portion of the property where such violation exists shall  
10 be removed by the owner and/or responsible party or, such devices will be removed by the city or  
11 their representative without liability to the city or it's representative by the owner and/or  
12 responsible party. After abatement, the city clerk shall send a statement of the cost of such  
13 abatement, including the city's administrative expenses, to the owner of the property. Until paid,  
14 such cost shall constitute a debt to the city collectible in any manner as provided under local or  
15 state laws, including the filing of a lien, or other available debt collection remedies.

16  
17 (e) In addition to abatement by removal as indicated in subsection (d) of this section, the owner  
18 or responsible party, upon conviction of creating, maintaining, permitting or allowing a nuisance  
19 upon the premises, may be fined as set out in section 1-15.

20  
21 **Section 2.** REPEALER. All ordinances or parts of ordinances in conflict herewith are hereby  
22 repealed.

23  
24 **Section 3.** SEVERABILITY. If any section, sentence, clause, or portion of this ordinance is for  
25 any reason held to be invalid, such decision shall not affect the validity of the remaining provisions  
26 of the ordinance.  
27

1 PASSED AND APPROVED by the Mayor and the Council of the City of Midwest City,  
2 Oklahoma, this \_\_\_\_\_ day of \_\_\_\_\_, 2021.

3  
4 **THE CITY OF MIDWEST CITY, OKLAHOMA**

5  
6  
7 \_\_\_\_\_  
8 MATTHEW D. DUKES, II, Mayor

9  
10 ATTEST:  
11  
12  
13 \_\_\_\_\_  
14 SARA HANCOCK, City Clerk

15  
16  
17 Approved as to form and legality this \_\_\_\_\_ day of \_\_\_\_\_, 2021.

18  
19  
20 \_\_\_\_\_  
21 DONALD D. MAISCH, City Attorney



**City Attorney, Donald D. Maisch**

100 N. Midwest Boulevard  
Midwest City, OK 73110  
DMaisch@midwestcityok.org  
Office: 405.739.1203  
[www.midwestcityok.org](http://www.midwestcityok.org)

**MEMORANDUM**

To: Chair and Members of the Ordinance Review Committee

From: Donald D. Maisch, City Attorney

Date: October 18, 2022

RE: Discussion and consideration for adoption, including any amendments, of a new ordinance located in the Midwest City Municipal Code, Chapter 42, Trees; Article III, Tree Trimming, Etc...; Section 42-55, Dead Trees on Private Property; and providing for a repealer, and severability. (D. Maisch – City Attorney).

---

The new ordinance to be located in Chapter 42, Trees; Article III, Tree Trimming, Etc...; Section 42-55, Dead Trees on Private Property; establishes that any dead tree or portion of a dead tree on private property is hereby deemed to be a public nuisance. The new ordinance sets time frames for removal of the dead tree or portions of a dead tree.

The proposed new ordinance establishes a municipal penalty schedule for violations of the provisions of this ordinance.

Recommended approval is at the pleasure of the Ordinance Review Committee.

Respectfully submitted,

Donald D. Maisch  
City Attorney



**THE CITY OF MIDWEST CITY, OKLAHOMA**

\_\_\_\_\_  
MATTHEW D. DUKES, II, Mayor

ATTEST:

\_\_\_\_\_  
SARA HANCOCK, City Clerk

Approved as to form and legality this \_\_\_\_\_ day of \_\_\_\_\_, 2022.

\_\_\_\_\_  
DONALD D. MAISCH, City Attorney



**ORDINANCE NO. \_\_\_\_\_**

AN NEW ORDINANCE IN THE MIDWEST CITY MUNICIPAL CODE, CHAPTER 42, TREES; ARTICLE III, TREE TRIMMING, ETC.; SECTION 42-55, DEAD TREES ON PRIVATE PROPERTY; PROVIDING FOR REPEALER AND SEVERABILITY.

BE IT ORDAINED BY THE COUNCIL OF THE CITY OF MIDWEST CITY, OKLAHOMA:

**ORDINANCE**

**Section 1.** That a new City Ordinance to be contained in Midwest City Municipal Code, Chapter 42, Trees; Article III, Tree Trimming, Etc., Section 42-55, Dead trees on private property; is hereby to read as follows:

42-55. Dead trees on private property.

- (A) Any dead tree, or any portion of a tree that is dead, including any tree branch or limb, that is located on private property is hereby declared to be a public nuisance.
- (B) It is the duty of any private property owner where the dead tree or any portion of a dead tree is located, to remove the dead tree or dead portion of the tree.
- (C) Upon discovery by the City of a dead tree or any portion of a dead tree on private property, the City shall give notice to the property owner. The property owner shall have thirty (30) days to properly remove the dead tree or portion of the dead tree. The notice shall be either mailed by first class mail using the United States Postal Service or hand-delivered to the property owner. If the property owner cannot be found, then the notice shall be posted at the location of the dead tree or dead portion of a tree.
- (D) If the property owner does not remove the dead tree or portion of the dead tree, within the thirty (30) day timeframe, then the property owner may receive a citation, requiring the removal of the dead tree, or dead portion of the tree. The citation may include a fine in an amount not to exceed \$250.00 for the initial citation. If a second citation is issued, said citation may include a fine not to exceed \$500.00. If a third or subsequent citation is issued, said citation may include a fine not to exceed \$1,000.00.

**Section 2.** REPEALER. All ordinances or parts of ordinances in conflict herewith are hereby repealed.

**Section 3.** SEVERABILITY. If any section, sentence, clause, or portion of this ordinance is for any reason held to be invalid, such decision shall not affect the validity of the remaining provisions of the ordinance.

Ordinance Amendments PASSED AND APPROVED by the Mayor and the Council of the City of Midwest City, Oklahoma, this \_\_\_\_\_ day of \_\_\_\_\_, 2022.

**THE CITY OF MIDWEST CITY, OKLAHOMA**

\_\_\_\_\_  
MATTHEW D. DUKES, II, Mayor

ATTEST:

\_\_\_\_\_  
SARA HANCOCK, City Clerk

Approved as to form and legality this \_\_\_\_\_ day of \_\_\_\_\_, 2022.

\_\_\_\_\_  
DONALD D. MAISCH, City Attorney



**City Attorney, Donald D. Maisch**

100 N. Midwest Boulevard  
Midwest City, OK 73110  
DMaisch@midwestcityok.org  
Office: 405.739.1203  
[www.midwestcityok.org](http://www.midwestcityok.org)

**MEMORANDUM**

To: Chair and Members of the Ordinance Review Committee

From: Donald D. Maisch, City Attorney

Date: October 18, 2022

RE: Discussion of the provisions of 9-124 of the Midwest City Municipal Code, Chapter 9, Building and Building Regulations; Article IV, Electricity; Division 3 – Electricians, Section 9-124, Defective workmanship or materials.

---

The proposed discussion item concerns when an electrician provides subpar workmanship on a electrical project for the City. The City Ordinances for the City of Midwest City already provides for:

Sec. 9-124. - Defective workmanship or materials.

Any person engaged in the business of electrical construction and the installation of wiring and apparatus for electric light, heat or power in the city who fails to correct promptly any defect in any work done by him contrary to this article, after having been notified thereof by the city, shall not be issued any further permits until such defect has been corrected. The registration of any person who continues to violate or persistently violates the ordinances of the city in regard to electrical work or the orders of the electrical inspector in relation to the same shall be suspended or revoked.

Discussion is at the pleasure of the Ordinance Review Committee.

Respectfully submitted,

Donald D. Maisch  
City Attorney



**City Attorney, Donald D. Maisch**

100 N. Midwest Boulevard  
Midwest City, OK 73110  
DMaisch@midwestcityok.org  
Office: 405.739.1203  
[www.midwestcityok.org](http://www.midwestcityok.org)

**MEMORANDUM**

To: Chair and Members of the Ordinance Review Committee

From: Donald D. Maisch, City Attorney

Date: October 18, 2022

RE: Discussion of the Administrative Fines contained in the Midwest City Municipal Code, Chapter 27, Nuisances; Article I, In General; Section 27-2, Declared unlawful; penalties.

---

---

This item is being submitted for discussion to the Ordinance Review Committee concerning the ability to assess an administrative fine in the amount of \$265.00. On July 21, 2021, the City Council for Midwest City increased the amount of the Administrative Fine from \$200.00 to \$265.00. The purpose of the Administrative Fine is to cover the administrative costs of the City when working nuisances under Chapter 27 of the City Ordinances. The question that is posed is whether to increase, decrease or continue with the Administrative Fine.

Discussion is at the pleasure of the Ordinance Review Committee.

Respectfully submitted,

Donald D. Maisch  
City Attorney

**Section 2.** That the Midwest City Municipal Code, Chapter 27 Nuisances, Article I, In General, Section 27-2, Declared Unlawful; Penalties; is hereby amended to read as follows:

(a) It shall be unlawful for the owner or responsible party to create or maintain a public nuisance within the city or to permit a public nuisance to remain on premises within the city.

(b) The punishment for every violation of this chapter shall be as set out in [section 1-15](#) of this Code. Each day a violation of this chapter continues shall constitute a separate offense of this chapter, and the fines associated with the offense shall increase for each subsequent violation that occurs within the calendar year, January 1 to December 31, as set out in [section 1-15](#).

(c) Where the city must abate a nuisance, there shall be assessed to the owner of the property an administrative fine of two hundred and sixty-five dollars (\$265.00) for each abatement contract for the property. For any abatement performed pursuant to section 27-14, the administrative fine may be assessed to either the owner of the property and/or the box owner.

---

TO : Ordinance Oversight Council Committee

FROM : Brandon Bundy, City Engineer

DATE : October 18, 2022

SUBJECT : Discussion and consideration for adoption, including any possible amendment of an ordinance amending Midwest City code, Chapter 37, Streets and Sidewalks, Article III, Section 37-67, Construction of Sidewalk; and providing for repealer and severability

---

This ordinance is being requested by Community Development staff. Currently, the code requires a minimum sidewalk width of 4 ft.

The 2010 ADA Standards for Accessible Design are the current federal standard regarding ADA requirements. Sidewalks on public right of way are under the jurisdiction of the Public Rights-of-Way Access Advisory Committee (PROWAG)

- R302.3 Continuous Width: Except as provided in R302.3.1 and R302.3.2, the continuous clear width of pedestrian access routes shall be 4.0 ft minimum, exclusive of the width of the curb.
- R302.4 Passing Spaces: Where the clear width of pedestrian access routes is less than 5.0 ft, passing spaces shall be provided at intervals of 200.0 feet maximum. Passing spaces shall be 5.0 ft minimum by 5.0 ft minimum. Passing spaces are permitted to overlap pedestrian access routes.

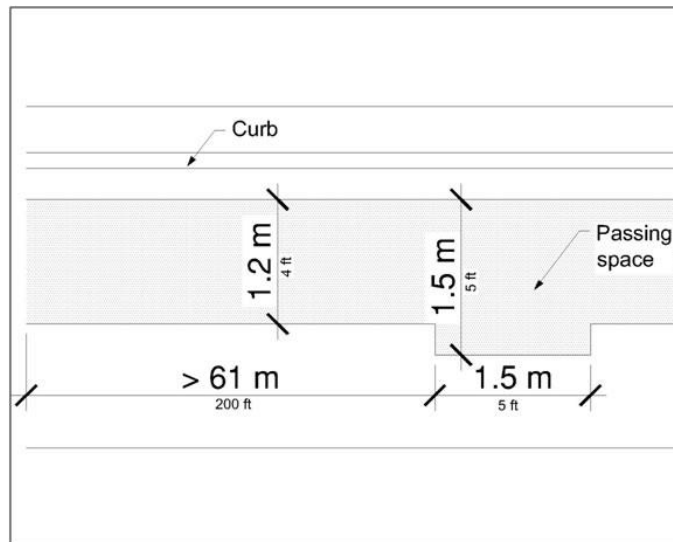

Therefore, our current code does not address the absolute minimum as set that there be passing spaces. To simplify code, staff recommends that the minimum be set at 5 ft wide. In practice, for the past 8 years, all sidewalks constructed under guidance of Community Development have

had a typical 5 ft wide cross section minimum. Midwest City's ADA Transition Committee has discussed this very issue multiple times. 4 ft is simply too narrow for anyone to pass a wheelchair. It is also uncomfortable to walk side by side on anything less than 5 ft.

At the regular meeting of the Sidewalk Committee, February 22<sup>nd</sup> 2022, the committee reviewed the ordinance and recommended a minimum width of 5 ft be considered before the Ordinance Review Committee.

At the special meeting of the Americans with Disabilities Act (ada) Transition Committee, May 23<sup>rd</sup>, 2022, the committee reviewed the ordinance and recommended a minimum width of 5 ft be considered before the Ordinance Review Committee.

The updated code will bring the City into compliance with this standard. In addition to the revisions from ADA, we propose deleting the existing exhibit which is covered in depth by our construction standards as well as deleting the paragraphs related to grandfathering current subdivisions. When this ordinance was originally passed in 1986, sidewalks were not standard practice; since that time, all subdivisions and commercial are required to have sidewalks unless waived by Council. As such, the old paragraphs related to the original passing need to be deleted to eliminate confusion.

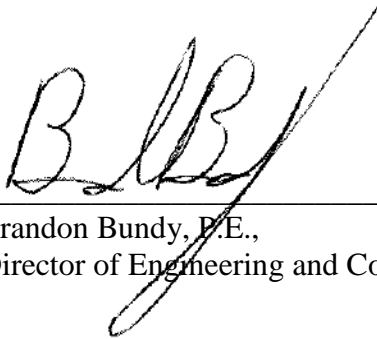
A handwritten signature in black ink, appearing to read 'B. Bundy', is written over a horizontal line. The signature is stylized and includes a long, sweeping flourish that extends to the right.

Brandon Bundy, P.E.,  
Director of Engineering and Construction Services

Attachments

1  
2  
3  
4  
5  
6  
7  
8  
9  
10  
11  
12  
13  
14  
15  
16  
17  
18  
19  
20  
21  
22  
23  
24  
25  
26  
27  
28  
29  
30  
31  
32  
33  
34  
35  
36

**ORDINANCE NO. \_\_\_\_\_**

**AN ORDINANCE AMENDING MIDWEST CITY CODE, SECTION 37, STREETS AND  
SIDEWALKS, BY AMENDING SUBSECTION 37-67, CONSTRUCTION OF SIDE-  
WALK, AND PROVIDING FOR REPEALER AND SEVERABILITY**

BE IT ORDAINED BY THE COUNCIL OF THE CITY OF MIDWEST CITY, OKLAHOMA:

**ORDINANCE**

**SECTION 1.** That Midwest City Code, Section 37, Streets and Sidewalks, by amending Sub-  
section 37-67, Construction of Sidewalk, to read as follows:

Sec. 37-67. - Construction of sidewalk.

- (a) In subdivisions where sidewalks have been installed partially, the following require-  
ments shall be applicable:
  - (1) When sidewalks exist partially on both sides of a street, the sidewalks on  
both sides of the street shall be continued to the intersecting streets.
  - (2) When sidewalks exist partially on only one side of a street, sidewalks on  
that side of the street shall be continued to the intersecting streets.
  - (3) When a sidewalk exists along the full length of a street between intersect-  
ing streets and no sidewalks exist on the other side of the subject street, no  
sidewalks shall be required on the side where no sidewalk exists.
  - (4) When a sidewalk exists on the circular part of a cul-de-sac, the sidewalk  
shall be continued on both sides of the street to the intersecting street.
- (b) Sidewalks required in section (a) above, shall be included in the paving/driveway per-  
mit obtained from the City of Midwest City. Sidewalks shall be constructed to a mini-  
mum width of five (5) feet and shall be placed into the street right-of-way one (1) foot  
off the property line and constructed as per standard drawing specifications on file in  
the city engineer's office.
- (c) If topographic or other physical conditions on the land will make strict application of  
this section result in exceptional practical difficulties, the city engineer is hereby au-  
thorized to allow such relocation or realignment of sidewalks as is necessary for its  
installation.
- (d) Sidewalks, where required, shall be part of the requirements for a building permit. No  
final certificate of occupancy or final water service shall be approved until all side-  
walks have been installed.
- (e) All sidewalks built on City right of way or easement shall be built to meet or exceed  
the American with Disabilities Act (ADA) and the current standards outlined by the  
United States Access Board.



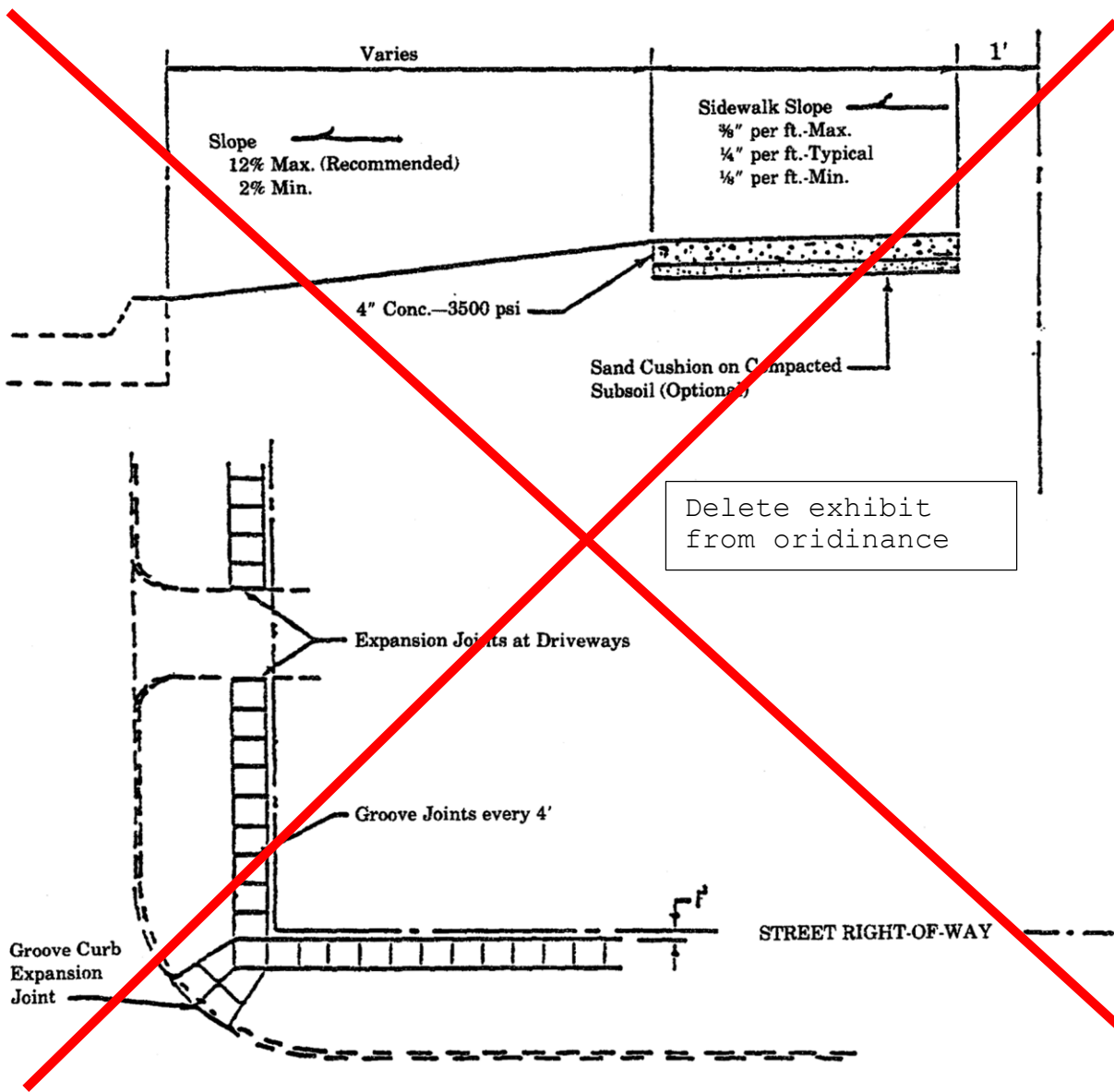

SECTION 2. REPEALER. All ordinances or parts of ordinances in conflict herewith are hereby repealed.

SECTION 3. SEVERABILITY. If any section, sentence, clause or portion of this ordinance is for any reason held to be invalid, such decision shall not affect the validity of the remaining portions of the ordinance.

PASSED AND APPROVED by the Mayor and Council of the City of Midwest City, Oklahoma, on the \_\_\_\_\_ day of \_\_\_\_\_, 2021.

THE CITY OF MIDWEST CITY, OKLAHOMA

\_\_\_\_\_  
MATTHEW D. DUKES II, Mayor

ATTEST:

\_\_\_\_\_  
SARA HANCOCK, City Clerk

APPROVED as to form and legality this \_\_\_\_\_ day of \_\_\_\_\_, 2021.

\_\_\_\_\_  
DONALD MAISCH, City Attorney