



TOWN COUNCIL REGULAR MEETING

Town Council Chambers, Moncks Corner Municipal
Complex, 118 Carolina Avenue
TUESDAY, NOVEMBER 14, 2023 at 6:00 PM

AGENDA

CALL TO ORDER

INVOCATION

PLEDGE OF ALLEGIANCE

PRESENTATIONS

- 1. Proclamation:** South Carolina Native American Heritage Month

APPROVAL OF MINUTES

- 2. Minutes:** Regular Meeting of Council - October 17, 2023

REPORTS

- 3. Mayor's Report:** Michael A. Locklear
- 4. Administrator's Report:** Jeffrey V. Lord

NEW BUSINESS

- 5. Consideration of Bids:** Lease Purchase - 2024 Ford F750 Sanitation Truck
- 6. Consideration of Bids:** Lease Purchase Financing Options - 2023 Ford F750 Sanitation Truck
- 7. First Reading:** An Ordinance to amend the business license ordinance to update the class schedule as required by ACT176 of 2020.

OLD BUSINESS

- 8. Old Business:** There is no old business to be brought before Council.

PUBLIC INPUT - Public Input will be limited to 3 minutes per individual

EXECUTIVE SESSION - Council may take action regarding matters discussed

- 9. Discussion:** Discuss a Personnel Matter

ADJOURNMENT

In accordance with the Americans with Disabilities Act, persons who need accommodation in order to attend or participate in this meeting should contact Town Hall at (843) 719- 7900 within 48 hours prior to the meeting in order to request such assistance.

Town of Moncks Corner

A Proclamation

"WHEREAS, American Indians, Alaskan natives, and Native Hawaiians have played a vital role in the life of our State and City, and Country and their many contributions have enhanced the freedom, prosperity and greatness of South Carolina; and

WHEREAS, There is one tribal community who is based in Moncks Corner, The Wassamasaw Tribe of Varnertown Indians, organized and incorporated (chartered) in the State of South Carolina as "body politic", **"State Recognized"** and who maintain the history, culture, lifestyles and unique heritage of South Carolina Native American people; and

WHEREAS, from ancient times to present Native American Indians have called Moncks Corner their home from various Native American Indian tribal cultures and bands throughout history including: Ashepoo, Cape Fear Indians, Catawba, Cheraw, Cherokee, Edisto, Escamacu, Etiwan, Iroquois, Kussoe, Kiawah, Pamlico, Pee Dee, Santee, Saraws, Sewee, Stono, Tuscarora, Waccamaw, Wando, Wassamassaw and Winyah. Many of these Native American descendants still reside in South Carolina and in Moncks Corner today; and

WHEREAS, Historic Native American Indian missions and schools were established to serve the native people such as the Barrows Mission, Groomsville School and Varner Indian School; and

WHEREAS, Native American Indians of the Varnertown community, also historically known as Summerville Indians, have contributed significantly towards a greater society. Individuals such as Geneva Varner Clark who proclaimed her Native heritage during the Great Depression; Henry Clark, the first Indian to register with the state as a Native American business owner; and William and Mary Varner who donated land for school, businesses and a church. A state historic marker now stands to designate the contributions of the Varnertown Indian people; and

WHEREAS, Many Native North Americans, Central Americans, and Alaskan Natives; and South Americans of Indian descent have come to be citizens and residents of Moncks Corner and the State of South Carolina, from many different parts of the western hemisphere; and

WHEREAS, Native American South Carolinians have served with valor and distinction in wartime, and their artistic, entrepreneurial, and other skills have truly enriched our South Carolinian heritage; and

WHEREAS, the members of the South Carolina General Assembly, by resolution, recognize November as National Native American History Month and declare November 18th, as Native American Awareness Day in South Carolina.

NOW; THEREFORE, I, Michael A. Locklear, Mayor of the Town of Moncks Corner, South Carolina, along with my fellow members of Moncks Corner Town Council, do hereby proclaim **November 2023** as

South Carolina Native American Heritage Month

in the Town of Moncks Corner and urge all citizens of Moncks Corner, South Carolina, to observe this month with appropriate programs, ceremonies, and activities.

Signed this 14th day of November, 2023

Michael A. Locklear, Mayor

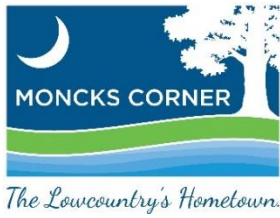

TOWN COUNCIL REGULAR MEETING

Town Council Chambers, Moncks Corner Municipal
Complex, 118 Carolina Avenue
TUESDAY, OCTOBER 17, 2023 at 6:00 PM

MINUTES

CALL TO ORDER

The regular meeting of the Town Council was called to order by Mayor Michael Locklear at 6:00 p.m.

Present:

Mayor Michael A. Locklear
Mayor Pro-Tem David A. Dennis, Jr.
Council Member DeWayne G. Kitts
Council Member James N. Law, Jr.
Council Member Latorie S. Lloyd
Council Member Chadwick D. Sweatman
Council Member James B. Ware, III

Staff Present:

John S. West, Town Attorney
Jeffrey V. Lord, Town Administrator
Marilyn M. Baker, Administrative Services Director/Clerk to Council
Justine H. Lovell, Finance Director
Rebecca T. Ellison, Recreation Director
R. Logan Faulkner, Public Service Director
Robert L. Gass, III, Fire Chief
Stephen G. Young, Police Chief
Lee W. Mixon, Jr., Police Captain
Justin S. Westbrook, Community Development Director
Rebecca Vetter, Business Development Manager
Mohamed A. Ibrahim, Technology Manager

INVOCATION

Invocation was delivered by Reverend Henry Dixon, Truth Tabernacle

PLEDGE OF ALLEGIANCE

The Pledge of Allegiance to the American Flag was led by Council Member James Ware.

APPROVAL OF MINUTES

1. **Minutes:** Regular Meeting of Council - September 19, 2023

Motion made by Council Member Law to approve the regular meeting minutes of September 19, 2023. Motion was seconded by Council Member Ware and approved unanimously as follows:

Voting Yea: Mayor Pro-Tem Dennis, Council Member Law, Council Member Kitts, Council Member Lloyd, Council Member Sweatman, Council Member Ware.

REPORTS

2. **Mayor's Report:** Michael A. Locklear

Mayor Locklear reported that he attended a ribbon cutting ceremony at the Trident United Way Berkeley Resource Connection Center on October 10th. The new Center is located at 500 South Live Oak Drive.

He also had the opportunity to speak at the Chamber of Commerce meeting. He provided a brief update and overview of Council's vision, future growth, and development plans for the Town. Approximately 40 people attended.

4. **Administrator's Report:** Jeffrey V. Lord

Administrator Lord provided a brief overview of the Park and Recreation Master Plan Report. The report consisted of the methodology of the survey, public survey results, group meetings, site visits, facility and amenity needs, importance, and priority investment ratings. The report focused on the master planning of the existing Moncks Corner Youth Fields, Dr. William H. Lacey Memorial Park, and Grady Park. It also features conceptual master plans for a brand-new Wellness Center, pickleball courts near Berkeley Middle School and a passive park on the recently acquired land under a FEMA grant. An opinion of probable construction costs was also completed for each of the parks. It is important to note that the conceptual master planning of the parks is based on GIS and aerial information and is not comprehensive. Administrator Lord suggested several options for funding the projects. He asked Council to review the report and let him know what their priorities are and then funding options can be addressed at that time.

NEW BUSINESS

5. **Bid Consideration:** Construction of Miracle League Restroom

Administrator Lord explained that staff received bids on October 6, 2023, to construct a restroom for the Miracle League Field that is designed to accommodate the users of the facility. Bids were received as follows:

Construction Services Group	\$215,000
Icon Contracting	\$ 98,638
Carolina Contracting Solutions	\$119,200

Icon Contracting was the lowest bid (\$98,638).

Funding: \$25,000 was awarded to the Town from Berkeley County's Discretionary Fund for this project. There is \$28,934.57 in unallocated funds remaining for the Miracle League Field. The balance of \$44,703.43 is available in the Abatement and Improvement Fund.

Staff recommended awarding the bid to Icon Contracting as the low bid at \$98,638 and authorizing staff to approve changes that reduce the cost of the project or do not increase the project more than 10%.

Motion was made by Council Member Law to approve Icon Contracting as the low bid at \$98,638 and authorize staff to approve changes that reduce the cost of the project or do not increase the project more than 10%. Motion was seconded by Council Member Ware. Motion to approve was unanimous as follows:

Voting Yea: Mayor Pro-Tem Dennis, Council Member Law, Council Member Kitts, Council Member Lloyd, Council Member Sweatman, Council Member Ware.

OLD BUSINESS

Old Business: There is no old business to be brought before Council.

PUBLIC INPUT:

Thomas Hamilton of 205 West Main Street reported that he had done a survey with 49 people in Town for 7 of the proposed recreation projects. Their number one on the survey was a splash pad, Lacey Park was number two, more benches, picnic tables and a pool for the Recreation Complex was also priority. His personal preference would be a second pickleball court at the Recreation Center. Unity Park came in last because people don't understand why an amphitheater is needed at Unity Park when we have all of our events at the Recreation Center.

EXECUTIVE SESSION:

7. **Discussion:** Negotiations related to a proposed contractual agreement

Motion was made by Council Member Law to go into executive session to discuss negotiations related to a proposed contractual agreement. Motion was seconded by Council Member Sweatman and unanimously approved as follows:

Voting Yea: Mayor Pro-Tem Dennis, Council Member Law, Council Member Lloyd, Council Member Kitts, Council Member Sweatman, Council Member Ware.

Out of Executive Session:

Motion was made by Mayor Pro-Tem Dennis to go out of executive session and to reconvene to the regular meeting of Council. Motion was seconded by Council Member Sweatman and unanimously approved as follows:

Voting Yea: Mayor Pro-Tem Dennis, Council Member Law, Council Member Lloyd, Council Member Kitts, Council Member Sweatman, Council Member Ware.

Reconvene:

Motion was made by Council Member Sweatman to reconvene to the regular meeting of Council. Motion was seconded by Council Member Ware and unanimously approved as follows:

Voting Yea: Mayor Pro-Tem Dennis, Council Member Law, Council Member Lloyd, Council Member Kitts, Council Member Sweatman, Council Member Ware.

Mayor Locklear had nothing to report out of executive session.

ADJOURNMENT:

Motion was made by Council Member Law, seconded by, Council Member Ware to adjourn the regular meeting of Council. The meeting was adjourned at 6:45 p.m. Motion was approved unanimously as follows.

Voting Yea: Mayor Pro-Tem Dennis, Council Member Law, Council Member Lloyd, Council Member Kitts, Council Member Sweatman, Council Member Ware

A copy of this meeting's agenda was e-mailed to the Post and Courier, The Berkeley Independent, Live 5 News, Channel 4, Channel 2, and The News Journal Scene. As required, the agenda was posted on the Municipal Complex bulletin board and the Town Website at least 24 hours prior to the meeting.

Minutes Approved and Adopted:

Marilyn M. Baker/Clerk to Council

November 14, 2023
DATE

TOWN OF MONCK'S CORNER REGULAR MEETING
Tuesday, November 14, 2023

Title: The purchase of a new 2023 F750 -RL garbage truck

Background: Due to the growth of subdivisions occurring in the Town of Moncks Corner, we need to purchase another garbage truck to meet the increases in capacity. The Town has received a total of three bid proposals.

The middle bid is from RDK Truck Sales. The proposal is \$202,166 and can be delivered immediately from date of purchase.

Model: F2023 FORD 4V F-SERIES 11YD
GVWR: 21,000 lbs.
Eng, Diesel: 270HP, Automatic Transmission

Bid Responses:

VENDOR	Carolina International Trucks	RDK TRUCK SALES	Amick Equipment
MANUFACTURER	Baker Products 2025 MV607 SBA Rear Loader	Ford 2023 Ford F750-RL	Peterbuilt 2024 220 26000LBS Paccar
MODEL	GVWR 25500	GVWR 21000	PX-7
BID	\$ 189,774	\$ 202,166	\$ 215,517
DELIVERY	6/25/2024	In Stock	11/30/2023

Exhibit: Middle Bid

Funding: Financing Through Banking Institute

Town Council action requested: Consider authorizing the purchase of a new F2023 Ford 4V F-Series from RDK Truck Sales.

Staff recommendation: Authorize the purchase of a new F2023 Ford 4V F-Series from RDK Truck Sales. This truck is what was budgeted for the FY23-24 year and is ready for pick up immediately to help with the increase in demand on sanitation.

3

Item 5.



MV607 SBA

Sales Proposal For:
TOWN OF MONCK'S CORNER

Presented By:
CAROLINA INTERNATIONAL TRUCKS, INC

INTERNATIONAL®

September 27, 2023

Prepared For:
 TOWN OF MONCK'S CORNER
 DOUG FULTON
 363 Peagler Way
 Moncks Corner, SC 29461-3693
 (843)834 - 3326

Presented By:
 CAROLINA INTERNATIONAL TRUCKS, INC
 Edmond Jones
 1619 BLUFF RD
 COLUMBIA SC 29201 -
 (803)799-4923

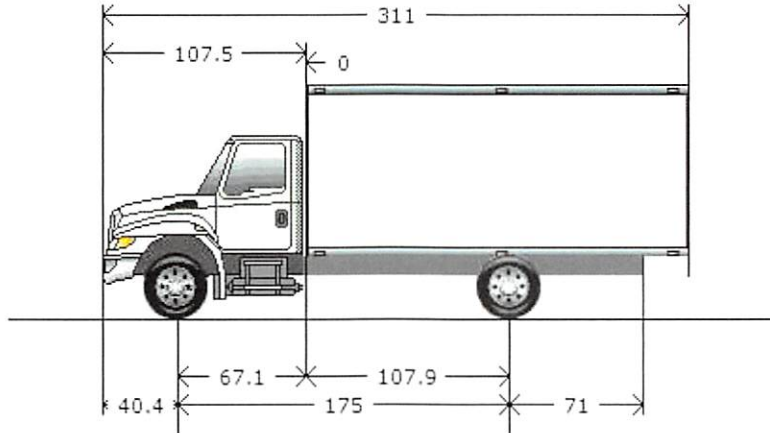

Model Profile
2025 MV607 SBA (MV607)

AXLE CONFIG:	4X2
APPLICATION:	Rear Loader
MISSION:	Requested GVWR: 25500. Calc. GVWR: 25999. Calc. GCWR: 46000 Calc. Start / Grade Ability: 41.64% / 2.33% @ 55 MPH Calc. Geared Speed: 87.4 MPH
DIMENSION:	Wheelbase: 175.00, CA: 107.90, Axle to Frame: 71.00
ENGINE, DIESEL:	{Cummins B6.7 250} EPA 2024, 250HP @ 2400 RPM, 660 lb-ft Torque @ 1600 RPM, 2600 RPM Governed Speed, 250 Peak HP (Max)
TRANSMISSION, AUTOMATIC:	{Allison 3500 RDS} 6th Generation Controls, Wide Ratio, 6-Speed with Double Overdrive, with PTO Provision, Less Retarder, Includes Oil Level Sensor, with 60,000-lb GVW Max, Refuse/Mixer Omit Item (Clutch & Control)
CLUTCH:	{Meritor MFS-10-122A} I-Beam Type, 10,000-lb Capacity
AXLE, FRONT NON-DRIVING:	{Dana Spicer S140} Single Reduction, 19,000-lb Capacity, 190 Wheel Ends Gear Ratio: 5.57
AXLE, REAR, SINGLE:	Conventional, Day Cab
CAB:	(2) 11R22.5 Load Range G HSR 3 (CONTINENTAL), 494 rev/mile, 75 MPH, All-Position
TIRE, FRONT:	(4) 11R22.5 Load Range G HDL2 (CONTINENTAL), 493 rev/mile, 75 MPH, Drive
TIRE, REAR:	23,500-lb Capacity, Vari-Rate Springs, with 4500-lb Capacity Auxiliary Rubber Springs
SUSPENSION, REAR, SINGLE:	Cab schematic 100WP
PAINT:	Location 1: 9219, Winter White (Std) Chassis schematic N/A

INTERNATIONAL®**Vehicle Specifications
2025 MV607 SBA (MV607)****September 27, 2023**

Code	Description
MV60700	Base Chassis, Model MV607 SBA with 175.00 Wheelbase, 107.90 CA, and 71.00 Axle to Frame.
1CAE	FRAME RAILS Heat Treated Alloy Steel (120,000 PSI Yield); 10.125" x 3.580" x 0.312" (257.2mm x 90.9mm x 8.0mm); 460.0" (11684mm) Maximum OAL
1WRN	BRACKET, CAB MOUNT Heavy Duty
4WBX	DUST SHIELDS, FRONT BRAKE for Air Cam Brakes
6DGG	DRIVELINE SYSTEM {Dana Spicer} 1710, for 4x2/6x2
10RHG	DUAL DRIVE Customer Does Not Intend to Convert to In-Cab Dual Drive Positions
10WGD	SPECIAL RATING, GVWR Limited to 25,999-lb GVWR
13BDP	TRANSMISSION, AUTOMATIC {Allison 3500 RDS} 6th Generation Controls, Wide Ratio, 6-Speed with Double Overdrive, with PTO Provision, Less Retarder, Includes Oil Level Sensor, with 60,000-lb GVW Max, Refuse/Mixer
13WUJ	ALLISON SPARE INPUT/OUTPUT for Rugged Duty Series (RDS), Front Loaders, Rear Loaders, Recycling/Packer Trucks, Package Number 142
13WYU	SHIFT CONTROL PARAMETERS {Allison} 3000 or 4000 Series Transmissions, Performance Programming
16SNT	MIRRORS (2) Aero Pedestal, Power Adjust, Heated, Turn Signals, Black Heads and Arms, 6.5" x 14" Flat Glass, Includes 6.5" x 6" Convex Mirrors, for 102" Load Width
1570	TOW HOOK, FRONT (2) Frame Mounted
1ANA	AXLE CONFIGURATION {Navistar} 4x2
1LEG	LICENSE PLATE HOLDER Includes Upper & Lower Mounting Plate Hardware, Mounted in Existing Holes in Front Bumper
1LNG	BUMPER, FRONT Contoured, Steel, Painted Gloss Black
1WEH	WHEELBASE RANGE 134" (340cm) Through and Including 197" (500cm)
2ASH	AXLE, FRONT NON-DRIVING {Meritor MFS-10-122A} I-Beam Type, 10,000-lb Capacity
3770	SPRINGS, FRONT AUXILIARY Rubber
3ADB	SUSPENSION, FRONT, SPRING Parabolic Taper Leaf, Shackle Type, 10,000-lb Capacity, with Shock Absorbers
4091	BRAKE SYSTEM, AIR Dual System for Straight Truck Applications
4AZA	AIR BRAKE ABS {Bendix AntiLock Brake System} 4-Channel (4 Sensor/4 Modulator) Full Vehicle Wheel Control System
4EDN	AIR DRYER {Bendix AD-9SI} with Heater, Includes Safety Valve
4EXP	BRAKE CHAMBERS, FRONT AXLE {Bendix} 20 SqiIn
4EXU	BRAKE CHAMBERS, REAR AXLE {Bendix EverSure} 30/30 SqiIn Spring Brake
4GBM	BRAKE, PARKING Manual Push-Pull Pneumatic Parking Brake
4LAG	SLACK ADJUSTERS, FRONT {Gunite} Automatic
4LGG	SLACK ADJUSTERS, REAR {Gunite} Automatic
4SPA	AIR COMPRESSOR {Cummins} 18.7 CFM
4VKJ	AIR TANK LOCATION (2) Mounted Under Battery Box, Outside Left Rail, Back of Cab, Perpendicular to Rail
4VLE	AIR DRYER LOCATION Mounted Inside Engine Compartment, Right Side

INTERNATIONAL®

**Vehicle Specifications
2025 MV607 SBA (MV607)**

September 27, 2023

<u>Code</u>	<u>Description</u>
4WDM	DUST SHIELDS, REAR BRAKE for Air Cam Brakes
4XDC	BRAKES, FRONT {Meritor 15X4 Q-PLUS CAST} Air S-Cam Type, Cast Spider, Fabricated Shoe, Double Anchor Pin, Size 15" X 4", 13,200-lb Capacity
4XDR	BRAKES, REAR {Meritor 16.5X7 Q-PLUS CAST} Air S-Cam Type, Cast Spider, Fabricated Shoe, Double Anchor Pin, Size 16.5" X 7", 23,000-lb Capacity per Axle
5708	STEERING COLUMN Tilting
5CAW	STEERING WHEEL 4-Spoke; 18" Dia., Black
5PSA	STEERING GEAR {Sheppard M100} Power
7BEU	AFTERTREATMENT COVER Aluminum
7BLV	EXHAUST SYSTEM Horizontal Aftertreatment System, Frame Mounted Right Side Under Cab, for Single Short Horizontal Tail Pipe, Frame Mounted Right Side Back of Cab
8000	ELECTRICAL SYSTEM 12-Volt, Standard Equipment
8518	CIGAR LIGHTER Includes Ash Cup
8718	POWER SOURCE Cigar Type Receptacle without Plug and Cord
8GXD	ALTERNATOR {Leece-Neville AV1160P2013} Brush Type, 12 Volt, 160 Amp Capacity, Pad Mount, with Remote Sense
8HAB	BODY BUILDER WIRING Back of Day Cab at Left Frame or Under Sleeper, Extended or Crew Cab at Left Frame; Includes Sealed Connectors for Tail/Amber Turn/Marker/ Backup/Accessory Power/Ground and Sealed Connector for Stop/Turn
8MJT	BATTERY SYSTEM {Fleetrite} Maintenance-Free, (2) 12-Volt 1900CCA Total, Top Threaded Stud
8RMZ	SPEAKERS (2) 6.5" Dual Cone Mounted in Both Doors, (2) 5.25" Dual Cone Mounted in Both B-Pillars
8RPR	ANTENNA for Increased Roof Clearance Applications
8RPS	RADIO AM/FM/WB/Clock/Bluetooth/USB Input/Auxiliary Input
8THB	BACK-UP ALARM Electric, 102 dBA
8VBE	HORN, ELECTRIC (1) Trumpet Style
8VUL	BATTERY BOX Steel, with Plastic Cover, 18" Wide, 2-4 Battery Capacity, Mounted Left Side Back of Cab
8VZK	TURN SIGNALS, FRONT Dual Face, LED, Amber/Red, Mounted on Top of Fender, Used with Standard Flush Mounted Front Turn Signal, Side Marker Lamps, Parking Lights and Reflectors
8WPH	CLEARANCE/MARKER LIGHTS (5) {Truck Lite} Amber LED Lights, Flush Mounted on Cab or Sunshade
8WPZ	TEST EXTERIOR LIGHTS Pre-Trip Inspection will Cycle all Exterior Lamps Except Back-up Lights
8WTK	STARTING MOTOR {Delco Remy 38MT Type 300} 12 Volt, Less Thermal Over-Crank Protection
8WWJ	INDICATOR, LOW COOLANT LEVEL with Audible Alarm
8XAH	CIRCUIT BREAKERS Manual-Reset (Main Panel) SAE Type III with Trip Indicators, Replaces All Fuses
8XHN	HORN, AIR Single Trumpet, Black, with Lanyard Pull Cord
8XKC	HEADLIGHTS Halogen, with Daytime Running Lights, Automatic Twilight Controlled
9AAB	LOGOS EXTERIOR Model Badges
9AAE	LOGOS EXTERIOR, ENGINE Badges
9HCW	GRILLE Molded in Black

INTERNATIONAL®**Vehicle Specifications
2025 MV607 SBA (MV607)****September 27, 2023**

<u>Code</u>	<u>Description</u>
9WBN	FENDER EXTENSIONS Painted
9WBW	FRONT END Tilting, Fiberglass, with Three Piece Construction, Dual Air Intakes
10060	PAINT SCHEMATIC, PT-1 Single Color, Design 100
10761	PAINT TYPE Base Coat/Clear Coat, 1-2 Tone
10AGB	COMMUNICATIONS MODULE Telematics Device with Over the Air Programming; Includes Five Year Data Plan and International 360
10BAE	LABEL, DEF "DEF ONLY"
10WCY	SAFETY TRIANGLES
11001	CLUTCH Omit Item (Clutch & Control)
12703	ANTI-FREEZE Red, Extended Life Coolant; To -40 Degrees F/ -40 Degrees C, Freeze Protection
12849	BLOCK HEATER, ENGINE 120V/1000W, for Cummins ISB/B6.7/ISL/L9 Engines
12EXU	ENGINE, DIESEL {Cummins B6.7 250} EPA 2024, 250HP @ 2400 RPM, 660 lb-ft Torque @ 1600 RPM, 2600 RPM Governed Speed, 250 Peak HP (Max)
12TSY	FAN DRIVE {Borg-Warner SA85} Viscous Type, Screw On
12VCE	AIR CLEANER Single Element, Fire Retardant Media
12VJR	EMISSION, CALENDAR YEAR {Cummins B6.7} EPA, OBD and GHG Certified for Calendar Year 2024
12VXT	THROTTLE, HAND CONTROL Engine Speed Control; Electronic, Stationary, Variable Speed; Mounted on Steering Wheel
12WPW	OIL PAN Extended Service Interval, 19 Quart Capacity, For Cummins ISB/B6.7 Engines
12WVG	EPA IDLE COMPLIANCE Low NOx Idle Engine, Complies with EPA Clean Air Regulations; Includes "Certified Clean Idle" Decal on Hood
12WZE	CARB IDLE COMPLIANCE Does Not Comply with California Clean Air Idle Regulations
12XBM	ENGINE CONTROL, REMOTE MOUNTED Provision for; Includes Wiring for Body Builder Installation of PTO Controls and Starter Lockout, with Ignition Switch Control, for Cummins B6.7 and L9 Engines
12XCC	RADIATOR Aluminum, 2-Row, Down Flow, Front to Back System, 640 SqIn Louvered, with 383 SqIn Charge Air Cooler, Includes In-Tank Oil Cooler
12XCS	CARB EMISSION WARR COMPLIANCE Does Not Comply with CARB Emission Warranty
13WET	TRANSMISSION SHIFT CONTROL Column Mounted Stalk Shifter, Not for Use with Allison 1000 & 2000 Series Transmission
13WLP	TRANSMISSION OIL Synthetic; 29 thru 42 Pints
13WVV	NEUTRAL AT STOP Allison Transmission Shifts to Neutral When Service Brake is Depressed and Vehicle is at Stop; Remains in Neutral Until Service Brake is Released
13XAA	PTO CONTROL, DASH MOUNTED For Customer Provided PTO; Includes Switch, Electric/Air Solenoid, Piping and Wiring
13XAN	PTO LOCATION Customer Does Not Intend to Install PTO
14AJG	AXLE, REAR, SINGLE {Dana Spicer S140} Single Reduction, 19,000-lb Capacity, 190 Wheel Ends . Gear Ratio: 5.57
14VAH	SUSPENSION, REAR, SINGLE 23,500-lb Capacity, Vari-Rate Springs, with 4500-lb Capacity Auxiliary Rubber Springs
14WMN	AXLE, REAR, LUBE {EmGard FE-75W-90} Synthetic Oil; 1 thru 29.99 Pints

INTERNATIONAL®

Vehicle Specifications
2025 MV607 SBA (MV607)

September 27, 2023

Code	Description
15LMN	FUEL/WATER SEPARATOR (Racor 400 Series,) 12 VDC Electric Heater, Includes Pre-Heater, with Primer Pump, Includes Water-in-Fuel Sensor
15LRE	LOCATION FUEL/WATER SEPARATOR Mounted Under Hood, Left Side, Above Front Axle
15SGG	FUEL TANK Top Draw, Non-Polished Aluminum, D-Style, 19" Tank Depth, 70 US Gal (265L), Mounted Left Side, Under Cab
15WDG	DEF TANK 7 US Gal (26L) Capacity, Frame Mounted Outside Left Rail, Under Cab
16030	CAB Conventional, Day Cab
16BAM	AIR CONDITIONER with Integral Heater and Defroster
16GED	GAUGE CLUSTER Base Level; English with English Electronic Speedometer
16HCH	SEATBELT WARNING LIGHT IND. Mounted in Dash, Will Flash when Park Brake is Disengaged and Driver Seatbelt Unfastened, Audible Alarm to Remind Driver to Fasten Seatbelt
16HHE	GAUGE, AIR CLEANER RESTRICTION (Filter-Minder) Mounted in Instrument Panel
16HKT	IP CLUSTER DISPLAY On Board Diagnostics Display of Fault Codes in Gauge Cluster
16JNT	SEAT, DRIVER (National 2000) Air Suspension, High Back with Integral Headrest, Vinyl, Isolator, 1 Chamber Lumbar, with 2 Position Front Cushion Adjust, -3 to +14 Degree Angle Back Adjust
16KAW	SEAT, TWO-MAN PASSENGER (National) Vinyl, with Under Seat Storage Compartment
16SSB	MIRROR, CONVEX, HOOD MOUNTED (2) Right and Left Sides, Breakaway, Black
16VKB	CAB INTERIOR TRIM Classic, for Day Cab
16VLM	CAB REAR SUSPENSION Rubber Suspension, for Low Cab Height
16WBY	ARM REST, RIGHT, DRIVER SEAT
16WHJ	HOSE CLAMPS, HEATER HOSE (Breeze) Belleville Washer Type
16WJU	WINDOW, POWER (2) and Power Door Locks, Left and Right Doors, Includes Express Down Feature
16WLS	FRESH AIR FILTER Attached to Air Intake Cover on Cowl Tray in Front of Windshield Under Hood
16WSE	LOW WASHER FLUID INDICATOR
16XJN	INSTRUMENT PANEL Flat Panel
16ZBT	ACCESS, CAB Steel, Driver & Passenger Sides, Two Steps per Door, for use with Day Cab and Extended Cab
27DTE	WHEELS, FRONT (Maxion 10038) DISC; 22.5x7.50 Rims, Painted Steel, 5-Hand Hole, 10-Stud, 285.75mm BC, Hub-Piloted, Flanged Nut, with Steel Hubs
28DTE	WHEELS, REAR (Maxion 10038) DUAL DISC; 22.5x7.50 Rims, Painted Steel, 5-Hand Hole, 10-Stud, 285.75mm BC, Hub-Piloted, Flanged Nut, with Steel Hubs
29PAR	PAINT IDENTITY, FRONT WHEELS Disc Front Wheels; with Vendor Applied White Powder Coat Paint
29PAS	PAINT IDENTITY, REAR WHEELS Disc Rear Wheels; with Vendor Applied White Powder Coat Paint
29WLK	WHEEL BEARING, FRONT, LUBE (EmGard FE-75W-90) Synthetic Oil
7372135432	(4) TIRE, REAR 11R22.5 Load Range G HDL2 (CONTINENTAL), 493 rev/mile, 75 MPH, Drive
7372135439	(2) TIRE, FRONT 11R22.5 Load Range G HSR 3 (CONTINENTAL), 494 rev/mile, 75 MPH, All-Position

Services Section:

INTERNATIONAL®

Vehicle Specifications
2025 MV607 SBA (MV607)

September 27, 2023

<u>Code</u>	<u>Description</u>
40129	WARRANTY Standard for MV Series, Effective with Vehicles Built July 1, 2017 or Later, CTS-2020A
1	NU LIFE - QUANTUM MD 11 YD. REAR LOADER

INTERNATIONAL®

Financial Summary
2025 MV607 SBA (MV607)

September 27, 2023

(US DOLLAR)

Description

Price

Net Sales Price:

\$189,774.78

Memo Item(s):

Total Taxes:

\$725.00

Note: Memo item(s) shown here are included in the above Net Sales Price.

Please feel free to contact me regarding these specifications should your interests or needs change. I am confident you will be pleased with the quality and service of an International vehicle.

Approved by Seller:

Accepted by Purchaser:

Official Title and Date

Firm or Business Name

Authorized Signature

Authorized Signature and Date

CAROLINA INTERNATIONAL TRUCKS, INC
1619 BLUFF RD
COLUMBIA SC 29201 -
(803)799-4923

This proposal is not binding upon the seller without Seller's Authorized Signature

Official Title and Date

The TOPS FET calculation is an estimate for reference purposes only. The seller or retailer is responsible for calculating and reporting/paying appropriate FET to the IRS.

The limited warranties applicable to the vehicles described herein are Navistar, Inc.'s standard printed warranties which are incorporated herein by reference and to which you have been provided a copy and hereby agree to their terms and conditions.

QUANTUM MD



CURBTENDER
www.curbtender.com

QUANTUM MD

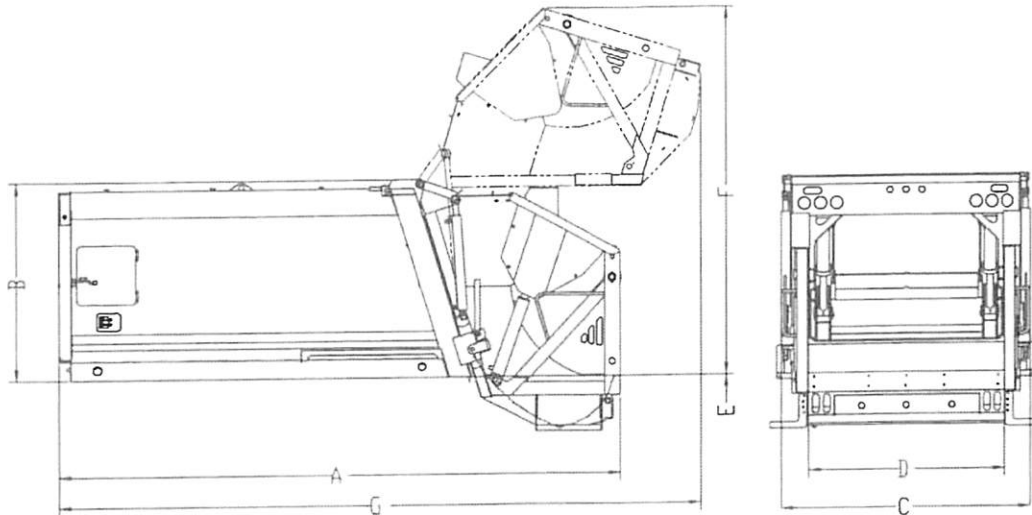

Body Specifications

	11 CU. YD.	13 CU. YD.
A: LENGTH OF BODY	191"	209"
B: HEIGHT OF BODY ABOVE CHASSIS	74"	74"
C: BODY WIDTH	94"	94"
D: HOPPER OPENING WIDTH	74"	74"
E: LOADING SILL BELOW CHASSIS FRAME	0"	0"
F: HOPPER OPENING HEIGHT	58"	58"
F: HEIGHT OF TAILGATE ABOVE CHASSIS FRAME (TAILGATE RAISED)	191"	191"
G: LENGTH OF BODY (TAILGATE RAISED)	221"	239"
CA: CAB TO AXLE MINIMUM	108"	126"
CF: MINIMUM USABLE CAB TO END OF FRAME	140"	158"
- HOPPER CAPACITY	1.75 CU. YD.	1.75 CU. YD.
- DYNAMIC HOPPER CAPACITY (CU.YD./MINUTE)	7 CU. YD.	7 CU. YD.
- BODY WEIGHT	8,400 LBS	8,750 LBS

Minimum Chassis Requirements

	29000 LBS *	33,000 LBS
MINIMUM GVWR	29000 LBS *	33,000 LBS
- FRONT AXLE	10,000 LBS	10,000 LBS
- REAR AXLE	19000 LBS	23,000 LBS
- REQUIRED FRAME HEIGHT	38" TO 40"	38" TO 40"

*11-YD QUANTUM CAN BE CONFIGURED FOR UNDER CDL WITH A 26,000 LBS MINIMUM GVWR (10,000 LBS FRONT AXLE & 16,000 LBS REAR AXLE). HOWEVER, THIS CONFIGURATION REDUCES THE ALLOWED LBS/CU. YD. BY 30% TO REMAIN AT OR BELOW MINIMUM GVWR.

Body Construction

- Roof: 11 gauge GR50
- Sides: 11 gauge GR50
- Floor: 11 gauge GR50
- Ejection Panel: 11 gauge GR50
- Sweep Face 3/16 GR100
- Tailgate side wall: 11 gauge GR50
- Upper, 7 gauge GR50 Lower
- Tailgate Floor: 3/16 AR400

Features

- High strength curved shell body
- Patented packing mechanism
- Rear Fenders standard
- Curved floor provides liquid sump
- Low body height
- Easy to maintain
- Pack cycle time of 15 seconds

Hydraulics

- Oil Reservoir: 25 gal. (94.6 liters)
- Oil Flow w/ Standard Pump: 25 GPM
- Operating Pressure: 3,000 PSI
- Engine RPM: 1,300 RPM
- Hose Burst Ratio: 4 to 1
- Return Filter: 10 micron
- Pack Cylinders: 4.0
- Sweep Cylinders: 4.0
- Eject Cylinders
 - 11 cu. yd: 4.5, 2 stage telescopic
 - 13 cu. yd: 5.0, 3 stage telescopic
- Tailgate Lift: 3.0

Optional Features

- Container roll bar with lip-and-latch
- Container lip-and-latch with 8,000 lb. drum winch
- Single & Dual tipper(s)
- Cart tipper tap-in-kits
- Work lights
- Strobe lights
- Broom and shovel holder
- Rear view color camera system



Quotation

NuLife Municipal Truck Center Inc

Company Address
 2266 Powdersville Rd Easley SC 29642
 864-371-6136

Date 9/26/2023
Quotation # 092623-2
Customer ID Municipal

Quotation For
 Carolina International Trucks
 2580 Oscar Johnson Drive
 Charleston SC 29405
 Ed Jones

Quotation valid until: 10/26/2023
Prepared by: STUART SIMMONS

Comments or Special Instructions
 11 YD REAR LOADER

Salesperson	P.O. Number	Ship Date	F.O.B. Point	Terms
John Downs	N/A	TBD	DELIVERED	NET 5

Quantity	Description	Unit Price	Sales Tax Included	Amount
1	Customer Furnished Chassis with Correct Clear CA (108"), GVW (Minimum 26,000#) and Curbtender 11RL Quantum MD Rear Loader	\$ 89,900.00	No	\$ 89,900.00
	Lower Hopper Sidewall Liners, Access Door Ladder, Proper PTO, Pump, EOS, Single Color LCD Rear Vision Camera System (Tailgate), All LED Body Lights, Dual Upper Tailgate Amber Strobing Lights, Dual Hopper Work Lights, Dual Driver Alert Buzzers, Dual Barker Rotary Cart Tipppers, 20# Exterior Fire Extinguisher & Bracket, Mounted, Painted Performance White (Body), & Delivery.			
1	1 Year Body & 1 Year Cylinder Warranty	Included in Above		
	2023 Supply Chain Volatility is affecting raw material and component availability, as well as costs. NMTCI reserves the right prior to mounting, and with the appropriate communication, to adjust pricing and estimated completion dates accordingly.			

If you have any questions concerning this quotation, please contact:
 Stuart Simmons

Thank you for your business!

Subtotal	\$ 89,900.00
Tax Rate	0.00%
Sales Tax	\$ -
Other	
TOTAL	\$ 89,900.00



BP Lifts

By Barker Products
1310 Miller Road, Greenville, SC 29607



Model HB15-45 Lifts



- 4 Models Available
- Dependable Smooth Acting 15K Helical Rotary Actuator
- Splined Shafts To Eliminate Arm Movement And Wear
- 45 Degree Dump Angle
- EZ Bolt On Kit Standard
- Meets ANSI Z245 Type B Specs Lifts All Standard American 2 Bar Carts
- Liftplate Arc Motion Makes Cart Attachment Fast And Easy On Unlevel Highway Conditions
- Double Wide Mounting Plate Available. Increases Hopper Height To Decrease Packing Cycles
- 37 to 47 Inch Mounting Heights
- 18 1/2 to 22 1/2 Inch Ground Clearance
- Use on Rear Loaders
- All Components Manufactured and Assembled In The US



Bp Lifts
By Barker Products
1310 Miller Road, Greenville, SC 29607



HB15N-4541

Envelope Dimensions

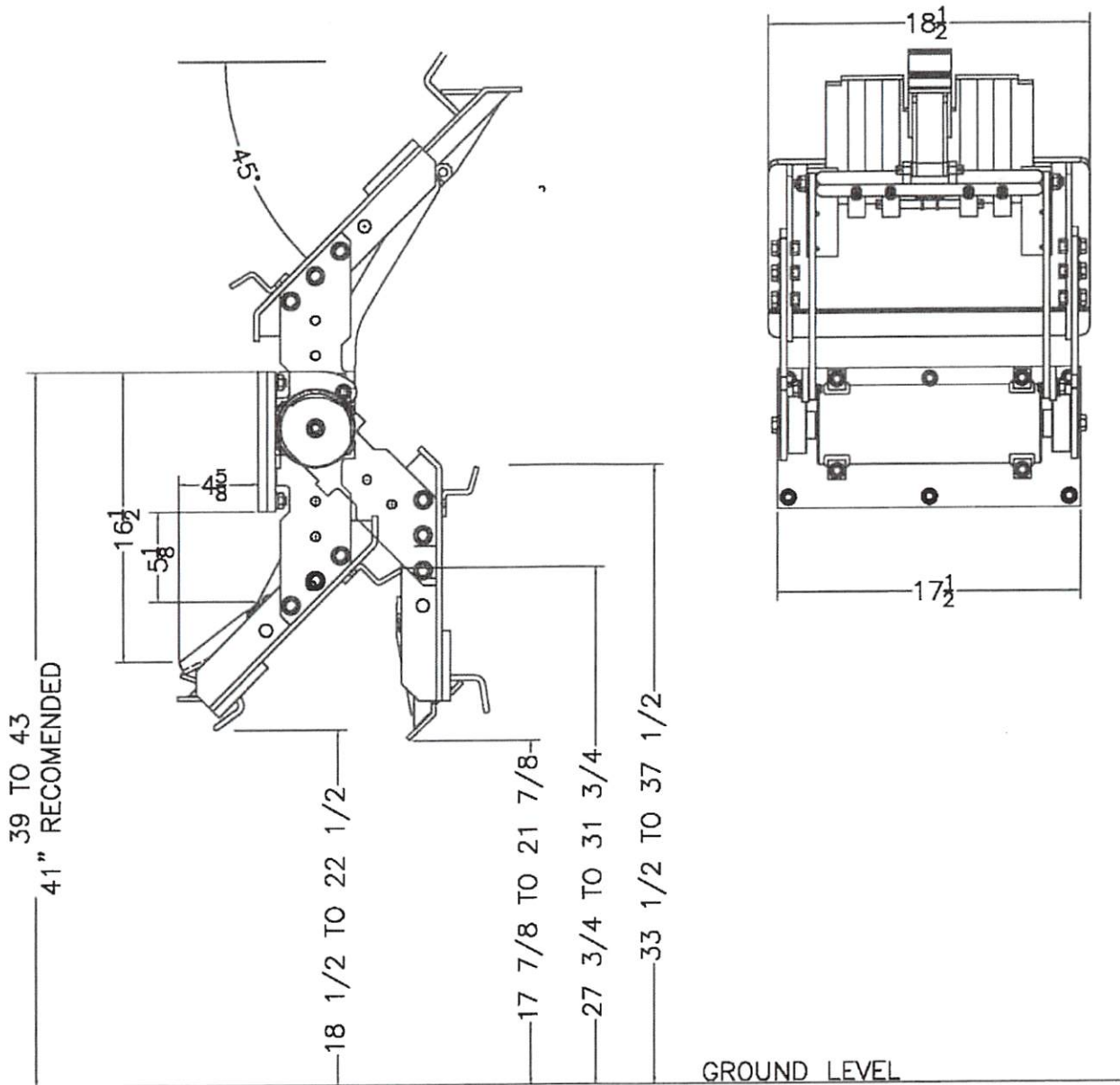



1310 Miller Road
Greenville, SC 296078

Barker Products

Lift Unit Specialist

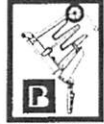

Phone:864-288-7384
Fax:864-297-1292

BPH SERIES LIFT UNIT WARRANTY

Barker Products warranties each new dump unit to be free of defects in material and workmanship under normal use and service for a period of 1 year or 2000 hours of operation, whichever comes first, from the date of delivery.

This warranty excludes any obligations by BARKER PRODUCTS for the cost of down time. BARKER PRODUCTS will not warranty any dump unit which has been subject to misuse, neglect, alteration, or damaged by an accident.

On any work not performed by BARKER PRODUCTS or it's representative, the customer will be responsible for freight charges on all parts shipped under warranty. Parts will be invoiced at time of shipment. Defective parts must be returned to BARKER PRODUCTS within 30 days. If the part is determined to be defective the customer will be credited for the original invoice.

Customer warranty labor charges must be approved by BARKER PRODUCTS in advance. If not contacted for approval, BARKER PRODUCTS will not be liable for the warranty labor charge.



RDK ASSETS INC
3214 Adamo Drive
Tampa, FL 33605
P: (813) 241-0711
F: (813) 241-0414



BILL TO
TOWN OF MONCK'S CORNER
363 MIRACLE PARK DRIVE
MONCK'S CORNER, SC 29461
P: (843) 719-7900

DELIVER TO
TOWN OF MONCK'S CORNER
363 MIRACLE PARK DRIVE
MONCK'S CORNER, SC 29461
P: (843) 719-7900

SALES QUOTE: MI101002194

PRINT DATE	ORDER STATUS	DELIVERY DATE	INVOICE DATE	SALESPERSON	CUSTOMER REFERENCE
10/5/2023	QUOTE	10/5/2023	10/5/2023	Mike R	

ID	YR - MAKE - MODEL	SERIAL NUMBERS / ITEM DESCRIPTION	PRICE
108894	2023 - FORD - F750 - RL	1FDWF7DC7PDF12097 PAC MAC RLM11-202305-005	199,900.00
		Vehicle - Price	199,900.00
		Remove the reeving winch and cut off the lip and latch and make look nice.	0.00
		Inspection Fee	394.00
		Freight Fee 468 miles x 4.00 RGN Trailer	1,872.00
		Total Price:	202,166.00

Total Due = **\$202,166.00**

x _____
Buyer Signature

x _____
Seller Signature

Date

Date



SALES QUOTE: M101002194

TERMS AND CONDITIONS:

1. Customer's responsibilities. Customer agrees to pay RDK Assets INC, dba RDK Truck Sales all charges required by law to be collected, including without limitation all tag, title, license, tire, battery and lien fees, and all federal, state and local taxes. Although RDK Assets INC, dba RDK Truck Sales has used its best efforts to accurately state the amounts due under this Agreement, Customer remains liable for any additional amounts which may be assessed by law against RDK Assets INC, dba RDK Truck Sales. Customer shall be responsible to pay RDK Assets INC, dba RDK Truck Sales for all amounts due to pay off any liens on Customer's trade-in, as may be required by such lienholder, regardless of whether the lienholder has quoted the wrong amount to RDK Assets INC, dba RDK Truck Sales, the payoff amount has changed after the date of such quote, or whether Customer has failed to disclose to RDK Assets INC, dba RDK Truck Sales all lienholders on the vehicle. In the event RDK Assets INC, dba RDK Truck Sales incurs any additional costs after sale of the vehicle, such as sales tax, federal excise tax, license, tag, title and transfer fees, Customer shall promptly reimburse RDK Assets INC, dba RDK Truck Sales for such costs upon demand. Unpaid or past due balances will be assessed an interest charge equal to the lesser of (i) one and one half percent (1 1/2 %) per month or (ii) the maximum rate permitted by law.

2. Deposit. Should RDK Assets INC, dba RDK Truck Sales fail to accept this offer or be unable to deliver the vehicle as promised, Customer's sole remedy against RDK Assets INC, dba RDK Truck Sales shall be a return of the deposit as liquidated damages. Should Customer fail to take delivery of the vehicle for any reason or otherwise breach this agreement, RDK Assets INC, dba RDK Truck Sales may elect to retain the deposit, and sue for any actual damages incurred by RDK Assets INC, dba RDK Truck Sales for work done, costs incurred, and for any incidental or consequential damages caused by Customer's breach.

3. Warranties. except as otherwise specified in the Warranty section on page one of this Agreement, and as evidenced by a Warranty Certificate signed by an authorized representative of RDK Assets INC, dba RDK Truck Sales, all used vehicles are sold "AS IS, WITHOUT WARRANTY", either express or implied. RDK ASSETS INC, dba RDK TRUCK SALES SPECIFICALLY DISCLAIMS ALL WARRANTIES OF MERCHANTABILITY OR FITNESS FOR A PARTICULAR PURPOSE, AND ALL OTHER REPRESENTATIONS TO THE CUSTOMER NOT EXPRESSLY SET FORTH IN THIS AGREEMENT OR IN THE WARRANTY CERTIFICATE. No other person is authorized to make any representations or warranties on behalf of RDK Assets INC, dba RDK Truck Sales, unless made or assumed in writing by RDK Assets INC, dba RDK Truck Sales.

4. Limitation of Liability. Customer shall fully inspect the vehicle at the time of delivery. Acceptance of the vehicle constitutes Customer's waiver of all claims against RDK Assets INC, dba RDK Truck Sales for all actual, incidental or consequential damages, including without limitation: a) loss, damage or delays for any reason; b) failure to supply any property ordered hereunder unless RDK Assets INC, dba RDK Truck Sales receives notification of such failure within one week of delivery; c) loss of use, loss of time, lost profits or income; d) changes in design, materials or specifications explicitly specified by the Customer; e) modifications to the vehicle that the Customer specifies to be performed by others; and f) defects in design, materials or workmanship unless RDK Assets INC, dba RDK Truck Sales receives notification of such defects within one week of delivery.

Customer shall defend, indemnify and hold harmless RDK Assets INC, dba RDK Truck Sales and its subsidiaries and affiliated companies, their officers, agents and employees against all loss, liability and expense, including reasonable attorney's fees, by reason of bodily injury including death, and property damage, sustained by any person or persons including but not limited to the officers, agents and employees of Customer, as a result of the Customer's maintenance, use, operation, servicing, transportation, defect in or failure of the vehicle, whether such bodily injury, death or property damage is due or claimed to be due in whole or in part, to any neglect, default, defect, fault, failure, act or omission, by or on behalf of RDK Assets INC, dba RDK Truck Sales, its officers, agents and employees or any other person, including but not limited to any claims of strict liability in tort, breach of warranty, and/or negligence.

5. Modifications by Others. Customer acknowledges that any requested modifications to the vehicle that the Customer specifies to be performed by others are Customer's sole responsibility, and Customer shall reimburse RDK Assets INC, dba RDK Truck Sales for the cost of such modifications, regardless of whether Customer takes delivery of the vehicle. RDK Assets INC, dba RDK Truck Sales is not liable for any defects in design, materials or workmanship, or any errors or omissions by such third parties.

6. Trade-in. The trade-in allowance set forth on page one of this agreement is based upon an estimate by RDK Assets INC, dba RDK Truck Sales of the trade-in described herein in its present mechanical condition and with the equipment and attachments as represented by the Customer. Such trade-in shall be subject to reappraisal by RDK Assets INC, dba RDK Truck Sales at the time of delivery of the vehicle. Customer shall deliver the trade-in empty of trash, in the same condition as at the time of the original appraisal, and shall be liable to RDK Assets INC, dba RDK Truck Sales for any decrease in the trade-in allowance due to changes in mechanical condition, equipment or attachments, and for costs of clean-up and disposal of trash or debris inside the vehicle. Customer represents that any such trade-in vehicle is customer's property and is not subject to any liens or encumbrances except as disclosed by customer to RDK Assets INC, dba RDK Truck Sales.

7. Entire Agreement. This Agreement contains the final, complete, and exclusive expression of the understanding between the parties with respect to the purchase and sale of the vehicle, and supersedes any prior or contemporaneous agreement or representation, oral or written, by any of them. Customer is not relying on any statement or representation by RDK Assets INC, dba RDK Truck Sales that is not set forth in this Agreement or another written document that is signed by an authorized representative of RDK Assets INC, dba RDK Truck Sales.

8. Governing Law; Venue; Waiver of Right to Jury Trial. This Agreement shall be governed by and construed and enforced in accordance with, the laws of the State of Florida, excluding laws of Florida relating to the resolution of conflict of laws of different jurisdictions. The forum selected for any proceeding or suit related to this Agreement shall be in the Circuit Court of the Thirteenth Judicial Circuit, in and for Hillsborough County, Florida, and the parties consent to this Court's personal jurisdiction over them, or if the State Court does not have subject matter jurisdiction, then in the District Court of the United States for the Middle District of Florida, Tampa Division, to which the parties also consent to personal jurisdiction. each party hereby waives any defense, whether asserted by motion or pleading, that Hillsborough County, Florida, is an improper or inconvenient venue. This is intended to be a mandatory and not a permissive forum selection provision. Customer hereby knowingly, voluntarily and intentionally waives any right Customer may have to a trial by jury of any claim, demand, action, counterclaim, whether in contract or in tort, in any way related to the purchase and sale of the vehicle hereunder.

9. No Waiver. RDK Assets INC, dba RDK Truck Sales shall not be deemed to have waived any of its rights or remedies hereunder unless such waiver is specific and in writing. No delay or omission by RDK Assets INC, dba RDK Truck Sales in exercising any of its rights or remedies hereunder shall constitute a waiver thereof, or shall constitute any further waiver thereafter. All rights and remedies of a party hereunder are cumulative and concurrent and the exercise of one right or remedy shall not be deemed to be a waiver or release of any other right or remedy.

10. Miscellaneous. Risk of loss shall pass to the Customer upon acceptance of delivery of the vehicle. A facsimile of this agreement shall have the same legal effect as an original hereof. Venue for any actions involving this agreement, including counterclaims, cross-claims or third party claims shall be exclusively in Hillsborough County, Florida, and this agreement shall be construed under the laws of the State of Florida. This agreement may not be assigned by Customer. This agreement expresses the entire agreement of the parties. If any part hereof is contrary to, prohibited by or deemed invalid under applicable laws or regulations of any jurisdiction, such provision shall be inapplicable and deemed omitted but shall not invalidate the remaining provisions hereof. In the event that RDK Assets INC, dba RDK Truck Sales is required to employ an attorney to enforce any of the terms of this agreement, Customer shall be liable for all reasonable attorney's fees and costs, regardless of whether suit is instituted, through and including all trials, appeals and bankruptcy proceedings.

I HAVE READ AND UNDERSTAND THE ABOVE TERMS AND CONDITIONS AND AGREE TO BE BOUND BY THEM.

CUSTOMER:
TOWN OF MONCK'S CORNER

Signature

Print Name

Title

Date

APPROVED:
RDK Assets INC dba RDK Truck Sales

Signature

Print Name

Title



3214 Adamo Drive
 Tampa, FL 33605
 Phone: (813) 241-0711 Fax: (813) 241-0414

VEHICLE SPEC SHEET: 108894

DATE	VIN	YEAR	MAKE	MODEL	MILES	SALESPERSON	PRICE
10/5/2023	1FDWF7DC7PDF12097	2023	FORD	F750	391	Robertson, Michael	199,900.00

TRANS MAKE: **TORQSHIFT**

TRANS MODEL: **6**

REAR AXLE MAKE:

REAR AXLE MODEL:

SUSPENSION TYPE: **LEAF SPRING**

FRONT CAPACITY: **12000**

REAR CAPACITY: **21000**

FRONT TIRE SIZE: **11/22.5**

REAR TIRE SIZE: **11/22.5**

LIFT AXLE Y/N: **N**

LIFT AXLE CAPACITY:

FRONT CAPACITY: **12000**

REAR CAPACITY: **21000**

FRONT TIRE SIZE: **11/22.5**

REAR TIRE SIZE: **11/22.5**

LEFT FRONT TIRE %: **100**

RIGHT FRONT TIRE %: **100**

RR FRONT TIRE %:

RR REAR TIRE %: **100**

LR FRONT TIRE %:

LR REAR TIRE %: **100**

PRICE: 199,900.00

TYPE: **RL**

YEAR: **2023**

MAKE: **FORD**

MODEL: **F750**

MILES: **391**

HOURS: **20**

ENGINE MAKE: **FORD CERTIFIED CLEAN IDLE CARB**

ENGINE MODEL: **4V F-SERIES**

HORSE POWER: **270**

BODY MAKE: **PAC MAC**

BODY MODEL: **RLM11**

BODY CAPACITY: **11 YD**

DISCLAIMER: All information listed above is believed to be accurate. Photos, specifications, prices, and all other information are subject to change or correction without notice. All liability is expressly disclaimed.

Item 5.





RDK Assets, inc. - dba RDK Truck Sales

Toll-Free: 1-888-735-8788
3214 Adamo Dr.
Tampa, FL. 33605
Phone: 813-241-0711
Fax: 813-241-0414
Email: info@rdk.com

Item 5.

WIRING & ACH INSTRUCTIONS

UPDATED February 26, 2021

The following information is required to wire funds to RDK Truck Sales:

Account Name:	RDK Assets Inc
Account Number:	703378130
Wire ABA Routing Number:	021000021
SWIFT Code:	CHASUS33
ACH ABA Routing Number:	267084131
Bank Name:	JP Morgan Chase Bank 100 N Tampa Street, Ste 3300 Tampa, FL 33602
Bank Contact:	Chris Nakamura Chris.Nakamura@jpmorgan.com

If you should have any questions or problems in expediting your wire to us, please do not hesitate to contact us.

WWW.RDK.COM



END USER: MONCKS CORNER
LOGAN FAULKNER
BODY INSTALL LOCATION: GA MOUNT FACILITY: SWAT,
207 HAI AVFRITT BLVD., STATESBORO GA 30458

For NCSA Contract Purchases:
Please send P.O. to Amick & NCSA including:
Contract #, Spec #, Contact Info, & Fed. Tax ID #
NCSA: kmitman@ncsheriffs.net
[LINK: NCSA Terms & Conditions](#)

CONTRACT #
24-08-0421
SPECIFICATION #
306

Description**Contract Price**

MODEL: **NEW WAY VIPER**
BODY SIZE: **11YD**
BODY PAINT: **WHITE**
BODY WARRANTY: **NEW WAY: 1 YR BODY & HYDRAULIC, 2 YR CYLINDER**

STANDARD EQUIPMENT INCLUDED

XL HOPPER - 2.7 YD CAPACITY
LED BODY LIGHTS, INCLUDING REVERSE AND LICENSE PLATE ARE STANDARD
BODY SIDE ACCESS DOOR
PTO SAFETY INTERLOCK ON FRONT ACCESS DOOR
SAFETY SHUT DOWN E-STOP CURBSIDE T/G
DRIVER ALERT BUZZER CURBSIDE T/G
REAR VIEW CAMERA - FLAT SCREEN MONITOR WITH AUDIO
FIRE EXTINGUISHER 10LB.(STANDARD ON MOUNTED UNITS)
TRIANGLE SAFETY KIT
HYDRAULIC TANK - FULLY ACCESSORIZED - IN BODY
INDUCTION HARDENED RODS - SLIDE & SWEEP CYLINDERS
ZINC COATED HYDRAULIC TUBES
QUICK CONNECT PRESSURE PORT AT FRONT VALVE
1-YEAR BODY STRUCTURAL WARRANTY
1-YEAR HYDRAULIC WARRANTY
2-YEAR CYLINDER WARRANTY

OPTIONAL UPGRADES AND ACCESSORIES INCLUDED

SHOVEL BROOM HOLDER
TAILGATE SEAL EXTENSION
12,000 LB. REEVING CYLINDER W/LATCH KIT
EXTRA VALVE SECTION AND EXTENDED HANDLE
EXTEND LOADSILL AND LATCH KIT FOR TIPPER INSTALL
HYDRAULIC TUBING TO TAILGATE FOR TIPPER CURBSIDE
ACRYLIC ENAMEL WHITE PAINT
LED WORK LIGHT (2) MOUNTED INSIDE UPPER TAILGATE SHINING IN HOPPER
STROBE LIGHT PACKAGE (INTEGRATED STROBE SYSTEM) (2) MOUNTED UPPER TAILGATE
STROBE LIGHT PACKAGE (INTEGRATED STROBE SYSTEM) (2) MOUNTED LOWER TAILGATE
STROBE LIGHT PACKAGE (INTEGRATED STROBE SYSTEM) (2) MOUNTED FRONT BULKHEAD
OPTIONAL COMPLETE MOUNTING KIT, SHIP OUT
IN CAB AIR CONTROLS FOR TAILGATE AND EJECT
QUICK DISCONNECT PRESSURE GAUGE

LOCAL OPTIONS INCLUDED

CART TIPPER BARKER MODEL HB15N-1539 (2)
INSTALL BODY AT SWAT
HOT SHIFT PTO WITH OVERSPEED (PUMP-PACK-ON-THE-GO)
NOTCH LOADSILL FOR TIPPER INSTALL
REMOVE REEVING CYLINDER WINCH, REPURPOSE VALVE AND ADD STEETSIDE LINKAGE AND

DEALER SERVICES INCLUDED

FREIGHT TO AMICK EQUIPMENT
BODY PDI
AECI MOBILE ON-SITE WARRANTY PKG., 12 MO.
ON-SITE TRAINING - PROVIDED BY REQUEST

DELIVERY OPTION INCLUDED:

AECI DELIVERS TO END USER.

COMMENTS:

Pricing Volatility Disclaimer - Despite recent improvements, orders may still be subject to further price increases which are out of our control - especially for the truck chassis. If a manufacturer announces a price increase that applies to your order, you'll be notified and provided with documentation. You will have the option to continue the order with the updated pricing, or cancel the order at no penalty. We sincerely appreciate your understanding during a tough season.

Subtotal:

\$

102,744.66

Contract Discount - Options / Accessories: \$ (1,540.18)
Subtotal: \$ 101,204.48

Chassis Description

MODEL: 2024 FREIGHTLINER M2 106
GVWR: 25500 LBS
ENG & TRAN: CUMMINS B6.7 DIESEL / ALLISON 3500 RDS A/T
PAINT: WHITE
COMMENTS: SEE CHASSIS SPECIFICATIONS FOR COMPLETE DETAILS.
NCSA Spec #: Sourced Good, Non-Contract Chassis
CHASSIS FREIGHT

Chassis Subtotal: \$ 108,740.00
Unit Subtotal: \$ 209,944.48
Tax - Motor Vehicle (SC IMF / NC HUT): N/A. Pay separately.
Unit Purchase Price: \$ 209,944.48

Payment Terms: Net 30: Muni's & Approved Chassis Dealers
Completion ETA: 2/4/24 Scheduled Completion Date
Note: ETAs are based on schedule at time of quote and are subject to change.
Chassis Dealers: Please include floorplan in chassis pricing, unless otherwise specified.

QUOTED BY: Dave Hull
DATE: 10/3/2023
VALID UNTIL: *Stock Unit, Subject to Sale.*
QUOTE ID:

ORDER ACCEPTANCE

SIGNATURE

DATE

ADDITIONAL OPTIONS: Prices shown in "additional options available" section are not included in the "Total" price and do not include taxes.
TAXES: Unless itemized above, prices do not include local, state or federal taxes.
MOTOR VEHICLE TAXES: AECI no longer collects SC "IMF" or NC "Highway Use Tax". Either the chassis dealer or the DMV will collect motor vehicle tax/fees when registering vehicle.
PAYMENT TERMS: Payment is due PRIOR to delivery. When ample credit has been extended to customer, payment is due within 30 Days of invoice.
TITLEWORK / MCO: Allow 5-10 business days after receipt of payment to process Title or Manufacturer's Certificate of Origin (MCO).
QUOTE EXPIRATION: Pricing is honored for 30 days from date quoted, barring extenuating circumstances such as, but not limited to, volatile markets, factory price increases, etc. AECI makes every effort to give as much notice as possible in such instances.
DELIVERY ESTIMATES: ETA's are based on production schedules at the time of quote and are subject to changes in truck or body production schedules as well other factors such as transportation delays, etc.
WEIGHT RESTRICTIONS: Operating overweight equipment can result in fines, damage to equipment or injury to operators. AECI makes every effort to quote equipment meeting local, state & federal weight regulations. Nevertheless, it is up to the end user to familiarize themselves with all applicable weight laws and avoid exceeding legal weight limits, regardless of truck's GVWR.
CHASSIS DEALERS: Please ensure chassis specs meet body manufacturer's minimum requirements, which are supplied upon request. Deviations may result in additional charges, for which the truck dealer will be responsible.
CHASSIS DEALER PAYMENT TERMS: Payment term begins when truck is delivered to customer or truck dealer for PDI, whichever is first. Payments received later than 15 DAYS are subject to penalty of Prime % APR, calculated on a daily basis. ANY EXCEPTIONS must be agreed to writing prior to order.
COOPERATIVE PURCHASING CONTRACTS: Cooperative purchasing contract such as NCSA, Sourcewell, etc. are a tool which satisfies the competitive bidding requirements for some municipalities. Amick Equipment (or its Body Manufacturer) are approved vendors on several contracts, authorized to offer awarded equipment according to each contract's terms and conditions. If a contract award included both body and chassis, then that contract clearly satisfies the bidding requirements for both body and chassis. Some of Amick's contracts were awarded for the body portion only. Upon request, Amick may offer a compatible chassis from another qualified contract holder or may offer a non-contract option. Unless explicitly stated, customers shall not assume that any of

VIPER™

S E R I E S



PACKING A POWERFUL BITE

The New Way® Viper™ is one of the most popular 9 to 13 yd³ mid-compact rear-loader bodies on the market today. Larger capacity Viper™ units are excellent for both residential and commercial work. With options including all varieties of residential cart tipplers and commercial containers, a rear-view camera and a two-year cylinder warranty, this venomous Viper™ is sure to paralyze the competition.



VIPER™

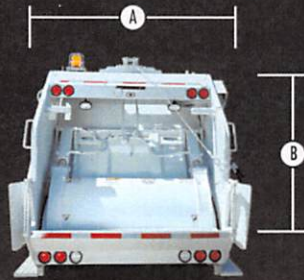

GENERAL SPECIFICATIONS

Model	9 V ^{**}	11 V	13 V
Body Capacity	9 yd ³	11 yd ³	13 yd ³
Body Width (A)	82"	96"	96"
Body Height (B)	71"	72"	72"
Body Length (C)	191.5"	195"	211"
* Approx. Body Weight	9,290 lbs	9,650 lbs	10,012 lbs
Hopper Capacity	2 yd ³	2.7 yd ³	2.7 yd ³
Hopper Opening Width	60"	80"	80"
Loading Sill Height	Frame	Frame	Frame
Hopper Cycle Time	26-30 secs.	22-24 secs.	22-24 secs.

MINIMUM CHASSIS SPECIFICATIONS (STANDARD)

Model	9 V ^{**}	11 V	13 V
** Minimum GVWR	23,000 lbs	26,000 lbs	29,000 lbs
Cab to Trunnion	84"	84"	102"

HYDRAULIC CYLINDER SPECIFICATIONS (STANDARD)

Model	9 V ^{**}	11 V	13 V
Slide Cylinders (2)	4"	4"	4"
Sweep Cylinders (2)	5"	5"	5"
Tailgate Cylinders (2)	3.5"	3.5"	3.5"
Ejection Cylinder	3-Stage 5.5"	3-Stage 5.5"	4-Stage 6.5"

BODY CONSTRUCTION

Roof & Sides	10 gauge	80K GR
Floor (center)	1/4"	50K GR
Floor (sides)	10 gauge	80K GR
Ejection Panel	10 gauge	50K GR
Sweep Panel	1/4"	80K GR
Tailgate (upper & lower)	10 gauge	50K GR
Hopper Floor	1/4"	50K GR
Hopper Floor (back)	1/4"	100K GR
Side Panel	7 gauge	50K GR

HYDRAULIC SYSTEMS

Oil Reservoir	45 gal
Oil Flow w/std. pump	25 gpm
Min. Accept. Oil Flow	20 gpm
Operating Pressure	2,350 psi
Engine RPM for STD gpm	1,350-1,550
Hydraulic Hoses	4-to-1 burst
Return Filter	10 micron

STANDARD EQUIPMENT

- Semi automatic cycling
- Accelerator kit
- Auto-lock tailgate
- Back up alarm
- All LED lights
- Upper rear lights
- Sight gauge on oil tank
- Chrome cylinder rods
- Side access door
- Driver alert buzzer
- Tailgate ajar indicator
- Pump
- Adjustable riding step
- Imron elite productive paint
- Color rear vision camera system

OPTIONAL EQUIPMENT

- Special lighting
- PTO
- Container lifts (commercial & residential)
- Pack at low idle
- Hopper liners
- Upgraded body steel package
- Body scale systems
- CNG fueling system
- Axalta Imron Elite finish paint

^{**}9 yd³ model will be built in Mexico with external hydraulic cylinders and made available to the U.S. market.

* Approximate Body Weight empty and exclusive of options.

** Any Chassis sent to Scranton Manufacturing with less than the minimum guideline requirements will not be mounted.
(Chassis must be capable of carrying the net weight of the body plus the weight of the refuse collected.)

AUTHORIZED NEW WAY DEALER



Sourcewell
Awarded Contract
Contract # 091219-NWY

NEW WAY Driving The Difference.®

a quality product of McLaughlin FAMILY COMPANIES • 800 831 1858 • www.newwaytrucks.com

20-1852 REV 05-20

S P E C I F I C A T I O N P R O P O S A L

Description	Weight Front	Weight Rear
Price Level		
M2 PRL-27M (EFF:MY24 ORDERS)		
Data Version		
SPECPRO21 DATA RELEASE VER 015		
Vehicle Configuration		
M2 106 CONVENTIONAL CHASSIS 2024 MODEL YEAR SPECIFIED SET BACK AXLE - TRUCK STRAIGHT TRUCK PROVISION LH PRIMARY STEERING LOCATION	5,709	3,450
General Service		
TRUCK CONFIGURATION DOMICILED, USA 50 STATES (INCLUDING CALIFORNIA AND CARB OPT-IN STATES) REFUSE SERVICE SANITATION BUSINESS SEGMENT MOIST BULK COMMODITY TERRAIN/DUTY: 100% (ALL) OF THE TIME, IN TRANSIT, IS SPENT ON PAVED ROADS MAXIMUM 8% EXPECTED GRADE SMOOTH CONCRETE OR ASPHALT PAVEMENT - MOST SEVERE IN-TRANSIT (BETWEEN SITES) ROAD SURFACE MEDIUM TRUCK WARRANTY EXPECTED FRONT AXLE(S) LOAD : 8000.0 lbs EXPECTED REAR DRIVE AXLE(S) LOAD : 17500.0 lbs EXPECTED GROSS VEHICLE WEIGHT CAPACITY : 25500.0 lbs		
Truck Service		
REFUSE, SIDE LOAD OR REAR PACKER BODY - UNLOADS IN A LANDFILL		

Description	Weight Front	Weight Rear
SCRANTON MANUFACTURING/NEW WAY EXPECTED BODY/PAYLOAD CG HEIGHT ABOVE FRAME "XX" INCHES : 32.0 in		
Engine		
CUM B6.7 250 HP @ 2400 RPM, 2600 GOV, 660 LB-FT @ 1600 RPM, REFUSE		
Electronic Parameters		
75 MPH ROAD SPEED LIMIT CRUISE CONTROL SPEED LIMIT SAME AS ROAD SPEED LIMIT PTO MODE ENGINE RPM LIMIT - 1100 RPM PTO RPM WITH CRUISE SET SWITCH - 700 RPM PTO RPM WITH CRUISE RESUME SWITCH - 800 RPM PTO MODE CANCEL VEHICLE SPEED - 5 MPH PTO GOVERNOR RAMP RATE - 250 RPM PER SECOND THREE REMOTE PTO SPEEDS PTO SPEED 1 SETTING - 700 RPM PTO SPEED 2 SETTING - 700 RPM PTO SPEED 3 SETTING - 700 RPM NO FLEET SPEC FOR PARAMETERIZATION PTO MINIMUM RPM - 700 REGEN INHIBIT SPEED THRESHOLD - 5 MPH		
Engine Equipment		
2010 EPA/CARB/GHG21 CONFIGURATION 2008 CARB EMISSION CERTIFICATION - CLEAN IDLE (INCLUDES 6X4 INCH LABEL ON LOWER FORWARD CORNER OF DRIVER DOOR) STANDARD OIL PAN ENGINE MOUNTED OIL CHECK AND FILL SIDE OF HOOD AIR INTAKE WITH FIREWALL MOUNTED DONALDSON AIR CLEANER DR 12V 160 AMP 28-SI QUADRAMOUNT PAD ALTERNATOR WITH REMOTE BATTERY VOLT SENSE (2) DTNA GENUINE, FLOODED STARTING, MIN 1900CCA, 350RC, THREADED STUD BATTERIES BATTERY BOX FRAME MOUNTED STANDARD BATTERY JUMPERS		

Description	Weight Front	Weight Rear
SINGLE BATTERY BOX FRAME MOUNTED LH SIDE UNDER CAB		
WIRE GROUND RETURN FOR BATTERY CABLES WITH ADDITIONAL FRAME GROUND RETURN		
NON-POLISHED BATTERY BOX COVER		
CAB AUXILIARY POWER CABLE	5	
POSITIVE LOAD DISCONNECT WITH CAB MOUNTED CONTROL SWITCH MOUNTED OUTBOARD DRIVER SEAT	2	
POSITIVE AND NEGATIVE POSTS FOR JUMPSTART LOCATED ON FRAME NEXT TO STARTER	2	
CUMMINS TURBOCHARGED 18.7 CFM AIR COMPRESSOR WITH INTERNAL SAFETY VALVE STANDARD MECHANICAL AIR COMPRESSOR GOVERNOR		
AIR COMPRESSOR DISCHARGE LINE		
ELECTRONIC ENGINE INTEGRAL SHUTDOWN PROTECTION SYSTEM		
CUMMINS ENGINE INTEGRAL BRAKE WITH VARIABLE GEOMETRY TURBO ON/OFF	20	
RH OUTBOARD UNDER STEP MOUNTED HORIZONTAL AFTERTREATMENT SYSTEM ASSEMBLY WITH RH HORIZONTAL TAILPIPE		
ENGINE AFTERTREATMENT DEVICE, AUTOMATIC OVER THE ROAD REGENERATION AND DASH MOUNTED REGENERATION REQUEST SWITCH		
STANDARD EXHAUST SYSTEM LENGTH		
RH STANDARD HORIZONTAL TAILPIPE		
6 GALLON DIESEL EXHAUST FLUID TANK		
100 PERCENT DIESEL EXHAUST FLUID FILL		
LH MEDIUM DUTY STANDARD DIESEL EXHAUST FLUID TANK LOCATION		
STANDARD DIESEL EXHAUST FLUID PUMP MOUNTING		
STANDARD DIESEL EXHAUST FLUID TANK CAP		
AIR POWERED ON/OFF ENGINE FAN CLUTCH		
AUTOMATIC FAN CONTROL WITHOUT DASH SWITCH, NON ENGINE MOUNTED		
CUMMINS SPIN ON FUEL FILTER		
FULL FLOW OIL FILTER		
700 SQUARE INCH ALUMINUM RADIATOR		

Description	Weight Front	Weight Rear
ANTIFREEZE TO -34F, ETHYLENE GLYCOL PRE-CHARGED SCA HEAVY DUTY COOLANT GATES BLUE STRIPE COOLANT HOSES OR EQUIVALENT CONSTANT TENSION HOSE CLAMPS FOR COOLANT HOSES RADIATOR DRAIN VALVE LOWER RADIATOR GUARD PHILLIPS-TEMRO 750 WATT/115 VOLT BLOCK HEATER BLACK PLASTIC ENGINE HEATER RECEPTACLE MOUNTED UNDER LH DOOR ALUMINUM FLYWHEEL HOUSING ELECTRIC GRID AIR INTAKE WARMER DELCO 12V 29MT STARTER WITH INTEGRATED MAGNETIC SWITCH	4	
Transmission		
ALLISON 3500 RDS AUTOMATIC TRANSMISSION WITH PTO PROVISION	200	60
Transmission Equipment		
ALLISON VOCATIONAL PACKAGE 170 - AVAILABLE ON 3000/4000 PRODUCT FAMILIES WITH VOCATIONAL MODEL RDS AND EVS ALLISON VOCATIONAL RATING FOR REFUSE APPLICATIONS AVAILABLE WITH ALL PRODUCT FAMILIES PRIMARY MODE GEARS, LOWEST GEAR 1, START GEAR 1, HIGHEST GEAR 6, AVAILABLE FOR 3000/4000 PRODUCT FAMILIES ONLY SECONDARY MODE GEARS, LOWEST GEAR 1, START GEAR 1, HIGHEST GEAR 6, AVAILABLE FOR 3000/4000 PRODUCT FAMILIES ONLY PRIMARY SHIFT SCHEDULE RECOMMENDED BY DTNA AND ALLISON, THIS DEFINED BY ENGINE AND VOCATIONAL USAGE SECONDARY SHIFT SCHEDULE RECOMMENDED BY DTNA AND ALLISON, THIS DEFINED BY ENGINE AND VOCATIONAL USAGE PRIMARY SHIFT SPEED RECOMMENDED BY DTNA AND ALLISON, THIS DEFINED BY ENGINE AND VOCATIONAL USAGE SECONDARY SHIFT SPEED RECOMMENDED BY DTNA AND ALLISON, THIS DEFINED BY ENGINE AND VOCATIONAL USAGE		

Description	Weight Front	Weight Rear
ENGINE BRAKE RANGE PRESELECT RECOMMENDED BY DTNA AND ALLISON, THIS DEFINED BY ENGINE AND VOCATIONAL USAGE		
ENGINE BRAKE RANGE ALTERNATE PRESELECT RECOMMENDED BY DTNA AND ALLISON, THIS DEFINED BY ENGINE AND VOCATIONAL USAGE		
FUEL SENSE 2.0 DISABLED - PERFORMANCE - TABLE BASED		
DRIVER SWITCH INPUT - DEFAULT - NO SWITCHES		
VEHICLE INTERFACE WIRING CONNECTOR WITH PDM AND NO BLUNT CUTS, AT BACK OF CAB		
ELECTRONIC TRANSMISSION CUSTOMER ACCESS CONNECTOR MOUNTED BACK OF CAB CUSTOMER INSTALLED CHELSEA 280 SERIES PTO		
PTO MOUNTING, LH SIDE OF MAIN TRANSMISSION ALLISON		
MAGNETIC PLUGS, ENGINE DRAIN, TRANSMISSION DRAIN, AXLE(S) FILL AND DRAIN		
PUSH BUTTON ELECTRONIC SHIFT CONTROL, DASH MOUNTED		
TRANSMISSION PROGNOSTICS - ENABLED 2013		
WATER TO OIL TRANSMISSION COOLER, IN RADIATOR END TANK		
TRANSMISSION OIL CHECK AND FILL WITH ELECTRONIC OIL LEVEL CHECK		
SYNTHETIC TRANSMISSION FLUID (TES-295 COMPLIANT)		

Front Axle and Equipment

DETROIT DA-F-8.0-3 8,000# FF1 71.5 KPI/3.74 DROP SINGLE FRONT AXLE		
MERITOR 15X4 Q+ CAM FRONT BRAKES		
NON-ASBESTOS FRONT BRAKE LINING		
CONMET CAST IRON FRONT BRAKE DRUMS		
FRONT BRAKE DUST SHIELDS	5	
FRONT OIL SEALS		
VENTED FRONT HUB CAPS WITH WINDOW, CENTER AND SIDE PLUGS - OIL		
STANDARD SPINDLE NUTS FOR ALL AXLES		
MERITOR AUTOMATIC FRONT SLACK ADJUSTERS		

Description	Weight Front	Weight Rear
TRW THP-60 POWER STEERING POWER STEERING PUMP 2 QUART SEE THROUGH POWER STEERING RESERVOIR CURRENT AVAILABLE SYNTHETIC 75W-90 FRONT AXLE LUBE		
Front Suspension		
10,000# TAPERLEAF FRONT SUSPENSION MAINTENANCE FREE RUBBER BUSHINGS - FRONT SUSPENSION FRONT SHOCK ABSORBERS		
Rear Axle and Equipment		
MS-17-14X 17,500# R-SERIES SINGLE REAR AXLE		-30
6.14 REAR AXLE RATIO IRON REAR AXLE CARRIER WITH STANDARD AXLE HOUSING		
MXL 17T MERITOR EXTENDED LUBE MAIN DRIVELINE WITH HALF ROUND YOKES	-20	-20
DRIVER CONTROLLED TRACTION DIFFERENTIAL - SINGLE REAR AXLE (1) DRIVER CONTROLLED DIFFERENTIAL LOCK REAR VALVE FOR SINGLE DRIVE AXLE BLINKING LAMP WITH EACH MODE SWITCH, DIFFERENTIAL UNLOCK WITH IGNITION OFF, ACTIVE <5 MPH MERITOR 16.5X7 Q+ CAST SPIDER HEAVY DUTY CAM REAR BRAKES, DOUBLE ANCHOR, FABRICATED SHOES NON-ASBESTOS REAR BRAKE LINING BRAKE CAMS AND CHAMBERS ON REAR SIDE OF DRIVE AXLE(S) CONMET CAST IRON REAR BRAKE DRUMS REAR BRAKE DUST SHIELDS REAR OIL SEALS WABCO TRISTOP D LONGSTROKE 1-DRIVE AXLE SPRING PARKING CHAMBERS MERITOR AUTOMATIC REAR SLACK ADJUSTERS CURRENT AVAILABLE SYNTHETIC 75W-90 REAR AXLE LUBE		20
		5
Rear Suspension		

Description	Weight Front	Weight Rear
23,000# FLAT LEAF SPRING REAR SUSPENSION WITH HELPER AND RADIUS ROD		120
SPRING SUSPENSION - NO AXLE SPACERS		
STANDARD AXLE SEATS IN AXLE CLAMP GROUP		
FORE/AFT CONTROL RODS		
Brake System		
AIR BRAKE PACKAGE		
WABCO 4S/4M ABS		
REINFORCED NYLON, FABRIC BRAID AND WIRE BRAID CHASSIS AIR LINES		
FIBER BRAID PARKING BRAKE HOSE		
STANDARD BRAKE SYSTEM VALVES		
STANDARD AIR SYSTEM PRESSURE PROTECTION SYSTEM		
STD U.S. FRONT BRAKE VALVE		
RELAY VALVE WITH 5-8 PSI CRACK PRESSURE, NO REAR PROPORTIONING VALVE		
BW AD-9 BRAKE LINE AIR DRYER WITH HEATER	20	
AIR DRYER FRAME MOUNTED		
STEEL AIR BRAKE RESERVOIRS		
PULL CABLES ON ALL AIR RESERVOIR(S)		
Trailer Connections		
UPGRADED CHASSIS MULTIPLEXING UNIT		
UPGRADED BULKHEAD MULTIPLEXING UNIT		
Wheelbase & Frame		
3900MM (154 INCH) WHEELBASE		
11/32X3-1/2X10-3/16 INCH STEEL FRAME (8.73MMX258.8MM/0.344X10.19 INCH) 120KSI	-120	130
2425MM (95 INCH) REAR FRAME OVERHANG		
FRAME OVERHANG RANGE: 91 INCH TO 100 INCH	-40	170
CALC'D BACK OF CAB TO REAR SUSP C/L (CA) : 87.99 in		
CALCULATED EFFECTIVE BACK OF CAB TO REAR SUSPENSION C/L (CA) : 84.99 in		
CALC'D FRAME LENGTH - OVERALL : 288.02 in		
CALCULATED FRAME SPACE LH SIDE : 53.28 in		
CALCULATED FRAME SPACE RH SIDE : 35.59 in		
SQUARE END OF FRAME		

Description	Weight Front	Weight Rear
FRONT CLOSING CROSSMEMBER		
STANDARD WEIGHT ENGINE CROSSMEMBER		
STANDARD CROSSMEMBER BACK OF TRANSMISSION		
STANDARD MIDSHIP #1 CROSSMEMBER(S)		
STANDARD REARMOST CROSSMEMBER		
STANDARD SUSPENSION CROSSMEMBER		
Chassis Equipment		
THREE-PIECE 14 INCH CHROMED STEEL BUMPER WITH COLLAPSIBLE ENDS	30	
FRONT TOW HOOKS - FRAME MOUNTED	15	
BUMPER MOUNTING FOR SINGLE LICENSE PLATE		
FENDER AND FRONT OF HOOD MOUNTED FRONT MUDFLAPS		
GRADE 8 THREADED HEX HEADED FRAME FASTENERS		
CLEAR FRAME RAILS FROM BACK OF CAB TO FRONT REAR SUSPENSION BRACKET, BOTH RAILS OUTBOARD		
Fuel Tanks		
50 GALLON/189 LITER SHORT RECTANGULAR ALUMINUM FUEL TANK - LH	20	
RECTANGULAR FUEL TANK(S)		
PLAIN ALUMINUM/PAINTED STEEL FUEL/HYDRAULIC TANK(S) WITH PAINTED BANDS		
FUEL TANK(S) FORWARD		
10 GALLONS ADDITIONAL FUEL		
PLAIN STEP FINISH		
FUEL TANK CAP(S)		
DETROIT FUEL/WATER SEPARATOR WITH WATER IN FUEL SENSOR, HAND PRIMER AND 12 VOLT PREHEATER"	-5	
EQUIFLO INBOARD FUEL SYSTEM		
HIGH TEMPERATURE REINFORCED NYLON FUEL LINE		
FUEL COOLER	10	
Tires		
CONTINENTAL HSR2 11R22.5 14 PLY RADIAL FRONT TIRES	16	

Description	Weight Front	Weight Rear
CONTINENTAL HDL2 11R22.5 14 PLY RADIAL REAR TIRES		44
Hubs		
CONMET PRESET PLUS PREMIUM IRON FRONT HUBS		
CONMET PRESET PLUS PREMIUM IRON REAR HUBS		
Wheels		
MAXION WHEELS 91541 22.5X8.25 10-HUB PILOT 6.20 INSET 2-HAND STEEL DISC FRONT WHEELS		
MAXION WHEELS 91541 22.5X8.25 10-HUB PILOT 2-HAND STEEL DISC REAR WHEELS		
FRONT WHEEL MOUNTING NUTS		
REAR WHEEL MOUNTING NUTS		
WHEEL STUDS FOR CUSTOMER INSTALLED HUB PILOTED DUALED ALUMINUM WHEELS, ALL		
Cab Exterior		
106 INCH BBC FLAT ROOF ALUMINUM CONVENTIONAL CAB		
AIR CAB MOUNTING		
NONREMOVABLE BUGSCREEN MOUNTED BEHIND GRILLE		
LH AND RH GRAB HANDLES		
HOOD MOUNTED CHROMED PLASTIC GRILLE		
CHROME HOOD MOUNTED AIR INTAKE GRILLE		
FIBERGLASS HOOD		
TUNNEL/FIREWALL LINER		
SINGLE 14 INCH ROUND POLISHED AIR HORN ROOF MOUNTED	4	
SINGLE ELECTRIC HORN		
SINGLE HORN SHIELD		
REAR LICENSE PLATE MOUNT END OF FRAME		
INTEGRAL HEADLIGHT/MARKER ASSEMBLY WITH CHROME BEZEL		
LED AERODYNAMIC MARKER LIGHTS		
DAYTIME RUNNING LIGHTS		
OMIT STOP/TAIL/BACKUP LIGHTS AND PROVIDE WIRING WITH SEPARATE STOP/TURN WIRES TO 4 FEET BEYOND END OF FRAME		-5
STANDARD FRONT TURN SIGNAL LAMPS		

Description	Weight Front	Weight Rear
DUAL WEST COAST BRIGHT FINISH HEATED MIRRORS WITH LH AND RH REMOTE		
DOOR MOUNTED MIRRORS		
102 INCH EQUIPMENT WIDTH		
LH AND RH 8 INCH BRIGHT FINISH CONVEX MIRRORS MOUNTED UNDER PRIMARY MIRRORS		
STANDARD SIDE/REAR REFLECTORS		
RH AFTERTREATMENT SYSTEM CAB ACCESS WITH PLAIN DIAMOND PLATE COVER		
COMPOSITE EXTERIOR SUN VISOR	10	
63X14 INCH TINTED REAR WINDOW		
TINTED DOOR GLASS LH AND RH WITH TINTED NON-OPERATING WING WINDOWS		
RH AND LH ELECTRIC POWERED WINDOWS, PASSENGER SWITCHES ON DOOR(S)	4	
1-PIECE SOLAR GREEN GLASS WINDSHIELD		
2 GALLON WINDSHIELD WASHER RESERVOIR WITH FLUID LEVEL INDICATOR, FRAME MOUNTED		
WHITE WINTERFRONT	2	
Cab Interior		
INTERIOR CONVENIENCE PACKAGE WITH CB PROVISION		
OPAL GRAY VINYL INTERIOR		
MOLDED DOOR PANEL WITH UPPER VINYL INSERTS		
MOLDED DOOR PANEL WITH UPPER VINYL INSERTS		
BLACK MATS WITH SINGLE INSULATION		
FORWARD ROOF MOUNTED CONSOLE WITH UPPER STORAGE COMPARTMENTS WITHOUT NETTING		
IN DASH STORAGE BIN		
PLASTIC MANIFEST BOX - LH DOOR		
(2) CUP HOLDERS LH AND RH DASH		
GRAY/CHARCOAL FLAT DASH		
SMART SWITCH EXPANSION MODULE		
HEATER, DEFROSTER AND AIR CONDITIONER		
STANDARD HVAC DUCTING		
MAIN HVAC CONTROLS WITH RECIRCULATION SWITCH		

Description	Weight Front	Weight Rear
STANDARD HEATER PLUMBING WITH BALL SHUTOFF VALVES AT SUPPLY LINES ONLY		
VALEO HEAVY DUTY A/C REFRIGERANT COMPRESSOR		
BINARY CONTROL, R-134A		
PREMIUM INSULATION		
SOLID-STATE CIRCUIT PROTECTION AND FUSES		
12V NEGATIVE GROUND ELECTRICAL SYSTEM		
DOMED DOOR ACTIVATED LH AND RH, DUAL READING LIGHTS, FORWARD CAB ROOF		
DOOR LOCKS AND IGNITION SWITCH KEYED THE SAME		
KEY QUANTITY OF 2		
LH AND RH ELECTRIC DOOR LOCKS		
(1) 12V POWER SUPPLY (1) DUAL 2.1 AMP USB CHARGER IN DASH		
BASIC ISRINGHAUSEN HIGH BACK AIR SUSPENSION DRIVERS SEAT WITH MECHANICAL LUMBAR AND INTEGRATED CUSHION EXTENSION	30	
2 MAN TOOL BOX MID BACK NON SUSPENSION PASSENGER SEAT	20	
INBOARD DRIVER SEAT ARMREST, NO PASSENGER SEAT ARMREST	2	
LH AND RH INTEGRAL DOOR PANEL ARMRESTS		
BLACK CORDURA PLUS CLOTH DRIVER SEAT COVER		
BLACK CORDURA PLUS CLOTH PASSENGER SEAT COVER		
BLACK SEAT BELTS		
ADJUSTABLE TILT AND TELESCOPING STEERING COLUMN	10	
4-SPOKE 18 INCH (450MM) STEERING WHEEL		
DRIVER AND PASSENGER INTERIOR SUN VISORS		
Instruments & Controls		
GRAY DRIVER INSTRUMENT PANEL		
GRAY CENTER INSTRUMENT PANEL		
ENGINE REMOTE INTERFACE WITH PARK BRAKE AND NEUTRAL INTERLOCKS		
BLACK GAUGE BEZELS		

Description	Weight Front	Weight Rear
LOW AIR PRESSURE INDICATOR LIGHT AND AUDIBLE ALARM		
2 INCH PRIMARY AND SECONDARY AIR PRESSURE GAUGES		
INTAKE MOUNTED AIR RESTRICTION INDICATOR WITH GRADUATIONS		
ELECTRONIC CRUISE CONTROL WITH SWITCHES IN LH SWITCH PANEL		
KEY OPERATED IGNITION SWITCH AND INTEGRAL START POSITION; 4 POSITION OFF/RUN/START/ACCESSORY		
ICU3S, 132X48 DISPLAY WITH DIAGNOSTICS, 28 LED WARNING LAMPS AND DATA LINKED		
HEAVY DUTY ONBOARD DIAGNOSTICS INTERFACE CONNECTOR LOCATED BELOW LH DASH		
2 INCH ELECTRIC FUEL GAUGE		
ENGINE REMOTE INTERFACE WITH PRESET FAST IDLE		
ENGINE REMOTE INTERFACE CONNECTOR AT BACK OF CAB		
ELECTRICAL ENGINE COOLANT TEMPERATURE GAUGE		
TRANSMISSION OIL TEMPERATURE INDICATOR LIGHT		
ENGINE AND TRIP HOUR METERS INTEGRAL WITHIN DRIVER DISPLAY		
(1) DASH MOUNTED PTO SWITCH WITH INDICATOR LAMP	10	
NO DR ASSIST SYSTEM		
ELECTRIC ENGINE OIL PRESSURE GAUGE		
OVERHEAD INSTRUMENT PANEL		
AM/FM/WB WORLD TUNER RADIO WITH BLUETOOTH, USB AND AUXILIARY INPUTS, J1939	10	
DASH MOUNTED RADIO		
(2) RADIO SPEAKERS IN CAB		
POWER AND GROUND WIRING PROVISION OVERHEAD		
CB WIRING ONLY TO ROOF/OVERHEAD CONSOLE; NO MOUNTING PROVISION		
MULTI-BAND AM/FM/WB/CB LH MIRROR MOUNTED ANTENNA SYSTEM		

Description	Weight Front	Weight Rear
<p>ELECTRONIC MPH SPEEDOMETER WITH SECONDARY KPH SCALE, WITHOUT ODOMETER</p> <p>STANDARD VEHICLE SPEED SENSOR</p> <p>ELECTRONIC 3000 RPM TACHOMETER</p> <p>IDLE LIMITER, ELECTRONIC ENGINE</p> <p>SIX ON/OFF ROCKER SWITCHES IN THE DASH WITH INDICATOR LIGHTS; FOUR WIRE TO CHASSIS AT BACK OF CAB, TWO UNWIRED, LABEL ALL OPT</p> <p>WORK BRAKE WITH RETURN TO GEAR, AUTO NEUTRAL, FOR DRIVE AXLE SERVICE BRAKES</p> <p>DIGITAL VOLTAGE DISPLAY INTEGRAL WITH DRIVER DISPLAY</p> <p>SINGLE ELECTRIC WINDSHIELD WIPER MOTOR WITH DELAY</p> <p>MARKER LIGHT SWITCH INTEGRAL WITH HEADLIGHT SWITCH</p> <p>ONE VALVE PARKING BRAKE SYSTEM WITH DASH VALVE CONTROL AUTONEUTRAL AND WARNING INDICATOR</p> <p>SELF CANCELING TURN SIGNAL SWITCH WITH DIMMER, WASHER/WIPER AND HAZARD IN HANDLE</p> <p>INTEGRAL ELECTRONIC TURN SIGNAL FLASHER WITH HAZARD LAMPS OVERRIDING STOP LAMPS</p>		
Design		
PAINT: ONE SOLID COLOR		
Color		
<p>CAB COLOR A: L0006EY WHITE ELITE EY</p> <p>BLACK, HIGH SOLIDS POLYURETHANE CHASSIS PAINT</p> <p>POWDER WHITE (N0006EA) FRONT WHEELS/RIMS (PKWHT21, TKWHT21, W, TW)</p> <p>POWDER WHITE (N0006EA) REAR WHEELS/RIMS (PKWHT21, TKWHT21, W, TW)</p> <p>SUNVISOR PAINTED SAME AS CAB COLOR A</p> <p>STANDARD E COAT/UNDERCOATING</p>		
Certification / Compliance		
<p>U.S. FMVSS CERTIFICATION, EXCEPT SALES CABS AND GLIDER KITS</p>		
Secondary Factory Options		

Description	Weight Front	Weight Rear
CORPORATE PDI CENTER IN-SERVICE ONLY		

TOTAL VEHICLE SUMMARY

Weight Summary			
	Weight Front	Weight Rear	Total Weight
Factory Weight ⁺	5975 lbs	3944 lbs	9919 lbs
Total Weight⁺	5975 lbs	3944 lbs	9919 lbs

Extended Warranty
 TOWING: 1 YEAR/UNLIMITED MILES/KM EXTENDED TOWING
 COVERAGE \$1200 CAP FEX APPLIES

(+) Weights shown are estimates only.
 If weight is critical, contact Customer Application Engineering.

(***) All cost increases for major components (Engines, Transmissions, Axles, Front and Rear Tires) and government mandated requirements, tariffs, and raw material surcharges will be passed through and added to factory invoices.

DIMENSIONS

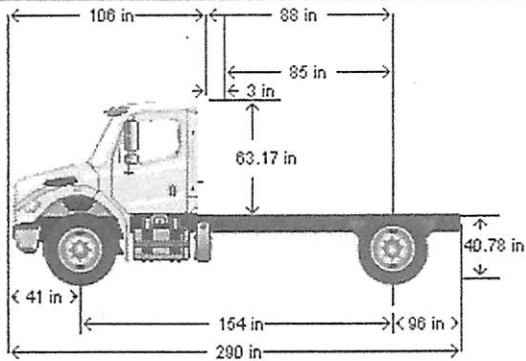

VEHICLE SPECIFICATIONS SUMMARY - DIMENSIONS

Model	M2106
Wheelbase (545)	3900MM (154 INCH) WHEELBASE
Rear Frame Overhang (552)	2425MM (95 INCH) REAR FRAME OVERHANG
Fifth Wheel (578)	NO FIFTH WHEEL
Mounting Location (577)	NO FIFTH WHEEL LOCATION
Maximum Forward Position (in)	0
Maximum Rearward Position (in)	0
Amount of Slide Travel (in)	0
Slide Increment (in)	0
Desired Slide Position (in)	0.0
Cab Size (829)	106 INCH BBC FLAT ROOF ALUMINUM CONVENTIONAL CAB
Sleeper (682)	NO SLEEPER BOX/SLEEPERCAB
Exhaust System (016)	RH OUTBOARD UNDER STEP MOUNTED HORIZONTAL AFTERTREATMENT SYSTEM ASSEMBLY WITH RH HORIZONTAL TAILPIPE

TABLE SUMMARY - DIMENSIONS	
----------------------------	--

Dimensions	Inches
Bumper to Back of Cab (BBC)	106.3
Bumper to Centerline of Front Axle (BA)	40.7
Front Axle to Back of Cab (AC)	65.6
Min. Cab to Body Clearance (CB)	3.0
Back of Cab to Centerline of Rear Axle(s) (CA)	88.0
Effective Back of Cab to Centerline of Rear Axle(s) (Effective CA)	85.0
Back of Cab Protrusions (Exhaust/Intake) (CP)	2.0
Back of Cab Protrusions (Side Extenders/Trim Tab) (CP)	0.0
Back of Cab Protrusions (CNG Tank)	0.0
Back of Cab Clearance (CL)	3.0
Back of Cab to End of Frame	183.5
Cab Height (CH)	63.2
Wheelbase (WB)	153.5
Frame Overhang (OH)	95.5
Overall Frame Length	288.0
Overall Length (OAL)	289.8
Rear Axle Spacing	0.0
Unladen Frame Height at Centerline of Rear Axle	40.8

Performance calculations are estimates only. If performance calculations are critical, please contact Customer Application Engineering.

OPERATING RANGE

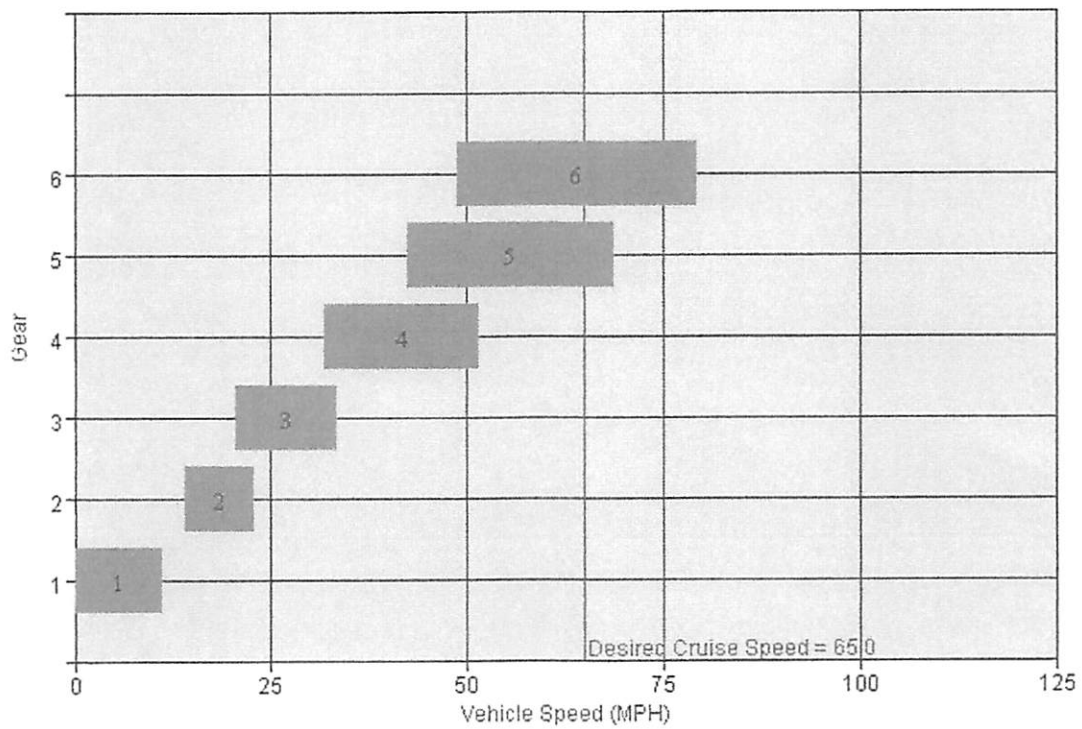

VEHICLE SPECIFICATIONS SUMMARY - OPERATING RANGE

Model M2106
Cab Size (829)..... 106 INCH BBC FLAT ROOF ALUMINUM CONVENTIONAL CAB
Desired Cruise Speed (mph) 65.0

Engine (101).....	CUM B6.7 250 HP @ 2400 RPM, 2600 GOV, 660 LB-FT @ 1600 RPM, REFUSE
RPM at Peak Torque	1600
Governed RPM	2600
Transmission (342).....	ALLISON 3500 RDS AUTOMATIC TRANSMISSION WITH PTO PROVISION
Gear Ratio: LL	N/A
Gear Ratio: L	N/A
Gear Ratio: 1	4.59
Gear Ratio: 2	2.25
Gear Ratio: 3	1.54
Gear Ratio: 4	1
Gear Ratio: 5	0.75
Gear Ratio: 6	0.65
Gear Ratio: 7	N/A
Gear Ratio: 8	N/A
Gear Ratio: 9	N/A
Gear Ratio: 10	N/A
Gear Ratio: 11	N/A
Gear Ratio: 12	N/A
Gear Ratio: 13	N/A
Gear Ratio: 14	N/A
Gear Ratio: 15	N/A
Gear Ratio: 16	N/A
Gear Ratio: 17	N/A
Gear Ratio: 18	N/A
Auxiliary Transmission (352).....	NO AUXILIARY TRANSMISSION
Low Gear Ratio	N/A
High Gear Ratio	N/A
Transfer Case (373).....	NO TRANSFER CASE
Low Gear Ratio	N/A
High Gear Ratio	N/A
Rear Axle (420)	MS-17-14X 17,500# R-SERIES SINGLE REAR AXLE
Number of Speeds	1
Rear Axle Gear Ratio(s)	6.14 REAR AXLE RATIO
Rear Tires (094)	CONTINENTAL HDL2 11R22.5 14 PLY RADIAL REAR TIRES
Revolutions per Mile	493

TABLE SUMMARY - OPERATING RANGE

Transmission Gear	Transmission Gear Ratio	Rear Axle Ratio	Overall Gear Ratio	Minimum Speed (MPH)	Maximum Speed (MPH)
1	4.59	6.14	28.18	0	11.2
2	2.25	6.14	13.81	14.1	22.9
3	1.54	6.14	9.46	20.6	33.5
4	1.00	6.14	6.14	31.7	51.5
5	0.75	6.14	4.60	42.3	68.7
6	0.65	6.14	3.99	48.8	79.3

Performance calculations are estimates only. If performance calculations are critical, please contact Customer Application Engineering.

TURNING RADIUS

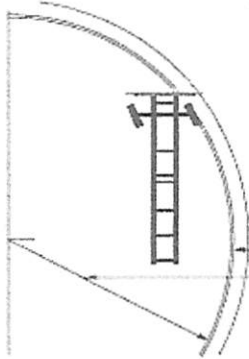

Turning radius graphic and data provided strictly for comparisons between model configurations. Weather, road surfaces, and tire treads affect the results. It is strongly suggested that actual vehicles be measured before constructing any roads/driveways using this information. For specific figures regarding your configuration, please contact your CAE representative.

	Dimensions	Tolerance
Wall to Wall Diameter (ft)	45.7	+/- 3.0
Curb to Curb Diameter (ft)	44.1	+/- 3.0
Turning Radius (ft)	21.6	+/- 1.5

VEHICLE SPECIFICATIONS SUMMARY - TURNING RADIUS

Model	M2106
Cab Size (829).....	106 INCH BBC FLAT ROOF ALUMINUM CONVENTIONAL CAB
Wheelbase (545)	3900MM (154 INCH) WHEELBASE
Front Tires (093).....	CONTINENTAL HSR2 11R22.5 14 PLY RADIAL FRONT TIRES
Width (in)	11.1
Front Axle (400).....	DETROIT DA-F-8.0-3 8,000# FF1 71.5 KPI/3.74 DROP SINGLE FRONT AXLE
Kingpin Intersection (in)	71.5
Bumper (556)	THREE-PIECE 14 INCH CHROMED STEEL BUMPER WITH COLLAPSIBLE ENDS
Width (in)	93.5
Bumper Miter to Front Axle (in)	21.458
Primary Steering Location (003)	LH PRIMARY STEERING LOCATION
Steering Gear (536).....	TRW THP-60 POWER STEERING
Dual Steering Gear	NONE
Ram.....	NONE
Rear Axle (420)	MS-17-14X 17,500# R-SERIES SINGLE REAR AXLE
Axle Spacing (624)	NO AXLE SPACING

OPERATING SPEED

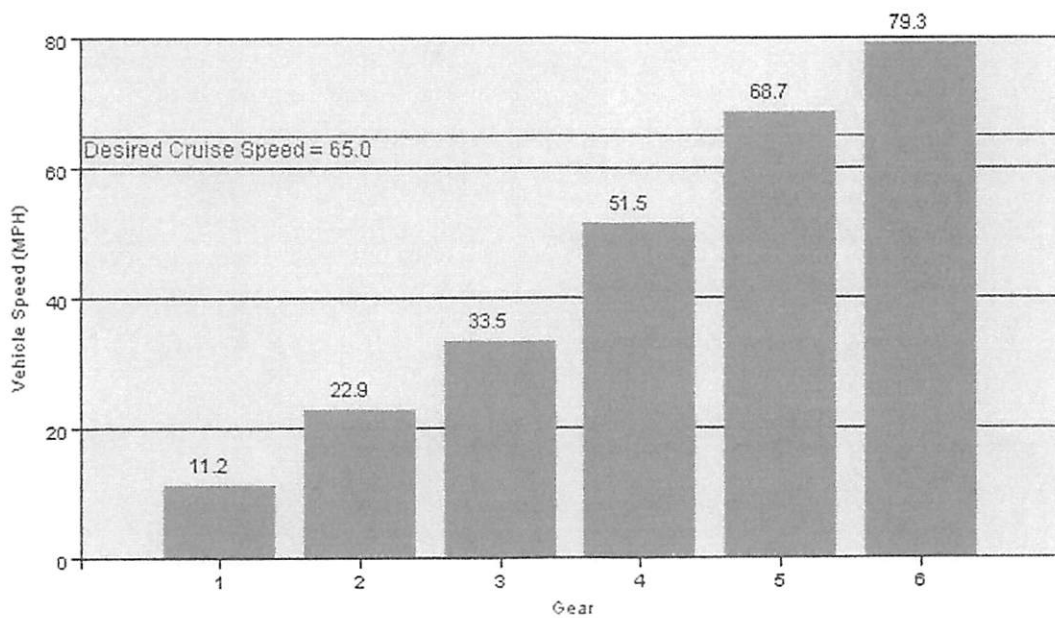

Rear Axle Ratio = 6.14

Engine RPM = 2600

VEHICLE SPECIFICATIONS SUMMARY - OPERATING SPEED

Model M2106
Cab Size (829)..... 106 INCH BBC FLAT ROOF ALUMINUM CONVENTIONAL CAB
Top Speed (mph)..... 79.3

Engine RPM 2600.0
 Desired Cruise Speed (mph) 65.0
 Engine (101)..... CUM B6.7 250 HP @ 2400 RPM, 2600 GOV, 660 LB-FT @ 1600 RPM, REFUSE
 Governed RPM 2600
 Transmission (342).....ALLISON 3500 RDS AUTOMATIC TRANSMISSION WITH PTO PROVISION
 Rear Axle (420) MS-17-14X 17,500# R-SERIES SINGLE REAR AXLE
 Number of Speeds..... 1
 Rear Axle Gear Ratio(s).....6.14 REAR AXLE RATIO
 Rear Tires (094)CONTINENTAL HDL2 11R22.5 14 PLY RADIAL REAR TIRES
 Revolutions per Mile 493
 Auxiliary Transmission (352)..... NO AUXILIARY TRANSMISSION
 High Gear Ratio N/A
 Low Gear Ratio..... N/A
 Transfer Case (373)..... NO TRANSFER CASE
 High Gear Ratio N/A
 Low Gear Ratio..... N/A

TABLE SUMMARY - OPERATING SPEED

Transmission Gear	Transmission Gear Ratio	Overall Gear Ratio	Vehicle Speed (MPH)
1	4.59	28.18	11.2
2	2.25	13.81	22.9
3	1.54	9.46	33.5
4	1.00	6.14	51.5
5	0.75	4.60	68.7
6	0.65	3.99	79.3
Desired Cruise Speed (mph)			65.0
Engine RPM			2600
Rear Axle Ratio			6.14
*Blue background represents value input by user.			

Performance calculations are estimates only. If performance calculations are critical, please contact Customer Application Engineering.

TOWN OF MONCK'S CORNER REGULAR MEETING
Tuesday, November 14, 2023

Title: Consider Bids for Equipment Lease Purchase

Background: Staff solicited bids for financing of a 2023 equipment lease purchase for a F750 sanitation truck. Requests for bids were solicited through mail and e-mail (approximately 7 banking companies were contacted), and Town's website.

Farmers and Merchants and First citizens bank were the only banks to submit a bid with the following rates:

Option 1

Farmers and Merchants Bank				
Rate	Terms	Payment Frequency	Yearly Payment Amount	Total Int Pd on life of Loan
5.88%	5 years	Monthly	\$ 46,765.92	\$ 31,663.87
5.84%	7 years	Monthly	\$ 35,254.44	\$ 44,615.14
5.88%	10 years	Monthly	\$ 26,787.48	\$ 65,709.24

Option 2

Farmers and Merchants Bank				
Rate	Terms	Payment Frequency	Yearly Payment Amount	Total Int Pd on life of Loan
5.82%	5 years	Quarterly	\$ 46,892.56	\$ 32,296.76
5.80%	7 years	Quarterly	\$ 35,345.36	\$ 45,251.53
5.89%	10 years	Quarterly	\$ 26,723.95	\$ 66,791.94

Option 3

First Citizens Bank				
Rate	Terms	Payment Frequency	Yearly Payment Amount	Total Int Pd on life of Loan
5.19%	5 years	Quarterly	\$ 43,861.96	\$ 28,109.22
5.30%	7 years	Quarterly	\$ 33,472.36	\$ 40,508.47

Town Council action requested: Consider awarding the bid to First Citizens Bank for a 5-year term at 5.19% and a quarterly payment frequency.

Staff recommendation: Approve awarding the bid to First Citizens Bank with the 5-year term. The FY23-24 budget was for \$45,000 in payments which the First citizens yearly payment amount is below that.



Farmers & Merchants Bank
OF SOUTH CAROLINA

October 30, 2023

Town of Moncks Corner
Attn: Jeff Lord, Town Administrator
118 Carolina Avenue
Moncks Corner SC 29461

RE: Bid Proposal for 2023 Ford F750 Sanitation Truck Lease Purchase

Dear Mr. Lord:

Farmers and Merchants Bank of South Carolina is pleased to present the following financing options for your review and consideration:

Option 1

Total Cost: \$202,166.00
Down Payment: \$ 0.00
Amount Financed: \$202,166.00
Payment Frequency: Monthly
Assumed Closing Date: Dec. 1, 2023
First Payment Date: January 1, 2024

Term in Years:	<u>5</u>	<u>7</u>	<u>10</u>
Approximate Payment:	\$3,897.58	\$2,938.00	\$2,232.68
Interest Rate:	5.88%	5.84%	5.88%

Option 2

Total Cost: \$202,166.00
Down Payment: \$ 0.00
Amount Financed: \$202,166.00
Payment Frequency: Quarterly
Assumed Closing Date: Dec. 1, 2023
First Payment Date: January 1, 2024

Term in Years:	<u>5</u>	<u>7</u>	<u>10</u>
Approximate Payment:	\$9,951.18	\$8,759.97	\$6,664.55
Interest Rate:	5.82%	5.80%	5.89%

- There are no documentation or closing fees associated with this proposal
- There are no pre-payment penalties
- Interest rates are fixed for the terms provided

- The quoted interest rate is valid for 30-days from the date of the proposal. To lock the interest rate, a credit submission would be required, and a credit approval attained within the same 30-day period. This financing is to be executed by December 1, 2023 or the Lessor reserves the right to adjust the interest rate. The proposal is subject to credit review and approval and mutually acceptable documentation.
- This proposal has been prepared assuming the lessee is bank qualified and that the proposed lease qualifies for Federal Income Tax Exempt Status for the Lessor under Section 103 of the IRS Code.

Our affiliate, Community Leasing Partners, will assist in the documentation and closing of this transaction on the above terms. The lease will be funded and serviced by Farmers and Merchants Bank of SC.

Thank you for allowing Farmers and Merchants Bank of SC the opportunity to provide this proposal. If you have any questions regarding the options presented, need additional options, or would like to proceed with the financing, then please contact me at (843) 719-5535 or bwest@fmbosc.com.

Sincerely,



Brian P. West
Chief Credit Officer



October 31, 2023

To: Jeff Lord, Town Administrator

Re: Proposal for 2023 Equipment Lease Purchase Agreement, Town of Moncks Corner, South Carolina

Following is our offer for the financing requested in the amount of \$202,166 (5-year and 7-year options):

Rate Structure	Maturity	Payment Structure
5.19% BQ	5 Years	Quarterly principal and interest payments.
Rate Structure	Maturity	Payment Structure
5.30% BQ	7 Years	Quarterly principal and interest payments.

This transaction can be closed using draft documents provided by First-Citizens Bank & Trust Company or Bond Counsel. There will be no closing costs or ongoing fees due to the Bank. In addition to executed transaction documents in form satisfactory to the Bank, you must provide an opinion of your attorney addressing certain matters, including, but not limited to:

1. The Lease Purchase is valid, legal, binding, and enforceable;
2. The tax status of the interest component of payments due under the financing. The attorney's opinion must state that the borrowing is designated as a "qualified tax-exempt obligation" under Section 265(b)(3)(B) of the Internal Revenue Code of 1986, as amended.

The borrowing entity must also designate the obligation as a "qualified tax-exempt obligation" prior to closing. It is recommended that this designation be included or recited in the borrowing ordinance/resolution. You or your advisors will be responsible for preparing and filing any IRS required documents.

The rate contained in this proposal is subject to change unless the loan is closed within 60 days of the date hereof. The loan will be prepayable in whole at par but not in part. If you have any questions, please contact Courtney Dunlap at 803-931-1721 or me at 803-931-1723.

Thank you for the opportunity to submit this proposal.

First-Citizens Bank & Trust Company

By: Steve Groth
Director of Government Lending

The foregoing proposal is accepted and approval of rate and funding is requested:

Town of Moncks Corner, South Carolina

By: _____

Title: _____

Date: _____

Town of Moncks Corner 2023 LP - 5 year

Computation Interval: Quarterly

Nominal Annual Rate: 5.190%

Cash Flow Data - Loans and Payments

Event	Date	Amount	Number	Period	End Date
1 Loan	12/15/2023	202,166.00	1		
2 Payment	01/15/2024	10,965.49	20	Quarterly	10/15/2028
3 Payment	01/15/2029	10,965.42	1		

TValue Amortization Schedule - U.S. Rule, 30E3/360

	Date	Payment	Interest	Principal	Balance
Loan	12/15/2023				202,166.00
2023 Totals		0.00	0.00	0.00	
1	01/15/2024	10,965.49	874.37	10,091.12	192,074.88
2	04/15/2024	10,965.49	2,492.17	8,473.32	183,601.56
3	07/15/2024	10,965.49	2,382.23	8,583.26	175,018.30
4	10/15/2024	10,965.49	2,270.86	8,694.63	166,323.67
2024 Totals		43,861.96	8,019.63	35,842.33	
5	01/15/2025	10,965.49	2,158.05	8,807.44	157,516.23
6	04/15/2025	10,965.49	2,043.77	8,921.72	148,594.51
7	07/15/2025	10,965.49	1,928.01	9,037.48	139,557.03
8	10/15/2025	10,965.49	1,810.75	9,154.74	130,402.29
2025 Totals		43,861.96	7,940.58	35,921.38	
9	01/15/2026	10,965.49	1,691.97	9,273.52	121,128.77
10	04/15/2026	10,965.49	1,571.65	9,393.84	111,734.93
11	07/15/2026	10,965.49	1,449.76	9,515.73	102,219.20
12	10/15/2026	10,965.49	1,326.29	9,639.20	92,580.00
2026 Totals		43,861.96	6,039.67	37,822.29	
13	01/15/2027	10,965.49	1,201.23	9,764.26	82,815.74
14	04/15/2027	10,965.49	1,074.53	9,890.96	72,924.78
15	07/15/2027	10,965.49	946.20	10,019.29	62,905.49
16	10/15/2027	10,965.49	816.20	10,149.29	52,756.20
2027 Totals		43,861.96	4,038.16	39,823.80	
17	01/15/2028	10,965.49	684.51	10,280.98	42,475.22
18	04/15/2028	10,965.49	551.12	10,414.37	32,060.85

Town of Moncks Corner 2023 LP - 5 year

	Date	Payment	Interest	Principal	Balance
19	07/15/2028	10,965.49	415.99	10,549.50	21,511.35
20	10/15/2028	10,965.49	279.11	10,686.38	10,824.97
2028 Totals		43,861.96	1,930.73	41,931.23	
21	01/15/2029	10,965.42	140.45	10,824.97	0.00
2029 Totals		10,965.42	140.45	10,824.97	
Grand Totals		230,275.22	28,109.22	202,166.00	

ANNUAL PERCENTAGE RATE	FINANCE CHARGE	Amount Financed	Total of Payments
The cost of your credit as a yearly rate.	The dollar amount the credit will cost you.	The amount of credit provided to you or on your behalf.	The amount you will have paid after you have made all payments as scheduled.
5.190%	\$28,109.22	\$202,166.00	\$230,275.22

Town of Moncks Corner 2023 LP - 7 year

Computation Interval: Quarterly

Nominal Annual Rate: 5.300%

Cash Flow Data - Loans and Payments

Event	Date	Amount	Number	Period	End Date
1 Loan	12/15/2023	202,166.00	1		
2 Payment	01/15/2024	8,368.09	28	Quarterly	10/15/2030
3 Payment	01/15/2031	8,367.95	1		

TValue Amortization Schedule - U.S. Rule, 30E3/360

	Date	Payment	Interest	Principal	Balance
Loan	12/15/2023				202,166.00
2023 Totals		0.00	0.00	0.00	
1	01/15/2024	8,368.09	892.90	7,475.19	194,690.81
2	04/15/2024	8,368.09	2,579.65	5,788.44	188,902.37
3	07/15/2024	8,368.09	2,502.96	5,865.13	183,037.24
4	10/15/2024	8,368.09	2,425.24	5,942.85	177,094.39
2024 Totals		33,472.36	8,400.75	25,071.61	
5	01/15/2025	8,368.09	2,346.50	6,021.59	171,072.80
6	04/15/2025	8,368.09	2,266.71	6,101.38	164,971.42
7	07/15/2025	8,368.09	2,185.87	6,182.22	158,789.20
8	10/15/2025	8,368.09	2,103.96	6,264.13	152,525.07
2025 Totals		33,472.36	8,903.04	24,569.32	
9	01/15/2026	8,368.09	2,020.96	6,347.13	146,177.94
10	04/15/2026	8,368.09	1,936.86	6,431.23	139,746.71
11	07/15/2026	8,368.09	1,851.64	6,516.45	133,230.26
12	10/15/2026	8,368.09	1,765.30	6,602.79	126,627.47
2026 Totals		33,472.36	7,574.76	25,897.60	
13	01/15/2027	8,368.09	1,677.81	6,690.28	119,937.19
14	04/15/2027	8,368.09	1,589.17	6,778.92	113,158.27
15	07/15/2027	8,368.09	1,499.35	6,868.74	106,289.53
16	10/15/2027	8,368.09	1,408.34	6,959.75	99,329.78
2027 Totals		33,472.36	6,174.67	27,297.69	
17	01/15/2028	8,368.09	1,316.12	7,051.97	92,277.81
18	04/15/2028	8,368.09	1,222.68	7,145.41	85,132.40

Town of Moncks Corner 2023 LP - 7 year

	Date	Payment	Interest	Principal	Balance
19	07/15/2028	8,368.09	1,128.00	7,240.09	77,892.31
20	10/15/2028	8,368.09	1,032.07	7,336.02	70,556.29
2028 Totals		33,472.36	4,698.87	28,773.49	
21	01/15/2029	8,368.09	934.87	7,433.22	63,123.07
22	04/15/2029	8,368.09	836.38	7,531.71	55,591.36
23	07/15/2029	8,368.09	736.59	7,631.50	47,959.86
24	10/15/2029	8,368.09	635.47	7,732.62	40,227.24
2029 Totals		33,472.36	3,143.31	30,329.05	
25	01/15/2030	8,368.09	533.01	7,835.08	32,392.16
26	04/15/2030	8,368.09	429.20	7,938.89	24,453.27
27	07/15/2030	8,368.09	324.01	8,044.08	16,409.19
28	10/15/2030	8,368.09	217.42	8,150.67	8,258.52
2030 Totals		33,472.36	1,503.64	31,968.72	
29	01/15/2031	8,367.95	109.43	8,258.52	0.00
2031 Totals		8,367.95	109.43	8,258.52	
Grand Totals		242,674.47	40,508.47	202,166.00	

ANNUAL PERCENTAGE RATE	FINANCE CHARGE	Amount Financed	Total of Payments
The cost of your credit as a yearly rate.	The dollar amount the credit will cost you.	The amount of credit provided to you or on your behalf.	The amount you will have paid after you have made all payments as scheduled.
5.300%	\$40,508.47	\$202,166.00	\$242,674.47

AN ORDINANCE 2023-___

**AMENDING THE BUSINESS LICENSE ORDINANCE OF THE TOWN OF MONCK'S CORNER TO
UPDATE THE CLASS SCHEDULE AS REQUIRED BY ACT 176 OF 2020.**

WHEREAS, the Town of Moncks Corner (the "Municipality") is authorized by S.C. Code Section 5-7-30 and Title 6, Chapter 1, Article 3 to impose a business license tax on gross income;

WHEREAS, by Act No. 176 of 2020, known as the South Carolina Business License Tax Standardization Act and codified at S.C. Code Sections 6-1-400 to -420 (the "Standardization Act"), the South Carolina General Assembly imposed additional requirements and conditions on the administration of business license taxes;

WHEREAS, the Standardization Act requires that by December thirty-first of every odd year, each municipality levying a business license tax must adopt, by ordinance, the latest Standardized Business License Class Schedule as recommended by the Municipal Association of South Carolina (the "Association") and adopted by the Director of the Revenue and Fiscal Affairs Office;

WHEREAS, following the enactment of the Standardization Act, the Municipality enacted Ordinance No. 2021-14 on 12-21-2021, and Ordinance No. 2023-01 on 02-21-2023 in order to comply with the requirements of the Standardization Act (the "Current Business License Ordinance");

WHEREAS, the Moncks Corner Council of the Municipality (the "Council") now wishes to amend the Current Business License Ordinance to adopt the latest Standardized Business License Class Schedule, as required by the Standardization Act, and to make other minor amendments as recommended by the Association;

NOW, THEREFORE, BE IT ORDAINED by the Mayor and Council of the Town of Moncks Corner, as follows:

SECTION 10-46. Amendments to Appendix A. Appendix A to the Current Business License Ordinance, the "Business License Rate Schedule," is hereby amended as follows:

- (a) Class 8.3 is hereby amended by deleting the NAICS Codes and replacing them with NAICS 517111, 517112, 517122 – Telephone Companies.
- (b) Class 8.6 is hereby amended and restated in its entirety to read as follows: "**8.6 NAICS Code Varies – Billiard or Pool Tables**. A business that offers the use of billiard or pool tables shall be subject to business license taxation under its natural class for all gross income of the business excluding the gross income attributable to the billiard or pool tables. In addition, the billiard or pool tables shall require their own separate business licenses pursuant to SC Code § 12-21-2746 and shall be subject to a license tax of \$5.00 per table measuring less than 3½ feet wide and 7 feet long, and \$12.50 per table longer than that."
- (c) The NAICS codes corresponding to Classes 9.41 and 9.42 have been eliminated.

Businesses that were previously classified into 9.41 or 9.42 shall be required to apply and pay for a business license in their natural class.

SECTION 2. Amendments to Appendix B. Appendix B to the Current Business License Ordinance, the “Business License Class Schedule,” is hereby amended as follows:

- (a) Classes 1 through 8 in Appendix B to the Current Business License Ordinance, the “Business License Class Schedule,” are hereby amended and restated as set forth on the attached Exhibit A.
- (b) Class 9 in Appendix B to the Current Business License Ordinance, the “Business License Class Schedule,” shall remain in full force and effect as set forth in the Current Business License Ordinance.
- (c) The NAICS codes corresponding to Classes 9.41 and 9.42 have been eliminated. Businesses that were previously classified into 9.41 or 9.42 shall be required to apply and pay for a business license in their natural class.

SECTION 3. Repealer, Effective Date. All ordinances in conflict with this ordinance are hereby repealed. This ordinance shall be effective with respect to the business license year beginning on May 1, 2024.

ENACTED IN REGULAR MEETING, this 19th day of December, 2023.

First reading: November 14, 2023

Final reading: December 19, 2023

Attest:

Marilyn M. Baker, Clerk to Council

Approved as to Form:

John S. West, Town Attorney

Mayor

Council:

**Exhibit A: Amendment to Classes 1 – 8 in Appendix B of the
Current Business License Ordinance**

Item 7.

**APPENDIX B
Classes 1 – 8: Business License Class Schedule by NAICS Codes**

NAICS Sector/Subsector	Industry Sector	Class
11	Agriculture, forestry, hunting and fishing	1
21	Mining	2
22	Utilities	1
31 - 33	Manufacturing	3
42	Wholesale trade	1
44 - 45	Retail trade	1
48 - 49	Transportation and warehousing	1
51	Information	4
52	Finance and insurance	7
53	Real estate and rental and leasing	7
54	Professional, scientific, and technical services	5
55	Management of companies	7
56	Administrative and support and waste management and remediation services	3
61	Educational services	3
62	Health care and social assistance	4
71	Arts, entertainment, and recreation	3
721	Accommodation	1
722	Food services and drinking places	2
81	Other services	4
Class 8	Subclasses	
23	Construction	8.1
482	Rail Transportation	8.2
517111	Wired Telecommunications Carriers	8.3
517112	Wireless Telecommunications Carriers (except Satellite)	8.3
517122	Agents for Wireless Telecommunications Services	8.3
5241	Insurance Carriers	8.4
5242	Insurance Brokers for non-admitted Insurance Carriers	8.4
713120	Amusement Parks and Arcades	8.51
713290	Nonpayout Amusement Machines	8.52
713990	All Other Amusement and Recreational Industries (pool tables)	8.6

2023 Class Schedule is based on a three-year average (2017 - 2019) of IRS statistical data.