



# CITY OF MILES CITY

## Regular Council Meeting Agenda

April 14, 2026 at 6:00 PM

City Council Chambers and online at zoom.us

---

Zoom ID: 4062343462 | Passcode: 59301

### CALL TO ORDER

### PLEDGE OF ALLEGIANCE

### ROLL CALL

#### 1. REQUEST OF CITIZENS AND PUBLIC COMMENT

- A. Jerry Grebenc, Land Use Services Director at Montana League of Cities and Towns, presentation on annexation of properties in municipalities like Miles City.

#### 2. APPROVAL OF COUNCIL MINUTES/COMMITTEE MINUTES

- [A.](#) Approve amended Council Meeting Minutes 0224 2026

#### 3. SCHEDULE MEETINGS

#### 4. APPOINTMENTS

#### 5. STAFF REPORTS & OTHER COMMITTEE MINUTES

- [A.](#) Building Department Staff Report

#### 6. CITY COUNCIL COMMENTS

#### 7. MAYOR COMMENTS

#### 8. UNFINISHED BUSINESS

- [A.](#) ORDINANCE NO. 1403 - (*First Reading*) AN ORDINANCE AMENDING SECTIONS 2-52, 2-54, 2-55, AND 2-60, OF THE CODE OF ORDINANCES OF MILES CITY, MONTANA, RELATED TO STANDING COMMITTEES AND CITY COUNCIL MEETING SCHEDULE.

#### 9. NEW BUSINESS

- [A.](#) RESOLUTION NO. 4678 - A RESOLUTION APPROVING CHANGE ORDERS WITH JACKSON CONTRACTOR GROUP, INC. RELATED TO THE MILES CITY FIRE HALL CONSTRUCTION PROJECT.

- B.** RESOLUTION NO. 4679 - A RESOLUTION APPROVING CHANGE ORDER 2 AND AMENDMENT TO TASK ORDER 3 WITH INTERSTATE ENGINEERING INC. AND DIAMOND J CONSTRUCTION, RELATED TO THE FLORENCE STACY MEMORIAL FOUNTAIN PROJECT.

## **10. ADJOURNMENT**

Public comment on any public matter that is not on the agenda of this meeting can be presented under Request of Citizens, provided it is within the jurisdiction of the City to address. Public comment will be entered into the minutes of this meeting. The City Council cannot take any action on a matter unless notice of the matter has been made on an agenda and an opportunity for public comment has been allowed on the matter. Public matter does not include contested cases and other adjudicative proceedings



# CITY OF MILES CITY

## Regular Council Meeting Minutes

February 24, 2026 at 6:00 PM

City Council Chambers and online at zoom.us

Zoom ID: 4062343462 | Passcode: 59301

### CALL TO ORDER

Mayor Grenz called the Council meeting to order at 6:00 pm

### PLEDGE OF ALLEGIANCE

Mayor Grenz led the Council into the Pledge of Allegiance

### ROLL CALL

#### PRESENT

Councilmember Dan Scott  
Councilmember Ed Pulecio  
Councilmember Rick Huber, arrived at 6:03 pm  
Councilmember Jeni Losey  
Councilmember Cody Steiner  
Councilmember Kevin Thomason  
Councilmember Brooke Bartholomew  
Councilmember Don Simpson  
Mayor Chris Grenz

ALSO PRESENT: City Attorney Dan Rice, Public Utilities Director Tom Speelmon, Police Chief Doug Colombik, Interim Fire Chief Ed Kanduch, Dispatch Director Lyne Anderson, Deputy Clerk/Payroll Officer-Minute Recorder Tamara Ellsworth.

### 1. REQUEST OF CITIZENS AND PUBLIC COMMENT

Susan Felstehausen, 1505 Comstock commented that based on the budget shortfall is there someone in office that can submit grants or have a grant writer. Mayor Grenz agreed and explained that we do not have a grant writer and currently our City Directors are in charges for applying for the grants necessary for their needs, he also discussed possibly having the City Treasurer become the grant writer.

### 2. APPROVAL OF COUNCIL MINUTES/COMMITTEE MINUTES

#### A. Regular City Council Meeting 0127 2026

Motion made by Councilmember Steiner, Seconded by Councilmember Simpson.  
Voting Yea: Councilmember Scott, Councilmember Pulecio, Councilmember Huber, Councilmember Losey, Councilmember Steiner, Councilmember Thomason, Councilmember Bartholomew, Councilmember Simpson

#### B. PUBLIC SERVICE COMMITTEE MINUTES 0205 2026

Motion made by Councilmember Thomason to approve with the corrections made to the minutes, Seconded by Councilmember Scott.

Voting Yea: Councilmember Scott, Councilmember Pulecio, Councilmember Huber, Councilmember Losey, Councilmember Steiner, Councilmember Thomason, Councilmember Bartholomew, Councilmember Simpson

Councilmember Losey a correction to the Public Service Minutes to reflect that the Committee decided that the nuisance policy will continue as it is and that there was no recommendation for a budget line to the Animal Control Officer.

C. PUBLIC SAFETY COMMITTEE MINUTES 0212 2026

Motion made by Councilmember Simpson, Seconded by Councilmember Pulecio. Voting Yea: Councilmember Scott, Councilmember Pulecio, Councilmember Huber, Councilmember Losey, Councilmember Steiner, Councilmember Thomason, Councilmember Bartholomew, Councilmember Simpson

3. SCHEDULE MEETINGS

Council Chairperson Bartholomew announce a Finance Committee meeting on March 12, 2026 at 6:00 pm regarding Business Licenses.

- A. Fire Department Owner/Architect/Contractor (OAC) Building Meeting 2/26/26 @ 9:00am at Jackson Office Trailer on Fire Department Site.

4. APPOINTMENTS

- A. City/County Health Board

- Donna Faber (Council Appointed)
- Jody Menyhart (City & County Appointed)

Motion made by Councilmember Huber to appoint Donna Faber to the City/County Health Board, Seconded by Councilmember Simpson. Voting Yea: Councilmember Scott, Councilmember Pulecio, Councilmember Huber, Councilmember Losey, Councilmember Steiner, Councilmember Thomason, Councilmember Bartholomew, Councilmember Simpson

Motion made by Councilmember Huber to appoint Jody Menyhart to the City/County Health Board, Seconded by Councilmember Scott.

Voting Yea: Councilmember Pulecio, Councilmember Losey, Councilmember Steiner, Councilmember Huber, Councilmember Thomason, Councilmember Scott, Councilmember Bartholomew, Councilmember Simpson.

- B. City Appointee - Donna Faber
- At-Large Appointee - Amber Trenka

5. STAFF REPORTS & OTHER COMMITTEE MINUTES

Police Chief Colombik handed out to the Council updates on the Pigeon Control.

Dispatch Director Anderson gave reports on the 911 and that there will be a meeting on March 10th, 2026. Two of her Dispatchers Maci Laedke and Kasey Warner passed their 911 certifications with a 98% and congratulated them.

- A. January 2026 Cash Report

Mayor Grenz let the Council know that he has requested that the City Clerk Rowe start attaching a cash report for the Council to review. He explained that the Ambulance fund is in the red (\$77,000) and cash operating in red (\$365,000). The taxes have not been posted and Deputy Clerk Ellsworth advised that the Ambulance has not been reconciled up to current.

**6. CITY COUNCIL COMMENTS**

Council Chairperson Bartholomew spoke in regards to the comment made by the Mayor Grenz in a previous meeting about defunding the Fire Department and explained that defunding is not the Council's desire. The Council does however feel that a restructure of how the Fire Departments scheduling, spending and funds do need to happen for the City budgets.

Councilmember Losey stated that due to all the Miles City Chatter and Facebook that it might be a good idea for the Council to have an external website application for the correct information to put on there. She stated that there would be no commenting from the Council but there would be links to reach out to the Council.

**7. MAYOR COMMENTS**

Mayor Grenz would like the Council's permission to look into a Labor negotiator for the upcoming union negotiations. The Council unanimously agreed to this request.

**8. PUBLIC HEARINGS**

- A. RESOLUTION NO. 4661 - A RESOLUTION PURSUANT TO §7-6-4006 OF THE MONTANA CODE ANNOTATED, AUTHORIZING AMENDMENT OF FINAL BUDGET FOR FY 2025-2026 TO INCREASE THE BUDGETED AMOUNT IN GENERAL FUND FOR UNBUDGETED EXPENDITURES.

Mayor Grenz opened the Public Hearing, called for proponents three times, called for opponents three times, upon hearing none the Public Hearing was closed.

- B. ORDINANCE 1401 - AN ORDINANCE REVISING CITY CODE SECTIONS 7-57 THROUGH 7-62 PERTAINING TO THE CITY OF MILES CITY URBAN RENEWAL DISTRICT BOARD OF COMMISSIONERS AND PROVIDING FOR AN EFFECTIVE DATE THEREOF.

Mayor Grenz opened the Public Hearing, called for proponents three times, called for opponents three times, upon hearing none the Public Hearing was closed.

**9. UNFINISHED BUSINESS**

- A. RESOLUTION NO. 4661 - *(Second Reading)* A RESOLUTION PURSUANT TO §7-6-4006 OF THE MONTANA CODE ANNOTATED, AUTHORIZING AMENDMENT OF FINAL BUDGET FOR FY 2025-2026 TO INCREASE THE BUDGETED AMOUNT IN GENERAL FUND FOR UNBUDGETED EXPENDITURES.

Motion made by Councilmember Huber, Seconded by Councilmember Simpson.  
Voting Yea: Councilmember Scott, Councilmember Pulecio, Councilmember Huber, Councilmember Losey, Councilmember Steiner, Councilmember Thomason, Councilmember Bartholomew, Councilmember Simpson

- B. ORDINANCE 1401 - *(Second Reading)* AN ORDINANCE REVISING CITY CODE SECTIONS 7-57 THROUGH 7-62 PERTAINING TO THE CITY OF MILES CITY URBAN RENEWAL DISTRICT BOARD OF COMMISSIONERS AND PROVIDING FOR AN EFFECTIVE DATE THEREOF.

Motion made by Councilmember Bartholomew, Seconded by Councilmember Losey.  
Voting Yea: Councilmember Scott, Councilmember Pulecio, Councilmember Huber,  
Councilmember Losey, Councilmember Steiner, Councilmember Thomason, Councilmember  
Bartholomew, Councilmember Simpson

**10. NEW BUSINESS**

- A. Appoint Chris Grenz, Ren Gardner (School District Representative), and Jason Strouf (County Representative) to the TIFD Committee.

Motion made by Councilmember Huber, Seconded by Councilmember Pulecio.  
Voting Yea: Councilmember Scott, Councilmember Pulecio, Councilmember Huber,  
Councilmember Losey, Councilmember Steiner, Councilmember Thomason, Councilmember  
Bartholomew, Councilmember Simpson

- B. APPROVE FUNDING FOR THE DEPUTY CLERK TO ATTEND THIS YEARS MMCT&FOA CONFERENCE

Motion made by Councilmember Huber, Seconded by Councilmember Losey.  
Voting Nay: Councilmember Scott, Councilmember Pulecio, Councilmember Huber,  
Councilmember Losey, Councilmember Steiner, Councilmember Thomason, Councilmember  
Bartholomew, Councilmember Simpson

It was discussed by the Council that due to the budget constraints there is currently no funding for training this year.

- C. APPROVE REQUEST FOR IMPROVEMENTS TO THE THREE G CONSTRUCTION LAND LEASE SITE

Motion made by Councilmember Thomason, Seconded by Councilmember Simpson.  
Voting Yea: Councilmember Scott, Councilmember Pulecio, Councilmember Huber,  
Councilmember Losey, Councilmember Steiner, Councilmember Thomason, Councilmember  
Bartholomew, Councilmember Simpson

Jason Gergen, 3506 Box Elder Street stated that the improvements that he is requesting approval for is to widen the approach so he would be able to get all of his equipment on the land lease site. He has obtained permission from the County and Transco as well. This would be of no cost to the City as he would be using all of his own resources and equipment. Councilmember Steiner did ask that in case he no longer leases this site will those improvements stay, Jason Gergen said yes they are permanent.

- D. DISCUSSION IN REGARDS TO THE TWISTED VAPES BUSINESS LOCATED AT 317 YELLOWSTONE AVE

Casey Wootan, 320 Yellowstone Ave, is representing the group/residents of this area and announced the current concerns of this property being zoned as Commercial and the Twisted Vapes Business on that such property. There has been 2 burglaries with live gunfire, neighbors are living in constant worry about the safety of their neighborhood. When this property was presented at a Zoning Board to become commercial they neighbors of this area were under the impression/understanding from the owner of this land that it would remain as is, used for a construction/shop. With that impression they did not show up for the meeting and express any concerns. With the Twisted Vapes Business the foot traffic has increased. Matt Hanvold, expressed his concerns as well as his house is right next to the Vape shop and his childrens bedrooms are facing it, he made Council aware of the fears that his family has had due to the robbery and would like the Vape business to be closed. He also disclosed that there is constant noise such as vehicles outside parked before the business opens with their vehicle music playing loudly, there are neon lights that stay on

constantly. This business has taken the comfort, calmness and safety of the neighborhood. Casey Wootan asked the Council to please rezone this property back to its original zoning of residential.

City Attorney Rice and Planner Joel Nelson, stated that once a property is zoned Commercial and if it were to go back to a zoning committee for a Residential zoning the Twisted Vapes Business will be grandfathered in unless the business is discontinued or closed for a year.

Councilmember Steiner asked Chief Colombik about the gunfire, the lights, the music from cars playing isn't this not a Public nuisance and Public Safety issue. City Attorney Rice stated that the Police Dept would have to deem this business highly unsafe.

Casey Wootan and all the neighbors next worry is that the Vape business will move into the vacant One Health building or some other time of business that is not safe for neighborhoods or children. They expressed their deep dissatisfaction with the Zoning Committee and the City for allowing this to happen. City Attorney Rice and Planner Joel Nelson responded that at the time of the zoning change it was presented as a boundary change and the existing commercial shop was already there and the zoning committee was not made aware of a Vape business being opened.

- E. APPROVE PITNEY BOWES LEASE AGREEMENT RENEWAL (\$51.24 annual decrease from last contract amount)

Motion made by Councilmember Thomason, Seconded by Councilmember Pulecio. Voting Yea: Councilmember Scott, Councilmember Pulecio, Councilmember Huber, Councilmember Losey, Councilmember Steiner, Councilmember Thomason, Councilmember Bartholomew, Councilmember Simpson

- F. APPROVE RESOLUTION NO. 4664 - (first reading) A RESOLUTION APPROVING A REVISED " PARKS AND RECREATION POLICY AND FEE SCHEDULE" FOR THE CITY OF MILES CITY, AND PROVIDING FOR A HEARING THERON.

Motion made by Councilmember Simpson, Seconded by Councilmember Bartholomew. Voting Yea: Councilmember Scott, Councilmember Pulecio, Councilmember Huber, Councilmember Losey, Councilmember Steiner, Councilmember Thomason, Councilmember Bartholomew, Councilmember Simpson

Councilmember Steiner is unsure what changes are being made to this Policy and would like more information. It was discussed that this is just a "first reading" and there will be plenty of time to gather that information.

- G. RESOLUTION NO. 4667 - A RESOLUTION APPROVING A CHANGE ORDER WITH INTERSTATE ENGINEERING TO ADDRESS CONTRACTOR COMMENT REVISIONS TO THE FLORENCE STACY MEMORIAL FOUNTAIN PROJECT.

Motion made by Councilmember Bartholomew, Seconded by Councilmember Losey. Voting Yea: Councilmember Scott, Councilmember Pulecio, Councilmember Huber, Councilmember Losey, Councilmember Steiner, Councilmember Thomason, Councilmember Bartholomew, Councilmember Simpson

Councilmember Huber had questions about the modified reduction in the fountain wall height. Public Utilities Director Speelmon stated that the original plan was a 4X6 size of marble panels, this ended up having to be a special order which would mean extra costs. So it was decided to go with the size that they have and that is why the modification to the wall height.

- H. RESOLUTION NO. 4668 - A RESOLUTION APPROVING A "CHANGE ORDER #001: ADDITIONAL COLUMN SUPPORT" WITH JACKSON CONTRACTOR GROUP, INC., FOR REPAIRS TO CONNORS STADIUM.

Motion made by Councilmember Huber, Seconded by Councilmember Thomason.  
Voting Yea: Councilmember Scott, Councilmember Pulecio, Councilmember Huber, Councilmember Losey, Councilmember Steiner, Councilmember Thomason, Councilmember Bartholomew, Councilmember Simpson

Chairperson Bartholomew gave the breakdown from the Public Works Director Malenovsky has given her of the funds that have been received. This is the have the columns sealed and painted.

- I. APPROVE RESOLUTION NO. 4670 - A CITY OF MILES CITY CITY COUNCIL RESOLUTION TO ADOPT AMENDMENTS TO THE MILES CITY GROWTH POLICY 2025

Motion made by Councilmember Pulecio, Seconded by Councilmember Scott.  
Voting Yea: Councilmember Scott, Councilmember Pulecio, Councilmember Huber, Councilmember Losey, Councilmember Steiner, Councilmember Thomason, Councilmember Bartholomew, Councilmember Simpson

- J. APPROVE RESOLUTION NO. 4671 - A RESOLUTION APPROVING CHANGE ORDER #007 WITH JACKSON CONTRACTOR GROUP, INC. RELATED TO THE MILES CITY FIRE HALL CONSTRUCTION PROJECT

Motion made by Councilmember Thomason, Seconded by Councilmember Huber.  
Voting Yea: Councilmember Scott, Councilmember Huber, Councilmember Losey, Councilmember Thomason, Councilmember Bartholomew, Councilmember Simpson  
Voting Nay: Councilmember Steiner  
Voting Abstaining: Councilmember Pulecio

Councilmember Huber asked why this wasn't presented at the Special Council committee meeting held on Feb 18th, Charlie Lohoff, Jackson Contracting stated that they missed the deadline to provide the proper change order documents. Councilmember Huber asked if there will be more change orders, Charlie Lohoff advised that there is a contingency fund that was put aside so these change orders are the unknowns and there may be.

Councilmember Losey asked what the purpose for the water outlets, Charlie Lohoff said that as of right now there are no outside water outlets on the east side of building, versus having the need for this possibly later on down the road it makes sense to do now while in construction phase. Councilmember Losey would like clarification about the electrical, plumbing and why the 3 orders. Interim Fire Cheif Kanduch and Charlie Lohoff gave explanations and reiterated that while in construction phase these are items that will or may be needed down then line, and due to continency set aside its best to do now versus incur costs later.

- K. REVIEW AND DISCUSS SPLASHPAD AND FROG POOL ENGINEERING REPORTS

Chairperson Bartholomew and Councilmember Losey discussed that there are maintenance issues arising with the Frog Pool and Splashpad, a previous Parks employee said the Frog Pool is leaking but when they had an analysis done there were no leaks found. Gave a review of the engineering report, Frog pool not leaking, no leaks found in the foundation of pool, there was a float that was stuck, noticed deferred maintenance to the Splashpad slides, they need to be waxed, these slides costs about 20k per slide. It was requested that the Council needs to made aware of what steps to insure maintenance to these structures are being done and will be maintained.

**11. ADJOURNMENT**

Public comment on any public matter that is not on the agenda of this meeting can be presented under Request of Citizens, provided it is within the jurisdiction of the City to address. Public comment will be entered into the minutes of this meeting. The City Council cannot take any action

on a matter unless notice of the matter has been made on an agenda and an opportunity for public comment has been allowed on the matter. Public matter does not include contested cases and other adjudicative proceedings

Motion made by Councilmember Simpson, Seconded by Councilmember Thomason.  
Voting Yea: Councilmember Scott, Councilmember Pulecio, Councilmember Huber,  
Councilmember Losey, Councilmember Steiner, Councilmember Thomason, Councilmember  
Bartholomew, Councilmember Simpson

Meeting adjourned at 7:34 pm



CITY OF  
**Miles City**  
MONTANA

**Building Department**

**Staff Report**

**February/March Totals**

Over the winter we started issuing Mechanical permits for Commercial projects and come July we will do Mechanical permits for Residential. I think that will be a good thing for the community and is one more step to making this department more of an all-inclusive Building department for our community.

March 1st we also re-implemented the siding permits that had been gone away with. Siding is a very important part of any structure and I think it is very important for that t get a set of eyes on it.

A few of the bigger projects from last year are still rolling right along, with a couple wrapping up soon or have already been wrapped up.

I'm really looking forward to this spring and summer and have some good projects that will be coming up in the near future that will be very beneficial for the community.

As always If any of you have any question please don't hesitate to reach out.

If I don't have the answer I'm pretty good and getting it.



**BUILDING PERMIT WORKSHEET**

**For: Feb-March 2026**

DATE	PRMT #	OWNER	PERMIT VALUE	NATURE OF CONSTRUCTION	ADDRESS	CONTRACTOR	VALUE OF CONSTRUCT.	CODE
25-Feb	25-26 0406		\$ 251.00	Remodel		Devin Morrison	\$ 15,000.00	RNR
#####	25-26 0428		\$ 195.00	Remodel		Self	\$ 11,000.00	RNR
9-Mar	25-26 0425		\$ 39.00	Remodel		Thomas Hall Prop Renovations	\$ 1,000.00	RNR
2/23	25-26 0403		\$ 63.00	Deck		Travis Forman	\$ 1,800.00	RR
2/10	25-26 0402		\$ 251.00	Remodel		Leroy Meidinger	\$ 15,000.00	RR
2/24	25-26 0404		\$ 391.00	Remodel		Tightline Design	\$ 25,000.00	RR
2/24	25-26 0405		\$ 1,120.00	New Home		Tightline Design	\$ 300,000.00	NR
3/18	25-26 0430		\$ 532.00	Remodel		Ray murnion	\$ 32,000.00	RR
3/20	25-26 0431		\$ 97.00	Remodel		Lk Advanced	\$ 4,000.00	RR
3/30	25-26 0434		\$ 181.00	Remodel		Mitch Lindberg	\$ 10,000.00	RR
3/13	25-26 0429		\$ 97.00	Deck		Darren Pitcher	\$ 3,122.00	RR
3/30	25-26 0435		\$ 100.00	Fence		Josh Boeder		Fence
3/26	25-26 0432		\$ 100.00	Fence		Devin Anzures		Fence
3/11	25-26 0427		\$ 39.00	Patio		Scott Ask	\$ 1,000.00	RR
3/4	25-26 0421		\$ 532.00	Mechanical		Jerrys Refridgeration	\$ 52,766.00	Mechanical
3/6	25-26 0424		\$ 33.00	Sidewalk		A1 concrete	\$ 800.00	Concrete
3/5	25-26-0422		\$ 100.00	Fence		Jares Fence		Fence
3/5	25-26 0423		\$ 100.00	Fence		Jares Fence		Fence
2/26	25-26 0408		\$ 543.00	RR		Manning Roofing	\$ 39,412.50	RR
2/26	25-26 0407		\$ 251.00	RR		Manning Roofing	\$ 14,930.26	RR
3/2	25-26 0420		\$ 100.00	Fence		Devon Anzures		Fence
2/24	25-26 0409		\$ 509.00	Deck and Siding		Manning Roofing	\$ 21,953.00	RR
3/26	25-26 0433		\$ 337.00	Mechanical		Jerrys Refridgeration	\$ 28,872.00	Mechanical
11-Mar	25-26 0426		\$ 104.00	Mechanical		Jerrys Refridgeration	\$ 4,250.00	Mechanical
11-Feb	ELEC-2026-0006		\$ 120.00	Electrical		C and J Electric		Electric
9-Mar	BLD-2026-0005		\$ 1,307.60	Roof top unit replacement		Jackson Contrator Group	\$ 155,831.00	RNR
23-Feb	BLD-2026-0006		\$ 1,292.00	New Shop		Oakland Improvements	\$ 100,000.00	NNR
3-Mar	ELEC-2026-0007		\$ 100.00	Electrical		C and J Electric		Electric
17-Mar	ELEC-2026-0008		\$ 75.00	Electrical		MC Electric		Electric
17-Mar	ELEC-2026-0009		\$ 70.00	Electrical		MC Electric		Electric
17-Mar	BLD-2026-0008		\$ 1,033.20	RNR		Aspen Contracting	\$ 106,900.00	RNR
30-Mar	ELEC-2026-0010		\$ 200.00	Electrical		C and J Electric		Electrical
30-Mar	ELEC-2026-0011		\$ 45.00	Electrical		C and J Electric		Electrical
31-Mar	ELEC-2026-0012		\$ 45.00	Electrical		MC Electric		Electrical

Value of Permits: \$ 10,352.80

Value of Construction: \$ 944,636.76

- # - New Residential (NR) - \$
- # - New Non-Residential (NNR) - \$
- # - Remodel Residential (RR) - \$
- # - Remodel Non-Residential (RNR) - \$
- # - New Garage/Carport (NG/C) - \$
- # - Remodel Garage/Carport (RG/C) - \$
- # - Fence - \$
- # - Concrete - \$
- # - Publicly Owned (PO) - \$
- # - Altered Public Owned (APO) - \$
- # - Accessory Building (A) - \$
- # - Remodel Accessory Building (RA) - \$
- # - Mobile Home (MH) - \$
- # - Demo - \$
- # - Void
- # - Swimming Pool, Paving, Signs, Billboards (Other) - \$

RR+E44:Q56

**ORDINANCE NO. 1403**

**AN ORDINANCE AMENDING SECTIONS 2-52, 2-54, 2-55, AND 2-60, OF THE CODE OF ORDINANCES OF MILES CITY, MONTANA, RELATED TO STANDING COMMITTEES AND CITY COUNCIL MEETING SCHEDULE.**

**WHEREAS**, the City Council has determined that rather than utilizing standing committees, that the Council will add an additional meeting date each month, and review all matters as a full Council in work sessions, rather than by committees;

**NOW, THEREFORE, BE IT ORDAINED**, by the City Council of the City of Miles City, Montana, as follows:

**Section 1.** Sections 2-52, 2-54, 2-55, and 2-60 of the Code of Ordinances of Miles City, Montana, is hereby **AMENDED** to read as follows:

Sec. 2-52 – **Meetings, Generally.** The city council shall hold its regular meetings for the transaction of municipal business on the second, third, and fourth Tuesdays in each month, and such other meetings to which the council may be adjourned or which may be called. Special meetings may be called by the mayor, at the request of three members of the council or at any time by the city clerk on request, after giving reasonable notice thereof in writing to all the members of the city council present in the city. All meetings, unless otherwise ordered for a good cause, shall be held in the city council chamber.

Sec. 2-54. - **Standing committees—Created and designated.** At the first regular meeting of the city council after the first Monday in January of each year, the mayor, with the approval of a majority of the membership of the city council, shall appoint standing committee consisting of four members of the city council, one from each ward, for the ensuing year as follows:

- ~~(1) Committee on finance.~~
- ~~(2) Committee on public safety.~~
- ~~(3) Committee on public services.~~
- ~~(4) (1) Committee on human resources.~~

Sec. 2-55. - **Same—Duties.**

~~(a) To the committee on finance shall be referred all policy matters related to the financial condition of the city including regular revenue and expenditures reviews; department budget preparation and reviews; auditing and passing upon all bills and claims presented against the city; and auditing of all books of accounts of all city officers. This committee shall also consider all policy matters related to apportionment, property rented or leased by the city and all zoning matters.~~

~~(b) To the committee on public safety shall be referred all policy matters related to the fire and ambulance and police departments, including dispatch and animal/parking control, of the city; all safety matters concerning the inspection and regulation of buildings and occupancy of buildings; all matters related to the prevention and abatement of nuisances as well as all matters related to city court.~~

~~(c) To the committee on public services shall be referred all policy matters related to streets and alleys of the city; water and sewer plant matters; mains and facilities, both public and private; and use of recreational facilities of the city including parks, playgrounds, libraries, public amusements and entertainment.~~

~~(d)~~ (a) To the committee on human resources shall be referred all policy matters related to the recruitment, management and development of the human resources of the city including periodic review of the pay and classification systems for city employees. This committee will serve as a review board for employee grievances as directed by written city policy or as directed by the city council. To this committee union grievances concerning "phase II" shall be referred for recommendation to the whole council. The committee will serve as a review board for probationary performance evaluations as provided by written policy or as directed by the city council.

(b) All other matters shall be reviewed by the full City Council.

**Sec. 2-60. - Order of business.**

(a) At all meetings of the city council, the order of business, unless otherwise directed by special order of the council and entered of record, shall be as follows:

~~(1) Minutes, reading and correcting if necessary, and approving minutes of last regular meeting and minutes of special or intervening meetings.~~

~~(2) Reports of officers.~~

~~(3) Reports of standing committees.~~

~~(4) Reports of special committees.~~

~~(5) Presentation of petitions and communications.~~

~~(6) Unfinished business.~~

~~(7) New business.~~

(1) Call to Order

(2) Pledge of Allegiance

(3) Roll Call

(4) Request of Citizens and Public Comment

(5) Approval of Council Minutes / Committee Minutes

(6) Schedule Meetings

(7) Appointments

(8) Staff Reports & Other Committee Minutes / Reports

(9) City Council Comments

(10) Mayor Comments

(11) Public Hearings

(12) Unfinished Business

(13) New Business

(14) Adjournment

(b) For good cause the mayor may, upon motion and majority vote, change the order of business.

(c) All questions relating to the priority of business shall be decided without debate.

**Section 2.** This Ordinance shall become effective thirty (30) days after its final passage.

Said Ordinance read and put on its passage this 14<sup>th</sup> day of April, 2026.

\_\_\_\_\_  
C.A. Grenz, Mayor

ATTEST:

\_\_\_\_\_  
Mary Rowe, City Clerk

**FINALLY PASSED AND ADOPTED** this \_\_\_\_ day of \_\_\_\_\_, 2026.

\_\_\_\_\_  
C.A. Grenz, Mayor

ATTEST:

\_\_\_\_\_  
Mary Rowe, City Clerk

**RESOLUTION NO. 4678**

**A RESOLUTION APPROVING CHANGE ORDERS WITH JACKSON CONTRACTOR GROUP, INC. RELATED TO THE MILES CITY FIRE HALL CONSTRUCTION PROJECT.**

**WHEREAS**, the City of Miles City has engaged Jackson Contractor Group, Inc., to construct the new MCFR Fire Hall building;

**AND WHEREAS**, changes to the construction plans and documents have been recommended, and are hereby presented to Council for approval in the form of 3 change orders;

**NOW THEREFORE, IT IS RESOLVED BY THE CITY COUNCIL OF THE CITY OF MILES CITY, MONTANA AS FOLLOWS:**

1. The following Change Orders are hereby approved: Change Order #010, #011, and #012, each described in detail and attached hereto as Exhibit "A," are hereby approved and adopted by this Council.
2. The Mayor shall have the authority to execute the same, and to bind the City thereto.

**SAID RESOLUTION FINALLY PASSED AND ADOPTED BY A DULY CONSTITUTED QUORUM OF THE CITY COUNCIL OF THE CITY OF MILES CITY, MONTANA, AT A REGULAR MEETING THIS 14<sup>TH</sup> DAY OF APRIL, 2026.**

\_\_\_\_\_  
C.A. Grenz, Mayor

ATTEST:

\_\_\_\_\_  
Mary Rowe, City Clerk



Miles City Office  
 PO Box 1298  
 Miles City, Montana 59301  
 Phone: (406) 234-5565  
 Fax: (406) 234-5566

**Project:** 02202405 - Miles City Fire & Ambulance  
 2800 Main Street  
 Miles City, Montana 59301  
 Phone: 509-993-4010

## Prime Contract Change Order #010: Change Order 10

<b>TO:</b>	City of Miles City PO Box 910 Miles City, Montana 59301	<b>FROM:</b>	Jackson Contractor Group, Inc. PO Box 967 Missoula Montana 59806
<b>DATE CREATED:</b>	4/ 08 /2026	<b>CREATED BY:</b>	Amy Lesh (Jackson Contractor Group, Inc.)
<b>CONTRACT STATUS:</b>	Pending - In Review	<b>REVISION:</b>	0
<b>DESIGNATED REVIEWER:</b>	Amy Lesh (Jackson Contractor Group, Inc.)	<b>REVIEWED BY:</b>	
<b>DUE DATE:</b>	04/15 /2026	<b>REVIEW DATE:</b>	
<b>INVOICED DATE:</b>		<b>PAID DATE:</b>	
<b>SCHEDULE IMPACT:</b>		<b>EXECUTED:</b>	No
<b>CONTRACT FOR:</b>	02202405-00:Miles City Fire and Rescue	<b>TOTAL AMOUNT:</b>	\$ 0.00

**DESCRIPTION:**  
 This change order is for additional line striping, in the apparatus bays and the north parking lot.

**ATTACHMENTS:**

This proposal is based on the usual cost elements such as labor, material, and normal mark ups, and does not include any amount for changes in the sequence or work delays, disruption, rescheduling, extended overhead, acceleration and or impacts, and the right is expressly reserved to make claim for any and all of these related items of cost prior to any final settlement of the contract.

**POTENTIAL CHANGE ORDERS IN THIS CHANGE ORDER:**

PCO #	Title	Schedule Impact	Amount
025	Additional Line Striping		0.00
<b>TOTAL:</b>			<b>\$0.00</b>

**CHANGE ORDER LINE ITEMS:**

**PCO # 025 : Additional Line Striping**

#	SubJob	Cost Code	Description	Type	Amount
1	N/A	32-1416 - 2.32C JT COATINGS	Apparatus Bay and North Parking Striping	Subcontract	\$ 1,767.50
2	N/A	01-2116 - CONTINGENCY	Contingency	Unallocated	(\$1,767.50)
<b>Subtotal:</b>					<b>\$0.00</b>
<b>GL Insurance: 0.85% Applies to All Line Items</b>					<b>0.00</b>
<b>Builders Risk Insurance: 0.50% Applies to All Line Items</b>					<b>0.00</b>
<b>Procure: ≈ 0.19% Applies to All Line Items</b>					<b>0.00</b>
<b>P&amp;P Bond: 0.64% Applies to All Line Items</b>					<b>0.00</b>
<b>Fee: 5.00% Applies to All Line Items</b>					<b>0.00</b>
<b>MGRT: 1.00% Applies to All Line Items</b>					<b>0.00</b>
<b>Grand Total:</b>					<b>\$0.00</b>

The original (Contract Sum)	\$ 4,753,879.00
Net change by previously authorized Change Orders	\$ 62,075.79
The contract sum prior to this Change Order was	\$ 4,815,954.79
The contract sum would be changed by this Change Order in the amount of	\$ 0.00
The new contract sum including this Change Order will be	\$ 4,815,954.79
The contract time will not be changed by this Change Order	



**From:** Jason Sorenson <jason@aaastripingusa.com>  
**Sent:** Tuesday, April 7, 2026 11:55 AM  
**To:** Amy Lesh  
**Subject:** RE: Miles City Fire Station - Arch Site Striping revisions 04.07.26.pdf

I come up with 1010 LF \* 1.75 a LF = \$1767.50

Im guessing it's the same trip?

If not, add the additional MOB of \$500

Thanks  
Jason

---

**From:** Amy Lesh <amyl@jacksoncontractorgroup.com>  
**Sent:** Tuesday, April 7, 2026 11:50 AM  
**To:** Jason Sorenson <jason@aaastripingusa.com>  
**Subject:** RE: Miles City Fire Station - Arch Site Striping revisions 04.07.26.pdf

Both, and the 6 lines to the north of the building.

Thanks,



**AMY LESH**  
**PROJECT MANAGER**  
[amyl@jacksoncontractorgroup.com](mailto:amyl@jacksoncontractorgroup.com)  
[www.jacksoncontractorgroup.com](http://www.jacksoncontractorgroup.com)  
PO Box 1298, Miles City, MT 59301  
P | 406-234-5565 M | 406-853-1785

f @ in v

---

**From:** Jason Sorenson <jason@aaastripingusa.com>  
**Sent:** Tuesday, April 7, 2026 11:48 AM  
**To:** Amy Lesh <amyl@jacksoncontractorgroup.com>  
**Subject:** RE: Miles City Fire Station - Arch Site Striping revisions 04.07.26.pdf

Amy,

Is it the lines outside on the gray or do you want the inside lines on the blue also?

Thanks  
Jason





# MILES CITY FIRE & AMBULANCE FACILITY RENOVIATION & ADDITION PROJECT

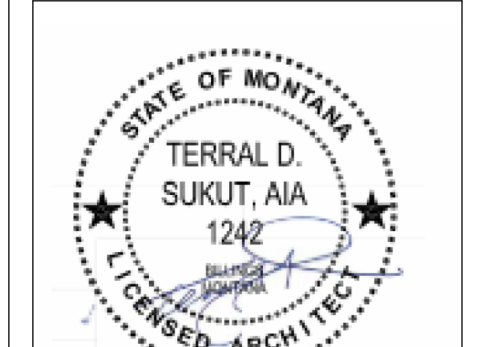
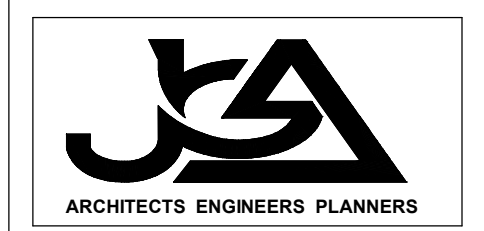

The professional services of the architect are provided for and are performed in the interests of Miles City Fire & Ambulance Facility. No contractual obligations are assumed by the architect for the benefit of any other person mentioned in the contract.

project: 2404  
date: 5/5/2025  
revisions:

**AS1.1**

### GENERAL NOTES

- SLOPE ALL SIDEWALKS, FILLS, AND PAVED AREAS AWAY FROM THE BUILDING. DO NOT EXCEED GROSS SLOPE OF 2% ON WALKS.
- ALL CURBS AND SIDEWALKS SHALL CONFORM TO LOCAL CODES AND ORDINANCES. VERIFY WITH THE CITY OF MILES CITY FOR STANDARDS.
- ALL SUB CONTRACTORS SUPPLIES SHALL VISIT THE SITE AND BECOME FAMILIAR WITH THE SCOPE OF WORK. CONTRACTOR SHALL VERIFY LOCATIONS OF ALL UNDERGROUND UTILITIES PRIOR TO INSTALLATION OF NEW IMPROVEMENTS.
- UNLESS OTHERWISE INDICATED, MEET EXISTING GRADES @ THE LIMIT OF DISTURBANCE.
- PROVIDE SLEEVES FOR IRRIGATION LINES TO ALL LANDSCAPE AREAS.
- DUST CONTROL MEASURES MUST BE IMPLEMENTED DURING CONSTRUCTION AS NECESSARY TO MINIMIZE BLOWING DUST.
- MEASURES MUST BE TAKEN DURING CONSTRUCTION ACTIVITIES TO MINIMIZE TRACK OUT (MUD, ROCKS, DEBRIS) FROM THE SITE ONTO THE PUBLIC STREETS.
- WHERE NEW CONC. ABUTS EXISTING, MATCH EXPANSION JOINT LOCATIONS, TYP.
- 6" COMPACTED BASE REQUIRED UNDER ALL NEW CONCRETE.
- MATCH ELEVATION OF ALL EXISTING CONCRETE SIDEWALKS WHERE MATCH UP CONCRETE IS BEING PLACED.

### KEYED NOTES

- NOTED THIS:
- 1 NEW CONCRETE CURB & GUTTER - SEE CIVIL DRAWINGS
  - 2 NEW ASPHALT PAVING AS AN ALTERNATE - SEE CIVIL DRAWINGS ALTERNATE C-1 CONCRETE PAVING ALTERNATE C-2 ASPHALT PAVING
  - 3 NEW CONCRETE STOOP
  - 4 NEW FLASHPOLE PROVIDED BY OWNER - SEE CIVIL DRAWINGS
  - 5 PROPERTY LINE
  - 6 SUBGRADE EXISTING SURFACE TO REMAIN - SEE CIVIL DRAWING
  - 7 PARKING BUMPER - SEE DETAIL - 3/AS1.1
  - 8 VINYL FENCE - SEE DETAIL - 1/AS1.1
  - 9 NOT USED
  - 10 ADA PARKING SYMBOL - SEE DETAIL - 8/AS1.1
  - 11 PIPE BOLLARD - SEE DETAIL - 5/AS1.1
  - 12 EXISTING SIDEWALK TO REMAIN

### CONCRETE JOINTS

- CONTRACTION JOINTS MAXIMUM 6'-0" O.C. - SEE 5/AS1.2 AND SPECIFICATION SECTION 03 30 00
- CONSTRUCTION JOINTS MAXIMUM 30'-0" O.C. - SEE 5/AS1.2 AND SPECIFICATION SECTION 03 30 00
- ISOLATION JOINTS WHERE CONC. PAVING ABUTS BUILDING OR SITE STRUCTURE - SEE 5/AS1.2 AND SPECIFICATION SECTION 03 30 00

### PARKING CALCULATION

1 SPACE PER 200 S.F. GROSS BUILDING:  
11,000 / 200 = 55 SPACES REQUIRED  
TOTAL SPACES PROVIDED = 61

### SITE PLAN LEGEND

- (E) PDMB
- NEW MILES CITY FIRE & AMBULANCE FACILITY
- EXISTING MILES CITY FIRE & AMBULANCE FACILITY
- CONCRETE
- ASPHALT
- SOD
- ROCK MULCH

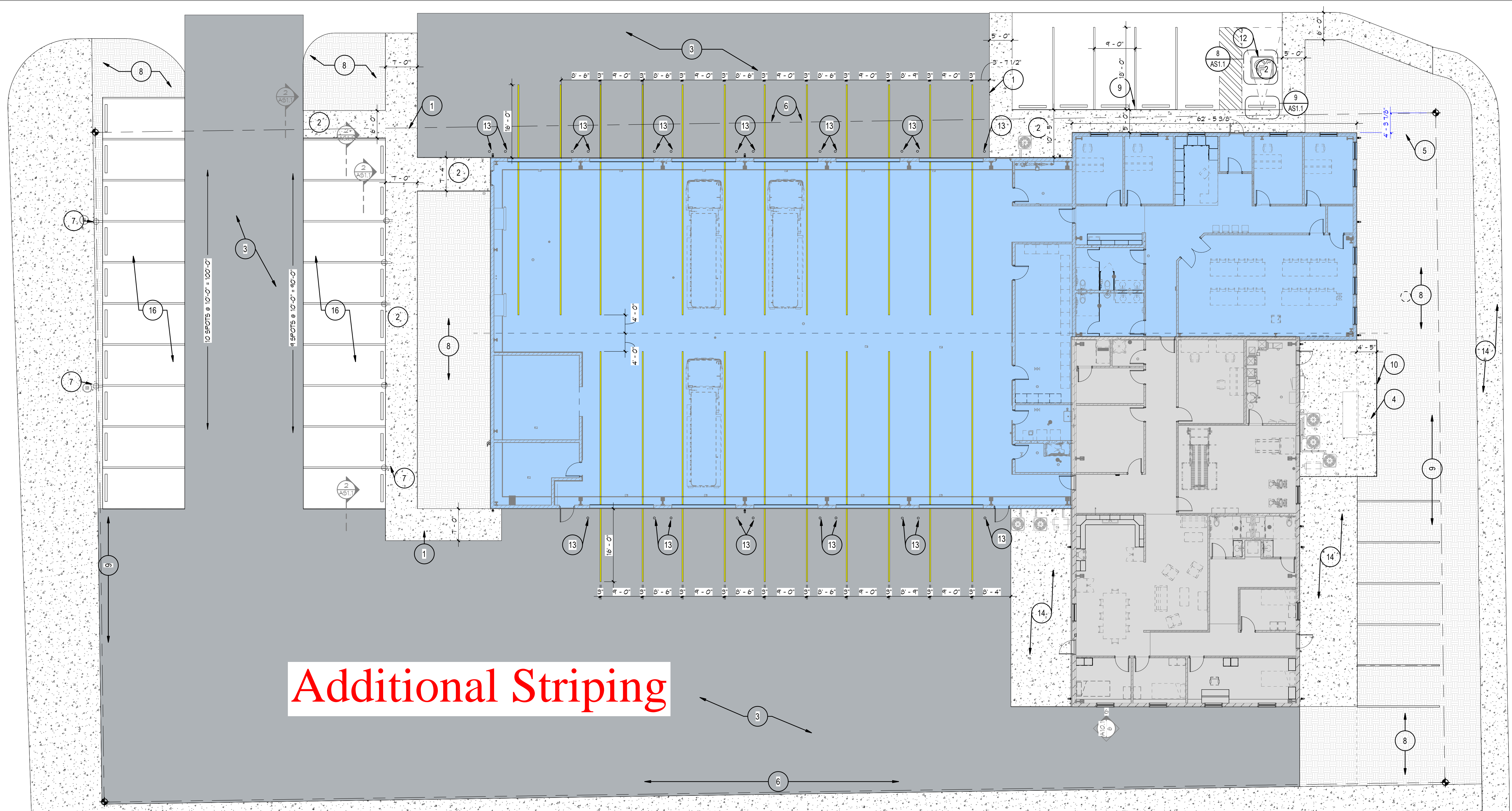

**Additional Striping**

1 ENLARGED SITE PLAN  
3/32" = 1'-0"

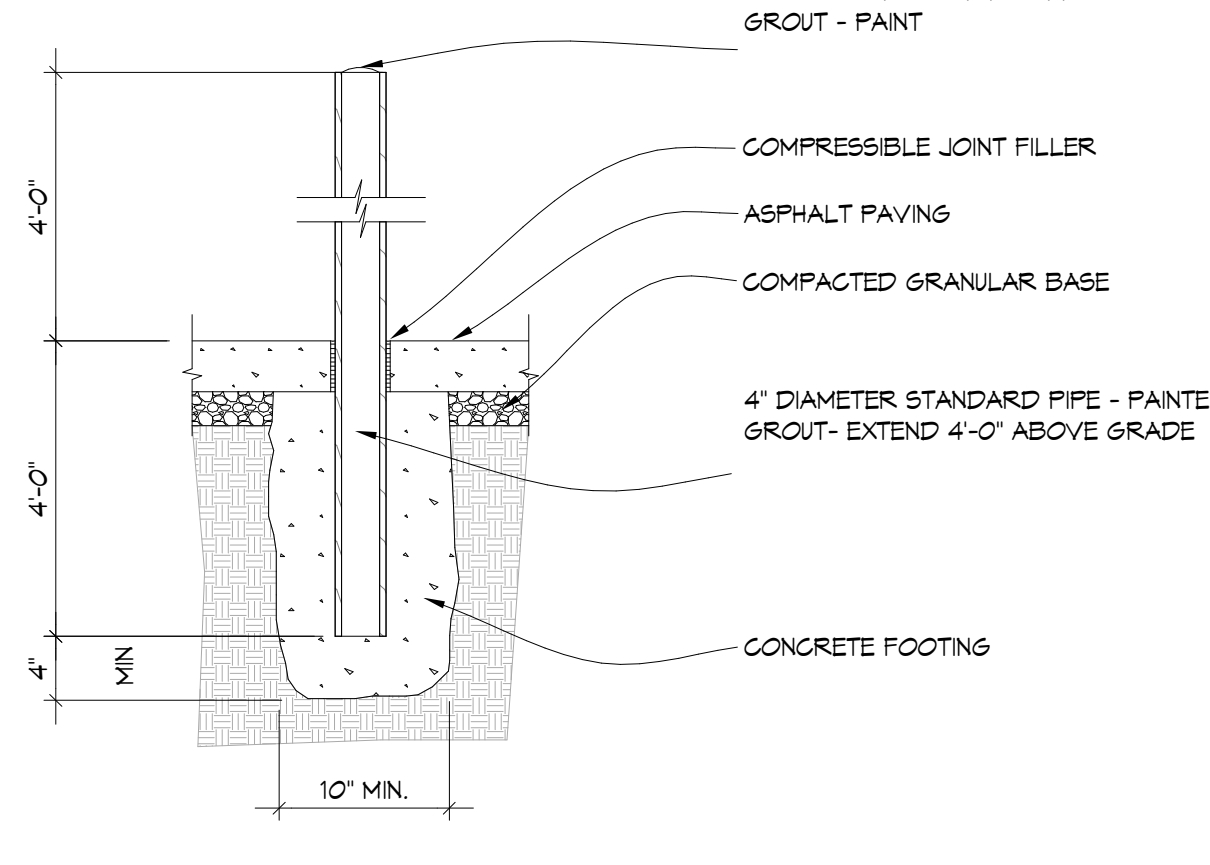
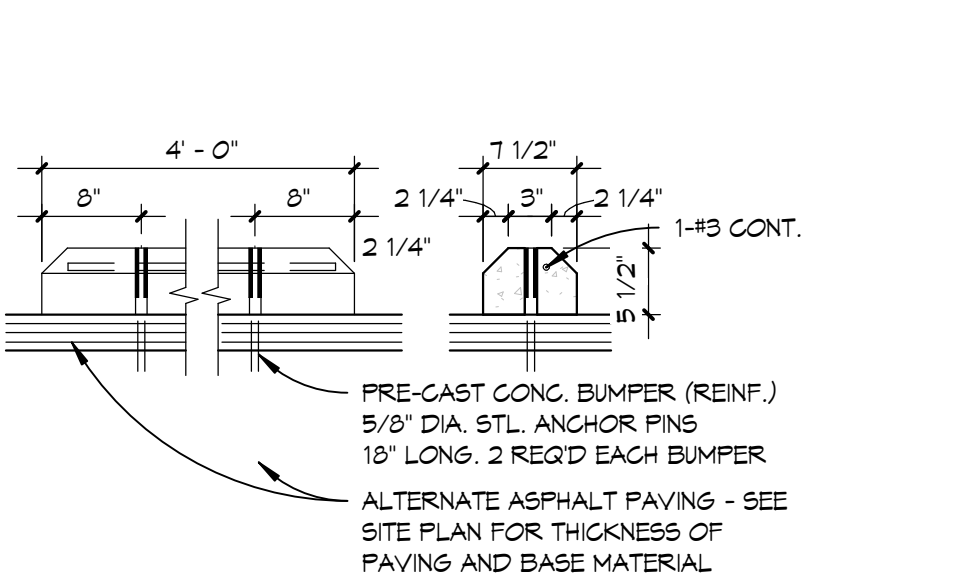
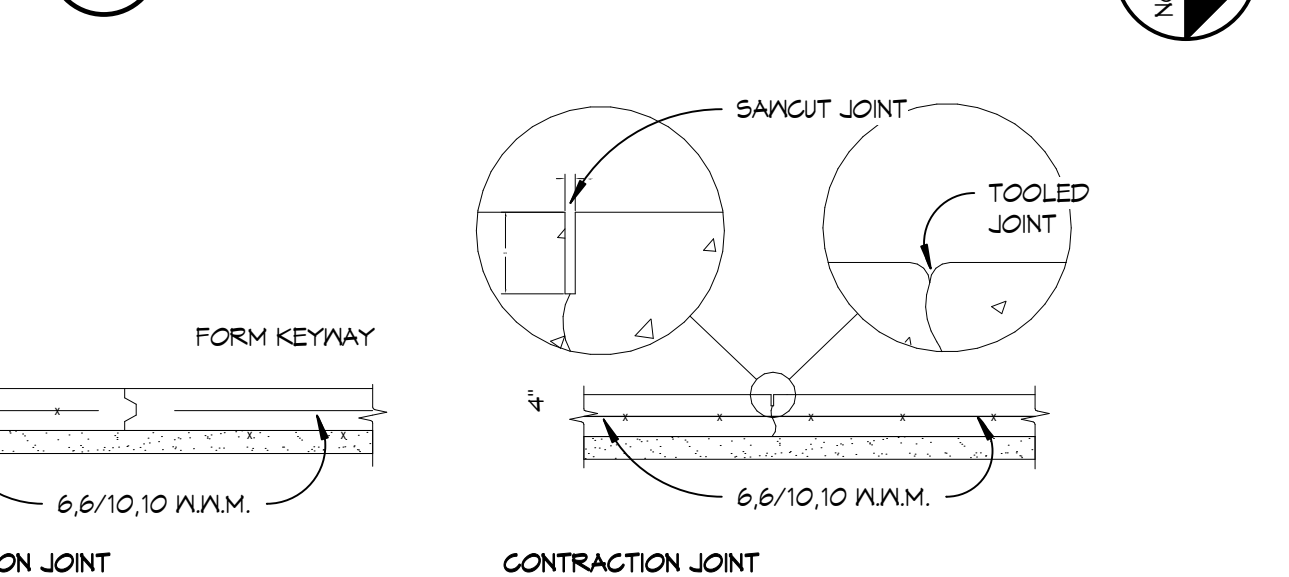
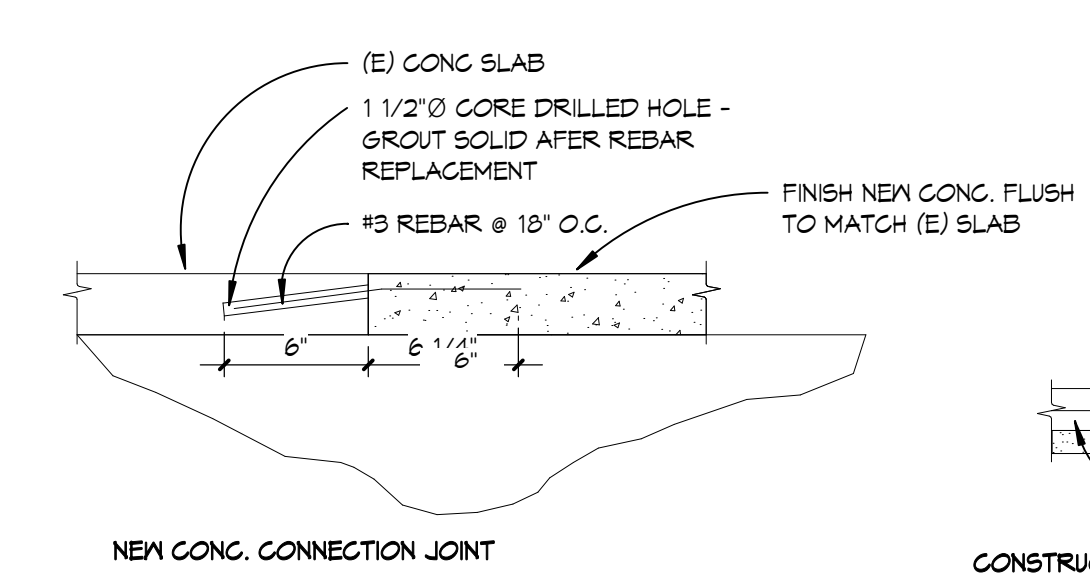

2 CONCRETE JOINT DETAILS  
1/12" = 1'-0"

3 PARKING BUMPER  
3" = 1'-0"

5 PIPE BOLLARD DETAIL  
1" = 1'-0"

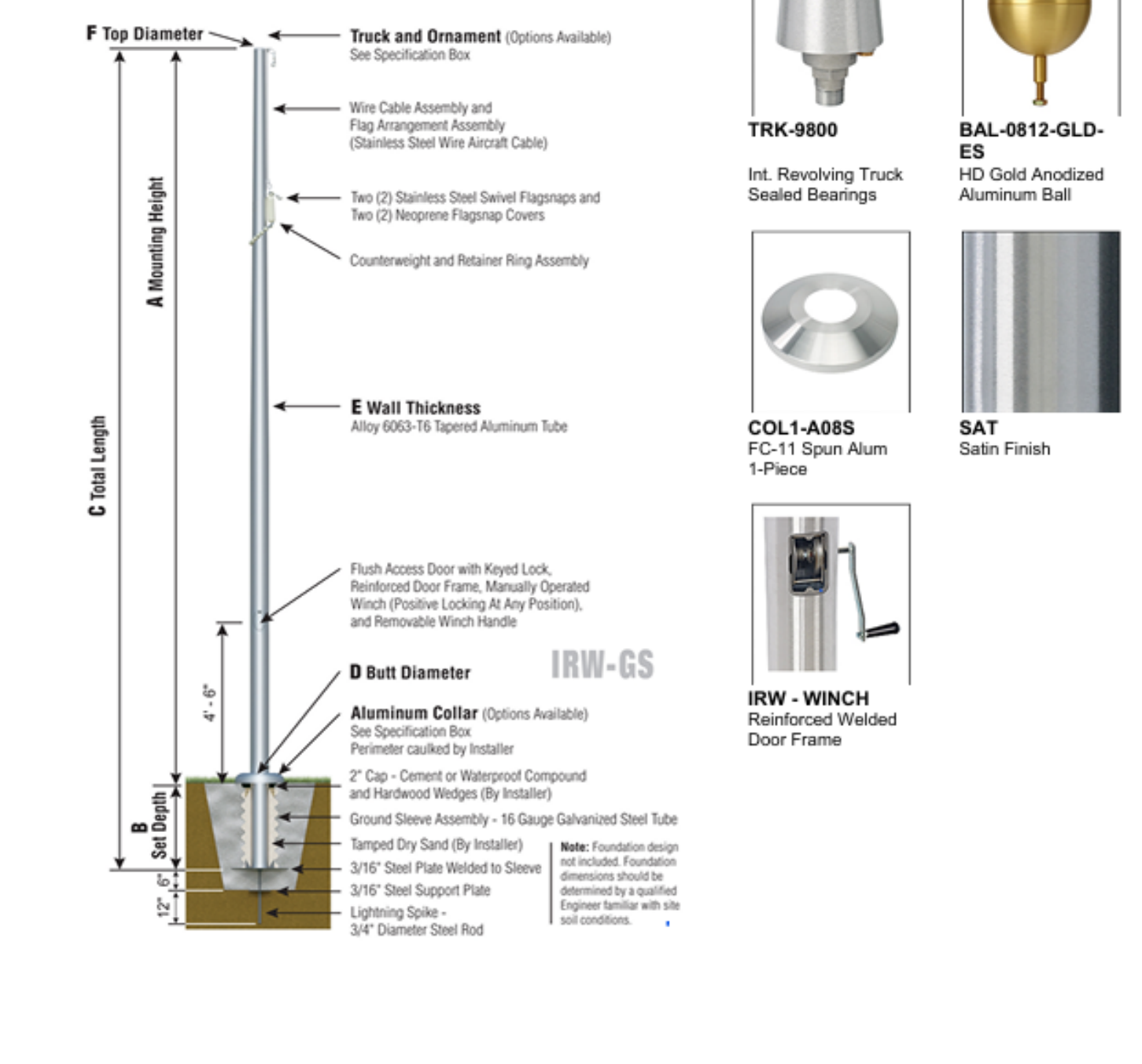
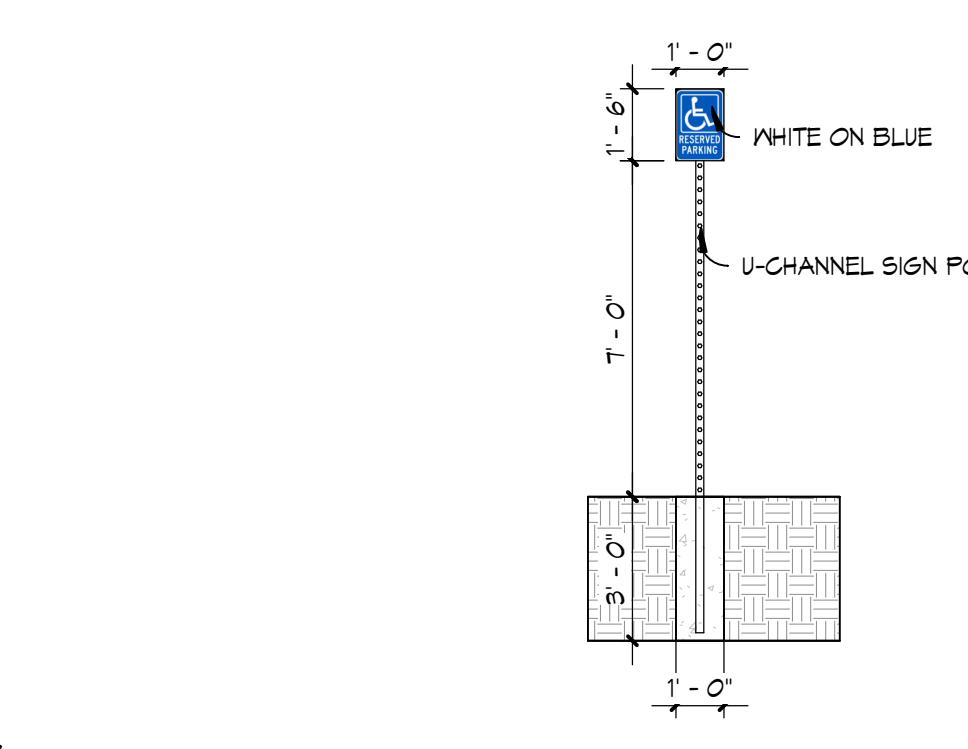
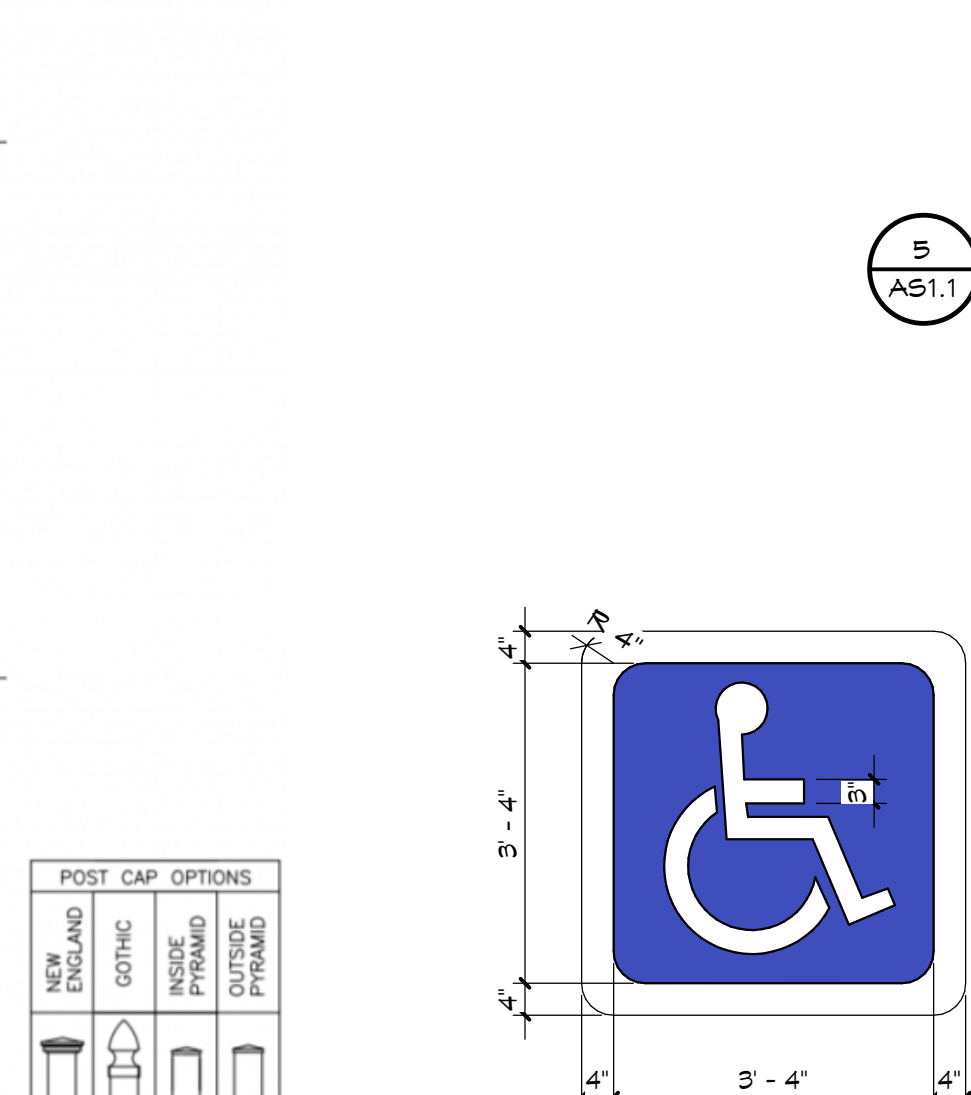
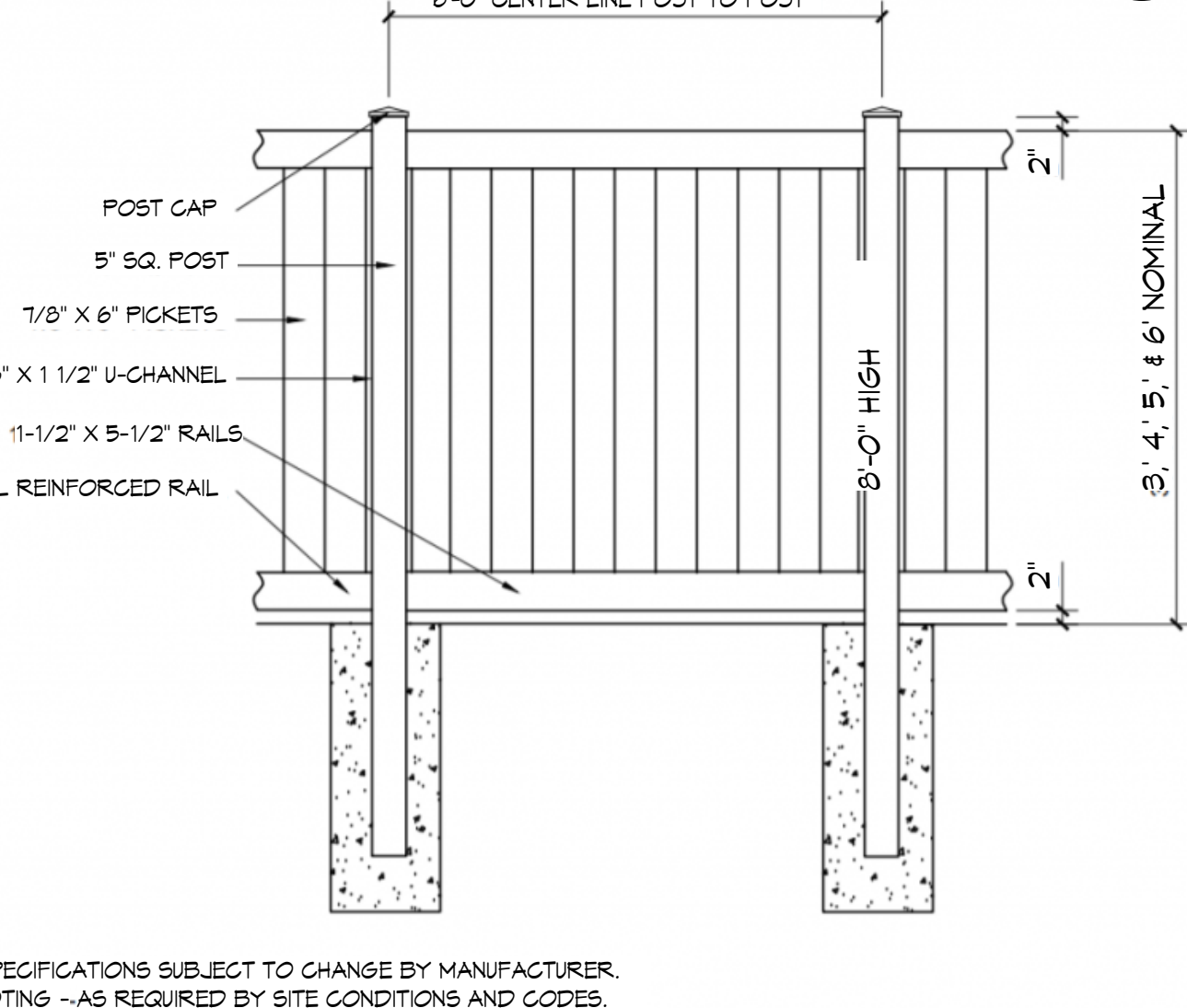
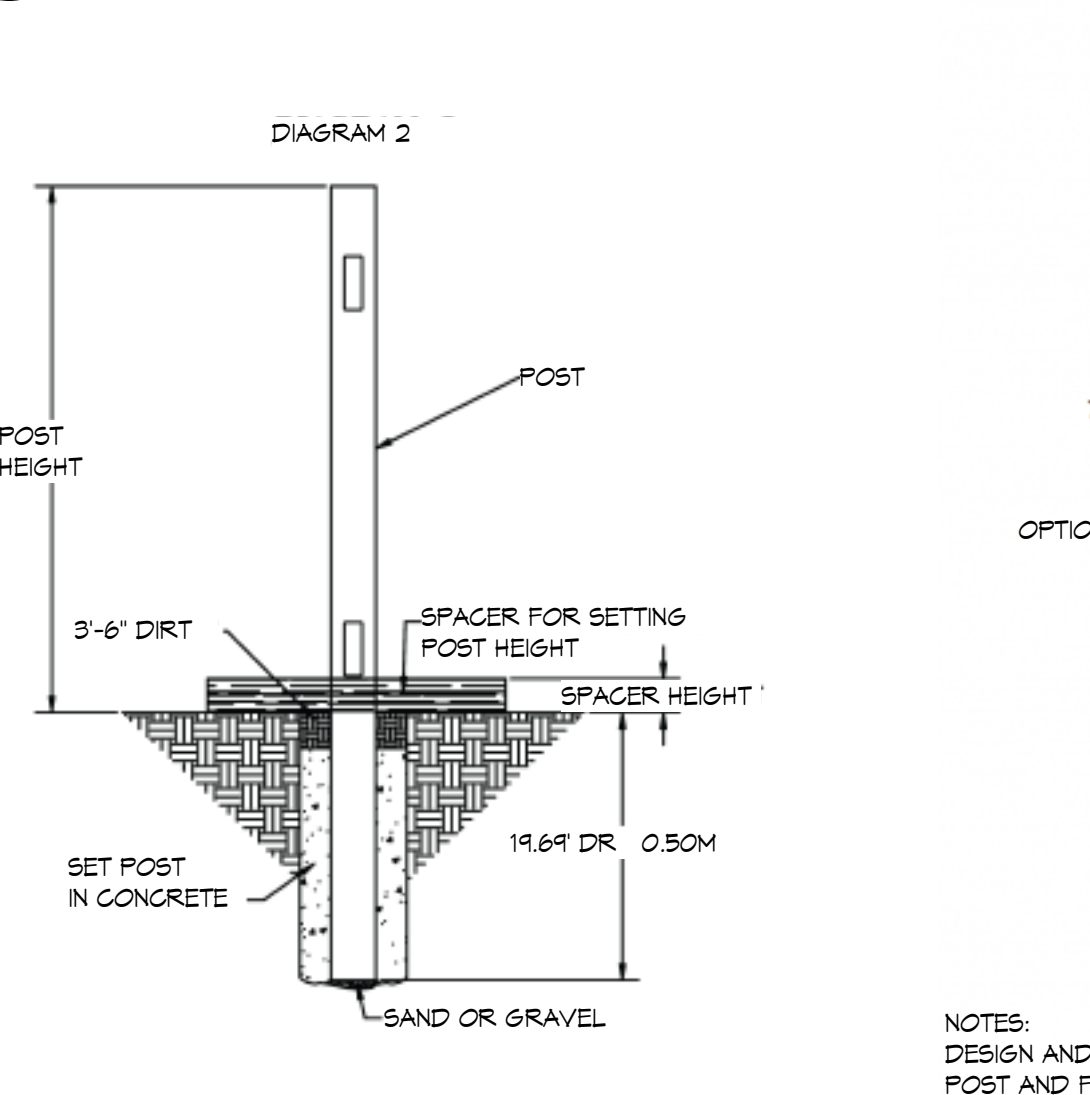

NOTES:  
DESIGN AND SPECIFICATIONS SUBJECT TO CHANGE BY MANUFACTURER.  
POST AND FOOTINGS --AS REQUIRED BY SITE CONDITIONS AND CODES.

Make foundation design as indicated. Foundation dimensions should be approved by a qualified engineer before use with this foundation.



Miles City Office  
 PO Box 1298  
 Miles City, Montana 59301  
 Phone: (406) 234-5565  
 Fax: (406) 234-5566

**Project:** 02202405 - Miles City Fire & Ambulance  
 2800 Main Street  
 Miles City, Montana 59301  
 Phone: 509-993-4010

## Prime Contract Change Order #011: Change Order 11

<b>TO:</b>	City of Miles City PO Box 910 Miles City, Montana 59301	<b>FROM:</b>	Jackson Contractor Group, Inc. PO Box 967 Missoula Montana 59806
<b>DATE CREATED:</b>	4/ 08 /2026	<b>CREATED BY:</b>	Amy Lesh (Jackson Contractor Group, Inc.)
<b>CONTRACT STATUS:</b>	Pending - In Review	<b>REVISION:</b>	0
<b>DESIGNATED REVIEWER:</b>	Amy Lesh (Jackson Contractor Group, Inc.)	<b>REVIEWED BY:</b>	
<b>DUE DATE:</b>	04/15 /2026	<b>REVIEW DATE:</b>	
<b>INVOICED DATE:</b>		<b>PAID DATE:</b>	
<b>SCHEDULE IMPACT:</b>		<b>EXECUTED:</b>	No
<b>CONTRACT FOR:</b>	02202405-00:Miles City Fire and Rescue	<b>TOTAL AMOUNT:</b>	\$ 0.00

**DESCRIPTION:**  
 This change order is for fencing to be added to the scope of the project, along the south and east property lines. This change was requested by the fire department at the OAC meeting on 3/26.

**ATTACHMENTS:**

This proposal is based on the usual cost elements such as labor, material, and normal mark ups, and does not include any amount for changes in the sequence or work delays, disruption, rescheduling, extended overhead, acceleration and or impacts, and the right is expressly reserved to make claim for any and all of these related items of cost prior to any final settlement of the contract.

**POTENTIAL CHANGE ORDERS IN THIS CHANGE ORDER:**

PCO #	Title	Schedule Impact	Amount
026	Additional Fence		0.00
<b>TOTAL:</b>			<b>\$0.00</b>

**CHANGE ORDER LINE ITEMS:**

**PCO # 026 : Additional Fence**

#	SubJob	Cost Code	Description	Type	Amount
1	N/A	32-3100 - 2.32D JARES FENCING	Site Fence - East and South	Subcontract	\$ 17,840.79
2	N/A	01-2116 - CONTINGENCY	Contingency	Unallocated	(\$17,840.79)
<b>Subtotal:</b>					<b>\$0.00</b>
<b>GL Insurance: 0.85% Applies to All Line Items</b>					<b>0.00</b>
<b>Builders Risk Insurance: 0.50% Applies to All Line Items</b>					<b>0.00</b>
<b>Procure: ≈ 0.19% Applies to All Line Items</b>					<b>0.00</b>
<b>P&amp;P Bond: 0.64% Applies to All Line Items</b>					<b>0.00</b>
<b>Fee: 5.00% Applies to All Line Items</b>					<b>0.00</b>
<b>MGRT: 1.00% Applies to All Line Items</b>					<b>0.00</b>
<b>Grand Total:</b>					<b>\$0.00</b>

The original (Contract Sum)	\$ 4,753,879.00
Net change by previously authorized Change Orders	\$ 62,075.79
The contract sum prior to this Change Order was	\$ 4,815,954.79
The contract sum would be changed by this Change Order in the amount of	\$ 0.00
The new contract sum including this Change Order will be	\$ 4,815,954.79
The contract time will not be changed by this Change Order	



**Terry Sukut (JGA Architects)**  
3395 Gabel Road, Suite 100  
Billings Montana 59102

**City of Miles City**  
PO Box 910  
Miles City Montana 59301

**Jackson Contractor Group, Inc.**  
PO Box 967  
Missoula Montana 59806

*Amy Leek*

4/8/2026

\_\_\_\_\_  
SIGNATURE DATE

\_\_\_\_\_  
SIGNATURE DATE

\_\_\_\_\_  
SIGNATURE DATE



Jares F Section 9, Item A.  
 10640 S. Frontage Rd.  
 Billings, MT 59101  
 (406) 651-1400  
 www.jaresfence.com  
 jeff@jaresfence.com

**QUOTATION/CONTRACT:**

**DATE:** 03/31/2026

**CUSTOMER:**

**JOB LOCATION:**

Jackson Contractor Group  
 146 Laura Louise Lane  
 Bozeman MT 59718

406-451-9601  
 ap@jacksoncontractorgroup.com  
 M/C Fire House Chain Link Add-On

**NOTES:**

Thank you for allowing Jares Fence Company to bid on your fence project. Please call or email me if you have any questions.  
 Thanks, Jeff

- Commercial Chain Link
- Chain Link Fabric - 9 Ga.
- Top Rail - 1 5/8" SS40
- Terminal Posts - 2 7/8" SS40
- Line Posts - 2 3/8" SS40
- Brace Rail - 1 5/8" SS40
- Gate Posts - 4" SS40
- Truss Rod - 3/8"
- Tension Wire - 7 Ga.
- Barb Wire - 4 Point

Materials and Labor as Shown:

- Tear Out and Haul Away Existing Chain Link Fence
- Install 423' of 6' High Chain Link
- Install 423' of Bottom Tension Wire

\* Privacy Slats Can be Installed at \$10LF. It Will Add \$4,230.00 to This Quote.

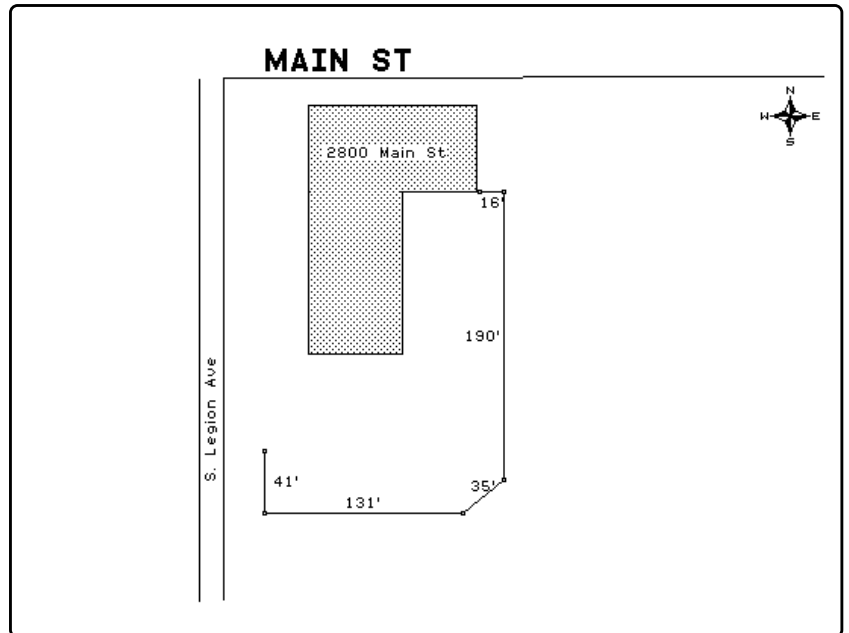

<b>Subtotal .....</b>	<b>\$</b>	<b>17840.79</b>
<b>Tax .....</b>	<b>\$</b>	<b>0.00</b>
<b>Grand Total .....</b>	<b>\$</b>	<b>17840.79</b>
<b>Down Payment .....</b>	<b>\$</b>	
<b>BALANCE DUE .....</b>	<b>\$</b>	<b>17840.79</b>

**Approved & Accepted for Customer:**

_____	_____
Customer	Date
_____	_____
Customer	Date

**Accepted for Jares Fence Company, Inc.:**

_____	_____
Salesperson	Date

**TERMS & CONDITIONS**

Section 9, Item A.

PROPOSAL EXPIRES 15 DAYS FROM DATE SHOWN. Jares Fence Company, Inc. agrees to guarantee above fence to be materials and workmanship for one year. Jares Fence Company, Inc. shall advise the customer as to local zoning regulations but responsibility for complying with said regulations and obtaining any required permits shall rest with the customer. Jares Fence Company, Inc. will assist the customer, upon request, in determining where the fence is to be erected, but under no circumstance does Jares Fence Company, Inc. assume any responsibility concerning property lines or in any way guarantee their accuracy. If property pins cannot be located it is recommended that the customer have the property surveyed.

Jares Fence Company, Inc. will assume the responsibility for having underground public utilities located and marked. However, Jares Fence Company, Inc. assumes no responsibility for unmarked sprinkler lines, or any other unmarked buried lines or objects. The customer will assume all liability for any damage caused by directing Jares Fence Company, Inc. to dig in the immediate vicinity of known utilities. The customer will assume all responsibility for excavated materials. The final billing will be based on the actual footage of fencing built and the work performed. Partial billing for materials delivered to the job site and work completed may be sent at weekly intervals. Adjustments for material used on this job and adjustments for labor will be charged or credited at the currently established rates. Additional charges for any extra work not covered in this contract that was requested by the customer will also be added. The full amount of this contract along with any additional charges will become payable upon completion of all work whether or not it has been invoiced. A finance charge of 1 1/2% per month (or a minimum of \$1.00), which is an annual percentage rate of 18%, shall be applied to accounts that are not paid within 10 days after completion of any work invoiced. All materials will remain the property of Jares Fence Company, Inc. until all invoices pertaining to this job are paid in full. The customer agrees to pay all interest and any costs, including reasonable attorney fees, incurred in the collection of this debt. It is agreed that if there is any litigation relating to this contract that the proper venue is Yellowstone County, Montana.

CUSTOMER INITIAL \_\_\_\_\_  
CUSTOMER INITIAL \_\_\_\_\_  
SALESPERSON INITIAL \_\_\_\_\_



Miles City Office  
 PO Box 1298  
 Miles City, Montana 59301  
 Phone: (406) 234-5565  
 Fax: (406) 234-5566

Project: 02202405 - Miles City Fire & Ambulance  
 2800 Main Street  
 Miles City, Montana 59301  
 Phone: 509-993-4010

## Prime Contract Change Order #012: Change Order 12

<b>TO:</b>	City of Miles City PO Box 910 Miles City, Montana 59301	<b>FROM:</b>	Jackson Contractor Group, Inc. PO Box 967 Missoula Montana 59806
<b>DATE CREATED:</b>	4/ 08 /2026	<b>CREATED BY:</b>	Amy Lesh (Jackson Contractor Group, Inc.)
<b>CONTRACT STATUS:</b>	Pending - In Review	<b>REVISION:</b>	0
<b>DESIGNATED REVIEWER:</b>	Amy Lesh (Jackson Contractor Group, Inc.)	<b>REVIEWED BY:</b>	
<b>DUE DATE:</b>	04/15 /2026	<b>REVIEW DATE:</b>	
<b>INVOICED DATE:</b>		<b>PAID DATE:</b>	
<b>SCHEDULE IMPACT:</b>		<b>EXECUTED:</b>	No
<b>CONTRACT FOR:</b>	02202405-00:Miles City Fire and Rescue	<b>TOTAL AMOUNT:</b>	\$ 0.00

**DESCRIPTION:**  
 This change order is for the option of adding privacy slats in the fence that corresponds with Change Order 11.

**ATTACHMENTS:**

This proposal is based on the usual cost elements such as labor, material, and normal mark ups, and does not include any amount for changes in the sequence or work delays, disruption, rescheduling, extended overhead, acceleration and or impacts, and the right is expressly reserved to make claim for any and all of these related items of cost prior to any final settlement of the contract.

**POTENTIAL CHANGE ORDERS IN THIS CHANGE ORDER:**

PCO #	Title	Schedule Impact	Amount
027	Privacy Slats in Additional Fence		0.00
<b>TOTAL:</b>			<b>\$0.00</b>

**CHANGE ORDER LINE ITEMS:**

**PCO # 027 : Privacy Slats in Additional Fence**

#	SubJob	Cost Code	Description	Type	Amount
1	N/A	32-3100 - 2.32D JARES FENCING	Privacy Slats	Subcontract	\$ 4,230.00
2	N/A	01-2116 - CONTINGENCY	Contingency	Unallocated	(\$4,230.00)
<b>Subtotal:</b>					<b>\$0.00</b>
<b>GL Insurance: 0.85% Applies to All Line Items</b>					<b>0.00</b>
<b>Builders Risk Insurance: 0.50% Applies to All Line Items</b>					<b>0.00</b>
<b>Procure: ≈ 0.19% Applies to All Line Items</b>					<b>0.00</b>
<b>P&amp;P Bond: 0.64% Applies to All Line Items</b>					<b>0.00</b>
<b>Fee: 5.00% Applies to All Line Items</b>					<b>0.00</b>
<b>MGRT: 1.00% Applies to All Line Items</b>					<b>0.00</b>
<b>Grand Total:</b>					<b>\$0.00</b>

The original (Contract Sum)	\$ 4,753,879.00
Net change by previously authorized Change Orders	\$ 62,075.79
The contract sum prior to this Change Order was	\$ 4,815,954.79
The contract sum would be changed by this Change Order in the amount of	\$ 0.00
The new contract sum including this Change Order will be	\$ 4,815,954.79
The contract time will not be changed by this Change Order	





Jares F Section 9, Item A.  
 10640 S. Frontage Rd.  
 Billings, MT 59101  
 (406) 651-1400  
 www.jaresfence.com  
 jeff@jaresfence.com

**QUOTATION/CONTRACT:**

**DATE:** 03/31/2026

**CUSTOMER:**

**JOB LOCATION:**

Jackson Contractor Group  
 146 Laura Louise Lane  
 Bozeman MT 59718

406-451-9601  
 ap@jacksoncontractorgroup.com  
 M/C Fire House Chain Link Add-On

**NOTES:**

Thank you for allowing Jares Fence Company to bid on your fence project. Please call or email me if you have any questions.  
 Thanks, Jeff

- Commercial Chain Link
- Chain Link Fabric - 9 Ga.
- Top Rail - 1 5/8" SS40
- Terminal Posts - 2 7/8" SS40
- Line Posts - 2 3/8" SS40
- Brace Rail - 1 5/8" SS40
- Gate Posts - 4" SS40
- Truss Rod - 3/8"
- Tension Wire - 7 Ga.
- Barb Wire - 4 Point

- Materials and Labor as Shown:
- Tear Out and Haul Away Existing Chain Link Fence
  - Install 423' of 6' High Chain Link
  - Install 423' of Bottom Tension Wire

\* Privacy Slats Can be Installed at \$10LF. It Will Add \$4,230.00 to This Quote.

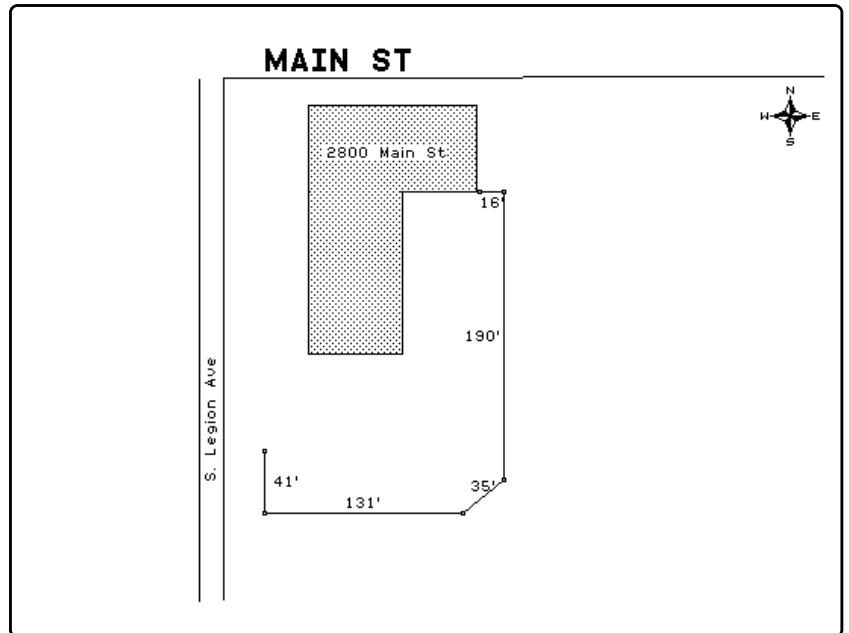

<b>Subtotal .....</b>	<b>\$</b>	<b>17840.79</b>
<b>Tax .....</b>	<b>\$</b>	<b>0.00</b>
<b>Grand Total .....</b>	<b>\$</b>	<b>17840.79</b>
<b>Down Payment .....</b>	<b>\$</b>	_____
<b>BALANCE DUE .....</b>	<b>\$</b>	<b>17840.79</b>

**Approved & Accepted for Customer:**

_____	_____
Customer	Date
_____	_____
Customer	Date

**Accepted for Jares Fence Company, Inc.:**

_____	_____
Salesperson	Date

**TERMS & CONDITIONS**

Section 9, Item A.

PROPOSAL EXPIRES 15 DAYS FROM DATE SHOWN. Jares Fence Company, Inc. agrees to guarantee above fence to be materials and workmanship for one year. Jares Fence Company, Inc. shall advise the customer as to local zoning regulations but responsibility for complying with said regulations and obtaining any required permits shall rest with the customer. Jares Fence Company, Inc. will assist the customer, upon request, in determining where the fence is to be erected, but under no circumstance does Jares Fence Company, Inc. assume any responsibility concerning property lines or in any way guarantee their accuracy. If property pins cannot be located it is recommended that the customer have the property surveyed.

Jares Fence Company, Inc. will assume the responsibility for having underground public utilities located and marked. However, Jares Fence Company, Inc. assumes no responsibility for unmarked sprinkler lines, or any other unmarked buried lines or objects. The customer will assume all liability for any damage caused by directing Jares Fence Company, Inc. to dig in the immediate vicinity of known utilities. The customer will assume all responsibility for excavated materials. The final billing will be based on the actual footage of fencing built and the work performed. Partial billing for materials delivered to the job site and work completed may be sent at weekly intervals. Adjustments for material used on this job and adjustments for labor will be charged or credited at the currently established rates. Additional charges for any extra work not covered in this contract that was requested by the customer will also be added. The full amount of this contract along with any additional charges will become payable upon completion of all work whether or not it has been invoiced. A finance charge of 1 1/2% per month (or a minimum of \$1.00), which is an annual percentage rate of 18%, shall be applied to accounts that are not paid within 10 days after completion of any work invoiced. All materials will remain the property of Jares Fence Company, Inc. until all invoices pertaining to this job are paid in full. The customer agrees to pay all interest and any costs, including reasonable attorney fees, incurred in the collection of this debt. It is agreed that if there is any litigation relating to this contract that the proper venue is Yellowstone County, Montana.

CUSTOMER INITIAL \_\_\_\_\_  
CUSTOMER INITIAL \_\_\_\_\_  
SALESPERSON INITIAL \_\_\_\_\_

**RESOLUTION NO. 4679**

**A RESOLUTION APPROVING CHANGE ORDER 2 AND AMENDMENT TO TASK ORDER 3 WITH INTERSTATE ENGINEERING INC. AND DIAMOND J CONSTRUCTION, RELATED TO THE FLORENCE STACY MEMORIAL FOUNTAIN PROJECT.**

**WHEREAS**, the City of Miles City has engaged Interstate Engineering, Inc., and Diamon J Construction have been retained to provide services related to the reconstruction of the Florence Stacy Memorial Fountain;

**AND WHEREAS**, changes to the construction plans and documents have been recommended, and are hereby presented to Council for approval in the form of Change Order No. 2 and Amendment to Task Order 3;

**NOW THEREFORE, IT IS RESOLVED BY THE CITY COUNCIL OF THE CITY OF MILES CITY, MONTANA AS FOLLOWS:**

1. The following Change Order is hereby approved: Change Order #2, described in detail and attached hereto as Exhibit "A," are hereby approved and adopted by this Council.
2. The following Amendment to Task Order is hereby approved: Amendment to Task Order 3, described in detail and attached hereto as Exhibit "B," are hereby approved and adopted by this Council.
3. The Mayor shall have the authority to execute the same, and to bind the City thereto.

**SAID RESOLUTION FINALLY PASSED AND ADOPTED BY A DULY CONSTITUTED QUORUM OF THE CITY COUNCIL OF THE CITY OF MILES CITY, MONTANA, AT A REGULAR MEETING THIS 14<sup>TH</sup> DAY OF APRIL, 2026.**

\_\_\_\_\_  
C.A. Grenz, Mayor

ATTEST:

\_\_\_\_\_  
Mary Rowe, City Clerk

**AMENDMENT TO TASK ORDER NO. 3**

---

**AMENDMENT TO TASK ORDER**

Amendment No. **[02]**

Owner: **[City of Miles City]**

Engineer: **[Interstate Engineering]**

Effective Date of Agreement: **[May 11, 2021]**

Nature of Amendment: (Check those that apply)

- Modifications to responsibilities of Owner
- Modifications of payment to Engineer
- Modifications to term of Task Order
- Modifications to other terms and conditions of the Task Order

Description of Modifications:

The Fountain is now entering the construction phase and the City of Miles City has requested that Interstate Engineering perform construction administration services. Interstate Engineering will review submittals from the contractor prior to the construction start date. Once construction has begun an On-site meeting with the Owner, Contractor and Engineer will be conducted by the Engineer. The city has requested that a representative be present at least weekly and at major milestones during construction. Interstate Engineering has estimated that there will be 10 days on site for Inspection.

Interstate Engineering will also provide construction staking for basic layout. Interstate will set 2 reference benchmarks for the contractor and provide basic staking for requested items. Any re-staking or additional requests are not part of this scope and can be provided at our current hourly rates. Interstate Engineering has estimated that construction staking will require 2 days on-site. Interstate Engineering will also review payment applications from the contractor during the course of construction.

As-built plans for the fountain will be provided to the city at a reasonable date after the construction is completed.

Additional services not mentioned above are not in the scope of this amendment but can be provided as requested at the rates in our current fee schedule.

The estimated fee for these additional services is Thirty-Four Thousand Five-Hundred Dollars (\$34,500.00). Actual engineering fees are unknown and are dependent upon Contractor’s performance, schedule, timeliness, and time required for Engineer’s presence on the job site. Actual fees will be based on actual hours worked. p

Owner and Engineer hereby agree to modify the above-referenced Task Order No. 3 as set forth in this Amendment. The Effective Date of the Amendment is **[February 24, 2026]**.

Owner  
City of Miles City  
\_\_\_\_\_  
(typed or printed name of organization)

By: \_\_\_\_\_  
\_\_\_\_\_  
(individual's signature)

Date: \_\_\_\_\_  
(date signed)

Name: \_\_\_\_\_  
(typed or printed)

Title: \_\_\_\_\_  
(typed or printed)

Engineer  
Interstate Engineering  
\_\_\_\_\_  
(typed or printed name of organization)

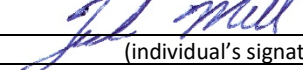
By:   
\_\_\_\_\_  
(individual's signature)

Date: 2/26/2026  
\_\_\_\_\_  
(date signed)

Name: Zach Mills  
\_\_\_\_\_  
(typed or printed)

Title: Project Manager  
\_\_\_\_\_  
(typed or printed)

**CHANGE ORDER NO.: 02**

Owner: City of Miles City  
 Engineer: Interstate Engineering  
 Contractor: Diamond J Companies  
 Project: Florence Stacy Fountain Renovation  
 Contract Name: Florence Stacy Fountain Renovation  
 Date Issued: 3/23/2026

Owner's Project No.:  
 Engineer's Project No.: WR24-00-132  
 Contractor's Project No.:

Effective Date of Change Order: 3/24/2026

The Contract is modified as follows upon execution of this Change Order:

Description: Added fountain spray nozzle and fittings, stop and waste valve for winterization, and control box

Attachments: Change Order Balance Sheet

Change in Contract Price	Change in Contract Times [State Contract Times as either a specific date or a number of days]
Original Contract Price: \$ <u>\$372,370.00</u>	Original Contract Times: Substantial Completion: <u>10/31/26</u> Ready for final payment: <u>12/31/26</u>
[Increase] [Decrease] from previously approved Change Orders No. 1 to No. <u>2</u> : \$ <u>+\$21,145.08</u>	[Increase] [Decrease] from previously approved Change Orders No.1 to No. <u>   </u> : Substantial Completion: <u>          </u> Ready for final payment: <u>          </u>
Contract Price prior to this Change Order: \$ <u>\$393,515.08</u>	Contract Times prior to this Change Order: Substantial Completion: <u>10/31/26</u> Ready for final payment: <u>12/31/26</u>
[Increase] [Decrease] this Change Order: \$ <u>+\$1,300</u>	[Increase] [Decrease] this Change Order: Substantial Completion: <u>0</u> Ready for final payment: <u>0</u>
Contract Price incorporating this Change Order: \$ <u>\$394,815.08</u>	Contract Times with all approved Change Orders: Substantial Completion: <u>10/31/26</u> Ready for final payment: <u>12/31/26</u>

Recommended by Engineer (if required)  
 By: *J. Mill*  
 Title: Project Engineer  
 Date: 3/23/26

Accepted by Contractor  
*[Signature]*  
Managing Member  
3/23/26

Authorized by Owner  
 By: \_\_\_\_\_  
 Title: \_\_\_\_\_  
 Date: \_\_\_\_\_

Approved by Funding Agency (if applicable)  
 \_\_\_\_\_  
 \_\_\_\_\_  
 \_\_\_\_\_