



PARKS & RECREATION COMMISSION REGULAR VIDEO MEETING

Thursday, May 4, 2023 at 5:00 PM

COMMISSIONERS:

Chair Jodi McCarthy
Vice Chair Peter Struck
Commissioners: Don Cohen,
Paul Burstein, Sara Marxen,
Rory Westberg, Ashley Hay

LOCATION & CONTACT

Zoom Meeting
Phone: 206.275.7600 | www.mercerisland.gov

We strive to create an inclusive and accessible experience. Those requiring accommodation for meetings should notify the Staff Liaison's Office 3 days prior to the meeting at 206.275.7870 or by emailing ryan.daly@mercerisland.gov.

Virtual Meeting Notice

The virtual meeting will be broadcast live on Zoom and recorded and saved on the City Council's [YouTube Channel](#)

Registering to Speak: Individuals wishing to speak live during Appearances will need to register their request with the staff liaison at **206.275.7861** or [email](#) and leave a message before 4 PM on the day of the Commission meeting. Please reference "Appearances" on your correspondence and state if you would like to speak either in person at Mercer Island Community & Event Center or remotely using Zoom. Each speaker will be allowed three (3) minutes to speak.

Join by Telephone at 5:00 PM: To listen to the meeting via telephone, please call **253.215.8782** and enter Webinar ID **825 9108 6996** and Password **896196** when prompted.

Join by Internet at 5:00 PM: To watch the meeting over the internet via your computer, follow these steps:

- 1) Click [this link](#)
- 2) If the Zoom app is not installed on your computer, you will be prompted to download it.
- 3) If prompted for Webinar ID, enter **825 9108 6996** and Password **896196**

Join in person at Mercer Island Community & Event Center at 5:00 PM: Mercer Island Community & Event Center
8236 SE 24th Street.

CALL TO ORDER & ROLL CALL - 5:00 PM

PUBLIC APPEARANCES

DEPARTMENT REPORT

1. Department Report

REGULAR BUSINESS [HYPERLINK "appIS80d34e03b253455db0ca10b38419e40a"](#)

2. [Approve the minutes of the March 2, 2023 Regular Meeting](#)
Recommended Action: [Approve minutes.](#)
3. [King County Library System Mercer Island Branch- Annual Update](#)
Recommended Action: [Receive presentation.](#)
4. [Aubrey Davis Park Trail Safety Improvement Project 30% Design](#)
Recommended Action: [Authorize the chair to transmit the 30% design recommendation to City Council](#)

OTHER BUSINESS

5. [PRC 2023 Planning Schedule Update](#)

6. [Commissioner Reports](#)

[ADJOURN](#)

City of Mercer Island

Parks and Recreation Commission

Department Report

May 4, 2023



City Hall Closure

- To ensure the safety of staff and visitors, City Hall is temporarily closed after disturbed tiles and materials were discovered that were later confirmed to contain asbestos.
- These materials are located in the building's boiler room, which also contains air-handling equipment.
- The City is working with experts to conduct testing throughout the building.
- It is estimated that testing and any subsequent remediation will require City Hall to remain closed throughout the month of May.
- Staff continue to provide services virtually or from alternate facilities during this time and there will be no change to Police or Public Works response.



Annual Boards & Commissions Recruitment Underway

- Extended!
- Our annual Advisory Boards & Commission recruitment has been extended through **May 12**.
- We are looking for volunteers to fill expiring terms on:
 - **Arts Council** (3 positions)
 - **Parks & Recreation Commission** (2 positions)
 - **Planning Commission** (2 positions)
 - **Design Commission** (2 positions; *landscape architects and urban planners* are encouraged to apply and will be given priority and considered for appointment before other applicants;)
- New this year: electronic application to streamline the process. Learn more and apply at www.mercerisland.gov/bc.

Those currently holding a seat, will remain until placements are made by City Council on June 6.



Improving Processes- MICEC

- We have a new efficiency tool at the MICEC: an online rental request form!
- This new online form creates a seamless process for our customers and gives them the ability to access and submit their rental request from anywhere!
- The form is user-friendly from your computer or phone and should increase customer satisfaction while also improving staff efficiency in processing rental requests.
- Check it out at: www.EventsOnMercer.com



Bike Skills Area- Update



Design and Construction

- Staff and American Ramp Company are preparing to submit for permits later this month.
- Volunteer opportunities to assist with removing old vegetation and other work to prepare the site for construction will be announced soon.
- We are still targeting a late summer/early fall construction window.

Safety on ICP Trails

- Safety improvements on 84th Ave SE are being designed by the City's Transportation Engineer and greenlighted for completion later this spring.
- The Parks Operations team is also coordinating vegetation trimming to improve trailhead sight lines on 84th Ave SE.
- Staff started conducting trail usage counts to establish a baseline for pedestrian, biking, and other trail uses. More counts will be conducted before the new facility opens.

Updates will be shared at <https://letstalk.mercergov.org/bike-skills-area-design>



Luther Burbank Park Projects (Grants)

All four grant requests for Luther Burbank Park were funded by the State Legislature, worth \$3.5 Million!

Luther Burbank Park Waterfront and Dock Replacement Project:

- \$1.5 million - Washington Wildlife & Recreation Program's Water Access Grants
- \$1.0 Million - Recreation & Conservation Office's Boating Facilities Program
- \$513,000 - Aquatic Lands Enhancement Account

Luther Burbank Park Boiler Building Renovation Project:

- *\$513,000 from the Washington State Historical Society's Heritage Capital Grant Projects.

A huge thank you to all that supported, and a whole lot of credit goes to Paul West the “Grant Whisperer”



Item 1.



Leap For Green Earth Day Fair – April 22!

- Thank you, Cedar Grove & The Mercer Island Community Fund for your sponsorship!
- The event included sustainability vendors, live entertainment, kid's crafts, electric vehicles, food vendors, a petting zoo, and more!
- Approx. 1,500 attendees
- Thank you to everyone who participated and came out for this fun event!



Mercer Island Farmers Market

- The Mercer Island Farmers Market 2023 Season kicks off **Sunday, June 4.**
- Enjoy live music and purchase fresh produce, hot/prepared food, and crafts.
- Located on SE 32nd Street, just north of Mercerdale Park.
- The Market runs every Sunday from 10am - 3pm through September.
- Get details music calendar, and vendor information at www.mifarmersmarket.org.





SUMMER CELEBRATION!

JULY 15, 2023

Join the fun at Mercer Island's largest event with elements of: community parade, live music, community booths, art vendors, kid's activities, food trucks, fireworks and more!

LOOKING FOR:
SPONSORS
COMMUNITY GROUPS
ART VENDORS
FOOD TRUCKS



Summer Celebration!

- Join MI Martial Arts, The Mercer Apartment Homes and The Mercer Island Community Fund in sponsoring Summer Celebration. Many opportunities still available.
- Applications for community groups, art vendors and food trucks is posted online.
- The Community Parade will return, thanks to Island Books, John L. Scott and Island Treats – application out soon!

Mercerisland.gov/SummerCelebration



Thank you!





PARKS & RECREATION COMMISSION

REGULAR MEETING MINUTES

March 2, 2023

CALL TO ORDER

Chair McCarthy called the meeting to order at 5:00pm via Zoom Online meeting.

ROLL CALL

Chair Jodi McCarthy, Vice Chair Peter Struck, and Commissioners Rory Westberg, Don Cohen, Paul Burstein, and Ashley Hay were present for the Parks & Recreation Commission.

Commissioner Sarah Marxen was absent.

Staff present were Chief of Operations Jason Kintner, Recreation Manager Ryan Daly, Senior CIP Project Manager Paul West, CIP Project Manager Sarah Bluvas, and Recreation Specialist Raven Gillis.

APPEARANCES

1. Kelly Sim commented on Pickleball and the Luther Burbank Park Sport Courts Renovation.
2. Jessica Prince commented on Pickleball and the Luther Burbank Park Sport Courts Renovation.

DEPARTMENT REPORT

1. Recreation Manager Ryan Daly reported on the following items:

- Staffing Updates
- Island Lanterns @ Mercerdale
- Good News: Luther Burbank Docks Project
- Calling All Mercer Island Artists
- Maintenance and Operations Update: Turf Blanket Pilot
- Leap for Green Fair Returns
- Summer Celebration Sponsors Needed
- Slumber Party at the Mercer Island Community and Event Center

REGULAR BUSINESS

It was moved by Struck; seconded by Cohen to:

Add an agenda item: Clarification on the Parks & Recreation Commission's recommendation to the city council for the 30% design of the Bike Skills Area

Passed: 6 – 0

2. Approval of Minutes

Minutes from the February 2, 2023 Regular Meeting were presented.

It was moved by Struck; seconded by Hay to:

Approve the minutes from the February 2, 2023 meeting

Passed: 6 – 0

3. **Aubrey Davis Park Trail Safety Improvement Project 30% Design**

CIP Project Manager Paul West, Cristina Strand from WSDOT, and consultants Bryce Corrigan, Liz Gibson, and Nandez Miller presented. Commissioners reviewed the presentation, asked questions, and provided feedback to staff.

It was moved by Hay; seconded by Struck to:

Include the Option 3 intersection design in the 30% design package.

Passed: 6 – 0

Staff will present the updated 30% design to the Commission as an agenda item at a future meeting.

4. **Luther Burbank Park Sport Courts Renovation**

CIP Project Manager Sarah Bluvas and consultant Eric Gold from DA Hogan presented. Commissioners reviewed the presentation and asked questions.

It was moved by Burstein; seconded by Westberg to:

Approve the recommendation to amend the project scope to convert a third Luther Burbank tennis court to pickleball use.

Passed: 6 – 0

5. **Parks & Recreation Commission's request for clarification on their recommendation to the City Council for the 30% design of the Bike Skill Area**

Staff answered Commissioners' questions and received their comments.

It was moved by Cohen; seconded by Hay to:

Request Staff bring back the Commissions' recommendation on the Bike Skills Area access trails to the Parks & Recreation Commission for action before commencing construction.

Failed: 2 – 4

It was moved by Hay; seconded by Burstein to:

Recommend to City Council that the entrance to the west of the tennis courts be an access trail to the Bike Skills Area as opposed to the east of the tennis courts, with a preference of a north entrance as well.

Failed: 3 – 3

It was moved by Westberg; seconded by Burstein to:

Endorse the west trail as the preferred option to access the Bike Skills Area

Passed: 4 – 2

OTHER BUSINESS

6. **2023 Planning Schedule Update**

Recreation Manager Ryan Daly provided an update noting the April meeting will be rescheduled (date TBD) due to the regularly scheduled meeting date landing on a holiday.

ADJOURNMENT at 7:53 PM



PARKS & RECREATION COMMISSION STAFF REPORT

Item 3
May 4, 2023
Regular Business

AGENDA ITEM INFORMATION

TITLE:	King County Library System Mercer Island Branch- Annual Update	<input checked="" type="checkbox"/> Discussion Only <input type="checkbox"/> Action Needed: <input type="checkbox"/> Motion <input type="checkbox"/> Ordinance <input type="checkbox"/> Resolution
RECOMMENDED ACTION:	Receive presentation.	

STAFF:	Ryan Daly, Recreation Manager
COUNCIL LIAISON:	Craig Reynolds
EXHIBITS:	1. PRC Questions to KCLS

SUMMARY

PURPOSE

The purpose of this agenda item is to provide the Parks and Recreation Commission and community with an annual update of operations at the King County Library System (KCLS) Mercer Island Branch, and to continue to provide a forum for the Mercer Island community to engage KCLS. The presentation will be focused on 2022 operations and what services to expect in 2023 at the Mercer Island branch of KCLS.

BACKGROUND

The purpose of the Parks & Recreation Commission is to serve in a policy advisory capacity to the City Council and any other board or commission of the city on matters involving the Mercer Island parks system, recreation programming, and the Mercer Island Community & Event Center.

Additionally, pursuant to MICC 3.53.020 and included in the various duties and responsibilities of the Parks and Recreation Commission is to “provide a forum for the community to express their views regarding library services on Mercer Island and serve in an advisory capacity to the King County Library System.”

KCLS provided their previous annual update to the Parks and Recreation Commission on [March 3, 2022](#).

DISCUSSION

Ahead of the meeting, city staff provided KCLS staff with a broad set of questions (Exhibit 1) submitted by commissioners to assist in the development and presentation of this annual update. Tonight, KCLS staff will utilize those questions to present current library services and plans for 2023.

RECOMMENDED ACTION

Receive presentation.

KCLS Annual Update Presentation
Parks and Recreation Commission Questions
(May 4, 2023)

**City staff solicited questions from the Parks and Recreation Commission and forwarded the following on to KCLS staff ahead to help inform on information to be presented.*

I. Review of the Past Year

- a. At the March '22 Park & Recreation Commission (“PRC”), Director Rosenblum provided feedback on the following topics:
 - i. Outreach – In the slide presentation, it was mentioned that the Mayor and City Council receive regular e-mail updates from KCLS.
 1. Are these e-mails different or separate in content to what is sent to Library patrons or the general public?
 - a. If so, is there any reason why those updates cannot be provided to interested community members?
 - ii. Hours – The executive director indicated they needed to look at data, etc. Can KCLS provide what data has been reviewed?
 - iii. Scheduling – It was mentioned by a KCLS staffer that a part of the scheduling process was to determine what services were most important to the specific library.
 1. How is the relative importance of various services determined?
 2. What input has been obtained or received from the community on these service offerings?
- b. Provide a data table like last year so the PRC can gain a better understanding of community usage patterns:
 - i. Patron traffic for the Mercer Island Library (by day and month) for the years 2021 & 2022.
 1. How do these activity levels compare to the system overall?
- c. What improvements have been made in the past year to the MI Library in terms of:
 - i. facilities,
 - ii. technology,
 - iii. programs,
 1. Summer Reading Program – What was the participation rate at the MI Library?
 - iv. circulation,
 1. During COVID, the turn time on holds and the recirculation of books was increased due to additional safety measures. The 1/6/23 Director’s Blog posting suggests of a “Lean Library Project” to reduce turnaround time of materials. A priori, are there quantifiable goals for this project in terms of turn times?

- v. safety,
 - 1. Has the MI Library had any reported incidents in the past year that could have affected staff and patron safety?
- vi. operating hours,
 - 1. Pre-Covid, the MI Library was open 7 days a week for a total of 63 hours.
 - 2. In December '22, the MI Library is open 6 days a week for a total of 42 hours (67% of pre-Covid)
 - 3. In its' 2023 list of strategic objectives, KCLS endeavors to increase operating hours by 26%, or about nine add'l hours for the MI Library
 - a. Please comment on the plans for the MI Library considering this objective
 - 4. A 2022 community survey compiled by Mercer Island high school students showed that residents strongly preferred that the MI Library should be open on Saturday
- vii. staffing levels – any changes?
- viii. volunteer opportunities – the Mercer Island community has a long history of volunteerism, and what's the status of a volunteer program, and is there an intent to expand/change?
- d. Describe the types of outreach efforts that have been employed to inform patrons of various library activities, e.g., programs, events, etc.
 - i. What has been successful (and how do you define success)?
- e. Has KCLS undertaken any “customer satisfaction” surveys, and if so, what are the results?
 - i. It was noted in a 5/6/22 e-mail from John Sheller to the City that such a survey was in the planning stages.
 - ii. In that same e-mail it was noted that KCLS “gathers feedback from our virtual outlets such as social media sites ...” Are there examples of how that feedback is then incorporated into policy or procedures?

II. Looking to the next year or two.....

- a. What types of improvements (see above for list) can the Mercer Island community expect to see at the MI Library?
- b. The City of Mercer Island is developing a Climate Action Plan that includes a strategy to respond to climate emergencies to protect residents from climate impacts (such as additional cooling centers and air shelters).
 - i. KCLS has designated several libraries as “cooling centers” when extreme heat is forecasted for its service area.
 - 1. What are the criteria for such a designation, and can the MI Library expect to qualify?

- c. Similarly, the MI Library has emergency generator capacity that would be useful when in the event of a large-scale electrical outage the MI Library could be made available for re-charging of phones, tablets, etc.
- d. Can you please suggest the ways the City of Mercer Island and community residents can help KCLS to make the MI Library better?

III. Questions From the Community

- a. Many community members have commented that it's difficult to get to know staff as they do not seem to stay very long. Please comment on how staff are placed at locations, and how they are rotated.
- b. When will the monthly Board of Trustee meetings be recorded for the community to watch on Youtube or some other streaming service. It's sometimes difficult to be available to watch live (or in-person) on the fourth Wednesday of the month. As an aside, the City of Mercer Island makes available its City Council meetings as well as several boards and commissions on Youtube for viewing.
- c. When a library patron submits a request to KCLS for the acquisition of a particular book or magazine title, what is the process that KCLS goes through to evaluate that request?
 - i. How many requests does KCLS receive in a year, and how many are approved?

Filter by:

(use CTRL + click to select multiple if check boxes are provided)

Branch Name

Mercer Island ▼

Year and Month

(Except 'Patrons Active ...' Count)

Select all

2021

January

February

March

April

May

June

July

August

September

October

November

December

2022

Incoming Traffic During Open Hours

32,146

Total count of persons entering **Mercer Island** through public doorways during open hours.

Average Incoming Traffic per Open Hour

45

Average count of persons entering **Mercer Island** through public doorways during open hours.

Activity at Mercer Island*

Physical Material Checkouts and Renewals

58,295

Total only includes physical item checkouts or renewals that occurred at **Mercer Island**. (Note that holds reassigned to be *retrieved* at an alternative location during a temporary closure will still *check out* from the original branch.)

*If lockers are present at the chosen location, the data includes locker usage.

Computer Sessions

2,426

Total number of of times a person logged on to a public computer at **Mercer Island**.

Public Computers Accessed

15

Total number of unique public computers accessed during the time period selected at **Mercer Island**.

Physical Material Checkouts and Renewals

102,448

Total includes physical item checkouts and renewals (online or in-person) for patrons whose home library is **Mercer Island**.

Digital Checkouts and Renewals

65,122

Total includes digital item checkouts for patrons whose home library is **Mercer Island**. This dataset is only updated once a month.

Patrons whose home library* is Mercer Island

Patrons Active During 2022

2022 ▼

11,688

Count of unique patrons whose home library is **Mercer Island** (including patrons with student cards) and who have logged in to library services at least once during the selected year.

New Patron Accounts Created

753

Count of new patron accounts created during the timeframe selected in which the original home library chosen was **Mercer Island**. This does **not** include school cards.

*Home library: "Assigned by the staff member; it should be the closest library to the patron's residence." ([Circulation Manual](#) 2.3.1.11).

Circulation Total

167,570

Sum of Physical and Digital Checkouts and Renewals for patrons whose home library is **Mercer Island**.

61%

Physical Circulations

39%

Digital Circulations

Filter by:

(use CTRL + click to select multiple if check boxes are provided)

Branch Name

Mercer Island ▼

Year and Month

(Except 'Patrons Active ...' Count)

Select all

2021

January

February

March

April

May

June

July

August

September

October

November

December

2022

Incoming Traffic During Open Hours

80,155

Total count of persons entering **Mercer Island** through public doorways during open hours.

Average Incoming Traffic per Open Hour

39

Average count of persons entering **Mercer Island** through public doorways during open hours.

Activity at Mercer Island*

Physical Material Checkouts and Renewals

178,730

Total only includes physical item checkouts or renewals that occurred at **Mercer Island**. (Note that holds reassigned to be *retrieved* at an alternative location during a temporary closure will still *check out* from the original branch.)

*If lockers are present at the chosen location, the data includes locker usage.

Computer Sessions

6,404

Total number of of times a person logged on to a public computer at **Mercer Island**.

Public Computers Accessed

17

Total number of unique public computers accessed during the time period selected at **Mercer Island**.

Physical Material Checkouts and Renewals

257,708

Total includes physical item checkouts and renewals (online or in-person) for patrons whose home library is **Mercer Island**.

Digital Checkouts and Renewals

236,627

Total includes digital item checkouts for patrons whose home library is **Mercer Island**. This dataset is only updated once a month.

Patrons whose home library* is Mercer Island

Patrons Active During 2022

2022 ▼

11,688

Count of unique patrons whose home library is **Mercer Island** (including patrons with student cards) and who have logged in to library services at least once during the selected year.

New Patron Accounts Created

1,954

Count of new patron accounts created during the timeframe selected in which the original home library chosen was **Mercer Island**. This does **not** include school cards.

*Home library: "Assigned by the staff member; it should be the closest library to the patron's residence." ([Circulation Manual](#) 2.3.1.11).

Circulation Total

494,335

Sum of Physical and Digital Checkouts and Renewals for patrons whose home library is **Mercer Island**.

52%

Physical Circulations

48%

Digital Circulations

PROGRAMS & SERVICES AT MERCER ISLAND LIBRARY

2022-2023

2022: A YEAR OF TRANSITION

In 2022 and 2023, we navigated a changing pandemic environment and worked to maintain connections with our Mercer Island communities. Planning for in-person programs resumed in April 2022, with restrictions that have slowly opened over time.

Here are some highlights from your Mercer Island Librarian Team, 2022 & 2023:

- Adult Services Librarian, David Dawson
- Teen Services Librarian, Carrie Bowman
- Children's Services Librarian, Kelcy Tiger

2022 Stats-At-A-Glance

Kids & Families

April – December 2022:

- 50 story times with more than 1200 people total attending
- Fridays:
 - Morning toddler time that now averages 75 people in attendance
 - Repeat toddler time that averages about 50 people
 - Afternoon preschool story time that has about 30 people in attendance each week

Teens

23 programs, connecting with over 475 teens, parents, and other adults

Examples: Chess; *Race to be Human* film and panel discussion; Games & Art at the Library

Adults & All Ages

Eight programs connecting with over 167 participants.

Examples of programs: Medicare Made Clear; Banned Books Week: Humanity in Print; The Ruins of Memory: Women's Voices of the Holocaust; and The Dickens Carolers.

Story Times



Chess

"I have been working with Chouchan Airapetian since 2017. She is the current WA State Women's Champion and is well respected in the chess community. She is also fantastic with kids of all abilities." --Carrie Bowman, Teen Service Librarian

Chess From Home (online)

For children, tweens and teens.

Join Chouchan Airapetian for online chess instruction and games. Participants will also play each other on chess.com.

Attendance ranged around 12-20 per session.

Chess at the Mercer Island Library (in person)

Join Chouchan Airapetian for chess instruction and games in the library. Challenge yourself and others!

Safety guidelines and current protocols followed.

Date – attendance

May 11 – 17

June 22 – 32

July 20 – 26

Aug 24 – 32

Nov 2 – 30

Nov 16 – 35

Nov 30 – 22

Dec 14 - 20



Race to be Human: Film and Panel Discussion

RACE to Be Human helps us understand the impact of racism through the stories and expertise of students, scholars and educators.

Sponsored by Mercer Island School District, MIHS PTSA-DEI, Parent Edge, Friends of the Mercer Island Library and Mercer Island Youth and Family Services.

Held at Mercer Island High School.

There were two other screenings in addition to this one.

Date – attendance

Oct 14 (MIHS staff, at MIHS) – 100 (paid by MIHS/MISD)

Oct 17 (at the library, film and discussion, no panel) – 7

Oct 17 (at MIHS, film and panel discussion) – 80

Oct 18 (at the library, film and discussion, no panel) – 8

The Ruins of Memory: Women's Voices from the Holocaust

November 1, 2022

Attendance: 16

Presented by Tales of the Alchemysts Theatre, a Jewish Literature & Music Performance Company.

This in-person performance featured selections from fiction, poetry, and oral histories primarily by (and about) female survivors and victims of the Holocaust—from both the Ashkenazi and Sephardic communities. The performance featured live music, sound, and movement, and combined these things with the spoken word and song.

--David



Item 3.

Picture Credit: Ghetto Fighters' House Museum, Photo Archive



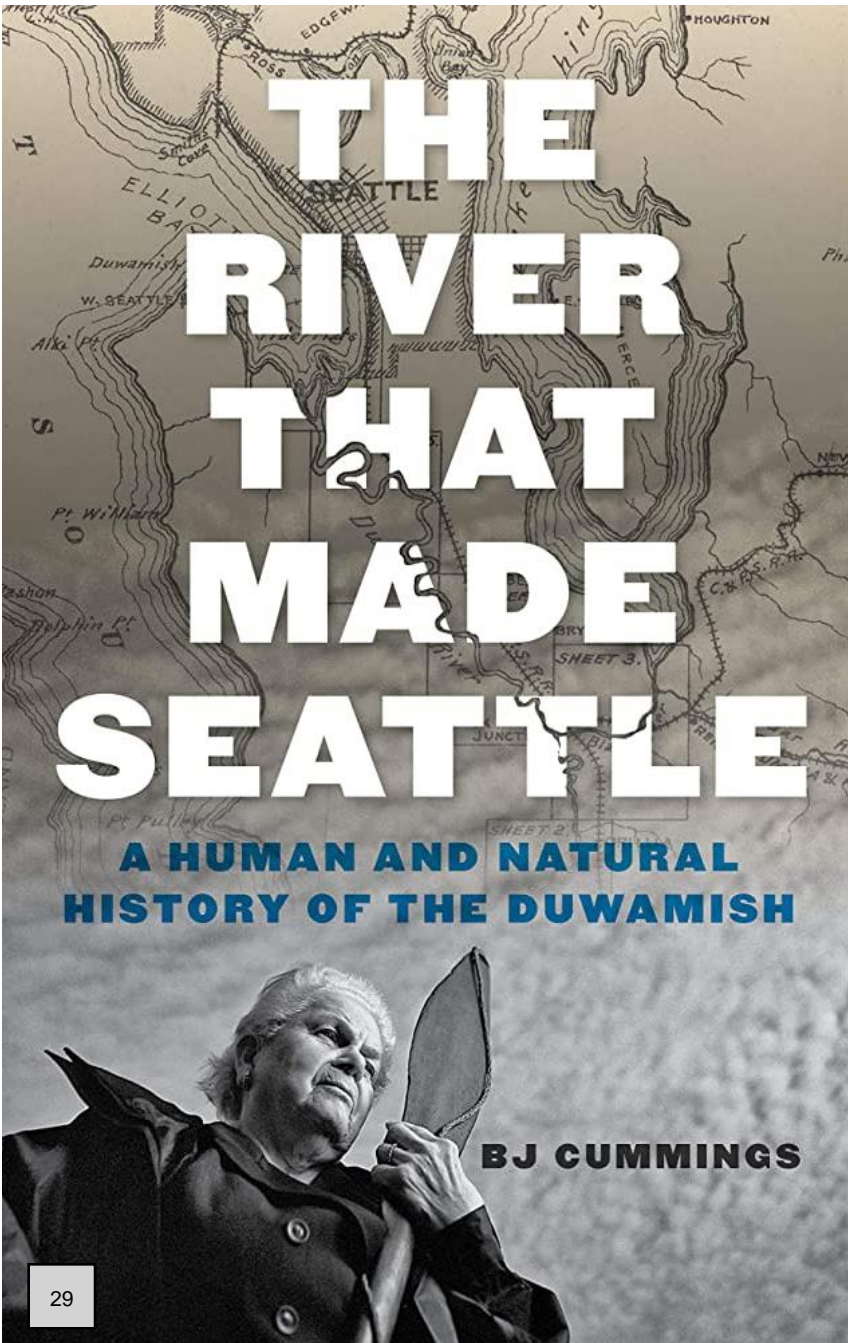

The River That Made Seattle

Tuesday, March 28th at 6:00 pm

Presented by BJ Cummings

For adults.

Attendance: 45

Once teeming with bountiful salmon and fertile plains, Seattle's Duwamish River drew both Native peoples and settlers to its shores over centuries for trading, transport, and sustenance. Unfortunately, the very utility of the river was its undoing, as decades of dumping led to the river being declared a Superfund cleanup site.

Much of Washington's history has been told through the perspective of its colonizers, obscuring and mythologizing the changes to these lands that have long been occupied by Native peoples. Through the story of the river, author BJ Cummings explores previously unrecorded Native and immigrant histories, and exposes settler falsehoods about the founding of the state. The river's story is a call to action to align future decisions with values of collaboration, respect, and justice.

In partnership with the Mercer Island Historical Society and sponsored by the Friends of the Mercer Island Library.

2023 Service Goals

Early Literacy Programming for Children (Children’s Services)

Continuing to offer quality literacy-based programming for children 5 and under, and their families.

Emphasize Programming and Engagement for Seniors

Instill a sense of community among our senior citizens by a return to mostly in-person programming. Respond to the needs and special interests of our seniors by emphasizing programs that focus on art, music, and film, as well as history, travel, and health.

Partnerships with High School & Middle School Clubs and Organizations (Teen Services)

Maintaining and strengthening relationships with the clubs at the high school.

Investigate a Partnership/Collaboration with Crest Learning Center (part of MIHS) (Teen Services)

Crest serves a diverse group of students, including students who identify as LGBTQ+. Crest is “carefully designed to offer a successful alternative pathway to graduation.”

Engagement with Elementary School Aged Children (Children’s Services)

Establishing regular literacy programming, as well as enrichment programs for elementary aged children in the library.

Coming Up...

Children's Services Programs

- **Friday Story Times continue:**
 - **Toddler Time at 10:05am and 11:15am**
 - **Preschool Story Time at 1:00pm**
- **Spring Forward program with Mikey the Rad Scientist, ages 1-5 with caregiver (May 26th, 10:30am)**

Adult Services Programs

- **Opera Preview: La Traviata (May 10th)**
- **Spring Forward with Mikey the Rad Scientist, Ages 1-5 with adult, May 26)**
- **Casablanca: An 80th Anniversary Appreciation (June 4)**

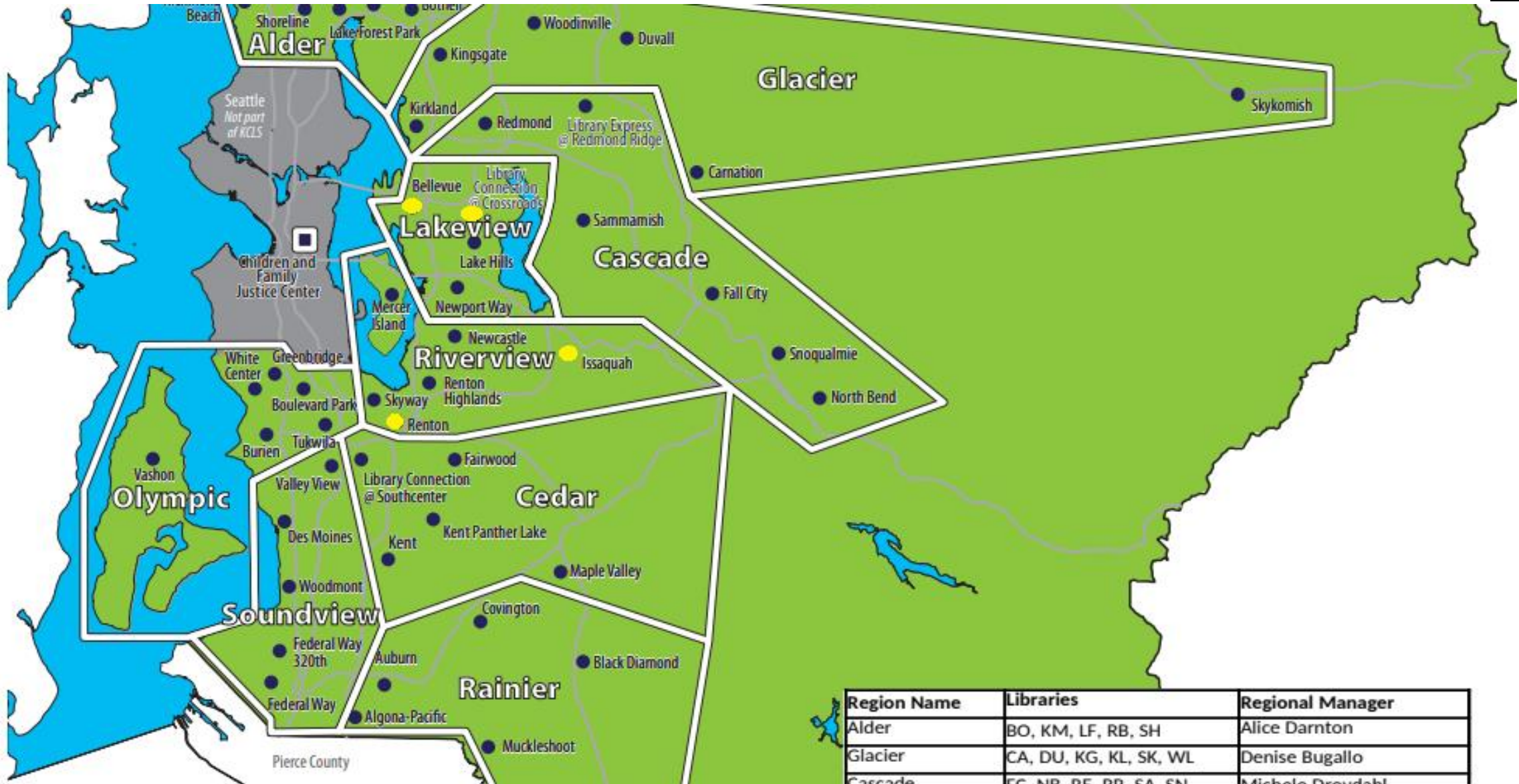

Future Engagement

- We plan to attend the monthly Parks & Recreation Commission Meetings more often by rotating Librarians, Operations Management (Joe), and I so we can foster a closer relationship
- Contact Information:
- Brian Candelori, Riverview Regional Manager
 - (Mercer Island, Issaquah, Newcastle, Renton, Renton Highlands, and Skyway)
 - brcandelori@kcls.org
 - 206.514.4470
- Joe Baldwin, Operations Manager
 - joebald@kcls.org
 - 206.236.3537

THANK YOU!



PARKS & RECREATION COMMISSION STAFF REPORT

Item 4
May 4, 2023
Regular Business

AGENDA ITEM INFORMATION

TITLE:	Aubrey Davis Park Trail Safety Improvement Project 30% Design	<input type="checkbox"/> Discussion Only
RECOMMENDED ACTION:	Review plans and transmittal memo; authorize the Chair to transmit the 30% design recommendation to City Council	<input checked="" type="checkbox"/> Action Needed: <input checked="" type="checkbox"/> Motion <input type="checkbox"/> Ordinance <input type="checkbox"/> Resolution

STAFF:	Paul West, Senior CIP Project Manager
COUNCIL LIAISON:	Craig Reynolds
EXHIBITS:	<ol style="list-style-type: none"> 30% Design Plans Revised Transmittal Memo Construction Cost Estimate

SUMMARY

The purpose of this staff report is to conclude the 30% design development process by the Parks and Recreation Commission (PRC) for the Aubrey Davis Trail Safety Improvement Project. And for the PRC to approve a memo which will convey its recommendation to the City Council.

BACKGROUND

In December 2019 the City Council approved the Aubrey Davis Park Master Plan and directed the City Manager and PRC to develop a recommendation for the use of a \$500,000 Department of Commerce Grant for trail safety improvements in the park. Over the past 3 years the PRC has engaged the community and developed a recommendation.

Engagement, input, and resolution about 30% design elements occurred at the following meetings:

- April 7, 2022:** The PRC reviewed public input from the online open house and survey in February 2022 and provided initial direction on the 30% design to the design team at KPG Psomas.
- June 2, 2022:** The PRC reviewed a 30% preliminary design presented by the design team. The focus of the discussion was on the restroom and 72nd Ave overpass area. The PRC agreed that most of the West Mercer Way improvements were a lower priority and that the trail intersection at the 72nd Ave overpass was a higher priority. PRC also discussed the extent of additional impervious surfacing, the effect of concrete versus asphalt paving in changing user behavior, and the effectiveness of placemaking elements in reducing trail user conflicts.
- July 7, 2022:** The PRC reviewed revisions to the 30% design. Revisions were mostly focused on the ballfield/restroom area and included reducing amenities, reducing pavement areas and increasing the diameter of a potential roundabout with grass or vegetation in the center.

- **September 1, 2022:** The design team went over a range of project details and addressed them in discussion with PRC. The PRC provided consensus on a proposed recommendation which evolved from recommending a specific 30% design to recommending that the 30% design proceed to 60% design, with PRC review at the conclusion of that design phase. Outstanding design issues were enumerated for additional review in the 60% design phase. The revision of the draft recommendation memo was turned over to a subcommittee for drafting.
- **January 5, 2023:** Between the September and January meetings, WSDOT provided the City its review of the potential roundabout design. As a result, staff presented PRC with two roundabout options for the 72nd Overpass trail intersection. Option 1, the larger roundabout with a 14' travel way and a prominent 16' diameter center island, was preferred by WSDOT and presented as the staff recommendation. Option 2, the smaller roundabout, had a 12' travel way and an at-grade 10' diameter concrete center. The PRC had many concerns about both options and asked staff to provide alternatives at its next meeting before recommending a 30% design.
- **March 2, 2023:** Staff returned with 3 options for the PRC to review. The PRC voted to include Option 3, improving the existing intersection, for the 72nd Overpass trail intersection in the 30% design. Staff agreed to present the PRC a complete 30% design package at its next meeting (tonight) which would include elements the PRC provided direction on.

THE TRANSMITTAL PACKAGE

The 30% design plans (Exhibit 1) have been updated from the version that was last reviewed at the [September 1, 2022](#) to include Option 3 components as directed by the PRC. The PRC's transmittal memo (Exhibit 2) provides City Council with an overview of the PRC's considerations in recommending this design concept. The agenda bill for City Council that accompanies the plans and memo will provide additional background information to document the design process. Included with this will be the most current construction cost estimate for the project (Exhibit 3).

NEXT STEPS

Once the design is approved by the PRC, City staff will work with the chair to transmit the memo to the City Council at its May 16 meeting. The Design Team will then develop the 60% design and, if directed by the City Council, return to the PRC in Q3 2023 for 60% design review. The project was originally scheduled to construct in spring 2023; however, construction is now expected to begin in fall 2023 or later.

RECOMMENDED ACTION

1. Approve the 30% design recommendation and;
2. Approve the transmittal memo and authorize the chair to submit the memo and recommendation to City Council.



CITY OF MERCER ISLAND

AUBREY DAVIS PARK TRAIL SAFETY IMPROVEMENTS JANUARY 2023

CITY PROJECT NUMBER: XXX

SCHEDULE OF DRAWINGS

<u>SHEET</u>	<u>DRAWINGS</u>
1	COVER SHEET
2-3	SHEET INDEX, SURVEY CONTROL AND ALIGNMENT DATA
4	LEGEND AND ABBREVIATIONS
5-6	TESC AND SITE PREPARATION PLANS
7	TESC AND SITE PREPARATION DETAILS
8-13	TRAIL IMPROVEMENT PLANS
14	TRAIL IMPROVEMENT DETAILS
* 15-17	SITE ELEMENT PLANS
* 18	SITE ELEMENT DETAILS
* 19-21	LANDSCAPE RESTORATION PLANS
* 22-23	LANDSCAPE SCHEDULE AND DETAILS
* 24-26	IRRIGATION RESTORATION PLANS
* 27	IRRIGATION SCHEDULE AND DETAILS
* 28-31	SIGN SCHEDULE AND DETAILS
* 32-33	TRAIL ILLUMINATION PLAN AND DETAILS

* THESE SHEETS NOT INCLUDED FOR THIS 30% SUBMITTAL. WILL BE INCLUDED IN 60%.

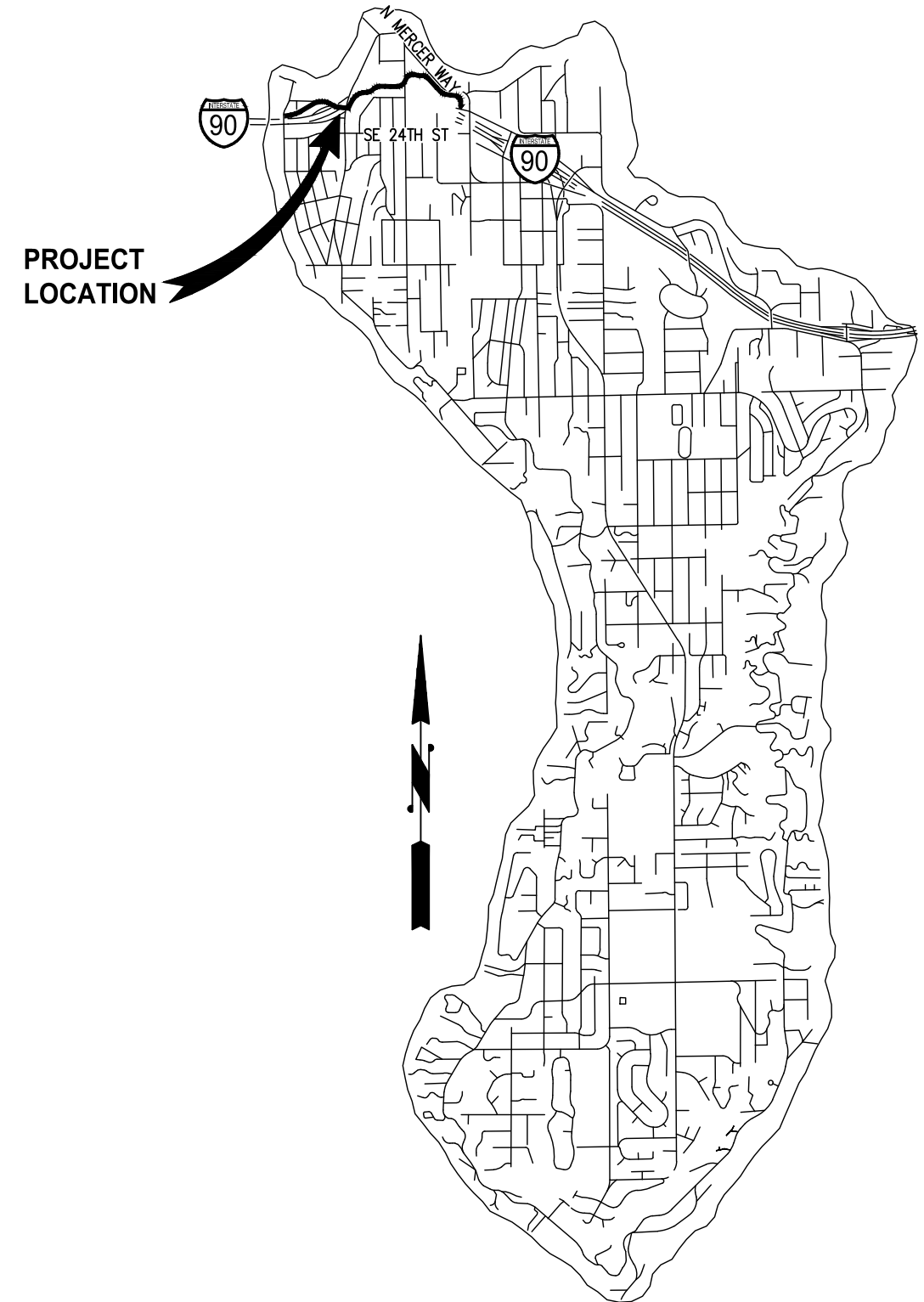

**CALL 2 DAYS
BEFORE YOU DIG
1-800-424-5555**

**30% REVIEW
SUBMITTAL**

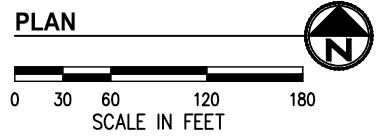
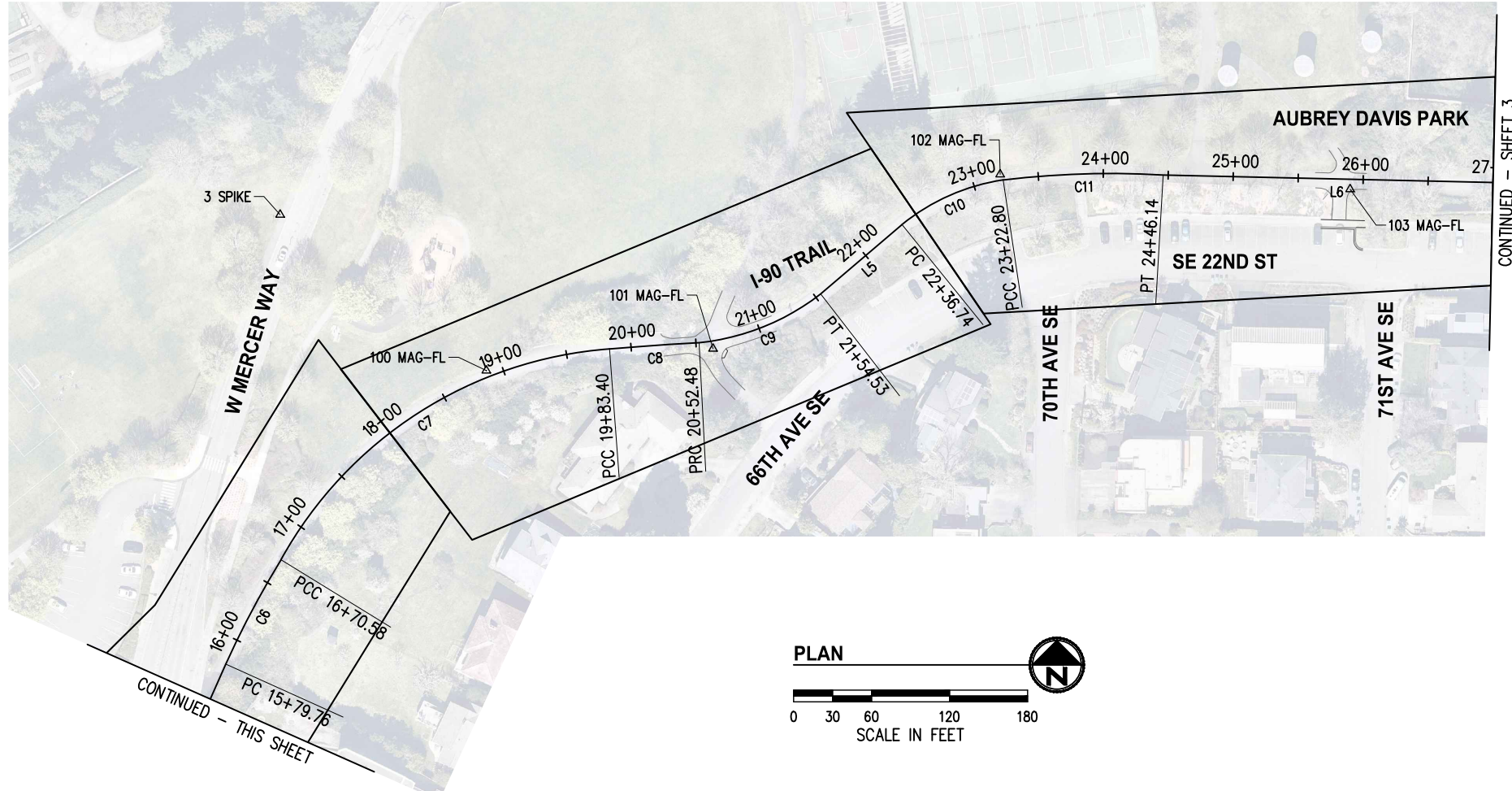
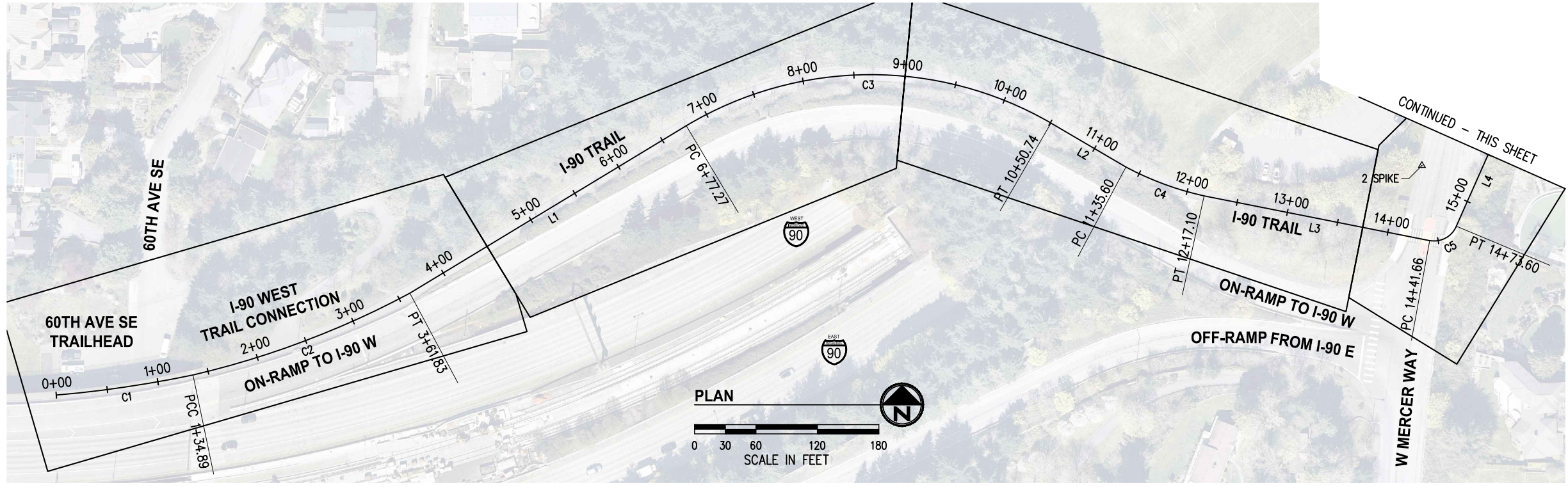

NOTES

- THE PURPOSE OF THIS TOPOGRAPHIC SURVEY IS FOR CIVIL ENGINEERING DESIGN. THIS IS NOT A BOUNDARY SURVEY. SOURCES OF BOUNDARY INFORMATION AS SHOWN INCLUDE FIELD-TIED MONUMENTATION, PLATS, COUNTY RECORDS OF SURVEY, AND AUDITOR INDEXING INFORMATION.
- THE LOCATIONS OF EXISTING UNDERGROUND UTILITY SYSTEMS, AS SHOWN HEREON, ARE TAKEN FROM UTILITY LOCATE PAINT MARKS OR AS-BUILT PLANS AND ARE SHOWN IN AN APPROXIMATE WAY ONLY.

THE CONTRACTOR SHALL DETERMINE THE EXACT LOCATION OF ALL EXISTING UTILITIES BEFORE COMMENCING WORK, AND AGREES TO BE FULLY RESPONSIBLE FOR ANY AND ALL DAMAGES WHICH MIGHT BE OCCASIONED BY THE CONTRACTOR'S FAILURE TO EXACTLY LOCATE AND PRESERVE ANY AND ALL UNDERGROUND UTILITIES. ALL LOCATOR SERVICES SHOULD BE CONTACTED PRIOR TO ANY CONSTRUCTION OR SUBSURFACE EXPLORATION. CALL 1-800-424-5555.
- FIELD SURVEY: KPG, NOVEMBER, 2021. LICENSEE MICHAEL R. BOWEN, P.L.S. NO. 29294/RONALD D. REICHEL, P.L.S. NO. 38015.
- CONTOUR INTERVAL = 1 FOOT, ±0.5 FOOT PER NATIONAL MAPPING STANDARDS. CONTOURS DERIVED FROM DIRECT FIELD OBSERVATIONS.
- STORM AND SEWER CONNECTIONS HAVE BEEN DRAWN FROM CENTER OF LID TO CENTER OF LID.
- THE LOCATIONS AND DIMENSIONS OF UNDERGROUND VAULTS HAVE NOT BEEN VERIFIED AND ARE APPROXIMATE.

HORIZONTAL AND VERTICAL DATUM

HORIZONTAL DATUM: NAD 83/11
 VERTICAL DATUM: NAVD 88
 HORIZONTAL AND VERTICAL DATUMS ESTABLISHED BY RTK GPS OBSERVATION UTILIZING WSRN (WASHINGTON STATE REFERENCE NETWORK) ALSO REFERENCING KPG JOB NUMBER 19033.

I-90 TRAIL			
NUMBER	LENGTH	RADIUS	BRNG/DELTA
C1	134.89	1127.09'	6°51'26"
C2	226.93	866.19'	15°00'39"
C3	373.47	350.67'	61°01'17"
C4	81.50	295.72'	15°47'25"
C5	31.93	23.56'	77°39'24"
C6	90.82	711.38'	7°18'53"
C7	312.82	315.72'	56°46'12"
C8	69.08	1819.45'	2°10'31"
C9	102.05	183.33'	31°53'39"
C10	86.06	161.95'	30°26'44"
C11	123.34	695.38'	10°09'46"
L1	315.442		N 58°46'42" E
L2	84.862		S 59°39'03" E
L3	224.567		S 78°46'35" E
L4	106.165		N 23°55'59" E
L5	82.209		N 49°31'50" E
L6	279.060		S 88°42'08" E

CONTROL POINT LIST				
PT #	DESCRIPTION	NORTHING	EASTING	ELEVATION
2	SPIKE	218611.57	1291363.16	132.74'
3	SPIKE	218994.76	1291481.64	133.62'
100	MAG-FL	218875.02	1291640.28	141.68'
101	MAG-FL	218891.80	1291814.64	154.79'
102	MAG-FL	219025.76	1292035.53	170.72'
103	MAG-FL	219014.32	1292304.75	167.34'
104	MAG-FL	219032.01	1292518.47	151.16'
105	MAG-FL	219215.42	1292658.91	141.86'
106	SPIKE	219249.71	1292560.03	141.51'
107	SPIKE	219295.67	1292715.03	138.94'

ECTS\MERCER IS\21098-Aubrey Davis Park Improvements\DESIGN\Drawings\Contract\21098SURVCTRL.dwg 3/31/2023 10:51 AM

NO.	DATE	BY	APPR.	REVISIONS

Approved By		21098SURVCTRL.dwg
ENGINEERING MANAGER	DATE	DESIGNED BY
PROJECT MANAGER	DATE	DRAWN BY
PROJECT ENGINEER	DATE	CHECKED BY



30% REVIEW SUBMITTAL



CITY OF MERCER ISLAND
 AUBREY DAVIS PARK
 TRAIL SAFETY IMPROVEMENTS

SHEET INDEX, SURVEY CONTROL AND ALIGNMENT DATA - 1	
KPG PROJECT No. 21098	SHT <u>2</u> OF <u>14</u>

ECTS\MERCER IS\21098-Aubrey Davis Park Improvements\DESIGN\Drawings\Contract\21098SURVCTRL.dwg 3/31/2023 10:51 AM

CONTINUED - SHEET 2

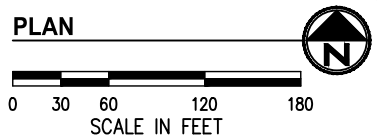
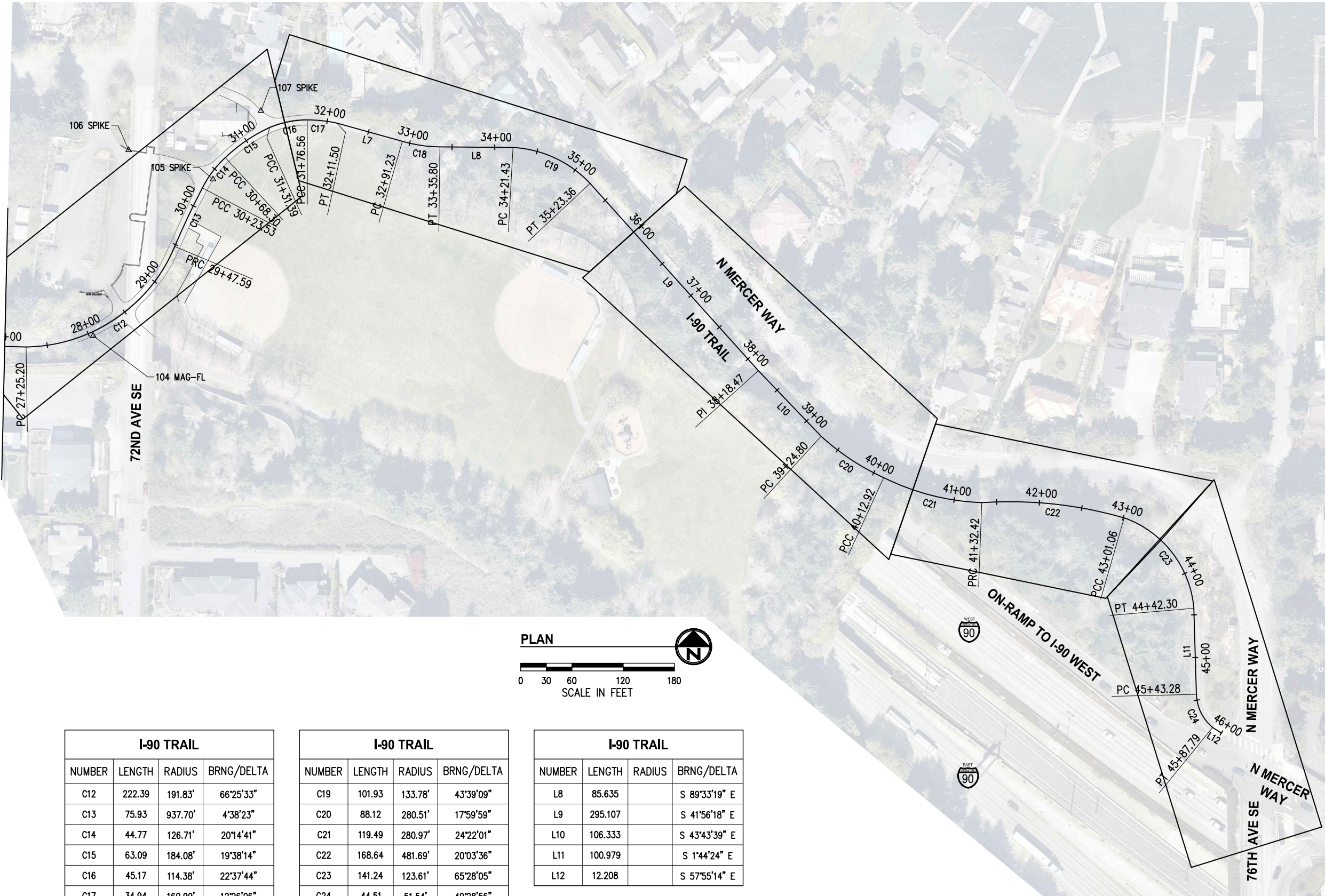

I-90 TRAIL			
NUMBER	LENGTH	RADIUS	BRNG/DELTA
C12	222.39	191.83'	66°25'33"
C13	75.93	937.70'	4°38'23"
C14	44.77	126.71'	20°14'41"
C15	63.09	184.08'	19°38'14"
C16	45.17	114.38'	22°37'44"
C17	34.94	160.99'	12°26'06"
C18	44.57	166.20'	15°21'48"

I-90 TRAIL			
NUMBER	LENGTH	RADIUS	BRNG/DELTA
C19	101.93	133.78'	43°39'09"
C20	88.12	280.51'	17°59'59"
C21	119.49	280.97'	24°22'01"
C22	168.64	481.69'	20°03'36"
C23	141.24	123.61'	65°28'05"
C24	44.51	51.54'	49°28'56"
L7	79.731		S 74°25'05" E

I-90 TRAIL			
NUMBER	LENGTH	RADIUS	BRNG/DELTA
L8	85.635		S 89°33'19" E
L9	295.107		S 41°56'18" E
L10	106.333		S 43°43'39" E
L11	100.979		S 1°44'24" E
L12	12.208		S 57°55'14" E

NOTES

- THE PURPOSE OF THIS TOPOGRAPHIC SURVEY IS FOR CIVIL ENGINEERING DESIGN. THIS IS NOT A BOUNDARY SURVEY. SOURCES OF BOUNDARY INFORMATION AS SHOWN INCLUDE FIELD-TIED MONUMENTATION, PLATS, COUNTY RECORDS OF SURVEY, AND AUDITOR INDEXING INFORMATION.
- THE LOCATIONS OF EXISTING UNDERGROUND UTILITY SYSTEMS, AS SHOWN HEREON, ARE TAKEN FROM UTILITY LOCATE PAINT MARKS OR AS-BUILT PLANS AND ARE SHOWN IN AN APPROXIMATE WAY ONLY.

THE CONTRACTOR SHALL DETERMINE THE EXACT LOCATION OF ALL EXISTING UTILITIES BEFORE COMMENCING WORK, AND AGREES TO BE FULLY RESPONSIBLE FOR ANY AND ALL DAMAGES WHICH MIGHT BE OCCASIONED BY THE CONTRACTOR'S FAILURE TO EXACTLY LOCATE AND PRESERVE ANY AND ALL UNDERGROUND UTILITIES. ALL LOCATOR SERVICES SHOULD BE CONTACTED PRIOR TO ANY CONSTRUCTION OR SUBSURFACE EXPLORATION. CALL 1-800-424-5555.
- FIELD SURVEY: KPG, NOVEMBER, 2021. LICENSEE MICHAEL R. BOWEN, P.L.S. NO. 29294/RONALD D. REICHEL, P.L.S. NO. 38015.
- CONTOUR INTERVAL = 1 FOOT, ±0.5 FOOT PER NATIONAL MAPPING STANDARDS. CONTOURS DERIVED FROM DIRECT FIELD OBSERVATIONS.
- STORM AND SEWER CONNECTIONS HAVE BEEN DRAWN FROM CENTER OF LID TO CENTER OF LID.
- THE LOCATIONS AND DIMENSIONS OF UNDERGROUND VAULTS HAVE NOT BEEN VERIFIED AND ARE APPROXIMATE.

HORIZONTAL AND VERTICAL DATUM

HORIZONTAL DATUM: NAD 83/11
 VERTICAL DATUM: NAVD 88
 HORIZONTAL AND VERTICAL DATUMS ESTABLISHED BY RTK GPS OBSERVATION UTILIZING WSRN (WASHINGTON STATE REFERENCE NETWORK) ALSO REFERENCING KPG JOB NUMBER 19033.

CONTROL POINT LIST				
PT #	DESCRIPTION	NORTHING	EASTING	ELEVATION
2	SPIKE	218611.57	1291363.16	132.74'
3	SPIKE	218994.76	1291481.64	133.62'
100	MAG-FL	218875.02	1291640.28	141.68'
101	MAG-FL	218891.80	1291814.64	154.79'
102	MAG-FL	219025.76	1292035.53	170.72'
103	MAG-FL	219014.32	1292304.75	167.34'
104	MAG-FL	219032.01	1292518.47	151.16'
105	MAG-FL	219215.42	1292658.91	141.86'
106	SPIKE	219249.71	1292560.03	141.51'
107	SPIKE	219295.67	1292715.03	138.94'

NO.	DATE	BY	APPR.	REVISIONS

Approved By		21098SURVCTRL.dwg
ENGINEERING MANAGER	DATE	FILENAME
PROJECT MANAGER	DATE	DESIGNED BY
PROJECT ENGINEER	DATE	DRAWN BY
		CHECKED BY
		DATE



30% REVIEW SUBMITTAL



CITY OF MERCER ISLAND
 AUBREY DAVIS PARK
 TRAIL SAFETY IMPROVEMENTS

SHEET INDEX, SURVEY CONTROL AND ALIGNMENT DATA - 2	
KPG PROJECT No. 21098	SHT <u>3</u> OF <u>14</u>

EXISTING LEGEND

MIC	MONUMENT IN CASE	①	TELEPHONE MANHOLE	— P —	PAINTED POWER
MON	SURFACE MONUMENT	T □	TELEPHONE RISER	— T —	PAINTED TELEPHONE
RC	REBAR & CAP	□	TELEPHONE VAULT LID	— FO —	PAINTED FIBER OPTIC
⊙	SPOT SHOT (DESCRIBED)	⊕	TELEPHONE POLE	— TV —	PAINTED TV
□	CATCH BASIN	TV	TV VAULT LID	— W —	PAINTED WATER
⊙	STORM DRAIN MANHOLE	FO	FIBER OPTIC MANHOLE	— G —	PAINTED GAS
⊕	YARD DRAIN	⊕	GAS VALVE	— SD —	STORM
⊕	DOWNSPOUT	⊕	GAS METER	— S —	SEWER
SD	STORM DRAIN CLEAN-OUT	⊕	WATER VALVE	— X —	FENCE
⊕	SEWER MANHOLE	⊕	WATER METER	~~~~~	HEDGE (HEIGHT NOTED)
SS	SEWER CLEAN-OUT	⊕	WATER MANHOLE	//////	BUILDING
⊕	POWER POLE	⊕	FIRE HYDRANT	————	PAINTED STRIPE
⊕	POWER POLE WITH UG CONNECT	⊕	FIRE DEPARTMENT CONNECT	RAISED-BUTTON SOLID STRIPE
□	POWER VAULT LID	⊕	UTILITY VAULT LID (GENERIC/UNKNOWN)	RAISED-BUTTON SKIP STRIPE
△	POWER TRANSFORMER	U	UTILITY ACCESS (GENERIC/UNKNOWN)	————	EDGE OF PAVEMENT
⊕	POWER METER	●	BORE SITE (WITH FIELD DESCRIPTION)	-----	FLOWLINE
⊕	POWER OUTLET	○	BOULDER	-----	CONTOUR
→	GUY ANCHOR	⊕	SIGN	-----	EXISTING RIGHT-OF-WAY LINE
⊕	TRAFFIC SIGNAL WITH LUMINAIRE	⊕	MAILBOX	-----	PROPERTY LINE
⊕	PEDESTRIAN SIGNAL	⊕	SHRUB	-----	CONCRETE
⊕	JUNCTION BOX TYPE 1, 2, 3	DT12(3)	DECIDUOUS TREE, DIAM. IN INCHES (# OF TRUNKS)	-----	GRAVEL
⊕	TRAFFIC CONTROL CABINET	CT12(3)	CONIFEROUS TREE, DIAM. IN INCHES (# OF TRUNKS)	-----	BRICK
⊕	TRAFFIC SERVICE CABINET			-----	METAL GRATE
⊕	TRAFFIC ATTENUATOR LOOP				
⊕	STREET LIGHT (LUMINAIRE)				
⊕	LOT LIGHT				
⊕	YARD LIGHT				

PROPOSED LEGEND

⊕	WATER METER
⊕	WATER VALVE
⊕	FIRE HYDRANT
⊕	SIGN
— X —	CHAIN LINK FENCE
⊕	DETECTABLE WARNING SURFACE
⊕	HMA CL 1/2" PG 64-22 FOR NEW PAVEMENT
⊕	REMOVE ASPHALT CONC PAVEMENT (ON SITE PREPARATION PLANS)
⊕	CEMENT CONCRETE
⊕	PERVIOUS CEMENT CONCRETE
⊕	RESERVOIR COURSE
⊕	CSTC
⊕	CSBC
⊕	TREE GRATE
⊕	DECORATIVE PEDESTRIAN LUMINAIRES AND POLE
⊕	SIGNAL POLE WITH DECORATIVE LUMINAIRE AND MAST ARM
⊕	SIGNAL CONTROLLER CABINET
⊕	ELECTRICAL SERVICE CABINET
⊕	BATTERY BACKUP POWER SUPPLY
⊕	JUNCTION BOX TYPE 1, 2, 8
⊕	CONDUIT

ABBREVIATIONS

AC	ASPHALT CONCRETE	MIC	MONUMENT IN CASE
ACP	ASPHALT CONCRETE PAVEMENT	MJ	MECHANICAL JOINT
ADA	AMERICANS WITH DISABILITIES ACT	MON	MONUMENT
AP	ANGLE POINT	N	NORTH OR NORTHING
APPROX	APPROXIMATE	NAVD	NORTH AMERICAN VERTICAL DATUM
BLDG	BUILDING	NO	NUMBER
CB	CATCH BASIN	NTS	NOT TO SCALE
CCP	CEMENT CONCRETE PAVEMENT	OC	ON CENTER
CDF	CONTROLLED DENSITY FILL	OD	OUTSIDE DIAMETER
CHLK	CHAINLINK	PC	POINT OF CURVE
CL	CENTERLINE	PCC	POINT OF COMPOUND CURVATURE
CL	CLASS	PCCP	PERVIOUS CEMENT CONCRETE PAVEMENT
CO	CLEANOUT	PI	POINT OF INTERSECTION
COMI	CITY OF MERCER ISLAND	POB	POINT OF BEGINNING
COL	COLUMN CONC CONCRETE	POE	POINT OF ENDING
CSBC	CRUSHED SURFACING BASE COURSE	PRC	POINT OF REVERSE CURVATURE
CSTC	CRUSHED SURFACING TOP COURSE	PT	POINT OF TANGENT
DI	DUCTILE IRON	PVC	POLYVINYL CHLORIDE OR
DIA	DIAMETER		POINT OF VERTICAL CURVATURE
DW	DRIVEWAY	PVT	POINT OF VERTICAL TANGENT
E	EAST OR EASTING	PVI	POINT OF VERTICAL INTERSECTION
EA	EACH	R	RADIUS
ELEV	ELEVATION	ROW	RIGHT OF WAY
EOP	EDGE OF PAVEMENT	RT	RIGHT
EW	EACH WAY	S	SLOPE OR SOUTH
EXIST	EXISTING	SD	STORM DRAIN
FF	FINISHED FLOOR	SDMH	STORM DRAIN MANHOLE
FL	FLOW LINE	SE	SOUTHEAST
FO	FIBER OPTIC	SHT	SHEET
FOC	FACE OF CURB	SQ	SQUARE
HMA	HOT MIX ASPHALT	SS	SANITARY SEWER
HORIZ	HORIZONTAL	SSMH	SANITARY SEWER MANHOLE
HP	HIGH POINT	ST	STREET
ID	INSIDE DIAMETER	STA	STATION
IE	INVERT ELEVATION	STD	STANDARD
IN	INCH/INCHES	STCR	STRUCTURE
JB	JUNCTION BOX	SW	SOUTHWEST
L	LENGTH LT LEFT	TYP	TYPICAL
LF	LINEAR FEET	VERT	VERTICAL
LP	LOW POINT	W	WEST
MAX	MAXIMUM	YD	YARD DRAIN
MIN	MINIMUM		
MH	MANHOLE		

ECTS\MERCER IS\21098-Aubrey Davis Park Improvements\DESIGN\Drawings\Contract\21098LEG-ABBRV.dwg 3/31/2023 10:51 AM

40	REVISIONS				Approved By		21098LEG-ABBRV.dwg		
	NO.	DATE	BY	APPR.	ENGINEERING MANAGER	DATE	DESIGNED BY	DATE	

KPG
PSOMAS
Seattle
3131 Elliott Avenue, Suite 400
Seattle, WA 98121 206.286.1640
Tacoma | Wenatchee | KPG.com

**30% REVIEW
SUBMITTAL**



**CITY OF MERCER ISLAND
AUBREY DAVIS PARK
TRAIL SAFETY IMPROVEMENTS**

LEGEND AND ABBREVIATIONS	
KPG PROJECT No. 21098	SHT <u>4</u> OF <u>14</u>

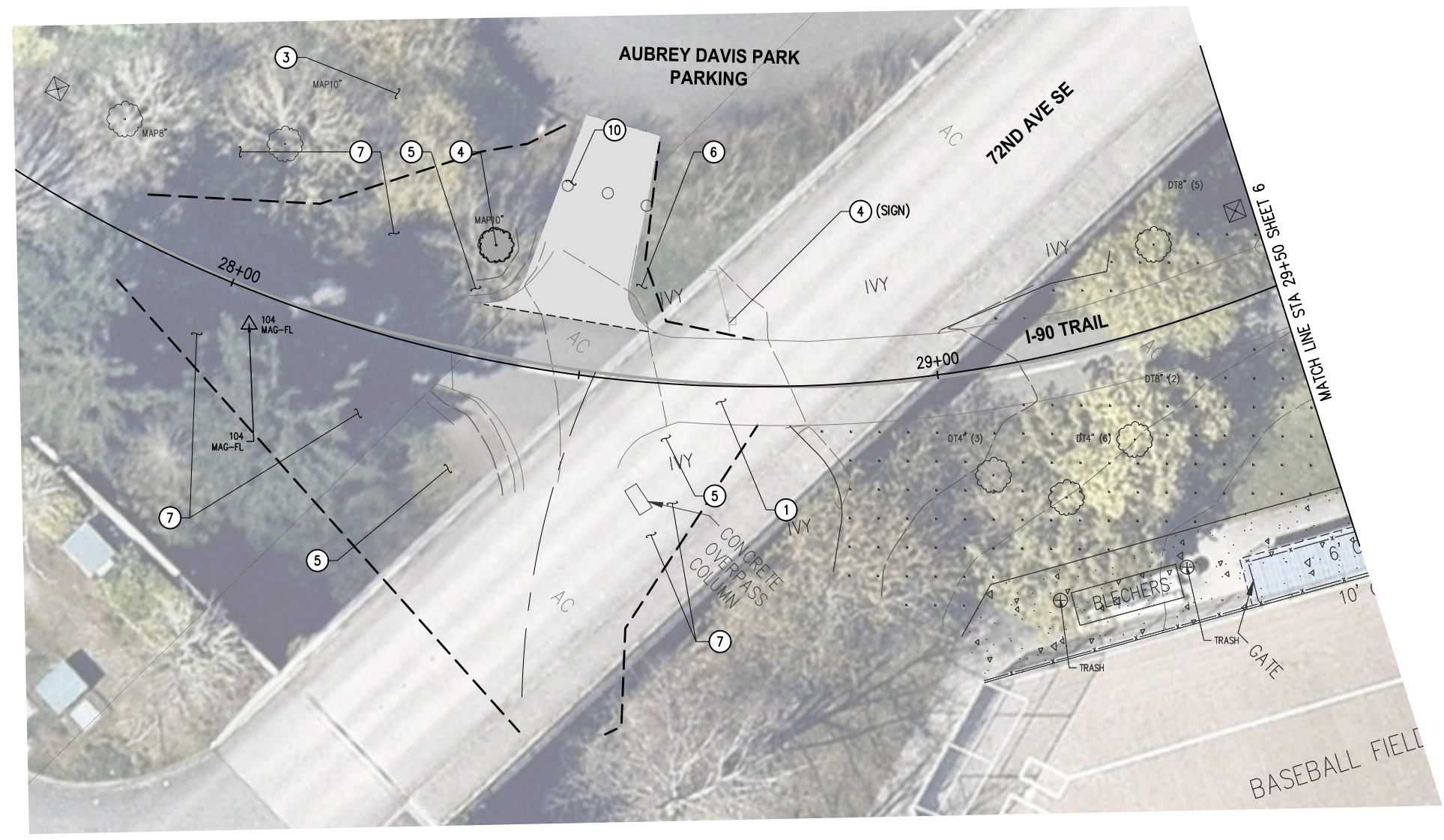

- GENERAL NOTES**
- CONTRACTOR SHALL SEQUENCE REMOVAL OF EXISTING FEATURES WITH CONSTRUCTION OF TRAIL IMPROVEMENTS TO MINIMIZE IMPACTS TO TRAIL USERS.
 - CONTRACTOR SHALL PROTECT ALL ABOVE AND BELOW GROUND UTILITIES AND IMPROVEMENTS THAT ARE TO REMAIN.
 - CONTRACTOR SHALL PROTECT ALL PLANT MATERIAL OUTSIDE OF CLEARING LIMITS.
 - CONTRACTOR SHALL MAINTAIN ACCESS FOR ALL ADJACENT PROPERTY OWNERS AND PARK USERS.
 - CONTRACTOR SHALL FURNISH AND INSTALL INLET PROTECTION IN ALL EXISTING AND NEW CATCH BASINS. CONTRACTOR SHALL INSTALL OTHER EROSION CONTROL MEASURES TO MINIMIZE SEDIMENT MIGRATION INTO STREAMS AND STORM DRAINAGE SYSTEMS.

- CONSTRUCTION NOTES**
- SAWCUT AND REMOVE ASPHALT PAVEMENT.
 - PRESERVE AND PROTECT.
 - REMOVE.
 - REMOVE GROUNDCOVER/GRASS WITHIN CLEARING LIMITS AS NECESSARY TO INSTALL PROPOSED IMPROVEMENTS.
 - REMOVE VEGETATION, THIS AREA.
TRIM/PRUNE EXISTING TREE(S), BUSH(ES), AND SHRUB(S) PER COMI STD DETAIL UF-4 AS NECESSARY TO INSTALL PROPOSED IMPROVEMENTS.
 - IMPROVEMENTS. CONTRACTOR SHALL VERIFY VEGETATION MANAGEMENT (TRIMMING/PRUNING) AREA WITH COMI PARKS DEPARTMENT PRIOR TO START OF WORK.
 - REMOVE BOLLARDS.

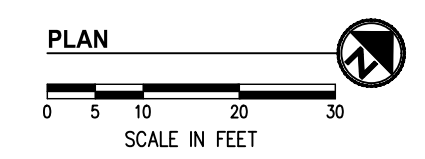

- LEGEND**
- REMOVE CEMENT CONC PAVEMENT
 - REMOVE ASPHALT PAVEMENT
 - REMOVE CURB AND GUTTER
 - REMOVE DECIDUOUS TREE
 - SAWCUT
 - HIGH VISIBILITY FENCE
 - CLEARING LIMITS

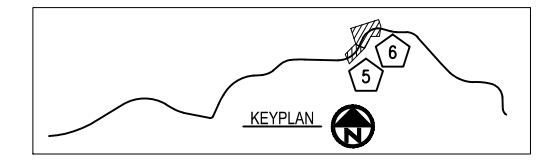

ECTS\MERCER IS\21098-Aubrey Davis Park Improvements\DESIGN\Drawings\Contract\21098TESC-SP.dwg 3/31/2023 10:52 AM

NO.	DATE	BY	APPR.	REVISIONS

Approved By		21098TESC-SP.dwg FILENAME	
ENGINEERING MANAGER	DATE	DESIGNED BY	DATE
PROJECT MANAGER	DATE	DRAWN BY	DATE
PROJECT ENGINEER	DATE	CHECKED BY	DATE

KPG
PSOMAS
Seattle
3131 Elliott Avenue, Suite 400
Seattle, WA 98121 206.286.1640
Tacoma | Wenatchee | KPG.com

**30% REVIEW
SUBMITTAL**



**CITY OF MERCER ISLAND
AUBREY DAVIS PARK
TRAIL SAFETY IMPROVEMENTS**

TESC AND SITE PREPARATION PLANS
STA 28+00 TO STA 29+50
KPG PROJECT No. 21098 SHT 5 OF 14







GENERAL NOTES

1. CONTRACTOR SHALL SEQUENCE REMOVAL OF EXISTING FEATURES WITH CONSTRUCTION OF TRAIL IMPROVEMENTS TO MINIMIZE IMPACTS TO TRAIL USERS.
2. CONTRACTOR SHALL PROTECT ALL ABOVE AND BELOW GROUND UTILITIES AND IMPROVEMENTS THAT ARE TO REMAIN.
3. CONTRACTOR SHALL PROTECT ALL PLANT MATERIAL OUTSIDE OF CLEARING LIMITS.
4. CONTRACTOR SHALL MAINTAIN ACCESS FOR ALL ADJACENT PROPERTY OWNERS AND PARK USERS.
5. CONTRACTOR SHALL FURNISH AND INSTALL INLET PROTECTION IN ALL EXISTING AND NEW CATCH BASINS. CONTRACTOR SHALL INSTALL OTHER EROSION CONTROL MEASURES TO MINIMIZE SEDIMENT MIGRATION INTO STREAMS AND STORM DRAINAGE SYSTEMS.

CONSTRUCTION NOTES

- ① SAWCUT AND REMOVE ASPHALT PAVEMENT.
- ② SAWCUT AND REMOVE CONCRETE PAVEMENT.
- ③ PRESERVE AND PROTECT.
- ④ REMOVE.
- ⑤ REMOVE GROUNDCOVER/GRASS WITHIN CLEARING LIMITS AS NECESSARY TO INSTALL PROPOSED IMPROVEMENTS.
- ⑥ REMOVE VEGETATION, THIS AREA.
TRIM/PRUNE EXISTING TREE(S), BUSH(ES), AND SHRUB(S) PER COMI STD DETAIL UF-4 AS NECESSARY TO INSTALL PROPOSED IMPROVEMENTS. CONTRACTOR SHALL VERIFY VEGETATION MANAGEMENT (TRIMMING/PRUNING) AREA WITH COMI PARKS DEPARTMENT PRIOR TO START OF WORK.
- ⑦ REMOVE DRINKING FOUNTAIN. CUT AND CAP SUPPLY LINE. MARK ON SURFACE FOR FUTURE CONNECTION OF NEW DRINKING FOUNTAIN.
- ⑧ REMOVE BENCH. CONTRACTOR SHALL STORE BENCH FOR REINSTALLATION.
- ⑨ REMOVE BOLLARDS.
- ⑩ PRESERVE AND PROTECT PEACE POLE.
- ⑪ REMOVE BIKE RACK. CONTRACTOR SHALL STORE FOR REINSTALLATION.
- ⑫ REMOVE DOG WASTE DISPENSER. CONTRACTOR SHALL STORE FOR REINSTALLATION.
- ⑬ REMOVE TRASH AND RECYCLE CONTAINERS. CONTRACTOR SHALL STORE FOR REINSTALLATION.

LEGEND

-  REMOVE CEMENT CONC PAVEMENT
-  REMOVE ASPHALT PAVEMENT
-  REMOVE CURB AND GUTTER
-  REMOVE DECIDUOUS TREE
-  SAWCUT
-  HIGH VISIBILITY FENCE
-  CLEARING LIMITS

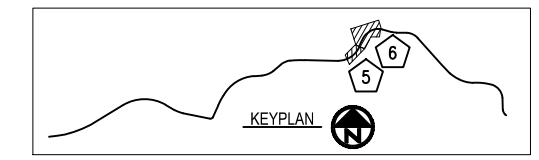

ECTS\MERCER IS\21098-Aubrey Davis Park Improvements\DESIGN\Drawings\Contract\21098TESC-SP.dwg 3/31/2023 10:52 AM

NO.	DATE	BY	APPR.	REVISIONS

Approved By		21098TESC-SP.dwg FILENAME	
ENGINEERING MANAGER	DATE	DESIGNED BY	DATE
PROJECT MANAGER	DATE	DRAWN BY	DATE
PROJECT ENGINEER	DATE	CHECKED BY	DATE

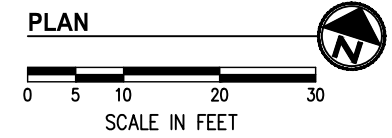

KPG
PSOMAS
Seattle
3131 Elliott Avenue, Suite 400
Seattle, WA 98121 206.286.1640
Tacoma | Wenatchee | KPG.com

**30% REVIEW
SUBMITTAL**



**CITY OF MERCER ISLAND
AUBREY DAVIS PARK
TRAIL SAFETY IMPROVEMENTS**

TESC AND SITE PREPARATION PLANS	
STA 29+50 TO STA 32+00	
KPG PROJECT No. 21098	SHT <u>6</u> OF <u>14</u>

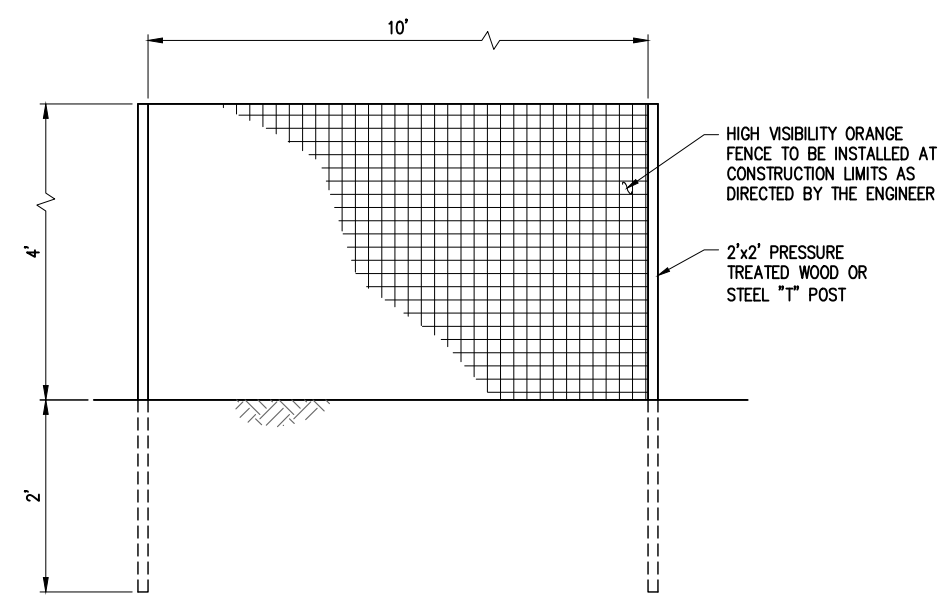

ELEVATION

NOTE:
PLACE AT GRADING LIMITS AND AROUND TREES TO BE PROTECTED WHERE DIRECTED BY THE ENGINEER.

HIGH VISIBILITY ORANGE FENCING
NTS

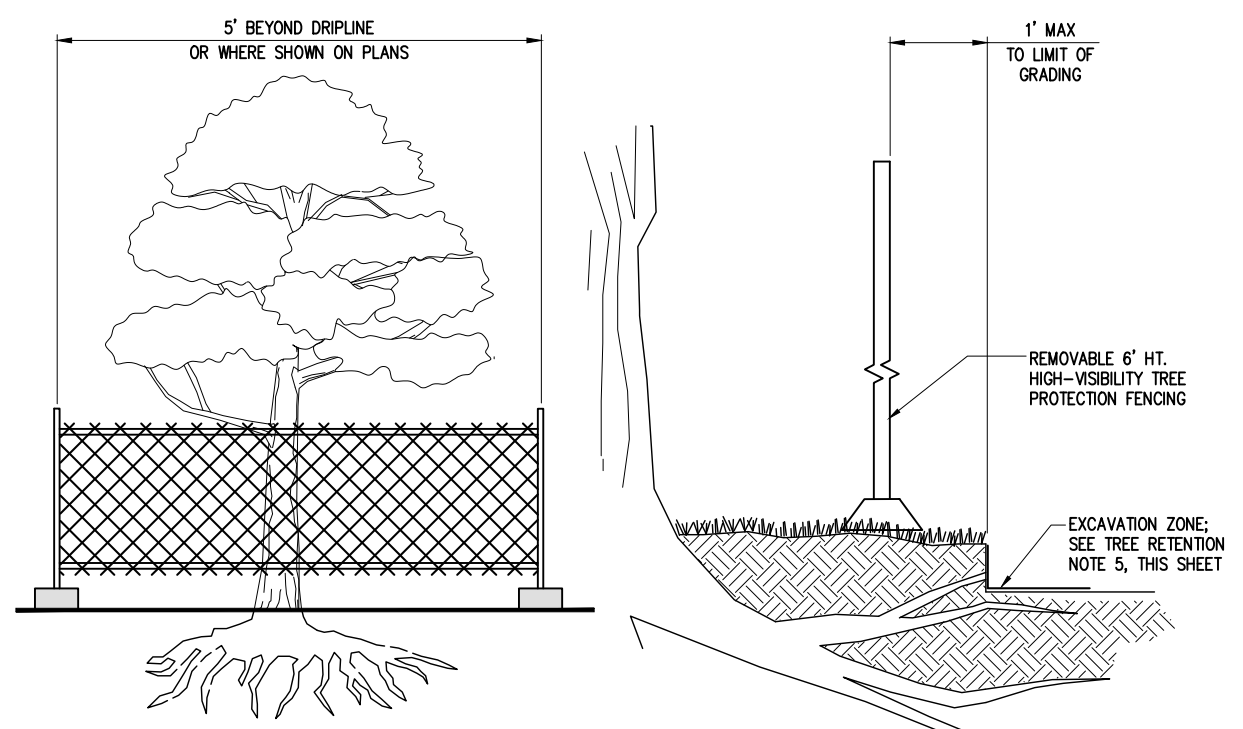

TREE PROTECTION DETAIL
NTS

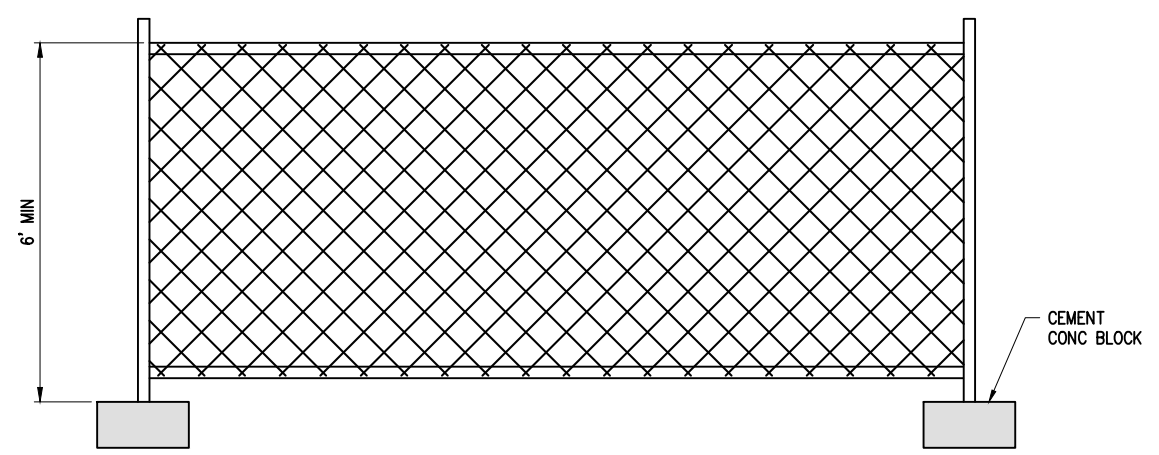

NOTES:
1. SIX FOOT HIGH TEMPORARY CHAIN LINK FENCE SHALL BE PLACED WHERE INDICATED ON PLANS. ACCESS GATES TO BE INSTALLED ONLY WHERE INDICATED ON PLANS. INSTALL FENCE POSTS USING CEMENT CONC. BLOCK FOOTINGS ONLY. AVOID DRIVING POSTS OR STAKES INTO EXISTING GROUND SURFACE.

TEMPORARY CHAIN LINK FENCE
NTS

ECTS\MERCER IS\21098-Aubrey Davis Park Improvements\DESIGN\Drawings\Contract\21098TESC-SP-DET.dwg 3/31/2023 10:52 AM

NO.	DATE	BY	APPR.	REVISIONS

Approved By		21098TESC-SP-DET.dwg FILENAME	
ENGINEERING MANAGER	DATE	DESIGNED BY	DATE
PROJECT MANAGER	DATE	DRAWN BY	DATE
PROJECT ENGINEER	DATE	CHECKED BY	DATE

KPG
PSOMAS
Seattle
3131 Elliott Avenue, Suite 400
Seattle, WA 98121 206.286.1640
Tacoma | Wenatchee | KPG.com

**30% REVIEW
SUBMITTAL**



**CITY OF MERCER ISLAND
AUBREY DAVIS PARK
TRAIL SAFETY IMPROVEMENTS**

TESC AND SITE PREPARATION DETAILS	
KPG PROJECT No. 21098	SHT <u>7</u> OF <u>14</u>

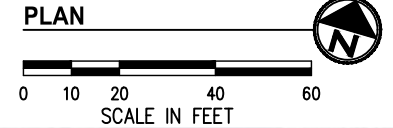
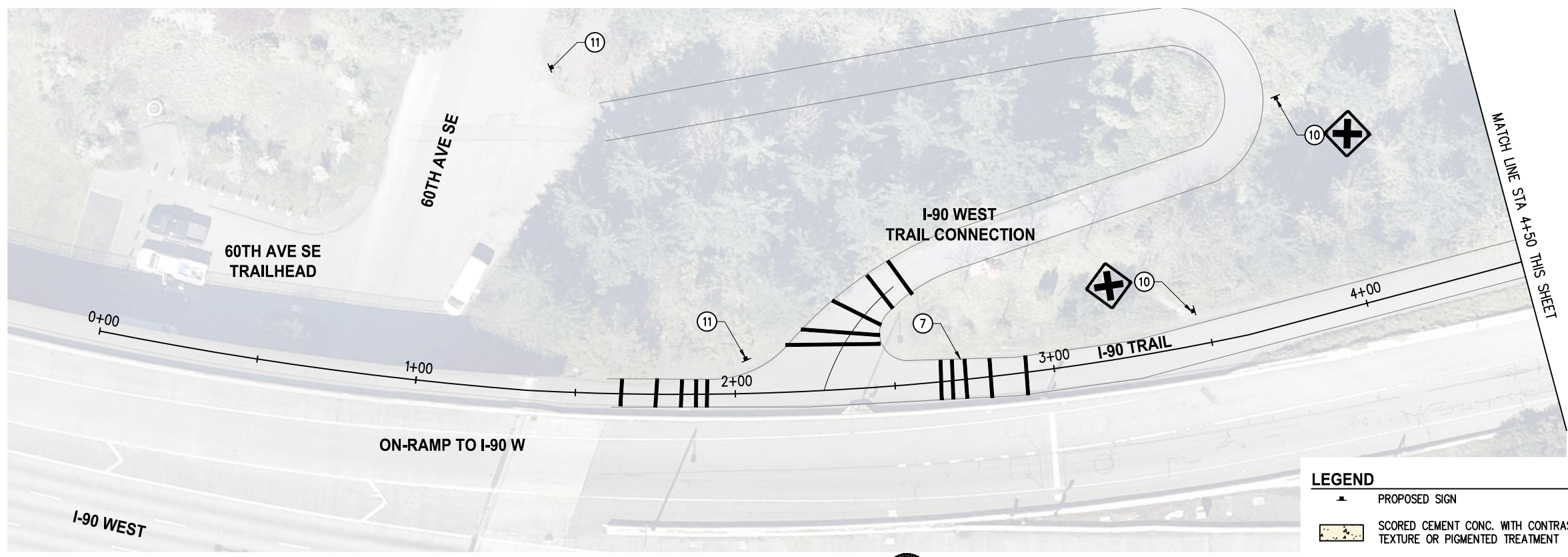

LEGEND

- PROPOSED SIGN
- SCORED CEMENT CONC. WITH CONTRASTING TEXTURE OR PIGMENTED TREATMENT
- HMA TRAIL OR PAVEMENT
- DETECTABLE WARNING SURFACE
- CEMENT CONCRETE TRAIL

- GENERAL NOTES**
- CONTRACTOR SHALL SEQUENCE REMOVAL OF EXISTING FEATURES WITH CONSTRUCTION OF TRAIL IMPROVEMENTS TO MINIMIZE IMPACTS TO TRAIL USERS.
 - CONTRACTOR SHALL PROVIDE AND MAINTAIN TEMPORARY PEDESTRIAN ROUTE AROUND CONSTRUCTION ACTIVITY FOR THE DURATION OF CONSTRUCTION.

- CONSTRUCTION NOTES**
- INSTALL PAINTED BAR PER DETAIL, SHEET 14.
 - INSTALL WARNING SIGN.
 - INSTALL WAYFINDING SIGN.
 - RESTORE TRAIL SHOULDER, SHEET 14.
 - INSTALL PAINTED PAVEMENT MARKING.

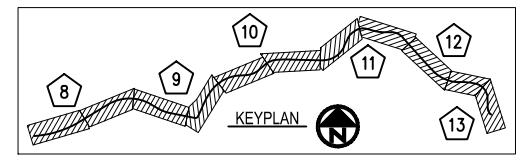
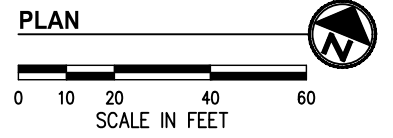
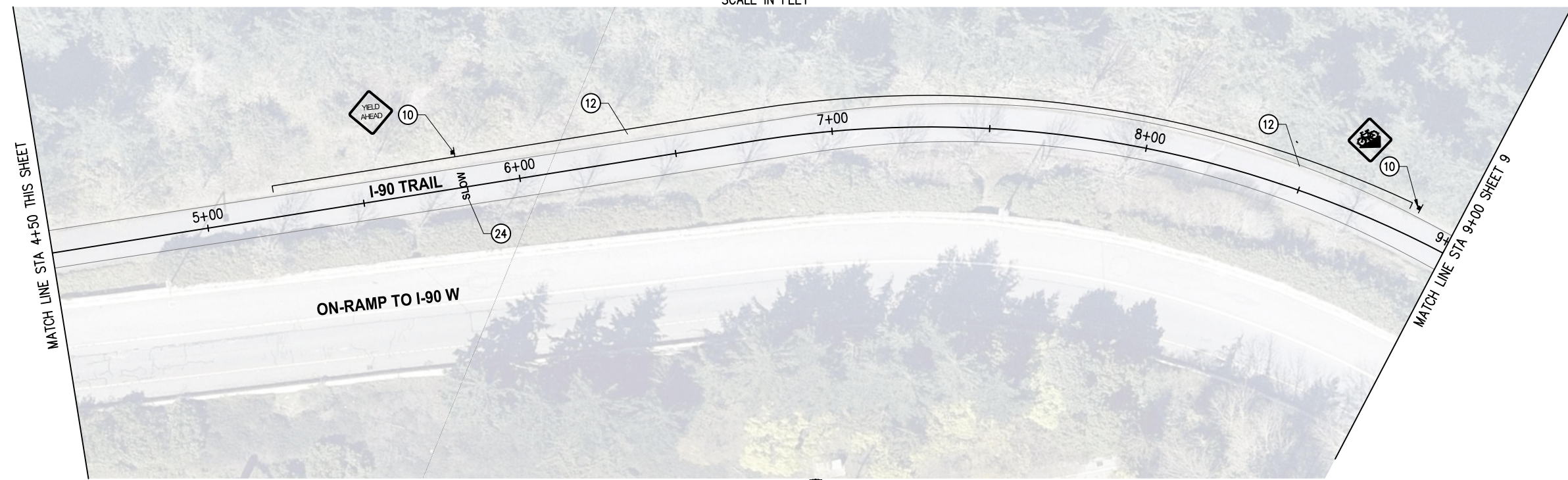

ECTS\MERCER IS\21098-Aubrey Davis Park Improvements\DESIGN\Drawings\Contract\21098TRAIL.dwg 3/31/2023 10:52 AM

NO.	DATE	BY	APPR.	REVISIONS
44				

Approved By		21098TRAIL.dwg
ENGINEERING MANAGER	DATE	FILENAME
DESIGNED BY	DATE	
PROJECT MANAGER	DATE	DRAWN BY
DRAWN BY	DATE	
PROJECT ENGINEER	DATE	CHECKED BY
CHECKED BY	DATE	

KPG
PSOMAS
Seattle
3131 Elliott Avenue, Suite 400
Seattle, WA 98121 206.286.1640
Tacoma | Wenatchee | KPG.com

30% REVIEW SUBMITTAL



**CITY OF MERCER ISLAND
AUBREY DAVIS PARK
TRAIL SAFETY IMPROVEMENTS**

**TRAIL IMPROVEMENT PLANS
STA 0+00 TO STA 9+00**
KPG PROJECT No. 21098 SHT 8 OF 14

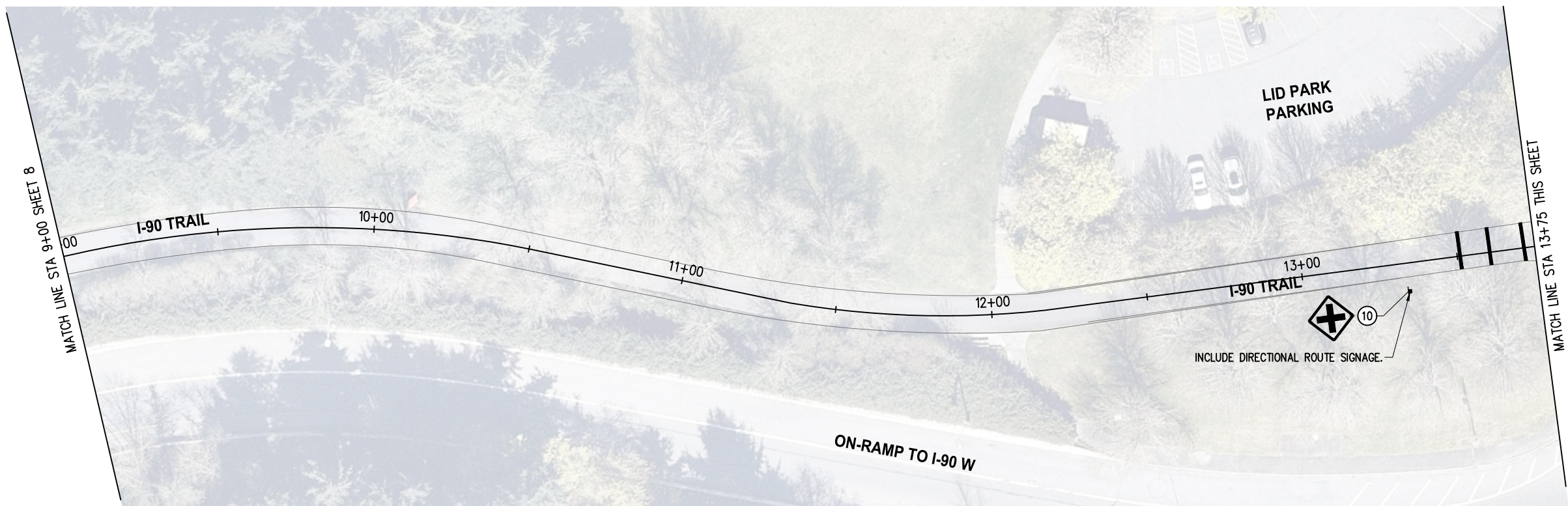

GENERAL NOTES

1. CONTRACTOR SHALL SEQUENCE REMOVAL OF EXISTING FEATURES WITH CONSTRUCTION OF TRAIL IMPROVEMENTS TO MINIMIZE IMPACTS TO TRAIL USERS.
2. CONTRACTOR SHALL PROVIDE AND MAINTAIN TEMPORARY PEDESTRIAN ROUTE AROUND CONSTRUCTION ACTIVITY FOR THE DURATION OF CONSTRUCTION.

CONSTRUCTION NOTES

- (7) INSTALL PAINTED BAR PER DETAIL, SHEET 14.
- (10) INSTALL WARNING SIGN.
- (11) INSTALL WAYFINDING SIGN.
- (12) RESTORE TRAIL SHOULDER, SHEET 14.

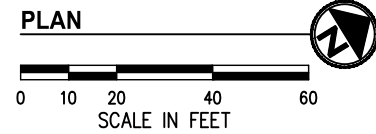
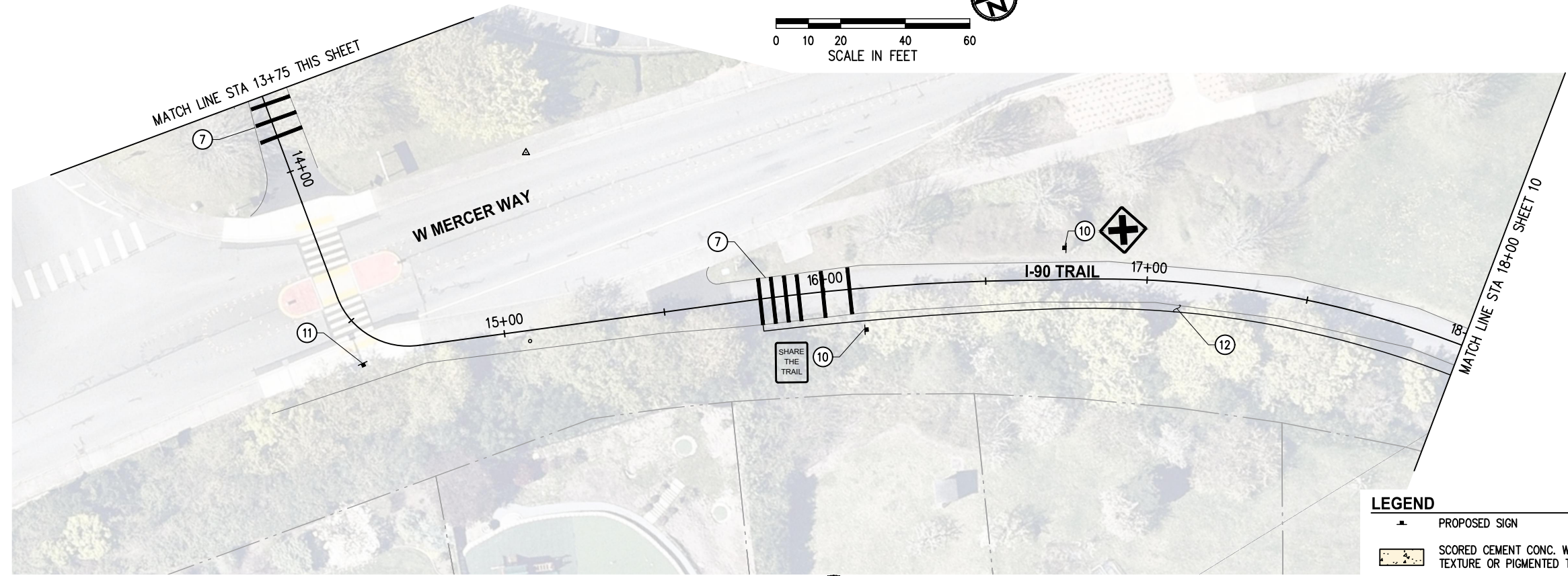
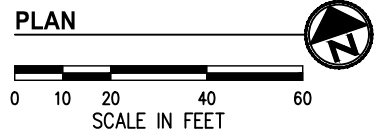

LEGEND

	PROPOSED SIGN
	SCORED CEMENT CONC. WITH CONTRASTING TEXTURE OR PIGMENTED TREATMENT
	HMA TRAIL OR PAVEMENT
	DETECTABLE WARNING SURFACE
	CEMENT CONCRETE TRAIL

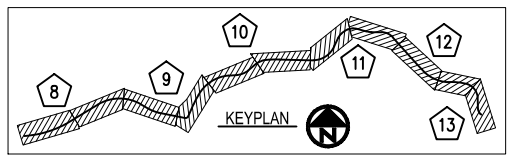

ECTS\MERCER IS\21098-Aubrey Davis Park Improvements\DESIGN\Drawings\Contract\21098TRAIL.dwg 3/31/2023 10:52 AM

NO.	DATE	BY	APPR.	REVISIONS
45				

Approved By		21098TRAIL.dwg
ENGINEERING MANAGER	DATE	DESIGNED BY
PROJECT MANAGER	DATE	DRAWN BY
PROJECT ENGINEER	DATE	CHECKED BY

KPG
PSOMAS
Seattle
3131 Elliott Avenue, Suite 400
Seattle, WA 98121 206.286.1640
Tacoma | Wenatchee | KPG.com

30% REVIEW SUBMITTAL



**CITY OF MERCER ISLAND
AUBREY DAVIS PARK
TRAIL SAFETY IMPROVEMENTS**

**TRAIL IMPROVEMENT PLANS
STA 9+00 TO STA 18+00**
KPG PROJECT No. 21098 SHT 9 OF 14

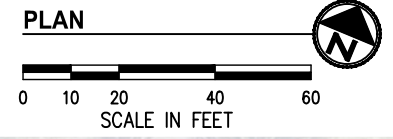
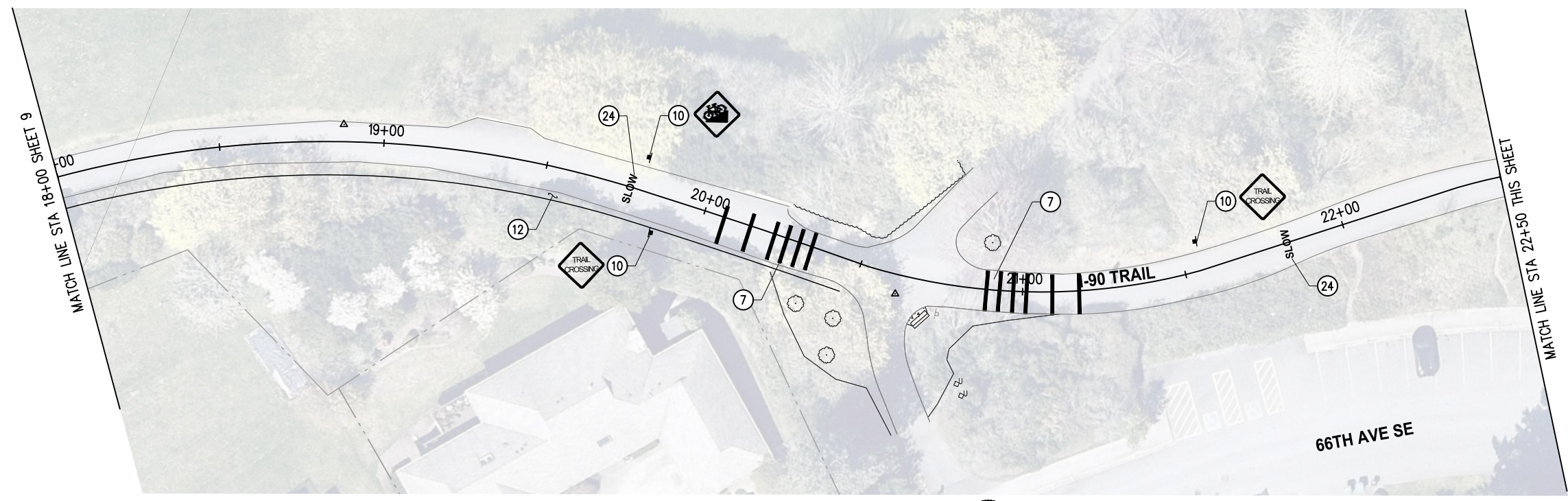

GENERAL NOTES

- CONTRACTOR SHALL SEQUENCE REMOVAL OF EXISTING FEATURES WITH CONSTRUCTION OF TRAIL IMPROVEMENTS TO MINIMIZE IMPACTS TO TRAIL USERS.
- CONTRACTOR SHALL PROVIDE AND MAINTAIN TEMPORARY PEDESTRIAN ROUTE AROUND CONSTRUCTION ACTIVITY FOR THE DURATION OF CONSTRUCTION.

CONSTRUCTION NOTES

- INSTALL HMA CL 1/2" PG58H-22 FOR WALKWAY. SEE TYPICAL SECTIONS, SHEET 14.
- INSTALL PAINTED BAR PER DETAIL, SHEET 14.
- INSTALL WARNING SIGN.
- INSTALL WAYFINDING SIGN.
- RESTORE TRAIL SHOULDER, SHEET 14.
- REMOVE BOLLARDS WITHIN PAVEMENT LIMITS.
- REMOVE AND SALVAGE PARK SIGN TO CITY.
- INSTALL PAINTED PAVEMENT MARKING.

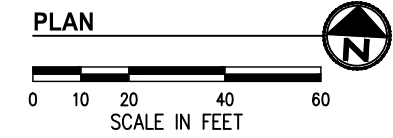
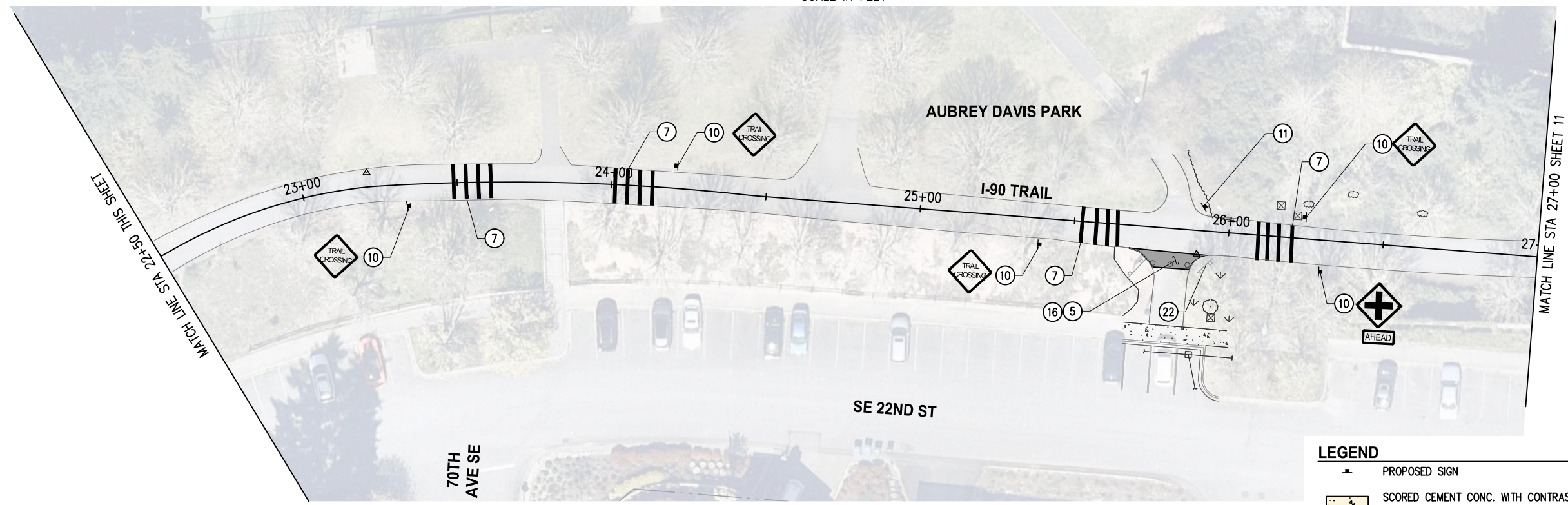

LEGEND

- PROPOSED SIGN
- SCORED CEMENT CONC. WITH CONTRASTING TEXTURE OR PIGMENTED TREATMENT
- HMA TRAIL OR PAVEMENT
- DETECTABLE WARNING SURFACE
- CEMENT CONCRETE TRAIL

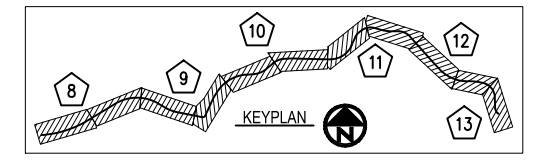

ECTS\MERCER IS\21098-Aubrey Davis Park Improvements\DESIGN\Drawings\Contract\21098TRAIL.dwg 3/31/2023 10:52 AM

NO.	DATE	BY	APPR.	REVISIONS
46				

Approved By		21098TRAIL.dwg
ENGINEERING MANAGER	DATE	DESIGNED BY
PROJECT MANAGER	DATE	DRAWN BY
PROJECT ENGINEER	DATE	CHECKED BY

KPG
P S O M A S
Seattle
3131 Elliott Avenue, Suite 400
Seattle, WA 98121 206.286.1640
Tacoma | Wenatchee | KPG.com

30% REVIEW SUBMITTAL



**CITY OF MERCER ISLAND
AUBREY DAVIS PARK
TRAIL SAFETY IMPROVEMENTS**

**TRAIL IMPROVEMENT PLANS
STA 18+00 TO STA 27+00**
KPG PROJECT No. 21098 SHT 10 OF 14

GENERAL NOTES

1. CONTRACTOR SHALL SEQUENCE REMOVAL OF EXISTING FEATURES WITH CONSTRUCTION OF TRAIL IMPROVEMENTS TO MINIMIZE IMPACTS TO TRAIL USERS.
2. CONTRACTOR SHALL PROVIDE AND MAINTAIN TEMPORARY PEDESTRIAN ROUTE AROUND CONSTRUCTION ACTIVITY FOR THE DURATION OF CONSTRUCTION.

CONSTRUCTION NOTES

- ① MATCH EXISTING PAVEMENT EDGE, FLUSH.
- ② CONSTRUCT CEMENT CONC TRAIL. SEE TYPICAL SECTION, SHEET 14.
- ⑤ INSTALL HMA CL 1/2" PG58H-22 FOR WALKWAY. SEE TYPICAL SECTIONS, SHEET 14.
- ⑦ INSTALL PAINTED BAR PER DETAIL, SHEET 14.
- ⑧ INSTALL SCORED CEMENT CONCRETE WITH CONTRASTING TEXTURE OR PIGMENTED TREATMENT.
- ⑨ LOW GROWING VEGETATED SHOULDER AREA.
- ⑩ INSTALL WARNING SIGN.
- ⑪ INSTALL WAYFINDING SIGN.
- ⑬ LAWN RESTORATION.
- ⑰ INSTALL LOW FENCING.
- ⑳ ROTATING MOVABLE SHARED SPACE BANNER (INSTALLED BY CITY).
- ㉔ INSTALL PAINTED PAVEMENT MARKING.

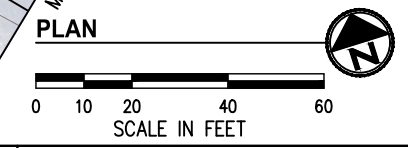
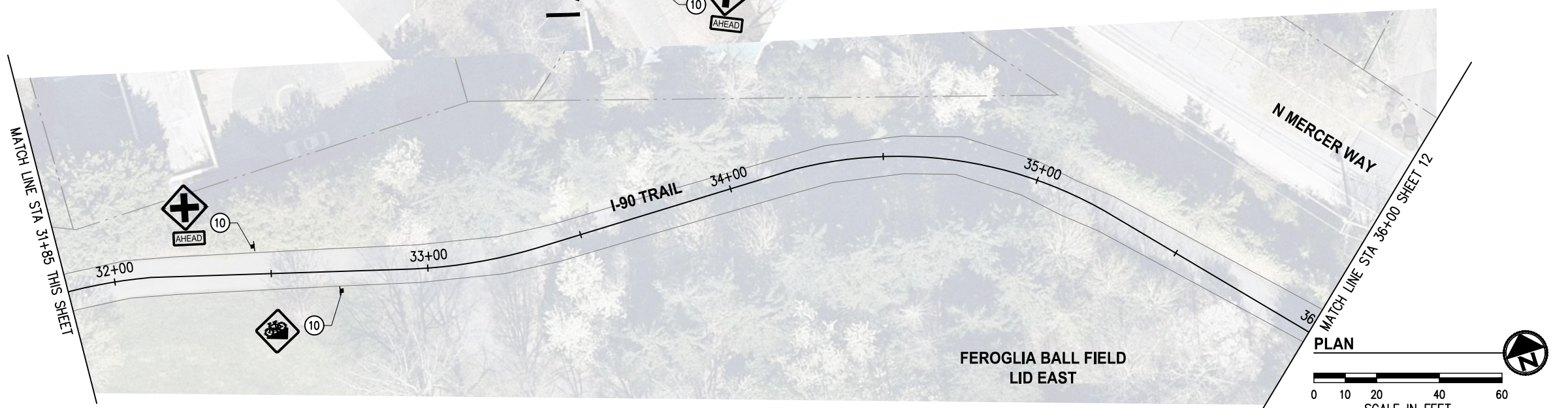
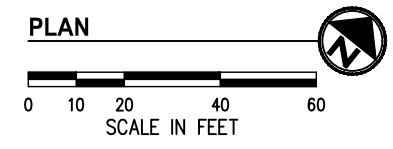
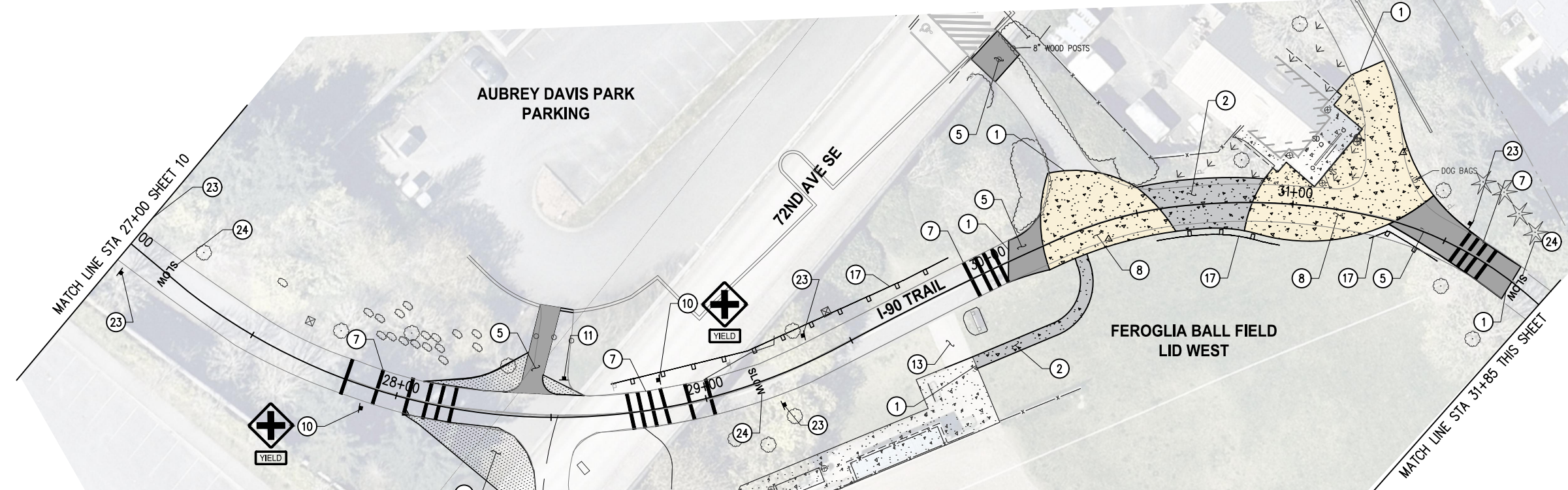

LEGEND

- ▲ PROPOSED SIGN
- ▨ SCORED CEMENT CONC. WITH CONTRASTING TEXTURE OR PIGMENTED TREATMENT
- ▩ HMA TRAIL OR PAVEMENT
- ▧ DETECTABLE WARNING SURFACE
- ▦ CEMENT CONCRETE TRAIL
- ▤ LOW GROWING VEGETATED SHOULDER

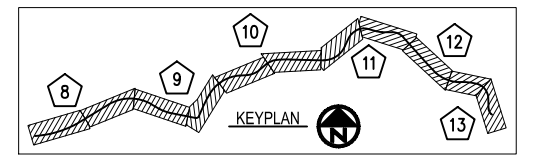

ECTS\MERCER IS\21098-Aubrey Davis Park Improvements\DESIGN\Drawings\Contract\21098TRAIL.dwg 3/31/2023 10:52 AM

NO.	DATE	BY	APPR.	REVISIONS

Approved By		21098TRAIL.dwg FILENAME	
ENGINEERING MANAGER	DATE	DESIGNED BY	DATE
PROJECT MANAGER	DATE	DRAWN BY	DATE
PROJECT ENGINEER	DATE	CHECKED BY	DATE

KPG
PSOMAS
Seattle
3131 Elliott Avenue, Suite 400
Seattle, WA 98121 206.286.1640
Tacoma | Wenatchee | KPG.com

**30% REVIEW
SUBMITTAL**



**CITY OF MERCER ISLAND
AUBREY DAVIS PARK
TRAIL SAFETY IMPROVEMENTS**

**TRAIL IMPROVEMENT PLANS
STA 27+00 TO STA 36+00**
KPG PROJECT No. 21098 SHT 11 OF 14

GENERAL NOTES

1. CONTRACTOR SHALL SEQUENCE REMOVAL OF EXISTING FEATURES WITH CONSTRUCTION OF TRAIL IMPROVEMENTS TO MINIMIZE IMPACTS TO TRAIL USERS.
2. CONTRACTOR SHALL PROVIDE AND MAINTAIN TEMPORARY PEDESTRIAN ROUTE AROUND CONSTRUCTION ACTIVITY FOR THE DURATION OF CONSTRUCTION.

CONSTRUCTION NOTES

10. INSTALL WARNING SIGN.
19. LOCATE EXISTING TRAIL CONNECTION. EXISTING VEGETATION SHALL BE TRIMMED, PRUNED, OR CLEARED FOR SIGHT DISTANCES ON I-90 TRAIL PER DIRECTION OF ENGINEER.

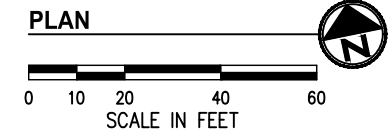
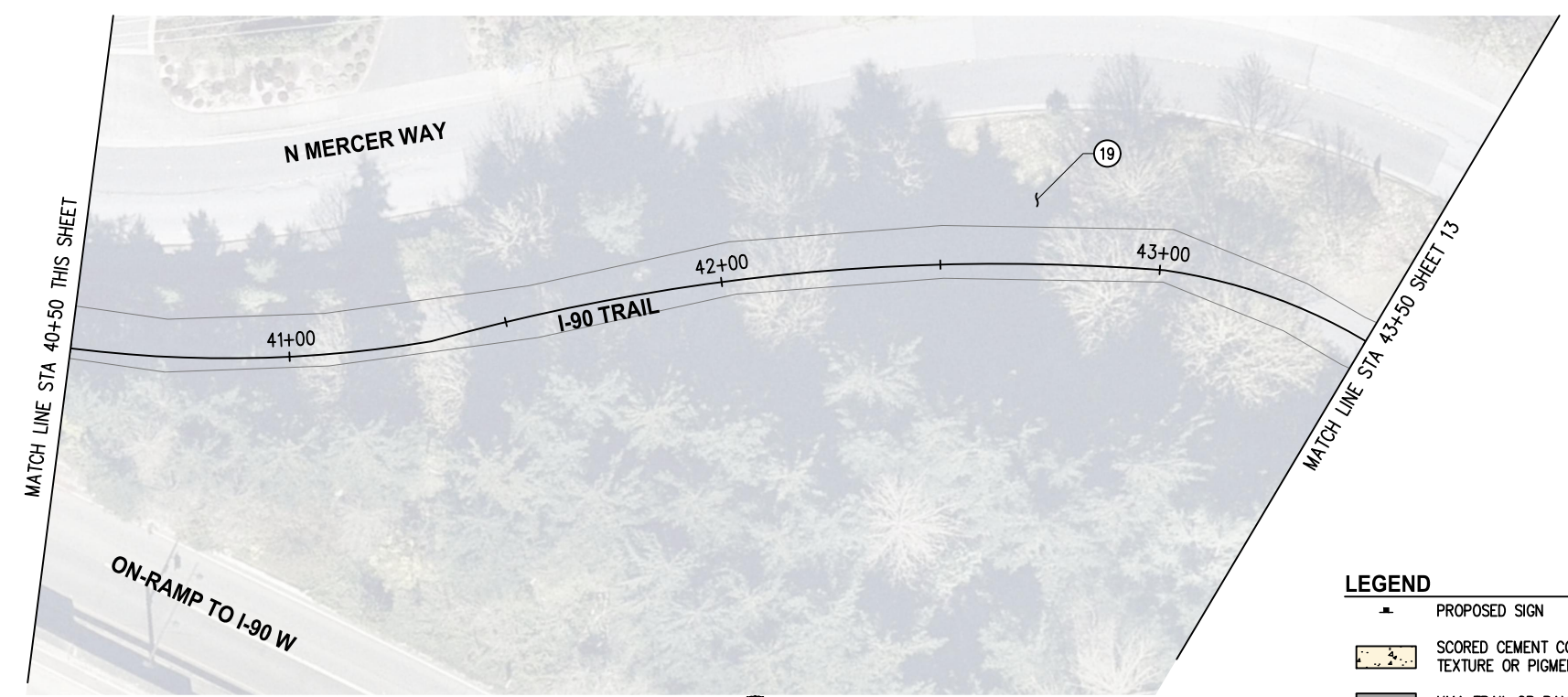
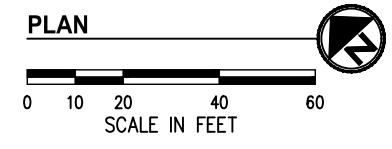
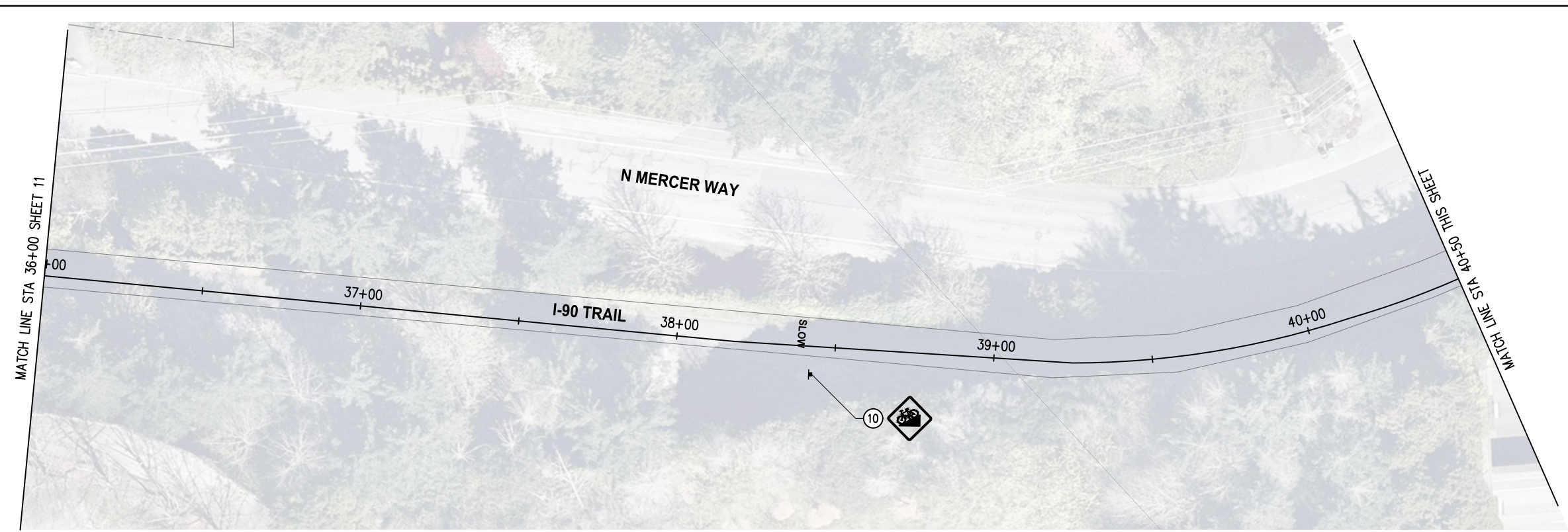

LEGEND

- PROPOSED SIGN
- SCORED CEMENT CONC. WITH CONTRASTING TEXTURE OR PIGMENTED TREATMENT
- HMA TRAIL OR PAVEMENT
- DETECTABLE WARNING SURFACE
- CEMENT CONCRETE TRAIL

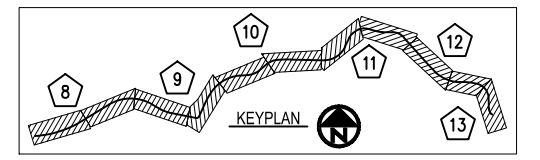

ECTS\MERCER IS\21098-Aubrey Davis Park Improvements\DESIGN\Drawings\Contract\21098TRAIL.dwg 3/31/2023 10:52 AM

NO.	DATE	BY	APPR.	REVISIONS

Approved By

ENGINEERING MANAGER	DATE	DESIGNED BY	DATE
PROJECT MANAGER	DATE	DRAWN BY	DATE
PROJECT ENGINEER	DATE	CHECKED BY	DATE

KPG PSOMAS
 Seattle
 3131 Elliott Avenue, Suite 400
 Seattle, WA 98121 206.286.1640
 Tacoma | Wenatchee | KPG.com

30% REVIEW SUBMITTAL



**CITY OF MERCER ISLAND
 AUBREY DAVIS PARK
 TRAIL SAFETY IMPROVEMENTS**

**TRAIL IMPROVEMENT PLANS
 STA 36+00 TO STA 43+50**
 KPG PROJECT No. 21098 SHT 12 OF 14

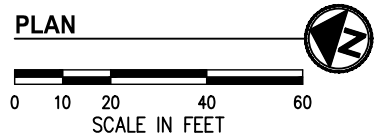
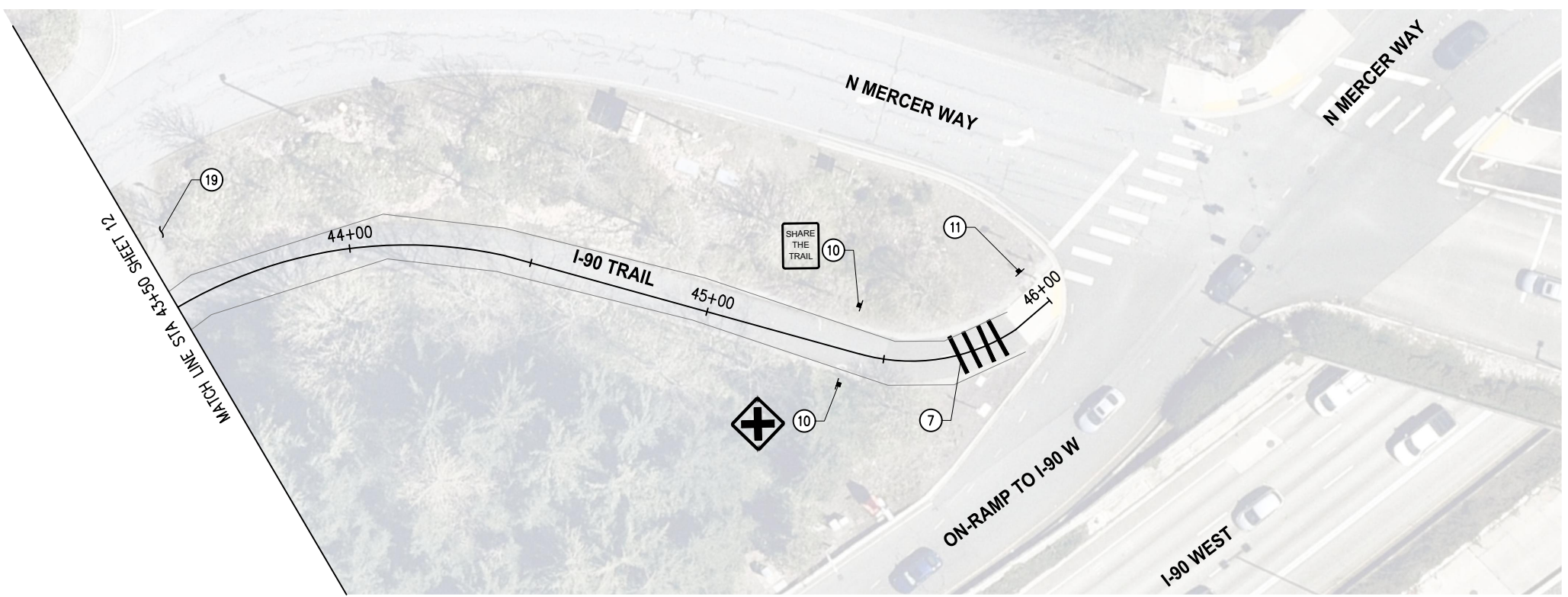

GENERAL NOTES

1. CONTRACTOR SHALL SEQUENCE REMOVAL OF EXISTING FEATURES WITH CONSTRUCTION OF TRAIL IMPROVEMENTS TO MINIMIZE IMPACTS TO TRAIL USERS.
2. CONTRACTOR SHALL PROVIDE AND MAINTAIN TEMPORARY PEDESTRIAN ROUTE AROUND CONSTRUCTION ACTIVITY FOR THE DURATION OF CONSTRUCTION.

CONSTRUCTION NOTES

7. INSTALL PAINTED BAR PER DETAIL, SHEET 14.
10. INSTALL WARNING SIGN.
11. INSTALL WAYFINDING SIGN.
19. LOCATE EXISTING TRAIL CONNECTION. EXISTING VEGETATION SHALL BE TRIMMED, PRUNED, OR CLEARED FOR SIGHT DISTANCES ON I-90 TRAIL PER DIRECTION OF ENGINEER.

LEGEND

- PROPOSED SIGN
- SCORED CEMENT CONC. WITH CONTRASTING TEXTURE OR PIGMENTED TREATMENT
- HMA TRAIL OR PAVEMENT
- DETECTABLE WARNING SURFACE
- CEMENT CONCRETE TRAIL

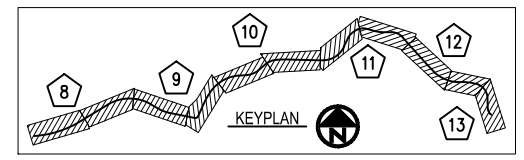

ECTS\MERCER IS\21098-Aubrey Davis Park Improvements\DESIGN\Drawings\Contract\21098TRAIL.dwg 3/31/2023 10:52 AM

NO.	DATE	BY	APPR.	REVISIONS

Approved By		21098TRAIL.dwg FILENAME	
ENGINEERING MANAGER	DATE	DESIGNED BY	DATE
PROJECT MANAGER	DATE	DRAWN BY	DATE
PROJECT ENGINEER	DATE	CHECKED BY	DATE

KPG
PSOMAS
Seattle
3131 Elliott Avenue, Suite 400
Seattle, WA 98121 206.286.1640
Tacoma | Wenatchee | KPG.com

**30% REVIEW
SUBMITTAL**



**CITY OF MERCER ISLAND
AUBREY DAVIS PARK
TRAIL SAFETY IMPROVEMENTS**

TRAIL IMPROVEMENT PLANS STA 43+50 TO STA 46+00	
KPG PROJECT No. 21098	SHT <u>13</u> OF <u>14</u>

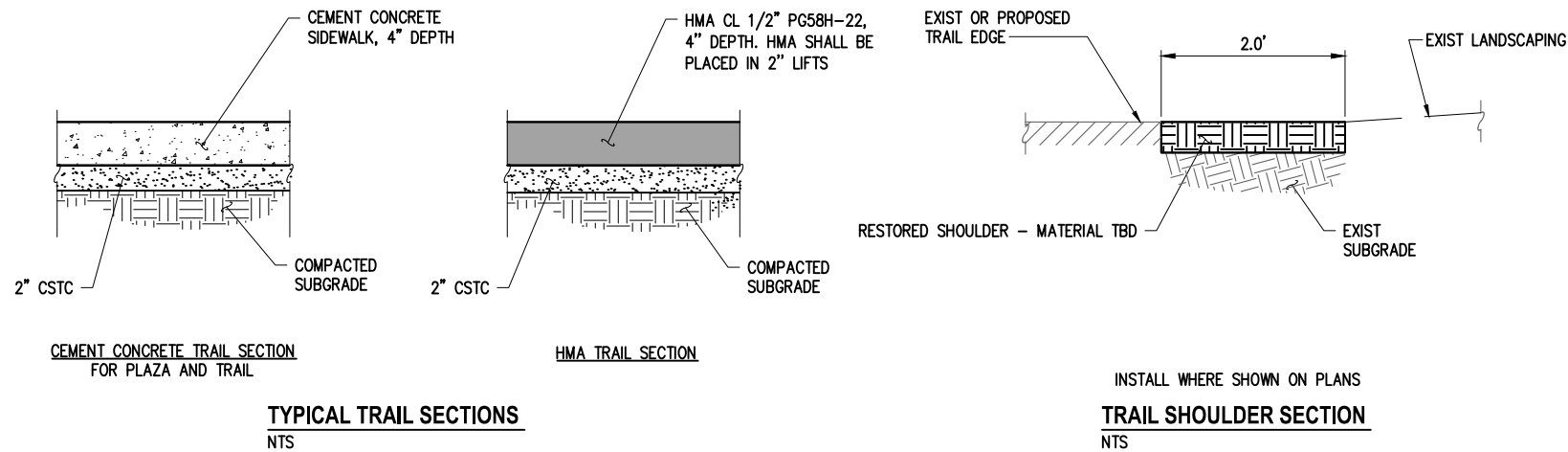

TYPICAL SECTION GENERAL NOTES

1. SUBGRADE PREPARATION SHALL BE IN ACCORDANCE WITH SECTION 2-06 OF THE STANDARD SPECIFICATIONS.
2. ADDITIONAL FILL MATERIAL REQUIRED FOR CONSTRUCTION SHALL BE APPROVED CRUSHED ROCK WHEN REQUIRED BY ENGINEER. FILL MATERIAL SHALL BE COMPACTED TO 95% MODIFIED PROCTOR DENSITY.
3. IF UNSUITABLE FOUNDATION IS ENCOUNTERED, THE CONTRACTOR SHALL CAREFULLY OVER EXCAVATE TO A MAXIMUM DEPTH OF 1.0' AND REPLACE WITH CRUSHED ROCK AS DIRECTED BY ENGINEER.
4. MAXIMUM COMPACTED HMA LIFT THICKNESS SHALL NOT EXCEED 0.17'.
5. ALL PAVEMENT SHALL BE CUT BY SAW CUTTING FULL DEPTH IN A NEAT VERTICAL LINE PRIOR TO REMOVING. ANY DAMAGE TO ADJACENT PAVEMENT SHALL BE REPAIRED BY THE CONTRACTOR AT NO EXPENSE TO THE OWNER.

TYPICAL TRAIL SECTIONS
NTS

INSTALL WHERE SHOWN ON PLANS
TRAIL SHOULDER SECTION
NTS

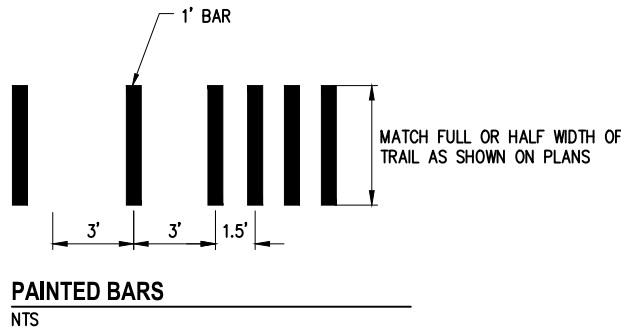

PAINTED BARS
NTS



PIGMENTED TREATMENT EXAMPLE - 77TH & SUNSET, MERCER ISLAND



CONTRASTING TEXTURE AND PIGMENTED TREATMENT EXAMPLE - YAKIMA AVE (MID-BLOCK), TACOMA



SCORED OR SAWCUT CONCRETE EXAMPLE

SCORED CEMENT CONCRETE WITH CONTRASTING TEXTURE OR PIGMENTED TREATMENT - EXAMPLES
(FOR PLAZA OR TRAIL CEMENT CONCRETE)

ECTS\MERCER IS\21098-Aubrey Davis Park Improvements\DESIGN\Drawings\Contract\21098TRAIL-DET.dwg 3/31/2023 10:52 AM

NO.	DATE	BY	APPR.	REVISIONS

Approved By		21098TRAIL-DET.dwg
ENGINEERING MANAGER	DATE	DESIGNED BY
PROJECT MANAGER	DATE	DRAWN BY
PROJECT ENGINEER	DATE	CHECKED BY

KPG
PSOMAS
Seattle
3131 Elliott Avenue, Suite 400
Seattle, WA 98121 206.286.1640
Tacoma | Wenatchee | KPG.com

**30% REVIEW
SUBMITTAL**



CITY OF MERCER ISLAND
AUBREY DAVIS PARK
TRAIL SAFETY IMPROVEMENTS

TRAIL IMPROVEMENT DETAILS	
KPG PROJECT No. 21098	SHT 14 OF 14



**PARKS AND RECREATION COMMISSION
CITY OF MERCER ISLAND, WASHINGTON**

9611 SE 36th Street | Mercer Island, WA 98040-3732
(206) 275-7793 | www.mercerisland.gov

DATE: May 4, 2023
TO: Mercer Island City Council
FROM: Parks and Recreation Commission
Jodi McCarthy, Chair, Peter Struck, Vice Chair, Don Cohen, Paul Burstein, Sara Marxen,
Rory Westberg, Ashley Hay
SUBJECT: Recommendation on Aubrey Davis Park Trail Safety Improvements 30% Design

The Mercer Island Parks and Recreation Commission (PRC) presents our recommendation on the Aubrey Davis Park Trail Safety Improvements 30% Design.

Summary Recommendation:

Our recommendation is to proceed to a 60% Design phase with further review by the Parks and Recreation Commission at the conclusion of that phase.

The PRC commenced review of this matter on April 7, 2022 and discussed the topic over six meetings. The project design team collected public input through a virtual open house held on February 17, 2022 and an online survey conducted from February 17 to March 17, 2022, as well as public comments received via the project page on Let’s Talk, emails, and from speakers at Commission meetings. The open house was attended by 24 people, and survey responses were received from 86 participants. This input from interested citizens and user groups was presented to the PRC for consideration before and during the course of its deliberations.

The 30% Design provides significant improvements to the intersections at the 72nd Avenue underpass area and the ballfield/restroom area intended to reduce speeds, channelize cross-trail traffic and alert all users to the “mixing zone” they are entering. The 30% design also includes minor signage, pavement markings and wayfinding at other intersections along the I-90 trail throughout the Lid Park.

Project Priorities:

The design prioritizes improvements that will directly enhance trail safety and focuses major improvements at the ballfield/restroom area, which is a critical area of concern.

Focus on safety

The PRC initially considered a suite of improvements that were collected from public input. With the limited budget, the PRC chose to prioritize improvements that would directly enhance safety. The utility of other improvements such as benches, kiosks, and pull-out areas was not as clear.

Focus on the ballfield/restroom and 72nd Ave. underpass areas

The initial design included substantial improvements at the West Mercer Way crossing. The PRC concluded that these improvements, while potentially useful, were not as critical to trail safety as the improvements proposed for the ballfield/restroom area and the 72nd Avenue underpass area. The PRC concluded that the project should focus trail improvements in those areas. In particular, the importance of safety enhancements at the entrance to the ballfield/restroom area, at the 72nd Avenue underpass, was identified as key to controlling traffic flow before trail users enter the “mixing zone” near the restroom.

Using concrete pavement to better define the ballfield/restroom mixing zone will further signal the need to be alert to the areas where park users enter the trail. Installation of low-level fencing will channel pedestrians to marked crossings and improve predictability for pedestrians and cyclists.

Several different options for the 72nd Ave. underpass area were considered over multiple Commission meetings. In addition to staff analysis and citizen input, the Commission solicited and received information and testimony from the Washington State Dept. of Transportation (WSDOT), the owner of the property.

On March 2, 2023, the Commission considered three options – two options contained concrete roundabouts and one option did not. WSDOT noted that all three options were acceptable. The Commission voted in favor of the option without a roundabout given that there is no evidence that a traffic feature of this magnitude is needed at this time. The preferred option features improved sight lines by removing vegetation, increases awareness with signage and pavement markings, and restores trail shoulders.

The recommended design improves safety, with the smallest increase in impervious surface, and lowest cost. Although City staff and the design consultant favored a roundabout model for the 72nd Ave. underpass area, they concur that the option the Commission chose will improve the safety at this trail intersection. The Commission notes that if trail usage increases, and if evidence indicates that a roundabout feature would further improve the safety of the area, this may be considered in future years.

Stay within the available budget:

While budget decisions are ultimately the City Council’s responsibility, trying to stay within budget as much as possible, while still including meaningful safety improvements, was a factor considered by the Commissioners.

Other Considerations:

On June 2, the PRC and the Mercer Island Arts Council held a joint meeting and discussed opportunities to integrate art and/or placemaking elements into the project that would be consistent with the Aubrey

Davis Park Master Plan. The PRC understands that placemaking elements incorporated into the trail could foster more considerate behaviors among trail users but also wants any features to be compatible with the park's natural landscape, including employing judicious selection of themes and colors. These recommendations will be transmitted to the Arts Council to further inform their discussions of how to use the project's 1% for Art in Public Places contribution (approximately \$3,500).

Conclusion:

We look forward to seeing this project advance to 60% Design and request the opportunity to provide our recommendation at the completion of that phase.



Aubrey Davis Park Trail Improvements
 30% Engineer's Opinion of Probable Construction Costs
 3/31/2023



No.	Spec No.	Description	Quantity	Unit	Unit Cost	Total
Trail + Restroom Improvements						
A1	1-04	Minor Change	1	EST	\$ 30,000.00	\$ 30,000.00
A2	1-05	Roadway Surveying	1	LS	\$ 5,000.00	\$ 5,000.00
A3	1-05	Record Drawings (Minimum Bid \$3,000)	1	LS	\$ 3,000.00	\$ 3,000.00
A4	1-07	ADA Feature Surveying	1	LS	\$ 5,000.00	\$ 5,000.00
A5	1-07	SPCC Plan	1	LS	\$ 1,000.00	\$ 1,000.00
A6	1-08	Type B Progress Schedule (Minimum Bid \$5,000)	1	LS	\$ 5,000.00	\$ 5,000.00
A7	1-09	Mobilization	1	LS	\$ 35,000.00	\$ 35,000.00
A8	1-10	Project Temporary Traffic Control	1	LS	\$ 10,000.00	\$ 10,000.00
A9	2-01	Clearing and Grubbing	1	LS	\$ 6,000.00	\$ 6,000.00
A10	2-02	Removal of Structures and Obstructions	1	LS	\$ 10,000.00	\$ 10,000.00
A11	2-02	Asphalt Pavement Removal Incl Haul	430	SY	\$ 25.00	\$ 10,750.00
A12	2-02	Cement Conc. Sidewalk Removal Incl Haul	40	SY	\$ 35.00	\$ 1,400.00
A13	2-03	Roadway Excavation Incl. Haul	1	LS	\$ 10,000.00	\$ 10,000.00
A14	4-04	Crushed Surfacing Top Course	100	TON	\$ 55.00	\$ 5,500.00
A15	5-04	HMA CI 1/2" PG 58H-22	30	TON	\$ 350.00	\$ 10,500.00
A16	8-01	Erosion/Water Pollution Control	1	EST	\$ 5,000.00	\$ 5,000.00
A17	8-02	Topsoil Type A	90	CY	\$ 55.00	\$ 4,950.00
A18	8-02	Wood Chip Mulch	90	CY	\$ 70.00	\$ 6,300.00
A19	8-02	Fine Compost	90	CY	\$ 55.00	\$ 4,950.00
A20	8-02	Seeded Lawn Installation	670	SY	\$ 3.00	\$ 2,010.00
A21	8-02	PSIPE	1	LS	\$ 5,000.00	\$ 5,000.00
A22	8-12	Temporary Chain Link Fence	350	LF	\$ 4.00	\$ 1,400.00
A23	8-12	Low Fencing	135	LF	\$ 30.00	\$ 4,050.00
A24	8-14	Cement Concrete Trail	390	SY	\$ 125.00	\$ 48,750.00
A25	8-14	Scored Cement Concrete with Contrasting Texture or Pigmented Treatment	290	SY	\$ 80.00	\$ 23,200.00
A26	8-20	Trail Illumination at Underpass	1	LS	\$ 40,000.00	\$ 40,000.00
A27	8-21	Permanent Signing	1	LS	\$ 25,300.00	\$ 25,300.00
A28	8-22	Channelization and Striping	1	LS	\$ 18,260.00	\$ 18,260.00
A30	8-35	Wayfinding Signage	5	EA	\$ 1,500.00	\$ 7,500.00
Subtotal						\$ 344,820.00
Sales Tax (10.1%)						\$ 34,826.82
Engineer's Opinion of Probable Construction Costs						\$ 379,646.82

Parks & Recreation Commission

2023 Planning Schedule

1st Thursday of Month- Regular Meetings

Updated: 2/24/23



Date	Meeting Type	Agenda Item
5-Jan	Regular	ADTS Improvement Project 30% Design Recommendation
		Bike Skills Area Conceptual Design Update
2-Feb	Regular	2023 CIP Projects Update
		Bike Skills Area Design Update
2-Mar	Regular	ADTS Improvement Project 30% Design Update
		LB Pickleball Court- Exclusivity Discussion
April Cancelled	Regular	
4-May	Regular	Mercer Island Library- Annual Update
		ADTS 30% and Memo
1-Jun	Regular	Chair/Vice-Chair Elections
		Recreation Facility Naming Policy
		*2022 Recreation Division Annual Report (Memo)
6-Jul	Regular	Bylaws Review
		Gift Acceptance Policy *update*
August		No Meetings Summer Break
7-Sep	Regular	
5-Oct	Regular	
2-Nov	Regular	
Dec. TBD	Regular	PROS Plan Goals and CIP Progress Update
		Recreation Policy Implementation Status Update (Memo)

Item Type	Items to be scheduled
------------------	------------------------------

Policy	Park Code/Rules Updates- signage in parks, appropriate uses of space, etc. <i>(as needed)</i>
Policy	Park Zoning - Planning Commission/CPD
Policy	Recreation Sponsorship
Policy	Recreation Service Scholarship
Project	Mercedale/Groveland & Clarke Master Plan Kick-off
Project	Luther Docks Project <i>(Periodic touch points)</i>
Project	Aubrey Davis Trail Safety Project <i>(Periodic touch points)</i>
Project	Bike Skills Area <i>(Periodic Touch points)</i>
Annual Agenda Items	
KCLS- Mercer Island Branch Operations Update (March)	
Annual PRC Chair/Vice-Chair Elections (May)	
PROS Plan Goals/Implementation Update (June)	
Annual Bylaws Review (July)	
Various CIP Recommendations (TBD)	
Annual Year-End Report	