



ARTS COUNCIL REGULAR VIDEO MEETING

Wednesday, October 19, 2022 | 5:30pm

BOARD MEMBERS:

Chair: Elizabeth Mitchell
Vice Chair: Suzanne Skone
Board Members: Daniel Becker, Rachel Blum,
Jonathan Harrington, Rosemary Moore, Lalo Bruhl

LOCATION & CONTACT

Zoom Meeting

In compliance with the Americans with Disabilities Act, those requiring accommodation for meetings should notify the Staff Liaison at least 24 hours prior to the meeting at 206.275.7706.

Virtual Meeting Notice

The virtual meeting will be broadcast live on Zoom and recorded and saved on the City's [YouTube Channel](#).

Registering to Speak: Individuals wishing to speak live during Appearances must register their request with the staff liaison at **206.275.7600** or [email](#) before 4 PM on the day of the Arts Council meeting. Please reference "Appearances" on your correspondence. Each speaker will be allowed three (3) minutes to speak.

Join by Telephone at 5:30 PM: To listen to the meeting via telephone, please call **253.215.8782** and enter Webinar ID **891 2336 1265** Password **076260** when prompted.

Join by Internet at 5:30 PM: To watch the meeting over the internet via your computer, follow these steps:

- 1) Click [this link](#).
- 2) If the Zoom app is not installed on your computer, you will be prompted to download it.
- 3) If prompted for Webinar ID, enter **891 2336 1265**; Enter Password **076260**

Join in person at Mercer Island Community & Event Center at 5:30 PM: Mercer Island Community & Event Center
8236 SE 24th Street.

CALL TO ORDER & ROLL CALL - 5:30 PM

PUBLIC APPEARANCES

DEPARTMENT REPORT

1. Department Report

REGULAR BUSINESS

2. Approve the minutes of the July 20, 2022 Regular Meeting
Recommended Action: Approve minutes.
3. Approve the minutes of the September 14, 2022 Special Meeting
Recommended Action: Approve minutes.
4. Arts Council Events Subcommittee Update
Recommended Action: Receive the update and provide input
5. Public Art Committee Update
Recommended Action: Receive the staff report and update from committee members
6. Policy Subcommittee Update
Recommended Action: Discuss and establish priorities

OTHER BUSINESS

7. 2023 Arts Council Planning Schedule Update

ADJOURNMENT

Mercer Island Arts Council

Item 1.



Department Report
October 19, 2022



Celebrating Art this October

- October is National Arts & Humanities Month!
- We're celebrating Mercer Island's art, culture, heritage, and more all month.
- Follow us on Instagram for a new post every week, and share your own MI art/culture experiences with us!
- To get started, visit <http://instagram.com/cityofmercerisland>

Rocktober Event for MI Seniors

- The Recreation team is hosting Rocktober, a free event for seniors at MICEC on **October 21, from 11:30am – 2pm.**
- Rocktober will be an afternoon of learning the Roots of Rock ‘n Roll, boxed lunch, root beer garden, a live band... and Elvis!
- Registration is required. Visit www.mercerisland.gov/calendar for event details.
- Our sincere thanks to Aljoya for sponsoring this event!



ROCKTOBER!

A FREE EVENT FOR OUR SENIOR COMMUNITY!

Presented by The City of Mercer Island & Aljoya

 **ALJOYA**
Where senior living is full of JOY.

Questions?
Contact Larry Almo at 206.230.0150 (Aljoya)
Contact Katie Herzog 206.795.8518 (City of MI)

OCTOBER 21 | 11:30AM - 2PM
MERCER ISLAND COMMUNITY & EVENT CENTER

SPECIAL GUEST SPEAKERS:

JESSI BON
WELCOME FROM THE CITY MANAGER

JOHN JENSEN 12 PM
THE ROOTS OF ROCK 'N ROLL

LARRY ALMO
THE ALJOYA COMMUNITY

SOUL SEARCHING BAND 1 PM
WITH SPECIAL GUESTS!

LIVE MUSIC, BOXED LUNCH*, ROOT BEER GARDEN, ELVIS AND MORE!

**Registration is required! Must be 3 days in advance for lunch*

206-275-7609 | COURSE #16566



MERCER ISLAND HALLO-WEEKEND

TRICK OR TREAT IN TOWN CENTER
Friday, October 28, 4 - 6pm

Find a map of participating businesses at www.mercerisland.gov/mihalloweekend

Coordinated by  

Pumpkin Walk
Sunday, October 30, 5 - 8pm
Mercerdale Park

Join a fun, family friendly walk along the Mercerdale loop. The path will be lined with a glowing display of carved pumpkins.

Carvers of all ages are encouraged to participate in the display. Carved pumpkins can be dropped off from 12pm - 4pm on the day of the event at Mercerdale Park. Pumpkins can be retrieved the following day (if desired).

Hallo-Weekend Events

- Town Center Trick or Treating, in partnership with the Chamber of Commerce, will be on Friday, October 28 from 4 – 6pm.
- The Pumpkin Walk is on Sunday, October 30 at Mercerdale Park from 5 – 8pm.
 - We need carved pumpkins for the event!
 - Carved pumpkins can be dropped off from 12-4pm on the day of the event at Mercerdale Park.
 - Fun additions this year including food trucks, a professional pumpkin carver, 88.9 The Bridge on-site for tunes, and more!
 - Special thanks to our sponsors: MI Martial Arts, John L. Scott & Greg Rosenwald Real Estate.
- Visit www.mercerisland.gov/mihalloweekend for all the details!



MIVAL Holiday Show 2022



- The MIVAL Holiday Show will be from Oct 24th through December 16th.
 - This year's 2022 annual Holiday Show will be held at MICEC (Mercer Island Community and Events Center) and MIVAL Gallery.
 - Be sure to stop by and see this year's works! The show often includes wreaths, ornaments, cards, jewelry, scarves, small 2D and 3D items. And, of course, holiday items are very popular.
- 

Illuminate MI

- Illuminate MI returns this winter with lights in Town Center!
- We will be hosting a Tree Lighting with various other community activities on the evening of December 2nd.
- More information will be out soon on our website and social media platforms, keep an eye out for more!

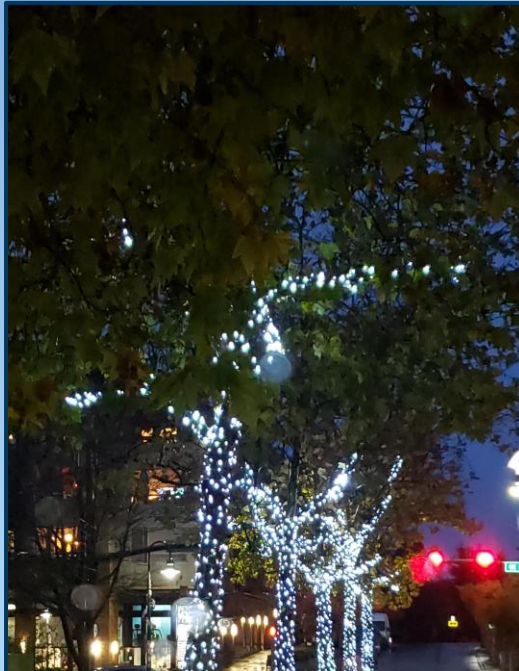

Thank You!





ARTS COUNCIL MINUTES

SPECIAL VIDEO MEETING

Wednesday, July 20, 2022

CALL TO ORDER

Chair Elizabeth Mitchell called the meeting to order at 6:32 pm via Zoom Online meeting.

ROLL CALL

Chair Mitchell, Vice Chair Suzanne Skone, Daniel Becker, Rachel Blum, Jonathan Harrington, and Rosemary Moore were present for the Arts Council.

Mayor Salim Nice was present.

Staff present were Ryan Daly, Sarah Bluvus, Eleanor Knight, and Raven Gillis.

PUBLIC APPEARANCES

No public appearances.

DEPARTMENT REPORT

Ryan Daly, Recreation Manager, introduced Eleanor Knight as the Arts Council Liaison. Eleanor Knight, Recreation Coordinator, reported on the following items:

- Summer Celebration!
- MIVAL Community Flags Project at Mercerdale Park!
- Shakespeare in the Park
- Mostly Music in The Park
- Kirk Robinson Skate Park Dedication – Save the Date! Thursday, 7/28 at 5pm
- Aubrey Davis Park Picnic Shelter project is complete and available to rent!

REGULAR BUSINESS

1. Approval of Minutes

Minutes from the April 20, 2022 Regular Meeting were presented.

It was moved by Becker; seconded by Harrington to:

Approve the minutes from the April 20, 2022 meeting

Passed: 6 – 0

2. Public Art Donation Proposal

Ryan Daly, Recreation Manager, and Sarah Bluvus, CIP Project Manager, introduced the Public Art Donation Proposal. Berger Partnership presented. Arts Council Members received the presentation, offered feedback and supported moving forward with the design proposal.

3. Mercer Island Arts Summit Review

Eleanor Knight presented. Arts Council received presentation and engaged in discussion.

4. Annual Arts Council Bylaws Review

Eleanor Knight presented the Arts Council Bylaws suggested edits to include Arts Council Members input, and the Arts Council Members provided consensus on the edits.

It was moved by Moore; seconded by Becker to:

Approve the Arts Council Bylaws as amended and pending the review of the City Clerk

Passed: 6 – 0

5. Arts Council Planning Schedule and Committee Update

Ryan Daly, Recreation Manager, and Sarah Bluvus, CIP Project Manager, provided the update to the Arts Council. Arts Council members received update, and:

- Provided consensus on adding a Special Meeting in September to discuss the Arts Elements on the Aubrey Davis Trail Safety Improvements 30% Design, and to receive an update on the Luther Docks 30% Design.
- Provided consensus to establishing a Public Art committee to help steward projects and bring information back to the Arts Council. Staff agreed to also include a primer on the 1% Fund during the September Special Meeting.
- Provided consensus to restart and streamline the Policy Committee and the Special Events Committee work, by dissolving the Arts Summit Committee, and to appoint Committee Chairs to oversee scheduling committee meetings and serve as a liaison between the committee, staff, and the full Arts Council. Chair Mitchell invited Arts Council Members to voice their interest in serving as Chair.
 - Moore stepped forward to serve as Policy Committee Chair.
 - Chair Mitchell stepped forward to serve as Special Events Committee Chair.

OTHER BUSINESS

The date and time of the Arts Council Special Meeting in September is to be determined. The next Arts Council Regular Meeting will take place Wednesday, October 19, at 5:30pm via Zoom.

ADJOURNMENT

The Regular Video Meeting adjourned at 7:54pm.



ARTS COUNCIL MINUTES SPECIAL VIDEO MEETING Wednesday, September 14, 2022

CALL TO ORDER

Chair Mitchell called the meeting to order at 5:35 pm via Zoom Online meeting.

ROLL CALL

Council Members Elizabeth Mitchell, Rosemary Moore, Daniel Becker were present. Suzanne Skone joined the meeting at 6:04pm.

Mayor Salim Nice was present.

Staff present were Ryan Daly, Sarah Bluvias, Paul West, and Eleanor Knight.

PUBLIC APPEARANCES

NO PUBLIC APPEARANCES

REGULAR BUSINESS

1. Overview of 1% for Art in Public Places Fund

Staff discussed 1% fund and requests that a Public Art Committee be formed.

The Arts Council lacked a quorum of members to vote; the Chair may elect to establish and assign members to the Committee.

2. Discussion of Luther Burbank Park Waterfront 1% for Art Opportunities

Paul West, CIP Project Manager, and an Anchor QEA consultant presented on 1% for Art Opportunities for the Luther Burbank Waterfront capital project.

3. Update on Aubrey Davis Park Trail Safety Improvements 1% for Art Opportunities

West presented an update on 1% for Art Opportunities for the Aubrey Davis Park Trail Safety Improvements capital project.

OTHER BUSINESS

It was moved by Becker; seconded by Moore to:

Reestablish the Public Art Committee

Passed: 4 – 0

ADJOURNMENT at 6:39 PM



ARTS COUNCIL STAFF REPORT

Item (4)
October 19, 2022
Regular Business

AGENDA ITEM INFORMATION

TITLE:	Arts Council Events Committee Update	<input checked="" type="checkbox"/> Discussion Only <input type="checkbox"/> Action Needed: <input type="checkbox"/> Motion <input type="checkbox"/> Ordinance <input type="checkbox"/> Resolution
RECOMMENDED ACTION:	Receive the staff report and update from committee members	

STAFF:	Katie Herzog
COUNCIL LIAISON:	Salim Nice
EXHIBITS:	

SUMMARY

At the April 20, 2022 Arts Council meeting, it was decided that an Events Committee be established to work with staff on priorities pertaining to city-coordinated special events, in relation to arts and culture and to meet goals set in the 2022 City Arts and Culture Work Plan. The committee is supported by Katie Herzog, Recreation Coordinator, and will meet regularly through 2023 to discuss the priorities and how they can be implemented with upcoming city-coordinated events. The Committee is recommending these objectives to be included in the 2023 – 2024 Arts and Culture Work plan.

The committee members include Chair Elizabeth Mitchell, Daniel Becker and Rachel Blum.

Staff members Katie Herzog and Eleanor Knight met with Chair Mitchell and Becker on September 7, 2022 for the first committee meeting. Discussions were centered around city-coordinated annual events, recommendations for improvements, goals from the 2022 Arts and Culture work plan, and key priorities and objectives to guide staff on ways to enhance future events.

The key objectives taken from the meeting, to recommend are:

1. Develop communication tools to easily share arts and culture events with the Mercer Island community.
2. Gain partnerships to expand activities for people of all ages within existing community events through arts and culture.
3. Work with event partners to engage in environmentally friendly efforts (event giveaways, promotional items).
4. Create presence and exposure at events for the Arts Council to engage with the community.

If endorsed, staff would prioritize these objectives to move forward to the Policy Committee to include within the Arts and Culture work plan for 2023/2024.

RECOMMENDED ACTION

Receive the staff report and update from committee members



Events Committee Update

Arts Council

October 19, 2022

Background

- April 20, 2022 – At the Arts Council meeting, it was decided that an events committee be established to inform staff on arts and culture priorities to enhance existing city-coordinated events.
- Members: Chair Elizabeth Mitchell, Daniel Becker & Rachel Blum
- The events committee met with staff on September 7 for our first meeting.





2022 City Arts and Culture Work Plan

PRIORITY 1: STABILIZE ARTS COUNCIL MEMBERSHIP,
VOLUNTEERSHIP, AND OPERATIONS

PRIORITY 3: GARNER COMMUNITY INPUT ON AND SUPPORT
OF CITY ARTS AND CULTURE



Objectives

1. Develop communication tools to easily share arts and culture events with the Mercer Island community.
2. Gain partnerships to expand activities for people of all ages within existing community events through arts and culture.
3. Work with event partners to engage in environmentally friendly efforts.
4. Create presence and exposure at events for the Arts Council to engage with the community.



Tonight

- Receive additional input from the committee members
- Encourage the Arts Council to discuss the objectives
- We will come back to this topic tonight to integrate these objectives into the City Arts and Culture workplan for 2023/2024





ARTS COUNCIL STAFF REPORT

Item 5
October 19, 2022
Regular Business

AGENDA ITEM INFORMATION

TITLE:	Public Art Committee Update	<input checked="" type="checkbox"/> Discussion Only <input type="checkbox"/> Action Needed: <input type="checkbox"/> Motion <input type="checkbox"/> Ordinance <input type="checkbox"/> Resolution
RECOMMENDED ACTION:	Receive the staff report and update from committee members.	

STAFF:	Sarah Bluvas, CIP Project Manager	
COUNCIL LIAISON:	Salim Nice	
EXHIBITS:	<ol style="list-style-type: none"> MICC 4.40.200 1% for Art in Public Places Fund Luther Burbank Docks and Waterfront Renovation Project 1% for Art Opportunities 	

SUMMARY

On September 14, the Arts Council established a Public Art Committee to work with staff on upcoming public art project and policy needs. The committee is supported by Sarah Bluvas, CIP Project Manager, and will meet regularly through 2023 to steward CIP-related public art projects, develop a recommended 1% spending plan, review existing and new public art policy drafts, and/or complete other projects as time and priority allow. The committee will ultimately be responsible for recommending public art policy items and projects to the full Arts Council for final review and endorsement. The Arts Council Chair appointed Daniel Becker and Suzanne Skone to the committee.

The committee’s first major project will be developing the request for proposals (RFP) for 1% for Art in Public Places Fund (1%) opportunities for the Luther Burbank Waterfront Improvements (LBWI) capital project. Per MICC 4.40.200 (**Exhibit 1**), the 1% fund pools contributions from qualifying capital improvement program (CIP) projects to support Art in Public Places (AIPP) projects on Mercer Island. Staff estimate a 1% contribution of \$40,000-\$50,000 from the LBWI and associated Luther Burbank docks/waterfront capital projects. CIP Project Manager Paul West has planned for using the estimated 1% contribution for functional art elements that integrate into the LBWI design. West and Noelle Higgins from Anchor QEA presented on arts integration on September 14 (**Exhibit 2**; 09.14.22 Meeting Materials: [Agenda Packet \[Item 2\]](#) | [Video Meeting Recording](#)). They requested that the Public Art Committee work with staff and the consultant to solicit an artist to integrate into the project team and develop arts elements to be included in the 90% design.

The committee, Bluvas, West, and Higgins kicked off this work on October 10, 2022. Below is a summary of the project work plan for the LBWI 1% integration.

- October 2022-March 2023: Artist solicitation process – Includes RFP development, selection process, Arts Council review, City Council appropriation, and contract execution

- March-June 2023: Concept development – Includes integrating into landscape architecture team, public process to collect community feedback on proposals, and conducting joint meeting with Arts Council and Parks & Recreation Commission
- June-October 2023: Arts Council recommendation – Includes two review rounds by Public Art Committee, presentation to Arts Council, and recommendation by Arts Council to be transmitted to the City Council with the 90% design

Additionally, the committee provided feedback on key components of the RFP, including:

- Preference for a regional call for artists (Pacific Northwest focus);
- Interest in a cohesive arts integration to pull the site together; and
- Interest in providing a project budget range that may necessitate recommending additional funds beyond the project estimated 1% contribution be appropriated from the existing 1% fund.

Staff and the consultant are drafting the RFP now to review it with the Public Art Committee at its second meeting on October 31, 2022. Following that meeting, the committee may request that the Arts Council schedule a special meeting in November or December to seek endorsement of the RFP from the full Arts Council.

RECOMMENDED ACTION

Receive the staff report and update from committee members.

4.40.200 1% for art in public places fund.

- A. There is established in the city treasury a special fund to be known and designated as the "1% for art in public places fund" for the purpose of providing funds for 1%-for-the-arts projects.
- B. As used in connection with the 1% for art in public places funds and 1%-for-the-arts projects, the following terms have the meanings set forth below:
1. *Acquisition of real property* means the purchase of parcels of land or existing buildings and structures, including associated costs such as appraisals or negotiations.
 2. *Art in public places* means any expression by an artist of visual works of art available to the public in an open city-owned facility in areas designated as public areas, or on non-city-owned property if the work of art is installed or financed, either in whole or in part, by the city.
 3. *Arts council* means the Mercer Island arts council.
 4. *Demolition costs* means the cost of removing buildings or other structures from the property.
 5. *Equipment* means equipment or furnishings that are portable.
 6. *Qualifying capital improvement project* means projects funded wholly or in part by the city to construct or remodel any public project including buildings, decorative or commemorative structures, parks or any portion thereof; and projects involving the construction, renovation or repair of public streets, sidewalks, and parking facilities.
- C. All authorizations and/or appropriations for qualifying capital improvement projects shall include an amount of not less than one percent of the total project cost to be set aside for transfer to the 1% for art in public places fund.
- D. For qualifying capital improvement projects, the minimum amount to be appropriated for art in public places shall be as follows:
1. When the total estimated cost of a project exceeds \$100,000.00 the amount shall be based on the total amount of the awarded contract as originally approved by the city council or as subsequently amended multiplied by one percent.
 2. When the estimated cost of the project is \$100,000.00 or less the amount shall be based on the estimated cost of the project multiplied by one percent.
- Provided, however, that any city-funded amount for the acquisition of real property or equipment or for demolition shall be excluded for the purposes of this calculation.
- E. In the case of a city project which involves the use of general obligation bond proceeds, funds appropriated shall be used for projects and for capital purposes consistent with the authorizing resolution or ordinance approved by the city council and the voters.
- F. The appropriations from qualifying capital improvement projects shall be pooled into the 1% for art in public places fund. The city council, upon advice and recommendation from the arts council, shall approve, from time to time, the amount to be authorized for 1%-for-the-arts projects. These funds shall be used for:
1. Selection, acquisition and installation or display of original works of visual art which may be an integral part of the project, or be placed in, on or about the project or in another public facility; and
 2. Repairs and maintenance of public art acquired with 1%-for-the-arts funds; and
 3. Other project-specific expenses of selection and acquisition; provided, that no part of the funds shall be used to pay administrative staffing expenses of the program.

-
- G. Any unexpended 1%-for-the-arts funds which remain in the 1% for art in public places fund at the end of any budget year shall not be transferred to the general fund or otherwise lapse, but said unexpended funds shall be carried forward from year to year until expended for the purposes set forth in this section, unless otherwise directed by the city council.
- H. Annually, the arts council shall make recommendations to the city council that will reflect short and long range planning for art works and sites regarding the appropriation of 1%-for-the-arts funds. The recommendations will relate to but will not be limited by the following:
1. Art projects will be responsive to the developing public art needs of the community;
 2. Art projects will reflect the scope, scale and character of the site; and
 3. Art projects will be part of new parks and building developments. The arts council shall carry out all necessary tasks and procedures consistent with established arts policies for the selection, placement and conservation of art works.
- I. All works of art purchased and commissioned from the 1% for art in public places fund shall be the property of the city and shall become part of the city art collection. The city art collection shall be developed, administered and operated by the Mercer Island Arts Council.

(Ord. 13C-10 § 1; Ord. A-108 § 1, 1993. Formerly 4.40.970—4.40.977)

Integrated Public Art Opportunities

Luther Burbank Dock Repair and Upland Improvements Project
60% Design

September 14, 2022

Presented by
Paul West, City of Mercer Island
Noelle Higgins, Anchor QEA



Agenda

Recap from Last Meeting

Boiler Building Interpretive Program

60% Design Update and Opportunities

Next Steps

Recap

- Last meeting in Sept 2021
- Reviewed 30% design
- Reviewed approach to Handsome Bollards
- Discussed opportunities for integrated public art



Handsome Bollards Proposed Openings



Opportunities for Integrated Art

Recommended theme – Nautical



Types of Art and Media

Sculptural elements to define entrances



mbauer Bay Park - Bellevue



Item 5.

Types of Art and Media

Sculptural elements to define entrances



Northwind Fishing Weir Legend
Susan Point
Green River Trail

Types of Art and Media

Paving treatments with embedded materials and text

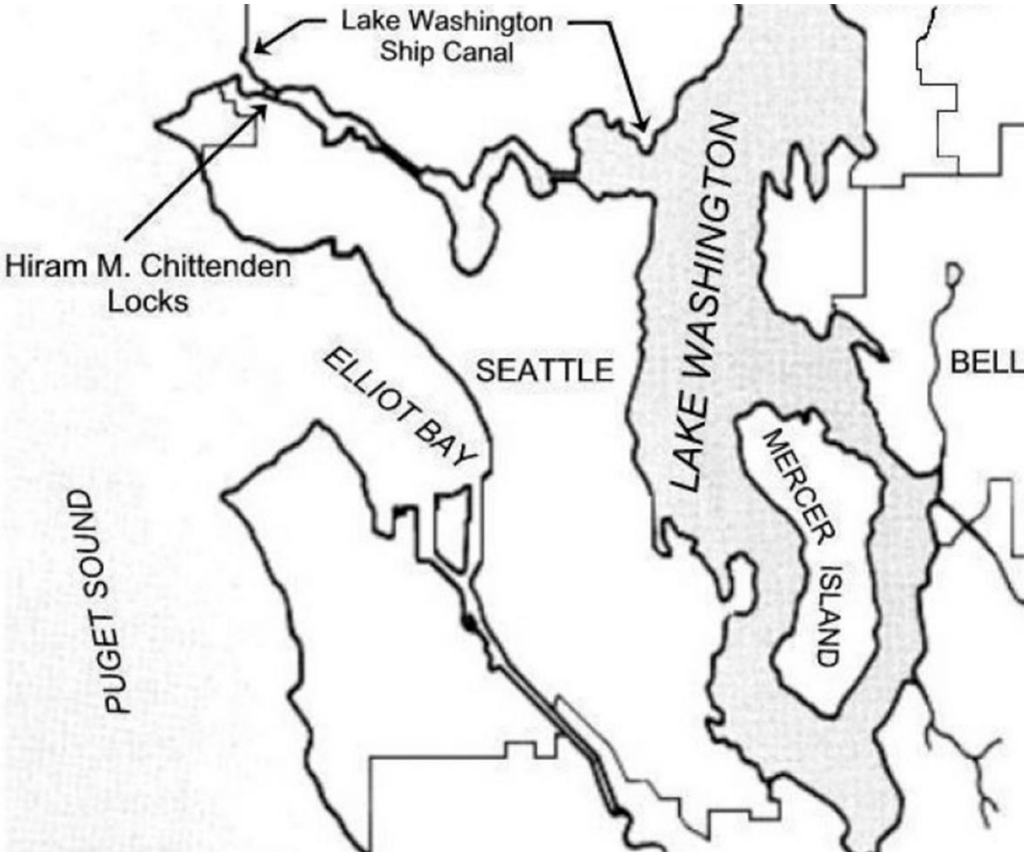

Types of Art/ and Media Custom park elements

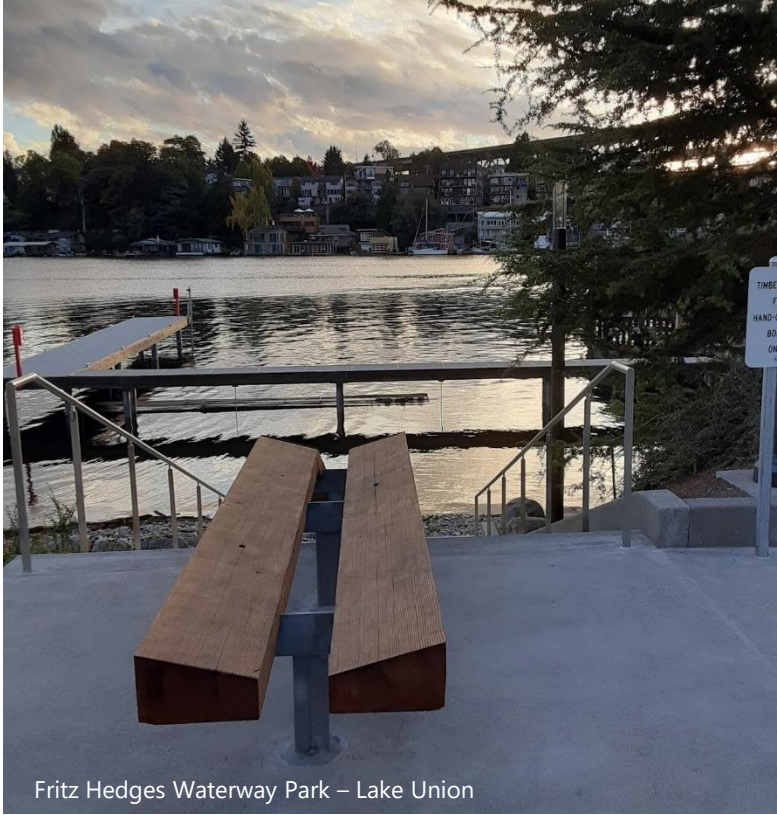

Fritz Hedges Waterway Park – Lake Union



Manitou Beach Public Access

Types of Art and Media

Custom park elements – railings, handrails, fences



Fritz Hedges Waterway Park – Lake Union



Manitou Beach Public Access



Water—The Essence of Life
Susan Point
West Seattle Pump Station

Types of Art and Media

Standalone and sculptural pieces



Compass, Alan Storey
Bellevue City Hall



The Blue Trees, Konstantin Dimopoulos
Burke-Gilman Trail

Boiler Building Interpretive Program

Artistic Plaques with QR Codes



Artistic plaque style for the Boys Parental School era (1903–1965) of Luther Burbank Park.

Minimum

- 1. The School Building
- 2. The Boiler Building
- 3. The Dairy Barn Ruins
- 4. The Remnant Fruit Trees

Add QR code to existing sign



Future phases to cover:

- 1. Natural history of park and lake
- 2. Pre-colonial history & First Peoples' experience
- 3. Park development history and modernist landscape architecture

Mercer Island's STQRY Platform

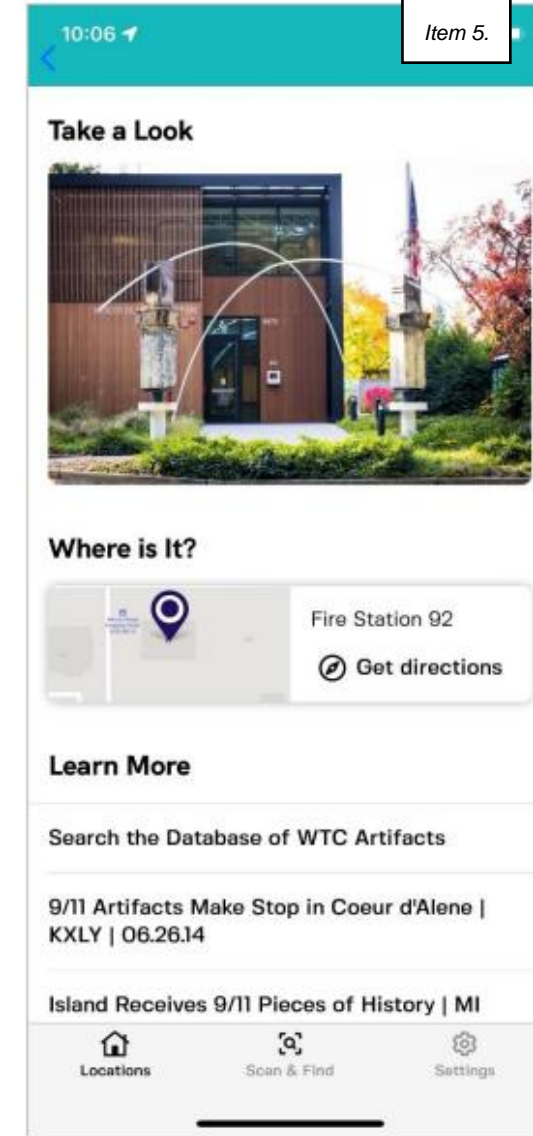
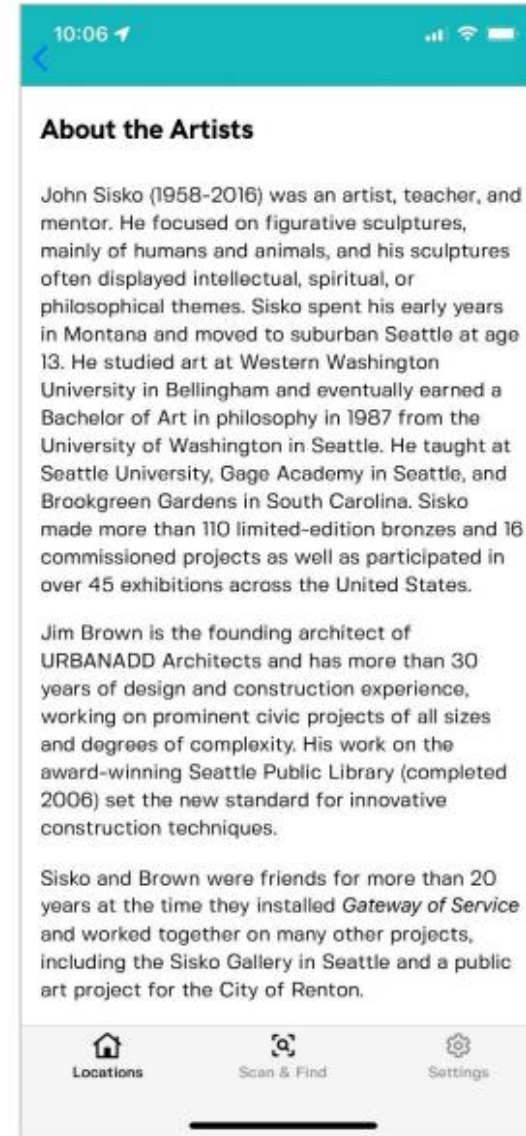
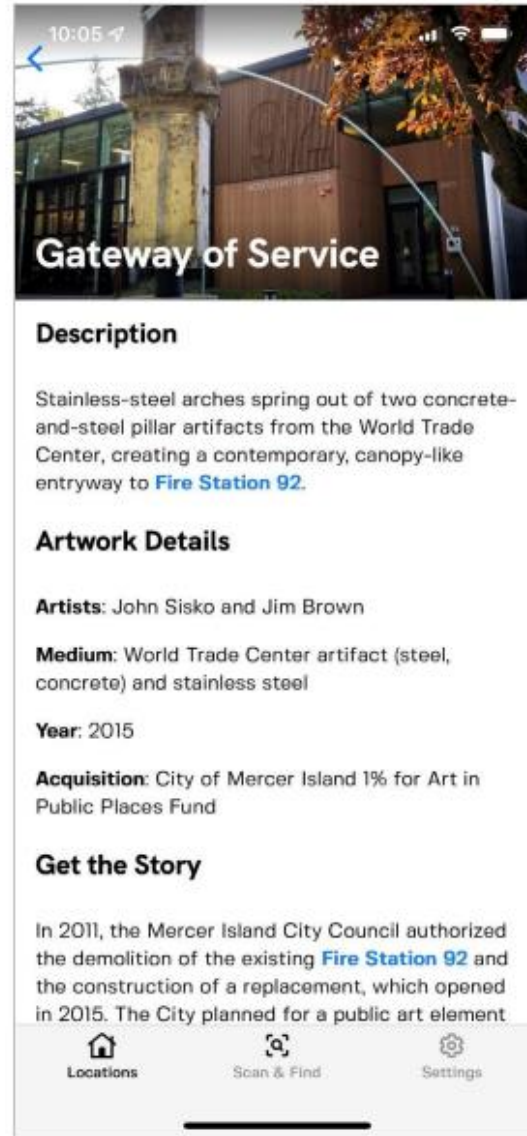

Screenshot examples of a Mercer Island art feature on the STQRY platform

Mercer Island's Interpretive Signage QR Code

example of Mercer Island's existing interpretive signs for public art. Try the QR code!

STAN
GEORGIA GERBER
2013

This artwork is part of the City of Mercer Island's permanent art collection. It was donated to the collection by Brandy & Pete Nordstrom.



60% Design Update and Opportunities

Overwater Stair Feature

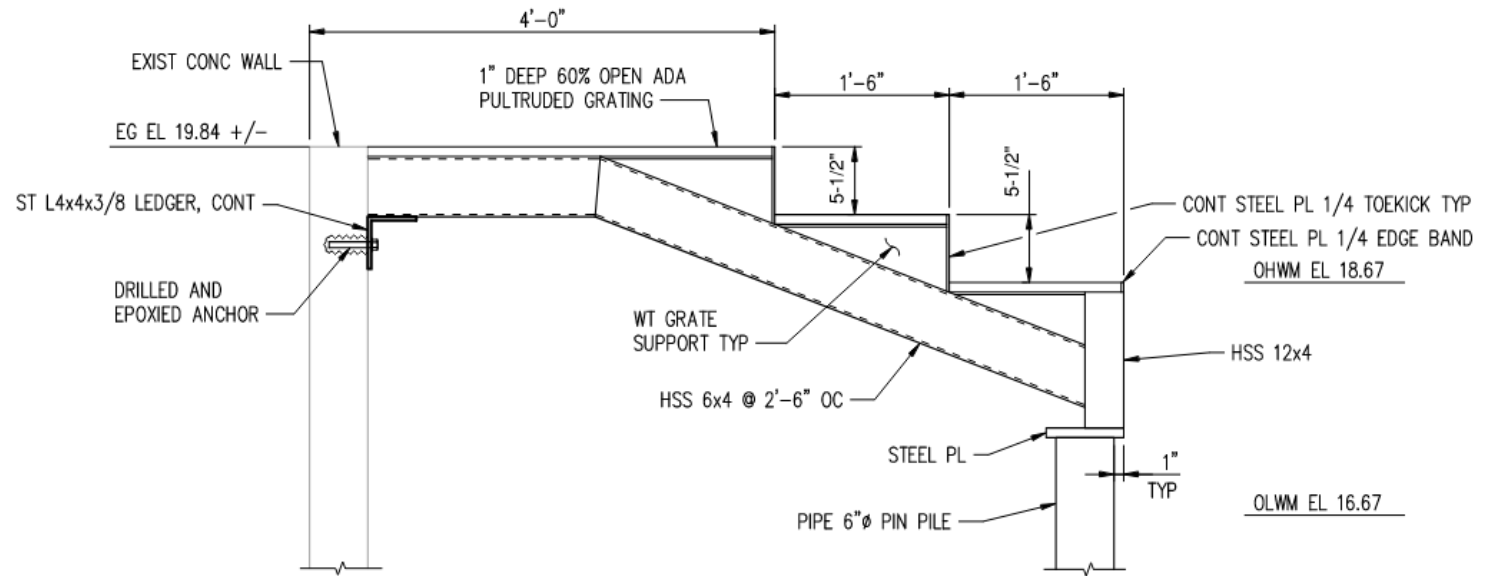

60% Design – Integrated Art Opportunities

Handrails

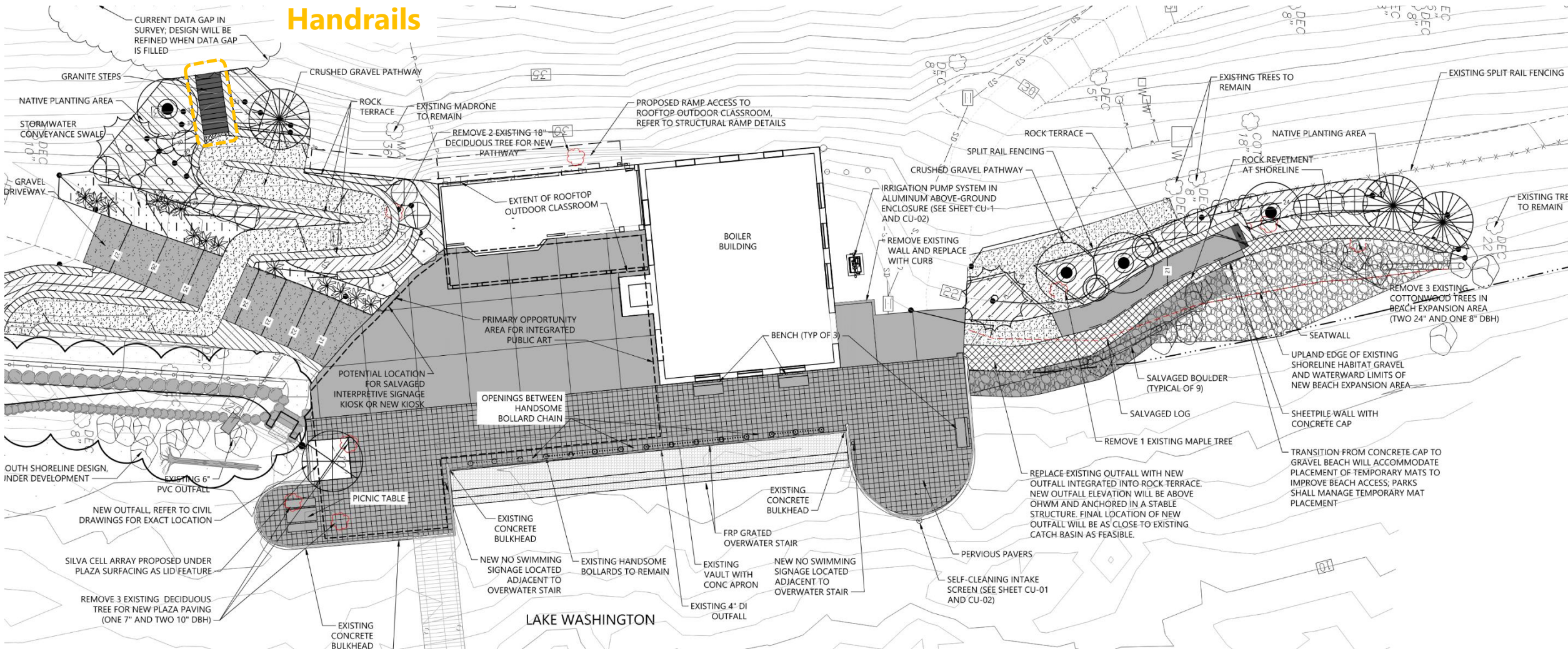

60% Design – Integrated Art Opportunities

Handrails

Lean Rail

Benches

Paving treatments

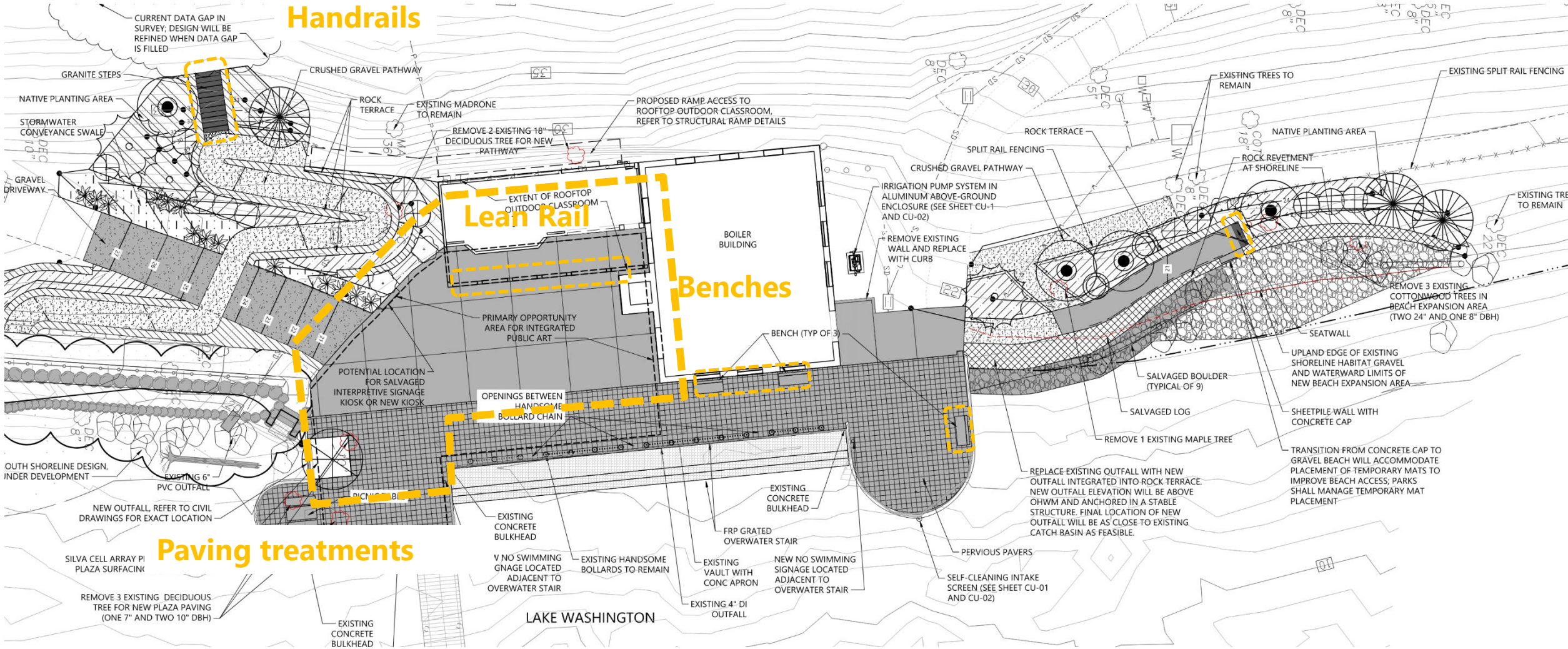

Thank you



ARTS COUNCIL STAFF REPORT

Item (6)
October 19, 2022
Regular Business

AGENDA ITEM INFORMATION

TITLE:	Policy Subcommittee Update	<input type="checkbox"/> Discussion Only <input checked="" type="checkbox"/> Action Needed: <input checked="" type="checkbox"/> Motion <input type="checkbox"/> Ordinance <input type="checkbox"/> Resolution
	RECOMMENDED ACTION:	

STAFF:	Eleanor Knight
COUNCIL LIAISON:	Salim Nice
EXHIBITS:	Exhibit 1: Draft 2023-2024 City Arts and Culture Priorities

SUMMARY

Background

During the first two regular meetings of the year, the Arts Council formed various Committees to assist staff in addressing items on the Recreation Division’s Arts & Culture Work Plan. The Policy Subcommittee is comprised of the following:

Policy Committee: Arts Council members Suzanne Skone, Jonathan Harrington, Rosemary Moore
Staff members: Eleanor Knight, Sarah Bluvas

The first major task of the subcommittee was to revise and bring forward the 2023-2024 City Arts and Culture Priorities. The discussion between committee members focused on the needs of the community, such as communication needs, stewarding sustainable practices, and cultural celebration. Committee members expressed the need for communication between arts community members (internal communication), as well as communication with the City and public (external communication). Communication as a priority was developed through discussions about the Arts Summit, held in June 2022, and the responses from art community members that were present. Committee discussions also led to a greater understanding of the need to encourage and support cultural celebration and diversity in the Mercer Island arts community. The committee discussed the need for support of cultural events and programs, as well as encouraging diversity citywide.

The proposed priority items are present in Exhibit 1. The priorities were developed by staff following two meetings with the subcommittee members, who discussed several perceived needs and desired actions for the upcoming biennium based on discussions with community members, arts organizations, and other stakeholders. Some examples of proposed actions that would fall under the proposed priorities are:

- Centralized communication for the Mercer Island arts community (Priority 1)
- Diversify offerings and encourage cultural celebration through arts programming and events (Priority 2)

These examples and other proposed actions would be included as subsections of the main priorities (e.g. 1.1, 2.1).

Staff is requesting that the Arts Council review the suggested priorities tonight. The Council will add, remove, or adjust the priorities for 2023/2024 City Arts and Culture, and suggest proposed actions that fall under these priorities. A motion can be made by the Council to endorse these priorities after discussion.

Next Steps

1. The Arts Council will discuss and define the priority items and proposed action items.
2. Staff will review the discussion and synthesize a final 2023-2024 City Arts and Culture Workplan.
3. The Workplan will be reviewed at the January 2023 meeting for endorsement.

RECOMMENDED ACTION

Discuss priorities, and possibly move to endorse.

2023-2024 City Arts and Culture Priorities

DRAFT

Priority Categories:

- Communications/Awareness
- Long-range Planning
- Partnerships
- Programs/Events

Priority 1: Strengthen community awareness of and support for Mercer Island’s arts & culture ecosystem.

Categories:

- Communications/Awareness
- Partnerships
- Programs/Events

Priority 2: Invite new dialogues and partnerships to support emerging arts and culture themes in the community.

Categories

- Communications
- Partnerships
- Programs/Events

Priority 3: Complete two major City arts and culture policy projects:

- 1. Update the Comprehensive Arts & Culture Plan (appendix to the Citywide Comprehensive Plan)**
- 2. Develop a Six-Year Spending Plan for the 1% for the Art in Public Places Fund**

Categories

- Long-Range Planning
- Partnerships
- Communications/Awareness

Priority 4: Deliver high-quality arts and culture programming to the Mercer Island community.

Categories:

- Partnerships
- Programs/Events

2023-2024 City Arts & Culture Workplan



Background

- Parks, Recreation & Open Space (PROS) Plan
 - Goal 6: Facilitate and promote comprehensive and engaging arts and culture experiences.
- 2022 City Arts and Culture Workplan Priorities
 - Priority 1. Stabilize Arts Council membership, volunteership, and operations.
 - Priority 2. Develop 2023-2024 City Arts and Culture workplan.
 - Priority 3. Garner community input on and support of City arts and culture.
 - Priority 4. Address City arts policy and procedure needs.

Committee Discussions

- First Policy Committee work item: Establish 2023-2024 City Arts and Culture Workplan
- Members: Rosemary Moore, Jonathan Harrington, Suzanne Skone
- Major topics of discussion:
 - Communication needs
 - Art Summit discussions
 - Stewarding sustainable practices
 - Encouraging diversity

Workplan Structure

- Example from 2022:
- *PRIORITY ITEM*: **PRIORITY 3**. Garner community input on and support of City Arts and Culture.
 - *OBJECTIVE ITEM*: **3.1** Deliver performing arts, visual arts, and other City arts and culture programs to the community.

2023-2024 Draft Priorities

Priority 1: Strengthen community awareness of and support for Mercer Island's arts & culture ecosystem.

Priority 2: Invite new dialogues and partnerships to support emerging arts and culture themes in the community.

Priority 3: Complete two major City arts and culture policy projects:

1. Update the Comprehensive Arts & Culture Plan (appendix to the Citywide Comprehensive Plan)
2. Develop a Six-Year Spending Plan for the 1% for the Art in Public Places Fund

Priority 4: Deliver high-quality arts and culture programming to the Mercer Island community.



Tonight

1. Discuss the priority items as a full group.
2. Discuss potential objectives for the 2023 – 2024 City Arts and Culture Workplan.
3. Discuss integration of Special Events Committee objectives and other suggestions regarding workplan priorities.

Next Steps

- Staff will refine a draft 2023-2024 City Arts and Culture Workplan.
- Staff will collaborate with the Policy Committee to review the draft.
- Staff will evaluate necessary resources needed to complete workplan items.
- The draft 2023-2024 City Arts and Culture Workplan will be presented at the January 2023 meeting for endorsement.

Arts Council

2023 Planning Schedule

Quarterly Meetings: 1/18; 4/19; 7/19 10/18



Updated: October 14, 2022

Meeting Date	Meeting Type	Agenda Item
18-Jan	Regular	2023/2024 City Arts & Culture Workplan Update
		2023 Events and Opportunities for AC Engagement
19-Apr	Regular	Update on Policy Development
		Update on Public Art Maintenance + Restoration
		6 Year Spending Plan for 1% Fund
June	Joint mtg w/ PRC	Aubrey Davis Trail Improvements
		2021 Year-End Review / 2022 Mid-Year Update
19-Jul	Regular	Potential Public Art/Project Donation
		Bylaws Review
		Planning Schedule and Subcommittee Update
September (TBD)	Special	Aubrey Davis Trail Safety Improvements 30% Design- Art Elements
		30% Design Luther Docks- update
		Establish Public Art Committee
18-Oct	Regular	2024 Planning schedule