



**BOARD OF COMMISSIONERS
SPECIAL MEETING (5:30 PM OR
IMMEDIATELY FOLLOWING 4PM
5/27/2026 BOC REGULAR
WORKSHOP) AGENDA
Wednesday, May 27, 2026 at 5:30 PM
Commission Chambers, 300 Municipal Drive,
Madeira Beach, FL 33708**

This Meeting will be televised on Spectrum Channel 640 and YouTube Streamed on the City's Website.

- 1. CALL TO ORDER**
- 2. ROLL CALL**
- 3. PUBLIC COMMENT**

Public participation is encouraged. If you are addressing the Commission, step to the podium and state your name and address for the record, and the organization or group you represent. Please limit your comments to five (5) minutes and do not include any topic on the agenda. Public comment on agenda items will be allowed when they come up.

If you would like someone at the City to follow up on a comment or question made at the meeting, you may fill out a comment card with the contact information and give it to the City Manager. Comment cards are available at the back table in the Commission Chambers. Completing a comment card is not mandatory.

- 4. AGENDA ITEM**

A. Approval of RFP 26-05 and Contract with Speeler Companies for Marina Seawall Replacement and Tom & Kitty Stuart Park Seawall Improvements

- 5. RESPOND TO PUBLIC COMMENTS/QUESTIONS**

- 6. ADJOURNMENT**

One or more Elected or Appointed Officials may be in attendance.

Any person who decides to appeal any decision of the Board of Commissioners with respect to any matter considered at this meeting will need a record of the proceedings and for such purposes may need to ensure

that a verbatim record of the proceedings is made, which record includes the testimony and evidence upon which the appeal is to be based. The law does not require the minutes to be transcribed verbatim; therefore, the applicant must make the necessary arrangements with a private reporter or private reporting firm and bear the resulting expense. In accordance with the Americans with Disability Act and F.S. 286.26; any person with a disability requiring reasonable accommodation to participate in this meeting should call the City Clerk at 727-391-9951, ext. 231 or 232 or email a written request to cvanblargan@madeirabeachfl.gov.



Memorandum

Meeting Details: May 27, 2026

Prepared For: Mayor & Board of Commissioners

From: Brian Crabtree, Marina Manager
Megan Wepfer, Public Works Director

Subject: Approval of RFP 26-05 Bid Award to Speeler Companies for Marina Seawall Replacement and Tom & Kitty Stuart Park Seawall Improvements

Background

The City issued RFP 26-05 seeking qualified contractors to complete seawall improvements at two critical waterfront locations: the City Marina and Tom & Kitty Stuart Park.

The Marina seawall project will consist of the replacement of 232' of seawall from the fuel dock to the cell phone tower. The seawall project will close in the old boat ramp near the cell tower. This space will be used for a new boat washdown area and additional vehicle parking. All the curbing along the seawall will be replaced as well.

As part of the evaluation process for Tom & Kitty Stuart Park, staff considered two construction options for the seawall replacement:

- **Option 1:** Installation of a vinyl seawall with cap
- **Option 2:** Construction of a concrete block seawall, designed similarly to the seawall installed at Archibald Park

After review and consideration of long-term durability and storm resiliency, staff believes Option 2—the concrete block seawall—is the preferred and best option.

This recommendation is based in part on the proven performance of the Archibald Park seawall, which held up exceptionally well during Hurricane Helene, with the exception of minor damage to the seawall cap. Staff believes replicating this construction method at Tom & Kitty Stuart Park will provide enhanced structural integrity, resilience against storm surge and wave action, and greater long-term value to the City.

Following bid review, Speeler Companies was determined to be the lowest responsive and responsible overall bidder, with a total bid amount of \$209,850.00.

Fiscal Impact

Total Project Cost: \$209,850.00

Funding Sources:

Marina Fund - \$151,900.00

Archibald Park Fund- \$57,950.00

Recommendation(s)

Staff recommends the Board of Commissioners approve the award of RFP 26-05 to Speeler Companies for the Marina Seawall Replacement and Tom & Kitty Stuart Park Seawall Improvements in the total amount of \$209,850.00, funded through the Marina Fund and the Archibald Park Fund.

Attachments

- Bid Tabulation Summary
- Speeler Companies Proposal
- Conceptual Seawall Design Options
- Marina Seawall Design Plans

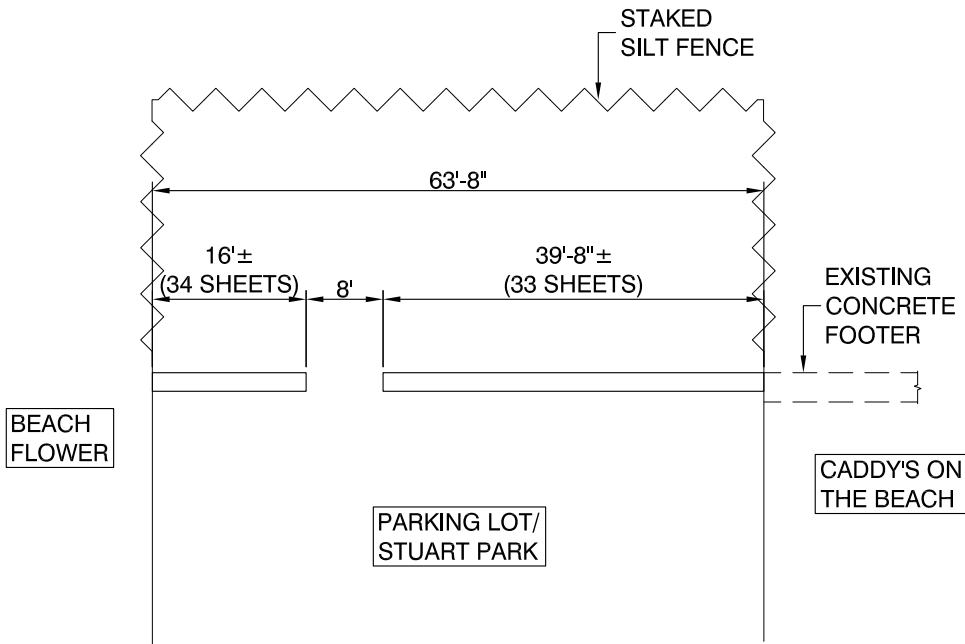

1
OPTION 1
OVERALL SITE PLAN VIEW
1 OF 2 1"=20'

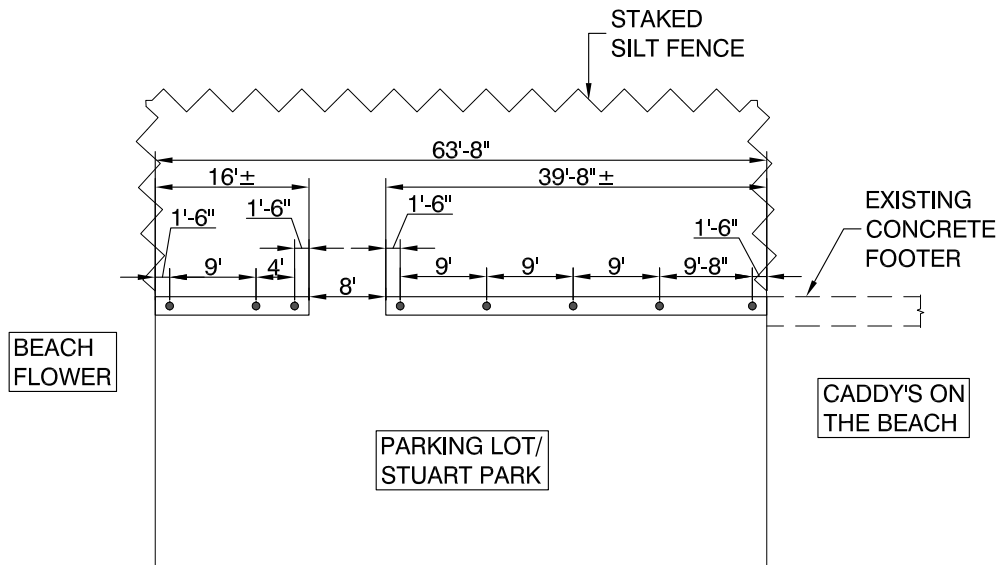

2
OPTION 2
OVERALL SITE PLAN VIEW
1 OF 2 1"=20'

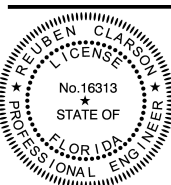

Digitally signed
by Reuben
Clarson, P.E.
Date:
2025.07.14
08:36:59 -04'00'

Reuben Clarson
CONSULTING
MARINE ENGINEERING
ASSESS, ADVISE, DESIGN
(CERT. OF AUTH. NO. 9206)
780 94TH AVENUE NORTH, SUITE 102, ST. PETERSBURG, FL 33702
P: (727) 895-4717 F: (727) 578-9542
WWW.REUBENCLARSONCONSULTING.COM

OWNER: CITY OF MADEIRA BEACH	CONTRACTOR:	DATE: 6-26-2025	SHEET: 1 OF 2
14070 GULF BLVD MADEIRA BEACH, FL		DRAWN/CHECK BY: KM/RC	REVISIONS: 7-7-2025 7-11-2025
WALL DESIGN		SCALE: N.T.S.	
		PROJ. NO. RR25-25MB440S	

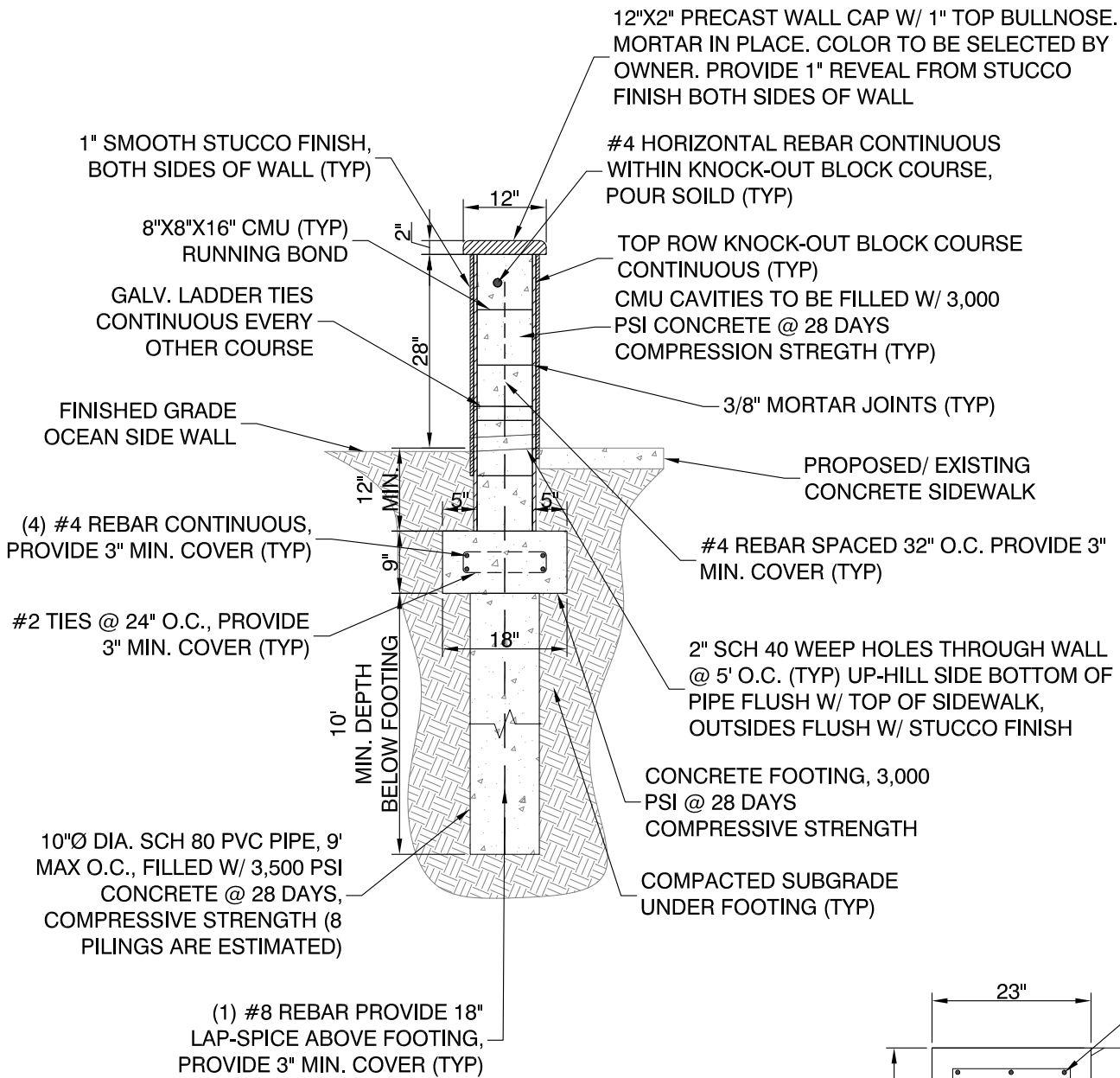

2 SEAWALL SECTION OPTION 2
2 OF 2 1/2"=1'

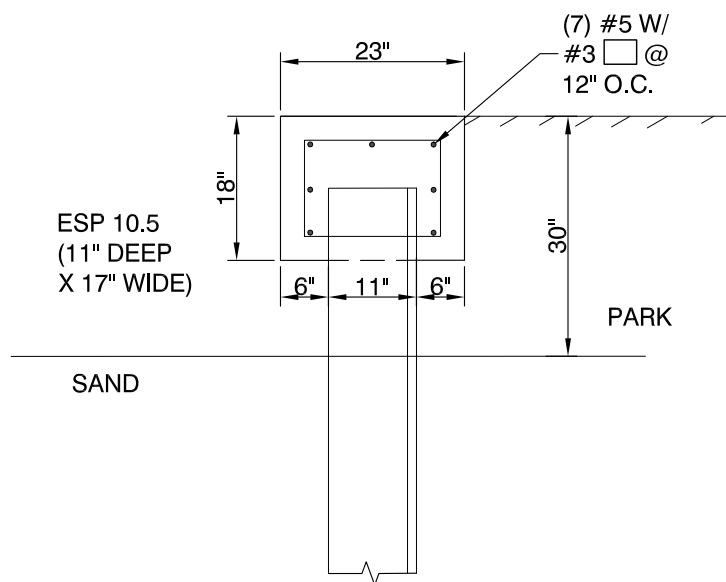

1 SEAWALL SECTION OPTION 1
2 OF 2 1/2"=1'

NOTES:
 1.) SHEETS-ESP 10.5 X 12' LONG
 2.) CONCRETE-5000 PSI AT 28 DAYS, FILLER 3500 PSI
 3.) REBAR-GRADE 60, PLAIN, 3" CONCRETE COVER
 4.) MEETS FBC 2023, 8TH EDITION.

Digitally signed by Reuben Clarson, P.E.
 No. 16313
 STATE OF FLORIDA
 Date: 2025.07.14
 08:39:14 -04'00'

Reuben Clarson
 CONSULTING
MARINE ENGINEERING
 ASSESS, ADVISE, DESIGN
 (CERT. OF AUTH. NO. 9206)
 780 94TH AVENUE NORTH, SUITE 102, ST. PETERSBURG, FL 33702
 P: (727) 895-4717 F: (727) 578-9542
 WWW.REUBENCLARSONCONSULTING.COM

OWNER: CITY OF MADEIRA BEACH	CONTRACTOR:	DATE: 6-26-2025	SHEET: 2 OF 2
14070 GULF BLVD MADEIRA BEACH, FL		DRAWN/CHECK BY: KM/RC	REVISIONS: 7-7-2025 7-11-2025
WALL DESIGN		SCALE: N.T.S.	
		PROJ. NO. RR25-25MB440S	

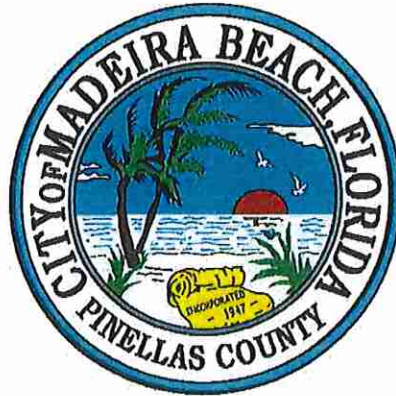

City of Madeira Beach

Request for Proposal (RFP)

RFP# 26-05

Marina Seawall Replacement Section #2

Due by 11:00 AM April 29th, 2026

City Hall

300 Municipal Drive

Madeira Beach, Florida 33708

PURPOSE AND INTRODUCTION

The City of Madeira Beach, Florida ("City") is requesting Proposals from Florida certified, licensed and otherwise qualified Contractors ("CONTRACTOR"), one of which may be selected by the City to enter into a Contract for the construction of a project known as "**RFP No. 26-05 Marina Seawall Replacement Section #2**" on City-owned property located at 503 150th Ave., 424 150th Ave., 14109 N Bayshore and the street end at 142nd and N Bayshore in Madeira Beach, Pinellas County, Florida. The subject site is located within the City of Madeira Beach. See attached plans for full specs. The Marina and 14109 N Bayshore will need to be demoed and rebuilt per the attached Approved Permit Drawings and Permit Conditions and the seawalls located at 424 150th and 142nd and N Bayshore will need to be repaired per the attached inspection reports. Permits will be acquired through the City of Madeira Beach.

MANDATORY PRE-BID MEETING

A **MANDATORY** Pre-Proposal Conference is scheduled for 11:30 a.m., on Thursday, March 26th, 2026, to be held on site at Madeira Beach Municipal Marina located at 503 150th Ave. in Madeira Beach, Florida. All persons and CONTRACTORS planning to submit a Proposal are required to attend this meeting, which will outline the project as described in this RFP and provide an opportunity for questions and answers for all interested persons. Contractors must allow sufficient time to ensure arrival prior to the indicated time. **PEOPLE ARRIVING PAST THE INDICATED TIME WILL NOT BE ELIGIBLE TO SUBMIT A PROPOSAL. PROPOSALS FROM THOSE WHO HAVE FAILED TO ATTEND WILL NOT BE OPENED.**

All Proposals must be submitted to the city in a sealed envelope and clearly marked: "**RFP No. 26-05 Marina Seawall Replacement Section #2**". All Proposals must be received in the Office of the City Clerk no later than 11:00 a.m. on Wednesday, April 29th, 2026, where they will be opened in a public forum at 11:30 a.m., on that same day. One (1) USB in PDF Format must be submitted. Any interpretations, clarifications or additional information not disclosed in this RFP and determined to be necessary by the City in response to questions, will be issued by means of addendum or addenda, which addendum or addenda will be posted to the City website, www.madeirabeachfl.gov, to all interested persons identified by the City as having received the bid documents. The Bidder is required to check the site to see if there has been any addendum or addenda posted for this Bid. Only questions answered and information supplied by means of such an addendum or addenda will be considered as binding. Oral interpretations, clarifications or other information will have no legal and binding effect. Bidders must allow sufficient time to ensure arrival prior to the stated time for the pre-bid meeting. Bids from those who have failed to attend will not be opened. Bidders arriving past the indicated time will not be eligible to submit a Bid.

Any responses received by the office of the City Clerk after the due date and time specified in this RFP will not be considered and will be returned unopened.

Corrections of any kind to any RFP must be initiated by an authorized representative of the CONTRACTOR. All Proposals must contain a manual signature of an authorized CONTRACTOR representative.

CONTACT INFORMATION

Please direct all technical inquiries concerning this Request for Proposals in writing to the following City representative. Questions must be submitted by the date listed in the calendar of events below.

Brian Crabtree
 Marina Manager
 503 150th Avenue
 Madeira Beach, Florida 33708
 (727) 399-2631 or (727) 409-0584
 bcrabtree@madeirabeachfl.gov

To submit a Request for Proposal, the submission must be **sealed and plainly marked "RFP No. 26-05 Marina Seawall Replacement Section #2" on the outside of the mailing envelope**, addressed to: City of Madeira Beach, 300 Municipal Dr., Madeira Beach, FL 33708.

The City of Madeira Beach reserves the right to reject any or all Proposals, to waive technical specifications or deficiencies, and to accept any Proposal that it may deem to be in the best interest of the City.

CALENDAR OF EVENTS

A. March 12, 2026,	Request for Proposal (RFP) release date
B. March 26, 2026,	Mandatory Pre-Bid Meeting 11:30AM
C. March 31, 2026,	Questions due
D. April 7, 2026,	Answers / Clarification Posted
E. April 29, 2026,	Bid Due 11:00 AM at City Hall
F. April 29, 2026,	Bid Opening 11:30 AM at City Hall
G. May 20, 2026,	Tentative BOC Workshop Discussion
H. June 10, 2026,	Tentative Bid & Contract award

SUBMITTAL REQUIREMENTS

Proposals shall include the following:

1. One (1) electronic copy (USB- PDF Format)
2. Completed Statement of Qualifications
3. Completed References form, containing at least five (5) professional references, including current contact name and phone number for similar contracts.
4. Completed Proposal Form
5. Certifications and business licenses.
 - a Include proof of corporation (sunbiz.org Division of Corporations)
6. Proof of Insurance as listed in the insurance section.
7. Signed contract with all exhibits signed and notarized.

ADDITIONAL CONDITIONS

- The “CITY” reserves the right to reject any or all proposals received, to request additional information, or to extend the deadline for submittals.
- Confidentiality of Documents: Upon receipt of proposals by the “CITY,” the proposals shall become the property of the “CITY” without compensation to the proponent, for disposition or usage by the “CITY” at its discretion. Pursuant to Florida Statute, Section 119.071(1)(b)2, all proposals submitted shall be subject to review as public records 30 days from opening, or earlier if an intended decision is reached before the 30-days expires.
- Costs to Prepare Responses: The “CITY” assumes no responsibility or obligation to the respondents and will make no payment for any costs associated with the preparation or submission of these proposals. RFP 2024-03: On-Call Electrical Services 6
- Equal Employment Opportunity: During the performance of this Contract, the “CONTRACTOR” agrees as follows: The “CONTRACTOR” will not discriminate against any employee or applicant for employment because of race, color, religion, sex, age, national origin, place of birth, or physical handicap.

CONFLICT OF INTEREST DISCLOSURE

Each Respondent shall complete and have notarized the attached disclosure form of any potential conflict of interest that the Respondent may have due to ownership, contracts, or interest associated with this project.

PUBLIC ENTITY CRIMES

Pursuant to Section 287.132 and 287.133 Florida Statutes, the “CITY,” as a public entity, may not consider a proposal package from, award any contract to, or transact any business in excess of the threshold amount set forth in Section 287.017 Florida Statutes with any person or affiliate on the convicted contractor list for the time periods specified unless such person has been removed from the list pursuant to law. A person or an affiliate who has been placed on the convicted vendor list following a conviction for a public entity crime may not submit on a contract to provide any goods or services to a public entity, may not submit a bid on a contract with a public entity for the construction or repair of a public building or public work, may not submit bids, proposals, or replies on leases of real property to a public entity, may not be awarded or perform work as a contractor, supplier, subcontractor, or consultant under a contract with a public entity, and may not transact business with any public entity in excess of the threshold amount supplied in Section 287.017, Florida Statutes, for CATEGORY TWO for a 16 period of thirty-six (36) months from the date of being placed on the convicted vendors list.

SCOPE OF SERVICES

This request for proposal will include the replacement of the seawall and cap for 232 feet of seawall at the Madeira Beach Municipal Marina located at 503 150th avenue Madeira Beach. The seawall project is 232 linear feet in total, all within water 6’ or less, measured from the bottom of the cap to the mudline. Project will include the temporary removal and replacement of all walkways to figure piers (4) and (1) gangway. All walkways and piers will match their original height to the seawall approximately 8 inches below the cap. Before work begins the contractor will survey the site for any utilities that will need to be

removed/disconnected during Construction. There are two main fuel supply lines that run underneath (24"-36" below) a concrete patch in the asphalt (see plans attached). Proper weight dispersion padding and care will need to be used while working in this area so not to damage the underground fuel lines. Any concrete damaged or removed during construction will need to be replaced to its original form. There is a 5-inch-tall curb, 115 linear foot in length that will need to be removed. This curb will need to be replaced with another 5-inch-tall curb totaling 135 linear feet installed with the proper drainage holes for storm water run-off. There is an old boat ramp that will need to be enclosed and filled in. A new section (30 feet) of seawall will need to be installed. The old ramp area will need to be filled with fill dirt, (see plans).

DESCRIPTION OF WORK

Marina Replacement: The 232 feet of seawall will need to be vinyl sheet piled. Seawall cap, tiebacks and dead men will need to be replaced or added. All dock finger piers (4 total) 12' long x 2' wide, will need new stringers and deck boards. Deck boards will need to be Azeck brand, Brownstone in color. Old boat ramp will need to be walled off and filled in, approximately 6,300 cubic feet of dirt. Any utilities that need to be moved or disconnected/reconnected will be identified by the contractor. Utilities will be disconnected/reconnected by the awarded contractor. See attached Design Plans.

CRITERIA FOR SELECTION OF CONTRACTORS

Proposals shall be reviewed by a selection committee, ranked based on the following criteria, and negotiation for contracts shall follow the order of ranking from highest to lowest score. Evaluation and ranking shall be based upon the criteria herein and the highest ranked Contractor shall be determined by tally of the number one ranked proposer(s) among the selection committee. The selection process shall be open to the public and records maintained in accordance with Florida Statutes.

In evaluating Bidders, Owner may consider the qualifications of Bidders and the qualifications and experience of Subcontractors, Suppliers, and other individuals or entities proposed for those portions of the Work for which the identity of Subcontractors, Suppliers, and other individuals or entities must be submitted as provided in the Supplementary Conditions.

Evaluation Scoring Criteria	Possible Points
Capability and qualifications of the proposer	20
Proven experience as demonstrated with recent contracts/projects for local government agencies within the State of Florida.	15
Resources and Availability – include a list of subcontractors	15
Client References and past performance	15
Total Bid Cost	35
Total	

AWARD

It is understood that the "CITY" of Madeira Beach is not obligated to make an award under, or because of, this RFP or to award such contract. The "CITY" of Madeira Beach reserves the right to award such contract, if any, to the best qualified Respondent(s). The "CITY" of Madeira Beach has the sole discretion and reserves the right to cancel this RFP, and to reject all proposal packages, to waive all informalities and/or irregularities, or to re-advertise with either the identical or revised specifications, if it is deemed to be in the "CITY" of Madeira Beach's best interest to do so.

PROPOSAL PACKAGE SECTIONS

The Respondent shall organize its proposal package into the following major sections:

- A. Statement of Qualification: To be submitted on the "CONTRACTOR" letterhead. The statement of interest shall:
 - o Concisely state the "CONTRACTOR"'s understanding of the RFP.
 - o Include additional relevant information not requested elsewhere in the RFP.
 - o The signature on the statement shall be that of a person authorized to represent and bind the "CONTRACTOR"
- B. References- current, or recent project relating to the RFP.
 - o Provide a minimum of five (5) references for work performed like the scope of this RFP.
- C. Proposal Form - signed and completed.
- D. CONTRACTOR Profile – Completed
- E. Hold Harmless Agreement – signed and completed.
- F. Sworn Statement to Section 287.133(3)(a), Florida Statutes, on Public Entity Crimes form- signed and completed.
- G. Immigration Affidavit certification- Signed and completed.
- H. Bid Tabulation Form
- I. Contractors Licenses
- J. Certificate of Insurance
- K. Signed Agreement for Dock replacement.
 - o Exhibit A Public Contracting and Environmental Crimes Certificate- signed and completed.
 - o Exhibit B Drug Free Workplace Certificate – Signed and completed.

STATEMENT OF QUALIFICATIONS

All questions must be answered, and the data given must be clear and comprehensive. This statement must be notarized. Add separate sheets or attachments, as necessary.

- 1. Name of Contractor: Douglas Speeler Jr
- 2. Name of Business (if different than #1): BCJ 2 LLC dba Speeler Foundations
- 3. Form of Entity: LLC
- 4. Permanent Main Office and Mailing addresses and pertinent contact information (phone, email, etc.):
6111 142nd Ave N Clearwater, FL 33760 Doug Speeler 727-535-5735 doug@speeler.com
- 5. Date Organized: Sept 2025
- 6. Where Organized: Clearwater, FL
- 7. How many years have you been engaged in the Marine Dock/Seawall building under your present name; also, state names and dates of previous business names, if any. BCJ 2 Sept 2025, Speeler Foundations, Inc Sept 2000
- 8. In the last five years, has "Contractor" ever been terminated from a contract or project? If so, explain situation.: No
- 9. In the last five years, has Contractor ever been party to litigation related to the Contractor's work? If so, explain situation.: No
- 10. List the most important contracts entered by the Contractor in the last year; identify contracting party and term of contract.: Marker One Marina, MHC Marker One LLC, One year
- 11. List your key personnel available for this contract.: Doug Speeler

The City of Madeira Beach reserves the right to request from finalist(s) the latest financial statements as well as to request such additional information as may be reasonably necessary to determine whether the Contractor should be awarded the service contract.

Doug
 Authorized Signature
5/14/26
 Date Signed

NOTARY

State of: Florida

County of: Pinellas

Sworn to and subscribed before me this 14th day of May, 2026

Personally Known X or Produced Identification _____
(Specify Type of Identification)

Signature of Notary *Lisa Sinclair*

My Commission Expires May 5 2030

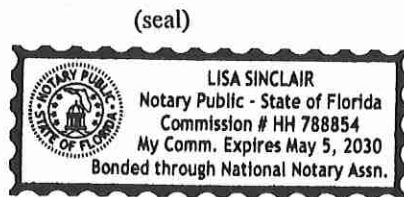



**SPEELER
COMPANIES**
DOCKS | LIFTS | SEAWALLS
BCJ 2 LLC dba Speeler Companies

Item 4A.

6111 142nd Ave. N.
Clearwater, FL 33760
Office (727) 535-5735
Fax (727) 535-6041
www.speeler.com

City of Madeira Beach
300 Municipal Dr
Madeira Beach, FL 33708

RE: RFP# 26-05 Marina Seawall Replacement Section #2

Speeler Foundations, Inc is a well-respected marine construction company located in Pinellas County, Florida that has been in business since 2000. Speeler Foundations, Inc has been operating under the name of BCJ 2 LLC dba Speeler Foundations since September 2025.

We have fifty-five (55) employees. Our employees have a wide range of marine construction experience; some have well over 22 years of experience.

Our work over the last 26 years spans residential, commercial and governmental projects. In addition to numerous residential projects, we have completed work for several municipalities including Madeira Beach, Gulfport, Clearwater, St Petersburg, Indian Shores, as well as the Florida Fish and Wildlife Commission, the St. Petersburg Sheriff's Dept, Pinellas County Water and Navigation and the U.S Coast Guard.

We believe that all of the above work experience puts us in a very good position to execute the requested work in a timely manner and with an excellent final product.

Thank you for the opportunity to bid this project. If there is any further information needed, please do not hesitate to contact us.

Respectfully Submitted

Douglas Speeler, Jr.
President/Contractor
BCJ 2 LLC dba Speeler Foundations



**SPEELER
COMPANIES**
DOCKS | LIFTS | SEAWALLS
BCJ 2 LLC dba Speeler Companies

Item 4A.

6111 142nd Ave. N.
Clearwater, FL 33760
Office (727) 535-5735
Fax (727) 535-6041
www.speeler.com

Madeira Beach Project LLC 1525 Lineal Feet
555 150th Ave
Madeira Beach, FL 33708
The Denunzio Group
Mike Flood 617-945-2555

Belleair Country Club 702 Lineal Feet
1 Country Club Ln
Belleair, FL 33756
Belleair Country Club
Ed Shaughnessy 727-641-4567

Madeira Beach Town Center 414 Lineal Feet
410 150th Ave
Madeira Beach, FL 33708
Karns Enterprises
Bill Karns 727-422-1016

City of Madeira Beach 22 Groins= +/- 4200 Lineal feet
300 Municipal Dr
Madeira Beach, FL 33708
RFP# 2023-14
Coastal Groins Restoration Project

City of Madeira Beach 702 Lineal Feet
300 Municipal Dr
Madeira Beach, FL 33708
RFP# 2024-03
City Owned Seawall Replacement and Repairs

REFERENCES

Please include the below information for all five (5) references as required.

Information below to be included for all five references in the proposal.

Contact Name Mike Flanigan

Business Name MHC Marker One LLC

Business Address 343 Causeway Blvd Dunedin, FL 34698

Contact Phone 813-542-9755

Contact Email mike_flanigan@equitylifestyle.com Other

Information (describe): Rebuild Marker One Marina and installation of new lifts

INSURANCE REQUIREMENTS

Insurance shall be in such form as will protect the Contractor from all claims and liabilities for damages for bodily injury, including accidental death, and for property damage, which may arise from operations under this contract, whether such operations by himself or anyone directly or indirectly employed by Contractor.

The awarded firm must file with the City of Madeira Beach certificates of insurance prior to commencement of work evidencing the City as a certificate holder as additionally insured with the following minimum coverage:

- Public and Commercial Liability Insurance not less than \$1,000,000.00.
- Comprehensive General Liability Insurance of \$1,000,000.00 for each occurrence.
- Personal Injury for \$1,000,000.00 each occurrence.

Owner's and Consultant's Protective Liability.

- Bodily injury liability \$1,000,000.00 each occurrence
- Property damage liability \$1,000,000.00 each occurrence
- Full Workers Comprehensive Insurance is required by Florida Law for all people employed by the contractor to perform work on this project.

Automotive Liability (covering the operation, maintenance and all owned, non-owned and hired vehicles).

- Bodily injury liability \$1,000,000.00 each occurrence
- Property damage liability \$1,000,000.00 each occurrence

INDEMNIFICATION

The Respondent shall hold harmless the City, its officers, and employees, from liabilities, damages, losses, and costs, including but not limited to, reasonable attorney's fees, to the extent caused by the negligence, recklessness, or intentional wrongful misconduct of the Respondent and any persons employed or utilized by the Respondent in the performance of the Contract.

REFERENCES

Please include the below information for all five (5) references as required.

Information below to be included for all five references in the proposal.

Contact Name Ed Shaughnessy

Business Name Belleair Country Club

Business Address One Country Club Way

Contact Phone 727-461-7171

Contact Email ed@belleaircc.com Other

Information (describe): Dock construction & boat lift installation

INSURANCE REQUIREMENTS

Insurance shall be in such form as will protect the Contractor from all claims and liabilities for damages for bodily injury, including accidental death, and for property damage, which may arise from operations under this contract, whether such operations by himself or anyone directly or indirectly employed by Contractor.

The awarded firm must file with the City of Madeira Beach certificates of insurance prior to commencement of work evidencing the City as a certificate holder as additionally insured with the following minimum coverage:

- Public and Commercial Liability Insurance not less than \$1,000,000.00.
- Comprehensive General Liability Insurance of \$1,000,000.00 for each occurrence.
- Personal Injury for \$1,000,000.00 each occurrence.

Owner's and Consultant's Protective Liability.

- Bodily injury liability \$1,000,000.00 each occurrence
- Property damage liability \$1,000,000.00 each occurrence
- Full Workers Comprehensive Insurance is required by Florida Law for all people employed by the contractor to perform work on this project.

Automotive Liability (covering the operation, maintenance and all owned, non-owned and hired vehicles).

- Bodily injury liability \$1,000,000.00 each occurrence
- Property damage liability \$1,000,000.00 each occurrence

INDEMNIFICATION

The Respondent shall hold harmless the City, its officers, and employees, from liabilities, damages, losses, and costs, including but not limited to, reasonable attorney's fees, to the extent caused by the negligence, recklessness, or intentional wrongful misconduct of the Respondent and any persons employed or utilized by the Respondent in the performance of the Contract.

REFERENCES

Please include the below information for all five (5) references as required.

Information below to be included for all five references in the proposal.

Contact Name Sam Lowrey

Business Name Gulfport Marina LLC- Marine Max

Business Address 6810 Gulfport Blvd S So. Pasadena 33707

Contact Phone 727-228-7672

Contact Email sam.lowrey@marinemax.com Other

Information (describe):

INSURANCE REQUIREMENTS

Insurance shall be in such form as will protect the Contractor from all claims and liabilities for damages for bodily injury, including accidental death, and for property damage, which may arise from operations under this contract, whether such operations by himself or anyone directly or indirectly employed by Contractor.

The awarded firm must file with the City of Madeira Beach certificates of insurance prior to commencement of work evidencing the City as a certificate holder as additionally insured with the following minimum coverage:

- Public and Commercial Liability Insurance not less than \$1,000,000.00.
- Comprehensive General Liability Insurance of \$1,000,000.00 for each occurrence.
- Personal Injury for \$1,000,000.00 each occurrence.

Owner's and Consultant's Protective Liability.

- Bodily injury liability \$1,000,000.00 each occurrence
- Property damage liability \$1,000,000.00 each occurrence
- Full Workers Comprehensive Insurance is required by Florida Law for all people employed by the contractor to perform work on this project.

Automotive Liability (covering the operation, maintenance and all owned, non-owned and hired vehicles).

- Bodily injury liability \$1,000,000.00 each occurrence
- Property damage liability \$1,000,000.00 each occurrence

INDEMNIFICATION

The Respondent shall hold harmless the City, its officers, and employees, from liabilities, damages, losses, and costs, including but not limited to, reasonable attorney's fees, to the extent caused by the negligence, recklessness, or intentional wrongful misconduct of the Respondent and any persons employed or utilized by the Respondent in the performance of the Contract.

REFERENCES

Please include the below information for all five (5) references as required.

Information below to be included for all five references in the proposal.

Contact Name Bob Lyons

Business Name Sunwest Construction - Multiple projects

Business Address 20001 Gulf Blvd Ste #1 Indian Shores 33785

Contact Phone 727-330-7772

Contact Email bob@sunwestconstructionllc.com Other

Information (describe):

INSURANCE REQUIREMENTS

Insurance shall be in such form as will protect the Contractor from all claims and liabilities for damages for bodily injury, including accidental death, and for property damage, which may arise from operations under this contract, whether such operations by himself or anyone directly or indirectly employed by Contractor.

The awarded firm must file with the City of Madeira Beach certificates of insurance prior to commencement of work evidencing the City as a certificate holder as additionally insured with the following minimum coverage:

- Public and Commercial Liability Insurance not less than \$1,000,000.00.
- Comprehensive General Liability Insurance of \$1,000,000.00 for each occurrence.
- Personal Injury for \$1,000,000.00 each occurrence.

Owner's and Consultant's Protective Liability.

- Bodily injury liability \$1,000,000.00 each occurrence
- Property damage liability \$1,000,000.00 each occurrence
- Full Workers Comprehensive Insurance is required by Florida Law for all people employed by the contractor to perform work on this project.

Automotive Liability (covering the operation, maintenance and all owned, non-owned and hired vehicles).

- Bodily injury liability \$1,000,000.00 each occurrence
- Property damage liability \$1,000,000.00 each occurrence

INDEMNIFICATION

The Respondent shall hold harmless the City, its officers, and employees, from liabilities, damages, losses, and costs, including but not limited to, reasonable attorney's fees, to the extent caused by the negligence, recklessness, or intentional wrongful misconduct of the Respondent and any persons employed or utilized by the Respondent in the performance of the Contract.

REFERENCES

Please include the below information for all five (5) references as required.

Information below to be included for all five references in the proposal.

Contact Name Terry Russell

Business Name Harborside Boat Club Madeira Beach

Business Address 20001 Gulf Blvd #5 Indian Shores 33785

Contact Phone 727-517-6143

Contact Email trussell@krmanagement.com Other

Information (describe): Dock rebuild

INSURANCE REQUIREMENTS

Insurance shall be in such form as will protect the Contractor from all claims and liabilities for damages for bodily injury, including accidental death, and for property damage, which may arise from operations under this contract, whether such operations by himself or anyone directly or indirectly employed by Contractor.

The awarded firm must file with the City of Madeira Beach certificates of insurance prior to commencement of work evidencing the City as a certificate holder as additionally insured with the following minimum coverage:

- Public and Commercial Liability Insurance not less than \$1,000,000.00.
- Comprehensive General Liability Insurance of \$1,000,000.00 for each occurrence.
- Personal Injury for \$1,000,000.00 each occurrence.

Owner's and Consultant's Protective Liability.

- Bodily injury liability \$1,000,000.00 each occurrence
- Property damage liability \$1,000,000.00 each occurrence
- Full Workers Comprehensive Insurance is required by Florida Law for all people employed by the contractor to perform work on this project.

Automotive Liability (covering the operation, maintenance and all owned, non-owned and hired vehicles).

- Bodily injury liability \$1,000,000.00 each occurrence
- Property damage liability \$1,000,000.00 each occurrence

INDEMNIFICATION

The Respondent shall hold harmless the City, its officers, and employees, from liabilities, damages, losses, and costs, including but not limited to, reasonable attorney's fees, to the extent caused by the negligence, recklessness, or intentional wrongful misconduct of the Respondent and any persons employed or utilized by the Respondent in the performance of the Contract.

NO COLLUSION

By offering a submission to this Request for Proposal, the responder certifies that no attempt has been made or will be made by the responder to induce any other person or firm to submit or not to submit a submission for the purpose of restricting competition. The only person(s) or principal(s) interested in this submission are named therein and that no person other than those therein mentioned has/have any interest in this submission or in agreement to be entered. Any prospective firm should make an affirmative statement in its proposals to the effect that, to its knowledge, its retention would not result in a conflict of interest with any party.

TERMINATION

The resulting contract may be canceled by the City when:

- a. When sufficient funds are not available to continue its full and faithful performance of this contract.
- b. Sub-standard or non-performance of contract.
- c. The City wishes to terminate it at any time and for any reason, upon giving thirty (30) days prior written notice to the other party.

The resulting contract may be canceled by either party in the event of substantial failure to perform in accordance with the terms by the other party through no fault of the terminating party.

SUBMITTAL WITHDRAWAL

After submittals are opened, corrections or modifications to submittals are not permitted, but a respondent may be permitted to withdraw an erroneous submittal prior to the award by the Board of Commissioners, if the following is established:

- a. That the respondent acted in good faith in submitting the submittal.
- b. That in preparing the submittal there was an error of such magnitude that enforcement of the submittal would work severe hardship upon the respondent.
- c. That the error was not the result of gross negligence or willful inattention on the part of the respondent.
- d. That the error was discovered and communicated to the City within twenty-four (24) hours of submittal opening, along with a request for permission to withdraw the submittal; or
- e. The respondent submits documentation and an explanation of how the error was made.

TAXES, FEES, CODES, LICENSING

The Contractor shall be responsible for payment of all required permits, licenses, taxes, or fees associated with the project. The Consultant shall also be responsible for compliance with all applicable codes, laws, and regulations.

COMPLIANCE WITH ALL APPLICABLE LAWS

Respondents shall comply with all applicable local, state, and federal laws and codes.

PROPOSALS FORM



Name of "CONTRACTOR" Submitting Proposals BCJ 2 LLC dba Speeler Foundations

Name of Person Submitting Proposals Douglas Speeler Jr

PROPOSER ACKNOWLEDGMENT

"The undersigned hereby declares that he/she has informed himself/herself fully in regard to all conditions to the work to be done, and that he/she has examined the RFP and Specifications for the work and comments here to attached. The "CONTRACTOR" proposes and agrees, if this submission is accepted, to contract with the "CITY" of Madeira Beach to furnish all necessary materials, equipment, labor, and services necessary to complete the work covered by the RFP and Contract Documents for this Project. The "CONTRACTOR" agrees to accept in full compensation for each item the prices named in the schedules incorporated herein."

BIDDER'S REPRESENTATIONS

In submitting this Bid, Bidder represents that:

- A. Bidder has examined and carefully studied the Bidding Documents, the other related data identified in the Bidding Documents, and the following Addenda, receipt of which is hereby acknowledged.

Addendum No.	Addendum Date
<u>RFP #26-05 #2</u>	<u>April 10, 2026</u>
<u>RFP #26-05 #3</u>	<u>April 22, 2026</u>
<u>RFP #26-05 #4</u>	<u>5-7-2026</u>
<u>RFP#26-05 # 1</u>	<u>4/7/2026</u>

- B. Bidder has visited the Site and become familiar with and is satisfied as to the general, local and Site conditions that may affect cost, progress, and performance of the Work.
- C. Bidder is familiar with and is satisfied as to all federal, state, and local Laws and Regulations that may affect cost, progress and performance of the Work.

- D. Bidder has carefully studied all: (1) reports of explorations and tests of subsurface conditions at the Site and all drawings of physical conditions in or relating to existing surface or subsurface structures at the Site.
- E. Bidder has obtained and carefully studied (or accepts the consequences for not doing so) all additional or supplementary examinations, investigations, explorations, tests, studies and data concerning conditions (surface, subsurface and Underground Facilities) at or contiguous to the Site which may affect cost, 19 progress, or performance of the Work or which relate to any aspect of the means, methods, techniques, sequences, and procedures of construction to be employed by Bidder, including applying the specific means, methods, techniques, sequences, and procedures of construction expressly required by the Bidding Documents to be employed by Bidder, and safety precautions and programs incident thereto.
- F. Bidder does not consider that any further examinations, investigations, explorations, tests, studies, or data are necessary for the determination of this Bid for performance of the Work at the price(s) bid and within the times and in accordance with the other terms and conditions of the Bidding Documents.
- G. Bidder is aware of the general nature of work to be performed by Owner and others at the Site that relates to the Work as indicated in the Bidding Documents.
- H. Bidder has correlated the information known to Bidder, information and observations obtained from visits to the Site, reports and drawings identified in the Bidding Documents, and all additional examinations, investigations, explorations, tests, studies, and data with the Bidding Documents.
- I. The Bidder has given Owner and Engineer written notice of all conflicts, errors, ambiguities, or discrepancies that Bidder has discovered in the Bidding Documents, and the written resolution thereof by Engineer is acceptable to Bidder.
- J. The Bidding Documents are generally sufficient to indicate and convey understanding of all terms and conditions for the performance of the Work for which this Bid is submitted.
- K. Bidder will submit written evidence of its authority to do business in the state where the Project is located not later than the date of its execution of the Agreement.

Signature D. A. S. P. J.

Date May 14, 2026

RFP Number 2023-09 Check if exception(s) or deviation(s) to specifications. Attach separate sheet(s) detailing reason and type for the exception or deviation.

HOLD HARMLESS AGREEMENT

The Contractor agrees to hold the City of Madeira Beach harmless against all claims for bodily injury, sickness, disease, death or personal injury or damage to property or loss of use resulting therefrom, arising out of the agreement, to the extent that such claims are attributable, in whole or in part, to a negligent act or omission by the Contractor.

The Contractor shall purchase and maintain workers' compensation insurance for all workers' compensation insurance and employers' liability in accordance with Florida Statute Chapter 440.

The Contractor shall also purchase any other coverage required by law for the benefit of employees.

Required insurance shall be documented in Certificates of Insurance and shall be provided to the "CITY" representative requesting the service.

By signature upon this form the Contractor stipulates that he/she agrees to the Hold Harmless Agreement, and to abide by all insurance requirements.

Douglas Speeler Jr
Contractor/ "CONTRACTOR"- Printed Name

Signature

RFP #26-05 Marina Seawall Replacement Section 2
Project Name

May 14, 2024
Date

The effective date of this Hold Harmless Agreement shall be the duration of this project.

SWORN STATEMENT TO SECTION 287.133(3)(a), FLORIDA STATUTES, ON PUBLIC ENTITY CRIMES FORM

THIS FORM MUST BE SIGNED AND SWORN TO IN THE PRESENCE OF A NOTARY PUBLIC OR OTHER OFFICIAL AUTHORIZED TO ADMINISTER OATHS.

1. This sworn statement is submitted to the "CITY" of Madeira Beach
By Douglas Speeler Jr President/Contractor
(Print individual's name and title)
for BCJ 2 LLC dba Speeler Foundations
(Print name of entity submitting sworn statement)
whose business address is 6111 142nd Ave N Clearwater, FL 33760 and (if applicable) its
Federal Employer Identification Number (FEIN) is 39-3346502.
2. I understand that a "public entity crime" as defined in Paragraph 287.133(1)(g), Florida Statutes, means a violation of any state or federal law by a person with respect to and directly related to the transaction of business with any public entity or with an agency or political subdivision of any other state or of the United States, including, but not limited to, any bid or contract for goods or services to be provided to any public entity or an agency or political subdivision of any other state or of the United States and involving antitrust, fraud, theft, bribery, collusion, racketeering, conspiracy, or material misrepresentation.
3. I understand that "convicted" or "conviction" as defined in Paragraph 287.133(1)(b), Florida Statutes, means a finding of guilt or a conviction of a public entity crime, with or without adjudication of guilt, in any federal or state trial court of record relating to charges brought by indictment or information after July 1, 1989, as a result of a jury verdict, nonjury trial, or entry of a plea of guilty or nolo contendere.
4. I understand that an "affiliate" as defined in Paragraph 287.133(1)(a), Florida Statutes, means:
 - a. A predecessor or successor of a person convicted of a public entity crime; or
 - b. An entity under the control of any natural person who is active in the management of the entity and who has been convicted of a public entity crime. The term "affiliate" includes those officers, directors, executives, partners, shareholders, employees, members, and agents who are active in the management of an affiliate. The ownership by one person of shares constituting a controlling interest in another person, or a pooling of equipment or income among persons when not for fair market value under an arm's length agreement, shall be a prima facie case that one person controls another person. A person who knowingly enters into a joint venture with a person who has been convicted of a public entity crime in Florida during the preceding 36 months shall be considered an affiliate.
 - c. I understand that a "person" as defined in Paragraph 287.133(1)(e), Florida Statutes, means any natural person or entity organized under the laws of any state or of the United States with the legal power to enter into a binding contract and which bids or applies to bid on contracts for the provision of goods or services by a public entity, or which otherwise transacts or applies to transact business with a public entity. The term "person" includes those officers, directors, executives, partners, shareholders, employees, members, and agents who are active in management of an entity.
 - d. Based on information and belief, the statement which I have marked below is true in relation to the entity submitting this sworn statement (indicate which statement applies).
 Neither the entity submitting this sworn statement, nor any of its officers, directors, executives, partners, shareholders, employees, members, or agents who are active in the management of the entity, nor any affiliate of the entity has been charged with and convicted of a public entity crime subsequent to July 1, 1989.
 The entity submitting this sworn statement, or one or more of its officers, directors, executives, partners, shareholders, employees, members, or agents who are active in the management of the entity, or an affiliate of the entity has been charged with and convicted of a public entity crime subsequent to July 1, 1989.

The entity submitting this sworn statement, or one or more of its officers, directors, executives, partners, shareholders, employees, members, or agents who are active in the management of the entity, or an affiliate of the entity has been charged with and convicted of a public entity crime after July 1, 1989. However, there has been a subsequent proceeding before a Hearing Officer of the State of Florida, Division of Administrative Hearings and the Final Order entered by the Hearing Officer determined that it was not in the public interest to place the entity submitting this sworn statement on the convicted "CONTRACTOR" list. (Attach a copy of the final order)

I UNDERSTAND THAT THE SUBMISSION OF THIS FORM TO THE CONTRACTING OFFICER FOR THE PUBLIC ENTITY IDENTIFIED IN PARAGRAPH 1 (ONE) ABOVE IS FOR THAT PUBLIC ENTITY ONLY AND, THAT THIS FORM IS VALID THROUGH DECEMBER 31 OF THE CALENDAR YEAR IN WHICH IT IS FILED. I ALSO UNDERSTAND THAT I AM REQUIRED TO INFORM THE PUBLIC ENTITY PRIOR TO ENTERING INTO A CONTRACT IN EXCESS OF THE THRESHOLD AMOUNT PROVIDED IN SECTION 287.017, FLORIDA STATUTES FOR CATEGORY TWO OF ANY CHANGE IN THE INFORMATION CONTAINED IN THIS FORM.

[Signature]
Authorized Signature
May 14, 2016
Date Signed

State of: Florida

County of: Pinellas

Sworn to and subscribed before me this 14 day of May, 2016

Personally Known [initials] or Produced Identification _____

(Specify Type of Identification)

[Signature]
Signature of Notary

My Commission Expires May 5, 2030

(seal)

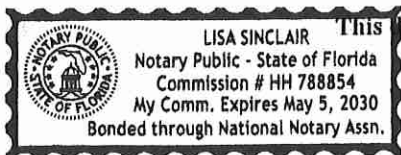

This document must be completed and returned with your submission.

IMMIGRATION AFFIDAVIT CERTIFICATION

This Affidavit is required and should be signed, notarized by an authorized principal of the firm, and submitted with formal Invitations to Bid (ITB's) and Request for Proposals (RFP) submittals. Further, Consultants/Bidders are required to enroll in the E-Verify program, and provide acceptable evidence of their enrollment, at the time of the submission of the Consultant/Bidder's proposal. Acceptable evidence consists of a copy of the properly completed E-Verify Company Profile page or a copy of the fully executed E-Verify Memorandum of Understanding for the company. Failure to include this Affidavit and acceptable evidence of enrollment in the E-Verify program may deem the Consultant/Bidder's proposal as nonresponsive.

The City of Madeira Beach will not intentionally award City contracts to any Consultant who knowingly employs unauthorized workers, constituting a violation of the employment provision contained in 8 U.S.C. Section 1324 a(e) Section 274A(e) of the Immigration and Nationality Act ("INA"). The City of Madeira Beach may consider the employment by any Consultant of unauthorized aliens a violation of Section 274A (e) of the INA. Such Violation by the recipient of the Employment Provisions contained in Section 274A(e) of the INA shall be grounds for unilateral termination of the contract by the City of Madeira Beach.

Consultant attests that they are fully compliant with all applicable immigration laws (specifically to the 1986 Immigration Act and subsequent Amendment(s)) and agrees to comply with the provisions of the Memorandum of Understanding with E-Verify and to provide proof of enrollment in The Employment Eligibility Verification System (E-Verify), operated by the Department of Homeland Security in partnership with the Social Security Administration at the time of submission of the Consultant/Bidder's proposal.

Company Name: BCJ 2 LLC dba Speeler Foundations
Print Name: Douglas Speeler Jr Title: President/Contractor
Signature: [Handwritten Signature] Date: May 14, 2026
State of: Florida
County of: Pinellas
Sworn to and subscribed before me this 14th day of May, 2026

Personally Known [Initials] or Produced Identification _____
(Specify Type of Identification)

[Handwritten Signature]
Signature of Notary
My Commission Expires May 5, 2030

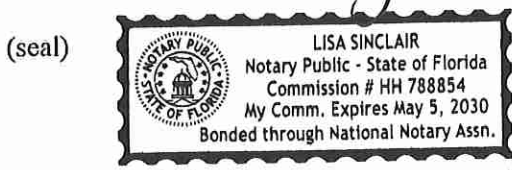

The signee of this affidavit guarantees, as evidenced by the affidavit required herein, the truth and accuracy of this affidavit to interrogatories hereinafter made. This document must be completed and returned with your submission.

BID TABULATION FORM – ADDENDUM#2 add on

Marina Seawall

Description	UNIT	EST. QUAN.	UNIT PRICE	AMOUNT
Cost of Material	LS	1	\$	\$ 72,200.00
Cost of Labor	LS	1	\$	\$ 72,200.00
Cost of Moving Utilities		1	\$	\$ 1,500.00
Cost of Dock/Pier Remove/Repair		1	\$	\$ 6,000.00
TOTAL Marina Project cost				\$ 151,900.00

Tom & Kitty Stuart Park Seawall- Include all Labor, Materials, and mobilization in both options

Option 1	\$ 39,750.00
Option 2	\$ 57,950.00

PROPOSED TOTAL BASE CONTRACT PRICE (Amount Written in numbers)
\$ 151,900.00

PROPOSED TOTAL BASE CONTRACT PRICE (Amount written in words) \$
One Hundred Fifty-One Thousand Nine Hundred Dollars

Signature: 

Printed Name: Douglas Speeler Jr

Date: May 14, 2026

Douglas R Speeler Jr
BCJ 2, LLC DBA SPEELER FOUNDATIONS
P.O. BOX 1767
LAKELAND, FL 33802

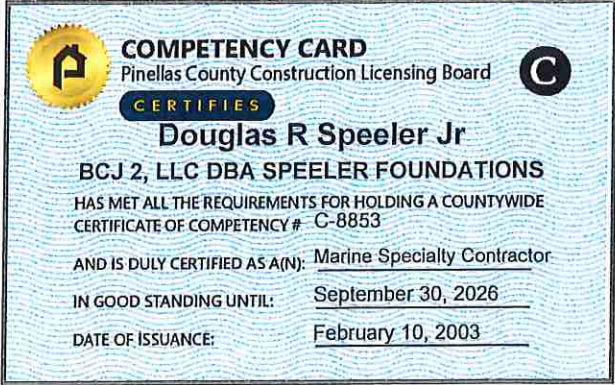



[Department of State](#) / [Division of Corporations](#) / [Search Records](#) / [Search by Entity Name](#) /

Detail by Entity Name

Florida Limited Liability Company

BCJ 2 LLC

Filing Information

Document Number L25000317028
FEI/EIN Number 39-3346502
Date Filed 07/09/2025
State FL
Status ACTIVE

Principal Address

1508 GEORGE JENKINS BLVD
LAKELAND, FL 33815

Mailing Address

PO BOX 1767
LAKELAND, FL 33802

Registered Agent Name & Address

CLARK CAMPBELL LANCASTER WORKMAN & AIRTH PA
500 SOUTH FLORIDA AVENUE
SUITE 800
LAKELAND, FL 33801

Authorized Person(s) Detail

Name & Address

Title MGR

FULBRIGHT, CHRIS
4163 BERKLEY ROAD
AUBURNDALE, FL 33823

Annual Reports

Report Year	Filed Date
2026	02/18/2026

Document Images

02/18/2026 -- ANNUAL REPORT	View image in PDF format
07/09/2025 -- Florida Limited Liability	View image in PDF format



[Previous on List](#) [Next on List](#) [Return to List](#)

Fictitious Name Search

No Filing History

Submit

Fictitious Name Detail

Fictitious Name

SPEELER FOUNDATIONS

Filing Information

Registration Number G25000114268
Status ACTIVE
Filed Date 09/03/2025
Expiration Date 12/31/2030
Current Owners 1
County MULTIPLE
Total Pages 1
Events Filed NONE
FEI/EIN Number NONE

Mailing Address

PO BOX 1767
LAKELAND, FL 33802

Owner Information

BCJ 2 LLC
 PO BOX 1767
 LAKELAND, FL 33802
FEI/EIN Number: 39-3346502
Document Number: L25000317028

Document Images

[09/03/2025 -- Fictitious Name Filing](#)

View image in PDF format

[Previous on List](#) [Next on List](#) [Return to List](#)

Fictitious Name Search

No Filing History

Submit

CERTIFICATE OF LIABILITY INSURANCE		Date 1/5/2026
Producer: Plymouth Insurance Agency 2739 U.S. Highway 19 N. Holiday, FL 34691 (727) 938-5562	This Certificate is issued as a matter of information only and confers no rights upon the Certificate Holder. This Certificate does not amend, extend or alter the coverage afforded by the policies below.	
Insured: South East Personnel Leasing, Inc. & Subsidiaries 2739 U.S. Highway 19 N. Holiday, FL 34691	Insurers Affording Coverage	
	Insurer A:	Lion Insurance Company
	Insurer B:	
	Insurer C:	
	Insurer D:	
	Insurer E:	

Coverages

The policies of insurance listed below have been issued to the insured named above for the policy period indicated. Notwithstanding any requirement, term or condition of any contract or other document with respect to which this certificate may be issued or may pertain, the insurance afforded by the policies described herein is subject to all the terms, exclusions, and conditions of such policies. Aggregate limits shown may have been reduced by paid claims.

INSR LTR	ADDL INSRD	Type of Insurance	Policy Number	Policy Effective Date (MM/DD/YY)	Policy Expiration Date (MM/DD/YY)	Limits																				
		GENERAL LIABILITY <input type="checkbox"/> Commercial General Liability <input type="checkbox"/> Claims Made <input type="checkbox"/> Occur <hr/> General aggregate limit applies per: <input type="checkbox"/> Policy <input type="checkbox"/> Project <input type="checkbox"/> LOC				Each Occurrence \$ Damage to rented premises (EA occurrence) \$ Med Exp \$ Personal Adv Injury \$ General Aggregate \$ Products - Comp/Op Agg \$																				
		AUTOMOBILE LIABILITY <input type="checkbox"/> Any Auto <input type="checkbox"/> All Owned Autos <input type="checkbox"/> Scheduled Autos <input type="checkbox"/> Hired Autos <input type="checkbox"/> Non-Owned Autos				Combined Single Limit (EA Accident) \$ Bodily Injury (Per Person) \$ Bodily Injury (Per Accident) \$ Property Damage (Per Accident) \$																				
		EXCESS/UMBRELLA LIABILITY <input type="checkbox"/> Occur <input type="checkbox"/> Claims Made Deductible				Each Occurrence Aggregate																				
A		Workers Compensation and Employers' Liability Any proprietor/partner/executive officer/member excluded? NO If Yes, describe under special provisions below.	WC 71949	01/01/2026	01/01/2027	<table border="1" style="width:100%; border-collapse: collapse;"> <tr> <td style="width: 5%; text-align: center;">X</td> <td style="width: 20%;">WC Statutory Limits</td> <td style="width: 5%;"></td> <td style="width: 10%;">OTH-ER</td> <td style="width: 60%;"></td> </tr> <tr> <td></td> <td>E.L. Each Accident</td> <td></td> <td></td> <td>\$1,000,000</td> </tr> <tr> <td></td> <td>E.L. Disease - Ea Employee</td> <td></td> <td></td> <td>\$1,000,000</td> </tr> <tr> <td></td> <td>E.L. Disease - Policy Limits</td> <td></td> <td></td> <td>\$1,000,000</td> </tr> </table>	X	WC Statutory Limits		OTH-ER			E.L. Each Accident			\$1,000,000		E.L. Disease - Ea Employee			\$1,000,000		E.L. Disease - Policy Limits			\$1,000,000
X	WC Statutory Limits		OTH-ER																							
	E.L. Each Accident			\$1,000,000																						
	E.L. Disease - Ea Employee			\$1,000,000																						
	E.L. Disease - Policy Limits			\$1,000,000																						

Other

Lion Insurance Company is A.M. Best Company rated A (Excellent). AMB # 12616

Descriptions of Operations/Locations/Vehicles/Exclusions added by Endorsement/Special Provisions: Client ID: 93-69-275

Coverage only applies to active employee(s) of South East Personnel Leasing, Inc. & Subsidiaries that are leased to the following "Client Company":

BCJ 2 LLC dba Speeler Foundations

Coverage only applies to injuries incurred by South East Personnel Leasing, Inc. & Subsidiaries active employee(s) , while working in: FL.
 Coverage does not apply to statutory employee(s) or independent contractor(s) of the Client Company or any other entity.
 A list of the active employee(s) leased to the Client Company can be obtained by emailing a request to certificates@lioninsurancecompany.com

Project Name:
 ISSUE 01-05-26 (KD)

Begin Date: 9/7/2025

CERTIFICATE HOLDER CITY OF MADEIRA BEACH 300 MUNICIPAL DRIVE MADEIRA BEACH, FL 33708	CANCELLATION Should any of the above described policies be cancelled before the expiration date thereof, the issuing insurer will endeavor to mail 30 days written notice to the certificate holder named to the left, but failure to do so shall impose no obligation or liability of any kind upon the insurer, its agents or representatives.
--	--

EXHIBIT A PUBLIC CONTRACTING AND ENVIRONMENTAL CRIMES CERTIFICATION

THIS FORM MUST BE SIGNED AND SWORN TO IN THE PRESENCE OF A NOTARY PUBLIC OR OTHER OFFICIAL AUTHORIZED TO ADMINISTER OATHS.

This sworn statement is submitted to the CITY OF MADEIRA BEACH by Douglas Speeler Jr President/Contractor
[print individual's name and title]
for BCJ 2 LLC dba Speeler Foundations

[print name of entity submitting sworn statement]

whose business address is: 6111 142nd Ave N Clearwater, FL 33760

and Federal Employer Identification Number (FEIN) is 39-3346502, if the entity has no FEIN, include the Social Security Number of the individual signing this sworn statement: _____

I understand that no person or entity shall be awarded or receive a City contract for public improvements, procurement of goods or services (including professional services) or a City lease, franchise, concession, or management agreement, or shall receive a grant of City monies unless such person or entity has submitted a written certification to the City that it has not:

1. been convicted of bribery or attempting to bribe a public officer or employee of the city, the State of Florida, or any other public entity, including, but not limited to the Government of the United States, any state, or any local government authority in the United States, in that officer's or employee's official capacity; or
2. been convicted of an agreement or collusion among bidders or prospective bidders in restraint of freedom of competition, by agreement to bid a fixed price, or otherwise; or
3. been convicted of a violation of an environmental law that, in the sole opinion of the City's Project Manager, reflects negatively upon the ability of the person or entity to conduct business in a responsible manner; or
4. made an admission of guilt of such conduct described in items (1), (2) or (3) above, which is a matter of record, but has not been prosecuted for such conduct, or has made an admission of guilt of such conduct, which is a matter of record, pursuant to formal prosecution. An admission of guilt shall be construed to include a plea of nolo contendere; or
5. where an officer, official, agent or employee of a business entity has been convicted of or has admitted guilt to any of the crimes set forth above on behalf of such and entity and pursuant to the direction or authorization of an official thereof (including the person committing the offense, if he is an official of the business entity), the business shall be chargeable with the conduct herein above set forth. A business entity shall be chargeable with the conduct of an affiliated entity, whether wholly owned, partially owned, or one which has common ownership or a common Board of Directors. For purposes of this Form, business entities are affiliated if, directly or indirectly, one business entity controls or has the power to control another business entity, or if an individual or group of individuals controls or has the power to control both entities. Indicia of control shall include, without limitation, interlocking management or ownership, identity of interests among family members, shared organization of a business entity following the ineligibility of a business entity under this Article, or using substantially the same management, ownership, or principles as the ineligible entity.

Any person or entity who claims that this Article is inapplicable to him/her/it because a conviction or judgment has been reversed by a court of competent jurisdiction, shall prove the same with documentation satisfactory to the City Manager. Upon presentation of such satisfactory proof, the person or entity shall be allowed to contract with the City. I UNDERSTAND THAT THE SUBMISSION OF THIS FORM TO THE CITY IS VALID THROUGH DECEMBER 31 OF THE CALENDAR YEAR IN WHICH IT IS FILED. I ALSO UNDERSTAND THAT ANY CONTRACT OR BUSINESS TRANSACTION SHALL PROVIDE FOR SUSPENSION OF PAYMENTS, OR TERMINATION, OR BOTH, IF THE CONTRACTING OFFICER OR THE CITY ADMINISTRATOR DETERMINES THAT SUCH PERSON OR ENTITY HAS MADE FALSE CERTIFICATION.

Signatory Requirement. In the case of a corporation, this affidavit shall be executed by the corporate president. In the case of a partnership, this affidavit shall be executed by the general partner(s). In the case of a business entity other than a partnership or a corporation, this affidavit shall be executed by an authorized agent of the entity or the individual.

[Signature]
Authorized Signature
Date Signed May 14/2026

State of: Florida

County of: Pinellas

Sworn to and subscribed before me this 14 day of May, 2026

Personally Known [Signature] or Produced Identification _____

(Specify Type of Identification)

[Signature] Signature of Notary

My Commission Expires May 5 2030

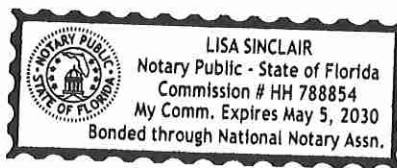

EXHIBIT B DRUG FREE WORKPLACE CERTIFICATION

THIS FORM MUST BE SIGNED AND SWORN TO IN THE PRESENCE OF A NOTARY PUBLIC OR OTHER OFFICIAL AUTHORIZED TO ADMINISTER OATHS.

This sworn statement is submitted to the City of Madeira Beach by Douglas Speeler Jr President/Contractor
[print individual's name and title]

for BCJ 2 LLC dba Speeler Foundations [print name of entity submitting sworn statement]

whose business address is: 6111 142nd Ave N Clearwater, FL 33760 and (if

applicable) its Federal Employer Identification Number (FEIN) is 39-3346502 (If the entity has no FEIN,

include the Social Security Number of the individual signing this sworn statement:

I understand that no person or entity shall be awarded or receive a City contract for public improvements, procurement of goods or services (including professional services) or a City lease, franchise, concession, or management agreement, or shall receive a grant of City monies unless such person or entity has submitted a written certification to the City that it will provide a drug free workplace by:

Providing a written statement to each employee notifying such employee that the unlawful manufacture, distribution, dispensation, possession, or use of a controlled substance as defined by §893.02(4), Florida Statutes, as the same may be amended from time to time, in the person's or entity's workplace is prohibited specifying the actions that will be taken against employees for violation of such prohibition. Such written statement shall inform employees about:

- (i) the dangers of drug abuse in the workplace.
 - (ii) the person's or entity's policy of maintaining a drug-free environment at all its workplaces, including but not limited to all locations where employees perform any task relating to any portion of such contract, business transaction or grant.
 - (iii) any available drug counseling, rehabilitation, and employee assistance programs; and
 - (iv) the penalties that may be imposed upon employees for drug abuse violations.
- (2) Requiring the employee to sign a copy of such written statement to acknowledge his or her receipt of same and advice as to the specifics of such policy. Such person or entity shall retain the statements signed by its employees. Such person or entity shall also post in a prominent place at all of its workplaces a written statement of its policy containing the foregoing elements (i) through (iv).
- (3) Notifying the employee in the statement required by subsection (1) that as a condition of employment the employee will:
- (i) abide by the terms of the statement; and
 - (ii) notify the employer of any criminal drug statute conviction for a violation occurring in the workplace no later than five (5) days after such a conviction.
- (4) Notifying the City within ten (10) days after receiving notice under subsection (3) from an employee or otherwise receiving actual notice of such conviction.

(5) Imposing appropriate personnel action against such employee up to and including termination; or requiring such employee to satisfactorily participate in a drug abuse assistance or rehabilitation program approved for such purposes by a federal, state, or local health, law enforcement, or other appropriate agency.

(6) Making a good faith effort to continue to maintain a drug free workplace through implementation of sections (1) through (5) stated above.

I UNDERSTAND THAT THE SUBMISSION OF THIS FORM TO THE CITY OF MADEIRA BEACH IS VALID THROUGH DECEMBER 31 OF THE CALENDAR YEAR IN WHICH IT IS FILED. I ALSO UNDERSTAND THAT ANY CONTRACT OR BUSINESS TRANSACTION SHALL PROVIDE FOR SUSPENSION OF PAYMENTS, OR TERMINATION, OR BOTH, IF THE CITY DETERMINES THAT:

- (1) Such person or entity has made false certification.
- (2) Such person or entity violates such certification by failing to carry out the requirements of sections (1), (2), (3), (4), (5), or (6) or subsection 3-101(7)(B); or
- (3) Such a number of employees of such person or entity have been convicted of violations occurring in the workplace as to indicate that such person or entity has failed to make a good faith effort to provide a drug free workplace as required by subsection 3-101(7)(B).

Signatory Requirement. In the case of a corporation, this affidavit shall be executed by the corporate president. In the case of a partnership, this affidavit shall be executed by the general partner(s). In the case of a business entity other than a partnership or a corporation, this affidavit shall be executed by an authorized agent of the entity or the individual.

[Signature]
 Authorized Signature
 Date Signed May 14, 2026

State of: Florida

County of: Pinellas

Sworn to and subscribed before me this 14 day of May, 2026

Personally Known p or Produced Identification _____

(Specify Type of Identification)

[Signature] Signature of Notary

My Commission Expires May 5 2030



CONTRACT

This **CONTRACT** made and entered into this ____ day of _____, 20__ by and between the City of Madeira Beach, Florida, a municipal corporation, hereinafter designated as the "City", and BCJ 2 LLC dba Speeler Foundations , of the City of Clearwater , County of Pinellas , and State of Florida, hereinafter designated as the Contractor".

WITNESSETH:

That the parties to this Contract each in consideration of the undertakings, promises, and agreements on the part of the other herein contained, do hereby undertake, promise, and agree as follows:

The Contractor, and its successors, assigns, executors, or administrators, in consideration of the sums of money as herein after set forth to be paid by the City and to the Contractor, shall and will at **their** own cost and expense perform all labor, furnish all materials, tools, and equipment for the following:

PROJECT NAME: RFP 26-05 Marina Seawall Replacement section #2

PROJECT #RFP 26-05

in the amount of \$ \$151,900.00

In accordance with the BID PROPOSAL submitted by the CONTRACTOR and technical supplemental specifications and such other special provisions and drawings, if any, as submitted by the City, together with any advertisement, instructions to bidders, general conditions, proposal and performance & payment bond, which may be hereto attached, and any drawings if any, which may be herein referred to, are hereby made a part of this contract, **including Exhibit A – CONTRACTOR BID RESPONSE and Exhibit B – Request for proposal**, and all of said work to be performed and completed by the Contractor and its successors and assigns shall be fully completed in a good and workmanlike manner to the satisfaction of the City.

If the Contractor should fail to comply with any of the terms, conditions, provisions, or stipulations as contained herein within the time specified for completion of the work to be performed by the Contractor, then the City, may at its option, avail itself of any or all remedies provided on its behalf and shall have the right to proceed to complete such work as Contractor is obligated to perform in accordance with the provisions as contained herein.

THE CONTRACTOR AND ITS SUCCESSORS AND ASSIGNS DOES HEREBY AGREE TO ASSUME THE DEFENSE OF ANY LEGAL ACTION WHICH MAY BE BROUGHT AGAINST THE CITY AS A RESULT OF THE CONTRACTOR'S ACTIVITIES ARISING OUT OF THIS CONTRACT AND FURTHERMORE, IN CONSIDERATION OF THE TERMS, STIPULATIONS AND CONDITIONS AS CONTAINED HEREIN, AGREES TO HOLD THE CITY FREE AND HARMLESS FROM ANY AND ALL CLAIMS FOR DAMAGES, COSTS OF SUITS, JUDGMENTS, OR DECREES RESULTING FROM ANY CLAIMS MADE UNDER THIS CONTRACT AGAINST THE CITY, OR THE CONTRACTOR, OR THE CONTRACTOR'S SUBCONTRACTORS, AGENTS, SERVANTS, OR EMPLOYEES RESULTING FROM ACTIVITIES BY THE AFOREMENTIONED CONTRACTOR, SUBCONTRACTORS, AGENTS, SERVANTS, OR EMPLOYEES.

In addition to the foregoing provisions, the Contractor agrees to conform to the following requirements:

In connection with the performance of work under this contract, the Contractor agrees not to discriminate against any employee or applicant for employment because of race, sex, religion, color, or national origin. The aforesaid provision shall include, but not be limited to, the following: employment, upgrading, demotion, or transfer; recruitment or recruitment advertising; lay off or termination; rates of pay or other forms of compensation; and selection for training, including apprenticeship. The Contractor agrees to post hereafter in conspicuous places,

available for employees or applicants for employment, notices to be provided by the contracting officer setting forth the provisions of the non-discrimination clause.

The Contractor further agrees to insert the foregoing provisions in all contracts hereunder, including contracts or agreements with labor unions and/or worker's representatives, except sub-contractors for standard commercial supplies or raw materials.

It is mutually agreed between the parties hereto that time is of the essence of this contract, and in the event that the work to be performed by the Contractor is not completed within the time stipulated herein, it is then further agreed that the City may deduct from such sums or compensation as may be due to the Contractor the sum of **\$1,000.00 per day** for each day that the work to be performed by the Contractor remains incomplete beyond the time limit specified herein, which sum of **\$1,000.00 per day** shall only and solely represent damages which the City has sustained by reason of the failure of the Contractor to complete the work within the time stipulated, it being further agreed that this sum is not to be construed as a penalty but is only to be construed as liquidated damages for failure of the Contractor to complete and perform all work within the time period as specified in this contract.

It is further mutually agreed between the City and the Contractor that if, any time after the execution of this contract and the surety bond which is attached hereto for the faithful performance of the terms and conditions as contained herein by the Contractor, that the City shall at any time deem the surety or sureties upon such performance bond to be unsatisfactory or if, for any reason, the said bond ceases to be adequate in amount to cover the performance of the work the Contractor shall, at Contractor's own expense, within ten (10) days after receipt of written notice from the City to do so, furnish an additional bond or bonds in such term and amounts and with such surety or sureties as shall be satisfactory to the City. If such an event occurs, no further payment shall be made to the Contractor under the terms and provisions of this contract until such new or additional security bond guaranteeing the faithful performance of the work under the terms hereof shall be completed and furnished to the City in a form satisfactory to it.

The successful bidder/contractor will be required to comply with Section 119.0701, Florida Statutes (2019), specifically to:

- (a) Keep and maintain public records that ordinarily and necessarily would be required by the City of Madeira Beach in order to perform the service.
- (b) Provide the public with access to public records on the same terms and conditions that the City of Madeira Beach would provide the records and at a cost that does not exceed the cost provided in this chapter or as otherwise provided by law.
- (c) Ensure that public records that are exempt or confidential and exempt from public records disclosure requirements are not disclosed except as authorized by law; and
- (d) Meet all requirements for retaining public records and transfer, at no cost, to the City of Madeira Beach all public records in possession of the contractor upon termination of the contract and destroy any duplicate public records that are exempt or confidential and exempt from public records disclosure requirements. All records stored electronically must be provided to the public agency in a format that is compatible with the information technology systems of the City of Madeira Beach.

In witness whereof, the parties hereto have executed this agreement as of the effective date.

City of Madeira Beach:

Attest:

By: _____
Mayor

By: _____
City Clerk

BCJ 2 dba Speeler Foundations

By: DNJ

Print Name: Douglas Speeler Jr

Title: President/Contractor

IN WITNESS, WHEREOF, the parties to the agreement have hereunto set their hands and seals and have executed this Agreement, in duplicate, the day and year first above written.

CITY OF MADEIRA BEACH
IN PINELLAS COUNTY, FLORIDA

By: (SEAL) City Manager

Countersigned:

By: _____
Mayor

Attest:

City Clerk

Approved as to form:

City Attorney

(Contractor must indicate whether Corporation,
Partnership, Company or Individual.)

(Contractor)

By: _____

(SEAL)

(The person signing shall, in their own handwriting, sign the principal's name, their own name, and their title; where the person is signing for a Corporation, they must, by Affidavit, show their authority to bind the Corporation).

AIA® Document A310™ – 2010

Bid Bond

CONTRACTOR:

(Name, legal status and address)
Speeler Marine Construction
6111 142nd Ave N
Clearwater, FL 33760

SURETY:

(Name, legal status and principal place of business)
Nationwide Mutual Insurance Company
1100 Locust St. Dept. 2006
Des Moines, IA 50391-2006

This document has important legal consequences. Consultation with an attorney is encouraged with respect to its completion or modification.

OWNER:

(Name, legal status and address)
The City of Madeira Beach, Florida
300 Municipal Drive
Madeira Beach, FL 33708

Any singular reference to Contractor, Surety, Owner or other party shall be considered plural where applicable.

BOND AMOUNT: Ten Percent of Principal Bid (10% OPB)

PROJECT:

(Name, location or address, and Project number, if any)

RFP-26-05-0-2026/BC Marina Seawall Replacement Section #2

The Contractor and Surety are bound to the Owner in the amount set forth above, for the payment of which the Contractor and Surety bind themselves, their heirs, executors, administrators, successors and assigns, jointly and severally, as provided herein. The conditions of this Bond are such that if the Owner accepts the bid of the Contractor within the time specified in the bid documents, or within such time period as may be agreed to by the Owner and Contractor, and the Contractor either (1) enters into a contract with the Owner in accordance with the terms of such bid, and gives such bond or bonds as may be specified in the bidding or Contract Documents, with a surety admitted in the jurisdiction of the Project and otherwise acceptable to the Owner, for the faithful performance of such Contract and for the prompt payment of labor and material furnished in the prosecution thereof; or (2) pays to the Owner the difference, not to exceed the amount of this Bond, between the amount specified in said bid and such larger amount for which the Owner may in good faith contract with another party to perform the work covered by said bid, then this obligation shall be null and void, otherwise to remain in full force and effect. The Surety hereby waives any notice of an agreement between the Owner and Contractor to extend the time in which the Owner may accept the bid. Waiver of notice by the Surety shall not apply to any extension exceeding sixty (60) days in the aggregate beyond the time for acceptance of bids specified in the bid documents, and the Owner and Contractor shall obtain the Surety's consent for an extension beyond sixty (60) days.

If this Bond is issued in connection with a subcontractor's bid to a Contractor, the term Contractor in this Bond shall be deemed to be Subcontractor and the term Owner shall be deemed to be Contractor.

When this Bond has been furnished to comply with a statutory or other legal requirement in the location of the Project, any provision in this Bond conflicting with said statutory or legal requirement shall be deemed deleted herefrom and provisions conforming to such statutory or other legal requirement shall be deemed incorporated herein. When so furnished, the intent is that this Bond shall be construed as a statutory bond and not as a common law bond.

Signed and sealed this 15th day of May, 2026

	Speeler Marine Construction	
_____	<i>(Principal)</i>	<i>(Seal)</i>
<i>(Witness)</i>		

	<i>(Title)</i>	
	Nationwide Mutual Insurance Company	
_____	<i>(Surety)</i>	<i>(Seal)</i>
<i>(Witness)</i>		

	<i>(Title)</i>	
	Allan B. Webb, Attorney-in-Fact	

CAUTION: You should sign an original AIA Contract Document, on which this text appears in-RED. An original assures that changes will not be obscured.

Power of Attorney

Bond Number:

KNOW ALL MEN BY THESE PRESENTS THAT:

Nationwide Mutual Insurance Company, an Ohio corporation

hereinafter referred to severally as the "Company" and collectively as "the Companies" does hereby make, constitute and appoint:

Allan Webb; Vicki Fetter; Stephen M. Harmon

each in their individual capacity, its true and lawful attorney-in-fact, with full power and authority to sign, seal, and execute on its behalf any and all bonds and undertakings, and other obligatory instruments of similar nature, in penalties not exceeding the sum of

One Million and no/100 -- Dollars (\$1,000,000.00)

and to bind the Company thereby, as fully and to the same extent as if such instruments were signed by the duly authorized officers of the Company; and all acts of said Attorney pursuant to the authority given are hereby ratified and confirmed.

This power of attorney is made and executed pursuant to and by authority of the following resolution duly adopted by the board of directors of the Company:

"RESOLVED, that the president, or any vice president be, and each hereby is, authorized and empowered to appoint attorneys-in-fact of the Company, and to authorize them to execute and deliver on behalf of the Company any and all bonds, forms, applications, memorandums, undertakings, recognizances, transfers, contracts of indemnity, policies, contracts guaranteeing the fidelity of persons holding positions of public or private trust, and other writings obligatory in nature that the business of the Company may require; and to modify or revoke, with or without cause, any such appointment or authority; provided, however, that the authority granted hereby shall in no way limit the authority of other duly authorized agents to sign and countersign any of said documents on behalf of the Company."

"RESOLVED FURTHER, that such attorneys-in-fact shall have full power and authority to execute and deliver any and all such documents and to bind the Company subject to the terms and limitations of the power of attorney issued to them, and to affix the seal of the Company thereto; provided, however, that said seal shall not be necessary for the validity of any such documents."

This power of attorney is signed and sealed under and by the following bylaws duly adopted by the board of directors of the Company.

Execution of Instruments. Any vice president, any assistant secretary or any assistant treasurer shall have the power and authority to sign or attest all approved documents, instruments, contracts, or other papers in connection with the operation of the business of the company in addition to the chairman of the board, the chief executive officer, president, treasurer or secretary; provided, however, the signature of any of them may be printed, engraved, or stamped on any approved document, contract, instrument, or other papers of the Company.

IN WITNESS WHEREOF, the Company has caused this instrument to be sealed and duly attested by the signature of its officer the 1st day of April, 2024.

[Handwritten Signature]

Antonio C. Albanese, Vice President of Nationwide Mutual Insurance Company

ACKNOWLEDGMENT

STATE OF NEW YORK COUNTY OF KINGS: ss

On this 1st day of April, 2024, before me came the above-named officer for the Company aforesaid, to me personally known to be the officer described in and who executed the preceding instrument, and he acknowledged the execution of the same, and being by me duly sworn, deposes and says, that he is the officer of the Company aforesaid, that the seal affixed hereto is the corporate seal of said Company, and the said corporate seal and his signature were duly affixed and subscribed to said instrument by the authority and direction of said Company.



Sharon Laburda
Notary Public, State of New York
No. 01LA6427697
Qualified in Kings County
Commission Expires January 3, 2026

[Handwritten Signature]

Notary Public
My Commission Expires
January 3, 2026

CERTIFICATE

I, Lezlie F. Chimienti, Assistant Secretary of the Company, do hereby certify that the foregoing is a full, true and correct copy of the original power of attorney issued by the Company; that the resolution included therein is a true and correct transcript from the minutes of the meetings of the boards of directors and the same has not been revoked or amended in any manner; that said Antonio C. Albanese was on the date of the execution of the foregoing power of attorney the duly elected officer of the Company, and the corporate seal and his signature as officer were duly affixed and subscribed to the said instrument by the authority of said board of directors; and the foregoing power of attorney is still in full force and effect.

IN WITNESS WHEREOF, I have hereunto subscribed my name as Assistant Secretary, and affixed the corporate seal of said Company this 15th day of May, 2026.

[Handwritten Signature]

Assistant Secretary

AIA[®] Document A310[™] – 2010

Bid Bond

CONTRACTOR:

(Name, legal status and address)

Speeler Marine Construction
6111 142nd Ave N
Clearwater, FL 33760

SURETY:

(Name, legal status and principal place of business)

Nationwide Mutual Insurance Company
1100 Locust St. Dept. 2006
Des Moines, IA 50391-2006

This document has important legal consequences. Consultation with an attorney is encouraged with respect to its completion or modification.

Any singular reference to Contractor, Surety, Owner or other party shall be considered plural where applicable.

OWNER:

(Name, legal status and address)

The City of Madeira Beach, Florida
300 Municipal Drive
Madeira Beach, FL 33708

BOND AMOUNT: Ten Percent of Principal Bid (10% OPB)

PROJECT:

(Name, location or address, and Project number, if any)

Tom & Kitty Stuart Park Seawall 14070 Gulf Blvd

The Contractor and Surety are bound to the Owner in the amount set forth above, for the payment of which the Contractor and Surety bind themselves, their heirs, executors, administrators, successors and assigns, jointly and severally, as provided herein. The conditions of this Bond are such that if the Owner accepts the bid of the Contractor within the time specified in the bid documents, or within such time period as may be agreed to by the Owner and Contractor, and the Contractor either (1) enters into a contract with the Owner in accordance with the terms of such bid, and gives such bond or bonds as may be specified in the bidding or Contract Documents, with a surety admitted in the jurisdiction of the Project and otherwise acceptable to the Owner, for the faithful performance of such Contract and for the prompt payment of labor and material furnished in the prosecution thereof; or (2) pays to the Owner the difference, not to exceed the amount of this Bond, between the amount specified in said bid and such larger amount for which the Owner may in good faith contract with another party to perform the work covered by said bid, then this obligation shall be null and void, otherwise to remain in full force and effect. The Surety hereby waives any notice of an agreement between the Owner and Contractor to extend the time in which the Owner may accept the bid. Waiver of notice by the Surety shall not apply to any extension exceeding sixty (60) days in the aggregate beyond the time for acceptance of bids specified in the bid documents, and the Owner and Contractor shall obtain the Surety's consent for an extension beyond sixty (60) days.

If this Bond is issued in connection with a subcontractor's bid to a Contractor, the term Contractor in this Bond shall be deemed to be Subcontractor and the term Owner shall be deemed to be Contractor.

When this Bond has been furnished to comply with a statutory or other legal requirement in the location of the Project, any provision in this Bond conflicting with said statutory or legal requirement shall be deemed deleted herefrom and provisions conforming to such statutory or other legal requirement shall be deemed incorporated herein. When so furnished, the intent is that this Bond shall be construed as a statutory bond and not as a common law bond.

Signed and sealed this 15th day of May, 2026

Speeler Marine Construction

(Principal)

(Seal)

(Witness)

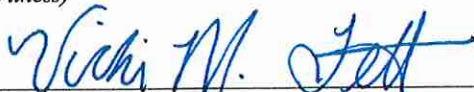

(Witness) Vicki M. Fetter, Sr Client Manager

(Title)

Nationwide Mutual Insurance Company

(Surety)

(Seal)

(Title) Allan B. Webb, Attorney-in-Fact

CAUTION: You should sign an original AIA Contract Document, on which this text appears in RED. An original assures that changes will not be obscured.

Init.

AIA Document A310[™] – 2010. Copyright © 1963, 1970 and 2010 by The American Institute of Architects. All rights reserved. **WARNING: This AIA[®] Document is protected by U.S. Copyright Law and International Treaties. Unauthorized reproduction or distribution of this AIA[®] Document, or any portion of it, may result in severe civil and criminal penalties, and will be prosecuted to the maximum extent possible under the law.** Purchasers are permitted to reproduce ten (10) copies of this document when completed. To report copyright violations of AIA Contract Documents, e-mail The American Institute of Architects' legal counsel, copyright@aia.org. 061110

Power of Attorney

Bond Number: NA

KNOW ALL MEN BY THESE PRESENTS THAT:

Nationwide Mutual Insurance Company, an Ohio corporation

hereinafter referred to severally as the "Company" and collectively as "the Companies" does hereby make, constitute and appoint:

Allan Webb; Vicki Fetter; Stephen M. Harmon

each in their individual capacity, its true and lawful attorney-in-fact, with full power and authority to sign, seal, and execute on its behalf any and all bonds and undertakings, and other obligatory instruments of similar nature, in penalties not exceeding the sum of

One Million and no/100 -- Dollars (\$1,000,000.00)

and to bind the Company thereby, as fully and to the same extent as if such instruments were signed by the duly authorized officers of the Company; and all acts of said Attorney pursuant to the authority given are hereby ratified and confirmed.

This power of attorney is made and executed pursuant to and by authority of the following resolution duly adopted by the board of directors of the Company:

"RESOLVED, that the president, or any vice president be, and each hereby is, authorized and empowered to appoint attorneys-in-fact of the Company, and to authorize them to execute and deliver on behalf of the Company any and all bonds, forms, applications, memorandums, undertakings, recognizances, transfers, contracts of indemnity, policies, contracts guaranteeing the fidelity of persons holding positions of public or private trust, and other writings obligatory in nature that the business of the Company may require; and to modify or revoke, with or without cause, any such appointment or authority; provided, however, that the authority granted hereby shall in no way limit the authority of other duly authorized agents to sign and countersign any of said documents on behalf of the Company."

"RESOLVED FURTHER, that such attorneys-in-fact shall have full power and authority to execute and deliver any and all such documents and to bind the Company subject to the terms and limitations of the power of attorney issued to them, and to affix the seal of the Company thereto; provided, however, that said seal shall not be necessary for the validity of any such documents."

This power of attorney is signed and sealed under and by the following bylaws duly adopted by the board of directors of the Company.

Execution of Instruments. Any vice president, any assistant secretary or any assistant treasurer shall have the power and authority to sign or attest all approved documents, instruments, contracts, or other papers in connection with the operation of the business of the company in addition to the chairman of the board, the chief executive officer, president, treasurer or secretary; provided, however, the signature of any of them may be printed, engraved, or stamped on any approved document, contract, instrument, or other papers of the Company.

IN WITNESS WHEREOF, the Company has caused this instrument to be sealed and duly attested by the signature of its officer the 1st day of April, 2024.

[Handwritten Signature]

Antonio C. Albanese, Vice President of Nationwide Mutual Insurance Company

ACKNOWLEDGMENT

STATE OF NEW YORK COUNTY OF KINGS: ss

On this 1st day of April, 2024, before me came the above-named officer for the Company aforesaid, to me personally known to be the officer described in and who executed the preceding instrument, and he acknowledged the execution of the same, and being by me duly sworn, deposes and says, that he is the officer of the Company aforesaid, that the seal affixed hereto is the corporate seal of said Company, and the said corporate seal and his signature were duly affixed and subscribed to said instrument by the authority and direction of said Company.



Sharon Laburda
Notary Public, State of New York
No. 01LA6427697
Qualified in Kings County
Commission Expires January 3, 2026

[Handwritten Signature]

Notary Public
My Commission Expires
January 3, 2026

CERTIFICATE

I, Lezlie F. Chimienti, Assistant Secretary of the Company, do hereby certify that the foregoing is a full, true and correct copy of the original power of attorney issued by the Company; that the resolution included therein is a true and correct transcript from the minutes of the meetings of the boards of directors and the same has not been revoked or amended in any manner; that said Antonio C. Albanese was on the date of the execution of the foregoing power of attorney the duly elected officer of the Company, and the corporate seal and his signature as officer were duly affixed and subscribed to the said instrument by the authority of said board of directors; and the foregoing power of attorney is still in full force and effect.

IN WITNESS WHEREOF, I have hereunto subscribed my name as Assistant Secretary, and affixed the corporate seal of said Company this 15th day of May, 2026.

[Handwritten Signature]

Assistant Secretary

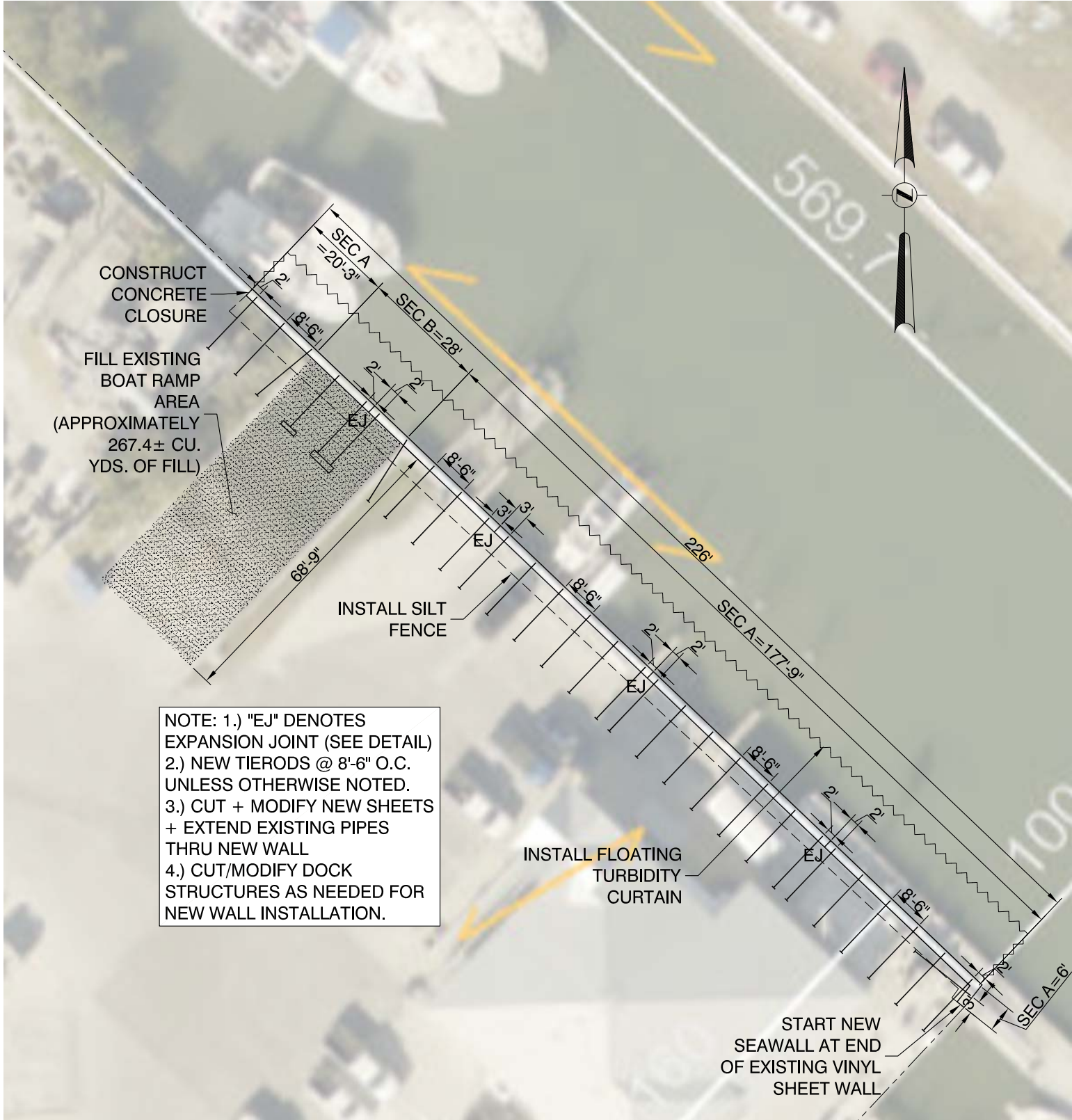

NOTE: 1.) "EJ" DENOTES EXPANSION JOINT (SEE DETAIL)
 2.) NEW TIER RODS @ 8'-6" O.C. UNLESS OTHERWISE NOTED.
 3.) CUT + MODIFY NEW SHEETS + EXTEND EXISTING PIPES THRU NEW WALL
 4.) CUT/MODIFY DOCK STRUCTURES AS NEEDED FOR NEW WALL INSTALLATION.

1 OVERALL SITE PLAN VIEW
 S1 1"=30'

Digitally signed by John B. Adams Jr., PE
 Date: 2026.02.27 12:01:07 -05'00'

Reuben Clarson CONSULTING
MARINE ENGINEERING
 ASSESS, ADVISE, DESIGN
 (CERT. OF AUTH. NO. 9206)
 780 94TH AVENUE NORTH, SUITE 102, ST. PETERSBURG, FL 33702
 P: (727) 895-4717 F: (727) 578-9542
 WWW.REUBENCLARSONCONSULTING.COM

OWNER: CITY OF MADEIRA BEACH	CONTRACTOR:	DATE: 2-26-2026	SHEET NO.: S1
503 150TH AVE MADEIRA BEACH, FL		DRAWN/CHECK BY: JH/JA	TOTAL SHEETS: 4
SEAWALL DESIGN		SCALE: N.T.S.	REVISIONS:
		PROJ. NO. RR26-26MB091S	

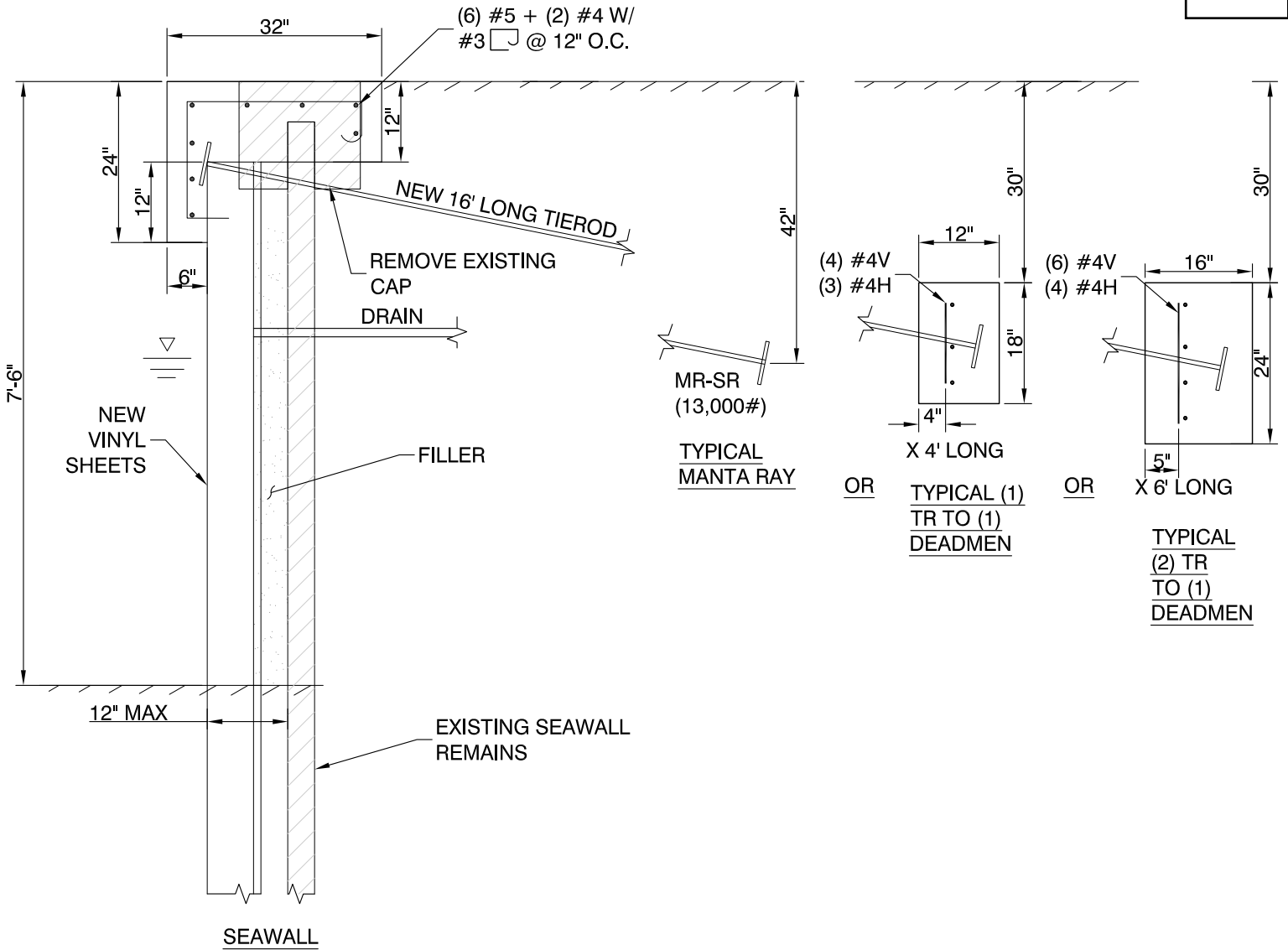

SEAWALL SECTION A VIEW

2
S2 1/2"=1'

NOTES:

- 1.) SHEETS-ESP 5.5, VANGUARD OR CL-9900 X 14' LONG.
- 2.) CONCRETE-5000 PSI AT 28 DAYS, FILLER 3500 PSI
- 3.) REBAR-GRADE 60, PLAIN, 3" CONCRETE COVER OR FIBERGLASS
- 4.) TIEBACKS-1"Ø X 16' LONG HDG, PVC ENCASED W/ (1) 6" X 6" X 1/2" HDG WASHERS & NUTS TO MR-SR MANTA RAY ANCHORS OR (2) 6" X 6" X 1/2" HDG WASHERS & NUTS INTO CONCRETE DEADMEN.
- 5.) DRAINS-1.25"Ø X 4' LONG SLIT TYPE PVC WELL POINT DRAINS @ 6' ON CENTER THROUGH BOTH WALLS 5" ABOVE THE BARNACLE LINE.
- 6.) NEW CAP AT EXISTING ELEVATION.
- 7.) MEETS FBC 2023, 8TH EDITION.

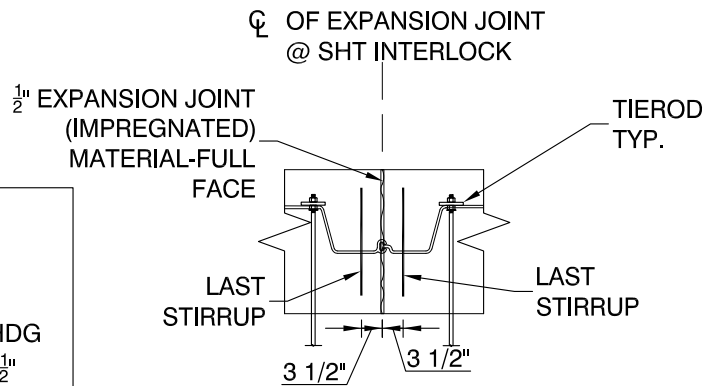

1 EXPANSION JOINT DETAIL
S2 N.T.S.

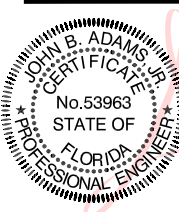

Digitally signed by John B. Adams Jr., PE
Date: 2026.02.27 12:01:24 -05'00'

Reuben Clarson
CONSULTING
MARINE ENGINEERING

ASSESS, ADVISE, DESIGN
(CERT. OF AUTH. NO. 9206)
780 94TH AVENUE NORTH, SUITE 102, ST. PETERSBURG, FL 33702
P: (727) 895-4717 F: (727) 578-9542
WWW.REUBENCLARSONCONSULTING.COM

OWNER: CITY OF MADEIRA BEACH	CONTRACTOR:	DATE: 2-26-2026	SHEET NO.: S2 TOTAL SHEETS: 4
503 150TH AVE MADEIRA BEACH, FL		DRAWN/CHECK BY: JH/JA	REVISIONS:
		SCALE: N.T.S.	
SEAWALL DESIGN		PROJ. NO. RR26-26MB091S	

Item 4A.

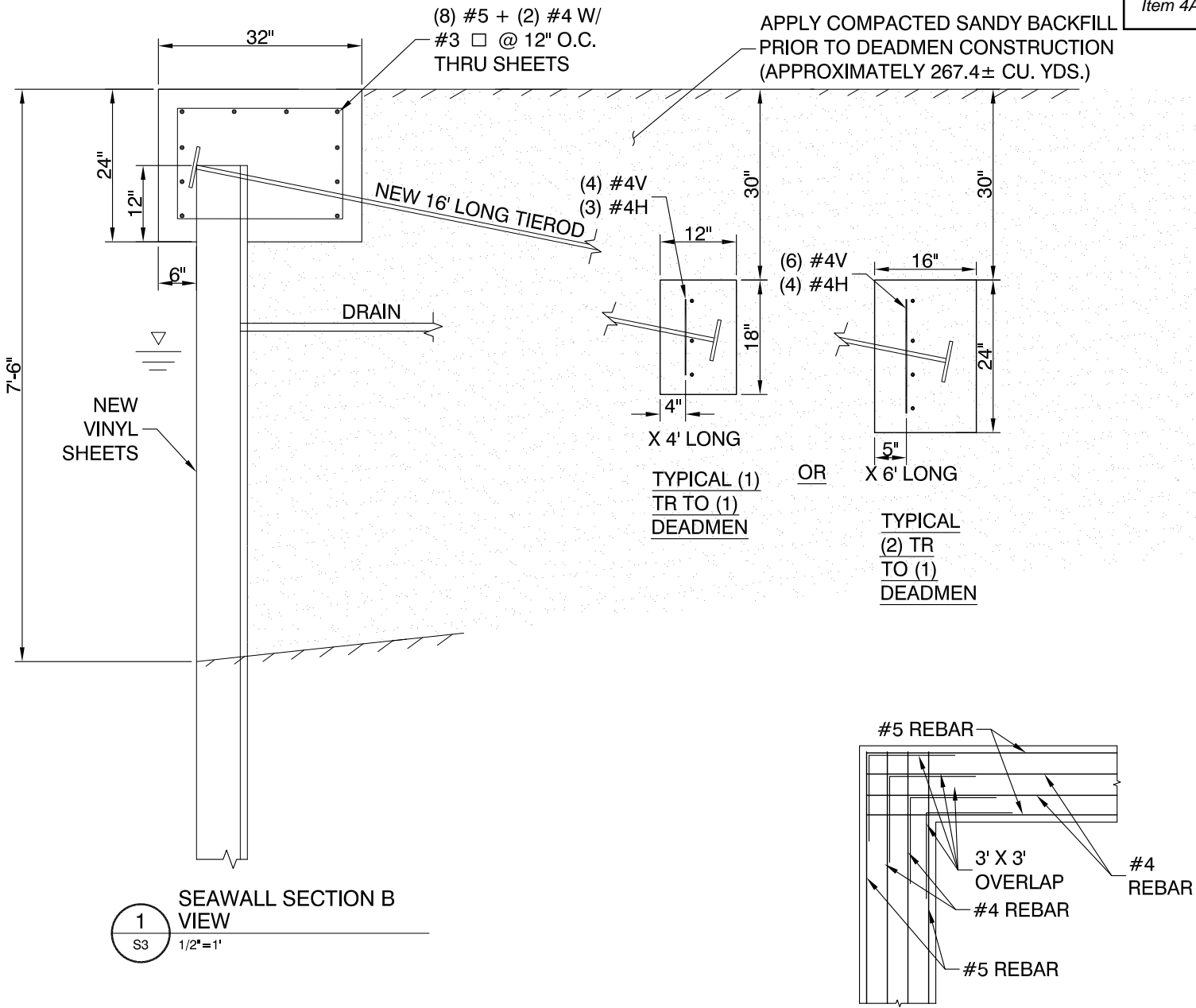

1 SEAWALL SECTION B VIEW
S3 1/2"=1'

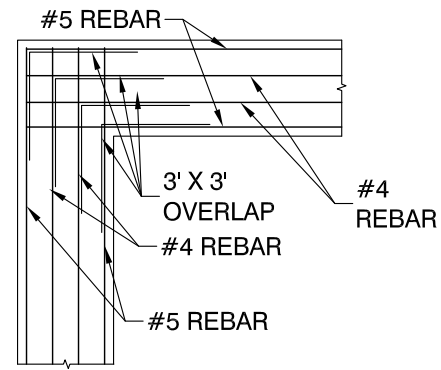

2 CORNER CAP DETAIL
S3 N.T.S.

- NOTES:**
- 1.) SHEETS-ESP 5.5, VANGUARD OR CL-9900 X 14' LONG.
 - 2.) CONCRETE-5000 PSI AT 28 DAYS, FILLER 3500 PSI
 - 3.) REBAR-GRADE 60, PLAIN, 3" CONCRETE COVER OR FIBERGLASS
 - 4.) TIEBACKS-1"Ø X 16' LONG HDG, PVC ENCASED W/ (2) 6" X 6" X 1/2" HDG WASHERS & NUTS INTO CONCRETE DEADMEN.
 - 5.) DRAINS-1.25"Ø X 4' LONG SLIT TYPE PVC WELL POINT DRAINS @ 6' ON CENTER THROUGH WALL 5" ABOVE THE BARNACLE LINE.
 - 6.) NEW CAP AT EXISTING ELEVATION.
 - 7.) MEETS FBC 2023, 8TH EDITION.

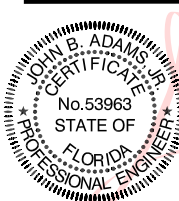

Digitally signed by John B. Adams Jr., PE
Date: 2026.02.27 12:02:12 -05'00'

Reuben Clarson
CONSULTING
MARINE ENGINEERING
ASSESS, ADVISE, DESIGN
(CERT. OF AUTH. NO. 9206)
780 94TH AVENUE NORTH, SUITE 102, ST. PETERSBURG, FL 33702
P: (727) 895-4717 F: (727) 578-9542
WWW.REUBENCLARSONCONSULTING.COM

OWNER: CITY OF MADEIRA BEACH	CONTRACTOR:	DATE: 2-26-2026	SHEET NO.: S3 TOTAL SHEETS: 4
503 150TH AVE MADEIRA BEACH, FL		DRAWN/CHECK BY: JH/JA	REVISIONS:
SEAWALL DESIGN		SCALE: N.T.S.	
		PROJ. NO. RR26-26MB091S	

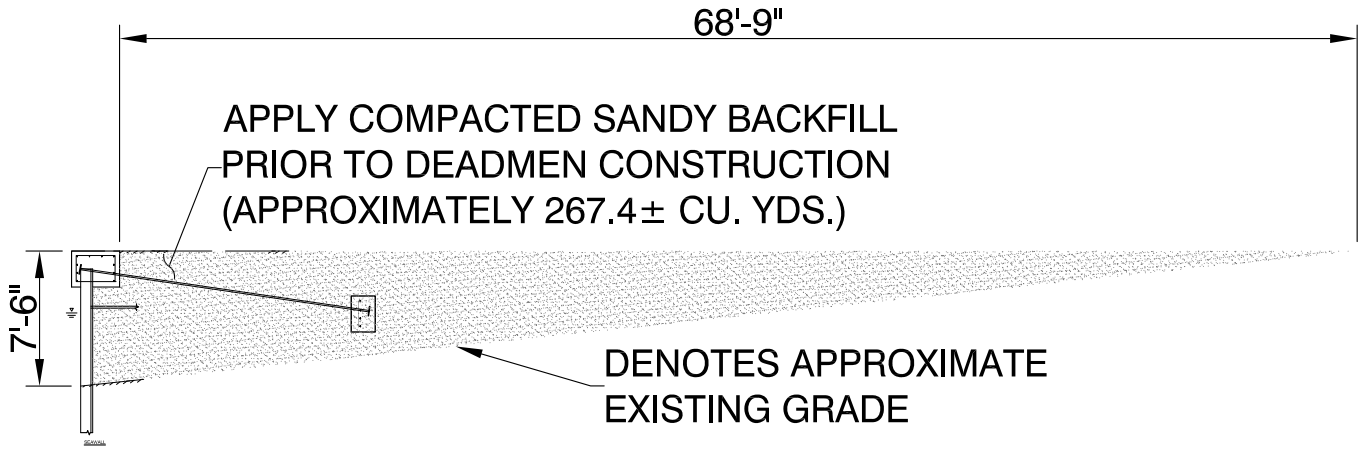

1
S4 3/32"=1'

EXISTING BOAT RAMP
FILL AREA DETAIL

Digitally signed
by John B.
Adams Jr., PE
Date:
2026.02.27
12:02:27 -05'00'

Reuben Clarson
CONSULTING
MARINE ENGINEERING
ASSESS, ADVISE, DESIGN
(CERT. OF AUTH. NO. 9206)
780 94TH AVENUE NORTH, SUITE 102, ST. PETERSBURG, FL 33702
P: (727) 895-4717 F: (727) 578-9542
WWW.REUBENCLARSONCONSULTING.COM

OWNER: CITY OF MADEIRA BEACH	CONTRACTOR:	DATE: 2-26-2026	SHEET NO.: S4 TOTAL SHEETS: 4
503 150TH AVE MADEIRA BEACH, FL		DRAWN/CHECK BY: JH/JA	REVISIONS:
		SCALE: N.T.S.	
SEAWALL DESIGN		PROJ. NO. RR26-26MB091S	

