



**BOARD OF COMMISSIONERS  
REGULAR MEETING AGENDA  
Wednesday, February 14, 2024 at 6:00 PM  
Commission Chambers, 300 Municipal Drive,  
Madeira Beach, FL 33708**

---

Meetings will be televised on Spectrum Channel 640 and YouTube Streamed on the City's Website.

---

- 1. CALL TO ORDER**
- 2. INVOCATION AND PLEDGE OF ALLEGIANCE - City Attorney Thomas Trask**
- 3. ROLL CALL**
- 4. APPROVAL OF THE AGENDA**
- 5. PROCLAMATIONS - Mayor/City Clerk**
- 6. PRESENTATIONS (limited to 10 minutes each)**
  - A. Presentation - Gulf Beaches Rotary Contribution**

**7. PUBLIC COMMENT**

*Public participation is encouraged. If you are addressing the Commission, step to the podium and state your name and address for the record. Please limit your comments to five (5) minutes and do not include any topic that is on the agenda. Public comment on agenda items will be allowed when they come up.*

*If you would like someone at the City to follow up on a comment or question made at the meeting, you may fill out a comment card with the contact information and give it to the City Manager. Comment cards are available at the back table in the Commission Chambers. It is not mandatory to complete a comment card.*

*For any quasi-judicial public hearings that might be on the agenda, an affected person may become a party to a quasi-judicial proceeding and can be entitled to present evidence at the hearing including the sworn testimony of witnesses and relevant exhibits and other documentary evidence and to cross-examine all witnesses by filing a notice of intent to be a party with the Community Development Director not less than five days prior to the hearing.*

**8. CONSENT AGENDA**

*Any member of the Board of Commissioners can ask to pull a consent item for separate discussion and vote.*

[A.](#) 2024-01-10, BOC Regular Meeting Minutes

[B.](#) 2024-01-24, BOC Regular Workshop Meeting Minutes

## **9. PUBLIC HEARINGS**

[A.](#) Ordinance 2024-01, Calling the March 19, 2024 Municipal Election – 2nd Reading & Public Hearing

[B.](#) Ordinance 2024-03, An ordinance adopting a code provision regarding parking meter overtime and failure to pay provisions - 1st Reading & Public Hearing

[C.](#) (2COP) Alcoholic Beverage License Application# 2024-01 Osaka Japanese and Thai Restaurant of Madeira Beach

## **10. UNFINISHED BUSINESS**

## **11. CONTRACTS/AGREEMENTS**

[A.](#) Field Internship Agreement with SPC

[B.](#) RFP 2023-11, Digital Information Sign Purchase

[C.](#) Purchase 2023 Chevy Silverado 5500 Regular Cab 2WD

[D.](#) Fireworks Agreement

## **12. NEW BUSINESS**

[A.](#) Tampa Bay Coastal Master Plan

## **13. STAFF REPORTS**

## **14. AGENDA SETTING - February 28, 2024 BOC Regular Workshop Meeting**

**A.** Purchase Kubota Mini Excavator

**B.** City Hall Satellite Office

**C.** RFI 2023-14 Coastal Groin Restoration bid discussion

**D.** JPV Activity Center and Zoning

**E.** TBBCC Check Presentation

**F.** Master Plan

## 15. REPORTS/CORRESPONDENCE

- A. Board of Commissioners
- B. City Attorney
- C. City Clerk's Report - February 2024
- D. City Manager's Reports - December 2023 and January 2024

## 16. ADJOURNMENT

### **One or more Elected or Appointed Officials may be in attendance.**

*Any person who decides to appeal any decision of the Board of Commissioners with respect to any matter considered at this meeting will need a record of the proceedings and for such purposes may need to ensure that a verbatim record of the proceedings is made, which record includes the testimony and evidence upon which the appeal is to be based. The law does not require the minutes to be transcribed verbatim; therefore, the applicant must make the necessary arrangements with a private reporter or private reporting firm and bear the resulting expense. In accordance with the Americans with Disability Act and F.S. 286.26; any person with a disability requiring reasonable accommodation to participate in this meeting should call the City Clerk at 727-391-9951, ext. 231 or 232 or email a written request to [cvanblargan@madeirabeachfl.gov](mailto:cvanblargan@madeirabeachfl.gov).*



**MINUTES**  
**BOARD OF COMMISSIONERS**  
**REGULAR MEETING**  
**JANUARY 10, 2024**  
**2:00 P.M.**

The City of Madeira Beach Board of Commissioners held a regular meeting at 2:00 p.m. on January 10, 2024, in the Patricia Shontz Commission Chambers at City Hall, located at 300 Municipal Drive, Madeira Beach, Florida.

**MEMBERS PRESENT:** James "Jim" Rostek, Mayor  
Ray Kerr, Vice Mayor/Commissioner District 2  
David Tagliarini, Commissioner District 1  
Eddie McGeehen, Commissioner District 3  
Anne-Marie Brooks, Commissioner District 4

**MEMBERS ABSENT:**

**CITY STAFF PRESENT:** Robin Gomez, City Manager  
Clara VanBlargan, City Clerk  
Andrew Laflin, Finance Director/City Treasurer  
Thomas Trask, City Attorney

**1. CALL TO ORDER**

Mayor Rostek called the meeting to order at 2:00 p.m.

**2. INVOCATION AND PLEDGE OF ALLEGIANCE**

City Attorney Tom Trask gave the Invocation and led the Pledge of Allegiance.

**3. ROLL CALL**

City Clerk Clara VanBlargan called the roll. All were present.

**4. APPROVAL OF THE AGENDA**

City Manager Gomez said the four presentations in Section 6. were moved to a future meeting.

Vice Mayor Kerr motioned to approve the agenda with the changes. Commissioner Brooks seconded the motion.

**ROLL CALL:**

Vice Mayor Kerr	"YES"
Commissioner Brooks	"YES"
Commissioner McGeehen	"YES"
Commissioner Tagliarini	"YES"
Mayor Rostek	"YES"

The motion carried 5-0.

**5. PROCLAMATIONS**

**A. Certified Registered Nurse Anesthetist Week; January 21-27, 2024**

Mayor Rostek read a proclamation proclaiming January 21-27, 2024 as Certified Registered Nurse Anesthetist Week. No one was present to accept the proclamation.

**6. PRESENTATIONS**

The four presentations were moved to a future meeting.

- A. Introduction of New Hires**
- B. Fire Crew of the Year, 2024**
- C. Fire Inspector Reclassification to Fire Marshal**
- D. Lieutenant Promotion**

**7. PUBLIC COMMENT**

Helen Price, a trustee of the Gulf Beaches Public Library, gave an update on the upcoming fundraising events and invited everyone to attend.

Bob Bello, 13301 Gulf Lane, thanked the City for the upgrades to the City’s dog park.

**8. CONSENT AGENDA**

- A. Approval of Minutes**
  - 2023-12-13, BOC Regular Meeting Minutes**

Vice Mayor Kerr motioned to approve the Consent Agenda as written. Commissioner Tagliarini seconded the motion.

**ROLL CALL:**

Vice Mayor Kerr	"YES"
-----------------	-------

Commissioner Tagliarini	"YES"
Commissioner McGeehen	"YES"
Commissioner Brooks	"YES"
Mayor Rostek	"YES"

The motion carried 5-0.

**9. PUBLIC HEARINGS**

**A. Ordinance 2023-21, Dune Protection and Beach Debris– 2<sup>nd</sup> Reading & Public Hearing**

City Attorney Tom Trask read Ordinance 2023-21 by title only:

**ORDINANCE 2023-21**

**AN ORDINANCE OF THE CITY OF MADEIRA BEACH, FLORIDA, AMENDING ARTICLE III (BEACH DEBRIS) OF CHAPTER 42 (OFFENSES AND MISCELLANEOUS PROVISIONS) OF THE MADEIRA BEACH CODE OF ORDINANCES TO AMEND THE PURPOSE TO INCLUDE COMMERCIAL PROPERTY; INCLUDE COMMERCIAL PROPERTY IN THE DEFINITIONS; ADD COMMERCIAL PROPERTY AND PROVISION RELATING TO BLOCKING PATHWAYS TO OBSTRUCTIONS ON THE BEACH PROVISION; REQUIRE PROPERTY TO BE STORED INSIDE DURING A NAMED STORM EVENT; INCLUDE COMMERCIAL PROPERTY IN LEAVE NO TRACE INFORMATIONAL SIGNS IN RENTAL UNITS; ADD PROHIBITION REGARDING CROSSING DUNES AND THE REMOVAL OF VEGETATION ON DUNES; PROVIDING FOR CONFLICT, SEVERABILITY AND CODIFICATION; AND PROVIDING FOR AN EFFECTIVE DATE.**

Mayor Rostek opened to public comment. There were no public comments.

Commissioner Brooks motioned to adopt Ordinance 2023-21, Dune Protection and Beach Debris, after 2<sup>nd</sup> Reading and Public Hearing. Commissioner Tagliarini seconded the motion.

**ROLL CALL:**

Commissioner Brooks	"YES"
Commissioner Tagliarini	"YES"
Commissioner McGeehen	"YES"
Vice Mayor Kerr	"YES"
Mayor Rostek	"YES"

The motion carried 5-0.

**B. Ordinance 2023-33, Amendment to Capital Improvement Element of the Comprehensive Plan – 2<sup>nd</sup> Reading and Public Hearing**

City Attorney Tom Trask read Ordinance 2023-33 by title only:

**ORDINANCE 2023-33**

**AN ORDINANCE OF THE CITY OF MADEIRA BEACH, FLORIDA, AMENDING THE CAPITAL IMPROVEMENTS ELEMENT OF THE COMPREHENSIVE PLAN OF THE CITY OF MADEIRA BEACH TO UPDATE THE CAPITAL IMPROVEMENT PROGRAM (CIP) SCHEDULE OF CAPITAL IMPROVEMENTS FOR FISCAL YEARS 2024 THROUGH 2030; PROVIDING FOR CONFLICT; PROVIDING FOR SEVERABILITY; AND PROVIDING FOR AN EFFECTIVE DATE.**

Mayor Rostek opened to public comment. There were no public comments.

Commissioner Brooks motioned to adopt Ordinance 2023-33, Amendment to Capital Improvement Element of the Comprehensive Plan, after 2<sup>nd</sup> Reading and Public Hearing. Commissioner Tagliarini seconded the motion.

**ROLL CALL:**

Commissioner Brooks	"YES"
Commissioner McGeehen	"YES"
Vice Mayor Kerr	"YES"
Commissioner Tagliarini	"YES"
Mayor Rostek	"YES"

The motion carried 5-0.

**C. Ordinance 2024-01, Calling the March 19, 2024 Municipal Election – 1st Reading & Public Hearing**

City Attorney Tom Trask read Ordinance 2024-01 by title only:

**ORDINANCE 2024-01**

**AN ORDINANCE OF THE CITY OF MADEIRA BEACH, FLORIDA, CALLING FOR A MUNICIPAL ELECTION ON MARCH 19, 2024, FOR THE PURPOSE OF PROVIDING FOR ONE CHARTER AMENDMENT; PROVIDING FOR PUBLICATION; AUTHORIZING ELECTION EXPENDITURES; IDENTIFYING THE PINELLAS COUNTY CANVASSING BOARD AS THE CANVASSING BOARD FOR THE MARCH 19, 2024 MUNICIPAL ELECTION; PROVIDING FOR POLLING PLACES; PROVIDING FOR REPEAL OF ORDINANCES OR PARTS OF**

**ORDINANCES IN CONFLICT HEREWITH TO THE EXTENT OF SUCH CONFLICT; AND PROVIDING FOR AN EFFECTIVE DATE.**

Mayor Rostek opened to public comment. There were no public comments.

City Clerk VanBlargan said David Tagliarini and Ray Kerr were the only two candidates who applied and qualified for the March 19, 2024 election ballot. She congratulated them. The only thing on the ballot would be the Charter Amendment to change the two week qualifying period to one week. It would take effect in December 2024 for the 2025 Municipal Election if it passes.

Vice Mayor Kerr proposed they push the Charter Amendment to the following election. He thought the turnout would be low. The City Clerk said the Presidential candidates for the primary would be on the ballot and she expects a good turnout.

Commissioner Tagliarini motioned to approve after 1st Reading and Public Hearing, Ordinance 2024-01, Calling the March 19, 2024 Municipal Election. Vice Mayor Kerr seconded the motion.

**ROLL CALL:**

Commissioner Tagliarini	"YES"
Vice Mayor Kerr	"YES"
Commissioner McGeehen	"YES"
Commissioner Brooks	"YES"
Mayor Rostek	"YES"

The motion carried 5-0.

**10. UNFINISHED BUSINESS**

**11. CONTRACTS/AGREEMENTS**

**A. FY24 Capital Garbage Truck Lease Approval**

Public Works Director Megan Wepfer said the lease for the truck is \$8,500 a month for a thirteen month period from RDK Trucks. She responded to questions and comments from the Board.

Mayor Rostek asked for an update on contracting the garbage pick-up. The City Manager said they would need to issue an RFP which would take a few months.

Vice Mayor Kerr said he cannot vote for a side loader whether it is a rental or a purchase. Director Wepfer said the reason they are considering a side loader is because she cannot get a full staff in sanitation.

Vice Mayor Kerr asked what the penalty would be to get out of the lease early. Director Wepfer said she thought there was a 30-day clause. Vice Mayor Kerr said the level of service has decreased



with the side loader. Director Wepfer said the rear-load truck will pick up the bulk and brush items on Wednesdays. The City Manager said they would look into every option available.

Mayor Rostek asked what would happen to the truck that is being replaced. Director Wepfer said it would be sold. It could take money off the lease.

Commissioner Tagliarini said they need to move forward based on Staff’s recommendation. Commissioners Brooks and McGeehen agreed.

Commissioner Brooks motioned to approve the FY24 Capital Garbage Truck Lease. Commissioner Tagliarini seconded the motion.

**ROLL CALL:**

Commissioner Brooks	"YES"
Commissioner Tagliarini	"YES"
Vice Mayor Kerr	"NO"
Commissioner McGeehen	"YES"
Mayor Rostek	"YES"

The motion carried 4-1.

**B. RFP #2023-09 Patriot Park Dock Replacement Bid Acceptance and Approval**

Director Wepfer explained the purpose of the item. The low bid was \$119,750.00, and the handrail \$20,000.00 which is not included in the bid. The project is over budget, but it is a necessity. Some of the pilings may need to be drilled which would be \$750.00 per piling. She asked the Board for approval to accept the bid with Speeler Companies not to exceed \$156,465.00.

Mayor Rostek opened to public comment. There were no public comments.

Commissioner Tagliarini motioned to approve RFP #2023-09 Patriot Park Dock Replacement Bid. Commissioner Brooks seconded the motion.

**ROLL CALL:**

Commissioner Tagliarini	"YES"
Commissioner Brooks	"YES"
Vice Mayor Kerr	"YES"
Commissioner McGeehen	"YES"
Mayor Rostek	"YES"

The motion carried 5-0.

**12. NEW BUSINESS**

### 13. STAFF REPORTS

#### A. City Clerk Report – December 2023

The City Clerk reported on the City Clerk Report for December 2023. The City needs to be in compliance with the Cyber Security Act and the policies need to be in place by January 1, 2025. Security software was purchased to go with the Barracuda software, and she has been working to implement it.

### 14. AGENDA SETTING – January 24, 2024 BOC Regular Workshop Meeting

#### A. Live-aboards, Boats Anchoring

#### B. Update on Ton and Kitty Stuart Park Resident Parking

#### C. Update on Fitness Center

#### D. JPV Zoning

Items added to the workshop agenda:

#### Commissioner Brooks

1. Outsourcing versus internal cost of trash pick-up

#### Commissioner McGeehen

1. Mulch and wood chip problem after flood waters recede

### 15. REPORTS/CORRESPONDENCE

#### A. Board of Commissioners

The Board of Commissioners had no report.

#### B. City Attorney

City Attorney Trask said he issued a memorandum updating the legislative efforts and bills that relate to local governments.

#### C. City Manager

The City Manager invited everyone to the 19<sup>th</sup> Annual Seafood Festival at John's Pass Village and Boardwalk beginning January 19<sup>th</sup>.

#### D. City Clerk

The City Clerk said they need to pick a date for the swearing-in ceremony. It needs to be after the election. The consensus of the Board was to add it to the next workshop meeting.

**16. ADJOURNMENT**

Mayor Rostek adjourned the meeting at 2:48 p.m.

\_\_\_\_\_  
James “Jim” Rostek, Mayor

ATTEST:

\_\_\_\_\_  
Clara VanBlargan, MMC, MSM, City Clerk

DRAFT



**MINUTES**  
**BOARD OF COMMISSIONERS**  
**REGULAR WORKSHOP MEETING**  
**JANUARY 24, 2024**  
**6:00 P.M.**

The City of Madeira Beach Board of Commissioners held a regular workshop meeting at 6:00 p.m. on January 24, 2024, in the Patricia Shontz Commission Chambers at City Hall, located at 300 Municipal Drive, Madeira Beach, Florida.

**MEMBERS PRESENT:** James "Jim" Rostek, Mayor  
Ray Kerr, Vice Mayor/Commissioner District 2  
David Tagliarini, Commissioner District 1  
Eddie McGeehen, Commissioner District 3  
Anne-Marie Brooks, Commissioner District 4

**MEMBERS ABSENT:**

**CITY STAFF PRESENT:** Robin Gomez, City Manager  
Clara VanBlargan, City Clerk  
Andrew Laflin, Finance Director/City Treasurer  
Thomas Trask, City Attorney

**1. CALL TO ORDER**

Mayor Rostek called the meeting to order at 6:00 p.m.

**2. ROLL CALL**

City Clerk Clara VanBlargan called the roll. All were present.

**3. PUBLIC COMMENT**

There were no public comments.

**4. PRESENTATIONS**

**A. Fire Crew of the Year**

Fire Chief Clint Belk recognized Madeira Beach Fire Department A shift as the first Fire Crew of the Year for 2023.

- Lt. George Hill
- Lt. John Sleppy

- Driver/Engineer Jamie McGaughey
- Firefighter/Paramedic Nick Lucas

### **B. Reclassification of Fire Inspector Perez to Fire Marshall**

Chief Belk recognized the promotion of Fire Inspector Raul Perez to Fire Marshall. He would be the first ever in Madeira Beach history.

### **C. Promotion -Lt. Sleppy**

Chief Belk recognized the promotion of Firefighter John Sleppy to Lieutenant. He has taken over the role of Training Officer and has been with the Fire Department for ten years.

### **D. Introduction of New Hires**

Chief Belk introduced the following new members of the Madeira Beach Fire Department:

- Chase Halfast, Firefighter/EMT
- Kyle Watts, Firefighter/EMT
- John Mortellitte, Firefighter/Paramedic
- Mario Barbara, Firefighter/Paramedic

### **E. Brian Lowack, President/CEO, Visit St. Pete/Clearwater**

Mr. Lowack explained the purpose of Visit St. Pete/Clearwater and the activities and events they do for the community.

The City Manager said the presentation will be made part of the Minutes and on the website.

## **5. BOARD OF COMMISSIONERS**

### **A. Discuss/Review Boats – Live-aboards and Anchoring**

Mayor Rostek opened to public comment.

John Garcia, 15334 Harbor Drive, stressed his concern for the safety and environmental impact on the area.

Brian Gonser, Seminole resident and owner of a Madeira Beach short-term rental, stressed environmental and safety concerns.

Belinda Gonser, Seminole resident, stressed concern about issues she encountered with the live-aboards.

Phil Secord, a Palmetto resident, said he was the regional Southwest Florida Marine Industries Association Manager. Some environmentalists are very concerned about derelict boats. His job is

to promote good, clean, and safe boating and anchoring in the counties he is involved in. Their position is to improve the boating industry and help it prosper.

Mayor Rostek reported on his research and gave a PowerPoint presentation. He focused on the improper use of Marine Sanitation Devices (MSDs).

The City Manager said Florida Statute 327.60 defines a live-aboard. Anchored or moored boats are not considered live-aboards. The people who live on them must adhere to the laws and regulations.

Mayor Rostek said there are 1.5 million vessels with MSDs boating in U.S. waters, generating 3.5 billion gallons of sewage, and there is no way of knowing how much is illegally discharged. They need to start protecting the waterways within the City limits. There are three "No Discharge Zones (NDZ)" in Florida where boaters cannot even discharge treated sewage. The Madeira Beach Marina offers boaters a free pumpout service, and he would like anchored or moored boaters to pump out every ten days. He wants boaters to show proof of an MSD pumpout with a date and time-stamped receipt. He is hoping for possible future municipal regulations and enforcement.

John Connolly, resident, did not think the pumpout should be limited to the boats within Madeira Beach.

Mayor Rostek said they could only regulate within the Madeira Beach boundary map. He would take it to the Big C.

John Garcia, 15334 Harbor Drive, said he was concerned about the illegal docking. It is a fairness issue. Residents pay property taxes to dock their boats, and the moored boats get to do it for free.

Mayor Rostek said they do not have enough acreage on the water to provide a mooring field. The City Manager said the Florida Statutes do not allow them to do it.

The City Manager said he would meet with Sergeant Blair from the Marine Unit and Captain Leiner, who oversees the City's agreement with the Sheriff's Office, and provide the information to the anchored boats in Madeira Beach.

Commissioner Brooks said a solution to save the waterways would be to get a pumpout boat and go to the anchored boats every eight or ten days and offer to pump them out.

The City Attorney said Florida Statute 327.60 is very specific as to the vessels the City can regulate. Section 4. A. states a vessel over 26 feet with an enclosed cabin with berthing facilities and houseboats can be required to show proof of sewage disposal within one of three no-discharge zones. Mayor Rostek said the three no-discharge zones are not located near this area. The City Attorney said Section 4. A. would not apply.

The City Attorney said Section 4.D. of the Statute states live-aboards, floating structures, and commercial vessels can only be regulated. He could prepare a code provision, but it would need

to be approved by the Florida Fish and Wildlife Conservation Commission before the Board could adopt it. The boats anchored in Madeira Beach waters do not meet any criteria.

Vice Mayor Kerr said their best alternative is to work with the Southwest Florida Marine Industries Association. It is a State issue, and the City needs to be given control. The City Attorney said the City of Clearwater is pursuing anchoring limitation areas where boundaries are set within City limits, and anchored boats must move every 45 days. It does not specify where or how far they need to move. It would not be a good option for the City.

Mayor Rostek asked if there was any way they could force the MSD pumpouts. The City Attorney said no. The Mayor asked if they could enforce the Clean Water Act, which requires boats to pump out three miles off-shore. The City Attorney it would need to be enforced federally since it is a federal law.

Commissioner Brooks said the pumpout boat is a wonderful option. At one time, there was a grant to assist in purchasing one. Marina Manager Brian Crabtree said a grant was obtained, but the Board of Commissioners at the time rejected it because they thought it would be too expensive to operate and maintain. The pumpout boat was kept at the Lighthouse Point Marina and is not in operation. He called to see what happened to it and has not received a response. The grants are selected for a body of water, and the boat must cover a certain amount of square footage. It would be a possibility to purchase the boat.

Vice Mayor Kerr asked if a pumpout boat would attract more boaters to anchor in their waters. He suggested taking it to the Big C and moving forward as a collective body.

Commissioner McGeehen said he would like to have more testing of the waters so they have more ammunition to take to the State.

Commissioner McGeehen said Florida Statute 327.44 states anchoring or mooring under bridges or adjacent to heavily traveled channels constitutes interference if unreasonable under the circumstances. He thought they should enforce the vessels obstructing the waterways more.

### **B. FEMA/City Participation in Mitigation Restoration/Flooding Prevention Program**

The City Manager gave a brief background on the item. He asked for direction from the Board on whether or not to proceed with the Grant programs that allow property owners to participate in the housing grant programs that FEMA provides. If they proceed, they would need a dedicated consultant to manage it because of unresolved issues in the past.

Marci Forbes, Community Development Engineer, reported the grants have to be sponsored by the City of Madeira Beach. There would be nothing the county could do.

Commissioner Tagliarini asked if the person monitoring it would be an existing employee or if it would be a new position. The City Manager said it would be a new position. Commissioner Tagliarini asked if the grant would cover it. The City Manager said he thought it would cover the

majority of it. Ms. Forbes said the grant gets spread out over various components, not just the construction of a property.

Vice Mayor Kerr said he had multiple conversations with residents who went through the process, and it is very restrictive. Most said they wished they would not have done it. He thought if they implemented it again, they would need to find a way to have the funds directly issued to the applicant. Ms. Forbes said they are managed as a pass-through system, which is mandated. She has not heard of any program that deviates from the pass-through process. Vice Mayor Kerr said FEMA was not a good steward. Once everything was approved, they should not have come back and said it was not approved.

Commissioner Brooks asked if they could not collect it from the property owner if they could not comply with FEMA's request for \$92,000.00. The City Attorney said they have an agreement with the property owner in addition to the grant agreement, and they are legally obligated to comply. But, if the statute of limitations has run out, the property owner may owe the money, but they have no legal obligation to pay.

Vice Mayor Kerr asked if a lien provision could be written in the contract. The City Attorney said only if FEMA and the Federal Division of Emergency Management allow it. Vice Mayor Kerr said they would need to have security on the money.

## 6. CITY CLERK

### **A. Board of Commissioners to schedule a Special Meeting in March following the March 19, 2024, Municipal Election and Certification of Election Results: Reporting the Election Results of the Charter Amendment and Induction into Office – Ray Kerr and David Tagliarini to serve a new two-year term as District Commissioner.**

City Clerk Clara VanBlargan said the Municipal Election is on March 19, 2024. The incumbents, David Tagliarini and Ray Kerr, who qualified during the qualifying period, their names would not be on the ballot. They had no opposition. Only the charter amendment would be on the ballot. She will report the certified final election results at the meeting when Commissioner Tagliarini and Commissioner Kerr are sworn into office.

The Board scheduled a special meeting at 5:30 p.m. on Wednesday, March 27, 2024, to read the final election results and to swear David Tagliarini and Ray Kerr into office to serve a new two-year term as District Commissioner.

## 7. COMMUNITY DEVELOPMENT

### **A. John's Pass Village Activity Center Zoning**

Mayor Rostek opened to public comment. There were no public comments.

Community Development Director Jenny Rowan said two public workshops were held, and a third one will be held on Saturday, January 27. She reviewed what was discussed at the meetings. Staff



would meet after the next public workshop to review the input and present it to the Board and the Planning Commission.

Director Rowan said the six character districts would be turned into six separate new zoning districts. The Special Area Plan is tied to the Comprehensive Plan, which guides the entire process. The Comprehensive Plan supports the unique character of John's Pass Village. When they start thinking about zoning, certain standards in the Countywide Strategies Plan need to be addressed.

Director Rowan said the county will meet on February 20 to establish the Activity Center on the Countywide Plan Map and the Land Use Strategy Map. It will come back to the Board of Commissioners at the March 13<sup>th</sup> regular meeting.

Commissioner Tagliarini asked for the response to the first two public workshop meetings. Director Rowan said there were more questions at the second meeting. Andrew Morris, Long Range Planner, said most of the discussion was about whether planned development rezoning should be allowed there and ensuring the Land Development Regulations keep the character.

Commissioner Tagliarini asked if the county requires them to offer a bonus option in a development agreement. Director Rowan said no. Commissioner Tagliarini asked how the City would benefit from offering the option. Mr. Morris said it allows for mitigating the impact of new development on the community. The City Manager said it allowed for negotiating.

After a brief discussion about density lodging with a development agreement, the Board asked the presenters to identify and include the structures with high densities in John's Pass Village in their next presentation.

## **8. MARINA DEPARTMENT**

### **A. RFP 2023-11 Digital Information Sign**

Marina Manager Brian Crabtree explained that RFP 2023-11 was for a digital sign at the Marina entrance on the south side of 150<sup>th</sup> at Tom Stewart Causeway. The purpose would be to get information out to visitors and residents. Two bids were received, and the low bid from I2 Visual, based in Fort Myers, was for \$45,313.

Vice Mayor Kerr asked if it was a two-sided sign. Manager Crabtree said yes. Vice Mayor Kerr asked if they could put marketing information on it. Manager Crabtree said as long as it was general information. Vice Mayor Kerr asked if he reached out to Brian Lowack with Visit St. Pete/Clearwater to see if they would contribute to it. Manager Crabtree said no, but he will. It was budgeted in the Marina Fund.

Mayor Rostek asked if electricity was there. Manager Crabtree said yes, and the cost to trench for electric was removed from the quote.

The Consensus of the Board was to move forward with it.

## 9. PARKING DIVISION

### A. Kitty Stuart Park Parking Lot Overview: Financial Status, Increased Utilization, and User Engagement

Parking Enforcement Supervisor Jamal Yahia gave an overview of what they observed during the three-month trial period of three resident spaces and an additional handicapped space in Tom and Kitty Stuart Park. There was a decrease in sales for October, November, and December. He asked for direction from the Board if they would like to keep the spaces. He responded to questions and comments from the Board.

Vice Mayor Kerr said he is for the handicapped parking, but the three added residential spaces would cost the City \$25,000 in potential revenue. The City Manager said it was a slower time of year, and the lots would fill up for longer periods of the day in January, February, and March.

Commissioner Brooks agreed with Vice Mayor Kerr. She was concerned about the long-term effects. Looking at how much money they were down in the off-season, what would the amount of revenue lost be during the in-season?

Commissioner Tagliarini said he would like to continue the trial. It is not always about revenues; sometimes, the returns are in the residents' quality of life.

The Consensus of the Board was to continue with the trial.

## 10. PUBLIC WORKS DEPARTMENT

### A. Refuse Collection Contracted Service Analysis

Finance Director Andrew Laflin reviewed his cost analysis for insourcing versus outsourcing the garbage collection. Outsourcing costs were hypothetical based on the recent bid results from the City of Belleair Beach. It would yield a fiscal savings of about \$150,000 annually.

Commissioner Brooks asked if the Belleair Beach bid included two weekly trash pick-ups and one-yard waste pick-up. Director Wepfer said she would have to read the bid, but if they would contract out, it would include all of it. The Belleair Beach bid would not have included any of the parks, the village, the beach, or any location with public cans.

Commissioner Brooks said she does not support outsourcing based on the feedback from the residents. It would be costly and time-consuming, and the residents would not want it.

Commissioner McGeehen agreed with Commissioner Brooks. He would hate to see the level of service drop for the amount of money they are looking at.

Mayor Rostek asked about the number of employees sanitation is down. Director Wepfer said one, but she had five interviews this week. The Mayor asked how much turnover there was in the last two years. Director Wepfer could not give an exact number.

Vice Mayor Kerr said he did not want to outsource but did not want the sidearm loader on the trucks. The sidearm beats up the totes and would be an added expense for repair.

Director Wepfer said she spoke to Jacksonville Beach about their issues with the sidearm loader. They had issues because it is a contracted service. Madeira Beach has a Broyhill with a sidearm, and it is programmed to meet the needs of the totes the City has. They always had one person on the ground and one in the truck.

The City Manager said they would try it. Director Wepfer said the truck is on a lease, and if they do not like it, they can return it and go back to a rear loader. The City Manager said it gives the City 100% control of the collection.

Commissioner Tagliarini said he is in favor of sacrificing the \$150,000 for the well-being of the customers.

Director Wepfer said the entire crew goes out after a storm to clean up the City, which is not a level of service they would get from a contracted service. It would be an additional cost to the City.

The Consensus of the Board was not to outsource the garbage collection.

## **11. RECREATION DEPARTMENT**

### **A. Fitness Center**

Recreation Director Jay Hatch gave an overview of the preliminary numbers for the three-month trial open registration of the fitness center. He asked for direction from the Board and responded to questions and comments.

Director Hatch said they faced many challenges, and if they decide to move forward, he would need to look at more equipment and technology. He reviewed the fiscal impact it would have.

Vice Mayor Kerr said he is still opposed to it. It should be dedicated to staff, and the City should not be in the business of having this type of facility. Commissioner Brooks agreed. It was not a gym that was intended for the public; it was meant for the Fire Department. The grant for the equipment was for them.

Commissioner McGeehen disagreed. He has only heard positive feedback and wants to keep it for the residents.

Commissioner Tagliarini said he is sympathetic to the problems but wants to leave it as it is. Mayor Rostek agreed.

The consensus of the Board was to bring back the yearly cost to continue with the open registration.

### **B. City Sponsored Fireworks**

Director Hatch said last year's fireworks contract from the RFP was for one year with two one-year option renewals. He would like to renew the contract for an additional year. He listed the following dates for the 2024 fireworks:

- March 16<sup>th</sup> - Rotary Carnival
- May 4<sup>th</sup> - Grouper Gala
- July 3<sup>rd</sup> - Independence Day
- November 11<sup>th</sup> – Veterans Day

Commissioner Brooks said the two concerns she heard from residents were returning to the Fourth of July and getting the barge back. Director Hatch said the barge is more expensive and difficult to obtain, but the goal is to get one this year. The July 3<sup>rd</sup> date is more affordable and easier to obtain a barge. The company utilizes a company for barges. Having the fireworks on July 3 would make it easier to get a barge and easier to get the police. The fireworks would be more affordable, and they would not have to pay overtime for staff.

The consensus of the Board was to bring a contract with proposed dates back to the next regular meeting for approval.

Commissioner Tagliarini announced he attended the Institute for Municipal Elected Officials I (IMEO I) in Gainesville the past weekend. It was very informative. Commissioner Brooks said she and Commissioner McGeehen completed IMEO I and II. They should do an ordinance making it a requirement for newly elected officials to attend the training.

**12. ADJOURNMENT**

Mayor Rostek adjourned the meeting at 9:48 p.m.

\_\_\_\_\_  
James “Jim” Rostek, Mayor

ATTEST:

\_\_\_\_\_  
Clara VanBlargan, MMC, MSM, City Clerk



## MEMORANDUM

**TO:** Honorable Mayor and Board of Commissioners  
**VIA:** Robin Gomez, City Manager  
**FROM:** Clara VanBlargan, City Clerk  
**DATE:** January 3, 2024  
**RE:** Ordinance 2024-01, Calling the March 19, 2024 Municipal Election – 2<sup>nd</sup> Reading & Public Hearing

### **Background**

The Board of Commissioners approved Ordinance 2024-01 after first reading and public hearing on Wednesday, January 10, 2024.

The Board of Commissioners adopted, after a second reading and public hearing, Ordinance 2023-24 at its regular meeting on December 13, 2023 placing a charter amendment on the March 19, 2024 Municipal Election Ballot for voter approval to change the qualifying period from the first two weeks in December to the first full week in December. Ordinance 2024-01, calling the March 19, 2024 Municipal Election was prepared for that purpose.

There will not be a race for Commissioner District 1 and Commissioner District 2 on the March 19, 2024 Municipal Ballot. Incumbents David Tagliarini (Commissioner District 1) and Ray Kerr (Commissioner District 2) will be sworn into office at a Board of Commissioners Special Meeting on Wednesday, March 27, 2024 at 5:30 p.m., to begin a new two-year term as District Commissioner. A light reception begins at 4:30 p.m. in the Commission Chambers. The Board of Commissioners Regular Workshop Meeting is at 6:00 p.m.

### **MARCH 19, 2024 MUNICIPAL ELECTION PROCEDURES (Ordinance 2024-01)**

An Election shall be held in the City of Madeira Beach, Florida, on Tuesday, March 19, 2024, for the purpose of voting on one charter amendment.

In accordance with City Charter Section 3.4, Subsection B, the Board of Commissioners shall designate the Pinellas County Canvassing Board to serve as the Canvassing Board for the City of Madeira Beach. The actions of the Canvassing Board shall be reported to the Board of Commissioners at its next meeting following the Election. The Board of Commissioners shall meet following the certification for the purpose of declaring the results of said Election.

The polling locations for City of Madeira Beach voters to vote in the March 19, 2024 Municipal Election are as follows:

- Precinct 415 - Madeira Beach Municipal Building, City Centre Room, 300 Municipal Drive, Madeira Beach, Florida;
- Precinct 301 – Calvary Church Seminole (Combined), 6155 113 Street, Seminole, Florida 33772.

If the voters approve the charter amendment at the March 19, 2024 Municipal Election, it will take effect for the candidate qualifying period beginning in December 2024 for the March 2025 Municipal Election.

Charter Amendment on the March 19, 2024 Municipal Ballot:

**City of Madeira Beach  
Charter Amendment**

**Amend Qualifying Period to the first full week in December.**

This charter amendment would amend Section 3.3(A) of the Charter to change the Candidate Qualifying Period to the first full week in December instead of the first two full weeks in December. Should the Charter be amended?

Yes  
No

The revised section of the Charter being proposed on the March 19, 2024 Municipal Ballot is:

**City Charter, Section 3.3 Nomination of Board of Commissioners.**

- (A) *Filing.* Every person who shall desire to become a candidate for nomination under the provisions of this Charter to the office of Mayor and District-Commissioner, shall qualify to become such candidate by filing with the City Clerk during the candidate qualifying period held during the first ~~two~~ full weeks in December, excluding weekends, beginning at Noon on Monday, the first day of the qualifying period and ending at Noon on Friday, the last day of the qualifying period. Under no circumstances shall the City Clerk accept any nomination petitions or filing fees after the close of the filing period as stated herein. Every person's application is to have his/her name printed upon the ballot as a candidate for nomination to the office for which he/she aspires, in which application, he/she shall declare from the district he/she is a candidate or so declare if he/she is a candidate for Mayor. All applications shall be accompanied by an affidavit the candidate is an elector and a resident of the City of Madeira Beach, Florida, for one (1) year immediately prior to the date of said application and has been a resident of said district for which he/she declares himself/herself to be a candidate for a period of six (6) months prior to the date of said application. With said application shall be filed a petition which shall indicate prominently the district from which the Petitioner is a candidate, or if he/she be a candidate for Mayor.

The relevant Florida Statutes are:

**Florida Statute 100.3605(1) (Conduct of Municipal Elections) provides:**

(1) The Florida Election Code, chapters 97-106, shall govern the conduct of a municipality's Election in the absence of an applicable special act, charter, or ordinance provision. No charter or ordinance provision shall be adopted which conflicts with or exempts a municipality from any provision in the Florida Election Code that expressly applies to municipalities.

**Florida Statute 105.031(6) (Qualification; filing fee; candidates oath; items required to be filed) provides:**

“Notwithstanding the qualifying period prescribed in this section, a qualifying office may accept and hold qualifying papers submitted not earlier than 14 days prior to the beginning of the qualifying period, **to be processed and filed during the qualifying period.**”

**Florida Statute 166.031(1) and (2) (Charter Amendments) provides:**

- (1) The governing body of a municipality may, by ordinance, or the electors of a municipality may, by petition signed by 10 percent of the registered electors as of the last preceding municipal general election, submit to the electors of said municipality a proposed amendment to its charter, which amendment may be to any part or to all of said charter except that part describing the boundaries of such municipality. The governing body of the municipality shall place the proposed amendment contained in the ordinance or petition to a vote of the electors at the next general election held within the municipality or at a special election called for such purpose.
- (2) Upon adoption of an amendment to the charter of a municipality by a majority of the electors voting in a referendum upon such amendment, the governing body of said municipality shall have the amendment incorporated into the charter and shall file the revised charter with the Department of State. All such amendments are effective on the date specified therein or as otherwise provided in the charter.

**Qualifying Period of Neighboring Cities and Towns**

City of Indian Rocks Beach – 6 days  
 City of St. Pete Beach – 10 days  
 City of Gulfport – 6 days  
 Town of North Redington Beach – 11 days  
 Town of Redington Shores – 11 days  
 Town of Redington Beach – 11 days  
 City of Clearwater – 10 days  
 City of Treasure Island – 11 days  
 City of Madeira Beach – 10 days

**Fiscal Impact**

The estimated cost for the Supervisor of Elections Office to administratively assist with the City of Madeira Beach Municipal Election on March 19, 2024 is \$1,589.10. The estimated cost to advertise Ordinance 2024-01 for a second reading and public hearing on February 14, 2024 is \$141.40.

**Recommendation**

The recommendation is for the Board of Commissioners to adopt, after second reading and public hearing, Ordinance 2024-01, calling for the March 19, 2024 Municipal Election.

**Attachments:**

- Ordinance 2024-01, Calling for the March 19, 2024 Municipal Election
- Ordinance 2024-01, Business Impact Estimate



**ORDINANCE 2024-01**

**AN ORDINANCE OF THE CITY OF MADEIRA BEACH, FLORIDA, CALLING FOR A MUNICIPAL ELECTION ON MARCH 19, 2024, FOR THE PURPOSE OF PROVIDING FOR ONE CHARTER AMENDMENT; PROVIDING FOR PUBLICATION; AUTHORIZING ELECTION EXPENDITURES; IDENTIFYING THE PINELLAS COUNTY CANVASSING BOARD AS THE CANVASSING BOARD FOR THE MARCH 19, 2024 MUNICIPAL ELECTION; PROVIDING FOR POLLING PLACES; PROVIDING FOR REPEAL OF ORDINANCES OR PARTS OF ORDINANCES IN CONFLICT HERewith TO THE EXTENT OF SUCH CONFLICT; AND PROVIDING FOR AN EFFECTIVE DATE.**

WHEREAS, the Board of Commissioners has considered and reviewed the proposed Charter amendment and received public comment at least two (2) public hearings on the proposed referendum ballot question;

**NOW, THEREFORE, BE IT ORDAINED BY THE BOARD OF COMMISSIONERS OF THE CITY OF MADEIRA BEACH, FLORIDA:**

**SECTION 1.** An Election shall be held in the City of Madeira Beach, Florida, on Tuesday, March 19, 2024, for the purpose of voting on one charter amendment.

**SECTION 2.** In accordance with City Charter Section 3.4, Subsection B, the Board of Commissioners shall designate the Pinellas County Canvassing Board to serve as the Canvassing Board for the City of Madeira Beach. The actions of the Canvassing Board shall be reported to the Board of Commissioners at its next meeting following the election. The Board of Commissioners shall meet following the certification for the purpose of declaring the results of said election.

**SECTION 3.** The polling locations for City of Madeira Beach voters to vote in the March 19, 2024 Municipal Election are as follows:

- Precinct 415 - Madeira Beach Municipal Building, City Centre Room, 300 Municipal Drive, Madeira Beach, Florida;
- Precinct 301 – Calvary Church Seminole (Combined), 6155 113 Street, Seminole, Florida 33772.

**SECTION 4.** All Ordinances or parts of Ordinances in conflict with the provisions of this Ordinance be hereby repealed insofar as the same affect this Ordinance.

**SECTION 5.** This Ordinance shall take effect immediately upon adoption in the manner provided by law.

**PASSED AND ADOPTED BY THE CITY OF MADEIRA BEACH, FLORIDA BOARD OF COMMISSIONERS, this \_\_\_\_\_ day of \_\_\_\_\_ 2024.**

\_\_\_\_\_  
James "Jim" Rostek, MAYOR

ATTEST:

\_\_\_\_\_  
Clara VanBlargan, MMC, MSM, CITY CLERK

APPROVED AS TO FORM:

\_\_\_\_\_  
Thomas J. Trask, CITY ATTORNEY

PASSED ON FIRST READING: \_\_\_\_\_

PUBLISHED: \_\_\_\_\_

PASSED ON SECOND READING: \_\_\_\_\_

# **Business Impact Estimate**

Proposed ordinance's title/reference:

## **ORDINANCE 2024-01**

**AN ORDINANCE OF THE CITY OF MADEIRA BEACH, FLORIDA, CALLING FOR A MUNICIPAL ELECTION ON MARCH 19, 2024, FOR THE PURPOSE OF PROVIDING FOR ONE CHARTER AMENDMENT; PROVIDING FOR PUBLICATION; AUTHORIZING ELECTION EXPENDITURES; IDENTIFYING THE PINELLAS COUNTY CANVASSING BOARD AS THE CANVASSING BOARD FOR THE MARCH 19, 2024 MUNICIPAL ELECTION; PROVIDING FOR POLLING PLACES; PROVIDING FOR REPEAL OF ORDINANCES OR PARTS OF ORDINANCES IN CONFLICT HERewith TO THE EXTENT OF SUCH CONFLICT; AND PROVIDING FOR AN EFFECTIVE DATE.**

This Business Impact Estimate is provided in accordance with section 166.041(4), Florida Statutes. If one or more boxes are checked below, this means the City of Madeira Beach is of the view that a business impact estimate is not required by state law<sup>1</sup> for the proposed ordinance, but the City of Madeira Beach is, nevertheless, providing this Business Impact Estimate as a courtesy and to avoid any procedural issues that could impact the enactment of the proposed ordinance. This Business Impact Estimate may be revised following its initial posting.

- The proposed ordinance is required for compliance with Federal or State law or regulation;
- The proposed ordinance relates to the issuance or refinancing of debt;
- The proposed ordinance relates to the adoption of budgets or budget amendments, including revenue sources necessary to fund the budget;
- The proposed ordinance is required to implement a contract or an agreement, including, but not limited to, any Federal, State, local, or private grant or other financial assistance accepted by the municipal government;
- The proposed ordinance is an emergency ordinance;
- The ordinance relates to procurement; or
- The proposed ordinance is enacted to implement the following:
  - a. Part II of Chapter 163, Florida Statutes, relating to growth policy, county and municipal planning, and land development regulation, including zoning, development orders, development agreements and development permits;
  - b. Sections 190.005 and 190.046, Florida Statutes, regarding community development districts;
  - c. Section 553.73, Florida Statutes, relating to the Florida Building Code; or

<sup>1</sup> See Section 166.041(4)(c), Florida Statutes.

d. Section 633.202, Florida Statutes, relating to the Florida Fire Prevention Code.

In accordance with the provisions of controlling law, even notwithstanding the fact that an exemption noted above may apply, the City of Madeira Beach hereby publishes the following information:

1. Summary of the proposed ordinance (must include a statement of the public purpose, such as serving the public health, safety, morals and welfare):

Calling the March 19, 2024 Municipal Election.

2. An estimate of the direct economic impact of the proposed ordinance on private, for-profit businesses in the City of Madeira Beach, if any:

- (a) An estimate of direct compliance costs that businesses may reasonably incur;
- (b) Any new charge or fee imposed by the proposed ordinance or for which businesses will be financially responsible; and
- (c) An estimate of the City of Madeira Beach's regulatory costs, including estimated revenues from any new charges or fees to cover such costs.

None.

3. Good faith estimate of the number of businesses likely to be impacted by the proposed ordinance:

None.

4. Additional information the governing body deems useful (if any):

**Tampa Bay Times**  
**Published Daily**

STATE OF FLORIDA  
COUNTY OF Pinellas, Hillsborough, Pasco,  
Hernando Citrus

}ss

Before the undersigned authority personally appeared **Deirdre Bonett** who on oath says that he/she is **Legal Advertising Representative** of the **Tampa Bay Times** a daily newspaper printed in St. Petersburg, in Pinellas County, Florida; that the attached copy of advertisement, being a Legal Notice in the matter **RE: ORDINANCE 2024-01** was published in said newspaper by print in the issues of: **1/31/24** or by publication on the newspaper's website, if authorized, on

Affiant further says the said **Tampa Bay Times** is a newspaper published in **Pinellas, Hillsborough, Pasco, Hernando Citrus** County, Florida and that the said newspaper has heretofore been continuously published in said **Pinellas, Hillsborough, Pasco, Hernando Citrus** County, Florida each day and has been entered as a second class mail matter at the post office in said **Pinellas, Hillsborough, Pasco, Hernando Citrus** County, Florida for a period of one year next preceding the first publication of the attached copy of advertisement, and affiant further says that he/she neither paid not promised any person, firm or corporation any discount, rebate, commission or refund for the purpose of securing this advertisement for publication in the said newspaper.

Signature Affiant

Sworn to and subscribed before me this **.01/31/2024**

Signature of Notary Public

Personally known         X         or produced identification

Type of identification produced \_\_\_\_\_

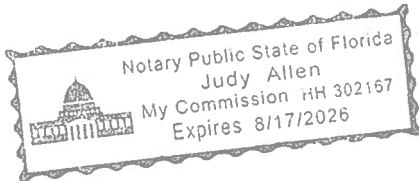

**NOTICE OF PUBLIC HEARINGS**  
**CITY OF MADEIRA BEACH**

In accordance with the City of Madeira Beach Code of Ordinances, the City of Madeira Beach City Charter, and Florida Statute §166.041(3)(a):

**NOTICE IS HEREBY GIVEN**, that the Board of Commissioners of the City of Madeira Beach will conduct a **Second Reading and Public Hearing for the adoption of proposed Ordinance 2024-01 on Wednesday, February 14, 2024, at 6:00 p.m.** The meeting will be held in the Patricia Shontz Commission Chambers located at 300 Municipal Drive, Madeira Beach, FL 33708. The title of said Ordinance is as follows:

**ORDINANCE 2024-01**

**AN ORDINANCE OF THE CITY OF MADEIRA BEACH, FLORIDA, CALLING FOR A MUNICIPAL ELECTION ON MARCH 19, 2024, FOR THE PURPOSE OF PROVIDING FOR ONE CHARTER AMENDMENT; PROVIDING FOR PUBLICATION; AUTHORIZING ELECTION EXPENDITURES; IDENTIFYING THE PINELLAS COUNTY CANVASSING BOARD AS THE CANVASSING BOARD FOR THE MARCH 19, 2024 MUNICIPAL ELECTION; PROVIDING FOR POLLING PLACES; PROVIDING FOR REPEAL OF ORDINANCES OR PARTS OF ORDINANCES IN CONFLICT HEREWITH TO THE EXTENT OF SUCH CONFLICT; AND PROVIDING FOR AN EFFECTIVE DATE.**

Interested parties may appear at the meeting and be heard with respect to the proposed ordinance. A copy of the proposed Ordinance is available for inspection in the City Clerk's Office between the hours of 8:30 a.m. and 4:00 p.m., Monday through Friday. If you would like more information regarding proposed Ordinance 2024-01, please contact the City Clerk at 727-391-9951, ext. 231 or 232 or email to [cvanblargan@madeirabeachfl.gov](mailto:cvanblargan@madeirabeachfl.gov).

The meeting will be aired on Public Access TV Spectrum Channel 640 and through the City's website.

Persons who wish to appeal any decision made by the Board of Commissioners with respect to any matter considered during either public hearing at this meeting will need a record of the proceedings, and for such purpose may need to ensure that verbatim record of the proceedings is made, which record includes the testimony and evidence upon which the appeal is based. It is the responsibility of the person making the appeal to bear the cost of hiring a private court reporter or private court recording firm to make the verbatim record.

In accordance with Section 286.26, Florida Statute, persons with disabilities needing special accommodations to participate in this meeting should contact the City Clerk's office no later than 48 hours prior to the meeting: (727) 391-9951, Ext. 231 or 223 or email a written request to [cvanblargan@madeirabeachfl.gov](mailto:cvanblargan@madeirabeachfl.gov).

Clara VanBlargan, MMC, MSM, City Clerk

**ORDINANCE 2024-03**

**AN ORDINANCE OF THE CITY OF MADEIRA BEACH, FLORIDA, CREATING SECTION 66-70 TO PROVIDE DUTIES OF VEHICLE OPERATORS TO ACTUATE PARKING METERS AND AMENDING SECTION 66-72 TO PROVIDE FOR ADDITIONAL LIMITATIONS ON PARKING IN CITY PARKING LOTS AND BEACH ACCESS EASEMENTS IN CHAPTER 66 (TRAFFIC AND VEHICLES) OF THE CODE OF ORDINANCES; PROVIDING FOR CONFLICT; PROVIDING FOR CODIFICATION; PROVIDING FOR SEVERABILITY; AND PROVIDING FOR AN EFFECTIVE DATE.**

**WHEREAS**, City Staff has reviewed the current provisions of Chapter 66 of the Code of Ordinances for the City of Madeira Beach and has recommended that Section 66-70 be created to provide for duties of vehicle operators to actuate parking meters and provide for parking beyond time fixed for such vehicles and that Section 66-72 be amended to provide for additional parking limitations; and

**WHEREAS**, the recommendations of the City Staff have been found meritorious by the Board of Commissioners; and

**WHEREAS**, the Board of Commissioners has received input from the public at two public hearings.

**NOW, THEREFORE, BE IT ORDAINED BY THE BOARD OF COMMISSIONERS OF THE CITY OF MADEIRA BEACH, FLORIDA, IN SESSION DULY AND REGULARLY ASSEMBLED:**

**Section 1.** That Section 66-70 (Duty of Operators of Vehicles to Actuate the Parking Meter; Parking Beyond Time Fixed for Such Vehicle) of Division 1 (Generally) of Article III (Stopping, Standing, Parking) of Chapter 66 (Traffic and Vehicles) of the Code of Ordinances of the City of Madeira Beach, Florida, is hereby created and shall read as follows:

**Sec. 66-70. Duty of operators of vehicles to actuate the parking meter; parking beyond time fixed for such vehicle.**

- (1) When any vehicle shall be parked in any time regulated parking space as designated pursuant to this chapter, where controlled by a parking meter, the owner or operator of such vehicle shall, upon entering the parking space, immediately actuate the parking meter. The parking meter may be actuated by manual or electronic means and/or by payment of authorized legal tender, and the parking space may then be used by such vehicle during the parking time limit prescribed for that parking space.
- (2) It is unlawful for any person to permit a vehicle to remain or be placed in any parking space when the parking meter indicates or displays a signal showing that such vehicle is parked overtime or when the pay station receipt indicates that parking time limits have expired.
- (3) It is unlawful for any person to permit a vehicle to remain in any parking space for more than two (2) hours after a citation has been issued for violation of subsection (2) of this section.
- (4) When signs are erected giving notice of time limits, no person shall park a vehicle in any parking meter space and/or zone for a continuous period of time longer than that period of time designated by such signs. In order to enforce this provision no person shall roll the tires of a vehicle or attempt to remove the markings made by a parking enforcement specialist prior to removing the vehicle from the parking space.

**Section 2.** That Section 66-72 (Limitations on Parking in City Parking Lots and Beach Access Easements) of Division 2 (Parking Meters, Permits and Limitations) of Article III (Stopping, Standing, Parking) of Chapter 66 (Traffic and Vehicles) of the Code of Ordinances of the City of Madeira Beach, Florida, is hereby amended to read as follows:

**Sec. 66-72. Limitations on parking in city parking lots and beach access easements.**

Parking of any type motor vehicle is allowed in the city parking lots and beach access easements subject to the following limitations:

- (1) All vehicles must park within the designated metered spaces;
- (2) No part of the vehicle may extend beyond the limits of the marked parking space;

- (3) Backing of vehicles into metered spaces is permitted if the license plate of the vehicle can still be readily observed (except where a no back in parking sign is posted for a particular lot or parking space);
- (4) Parking in front of a driveway, blocking access for residents or emergency vehicles is prohibited;
- (5) Double parking is prohibited. Double parking refers to parking next to or obstructing another parked vehicle, wholly or partially;
- (6) Parking too close to an intersection obstructing visibility for other drivers is prohibited;
- (7) Parking on the sidewalk or pedestrian walkway obstructing pedestrian traffic is prohibited;
- (8) Parking in a bus zone or bus stop impeding public transportation is prohibited;
- (9) Unauthorized parking in a reserved spot for employees or residents is prohibited. This includes parking in a designated space without proper authorization;
- (10) Parking in a manner that obstructs access to public facilities, like mailboxes or trash bins is prohibited;
- (11) Parking in a manner that obstructs visibility for other drivers, such as parking on a curve is prohibited;
- (12) Parking in a manner that blocks access to essential infrastructure, like fire hydrants or utility boxes is prohibited;
- (13) Parking within fifteen (15) feet on either side of a fire hydrant or in a designated tow-away zone is prohibited;
- (14) Parking in a bike lane or crosswalk endangering cyclists and pedestrians is prohibited;
- (15) Except when otherwise provided in this chapter, every vehicle stopped or parked upon a one-way roadway shall be so stopped or parked parallel to the curb or edge of the roadway, in the direction of authorized traffic movement, with its right-hand wheels within 12 inches of the right-hand curb or edge of the roadway, or its left wheels within 12 inches of the left-hand curb or edge of the roadway;
- (16) Parking is only allowed during the hours of 6:00 a.m. to 12:00 midnight, unless otherwise posted;
- (17) Meters are in effect on all lots during the allowable hours of operation, seven days a week; and
- (18) Parking is prohibited in all areas during the hours of 12:00 midnight to 6:00 a.m. daily, unless otherwise posted.



**Section 3.** For purposes of codification of any existing section of the Madeira Beach Code herein amended, words **underlined** represent additions to original text, words **~~stricken~~** are deletions from the original text, and words neither underlined nor stricken remain unchanged.

**Section 4.** Ordinances or parts of ordinances in conflict herewith to the extent that such conflict exists are hereby repealed.

**Section 5.** In the event a court of competent jurisdiction finds any part or provision of the Ordinance unconstitutional or unenforceable as a matter of law, the same shall be stricken and the remainder of the Ordinance shall continue in full force and effect.

**Section 6.** The Codifier shall codify the substantive amendments to the Code of Ordinances of the City of Madeira Beach contained in Sections 1 and 2 of this Ordinance as provided for herein and shall not codify the exordial clauses nor any other sections not designated for codification.

**Section 7.** Pursuant to Florida Statutes §166.041(4), this Ordinance shall take effect immediately upon adoption.

**PASSED AND ADOPTED BY THE BOARD OF COMMISSIONERS OF THE CITY OF MADEIRA BEACH, FLORIDA, THIS \_\_\_\_\_ day of \_\_\_\_\_, 2024.**

\_\_\_\_\_  
James "Jim" Rostek, Mayor

**ATTEST:**

\_\_\_\_\_  
Clara VanBlargan, MMC, MSM, City Clerk

**APPROVED AS TO FORM:**

\_\_\_\_\_  
Thomas J. Trask, City Attorney

PASSED ON FIRST READING: \_\_\_\_\_

PUBLISHED: \_\_\_\_\_

PASSED ON SECOND READING: \_\_\_\_\_



## Memorandum

**Meeting Details:** February 14, 2024 – BOC Regular Meeting

**Prepared For:** Hon. Mayor Rostek and Board of Commissioners

**From:** Community Development Department

**Subject:** Public Hearing for (2COP) ALCOHOLIC BEVERAGE LICENSE APPLICATION # 2024-01 for Osaka Japanese and Thai Restaurant of Madeira Beach located at 696 150th Ave, Madeira Beach, Florida 33708

### **Background:**

Pursuant to Land Development Code Article VI, Division 6, Alcoholic Beverages, the applicant for ABP 2024-01 is requesting authorization from the Board of Commissioners for the approval of a (2COP) alcoholic beverage license for the sale of beer and wine for consumption on premises at Osaka Japanese and Thai Restaurant of Madeira Beach located at 696 150<sup>th</sup> Avenue Madeira Beach, Florida 33708. This establishment is located in the C-3, Retail Commercial Zoning District. The future land use designation for the property is Commercial General.

Pursuant to Section 110-539, the Notice of Public Hearing has been properly sent to all property owners within 300 feet of the subject property 15 days prior to the scheduled consideration by the Board of Commission. Such notice has also been posted on the subject property, at the Gulf Beaches Public Library, City Hall, and the City of Madeira Beach website.

### **Discussion:**

When considering the alcoholic beverage license application, the Board of Commissioners shall consider the following factors:

- (1) **The extent to which the location and the extent to which the proposed alcoholic beverage request will adversely affect the character of the existing neighborhood.**

Permitting Osaka Japanese and Thai Restaurant of Madeira Beach to serve beer and wine for consumption on premises would not adversely affect the character of the existing

neighborhood. The existing neighborhood is mostly commercial uses. Within the past five years, there was previously a sushi restaurant (Hinata Japanese Steakhouse & Seafood) at this location that was approved for the same type of (2COP) alcoholic beverage license in 2016 (ASP#2016-02).

**(2) The extent to which traffic generated as a result of the location of the proposed alcoholic beverage request will create congestion or present a safety hazard.**

Previously a restaurant with a (2COP) alcoholic beverage license was located at this location. The minimum parking requirements of this property exceed the requirements of (sec. 110-971). Additional traffic and congestion should not be created by the proposed alcohol use. The proposed alcohol use does not present a safety hazard.

**(3) Whether or not the proposed use is compatible with the particular location for which it is proposed.**

This proposed alcohol use is compatible with the location. Other businesses in this shopping center also serve alcohol such as Slyce Madeira Beach, another restaurant within the same shopping center.

**(4) Whether or not the proposed use will adversely affect the public safety.**

Public safety should not be adversely affected by Osaka Japanese and Thai Restaurant of Madeira Beach serving beer and wine for consumption on the premises. The restaurant is more than 300 feet away from any established church, synagogue, temple, or place of religious worship, public or private school operated for the instruction of minors, or youth recreation (community) center. This 300-foot requirement is the minimum distance required for bars and clubs located in the C-3, Zoning District (sec. 110-530) and does not need to be met for restaurants.

**(5) No application for review under this section shall be considered until the applicant has paid in full any outstanding charges, fees, interest, fines or penalties owed by the applicant to the city under any section of the Code.**

The applicant has no outstanding fines or penalties owed to the City under any section of the Code.

**Fiscal Impact:** N/A

**Recommendation(s):** Staff recommends the approval of ABP 2024-01.

**Attachments:**

Local Application

State Application

Floor Plan

Public Notice Mailing and Posting

ABP #: 2024-01



**CITY OF MADEIRA BEACH**  
PLANNING & ZONING DEPARTMENT  
300 MUNICIPAL DRIVE ♦ MADEIRA BEACH, FLORIDA 33708  
(727) 391-9951 EXT. 255  
[planning@madeirabeachfl.gov](mailto:planning@madeirabeachfl.gov)



**ALCOHOLIC BEVERAGE PERMIT APPLICATION**

**Applicant: Name and Address**

**Property Owner: Name and Address**

Osaka Japanese and Thai of Madeira beach  
696 150th Ave  
Madeira Beach, FL, 33708

Publix Real Estate  
150th Ave  
Madeira Beach, FL, 33708

Telephone: (727) 483-4869  
Email: m.Chenlada@hotmail.com

Telephone: (863) 688-1188 Ext. 52288  
Email: Amber.Moulton@publix.com

Type of Ownership:  Individual  Partnership  Corporation  LLC

Name of Business: Osaka Japanese and Thai Business Phone: \_\_\_\_\_

Parcel Identification: 03-31-15-25128-001-0010

Legal Description: EDGEWATER ESTATES UNIT 12 PTS OF BLK 1, LOT 1  
& BLK 2, LOT 1 DESC AS BEG MOST WLY COR OF LOT 1, BLK 1 TH  
N SIDE 558 FT TH S SIDE 40 FT (S) TH S SIDE 362 FT  
Number of Seats: Inside: 91 Outside: \_\_\_\_\_

Number of Employees: 10

Zoning District: MADEIRA BEACH (MB) C-3

Future Land Use: COMMERCIAL GENERAL

Classification:

- Package store, beer & wine
- Package store, beer, wine, liquor
- Bar
- Retail Store, beer, wine
- Restaurants
- Club
- Charter Boats

Number of Parking Spaces: 190 HHC Parking Spaces: 8 H Bike Racks: 3

**DISCLAIMER:** According to Florida Statutes, Chapter 119, it is the policy of this state that all state, county, and municipal records are open for personal inspection and copying by any person. Providing access to public records is a duty of each agency. All documents and information not specified in F.S. 119.071 and 119.0713 are subject to public record requests.

ABP #: \_\_\_\_\_

Hours of Operation:

- Monday: 11:00 am - 11:00 pm
- Tuesday: 11:00 am - 11:00 pm
- Wednesday: 11:00 am - 11:00 pm
- Thursday: 11:00 am - 11:00 pm
- Friday: 11:00 am - 11:00 pm
- Saturday: 11:00 am - 11:00 pm
- Sunday: 11:00 am - 11:00 pm

General Description of Business: Full Service Restaurant  
2 COP

Supporting Materials Required:

- Property Owner's Written Approval
- Property Survey
- Site Plan

Package Store Requisition: On a separate attached page, please answer the following questions:

1. The extent to which the location and the extent to which the proposed alcoholic beverage request will adversely affect the character of the existing neighborhood.
2. The extent to which traffic generated as a result of the location of the proposed alcoholic beverage request will create congestion or present a safety hazard.
3. Whether or not the proposed use is compatible with the particular location for which it is proposed.
4. Whether or not the proposed use will adversely affect the public safety.
5. No application for review under this section shall be considered until the applicant has paid in full any outstanding charges, fees, interest, fines or penalties owned by the applicant to the City under any section of the code.

DISCLAIMER: According to Florida Statutes, Chapter 119, it is the policy of this state that all state, county, and municipal records are open for personal inspection and copying by any person. Providing access to public records is a duty of each agency. All documents and information not specified in F.S. 119.071 and 119.0713 are subject to public record requests.

1.The extent to which the location and extent to which the proposed alcoholic beverage request will adversely affect the character of the existing neighborhood.

Having alcoholic beverages will not adversely affect the neighborhood, as there are several locations surrounding the location that provide alcoholic beverages.

2.The extent to which traffic generated as a result of the location of the proposed alcoholic beverage request will create congestion or present a safety hazard.

It will not present a traffic congestion problem, as there are several locations nearby that also provide alcoholic beverages.

3.Wether or not the proposed use is compatible with the particular location for which it is proposed.

It is compatible as there are several locations nearby that also provide alcoholic beverages.

4. Whether or not the proposed use will adversely affect the public safety.

The proposed location will not adversely affect the public safety, as there are several locations nearby that also provide alcoholic beverages.

5. No application for review under this section shall be considered until the applicant has paid in full any outstanding charge , fees, interest, fines or penalties owned by the applicant to the City under any section of the code.

No fees are owed at this time as this is our first location in the Madeira Beach area.



ABP #: \_\_\_\_\_

**Affidavit of Applicant:**

I understand that this Alcoholic Beverage Permit Application, with its attachments, becomes a permanent record for the City of Madeira Beach and hereby certify that all statements made herein together with any attachments, are true to the best of my knowledge.

**DISCLAIMER:** According to Florida Statutes, Chapter 119, it is the policy of this state that all state, county, and municipal records are open for personal inspection and copying by any person. Providing access to public records is a duty of each agency. All documents and information not specified in F.S. 119.071 and 119.0713 are subject to public record requests.

ABP #: 2024-01

Signature of Applicant:  Date: \_\_\_\_\_

**\*\*For City of Madeira Beach Use Only\*\***

Fee: \$800.00  Check # \_\_\_\_\_  Cash  Receipt # \_\_\_\_\_

Date Received: 1-12-24 Received by: 

ABP# Assigned: 2024-01

BOC Hearing Date: 2-14-24  Approved  Denied

\_\_\_\_\_  
Community Development Director Date: \_\_\_\_\_

\_\_\_\_\_  
City Manager Date: \_\_\_\_\_

**DISCLAIMER:** According to Florida Statutes, Chapter 119, it is the policy of this state that all state, county, and municipal records are open for personal inspection and copying by any person. Providing access to public records is a duty of each agency. All documents and information not specified in F.S. 119.071 and 119.0713 are subject to public record requests.

# 1459

AN ALTAZASM LAND TITLE SURVEY  
 OF A PORTION OF  
 EISENVAUER BEATIES UNIT NO. 12 PER PLAT BOOK 441 PAGE 18  
 SECTION 2 TOWNSHIP 31 SOUTH RANGE 15 EAST  
 PINEHILLS COUNTY, FLORIDA

*Public owns the submerged lands (water)*  
*There is a license agreement with MOP provided they are responsible for repair maintenance, etc of the dock.*

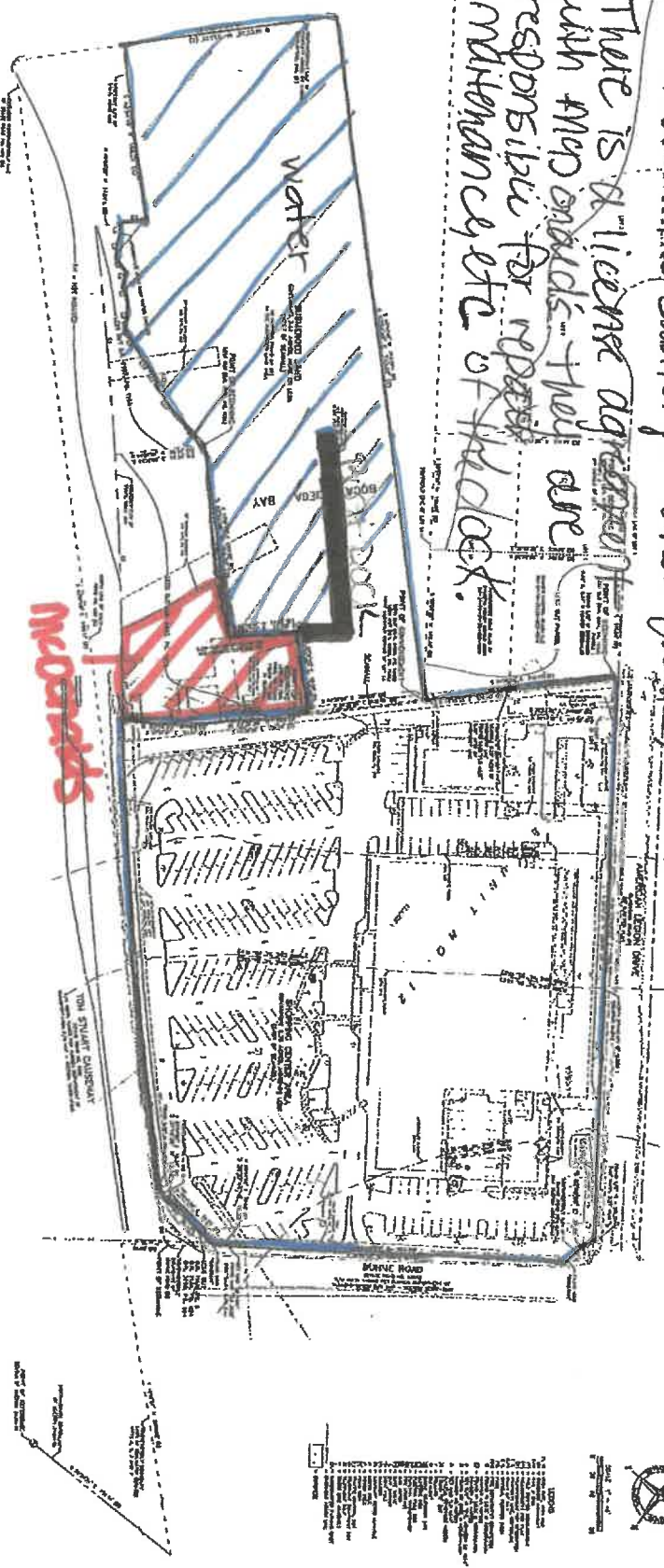

NO.	DESCRIPTION	AMOUNT
1	...	...
2	...	...
3	...	...
4	...	...
5	...	...
6	...	...
7	...	...
8	...	...
9	...	...
10	...	...
11	...	...
12	...	...
13	...	...
14	...	...
15	...	...
16	...	...
17	...	...
18	...	...
19	...	...
20	...	...
21	...	...
22	...	...
23	...	...
24	...	...
25	...	...
26	...	...
27	...	...
28	...	...
29	...	...
30	...	...
31	...	...
32	...	...
33	...	...
34	...	...
35	...	...
36	...	...
37	...	...
38	...	...
39	...	...
40	...	...
41	...	...
42	...	...
43	...	...
44	...	...
45	...	...
46	...	...
47	...	...
48	...	...
49	...	...
50	...	...
51	...	...
52	...	...
53	...	...
54	...	...
55	...	...
56	...	...
57	...	...
58	...	...
59	...	...
60	...	...
61	...	...
62	...	...
63	...	...
64	...	...
65	...	...
66	...	...
67	...	...
68	...	...
69	...	...
70	...	...
71	...	...
72	...	...
73	...	...
74	...	...
75	...	...
76	...	...
77	...	...
78	...	...
79	...	...
80	...	...
81	...	...
82	...	...
83	...	...
84	...	...
85	...	...
86	...	...
87	...	...
88	...	...
89	...	...
90	...	...
91	...	...
92	...	...
93	...	...
94	...	...
95	...	...
96	...	...
97	...	...
98	...	...
99	...	...
100	...	...

... of the State of Florida, do hereby certify that the within and foregoing is a true and correct copy of the original as the same appears on the records of the Office of the State Surveyor, at Tallahassee, Florida, this 15th day of August, 1954.

STATE SURVEYOR

... of the State of Florida, do hereby certify that the within and foregoing is a true and correct copy of the original as the same appears on the records of the Office of the State Surveyor, at Tallahassee, Florida, this 15th day of August, 1954.

STATE SURVEYOR

SEE SHEET 2 FOR LAYOUT/DETAILS

CHASOV ASSOCIATES  
 BOUNDARY SURVEY  
 Public Surveyors  
 Modern Beach  
 Park

CHASOV ASSOCIATES  
 BOUNDARY SURVEYORS  
 MODERN BEACH PARK

SCALE: 1" = 3' (1/4" = 3 FT.)

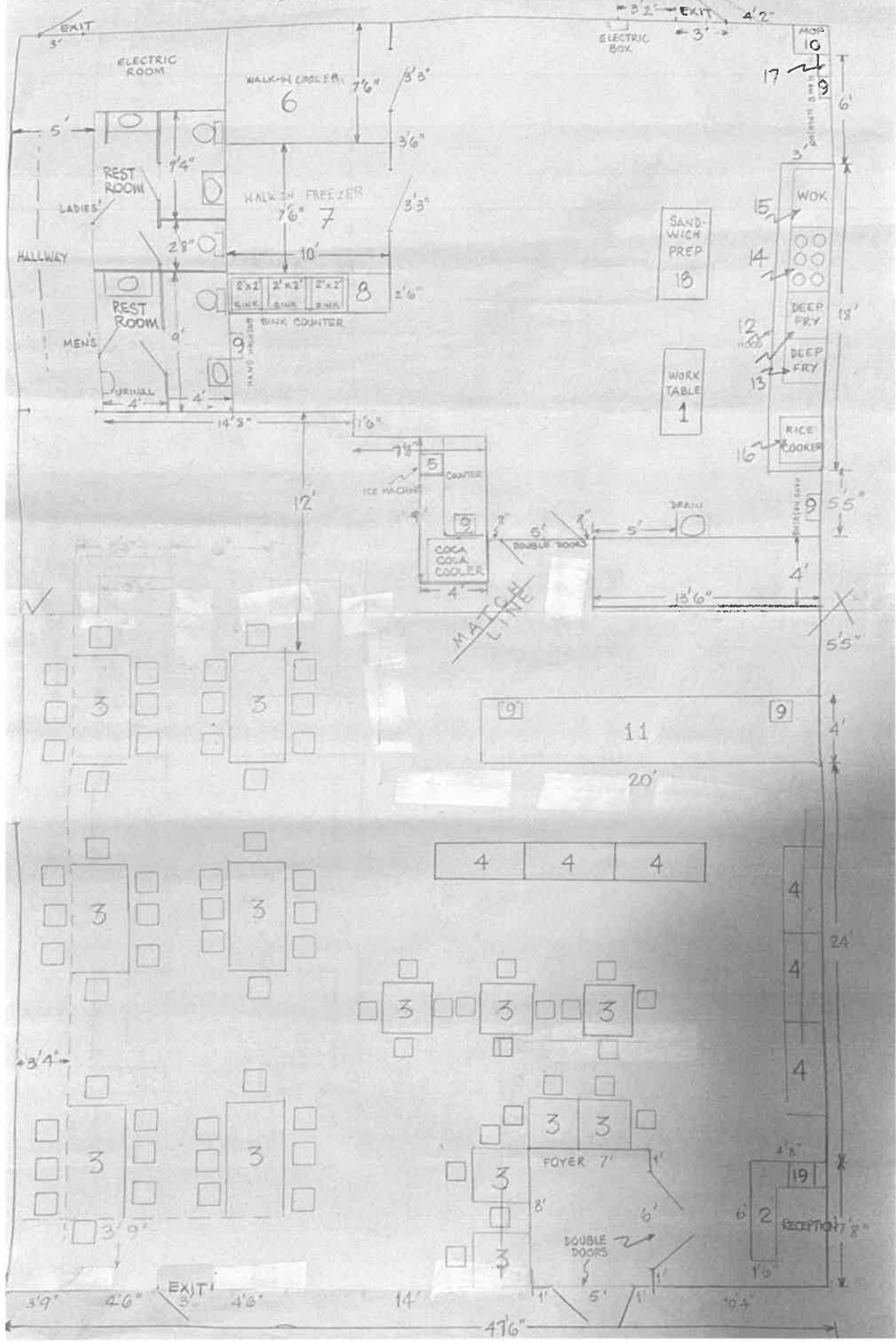

1  
2  
3  
4  
5  
6  
7  
8  
9  
10  
11  
12  
13  
14  
15  
16  
17  
18  
19  
20  
21  
22  
23  
24  
25  
26  
27  
28  
29  
30  
31  
32  
33  
34  
35  
36  
37  
38  
39  
40  
41  
42  
43  
44  
45  
46  
47  
48  
49  
50  
51  
52  
53  
54  
55  
56  
57  
58  
59  
60  
61  
62  
63  
64  
65  
66  
67  
68  
69  
70  
71  
72  
73  
74  
75  
76  
77  
78  
79  
80  
81  
82  
83  
84  
85  
86  
87  
88  
89  
90  
91  
92  
93  
94  
95  
96  
97  
98  
99  
100

LEASE AGREEMENT

Between

PUBLIX SUPER MARKETS, INC.,  
a Florida corporation,  
as Landlord,

and

OSAKA JAPANESE AND THAI OF MADEIRA BEACH, INC.,  
a Florida corporation,  
as Tenant,

Dated  
as of

\_\_\_\_\_, 2023

**1.6 Quiet Enjoyment.** Landlord covenants and agrees that so long as Tenant shall (i) timely pay all Rent due to Landlord from Tenant hereunder and (ii) keep, observe and perform all covenants, promises and agreements on Tenant's part to be kept, observed and performed hereunder, that Tenant shall be entitled to quiet enjoyment of the Premises free of any interference from Landlord; subject to the terms and conditions of this Lease.

## **ARTICLE 2 - TERM**

**2.1 Initial Term; Commencement Date.** The initial term (the "Initial Term") of this Lease shall commence on the date specified in Section 1.1(i) (the "Commencement Date") and shall continue for the term set forth in Section 1.1(b).

**2.2 Option to Renew.** Tenant shall have and is hereby granted one (1) option to renew the Term of this Lease for an additional five (5) Lease Years (the "Renewal Term"); subject to the conditions set forth in this Section 2.2. The Renewal Term shall be upon the same terms, covenants, conditions and Rent as set forth herein, subject to adjustments to the Base Rent described in Section 4.2 below; provided that: (i) Tenant is not in default of the Lease at the time of exercise of the renewal option, nor in default on the date of commencement of the Renewal Term; (ii) Tenant is the original Tenant under this Lease and has not acquired its interest in this Lease pursuant to Article 13 below; and (iii) Tenant has not been late in the payment of Rent more than twice during any twelve (12) month period during the Initial Term. Tenant may exercise the renewal option by giving written notice to Landlord not less than six (6) months, nor more than nine (9) months, prior to the expiration of the Initial Term. Should Tenant fail to give Landlord such timely written notice during the required period, all remaining rights of renewal shall automatically expire.

**2.3 Early Occupancy.** Tenant shall have the right to enter and occupy the Premises prior to the Commencement Date only upon the following terms and conditions:

(a) All terms and conditions of this Lease shall apply and shall be in full force and effect upon the Possession Date, other than the terms and conditions regarding payment of Rent, which shall be in full force and effect as of the Commencement Date.

(b) Tenant may take occupancy of the Premises upon receipt of written notice of delivery of the Premises from Landlord, but Tenant's right to take occupancy is contingent upon Tenant delivering to Landlord the following: (i) one month's Rent pursuant to Article 4 of this Lease (although not credited until the Commencement Date); (ii) security deposit pursuant to Section 4.11 of this Lease; and (iii) certificate(s) of insurance pursuant to Article 8 of this Lease.

(c) Tenant's activities within the Premises shall be at Tenant's sole risk, and Landlord shall not be responsible for the safety of Tenant or Tenant's employees or the condition or loss of any personal property brought on to the Premises.

**2.4 Construction of Improvements.** Construction to be performed in the Premises prior to the Commencement Date, if any, shall be in accordance with the terms and conditions set forth in attached Rider 1.1(n). If no Rider 1.1(n) is attached to this Lease, Tenant may only perform construction in the Premises upon written consent of Landlord, which may be withheld or conditioned at Landlord's sole discretion.

## **ARTICLE 3 - USE AND OPERATION OF PREMISES**

**3.1 Permitted Use.** Tenant covenants that throughout the Term, Tenant shall continuously use and occupy the Premises solely and only for the purpose of operating thereon a Japanese Sushi and Thai restaurant, offering sit down dining and carry-out service, and the sale of beer and wine for on-premises consumption only (provided Tenant maintains all insurance required under this Lease, including, without limitation, "dram shop" liability insurance in accordance with Rider 1.1(l) – "Addendum to Lease") (the "Permitted Use"), and for absolutely no other use or purpose whatsoever. Tenant shall conduct its business in the Premises solely under the trade name specified in Section 1.1(a).

**3.2 Requirements and Restrictions.** Tenant agrees that it (a) will not, without Landlord's consent, conduct or permit to be conducted any auction, fire, bankruptcy or going-out-of-business sale, or similar type sale, in connection with the Premises; provided, however, that this provision shall not restrict the absolute freedom of Tenant to determine its own selling prices nor shall it preclude the conduct of periodical seasonal, promotional or clearance sales; (b) will not use or permit the use of any apparatus for sound reproduction or transmission or of any musical instrument in such manner that the sounds so reproduced, transmitted or produced shall be audible beyond the interior of the Premises; will not permit the use of any apparatus, advertising medium or the like which can be seen, heard or experienced outside the Premises, including, but not limited to,

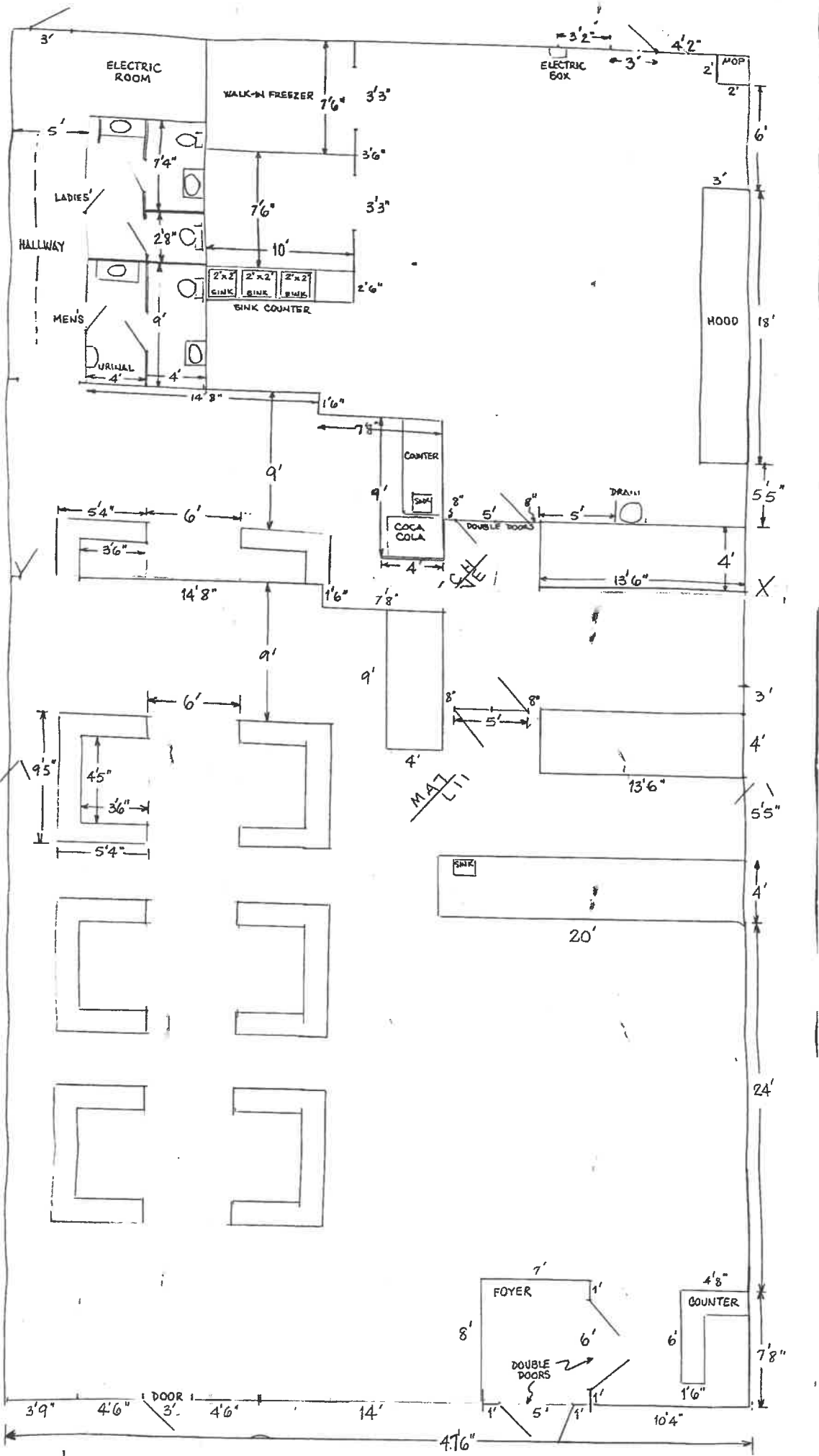



## MEMORANDUM

### PUBLIC NOTICE

The Board of Commissioners of the City of Madeira Beach will hold a Public Hearing on **February 14, 2024, at 6:00 p.m.**, or as soon thereafter as the matter may be heard, at the Patricia Shontz Commission Chambers at 300 Municipal Drive, Madeira Beach, Florida 33708 to review an application for the approval by the Board of Commissioners of a (2COP) alcoholic beverage license for the sale of beer and wine for consumption on premises at Osaka Japanese and Thai Restaurant of Madeira Beach located at 696 150th Avenue, Madeira Beach, FL 33708. This establishment is located in the C-3, Retail Commercial Zoning District and the future land use designation is Commercial General.

### (2COP) ALCOHOLIC BEVERAGE LICENSE APPLICATION # 2024-01

**Applicant(s):** Osaka Japanese and Thai Restaurant of Madeira Beach INC

**Business Location:** 696 150th Ave, Madeira Beach, FL 33708

**Business:** Osaka Japanese and Thai Restaurant of Madeira Beach

#### **Application Request:**

Pursuant to Land Development Code Article VI, Division 6, Alcoholic Beverages, the applicant for ABP 2024-01, is seeking a (2COP) alcoholic beverage license for the sale of beer and wine for consumption on premises at Osaka Japanese and Thai Restaurant of Madeira Beach located at 696 150th Avenue Madeira Beach, FL 33708. This establishment is located in the C-3, Retail Commercial Zoning District. The future land use designation for the property is Commercial General.

#### **Note:**

You have received this notice, pursuant to City Code Section 110-539, because you are a property owner within 300 feet of the subject property. If you are desirous of voicing approval or disapproval of this application, you may attend the Public Hearing for this application.

A copy of the application is available for inspection in the Community Development Department between the hours of 8:30 a.m. and 4:00 p.m., Monday through Friday. If you would like more information regarding the application, please contact Andrew Morris, Long Range Planner at 727-391-9951, ext. 296 or [amorris@madeirabeachfl.gov](mailto:amorris@madeirabeachfl.gov).





Any affected person may become a party to this proceeding and can be entitled to present evidence at the hearing including the sworn testimony of witnesses and relevant exhibits and other documentary evidence and to cross-examine all witnesses by filing the attached Notice of Intent to be a party with the Community Development Department not less than five days prior to commencement of the hearing. The completed form may be emailed or submitted in person to the following:

Community Development Department  
300 Municipal Drive  
Madeira Beach, FL 33708

Andrew Morris, Long Range Planner  
amorris@madeirabeachfl.gov  
727-391-9951, ext. 296

**Posted:**

January 26, 2024 @ Property Site, Gulf Beaches Public Library, City Hall, City of Madeira Beach, and Website Posting Locations.

**Note:** One or more Elected or Appointed Officials may be in attendance. Any person who decides to appeal any decision of the Board of Commissioners with respect to any matter considered at this meeting will need a record of the proceedings and for such purposes may need to ensure that a verbatim record of the proceedings is made, which record includes the testimony and evidence upon which the appeal is to be based. The law does not require the City to transcribe verbatim minutes; therefore, the affected party must make the necessary arrangements with a private reporter or private reporting firm and bear the resulting expense. In accordance with Section 286.26, Florida Statutes, persons with disabilities needing special accommodations to participate in this meeting must contact Community Development Director, Jenny Rowan no later than 48 hours prior to the meeting: (727) 391-9951, Ext. 255 or 244 or send a written request to [planning@madeirabeachfl.gov](mailto:planning@madeirabeachfl.gov).





**NOTICE OF INTENT TO BE AN AFFECTED PARTY**

**AFFECTED PERSON INFORMATION**

Name: \_\_\_\_\_

Address: \_\_\_\_\_

\_\_\_\_\_

Telephone: \_\_\_\_\_ Fax: \_\_\_\_\_

Email: \_\_\_\_\_

**APPLICATION INFORMATION**

Case No or Application No., whichever applies: \_\_\_\_\_

Applicants Name: \_\_\_\_\_

\_\_\_\_\_  
Signature of Affected Person

\_\_\_\_\_  
Date

Note: One or more Elected or Appointed Officials may be in attendance. Any person who decides to appeal any decision of the Board of Commissioners with respect to any matter considered at this meeting will need a record of the proceedings and for such purposes may need to ensure that a verbatim record of the proceedings is made, which record includes the testimony and evidence upon which the appeal is to be based. The law does not require the City to transcribe verbatim minutes; therefore, the applicant must make the necessary arrangements with a private reporter or private reporting firm and bear the resulting expense. In accordance with the Americans with Disability Act and F.S. 286.26; any person with a disability requiring reasonable accommodation in order to participate in this meeting should call 727-391-9951 or fax a written request to 727-399-1131.



### AFFIDAVIT OF POSTING

Date: 1/26/2024  
Postings for: ABP-2024-01

Before me this day Lisa Scheumann personally appeared. He/she has posted public notices at the locations indicated in the notice document(s).

Lisa Scheumann  
Signature

STATE OF FLORIDA  
COUNTY OF PINELLAS

Sworn to and subscribed before me this 26<sup>th</sup> day of January, 20 24.

Personally known or produced \_\_\_\_\_ as identification.



Samantha Arison  
Notary Public

1/26/24  
Date

\*Copy of public notice is attached.





MEMORANDUM

PUBLIC NOTICE

The Board of Commissioners of the City of Madeira Beach will hold a Public Hearing on February 14, 2024, at 6:00 p.m., or as soon thereafter as the matter may be heard, at the Patricia Shontz Commission Chambers at 300 Municipal Drive, Madeira Beach, Florida 33708 to review an application for the approval by the Board of Commissioners of a (2COP) alcoholic beverage license for the sale of beer and wine for consumption on premises at Osaka Japanese and Thai Restaurant of Madeira Beach located at 696 150th Avenue, Madeira Beach, FL 33708. This establishment is located in the C-3, Retail Commercial Zoning District and the future land use designation is Commercial General.

(2COP) ALCOHOLIC BEVERAGE LICENSE APPLICATION # 2024-01

Applicant(s): Osaka Japanese and Thai Restaurant of Madeira Beach INC

Business Location: 696 150th Ave, Madeira Beach, FL 33708

Business: Osaka Japanese and Thai Restaurant of Madeira Beach

Application Request:

Pursuant to Land Development Code Article VI, Division 6, Alcoholic Beverages, the applicant for ABP 2024-01, is seeking a (2COP) alcoholic beverage license for the sale of beer and wine for consumption on premises at Osaka Japanese and Thai Restaurant of Madeira Beach located at 696 150th Avenue Madeira Beach, FL 33708. This establishment is located in the C-3, Retail Commercial Zoning District. The future land use designation for the property is Commercial General.

Note:

You have received this notice, pursuant to City Code Section 110-539, because you are a property owner within 300 feet of the subject property. If you are desirous of voicing approval or disapproval of this application, you may attend the Public Hearing for this application.

A copy of the application is available for inspection in the Community Development Department between the hours of 8:30 a.m. and 4:00 p.m., Monday through Friday. If you would like more information regarding the application, please contact Andrew Morris, Long Range Planner at 727-391-9951, ext. 296 or amorris@madeirabeachfl.gov.

ABP 2024-01 Page 1



## **ABP 2024-01 Osaka Japanese and Thai Restaurant of Madeira Beach**

[ABP 2024-01 Osaka Japanese and Thai Restaurant of Madeira Beach Public Notice](#)

[ABP 2024-01 Osaka Japanese and Thai Restaurant of Madeira Beach Local App](#)

<https://madeirabeachfl.gov/plan-review-documents/>

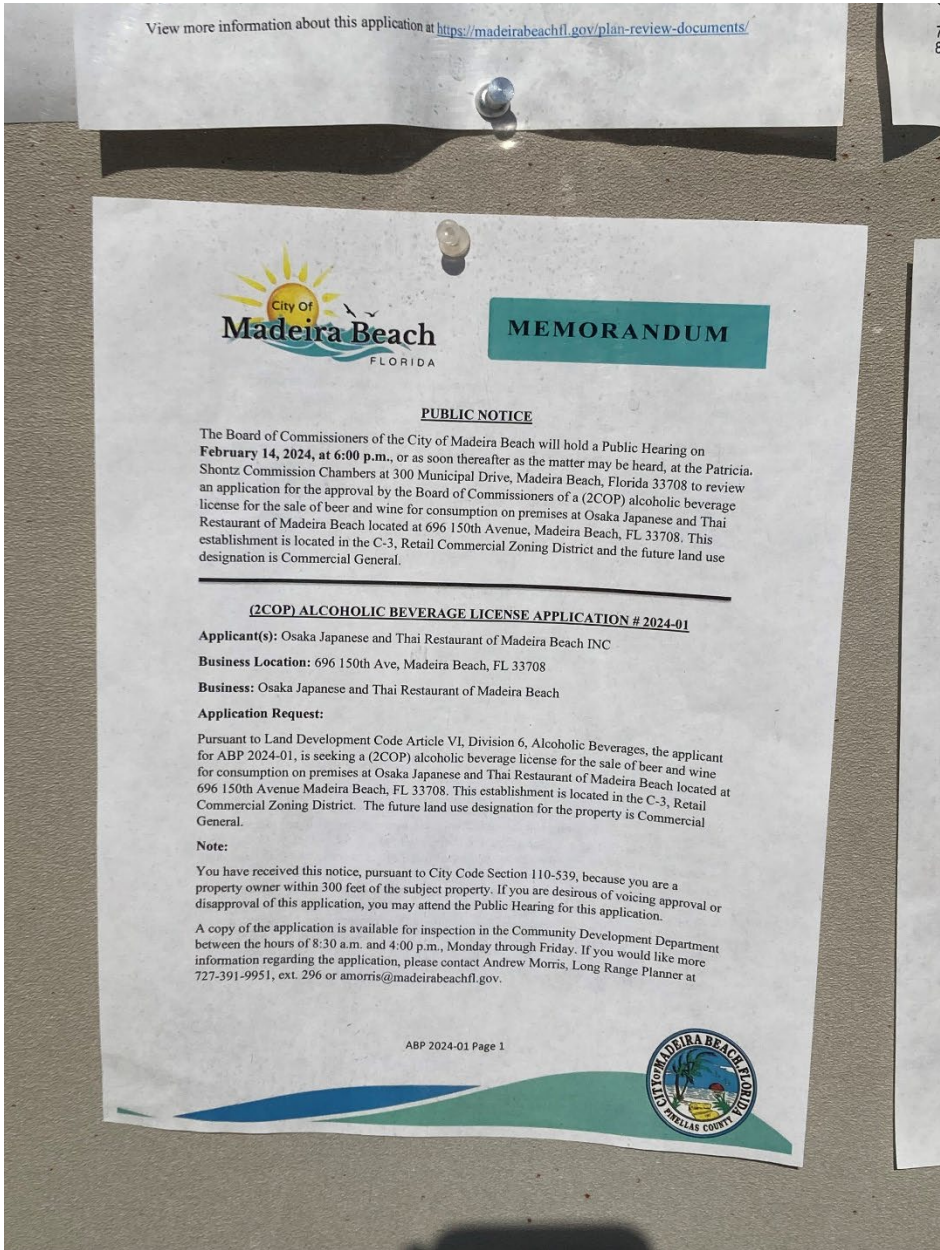

View more information about this application at <https://madeirabeachfl.gov/plan-review-documents/>



**MEMORANDUM**

**PUBLIC NOTICE**

The Board of Commissioners of the City of Madeira Beach will hold a Public Hearing on **February 14, 2024, at 6:00 p.m.**, or as soon thereafter as the matter may be heard, at the Patricia Shontz Commission Chambers at 300 Municipal Drive, Madeira Beach, Florida 33708 to review an application for the approval by the Board of Commissioners of a (2COP) alcoholic beverage license for the sale of beer and wine for consumption on premises at Osaka Japanese and Thai Restaurant of Madeira Beach located at 696 150th Avenue, Madeira Beach, FL 33708. This establishment is located in the C-3, Retail Commercial Zoning District and the future land use designation is Commercial General.

**(2COP) ALCOHOLIC BEVERAGE LICENSE APPLICATION # 2024-01**

**Applicant(s):** Osaka Japanese and Thai Restaurant of Madeira Beach INC

**Business Location:** 696 150th Ave, Madeira Beach, FL 33708

**Business:** Osaka Japanese and Thai Restaurant of Madeira Beach

**Application Request:**

Pursuant to Land Development Code Article VI, Division 6, Alcoholic Beverages, the applicant for ABP 2024-01, is seeking a (2COP) alcoholic beverage license for the sale of beer and wine for consumption on premises at Osaka Japanese and Thai Restaurant of Madeira Beach located at 696 150th Avenue Madeira Beach, FL 33708. This establishment is located in the C-3, Retail Commercial Zoning District. The future land use designation for the property is Commercial General.

**Note:**

You have received this notice, pursuant to City Code Section 110-539, because you are a property owner within 300 feet of the subject property. If you are desirous of voicing approval or disapproval of this application, you may attend the Public Hearing for this application.

A copy of the application is available for inspection in the Community Development Department between the hours of 8:30 a.m. and 4:00 p.m., Monday through Friday. If you would like more information regarding the application, please contact Andrew Morris, Long Range Planner at 727-391-9951, ext. 296 or amorris@madeirabeachfl.gov.





### AFFIDAVIT OF MAILING

Date: 1/26/24

Mailings for Case # ABP-2024-01

STATE OF FLORIDA  
COUNTY OF PINELLAS

Before me this day Lisa Skewermann personally appeared. He/she has mailed public notices to property owners within a 300 foot radius of the subject property.

Sworn and subscribed before me this 26<sup>th</sup> day of Jan 2024.

Personally known or produced \_\_\_\_\_ as identification.



Samantha Arison  
Notary Public

01/26/24  
Date

\*Copy of public notice is attached.





**MIKE TWITTY, MAI, CFA**  
**Pinellas County Property Appraiser**

[www.pcpao.gov](http://www.pcpao.gov)

[mike@pcpao.gov](mailto:mike@pcpao.gov)

Run Date: 19 Jan 2024

Subject Parcel: 03-31-15-25128-001-0010

Radius: 300 feet

Parcel Count: 157

Total pages: 7

Public information is furnished by the Property Appraiser's Office and must be accepted by the recipient with the understanding that the information received was developed and collected for the purpose of developing a Property Value Roll per Florida Statute. The Pinellas County Property Appraiser's Office makes no warranties, expressed or implied, concerning the accuracy, completeness, reliability or suitability of this information for any other particular use. The Pinellas County Property Appraiser's Office assumes no liability whatsoever associated with the use or misuse of such information.

EISBRENER, ROGER W TRE  
EISBRENER, ROGER W REV LIV TRUST  
5008 W BOXWOOD LN  
APPLETON, WI 54913-8483

AGAG, ABDELMONEM  
AHMED, AHMED SAAD EL-DIN  
2506 46TH ST  
ASTORIA, NY 11103-1107

KOVACH, BERNARD J  
KOVACH, MARSHA L  
612 WYNDCLIFT CIR  
AUSTINTOWN, OH 44515-4367

FOY, RICHARD F JR TRE  
FOY, MARY JANE TRE  
98 OAK ST  
AVON, MA 02322-1861

CARROLL, JAMES W  
CARROLL, VELMA A  
481 SHANNON CRES  
BURLINGTON ON L7L 2R6,  
CANADA

MCDONALDS CORP  
C/O REAL ESTATE TAX DEPT  
110 N CARPENTER ST  
CHICAGO, IL 60607-4106

LAWLOR FAMILY REVOCABLE TRUST  
LAWLOR, ROBERT MARTIN TRE  
343 W OLD TOWN CT STE 703  
CHICAGO, IL 60610-7694

SIWEK, JOSEPH P & MARY E REV LIV TRUST  
SIWEK, JOSEPH P TRE  
10906 S HOYNE AVE  
CHICAGO, IL 60643-3323

MUSCA PROPERTIES LLC  
C/O WALGREENS 15192  
PO BOX 1159  
DEERFIELD, IL 60015-6002

BAIARDI, JANET  
BAIARDI-MARRAS, MARY ANN  
17146 FAIRFIELD ST  
DETROIT, MI 48221-3022

HERT, KEVIN  
HERT, DEBRA  
13486 E 131ST ST  
FISHERS, IN 46037-6291

MOELLER, ROBERT  
MOELLER, LESLIE  
1832 HICKORY TRACE DR  
FLEMING ISLAND, FL 32003-8387

MCMAHON, JAMES J  
MCMAHON, LAUREL E  
465 W 11TH ST  
GARNER, IA 50438-1801

WHITE, ROBERT G JR LIV TRUST  
WHITE, ROBERT G JR TRE  
2061 EASTWOOD BEACH DR  
GRASS LAKE, MI 49240-9311

BIDDLE, GARY W TRE  
BIDDLE, GARY WAYNE TRUST  
408 FULTON ST  
HEYWORTH, IL 61745-8801

SMITH, LYLE R & SUSAN G JNT TRUST  
SMITH, SUSAN G TRE  
2940 EAST 630 N  
HUNTINGTON, IN 46750-9673

VANDERPLAS, STEVEN E TRE  
VANDERPLAS, DEBORAH R TRE  
13300 INDIAN ROCKS RD UNIT 1201  
LARGO, FL 33774-2012

PHIFER, RICHARD JOSEPH  
PIPITHAKUL-PHIFER, BHENSIRI  
9999 AMBER FIELD ST  
LAS VEGAS, NV 89178-8901

SAUNDERS, RUSTY  
SAUNDERS, NANCY  
664 AMERICAN LEGION DR  
MADEIRA BEACH, FL 33708-2819

MINA, EHAB M  
MINA, SHELLEY J  
660 AMERICAN LEGION DR  
MADEIRA BEACH, FL 33708-2819

ARNOLD, GERALD  
ARNOLD, KATHY E  
4550 COVE CIR APT 909  
MADEIRA BEACH, FL 33708-6901

LEICHTFUSS, ROBERT B & JOAN E REV TRUST  
LEICHTFUSS, ROBERT B TRE  
4550 COVE CIR APT 806  
MADEIRA BEACH, FL 33708-6901

HARBORSIDE BOAT CLUB MADEIRA BEACH  
CONDO ASSN INC  
C/O CONDO MANAGEMENT PLUS  
PO BOX 86507  
MADEIRA BEACH, FL 33738-6507

HARBORSIDE BOAT CLUB MADEIRA BEACH  
CONDO ASSN INC  
C/O CONDO MANAGEMENT PLUS  
PO BOX 86507  
MADEIRA BEACH, FL 33738-6507

RIEFLER, KATHLEEN K  
RIEFLER, EDWARD A  
4155 NW TOWNLINE RD  
MARCELLUS, NY 13108-9607

BARBER, RONALD J JR  
BARBER, VALERIE ROSE  
1 LEE TER  
MARLTON, NJ 08053-2114

SEIPELT-RYAN, PATRICIA A TRE  
SEIPELT-RYAN, PATRICIA A LIV TRUST  
1301 ST ANDREWS CIR  
MILDFORD, OH 45150-2972

CUNNINGHAM, JAMES  
CUNNINGHAM, CATHERINE  
6 TULIP LN  
MONROE, NY 10950-1017

JONES, JOHN J  
JONES, NELLIE R  
250 W 78TH ST APT 2BF  
NEW YORK, NY 10024-6675

BREWER, PAUL E  
BREWER, MELODY F  
412 WALDEN DR  
OTSEGO, MI 49078-9652

JONES, JOHN W SR  
JONES, CATHY S  
20 WHISPERING PINES TRL  
PACIFIC, MO 63069-4693

JORGENSEN, DARLENE P  
VETTERLI, ROBERT E  
330 HIGGINS RD APT A  
PARK RIDGE, IL 60068-5773

WHYTE, KAREN J  
GORDON, THOMAS  
6123 HIGH ST  
PENNSAUKEN, NJ 08110-2737

ZHONG, JIANHUI  
WANG, TONG  
2 SUTTON POINT  
PITTSFORD, NY 14534-4616

CARR, WILLIAM JAMES  
CARR, ANNA MARIA  
7477 CLARKE DR  
PORT FRANKS ON NOM 2L0,  
CANADA

PINE, RICHARD  
PINE, CYNTHIA  
16480 REDINGTON DR  
REDINGTON BEACH, FL 33708-1550

RYKSE, MARTINUS  
RYKSE, ANDREW M  
408 PROSPECT POINT RD  
RIDGWAY ON LOS 1N0,  
CANADA

EXTRA SPACE PROPERTIES EIGHTY SIX LLC  
C/O PARADIGM TAX GROUP ESS NO1314  
PO BOX 71870  
SALT LAKE CITY, UT 84171-0870

LA TRACE, ADRIAN E 2012 TRUST  
LA TRACE, ADRIAN E TRE  
9388 PEBBLE BEACH CT E  
SEMINOLE, FL 33777-4532

MUNSON, ROBERT J SR REV LIV TRUST  
MUNSON, MARIE E REV LIV TRUST  
7815 2ND AVE S  
ST PETERSBURG, FL 33707-1021

SEA TOWERS OWNERS ASSN INC  
ATTN: WASHINGTON TOWERS  
4570 COVE CIR N  
ST PETERSBURG, FL 33708

GROSSO, MARY FRANCES  
GROSSO, TIMOTHY ROGER  
4550 CLOVE COVE CIR UNIT 305  
ST PETERSBURG, FL 33708

HANSEN, EDWARD T TRE  
ALCOTT, ARLENE R TRE  
4550 COVE CIR APT 208  
ST PETERSBURG, FL 33708-2845

HUTSON, CHARLES E TRE  
HUTSON, LINDA L TRE  
4550 COVE CIR APT 107  
ST PETERSBURG, FL 33708-2845

DRIGGS, ROBERT  
DRIGGS, JEANNE  
4550 COVE CIR UNIT 203  
ST PETERSBURG, FL 33708-2845

ALCOTT, ELMER D  
SHAW, KAREN R  
4550 COVE CIR APT 209  
ST PETERSBURG, FL 33708-2845

BELFIGLIO, RALPH JR  
MURRAY, DEANNE S  
4550 COVE CIR UNIT 102  
ST PETERSBURG, FL 33708-2845

CORREIA, JOHN  
CORREIA, CIDALIA  
4550 COVE CIR APT 303  
ST PETERSBURG, FL 33708-2845

ROCK, MARIE L  
MARKUNAS, RICHARD  
4550 COVE CIR APT 507  
ST PETERSBURG, FL 33708-2846

GOLDEN, JACK L  
GOLDEN, ERIKA  
4550 COVE CIR APT 608  
ST PETERSBURG, FL 33708-2846

EBERHARDT, THOMAS  
EBERHARDT, JILLENE  
4550 COVE CIR UNIT 509  
ST PETERSBURG, FL 33708-2846

OLVERA, GUILLERMO  
OLVERA, RITA  
4550 COVE CIR APT 409  
ST PETERSBURG, FL 33708-2846

NOWAK FAMILY TRUST  
NOWAK, VINCENT J TRE  
4550 COVE CIR UNIT 403  
ST PETERSBURG, FL 33708-2846

BOCHENEK, MICHAEL JOHN  
BOCHENEK, JUDITH LEE  
4550 COVE CIR APT 1102  
ST PETERSBURG, FL 33708-2847

SCHMIDT, ROBERT F JR  
SCHMIDT, JOAN  
4550 COVE CIR APT 1201  
ST PETERSBURG, FL 33708-2847

SONNENBERG, TERENCE R  
SONNENBERG, MARJORIE  
4550 COVE CIR UNIT 1109  
ST PETERSBURG, FL 33708-2847

MCILWAIN, DAVID L  
MCILWAIN, JANET E  
4550 COVE CIR UNIT 1008  
ST PETERSBURG, FL 33708-2847

GLAUCH, CHERI L TRUST  
GLAUCH, CHERI L TRE  
4550 COVE CIR UNIT 1106  
ST PETERSBURG, FL 33708-2847

CHODOR, WALTER  
CHODOR, PENNY  
4550 COVE CIR APT 1002  
ST PETERSBURG, FL 33708-2847

SKOT, LIZ SMITH  
SMITH, GARY MARK  
4550 COVE CIR APT 1208  
ST PETERSBURG, FL 33708-2847

SPENCER, RAYMOND J  
SPENCER, ARIADNA D  
4550 COVE CIR APT 1108  
ST PETERSBURG, FL 33708-2847

ELDRIDGE, RALPH E  
ELDRIDGE, ARGIRO F  
4550 COVE CIR UNIT 1104  
ST PETERSBURG, FL 33708-2847

REGALADO, JUAN CARLOS  
ASNALEMA, LOLITA E  
4550 COVE CIR UNIT 802  
ST PETERSBURG, FL 33708-6901

JENSEN, DAVID E  
JENSEN, CHRISANNE  
4550 COVE CIR APT 902  
ST PETERSBURG, FL 33708-6901

CONNER, THOMAS W  
CONNER, BEATRICE B  
4550 COVE CIR UNIT 703  
ST PETERSBURG, FL 33708-6901

RZESZUT, MARGARET A TRE  
RZESZUT, FRANCIS A & MARGARET REV LIV  
TRUST  
4550 COVE CIR UNIT 708  
ST PETERSBURG, FL 33708-6901

KJELLBERG, PATRICK D  
KJELLBERG, RICHARD D  
4550 COVE CIR UNIT 709  
ST PETERSBURG, FL 33708-6901

ANCHA FAMILY TRUST  
ANCHA, SCOTT M TRE  
14706 CASTELLETO DR  
TAMPA, FL 33626-3302

RANKIN, JANET  
RANKIN, PATRICK  
1603 POWDER RIDGE DR  
VALRICO, FL 33594-4026

KLEIN, HEATH D  
KLEIN, AMY L  
505 N 6TH ST  
VINCENNES, IN 47591-2112

BROCHE, EDWARD A  
BROCHE, MARI-JO  
5224 WOLF RD  
WESTERN SPRINGS, IL 60558-1819

ROBERTSON, HELEN  
ROBERTSON, CRAIG  
14 CLUFF CT  
WHITBY ON L1P 1R5,  
CANADA

MUSCA PROPERTIES LLC  
C/O INDUSTRY CONSULTING GROUP INC  
PO BOX 1919  
WICHITA FALLS, TX 76307-1919

PUBLIX SUPER MARKETS INC  
P O BOX 32018  
LAKELAND, FL 33802-2018

FOBURG, KEITH  
581 JOHN PASS AVE  
MADEIRA BEACH, FL 33708-2368

MID-ATLANTIC PROPERTIES LLC  
2250 OLD IVY RD STE 1  
CHARLOTTESVILLE, VA 22903-4820

RINES, JOE  
4550 COVE CIR APT 404  
ST PETERSBURG, FL 33708-2846

MILLER, TERRELL  
3604 HYCLIFFE AVE  
LOUISVILLE, KY 40207-3716

SEA E O LLC  
1 KENT DR  
LARGO, FL 33774-1033

SCHOENECKER, MICHAEL  
43 WILKSHIRE PL  
LANCASTER, NY 14086-2703

AHRNS, DENNIS E  
337 S WALNUT ST  
BAY CITY, MI 48706-4972

WHATLEY, PAUL STEPHEN  
4550 COVE CIRCLE APT 406  
ST PETERSBURG, FL 33708-2846

TUMA, RICHARD ROY  
4550 COVE CIR UNIT 306  
ST PETERSBURG, FL 33708-2845

NIKSUR LLC  
11755 MARLA LN  
SEMINOLE, FL 33772-2217

MOHARERI, FATEMEH S  
4550 COVE CIR APT 103  
ST PETERSBURG, FL 33708-2845

PINELLAS BD OF PUB INST  
PO BOX 2942  
LARGO, FL 33779-2942

DIRTY DUCK PORT FOLIO LLC  
16004 GULF BLVD  
REDINGTON BEACH, FL 33708-1661

RNM INVESTMENTS LLC  
3145 CECELIA DR  
APOPKA, FL 32703-7815

GREACEN, PAMELA H  
16120 GULF BLVD  
REDINGTON BEACH, FL 33708-1628

FANNING, ROBERT T JR  
4550 COVE CIR UNIT 906  
ST PETERSBURG, FL 33708-6901

MORGAN, ELIZABETH A  
4550 COVE CIR APT 307  
ST PETERSBURG, FL 33708-2845

STEVENSON, KAREN  
4550 COVE CIR APT 205  
ST PETERSBURG, FL 33708-2845

SCHIFFGEN, JOHN S  
4550 COVE CIR UNIT 1202  
ST PETERSBURG, FL 33708-2847

JACOB, NAJIB M  
1001 41ST AVE NE  
ST PETERSBURG, FL 33703-5231

INTREPID PROPERTIES LLC  
2045 CENTRE STONE CT STE A  
COLUMBUS, GA 31904-4561

BGWOLF80-3 LLC  
12328 104TH AVE N  
LARGO, FL 33778-3410

MROWINSKI, YRMA  
11183 102ND AVE  
SEMINOLE, FL 33778-4119

FULLER, BRIGITTE  
PO BOX 3443  
TOMS RIVER, NJ 08756-3443

A J M PROPERTIES LLC  
59 NEW WILMONT RD  
SCARSDALE, NY 10583

KASIKOVIC, LJUBAN  
180 30TH AVE N  
ST PETERSBURG, FL 33704-2911

FULLER, MICHAEL W  
4550 COVE CIR UNIT 405  
ST PETERSBURG, FL 33708-2846

SIEGEL, DARLIN E  
4550 COVE CIR APT 304  
ST PETERSBURG, FL 33708-2845

TOWNSEND, WILLIAM G  
4550 COVE CIR APT 108  
ST PETERSBURG, FL 33708-2845

AMERICAN LEGION INC AUGUSTUS RUSER JR  
POST 273  
PO BOX 8115  
ST PETERSBURG, FL 33738-8115

TRANQUIL SHORES LLC  
4300 DUHME RD  
MADEIRA BEACH, FL 33708-2892

REC INVESTMENTS INC  
4350 DUHME RD  
MADEIRA BEACH, FL 33708-2809

FRIENDSHIP COMMUNITY CHURCH INC  
4321 DUHME RD  
ST PETERSBURG, FL 33708-2826

SEA TOWERS OWNERS ASSN  
4600 DUHME RD  
ST PETERSBURG, FL 33708-4899

SANTANA INVESTMENTS LLC  
1250 S TAMIAMI TRL STE 402  
SARASOTA, FL 34239-2221

DIRTY DUCK PORT FOLIO LLC  
16004 GULF BLVD  
REDINGTON BEACH, FL 33708-1661

FOBURG, KEITH  
581 JOHNS PASS AVE  
MADEIRA BEACH, FL 33708-2368

JARGDG LLC  
601 AMERICAN LEGION DR UNIT A-901  
MADEIRA BEACH, FL 33708-2982

MATHIEU, GREGORY R  
668 AMERICAN LEGION DR  
MADEIRA BEACH, FL 33708-2819

MCGUIGAN, BRIAN P  
4550 COVE CIR APT 508  
ST PETERSBURG, FL 33708-2846

BEYUS, CAROL R  
4550 COVE CIR UNIT 401  
ST PETERSBURG, FL 33708-2846

GREENE, RICHARD JAMES  
5916 VAN BUREN ST  
NEW PORT RICHEY, FL 34653-4248

MATTHEWS, LINDA SHARON  
4550 COVE CIR APT 1103  
ST PETERSBURG, FL 33708-2847

DUNN, ROBERT J  
4550 COVE CIR UNIT 101  
ST PETERSBURG, FL 33708-2845

ROBERTS, DONNA  
4550 COVE CIR UNIT 1007  
ST PETERSBURG, FL 33708-2847

PARKER, ANDREW J  
4550 COVE CIR APT 1005  
ST PETERSBURG, FL 33708-2847

SELBY, ROBERT  
3560 BURNTWOOD CT  
HOLIDAY, FL 34691-2518

LONGBOAT DEVELOPMENT LLC  
1101 E CUMBERLAND AVE  
TAMPA, FL 33602-4231

WATTS, KATHRYN  
4550 COVE CIR APT 607  
ST PETERSBURG, FL 33708-2864

KRUNIC, EDITA  
3 PATERSON RD  
LEBANON, NJ 08833-3036

ROWELL, SUSAN  
4550 COVE CIR  
ST PETERSBURG, FL 33708-2884

ROE, MARY GLORIA  
4550 COVE CIR UNIT 1209  
ST PETERSBURG, FL 33708-2847

MCPMAHON, LAUREL E  
205 FAIRWAY CIR  
GARNER, IA 50438-1053

ADAMS, DALE  
4550 COVE CIR APT109  
MADEIRA BEACH, FL 33708-2845

SEA TOWERS OWNERS ASSN INC  
4570 COVE CIR N  
ST PETERSBURG, FL 33708

SHANER MADEIRA BEACH LLC  
1965 WADDLE RD  
STATE COLLEGE, PA 16803-1639

AMERICAN LEGION INC AUGUSTUS RUSER JR  
POST 273  
PO BOX 8115  
ST PETERSBURG, FL 33738-8115

NIEMI, BRIAN A  
662 AMERICAN LEGION DR  
MADEIRA BEACH, FL 33708-2819

WE NATION LLC  
27493 SOULT RD  
BROOKSVILLE, FL 34602-5430

NRB ESCAPE LLC  
548 PALMETTO RD  
BELLEAIR, FL 33756-1436

DAVIS, SALLY S MANAGEMENT TRUST  
4938 INDIAN VALLEY RD  
BIRMINGHAM, AL 35244-3214

INTREPID PROPERTIES LLC  
2045 CENTRE STONE CT STE A  
COLUMBUS, GA 31904-4561

HARBORSIDE DOCK PARTNERS LLC  
101 NE 79TH ST  
MIAMI, FL 33138-4816

WAN, KATHERINE KUHN  
225 GREENMONT CIR  
ALPHARETTA, GA 30009-3499

MIREAU, THOMAS G  
5681 POINTE DR  
EAST CHINA, MI 48054-4164

LAMUNION, CYNTHIA M  
4550 COVE CIR UNIT 801  
ST PETERSBURG, FL 33708-6901

BURGESS, MICHAEL EST  
4550 COVE CIR APT 606  
ST PETERSBURG, FL 33708-2846

JEROME, CATHERINE  
4550 COVE CIR UNIT 605  
ST PETERSBURG, FL 33708-2846

GAGNON, SUSAN M  
4550 COVE CIR UNIT 604  
ST PETERSBURG, FL 33708-2846

MAMROT, JIMANINE A  
200 LAFAYETTE LN  
HOFFMAN ESTATES, IL 60169-4131

FRAIN, ELIZABETH H TRUST  
4550 COVE CIR APT 201  
ST PETERSBURG, FL 33708-2845

LAABS, GARY  
15441 BAYSIDE AVE  
CLEAR LAKE, IA 50428-8759

WE NATION LLC  
27493 SOULT RD  
BROOKSVILLE, FL 34602-5430

CARR, MELISSA  
4550 COVE CIR UNIT 903  
MADEIRA BEACH, FL 33708-6901

ARENTH, DONNA J  
4550 COVE CIR APT 803  
ST PETERSBURG, FL 33708-6901

SLADEWSKI, BILL EDWARD  
4550 COVE CIR UNIT 506  
ST PETERSBURG, FL 33708-2846

GILBERT, SUSAN BAREND  
4550 COVE CIR UNIT 505  
ST PETERSBURG, FL 33708-2846

MURPHY, SHERYL  
13105 BURDETTE CIR  
OMAHA, NE 68164-3929

CESARE, PAUL E  
4550 COVE CIR APT 309  
ST PETERSBURG, FL 33708-2845

PHAM, KIM LAN THI  
4550 COVE CIR UNIT 202  
ST PETERSBURG, FL 33708-2845

HULEN, MICHAEL  
47 RICH ST APT C  
WALTHAM, MA 02451-3693

WASHINGTON TOWERS ASSN  
4550 COVE CIR \$ 105  
MADEIRA BEACH, FL 33708-2845

AMERIC PROPERTIES 4330 LLC  
4055 CR 721  
WEBSTER, FL 33597-4313



# MEMORANDUM

**TO:** Hon. Mayor and Board of Commissioners  
**THROUGH:** Robin Gomez, City Manager  
**FROM:** Clint Belk, Fire Chief  
**DATE:** February 14, 2024  
**RE:** **Field Internship Agreement; SPC’s Emergency Medical Services Program**

---

### Background

Recently hired FF/EMT Halfast and FF/EMT Watts will be entering into the Emergency Medical Service Program through St. Pete College to complete their Paramedic schooling. The City, student and SPC must enter into a Field Internship Agreement to complete the onboarding process.

### Fiscal Impact

Both students are covering the cost of the education without financial impact to the City.

### Recommendation

Staff recommends approval of the Field Internship Agreement which is attached for review.

### **Attachment(s):**

- Field Internship Agreements with SPC, Emergency Medical Services Program; (Individual agreements FF/EMT Halfast, FF/EMT Watts)
- Appendix A– Release Agreement
- Exhibit B – Process for ON-Duty Firefighters Accomplishing Student SPC Field Internship Ride Time





*St. Petersburg College*  
**EMERGENCY MEDICAL SERVICES PROGRAM**

**FIELD INTERNSHIP AGREEMENT**

THIS AGREEMENT made and entered into by and between the **BOARD OF TRUSTEES OF ST. PETERSBURG COLLEGE**, Post Office Box 13489, St. Petersburg, Florida, 33733, hereinafter referred to as the College, and **CITY OF MADEIRA BEACH**, 300 Municipal Drive, Madeira Beach, Florida 33708, hereinafter referred to as the Agency.

W I T N E S S E T H

WHEREAS, the College offers an approved program of study in the field of Emergency Medical Services, and

WHEREAS, the College desires that its students obtain the necessary clinical and hands-on experience with the Agency in order to meet the requirements of the Emergency Medical Services program, and

WHEREAS, the Agency desires to cooperate with the College in implementing the above-stated objective.

NOW, THEREFORE, in consideration of the premises and the mutual promises contained in this Agreement, the Agency and the College, by their duly constituted and authorized officers, agree as follows:

THAT the students enrolled in the above-named program and the faculty at the College may ride with fire rescue units of the Agency subject to the following mutually agreed conditions:

1. That neither the College nor the Agency will discriminate on the basis of race, color, ethnicity, religion, sex, age, national origin, marital status, pregnancy, sexual orientation, gender identity, genetic information, or against any qualified individual with disabilities in its employment practices or in the admission and treatment of students. The College and the Agency recognize that sexual harassment constitutes discrimination on the basis of sex and neither party will not tolerate such conduct.
2. The College will provide the Agency with a list of all students and instructors who will be assigned to fire rescue in the Emergency Medical Services Program.
3. The College will be responsible for assuring that the Agency is in receipt, from each student and instructor participating, of a signed release agreement. (An example of the release agreement to be provided is attached as Exhibit A. The student signs the release in triplicate; the original goes to the Agency, one copy is retained in the student's file and the third copy is retained by the student.)

4. The College through the Florida College System Risk Management Consortium (FCSRMC) shall obtain and maintain occurrence-type professional liability insurance coverage in amounts not less than \$2,000,000 per incident and \$5,000,000 annual aggregate covering the students and any faculty members for instruction/supervision of students only. The College shall provide a certificate of insurance to the Agency evidencing such insurance coverage if required by the Agency. Should any of the above-described policies be cancelled before the expiration date thereof, notice will be delivered in accordance with the policy provisions.
5. Students who are employed by the Agency participating in the field internship while on duty are required to sign the "Process for On-duty Firefighters Accomplishing Student SPC Field Internship Ride Time" form attached hereto as Exhibit B.
6. The Agency reserves the right to withdraw its permission to allow participation of a particular student or instructor. Further, Agency reserves the right to withdraw its permission to all students or instructors in the program if and when it becomes apparent that: (1) the students or instructors are hindering the performance of the emergency medical personnel of the Agency; (2) the students or instructors are jeopardizing the health or safety of the patients or the emergency medical personnel; (3) the students or instructors are not cooperating with the emergency medical personnel; or (4) the students or instructors are subjecting themselves or the Agency's employees to liability for which no insurance has been provided.
7. The Agency shall provide to enrolled students of the College the opportunity for necessary clinical experience required for said program. Students shall undertake said clinical experience under supervision of the Agency's paramedic field preceptor. The number of students accepted under this program shall be agreed to by the parties for each term.
8. The Agency shall have ultimate responsibility for the care and treatment of the patient/client.
9. The Agency shall comply with students' privacy rights under federal and state laws regarding students' educational records.
10. The College and students shall comply with all applicable federal and state laws and regulations, and rules and policies of the Agency regarding the confidentiality of patient information.

THIS AGREEMENT shall become effective upon the date of signature of both parties, and shall be automatically renewed from year to year unless either party requests a change or termination thereof.

THIS AGREEMENT may be terminated upon the giving of written notice by either party to the other party thirty (30) days before the first day of August of any given year, PROVIDED, HOWEVER, such termination shall not become effective as to students already enrolled and participating in the program until they shall have had an opportunity to complete the program at the Agency to meet the course of study requirements for graduation.

ANY NOTICE required or permitted to be given under this agreement shall be sufficient if in writing and sent by certified mail, return receipt requested, to either of the parties. Notice shall be effective upon compliance with this section.

THE UNDERSIGNED have the authority to enter into this agreement and to bind their respective institution or entity.

IN WITNESS WHEREOF, the parties have executed this agreement on the dates hereinafter stated:

**CITY OF MADEIRA BEACH**

**BOARD OF TRUSTEES OF  
ST. PETERSBURG COLLEGE**

BY: \_\_\_\_\_

James "Jim" Rostek, Mayor

Date: \_\_\_\_\_

BY:  \_\_\_\_\_

Name: Matthew Liao-Troth,

Title: Vice President, Academic Affairs

Date: 12/4/23

BY: \_\_\_\_\_

Clara Van Blargan, City Clerk

Date: \_\_\_\_\_

General Counsel's Office:  
Appr. as to Form/Content HCps  
Appr. by ML on 11/29/23

BY: \_\_\_\_\_

Thomas J. Trask, City Attorney

Date: \_\_\_\_\_

**EXHIBIT A****RELEASE AGREEMENT**

WHEREAS, the BOARD OF TRUSTEES OF ST. PETERSBURG COLLEGE, hereinafter known as the "College," and the CITY OF MADEIRA BEACH, hereinafter known as the "Agency," have signed an agreement to allow students and instructors of the College who are enrolled in the Emergency Medical Services Program to participate in emergency medical services provided by the Agency, including riding in Agency vehicles and assisting when necessary in rendering emergency medical care; and

WHEREAS, \_\_\_\_\_, a \_\_\_\_\_ of St. Petersburg College, and a member of the Emergency Medical Services Program, hereinafter known as the "Participant," desires to participate in the above described program with the Agency; and

WHEREAS, the College has available a professional liability insurance policy for students and instructors enrolled in the Emergency Medical Services Program with limits of liability of \$2,000,000 each incident/\$5,000,000 annual aggregate.

NOW, THEREFORE, in consideration of the foregoing and in consideration of the Agency's grant of permission to participate in the Emergency Medical Services Program of the Agency and to ride in Agency vehicles, the Participant hereby agrees as follows:

1. To enroll and pay the student fee for said professional liability insurance policy that is available to students or instructors during the entire period that she/he is participating in the program.
2. Not to participate in or become a party to any kind of claim, cause of action, demand or suit that may arise by his/her participating in the program in Agency vehicles against the Agency, its officers, employees, agents, and servants.
3. That Participant, for him or herself, his or her heirs and personal representatives, hereby assume all liabilities, risks, injuries and hazards incidental for participation in the Emergency Medical Services Program with the City of Madeira Beach Fire Department ("Program"), including to, from or during said Program. Participant acknowledges the fact that this Program may/or does involve physical contact or other conditions where injuries may occur, and recognizes and acknowledges that EMTs and paramedics can be and are often assigned duties which involve danger and exposure to hazardous or potentially fatal circumstances and serious risks of injury or death. EMT and paramedics duties involve emergencies or exposure to dangers which will not be avoided because of my presence. Participant does hereby waive, release and hold harmless the City of Madeira Beach, its officers, agents, employees, specifically including the individual fire department employees with whom Participant comes in contact with for any claim, demand, liability, suit, charge or compensation for loss or injury of any kind arising out of a loss or injury, including a losses or injuries arising from the negligence of the City of Madeira Beach, its officers, agents, employees, specifically including the individual fire department employees, participants and instructors of the Program. Participant assumes all risk of injury, liability and loss arising from my participation in or presence at said Program. Participant acknowledges that the City of Madeira Beach will not assume any costs relating to any injury Participant may suffer while involved in this Program. This waiver, release and indemnification is in consideration of the City of Madeira Beach permitting Participants participation in the Program. Participant acknowledges that absent this release, waiver and indemnification, the City of Madeira Beach and the individual fire department employees, EMTs and paramedics would not have offered or allowed me access to the Program because of unacceptable exposure to liability claims or expense of providing a program that is risk free.

4. That she/he is fully aware that she/he is not an employee of the Agency for any purpose, has no authority on behalf of the Agency, will receive no payment or benefits as a result of participation in the program, and inasmuch as she/he is not an employee of the Agency, she/he will not be entitled to worker's compensation benefits from the Agency as a result of the program.

IN WITNESS WHEREOF, the Participant has caused this Release Agreement to be executed this \_\_\_\_\_ day of \_\_\_\_\_, 20\_\_\_\_.

WITNESS:

\_\_\_\_\_

\_\_\_\_\_

(Participant's Signature)

**EXHIBIT B**

**PROCESS FOR ON-DUTY FIREFIGHTERS ACCOMPLISHING  
STUDENT SPC FIELD INTERNSHIP RIDE TIME**

1. Students will wear approved SPC EMS Program uniform as defined by the EMS Program Director. This includes Student ID badge during the entire time the firefighter is acting in student status, as well as wearing only the SPC EMS Student vest as required (not the agency vest) while in student status.
2. Ride time will not begin before 0800 hours and will end no later than 2300 hours on the same day. If requested by the station officer, ride time will end earlier. Instructor must be notified. SPC Paramedic students employed by participating community partners are permitted to perform 24-hour shifts, with the approval of the department Chief, EMS Chief, or department equivalent.
3. No SPC EMS student shall perform skills at the Advanced Life Support level except while in student status, and under the direct supervision of an approved college preceptor. Violation of this rule will result in immediate termination of the student from the EMS program.
4. Students shall never be with a patient by themselves; they will always be with their assigned preceptor.
5. In accordance with the SPC EMS department syllabus and handbook, students must complete a minimum of 364 hours of ride time to meet the program’s field experience and internship requirements.
6. Attending field internship without turning in a schedule for approval in a timely manner **before** the requested shifts will not be allowed. According to SPC EMS Program policies, any changes to the prior-approved schedule (i.e., station change, preceptor change, or date change) must be approved verbally by the assigned instructor **before** the ride time. There will be no exceptions. This may require the student taking time off from work to accomplish the required hours in the assigned time period. If this is not done, the ride time will not count and the student will be disciplined, with possible termination from the EMS program.
7. In accordance with Florida administrative code 64J, students may complete up to 20% (72.8 hours) of the field internship experience to be done aboard an advanced life support permitted vehicle other than an ambulance.

**Your behavior and cooperation will determine whether this shift based program will continue.**

*Student’s printed name:* \_\_\_\_\_

*Student’s signature:* \_\_\_\_\_

*Witness:* \_\_\_\_\_

*Date:* \_\_\_\_\_



# Memorandum

**Meeting Details:** February 14, 2024

**Prepared For:** Mayor & Board of Commissioners

**From:** Brian Crabtree, Marina Manager

**Subject:** RFP 2023-11 Digital Information Sign

**Background:**

The Project will include upgrading and replacement of the existing Marina track letter sign, using the existing poles and top “Madeira Beach Marina” sign. This Digital Information Sign will help the city communicate important information to residents and visitors of Madeira Beach. The sign will be accessible to select city employees to post information through internet and cellular data pathways.

**Fiscal Impact:**

I2 Visual Quote \$45,313.00 (with the removal of trench and run electrical \$6,500.00)

**Recommendation(s):**

Staff recommends approval to accept the bid and approve i2 Visual to proceed with the purchase and installation of the digital sign for the amount of \$45,313.00.

**Attachments**

- ⌵ Bid Submittals

i2 Visual, Inc.  
 1606 Benchmark Ave.  
 Fort Myers, FL 33905



Item 11B.

Phone: (239) 687-3223  
 sales@i2visual.com  
 i2visual.com

Bill to  
**City of Madeira Beach**  
 300 Municipal Drive  
 Madeira Beach, FL 33708

Ship to  
**City Marina 150th Avenue**  
 503 150th Avenue  
 Madeira Beach, FL 33708

**Quote #: q11030**

Quote Date: 1/5/2024

Item	Description	Quantity	Price	Amount
Sales	Replace manual readerboard with Watchfire EMC Pixel Pitch: W10mm LED RGB Pixel Matrix: 150 X 180 Ventilation Style: Front Ventilation Cabinet Size: 5ft 5in H x 6ft 3in L x 8in D Viewing Area: 5ft H x 6ft L Cabinet Style: Double Face Character Size: 18 lines / 36.0 Characters at a 3" type Approx. Weight: 763.00 Lbs. Warranty: 5 year parts and onsite labor Electrical Service: 120 VOLT 36.0 amps Software Ignite OPx (cloud-based) Software Training Web Based Software Training Wireless Data Plan Life-of-sign Data Plan	1	\$41,063.00	\$41,063.00
Sales	Fabricate new 7" x 13' 2" white pole covers	2	\$325.00	\$650.00
Sales	Installation including removal and disposal of existing readerboards includes hookup to existing electrical	1	\$3,600.00	\$3,600.00

Tax: \$0.00

Total: \$45,313.00



i2 Visual, Inc.  
1606 Benchmark Ave.  
Fort Myers, FL 33905



Item 11B.

Phone: (239) 687-3223  
sales@i2visual.com  
i2visual.com

**Authorization**

I hereby authorize i2 Visual, Inc. to complete the proposed service, repair, or replacement and agree to pay the invoiced amount upon completion. I additionally certify that I am fully authorized to authorize this work and commit to payment.

---

**Acceptance**

I accept the services performed by i2 Visual, Inc. are to my satisfaction.

---



# **TAB A**

## **STATEMENT OF QUALIFICATION**

## STATEMENT OF QUALIFICATIONS

All questions must be answered, and the data given must be clear and comprehensive. This statement must be notarized. Add separate sheets or attachments, as necessary.

1. Name of Contractor: i2 isual, n .
2. Name of Business (if different than #1): \_\_\_\_\_
3. Form of Entity: or oration
4. Permanent Main Office and Mailing addresses and pertinent contact information (phone, email, etc.):  
1 0 en h ar e., Fort yers, F 33 05 23 87-3223 sales i2 isual. o
5. Date Organized: 02 24 2011
6. Where Organized: Fort yers, Florida
7. How many years have you been engaged in the Marine Dock building under your present name; also, state names and dates of previous business names, if any. \_\_\_\_\_
8. In the last five years, has "Contractor" ever been terminated from a contract or project? If so, explain situation.: o
9. In the last five years, has Contractor ever been party to litigation related to the Contractor's work? If so, explain situation.: o
10. List the most important contracts entered by the Contractor in the last year; identify contracting party and term of contract.: orth rail - u ly 3 digital signs. ne 1 17 40 sign. o 2 15 signs.
11. List your key personnel available for this contract.: ohn ose, helesa ose, ay ond rayton, hu ro n, hanta ia ery  
The City of Madeira Beach reserves the right to request from finalist(s) the latest financial statements as well as to request such additional information as may be reasonably necessary to determine whether the Contractor should be awarded the service contract.

\_\_\_\_\_  
Authorized Signature

01 08 2024

\_\_\_\_\_  
Date Signed

### NOTARY

State of: \_\_\_\_\_

County of: \_\_\_\_\_

Sworn to and subscribed before me this \_\_\_\_\_ day of \_\_\_\_\_, 20\_\_.

Personally Known \_\_\_\_\_ or Produced Identification \_\_\_\_\_  
(Specify Type of Identification)

Signature of Notary \_\_\_\_\_ (seal)

My Commission Expires \_\_\_\_\_



City of Madeira Beach  
300 Municipal Drive  
Madeira Beach, FL 33708

Attn: City of Madeira Beach

i2 Visual, Inc. is pleased to have the opportunity to negotiate this project. We are a diverse team of over 40 with a fleet of more than 20 service and installation vehicles, a state-of-the-art manufacturing facility and a highly experienced project management team.

We specialize in LED digital signage and can offer unique solutions to difficult challenges. We offer a 5 year parts and on site labor warranty, as well as other extended warranty options.

The i2 Visual team is fully understands the job and are fully capable of providing pole sign rehab, removal of the lower sign can with zip track, and installing a new double sided 5x6w LED Sign. We have a staff member who fully dedicates her time to securing permits and job completion inspections.

i2 Visual's staff includes several highly trained and experienced team leaders with full comprehension of LCD and LED video, as well as sound applications from design, implementation, installation, training, and service. The company also maintains a fully staffed 24 hour technical support department.

Our client base includes:

- Nova Southeastern University
- Valencia College
- School District of Lee County
- School District of Hillsborough County
- Florida State Fair
- Sarasota County Government

We're a state certified electrical sign contractor ES000361, and have 2 Digital Signage Certified Experts on staff, as well as one LEED AP.

Sincerely,

A handwritten signature in black ink that reads 'John F. Hose'.

John Hose, President



# ABOUT i2 VISUAL

STATE OF THE ART EQUIPMENT  
COUPLED WITH  
i2 VISUAL'S EXPERIENCED  
DEDICATED PROFESSIONALS  
PROMISE TO MAKE  
YOUR NEXT PROJECT  
SOMETHING TO BE PROUD OF.

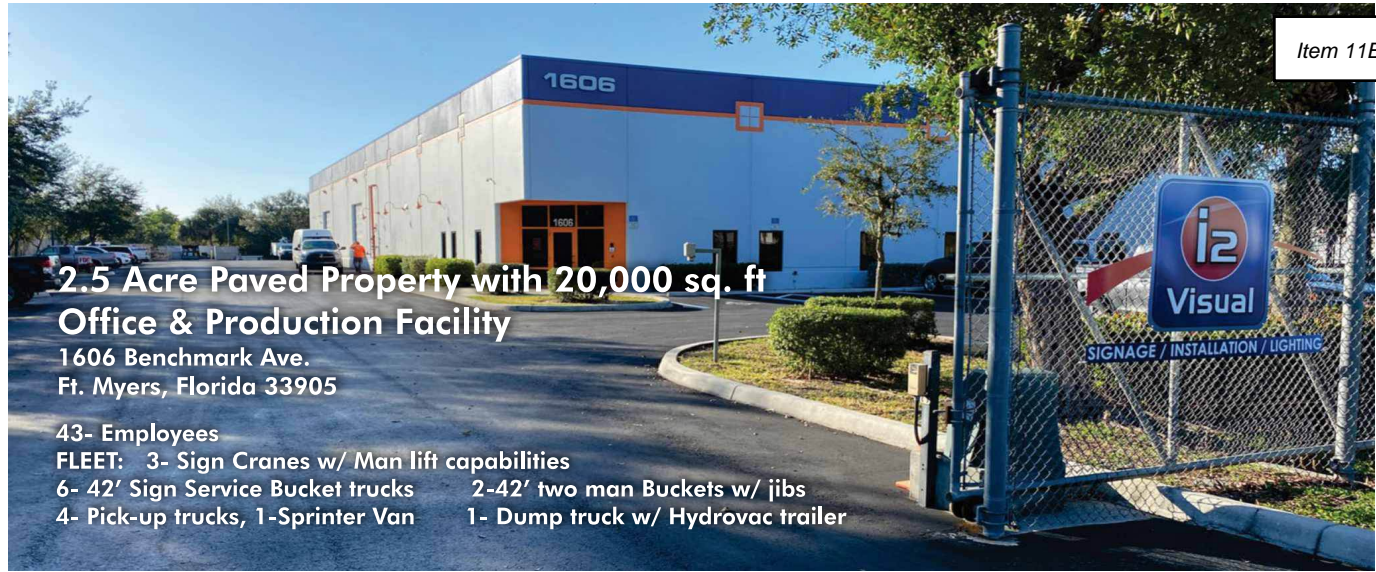

Item 11B.

**2.5 Acre Paved Property with 20,000 sq. ft  
Office & Production Facility**  
1606 Benchmark Ave.  
Ft. Myers, Florida 33905

43- Employees  
FLEET: 3- Sign Cranes w/ Man lift capabilities  
6- 42' Sign Service Bucket trucks      2-42' two man Buckets w/ jibs  
4- Pick-up trucks, 1-Sprinter Van      1- Dump truck w/ Hydrovac trailer

## S E R V I C E S

STATEWIDE SERVICE AREA

### Professional Design & Consulting Services

i2 Visual provides specifications and creative designs specifically for today's projects, from interior code required ADA signage, wayfinding / directional systems and identification signage. They will help maintain consistency of existing signage programs as new signage added. i2 Visual is a state certified electrical sign contractor.

### Fabrication & Manufacturing

i2 Visual has manufacturing capabilities in house: CNC Router, CNC Lasers, Rotary Engraving, ADA Signage manufacturing with 3d sign printing as well as conventional manufacturing and assembly including a full metal fabrication shop.

### Installation

i2 Visual has one of the largest team of experienced technicians and fleet of specialty vehicles for digging, lifting, moving, assembling and installing signs from small ADA signage, Building Identification, freestanding signage, banners, large scoreboards and digital displays. If you have your own signage and need it installed, they will install it for you.

### Maintenance & Service

i2 Visual can provide service on all electrical signage including scoreboards and digital displays. They can refurbish existing signs and can convert lighting to more cost affective LED lighting.

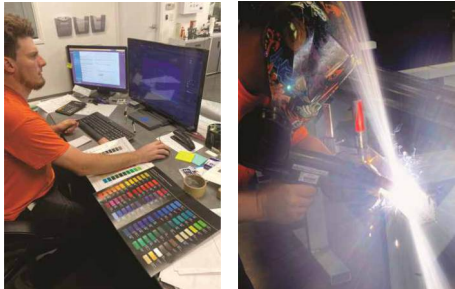

i2 VISUAL INC. 1606 BENCHMARK AVE. FORT MYERS, FLORIDA 239-687-3223 866-420-9909 STATE LICENSE ES0000361 SALES@I2VISUAL.COM

THE WISE CHOICE



## I2 VISUAL, INC. KEY PEOPLE



JOHN F. HOSE  
PRESIDENT  
QUALIFIER ES0000361

John is a graduate of the University of Washington and former U. S. Navy electronics technician. He has been involved in the electrical sign industry in Florida since 1987. He was the founder of Images Graphic Specialties and has been working with government agencies for over 30 years. He is a Florida State Certified Electrical Sign Contractor, a Digital Signage Certified Expert (DSCE), a LEED Associated Professional (green building Expert).



RICHARD E. ROBERTS  
CREATIVE DIRECTOR

Richard has been involved in all phases of the electric sign industry since 1975. He is a Digital Signage Certified Expert (DSCE). Ric is a former Lee County Board of Adjustment and Appeals Board Member, former Daytona Beach Community College Community Advisory Board member for Advertising and Graphic Arts Program.



CHELSEA HOSE  
VICE PRESIDENT

Chelsea attended Florida Southwestern State College and has been involved in the sign industry for her adult life. She is currently serving on the International Sign Association "Young Elite 35", an exclusive group promoting education and professionalism in the industry. She is Currently VP of Operations and is responsible for the overall management team, manufacturing and service / installation.













CHARLES BROWN  
FIELD OPERATIONS

Charles (Chuck) has been installing and servicing all types of electrical signs for 30 plus years. He has worked for Federal Sign, Image Graphic Specialties and Certified Maintenance. He is skilled with UL listings, NEC regulations, concrete and structural steel. He has vast experience repairing most of the major electronic sign manufacturer's products.



## QUALIFICATIONS

-  **i2 Visual is a major provider of signage and sign installation services with statewide coverage. They are staffed and experienced to successfully design, permit, manage, manufacture and install most any sign projects.**
-  **Florida Certified Electrical Sign Specialty Contractor ES-0000361**
-  **Experienced in Electronic Displays and Standard Signs**
-  **Experienced Working on Right-of way projects ( MOT Planning )**
-  **4- Sign Cranes w/ man lift capabilities , 8 Special Sign Service Bucket trucks 1-Dump truck w/ Hydrovac Trailer  
4-pick-up trucks, Large Sprinter Van. 5 utility trailers**
-  **In-house Design**
-  **In-house Manufacturing Capabilities**
-  **Experience with Schools and Government Projects**
-  **Financially Stable, fully licensed, bonded and insured - over \$5,000,000 in annual sales**
-  **40 full time employees**

\_\_\_\_\_

\_\_\_\_\_

\_\_\_\_\_

\_\_\_\_\_

\_\_\_\_\_

\_\_\_\_\_

\_\_\_\_\_

\_\_\_\_\_



# TAB B

## REFERENCES



## REFERENCES

Please include the below information for all five (5) references as required.

**Information below to be included for all five references in the proposal.**

Contact Name Joshua at her

Business Name South West Florida International Airport

Business Address 11000 International Business Center, Fort Myers, FL 33133

Contact Phone 239-51-4141

Contact Email Joshua@swfla.com Other \_\_\_\_\_

Information (describe): Manufacture and install 2 large signs and 4 radar feed signs

**\*See attached sheet for more references**

## INSURANCE REQUIREMENTS

Insurance shall be in such form as will protect the Contractor from all claims and liabilities for damages for bodily injury, including accidental death, and for property damage, which may arise from operations under this contract, whether such operations by himself or anyone directly or indirectly employed by Contractor.

The awarded firm must file with the City of Madeira Beach certificates of insurance prior to commencement of work evidencing the City as a certificate holder as additionally insured with the following minimum coverage:

- Public and Commercial Liability Insurance not less than \$1,000,000.00.
- Comprehensive General Liability Insurance of \$1,000,000.00 for each occurrence.
- Personal Injury for \$1,000,000.00 each occurrence.

Owner’s and Consultant’s Protective Liability.

- Bodily injury liability \$1,000,000.00 each occurrence
- Property damage liability \$1,000,000.00 each occurrence
- Full Workers Comprehensive Insurance is required by Florida Law for all people employed by the contractor to perform work on this project.

Automotive Liability (covering the operation, maintenance and all owned, non-owned and hired vehicles).

- Bodily injury liability \$1,000,000.00 each occurrence
- Property damage liability \$1,000,000.00 each occurrence

## INDEMNIFICATION

The Respondent shall hold harmless the City, its officers, and employees, from liabilities, damages, losses, and costs, including but not limited to, reasonable attorney’s fees, to the extent caused by the negligence, recklessness, or intentional wrongful misconduct of the Respondent and any persons employed or utilized by the Respondent in the performance of the Contract.

**REFERENCES**

Contact Name: Joshua Hatcher

Business Name: Southwest Florida International Airport

Business Address: 11000 Terminal Access Rd, Fort Myers, FL 33913

Contact Phone: (239) 561-4141

Contact Email: [jhatcher@oakfl.com](mailto:jhatcher@oakfl.com)

Information (describe): Manufacture and Install 2 large LED signs and 4 radar feedback signs.

Contact Name: Joshua Austin

Business Name: Valencia College

Business Address: 500 W Livingston St Orlando, FL 32801

Contact Phone: (407)-582-1486

Contact Email: [jaustin27@valenciacollege.edu](mailto:jaustin27@valenciacollege.edu)

Information (describe): Furnish and Install LED sign upgrades at all campuses.

Contact Name: Joseph Edwards

Business Name: North Fort Myers High School / School District of Lee County

Business Address: 5000 Orange Grove Blvd, North Fort Myers, FL 33903

Contact Phone: (239) 292-1689

Contact Email: [josephne@leeschools.net](mailto:josephne@leeschools.net)

Information (describe): Furnish and Install 12' x 24' full video scoreboard and digital signage.

Contact Name: Amit Patel

Business Name: Florida State Fair

Business Address: 4800 US-301, Tampa, FL 33610

Contact Phone: (813) 363-5514

Contact Email: [amit.patel@floridastatefair.com](mailto:amit.patel@floridastatefair.com)

Information (describe): Furnish and Install 2 large 18' x 34' LED Signs 10mm.

Item 11B.

Contact Name: Greg Heyn

Business Name: Disney ESPN Wide World of Sports

Business Address: 700 S Victory Way, Orlando, FL 34747

Contact Phone: (407) 341-5180

Contact Email: Gregory.heyn@disney.com

Information (describe): Furnish and Install LED Signs and Scoreboards.



# TAB C FORMS

# PROPOSALS FORM



Name of "CONTRACTOR" Submitting Proposals isual, n .

Name of Person Submitting Proposals ohn ose

### PROPOSER ACKNOWLEDGMENT

"The undersigned hereby declares that he/she has informed himself/herself fully in regard to all conditions to the work to be done, and that he/she has examined the RFP and Specifications for the work and comments here to attached. The "CONTRACTOR" proposes and agrees, if this submission is accepted, to contract with the "CITY" of Madeira Beach to furnish all necessary materials, equipment, labor, and services necessary to complete the work covered by the RFP and Contract Documents for this Project. The "CONTRACTOR" agrees to accept in full compensation for each item the prices named in the schedules incorporated herein."

### BIDDER'S REPRESENTATIONS

In submitting this Bid, Bidder represents that:

- A. Bidder has examined and carefully studied the Bidding Documents, the other related data identified in the Bidding Documents, and the following Addenda, receipt of which is hereby acknowledged.

Addendum No.	Addendum Date
_____	_____
_____	_____
_____	_____

- B. Bidder has visited the Site and become familiar with and is satisfied as to the general, local and Site conditions that may affect cost, progress, and performance of the Work.
- C. Bidder is familiar with and is satisfied as to all federal, state, and local Laws and Regulations that may affect cost, progress and performance of the Work.

- D. Bidder has carefully studied all: (1) reports of explorations and tests of subsurface conditions at the Site and all drawings of physical conditions in or relating to existing surface or subsurface structures at the Site.
- E. Bidder has obtained and carefully studied (or accepts the consequences for not doing so) all additional or supplementary examinations, investigations, explorations, tests, studies and data concerning conditions (surface, subsurface and Underground Facilities) at or contiguous to the Site which may affect cost, 19 progress, or performance of the Work or which relate to any aspect of the means, methods, techniques, sequences, and procedures of construction to be employed by Bidder, including applying the specific means, methods, techniques, sequences, and procedures of construction expressly required by the Bidding Documents to be employed by Bidder, and safety precautions and programs incident thereto.
- F. Bidder does not consider that any further examinations, investigations, explorations, tests, studies, or data are necessary for the determination of this Bid for performance of the Work at the price(s) bid and within the times and in accordance with the other terms and conditions of the Bidding Documents.
- G. Bidder is aware of the general nature of work to be performed by Owner and others at the Site that relates to the Work as indicated in the Bidding Documents.
- H. Bidder has correlated the information known to Bidder, information and observations obtained from visits to the Site, reports and drawings identified in the Bidding Documents, and all additional examinations, investigations, explorations, tests, studies, and data with the Bidding Documents.
- I. The Bidder has given Owner and Engineer written notice of all conflicts, errors, ambiguities, or discrepancies that Bidder has discovered in the Bidding Documents, and the written resolution thereof by Engineer is acceptable to Bidder.
- J. The Bidding Documents are generally sufficient to indicate and convey understanding of all terms and conditions for the performance of the Work for which this Bid is submitted.
- K. Bidder will submit written evidence of its authority to do business in the state where the Project is located not later than the date of its execution of the Agreement.

Signature \_\_\_\_\_

Date 01 08 2024

RFP Number 2023-09 Check if exception(s) or deviation(s) to specifications. Attach separate sheet(s) detailing reason and type for the exception or deviation.

# “CONTRACTOR” PROFILE

Submitted by (Company Name) \_\_\_\_\_

Circle one of the following:

**Corporation**      Partnership      Individual      Joint Venture

Other Describe: \_\_\_\_\_

Florida Contractor License Number: 00003 1

Expiration Date: August 31, 2024 Unique Entity ID: 5 21 FEIN: 27-5113425

Office Location: 10 Lenox Ave., Fort Myers, FL 33905

Number of people in your organization: 40

Length of time the Contractor has been doing business under this name in Florida: 12 years years.

Length of time your firm has provided services to governmental clients: 12 years years.

Under what other name(s) has your firm operated: \_\_\_\_\_

Has or is your firm currently involved in any formal court proceedings regarding any of your contracts?

YES

**NO**

If yes, Include a detailed explanation.

\_\_\_\_\_  
\_\_\_\_\_  
\_\_\_\_\_  
\_\_\_\_\_  
\_\_\_\_\_  
\_\_\_\_\_  
\_\_\_\_\_  
\_\_\_\_\_  
\_\_\_\_\_  
\_\_\_\_\_  
\_\_\_\_\_

## HOLD HARMLESS AGREEMENT

The Contractor agrees to hold the City of Madeira Beach harmless against all claims for bodily injury, sickness, disease, death or personal injury or damage to property or loss of use resulting therefrom, arising out of the agreement, to the extent that such claims are attributable, in whole or in part, to a negligent act or omission by the Contractor.

The Contractor shall purchase and maintain workers' compensation insurance for all workers' compensation insurance and employers' liability in accordance with Florida Statute Chapter 440.

The Contractor shall also purchase any other coverage required by law for the benefit of employees.

Required insurance shall be documented in Certificates of Insurance and shall be provided to the "CITY" representative requesting the service.

By signature upon this form the Contractor stipulates that he/she agrees to the Hold Harmless Agreement, and to abide by all insurance requirements.

John Rose  
Contractor/ "CONTRACTOR"- Printed Name

\_\_\_\_\_  
Signature

2023-11 digital information sign ity marina 150th avenue  
Project Name

01 08 2024  
Date

**The effective date of this Hold Harmless Agreement shall be the duration of this project.**



# SWORN STATEMENT TO SECTION 287.133(3)(a), FLORIDA STATUTES, ON PUBLIC ENTITY CRIMES FORM

THIS FORM MUST BE SIGNED AND SWORN TO IN THE PRESENCE OF A NOTARY PUBLIC OR OTHER OFFICIAL AUTHORIZED TO ADMINISTER OATHS.

1. This sworn statement is submitted to the "CITY" of Madeira Beach

By ohn ose, resident  
(Print individual's name and title)

for isual, n .  
(Print name of entity submitting sworn statement)

whose business address is 10 enh ar e., Fort yers, F 33 05 and (if applicable) its Federal Employer Identification Number (FEIN) is 27-5113425.

- 2. I understand that a "public entity crime" as defined in Paragraph 287.133(1)(g), Florida Statutes, means a violation of any state or federal law by a person with respect to and directly related to the transaction of business with any public entity or with an agency or political subdivision of any other state or of the United States, including, but not limited to, any bid or contract for goods or services to be provided to any public entity or an agency or political subdivision of any other state or of the United States and involving antitrust, fraud, theft, bribery, collusion, racketeering, conspiracy, or material misrepresentation.
- 3. I understand that "convicted" or "conviction" as defined in Paragraph 287.133(1)(b), Florida Statutes, means a finding of guilt or a conviction of a public entity crime, with or without adjudication of guilt, in any federal or state trial court of record relating to charges brought by indictment or information after July 1, 1989, as a result of a jury verdict, nonjury trial, or entry of a plea of guilty or nolo contendere.
- 4. I understand that an "affiliate" as defined in Paragraph 287.133(1)(a), Florida Statutes, means:
  - a. A predecessor or successor of a person convicted of a public entity crime; or
  - b. An entity under the control of any natural person who is active in the management of the entity and who has been convicted of a public entity crime. The term "affiliate" includes those officers, directors, executives, partners, shareholders, employees, members, and agents who are active in the management of an affiliate. The ownership by one person of shares constituting a controlling interest in another person, or a pooling of equipment or income among persons when not for fair market value under an arm's length agreement, shall be a prima facie case that one person controls another person. A person who knowingly enters into a joint venture with a person who has been convicted of a public entity crime in Florida during the preceding 36 months shall be considered an affiliate.
  - c. I understand that a "person" as defined in Paragraph 287.133(1)(e), **Florida Statutes**, means any natural person or entity organized under the laws of any state or of the United States with the legal power to enter into a binding contract and which bids or applies to bid on contracts for the provision of goods or services by a public entity, or which otherwise transacts or applies to transact business with a public entity. The term "person" includes those officers, directors, executives, partners, shareholders, employees, members, and agents who are active in management of an entity.
  - d. Based on information and belief, the statement which I have marked below is true in relation to the entity submitting this sworn statement (indicate which statement applies).

                     Neither the entity submitting this sworn statement, nor any of its officers, directors, executives, partners, shareholders, employees, members, or agents who are active in the management of the entity, nor any affiliate of the entity has been charged with and convicted of a public entity crime subsequent to July 1, 1989.

                     The entity submitting this sworn statement, or one or more of its officers, directors, executives, partners, shareholders, employees, members, or agents who are active in the management of the entity, or an affiliate of the entity has been charged with and convicted of a public entity crime subsequent to July 1, 1989.

\_\_\_\_\_ The entity submitting this sworn statement, or one or more of its officers, directors, executives, partners, shareholders, employees, members, or agents who are active in the management of the entity, or an affiliate of the entity has been charged with and convicted of a public entity crime after July 1, 1989. However, there has been a subsequent proceeding before a Hearing Officer of the State of Florida, Division of Administrative Hearings and the Final Order entered by the Hearing Officer determined that it was not in the public interest to place the entity submitting this sworn statement on the convicted "CONTRACTOR" list. (Attach a copy of the final order)

I UNDERSTAND THAT THE SUBMISSION OF THIS FORM TO THE CONTRACTING OFFICER FOR THE PUBLIC ENTITY IDENTIFIED IN PARAGRAPH 1 (ONE) ABOVE IS FOR THAT PUBLIC ENTITY ONLY AND, THAT THIS FORM IS VALID THROUGH DECEMBER 31 OF THE CALENDAR YEAR IN WHICH IT IS FILED. I ALSO UNDERSTAND THAT I AM REQUIRED TO INFORM THE PUBLIC ENTITY PRIOR TO ENTERING INTO A CONTRACT IN EXCESS OF THE THRESHOLD AMOUNT PROVIDED IN SECTION 287.017, FLORIDA STATUTES FOR CATEGORY TWO OF ANY CHANGE IN THE INFORMATION CONTAINED IN THIS FORM. \_\_\_\_\_

Authorized Signature

01 08 2024

Date Signed

State of: \_\_\_\_\_

County of: \_\_\_\_\_

Sworn to and subscribed before me this \_\_\_\_\_ day of \_\_\_\_\_, 20\_\_.

Personally Known \_\_\_\_\_ or Produced Identification \_\_\_\_\_

(Specify Type of Identification)

\_\_\_\_\_  
Signature of Notary

My Commission Expires \_\_\_\_\_

(seal)

**This document must be completed and returned with your submission.**

## IMMIGRATION AFFIDAVIT CERTIFICATION

This Affidavit is required and should be signed, notarized by an authorized principal of the firm, and submitted with formal Invitations to Bid (ITB's) and Request for Proposals (RFP) submittals. Further, Consultants/Bidders are required to enroll in the E-Verify program, and provide acceptable evidence of their enrollment, at the time of the submission of the Consultant/Bidder's proposal. Acceptable evidence consists of a copy of the properly completed E-Verify Company Profile page or a copy of the fully executed E-Verify Memorandum of Understanding for the company. Failure to include this Affidavit and acceptable evidence of enrollment in the E-Verify program may deem the Consultant/Bidder's proposal as nonresponsive.

The City of Madeira Beach will not intentionally award City contracts to any Consultant who knowingly employs unauthorized workers, constituting a violation of the employment provision contained in 8 U.S.C. Section 1324 a(e) Section 274A(e) of the Immigration and Nationality Act ("INA"). The City of Madeira Beach may consider the employment by any Consultant of unauthorized aliens a violation of Section 274A (e) of the INA. Such Violation by the recipient of the Employment Provisions contained in Section 274A(e) of the INA shall be grounds for unilateral termination of the contract by the City of Madeira Beach.

Consultant attests that they are fully compliant with all applicable immigration laws (specifically to the 1986 Immigration Act and subsequent Amendment(s)) and agrees to comply with the provisions of the Memorandum of Understanding with E-Verify and to provide proof of enrollment in The Employment Eligibility Verification System (E-Verify), operated by the Department of Homeland Security in partnership with the Social Security Administration at the time of submission of the Consultant/Bidder's proposal.

Company Name: ij2 isual, n .  
Print Name: ohn ose Title: resident  
Signature \_\_\_\_\_ Date: 01 08 2024  
State of: Florida  
County of: ee  
Sworn to and subscribed before me this \_\_\_\_\_ day of \_\_\_\_\_, 20\_\_.

Personally Known \_\_\_\_\_ or Produced Identification \_\_\_\_\_  
(Specify Type of Identification)

\_\_\_\_\_  
Signature of Notary  
My Commission Expires \_\_\_\_\_

(seal)

The signee of this affidavit guarantees, as evidenced by the affidavit required herein, the truth and accuracy of this affidavit to interrogatories hereinafter made. This document must be completed and returned with your submission.

### BID TABULATION FORM

Description	UNIT	EST. QUAN.	UNIT PRICE	AMOUNT
5x6w Digital LED Sign: Total Cost	LS	1	\$ 41,030.00	\$ 41,030.00
Parts and Labor: Total Cost	LS	1	\$ 10,750.00	\$ 10,750.00
TOTAL Project cost				\$ 51,813.00

PROPOSED TOTAL BASE CONTRACT PRICE (Amount Written in numbers) \$ 51,813.00

PROPOSED TOTAL BASE CONTRACT PRICE (Amount written in words) \$ Fifty-one thousand, eight hundred thirteen dollars.

**\*See attached quote for optional reduced pricing**

Signature: \_\_\_\_\_

Printed Name: ohn ose

Date: 01 08 2024

i2 Visual, Inc.  
 1606 Benchmark Ave.  
 Fort Myers, FL 33905



Item 11B.

Phone: (239) 687-3223  
 sales@i2visual.com  
 i2visual.com

Bill to  
**City of Madeira Beach**  
 300 Municipal Drive  
 Madeira Beach, FL 33708

Ship to  
**City Marina 150th Avenue**  
 503 150th Avenue  
 Madeira Beach, FL 33708

**Quote #: q11030**

Quote Date: 1/5/2024

Item	Description	Quantity	Price	Amount
Sales	Replace manual readerboard with Watchfire EMC Pixel Pitch: W10mm LED RGB Pixel Matrix: 150 X 180 Ventilation Style: Front Ventilation Cabinet Size: 5ft 5in H x 6ft 3in L x 8in D Viewing Area: 5ft H x 6ft L Cabinet Style: Double Face Character Size: 18 lines / 36.0 Characters at a 3" type Approx. Weight: 763.00 Lbs. Warranty: 5 year parts and onsite labor Electrical Service: 120 VOLT 36.0 amps Software Ignite OPx (cloud-based) Software Training Web Based Software Training Wireless Data Plan Life-of-sign Data Plan	1	\$41,063.00	\$41,063.00
Sales	Fabricate new 7" x 13' 2" white pole covers	2	\$325.00	\$650.00
Sales	Installation including removal and disposal of existing readerboards includes hookup to existing electrical	1	\$3,600.00	\$3,600.00
Sales	OPTION 1 - trench and run electrical approximately 100' from nearby meter and panel	1	\$6,500.00	\$6,500.00
Sales	OPTION 2 - Deduct \$12,500 for providing ADS EMC with same specifications as above except Warranty: 5 years parts, 1 year on site labor	1	\$0.00	\$0.00

i2 Visual, Inc.  
1606 Benchmark Ave.  
Fort Myers, FL 33905



Item 11B.

Phone: (239) 687-3223  
sales@i2visual.com  
i2visual.com

Tax: \$0.00

Total: \$51,813.00

CURRENT  
SIGN

PROPOSED  
SIGN



REPLACE POLE COVERS

1 - BEAM Poles  
7 1/2" Square Pole Cover  
Color: White

REPLACE PAN FACED  
WITH EMC SIGN

SIZE: 6'W x5'H

# Madeira Beach Pylon Sign

Client Name: City of Madeira Beach  
Project Name: Madeira Beach Pylon Sign  
Address: TBD

Drawing #: 001\_LC  
Date: 01-05-23



Customer Approved: \_\_\_\_\_

Date: \_\_\_\_\_

Please review final artwork carefully. Your approval will indicate acceptance of materials including responsibility for errors, omissions and legal and ethical compliance.

i2 Visual, Inc.  
1606 Benchmark Ave.  
Ft. Myers, FL 33905  
(239) 209-6767





# TAB D LICENSES





Ron DeSantis, Governor

Melanie S. Griffin, Secretary

Item 11B.



**STATE OF FLORIDA**  
**DEPARTMENT OF BUSINESS AND PROFESSIONAL REGULATION**

**ELECTRICAL CONTRACTORS' LICENSING BOARD**

THE SPECIALTY ELECTRICAL CONTRACTOR HEREIN IS CERTIFIED UNDER THE  
PROVISIONS OF CHAPTER 489, FLORIDA STATUTES

AS A SIGN ELECTRICAL SPECIALIST

**HOSE, JOHN FREDERICK**

12 VISUAL INC  
1606 BENCHMARK AVE.  
FORT MYERS FL 33905

**LICENSE NUMBER: ES0000361**

**EXPIRATION DATE: AUGUST 31, 2024**

Always verify licenses online at [MyFloridaLicense.com](http://MyFloridaLicense.com)



Do not alter this document in any form.

This is your license. It is unlawful for anyone other than the licensee to use this document.



**The City of Fort Myers, Florida**

**Community Development Department**

**1825 Hendry Street, #101**

**Fort Myers, Florida 33901**

**Telephone: 239-321-7990**

Item 11B.

**SPECIALTY CONTRACTOR**

**EFFECTIVE 09/09/2023 - EXPIRING 09/30/2024**

**I 2 VISUAL INC  
1606 BENCHMARK AVE  
FORT MYERS, FL 33905**

**Business Tax #: BUS-000673-2021**

Dear Business Owner,

The City of Fort Myers wish you success with your business. The Business Tax Receipt below is valid from 09/09/2023 until 09/30/2024.

Annual renewal notices are mailed in July to the address of record at that time. If you need to change the business name, mailing address, contact data, location and/or closing the business, please contact our office:

**CDD/Business Tax  
1825 Hendry Street  
Suite 101  
Fort Myers, FL 33901  
(239) 321-7990**

**Description: ELECTRICAL CONTRACTOR**



**CITY OF FORT MYERS FLORIDA  
Business Tax Receipt**

**Effective 09/09/2023 - Expiring 9/30/23**

**1606 BENCHMARK AVE  
i 2 VISUAL INC  
Business Tax #: BUS-000673-2021**

Is hereby registered\* business, profession, or occupation of:

**(121 e.) Signs**

**ALCOHOL SALES PERMITTED: No**

**HOMEBASED: No**

**Owner: i 2 VISUAL INC, 1606 BENCHMARK AVE, FORT MYERS, FL 33905**

**POST THIS RECEIPT IN A CONSPICUOUS PLACE AT YOUR BUSINESS LOCATION**

**\*Any violation of applicable chapter of the City Code of Ordinances may cancel this receipt**



Local Business Tax Receipt

Item 11B.

I2 VISUAL INC
HOSE JOHN F
1606 BENCHMARK AVE
FT MYERS, FL 33905

Dear Business Owner:

Your 2023 - 2024 Lee County Local Business Tax Receipt is attached below for account number / receipt:
number: 1046554 / 1701225

If there is a change in one of the following, refer to the instructions on the back of this receipt.

- Business name
• Ownership
• Physical location
• Business closed

This is not a bill, Detach the bottom portion and display in a public location.

I hope you have a successful year.

Sincerely,

Handwritten signature of R. Noelle Branning

Lee County Tax Collector

Handwritten flourish

2023-2024
LEE COUNTY LOCAL BUSINESS TAX RECEIPT

Account Number: 1046554
Receipt Number: 1701225
State License Number: ES0000361

Account Expires: September 30, 2024

Location:
1606 BENCHMARK AVE
FT MYERS, FL 33905

I2 VISUAL INC
HOSE JOHN F
1606 BENCHMARK AVE
FT MYERS, FL 33905

May engage in the business of:
SPECIALTY CONTRACTOR-CERTIFIED
THIS LOCAL BUSINESS TAX RECEIPT IS NON REGULATORY

Payment Information:
PAID INT-00-01357505 07/24/2023
\$ 50.00



[Department of State](#) / [Division of Corporations](#) / [Search Records](#) / [Search by Entity Name](#) /

## Detail by Entity Name

Florida Profit Corporation  
I2 VISUAL, INC.

### Filing Information

<b>Document Number</b>	P11000019027
<b>FEI/EIN Number</b>	27-5113425
<b>Date Filed</b>	02/24/2011
<b>State</b>	FL
<b>Status</b>	ACTIVE
<b>Last Event</b>	AMENDMENT
<b>Event Date Filed</b>	11/09/2018
<b>Event Effective Date</b>	NONE

### Principal Address

1606 Benchmark Ave.  
Fort Myers, FL 33905

Changed: 12/22/2021

### Mailing Address

1606 Benchmark Ave.  
Fort Myers, FL 33905

Changed: 12/22/2021

### Registered Agent Name & Address

Corporate Legal Solutions  
12670 NEW BRITTANY BLVD, SUITE 101  
FORT MYERS, FL 33907

Name Changed: 04/26/2023

Address Changed: 04/25/2021

### Officer/Director Detail

#### **Name & Address**

Title DPT

Item 11B.

HOSE, JOHN F  
17660 Wells Rd.  
NORTH FORT MYERS, FL 33917

Title S

ROBERTS, RICHARD E  
8227 W JAMESTOWN CIR  
NORTH FORT MYERS, FL 33917

Title DVP

HOSE, CHELSEA  
6142 Hellman Ave  
FORT MYERS, FL 33905

**Annual Reports**

Report Year	Filed Date
2021	04/25/2021
2022	05/01/2022
2023	04/26/2023

**Document Images**

<a href="#">04/26/2023 -- ANNUAL REPORT</a>	View image in PDF format
<a href="#">05/01/2022 -- ANNUAL REPORT</a>	View image in PDF format
<a href="#">12/22/2021 -- AMENDED ANNUAL REPORT</a>	View image in PDF format
<a href="#">04/25/2021 -- ANNUAL REPORT</a>	View image in PDF format
<a href="#">06/02/2020 -- ANNUAL REPORT</a>	View image in PDF format
<a href="#">03/26/2019 -- ANNUAL REPORT</a>	View image in PDF format
<a href="#">11/09/2018 -- Amendment</a>	View image in PDF format
<a href="#">04/11/2018 -- ANNUAL REPORT</a>	View image in PDF format
<a href="#">03/30/2017 -- ANNUAL REPORT</a>	View image in PDF format
<a href="#">04/12/2016 -- ANNUAL REPORT</a>	View image in PDF format
<a href="#">04/22/2015 -- ANNUAL REPORT</a>	View image in PDF format
<a href="#">04/28/2014 -- ANNUAL REPORT</a>	View image in PDF format
<a href="#">04/01/2013 -- ANNUAL REPORT</a>	View image in PDF format
<a href="#">04/26/2012 -- ANNUAL REPORT</a>	View image in PDF format
<a href="#">02/24/2011 -- Domestic Profit</a>	View image in PDF format



18



# Installation

i2 Visual is experienced and well equipped to install signs from the ground up.

- \*Channel Letters \* Pylons \* Monuments
- \*Traffic Signs \* Wayfinding Signage \* More

[sales@i2visual.com](mailto:sales@i2visual.com)  
 239-687-3223

Above) One of i2 Visual's experienced install teams finishing one of two new FDOT standard multi-post traffic signs for Charlotte County Florida (footers, break-away structure and sign panel.)

Above) An i2 Visual's team shown using their Hydro-Vac machine to dig close to utilities without damaging them. This is a very useful machine to avoid issues on today's crowded installation sites.

**STATE CERTIFIED ELECTRICAL SIGN CONTRACTOR #ES000361**

i2 VISUAL INC. 1606 BENCHMARK AVE. FORT MYERS, FLORIDA 239-687-3223 866-420-9909 STATE LICENSE ES0000361 SALES@I2VISUAL.COM

THE WISE CHOICE



**TAB E**  
**CERTIFICATE**  
**OF**  
**INSURANCE**



# CERTIFICATE OF LIABILITY INSURANCE

DATE: 0  
Item 11B.

THIS CERTIFICATE IS ISSUED AS A MATTER OF INFORMATION ONLY AND CONFERS NO RIGHTS UPON THE CERTIFICATE HOLDER. THIS CERTIFICATE DOES NOT AFFIRMATIVELY OR NEGATIVELY AMEND, EXTEND OR ALTER THE COVERAGE AFFORDED BY THE POLICIES BELOW. THIS CERTIFICATE OF INSURANCE DOES NOT CONSTITUTE A CONTRACT BETWEEN THE ISSUING INSURER(S), AUTHORIZED REPRESENTATIVE OR PRODUCER, AND THE CERTIFICATE HOLDER.

IMPORTANT: If the certificate holder is an ADDITIONAL INSURED, the policy(ies) must have ADDITIONAL INSURED provisions or be endorsed. If SUBROGATION IS WAIVED, subject to the terms and conditions of the policy, certain policies may require an endorsement. A statement on this certificate does not confer rights to the certificate holder in lieu of such endorsement(s).

<b>PRODUCER</b> Herndon-Carr & Company 10501 Six Mile Cypress Pkwy Suite 101 Fort Myers FL 33966-6400	<b>CONTACT NAME:</b> Diana (Dee-Dee) Thompson <b>PHONE (A/C, No, Ext):</b> (239) 939-1996 <b>E-MAIL ADDRESS:</b> dthompson@insuresig.com	<b>FAX (A/C, No):</b> (239) 205-6072
	<b>INSURER(S) AFFORDING COVERAGE</b>	
<b>INSURED</b> i2 Visual, Inc. 1606 Benchmark Avenue Fort Myers FL 33905	<b>INSURER A:</b> Greenwich Insurance Company, A+ XV NAIC # 22322	
	<b>INSURER B:</b> American Interstate Insurance Company, A IX NAIC # 31895	
	<b>INSURER C:</b>	
	<b>INSURER D:</b>	
	<b>INSURER E:</b>	
	<b>INSURER F:</b>	

**COVERAGES** CERTIFICATE NUMBER: CL2342624607 REVISION NUMBER:

THIS IS TO CERTIFY THAT THE POLICIES OF INSURANCE LISTED BELOW HAVE BEEN ISSUED TO THE INSURED NAMED ABOVE FOR THE POLICY PERIOD INDICATED. NOTWITHSTANDING ANY REQUIREMENT, TERM OR CONDITION OF ANY CONTRACT OR OTHER DOCUMENT WITH RESPECT TO WHICH THIS CERTIFICATE MAY BE ISSUED OR MAY PERTAIN, THE INSURANCE AFFORDED BY THE POLICIES DESCRIBED HEREIN IS SUBJECT TO ALL THE TERMS, EXCLUSIONS AND CONDITIONS OF SUCH POLICIES. LIMITS SHOWN MAY HAVE BEEN REDUCED BY PAID CLAIMS.

INSR LTR	TYPE OF INSURANCE	ADDL INSD	SUBR WVD	POLICY NUMBER	POLICY EFF (MM/DD/YYYY)	POLICY EXP (MM/DD/YYYY)	LIMITS
A	<input checked="" type="checkbox"/> <b>COMMERCIAL GENERAL LIABILITY</b> <input type="checkbox"/> CLAIMS-MADE <input checked="" type="checkbox"/> OCCUR GEN'L AGGREGATE LIMIT APPLIES PER: <input type="checkbox"/> POLICY <input checked="" type="checkbox"/> PRO-JECT <input type="checkbox"/> LOC OTHER:			NGL-1003112-03	03/20/2023	03/20/2024	EACH OCCURRENCE \$ 1,000,000 DAMAGE TO RENTED PREMISES (Ea occurrence) \$ 100,000 MED EXP (Any one person) \$ 10,000 PERSONAL & ADV INJURY \$ 1,000,000 GENERAL AGGREGATE \$ 2,000,000 PRODUCTS - COMP/OP AGG \$ 2,000,000
A	<b>AUTOMOBILE LIABILITY</b> <input checked="" type="checkbox"/> ANY AUTO <input type="checkbox"/> OWNED AUTOS ONLY <input type="checkbox"/> SCHEDULED AUTOS <input checked="" type="checkbox"/> HIRED AUTOS ONLY <input checked="" type="checkbox"/> NON-OWNED AUTOS ONLY			NBA-1003111-03	03/20/2023	03/20/2024	COMBINED SINGLE LIMIT (Ea accident) \$ 1,000,000 BODILY INJURY (Per person) \$ BODILY INJURY (Per accident) \$ PROPERTY DAMAGE (Per accident) \$
A	<input checked="" type="checkbox"/> <b>UMBRELLA LIAB</b> <input checked="" type="checkbox"/> OCCUR <input type="checkbox"/> <b>EXCESS LIAB</b> <input type="checkbox"/> CLAIMS-MADE DED RETENTION \$			NEC-6006067-03	03/20/2023	03/20/2024	EACH OCCURRENCE \$ 5,000,000 AGGREGATE \$ 5,000,000
B	<b>WORKERS COMPENSATION AND EMPLOYERS' LIABILITY</b> ANY PROPRIETOR/PARTNER/EXECUTIVE OFFICER/MEMBER EXCLUDED? (Mandatory in NH) If yes, describe under DESCRIPTION OF OPERATIONS below	Y/N Y	N/A	AVWCFL3178232023	05/09/2023	05/09/2024	<input checked="" type="checkbox"/> PER STATUTE <input type="checkbox"/> OTH-ER E.L. EACH ACCIDENT \$ 1,000,000 E.L. DISEASE - EA EMPLOYEE \$ 1,000,000 E.L. DISEASE - POLICY LIMIT \$ 1,000,000

DESCRIPTION OF OPERATIONS / LOCATIONS / VEHICLES (ACORD 101, Additional Remarks Schedule, may be attached if more space is required)

When required by contract or agreement and permitted by law, subject to policy terms, conditions and exclusions, the Additional Insured blanket endorsement is automatic and applies in favor of the Certificate Holder in respects to the operations of the insured, on behalf of the Certificate Holder.

GENERAL LIABILITY - BLANKET ADDITIONAL INSURED, BLANKET ADDITIONAL INSURED COMPLETED OPS, BLANKET WAIVER OF SUBROGATION. COVERAGE IS PRIMARY AND NON-CONTRIBUTORY  
BUSINESS AUTO - BLANKET ADDITIONAL INSURED, BLANKET WAIVER OF SUBROGATION. COVERAGE IS PRIMARY AND NON-CONTRIBUTORY.

### CERTIFICATE HOLDER

### CANCELLATION

City of Madeira Beach 300 Municipal Drive  Madeira Beach FL 33708	SHOULD ANY OF THE ABOVE DESCRIBED POLICIES BE CANCELLED BEFORE THE EXPIRATION DATE THEREOF, NOTICE WILL BE DELIVERED IN ACCORDANCE WITH THE POLICY PROVISIONS.  AUTHORIZED REPRESENTATIVE 
--	--



AGENCY CUSTOMER ID: 00200186

Item 11B.

LOC #: \_\_\_\_\_



# ADDITIONAL REMARKS SCHEDULE

Page \_\_\_\_\_ of \_\_\_\_\_

AGENCY Herndon-Carr & Company		NAMED INSURED i2 Visual, Inc.	
POLICY NUMBER			
CARRIER	NAIC CODE	EFFECTIVE DATE:	

### ADDITIONAL REMARKS

**THIS ADDITIONAL REMARKS FORM IS A SCHEDULE TO ACORD FORM,**

**FORM NUMBER:** 25      **FORM TITLE:** Certificate of Liability Insurance

NON-CONTRIBUTORY.  
WORKERS COMPENSATION - BLANKET WAIVER OF SUBROGATION



# TAB F

## SIGNED AGREEMENT

# EXHIBIT A PUBLIC CONTRACTING AND ENVIRONMENTAL CRIMES CERTIFICATION

THIS FORM MUST BE SIGNED AND SWORN TO IN THE PRESENCE OF A NOTARY PUBLIC OR OTHER OFFICIAL AUTHORIZED TO ADMINISTER OATHS.

This sworn statement is submitted to the CITY OF MADEIRA BEACH by ohn ose, resident  
[print individual's name and title]

for individual, n.  
[print name of entity submitting sworn statement]

whose business address is: 10 en h ar e., Fort yers, F 33 05

and Federal Employer Identification Number (FEIN) is 27-5113425, if the entity has no FEIN, include the Social Security Number of the individual signing this sworn statement: \_\_\_\_\_

I understand that no person or entity shall be awarded or receive a City contract for public improvements, procurement of goods or services (including professional services) or a City lease, franchise, concession, or management agreement, or shall receive a grant of City monies unless such person or entity has submitted a written certification to the City that it has not:

1. been convicted of bribery or attempting to bribe a public officer or employee of the city, the State of Florida, or any other public entity, including, but not limited to the Government of the United States, any state, or any local government authority in the United States, in that officer's or employee's official capacity; or
2. been convicted of an agreement or collusion among bidders or prospective bidders in restraint of freedom of competition, by agreement to bid a fixed price, or otherwise; or
3. been convicted of a violation of an environmental law that, in the sole opinion of the City's Project Manager, reflects negatively upon the ability of the person or entity to conduct business in a responsible manner; or
4. made an admission of guilt of such conduct described in items (1), (2) or (3) above, which is a matter of record, but has not been prosecuted for such conduct, or has made an admission of guilt of such conduct, which is a matter of record, pursuant to formal prosecution. An admission of guilt shall be construed to include a plea of nolo contendere; or
5. where an officer, official, agent or employee of a business entity has been convicted of or has admitted guilt to any of the crimes set forth above on behalf of such and entity and pursuant to the direction or authorization of an official thereof (including the person committing the offense, if he is an official of the business entity), the business shall be chargeable with the conduct herein above set forth. A business entity shall be chargeable with the conduct of an affiliated entity, whether wholly owned, partially owned, or one which has common ownership or a common Board of Directors. For purposes of this Form, business entities are affiliated if, directly or indirectly, one business entity controls or has the power to control another business entity, or if an individual or group of individuals controls or has the power to control both entities. Indicia of control shall include, without limitation, interlocking management or ownership, identity of interests among family members, shared organization of a business entity following the ineligibility of a business entity under this Article, or using substantially the same management, ownership, or principles as the ineligible entity.

Any person or entity who claims that this Article is inapplicable to him/her/it because a conviction or judgment has been reversed by a court of competent jurisdiction, shall prove the same with documentation satisfactory to the City Manager. Upon presentation of such satisfactory proof, the person or entity shall be allowed to contract with the City.

I UNDERSTAND THAT THE SUBMISSION OF THIS FORM TO THE CITY IS VALID THROUGH DECEMBER 31 OF THE CALENDAR YEAR IN WHICH IT IS FILED. I ALSO UNDERSTAND THAT ANY CONTRACT OR BUSINESS TRANSACTION SHALL PROVIDE FOR SUSPENSION OF PAYMENTS, OR TERMINATION, OR BOTH, IF THE CONTRACTING OFFICER OR THE CITY ADMINISTRATOR DETERMINES THAT SUCH PERSON OR ENTITY HAS MADE FALSE CERTIFICATION.

Signatory Requirement. In the case of a corporation, this affidavit shall be executed by the corporate president. In the case of a partnership, this affidavit shall be executed by the general partner(s). In the case of a business entity other than a partnership or a corporation, this affidavit shall be executed by an authorized agent of the entity or the individual.

\_\_\_\_\_  
Authorized Signature  
01 08 2024  
\_\_\_\_\_  
Date Signed

State of: \_\_\_\_\_

County of: \_\_\_\_\_

Sworn to and subscribed before me this \_\_\_\_\_ day of \_\_\_\_\_, 20\_\_.

Personally Known \_\_\_\_\_ or Produced Identification \_\_\_\_\_

(Specify Type of Identification)

\_\_\_\_\_ Signature of Notary

My Commission Expires \_\_\_\_\_

## EXHIBIT B

### DRUG FREE WORKPLACE CERTIFICATION

THIS FORM MUST BE SIGNED AND SWORN TO IN THE PRESENCE OF A NOTARY PUBLIC OR OTHER OFFICIAL AUTHORIZED TO ADMINISTER OATHS.

This sworn statement is submitted to the City of Madeira Beach by John Rose, resident  
[print individual's name and title]

for individual, n . [print name of entity submitting sworn statement]

whose business address is: 10enhare., Fort Myers, FL 3305 and (if applicable) its Federal Employer Identification Number (FEIN) is 27-5113425 (If the entity has no FEIN, include the Social Security Number of the individual signing this sworn statement: \_\_\_\_\_)

I understand that no person or entity shall be awarded or receive a City contract for public improvements, procurement of goods or services (including professional services) or a City lease, franchise, concession, or management agreement, or shall receive a grant of City monies unless such person or entity has submitted a written certification to the City that it will provide a drug free workplace by:

Providing a written statement to each employee notifying such employee that the unlawful manufacture, distribution, dispensation, possession, or use of a controlled substance as defined by §893.02(4), Florida Statutes, as the same may be amended from time to time, in the person's or entity's workplace is prohibited specifying the actions that will be taken against employees for violation of such prohibition. Such written statement shall inform employees about:

- (i) the dangers of drug abuse in the workplace.
  - (ii) the person's or entity's policy of maintaining a drug-free environment at all its workplaces, including but not limited to all locations where employees perform any task relating to any portion of such contract, business transaction or grant.
  - (iii) any available drug counseling, rehabilitation, and employee assistance programs; and
  - (iv) the penalties that may be imposed upon employees for drug abuse violations.
- (2) Requiring the employee to sign a copy of such written statement to acknowledge his or her receipt of same and advice as to the specifics of such policy. Such person or entity shall retain the statements signed by its employees. Such person or entity shall also post in a prominent place at all of its workplaces a written statement of its policy containing the foregoing elements (i) through (iv).
  - (3) Notifying the employee in the statement required by subsection (1) that as a condition of employment the employee will:
    - (i) abide by the terms of the statement; and
    - (ii) notify the employer of any criminal drug statute conviction for a violation occurring in the workplace no later than five (5) days after such a conviction.
  - (4) Notifying the City within ten (10) days after receiving notice under subsection (3) from an employee or otherwise receiving actual notice of such conviction.
  - (5) Imposing appropriate personnel action against such employee up to and including termination; or requiring such employee to satisfactorily participate in a drug abuse assistance or rehabilitation program approved for such purposes by a federal, state, or local health, law enforcement, or other appropriate agency.
  - (6) Making a good faith effort to continue to maintain a drug free workplace through implementation of sections (1) through (5) stated above.

I UNDERSTAND THAT THE SUBMISSION OF THIS FORM TO THE CITY OF MADEIRA BEACH IS

VALID THROUGH DECEMBER 31 OF THE CALENDAR YEAR IN WHICH IT IS FILED. I ALSO UNDERSTAND THAT ANY CONTRACT OR BUSINESS TRANSACTION SHALL PROVIDE FOR SUSPENSION OF PAYMENTS, OR TERMINATION, OR BOTH, IF THE CITY DETERMINES THAT:

- (1) Such person or entity has made false certification.
- (2) Such person or entity violates such certification by failing to carry out the requirements of sections (1), (2), (3), (4), (5), or (6) or subsection 3-101(7)(B); or
- (3) Such a number of employees of such person or entity have been convicted of violations occurring in the workplace as to indicate that such person or entity has failed to make a good faith effort to provide a drug free workplace as required by subsection 3-101(7)(B).

**Signatory Requirement.** In the case of a corporation, this affidavit shall be executed by the corporate president. In the case of a partnership, this affidavit shall be executed by the general partner(s). In the case of a business entity other than a partnership or a corporation, this affidavit shall be executed by an authorized agent of the entity or the individual.

\_\_\_\_\_  
 Authorized Signature  
 01 08 2024  
 \_\_\_\_\_  
 Date Signed

State of: \_\_\_\_\_

County of: \_\_\_\_\_

Sworn to and subscribed before me this \_\_\_\_\_ day of \_\_\_\_\_, 20\_\_.

Personally Known \_\_\_\_\_ or Produced Identification \_\_\_\_\_

(Specify Type of Identification)

\_\_\_\_\_ Signature of Notary

My Commission Expires \_\_\_\_\_



# TAB A

## STATEMENT OF QUALIFICATION

### STATEMENT OF QUALIFICATIONS

All questions must be answered, and the data given must be clear and comprehensive. This statement must be notarized. Add separate sheets or attachments, as necessary.

- 1. Name of Contractor: i2 Visual, Inc.
- 2. Name of Business (if different than #1): \_\_\_\_\_
- 3. Form of Entity: Corporation
- 4. Permanent Main Office and Mailing addresses and pertinent contact information (phone, email, etc.):  
1606 Benchmark Ave., Fort Myers, FL 33905 (239) 687-3223 sales@i2visual.com
- 5. Date Organized: 02/24/2011
- 6. Where Organized: Fort Myers, Florida
- 7. How many years have you been engaged in the Marine Dock building under your present name; also, state names and dates of previous business names, if any. N/A
- 8. In the last five years, has "Contractor" ever been terminated from a contract or project? If so, explain situation.: No
- 9. In the last five years, has Contractor ever been party to litigation related to the Contractor's work? If so, explain situation.: No
- 10. List the most important contracts entered by the Contractor in the last year; identify contracting party and term of contract.: North Trail RV - Supply 3 digital signs. One (1) 17' x 40' sign. Two (2) 6' x 15' signs.
- 11. List your key personnel available for this contract.: John Hose, Chelesa Hose, Raymond Brayton, Chuck Brown, Schantavia Ivery  
The City of Madeira Beach reserves the right to request from finalist(s) the latest financial statements as well as to request such additional information as may be reasonably necessary to determine whether the Contractor should be awarded the service contract.

*John T. Hose*

Authorized Signature

01/08/2024

Date Signed

### NOTARY

State of: Florida

County of: Lee

Sworn to and subscribed before me this 8 day of January, 2024

Personally Known  or Produced Identification \_\_\_\_\_  
(Specify Type of Identification)

Signature of Notary [Signature]

(seal)

My Commission Expires 4/6/2026



SUSAN LONG  
Notary Public  
State of Florida  
Comm# HH205915  
Expires 4/6/2026





City of Madeira Beach  
300 Municipal Drive  
Madeira Beach, FL 33708

Attn: City of Madeira Beach

i2 Visual, Inc. is pleased to have the opportunity to negotiate this project. We are a diverse team of over 40 with a fleet of more than 20 service and installation vehicles, a state-of-the-art manufacturing facility and a highly experienced project management team.

We specialize in LED digital signage and can offer unique solutions to difficult challenges. We offer a 5 year parts and on site labor warranty, as well as other extended warranty options.

The i2 Visual team is fully understands the job and are fully capable of providing pole sign rehab, removal of the lower sign can with zip track, and installing a new double sided 5x6w LED Sign. We have a staff member who fully dedicates her time to securing permits and job completion inspections.

i2 Visual's staff includes several highly trained and experienced team leaders with full comprehension of LCD and LED video, as well as sound applications from design, implementation, installation, training, and service. The company also maintains a fully staffed 24 hour technical support department.

Our client base includes:

- Nova Southeastern University
- Valencia College
- School District of Lee County
- School District of Hillsborough County
- Florida State Fair
- Sarasota County Government

We're a state certified electrical sign contractor ES000361, and have 2 Digital Signage Certified Experts on staff, as well as one LEED AP.

Sincerely,

A handwritten signature in black ink that reads "John F. Hose".

John Hose, President



# ABOUT i2 VISUAL

STATE OF THE ART EQUIPMENT  
COUPLED WITH  
i2 VISUAL'S EXPERIENCED  
DEDICATED PROFESSIONALS  
PROMISE TO MAKE  
YOUR NEXT PROJECT  
SOMETHING TO BE PROUD OF.

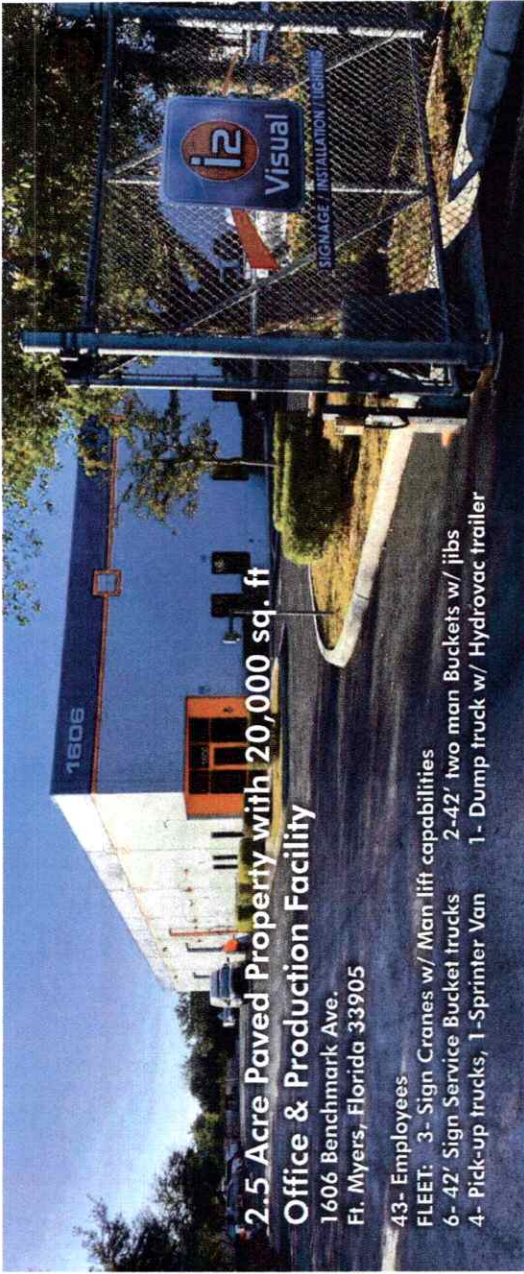

**2.5 Acre Paved Property with 20,000 sq. ft  
Office & Production Facility**  
1606 Benchmark Ave.  
Ft. Myers, Florida 33905

43- Employees  
FLEET: 3- Sign Cranes w/ Man lift capabilities  
6- 42' Sign Service Bucket trucks 2-42' two man Buckets w/ jibs  
4- Pick-up trucks, 1-Sprinter Van 1- Dump truck w/ Hydrovac trailer

## S E R V I C E S

STATEWIDE SERVICE AREA

### Professional Design & Consulting Services

i2 Visual provides specifications and creative designs specifically for today's projects, from interior code required ADA signage, wayfinding / directional systems and identification signage. They will help maintain consistency of existing signage programs as new signage added. i2 Visual is a state certified electrical sign contractor.

### Fabrication & Manufacturing

i2 Visual has manufacturing capabilities in house:  
CNC Router, CNC Lasers, Rotary Engraving, ADA Signage manufacturing with 3d sign printing as well as conventional manufacturing and assembly including a full metal fabrication shop.

### Installation

i2 Visual has one of the largest team of experienced technicians and fleet of specialty vehicles for digging, lifting, moving, assembling and installing signs from small ADA signage, Building Identification, freestanding signage, banners, large scoreboards and digital displays. If you have your own signage and need it installed, they will install it for you.

### Maintenance & Service

i2 Visual can provide service on all electrical signage including scoreboards and digital displays. They can refurbish existing signs and can convert lighting to more cost effective LED lighting.

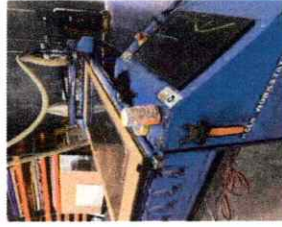

i2 VISUAL INC. 1606 BENCHMARK AVE. FORT MYERS, FLORIDA 239-687-3223 866-420-9909 STATE LICENSE ES0000361 SALES@I2VISUAL.COM

THE WISE CHOICE



## I2 VISUAL, INC. KEY PEOPLE



JOHN F. HOSE  
PRESIDENT  
QUALIFIER E50000361

John is a graduate of the University of Washington and former U. S. Navy electronics technician. He has been involved in the electrical sign industry in Florida since 1987. He was the founder of Images Graphic. Specialties and has been working with government agencies for over 30 years. He is a Florida State Certified Electrical Sign Contractor, a Digital Signage Certified Expert (DSCE), a LEED Associated Professional (green building Expert).



RICHARD E. ROBERTS  
CREATIVE DIRECTOR

Richard has been involved in all phases of the electric sign industry since 1975. He is a Digital Signage Certified Expert (DSCE). Ric. is a former Lee County Board of Adjustment and Appeals Board Member, former Daytona Beach Community College Community Advisory Board member for Advertising and Graphic Arts Program.



CHELSEA HOSE  
VICE PRESIDENT

Chelsea attended Florida Southwestern State College and has been involved in the sign industry for her adult life. She is currently serving on the International Sign Association "Young Elite 35", an exclusive group promoting education and professionalism in the industry. She is Currently VP of Operations and is responsible for the overall management team, manufacturing and service / installation.



CHARLES BROWN  
FIELD OPERATIONS











Charles (Chuck) has been installing and servicing all types of electrical signs for 30 plus years. He has worked for Federal Sign, Image Graphic Specialties and Certified Maintenance. He is skilled with UL listings, NEC regulations, concrete and structural steel. He has vast experience repairing most of the major electronic sign manufacturer's products.

I2 VISUAL INC. 1606 BENCHMARK AVE. FORT MYERS, FLORIDA 239-687-3223 866-420-9909 STATE LICENSE E50000361 SALES@I2VISUAL.COM

THE WISE CHOICE



## QUALIFICATIONS

-  i2 Visual is a major provider of signage and sign installation services with statewide coverage. They are staffed and experienced to successfully design, permit, manage, manufacture and install most any sign projects.
-  Florida Certified Electrical Sign Specialty Contractor ES-0000361
-  Experienced in Electronic Displays and Standard Signs
-  Experienced Working on Right-of way projects ( MOT Planning )
-  4- Sign Cranes w/ man lift capabilities , 8 Special Sign Service Bucket trucks 1-Dump truck w/ Hydrovac Trailer  
4-pick-up trucks, Large Sprinter Van. 5 utility trailers
-  In-house Design
-  In-house Manufacturing Capabilities
-  Experience with Schools and Government Projects
-  Financially Stable, fully licensed, bonded and insured - over \$5,000,000 in annual sales
-  40 full time employees

i2 VISUAL INC. 1606 BENCHMARK AVE. FORT MYERS, FLORIDA 239-687-3223 866-420-9909 STATE LICENSE ES0000361 SALES@I2VISUAL.COM

THE WISE CHOICE

PAGE 8



# TAB B

## REFERENCES

## REFERENCES

Please include the below information for all five (5) references as required.

**Information below to be included for all five references in the proposal.**

Contact Name Joshua Hatcher

Business Name Southwest Florida International Airport

Business Address 11000 Terminal Access Rd, Fort Myers, FL 33913

Contact Phone (239) 561-4141

Contact Email jhatcher@oakfl.com Other

Information (describe): Manufacture and Install 2 large LED signs and 4 radar feedback signs

*\*See attached sheet for more references*

## INSURANCE REQUIREMENTS

Insurance shall be in such form as will protect the Contractor from all claims and liabilities for damages for bodily injury, including accidental death, and for property damage, which may arise from operations under this contract, whether such operations by himself or anyone directly or indirectly employed by Contractor.

The awarded firm must file with the City of Madeira Beach certificates of insurance prior to commencement of work evidencing the City as a certificate holder as additionally insured with the following minimum coverage:

- Public and Commercial Liability Insurance not less than \$1,000,000.00.
- Comprehensive General Liability Insurance of \$1,000,000.00 for each occurrence.
- Personal Injury for \$1,000,000.00 each occurrence.

Owner's and Consultant's Protective Liability.

- Bodily injury liability \$1,000,000.00 each occurrence
- Property damage liability \$1,000,000.00 each occurrence
- Full Workers Comprehensive Insurance is required by Florida Law for all people employed by the contractor to perform work on this project.

Automotive Liability (covering the operation, maintenance and all owned, non-owned and hired vehicles).

- Bodily injury liability \$1,000,000.00 each occurrence
- Property damage liability \$1,000,000.00 each occurrence

## INDEMNIFICATION

The Respondent shall hold harmless the City, its officers, and employees, from liabilities, damages, losses, and costs, including but not limited to, reasonable attorney's fees, to the extent caused by the negligence, recklessness, or intentional wrongful misconduct of the Respondent and any persons employed or utilized by the Respondent in the performance of the Contract.

## REFERENCES

Contact Name: Joshua Hatcher

Business Name: Southwest Florida International Airport

Business Address: 11000 Terminal Access Rd, Fort Myers, FL 33913

Contact Phone: (239) 561-4141

Contact Email: [jhatcher@oakfl.com](mailto:jhatcher@oakfl.com)

Information (describe): Manufacture and Install 2 large LED signs and 4 radar feedback signs.

Contact Name: Joshua Austin

Business Name: Valencia College

Business Address: 500 W Livingston St Orlando, FL 32801

Contact Phone: (407)-582-1486

Contact Email: [jaustin27@valenciacollege.edu](mailto:jaustin27@valenciacollege.edu)

Information (describe): Furnish and Install LED sign upgrades at all campuses.

Contact Name: Joseph Edwards

Business Name: North Fort Myers High School / School District of Lee County

Business Address: 5000 Orange Grove Blvd, North Fort Myers, FL 33903

Contact Phone: (239) 292-1689

Contact Email: [josephne@leeschools.net](mailto:josephne@leeschools.net)

Information (describe): Furnish and Install 12' x 24' full video scoreboard and digital signage.

Contact Name: Amit Patel

Business Name: Florida State Fair

Business Address: 4800 US-301, Tampa, FL 33610

Contact Phone: (813) 363-5514

Contact Email: [amit.patel@floridastatefair.com](mailto:amit.patel@floridastatefair.com)

Information (describe): Furnish and Install 2 large 18' x 34' LED Signs 10mm.

Contact Name: Greg Heyn

Business Name: Disney ESPN Wide World of Sports

Business Address: 700 S Victory Way, Orlando, FL 34747

Contact Phone: (407) 341-5180

Contact Email: Gregory.heyn@disney.com

Information (describe): Furnish and Install LED Signs and Scoreboards.





# TAB C FORMS

# PROPOSALS FORM



Name of "CONTRACTOR" Submitting Proposals i2 Visual, Inc.

Name of Person Submitting Proposals John Hose

### PROPOSER ACKNOWLEDGMENT

"The undersigned hereby declares that he/she has informed himself/herself fully in regard to all conditions to the work to be done, and that he/she has examined the RFP and Specifications for the work and comments here to attached. The "CONTRACTOR" proposes and agrees, if this submission is accepted, to contract with the "CITY" of Madeira Beach to furnish all necessary materials, equipment, labor, and services necessary to complete the work covered by the RFP and Contract Documents for this Project. The "CONTRACTOR" agrees to accept in full compensation for each item the prices named in the schedules incorporated herein."

### BIDDER'S REPRESENTATIONS

In submitting this Bid, Bidder represents that:

- A. Bidder has examined and carefully studied the Bidding Documents, the other related data identified in the Bidding Documents, and the following Addenda, receipt of which is hereby acknowledged.

Addendum No.	Addendum Date
_____	_____
_____	_____
_____	_____

- B. Bidder has visited the Site and become familiar with and is satisfied as to the general, local and Site conditions that may affect cost, progress, and performance of the Work.
- C. Bidder is familiar with and is satisfied as to all federal, state, and local Laws and Regulations that may affect cost, progress and performance of the Work.

- D. Bidder has carefully studied all: (1) reports of explorations and tests of subsurface conditions at the Site and all drawings of physical conditions in or relating to existing surface or subsurface structures at the Site.
- E. Bidder has obtained and carefully studied (or accepts the consequences for not doing so) all additional or supplementary examinations, investigations, explorations, tests, studies and data concerning conditions (surface, subsurface and Underground Facilities) at or contiguous to the Site which may affect cost, 19 progress, or performance of the Work or which relate to any aspect of the means, methods, techniques, sequences, and procedures of construction to be employed by Bidder, including applying the specific means, methods, techniques, sequences, and procedures of construction expressly required by the Bidding Documents to be employed by Bidder, and safety precautions and programs incident thereto.
- F. Bidder does not consider that any further examinations, investigations, explorations, tests, studies, or data are necessary for the determination of this Bid for performance of the Work at the price(s) bid and within the times and in accordance with the other terms and conditions of the Bidding Documents.
- G. Bidder is aware of the general nature of work to be performed by Owner and others at the Site that relates to the Work as indicated in the Bidding Documents.
- H. Bidder has correlated the information known to Bidder, information and observations obtained from visits to the Site, reports and drawings identified in the Bidding Documents, and all additional examinations, investigations, explorations, tests, studies, and data with the Bidding Documents.
- I. The Bidder has given Owner and Engineer written notice of all conflicts, errors, ambiguities, or discrepancies that Bidder has discovered in the Bidding Documents, and the written resolution thereof by Engineer is acceptable to Bidder.
- J. The Bidding Documents are generally sufficient to indicate and convey understanding of all terms and conditions for the performance of the Work for which this Bid is submitted.
- K. Bidder will submit written evidence of its authority to do business in the state where the Project is located not later than the date of its execution of the Agreement.

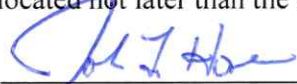
Signature 

Date 01/08/2024

RFP Number 2023-09 Check if exception(s) or deviation(s) to specifications. Attach separate sheet(s) detailing reason and type for the exception or deviation.

### “CONTRACTOR” PROFILE

i2 Visual, Inc.  
Submitted by (Company Name)

Circle one of the following:

**Corporation**

**Partnership**

**Individual**

**Joint Venture**

Other Describe: \_\_\_\_\_

Florida Contractor License Number: ES0000361

Expiration Date: August 31, 2024 Unique Entity ID: J5HEGTJ6ND21 FEIN: 27-5113425

Office Location: 1606 Benchmark Ave., Fort Myers, FL 33905

Number of people in your organization: 40

Length of time the Contractor has been doing business under this name in Florida: 12 years years.

Length of time your firm has provided services to governmental clients: 12 years years.

Under what other name(s) has your firm operated: N/A

Has or is your firm currently involved in any formal court proceedings regarding any of your contracts?

YES

**NO**

If yes, Include a detailed explanation.

N/A  
\_\_\_\_\_  
\_\_\_\_\_  
\_\_\_\_\_  
\_\_\_\_\_  
\_\_\_\_\_  
\_\_\_\_\_  
\_\_\_\_\_  
\_\_\_\_\_  
\_\_\_\_\_  
\_\_\_\_\_

### HOLD HARMLESS AGREEMENT

The Contractor agrees to hold the City of Madeira Beach harmless against all claims for bodily injury, sickness, disease, death or personal injury or damage to property or loss of use resulting therefrom, arising out of the agreement, to the extent that such claims are attributable, in whole or in part, to a negligent act or omission by the Contractor.

The Contractor shall purchase and maintain workers' compensation insurance for all workers' compensation insurance and employers' liability in accordance with Florida Statute Chapter 440.

The Contractor shall also purchase any other coverage required by law for the benefit of employees.

Required insurance shall be documented in Certificates of Insurance and shall be provided to the "CITY" representative requesting the service.

By signature upon this form the Contractor stipulates that he/she agrees to the Hold Harmless Agreement, and to abide by all insurance requirements.

John Hose  
Contractor/ "CONTRACTOR"- Printed Name

  
Signature

2023-11 Digital Information Sign City Marina 150th Avenue  
Project Name

01/08/2024  
Date

**The effective date of this Hold Harmless Agreement shall be the duration of this project.**

## SWORN STATEMENT TO SECTION 287.133(3)(a), FLORIDA STATUTES, ON PUBLIC ENTITY CRIMES FORM

THIS FORM MUST BE SIGNED AND SWORN TO IN THE PRESENCE OF A NOTARY PUBLIC OR OTHER OFFICIAL AUTHORIZED TO ADMINISTER OATHS.

1. This sworn statement is submitted to the "CITY" of Madeira Beach

By John Hose, President  
(Print individual's name and title)

for i2 Visual, Inc.  
(Print name of entity submitting sworn statement)

whose business address is 1606 Benchmark Ave., Fort Myers, FL 33905 and (if applicable) its Federal Employer Identification Number (FEIN) is 27-5113425.

2. I understand that a "public entity crime" as defined in Paragraph 287.133(1)(g), Florida Statutes, means a violation of any state or federal law by a person with respect to and directly related to the transaction of business with any public entity or with an agency or political subdivision of any other state or of the United States, including, but not limited to, any bid or contract for goods or services to be provided to any public entity or an agency or political subdivision of any other state or of the United States and involving antitrust, fraud, theft, bribery, collusion, racketeering, conspiracy, or material misrepresentation.
3. I understand that "convicted" or "conviction" as defined in Paragraph 287.133(1)(b), Florida Statutes, means a finding of guilt or a conviction of a public entity crime, with or without adjudication of guilt, in any federal or state trial court of record relating to charges brought by indictment or information after July 1, 1989, as a result of a jury verdict, nonjury trial, or entry of a plea of guilty or nolo contendere.
4. I understand that an "affiliate" as defined in Paragraph 287.133(1)(a), Florida Statutes, means:
  - a. A predecessor or successor of a person convicted of a public entity crime; or
  - b. An entity under the control of any natural person who is active in the management of the entity and who has been convicted of a public entity crime. The term "affiliate" includes those officers, directors, executives, partners, shareholders, employees, members, and agents who are active in the management of an affiliate. The ownership by one person of shares constituting a controlling interest in another person, or a pooling of equipment or income among persons when not for fair market value under an arm's length agreement, shall be a prima facie case that one person controls another person. A person who knowingly enters into a joint venture with a person who has been convicted of a public entity crime in Florida during the preceding 36 months shall be considered an affiliate.
  - c. I understand that a "person" as defined in Paragraph 287.133(1)(e), **Florida Statutes**, means any natural person or entity organized under the laws of any state or of the United States with the legal power to enter into a binding contract and which bids or applies to bid on contracts for the provision of goods or services by a public entity, or which otherwise transacts or applies to transact business with a public entity. The term "person" includes those officers, directors, executives, partners, shareholders, employees, members, and agents who are active in management of an entity.
  - d. Based on information and belief, the statement which I have marked below is true in relation to the entity submitting this sworn statement (indicate which statement applies).
 

  X   Neither the entity submitting this sworn statement, nor any of its officers, directors, executives, partners, shareholders, employees, members, or agents who are active in the management of the entity, nor any affiliate of the entity has been charged with and convicted of a public entity crime subsequent to July 1, 1989.

\_\_\_\_\_ The entity submitting this sworn statement, or one or more of its officers, directors, executives, partners, shareholders, employees, members, or agents who are active in the management of the entity, or an affiliate of the entity has been charged with and convicted of a public entity crime subsequent to July 1, 1989.

\_\_\_\_\_The entity submitting this sworn statement, or one or more of its officers, directors, executives, partners, shareholders, employees, members, or agents who are active in the management of the entity, or an affiliate of the entity has been charged with and convicted of a public entity crime after July 1, 1989. However, there has been a subsequent proceeding before a Hearing Officer of the State of Florida, Division of Administrative Hearings and the Final Order entered by the Hearing Officer determined that it was not in the public interest to place the entity submitting this sworn statement on the convicted "CONTRACTOR" list. (Attach a copy of the final order)

I UNDERSTAND THAT THE SUBMISSION OF THIS FORM TO THE CONTRACTING OFFICER FOR THE PUBLIC ENTITY IDENTIFIED IN PARAGRAPH 1 (ONE) ABOVE IS FOR THAT PUBLIC ENTITY ONLY AND, THAT THIS FORM IS VALID THROUGH DECEMBER 31 OF THE CALENDAR YEAR IN WHICH IT IS FILED. I ALSO UNDERSTAND THAT I AM REQUIRED TO INFORM THE PUBLIC ENTITY PRIOR TO ENTERING INTO A CONTRACT IN EXCESS OF THE THRESHOLD AMOUNT PROVIDED IN SECTION 287.017, FLORIDA STATUTES FOR CATEGORY TWO OF ANY CHANGE IN THE INFORMATION CONTAINED IN THIS FORM.

\_\_\_\_\_  
Authorized Signature

01/08/2024  
\_\_\_\_\_  
Date Signed

State of: Florida

County of: Lee

Sworn to and subscribed before me this 8 day of January, 2024

Personally Known  or Produced Identification \_\_\_\_\_

(Specify Type of Identification)

\_\_\_\_\_  
Signature of Notary

My Commission Expires 4/6/2026

(seal)



**SUSAN LONG**  
Notary Public  
State of Florida  
Comm# HH205915  
Expires 4/6/2026

**This document must be completed and returned with your submission.**

## IMMIGRATION AFFIDAVIT CERTIFICATION

This Affidavit is required and should be signed, notarized by an authorized principal of the firm, and submitted with formal Invitations to Bid (ITB's) and Request for Proposals (RFP) submittals. Further, Consultants/Bidders are required to enroll in the E-Verify program, and provide acceptable evidence of their enrollment, at the time of the submission of the Consultant/Bidder's proposal. Acceptable evidence consists of a copy of the properly completed E-Verify Company Profile page or a copy of the fully executed E-Verify Memorandum of Understanding for the company. Failure to include this Affidavit and acceptable evidence of enrollment in the E-Verify program may deem the Consultant/Bidder's proposal as nonresponsive.

The City of Madeira Beach will not intentionally award City contracts to any Consultant who knowingly employs unauthorized workers, constituting a violation of the employment provision contained in 8 U.S.C. Section 1324 a(e) Section 274A(e) of the Immigration and Nationality Act ("INA"). The City of Madeira Beach may consider the employment by any Consultant of unauthorized aliens a violation of Section 274A (e) of the INA. Such Violation by the recipient of the Employment Provisions contained in Section 274A(e) of the INA shall be grounds for unilateral termination of the contract by the City of Madeira Beach.

Consultant attests that they are fully compliant with all applicable immigration laws (specifically to the 1986 Immigration Act and subsequent Amendment(s)) and agrees to comply with the provisions of the Memorandum of Understanding with E-Verify and to provide proof of enrollment in The Employment Eligibility Verification System (E-Verify), operated by the Department of Homeland Security in partnership with the Social Security Administration at the time of submission of the Consultant/Bidder's proposal.

Company Name: i2 Visual, Inc.  
Print Name: John Hose Title: President  
Signature: *[Handwritten Signature]* Date: 01/08/2024  
State of: Florida  
County of: Lee  
Sworn to and subscribed before me this 8 day of January, 2024

Personally Known  or Produced Identification \_\_\_\_\_  
(Specify Type of Identification)

*[Handwritten Signature]*  
Signature of Notary  
My Commission Expires 4/6/2026

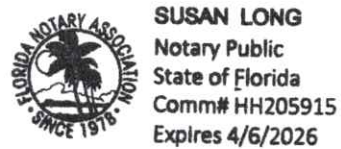

(seal)

The signee of this affidavit guarantees, as evidenced by the affidavit required herein, the truth and accuracy of this affidavit to interrogatories hereinafter made. This document must be completed and returned with your submission.



### BID TABULATION FORM

Description	UNIT	EST. QUAN.	UNIT PRICE	AMOUNT
5x6w Digital LED Sign: Total Cost	LS	1	\$ 41,063.00	\$ 41,063.00
Parts and Labor: Total Cost	LS	1	\$ 10,750.00	\$ 10,750.00
TOTAL Project cost				\$ 51,813.00

PROPOSED TOTAL BASE CONTRACT PRICE (Amount Written in numbers) \$ 51,813.00

PROPOSED TOTAL BASE CONTRACT PRICE (Amount written in words) \$ Fifty-one thousand, eight hundred thirteen dollars.

**\*See attached quote for optional reduced pricing**

Signature: 

Printed Name: John Hose

Date: 01/08/2024

i2 Visual, Inc.  
 1606 Benchmark Ave.  
 Fort Myers, FL 33905



Phone: (239) 687-3223  
 sales@i2visual.com  
 i2visual.com

Bill to  
**City of Madeira Beach**  
 300 Municipal Drive  
 Madeira Beach, FL 33708

Ship to  
**City Marina 150th Avenue**  
 503 150th Avenue  
 Madeira Beach, FL 33708

Quote #: q11030

Quote Date: 1/5/2024

Item	Description	Quantity	Price	Amount
Sales	Replace manual readerboard with Watchfire EMC Pixel Pitch: W10mm LED RGB Pixel Matrix: 150 X 180 Ventilation Style: Front Ventilation Cabinet Size: 5ft 5in H x 6ft 3in L x 8in D Viewing Area: 5ft H x 6ft L Cabinet Style: Double Face Character Size: 18 lines / 36.0 Characters at a 3" type Approx. Weight: 763.00 Lbs. Warranty: 5 year parts and onsite labor Electrical Service: 120 VOLT 36.0 amps Software Ignite OPx (cloud-based) Software Training Web Based Software Training Wireless Data Plan Life-of-sign Data Plan	1	\$41,063.00	\$41,063.00
Sales	Fabricate new 7" x 13' 2" white pole covers	2	\$325.00	\$650.00
Sales	Installation including removal and disposal of existing readerboards includes hookup to existing electrical	1	\$3,600.00	\$3,600.00
Sales	OPTION 1 - trench and run electrical approximately 100' from nearby meter and panel	1	\$6,500.00	\$6,500.00
Sales	OPTION 2 - Deduct \$12,500 for providing ADS EMC with same specifications as above except Warranty: 5 years parts, 1 year on site labor	1	\$0.00	\$0.00

i2 Visual, Inc.  
1606 Benchmark Ave.  
Fort Myers, FL 33905



Phone: (239) 687-3223  
sales@i2visual.com  
i2visual.com

Tax: \$0.00

Total: \$51,813.00

CURRENT  
**SIGN**



REPLACE POLE COVERS  
1 - BEAM Poles  
7 1/2" Square Pole Cover  
Color: White

PROPOSED  
**SIGN**



REPLACE PAN FACED  
WITH EMC SIGN  
SIZE: 6'W x5'H

Madeira Beach Pylon Sign

Client Name: City of Madeira Beach  
Project Name: Madeira Beach Pylon Sign  
Address: TBD

Drawing #: 001\_LLC  
Date: 01-05-23



i2 Visual, Inc.  
1604 Benchmark Ave.  
Fl. Myers, FL 33905  
(239) 209-6767

Customer Approved: \_\_\_\_\_  
Date: \_\_\_\_\_

Please review final artwork carefully. Your approval will indicate acceptance of materials including responsibility for errors, omissions and legal and ethical compliance.



# TAB D LICENSES

Ron DeSantis, Governor



Melanie S. Griffin, Secretary



**STATE OF FLORIDA  
DEPARTMENT OF BUSINESS AND PROFESSIONAL REGULATION**

**ELECTRICAL CONTRACTORS' LICENSING BOARD**

THE SPECIALTY ELECTRICAL CONTRACTOR HEREIN IS CERTIFIED UNDER THE  
PROVISIONS OF CHAPTER 489, FLORIDA STATUTES

AS A SIGN ELECTRICAL SPECIALIST

**HOSE, JOHN FREDERICK**

I2 VISUAL INC  
1606 BENCHMARK AVE.  
FORT MYERS FL 33905

**LICENSE NUMBER: ES0000361**

**EXPIRATION DATE: AUGUST 31, 2024**

Always verify licenses online at [MyFloridaLicense.com](http://MyFloridaLicense.com)



Do not alter this document in any form.

This is your license. It is unlawful for anyone other than the licensee to use this document.



**The City of Fort Myers, Florida**  
Community Development Department  
1825 Hendry Street, #101  
Fort Myers, Florida 33901  
Telephone: 239-321-7990

**SPECIALTY CONTRACTOR**

**EFFECTIVE 09/09/2023 - EXPIRING 09/30/2024**

**I 2 VISUAL INC**  
**1606 BENCHMARK AVE**  
**FORT MYERS, FL 33905**

**Business Tax #: BUS-000673-2021**

Dear Business Owner,

The City of Fort Myers wish you success with your business. The Business Tax Receipt below is valid from 09/09/2023 until 09/30/2024.

Annual renewal notices are mailed in July to the address of record at that time. If you need to change the business name, mailing address, contact data, location and/or closing the business, please contact our office:

**CDD/Business Tax**  
**1825 Hendry Street**  
**Suite 101**  
**Fort Myers, FL 33901**  
**(239) 321-7990**

**Description: ELECTRICAL CONTRACTOR**



**CITY OF FORT MYERS FLORIDA**  
**Business Tax Receipt**

**Effective 09/09/2023 - Expiring 9/30/23**

**1606 BENCHMARK AVE**  
**i 2 VISUAL INC**  
**Business Tax #: BUS-000673-2021**

is hereby registered\* business, profession, or occupation of:

**(121 e.) Signs**

**ALCOHOL SALES PERMITTED: No**

**HOMEBASED: No**

**Owner: i 2 VISUAL INC, 1606 BENCHMARK AVE, FORT MYERS, FL 33905**

**POST THIS RECEIPT IN A CONSPICUOUS PLACE AT YOUR BUSINESS LOCATION**

\*Any violation of applicable chapter of the City Code of Ordinances may cancel this receipt



# Local Business Tax Receipt

12 VISUAL INC  
HOSE JOHN F  
1606 BENCHMARK AVE  
FT MYERS, FL 33905

Dear Business Owner:

Your 2023 - 2024 Lee County Local Business Tax Receipt is attached below for account number / receipt number: 1046554 / 1701225

If there is a change in one of the following, refer to the instructions on the back of this receipt.

- Business name
- Ownership
- Physical location
- Business closed

This is not a bill. Detach the bottom portion and display in a public location.

I hope you have a successful year.

Sincerely,

Lee County Tax Collector

## 2023-2024 LEE COUNTY LOCAL BUSINESS TAX RECEIPT

Account Number: 1046554  
Receipt Number: 1701225  
State License Number: ES0000361

Account Expires: September 30, 2024

Location:  
1606 BENCHMARK AVE  
FT MYERS, FL 33905

May engage in the business of:
SPECIALTY CONTRACTOR-CERTIFIED
THIS LOCAL BUSINESS TAX RECEIPT IS NON REGULATORY

12 VISUAL INC  
HOSE JOHN F  
1606 BENCHMARK AVE  
FT MYERS, FL 33905

Payment Information:
PAID INT-00-01357505 07/24/2023
\$ 50.00





[Department of State](#) / [Division of Corporations](#) / [Search Records](#) / [Search by Entity Name](#) /

## Detail by Entity Name

Florida Profit Corporation  
I2 VISUAL, INC.

### Filing Information

**Document Number** P11000019027  
**FEI/EIN Number** 27-5113425  
**Date Filed** 02/24/2011  
**State** FL  
**Status** ACTIVE  
**Last Event** AMENDMENT  
**Event Date Filed** 11/09/2018  
**Event Effective Date** NONE

### Principal Address

1606 Benchmark Ave.  
Fort Myers, FL 33905

Changed: 12/22/2021

### Mailing Address

1606 Benchmark Ave.  
Fort Myers, FL 33905

Changed: 12/22/2021

### Registered Agent Name & Address

Corporate Legal Solutions  
12670 NEW BRITTANY BLVD, SUITE 101  
FORT MYERS, FL 33907

Name Changed: 04/26/2023

Address Changed: 04/25/2021

### Officer/Director Detail

#### **Name & Address**

Title DPT

HOSE, JOHN F  
17660 Wells Rd.  
NORTH FORT MYERS, FL 33917

Title S

ROBERTS, RICHARD E  
8227 W JAMESTOWN CIR  
NORTH FORT MYERS, FL 33917

Title DVP

HOSE, CHELSEA  
6142 Hellman Ave  
FORT MYERS, FL 33905

**Annual Reports**

Report Year	Filed Date
2021	04/25/2021
2022	05/01/2022
2023	04/26/2023

**Document Images**

<a href="#">04/26/2023 -- ANNUAL REPORT</a>	View image in PDF format
<a href="#">05/01/2022 -- ANNUAL REPORT</a>	View image in PDF format
<a href="#">12/22/2021 -- AMENDED ANNUAL REPORT</a>	View image in PDF format
<a href="#">04/25/2021 -- ANNUAL REPORT</a>	View image in PDF format
<a href="#">06/02/2020 -- ANNUAL REPORT</a>	View image in PDF format
<a href="#">03/26/2019 -- ANNUAL REPORT</a>	View image in PDF format
<a href="#">11/09/2018 -- Amendment</a>	View image in PDF format
<a href="#">04/11/2018 -- ANNUAL REPORT</a>	View image in PDF format
<a href="#">03/30/2017 -- ANNUAL REPORT</a>	View image in PDF format
<a href="#">04/12/2016 -- ANNUAL REPORT</a>	View image in PDF format
<a href="#">04/22/2015 -- ANNUAL REPORT</a>	View image in PDF format
<a href="#">04/28/2014 -- ANNUAL REPORT</a>	View image in PDF format
<a href="#">04/01/2013 -- ANNUAL REPORT</a>	View image in PDF format
<a href="#">04/26/2012 -- ANNUAL REPORT</a>	View image in PDF format
<a href="#">02/24/2011 -- Domestic Profit</a>	View image in PDF format



Above) An i2 Visual's team shown using their Hydro-Vac machine to dig close to utilities without damaging them. This is a very useful machine to avoid issues on today's crowded installation sites.



## Installation

i2 Visual is experienced and well equipped to install signs from the ground up.

- \*Channel Letters \* Pylons \* Monuments
- \*Traffic Signs \* Wayfinding Signage \* More

**sales@i2visual.com**  
**239-687-3223**



Above) One of i2 Visual's experienced install teams finishing one of two new FDOT standard multi-post traffic signs for Charlotte County Florida (footers, break-away structure and sign panel.)

**STATE CERTIFIED ELECTRICAL SIGN CONTRACTOR #ES000361**

I2 VISUAL INC. 1606 BENCHMARK AVE. FORT MYERS, FLORIDA 239-687-3223 866-420-9909 STATE LICENSE ES0000361 SALES@I2VISUAL.COM

THE WISE CHOICE



**TAB E**  
**CERTIFICATE**  
**OF**  
**INSURANCE**



# CERTIFICATE OF LIABILITY INSURANCE

Item 11B.

DATE (MM/DD/YYYY)

01/04/2024

**THIS CERTIFICATE IS ISSUED AS A MATTER OF INFORMATION ONLY AND CONFERS NO RIGHTS UPON THE CERTIFICATE HOLDER. THIS CERTIFICATE DOES NOT AFFIRMATIVELY OR NEGATIVELY AMEND, EXTEND OR ALTER THE COVERAGE AFFORDED BY THE POLICIES BELOW. THIS CERTIFICATE OF INSURANCE DOES NOT CONSTITUTE A CONTRACT BETWEEN THE ISSUING INSURER(S), AUTHORIZED REPRESENTATIVE OR PRODUCER, AND THE CERTIFICATE HOLDER.**

**IMPORTANT: If the certificate holder is an ADDITIONAL INSURED, the policy(ies) must have ADDITIONAL INSURED provisions or be endorsed. If SUBROGATION IS WAIVED, subject to the terms and conditions of the policy, certain policies may require an endorsement. A statement on this certificate does not confer rights to the certificate holder in lieu of such endorsement(s).**

<b>PRODUCER</b> Herndon-Carr & Company 10501 Six Mile Cypress Pkwy Suite 101 Fort Myers FL 33966-6400		<b>CONTACT NAME:</b> Diana (Dee-Dee) Thompson <b>PHONE (A/C, No, Ext):</b> (239) 939-1996 <b>FAX (A/C, No):</b> (239) 205-6072 <b>E-MAIL ADDRESS:</b> dthompson@insuresig.com																						
<b>INSURED</b> i2 Visual, Inc. 1606 Benchmark Avenue Fort Myers FL 33905		<table border="1"> <thead> <tr> <th colspan="2">INSURER(S) AFFORDING COVERAGE</th> <th>NAIC #</th> </tr> </thead> <tbody> <tr> <td>INSURER A:</td> <td>Greenwich Insurance Company, A+ XV</td> <td>22322</td> </tr> <tr> <td>INSURER B:</td> <td>American Interstate Insurance Company, A IX</td> <td>31895</td> </tr> <tr> <td>INSURER C:</td> <td></td> <td></td> </tr> <tr> <td>INSURER D:</td> <td></td> <td></td> </tr> <tr> <td>INSURER E:</td> <td></td> <td></td> </tr> <tr> <td>INSURER F:</td> <td></td> <td></td> </tr> </tbody> </table>		INSURER(S) AFFORDING COVERAGE		NAIC #	INSURER A:	Greenwich Insurance Company, A+ XV	22322	INSURER B:	American Interstate Insurance Company, A IX	31895	INSURER C:			INSURER D:			INSURER E:			INSURER F:		
INSURER(S) AFFORDING COVERAGE		NAIC #																						
INSURER A:	Greenwich Insurance Company, A+ XV	22322																						
INSURER B:	American Interstate Insurance Company, A IX	31895																						
INSURER C:																								
INSURER D:																								
INSURER E:																								
INSURER F:																								

**COVERAGES**      **CERTIFICATE NUMBER:** CL2342624607      **REVISION NUMBER:**

THIS IS TO CERTIFY THAT THE POLICIES OF INSURANCE LISTED BELOW HAVE BEEN ISSUED TO THE INSURED NAMED ABOVE FOR THE POLICY PERIOD INDICATED. NOTWITHSTANDING ANY REQUIREMENT, TERM OR CONDITION OF ANY CONTRACT OR OTHER DOCUMENT WITH RESPECT TO WHICH THIS CERTIFICATE MAY BE ISSUED OR MAY PERTAIN, THE INSURANCE AFFORDED BY THE POLICIES DESCRIBED HEREIN IS SUBJECT TO ALL THE TERMS, EXCLUSIONS AND CONDITIONS OF SUCH POLICIES. LIMITS SHOWN MAY HAVE BEEN REDUCED BY PAID CLAIMS.

INSR LTR	TYPE OF INSURANCE	ADDL SUBR INSD WVD	POLICY NUMBER	POLICY EFF (MM/DD/YYYY)	POLICY EXP (MM/DD/YYYY)	LIMITS	
A	<input checked="" type="checkbox"/> <b>COMMERCIAL GENERAL LIABILITY</b> <input type="checkbox"/> CLAIMS-MADE <input checked="" type="checkbox"/> OCCUR  GEN'L AGGREGATE LIMIT APPLIES PER: <input type="checkbox"/> POLICY <input checked="" type="checkbox"/> PROJECT <input type="checkbox"/> LOC OTHER:		NGL-1003112-03	03/20/2023	03/20/2024	EACH OCCURRENCE \$ 1,000,000 DAMAGES TO RENTED PREMISES (Ea occurrence) \$ 100,000 MED EXP (Any one person) \$ 10,000 PERSONAL & ADV INJURY \$ 1,000,000 GENERAL AGGREGATE \$ 2,000,000 PRODUCTS - COMP/OP AGG \$ 2,000,000 \$	
A	<b>AUTOMOBILE LIABILITY</b> <input checked="" type="checkbox"/> ANY AUTO <input type="checkbox"/> OWNED AUTOS ONLY <input type="checkbox"/> SCHEDULED AUTOS <input checked="" type="checkbox"/> HIRED AUTOS ONLY <input checked="" type="checkbox"/> NON-OWNED AUTOS ONLY		NBA-1003111-03	03/20/2023	03/20/2024	COMBINED SINGLE LIMIT (Ea accident) \$ 1,000,000 BODILY INJURY (Per person) \$ BODILY INJURY (Per accident) \$ PROPERTY DAMAGE (Per accident) \$ \$	
A	<input checked="" type="checkbox"/> <b>UMBRELLA LIAB</b> <input checked="" type="checkbox"/> OCCUR <input type="checkbox"/> EXCESS LIAB <input type="checkbox"/> CLAIMS-MADE DED    RETENTION \$		NEC-6006067-03	03/20/2023	03/20/2024	EACH OCCURRENCE \$ 5,000,000 AGGREGATE \$ 5,000,000 \$	
B	<b>WORKERS COMPENSATION AND EMPLOYERS' LIABILITY</b> ANY PROPRIETOR/PARTNER/EXECUTIVE OFFICER/MEMBER EXCLUDED? (Mandatory in NH) If yes, describe under DESCRIPTION OF OPERATIONS below	Y/N Y	N/A	AVWFCFL3178232023	05/09/2023	05/09/2024	<input checked="" type="checkbox"/> PER STATUTE <input type="checkbox"/> OTH-ER E.L. EACH ACCIDENT \$ 1,000,000 E.L. DISEASE - EA EMPLOYEE \$ 1,000,000 E.L. DISEASE - POLICY LIMIT \$ 1,000,000

DESCRIPTION OF OPERATIONS / LOCATIONS / VEHICLES (ACORD 101, Additional Remarks Schedule, may be attached if more space is required)  
When required by contract or agreement and permitted by law, subject to policy terms, conditions and exclusions, the Additional Insured blanket endorsement is automatic and applies in favor of the Certificate Holder in respects to the operations of the insured, on behalf of the Certificate Holder.

GENERAL LIABILITY - BLANKET ADDITIONAL INSURED, BLANKET ADDITIONAL INSURED COMPLETED OPS, BLANKET WAIVER OF SUBROGATION. COVERAGE IS PRIMARY AND NON-CONTRIBUTORY  
BUSINESS AUTO - BLANKET ADDITIONAL INSURED, BLANKET WAIVER OF SUBROGATION. COVERAGE IS PRIMARY AND NON-CONTRIBUTORY.

<b>CERTIFICATE HOLDER</b>		<b>CANCELLATION</b>	
City of Madeira Beach 300 Municipal Drive  Madeira Beach FL 33708		SHOULD ANY OF THE ABOVE DESCRIBED POLICIES BE CANCELLED BEFORE THE EXPIRATION DATE THEREOF, NOTICE WILL BE DELIVERED IN ACCORDANCE WITH THE POLICY PROVISIONS.  AUTHORIZED REPRESENTATIVE 	

© 1988-2015 ACORD CORPORATION. All rights reserved.

AGENCY CUSTOMER ID: 00200186

LOC #: \_\_\_\_\_



### ADDITIONAL REMARKS SCHEDULE

Page \_\_\_\_ of \_\_\_\_

AGENCY Herndon-Carr & Company		NAMED INSURED i2 Visual, Inc.	
POLICY NUMBER			
CARRIER	NAIC CODE	EFFECTIVE DATE:	

**ADDITIONAL REMARKS**

**THIS ADDITIONAL REMARKS FORM IS A SCHEDULE TO ACORD FORM,**  
**FORM NUMBER:** 25      **FORM TITLE:** Certificate of Liability Insurance

NON-CONTRIBUTORY.  
 WORKERS COMPENSATION - BLANKET WAIVER OF SUBROGATION



# **TAB F**

## **SIGNED AGREEMENTS**

**EXHIBIT A**  
**PUBLIC CONTRACTING AND ENVIRONMENTAL CRIMES CERTIFICATION**

THIS FORM MUST BE SIGNED AND SWORN TO IN THE PRESENCE OF A NOTARY PUBLIC OR OTHER OFFICIAL AUTHORIZED TO ADMINISTER OATHS.

This sworn statement is submitted to the CITY OF MADEIRA BEACH by John Hose, President  
[print individual's name and title]

for i2 Visual, Inc.  
[print name of entity submitting sworn statement]

whose business address is: 1606 Benchmark Ave., Fort Myers, FL 33905

and Federal Employer Identification Number (FEIN) is 27-5113425, if the entity has no FEIN, include the Social Security Number of the individual signing this sworn statement: \_\_\_\_\_

I understand that no person or entity shall be awarded or receive a City contract for public improvements, procurement of goods or services (including professional services) or a City lease, franchise, concession, or management agreement, or shall receive a grant of City monies unless such person or entity has submitted a written certification to the City that it has not:

1. been convicted of bribery or attempting to bribe a public officer or employee of the city, the State of Florida, or any other public entity, including, but not limited to the Government of the United States, any state, or any local government authority in the United States, in that officer's or employee's official capacity; or
2. been convicted of an agreement or collusion among bidders or prospective bidders in restraint of freedom of competition, by agreement to bid a fixed price, or otherwise; or
3. been convicted of a violation of an environmental law that, in the sole opinion of the City's Project Manager, reflects negatively upon the ability of the person or entity to conduct business in a responsible manner; or
4. made an admission of guilt of such conduct described in items (1), (2) or (3) above, which is a matter of record, but has not been prosecuted for such conduct, or has made an admission of guilt of such conduct, which is a matter of record, pursuant to formal prosecution. An admission of guilt shall be construed to include a plea of nolo contendere; or
5. where an officer, official, agent or employee of a business entity has been convicted of or has admitted guilt to any of the crimes set forth above on behalf of such and entity and pursuant to the direction or authorization of an official thereof (including the person committing the offense, if he is an official of the business entity), the business shall be chargeable with the conduct herein above set forth. A business entity shall be chargeable with the conduct of an affiliated entity, whether wholly owned, partially owned, or one which has common ownership or a common Board of Directors. For purposes of this Form, business entities are affiliated if, directly or indirectly, one business entity controls or has the power to control another business entity, or if an individual or group of individuals controls or has the power to control both entities. Indicia of control shall include, without limitation, interlocking management or ownership, identity of interests among family members, shared organization of a business entity following the ineligibility of a business entity under this Article, or using substantially the same management, ownership, or principles as the ineligible entity.

Any person or entity who claims that this Article is inapplicable to him/her/it because a conviction or judgment has been reversed by a court of competent jurisdiction, shall prove the same with documentation satisfactory to the City Manager. Upon presentation of such satisfactory proof, the person or entity shall be allowed to contract with the City.

I UNDERSTAND THAT THE SUBMISSION OF THIS FORM TO THE CITY IS VALID THROUGH DECEMBER 31 OF THE CALENDAR YEAR IN WHICH IT IS FILED. I ALSO UNDERSTAND THAT ANY CONTRACT OR BUSINESS TRANSACTION SHALL PROVIDE FOR SUSPENSION OF PAYMENTS, OR TERMINATION, OR BOTH, IF THE CONTRACTING OFFICER OR THE CITY ADMINISTRATOR DETERMINES THAT SUCH PERSON OR ENTITY HAS MADE FALSE CERTIFICATION.



Signatory Requirement. In the case of a corporation, this affidavit shall be executed by the corporate president. In the case of a partnership, this affidavit shall be executed by the general partner(s). In the case of a business entity other than a partnership or a corporation, this affidavit shall be executed by an authorized agent of the entity or the individual.

*[Handwritten Signature]*

Authorized Signature

01/08/2024

Date Signed

State of: Florida

County of: Lee

Sworn to and subscribed before me this 8 day of January, 2024

Personally Known  or Produced Identification \_\_\_\_\_

(Specify Type of Identification)

*[Handwritten Signature]* Signature of Notary

My Commission Expires 4/6/2026



**SUSAN LONG**  
Notary Public  
State of Florida  
Comm# HH205915  
Expires 4/6/2026

## EXHIBIT B DRUG FREE WORKPLACE CERTIFICATION

THIS FORM MUST BE SIGNED AND SWORN TO IN THE PRESENCE OF A NOTARY PUBLIC OR OTHER OFFICIAL AUTHORIZED TO ADMINISTER OATHS.

This sworn statement is submitted to the City of Madeira Beach by John Hose, President  
[print individual's name and title]

for i2 Visual, Inc. [print name of entity submitting sworn statement]

whose business address is: 1606 Benchmark Ave., Fort Myers, FL 33905 and (if applicable) its Federal Employer Identification Number (FEIN) is 27-5113425 (If the entity has no FEIN, include the Social Security Number of the individual signing this sworn statement: \_\_\_\_\_)

I understand that no person or entity shall be awarded or receive a City contract for public improvements, procurement of goods or services (including professional services) or a City lease, franchise, concession, or management agreement, or shall receive a grant of City monies unless such person or entity has submitted a written certification to the City that it will provide a drug free workplace by:

Providing a written statement to each employee notifying such employee that the unlawful manufacture, distribution, dispensation, possession, or use of a controlled substance as defined by §893.02(4), Florida Statutes, as the same may be amended from time to time, in the person's or entity's workplace is prohibited specifying the actions that will be taken against employees for violation of such prohibition. Such written statement shall inform employees about:

- (i) the dangers of drug abuse in the workplace.
  - (ii) the person's or entity's policy of maintaining a drug-free environment at all its workplaces, including but not limited to all locations where employees perform any task relating to any portion of such contract, business transaction or grant.
  - (iii) any available drug counseling, rehabilitation, and employee assistance programs; and
  - (iv) the penalties that may be imposed upon employees for drug abuse violations.
- (2) Requiring the employee to sign a copy of such written statement to acknowledge his or her receipt of same and advice as to the specifics of such policy. Such person or entity shall retain the statements signed by its employees. Such person or entity shall also post in a prominent place at all of its workplaces a written statement of its policy containing the foregoing elements (i) through (iv).
- (3) Notifying the employee in the statement required by subsection (1) that as a condition of employment the employee will:
- (i) abide by the terms of the statement; and
  - (ii) notify the employer of any criminal drug statute conviction for a violation occurring in the workplace no later than five (5) days after such a conviction.
- (4) Notifying the City within ten (10) days after receiving notice under subsection (3) from an employee or otherwise receiving actual notice of such conviction.
- (5) Imposing appropriate personnel action against such employee up to and including termination; or requiring such employee to satisfactorily participate in a drug abuse assistance or rehabilitation program approved for such purposes by a federal, state, or local health, law enforcement, or other appropriate agency.
- (6) Making a good faith effort to continue to maintain a drug free workplace through implementation of sections (1) through (5) stated above.

I UNDERSTAND THAT THE SUBMISSION OF THIS FORM TO THE CITY OF MADEIRA BEACH IS

VALID THROUGH DECEMBER 31 OF THE CALENDAR YEAR IN WHICH IT IS FILED. I ALSO UNDERSTAND THAT ANY CONTRACT OR BUSINESS TRANSACTION SHALL PROVIDE FOR SUSPENSION OF PAYMENTS, OR TERMINATION, OR BOTH, IF THE CITY DETERMINES THAT:

- (1) Such person or entity has made false certification.
- (2) Such person or entity violates such certification by failing to carry out the requirements of sections (1), (2), (3), (4), (5), or (6) or subsection 3-101(7)(B); or
- (3) Such a number of employees of such person or entity have been convicted of violations occurring in the workplace as to indicate that such person or entity has failed to make a good faith effort to provide a drug free workplace as required by subsection 3-101(7)(B).

**Signatory Requirement.** In the case of a corporation, this affidavit shall be executed by the corporate president. In the case of a partnership, this affidavit shall be executed by the general partner(s). In the case of a business entity other than a partnership or a corporation, this affidavit shall be executed by an authorized agent of the entity or the individual.

*[Handwritten Signature]*

Authorized Signature

01/08/2024

Date Signed

State of: Florida

County of: Lee

Sworn to and subscribed before me this 8 day of January, 2024

Personally Known  or Produced Identification \_\_\_\_\_

(Specify Type of Identification)

*[Handwritten Signature]*  
Signature of Notary

My Commission Expires 4/6/2026



**SUSAN LONG**  
Notary Public  
State of Florida  
Comm# HH205915  
Expires 4/6/2026



# Memorandum

**Meeting Details:** February 14, 2024

**Prepared For:** Mayor & Board of Commissioners

**From:** Megan Wepfer, Public Works Director

**Subject:** Purchase 2023 Chevy Silverado 5500 Regular Cab 2WD

---

## Background

The public works department is requesting approval to purchase a 2023 Chevy Silverado 5500 Regular Cab 2WD that has been discussed during budget workshops and approved in the final FY24 budget. The truck has been budgeted in the Public Works Administration budget for \$75,000. Alan Jay is on the City of Tallahassee Purchasing Contract 5179-2023 City of Tallahassee. This truck will replace a 2004 Ford F550 that serves as the chassis for the Duralift Bucket truck which is used in various departments. The Duralift will be removed from the current truck and installed on the new one. Swapping the Duralift will require additional cost from a Fabricator but will stay within the allocated budget of \$75,000.

## Fiscal Impact

\$75,000 has been budgeted in FY24 and the truck price is \$54,880.00. With the fabrication needed to switch the body staff will stay within budget.

## Recommendation(s)

Staff recommends the approval of the 2023 Chevy Silverado 5500 Regular Cab 2WD from Alan Jay for the amount of \$54,880.00.

## Attachments

- Alan Jay Quote
- Duralift Specs

Call Us first, for all of your Fleet Automotive, & Light Truck needs.

Quote

PHONE (800) ALANJAY (252-6529)		DIRECT 863-402-4234	WWW.ALANJAY.COM	52178-2
Corporate Office	2003 U.S. 27 South Sebring, FL 33870	MOBILE 863-273-1105	Mailing Address	P.O. BOX 9200 Sebring, FL 33871-9200
		FAX 863-402-4221		

ORIGINAL QUOTE DATE  
1/29/2024

## QUICK QUOTE SHEET

REVISED QUOTE DATE  
1/29/2024

REQUESTING AGENCY	MADEIRA BEACH, CITY OF		
CONTACT PERSON	MEGAN WEPFER	EMAIL	<a href="mailto:mwepfer@madeirabeachfl.gov">mwepfer@madeirabeachfl.gov</a>
PHONE	727-543-8154	MOBILE	FAX

### CONTRACT NUMBER 5179 - 2023 CITY OF TALLAHASSEE

MODEL	CC56403 R7N 1WT	MSRP	\$63,301.64
	2023 CHEVY SILVERADO 5500 MEDIUM DUTY REGULAR CAB 2WD 1WT 60" CA		
CUSTOMER ID		GOVERNMENT PRICE	\$49,590.00
BED LENGTH	60"CA		

\*\* All vehicles will be ordered white w/ darkest interior unless clearly stated otherwise on purchase order.

#### FACTORY OPTIONS

#### DESCRIPTION

FACTORY OPTIONS	DESCRIPTION	
066	OPTIONS Rear axle, 4.10 ratio	\$0.00
1WT	Work Truck Preferred Equipment Group	\$0.00
9L3	Spare tire delete	\$0.00
A31	Windows, power with driver express up and down and express down on all other windows	\$285.00
AE7	Seats, front 40/20/40 split-bench, 3-passenger	\$0.00
AQQ	Remote Keyless Entry	\$170.00
BJA	Fuel Fill Kit	\$120.00
BTN	Battery, top post threaded, battery jump start stud	\$45.00
DPN	Mirrors, outside heated power-adjustable vertical trailering, upper glass, manual-folding and extending, black.	\$350.00
ED9	Wheelbase, 165" (419.1 cm), 84" CA	\$170.00
F59	Front stabilizer bar	\$170.00
FTC	Front axle, 6,250 lb. (2,835 kg), Dana Spicer D800-N, "I"-beam, non-driving	\$0.00
FTW	Front suspension, 6,250 lb. (2,835 kg) multi-leaf, includes shock absorbers	\$0.00
G68	Shock Absorbers, rear	\$0.00
G7C	Red Hot	\$0.00
G86	Axle, limited slip, Dana Spicer Truetrac, torque proportioning limited slip	\$390.00
GR4	Rear suspension, 13,500 lb. (6,123 kg) multi-leaf, vari-rate	\$20.00
GZG	GVWR, 19,500 lb. (8845 kg)	\$2,250.00
H2Q	Dark Ash seats with Jet Black interior accents, Vinyl seat trim	\$0.00
HD2	Rear axle, 13,500 lb. (6,124 kg) Dana Spicer S14-110, single reduction	\$350.00
IOB	Audio system, 7" diagonal color touch-screen with Chevrolet Infotainment	\$270.00
L5D	Engine, Duramax 6.6L Turbo-Diesel V8, B20-Diesel compatible	\$0.00
MIU	Rugged Duty Service Transmission, Automatic close-ratio 6 SPD with double overdrive, Allison, A1700RDS	\$285.00
N12	Exhaust system, rear exit	\$45.00
PTO	Power Take Off, engine control provisions	\$275.00
PWR	Wheels, 19.5" x 6.75", steel, Grey painted, 8-holes, hub piloted	\$75.00
R6G	26,000 lb. GCWR (11,793 kg)	\$0.00
R7N	5500 HD Series	\$0.00
UQ3	6-speaker audio system	\$0.00
V76	Recovery hooks, front, frame-mounted, Black	\$20.00
XDK	Tires, front 225/70R19.5G highway blackwall Goodyear	\$0.00
YAL	Tires, rear 225/70R19.5G highway blackwall Goodyear	\$0.00
ZY1	Paint, solid	\$0.00
	Bluetooth for phone, personal cell phone connectivity to vehicle audio system	\$0.00

FACTORY OPTIONS \$5,149

### CONTRACT NUMBER 5179 - 2023 CITY OF TALLAHASSEE

AFTERMARKET OPTIONS	DESCRIPTION	
CHASSIS ONLY	CUSTOMER TO FACILITATE COMPLETED VEHICLE CERTIFICATION & REGISTER WITH 2ND STAGE MSO AT A LATER TIME ONCE BODY IS SWAPPED.	\$0.00
EWD	EXTENDED WARRANTY DECLINED	\$0.00
NO-TEMP	TEMP TAG NOT REQUESTED, CUSTOMER WILL HANDLE THEIR OWN TAG WORK.	\$0.00
<b>AFTERMARKET OPTIONS</b>		<b>\$0.00</b>

<b>TRADE IN</b>		<b>TOTAL COST</b>	<b>\$54,880.00</b>
	<b>YES WE TAKE TRADE INS ~~~ ASK ABOUT MUNICIPAL FINANCING ~~~</b>		\$0.00
	<b>TOTAL COST LESS TRADE IN(S)</b>	<b>QTY 1</b>	<b>\$54,880.00</b>

Estimated Annual payments for 60 months paid in advance: \$12,290.86  
 Municipal finance for any essential use vehicle, requires lender approval, WAC.

**Comments**      **ORDERED UNIT VIN: [PH624540]**

VEHICLE QUOTED BY      **ASHLEE WILSON**      GOVERNMENT ACCOUNT MANAGER      [Ashlee.Wilson@AlanJay.com](mailto:Ashlee.Wilson@AlanJay.com)

*"I Want to be Your Fleet Provider"*

*I appreciate the opportunity to submit this quotation. Please review it carefully. If there are any errors or changes, please feel free to contact me at any time. I am always happy to be of assistance.*



# Alan Jay Fleet Sales

Chris Wilson | 863-402-4234 | chris.wilson@alanjay.com

Item 11C.

Vehicle: [Fleet] 2023 Chevrolet Silverado MD (CC56403) 2WD Reg Cab Work Truck (✔ Complete)



Note: Photo may not represent exact vehicle or selected equipment.

## Window Sticker

### SUMMARY

[Fleet] 2023 Chevrolet Silverado MD (CC56403) 2WD Reg Cab Work Truck

MSRP: \$56,105.00

Interior: Dark Ash seats with Jet Black interior accents, Vinyl seat trim

Exterior 1: Red Hot

Exterior 2: No color has been selected.

Engine, Duramax 6.6L Turbo-Diesel V8, B20-Diesel compatible

Rugged Duty Service Transmission, Automatic close-ratio 6 SPD with double overdrive, Allison, A1700RDS

### OPTIONS

CODE	MODEL	MSRP
CC56403	[Fleet] 2023 Chevrolet Silverado MD (CC56403) 2WD Reg Cab Work Truck	\$56,105.00
<b>OPTIONS</b>		
066	Rear axle, 4.10 ratio	\$0.00
1WT	Work Truck Preferred Equipment Group	\$0.00
9L3	Spare tire delete	\$0.00
A31	Windows, power with driver express up and down and express down on all other windows	\$290.00
AE7	Seats, front 40/20/40 split-bench, 3-passenger	\$0.00
AQQ	Remote Keyless Entry	\$175.00
BJA	Fuel Fill Kit	\$125.00
BTN	Battery, top post threaded, battery jump start stud	\$50.00
DPN	Mirrors, outside heated power-adjustable vertical trailing, upper glass, manual-folding and extending, black.	\$355.00
ED9	Wheelbase, 165" (419.1 cm), 84" CA	\$175.00
F59	Front stabilizer bar	\$175.00

This document contains information considered Confidential between GM and its Clients uniquely. The information provided is not intended for public disclosure. Prices, specifications, and availability are subject to change without notice, and do not include certain fees, taxes and charges that may be required by law or vary by manufacturer or region. Performance figures are guidelines only, and actual performance may vary. Photos may not represent actual vehicles or exact configurations. Content based on report preparer's input is subject to the accuracy of the input provided.

Data Version: 17875. Data Updated: Nov 3, 2022 6:50:00 PM PDT.



# Alan Jay Fleet Sales

Chris Wilson | 863-402-4234 | chris.wilson@alanjay.com

Item 11C.

Vehicle: [Fleet] 2023 Chevrolet Silverado MD (CC56403) 2WD Reg Cab Work Truck (✔ Complete)

FTC	Front axle, 6,250 lb. (2,835 kg), Dana Spicer D800-N, "I"-beam, non-driving		\$0.00
FTW	Front suspension, 6,250 lb. (2,835 kg) multi-leaf, includes shock absorbers		\$0.00
G68	Shock Absorbers, rear	Inc.	
G7C	Red Hot		\$0.00
G86	Axle, limited slip, Dana Spicer Truetrac, torque proportioning limited slip		\$395.00
GR4	Rear suspension, 13,500 lb. (6,123 kg) multi-leaf, vari-rate		\$25.00
GZG	GVWR, 19,500 lb. (8845 kg)		\$2,255.00
H2Q	Dark Ash seats with Jet Black interior accents, Vinyl seat trim		\$0.00
HD2	Rear axle, 13,500 lb. (6,124 kg) Dana Spicer S14-110, single reduction		\$355.00
IOB	Audio system, 7" diagonal color touch-screen with Chevrolet Infotainment		\$275.00
L5D	Engine, Duramax 6.6L Turbo-Diesel V8, B20-Diesel compatible		\$0.00
MIU	Rugged Duty Service Transmission, Automatic close-ratio 6 SPD with double overdrive, Allison, A1700RDS		\$290.00
N12	Exhaust system, rear exit		\$50.00
PTO	Power Take Off, engine control provisions		\$280.00
PWR	Wheels, 19.5" x 6.75", steel, Grey painted, 8-holes, hub piloted		\$80.00
R6G	26,000 lb. GCWR (11,793 kg)		\$0.00
R7N	5500 HD Series	Inc.	
UQ3	6-speaker audio system	Inc.	
V76	Recovery hooks, front, frame-mounted, black		\$25.00
XDK	Tires, front 225/70R19.5G highway blackwall Goodyear		\$0.00
YAL	Tires, rear 225/70R19.5G highway blackwall Goodyear		\$0.00
ZY1	Paint, solid		\$0.00
—	Bluetooth for phone, personal cell phone connectivity to vehicle audio system	Inc.	

<b>SUBTOTAL</b>	<b>\$61,480.00</b>
Adjustments Total	\$0.00
Tire Weight Tax	\$26.64
Destination Charge	\$1,795.00

This document contains information considered Confidential between GM and its Clients uniquely. The information provided is not intended for public disclosure. Prices, specifications, and availability are subject to change without notice, and do not include certain fees, taxes and charges that may be required by law or vary by manufacturer or region. Performance figures are guidelines only, and actual performance may vary. Photos may not represent actual vehicles or exact configurations. Content based on report preparer's input is subject to the accuracy of the input provided.

Data Version: 17875. Data Updated: Nov 3, 2022 6:50:00 PM PDT.





# Alan Jay Fleet Sales

Chris Wilson | 863-402-4234 | chris.wilson@alanjay.com

Item 11C.

Vehicle: [Fleet] 2023 Chevrolet Silverado MD (CC56403) 2WD Reg Cab Work Truck ( Complete )

**TOTAL PRICE**

**\$63,301.64**

## Standard Equipment

### Mechanical

GVWR, 16,500 lb. (7484 kg) (Silverado 4500 HD 2WD Regular Cab models require one of the following combinations: (1) (FTC) 6.25k front axle and (FTW) 6.25k front suspension and (GL4) 11k rear axle and (GR3) 11k rear suspension. (2) (FTC) 6.25k front axle and (FTW) 6.25k front suspension and one of the following rear axles: (HD2) 13.5k rear axle, (HD1) 15k rear axle or (J27) 15.5k rear axle and (GR4) 13.5k rear suspension. (3) (FTA) 7k front axle and (FK6) 7k front suspension and (FN1) 10k rear axle or (GL4) 11k rear axle and (GR3) 11k rear suspension or (G40) 12K Rear air suspension. (4) (FTA) 7k front axle and (FK6) 7k front suspension and (HD1) 15k rear axle or (J27) 15.5k rear axle and one of the following rear suspensions: (GR4) 13.5k rear suspension, (FU7) 15.5k rear suspension, (GP1) 13.5K rear air suspension, (GP8) 15.5k rear air suspension, (91B) 13.5k LiquidSpring prep single volume rear suspension, (91C) 13.5k LiquidSpring prep stacked volume rear suspension, (91D) 15.5k LiquidSpring prep single volume rear suspension or (91E) 15.5k LiquidSpring prep stacked volume rear suspension.) (STD)

Emissions, 50 state certification

Emissions, USA 50 State certified

Engine, Duramax 6.6L Turbo-Diesel V8, B20-Diesel compatible 350 hp @ 2700 rpm, 700 lb.-ft. torque @ 1600 rpm (STD)

Highway Service Transmission, Automatic close-ratio 6 SPD with double overdrive, Allison, A1700HS ratios: 3.10 1ST, 1.80 2ND, 1.40 3RD, 1.00 4TH, 0.70 5TH, 0.61 6TH Highway Series, 19.5K GVW & 26K GCW Max., requires PTX and park pawl. Available with GVWs less than or equal to 19.5K (Requires (C7Y) 14,001 lb. GVWR, (C5B) 15,000 lb. GVWR, (C7P) 16,000 lb. GVWR, (C7R) 16,500 lb. GVWR, (GZX) 17,500 lb. GVWR, (GZJ) 18,000 lb. GVWR or (GZG) 19,500 lb. GVWR. Requires (R6G) 26,000 lb. GCWR (11,793 kg).) (STD)

Rear axle, 4.10 ratio Max road speed: 79 MPH

Wheelbase, 141" (358.1 cm), 60" CA (Requires (F0C) 49" axle to end of frame, (F0D) 63" axle to end of frame or (F0K) 91" axle to end of frame and (NPR) exhaust. Requires (PCJ) Vocational Specific Heavy Suspension Package, when ordering (FTA) 7,000 lb. Front axle/(FK6) 7,000 lb. Front suspension or (FTL) 8,000 lb. Front axle/(FSN) 8,000 lb. Front suspension and/or (FU7) 15,500 lb. rear suspension. Not available with rear air suspensions or (91B), (91C), (91D) or (91E) prep for LiquidSpring rear suspension.) (STD)

Front axle, 6,250 lb. (2,835 kg), Dana Spicer D800-N, "I"-beam, non-driving (Requires (FTW) 6,250 lb. front suspension. Includes (G68) rear shock absorbers. Not available with rear air suspensions.)

Front suspension, 6,250 lb. (2,835 kg) multi-leaf, includes shock absorbers (Not available with rear air suspensions.) (STD)

Rear axle, 11,000 lb. (4,999 kg) Dana Spicer S14-110, single reduction

Rear suspension, 11,000 lb. (4,990 kg) multi-leaf, vari-rate (Not available with air suspension.) (STD)

Neutral-at-Stop Automatic transmission shifts to neutral when the service brake is depressed while the vehicle is at a complete stop, and remains in neutral until the service brake is released

Transmission shift control calibration, fuel sense Performance

Rear wheel drive

Batteries, heavy-duty dual 1100 cold-cranking amps includes battery box mounted to left side under cab

This document contains information considered Confidential between GM and its Clients uniquely. The information provided is not intended for public disclosure. Prices, specifications, and availability are subject to change without notice, and do not include certain fees, taxes and charges that may be required by law or vary by manufacturer or region. Performance figures are guidelines only, and actual performance may vary. Photos may not represent actual vehicles or exact configurations. Content based on report preparer's input is subject to the accuracy of the input provided.

Data Version: 17875. Data Updated: Nov 3, 2022 6:50:00 PM PDT.



# Alan Jay Fleet Sales

Chris Wilson | 863-402-4234 | chris.wilson@alanjay.com

Item 11C.

Vehicle: [Fleet] 2023 Chevrolet Silverado MD (CC56403) 2WD Reg Cab Work Truck (✔ Complete)

## Mechanical

- Alternator, 150 amps
- Trailing provisions, trailing wire harness only, trailer combined (Stop/Tail/Turn) connection socket and harness mounted at rear of frame.
- Trailer brake controller, integrated
- Incomplete vehicle
- Axle to End of Frame, 49" (Requires wheelbase (ED5) 201", (ED9) 165", (ER2) 189" or (FQT) 141". Not available with (G40), (GP1) or (GP8) rear air suspension.)
- Axle, Open rear axle, non-locking rear
- Axle lubricant, rear, synthetic oil EmGard FE -75W-90
- Shock Absorbers, rear (Included with (FTC) 6,250 lb. front axle.)
- Steering, power (Bosch S2 8014 Plus)
- Brakes, hydraulic, heavy duty Bosch/Meritor/Wabco system with 4-channel (ABS) (Includes (J69) driveline park brake.)
- Fuel tank, rear only, 40 gallon mounted between frame side rails and behind rear axle
- Fuel, diesel B20
- Capped Fuel Fill
- Exhaust system, right side exit, behind rear wheels (Requires (FQT) 141" wheelbase.)
- Exhaust brake

## Exterior

- Wheels, 19.5" x 6.75", steel, Black painted, 8-holes, hub piloted (STD)
- Tires, front 225/70R19.5G highway blackwall Goodyear Max Axle Load: 7,940 lb. (Requires (YAL) Tires, rear 225/70R19.5G highway blackwall Goodyear, Max Axle Load: 15,000 lb. or (YMF) Tires, rear 225/70R19.5G traction blackwall Goodyear, Max Axle Load: 15,000 lb.) (STD)
- Tires, rear 225/70R19.5G highway blackwall Goodyear Max Axle Load: 15,000 lb. (STD)
- Spare tire delete (STD)
- Wheel, spare delete
- Bumper, front, Black
- Assist steps
- Front fender extension, painted body color
- Grille, base, molded in color, Black
- Grille guard screen, insect protection (mounted behind grille)
- Headlamps, halogen projector-beam

This document contains information considered Confidential between GM and its Clients uniquely. The information provided is not intended for public disclosure. Prices, specifications, and availability are subject to change without notice, and do not include certain fees, taxes and charges that may be required by law or vary by manufacturer or region. Performance figures are guidelines only, and actual performance may vary. Photos may not represent actual vehicles or exact configurations. Content based on report preparer's input is subject to the accuracy of the input provided.  
 Data Version: 17875. Data Updated: Nov 3, 2022 6:50:00 PM PDT.



# Alan Jay Fleet Sales

Chris Wilson | 863-402-4234 | chris.wilson@alanjay.com

Item 11C.

Vehicle: [Fleet] 2023 Chevrolet Silverado MD (CC56403) 2WD Reg Cab Work Truck (✔ Complete)

## Exterior

- Lamps, cargo area, cab mounted with switch on center switch bank
- Lamps, Smoked Amber roof marker
- Lamps, rear, stop/turn/backup (1-piece assembly) with license plate light
- Mirrors, outside high-visibility vertical camper-style, Black with manual folding and extension and lower convex spotter glass
- Glass, solar absorbing, tinted
- Antenna, fixed mast
- Door handles, Black

## Entertainment

- Audio system, 4.2" diagonal color display AM/FM stereo with USB port and auxiliary jack (Requires (AE7) front 40/20/40 split-bench seat. Not available with (UE1) OnStar or (U2K) SiriusXM Radio.) (STD)
- SiriusXM, delete
- Audio system feature, 4-speaker system

## Interior

- Seats, front 40/20/40 split-bench, 3-passenger driver and front passenger recline with outboard head restraints and center fold-down armrest with storage. Vinyl has fixed lumbar and cloth has manually adjustable driver lumbar. (STD)
- Interior trim, Jet Black/Dark Ash (Required and only available with (H2Q/H2R) Dark Ash seats with Jet Black interior accents.)
- Seat trim, Vinyl
- Seat Belt, Black
- Floor covering, Graphite-colored rubberized-vinyl
- Steering wheel, urethane
- Steering column, manual Tilt-Wheel
- Instrumentation, 6-gauge cluster featuring speedometer, fuel level, engine temperature, tachometer, voltage and oil pressure
- Speedometer, miles/kilometers
- Driver Information Center, 3.5-inch diagonal monochromatic display, provides warning messages and basic vehicle information
- Upfitter switch kit provides up to 4-30 amp circuits to facilitate installation of aftermarket electrical accessories located on the instrument panel
- Windows, manual driver and front passenger
- Door locks, power

This document contains information considered Confidential between GM and its Clients uniquely. The information provided is not intended for public disclosure. Prices, specifications, and availability are subject to change without notice, and do not include certain fees, taxes and charges that may be required by law or vary by manufacturer or region. Performance figures are guidelines only, and actual performance may vary. Photos may not represent actual vehicles or exact configurations. Content based on report preparer's input is subject to the accuracy of the input provided.  
 Data Version: 17875. Data Updated: Nov 3, 2022 6:50:00 PM PDT.



# Alan Jay Fleet Sales

Chris Wilson | 863-402-4234 | chris.wilson@alanjay.com

Item 11C.

Vehicle: [Fleet] 2023 Chevrolet Silverado MD (CC56403) 2WD Reg Cab Work Truck ( Complete )

## Interior

Cruise control, steering wheel-mounted

Air conditioning, single-zone

Mirror, inside rearview manual day/night

Visors, driver and front passenger, vinyl

Assist handle, front passenger and driver on A-pillars

## Safety-Mechanical

Brake, parking, driveline park brake system

StabiliTrak, Electronic Stability Control System with Traction Control includes Electronic Trailer Sway Control and Hill Start Assist

Traction control

## Safety-Exterior

Daytime Running Lamps, with automatic exterior lamp control

## Safety-Interior

Airbags, Single-stage frontal airbags for driver and front outboard passenger; Seat-mounted side-impact airbags for driver and front outboard passenger; Head-curtain airbags for front outboard seating positions; Includes airbag deactivation switch for front outboard passenger airbag (Always use seat belts and child restraints. Children are safer when properly secured in a rear seat in the appropriate child restraint. See the Owner's Manual for more information.)

Airbag deactivation switch, frontal passenger-side (Included and only available with (AY0) airbags.)

OnStar, delete

Rear Vision Camera, display integrated into Radio (Shipped loose in cab for upfitter installation.)

Horn, single-note

This document contains information considered Confidential between GM and its Clients uniquely. The information provided is not intended for public disclosure. Prices, specifications, and availability are subject to change without notice, and do not include certain fees, taxes and charges that may be required by law or vary by manufacturer or region. Performance figures are guidelines only, and actual performance may vary. Photos may not represent actual vehicles or exact configurations. Content based on report preparer's input is subject to the accuracy of the input provided.

Data Version: 17875. Data Updated: Nov 3, 2022 6:50:00 PM PDT.



# Alan Jay Fleet Sales

Chris Wilson | 863-402-4234 | chris.wilson@alanjay.com

Item 11C.

Vehicle: [Fleet] 2023 Chevrolet Silverado MD (CC56403) 2WD Reg Cab Work Truck (✔ Complete)

## WARRANTY

Warranty Note: <<< Preliminary 2023 Warranty >>>  
Basic Years: 3  
Basic Miles/km: 36,000  
Drivetrain Years (Allison Basic): 5  
Drivetrain Years: 5  
Drivetrain Miles/km (Allison Basic): Unlimited  
Drivetrain Miles/km: 100,000  
Drivetrain Note: Duramax Diesel  
Corrosion Years (Rust-Through): 6  
Corrosion Years: 3  
Corrosion Miles/km (Rust-Through): 100,000  
Corrosion Miles/km: 36,000  
Roadside Assistance Years: 5  
Roadside Assistance Miles/km: 100,000  
Maintenance Note: 1 Year/1 Visit

This document contains information considered Confidential between GM and its Clients uniquely. The information provided is not intended for public disclosure. Prices, specifications, and availability are subject to change without notice, and do not include certain fees, taxes and charges that may be required by law or vary by manufacturer or region. Performance figures are guidelines only, and actual performance may vary. Photos may not represent actual vehicles or exact configurations. Content based on report preparer's input is subject to the accuracy of the input provided.

Data Version: 17875. Data Updated: Nov 3, 2022 6:50:00 PM PDT.



# Alan Jay Fleet Sales

Chris Wilson | 863-402-4234 | chris.wilson@alanjay.com

Item 11C.

Vehicle: [Fleet] 2023 Chevrolet Silverado MD (CC56403) 2WD Reg Cab Work Truck (✔ Complete)

## Technical Specifications

### Dimensions

#### Interior Dimensions

Passenger Capacity	3	Front Head Room	42.8 in
Front Leg Room	45.28 in	Front Shoulder Room	66.02 in
Front Hip Room	60.75 in		

#### Exterior Dimensions

Wheelbase	165 in	Length, Overall w/o rear bumper	N/A
Length, Overall	248.5 in	Width, Max w/o mirrors	92.7 in
Height, Overall	82.81 in	Overhang, Front	34.4 in
Overhang, Rear w/o bumper	49 in	Front Bumper to Back of Cab	115.47 in
Cab to Axle	84 in	Cab to End of Frame	133.1 in
Ground to Top of Load Floor	N/A	Ground to Top of Frame	N/A
Frame Width, Rear	34.1 in	Ground Clearance, Front	N/A
Ground Clearance, Rear	N/A	Body Length	0.0 ft
Cab to Body	3.0 in	Frontal Area	ft <sup>2</sup>

### Medium Duty

#### Medium Duty Performance

Front Axle %	63.64	Rear Axle %	36.36
Driver Weight	350.0 lbs	Front Ground Load	5085.00 lbs
Rear Ground Load	2905.00 lbs	1st gear High Speed (High Axle Gear)	21.39 MPH
2nd gear High Speed (High Axle Gear)	36.84 MPH	3rd gear High Speed (High Axle Gear)	47.36 MPH
4th gear High Speed (High Axle Gear)	66.31 MPH	5th gear High Speed (High Axle Gear)	94.73 MPH
6th gear High Speed (High Axle Gear)	108.71 MPH	1st gear Low Speed (High Axle Gear)	11.80 MPH
2nd gear Low Speed (High Axle Gear)	20.33 MPH	3rd gear Low Speed (High Axle Gear)	26.13 MPH
4th gear Low Speed (High Axle Gear)	36.59 MPH	5th gear Low Speed (High Axle Gear)	52.26 MPH
6th gear Low Speed (High Axle Gear)	59.98 MPH	1st gear High Speed (Low Axle Gear)	N/A
2nd gear High Speed (Low Axle Gear)	N/A	3rd gear High Speed (Low Axle Gear)	N/A
4th gear High Speed (Low Axle Gear)	N/A	5th gear High Speed (Low Axle Gear)	N/A

This document contains information considered Confidential between GM and its Clients uniquely. The information provided is not intended for public disclosure. Prices, specifications, and availability are subject to change without notice, and do not include certain fees, taxes and charges that may be required by law or vary by manufacturer or region. Performance figures are guidelines only, and actual performance may vary. Photos may not represent actual vehicles or exact configurations. Content based on report preparer's input is subject to the accuracy of the input provided.

Data Version: 17875. Data Updated: Nov 3, 2022 6:50:00 PM PDT.



# Alan Jay Fleet Sales

Chris Wilson | 863-402-4234 | chris.wilson@alanjay.com

Item 11C.

Vehicle: [Fleet] 2023 Chevrolet Silverado MD (CC56403) 2WD Reg Cab Work Truck (✔ Complete)

## Medium Duty

### Medium Duty Performance

6th gear High Speed (Low Axle Gear)	N/A	1st gear Low Speed (Low Axle Gear)	N/A
2nd gear Low Speed (Low Axle Gear)	N/A	3rd gear Low Speed (Low Axle Gear)	N/A
4th gear Low Speed (Low Axle Gear)	N/A	5th gear Low Speed (Low Axle Gear)	N/A
6th gear Low Speed (Low Axle Gear)	N/A	Reduction	22.42
Torque @ Clutch Engage	N/A	Starting Grade Index	N/A
1st Gear Tractive Effort (High Axle Gear)	5921.84	2nd Gear Tractive Effort (High Axle Gear)	3438.49
3rd Gear Tractive Effort (High Axle Gear)	2674.38	4th Gear Tractive Effort (High Axle Gear)	1910.27
5th Gear Tractive Effort (High Axle Gear)	1337.19	6th Gear Tractive Effort (High Axle Gear)	1165.27
1st Gear Tractive Effort (Low Axle Gear)	N/A	2nd Gear Tractive Effort (Low Axle Gear)	N/A
3rd Gear Tractive Effort (Low Axle Gear)	N/A	4th Gear Tractive Effort (Low Axle Gear)	N/A
5th Gear Tractive Effort (Low Axle Gear)	N/A	6th Gear Tractive Effort (Low Axle Gear)	N/A
1st Gear Gradeability (High Axle Gear)	27.43	2nd Gear Gradeability (High Axle Gear)	14.86
3rd Gear Gradeability (High Axle Gear)	10.53	4th Gear Gradeability (High Axle Gear)	5.29
5th Gear Gradeability (High Axle Gear)	-0.76	6th Gear Gradeability (High Axle Gear)	-3.61
1st Gear Gradeability (Low Axle Gear)	50.71	2nd Gear Gradeability (Low Axle Gear)	28.95
3rd Gear Gradeability (Low Axle Gear)	22.11	4th Gear Gradeability (Low Axle Gear)	14.98
5th Gear Gradeability (Low Axle Gear)	8.97	6th Gear Gradeability (Low Axle Gear)	6.84
Geared Road Speed	108.71 MPH	Actual Loaded Speed	66.3 MPH In 4th Hi @ 2900 RPM MPH
Grade (%)	2.0	Maximum Speed Gradeability	14.2% @ 2539 RPM @ 79 MPH
Torque Converter	1.764	Maximum Capacity @ 0° F	2200.00
% of Body on Front Axle	49.09	% of Body on Rear Axle	50.91
Body Weight Front	0.00 lbs	Body Weight Rear	0.00 lbs
Actual Loaded Speed (First Part, MPH)	66.3 MPH	Actual Loaded Speed (Second Part, RPM)	2900
Actual Loaded Speed (Third Part, Gear)	4	Road Type	Concrete
Body Weight	0.0 lbs	Driver Weight Front	350.00 lbs
Driver Weight Rear	0.00 lbs	Medium Duty Body Type	None
Front Total Load	5085.00 lbs	Rear Total Load	2905.00 lbs

This document contains information considered Confidential between GM and its Clients uniquely. The information provided is not intended for public disclosure. Prices, specifications, and availability are subject to change without notice, and do not include certain fees, taxes and charges that may be required by law or vary by manufacturer or region. Performance figures are guidelines only, and actual performance may vary. Photos may not represent actual vehicles or exact configurations. Content based on report preparer's input is subject to the accuracy of the input provided.

Data Version: 17875. Data Updated: Nov 3, 2022 6:50:00 PM PDT.



# Alan Jay Fleet Sales

Chris Wilson | 863-402-4234 | chris.wilson@alanjay.com

Item 11C.

Vehicle: [Fleet] 2023 Chevrolet Silverado MD (CC56403) 2WD Reg Cab Work Truck (✔ Complete)

## Weight Distribution

### SPECIFICATION SUMMARY

Model #	CC56403
Truck/Tractor	
Wheelbase (WB)	165 in
Cab to Axle (CA)	84 in
Cab to Body/Swing Clear (BOC)	3.0 in
Body Length	0.0 ft
Body Weight	0.0 lbs
Cargo Weight	0.00 lbs
Front GAWR	6250 lbs
Rear GAWR	13500 lbs
GVWR	19500.00 lbs

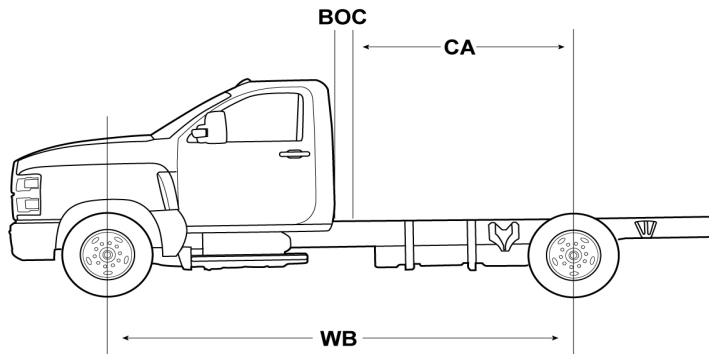

CA: 84 in  
 BOC: 3.0 in  
 WB: 165 in

**Fr%: 63.64**  
**Front Wt: 5085.00 lbs**

**Rr%: 36.36**  
**Rear Wt: 2905.00 lbs**

GAWR/GVWR	GVW	Remaining Payload Wt
19500.00 lbs	7990.00 lbs	11,510.00 lbs

This document contains information considered Confidential between GM and its Clients uniquely. The information provided is not intended for public disclosure. Prices, specifications, and availability are subject to change without notice, and do not include certain fees, taxes and charges that may be required by law or vary by manufacturer or region. Performance figures are guidelines only, and actual performance may vary. Photos may not represent actual vehicles or exact configurations. Content based on report preparer's input is subject to the accuracy of the input provided.

Data Version: 17875. Data Updated: Nov 3, 2022 6:50:00 PM PDT.





# Alan Jay Fleet Sales

Chris Wilson | 863-402-4234 | chris.wilson@alanjay.com

Item 11C.

Vehicle: [Fleet] 2023 Chevrolet Silverado MD (CC56403) 2WD Reg Cab Work Truck ( Complete )

## Weight Distribution

### SPECIFICATION DETAILS

	Front Axle	Rear Axle	Total
<b>Actual</b>			
Chassis	4735.00 lbs	2905.00 lbs	7640.00 lbs
Body	0.00 lbs	0.00 lbs	0.0 lbs
Payload	0.00 lbs	0.00 lbs	0.00 lbs
Trailer			0.0 lbs
Totals	5085.00 lbs	2905.00 lbs	7990.00 lbs
<b>Capacity</b>			
Axle	6250 lbs	13500 lbs	19750.00 lbs
Suspension	6250 lbs	13500 lbs	19,750.00 lbs
Tire	7940 lbs	15000 lbs	22940.00
Total Axle Rating	6250.00 lbs	13500.00 lbs	19750.00 lbs

This document contains information considered Confidential between GM and its Clients uniquely. The information provided is not intended for public disclosure. Prices, specifications, and availability are subject to change without notice, and do not include certain fees, taxes and charges that may be required by law or vary by manufacturer or region. Performance figures are guidelines only, and actual performance may vary. Photos may not represent actual vehicles or exact configurations. Content based on report preparer's input is subject to the accuracy of the input provided.

Data Version: 17875. Data Updated: Nov 3, 2022 6:50:00 PM PDT.



# Alan Jay Fleet Sales

Chris Wilson | 863-402-4234 | chris.wilson@alanjay.com

Item 11C.

Vehicle: [Fleet] 2023 Chevrolet Silverado MD (CC56403) 2WD Reg Cab Work Truck (✔ Complete)

## Geared Road Speed

### SPECIFICATION SUMMARY

<b>Model #</b>	CC56403
<b>Engine Order Code</b>	L5D
Model Manufacturer	Duramax
Type	Turbocharged Diesel V8
Displacement	6.6L/402
Horsepower	350 @ 2700
Starting Torque	N/A
<b>Transmission Order Code</b>	MIU
Model Manufacturer	Allison
Type	6-Speed Automatic
<b>Rear Axle Order Code</b>	HD2
Model Manufacturer	A1700RDS Allison
Weight Rating	13500 lbs
Ratio:1	4.10
<b>Rear Tires</b>	225/70R19.5G
<b>Revolutions/Mile Front</b>	640
<b>Revolutions/Mile Rear</b>	640
<b>Surface Type</b>	Concrete
<b>Desired Grade</b>	2%

Geared Road Speed

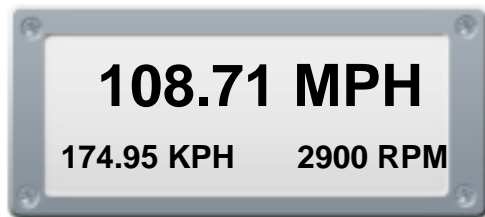

0% Grade in 4th gear

Actual Loaded Speed

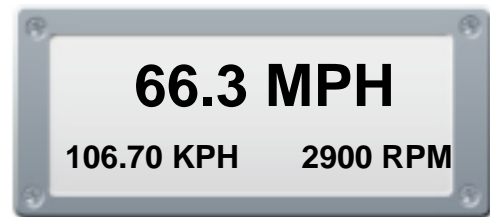

2% Grade in 4th gear

Note: Simulated speedometer appearance may not correspond with selected equipment.

This document contains information considered Confidential between GM and its Clients uniquely. The information provided is not intended for public disclosure. Prices, specifications, and availability are subject to change without notice, and do not include certain fees, taxes and charges that may be required by law or vary by manufacturer or region. Performance figures are guidelines only, and actual performance may vary. Photos may not represent actual vehicles or exact configurations. Content based on report preparer's input is subject to the accuracy of the input provided.

Data Version: 17875. Data Updated: Nov 3, 2022 6:50:00 PM PDT.



# Alan Jay Fleet Sales

Chris Wilson | 863-402-4234 | chris.wilson@alanjay.com

Item 11C.

Vehicle: [Fleet] 2023 Chevrolet Silverado MD (CC56403) 2WD Reg Cab Work Truck (✔ Complete)

## Gradeability Chart

### SPECIFICATION SUMMARY

<b>Model #</b>	CC56403
<b>Engine Order Code</b>	L5D
Model Manufacturer	Duramax
Type	Turbocharged Diesel V8
Displacement	6.6L/402
Horsepower	350 @ 2700
Starting Torque	N/A
<b>Transmission Order Code</b>	MIU
Model Manufacturer	Allison
Type	6-Speed Automatic
<b>Rear Axle Order Code</b>	HD2
Model Manufacturer	A1700RDS Allison
Weight Rating	13500 lbs
Ratio:1	4.10
<b>Rear Tires</b>	225/70R19.5G
<b>Revolutions/Mile Front</b>	640
<b>Revolutions/Mile Rear</b>	640
<b>Surface Type</b>	Concrete
<b>Desired Grade</b>	2%

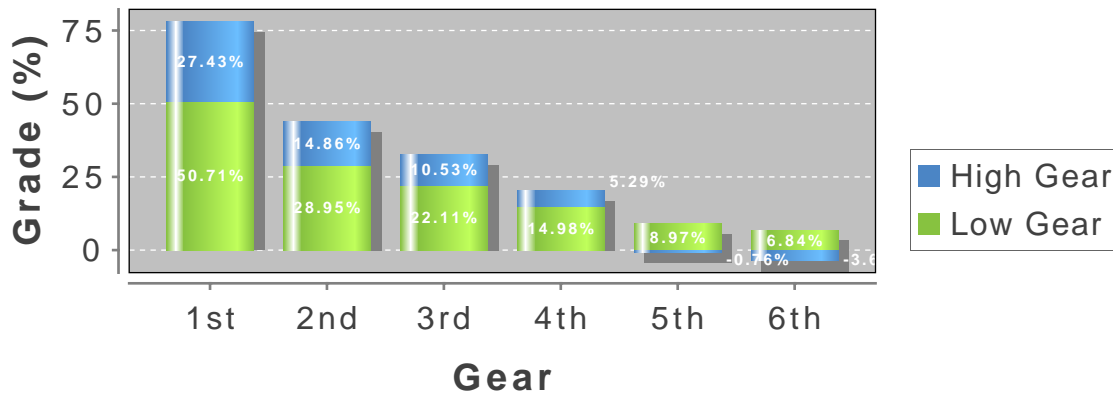

This document contains information considered Confidential between GM and its Clients uniquely. The information provided is not intended for public disclosure. Prices, specifications, and availability are subject to change without notice, and do not include certain fees, taxes and charges that may be required by law or vary by manufacturer or region. Performance figures are guidelines only, and actual performance may vary. Photos may not represent actual vehicles or exact configurations. Content based on report preparer's input is subject to the accuracy of the input provided.

Data Version: 17875. Data Updated: Nov 3, 2022 6:50:00 PM PDT.



# Alan Jay Fleet Sales

Chris Wilson | 863-402-4234 | chris.wilson@alanjay.com

Item 11C.

Vehicle: [Fleet] 2023 Chevrolet Silverado MD (CC56403) 2WD Reg Cab Work Truck (✔ Complete)

## Turning Circle

### SPECIFICATION SUMMARY

<b>Model #</b>	CC56403
<b>Front Axle Order Code</b>	FTC
Capacity (lbs)	6250 lbs
<b>Wheelbase Order Code</b>	ED9
Wheelbase (in)	165 in
<b>Front Wheel Order Code</b>	
Size/Type (in)	19.5 x 6.75 in
<b>Front Tire Order Code</b>	XDK
Size/Type	225/70R19.5G

### Wall to Wall (ft): 48.8 ft

Wall to Wall diameter is measured from the outermost part of the cab.

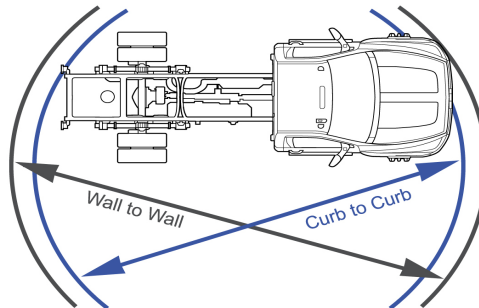

### Curb to Curb (ft): 47.2 ft

Curb to Curb diameter is measured from the outside of the front tire.

This document contains information considered Confidential between GM and its Clients uniquely. The information provided is not intended for public disclosure. Prices, specifications, and availability are subject to change without notice, and do not include certain fees, taxes and charges that may be required by law or vary by manufacturer or region. Performance figures are guidelines only, and actual performance may vary. Photos may not represent actual vehicles or exact configurations. Content based on report preparer's input is subject to the accuracy of the input provided.

Data Version: 17875. Data Updated: Nov 3, 2022 6:50:00 PM PDT.







GOVERNMENT  
CONTRACT  
SPECIALIST

ALAN JAY  
FLEET CENTER

ALAN JAY  
FLEET CENTER

PH571864

VIN 9-27-23

AA-2

GOODYEAR

# DT2 SERIES

Models: DT2-31, DT2-29

# DUR-A-LIFT®



DTS-29 PICTURED

WWW.DUR-A-LIFT.COM

## SPECIFICATIONS

	DT2-31	DT2-29
WORKING HEIGHT	<b>36'</b>	<b>34'</b>
SIDE REACH (SIDE HUNG)	<b>22'8"</b>	<b>20'8"</b>
SIDE REACH (END HUNG)	<b>24'6"</b>	<b>22'6"</b>
APPROX. STOWED TRAVEL HEIGHT	<b>10'6"</b>	<b>10'6"</b>
HEIGHT TO BOTTOM OF PLATFORM	<b>31'</b>	<b>29'</b>
BASKET CAPACITY	<b>350#</b>	<b>400#</b>
APPROX. LIFT WEIGHT	<b>1950#</b>	<b>1850#</b>
MAIN BOOM TRAVEL	<b>-25 to 75</b>	<b>-25 to 75</b>
EXTENSION TRAVEL	<b>122.5"</b>	<b>110.5"</b>

Dur-A-Lift Inc. reserves the right to improve models and change specifications without notice or obligation. Dur-A-Lift equipment meets or exceeds all applicable ANSI Standards as of the date of manufacture.

- TELESCOPIC, PERSONNEL
- WORKING HEIGHT UP TO 36'
- SIDE REACH UP TO 29'6"
- UP TO 400# BASKET CAPACITY
- END OR SIDE-HUNG BASKET
- COMPACT DESIGN AND STOWING
- OPTIONS AVAILABLE FOR USE WITH A 9' BODY
- INSULATED (DT2) OR NON-INSULATED (DT2S)

**MANY WAYS TO CUSTOMIZE!**

**DUR-A-LIFT®**  
**WE SPEAK BUCKET TRUCK**



# DT2 SERIES

Models: DT2-31, DT2-29

Item 11C.  
**DUR-A-LIFT**  
WE SPEAK BUCKET TRUCK

## STANDARD

**CONTROLS:** Proportional controls; non-proportional controls (DT2S TS); lower controls with override; engine start/stop from the basket; individual control levers

**HYDRAULIC SYSTEM:** Rated pressure is 2200 PSI; operating pressure is 2000 PSI; open center hydraulic system

**MECHANICAL SYSTEM:** Telescoping boom action; offset main boom reduces travel height; shear ball rotation driven; fully enclosed worm gear box; non-continuous rotation; insulated extension boom (DT2); 24"x24"x42" basket; side hung basket

## OPTIONAL

Single hand joystick upper control; outrigger or torsion bars; 12v D.C. backup; end hung basket; basket offered in various sizes and configurations; basket liner (DT2); basket cover; continuous rotation (FP); tool trays of various sizes; tool circuits; tail shelf with walkup steps; main boom fiberglass insert (DT2); paint color; insulated option available (DT2S)

## INSULATED OR NON-INSULATED

**DT2:** insulated (full pressure controls only; Category D)

**DT2S:** non-insulated (drive/battery, two speed or full pressure controls)

## REACH DIAGRAM

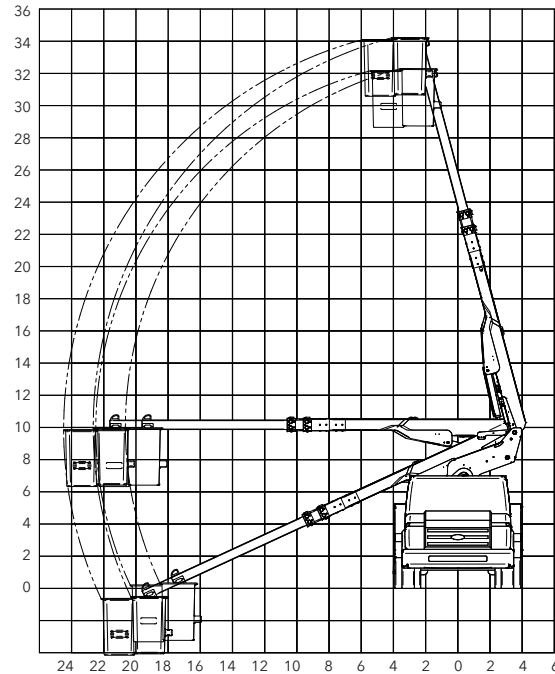

CHASSIS REQUIREMENT, MIN.: 14,000 GVWR  
CHASSIS CAB TO AXLE REQUIREMENT, MIN.: 84" (DT2-31); 60" (DT2-29)



WWW.DUR-A-LIFT.COM



## BUILT FOR YOU

Ask about available chassis, body, tailshelf, and basket options.

## GO GREEN Clean. Quiet. Powerful.

Available with hybrid aerial operation. +  
++  
+++



## MEMORANDUM

TO: Honorable Mayor and Board of Commissioners  
VIA: Robin Gomez, City Manager  
FROM: Jay Hatch, Recreation Director  
DATE: February 6, 2024  
**RE: Fireworks Agreement**

---

### **Background**

On February 1, 2023, the City of Madeira Beach released a Request for Proposals for Annual Fireworks Displays. The City selected Master Pyro LLC for the 2023 fireworks displays. The contract for the display ended in November 2023 and is due for a new RFP.

Following the dates from previous years, the fireworks displays would take place on the following dates in 2024:

March 16, May 4, July 3, November 9

### **Fiscal Impact**

\$30,000 is currently budgeted for FY 2024

### **Recommendation**

Staff recommends approval of the 2024 Fireworks Agreement with Master Pyro LLC.

### **Attachments**

2024 Madeira Beach Fireworks Agreement

**AGREEMENT FOR FIREWORKS DISPLAYS**

THIS AGREEMENT made and entered into on the \_\_\_\_ day of February, 2024 (the “Effective Date”), by and between MASTER PYRO DISPLAY, L.L.C., a Florida Limited Liability Company with a Principal Address of 3332 Victoria Park Road, Jacksonville, FL 32216 (“Contractor”) and the CITY OF MADEIRA BEACH, a Florida Municipal Corporation (“City”).

WHEREAS, on February 1, 2023, the City issued RFP No.: 23-01, requesting proposals from qualified companies to provide fireworks displays on March 17, 2023, May 6, 2023, July 3, 2023, and November 11, 2023; and

WHEREAS, on February 15, 2023, Contractor submitted a proposal outlining its proposed services and related charges; and

WHEREAS, having considered the responsive proposals received and found Contractor to be responsive and responsible, and having found Contractor’s proposal to be the most beneficial to the City’s needs, the City chose to negotiate final contract terms with Contractor; and

WHEREAS, the City and Contractor have agreed to exercise a one year contract renewal, per the terms of the issued RFP: and

WHEREAS, the City and Contractor having agreed on final contractual terms, have agreed to enter this Agreement.

NOW, THEREFORE in consideration of the promises and covenants contained herein, the Parties agree as follows:

**1. Contract Documents; Order of Precedence.**

This Agreement shall consist of the following documents, and in the event of any conflict as to a term or condition between them, the earlier listed document shall control over the later listed document:

- This Agreement
- RFP No.: 23-01 (attached hereto and incorporated herein as **Exhibit A**)
- Contractor’s Proposal including any attachments or exhibits thereto referenced in the Proposal (attached hereto and incorporated herein as **Exhibit B**)

**2. Contractor Duties.**

Contractor shall provide to the City fireworks displays on March 16, 2024, May 4, 2024, July 3, 2024, and November 9, 2024 in the manner set forth in its Proposal, and in full compliance with all applicable safety rule, regulations and industry best practices as are referenced in the City’s RFP, Contractor’s Proposal, or are otherwise provided for by law.

**3. Term.**

The term of this Agreement shall be from the Effective Date through November 30, 2024.

**4. Payment**

Pursuant to Florida Statutes §§ 218.73 and 218.74, Contractor shall be paid the following fees: \$5,000.00 for the March 16<sup>th</sup> display, \$5,000.00 for the May 4<sup>th</sup> display, \$20,000.00 for the July 3<sup>rd</sup> display and \$5,000.00 for the November 9<sup>th</sup> display not more than forty-five (45) days after it has submitted to the City a proper invoice, which invoice shall be submitted only after the Contractor's required services have been completed.

Improper payment requests shall be addressed by the City as provided for in Florida Statutes § 218.76, and any disputes with respect to payment of an invoice shall be determined as provided for in that statute and any associated City procurement codes or procedures addressing resolution of payment disputes.

**5. Amendments.**

This Agreement may only be altered by written amendment executed by authorized officials of both Parties.

**6. Severability.**

In the event that any provision or portion hereof of any Contract Document shall be found to be invalid or unenforceable, then such provisions or portion thereof shall be performed in accordance with the applicable laws. The invalidity or unenforceability of any provision or portion of any Contract Document shall not affect the validity or enforceability of any other provision of the Contract Documents.

**7. Miscellaneous Terms.**

A. Each Party to this Agreement represents and warrants to the other Party that (i) they are duly organized, qualified and existing entities under the laws of the State of Florida, and (ii) all appropriate authority exists so as to duly authorize the persons executing this Agreement to so execute the same fully bind the Party on whose behalf they are executing.

**B. Immigration Compliance; E-Verify.** Contractor acknowledges that it is responsible for complying with the provisions of the Immigration Reform and Control Act of 1986, U.S.C. § 1324, et seq., and regulations relating thereto. Failure to comply with the above statutory provisions shall be considered a material breach and shall be grounds for immediate termination of this Agreement. The Contractor's employment of unauthorized aliens is a violation of § 274(e) of the Federal Immigration and Employment Act. The Contractor shall utilize the U.S. Department of Homeland Security's E-Verify system to verify the employment eligibility of all new employees hired during the term of this

Agreement and shall require the same verification procedure of any Subcontractors authorized by the Owner. Pursuant to Florida Statutes § 448.095(2), beginning January 1<sup>st</sup> 2021, Contractor shall register with and use the E-Verify system to verify the work authorization status of all newly hired employees. Contractor's contract with the City cannot be renewed unless, at the time of renewal, Contractor certifies in writing to the City that it has registered with and uses the E-Verify system. If Contractor enters into a contract with a subcontractor, the subcontractor must provide the Contractor with an affidavit stating that the subcontractor does not employ, contract with, or subcontract with an unauthorized alien and Contractor shall maintain a copy of such affidavit for the duration of the contract. If Contractor develops a good faith belief that any subcontractor with which it is contracting has knowingly violated Florida Statutes § 448.09(1) (making it unlawful for any person knowingly to employ, hire, recruit, or refer, either for herself or himself or on behalf of another, for private or public employment within the state, an alien who is not duly authorized to work by the immigration laws or the Attorney General of the United States) Contractor shall terminate the contract with the subcontractor. If the City develops a good faith belief that Contractor has knowingly violated Florida Statutes § 448.09(1) (making it unlawful for any person knowingly to employ, hire, recruit, or refer, either for herself or himself or on behalf of another, for private or public employment within the state, an alien who is not duly authorized to work by the immigration laws or the Attorney General of the United States) the City shall terminate this contract. Pursuant to Florida Statutes § 448.095(2)(c)(3), termination under the above-circumstances is not a breach of contract and may not be considered as such.

**C. No Third-Party Beneficiary.** This Agreement is for the benefit of the Parties and their respective successors and permitted assigns, and it is not the intent of the Parties to enter this Agreement for any other person's or entity's benefit.

**D. Jurisdiction, Venue, Applicable Law.** In the event of any litigation between the Parties with respect to the interpretation or enforcement of this Agreement, same shall be conducted, if in state court, in the appropriate circuit or county court in and for Pinellas County, Florida, and if in federal court, in the United States District Court for the Middle District of Florida, Tampa Division. In any such litigation, the substantive and procedural laws of the State of Florida shall be applied.

**E. Public Records.** In accordance with Florida Statutes § 119.0701, the Contractor shall:

1. Keep and maintain public records required by the City to perform the service.
2. Upon request from the City's custodian of public records, provide the requesting City with a copy of the requested records or allow the records to be inspected or copied within a reasonable time at a cost that does not exceed the cost provided in this chapter or as otherwise provided by law.
3. Ensure that public records that are exempt or confidential and exempt from public records disclosure requirements are not disclosed except as authorized by law for the duration of the contract term and following completion of the contract if the contractor does not transfer the records to the City.

4. Upon completion of the contract, transfer, at no cost, to the City all public records in possession of the Contractor or keep and maintain public records required by the City to perform the service. If the Contractor transfers all public records to the City upon completion of the contract, the Contractor shall destroy any duplicate public records that are exempt or confidential and exempt from public records disclosure requirements. If the Contractor keeps and maintains public records upon completion of the contract, the Contractor shall meet all applicable requirements for retaining public records. All records stored electronically must be provided to the City, upon request from the City's custodian of public records, in a format that is compatible with the information technology systems of the City.

**IF THE CONTRACTOR HAS QUESTIONS REGARDING THE APPLICATION OF CHAPTER 119, FLORIDA STATUTES, TO THE CONTRACTOR'S DUTY TO PROVIDE PUBLIC RECORDS RELATING TO THIS CONTRACT, CONTACT THE CUSTODIAN OF PUBLIC RECORDS AT THE CITY MADEIRA BEACH, CITY CLERK'S OFFICE, AT:**

**TELEPHONE: 727- 391-9951**

**EMAIL: [cvanblargan@madeirabeachfl.gov](mailto:cvanblargan@madeirabeachfl.gov)**

**ADDRESS: 300 Municipal Drive, Madeira Beach, FL 33708**

**F. Assignment and Subcontracting.** The City has selected Contractor for its stated skills, abilities and unique product offerings, as represented to the City by Contractor's solicitation response and via other means. Contractor has represented to the City that it has the in-house capabilities, resources and expertise to perform the services required by this Agreement except as otherwise expressly set forth in this Agreement. Therefore, except in the case of a sale, transfer or assignment of all or substantially all of the assets of Contractor to a successor who has asserted its intent to continue the business of Contractor, Contractor shall not assign or transfer any right or duty under this Agreement to any other party without the prior written consent of the City. In the unlikely event Contractor asserts it is necessary to subcontract for the services of third parties to perform any service or provide any product under this Agreement not already provided for therein, Contractor shall first obtain prior written approval of the City. Approval to utilize any third party shall not relieve Contractor from any direct liability or responsibility to the City pursuant to the provisions of this Agreement, or obligate City to make any payments other than payments due to Contractor as outlined in this Agreement. While requests to subcontract are strongly discouraged and unlikely to be granted, in the event the City grants such permission, Contractor is obligated to ensure any such subcontractor's contract incorporates the terms and conditions of this Agreement and acknowledges the City as an intended third-party beneficiary.

**G. Notices.** Any and all notices sent pursuant to this Agreement shall be given in writing via certified mail or overnight courier and shall be delivered to the following addresses:



**As to Contractor:**

Brian Acosta, Manager  
Master Pyro Display, L.L.C.  
3332 Victoria Park Road  
Jacksonville, Florida 32216

**As to City:**

Robin Gomez, City Manager  
City of Madeira Beach  
300 Municipal Drive  
Madeira Beach, FL 33708

IN WITNESS WHEREOF the Parties hereto have executed this Agreement as of the day and year first written above.

CITY OF MADEIRA BEACH

MASTER PYRO DISPLAY. L.L.C.

By: \_\_\_\_\_  
Robin Gomez, City Manager

By: \_\_\_\_\_  
Brian Acosta, Manager

**(Acknowledgment of Contractor)**

State of Florida  
County of Duval  
City of Jacksonville

The foregoing Agreement was acknowledged before me this \_\_\_ day of \_\_\_\_\_, 2024, by Brian Acosta, Manager of Master Pyro Display, L.L.C. (“Contractor”), on behalf of the Contractor. He is personally known to me or has produced \_\_\_\_\_, as identification and appeared before me at the time of notarization.

Brian Acosta warrants that he is authorized by the Contractor to execute the foregoing Agreement.

(SEAL)

\_\_\_\_\_  
NOTARY PUBLIC:

My commission expires:



1. Provide a copy of your firm's Occupational License No. with the Expiration Date (if applicable).
2. Provide a copy of your firm's Federal Employer Tax ID certificate.
3. Provide a copy of all your current insurance coverages for General Liability, Automobile and Worker's Compensation.
4. Provide evidence of a certification through Pinellas County Licensing Board (if applicable).
5. Provide documentation that your firm is registered with the Florida Division of Corporations to do business within the state of Florida.



# Memorandum

**Meeting Details:** February 14, 2024

**Prepared For:** Mayor & Board of Commissioners

**From:** Megan Wepfer, Public Works Director

**Subject:** Tampa Bay Coastal Master Plan

## Background

The TBRPC is in the process of creating a project proposal to develop a Tampa Bay Coastal Master Plan (TBCMP), similar to [Louisiana's](#). We were among the 120 (out of 869) selected by NOAA to submit a full application for their [Climate Resilience Regional Challenge](#) track one funding (we are requesting \$2 million). It would likely be a 4-year project.

A broad summary of the TBCMP: The plan will equip the region with compound flooding maps and a prioritized list of feasible restoration and risk reduction project concepts, both structural and nonstructural, that will serve as guidance to equitably address the many challenges posed by high-tide flooding, storm surge, rainfall-related flooding, and future sea level rise. Our initial Letter of Intent is attached.

It hasn't officially kicked off, but the extensive application required by NOAA is serving as the impetus for building the project's framework for completion. Here is a link to the current working proposal we will be submitting to NOAA for funding, and we will be using this for applying to other grants:

[https://docs.google.com/document/d/1-e9AbR7YOSXh9IbapeDas7\\_8MWkWBjrgllumykweomg/edit?usp=sharing](https://docs.google.com/document/d/1-e9AbR7YOSXh9IbapeDas7_8MWkWBjrgllumykweomg/edit?usp=sharing)

The plan will be designed for local governments in the Tampa Bay region, so their participation is essential for this project's success. Tampa, St. Pete, Oldsmar, Pinellas, Hillsborough, Crystal River, Pasco, and others are already involved. **I am sending this email to get the City of Madeira Beach's support and participation in the project.** I'm hoping to include the local governments as "collaborators" on the project since local gov't staff will be our primary end users/implementers. See the attached document for more information on the distinction between "collaborators" vs "partners."

## Fiscal Impact

There is no fiscal responsibility other than staff time participating in Workgroup meetings and training workshops.

**Recommendation(s)**

Staff recommends the Board of Commissioners approve staff to continue with the letter of support to participate in the Tampa Bay Coastal Master Plan, coordinated by Tampa Bay Regional Planning Council.

**Attachments**

- ⊃ Letter of Support
- ⊃ Overview Summary
- ⊃ Partner vs Collaborator

**Project Title:** Tampa Bay Coastal Master Plan (TBCMP)

**Lead Applicant:** Tampa Bay Regional Planning Council  
4000 Gateway Centre Blvd. Suite 100  
727-570-5151  
[info@tbrpc.org](mailto:info@tbrpc.org)

**Project Director:** Alana Todd  
Principal Environmental Planner  
Tampa Bay Regional Planning Council  
4000 Gateway Centre Blvd. Suite 100  
727-570-5151 ext. 40  
[alana@tbrpc.org](mailto:alana@tbrpc.org)

**Geographic Description:** The Tampa Bay region, located on the Gulf coast of Florida, covers an area of approximately 2,200 square miles and is characterized by its extensive coastal waterways and urban centers at typical elevations of 2-10 m above mean sea level. The region is home to 3.8 million. Tampa, St. Petersburg, and Clearwater are the largest and most prominent cities within the Tampa Bay metropolitan area, although there are nearly 60 municipalities, many of which are active members of the Tampa Bay Regional Planning Council (TBRPC). The region’s population is growing rapidly and protection and planning is needed to address compounding environmental stressors.

**Participating Jurisdictions:** Citrus, Hernando, Pasco, Pinellas, Hillsborough, and Manatee Counties and their municipalities

**Confirmed Collaborators:** All participating jurisdictions, Tampa Bay Estuary Program, National Wildlife Federation, University of Florida (UF) & Florida Sea Grant, University of South Florida (USF), University of Central Florida (UCF), Tampa Bay Watch, MacDill Air Force Base, Hillsborough Planning Commission, Ecosphere Restoration Institute, Progress Village Civic Council, Florida Clinicians for Climate Action, Alianza for Progress, Institute for Equitable Development, Environmental Protection Commission of Hillsborough County, US Fish and Wildlife Service, Tampa Bay Waterkeeper

**Period of Performance:** October 1, 2024 – September 30, 2028 (estimated; dependent on funding)

**Resilience Vision**

The Tampa Bay region envisions resilience as the ability and enduring capacity of its diverse coastal communities and habitats to mitigate and adapt to the risks posed by long-term climatic changes and short-term weather extremes. As groundwater and sea levels rise, and the pace and extent of coastal flooding and erosion accelerates, communities throughout the Tampa Bay region are faced with the difficult challenge of deciding how to prepare for and adapt to these changing conditions, especially with our most vulnerable residents. Adaptation strategies can range from building and fortifying infrastructure, to habitat restoration and incorporating nature-based solutions, to planned community or asset relocation. Each approach comes with its own costs, benefits and trade-offs, and community members and asset managers must engage in thoughtful discussions about risk and which mitigation strategies are most appropriate for their specific circumstances.

In the proposed project, the Tampa Bay Regional Planning Council (TBRPC) and its partners will facilitate a cross-jurisdictional and multi-stakeholder planning process to develop a Coastal Master Plan for the Tampa Bay region that illustrates how the Gulf coast will change over time, proposing a coordinated suite of enduring, local adaptation pathways in response to the many risks to our diverse communities. The plan will equip the region with a prioritized list of feasible restoration and risk reduction project concepts,

both structural and nonstructural, that will serve as guidance to equitably address the many challenges posed by high-tide flooding, storm surge, rainfall-related flooding, and future sea level rise in vulnerable areas, particularly historically marginalized, underserved, and underrepresented communities. This four-year planning process and the resulting plan will be grounded by extensive community engagement, regional collaboration, the latest scientific information, and key social and ecological metrics, as well as pertinent tools, studies, and cost considerations. The project team will leverage existing resources and collaboratives, including the Tampa Bay Regional Resiliency Coalition, as well as build new community connections, to catalyze crucial conversations about risks from flood and storm surge exposure, and practical, equitable initiatives to adapt more than 700 miles of coastline in the Tampa Bay area. This approach will create a cohesive, enduring strategy that will mobilize the region’s broader resiliency vision and goals, while supporting local and regional efforts to fund and implement resilience and adaptation actions.

### **Regional Context**

The Tampa Bay region is home to 3.8 million people (about twice the population of Nebraska despite being 10 times smaller in size) spread across communities of diverse cultures, socioeconomic backgrounds, and geographies. The region is also home to world-renowned Gulf beaches and Florida’s largest open-water estuary, which are inextricably linked to the local economy and livelihoods of residents. Water is vital to the region, but it also puts our communities at significant risk of coastal and inland flooding. According to *The 3rd National Risk Assessment* from First Street Foundation (2021), many of the Tampa Bay region’s counties face major to severe flood risk today, and are among those in the state with the highest projected growth in flood risk over the next 30 years. Local governments in the Tampa Bay region tend to carry out projects as the need arises, and resilience considerations are commonly integrated into existing capital improvement projects. Local governments are beginning to pursue resilience projects for their own sake, but there is little coordination across the region and there is no current strategic plan for long-term coastal adaptation at a regional scale. The proposed planning project will build upon existing regional collaboratives to engage more communities and advance joint actions that will accelerate the region’s climate resilience and adaptation practices.

Since 1962, the TBRPC has convened local governments and gubernatorial appointees to plan for and coordinate intergovernmental solutions to complex, large-scale issues. The TBRPC membership includes 21 municipalities from within the six-county Tampa Bay region—Citrus, Hernando, Pasco, Pinellas, Hillsborough, and Manatee Counties — as well as gubernatorial appointees and state agencies. An integral part of the TBRPC since 1985, the Agency on Bay Management is a committee that serves as a broad-based forum for open discussion of the issues involving the Tampa Bay estuary, and a voice for protection, restoration, and wise use of its natural resources by the entire region.

Under the leadership of the TBRPC, the Tampa Bay Regional Resiliency Coalition (the Coalition) was formed in 2018 to synchronize climate adaptation and mitigation activities and provide access to resources to advance local and regional responses to disruptions resulting from the impacts of climate change. In five years, the Coalition has grown to 33 member governments and more than 90 resilience partners. The Coalition adopted the first Regional Resiliency Action Plan (RRAP) in 2022 to serve as a five-year roadmap of general local and regional adaptation and mitigation actions. The proposed regional-scale coastal master plan will complement the RRAP in building local governments’ capacity and progress towards implementation, while promoting efficient, well-informed decision-making as well as pre-positioning them for other funding opportunities. The resulting plan will serve as an adaptation resource and guide for decision-makers to maximize enduring community benefits that support a thriving coast where people can continue to live, work, and enjoy the region’s unique features.

### **Proposed Activities and Outcomes**

The Tampa Bay Coastal Master Plan (TBCMP) will guide investments in coastal restoration, resilience, and risk reduction across the region by effectively communicating anticipated landscape and hydrologic changes and proposing a suite of potential projects to advance the region’s adaptation to current and future flood impacts. As the first of its kind in the state, the TBCMP will foster the ongoing, iterative process of adaptive management to ensure long-term capacity building and progress to advance adaptation actions across the Tampa Bay region. The activities include: (1) convening stakeholders to identify a four-year

planning process; (2) regional flood risk analysis; (3) solicitation of adaptation projects; (4) iterative review and evaluation of projects; (5) report publication.

**Essential stakeholders and community members will be convened to identify a shared vision, goals, and methodology for the plan’s development.** With input from community leaders and other stakeholders, project partners will develop a four-year planning process and outreach strategies to maximize regional coordination, transparency, and innovation. Ad hoc technical and community advisory workgroups will be established to support deliberative discussions throughout the process, ensuring that iterative engagement and shared goals are achieved. The planning process and outreach efforts will be designed to support future replication and enduring capacity for adaptation.

The inclusive planning process of the TBCMP will reach beyond governmental partners, a common barrier for large-scale planning efforts, to deeply engage underserved communities to ensure the project and its outcomes equitably reflect the interests, values, and priorities of all residents. Key stakeholders will include community members, business owners, scientists, health professionals, resilience experts, local, state, and federal agencies, and other interested parties. The TBCMP outreach effort will leverage the existing stakeholder network of the Coalition and the Agency on Bay Management, as well as the recommendations of the Tampa Bay Estuary Program’s [Equity Strategy](#). Additionally, outreach to new stakeholders, especially historically underrepresented communities, will be prioritized to build inclusivity and diversity into the master plan process. As much as possible, engagement will begin at existing community-based meetings and events to ensure the greatest reach and inclusive dialogue. Relationship-building will engage diverse community leaders, such as faith-based leaders and community champions, who will be compensated for participating in project meetings. The TBCMP team will engage with stakeholders throughout the entire process and beyond, further fostering enduring capacity to advance adaptation efforts.

**Outcomes include:** (1) regional advisory workgroups with diverse membership; (2) equitable outreach strategy; (3) four-year replicable planning process and timeline that underpins a shared vision and goals; (4) relationship-building and increased community awareness and participation in coastal resilience efforts; (5) historically underserved communities engaged in community meetings and represented in the workgroups.

**Existing data, tools, and local knowledge will be compiled and adapted, as needed, to conduct a region-wide risk analysis identifying areas with high exposure to flooding.** A regional risk assessment will help to analyze current and future flood risk and community vulnerabilities to inform proactive measures that provide resiliency and adaptation from storm surges and other flooding events. Through modeling, the project team will develop probabilistic flood maps for the Tampa Bay region by incorporating the effects of storm surge, sea level rise and rainfall on coastal and riverine flooding. Jurisdictions throughout the region have completed or are in the process of completing risk assessments that provide readily available data for regional critical assets and mitigation focus areas. In addition, the project team will leverage available tools and modeling resources developed by local and state agencies including the Florida Flood Hub for Applied Research and Innovation, University of Florida, University of South Florida, and University of Central Florida, such as the [Adaptation of Coastal Urban and Natural Ecosystems \(ACUNE\) Geo Tool](#), the Tampa Bay Water Integrated Hydrologic Model, and the [Tampa Bay Coastal Ocean Model \(TBCOM\)](#). One or more local universities will be contracted to perform the modeling needed for the risk assessment and subsequent project evaluations.

At-risk communities, both waterfront (gulf, bay, and riverine) and inland, will be identified across the region’s coastal counties using existing public resources and local knowledge. Underserved and marginalized communities will be identified and prioritized in the assessment using resident insights and tools such as the USC’s Social Vulnerability Index, CDC/ATSDR Social Vulnerability Index, FEMA National Risk Index, EPA’s Environmental Justice Screening and Mapping tool, the Tampa Bay Estuary Program’s [Equity Strategy](#) (expanded to the entire region), and University of South Florida’s Community Resiliency Information System (CRIS) platform. This approach will help prioritize locations for adaptation projects that maximize the equitable flow of benefits to underserved communities across the region. The planning process will facilitate interactive engagement such as community coastal mapping exercises and deliberative community discussions about residents’ experiences with flooding, their risks, and the trade-offs associated with actions we can take now to achieve a more resilient future.

Outcomes include: (1) regional maps illustrating current and future flood risks; (2) identification of at-risk communities, especially underserved, to inform project locations; (3) community meetings and risk messaging for the public.

**Potential project concepts will be solicited from the public, members of advisory groups, and Coalition members to address key coastal and inland flooding concerns across the region.** Informed by the risk assessment, the TBCMP team will work with public and private sector partners to solicit new project ideas, refine project concepts, and listen to residents to identify areas of need. Regional meetings will foster innovation and multi-jurisdictional consensus on new potential coastal protection project concepts, including restoration and structural and non-structural risk reduction projects. Structural risk reduction projects encompass large-scale infrastructure changes to reduce flooding and enhance coastal protection; emphasis will be on nature-based solutions. Nonstructural measures can be applied across all communities, such as elevating residences, commercial floodproofing, and resilience policies. In addition, the plan will include approaches to restore, create, and sustain ecosystems for resilience benefits that align with the project vision and regional restoration goals. Project concepts will leverage existing resources, like beneficial reuse of sediment from the Army Corps of Engineers' maintenance dredging, to lower costs and increase feasibility of implementation.

Components of ongoing county-level Adaptation Plans that have regional potential, whether by design or expansion through TBCMP-related evaluations, may also become candidate project concepts for inclusion in the TBCMP. The project team will prioritize engagement with underrepresented communities throughout the process to ensure their values and concerns are reflected in the plan and to empower engagement in the planning process by increasing awareness about current risks and brainstorming potential solutions. Underrepresented community members (compensated for their time) and local government staff will participate in professional development workshops –hosted by the University of Florida and HBCU Florida A&M University– and become integral in co-developing structural and nonstructural project ideas to advance through the assessment process as suggested in the NAAEE Community Guidelines for Excellence. Outreach themes, highlights, priorities, takeaways, and outcomes will be tracked and reflected in the final TBCMP.

Outcomes include: (1) broad list of adaptation project concepts around the region, including those developed by communities; (2) through workshops and deliberative community discussions, local government staff will be better equipped to more effectively understand and communicate risk and co-design solutions with those most impacted communities.

**Candidate projects will be iteratively reviewed and evaluated to determine their effectiveness at reducing flood risks, producing equitable outcomes, and feasibility for implementation.** By evaluating restoration or risk reduction project concepts and advancing promising ideas, the master plan process will support more comprehensive implementation efforts. An engineering firm will be contracted to refine the project concepts for further evaluation. Candidate projects will be evaluated with geospatial land loss and inundation models (as funding allows), cost benefit analyses, as well as other impacts on important social and ecological metrics (such as navigation, equity, health, housing, habitat impacts, and community vulnerability) and other residents' concerns. Furthermore, the master plan will use data of current and future conditions and estimates of flood-related damages to the region's communities and assets to assess the potential benefits of restoration and risk reduction projects, identifying those projects that most effectively support flexible adaptation pathways.

Outcomes include: (1) project assessment methodology, including modeling, cost benefit analyses, and qualitative indicator matrix; (2) prioritized list of effective restoration and risk reduction projects.

**A final Tampa Bay Coastal Master Plan will communicate flood risks around the region, and prioritize risk reduction and restoration projects to support enduring adaptation.** The planning process and results will be detailed in a final report summarizing future landscape changes and tangible adaptation pathways that provide co-benefits to the region's most vulnerable communities and ecosystems. The project team will host community and advisory group meetings to gather feedback on the draft plan, ensuring it reflects the shared vision. Subsequent meetings and outreach sessions will facilitate the dissemination of the final plan and related resources. A dashboard will complement the master plan, enabling full access to data, information, and visuals developed through the planning process. Three-dimensional (3D) renderings of vulnerable areas with and without the proposed projects will be created to illustrate site-specific flood risks

and feasible solutions. These visuals will help communicate risk to residents and other public and private partners, highlighting how pilot project concepts across the region will progress adaptation efforts and enhance community resilience.

This TBCMP planning process and final report will facilitate project identification and advancement to allow expedited execution of projects as funding becomes available, such as the NOAA Transformational Habitat Restoration and Coastal Resilience Grants. The TBCMP will not be too prescriptive about project details so that designs can be customized, and appropriately engineered, to site-specific conditions when implemented. To ensure enduring capacity for implementation, the project team will identify sources of potential funding to be incorporated within the plan. The TBCMP will provide a valuable communication resource for underserved and underrepresented communities to better understand their flood exposure, how the coast will change over time, and place-based adaptation pathways. Educational resources, such as engagement best practices and outreach materials, developed throughout the project by the National Wildlife Federation and University of Florida, will help ensure staff continue to engage the community through deliberative discussions about risk and the ongoing process of adaptation. Finally, the TBCMP will be updated on a six-year cycle so efforts are sustained.

Outcomes include (1) a published plan illustrating flood risks over time and corresponding restoration and risk reduction projects; (2) an interactive dashboard and select 3D renderings of projects will assist in communication efforts; (3) regional coordination and community support to advance concerted adaptation actions; (4) local government staff, especially in under resourced northern counties of the region, will have more capacity to take efficient and effective action when implementation funds become available; (5) nature-based projects will provide resilience co-benefits to habitats and communities; (6) the region’s underserved communities will have new adaptation resources and be better positioned to receive large-scale risk reduction projects.

**Budget**

Total - \$3,000,000-\$5,000,000

Requested to date –

\$2,000,000 NOAA Climate Resilience Regional Challenge (2024) - TBD



## Tampa Bay Coastal Master Plan

### Partner vs Collaborator & Letters of Support

#### Partner:

Individuals and entities that are supportive of the proposed effort but **do not** participate in overall decision-making and do not commit to regular and sustained engagement in collaborative activities.

#### Collaborator:

Eligible entity who contributes substantially to the regional team's overall strategic direction and decision-making, and is committed to long-term interactions based on shared missions and goals.

- Participate in Advisory Team meetings, convened as needed, to support project decision-making.
- Stakeholder engagement: Actively engage with community members, especially those from underserved communities, to ensure that projects are supported by and meet the needs of all community members. Attend workgroup meetings and applicable training workshops (~2) for local gov't staff.
- Report dissemination: Facilitate the report and dashboard circulation and education. Continue engaging communities about flood risk and potential solutions.

#### Both:

Participate in **Technical** or **Community** Workgroup meetings - this project will likely entail bi-monthly or quarterly meetings with partners and collaborators for updates and to facilitate work on the following activities:

- **Risk assessment and data collection:** Compile regional and local data and needs to assess current and future flood risks
- **Project selection:** Identify and propose projects to mitigate flood damages; develop a screening and prioritization process for final projects.
- **Equitable Outreach & Engagement strategy:** develop and carry out an outreach strategy to maximize regional coordination, participation, transparency, and innovation

#### Letters of support:

Send to Alana Todd by February 1st.

- ***NOAA discourages form letters of support; NOAA encourages letters describing why the Tampa Bay Coastal Master Plan (and its development process) is important to the region, and what your organization's roles, responsibilities, or commitments will be during the project - see activities above.***

Address to:

Alana Todd

Principal Environmental Planner

Tampa Bay Regional Planning Council

4000 Gateway Centre Blvd #100, Pinellas Park, FL 33782

alana@tbrpc.org

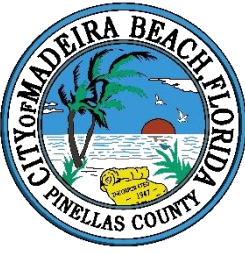

300 Municipal Drive  
Madeira Beach, Florida 33708  
727-391-9951  
Fax 727-395-9361  
[www.madeirabeachfl.gov](http://www.madeirabeachfl.gov)

---

January 26, 2024

Alana Todd  
Senior Environmental Planner  
Tampa Bay Regional Planning Council  
4000 Gateway Centre Blvd., Suite 100  
Pinellas Park, FL 33782

RE: Tampa Bay Coastal Master Plan -Letter of Support

Dear Ms. Todd,

The City of Madeira Beach City Council Supports the Tampa Bay Regional Planning Council's application for federal funding to develop a coastal master plan for the Tampa Bay Region. As a barrier island Madeira Beach is vulnerable to storm surge and the city realizes the importance of developing strategies to minimize the flood risks to our community. The City of Madeira Beach has been heavily impacted by two (2) flooding events in 2023 which intensifies the need to fortify our infrastructure and risk messaging to our community.

The City of Madeira Beach recognizes the importance of working with our neighboring communities to develop a vision, goals, and policy for further plan development. Madeira Beach is thrilled to be a part of the collaboration for the Coastal Master Plan and would like to thank Tampa Bay Regional Planning Council for including our barrier island.

Sincerely,

Jim Rostek, Mayor  
City of Madeira Beach

CC: Robin Gomez, City Manager  
Megan Wepfer, Public Works Director  
Jenny Rowan, Planning and Zoning Director

**CITY CLERK REPORT  
FEBRUARY 2024**

**BOARD OF COMMISSIONERS (BOC) MEETINGS**

Commission Chambers, 300 Municipal Drive, Madeira Beach, FL 33708

Regularly scheduled meetings are held (Dates and Times subject to change):

- Regular Meeting 2<sup>nd</sup> Wednesday @ 6 p.m.
- Budget Workshop Meeting 4<sup>th</sup> Wednesday @ 4 p.m. (May through August)
- Regular Workshop Meeting 4<sup>th</sup> Wednesday @ 6 p.m.

February 2024 BOC Meetings

- Regular Meeting Wednesday, February 14, 2024 @ 6 p.m.
- Regular Workshop Wednesday, February 28, 2024 @ 6 p.m.

March 2024 BOC Meetings

- Regular Meeting Wednesday, March 13, 2024 @ 2 p.m.
- Special Meeting Wednesday, March 27, 2024 @ 5:30 p.m.
- Regular Workshop Meeting Wednesday, March 27, 2024 @ 6 p.m.

**BOARD MEMBER VACANCY ANNOUNCEMENT**

The City of Madeira Beach is seeking applications to fill one expired term on the Civil Service Commission.

Civil Service Commission – Three-Year Term expiring on October 30, 2026

- Civil Service Commission – 5-member board – regular meetings held quarterly. Additional meetings are held for special projects and employee grievance/appeal hearings. Dates and times vary.
- Members must be City of Madeira Beach citizens eligible to vote in the City elections.
- Appointments are made consistent with the Charter based on demonstrated experience or interest in the subject matter.

For additional information, please contact City Clerk Clara VanBlargan at 727-391-9951, ext. 231 or 232; [cvanblargan@madeirabeachfl.gov](mailto:cvanblargan@madeirabeachfl.gov)

Boards, Commissions, and Committees are valuable to the local government process. The members are volunteers and provide a great service to the City and to the community. Duties and responsibilities include reviewing the City’s policies and procedures, Code of Ordinances, and the City Charter and making recommendations to the Board of Commissioners.

Members of the Civil Service Commission serve without compensation but may be reimbursed for training, travel, mileage, and per diem expenses provided by law.

Interested persons must submit an application to the City Clerk no later than Wednesday, April 3, 2024, to be considered for appointment at the 6:00 p.m., Wednesday, April 10, 2024, Board of Commissioners Regular Meeting held in the Commission Chambers, 300 Municipal Drive, Madeira Beach, FL 33708.

Applications may be obtained

- City Clerk’s Office - City Hall, 2<sup>nd</sup> Floor, 300 Municipal Drive, Madeira Beach, 33708
- Email - City Clerk @ [cvanblargan@madeirabeachfl.gov](mailto:cvanblargan@madeirabeachfl.gov)
- City’s website @ <https://madeirabeachfl.gov/advisory-boards/>

Submit completed and signed applications to:

City Clerk  
City of Madeira Beach  
300 Municipal Drive  
Madeira Beach, FL 33708  
[cvanblargan@madeirabeachfl.gov](mailto:cvanblargan@madeirabeachfl.gov)  
727-391-9951, ext. 231 or 232

**MARCH 19, 2024 MUNICIPAL ELECTION**

An Election shall be held in the City of Madeira Beach, Florida, on Tuesday, March 19, 2024, for the purpose of voting on one charter amendment.

The Pinellas County Canvassing Board serves as the Canvassing Board for the City of Madeira Beach. The actions of the Canvassing Board shall be reported to the Board of Commissioners at its next meeting following the election. The Board of Commissioners shall meet following the certification for the purpose of declaring the results of said election.

The polling locations for City of Madeira Beach voters to vote in the March 19, 2024 Municipal Election are as follows:

- Precinct 415 - Madeira Beach Municipal Building, City Centre Room, 300 Municipal Drive, Madeira Beach, Florida;
- Precinct 301 – Calvary Church Seminole (Combined), 6155 113 Street, Seminole, Florida 33772.

Charter Amendment question on the March 19, 2024 Municipal Election Ballot:

**City of Madeira Beach  
Charter Amendment**

**Amend Qualifying Period to the first full week in December.**

This charter amendment would amend Section 3.3(A) of the Charter to change the Candidate Qualifying Period to the first full week in December instead of the first two full weeks in December. Should the Charter be amended?

Yes  
No

If the voters approve the charter amendment at the March 19, 2024 Municipal Election, it will take effect for the candidate qualifying period beginning in December 2024 for the March 2025 Municipal Election.

There will not be a race for Commissioner District 1 and Commissioner District 2 on the March 19, 2024 Municipal Ballot. Incumbents David Tagliarini (Commissioner District 1) and Ray Kerr (Commissioner District 2) were the only candidates who qualified during the qualifying period in December 2023 to have their names placed on the March 19, 2024 Municipal Election Ballot. No one else applied during the qualifying period. They will be sworn into office at a Special Board of Commissioners meeting on Wednesday, March 27, 2024 at 5:30 p.m., to begin a new two-year term as District Commissioner. A light reception begins at 4:30 p.m. in the Commission Chambers. The Board of Commissioners Regular Workshop Meeting is at 6:00 p.m.

Congratulations to Commissioners David Tagliarini and Ray Kerr!!!!

### **CITY OF MADEIRA BEACH HISTORY**

Report of “History Notes” prepared by Charles J. Gallagher who served 37 years at the Madeira Beach Police Department from February 1951 through October 3, 1987.

More history to follow!

This report of "History Notes" was prepared by Charles J. Gallagher who served on the Madeira Beach Police Department from February, 1951 through October 3rd, 1987, serving almost 37 years.

During this tenure, Gallagher served as patrolman, sergeant, (skipped lieutenant), captain, chief and his last 13 years with the City, served as Police Superintendent and aide to the City Manager.

1947MADEIRA BEACH HISTORY NOTES

- 5-14-47 ● First Town Councilmen meeting held at the Real Estate office of George Gaines at 141st Ave and Gulf Blvd.
- Richard Maduro sworn in as first Town Clerk and Fred Rockwell as Town Marshall. Ross Welhof elected President of the Council.
- 10-28-47 ● Representatives of South Madeira asked about joining Madeira Beach.
- 8-12-47 ● Approved contact with Florida Power for 15 street lights on Gulf Blvd and 4 on Welch Causeway (150th Ave). John Robbins appointed Fire Marshall.
- 9-21-47 ● Appointed Larry Childs as Town Attorney for \$25.00 per meeting.

1948

MADEIRA BEACH HISTORY NOTES

- 1-7-48 ● Council advised that fire truck enroute from Youngstown, Ohio. Freight charges a little less than \$400.00.  
● Police Chief Fairley Sullivan salary approved at \$50.00 per week plus \$15.00 car allowance.
- 1-13-48 ● Town Clerks salary raised to \$75.00 a month.  
● Town has collected \$455.00 in fines.
- 2-3-48 ● Approved installation of fire hydrant bwtween 145th Avenue and 150th for \$235.00 installed.
- 3-30-48 ● Resolution to purchase Soft Water Blvd at 14509 Gulf Blvd, for \$7,000 which became the first Town Hall owned by the Town.  
● Discussed two-way radio for police car.
- 7-6-48 ● Approved purchase of uniforms for police.
- 9-28-48 ● Approved police salary at \$65.00 per week and \$15.00 to buy uniforms.  
● Approved fire siren for the Town at \$275.00.



1949

MADEIRA BEACH HISTORY NOTES

- 2-8-49 ● Approved Town Clerk to ring fire siren at Noon.
- 3-22-49 ● Report on bank balance \$ 1,647.09.
- 4-12-49 ● Approved two-way radio in police car. Dispatching was by St.Petersburg Police. Madeira car was car 86.  
● Approved \$600.00 for fire hydrants.
- 4-26-49 ● Resolution to "hard surface" certain streets.
- 5-24-49 ● Carl Schneider became Police Chief.  
● John Robbins appointed Fire Chief.
- 12-14-49 ● Charles Sullivan appointed police officer (in the 50's became Chief.)

MADEIRA BEACH HISTORY NOTES

- 1-25-50 ● Approved of payment of \$2,355.00 for new fire hydrants.
- Approved purchase of Chief Schneiders car for police car.
- 2-8-50 ● 100 street name signs ordered.
- 4-12-50 ● Approved American Legion Club House at 14700 Gulf Blvd.
- 5-10-50 ● Approved pay raise for Officer Charles Sullivan to \$54.00 per week.
- 5-15-50 ● Special meeting to discuss annexing South Madeira.
- 9-13-50 ● Accepted bid on American La France fire truck for \$7,598.91.
- 10-25-50 ● John Robbins appointed fireman at \$60.00 per week (he became Chief in early 50's).
- Discussion on purchase of police car. Bids were; Ford \$1,458.69, Chev \$1,477.37 and Ply \$1,479.19. Tabled.
- 11-22-50 ● Approved fire contract with Redington Bch for \$500.00, 11-1-50 to 11-1-51. South Madeira 8-21-50 to 8-20-51 for \$300.00.
- Approved \$200.00 for Christmas Lights in center of Town. Discussion on dog ordinance and dredge operation noise late at night (this was the period of time that developers were dredging the bay making "fills" or fingers of land for residential areas.

MADEIRA BEACH HISTORY NOTES

DATE	ITEM
1-5-51	● Special meeting to purge list of freeholders.
1-9-51	● Election for sewer bonds \$325,000 at 6%.
2-26-51	● Representations of both Madeira Beach and South Madeira Beach on proposed charter for merger of both Towns.
2-28-51	● Approved hiring 3rd full time Police Officer (Gallagher)
3-14-51	● Approved permit for Wilgelm-Booth funeral homes to operate ambulance service at 14809 Gulf Blvd.
3-28-51	● Approved purchase of Police Crusier for \$2,363.17.
4-25-51	● City Attorney authorized to present Madeira Beach Charter to State Legislature for approval.
3-9-51	● Delivery of new fire truck, fully equipted for \$8,565.76.
6-27-51	● Discussions on proposed merger of Madeira Beach and South Madeira Beach ( Madeira Beach boundries were 155th Avenue South to 140th Ave. South Madeira Beach South from 140th Ave to John's Pass.
7-11-51	● Approved sewer lateral bid.
8-8-51	● Merger of Madeira Beach and South Madeira Beach becoming the City of Madeira Beach. City Attony Larry Childs gave oath of office to first Commission; Emil Martin, Claude Miller, Thomas Huff, Sherill Clabo, Everett Siederburg, R.H. Noble, Ed Logan, Dave Campfield, Ed Herring, and James Tuttle (absent). Siedenbug nominated first Ma yor for the new City.
9-21-51	● First election for City of Madeira Beach.
10-23-51	● Approved City budget;
	Police - \$ 18,789.56.....(Salaries \$13,520.00)
	Fire - 14,643.24 ( " 9,340.00
	Admin 12,272.94 ( " 4,920.00)

1952

MADEIRA BEACH HISTORY NOTES

- 1-21-52 ● Special meeting to open sewer line bids.
- 2-12-52 ● Approved to allow Sunshine Beach (now Treasure Island in the John's Pass area) to use Madeira Beach Jail for Sunshine Beach prisoners at \$1.00 per day.
- 2-26-52 ● Approved sewer bond bid to Goodbody & Co., Herbert J. Sims & Co., Inc. and Sullivan, Nelson & Gross, Inc. for \$773,000.00.  
● Approved purchase of first Public Works truck for \$3,440.95, a 1½ ton stake body Dodge.
- 4-22-52 ● Approved for City to take over Library on 140th Avenue from the Gulf Beach Womens Club for \$2,500 per year as of June 1st, 1952 but Commission to work in conjunction with the Womens Club.  
● Approved the use of parking meters.
- 6-10-52 ● Doug Rodenbaugh appointed Chief of Police. He had been Sergeant.
- 8-12-52 ● Approved the purchase of 65 additional street lights at \$20.00 each.
- 10-28-52 ● Installed fire sirens, one at 132nd Avenue and Gulf Blvd, the second on the water tank on 150th Avenue.
- 11-10-52 ● Installation of parking meters to start on Madeira Way. Straw vote on proposed City Manager form of government; 592 for 314 against. 12 votes voided.

1953

MADEIRA BEACH HISTORY NOTES

- 1-27-53 ● Approved purchase of Air Conditioner for City Hall, a 5-ton GE used only 8 months for \$1,500.00 with (1) year warranty.  
● Carl Parker appointed associate Judge.
- 2-10-53 ● Recommended man be hired to enforce, repair and collect money from parking meters now at both north and south ends of the City.  
● Sewer plant dedication.
- 3-3-53 ● Approved papers for new City Charter to be presented to Legislator reference City Manager Government.
- 3-24-53 ● Approved purchase of police dog for Police Dept.  
● Approved hiring man for parking meters.

MAJOR EVENTS  
MADEIRA BEACH

- 1848 ● Hurrican that lashed Tampa Bay made a cut through the existing islands forming "John's Pass". John's Pass was named after John Lewick, an early pioneer who used the area to catch sea turtles.
- 1913 ● A realtor named Walter Fuller bought Treasure Island for \$800.00. He formed a development company and sold shares for \$1,000.00. Albert Archibald contiued with development until he owned most of Treasure Island. Later he formed the Madeira Holding Company.
- 1927 ● Welch Causeway and bridge built (now known as Tom Stuart Causeway) Madeira Beach Causeway and 150th Avenue.
- 1927 ● John's Pass bridge built.
- 1953 ● E.C.Brandon named Madeira Beach first City Manager.
- 1953 ● Sanitary sewer system and treatment plant put into operation.
- 1955 ● Police Department installed their own radio station, dispatching their own units. The station was based in Madeira Beach City Hall where the Police and Fire Departments were located, 14509 Gulf Blvd.
- 1961 ● Started construction on 4-laning 150th Avenue and new Madeira Causeway bridge.
- 1964 ● Construction of new Madeira Beach City Hall including facilities for Police and Fire also land for future development of recreational facilities.
- 1957 ● Completion of Madeira Beach Shopping Center (Publix Market).

# CITY OF MADEIRA BEACH PUBLIC NOTICE

## BOARD MEMBER VACANCY ANNOUNCEMENT

The City of Madeira Beach is seeking applications to fill an expired term on the Civil Service Commission. The new term expires on October 30, 2026.

- Civil Service Commission – 5-member board – regular meetings held quarterly. Additional meetings are held for special projects and employee grievance/appeal hearings. Dates and times vary.
- Members must be a City of Madeira Beach citizen and eligible to vote in the City elections.
- Appointments are made consistent with the Charter based on demonstrated experience or interest in the subject matter.

For additional information, please contact City Clerk Clara VanBlargan at 727-391-9951, ext. 231 or 232; [cvanblargan@madeirabeachfl.gov](mailto:cvanblargan@madeirabeachfl.gov)

Boards, Commissions, and Committees are a valuable part of the local government process. The members are volunteers and provide a great service to the City and to the community. Duties and responsibilities include assisting in reviewing the City's policies and procedures, Code of Ordinances, and the City Charter, and making recommendations to the Board of Commissioners.

Members of the Civil Service Commission serve without compensation but may be reimbursed for training, travel, mileage, and per diem expenses provided by law.

Interested persons must submit an application to the City Clerk no later than Tuesday, April 2, 2024 to be considered for appointment at the 6:00 p.m., Wednesday, April 10, 2024, Board of Commissioners Regular Meeting located in the Commission Chambers, 300 Municipal Drive, Madeira Beach, FL 33708.

Applications may also be obtained at City Hall, downloaded on the City's website at <https://madeirabeachfl.gov/advisory-boards/> or obtained from the City Clerk.

**Submit completed and signed applications to:**

City Clerk  
City of Madeira Beach  
300 Municipal Drive  
Madeira Beach, FL 33708  
[cvanblargan@madeirabeachfl.gov](mailto:cvanblargan@madeirabeachfl.gov)  
727-391-9951, ext. 231 or 232



# CITY OF MADEIRA BEACH, FLORIDA

300 MUNICIPAL DRIVE, MADEIRA BEACH FL 33708  
CITY CLERK'S OFFICE  
TELEPHONE: 727-391-9951, EXT 231 or 232

## APPLICATION FOR APPOINTMENT TO BOARD OR COMMISSION

Please indicate your preference of board or commission:

- Civil Service Commission
- Gulf Beaches Public Library Board
- Planning Commission
- Other \_\_\_\_\_

Are you a Madeira Beach Resident?  Yes  No

Are you an elector (qualified voter) of the City of Madeira Beach?  Yes  No

Are you related to a City of Madeira Beach employee or elected official? If yes, please state the name of employee or elected official and relationship:  Yes  No

**Name:** \_\_\_\_\_

**Relationship:** \_\_\_\_\_

Are you available for:

Daytime meetings	<input type="checkbox"/> Yes	<input type="checkbox"/> No
Evening meetings	<input type="checkbox"/> Yes	<input type="checkbox"/> No

### Why would you like to be considered as a candidate for service on this Board?

\_\_\_\_\_  
\_\_\_\_\_

Name: \_\_\_\_\_ Phone: \_\_\_\_\_

Address: \_\_\_\_\_

E-Mail: \_\_\_\_\_

Present Occupation: \_\_\_\_\_

If retired, what was your last occupation? \_\_\_\_\_

Please list any experience, special education, skills or talents that would be beneficial to the appointment you are seeking: \_\_\_\_\_  
\_\_\_\_\_  
\_\_\_\_\_





Happy Holidays to you, your families, and your friends. Hopefully you enjoyed the many holidays celebrating with music, meals, local public events, gatherings with family and friends, or in various other celebrations and activities. From holiday lights on Gulf Blvd and 150<sup>th</sup> Ave to our John's Pass Tree lighting on Dec 2 to the annual Festival of Lights Boat Parade and Merry Market held at R.O.C. Park on Saturday, Dec 9 to the weekly Wednesday Madeira Market on Madeira Way, thousands enjoyed the various festivities that make December a very magical and festive month. Hopefully you like my family and I enjoyed the wonderful and festive décor all month long. Thank you to all who coordinated, assisted, and/or volunteered to make all events and activities very successful. Please continue reading below to learn of the upcoming January 2023 events, updates on various City projects, and numerous data and statistics from City departments.

**HAPPY NEW YEAR, 2024 !!**



***John's Pass Bell Tower Holiday Decor***

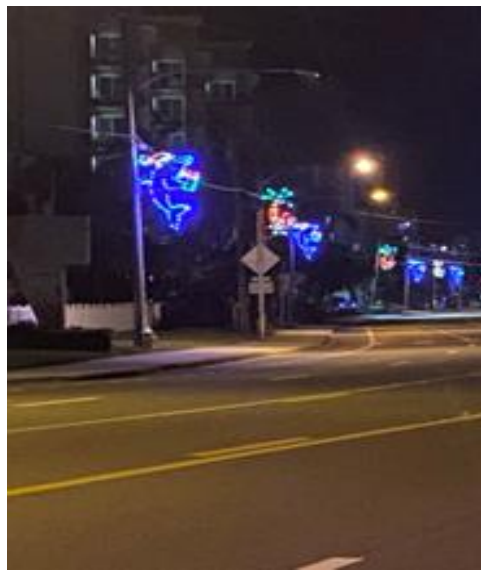

***Gulf Blvd Holiday Lights***



***Festival of Lights Holiday Boat Parade***

We ended a very successful 2023 with great anticipation and excitement to an even more exceptional 2024. I continue to be extremely thankful for the Board of Commissioner's support while working alongside very dedicated, knowledgeable, and professional staff. Throughout all of 2023 City staff continued to provide the most efficient and effective city services to ensure Madeira Beach remains a fabulous place to live, learn, work, play, and visit. All the men and the women in

our City departments continued to daily provide a variety of services such as prevention/response, beautification, building/code inspections, processing applications, recreation, special events, parking, and much more with great dedication, professionalism, and compassion. Collectively, our daily focus continues to ensure Madeira Beach remains a very safe City that properly maintains its infrastructure and beauty and seeks to continue to properly manage and enhance its economic development and redevelopment.

Many of you stopped by our new look City Hall 2<sup>nd</sup> floor lobby that held a grand reopening in February 2023. We continue to provide various City items for sale showcasing our City pride. Please stop by Mondays through Fridays from 8:30 am to 4:30 pm, to view and possibly purchase one of the new City of Madeira Beach shirts, hats, photo prints, stickers, and other items. Please help us showcase our unique Madeira Beach identity by wearing or displaying one of the new items.

As in prior months, thousands enjoyed a variety of December activities from the monthly Trash Pirates clean-up to softball tournaments to the annual John’s pass Village tree lighting to the Final Friday music festival. I am extremely appreciative of all individuals and organizations that participated in any way from organizing, coordinating, volunteering, attending, etc., to help make all these events very successful. Please read on to learn of the many January events, updates on various City projects, and numerous data and statistics from City departments.

**City Hall 2<sup>nd</sup> Floor Lobby – City shirts, hats, prints, bags, vanity license plate, etc., for sale**



Our newest logo seen on short and long-sleeved shirts was (and continues to be) quite a hit this past Holiday season as hundreds showed our Madeira Beach Holidays In Paradise logo –



Please continue to reach out to me or any City staff via the following methods/means for any City matter. We are here to provide the most efficient and effective City services for all our residents, businesses, and visitors that continue to live in and/or visit our fabulous *2 miles long and a smile wide* City we call Madeira Beach:

- City internet/web site: [www.madeirabeachfl.gov](http://www.madeirabeachfl.gov)

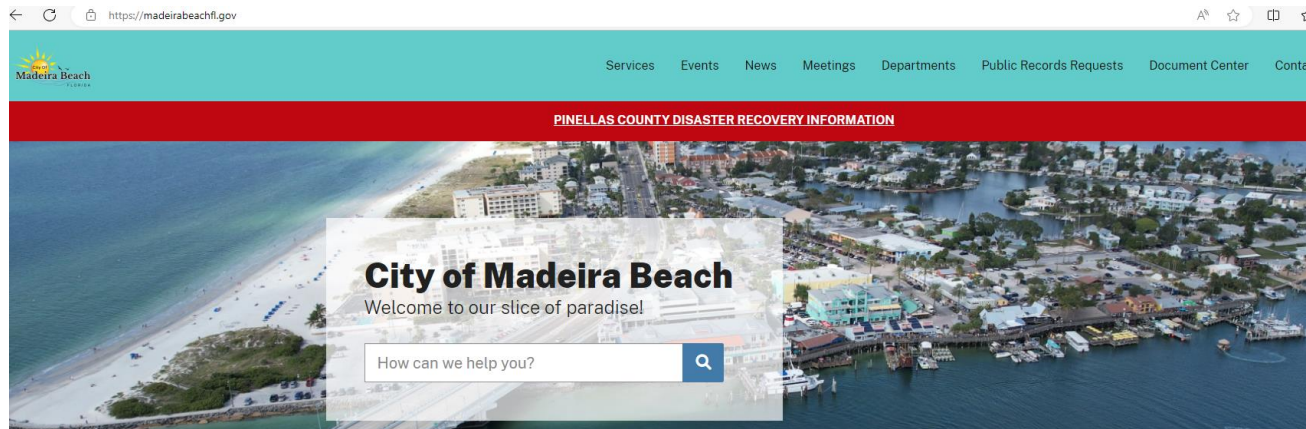

- Via email (listed on our website): [rgomez@madeirabeachfl.gov](mailto:rgomez@madeirabeachfl.gov)  
-all city employee emails are the first letter of the first name followed by last name
- On the phone (main line): **727-391-9951**
- Robin Gomez' cell phone: **727-580-8014**  
-additional phone #'s listed on website
- In person at City Hall, 300 Municipal Dr, open M-F 8 am to 4:30 pm: to obtain a resident permit parking pass/sticker, purchase our 75<sup>th</sup> anniversary items (shirts, hats, etc), to ask a question(s), or to just say hello
- In person at City Hall Commission Chambers, for our monthly Board of Commission meetings:
  - Regular Meeting on the 2<sup>nd</sup> Tuesday of each month
  - Workshop Meeting on the 4<sup>th</sup> Tuesday of each month
  - both typically begin at 6pm

Also, please sign up to receive City of Madeira Beach emails on upcoming events, activities, meetings, etc., on our Website:

[www.madeirabeachfl.gov](http://www.madeirabeachfl.gov)

On home page, scroll all the way to the bottom, choose **subscribe** on the right in the HELP column

<p>Flood Protection</p> <p><a href="#">Emergency Management</a></p> <p><a href="#">FEMA.gov</a></p> <p><a href="#">FloodSmart.gov</a></p> <p><a href="#">Ready.gov/floods</a></p>	<p>Help</p> <p><a href="#">Services</a></p> <p><a href="#">Contact</a></p> <p><a href="#">Subscribe</a></p> <p><a href="#">Directory</a></p> <p><a href="#">Accessibility</a></p> <p><a href="#">Sitemap</a></p>
---	--

## SAND DUNES RESTORATION / SHORE STABILIZATION PROJECT

Item 15D.

Pinellas County contractor, Gator Dredging, completed the sand dunes restoration on Monday, December 5. The approximately 1,800 linear feet area receiving additional sand stretched from the southern property line of the Ocean Sands Condo buildings, just South of Archibald Park, North to the north property line for the Sereno Condos/Townhomes just North of Archibald Park:



A separate contractor began the plantings on the last week of December hoping to complete just after the new year. Again, signs posted on site continue to remind all to please stay off and do not walk on, through, etc., the new sand dunes. The City of Madeira Beach greatly appreciates everyone's cooperation.

## **ANOTHER WINTER STORM - FLOODING**

Unfortunately, various properties in our City once again on the overnight of Saturday, Dec 16 into Sunday, Dec 17, experiencing flooding as a winter storm pushed considerable Gulf water onto our City streets particularly from 140<sup>th</sup> to the North. Difficult for some of our low-lying areas to prevent rising waters; fortunately the recently installed/revitalized sand dunes in and around Archibald Park did keep water and sand off the Archibald Park areas including the parking lot. Approximately 1/3 of that sand did wash away, but enough was left to allow the County's contractor to continue with the plantings.



**Please continue to stay vigilant and prepared as these winter and spring storms can be even more impactful than storms during hurricane season.**

# FEMA- December Plan

This month plan ahead and take steps to make sure you are covered with flood insurance!

Take a look below for some helpful tips on how and what to get covered by your policy.

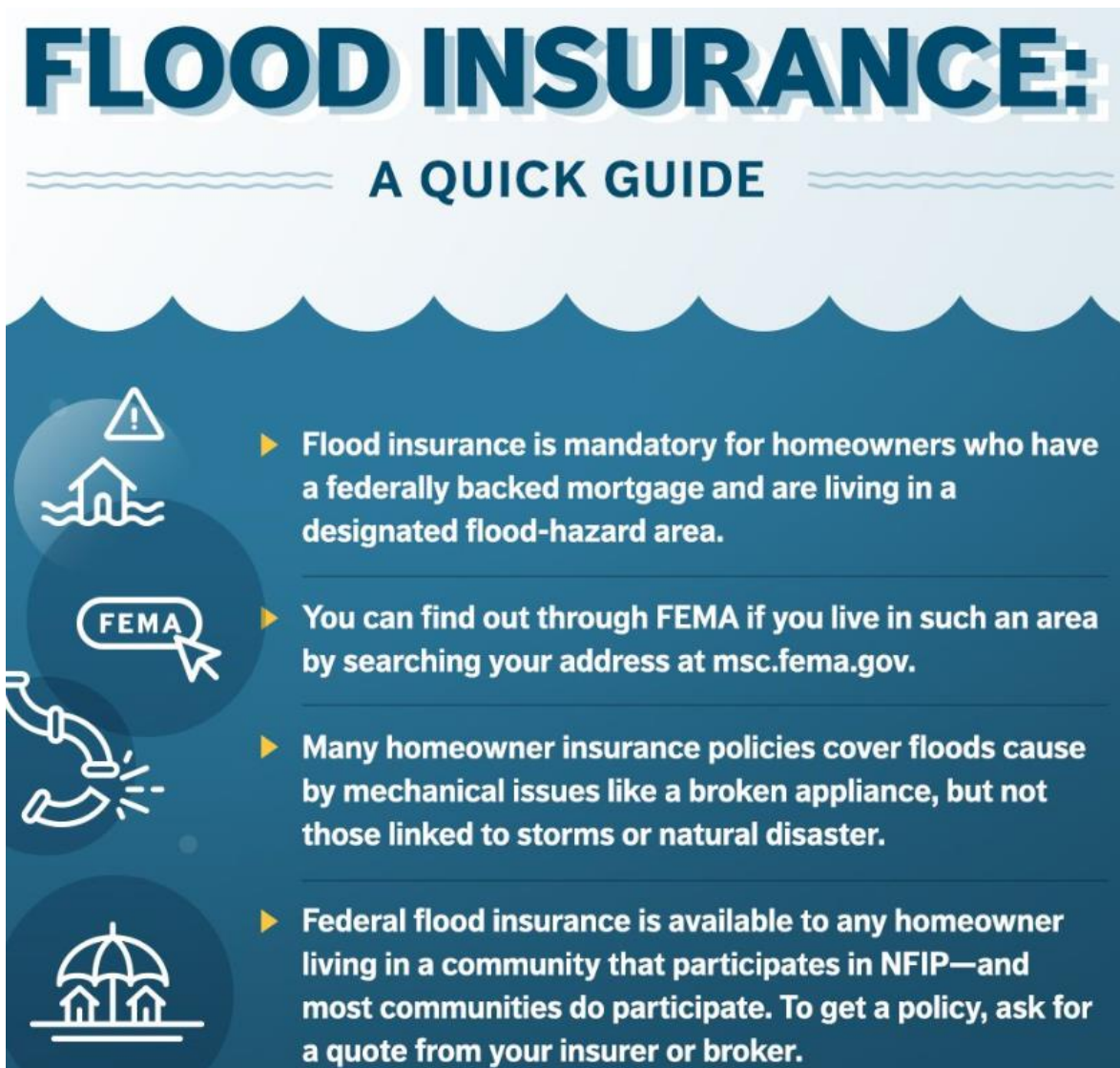



## FLOOD INSURANCE:

### A QUICK GUIDE

- 

▶ Flood insurance is mandatory for homeowners who have a federally backed mortgage and are living in a designated flood-hazard area.
- 

▶ You can find out through FEMA if you live in such an area by searching your address at [msc.fema.gov](https://www.msc.fema.gov).
- 

▶ Many homeowner insurance policies cover floods cause by mechanical issues like a broken appliance, but not those linked to storms or natural disaster.
- 

▶ Federal flood insurance is available to any homeowner living in a community that participates in NFIP—and most communities do participate. To get a policy, ask for a quote from your insurer or broker.

# Ready Pinellas Emergency Planning Mobile App

## Introducing the new and improved Ready Pinellas mobile app!

**Ready Pinellas** is designed to help residents prepare themselves and their families before, during and after a storm. It is available for free download on the Apple [App Store](#) and [Google Play](#) store.

**Note: Android device users who already had the previous Ready Pinellas app installed will need to download the new app from the Google Play store and remove the old app from their devices.** Apple device (iPhone and iPad) users will see the app automatically updated.

The new app features a refreshed design and user experience, additional information and tips, and convenient checklists to make sure you and your family are prepared. App users can use emergency supply checklist, home inventory and emergency contacts tools to build a personal emergency plan.

As a storm approaches, the app will provide real-time updates to help keep you safe, including detailed information that is available at your fingertips even if you lose internet connectivity. It will provide resources to contact us year-round and during a disaster and give you tips to Stay Informed.



## Ready Pinellas App Features

- **Know Your Zone:** If you have your locator services on, the app will tell you if you are in a designated evacuation zone. You can also look up other addresses to see if they are in an evacuation zone. Remember: Evacuation zones were updated for the 2022 hurricane season, so you may have a new zone. When a storm is approaching, it will tell you if Pinellas County is in the 5-day or 3-day cone and if an evacuation order has been issued.
- **Make a Plan:** Use our emergency supply checklist, home inventory and emergency contacts tools to build a personal emergency plan that you can share. You can take pictures of items for your home inventory.
- **Push Notifications:** Through the app, you will receive informational and emergency notifications from Pinellas County Emergency Management, the National Weather Service and [Alert Pinellas](#).
- **Special Needs:** You can learn more about special needs assistance, which is intended for those who need transportation or require minimal medical assistance while seeking public shelter. You can register from the app.
- **Preparedness Tips:** Learn how to prepare your family, pets, home, condo, mobile home, boat and more.
- **Safety Tips:** Find information on What to Do Now before, during, and after an event. Learn about year-round preparedness, how to clean up after a flood or food safety if power has been out.
- **Report Damages** after a storm has hit Pinellas County.



## CITY CLEAN-UPS & BEAUTIFICATION

Thank you very much to our fabulous Trash Pirates and Trash Turtles that once again held clean-ups in December and more planned for January and February:

### Trash Pirates of Mad Beach



### Trash Turtles



Thank you to all the wonderful volunteers, family, and friends that continue to make our community a better place to live, learn, work, and play. The pounds and pounds of trash removed at the clean-ups on December 2 and December 9 truly make our slice of paradise shine. The City very much appreciates all your efforts. Please continue to look forward to future monthly clean-ups by the Trash Pirates and Trash Turtles of Madeira Beach.

## CITY SANITATION & RECYCLING

**REMINDER:** Trash containers need to be stored somewhere other than curbside, and wheeled out to the curb for collection no earlier than 5:30 pm the day prior to collection, and removed away from the curb by sunset the day of collection. If your container is damaged or missing please contact the City of Madeira Beach Public Works/Sanitation department at 727.543.8154. The City of Madeira Beach greatly appreciates everyone’s patience and understanding with the trash collection change that will help to keep our City even cleaner.

Please remember the following items may be recycled:

- PAPER** newspaper, magazines, junk mail, computer/printer paper, catalogs, brown/white/colored paper bags, paperboard cartons, wrapping paper
- CARDBOARD** cereal boxes (without plastic liner), soda cartons (without plastic wrap), cardboard boxes (flattened, no larger than a 4’ x 4’ square)
- GLASS** all clear, brown, green glass FOOD and BEVERAGE bottles (must be rinsed out with no residue and lids/caps removed)
- PLASTIC** all plastic FOOD and BEVERAGE containers that have the Recycle symbol and a number 1 or 2 (must be rinsed out with no residue and lids/caps removed)
- METAL** aluminum FOOD and BEVERAGE cans (rinsed out with no residue and lids/caps removed), tin FOOD and BEVERAGE cans (rinsed out no

residue and lids/caps removed), clean aluminum foil pans, empty aerosol cans

**ITEMS NOT RECYCLABLE:** plastic bags, egg cartons, Styrofoam, pizza boxes (normally only the top/lid may be recycled if it is super clean-no cheese/grease/toppings)

ANY & ALL TRASH – please dispose of trash in appropriate trash bags and receptacles.

**Thank you for recycling responsibly.**

WELCOME TO WASTE PRO  
EFFECTIVE JANUARY 4<sup>TH</sup> WE WILL PROVIDE YOUR  
WEEKLY RECYCLING COLLECTION

**RECYCLE RIGHT**

Plastic bottles, jugs, and glass  

Metal cans  

Cardboard boxes  

Paper  



**DO NOT use your cart until JANUARY 4<sup>TH</sup>**  
 If you do not receive your cart between the week of December 26th-30th please contact Waste Pro at 727-452-5278.

Cart delivery will occur the week of **DECEMBER 26th - 30th, 2022**

Questions? Please visit us online [www.wasteprousa.com](http://www.wasteprousa.com) or call us 727-452-5278.



**REDUCE, REUSE, RECYCLE**

**Recycling Statistics for December 2023:**

**City of Madeira Beach Monthly Report  
December 2023**

RECYCLING STATISTICS		
MATERIAL	Tons	%
Aluminum	0.83	2.00%
Cardboard	5.33	12.80%
Mixed Glass	16.04	38.50%
ONP	4.92	11.80%
Plastic	3.29	7.90%
Tin	0.50	1.20%
Contamination	10.75	25.80%
<b>TOTAL</b>	<b>41.66</b>	

## **Cameras throughout Madeira Beach**

The below internet links will take you to live web cameras of Madeira Beach sand views – helpful to see how busy locations may be, wave action, observe the City sand rake, and/or weather conditions – take a look:

Hubbard’s Marina earth cam <https://myearthcam.com/hubbardsmarina>

Baynews9 Camera at John’s Pass Park <https://www.baynews9.com/fl/tampa/weather/bay-news-9-cameras>

Commodore Beach Club <https://commodorebeachclub.com/resort-details/live-webcam>

## **BUILDING DEPARTMENT**

The Building Department now has online permitting available! Click the link below to sign up:  
<https://www.mgoconnect.org/cp/portal>

This will allow residents and contractors to apply for a permit online and look at the status of the permit without stepping foot in City Hall!

Reminder, the Building and Community Development Departments now have open office hours on Wednesdays from 1pm to 3pm, first come first served. Can't make it then? Call the City Hall to make an appointm... See more



## **PARKING**

A few reminders regarding **resident** and **visitor** parking:

1. Residents can obtain up to 3 **RESIDENT PARKING PASSES** at no charge, that allow residents to park in any City of Madeira Beach lot while the lot is open as well as on streets that allow resident parking. No overnight parking is allowed at any City lot using the **RESIDENT PARKING PASS** (everyone can use the overnight parking lot areas by paying the \$3/hour fee). Property owners are also eligible to receive parking passes with a valid driver's license and vehicle registration.

2024 Resident Parking passes are available in-person at City Hall or on-line at the City's website, [www.madeirabeachfl.gov](http://www.madeirabeachfl.gov). Please remember your driver's license and vehicle registration must be presented and must be valid.

2. **VISITOR PARKING** is available at all City of Madeira Beach lots and the John's Pass Boardwalk & Village on-street spaces and the lot adjacent to the VFW (entrance off 129<sup>th</sup> Ave E) by paying the hourly rate of \$3 (may pay using the ParkMobile app or at a kiosk/meter located at each lot). Overnight parking is only allowed at City of Madeira Beach lots located from 130<sup>th</sup> Ave to 136<sup>th</sup> Ave (entrances off Gulf Blvd) – not allowed at the John's Pass Parking lot and the Archibald Park Parking lot – by paying the \$3/hr rate (available for up to 7 days).
3. Please keep in mind, particularly visitors, that there are other privately-run/managed parking lots throughout our City that typically charge \$4-\$8/hour as well as the occasional \$20 - \$45 full day rate/charge. These lots are NOT owned/managed/enforced by the City of Madeira Beach.
4. To alleviate various residential street congestion due to construction sites, we will be issuing parking permits to construction workers, contractors/sub-contractors, and related vehicles/trucks to ensure they park correctly, mainly not blocking any streets (particularly for emergency vehicle access). Information is on our City website under Parking.

## GULF BEACHES LIBRARY

Hopefully, many of you have visited our wonderful **Gulf Beaches Library** located at 200 Municipal Dr, next to Madeira Beach Fire Station 25, across the street from the Winn Dixie shopping plaza. The library offers many exceptional services from borrowing books, cd's, museum passes to a monthly newsletter to kids/children's programs to a writer's group to the showing of various popular films to a book club.

A significant amount of information on programs, activities, and much more can be found at their internet/website:

[www.gulfbeacheslibrary.org](http://www.gulfbeacheslibrary.org)

Please check it out if you have not already and also sign up for their wonderful newsletter:



### Sign Up for Library Newsletter

*\* Indicates required field*

Name \*

First Last

First Last

Email \*

I agree to receiving marketing and promotional materials \*

**Subscribe to Newsletter**

### Library Hours

Mon. 10 am - 6pm  
Tues. 10 am - 8 pm  
Wed. 10 am - 6pm  
Thurs. 10 am - 6pm  
Fri. 10 am - 6pm  
Sat. 10 am - 5 pm  
Sun. Closed

**MARCH 19, 2024 MUNICIPAL ELECTION**

**SEATS UP FOR ELECTION TERM OF OFFICE ANNUAL SALARY**

Commissioner District 1 - Two-Year Term - \$7,500

Commissioner District 2 - Two-Year Term - \$7,500

*(Madeira Beach Charter Section 2.2(B) and Ordinance 2023-23)*

During the candidate qualifying period held from noon on Monday, December 4, 2023 to noon on Friday, December 15, 2023, one candidate qualified for Commissioner District 1 and one candidate qualified for Commissioner District 2.

The Commissioner District 1 and Commissioner District 2 will not appear on the March 19, 2024 election ballot. David Tagliarini will serve as the elected Commissioner for District 1 and Ray Kerr will serve as the elected Commissioner for District 2.

Induction of the above two will occur at 5 pm on Wed, March 27, 2024, at the City Hall Commission Chambers.

On march 19, 2024, there will also be one BALLOT QUESTION. The following measure shall be placed on the General Election ballot for March 19, 2024 to be voted upon by the qualified electors of the City of Madeira Beach, Florida and this amendment shall become effective immediately upon approval by a majority of the electors voting on this referendum question:

No. 1 Charter Amendment

Amend qualifying period to the first full week in December.

This charter amendment would amend Section 3.3(A) of the Charter to change the Candidate Qualifying Period to the first full week in December instead of the first two full weeks in December. Should the Charter be amended?

Yes

No

**POLLING LOCATIONS FOR THE MARCH 14, 2023 MUNICIPAL ELECTION**

- **Precinct 415** - Madeira Beach Municipal Building, City Centre Room, 300 Municipal Drive, Madeira Beach, Florida 33708 will be open March 14, 2023, from 7:00 a.m. to 7:00 p.m.
  - **Precinct 301** - Calvary Church Seminole (Combined), 6155 113 Street, Seminole Florida 33772 will be open March 14, 2023, from 7:00 a.m. to 7:00 p.m.
-

**MADEIRA BEACH MARKET**

Please remember to visit our weekly Market on Madeira Way showcasing over 30 local vendors selling a variety of crafts, arts, clothing, yummy food selections, fresh produce, and much more. Join us on Madeira Way every Wednesday from 10 am to 2 pm, until May 2023 to shop local including many gift options. Residents and visitors alike will be impressed with the variety of items available for purchase.

**UPCOMING SPECIAL EVENTS/ACTIVITIES/MEETINGS**

- (1) **Trash Pirates monthly clean up** at John's Pass Bell Tower area and Archibald Park, Sat, Jan 6, 8 am.
- (2) **CITY PLANNING COMMISSION MEETING**, Mon, Jan 8, 6 pm, CITY HALL – Commission Chambers
- (3) **CITY COMMISSION REGULAR MEETING**, Wed, Jan 10, 6 pm, CITY HALL – Commission Chambers
- (4) **JOHN'S PASS SEAFOOD FESTIVAL**, Fri, Jan 19, noon to 9 pm; Sat, Jan 20, 10 am to 9 pm; Sun, Jan 21, 10 am to 6 pm
- (5) **BOARD OF COMMISSIONERS WORKSHOP** CITY HALL, Wed, Jan 24, 6 pm, – Commission Chambers
- (6) **Final Friday**, Friday, January 26, 6 pm, John's Pass
- (7) **Breakfast with the City Manager**, Saturday, February 3, 9:30 am, Archibald Park Snack Shack

## **Building Official(s) – Development Report (December- 2023)**

City Building Official, Frank DeSantis reports that our redevelopment/economic development continues at a steady pace including several large condominium projects on-going and/or under current plan review.

- The **Schooner Resort** is under review
- **410 150<sup>th</sup> Ave.** Demo permit issued.
- The **Tiki Docks Bar & Grill** permit has been issued.
  - ✓ Interior and Exterior almost complete
  - ✓ Tiki hut and pavers complete
  - ✓ Grease trap to be connected followed by irrigation and sod.
- **15405 Gulf Blvd. Azul Townhomes**
  - ✓ Cabinets are installed and counter tops have been templated.
  - ✓ Doors and tile 95% complete.
  - ✓ Vinyl flooring continues.
  - ✓ Elevator(s) install to start the week of the 15th.
  - ✓ F.D.E.P. and P.C.U. fees have been paid.
  - ✓ Phase 2 drywall is near complete
  - ✓ M.E.P. inspections to be scheduled
- **200 150th Ave. Harbor at Town Center**
  - ✓ Elevators are complete. State inspection and fire inspection to follow.
  - ✓ Permanent power is on.
  - ✓ The pool is dug, and reinforcing is installed.
  - ✓ Front sidewalks are ready to pour.
  - ✓ All construction fencing has been removed.
  - ✓ Final inspection(s) to be scheduled soon.
- The **Holiday Isles projects** (*The Development Order expires October 20, 2024*)
  - ✓ **555 150<sup>th</sup> Ave.** (Hampton Inn Hotel) – (*The permit #4082 expires July 1, 2024*)  
Site clearing and grading work continues – expected to be complete in two to three weeks.
  - ✓ **565 150<sup>th</sup> Ave.** (31-unit building) – (*The permit #20210386 expires January 26, 2026*)  
New silt fencing installed, no scheduled date to start

### **PERMIT TYPES ISSUED (12/01/2023 through 12/31/2023):**

- |  |  |  |
|--|--|--|
| • <b>SFH projects – (0)</b><br><i>Single Family Homes</i>                    | • <b>Commercial projects – (2)</b><br><i>Remodel</i>         | • <b>Residential projects – (6)</b><br><i>Remodel</i>    |
| • <b>Docks &amp; Lift projects – (9)</b><br><i>Replacement &amp; Repairs</i> | • <b>Roof – (6)</b><br><i>New &amp; Re-roof</i>              | • <b>Fence – (10)</b><br><i>New &amp; Replacement</i>    |
| • <b>Generator projects – (0)</b><br><i>New Generator</i>                    | • <b>Swimming Pool – (2)</b><br><i>New</i>                   | • <b>Seawall– (1)</b><br><i>New Seawall &amp; Cap</i>    |
| • <b>Demo Permits – (3)</b><br><i>Demolition</i>                             | • <b>Driveway/Pavers – (7)</b><br><i>New</i>                 | • <b>Deck – (0)</b><br><i>New &amp; Replacement</i>      |
| • <b>Windows/Doors – (22)</b><br><i>Replacement</i>                          | • <b>Mechanical E/C/O's – (14)</b><br><i>New AC units</i>    | • <b>Sign projects – (1)</b><br><i>New Sign Permits</i>  |
| • <b>Electrical Permits – (5)</b><br><i>Meter, Panel C/O's</i>               | • <b>Plumbing HW C/O's – (9)</b><br><i>Hot Water Heaters</i> | • <b>Solar Permits – (0)</b><br><i>New Solar Permits</i> |



**Monthly Totals (12/01/2023 through 12/31/2023):****➤ Building Department:**

1. 103 different types of permits were processed & issued.
2. \$56,566.18 Permit fees collected.
3. \$2,072,549 Permit estimated value or cost.
4. 171 completed inspections (average 13 +/- per day)

**➤ Building Code Compliance & Residential Rental Inspections:**

1. 4 new code compliance cases were created.
2. 11 code compliance cases being resolved.
3. 62 open/outstanding code compliance cases.
4. 0 residential rental inspections for the month of December

**Community Development**

We continue to experience a high plan review volume. Staff continued making improved progress on plan review leading to a 1-2 week turn-around time.

Various staff attended the MGO conference in New Orleans December 11-14; a very educational and enlightening time learning more on our software.

Public meetings for John's Pass Village Zoning Public Workshop have been scheduled for 1/18/2024, 1/23/2024, and 1/27/2024.

The LPA meeting for December was cancelled as there were no agenda items.

Staff audited two property management companies for BTR compliance so far.

Staff additionally completed damage assessment from the December storm on 12/22/23.

**MARINA**

<b>Account #</b>	<b>Description</b>	<b>Oct'23</b>	<b>Nov'23</b>	<b>Dec'23</b>
405.9300.347500	ATM Service Charge	-	-	-
405.9300.347901	Unleaded Fuel Sales	153,969.74	160,573.74	99,557.48
405.9300.347902	Diesel Sales	9,228.65	7,495.39	11,003.36
405.9300.347903	Diesel - Commerical	36,334.16	27,119.20	21,559.97
405.9300.347904	Purchases Fuel	-	-	-
405.9300.347905	Propane Sales	160.93	183.92	206.91
405.9300.347906	Propane - Exempt	22.99	22.99	-
405.9300.347907	Purchases Propane	-	-	-
405.9300.347908	Misc Store Income-Taxable	17,513.88	18,899.35	16,118.21
405.9300.347909	Misc Store Income-Non Taxable	204.00	146.00	103.99
405.9300.347910	Purchases Store	-	-	-
405.9300.347911	Dry Storage Fees	11,335.05	11,204.34	11,204.34
405.9300.347912	Transient Rentals	6,825.88	8,045.09	5,830.87
405.9300.347913	Marina Slip Rent	20,618.00	21,615.00	21,615.00
405.9300.347914	Annual Fishing Tournament	-	-	-
405.9300.347915	Land & Sea Sales	-	-	-
405.9300.347916	Late Fees	-	-	-
405.9300.347917	Boat Ramp Parking	510.28	402.81	325.25
405.9300.361100	Interest Earnings	14,528.90	9,737.35	-
405.9300.364000	Sale/Disposition of Capital Assets	-	-	-
405.9300.369900	Other Miscellaneous Revenues	-	-	-
405.9300.369903	Refund Prior Year Expenses	-	-	-
405.9300.369904	Sales Tax Collection Allowance	30.00	30.00	30.00
405.9300.369912	Boat Ramp Fees	-	-	-
405.9300.369913	Commission - Laundry Equipment	55.00	51.25	65.50
405.9300.380000	Other Sources	-	-	-
405.9300.380001	Fund Balance/Net Position Carryover	-	-	-
405.9300.381002	Transfer from Sanitation Fund	-	-	-
405.9300.381003	Transfer from Stormwater Fund	-	-	-
405.9300.389201	Federal Grant - Clean Vessel	-	-	-
405.9300.389801	Asset Transfer In from Governmenta	-	-	-
		271,337.46	265,526.43	187,620.88

Marina Revenue

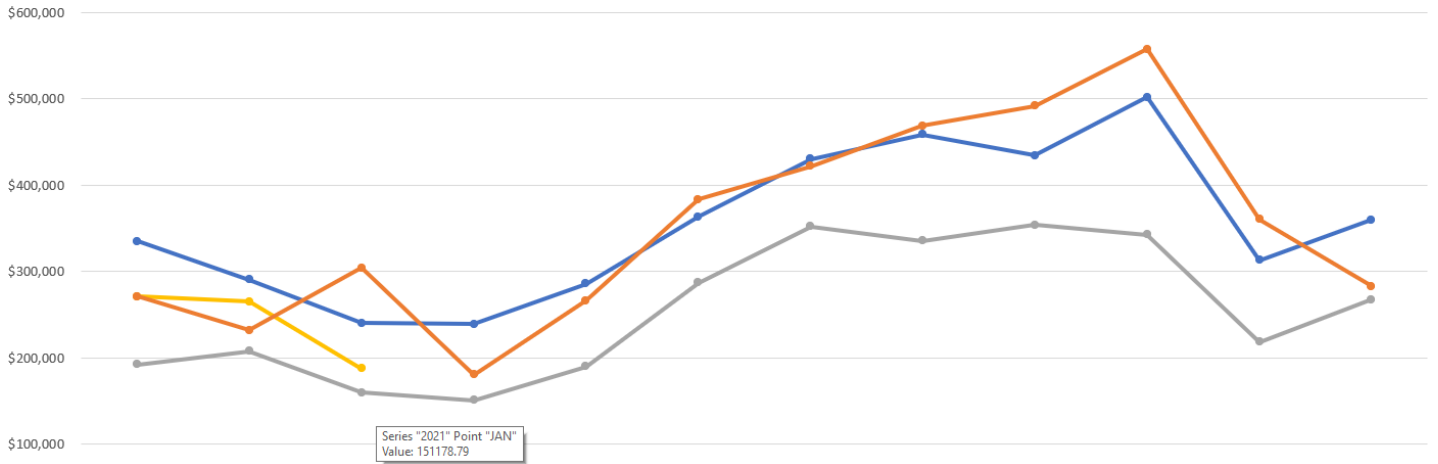

	OCT	NOV	DEC	JAN	FEB	MAR	APR	MAY	JUN	JUL	AUG	SEP
2024	\$271,337	\$265,526	\$187,621									
2023	\$334,925	\$290,757	\$240,510	\$239,249	\$285,894	\$363,739	\$430,161	\$458,538	\$434,419	\$502,245	\$313,295	\$360,210
2022	\$271,397	\$232,080	\$304,214	\$180,592	\$266,290	\$383,871	\$422,069	\$469,091	\$491,795	\$557,708	\$360,607	\$282,702
2021	\$192,415	\$207,580	\$160,079	\$151,179	\$190,312	\$286,880	\$352,391	\$335,820	\$354,060	\$342,625	\$218,696	\$267,853

FY 24           \$ 724,484  
 FY 23           \$4,253,942  
 FY 22           \$4,222,416  
 FY 21           \$3,059,890

**PARKING**

<b>Month</b>	<b>Parking Meter</b>	<b>Parking Fines</b>	<b>Monthly Totals</b>
<b>Oct-22</b>	237,794.00	45,415.00	283,209.00
<b>Nov-22</b>	187,490.14	61,243.40	248,733.54
<b>Dec-22</b>	185,507.38	47,895.00	233,402.38
<b>Jan-23</b>	224,453.63	55,195.00	279,648.63
<b>Feb-23</b>	290,884.45	51,505.50	342,389.95
<b>Mar-23</b>	369,009.87	75,542.00	444,551.87
<b>Apr-23</b>	375,567.76	61,521.00	437,088.76
<b>May-23</b>	370,646.79	51,127.00	421,773.79
<b>Jun-23</b>	365,286.89	58,372.00	423,658.89
<b>Jul-23</b>	402,082.94	40,345.20	442,428.14
<b>Aug-23</b>	259,525.73	42,049.00	301,574.73
<b>Sep-23</b>	228,913.22	34,995.00	263,908.22
<b>Fiscal Year 2023</b>	<b>\$ 3,497,162.80</b>	<b>\$ 625,205.10</b>	<b>\$ 4,122,367.90</b>
<b>Oct-23</b>	235,464.24	36,881.00	272,345.24
<b>Nov-23</b>	187,037.59	39,142.00	226,179.59
<b>Dec-23</b>	161,644.23	32,720.00	194,364.23
<b>Jan-24</b>	-	-	-
<b>Feb-24</b>	-	-	-
<b>Mar-24</b>	-	-	-
<b>Apr-24</b>	-	-	-
<b>May-24</b>	-	-	-
<b>Jun-24</b>	-	-	-
<b>Jul-24</b>	-	-	-
<b>Aug-24</b>	-	-	-
<b>Sep-24</b>	-	-	-
<b>Fiscal Year 2024</b>	<b>\$ 584,146.06</b>	<b>\$ 108,743.00</b>	<b>\$ 692,889.06</b>

**ADDITIONAL REVENUE (\$0.50) FOR PARKING GARAGE**

Item 15D.

Month	Fiscal Year			Gross Totals
	2022	2023	2024	
October	-	33,085.26	32,000.71	65,085.97
November	-	26,826.15	26,538.19	53,364.34
December	24,476.64	27,153.76	24,435.16	76,065.56
January	30,337.91	32,123.83	-	62,461.74
February	35,171.98	39,748.42	-	74,920.40
March	50,111.85	50,661.11	-	100,772.96
April	47,236.29	51,249.95	-	98,486.24
May	46,699.86	49,261.28	-	95,961.14
June	46,141.33	49,065.97	-	95,207.30
July	53,959.46	53,323.57	-	107,283.03
August	39,613.94	34,712.30	-	74,326.24
September	27,021.32	30,171.79	-	57,193.11
<b>Annual Totals</b>	<b>\$ 400,770.58</b>	<b>\$ 477,383.39</b>	<b>\$ 82,974.06</b>	<b>\$ 961,128.03</b>

Happy 2024! I wish all of you the very best everyday throughout 2024. We ended a very successful 2023 that began with a new recycling company and processes that greatly improved and increased residential recycling with over 75% of all materials collected eligible to be recycled; numerous beautification improvements at our pocket parks, various medians on 150<sup>th</sup> Ave, and John's Pass Village; enhanced on-line services accessibility in Parking, Building Permits, and Community Development; resurfaced parking lots near John's Pass Village; and over-all enhancements in City equipment, resources, and personnel. We begin 2024 with much excitement as 2023 concluded various preparations for sizeable projects from the beach groins restoration, to dredging a part of the John's Pass waterway to new restrooms at Archibald Park to a new Public Works structure. Our revenues continued to experienced growth particularly in our Marina, Parking, and over-all General Fund; while responsibly controlling rising expenditures.

2023 concluded with an even larger number of visitors to Pinellas County and Madeira Beach as evidenced by various metrics including passenger counts at the St Pete Clearwater International Airport, Bed Tax (Tourist Development) Collections, City Parking revenues, and over-all observations, data, and comments from businesses and residents. While we also began experiencing more traffic and wait times at our stores and restaurants, I am reminded we can still enjoy our slice of paradise every day walking on our pristine sand, viewing spectacular sunsets and celestial views, or simply enjoying a peaceful fishing or other water excursion. Whatever your hobby or enjoyment, please take some time to enjoy our wonderful city and the many outdoor amenities.

**HAPPY NEW YEAR, 2024 !!**



***New welcome sign***



***Eclectic Gulf Sky shortly after sunset***

I hope many of you enjoyed our various meetings, activities, and events throughout January including the annual Seafood Festival at John's Pass Village, Final Friday at the John's Pass bell tower area, a beach clean-up, and our Commission meetings. Please continue reading to learn of February meetings, activities, and events, all listed on the City's website: [www.madeirabeachfl.gov](http://www.madeirabeachfl.gov).

A reminder to visit our new-look City Hall 2<sup>nd</sup> floor lobby that will continue to provide various City items for sale showcasing our City pride. Please stop by Mondays through Fridays from 8:30 am to 4:30 pm, to view and possibly purchase one of the new City of Madeira Beach shirts, hats, photo prints, stickers, and other items. Please help us showcase our unique Madeira Beach identity by wearing or displaying one of the new items.



Please continue to reach out to me or any City staff via the following methods/means for any City matter. We are here to provide the most efficient and effective City services for all our residents, businesses, and visitors that continue to live in and/or visit our fabulous *2 miles long and a smile wide* City we call Madeira Beach:

- City internet/web site: [www.madeirabeachfl.gov](http://www.madeirabeachfl.gov)

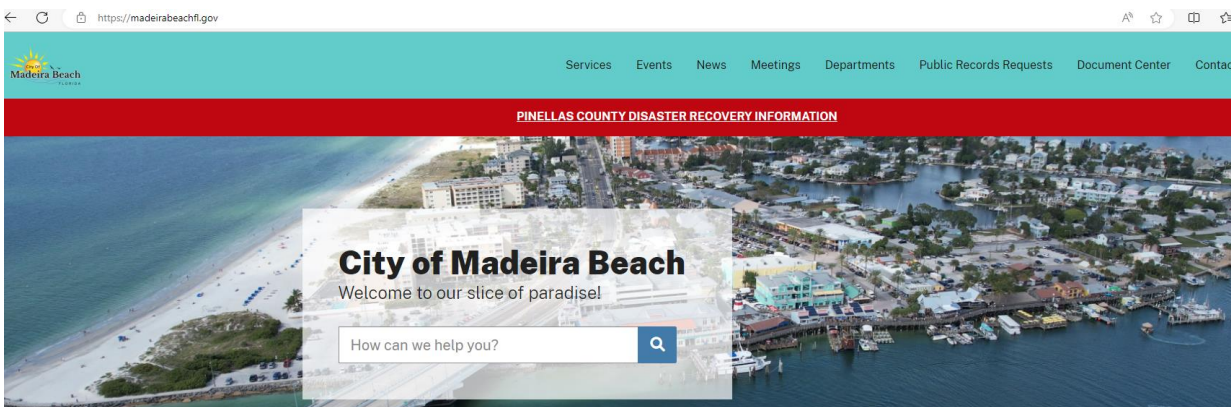

- Via email (listed on our website): [rgomez@madeirabeachfl.gov](mailto:rgomez@madeirabeachfl.gov)  
-all city employee emails are the first letter of the first name followed by last name
- On the phone (main line): **727-391-9951**
- Robin Gomez' cell phone: **727-580-8014**  
-additional phone #'s listed on website
- In person at City Hall, 300 Municipal Dr, open M-F 8 am to 4:30 pm: to obtain a resident permit parking pass/sticker, purchase our 75<sup>th</sup> anniversary items (shirts, hats, etc), to ask a question(s), or to just say hello
- In person at City Hall Commission Chambers, for our monthly Board of Commission meetings: Regular Meeting on the 2<sup>nd</sup> Tuesday of each month  
Workshop Meeting on the 4<sup>th</sup> Tuesday of each month  
-both typically begin at 6pm

Also, please sign up to receive City of Madeira Beach emails on upcoming events, activities, meetings, etc., on our Website:

[www.madeirabeachfl.gov](http://www.madeirabeachfl.gov)

On home page, scroll all the way to the bottom, choose **subscribe** on the right in the HELP column

<p><b>Flood Protection</b></p> <p><a href="#">Emergency Management</a></p> <p><a href="#">FEMA.gov</a></p> <p><a href="#">FloodSmart.gov</a></p> <p><a href="#">Ready.gov/floods</a></p>	<p><b>Help</b></p> <p><a href="#">Services</a></p> <p><a href="#">Contact</a></p> <p><a href="#">Subscribe</a></p> <p><a href="#">Directory</a></p> <p><a href="#">Accessibility</a></p> <p><a href="#">Sitemap</a></p>
--	---

January saw the conclusion of a few City projects from median beautification to renovations of a reflective fountain/pool at ROC Park to a new boat lift also at ROC park, a few images:

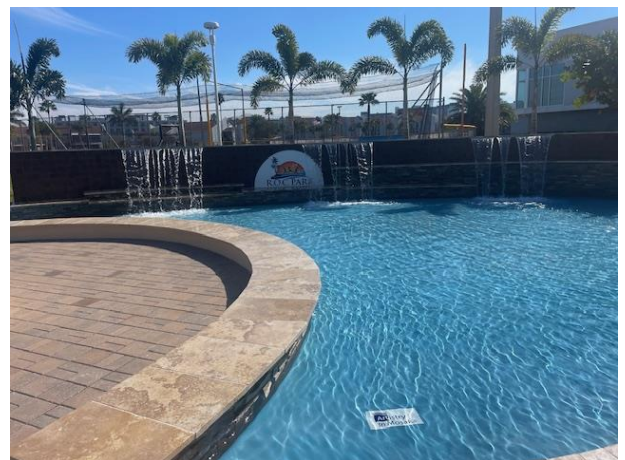

**ROC Park Reflection Fountain/Pool**



***New City Boat Lift for City Boat***



***Adjacent to the City's Fire Rescue Boat***



**New City Hall sign on new landscaped area**

# FEMA- January Plan



After an emergency, you may need to survive on your own for several days. Being prepared means having your own food, water and other supplies to last for several days. A disaster supplies kit is a collection of basic items your household may need in the event of an emergency.



Make sure your emergency kit is stocked with the items on the checklist below. [Download a printable version](#) to take with you to the store. Once you take a look at the basic items consider what unique needs your family might have, such as supplies for pets or seniors.

## Basic Disaster Supplies Kit

To assemble your kit store items in airtight plastic bags and put your entire disaster supplies kit in one or two easy-to-carry containers such as plastic bins or a duffel bag.

A basic emergency supply kit could include the following recommended items:

- ✓ Water (one gallon per person per day for several days, for drinking and sanitation)
- ✓ Food (at least a several-day supply of non-perishable food)
- ✓ Battery-powered or hand crank radio and a NOAA Weather Radio with tone alert
- ✓ Flashlight
- ✓ First aid kit
- ✓ Extra batteries
- ✓ Whistle (to signal for help)
- ✓ Dust mask (to help filter contaminated air)
- ✓ Plastic sheeting and duct tape (to shelter in place)

## Maintaining Your Kit:

After assembling your kit remember to maintain it so it's ready when needed:

- Keep canned food in a cool, dry place.
- Store boxed food in tightly closed plastic or metal containers.
- Replace expired items as needed.
- Re-think your needs every year and update your kit as your family's needs change.

## Kit Storage Locations

Since you do not know where you will be when an emergency occurs, prepare supplies for home, work and cars.

- **Home:** Keep this kit in a designated place and have it ready in case you have to leave your home quickly. Make sure all family members know where the kit is kept.
- **Work:** Be prepared to shelter at work for at least 24 hours. Your work kit should include food, water and other necessities like medicines, as well as comfortable walking shoes, stored in a "grab and go" case.
- **Car:** In case you are stranded, keep a kit of emergency supplies in your car.

**Please continue to stay vigilant and prepared as these winter and spring storms can be even more impactful than storms during hurricane season.**

# Ready Pinellas Emergency Planning Mobile App

## Introducing the new and improved Ready Pinellas mobile app!

**Ready Pinellas** is designed to help residents prepare themselves and their families before, during and after a storm. It is available for free download on the Apple [App Store](#) and [Google Play](#) store.

**Note: Android device users who already had the previous Ready Pinellas app installed will need to download the new app from the Google Play store and remove the old app from their devices.** Apple device (iPhone and iPad) users will see the app automatically updated.

The new app features a refreshed design and user experience, additional information and tips, and convenient checklists to make sure you and your family are prepared. App users can use emergency supply checklist, home inventory and emergency contacts tools to build a personal emergency plan.

As a storm approaches, the app will provide real-time updates to help keep you safe, including detailed information that is available at your fingertips even if you lose internet connectivity. It will provide resources to contact us year-round and during a disaster and give you tips to Stay Informed.



## Ready Pinellas App Features

- **Know Your Zone:** If you have your locator services on, the app will tell you if you are in a designated evacuation zone. You can also look up other addresses to see if they are in an evacuation zone. Remember: Evacuation zones were updated for the 2022 hurricane season, so you may have a new zone. When a storm is approaching, it will tell you if Pinellas County is in the 5-day or 3-day cone and if an evacuation order has been issued.
- **Make a Plan:** Use our emergency supply checklist, home inventory and emergency contacts tools to build a personal emergency plan that you can share. You can take pictures of items for your home inventory.
- **Push Notifications:** Through the app, you will receive informational and emergency notifications from Pinellas County Emergency Management, the National Weather Service and [Alert Pinellas](#).
- **Special Needs:** You can learn more about special needs assistance, which is intended for those who need transportation or require minimal medical assistance while seeking public shelter. You can register from the app.
- **Preparedness Tips:** Learn how to prepare your family, pets, home, condo, mobile home, boat and more.
- **Safety Tips:** Find information on What to Do Now before, during, and after an event. Learn about year-round preparedness, how to clean up after a flood or food safety if power has been out.
- **Report Damages** after a storm has hit Pinellas County.

### CITY CLEAN-UPS & BEAUTIFICATION

Thank you very much to our fabulous Trash Pirates that once again held A clean-up on January 6 with more planned for February:

#### Trash Pirates of Mad Beach



Thank you to all the wonderful volunteers, family, and friends that continue to make our community a better place to live, learn, work, and play. The pounds and pounds of trash removed at the clean-up on January 6 truly made our slice of paradise shine. The City very much appreciates all your efforts. Please continue to look forward to future monthly clean-ups by the Trash Pirates and Trash Turtles of Madeira Beach.

# GULF BEACHES LIBRARY

Hopefully, many of you have visited our wonderful **Gulf Beaches Library** located at 200 Municipal Dr, next to Madeira Beach Fire Station 25, across the street from the Winn Dixie shopping plaza. The library offers many exceptional services from borrowing books, cd's, museum passes to a monthly newsletter to kids/children's programs to a writer's group to the showing of various popular films to a book club.

A significant amount of information on programs, activities, and much more can be found at their internet/website:

[www.gulfbeacheslibrary.org](http://www.gulfbeacheslibrary.org)

Please check it out if you have not already and also sign up for their wonderful newsletter:



## Sign Up for Library Newsletter

*\* Indicates required field*

Name \*

First Last

First Last

Email \*

I agree to receiving marketing and promotional materials \*

**Subscribe to Newsletter**

## Library Hours

Mon. 10 am - 6pm  
Tues. 10 am - 8 pm  
Wed. 10 am - 6pm  
Thurs. 10 am - 6pm  
Fri. 10 am - 6pm  
Sat. 10 am - 5 pm  
Sun. Closed

On Thursday, Jan 25, the Gulf Beaches Public Library celebrated an open house with a goal to promote additional library usage, raise funds, and bring over-all library awareness throughout the 5 cities/towns served. Dozens enjoyed a fun-filled evening with the opening of a time capsule that returned various memories nearly 5 decades old.

### Celebrate the New Year with a New Library!



GULF BEACHES PUBLIC LIBRARY  
OPEN HOUSE FUNDRAISER

Thursday, January 25<sup>th</sup>, 2024 5-8 PM

Light Refreshments, Complimentary Beer &

Wine, Gift Baskets & Silent Auction

We have a **Time Capsule**, which we will open at 7:30 PM!

The Library is also offering an opportunity to purchase a commemorative brick to help the Lib fundraising campaign, information below:



For questions, please contact at Richard Nagrabski  
 gulfbeachesbuyabrick@gmail.com or call 727-313-2952  
 To Order Online, Scan QR Code or visit  
 www.fundraisingbrick.com/gbpl/  
 To pay by check, complete this form & return  
 with payment to: Gulf Beaches Public Library  
 200 Municipal Drive, Madeira Beach, Florida 33708  
 Make Checks Payable To: Gulf Beaches Public Library

1 ♥	2 ✂	3 ★	4 🐬
5 🌀	6 ⚓	7 🚤	8 🐬
9 🌴	10 🗼	11 🦩	12 🐾

Gulf Beach Publ Lib  
 4x8 W/Out Clipart  
 3 Lines-20 Char/Line

GulfBeachPubLib  
 4x8 W/Clipart  
 3 Lines-15 Char

Brick Order Deadline: July 25, 2024



### CITY SANITATION & RECYCLING

**REMINDER:** Trash containers need to be stored somewhere other than curbside, and wheeled out to the curb for collection no earlier than 5:30 pm the day prior to collection, and removed away from the curb by sunset the day of collection. If your container is damaged or missing please contact the City of Madeira Beach Public Works/Sanitation department at 727.543.8154. The City of Madeira Beach greatly appreciates everyone’s patience and participation with our current trash collection procedures designed to keep our City even cleaner.

Please remember the following items may be recycled:

**PAPER** newspaper, magazines, junk mail, computer/printer paper, catalogs, brown/white/colored paper bags, paperboard cartons, wrapping paper

**CARDBOARD** cereal boxes (without plastic liner), soda cartons (without plastic wrap), cardboard boxes (flattened, no larger than a 4’ x 4’ square)

**GLASS** all clear, brown, green glass FOOD and BEVERAGE bottles (must be rinsed out with no residue and lids/caps removed)

**PLASTIC** all plastic FOOD and BEVERAGE containers that have the Recycle symbol and a number 1 or 2 (must be rinsed out with no residue and lids/caps removed)

**METAL** aluminum FOOD and BEVERAGE cans (rinsed out with no residue and lids/caps removed), tin FOOD and BEVERAGE cans (rinsed out no residue and lids/caps removed), clean aluminum foil pans, empty aerosol cans

**ITEMS NOT RECYCLABLE:** plastic bags, egg cartons, Styrofoam, pizza boxes (normally only the top/lid may be recycled if it is super clean-no cheese/grease/toppings)

ANY & ALL TRASH – please dispose of trash in appropriate trash bags and receptacles.

**Thank you for recycling responsibly.**

WELCOME TO WASTE PRO  
EFFECTIVE JANUARY 4<sup>TH</sup> WE WILL PROVIDE YOUR  
WEEKLY RECYCLING COLLECTION

**RECYCLE RIGHT**

Plastic bottles, jugs, and glass  

Metal cans  

Cardboard boxes  

Paper  



**DO NOT use your cart until JANUARY 4<sup>TH</sup>**  
 If you do not receive your cart between the week of December 26th-30th please contact Waste Pro at 727-452-5278.

Cart delivery will occur the week of **DECEMBER 26th - 30th, 2022**

Questions? Please visit us online [www.wasteprousa.com](http://www.wasteprousa.com) or call us 727-452-5278.



**REDUCE, REUSE, RECYCLE**

**Recycling Statistics for July to Dec 2023:**

	JUL	AUG	SEP	OCT	NOV	DEC
<b>Aluminum</b>	0.66	0.70	0.73	0.88	0.92	0.83
<b>Cardboard</b>	4.24	4.46	4.70	4.38	5.92	5.33
<b>Mixed Glass</b>	12.74	13.42	14.12	13.17	17.80	16.04
<b>ONP</b>	3.90	4.11	4.33	4.04	5.46	4.92
<b>Plastic</b>	2.61	2.75	2.90	2.70	3.65	3.29
<b>Tin</b>	0.40	0.42	0.44	0.41	0.55	0.50
<b>Contaminated</b>	8.54	8.99	9.46	8.83	11.93	10.75
<b>TOTAL</b>	33.09	34.85	36.68	34.41	46.23	41.66

Over-all a very good (low) contamination rate of %26.

## **Cameras throughout Madeira Beach**

The below internet links will take you to live web cameras of Madeira Beach sand views – helpful to see how busy locations may be, wave action, observe the City sand rake, and/or weather conditions – take a look:

Hubbard’s Marina earth cam <https://myearthcam.com/hubbardsmarina>

Baynews9 Camera at John’s Pass Park <https://www.baynews9.com/fl/tampa/weather/bay-news-9-cameras>

Commodore Beach Club <https://commodorebeachclub.com/resort-details/live-webcam>

## **BUILDING DEPARTMENT**

The Building Department now has online permitting available! Click the link below to sign up:  
<https://www.mgoconnect.org/cp/portal>

This will allow residents and contractors to apply for a permit online and look at the status of the permit without stepping foot in City Hall!

Reminder, the Building and Community Development Departments now have open office hours on Wednesdays from 1pm to 3pm, first come first served. Can't make it then? Call the City Hall to make an appointm... See more





## **PARKING**

A few reminders regarding **resident** and **visitor** parking:

1. Residents can obtain up to 3 **RESIDENT PARKING PASSES** at no charge, that allow residents to park in any City of Madeira Beach lot while the lot is open as well as on streets that allow resident parking. No overnight parking is allowed at any City lot using the **RESIDENT PARKING PASS** (everyone can use the overnight parking lot areas by paying the \$3/hour fee). Property owners are also eligible to receive parking passes with a valid driver's license and vehicle registration.

2024 Resident Parking passes are available in-person at City Hall or on-line at the City's website, [www.madeirabeachfl.gov](http://www.madeirabeachfl.gov). Please remember your driver's license and vehicle registration must be presented and must be valid.

2. **VISITOR PARKING** is available at all City of Madeira Beach lots and the John's Pass Boardwalk & Village on-street spaces and the lot adjacent to the VFW (entrance off 129<sup>th</sup> Ave E) by paying the hourly rate of \$3 (may pay using the ParkMobile app or at a kiosk/meter located at each lot). Overnight parking is only allowed at City of Madeira Beach lots located from 130<sup>th</sup> Ave to 136<sup>th</sup> Ave (entrances off Gulf Blvd) – not allowed at the John's Pass Parking lot and the Archibald Park Parking lot – by paying the \$3/hr rate (available for up to 7 days).
3. Please keep in mind, particularly visitors, that there are other privately-run/managed parking lots throughout our City that typically charge \$4-\$8/hour as well as the occasional \$20 - \$45 full day rate/charge. These lots are NOT owned/managed/enforced by the City of Madeira Beach.
4. To alleviate various residential street congestion due to construction sites, we will be issuing parking permits to construction workers, contractors/sub-contractors, and related vehicles/trucks to ensure they park correctly, mainly not blocking any streets (particularly for emergency vehicle access). Information is on our City website under Parking.

**MARCH 19, 2024 MUNICIPAL ELECTION**

**TO THE QUALIFIED ELECTORS** of the City of Madeira Beach, Florida, in accordance with the provisions of the City Charter, City of Madeira Beach, Florida and the State of Florida Election Code, **PUBLIC NOTICE** is hereby given and published that a Municipal Election will be held on Tuesday, March 19, 2024, in the City of Madeira Beach, Florida, for the purpose to get voter approval on one Charter Amendment.

There will not be a race for Commissioner District 1 and Commissioner District 2 on the March 19, 2024 Municipal Ballot. Incumbents David Tagliarini (Commissioner District 1) and Ray Kerr (Commissioner District 2) were the only candidates who qualified during the qualifying period in December 2023 to have their names placed on the March 19, 2024 Municipal Election Ballot. No one else applied during the qualifying period. David Tagliarini and Ray Kerr will be sworn into office at the Board of Commissioners Special Meeting on Wednesday, March 27, 2024 at 5:30 p.m. to begin their new two-year term as District Commissioner. A light food reception begins at 4:30 p.m. Board of Commissioners Regular Workshop Meeting at 6:00 p.m. All events will be held in Commission Chambers, 300 Municipal Drive, Madeira Beach, FL 33708.

**BALLOT QUESTION**  
**MARCH 19, 2024 MUNICIPAL ELECTION BALLOT**

**City of Madeira Beach**  
**Charter Amendment**

**Amend Qualifying Period to the First Full Week in December**

This charter amendment would amend Section 3.3(A) of the Charter to change the Candidate Qualifying Period to the first full week in December instead of the first two full weeks in December. Should the Charter be amended?

- Yes
- No

If the voters approve the charter amendment at the March 19, 2024 Municipal Election, it will take effect for the candidate qualifying period beginning in December 2024 for the March 2025 Municipal Election.

**POLLING LOCATIONS**

- Precinct 415 - Madeira Beach Municipal Building, City Centre Room, 300 Municipal Drive Madeira Beach, Florida 33708 will be open March 19, 2024, from 7:00 a.m. to 7:00 p.m.
- Precinct 301 - Calvary Church Seminole (Combined), 6155 113 Street, Seminole Florida 33772 will be open March 19, 2024, from 7:00 a.m. to 7:00 p.m.



Please remember to visit our weekly Market on Madeira Way showcasing over 30 vendors selling a variety of crafts, arts, clothing, yummy food selections, fresh produce, and much more. Join us on Madeira Way every Wednesday from 10 am to 2 pm, until May 2024 to shop local including many gift options. Residents and visitors alike will be impressed with the variety of items available for purchase.

**UPCOMING SPECIAL EVENTS/ACTIVITIES/MEETINGS**

- (1) **Trash Pirates monthly clean up** at John’s Pass Bell Tower area and Archibald Park, Sat, Feb 3, 8 am.
- (2) **CITY PLANNING COMMISSION MEETING**, Mon, Feb 5, 6 pm, CITY HALL – Commission Chambers
- (3) **BOCA CIEGA STREET ENDS NEIGHBORHOOD MEETING**, Tue, Feb 13, 6 pm; CITY HALL – COMMISSION CHAMBERS
- (4) **CITY COMMISSION REGULAR MEETING**, Wed, Feb 14, 6 pm, CITY HALL – Commission Chambers
- (5) **The Spring Games College Softball Games**, Thu, Feb 22 – Sun, Feb 25, ROC Park Softball Fields, schedule, teams, and additional information at: [www.thespringgames.com](http://www.thespringgames.com)
- (6) **Final Friday**, Friday, February 23, 6 pm, John’s Pass Village & Boardwalk
- (7) **BOARD OF COMMISSIONERS WORKSHOP** CITY HALL, Wed, Feb 28, 6 pm, – Commission Chambers

## **Building Official(s) – Development Report (January- 2024)**

City Building Official, Frank DeSantis reports that our redevelopment/economic development continues at a steady pace including several large condominium projects on-going and/or under current plan review.

- The **Schooner Resort** is under review
- **410 150<sup>th</sup> Ave.** Demo permit issued.
- The **Tiki Docks Bar & Grill** permit has been issued.
  - ✓ Restaurant is ready
  - ✓ Grease trap work to begin 02/05 followed by grading, clean-up, irrigation and sod install.
- **15405 Gulf Blvd. Azul Townhomes**
  - Phase #1**
    - ✓ All cabinets and counter tops are complete.
    - ✓ All doors are in.
    - ✓ Tile and vinyl flooring are complete.
    - ✓ Elevators are on site and are being installed.
    - ✓ Garage doors are complete.
    - ✓ Awnings are complete.
    - ✓ Exterior handrails are complete.
    - ✓ Rooftop C.U.s are complete.
    - ✓ Calling for electrical insp. For Duke meter release.
  - Phase #2**
    - ✓ Drywall is complete (B)
    - ✓ Doors are nearing completion.
    - ✓ Tile and vinyl are nearing completion.
    - ✓ Rooftop C.U.s are complete.
    - ✓ Awnings are complete.
    - ✓ Drywall is nearing completion (C).
    - ✓ Awnings are complete. (C)
    - ✓ Rooftop C.U.s are complete.
- **200 150<sup>th</sup> Ave. Harbor at Town Center**
  - ✓ Final building inspection to be scheduled soon.
- The **Holiday Isles projects** *(The Development Order expires October 20, 2024)*
  - ✓ **555 150<sup>th</sup> Ave.** (Hampton Inn Hotel) – *(The permit #4082 expires July 1, 2024)*  
Site clearing and grading work continues – expected to be complete in two to three weeks.
  - ✓ **565 150<sup>th</sup> Ave.** (31-unit building) – *(The permit #20210386 expires January 26, 2026)*  
New silt fencing installed, no scheduled date to start

### **PERMIT TYPES ISSUED (01/01/2024 through 01/31/2024):**

- **SFH projects – (2)**  
*Single Family Homes*
- **Commercial projects – (2)**  
*Remodel*
- **Residential projects – (7)**  
*Remodel*
- **Docks & Lift projects – (6)**  
*Replacement &*
- **Roof – (4)**  
*New & Re-roof*
- **Fence – (4)**  
*New & Replacement*
- Repairs*
- **Generator projects – (0)**  
*New Generator*
- **Swimming Pool – (3)**  
*New*
- **Seawall– (2)**  
*New Seawall & Cap*
- **Demo Permits – (3)**  
*Demolition*
- **Driveway/Pavers – (1)**  
*New*
- **Deck – (0)**  
*New & Replacement*
- **Windows/Doors – (26)**  
*Replacement*
- **Mechanical E/C/O’s – (18)**  
*New AC units*
- **Sign projects – (2)**  
*New Sign Permits*
- **Electrical Permits – (9)**  
*Meter, Panel C/O’s*
- **Plumbing HW C/O’s – (6)**  
*Hot Water Heaters*
- **Solar Permits – (0)**  
*New Solar Permits*

**Monthly Totals (01/01/2024 through 01/31/2024):**

- **Building Department:**
  1. 102 different types of permits were processed & issued.
  2. \$144,336.84 Permit fees collected.
  3. \$4,986,582.72 Permit estimated value or cost.
  4. 202 completed inspections (average 12 +/- per day)
- **Building Code Compliance & Residential Rental Inspections:**
  1. 10 new code compliance cases were created.
  2. 4 code compliance cases being resolved.
  3. 59 open/outstanding code compliance cases.
  4. 0 residential rental inspections for the month of January

**Community Development**

Continued experiencing a high plan review volume with approximately 35-40 items in the queue and a turn-around time of 2-4 weeks.

Business Tax Receipts (BTR) staff held an initial with our software vendor, MGO regarding the new software for BTR and Applications. We are currently waiting for the initial version for testing.

Public meetings for John’s Pass Village Zoning Public Workshop were held on 1/18/2024, 1/23/2024, and 1/27/2024. The crowd size was between 8-15 people for all the meetings and we gathered some useful information regarding changes that residents would like to see.

We interviewed and made an offer of employment for the position of Planner II with a start date of 2/20/2024.

Currently, one staff member is out due to a family medical emergency with our contracted engineering firm covering some of the engineering review work and other Community Development covering the open Wednesday public hours.

## **MARINA**

On March 23<sup>rd</sup> the City of Madeira Beach and the Municipal Marina will hold the 13<sup>th</sup> Annual Great American Grunt Hunt. This unique event is special to Madeira Beach because it incorporates the traditional fishing vibe of the city along with the involvement of young and inexperienced anglers to enjoy a Fishing Tournament that they can compete in. The idea was to get the whole Family involved, from you 80-year-old grandparent to your 8-year-old grandchildren. The White Grunt is the perfect species for such an occasion. White Grunts are one of our most predominant reef fish on the Gulf coast and can be caught on almost any type of structure in depths ranging from 10 to 100 feet of water. Grunts are not picky eaters but seem to prefer baits like cut squid, threadfins, and live or frozen shrimp. Many different rigs can be used, but it seems that most of the charter boats prefer a multiple hook “chicken rig” or a knocker rig with a 2oz lead.

Youth anglers 14 years and younger are available to enter in both overall and youth divisions. For anglers looking for more of a challenge we have added a hook and line only Hogfish division. This part of the tournament is optional for \$25 and the top three anglers are eligible for prize money. Probably the star of the show is our Community Fish Fry. With loads of fresh fish available we offer everyone an awesome fish fry dinner with fresh fish, fries, and slaw for only \$15 a plate. The food is expertly prepared by Snapper’s restaurant, and we have never let anyone go home hungry. For more information, please visit our website, [madeirabeachmarina.com](http://madeirabeachmarina.com) or join us at the Captain’s Party on March 21<sup>st</sup>. The Captains Party will have a huge raffle, 50/50, food, tournament apparel, registration, and of course some adult beverages. Look forward to seeing you there!

We will be moving forward this month with the addition of a Digital Information Sign at the Marina, along 150<sup>th</sup> Avenue. This project went out to bid in November and we have selected the low bid option of i2 Visual, Inc. The project upon completion will help modernize the existing sign and help spread important information about the City to our residents and visitors. We will hopefully be starting this project very soon and have it completed by springtime.

We have had some staffing change within the Marina. One of our Senior Marina Attendants, Boris Buncic, has moved on to further his professional career. We wish Mr. Buncic the best of luck and appreciate everything he has done for us in his 2+ years of service. I am happy to promote Colton Carier into the full time Marina Attendant Position. Mr. Carier has spent several years split between the Public Works Department and the Marina. The transition has been quite smooth as Mr. Carier has several years experience at the Marina and its customers. The Marina is taking applications for a part-time Marina Attendant now, and we hope to fill the position soon.

**MARINA REVENUE through Jan 2024:**

Account #	Description	Oct'23	Nov'23	Dec'23	Jan'24
405.9300.347500	ATM Service Charge	-	-	-	157.00
405.9300.347901	Unleaded Fuel Sales	153,969.74	160,573.74	99,557.48	74,107.49
405.9300.347902	Diesel Sales	9,228.65	7,495.39	11,003.36	13,599.55
405.9300.347903	Diesel - Commerical	36,334.16	27,119.20	21,559.97	23,409.26
405.9300.347904	Purchases Fuel	-	-	-	-
405.9300.347905	Propane Sales	160.93	183.92	206.91	206.91
405.9300.347906	Propane - Exempt	22.99	22.99	-	-
405.9300.347907	Purchases Propane	-	-	-	-
405.9300.347908	Misc Store Income-Taxable	17,513.88	18,899.35	16,118.21	14,682.04
405.9300.347909	Misc Store Income-Non Taxable	204.00	146.00	103.99	121.00
405.9300.347910	Purchases Store	-	-	-	-
405.9300.347911	Dry Storage Fees	11,335.05	11,204.34	11,204.34	11,463.38
405.9300.347912	Transient Rentals	6,825.88	8,045.09	5,830.87	6,716.10
405.9300.347913	Marina Slip Rent	20,618.00	21,615.00	21,615.00	21,615.00
405.9300.347914	Annual Fishing Tournament	-	-	-	-
405.9300.347915	Land & Sea Sales	-	-	-	-
405.9300.347916	Late Fees	-	-	-	-
405.9300.347917	Boat Ramp Parking	510.28	402.81	325.25	262.62
405.9300.361100	Interest Earnings	14,528.90	13,015.69	3,372.50	3,374.13
405.9300.364000	Sale/Disposition of Capital Assets	-	-	-	-
405.9300.369900	Other Miscellaneous Revenues	-	-	-	-
405.9300.369903	Refund Prior Year Expenses	-	-	-	-
405.9300.369904	Sales Tax Collection Allowance	30.00	30.00	30.00	30.00
405.9300.369912	Boat Ramp Fees	-	-	-	-
405.9300.369913	Commission - Laundry Equipment	55.00	51.25	65.50	45.50
405.9300.380000	Other Sources	-	-	-	-
405.9300.380001	Fund Balance/Net Position Carryover	-	-	-	-
405.9300.381002	Transfer from Sanitation Fund	-	-	-	-
405.9300.381003	Transfer from Stormwater Fund	-	-	-	-
405.9300.389201	Federal Grant - Clean Vessel	-	-	-	-
405.9300.389801	Asset Transfer In from Governmental	-	-	-	-
		271,337.46	268,804.77	190,993.38	169,789.98

**TOTAL: \$900,925.59**

**PARKING REVENUE – FY 23 & FY 24 thru Jan 2024**

Month	Parking Meter	Parking Fines	Monthly Totals
Oct-22	237,794.00	45,415.00	283,209.00
Nov-22	187,490.14	61,243.40	248,733.54
Dec-22	185,507.38	47,895.00	233,402.38
Jan-23	224,453.63	55,195.00	279,648.63
Feb-23	290,884.45	51,505.50	342,389.95
Mar-23	369,009.87	75,542.00	444,551.87
Apr-23	375,567.76	61,521.00	437,088.76
May-23	370,646.79	51,127.00	421,773.79
Jun-23	365,286.89	58,372.00	423,658.89
Jul-23	402,082.94	40,345.20	442,428.14
Aug-23	259,525.73	42,049.00	301,574.73
Sep-23	228,913.22	34,995.00	263,908.22
<hr/>			
<b>Fiscal Year 2023</b>	<b>\$ 3,497,162.80</b>	<b>\$ 625,205.10</b>	<b>\$ 4,122,367.90</b>
<hr/>			
Oct-23	235,464.24	36,881.00	272,345.24
Nov-23	187,037.59	39,142.00	226,179.59
Dec-23	161,639.03	32,960.00	194,599.03
Jan-24	177,993.18	43,720.00	221,713.18
Feb-24	-	-	-
Mar-24	-	-	-
Apr-24	-	-	-
May-24	-	-	-
Jun-24	-	-	-
Jul-24	-	-	-
Aug-24	-	-	-
Sep-24	-	-	-
<hr/>			
<b>Fiscal Year 2024</b>	<b>\$ 762,134.04</b>	<b>\$ 152,703.00</b>	<b>\$ 914,837.04</b>



## **PUBLIC WORKS**

### **Project Updates**

#### **Dune Restoration Project**

- Completed from 15316 Gulf Blvd to 14950 Gulf Blvd.
- Staff in progress of installing landscape timbers with decorative rope to keep new dunes protected.

#### **Beach Groin Renourishment Project**

- Invitation to Bid (ITB #2023-14) will be publicly opened February 8, 2024 at 10AM.

#### **Area 3 – E Parsley, W Parsley, Marguerite, A Street, B Street, and Lynn Way. Roadway and Drainage improvement Project.**

- Working on Temporary Construction Easements for the removal and replacement of all stormwater pipes.
- Waiting on Permits and notice to proceed from SWFWMD and FDOT

#### **Gulf Lane and Beach Access roadway and drainage improvements**

- Project is underway.
- Completion set for End of February

#### **Gulf Blvd Utility Undergrounding**

- The binding Cost Estimate was paid to Duke Energy in June 2023, but we are still waiting for Material.
- Duke has ordered all the material but there is no set date for delivery.

#### **Area 6A Roadway and Drainage Improvement project**

- Engineering has begun, and estimated construction will start August 2024.

#### **Patriot Park Dock Replacement**

- Request for Proposals (RFP) has been opened and project awarded to Speeler CO. Project estimated to start end of February.

# KEEP IT CLEAN!

*Stormwater runoff collects chemicals, pet waste, litter, leaves and dirt. Stormwater is not treated before entering our waterways. You can help keep our water and wildlife healthy.*

## PREVENT POLLUTION - YOU'VE GOT THIS!

Don't blow debris into the street or gutter. When storm drains get clogged water can flood streets and homes. Recycle grass clippings and leaves on your lawn.

Pick up after your pets. Pet waste if left on the ground can wash into nearby bodies of water spreading bacteria and diseases.

Never dump chemicals or oils down the storm drains. Dispose of them free at the County's collection center or at a mobile collection event.

Learn more at:

[www.pinellascounty.org/solidwaste/swapshop.htm](http://www.pinellascounty.org/solidwaste/swapshop.htm)

Dispose of swimming pool water properly. Turn off the chlorinator and allow levels to drop to zero. Water can then flow through the landscape.

Commercial properties and business waste: Keep dumpster lids closed, the drain plugged and have them emptied regularly.

*For more information about protecting our watershed or to report a violation call (727) 543-8154 or visit: [www.madeirabeachfl.gov](http://www.madeirabeachfl.gov)*

