



COMMON COUNCIL MEETING AGENDA

April 14, 2026 at 6:30 PM

303 Mansion Street Mauston, WI

1. Call to Order/Roll Call

2. Pledge of Allegiance

3. Discussion and Action Regarding Minutes

a. March 24, 2026

4. Citizens Address to the Council

Public comments from citizens regarding items on, or not on the agenda. Register before speaking. State full name and full address when addressing the Council. The Council members may not debate but can ask clarifying questions with the citizens making the comments. Individual presentations are limited to three minutes.

5. Reports from Committees, Boards, and Commissions

Chair/Representative of Body please state your full name and the Body you are representing

6. Ordinances, Licenses, and Permits Committee Report

a. Second Reading and Action Regarding Ordinance 2026-2083, Amending Chapter 32, Streets and Sidewalks, Article 1, Sec 32-5(b)

7. Personnel and Negotiating Committee Report

a. Discussion and Action Regarding the Amendment of the Employee Handbook, Section 7.4 - Attendance with Inclement Weather

8. Public Works Committee Report

a. Discussion and Action Regarding the Purchase of Sewer Bypass Pumps from Crane Engineering per the ERF

b. Director of Public Works

9. Finance and Purchasing Committee Report

a. Discussion and Action Regarding Vouchers In the Amount of \$882,379.83

b. Discussion and Action Regarding the Jefferson Fire & Safety Quote in the Amount of \$37,166.40 for SCBA Packs

- c. Discussion and Action Regarding Fence Quote's for the New Dog Park on the corner of Loomis Drive and Arlington Avenue

10. Fire Chief's Report

- a. March Reports

11. City Council Report

12. Mayor's Report

- a. Discussion and Update Regarding the Process for Citizen Inquiry

13. City Administrator's Report

- a. Discussion and Action Regarding the Creation of a City of Mauston Theme
- b. Discussion and Update Regarding Board of Review Training for Council Members
- c. Discussion and Action Regarding Powers Road Land Annexation
- d. Discussion and Update Regarding Municipal Court Fees

14. Adjourn

NOTICE:

It is possible that action will be taken on any of the items on the agenda and that the agenda may be discussed in any order. It is also possible that a quorum of other governmental bodies of the municipality may be in attendance at the above-stated meeting to gather information; no action will be taken by any governmental body at the above-stated meeting other than the governmental body specifically referred to above in this notice.

Also, upon reasonable notice, efforts will be made to accommodate the needs of disabled individuals through appropriate aids and services. For additional information or to request this service, contact City Deputy Clerk Carole Wolff at (608) 747-2706.

Any member of the public wishing to join the meeting telephonically should call City Hall by 4pm the day of the meeting. Staff will be happy to provide instructions on joining the meeting by phone. City Hall main number: 608-847-6676



COMMON COMMITTEE MEETING MINUTES

March 24, 2026 at 6:30 PM

303 Mansion Street Mauston, WI

1. **Call to Order/Roll Call:** The Common Council meeting was called to order on Tuesday, March 24, 2026, at 6:30 p.m. by Mayor Darryl Teske. Members present were Jim Allaby, Mary Bender, Barb Hoilien, Casey Radcliff, and Kayla Thomas. Also present were Police Chief Mike Zilisch and Deputy Clerk Carole Wolff. Absent were Vivian Gabower, Leanna Hagen, and City Administrator Daron Haugh.
2. **Pledge of Allegiance:** Mayor Teske led the Pledge of Allegiance.
3. **Minutes:** Motion by Thomas, seconded by Bender, to approve the March 10, 2026, minutes. Motion carried by voice vote.
4. **Citizens Address to the Council:** None
5. **Reports from Committees, Boards, and Commissions:** Hatch Public Library Update: A representative of the Library reported that the upstairs carpet replacement is underway and the lower level is expected to be completed by May. The project is progressing well, and appreciation was expressed to the City for assistance with grant funding and financial management.
6. **Ordinance, Licenses, and Permits Committee**
 - a. Ordinance 2026-2083 Amending Chapter 32, Streets and Sidewalks, Article I, Sec. 32-5(b): The first reading was completed.
 - b. Ordinance 2026-2082: Motion by Allaby, seconded by Bender, to approve Ordinance 2026-2082, Amending Chapter 32, Enforcement and Penalties, Article I, Sec. 32-2. Motion carried by voice vote.
7. **Finance and Purchasing Committee Report**
 - a. Vouchers: Motion by Radcliff, seconded by Hoilien, to approve vouchers in the amount of \$700,752.77. Motion carried by unanimous voice vote.
 - b. Pay App #7: Motion by Radcliff, seconded by Hoilien, to approve Pay App #7 payable to Market & Johnson, in the amount of \$304,911.41. Motion carried by unanimous voice vote.
 - c. Change Order #24: Motion by Radcliff, seconded by Bender, to approve Change Order #24, payable to Market & Johnson, in the amount of \$16,436.64. Motion carried by unanimous voice vote.

- d. Change Order #25: Motion by Radcliff, seconded by Hoilien, to approve Change Order #25 payable to Market & Johnson, in the amount of \$1,041.11. Motion carried by unanimous voice vote.
- e. Change Order #26: Motion by Radcliff, seconded by Hoilien, to approve Change Order #26, payable to Market & Johnson, in the amount of \$1,056.44. Motion carried by unanimous voice vote. Discussion followed noting that the library renovation is progressing well, with the basement expected to be completed by May 2026. The change orders are being funded by the library certificate of deposit (CD) and not by City funds.

8. Police Chief's Report

- a. February Report: Police Chief Zilisch reviewed the report highlighting the success of the YANA program and proactive efforts by officers to ensure community safety.
- b. 2025 Report: Zilisch reviewed the 2025 report, highlighting accomplishments and challenges.

9. City Council Report: Nothing to report.

10. Mayor's Report

- a. Amending the Employee Handbook: Inclement Weather Policy: Discussion occurred regarding the current policy, which allows employees to use personal or benefit time or make up missed time when City offices are closed, while essential personnel are not affected. Council members discussed potential flexibility, including remote work options where appropriate and allowing unpaid time without impacting performance evaluations. It was noted that the Mayor or City Administrator should have authority to close the office if warranted by weather. Council members agreed the policy should be rewritten to provide further clarification.

11. City Administrator's Report

- a. Open Book and Board of Review: Open Book will be held on May 8, 2026, from 10:00 a.m. to 4:00 p.m. by phone, and the Board of Review will be held on June 9, 2026, from 5:00 p.m. to 7:00 p.m. These dates were reviewed.

12. Adjourn: Motion by Hoilien, seconded by Thomas, to adjourn. Motion carried by voice vote. Meeting adjourned at 7:26 p.m.

Chair

Date

**ORDINANCE NO. 2026-2083 AMENDING
CHAPTER 32 STREETS AND SIDEWALKS
ARTICLE I, SEC 32-5(b)**

WHEREAS, the Mauston Common Council that snow and ice accumulation on sidewalks presents a significant public safety concern; and

WHEREAS, the Common Council finds it necessary to clarify snow removal responsibilities and enforcement procedures to ensure sidewalks remain safe and accessible for pedestrians;

NOW THEREFORE, on a motion duly made and seconded, the Mauston Common Council hereby amends Chapter 32, Article I, Section 32-5(b) of the Code of Ordinances as follows:

Sec. 32-5. Snow and Ice Removal.

~~The owner and occupants of any parcel or lot which fronts upon or abuts any sidewalk shall keep said sidewalk clear of all snow and ice. In the event of snow and/or ice accumulating on said sidewalk due to natural means and/or by any other means, said sidewalk shall be cleared of all accumulated snow and/or ice within 24 hours from the time the snow and/or ice cease to accumulate on said sidewalk. Sidewalks are to be kept clear of snow and ice to a minimum of three feet in width, except that sidewalks located in any district zoned commercial shall be kept clear to their full, maximum width. In the event that ice is formed on any sidewalk in such a manner that it cannot be removed, said sidewalk shall be kept sprinkled with sand and/or salt to permit safe travel by pedestrians.~~

Snow and ice removal is deemed to be a public safety issue. The owner and occupants of any parcel or lot which fronts upon or abuts any sidewalk shall keep said sidewalk clear of all snow and ice. In the event of snow and/or ice accumulating on said sidewalk due to natural means and/or by any other means, said sidewalk shall be cleared of all accumulated snow and/or ice within twenty-four (24) hours from the time the snow and/or ice cease to accumulate on said sidewalk.

Sidewalks shall be kept clear of snow and ice to a minimum width of three (3) feet, except that sidewalks located in any district zoned commercial shall be kept clear to their full width. In the event that ice forms on any sidewalk in such a manner that it cannot be removed, the sidewalk shall be sprinkled with sand and/or salt to permit safe pedestrian travel.

If the twenty-four (24) hour period following cessation of snowfall or ice accumulation has expired and the snow and ice have not been cleared from the sidewalk, the City, after 24 hour's notice to the homeowner or occupant, may immediately cause the snow and/or ice to be removed without further notice. Notice may be provided in person, in writing, or by telephone to the homeowner or occupant of the need to remove the snow and ice. The cost of such removal shall be charged to the responsible person in the manner provided under Sec. 32-2(3).

APPROVED:

ATTEST:

Darryl D.D. Teske, Mayor

Daron Haugh, Administrator

- Date of Plan Commission Recommendation (if applicable): _____

- Date of Public Hearing (if applicable): _____
- Date of Readings: _____
- Date of Adoption: _____
- Votes:
 - Ayes__ Nays__ Absent__ Abstention _____

- Date of Publication: _____

7.4 Attendance

Attendance is a critical component of job performance. It is expected that employees report for work on scheduled days, do not come in late, do not leave early, get permission before coming in late or leaving early, give advance notice of an absence when possible, report absences properly and in a timely manner, and submit medical certification, if required, for illness. Violation of these expectations may lead to discipline up to and including discharge.

It is the policy of the City, pursuant to the principles of public accountability, that taxpayer funds not be used to pay public employees for hours not worked.

~~All employees shall be required to work on their normally scheduled work days regardless of inclement weather conditions. During winter months, the City will attempt to maintain regular business hours during all winter storms. If an employee is unwilling or unable to come to work due to weather conditions, paid leave should be used for any work hours missed. This shall not prevent individual use of flex time and/or working remotely when appropriate and approved by an employee's supervisor.~~

Employees are expected to report to work on their regularly scheduled days, even during inclement weather. The City will make every effort to maintain normal business hours throughout winter storms. If an employee cannot or chooses not to report to work due to weather conditions, they must use benefit time for any missed hours. As an alternative, with supervisor approval, employees may flex their schedule—provided that the missed time is made up within the same work week.

In the event of severe weather, the City Administrator or Mayor may decide to close City Hall after consulting with Department Heads about road conditions and safety. If City Hall is closed, employees will be required to use benefit time for that day.



Section 8, Item a.

QUOTE

Headquarters
707 Ford Street, Kimberly, WI 54136
t. 920-733-4425 f. 920-733-0211

Minnesota Office
12265 Nicollet Ave., Burnsville, MN 55337
t. 952-444-1949

Number CESQ63565-01
Date Mar 27, 2026
Expires Apr 10, 2026

Sold To

Ship To

Sales Rep

Mauston, City of
Rob Nelson
303 MANSION STREET
MAUSTON, WI 53948

Mauston, City of
Rob Nelson
303 MANSION STREET
MAUSTON, WI 53948

Fluid Technology Sales
Travis Walker 920-219-1090
t.walker@craneengineering.net

rnelson@mauston.com
Phone 608-847-6676
Fax 608-847-5023

rnelson@mauston.com
Phone 608-847-6676
Fax 608-847-5023

Application Engineer
Emily Dreyer
e.dreyer@craneengineering.net

Here is the quote you requested.

Terms	RFQ	Ship Via	FOB	Crane Order#
n15		Best Way	Warehouse	

Line	Qty	Product	Lead Time	Unit Price	Ext. Price
1	1	PA6A60-4045T S5 Prime Aire Dry Prime Engine Driven Pump with Highway Trailer (Electric Braking System) and Dual Float Switch Adder 6" x 6" Pump 3" Solid Size Deere Engine	16 Weeks ARO	\$74,600.00	\$74,600.00
2	1	VPA6A60C-4LE2T FT4 Valu Prime Diesel Engine Driven with Optional Wheel Kit and Dual Float Switch 6" x 6" Pump Size 3" Solid Size Isuzu Engine	1-2 Weeks ARO	\$49,400.00	\$49,400.00

Total \$124,000.00

Please contact me if I can be of further assistance.

Does not include tax and shipping charges unless stated above.
Effective Nov. 1st, 2025, all new orders paid by credit card will be assessed a 3% fee. If you wish to pay by ACH, please email ar@craneengineering.net to request banking information.

We reserve the right to adjust quoted pricing due to the current volatility of the materials market.
We will make every effort to maintain the quoted price.

Crane Engineering/Professional Pump | Terms and Conditions

1. **Governing Provisions.** These Terms and Conditions of Sale (the "Agreement") constitute an offer by Crane Engineering Sales, Inc. ("Seller") to provide the Products as set forth on the Contract of Sale attached to this Agreement (the "Products") to Buyer, subject to the terms and conditions set forth below. Buyer may not modify, renounce or waive any term or condition hereof or any of Seller's rights hereunder unless Seller consents in writing. Seller agrees to provide the Products to Buyer only on the terms of this Agreement (except as supplemented and/or modified by the parties Contract of Sale), notwithstanding any language in Buyer's purchase order, if one exists, or other writing or oral representation previously or hereafter received by Seller purporting to modify or replace the terms of this Agreement with any different or additional terms or reciting that provision or delivery of the Products or any other action or inaction by Seller constitutes agreement or consent by Seller to such modification or replacement. SELLER'S AGREEMENT TO PROVIDE THE PRODUCTS IS EXPRESSLY CONDITIONED ON BUYER'S ASSENT TO ALL OF THE TERMS AND CONDITIONS SET FORTH BELOW AND, NOTWITHSTANDING BUYER'S SUBMISSION OF A PURCHASE ORDER, THE TERMS AND CONDITIONS OF SALE OF THIS AGREEMENT (AND THE DISTRIBUTOR AGREEMENT) SHALL CONTROL.
2. **Purchase Orders and Payment.** All orders must be accompanied by a signed purchase order and must be approved for credit. For orders under \$50,000 the terms are net 15 days from the date of invoice, unless agreed to otherwise in writing by both parties prior to order entry. Seller may require full or partial payment or a payment guarantee in advance of shipment whenever, in its opinion, the financial condition of the Buyer so warrants. For orders exceeding \$50,000 in sell price, terms of payment will be 40% down with order, 20% payable upon approved drawings, 20% payable upon inspection and approval of assembly prior to shipment (witness test available as an optional charge), 10% payable upon shipment, and 10% payable upon commissioning of equipment not to exceed 90 days from shipment. Note: Equipment will be shipped after receipt of 80% of the value of the order. From time to time Buyer (or its Customers) will be asked to fill out a credit application, which is subject to Seller's Credit Department's approval. Seller reserves the right to change the terms and required method of payment at any time, and to charge Buyer a 1.25% finance charge per month on any past due amounts, or the highest rate applicable by law. Buyer agrees to reimburse Seller for all costs incurred by Seller in collecting any sums owed by Buyer to Seller, including without limitation, interest and attorney's fees. Each purchase order that Buyer delivers to Seller for the purchase of Products ("Order") shall set forth the following terms as agreed upon by Seller and Buyer for such Order: the quantity, description and prices of the Products being ordered; the address for delivery of the Products; requested delivery dates; shipping instructions; and the address to which Seller's invoice shall be sent. Any other terms contained in any Order shall be objected to by Seller without need for further notice of objection, shall not be binding upon Seller and shall have no force or effect. Buyer's mutually agreed change orders shall be subject to all provisions of this Agreement, whether or not the Order or change order so states. All Orders shall be subject to Seller's acceptance. Seller shall promptly provide notice to Buyer of acceptance or rejection of Buyer's Orders.
3. **Acceptance.** Buyer shall be deemed to have accepted this Agreement on the earliest to occur of the following: (a) Seller's receipt of Buyer's Order, if Seller has previously supplied Buyer with a copy of the terms and conditions of sales set forth in this Agreement, (b) Buyer's payment of any amounts due under this Agreement; (c) Buyer's or its representative's or customer's receipt of the Products; or (d) any other event constituting acceptance under applicable law.
4. **Cancellation or Modification.** Buyer may not cancel or modify any Order except upon terms accepted by Seller in a writing signed by Seller's authorized officer. In the event of such cancellation or modification, Buyer shall compensate Seller for all resulting costs and damages, including, but not limited to, out-of-pocket expenses, lost profit, allocable overhead and all other incidental and consequential damages.
5. **Returns.** No Products may be returned to Seller for refund or credit without Seller's prior written approval and, if permitted, shall be subject to an inspection/restocking charge and/or depreciation fee when applicable, plus the costs of freight, packaging and insurance costs.
6. **Prices.** Buyer shall purchase from Seller the Products at the prices determined by Seller from time to time. Seller may at any time and in its sole discretion change the prices of Products, without notice, and the price at time of shipment applies except when specifically covered by a firm price quotation. Unless otherwise agreed in writing, all prices shall be F.O.B. Shipping Point.
7. **Taxes and Other Costs.** All charges for freight, insurance, any sales, use, excise and other federal, state and local taxes, broker fees, or required by any governmental agency incident to the sale shall be paid by Buyer in addition to the price for the Products unless otherwise agreed upon. Such charges will be added at rates in effect at time of delivery except when forbidden by law to be collected by Seller from Buyer, unless Buyer furnishes Seller an exemption certificate acceptable to taxing authorities.
8. **Delivery.** Delivery dates are approximate. Seller shall not be liable for any loss or damage due to delays in delivery or manufacture, resulting from causes beyond Seller's reasonable control, including, without limitation, an event of Force Majeure (as defined below). Partial deliveries shall be permitted. Title to Products and all risk of loss of or damage to Products shall pass to Buyer when Seller delivers the Products to the F.O.B. shipping point. Seller is not responsible for loss or damage in transit. If shipment is deferred at Buyer's (or its Customer's) request beyond the shipping date specified in the original Order, Seller reserves the right to immediately bill Buyer (or its Customer, as the case may be) for such unshipped portion, and for expenses incurred for storage, it being understood that unshipped material become Buyer's (or its Customer's, as the case may be) property and Seller's liability is that of warehouseman only.
9. **Warranties and Remedy.** Seller warrants that all new Products manufactured by Seller will be free from material defects in workmanship and material for a period of 12 months from date of delivery under normal use and service. The warranty for all components in Seller's Products and all parts and Products not manufactured by Seller is limited to the warranty specified by original manufacturer of such component, part or Product. Buyer must make claims to Seller in writing for shortages in the Products within 10 days following the date of delivery of the Products and for defects in the Products within the Warranty Time Period specified herein and, in either case, within ten days after discovery of such shortage or defect. Buyer's failure to inspect the Products and/or make a claim pursuant to this section for shortages within 10 days following the date of delivery of the Products and for defects within the specified Warranty Time Period and, in either case, within ten days after discovering such shortage or defect shall constitute Buyer's irrevocable acceptance of the Products and Buyer's acknowledgment that the Products fully comply with the terms, conditions and specifications of this Agreement.

Seller's obligation under this warranty is limited to repairing or replacing, at Seller's option, any part which upon Seller's examination proves defective. Alternatively, at Seller's option, Seller may grant Buyer a credit toward future purchases in the amount of the net price paid for any Products proved to be defective. All credits are subject to inspection and approval by Seller's authorized representatives. Such warranty satisfaction shall be available only: (a) with respect to shortages, in the 10 days following the date of delivery of the Products; and (b) with respect to defects, within the specified Warranty Time Period; provided, however, Seller is notified in writing within ten days after discovery of alleged shortage or defect and the defect has not been caused by Buyer's or its representative's or customer's misuse, neglect or alteration or by physical environment.

Crane Engineering | Terms and Conditions

This warranty excludes Products and any parts, failures and damage:

- (i) to which repair or replacement becomes necessary due to normal wear and tear;
- (ii) which are exhaustible items, including but not limited to such items as filter bags and seals;
- (iii) on which repairs, alterations or adjustments have been performed or begun by Buyer or any third party without Seller's consent;
- (iv) which are not promptly reported to Seller within the warranty period above;
- (v) which are modified without Seller's written approval;
- (vi) which are due to negligence other than that of Seller;
- (vii) which are due to accident, misuse, abuse, overloading, jamming, improper installation (other than installations made by Seller), improper operation, or abnormal conditions of temperature, moisture, dirt or corrosive matter or other environmental factors; or
- (viii) which have been damaged otherwise without the fault of Seller.

Seller's obligation or liability under this warranty does not include any transportation or other charges or liability for direct, indirect, special or consequential damages or delay resulting from the improper use or application of the product or the substitution upon it of parts or accessories not approved by Seller or repair by anyone other than a Seller authorized representative. Buyer shall be responsible for all parts and service technician charges relating to work not covered by warranty. Buyer shall pay Seller for such parts and service work not under warranty within 15 days of the date of Seller's invoice. A past due charge of 1.25% per month shall apply to amounts past due.

10. LIMITATION OF LIABILITY. SELLER'S AGGREGATE LIABILITY WITH RESPECT TO DEFECTIVE PRODUCTS SHALL BE LIMITED TO THE MONIES PAID BY BUYER TO SELLER FOR THE DEFECTIVE PRODUCTS MANUFACTURED BY SELLER. SELLER EXTENDS NO WARRANTY, INCLUDING WITHOUT LIMITATION ANY WARRANTY AGAINST DEFECTS, IN PRODUCTS MANUFACTURED BY PARTIES OTHER THAN SELLER.

SELLER SHALL NOT BE LIABLE TO BUYER, OR TO ANYONE CLAIMING UNDER BUYER, FOR ANY OTHER OBLIGATIONS OR LIABILITIES, INCLUDING, BUT NOT LIMITED TO, OBLIGATIONS OR LIABILITIES ARISING OUT OF BREACH OF CONTRACT OR WARRANTY, NEGLIGENCE OR OTHER TORT OR ANY THEORY OF STRICT LIABILITY, WITH RESPECT TO THE PRODUCTS OR SELLER'S UNDERTAKINGS, ACTS OR OMISSIONS. IN NO EVENT SHALL SELLER BE LIABLE FOR INDIRECT, INCIDENTAL OR CONSEQUENTIAL DAMAGES OF BUYER, ITS CUSTOMERS OR USERS OF THE PRODUCTS, INCLUDING BUT NOT LIMITED TO, LOSS OF PROFITS.

11. DISCLAIMER OF IMPLIED WARRANTIES. SELLER AND BUYER AGREE THAT THE FOREGOING WARRANTIES ARE EXCLUSIVE AND IN LIEU OF ALL OTHER EXPRESS OR IMPLIED WARRANTIES, INCLUDING, BUT NOT LIMITED TO, ANY WARRANTY OF MERCHANTABILITY OR THE IMPLIED WARRANTY OF FITNESS FOR A PARTICULAR PURPOSE. SELLER HEREBY DISCLAIMS ALL OTHER EXPRESS OR IMPLIED WARRANTIES. Any oral or written description of the Products is for the sole purpose of identifying the Products and shall not be construed as an express warranty.

12. ASSIGNMENT. BUYER SHALL NOT, WITHOUT THE PRIOR WRITTEN CONSENT OF SELLER, ASSIGN ITS RIGHTS OR OBLIGATIONS UNDER THIS AGREEMENT TO ANY THIRD PARTY. SUBJECT TO THE FOREGOING, THIS AGREEMENT SHALL BIND AND INURE TO THE BENEFIT OF SELLER AND BUYER AND THEIR RESPECTIVE PERMITTED SUCCESSORS AND ASSIGNS.

13. Force Majeure. Seller shall be entitled to suspend performance of its obligations under the Agreement to the extent that such performance is impeded by circumstances beyond the reasonable control of Seller, including, but not limited to war (whether declared or not), revolution, national strikes, natural disasters, acts of government, export or import prohibitions, fire, explosions, floods, accidents, sabotage, civil unrest, riots, and breakage or loss during transportation or storage as well as subcontractors' material and part shortages and delivery delays.

14. Governing Law and Jurisdiction. This Agreement shall be governed by and construed in accordance with the internal laws of the State of Wisconsin. Upon termination of this Agreement for any reason, Seller shall have all of the rights and remedies provided by law, including without limitation the rights of a secured party under Chapter 409, Wisconsin Statutes or any successor statute or similar statute in the jurisdiction where Buyer is located or stores the Products.

15. Miscellaneous. Seller reserves the right to correct clerical or similar errors relating to price or any other term shown in this Agreement. If any provision of this Agreement shall be determined to be invalid, illegal or unenforceable, the validity, legality and enforceability of the remaining provisions shall not in any way be affected thereby. No waiver of breach of any of the provisions of this Agreement shall be construed to be a waiver of any succeeding breach of the same or any other provision.



Priming Assisted Centrifugal Pump w/Autostart

Model PA6A60-4045T S5

Size 6" x 6"



Total Head		Capacity of Pump in U.S. Gallons per Minute (GPM) at Continuous Performance			
P.S.I.	Feet				
59.4	137	320	320	320	320
52.0	120	710	780	780	780
43.4	100	770	1050	1240	1260
34.7	80	800	1085	1360	1560
26.0	60	825	1130	1430	1640
17.3	40	850	1180	1485	1700
Suction Lift		25'	20'	15'	10'

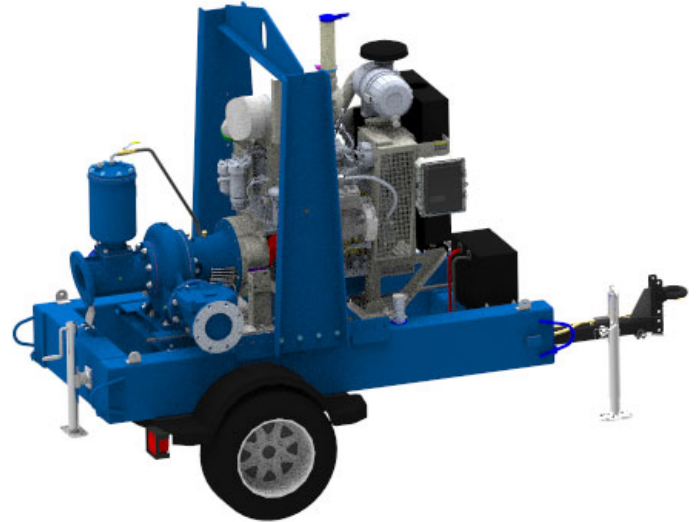

SHOWN WITH OPTIONAL WHEEL KIT

PUMP SPECIFICATIONS

Size: 6" x 6" (152 mm x 152 mm) Flanged.
Casing: Gray Iron 30.
 Maximum Operating Pressure 99 psi (683 kPa).*
Semi-Open Type, Two Vane Impeller: Ductile Iron 65-45-12.
 Handles 3" (76,2 mm) Diameter Spherical Solids.
Impeller Shaft: Stainless Steel 17-4 PH.
Shaft Sleeve: Stainless Steel 17-4 PH.
Replaceable Wear Plate: Steel 1015.
Intermediate Bracket: Gray Iron 30.
Seal Plate: Gray Iron 30.
Seal: Mechanical, Oil-Lubricated, Double Floating Self-Aligning. Silicon Carbide Rotating and Stationary Faces. Stainless Steel 316 Stationary Seat. Fluorocarbon Elastomers (DuPont Viton® or Equivalent). Stainless Steel 18-8 Cage and Spring. Maximum Temperature of Liquid Pumped 160°F (71°C).*
Priming Chamber: Gray Iron 30 Housing w/Stainless Steel Float and Linage.
Discharge Check Valve: Ductile Iron w/Buna-N Flapper.
Radial Bearing: Open Single Row Ball.
Thrust Bearing: Open Double Row Ball.
Bearing and Seal Cavity Lubrication: SAE 30 Non-Detergent Oil.
Flanges: Gray Iron 30.
Gaskets: Resistant Synthetic Rubber, Cork, PTFE, Vegetable Fiber, and Compressed Synthetic Fibers.
Hardware: Standard Plated Steel.
Bearing and Seal Cavity Oil Level Sight Gauges.
**Consult Factory for Applications Exceeding Maximum Pressure and/or Temperature Indicated.*
Standard Equipment: Hoisting Bail. Skid Base. Strainer. Gear-Driven Air Compressor. [Full Feature Control Panel](#) [Single Ball Type Float Switch](#).**
Optional Equipment: Battery. Skid Drag Base Kit Heated Priming Chamber Kit. Suction and Discharge NPT Threaded Flange Kits. High Speed (55 MPH/89 KM/H) Single Axle Pneumatic-Tired Wheel Kit^{w/wo} DOT-Approved Lights and Electric Brakes. [Tandem Axle Over-the-Road Trailer](#) (Meets DOT Requirements) Available w/Either Electric or Hydraulic Surge Brakes, Running Lights, Jack Stands and Safety Cables. Submersible Transducer Liquid Level Sensor.
****50 Ft. (15 m) Standard Length; Dual Switches and Alternate Cable Lengths Available From the Factory.**

WARNING!
 Do not use in explosive atmosphere or for pumping volatile flammable liquids.

ENGINE SPECIFICATIONS

Model: John Deere 4045T.
EPA Tier: Stage 5.
Type: Four Cylinder, Four Cycle, Turbocharged, Liquid Cooled Diesel Engine.
Displacement: 276 Cu. In. (4,5 liters).
Lubrication: Forced Circulation.
Air Cleaner: Dry Type.
Fuel Tank: 70 U.S. Gals. (265 liters).
Full Load Operating Time: 23 Hrs.
Starter: 12V Electric.
Standard Features: Muffler w/Guard and Weather Cap, DOC/DPF Exhaust After-Treatment System.
Engine Control Features: Padlockable Box with Throttle Control, Tachometer, Coolant Temperature, Oil Pressure, Voltage and Overstart Indicators/Shut-downs. Manual/Stop/Auto Keyswitch. Audible Startup Warning Delay. Fuel Level Display/Alarm/Shutdown Electronic Fuel Level Sensor.

JOHN DEERE PUBLISHED PERFORMANCE:
 Maximum Net Continuous BHP
 74 (55 kW) @ 2400 RPM



GORMAN-RUPP PUMPS

www.grpumps.com

Specifications Subject to Change Without Notice

Printed in U.S.A.

Specification Data
SECTION 42, PAGE 906

APPROXIMATE DIMENSIONS and WEIGHTS

NET WEIGHT: 3495 LBS. (1585 KG.)
SHIPPING WEIGHT: 3750 LBS. (1701 KG.)
EXPORT CRATE SIZE: 278 CU. FT. (7,9 CU. M.)

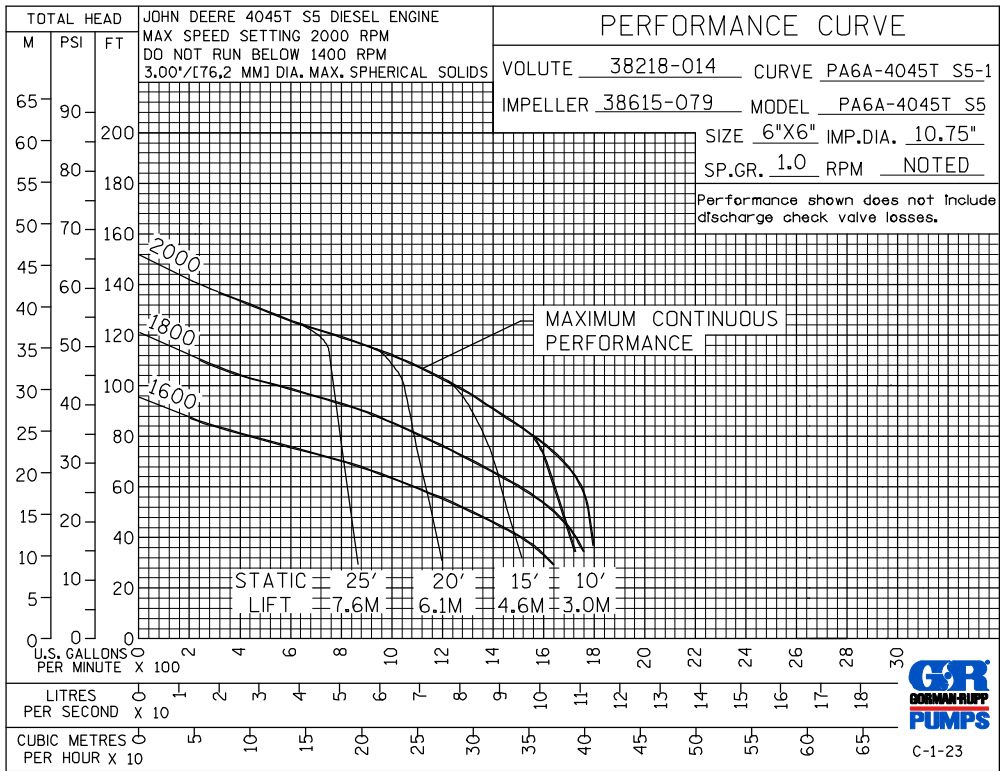
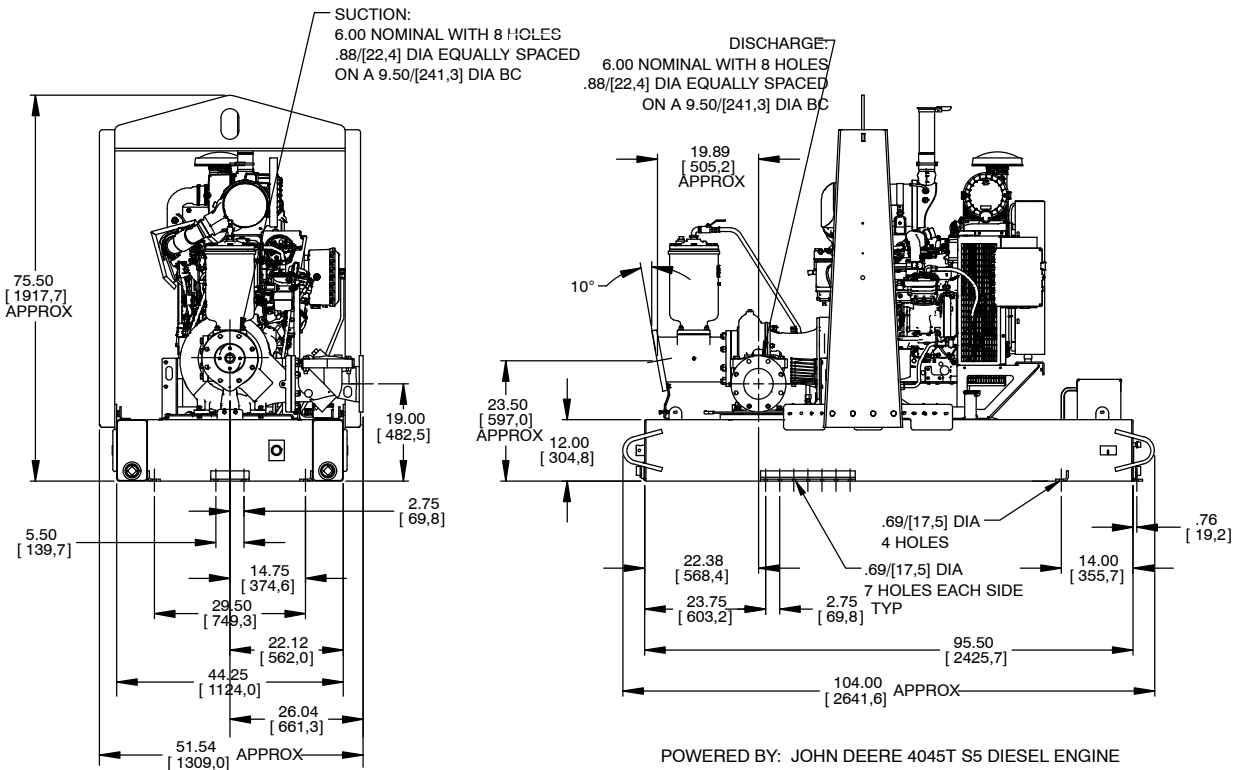

GORMAN-RUPP PUMPS

www.grpumps.com

Specifications Subject to Change Without Notice

Printed in U.S.A.

Priming Assisted Centrifugal Pump w/Autostart Model VPA6A60C-4LE2T FT4



Size 6" x 6"



Total Head		Capacity of Pump in U.S. Gallons per Minute (GPM) at Continuous Performance			
P.S.I.	Feet				
41.2	95	390	390	390	390
39.0	90	450	570	570	570
34.7	80	530	700	830	900
30.3	70	615	805	975	1110
26.0	60	690	900	1100	1245
21.7	50	760	1000	1175	1375
17.3	40	830	1080	1250	1485
13.0	30	870	1130	1320	1595
8.7	20	910	1185	1390	1650
Suction Lift		20'	15'	10'	5'



PUMP SPECIFICATIONS

- Size:** 6" x 6" (152 mm x 152 mm) Flanged.
- Casing:** Gray Iron 30.
Maximum Operating Pressure 62 psi (428 kPa).
Maximum Temperature of Liquid Pumped 160°F (71°C).*
- Semi-Open Type, Two Vane Impeller:** Ductile Iron 65-45-12.
Handles 3" (76,2 mm) Diameter Spherical Solids.
- Impeller Shaft:** Alloy Steel 4150.
- Replaceable Wear Plate:** Carbon Steel ASTM A36.
- Bearing Housing:** Gray Iron 30.
- Seal Plate:** Gray Iron 30.
- Seal:** Type 31, Mechanical, Oil-Lubricated. Silicon Carbide Rotating and Stationary Faces. Nitrile Elastomers. Stainless Steel 18-8 Cage and Spring.
- Shaft Sleeve:** Alloy Steel 4130.
- Priming Chamber:** Gray Iron 30 Housing w/Stainless Steel Float and Linkage.
- Discharge Check Valve:** Ductile Iron Housing with Welded Nickel Seat and Buna-N Flapper.
- Bearings:** Permanently Lubricated Single Row Ball.
- Seal Cavity Lubrication:** SAE 30 Non-Detergent Oil.
- Gaskets:** Red Rubber.
- O-Rings:** Buna-N.
- Hardware:** Standard Plated Steel.

*Consult Factory for Applications Exceeding Maximum Pressure and/or Temperature Indicated.

Standard Equipment: Belt-Driven Air Compressor. Hoisting Bail. Combination Skid Base w/Fuel Tank. Strainer. Standard Auto-start Control Panel [Single Ball Type Float Switch](#).**

Optional Equipment: Battery. Skid Drag Base Kit. High Speed (55 MPH/89 KM/H) Single Axle Pneumatic-Tired Wheel Kit w/ DOT-Approved Lights and Electric Brakes.

**50 Ft. (15 m) Standard Length; Dual Switches and Alternate Cable Lengths Available From the Factory.

WARNING!

Do not use in explosive atmosphere or for pumping volatile flammable liquids.

ENGINE SPECIFICATIONS

- Model:** Isuzu 4LE2T.
- EPA Tier:** Final Tier 4.
- Type:** Four Cylinder, Turbocharged Diesel Engine.
- Displacement:** 134 Cu. In. (2,2 Liters).
- Lubrication:** Forced Circulation.
- Governor:** Electronic.
- Air Cleaner:** Dry Type.
- Fuel Tank:** 34 U.S. Gals. (128,7 Liters).
- Full Load Operating Time:** 20.6 Hrs.
- Starter:** 12V Electric.
- Standard Features:** Muffler w/Weather Cap. DOC Exhaust After-Treatment System.
- Optional:** Electronic Fuel Level Sensor.
- Engine Control Features:** Padlockable Box with Throttle Control, Tachometer, Coolant Temperature, Oil Pressure, Voltage and Overstart Indicators/Shut-downs. Manual/Stop/Auto Keyswitch. Audible Startup Warning Delay. Fuel Level Display/Alarm/Shut-down (For Use With Optional Fuel Level Sensor).

ISUZU PUBLISHED PERFORMANCE:

Maximum Gross Continuous BHP
48 (35.8 kW) @ 2400 RPM



GORMAN-RUPP PUMPS

www.grpumps.com

Specifications Subject to Change Without Notice

Printed in U.S.A.

Specification Data
SECTION 41, PAGE 200

APPROXIMATE
DIMENSIONS and WEIGHTS

SKID BASE
NET WEIGHT: 1820 LBS. (825,5 KG.)
SHIPPING WEIGHT: 2070 LBS. (939,0 KG.)
EXPORT CRATE SIZE: 133.6 CU. FT. (3,8 CU. M.)

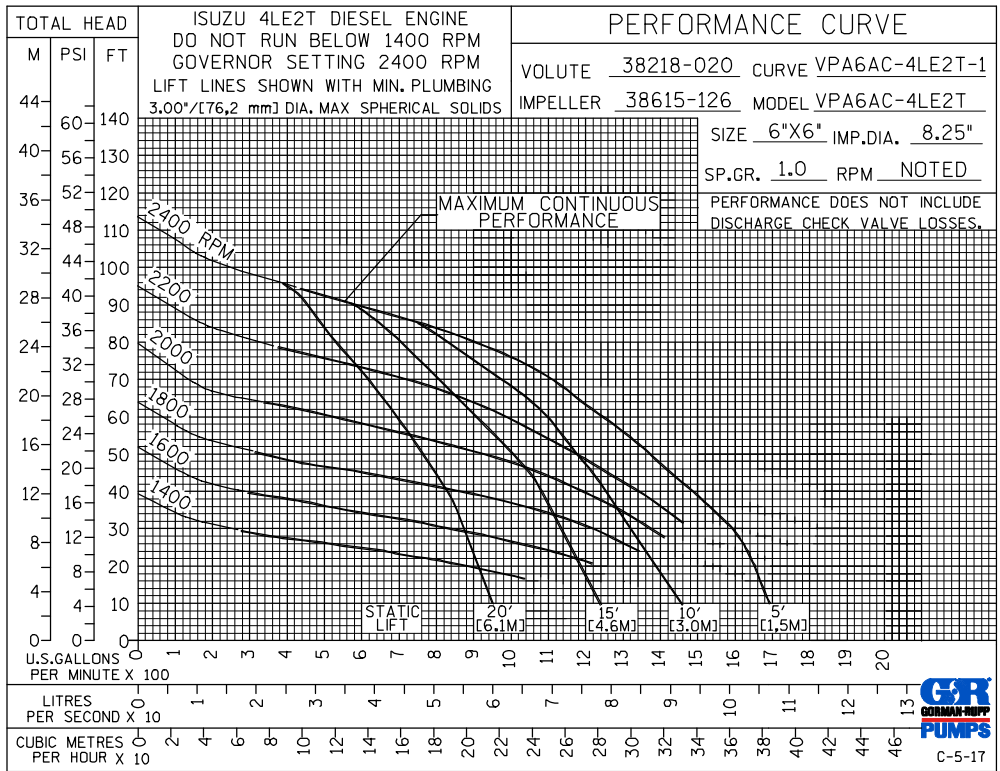
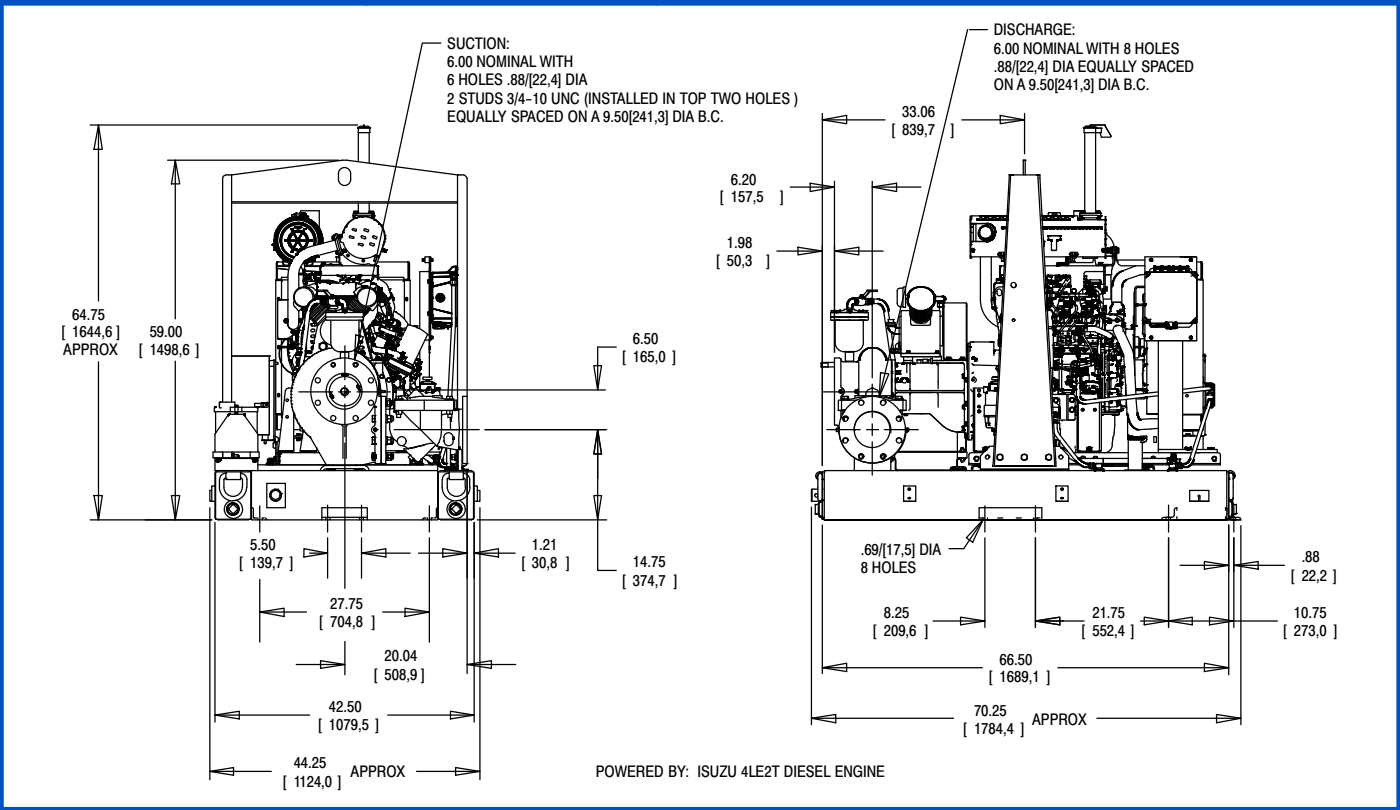

GORMAN-RUPP PUMPS

www.grpumps.com

Specifications Subject to Change Without Notice

Printed in U.S.A.

April 14, 2026

ACH Payments & Checks #42375 - #42449

03/21/26– 04/10/26

Total Vouchers = \$868,961.86

ERF Vouchers = \$13,417.97

Plus

Payroll = \$69,724.86

Total to Approve \$882,379.83



4/09/2026 10:47 AM

Reprint Check Register - Quick Report - ALL

Page: 1
ACCT

Equipment Replacement Checking

Accounting Checks

Posted From: 3/21/2026 From Account:
Thru: 4/10/2026 Thru Account:

Check Nbr	Check Date	Payee	Amount
2333	4/09/2026	Belco Vehicle Solutions, LLC PD - Squad Prep	13,417.91
Grand Total			13,417.91



4/09/2026 10:47 AM

Reprint Check Register - Quick Report - ALL

Page: 2
ACCT

Equipment Replacement Checking

Accounting Checks

Posted From: 3/21/2026

From Account:

Thru: 4/10/2026

Thru Account:

Amount

Total Expenditure from Fund # 405 - Equipment Replacement Fund	13,417.91
Total Expenditure from all Funds	13,417.91



4/09/2026 10:44 AM

Reprint Check Register - Quick Report - ALL

Page: 1
ACCT

CITY OF MAUSTON POOLED CASH

Accounting Checks

Posted From: 3/21/2026 From Account:
Thru: 4/10/2026 Thru Account:

Check Nbr	Check Date	Payee	Amount
FIT	4/02/2026	Federal Tax Withholding	22,079.89
	Manual Check	FED/FICA Payroll Taxes 04.03.26	
42375	3/25/2026	ABEDNEGO Fire Protection, LLC FD - Hydrostatic testing	945.00
42376	3/25/2026	BAYCOM, Inc PD - radio repairs/maint	1,602.00
42377	3/25/2026	BTU Management, Inc Library - pleated filters	415.92
42378	3/25/2026	Cengage Group Library - Adult Books	163.95
42379	3/25/2026	Column Software PBC Zoning - Publications	39.30
42380	3/25/2026	Core & Main LP Wtr - items for maint/repairs	331.11
42381	3/25/2026	Duffy, Mike Swr/Wtr - Annual PPE reimbursement	195.39
42382	3/25/2026	Emplify Health Water - Random Testing	81.00
42383	3/25/2026	Fischbach Trucking, Inc Streets - snow removal	460.00
42384	3/25/2026	Heartland Business Systems Library - Annual Service Agreement	630.00
42385	3/25/2026	J.C. Dairy Promotion Council City of Mauston - 13th Annual Cowtastic	50.00
42386	3/25/2026	Juneau County Highway Department City of Mauston - Fuel expense for month	108.99
42387	3/25/2026	Lange Plumbing & Heating, Inc Library - Bathroom Maint	151.00
42388	3/25/2026	Mauston Area School District Admin - February 26 MH tax school share	744.92
42389	3/25/2026	MicroMarketing LLC Library - Adult Books	263.94
42390	3/25/2026	Midwest Tape Library - Adult Visuals	21.24
42391	3/25/2026	Minard, Mike Parks - Annual boot allowance	200.00



4/09/2026 10:44 AM

Reprint Check Register - Quick Report - ALL

Page: 2
ACCT

CITY OF MAUSTON POOLED CASH

Accounting Checks

Posted From: 3/21/2026 From Account:
Thru: 4/10/2026 Thru Account:

Check Nbr	Check Date	Payee	Amount
42392	3/25/2026	MSA Professional Services Library - FFP Admin 24-26	1,216.00
42393	3/25/2026	Northside Mobil PD - Towing Services	285.00
42394	3/25/2026	Playaway Products Library - Adult Audio	354.40
42395	3/25/2026	Pomp's Tire Service, Inc Streets - items for maint/repairs	604.36
42396	3/25/2026	Rhyme Business Products Library - Copier lease fees	1,264.29
42397	3/25/2026	Rhyme Business Products City of Mauston - Copier lease fees	633.00
42398	3/25/2026	River Architects Inc. Library - RA#1560 Architectural Services	1,390.00
42399	3/25/2026	Rudig-Jensen Ford, Inc PD - items for maint/repairs	129.92
42400	3/25/2026	WI DNR Water - Certification Renewal	70.00
42401	3/25/2026	Worksite Wellness Center Water - Random Testing	30.00
42402	4/02/2026	Cintas City of Mauston - Building floor mats	107.64
42403	4/02/2026	Column Software PBC City of Mauston - Publications	259.85
42404	4/02/2026	Delta Dental of Wisconsin City of Mauston - Dental Premiums	2,805.31
42405	4/02/2026	Dutton, Shawn Water - Training expense/mileage	187.60
42406	4/02/2026	Interstate Billing Service, Inc FD - items for maint/repairs	335.96
42407	4/02/2026	J.C. Dairy Promotion Council PD - 13th annual Cowtastic event	50.00
42408	4/02/2026	Johnson Block & Company Inc City of Mauston - Audit 25 Pro Fees	7,468.00
42409	4/02/2026	LN Worksite Billing Department City of Mauston - Liberty payroll deduct	2,498.12



4/09/2026 10:44 AM

Reprint Check Register - Quick Report - ALL

Page: 3
ACCT

CITY OF MAUSTON POOLED CASH

Accounting Checks

Posted From: 3/21/2026 From Account:
Thru: 4/10/2026 Thru Account:

Check Nbr	Check Date	Payee	Amount
42410	4/02/2026	Mauston Area Ambulance Assn., Inc PD - legal blood draw x5	625.00
42411	4/02/2026	Slama Equipment Parks/Streets - items for maint/repairs	939.27
42412	4/02/2026	VSP Vision Service Plan City of Mauston - Vision Ins Expense	668.10
42413	4/02/2026	WI SCTF Child Support Withheld - 04.03.26	322.61
42414	4/02/2026	Market & Johnson Library - Pay App 7	304,911.41
42415	4/09/2026	3RT Networks, LLC Library FFP - IT service pro fees	19,391.80
42416	4/09/2026	Amazon Capital Services, Inc Library - Monthly Statement	474.75
42417	4/09/2026	Armstrong Software GMTA - Mobile App License Fee	5,400.00
42418	4/09/2026	AT&T Mobility City of Mauston - Monthly Phone Service	751.77
42419	4/09/2026	Baer Insurance Services, Inc City of Mauston - 2nd Qtr 26 Premiums	30,169.25
42420	4/09/2026	BAYCOM, Inc PD - Programming New Mobile	130.00
42421	4/09/2026	Blackstone Technologies, LLC Streets - Performance Patch Kit	262.00
42422	4/09/2026	Capital Newspapers Elections - Spring election publication	413.16
42423	4/09/2026	Cengage Group Library - Adult books	190.98
42424	4/09/2026	Column Software PBC City of Mauston - Publications	11.81
42425	4/09/2026	Conway Shield FD - PPE Gear	68.50
42426	4/09/2026	CT Laboratories Swr - Sample Testing	3,930.00
42427	4/09/2026	Demco, INC Library - items for book processing	410.10



4/09/2026 10:44 AM

Reprint Check Register - Quick Report - ALL

Page: 4
ACCT

CITY OF MAUSTON POOLED CASH

Accounting Checks

Posted From: 3/21/2026 From Account:
Thru: 4/10/2026 Thru Account:

Check Nbr	Check Date	Payee	Amount
42428	4/09/2026	Diane Kropiwka Admin - Pro Fees	162.50
42429	4/09/2026	Gerke, Jason City of Mauston - 4th of July Event	500.00
42430	4/09/2026	Holiday Wholesale Library - Cleaning Supplies	147.80
42431	4/09/2026	Ingram Library Services Library - Adult/Childrens Books	513.23
42432	4/09/2026	Jefferson Fire & Safety, Inc FD - items/labor for maint/repairs	2,352.48
42433	4/09/2026	Kanopy Inc Library - tickets for videos	41.65
42434	4/09/2026	Krus Extinguishers, LLC City of Mauston - Fire Alarm System	796.61
42435	4/09/2026	Lange Plumbing & Heating, Inc Library - Bathroom Maint	167.99
42436	4/09/2026	LENS Equipment PD - 12 month unlimited data service	499.00
42437	4/09/2026	MicroMarketing LLC Library - Adult Books	339.38
42438	4/09/2026	Midwest Tape Library - Hoopla for month	1,840.17
42439	4/09/2026	MSA Professional Services Library - FFP Admin 24-26	1,324.00
42440	4/09/2026	Pitney Bowes Global Financial Services LLC City of Mauston - Lesase Fees/Ink	454.02
42441	4/09/2026	Republic Services #935 City of Mauston - Residential pick-up	20,042.68
42442	4/09/2026	Rhyme Business Products Library - Copier lease fees	632.57
42443	4/09/2026	Rhyme Business Products, LLC Library - FFP Admin 24-26 copier machine	7,499.00
42444	4/09/2026	Spee-Dee Delivery Service, Inc Swr/Wtr/Admin - Shipping fees	190.63
42445	4/09/2026	Staples Business Advantage Admin - office supplies	136.45



4/09/2026 10:44 AM

Reprint Check Register - Quick Report - ALL

Page: 5
ACCT

CITY OF MAUSTON POOLED CASH

Accounting Checks

Posted From: 3/21/2026 From Account:
Thru: 4/10/2026 Thru Account:

Check Nbr	Check Date	Payee	Amount
42446	4/09/2026	State of WI - Environmental Improvement Fund Debt - 2020 & 2024 Clean Water Fund	357,101.04
42447	4/09/2026	The Straight Thread LLC Library FFP - Upholstery of armchairs	15,952.00
42448	4/09/2026	UBS Financial Services, Inc. FD - 2025 annual FD retirement	1,731.00
42449	4/09/2026	Wisconsin Department of Justice Admin - Background checks	49.00
WITAX	4/07/2026	Wis Tax Withholding WI Payroll Taxes 04.03.26	3,868.63
ALLIANT	3/25/2026	Alliant - 1735130000 City of Mauston - Electric & Gas fees	8,150.51
ALLIANT	3/26/2026	Alliant - 2484600000 City of Mauston - Electric & Gas fees	40.06
ALLIANT	3/21/2026	Alliant - 0849610000 City of Mauston - Electric & Gas fees	3.18
ALLIANT	3/25/2026	Alliant - 3183940000 City of Mauston - Electric & Gas fees	365.68
ALLIANT	3/25/2026	Alliant - 1457140000 City of Mauston - Electric & Gas fees	7,279.31
ALLIANT	3/25/2026	Alliant - 2190000000 City of Mauston - Electric & Gas fees	639.06
ALLIANT	3/13/2026	Alliant - 4415730000 City of Mauston - Electric & Gas fees	4,264.69
ALLIANT	3/25/2026	Alliant - 3487864265 City of Mauston - Electric & Gas fees	32.86
ALLIANT	3/25/2026	Alliant - 1287210000 City of Mauston - Electric & Gas fees	425.93
ALLIANT	3/25/2026	Alliant - 5049940000 City of Mauston - Electric & Gas fees	5,094.74
DEFCOMP	4/02/2026	Wells Fargo - Great West Deferred Comp Deferred Comp - Payroll 04.03.26	3,010.00
UTILITIES	4/06/2026	City of Mauston City of Mauston - Monthly Utilities	6,037.15
Simplifile	3/19/2026	Simplifile E-recording Zoning - CUP Resolution 26-P-01	33.25



4/09/2026 10:44 AM

Reprint Check Register - Quick Report - ALL

Page: 6
ACCT

CITY OF MAUSTON POOLED CASH

Accounting Checks

Posted From: 3/21/2026 From Account:
Thru: 4/10/2026 Thru Account:

Check Nbr	Check Date	Payee	Amount
Grand Total			868,961.86



4/09/2026 10:44 AM

Reprint Check Register - Quick Report - ALL

Page: 7
ACCT

CITY OF MAUSTON POOLED CASH

Accounting Checks

Posted From: 3/21/2026 From Account:
Thru: 4/10/2026 Thru Account:

	Amount
Total Expenditure from Fund # 100 - General Fund	113,520.99
Total Expenditure from Fund # 109 - Cemetery Fund	902.61
Total Expenditure from Fund # 250 - Library Fund	12,450.14
Total Expenditure from Fund # 280 - Taxi Fund	252.99
Total Expenditure from Fund # 340 - TID 4 Fund	400.00
Total Expenditure from Fund # 350 - TID 5 Fund	400.00
Total Expenditure from Fund # 370 - TID 6 Fund	100.00
Total Expenditure from Fund # 400 - Capital Projects Fund	351,684.21
Total Expenditure from Fund # 610 - Water Utility Fund	11,978.45
Total Expenditure from Fund # 620 - Sewer Utility Fund	377,272.47
Total Expenditure from all Funds	868,961.86



Fund: 100 - General Fund

Account Number		2026		2026 Budget	Budget Status	% of Budget
		2026 April	Actual 04/09/2026			
100-00-41110-000-000	General Property Taxes	0.00	2,791,277.83	2,615,590.00	175,687.83	106.72
100-00-41140-000-000	Mobile Home Park Permits/Taxes	0.00	6,384.52	25,000.00	-18,615.48	25.54
100-00-41150-000-000	Manage Forest Land Tax	0.00	0.00	0.00	0.00	0.00
100-00-41210-000-000	Room Tax	0.00	13,220.39	70,000.00	-56,779.61	18.89
100-00-41220-000-000	GMTA 70% Room Tax	0.00	30,847.58	160,000.00	-129,152.42	19.28
100-00-41220-100-000	Other Revenues	0.00	0.00	0.00	0.00	0.00
100-00-41300-000-000	Payment in Lieu of Taxes	0.00	1,100.00	18,500.00	-17,400.00	5.95
100-00-41310-000-000	Reg Mun Owned Taxes	0.00	0.00	105,715.00	-105,715.00	0.00
100-00-41810-000-000	Intrst-Delinq Mobile Home Tax	0.00	0.00	0.00	0.00	0.00
100-00-41820-000-000	Intrst-Delinq PP Tax	0.00	0.00	0.00	0.00	0.00
100-00-41900-000-000	Other Tax Collections	0.00	0.00	0.00	0.00	0.00
Taxes		0.00	2,842,830.32	2,994,805.00	-151,974.68	94.93
100-00-43300-000-000	Other Federal Payments	0.00	0.00	0.00	0.00	0.00
100-00-43410-000-000	State Shared Revenues	0.00	0.00	1,282,487.00	-1,282,487.00	0.00
100-00-43410-100-000	Utility Aid Payment	0.00	0.00	35,699.00	-35,699.00	0.00
100-00-43410-200-000	Expenditure Restraint Pmt	0.00	0.00	75,366.00	-75,366.00	0.00
100-00-43410-300-000	Personal Property Aid	0.00	0.00	58,381.00	-58,381.00	0.00
100-00-43420-000-000	Fire Ins Tax from State	0.00	0.00	16,350.00	-16,350.00	0.00
100-00-43521-000-000	PD Overtime/DOT Grants	0.00	0.00	0.00	0.00	0.00
100-00-43522-000-000	State Law Enforcement Training	0.00	0.00	2,080.00	-2,080.00	0.00
100-00-43524-000-000	Forest Fire Protect Grant (FD)	0.00	0.00	0.00	0.00	0.00
100-00-43525-000-000	Equipment Grants	0.00	0.00	0.00	0.00	0.00
100-00-43530-000-000	State Transportatoin Aids	104,071.36	208,142.72	416,532.00	-208,389.28	49.97
100-00-43531-000-000	State Aid Connecting Streets	22,902.88	45,805.76	91,612.00	-45,806.24	50.00
100-00-43532-000-000	COVID-19 R2R Grant Aid	0.00	0.00	0.00	0.00	0.00
100-00-43533-000-000	State Aid Computers	0.00	0.00	9,488.00	-9,488.00	0.00
100-00-43549-000-000	DNR Recycling	0.00	0.00	13,340.00	-13,340.00	0.00
100-00-43600-000-000	Other State Payments	0.00	0.00	0.00	0.00	0.00
100-00-43610-000-000	Payment for Municipal Services	0.00	160,835.18	160,772.00	63.18	100.04
100-00-43660-000-000	Environmental Impact Rev (ATC)	0.00	0.00	16,351.00	-16,351.00	0.00
Intergovernmental Revenues		126,974.24	414,783.66	2,178,458.00	-1,763,674.34	19.04
100-00-44110-000-000	Liquor License/Malt Bevs Fee	0.00	255.00	9,000.00	-8,745.00	2.83
100-00-44121-000-000	Cable TV Licenses	0.00	3,799.57	20,388.00	-16,588.43	18.64
100-00-44121-000-100	VSP Fee Subsidy	0.00	0.00	4,308.00	-4,308.00	0.00
100-00-44130-000-000	Operator, Cig & Amuse Device	0.00	40.00	6,000.00	-5,960.00	0.67
100-00-44200-000-000	Dog & Cat Licenses	0.00	0.00	0.00	0.00	0.00
100-00-44201-000-000	Chicken permit	0.00	0.00	100.00	-100.00	0.00
100-00-44301-000-000	Fire Inspection Fee	-75.00	225.00	1,000.00	-775.00	22.50
100-00-44400-000-000	Bldg & Zoning Permit	1,006.00	9,640.00	85,281.00	-75,641.00	11.30
100-00-44410-000-000	Rental Inspection	0.00	0.00	0.00	0.00	0.00
100-00-44910-000-000	Other Permits/Fees(Sellers,MH)	0.00	0.00	400.00	-400.00	0.00
Licenses & Permits		931.00	13,959.57	126,477.00	-112,517.43	11.04
100-00-45115-000-000	Muni Court Fees (City)	0.00	7,787.58	30,000.00	-22,212.42	25.96
100-00-45116-000-000	Muni Court Fines (City)	0.00	17,272.12	60,000.00	-42,727.88	28.79



Fund: 100 - General Fund

Account Number		2026		2026 Budget	Budget Status	% of Budget
		2026 April	Actual 04/09/2026			
100-00-45120-000-000	County Court Fines/Forfeitures	0.00	455.34	3,500.00	-3,044.66	13.01
100-00-45130-000-000	Parking Violations	555.00	4,646.00	20,000.00	-15,354.00	23.23
100-00-45140-000-000	Police Undercover Local Rev	0.00	0.00	0.00	0.00	0.00
100-00-45141-000-000	Police Fed Equity Share Rev	0.00	0.00	0.00	0.00	0.00
Fines & Forfeitures		555.00	30,161.04	113,500.00	-83,338.96	26.57
100-00-46100-000-000	Misc. General Revenues	2,971.00	2,971.00	0.00	2,971.00	0.00
100-00-46101-000-000	Admin Service Fee	0.00	0.00	0.00	0.00	0.00
100-00-46210-000-000	Police A/R,Supoena, Fees, Tows	10.00	318.00	750.00	-432.00	42.40
100-00-46220-000-000	Township Rural Fire Reimbursmt	230,478.00	230,478.00	230,478.00	0.00	100.00
100-00-46220-001-000	Township Rural Fire 2% Dues	0.00	0.00	0.00	0.00	0.00
100-00-46223-000-000	Emergency Response Fee Revenue	-500.00	8,541.05	45,000.00	-36,458.95	18.98
100-00-46230-000-000	Ambulance Assessment fee	120.49	54,008.41	296,590.00	-242,581.59	18.21
100-00-46322-000-000	Assessments:C&G/Sidewalk	249.14	20,851.21	107,199.00	-86,347.79	19.45
100-00-46323-000-100	Service Charge (Mowing)	0.00	4,000.00	5,000.00	-1,000.00	80.00
100-00-46323-000-200	Service Charge (Shovel)	0.00	0.00	1,000.00	-1,000.00	0.00
100-00-46370-000-000	Boat Launch Fees	25.00	195.00	3,500.00	-3,305.00	5.57
100-00-46420-000-000	Garbage Collection Revenue	142.82	42,404.95	240,525.00	-198,120.05	17.63
100-00-46423-000-000	Large Item Pick up Rev	0.00	0.00	0.00	0.00	0.00
100-00-46540-300-000	FD UBS Investment	0.00	0.00	0.00	0.00	0.00
100-00-46700-000-000	Summer Rec Revenue	0.00	0.00	0.00	0.00	0.00
100-00-46721-000-000	Tree Tribute Program Revenue	0.00	560.00	1,000.00	-440.00	56.00
Public Charges for Services		233,496.45	364,327.62	931,042.00	-566,714.38	39.13
100-00-48100-000-000	Interest Temporary Investment	0.00	36,542.24	17,500.00	19,042.24	208.81
100-00-48100-100-000	UBS FD Interest Income	0.00	1,512.04	0.00	1,512.04	0.00
100-00-48102-400-000	Interest - Lenorud	0.00	0.00	0.00	0.00	0.00
100-00-48102-500-000	Interest - Games 4 Us	0.00	0.00	0.00	0.00	0.00
100-00-48102-600-000	Interest - Rehab Bar	0.00	0.00	0.00	0.00	0.00
100-00-48102-700-000	Interest - PSD	0.00	0.00	0.00	0.00	0.00
100-00-48120-000-000	Interest on Special Assessment	0.00	-115.50	2,500.00	-2,615.50	-4.62
100-00-48121-000-000	Interest from Due From TSA	0.00	0.00	0.00	0.00	0.00
100-00-48130-000-000	Interest on K9 account	0.00	9,683.24	5,000.00	4,683.24	193.66
100-00-48130-000-001	FD Donation CD Revenue	0.00	3,908.48	5,000.00	-1,091.52	78.17
100-00-48130-000-002	FD Raffle CD Revenue	0.00	390.95	0.00	390.95	0.00
100-00-48150-000-000	Interest Parkland Dedication	0.00	115.33	500.00	-384.67	23.07
100-00-48210-000-000	Rent of City Property	0.00	50.00	5,000.00	-4,950.00	1.00
100-00-48220-000-000	Rent of Fairgrounds/Parks	0.00	1,125.00	3,500.00	-2,375.00	32.14
100-00-48221-000-000	Concession Stand Shared Rev	0.00	0.00	0.00	0.00	0.00
100-00-48230-000-000	Fee for Car Wash & Veh. Maint.	0.00	0.00	0.00	0.00	0.00
100-00-48310-000-000	Sale of City Property	0.00	43.60	0.00	43.60	0.00
100-00-48410-000-000	Insurance/Damage Recoveries	0.00	6,682.88	0.00	6,682.88	0.00
100-00-48500-000-000	Donations	0.00	67,281.45	20,000.00	47,281.45	336.41
100-00-48500-000-100	K9 Unit Donations	0.00	290.00	500.00	-210.00	58.00
100-00-48500-900-000	FD Special Funds Donations	0.00	6,011.00	0.00	6,011.00	0.00
100-00-48700-000-000	Miscellaneous Revenue	0.00	629.51	15,000.00	-14,370.49	4.20
100-00-48710-000-000	School Liaison Contribution/Rv	0.00	0.00	62,790.00	-62,790.00	0.00
100-00-48711-000-000	GMTA Misc Revenue	0.00	0.00	0.00	0.00	0.00



Fund: 100 - General Fund

Account Number		2026		2026 Budget	Budget Status	% of Budget
		2026 April	Actual 04/09/2026			
100-00-48810-000-000	Parkland Dedication Revenue	0.00	0.00	0.00	0.00	0.00
100-00-48820-000-000	Parks Fund Raising Revenue	0.00	0.00	0.00	0.00	0.00
=====						
Miscellaneous		0.00	134,150.22	137,290.00	-3,139.78	97.71
=====						
100-00-49100-000-000	Proceeds from Long Term Debt	0.00	0.00	0.00	0.00	0.00
100-00-49150-000-000	Proceeds from Debt Premium	0.00	0.00	0.00	0.00	0.00
100-00-49200-000-000	Transfer In from 20 % Room Tax	0.00	0.00	0.00	0.00	0.00
100-00-49210-000-000	Transfer In	0.00	0.00	0.00	0.00	0.00
100-00-49240-000-000	Transfer from CDBG	0.00	0.00	0.00	0.00	0.00
100-00-49310-000-000	Transfer in-TIF	0.00	0.00	0.00	0.00	0.00
100-00-49500-000-000	Proceeds from Refunding Bonds	0.00	0.00	0.00	0.00	0.00
=====						
Other Financing Sources		0.00	0.00	0.00	0.00	0.00
=====						
=====						
Total Revenues		361,956.69	3,800,212.43	6,481,572.00	-2,681,359.57	58.63
=====						



Fund: 100 - General Fund

Account Number		2026		2026 Budget	Budget Status	% of Budget
		2026 April	Actual 04/09/2026			
100-00-51110-110-000	Salary/Wages	830.79	5,815.53	21,600.00	15,784.47	26.92
100-00-51110-130-000	FICA/Medicare	63.55	444.85	2,055.00	1,610.15	21.65
100-00-51110-160-000	Employee Recog	0.00	200.00	1,250.00	1,050.00	16.00
100-00-51110-211-000	Audit	1,984.00	10,312.00	25,000.00	14,688.00	41.25
100-00-51110-212-000	Assessing	0.00	2,586.26	12,500.00	9,913.74	20.69
100-00-51110-213-000	Legal	0.00	0.00	0.00	0.00	0.00
100-00-51110-312-000	Code Maintenance	0.00	2,947.64	4,000.00	1,052.36	73.69
100-00-51110-313-000	Elections	413.16	413.16	6,250.00	5,836.84	6.61
100-00-51110-313-100	Supplies for COVID-19	0.00	0.00	0.00	0.00	0.00
100-00-51110-330-000	Educ/Trng/Travel	0.00	0.00	100.00	100.00	0.00
100-00-51110-390-000	Miscellaneous	0.00	0.00	1,000.00	1,000.00	0.00
100-00-51110-591-000	Bad Debt & Write offs	0.00	0.00	0.00	0.00	0.00
100-00-51120-213-000	Legal	0.00	0.00	0.00	0.00	0.00
100-00-51120-330-000	Educ/Trng/Travel	0.00	0.00	0.00	0.00	0.00
100-00-51120-390-000	Miscellaneous	0.00	0.00	750.00	750.00	0.00
100-00-51250-110-000	Judge & Clerk Wage	1,698.08	11,673.00	42,440.00	30,767.00	27.50
100-00-51250-130-000	FICA/Medicare	126.25	868.04	3,247.00	2,378.96	26.73
100-00-51250-131-000	Health Insurance	0.00	7,540.68	18,098.00	10,557.32	41.67
100-00-51250-132-000	FSA Contribution	0.00	178.72	600.00	421.28	29.79
100-00-51250-133-000	Dental Insurance	89.62	358.48	807.00	448.52	44.42
100-00-51250-134-000	Vision Insurance	23.02	92.08	207.00	114.92	44.48
100-00-51250-135-000	Retirement	91.80	627.19	2,264.00	1,636.81	27.70
100-00-51250-210-000	Legal & Administration	0.00	0.00	500.00	500.00	0.00
100-00-51250-224-000	Telephone/Fax	0.00	66.33	300.00	233.67	22.11
100-00-51250-290-000	Jail Services	0.00	0.00	250.00	250.00	0.00
100-00-51250-310-000	Office Supplies	100.02	849.32	2,850.00	2,000.68	29.80
100-00-51250-313-100	Supplies for COVID-19	0.00	0.00	0.00	0.00	0.00
100-00-51250-321-000	Publication	0.00	0.00	0.00	0.00	0.00
100-00-51250-330-000	Educ/Trng/Travel	0.00	1,005.00	2,250.00	1,245.00	44.67
100-00-51250-353-000	Info Tech	0.00	7,993.54	7,850.00	-143.54	101.83
100-00-51250-390-000	Miscellaneous	0.00	0.00	100.00	100.00	0.00
100-00-51400-110-000	Salary/Wages	7,204.99	50,732.59	193,693.00	142,960.41	26.19
100-00-51400-130-000	FICA/Medicare	547.11	3,851.63	14,818.00	10,966.37	25.99
100-00-51400-131-000	Health Insurance	62.50	8,227.27	38,912.00	30,684.73	21.14
100-00-51400-132-000	FSA Contribution	0.00	239.56	1,625.00	1,385.44	14.74
100-00-51400-133-000	Dental Insurance	103.39	413.56	2,093.00	1,679.44	19.76
100-00-51400-134-000	Vision Insurance	36.50	146.00	577.00	431.00	25.30
100-00-51400-135-000	Retirement	484.65	3,416.61	13,172.00	9,755.39	25.94
100-00-51400-210-000	Professional Service	0.00	10.00	1,500.00	1,490.00	0.67
100-00-51400-211-000	Background Checks	49.00	77.00	1,650.00	1,573.00	4.67
100-00-51400-213-000	Legal	0.00	319.00	6,750.00	6,431.00	4.73
100-00-51400-216-000	Hire & Recruitment	0.00	39.00	1,500.00	1,461.00	2.60
100-00-51400-221-000	Electricity	0.00	1,718.74	8,750.00	7,031.26	19.64
100-00-51400-222-000	Gas/Heat	0.00	1,683.22	3,250.00	1,566.78	51.79
100-00-51400-223-000	Water/Sewer	277.62	704.42	3,750.00	3,045.58	18.78
100-00-51400-224-000	Telephone/Fax	0.00	1,033.39	3,250.00	2,216.61	31.80
100-00-51400-240-000	Building Maintenance	0.00	1,700.75	3,500.00	1,799.25	48.59
100-00-51400-290-000	Contractual Services	162.50	15,675.45	32,500.00	16,824.55	48.23
100-00-51400-310-000	Office Supplies	190.39	930.02	3,750.00	2,819.98	24.80



Fund: 100 - General Fund

Account Number		2026		2026 Budget	Budget Status	% of Budget
		2026 April	Actual 04/09/2026			
100-00-51400-311-000	Postage/Shipping	100.02	475.02	2,000.00	1,524.98	23.75
100-00-51400-313-000	Custodial Supplies	0.00	358.42	3,000.00	2,641.58	11.95
100-00-51400-313-100	Supplies for COVID-19	0.00	0.00	0.00	0.00	0.00
100-00-51400-320-000	Memberships/Dues	0.00	1,817.30	3,000.00	1,182.70	60.58
100-00-51400-321-000	Publications	271.66	507.90	3,500.00	2,992.10	14.51
100-00-51400-330-000	Educ/Trng/Travel	0.00	1,498.00	5,000.00	3,502.00	29.96
100-00-51400-350-000	Equip Maint (Non-Office)	0.00	0.00	500.00	500.00	0.00
100-00-51400-352-000	Office Equip Maint	0.00	1,308.11	2,500.00	1,191.89	52.32
100-00-51400-353-000	Info Tech	0.00	8,094.81	12,500.00	4,405.19	64.76
100-00-51400-390-000	Miscellaneous	0.00	50.00	125.00	75.00	40.00
100-00-51400-510-000	Ins (Non-Labor)	4,760.11	19,385.08	32,250.00	12,864.92	60.11
100-00-51400-520-000	FSA Total Admin Fees	0.00	358.00	2,500.00	2,142.00	14.32
100-00-51400-740-000	Losses/Damages	0.00	0.00	0.00	0.00	0.00
100-00-51400-790-000	Donations/Grants Expenditures	0.00	0.00	0.00	0.00	0.00
100-00-51400-821-000	Building Improvement	0.00	0.00	0.00	0.00	0.00
Administration		19,670.73	178,742.67	558,183.00	379,440.33	32.02
100-00-52100-110-000	Salary/Wages	39,515.07	289,723.46	1,038,312.00	748,588.54	27.90
100-00-52100-111-000	Clerical OT Wages	0.00	0.00	1,315.00	1,315.00	0.00
100-00-52100-112-000	Officer PT Wages	0.00	0.00	0.00	0.00	0.00
100-00-52100-116-000	Officer OT Wages	987.99	19,014.60	68,345.00	49,330.40	27.82
100-00-52100-121-000	Crossing Guard Wages	0.00	0.00	10,500.00	10,500.00	0.00
100-00-52100-130-000	FICA/Medicare	2,899.34	23,210.66	85,563.00	62,352.34	27.13
100-00-52100-131-000	Health Insurance	250.00	59,992.27	284,046.00	224,053.73	21.12
100-00-52100-132-000	FSA Contribution	0.00	3,932.60	7,000.00	3,067.40	56.18
100-00-52100-133-000	Dental Insurance	983.81	3,935.24	11,207.00	7,271.76	35.11
100-00-52100-134-000	Vision Insurance	205.65	822.60	2,628.00	1,805.40	31.30
100-00-52100-135-000	Retirement	5,999.19	43,254.86	163,980.00	120,725.14	26.38
100-00-52100-191-000	Protective Cloth/Gear	-675.00	7,425.00	11,750.00	4,325.00	63.19
100-00-52100-213-000	Legal	0.00	2,249.40	15,000.00	12,750.60	15.00
100-00-52100-216-000	Hire & Recruitment	0.00	0.00	750.00	750.00	0.00
100-00-52100-217-000	Investigations	1,124.00	4,455.00	10,000.00	5,545.00	44.55
100-00-52100-217-100	K9 Unit Expenses	0.00	1,150.00	2,000.00	850.00	57.50
100-00-52100-217-200	Undercover Local Expenses	0.00	2,579.61	0.00	-2,579.61	0.00
100-00-52100-217-300	Fed Equity Share Expenses	0.00	0.00	0.00	0.00	0.00
100-00-52100-217-900	K9 Unit Special Acct Expenses	0.00	0.00	0.00	0.00	0.00
100-00-52100-221-000	PD Electricity	0.00	1,330.15	6,250.00	4,919.85	21.28
100-00-52100-222-000	PD Heating Gas	0.00	1,377.17	4,700.00	3,322.83	29.30
100-00-52100-223-000	Police Water/Sewer	227.15	459.70	4,150.00	3,690.30	11.08
100-00-52100-224-000	Telephone/Fax	465.86	1,860.06	9,500.00	7,639.94	19.58
100-00-52100-290-000	Contractual Service	0.00	5,936.15	15,000.00	9,063.85	39.57
100-00-52100-310-000	Office Supplies	0.00	1,495.74	2,250.00	754.26	66.48
100-00-52100-313-000	Cleaning supplies-PD	0.00	289.64	1,750.00	1,460.36	16.55
100-00-52100-313-100	Supplies for COVID-19	0.00	0.00	0.00	0.00	0.00
100-00-52100-320-000	Membership/Dues	0.00	100.00	500.00	400.00	20.00
100-00-52100-321-000	Publications	0.00	0.00	0.00	0.00	0.00
100-00-52100-330-000	Educ/Trng/Travel	-251.22	1,267.25	12,250.00	10,982.75	10.34
100-00-52100-331-000	Motor Fuel	0.00	3,039.93	18,500.00	15,460.07	16.43



Fund: 100 - General Fund

Account Number		2026		2026 Budget	Budget Status	% of Budget
		2026 April	Actual 04/09/2026			
100-00-52100-341-000	Prof Equip/Supplies	-1,321.00	1,913.70	22,000.00	20,086.30	8.70
100-00-52100-352-000	Office Equip Maint/Service	0.00	63.19	2,750.00	2,686.81	2.30
100-00-52100-353-000	Info Tech	0.00	5,430.56	12,500.00	7,069.44	43.44
100-00-52100-354-000	Equipmnt Maint (Non Office)	130.00	1,618.90	6,000.00	4,381.10	26.98
100-00-52100-361-000	Building Maintenance	0.00	0.00	4,500.00	4,500.00	0.00
100-00-52100-390-000	Miscellaneous	50.00	50.00	500.00	450.00	10.00
100-00-52100-510-000	Ins (non-labor)	8,966.74	18,996.74	42,000.00	23,003.26	45.23
100-00-52100-740-000	Losses/Damages	0.00	0.00	0.00	0.00	0.00
100-00-52100-790-000	Donations/Grants Expenditures	0.00	0.00	0.00	0.00	0.00
100-00-52200-110-000	Salary/Wages	0.00	0.00	21,850.00	21,850.00	0.00
100-00-52200-120-000	Hourly Wages	0.00	3,832.00	25,614.00	21,782.00	14.96
100-00-52200-120-100	Fire calls wages	0.00	0.00	95,000.00	95,000.00	0.00
100-00-52200-130-000	FICA/Medicare	0.00	284.08	10,899.00	10,614.92	2.61
100-00-52200-131-000	Health Insurance	0.00	0.00	0.00	0.00	0.00
100-00-52200-132-000	FSA Contribution	0.00	0.00	0.00	0.00	0.00
100-00-52200-133-000	Dental Insurance	0.00	0.00	0.00	0.00	0.00
100-00-52200-134-000	Vision Insurance	0.00	0.00	0.00	0.00	0.00
100-00-52200-135-000	Retirement	1,731.00	2,307.00	4,000.00	1,693.00	57.68
100-00-52200-191-000	Protective Clothing/Gear	68.50	105.43	2,500.00	2,394.57	4.22
100-00-52200-213-000	Legal	0.00	0.00	0.00	0.00	0.00
100-00-52200-221-000	Electricity	0.00	1,132.15	3,800.00	2,667.85	29.79
100-00-52200-222-000	Heating Gas	0.00	2,561.59	7,669.00	5,107.41	33.40
100-00-52200-223-000	Water/Sewer	835.28	1,671.87	8,330.00	6,658.13	20.07
100-00-52200-224-000	Telephone/Fax	233.95	884.23	3,750.00	2,865.77	23.58
100-00-52200-241-000	Extinguisher Maint/Repair	174.00	174.00	150.00	-24.00	116.00
100-00-52200-290-000	Outside Contractual services	0.00	0.00	0.00	0.00	0.00
100-00-52200-292-000	Hydrant Rental	0.00	0.00	0.00	0.00	0.00
100-00-52200-310-000	Office Supplies	0.00	34.96	700.00	665.04	4.99
100-00-52200-313-100	Supplies for COVID-19	0.00	0.00	0.00	0.00	0.00
100-00-52200-321-000	Publications	0.00	0.00	0.00	0.00	0.00
100-00-52200-330-000	Educ/Trng/Travel	0.00	986.81	3,000.00	2,013.19	32.89
100-00-52200-331-000	Motor Fuel	0.00	1,048.92	5,500.00	4,451.08	19.07
100-00-52200-331-001	Motor Fuel for TRFA	0.00	0.00	0.00	0.00	0.00
100-00-52200-352-000	Office Equip Maint/Service	0.00	21.09	0.00	-21.09	0.00
100-00-52200-353-000	Info Tech	0.00	1,415.88	2,250.00	834.12	62.93
100-00-52200-354-000	Equipmnt Maint (Non-Office)	2,352.48	3,328.21	10,000.00	6,671.79	33.28
100-00-52200-355-000	Truck Maintenance	335.96	641.08	10,000.00	9,358.92	6.41
100-00-52200-357-000	Pager & Radio Repair	0.00	0.00	7,500.00	7,500.00	0.00
100-00-52200-361-000	Building Maintenance	0.00	1,028.16	7,000.00	5,971.84	14.69
100-00-52200-390-000	Miscellaneous	0.00	1,622.14	4,377.00	2,754.86	37.06
100-00-52200-510-000	Ins (non-labor)	6,469.20	21,458.40	32,500.00	11,041.60	66.03
100-00-52200-740-000	Losses/Damages	0.00	0.00	0.00	0.00	0.00
100-00-52200-790-000	Donations/Grants Expenditures	0.00	0.00	0.00	0.00	0.00
100-00-52200-811-000	Equipment Purchases	0.00	0.00	20,250.00	20,250.00	0.00
100-00-52200-811-001	State Issued 2% Dues	0.00	0.00	16,351.00	16,351.00	0.00
100-00-52200-821-000	FD Building Improvement	0.00	0.00	0.00	0.00	0.00
100-00-52200-900-000	FD Special Funds Expense	0.00	3,947.71	0.00	-3,947.71	0.00
100-00-52300-215-000	Ambulance Contract Assessment	0.00	148,295.00	296,590.00	148,295.00	50.00
100-00-52400-240-000	Weather Siren Maintenance	0.00	0.00	1,022.00	1,022.00	0.00



Fund: 100 - General Fund

Account Number		2026		2026 Budget	Budget Status	% of Budget
		2026 April	Actual 04/09/2026			
100-00-52400-740-000	Losses/Damages	0.00	0.00	0.00	0.00	0.00
Public Safety						
		71,757.95	703,754.89	2,478,098.00	1,774,343.11	28.40
100-00-53100-110-000	Wage/Salary	16,998.35	109,181.11	358,612.00	249,430.89	30.45
100-00-53100-130-000	FICA/Medicare	1,236.06	7,878.40	27,434.00	19,555.60	28.72
100-00-53100-131-000	Health Insurance	43.75	26,744.41	131,956.00	105,211.59	20.27
100-00-53100-132-000	FSA Contribution	0.00	182.48	4,690.00	4,507.52	3.89
100-00-53100-133-000	Dental Insurance	434.54	1,738.16	6,305.00	4,566.84	27.57
100-00-53100-134-000	Vision Insurance	114.23	456.92	1,619.00	1,162.08	28.22
100-00-53100-135-000	Retirement	1,223.89	7,861.09	25,820.00	17,958.91	30.45
100-00-53100-191-000	Protective Clthng/Gear	0.00	495.51	2,000.00	1,504.49	24.78
100-00-53100-213-000	Legal	0.00	0.00	0.00	0.00	0.00
100-00-53100-215-000	Hired Services	373.11	373.11	0.00	-373.11	0.00
100-00-53100-218-000	Drug Testing	0.00	0.00	377.00	377.00	0.00
100-00-53100-221-000	Electricity	0.00	3,026.18	7,242.00	4,215.82	41.79
100-00-53100-223-000	Water/Sewer	918.66	1,811.46	9,300.00	7,488.54	19.48
100-00-53100-224-000	Telephone/Fax	0.00	379.24	2,014.00	1,634.76	18.83
100-00-53100-231-000	Signage	0.00	771.53	2,000.00	1,228.47	38.58
100-00-53100-232-000	Tree/Brush Removal	0.00	0.00	0.00	0.00	0.00
100-00-53100-240-000	Maintenance/Repair	262.00	2,362.68	75,000.00	72,637.32	3.15
100-00-53100-290-000	Contractual Service	0.00	277.77	5,500.00	5,222.23	5.05
100-00-53100-290-100	Contractual Serv - Mow	0.00	0.00	0.00	0.00	0.00
100-00-53100-290-102	Contractual Serv -Shovel	0.00	0.00	0.00	0.00	0.00
100-00-53100-291-000	Equipment Rental	0.00	0.00	500.00	500.00	0.00
100-00-53100-294-000	State/Other Fees	0.00	0.00	0.00	0.00	0.00
100-00-53100-310-000	Office Supplies	0.00	190.33	668.00	477.67	28.49
100-00-53100-313-100	Supplies for COVID-19	0.00	0.00	0.00	0.00	0.00
100-00-53100-320-000	Memberships/Dues	0.00	0.00	300.00	300.00	0.00
100-00-53100-321-000	Publications	0.00	0.00	306.00	306.00	0.00
100-00-53100-330-000	Educ/Trng/Travel	0.00	19.00	550.00	531.00	3.45
100-00-53100-331-000	Motor Fuel	0.00	1,221.02	15,000.00	13,778.98	8.14
100-00-53100-340-000	Hand Tls,Matals,Spplies	0.00	4,853.78	10,000.00	5,146.22	48.54
100-00-53100-352-000	Office Equip Maint.	0.00	77.14	304.00	226.86	25.38
100-00-53100-353-000	Info Tech	0.00	3,983.62	2,974.00	-1,009.62	133.95
100-00-53100-354-000	Equip Maint (Non-Office)	78.60	6,523.55	25,345.00	18,821.45	25.74
100-00-53100-361-000	Building Maintenance	92.58	2,171.81	6,022.00	3,850.19	36.06
100-00-53100-362-000	Grounds Maintenance	0.00	0.00	1,000.00	1,000.00	0.00
100-00-53100-390-000	Miscellaneous	0.00	0.00	0.00	0.00	0.00
100-00-53100-510-000	Ins (Non-Labor)	4,183.76	25,002.98	35,000.00	9,997.02	71.44
100-00-53100-740-000	Losses/Damages	0.00	3,059.37	0.00	-3,059.37	0.00
100-00-53100-790-000	Donations/Grants Expenditures	0.00	0.00	0.00	0.00	0.00
100-00-53100-821-000	Building Improvement	0.00	0.00	0.00	0.00	0.00
100-00-53320-215-000	Hired/Contractual	0.00	460.00	20,000.00	19,540.00	2.30
100-00-53320-291-000	Equipment Rental	0.00	0.00	0.00	0.00	0.00
100-00-53320-340-000	Hand Tool,Mater./Supplies	0.00	252.22	1,000.00	747.78	25.22
100-00-53320-354-000	Equip Maint (Non-Office)	0.00	0.00	10,000.00	10,000.00	0.00
100-00-53320-371-000	Salt/Sand	0.00	32,662.44	67,200.00	34,537.56	48.60
100-00-53320-372-000	Contingency for Snow	0.00	0.00	0.00	0.00	0.00



Fund: 100 - General Fund

Account Number		2026		2026 Budget	Budget Status	% of Budget
		2026 April	Actual 04/09/2026			
100-00-53320-390-000	Miscellaneous	0.00	0.00	0.00	0.00	0.00
100-00-53330-221-000	Electricity - Signals	0.00	947.05	6,510.00	5,562.95	14.55
100-00-53330-240-000	Maint/Repair - Signals	0.00	0.00	4,711.00	4,711.00	0.00
100-00-53330-390-000	Miscellaneous - Signals	0.00	0.00	0.00	0.00	0.00
100-00-53340-354-000	Equip Maint (Non-Office)	0.00	6,245.57	25,000.00	18,754.43	24.98
100-00-53340-390-000	Miscellaneous	0.00	0.00	0.00	0.00	0.00
100-00-53420-221-000	Electricity	0.00	10,353.28	45,600.00	35,246.72	22.70
100-00-53420-240-000	Maint/Repair	0.00	0.00	9,693.00	9,693.00	0.00
100-00-53420-354-000	Equip Maint (Non-Office)	0.00	0.00	0.00	0.00	0.00
100-00-53420-373-000	Lights Installation	0.00	0.00	0.00	0.00	0.00
100-00-53420-390-000	Miscellaneous	0.00	0.00	0.00	0.00	0.00
100-00-53500-291-000	Non-City Equipment Rental	0.00	0.00	0.00	0.00	0.00
100-00-53500-390-000	Non-City Miscellaneous	0.00	0.00	0.00	0.00	0.00
100-00-53510-720-000	Contribution to Airport	0.00	24,213.28	24,213.00	-0.28	100.00
100-00-53540-000-000	Boat Launch Site Maint	0.00	150.00	3,359.00	3,209.00	4.47
100-00-53620-220-000	Refuse Collection Contract	20,042.68	60,128.04	240,525.00	180,396.96	25.00
100-00-53621-220-000	Large Item Garbage Exp	0.00	0.00	0.00	0.00	0.00
100-00-53622-220-000	Garage disposal abatements	0.00	6,253.75	0.00	-6,253.75	0.00
Public Works		46,002.21	352,308.28	1,215,649.00	863,340.72	28.98
100-00-54910-720-000	Contribution to Cemetery	0.00	25,000.00	25,000.00	0.00	100.00
Health & Human Services		0.00	25,000.00	25,000.00	0.00	100.00
100-00-55200-110-000	Salary/Wages	4,317.37	29,767.52	161,406.00	131,638.48	18.44
100-00-55200-130-000	FICA/Medicare	316.27	2,159.51	12,348.00	10,188.49	17.49
100-00-55200-131-000	Health Insurance	0.00	6,409.59	28,188.00	21,778.41	22.74
100-00-55200-132-000	FSA Contribution	0.00	0.00	850.00	850.00	0.00
100-00-55200-133-000	Dental Insurance	137.64	550.56	1,143.00	592.44	48.17
100-00-55200-134-000	Vision Insurance	37.58	148.01	293.00	144.99	50.52
100-00-55200-135-000	Retirement	264.83	2,043.20	8,057.00	6,013.80	25.36
100-00-55200-191-000	Protective Clthng/Gear	0.00	200.00	1,000.00	800.00	20.00
100-00-55200-221-000	Electricity	0.00	784.71	6,000.00	5,215.29	13.08
100-00-55200-223-000	Water/Sewer	784.33	1,568.66	24,000.00	22,431.34	6.54
100-00-55200-224-000	Telephone/Fax	0.00	762.47	2,000.00	1,237.53	38.12
100-00-55200-232-000	Trees & Brush	0.00	291.60	10,000.00	9,708.40	2.92
100-00-55200-313-100	Supplies for COVID-19	0.00	0.00	0.00	0.00	0.00
100-00-55200-330-000	Educ/Trng/Travel	0.00	625.00	1,250.00	625.00	50.00
100-00-55200-340-000	Hand Tools,Material,Supp	0.00	111.27	3,479.00	3,367.73	3.20
100-00-55200-353-000	IT Service Fees	0.00	777.26	0.00	-777.26	0.00
100-00-55200-354-000	Equip Maint (Non-Office)	860.67	1,871.16	5,218.00	3,346.84	35.86
100-00-55200-361-000	Building Maintenance	0.00	1,500.00	7,500.00	6,000.00	20.00
100-00-55200-362-000	Grounds Maintenance	0.00	1,298.78	13,000.00	11,701.22	9.99
100-00-55200-363-000	Tree Tribute Program Expense	0.00	0.00	160.00	160.00	0.00
100-00-55200-364-000	Parks Fund Raising Expenses	0.00	0.00	0.00	0.00	0.00
100-00-55200-390-000	Miscellaneous	0.00	282.96	0.00	-282.96	0.00
100-00-55200-510-000	Ins (Non-Labor)	1,709.49	8,816.86	12,250.00	3,433.14	71.97
100-00-55200-740-000	Losses/Damages	0.00	0.00	0.00	0.00	0.00
100-00-55200-790-000	Donations/Grants Expenditures	0.00	851.77	0.00	-851.77	0.00



Fund: 100 - General Fund

Account Number		2026		2026 Budget	Budget Status	% of Budget
		2026 April	Actual 04/09/2026			
100-00-55200-820-000	Expenditure of Parkland Ded.	0.00	0.00	0.00	0.00	0.00
100-00-55200-821-000	Building Improvement	0.00	0.00	0.00	0.00	0.00
100-00-55300-110-000	Salary/Wages	0.00	0.00	0.00	0.00	0.00
100-00-55300-130-000	FICA/Medicare	0.00	0.00	0.00	0.00	0.00
100-00-55300-135-000	Retirement	0.00	0.00	0.00	0.00	0.00
100-00-55300-220-000	Transportation	0.00	0.00	0.00	0.00	0.00
100-00-55300-224-000	Telephone/Fax	0.00	0.00	0.00	0.00	0.00
100-00-55300-310-000	Office Supplies	0.00	0.00	0.00	0.00	0.00
100-00-55300-313-100	Supplies for COVID-19	0.00	0.00	0.00	0.00	0.00
100-00-55300-330-000	Educ/Trng/Travel	0.00	0.00	0.00	0.00	0.00
100-00-55300-390-000	Miscellaneous	0.00	0.00	0.00	0.00	0.00
100-00-55300-395-000	Arts/Crafts	0.00	0.00	0.00	0.00	0.00
100-00-55300-396-000	Softball/Baseball	0.00	0.00	0.00	0.00	0.00
100-00-55300-397-000	Rec Tennis	0.00	0.00	0.00	0.00	0.00
100-00-55300-398-000	Golf	0.00	0.00	0.00	0.00	0.00
100-00-55300-399-000	Special Events	0.00	0.00	0.00	0.00	0.00
100-00-55300-814-000	Baseball Equip/Uniform	0.00	0.00	0.00	0.00	0.00
100-00-55310-390-000	Celebrations/Entertainment	500.00	13,823.63	30,000.00	16,176.37	46.08
Culture, Recreation & Educ		8,928.18	74,644.52	328,142.00	253,497.48	22.75
100-00-56400-110-000	Salary/Wages	950.20	7,685.34	23,448.00	15,762.66	32.78
100-00-56400-130-000	FICA/Medicare	68.82	561.07	1,794.00	1,232.93	31.27
100-00-56400-131-000	Health Insurance	0.00	1,885.17	10,557.00	8,671.83	17.86
100-00-56400-132-000	FSA Contribution	0.00	129.95	350.00	220.05	37.13
100-00-56400-133-000	Dental Insurance	28.01	112.04	471.00	358.96	23.79
100-00-56400-134-000	Vision Insurance	7.19	28.76	121.00	92.24	23.77
100-00-56400-135-000	Retirement	68.41	553.31	1,688.00	1,134.69	32.78
100-00-56400-202-000	Building Inspections	0.00	4,718.00	61,266.00	56,548.00	7.70
100-00-56400-213-000	Legal/Recording	0.00	159.25	2,137.00	1,977.75	7.45
100-00-56400-214-000	Map & Planning Services	0.00	0.00	5,000.00	5,000.00	0.00
100-00-56400-220-000	Rental Inspection	0.00	0.00	0.00	0.00	0.00
100-00-56400-224-000	Telephone/Fax	0.00	19.00	456.00	437.00	4.17
100-00-56400-290-000	Code Enforcement Services	0.00	0.00	0.00	0.00	0.00
100-00-56400-310-000	Office Supplies	0.00	23.97	304.00	280.03	7.88
100-00-56400-321-000	Publications	0.00	85.75	445.00	359.25	19.27
100-00-56400-330-000	Educ/Trng/Travel	0.00	0.00	250.00	250.00	0.00
100-00-56400-353-000	InfoTech	0.00	0.00	250.00	250.00	0.00
100-00-56400-390-000	Miscellaneous	0.00	0.00	0.00	0.00	0.00
100-00-56700-210-000	Economic Devel Prof Services	0.00	0.00	2,500.00	2,500.00	0.00
100-00-56700-390-000	Econ Dev Misc	0.00	0.00	0.00	0.00	0.00
100-00-56710-000-000	Tourism	0.00	0.00	160,000.00	160,000.00	0.00
100-00-56710-210-000	Professional Service	5,400.00	30,470.00	0.00	-30,470.00	0.00
100-00-56710-240-000	Building/Equip Maintenance	0.00	0.00	0.00	0.00	0.00
100-00-56710-310-000	Office Supplies	0.00	879.48	0.00	-879.48	0.00
100-00-56710-311-000	Postage Expense	0.00	0.00	0.00	0.00	0.00
100-00-56710-330-000	Travel/Educ./Training	0.00	0.00	0.00	0.00	0.00
100-00-56710-400-000	Marketing Misc.	0.00	79.13	0.00	-79.13	0.00
100-00-56710-400-100	Tourism Development	0.00	0.00	0.00	0.00	0.00



Fund: 100 - General Fund

Account Number		2026		2026 Budget	Budget Status	% of Budget
		2026 April	Actual 04/09/2026			
100-00-56710-400-200	Digital Marketing	0.00	0.00	0.00	0.00	0.00
100-00-56710-400-300	Purchased Media	0.00	0.00	0.00	0.00	0.00
100-00-56710-400-400	TV	0.00	0.00	0.00	0.00	0.00
100-00-56710-400-500	Print Media	0.00	5,584.00	0.00	-5,584.00	0.00
100-00-56710-500-000	Event Support Grants	0.00	19,574.24	0.00	-19,574.24	0.00
Conservation & Development		6,522.63	72,548.46	271,037.00	198,488.54	26.77
100-00-57100-000-000	Contingency	0.00	840.00	15,000.00	14,160.00	5.60
100-00-57331-000-000	Highway & Street Outlay- local	0.00	0.00	0.00	0.00	0.00
Capital Outlay		0.00	840.00	15,000.00	14,160.00	5.60
100-00-58100-000-000	Debt Principal Payment	0.00	0.00	378,449.00	378,449.00	0.00
100-00-58200-000-000	Debt Interest	0.00	25,096.88	179,716.00	154,619.12	13.96
100-00-58200-690-000	Debt Issuance Cost	0.00	0.00	0.00	0.00	0.00
100-00-58230-691-000	Other Debt Expenses	0.00	400.00	800.00	400.00	50.00
Debt		0.00	25,496.88	558,965.00	533,468.12	4.56
100-00-59201-000-000	Contribution to Library	0.00	400,000.00	400,000.00	0.00	100.00
100-00-59202-000-000	Contribution to Taxi	0.00	74,500.00	74,500.00	0.00	100.00
100-00-59210-000-000	TRANSFER TO GENERAL	0.00	0.00	0.00	0.00	0.00
100-00-59230-000-000	Transfer to Equip Replace	0.00	0.00	0.00	0.00	0.00
100-00-59230-000-100	Transfer to ERF Admin	0.00	12,000.00	12,000.00	0.00	100.00
100-00-59230-000-200	Transfer to ERF Police	0.00	105,000.00	105,000.00	0.00	100.00
100-00-59230-000-300	Transfer to ERF Fire	0.00	205,000.00	205,000.00	0.00	100.00
100-00-59230-000-400	Transfer to ERF Streets	0.00	100,000.00	100,000.00	0.00	100.00
100-00-59230-000-500	Transfer to ERF Parks	0.00	35,000.00	35,000.00	0.00	100.00
100-00-59230-000-600	Transfer to ERF Build Maint	0.00	25,000.00	25,000.00	0.00	100.00
100-00-59230-000-700	Transfer to ERF From PD CD	0.00	0.00	0.00	0.00	0.00
100-00-59240-000-000	Transfer to Capital Projects	0.00	75,000.00	75,000.00	0.00	100.00
Interfund Transfers		0.00	1,031,500.00	1,031,500.00	0.00	100.00
Total Expenses		152,881.70	2,464,835.70	6,481,574.00	4,016,738.30	38.03
Net Totals		209,074.99	1,335,376.73	-2.00	-1,335,378.73	



Jefferson Fire and Safety, Inc.
 7620 Donna Drive
 Middleton, WI, 53562
 Phone: 608-836-0068
 Web: www.jeffersonfire.com

Section 9, Item b.

Quote

Order No: 248798
 Order Date: 4/2/2026
 Due Date: 4/2/2026
 Salesperson: Gordy Durand
 Customer ID: 03209

BILL TO:	SHIP TO:
Mauston Fire Department 303 Mansion Street Mauston WI 53948	Mauston Fire Department 303 Mansion Street Mauston WI 53948

CUSTOMER P.O. NO.	TERMS	CONTACT
	Net 20 Days	Brent Lenorud
FOB POINT	SHIPPING TERMS	SHIP VIA
		UPS

ITEM	ITEM DESCRIPTION	QTY.	UNIT PRICE	EXT PRICE
STC NS	Scott X5914021305304, X3PRO, 4500psi, SC, EBSS, 2025 NFPA compliant	4.00	7,864.36	31,457.44
STC 200129-01	Scott Safety Cylinder & Valve, 4.5, 45-Min, Snap Change	4.00	1,427.24	5,708.96

Signature

Date

Where applicable, freight and/or tariff surcharge will be added to the invoice. All returns must be received within 30 days of delivery and may be subject to a 25% restocking fee. Custom orders cannot be returned. Visit our website for complete details: www.jeffersonfire.com

*** Credit card payments will incur a 3% processing fee ***

Sales Total:	37,166.40
Freight:	0.00
Tax Total:	0.00
Total (USD):	37,166.40

G-Line Fence & Landscaping

Property Maintenance
Lawn Care & Snowplowing

— It's all about your lawn —

Brian Granger, Owner

402 W. Court St.
New Lisbon, WI 53950

Phone: 608-562-6179
Cell: 608-547-1317

PROPOSAL SUBMITTED TO <i>City of Mauston</i>		PHONE <i>847-6676</i>	DATE <i>March 31, 26</i>
STREET <i>303 Mansion St</i>		JOB NAME	
CITY, STATE AND ZIP CODE <i>Mauston WI</i>		JOB LOCATION <i>Dog Park Lommis / Arlington</i>	
ARCHITECT	DATE OF PLANS	<i>Jordan Wilke 548-2831</i>	JOB PHONE

We hereby submit specifications and estimates for:

271' 4" tall ChainLink fence galv. (Silver) *2 1/2" term posts*
attach to existing fence *2" Line posts*
2 4' walk gates *1 5/8" top Rail*
1 10' double drive gates *9 gauge fence*

all material & labor to complete project.

Air drive all posts to help prevent frost heave.

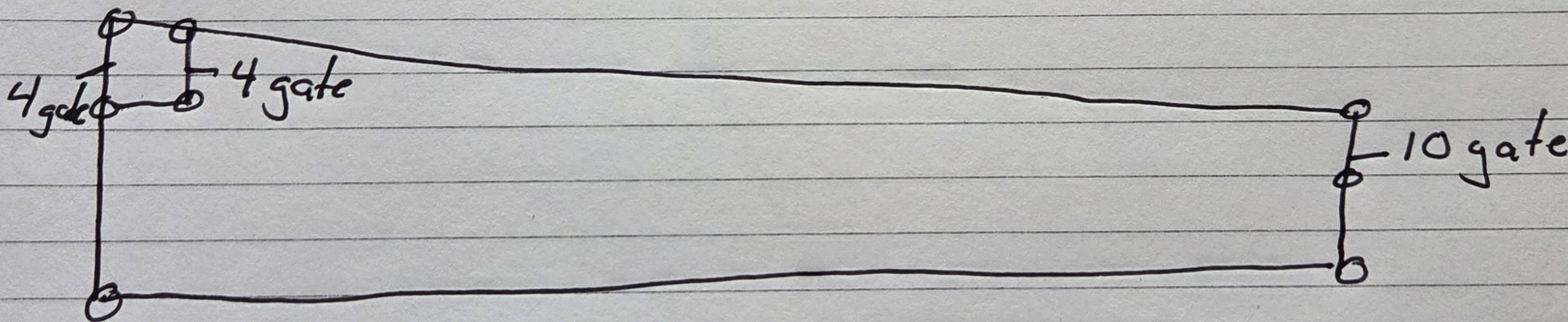

We Propose hereby to furnish material and labor — complete in accordance with above specifications, for the sum of:

materials upfront to order \$4212⁰⁰ dollars (\$ *6480⁰⁰*)
labor upon completion \$2268⁰⁰

ent to be made as follows:

rial is guaranteed to be as specified. All work to be completed in a workmanlike manner g to standard practices. Any alteration or deviation from above specifications involving sts will be executed only upon written orders, and will become an extra charge over and e estimate. All agreements contingent upon strikes, accidents or delays beyond our Owner to carry fire, tornado and other necessary insurance. Our workers are fully covered men's Compensation Insurance.

Authorized Signature _____

Note: This proposal may be withdrawn by us if not accepted within 10 days

Importance of Proposal — The above prices, specifications conditions are satisfactory and are hereby accepted. You are authorized work as specified. Payment will be made as outlined above.

Signature *X*

Signature _____

Acceptance: *X*



3210 Mecca Drive
Plover, WI 54467
 800-472-0505 or 715-341-4411

910 W Plummer Ct
Neenah, WI 54956
 800-310-0600 or 920-886-6676

www.americanfencewi.com

Quote 002

Section 9, Item c.

Date: 3/30/2026

Contact: Jordan Wilke

Business Telephone: 608-847-4070 #6

2nd Telephone: 608-548-2831

Proposal To:

CITY OF MAUSTON
1260 North Road
MAUSTON, WI 53948-1329

Job Site:

New Dog Park
Loomis and Arlington
Mauston, WI 53948

Description

Price

Furnish material, labor, and equipment to install 271' of 4' high galvanized chain link fence. The fence will include (1) 8'x4' double swing gate, (2) 4'x4' single swing gates, 3" terminal/gate posts driven 4' or to fail, 2" line posts driven 4' or to fail, 1-5/8" top rail, 4' high 9ga. galvanized chain link fence.

\$5,950.00

Option for bottom tension wire. ADD: \$175.00

Terms:
Net 10 days.

THANK YOU!
Please sign 2 copies
and return one.

Subtotal: \$5,950.00
 Freight: \$0.00
 Sales Tax: \$0.00
 Total Amount: \$5,950.00

Project Manager *Alex Zarecki*

Proposal Accepted by: _____

Prices are valid through: _____

Customer Purchase Order#: _____
 (for business use)

- 1) Customer hereby assumes full responsibility for the location of the line upon which said fence materials are to be installed.
- 2) Private lines not marked by Diggers Hotline such as electric, LP gas, sprinklers, underground cables or pipes are the customers responsibility to locate.
- 3) Customer agrees to remove existing old fences and shrubs and dispose of spoils unless otherwise specified.
- 4) Customer is responsible for building permits if necessary.
- 5) More or less material other than the amount contracted for will be debited or credited at current rates.
- 6) American Fence Company reserves the right to make additional charges to the customer in the event of unusual ground conditions (such as rock formation) that impede the installation. Additional charges shall be based on actual additional labor required to complete installation under the circumstances.
- 7) All accounts are payable in full within ten (10) days of the date of the invoice. 1.5% per month (18% per year) late fee will be assessed on past due accounts.
- 8) Customer agrees to pay all costs of collection incurred by American Fence Company before and after judgment, including reasonable attorney fees. All parties agree that if collection action becomes necessary, all collections will be filed in Winnebago County, Wisconsin.
- 9) As required by the Wisconsin construction lien law, builder hereby notifies owner that persons or companies furnishing labor or materials for the construction on owner's land may have lien rights on owner's land and building if not paid. Those entitled to lien rights, in addition to the above signed builder, are those who contract directly with the owner or those who give the owner notice within 60 days after they first furnish labor or materials for the construction. Accordingly, owner probably will receive notices from those who furnish labor or materials for the construction, and should give a copy of each notice received to the mortgage lender, if any. Builder agrees to cooperate with the owner and the owner's lender, if any, to see that all potential lien claimants are duly paid.
- 10) Quotes are valid for 30 days unless otherwise specified.
- 11) Owner consents to American Fence Company personnel taking photos of work in-progress and finished work for marketing purposes.
- 12) Credit card payments exceeding \$2,500.00 will be subjected to a 2% convenience fee per sale. Credit card fees are non-refundable.



THE MAUSTON FIRE DEPARTMENT

MEMBERS OF JUNEAU COUNTY FIREFIGHTER'S ASSOCIATION

MAUSTON, WISCONSIN 53948

March 2026

In March the Fire Department responded to 13 calls. There were 9 calls in the city and 4 calls in the rural area.

The city had 256 man hours.

The Rural had 106 man hours.

Two drills resulted in 82 man hours.

Mauston controlled burn 48 man hours.

3 Community events resulted in 19 man hours.

The total man hours for March were 521 hours.

Brent Lenrorud

Chief

**MAUSTON FIRE DEPARTMENT
MEMBERS OF JUNEAU COUNTY FIREFIGHTER'S ASSOCIATION
MAUSTON, WI 53948**

Section 10, Item a.

Report For March 2026

Date	Call Number	Description	Address
3/2/2026	260024	Vehicle fire	Dlaske Rd & Curtis Rd.
3/7/2026	260025	Brush fire	W6357 Chapel Rd.
3/7/2026	260026	Gas Leak	Ensch St. & Veterans St.
3/8/2026	260027	Gas Leak	536 LaCrosse St.
3/9/2026	260028	Stucture fire	W6135 Genevieve St.
3/15/2026	260029	Crash Injury	MM69 WB
3/16/2026	260030	Smell of smoke	950 Herriot Dr.
3/16/2026	260031	Medical	W4723 51 St. St.
3/16/2026	260032	Medical	611 Tremont St.
3/17/2026	260033	Crash Injury	N.Union St. & Meyer Rd.
3/17/2026	260034	Crash Injury	Kennedy St. & Gateway Av.
3/21/2026	260035	Crash Injury	104 Lodge Ln.
3/26/2026	260036	Crash Injury	MM71 WB

**MAUSTON FIRE DEPARTMENT
MEMBERS OF JUNEAU COUNTY FIREFIGHTER'S ASSOCIATION
MAUSTON, WI 53948**

Section 10, Item a.

Complaint Type	Responsible Department/Authority	Typical Procedure
Street/Sidewalk/snow Issues	Public Works Dept. (Rob or Kerry)	Submit via online complaint/inquiry form or call Public Works.
Trash, Recycling, & Sanitation	Public Works Dept. (Val or Rob)	Call Public Works/Utility, or use online complaint/inquiry form.
Water/Sewer Service	Public Works Dept. (Rob or Shawn)	Call Water/Sewer or use city website. Submit online complaint/inquiry form.
Parks & Recreation Facilities	Parks Dept. (Rob or Jordan)	Contact Parks Division of Public Works, or City Hall. Submit online complaint form.
Taxi - Shared Ride Program	Utility Dept. (Val or Daron)	Submit via online complaint/inquiry form or call City Hall. Can escalate to Running Inc., the contracted service company.
Cemetery	Parks Dept. (Rob or Jordan)	Contact Parks Division of Public Works, or City Hall. Submit online complaint form.
Zoning, Planning, & Permitting	Zoning Admin/City Admin (Val or Daron)	Submit to Zoning Admin or City Admin.
Economic Development	City Admin/Zoning Admin (Daron or Val)	Contact City Admin/Zoning Admin via in-person, calling directly, submit via online inquiry form.
Property Maintenance/Code Enforcement	Police Department (Chief)	Report to Police Chief or City Admin; May escalate to Ordinance Committee.
Police Conduct or Crime Reporting	Police Department (Chief)	Call Police Department or use official complaint form.
Fire Department Concerns	Fire Dept. (Fire Chief/Asst Fire Chief)	Report to Admin, then will filter down. May escalate to PFC.
Library Services	Library Dept./Library Board	Contact Library staff or Library Board.
Elections & Voting	City Admin/Deputy Clerk (Daron/Carole)	Contact City Clerk/Admin Office. Submit online complaint/inquiry form.
City Employee Conduct	Admin Dept./City Admin	Submit to Admin; may escalate to Personnel Committee.
Budget/Finance Issues	City Admin/Deputy Treasurer (Daron/Sadie)	Submit to City Admin/Deputy Treasurer.; may escalate to Council.
Permitting/Licenses	City Admin/Deputy Clerk (Daron/Carole)	Submit to Admin; reviewed by Committee. Submit via online complaint/inquiry form.
Airport/Ambulance/Extraterritorial	Airport Comm., Ambulance Assoc., Extraterritorial Comm.	Contact airport, ambulance, extraterritorial directly. Can contact City Admin to coordinate contacts.
Appeals (Zoning, etc.)	Zoning Admin/City Admin (Val or Daron)	Submit formal appeal through Zoning Admin/City Admin.
Library Policy/Board Issues	Library Director (Bridget Christenson)	Contact Library Director.
Police & Fire Oversight	Police & Fire Commission	Submit formal complaint to City Admin.
General City Governance	Mayor/City Council	Contact City Admin. Submit via online complaint/inquiry form.
Municipal Court Issues	Municipal Judge/Municipal Court	Contact Court Clerk.

Section 13, Item c.

▼ powers ave mauston wi X Q

Show search results for powers...

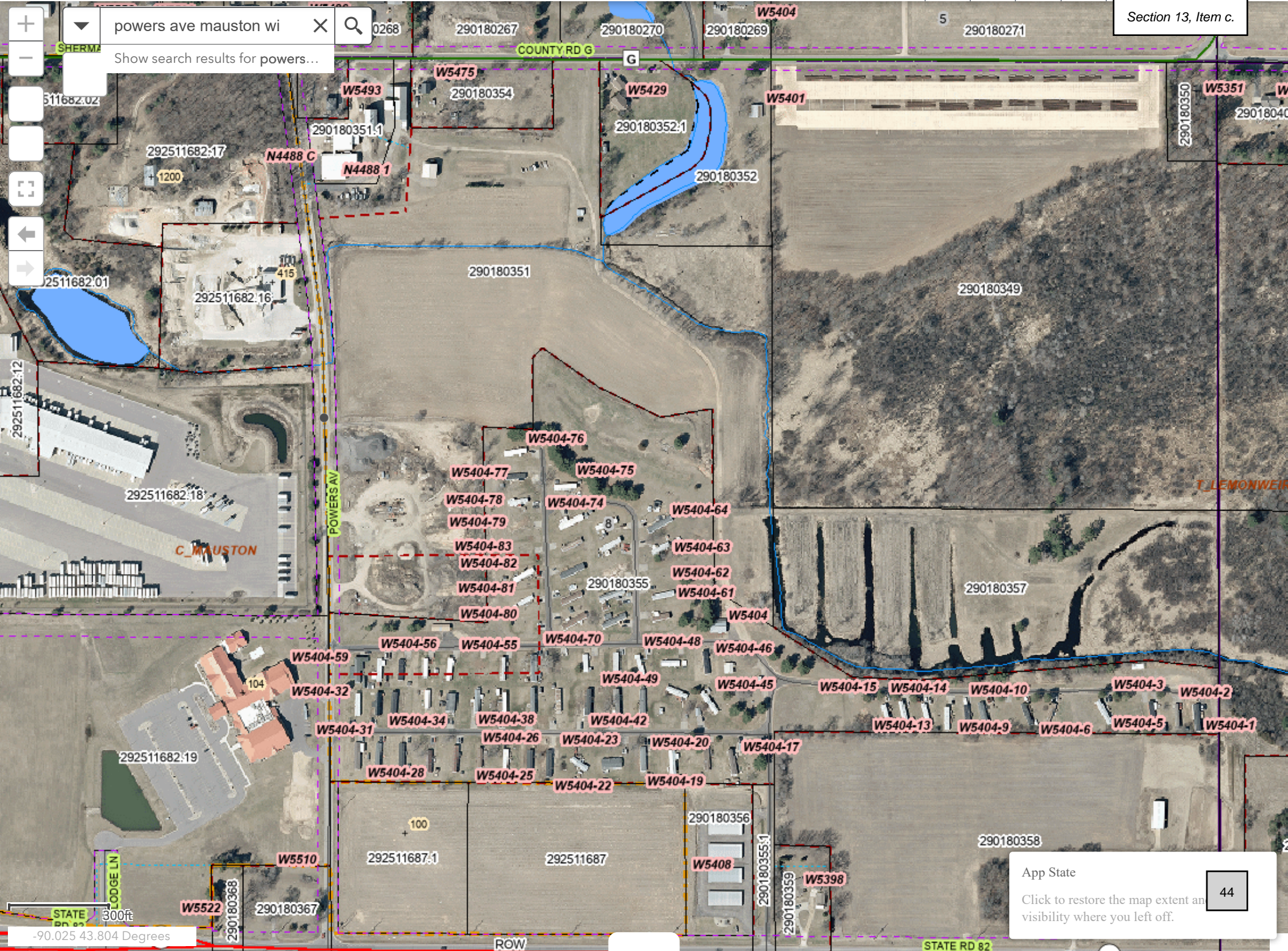

App State

Click to restore the map extent and visibility where you left off.

44