



CITY COUNCIL MEETING AGENDA

Thursday, March 14, 2024 at 6:30 PM

Council Chambers

1. CALL TO ORDER

- A. Invocation and Pledge to the Flag
- B. Roll Call
- C. Adoption of Agenda

2. CONSENT AGENDA

- [A.](#) 2024 LMIG Additional Funding
- [B.](#) Stormwater Drainage Projects Engineering
- [C.](#) Chandler Haulk Pump Station Force Main Replacement
- [D.](#) 02-08-2024 Regular Council Meeting Minutes
- [E.](#) February Financial Report

3. PLANNING & DEVELOPMENT COMMITTEE REPORT

- [A.](#) **Case #R24-005** – The Revive Lane Group c/o Anderson Tate & Carr filed an application requesting to rezone approximately 11.602+/- acres located at 246 Line Street, Loganville, GA 30052, Map/Parcel #LG040062, Walton County, GA. The property owner is Lock N Roll Storage, LLC. The current zoning is MHP and the requested zoning is RM-6 with the proposed development of fee-simple townhomes.
- [B.](#) **Case #R24-006** – The Revive Lane Group c/o Anderson Tate & Carr filed an application requesting to rezone approximately 4.981+/- acres located at 234 Line Street, Loganville, GA 30052, Map/Parcel #LG040063, Walton County, GA. The property owner is Ronald Clifford Peeler. The current zoning is LI and the requested zoning is RM-6 with the proposed development of fee-simple townhomes.
- C. Planning Commission Interviews

4. FINANCE / HUMAN RESOURCES COMMITTEE REPORT

5. PUBLIC SAFETY COMMITTEE REPORT

6. PUBLIC UTILITIES / TRANSPORTATION COMMITTEE REPORT

- [A.](#) Logan Pump Grinder - \$41,903.00

7. PUBLIC WORKS / FACILITIES COMMITTEE REPORT

- [A.](#) Anna Holbrook Remodel

8. ECONOMIC DEVELOPMENT COMMITTEE REPORT

9. CITY MANAGER'S REPORT

10. CITY ATTORNEY'S UPDATES / REPORTS

- [A.](#) New Chapter 4 - Alcohol Ordinance - Discussion
- [B.](#) 2025-2030 Walton County SPLOST IGA - Action

11. EXECUTIVE SESSION

12. ADJOURNMENT

*Denotes Non-Budgeted Items subject to Reserve Funds

The Mayor and Council may choose to go into executive session as needed in compliance with Georgia Law. The City of Loganville reserves the right to make changes to the agenda as necessary. Any additions and/or corrections to the agenda will be posted immediately at City Hall.



4303 Lawrenceville Highway • Loganville, GA 30052 • 770-466-1165 • www.loganville-ga.gov

Staff Report

To: Honorable Mayor Baliles and Members of the City Council

From: Danny Roberts, City Manager

Date: March 11, 2024

Subject: Approval of 2024 LMIG Additional Funds

RECOMMENDATION:

Staff recommends the City Council to authorize staff to apply for 2024 Additional LMIG funding.

FISCAL IMPLICATION:

There would be no fiscal implication to the fund due to no match requirements. GDOT has informed us that these additional funds will be close to our original 2024 LMIG funds.

BACKGROUND:

The city was awarded \$160,252.28 from the 2024 LMIG at the end of 2023. On February 7, 2024 the House approved an additional \$200 million in grant funds to be distributed to counties and cities. The allocation of additional funds will be available beginning April 1, 2024, and applications for this funding must be submitted by June 30, 2024.

Staff Report
Department of Public Utilities

To: Honorable Mayor Baliles and Members of the City Council

Through: Danny Roberts, City Manager

From: Brandon Phillips, Director of Utilities

Date: March 14, 2024

Subject: Stormwater Projects

RECOMMENDATION:

Staff recommends that the City Council approve Precision Planning Inc. to provide field engineering, plans & specifications, bid administration, and construction support for five storm water projects.

FISCAL IMPLICATION:

PPI's quote for these services are \$49192.50 (5% contingency). Funding source is ARPA.

BACKGROUND:

Projects consists of replacement and/or rehabilitation of of corrugated metal pipe on Overlook Drive 130 linear feet, Holly Court 33 linear feet, Huntington Drive 34 linear feet, Granite Lane 163 linear feet, and detention pond at Park Place.



March 8, 2024

City of Loganville
Mr. Brandon Phillips, Public Utilities Director
P.O. Box 39
Loganville, GA 30052

RE: Loganville Storm Sewer Replacement and Rehabilitation Project

Brandon:

Precision Planning, Inc. (PPI) is pleased to submit this fee proposal for field surveying, engineering analysis, construction drawings, bid phase administration, and construction support services to the City of Loganville (Client) for the above-referenced project. SUE Level B utility location services will also be provided by subconsultant NV5. The project will include storm sewer replacement and/or rehabilitation on Overlook Drive (130 LF), Holly Court (33 LF), Huntington Drive (34 LF), Granite Lane (163 LF), and detention pond maintenance in the Park Place subdivision.

Based on our experience with similar projects, we propose the following scope of services:

Task 1 Field Survey and Preliminary Engineering Lump Sum \$15,280.00

- A. The City of Loganville will coordinate utility location services prior to field survey activities, by marking each crossing and requesting an 811 utility locate ticket.
- B. PPI will perform a field location and topographic survey of the identified storm sewer segments including pipe inverts, structure locations and elevations, locate visibly marked underground utilities and above ground features within the projected limits of construction.
- C. PPI will perform a limited topographic survey of the Park Place stormwater detention pond to provide sufficient data for the development of a remediation plan.
- D. Establish existing right-of-way and property lines using boundary information obtained from courthouse research and tax maps. Property lines will not be located or established in the field.
- E. The City of Loganville will assist in coordinating the location of underground utilities within the project limits.
- F. Evaluate existing storm sewer conditions, determine limits of pipe replacement and/or rehabilitation required, and present options for the City’s consideration.

ESTIMATED COMPLETION TIME: Four (4) weeks after receiving a *Notice to Proceed*

Task 2 Storm Sewer Rehabilitation Plans and Specifications Lump Sum \$17,860.00

- A. Based on the rehabilitation method selected by the City, PPI will prepare a set of rehabilitation plans and technical specifications for bid purposes. The plans will consist of a cover sheet, site plan, storm sewer profile, erosion control plans, and technical specifications as required.
- B. PPI will prepare an abbreviated set of bid/proposal documents for the City’s use in soliciting bids and/or proposals for the work.
- C. PPI will submit final plans for Land Disturbance Permitting.
- D. PPI will prepare temporary construction easement agreements and exhibits for areas outside of the existing permanent easement that may be required for construction activities. The City of Loganville will acquire all required easements for the project.

City of Loganville
 Mr. Brandon Phillips, Public Utilities Director
 March 8, 2024
 Page 2

ESTIMATED COMPLETION TIME: Four (4) weeks for submittal to the Client after completion of Task 1

Task 3 Bid Phase Administration Lump Sum \$5,340.00

- A. PPI will provide an Invitation to Bid or Request for Proposal Notice to the City for advertisement.
- B. PPI will forward copies of documents to qualified contractors via email, and attend a project Pre-Bid Meeting if required.
- C. PPI will prepare a *Tabulation of Bids* received, review each bid, verify contractor references, and issue a *Recommendation of Award* for consideration by City Council.
- D. PPI will provide a draft contract agreement for use by the City.

ESTIMATED COMPLETION TIME: Four (4) to Six (6) weeks

Task 4 Construction Phase Support Services (Allowance) Hourly Not to Exceed \$7,520.00

- A. Perform periodic field visits and prepare work progress reports as requested by Client.
- B. Review and process pay request by contractor during construction as requested by the Client.

Fee Schedule and Summary

Description	Lump Sum Fee
Field Survey and Preliminary Engineering	\$15,280.00
Storm Sewer Rehabilitation Plans/Specifications	\$17,860.00
Bid Phase Administration	\$5,340.00
Direct Expenses (equipment, mileage, reproduction, postage)	\$850.00
DESIGN SERVICES SUB-TOTAL:	\$39,330.00
Construction Phase Assistance (Hourly Allowance)	\$7,520.00
TOTAL PROJECT FEE:	\$46,850.00

Exclusions

The following items are not included within the scope of services:

- A. Boundary surveys and or easement plats. It is assumed that storm sewer replacement and/or rehabilitation will be completed within existing storm sewer easements.
- B. Storm Sewer CCTV survey.
- C. Right-of-Way or Easement Acquisition Services
- D. Stream/Wetland Mitigation or 404 permitting services
- E. Georgia EPD Stream Buffer Variance
- F. Construction staking
- G. Geotechnical Services

City of Loganville
Mr. Brandon Phillips, Public Utilities Director
March 8, 2024
Page 3

Our Standard General Conditions and Schedule of Hourly Rates are attached and made part of this proposal. Should you require any additional services, they would be negotiated in advance or computed for a fee based on the attached schedule of hourly rates.

We look forward to your acceptance of this proposal and to a successful working relationship with you. Should you find this proposal satisfactory, **please sign below, initial each page where indicated, and return a completed copy to our office.** If we may be of further service, or if there are any questions, please do not hesitate to contact us.

Sincerely,

Jimmy Parker, P.E.
Executive Vice President

F:\MARKETING\Loganville\Storm Sewer Rehab Replacement\Loganville Storm Sewer Rehab and Replacement.docx

Attachments: Standard General Conditions
Hourly Rate Schedule

Authorization given this _____ day

of _____, 2024

By: _____

Title: _____

2023 CIVIL STANDARD HOURLY RATE SCHEDULE

Senior Principal Engineer	\$200.00/Hour
Principal Engineer	\$185.00/Hour
Senior Project Manager	\$165.00/Hour
Project Manager.....	\$140.00/Hour
Project Engineer III	\$125.00/Hour
Project Engineer II.....	\$110.00/Hour
Project Engineer I.....	\$95.00/Hour
Senior Landscape Architect.....	\$150.00/Hour
Landscape Architect.....	\$90.00/Hour
Senior Project Architect	\$150.00/Hour
Project Architect	\$125.00/Hour
Principal Planner	\$125.00/Hour
Senior Engineering Technician	\$95.00/Hour
Engineering Technician	\$80.00/Hour
CADD Designer	\$60.00/Hour
Project Administrator.....	\$90.00/Hour
Senior Project Assistant	\$80.00/Hour
Project Assistant.....	\$60.00/Hour
Construction Observer	\$100.00/Hour
Registered Land Surveyor (RLS)	\$150.00/Hour
Survey Manager	\$125.00/Hour
Survey Coordinator	\$110.00/Hour
Survey Technician	\$90.00/Hour
Surveying Crew.....	\$175.00/Hour
Senior Electrical Engineer	\$150.00/Hour

STANDARD GENERAL CONDITIONS

- A. In accepting and utilizing any drawings, reports and data on any form of electronic media generated and furnished by Precision Planning, Inc., the Owner/Client agrees that all such electronic files are instruments of service of Precision Planning, Inc., who shall be deemed the author, and shall retain all common law, statutory law and other rights, without limitation, including copyrights.

Intelligent data, including but not limited to Building Information Modeling (BIM) and 3D Grading/Surface Modeling, are instruments of service. When transmitted, this data shall be for the sole purpose of visualization of design ideas by the Owner/Client and shall not constitute or supplement the contract documents. Differences may exist between these models and the corresponding hard copy contract documents, and Precision Planning, Inc. makes no representation about their accuracy or completeness.

The Owner/Client agrees not to reuse these electronic files, in whole or in part, for any purpose other than for the Project. The Owner/Client agrees not to transfer these electronic files to others without the prior written consent of Precision Planning, Inc. The Owner/Client further agrees that Precision Planning, Inc. shall have no responsibility or liability to Owner/Client or others for any changes made by anyone other than Precision Planning, Inc. or for any reuse of the electronic files without the prior written consent of Precision Planning, Inc.

In addition, the Owner/Client agrees, to the fullest extent permitted by law, to indemnify and hold harmless Precision Planning, Inc., its officers, directors, employees and subconsultants (collectively, Consultant) against all damages, liabilities or costs, including reasonable attorneys' fees and defense costs, arising from any changes made by anyone other than Precision Planning, Inc. or from any use or reuse of the electronic files without the prior written consent of Precision Planning, Inc..

Under no circumstances shall delivery of electronic files for use by the Owner/Client be deemed a sale by Precision Planning, Inc., and Precision Planning, Inc. makes no warranties, either express or implied, of merchantability and fitness for any particular purpose. In no event shall Precision Planning, Inc. be liable for indirect or consequential damages as a result of the Owner/Client's unauthorized use or reuse of the electronic files.

- B. There shall be no assignments of any portion of the work as described within the above proposal or during any phase of the work without the written consent by Precision Planning, Inc. There shall be no disclosures of the scope of services and/or fees, as outlined within this proposal, to any third parties without the written consent of Precision Planning, Inc. There shall not be any re-use or reproduction of this proposal or design documents without the written consent of Precision Planning, Inc.
- C. Our professional services shall be performed, our findings obtained, and our recommendations prepared in accordance with generally accepted planning, engineering, land surveying, architectural and landscape architectural practices. This warranty is in lieu of all other warranties either implied or expressed. Precision Planning, Inc. assumes no responsibility for interpretation made by others based upon the work or recommendations made by Precision Planning, Inc.



Initials: _____
January 27, 2021

D. In recognition of the relative risks and benefits of the Project to both the Owner/Client and Precision Planning, Inc., the risks have been allocated such that the Owner/Client agrees, to the fullest extent permitted by law, to limit the liability of Precision Planning, Inc. and its officers, directors, employees, shareholders, owners and subconsultants for any and all claims, losses, costs, damages of any nature whatsoever or claims expenses from any cause or causes, including attorney's fees and costs and expert-witness fees and costs, so that the total aggregate liability of Precision Planning, Inc. and its officers, directors, employees, shareholders, owners and subconsultants shall not exceed \$50,000 or the amount of Precision Planning, Inc.'s total fee for services rendered on this Project, whichever is greater. It is intended that this limitation apply to any and all liability or cause of action, including without limitation active and passive negligence, however alleged or arising, unless otherwise prohibited by law. In no event shall the Consultant's liability exceed the amount of available insurance proceeds.

If Owner/Client prefers to have higher limits of professional liability, the limits can be increased to a maximum of one million (\$1,000,000.00) dollars upon Owner/Client's written request at the time of acceptance of this proposal provided that the Owner/Client agrees to pay an additional consideration of ten percent (10%) of the total fee or \$1,000.00, whichever is greater. The additional charge for the higher liability limits is because of the greater risk assumed and is not a charge for additional professional liability insurance.

E. Precision Planning, Inc. agrees, to the fullest extent permitted by law, to indemnify and hold harmless the Owner/Client, its officers, directors and employees (collectively, Owner/Client) against all damages and liabilities, to the extent caused by Precision Planning, Inc.'s negligent performance of professional services under this Agreement and that of its subconsultants or anyone for whom Precision Planning, Inc. is legally liable.

The Owner/Client agrees, to the fullest extent permitted by law, to indemnify and hold harmless Precision Planning, Inc., its officers, directors and employees and subconsultants (collectively, Precision Planning, Inc.) against all damages and liabilities, to the extent caused by the Owner/Client's negligent acts in connection with the Project and the acts of its contractors, subcontractors or consultants or anyone for whom the Owner/Client is legally liable.

Neither the Owner/Client nor Precision Planning, Inc. shall be obligated to indemnify the other party in any manner whatsoever for the other party's own negligence or for the negligence of others.

F. In the event the Owner/Client makes a claim against Precision Planning, Inc. at law or otherwise, for an alleged error, omission or other act arising out of the performance of our professional services, and the Owner/Client fails to prove such claim, then the Owner/Client shall bear all cost incurred by Precision Planning, Inc. in defending itself against such claim(s). The reciprocal of this clause (i.e., a claim made by Precision Planning, Inc. against the Owner/Client where failure of proof of claim is established, financial responsibility for Owner/Client's defense shall rest upon Precision Planning, Inc.) is hereby made a part of this agreement.

G. It is understood and agreed that Precision Planning, Inc. shall not be held responsible for any inaccuracies in any materials, data or records of any other person, firm or agency which are provided to it and/or may be utilized by it in the performance of specific services.



Initials: _____

January 27, 2021

H. Reimbursable expenses including mileage, photographic enlargements, reductions and reproduction, blueprinting, and courier services shall be billed at a rate of actual cost times 1.1. When overnight stay is required, it shall be billed as actual subsistence cost times 1.1.

NOTE: No back-up data or copies of bills will be provided for reimbursable expenses invoiced under this agreement. Should back-up data be requested, it will be provided for an administrative fee of \$100.00 per monthly invoice requiring verification, plus \$1.00 per copy of back-up data provided.

I. In the event additional services beyond the scope of work listed above are required by Owner/Client, Precision Planning, Inc. shall perform these services for an amount equal to normal hourly charges on work actually performed upon receipt of an approved Change Order signed by both parties. Precision Planning, Inc. shall submit monthly invoices for services outlined in this agreement. Payment is due upon receipt of invoice. Finance charges of one and one-half percent (1.5%) will be added to any unpaid balance at the end of thirty (30) days (APR 18%).

J. The Owner/Client or Precision Planning, Inc. may terminate this Agreement without penalty upon giving the other party ten (10) calendar days' notice in writing. In the event either party terminates for convenience, the Owner/Client shall pay Precision Planning, Inc. within seven (7) calendar days of receipt of Precision Planning, Inc.'s invoices for all services rendered and all reimbursable costs up to the date of termination. In addition, the Owner/Client shall pay Precision Planning, Inc. for all expenses reasonably incurred by Precision Planning, Inc. in connection with the orderly termination of this Agreement, including but not limited to associated overhead costs and all other expenses directly resulting from the termination. In the event government regulations are amended or changed in any way, or if the services outlined in this proposal have not been authorized within thirty (30) days of the date of this proposal, fees quoted are subject to renegotiation.

K. Services required by unexpected events which are outside Precision Planning, Inc.'s reasonable control including, but not limited to, services resulting from extended schedules shall be compensated as additional services.



Initials: _____
January 27, 2021

Staff Report
Department of Public Utilities

To: Honorable Mayor Baliles and Members of the City Council

Through: Danny Roberts, City Manager

From: Brandon Phillips, Director of Utilities

Date: March 14, 2024

Subject: Chandler Haulk Force Main Project Engineering

RECOMMENDATION:

Staff recommends the City Council approve Precision Planning Inc. to provide design and engineering, surveying, bid administration, & construction support.

FISCAL IMPLICATION:

PPI's quote for this project total \$97539.75 (5% contingency). Funding source capital recovery & and/or ARPA.

BACKGROUND:

The Chandler Haulk pump station and force main was installed in 2001. The existing force main is approximately 5,500 linear feet in length. Due to age and hydrogen sulfide the 8-inch ductile iron pipe needs to be replaced. We plan to evaluate an alternate route to Claude Brewer Road to reduce property disturbances, and to improve future maintenance access.



February 16, 2024

City of Loganville
Mr. Brandon Phillips, Public Utilities Director
P.O. Box 39
Loganville, GA 30052

Re: Engineering Services Proposal - Chandler Haulk Sewer Force Main Replacement Project

Brandon:

Precision Planning, Inc. (*PPI*) appreciates the opportunity to submit this proposal to the City of Loganville (*Client*) for the design of a new 8-inch sewer force main from the existing Chandler Haulk Pump Station to Baker-Carter Drive; including combination air release valves as required. Based on our experience with similar projects, we present the following scope of services and fee proposal for the City's review and consideration.

PROJECT UNDERSTANDING AND APPROACH

As reported by City staff, the existing Chandler Haulk force main consists of severely corroded 8-inch ductile iron pipe, likely due to hydrogen sulfide (H₂S) concentrations originating at the Chandler Haulk Pump Station. The current force main route is approximately 5,500 linear feet in length, beginning at the Chandler Haulk Pump Station and running mostly cross country through portions of the Chandler Walk, Huntington Ridge and Towler Shoals residential subdivisions. The force main discharge point is an existing gravity manhole located on the south side of Baker Carter Drive.

Based on our preliminary evaluation of the existing force main route, a 30' sanitary sewer easement was recorded on the final plats for the Chandler Walk and Huntington Ridge Subdivisions, however most of the recorded easement is shared with the existing gravity sewer. The final plat for the Towler Shoals subdivision does not reference the existing sewer force main or any dedicated easements. Given that the existing recorded easements would not provide sufficient width to replace the existing force main without additional permanent and/or temporary easements, we would like to evaluate an alternate route for the force main replacement project within the right-of-way of Claude Brewer Road to reduce required easement acquisition and improve future maintenance access.

The project will be designed and bid under a single contract including new 8-inch PVC or HDPE sewer force main, combination air/vacuum release valves and miscellaneous appurtenances. PPI will provide survey and engineering services to prepare final design drawings and contract documents; as well as permitting, bid phase, and construction phase support services.

City of Loganville – Chandler Haulk Force Main Replacement
February 16, 2024
Page 2

Based on our understanding of the project, we have developed the following Scope of Work.

SCOPE OF WORK

Task 1 – Force Main Routing Assessment

Due to anticipated issues with additional easement acquisition through portions of the existing Chandler Walk, Huntington Ridge, and Towler Shoals residential subdivisions; PPI proposes an alternate force main alignment from the existing Chandler Haulk pump station due east to Claude Brewer Road. The new sewer force main would then proceed north within the right-of-way of Claude Brewer Road to a discharge point to be defined by the City of Loganville.

PPI will prepare a preliminary alternate alignment, and assist City staff in meeting with local property owners regarding potential easement acquisition.

Task2 - Preliminary Engineering and Topographic Survey

Once the force main route is identified, PPI will perform a field run topographic and location survey of the proposed force main route, pump station site, and proposed discharge manhole location. PPI will horizontally locate all existing visible utilities and other existing ground features. The City of Loganville will request 811 utility locates along the project corridor. Right-of-way widths and property boundary information will be obtained from available County records. Information gathered will be compiled in a CAD file and will serve as a base map for final design. Survey services will include:

- Establish survey control points on Georgia State Plane Datum
- Prepare easement exhibits and agreements for acquisition purposes

Task 3 – Detailed Design & Permitting

Using the survey information collected, PPI will assess project static and friction losses in the proposed sewer force main; and verify current pump station design criteria and/or modifications required. PPI will also perform detailed design of the proposed sewer force main and required combination air/vacuum release valves. Work under this task will include the following:

- Sewer Force Main Design
 - Identify and confirm force main alignment, location, potential utility conflicts, environmental concerns, and required connection points.
 - Identify any required easements or land acquisition requirements.
 - Design sewer force main and related appurtenances.
 - Erosion Control Plans
- Chandler Haulk Pump Station Evaluation
 - PPI will complete an inspection and drawdown test at the Chandler Haulk Pump Station to assess current pump condition and capacity. The City of Loganville will provide current pump station data including pump type, model, installation date, impeller size, and available asbuilt data.
 - PPI will complete a hydraulic assessment of the proposed force main route to identify any required operational improvements at the Chandler Haulk Pump Station.
 - We assume existing electrical and instrumentation systems are sufficient for future pump station operations, and no IEC improvements are included in this scope of services.
- Permitting
 - Prepare construction plans, specifications, and technical reports for GaEPD submittal
 - Obtain County/City/NRCS Erosion Control approval

Initials: _____

City of Loganville – Chandler Haulk Force Main Replacement
February 16, 2024
Page 3

PPI will prepare the final construction drawings and contract documents in accordance with the *City of Loganville Sewer System Standards* latest edition. Technical Specifications will be developed as needed for items not covered in the Standards. PPI will submit copies of the construction drawings to County, City and Georgia EPD as necessary for review and approval. The construction documents prepared for bids will include:

- Title Sheet
- Sewer Force Main Plan and Profile Sheets
- Construction Details
- Erosion, Sedimentation and Pollution Control Plan (ES&PC)
- Erosion and Sedimentation Control Details
- Division 0 and Division 1 Contract Documents
- Technical Specifications as necessary

Following final plan approval, PPI will prepare and submit a preliminary opinion of probable construction costs. Upon completion of construction, PPI will prepare record drawings based on the contractor’s red lined set of plans. City will receive one full size hard copy of the record drawings and one digital copy in .pdf format.

Task 4 - Bid Phase Assistance

Once agency approvals have been obtained, PPI will provide up to ten (10) sets of bid plans and ten (10) copies of the contract documents for use in advertising and bidding the project. PPI will assist the City with bidding the project including bid document distribution to prospective bidders, plan holders list management, addendum preparation (if any), pre-bid meeting attendance, bid opening attendance, bid tabulation, bid review/contractor qualifications, and recommendation of award.

Task 5 - Construction Phase Support

Work under this subtask will be provided on an hourly basis as requested by the City. PPI may provide periodic site visits, review and respond to contractor request for information, assist in the review of monthly pay requests/change order requests, or other support services as requested.

ASSUMPTIONS AND EXCLUSIONS

- The City of Loganville will provide day to day construction inspection and administration services, with hourly supplemental assistance from PPI.
- Geotechnical services are included as an allowance in the Compensation section of this proposal for geotechnical investigation of the selected force main route.
- Easement acquisition services are not included. The preparation of, and the survey for, meets and bounds easement plats for condemnation or contested easements are not included, but may be provided at additional cost.
- A United States Army Corps of Engineers (USACE) Individual Permit Application or Preconstruction Notification (PCN) is not anticipated and, therefore, was not included as a part of this Scope.
- Plan review fees shall be considered as an additional direct reimbursable cost or shall be paid for separately by the City.
- Up to ten (10) sets of final construction plans will be provided. Reproduction of additional plan sets shall be billed separately.
- The City shall be responsible for all coordination with existing residents regarding construction schedule and other project related issues.
- Construction staking is not included in the Scope of this project. If requested, construction staking may be provided at our standard hourly rates.

Initials: _____

City of Loganville – Chandler Haulk Force Main Replacement
 February 16, 2024
 Page 4

COMPENSATION

The following table provides a breakdown of the project fees and anticipated schedule, for your review.

PROJECT TASK	DURATION* (Months)	FEE (Lump Sum)
Task 1 – Force Main Routing Assessment	0.5	\$5,020.00
Task 2 – Preliminary Engineering and Topographic Survey	1.0	\$26,935.00
Task 3 – Detailed Design and Permitting	3.0	\$29,540.00
Task 4 – Bid Phase Assistance	1.5	\$4,155.00
DESIGN SERVICES SUB-TOTAL:	6 Months	\$65,650.00
Task 5 – Construction Phase Assistance <i>(Hourly Allowance)</i>		\$18,845.00
Geotechnical Allowance		\$8,000
Direct Expenses <i>(Mileage, Plan Reproduction, etc.)</i>		\$400.00
TOTAL PROJECT FEE:		\$92,895.00
Additional Services if Requested:		
Formal Easement Plat for Condemnation (Add'l Cost per Each)		\$1,200.00

*** Work will be invoiced on a monthly basis, based on the percentage of work complete.*

Again, we appreciate the opportunity to this proposal for engineering services, and we look forward to assisting you in the successful completion of this very important project. Should you have any questions or comments regarding this proposal, please feel free to contact me by phone at 404-790-9000 or by email at jparker@ppi.us.

Sincerely,



Jimmy Parker, P.E.
 Executive Vice President

F:\MARKETING\Loganville\Chandler Haulk Force Main Replacement Project\Chandler Haulk Force Main Replacement.docx

Attachment: Standard General Conditions
 Standard Hourly Rates Schedule

Authorization given this _____ day of _____, 2024

By: _____

Title: _____

Initials: _____

2023 CIVIL STANDARD HOURLY RATE SCHEDULE

Senior Principal Engineer	\$200.00/Hour
Principal Engineer	\$185.00/Hour
Senior Project Manager	\$165.00/Hour
Project Manager.....	\$140.00/Hour
Project Engineer III.....	\$125.00/Hour
Project Engineer II.....	\$110.00/Hour
Project Engineer I.....	\$95.00/Hour
Senior Landscape Architect.....	\$150.00/Hour
Landscape Architect.....	\$90.00/Hour
Senior Project Architect	\$150.00/Hour
Project Architect	\$125.00/Hour
Principal Planner	\$125.00/Hour
Senior Engineering Technician	\$95.00/Hour
Engineering Technician	\$80.00/Hour
CADD Designer	\$60.00/Hour
Project Administrator.....	\$90.00/Hour
Senior Project Assistant	\$80.00/Hour
Project Assistant.....	\$60.00/Hour
Construction Observer	\$100.00/Hour
Registered Land Surveyor (RLS)	\$150.00/Hour
Survey Manager	\$125.00/Hour
Survey Coordinator	\$110.00/Hour
Survey Technician	\$90.00/Hour
Surveying Crew.....	\$175.00/Hour
Senior Electrical Engineer	\$150.00/Hour



Initials: _____

STANDARD GENERAL CONDITIONS

- A. In accepting and utilizing any drawings, reports and data on any form of electronic media generated and furnished by Precision Planning, Inc., the Owner/Client agrees that all such electronic files are instruments of service of Precision Planning, Inc., who shall be deemed the author, and shall retain all common law, statutory law and other rights, without limitation, including copyrights.

Intelligent data, including but not limited to Building Information Modeling (BIM) and 3D Grading/Surface Modeling, are instruments of service. When transmitted, this data shall be for the sole purpose of visualization of design ideas by the Owner/Client and shall not constitute or supplement the contract documents. Differences may exist between these models and the corresponding hard copy contract documents, and Precision Planning, Inc. makes no representation about their accuracy or completeness.

The Owner/Client agrees not to reuse these electronic files, in whole or in part, for any purpose other than for the Project. The Owner/Client agrees not to transfer these electronic files to others without the prior written consent of Precision Planning, Inc. The Owner/Client further agrees that Precision Planning, Inc. shall have no responsibility or liability to Owner/Client or others for any changes made by anyone other than Precision Planning, Inc. or for any reuse of the electronic files without the prior written consent of Precision Planning, Inc.

In addition, the Owner/Client agrees, to the fullest extent permitted by law, to indemnify and hold harmless Precision Planning, Inc., its officers, directors, employees and subconsultants (collectively, Consultant) against all damages, liabilities or costs, including reasonable attorneys' fees and defense costs, arising from any changes made by anyone other than Precision Planning, Inc. or from any use or reuse of the electronic files without the prior written consent of Precision Planning, Inc..

Under no circumstances shall delivery of electronic files for use by the Owner/Client be deemed a sale by Precision Planning, Inc., and Precision Planning, Inc. makes no warranties, either express or implied, of merchantability and fitness for any particular purpose. In no event shall Precision Planning, Inc. be liable for indirect or consequential damages as a result of the Owner/Client's unauthorized use or reuse of the electronic files.

- B. There shall be no assignments of any portion of the work as described within the above proposal or during any phase of the work without the written consent by Precision Planning, Inc. There shall be no disclosures of the scope of services and/or fees, as outlined within this proposal, to any third parties without the written consent of Precision Planning, Inc. There shall not be any re-use or reproduction of this proposal or design documents without the written consent of Precision Planning, Inc.
- C. Our professional services shall be performed, our findings obtained, and our recommendations prepared in accordance with generally accepted planning, engineering, land surveying, architectural and landscape architectural practices. This warranty is in lieu of all other warranties either implied or expressed. Precision Planning, Inc. assumes no responsibility for interpretation made by others based upon the work or recommendations made by Precision Planning, Inc.



Initials: _____
 January 27, 2021

D. In recognition of the relative risks and benefits of the Project to both the Owner/Client and Precision Planning, Inc., the risks have been allocated such that the Owner/Client agrees, to the fullest extent permitted by law, to limit the liability of Precision Planning, Inc. and its officers, directors, employees, shareholders, owners and subconsultants for any and all claims, losses, costs, damages of any nature whatsoever or claims expenses from any cause or causes, including attorney's fees and costs and expert-witness fees and costs, so that the total aggregate liability of Precision Planning, Inc. and its officers, directors, employees, shareholders, owners and subconsultants shall not exceed \$50,000 or the amount of Precision Planning, Inc.'s total fee for services rendered on this Project, whichever is greater. It is intended that this limitation apply to any and all liability or cause of action, including without limitation active and passive negligence, however alleged or arising, unless otherwise prohibited by law. In no event shall the Consultant's liability exceed the amount of available insurance proceeds.

If Owner/Client prefers to have higher limits of professional liability, the limits can be increased to a maximum of one million (\$1,000,000.00) dollars upon Owner/Client's written request at the time of acceptance of this proposal provided that the Owner/Client agrees to pay an additional consideration of ten percent (10%) of the total fee or \$1,000.00, whichever is greater. The additional charge for the higher liability limits is because of the greater risk assumed and is not a charge for additional professional liability insurance.

E. Precision Planning, Inc. agrees, to the fullest extent permitted by law, to indemnify and hold harmless the Owner/Client, its officers, directors and employees (collectively, Owner/Client) against all damages and liabilities, to the extent caused by Precision Planning, Inc.'s negligent performance of professional services under this Agreement and that of its subconsultants or anyone for whom Precision Planning, Inc. is legally liable.

The Owner/Client agrees, to the fullest extent permitted by law, to indemnify and hold harmless Precision Planning, Inc., its officers, directors and employees and subconsultants (collectively, Precision Planning, Inc.) against all damages and liabilities, to the extent caused by the Owner/Client's negligent acts in connection with the Project and the acts of its contractors, subcontractors or consultants or anyone for whom the Owner/Client is legally liable.

Neither the Owner/Client nor Precision Planning, Inc. shall be obligated to indemnify the other party in any manner whatsoever for the other party's own negligence or for the negligence of others.

F. In the event the Owner/Client makes a claim against Precision Planning, Inc. at law or otherwise, for an alleged error, omission or other act arising out of the performance of our professional services, and the Owner/Client fails to prove such claim, then the Owner/Client shall bear all cost incurred by Precision Planning, Inc. in defending itself against such claim(s). The reciprocal of this clause (i.e., a claim made by Precision Planning, Inc. against the Owner/Client where failure of proof of claim is established, financial responsibility for Owner/Client's defense shall rest upon Precision Planning, Inc.) is hereby made a part of this agreement.

G. It is understood and agreed that Precision Planning, Inc. shall not be held responsible for any inaccuracies in any materials, data or records of any other person, firm or agency which are provided to it and/or may be utilized by it in the performance of specific services.



Initials: _____

January 27, 2021

H. Reimbursable expenses including mileage, photographic enlargements, reductions and reproduction, blueprinting, and courier services shall be billed at a rate of actual cost times 1.1. When overnight stay is required, it shall be billed as actual subsistence cost times 1.1.

NOTE: No back-up data or copies of bills will be provided for reimbursable expenses invoiced under this agreement. Should back-up data be requested, it will be provided for an administrative fee of \$100.00 per monthly invoice requiring verification, plus \$1.00 per copy of back-up data provided.

I. In the event additional services beyond the scope of work listed above are required by Owner/Client, Precision Planning, Inc. shall perform these services for an amount equal to normal hourly charges on work actually performed upon receipt of an approved Change Order signed by both parties. Precision Planning, Inc. shall submit monthly invoices for services outlined in this agreement. Payment is due upon receipt of invoice. Finance charges of one and one-half percent (1.5%) will be added to any unpaid balance at the end of thirty (30) days (APR 18%).

J. The Owner/Client or Precision Planning, Inc. may terminate this Agreement without penalty upon giving the other party ten (10) calendar days' notice in writing. In the event either party terminates for convenience, the Owner/Client shall pay Precision Planning, Inc. within seven (7) calendar days of receipt of Precision Planning, Inc.'s invoices for all services rendered and all reimbursable costs up to the date of termination. In addition, the Owner/Client shall pay Precision Planning, Inc. for all expenses reasonably incurred by Precision Planning, Inc. in connection with the orderly termination of this Agreement, including but not limited to associated overhead costs and all other expenses directly resulting from the termination. In the event government regulations are amended or changed in any way, or if the services outlined in this proposal have not been authorized within thirty (30) days of the date of this proposal, fees quoted are subject to renegotiation.

K. Services required by unexpected events which are outside Precision Planning, Inc.'s reasonable control including, but not limited to, services resulting from extended schedules shall be compensated as additional services.



Initials: _____

January 27, 2021



CITY COUNCIL MEETING MINUTES
Thursday, February 08, 2024 at 6:30 PM
Council Chambers

1. CALL TO ORDER

Mayor Skip Baliles called the meeting to order at 6:30pm.

A. Invocation and Pledge to the Flag

Mark Myers gave the invocation, led the pledge to the flag and sang the National Anthem.

A moment of silence was observed for the 3 Georgia Army Reservists killed recently in a drone attack in Jordan - Sgt. William Jerome Rivers, Sgt. Kennedy Sanders and Sgt. Breonna Moffett.

B. Roll Call

PRESENT

- Mayor Skip Baliles
- Council Member Anne Huntsinger
- Council Member Melanie Long
- Council Member Lisa Newberry
- Council Member Branden Whitfield
- Council Member Patti Wolfe

ABSENT

- Council Member Bill DuVall

C. Adoption of Agenda

Motion made by Council Member Newberry to remove the Zoning Map from the agenda. Seconded by Council Member Long. Voting

Yea: Council Member Huntsinger, Council Member Long, Council Member Newberry, Council Member Whitfield, Council Member Wolfe.

Motion carried 5-0.

Motion made by Council Member Huntsinger to adopt the amended agenda. Seconded by Council Member Whitfield.

Voting Yea: Council Member Huntsinger, Council Member Long, Council Member Newberry, Council Member Whitfield, Council Member Wolfe.

Motion carried 5-0.

2. CONSENT AGENDA

Motion made by Council Member Huntsinger to approve the Consent Agenda as follows:

- A. State Wide Mutual Aid Agreement - Walton County
- B. 01-11-2024 Council Meeting Minutes
- C. January Financial Report

Seconded by Council Member Long.

Voting Yea: Council Member Huntsinger, Council Member Long, Council Member Newberry, Council Member Whitfield, Council Member Wolfe.

Motion carried 5-0.

3. PLANNING & DEVELOPMENT COMMITTEE REPORT

A. Case #R24-001 – Koch Orthodontics filed an application requesting to rezone approximately 0.854+/- acres located at 123 Bobby Boss Road, Loganville, GA 30052, Map/Parcel #LG060141, Walton County, GA. The property owner is Strive Real Estate Loganville, LLC. The current zoning is CBD and the requested zoning is CH with the proposed development of an office for orthodontic practice.

Motion made by Council Member Newberry to approve the rezoning with the following conditions:

1. Property shall be used for dental, medical or other office use. The property shall not be used for the following: Automotive body repair Automotive car wash Automotive parts stores Auto repair shops or tire stores including lubrication or tune-up centers (full-service and self-service) Automotive service stations, with or without fuel pumps. Convenience food stores with or without fuel pumps Drive-in restaurants. Garages. Hotels Lawnmower repair shops Machine, welding, radiator or muffler repair shops Recreation facilities (indoor, such as bowling alleys, skating rinks, and movie theaters, and commercial outdoor, such as miniature golf courses, driving ranges, water slides or drive-in theaters) Recovered materials processing facility Restaurants and lounges
2. The Applicant shall plant a row of evergreen trees adjacent to the northeastern edge of its parking lot (nearest Tax Parcel LG050037) and behind its dumpster enclosure. Trees shall be at least six feet in height at the time of planting.
3. Lighting shall be contained in cut-off type luminaries and shall be directed in toward the property so as not to shine directly into adjacent properties or rights-of-way.
4. The dumpster shall be screened in accordance with the City’s regulations.
5. The 75 foot stream buffer shall be undisturbed except as permitted by the City’s regulations.

Seconded by Council Member Wolfe.

Voting Yea: Council Member Huntsinger, Council Member Newberry, Council Member Whitfield, Council Member Wolfe

Voting Abstaining: Council Member Long.

Motion carried 4-0.

B. Case #R24-002 – Koch Orthodontics filed an application requesting to rezone approximately 2.68+/- acres located at 115 Bobby Boss Road, Loganville, GA 30052, Map/Parcel #LG050036, Walton County, GA. The property owner is Strive Real Estate Loganville, LLC. The current zoning is CBD and the requested zoning is CH with the proposed development of an office for orthodontic practice

Motion made by Council Member Newberry to approve the rezone with the following conditions:

1. Property shall be used for dental, medical or other office use. The property shall not be used for the following: Automotive body repair Automotive car wash Automotive parts stores Auto repair shops or tire stores including lubrication or tune-up centers (full-service and self-service) Automotive service stations, with or without fuel pumps. Convenience food stores with or without fuel pumps Drive-in restaurants. Garages. Hotels Lawnmower repair shops Machine, welding, radiator or muffler repair shops Recreation facilities (indoor, such as bowling alleys, skating rinks,

and movie theaters, and commercial outdoor, such as miniature golf courses, driving ranges, water slides or drive-in theaters) Recovered materials processing facility Restaurants and lounges

- 2. The Applicant shall plant a row of evergreen trees adjacent to the northeastern edge of its parking lot (nearest Tax Parcel LG050037) and behind its dumpster enclosure. Trees shall be at least six feet in height at the time of planting.
- 3. Lighting shall be contained in cut-off type luminaries and shall be directed in toward the property so as not to shine directly into adjacent properties or rights-of-way.
- 4. The dumpster shall be screened in accordance with the City’s regulations.
- 5. The 75 foot stream buffer shall be undisturbed except as permitted by the City’s regulations.

Seconded by Council Member Wolfe.

Voting Yea: Council Member Huntsinger, Council Member Newberry, Council Member Whitfield, Council Member Wolfe.

Voting Abstaining: Council Member Long

Motion carried 4-0.

4. CITY ATTORNEY’S UPDATES / REPORTS

A. Open Records Resolution - Action

Motion made by Council Member Huntsinger. Seconded by Council Member Whitfield.

Voting Yea: Council Member Huntsinger, Council Member Long, Council Member Newberry, Council Member Whitfield, Council Member Wolfe.

Motion carried 5-0.

B. Development Regulations Update - Action

Motion made by Council Member Whitfield. Seconded by Council Member Huntsinger.

Voting Yea: Council Member Huntsinger, Council Member Long, Council Member Newberry, Council Member Whitfield, Council Member Wolfe.

Motion carried 5-0.

5. ADJOURNMENT

Motion made by Council Member Long. Seconded by Council Member Newberry.

Voting Yea: Council Member Huntsinger, Council Member Long, Council Member Newberry, Council Member Whitfield, Council Member Wolfe.

Motion carried 5-0.

Meeting adjourned at 6:52pm.

Skip Baliles
Mayor

Kristi Ash
Deputy Clerk



City of Loganville

Income Statement
Account Summary

Section 2, Item E.

For Fiscal: 2023-2024 Period Ending: 02/29/2024

	Original Total Budget	Current Total Budget	MTD Activity	YTD Activity	Budget Remaining	
Fund: 100 - General Fund						
Department: 0000 - Non-Departmental						
100-0000-311100	Real Property Taxes - Current	7,000,000.00	7,000,000.00	56,147.43	7,035,172.15	-35,172.15
100-0000-311131	Motor Vehicle Tax - Current	40,000.00	40,000.00	3,103.92	16,329.37	23,670.63
100-0000-311132	Mobile Home Tax - Current	7,000.00	7,000.00	363.70	610.13	6,389.87
100-0000-311133	Intangible Tax - Current	130,000.00	130,000.00	4,926.48	54,820.42	75,179.58
100-0000-311300	Personal Property - Current	445,000.00	445,000.00	-87.00	454,483.18	-9,483.18
100-0000-311315	Motor Vehicle Tavn Taxes	600,000.00	600,000.00	58,022.35	383,589.79	216,410.21
100-0000-311600	Real Estate Transfer Tax	45,000.00	45,000.00	26,654.57	50,301.50	-5,301.50
100-0000-311700	Electric Franchise Tax	670,000.00	670,000.00	467,205.06	715,199.97	-45,199.97
100-0000-311730	Gas Franchise Tax	110,000.00	110,000.00	0.00	126,033.77	-16,033.77
100-0000-311750	Television Cable Franchise Tax	110,000.00	110,000.00	24,032.55	75,643.21	34,356.79
100-0000-311760	Telephone Franchise Tax	5,000.00	5,000.00	0.00	3,628.98	1,371.02
100-0000-313100	Local Option Sales Tax & Use Tax	1,900,000.00	1,900,000.00	140,856.87	1,069,582.86	830,417.14
100-0000-314100	Excise Tax By Drink	40,000.00	40,000.00	2,851.63	29,240.10	10,759.90
100-0000-314200	Alcoholic Beverage Excise Tax	450,000.00	450,000.00	31,612.98	296,102.77	153,897.23
100-0000-316100	Business & Occupation Taxes	500,000.00	500,000.00	53,901.20	410,902.29	89,097.71
100-0000-316200	Insurance Premium Taxes	1,250,000.00	1,250,000.00	0.00	1,253,830.06	-3,830.06
100-0000-316400	Energy Excise Tax Gw	1,000.00	1,000.00	137.27	1,004.19	-4.19
100-0000-319110	Real Property Tax Penalties	25,000.00	25,000.00	4,548.78	18,029.06	6,970.94
100-0000-319120	Personal Property Tax Penalties	5,000.00	5,000.00	715.19	3,852.04	1,147.96
100-0000-319500	Fifa	4,000.00	4,000.00	1,600.00	2,800.00	1,200.00
100-0000-321110	Beer & Wine License / Permit	32,000.00	32,000.00	0.00	34,100.00	-2,100.00
100-0000-321140	Liquor License / Permit	38,000.00	38,000.00	0.00	51,150.00	-13,150.00
100-0000-322200	Sign Permits	6,000.00	6,000.00	675.00	6,900.00	-900.00
100-0000-322240	Development Permits	5,000.00	5,000.00	250.00	602.50	4,397.50
100-0000-323100	Building Permits	150,000.00	150,000.00	21,091.48	127,664.31	22,335.69
100-0000-323190	Fire Inspections	65,000.00	65,000.00	4,925.00	41,252.50	23,747.50
100-0000-335100	Htrg Credit	0.00	0.00	0.00	457,955.36	-457,955.36
100-0000-335120	Intergovernmental Revenues	140,000.00	140,000.00	0.00	133,794.92	6,205.08
100-0000-335121	Lmig Road Work	140,000.00	140,000.00	0.00	160,252.28	-20,252.28
100-0000-337102	Dea Reimbursement	0.00	0.00	0.00	3,097.47	-3,097.47
100-0000-338000	Housing Auth - In Lieu Of Taxes	2,200.00	2,200.00	0.00	0.00	2,200.00
100-0000-341120	Probation Fee	180,000.00	180,000.00	17,282.50	96,395.37	83,604.63
100-0000-341300	Administrative Fee - Capital Recove	50,000.00	50,000.00	5,089.68	22,192.53	27,807.47
100-0000-341301	Engineering Plan Review Fees	15,000.00	15,000.00	0.00	7,624.34	7,375.66
100-0000-341302	Administrative Plan Review Fees	100,000.00	100,000.00	8,418.08	66,167.88	33,832.12
100-0000-341303	Annexation Application	1,000.00	1,000.00	0.00	0.00	1,000.00
100-0000-341304	Alcoholic Beverage Application	1,600.00	1,600.00	0.00	0.00	1,600.00
100-0000-341305	Rezoning Application	2,000.00	2,000.00	0.00	3,000.00	-1,000.00
100-0000-341306	Variance Application	1,000.00	1,000.00	500.00	900.00	100.00
100-0000-341390	Epd - Npdes Fees	1,000.00	1,000.00	0.00	56.40	943.60
100-0000-341392	Land Disturbance Permit	2,000.00	2,000.00	0.00	100.00	1,900.00
100-0000-341400	Printing & Duplicating Services	500.00	500.00	10.00	860.38	-360.38
100-0000-341700	Admin Charges	70,000.00	70,000.00	9,150.00	44,275.00	25,725.00
100-0000-341910	Election Qualifying Fee	540.00	540.00	0.00	1,440.00	-900.00
100-0000-342120	Accident Reports	5,000.00	5,000.00	575.00	5,400.23	-400.23
100-0000-342320	Fingerprinting Fees	100.00	100.00	0.00	-18.00	118.00
100-0000-346400	Background Check Fees	7,000.00	7,000.00	585.00	6,070.00	930.00
100-0000-349300	Bad Check Fees	100.00	100.00	0.00	30.00	70.00
100-0000-349900	Other Charges for Service-Tech Services	0.00	0.00	80.00	320.00	-320.00
100-0000-351170	Municipal Court Fines	375,000.00	375,000.00	23,020.00	229,260.19	145,739.81
100-0000-351171	Code Enforcement Fines	500.00	500.00	0.00	725.00	-225.00

Income Statement

For Fiscal: 2023-2024 Period En

		Original Total Budget	Current Total Budget	MTD Activity	YTD Activity	Budget Remaining
100-0000-351175	Fire Fines And Fees	500.00	500.00	0.00	300.00	200.00
100-0000-361000	Interest Revenues	30,000.00	30,000.00	2,730.39	45,611.90	-15,611.90
100-0000-371200	Fire Fund Donations	0.00	0.00	0.00	330.00	-330.00
100-0000-371250	Police Fund Donations	100.00	100.00	0.00	23,580.64	-23,480.64
100-0000-383000	Insurance Proceeds	0.00	0.00	-1,849.40	0.00	0.00
100-0000-389000	Bank Charges & Misc.	3,000.00	3,000.00	958.48	-3,944.02	6,944.02
100-0000-389150	Rental Receipts	70,000.00	70,000.00	10,250.00	50,925.00	19,075.00
100-0000-389175	Event Receipts	70,000.00	70,000.00	4,000.00	46,613.58	23,386.42
100-0000-391220	Transfers In - Sanitation Fund	250,000.00	250,000.00	0.00	0.00	250,000.00
100-0000-391230	Transfer In - Hotel/Motel	35,000.00	35,000.00	7,021.44	19,609.83	15,390.17
100-0000-392000	Sale Of Surplus Property	0.00	0.00	0.00	43.20	-43.20
Department: 0000 - Non-Departmental Total:		15,186,140.00	15,186,140.00	991,355.63	13,685,794.63	1,500,345.37

Department: 1100 - Legislative

100-1100-511100	Salaries & Wages - Council	48,000.00	48,000.00	4,000.00	32,000.00	16,000.00
100-1100-512200	Fica & Medicare	3,800.00	3,800.00	306.00	2,448.00	1,352.00
100-1100-512400	Pmts To Retirement Sys	6,850.00	6,850.00	607.32	4,858.56	1,991.44
100-1100-512810	Uniforms	1,500.00	1,500.00	0.00	16.00	1,484.00
100-1100-521301	Computer Services	1,000.00	1,000.00	0.00	0.00	1,000.00
100-1100-523400	Printing & Binding	250.00	250.00	98.53	232.53	17.47
100-1100-523500	Travel	2,500.00	2,500.00	0.00	0.00	2,500.00
100-1100-523600	Dues & Fees	1,000.00	1,000.00	0.00	0.00	1,000.00
100-1100-523700	Education & Training	20,000.00	20,000.00	0.00	3,036.56	16,963.44
100-1100-523900	Other	1,000.00	1,000.00	0.00	10.50	989.50
100-1100-529910	Municipal Meetings	1,000.00	1,000.00	264.00	334.40	665.60
100-1100-531100	General Supplies & Mater	500.00	650.00	0.00	623.38	26.62
100-1100-531300	Food	1,000.00	850.00	63.60	63.60	786.40
100-1100-531700	Other Supplies	500.00	500.00	0.00	0.00	500.00
Department: 1100 - Legislative Total:		88,900.00	88,900.00	5,339.45	43,623.53	45,276.47

Department: 1300 - Executive

100-1300-511100	Salaries & Wages - Executive	272,230.00	272,230.00	24,776.46	198,927.34	73,302.66
100-1300-511300	Overtime Pay	500.00	500.00	0.00	0.00	500.00
100-1300-512100	Group Insurance	89,352.00	89,352.00	7,707.89	60,377.62	28,974.38
100-1300-512200	Fica & Medicare	24,000.00	24,000.00	1,858.09	15,233.60	8,766.40
100-1300-512400	Pmts To Retirement Sys	36,720.00	36,720.00	3,450.64	27,605.12	9,114.88
100-1300-512700	Workers Compensation	500.00	802.70	0.00	802.70	0.00
100-1300-512810	Uniforms	500.00	2,719.67	1,952.76	4,672.43	-1,952.76
100-1300-521200	Professional Services	60,000.00	54,750.00	0.00	39,500.00	15,250.00
100-1300-521201	Legal Expenses	0.00	5,250.00	0.00	5,250.00	0.00
100-1300-521202	Engineering Fees	45,000.00	42,477.63	0.00	41,015.00	1,462.63
100-1300-523400	Printing & Binding	1,000.00	1,000.00	0.00	0.00	1,000.00
100-1300-523500	Travel	3,000.00	3,000.00	0.00	658.81	2,341.19
100-1300-523510	City Manager Car Allowance	9,100.00	9,100.00	700.00	5,950.00	3,150.00
100-1300-523600	Dues & Fees	4,000.00	4,000.00	130.00	176.00	3,824.00
100-1300-523700	Education & Training	2,500.00	2,500.00	0.00	1,624.28	875.72
100-1300-523900	Other	3,000.00	3,000.00	0.00	135.00	2,865.00
100-1300-529989	Contingency	1,000.00	1,000.00	0.00	0.00	1,000.00
100-1300-531100	General Supplies & Mater	1,500.00	1,500.00	0.00	240.54	1,259.46
100-1300-531101	Office Supplies	1,000.00	1,000.00	0.00	472.63	527.37
100-1300-531114	Flowers & Plants	500.00	500.00	0.00	226.48	273.52
100-1300-531300	Food	3,000.00	3,000.00	140.40	722.04	2,277.96
100-1300-531600	Sm Equip Purchase <\$5,000	2,000.00	2,000.00	0.00	0.00	2,000.00
100-1300-531700	Other Supplies	500.00	500.00	0.00	0.00	500.00
Department: 1300 - Executive Total:		560,902.00	560,902.00	40,716.24	403,589.59	157,312.41

Department: 1400 - Elections

100-1400-521206	Election Expense-Contract Service	30,000.00	30,000.00	0.00	28,633.11	1,366.89
100-1400-523301	Advertising Expense	500.00	500.00	0.00	0.00	500.00
100-1400-531100	General Supplies & Mater	1,000.00	1,000.00	0.00	0.00	1,000.00
Department: 1400 - Elections Total:		31,500.00	31,500.00	0.00	28,633.11	2,866.89

Income Statement

For Fiscal: 2023-2024 Period En

Section 2, Item E.

		Original Total Budget	Current Total Budget	MTD Activity	YTD Activity	Budget Remaining
Department: 1510 - Financial Administration						
100-1510-511100	Salaries & Wages - Gen Adm/Ch	310,000.00	310,000.00	40,190.73	238,437.12	71,562.88
100-1510-511300	Overtime Pay	2,400.00	2,400.00	193.98	1,534.34	865.66
100-1510-512100	Group Insurance	110,900.00	110,900.00	14,300.25	79,211.25	31,688.75
100-1510-512200	Fica & Medicare	24,000.00	24,000.00	2,950.03	18,211.67	5,788.33
100-1510-512400	Pmts To Retirement Sys	42,000.00	42,000.00	3,952.55	31,620.40	10,379.60
100-1510-512700	Workers Compensation	3,000.00	4,284.30	0.00	4,284.30	0.00
100-1510-521101	Fifa Expense	1,500.00	1,500.00	213.00	730.00	770.00
100-1510-521200	City Attorney & Retainer	120,000.00	120,000.00	0.00	124,179.02	-4,179.02
100-1510-521203	Audit Fees	20,000.00	20,000.00	0.00	14,200.00	5,800.00
100-1510-521205	Cpa Expense	12,000.00	12,000.00	0.00	10,033.75	1,966.25
100-1510-521207	Codification Of City Code	2,000.00	2,447.50	8,397.50	8,397.50	-5,950.00
100-1510-521302	Drug Testing	0.00	50.00	0.00	50.00	0.00
100-1510-523130	General Liability	49,000.00	57,369.00	0.00	57,369.00	0.00
100-1510-523201	Postage	7,500.00	7,500.00	0.00	4,393.49	3,106.51
100-1510-523301	Advertising Expense	1,500.00	2,316.00	0.00	2,316.00	0.00
100-1510-523400	Printing & Binding	1,500.00	215.70	0.00	0.00	215.70
100-1510-523500	Travel	0.00	495.38	0.00	495.38	0.00
100-1510-523600	Dues & Fees	10,000.00	10,000.00	0.00	10,042.89	-42.89
100-1510-523700	Education & Training	1,000.00	504.62	0.00	0.00	504.62
100-1510-523900	Other	4,000.00	4,000.00	0.00	535.00	3,465.00
100-1510-531100	General Supplies & Materials	4,000.00	4,000.00	134.16	2,039.73	1,960.27
100-1510-531101	Office Supplies	6,500.00	6,500.00	628.33	4,879.02	1,620.98
100-1510-531112	Flowers & Plants	500.00	500.00	0.00	0.00	500.00
100-1510-531600	Sm Equip Purchase <\$5,000	1,000.00	1,000.00	0.00	0.00	1,000.00
100-1510-541200	Site Improvements	20,000.00	10,317.50	0.00	0.00	10,317.50
100-1510-581200	Principal - Lease	111,920.00	111,920.00	0.00	55,653.51	56,266.49
100-1510-582200	Interest - Leases	21,025.00	21,025.00	0.00	10,817.13	10,207.87
Department: 1510 - Financial Administration Total:		887,245.00	887,245.00	70,960.53	679,430.50	207,814.50
Department: 1535 - It - Data Processing/Mis						
100-1535-511100	Regular Pay	154,000.00	154,000.00	15,009.06	113,130.74	40,869.26
100-1535-511300	Overtime Pay	1,500.00	1,500.00	292.44	782.32	717.68
100-1535-512100	Group Insurance	35,000.00	35,000.00	2,686.75	21,048.50	13,951.50
100-1535-512200	Fica & Medicare	11,500.00	11,500.00	1,144.85	8,659.87	2,840.13
100-1535-512400	Pmts To Retirement Sys	21,000.00	21,000.00	1,967.42	15,739.36	5,260.64
100-1535-512810	Uniforms	1,000.00	1,000.00	0.00	743.93	256.07
100-1535-521208	Professional Service	5,000.00	5,000.00	0.00	4,450.00	550.00
100-1535-521301	Computer Services	158,000.00	151,100.00	1,959.12	83,837.72	67,262.28
100-1535-521302	Drug Testing	50.00	50.00	0.00	0.00	50.00
100-1535-522201	Office Equip-Rep & Maint	27,000.00	27,000.00	1,889.52	18,536.60	8,463.40
100-1535-522206	Computer Repair & Maint	17,000.00	17,000.00	413.35	1,365.71	15,634.29
100-1535-522320	Rental-Equipment/Vehicle	0.00	0.00	325.00	325.00	-325.00
100-1535-523130	General Liability	13,100.00	25,810.00	0.00	25,808.00	2.00
100-1535-523200	Telephone	58,000.00	58,000.00	4,571.80	36,154.43	21,845.57
100-1535-523201	Postage	250.00	250.00	29.84	79.10	170.90
100-1535-523500	Travel	800.00	800.00	0.00	0.00	800.00
100-1535-523600	Dues & Fees	1,500.00	1,500.00	0.00	339.00	1,161.00
100-1535-523700	Education & Training	11,100.00	11,100.00	0.00	175.00	10,925.00
100-1535-523900	Other	1,000.00	1,000.00	0.00	0.00	1,000.00
100-1535-531100	General Supplies & Mater	800.00	800.00	0.00	1,172.10	-372.10
100-1535-531101	Office Supplies	1,500.00	1,500.00	0.00	773.85	726.15
100-1535-531102	Computer Supplies	2,000.00	2,000.00	0.00	859.80	1,140.20
100-1535-531600	Sm Equip Purchase <\$5,000	39,000.00	33,190.00	10,073.23	26,620.71	6,569.29
Department: 1535 - It - Data Processing/Mis Total:		560,100.00	560,100.00	40,362.38	360,601.74	199,498.26
Department: 1565 - General Gov Building & PI						
100-1565-511100	Regular Pay	95,050.00	95,050.00	8,557.20	66,654.35	28,395.65
100-1565-512100	Group Insurance	55,000.00	55,000.00	4,311.75	33,648.00	21,352.00
100-1565-512200	Fica & Medicare	7,271.00	7,271.00	632.64	5,020.00	2,251.00
100-1565-512400	Pmts To Retirement Sys	13,000.00	13,000.00	1,202.59	9,620.72	3,379.28

Income Statement

For Fiscal: 2023-2024 Period En

		Original Total Budget	Current Total Budget	MTD Activity	YTD Activity	Budget Remaining
100-1565-512700	Workers Compensation	25,000.00	25,000.00	0.00	20,682.41	4,317.59
100-1565-512810	Uniforms	2,500.00	2,500.00	0.00	0.00	2,500.00
100-1565-521200	Contracted Professional Services	40,000.00	40,000.00	1,369.20	22,858.23	17,141.77
100-1565-521302	Drug Testing	100.00	100.00	0.00	0.00	100.00
100-1565-522203	Mach & Equip Rep & Maint	1,500.00	1,500.00	0.00	0.00	1,500.00
100-1565-522204	Building Repairs & Maint	135,000.00	135,000.00	11,051.22	53,327.79	81,672.21
100-1565-523140	Property Insurance	17,000.00	21,014.00	0.00	21,014.00	0.00
100-1565-523500	Travel	500.00	500.00	0.00	0.00	500.00
100-1565-523700	Education & Training	1,000.00	1,000.00	0.00	0.00	1,000.00
100-1565-523800	Licenses	100.00	100.00	0.00	0.00	100.00
100-1565-523900	Other	2,500.00	2,500.00	210.94	300.94	2,199.06
100-1565-531100	General Supplies & Mater	15,000.00	15,000.00	0.00	1,828.47	13,171.53
100-1565-531105	Hand Tools	1,500.00	1,500.00	0.00	321.93	1,178.07
100-1565-531210	Water & Sewer Utility	60,000.00	60,000.00	4,120.14	29,027.32	30,972.68
100-1565-531220	Natural Gas	35,000.00	35,000.00	6,809.11	21,996.96	13,003.04
100-1565-531230	Electricity	190,000.00	190,000.00	15,542.02	100,868.21	89,131.79
100-1565-531600	Sm Equip Purchase <\$5,000	3,187.00	3,187.00	0.00	0.00	3,187.00
100-1565-531700	Other Supplies	2,000.00	2,000.00	0.00	32.27	1,967.73
100-1565-541200	Site Improvements	190,000.00	190,000.00	0.00	0.00	190,000.00
100-1565-542100	Machinery	20,000.00	15,986.00	0.00	0.00	15,986.00
Department: 1565 - General Gov Building & PI Total:		912,208.00	912,208.00	53,806.81	387,201.60	525,006.40

Department: 2000 - Judicial

100-2000-511100	Salaries & Wages - Municipal Court	210,000.00	210,000.00	16,924.40	134,056.72	75,943.28
100-2000-511300	Overtime Pay	250.00	450.00	109.42	460.68	-10.68
100-2000-512100	Group Insurance	50,000.00	50,000.00	4,436.75	32,024.50	17,975.50
100-2000-512200	Fica & Medicare	16,100.00	16,100.00	1,252.80	10,066.32	6,033.68
100-2000-512400	Pmts To Retirement Sys	32,000.00	32,000.00	2,660.13	21,281.04	10,718.96
100-2000-521201	Legal Expenses	0.00	0.00	0.00	295.50	-295.50
100-2000-521202	Judge	35,000.00	35,000.00	2,916.66	23,333.28	11,666.72
100-2000-521204	Solicitor	30,000.00	30,000.00	0.00	17,500.00	12,500.00
100-2000-521205	Public Defender	22,000.00	22,000.00	0.00	3,872.00	18,128.00
100-2000-521210	Contract Labor - Other	3,500.00	3,500.00	0.00	1,150.00	2,350.00
100-2000-523500	Travel	1,000.00	1,000.00	0.00	1,015.34	-15.34
100-2000-523600	Dues & Fees	300.00	300.00	0.00	120.00	180.00
100-2000-523700	Education & Training	2,500.00	2,500.00	0.00	659.04	1,840.96
100-2000-523900	Other	500.00	300.00	2.23	103.04	196.96
100-2000-531100	General Supplies & Mater	3,000.00	3,000.00	0.00	1,292.94	1,707.06
100-2000-571010	Prisoner Expense	45,000.00	45,000.00	3,027.07	19,988.30	25,011.70
100-2000-571030	Peace Officer'S A&B Fund	50,000.00	50,000.00	3,111.06	18,580.93	31,419.07
100-2000-571040	Local Victim Assistance Fund	25,000.00	25,000.00	1,493.13	9,375.07	15,624.93
100-2000-571050	Drug Abuse Education	7,000.00	7,000.00	267.87	3,955.49	3,044.51
100-2000-571060	Courtware Solutions	66,000.00	66,000.00	5,500.00	34,500.00	31,500.00
100-2000-571090	Consolidated Remittance	95,000.00	95,000.00	6,385.29	40,318.76	54,681.24
Department: 2000 - Judicial Total:		694,150.00	694,150.00	48,086.81	373,948.95	320,201.05

Department: 3200 - Police

100-3200-511100	Salaries & Wages - Police	2,021,840.00	2,021,840.00	166,261.69	1,401,253.84	620,586.16
100-3200-511300	Overtime Pay	120,000.00	120,000.00	5,180.47	90,870.77	29,129.23
100-3200-511301	Overtime Pay Dea	50,000.00	50,000.00	4,104.68	42,039.21	7,960.79
100-3200-512100	Group Insurance	730,000.00	730,000.00	53,364.50	467,540.75	262,459.25
100-3200-512200	Fica & Medicare	166,500.00	166,500.00	12,731.80	113,695.51	52,804.49
100-3200-512400	Pmts To Retirement Sys	279,000.00	279,000.00	27,099.01	216,792.08	62,207.92
100-3200-512700	Workers Compensation	100,000.00	100,000.00	0.00	91,200.64	8,799.36
100-3200-512810	Uniforms	28,000.00	28,000.00	305.88	14,997.92	13,002.08
100-3200-521201	Legal Expenses	0.00	1,500.00	0.00	1,455.75	44.25
100-3200-521209	Professional Service	7,000.00	7,000.00	738.69	5,619.11	1,380.89
100-3200-521301	Computer Services	4,000.00	500.00	0.00	0.00	500.00
100-3200-521302	Pre-Employment Screening	2,000.00	2,000.00	325.00	1,100.00	900.00
100-3200-522201	Office Equip-Rep & Maint	1,500.00	1,500.00	0.00	0.00	1,500.00
100-3200-522203	Mach & Equip Rep & Maint	8,500.00	8,500.00	276.00	2,346.86	6,153.14

Income Statement

For Fiscal: 2023-2024 Period En

		Original Total Budget	Current Total Budget	MTD Activity	YTD Activity	Budget Remaining
100-3200-523160	Law Enforcement Liabili	25,000.00	25,000.00	0.00	22,447.00	2,553.00
100-3200-523400	Printing & Binding	2,000.00	2,000.00	0.00	1,140.00	860.00
100-3200-523500	Travel	2,000.00	2,000.00	318.00	665.00	1,335.00
100-3200-523600	Dues & Fees	2,000.00	2,000.00	62.00	431.00	1,569.00
100-3200-523700	Education & Training	4,000.00	6,000.00	623.89	7,994.89	-1,994.89
100-3200-523900	Other	3,000.00	3,000.00	0.00	27.38	2,972.62
100-3200-523905	Police Fund Expenses	3,000.00	26,230.64	0.00	23,012.76	3,217.88
100-3200-523910	D.A.R.E Expenses	1,500.00	1,500.00	312.00	631.79	868.21
100-3200-531100	General Supplies & Mater	18,000.00	18,000.00	2,310.81	9,206.76	8,793.24
100-3200-531101	Office Supplies	13,000.00	13,000.00	934.10	7,885.09	5,114.91
100-3200-531104	Ammunition	15,000.00	15,000.00	0.00	4,328.44	10,671.56
100-3200-531270	Gasoline Expense	0.00	0.00	0.00	0.00	0.00
100-3200-531600	Sm Equip Purchase <\$5,000	7,500.00	7,500.00	0.00	4,281.60	3,218.40
100-3200-531730	Neighborhood Watch	500.00	500.00	0.00	0.00	500.00
100-3200-541200	Site Improvements	60,000.00	60,000.00	0.00	0.00	60,000.00
100-3200-542200	Vehicles	100,000.00	100,000.00	0.00	85,369.30	14,630.70
100-3200-571010	Prisoner Expense	5,000.00	5,000.00	0.00	0.00	5,000.00
Department: 3200 - Police Total:		3,779,840.00	3,803,070.64	274,948.52	2,616,333.45	1,186,737.19
Department: 3500 - Fire						
100-3500-511100	Salaries & Wages - Fire Dept	1,905,000.00	1,905,000.00	159,103.06	1,264,282.49	640,717.51
100-3500-511300	Overtime Pay	70,000.00	70,000.00	3,804.96	55,647.19	14,352.81
100-3500-512100	Group Insurance	673,725.00	673,725.00	42,373.75	337,602.25	336,122.75
100-3500-512110	Fire Cancer Insurance-Hb 146	5,256.00	5,256.00	2,037.06	3,961.41	1,294.59
100-3500-512200	Fica & Medicare	151,200.00	151,200.00	11,880.64	98,346.27	52,853.73
100-3500-512400	Pmts To Retirement Sys	267,000.00	267,000.00	24,988.12	199,904.96	67,095.04
100-3500-512700	Workers Compensation	60,000.00	60,000.00	0.00	49,788.81	10,211.19
100-3500-512810	Uniforms	20,000.00	20,000.00	523.94	4,046.59	15,953.41
100-3500-521201	Legal Expenses	0.00	0.00	0.00	1,455.75	-1,455.75
100-3500-521208	Professional -Med Service	12,000.00	12,000.00	0.00	170.00	11,830.00
100-3500-521302	Drug Testing	500.00	500.00	0.00	150.00	350.00
100-3500-522203	Mach & Equip Rep & Maint	27,500.00	27,500.00	0.00	17,143.56	10,356.44
100-3500-523500	Travel	3,000.00	3,000.00	0.00	0.00	3,000.00
100-3500-523600	Dues & Fees	3,000.00	3,000.00	525.00	602.75	2,397.25
100-3500-523700	Education & Training	10,000.00	10,000.00	309.00	2,874.46	7,125.54
100-3500-523750	Fire Prevention & Train	3,000.00	3,000.00	0.00	0.00	3,000.00
100-3500-523800	Licenses	500.00	500.00	255.00	298.25	201.75
100-3500-523900	Other	3,500.00	3,500.00	303.67	901.44	2,598.56
100-3500-531100	General Supplies & Mater	10,000.00	10,000.00	570.75	2,768.76	7,231.24
100-3500-531101	Office Supplies	2,000.00	2,000.00	70.66	1,991.68	8.32
100-3500-531600	Sm Equip Purchase <\$5,000	35,000.00	35,000.00	0.00	20,226.58	14,773.42
100-3500-531700	Other Supplies	1,000.00	1,000.00	0.00	805.00	195.00
100-3500-531710	Medical Supplies	17,000.00	17,000.00	0.00	3,861.73	13,138.27
100-3500-581200	Principal - Lease	149,853.00	149,853.00	149,852.54	149,852.54	0.46
100-3500-582200	Interest - Leases	7,648.00	7,648.00	7,647.73	7,647.73	0.27
Department: 3500 - Fire Total:		3,437,682.00	3,437,682.00	404,245.88	2,224,330.20	1,213,351.80
Department: 4100 - Public Works						
100-4100-511100	Salaries & Wages - Public Works	393,500.00	393,500.00	30,308.99	249,840.03	143,659.97
100-4100-511300	Overtime Pay	1,000.00	1,000.00	0.00	927.14	72.86
100-4100-512100	Group Insurance	220,000.00	220,000.00	15,168.75	125,532.75	94,467.25
100-4100-512200	Fica & Medicare	25,000.00	25,000.00	2,133.81	17,975.72	7,024.28
100-4100-512400	Pmts To Retirement Sys	55,000.00	55,000.00	4,991.30	39,930.40	15,069.60
100-4100-512700	Workers Compensation	60,000.00	60,000.00	0.00	53,259.88	6,740.12
100-4100-512810	Uniforms	8,000.00	8,000.00	1,095.10	4,669.92	3,330.08
100-4100-521302	Drug Testing	100.00	100.00	0.00	50.00	50.00
100-4100-522140	Lawn Care	8,000.00	8,000.00	404.00	3,484.00	4,516.00
100-4100-522203	Mach & Equip Rep & Maint	10,000.00	10,000.00	1,532.52	8,014.75	1,985.25
100-4100-522320	Rental-Equipment/Vehicle	3,000.00	3,000.00	1,014.80	2,312.80	687.20
100-4100-523900	Other	5,000.00	5,000.00	2,170.76	4,459.38	540.62
100-4100-531100	General Supplies & Materials	8,000.00	8,000.00	0.00	7,990.13	9.87

Income Statement

For Fiscal: 2023-2024 Period En

Section 2, Item E.

		Original Total Budget	Current Total Budget	MTD Activity	YTD Activity	Budget Remaining
100-4100-531105	Hand Tools	2,000.00	2,000.00	199.99	199.99	1,800.01
100-4100-531250	Oil Expense	1,000.00	1,000.00	45.52	45.52	954.48
100-4100-531600	Sm Equip Purchase <\$5,000	5,000.00	5,000.00	0.00	387.09	4,612.91
100-4100-531700	Other Supplies	5,000.00	5,000.00	1,170.25	1,170.25	3,829.75
Department: 4100 - Public Works Total:		809,600.00	809,600.00	60,235.79	520,249.75	289,350.25
Department: 4200 - Highways And Streets						
100-4200-511100	Regular Pay	207,000.00	207,000.00	9,844.00	118,592.23	88,407.77
100-4200-511300	Overtime Pay	5,000.00	5,000.00	0.00	2,311.82	2,688.18
100-4200-512100	Group Insurance	85,000.00	85,000.00	2,657.25	49,113.50	35,886.50
100-4200-512200	Fica & Medicare	15,500.00	15,500.00	715.85	9,036.93	6,463.07
100-4200-512400	Pmts To Retirement Sys	30,000.00	30,000.00	2,682.27	21,458.16	8,541.84
100-4200-512810	Uniforms	500.00	500.00	130.50	650.55	-150.55
100-4200-521202	Engineering Fees	50,000.00	50,000.00	0.00	15,546.59	34,453.41
100-4200-521302	Drug Test & Med Service	200.00	200.00	0.00	0.00	200.00
100-4200-521303	Technical Services	3,200.00	3,200.00	0.00	3,087.00	113.00
100-4200-521307	Technical Service-Mapping	6,000.00	6,000.00	0.00	0.00	6,000.00
100-4200-522203	Mach & Equip Rep & Maint	12,000.00	12,000.00	1,395.90	4,782.15	7,217.85
100-4200-522211	Sidewalk Repair & Maint	15,000.00	15,000.00	1,375.75	29,478.25	-14,478.25
100-4200-523500	Travel	500.00	500.00	0.00	0.00	500.00
100-4200-523600	Dues & Fees	250.00	250.00	0.00	0.00	250.00
100-4200-523700	Education & Training	2,500.00	2,500.00	0.00	250.00	2,250.00
100-4200-523800	Licenses	250.00	250.00	0.00	0.00	250.00
100-4200-523900	Other	1,000.00	1,000.00	0.00	0.00	1,000.00
100-4200-531100	General Supplies & Mater	8,000.00	8,000.00	412.10	4,701.50	3,298.50
100-4200-531101	Office Supplies	1,000.00	1,000.00	0.00	0.00	1,000.00
100-4200-531105	Hand Tools	2,500.00	2,500.00	0.00	719.12	1,780.88
100-4200-531109	Chemicals	8,500.00	8,500.00	0.00	0.00	8,500.00
100-4200-531110	Street Repair	500,000.00	500,000.00	5,377.00	170,183.28	329,816.72
100-4200-531111	Traffic Light Maintenance	2,000.00	2,000.00	0.00	0.00	2,000.00
100-4200-531112	Lmig Street Repair & Maint	140,000.00	140,000.00	0.00	139,734.35	265.65
100-4200-531113	Street Signs	10,000.00	10,000.00	0.00	4,786.90	5,213.10
100-4200-531531	Traffic Signal - Utility	3,000.00	3,000.00	165.53	1,034.32	1,965.68
100-4200-531532	Street Light - Utility	175,000.00	175,000.00	17,989.72	114,446.85	60,553.15
100-4200-531600	Sm Equip Purchase <\$5,000	5,000.00	5,000.00	0.00	8,000.00	-3,000.00
100-4200-531610	Infrastructure < \$25,000	25,000.00	25,000.00	0.00	0.00	25,000.00
100-4200-541466	Street Improvements	100,000.00	100,000.00	0.00	0.00	100,000.00
100-4200-542100	Machinery	100,000.00	100,000.00	0.00	122,230.55	-22,230.55
Department: 4200 - Highways And Streets Total:		1,513,900.00	1,513,900.00	42,745.87	820,144.05	693,755.95
Department: 4900 - Fleet Maintenance & Shop						
100-4900-511100	Regular Pay-Fleet Maint & Shop	197,000.00	197,000.00	17,934.90	139,775.42	57,224.58
100-4900-511300	Overtime Pay	1,000.00	1,000.00	0.00	120.89	879.11
100-4900-512100	Group Insurance	84,000.00	84,000.00	7,507.75	56,147.00	27,853.00
100-4900-512200	Fica & Medicare	15,500.00	15,500.00	1,279.52	10,296.39	5,203.61
100-4900-512400	Payments To Retirement	30,000.00	30,000.00	2,505.14	20,041.12	9,958.88
100-4900-512700	Workers Compensation	5,000.00	5,000.00	0.00	4,047.75	952.25
100-4900-512810	Uniforms	4,500.00	4,500.00	141.62	1,619.46	2,880.54
100-4900-521302	Drug Testing	50.00	50.00	0.00	0.00	50.00
100-4900-522202	Auto & Truck Rep & Maint	140,000.00	140,000.00	15,026.78	78,395.03	61,604.97
100-4900-522203	Mach & Equip Rep & Maint	5,000.00	5,000.00	0.00	4,284.78	715.22
100-4900-523170	Auto Liability	105,000.00	105,000.00	0.00	116,783.00	-11,783.00
100-4900-523500	Travel	2,000.00	2,000.00	0.00	0.00	2,000.00
100-4900-523600	Dues & Fees	250.00	250.00	0.00	0.00	250.00
100-4900-523900	Other	1,000.00	1,000.00	63.94	524.96	475.04
100-4900-531100	General Supplies & Mater	5,000.00	5,000.00	201.48	3,023.24	1,976.76
100-4900-531101	Office Supplies	1,000.00	1,000.00	0.00	169.75	830.25
100-4900-531105	Hand Tools	5,000.00	5,000.00	0.00	914.26	4,085.74
100-4900-531250	Oil Expense	7,500.00	7,500.00	0.00	1,903.65	5,596.35
100-4900-531270	Gasoline Expense	200,000.00	200,000.00	13,641.83	108,539.56	91,460.44
100-4900-531600	Sm Equip Purchase <\$5000	15,000.00	15,000.00	2,519.92	6,635.32	8,364.68

Income Statement

For Fiscal: 2023-2024 Period En

	Original Total Budget	Current Total Budget	MTD Activity	YTD Activity	Budget Remaining
100-4900-542200 Vehicles	135,000.00	135,000.00	0.00	0.00	135,000.00
Department: 4900 - Fleet Maintenance & Shop Total:	958,800.00	958,800.00	60,822.88	553,221.58	405,578.42
Department: 6500 - Libraries					
100-6500-522204 Building Repairs & Maint	7,000.00	7,000.00	0.00	2,318.57	4,681.43
100-6500-572030 Library - Uncle Remus	133,238.00	133,238.00	0.00	66,619.00	66,619.00
Department: 6500 - Libraries Total:	140,238.00	140,238.00	0.00	68,937.57	71,300.43
Department: 7400 - Planning & Zoning					
100-7400-511100 Salaries & Wages - P & Dev	249,000.00	249,000.00	19,973.10	210,479.05	38,520.95
100-7400-511300 Overtime Pay	1,000.00	1,000.00	100.96	644.99	355.01
100-7400-512100 Group Insurance	64,200.00	64,200.00	958.00	42,272.00	21,928.00
100-7400-512200 Fica & Medicare	19,125.00	19,125.00	1,508.33	16,000.79	3,124.21
100-7400-512400 Pmts To Retirement Sys	40,000.00	40,000.00	3,163.05	25,304.40	14,695.60
100-7400-512810 Uniforms	1,500.00	1,500.00	0.00	0.00	1,500.00
100-7400-521201 Legal Expenses	10,000.00	10,000.00	0.00	0.00	10,000.00
100-7400-521202 Engineering Fees	20,000.00	20,000.00	0.00	15,400.00	4,600.00
100-7400-521302 Drug Testing	100.00	100.00	0.00	0.00	100.00
100-7400-521312 Planning Commissioners	2,400.00	2,400.00	0.00	0.00	2,400.00
100-7400-523301 Advertising Expense	500.00	500.00	45.00	115.00	385.00
100-7400-523400 Printing & Binding	1,000.00	1,000.00	0.00	0.00	1,000.00
100-7400-523500 Travel	1,000.00	1,000.00	0.00	280.69	719.31
100-7400-523600 Dues & Fees	400.00	400.00	171.97	171.97	228.03
100-7400-523700 Education & Training	4,500.00	4,500.00	425.00	2,321.32	2,178.68
100-7400-523800 Licenses	400.00	400.00	0.00	73.20	326.80
100-7400-523900 Other	1,000.00	1,000.00	0.00	20.00	980.00
100-7400-531100 General Supplies & Mater	2,000.00	2,000.00	0.00	0.00	2,000.00
100-7400-531101 Office Supplies	2,000.00	2,000.00	57.97	1,297.67	702.33
100-7400-531102 Computer Supplies	2,000.00	2,000.00	0.00	0.00	2,000.00
100-7400-531600 Sm Equip Purchase <\$5,000	1,000.00	1,000.00	0.00	93.89	906.11
Department: 7400 - Planning & Zoning Total:	423,125.00	423,125.00	26,403.38	314,474.97	108,650.03
Department: 7545 - Economic Development -					
100-7545-511100 Regular Pay	117,000.00	117,000.00	13,675.04	108,360.66	8,639.34
100-7545-511300 Overtime Pay	52,500.00	44,500.00	338.49	22,728.28	21,771.72
100-7545-512100 Group Insurance	48,000.00	48,000.00	3,397.50	26,617.50	21,382.50
100-7545-512200 Fica & Medicare	12,500.00	12,500.00	1,033.08	9,780.95	2,719.05
100-7545-512400 Payments To Retirement	22,200.00	22,200.00	2,144.55	17,156.40	5,043.60
100-7545-512810 Uniforms	500.00	0.00	0.00	0.00	0.00
100-7545-523301 Advertising Expense	3,500.00	3,500.00	0.00	707.15	2,792.85
100-7545-523400 Printing	2,500.00	7,500.00	0.00	0.00	7,500.00
100-7545-523500 Travel Expense	0.00	595.00	0.00	594.96	0.04
100-7545-523600 Dues & Fees	1,500.00	1,729.00	435.00	1,729.00	0.00
100-7545-523900 Other	500.00	500.00	0.00	0.00	500.00
100-7545-531100 General Supplies & Materials	15,000.00	14,771.00	80.00	12,089.76	2,681.24
100-7545-531112 Flowers	250.00	250.00	0.00	71.68	178.32
100-7545-531300 Food	12,000.00	12,000.00	257.58	7,281.54	4,718.46
100-7545-572010 Events - Etc.	100,000.00	102,905.00	17,803.00	64,402.43	38,502.57
Department: 7545 - Economic Development - Total:	387,950.00	387,950.00	39,164.24	271,520.31	116,429.69
Fund: 100 - General Fund Surplus (Deficit):	0.00	-23,230.64	-176,483.15	4,019,553.73	
Fund: 210 - Confiscated Asset Fund					
Department: 0000 - Non-Departmental					
210-0000-381001 Confiscated Assets	5,000.00	5,000.00	0.00	0.00	5,000.00
210-0000-381010 Federal Confiscated Assets	100,000.00	100,000.00	2,694.12	42,676.95	57,323.05
Department: 0000 - Non-Departmental Total:	105,000.00	105,000.00	2,694.12	42,676.95	62,323.05
Department: 3200 - Police					
210-3200-512810 Uniforms	1,000.00	1,000.00	0.00	0.00	1,000.00
210-3200-523901 Other -- Federal Forfeiture	50,000.00	50,000.00	0.00	41,299.30	8,700.70
210-3200-531100 General Supplies & Mater	0.00	0.00	0.00	0.00	0.00
210-3200-531600 Sm Equip Federal <\$5000	50,000.00	50,000.00	0.00	0.00	50,000.00

Income Statement

For Fiscal: 2023-2024 Period End

	Original Total Budget	Current Total Budget	MTD Activity	YTD Activity	Budget Remaining
210-3200-531601 Small Equip Confiscated <\$5000	4,000.00	4,000.00	0.00	0.00	4,000.00
Department: 3200 - Police Total:	105,000.00	105,000.00	0.00	41,299.30	63,700.70
Fund: 210 - Confiscated Asset Fund Surplus (Deficit):	0.00	0.00	2,694.12	1,377.65	
Fund: 275 - Hotel/Motel Fund					
Department: 0000 - Non-Departmental					
275-0000-314100 Hotel / Motel Tax	70,000.00	70,000.00	5,046.50	37,740.11	32,259.89
Department: 0000 - Non-Departmental Total:	70,000.00	70,000.00	5,046.50	37,740.11	32,259.89
Department: 7540 - Tourism					
275-7540-523301 Advertising Expense	10,000.00	10,000.00	1,632.50	9,590.11	409.89
275-7540-572010 Chamber - Hotel/Motel	10,000.00	10,000.00	0.00	3,000.00	7,000.00
275-7540-611050 Transfer Out - General	50,000.00	50,000.00	7,021.44	19,609.83	30,390.17
Department: 7540 - Tourism Total:	70,000.00	70,000.00	8,653.94	32,199.94	37,800.06
Fund: 275 - Hotel/Motel Fund Surplus (Deficit):	0.00	0.00	-3,607.44	5,540.17	
Fund: 320 - Gw Splost 2017					
Department: 0000 - Non-Departmental					
320-0000-335120 Intergovernmental Revenues	0.00	0.00	0.00	536,057.00	-536,057.00
320-0000-337101 Recreation Gw	1,338,781.00	1,338,781.00	0.00	0.00	1,338,781.00
320-0000-337103 Transportation Gw	1,320,649.00	1,320,649.00	0.00	0.00	1,320,649.00
320-0000-337104 W&S Capital Improvements Gw	380,604.00	380,604.00	0.00	0.00	380,604.00
320-0000-361000 Interest Revenues	0.00	0.00	0.00	2,757.92	-2,757.92
Department: 0000 - Non-Departmental Total:	3,040,034.00	3,040,034.00	0.00	538,814.92	2,501,219.08
Department: 4200 - Highways And Streets					
320-4200-541410 Transp-Old Loganville Sidewalk	1,320,649.00	1,320,649.00	0.00	30,689.92	1,289,959.08
Department: 4200 - Highways And Streets Total:	1,320,649.00	1,320,649.00	0.00	30,689.92	1,289,959.08
Department: 4400 - Water					
320-4400-541400 Infrastructure-Dest Park	380,604.00	380,604.00	0.00	114,712.20	265,891.80
Department: 4400 - Water Total:	380,604.00	380,604.00	0.00	114,712.20	265,891.80
Department: 6200 - Parks					
320-6200-541300 Buildings-Park	0.00	0.00	0.00	-77,054.45	77,054.45
320-6200-541400 Recreation - Infrastructure	1,338,781.00	1,338,781.00	0.00	157,085.09	1,181,695.91
Department: 6200 - Parks Total:	1,338,781.00	1,338,781.00	0.00	80,030.64	1,258,750.36
Fund: 320 - Gw Splost 2017 Surplus (Deficit):	0.00	0.00	0.00	313,382.16	
Fund: 321 - Wc Splost 2019					
Department: 0000 - Non-Departmental					
321-0000-337103 Transportation Wc Splost 2019	3,218,899.00	3,218,899.00	107,301.38	1,161,870.86	2,057,028.14
321-0000-337104 Public Safety Wc Splost 2019	2,354,726.00	2,354,726.00	78,494.35	687,455.53	1,667,270.47
321-0000-337105 Parks And Rec Walton Splost 2019	226,193.00	226,193.00	7,540.10	66,036.37	160,156.63
321-0000-361000 Interest Revenues	0.00	0.00	17,096.49	144,903.49	-144,903.49
321-0000-389000 Bank Charges & Misc.	0.00	0.00	-15.00	-344.00	344.00
Department: 0000 - Non-Departmental Total:	5,799,818.00	5,799,818.00	210,417.32	2,059,922.25	3,739,895.75
Department: 3200 - Police					
321-3200-531600 Small Equip Purchase < \$5000	0.00	0.00	0.00	0.00	0.00
321-3200-541300 Public Safety Buildings	2,354,726.00	2,354,726.00	0.00	0.00	2,354,726.00
321-3200-542100 Machinery/ Equipment	0.00	0.00	0.00	276,776.10	-276,776.10
321-3200-542200 Vehicles	0.00	0.00	0.00	50,208.41	-50,208.41
Department: 3200 - Police Total:	2,354,726.00	2,354,726.00	0.00	326,984.51	2,027,741.49
Department: 3500 - Fire					
321-3500-531600 Small Equip Purchase < \$5000	0.00	0.00	47,653.00	47,653.00	-47,653.00
321-3500-542200 Vehicles	0.00	111,971.00	5,042.00	1,125,417.00	-1,013,446.00
Department: 3500 - Fire Total:	0.00	111,971.00	52,695.00	1,173,070.00	-1,061,099.00
Department: 4200 - Highways And Streets					
321-4200-541400 Transportation Infrastructure	3,218,899.00	3,218,899.00	0.00	0.00	3,218,899.00
Department: 4200 - Highways And Streets Total:	3,218,899.00	3,218,899.00	0.00	0.00	3,218,899.00

Income Statement

For Fiscal: 2023-2024 Period En

Section 2, Item E.

		Original Total Budget	Current Total Budget	MTD Activity	YTD Activity	Budget Remaining
Department: 6200 - Parks						
321-6200-542100	Machinery/ Equipment	226,193.00	226,193.00	0.00	0.00	226,193.00
	Department: 6200 - Parks Total:	226,193.00	226,193.00	0.00	0.00	226,193.00
	Fund: 321 - Wc Splost 2019 Surplus (Deficit):	0.00	-111,971.00	157,722.32	559,867.74	
Fund: 324 - GW SPLOST 2023						
Department: 0000 - Non-Departmental						
324-0000-337101	Splost 23 Transportation	2,559,746.00	2,559,746.00	41,636.20	423,870.89	2,135,875.11
324-0000-337102	Splost 23 - Public Safety-Facilities & Equip	600,000.00	600,000.00	9,495.98	67,500.78	532,499.22
324-0000-337103	Splost 23 Recreational	750,000.00	750,000.00	12,417.81	88,270.23	661,729.77
324-0000-337104	Splost 23 Water & Sewer Capital Improvem...	574,642.00	574,642.00	9,495.98	67,500.78	507,141.22
324-0000-361000	Interest Income	0.00	0.00	1,496.97	6,249.34	-6,249.34
324-0000-389000	Bank Charges and Misc	0.00	0.00	-95.00	-707.00	707.00
	Department: 0000 - Non-Departmental Total:	4,484,388.00	4,484,388.00	74,447.94	652,685.02	3,831,702.98
Department: 3200 - Police						
324-3200-541300	Police Public Safety Facilities	300,000.00	300,000.00	0.00	0.00	300,000.00
	Department: 3200 - Police Total:	300,000.00	300,000.00	0.00	0.00	300,000.00
Department: 3500 - Fire						
324-3500-522204	Building Repairs and Maint	0.00	0.00	0.00	0.00	0.00
324-3500-541300	Fire Public Safety Facilities	300,000.00	300,000.00	0.00	0.00	300,000.00
	Department: 3500 - Fire Total:	300,000.00	300,000.00	0.00	0.00	300,000.00
Department: 4200 - Highways And Streets						
324-4200-541400	Transportation Infrastructure	2,559,746.00	2,559,746.00	0.00	0.00	2,559,746.00
	Department: 4200 - Highways And Streets Total:	2,559,746.00	2,559,746.00	0.00	0.00	2,559,746.00
Department: 4330 - Sewer Collections						
324-4330-541400	Sewer Infrastructure	287,321.00	287,321.00	0.00	0.00	287,321.00
	Department: 4330 - Sewer Collections Total:	287,321.00	287,321.00	0.00	0.00	287,321.00
Department: 4400 - Water						
324-4400-541400	Water Infrastructure	287,321.00	287,321.00	0.00	0.00	287,321.00
	Department: 4400 - Water Total:	287,321.00	287,321.00	0.00	0.00	287,321.00
Department: 6200 - Parks						
324-6200-541400	Recreational Infrastructure	750,000.00	750,000.00	0.00	0.00	750,000.00
	Department: 6200 - Parks Total:	750,000.00	750,000.00	0.00	0.00	750,000.00
	Fund: 324 - GW SPLOST 2023 Surplus (Deficit):	0.00	0.00	74,447.94	652,685.02	
Fund: 371 - ARPA						
Department: 0000 - Non-Departmental						
371-0000-361000	Interest Revenue	0.00	0.00	10,525.01	91,536.27	-91,536.27
	Department: 0000 - Non-Departmental Total:	0.00	0.00	10,525.01	91,536.27	-91,536.27
Department: 4200 - Highways And Streets						
371-4200-541400	Street Infrastructure	0.00	0.00	194,381.58	194,381.58	-194,381.58
	Department: 4200 - Highways And Streets Total:	0.00	0.00	194,381.58	194,381.58	-194,381.58
Department: 4300 - Water Quality Control						
371-4300-541400	Infrastructure	0.00	350,000.00	0.00	0.00	350,000.00
371-4300-542200	Vehicles	0.00	0.00	126,787.88	126,787.88	-126,787.88
	Department: 4300 - Water Quality Control Total:	0.00	350,000.00	126,787.88	126,787.88	223,212.12
Department: 4330 - Sewer Collections						
371-4330-522205	Infrastructure Repair & Maintenance	0.00	0.00	0.00	29,420.00	-29,420.00
	Department: 4330 - Sewer Collections Total:	0.00	0.00	0.00	29,420.00	-29,420.00
Department: 4400 - Water						
371-4400-541410	Water Infrastructure	0.00	0.00	0.00	-309,400.03	309,400.03
	Department: 4400 - Water Total:	0.00	0.00	0.00	-309,400.03	309,400.03
	Fund: 371 - ARPA Surplus (Deficit):	0.00	-350,000.00	-310,644.45	50,346.84	
Fund: 375 - Capital Recovery-Impact Fees						
Department: 0000 - Non-Departmental						
375-0000-341320	Capital Recovery Impact Fee	500,000.00	500,000.00	0.00	149,346.36	350,653.64

Income Statement

For Fiscal: 2023-2024 Period End

	Original Total Budget	Current Total Budget	MTD Activity	YTD Activity	Budget Remaining
375-0000-361000 Interest Revenues	0.00	0.00	0.00	31,661.39	-31,661.39
Department: 0000 - Non-Departmental Total:	500,000.00	500,000.00	0.00	181,007.75	318,992.25
Department: 4400 - Water					
375-4400-541400 Infrastructure	500,000.00	500,000.00	0.00	0.00	500,000.00
Department: 4400 - Water Total:	500,000.00	500,000.00	0.00	0.00	500,000.00
Fund: 375 - Capital Recovery-Impact Fees Surplus (Deficit):	0.00	0.00	0.00	181,007.75	
Fund: 505 - Water & Sewer Fund					
Department: 0000 - Non-Departmental					
505-0000-341320 Capital Recovery Fee	0.00	0.00	43,925.40	43,925.40	-43,925.40
505-0000-341321 Capital Recovery - Plan Review	7,500.00	7,500.00	111.62	613.91	6,886.09
505-0000-344190 Other Charges	0.00	0.00	-29.28	-1,064.23	1,064.23
505-0000-344211 Water Sales / Collection	3,650,000.00	3,650,000.00	280,202.76	2,323,277.94	1,326,722.06
505-0000-344212 Water Tap Fees	500,000.00	500,000.00	38,250.00	168,300.00	331,700.00
505-0000-344213 Backflow	19,000.00	19,000.00	11,550.00	13,080.00	5,920.00
505-0000-344214 Sprinkler Meter Fees	5,000.00	5,000.00	0.00	0.00	5,000.00
505-0000-344215 Hydrant Meter Fees	4,500.00	4,500.00	294.89	6,844.62	-2,344.62
505-0000-344255 Sewer Sales / Collection	3,050,000.00	3,050,000.00	247,472.96	1,986,002.72	1,063,997.28
505-0000-344256 Sewer Tap Fees	850,000.00	850,000.00	81,900.00	372,600.00	477,400.00
505-0000-344257 Dumping Tickets	550,000.00	550,000.00	42,975.00	279,900.00	270,100.00
505-0000-344258 Grease Trap Fees	12,000.00	12,000.00	1,500.00	8,850.00	3,150.00
505-0000-344260 Storm Water Utility	600,000.00	600,000.00	49,021.90	363,772.85	236,227.15
505-0000-349300 Bad Check Fees	1,500.00	1,500.00	7.98	2,820.61	-1,320.61
505-0000-349900 Water & Sewer Late Fees	200,000.00	200,000.00	13,989.36	119,738.82	80,261.18
505-0000-349910 Administrative Fees	100,000.00	100,000.00	15,675.03	70,185.03	29,814.97
505-0000-361000 Interest Revenues	15,000.00	15,000.00	8,066.12	67,180.18	-52,180.18
505-0000-389000 Bank Charges & Etc.	3,000.00	3,000.00	-1,011.72	-40,669.34	43,669.34
505-0000-391100 Collections -Bad Debt	0.00	0.00	-201.74	-2,968.65	2,968.65
Department: 0000 - Non-Departmental Total:	9,567,500.00	9,567,500.00	833,700.28	5,782,389.86	3,785,110.14
Department: 4300 - Water Quality Control					
505-4300-511100 Salaries & Wages - Wqc	602,770.00	602,770.00	49,980.73	348,859.65	253,910.35
505-4300-511300 Overtime Pay	15,000.00	15,000.00	474.66	7,208.91	7,791.09
505-4300-512100 Group Insurance	275,000.00	275,000.00	18,897.50	147,169.50	127,830.50
505-4300-512200 Fica & Medicare	46,112.00	46,112.00	3,608.72	28,886.58	17,225.42
505-4300-512400 Pmts To Retirement Sys	81,846.00	81,846.00	7,816.16	62,529.28	19,316.72
505-4300-512810 Uniforms	45,000.00	45,000.00	1,327.05	18,564.25	26,435.75
505-4300-521201 Legal Expenses	15,000.00	15,000.00	0.00	0.00	15,000.00
505-4300-521202 Engineering Fees	10,000.00	8,000.00	0.00	1,495.00	6,505.00
505-4300-521208 Professional -Med Service	1,500.00	1,500.00	0.00	0.00	1,500.00
505-4300-521301 Computer Services	115,000.00	69,303.00	2,389.75	60,881.24	8,421.76
505-4300-521302 Drug Testing	500.00	500.00	0.00	50.00	450.00
505-4300-521307 Technical Service	30,000.00	15,000.00	0.00	466.00	14,534.00
505-4300-521320 Outside Lab Service	15,000.00	15,000.00	380.18	3,721.38	11,278.62
505-4300-521330 W E T Sampling	10,000.00	5,000.00	0.00	0.00	5,000.00
505-4300-522110 Disposal (Sludge)	10,000.00	0.00	0.00	0.00	0.00
505-4300-522201 Office Equip-Rep & Maint	10,500.00	10,500.00	443.08	5,227.64	5,272.36
505-4300-522202 Auto & Truck Rep & Maint	50,000.00	50,000.00	1,636.43	33,143.31	16,856.69
505-4300-522203 Mach & Equip Rep & Maint	55,000.00	5,000.00	887.96	1,833.66	3,166.34
505-4300-522204 Building Repairs & Maint	25,000.00	14,458.00	287.68	5,056.64	9,401.36
505-4300-522205 Infrastructure Rep & Main	100,000.00	275,735.00	3,918.25	276,880.99	-1,145.99
505-4300-522206 Computer Repair & Maint	3,000.00	3,000.00	0.00	1,249.09	1,750.91
505-4300-522320 Rental-Equipment/Vehicle	2,000.00	0.00	0.00	0.00	0.00
505-4300-523130 General Liability	46,000.00	56,542.00	0.00	56,542.00	0.00
505-4300-523140 Property Insurance	30,000.00	34,014.00	0.00	34,014.00	0.00
505-4300-523170 Auto Liability	20,000.00	50,000.00	0.00	50,000.00	0.00
505-4300-523200 Telephone	15,000.00	22,420.00	1,428.55	23,518.38	-1,098.38
505-4300-523500 Travel	1,000.00	1,000.00	0.00	0.00	1,000.00
505-4300-523600 Dues & Fees	3,000.00	3,000.00	0.00	1,241.25	1,758.75
505-4300-523700 Education & Training	10,000.00	10,000.00	0.00	1,798.20	8,201.80

Income Statement

For Fiscal: 2023-2024 Period En

		Original Total Budget	Current Total Budget	MTD Activity	YTD Activity	Budget Remaining
505-4300-523800	Licenses	1,000.00	1,000.00	0.00	0.00	1,000.00
505-4300-523900	Other	2,000.00	2,000.00	1,832.00	301.36	1,698.64
505-4300-531100	General Supplies & Mater	10,000.00	10,000.00	0.00	3,826.85	6,173.15
505-4300-531101	Office Supplies	4,000.00	4,000.00	0.00	3,179.50	820.50
505-4300-531102	Computer Supplies	5,000.00	0.00	422.99	422.99	-422.99
505-4300-531103	Lab Supplies	20,000.00	20,000.00	1,676.02	13,432.63	6,567.37
505-4300-531105	Hand Tools	1,500.00	1,500.00	0.00	0.00	1,500.00
505-4300-531109	Chemicals	150,000.00	150,000.00	7,521.04	109,598.88	40,401.12
505-4300-531220	Natural Gas	1,200.00	1,200.00	101.34	711.90	488.10
505-4300-531230	Electricity	400,000.00	400,000.00	41,394.45	249,048.80	150,951.20
505-4300-531250	Oil Expense	5,000.00	5,000.00	0.00	2,174.38	2,825.62
505-4300-531270	Gasoline Expense	60,000.00	60,000.00	5,274.47	46,822.85	13,177.15
505-4300-531600	Sm Equip Purchase <\$5,000	5,000.00	5,000.00	0.00	497.68	4,502.32
505-4300-531700	Other Supplies	1,000.00	1,000.00	0.00	130.00	870.00
505-4300-561000	Depreciation	388,824.00	388,824.00	0.00	0.00	388,824.00
505-4300-562000	Amortization	24,600.00	24,600.00	0.00	0.00	24,600.00
505-4300-581100	Principal - Bonds	995,000.00	995,000.00	0.00	0.00	995,000.00
505-4300-582100	Interest - Bonds	625,432.00	625,432.00	0.00	312,819.58	312,612.42
Department: 4300 - Water Quality Control Total:		4,342,784.00	4,425,256.00	151,699.01	1,913,304.35	2,511,951.65
Department: 4320 - Stormwater						
505-4320-511100	Regular Pay	223,066.00	223,066.00	19,780.67	146,273.35	76,792.65
505-4320-511300	Overtime Pay	6,000.00	6,000.00	394.22	5,565.57	434.43
505-4320-512100	Group Insurance	58,913.00	58,913.00	5,427.50	38,249.50	20,663.50
505-4320-512200	Fica & Medicare	17,065.00	17,065.00	1,496.58	12,066.59	4,998.41
505-4320-512400	Pmts To Retirement Sys	29,676.00	34,676.00	2,898.19	23,185.52	11,490.48
505-4320-512700	Workers Compensation	3,000.00	3,000.00	0.00	0.00	3,000.00
505-4320-521202	Engineering Fees	50,000.00	50,000.00	3,217.50	23,275.15	26,724.85
505-4320-521307	Technical Service Mapping	25,000.00	25,000.00	2,000.00	14,560.00	10,440.00
505-4320-521320	Outside Lab Service	17,000.00	25,000.00	0.00	12,813.70	12,186.30
505-4320-521370	Auto Liability	1,000.00	1,000.00	0.00	0.00	1,000.00
505-4320-522203	Mach & Equip Rep & Maint	8,000.00	4,580.00	0.00	915.69	3,664.31
505-4320-522205	Infrastructure Rep & Main	75,000.00	67,000.00	7,000.00	43,800.66	23,199.34
505-4320-522320	Rental-Equipment/Vehicle	2,000.00	0.00	0.00	0.00	0.00
505-4320-523301	Advertising Expense	1,500.00	1,900.00	0.00	773.47	1,126.53
505-4320-523400	Printing & Binding	3,000.00	3,000.00	0.00	2,274.73	725.27
505-4320-523700	Education & Training	2,000.00	1,600.00	225.00	225.00	1,375.00
505-4320-523800	Licenses	500.00	500.00	0.00	0.00	500.00
505-4320-523900	Other	2,000.00	2,000.00	0.00	462.85	1,537.15
505-4320-531100	General Supplies & Mater	10,000.00	10,000.00	0.00	1,457.80	8,542.20
505-4320-531101	Office Supplies	2,000.00	0.00	0.00	0.00	0.00
505-4320-531105	Hand Tools	2,000.00	1,000.00	0.00	0.00	1,000.00
505-4320-531109	Chemicals	5,000.00	5,000.00	0.00	1,887.50	3,112.50
505-4320-531600	Sm Equip Purchase <\$5,000	5,000.00	0.00	0.00	0.00	0.00
505-4320-531700	Other Supplies	3,000.00	3,000.00	0.00	0.00	3,000.00
505-4320-542100	Machinery	10,000.00	0.00	0.00	0.00	0.00
505-4320-561000	Depreciation	77,500.00	77,500.00	0.00	0.00	77,500.00
Department: 4320 - Stormwater Total:		639,220.00	620,800.00	42,439.66	327,787.08	293,012.92
Department: 4330 - Sewer Collections						
505-4330-511100	Regular Pay	260,560.00	260,560.00	15,279.24	117,476.10	143,083.90
505-4330-511300	Overtime Pay	20,000.00	35,000.00	1,286.53	22,425.04	12,574.96
505-4330-512100	Group Insurance	110,000.00	110,000.00	7,072.25	54,454.50	55,545.50
505-4330-512200	Fica & Medicare	19,933.00	19,933.00	1,227.53	11,410.39	8,522.61
505-4330-512400	Retirement	33,211.00	39,211.00	3,549.70	28,397.60	10,813.40
505-4330-521202	Engineering Fees	15,000.00	4,000.00	0.00	1,350.00	2,650.00
505-4330-521302	Drug Testing	0.00	0.00	0.00	50.00	-50.00
505-4330-521303	Tech Services	7,500.00	21,000.00	0.00	14,239.25	6,760.75
505-4330-521306	Tech Service Generator	9,000.00	8,000.00	0.00	2,994.00	5,006.00
505-4330-521307	Tech Sev Gis Mapping	20,000.00	15,000.00	0.00	8,815.87	6,184.13
505-4330-522110	Septic Disposal	12,000.00	41,000.00	4,050.00	43,800.00	-2,800.00

Income Statement

For Fiscal: 2023-2024 Period En

		Original Total Budget	Current Total Budget	MTD Activity	YTD Activity	Budget Remaining
505-4330-522203	Mach & Equip Rep & Maint	15,000.00	15,000.00	0.00	9,468.78	5,531.22
505-4330-522205	Infrastructure Rep & Maint	100,000.00	140,000.00	28,647.75	158,231.56	-18,231.56
505-4330-522320	Rental Equip/ Vehicle	1,000.00	18,000.00	0.00	17,884.63	115.37
505-4330-523301	Advertising Expense	1,000.00	0.00	0.00	0.00	0.00
505-4330-523500	Travel	2,000.00	0.00	0.00	0.00	0.00
505-4330-523600	Dues & Fees	1,000.00	0.00	0.00	0.00	0.00
505-4330-523700	Education & Training	5,000.00	1,986.00	0.00	1,177.00	809.00
505-4330-523800	Licenses	1,000.00	1,000.00	0.00	30.00	970.00
505-4330-523900	Other	1,500.00	1,500.00	96.24	173.96	1,326.04
505-4330-531100	General Supplies & Materials	10,000.00	10,000.00	2,420.53	8,178.63	1,821.37
505-4330-531101	Office Supplies	1,500.00	1,500.00	585.22	1,374.93	125.07
505-4330-531105	Hand Tools	2,500.00	0.00	0.00	0.00	0.00
505-4330-531109	Chemicals	16,041.00	11,541.00	5,385.00	10,161.50	1,379.50
505-4330-531220	Natural Gas	500.00	500.00	0.00	0.00	500.00
505-4330-531600	Sm Equip <\$5,000	5,000.00	0.00	0.00	0.00	0.00
505-4330-531700	Other Supplies	1,000.00	0.00	0.00	0.00	0.00
Department: 4330 - Sewer Collections Total:		671,245.00	754,731.00	69,599.99	512,093.74	242,637.26
Department: 4400 - Water						
505-4400-511100	Salaries & Wages - Water	628,687.00	628,687.00	31,826.68	304,966.33	323,720.67
505-4400-511300	Overtime Pay	35,000.00	35,000.00	973.14	15,472.30	19,527.70
505-4400-512100	Group Insurance	260,000.00	260,000.00	13,847.00	141,799.25	118,200.75
505-4400-512200	Fica & Medicare	48,095.00	48,095.00	2,363.50	25,158.91	22,936.09
505-4400-512400	Pmts To Retirement Sys	85,571.00	93,571.00	8,397.11	67,176.88	26,394.12
505-4400-512700	Workers Compensation	50,000.00	54,500.00	0.00	53,538.01	961.99
505-4400-521202	Engineering Fees	30,000.00	15,000.00	0.00	0.00	15,000.00
505-4400-521203	Audit Fees	16,000.00	16,000.00	0.00	0.00	16,000.00
505-4400-521302	Drug Testing	0.00	0.00	0.00	230.00	-230.00
505-4400-521304	Tech Service -Utility Prot	4,300.00	4,400.00	0.00	4,305.90	94.10
505-4400-521305	Techserv -Utility Service	55,500.00	55,500.00	6,069.71	18,209.13	37,290.87
505-4400-521307	Technical Service	63,400.00	78,400.00	1,360.00	18,422.40	59,977.60
505-4400-521320	Outside Lab Service	8,000.00	8,000.00	188.76	1,627.12	6,372.88
505-4400-522201	Office Equip-Rep & Maint	1,000.00	1,000.00	0.00	0.00	1,000.00
505-4400-522203	Mach & Equip Rep & Maint	15,000.00	14,900.00	0.00	2,642.42	12,257.58
505-4400-522205	Infrastructure Rep & Main	180,000.00	172,000.00	27,041.46	135,200.64	36,799.36
505-4400-522320	Rental-Equipment/Vehicle	1,000.00	1,000.00	0.00	0.00	1,000.00
505-4400-523201	Postage	34,000.00	34,000.00	2,762.34	21,673.01	12,326.99
505-4400-523301	Advertising Expense	100.00	2,250.00	0.00	1,664.00	586.00
505-4400-523400	Printing & Binding	15,000.00	15,000.00	1,018.72	6,881.60	8,118.40
505-4400-523500	Travel	1,500.00	0.00	0.00	0.00	0.00
505-4400-523600	Dues & Fees	4,500.00	0.00	0.00	0.00	0.00
505-4400-523700	Education & Training	7,000.00	5,350.00	0.00	3,105.00	2,245.00
505-4400-523800	Licenses	1,000.00	1,000.00	0.00	112.00	888.00
505-4400-523900	Other	1,000.00	1,000.00	131.59	957.73	42.27
505-4400-531100	General Supplies & Mater	18,000.00	18,000.00	226.24	4,233.22	13,766.78
505-4400-531101	Office Supplies	2,000.00	3,500.00	0.00	2,998.62	501.38
505-4400-531103	Lab Supplies	3,000.00	3,000.00	0.00	0.00	3,000.00
505-4400-531105	Hand Tools	3,000.00	3,000.00	0.00	0.00	3,000.00
505-4400-531109	Chemicals	3,000.00	2,500.00	0.00	0.00	2,500.00
505-4400-531210	Water & Sewer Utility	24,000.00	24,000.00	17,753.40	24,443.46	-443.46
505-4400-531220	Natural Gas	0.00	0.00	0.00	3,914.10	-3,914.10
505-4400-531510	Purchased Water	1,800,000.00	1,800,000.00	152,539.64	1,118,878.11	681,121.89
505-4400-531591	Water Meters	100,000.00	100,000.00	0.00	74,105.00	25,895.00
505-4400-531600	Sm Equip Purchase <\$5,000	5,000.00	5,000.00	0.00	0.00	5,000.00
505-4400-531700	Other Supplies	1,000.00	1,000.00	0.00	0.00	1,000.00
505-4400-541410	Infrastructure-Walton Water Line	0.00	0.00	0.00	-310,897.53	310,897.53
505-4400-542100	Machinery	147,538.00	0.00	0.00	0.00	0.00
505-4400-561000	Depreciation	247,860.00	247,860.00	0.00	0.00	247,860.00
505-4400-562000	Amortization	14,200.00	14,200.00	0.00	0.00	14,200.00

Income Statement

For Fiscal: 2023-2024 Period En

Section 2, Item E.

	Original Total Budget	Current Total Budget	MTD Activity	YTD Activity	Budget Remaining
505-4400-574000 Bad Debt	0.00	0.00	0.00	437.91	-437.91
Department: 4400 - Water Total:	3,914,251.00	3,766,713.00	266,499.29	1,741,255.52	2,025,457.48
Fund: 505 - Water & Sewer Fund Surplus (Deficit):	0.00	0.00	303,462.33	1,287,949.17	
Fund: 540 - Solid Waste Fund					
Department: 0000 - Non-Departmental					
540-0000-311790 Sanitation Franchise Tax	90,000.00	90,000.00	8,276.99	60,096.00	29,904.00
540-0000-344110 Sanitation Sales / Collection	2,500,000.00	2,500,000.00	243,854.58	1,890,283.44	609,716.56
540-0000-361000 Interest Revenues	25,000.00	25,000.00	3,695.55	31,156.99	-6,156.99
Department: 0000 - Non-Departmental Total:	2,615,000.00	2,615,000.00	255,827.12	1,981,536.43	633,463.57
Department: 4510 - Solid Waste Admin					
540-4510-522110 Disposal	1,710,000.00	1,710,000.00	170,110.42	1,160,568.04	549,431.96
540-4510-522111 Roll Off Dumpsters	605,000.00	605,000.00	37,020.38	342,072.81	262,927.19
540-4510-611050 Transfer Out - General	300,000.00	300,000.00	0.00	0.00	300,000.00
Department: 4510 - Solid Waste Admin Total:	2,615,000.00	2,615,000.00	207,130.80	1,502,640.85	1,112,359.15
Fund: 540 - Solid Waste Fund Surplus (Deficit):	0.00	0.00	48,696.32	478,895.58	
Total Surplus (Deficit):	0.00	-485,201.64	96,287.99	7,550,605.81	

Group Summary

Department	Original Total Budget	Current Total Budget	MTD Activity	YTD Activity	Budget Remaining
Fund: 100 - General Fund					
0000 - Non-Departmental	15,186,140.00	15,186,140.00	991,355.63	13,685,794.63	1,500,345.37
1100 - Legislative	88,900.00	88,900.00	5,339.45	43,623.53	45,276.47
1300 - Executive	560,902.00	560,902.00	40,716.24	403,589.59	157,312.41
1400 - Elections	31,500.00	31,500.00	0.00	28,633.11	2,866.89
1510 - Financial Administration	887,245.00	887,245.00	70,960.53	679,430.50	207,814.50
1535 - It - Data Processing/Mis	560,100.00	560,100.00	40,362.38	360,601.74	199,498.26
1565 - General Gov Building & Pl	912,208.00	912,208.00	53,806.81	387,201.60	525,006.40
2000 - Judicial	694,150.00	694,150.00	48,086.81	373,948.95	320,201.05
3200 - Police	3,779,840.00	3,803,070.64	274,948.52	2,616,333.45	1,186,737.19
3500 - Fire	3,437,682.00	3,437,682.00	404,245.88	2,224,330.20	1,213,351.80
4100 - Public Works	809,600.00	809,600.00	60,235.79	520,249.75	289,350.25
4200 - Highways And Streets	1,513,900.00	1,513,900.00	42,745.87	820,144.05	693,755.95
4900 - Fleet Maintenance & Shop	958,800.00	958,800.00	60,822.88	553,221.58	405,578.42
6500 - Libraries	140,238.00	140,238.00	0.00	68,937.57	71,300.43
7400 - Planning & Zoning	423,125.00	423,125.00	26,403.38	314,474.97	108,650.03
7545 - Economic Development -	387,950.00	387,950.00	39,164.24	271,520.31	116,429.69
Fund: 100 - General Fund Surplus (Deficit):	0.00	-23,230.64	-176,483.15	4,019,553.73	-4,042,784.37
Fund: 210 - Confiscated Asset Fund					
0000 - Non-Departmental	105,000.00	105,000.00	2,694.12	42,676.95	62,323.05
3200 - Police	105,000.00	105,000.00	0.00	41,299.30	63,700.70
Fund: 210 - Confiscated Asset Fund Surplus (Deficit):	0.00	0.00	2,694.12	1,377.65	-1,377.65
Fund: 275 - Hotel/Motel Fund					
0000 - Non-Departmental	70,000.00	70,000.00	5,046.50	37,740.11	32,259.89
7540 - Tourism	70,000.00	70,000.00	8,653.94	32,199.94	37,800.06
Fund: 275 - Hotel/Motel Fund Surplus (Deficit):	0.00	0.00	-3,607.44	5,540.17	-5,540.17
Fund: 320 - Gw Splost 2017					
0000 - Non-Departmental	3,040,034.00	3,040,034.00	0.00	538,814.92	2,501,219.08
4200 - Highways And Streets	1,320,649.00	1,320,649.00	0.00	30,689.92	1,289,959.08
4400 - Water	380,604.00	380,604.00	0.00	114,712.20	265,891.80
6200 - Parks	1,338,781.00	1,338,781.00	0.00	80,030.64	1,258,750.36
Fund: 320 - Gw Splost 2017 Surplus (Deficit):	0.00	0.00	0.00	313,382.16	-313,382.16
Fund: 321 - Wc Splost 2019					
0000 - Non-Departmental	5,799,818.00	5,799,818.00	210,417.32	2,059,922.25	3,739,895.75
3200 - Police	2,354,726.00	2,354,726.00	0.00	326,984.51	2,027,741.49
3500 - Fire	0.00	111,971.00	52,695.00	1,173,070.00	-1,061,099.00
4200 - Highways And Streets	3,218,899.00	3,218,899.00	0.00	0.00	3,218,899.00
6200 - Parks	226,193.00	226,193.00	0.00	0.00	226,193.00
Fund: 321 - Wc Splost 2019 Surplus (Deficit):	0.00	-111,971.00	157,722.32	559,867.74	-671,838.74
Fund: 324 - GW SPLOST 2023					
0000 - Non-Departmental	4,484,388.00	4,484,388.00	74,447.94	652,685.02	3,831,702.98
3200 - Police	300,000.00	300,000.00	0.00	0.00	300,000.00
3500 - Fire	300,000.00	300,000.00	0.00	0.00	300,000.00
4200 - Highways And Streets	2,559,746.00	2,559,746.00	0.00	0.00	2,559,746.00
4330 - Sewer Collections	287,321.00	287,321.00	0.00	0.00	287,321.00
4400 - Water	287,321.00	287,321.00	0.00	0.00	287,321.00
6200 - Parks	750,000.00	750,000.00	0.00	0.00	750,000.00
Fund: 324 - GW SPLOST 2023 Surplus (Deficit):	0.00	0.00	74,447.94	652,685.02	-652,685.02
Fund: 371 - ARPA					
0000 - Non-Departmental	0.00	0.00	10,525.01	91,536.27	-91,536.27
4200 - Highways And Streets	0.00	0.00	194,381.58	194,381.58	-194,381.58
4300 - Water Quality Control	0.00	350,000.00	126,787.88	126,787.88	223,212.12
4330 - Sewer Collections	0.00	0.00	0.00	29,420.00	-29,420.00
4400 - Water	0.00	0.00	0.00	-309,400.03	309,400.03
Fund: 371 - ARPA Surplus (Deficit):	0.00	-350,000.00	-310,644.45	50,346.84	-400,346.84

Income Statement

For Fiscal: 2023-2024 Period En

Section 2, Item E.

Department	Original Total Budget	Current Total Budget	MTD Activity	YTD Activity	Budget Remaining
Fund: 375 - Capital Recovery-Impact Fees					
0000 - Non-Departmental	500,000.00	500,000.00	0.00	181,007.75	318,992.25
4400 - Water	500,000.00	500,000.00	0.00	0.00	500,000.00
Fund: 375 - Capital Recovery-Impact Fees Surplus (Deficit):	0.00	0.00	0.00	181,007.75	-181,007.75
Fund: 505 - Water & Sewer Fund					
0000 - Non-Departmental	9,567,500.00	9,567,500.00	833,700.28	5,782,389.86	3,785,110.14
4300 - Water Quality Control	4,342,784.00	4,425,256.00	151,699.01	1,913,304.35	2,511,951.65
4320 - Stormwater	639,220.00	620,800.00	42,439.66	327,787.08	293,012.92
4330 - Sewer Collections	671,245.00	754,731.00	69,599.99	512,093.74	242,637.26
4400 - Water	3,914,251.00	3,766,713.00	266,499.29	1,741,255.52	2,025,457.48
Fund: 505 - Water & Sewer Fund Surplus (Deficit):	0.00	0.00	303,462.33	1,287,949.17	-1,287,949.17
Fund: 540 - Solid Waste Fund					
0000 - Non-Departmental	2,615,000.00	2,615,000.00	255,827.12	1,981,536.43	633,463.57
4510 - Solid Waste Admin	2,615,000.00	2,615,000.00	207,130.80	1,502,640.85	1,112,359.15
Fund: 540 - Solid Waste Fund Surplus (Deficit):	0.00	0.00	48,696.32	478,895.58	-478,895.58
Total Surplus (Deficit):	0.00	-485,201.64	96,287.99	7,550,605.81	

Fund Summary

Fund	Original Total Budget	Current Total Budget	MTD Activity	YTD Activity	Budget Remaining
100 - General Fund	0.00	-23,230.64	-176,483.15	4,019,553.73	-4,042,784.37
210 - Confiscated Asset Fund	0.00	0.00	2,694.12	1,377.65	-1,377.65
275 - Hotel/Motel Fund	0.00	0.00	-3,607.44	5,540.17	-5,540.17
320 - Gw Splost 2017	0.00	0.00	0.00	313,382.16	-313,382.16
321 - Wc Splost 2019	0.00	-111,971.00	157,722.32	559,867.74	-671,838.74
324 - GW SPLOST 2023	0.00	0.00	74,447.94	652,685.02	-652,685.02
371 - ARPA	0.00	-350,000.00	-310,644.45	50,346.84	-400,346.84
375 - Capital Recovery-Impac...	0.00	0.00	0.00	181,007.75	-181,007.75
505 - Water & Sewer Fund	0.00	0.00	303,462.33	1,287,949.17	-1,287,949.17
540 - Solid Waste Fund	0.00	0.00	48,696.32	478,895.58	-478,895.58
Total Surplus (Deficit):	0.00	-485,201.64	96,287.99	7,550,605.81	

Applicant's Certification

The undersigned hereby certifies that they are authorized by the property owner(s) to make this application and that all information contained herein is complete and accurate, to the best of their knowledge.

Melody A. Glouton 01/05/2024
Applicant's Signature Date

MELODY A. GLOUTON, ATTORNEY
Print Name and Title

Sworn to and subscribed before me this 5th day of January, 2024.

(Seal) [Signature]
Signature of Notary Public



Property Owner's Certification
(complete a separate form for each owner)

The undersigned hereby certifies that they are: (check all that apply)

- a) _____ the owner of record of property contained in this application, and/or
- b) the Chief Executive of a corporation or other business entity with ownership interest in the property and is duly authorized to make this application, and

that all information contained in this application is complete and accurate to the best of their knowledge.

Jeff C. Henson 12-14-2023
Owner's Signature Date

Jeff Henson Manager Lock-n-Roll Storage, LLC
Print Name and Title

Sworn to and subscribed before me this 14th day of Dec, 2023.

(Seal) [Signature]
Signature of Notary Public



**DESCRIPTION OF
Tract 1 – 246 Line Street**

All that tract or parcel of land lying and being in Land Lot 161 of the 5th District, City of Loganville, Gwinnett County and Walton County, Georgia and being more particularly described as follows:

Beginning at a 1/2 inch rebar set at the intersection of the southwestern right of way line of Georgia State Route 20 (right of way width varies), also known as Loganville Highway, and the northwestern right of way line of Line Street (40 feet right of way width); thence proceeding along said right of way line of Line Street South 59 degrees 41 minutes 40 seconds West a distance of 478.22 feet to a 2 inch open top pipe found; thence leaving said right of way line of Line Street and proceeding North 29 degrees 50 minutes 14 seconds West a distance of 1717.41 feet to a 1/2 inch rebar found; thence North 58 degrees 11 minutes 21 seconds East a distance of 254.59 feet to a 1/2 inch rebar set; thence South 29 degrees 30 minutes 26 seconds East a distance of 1394.22 feet to a 1/2 inch rebar set; thence North 61 degrees 39 minutes 18 seconds East a distance of 233.27 feet to a 1/2 inch rebar set on the southwestern right of way line of Georgia State Route 20; thence proceeding along said right of way line of Georgia State Route 20 South 29 degrees 35 minutes 20 seconds East a distance of 322.00 feet to a 1/2 inch rebar set, said point being the Point of Beginning.

Said tract contains 505,371 square feet or 11.602 acres.

The above described property is shown on a Boundary Survey for Line Street Properties, prepared by Travis Pruitt & Associates, Inc., dated November 21, 2023. (FN: 218-E-038)

**DESCRIPTION OF
Total Tract**

All that tract or parcel of land lying and being in Land Lot 161 of the 5th District, City of Loganville, Gwinnett County and Walton County, Georgia and being more particularly described as follows:

Beginning at a 1/2 inch rebar set at the intersection of the southwestern right of way line of Georgia State Route 20 (right of way width varies), also known as Loganville Highway, and the northwestern right of way line of Line Street (40 feet right of way width); thence proceeding along said right of way line of Line Street the following courses and distances: South 59 degrees 41 minutes 40 seconds West a distance of 478.22 feet to a 2 inch open top pipe found and South 60 degrees 36 minutes 41 seconds West a distance of 121.25 feet to a 1/2 inch crimp top pipe found; thence leaving said right of way line of Line Street and proceeding North 30 degrees 11 minutes 34 seconds West a distance of 1711.41 feet to a 1/2 inch rebar found; thence North 57 degrees 57 minutes 13 seconds East a distance of 131.96 feet to a 1/2 inch rebar found; thence North 58 degrees 11 minutes 21 seconds East a distance of 254.59 feet to a 1/2 inch rebar set; thence South 29 degrees 30 minutes 26 seconds East a distance of 1394.22 feet to a 1/2 inch rebar set; thence North 61 degrees 39 minutes 18 seconds East a distance of 233.27 feet to a 1/2 inch rebar set on the southwestern right of way line of Georgia State Route 20; thence proceeding along said right of way line of Georgia State Route 20 South 29 degrees 35 minutes 20 seconds East a distance of 322.00 feet to a 1/2 inch rebar set, said point being the Point of Beginning.

Said tract contains 722,342 square feet or 16.583 acres.

The above described property is shown on a Boundary Survey for Line Street Properties, prepared by Travis Pruitt & Associates, Inc., dated November 21, 2023. (FN: 218-E-038)

Application # R 24-005

DISCLOSURE OF CAMPAIGN CONTRIBUTIONS

The undersigned, making application for rezoning with the City of Loganville, Georgia, have complied with the Official Code of Georgia, Section 36-67A-1, et. seq., Conflict of Interest in Zoning Actions, and has submitted or attached the required information as requested below.

_____ Applicant's Signature	_____ Date	_____ Print Name
<i>Melody A. Glouton</i> Signature of Applicant's Attorney or Agent	<i>1/5/24</i> Date	Melody A. Glouton Print Name

Has the Applicant, attorney for applicant, or other agent, within the two years immediately preceding the filing of this application, made campaign contributions aggregating \$250.00 or more to the Mayor, Member of the City Council or member of the Planning Commission of the City of Loganville, Georgia?

_____ YES x NO

If YES, complete the following:

NAME OF INDIVIDUAL MAKING CONTRIBUTION _____

NAME & OFFICIAL POSITION OF GOVERNMENT OFFICIAL	CONTRIBUTIONS (List all aggregating to \$250 or more)	DATE OF CONTRIBUTION
_____	_____	_____
_____	_____	_____
_____	_____	_____
_____	_____	_____

Attach additional sheets as necessary to disclose and describe all contributions.

**COMBINED LETTER OF INTENT
AND JUSTIFICATION FOR REZONING**

**Rezoning Application
City of Loganville, Walton County, Georgia**

Applicant:

The Revive Land Group, LLC

Property:

Tax Parcel ID LG040062 (11.602 acres)

and

Tax Parcel ID LG040063 (4.981 acres)

Total: ±16.58 Acres of Land

Located at 246 and 234 Line Street, Loganville, Georgia 30052

From MHP and LI to RM-6

Submitted for Applicant by:

Melody A. Glouton, Esq.

ANDERSEN TATE & CARR, P.C.

One Sugarloaf Centre

1960 Satellite Blvd.

Suite 4000

Duluth, Georgia 30097

770.822.0900

mglouton@atclawfirm.com

I. INTRODUCTION

This Application for Rezoning is submitted for a 16.58-acre assemblage of land located at 246 and 234 Line Street, just west of its intersection with Loganville Highway (hereinafter the “Property”).¹ The Property is an assemblage of two (2) tax parcels, with frontage along both Loganville Highway and Line Street. The Property is shown on the survey prepared by Travis Pruitt & Associates, Inc., dated December 20, 2023, and filed with this Application.

The Property is currently zoned MHP (Manufactured Home Park) and LI (Light Industrial) pursuant to the Code of the City of Loganville, Georgia (the “Code”). The Applicant, The Revive Land Group, LLC (the “Applicant”) now seeks approval to rezone the Property to RM-6 (Multifamily Residential Medium Density) to develop a distinctive and attractive townhome community with 93 units.

This document is submitted as the Letter of Intent, Response to Standard Governing the Exercise of Zoning Power, and other materials required by the Code.

I. DESCRIPTION OF THE PROPERTY AND SURROUNDING AREA

The Property consists of two (2) tax parcels and contains 16.58-acres. While there are two personal residences located on the Property, the majority of the site is undeveloped and partially wooded. As shown on the City of Loganville Zoning Map, the Property is surrounded by industrial and residential uses. The following is a summary of the surrounding zoning classifications:



¹ Tract 1, Tax Parcel ID LG040062, is located at 246 Line Street, and consists of 11.602 acres. Tract 2, Tax Parcel ID LG040063, is located at 234 Line Street, and consists of 4.981 acres.

II. PROJECT SUMMARY

As shown on the conceptual site plan dated November 10, 2023, and filed with this Application (hereinafter the “Site Plan”), the Applicant proposes to develop the Property into a distinctive and attractive residential townhome community. The Applicant is proposing to rezone 16.58 acres from MHP and LI to RM-6 to accommodate the development of a townhome community with 93 units for a proposed density of 5.61 units per acre. As indicated above, the site is surrounded by industrial and residential properties and the development would provide an opportunity for transition from industrial to medium density housing. Moreover, the proposal would provide for an additional housing type for the citizens of Loganville and be a catalyst for the revitalization of downtown Loganville. As shown in the Site Plan, the community would include townhomes with a minimum square footage of 1,800 and two-car garages. While market conditions can fluctuate, the Applicant anticipates the price range of the townhomes to range from \$300,000 to 375,000. The architectural style of the townhomes would be constructed with a variety of facades, including brick, stacked stone, hardie plank, shake, board and batten. The site is designed for a full access driveway on Line Street. For reference, the Applicant has included sample elevations with this Application.

III. SITE IMPACT ANALYSIS

The Applicant submits its written impact analysis which shows that rezoning to LI satisfies the responses to evaluation criteria as follows:

1. How does the proposed use impact the overall appearance of the City and aesthetic conditions of adjacent parcels?
 - A. The Property is adjacent to existing industrial and residential uses. The site will be developed with quality architectural elements consistent with the City’s development regulations and will not adversely impact the overall appearance of adjacent parcels. Rezoning the Property to RM-6 will also permit a use that is suitable in view of the use and development of adjacent and nearby property.

2. How does the proposed use impact thoroughfare congestion and traffic safety?
 - A. Rezoning the Property to RM-6 will not result in a use which will or could cause an excessive or burdensome use of existing streets, transportation facilities or schools. While the Property has frontage on both Line Street and Loganville Highway, the community has been designed for single access on Line Street. The Applicant completed a traffic impact analysis as part of this submittal and the results of the future conditions traffic analysis indicated that the stop-controlled approaches will continue to operate at a level of service “C” or better in both the AM and PM peak hours.

3. How does the proposed use impact population density and the potential for overcrowding and urban sprawl?

A. The proposed residential use is suitable in view of the existing development of adjacent and nearby properties. The development will provide additional housing supply in the community and would not create overcrowding. More importantly, the development will provide housing to support the revitalization of downtown Loganville.

4. How does the proposed use impact the provision of water, sewerage, transportation and other urban infrastructure services?

A. The proposed use is a medium density residential use compared to surrounding industrial and residential uses on adjacent properties as it relates to water, sewer, and transportation infrastructure. The development will not result in an excessive or burdensome use of the infrastructure. The City of Loganville Public Utilities department has further confirmed that sewer capacity is available and able to serve the development. Moreover, any potential impacts on public facilities such as traffic, utility demand, stormwater, and schools can be mitigated with appropriate zoning conditions and site development requirements.

5. How does the proposed zoning provide protection of property against blight and depreciation?

A. The proposed zoning activates a site that is currently zoned for manufactured homes and industrial uses. The development of a townhome community brings new economic investment to the City and provides additional housing options. The development would further help in the revitalization of downtown Loganville.

6. How is the proposed use and zoning consistent with the adopted Comprehensive Plan?

A. The proposed use is a less intense use of the Property than some permitted uses under the current zoning classification of LI (Light Industrial District). In addition, development of the site with townhomes as opposed to manufactured homes would serve existing residents in the community as well as new residents seeking housing in the City.

7. In what way does the proposed zoning affect adjacent property owners if the request is approved?

A. The proposed rezoning will have little to no effect on adjacent property owners as the intended residential use will be less intensive than what is permitted under the industrial classification. Likewise, a townhome community will provide greater economic growth as opposed to a manufactured home community.

8. What is the impact upon adjacent property owners if the request is not approved?
 - A. The Property is currently occupied with two residential homes and some accessory structures. Should the Property not be rezoned to allow for townhomes, the area where the Property is located will be deprived of new residential investment that is complimentary to the surrounding uses. The proposed rezoning brings a complimentary use to the surrounding properties and will further support the existing business in the community.

9. Describe any other factors affecting the health, safety, morals, aesthetics, convenience, order, prosperity, or the general welfare of the present and future inhabitants of the City of Loganville.
 - A. The proposed rezoning would have a positive effect on the aesthetics and prosperity of the present and future citizens of the City by bringing new development to an essentially undeveloped site. The proposed development will provide quality architecture and needed housing supply to the City's current and future residents. The proposed use would be of low impact compared to its current zoning classifications and would not affect the health, safety, or morals of the City's current or future residents.

IV. JUSTIFICATION FOR REZONING

The Applicant respectfully submits that "The Code of the City of Loganville, Georgia" (the "Code"), as amended from time to time, to the extent that it classifies the Property in any zoning district that would preclude development of a townhome community is unconstitutional as a taking of property, a denial of equal protection, an arbitrary and capricious act, and an unlawful delegation of authority under the specific constitutional provisions later set forth herein. Any existing inconsistent zoning of the Property pursuant to the Code deprives the Applicant and Property owner of any alternative reasonable use and development of the Property. Additionally, all other zoning classifications, including ones intervening between the existing classification and that requested herein, would deprive the Applicant and Property owner of any reasonable use and development of the Property. Further, any attempt by the Mayor and Council of the City of Loganville to impose greater restrictions upon the manner in which the Property will be developed than presently exist would be equally unlawful.

Accordingly, Applicant submits that the current zoning classifications and any other zoning of the Property save for what has been requested as established in the Code constitute an arbitrary and unreasonable use of the zoning and police powers because they bear no substantial relationship to the public health, safety, morality or general welfare of the public and substantially harm the Applicant and Property owner. All inconsistent zoning classifications between the existing zoning and the zoning requested hereunder would constitute an arbitrary and unreasonable use of the zoning and police powers because they bear or would bear no substantial relationship to the public health, safety, morality, or general welfare of the public and would substantially harm the Applicant and Property owner. Further, the existing inconsistent zoning classification constitutes, and all zoning and plan classifications intervening between the existing inconsistent zoning classification and that required to develop this Project would constitute, a taking of the owner's

private property without just compensation and without due process in violation of the Fifth Amendment and Fourteenth Amendment of the Constitution of the United States, and Article I, Section I, Paragraph I and Article I, Section III, Paragraph I of the Constitution of the State of Georgia and the Due Process and Equal Protection Clauses of the Fourteenth Amendment to the Constitution of the United States.

Further, the Applicant respectfully submits that failure to approve the requested rezoning to RM-6 would be unconstitutional and would discriminate in an arbitrary, capricious and unreasonable manner between the Applicant and Property owner and owners of similarly situated property in violation of Article I, Section III, Paragraph I of the Constitution of the State of Georgia and the Equal Protection Clause of the Fourteenth Amendment of the Constitution of the United States.

Finally, the Applicant respectfully submits that the Mayor and Council of the City of Loganville cannot lawfully impose more restrictive standards upon the development of the Property than presently exist, as to do so not only would constitute a taking of the Property as set forth above, but also would amount to an unlawful delegation of their authority, in response to neighborhood opposition, in violation of Article IX, Section IV, Paragraph II of the Georgia Constitution.

This Application meets favorably with the prescribed test set out by the Georgia Supreme Court to be used in establishing the constitutional balance between private property rights and zoning and planning as an expression of the government’s police power. See Guhl v. Holcomb Bridge Road Corp., 238 Ga. 322 (1977).

V. CONCLUSION

For the foregoing reasons, the Applicant respectfully requests that this Application to Rezone from MHP and LI to RM-6 be approved. The Applicant welcomes the opportunity to meet with the City of Loganville Planning Department staff to answer any questions or to address any concerns relating to this Letter of Intent or supporting materials.

Respectfully submitted this 5th day of January, 2024.

ANDERSEN, TATE & CARR, P.C.

Melody A. Glouton

Melody A. Glouton, Esq.

Enclosures
MAG/dwb

4880-9828-9818, v. 1

Adjoining Property Owners List
The Revive Land Group Rezoning Application

CMEC, LLC
627 EDGELEY LANE
LAWRENCEVILLE, GA 30044

5.43 ACRES
4075 LAWRENCEVILLE ROAD, LOGANVILLE 30052 | R5161 001A

JANE H. HUDSON
4077 LAWRENCEVILLE ROAD
LOGANVILLE, GA 30052

1.04 ACRES
4077 LAWRENCEVILLE STREET, LOGANVILLE 30052 | R5161 038

KRISNA INVESTMENT LLC
3142 PINE CONE COURT
LILBURN, GA 30047

0.91 ACRES
4045 LAWRENCEVILLE STREET, LOGANVILLE 30052 | R5161 003

PINK HAMMER RENOVATIONS, LLC
1949 FLOYE DRIVE
LOGANVILLE, GA 30042

0.94 ACRES
4055 LAWRENCEVILLE ROAD, LOGANVILLE 30052 | R5161 002

MARY ANN KILGORE RICHARDS AND RODNEY KELVIN RICHARDS, SR.
922 ULYSSES STREET
LEXINGTON, NC 27292

28.51 ACRES
3918 PECAN ROAD, LOGANVILLE 30052 | R5161 011

MARGARET HAMMOND
4128 PECAN STREET
LOGANVILLE, GA 30052

17.00 ACRES
4128 PECAN ROAD, LOGANVILLE 30052 | R5161 012

B&R BROTHERS HOLDINGS LLC
1210 WEBB GIN HOUSE ROAD
LAWRENCEVILLE, GA 30045

0.37 ACRES
4138 PECAN STREET, LOGANVILLE 30052 | R5161 044

B&R BROTHERS HOLDINGS LLC
1210 WEBB GIN HOUSE ROAD
LAWRENCEVILLE, GA 30045

3.12 ACRES
232 LINE STREET, LOGANVILLE 30052 | LG040064A00

JAMES KENNETH AND LINDA H. GUTHRIE
P.O. BOX 1245
LOGANVILLE, GA 30052

2.47 ACRES
4125 LAWRENCEVILLE ROAD, LOGANVILLE 30052 | LG040061

4883-5668-0090, v. 1







City of Loganville

Public Utilities
Brandon Phillips
Director
P.O. Box 39
Loganville, GA 30052

Tel: 770-466-3240

November 28, 2023

The Revive Land Group

Re: Proposed 234 and 246 Line Street Development Sewer Capacity

To Whom It May Concern:

The intent of this letter is to inform you that the City of Loganville does have the current capacity to service this development.

If you have any questions concerning this matter, please call my office at 770-466-0911

Travis Toney
City of Loganville
Sewer Supervisor



Planning & Development
4303 Lawrenceville Road
Loganville, GA 30052
Phone 770.466.2633
Fax: 770.554.5556

Case #: R24-005

Applicant: The Revive Land Group

Property Owner: Lock N Roll Storage LLC

Property Location: 246 Line Street

Tax Map/Parcel: LG040062

Property Size: 11.602

Current Zoning: MHP

Request: RM-6

Proposed Use: Combine two parcels together for 93 fee-simple townhome complex.

Applicant’s Request

The applicant is seeking to combine two parcels – one zoned MHP and the other LI – for the development of a neighborhood of townhomes.

Existing Conditions

The property has maintained the MHP zoning dating back to 1987, where the City’s official zoning map identified a piece of the current parcel with that classification. A 1,055-square-foot home dating back to the 1930s currently remains on the property, as do two accessory structures. County records indicate that the property reported a varying number of lots for mobile homes, though the last one was reportedly removed on Jan. 23, 2014.

Zoning in the area is mixed, with R-44, R-16 and Light Industrial zoning classifications in the immediate area. It should also be noted that there are four duplexes across the street which were zoned RM-4 dating back to 1987 but under the current zoning map they are classified as R-16.

The current owner purchased the property in 2021. The property spans two counties, with 6.09 acres in Walton and the remainder in Gwinnett.

Impact Analysis

What is the impact upon the overall appearance of the City and impacts upon aesthetic conditions of adjacent parcels? The parcel of land along Lawrenceville Road has the appearance of overgrowth and a chain-link fence. The vacant lot appearance is continued along Line Street until you reach the house that remains on the property. The impact on the aesthetic conditions would be subjective, as some would prefer a more natural view versus one of townhomes. With most of the buildings being located on the Walton County side of the project, as a result of the detention pond location and identified water and resulting buffer, there is little impact from this project on the Gwinnett County side. It would likely also have no impact on the adjacent LI. While there is some multi-family housing already in the immediate vicinity, it is not to the scale of this project.

What is the impact upon thoroughfare congestion and traffic safety? Staff recommended a traffic study be completed by the applicant to assess the impact on an already burdened secondary street. The traffic study shows negligible impact from the project because the intersection already has difficulties that would not necessarily be made worse by this project. While there are a number of different routes that can be taken to access Lawrenceville Road, Main Street and even Highway 78, it is hard to overlook the likely congestion and subsequent safety issues that would arise in the immediate area with the addition of more than 100 cars to the area.

What is the impact upon population density and the potential for overcrowding and urban sprawl? While there is multi-family housing in the area, it is less than one-tenth the size of this project. So a project of this scale into an area that is mostly single-family housing will have a noticeable impact on population density and potentially create overcrowding in the vicinity.

What is the impact upon the provision of water, sewerage, transportation and other urban infrastructure services? Water and sewer service are available to the project. The intersection of Line Street and Lawrenceville Road has already been identified as one in need of improvement by the City's own comprehensive traffic study, so the addition of this project would likely negatively impact transportation in the area.

How does the proposed use provide protection of property against blight and depreciation? While the property is not blighted, the current project would develop an otherwise underutilized piece of land. Research is inconclusive or mixed on the impact of townhomes on nearby property values, though townhomes are considered to be more beneficial to adjacent property values when compared to mobile homes.

Is the proposed use consistent with the adopted Comprehensive Plan? The City's future land use map shows this property maintaining a residential zoning (Note: the map does not make a distinction between single-family and multi-family housing).

What is the impact upon adjacent property owners if the request is approved? As outlined in the sections above, the biggest impacts will be traffic and aesthetics. While townhomes can be viewed as a natural transition from light industrial and other commercial uses in the area to residential, the fact remains that the project would stand out when surrounded by smaller single-family homes (the multi-family housing in the area is single story and blends in more with its surroundings). And while many residents in the area are likely to know a variety of different ways to get to where they are going, this may be hampered by the possibility that they may not even be able to get out of their driveways if traffic is backed up worse than current conditions.

What is the impact upon adjacent property owners if the request is not approved? The property will likely exist as it currently does because the project will likely not move forward, though the opportunity would still exist for the property to house up to 40 mobile homes.

Are there any other factors effecting the health, safety, morals, aesthetics, convenience, order, prosperity, or the general welfare of the present and future inhabitants of the City of Loganville? The City of Loganville's 2022 Comprehensive Plan, in its analysis of Planning, Land Use and Housing, noted that 78 percent of the housing stock in the City is single-family use while less than 1 percent are structures that have more than 20 units. The study identifies the need for of what is called the "Missing Middle" housing, or medium density housing. This is defined as being a range of multi-family or clustered housing types compatible in scale with single-family or transitional neighborhoods. The applicant has described his project as being a transitional neighborhood, though the scale of this development is on the larger side of what would be an ideal fit in this area.

Currently, the Mobile Home Park zoning designation is comparable to RM-4. The applicant is asking for RM-6, which would result in an increase in density in the area of about 22 residences for this parcel.

Recommended action: Staff recommendations are to approve the rezone with the following conditions:

- Create a second entrance to the project, ideally with access to Lawrenceville Road.
- Widen the roadway on Line Street, creating dedicated left turn and right turn lanes for no fewer than 5 cars attempting to turn onto Lawrenceville Road.
- Planting of screening evergreen trees between the townhomes and 4125 Lawrenceville Road, 4077 Lawrenceville Road, and 4075 Lawrenceville Road (but not within the sewer easement) as well as 4138 Pecan St.

Amended Staff Recommendations: After a meeting on Feb. 9, 2024, with the applicant and representatives from the City's Streets and Highway Department and Fire Department, the Staff Recommendation is to approve the rezone with the following conditions:

1. As a result of complications in meeting various roadway design criteria for a second entrance to the complex, staff amends its first recommendation to require a second driveway along Lawrenceville Road that will serve only as an emergency access point that will be gated with a Knox Box subject to GDOT approval.
2. No changes to the second condition. (Widen the roadway on Line Street, creating dedicated left turn and right turn lanes for no fewer than 5 cars attempting to turn onto Lawrenceville Road, subject to GDOT approval).
3. Amend the third recommendation to state the need for the installation of a privacy fence and planting of screening evergreen trees as infill where necessary between the townhomes and abutting residential parcels located at 4077 and 4125 Lawrenceville Highway as well as along the property line with 4075 Lawrenceville Highway to the stream buffer. Nothing is to be done within the sewer easement or stormwater pond access easement. This will be subject to review by Planning Staff before the issuance of a development permit.

Planning Commission Recommended Conditions

The Planning Commission voted 4-2 to approve the re-zone with the following conditions:

- 1. Require a second driveway along Lawrenceville Road that will serve as an emergency access point that will be gated with a Knox Box, subject to GDOT approval.
- 2. Widen the roadway on Line Street, creating a dedicated left turn and right turn lanes for no fewer than 5 cars attempting to turn onto Lawrenceville Road, subject to GDOT approval.
- 3. Installation of an 8-foot, chain-link fence between the townhomes and abutting residential parcels located at 4077 and 4125 Lawrenceville Road and along the property line with 4075 Lawrenceville Road to the stream buffer. Nothing is to be done within the sewer easement or stormwater pond access easement. This will be subject to review by Planning Department staff before the issuance of a development permit.
- 4. Ensure that the HOA is responsible for limiting the number of townhomes that can be rented to 15 percent of the total project at any given point in time.
- 5. Create a covered pavilion in the one of the common areas of the project.

City Council Conditions

Application # R 24-006

Applicant's Certification

The undersigned hereby certifies that they are authorized by the property owner(s) to make this application and that all information contained herein is complete and accurate, to the best of their knowledge.

Melody A. Glouton
Applicant's Signature

01/05/2024

Date

MELODY A, GLOUTON, ATTORNEY

Print Name and Title

Sworn to and subscribed before me this 5th day of January, 2024.

(Seal)

Daphne Wilson Boyd
Signature of Notary Public



Property Owner's Certification
(complete a separate form for each owner)

The undersigned hereby certifies that they are: (check all that apply)

- a) the owner of record of property contained in this application, and/or
- b) the Chief Executive of a corporation or other business entity with ownership interest in the property and is duly authorized to make this application, and

that all information contained in this application is complete and accurate to the best of their knowledge.

Cliff Rector
Owner's Signature

12/14/23
Date

CLIFF Rector

Print Name and Title

Sworn to and subscribed before me this 14 day of December, 2023.

(Seal)



Mandy Andrews
Signature of Notary Public

**DESCRIPTION OF
Tract 2 – 234 Line Street**

All that tract or parcel of land lying and being in Land Lot 161 of the 5th District, City of Loganville, Gwinnett County and Walton County, Georgia and being more particularly described as follows:

To find the Point of Beginning commence at a 1/2 inch rebar set at the intersection of the southwestern right of way line of Georgia State Route 20 (right of way width varies), also known as Loganville Highway, and the northwestern right of way line of Line Street (40 feet right of way width); thence proceeding along said right of way line of Line Street South 59 degrees 41 minutes 40 seconds West a distance of 478.22 feet to a 2 inch open top pipe found, said point being the Point of Beginning.

From the Point of Beginning as thus established, continuing along said right of way line of Line Street South 60 degrees 36 minutes 41 seconds West a distance of 121.25 feet to a 1/2 inch crimp top pipe found; thence leaving said right of way line of Line Street and proceeding North 30 degrees 11 minutes 34 seconds West a distance of 1711.41 feet to a 1/2 inch rebar found; thence North 57 degrees 57 minutes 13 seconds East a distance of 131.96 feet to a 1/2 inch rebar found; thence South 29 degrees 50 minutes 14 seconds East a distance of 1717.41 feet to a 2 inch open top pipe found, said point being the Point of Beginning.

Said tract contains 216,971 square feet or 4.981 acres.

The above described property is shown on a Boundary Survey for Line Street Properties, prepared by Travis Pruitt & Associates, Inc., dated November 21, 2023. (FN: 218-E-038)

DESCRIPTION OF

Total Tract

All that tract or parcel of land lying and being in Land Lot 161 of the 5th District, City of Loganville, Gwinnett County and Walton County, Georgia and being more particularly described as follows:

Beginning at a 1/2 inch rebar set at the intersection of the southwestern right of way line of Georgia State Route 20 (right of way width varies), also known as Loganville Highway, and the northwestern right of way line of Line Street (40 feet right of way width); thence proceeding along said right of way line of Line Street the following courses and distances: South 59 degrees 41 minutes 40 seconds West a distance of 478.22 feet to a 2 inch open top pipe found and South 60 degrees 36 minutes 41 seconds West a distance of 121.25 feet to a 1/2 inch crimp top pipe found; thence leaving said right of way line of Line Street and proceeding North 30 degrees 11 minutes 34 seconds West a distance of 1711.41 feet to a 1/2 inch rebar found; thence North 57 degrees 57 minutes 13 seconds East a distance of 131.96 feet to a 1/2 inch rebar found; thence North 58 degrees 11 minutes 21 seconds East a distance of 254.59 feet to a 1/2 inch rebar set; thence South 29 degrees 30 minutes 26 seconds East a distance of 1394.22 feet to a 1/2 inch rebar set; thence North 61 degrees 39 minutes 18 seconds East a distance of 233.27 feet to a 1/2 inch rebar set on the southwestern right of way line of Georgia State Route 20; thence proceeding along said right of way line of Georgia State Route 20 South 29 degrees 35 minutes 20 seconds East a distance of 322.00 feet to a 1/2 inch rebar set, said point being the Point of Beginning.

Said tract contains 722,342 square feet or 16.583 acres.

The above described property is shown on a Boundary Survey for Line Street Properties, prepared by Travis Pruitt & Associates, Inc., dated November 21, 2023. (FN: 218-E-038)



LEGEND

○	ADJACENT PROPERTY	P.O.B.	PROPERTY OF ADJACENT	101	ADJACENT DISTANCE
○	ADJACENT PROPERTY	P.O.C.	PROPERTY OF ADJACENT	102	ADJACENT DISTANCE
○	ADJACENT PROPERTY	P.O.D.	PROPERTY OF ADJACENT	103	ADJACENT DISTANCE
○	ADJACENT PROPERTY	P.O.E.	PROPERTY OF ADJACENT	104	ADJACENT DISTANCE
○	ADJACENT PROPERTY	P.O.F.	PROPERTY OF ADJACENT	105	ADJACENT DISTANCE
○	ADJACENT PROPERTY	P.O.G.	PROPERTY OF ADJACENT	106	ADJACENT DISTANCE
○	ADJACENT PROPERTY	P.O.H.	PROPERTY OF ADJACENT	107	ADJACENT DISTANCE
○	ADJACENT PROPERTY	P.O.I.	PROPERTY OF ADJACENT	108	ADJACENT DISTANCE
○	ADJACENT PROPERTY	P.O.J.	PROPERTY OF ADJACENT	109	ADJACENT DISTANCE
○	ADJACENT PROPERTY	P.O.K.	PROPERTY OF ADJACENT	110	ADJACENT DISTANCE
○	ADJACENT PROPERTY	P.O.L.	PROPERTY OF ADJACENT	111	ADJACENT DISTANCE
○	ADJACENT PROPERTY	P.O.M.	PROPERTY OF ADJACENT	112	ADJACENT DISTANCE
○	ADJACENT PROPERTY	P.O.N.	PROPERTY OF ADJACENT	113	ADJACENT DISTANCE
○	ADJACENT PROPERTY	P.O.O.	PROPERTY OF ADJACENT	114	ADJACENT DISTANCE
○	ADJACENT PROPERTY	P.O.P.	PROPERTY OF ADJACENT	115	ADJACENT DISTANCE
○	ADJACENT PROPERTY	P.O.Q.	PROPERTY OF ADJACENT	116	ADJACENT DISTANCE
○	ADJACENT PROPERTY	P.O.R.	PROPERTY OF ADJACENT	117	ADJACENT DISTANCE
○	ADJACENT PROPERTY	P.O.S.	PROPERTY OF ADJACENT	118	ADJACENT DISTANCE
○	ADJACENT PROPERTY	P.O.T.	PROPERTY OF ADJACENT	119	ADJACENT DISTANCE
○	ADJACENT PROPERTY	P.O.U.	PROPERTY OF ADJACENT	120	ADJACENT DISTANCE
○	ADJACENT PROPERTY	P.O.V.	PROPERTY OF ADJACENT	121	ADJACENT DISTANCE
○	ADJACENT PROPERTY	P.O.W.	PROPERTY OF ADJACENT	122	ADJACENT DISTANCE
○	ADJACENT PROPERTY	P.O.X.	PROPERTY OF ADJACENT	123	ADJACENT DISTANCE
○	ADJACENT PROPERTY	P.O.Y.	PROPERTY OF ADJACENT	124	ADJACENT DISTANCE
○	ADJACENT PROPERTY	P.O.Z.	PROPERTY OF ADJACENT	125	ADJACENT DISTANCE

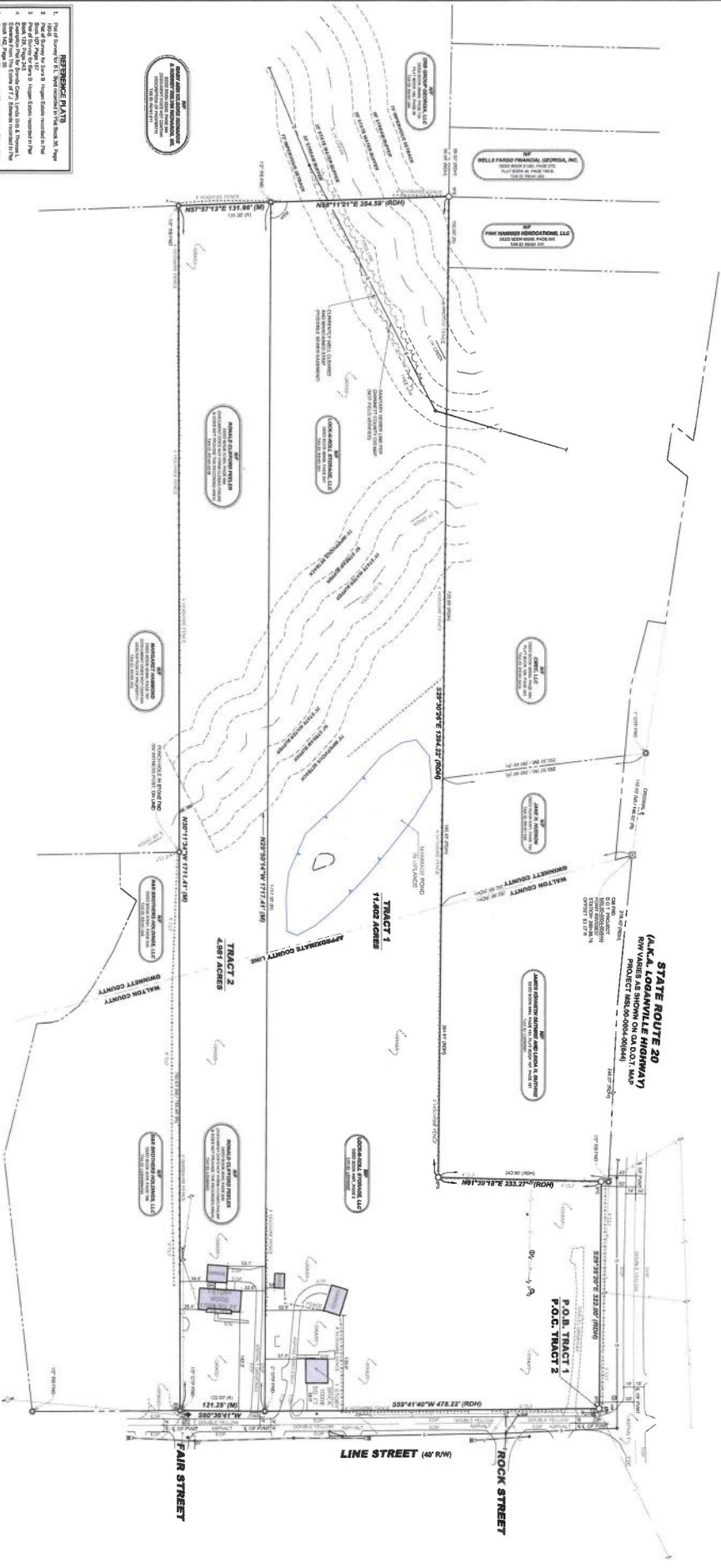

RECORDING PLATS

1. Plat of Survey for E. 1/4 of Section 16, T. 12 N., R. 12 E., S. 12, 2008
2. Plat of Survey for E. 1/4 of Section 16, T. 12 N., R. 12 E., S. 12, 2008
3. Plat of Survey for E. 1/4 of Section 16, T. 12 N., R. 12 E., S. 12, 2008
4. Plat of Survey for E. 1/4 of Section 16, T. 12 N., R. 12 E., S. 12, 2008
5. Plat of Survey for E. 1/4 of Section 16, T. 12 N., R. 12 E., S. 12, 2008

NOTES

1. This plat was prepared by the Surveyor General of the State of Georgia, based on the original survey records and the field notes of the Surveyor General, and is subject to the provisions of the Georgia Surveying Act of 1997, as amended.
2. The Surveyor General is not responsible for the accuracy of the information provided by the adjacent property owners.
3. The Surveyor General is not responsible for the accuracy of the information provided by the adjacent property owners.
4. The Surveyor General is not responsible for the accuracy of the information provided by the adjacent property owners.
5. The Surveyor General is not responsible for the accuracy of the information provided by the adjacent property owners.

PROPERTY DESCRIPTION - TRACT 1

That certain parcel of land, more or less, situated in the County of Walton, State of Georgia, and being a portion of the land described in the plat of survey for E. 1/4 of Section 16, T. 12 N., R. 12 E., S. 12, 2008, and being more or less as shown on the attached plat of survey, containing 11.602 acres, more or less, and being the same as shown on the attached plat of survey.

PROPERTY DESCRIPTION - TRACT 2

That certain parcel of land, more or less, situated in the County of Walton, State of Georgia, and being a portion of the land described in the plat of survey for E. 1/4 of Section 16, T. 12 N., R. 12 E., S. 12, 2008, and being more or less as shown on the attached plat of survey, containing 4.891 acres, more or less, and being the same as shown on the attached plat of survey.

PROPERTY DESCRIPTION - TRACT 3

That certain parcel of land, more or less, situated in the County of Walton, State of Georgia, and being a portion of the land described in the plat of survey for E. 1/4 of Section 16, T. 12 N., R. 12 E., S. 12, 2008, and being more or less as shown on the attached plat of survey, containing 4.891 acres, more or less, and being the same as shown on the attached plat of survey.

CERTIFICATION

I, the undersigned, Surveyor General of the State of Georgia, do hereby certify that the foregoing is a true and correct copy of the original survey records and the field notes of the Surveyor General, and that the same are in accordance with the provisions of the Georgia Surveying Act of 1997, as amended.

REVISIONS

NO.	DATE	DESCRIPTION
1	12-20-23	Initial Survey

BOUNDARY SURVEY

LINE STREET PROPERTIES

Prepared by: **TravelPruitt Associates, Inc.**

3117 Park Drive, Suite 800
 Marietta, Georgia 30066
 Phone: (770) 418-7511
 Fax: (770) 418-8788
 www.travelpruitt.com

Application # R 24-006

DISCLOSURE OF CAMPAIGN CONTRIBUTIONS

The undersigned, making application for rezoning with the City of Loganville, Georgia, have complied with the Official Code of Georgia, Section 36-67A-1, et. seq., Conflict of Interest in Zoning Actions, and has submitted or attached the required information as requested below.

Applicant's Signature

Date

Print Name

Melody A. Glouton

1/5/24

Signature of Applicant's
Attorney or Agent

Date

Melody A. Glouton
Print Name

Has the Applicant, attorney for applicant, or other agent, within the two years immediately preceding the filing of this application, made campaign contributions aggregating \$250.00 or more to the Mayor, Member of the City Council or member of the Planning Commission of the City of Loganville, Georgia?

_____ YES x _____ NO

If YES, complete the following:

NAME OF INDIVIDUAL MAKING CONTRIBUTION _____

NAME & OFFICIAL POSITION
OF GOVERNMENT OFFICIAL

CONTRIBUTIONS (List all
aggregating to \$250 or more)

DATE OF
CONTRIBUTION

Attach additional sheets as necessary to disclose and describe all contributions.

**COMBINED LETTER OF INTENT
AND JUSTIFICATION FOR REZONING**

**Rezoning Application
City of Loganville, Walton County, Georgia**

Applicant:

The Revive Land Group, LLC

Property:

Tax Parcel ID LG040062 (11.602 acres)
and
Tax Parcel ID LG040063 (4.981 acres)

Total: ±16.58 Acres of Land
Located at 246 and 234 Line Street, Loganville, Georgia 30052
From MHP and LI to RM-6

Submitted for Applicant by:

Melody A. Glouton, Esq.
ANDERSEN TATE & CARR, P.C.
One Sugarloaf Centre
1960 Satellite Blvd.
Suite 4000
Duluth, Georgia 30097
770.822.0900
mglouton@atclawfirm.com

I. INTRODUCTION

This Application for Rezoning is submitted for a 16.58-acre assemblage of land located at 246 and 234 Line Street, just west of its intersection with Loganville Highway (hereinafter the “Property”).¹ The Property is an assemblage of two (2) tax parcels, with frontage along both Loganville Highway and Line Street. The Property is shown on the survey prepared by Travis Pruitt & Associates, Inc., dated December 20, 2023, and filed with this Application.

The Property is currently zoned MHP (Manufactured Home Park) and LI (Light Industrial) pursuant to the Code of the City of Loganville, Georgia (the “Code”). The Applicant, The Revive Land Group, LLC (the “Applicant”) now seeks approval to rezone the Property to RM-6 (Multifamily Residential Medium Density) to develop a distinctive and attractive townhome community with 93 units.

This document is submitted as the Letter of Intent, Response to Standard Governing the Exercise of Zoning Power, and other materials required by the Code.

I. DESCRIPTION OF THE PROPERTY AND SURROUNDING AREA

The Property consists of two (2) tax parcels and contains 16.58-acres. While there are two personal residences located on the Property, the majority of the site is undeveloped and partially wooded. As shown on the City of Loganville Zoning Map, the Property is surrounded by industrial and residential uses. The following is a summary of the surrounding zoning classifications:



¹ Tract 1, Tax Parcel ID LG040062, is located at 246 Line Street, and consists of 11.602 acres. Tract 2, Tax Parcel ID LG040063, is located at 234 Line Street, and consists of 4.981 acres.

II. PROJECT SUMMARY

As shown on the conceptual site plan dated November 10, 2023, and filed with this Application (hereinafter the “Site Plan”), the Applicant proposes to develop the Property into a distinctive and attractive residential townhome community. The Applicant is proposing to rezone 16.58 acres from MHP and LI to RM-6 to accommodate the development of a townhome community with 93 units for a proposed density of 5.61 units per acre. As indicated above, the site is surrounded by industrial and residential properties and the development would provide an opportunity for transition from industrial to medium density housing. Moreover, the proposal would provide for an additional housing type for the citizens of Loganville and be a catalyst for the revitalization of downtown Loganville. As shown in the Site Plan, the community would include townhomes with a minimum square footage of 1,800 and two-car garages. While market conditions can fluctuate, the Applicant anticipates the price range of the townhomes to range from \$300,000 to 375,000. The architectural style of the townhomes would be constructed with a variety of facades, including brick, stacked stone, hardie plank, shake, board and batten. The site is designed for a full access driveway on Line Street. For reference, the Applicant has included sample elevations with this Application.

III. SITE IMPACT ANALYSIS

The Applicant submits its written impact analysis which shows that rezoning to LI satisfies the responses to evaluation criteria as follows:

1. How does the proposed use impact the overall appearance of the City and aesthetic conditions of adjacent parcels?
 - A. The Property is adjacent to existing industrial and residential uses. The site will be developed with quality architectural elements consistent with the City’s development regulations and will not adversely impact the overall appearance of adjacent parcels. Rezoning the Property to RM-6 will also permit a use that is suitable in view of the use and development of adjacent and nearby property.

2. How does the proposed use impact thoroughfare congestion and traffic safety?
 - A. Rezoning the Property to RM-6 will not result in a use which will or could cause an excessive or burdensome use of existing streets, transportation facilities or schools. While the Property has frontage on both Line Street and Loganville Highway, the community has been designed for single access on Line Street. The Applicant completed a traffic impact analysis as part of this submittal and the results of the future conditions traffic analysis indicated that the stop-controlled approaches will continue to operate at a level of service “C” or better in both the AM and PM peak hours.

3. How does the proposed use impact population density and the potential for overcrowding and urban sprawl?
 - A. The proposed residential use is suitable in view of the existing development of adjacent and nearby properties. The development will provide additional housing supply in the community and would not create overcrowding. More importantly, the development will provide housing to support the revitalization of downtown Loganville.

4. How does the proposed use impact the provision of water, sewerage, transportation and other urban infrastructure services?
 - A. The proposed use is a medium density residential use compared to surrounding industrial and residential uses on adjacent properties as it relates to water, sewer, and transportation infrastructure. The development will not result in an excessive or burdensome use of the infrastructure. The City of Loganville Public Utilities department has further confirmed that sewer capacity is available and able to serve the development. Moreover, any potential impacts on public facilities such as traffic, utility demand, stormwater, and schools can be mitigated with appropriate zoning conditions and site development requirements.

5. How does the proposed zoning provide protection of property against blight and depreciation?
 - A. The proposed zoning activates a site that is currently zoned for manufactured homes and industrial uses. The development of a townhome community brings new economic investment to the City and provides additional housing options. The development would further help in the revitalization of downtown Loganville.

6. How is the proposed use and zoning consistent with the adopted Comprehensive Plan?
 - A. The proposed use is a less intense use of the Property than some permitted uses under the current zoning classification of LI (Light Industrial District). In addition, development of the site with townhomes as opposed to manufactured homes would serve existing residents in the community as well as new residents seeking housing in the City.

7. In what way does the proposed zoning affect adjacent property owners if the request is approved?
 - A. The proposed rezoning will have little to no effect on adjacent property owners as the intended residential use will be less intensive than what is permitted under the industrial classification. Likewise, a townhome community will provide greater economic growth as opposed to a manufactured home community.

8. What is the impact upon adjacent property owners if the request is not approved?
 - A. The Property is currently occupied with two residential homes and some accessory structures. Should the Property not be rezoned to allow for townhomes, the area where the Property is located will be deprived of new residential investment that is complimentary to the surrounding uses. The proposed rezoning brings a complimentary use to the surrounding properties and will further support the existing business in the community.

9. Describe any other factors affecting the health, safety, morals, aesthetics, convenience, order, prosperity, or the general welfare of the present and future inhabitants of the City of Loganville.
 - A. The proposed rezoning would have a positive effect on the aesthetics and prosperity of the present and future citizens of the City by bringing new development to an essentially undeveloped site. The proposed development will provide quality architecture and needed housing supply to the City's current and future residents. The proposed use would be of low impact compared to its current zoning classifications and would not affect the health, safety, or morals of the City's current or future residents.

IV. JUSTIFICATION FOR REZONING

The Applicant respectfully submits that "The Code of the City of Loganville, Georgia" (the "Code"), as amended from time to time, to the extent that it classifies the Property in any zoning district that would preclude development of a townhome community is unconstitutional as a taking of property, a denial of equal protection, an arbitrary and capricious act, and an unlawful delegation of authority under the specific constitutional provisions later set forth herein. Any existing inconsistent zoning of the Property pursuant to the Code deprives the Applicant and Property owner of any alternative reasonable use and development of the Property. Additionally, all other zoning classifications, including ones intervening between the existing classification and that requested herein, would deprive the Applicant and Property owner of any reasonable use and development of the Property. Further, any attempt by the Mayor and Council of the City of Loganville to impose greater restrictions upon the manner in which the Property will be developed than presently exist would be equally unlawful.

Accordingly, Applicant submits that the current zoning classifications and any other zoning of the Property save for what has been requested as established in the Code constitute an arbitrary and unreasonable use of the zoning and police powers because they bear no substantial relationship to the public health, safety, morality or general welfare of the public and substantially harm the Applicant and Property owner. All inconsistent zoning classifications between the existing zoning and the zoning requested hereunder would constitute an arbitrary and unreasonable use of the zoning and police powers because they bear or would bear no substantial relationship to the public health, safety, morality, or general welfare of the public and would substantially harm the Applicant and Property owner. Further, the existing inconsistent zoning classification constitutes, and all zoning and plan classifications intervening between the existing inconsistent zoning classification and that required to develop this Project would constitute, a taking of the owner's

private property without just compensation and without due process in violation of the Fifth Amendment and Fourteenth Amendment of the Constitution of the United States, and Article I, Section I, Paragraph I and Article I, Section III, Paragraph I of the Constitution of the State of Georgia and the Due Process and Equal Protection Clauses of the Fourteenth Amendment to the Constitution of the United States.

Further, the Applicant respectfully submits that failure to approve the requested rezoning to RM-6 would be unconstitutional and would discriminate in an arbitrary, capricious and unreasonable manner between the Applicant and Property owner and owners of similarly situated property in violation of Article I, Section III, Paragraph I of the Constitution of the State of Georgia and the Equal Protection Clause of the Fourteenth Amendment of the Constitution of the United States.

Finally, the Applicant respectfully submits that the Mayor and Council of the City of Loganville cannot lawfully impose more restrictive standards upon the development of the Property than presently exist, as to do so not only would constitute a taking of the Property as set forth above, but also would amount to an unlawful delegation of their authority, in response to neighborhood opposition, in violation of Article IX, Section IV, Paragraph II of the Georgia Constitution.

This Application meets favorably with the prescribed test set out by the Georgia Supreme Court to be used in establishing the constitutional balance between private property rights and zoning and planning as an expression of the government’s police power. See Guhl v. Holcomb Bridge Road Corp., 238 Ga. 322 (1977).

V. CONCLUSION

For the foregoing reasons, the Applicant respectfully requests that this Application to Rezone from MHP and LI to RM-6 be approved. The Applicant welcomes the opportunity to meet with the City of Loganville Planning Department staff to answer any questions or to address any concerns relating to this Letter of Intent or supporting materials.

Respectfully submitted this 5th day of January, 2024.

ANDERSEN, TATE & CARR, P.C.

Melody A. Glouton

Melody A. Glouton, Esq.

Enclosures
MAG/dwb

4880-9828-9818, v. 1

GENERAL NOTES:

1. THIS CONCEPTUAL SITE PLAN IS FOR INFORMATIONAL PURPOSES ONLY. IT IS NOT TO BE USED FOR CONSTRUCTION OR FOR ANY OTHER PURPOSES WITHOUT THE WRITTEN APPROVAL OF THE CITY OF WALTON. THE CITY OF WALTON IS NOT RESPONSIBLE FOR ANY ERRORS OR OMISSIONS IN THIS PLAN. THE CITY OF WALTON IS NOT PROVIDING ANY WARRANTIES, EXPRESS OR IMPLIED, REGARDING THE ACCURACY OR COMPLETENESS OF THIS PLAN. THE CITY OF WALTON IS NOT PROVIDING ANY SERVICES OR PRODUCTS IN CONNECTION WITH THIS PLAN. THE CITY OF WALTON IS NOT PROVIDING ANY FINANCIAL ASSISTANCE OR OTHER BENEFITS IN CONNECTION WITH THIS PLAN. THE CITY OF WALTON IS NOT PROVIDING ANY OTHER SERVICES OR PRODUCTS IN CONNECTION WITH THIS PLAN.



24 HOUR CONTACT:
NEVILLE ALISON
678-223-8978

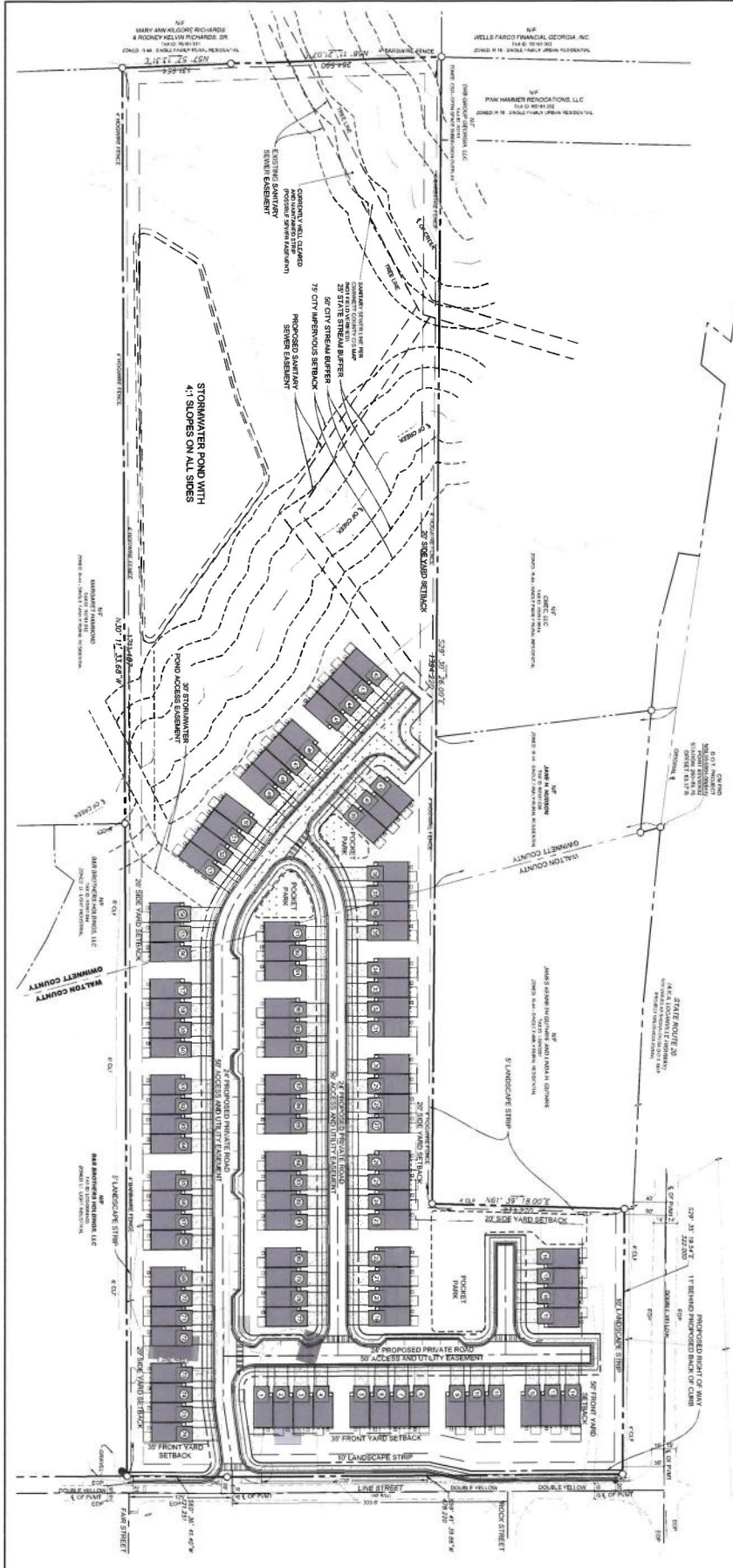

ITEM	DESCRIPTION	QUANTITY	UNIT	PRICE	TOTAL
1	CONCEPTUAL SITE PLAN	1	SET	1000.00	1000.00
2	LANDSCAPE STRIP	100	LINEAL FEET	10.00	1000.00
3	PROPOSED PRIVATE ROAD	1	SECTION	5000.00	5000.00
4	STORMWATER POND	1	UNIT	2000.00	2000.00
5	PARKING SPACES	100	SPACES	10.00	1000.00
6	LANDSCAPING	100	SPACES	10.00	1000.00
7	PROPOSED PRIVATE ROAD	1	SECTION	5000.00	5000.00
8	STORMWATER POND	1	UNIT	2000.00	2000.00
9	PARKING SPACES	100	SPACES	10.00	1000.00
10	LANDSCAPING	100	SPACES	10.00	1000.00

CITY OF WALTON
WALTON COUNTY, GEORGIA

NEVILLE ALISON
REGISTERED PROFESSIONAL ENGINEER
STATE OF GEORGIA
NO. 10000

JAMES M. ANDERSON
REGISTERED PROFESSIONAL ENGINEER
STATE OF GEORGIA
NO. 10000

NOV 10, 2023

Z-001

CONCEPTUAL SITE PLAN

23019

Adjoining Property Owners List
The Revive Land Group Rezoning Application

CMEC, LLC
627 EDGELEY LANE
LAWRENCEVILLE, GA 30044

5.43 ACRES
4075 LAWRENCEVILLE ROAD, LOGANVILLE 30052 | **R5161 001A**

JANE H. HUDSON
4077 LAWRENCEVILLE ROAD
LOGANVILLE, GA 30052

1.04 ACRES
4077 LAWRENCEVILLE STREET, LOGANVILLE 30052 | **R5161 038**

KRISNA INVESTMENT LLC
3142 PINE CONE COURT
LILBURN, GA 30047

0.91 ACRES
4045 LAWRENCEVILLE STREET, LOGANVILLE 30052 | **R5161 003**

PINK HAMMER RENOVATIONS, LLC
1949 FLOYE DRIVE
LOGANVILLE, GA 30042

0.94 ACRES
4055 LAWRENCEVILLE ROAD, LOGANVILLE 30052 | **R5161 002**

MARY ANN KILGORE RICHARDS AND RODNEY KELVIN RICHARDS, SR.
922 ULYSSES STREET
LEXINGTON, NC 27292

28.51 ACRES
3918 PECAN ROAD, LOGANVILLE 30052 | **R5161 011**

MARGARET HAMMOND
4128 PECAN STREET
LOGANVILLE, GA 30052

17.00 ACRES
4128 PECAN ROAD, LOGANVILLE 30052 | **R5161 012**

B&R BROTHERS HOLDINGS LLC
1210 WEBB GIN HOUSE ROAD
LAWRENCEVILLE, GA 30045

0.37 ACRES
4138 PECAN STREET, LOGANVILLE 30052 | **R5161 044**

B&R BROTHERS HOLDINGS LLC
1210 WEBB GIN HOUSE ROAD
LAWRENCEVILLE, GA 30045

3.12 ACRES
232 LINE STREET, LOGANVILLE 30052 | **LG040064A00**

JAMES KENNETH AND LINDA H. GUTHRIE
P.O. BOX 1245
LOGANVILLE, GA 30052

2.47 ACRES
4125 LAWRENCEVILLE ROAD, LOGANVILLE 30052 | **LG040061**







City of Loganville

Public Utilities
Brandon Phillips
Director
P.O. Box 39
Loganville, GA 30052
Tel: 770-466-3240

November 28, 2023

The Revive Land Group

Re: Proposed 234 and 246 Line Street Development Sewer Capacity

To Whom It May Concern:

The intent of this letter is to inform you that the City of Loganville does have the current capacity to service this development.

If you have any questions concerning this matter, please call my office at 770-466-0911

Travis Toney
City of Loganville
Sewer Supervisor



Planning & Development
4303 Lawrenceville Road
Loganville, GA 30052
Phone 770.466.2633
Fax: 770.554.5556

Case #: R24-006

Applicant: The Revive Land Group

Property Owner: Ronald Clifford Peeler

Property Location: 234 Line Street

Tax Map/Parcel: LG040063

Property Size: 4.981

Current Zoning: LI

Request: RM-6

Proposed Use: Combine two parcels together for 93 fee-simple townhome complex.

Applicant’s Request

The applicant is seeking to combine two parcels – one zoned MHP and the other LI – for the development of a neighborhood of townhomes.

Existing Conditions

The property has been residential for much of its history and was designated R-44 zoning according to the 2005 zoning map. In 2007, the re-zone application was filed to convert the parcel from R-44 to LI for a proposed business park that would house 11 buildings each totaling 5,000 square feet. The case was approved the Loganville City Council on May 10, 2007, with conditions to limit the property to those allowed by the LI District excluding truck and bus terminal, service station and auto or other vehicle sales as well as maintaining a buffer of at least 30 feet and the buffer is to contain a 4-foot chain-link fence and evergreen trees. This project was not developed and there exists a 1,700 square foot home built in the 1960s.

Zoning in the area is mixed, with R-44, R-16 and Light Industrial zoning classifications in the immediate area. It should also be noted that there are four duplexes across the street which were zoned RM-4 dating back to 1987 but under the current zoning map they are classified as R-16.

The current owner purchased the property in 1996. The property spans two counties, with 2 acres in Walton and the remainder in Gwinnett.

Impact Analysis

What is the impact upon the overall appearance of the City and impacts upon aesthetic conditions of adjacent parcels? The overall appearance now is one of a single-family home. This would drastically change as one building is replaced with more than 20 townhomes. But there are 30-plus different uses that could be utilized on this lot in its current LI zoning that would potentially have a more detrimental impact on the aesthetics in the area.

What is the impact upon thoroughfare congestion and traffic safety? Going from the LI zoning to RM-6 would increase traffic in the area and, as a result, impact congestion. While this parcel does not have as much of a direct impact, the overall project itself will have a large impact on the intersection of Line Street and Lawrenceville Road, which has already been identified by the City’s comprehensive traffic study as an intersection in need of improvement.

What is the impact upon population density and the potential for overcrowding and urban sprawl? Going to RM-6 zoning will increase population density and overcrowding when compared to the LI zoning.

What is the impact upon the provision of water, sewerage, transportation and other urban infrastructure services? Water and sewer service are available to the project. The intersection of Line Street and Lawrenceville Road has already been identified as one in need of improvement by the City’s own comprehensive traffic study, so the addition of this project would likely negatively impact transportation in the area.

How does the proposed use provide protection of property against blight and depreciation? While the property is not blighted, the current project would develop an otherwise underutilized piece of land. Any change of zoning is likely to impact valuation of land in the area but a return to residential zoning for this parcel would likely have a positive impact to nearby homeowners.

Is the proposed use consistent with the adopted Comprehensive Plan? The City’s future land use map shows this property with a residential zoning (Note: the map does not make a distinction between single-family and multi-family housing).

What is the impact upon adjacent property owners if the request is approved? The impact would be negligible as the parcel to the west/southwest is LI and the parcel to the east/northeast is part of the overall project being proposed. Impact to the other adjacent owners on the Gwinnett County side of the project would have limited impact as the detention pond and buffer areas around the creek limit building on that side of the project.

What is the impact upon adjacent property owners if the request is not approved? The property will likely sit as it has existed since the 2007 re-zone.

Are there any other factors effecting the health, safety, morals, aesthetics, convenience, order, prosperity, or the general welfare of the present and future inhabitants of the City of Loganville? The City of Loganville’s 2022 Comprehensive Plan, in its analysis of Planning, Land Use and Housing, noted that 78 percent of the housing stock in the City is single-family use while less than 1 percent are structures that have more than 20 units. The study identifies the need for of what is called the “Missing Middle” housing, or medium density housing. This is defined as being a range of multi-family or clustered housing types compatible in scale with single-family or transitional neighborhoods. The applicant has described his project as being a transitional neighborhood, though the scale of this development is on the larger side of what would be an ideal fit in this area.

Recommended action: Staff recommendations are to approve the rezone with the following conditions:

- Create a second entrance to the project, ideally with access to Lawrenceville Road.
- Widen the roadway on Line Street, creating dedicated left turn and right turn lanes for no fewer than 5 cars attempting to turn onto Lawrenceville Road.
- Planting of screening evergreen trees between the townhomes and 4125 Lawrenceville Road, 4077 Lawrenceville Road, and 4075 Lawrenceville Road (but not within the sewer easement) as well as 4138 Pecan St.

Amended Staff Recommendations: After a meeting on Feb. 9, 2024, with the applicant and representatives from the City’s Streets and Highway Department and Fire Department, the Staff Recommendation is to approve the rezone with the following conditions:

1. As a result of complications in meeting various roadway design criteria for a second entrance to the complex, staff amends its first recommendation to require a second driveway along Lawrenceville Road that will serve only as an emergency access point that will be gated with a Knox Box subject to GDOT approval.
2. No changes to the second condition. (Widen the roadway on Line Street, creating dedicated left turn and right turn lanes for no fewer than 5 cars attempting to turn onto Lawrenceville Road, subject to GDOT approval).
3. Amend the third recommendation to state the need for the installation of a privacy fence and planting of screening evergreen trees as infill where necessary between the townhomes and abutting residential parcels located at 4077 and 4125 Lawrenceville Road as well as along the property line with 4075 Lawrenceville Road to the stream buffer. Nothing is to be done within the sewer easement or stormwater pond access easement. This will be subject to review by Planning Staff before the issuance of a development permit.

Planning Commission Recommended Conditions

The Planning Commission voted 4-2 to approve the re-zone with the following conditions:

1. Require a second driveway along Lawrenceville Road that will serve as an emergency access point that will be gated with a Knox Box, subject to GDOT approval.
2. Widen the roadway on Line Street, creating a dedicated left turn and right turn lanes for no fewer than 5 cars attempting to turn onto Lawrenceville Road, subject to GDOT approval.
3. Installation of an 8-foot, chain-link fence between the townhomes and abutting residential parcels located at 4077 and 4125 Lawrenceville Road and along the property line with 4075 Lawrenceville Road to the stream buffer. Nothing is to be done within the sewer easement or stormwater pond access easement. This will be subject to review by Planning Department staff before the issuance of a development permit.
4. Ensure that the HOA is responsible for limiting the number of townhomes that can be rented to 15 percent of the total project at any given point in time.
5. Create a covered pavilion in the one of the common areas of the project.

City Council Conditions

**TRAFFIC IMPACT STUDY
FOR
SOMERSET AT WALTON RESIDENTIAL DEVELOPMENT**

**CITY OF LOGANVILLE
WALTON COUNTY, GEORGIA**



Prepared for:
The Revive Land Group, LLC
3500 Lenix Road, Suite 625
Atlanta, GA 30326

Prepared By:



A&R Engineering Inc.
2160 Kingston Court, Suite O
Marietta, GA 30067
Tel: (770) 690-9255 Fax: (770) 690-9210
www.areng.com

December 06, 2023
A & R Project # 23-209

TABLE OF CONTENTS

Item	Page
1.0 Introduction	1
2.0 Existing Facilities / Conditions	3
2.1 Roadway Facilities	3
2.1.1 SR 20 (Loganville Highway)	3
2.1.2 Line Street	3
2.1.3 Fair Street	3
2.1.4 Rock Street	3
3.0 Study Methodology	4
3.1 Unsignalized Intersections	4
3.2 Signalized Intersections	5
4.0 Existing 2023 Traffic Analysis.....	6
4.1 Existing Traffic Volumes	6
4.2 Existing Traffic Operations	9
5.0 Proposed Development.....	10
5.1 Trip Generation	12
5.2 Trip Distribution	12
6.0 Future 2025 Traffic Analysis	14
6.1 Future “No-Build” Conditions	14
6.1.1 Annual Traffic Growth.....	14
6.2 Future “Build” Conditions	14
6.3 Auxiliary Lane Analysis	17
6.3.1 Left Turn Lane Analysis	17
6.3.2 Deceleration Turn Lane Analysis.....	17
6.4 Future Traffic Operations.....	18
7.0 Conclusions and Recommendations.....	20
7.1 Recommendations for Site Access Configuration	20
Appendix	

LIST OF TABLES

Item	Page
Table 1 – Level-of-service Criteria for Unsignalized Intersections.....	4
Table 2 – Level-of-service Criteria for Signalized Intersections	5
Table 3 – Existing Intersection Operations	9
Table 4 – Trip Generation	12
Table 5 – GDOT Requirements for Left Turn Lanes	17
Table 6 – GDOT Requirements for Deceleration Lanes	17
Table 7 – Future Intersection Operations.....	18

LIST OF FIGURES

Item	Page
Figure 1 – Location Map.....	2
Figure 2 – Existing Weekday Peak Hour Volumes.....	7
Figure 3 – Existing Traffic Control and Lane Geometry	8
Figure 4 – Site Plan.....	11
Figure 5 – Trip Distribution and Site Generated Peak Hour Volumes	13
Figure 6 – Future (No-Build) Peak Hour Volumes.....	15
Figure 7 – Future (Build) Peak Hour Volumes.....	16
Figure 8 – Future Traffic Control and Lane Geometry.....	19

1.0 INTRODUCTION

The purpose of this study is to determine the traffic impact from the proposed residential development that will be located at 246 Line Street in the City of Loganville (Walton County), Georgia. The traffic analysis includes evaluation of the current operations and future conditions with the traffic generated by the development. The residential development will consist of 93 townhomes and proposes one full access driveway on Line Street.



The AM and PM peak hours have been analyzed in this study. In addition to the site access points, this study includes the evaluation of traffic operations at the intersections of:

- Line Street at Fair Street
- Line Street at Rock Street
- Line Street at SR 20 (Loganville Highway)

Recommendations to improve traffic operations have been identified as appropriate and are discussed in detail in the following sections of the report. The location of the development and the surrounding roadway network are shown in Figure 1.

Study Intersections



LOCATION MAP

FIGURE 1

A&R Engineering Inc.

2.0 EXISTING FACILITIES / CONDITIONS

2.1 Roadway Facilities

The following is a brief description of each of the roadway facilities located in proximity to the site:

2.1.1 SR 20 (Loganville Highway)

SR 20 (Loganville Highway) is a north-south, two-lane, undivided roadway with a posted speed limit of 45 mph in the vicinity of the site. GDOT traffic counts (Station ID: 297-0107) indicate that the daily traffic volume on SR 20 (Loganville Highway) in 2022 was 19,300 vehicles per day south of Line Street. GDOT classifies SR 20 (Loganville Highway) as an urban minor arterial roadway.

2.1.2 Line Street

Line Street is an east-west, two-lane, undivided roadway with a posted speed limit of 25 mph in the vicinity of the site.

2.1.3 Fair Street

Fair Street is a north-south, two-lane, undivided roadway with a posted speed limit of 25 mph in the vicinity of the site.

2.1.4 Rock Street

Fair Street is a north-south, two-lane, undivided roadway in the vicinity of the site.

3.0 STUDY METHODOLOGY

In this study, the methodology used for evaluating traffic operations at each of the subject intersections is based on the criteria set forth in the Transportation Research Board’s Highway Capacity Manual, 6th edition (HCM 6). Synchro software, which utilizes the HCM methodology, was used for the analysis. The following is a description of the methodology employed for the analysis of unsignalized and signalized intersections.

3.1 Unsignalized Intersections

For unsignalized intersections controlled by a stop sign on minor streets, the level of service (LOS) for motor vehicles with controlled movements is determined by the computed control delay according to the thresholds stated in Table 1 below. LOS is determined for each minor street movement (or shared movement), as well as major street left turns. LOS is not defined for the intersection as a whole or for major street approaches. The LOS of any controlled movement which experiences a volume-to-capacity ratio greater than 1 is designated as “F” regardless of the control delay.

Control delay for unsignalized intersections includes the initial deceleration delay, queue move-up time, stopped delay, and final acceleration delay. Several factors affect the control delay for unsignalized intersections, such as the availability and distribution of gaps in the conflicting traffic stream, critical gaps, and follow-up time for a vehicle in the queue.

Level of service is assigned a letter designation from “A” through “F”. Level of service “A” indicates excellent operations with little delay to motorists, while level of service “F” exists when there are insufficient gaps of acceptable size to allow vehicles on the side street to cross the main road without experiencing long delays.

TABLE 1 — LEVEL-OF-SERVICE CRITERIA FOR UNSIGNALIZED INTERSECTIONS		
Control Delay (sec/vehicle)	LOS by Volume-to-Capacity Ratio*	
	v/c ≤ 1.0	v/c > 1.0
≤ 10	A	F
> 10 and ≤ 15	B	F
> 15 and ≤ 25	C	F
> 25 and ≤ 35	D	F
> 35 and ≤ 50	E	F
> 50	F	F

*The LOS criteria apply to each lane on a given approach and to each approach on the minor street. LOS is not calculated for Major-street approaches or for the intersection.

Source: Highway Capacity Manual, 6th edition, Exhibit 20-2 *LOS Criteria: Motorized Vehicle Mode*

3.2 Signalized Intersections

According to HCM procedures, LOS can be calculated for the entire intersection, each intersection approach, and each lane group. HCM uses control delay alone to characterize LOS for the entire intersection or an approach. Control delay per vehicle is composed of initial deceleration delay, queue move-up time, stopped delay, and final acceleration delay. Both control delay and volume-to-capacity ratio are used to characterize LOS for a lane group. A volume-to-capacity ratio greater than 1.0 for a lane group indicates failure from capacity perspective. Therefore, such a lane group is assigned LOS F regardless of the amount of control delay.

Table 2 below summarizes the LOS criteria from HCM for motorized vehicles at signalized intersection.

TABLE 2 — LEVEL-OF-SERVICE CRITERIA FOR SIGNALIZED INTERSECTIONS		
Control Delay (sec/vehicle) *	LOS for Lane Group by Volume-to-Capacity Ratio*	
	v/c ≤ 1.0	v/c > 1.0
≤ 10	A	F
> 10 and ≤ 20	B	F
> 20 and ≤ 35	C	F
> 35 and ≤ 55	D	F
> 55 and ≤ 80	E	F
> 80	F	F

*For approach-based and intersection wide assessments, LOS is defined solely by control delay

Source: Highway Capacity Manual, 6th edition, Exhibit 19-8 *LOS Criteria: Motorized Vehicle Mode*

LOS A is typically assigned when the volume-to-capacity (v/c) ratio is low and either progression is exceptionally favorable, or the cycle length is very short. LOS B is typically assigned when the v/c ratio is low and either progression is highly favorable, or the cycle length is short. However, more vehicles are stopped than with LOS A. LOS C is typically assigned when progression is favorable, or the cycle length is moderate. Individual *cycle failures* (one or more queued vehicles are not able to depart because of insufficient capacity during the cycle) may begin to appear at this level. Many vehicles still pass through the intersection without stopping, but the number of vehicles stopping is significant. LOS D is typically assigned when the v/c ratio is high and either progression is ineffective, or the cycle length is long. There are many vehicle-stops and individual cycle failures are noticeable. LOS E is typically assigned when the v/c ratio is high, progression is very poor, the cycle length is long, and individual cycle failures are frequent. LOS F is typically assigned when the v/c ratio is very high, progression is very poor, the cycle length is long, and most cycles fail to clear the queue.

4.0 EXISTING 2023 TRAFFIC ANALYSIS

4.1 Existing Traffic Volumes

Existing traffic counts were obtained at the following study intersections:

- Line Street at Fair Street
- Line Street at Rock Street
- Line Street at SR 20 (Loganville Highway)

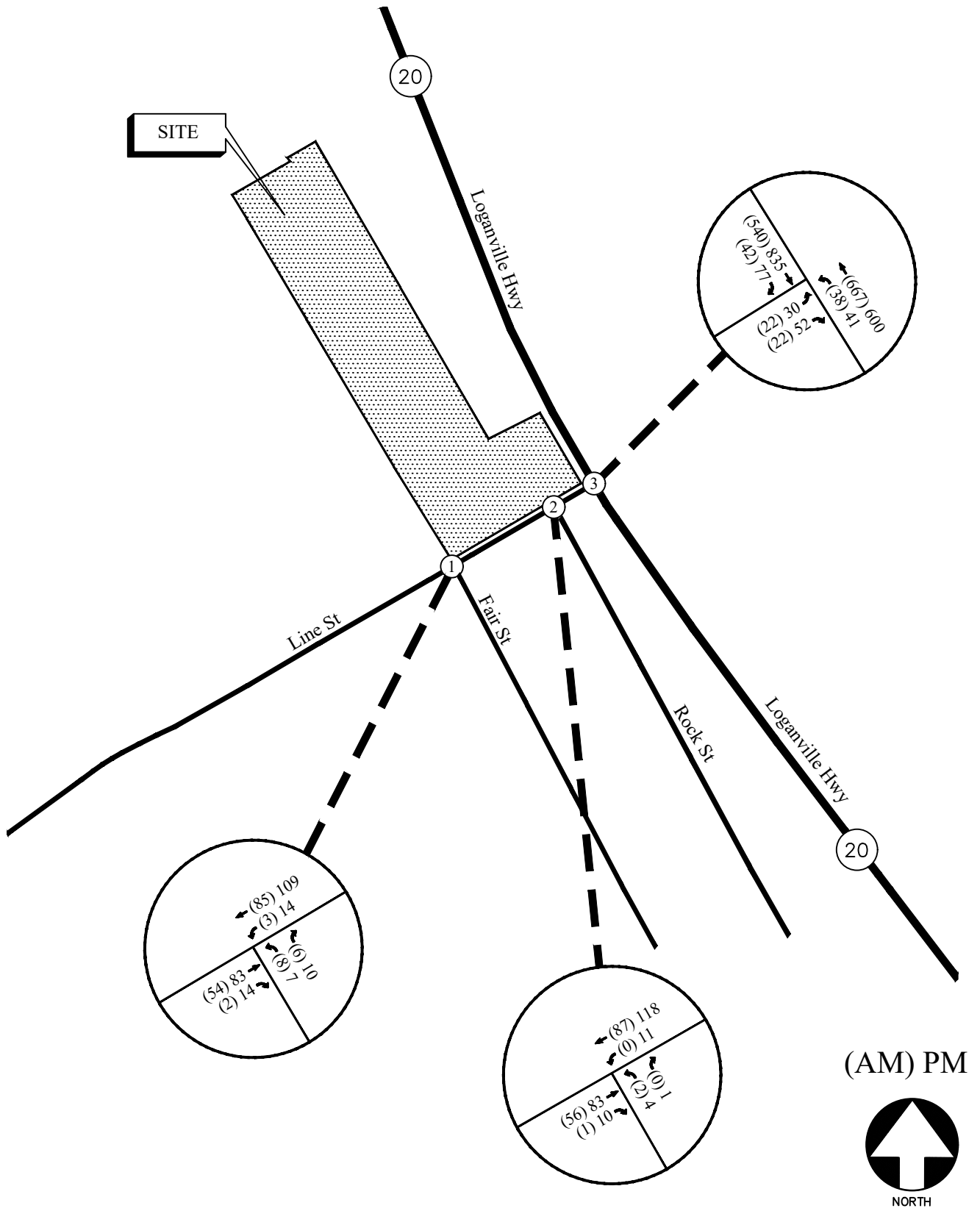

Turning movement counts were collected on Thursday, November 16, 2023. All turning movement counts were recorded during the AM and PM peak hours between 7:00 am to 9:00 am and 4:00 pm to 6:00 pm, respectively. The four consecutive 15-minute interval volumes that summed to produce the highest volume at the intersections were then determined. These volumes make up the peak hour traffic volumes for the intersections counted and are shown in Figure 2. The existing traffic control and lane geometry for the intersections are shown in Figure 3.



EXISTING WEEKDAY PEAK-HOUR VOLUMES

FIGURE 2
A&R Engineering Inc.

LEGEND

- Ex  Existing Stop Sign
- Ex  Existing Lane Arrow
- Ex  Existing Traffic Signal

Section 3, Item B.

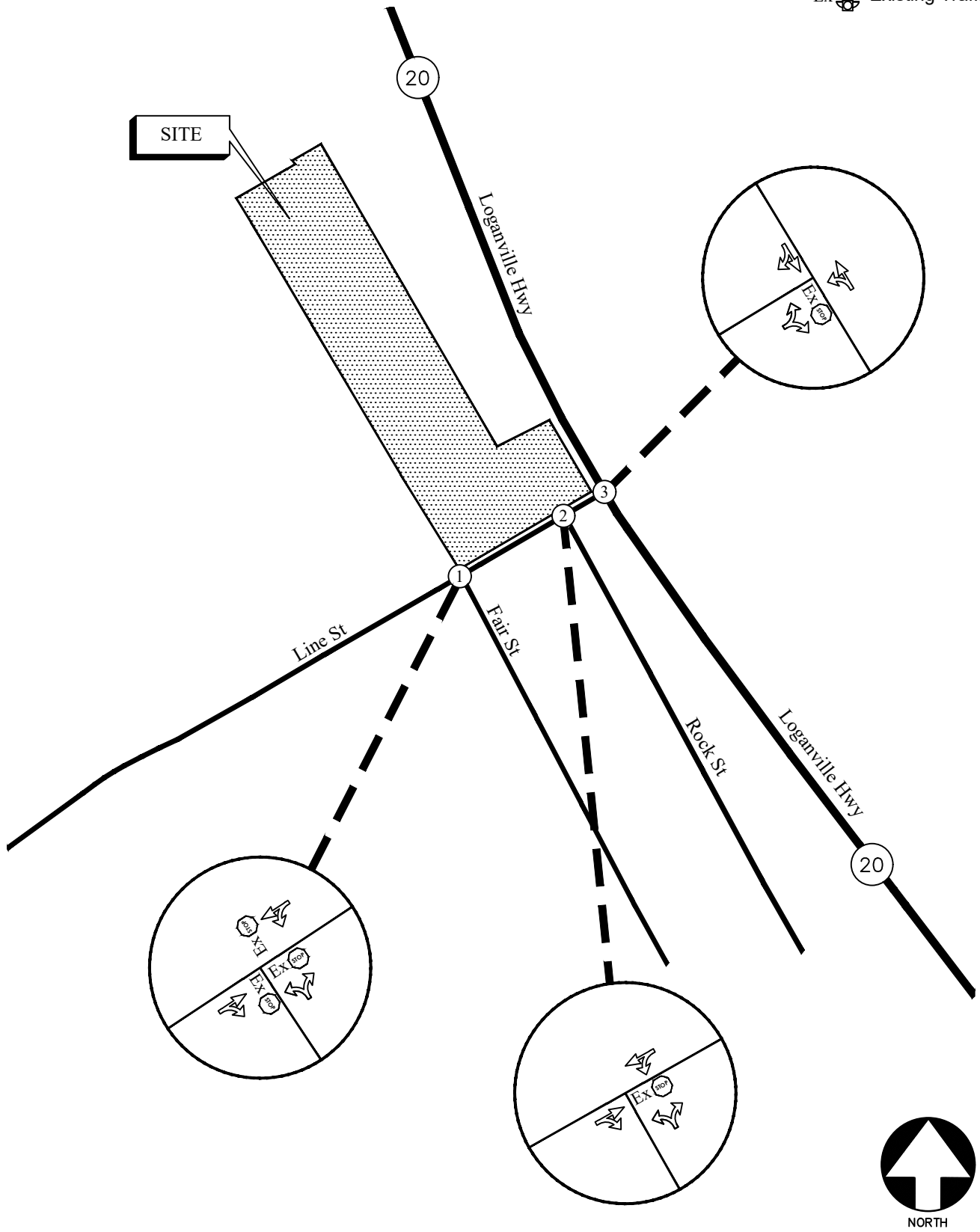

EXISTING TRAFFIC CONTROL AND LANE GEOMETRY

FIGURE 3

A&R Engineering Inc.

4.2 Existing Traffic Operations

Existing 2023 traffic operations were analyzed at the study intersections in accordance with the HCM methodology. The results of the analysis are shown in Table 3.

TABLE 3 – EXISTING INTERSECTION OPERATIONS				
Intersection		Traffic Control	LOS (Delay)	
			AM Peak Hour	PM Peak Hour
1	<u>Line Street @ Fair Street</u>	All-Way Stop-Controlled	A (7.4)	A (7.6)
	-Eastbound Approach		A (7.3)	A (7.5)
	-Westbound Approach		A (7.5)	A (7.8)
	-Northbound Approach		A (7.2)	A (7.2)
2	<u>Line Street @ Rock Street</u>	Stop-Controlled on NB Approach	A (7.3)	A (7.4)
	-Westbound Left		A (9.4)	A (9.9)
	-Northbound Approach			
3	<u>Line Street @ SR 20 (Loganville Highway)</u>	Stop-Controlled on EB Approach	C (24.7)	E (41.4)
	-Eastbound Approach		A (8.9)	B (10.3)
	-Northbound Left			

The results of the existing traffic operations analysis indicate that the stop-controlled approaches at the study intersections are operating at a level of service “C” or better in both the AM and PM peak hours, except for the eastbound approach at the intersection of Line Street and SR 20 (Loganville Highway), which is performing at a level of service “E” during the PM peak hour.

5.0 PROPOSED DEVELOPMENT

The residential development will consist of 93 townhomes and proposes one full access driveway on Line Street.



A site plan is shown in Figure 4.

GENERAL NOTES:

1. STREAMS AND WETLANDS ARE LOCATED ON THE SITE
2. TOPOGRAPHY IS LOCATED ON THE SITE
3. NO POWER OR GAS PIPING EASEMENTS ARE LOCATED ON THE SITE
4. NO COSECTIONS ARE LOCKED ON THE SITE
5. SIZE AND LOCATION OF PROPOSED STRUCTURES AS INDICATED ON THE SITE PLAN
6. SPLIT OUT ON LAWRENCEVILLE ROAD STATE ROUTE 20 IS 43 MPH.
7. SPLIT OUT ON LINE STREET IS 24 MPH.
8. WATER UTILITY PROVIDER IS CITY OF LOGANVILLE.
9. SEWAGE TREATMENT PROVIDER IS CITY OF LOGANVILLE.



24 HOUR CONTACT:
NEVILLE ALLISON
678-223-8978



SITE DATA	
SITE AREA	17.09 ACRES
ZONING	RHS-6
EXISTING ZONING	MFR (MANUFACTURED HOME DISTRICT)
PROPOSED ZONING	RHS-6
ZONING JURISDICTION	CITY OF LOGANVILLE
RESIDENTIAL STRUCTURE INFORMATION	
NO. OF UNITS	60 UNITS
MAXIMUM HEIGHT	30 FEET
NUMBER OF STORIES	TWO STORY
MINIMUM UNIT SIZE	1,800 SF
PROPOSED DENSITY	3.44 UNITS PER ACRE
MINIMUM SETBACKS	
MAXIMUM DENSITY	6 UNITS PER ACRE
MINIMUM LOT WIDTH	N/A
MINIMUM FRONT YARD	30 FEET MAJOR COLLECTOR STREET
MINIMUM FRONT YARD	30 FEET MINOR COLLECTOR STREET
MINIMUM REAR YARD	20 FEET
MINIMUM SIDE YARD	20 FEET
MINIMUM BETWEEN BUILDINGS	20 FEET
MAXIMUM BUILDING HEIGHT	30 FEET
LANDSCAPING STRIP ADJACENT TO PUBLIC RIGHT OF WAY	10 FEET
LANDSCAPING STRIP ADJACENT TO SIDE LOTS	5 FEET
PARKING REQUIREMENTS	
REQUIRED RESIDENT SPACES	1 PER BEDROOM OR 279 SPACES
PROPOSED RESIDENT SPACES	1 PER BEDROOM OR 279 SPACES
GUEST SPACES	75 SPACES



THE REVIVE LAND GROUP
Part of Peachtree Group

SOURCE, ENTITLE, REVIVE.

ONE ALLIANCE CENTER
3500 LENOX ROAD
SUITE 625
ATLANTA, GEORGIA 30326
O: (678) 223-8978
WWW.THEREVIVELANDGROUP.COM

PROJECT:
SOMERSET AT WALTON

A MASTER PLANNED RESIDENTIAL DEVELOPMENT

234 & 246 LINE STREET

CITY OF LOGANVILLE
WINNETT COUNTY & WATSON COUNTY
GEORGIA

LAND LOT:
DISTRICT:

CLIENT:
THE REVIVE LAND GROUP
Part of Peachtree Group

SOURCE, ENTITLE, REVIVE.

ONE ALLIANCE CENTER
3500 LENOX ROAD
SUITE 625
ATLANTA, GEORGIA 30326
O: (678) 223-8978
THEREVIVELANDGROUP.COM

REVISION	NO.	DATE

PROJECT NUMBER:
23019

SEALED AND SIGNED IN ACCORDANCE WITH THE PROFESSIONAL ENGINEERING ACT OF THE STATE OF GEORGIA

NOV 10, 2023



NOV 10, 2023

CONCEPTUAL SITE PLAN

SHEET
Z-001

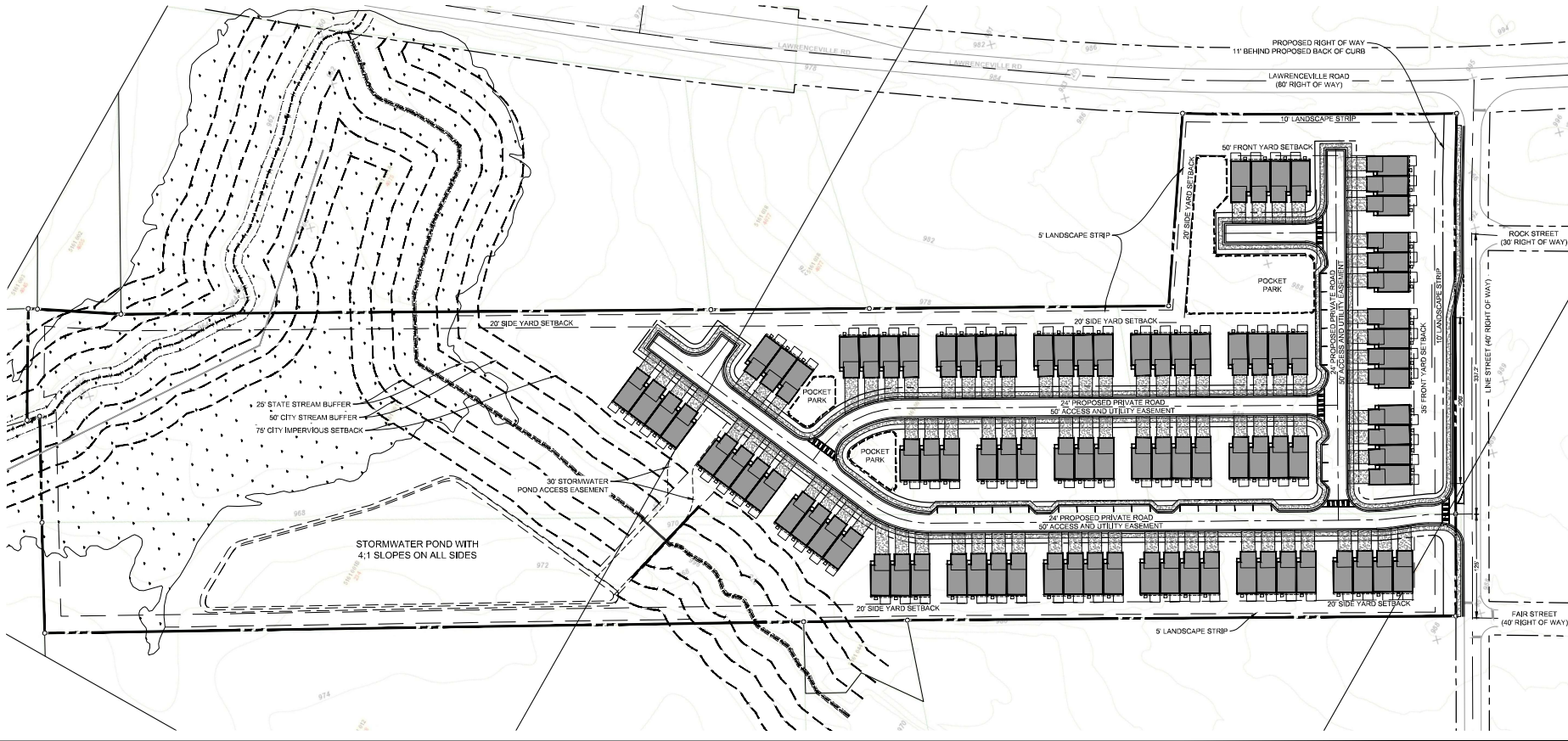

Figure 4 – Site Plan

5.1 Trip Generation

Trip generation estimates for the project were based on the rates and equations published in the 11th edition of the Institute of Transportation Engineers (ITE) Trip Generation report. This reference contains traffic volume count data collected at similar facilities nationwide. The trip generation was based on the ITE land use category 215 – *Single-Family Attached Housing*. The calculated total trip generation for the proposed development is shown in Table 4.

TABLE 4 – TRIP GENERATION								
Land Use	Size	AM Peak Hour			PM Peak Hour			24 Hour
		Enter	Exit	Total	Enter	Exit	Total	Two-Way
ITE 215 – Single-Family Attached Housing	93 Units	11	32	43	31	21	52	658

5.2 Trip Distribution

The trip distribution describes how traffic arrives and departs from the site. An overall trip distribution was developed for the site based on a review of the existing travel patterns in the area and the locations of major roadways and highways that will serve the development. The site-generated peak hour traffic volumes, shown in Table 4, were assigned to the study area intersections based on this distribution. The outer-leg distribution and AM and PM peak hour new traffic generated by the site are shown in Figure 5.

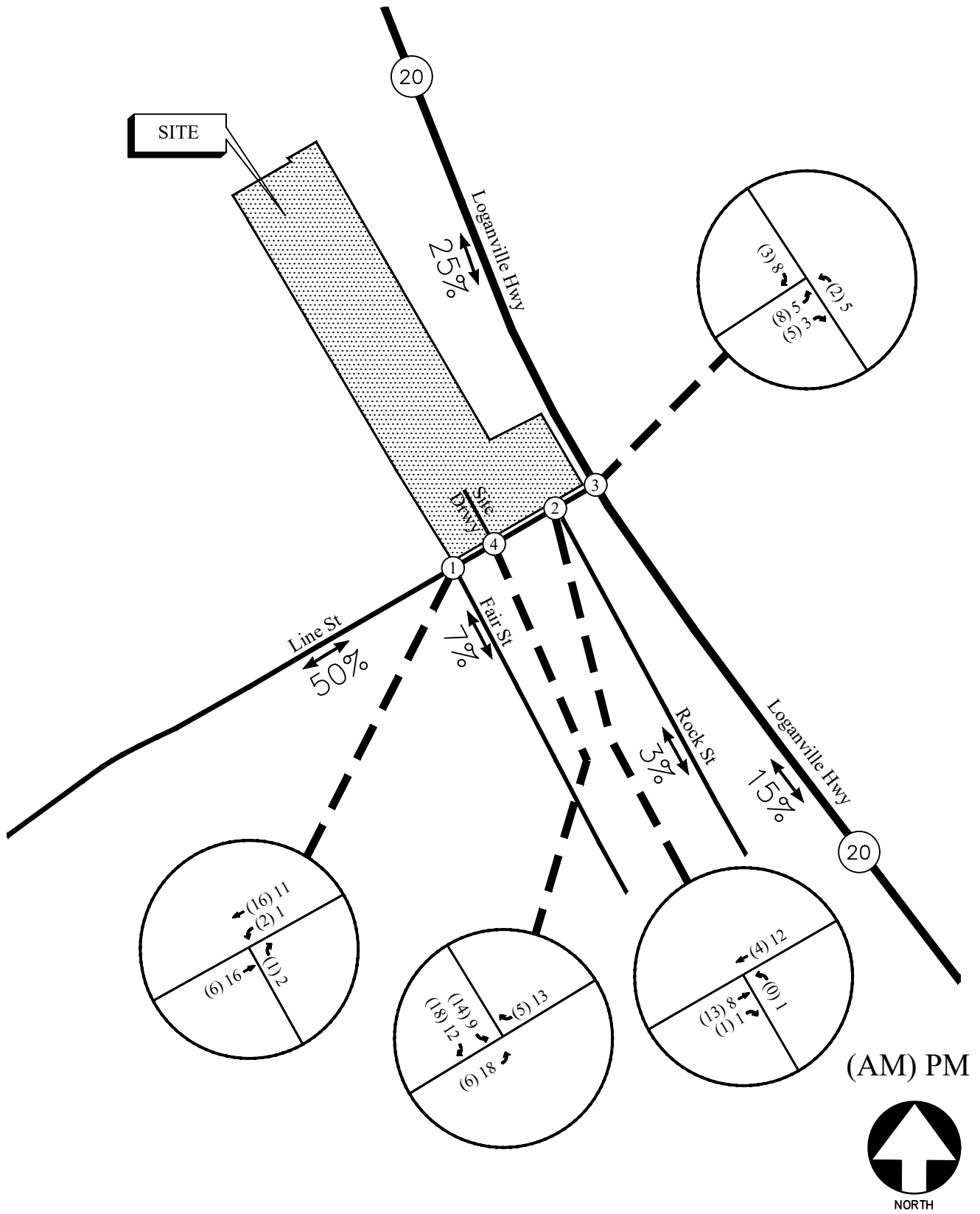

TRIP DISTRIBUTION AND SITE-GENERATED
WEEKDAY PEAK HOUR VOLUMES

FIGURE 5
A&R Engineering Inc.

6.0 FUTURE 2025 TRAFFIC ANALYSIS

The future 2025 traffic operations are analysed for the “Build” and “No-Build” conditions.

6.1 Future “No-Build” Conditions

The “No-Build” (or background) conditions provide an assessment of how traffic will operate in the study horizon year without the study site being developed as proposed, with projected increases in through traffic volumes due to normal annual growth. The future “No-Build” volumes consist of the existing traffic volumes (Figure 2) plus increases for annual growth of through traffic.

6.1.1 Annual Traffic Growth

To evaluate future traffic operations in this area, a projection of normal traffic growth was applied to the existing volumes. The Georgia Department of Transportation recorded average daily traffic volumes at several locations in the vicinity of the site. Reviewing the growth over the last three years revealed a traffic volume increase of approximately 1% in the area. This growth factor was applied to the existing traffic volumes between collector and arterial roadways to estimate the future year traffic volumes prior to the addition of site-generated traffic. The resulting Future “No-Build” volumes on the roadway are shown in Figure 6.

6.2 Future “Build” Conditions

The “Build” or development conditions include the estimated background traffic from the “No-Build” conditions plus the added traffic from the proposed development. To evaluate future traffic operations in this area, the additional traffic volumes from the site (Figure 5) were added to base traffic volumes (Figure 6) to calculate the future traffic volumes after the construction of the development. These total future “Build” traffic volumes are shown in Figure 7.

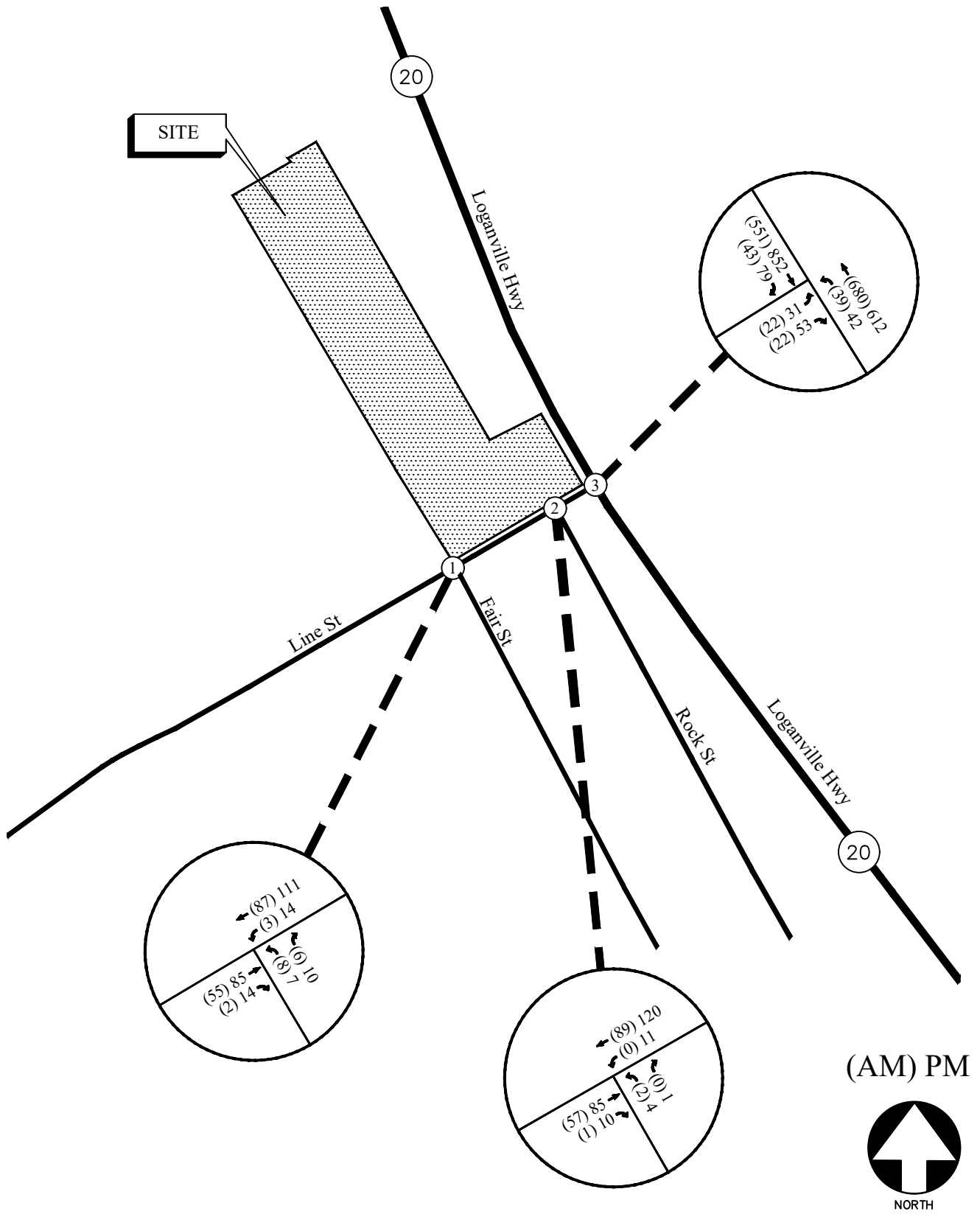

FUTURE (NO-BUILD) WEEKDAY PEAK HOUR VOLUMES

FIGURE 6
A&R Engineering Inc.

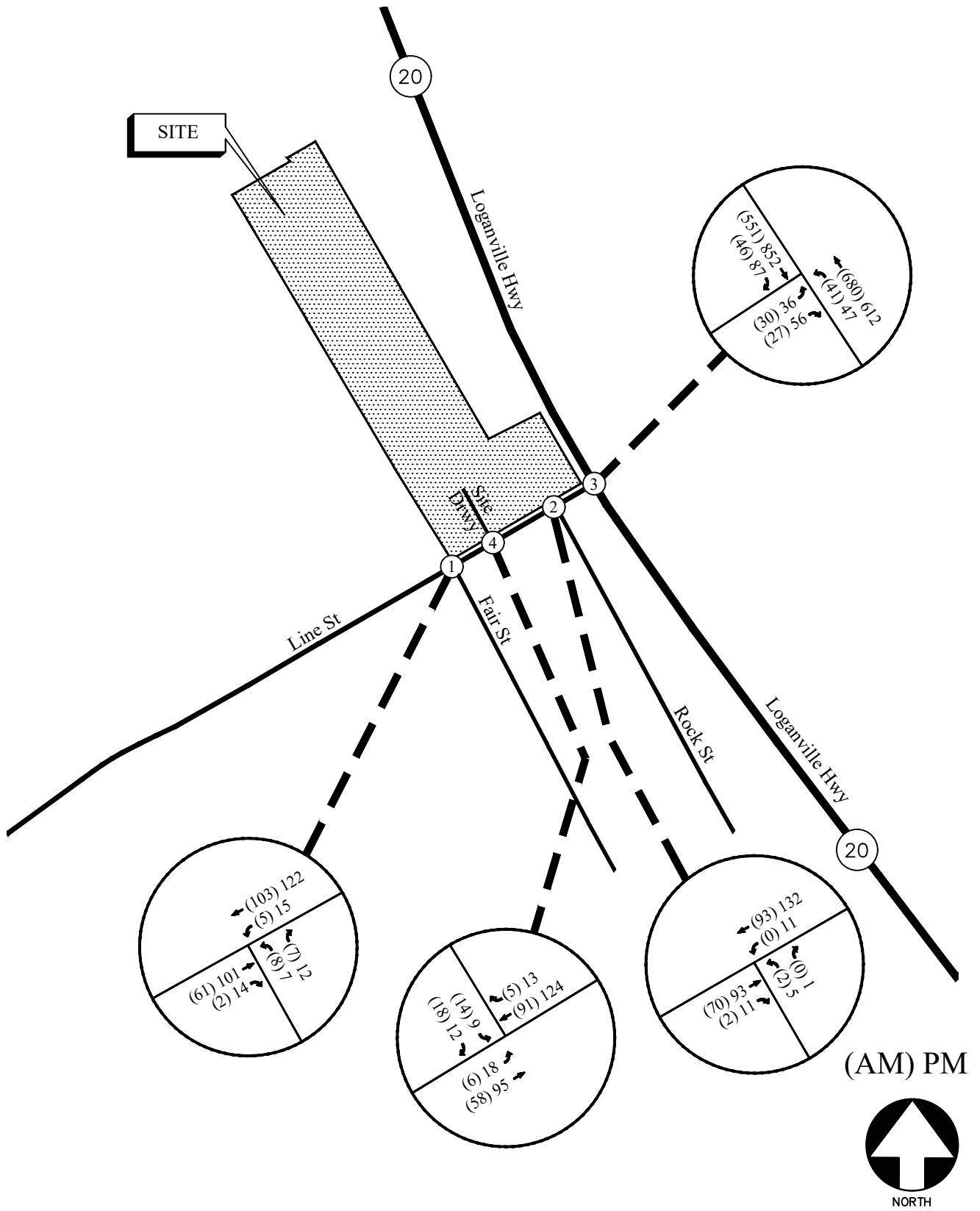

FUTURE (BUILD) WEEKDAY PEAK HOUR VOLUMES

FIGURE 7
A&R Engineering Inc.

6.3 Auxiliary Lane Analysis

Included below are analyses for a left turn lane and a right turn lane at the site driveway per GDOT standards. The analyses below are based off the trip distribution included in Section 5.2. According to the ITE trip generation, the 24-hour two-way volume for traffic entering and exiting the site is 658 vehicles. The ADT on Line Street was assumed to be less than 6,000 vehicles per day based on recorded GDOT volumes on the surrounding roadway network.

6.3.1 Left Turn Lane Analysis

According to GDOT standards, for a two-lane roadway with an AADT of less than 6,000 vehicles and a posted speed limit of 25 mph, the daily site-generated traffic left turn movements threshold to warrant a turn lane is 300 left-turning vehicles a day. The projected left turn volumes per day for the proposed driveway is shown in Table 5.

TABLE 5 – GDOT REQUIREMENTS FOR LEFT TURN LANES					
Intersection	Left Turn Traffic (% total entering)	Left Turn Volume (vehicles/day)	Roadway Speed / # Lanes / ADT	GDOT Threshold (vehicles/ day)	Warrants Met?
Line Street @ Site Driveway	57%	<p style="text-align: center;">188 (Total Trips) ÷ 2 × 0.57 = (658) ÷ 2 × 0.57 = 188</p>	25 mph / 2-Lane / < 6,000	300	No

A left turn lane is not warranted at the site driveway per GDOT standards.

6.3.2 Deceleration Turn Lane Analysis

For a two-lane roadway with an AADT of less than 6,000 vehicles and a posted speed limit of 25 mph, the daily site-generated traffic right turn movements threshold to warrant a deceleration lane is 200 right-turning vehicles a day. The projected right turn volumes per day for the proposed driveway is shown in Table 6.

TABLE 6 – GDOT REQUIREMENTS FOR DECELERATION LANES					
Intersection	Left Turn Traffic (% total entering)	Right Turn Volume (vehicles/day)	Roadway Speed / # Lanes / ADT	GDOT Threshold (vehicles/ day)	Warrants Met?
Line Street @ Site Driveway	43%	<p style="text-align: center;">141 (Total Trips) ÷ 2 × 0.43 = (658) ÷ 2 × 0.43 = 141</p>	25 mph / 2-Lane / < 6,000	200	No

A right turn lane is not warranted at the site driveway per GDOT standards.

6.4 Future Traffic Operations

The future “No-Build” and “Build” traffic operations were analysed using the volumes in Figure 6 and Figure 7, respectively. The results of the future traffic operations analysis are shown below in Table 7. Recommendations on traffic control and lane geometry are shown in Figure 8.

TABLE 7 – FUTURE INTERSECTION OPERATIONS					
Intersection		LOS (Delay)			
		NO-BUILD		BUILD-OUT	
		AM Peak	PM Peak	AM Peak	PM Peak
1	Line Street @ Fair Street	A (7.4)	A (7.6)	A (7.6)	A (7.7)
	-Eastbound Approach	A (7.3)	A (7.5)	A (7.4)	A (7.6)
	-Westbound Approach	A (7.5)	A (7.8)	A (7.7)	A (7.9)
	-Northbound Approach	A (7.2)	A (7.2)	A (7.2)	A (7.3)
2	Line Street @ Rock Street				
	-Westbound Left	A (7.3)	A (7.5)	A (7.4)	A (7.5)
	-Northbound Approach	A (9.5)	A (9.9)	A (9.6)	B (10.1)
3	Line Street @ SR 20 (Loganville Highway)				
	-Eastbound Approach	D (25.6)	E (43.7)	D (28.6)	E (48.5)
	-Northbound Left	A (8.9)	B (10.3)	A (8.9)	B (10.4)
4	Line Street @ Site Drwy				
	-Eastbound Left	-	-	A (7.4)	A (7.5)
	-Southbound Approach			A (9.2)	A (9.6)

The results of the future conditions traffic analysis indicated that the stop-controlled approaches at the study intersections will continue to operate at a level of service “C” or better in both the AM and PM peak hours, except for the eastbound approach at the intersection of Line Street and SR 20 (Loganville Highway), which will perform at a level of service “E” during the PM peak hour under both “No-Build” and “Build” conditions. It is not unusual for side streets that are stop sign controlled to experience higher delays due to the time gap required to make turning movements on busy arterial roadways.

LEGEND

- | | | | |
|--|--------------------------|---|--------------------------|
| Ex  | Existing Signed Approach |  | Proposed Signed Approach |
| Ex  | Existing Lane Geometry |  | Proposed Lane Geometry |
| Ex  | Existing Traffic Signal |  | Proposed Traffic Signal |

Section 3, Item B.

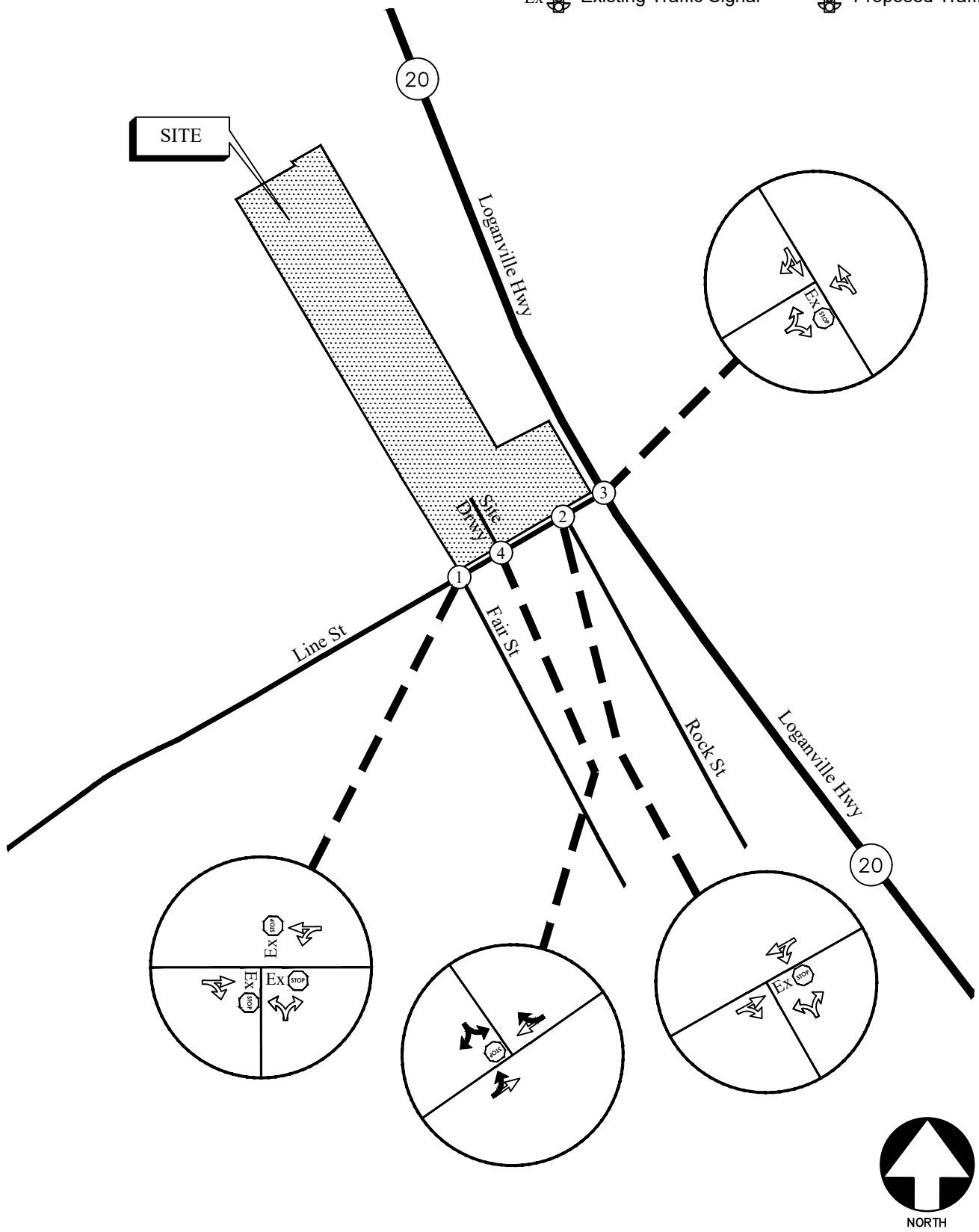

FUTURE TRAFFIC CONTROL AND LANE GEOMETRY

**FIGURE 8
A&R Engineering Inc.**

7.0 CONCLUSIONS AND RECOMMENDATIONS

Traffic impacts were evaluated for the proposed residential development that will be located at 246 Line Street in the City of Loganville (Walton County), Georgia. The residential development will consist of 93 townhomes and proposes one full access driveway on Line Street.

Existing and future operations after completion of the project were analysed at the intersections of:

- Line Street at Fair Street
- Line Street at Rock Street
- Line Street at SR 20 (Loganville Highway)
- Line Street at Site Driveway

The results of the future conditions traffic analysis indicated that the stop-controlled approaches at the study intersections will continue to operate at a level of service “C” or better in both the AM and PM peak hours, except for the eastbound approach at the intersection of Line Street and SR 20 (Loganville Highway), which will perform at a level of service “E” during the PM peak hour under both “No-Build” and “Build” conditions. It is not unusual for side streets that are stop sign controlled to experience higher delays due to the time gap required to make turning movements on busy arterial roadways. Based on the analysis, the proposed development will have minimal impact on traffic operations in the study network.

7.1 Recommendations for Site Access Configuration

The following access configuration is recommended for the proposed site driveway intersection:

- Site Driveway: Full access driveway on Line Street
 - One entering lane and one exiting lane
 - Stop-sign controlled on the driveway with Line Street remaining free flow
 - Provide/confirm adequate sight distance per AASHTO standards

Appendix

Existing Intersection Traffic Counts
Linear Regression of Daily Traffic.....
Existing Intersection Analysis.....
Future “No-Build” Intersection Analysis
Future “Build” Intersection Analysis.....
Traffic Volume Worksheets

EXISTING INTERSECTION TRAFFIC COUNTS

A & R Engineering, Inc.

2160 Kingston Court, Suite 'O'
Marietta, GA 30067

TMC Data
Line Street @ Fair Street
7-9 am | 4-6 pm

File Name : 20230390
Site Code : 20230390
Start Date : 11-16-2023
Page No : 1

Groups Printed- Cars, Buses & Trucks

Start Time	Fair Street Northbound				Southbound				Line Street Eastbound				Line Street Westbound				Int. Total
	Left	Thru	Right	App. Total	Left	Thru	Right	App. Total	Left	Thru	Right	App. Total	Left	Thru	Right	App. Total	
07:00 AM	1	0	2	3	0	0	0	0	0	5	0	5	1	18	0	19	27
07:15 AM	5	0	0	5	0	0	0	0	0	10	1	11	0	16	0	16	32
07:30 AM	1	0	0	1	0	0	0	0	0	23	0	23	1	23	0	24	48
07:45 AM	1	0	1	2	0	0	0	0	0	8	0	8	1	17	0	18	28
Total	8	0	3	11	0	0	0	0	0	46	1	47	3	74	0	77	135
08:00 AM	2	0	0	2	0	0	0	0	0	12	0	12	1	20	0	21	35
08:15 AM	1	0	1	2	0	0	0	0	0	19	1	20	0	19	0	19	41
08:30 AM	1	0	1	2	0	0	0	0	0	17	1	18	0	27	0	27	47
08:45 AM	4	0	4	8	0	0	0	0	0	6	0	6	2	19	0	21	35
Total	8	0	6	14	0	0	0	0	0	54	2	56	3	85	0	88	158
*** BREAK ***																	
04:00 PM	6	0	2	8	0	0	0	0	0	20	5	25	3	20	0	23	56
04:15 PM	0	0	1	1	0	0	0	0	0	18	2	20	2	33	0	35	56
04:30 PM	3	0	0	3	0	0	0	0	0	14	2	16	3	31	0	34	53
04:45 PM	4	0	0	4	0	0	0	0	0	22	5	27	1	24	0	25	56
Total	13	0	3	16	0	0	0	0	0	74	14	88	9	108	0	117	221
05:00 PM	1	0	1	2	0	0	0	0	0	29	3	32	4	24	0	28	62
05:15 PM	3	0	5	8	0	0	0	0	0	20	4	24	1	21	0	22	54
05:30 PM	2	0	1	3	0	0	0	0	0	13	6	19	1	35	0	36	58
05:45 PM	1	0	3	4	0	0	0	0	0	21	1	22	8	29	0	37	63
Total	7	0	10	17	0	0	0	0	0	83	14	97	14	109	0	123	237
Grand Total	36	0	22	58	0	0	0	0	0	257	31	288	29	376	0	405	751
Apprch %	62.1	0	37.9		0	0	0		0	89.2	10.8		7.2	92.8	0		
Total %	4.8	0	2.9	7.7	0	0	0	0	0	34.2	4.1	38.3	3.9	50.1	0	53.9	

A & R Engineering, Inc.

2160 Kingston Court, Suite 'O'
Marietta, GA 30067

TMC Data
Line Street @ Fair Street
7-9 am | 4-6 pm

File Name : 20230390
Site Code : 20230390
Start Date : 11-16-2023
Page No : 2

Start Time	Fair Street Northbound				Southbound				Line Street Eastbound				Line Street Westbound				Int. Total
	Left	Thru	Right	App. Total	Left	Thru	Right	App. Total	Left	Thru	Right	App. Total	Left	Thru	Right	App. Total	
Peak Hour Analysis From 07:00 AM to 08:45 AM - Peak 1 of 1																	
Peak Hour for Entire Intersection Begins at 08:00 AM																	
08:00 AM	2	0	0	2	0	0	0	0	0	12	0	12	1	20	0	21	35
08:15 AM	1	0	1	2	0	0	0	0	0	19	1	20	0	19	0	19	41
08:30 AM	1	0	1	2	0	0	0	0	0	17	1	18	0	27	0	27	47
08:45 AM	4	0	4	8	0	0	0	0	0	6	0	6	2	19	0	21	35
Total Volume	8	0	6	14	0	0	0	0	0	54	2	56	3	85	0	88	158
% App. Total	57.1	0	42.9		0	0	0		0	96.4	3.6		3.4	96.6	0		
PHF	.500	.000	.375	.438	.000	.000	.000	.000	.000	.711	.500	.700	.375	.787	.000	.815	.840

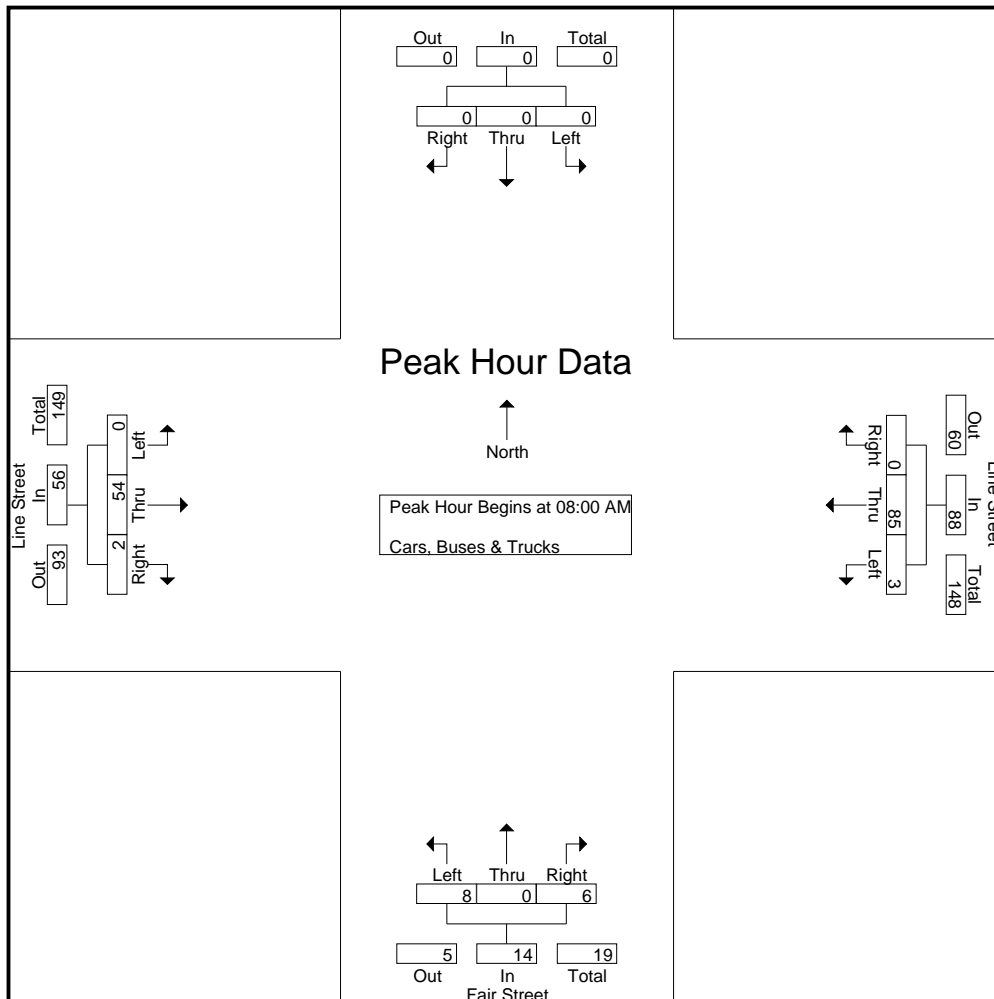

A & R Engineering, Inc.

2160 Kingston Court, Suite 'O'
Marietta, GA 30067

TMC Data
Line Street @ Fair Street
7-9 am | 4-6 pm

File Name : 20230390
Site Code : 20230390
Start Date : 11-16-2023
Page No : 3

Start Time	Fair Street Northbound				Southbound				Line Street Eastbound				Line Street Westbound				Int. Total
	Left	Thru	Right	App. Total	Left	Thru	Right	App. Total	Left	Thru	Right	App. Total	Left	Thru	Right	App. Total	
Peak Hour Analysis From 04:00 PM to 05:45 PM - Peak 1 of 1																	
Peak Hour for Entire Intersection Begins at 05:00 PM																	
05:00 PM	1	0	1	2	0	0	0	0	0	29	3	32	4	24	0	28	62
05:15 PM	3	0	5	8	0	0	0	0	0	20	4	24	1	21	0	22	54
05:30 PM	2	0	1	3	0	0	0	0	0	13	6	19	1	35	0	36	58
05:45 PM	1	0	3	4	0	0	0	0	0	21	1	22	8	29	0	37	63
Total Volume	7	0	10	17	0	0	0	0	0	83	14	97	14	109	0	123	237
% App. Total	41.2	0	58.8		0	0	0			85.6	14.4		11.4	88.6	0		
PHF	.583	.000	.500	.531	.000	.000	.000	.000	.000	.716	.583	.758	.438	.779	.000	.831	.940

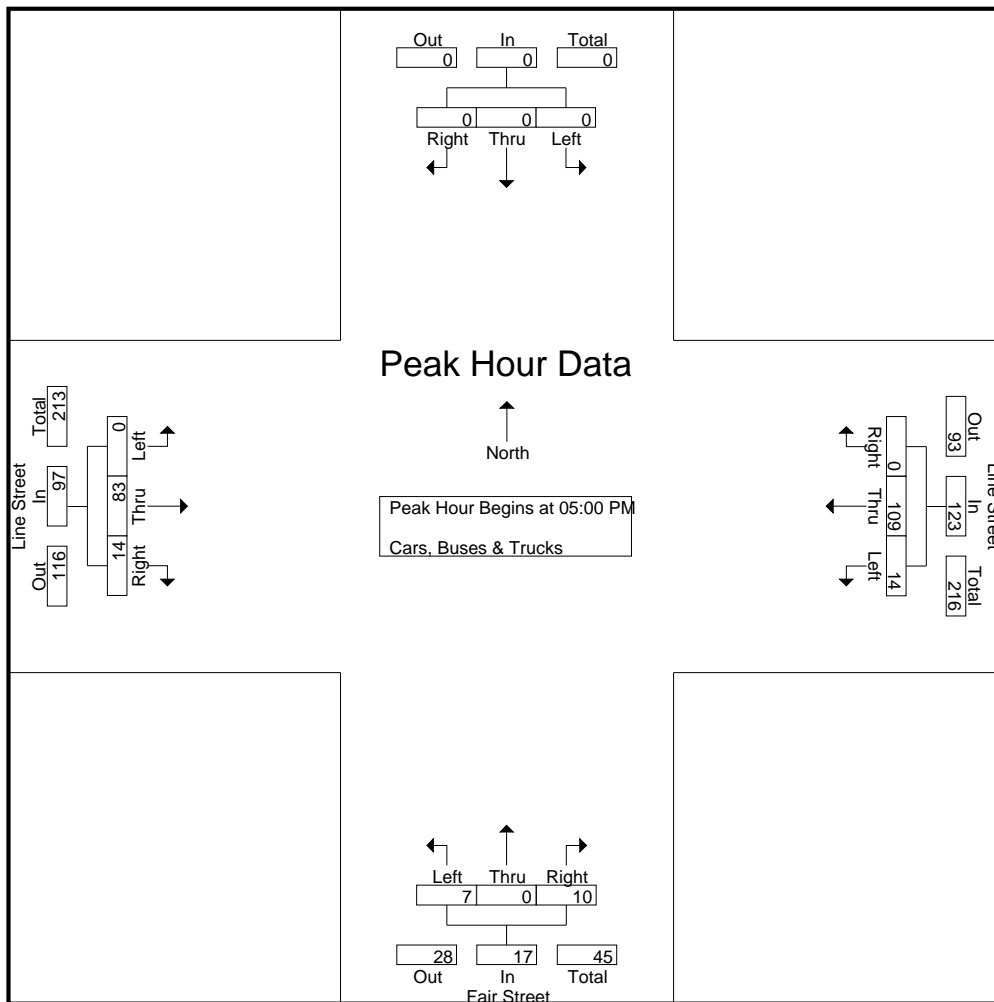

A & R Engineering, Inc.

2160 Kingston Court, Suite 'O'
Marietta, GA 30067

TMC Data
Line Street @ Rock Street
7-9 am | 4-6 pm

File Name : 20230391
Site Code : 20230391
Start Date : 11-16-2023
Page No : 1

Groups Printed- Cars, Buses & Trucks

Start Time	Rock Street Northbound				Southbound				Line Street Eastbound				Line Street Westbound				Int. Total
	Left	Thru	Right	App. Total	Left	Thru	Right	App. Total	Left	Thru	Right	App. Total	Left	Thru	Right	App. Total	
07:00 AM	0	0	0	0	0	0	0	0	0	7	0	7	0	19	0	19	26
07:15 AM	0	0	0	0	0	0	0	0	0	10	0	10	0	16	0	16	26
07:30 AM	1	0	0	1	0	0	0	0	0	8	1	9	0	22	0	22	32
07:45 AM	0	0	0	0	0	0	0	0	0	8	0	8	0	18	0	18	26
Total	1	0	0	1	0	0	0	0	0	33	1	34	0	75	0	75	110
08:00 AM	0	0	0	0	0	0	0	0	0	12	0	12	0	21	0	21	33
08:15 AM	1	0	0	1	0	0	0	0	0	16	1	17	0	19	0	19	37
08:30 AM	0	0	0	0	0	0	0	0	0	18	0	18	0	27	0	27	45
08:45 AM	1	0	0	1	0	0	0	0	0	10	0	10	0	20	0	20	31
Total	2	0	0	2	0	0	0	0	0	56	1	57	0	87	0	87	146
*** BREAK ***																	
04:00 PM	0	0	0	0	0	0	0	0	0	26	1	27	0	22	0	22	49
04:15 PM	0	0	1	1	0	0	0	0	0	19	0	19	0	35	0	35	55
04:30 PM	1	0	0	1	0	0	0	0	0	13	0	13	0	33	0	33	47
04:45 PM	0	0	0	0	0	0	0	0	0	22	0	22	0	25	0	25	47
Total	1	0	1	2	0	0	0	0	0	80	1	81	0	115	0	115	198
05:00 PM	3	0	0	3	0	0	0	0	0	27	3	30	0	25	0	25	58
05:15 PM	1	0	0	1	0	0	0	0	0	24	1	25	1	20	0	21	47
05:30 PM	0	0	0	0	0	0	0	0	0	13	1	14	1	36	0	37	51
05:45 PM	0	0	1	1	0	0	0	0	0	19	5	24	9	37	0	46	71
Total	4	0	1	5	0	0	0	0	0	83	10	93	11	118	0	129	227
Grand Total	8	0	2	10	0	0	0	0	0	252	13	265	11	395	0	406	681
Apprch %	80	0	20		0	0	0		0	95.1	4.9		2.7	97.3	0		
Total %	1.2	0	0.3	1.5	0	0	0	0	0	37	1.9	38.9	1.6	58	0	59.6	

A & R Engineering, Inc.

2160 Kingston Court, Suite 'O'
Marietta, GA 30067

TMC Data
Line Street @ Rock Street
7-9 am | 4-6 pm

File Name : 20230391
Site Code : 20230391
Start Date : 11-16-2023
Page No : 2

Start Time	Rock Street Northbound				Southbound				Line Street Eastbound				Line Street Westbound				Int. Total	
	Left	Thru	Right	App. Total	Left	Thru	Right	App. Total	Left	Thru	Right	App. Total	Left	Thru	Right	App. Total		
Peak Hour Analysis From 07:00 AM to 08:45 AM - Peak 1 of 1																		
Peak Hour for Entire Intersection Begins at 08:00 AM																		
08:00 AM	0	0	0	0	0	0	0	0	0	12	0	12	0	21	0	21	0	33
08:15 AM	1	0	0	1	0	0	0	0	0	16	1	17	0	19	0	19	0	37
08:30 AM	0	0	0	0	0	0	0	0	0	18	0	18	0	27	0	27	0	45
08:45 AM	1	0	0	1	0	0	0	0	0	10	0	10	0	20	0	20	0	31
Total Volume	2	0	0	2	0	0	0	0	0	56	1	57	0	87	0	87	0	146
% App. Total	100	0	0		0	0	0		0	98.2	1.8		0	100	0		0	
PHF	.500	.000	.000	.500	.000	.000	.000	.000	.000	.778	.250	.792	.000	.806	.000	.806	.811	

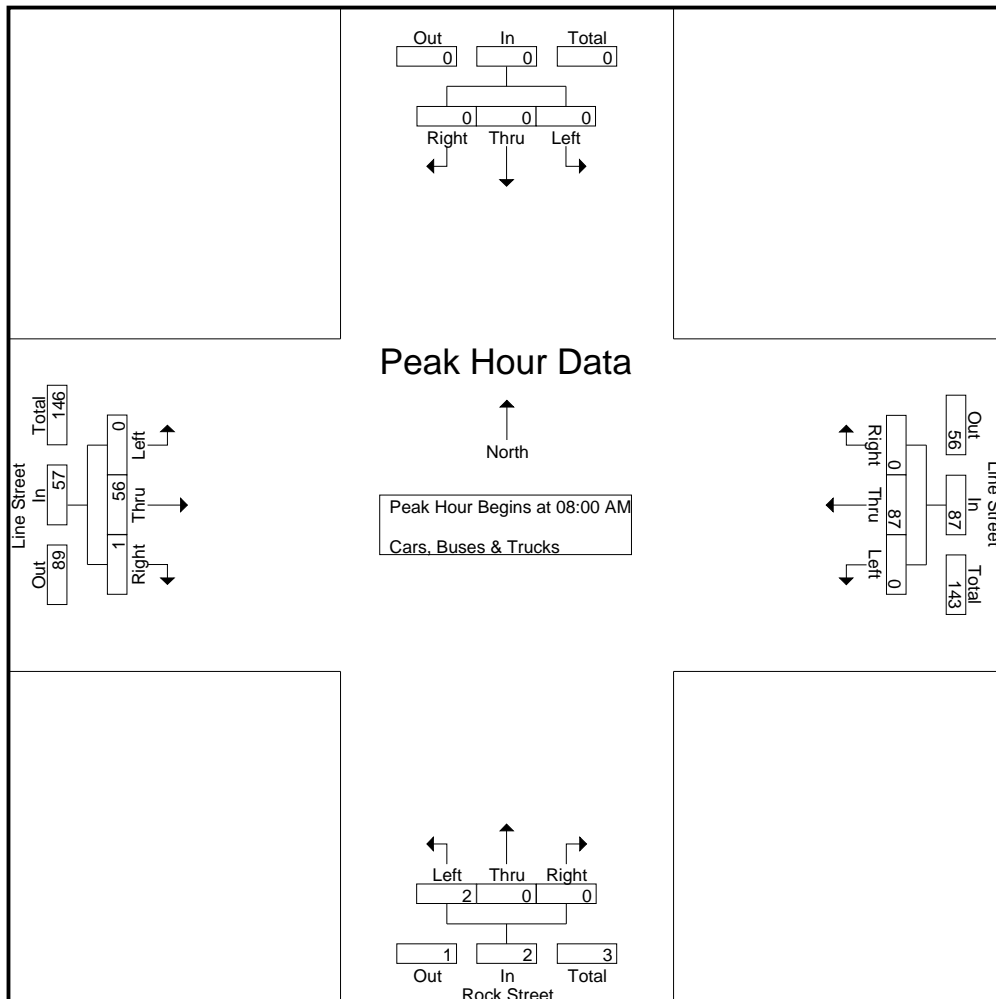

A & R Engineering, Inc.

2160 Kingston Court, Suite 'O'
Marietta, GA 30067

TMC Data
Line Street @ Rock Street
7-9 am | 4-6 pm

File Name : 20230391
Site Code : 20230391
Start Date : 11-16-2023
Page No : 3

Start Time	Rock Street Northbound				Southbound				Line Street Eastbound				Line Street Westbound				Int. Total
	Left	Thru	Right	App. Total	Left	Thru	Right	App. Total	Left	Thru	Right	App. Total	Left	Thru	Right	App. Total	
Peak Hour Analysis From 04:00 PM to 05:45 PM - Peak 1 of 1																	
Peak Hour for Entire Intersection Begins at 05:00 PM																	
05:00 PM	3	0	0	3	0	0	0	0	0	27	3	30	0	25	0	25	58
05:15 PM	1	0	0	1	0	0	0	0	0	24	1	25	1	20	0	21	47
05:30 PM	0	0	0	0	0	0	0	0	0	13	1	14	1	36	0	37	51
05:45 PM	0	0	1	1	0	0	0	0	0	19	5	24	9	37	0	46	71
Total Volume	4	0	1	5	0	0	0	0	0	83	10	93	11	118	0	129	227
% App. Total	80	0	20		0	0	0		0	89.2	10.8		8.5	91.5	0		
PHF	.333	.000	.250	.417	.000	.000	.000	.000	.000	.769	.500	.775	.306	.797	.000	.701	.799

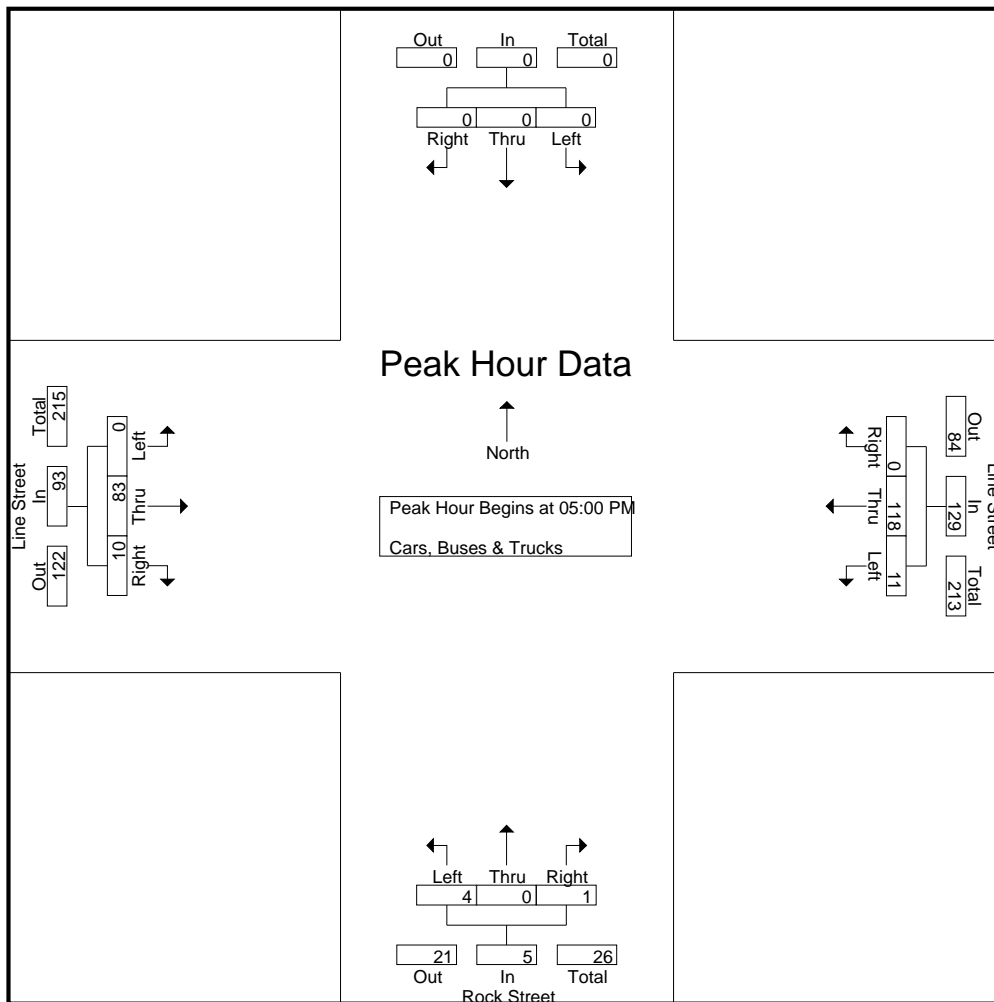

A & R Engineering, Inc.

2160 Kingston Court, Suite 'O'
Marietta, GA 30067

TMC Data
SR 20 (Loganville Hwy) @ Line Street
7-9 am | 4-6 pm

File Name : 20230389
Site Code : 20230389
Start Date : 11-16-2023
Page No : 1

Groups Printed- Cars, Buses & Trucks

Start Time	SR 20 (Loganville Hwy) Northbound				SR 20 (Loganville Hwy) Southbound				Line St Eastbound				Westbound				Int. Total
	Left	Thru	Right	App. Total	Left	Thru	Right	App. Total	Left	Thru	Right	App. Total	Left	Thru	Right	App. Total	
07:00 AM	9	197	0	206	0	125	10	135	2	0	5	7	0	0	0	0	348
07:15 AM	7	170	0	177	0	122	9	131	5	0	5	10	0	0	0	0	318
07:30 AM	10	147	0	157	0	143	12	155	5	0	3	8	0	0	0	0	320
07:45 AM	8	155	0	163	0	136	10	146	2	0	6	8	0	0	0	0	317
Total	34	669	0	703	0	526	41	567	14	0	19	33	0	0	0	0	1303
08:00 AM	10	184	0	194	0	123	11	134	6	0	6	12	0	0	0	0	340
08:15 AM	10	181	0	191	0	138	9	147	9	0	7	16	0	0	0	0	354
08:30 AM	10	167	0	177	0	99	17	116	10	0	8	18	0	0	0	0	311
08:45 AM	4	141	0	145	0	121	16	137	6	0	4	10	0	0	0	0	292
Total	34	673	0	707	0	481	53	534	31	0	25	56	0	0	0	0	1297
*** BREAK ***																	
04:00 PM	5	137	0	142	0	204	17	221	10	0	16	26	0	0	0	0	389
04:15 PM	7	154	0	161	0	221	28	249	11	0	9	20	0	0	0	0	430
04:30 PM	10	162	0	172	0	203	23	226	2	0	11	13	0	0	0	0	411
04:45 PM	14	143	0	157	0	207	11	218	6	0	16	22	0	0	0	0	397
Total	36	596	0	632	0	835	79	914	29	0	52	81	0	0	0	0	1627
05:00 PM	10	141	0	151	0	204	15	219	11	0	16	27	0	0	0	0	397
05:15 PM	9	153	0	162	0	190	12	202	3	0	21	24	0	0	0	0	388
05:30 PM	7	146	0	153	0	207	30	237	8	0	5	13	0	0	0	0	403
05:45 PM	11	134	0	145	0	189	35	224	8	0	12	20	0	0	0	0	389
Total	37	574	0	611	0	790	92	882	30	0	54	84	0	0	0	0	1577
Grand Total	141	2512	0	2653	0	2632	265	2897	104	0	150	254	0	0	0	0	5804
Apprch %	5.3	94.7	0		0	90.9	9.1		40.9	0	59.1		0	0	0		
Total %	2.4	43.3	0	45.7	0	45.3	4.6	49.9	1.8	0	2.6	4.4	0	0	0	0	

A & R Engineering, Inc.

2160 Kingston Court, Suite 'O'
Marietta, GA 30067

TMC Data
SR 20 (Loganville Hwy) @ Line Street
7-9 am | 4-6 pm

File Name : 20230389
Site Code : 20230389
Start Date : 11-16-2023
Page No : 2

Start Time	SR 20 (Loganville Hwy) Northbound				SR 20 (Loganville Hwy) Southbound				Line St Eastbound				Westbound				Int. Total
	Left	Thru	Right	App. Total	Left	Thru	Right	App. Total	Left	Thru	Right	App. Total	Left	Thru	Right	App. Total	
Peak Hour Analysis From 07:00 AM to 08:45 AM - Peak 1 of 1																	
Peak Hour for Entire Intersection Begins at 07:30 AM																	
07:30 AM	10	147	0	157	0	143	12	155	5	0	3	8	0	0	0	0	320
07:45 AM	8	155	0	163	0	136	10	146	2	0	6	8	0	0	0	0	317
08:00 AM	10	184	0	194	0	123	11	134	6	0	6	12	0	0	0	0	340
08:15 AM	10	181	0	191	0	138	9	147	9	0	7	16	0	0	0	0	354
Total Volume	38	667	0	705	0	540	42	582	22	0	22	44	0	0	0	0	1331
% App. Total	5.4	94.6	0		0	92.8	7.2		50	0	50		0	0	0		
PHF	.950	.906	.000	.909	.000	.944	.875	.939	.611	.000	.786	.688	.000	.000	.000	.000	.940

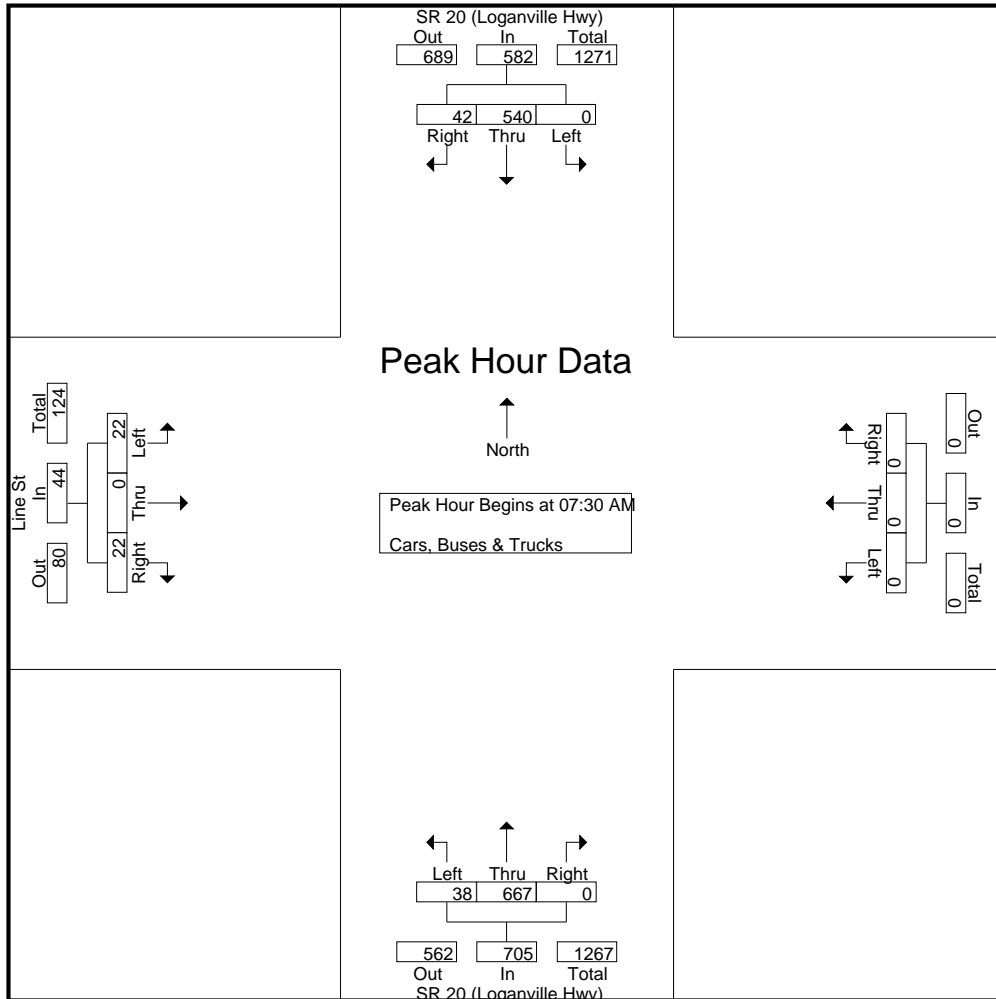

A & R Engineering, Inc.

2160 Kingston Court, Suite 'O'
Marietta, GA 30067

TMC Data
SR 20 (Loganville Hwy) @ Line Street
7-9 am | 4-6 pm

File Name : 20230389
Site Code : 20230389
Start Date : 11-16-2023
Page No : 3

Start Time	SR 20 (Loganville Hwy) Northbound				SR 20 (Loganville Hwy) Southbound				Line St Eastbound				Westbound				Int. Total
	Left	Thru	Right	App. Total	Left	Thru	Right	App. Total	Left	Thru	Right	App. Total	Left	Thru	Right	App. Total	
Peak Hour Analysis From 04:00 PM to 05:45 PM - Peak 1 of 1																	
Peak Hour for Entire Intersection Begins at 04:15 PM																	
04:15 PM	7	154	0	161	0	221	28	249	11	0	9	20	0	0	0	0	430
04:30 PM	10	162	0	172	0	203	23	226	2	0	11	13	0	0	0	0	411
04:45 PM	14	143	0	157	0	207	11	218	6	0	16	22	0	0	0	0	397
05:00 PM	10	141	0	151	0	204	15	219	11	0	16	27	0	0	0	0	397
Total Volume	41	600	0	641	0	835	77	912	30	0	52	82	0	0	0	0	1635
% App. Total	6.4	93.6	0		0	91.6	8.4		36.6	0	63.4		0	0	0		
PHF	.732	.926	.000	.932	.000	.945	.688	.916	.682	.000	.813	.759	.000	.000	.000	.000	.951

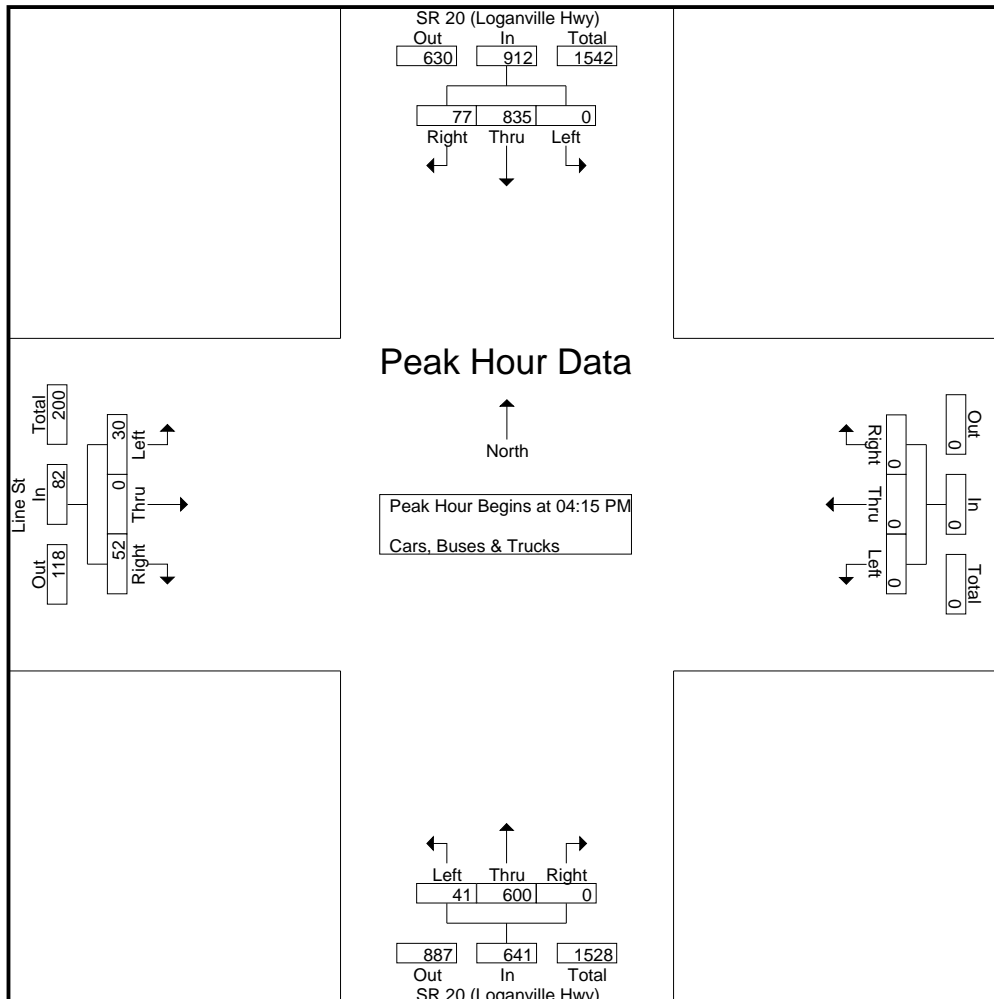

LINEAR REGRESSION OF DAILY TRAFFIC

Location	Growth Rate	R Squared	Station ID	Route	2017	2018	2019
Loganville Hwy (SE of Line St)	0.5%	0.75	297-0107	00002000	19,300	19,300	19,500
Logan Dr (NW of Cross St)	3.0%	0.96	297-0441	00053413	1,980	2,060	2,100
CS Floyd Rd (SW of Fair St)	1.8%	1.00	297-0109	00053313	4,910	4,990	5,090
Old Loganville Rd (W of Chase Ct)	1.8%	0.99	135-8053	00031000	7,190	7,300	7,450
SR 20 (Lawrenceville Hwy) (N of Ray Rd)	1.4%	0.75	297-0124	00002000	18,400	18,400	18,900
Weighted Average	1.2%	0.90	Sum of Count Stations =		51,780	52,050	53,040

Location	Traffic Counter	RCLINK	2017	2018	2019
Loganville Hwy (SE of Line St)	297-0107	00002000	19,300	19,300	19,500



Growth Rate
Trend Line

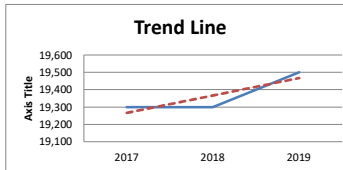

0.5% Intercept -182,433 Slope 100.00
19,267 19,367 19,467

Location	Traffic Counter	RCLINK	2017	2018	2019
Logan Dr (NW of Cross St)	297-0441	00053413	1,980	2,060	2,100



Growth Rate
Trend Line

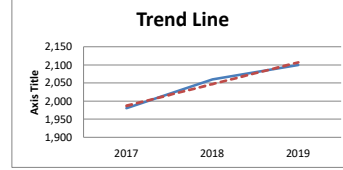

3.0% Intercept -119,033 Slope 60.00
1,987 2,047 2,107

Location	Traffic Counter	RCLINK	2017	2018	2019
CS Floyd Rd (SW of Fair St)	297-0109	00053313	4,910	4,990	5,090

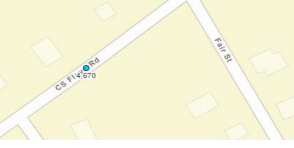

Growth Rate
Trend Line

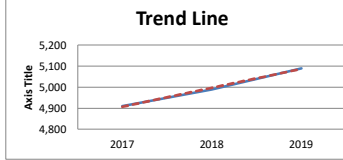

1.8% Intercept -176,623 Slope 90.00
4,907 4,997 5,087

Location	Traffic Counter	RCLINK	2017	2018	2019
Old Loganville Rd (W of Chase Ct)	135-8053	00031000	7,190	7,300	7,450



Growth Rate
Trend Line

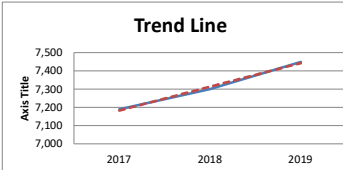

1.8% Intercept -255,027 Slope 130.00
7,183 7,313 7,443

Location	Traffic Counter	RCLINK	2017	2018	2019
SR 20 (Lawrenceville Hwy) (N of Ray Rd)	297-0124	00002000	18,400	18,400	18,900

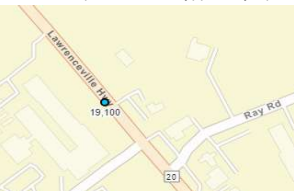

Growth Rate
Trend Line

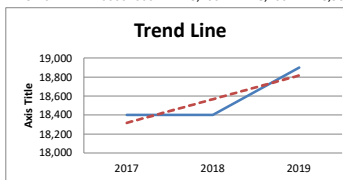

1.4% Intercept -485,933 Slope 250.00
18,317 18,567 18,817

Weighted Average	2017	2018	2019
Sum of Count Stations	51,780	52,050	53,040

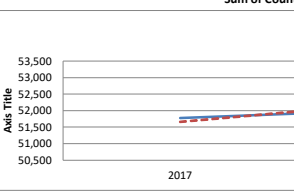

Growth Rate
Trend Line

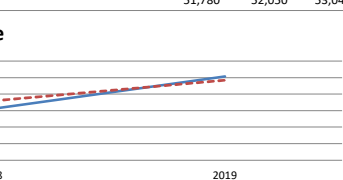

1.2% Intercept -1,219,050 Slope 630.00
51,660 52,290 52,920

EXISTING INTERSECTION ANALYSIS

Intersection	
Intersection Delay, s/veh	7.4
Intersection LOS	A

Movement	EBT	EBR	WBL	WBT	NBL	NBR
Lane Configurations	↻			↻	↻	
Traffic Vol, veh/h	54	2	3	85	8	6
Future Vol, veh/h	54	2	3	85	8	6
Peak Hour Factor	0.84	0.84	0.84	0.84	0.84	0.84
Heavy Vehicles, %	0	0	0	0	0	0
Mvmt Flow	64	2	4	101	10	7
Number of Lanes	1	0	0	1	1	0

Approach	EB	WB	NB
Opposing Approach	WB	EB	
Opposing Lanes	1	1	0
Conflicting Approach Left		NB	EB
Conflicting Lanes Left	0	1	1
Conflicting Approach Right	NB		WB
Conflicting Lanes Right	1	0	1
HCM Control Delay	7.3	7.5	7.2
HCM LOS	A	A	A

Lane	NBLn1	EBLn1	WBLn1
Vol Left, %	57%	0%	3%
Vol Thru, %	0%	96%	97%
Vol Right, %	43%	4%	0%
Sign Control	Stop	Stop	Stop
Traffic Vol by Lane	14	56	88
LT Vol	8	0	3
Through Vol	0	54	85
RT Vol	6	2	0
Lane Flow Rate	17	67	105
Geometry Grp	1	1	1
Degree of Util (X)	0.019	0.074	0.116
Departure Headway (Hd)	4.05	3.986	3.986
Convergence, Y/N	Yes	Yes	Yes
Cap	874	898	900
Service Time	2.122	2.014	2.006
HCM Lane V/C Ratio	0.019	0.075	0.117
HCM Control Delay	7.2	7.3	7.5
HCM Lane LOS	A	A	A
HCM 95th-tile Q	0.1	0.2	0.4

HCM 6th TWSC
2: Rock Street & Line Street

Intersection						
Int Delay, s/veh	0.2					
Movement	EBT	EBR	WBL	WBT	NBL	NBR
Lane Configurations						
Traffic Vol, veh/h	56	1	1	87	2	0
Future Vol, veh/h	56	1	1	87	2	0
Conflicting Peds, #/hr	0	0	0	0	0	0
Sign Control	Free	Free	Free	Free	Stop	Stop
RT Channelized	-	None	-	None	-	None
Storage Length	-	-	-	-	0	-
Veh in Median Storage, #	0	-	-	0	0	-
Grade, %	0	-	-	0	0	-
Peak Hour Factor	81	81	81	81	81	81
Heavy Vehicles, %	0	0	0	0	0	0
Mvmt Flow	69	1	1	107	2	0
Major/Minor	Major1	Major2	Minor1			
Conflicting Flow All	0	0	70	0	179	70
Stage 1	-	-	-	-	70	-
Stage 2	-	-	-	-	109	-
Critical Hdwy	-	-	4.1	-	6.4	6.2
Critical Hdwy Stg 1	-	-	-	-	5.4	-
Critical Hdwy Stg 2	-	-	-	-	5.4	-
Follow-up Hdwy	-	-	2.2	-	3.5	3.3
Pot Cap-1 Maneuver	-	-	1544	-	815	998
Stage 1	-	-	-	-	958	-
Stage 2	-	-	-	-	921	-
Platoon blocked, %	-	-	-	-	-	-
Mov Cap-1 Maneuver	-	-	1544	-	814	998
Mov Cap-2 Maneuver	-	-	-	-	814	-
Stage 1	-	-	-	-	958	-
Stage 2	-	-	-	-	920	-
Approach	EB	WB	NB			
HCM Control Delay, s	0	0.1	9.4			
HCM LOS				A		
Minor Lane/Major Mvmt	NBLn1	EBT	EBR	WBL	WBT	
Capacity (veh/h)	814	-	-	1544	-	
HCM Lane V/C Ratio	0.003	-	-	0.001	-	
HCM Control Delay (s)	9.4	-	-	7.3	0	
HCM Lane LOS	A	-	-	A	A	
HCM 95th %tile Q(veh)	0	-	-	0	-	

Intersection						
Int Delay, s/veh	1.1					
Movement	EBL	EBR	NBL	NBT	SBT	SBR
Lane Configurations	T		T		T	
Traffic Vol, veh/h	22	22	38	667	540	42
Future Vol, veh/h	22	22	38	667	540	42
Conflicting Peds, #/hr	0	0	0	0	0	0
Sign Control	Stop	Stop	Free	Free	Free	Free
RT Channelized	-	None	-	None	-	None
Storage Length	0	-	-	-	-	-
Veh in Median Storage, #	0	-	-	0	0	-
Grade, %	0	-	-	0	0	-
Peak Hour Factor	94	94	94	94	94	94
Heavy Vehicles, %	0	0	0	2	2	0
Mvmt Flow	23	23	40	710	574	45

Major/Minor	Minor2	Major1	Major2			
Conflicting Flow All	1387	597	619	0	-	0
Stage 1	597	-	-	-	-	-
Stage 2	790	-	-	-	-	-
Critical Hdwy	6.4	6.2	4.1	-	-	-
Critical Hdwy Stg 1	5.4	-	-	-	-	-
Critical Hdwy Stg 2	5.4	-	-	-	-	-
Follow-up Hdwy	3.5	3.3	2.2	-	-	-
Pot Cap-1 Maneuver	159	507	971	-	-	-
Stage 1	554	-	-	-	-	-
Stage 2	451	-	-	-	-	-
Platoon blocked, %				-	-	-
Mov Cap-1 Maneuver	148	507	971	-	-	-
Mov Cap-2 Maneuver	148	-	-	-	-	-
Stage 1	516	-	-	-	-	-
Stage 2	451	-	-	-	-	-

Approach	EB	NB	SB
HCM Control Delay, s	24.7	0.5	0
HCM LOS	C		

Minor Lane/Major Mvmt	NBL	NBT	EBLn1	SBT	SBR
Capacity (veh/h)	971	-	229	-	-
HCM Lane V/C Ratio	0.042	-	0.204	-	-
HCM Control Delay (s)	8.9	0	24.7	-	-
HCM Lane LOS	A	A	C	-	-
HCM 95th %tile Q(veh)	0.1	-	0.7	-	-

Intersection	
Intersection Delay, s/veh	7.6
Intersection LOS	A

Movement	EBT	EBR	WBL	WBT	NBL	NBR
Lane Configurations	↻			↻	↻	
Traffic Vol, veh/h	83	14	14	109	7	10
Future Vol, veh/h	83	14	14	109	7	10
Peak Hour Factor	0.94	0.94	0.94	0.94	0.94	0.94
Heavy Vehicles, %	0	0	0	0	0	0
Mvmt Flow	88	15	15	116	7	11
Number of Lanes	1	0	0	1	1	0

Approach	EB	WB	NB
Opposing Approach	WB	EB	
Opposing Lanes	1	1	0
Conflicting Approach Left		NB	EB
Conflicting Lanes Left	0	1	1
Conflicting Approach Right	NB		WB
Conflicting Lanes Right	1	0	1
HCM Control Delay	7.5	7.8	7.2
HCM LOS	A	A	A

Lane	NBLn1	EBLn1	WBLn1
Vol Left, %	41%	0%	11%
Vol Thru, %	0%	86%	89%
Vol Right, %	59%	14%	0%
Sign Control	Stop	Stop	Stop
Traffic Vol by Lane	17	97	123
LT Vol	7	0	14
Through Vol	0	83	109
RT Vol	10	14	0
Lane Flow Rate	18	103	131
Geometry Grp	1	1	1
Degree of Util (X)	0.02	0.113	0.147
Departure Headway (Hd)	4.027	3.942	4.032
Convergence, Y/N	Yes	Yes	Yes
Cap	873	907	890
Service Time	2.125	1.976	2.057
HCM Lane V/C Ratio	0.021	0.114	0.147
HCM Control Delay	7.2	7.5	7.8
HCM Lane LOS	A	A	A
HCM 95th-tile Q	0.1	0.4	0.5

HCM 6th TWSC
2: Rock Street & Line Street

Intersection						
Int Delay, s/veh	0.6					
Movement	EBT	EBR	WBL	WBT	NBL	NBR
Lane Configurations	T		T		T	
Traffic Vol, veh/h	83	10	11	118	4	1
Future Vol, veh/h	83	10	11	118	4	1
Conflicting Peds, #/hr	0	0	0	0	0	0
Sign Control	Free	Free	Free	Free	Stop	Stop
RT Channelized	-	None	-	None	-	None
Storage Length	-	-	-	-	0	-
Veh in Median Storage, #	0	-	-	0	0	-
Grade, %	0	-	-	0	0	-
Peak Hour Factor	80	80	80	80	80	80
Heavy Vehicles, %	0	0	0	0	0	0
Mvmt Flow	104	13	14	148	5	1

Major/Minor	Major1	Major2	Minor1	Minor2	Minor3
Conflicting Flow All	0	0	117	0	287
Stage 1	-	-	-	-	111
Stage 2	-	-	-	-	176
Critical Hdwy	-	-	4.1	-	6.4
Critical Hdwy Stg 1	-	-	-	-	5.4
Critical Hdwy Stg 2	-	-	-	-	5.4
Follow-up Hdwy	-	-	2.2	-	3.5
Pot Cap-1 Maneuver	-	-	1484	-	708
Stage 1	-	-	-	-	919
Stage 2	-	-	-	-	859
Platoon blocked, %	-	-	-	-	-
Mov Cap-1 Maneuver	-	-	1484	-	701
Mov Cap-2 Maneuver	-	-	-	-	701
Stage 1	-	-	-	-	919
Stage 2	-	-	-	-	850

Approach	EB	WB	NB
HCM Control Delay, s	0	0.6	9.9
HCM LOS			A

Minor Lane/Major Mvmt	NBLn1	EBT	EBR	WBL	WBT
Capacity (veh/h)	740	-	-	1484	-
HCM Lane V/C Ratio	0.008	-	-	0.009	-
HCM Control Delay (s)	9.9	-	-	7.4	0
HCM Lane LOS	A	-	-	A	A
HCM 95th %tile Q(veh)	0	-	-	0	-

Intersection						
Int Delay, s/veh	2.4					
Movement	EBL	EBR	NBL	NBT	SBT	SBR
Lane Configurations	T			T		
Traffic Vol, veh/h	30	52	41	600	835	77
Future Vol, veh/h	30	52	41	600	835	77
Conflicting Peds, #/hr	0	0	0	0	0	0
Sign Control	Stop	Stop	Free	Free	Free	Free
RT Channelized	-	None	-	None	-	None
Storage Length	0	-	-	-	-	-
Veh in Median Storage, #	0	-	-	0	0	-
Grade, %	0	-	-	0	0	-
Peak Hour Factor	95	95	95	95	95	95
Heavy Vehicles, %	0	0	0	2	2	0
Mvmt Flow	32	55	43	632	879	81

Major/Minor	Minor2	Major1	Major2			
Conflicting Flow All	1638	920	960	0	-	0
Stage 1	920	-	-	-	-	-
Stage 2	718	-	-	-	-	-
Critical Hdwy	6.4	6.2	4.1	-	-	-
Critical Hdwy Stg 1	5.4	-	-	-	-	-
Critical Hdwy Stg 2	5.4	-	-	-	-	-
Follow-up Hdwy	3.5	3.3	2.2	-	-	-
Pot Cap-1 Maneuver	112	331	725	-	-	-
Stage 1	392	-	-	-	-	-
Stage 2	487	-	-	-	-	-
Platoon blocked, %				-	-	-
Mov Cap-1 Maneuver	102	331	725	-	-	-
Mov Cap-2 Maneuver	102	-	-	-	-	-
Stage 1	356	-	-	-	-	-
Stage 2	487	-	-	-	-	-

Approach	EB	NB	SB
HCM Control Delay, s	41.4	0.7	0
HCM LOS	E		

Minor Lane/Major Mvmt	NBL	NBT	EBLn1	SBT	SBR
Capacity (veh/h)	725	-	182	-	-
HCM Lane V/C Ratio	0.06	-	0.474	-	-
HCM Control Delay (s)	10.3	0	41.4	-	-
HCM Lane LOS	B	A	E	-	-
HCM 95th %tile Q(veh)	0.2	-	2.3	-	-

**FUTURE “NO-BUILD” INTERSECTION
ANALYSIS**

Intersection	
Intersection Delay, s/veh	7.4
Intersection LOS	A

Movement	EBT	EBR	WBL	WBT	NBL	NBR
Lane Configurations						
Traffic Vol, veh/h	55	2	3	87	8	6
Future Vol, veh/h	55	2	3	87	8	6
Peak Hour Factor	0.84	0.84	0.84	0.84	0.84	0.84
Heavy Vehicles, %	0	0	0	0	0	0
Mvmt Flow	65	2	4	104	10	7
Number of Lanes	1	0	0	1	1	0

Approach	EB	WB	NB
Opposing Approach	WB	EB	
Opposing Lanes	1	1	0
Conflicting Approach Left		NB	EB
Conflicting Lanes Left	0	1	1
Conflicting Approach Right	NB		WB
Conflicting Lanes Right	1	0	1
HCM Control Delay	7.3	7.5	7.2
HCM LOS	A	A	A

Lane	NBLn1	EBLn1	WBLn1
Vol Left, %	57%	0%	3%
Vol Thru, %	0%	96%	97%
Vol Right, %	43%	4%	0%
Sign Control	Stop	Stop	Stop
Traffic Vol by Lane	14	57	90
LT Vol	8	0	3
Through Vol	0	55	87
RT Vol	6	2	0
Lane Flow Rate	17	68	107
Geometry Grp	1	1	1
Degree of Util (X)	0.019	0.075	0.119
Departure Headway (Hd)	4.056	3.988	3.987
Convergence, Y/N	Yes	Yes	Yes
Cap	872	898	900
Service Time	2.13	2.016	2.007
HCM Lane V/C Ratio	0.019	0.076	0.119
HCM Control Delay	7.2	7.3	7.5
HCM Lane LOS	A	A	A
HCM 95th-tile Q	0.1	0.2	0.4

Intersection						
Int Delay, s/veh	0.2					
Movement	EBT	EBR	WBL	WBT	NBL	NBR
Lane Configurations						
Traffic Vol, veh/h	57	1	1	89	2	0
Future Vol, veh/h	57	1	1	89	2	0
Conflicting Peds, #/hr	0	0	0	0	0	0
Sign Control	Free	Free	Free	Free	Stop	Stop
RT Channelized	-	None	-	None	-	None
Storage Length	-	-	-	-	0	-
Veh in Median Storage, #	0	-	-	0	0	-
Grade, %	0	-	-	0	0	-
Peak Hour Factor	81	81	81	81	81	81
Heavy Vehicles, %	0	0	0	0	0	0
Mvmt Flow	70	1	1	110	2	0

Major/Minor	Major1	Major2	Minor1		
Conflicting Flow All	0	0	71	0	183
Stage 1	-	-	-	-	71
Stage 2	-	-	-	-	112
Critical Hdwy	-	-	4.1	-	6.4
Critical Hdwy Stg 1	-	-	-	-	5.4
Critical Hdwy Stg 2	-	-	-	-	5.4
Follow-up Hdwy	-	-	2.2	-	3.5
Pot Cap-1 Maneuver	-	-	1542	-	811
Stage 1	-	-	-	-	957
Stage 2	-	-	-	-	918
Platoon blocked, %	-	-	-	-	-
Mov Cap-1 Maneuver	-	-	1542	-	810
Mov Cap-2 Maneuver	-	-	-	-	810
Stage 1	-	-	-	-	957
Stage 2	-	-	-	-	917

Approach	EB	WB	NB
HCM Control Delay, s	0	0.1	9.5
HCM LOS			A

Minor Lane/Major Mvmt	NBLn1	EBT	EBR	WBL	WBT
Capacity (veh/h)	810	-	-	1542	-
HCM Lane V/C Ratio	0.003	-	-	0.001	-
HCM Control Delay (s)	9.5	-	-	7.3	0
HCM Lane LOS	A	-	-	A	A
HCM 95th %tile Q(veh)	0	-	-	0	-

Intersection						
Int Delay, s/veh	1.1					
Movement	EBL	EBR	NBL	NBT	SBT	SBR
Lane Configurations	T		T		T	
Traffic Vol, veh/h	22	22	39	680	551	43
Future Vol, veh/h	22	22	39	680	551	43
Conflicting Peds, #/hr	0	0	0	0	0	0
Sign Control	Stop	Stop	Free	Free	Free	Free
RT Channelized	-	None	-	None	-	None
Storage Length	0	-	-	-	-	-
Veh in Median Storage, #	0	-	-	0	0	-
Grade, %	0	-	-	0	0	-
Peak Hour Factor	94	94	94	94	94	94
Heavy Vehicles, %	0	0	0	2	2	0
Mvmt Flow	23	23	41	723	586	46

Major/Minor	Minor2	Major1	Major2			
Conflicting Flow All	1414	609	632	0	-	0
Stage 1	609	-	-	-	-	-
Stage 2	805	-	-	-	-	-
Critical Hdwy	6.4	6.2	4.1	-	-	-
Critical Hdwy Stg 1	5.4	-	-	-	-	-
Critical Hdwy Stg 2	5.4	-	-	-	-	-
Follow-up Hdwy	3.5	3.3	2.2	-	-	-
Pot Cap-1 Maneuver	153	499	960	-	-	-
Stage 1	547	-	-	-	-	-
Stage 2	443	-	-	-	-	-
Platoon blocked, %				-	-	-
Mov Cap-1 Maneuver	142	499	960	-	-	-
Mov Cap-2 Maneuver	142	-	-	-	-	-
Stage 1	508	-	-	-	-	-
Stage 2	443	-	-	-	-	-

Approach	EB	NB	SB
HCM Control Delay, s	25.6	0.5	0
HCM LOS	D		

Minor Lane/Major Mvmt	NBL	NBT	EBLn1	SBT	SBR
Capacity (veh/h)	960	-	221	-	-
HCM Lane V/C Ratio	0.043	-	0.212	-	-
HCM Control Delay (s)	8.9	0	25.6	-	-
HCM Lane LOS	A	A	D	-	-
HCM 95th %tile Q(veh)	0.1	-	0.8	-	-

Intersection	
Intersection Delay, s/veh	7.6
Intersection LOS	A

Movement	EBT	EBR	WBL	WBT	NBL	NBR
Lane Configurations						
Traffic Vol, veh/h	85	14	14	111	7	10
Future Vol, veh/h	85	14	14	111	7	10
Peak Hour Factor	0.94	0.94	0.94	0.94	0.94	0.94
Heavy Vehicles, %	0	0	0	0	0	0
Mvmt Flow	90	15	15	118	7	11
Number of Lanes	1	0	0	1	1	0

Approach	EB	WB	NB
Opposing Approach	WB	EB	
Opposing Lanes	1	1	0
Conflicting Approach Left		NB	EB
Conflicting Lanes Left	0	1	1
Conflicting Approach Right	NB		WB
Conflicting Lanes Right	1	0	1
HCM Control Delay	7.5	7.8	7.2
HCM LOS	A	A	A

Lane	NBLn1	EBLn1	WBLn1
Vol Left, %	41%	0%	11%
Vol Thru, %	0%	86%	89%
Vol Right, %	59%	14%	0%
Sign Control	Stop	Stop	Stop
Traffic Vol by Lane	17	99	125
LT Vol	7	0	14
Through Vol	0	85	111
RT Vol	10	14	0
Lane Flow Rate	18	105	133
Geometry Grp	1	1	1
Degree of Util (X)	0.02	0.115	0.149
Departure Headway (Hd)	4.035	3.946	4.033
Convergence, Y/N	Yes	Yes	Yes
Cap	872	906	888
Service Time	2.132	1.98	2.059
HCM Lane V/C Ratio	0.021	0.116	0.15
HCM Control Delay	7.2	7.5	7.8
HCM Lane LOS	A	A	A
HCM 95th-tile Q	0.1	0.4	0.5

Intersection						
Int Delay, s/veh	0.6					
Movement	EBT	EBR	WBL	WBT	NBL	NBR
Lane Configurations						
Traffic Vol, veh/h	85	10	11	120	4	1
Future Vol, veh/h	85	10	11	120	4	1
Conflicting Peds, #/hr	0	0	0	0	0	0
Sign Control	Free	Free	Free	Free	Stop	Stop
RT Channelized	-	None	-	None	-	None
Storage Length	-	-	-	-	0	-
Veh in Median Storage, #	0	-	-	0	0	-
Grade, %	0	-	-	0	0	-
Peak Hour Factor	80	80	80	80	80	80
Heavy Vehicles, %	0	0	0	0	0	0
Mvmt Flow	106	13	14	150	5	1

Major/Minor	Major1	Major2	Minor1	Minor2	Minor3
Conflicting Flow All	0	0	119	0	291
Stage 1	-	-	-	-	113
Stage 2	-	-	-	-	178
Critical Hdwy	-	-	4.1	-	6.4
Critical Hdwy Stg 1	-	-	-	-	5.4
Critical Hdwy Stg 2	-	-	-	-	5.4
Follow-up Hdwy	-	-	2.2	-	3.5
Pot Cap-1 Maneuver	-	-	1482	-	704
Stage 1	-	-	-	-	917
Stage 2	-	-	-	-	858
Platoon blocked, %	-	-	-	-	-
Mov Cap-1 Maneuver	-	-	1482	-	697
Mov Cap-2 Maneuver	-	-	-	-	697
Stage 1	-	-	-	-	917
Stage 2	-	-	-	-	849

Approach	EB	WB	NB
HCM Control Delay, s	0	0.6	9.9
HCM LOS			A

Minor Lane/Major Mvmt	NBLn1	EBT	EBR	WBL	WBT
Capacity (veh/h)	736	-	-	1482	-
HCM Lane V/C Ratio	0.008	-	-	0.009	-
HCM Control Delay (s)	9.9	-	-	7.5	0
HCM Lane LOS	A	-	-	A	A
HCM 95th %tile Q(veh)	0	-	-	0	-

Intersection						
Int Delay, s/veh	2.5					
Movement	EBL	EBR	NBL	NBT	SBT	SBR
Lane Configurations	T			T		
Traffic Vol, veh/h	31	53	42	612	852	79
Future Vol, veh/h	31	53	42	612	852	79
Conflicting Peds, #/hr	0	0	0	0	0	0
Sign Control	Stop	Stop	Free	Free	Free	Free
RT Channelized	-	None	-	None	-	None
Storage Length	0	-	-	-	-	-
Veh in Median Storage, #	0	-	-	0	0	-
Grade, %	0	-	-	0	0	-
Peak Hour Factor	96	96	96	96	96	96
Heavy Vehicles, %	0	0	0	2	2	0
Mvmt Flow	32	55	44	638	888	82

Major/Minor	Minor2	Major1	Major2			
Conflicting Flow All	1655	929	970	0	-	0
Stage 1	929	-	-	-	-	-
Stage 2	726	-	-	-	-	-
Critical Hdwy	6.4	6.2	4.1	-	-	-
Critical Hdwy Stg 1	5.4	-	-	-	-	-
Critical Hdwy Stg 2	5.4	-	-	-	-	-
Follow-up Hdwy	3.5	3.3	2.2	-	-	-
Pot Cap-1 Maneuver	109	327	719	-	-	-
Stage 1	388	-	-	-	-	-
Stage 2	483	-	-	-	-	-
Platoon blocked, %				-	-	-
Mov Cap-1 Maneuver	99	327	719	-	-	-
Mov Cap-2 Maneuver	99	-	-	-	-	-
Stage 1	351	-	-	-	-	-
Stage 2	483	-	-	-	-	-

Approach	EB	NB	SB
HCM Control Delay, s	43.7	0.7	0
HCM LOS	E		

Minor Lane/Major Mvmt	NBL	NBT	EBLn1	SBT	SBR
Capacity (veh/h)	719	-	177	-	-
HCM Lane V/C Ratio	0.061	-	0.494	-	-
HCM Control Delay (s)	10.3	0	43.7	-	-
HCM Lane LOS	B	A	E	-	-
HCM 95th %tile Q(veh)	0.2	-	2.4	-	-

FUTURE "BUILD" INTERSECTION ANALYSIS

Intersection	
Intersection Delay, s/veh	7.6
Intersection LOS	A

Movement	EBT	EBR	WBL	WBT	NBL	NBR
Lane Configurations						
Traffic Vol, veh/h	61	2	5	103	8	7
Future Vol, veh/h	61	2	5	103	8	7
Peak Hour Factor	0.84	0.84	0.84	0.84	0.84	0.84
Heavy Vehicles, %	0	0	0	0	0	0
Mvmt Flow	73	2	6	123	10	8
Number of Lanes	1	0	0	1	1	0

Approach	EB	WB	NB
Opposing Approach	WB	EB	
Opposing Lanes	1	1	0
Conflicting Approach Left		NB	EB
Conflicting Lanes Left	0	1	1
Conflicting Approach Right	NB		WB
Conflicting Lanes Right	1	0	1
HCM Control Delay	7.4	7.7	7.2
HCM LOS	A	A	A

Lane	NBLn1	EBLn1	WBLn1
Vol Left, %	53%	0%	5%
Vol Thru, %	0%	97%	95%
Vol Right, %	47%	3%	0%
Sign Control	Stop	Stop	Stop
Traffic Vol by Lane	15	63	108
LT Vol	8	0	5
Through Vol	0	61	103
RT Vol	7	2	0
Lane Flow Rate	18	75	129
Geometry Grp	1	1	1
Degree of Util (X)	0.02	0.084	0.143
Departure Headway (Hd)	4.074	4.008	3.997
Convergence, Y/N	Yes	Yes	Yes
Cap	865	892	897
Service Time	2.161	2.041	2.019
HCM Lane V/C Ratio	0.021	0.084	0.144
HCM Control Delay	7.2	7.4	7.7
HCM Lane LOS	A	A	A
HCM 95th-tile Q	0.1	0.3	0.5

Intersection						
Int Delay, s/veh	0.2					
Movement	EBT	EBR	WBL	WBT	NBL	NBR
Lane Configurations						
Traffic Vol, veh/h	70	2	1	93	2	0
Future Vol, veh/h	70	2	1	93	2	0
Conflicting Peds, #/hr	0	0	0	0	0	0
Sign Control	Free	Free	Free	Free	Stop	Stop
RT Channelized	-	None	-	None	-	None
Storage Length	-	-	-	-	0	-
Veh in Median Storage, #	0	-	-	0	0	-
Grade, %	0	-	-	0	0	-
Peak Hour Factor	81	81	81	81	81	81
Heavy Vehicles, %	0	0	0	0	0	0
Mvmt Flow	86	2	1	115	2	0

Major/Minor	Major1	Major2	Minor1		
Conflicting Flow All	0	0	88	0	204
Stage 1	-	-	-	-	87
Stage 2	-	-	-	-	117
Critical Hdwy	-	-	4.1	-	6.4
Critical Hdwy Stg 1	-	-	-	-	5.4
Critical Hdwy Stg 2	-	-	-	-	5.4
Follow-up Hdwy	-	-	2.2	-	3.5
Pot Cap-1 Maneuver	-	-	1520	-	789
Stage 1	-	-	-	-	941
Stage 2	-	-	-	-	913
Platoon blocked, %	-	-	-	-	-
Mov Cap-1 Maneuver	-	-	1520	-	788
Mov Cap-2 Maneuver	-	-	-	-	788
Stage 1	-	-	-	-	941
Stage 2	-	-	-	-	912

Approach	EB	WB	NB
HCM Control Delay, s	0	0.1	9.6
HCM LOS			A

Minor Lane/Major Mvmt	NBLn1	EBT	EBR	WBL	WBT
Capacity (veh/h)	788	-	-	1520	-
HCM Lane V/C Ratio	0.003	-	-	0.001	-
HCM Control Delay (s)	9.6	-	-	7.4	0
HCM Lane LOS	A	-	-	A	A
HCM 95th %tile Q(veh)	0	-	-	0	-

Intersection						
Int Delay, s/veh	1.4					
Movement	EBL	EBR	NBL	NBT	SBT	SBR
Lane Configurations						
Traffic Vol, veh/h	30	27	41	680	551	46
Future Vol, veh/h	30	27	41	680	551	46
Conflicting Peds, #/hr	0	0	0	0	0	0
Sign Control	Stop	Stop	Free	Free	Free	Free
RT Channelized	-	None	-	None	-	None
Storage Length	0	-	-	-	-	-
Veh in Median Storage, #	0	-	-	0	0	-
Grade, %	0	-	-	0	0	-
Peak Hour Factor	94	94	94	94	94	94
Heavy Vehicles, %	0	0	0	2	2	0
Mvmt Flow	32	29	44	723	586	49

Major/Minor	Minor2	Major1	Major2			
Conflicting Flow All	1422	611	635	0	-	0
Stage 1	611	-	-	-	-	-
Stage 2	811	-	-	-	-	-
Critical Hdwy	6.4	6.2	4.1	-	-	-
Critical Hdwy Stg 1	5.4	-	-	-	-	-
Critical Hdwy Stg 2	5.4	-	-	-	-	-
Follow-up Hdwy	3.5	3.3	2.2	-	-	-
Pot Cap-1 Maneuver	152	497	958	-	-	-
Stage 1	546	-	-	-	-	-
Stage 2	440	-	-	-	-	-
Platoon blocked, %				-	-	-
Mov Cap-1 Maneuver	140	497	958	-	-	-
Mov Cap-2 Maneuver	140	-	-	-	-	-
Stage 1	504	-	-	-	-	-
Stage 2	440	-	-	-	-	-

Approach	EB	NB	SB
HCM Control Delay, s	28.6	0.5	0
HCM LOS	D		

Minor Lane/Major Mvmt	NBL	NBT	EBLn1	SBT	SBR
Capacity (veh/h)	958	-	212	-	-
HCM Lane V/C Ratio	0.046	-	0.286	-	-
HCM Control Delay (s)	8.9	0	28.6	-	-
HCM Lane LOS	A	A	D	-	-
HCM 95th %tile Q(veh)	0.1	-	1.1	-	-

Intersection						
Int Delay, s/veh	1.8					
Movement	EBL	EBT	WBT	WBR	SBL	SBR
Lane Configurations		↕	↕		↕	
Traffic Vol, veh/h	6	58	91	5	14	18
Future Vol, veh/h	6	58	91	5	14	18
Conflicting Peds, #/hr	0	0	0	0	0	0
Sign Control	Free	Free	Free	Free	Stop	Stop
RT Channelized	-	None	-	None	-	None
Storage Length	-	-	-	-	0	-
Veh in Median Storage, #	-	0	0	-	0	-
Grade, %	-	0	0	-	0	-
Peak Hour Factor	92	92	92	92	92	92
Heavy Vehicles, %	0	0	0	0	0	0
Mvmt Flow	7	63	99	5	15	20

Major/Minor	Major1	Major2	Minor2		
Conflicting Flow All	104	0	-	0	179
Stage 1	-	-	-	-	102
Stage 2	-	-	-	-	77
Critical Hdwy	4.1	-	-	-	6.4
Critical Hdwy Stg 1	-	-	-	-	5.4
Critical Hdwy Stg 2	-	-	-	-	5.4
Follow-up Hdwy	2.2	-	-	-	3.5
Pot Cap-1 Maneuver	1500	-	-	-	815
Stage 1	-	-	-	-	927
Stage 2	-	-	-	-	951
Platoon blocked, %		-	-	-	
Mov Cap-1 Maneuver	1500	-	-	-	811
Mov Cap-2 Maneuver	-	-	-	-	811
Stage 1	-	-	-	-	922
Stage 2	-	-	-	-	951

Approach	EB	WB	SB
HCM Control Delay, s	0.7	0	9.2
HCM LOS			A

Minor Lane/Major Mvmt	EBL	EBT	WBT	WBR	SBLn1
Capacity (veh/h)	1500	-	-	-	888
HCM Lane V/C Ratio	0.004	-	-	-	0.039
HCM Control Delay (s)	7.4	0	-	-	9.2
HCM Lane LOS	A	A	-	-	A
HCM 95th %tile Q(veh)	0	-	-	-	0.1

Intersection	
Intersection Delay, s/veh	7.7
Intersection LOS	A

Movement	EBT	EBR	WBL	WBT	NBL	NBR
Lane Configurations						
Traffic Vol, veh/h	101	14	15	122	7	12
Future Vol, veh/h	101	14	15	122	7	12
Peak Hour Factor	0.94	0.94	0.94	0.94	0.94	0.94
Heavy Vehicles, %	0	0	0	0	0	0
Mvmt Flow	107	15	16	130	7	13
Number of Lanes	1	0	0	1	1	0

Approach	EB	WB	NB
Opposing Approach	WB	EB	
Opposing Lanes	1	1	0
Conflicting Approach Left		NB	EB
Conflicting Lanes Left	0	1	1
Conflicting Approach Right	NB		WB
Conflicting Lanes Right	1	0	1
HCM Control Delay	7.6	7.9	7.3
HCM LOS	A	A	A

Lane	NBLn1	EBLn1	WBLn1
Vol Left, %	37%	0%	11%
Vol Thru, %	0%	88%	89%
Vol Right, %	63%	12%	0%
Sign Control	Stop	Stop	Stop
Traffic Vol by Lane	19	115	137
LT Vol	7	0	15
Through Vol	0	101	122
RT Vol	12	14	0
Lane Flow Rate	20	122	146
Geometry Grp	1	1	1
Degree of Util (X)	0.023	0.135	0.164
Departure Headway (Hd)	4.162	3.972	4.049
Convergence, Y/N	Yes	Yes	Yes
Cap	865	899	885
Service Time	2.162	2.01	2.081
HCM Lane V/C Ratio	0.023	0.136	0.165
HCM Control Delay	7.3	7.6	7.9
HCM Lane LOS	A	A	A
HCM 95th-tile Q	0.1	0.5	0.6

Intersection						
Int Delay, s/veh	0.6					
Movement	EBT	EBR	WBL	WBT	NBL	NBR
Lane Configurations						
Traffic Vol, veh/h	93	11	11	132	5	1
Future Vol, veh/h	93	11	11	132	5	1
Conflicting Peds, #/hr	0	0	0	0	0	0
Sign Control	Free	Free	Free	Free	Stop	Stop
RT Channelized	-	None	-	None	-	None
Storage Length	-	-	-	-	0	-
Veh in Median Storage, #	0	-	-	0	0	-
Grade, %	0	-	-	0	0	-
Peak Hour Factor	80	80	80	80	80	80
Heavy Vehicles, %	0	0	0	0	0	0
Mvmt Flow	116	14	14	165	6	1

Major/Minor	Major1	Major2	Minor1		
Conflicting Flow All	0	0	130	0	316
Stage 1	-	-	-	-	123
Stage 2	-	-	-	-	193
Critical Hdwy	-	-	4.1	-	6.4
Critical Hdwy Stg 1	-	-	-	-	5.4
Critical Hdwy Stg 2	-	-	-	-	5.4
Follow-up Hdwy	-	-	2.2	-	3.5
Pot Cap-1 Maneuver	-	-	1468	-	681
Stage 1	-	-	-	-	907
Stage 2	-	-	-	-	845
Platoon blocked, %	-	-	-	-	-
Mov Cap-1 Maneuver	-	-	1468	-	674
Mov Cap-2 Maneuver	-	-	-	-	674
Stage 1	-	-	-	-	907
Stage 2	-	-	-	-	837

Approach	EB	WB	NB
HCM Control Delay, s	0	0.6	10.1
HCM LOS			B

Minor Lane/Major Mvmt	NBLn1	EBT	EBR	WBL	WBT
Capacity (veh/h)	707	-	-	1468	-
HCM Lane V/C Ratio	0.011	-	-	0.009	-
HCM Control Delay (s)	10.1	-	-	7.5	0
HCM Lane LOS	B	-	-	A	A
HCM 95th %tile Q(veh)	0	-	-	0	-

Intersection						
Int Delay, s/veh	2.9					
Movement	EBL	EBR	NBL	NBT	SBT	SBR
Lane Configurations	T		T		T	
Traffic Vol, veh/h	36	56	47	612	852	87
Future Vol, veh/h	36	56	47	612	852	87
Conflicting Peds, #/hr	0	0	0	0	0	0
Sign Control	Stop	Stop	Free	Free	Free	Free
RT Channelized	-	None	-	None	-	None
Storage Length	0	-	-	-	-	-
Veh in Median Storage, #	0	-	-	0	0	-
Grade, %	0	-	-	0	0	-
Peak Hour Factor	97	97	97	97	97	97
Heavy Vehicles, %	0	0	0	2	2	0
Mvmt Flow	37	58	48	631	878	90

Major/Minor	Minor2	Major1	Major2			
Conflicting Flow All	1650	923	968	0	-	0
Stage 1	923	-	-	-	-	-
Stage 2	727	-	-	-	-	-
Critical Hdwy	6.4	6.2	4.1	-	-	-
Critical Hdwy Stg 1	5.4	-	-	-	-	-
Critical Hdwy Stg 2	5.4	-	-	-	-	-
Follow-up Hdwy	3.5	3.3	2.2	-	-	-
Pot Cap-1 Maneuver	110	330	720	-	-	-
Stage 1	390	-	-	-	-	-
Stage 2	482	-	-	-	-	-
Platoon blocked, %				-	-	-
Mov Cap-1 Maneuver	99	330	720	-	-	-
Mov Cap-2 Maneuver	99	-	-	-	-	-
Stage 1	350	-	-	-	-	-
Stage 2	482	-	-	-	-	-

Approach	EB	NB	SB
HCM Control Delay, s	48.5	0.7	0
HCM LOS	E		

Minor Lane/Major Mvmt	NBL	NBT	EBLn1	SBT	SBR
Capacity (veh/h)	720	-	173	-	-
HCM Lane V/C Ratio	0.067	-	0.548	-	-
HCM Control Delay (s)	10.4	0	48.5	-	-
HCM Lane LOS	B	A	E	-	-
HCM 95th %tile Q(veh)	0.2	-	2.8	-	-

Intersection						
Int Delay, s/veh	1.2					
Movement	EBL	EBT	WBT	WBR	SBL	SBR
Lane Configurations		↶	↷		↶	
Traffic Vol, veh/h	18	95	124	13	9	12
Future Vol, veh/h	18	95	124	13	9	12
Conflicting Peds, #/hr	0	0	0	0	0	0
Sign Control	Free	Free	Free	Free	Stop	Stop
RT Channelized	-	None	-	None	-	None
Storage Length	-	-	-	-	0	-
Veh in Median Storage, #	-	0	0	-	0	-
Grade, %	-	0	0	-	0	-
Peak Hour Factor	92	92	92	92	92	92
Heavy Vehicles, %	0	0	0	0	0	2
Mvmt Flow	20	103	135	14	10	13

Major/Minor	Major1	Major2	Minor2		
Conflicting Flow All	149	0	-	0	285 142
Stage 1	-	-	-	-	142 -
Stage 2	-	-	-	-	143 -
Critical Hdwy	4.1	-	-	-	6.4 6.22
Critical Hdwy Stg 1	-	-	-	-	5.4 -
Critical Hdwy Stg 2	-	-	-	-	5.4 -
Follow-up Hdwy	2.2	-	-	-	3.5 3.318
Pot Cap-1 Maneuver	1445	-	-	-	710 906
Stage 1	-	-	-	-	890 -
Stage 2	-	-	-	-	889 -
Platoon blocked, %		-	-	-	
Mov Cap-1 Maneuver	1445	-	-	-	699 906
Mov Cap-2 Maneuver	-	-	-	-	699 -
Stage 1	-	-	-	-	877 -
Stage 2	-	-	-	-	889 -

Approach	EB	WB	SB
HCM Control Delay, s	1.2	0	9.6
HCM LOS			A

Minor Lane/Major Mvmt	EBL	EBT	WBT	WBR	SBLn1
Capacity (veh/h)	1445	-	-	-	804
HCM Lane V/C Ratio	0.014	-	-	-	0.028
HCM Control Delay (s)	7.5	0	-	-	9.6
HCM Lane LOS	A	A	-	-	A
HCM 95th %tile Q(veh)	0	-	-	-	0.1

TRAFFIC VOLUME WORKSHEETS

23-209 Somerset at Walton Residential Development - Loganville, GA - TIS
Traffic Volumes

A&R Engineering
December 2023

1. Line Street @ Fair Street

A.M. Peak Hour

Condition	Fair Street Northbound				- Southbound				Line Street Eastbound				Line Street Westbound			
	L	T	R	Tot	L	T	R	Tot	L	T	R	Tot	L	T	R	Tot
Existing 2023 Traffic Counts:	8	0	6	14	0	0	0	0	0	54	2	56	3	85	0	88
Growth Factor (%):	1	1	1		1	1	1		1	1	1		1	1	1	
No-Build 2025 Volumes:	8	0	6	14	0	0	0	0	0	55	2	57	3	87	0	90
Total New Trips:	0	0	1	1	0	0	0	0	0	6	0	6	2	16	0	18
Future 2025 Traffic Volumes:	8	0	7	15	0	0	0	0	0	61	2	63	5	103	0	108

P.M. Peak Hour

Condition	Fair Street Northbound				- Southbound				Line Street Eastbound				Line Street Westbound			
	L	T	R	Tot	L	T	R	Tot	L	T	R	Tot	L	T	R	Tot
Existing 2023 Traffic Counts:	7	0	10	17	0	0	0	0	0	83	14	97	14	109	0	123
Growth Factor (%):	1	1	1		1	1	1		1	1	1		1	1	1	
No-Build 2025 Volumes:	7	0	10	17	0	0	0	0	0	85	14	99	14	111	0	125
Total New Trips:	0	0	2	2	0	0	0	0	0	16	0	16	1	11	0	12
Future 2025 Traffic Volumes:	7	0	12	19	0	0	0	0	0	101	14	115	15	122	0	137

23-209 Somerset at Walton Residential Development - Loganville, GA - TIS
Traffic Volumes

A&R Engineering
December 2023

2.Line Street @ Rock Street

A.M. Peak Hour

Condition	Rock Street Northbound				- Southbound				Line Street Eastbound				Line Street Westbound			
	L	T	R	Tot	L	T	R	Tot	L	T	R	Tot	L	T	R	Tot
Existing 2023 Traffic Counts:	2	0	0	2	0	0	0	0	0	56	1	57	0	87	0	87
Growth Factor (%):	1	1	1		1	1	1		1	1	1		1	1	1	
No-Build 2025 Volumes:	2	0	0	2	0	0	0	0	0	57	1	58	0	89	0	89
Total New Trips:	0	0	0	0	0	0	0	0	0	13	1	14	0	4	0	4
Future 2025 Traffic Volumes:	2	0	0	2	0	0	0	0	0	70	2	72	0	93	0	93

P.M. Peak Hour

Condition	Rock Street Northbound				- Southbound				Line Street Eastbound				Line Street Westbound			
	L	T	R	Tot	L	T	R	Tot	L	T	R	Tot	L	T	R	Tot
Existing 2023 Traffic Counts:	4	0	1	5	0	0	0	0	0	83	10	93	11	118	0	129
Growth Factor (%):	1	1	1		1	1	1		1	1	1		1	1	1	
No-Build 2025 Volumes:	4	0	1	5	0	0	0	0	0	85	10	95	11	120	0	131
Total New Trips:	1	0	0	1	0	0	0	0	0	8	1	9	0	12	0	12
Future 2025 Traffic Volumes:	5	0	1	6	0	0	0	0	0	93	11	104	11	132	0	143

23-209 Somerset at Walton Residential Development - Loganville, GA - TIS
Traffic Volumes

A&R Engineering
December 2023

3.Line Street @ SR 20

A.M. Peak Hour

Condition	SR 20 (Loganville Highway) Northbound				SR 20 (Loganville Highway) Southbound				Line Street Eastbound				- Westbound			
	L	T	R	Tot	L	T	R	Tot	L	T	R	Tot	L	T	R	Tot
Existing 2023 Traffic Counts:	38	667	0	705	0	540	42	582	22	0	22	44	0	0	0	0
Growth Factor (%):	1	1	1		1	1	1		1	1	1		1	1	1	
No-Build 2025 Volumes:	39	680	0	719	0	551	43	594	22	0	22	44	0	0	0	0
Total New Trips:	2	0	0	2	0	0	3	3	8	0	5	13	0	0	0	0
Future 2025 Traffic Volumes:	41	680	0	721	0	551	46	597	30	0	27	57	0	0	0	0

P.M. Peak Hour

Condition	SR 20 (Loganville Highway) Northbound				SR 20 (Loganville Highway) Southbound				Line Street Eastbound				- Westbound			
	L	T	R	Tot	L	T	R	Tot	L	T	R	Tot	L	T	R	Tot
Existing 2023 Traffic Counts:	41	600	0	641	0	835	77	912	30	0	52	82	0	0	0	0
Growth Factor (%):	1	1	1		1	1	1		1	1	1		1	1	1	
No-Build 2025 Volumes:	42	612	0	654	0	852	79	931	31	0	53	84	0	0	0	0
Total New Trips:	5	0	0	5	0	0	8	8	5	0	3	8	0	0	0	0
Future 2025 Traffic Volumes:	47	612	0	659	0	852	87	939	36	0	56	92	0	0	0	0

23-209 Somerset at Walton Residential Development - Loganville, GA - TIS
Traffic Volumes

A&R Engineering
 December 2023

4. Line Street @ Site Drwy

A.M. Peak Hour

Condition	- Northbound				Site Driveway Southbound				Line Street Eastbound				Line Street Westbound			
	L	T	R	Tot	L	T	R	Tot	L	T	R	Tot	L	T	R	Tot
Existing 2023 Traffic Counts:	0	0	0	0	0	0	0	0	0	57	0	57	0	89	0	89
Growth Factor (%):	1	1	1		1	1	1		1	1	1		1	1	1	
No-Build 2025 Volumes:	0	0	0	0	0	0	0	0	0	58	0	58	0	91	0	91
Total New Trips:	0	0	0	0	14	0	18	32	6	0	0	6	0	0	5	5
Future 2025 Traffic Volumes:	0	0	0	0	14	0	18	32	6	58	0	64	0	91	5	96

P.M. Peak Hour

Condition	- Northbound				Site Driveway Southbound				Line Street Eastbound				Line Street Westbound			
	L	T	R	Tot	L	T	R	Tot	L	T	R	Tot	L	T	R	Tot
Existing 2023 Traffic Counts:	0	0	0	0	0	0	0	0	0	93	0	93	0	122	0	122
Growth Factor (%):	1	1	1		1	1	1		1	1	1		1	1	1	
No-Build 2025 Volumes:	0	0	0	0	0	0	0	0	0	95	0	95	0	124	0	124
Total New Trips:	0	0	0	0	9	0	12	21	18	0	0	18	0	0	13	13
Future 2025 Traffic Volumes:	0	0	0	0	9	0	12	21	18	95	0	113	0	124	13	137

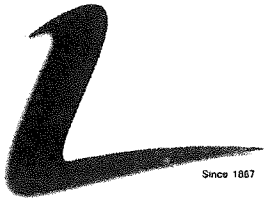

where people matter

Staff Report Department of Public Utilities

City of Loganville

Public Utilities
Brandon Phillips
Director

P.O. Box 39
Loganville, GA 30052

Tel: 770-466-3240

To: Honorable Mayor Baliles and Members of the City Council

Through: Danny Roberts, City Manager

From: Brandon Phillips, Director of Utilities

Date: March 14, 2024

Subject: Grinder for Logan Point Pump Station

RECOMMENDATION:

Staff recommends that the City Council approve the installation of a debris grinder for Logan Point sewer pump station.

FISCAL IMPLICATION:

The Utilities Department is requesting approval for JJA Enterprises to install a grinder at Logan Point pump station in the amount of \$41,903.00.

BACKGROUND:

Logan Point pump station is our largest station, and we are currently experiencing high levels of rags and debris resulting in higher maintenance and labor costs. Both pumps were repaired last year due to failure. This grinder will break down larger debris to allow it to pass through the station without causing clogs or potential damage to our pumps, and in return, lowering our maintenance and labor costs.

Staff Report Department of Facilities

To: Honorable Mayor Baliles and Members of the City Council

Through: Danny Roberts, City Manager

From: Dustin McAlpin, Director of Facilities

Date: March 14, 2024

Subject: Anna Holbrook Remodel

RECOMMENDATION:

Staff recommends the City Council approve the remodel/upgrades for the Anna Holbrook Building. Remodel consists of painting, new flooring, doors, lighting, and bathroom upgrades.

FISCAL IMPLICATION:

NTE for this project is \$26,500 (5% contingency). Funding source general fund building and repair line item.

BACKGROUND:

Anna Holbrook Club leased the building to City of Loganville on October 27, 2004. Terms of lease are for 30 years which expires December 31, 2054. Within the lease agreement COL has the right to make whatever alterations, additions or physical changes deem necessary.

AN ORDINANCE OF THE MAYOR AND COUNCIL OF THE CITY OF LOGANVILLE, GEORGIA, TO UPDATE AND SUPPLANT CHAPTER 4 – ALCOHOLIC BEVERAGES, OF THE CODE OF THE CITY OF LOGANVILLE, GEORGIA

THE COUNCIL OF THE CITY OF LOGANVILLE HEREBY ORDAINS AS FOLLOWS:

ARTICLE I.

The Code of the City of Loganville, Georgia, is hereby amended by deleting the currently existing Chapter 4 – Alcoholic Beverages in its entirety and replacing it with a new Chapter 4 – Alcoholic Beverages as follows:

SEE “**EXHIBIT A**” ATTACHED HERETO AND INCORPORATED HEREIN BY REFERENCE FOR THE COMPLETE TEXT AMENDMENT.

Note: Text which is stricken through shall be removed from the Code of the City of Loganville, Georgia. Text which is italicized shall be added to the Code of the City of Loganville, Georgia.

ARTICLE II.

All ordinances or parts of ordinances in conflict herewith are hereby repealed.

ARTICLE III.

This ordinance shall take effect from and after its adoption by the Mayor and Council of the City of Loganville, Georgia.

READ AND ADOPTED, this ___ day of _____, 2024.

CITY OF LOGANVILLE, GEORGIA

By: _____ (SEAL)

Skip Baliles, Mayor

Attest: _____ (SEAL)

Kristi Ash, Deputy Clerk

EXHIBIT "A"

Chapter 4 ALCOHOLIC BEVERAGES¹

ARTICLE I. IN GENERAL

Sec. 4-1. Definitions.

The following words, terms and phrases, when used in this chapter, shall have the meanings ascribed to them in this section, except where the context clearly indicates a different meaning:

Alcohol means ethyl alcohol, hydrated oxide of the ethyl, or spirits of wine, from whatever source or by whatever process produced.

Alcoholic beverages means and includes, but is not limited to, all alcohol, distilled spirits, beer, malt beverage, wine, or fortified wine.

Applicant means an individual who files an application to obtain any license authorized by this chapter and:

- (1) If a corporation, may be the president, a vice president, secretary or treasurer of the corporation or the corporation's general manager at the particular business location. Otherwise, no other individual may qualify as an applicant on behalf of a business. Corporate applicants must either be incorporated in the state or must have registered to do business in the state through the secretary of state's office.
- (2) If a partnership, each co-owner of the partnership.
- (3) If an individual proprietor, that individual.
- (4) If a firm or association, the person with the greatest proprietary interest.

Application means a form supplied by the city for the purpose of applying for any license authorized by this chapter.

Bona fide private club means any nonprofit association organized under the laws of this state which:

- (1) Has been in existence at least one year prior to the filing of its application for a license to be issued pursuant to this chapter;
- (2) Has at least 75 regular dues-paying members;
- (3) Owns, hires, or leases a building or space within a building for the reasonable use of its members, which building or space:
 - a. Has suitable kitchen and dining room space and equipment; and

¹Editor's note(s)—Sections 1, 2, 4 and 5 of an ordinance adopted Dec. 13, 2012, amended ch. 4 in its entirety to read as herein set out. Former ch. 4, §§ 4-1—4-134, pertained to similar subject matter, and derived from: Code 1994, § 18-235; Ord. of Feb. 14, 2008, §§ 18-201—18-245; Ord. of Dec. 10, 2009, §§ 1, 2; Ord. of Nov. 8, 2010(1), § 1.

State law reference(s)—Alcoholic beverages, O.C.G.A. § 3-1-1 et seq.; local regulation of alcohol generally, O.C.G.A. § 3-3-1 et seq.

b. — Is staffed with a sufficient number of employees for cooking, preparing, and serving meals for its members and guests; and

(4) — Has no member, officer, agent or employee directly or indirectly receiving, in the form of salary or other compensation, any profits from the sale of alcoholic beverages beyond a fixed salary.

Building code means and includes all building, plumbing and electrical codes and any other similar technical code of the city.

Business day means a day on which City Hall is open for business.

Church means a permanent building where persons regularly assemble for religious worship.

County line means the boundary between Gwinnett County and Walton County.

Distance means the measurement in horizontal linear feet from the front door of the proposed licensee's premises in a straight line to the nearest public sidewalk, walkway, street, road or highway by the nearest route to the front door of the building or to the nearest portion of the ground, whichever is applicable. For the purposes of this chapter, distances shall be measured along the pedestrian route of travel to and from the premises.

Distilled spirits means any alcoholic beverage obtained by distillation or containing more than 21 percent alcohol by volume, including but not limited to, whiskey, rum, gin, brandy, vodka, tequila and fortified wines.

Family means any person related within the first degree of consanguinity or affinity as determined according to civil law.

Fortified wine means any alcoholic beverage containing more than 21 percent alcohol by volume made from fruits, berries or grapes either by natural fermentation or by natural fermentation with other ingredients added, including but not limited to, brandy.

Hotel means any building or structure kept, used, maintained, advertised and held out to the public as a place where a minimum of 50 sleeping accommodations are offered for adequate pay to travelers and guests, and food is actually served and consumed in one or more dining rooms, having an adequate and sanitary kitchen and minimum seating capacity of 60, such sleeping accommodations and dining rooms being conducted on the same premises.

Individual means a natural person.

Interest in license means an interest held by an owner or co-owner of a license; a partner of a partnership which owns or co-owns a license; a stockholder in any corporation which owns or co-owns a license; an owner, co-owner, lessor, sublessor, partner in a partnership or stockholder in a corporation owning or leasing any real estate on which is located a retail consumption dealer, a retail dealer or wholesale dealer; or anyone sharing in the income or corpus of any trust or estate having such an interest.

License means authorization granted by the city to operate as a retail consumption dealer, retail dealer or wholesale dealer.

Licensee means a person holding a license.

Malt beverage means any alcoholic beverage obtained by the fermentation of any infusion or decoction of barley, malt, hops or any other similar product, or any combination of such products in water, containing not more than six percent alcohol by volume, and including ale, porter, brown stout, lager beer, small beer and strong beer, but not including sake.

Motel means any building or structure kept, used, maintained, advertised and held out to the public as a place where a minimum of 50 sleeping accommodations are offered for adequate pay to travelers and guests, and food is actually served and consumed in one or more dining rooms, having an adequate and sanitary kitchen and a minimum seating capacity of 60, such sleeping accommodations and dining rooms being conducted on the same premises.

Package means a bottle, can, keg, barrel or other original consumer container.

Premises means the definite closed or partitioned establishment, whether room, shop or building wherein alcoholic beverages are sold or consumed. The term "premises" shall also include any privately owned or leased courtyard or patio that is architecturally visibly defined.

Principal business, when used in this chapter, means that at least 75 percent of the receipts of such business shall come from the sale of food. To be included in the tabulation of receipts for the purpose of this calculation are all receipts of all persons laboring on the premises, including the services of all independent contractors, performers, servers, entertainers, or other nonemployee personnel not to include, however, persons who are called to the premises from other licensed businesses to perform service, repair or construction on equipment or building premises. For purposes of this chapter the calculations of receipts for alcoholic beverages shall be made pursuant to the scheduling of pricing and the regulations contained therein as required by this chapter.

Private residence means a house, dwelling, condominium or duplex wherein not less than one, nor more than two families customarily reside, but does not include a mobile home; an apartment house having facilities for the housing of more than two families; a boardinghouse or roominghouse where there are five or more boarders; any residence located in a commercially or industrially zoned district; or any residence which has been unoccupied for a period of six consecutive months immediately prior to the filing of an application by a proposed licensee.

Restaurant means a public place selling and preparing food for consumption by the public. Such establishment must own, hire or lease a building or space in a building for such a purpose. The establishment must also have a suitable kitchen as defined by the appropriate county health and state health regulations and dining room space and sufficient equipment therefor. It must have a full service kitchen with a three compartment pot sink, stove or grill permanently installed, appropriate refrigeration equipment, and with a sufficient number of employees for cooking, preparing and serving meals for its guests every hour which the establishment is open. The establishment must seat at least 50 people or more and derive at least 50 percent of its total annual gross sales from the preparation of meals or food. The establishment must also have a minimum of 1,500 square feet of space, and the establishment must meet all of the minimum building and zoning requirements as provided in applicable ordinances now in force in the city or such ordinances as amended, supplemented or newly acted by the city council.

Restaurant/bar means a public place selling and preparing food for consumption by the public. Such establishment must own, hire or lease a building or space in a building for such a purpose. The establishment must also have a suitable kitchen as defined by the appropriate county health and state health regulations and dining room space and sufficient equipment therefor. It must have a full service kitchen with a three compartment pot sink, stove or grill permanently installed, appropriate refrigeration equipment, and with a sufficient number of employees for cooking, preparing and serving meals for its guests every hour which the establishment is open. The establishment must seat at least 50 people or more and derive at least 25 percent of its total annual gross sales from the preparation of meals or food. The establishment must also have a minimum of 1,500 square feet of space, and the establishment must meet all of the minimum building and zoning requirements as provided in applicable ordinances now in force in the city or such ordinances as amended, supplemented or newly acted by the city council. An establishment meeting this definition may only be located in the Main Street District, as defined by the attached Main Street District Map.

Retail consumption dealer means any person who sells alcoholic beverages to consumers for consumption on the premises only and not for resale or to go.

Retail dealer or retail package dealer means any person who sells alcoholic beverages in unbroken packages to consumers only to go, not for resale and not for consumption on the premises.

School means state, county, city or church schools and such buildings at such other schools in which are taught subjects commonly taught in the common schools and colleges of this state and which are public schools or private schools as defined in O.C.G.A. § 20-2-690(b).

Seating capacity means the amount of individual seating which is located at tables for the purpose of serving the dining public, but not including any seating located in a bar or other area designated primarily for the serving of alcoholic beverages.

Wholesale dealer means any person who sells alcoholic beverages to retail dealers or other wholesale dealers for resale.

Wine means any alcoholic beverage containing not more than 21 percent alcohol by volume made from fruits, berries or grapes either by natural fermentation or by natural fermentation with brandy added, including, but not limited to, sparkling wine, champagne, combinations of such beverages, vermouth, special natural wine, rectified wine and like products, but not including cooking wine mixed with salt or other ingredients so as to render it unfit for human consumption as a beverage.

(Ord. of 12-13-2012, § 1; Ord. of 4-11-2019(1), §§ 1, 2; Ord. of 6-13-2019(2), §§ 1, 2; Ord. of 9-12-2019, §§ 1, 2)

State law reference(s)—Definitions, O.C.G.A. § 3-1-2.

Sec. 4-2. Reserved.

Sec. 4-3. Intent.

The businesses of manufacturing, distributing, selling, handling and otherwise dealing in or processing alcoholic beverages are privileges and not rights pursuant to O.C.G.A. § 3-3-1, and such privileges shall not be exercised within the city limits without full compliance with the licensing, regulatory and revenue requirements of this chapter.

(Ord. of 12-13-2012, § 1)

Sec. 4-4. Authority of city manager.

- (a) The city manager or his/her designee shall review all applications for an alcoholic beverage license for compliance with this chapter. All applicants shall furnish upon request all data, information and records necessary for a complete investigation.
- (b) The city manager or his/her designee shall also have authority to prescribe such forms as it deems necessary for the proper administration of this chapter.

(Ord. of 12-13-2012, § 1)

Sec. 4-5. Grandfathering.

- (a) So as to prevent an unconstitutional taking of property, all licensees for alcoholic beverages within the city in compliance with city ordinance requirements involving residency, distance, location, parking and type of building structure in effect at the time of first receiving the licenses and continuing to be in compliance therewith shall be exempt from the additional or new requirements of this chapter involving residency, distance, location, parking and type of building structure. Renewals of such licenses shall also be deemed in compliance hereunder to the extent provided in this subsection.
- (b) Transfers of business ownership at the same location shall be deemed in compliance hereunder with regard to the city ordinance requirements involving distance, location, parking and type of building structure, provided that such business complied with such requirements at the time a license was first issued for such business and further provided that such business has continuously been in compliance with such requirements.
- (c) Business transfers to new locations and new licenses must comply with all requirements of this chapter.

(Ord. of 12-13-2012, § 1)

~~Sec. 4-6. No sales to minors.~~

- ~~(a) It shall be unlawful for any person under 21 years of age to buy or allow to be bought for him any alcoholic beverage from any place where these beverages are kept.~~
- ~~(b) It shall be unlawful for any person in charge of, or employed in any place of business where alcoholic beverages are kept, to permit any person under 21 years of age to buy or to allow to be bought for any person under 21 years of age any alcoholic beverages in or from the place of business.~~
- ~~(c) It shall be unlawful for any person to furnish or serve any person under 21 years of age with any alcoholic beverage. A valid driver's license, valid state identification card, or valid military identification card may be reasonably accepted by the person hereunder as sufficient evidence of age.~~
- ~~(d) Any attempt to commit an act made unlawful by this section shall itself be unlawful.~~
- ~~(e) It shall be unlawful for any person under 21 years of age to falsely represent his age, in any manner whatever, for the purpose of illegally obtaining any alcoholic beverages.~~
- ~~(f) It shall be unlawful for any person to allow or require a person in his employment under 18 years of age to dispense, serve, sell or take orders for any alcoholic beverage; provided, however, that the provisions of this section shall not prohibit persons under 18 years of age who are employed in supermarkets, convenience stores or drug stores from selling or handling alcoholic beverages which are sold for consumption off the premises.~~
- ~~(g) It shall be unlawful for any person who is under 21 years of age to have in his possession, or under his control, at any place whatever in the city, any alcoholic beverage, unless otherwise provided by law.~~
- ~~(h) Violation of any provisions of this section shall constitute an offense hereunder and shall be punishable in the municipal court; provided violation of this section by persons who have not yet reached the age of 17 years shall be handled as provided by law.~~

~~(Ord. of 12-13-2012, § 1)~~

~~Sec. 4-7. Minors prohibited from premises.~~

- ~~(a) Licensees under this chapter shall not allow minors to be in, frequent or loiter about the licensed premises unless accompanied by an adult.~~
- ~~(b) This section shall not apply to restaurants, bona fide private clubs, or others whose predominant business is other than the sale of alcoholic beverages, for example, grocery or convenience stores. Nor shall this section apply to minors who are employees of the business.~~

~~(Ord. of 12-13-2012, § 1)~~

~~State law reference(s) — Underage persons, O.C.G.A. § 3-3-23 et seq.~~

~~Secs. 4-8 — 4-32. Reserved.~~

~~ARTICLE II. DEALERS AND MANUFACTURERS~~

~~DIVISION 1. EXCISE TAXES~~

Sec. 4-33. Purpose; tax in addition to other fees and taxes.

- (a) ~~The purpose of this division is to establish a system of excise taxes in conformity with state law in order to maximize the revenue permitted to the city under state law.~~
 - (b) ~~Taxes nonexclusive.~~ The excise taxes provided within this section shall be in addition to any license fee, tax or other charge which now or in the future may be imposed upon a licensee selling malt beverages, wine and/or distilled spirits at retail or wholesale within the municipal limits of the city.
- (Ord. of 12-13-2012, § 2)

Sec. 4-34. Excise tax levied on wholesale dealers.

- (a) ~~Scope of section.~~ In addition to all other taxes or license fees imposed upon wholesale dealers, there is imposed and levied upon all licensed wholesale dealers engaged in the city in the business of selling malt beverages, wine, and/or distilled spirits to retailers within the city an excise tax for the privilege of doing such business in the city, to be computed and collected as set forth in this section.
- (b) ~~Basis for computation of tax on malt beverages.~~
 - (1) ~~Malt beverages—Bulk containers.~~ All malt beverages including those commonly known as tap or draught beer when sold in or from a barrel or from a bulk container shall be subject to a tax imposed on the wholesale dealer selling such malt beverage within the municipal limits of the city. The tax of \$6.00 on each container sold containing not more than 15.5 gallons and a proportional tax at the same rate on all fractional parts less than 15.5 gallons shall be imposed.
 - (2) ~~Malt beverages—Not in bulk containers.~~ All malt beverages sold in bottles, cans or other containers, except those included in subsection (b)(1) of this section, shall be subject to an excise tax of \$0.05 per 12 ounces and a proportional tax at the same rate on all fractional parts of 12 ounces, which tax shall be levied and imposed on each wholesale dealer selling malt beverages within the city.
- (c) ~~Basis for computation of tax on wine.~~ The tax levied hereunder shall be computed on the basis of \$0.22 per liter for wine sold by wholesalers to retailers within the city. The \$0.22 per liter shall be prorated down on fractional parts of liters, so that each bottle or each individual size container shall be taxed on the basis of \$0.22 per liter.
- (d) ~~Basis for computation of tax on package sales of distilled spirits.~~ The tax levied hereunder shall be computed on the basis of \$0.22 per liter for distilled spirits sold by the package, excluding fortified wine, sold by wholesalers to retailers within the city. The \$0.22 per liter shall be prorated down on fractional parts of liters, so that each bottle or each individual size container shall be taxed on the basis of \$0.22 per liter.
- (e) ~~Computations, payment, duties of wholesale dealer and distributor.~~ The tax imposed shall be computed and payable monthly.
 - (1) ~~Record keeping.~~ Each wholesale dealer or distributor selling, shipping, or delivering wine, malt beverages and/or distilled spirits to any retail dealer in the city, whether delivered to the retail dealer's place of business in the city or elsewhere for resale in the city, shall, as a condition to the privilege of conducting said business in the city, keep and maintain true and correct records of all sales, shipments or deliveries of alcoholic beverages to each retail dealer in the city. Such records are to be preserved for a period of not less than one year and made available on request for the inspection of any duly authorized representative of the city.
 - (2) ~~Report requirements.~~ On or before the tenth day of each calendar month, each wholesaler shall make a verified and comprehensive report to the city which shall correctly show and reflect all sales and deliveries of wine, malt beverages and/or distilled spirits to or for retail dealers in the city for the calendar month immediately preceding the date of said report. Said report shall show the name and

address of each retail dealer, the quantities delivered to each retail dealer, the amount of excise tax due under the terms of this section, and such other reasonable information as may be requested by the city. Said report shall be accompanied by remittance payable to the city for all taxes due, as shown on said report.

- (3) ~~Penalty for late payment.~~ The excise tax levied in this section is hereby levied upon the wholesaler licensed to do business in the city. In the event the tax due hereunder is not paid on or before the tenth day of each calendar month, a ten percent penalty on the gross tax will be levied by the city against each defaulting wholesale licensee for whom the tax is not paid on or before the tenth day of the month.
- (4) ~~False reporting.~~ Filing of a false or fraudulent report shall render the wholesale dealer making such report liable for a penalty equal to 50 percent of the amount of the remittance which would be required under a truthful and accurate report, and/or a penalty of \$100.00 whichever penalty is greater.
- (5) ~~Noncompliance by wholesale dealer.~~ If any wholesale dealer fails or refuses to make the reports required herein, the city shall notify such dealer in writing and if the reports are not made and the taxes are not remitted within five days from the date of such notice, the license of such wholesale dealer may be revoked as provided in this article.
- (6) ~~Violations.~~ Any person violating any of the provisions of this section or who shall assist any wholesale dealer in alcoholic beverages in the city to evade or avoid the payment of the taxes herein provided for shall be guilty of a violation of this section and, on conviction thereof in the municipal court, shall be fined or sentenced as provided by this Code, and any such person so convicted shall also be subject to having his license suspended or revoked.
- (7) ~~Performance bond required.~~ To ensure payment of the excise tax levied hereby and prior to the issuance of any wholesale alcoholic beverage license in the city, an applicant must post and file with the city manager, along with the license application, a performance bond conditioned upon the faithful observance and performance by the applicant of the rules and regulations contained in this chapter, and upon the payment of any taxes due to the city. Upon the violation of this chapter, or any part thereof, such bond will be forfeited as determined by the public safety committee of the city council at a hearing held for that purpose upon three days' written notice given to the licensee concerned. Bond shall be payable to the city and shall be in the amount of \$1,000.00 and shall be in a form acceptable to the city manager. This bond is required in addition to any other bond required in this article.
- (8) ~~Stamps.~~ No decal, stamp or other identifying mark shall be required on malt beverages, wine, and/or distilled spirits sold within the city.

(Ord. of 12-13-2012, § 2)

State law reference(s)—Excise tax on distilled spirits, O.C.G.A. § 3-4-80; excise tax on malt beverages, O.C.G.A. § 3-5-80 et seq.; excise tax on wine, O.C.G.A. § 3-6-60 et seq.

Sec. 4-35. Excise tax levied upon sale of distilled spirits by the drink.

- (a) Every purchaser of distilled spirits by the drink within the city limits shall be liable for a tax thereon at the rate of three percent of the retail price or charge for such drink. Such taxes shall be collected by retail consumption licensees hereunder, and such licensees shall remit the tax to the city manager on or before the tenth day of the succeeding month along with a summary of the licensee's gross sales derived from the sale of distilled spirits by the drink for the preceding month. Gross sales shall include all credit card sales, and taxes collected thereon shall be submitted to the city manager in the same manner and to the same extent as required of cash sales.
- (b) Licensees collecting the tax provided for in this section shall be allowed a percentage of the tax due and accounted for and shall be reimbursed in the form of a deduction in submitting, reporting and paying the

amount due, if the amount is not delinquent at the time of payment. The rate of deduction should be the same rate authorized for deductions from state tax under O.C.G.A. § 48-8-1 et seq., as provided in O.C.G.A. § 3-4-133.

- (c) ~~Excise taxes levied under this section and received by the city after the 20th day of the month shall be charged a ten percent penalty.~~
- (d) ~~In the event the city manager deems it necessary to verify the excise tax submitted to the city pursuant to this section, for any month, he or she shall notify the licensee of such need for verification, and the licensee shall submit a verified comprehensive report to the city manager, prepared by an auditor, reflecting all sales under this section by the licensee and the taxes submitted to the city. The licensee shall have 30 business days to submit such a report to the city manager following such a request.~~
- (e) ~~Failure to comply with any of the provisions of this section constitutes a violation of this chapter and may result in revocation or suspension of a retail consumption or other alcoholic beverage license.~~

(Ord. of 12-13-2012, § 2)

State law reference(s) — Excise tax on malt beverages, O.C.G.A. § 3-3-130.

Secs. 4-36—4-54. Reserved.

DIVISION 2. LICENSES

Sec. 4-55. Required; classifications; fees.

- (a) ~~No malt beverage, wines, spirituous liquors or any other alcoholic beverage shall be stored for sale, delivered, sold or manufactured in the city except under a license issued pursuant to this article and then only for the specific beverage and manner of sale provided in the license.~~
- (b) ~~The requirements of this article shall be in addition to any other requirements for business licenses under this Code, and if other provisions of this Code conflict with this article then this article shall control.~~
- (c) ~~Licenses which may be issued under this article are as follows:~~
 - (1) ~~Retail consumption dealer, including restaurants, bona fide private clubs, etc.:~~
 - a. ~~For distilled spirits, malt beverage and wine.~~
 - b. ~~For malt beverage only.~~
 - c. ~~For wine only.~~
 - d. ~~For malt beverage and wine only.~~
 - (2) ~~Retail package dealer and/or wholesale dealer:~~
 - a. ~~For malt beverage only.~~
 - b. ~~For wine only.~~
 - c. ~~For malt beverage and wine only.~~
 - d. ~~For distilled spirits, malt beverage and wine.~~
 - (3) ~~No retail package dealer or wholesale licensee shall hold any consumption on the premises license for the same location, with the exception of an ancillary wine tasting permit addressed in section 4-71.~~
- (d) ~~Upon the filing of an application for a new or renewal license pursuant to this chapter, the applicant shall pay a fee for such application as established and set forth by the city. The application fee shall cover the costs of~~

advertisement, investigation, and processing of the application, and any other administrative costs related to functions performed by the city in regard to such applications. In addition, the applicant shall pay an annual license fee for each new or renewed license it obtains from the city pursuant to this chapter. Such license fees shall be established by the city from time to time in accordance with the classification of alcoholic beverage licenses as set forth in this section. Such annual license fee shall not be pro-rated and shall not be refundable except as otherwise set forth in this chapter.

- (e) ~~If the wholesale dealer's principal place of business is located within the city, the city will levy a license fee in accordance with the classification into which the applicant falls. In addition to the general occupation tax, the wholesale dealer shall also pay a processing fee in the amount established by the city to cover the expenses of investigation and processing. The applications of wholesale dealers located within the city must be approved by the city manager or his/her designee.~~
- (f) ~~The annual license fee for a bona fide club, due to its nonprofit status, may be reduced as set forth in the fee schedule established by the city. A bona fide club shall pay the scheduled application or renewal fee at the time it makes application for a consumption license.~~
- (g) ~~No city alcohol license shall be effective until the licensee also obtains a state alcohol license.~~

(Ord. of 12-13-2012, § 4)

Sec. 4-56. Application—Filing; form; contents; information.

- (a) ~~*Application/applicant.* All individuals desiring to obtain a license required under this chapter shall make written application to the city at the City Hall for such privilege upon forms to be prepared and approved by the city. Such applications shall state:~~
 - (1) ~~The name and address of the applicant, as that term is defined in section 4-1 above. The applicant applying on behalf of a business shall be the owner of the proposed business, if the business is solely owned. If the applicant is a partnership, the names and addresses of the partners shall be included; if a corporation, the names and addresses of the officers and the managing member, and the names and addresses of any shareholder or member holding at least 20 percent interest in the business;~~
 - (2) ~~The name and address of the general manager of the particular business location;~~
 - (3) ~~The nature and character of the proposed business to be carried on by the applicant and the address where the proposed business is to be located;~~
 - (4) ~~Any such other information as may be required by mayor and city council, the city manager, or the police department, and shall be sworn to by the applicant or agent thereof.~~
 - (5) ~~*Corporation.* Corporate applicants must either be incorporated in the state or must be registered to do business in the state through the secretary of state's office.~~
 - (6) ~~*Hotel or motel.* The hotel or motel must qualify as a restaurant as defined in section 4-1 in order to apply for a license under this chapter.~~
- (b) ~~*Information required within 20 business days of request.* All applications for a license under this chapter shall furnish all data, information and records requested by the city, through any authorized officer such as the city manager, and failure to furnish such data, information and records within 20 business days from the date of such request shall automatically serve to dismiss, with prejudice, the application. Applicants by filing an application agree to produce for oral interrogation any persons requested by the city through its duly authorized representative, such as the city manager, chief of police, or mayor and city council, and considered as being important in the ascertainment of the facts relative to the issuance or denial of such license. The failure to produce such persons within 20 business days after being requested to do so shall result in the automatic denial, with prejudice, of such application.~~

- (c) ~~Information required.~~ All applications for a new license under this article must be, and applications for a renewal license may be required to be, accompanied by a full and complete statement under oath of information in addition to that information referenced above and including but not limited to:
 - (1) ~~The names and addresses of each person having at least a 20 percent financial interest in this business by way of ownership of building, stock, receipt of income or otherwise. Whether any such person, or any member of such person's family has any interest in any other business which sells alcoholic beverages, either by the drink or by the package, and if so, the name, address, type of business of such business;~~
 - (2) ~~The name and address for the past ten years of each individual licensee, including the registered agent where necessary;~~
 - (3) ~~Each applicant shall provide his or her birth date; Social Security number; home and business addresses; home, business and cell phone numbers; and other information as may be requested by the city in the application. This information also shall be required for the registered agent, if necessary, and the general manager of the particular location for which a license is sought. Each applicant, corporate officer (if applicable), registered agent (if applicable), and general manager shall sign a consent form which shall authorize the city to obtain and review a criminal history background check on such individual;~~
 - (4) ~~The ownership of the land and building where the proposed retail business is to be operated;~~
 - (5) ~~The amount of rental to be paid for such land and building and the manner in which the same is determined and to whom and what intervals it is paid;~~
 - (6) ~~The names and addresses, by affidavit from the owner, lessor or sublessor of such land and building, of all persons having any whole, partial, beneficial or other interest in and to the land and building on and in which the business is located; and~~
 - (7) ~~Any other information called for as part of the application by the city manager or his designee.~~
- (d) ~~Application must be complete.~~ Each application furnished under this section must be complete in its entirety before being accepted by the city for filing and processing.
- (e) ~~Receipt of Code.~~ As a prerequisite to the issuance of any new license under this chapter and as a prerequisite to the issuance of a renewed license under this chapter, all applicants and existing licensees shall be required to execute and deliver to the city a verified statement indicating receipt of this Code relating to alcoholic beverages.
- (f) ~~Employee training.~~ All applicants and existing licensees shall ensure that employees are properly trained to prevent intoxication, drunk driving, underage drinking, and other alcohol-related problems.
- (g) (1) ~~Fingerprints required.~~ A new applicant for a license to sell alcoholic beverages shall be required to submit his or her fingerprints to the Walton County Probate Court to be used for criminal investigation. For renewal applicants, fingerprints are not required but the application shall include a background check of the applicant, to be processed by the Walton County Probate Court. The Walton County Probate Court requires payments of processing fees for fingerprints and background checks.
- (2) ~~Criminal history.~~ No applicant shall have been convicted, nor have entered a plea of nolo contendere within the ten years immediately preceding the date of application for any felony or have violated any federal, state, city or county law or regulation regarding alcoholic beverages and illegal drugs, their sale, consumption, distribution or manufacture. This prohibition shall also apply to the general manager who shall have managerial and supervisory authority over the particular location for which a license is sought. In those instances involving partnerships, this prohibition shall apply to all partners. In those instances involving corporations, this prohibition shall also apply to the corporation's officers and registered agent.

- ~~(h) — *Photograph required.* All applicants and existing licensees shall submit a color photograph which is two-inch by two-inch in size taken within the past year.~~
- ~~(i) — *Residency required.* Each applicant for a license under this article shall have been and continue to be a bona fide resident of the state for the period of three years immediately preceding the date of application and shall remain a bona fide resident of the state during all times that the license and any renewal thereof is in effect. All applicants and all registered agents shall be at least 18 years of age.~~
- ~~(j) — *No applicant shall be indebted to the city for any fees, costs, or penalties.* Each applicant's accounts with the city for fees, taxes, utilities, or other charges imposed under the Code of Ordinances shall be current at the time of application and remain in good standing.~~
- ~~(k) — *Registered agent required.*
 - ~~(1) — All applications for licenses under this article shall nominate and name in the application one or more residents of the state as the registered agent and representative of the applicant to receive all communications, notices, services or process or other papers or documents on behalf of the applicant in connection with any matter arising out of or connected with the issuance, holding, suspension, revocation or other action with respect to any city license. The applicant shall give the mailing address of such registered agent, and the mailing to any registered agent at that address of any notice required to be given under this article or any other law shall be sufficient notice to the applicant/licensee.~~
 - ~~(2) — Such registered agent shall be a representative of the licensee and must be approved by the city manager or his designee. The city manager shall refuse to approve any registered agent who is not a bona fide resident of the state or who has been convicted, within the ten years preceding his nomination, of any felony of any kind or any misdemeanor relating to an alcoholic beverage business or any state law or county or municipal ordinance violation relating to any alcoholic beverage business.~~
 - ~~(3) — If any registered agent shall cease to be a representative of the licensee or shall cease to be a resident of the state or in any manner ceases to meet the requirements of this section, the licensee shall notify the city manager in writing of such event and shall nominate a new registered agent within five business days after such event occurs. Such new registered agent shall meet the requirements of this section and must be approved by the city manager or his designee. The city shall charge a fee for a change of the licensee's registered agent; provided, however, that if the licensee fails to notify the city and nominate a new registered agent within said five-day period, then the city shall charge a higher fee for a change of the licensee's registered agent and/or revoke the licensee's license. The fees for a change of the licensee's registered agent shall be set by the mayor and city council.~~~~
- ~~(l) — *Premises and survey requirements.* The application shall contain:
 - ~~(1) — A description of the business operation, its location, and facilities;~~
 - ~~(2) — A blueprint or scale drawing of the business facilities, except as provided in subsection 4-58(a);~~
 - ~~(3) — A survey performed and signed by a certified surveyor and dated no more than 30 days prior to the filing of the application which indicates the location of the business and the distance to the nearest residence, school, church, library and alcoholic treatment center.~~~~
- ~~(m) — In determining whether or not any application shall be granted and a license issued, the city shall consider, in addition to the grounds set forth above, the following information in the public interest and welfare:
 - ~~(1) — The manner in which the license representative or any individual listed on the application or partner has conducted any business within the city as to the necessity for unusual law enforcement observation and inspection in order to prevent the violation of any law, regulation or ordinance or as to the necessity for city action to compel the applicant's and/or licensee's adherence to any city law, regulation or ordinance;~~
 - ~~(2) — The location for which the license is sought as to traffic congestion, public safety, the general character of the neighborhood and the effect of such an operation on surrounding property values; and~~~~

~~(3) Whether the license representative or any individual listed on the application or partner has ever had an alcoholic beverage or business license suspended or revoked by the state or any political subdivision thereof, including the city.~~

~~(n) Additional information required for retail consumption license. Any applicant for a retail consumption license as a restaurant under this article shall provide, in addition to all other required information, a signed return on a form provided by the city manager setting forth the amount of gross receipts and the allocation of such receipts to the serving of meals for the entire preceding calendar year, to be used as an estimate as the gross receipts and the allocation of those receipts to the serving of meals for the current year. Where an applicant seeking a retail consumption license as a restaurant operated as a restaurant for only part of the preceding year, the amount of gross receipts for such part, including the allocation of such receipts to the serving of meals, shall be set forth in such return. Such return shall be used as the estimate of the gross receipts and the allocation of those gross receipts to the serving of food for the business for the current calendar year.~~

~~(o) Oath. The application shall also contain a form of oath providing that the information disclosed in the application is true and correct, and providing further that the applicant will abide by, observe and conduct his business according to the rules and regulations prescribed by the city, the laws of the state pertaining to alcoholic beverages and the rules and regulations of the state department of revenue in respect thereto. The oath shall be taken by the applicant and the agent in charge of the establishment if different from or additional to the applicant.~~

~~(p) Misleading, omitting or obsolete information.~~

~~(1) Any untrue or misleading information contained in or material omission left out of an original or renewal application for an alcoholic beverage license shall be cause sufficient for the denial thereof.~~

~~(2) Any information that changes or otherwise becomes obsolete shall be reported immediately.~~

~~(3) When any license that is issued on the basis of an application containing misleading or untrue information or omitted or unreported changed material information, such circumstances shall be cause for revocation of same.~~

~~(q) Fee. Each application for an initial license or a renewal of an existing license shall be accompanied by a nonrefundable application fee in an amount set by the city in the schedule approved by the city council.~~

~~(Ord. of 12-13-2012, § 4)~~

Sec. 4-57. Notice of application.

The applicant shall cause to be placed upon the location of the proposed premises to be licensed, signs of a size, number and form prescribed by the city manager or his designee, stating the names of owners and address of the applicant, type of license applied for and the business name and location applied for. Said signs shall be posted at the location within five days of submission of the application and must remain in place until a final determination has been made on the license.

~~(Ord. of 12-13-2012, § 4)~~

Sec. 4-58. Additional application requirements for retail dealers in distilled spirits by the package.

~~(a) Licensed premises' building requirements:~~

~~(1) No license to sell distilled spirits by the package shall be effective until the building in which the business will be located is complete, detailed plans of the building and outside premises have been submitted to and approved by the city, and the city has issued a certificate of occupancy for the building. For initial qualification for a license, however, the applicant need not comply with subsection~~

~~4-56(1)(2) if the building is not complete at the time application is made. In lieu of blueprints, the applicant must attach to his or her initial application a survey as required in subsection 4-56(1)(3), a rendering of the proposed building, and a site plan. The proposed building shall be subject to final inspection and approval when completed by the building inspector, the fire marshal, the planning director, and shall comply with other ordinances of the city for zoning, storage, parking, buffers and other issues. The proposed building also shall comply with all regulations of the state revenue commissioner and all the laws of the state.~~

- ~~(2) Each building in which the business will be located shall contain sufficient lighting so that the building itself and the premises on all sides of the building shall be readily visible at all times from the front of the street on which the building is located. The lighting shall reveal the inside retail area of the building and shall reveal all of the outside premises of the building.~~
- ~~(3) The licensed premises must be within a freestanding building completely and physically separate from any other business activities. The building must contain a minimum of 10,000 square feet of heated and air conditioned space.~~
- ~~(4) The building in which the licensed premises is located shall be finished with brick and glass except for incidental metal trim.~~
- ~~(5) The licensed premises shall allow ingress and egress for customers and their purchases through a door opening to the outside and facing a public street or public pedestrian area.~~
- ~~(6) The building shall be owned or leased by the applicant for a license to sell distilled spirits by the package, and proof of ownership or lease is required.~~
- ~~(7) The licensee is required to install security cameras and otherwise to comply with section 4-134 of this chapter.~~
- ~~(b) *Performance bond required:* Before any license to sell distilled spirits by the package is granted, the applicant must post with the city, along with his or her application, a performance bond on the construction with an insurance company as surety. This bond shall require the faithful observance and performance by the licensee of the rules and regulations contained in this article. Upon the violation of this article, or any part of this article, the amount of the bond to be forfeited will be determined by the seriousness of the violations as determined by the city. The bond is to be approved by the city and shall be properly executed. The bond is to be in the amount of \$100.00 for a wholesale license and \$2,500.00 for a retail license. A cash bond is acceptable. The money will be held in escrow. The applicant must fill out a bond letter, available at the department of planning and development.~~
- ~~(c) *Proof of insurance required:* The applicant for a license to sell distilled spirits by the package shall provide proof of comprehensive general liability insurance, including liquor liability coverage, for the licensed premises with coverage of at least \$2,000,000.00 per occurrence, inclusive of personal injury, bodily injury, death, and property damage, and an umbrella policy with coverage of at least \$2,000,000.00 per occurrence. At the time a license application is submitted, the city will accept as proof of insurance a quote from a reputable insurance company. The applicant may need to ask the insurance company for an extension of the quote. Prior to opening a package store, and thereafter at the time of renewing a license, a licensee must submit a certificate of insurance to the city planning department. Failure to do so is cause for revocation of a license.~~
- ~~(d) *Proof of inventory required:* The applicant for a license to sell distilled spirits by the package shall provide proof that it will maintain a wholesale inventory valued at \$600,000.00. An affidavit of the applicant satisfies this requirement.~~
- ~~(e) *Letter of credit:* The applicant for a license to sell distilled spirits by the package shall furnish the city a letter of credit in the amount of at least \$2,000,000.00 per application.~~
- ~~(f) *Number of licenses to be determined by population:* The city shall issue no more than two licenses for the retail sale of distilled spirits, malt beverages, and wine by the package until such time as the number of city~~

residents reaches 30,000, as the population has been determined by a certified census count of the United States Census Bureau, at which time the city may issue an additional license or licenses so long as thereafter the number of licenses in operation within the city limits at any one time shall not exceed one license to sell packaged distilled spirits for each 10,000 city residents as determined by a certified census of the United States Census Bureau.

(g) ~~No Sunday sales:~~ No retailer of distilled spirits by the package shall permit his place of business to be open for the sale of such beverages on Sundays or on days or times prohibited by state law.

(Ord. of 12-13-2012, § 4; Ord. of 2-18-2014(1), § 1; Ord. of 9-10-2015, §§ 1-3)

Sec. 4-59. Grant or denial of license.

(a) ~~Grant or denial of license for retail package dealer for malt beverage and/or wine only, or for retail consumption dealer, or for wholesale dealer.~~

(1) ~~All applications shall be submitted during business hours to the city manager or his/her designee, who shall mark the application with the time and date received. Upon the filing of an application for a retail package or wholesale dealer for malt beverages and/or wine, or upon the filing of a retail consumption license, the city manager shall have five business days to review the application and to send a copy of the application to all affected departments of city government to determine compliance with city regulations and laws. Each department notified shall submit a report within 20 business days of receipt of the application to the city manager which states whether there are any objections to the application.~~

(2) ~~Within 20 business days from the date the city manager receives all department notifications, the city manager shall render a written determination as to whether the application complies with the requirements of this chapter and shall include a decision either to grant or to deny the license sought.~~

(3) ~~The written decision shall be sent by certified mail to the applicant whose application was considered. If the decision of the city manager is to deny the requested license, then the letter to the applicant shall set forth in reasonable detail the grounds upon which the license is being denied.~~

(4) ~~The city manager or his designee may deny a city license or renewal thereof under this article on any of the following grounds:~~

- a. ~~Failure to meet state requirements for state license;~~
- b. ~~Failure to pay all required fees and taxes;~~
- c. ~~Failure to provide valid information, documents and the like required by this article;~~
- d. ~~False information in the application or attached documents;~~
- e. ~~Improper residency of applicant, owner or registered agents;~~
- f. ~~Failure to post and maintain proper signs and advertisements required in this article;~~
- g. ~~Failure to meet distance, location or number of business requirements;~~
- h. ~~Prior convictions as herein provided; or~~
- i. ~~Failure to meet any other requirements in this article for a license or any other requirement in any other provision of this Code or the Charter.~~

(5) ~~The letter shall further advise the applicant of the right to appeal the decision to the mayor and city council within 20 business days of the date on which the applicant receives by certified mail the written decision of the city manager.~~

(b) ~~Grant or denial of license for retail package dealer for distilled spirits.~~

- ~~(1) The city shall publish notice of availability of any license(s) to sell distilled spirits by the package in a newspaper of general circulation in the city and state the deadline for filing an application. Such notice shall be published at least once a week for two consecutive weeks. The application deadline shall be at least 20 business days after publication. All applications for a license to sell distilled spirits by the package shall be submitted during business hours to the city manager or his/her designee, who shall mark the application with the time and date received.~~
- ~~(2) Upon the filing of an application, the city manager shall have five business days to review the application and to send a copy of the application to all affected departments of city government to determine compliance with city regulations and laws. Each department notified shall submit a report within 20 business days of receipt of the application to the city manager which states whether there are any objections to the application.~~
- ~~(3) Within 20 business days from the date the city manager receives all department notifications, the city manager shall render a written determination as to whether the application complies with the requirements of this chapter.~~
- ~~(4) The written determination shall be sent by certified mail to the applicant whose application was considered.~~
- ~~(5) If the decision of the city manager is to deny the requested license, then the letter to the applicant shall set forth in reasonable detail the grounds upon which the license is being denied. The letter shall further advise the applicant of the right to appeal the decision to the mayor and city council within 20 business days of the date on which the written decision of the city manager is sent by certified mail.~~
- ~~(6) The city manager or his designee may deny a city license or renewal thereof under this article on any of the following grounds:
 - ~~a. Failure to meet state requirements for state license;~~
 - ~~b. Failure to pay all required fees and taxes;~~
 - ~~c. Failure to provide valid information, documents and the like required by this article;~~
 - ~~d. False information in the application or attached documents;~~
 - ~~e. Improper residency of applicant, owner or registered agents;~~
 - ~~f. Failure to post and maintain proper signs and advertisements required in this article;~~
 - ~~g. Failure to meet distance, location or number of business requirements;~~
 - ~~h. Prior convictions as herein provided; or~~
 - ~~i. Failure to meet any other requirements in this article for a license or any other requirement in any other provision of this Code or the Charter.~~~~
- ~~(7) If the city manager determines that the applicant meets the criteria for a license to sell distilled spirits by the package within the Loganville city limits, but there are more qualified applicants than available licenses, then the city manager shall send a letter by certified mail to the applicant notifying him or her that a licensee or licensees to sell distilled spirits by the package shall be selected by lot at a meeting of the city council and of the date, time and place of said meeting.~~
- ~~(8) The letter shall further advise the applicant of the right to appeal the decision to the mayor and city council within 20 business days of the date on which the lottery takes place.~~

~~(Ord. of 12-13-2012, § 4)~~

Sec. 4-60. Appeal to mayor and city council.

- (a) Any applicant who wishes to appeal the decision of the city manager or the results of the lottery shall file a written appeal of the decision with the city manager within 20 business days as referenced in section 4-59 above. The city manager will schedule a hearing before the mayor and city council at which the applicant will be given the opportunity to present additional information and evidence and to cross-examine witnesses. This hearing, which shall be transcribed by a court reporter, shall take place within 30 business days of the date of the applicant's written appeal to the city manager.
- (b) The standards to be applied by the mayor and city council, acting in its judicial capacity to grant or deny a license, shall include whether, in the best judgment of the mayor and city council, the applicant, based on all information obtained in the application process, possesses the qualities of sound judgment and discretion necessary for one who dispenses alcoholic beverages to the public generally.
- (c) In addition to the foregoing standards, should any license representative of the applicant fail to attend a meeting at which it is considered before the mayor and city council regarding a new license, a request to change a licensee or a license representative, or a request to relocate the business of a licensee, the mayor and city council may consider such application or request to have been withdrawn by the applicant. The application fee is nonrefundable.
- (d) Within 30 business days of the date of the appeal hearing, the mayor and city council shall make a written determination as to whether the license should be granted or denied. In the event that the mayor and city council's decision is to deny the license, the grounds for such denial shall be included in the written determination.
- (e) The city manager, or his designee, shall send the written determination of the mayor and city council by certified mail to the applicant or licensee at the address shown on the application within three business days of the date of the action taken by the mayor and city council.
- (f) *Appeal.* The decision of the mayor and city council shall be final unless the decision is appealed by certiorari to the superior court of the county within which lies the premises for which adverse action is being taken, which will be either Walton or Gwinnett County. Such appeal must be filed within 30 business days of the date the applicant receives the written determination by certified mail.
- (g) In all instances in which an application is denied under the provisions of this section, the applicant may not re-apply for a license for at least 24 months from the final date of such denial. This prohibition shall not apply to the denial of an application based on a failure to meet distance requirements.

(Ord. of 12-13-2012, § 4)

Sec. 4-61. Temporary licenses.

- (a) Persons making alcoholic beverage license applications pursuant to this chapter 4 because of a change in ownership of the retail licensed establishment, after properly filing all required documents, may be authorized by the city manager to operate pursuant to a temporary license. Before any such temporary license may be issued, the applicant must have filed with the city the following documents and materials under the conditions indicated:
 - (1) All documents required by city and pursuant to the Code for obtaining a license appropriate to the type business for which application is made, including payment by certified check, money order or cashier's check of the license fee at the time of submission of the license application.
 - (2) A written request, on forms to be provided by the city, by the applicant for a temporary license to the city manager.

- ~~(3) The applicant, licensee and agent for the temporary license must be identical to the applicant, licensee and agent indicated on the related annual alcoholic beverage license application.~~
- ~~(4) A written, notarized statement, on forms to be provided by the city, indicating that the applicant, temporary licensee and agent waive any and all rights available to them to appeal the decision by the city manager to deny their application for a temporary license or to revoke a temporary license that has been issued to them, and that the applicant, temporary licensee and agent agree to all conditions set forth in this section. As used in this section, "rights to appeal" shall include, but not be limited to, injunctive relief, writ of certiorari, writ of mandamus, writ of prohibition, or any court action which relates in any way to said decision(s).~~
- ~~(5) When preliminary records checks have been completed, determined and judgments made, and the city manager is satisfied that the location for the proposed license substantially complies with the provisions of the Code authorizing such license in the city, a temporary license may be issued if deemed appropriate by the city manager.~~
- ~~(6) The duration of any temporary license issued shall not exceed 120 days.~~
- ~~(7) A temporary license shall not be issued to any entity, real or artificial, who owes the city any monies at the time a temporary license is sought.~~
- ~~(8) There shall be assessed and paid by cashier's check, money order or certified check a nonrefundable temporary license fee which shall be established by the mayor and city council. This fee shall be in addition to all other fees required by the Code.~~
- ~~(9) The issuance and duration of any temporary license pursuant to the conditions stated in this section is within the sole discretion of the city manager and such temporary license may be revoked by the city manager at any time without notice, cause, hearing or refund of any portion of the temporary license fee.~~
- ~~(10) The issuance of the temporary license pursuant to the above conditions does not eliminate or alter in any way the requirement that the applicant must otherwise follow the application process provided in the remaining provisions of this Code.~~
- ~~(b) There shall be no vested right to, or protectable property interest in, the issuance of a temporary license as provided for in this section, or to the issuance of any license issued pursuant to this chapter.~~
- ~~(c) During any one calendar year, there shall be not more than one temporary license granted for any single retail licensed establishment, as such temporary licenses are provided for in this section.~~
- ~~(d) The city manager shall notify the mayor and city council within three days after receiving an application for a temporary license. Such notification shall also include the name of the applicant and the address of the proposed retail license establishment to receive the temporary license.~~

~~(Ord. of 12-13-2012, § 4)~~

~~Sec. 4-62. Eligibility for retail consumption.~~

~~No retail consumption license shall be issued to any applicant whose establishment does not meet the requirements of a restaurant or bona fide private club, with the exception of an ancillary wine tasting permit as addressed in section 4-71 and a special event permit as addressed in section 4-71.1.~~

~~(Ord. of 12-13-2012, § 4; Ord. of 6-12-2014(1), § 1)~~

~~Sec. 4-63. Time limits on opening and continuing business.~~

- ~~(a) All persons and/or businesses issued licenses under this article must open for business within 90 days after the issuance of the city license, except that new construction of a retail package store for distilled spirits shall~~

~~be complete, and the licensed premises must open for business, within 12 months after completion of the appeal process pertaining to applications for a license to sell distilled spirits by the package in the same county as licensee. The appeal process shall be deemed complete upon expiration of the time to file an appeal or upon issuance of a court order where appeal rights have been exhausted. Any applicant unable to comply with the time limit of this subsection may make written request to the city manager for an extension of time and the city manager at his discretion may grant or deny the request. Failure to open for business within the time set forth herein shall constitute a forfeiture and cancellation of the issued license and no refund of license fees or business taxes shall be made.~~

- ~~(b) This section shall apply retroactively to licenses to sell distilled spirits by the package that have been issued as of the date of adoption of this chapter.~~
- ~~(c) Any license issued under this article shall automatically be null and void where the licensed person and/or business has not operated or been open to the public for six consecutive months, except as allowed for construction in subsection (a). Any licensee unable to comply with the time limit of this subsection may make written request to the city manager for an extension of time and city manager at his discretion may grant or deny the request.~~

~~(Ord. of 12-13-2012, § 4; Ord. of 10-10-2013, § 1)~~

Sec. 4-64. Restrictions.

- ~~(a) No person who has any direct financial interest in a license for the sale of alcoholic beverages at wholesale shall hold any other license or an interest in any other license under the terms of this article unless otherwise allowed by state law.~~
- ~~(b) No person shall have an interest in more than two retail consumption licenses.~~
- ~~(c) No elected or full-time appointed official of the city or any person related within the first degree of consanguinity or affinity under civil law to such an official of the city shall own any interest in any license issued under this article unless one of the following conditions is met:

 - ~~(1) The interest was obtained prior to election or appointment to office;~~
 - ~~(2) The interest is declared in writing at the time the application for said license is made and said elected or full-time appointed official shall not participate in official action or consideration of license; or~~
 - ~~(3) The interest obtained in an ongoing business holding a license is declared in writing at the time of the acquisition and filed with the city manager.~~~~

~~(Ord. of 12-13-2012, § 4)~~

Sec. 4-65. Business location; required distances.

- ~~(a) Unless the following uses of property are pre-existing, nonconforming uses under the city's zoning regulations, licenses shall not be issued to authorize the sale of alcoholic beverages at any location which does not meet or exceed the following minimum distance separation requirements from the following establishments:

 - ~~(1) For retail consumption dealers located outside the Main Street district, as defined by the attached Main Street district map, the licensee's premises cannot be located:

 - ~~a. In or within 50 yards of any church grounds;~~
 - ~~b. In or within 50 yards of any structure used as a residences at the time of application;~~
 - ~~c. In or within 100 yards of the property line of the tract of land on which a school building, school grounds, or college campus is located; or~~~~~~

- d. ~~In or within 100 yards of any public library which is on the same side of the street as the proposed location.~~
- (2) ~~For a retail dealer in malt beverages and/or wine by the package, the licensee's premises cannot be located:~~
 - a. ~~In or within 200 yards of any church grounds; or~~
 - b. ~~In or within 200 yards of the property line of the tract of land on which a school building, school grounds, or college campus is located.~~
 - c. ~~In or within 200 yards of any retail dealer in distilled spirits by the package.~~
- (3) ~~For a retail dealer in distilled spirits by the package, the licensee's premises cannot be located:~~
 - a. ~~In or within 200 yards of any church grounds; or~~
 - b. ~~In or within 200 yards of the property line of the tract of land on which a school building, school grounds, or college campus is located.~~
 - c. ~~In or within 500 yards of any other retail dealer in distilled spirits by the package.~~
 - d. ~~In or within 200 yards of any retail dealer in malt beverages and/or wine by the package.~~
- (4) ~~For a wholesale dealer in distilled spirits, malt beverages and/or wine, the licensee's premises cannot be located:~~
 - a. ~~In or within 200 yards of any church grounds; or~~
 - b. ~~In or within 200 yards of the property line of the tract of land on which a school building, school grounds, or college campus is located.~~
- (5) ~~For a bona fide private club, the licensee's premises cannot be located:~~
 - a. ~~In or within 100 yards of any church grounds;~~
 - b. ~~In or within 100 yards of any structure used as a residences at the time of application;~~
 - c. ~~In or within 200 yards of the property line of the tract of land on which a school building, school grounds, or college campus is located; or~~
 - d. ~~In or within 100 yards of any public library which is on the same side of the street as the proposed location.~~
- (b) ~~No person shall sell distilled spirits in or within 100 yards of any alcoholic treatment center owned and operated by the state or county or municipal government.~~
- (c) ~~No person shall sell alcohol, distilled spirits, wine or malt beverages for consumption on the premises in or within 100 yards of any housing authority property as defined by O.C.G.A. § 3-3-21. This subsection shall not apply at any location for which a new license is applied for if the sale of alcoholic beverages for consumption on the premises was lawful at such location at any time during the 12 months immediately preceding such application.~~
- (d) ~~With the exception of measuring distances to schools which shall be measured from the property line of the tract of land on which a school building, school grounds or college campus is located to the front door of the building, or to the nearest portion of the grounds, whichever is applicable, all other distances shall be measured in the following manner:~~
 - (1) ~~From the front door of the structure or partial building unit from which beverage alcohol is sold or offered for sale; thence~~
 - (2) ~~In a straight line, regardless of obstructions, to the nearest public sidewalk, walkway, street, road or highway; thence~~

- ~~(3) Along such public sidewalk, walkway, street, road or highway by the nearest route; thence~~
- ~~(4) To the front door of the building, or to the nearest portion of the grounds, whichever is applicable.~~

- ~~(e) For the purposes of this section, the term "non-accessory structure" means any structure located on the school ground, college campus, residential lot, library or alcoholic treatment center which would not be considered an accessory use under the appropriate interpretations of the city zoning regulations.~~
- ~~(f) Notwithstanding anything to the contrary herein, no church that becomes located near or expands into the vicinity of a licensee under this article shall be entitled to object to the location of a licensee and no license shall be denied because it is within the prohibited footage as set forth in subsection (a) of this section. In addition, no license shall be denied because the location is within the prohibited footage of a temporary church.~~
- ~~(g) Grandfather provision. No license which is in effect on the date the ordinance codified in this chapter is enacted shall be revoked before its date of expiration by reason of the distance regulations set out in this subsection if the license was granted in reliance on another distance regulation previously in effect at the time the license was issued. No application for a license or for a renewal license shall be denied by reason of distance regulations set out in this subsection if the application is for a premises for which a license was granted prior to the date the ordinance codified in this chapter became effective, in reliance on another distance regulations previously in effect at the time the application for the license was filed.~~

~~(Ord. of 12-13-2012, § 4; Ord. of 9-10-2015, § 4; Ord. of 4-11-2019(1), § 2)~~

~~State law reference(s)—Sale of alcoholic beverages near churches, schools or college campus, O.C.G.A. § 3-3-21.~~

Sec. 4-66. Zoning district.

~~No license shall be issued under this article unless the applicant's place of business is located in an area of the city that is zoned commercial as designated by the city's zoning regulations.~~

~~(Ord. of 12-13-2012, § 4)~~

Sec. 4-67. Calendar year term.

- ~~(a) All licenses issued under this article shall remain in effect for the calendar year of issuance (i.e., for all licenses granted between January 1 and December 31 of a given calendar year, the license shall remain in effect until the close of business on December 31 of that same calendar year). No license shall extend from one calendar year into the next.~~
- ~~(b) All renewal applications, containing all information required by this article and applicable fees are due on or before November 15 of the year in which the license expires, and no licensee shall have any vested right to the renewal of any city license. Renewal applications made after November 15 shall be subject to a 20 percent penalty on the applicable license fee and one percent interest per month delinquent.~~
- ~~(c) No license under this article may be renewed if the licensee could be denied a new license under this article.~~

~~(Ord. of 12-13-2012, § 4)~~

Sec. 4-68. Transfer of location.

- ~~(a) Any business and/or person licensed under this article that moves from one location in the city to another location in the city shall make application for a new license as if for an original license on or before the day of moving in the manner set forth in this chapter of the City of Loganville Code of Ordinances. The license can be valid at the new location only if the new location conforms to the zoning regulations of the city and all other requirements of this Code.~~

- (b) ~~The new license application shall be accompanied by a nonrefundable administrative fee. This administrative fee shall be separate and in addition to the occupation tax and/or business license tax.~~
 - (c) ~~This administrative fee shall be set by the mayor and council.~~
- (Ord. of 12-13-2012, § 4)

Sec. 4-69. Transfer of ownership.

- (a) ~~The transfer of ownership of a business requiring an alcohol license shall be considered in the same manner as the termination of the business and the establishment and application of a new business. In the event that the owner of a business requiring an alcohol license desires to transfer the same, or in the event that any interest in the business for which the license was issued is sold or otherwise transferred, then the purchaser or transferee of such license or interest shall apply to the city as if for an original license on or before the date on which such sale or transfer is made.~~
 - (1) ~~Notwithstanding the foregoing, in the case of a corporation, a new alcohol license shall not be required as herein provided unless a change in stock ownership in the corporation results in ownership of more than 50 percent of the outstanding corporate stock, voting or otherwise, by persons or combinations of persons not owners of such stock at the time the license was issued. The term "any interest" is defined as being an ownership of stock or control of 50 percent or more of the partnership or corporation.~~
 - (2) ~~Notwithstanding the foregoing, one or more partners in a partnership holding a license may withdraw in favor of one or more of the existing partners.~~
- (b) ~~The transfer of ownership of a business shall not affect the distance requirements previously approved by the city.~~
- (c) ~~In case of the death of any natural person holding a city alcohol license, or any interest therein, the license may be transferred to the administrator, executor of the lawful heir or devisee of the deceased person by filing a new application with the city for the change in license ownership within 75 days of such death. The business involved may continue to operate until disposition of the application. No additional fees or business taxes shall be charged above what would be due if the business, or portion thereof, remained under the deceased person's ownership.~~
- (d) ~~*Distilled spirits package stores.* For retail package dealer licenses to sell distilled spirits, the city shall process the application in accordance with subsection 4-59(a) in the case of transfer of ownership. If a license becomes available by means other than transfer or death, then the city shall process the application in accordance with subsection 4-59(b).~~

(Ord. of 12-13-2012, § 4)

Sec. 4-70. Completion of premises proposed to be licensed.

~~Where a building in which any person intends to operate under the provisions of this article is, at the time of the application for the license, not in existence or not yet completed, a license may be issued for the location provided the plans for the proposed building show clearly a compliance with the other provisions of this article. No sales or consumption shall be allowed in the establishment until it has been completed in accordance with the plans and is in conformity with all of the other provisions of this article and this Code.~~

(Ord. of 12-13-2012, § 4)

Sec. 4-71. Wine tastings.

- (a) ~~Eligibility.~~ The holder of a current, valid retail package dealer license for wine only or of a current, valid retail package dealer license for malt beverage and wine only shall be eligible for an ancillary wine tasting permit to provide samples of wine offered for sale to customers under the conditions set forth in this section. To obtain a wine tasting permit from the city, an applicant also must hold a current, valid wine license in the state.
- (b) ~~Permit application.~~ An applicant for a wine tasting permit shall file with the city manager or his designee an application and a permit fee in an amount to be established by the city. The form necessary for such application shall be furnished by the city.
- (c) ~~Conditions.~~ A wine tasting permit shall allow the holder to provide samples of wine to the public for consumption on the premises under the following conditions:
- (1) ~~Wine tasting shall be on limited occasions when a customer requests a sample of a wine offered for sale within the premises, or in connection with instructional classes designed to promote wine appreciation and education.~~
 - (2) ~~Wine tasting is permitted only within the enclosed portion of the premises.~~
 - (3) ~~Wine bottles shall be opened only by the licensee or an employee of the licensee, and samples shall be poured only by the licensee and/or an employee.~~
 - (4) ~~Samples shall not exceed two ounces, and no customer shall consume more than eight ounces in any two-hour period. No individual under 21 years of age shall be permitted to consume any sample.~~
 - (5) ~~No open or unsealed containers of wine shall be removed from the licensed premises.~~
 - (6) ~~No wine tasting may be conducted on the premises of any place of business licensed to sell distilled spirits in original packages for off-premises consumption.~~
 - (7) ~~No wine tasting may be conducted on the premises of a malt beverage and wine store operating in connection with a retail package dealer licensed to sell distilled spirits in original packages for off-premises consumption.~~
 - (8) ~~All wines secured for tasting purposes must be obtained through a wholesale wine outlet.~~
 - (9) ~~The applicant shall maintain on the premises and offer for sale at all times a variety of wines from at least 50 manufacturers of wine.~~
 - (10) ~~The applicant's establishment shall have minimum interior floor area of 500 square feet devoted to the storage, display and sale of wine.~~
 - (11) ~~Wine tasting for customers shall be conducted only at a counter area constituting no more than ten percent of the entire floor area of the premises.~~
 - (12) ~~The holder of a wine tasting permit may conduct educational classes with tasting not more than two times per week for a period not to exceed three consecutive hours. All conditions set forth in this section shall apply to such classes, except for the limitation on floor area where the classes can be conducted.~~
 - (13) ~~The holder of an ancillary wine tasting permit shall not charge a fee to participate in wine tasting classes nor for individual samples of wine.~~
 - (14) ~~All permit holders must comply with this Code section, other city ordinances, and all state statutes and regulations pertaining to the sale and distribution of alcoholic beverages, including but not limited to, those dealing with hours of operation, zoning, and distance requirements.~~

(Ord. of 12-13-2012, § 4)

Sec. 4-71.1. Eligibility for issuance of a temporary special event beer and/or wine license.

- (a) A temporary license may be issued to any person, firm or corporation, for a period not to exceed three days for any one event, for an approved special event at the Rock Gym, Ag Building, Anna Holbrook Building, Town Green or the field next to city hall. The person, firm or corporation must complete an application and pay the fee that required by the city and shall be required to comply with all the general ordinances and regulations for an on-premises consumption establishment with the exception of the full-service kitchen requirement. Said temporary licenses may be applied for no later than 60 days prior to the event and issued to any one person, firm or corporation up to ten times per calendar year. The applicant seeking a temporary license must also obtain a state-issued temporary special event permit.
 - (b) The special event must meet the following criterion prior to the issuance of a license to sell alcoholic beverages:
 - (1) The special event must receive approval from the city police department on crowd control and security measures. The police chief or his designee will determine the amount of officers required at an event.
 - (2) The special event must receive approval from the city's streets and highways department on traffic control measures.
 - (3) A site plan for the event must be approved by the city manager or his designee.
 - (c) The city manager or the police chief or a designee may immediately revoke any temporary license for a special event if it is determined continued alcohol sales may endanger the health, welfare or safety of the public.
 - (d) As a condition on the issuance of temporary special event license, the licensee shall indemnify and hold the city harmless from any and all claims, demands or causes of action which may arise from activities associated with the special event.
 - (e) Vendors shall ensure that any and all alcoholic beverages sold in compliance with this ordinance shall be in plastic cups, plastic bottles, or aluminum cans.
- (Ord. of 3-11-2021 (1))

Editor's note(s) — Ord. of 3-11-2021(1), repealed the former § 4-71.1, and enacted a new § 4-71.1 as set out herein. The former section pertained to special events and derived from Ord. of 6-12-2014(1), § 2.

Sec. 4-71.2. Reserved.

Editor's note(s) — Ord. of 3-11-2021(1), repealed § 4-71.2, which pertained to malt beverage/wine consumption on the premises at special events and derived from Ord. of 10-6-2014(1), § 1.

Sec. 4-72. Compliance inspections; grounds for adverse action; notice; hearing; penalties.

- (a) *Periodic inspection.* Sworn officers of the police department or code enforcement officers of the city shall have the authority to inspect establishments licensed under this chapter during the hours in which the premises are open for business. The inspections shall be made for the purpose of verifying compliance with the requirements of this chapter.
- (b) *Automatic revocation.* Whenever the state shall revoke any permit or license to sell alcoholic beverages, the city license to deal in such products, issued pursuant to this chapter, shall thereupon be automatically revoked without any action by the city being necessary.
- (c) *Investigations.* The mayor and city council shall have the right to make such inquiry or investigation as it may find to be reasonably necessary to determine compliance with this chapter. Such investigation may consist, among other actions, of calling licensees for examination under oath, obtaining evidence under oath from

other persons; the procurement of documents and records including records of the licensee, and inspection and examination of records and documents from whatever source obtainable.

- (d) ~~Grounds for adverse action by mayor and city council.~~ The mayor and city council may find due cause to impose a probationary period on a license; to suspend, revoke or refuse to renew a license; and/or to impose a monetary fine upon the licensee if it finds that the licensee under this chapter or the licensee's agents, employees, or independent contractors, whether compensated or not, commits any of the following violations, each of which shall constitute grounds upon which adverse action may be taken by the mayor and city council against the licensee:
- (1) ~~The selling to or serving of any alcoholic beverage to any person below the age of 21 years.~~
 - (2) ~~The conviction of any felony reasonably related to the ability of the licensee to operate and maintain the premises in a proper manner or of any crime of moral turpitude.~~
 - (3) ~~The performance of any act prohibited by this chapter or the failure to perform any act required by this chapter as well as the violation of any city or state law or regulation governing the manufacture, sale, distribution or transportation of alcoholic beverages.~~
 - (4) ~~Permitting the solicitation of patrons on the licensed premises for prostitution or any other unlawful act where the licensee or the licensee's employee or agent knew or should have known of such conduct.~~
 - (5) ~~The selling or serving of any alcoholic beverage to any person that the licensee or the licensee's employee or agent knew or should have known to be in a state of intoxication.~~
 - (6) ~~The failure to comply with any and all federal, state or municipal tax laws and regulations applicable to the operation of establishments licensed to sell alcoholic beverages.~~
 - (7) ~~The failure to furnish within 30 days of said request any and all data, information and/or records related to the operation of the licensed establishment when such has been requested by the city manager or mayor and city council.~~
 - (8) ~~The failure to maintain any and all of the general qualifications applicable to the initial issuance of a license as set forth in sections 4-56, 4-58, and any other section of chapter 4 in which initial qualifications for issuance are set forth.~~
 - (9) ~~The failure to obtain prior approval of the city to change the licensee's type of license pursuant to this chapter.~~
 - (10) ~~Failure by the licensee to adequately supervise and monitor the conduct of its employees, agents, independent contractors, patrons and others on the licensed premises or on any property owned or leased by the licensee, including but not limited to, parking lots and parking areas, or on any parking lots or areas which may be lawfully used by patrons of a licensed establishment, in order to protect the safety and well-being of the general public and of those utilizing the premises.~~
 - (11) ~~The violation of any local, state or federal law, ordinance or regulation governing the operation of establishments licensed to sell alcoholic beverages or which are reasonably related to the operation of such establishments.~~
 - (12) ~~Permitting the sale of illegal drugs on the licensed premises where the licensee or the licensee's employee or agent knew or should have known of such conduct.~~
 - (13) ~~Making any false statement of a material fact on the application for license or renewal thereof, or on any document required to be filed with the mayor and city council.~~
 - (14) ~~Failing to give timely notice of any change of ownership interest as required by this chapter.~~
 - (15) ~~The operation of the business of the licensee in such a manner as to create a public nuisance, or in a manner contrary to public welfare, safety, health or morals.~~

- ~~(16) Failure to meet any obligations to pay fees, taxes or penalties imposed under the provisions of this chapter or elsewhere in the Code of Ordinances.~~
- ~~(e) Notice and hearing regarding adverse action.~~
 - ~~(1) No license shall be denied, suspended or revoked; nor shall any monetary fine be imposed upon a licensee, without the opportunity for a hearing as provided in this chapter.~~
 - ~~(2) The mayor and city council shall provide written notice to the applicant or licensee of its intent to deny, suspend or revoke the license and/or to impose a monetary fine on a licensee. Such written notification shall be sent by certified mail to the applicant or licensee at the address shown on the application, and the applicant shall be directed to show cause as to why the proposed action should not be taken by the mayor and city council. The notice shall:
 - ~~a. Advise the applicant or licensee of the time and place specified for the hearing, which hearing shall be held not more than 20 business days (if the notice is mailed) or 15 business days (if the notice is hand delivered), but not less than ten business days from the date of the service of the notice (the timing of the hearing can be shortened or extended by mutual agreement between the applicant or licensee and the city).~~
 - ~~b. Shall set forth in reasonable detail the action to be taken, the grounds for such action and the factual basis supporting those grounds; and~~
 - ~~c. Advise the applicant or licensee of the right to present evidence, witnesses and/or arguments and to be represented by counsel at the hearing.~~~~
 - ~~(3) A hearing, which shall be recorded by a court reporter, shall be conducted by the mayor and city council and the findings and final determination of the mayor and city council shall be set forth in writing.~~
 - ~~(4) The mayor and city council may deny applications for transfer of location or transfer of ownership and may revoke, suspend or refuse to renew any license. In lieu of suspension, revocation or the failure to renew, the mayor and city council may impose a fine upon any licensee holding a license to sell alcoholic beverages in an amount not to exceed \$1,000.00 for each violation occurring on the licensee's licensed premises.~~
 - ~~(5) The city manager, or his designee, shall send the written determination of the mayor and city council by certified mail to the applicant or licensee at the address shown on the application within three business days of the date of the action taken by the action by the mayor and city council.~~
- ~~(f) Appeal. The decision of the mayor and city council shall be final unless the decision is appealed by certiorari to the superior court of the county within which lies the premises for which adverse action is being taken, which will be either Walton or Gwinnett County. Such appeal must be filed within 30 business days of the date the applicant or licensee receives the written determination by certified mail.~~
- ~~(g) Criminal prosecution. Any adverse action taken by the mayor and city council with regard to a license issued pursuant to this chapter shall not preclude, and may be in addition to, any criminal prosecution by any proper authority of the city, county, state or federal government.~~
- ~~(h) No application for new license before 24 months after revocation. When a license has been revoked under the provisions of this chapter, no application for a new alcoholic beverage license for the same location will be received for a period of 24 months and no application for a new license from the licensee involved shall be received for a period of 24 months.~~
- ~~(i) Refunds. If a license issued under this chapter is denied, suspended or revoked, the licensee shall not be entitled to a refund of any portion of the application, license or other fees previously remitted.~~

~~(Ord. of 12-13-2012, § 4)~~

~~Secs. 4-73—4-99. Reserved.~~

~~DIVISION 3. OPERATING REGULATIONS~~

~~Sec. 4-100. Business entrance.~~

~~The front entrance of all premises licensed under this article shall be clearly visible from a public street; provided, however, that this restriction shall not apply where the premises are located in a private club, shopping center or multiple-story business building.~~

~~(Ord. of 12-13-2012, § 5)~~

~~Sec. 4-101. Annexed area.~~

~~All retail consumption dealers, retail dealers and wholesale dealers operating lawfully at a location outside the corporate limits of the city and thereafter annexed into the city shall continue operation subject to this article whenever possible.~~

~~(Ord. of 12-13-2012, § 5)~~

~~Sec. 4-102. Sales on certain premises; excepted.~~

~~(a) No retail package dealer license shall be issued to any applicant whose business does not have at least a \$15,000.00 inventory of food, tobacco products, household supplies or periodicals, the values of such items being the same as those indicated in the applicant's annual returns to the county tax commissioner for ad valorem tax purposes. In any event, the values so indicated shall be the cost of such items to the applicant and not the price that the applicant charges in retail stores. However, automotive supplies specifically shall not be considered in determining such inventory.~~

~~(b) This section shall not apply to any retail dealer licensed by the city to sell distilled spirits by the package.~~

~~(Ord. of 12-13-2012, § 5)~~

~~Sec. 4-103. Open containers.~~

~~(a) No bottle or other container of alcoholic beverages shall be opened or consumed by any person on the premises upon which the place of business is conducted and licensed under this article, whether the bottle or other container so opened or consumed was bought or obtained at the place of business or elsewhere, unless the premises is licensed for consumption on the premises under this chapter. This Code section shall not prohibit wine tasting in connection with a valid wine tasting permit under the conditions set forth in section 4-71.~~

~~(b) No establishment licensed under this article to sell alcoholic beverages shall allow a person to leave that premises with alcoholic beverages in an open cup, bottle, can or other open container.~~

~~(c) At no time shall a person be permitted to leave the interior of a restaurant with an alcoholic beverage in an open container unless the customer remains on the premises and the premises is a permitted outdoor dining restaurant.~~

~~(Ord. of 12-13-2012, § 5; Ord. of 9-14-2023, Art. I(Exh. A))~~

Sec. 4-104. Brown bagging.

(a) ~~Definitions.~~ The following words, terms and phrases, when used in this section, shall have the meanings ascribed to them in this subsection, except where the context clearly indicates a different meaning:

~~Brown bagging~~ means the bringing, taking or carrying of any alcoholic beverage into a business licensed to operate within the city but not licensed for the consumption of alcoholic beverages on the premises; provided that bringing an alcoholic beverage into a house, apartment, room or other unit designed for private residential occupancy shall not fall within this definition.

(b) ~~Brown bagging shall include the following prohibited acts:~~

- (1) ~~Any person who brown bags;~~
- (2) ~~Any person participating in consumption of any alcoholic beverage being brown bagged;~~
- (3) ~~Any person who consumes an alcoholic beverage on any premises holding a business license, except for those premises licensed for on-premises consumption of alcoholic beverages or otherwise exempted from the definition of brown bagging by virtue of the private residential character of the occupancy;~~
- (4) ~~Any employee of the business establishment in whose presence brown bagging knowingly or with reckless indifference occurs.~~

(c) ~~Brown bagging is prohibited within the city.~~

(d) ~~The license of any premises upon which brown bagging knowingly or with reckless indifference occurs shall be subject to suspension or revocation of the license by the city. Any conviction or plea of guilty or nolo contendere in the municipal court to a charge of brown bagging shall be admissible in a license suspension or revocation consideration or proceeding.~~

(Ord. of 12-13-2012, § 5)

Sec. 4-105. Business hours—Sales by retail consumption dealers.

(a) ~~With the exception of Sundays, retail consumption dealers may sell, dispense or deliver alcoholic beverages to any customer between the hours of 8:00 a.m. and 2:00 a.m. On Sundays, retail consumption dealers may sell, dispense or deliver alcoholic beverages to any customer between the hours of 12:30 p.m. and 2:00 a.m.~~

(b) ~~It shall be unlawful for retail consumption dealers to fail to remove from their retail service area within normal access to the public any and all cans, bottles, glasses, mugs, pitchers, cups or other containers for alcoholic beverages or to otherwise allow consumption of alcoholic beverages on its premises except during the times set forth in subsection (a) of this section.~~

(Ord. of 12-13-2012, § 5; Ord. of 8-13-2015, § 1)

Sec. 4-106. Same—Sales by wholesale dealers.

~~Wholesale dealers shall engage in their business only from sunrise to sunset.~~

(Ord. of 12-13-2012, § 5)

Sec. 4-107. Same—Sales by retail package dealers.

~~Retail dealers of malt beverages and/or wine by the package shall not engage in the sale of alcoholic beverages except between the hours of 8:00 a.m. and 12:00 midnight on weekdays and Saturdays and between~~

the hours of 12:30 p.m. and 11:30 p.m. on Sundays. Retail dealers of distilled spirits by the package shall not engage in the sale of alcoholic beverages except between the hours of 8:00 a.m. and 12:00 midnight on weekdays and Saturdays.

(Ord. of 12-13-2012, § 5)

Sec. 4-108. Sales on election days.

It shall be unlawful for any person to sell alcoholic beverages within 250 feet of any polling place or of the outer edge of any building within which such polling place is established on primary or election days. In this section, the term "day" means that period of time beginning with the opening of the polls and ending with the closing of the polls.

(Ord. of 12-13-2012, § 5)

Sec. 4-109. Change of time affecting closing hours.

On those days when the time changes, a licensee shall determine closing hour at the end of the business day by the same time on which he opened that regular business day. The closing hour for the sale and purchase of spirituous liquors, malt beverages or wine under this section shall be determined as follows:

- (1) On the day when the time changes from Eastern Standard Time to Daylight Saving Time, the closing hour shall be determined by Eastern Standard Time.
- (2) On the day when the time changes from Daylight Saving Time to Eastern Standard Time, the closing hour shall be determined by Daylight Saving Time.

(Ord. of 12-13-2012, § 5)

Sec. 4-110. Vacating premises.

Notwithstanding any other local regulation, whenever a closing time is provided, the premises shall be vacated within 30 minutes by all except personnel of such establishment, and no alcoholic beverages shall be dispensed after such closing time.

(Ord. of 12-13-2012, § 5)

State law reference(s)—Days and hours of sale, O.C.G.A. § 3-3-20.

Sec. 4-111. Delivery of alcoholic beverages.

No deliveries of alcoholic beverages shall be made except on the premises in which such beverages are sold.

(Ord. of 12-13-2012, § 5)

Sec. 4-112. Condition of premises.

All premises operating with a license under this article shall be kept clean and in proper sanitary condition and in full compliance with the provisions and regulations governing the conditions of premises used for storage and sale of food for human consumption.

(Ord. of 12-13-2012, § 5)

~~Sec. 4-113. Slot machines, etc., prohibited on premises.~~

No licensee shall permit on his premises any slot machines, pinball machines or electronic games of any kind or character or any coin-operated machines operated for gambling purposes.

(Ord. of 12-13-2012, § 5)

~~Sec. 4-114. Disturbances, obscenity, public indecency prohibited.~~

It shall be unlawful to permit any disturbance of the peace, obscenity, or public indecency on the premises of any establishment licensed under this article.

(Ord. of 12-13-2012, § 5)

~~Sec. 4-115. Leaving premises without paying.~~

No person shall leave the premises of the licensee without paying his charges for the sale of alcoholic beverages.

(Ord. of 12-13-2012, § 5)

~~Sec. 4-116. Interior visibility.~~

No screen, blind, curtain, partition, article or thing which shall prevent a clear view into the interior shall be permitted in the window or upon the doors of any retail dealer's store, and no booth, screen, partition or other obstruction shall be permitted within the interior of any such store. Each such retail store shall be so lighted that the interior of the store is visible day and night.

(Ord. of 12-13-2012, § 5)

~~Sec. 4-117. Display of city license number.~~

Each retail dealer licensed under this article to sell shall have printed on the front window of the licensed premises the inscription "City Retail License No. _____" in uniform letters not less than four inches in height; however, if a licensee so desires he may have his name displayed on the inside of the window in like manner or in neon or other electric lights. Such sign shall be parallel with the window and so constructed as not to extend more than six inches from the window.

(Ord. of 12-13-2012, § 5)

~~Sec. 4-118. Posting signs—Concerning age restrictions.~~

The retail licensee shall post in a conspicuous place where the actual transaction takes place within the licensed premises a sign stating that no alcoholic beverages or spirituous liquors shall be sold to or purchased by any person under 21 years of age and that it shall be unlawful for any person under the age of 21 to falsely misrepresent his age in any manner whatsoever to a licensee. Such sign shall be printed in uniform letters not less than one inch in height.

(Ord. of 12-13-2012, § 5)

State law reference(s)—Signs relative to underage persons, O.C.G.A. § 3-3-24.2.

Sec. 4-119. Same—Prohibiting on-premises consumption.

The retail package dealer licensee shall display at any entrances or exits to the licensed premises a sign which shall state that it is unlawful to consume any alcoholic beverages (except at a permitted wine tasting) or to open any container of alcoholic beverages on the licensed premises or any parking area adjacent thereto. Further, such signs which are necessary shall also be placed in such a manner as to be visible from any parking area adjacent to the licensed premises.

(Ord. of 12-13-2012, § 5)

Sec. 4-120. Condition of signs.

All signs required by this division shall be clearly visible and lettering shall be dark and unfaded.

(Ord. of 12-13-2012, § 5)

Sec. 4-121. Prices.

- (a) Each retail package dealer shall have conspicuously displayed within the interior of the licensed premises not less than four copies of a printed price list of the alcoholic beverages offered for sale and one printed copy of these regulations; provided that a licensee, in lieu of having four copies of a printed price list, may have the price placed on the bottles or on the bottom of the shelf where the alcoholic beverages are exhibited for sale.
- (b) All retail consumption dealers hereunder, except bona fide private clubs, shall display in prominent places their current prices of alcoholic beverages and admission and cover charges.
- (c) Licensees shall file a copy of their price lists with the city clerk and shall furnish to any customer that so desires an itemized bill of charges which shall not exceed the price list furnished to the police department. Upon any increase or decrease of prices, a new list must be filed with the city clerk.

(Ord. of 12-13-2012, § 5)

Sec. 4-122. Broken seals.

- (a) It shall be unlawful for any person, except a licensee, his manager or agent in charge of licensed premises, to carry into or have in his possession on any premises any alcoholic beverages in the original package, the seal of which has been broken or the original package opened.
- (b) Notwithstanding any other contrary provisions, any restaurant which is licensed to sell alcoholic beverages for consumption on the premises may permit a patron to remove one unsealed bottle of wine per patron for consumption off premises, if the patron has purchased a meal and consumed a portion of the bottle of wine which has been purchased on the premises with such meal on the restaurant's premises. A partially consumed bottle of wine that is to be removed from the premises must be securely resealed by the licensee or its employees before removal from the premises. The partially consumed bottle of wine shall be placed in a bag or other container that is secured in such a manner that it is visibly apparent if the container has been subsequently opened or tampered with, and a dated receipt for the bottle of wine and meal shall be provided by the licensee and attached to the container. If transported in a motor vehicle, the container with the resealed bottle of wine shall be placed in a locked glove compartment, a locked trunk, or the area behind the last upright seat of a motor vehicle that is not equipped with a trunk.

(Ord. of 12-13-2012, § 5)

State law reference(s)—Breaking of packages of alcohol on premises, O.C.G.A. § 3-3-26; removal of partially consumed bottle of wine from premises, O.C.G.A. § 3-6-4.

Sec. 4-123. Sales outside premises in permit.

It shall be unlawful for any sales to be made outside of the place of business licensed for such sale except as permitted in this article.

(Ord. of 12-13-2012, § 5)

Sec. 4-124. Reuse of bottles.

It shall be illegal for the licensee under this article to add to the contents of a bottle or to refill empty bottles or in any other manner to misrepresent the quantity, quality or brand name of any alcoholic beverage.

(Ord. of 12-13-2012, § 5)

Sec. 4-125. Copy of regulations.

It shall be the duty of the management of the premises licensed under this article to maintain a copy of these regulations on such premises and to instruct each and every employee of the terms thereof.

(Ord. of 12-13-2012, § 5)

Sec. 4-126. Verification of age.

(a) It shall unlawful for any agent, officer or employee of a licensee to fail to properly check the identification of any patron when selling or otherwise providing any alcoholic beverage, which failure results in an underage person being sold or served, or to have in his possession while on the licensee's premises, any alcoholic beverage.

(b) For the purposes of this section, the term "identification" means any document issued by any governmental agency containing a description of the person so identified, such person's photograph and such person's date of birth. As used herein, the term "identification" includes without being limited to, a passport, a military identification card, a driver's license, or a state department of public safety identification card.

(c) Notwithstanding any criminal prosecution which may result from a violation of this section, any licensee employing any officer, agent or employee that fails to comply with the provisions of subsection (a) of this section, which failure results in an underage person being sold or served, or to have in his possession while on the licensee's premises an alcoholic beverage, may have his license revoked.

(Ord. of 12-13-2012, § 5)

State law reference(s)—Verification of age, O.C.G.A. § 3-3-23.

Sec. 4-127. Alcoholic beverages prohibited in billiard and pool rooms.

It shall be unlawful for any person who holds a license for the sale of alcoholic beverages to keep, operate or maintain billiard tables, pool tables or any other table of like character on such licensed premises, except under the following circumstances:

- (1) For retail consumption dealers, the licensee derives at least 75 percent of its revenue from the sale of products or services other than alcoholic beverages; or

~~(2) For retail package dealers, the licensee derives at least 50 percent of its total annual gross revenues from the sale of products or services other than alcoholic beverages.~~

~~(Ord. of 12-13-2012, § 5)~~

~~Sec. 4-128. Sale or dispensing from drive-through windows prohibited; penalties.~~

~~(a) It shall be unlawful for retail dealers to sell, dispense or deliver alcoholic beverages to any customer unless such sale, dispensing or delivery shall occur completely within the structured interior walls of the retail dealer's business.~~

~~(b) No sale, dispensing or delivery of alcoholic beverages shall occur through any drive-through window or other opening in the structural walls of the business.~~

~~(Ord. of 12-13-2012, § 5)~~

~~Sec. 4-129. Fire regulations.~~

~~Where a minimum sleeping or seating capacity is prescribed, the same shall be judged by reasonable standards. The fire department shall, upon the request of the city clerk, inspect such premises and report its findings. All premises licensed under this article shall conform at all times with the fire regulations established by the city.~~

~~(Ord. of 12-13-2012, § 5)~~

~~Sec. 4-130. Drinks to be served only by employees.~~

~~Drinks sold by licensees under this article shall be served only by employees of the licensee.~~

~~(Ord. of 12-13-2012, § 5)~~

~~Sec. 4-131. Service in back rooms prohibited.~~

~~The sale of alcoholic beverages for consumption by persons in any back room or side room which is not normally open to the general public use is prohibited, except that private parties or conventions which have been scheduled in advance may be served in public or private dining rooms or meeting rooms.~~

~~(Ord. of 12-13-2012, § 5)~~

~~Sec. 4-132. Live nudity and sexually explicit conduct prohibited.~~

~~(a) Definitions. The following words, terms and phrases, when used in this section, shall have the meanings ascribed to them in this subsection, except where the context clearly indicates a different meaning:~~

~~*Alcohol beverage establishment* means any licensee holding a license under this article for the sale of alcoholic beverages for consumption on the premises.~~

~~*Substantially nude* means dressed or undressed in a manner so as to plainly expose to view any portion of a male's or female's pubic hair, anus, cleft of the buttocks, vulva, or genitals, or any portion of the female breasts below the top of the areola.~~

~~(b) Prohibited acts enumerated.~~

~~(1) No person shall appear substantially nude in any establishment holding a license to sell alcohol.~~

- ~~(2) No owner or manager of an alcoholic beverage establishment shall permit any person to appear substantially nude on the licensed premises.~~
- ~~(3) No owner or manager of an alcoholic beverage establishment shall permit any person to perform live acts of or live acts which constitute or simulate:
 - ~~a. Actual or simulated sexual intercourse, oral copulation, anal intercourse, oral anal copulation, bestiality, direct physical stimulation of unclothed genitals, flagellation or torture in the context of a sexual relationship and any of the following sexually oriented acts or conduct: anilingus, buggery, coprophagy, coprophilia, cunnilingus, fellatio, necrophilia, pederasty, pedophilia, piquerism, sapphism, zoerasty or any sexual acts which are prohibited by law.~~
 - ~~b. The touching, caressing, or fondling of the breast, buttocks, anus, or genitals; provided that random acts of patrons or employees, whose actions do not constitute actions taken pursuant to encouragement or acquiescence of the management of the establishment and are not for the purposes of entertainment, promotion, publicity, or notoriety, shall not constitute violations of this section.~~
 - ~~c. The holding, promotion, sponsoring or allowing of any contests, promotion, special night, event, or any other activity, where patrons of a licensed establishment are encouraged or allowed to engage in any of the conduct described in subsections (b)(3)a and b of this section; provided, however, that nothing contained in this section shall apply to the premises of any mainstream performance house, museum, or theater which derives less than 20 percent of its gross annual income from the sale of alcoholic beverages.~~~~
- ~~(c) Acts prohibited. No person shall engage in any of the acts identified in subsection (b)(3) of this section on the premises of an alcoholic beverage establishment.~~
- ~~(d) Application of restrictions. The restrictions of subsections (b) and (c) of this section shall apply to all persons physically present and only physically present on the licensed premises regardless of whether such persons are categorized as employees, patrons, independent contractors or otherwise.~~
- ~~(e) Suspension or revocation of business license. In addition to prosecution of any person for violation of this section, the license of any premises upon which a violation of this section occurs shall be subject to suspension or revocation action, which shall follow the procedures outlined in this article. Any conviction or plea of guilty or nolo contendere in the municipal court to a charge of violation of this section shall be admissible in a license suspension or revocation proceeding.~~

~~(Ord. of 12-13-2012, § 5)~~

Sec. 4-133. Pricing.

- ~~(a) Each licensee shall maintain a schedule of the prices charged for all alcoholic beverages to be served and consumed on the licensed premises or in any room or part thereof. The licensee shall not vary the schedule of prices from day to day or from hour to hour within a single day. The schedule of prices shall be posted in a conspicuous manner so as to be in view of the paying public, and such schedule shall be effective for not less than one calendar week.~~
- ~~(b) Except as authorized by a valid wine tasting permit addressed in section 4-71, no licensee or employee or agent of a licensee shall:
 - ~~(1) Offer or deliver any free alcoholic beverage to any person or group of persons;~~
 - ~~(2) Deliver more than two alcoholic beverages to one person at one time;~~
 - ~~(3) Sell, offer to sell, or deliver to any person or group of persons any alcoholic beverage at a price less than the price regularly charged for such alcoholic beverage during the same calendar week, except at private functions not opened to the public;~~~~

- (4) ~~Sell, offer to sell, or deliver to any person or group of persons an unlimited number of alcoholic beverages during any set period of time for a fixed price, except at private functions not opened to the public;~~
 - (5) ~~Sell, offer to sell, or deliver alcoholic beverages to any person or group of persons at any one day at prices less than those charged the general public on that day, except at private functions not opened to the public;~~
 - (6) ~~Sell, offer to sell, or deliver alcoholic beverages, including malt beverages, by the pitcher, except to two or more persons at any one time;~~
 - (7) ~~Increase the volume of alcohol contained in a drink without increasing proportionately the price regularly charged for such alcoholic beverage during the same calendar week;~~
 - (8) ~~Encourage or permit on the licensed premises any game or contest which involves the drinking of alcoholic beverages or the awarding of alcoholic beverages as a prize.~~
 - (c) ~~No licensee shall advertise or promote in any way, whether within or without the licensed premises, any of the practices prohibited under subsection (b) of this section.~~
 - (d) ~~No provision of this section shall be construed to prohibit licensees from offering free food or entertainment at any time, provided all patrons are allowed equal access to such free food, or to prohibit the sale or delivery of wine by the bottle or carafe when sold with meals or to more than one person. Otherwise no food and alcoholic beverage package may be offered by any licensee.~~
- (Ord. of 12-13-2012, § 5)

Sec. 4-134. Security cameras required for certain establishments selling alcoholic beverages.

- (a) ~~Any licensee who sells any alcoholic beverage packages to go, is hereby required to install a continuous video recording system dedicated to each register area with camera and lens of a type, number and location approved by the chief of police department. Such cameras must be capable of producing a retrievable and identifiable image on file or tape that can be made a permanent record and that can be enlarged through projection or other means.~~
- (b) ~~Cameras meeting the requirements of this section shall be maintained in proper working order at all times and shall be in operation at all hours in which such establishment is open for business. The camera shall be subject to periodic inspection by city personnel. In the event the camera becomes inoperable, the licensee must have the camera repaired or have availability of a backup camera system within a ten-day period of time. In addition, in the event the camera becomes inoperable, the licensee must immediately notify the city clerk or his designee. If a crime occurs or an employee believes a crime has occurred, the police department shall be contacted immediately and the film retrieved by a designated police officer.~~
- (c) ~~Violation of any provision under this section shall constitute an offense hereunder and shall be punishable as follows:
 - (1) ~~On a first offense there shall be a minimum fine of \$250.00. In addition to said fine, the judge of the municipal court may impose, at his discretion, a suspension of all city alcoholic beverage licenses at the establishment for a period of time not to exceed 30 days.~~
 - (2) ~~On the second offense, if within 12 months of the first, there shall be a fine of \$1,000.00. In addition to said fine, the judge of the municipal court may impose, at his discretion, a suspension of all alcoholic beverage licenses at the establishment for a minimum of 60 days.~~
 - (3) ~~Any further offenses shall subject the licensee to automatic revocation of the alcohol license.~~~~

(Ord. of 12-13-2012, § 5)

~~Secs. 4-135—4-160. Reserved.~~

Chapter 4 ALCOHOLIC BEVERAGES
ARTICLE I. IN GENERAL¹

Sec. 4-1. Definitions.

The following words, terms and phrases, when used in this chapter, shall have the meanings ascribed to them in this section, except where the context clearly indicates a different meaning:

Alcohol means ethyl alcohol, hydrated oxide of ethyl, or spirits of wine, from whatever source or by whatever process produced.

Alcoholic beverage means and includes all alcohol, distilled spirits, beer, malt beverage, wine or fortified wine as defined in this section.

Application means a form supplied by the city for the purpose of applying for any license authorized by this chapter.

Beer or malt beverage means any alcoholic beverage obtained by the fermentation of any infusion or decoction of barley, malt, hops, or any other product, or any combination of such products in water containing not more than 14 percent alcohol by volume, and including ale, porter, brown, stout, lager, beer, small beer and strong beer. The term "malt beverage" does not include sake, known as Japanese rice wine.

Brewery means a large or industrial scale manufacturer of alcoholic malt beverages for the purpose of wholesale distribution. Such use must be connected to public water and sewer.

Brewpub means any restaurant in which malt beverages are manufactured, subject to the barrel production limitation prescribed in O.C.G.A. § 3-5-36. Barrels of malt beverages sold to licensed wholesale dealers for distribution or to the public for consumption off the premises as authorized by State law shall not be used when determining the total annual gross food and beverage sales as required under this chapter.

Church means a permanent building where persons regularly assemble for religious worship.

Distilled spirits or spirituous liquor means any alcoholic beverage obtained by distillation or containing more than 21 percent alcohol by volume, including but not limited to, all fortified wines.

Distiller means a manufacturer of distilled spirits.

Distillery means a large or industrial scale manufacturer of alcoholic distilled spirits for the purpose of wholesale distribution. Such use must be connected to public water and sewer.

Eating establishment means any public place, including a place available for rental by the public, selling prepared food for consumption by the public on the premises with a full service kitchen. A full service kitchen will consist of a three-compartment pot sink, a stove or grill permanently installed, and refrigerator, all of which must be approved by the health and fire departments. An eating establishment will regularly serve food every hour they are open and selling any alcoholic beverages.

Fortified wine means any alcoholic beverage containing more than 24 percent alcohol by volume made from fruits, berries, or grapes, either by natural fermentation or by natural fermentation with brandy added. Fortified wine includes, but is not limited to, brandy.

Governing authority means the mayor and council of the City of Loganville.

Growler means a reusable, resealable, and professionally sanitized jug used to transport malt beverages or wine for off-premises consumption that is not to exceed 64 ounces and is filled with malt beverages or wine from a

¹ State law reference(s)—Georgia Alcoholic Beverage Code, O.C.G.A. § 3-1-1 et seq.; public drunkenness, O.C.G.A. § 16-11-41; furnishing alcoholic beverages to persons under 21 years of age, jurisdiction of municipal courts, O.C.G.A. § 36-32-10; driving under the influence of alcohol or drugs, O.C.G.A. § 40-6-391.

keg by a licensee, or an employee of a licensee, with a malt beverage and/or wine license for consumption off premises issued by the City of Loganville.

Hotel means any facility, or any portion of a facility, where a room, rooms or lodgings are furnished for value to any person, persons or legal entity, including a hotel, motel, inn, bed and breakfast, lodge, or any other place in which rooms, lodgings or accommodations are regularly furnished for value. For the purposes of this article, such hotel shall maintain a minimum of four separate and distinct rooms available for hire. Motels and bed and breakfast establishments meeting the qualifications set out in this definition for hotels shall be classified in the same category as hotels.

Indoor commercial recreational establishment means and is limited to an establishment which:

- (1) Regularly serves prepared food, with a full service kitchen (a full service kitchen will consist of a three-compartment pot sink, a stove or grill permanently installed, and a refrigerator, all of which must be approved by the health and fire departments), prepared to serve food every hour they are open and deriving at least 70 percent of its total annual gross sales from the sale of prepared meals or foods and recreation activities; and*
- (2) Wherein the sale of food and alcoholic beverages is incidental to its primary enterprise and activity on the premises.*

The primary activity on the premises of the indoor commercial recreational establishment shall be family-oriented in nature, generally meaning a use which attracts a range of individuals from all age groups. Uses may specifically include, but are not limited to, dinner theatres, bowling centers, and other similar uses. Outdoor commercial recreation is not included, nor shall concession sales of alcoholic beverages be permitted. Bingo parlors, dance halls, nightclubs, taverns, billiard parlors, video arcades, skating arenas, adult entertainment and/or sexually related entertainment activities, and similar uses are specifically excluded from this definition of indoor commercial recreational establishments.

Indoor publicly owned civic and cultural center means and is limited to publicly owned establishments in which:

The sale of food and alcoholic beverages are incidental to its primary enterprise and activity on the premises. Indoor publicly owned civic and cultural centers may include any publicly owned building or facility where events or functions are held for the purpose of recognizing and advancing the civic, cultural, artistic and entertainment interests of the City of Loganville.

License means an authorization granted by the city to operate as a retail consumption dealer, retail package dealer, or wholesale dealer or manufacturer as outlined under this chapter.

Licensee means the individual to whom a license is issued or, in the case of a partnership, corporation or limited liability company, all partners, officers, and directors of the partnership, corporation or limited liability company.

Liter means a metric measurement currently used by the United States.

Loganville Mainstreet District means that certain property depicted in Chapter 119 – Zoning, Section 250(b) of this Code.

Manufacturer means any maker, producer, or bottler of an alcoholic beverage. The term "manufacturer" also means in the case of distilled spirits, any person engaged in distilling, rectifying, or blending any distilled spirits; in the case of malt beverage, any brewer.

Microbrewery means an establishment in which not more than fifteen thousand (15,000) barrels of beer or malt beverages are manufactured or brewed on the licensed premises in a calendar year and in which such manufactured or brewed beer or malt beverages may be sold for consumption on the premises and consumption off premises, subject to the limitations prescribed in O.C.G.A. § 3-5-24.1. As used in this definition, the term "barrel" shall be defined as set forth in O.C.G.A. § 3-5-1.

Microdistillery means an establishment in which not more than 10,000 barrels of distilled spirits are manufactured on the licensed premises in a calendar year and in which such manufactured distilled spirits may be sold for consumption on the premises and consumption off premises, subject to the limitations prescribed in O.C.G.A. § 3-4-24.2. As used in this definition, the term "barrel" shall be defined as set forth in O.C.G.A. § 3-4-1.

Package means a bottle, can, keg, barrel, or other original consumer container. Retail package alcoholic beverages shall include all alcoholic beverages in their original container, sold at retail to the final consumer, and not for resale.

Person means any individual, firm, partnership, cooperative, nonprofit membership corporation, joint venture, association, company, corporation, agency, syndicate, estate, trust, business trust, receiver, fiduciary, limited liability company or other group or combination acting as a unit, body politic, or political subdivision, whether public, private, or quasipublic.

Retail consumption dealer means any person who sells alcoholic beverages for consumption on the premises, at retail, only to consumers and not for resale.

Retail package dealer means any person who sells unbroken packages, at retail, only to consumers and not for resale.

Special events facility means a facility that meets all of the following criteria:

- (1) Is regularly available for use to public or private groups or persons for a fee;*
- (2) Regularly is rented for a fee for special occasions such as weddings, meetings, banquets, catered events, parties or similar gatherings;*
- (3) Is located within the boundaries of the Main Street District of the City of Loganville;*
- (4) Hosts a minimum of 18 events for a fee per calendar year;*
- (5) Consists of a minimum of 1,000 square feet of rentable meeting and/or event space;*
- (6) Has adequate and accessible restroom facilities.*

Wholesaler or wholesale dealer means any person who sells alcoholic beverages to other wholesale dealers, to retail package dealers, or to retail consumption dealers.

Wine means any alcoholic beverage containing not more than 24 percent alcohol made from fruits, berries, or grapes either by natural fermentation or by natural fermentation with brandy added. Wine includes, but is not limited to, all sparkling wines, champagnes, combinations of such beverages, vermouths, special natural wines, rectified wines, and like products. The term "wine" does not include cooking wine mixed with salt or other ingredients so as to render it unfit for human consumption as a beverage. A liquid shall first be deemed to be a wine at the point in the manufacturing process when it conforms to the definition of wine contained in this section.

Wine Shop means a retail establishment that specializes primarily in the sale of wine and wine-related products.

State law reference(s)—Similar provisions, O.C.G.A. § 3-1-2.

Sec. 4-2. Penalties for violation of chapter.

Any person convicted of a violation of this chapter shall be punished as provided in section 1-8 of this Code of Ordinances, or otherwise as may be provided by applicable law.

Sec. 4-2.1. Notice; Department of Revenue.

In the event that any licensee or employee of a licensee becomes subject to disciplinary action from citation or arrest arising from the violation of any state or local law, rule, regulation or ordinance relating to the manufacture, distribution, sale, or possession of alcoholic beverages, the City shall notify the Georgia Department of Revenue of the violation within 45 days of issuance of citation or arrest.

Sec. 4-3. Sale in the city; license a privilege.

- (a) *Alcoholic beverages may be sold in the city only under a license granted by the city manager upon the terms and conditions provided in this chapter.*
- (b) *All licenses in this chapter shall be a mere grant of privilege to carry on the business during the term of the license, subject to all terms and conditions imposed by this chapter and state law.*
- (c) *All licenses pursuant to this chapter shall have printed on the front these words: "This license is a mere privilege subject to be revoked and annulled, and is subject to any further ordinances which may be enacted."*
- (d) *Any holder of a license issued pursuant to this chapter is required to apply for and obtain an alcoholic beverage license from the state before any sales commence. Additionally, city licensees are required to abide by all applicable state regulations and laws.*

State law reference(s)—Permit or license from governing authority required for wholesale or retail sales of alcoholic beverages; due process guidelines; fingerprints, O.C.G.A. § 3-3-2.

Sec. 4-4. Sale or possession for sale without license or beyond boundaries of premises covered by license.

It shall be unlawful for any person, corporation, partnership or other legal entity to sell, or possess for the purpose of sale at any business location any alcoholic beverage where the person does not have a license granted by the city to sell or possess for sale these alcoholic beverages, or to sell or make deliveries beyond the boundaries of the premises covered by the license.

State law reference(s)—Licenses, § 3-3-3; violation of criminal provisions of title, § 3-1-4; dealing in alcoholic beverages declared privilege, § 3-3-1.; jurisdiction of municipal courts, § 36-32-1 et. seq.

Sec. 4-5. Separate application and separate license for each location of sale.

Separate applications must be made for each location and separate licenses must be issued.

Sec. 4-6. Authority of city manager.

- (a) *The city manager or his/her designee shall review all new applications and renewal of applications for an alcoholic beverage license for compliance with this chapter and either approve or deny said application in accordance with this chapter. All applicants shall furnish upon request all data, information and records necessary for a complete investigation.*
- (b) *The city manager or his/her designee shall also have authority to prescribe such forms as it deems necessary for the proper administration of this chapter.*

Sec. 4-6.1. Application forms.

- (a) *All persons desiring to sell alcoholic beverages shall make application on the forms prescribed by the city manager.*

- (b) *The application shall include, but shall not be limited to, the name and address of the applicant; the proposed business to be carried on; if a partnership, the names and residence address of the partners; if a limited liability company, the name and address of the manager(s) and the name of any person or legal entity owning at least 20 percent of the limited liability company; if a corporation, the names of the officers, the name and address of the registered agent for service of process, the name of the manager(s), and the name of all shareholders holding at least 20 percent of any class of corporate stock, or any other entity having a financial interest in each entity which is to own or operate the establishment for which a license is sought. If the manager changes, the applicant must furnish the city manager the name and address of the new manager and other information as requested within ten days of such change.*
- (c) *All applicants shall furnish data, fingerprints, financial responsibility and other records as required by the city manager and to ensure compliance with the provisions of this chapter. Failure to furnish data pursuant to such request shall automatically serve to dismiss the application with prejudice.*
- (d) *All applications shall be sworn to by the applicant before a notary public or other officer empowered by law to administer oaths.*
- (e) *In all instances in which an application is denied under the provisions of this chapter the applicant may not reapply for a license for at least one year from the final date of such denial.*
- (f) *The city manager shall promptly provide written notice to any applicant whose application is denied under the provisions of this chapter. Such written notification shall set forth in reasonable detail the reasons for such denial and shall advise the applicant of the right to appeal under the provisions of this chapter.*

Sec. 4-7. Withdrawal of application.

Any license application made pursuant to this chapter may be withdrawn by the applicant at any time. If the application is withdrawn before the license is issued, any sums deposited as license fees will be refunded. After issuance of the license, no refunds will be made. No refunds shall be made under any circumstances for investigative and administrative expenses required under this chapter.

Sec. 4-8. Licensing qualifications.

- (a) *No license for the sale of alcoholic beverages shall be granted to any person who is not a citizen of the United States or an alien lawfully admitted for permanent residence.*
- (b) *Where the applicant is a partnership, limited liability company or corporation, the provisions of this section shall apply to all its partners, officers, manager(s) and majority stockholders. In the case of a corporation, the license shall be issued jointly to the corporation and the majority stockholder, if an individual. Where the majority stockholder is not an individual, the license shall be issued jointly to the corporation and its agent registered under the provisions of this subsection. In the case of a partnership, the license will be issued to all the partners owning at least 20 percent of the partnership. If no partner owns 20 percent of the partnership, then the general partner, managing partner or the partner with the greatest ownership will be licensed. In the case of a limited liability company, the license will be issued jointly to the limited liability company and manager(s).*
- (c) *No person, firm, limited liability company or corporation shall be granted any alcoholic beverage license unless it shall appear to the satisfaction of the city attorney that such person, manager(s), partners in the firm, or officers and directors of the corporation have not been convicted or pleaded guilty or entered a plea of nolo contendere to and have been released from parole or probation concerning any crime involving moral turpitude, illegal gambling or illegal possession or sale of controlled substances or the illegal possession or sale of alcoholic beverages, including the sale or transfer of alcoholic beverages to minors in a manner contrary to law, keeping a place of prostitution, pandering, pimping, public indecency, prostitution, solicitation of sodomy, or any sexually related crime within a period of ten years immediately prior to the filing of such application. At the time an application is submitted for any alcoholic beverage license, the applicant shall, by a duly sworn affidavit, certify that neither the applicant, nor any of the other owners of the*

establishment, has been convicted or has pleaded guilty or entered a plea of nolo contendere to any crime involving moral turpitude, illegal gambling or illegal possession or sale of controlled substances or the illegal possession or sale of alcoholic beverages, including the sale or transfer of alcoholic beverages to minors in a manner contrary to law, keeping a place of prostitution, pandering, pimping, public indecency, prostitution, solicitation of sodomy, or any sexually related crime within a period of ten years immediately prior to the filing of such application. Should any applicant, partner, shareholder, manager or officer instrumental in the sale or dispensing of any alcoholic beverage, after a license has been granted, be convicted or plead guilty or nolo contendere to a crime involving moral turpitude, illegal gambling or illegal possession or sale of controlled substances or the illegal possession or sale of alcoholic beverages, including the sale or transfer of alcoholic beverages to minors in a manner contrary to law, keeping a place of prostitution, pandering, pimping, public indecency, prostitution, solicitation of sodomy, or any sexually related crime, the license issued hereunder shall be immediately revoked and cancelled.

- (d) No license for the sale of alcoholic beverages shall be granted to any person convicted under any federal, state or local law of any felony, within 15 years prior to the filing of application for such license.*
- (e) No license for the sale of alcoholic beverages shall be granted to any person who has had any license issued under the police powers of the city previously revoked within two years prior to the filing of the application.*
- (f) The city manager may decline to issue a license when any person having any ownership interest in the operation of such place of business or control over such place of business does not meet the same character requirements as set forth in this section for the licensee.*
- (g) All licensed establishments must have and continuously maintain within the city limits of Loganville, a registered agent upon whom any process, notice or demand required or permitted by law or under this chapter to be served upon the licensee or owner may be served. This person must be a resident of the city, or a licensed attorney practicing law that maintains an office in the city. The licensee shall file the name of such agent, along with the written consent of such agent, with the city manager and shall be in such form as he may prescribe.*
- (h) All applicants for any alcoholic beverage license must be of good character, and all operators, managers, clerks, or other employees shall be of like character. Corporate or firm applicants shall be of good business reputation.*
- (i) A license application may be denied to any applicant for any alcoholic beverage license where it appears that the applicant would not have adequate financial participation in the proposed business to direct and manage its affairs, or where it appears that the application is intended to be a mere surrogate for a person or persons who would not otherwise qualify for a license for any reason whatsoever.*
- (j) The city manager in his discretion may consider any extenuating circumstances which may reflect favorably or unfavorably on the applicant, application or the proposed location of the business. If in its judgment, circumstances are such that the granting of the license would not be in the best interests of the city or general public, such circumstances may be grounds for denying the application.*
- (k) The city manager shall have the right to examine, or cause to be examined, under oath, any applicant for a local license or for a renewal thereof, or any licensee upon whom notice of revocation or suspension has been served as provided by statute, and to examine or cause to be examined the books and records of any such applicant or licensee; to hear testimony and take proof for his information in the performance of his duties, and for such purpose to issue subpoenas which shall be effective in any part of this state.*

State law reference(s)—Governing authority shall set forth ascertainable standards pertaining to the granting, refusal, suspension or revocation of alcoholic beverage permits or licenses, O.C.G.A. § 3-3-2.

Sec. 4-8.1. Licenses required.

- (a) No malt beverage, wines, spirituous liquors or any other alcoholic beverage shall be stored for sale, delivered, sold or manufactured in the city except under a license issued pursuant to this Chapter and then only for the specific beverage and manner of sale provided in the license.*

- (b) *The requirements of this article shall be in addition to any other requirements for business licenses under this Code, and if other provisions of this Code conflict with this Chapter then this Chapter shall control.*
- (c) *Any annual license fee issued under this Chapter shall not be pro-rated and shall not be refundable except as otherwise set forth in this chapter.*

Sec. 4-9. Distance requirements; Election Days.

(a)(1) *No person knowingly and intentionally may sell or offer to sell by the package:*

- (A) *Any distilled spirits in or within 100 yards of any church building or within 200 yards of any school building, educational building, school grounds, or college campus;*
- (B) *Any wine or malt beverages within 100 yards of any school building, school grounds, or college campus. Nothing in this subparagraph shall prohibit a grocery store licensed for the retail sale of only wine and malt beverages for consumption off the premises from selling wine or malt beverages within 100 yards of any school building, or college campus, where so permitted by resolution or ordinance of the City; or*
- (C) *Any distilled spirits, wine, or malt beverages within 100 yards of an alcoholic treatment center owned and operated by the State of Georgia or the City of Loganville.*

(2) *As used in this subsection, the term "school building" or "educational building" shall apply only to state, county, city, or church school buildings and to such buildings at such other schools in which are taught subjects commonly taught in the common schools and colleges of this state and which are public schools or private schools as defined in subsection (b) of Code Section 20-2-690.*

(b) *Nothing contained in this Code section shall prohibit the licensing of the sale or distribution of alcoholic beverages by:*

- (1) *Hotels of 50 rooms or more which have been in continuous operation for a period of at least five years preceding July 1, 1981;*
- (2) *Bona fide private clubs, owning their own buildings, subject to licensing under this Chapter;*
- (3) *Licensees for the retail sale of alcoholic beverages for consumption on the premises only;*

(c) *For purposes of this section, distance shall be measured by the most direct route of travel on the ground and shall be measured in the following manner:*

- (1) *From the main physical entrance (i.e. the front door) of the establishment from which alcoholic beverages are sold or offered for sale;*
- (2) *In a straight line, regardless of obstructions, to the nearest public sidewalk, walkway, street, road or highway by the nearest route;*
- (3) *Along such public sidewalk, walkway, street, road or highway by the nearest route;*
- (4) *To the main physical entrance (i.e. the front door) of the church building, school building or college campus.*

(d) *No location which is licensed to sell alcoholic beverages on the effective date of the ordinance from which this section is derived shall be denied continued operation under an existing license, or denied any renewal of such license, nor shall any new owner of the location be denied a new license based upon the measurements set forth in this section.*

(e) *As to any location licensed in the future, if the distance requirements in this section are met at the time of issuance of any license, the subsequent opening and operation of a church or school within the distance prohibited herein shall not prevent the continuance of an existing license or the renewal thereof or the issuance of a new license to any subsequent owner of such property; provided, however, that the distance requirements herein shall not apply at any location for which a new license is applied for if the sale of*

alcoholic beverages was lawful at such location at any time during the six months immediately preceding such application.

- (f) *It shall be unlawful for any person to sell alcoholic beverages within 250 feet of any polling place or of the outer edge of any building within which such polling place is established on primary or election days. In this section, the term "day" means that period of time beginning with the opening of the polls and ending with the closing of the polls.*

State law reference— Sale of alcoholic beverages on Sundays and election days prohibited; exceptions, O.C.G.A. § 3-3-20; Sales of alcoholic beverages near church, school, or housing authority property; prohibitions, O.C.G.A. § 3-3-21.

Sec. 4-10. License fee scale.

Before a license shall be granted, the applicant therefor shall comply with all rules and regulations adopted by the mayor and city council regulating the sale of alcoholic beverages and each applicant shall pay a license fee in accordance with the scale fixed, from time to time, by the mayor and city council contained in section 4-11 and kept on file with the city manager.

Sec. 4-11. Fees enumerated.

License fees applicable to this chapter shall be as follows:

- (1) *Retail dealers of distilled spirits to be consumed on the premises, \$3,500.00 per year.*
- (2) *Retail dealers of beer and wine to be consumed on the premises, \$1,000.00 per year.*
- (3) *Retail dealers of beer and wine sold in original packages for consumption off the premises, \$1,000.00 per year.*
- (4) *Retail Package Dealer of beer, wine, and distilled spirits for consumption off the premises, \$4,500.00 per year.*
- (5) *Wholesale dealers in beer and wine, whose principal place of business is in the city, \$1,000.00 per year.*
- (6) *Wholesale dealers in distilled spirits whose principal place of business is in the city, \$3,500.00 per year.*
- (7) *Wholesale dealers in alcoholic beverages whose principal place of business is not in the city, \$100.00 per year.*
- (8) *Temporary license for nonprofit organizations, \$25.00 per day.*
- (9) *Temporary license for for-profit organizations, \$150.00 per day.*
- (10) *Non profit private club, beer and wine to be consumed on the premises, \$1,000.00 per year.*
- (11) *Non profit private club, distilled spirits to be consumed on the premises, \$3,000.00 per year.*
- (12) *Hotel/motel "in-room service," \$250.00 per year.*
- (13) *Distilleries or micro-distilleries, \$3,000.00 per year.*
- (14) *Breweries or micro-breweries, \$1,000.00 per year.*
- (15) *Brewpubs, \$750.00 per year.*
- (16) *Wine Shops, \$750.00 per year.*
- (17) *Beer and wine amenities license, \$100.00 per year.*
- (18) *Alcoholic beverage caterer beer and wine license, \$1,000.00 per year.*
- (19) *Alcoholic beverage caterer distilled spirits license, \$1,000.00 per year.*

(20) *Special Events Facility, beer and wine to be consumed on the premises, \$1,000.00 per year.*

(21) *Special Events Facility, distilled spirits to be consumed on premises, \$3,000.00 per year.*

Sec. 4-12. Collection of fee or tax sums due.

If any person shall fail to pay any sums due under this chapter, the city manager or designee shall issue an execution against the person so delinquent and his property, for the amount of the delinquent fee or tax.

Sec. 4-13. Transferability of license.

- (a) *No license for the sale of alcoholic beverages shall be transferable, except as otherwise provided in this section.*
- (b) *In case of the death of a licensee, the establishment shall be allowed to continue to sell alcoholic beverages for a period of 45 days from the date of death or until expiration of the license or until approval of a new licensee, whichever shall first occur.*
- (c) *If a license is surrendered or a licensee severs his association with a licensed establishment, the establishment may continue to sell alcoholic beverages for a period of 45 days from the date of surrender, or from the date determined by the city manager to be the date of severance, provided a new application for a license is made within ten days of surrender or severance. Upon issuance of a new license, the authorization to sell under the previous license shall be revoked by operation of law. No additional license fees shall be required during the period for which the original license was issued.*
- (d) *Nothing in this section, however, shall prohibit one or more of the partners of a partnership holding a license to withdraw from the partnership in favor of one or more of the partners who were partners at the time of the issuance of the license. Further, this section shall not prohibit transfer of stock between persons who held stock in the corporation at the time of issuance of the license.*
- (e) *Except as provided in subsections (a) through (d) of this section, any change in the ownership of any entity holding a license hereunder shall cancel and revoke any license pursuant to this chapter automatically, without the necessity of any hearing.*
- (f) *Violation of this section shall result in revocation of the license being used and subject the license holders to penalties as outlined in section 4-2. No license will be issued to the old or the new owner in the city for one year from the date of any such violation.*
- (g) *Should a licensee make application to the city manager for a transfer of location and should such a transfer of a location be approved, with no change of ownership of the business, the license fee paid for the previous license shall be applied to the new location. Each applicant for a transfer of location shall pay a transfer fee in the amount of \$300.00.*

Sec. 4-14. Display of license at place of business.

The city alcoholic beverage license shall at all times be kept plainly exposed to view to the public at the place of the business of the licensee.

Sec. 4-15. Expiration; renewal of license.

- (a) *All licenses granted hereunder shall be for the calendar year and shall expire automatically every December 31 of each calendar year. The full license fee must be paid for a license application filed prior to July 1 of the license year. One-half of a full license fee shall be paid for any license application filed after July 1 of the license year, except for applications for temporary licenses under section 4-11(8) and section 4-11(9), which shall not be reduced.*

- (b) *All renewal applications shall be submitted to the city manager on forms approved by him and shall include the following:*
- i. All standard renewal application and license fees;*
 - ii. An affidavit affirming that all the information contained in the licensee's initial application remains true and correct, or in the alternative provides updated information in compliance with this Chapter.*
 - iii. An updated background check.*
- (c) *An application for a renewal of license shall not be granted to a licensee whose license has expired.*
- (d) *Any licensee desiring to discontinue business at one location and commence business at another location must make a completely new application for the new location.*
- (e) *No refund of renewal fees shall be made once a renewal license is issued.*

Sec. 4-16. Automatic license forfeiture for nonuse.

Any holder of any license hereunder who shall for a period of three consecutive months after the license has been issued cease to operate the business and sale of the product or products authorized shall after the said three-month period automatically forfeit the license without the necessity of any further action.

Sec. 4-17. Suspension or revocation of license.

- (a) *A license may be suspended or revoked by the city manager where the licensee furnishes fraudulent or untruthful information in the application for a license and for failure to pay all fees, taxes or other charges imposed under the provisions of this chapter.*
- (b) *Whenever the state shall revoke any permit or license to sell alcoholic beverages, the city license issued hereunder shall thereupon be automatically revoked. The chief of police, upon notice of this revocation from the city manager, shall take the necessary steps to see that signs are removed and that all alcoholic beverage sales cease.*
- (c) *Any licensed establishment that is found to be in violation of section 4-38 or 4-41 shall be subject to immediate license revocation.*
- (d) *The city manager shall revoke the license of any licensee whose license has been suspended two or more times in any consecutive twelve-month period.*
- (e) *The city manager shall revoke the license for any premises where alcoholic beverages have been sold or distributed during a period of suspension.*
- (f) *The city manager may suspend or revoke the license of any establishment which does not meet the licensing qualifications set forth in this chapter at any time such knowledge becomes known to him.*
- (g) *An act or omission of a licensee, owner of more than 20 percent interest in the licensed establishment, or employee of the licensee or licensed establishment willingly or knowingly performed which constitutes a violation of federal or state law relating to alcoholic beverages or of any provision of this chapter, will subject the licensee to suspension or revocation of its license in accordance with the provisions of this chapter, when the city manager determines to his own satisfaction that the act or omission did occur, regardless of whether any criminal prosecution or conviction ensues; provided, however, in the case of an employee, the city manager must determine that the acts of the employee were known to or under reasonable circumstances should have been known to the licensee, were condoned by the licensee, or where the licensee has not established practices or procedures to prevent the violation from occurring.*
- (h) *Whenever it can be shown that a licensee under this chapter no longer maintains adequate financial responsibility upon which issuance of the license was conditioned, or whenever the licensee has defaulted in any obligation of any kind whatsoever, lawfully owing to the city, the license shall be revoked.*

- (i) *Wherever this chapter permits the city manager to suspend any license issued under this chapter but does not mandate the period of such suspension, such discretion shall be exercised within the guidelines of this subsection.*
- (1) *No suspension shall be for a period of time longer than the time remaining on such license.*
 - (2) *The following factors shall be considered on any revocation or suspension as set out above:*
 - a. *Consistency of penalties mandated by this chapter and those set by the city manager.*
 - b. *Likelihood of deterring future wrongdoing.*
 - c. *Impact of the offense on the community.*
 - d. *Any mitigating circumstances or remedial or corrective steps taken by the licensee.*
 - e. *Any aggravating circumstances or failure by the licensee to take remedial or corrective steps.*
- (j) *In addition to the above, a license may be suspended or revoked by the city manager for good cause. The city manager may consider the public health, public safety, or public well-being of the City's citizens in making his decision to suspend or revoke a license. Said decision shall be subject to appeal rights as outlined herein in Section 4-18.*

Sec. 4-18. Hearings.

- (a) *No license shall be denied, suspended or revoked without the opportunity for a hearing as hereinafter provided.*
- (b) *The city manager shall provide written notice to the applicant or licensee of any decision to deny, suspend or revoke the license. Such written notification shall set forth in reasonable detail the reasons for such action and shall notify the applicant or licensee of the right to appeal under the provisions of this chapter. Any applicant or licensee who is aggrieved or adversely affected by a final action of the city manager may have a review thereof by appeal to the mayor and city council. Such appeal shall be by written petition, filed in the office of the city manager within 15 days after the final order or action of the city manager and, in order to defray administrative costs, must be accompanied by a filing fee of \$50.00. The city manager, at his discretion, may waive or reduce the filing fee amount if it is determined the fee would create a hardship on the individual filing said appeal. The mayor and city council may, at the request of the appellant, refund the filing fee by a majority vote.*
- (c) *The mayor and city council shall determine all issues under this appeal process by a majority vote. Should the mayor and city council be unable to reach a decision by majority vote, the action taken by the city manager shall be upheld automatically.*
- (d) *A hearing shall be conducted on each appeal within 45 days of the date of filing with the city manager unless a continuance of such date is agreed to by the appellant and the city manager. The appellant at such hearing shall have the right to be represented by an attorney, at the expense of the appellant, and to present evidence and cross examine witnesses. Should the appellant desire an official transcript of the appeal proceedings, then such request must be made at least three days prior to such hearing. The appellant shall have the burden of proof on any such appeal. Before hearing an appeal, each member of the city council shall sign an affidavit to be part of the record that he is not related to any owner of the licensed establishment in question in the appeal being considered and that he has no financial interest in the outcome of the appeal. Should any council member be unable to sign such an affidavit, that member shall not serve on that appeal and the case shall be heard by the remaining members of the city council.*
- (e) *The findings of the mayor and city council shall be forwarded to the city manager within 15 days after the conclusion of the hearing, and it shall be the duty of the city manager to notify the appellant of the decision of the mayor and city council.*

- (f) *The findings of the city council shall be final unless appealed within 30 days of the date of said finding by writ of certiorari to the Superior Court of Walton County pursuant to O.C.G.A. § 5-3-1 et seq.*

Sec. 4-19. Notice.

For the purpose of this chapter, notice shall be deemed delivered three days after the date of deposit to the United States Postal Service by certified mail or statutory overnight delivery.

Sec. 4-20. Reserved.

Sec. 4-21. Audits of licensees.

- (a) *If the city manager deems it necessary to conduct an audit of the records and books of the licensee, he shall notify the licensee of the date, time and place of the audit. The city manager may designate the city's internal auditor or other designated person to perform any audit authorized in this chapter. The licensee shall cooperate with the audit or forfeit any license(s) issued under this chapter.*
- (b) *All licensed establishments must maintain the following records for a three-year period and make them available for audit at the licensed premises:*
- (1) *Monthly income or operating statements;*
 - (2) *Daily sales receipts showing liquor, beer, wine and food sales separately (this requirement does not apply to package beer and wine licensees);*
 - (3) *Daily cash register receipts such as Z tapes or guest tickets;*
 - (4) *Monthly state sales and use tax reports;*
 - (5) *Federal income tax returns with all Form 1099s and W-2s.*

Sec. 4-22. Retailer to purchase from licensed wholesaler only.

- (a) *No retailer shall purchase alcoholic beverages from any person other than a wholesaler licensed under this chapter. No wholesaler shall sell any alcoholic beverage to anyone other than a retailer licensed under this chapter; provided, however, that this section shall not prohibit the purchase by one retailer of another retailer's entire stock in a bona fide purchase of an ongoing business.*
- (b) *The city manager or his designee may request, from time to time, information concerning purchases and sales of alcoholic beverages from retailers and wholesalers.*

Sec. 4-23. Retail dealers to store inventory only on premises.

No retail dealer licensed under this chapter shall keep any alcoholic beverages at any place except the licensed place of business. No retail dealer shall be permitted to enter into any type of arrangement whereby alcoholic beverages owned by a licensee are stored by a licensed wholesaler.

Sec. 4-24. Bring your own bottle (brown bagging) prohibited.

Except where allowed in this chapter in regard to corkage services in section 4-109 and special event facilities in article VII, no person shall bring his or her own alcoholic beverage, into any establishment either licensed or unlicensed to serve alcoholic beverages.

Sec. 4-25. Addition to contents of alcoholic beverages prohibited.

No one shall add to or permit the adding to any alcoholic beverage or refill any alcoholic beverage manufacturer's container in any manner.

Sec. 4-26. Poured alcohol to be transported by employees.

Poured alcoholic beverages will be transported from point of dispensing to the customer by appropriate employees only.

Sec. 4-27. Licensees to maintain a copy of this chapter; employees to be familiar with terms; licensee responsible for violations.

Each licensee licensed under this chapter shall keep a copy of this chapter in the licensed premises and shall instruct any person working there with respect to the terms, conditions and requirements of this chapter; and each licensee, the licensee's agents and employees selling alcoholic beverages shall at all times be familiar with the terms of this chapter.

Sec. 4-28. Employment of underage persons prohibited; exceptions.

- (a) No person shall allow or require a person in his employment under 18 years of age to dispense, serve, sell, or take orders for any alcoholic beverage.
- (b) The provisions of this section shall not prohibit persons under 18 years of age who are employed in supermarkets or convenience stores from selling or handling alcoholic beverages which are sold for consumption off the premises.

Sec. 4-29. Failure to require and properly check identification.

It shall be a violation of this chapter not to require and properly check identification to ensure an underage person is not sold, served, or permitted to have in his possession, alcoholic beverages while in a licensed establishment. The term "identification" in this section shall mean any document issued by a governmental agency containing a description of the person, such person's photograph, and giving such person's date of birth and shall include, without being limited to, a passport, military ID card, driver's license or state department of public safety ID card.

Sec. 4-30. Prohibited actions of licensees; penalties.

- (a) No licensee or employee of a licensee under this chapter, shall do any of the following upon the licensed premises:
 - (1) Sell or offer to sell any distilled spirits, wines, malt beverages, or any other alcoholic beverage to any person under the age of 21 years.
 - (2) Sell or offer to sell any alcoholic beverages to any person who is noticeably intoxicated whose intemperate habits are known to the licensee or his employees.
 - (3) Sell alcoholic beverages upon the licensed premises or permit alcoholic beverages to be consumed thereon, on any day or at any time when the sale or consumption is prohibited by law.
- (b) No person who holds a license to sell alcoholic beverages by the drink shall allow any minors to be in, frequent or loiter about the licensed premises of the establishment unless such minors are accompanied by a parent, legal guardian, or custodian; provided, however, that such minors shall be permitted in eating establishments, indoor commercial recreational establishments, or private clubs as defined in this chapter

without being accompanied by a parent, legal guardian, or custodian and provided further that this section shall not apply to minors who are employees under this chapter.

- (c) *Any licensed establishment where two or more violations of this section, or O.C.G.A. § 3-3-23 have occurred within any 24-month period shall be punished as follows:*
- (1) *For the second violation within any 24-month period, suspension of said license(s) for a period not to exceed 90 days.*
 - (2) *For the third and any subsequent violation within any 24-month period, suspension of license(s) for a period not to exceed one year.*

State law reference(s)—Furnishing to, purchase of, or possession by persons under 21 years of age of alcoholic beverages; use of false identification; proper identification for sale of alcoholic beverages; dispensing, serving, etc., of alcoholic beverages by persons under 21 years of age in the course of employment; seller's duty to request proper identification, O.C.G.A. § 3-3-23.

Sec. 4-31. Purchase or possession of alcoholic beverages by underage persons.

Except as otherwise authorized by law:

- (1) *No person under 21 years of age shall purchase, attempt to purchase, or knowingly possess any alcoholic beverage;*
- (2) *No person under 21 years of age shall misrepresent such person's age in any manner whatsoever for the purpose of obtaining illegally any alcoholic beverage;*
- (3) *No person knowingly or intentionally shall act as an agent to purchase or acquire any alcoholic beverage for or on behalf of a person under 21 years of age; and,*
- (4) *No person under 21 years of age shall misrepresent his identity or use any false identification for the purpose of purchasing or obtaining any alcoholic beverage.*

State law reference(s)—Similar provisions, O.C.G.A. § 3-3-23.

Sec. 4-32. Regulations as to employees and managers.

The following regulations shall apply to all establishments holding a license for consumption of alcoholic beverages on the premises:

- (1) *Any licensee for consumption on the premises shall require all persons employed as managers, servers, bartenders, doorpersons, or any other employee, agent or subcontractor with the responsibility for handling, serving, mixing or dispensing alcoholic beverages to obtain a server certification with proper training from a third party vendor approved by the city no later than three days after commencement of his or her employment. The licensee or the employee of the licensee shall pay a fee as provided for by the third party vendor for such server certification.*
- (2) *The City may select one or more designated third party vendors approved for the issuance of server certifications. A list of designated vendors shall be kept by and made available to licensees by the city manager.*
- (3) *Any person who has been convicted of a violation of any law, ordinance or regulation governing the sale of alcoholic beverages, a violent crime or possession of illegal drugs in the three years immediately preceding the date of the certification shall not be eligible to receive a server certification.*
- (4) *Only those persons maintaining a valid server certification required herein shall be permitted by a licensee to dispense, pour, mix or otherwise handle any alcoholic beverage on behalf of said licensee. Licensees found to be in violation of this section shall be subject to penalties as set forth in section 4-2.*

- (5) *All licensees shall maintain on the licensed premises a written log of all employees, a copy of a government issued photo identification of each employee and proof of the server certification required for each employee. Upon the request of a City of Loganville police officer, the city marshal or city manager, the licensee or manager on duty must present a manifest indicating employees on duty required to hold such certification. Such records and manifests may also be kept by a third party vendor who shall provide access to the server certifications to the city upon request.*
- (6) *All persons required to maintain server certification under this section shall keep proof of the same on their person at all times while working in any licensed establishment and shall display the same upon the request of any police officer or code enforcement official of the city.*
- (7) *Any person required to maintain server certification under this section who is cited for a violation of this chapter or any state law governing dispensing of alcohol and who either enters a plea of guilty or nolo contendere or is convicted of such violation shall no longer be eligible for server certification for a period of three years from the date of said plea or conviction.*

Sec. 4-33. Open area and patio sales.

- (a) *Alcoholic beverage sales can be made by a licensed on-premises consumption establishment in a patio/open area type environment if the establishment has been approved to do so by the city manager.*
- (b) *The patio/open area shall be enclosed by some structure or stanchions providing for public ingress/egress only through the main licensed premises. The purpose of this requirement is to prevent a customer from leaving the outside sales area with an open drink without the licensee's knowledge.*
- (c) *The height of such structure shall be a minimum of three feet above ground level. It does not have to be solid nor does it have to restrict visibility into or out of the patio/open sales area. It must be permitted and approved by the city manager or his designee.*
- (d) *The only exit from this type area is to be through the licensed establishment's main premises and through an approved fire exit, not for general public use unless an emergency exists.*
- (e) *If a licensee desires a patio/open sales area inside an existing structure, plans will be reviewed and approved on an individual basis by the city manager or his designee. Interior type patio/open sales areas must also meet the requirements of the city's development and fire codes.*
- (f) *Nothing contained in this section shall prohibit a hotel or motel with an on the premises consumption license from making sales and allowing consumption of alcoholic beverages in ballrooms, meeting rooms, reception rooms, or patio areas of such hotel or motel, provided such functions are catered in connection with a meeting, conference, convention or similar type gathering at such hotel or motel. "Patio areas," as that term is used in this subsection, do not have to conform to the standards in this section.*

Sec. 4-34. No consumption outside premises.

- (a) *Except as otherwise permitted in this chapter, it is prohibited for customers to leave a licensed premises with open alcoholic beverages, and it is the licensee's responsibility to ensure that no open beverages are sold and carried out. However, nothing in this section shall be construed to prohibit the carrying out of alcoholic beverages for consumption at a publicly owned or privately owned golf course.*
- (b) *Except as otherwise permitted in this chapter, it is prohibited for customers to gather outside an alcoholic beverage establishment and consume alcoholic beverages.*
- (c) *Except as otherwise permitted in this chapter, it is prohibited for the manager or any employee to allow persons to gather outside an alcoholic beverage establishment and consume alcoholic beverages.*
- (d) *Notwithstanding any other contrary provision of law, any eating establishment which is licensed to sell alcoholic beverages for consumption on the premises may permit a patron to remove one unsealed bottle of*

wine per patron for consumption off premises. A partially consumed bottle of wine that is to be removed from the premises must be securely corked and resealed by the licensee or its employees before removal from the premises. The partially consumed bottle of wine shall be placed in a bag or other container that is secured in such a manner that it is visibly apparent if the container has been subsequently opened or tampered with, and a dated receipt for the bottle of wine shall be provided by the licensee and attached to the container. If transported in a motor vehicle, the container with the resealed bottle of wine shall be placed in a locked glove compartment, a locked trunk, or the area behind the last upright seat of a motor vehicle that is not equipped with a trunk.

Sec. 4-34.1. Open containers.

- (a) No bottle or other container of alcoholic beverages shall be opened or consumed by any person on the premises upon which the place of business is conducted and licensed under this article, whether the bottle or other container so opened or consumed was bought or obtained at the place of business or elsewhere, unless the premises is licensed for consumption on the premises under this chapter. This Code section shall not prohibit wine tasting in connection with a valid wine tasting permit under the conditions set forth in section 4-112.
- (b) No establishment licensed under this article to sell alcoholic beverages shall allow a person to leave that premises with alcoholic beverages in an open cup, bottle, can or other open container, except as authorized by Section 4-36 of this Chapter.
- (c) At no time shall a person be permitted to leave the interior of a restaurant with an alcoholic beverage in an open container unless the customer remains on the premises and the premises is a permitted outdoor dining restaurant, except as authorized by Section 4-36 of this Chapter.

Sec. 4-35. Specifications of premises.

No alcoholic beverage license shall be issued to any person unless the building in which the business will be located is complete and detailed plans of the building and outside premises are attached to the application, or unless proposed plans and specifications and a building permit of a proposed building to be built are attached to the application. The completed building or the proposed building shall comply with ordinances of the city, regulations of the state revenue commissioner and the state. The proposed building shall also be subject to final inspection and approval when completed by the city manager and the fire department. Each building in which the business will be located shall contain a minimum of 500 lumens per square meter of floor space of interior lighting to be on and operating at all times while alcohol is being served in the premises, and sufficient exterior lighting so that the building itself and the premises on all sides of the building are readily visible at all times from the front of the street on which the building is located so as to reveal all of the outside premises of such building. Each applicant for an alcoholic beverage license shall attach to the application evidence of ownership of the building or proposed building, or a copy of the lease if the applicant is leasing the building. All premises for which an alcoholic beverage license shall be issued shall afford therein adequate sanitary and accessible toilet facilities available for use by the public and shall be adequately illuminated so that all hallways, passage ways and open areas may be clearly seen by the customers therein.

Sec. 4-36. Loganville Mainstreet District.

- (a) The provisions of this section are intended to set forth certain exceptions and provisions applicable only to licensees whose establishments are located within the Loganville Mainstreet District holding licenses to sell alcoholic beverages for consumption on the premises. Except as specifically set forth in this section to the contrary, all such licensees remain subject to all other provisions of this chapter.

- (b) *As used in this chapter, the term "Loganville Mainstreet District" shall be defined as that certain property depicted in Chapter 119 – Zoning, Section 250(b) of this Ordinance.*
- (c) *Outside consumption of alcoholic beverages by the drink shall be permitted within the Loganville Mainstreet District under the following conditions:*
 - (1) *Any licensee who desires to sell alcoholic beverages for outside consumption within the Loganville Mainstreet District must possess an alcoholic beverage license for on premises consumption in good standing with the City of Loganville and the State of Georgia.*
 - (2) *Any establishment licensed to sell alcoholic beverages by the drink for consumption on the premises is authorized to dispense alcoholic beverages in a clear plastic cup with the city's approved logo for such purpose, as approved by the city manager imprinted thereon for consumption outside of the premises. Dispensing beer and/or wine in a can, bottle, or glass container for consumption outside in the designated area(s) is prohibited. Said clear plastic cups shall be purchased from the code enforcement officer or his designee at prices established by the city manager.*
 - (3) *No establishment shall dispense to any person more than one drink at a time for consumption outside of the premises within the Loganville Mainstreet District.*
 - (4) *No container in which an alcoholic beverage is dispensed for consumption in the designated area(s) shall exceed 16 fluid ounces in size.*
 - (5) *No alcoholic beverages shall be sold and/or consumed outside and within the Loganville Mainstreet District except within the authorized hours of sale of the establishment where purchased.*
 - (6) *Food must be served during any period of time that alcoholic beverages are served. A licensed establishment shall always maintain the correct ratio of food to alcoholic beverage sales.*
- (d) *Outside consumption of alcoholic beverages by the drink by residents living in the Loganville Mainstreet District shall be permitted within the Loganville Mainstreet District under the following conditions:*
 - (1) *Residents living in the Loganville Mainstreet District shall be permitted to purchase clear plastic cups with the city's approved logo for such purposes as approved by the city manager imprinted thereon for personal use and outside consumption of alcoholic beverages within the Loganville Mainstreet District.*
 - (2) *Said clear plastic cups shall be purchased at prices established by the city manager.*
 - (3) *No resident shall be in possession of more than one drink contained in an approved clear plastic cup at any given time while partaking in outside consumption in the Loganville Mainstreet District.*
 - (4) *No resident shall be in possession of a drink contained in an approved clear plastic cup outside of the authorized hours of sale under this chapter within the Loganville Mainstreet District.*
 - (5) *All other rules of general applicability of this Section shall apply to residents of the Loganville Mainstreet District using clear plastic cups for personal use.*
- (e) *The following additional regulations shall apply to the Loganville Mainstreet District:*
 - (1) *The possession of any open can, bottle, or glass container of alcoholic beverages for outside consumption within the Loganville Mainstreet District is prohibited.*
 - (2) *The possession of any container of alcoholic beverages for outside consumption within the Loganville Mainstreet District exceeding 16 ounces is prohibited.*
- (f) *Nothing in this section shall relieve licensees from complying with all other provisions of this chapter and state law.*

Sec. 4-37. Eligibility for issuance of a temporary special event license.

- (a) *A temporary license may be issued to any person, firm or corporation, for a period not to exceed three days for any one event for an approved special event. The person, firm or corporation must make application and pay the fee that may be required by this chapter and shall be required to comply with all the general ordinances and regulations for an on-premises consumption establishment with the exception of the full-service kitchen requirement. Said temporary licenses may be applied for and issued to any one person, firm or corporation up to twelve times per calendar year. The applicant seeking a temporary license must also obtain a state-issued temporary special event permit. Applicants seeking a temporary license need not be licensed as an alcoholic beverage caterer pursuant to article XI of this chapter.*
- (b) *The special event must meet the following criterion prior to the issuance of a license to sell alcoholic beverages:*
 - (1) *The special event must receive approval from the city police department on crowd control and security measures.*
 - (2) *The special event must receive approval from the city department of transportation, traffic operations section, on traffic control measures.*
 - (3) *The location at which the special event is to take place must be properly zoned and approved by the city manager.*
 - (4) *The premises at which the special event is to take place must be approved by the city manager.*
- (c) *At least one employee or volunteer of the special event licensee, working the special event in any position dispensing, selling, serving, taking orders or mixing alcoholic beverages shall be required to obtain a server certification pursuant to section 4-32 for the special event.*
- (d) *The city manager or the chief of police or his designee may immediately revoke any temporary license for a special event if it is determined continued alcohol sales may endanger the health, welfare or safety of the public.*
- (e) *As a condition on the issuance of a temporary special event license, the licensee shall indemnify and hold the city harmless from any and all claims, demands or causes of action which may arise from activities associated with the special event.*

Sec. 4-38. Solicitation prohibited.

No retail consumption dealers licensed under this chapter shall require, permit, suffer, encourage, or induce any employee or person to solicit in the licensed premises for himself, or for any person other than the patron and guest of the patron, the purchase by the patron of any drink, whether alcoholic beverage or nonalcoholic beverage or money with which to purchase the beverage; nor shall any licensee pay a commission or any other compensation to any person frequenting his establishment or to his agent or manager to solicit for himself or for others, the purchase by the patron of any drink, whether alcoholic beverage or nonalcoholic beverage or money with which to purchase the beverage.

Sec. 4-39. Inspection of licensed establishments by the police department.

Sworn officers of the police department and the city marshal and the city manager or his designee shall have the authority to inspect establishments licensed under this chapter during the hours in which the premises are open for business. These inspections shall be made for the purpose of verifying compliance with the requirements of this chapter and state law. This section is not intended to limit the authority of the city manager or any other city officer to conduct inspections authorized by other provisions of this code.

Sec. 4-40. Establishment can be closed in cases of emergency.

The mayor, city manager or the chief of police, or their designee, may immediately close an establishment licensed under this chapter in case of emergency, for the safety of the public or to investigate a crime, for a period of time not to exceed 24 hours.

Sec. 4-41. Types of entertainment, attire and conduct prohibited.

(a) *Preamble and purpose.*

- (1) *Based upon the experiences of other counties and municipalities, including, but not limited to, Atlanta and Fulton County, Georgia; DeKalb County, Georgia; Gwinnett County, Georgia; Austin, Texas; Seattle and Renton, Washington; New York, New York; Los Angeles, California; and Ft. Lauderdale and Palm Beach, Florida, which experiences the city council believes are relevant to the problems faced by the city and based upon the evidence and testimony of the citizens and experts who have appeared before such bodies, the city council takes note of the notorious and self-evident conditions attendant to the commercial exploitation of human sexuality, which do not vary greatly among generally comparable communities within our country.*
- (2) *Moreover, it is the finding of the city council that public nudity and semi-nudity, under certain circumstances, particularly circumstances relating to the sale and consumption of alcoholic beverages in so-called "nude bars" or establishments offering so-called "nude entertainment" or "erotic entertainment" begets criminal behavior and tends to create undesirable community conditions. Among the acts of criminal behavior identified with nudity and alcohol are disorderly conduct, prostitution, and drug trafficking and use. Among the undesirable community conditions identified with nudity and alcohol are depression of property values in the surrounding neighborhoods, increased expenditure for and allocation of law enforcement personnel to preserve law and order, increased burden on the judicial system as a consequence of the criminal behavior hereinabove described, and acceleration of community blight by the concentration of such establishments in particular areas. Therefore, the limitation of nude or semi-nude conduct in establishments licensed to sell alcohol for consumption on the premises is in the public welfare and is a matter of governmental interest and concern to prevent the occurrence of criminal behavior and undesirable community conditions normally associated with establishments which serve alcohol and also allow and/or encourage nudity or semi-nudity.*

(b) *Prohibited activities. Any establishment licensed under the provisions of this chapter is prohibited from permitting or engaging in the following activities:*

- (1) *The employment or use of any person, in any capacity, in the sale or service of alcoholic beverages while such person is unclothed or in such attire, costume or clothing as to expose to view any portion of the female breast below the top of the areola or any portion of the pubic hair, anus, cleft of the buttocks, vulva or genitals;*
- (2) *Live entertainment which provides or features nude or semi-nude or erotic dancing, or the performance of obscene acts which simulate:*
 - a. *Sexual intercourse, masturbation, sodomy, bestiality, oral copulation, flagellation or any sexual acts which are prohibited by law;*
 - b. *The touching, caressing or fondling of the breast, buttock, anus or genitals; or*
 - c. *The displaying of the pubic hair, anus, vulva or genitals;*

- (3) *The showing of any film, still pictures, electronic reproduction or other visual reproductions depicting any of the acts described in subsection (b)(2) of this section, which are obscene under state law; or*
- (4) *The holding, promotion or allowance of any contest, promotion, special night or any other activity where patrons of the licensed establishment are encouraged or allowed to engage in any of the above-prohibited conduct.*
- (c) *Mainstream activity excluded. Notwithstanding the prohibitions in subsection (b) of this section, nothing in this chapter shall or is intended to apply to theatrical or motion picture performance houses, museums, or the like where the consumption or service of alcohol is not a primary purpose or mainstream activity of such establishment.*

Sec. 4-42. Security cameras required for selling alcoholic beverages.

- (a) *Any licensee who sells any alcoholic beverage is hereby required to install a continuous video recording system dedicated to each entrance, exit, and register areas with camera and lens of a type, number and location approved by the chief of police department. Such cameras must be capable of producing a retrievable and identifiable image of not less than 1920 x 1080 video quality resolution on file or tape that can be made a permanent record and that can be enlarged through projection or other means. Licensee shall at all times retain the most recent 30-day history of video footage from cameras.*
- (b) *Cameras meeting the requirements of this section shall be maintained in proper working order at all times and shall be in operation at all hours in which such establishment is open for business. The camera shall be subject to periodic inspection by city personnel. In the event the camera becomes inoperable, the licensee must have the camera repaired or have availability of a backup camera system within a five-day period of time. In addition, in the event the camera becomes inoperable, the licensee must immediately notify the city clerk or his/her designee. If a crime occurs or an employee believes a crime has occurred, the police department shall be contacted immediately and the film retrieved by a designated police officer.*
- (c) *Violation of any provision under this section shall constitute an offense hereunder and shall be punishable as follows:*
 - (1) *On a first offense there shall be a minimum fine of \$250.00.*
 - (2) *On the second offense, if within 12 months of the first, there shall be a fine of \$1,000.00.*
 - (3) *Any violation of this Section shall subject the license issued under this Chapter to suspension or revocation pursuant to to Section 4-17 of this Chapter.*

Sec. 4-43. Zoning Requirements.

Only establishments located within the appropriate zoning classification may sell alcohol under this Chapter and shall have a zoning classification permissive of the type of establishment (i.e. retailer, distillery, brewery, brewpub, microbrewery, microdistillery), and comply with all zoning regulations as required by the zoning ordinance of the City of Loganville.

Secs. 4-44—4-80. Reserved.

ARTICLE II. RETAIL SALES OF DISTILLED SPIRITS FOR CONSUMPTION ON THE PREMISES²

Sec. 4-81. Locations where permitted.

No distilled spirits may be sold by the drink for consumption on the premises where sold except:

- (1) In eating establishments regularly serving prepared food, with a full service kitchen. A full service kitchen will consist of a three-compartment pot sink, a stove or grill permanently installed, and a refrigerator, all of which must be approved by the health and fire departments. Such eating establishment must serve food during all hours that alcoholic beverages are being served, and derive at least as much gross receipts annually from the sale of prepared meals or food as it derives from the sale of distilled spirits.*
- (2) In indoor commercial recreation establishments.*
- (3) In an indoor publicly owned civic and cultural center deriving at least 70 percent of its total annual gross sales from operational activities other than alcohol sales.*
- (4) At a publicly or privately owned golf course.*
- (5) In public stadiums, coliseums or auditoriums.*
- (6) In private clubs.*
- (7) In in-room service for hotels and motels.*
- (8) In special event facilities.*

Sec. 4-82. Investigative and administrative costs.

Each application for a license under this article shall be accompanied by a certified check for the full amount of the license fee, together with a separate certified check or cash in the amount of \$250.00 to defray investigative and administrative costs. If the applicant is denied a license, the deposit representing the license fee shall be refunded; but the \$250.00 cost paid for investigation and administrative costs shall be retained. However, any person applying for more than one license shall pay only one fee to defray investigative and administrative expenses, which fee shall be the largest of the investigative and administrative fees authorized under this chapter. Any applicant for a license under this article who has in existence at the time of making the new application an existing license under this article shall pay no investigative and administrative costs.

Sec. 4-83. Advertising in official gazette of county.

A notice of each application to sell distilled spirits by consumption shall be advertised in the official gazette of the county in which the licensee's location is located, once a week for two weeks immediately preceding consideration of the application.

Sec. 4-84. Hours and days of sale.

- (a) Distilled spirits shall not be sold for consumption on the premises except between the hours of 8:00 a.m. until 2:00 a.m. Monday through Saturday.*
- (b) Distilled spirits shall not be sold for consumption at any time in violation of state law or any local ordinance or regulation or of any special order of the mayor and city council.*

²State law reference(s)—Retail sales of distilled spirits by the drink, O.C.G.A. § 3-4-90 et. seq.

- (c) *The sale of distilled spirits for consumption on the premises is permitted on Sundays from 12:30 p.m. until 2:00 a.m. in the following establishments provided a Sunday sales license has been obtained:*
- (d) *Distilled spirits may be sold for consumption on the premises from 12:00 midnight to 2:00 a.m. on January 1, New Year's Day of any year.*

Secs. 4-85—4-105. Reserved.

**ARTICLE III. RETAIL SALES OF MALT BEVERAGES AND WINE FOR CONSUMPTION
ON THE PREMISES**

Sec. 4-106. Type of retail establishment where permitted.

No beer or wine shall be sold for consumption on the premises where sold except:

- (1) *In eating establishments having a full service kitchen (a full service kitchen will consist of a three-compartment sink, a stove or grill permanently installed, and a refrigerator, all of which must be approved by the health and fire departments), that remains open and regularly prepares and serves food during all hours in which the eating establishment is serving alcoholic beverages.*
- (2) *In indoor commercial recreation establishments.*
- (3) *In an indoor publicly owned civic and cultural center deriving at least 70 percent of its total annual gross sales from operational activities other than alcohol sales.*
- (4) *At a publicly or privately owned golf course.*
- (5) *At a public stadium, coliseum or auditorium.*
- (6) *At a business establishment holding an amenities license pursuant to section 4-111.*
- (7) *At a business establishment holding an on premises consumption license subject to and in compliance with the volume/sales ratio requirement of the Mainstreet District as outlined in section 4-110.*
- (8) *In private clubs.*
- (9) *In in-room service for hotels and motels.*
- (10) *In special event facilities.*
- (11) *At Wine Shops.*

Sec. 4-107. Investigative and administrative costs.

Each application for a license under this article shall be accompanied by a certified check for the full amount of the license fee, together with a separate certified check or cash in the amount of \$250.00 to defray investigative and administrative costs. If the application is denied and the license refused, or if the applicant withdraws his application prior to its being issued, the license fee shall be refunded; but the \$250.00 costs paid for investigation and administration shall be retained. Any person applying for more than one license shall pay only one fee to defray investigative and administrative expenses, which fee shall be the largest of the investigative and administrative fees authorized under this chapter. Any applicant for a license under this article who has in existence at the time of making the new application an existing license under this article shall pay no investigative and administrative costs.

Sec. 4-108. Hours and days of sale.

- (a) *Beer or wine shall not be sold for consumption on the premises except between the hours of 8:00 a.m. and 2:00 a.m. Monday through Saturday.*

- (b) *No beer or wine shall be sold for consumption at any time in violation of state law or any local ordinance or regulation or of any special order of the mayor and city council.*
- (c) *The sale of beer or wine on the premises is permitted on Sundays from 12:30 p.m. until 2:00 a.m. in the following establishments provided a Sunday sales license has been obtained:*
- (d) *Beer and/or wine may be sold for consumption on the premises from 12:00 midnight to 2:00 a.m. on January 1, New Year's Day of any year.*

Sec. 4-109. Corkage services.

- (a) *An eating establishment that possesses a valid license for the retail sale of beer or wine for consumption on premises may permit patrons to bring, possess and consume bottles of wine that are owned by the patron and brought unopened onto the premises under the following conditions:*
 - (1) *No more than 750 milliliters of wine, per patron over the age of 21, per meal, shall be permitted to be uncorked.*
 - (2) *Only patrons seated at tables or booths shall be permitted to consume wine that has been provided by the patron.*
 - (3) *Patron provided wine may only be consumed by individuals who order and are served a meal by the licensee.*
 - (4) *Every bottle of wine brought onto the premises by a patron must be opened by the licensee's personnel.*
 - (5) *A patron may remove a partially consumed uncorked bottle of wine from the premises only if the requirements set forth in section 4-34(d) are met.*
- (b) *Eating establishments may at their discretion charge corkage fees for such services.*

Sec. 4-110. Sales volume ratio for select businesses

- (a) *Any business required to pay a business occupation tax that does not otherwise meet the criteria of section 4-106 and is located in the Mainstreet District, may obtain an on premises consumption license for malt beverages and wine subject to the following conditions:*
 - (1) *The sale of alcoholic beverages shall be clearly incidental to the primary business conducted on the premises.*
 - (2) *On premises consumption licensees shall maintain at least 70 percent of their business volume from the sale of other merchandise or services, not including alcoholic beverages.*
- (b) *To qualify for such license, a retail business establishment must be open to the public for business a minimum of 32 hours per week.*

Sec. 4-111. Amenity license

- (a) *A non-eating establishment that offers beer or wine as an act of hospitality, where it is clearly a secondary function of the business, shall be eligible to apply for a beer or wine amenity permit. Eating establishments shall not be eligible for a beer or wine amenity permit.*
- (b) *An amenity permit shall allow the permit holder to offer beer or wine as an act of hospitality and shall not be part of the core operations of such establishments.*
- (c) *The initial amenity permit application shall be subject to the standard application process as outlined in Section 4-107.*
- (d) *All amenities license holders must also possess a valid alcohol license for the state.*

Secs. 4-113—4-135. Reserved.

ARTICLE IV. RETAIL PACKAGE SALES OF DISTILLED SPIRITS

Sec. 4-200. Type of retail establishment where permitted.

No retail package sales of distilled spirits may be sold unless the licensee is licensed as a retail package dealer of distilled spirits and meets all other requirements of this Chapter.

Sec. 4-201. Hours and days of sale.

- (a) *Retail package licensees shall not engage in the sale of malt beverages, wine, and distilled spirits except between the hours of 8:00 a.m. and 12:00 midnight Monday through Saturday and 12:30 p.m. and 11:30 p.m. on Sunday.*
- (b) *Retail package malt beverages, wine, or distilled spirits shall not be sold at any time in violation of any state law or local ordinance or regulations or of any special order of the mayor and city council.*

Sec. 4-202. Use of tags or labels to indicate prices.

Retailers shall indicate plainly by tags or labels on the bottles or containers or on the shelf immediately below where the containers are placed the prices of all alcoholic beverages exposed or offered for sale.

Sec. 4-203. Quantity sale requirements.

Single cans or bottles or other properly packaged containers of alcoholic beverages may be sold.

Sec. 4-204. Investigative and administrative costs.

Each application for a license under this article shall be accompanied by a certified check for the full amount of the license fee, together with a separate certified check or cash in the amount of \$250.00 to defray investigative and administrative costs. If the application is denied and the license refused, or if the applicant withdraws his application prior to its being issued, the license fee shall be refunded; but the \$250.00 cost paid for investigation and administration shall be retained. However, any person applying for more than one license shall pay only one fee to defray investigative and administrative expenses, which fee shall be the largest of the investigative and administrative fees authorized under this chapter. As to any applicant for a license under this article who has in existence at the time of making the new application an existing license under this article, there shall be no investigative and administrative fee.

Sec. 4-205. Additional application requirements for retail dealers in distilled spirits by the package.

- (a) *Licensed premises' building requirements:*
 - (1) *No license to sell distilled spirits by the package shall be effective until the building in which the business will be located is complete, detailed plans of the building and outside premises have been submitted to and approved by the city, and the city has issued a certificate of occupancy for the building. In the event the building is not complete, the applicant must attach to his or her initial application a survey of the property, a rendering of the proposed building, and a site plan. The proposed building shall be subject to final inspection and approval when completed by the building inspector, the fire marshal, the planning director, and shall comply with other ordinances of the city for zoning, storage, parking, buffers and other issues. The proposed building also shall comply with all regulations of the state revenue commissioner and all the laws of the state.*

- (2) Each building in which the business will be located shall contain sufficient lighting so that the building itself and the premises on all sides of the building shall be readily visible at all times from the front of the street on which the building is located. The lighting shall reveal the inside retail area of the building and shall reveal all of the outside premises of the building.
 - (3) The licensed premises must be within a freestanding building completely and physically separate from any other business activities. The building must contain a minimum of 10,000 square feet of heated and air conditioned space.
 - (4) The building in which the licensed premises is located shall be finished with brick and glass except for incidental metal trim.
 - (5) The licensed premises shall allow ingress and egress for customers and their purchases through a door opening to the outside and facing a public street or public pedestrian area.
 - (6) The building shall be owned or leased by the applicant for a license to sell distilled spirits by the package, and proof of ownership or lease is required.
 - (7) The licensee is required to install security cameras and otherwise to comply with section 4-42 of this chapter.
- (b) *Performance bond required:* Before any license to sell distilled spirits by the package is granted, the applicant must post with the city, along with his or her application, a performance bond on the construction with an insurance company as surety. This bond shall require the faithful observance and performance by the licensee of the rules and regulations contained in this article. Upon the violation of this article, or any part of this article, the amount of the bond to be forfeited will be determined by the seriousness of the violations as determined by the city. The bond is to be approved by the city and shall be properly executed. The bond is to be in the amount of \$100.00 for a wholesale license and \$2,500.00 for a retail license. A cash bond is acceptable. The money will be held in escrow. The applicant must fill out a bond letter, available at the department of planning and development.
- (c) *Proof of insurance required:* The applicant for a license to sell distilled spirits by the package shall provide proof of comprehensive general liability insurance, including liquor liability coverage, for the licensed premises with coverage of at least \$2,000,000.00 per occurrence, inclusive of personal injury, bodily injury, death, and property damage, and an umbrella policy with coverage of at least \$2,000,000.00 per occurrence. At the time a license application is submitted, the city will accept as proof of insurance a quote from a reputable insurance company. The applicant may need to ask the insurance company for an extension of the quote. Prior to opening a package store, and thereafter at the time of renewing a license, a licensee must submit a certificate of insurance to the city planning department. Failure to do so is cause for revocation of a license.
- (d) *Proof of inventory required:* The applicant for a license to sell distilled spirits by the package shall provide proof that it will maintain a wholesale inventory valued at \$600,000.00. An affidavit of the applicant satisfies this requirement.
- (e) *Letter of credit:* The applicant for a license to sell distilled spirits by the package shall furnish the city a letter of credit in the amount of at least \$2,000,000.00 per application.

Sec. 4-206. Number of licenses in the City is limited.

- (a) *Number of licenses to be determined by population:* The city shall issue no more than two licenses for the retail sale of distilled spirits, malt beverages, and wine by the package until such time as the number of city residents reaches 30,000, as the population has been determined by a certified census count of the United States Census Bureau, at which time the city may issue an additional license or licenses so long as thereafter the number of licenses in operation within the city limits at any one time shall not exceed one license to sell packaged distilled spirits for each 10,000 city residents as determined by a certified census of the United States Census Bureau.

- (b) In the event the City has any open license availability for the retail package sale of distilled spirits, the City shall follow the procedures set forth in subsection (c) of this Section 4-206 in determining to whom the additional open license shall be issued to.
- (c) *Grant or denial of license for open, available retail package dealer for distilled spirits.*
- (1) The city shall publish notice of availability of any license(s) to sell distilled spirits by the package in a newspaper of general circulation in the city and state the deadline for filing an application. Such notice shall be published at least once a week for two consecutive weeks. The application deadline shall be at least 20 business days after publication. All applications for a license to sell distilled spirits by the package shall be submitted during business hours to the city manager or his/her designee, who shall mark the application with the time and date received.
 - (2) Upon the filing of an application, the city manager shall have five business days to review the application and to send a copy of the application to all affected departments of city government to determine compliance with city regulations and laws. Each department notified shall submit a report within 20 business days of receipt of the application to the city manager which states whether there are any objections to the application.
 - (3) Within 20 business days from the date the city manager receives all department notifications, the city manager shall render a written determination as to whether the application complies with the requirements of this chapter.
 - (4) The written determination shall be sent by certified mail to the applicant whose application was considered.
 - (5) If the decision of the city manager is to deny the requested license, then the letter to the applicant shall set forth in reasonable detail the grounds upon which the license is being denied. The letter shall further advise the applicant of the right to appeal the decision to the mayor and city council within 20 business days of the date on which the written decision of the city manager is sent by certified mail.
 - (6) The city manager or his designee may deny a city license under this article on any of the following grounds:
 - a. Failure to meet state requirements for state license;
 - b. Failure to pay all required fees and taxes;
 - c. Failure to provide valid information, documents and the like required by this article;
 - d. False information in the application or attached documents;
 - e. Improper residency of applicant, owner or registered agents;
 - f. Failure to post and maintain proper signs and advertisements required in this article;
 - g. Failure to meet distance, location or number of business requirements;
 - h. Prior convictions as herein provided; or
 - i. Failure to meet any other requirements in this article for a license or any other requirement in any other provision of this Code or the Charter.
 - (7) If the city manager determines that the applicant meets the criteria for a license to sell distilled spirits by the package within the Loganville city limits, but there are more qualified applicants than available licenses, then the city manager shall send a letter by certified mail to the applicant notifying him or her that a licensee or licensees to sell distilled spirits by the package shall be selected by lottery at a meeting of the city council and of the date, time and place of said meeting.
 - (8) The letter shall further advise the applicant of the right to appeal the decision to the mayor and city council within 20 business days of the date on which the lottery takes place.

Sec. 4-207. Tasting Events.

- (a) *Eligibility. The holder of a current, valid retail package dealer license of distilled spirits shall be authorized to conduct up to 52 tasting events per calendar year, subject to the following terms and conditions:*
- (b) *Conditions. A valid retail package dealer license of distilled spirits shall allow the holder to provide samples of either malt beverages, wine, or distilled spirits to the public for consumption on the premises under the following conditions:*
- (1) *A tasting event shall only take place on the licensed premises and only at times at which such alcoholic beverages may be lawfully sold on such licensed premises;*
 - (2) *Only one tasting event per day and only one tasting event per week may be held on the licensed premises and such tasting event shall not exceed four hours;*
 - (3) *Only one type of alcoholic beverage may be served at a tasting event, either malt beverages, wine, or distilled spirits; provided, however, that more than one brand of such type of alcoholic beverage may be offered so long as not more than four packages are open at any one time;*
 - (4) *If the tasting event is for malt beverages, a consumer shall not be served more than eight ounces of malt beverages during such tasting event. If the tasting event is for wine, a consumer shall not be served more than five ounces of wine during such tasting event. If the tasting event is for distilled spirits, a consumer shall not be served more than one and one-half ounces of distilled spirits during such tasting event;*
 - (5) *Only alcoholic beverages that the licensee is licensed to sell on the licensed premises may be offered as part of a tasting event, and such alcoholic beverages shall be part of the licensee's inventory;*
 - (6) *Only food that is lawful to sell on the licensed premises, under this title or under any rules or regulations of the commissioner, may be served as part of a tasting event. Such food shall be offered at no cost to the consumer;*
 - (7) *Any operator or employee of the licensee may refuse to provide any brand, type, or quantity of alcoholic beverage to any consumer;*
 - (8) *Any broken package containing alcoholic beverages on the licensed premises that is not licensed for retail sales for consumption on the premises shall be kept locked in a secure room or cabinet by the operator of the licensed premises except when in use during a tasting event;*
 - (9) *Representatives and salespersons of manufacturers or wholesalers may attend a tasting event; provided, however, that such representatives and salespersons shall not host the tasting event, pour any alcoholic beverage, or provide anything of value to any consumer or to the licensee or an employee of a licensee; and*
 - (10) *Tasting Events for customers shall be conducted only at a counter area constituting no more than ten percent of the entire floor area of the premises.*

Secs. 4-208—4-300. Reserved.

ARTICLE V. RETAIL PACKAGE SALES OF MALT BEVERAGES AND WINE³

Sec. 4-301. Type of retail establishment where permitted.

Unless the licensee is also licensed as a retail dealer of distilled spirits under Article IV of this Chapter, no beer or wine shall be sold at retail except in establishments maintaining at least 50 percent of the floor space and storage area in a manner which is devoted principally to the retail sale of products that are not alcoholic beverages.

Sec. 4-302. Hours and days of sale.

- (a) Retail package licensees shall not engage in the sale of beer or wine except between the hours of 8:00 a.m. and 12:00 midnight Monday through Saturday and 12:30 p.m. and 11:30 p.m. on Sunday.*
- (b) Retail package beer or wine shall not be sold at any time in violation of any state law or local ordinance or regulations or of any special order of the mayor and city council.*

Sec. 4-303. Use of tags or labels to indicate prices.

Retailers shall indicate plainly by tags or labels on the bottles or containers or on the shelf immediately below where the containers are placed the prices of all beer and wine exposed or offered for sale.

Sec. 4-304. Quantity sale requirements.

Single cans or bottles or other properly packaged containers of alcoholic beverages may be sold.

Sec. 4-305. Investigative and administrative costs.

Each application for a license under this article shall be accompanied by a certified check for the full amount of the license fee, together with a separate certified check or cash in the amount of \$250.00 to defray investigative and administrative costs. If the application is denied and the license refused, or if the applicant withdraws his application prior to its being issued, the license fee shall be refunded; but the \$250.00 cost paid for investigation and administration shall be retained. However, any person applying for more than one license shall pay only one fee to defray investigative and administrative expenses, which fee shall be the largest of the investigative and administrative fees authorized under this chapter. As to any applicant for a license under this article who has in existence at the time of making the new application an existing license under this article, there shall be no investigative and administrative fee.

Sec. 4-306. Growler sales.

Licensees holding a retail beer and wine package license pursuant to this article may fill growlers with malt beverages or wine at the licensed location subject to the following requirements:

- (1) At least 50 percent of the licensee's total gross alcohol sales are from packaged sale of malt beverages or wine and the licensee's premises have a minimum of 400 square feet of floor space dedicated to the display of packaged malt beverages or wine offered for sale.*
- (2) A growler shall not exceed 64 ounces. Growlers may only be filled from kegs or barrels procured by the licensee from a duly licensed wholesaler.*
- (3) Only professionally sanitized and sealed growlers may be filled and made available for retail sale.*
- (4) Each growler must be securely sealed and removed from the premises in its original sealed condition.*

³State law reference(s)—License requirements, O.C.G.A. §§ 3-5-42, 3-6-40.

- (5) *Samples of tap malt beverages or wine may be made available. No individual shall be allowed to sample more than a total of 24 ounces which shall be comprised of at least four different varieties of malt beverages or wine.*
- (6) *A licensee may charge a fee for samples of tap malt beverages or wine.*

Secs. 4-307-330. Reserved.

ARTICLE VI. PRIVATE CLUBS⁴

Sec. 4-331. Definitions.

The following words, terms and phrases, when used in this article, shall have the meanings ascribed to them in this section, except where the context clearly indicates a different meaning:

Fixed salary means the amount of compensation paid any member, officer, agent, or employee of a bona fide private club as may be fixed for him by its members at a prior annual meeting or by the governing body out of the general revenue of the club and shall not include a commission on any profits from the sale of alcoholic beverages. For the purpose of this definition, tips or gratuities which are added to the bills under club regulation shall not be considered as profits from the sale of alcoholic beverages.

Private club means any nonprofit association organized under the laws of this state which:

- (1) *Has been in existence at least one year prior to the filing of its application for a license to be issued pursuant to this article;*
- (2) *Has at least 75 regular dues-paying members;*
- (3) *Owns, hires or leases a building or space within a building for the reasonable use of its members with:*
 - a. *Suitable kitchen and dining room space and equipment;*
 - b. *A sufficient number of employees for cooking, preparing and serving meals for its members and guests; and*
- (4) *Has no member, officer, agent or employee directly or indirectly receiving, in the form of salary or other compensation, any profits from the sale of alcoholic beverages beyond a fixed salary.*

Sports club means an association or corporation organized and existing under the laws of the state, organized and operated primarily to provide a location for the patrons thereof to engage in sporting events. To qualify for an alcoholic beverage consumption on-premise license, a sports club must have been actively in operation within the city at least two years prior to an application for license under this chapter; provided, however, the two-year operational requirement shall not apply to golf club associations or golf club corporations where the selling or the serving of alcoholic beverages is to take place on the golf course premises. A sports club organized or operated primarily for serving of alcoholic beverages shall not qualify for licensing under this article, and accordingly shall not be permitted to serve alcoholic beverages at any time. Unless otherwise indicated, a sports club licensee shall comply with all other requirements imposed upon retail consumption dealers.

Sec. 4-332. Regulation of sale of alcoholic beverages.

Private clubs or sports clubs may sell and dispense alcoholic beverages upon compliance with all applicable ordinances and regulations of the city governing the sale of such beverages and upon payment of such license fees and taxes as may be required by this chapter.

⁴State law reference(s)—Sale of distilled spirits by private clubs, O.C.G.A. § 3-7-1 et. seq.

Sec. 4-333. Certain organizations exempt from food establishment requirements.

Veterans' organizations, fraternal organizations, and other nonprofit organizations currently having tax exempt status under either the United States Internal Revenue Code or the state income tax law shall not be required to operate a food establishment serving prepared food. However, any such organization selling or dispensing alcoholic beverages shall be subject to all ordinance regulations dealing with general licensing and on-premise consumption establishments under this chapter.

Sec. 4-334. Investigative and administrative costs.

Each application for a license under this article shall be accompanied by a certified check for the full amount of the license fee, together with a separate certified check or cash in the amount of \$250.00 to defray investigative and administrative costs. If the application is denied and the license refused, the deposit representing the license fee shall be refunded; but the \$250.00 cost paid for investigation and administration shall be retained. However, any person applying for more than one license shall pay only one fee to defray investigative and administrative expenses, which fee shall be the largest of the investigative and administrative fees authorized under this chapter. Any applicant for a license under this article who has in existence at the time of making the new application an existing license under this article shall pay no investigative and administrative costs.

Sec. 4-335. Hours and days of sale.

- (a) No alcoholic beverages shall be sold for consumption on the premises of private clubs except between the hours of 8:00 a.m. and 2:00 a.m. Monday through Saturday.
- (b) Alcoholic beverages shall not be sold for consumption at any time in violation of any state law or local ordinance or regulation or of any special order of the mayor and city council.
- (c) The sale of alcoholic beverages for consumption on the premises is permitted on Sundays from 12:30 p.m. until 2:00 a.m. in a private club or sports club provided a Sunday sales license has been obtained.

Secs. 4-336—4-350. Reserved.**ARTICLE VII. SPECIAL EVENT VENUES****Sec. 4-351. Preamble and purpose.**

The city recognizes the valuable economic impact of special events facilities being located throughout the Loganville Mainstreet District. The distribution and consumption of alcoholic beverages at special events facilities is attendant with the normal and customary types of events held at such facilities, i.e., weddings, meetings, banquets, catered events, parties or similar gatherings. To encourage such economic impact of these facilities while ensuring the safety, health and general welfare of the public, special events facilities must obtain a license to sell alcoholic beverages at said facilities and must also register with the city annually for operating a special events facility.

Sec. 4-352. Sale without a license prohibited.

Any special events facility that wishes to sell alcoholic beverages for consumption on premises shall be required to first obtain an appropriate state license in accordance with the laws and regulations of the State of Georgia, the Department of Revenue of the State of Georgia, as well as a city license pursuant to Articles II and III of this chapter and comply with all other rules and regulations contained herein. Any sale of alcoholic beverages by the Special Events Facility without said licensure is strictly prohibited.

Sec. 4-353. Registration required.

Any special events facility that does not sell alcoholic beverages for consumption on premises but that allows alcoholic beverages to be consumed at said facility by private guests attending a private event must first register with the city on forms prepared by the city manager and pay an annual registration fee of \$300.00 per facility. Said registration fee shall be paid upon initial registration and annually by February 1 of each calendar year.

Sec. 4-354. Investigative and administrative costs.

Each application seeking a license to sell alcoholic beverages or seeking registration of a special events facility as required herein shall be accompanied by a certified check for the full amount of the license or registration fee, together with a separate certified check or cash in the amount of \$250.00 to defray investigative and administrative costs. If the application is denied and the license refused, the deposit representing the license fee shall be refunded; but the \$250.00 cost paid for investigation and administration shall be retained. However, any person applying for more than one license shall pay only one fee to defray investigative and administrative expenses, which fee shall be the largest of the investigative and administrative fees authorized under this chapter. Any applicant for a license or registration under this article who has in existence at the time of making the new application an existing license or active registration under this article shall pay no investigative and administrative costs.

Sec. 4-355. Alcoholic beverages must be purchased from retailer.

Any alcoholic beverage consumed at a special events facility by private guests attending a private event must be purchased from either the special events venue itself, a licensed caterer under this Chapter or a package retailer authorized to sell said beverages for off premise consumption.

Sec. 4-356. Licensed alcoholic beverage caterer pouring.

A licensed alcoholic beverage caterer, licensed by the state pursuant to O.C.G.A. § 3-11-1, et seq. may distribute and sell alcoholic beverages at a special events facility in the city so long as the licensed alcoholic beverage caterer complies with all requirements of O.C.G.A. § 3-11-1, et seq. and the special events facility has first registered with the city pursuant to section 4-353 hereinabove.

Sec. 4-357. Facility must be approved.

A special events facility must first be approved by the city manager and the city fire department prior to conducting operations as a special events facility.

Sec. 4-358. Timing of sales or consumption.

All sales of alcoholic beverages or consumption of alcoholic beverages at special events facilities shall comply in all respects to the time restrictions found in sections 6-84 and 6-108 herein.

Secs. 4-359—4-400. Reserved.

ARTICLE VIII. HOTEL-MOTEL IN-ROOM SERVICE⁵

Sec. 4-401. License.

- (a) Any hotel as defined herein may provide in-room service of malt beverages and wine after obtaining a license for the same in accordance with the terms of this article.
- (b) The sale of malt beverages and wine by in-room service shall be subject to all restrictions and limitations imposed by this chapter, and shall be authorized only on such days and only during such hours as the sale of alcoholic beverages is otherwise authorized.

Sec. 4-402 In-room service.

- (a) For purposes of this chapter, "in-room service" consists of:
 - (1) The delivery of malt beverages and wine in unbroken packages by an employee of the hotel to a registered guest's room when such beverages have been ordered by the guest and when the guest shall be billed for the cost of such beverages at the time of delivery and when the sale of such beverages is completed at the time of delivery or,
 - (2) The provision of a cabinet, refrigerator, mini-bar or other facility located in a hotel's guest room which contains malt beverages or wine and which is accessible only to the guest and for which the sale of malt beverages or wine contained therein is final at the time requested except for a credit which may be given to the guest for any unused portion.
- (b) In order to be eligible for an in-room service license, a hotel must:
 - (1) Be used and held out to the public as a place where sleeping accommodations are offered to guests for adequate pay, and meet other standards and conditions of a "hotel" as defined in this article; and;
 - (2) Contain four or more separate and distinct rooms used for the sleeping accommodations of guests.
- (c) A hotel may consist of a single building or may consist of two or more buildings located on the same premises and used in connection with the hotel operation.
- (d) A facility which is styled as a motel, motor lodge, inn, bed and breakfast or other similar appellation may be licensed as a hotel if it meets the requirements of this article.

Sec. 4-403. Operation of lounge, restaurant or supper club.

A hotel may grant permission for the operation of a lounge, restaurant, or supper club on its premises; such an operation may be granted on premises consumption license pursuant to articles II or III herein if it meets the other applicable requirements of said articles and this chapter and acquires said specific license and pays for such.

Sec. 4-404. Investigative and administrative costs.

Each application for a license under this article shall be accompanied by a certified check for the full amount of the license fee, together with a separate certified check or cash in the amount of \$250.00 to defray investigative and administrative costs. If the application is denied and the license refused, the deposit representing the license fee shall be refunded; but the \$250.00 cost paid for investigation and administration shall be retained. However, any person applying for more than one license shall pay only one fee to defray investigative and administrative expenses, which fee shall be the largest of the investigative and administrative fees authorized under this chapter.

⁵State law reference(s)—In-room sales by hotels and motels, O.C.G.A. § 3-9-10 et seq.

Any applicant for a license under this article who has in existence at the time of making the new application an existing license under this article shall pay no investigative and administrative costs.

Sec. 4-405. General provisions.

All alcoholic beverages sold pursuant to this article shall be purchased from a licensed wholesale dealer and shall be subject to all taxes imposed under Article XII of this Chapter, including the excise tax on the retail sale by the drink of alcoholic beverages containing distilled spirits.

Secs. 4-406—4-420. Reserved.

ARTICLE IX. BREWPUBS, BREWERIES AND DISTILLERIES⁶

Sec. 4-421. License required.

No person shall be permitted to operate a brewpub, brewery, micro-brewery, distillery or micro-distillery without first obtaining a license from the state and the city pursuant to this chapter.

Sec. 4-422. Investigative and administrative costs.

Each application for a license under this article shall be accompanied by a certified check for the full amount of the license fee, together with a separate certified check or cash in the amount of \$250.00 to defray investigative and administrative costs. If the application is denied and the license refused, the deposit representing the license fee shall be refunded; but the \$250.00 cost paid for investigation and administration shall be retained. However, any person applying for more than one license shall pay only one fee to defray investigative and administrative expenses, which fee shall be the largest of the investigative and administrative fees authorized under this chapter. Any applicant for a license under this article who has in existence at the time of making the new application an existing license under this article shall pay no investigative and administrative costs.

Sec. 4-423. Brewpubs.

- (a) No individual shall be permitted to own or operate a brewpub without first obtaining a proper brewpub license from the city and the state. Each brewpub licensee shall comply with all other applicable state and local license requirements.
- (b) A brewpub license authorizes the holder of such license to:
 - (1) Manufacture on the licensed premises not more than 10,000 barrels of malt beverage in a calendar year solely for retail sale.
 - (2) Operate an eating establishment that shall be the sole retail outlet for such malt beverage and may offer for sale for consumption on premises any other alcoholic beverages produced by other manufacturers which are authorized for retail sale under this chapter, provided that such alcoholic beverages are purchased from a licensed wholesale dealer and, provided further, in addition to malt beverages manufactured on the premises, each brew pub licensee shall offer for sale commercially available canned or bottled malt beverages purchased from a licensed wholesale dealer.

⁶State law reference(s)—Limited exception, malt beverage taprooms, O.C.G.A. § 3-5-24.1; Brewpubs; limited exception to prohibition against ownership and employment interests between manufacture, distribution, and sale of malt beverages, O.C.G.A. §3-5-36; Limited exception; sale of distilled spirits on premises, O.C.G.A. § 3-4-24.2.

- (3) *Sell up to a maximum of 5,000 barrels annually of such malt beverage to licensed wholesale dealers. Under no circumstances shall such malt beverages be sold by a brewpub licensee to any person holding a retail consumption dealer's license or a retailer's license for the purpose of resale.*
- (4) *Sell malt beverages manufactured on the premises by the package at retail for consumption off the premises.*
- (c) *Possession of a brewpub license shall not prevent the holder of such license from obtaining any other license available under this chapter for the same premises.*
- (d) *A brewpub licensee shall pay all state and local license fees and excise taxes applicable to individuals licensed under this chapter as manufacturers, retailers and, where applicable, wholesale dealers.*
- (e) *Except as set forth in this section, a brewpub licensee shall be subject to all other provisions of this chapter.*

Sec. 4-424. Breweries.

- (a) *No individual shall be permitted to own or operate a brewery without first obtaining a proper brewery license from the city and the state. Each brewery license shall comply with all other applicable state and local license requirements.*
- (b) *A licensed brewery is authorized to manufacture malt beverages for wholesale sale primarily to wholesale dealers.*
- (c) *A licensed brewery shall comply with O.C.G.A. § 3-5-24.1 relating to the sale of malt beverages to the public for onsite consumption or offsite package sales and may sell on all days and at all times that sales of malt beverages by retailers are lawful within the city.*
- (d) *A brewery licensee shall pay all state and local license fees and excise taxes applicable to individuals licensed under this chapter as manufacturers, retailers and, where applicable, wholesale dealers.*
- (e) *Breweries shall not be permitted within the boundaries of the Mainstreet District of the City of Loganville.*
- (f) *Except as set forth in this section, a brewery licensee shall be subject to all other provisions of this chapter.*

Sec. 4-425. Distilleries.

- (a) *No individual shall be permitted to own or operate a distillery without first obtaining a proper distillery license from the city and the state. Each distillery licensee shall comply with all other applicable state and local license requirements.*
- (b) *A licensed distillery is authorized to manufacture distilled spirits for sale primarily to wholesale dealers.*
- (c) *A licensed distillery shall comply with O.C.G.A. § 3-4-24.2 relating to the sale of distilled spirits to the public for onsite consumption or offsite package sales and may sell on all days and at times that sales of distilled spirits by retailers are lawful within the city.*
- (d) *A distillery licensed under this chapter shall pay all state and local license fees and excise taxes applicable to individuals licensed under this chapter as manufacturers, retailers and, where applicable, wholesale dealers.*
- (e) *Distilleries shall not be permitted within the boundaries of the Mainstreet District of the City of Loganville.*
- (f) *Except as set forth in this section, a distillery licensee shall be subject to all other provisions of this chapter.*

Sec. 4-426. Micro-breweries.

- (a) *No individual shall be permitted to own or operate a micro-brewery without first obtaining a proper micro-brewery license from the city and the state. Each micro-brewery shall comply with all other applicable state and local license requirements.*

- (b) *A licensed micro-brewery is authorized to manufacture malt beverages for sale primarily to wholesale dealers.*
- (c) *A licensed micro-brewery shall comply with O.C.G.A. § 3-5-24.1 relating to the sale of malt beverages to the public for onsite consumption or offsite package sales and may sell on all days and at all times that sales of malt beverages by retailers are lawful within the city.*
- (d) *A micro-brewery licensee shall pay all state and local license fees and excise taxes applicable to individuals licensed under this chapter as manufacturers, retailers and, where applicable, wholesale dealers.*
- (e) *Except as set forth in this section, a micro-brewery licensee shall be subject to all other provisions of this chapter.*

Sec. 4-427. Micro-distilleries.

- (a) *No individual shall be permitted to own or operate a micro-distillery without first obtaining a proper micro-distillery license from the city and the state. Each micro-distillery licensee shall comply with all other applicable state and local license requirements.*
- (b) *A licensed micro-distillery is authorized to manufacture distilled spirits for sale primarily to wholesale dealers.*
- (c) *A licensed micro-distillery shall comply with O.C.G.A. § 3-4-24.2 relating to the sale of distilled spirits to the public for onsite consumption or offsite packaging sales and may sell at all times that sales of distilled spirits by retailers are lawful within the city.*
- (d) *A micro-distillery licensee shall pay all state and local license fees and excise taxes applicable to individuals licensed under this chapter as manufacturers, retailers and, where applicable, wholesale dealers.*
- (e) *Except as set forth in this section, a micro-distillery licensee shall be subject to all other provisions of this chapter.*

Secs. 4-428—4-600. Reserved.

ARTICLE X. WHOLESALERS

Sec. 4-601. Special provisions applicable to wholesale purchases.

- (a) *Any person desiring to sell at wholesale any alcoholic beverages in the city shall make application to the city manager for a license to do so, which application shall be in writing on the prescribed forms, and pay any license fee as set by this chapter.*
- (b) *No person who has any direct financial interest in any license for the retail sale of any alcoholic beverages in the city shall be allowed to have any interest or ownership in any wholesale alcoholic beverage license issued by the city.*
- (c) *No retailer shall purchase any alcoholic beverage from any person other than a wholesaler licensed under this article. No wholesaler shall sell any alcoholic beverage to any person other than a retailer licensed under this chapter; provided, however, that this section shall not prohibit the purchase by one retailer of another retailer's entire stock in a bona fide purchase of an ongoing business.*
- (d) *No alcoholic beverage shall be delivered to any retail sales outlet in the city except by a duly licensed wholesaler. The name of the wholesale distributor shall be clearly marked on the delivery vehicle.*

Sec. 4-602. Hours and days of sale.

Wholesalers shall not engage in the wholesale sale of alcoholic beverages except between the hours of 7:00 a.m. and 6:00 p.m. Monday through Saturday. There shall be no wholesale sales of alcoholic beverages on Sunday.

Sec. 4-603. Audit and penalties.

If the city manager deems it necessary to conduct an audit of the records and books of the wholesale licensee, he shall notify the licensee of the date, time and place of the audit.

Secs. 4-604—4-700. Reserved.**ARTICLE XI. ALCOHOLIC BEVERAGE CATERERS****Sec. 4-701. Definitions.**

The following words, terms and phrases, when used in this chapter, shall have the meanings ascribed to them in this section, except where the context clearly indicates a different meaning:

Alcoholic beverage caterer means any person licensed for the sale of alcoholic beverages by the State and who possesses a license by a local government in the State authorizing such person to sell and dispense alcoholic beverages by the drink in connection with an authorized catered function.

Authorized catered function means an event at a location not otherwise licensed for consumption of alcoholic beverages by the drink at which alcoholic beverages are furnished, served, sold and dispensed to persons present at the event, by the drink, pursuant to a permit obtained under this section.

Sec. 4-702. License requirements and restrictions.

An alcoholic beverage caterer, after properly obtaining a license to do so, may engage in the service and sell of malt beverages, wine or spiritous liquors by the drink at authorized catered functions as follows:

- (1) *Licenses may be obtained for the purposes of selling or dispensing alcoholic beverages by the drink on premises on which authorized catered functions are to be held.*
- (2) *Such license may be obtained only by those persons, firms, or corporations with a valid local beverage alcohol license and a valid state retail dealer license.*
- (3) *Such licenses shall only authorize the alcoholic beverage caterer to sell those alcoholic beverages for which he or she is licensed.*
- (4) *Before a licensed alcoholic beverage caterer may sell, serve or dispense alcoholic beverages at any authorized catered function, such alcoholic beverage caterer shall obtain an event permit from the city at least ten business days prior to the event.*
- (5) *The application for an event permit shall include the name of the licensed alcoholic beverage caterer, the alcoholic beverage caterer's license number, and the date, address and time of the event.*
- (6) *No event permit fee shall be charged for the alcoholic beverage caterers licensed by the city.*
- (7) *For alcoholic beverage caterers licensed by jurisdictions other than the city, a permit fee of \$250.00 per event shall be charged.*
- (8) *The event permit shall be good for the specific event at the specific address and times set forth in the application.*
- (9) *The event permit and a copy of the alcoholic beverage caterer's state and local licenses shall be kept in the vehicle used to transport alcoholic beverages to the event at all times during which the event permit is in effect.*
- (10) *Caterers licensed by the city or any other jurisdiction shall maintain records of alcoholic beverages transported for each event as may be required by state law.*

Sec. 4-703. Age restrictions.

No licensed alcoholic beverage caterer shall employ any person under 21 years of age to dispense, serve, sell or handle alcoholic beverages at authorized catered functions.

Sec. 4-704. Excise taxes.

Excise taxes are imposed upon alcoholic beverage caterers and shall be paid as required by this chapter and Georgia law.

Sec. 4-705. State law compliance.

The licensed alcoholic beverage caterer shall comply with all provisions set forth in this chapter and shall be subject to the mandates of O.C.G.A. § 3-11-1, et. seq.

Sec. 4-706. Investigative and administrative costs.

Each application seeking a license to sell alcoholic beverages as an alcoholic beverage caterer shall be accompanied by a certified check for the full amount of the license or registration fee, together with a separate certified check or cash in the amount of \$250.00 to defray investigative and administrative costs. If the application is denied and the license refused, the deposit representing the license fee shall be refunded; but the \$250.00 cost paid for investigation and administration shall be retained. However, any person applying for more than one license shall pay only one fee to defray investigative and administrative expenses, which fee shall be the largest of the investigative and administrative fees authorized under this chapter. Any applicant for a license or registration under this article who has in existence at the time of making the new application an existing license or active registration under this article shall pay no investigative and administrative costs.

Sec. 4-707. Timing of sales or consumption.

All sales of alcoholic beverages or consumption of alcoholic beverages at authorized catered events shall comply in all respects to the time restrictions found in sections 6-84 and 6-108 herein.

ARTICLE XII. ALCOHOLIC BEVERAGE EXCISE TAXES

Sec. 4-708. Malt beverage excise tax; collection.

- (a) In addition to the retail malt beverage license fee, there is imposed and levied an excise tax upon all retail dealers in malt beverages within the city limits in the maximum amount allowed by state law.
- (b) It shall be unlawful and a violation of this article for any retailer to possess, own, hold, store, display or sell any malt beverage on which the tax has not been paid.
- (c) Each distributor, wholesale dealer or manufacturer selling, shipping or delivering malt beverages to any retail dealer in the city shall collect the excise tax as set forth in subsection (a) of this section and shall remit the tax to the city not later than the tenth of the month following collection. Each monthly remittance will be accompanied by invoice copies of all sales or deliveries to all retailers in the city for resale in the city, together with the sworn affidavit of such distributor, wholesale dealer or manufacturer, that the attached invoices are true, correct and complete.

State law reference(s)—Imposition of excise tax on malt beverages required, O.C.G.A. § 3-5-80.

Sec. 4-709. Wine excise tax; collection.

- (a) *In addition to the annual retail wine license fee, there is imposed and levied an excise tax upon all retail dealers in wine within the city limits in the maximum amount allowed by state law.*
- (b) *It shall be unlawful and a violation of this article for any retailer to possess, own, hold, store, display or sell any wine on which the tax has not been paid.*
- (c) *Each distributor, wholesale dealer or manufacturer selling, shipping or delivering wine to any retail dealer in the city shall collect the excise tax as set forth in subsection (a) of this section and shall remit the tax to the city not later than the tenth of the month following collection. Each monthly remittance will be accompanied by invoice copies of all sales or deliveries to all retailers in the city for resale in the city, together with the sworn affidavit of such distributor, wholesale dealer or manufacturer, that the attached invoices are true, correct and complete.*

State law reference(s)—Authorization to levy tax on wine, O.C.G.A. § 3-6-60.

Sec. 4-710. Distilled spirits excise tax; collection.

- (a) *In addition to the annual retail distilled spirits license fee, there is imposed and levied an excise tax upon all retail dealers in distilled spirits within the city limits in the maximum amount allowed by state law.*
- (b) *It shall be unlawful and a violation of this article for any retailer to possess, own, hold, store, display or sell any distilled spirits on which the tax has not been paid.*
- (c) *Each distributor, wholesale dealer or manufacturer selling, shipping or delivering distilled spirits to any retail dealer in the city shall collect the excise tax as set forth in subsection (a) of this section and shall remit the tax to the city not later than the tenth of the month following collection. Each monthly remittance will be accompanied by invoice copies of all sales or deliveries to all retailers in the city for resale in the city, together with the sworn affidavit of such distributor, wholesale dealer or manufacturer, that the attached invoices are true, correct and complete.*

State law reference(s)—Authority to impose excise tax on sale of distilled spirits by the drink, O.C.G.A. § 3-7-60.

Sec. 4-711. Consumption by the drink tax.

- (a) *In addition to all other taxes and license fees imposed upon licenses for the sale of alcoholic beverages for consumption on the premises engaged in the business of selling alcoholic beverages, there is imposed and levied upon all licensees within the city an excise tax on all distilled spirits served and poured for consumption on the premises. The tax levied hereunder shall be computed on the basis of three percent per drink of spirituous liquor sold, and shall further be computed and payable monthly. Each licensee hereunder, as a condition to the privilege of holding such license in the city shall:
 - (1) *Keep and maintain true and correct records of all sales of spirituous liquors, such records to be preserved for a period of not less than one year and to be made available on request for the inspection of any duly authorized representative of the city.*
 - (2) *On or before the tenth day of each calendar month, each licensee hereunder, shall make a verified and comprehensive report to the city which shall correctly show and reflect all sales of spirituous liquors at his establishment for the calendar month immediately preceding the date of such report. Such report shall show the quantity of spirituous liquor sold, the amount of excise tax collected under the terms of this section, and such other reasonable information as may be requested by the city. Such report shall be accompanied by remittance payable to the city for all taxes collected or due, as shown on such report. If the tax due under this section is not paid on or before the tenth day of each calendar month, a ten percent penalty on the gross tax will be levied by the city against each defaulting licensee for whom the tax is not paid on or before the tenth day of the month.**

- (3) *It shall be a violation of this article for any person to sell within the city any spirituous liquors on which the taxes hereon provided have not been held in trust to be remitted to the city by the tenth day of the following month. Any person violating any of the provisions of this article or who shall assist any licensee hereunder, to evade or avoid payment of the taxes hereon provided for shall be guilty of a violation of this section and on conviction thereof be punished as provided in section 4-2, and any such person so convicted shall also be subject to having his license suspended or revoked.*

State law reference(s)—Authority to impose excise tax on sale of distilled spirits by the drink, O.C.G.A. § 3-4-130.

Sec. 4-712. Tax in addition to license fee.

The excise taxes imposed by this article shall be in addition to any license fee, occupation tax, or charge which may now or in the future be imposed upon the business of selling alcoholic beverages at retail or wholesale within the city.

Sec. 4-713. Retailers' records.

All retail dealers in malt beverages and/or wine, and all persons selling malt beverages and/or wine at retail, shall keep a complete and correct record of all purchases of malt beverages and wine, and shall require all persons from whom they purchase malt beverages or wine to furnish and deliver to them, at the time of delivery of such beverages, a correct invoice of purchase, which invoice shall be kept and preserved by the retailer at his place of business for a period of six months from the date of purchase. Such invoices and all records of retailers of malt beverages and/or wine shall be subject to inspection by any authorized representative of the city. All records of purchase shall be kept a period of at least three years from the date of such purchase or sale before being destroyed.

Sec. 4-714. Penalty for violation of article.

Any person who shall submit a return required by this article which is false or fraudulent, or who shall assist any person to evade the payment of any license tax provided in this article, shall, upon conviction, be punished as provided in section 4-2.

Secs. 4-715—4-715. Reserved.

SPECIAL PURPOSE LOCAL OPTION SALES TAX
INTERGOVERNMENTAL CONTRACT

This Intergovernmental Contract (the "Contract"), is between Walton County, Georgia (the "County"), the City of Monroe ("Monroe"), the City of Loganville ("Loganville"), the City of Social Circle ("Social Circle"), the City of Walnut Grove ("Walnut Grove"), the City of Good Hope ("Good Hope"), the City of Jersey ("Jersey") and the City of Between ("Between" and together with Monroe, Loganville, Social Circle, Walnut Grove, Good Hope and Jersey, the "Cities").

PREAMBLE

Article 3 of Chapter 8 of Title 48 of the Official Code of Georgia Annotated, as amended (the "Act"), provides for the creation of a special district in each county in the State of Georgia and authorizes the imposition of a one percent sales and use tax (the "Sales and Use Tax") in such district for the purposes specified therein.

The County and the Cities wish to continue the Sales and Use Tax presently in effect, which expires on December 31, 2024, and are entering into this Contract for the purpose of specifying the projects to be funded with such Sales and Use Tax and providing for the distribution of the proceeds of the Sales and Use Tax.

In consideration of the mutual agreements of the County and the Cities in this Contract, and for other good and valuable consideration, the receipt and sufficiency of which the County and the Cities acknowledge, the County and the Cities agree as follows:

Section 1. Representations of the Cities.

Each of the Cities hereby represents as follows:

- (a) It is a municipal corporation as defined by law and judicial interpretation and a "qualified municipality" as such term is defined in the Act and has been duly authorized to execute and deliver this Contract and to perform its obligations hereunder, and such authorization has not been revoked or rescinded.
- (b) The execution and delivery of this Contract by the City, and the performance of its obligations hereunder, does not violate any provision of the Constitution or laws of the State of Georgia or any order, rule or regulation of any judicial or governmental agency binding on the City, or violate or constitute (with the passage of time or the provision of notice or both) a breach of or a default under any agreement, contract, instrument, ordinance or other resolution of the City or by which the City is bound.
- (c) To the knowledge of the City, there is no litigation pending or threatened challenging the existence or powers of the City or the ability of the City to enter into this Contract, or seeking to restrain or enjoin the City from entering into this Contract or acquiring, constructing or installing any of the projects sought to be financed from the proceeds of the Sales and Use Tax.

Section 2. Representations of the County.

The County hereby represents as follows:

- (a) It is a political subdivision of the State of Georgia and has been duly authorized to execute and deliver this Contract and to perform its obligations hereunder, and such authorization has not been revoked or rescinded.
- (b) The execution and delivery of this Contract by the County, and the performance of its obligations hereunder, does not violate any provision of the Constitution or laws of the State of Georgia or any order, rule or regulation of any judicial or governmental agency binding on the County, or violate or constitute (with the passage of time or the provision of notice or both) a breach of or a default under any agreement, contract, instrument, ordinance or other resolution of the County or by which the County is bound.
- (c) To the knowledge of the County, there is no litigation pending or threatened challenging the existence or powers of the County or the ability of the County to enter into this Contract, or seeking to restrain or enjoin the County from entering into this Contract, imposing the Sales and Use Tax or acquiring, constructing or installing any of the projects of the County sought to be financed from the proceeds of the Sales and Use Tax.

Section 3. Referendum for Imposition of Sales and Use Tax.

The County agrees that it will take all actions necessary to call a referendum, to be held in all the voting precincts in the County, on the 21st day of May, 2024, or on such other date as the County and the Cities shall mutually agree, for the purpose of submitting to the qualified voters of the County for their approval, the question of whether or not a Sales and Use Tax of one percent shall be imposed on all sales and uses in the special district which consists of Walton County, as authorized by the Act for 24 calendar quarters (six years) for the purpose of funding the projects described in this Contract (collectively the "Projects" or as to any City or the County, the "Projects" of such City or County). The amount of money to be raised by the Sales and Use Tax is estimated to be \$120,000,000. The Projects and the estimated amount of Sales Tax and Use Tax attributable to each Project is shown on Schedule A attached to this Contract.

Section 4. Conditions Precedent.

The obligations of all parties under this Contract are conditioned upon the following events:

- (a) The adoption of a resolution by the Board of Commissioners of Walton County authorizing the imposition of the Sales and Use Tax and calling the referendum described above.
- (b) The approval of the Sales and Use Tax by a majority of the voters in the County voting in the election for those purposes as required by the Act.

Section 5. County Sales and Use Tax Fund; Separate Accounts; No Commingling.

Prior to the first date on which the Sales and Use Tax will be collected, the County shall establish a special fund or account designated as the 2025 Special Purpose Local Option Sales Tax Fund for the County (the "Project Fund Account" of the County), and each City shall create a special fund or account to be designated as the 2025 Special Purpose Local Option Sales Tax Fund for each such City (each such fund or account, the "Project Fund Account" of such City). The County shall select a local bank which shall act as a depository and custodian of the Project Fund Account of the County upon such terms and conditions as may be acceptable to the County, and each City shall select a local bank which shall act as a depository and custodian of the Project Fund Account of each such City upon such terms and conditions as may be acceptable to each such City. All Sales and Use Tax proceeds shall be maintained by the County and each City in the separate accounts or funds established pursuant to this Section. Sales and Use Tax proceeds shall not be commingled with other funds of the County or Cities and shall be used exclusively for the purposes detailed in this Contract. No funds other than Sales and Use Tax proceeds shall be placed in such funds or accounts.

Section 6. Procedure for Disbursement of Sales and Use Tax Proceeds.

Upon receipt by the County of Sales and Use Tax proceeds collected by the state department of revenue, the County shall immediately deposit said proceeds in the County's Project Fund Account and, within ten (10) business days thereof, disburse the Sales and Use Tax proceeds due to each City in accordance with Section 7. The proceeds shall be deposited in the Project Fund Account established by each City in accordance with Section 5. Should any City cease to exist as a legal entity before all funds are distributed under this Contract, that City's share of the funds subsequent to dissolution shall be paid to the County as part of the County's share unless an act of the Georgia General Assembly makes the defunct City part of another successor city. If such an act is passed, the defunct City's share shall be paid to the successor city in addition to all other funds to which the successor city would otherwise be entitled.

Section 7. Priority and Order of Project Funding.

The parties hereto agree that the proceeds of the Sales and Use Tax received each month will be applied as follows (and in the order indicated below):

- (a) First, the Sales and Use Tax receipts shall be deposited into the Project Fund Account of the County in an amount equal to \$480,000 per month, the monthly amount needed for the County to make installment payments to the Walton Industrial Building Authority for the acquisition of the Public Safety Complex as shown on Schedule A.
- (b) Next, the Sales and Use Tax receipts shall be deposited into the Project Fund Account of the County and each of the Cities in accordance with the percentages shown in the column with the heading "Allocation of Sales and Use Tax Proceeds After Funding the County's Acquisition of the Public Safety Complex from the Walton Industrial Building Authority" on Schedule B.

Except as provided in Section 8 of this Agreement, any change to the priority or schedule must be agreed to in writing by all parties to this Contract.

Section 8. Completion of Projects.

The County and Cities acknowledge that the costs shown for each project described on Schedule A are estimated amounts. If a county project has been satisfactorily completed at a cost less than the estimated cost listed for that project in Schedule A, the County may apply the remaining unexpended funds to any other county project in Schedule A. If a city project has been satisfactorily completed at a cost less than the estimated cost listed for that project in Schedule A, the City may apply the remaining unexpended funds to any other project included for that City in Schedule A.

Within thirty (30) days after the Projects of any City have been completed, such City shall file with the County a Certificate of Completion signed by the Mayor, City Manager or other Authorized Signatory, setting forth the date on which the final Project or Projects were completed and stating that all Sales and Use Tax proceeds deposited into the Project Fund Account for such City have been applied to the Project or Projects or otherwise applied in accordance with the Act.

Section 9. Audits.

(a) Each of the Cities and the County shall include in its annual audit the schedule required by Section 48-8-121 of the Act relating to each Project approved for such City or the County in the referendum. Each of the Cities and the County shall publish the report relating to the Projects of such City and County as required by Section 48-8-122 of the Act. Each City and the County agrees that the proceeds received from the Sales and Use Tax shall be used by the County or the City, as the case may be, exclusively for the purpose or purposes specified in the resolution calling for the referendum except as may otherwise be permitted under the Act. Each of the Cities and the County shall be responsible for their own expenses incurred in maintaining such records and making any such reports.

(b) The County and each of the Cities shall have no liability to each other for the failure by any City or the County to spend the proceeds received from the Sales and Use Tax for the purposes authorized in the referendum, although the County shall have the right, but not the duty, to seek to enforce the obligation of each of the Cities to apply the proceeds received from the Sales and Use Tax in accordance with the Act and the referendum.

Section 10. Other Expenses; Reimbursement.

The parties to this Contract acknowledge that the fees and expenses relating to, or incurred incident to, calling the referendum for the imposition of the Sales and Use Tax shall be paid by the County and each City shall reimburse the County for their pro rata share of any such expenses in accordance with the "Percentage of Sales Tax Proceeds for Projects" on Schedule B. The County shall from time to time provide notification to the Cities of any other expenses relating to the Sales and Use Tax proceeds. Each of the Cities agrees that it will be liable to the County for their pro rata share of any such expenses in accordance with the "Percentage of Sales Tax Proceeds for Projects" on Schedule B. In the event that following the passage of the referendum relating to the imposition of the Sales and Use Tax, any litigation or threatened litigation, audit or investigation relating to the imposition of the Sales and Use Tax or the use of the proceeds of the Sales and Use Tax or other similar matters relating thereto shall occur, the County

shall have the right on behalf of itself and the Cities to conduct such litigation or handle such threatened litigation, audit or other investigation and to retain such attorneys and other experts as may be required or appropriate in connection therewith. The County shall give prompt notice to the Cities of the institution of any such litigation or threatened litigation, audit or investigation. Each of the Cities agrees that it will be liable to the County for their pro rata share of the costs of such litigation or threatened litigation, audit or investigation, or for the cost of any judgment or settlement of such litigation or threatened litigation, audit or investigation in accordance with the "Percentage of Sales Tax Proceeds for Projects" on Schedule B. The Cities agree that any payment required to be made to the County under this Section shall be made promptly upon receipt by the City of a statement therefor from the County.

Nothing in this Section shall preclude any City or the County (either individually or collectively) from seeking repayment from, or from instituting any action against, any other party to this Contract to the extent that any action or inaction on the part of any party or parties to this Contract results in liability to the County or the Cities whether directly or indirectly pursuant to this Section of this Contract, and the costs of any such action shall not be shared as provided in this Section but shall be costs of the parties involved in such action.

Section 11. Term of this Contract.

The term of this Contract (assuming the conditions precedent in Section 5 have been satisfied) shall expire at the later of (i) October 1, 2031 or (ii) the date on which any moneys held in any accounts or sub-accounts established under this Contract are fully depleted, but in no event shall this Contract run for more than 50 years from the date hereof.

Section 12. Arbitration.

The parties hereto agree to submit any controversy arising under this Contract to arbitration pursuant to the provisions of O.C.G.A. § 9-9-1 et seq., the Georgia Arbitration Code. Such arbitration shall in all respects be governed by the provisions of the Arbitration Code and the parties hereby agree to comply with and be governed by the provisions of the Arbitration Code as to any controversy so submitted to arbitration.

Section 13. Counterparts.

This Contract may be executed in several counterparts, each of which shall be deemed an original and all of which together shall constitute one and the same instrument.

Section 14. Governing Law.

This Contract and all transactions contemplated hereby shall be governed by, construed and enforced in accordance with the laws of the State of Georgia.

Section 15. Severability.

Should any provision of this Contract or application thereof to any person, entity or circumstance be held invalid or unenforceable, the remainder of this Contract or the application of such provision to any person, entity or circumstance, other than those to which it is held invalid or unenforceable,

shall not be affected thereby, and each provision of this Contract shall be valid and enforceable to the full extent permitted by law.

Section 16. Notices.

All notices, demands or requests required or permitted to be given pursuant to this Contract shall be in writing and shall be deemed to have been properly given or served and shall be effective on being deposited or placed in the United States mail, postage prepaid and registered or certified with return receipt requested to the addresses appearing below, or when delivered by hand to the addresses indicated below:

- (a) As to Walton County:
Walton County Board of Commissioners
Attention: Chairman
111 South Broad Street
Monroe, GA 30655

- (b) As to the City of Monroe:
City of Monroe
Attention: Mayor
215 North Broad Street
Monroe, GA 30655

- (c) As to the City of Loganville:
City of Loganville
Attention: Mayor
P.O. Box 39
4303 Lawrenceville Road
Loganville, GA 30052

- (d) As to the City of Social Circle:
City of Social Circle
Attention: Mayor
P.O. Box 310
166 North Cherokee Road
Social Circle, GA 30025

- (d) As to the City of Walnut Grove:
City of Walnut Grove
Attention: Mayor
2581 Leone Avenue
Loganville, GA 30052

- (e) As to the City of Good Hope:
City of Good Hope
Attention: Mayor
P.O. Box 10
169 Highway 83 South

Good Hope, GA 30641

(g) As to the City of Jersey:

City of Jersey
Attention: Mayor
P.O. Box 218
Jersey, GA 30018

(h) As to the City of Between:

City of Between
Attention: Mayor
P.O. Box 46
1926 New Hope Church Road
Monroe, GA 30655

Any party to this Contract, may, in the manner provided herein for the giving of notices, specify another or different address to which notices under this Contract must be sent by giving notice thereof to each other party to this Contract.

[Signature Pages Follow]

IN WITNESS WHEREOF, all parties hereto have agreed as of the 13th day of February, 2024.

WALTON COUNTY, GEORGIA

By: _____
Chairman

(SEAL)

Attest:

Clerk

CITY OF MONROE

By: _____
Mayor

(SEAL)

Attest:

Clerk

CITY OF LOGANVILLE

By: _____
Mayor

(SEAL)

Attest:

Clerk

[Special Purpose Local Option Sales Tax Intergovernmental Contract]

CITY OF SOCIAL CIRCLE

By: _____
Mayor

(SEAL)

Attest:

Clerk

CITY OF WALNUT GROVE

By: _____
Mayor

(SEAL)

Attest:

Clerk

CITY OF GOOD HOPE

By: _____
Mayor

(SEAL)

Attest:

Clerk

[Special Purpose Local Option Sales Tax Intergovernmental Contract]

CITY OF JERSEY

By: _____
Mayor

(SEAL)

Attest:

Clerk

CITY OF BETWEEEN

By: _____
Mayor

(SEAL)

Attest:

Clerk

[Special Purpose Local Option Sales Tax Intergovernmental Contract]

SCHEDULE A

Walton County, Georgia
Sales and Use Tax 2025-2030

Entity	Project	Estimated Costs of Projects
Walton County	Installment payments to the Walton Industrial Building Authority for the acquisition of the Public Safety Complex	\$34,560,000.00
	Transportation projects	\$20,500,000.00
	Parks and recreation projects including the right to make installment payments to the Walton County Public Facilities Authority for the acquisition of the Walnut Grove Park	\$13,000,000.00
	Building projects	\$12,000,000.00
	Water system improvements	\$3,500,000.00
	Vehicle and major equipment acquisition	\$2,264,000.00
	subtotal	\$85,824,000.00
City of Monroe	Public safety projects, vehicles, and equipment	\$6,168,477.20
	Transportation projects	\$6,168,477.20
	Monroe public facilities capital improvements	\$1,079,483.51
	Parks capital improvements	\$2,004,755.09
	subtotal	\$15,421,193.00
City of Loganville	Parks and recreation projects	\$255,026.12
	Public safety projects	\$623,397.18
	Public utility projects	\$5,440,557.22
	Transportation projects	\$5,015,513.69
	subtotal	\$11,334,494.21
City of Social Circle	Transportation projects	\$1,400,000.00
	Water and sewer projects	\$1,200,000.00
	Public safety projects	\$2,124,849.00
	Parks and recreation projects	\$413,482.60
	subtotal	\$5,138,331.60
City of Good Hope	Transportation projects	\$192,609.96
	Parks and recreation projects	\$87,549.98
	Building upgrades	\$70,039.98
	subtotal	\$350,199.92
City of Walnut Grove	Vehicles and major equipment	\$36,500.00
	Sewer expansion/infrastructure	\$800,000.00
	Transportation, drainage, paving and sidewalk projects	\$433,676.00
	Building upgrades	\$63,500.00
	Parks and recreation projects	\$32,000.39
	subtotal	\$1,365,676.39
City of Jersey	Transportation projects	\$25,000.00
	Water system improvements	\$25,000.00
	Building projects	\$75,823.56

	Parks and recreation projects	\$25,000.00
	subtotal	\$150,823.56
City of Between	Transportation projects	\$25,000.00
	Building upgrades and improvements	\$390,281.32
	subtotal	\$415,281.32
	TOTAL	\$120,000,000.00

[Special Purpose Local Option Sales Tax Intergovernmental Contract]

SCHEDULE B

Walton County, Georgia
Sales and Use Tax 2025-2030

Allocation of Sales and Use Tax Proceeds			
Entity		Estimated Costs of Projects	Allocation of Proceeds After Monthly Funding of County's Acquisition of Public Safety Complex from Walton Industrial Building Authority
Walton County, Georgia		\$85,824,000.00*	60.0000%
City of Monroe		\$15,421,193.00	18.0491%
City of Loganville		\$11,334,494.21	13.2660%
City of Social Circle		\$5,138,331.60	6.0140%
City of Good Hope		\$350,199.92	0.4099%
City of Walnut Grove		\$1,365,676.39	1.5984%
City of Jersey		\$150,823.56	0.1765%
City of Between		\$415,281.32	0.4861%
TOTAL		\$120,000,000	100.00%
		*Includes \$34,560,000.00 for the County's installment payments to the Walton Industrial Building Authority for the acquisition of the Public Safety Complex	

[Special Purpose Local Option Sales Tax Intergovernmental Contract]



4303 Lawrenceville Highway • Loganville, GA 30052 • 770-466-1165 • www.loganville-ga.gov

2025 WALTON COUNTY SPLOST (6 yrs)
January 1, 2025 – December 31, 2030

Parks & Recreation Projects – 2.2500% **\$ 255,026.12**

- 1. Infrastructure upgrades to parks
- 2. Equipment upgrades

Public Safety Projects – 5.5000% **\$ 623,397.18**

- 1. Purchase new police car / suvs
- 2. Equipment for both police and fire (bulletproof vest, cameras and structure firefighting gear)

Public Utilities Projects – 48.0000% **\$ 5,440,557.22**

- 1. Capital Projects (replace sewer, stormwater & water lines)
- 2. Equipment

Transportation Projects – 44.2500% **\$ 5,015,513.69**

- 1. KCI traffic study projects
- 2. Utilities relocation for Ga Hwy 20
- 3. Paving throughout city

Total for Loganville 2025-2030 WC SPLOST **\$ 11,334,494.21**