



# Livingston City Commission Agenda

May 02, 2017

6:30 PM

City – County Complex, Community Room

1. Call to Order

2. Roll Call

3. Moment of Silence

4. Pledge of Allegiance

5. Consent Items

- A. CONSENT - Approve minutes from regular 4.18.17 regular commission meeting Page 4
- B. CONSENT - Approve Claims for second half of April 2017 Page 8
- C. CONSENT - Approve Steve Koonz and Darin MacKenzie to City/County Joint Airport Board Page 23
- D. CONSENT - Approve Tyler Erickson, David DePuy and Dale Sexton to Livingston Building Improvement District Board Page 28

6. Proclamations

- A. PROCLAMATION - Youth Week Proclamation Page 33

7. Scheduled Public Comment

- A. SCHEDULED PUBLIC COMMENT - Chief MacInnes to speak in honor of Captain Walker's retirement
- B. SCHEDULED PUBLIC COMMENT - Marilyn Hartley from the Cannon Committee Page 35

8. Public Hearings

- A. ORDINANCE NO. 2063 - AN ORDINANCE OF THE CITY COMMISSION OF THE CITY OF LIVINGSTON, MONTANA, AMENDING SECTION 4-41, ENTITLED "CIVIL OFFENSES, EXCEPTIONS," BY ADDING AN EXCEPTION TO SUBPART C PERTAINING TO THE BOZEMAN TRAIL CONNECTOR LOCATED BETWEEN JACK WEIMER MEMORIAL PARK AND FLESHMAN CREEK ROAD IN LIVINGSTON, MONTANA. Page 41
- B. ORDINANCE NO. 2064 - AN ORDINANCE OF THE CITY COMMISSION OF THE CITY OF LIVINGSTON, MONTANA, AMENDING ORDINANCE 2049 AND CHAPTER 9, ARTICLE IV OF THE LIVINGSTON MUNICIPAL COE ENTITLED "PARKING, STOPPING, AND STANDING" BY ESTABLISHING FIRE DEPARTMENT PARKING ON EITHER SIDE OF THE CALLENDER STREET ENTRANCE STREET ENTRANCE AND ESTABLISHING A CIVIL PENALTY FOR VIOLATION THEREOF. Page 48

9. Ordinances

- A. ORDINANCE NO. 2065 - AN ORDINANCE OF THE CITY COMMISSION OF THE CITY OF LIVINGSTON, MONTANA, AMENDING SECTION 8-5 OF THE LIVINGSTON MUNICIPAL CODE ENTITLED "DAILY ACCOUNT OF FUNDS COLLECTED; MONTHLY REPORT, CONTENTS" AND SPECIFICALLY AMENDING THE PROCEDURE, CONTENT AND TIME OF THE CITY COURT MONTHLY REPORT. Page 73

10. Resolutions

- A. RESOLUTION NO. 4725 - A RESOLUTION OF THE CITY COMMISSION OF THE CITY OF LIVINGSTON, MONTANA, AUTHORIZING PARTICIPATION IN THE BOARD OF INVESTMENTS OF THE STATE OF MONTANA SHORT TERM INVESTMENT POOL AND AUTHORIZING THE EXECUTION AND DELIVERY OF DOCUMENTS RELATED THERETO. Page 78
- B. RESOLUTION NO. 4726 - A RESOLUTION OF THE CITY COMMISSION OF THE CITY OF LIVINGSTON, MONTANA, ACCEPTING THE SEWER EXTENSION FROM HOMES ON 400 AND 500 BLOCK OF NORTH 10TH STREET AND HOMES NEAR THE 700 BLOCK OF NORTH 10TH STREET NEAR WEST RESERVOIR STREET. Page 87

11. Action Items

12. City Manager Comment

13. City Commission Comments

14. Public Comments

*Individuals are reminded that public comments should be limited to items over which the City Commission has supervision, control, jurisdiction, or advisory power (MCA 2-3-202).*

15. Adjournment

**Calendar of Events**

May 2, 2017 - 6:30 p.m. - City Commission regular meeting, Community Room, City/County Complex

May 3, 2017 - 4:00 p.m. - City - County Joint Meeting, MSU Extension, 119 South 3rd Street

May 3, 2017 - 5:00 p.m. - City- County Economic Community Development Committee Meeting, MSU Extension Office, 119 South 3rd St.

May 9, 2017 -7:00 p.m. - City Board of Adjustments regular meeting, Community Room, City/County Complex

May 10, 2017 - 3:30 p.m. - Historic Preservation Committee regular meeting, Community Room, City/County Complex

May 15, 2017 - 4:30 p.m. - City- County Compact meeting, MSU Extension, 119 South 3rd Street

May 16, 2017 - 5:30 p.m. - 6:30 p.m. - City Commission closed meeting to discuss litigation strategy

May 16, 2017 - 6:30 p.m. - City Commission regular meeting, Community Room, City/County Complex

May 17, 2017 - 8:30 a.m. - Urban Renewal Agency regular meeting, Community Room, City/County Complex

May 17, 2017 - 5:30 p.m. - Planning Board regular meeting, Community Room, City/County Complex

May 17, 2017 - 4:00 p.m. - Library Board regular meeting, Livingston - Park County Library, 228 West Callender

May 19, 2017 - National Bike to Work Day

May 24, 2017 - 6:00 p.m. - Parks and Trails regular meeting, Community Room, City/County Complex

## Supplemental Material

### Notice

- **Public Comment:** The public can speak about an item on the agenda during discussion of that item by coming up to the table or podium, signing-in, and then waiting to be recognized by the Chairman. Individuals are reminded that public comments should be limited to items over which the City Commission has supervision, control, jurisdiction, or advisory power (MCA 2-3-202).
- **Meeting Recording:** An audio and/or video recording of the meeting, or any portion thereof, may be purchased by contacting the City Administration. The City does not warrant the audio and/or video recording as to content, quality, or clarity.
- **Special Accommodation:** If you need special accommodations to attend or participate in our meeting, please contact the Fire Department at least 24 hours in advance of the specific meeting you are planning on attending.

**Backup material for agenda item:**

- A. CONSENT - Approve minutes from regular 4.18.17 regular commission meeting

# MINUTES

**Livingston City Commission**  
**April 18, 2017**  
**6:30 p.m.**  
**City- County Complex, Community Room**

**1. Call to Order**

**2. Roll Call**

- Bennett, Hogle, Friedman, Schwarz and Sandberg were present.

**3. Moment of Silence**

**4. Pledge of allegiance**

**5. Consent Items (00:02:04)**

**A. CONSENT - Approve Minutes from 4.4.17 regular commission meeting**

**B. CONSENT - Approve bills from first half of April 2017**

- Friedman made a motion to approve Consent Items A and B. Hogle seconded.
  - All in favor, motion passed 5-0.

**6. Proclamations**

**ACTION ITEM A: DISCUSS/APPROVE/DENY - Motion to pull tabled items from March 7, 2017 regular Commission Meeting and proceed with Public Hearing (00:03:44)**

- Schwarz made a motion to pull the items tabled from the March 7, 2017 regular Commission Meeting and proceed with Public Hearing. Hogle seconded.
  - Motion passed 4-1. (Sandberg opposed.)

**7. Scheduled Public Comment**

**8. Public Hearings**

**A. PUBLIC HEARING - Public Comment on Proposed Northtown Livingston LLC request for Zone Change (00:07:05)**

- Mark Narden made comments (01:07:48)
- Lee Strancek made comments (01:12:21)
- Rose Klumpers made comments (01:14:09)

- Mary Ples made comments (01:15:40)
- Mark Pesa made comments (01:20:34)
- Brooke Weimer made comments (01:23:47)
- Karla Pettit made comments (01:26:49)
- Tom Gierhan made comments (01:34:10)
- Cliff Schaefer made comments (01:36:00)
- JC Carmeichel made comments (01:41:41)
- Michael Pincon made comments (01:44:44)
- Jamie Chu made comments (01:46:39)
- Kerwin Klumpers made comments (01:49:20)
- Kelly O’Hara made comments (01:57:20)
  
- Chairman Bennett called for a ten minute recess (01:57:20)
- Meeting reconvened (02:13:10)

**9. Ordinances**

**10. Resolutions**

**11. Action Items**

**B DISCUSS/APPROVE/DENY - Northtown Livingston, LLC request for zone change (02:13:30)**

- Mark Nardin made comments (03:13:21)
- Donna Fairchild made comments (03:17:21)
- JC Carmiechel made comments (03:20:04)
  
- Friedman made a motion to extend the meeting. Schwarz seconded.
  - All in favor, motion passed 5-0.
  
- Brooke Weimer made comments (03:48:09)
  
- Friedman made a motion to approve Northtown Livingston, LLC request for zone change. Bennett seconded.
  - Motion failed 3-2. (Schwarz and Sandberg opposed. Super majority required.)

**C DISCUSS/APPROVE/DENY - Proposed Northtown Livingston LLC Subdivision**

- Action Item C not discussed as Action Item B failed.

**12. City Manager Comment (03:31:52)**

**13. City Commission Comments**

- Sandberg made comments (03:32:24)
- Friedman made comments (03:33:22)
- Hoglund made comments (03:33:38)

**14. Public Comments**

- Patricia Grabow made comments (03:36:24)

**15. Adjournment (03:37:28) 10:06 p.m.**

**Backup material for agenda item:**

- B. Approve Claims for second half of April 2017



For doc #s from 31666 to 31797, Operating Cash  
\* ... Over spent expenditure

Claim	Check	Invoice	Vendor #/Name/ #/Inv Date/Description	Document \$/ Line \$	Disc \$	PO #	Fund	Org	Acct	Object	Proj	Cash Account
31674		3255	INDUSTRIAL COMMUNICATIONS & 18715 12/15/16 Net Clock	11,434.25 8,692.00*			2300	132	420160	940		101000
	18822	01/30/17	Network Switch	410.00*			2300	132	420160	940		101000
	18958	03/16/17	Encore headsets	472.00*			2300	132	420160	940		101000
	18882	02/23/17	Service Agreement12/16-2/28/17	1,860.25			2300	132	420160	350		101000
31676		3529	KASTING,KAUFFMAN & MERSEN PC 199629 04/12/17 Legal Service C Berntsen	1,447.74 1,078.36*			1000	107	411100	350		101000
	199631	04/12/17	Legal Service D. Taylor	297.50*			1000	107	411100	350		101000
	199629	04/12/17	Legal Service G. Lutes	71.88*			1000	107	411100	350		101000
31677		1522	DAVE'S LOCK & KEY 10451 04/10/17 Master Rekey locks, keys	1,416.00 148.00*			2300	132	420160	940		101000
	10200	04/12/17	9 New Locks on doors	775.00*			2300	132	420160	940		101000
	10455	04/17/17	Tumbler lock installed	493.00*			2300	132	420160	940		101000
31678		3020	SECURITY SOLUTIONS, INC. 6531 03/31/17 3 Interior Alarm Lock Doors	2,739.00 2,739.00*			2300	132	420160	940		101000
31679		999999	O'CONNOR, TERESA 16-17 05/02/17 Flex Account	252.00 252.00			7910		212970			101000
31680		54	GATEWAY OFFICE SUPPLY 36063 04/19/17 Paper & Files	20.45 20.45			1000	123	411700	211		101000
31681		250	INSTY-PRINTS 20618 04/19/17 Name Plate - Jay Poteen	22.75 22.75			1000	123	411700	211		101000
31682		3680	FETTERHOFF, PAIGE 16-17 04/20/17 Reimburse Flex Daycare	569.55 569.55			7910		212970			101000
31683		999999	MISKA, DIANE CR16-0002 04/13/17 Restitution release J. Munr	80.00 80.00			1000		351030			101000
31684		999999	MISKA, DIANE CR16-0001 04/13/17 Restitution Release D. Munr	80.00 80.00			1000		351030			101000
31685		109	MAILING SYSTEMS PLUS MORE 4667 04/17/17 Mian Ink Cartridge & label tap	275.38 275.38			1000	123	411700	310		101000
31686		2608	STATE OF MONTANA - ITSD 20170331 03/31/17 33% Video Conferencing	109.29 109.29			1000	102	410360	380		101000

For doc #s from 31666 to 31797, Operating Cash  
\* ... Over spent expenditure

Claim	Check	Invoice #/Inv Date	Vendor #/Name/ Date/Description	Document \$/ Line \$	Disc \$	PO #	Fund	Org	Acct	Object	Proj	Cash Account
31687	17200908	04/12/17	1747 CANON FINANCIAL SERVICES, INC Canon Lease	86.10 86.10*			1000	109	460442	320		101000
31688	31705 317015	04/07/17 04/07/17	278 MMIA Deductible recovery L. Carey Deductible recovery R. Palmare	3,000.00 1,500.00* 1,500.00*			5310 5310	503	510331	511 511		101000 101000
31689	308503	04/12/17	64 NEWMAN TRAFFIC SIGNS Fire Dept Parking sings	58.42 58.42			1000	141	420400	220		101000
31690	45929	04/03/17	3371 BALCO UNIFORM COMPANY, INC. Reserve Uniform	100.99 100.99			5510	142	420402	148		101000
31691	34-119	04/05/17	58 MSU FIRE TRAINING SCHOOL firefighter 2 (Franz)	1,550.00 1,550.00			1000	141	420400	380		101000
31692	1122747	04/12/17	2666 MUNICIPAL EMERGENCY SERVICES Bunkder boot	305.31 305.31			1000	141	420410	220		101000
31693	36042	04/18/17	54 GATEWAY OFFICE SUPPLY Office supplies	34.04 34.04			5510	142	420730	210		101000
31694	82468422	04/18/17	2662 BOUND TREE MEDICAL, LLC Patient supplies	291.34 291.34			5510	142	420730	210		101000
31695	528195	04/04/17	1845 GENERAL DISTRIBUTING COMPANY Oxygen	143.36 143.36			5510	142	420730	235		101000
31696	18040	04/18/17	55 LIVINGSTON HEALTH CARE-MEMORIAL Patient supplies	42.05 42.05			5510	142	420730	235		101000
31697	40017-04 40017-04 40017-04	04/17/17 04/17/17 04/17/17	999999 STONEMAN, JOHN Overpayment on acct Overpayment on acct Overpayment on acct	50.04 16.68 16.68 16.68			5210 5310 5410		343021 343031 343041			101000 101000 101000
31698	URA 2017	04/14/17	3684 TRIPLE M COOKING 16-17 URA Grant - Triple Co	23,000.00 23,000.00			2310		470300	940		101000
31699	2609	04/10/17	3289 ALL WASHED UP , LLC 37% Window Clean Courthouse	249.75 249.75			1000	121	411230	360		101000

04/26/17  
09:21:42

CITY OF LIVINGSTON  
Claim Approval List  
For the Accounting Period: 5/17

Page: 3 of 14  
Report ID: AP100

For doc #s from 31666 to 31797, Operating Cash  
\* ... Over spent expenditure

Claim	Check	Invoice #/Inv Date	Vendor #/Name/ Date/Description	Document \$/ Line \$	Disc \$	PO #	Fund	Org	Acct	Object	Proj	Cash Account
31700	4	04/30/17	2197 TUBAUGH, MATTHEW F. Settlement Payment	18,750.00 18,750.00			1000	131	420100	814		101000
31701	20459973	04/06/17	1783 J & H OFFICE EQUIPMENT Canon copier lease	275.29 275.29*			1000	123	411700	368		101000
31702	16-17	05/03/17	353 BOWLES, SCOTT Flex account	49.20 49.20			7910		212970			101000
31703	Sept 2015	04/21/17	3146 OFFICE OF THE STATE PUBLIC Public Defender Fees Sept 2	550.00 550.00			1000		351036			101000
31704	Oct 2015	04/21/17	3146 OFFICE OF THE STATE PUBLIC Public Defender Fees Oct 201	300.00 300.00			1000		351036			101000
31705	10382	03/31/17	1522 DAVE'S LOCK & KEY Dispatch lock upgrades	670.00 670.00*			2300	132	420160	940		101000
31706	16-17	04/11/17	3596 DENTON, KRISTINE Travel to Lewistown conference	154.08 154.08			1000	102	410360	370		101000
31707	2017	04/12/17	3307 MJC&MCCA Spring Regional Meeting	35.00 35.00			1000	102	410360	380		101000
31708	41005	03/31/17	3633 BILLING DOCUMENT SPECIALISTS Online monthly maintenance	320.00 106.67			5210	502	430570	213		101000
	41005	03/31/17	Online monthly maintenance	106.67			5310	503	430670	213		101000
	41005	03/31/17	Online monthly maintenance	106.66			5410	504	430870	213		101000
31709	835891768	04/01/17	2823 WEST PAYMENT CENTER - Thomson Charges - March	287.00 287.00			1000	107	411100	334		101000
31710	33986	04/12/17	2999 TEAR IT UP L.L.C. Shred 440 lbs -Archives	154.80 106.00*			1000	123	411700	360		101000
	33985	04/12/17	Shred 154 lbs Courthouse	48.80*			1000	123	411700	360		101000
31711	20450	04/07/17	250 INSTY-PRINTS Name Plate - Michael Kardoes	22.75 22.75			1000	123	411700	211		101000
31712	2899	04/02/17	3042 ARTISTIC LANDSCAPING,LLC 37% Power rake & Aerate lawn	168.35 168.35			1000	121	411230	360		101000



04/26/17  
09:21:42

CITY OF LIVINGSTON  
Claim Approval List  
For the Accounting Period: 5/17

Page: 5 of 14  
Report ID: AP100

For doc #s from 31666 to 31797, Operating Cash  
\* ... Over spent expenditure

Claim	Check	Invoice	Vendor #/Name/ #/Inv Date/Description	Document \$/ Line \$	Disc \$	PO #	Fund	Org	Acct	Object	Proj	Cash Account
	1441030-2	04/10/17	D and Geyser Well House	1,487.39			5210	502	430515	341		101000
	0709874-2	04/07/17	Werner Addition pump	103.67			5210	502	430515	341		101000
31722			151 NORTHWESTERN ENERGY	1,101.01								
	1498936-2	04/13/17	I90 and 89S	5.85			2400		420100	340		101000
	0709796-7	04/13/17	97 View Vista Dr	5.85			2400		420100	340		101000
	1893530-4	04/13/17	600 W Park	70.27			2400		420100	340		101000
	1493850-0	04/13/17	412 W Callender	88.43			2400		420100	340		101000
	3141997-1	04/13/17	C and D on Lewis	29.91			2400		420100	340		101000
	2023484-5	04/13/17	1100 W Geyser	8.05			2400		420100	340		101000
	2023479-5	04/13/17	900 W Geyser	8.30			2400		420100	340		101000
	2114861-4	04/13/17	132 South B	171.02			2400		420100	340		101000
	1893536-1	04/13/17	E Street and ally	54.44			2400		420100	340		101000
	1893541-1	04/13/17	18 W Park	95.90			2400		420100	340		101000
	1747572-4	04/13/17	F and G on Callender	47.63			2400		420100	340		101000
	1747570-8	04/13/17	D and E on Callender	69.38			2400		420100	340		101000
	1613803-4	04/13/17	M and N on Callender	71.04			2400		420100	340		101000
	1290352-2	04/13/17	School Flasher Park and 13t	8.36			2400		420100	340		101000
	1134879-4	04/13/17	N 7th and Montana and Chino	53.62			2400		420100	340		101000
	1134866-1	04/13/17	N 2nd and Montana and Chino	83.18			2400		420100	340		101000
	0709869-2	04/13/17	Carol Lane	120.11			2400		420100	340		101000
	3093027-5	04/13/17	105 West Park	41.25			2400		420100	340		101000
	3093023-4	04/13/17	320 North Main	17.23			2400		420100	340		101000
	3093003-6	04/13/17	114 West Summit	31.76			2400		420100	340		101000
	3184602-5	04/13/17	202 South 2nd	19.43			2400		420100	340		101000
31723			151 NORTHWESTERN ENERGY	9,079.75								
	0709793-4	04/13/17	City shop 50% 406 Bennett	291.02			2500	151	430220	341		101000
	0709793-4	04/13/17	City shop 50% 406 Bennett	291.02*			5410	504	430820	341		101000
	2171060-3	04/13/17	Scale House 408 Bennett str	67.91*			5410	504	430820	341		101000
	1728687-3	04/06/17	Transfer Station 408 Bennet	570.34*			5410	504	430820	341		101000
	0709794-2	04/06/17	WWTP 316 Bennett	7,311.37			5310	503	430640	341		101000
	0720048-8	04/06/17	330 Bennett 1/4	111.43			5210	502	430520	341		101000
	0720048-8	04/06/17	330 Bennett 1/4	111.44			5310	503	430620	341		101000
	0720048-8	04/06/17	330 Bennett 1/4	111.44*			5410	504	430820	341		101000
	0720048-8	04/06/17	330 Bennett 1/4	111.43			1000	106	411030	341		101000
	3267010-1	04/06/17	330 Bennett - Compactor	43.81*			5410	504	430820	341		101000
	3015965-1	04/13/17	330 Bennett Fire training c	58.54			1000	141	420400	341		101000
31724			22 ALL SERVICE TIRE & ALIGNMENT,	20.00								
	51960	04/12/17	997 tire	10.00			1000	155	430930	361		101000
	51763	03/14/17	Mower	10.00			1000	155	430930	231		101000

For doc #s from 31666 to 31797, Operating Cash  
\* ... Over spent expenditure

Claim	Check	Invoice #/Inv Date/Description	Vendor #/Name/	Document \$/ Line \$	Disc \$	PO #	Fund	Org	Acct	Object	Proj	Cash Account
31725		3223 BERG'S OVERHEAD DOOR LLC		90.00								
	2022 04/14/17	Transfer station		90.00			5410	504	430830	361		101000
31726		23 CARQUEST AUTO PARTS		893.80								
	1912371480	02/21/17 Air filter		31.03*			2500	151	430240	232		101000
	1912374904	04/05/17 Air filter		363.80*			2500	151	430240	232		101000
	1912374558	03/31/17 Mowers		474.24			1000	155	430930	231		101000
	1912375230	04/07/17 Wiper blade		15.99			1000	155	430950	232		101000
	1912376226	04/20/17 Garbage truck		8.74			5410	504	430830	232		101000
31727		54 GATEWAY OFFICE SUPPLY		26.26								
	398 03/27/17	UPS MSE labs		13.13			5210	502	430515	355		101000
	398 02/27/17	UPS MSE labs		13.13			5210	502	430515	355		101000
31728		2874 HD SUPPLY WATERWORKS, LTD.		743.36								
	984639 03/30/17	Starlo parts		466.88*			3200		490200	940		101000
	127926 12/08/16	Supplies		171.34			5310	503	430625	231		101000
	124437 12/05/17	Gasket and leak detector		105.14			5210	502	430515	231		101000
31729		250 INSTY-PRINTS		41.50								
	43401 04/13/17	Daily well logs		41.50			5210	502	430515	231		101000
31730		102 INDUSTRIAL TOWEL		66.67								
	15713 04/21/17	Mat cleaning		8.56			5210	502	430510	224		101000
	15713 04/21/17	Mat cleaning		8.55			5310	503	430610	224		101000
	15713 04/21/17	Mat cleaning		8.55			2500	151	430220	224		101000
	15713 04/21/17	Mat cleaning		8.55			5410	504	430820	220		101000
	15713 04/21/17	Mat cleaning		8.56			1000	106	411030	200		101000
	15713 04/21/17	Slate WWTP		23.90			5310	503	430610	224		101000
31731		2426 GRANITE TECHNOLOGY SOLUTIONS,		4,798.00								
	20653 02/28/17	Cableing - PD		1,411.00*			2300	132	420160	940		101000
	20652 02/28/17	Cableing -Dispatch		2,210.00*			2300	132	420160	940		101000
	20655 02/28/17	Cableing -Civic Center		1,177.00			1000	109	460449	368		101000
31732		3387 J & H, Inc.		125.91								
	500640 04/07/17	Copier monthly maint. water		25.18			5210	502	430515	368		101000
	500640 04/07/17	Copier monthly maint. sewer		25.18			5310	503	430625	368		101000
	500640 04/07/17	Copier monthly maint. solid wa		25.18			5410	504	430830	368		101000
	500640 04/07/17	Copier monthly maint. street		25.18			2500	151	430240	368		101000
	500640 04/07/17	Copier monthly maint. building		25.19			1000	106	411030	368		101000

For doc #s from 31666 to 31797, Operating Cash  
\* ... Over spent expenditure

Claim	Check	Invoice #/Inv Date	Vendor #/Name/ Date/Description	Document \$/ Line \$	Disc \$	PO #	Fund	Org	Acct	Object	Proj	Cash Account
31733	16-17	04/20/17	3454 BURNS, CORRIE Gymnastics Instruction (Feb-Ap	2,610.00 2,610.00			1000	109	460449	316		101000
31734	16-17	04/20/17	3466 KIRK MICHAELS ARCHITECT, INC. Police Remodel (Bid Notices)	2,084.36 2,084.36*			2300	132	420160	940		101000
31735	501161	04/14/17	3387 J & H, Inc. Copier	272.21 177.50			1000	109	460449	368		101000
	16535	04/13/17	Copier	94.71			1000	109	460449	368		101000
31736	16-17	03/25/17	3444 LOWY, LISA Reimburse office supplie	32.50 32.50			1000	109	460449	368		101000
31737	16-17	04/20/17	1292 PARK COUNTY RURAL FIRE DISTRICT City Portion of HR Training se	1,200.00 1,200.00			1000	109	410450	350		101000
31738	0521017	05/01/17	3407 LIVINGSTON DAYCARE, LLC Parking lot lease - May	900.00 900.00			1000	121	411230	532		101000
31739	431198	04/12/17	15 JOHN DEERE FINANCIAL Mower	41.80 41.80			1000	155	460430	231		101000
31740	709868	04/10/14	151 NORTHWESTERN ENERGY 37% Facility	2,826.93 8.52			1000	121	411230	341		101000
	709935	04/10/14	37% Facility	2,419.41			1000	121	411230	341		101000
	3286284	04/10/14	101 Star Road	155.55			1000	121	411230	341		101000
	3120133	04/10/14	110 S. B Street	140.53			1000	121	411230	341		101000
	3120134	04/10/14	112 S. B Street	102.92			1000	121	411230	341		101000
31741	48665	04/12/17	1390 KEN'S EQUIPMENT REPAIR, INC 410E	41.50 41.50			5210	502	430515	362		101000
31742	209796	04/10/17	26 LIVINGSTON ACE HARDWARE - Scoop	597.12 79.98			2500	151	430240	231		101000
	209790	04/10/17	Shop	116.30			1000	155	460430	231		101000
	209803	04/10/17	Pool	16.78			1000	155	460445	231		101000
	209826	04/10/17	Tools	66.09			1000	155	430950	940		101000
	209350	03/30/17	Starlo	33.96*			3200		490200	940		101000
	209261	03/28/17	Supplies	5.99			5210	502	430515	231		101000
	209464	04/03/17	Supplies	2.59			5210	502	430515	231		101000
	210102	04/17/17	Blower	26.49			1000	155	460430	231		101000
	210216	04/19/17	Irrigation	25.98			1000	155	460430	231		101000
	210227	04/19/17	Legion field	35.32			1000	155	460430	231		101000
	210198	04/18/17	Legion field	22.98			1000	155	460430	231		101000
	210287	04/20/17	Eup. repair	33.15			1000	155	460430	231		101000
	210310	04/20/17	Legion field	2.99			1000	155	460430	231		101000

04/26/17  
09:21:42

CITY OF LIVINGSTON  
Claim Approval List  
For the Accounting Period: 5/17

Page: 8 of 14  
Report ID: AP100

For doc #s from 31666 to 31797, Operating Cash  
\* ... Over spent expenditure

Claim	Check	Invoice	Vendor #/Name/ #/Inv Date/Description	Document \$/ Line \$	Disc \$	PO #	Fund	Org	Acct	Object	Proj	Cash Account
	209867	04/11/17	Pool	19.90			1000	155	460445	231		101000
	209565	04/04/17	Cemetery	87.95			1000	155	430930	361		101000
	210345	04/21/17	Garbage trucks	20.67			5410	504	430830	231		101000
31744			162 CENTURYLINK	800.12								
	3850	04/04/17	Sewer Plant	176.34			5310	503	430640	343		101000
	0082	04/04/17	City shop 50%	30.61*			2500	151	430220	343		101000
	0082	04/04/17	City shop 12%	7.35			5310	503	430620	343		101000
	0082	04/04/17	City shop 38%	23.25			5410	504	430820	343		101000
	5606	04/04/17	Utility 1/3	0.00			5210	502	430520	343		101000
	5570	04/04/17	Utility 1/3	0.00			5310	503	430620	343		101000
	5570	04/04/17	Utility 1/3	0.00			5410	504	430820	343		101000
	5240	04/04/17	Scale House	92.00*			5410	504	430870	346		101000
	0149	04/04/17	Civic Center	98.94*			1000	109	460449	343		101000
	6003	04/14/17	Finance Office 110 S. B	371.63			1000	122	411300	343		101000
	0083	04/04/17	Building Dept.	0.00			1000	143	420403	343		101000
	6436	04/04/17	Park Dept	0.00*			1000	153	460430	343		101000
31745			2904 FISHER SAND AND GRAVEL	5,681.57								
	32715	03/31/17	Miles lane	4,553.55*			2399		430240	960		101000
	31495	03/18/17	Gravel	1,128.02			5310	503	430630	960		101000
31746			3040 MIDWAY RENTAL, INC.	708.90								
	5-731116	03/24/17	Compactor	708.90			5310	503	430630	960		101000
31749			10 MOBILE REPAIR & WELDING, INC	125.13								
	28311	04/05/17	Starlo welding	125.13*			3200		490200	940		101000
31750			112 MONTANA RAIL LINK	733.50								
	801908	03/01/17	MRL Lease	733.50			5310	503	430610	535		101000
31751			2731 MONTANA WASTE SYSTEMS, INC	63,918.81								
	1209379	03/31/17	Transfer fees	63,918.81			5410	504	430840	396		101000
31752			34 MOUNTAIN AIR SPORTS	381.60								
	16807	03/24/17	Shirts and hoodies	76.32			1000	155	430950	148		101000
	16807	03/24/17	Shirts and hoodies	76.32			2500	151	430240	148		101000
	16807	03/24/17	Shirts and hoodies	76.32			5210	502	430515	148		101000
	16807	03/24/17	Shirts and hoodies	76.32			5310	503	430625	148		101000
	16807	03/24/17	Shirts and hoodies	76.32			5410	504	430830	148		101000
31753			1920 HORIZON AUTO PARTS	180.32								
	789556	04/07/17	Beacon	180.32*			2500	151	430240	232		101000



For doc #s from 31666 to 31797, Operating Cash  
\* ... Over spent expenditure

Claim	Check	Invoice	Vendor #/Name/ #/Inv Date/Description	Document \$/ Line \$	Disc \$	PO #	Fund	Org	Acct	Object	Proj	Cash Account
31754		64	NEWMAN TRAFFIC SIGNS	12,271.91								
	0307986	03/28/17	Street signs	1,827.27*			2820	210	430240	241		101000
	0308150	03/31/17	Street signs	5,000.00			2500	151	430240	940		101000
	0308150	03/31/17	Street signs	5,444.64*			2820	210	430240	241		101000
31755		1199	O'CONNOR'S BODY SHOP, LLC	778.00								
	3258	04/14/17	GMC Sierra 1500	778.00			5210	502	430515	362		101000
31756		2437	O'REILLY AUTOMOTIVE, INC	13.99								
	1558487921	04/07/17	Gloves	13.99			1000	155	460430	231		101000
31757		16	PARISI WESTERN PLUMBING &	13.45								
	41281	03/23/17	Supplies	37.35			5310	503	430625	231		101000
	40556	02/15/16	Supplies - duplicate payment	-23.90			5210	502	430515	231		101000
31758		1718	SOLID WASTE SYSTEMS, INC.	1,398.42								
	0092644	01/23/17	Parts for 570-571 garbage tru	1,398.42			5410	504	430830	232		101000
31759		3353	STORY DISTRIBUTING	656.99								
	76302	04/11/17	Diesel fuel 287g	642.59*			1000	123	411700	236		101000
	76302	04/11/17	Additive 18oz	14.40*			1000	123	411700	236		101000
31760		2991	TITAN MACHINERY	615.44								
	9144920	04/04/17	Cylinders	615.44*			2500	151	430240	232		101000
31762		3020	SECURITY SOLUTIONS, INC.	1,826.00								
	6530	03/31/17	Dispatch Remodel	1,826.00*			2300	132	420160	940		101000
31763		1384	TIMBER TRAILS	137.00								
	16-17	03/12/16	Police bike maintenance	137.00			1000	131	420100	360		101000
31764		3371	BALCO UNIFORM COMPANY, INC.	83.10								
	46073-2	04/10/17	New Hire Gear	37.10			1000	131	420100	220		101000
	52661	04/12/17	New Hire Gear	16.00			1000	131	420100	220		101000
	46220	04/12/17	New Hire Gear	30.00			1000	131	420100	220		101000
31765		22	ALL SERVICE TIRE & ALIGNMENT,	41.00								
	51997	04/19/17	Oil Change	41.00			1000	131	420100	360		101000
31766		2951	MT LAW ENFORCEMENT TESTING	128.00								
	2017	01/29/17	Membership dues	28.00			1000	131	420100	334		101000
	2017	04/18/17	New Hire fees	100.00			1000	131	420100	350		101000

For doc #s from 31666 to 31797, Operating Cash  
\* ... Over spent expenditure

Claim	Check	Invoice	Vendor #/Name/ #/Inv Date/Description	Document \$/ Line \$	Disc \$	PO #	Fund	Org	Acct	Object	Proj	Cash Account
31767	34445	01/31/17	3685 CRESTMARK Old computer return surcharge	750.00 750.00			1000	131	420100	311		101000
31768	10410	04/12/17	642 MONTANA LAW ENFORCEMENT ACADEMY Training Tuition - Engle	395.00 350.00			1000	131	420100	380		101000
	10410	04/12/17	Meals, lodging MLEA	45.00*			1000	131	420100	370		101000
31769	9783291378	04/04/17	879 VERIZON WIRELESS Air Cards - March	406.35 406.35			1000	131	420100	347		101000
31770	296333	04/06/17	738 SIRCHIE Evidence collection supplies	461.59 461.59			1000	131	420100	220		101000
31771	20802	03/30/17	2426 GRANITE TECHNOLOGY SOLUTIONS, Monthly IT Support - March	1,471.00 60.00			1000	131	420100	350		101000
	20800	03/30/17	Remodel Cable Install	1,411.00*			2300	132	420160	940		101000
31772	13156	04/07/17	3237 WHISTLER TOWING, LLC Abandon Vehicle tow 77 RV	85.00 85.00			1000	131	420100	350		101000
31773	21843	04/12/17	1687 HANSER'S AUTOMOTIVE & WRECKER suspect Vehicle tow 2000 Chevy	90.00 90.00			1000	131	420100	350		101000
31774	313837182	03/27/17	292 UPS STORE #2420, THE Package to Crime lab	9.71 9.71			1000	123	411700	310		101000
31776	209059	03/23/17	26 LIVINGSTON ACE HARDWARE - Paint Mat'ls	120.32 14.97*			1000	109	460449	220		101000
	209257	03/28/17	Fasteners	1.39*			1000	109	460449	220		101000
	209331	03/01/17	Drop cloth	4.99*			1000	109	460449	220		101000
	210252	04/19/17	Paint - Conference room/office	98.97*			1000	109	460449	220		101000
31777	16-17	04/03/17	3364 CITY OF LIVINGSTON Water for office	10.75 10.75*			1000	109	460449	220		101000
31778	20355	03/30/17	250 INSTY-PRINTS Business Cards- Maggie	49.90 24.95			1000	109	460449	320		101000
	20355	03/30/17	Business Cards- Kardoes	24.95*			1000	103	410400	200		101000
31779	35949	04/05/17	54 GATEWAY OFFICE SUPPLY Envelopes - Yth BB mat'l	30.38 12.00*			1000	109	460449	220		101000
	35681	04/10/17	1" letters- Rec. Dept sign	3.39*			1000	109	460449	220		101000
	36023	04/17/17	Envelopes - Summerfest	14.99*			2210	109	460439	350		101000

For doc #s from 31666 to 31797, Operating Cash  
\* ... Over spent expenditure

Claim	Check	Invoice #/Inv Date/Description	Vendor #/Name/	Document \$/ Line \$	Disc \$	PO #	Fund	Org	Acct	Object	Proj	Cash Account
31780		3390 TD&H ENGINEERING, INC		18,845.31								
	9173	04/14/17 080 Hydro geologic Study		54.25			5210	502	430520	940		101000
	9173	04/14/17 027 Storm water study		108.50*			2399		430240	960		101000
	9173	04/14/17 026 Booster station		1,263.50*			3200		490200	940		101000
	9173	04/14/17 029 Livingston Healthcare Revi		739.75			5310	503	430610	352		101000
	9173	04/14/17 029 Livingston Healthcare Revi		739.75			5210	502	430515	350		101000
	9173	04/14/17 022 6th and 7th Water Main		2,666.75			5210	502	430520	960		101000
	9173	04/14/17 020 General Civil		399.70			5310	503	430610	352		101000
	9173	04/14/17 020 General Civil		399.70			5210	502	430515	350		101000
	9173	04/14/17 020 General Civil-Weekly mee		400.00			2500	151	430220	352		101000
	9173	04/14/17 028 Transportation Master Plan		8,024.91*			2399		430240	960		101000
	9173	04/14/17 081 10th street sewer main		522.75			5310	503	430610	352		101000
	9173	04/14/17 060 PRV Inspection		3,204.75			5210	502	430515	350		101000
	9173	04/14/17 Vault Project		321.00			2310		470300	940		101000
31781		999999 SIMMONS, GWEN		32.14								
	16-17	04/13/17 Fruit - PIR day		32.14*			1000	109	460449	226		101000
31782		999999 WARNER, MARGARET		269.00								
	TK16-0056	04/21/17 Restitution Justyne Aurty		170.00			1000		341010			101000
	TK16-0055	04/21/17 Restitution Justyne Aurty		99.00			1000		341010			101000
31783		3390 TD&H ENGINEERING, INC		313.50								
	9174	04/24/17 2016 CIP		70.54*			2500	151	430240	960		101000
	9174	04/24/17 2016 CIP		172.42			5210	502	430520	960		101000
	9174	04/24/17 2016 CIP		70.54			5310	503	430630	960		101000
31784		999999 MISKA, DIANE		40.00								
	CR16-0002	04/19/17 Restitution J. Munro		20.00			1000		341010			101000
	CR16-0001	04/19/17 Restitution D. Munro		20.00			1000		341010			101000
31785		3390 TD&H ENGINEERING, INC		655.00								
	9175	04/24/17 Livingston Vault Infill		655.00			2310		470300	940		101000
31786		3043 STAHLY ENGINEERING, INC		1,440.00								
	10	04/10/17 PRV Enigneering		1,440.00			5210	502	430515	350		101000
31787		3605 ADVANCED ENGINEERING &		242,582.41								
	51716	02/10/17 WRF Upgrade		242,582.41*			5310	503	430640	940		101000
31788		2705 CITY OF LIVINGSTON		22.98								
	16-17	04/02/17 coffee creamers		6.38			1000	123	411700	211		101000
	16-17	03/20/17 Postage		6.65			1000	123	411700	310		101000
	16-17	04/25/17 Postage		9.95			1000	123	411700	310		101000

For doc #s from 31666 to 31797, Operating Cash  
\* ... Over spent expenditure

Claim	Check	Invoice	Vendor #/Name/ #/Inv Date/Description	Document \$/ Line \$	Disc \$	PO #	Fund	Org	Acct	Object	Proj	Cash Account
31789	209628	04/05/17	26 LIVINGSTON ACE HARDWARE - Supplies	65.28 65.28			5310	503	430640	231		101000
31790	1411893	04/11/17	2830 LEHRKIND'S COCA-COLA Water	17.30 17.30			5310	503	430640	225		101000
31791	1912375301	04/08/17	23 CARQUEST AUTO PARTS Oil filters	20.62 20.62			5310	503	430640	231		101000
31792	3	04/25/17	3650 BARRY DAMSCEN CONSULTING, LLC Solid Waste Study per Res.4676	2,690.51 2,690.51			5410	504	430835	940		101000
31793	2017	04/25/17	1157 U.S. POSTAL SERVICE Permit - Bulk Mail	225.00 75.00			5210		343021			101000
	2017	04/25/17	Permit - Bulk Mail	75.00			5310		343031			101000
	2017	04/25/17	Permit - Bulk Mail	75.00			5410		343041			101000
31794	14787	04/13/17	102 INDUSTRIAL TOWEL Rug Maintenance	37.70 37.70			1000	121	411230	360		101000
31795	1007	04/13/17	3491 COFFMAN'S PEAK ELECTRIC, LLC Install LED Lamps & Fixtures	1,097.00 548.50			5210	502	430520	924		101000
	1007	04/13/17	Install LED Lamps & Fixtures	548.50			5310	503	430620	924		101000
31796	0179878	04/04/17	3440 CHARTER COMMUNICATIONS Internet - Public Works	885.97 885.97*			1000	122	411300	346		101000
31797	5606	04/04/17	162 CENTURYLINK Utility 1/3	591.51 82.57			5210	502	430520	343		101000
	5570	04/04/17	Utility 1/3	82.57			5310	503	430620	343		101000
	5570	04/04/17	Utility 1/3	82.56			5410	504	430820	343		101000
	0083	04/04/17	Building Dept.	159.10			1000	143	420403	343		101000
	6436	04/04/17	Park Dept	103.39*			1000	153	460430	343		101000
	4903	04/04/17	Planning Dept	81.32			1000	106	411030	343		101000
			<b># of Claims</b>	<b>117</b>	<b>Total:</b>	<b>696,678.44</b>						

<b>Fund/Account</b>	<b>Amount</b>
1000 GENERAL	
101000 CASH	\$41,995.98
2210 RECREATION DEPARTMENT	
101000 CASH	\$14.99
2300 COMMUNICATIONS/DISPATCH SERVICES	
101000 CASH	\$25,201.61
2310 TAX INCREMENT DISTRICT - DOWNTOWN	
101000 CASH	\$23,976.00
2399 IMPACT FEES	
101000 CASH	\$12,686.96
2400 LIGHT MAINTENANCE	
101000 CASH	\$1,573.36
2500 STREET MAINTENANCE	
101000 CASH	\$7,172.79
2700 PARK IMPROVEMENT SPECIAL REVENUE FUND	
101000 CASH	\$8,500.00
2820 GAS TAX	
101000 CASH	\$7,271.91
3200 WEST END TAX INCREMENT DISTRICT	
101000 CASH	\$1,889.47
5210 WATER OPERATING	
101000 CASH	\$14,226.49
5310 SEWER OPERATING	
101000 CASH	\$259,817.08
5410 SOLID WASTE	
101000 CASH	\$290,841.37
5510 AMBULANCE SERVICES	
101000 CASH	\$639.68
7910 PAYROLL FUND	
101000 CASH	\$870.75
<b>Total:</b>	<b>\$696,678.44</b>

04/26/17  
09:21:43

CITY OF LIVINGSTON  
Claim Approval Signature Page  
For the Accounting Period: 5/17

Page: 14 of 14  
Report ID: AP100A

LISA LOWY \_\_\_\_\_  
INTERIM - CITY MANAGER

**Backup material for agenda item:**

- C. CONSENT - Approve Steve Koonz and Darin MacKenzie to City/County Joint Airport Board**

City of Livingston  
Application for Appointed Office  
(Revised 3/17/03)

Appointed Position Seeking: AIRPORT BOARD

Date of Application: 10 FEB 2017

Name: STEVE KOONTZ  
Address: 1007 EAGLE CT  
Telephone: daytime 406.220-8181  
Fax Number: N/A

Signed: [Signature]  
after 5:00 p.m.: 220-8181  
e-mail address: SKOONTZ@Q.COM

- 1. Are you a resident of the City of Livingston? YES
- 2. Are you a registered voter? YES
- 3. Will you be at least 18 years of age at the time of the appointment? YES

4. Describe the reasons you are interested in this appointment: I USE THE AIRPORT & I HAVE A HANGAR & PLANE - THEREFORE, I AM INTERESTED IN ITS WELL BEING,

5. Describe any background, experience and interests that you have which may assist you in performing the responsibilities of this appointment:

- A. Occupation: CONTRACTOR
- B. Education: 3 YRS ENGINEERING
- C. Experience: FIRST FLEW THERE IN 1976 INVOLVED IN MANY CONSTRUCTION PROJECTS

(please attach a detailed resume if desired)

6. Have you served on any previous boards or in any governmental positions in the past? HIGH SCHOOL BOARD

7. Are you currently serving on any Community Boards? NO  
A. If yes, please describe those boards.

8. Current Employer? KOONTZ CONST, INC.

9. Are you available for night meetings? YES

10. Are you available for daytime meetings? YES - BUT LIMITED

11. Do you foresee any potential conflicts of interest that you might have in executing the duties of this appointed office? NO

12. If conflict of interest arose for you, how would you deal with it as an appointed member of this board? EXCUSE MYSELF



**City of Livingston**  
**Application for Appointed Office**  
(Revised 3/17/03)

**Appointed Position Seeking:** Airport Board

**Date of Application:** \_\_\_\_\_

Name: DARIN MACKENZIE  
Address: 312 S. F STREET  
Telephone: daytime 600-9454  
Fax Number: —

Signed: D. Mackenzie  
after 5:00 p.m.: 600-9454  
e-mail address: DARIN.MACKENZIEENGINEERING@gmail.com

- 1. Are you a resident of the City of Livingston? YES
- 2. Are you a registered voter? YES
- 3. Will you be at least 18 years of age at the time of the appointment? YES
- 4. Describe the reasons you are interested in this appointment: I AM A PILOT WITH MY PLANE BASED AT MISSION FIELD.

- 5. Describe any background, experience and interests that you have which may assist you in performing the responsibilities of this appointment:
  - A. Occupation: CONSTRUCTION CONSULTANT
  - B. Education: CONSTRUCTION ENGINEER FROM O.S.U.
  - C. Experience: 25 YEARS OF INDUSTRIAL / COMMERCIAL CONSTRUCTION

(please attach a detailed resume if desired)

6. Have you served on any previous boards or in any governmental positions in the past? No

7. Are you currently serving on any Community Boards? No  
A. If yes, please describe those boards. —

8. Current Employer? MACKENZIE ENGINEERING

9. Are you available for night meetings? YES

10. Are you available for daytime meetings? YES

11. Do you foresee any potential conflicts of interest that you might have in executing the duties of this appointed office? No

12. If conflict of interest arose for you, how would you deal with it as an appointed member of this board? DISCUSS W/ BOARD & DETERMINE COURSE OF ACTION.

City of Livingston  
Application for Appointed Office  
(Revised 3/17/03)

Appointed Position Seeking: CITY / COUNTY AIRPORT BOARD

Date of Application: 3/31/2017

Name: DONALD HISER

Signed: [Signature]

Address: 105 MOON CIRCLE DR.

Telephone: daytime (406) 224-0698

after 5:00 p.m.: (406) 224-0698

Fax Number: N/A

e-mail address: don.hiser@gmail.com

1. Are you a resident of the City of Livingston? YES

2. Are you a registered voter? YES

3. Will you be at least 18 years of age at the time of the appointment? YES

4. Describe the reasons you are interested in this appointment: I AM A PILOT, AND FEEL IT WOULD BE INTERESTING TO BE A PART OF THIS BOARD AND TO BE A PART OF ITS GROWTH AND DECISIONS PERTAINING TO OUR AIRPORT.

5. Describe any background, experience and interests that you have which may assist you in performing the responsibilities of this appointment:

A. Occupation: LABORER AT IRRIGATION INNOVATIONS

B. Education: AAS IN AVIATION FROM MONTANA STATE UNIVERSITY

C. Experience: 3 YEARS AS A FIXED WING PILOT, FORMER HELICOPTOR AIRCREW MEMBER/FIREFIGHTER FOR MONTANA DNRC.

(please attach a detailed resume if desired)

6. Have you served on any previous boards or in any governmental positions in the past? NO

7. Are you currently serving on any Community Boards? NO

A. If yes, please describe those boards. \_\_\_\_\_

8. Current Employer? IRRIGATION INNOVATIONS

9. Are you available for night meetings? YES

10. Are you available for daytime meetings? YES

11. Do you foresee any potential conflicts of interest that you might have in executing the duties of this appointed office? NO

12. If conflict of interest arose for you, how would you deal with it as an appointed member of this board? I WOULD FIND WAYS TO <sup>OR</sup> MITIGATION MITIGATE SUCH CONFLICTS

VIA TIME MANAGEMENT IN PROPER SCHEDULING OF WORK AND MEETINGS, AS WELL AS WORK WITH PARTIES INVOLVED IN POSSIBLE CONFLICTS OF INTEREST TO ARRIVE AT A WORKABLE SOLUTION SO AS TO KEEP WORK ON THIS BOARD MOVING FORWARD.

**THIS APPLICATION WILL BE KEPT ON FILE FOR 6 MONTHS AND THEN DISCARDED.**

## CITY/COUNTY JOINT AIRPORT BOARD

414 E Callender St  
Livingston, MT 59047  
406-222-4194

April 24, 2017

To: Livingston City Commissioner's  
From: City County Airport Board

Re: Airport Board Member Recommendations

Greetings to All,

The City County Airport Board has two City positions open on our board due to the resignation of members George Denton and Kerry LaDuke. The City advertised the opening and received three applications. Both positions expire at the end of June, 2017. The new members will complete their predecessors remaining 2 months and a new four year term will begin July 1, 2017 and run through June 31, 2021. The Airport Board has reviewed the applications and are unanimous in our choice. We would like to recommend the two applicants who seem the best suited.

Steve Koontz is a pilot who owns a hangar at Mission Field and has been diligent in attending our meetings. He has an interest in improving our current facility at Mission Field.

Darin MacKenzie is also a pilot who rents a T Hangar at Mission Field. He attended our last meeting and has expressed an interest in joining our board.

We highly recommend that the City Commission appoint Mr. Steve Koontz and Mr. Darin Mackenzie to represent the City of Livingston on the City County Joint Airport Board.

Sincerely,

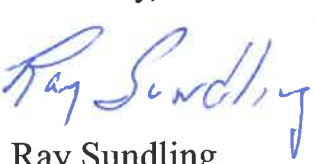

Ray Sundling  
Airport Board Chairman

**Backup material for agenda item:**

- D. CONSENT - Approve Tyler Erickson, David DePuy and Dale Sexton to Livingston Building Improvement District Board

City of Livingston  
Application for Appointed Office  
(Revised 3/17/03)

Appointed Position Seeking: LBID Board position

Date of Application: 3/23/17

Name: TREE ERICKSON

Signed: [Signature]

Address: P.O. Box 2290

Telephone: daytime 406-222-8948

after 5:00 p.m.: 602 315 5833

Fax Number: 222 - 5341

e-mail address: terickson@americanbankmontana.com

1. Are you a resident of the City of Livingston? No

2. Are you a registered voter? Yes

3. Will you be at least 18 years of age at the time of the appointment? Yes

4. Describe the reasons you are interested in this appointment: I Love Livingston. I grew up here and care about it's future. I believe LBID will play a major role in the future of Livingston. When aligned accordingly with other civic entities - the economic impact is substantial.

5. Describe any background, experience and interests that you have which may assist you in performing the responsibilities of this appointment:

A. Occupation: Banker

B. Education: ASU - BSA Fine Arts / Art History

C. Experience: 16 years as Director of American Bank. 10 years of experience @ American Bank: Personal Banking / Branch Management / Marketing / Development / Consulting.

(please attach a detailed resume if desired)

6. Have you served on any previous boards or in any governmental positions in the past? BYEP (Big Sky Youth Empowerment), LHC (Livingston Health Care), VL (Voice Livingston)

LBID (Livingston Business Improvement District)

7. Are you currently serving on any Community Boards? YES

A. If yes, please describe those boards. BYEP (Fundraising Committee), LBID

8. Current Employer? American Bank

9. Are you available for night meetings? YES

10. Are you available for daytime meetings? YES

11. Do you foresee any potential conflicts of interest that you might have in executing the duties of this appointed office? No

12. If conflict of interest arose for you, how would you deal with it as an appointed member of this board? I would notify the board immediately. I trust that my fellow Board members will vet it accordingly.

**City of Livingston**  
**Application for Appointed Office**

(Revised 3/17/03)

**Appointed Position Seeking:** BUSINESS Imp. DISTRICT

**Date of Application:** 3/24/2017

Name: DAVID W. DePuy

Signed: David W. DePuy

Address: P.O. Box 487

Telephone: daytime 222-1524

after 5:00 p.m.: 222-1524

Fax Number: 222-1524

e-mail address: ddw1016@gmail.com

1. Are you a resident of the City of Livingston? Yes

2. Are you a registered voter? Yes

3. Will you be at least 18 years of age at the time of the appointment? Yes

4. Describe the reasons you are interested in this appointment: SERVING ON BOARD SINCE STARTED, OWN TWO BUILDINGS IN BUSINESS DISTRICT

5. Describe any background, experience and interests that you have which may assist you in performing the responsibilities of this appointment:

A. Occupation: RETIRED ATTORNEY

B. Education: COLLEGE

C. Experience: 60 YEARS AS ATTORNEY, RAISED ON RANCH

(please attach a detailed resume if desired)

6. Have you served on any previous boards or in any governmental positions in the past? YELLOWSTONE GATEWAY MUSEUM

7. Are you currently serving on any Community Boards? NO

A. If yes, please describe those boards.

8. Current Employer? RETIRED

9. Are you available for night meetings? Yes

10. Are you available for daytime meetings? Yes

11. Do you foresee any potential conflicts of interest that you might have in executing the duties of this appointed office? NO

12. If conflict of interest arose for you, how would you deal with it as an appointed member of this board? REUSE MYSELF

**THIS APPLICATION WILL BE KEPT ON FILE FOR 6 MONTHS AND THEN DISCARDED.**

**City of Livingston**  
**Application for Appointed Office**  
 (Revised 3/17/03)

Appointed Position Seeking: LBID Board

Date of Application: 3/30/17

Name: Dale P. Sexton

Signed: Dale P. Sexton

Address: 323 N. Main

Telephone: daytime 406-222-7305

after 5:00 p.m.: Same

Fax Number: 406-222-1064

e-mail address: Sextonemontana.com

1. Are you a resident of the City of Livingston? yes
2. Are you a registered voter? yes
3. Will you be at least 18 years of age at the time of the appointment? yes
4. Describe the reasons you are interested in this appointment: As a building owner within the business district I appreciate the efforts and enjoy contributing to the LBID.

5. Describe any background, experience and interests that you have which may assist you in performing the responsibilities of this appointment:

A. Occupation: Business Owner - Timber Trails

B. Education: BA marketing Missoula Economics

C. Experience: Business Owner Timber Trails, Fly Fishing Owl Ditch - Hawkridge Outfitters

(please attach a detailed resume if desired)

6. Have you served on any previous boards or in any governmental positions in the past? \_\_\_\_\_

Paria County Economic Development Council, Counter Point, LBID  
 Gallatin National Forest Avalanche Center, Gallatin Nat'l Forest Collaborative

7. Are you currently serving on any Community Boards? LBID, Counterpoint

A. If yes, please describe those boards. Advocate for business and Adults w/ disabilities

8. Current Employer? Timber Trails

9. Are you available for night meetings? yes

10. Are you available for daytime meetings? yes

11. Do you foresee any potential conflicts of interest that you might have in executing the duties of this appointed office? no

12. If conflict of interest arose for you, how would you deal with it as an appointed member of this board? recusal

**THIS APPLICATION WILL BE KEPT ON FILE FOR 6 MONTHS AND THEN DISCARDED.**

2015-2016 BOARD OF TRUSTEES

KRISTEN GALBRAITH  
CHAIR

DALE SEXTON  
VICE-CHAIR

BETTY LAMRES

DAN KAUL

DAVID DEPUY

KARLA PETTIT

TYLER ERICKSON

April 20, 2017

To: City of Livingston Commission

At our April 20th board meeting for the Livingston Business Improvement District (LBID), board members reviewed four applications for consideration of three open seats for LBID board member representation. Those applications included incumbent members Dale Sexton, Tyler Erickson and David DePuy and an application from Nicole Devine. The board unanimously voted to approve re-appointment of the three incumbent members – Dale Sexton, Tyler Erickson and David DePuy.

Please contact me at 406-220-9600 should you have any questions regarding our decision.

Yours,

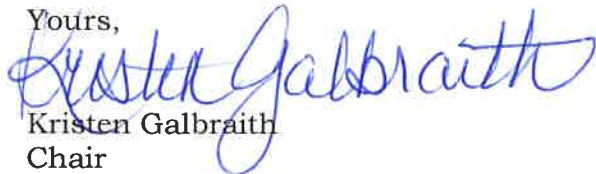

Kristen Galbraith  
Chair



**Backup material for agenda item:**

- A. PROCLAMATION - Youth Week Proclamation

**City Manager**  
Michael Kardoes

414 East Callender Street  
Livingston, Montana 59047  
(406) 222-2005 phone  
(406) 222-6823 fax  
[citymanager@livingstonmontana.org](mailto:citymanager@livingstonmontana.org)  
[www.livingstonmontana.org](http://www.livingstonmontana.org)

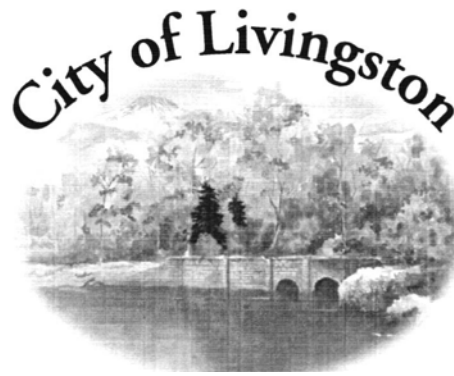

**Chairman**  
James Bennett

34

**Vice Chairman**  
Dorel Hoglund

**Commissioners**  
Mel Friedman  
Quentin Schwarz  
Sarah Sandberg

Incorporated 1889

May 2, 2017

## YOUTH WEEK PROCLAMATION

Whereas, The Benevolent and Protective Order of Elks has designated May 1 – May 7, as Youth Week to honor America’s Junior Citizens for their accomplishments, and to give fitting recognition of the services to Community, State, and Nation; and,

Whereas Livingston Elks Lodge #246 will sponsor an observance during that week in tribute to the Junior Citizens of this Community; and,

Whereas, no event could be more deserving of our support and participation than one dedicated to these young people who represent the Nation’s greatest resource, and who in the years ahead will assume the responsibility for the advancement of our free society; and,

Whereas, our Youth need the guidance, inspiration and encouragement which we alone can give in order to help develop those qualities of character essential for future leadership; and go forth to serve America; and,

Whereas, to achieve this worthy objective we should demonstrate our partnership with Youth, our understanding of their hopes and aspirations and a sincere willingness to help prepare them in every way for the responsibilities and opportunities of citizenship:

Now, Therefore, I James Bennett, Chairperson of Livingston, MT, City Commission do hereby proclaim the first week of May, 2017 as Youth Week, and urge all departments of government, civic, fraternal and patriotic groups, our citizens generally, to participate wholeheartedly in its observance.

---

James Bennett, Chairperson  
Livingston, Montana City Commission

---

Lisa Harreld  
Recording Secretary



**Backup material for agenda item:**

- B. SCHEDULED PUBLIC COMMENT - Marilyn Hartley from the Cannon Committee



## Park County Cannon Committee Commission Approval Request

April 21, 2017

To: Park County Commission  
( w/ copy to City Commission )

This Committee has completed the design phase of determining best display of the County's historic cannon. Attached please find rough drawings of the chosen structure and a photo showing our choice for positioning on the front lawn. We had hoped to have an artist's rendition for you, but it will not be done in time to include for your consideration / approval.

At this time, the Committee is requesting of the Commission to approve both the design and placement of the display. Because we would like to place the structure where the big rock is located, it is also requested that you decide the fate of the rock. It can be moved and incorporated into the landscaping, or totally disposed of. The Committee does not assume that it is authorized to make that decision. With your approval, we can then break ground and begin construction. Recently, it came to our attention that the big rock was brought in from the old Poor Farm where it was a memorial to those who struggled there. You could decide to return it there.

During our process, it became clear that we wanted to replicate the original pedestal that the cannon sat on, but it was not visually pleasing to simply enclose the odd shape of the pedestal. Our contractor suggested the current proposed design as a way to satisfy desire for the original, while creating an overall, visually-pleasing result. We are all very much in favor of this concept.

I will be present at your meeting(s) to approve should you have any questions or concerns.

We appreciate the opportunity to serve our community in this manner and look forward to seeing it through to fruition.

A handwritten signature in blue ink that reads "Marilyn Hartley". The signature is fluid and cursive.

Park County Cannon Committee  
Marilyn Hartley, Chair  
414 E Callender St  
Livingston, MT 59047

406-222-4192  
[mhartley@parkcounty.org](mailto:mhartley@parkcounty.org)



### **Proposed site for cannon display**

. . . . where the big rock sits.

- Rock could be moved to the side
- Bench would be incorporated in with enhanced landscaping.

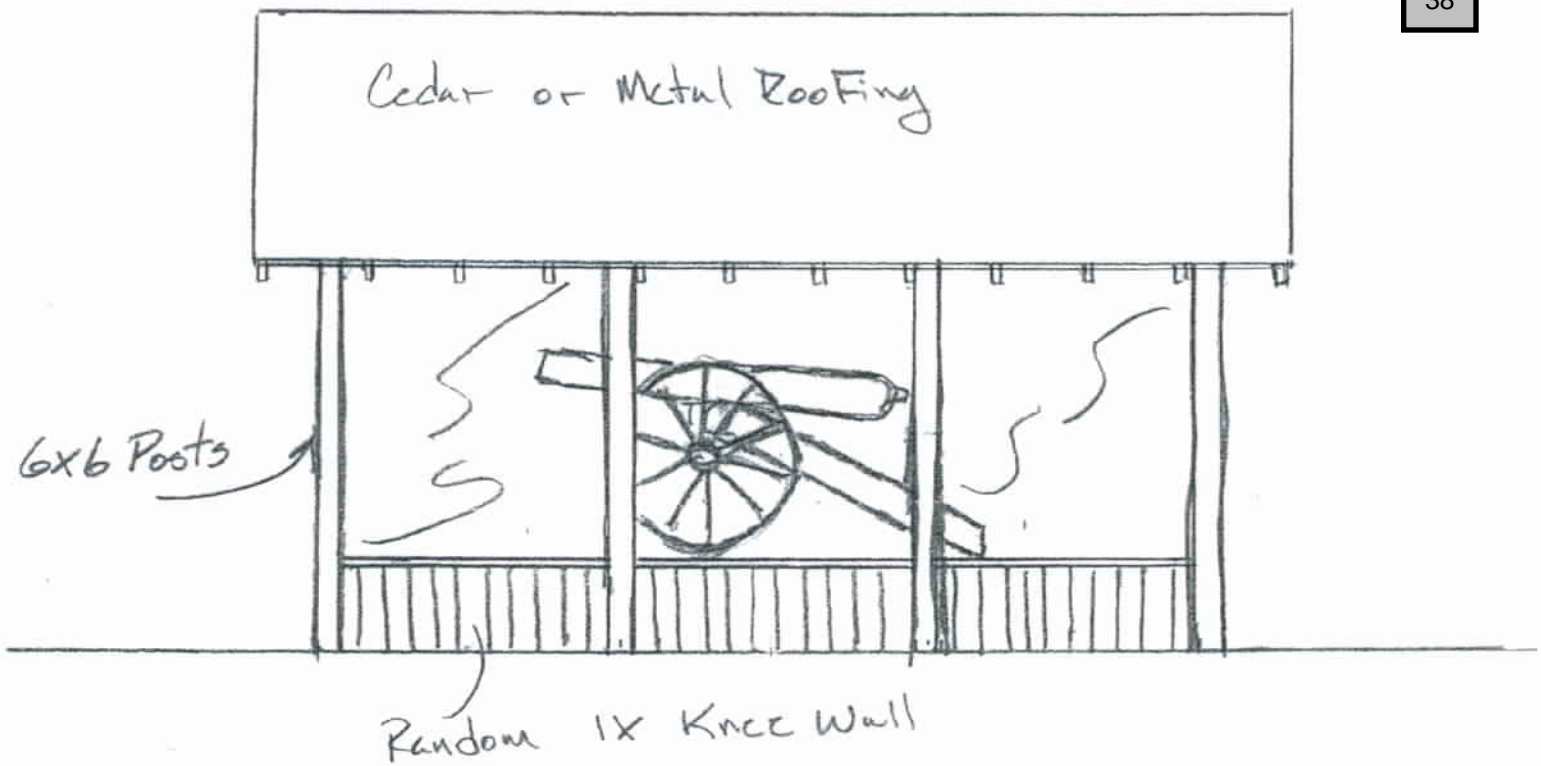

### Rough drawing of display

Original pedestal base will be replicated in size and shape with walkway around it inside the display structure.

Large doors on west end will allow for cannon to be brought out for parades, etc.

Back wall is solid for future painted backdrop and/or historical photography .

Front and east end to be store-front glass

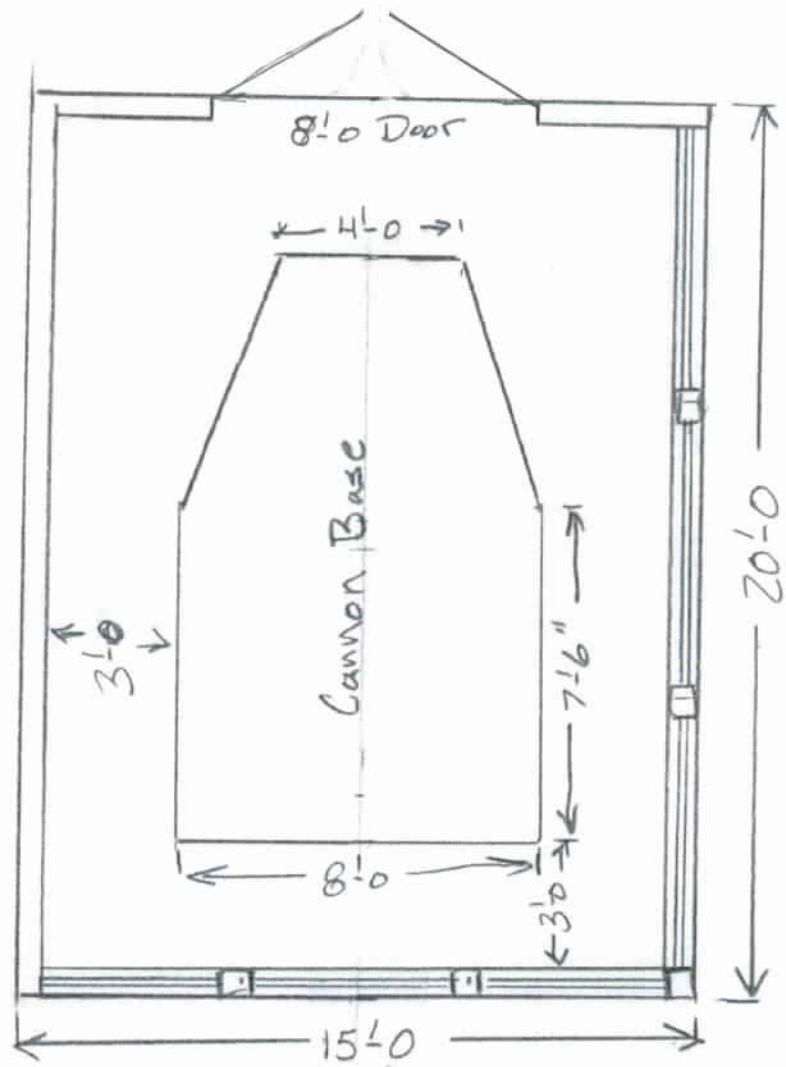

- 6x6 Timber Post
- 6x8 Timber Beam
- 2x6 Exposed RS Rafters
- Metal or Cedar Roofing

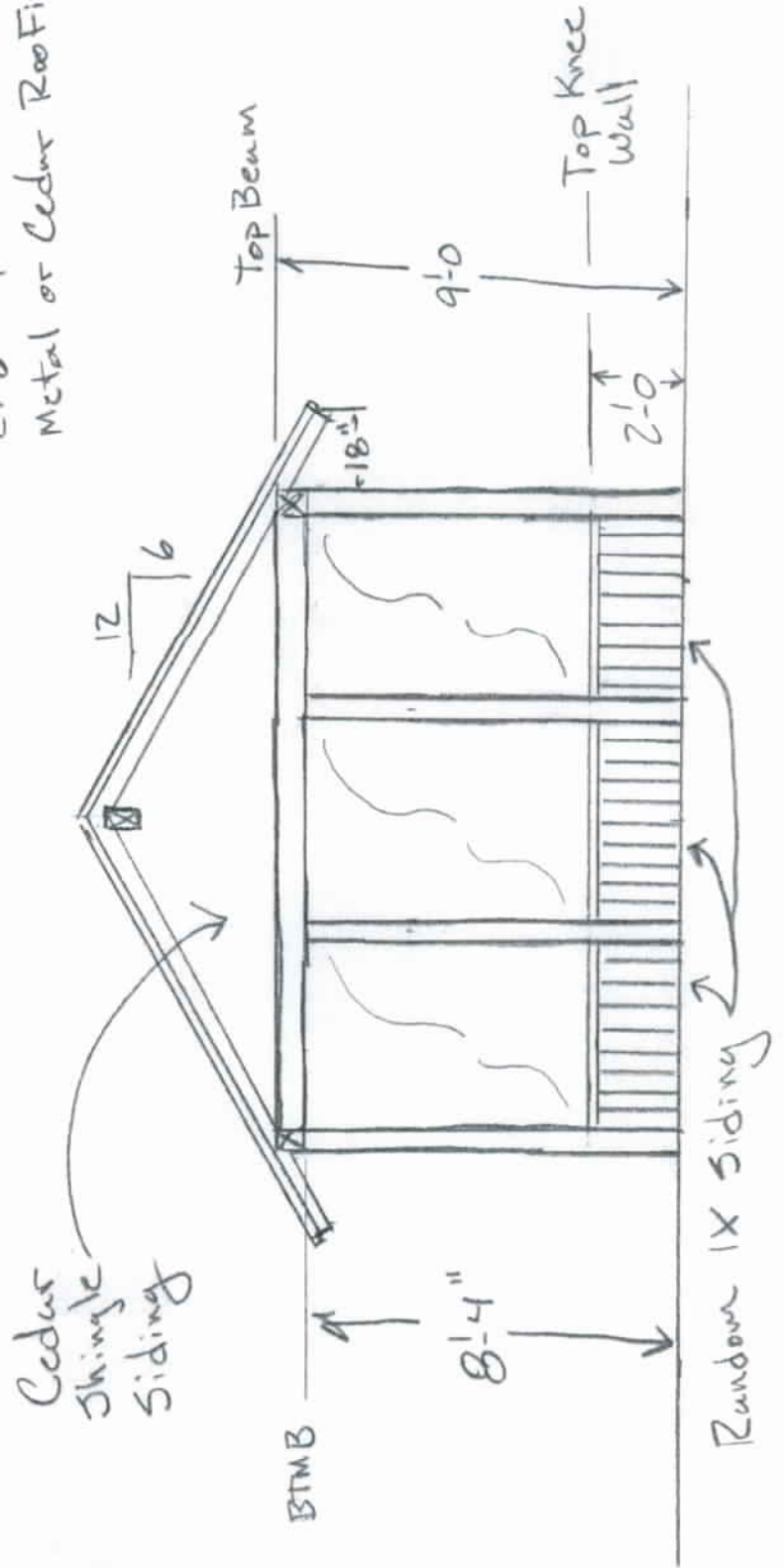



**Backup material for agenda item:**

- A. ORDINANCE NO. 2063 - AN ORDINANCE OF THE CITY COMMISSION OF THE CITY OF LIVINGSTON, MONTANA, AMENDING SECTION 4-41, ENTITLED "CIVIL OFFENSES, EXCEPTIONS," BY ADDING AN EXCEPTION TO SUBPART C PERTAINING TO THE BOZEMAN TRAIL CONNECTOR LOCATED BETWEEN JACK WEIMER MEMORIAL PARK AND FLESHMAN CREEK ROAD IN LIVINGSTON, MONTANA.

**ORDINANCE NO. 2063**

**AN ORDINANCE OF THE CITY COMMISSION OF THE CITY OF LIVINGSTON, MONTANA, AMENDING SECTION 4-41, ENTITLED “CIVIL OFFENSES, EXCEPTIONS,” BY ADDING AN EXCEPTION TO SUBPART C PERTAINING TO THE BOZEMAN TRAIL CONNECTOR LOCATED BETWEEN JACK WEIMER MEMORIAL PARK AND FLESHMAN CREEK ROAD IN LIVINGSTON, MONTANA.**

---

**Purpose**

The purpose of this Ordinance is provide for the public health, safety and welfare of the community by designating an additional area where dog owners are permitted to allow their dogs to run about without the need for a leash or other restraint. The Livingston City Commission finds that designating Waterworks Park as an off-leash area adds to the general health and welfare of the community by, among other things: (a) encouraging outdoor activities and exercise with dogs; and (b) reducing the likelihood of dogs being found off-leash in other areas of the City.

---

**WHEREAS**, the Code of Ordinances, City of Livingston, Montana, presently provides that it is unlawful and punishable as a civil offense for a person to allow or permit a dog, fowl, livestock, amphibian, reptile, or insect to be found running at large; and

**WHEREAS**, the Code of Ordinances, City of Livingston, Montana, also provides certain areas where the prohibition on dogs running at large has been relaxed, which areas include parts of Miles Park, parts of Mayor’s Landing Park, the Water Works Park, and areas along View Vista Drive, all as more specifically described in the Code; and

**WHEREAS**, local dog owners desire an additional place to allow their dogs to roam about without being leashed or otherwise restrained; and

**WHEREAS**, the Livingston Parks & Trails committee recently recommended the Livingston

City Commission designate the Bozeman Trail Connector (a one mile trail located between Jack Weimer Memorial Park and Fleshman Creek Road, behind the Mountain View Cemetery) as an off-leash area.

**NOW, THEREFORE, BE IT ORDAINED** by the Livingston City Commission as follows:

**SECTION 1**

That Section 4-41 of the Livingston Municipal Code is hereby amended, with additions underlined, as follows:

**Sec. 4-41. - Civil offenses, exceptions.**

- A. Nuisance Animal. It is unlawful and punishable as a civil offense for a person to allow or permit an animal to be a nuisance animal.
- B. It is unlawful and punishable as a civil offense for a person to allow or permit a dog, fowl, livestock, amphibian, reptile, or insect to be found running at large.
- C. Exceptions to running at large are as follows:
  - 1. A person may accompany a dog without a leash in Miles Park, along the north bank of the Yellowstone River provided the dog is trained for and will respond to voice command or other control and provided the dog is no more than twenty (20) yards from the person with voice control, with the exception that no dogs are permitted on the playing fields of the ball parks, nor in the pedestrian areas and viewing stands located between the ball fields.
  - 2. A person may allow a dog to run in Mayor's Landing Park under voice command or other control, i.e. without a leash provided the dog is trained for and will respond to voice command.
  - 3. A person may allow a dog to run unrestrained by leash or other restraint on View Vista Drive from the posted sign at the driveway to the golf driving range to Mayor's Landing Park so long as the dog is under voice command or other control and provided that the dog is trained for and will respond to voice command or other control and provided that the dog is no more than twenty (20) yards from the person exercising voice or other control.

4. A person may allow a dog to run unrestrained by leash or other restraint within the confines of Waterworks Park (also known as “9<sup>th</sup> Street Park” and the “Water Plant Park”) so long as the dog is under voice command or other control and provided that the dog is trained for and will respond to voice command or other control. However, dogs must be leashed whenever there is any organized activity at the park, including but not limited to soccer games or practices.

5. A person may allow a dog to run unrestrained by leash or other restraint along the Bozeman Trail Connector so long as the dog is under voice command or other control and provided that the dog is trained for and will respond to voice command or other control. However, dogs must be leashed whenever there is any organized activity on the trail and/or at a trailhead, and may not chase or otherwise harass wildlife.

- D. Any person who takes a dog to Miles Park, View Vista Drive, Mayor’s Landing or onto any other City property, City Trail, or City right-of-way shall remove any dog feces deposited by said dog and dispose of said feces in a trash container. It is unlawful and punishable as a civil offense for any person to fail to remove and properly dispose of dog feces deposited by his or her dog in Miles Park, View Vista Drive, Mayor’s Landing or any other City property, City Trail, or City right-of-way.
- E. It is unlawful and punishable as a civil offense for any person to exercise or run a dog by using a moving motor vehicle while upon a City street or right-of-way.
- F. Cruelty to animals is a crime under State law. The City of Livingston has a zero tolerance policy for cruelty to animals and any suspected animal cruelty is a threat to public safety as animal cruelty has been linked to domestic violence and other criminal behavior, and all reports of animal cruelty will be aggressively investigated and prosecuted in accordance with State law.
- G. Any violation of this Section is an absolute liability offense as described in Section 4-8. Any and all owners as defined in Section 4-1 or the sole registered owner listed on the City license for the animal are jointly and severally liable for the civil offenses listed in this Section regardless of proximity or intent.

**SECTION 2**

**Statutory Interpretation and Repealer:**

Any and all resolutions, ordinances and sections of the Livingston Municipal Code and

**Ordinance No. 2063**

**Amending Sec. 4-41 to make the Bozeman Trail Connector an off-leash area**

**Page 3**

parts thereof in conflict herewith are hereby repealed.

### SECTION 3

#### **Severability:**

If any provision of this ordinance or the application thereof to any person or circumstance is held invalid by a court having competent jurisdiction, such invalidity shall not affect the other provisions of this ordinance which may be given effect without the invalid provisions or application, and to this end, the provisions of this ordinance are declared to be severable.

### SECTION 4

#### **Savings provision:**

This ordinance does not affect the rights or duties that mature, penalties and assessments that were incurred or proceedings that began before the effective date of this ordinance.

### SECTION 5

#### **Effective date:**

This ordinance will become effective 30 days after the second and final adoption.

\* \* \* \* \*

**PASSED** by the City Commission of the City of Livingston, Montana, on first reading at a regular session thereof held on the \_\_\_ day of \_\_\_\_\_, 201\_\_.

---

**JAMES BENNETT - Chairman**

**ATTEST:**

**Ordinance No. 2063**

**Amending Sec. 4-41 to make the Bozeman Trail Connector an off-leash area**

**Page 4**

\_\_\_\_\_  
**LISA HARRELD**  
Recording Secretary

**PASSED, ADOPTED AND APPROVED** by the City Commission of the City of  
Livingston, Montana, on second reading at a regular session thereof held on the \_\_\_\_ day of  
\_\_\_\_\_, 201\_\_.

\_\_\_\_\_  
**JAMES BENNETT - Chairman**

**ATTEST:**

**APPROVED AS TO FORM:**

\_\_\_\_\_  
**LISA HARRELD**  
Recording Secretary

\_\_\_\_\_  
**COURTNEY LAWELLIN**  
Livingston City Attorney



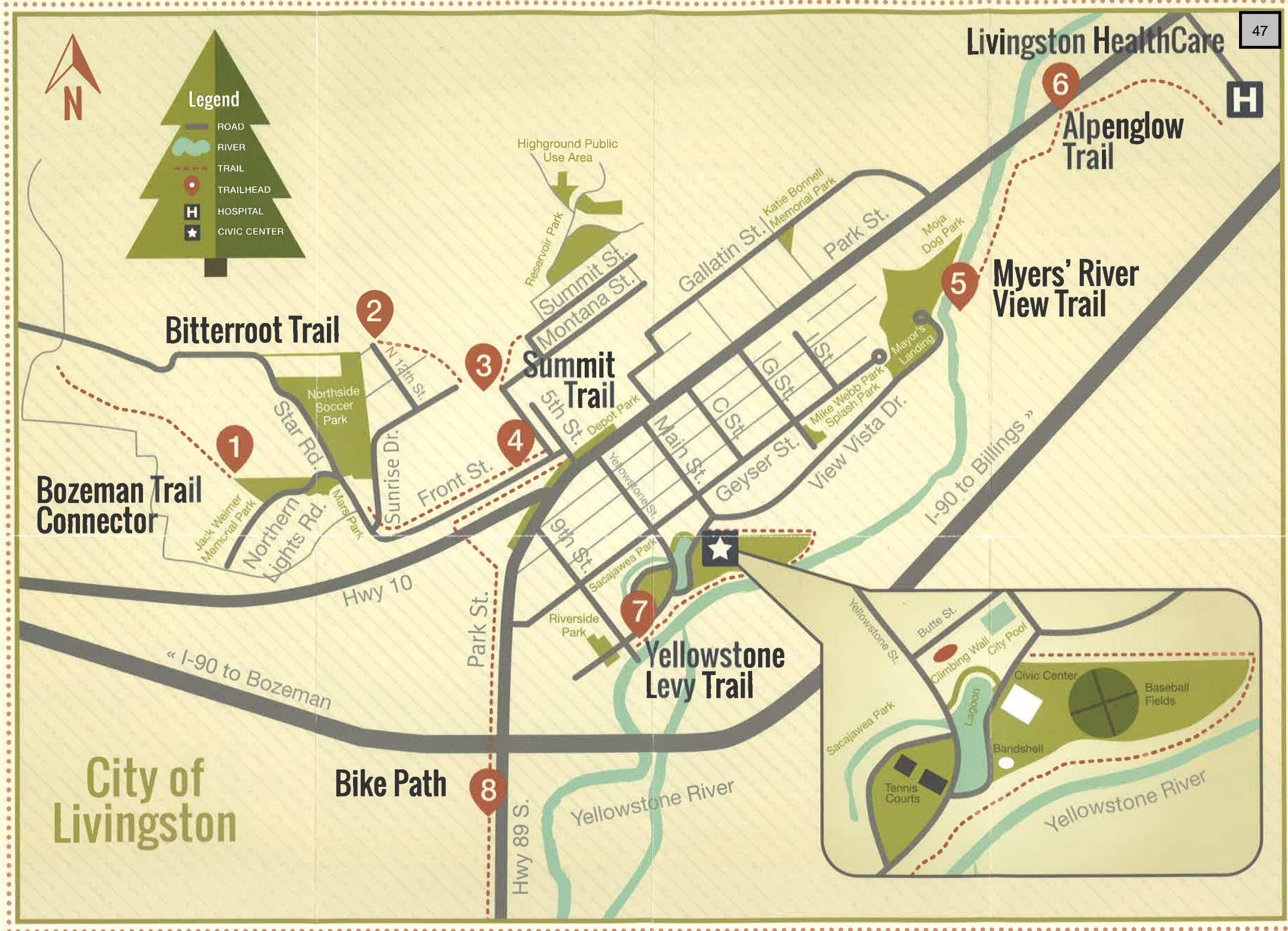

For more Livingston Trails Rx information and event listings, visit [www.LivingstonTrailsRx.com](http://www.LivingstonTrailsRx.com). Livingston parks and trails are designated tobacco-free zones. Please do not use tobacco in these areas. Trails Rx maps were made possible through the Montana Fish, Wildlife, and Parks Recreational Trail Program.

**Backup material for agenda item:**

- B. ORDINANCE NO. 2064 - AN ORDINANCE OF THE CITY COMMISSION OF THE CITY OF LIVINGSTON, MONTANA, AMENDING ORDINANCE 2049 AND CHAPTER 9, ARTICLE IV OF THE LIVINGSTON MUNICIPAL COE ENTITLED "PARKING, STOPPING, AND STANDING" BY ESTABLISHING FIRE DEPARTMENT PARKING ON EITHER SIDE OF THE CALLENDER STREET ENTRANCE STREET ENTRANCE AND ESTABLISHING A CIVIL PENALTY FOR VIOLATION THEREOF.



**ORDINANCE NO. 2064**

**AN ORDINANCE OF THE CITY COMMISSION OF THE CITY OF LIVINGSTON, MONTANA, AMENDING ORDINANCE 2049 AND CHAPTER 9, ARTICLE IV OF THE LIVINGSTON MUNICIPAL CODE ENTITLED “PARKING, STOPPING, AND STANDING” BY ESTABLISHING FIRE DEPARTMENT PARKING ON EITHER SIDE OF THE CALLENDER STREET ENTRANCE AND ESTABLISHING A CIVIL PENALTY FOR VIOLATION THEREOF.**

**Preamble.**

The purpose of this Ordinance is provide for the public health, safety and welfare of the community by providing Livingston Fire and Rescue with parking adjacent to the Fire Station and establishing a civil penalty for violation thereof.

\* \* \* \* \*

**WHEREAS,** to create immediate access of Livingston Fire and Rescue Command staff to their vehicles and to restrict parking time in certain areas to allow for access to fire department command vehicles by command staff.

**NOW, THEREFORE, BE IT ORDAINED** by the City Commission of the City of Livingston, Montana, as follows:

**SECTION 1**

That Ordinance No. 2049 as codified by Chapter 9 of the Livingston Municipal Code is hereby amended, with additions underlined and deletions struck through, as follows:

**9-221. Unlawful parking generally, repairs or for sale.**

(a) It shall be unlawful for any person to, use or occupy any portion of any street within the Restricted or Congested Area limits of the City for the purpose of setting up, assembling, experimenting with, overhauling or repairing any engine or machinery of any sort, for, any

**Ordinance No. 2064  
Designating Fire Command Parking on either side of the Callendar Street entrance to the Fire Station..**

implements, any vehicles or washing or greasing any vehicle, or to stand, keep or park any motor vehicle in the possession or custody of any garage, on any street, or for displaying any vehicle for sale.

(b) It shall be unlawful to make repairs or conduct maintenance on motor vehicles on any public street other than emergency repair which is defined as the required repair sufficient to get a temporarily stalled vehicle to a repair shop or garage.

**Section 9-222. Parking prohibited in certain places generally.**

It shall be a civil offense for the operator of a vehicle to stop, stand or park such vehicle or trailer in any of the following places, except when necessary to avoid conflict with other traffic or in compliance with the direction of a police officer or traffic control sign or signal:

A. Within an intersection. The minimum civil penalty under this subsection shall be Twenty Dollars (\$20.00).

B. On any crosswalk, sidewalk or boulevard. The minimum civil penalty under this subsection shall be Twenty Dollars (\$20.00).

C. Upon the approach to an intersection within ten (10) feet of the inside boundary line of the sidewalk, or if no sidewalk is in place within twenty (20) feet of the intercepting roadway, except that this provision shall not apply to alleys. The minimum civil penalty under this subsection shall be Twenty Dollars (\$20.00).

D. Within twenty (20) feet of the driveway entrance to any fire station, except for fire vehicles in spaces designated by signs. The minimum civil penalty under this subsection shall be twenty-five dollars (\$25.00)

E. Within fifteen (15) feet of a fire hydrant. The minimum civil penalty under this subsection shall be twenty-five dollars (\$25.00).

F. In front of a functional private driveway. A functional private driveway means a driveway capable of actually being used by a motor vehicle to access a garage or private parking area and not merely a curb cut. The minimum civil penalty under this subsection shall be Twenty Dollars (\$20.00).

G. Alongside or opposite any street excavation or construction when such standing or parking would obstruct traffic. The minimum civil penalty under this subsection shall be Twenty Dollars (\$20.00).

H. In an alley when to so stop in such alley would obstruct traffic through such alley or obstruct access to a garage, driveway or entryway. The minimum civil penalty under this subsection shall be Twenty Dollars (\$20.00).

I. In any City owned, leased, or operated parking lot in violation of a posted no parking sign or a no parking sign after designated hours. The minimum civil penalty under this subsection shall be twenty-five dollars (\$25.00).

J. In any parking space designated by sign that reserves the parking space for handicapped persons only. A fine of not less than one hundred dollars (\$100.00) shall be imposed upon any person violating this section.

K. Any designated fire zone adjoining any public school or any public building. The minimum civil penalty under this subsection shall be Twenty-five dollars (\$25.00).

L. No parking shall be allowed on either side of Park Street between 5th Street

and 6<sup>th</sup> Street. The minimum civil penalty under this subsection shall be Twenty Dollars (\$20.00).

M. No parking shall be allowed on either side of “H” Street between Butte Street and View Vista Drive. The minimum civil penalty under this subsection shall be Twenty Dollars (\$20.00).

N. It is unlawful for any unauthorized vehicle or equipment to park in any parking space that is properly marked or barricaded with a permit issued under Section 9-248. The minimum civil penalty under this subsection shall be Twenty Dollars (\$20.00) and the vehicle shall be subject to impoundment.

**Section 9-224. Vehicles exceeding eighteen feet in length to park parallel.**

No vehicle of greater length than eighteen (18) feet shall be parked upon the streets within the Restricted or Congested Area limits, except upon those streets where parking is parallel with the curb. The “Restricted or Congested Area” is defined by Section 9-1 of the Livingston Municipal Code. The minimum civil penalty under this subsection shall be Twenty Dollars (\$20.00).

**Section 9-225. Manner of Parking**

All motor vehicles parked upon any street in this City shall be parked as follows:

(a) Whenever any motor vehicle is parked upon any street in this City, it shall be headed as though proceeding upon the right side of the street.

(b) Motor vehicles shall be parked head-in to the curb at the angle and between painted stripes or other markings upon the pavement where such head-in parking is

**Ordinance No. 2064**

**Designating Fire Command Parking on either side of the Callendar Street entrance to the Fire Station.**

indicated.

(c) Motor vehicles shall be parked parallel with the curb where such parallel parking is indicated by a painted strip or other markings upon the pavements, and the entire vehicle shall be within such painted strip or other marking.

(d) Whenever the owner or driver of a vehicle discovers that his vehicle is parked immediately in front of or close to a building to which the fire department has been summoned he shall immediately remove such vehicle from such area.

(e) The minimum civil penalty under this subsection shall be Twenty Dollars (\$20.00).

**Section 9-226. Proximity to curb; position.**

Except when necessary in obedience to, traffic regulations or traffic signs or signals, the operator of a vehicle shall not stop, stand or park, such vehicle in a roadway other than parallel with the edge of the roadway, headed in the direction of traffic, and with the curb-side wheels of the vehicle within eighteen (18) inches of the edge of the roadway, except as permitted for loading and unloading. The minimum civil penalty under this subsection shall be Twenty Dollars (\$20.00).

**Section 9-227. Parking in alley in fire district.**

No person shall stop, stand or park a vehicle for any purpose other than the loading or unloading of person or materials for longer than 30 minutes at any one time in any alley within the Fire Limit District of the City. The Fire Limit District is defined by Section 6-8 of the Livingston Municipal Code. The minimum civil penalty under this subsection shall be Twenty-

**Ordinance No. 2064**

**Designating Fire Command Parking on either side of the Callendar Street entrance to the Fire Station.**

five dollars (\$25.00).

**Section 9-228. Double parking prohibited; exception for delivery of merchandise.**

No driver or operator of a motor vehicle shall stop such motor vehicle abreast of another vehicle parked parallel to the curb or edge of the roadway, nor at the back or rear of any vehicle parked at an angle to the curb or edge of the roadway where such angle parking is permitted; provided double parking shall be permitted, not to exceed ten minutes duration, for the purpose of delivery of merchandise provided the full street is not obstructed. The minimum civil penalty under this subsection shall be Twenty Dollars.

**Section 9-229. Parking for loading and unloading.**

When it is necessary to place the rear of any motor truck against the curb on any street in this City for the purpose of actually loading or unloading of heavy freight, household goods, office equipment or other large items, such motor truck shall be parked at an angle of forty-five (45) degrees from the curb, and headed in the same direction as vehicular traffic upon any such street, and the front of any such motor truck shall project a minimum distance into the line of vehicular traffic. Further, such vehicle shall not remain backed up to the curb except while actually loading and unloading and in no case longer than the actual loading or unloading required. The minimum civil penalty under this subsection shall be Twenty Dollars (\$20.00).

**Section 9-230. Parking illegally in loading zones.**

No person shall stop, stand or park a vehicle in any zone designated as a loading zone for any purpose other than loading or unloading passengers or material. The minimum civil penalty

**Ordinance No. 2064**

**Designating Fire Command Parking on either side of the Callendar Street entrance to the Fire Station.**

under this subsection shall be Twenty Dollars (20.00).

**Section 9.231. Parking as to impede traffic.**

It shall be unlawful for any operator to stop, stand or park any vehicle that hinders the free movement of vehicular traffic, except that this provision shall not apply to the operator of a vehicle stopped momentarily during the actual loading or unloading of passengers if such stopping does not actually impede traffic, nor shall it apply to a necessary stop in obedience to traffic regulations or traffic signs or signals of a police officer. The minimum civil penalty under this subsection shall be Twenty Dollars (\$20.00).

**9-232. Restricted parking zones-designation and marking; regulations.**

A. The City Commission is authorized and directed at any time, when in their judgment it shall be necessary, to designate restricted parking areas within the City, and they may in such restricted parking areas prohibit the parking of vehicles, or fix a time limit for the parking of such vehicles.

B. It shall be unlawful for any operator of a vehicle to park the same on any of the streets of the City in violation of a posted restricted parking area. The minimum civil penalty under this section shall be a fine of Twenty Dollars (\$20.00).

**Section 9-234. Restricted parking zones - fifteen minutes parking zones.**

The operator of any vehicle shall not park such vehicle for more than fifteen (15) minutes at any one time in the following described 15 minute parking zones:

- a. on the west side of Second Street from the intersection of Second Street and Callender Street, north to the driveway on the northly boundary of the United

**Ordinance No. 2064  
Designating Fire Command Parking on either side of the Callendar Street entrance to the Fire Station.**

States Post Office during the hours of 9:00 a.m. to 5:00 p.m. The minimum civil penalty under this subsection shall be Twenty Dollars (\$20.00).

- b. in the designated 15 minute parking zone on the easterly side of Second Street in front of American Bank, 120 North 2<sup>nd</sup> Street, Livingston, Montana. The minimum civil penalty under this subsection shall be Twenty Dollars (\$20.00).
- c. in the two (2) parking spaces designated for 15 minute parking on the southerly side of Callender Street just west of its intersection with 2<sup>nd</sup> Street, which parking spaces are adjacent to First Interstate Bank. The minimum civil penalty under this subsection shall Twenty Dollars (\$20.00).
- d. in the parking space designated for 15 minute parking on the westerly side of Main Street in front of Gavne Insurance, 406 South Main Street, Livingston, Montana. The minimum civil penalty under this subsection shall be Twenty Dollars (\$20.00).

**Section 9-235. Restricted parking zones commercial vehicles in residential districts at night.**

(A) For the purpose of this section a commercial vehicle is defined as any motor vehicle or trailer weighing greater than sixteen thousand (16,000) pounds as such weights are stamped on vehicles according to the laws of the State, and requiring a Montana license plate thereof designating the vehicle as a truck or trailer by having stamped or imprinted on the plate the letter "T" or "TR" as part of the license plate numbering.

(B) For the purposes of this section residential districts are defined as all of the streets in



the City other than the following: Main Street from Park Street to Geysler Street, Second Street from Park Street to Clark Street, B street from. Park Street to Clark Street, Park Street from Third Street to the City Limits on the easterly end of Livingston, Callender Street from Third Street to B Street Lewis Street from Third Street to. B Street Lewis Street from Third Street to B Street, and Clark Street from Second Street to B Street.

(C) Between the hours of six (6) p.m. and eight (8) a.m. there shall be no parking of commercial vehicles as herein defined.

(D) Emergency vehicles, which are defined as ambulances, automobile wreckers, public utility service trucks, hearses and fire trucks are excepted from this section.

(E) The minimum civil penalty under this subsection shall be Twenty Dollars (\$20.00).

**Section 9-236. Storage on streets - not licensed or inoperable motor vehicle.**

It shall be civil offense for any owner or operator of a motor vehicle, not licensed or which is wrecked, dismantled, in a partially dismantled condition, inoperative, i.e. not capable of moving under its own power or in an unsafe conditions as defined by 61-9-101 *et seq.* of the Montana Code Annotated to park, store or leave the same upon any street of the City for more than seventy-two hours. The minimum civil penalty under this subsection shall be Twenty Dollars (\$20.00).

**Section 9-237. Storage on streets - trailers, motor homes, etc..**

It shall be a civil offense for any owner or person in possession of a trailer or trailer house or motor home to store or leave the same upon any street of the City for more than five (5) consecutive days. The minimum civil penalty under this subsection shall be Twenty Dollars

**Ordinance No. 2064**

**Designating Fire Command Parking on either side of the Callendar Street entrance to the Fire Station.**

(\$20.00).

**Section 9-238. Parking in depository driveways.**

(A) The purpose of this section is to provide the public with safe and secure access from City Streets to places of deposit with financial institutions and to hereby protect life and property.

(B) It shall be a civil offense for any owner or operator of a motor vehicle to park or stop a motor vehicle in a driveway area designated by a financial institution and the Chief of Police as a depository driveway lane between the hours of 8:00 o'clock a.m. and 5:30 o'clock p.m. Monday through Friday. This section shall not apply to any person parking or stopping in the driveway lane for the purpose of using depository services.

(C) The minimum civil penalty under this subsection shall be Twenty Dollars (\$20.00).

**Section 9-240. Parking - City Park Property.**

No person shall park a motor vehicle upon any street or road in or around the perimeter of Sacajawea or Miles Park, upon City Park grounds, or upon City park parking areas after 11:00 p.m. The minimum civil penalty under this subsection shall be Twenty Dollars (\$20.00).

This section shall not apply to persons who have been given authorization from the City Commission for camping overnight or overnight stays pursuant to Section 10-26.

**Section 9-241. Parking Overnight or camping.**

No person may park a motor vehicle upon the City streets for purposes of camping or remaining in the vehicle overnight. The minimum civil penalty under this subsection shall be Twenty Dollars (\$20.00).

**Section 9-242. Loading/unloading zones established.**

1. An loading/unloading zone for one parking spot is hereby established for the purpose of dropping off and picking up children for the child care center located at 210 East Lewis Street. No vehicle shall park longer than 5 minutes at said location during the hours of 7:30 a.m. to 7:00 p.m., Monday through Saturday. The minimum civil penalty under this subsection shall be Twenty Dollars (\$20.00).

**Section 9-243. Reserved.**

**Sec. 9-243 Restricted Parking Zones - Reserved Spaces for Handicapped or Disabled Persons.**

**A. Definitions:**

1. For the purpose of this section, "special parking spaces" are defined as on street parking spaces reserved for disabled persons who were issued a permit, license plate, or placard by the State of Montana in accordance with MCA 49-4-302 Montana Code Annotated (MCA) which entitles a person to park a motor vehicle in a special parking space reserved for a person with a disability, whether on public property or on private property available for public use, when the person for whom the permit was issued is using the special parking space to enter or exit the vehicle.

2. "Special reserved parking spaces" are defined as restricted on street parking spaces reserved for the personal use of a disabled person(s) who has been issued a special parking permit by the State of Montana under MCA 49-4-301(1).

**A. Special Parking Spaces:** Any person requesting an on-street special parking space shall make written application to the Public Works Department using a form provided by the City. The application shall state the name and address of the applicant, the location of the requested space and the reason for the request. All eligible applications will be reviewed by City staff and submitted to the City Commission for approval.

1. The following factors will be taken into consideration and used as criteria in approving signs for special parking spaces on public streets:

- a. Existing parking problems in the area where the sign is being requested.
- b. Overall availability of parking in the area where the sign is being

**Ordinance No. 2064**

**Designating Fire Command Parking on either side of the Callendar Street entrance to the Fire Station.**

requested.

- c. The availability of reasonably accessible and practicable off street parking in close proximity to the area where the sign is being requested.
- d. The nature and use of the adjacent buildings.
  - i. The requested space must comply with applicable regulations and legal mandates in terms of dimensional requirements and location as specified in 49-4-302 MCA as follows:

In accordance with subsection (2), the governing body of a city, town, or county or appropriate state agency may impose all, but not less than all, of the following requirements with respect to any special parking space constructed after September 30, 1985, and reserved for a person with a disability or a permit holder on ways of this state open to the public, as defined in 61-8-101:

(a) The space must be located on a smooth, level surface as near as practicable to building entrances or walkways that have curb cuts and appropriately designed ramps and access lanes to accommodate wheelchairs.

(b) If parallel to curbside, the parking space must be separated from an adjacent space, either in the front or the rear, by at least 5 feet of striped no-parking area.

(c) If at an angle to curbside, the parking space must be at least 8 feet wide and free of obstruction if located at the end of a line of angle parking spaces, and each other angle parking space designated for a person with a disability must be at least 13 feet wide.

(d) A parking space reserved for a person with a disability must be designated by a sign showing the international symbol of accessibility, indicating that a permit is required, and stating the penalty for a violation. In order to meet the penalty statement requirement, signs existing on October 1, 1993, must have attached a decal stating the penalty for a violation. The sign must be attached to a wall or post in a way that it is not obscured by a vehicle parked in the space.

This section shall not limit the City from exercising its own discretion in establishing special parking spaces on public streets at other locations as deemed appropriate and as approved by the City Commission.

- b. Once approved by the City Commission, the special parking space must be designated by a sign showing the international symbol of accessibility, indicating that a permit is required, and having a decal stating the penalty for a violation. The sign must be attached to a wall or post in a way that is not obscured. The parking space shall be in compliance with any other applicable regulations and legal mandates in terms of dimensional requirements and location.

- c. A special parking space may be removed, as approved by the City Commission, if there is a change in the circumstances such that the parking space shall no longer be appropriate under the criteria referred to herein.

**B. Special Reserved Parking Space.** A disabled person may request an on-street special reserved parking space restricted for their personal use in a residential area outside of the two-hour parking zone. The application shall be made in writing to the Public Works Department using a form provided by the City. The application shall state the name and address of the applicant, the location of the requested space, the reason for the request, and list the license number(s) of the vehicle(s) authorized to use the space. All eligible applications will be reviewed by City staff and submitted to the City Commission for approval. If the City Commission approves the personalized special parking space, the applicant will be notified and shall submit a non-refundable \$50 fee to pay for the installation of the sign. The sign will be installed after payment of the fee.

- a. The criteria for designating an on street special reserved parking space restricted for the personal use of disabled persons outside of the 2-hour parking zone shall be as follows:
  - i. The applicant must show that (1) they operate a vehicle(s), registered under MCA 61-3-332(9) or MCA 61-3-458(3)(b) or(3)(i), that displays a specialty inscribed license plate issued by the state of Montana to disabled persons and displaying a wheelchair symbol or the letters "DV" issued to disabled veterans or; (2) they possess a permit issued under MCA 49-4-301(1) and MCA 49-4-304. A copy of the vehicle registration or permit must accompany the application;
  - ii. The requested special reserved parking space must be adjacent to the applicant's permanent residence.
  - iii. No more than one special reserved parking space shall be provided to any one individual, or more than one special reserved parking space provided per dwelling unit.
  - iv. No more than two vehicles may be designated as being authorized to use the space.
  - v. No reserved parking space shall be provided within the downtown Two-Hour Parking Zone, as identified in Section 9-246 of this chapter.

**Ordinance No. 2064**

**Designating Fire Command Parking on either side of the Callendar Street entrance to the Fire Station.**

**Page 13**

vi. No reserved parking space shall be provided if reasonably accessible and practicable off street parking exists at the requested location.

vii. The requested space must be able to comply with the requirements of 49-4-302(4) MCA as follows:

1. In accordance with subsection (2), the governing body of a city, town, or county or appropriate state agency may impose all, but not less than all, of the following requirements with respect to any special parking space constructed after September 30, 1985, and reserved for a person with a disability or a permit holder on ways of this state open to the public, as defined in 61-8-101:

(a) The space must be located on a smooth, level surface as near as practicable to building entrances or walkways that have curb cuts and appropriately designed ramps and access lanes to accommodate wheelchairs.

(b) If parallel to curbside, the parking space must be separated from an adjacent space, either in the front or the rear, by at least 5 feet of striped no-parking area.

(c) If at an angle to curbside, the parking space must be at least 8 feet wide and free of obstruction if located at the end of a line of angle parking spaces, and each other angle parking space designated for a person with a disability must be at least 13 feet wide.

(d) A parking space reserved for a person with a disability must be designated by a sign showing the international symbol of accessibility, indicating that a permit is required, and stating the penalty for a violation. In order to meet the penalty statement requirement, signs existing on October 1, 1993, must have attached a decal stating the penalty for a violation. The sign must be attached to a wall or post in a way that it is not obscured by a vehicle parked in the space.

b. Once approved by the City Commission, the special reserved parking space must be designated by a sign displaying the license plate number(s) of the vehicle(s) authorized to park in the special reserved parking space and stating the penalty for violation. The sign must be attached to a wall or post in a way that is not obscured.

- c. Reapplications to maintain a special reserved parking space must be made by December 31st of each year. A fee of \$5.00 is required with each reapplication. If the reapplication is not received by December 31st, the person will be notified by mail and an application form shall accompany such notice. The sign will be removed if the reapplication is not received within 30 days.
- d. If a person who has been provided a special reserved parking space moves to a new residence within the City limits, and a space is needed for the new residence, the City will relocate the sign to the new location without additional fee if the City is promptly notified of the change of address and provided that the new address is in a residential area outside of the 2-hour parking zone.
- e. A special reserved parking space shall promptly be removed if there is a change in the circumstances such that the parking space shall no longer be appropriate under the criteria referred to herein.

**Section 9-244. Parking Restrictions for B Street Parking Lot.**

No parking of vehicles, trailers or equipment shall be allowed between the hours of 3:00 o'clock a.m. and 6:00 o'clock a.m. in the B Street Parking Lot which is described as being Lots 17 through 27 of Block 77 of the Original Townsite to the City of Livingston, Montana. The minimum civil penalty under this subsection shall be Twenty Dollars (\$20.00).

**Section 9-245. Parking upon City or County owned premises**

No person shall park his motor vehicle upon a parking area or lot owned by the City or County except in designated parking stalls which shall be denoted by white painted lines upon the parking surface. The minimum civil penalty under this subsection shall be Twenty Dollars (\$20.00).

**Section 9-246. Two Hour Parking Zones.**

**A. Downtown 2-hour parking zone.**

- 1. The following streets or portions of streets are designated as two-hour parking

**Ordinance No. 2064**

**Designating Fire Command Parking on either side of the Callendar Street entrance to the Fire Station.**

zones between the hours of 9:00 o'clock a.m. and 5:00 o'clock p.m., except upon Sundays and legal holidays:

- a. B Street from Park Street to Lewis Street;
  - b. Third Street from Park Street to Callender Street;
  - c. West Lewis from Main to Third Street;
  - d. West side of South Second Street from Lewis Street to the south line of Lot 10 in Block 94 of the Original Townsite;
  - e. East side of south Second Street from Lewis Street to Clark Street
  - f. Callender Street from Third Street to B Street;
  - g. South side of east Callender Street from B Street east for three {3} parking places;
  - h. The south side of Park Street from Third to B Street;
  - i. East Lewis Street from Main Street to B Street;
  - j. Main Street from Park Street to Clark Street;
  - k. The West side of Main Street in front of Lots 1, 2, 3, 15, and 16 of Block 111 of the Original Townsite to the City of Livingston
  - l. The Eastside of Main Street in front of Lots 29 and 30 of Block 110 of the Original Townsite to the City of Livingston;
  - m. Second Street from Park Street to Lewis Street;
  - n. The north side of Clark Street from the alley between Main and B Streets to the alley between Main and Second Streets;
  - o. The south side of Clark Street from the alley between Main and Second Street to Main Street;
  - p. The south side of Geyser Street from the alley in the 100 Block of East Geyser to Main Street.
2. The minimum civil penalty under this subsection shall be Twenty Dollars



(\$20.00).

**B. City-County Complex 2-hour Parking Zone.**

**(a) Designation of City-County Complex Parking Zone.** The following lots, streets or portions of streets are designated as two-hour parking zones between the hours of 9:00 o'clock a.m. and 5:00 o'clock p.m., except upon Sundays and legal holidays, as follows:

- 1. the paved public parking lot immediately behind and adjacent to the City-County Complex;
- 2. that portion of "D" Street running north from the alley between Callender Street and Lewis Street only on that side of "D" Street which is adjacent to and abuts the lots upon which the City-County Complex is situated;
- 3. that portion of "E" Street running north from the alley between Callender Street and Lewis Street only on that side of "E" Street which is adjacent to and abuts the lots upon, which the City-County Complex is located; and
- 4. both sides of Callender Street between "D" Street and "E" Street which has not been zoned for fifteen (15) minute parking or signed for one vehicle length on either side of the Fire Department entrance on Callendar Street for command vehicles.

**(b) Parking Violations and exceptions.**

(i) It is a civil offense for any person. between the hours of 8:00 o'clock a.m. and 5:00 o'clock p.m. on Monday through Friday, to park his or her vehicle in the City-County Complex designated two (2) hour parking zone in excess of two (2) hours per day on each and every day the parking restriction is in effect; the two (2) hour parking limitation is the total time allotment per day per vehicle thereby having the effect of preventing vehicles being moved to gain an additional two (2) hours of parking.

(ii) Persons called for jury trial in any of the courts situated in the City-County Complex shall be exempted from the punishment set forth hereinafter upon written proof to the Clerk of the City Court that they were called for jury service at the date and time

they received the citation for violating the two (2) hour parking zone.

(iii) City or county employees that respond to an emergency shall be exempted from the punishment set forth hereinafter upon written proof to the Clerk of the City Court that they were responding to an emergency at the date and time they received the citation for violating the two (2) hour parking zone.

(iv) Drivers of vehicles legally parking in a parking spot designated for official vehicles by the City-County Complex parking plan are also exempted from the regulations and punishment set forth herein.

**(c) Punishment.**

The civil penalty for violating section 2(b)(i) shall be by fine only in the amount of Twenty dollars (\$20.00) per violation.

**3. Exception to 2 hour downtown parking zones.**

Persons, firms or entities are exempt from the requirements of this section upon obtaining a permit authorized in section 9-248.

**Section 9-247. Enforcement Officer.**

Personnel, in addition to regularly appointed peace officers, upon being duly appointed by the City Manager, may issue a parking ticket for violations that may be placed upon any vehicle in violation of Article IV - Parking, Stopping and Standing.

**Section 9-248. Extended Parking Permit.**

A. A person, firm or entity, engaged in construction or remodeling of a premises located in a restricted two hour parking zone may obtain a permit for extended parking or reserving a parking space adjacent to the property under construction.

1. Permits for extended parking will be issued on a per day basis and may be utilized by vehicles or equipment involved with the construction project. The person, firm or entity obtaining the permit will be responsible for placing a City provided placard or sticker on the vehicle or equipment which shall be

**Ordinance No. 2064**

**Designating Fire Command Parking on either side of the Callendar Street entrance to the Fire Station.**

conspicuously displayed.

- 2. Permits for reserving a parking space will be issued on a per day basis and apply to a designated parking space or spaces adjacent to the property under remodel or construction. The City will provide signs and/or barricades for each reserved space.

B. Permits shall be obtained from the Building Department. Fees for the extended parking permits and reserved parking spaces will be set by resolution of the City Commission.

**Section 9-249. Vicarious Liability.**

(a) All violations of the parking ordinances are hereby deemed an absolute liability upon the registered owner of the motor vehicle.

(b) It shall be no defense to any parking violation that the motor vehicle was illegally parked by another unless it is shown the vehicle was being used without the consent of the registered owner. (See City of Missoula v. Shea, 661 P.2d 410 (Mont. 1983).

**Section 9-250 Vehicle Immobilization authorized.**

The City of Livingston Police Department is hereby authorized to use a vehicle immobilizer, hereinafter referred to as the “boot,” to immobilize any vehicle that is parked upon a City street, alley or parking lot open to the public which has received five (5) or more parking tickets which are due and have not been paid, and at least one of the parking tickets has been unpaid for 30 days or more.

Prior to immobilizing a vehicle, the City shall mail to the registered owner of the vehicle at the address provided by the State of Montana Department of Motor Vehicles a notice which will state the following:

- a) That there are five (5) or more unpaid parking tickets which are due and outstanding and that at least one of which has been unpaid for 30 days or more;
- b) That the vehicle will be immobilized if all of the unpaid parking tickets which are due are not paid within ten (10) days of the notice’s date;

- c) That if the vehicle is immobilized, the City will charge an immobilization fee of Fifty Dollars (\$50.00); and
- d) That if release of the vehicle is not obtained within 48 hours of immobilization, the vehicle will be towed and impounded which will result in towing charges and impound fees being imposed in addition to the parking fines and immobilization fees.

Service of notice shall be deemed effective on the date of mailing to the address of the vehicle’s registered owner as maintained by the Montana Department of Motor Vehicles.

**Section 9-251. Procedure for vehicle immobilization and release.**

(a) After the ten (10) day period provided in the notice has past without payment, the Finance Officer will thereafter notify the Police Chief to immobilize the vehicle. The Police Department when immobilizing the vehicle shall affix a conspicuous notice to the vehicle notifying the driver of the following:

1. That the vehicle has been immobilized pursuant to Section 9-250 of the Livingston Municipal Code;
2. That the vehicle will be released from immobilization by paying all outstanding parking tickets and immobilization fee during business hours at the Livingston City Offices located at 414 East Callender Street;
3. That if the release of the vehicle is not obtained within forty-eight (48) hours, the vehicle will be towed and impounded as provided in Section 9-252 of the Livingston Municipal Code and that a towing fee and impound fee will be charged; and
4. That any attempt to remove or attempt to remove the boot before obtaining the release as herein provided is unlawful and punishable as a misdemeanor and that if any damage is done to the boot, additional charges will be assessed to repair or replace the boot; and

5. That a hearing on the immobilization, towing or impound may be requested by filing a written request with the City Court to determine if the City did not follow the procedures set forth in §§ 9-250, 9-251 or 9-252 of the Livingston Municipal Code.

(b) An immobilized vehicle shall not be released by the City until all outstanding and due parking fines and the immobilization fee are paid, or by posting a bond.

(c) A towed and impounded vehicle will not be released by the City until all outstanding and due parking fines, immobilization fee, towing charges and impound fees are paid, or by posting a bond.

**Section 9-252, Towing and Impound.**

(a) Any vehicle which has not been released from immobilization after forty-eight (48) hours as provided by Section 9-251, will be towed and impounded by the City.

(b) In the event the vehicle is towed and impounded, the City will notify the registered owner of the vehicle by mail of the fact that the vehicle has been towed and impounded and the procedure to obtain the vehicle’s release.

**Section 9-253, Appeal of immobilization, towing and impound.**

Following immobilization, towing and impound of a vehicle, the registered owner may request a hearing before the City Court by filing a request setting forth the name of the person making the request, the facts and circumstances upon which the request is based and the relief requested. A copy of the request will be mailed or delivered to the City Attorney. The City Judge shall attempt to timely schedule a hearing to determine whether the immobilization, towing or impound was in violation of §§ 9-250, 9-251 or 9-252 of the Livingston Municipal Code. If the City Judge finds that the immobilization, towing or impounding was in violation of §§ 9-250, 9-251 or 9-252 of the Livingston Municipal Code, the vehicle will be immediately released and the registered owner or any other person having an interest in the vehicle shall not be held liable for any fees or costs incurred and in that event any fees or costs paid shall be

**Ordinance No. 2064  
Designating Fire Command Parking on either side of the Callendar Street entrance to the Fire Station.**

refunded to the person paying the fees or costs, however, any such release shall not excuse payment of unpaid fines for any outstanding parking tickets.

**Section 9-254, Criminal Offense and Penalty.**

A person commits the offense of unauthorized release of an immobilized vehicle if he purposely or knowingly removes or attempts to remove the immobilizing device (boot) from a vehicle before obtaining the vehicle’s release from the Livingston Police Department. A person convicted of unauthorized release of an immobilized vehicle may be punished by a fine not to exceed \$500.00 and/or imprisonment in the county jail for a term not to exceed six (6) months. In addition, if damage is done to the boot, the Court may impose restitution for the repair or replacement of the boot.

**SECTION 2**

**Statutory Interpretation and Repealer:**

Any and all resolutions, ordinances and sections of the Livingston Municipal Code and parts thereof in conflict herewith are hereby repealed.

**SECTION 3**

**Severability:**

If any provision of this ordinance or the application thereof to any person or circumstance is held invalid, such invalidity shall not affect the other provisions of this ordinance which may be given effect without the invalid provision or application and, to this end, the provisions of this ordinance are declared to be severable.

**SECTION 4**

**Savings Provision:**

This ordinance does not affect the rights or duties that matured, penalties and assessments that were incurred or proceedings that begun before the effective dates of this ordinance.

**SECTION 5**

**Effective date:**

**Ordinance No. 2064  
Designating Fire Command Parking on either side of the Callendar Street entrance to the Fire Station.**

This ordinance will become effective 30 days after second and final adoption.

\* \* \* \* \*

**PASSED** by the City Commission of the City of Livingston, Montana, upon first reading at a regular session thereof held on the \_\_\_\_\_ day of April, 2017.

\_\_\_\_\_  
**JAMES BENNETT - Chairman**

**ATTEST:**

\_\_\_\_\_  
**LISA HARRELD**  
**Recording Secretary**

\* \* \* \* \*

**PASSED, ADOPTED AND APPROVED** by the City Commission of the City of Livingston, Montana, on second reading at a regular session thereof held on the \_\_\_\_\_ day of \_\_\_\_\_, 2017.

\_\_\_\_\_  
**JAMES BENNETT - Chairman**

**ATTEST:**

**APPROVED AS TO FORM:**

\_\_\_\_\_  
**LISA HARRELD**  
**Recording Secretary**

\_\_\_\_\_  
**COURTNEY LAWELLIN**  
**City Attorney**

NOTICE

The public is invited to attend and comment at a public hearing to be held on May 2, 2017, at 6:30 p.m. in the Community Room of the City County Complex, 414 East Callender Street, Livingston, Montana, on the first reading of **ORDINANCE NO. 2065** entitled **AN ORDINANCE OF THE CITY COMMISSION OF THE CITY OF LIVINGSTON, MONTANA, AMENDING ORDINANCE 2049 AND CHAPTER 9, ARTICLE IV OF THE LIVINGSTON MUNICIPAL CODE ENTITLED “PARKING, STOPPING, AND STANDING” BY ESTABLISHING FIRE DEPARTMENT PARKING ON EITHER SIDE OF THE CALLENDAR STREET ENTRANCE AND ESTABLISHING A CIVIL PENALTY FOR VIOLATION THEREOF**. A copy of the ordinance is available for inspection at the City Office, 414 East Callender Street, Livingston, MT 59047. For further information call the City Attorney at (406) 823-6007.

(Notice must be published two (2) times at least six (6) days apart. Mont. Code Ann. § 7-1-4127(7). Further, notice must be posted on the City Bulletin Board, and copies are to be made available for the public. Mont. Code Ann. § 7-5-103.)



**Backup material for agenda item:**

- A. ORDINANCE NO. 2065 - AN ORDINANCE OF THE CITY COMMISSION OF THE CITY OF LIVINGSTON, MONTANA, AMENDING SECTION 8-5 OF THE LIVINGSTON MUNICIPAL CODE ENTITLED "DAILY ACCOUNT OF FUNDS COLLECTED; MONTHLY REPORT, CONTENTS" AND SPECIFICALLY AMENDING THE PROCEDURE, CONTENT AND TIME OF THE CITY COURT MONTHLY REPORT.

**ORDINANCE NO. 2065**

**AN ORDINANCE OF THE CITY COMMISSION OF THE CITY OF LIVINGSTON, MONTANA, AMENDING SECTION 8-5 OF THE LIVINGSTON MUNICIPAL CODE ENTITLED “DAILY ACCOUNT OF FUNDS COLLECTED; MONTHLY REPORT, CONTENTS” AND SPECIFICALLY AMENDING THE PROCEDURE, CONTENT AND TIME OF THE CITY COURT MONTHLY REPORT.**

\* \* \* \* \*

**Purpose.**

The purpose of this Ordinance is to provide a procedure that will reflect a more accurate monthly City Court report to the Livingston City Commission.

\* \* \* \* \*

**WHEREAS**, currently Ordinance Section 8-5 requires the City Judge to present a report to the Livingston City Commission at the first Commission meeting of every month, giving a statement of cases tried for offenses against the City, and fines and costs collected during the preceding calendar month, accompanied by receipts from the City for the amounts of such fines and costs; and

**WHEREAS**, the Livingston City Commission believes requiring the City Judge to submit a written report to the Livingston City Commission at the second Commission meeting of every month which would include a statement of cases disposed, fines and costs collected during the preceding calendar month, and a reconciliation from the City Finance Office would provide a procedure that will reflect a more accurate monthly City Court report to the Livingston City Commission.

**NOW, THEREFORE, BE IT ORDAINED** by the City Commission of the City of

**Ordinance No. 2065**  
**Amending the procedure, content and time of the monthly City Court report to the Livingston City Commission.**  
**Page 1**

Livingston, Montana, as follows:

That Section 8-5 of Chapter 8 of the Livingston Municipal Code is hereby amended, with strike through deletions and additions underlined and in bold, as follows:

- **Section. 8-5. – Daily account of funds collected; monthly report, contents.**

It shall be the duty of the City Judge to turn over each day to the City all fines received.

At the ~~first~~ **second** meeting in each month, the City Judge shall ~~present~~ **submit** to the City Commission a report, in writing, giving a statement of cases ~~tried for offenses~~ against the City, **disposed** and fines and costs collected, during the preceding calendar month, which report shall be accompanied by ~~receipts from the City for the amount of such fines and costs.~~ **a reconciliation from the City Finance Office.**

**Effective date:**

This ordinance will become effective 30 days after the second and final adoption.

**PASSED** by the City Commission of the City of Livingston, Montana, on first reading at a regular session thereof held on the 2<sup>nd</sup> day of May, 2017

---

**JAMES BENNETT- Chairman**

**ATTEST:**

---

**LISA HARRELD**  
**Recording Secretary**

\* \* \* \* \*

**Ordinance No. 2065**  
**Amending the procedure, content and time of the monthly City Court report to the Livingston City Commission.**  
**Page 2**

**PASSED, ADOPTED AND APPROVED** by the City Commission of the City of Livingston, Montana, on second reading at a regular session thereof held on the 16<sup>th</sup> day of May, 2017.

---

**JAMES BENNETT - Chairman**

**ATTEST:**

**APPROVED AS TO FORM:**

---

**LISA HARRELD**  
**Recording Secretary**

---

**JAY PORTEEN**  
**City Attorney**

**Ordinance No. 2065**  
**Amending the procedure, content and time of the monthly City Court report to the Livingston City Commission.**  
**Page 3**

## NOTICE

The public is invited to attend and comment at a public hearing to be held on May 16<sup>th</sup>, 2017, at 6:30 p.m. in the Community Room of the City County Complex, 414 East Callender Street, Livingston, Montana, on the second reading of **ORDINANCE NO. 2065** entitled **AN ORDINANCE OF THE CITY COMMISSION OF THE CITY OF LIVINGSTON, MONTANA, AMENDING SECTION 8-5 OF THE LIVINGSTON MUNICIPAL CODE ENTITLED “DAILY ACCOUNT OF FUNDS COLLECTED; MONTHLY REPORT, CONTENTS” AND SPECIFICALLY AMENDING THE PROCEDURE, CONTENT AND TIME OF THE CITY COURT MONTHLY REPORT.**

A copy of the ordinance is available for inspection at the City Office, 414 East Callender Street, Livingston, MT 59047. For further information call the City Attorney at (406)823-6007.

(Notice must be published twice at least 6 days apart. (7-1-4127(6) and posted on the City Bulletin Board, and copies available for the public (7-5-103 MCA).

**Backup material for agenda item:**

- A. RESOLUTION NO. 4725 - A RESOLUTION OF THE CITY COMMISSION OF THE CITY OF LIVINGSTON, MONTANA, AUTHORIZING PARTICIPATION IN THE BOARD OF INVESTMENTS OF THE STATE OF MONTANA SHORT TERM INVESTMENT POOL AND AUTHORIZING THE EXECUTION AND DELIVERY OF DOCUMENTS RELATED THERETO.

RESOLUTION AUTHORIZING PARTICIPATION IN THE SHORT TERM INVESTMENT POOL (STIP)  
MONTANA BOARD OF INVESTMENTS

CERTIFICATE AS TO  
RESOLUTION NO. 4725 AND ADOPTING VOTE

Political Subdivision: City of Livingston  
Governing Body: \_\_\_\_\_

Type, date, time and place of meeting: A \_\_\_\_\_ meeting held on \_\_\_\_\_  
at \_\_\_\_\_ o'clock \_\_\_\_m. in \_\_\_\_\_, Montana.

Members present:

Members absent:

I, the undersigned, being the duly qualified and acting recording officer of the political subdivision identified above ("Participant"), certify that the attached RESOLUTION AUTHORIZING PARTICIPATION IN THE BOARD OF INVESTMENTS OF THE STATE OF MONTANA SHORT TERM INVESTMENT POOL AND AUTHORIZING THE EXECUTION AND DELIVERY OF DOCUMENTS RELATED THERETO ("Resolution") and Exhibits A and B thereto are true and correct copies of the Resolution and Exhibits A and B on file in the original records of the Participant and in my legal custody; that the Resolution and Exhibits A and B were duly approved and adopted by the Governing Body of the Participant at the above described meeting, which meeting was attended throughout by the members indicated above, constituting a quorum of the Governing Body, pursuant to public notice of such meeting as required by law; and that the Resolution and Exhibits A and B have not as of the date hereof been amended or repealed.

WITNESS my hand officially as such recording officer this \_\_\_\_ day of \_\_\_\_\_, 20 \_\_\_\_.

By \_\_\_\_\_  
Its \_\_\_\_\_

RESOLUTION NO. 4725

RESOLUTION AUTHORIZING PARTICIPATION IN THE BOARD OF INVESTMENTS OF THE STATE OF MONTANA SHORT TERM INVESTMENT POOL (STIP) AND AUTHORIZING THE EXECUTION AND DELIVERY OF DOCUMENTS RELATED THERETO

BE IT RESOLVED BY THE Livingston City Commission (the Governing Body) of City of Livingston (the Participant) AS FOLLOWS:

ARTICLE I

DEFINITIONS

Section 1.01 The following terms will have the meanings indicated below for all purposes of this Resolution unless the context clearly requires otherwise:

Section 1.02 Account shall mean a specific Participant Bank account assigned by the Bank to be used in conducting transactions through the STIP Program.

Section 1.03 Agreement shall mean the agreements of the Participant as contained within this Resolution.

Section 1.04 Authorized Representative shall mean the officer or official of the Participant designated and duly authorized by the Governing Body as set forth below to enable the Participant's participation in the STIP Program.

Section 1.05 Authorized Delegate shall mean any lawful officer, official or employee of the Participant who has been delegated authority by the Authorized Representative as provided in this Resolution to initiate transactions using the Board's STIP Program.

Section 1.06 Bank shall mean a financial institution designated and authorized as provided in this Resolution to send and receive money on behalf of the Participant for purposes of participation in the STIP Program.

Section 1.07 Board shall mean the Board of Investments of the State of Montana, a public body corporate organized and existing under the laws of the State and its successors and assigns.

Section 1.08 Exhibit A (STIP Participation Information Sheet) shall mean the document attached to and incorporated into this Resolution as provided in Article IV, Section 4.01. that provides information necessary for the Participant to participate in STIP.

Section 1.09 Exhibit B (Electronic Funds Transfer Authorization Form) shall mean the document attached to and incorporated into this Resolution as provided in Article IV, Section 4.01 that provides instructions for the Board and its agents to administer and manage the Participant's participation, transactions and shares in the STIP Program.

Section 1.10 Governing Body shall mean the governing body of the above-named political subdivision (Participant) authorized by Montana state law to participate in the STIP Program as further specified in this Resolution.

Section 1.11 Participant shall mean the political subdivision requesting participation in the Board's Short Term Investment Pool.



Section 1.12 Short Term Investment Pool, STIP, or Program shall mean the Board's Short Term Investment Pool Program as authorized by law and as more fully defined and described in the Board's policies and procedures, as may be amended from time to time.

## ARTICLE II

### SHORT TERM INVESTMENT POOL PARTICIPATION AGREEMENT

Section 2.01 Participation Agreement. By approving and adopting this Resolution and Exhibits A and B, the Governing Body requests and agrees to participation of Participant in the STIP Program, and agrees that Participant will comply with and be bound by all laws, policies, procedures and participation requirements applicable to the STIP Program, as may be amended from time to time.

Section 2.02 STIP Program Description. The STIP Program is an investment program administered under the direction of the Montana Board of Investments as authorized by the Unified Investment Program. As more fully set forth in Board policies and procedures, STIP is available to state and local governments to serve their short term cash flow and deposit needs and its objectives are to preserve capital and to maintain high liquidity. The Program has the following attributes, as more fully set forth in applicable Board policies, procedures and participation requirements, which are subject to change upon the sole determination of the Board:

- 1) STIP transactions are fixed at \$1 per share;
- 2) STIP interest on pool assets accrues daily;
- 3) STIP earnings distribution method: Interest is distributed at the beginning of the month and can be distributed as cash to the designated Bank or the earnings can be reinvested into STIP;
- 4) Buying or selling shares in STIP requires one (1) business days' notice; transactions for which notice is received after 2:00 p.m. will be processed two (2) business days after receipt of the original notice;
- 5) Access to STIP is only through an electronic, web-based portal; no cash, checks or notifications by fax, phone or email will be accepted;
- 6) STIP's web portal provides real-time information on each account including: investment balances, buys, sells, pending transactions, and transaction notes, as determined by the authorized user; and
- 7) The Board accounts and reports on its financial statement STIP investment on a Net Asset Value (NAV) basis. A NAV per share of a STIP unit will be shown on the Board's website for each month-end period <http://investmentmt.com/MonthlyNetAssetValue>.

Section 2.03 Review of Policies, Procedures and Participation Requirements. Participant acknowledges and represents that it has reviewed to its satisfaction all Board policies, procedures and participation requirements applicable to the STIP Program. <http://investmentmt.com/STIP>

Section 2.04 Authorized Representative: The Governing Body designates Paige Fetterhoff, who holds the position of Director of Finance as the Participant's Authorized Representative to make transactions between STIP and the Bank.

The Governing Body: (check one) DOES  DOES NOT  allow the Authorized Representative to appoint and delete additional Authorized Delegate(s) on behalf of the Participant. If "DOES" is checked, any addition or deletion of an Authorized Delegate requires notice via the submission of a completed Exhibit A (STIP Participation Information Sheet) to the Board by the Authorized Representative before transactions will be accepted and processed as directed by the Authorized Delegate.

The Governing Body designates and authorizes Participant's Bank, (the Bank), identified in Exhibit B attached, designating the Account Number and ABA Number to send or transfer funds to the State Treasurer for purchase of STIP shares and to deposit distributions of and withdraw proceeds resulting from sales of STIP shares in the Bank's Account identified in Exhibit B attached which is a (check one) checking account  savings account .

The Governing Body: (check one) DOES  DOES NOT  allow the Authorized Representative to change either the Bank or the Account; if 'DOES' is checked, the Board will notify both the office of the Authorized Representative AND the office of the Governing Body within three (3) business days that such a change has been made.

The Governing Body: (check one) DOES  DOES NOT  allow the Authorized Representative to change the earnings distribution method; if DOES NOT is checked, the Governing Body chooses the following earnings distribution method (check one) reinvest cash earnings into STIP  distribute cash earnings to the Bank .

Section 2.05 Change of Authorized Representative. Any change to the Authorized Representative requires a new Resolution adopted by the Governing Body; however the absence of an Authorized Representative does not nullify the authority of the Authorized Delegate(s) then in effect and so authorized to make STIP transactions.

Section 2.06 Annual Confirmation. The Board will provide on an annual basis to both the Governing Body and the Authorized Representative the following information as appears on the Board's records:

1. The name of the Authorized Representative;
2. The name(s) of any Authorized Delegate(s); and
3. The name of the Bank and the associated Account Number (truncated).

Section 2.07 Effective Date. Participant's Agreement as set forth in this Resolution will take effect when the Certificate as to Resolution and Adopting Vote, this Resolution and Exhibits A and B, each completed, dated and duly executed, are delivered to and received by the Board and will stay in effect until terminated in writing by the Governing Body.

### ARTICLE III

#### MISCELLANEOUS

Section 3.01 No Guaranteed Return. The Governing Body understands and agrees that there is no minimum or maximum amount of interest rate or any guaranteed rate of return on STIP shares or funds invested in STIP shares.

Section 3.02 Voluntary Participation. By adopting this Resolution, the Governing Body acknowledges that it is not compelled to participate in STIP, and that its participation in STIP is voluntary, and accepts and agrees to the Program, its administration and governance, and its policies, procedures and participation requirements as set forth by law and the Board.

Section 3.03 Responsibility for Participant Mistakes. The Governing Body and Participant agree to hold the State of Montana, the Board, and their members, officials and employees harmless for the acts, omissions and mistakes of the Participant, Governing Body and their members, officials and employees, including but not limited to: Authorized Representative or Authorized Delegate who, for any reason, is not qualified or properly listed with the Board as a permissible representative to authorize transactions using the STIP Program; wrong instructions as to amounts or timing of sales or purchases; or missed deadlines.

Section 3.04 No Warranty. The Governing Body and Participant acknowledge and agree that the Board makes no warranty that funds will be immediately available in the event of any failure of a third party or that Governing Body will not suffer losses due to acts of God, or other calamities, or other market dislocations or interruptions.

Section 3.05 Participation Conditions; STIP Administration. The Governing Body and Participant acknowledge and agree that the Board will allow participation in STIP by and conduct STIP business

with only those parties it determines are qualified and authorized to participate in the Program and which abide by the Board's policies, procedures and participation requirements; that the Board administers the STIP Program subject to Montana law and prudent fiduciary practices as required by Montana law and Board policy; and that the Board is legally bound to manage the Unified Investment Program, which includes STIP, in accordance with the prudent expert rule as set forth in Montana law.

Section 3.06 STIP Not Insured Against Loss. The Governing Body and Participant understand and acknowledge that the Board's STIP Program is NOT FDIC insured or otherwise insured or guaranteed by the federal government, the State of Montana, the Board or any other entity against investment losses. The Governing Body and Participant further understand and acknowledge that the Board's STIP policy requires maintenance of a reserve fund to offset possible losses and that STIP interest earnings may be used to fund this reserve before the net earnings are distributed to the STIP Participants, but that such reserves may not be adequate to cover investment losses.

ARTICLE IV

EXHIBITS A AND B

Section 4.01 Approval and Adoption of Exhibits A and B. Attached to this Resolution as Exhibits A and B, are the STIP Participation Information Sheet, and the Electronic Funds Transfer Authorization Form, which together provide the instructions and the details required by the Board to enable Participant's participation in the STIP Program. The Governing Body and Participant represent and agree that the attached Exhibits A and B have been completed and executed by the Participant's Authorized Representative and that Exhibits A and B must be complete and acceptable to the Board before participation will be allowed in the STIP Program. Exhibits A and B are hereby incorporated into and made a part of this Resolution, and are approved and adopted by the Governing Body as if set forth fully herein.

APPROVED AND ADOPTED by the \_\_\_\_\_ this \_\_\_\_\_ day  
of \_\_\_\_\_, 20\_\_\_\_.

By \_\_\_\_\_  
Its \_\_\_\_\_

Attest:

By \_\_\_\_\_  
Its \_\_\_\_\_

<b>STIP PARTICIPATION INFORMATION SHEET</b>							
STIP Program Manager Montana Board of Investments boi_stip@mt.gov PO Box 200126                      Helena, MT 59620-0126 Phone 406.444.0003                      Fax 406.444.4268				<i>For Official Use Only</i>			
<b>Requests must be submitted by Authorized Representative of the Participant.</b>				STIP DATA <input style="width: 60px;" type="text"/>	<input style="width: 60px;" type="text"/>		
				INVEST TA <input style="width: 60px;" type="text"/>	<input style="width: 60px;" type="text"/>		
				ACCT ID <input style="width: 60px;" type="text"/>	<input style="width: 60px;" type="text"/>		
<i>The STIP Participant listed below hereby agrees to participate in the STIP Program as established under Section 17-6-204, MCA., and the terms and conditions of STIP operations as determined and set by the Montana Board of Investments and warrants as follows:</i>							
<b>Section 1. STIP Participant Information Summary</b>							
STIP Participant Name →	City of Livingston			Tax Identification Number (TIN) →	81-6001286		
Mailing Address →	110 S B St	City →	Livingston	State →	MT	Zip →	59047
STIP Account # → <i>(For official use only)</i>							
Authorized Representative Name, First →	Paige	Name, Last →	Fetterhoff		Title →	Director of Finance	
Telephone Number →	(406) 823-6003	Fax Number →	222-4714		E-mail →	pfetterhoff@livingston	
<b>Section 2. Investment and Earnings Information</b>							
The STIP Participant has the option to either reinvest their earnings or distribute earnings.							
<b>Check one box only.</b>							
Reinvest Earnings <input checked="" type="checkbox"/>				Distribute Earnings <input type="checkbox"/>			
<b>Section 3. Authorized Delegates</b>							
The Authorized Delegate(s) whose name(s) appears below is (are) authorized to purchase and sell shares in STIP for the Participant.							
Name, First →		Name, Last →		E-Mail →			
Name, First →		Name, Last →		E-Mail →			
Name, First →		Name, Last →		E-Mail →			
I hereby certify as the Authorized Representative of the STIP Participant that all of the information contained herein is true, accurate and complete as of the date hereof.							
Signature →				Date →			
Printed Name →				Title →			

## Exhibit B

<b>ELECTRONIC FUNDS TRANSFER AUTHORIZATION FORM</b>					
STIP Program Manager Montana Board of Investments boi_stip@mt.gov					
PO Box 200126		Helena, MT 59620-0126			
Phone 406.444.0003		Fax 406.444.4268			
<b>Local Government Name:</b>			City of Livingston		
<b>STIP Account #:</b> <i>(For official use only)</i>					
<p>I, the undersigned, a duly Authorized Representative of the local governing board, hereby authorize the Montana Board of Investments to initiate electronic debit and/or credit to the following account. The Authorized Representative acknowledges the origination of ACH transactions to the listed account complies with the provisions of U.S. law.</p> <p>Any sale, purchase, or distribution of funds will be made by Electronic Funds Transfer or wire debiting or crediting the appropriate treasury or shareholder bank account. Please specify the local government depository.</p> <p style="text-align: center;"><b>Check one transaction type only.</b></p>					
Checking Account <input checked="" type="checkbox"/>			Savings Account <input type="checkbox"/>		
Name of Bank →		First Interstate Bank		Routing/ABA No → 092901683	
Address →		207 W Callender St.			
City →		Livingston		State → MT Zip → 59047	
Account Number →		5464150198			
I hereby certify as the Authorized Representative of the STIP Participant that all of the information contained herein is true, accurate and complete as of the date hereof.					
Signature →				Date →	
Printed Name →				Title →	
Please notify the Montana Board of Investments if you have applied a filter or a block to your account.					



**Backup material for agenda item:**

- B. RESOLUTION NO. 4726 - A RESOLUTION OF THE CITY COMMISSION OF THE CITY OF LIVINGSTON, MONTANA, ACCEPTING THE SEWER EXTENSION FROM HOMES ON 400 AND 500 BLOCK OF NORTH 10TH STREET AND HOMES NEAR THE 700 BLOCK OF NORTH 10TH STREET NEAR WEST RESERVOIR STREET.

**RESOLUTION NO. 4726**

**A RESOLUTION OF THE CITY COMMISSION OF THE CITY OF LIVINGSTON, MONTANA, ACCEPTING THE SEWER EXTENSION FROM HOMES ON 400 AND 500 BLOCK OF NORTH 10<sup>TH</sup> STREET AND HOMES NEAR THE 700 BLOCK OF NORTH 10<sup>TH</sup> STREET NEAR WEST RESERVOIR STREET.**

**WHEREAS**, in connection with development and construction of homes on 400 and 500 block of North 10<sup>th</sup> Street and homes near the 700 block of North 10<sup>th</sup> Street near West Reservoir Street in Livingston, Montana;

**WHEREAS**, the new sewer utility lines are connected to the City of Livingston’s existing sewer systems and are waiting for the City’s acceptance;

**WHEREAS**, the Code of Ordinances, City of Livingston, Montana provides that the City of Livingston’s water and sewer systems can be extended;

**WHEREAS**, the City of Livingston and property owners identified as Harry Marrinow entered into an agreement whereby the property owner paid for the engineering and construction of the sewer extensions from the end of the city mains to the individual properties on the 700 block of North 10<sup>th</sup> Street and the City of Livingston paid for and installed the sewer extension on the 400 and 500 block of North 10<sup>th</sup> Street; and

**WHEREAS**, the property owner and their engineer, and Public Works Director Shannon Holmes, on behalf of the City of Livingston, have both requested that the City of Livingston accept the aforementioned sewer into the City’s system;

**NOW, THEREFORE, BE IT RESOLVED**, by the City Commission of the City of Livingston, Montana, as follows:

That the sewer main extension from the 400 and 500 block of North 10<sup>th</sup> Street and homes near the 700 block of North 10<sup>th</sup> Street are hereby accepted into the City of Livingston’s sewer utility system.

**PASSED AND ADOPTED** by the City Commission of the City of Livingston, this 2<sup>nd</sup> day of May, 2017.

---

**JAMES BENNETT - Chairman**



**ATTEST:**

**APPROVED AS TO FORM:**

---

**LISA HARRELD**  
**Recording Secretary**

---

**JAY PORTEEN**  
**City Attorney**



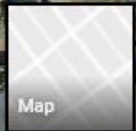

Mountain Springs Baptist Church

Google





February 2, 2017

Keith Waring, PE  
TD&H Engineering  
234 East Babcock Street, Suite 3  
Bozeman, MT 59715

RE: 10<sup>th</sup> Street Sewer Rehab, EQ#17-1605

Dear Mr. Waring:

I have reviewed the information you submitted on January 19, 2017 and additional information submitted by Brendan Elkins on January 31, 2017. I have reviewed the information for 10<sup>th</sup> Street Sewer Rehab project in accordance with Circular DEQ-2, Design Standards for Public Sewage Systems and the Administrative Rules of Montana. The request to install approximately 269ft of new 8" sewer main and a new sewer manhole within Park County is hereby approved. A copy of the plan bearing the approval stamp of the Department of Environmental Quality is enclosed. A second set will be retained as Department record.

Department approval of this project covers only those portions of the plans and specifications that are subject to the Department's review authority under the Public Water Supply Laws (MCA 75-6) and the Administrative Rules promulgated thereunder (ARM 17,38). This approval does not cover items found within the plans and specifications that are outside of the Department's review authority, including but not limited to, electrical work, architecture, site grading or water and sewer service connections.

The project may not be placed into service until the project engineer or designer certifies by letter to the Department that the activated portion of the project was constructed in substantial accordance with the plans and specifications approved by the Department and there are no deviations from the design standards other than those previously approved by the department. Within 90 days after the completion of construction, a complete set of certified "as-built" drawings must be signed and submitted to the department.

Construction of this project must be completed within three years of this date. If more than three years elapse before completing construction, plans and specifications must be resubmitted and approved before construction begins. Thank you for your efforts to meet our requirements. If I can offer any further information or assistance, please feel free to contact me at (406) 444-6713.

Sincerely,  
  
Paul Simonich, PE  
Public Water and Subdivisions Bureau

cc: Park County EH Office



**GENERAL NOTES**

1. THE CONTRACTOR SHALL NOTIFY ALL UTILITY OWNERS IN WRITING AND SHALL BE RESPONSIBLE FOR SECURING THE EXACT LOCATION OF ALL EXISTING UTILITIES BEFORE BEGINNING EXCAVATION. THE CONTRACTOR SHALL BE RESPONSIBLE FOR NOTIFYING THE CITY OF LIVINGSTON, MONTANA, AND THE MONTANA PUBLIC WORKS STANDARD SPECIFICATIONS SIXTH EDITION.
2. ALL POWER, TELEPHONE AND OTHER UTILITY POLES OR CUM MERS SHALL INTERFERE WITH CONSTRUCTION SHALL BE REMOVED OR RELOCATED BY THE UTILITY COMPANY.
3. THE CONTRACTOR SHALL BE RESPONSIBLE FOR ANY NECESSARY PERMITS.
4. THE CONTRACTOR SHALL EXCAVATE ALL WATER LINES PRIOR TO BEGINNING EXCAVATION TO ENSURE CROSSING CLEARANCE. THE CONTRACTOR SHALL NOTIFY THE CITY OF LIVINGSTON WATER AND SEWER DEPARTMENT PRIOR TO EXCAVATION.
5. THE CONTRACTOR SHALL BE RESPONSIBLE FOR EXCAVATING FITTINGS AND CONFORMING REQUIREMENTS PRIOR TO ORDERING NEW FITTINGS.
6. THE CONTRACTOR SHALL BE RESPONSIBLE FOR ANY NECESSARY PERMITS. IT WILL BE THE CONTRACTOR'S RESPONSIBILITY TO FOLLOW ALL STATE STORM DRAIN REQUIREMENTS.
7. ALL QUARTERS AND DAMAGE DITCHES AFFECTED BY CONSTRUCTION SHALL BE RESTORED TO ORIGINAL CONDITION, UNLESS OTHERWISE NOTED ON PLANS.
8. ALL STREET & TRAFFIC SIGNS THAT INTERFERE WITH CONSTRUCTION SHALL BE REMOVED & RESET BY CONTRACTOR.
9. CONTRACTOR SHALL REMOVE ANY OBSTACLE (FENCES, CONCRETE SLABS, ETC.) THAT INTERFERE WITH CONSTRUCTION UPON APPROVAL OF PROJECT ENGINEER.
10. ALL CIVIL WORK SHALL BE CONDUCTED IN CONFORMANCE WITH THE SIXTH EDITION OF MONTANA PUBLIC WORKS STANDARD SPECIFICATIONS AND THE CITY OF LIVINGSTON STANDARD SPECIFICATIONS SIXTH EDITION.
11. CONTRACTOR SHALL FIELD VERIFY LINE AND GRADE OF EXISTING CONNECTIONS.
12. CONTRACTOR SHALL REMOVE, REGRADE, CLEANING/SWEEPING OF MATERIAL THAT IS DAMAGED ONTO ADJACENT STREETS.
13. ALL SIGNATURES, BARRS AND SIGNS SHALL BE CONSTRUCTED IN ACCORDANCE WITH CURRENT MUTCD AND ADA REQUIREMENTS.
14. CONTRACTOR TO INSTALL AND MAINTAIN ALL STORMWATER BARRS THROUGH THE ENTIRE CONSTRUCTION PERIOD.
15. ALL DAMAGED ASPHALT, CONCRETE CURB AND GUTTER, AND CONCRETE SIDEWALK OUTSIDE OF THE PROJECT LIMITS SHALL BE RESTORED AT THE EXPENSE OF THE CONTRACTOR.
16. CONTRACTOR SHALL PROVIDE ALL TRAFFIC CONTROL NECESSARY FOR WORK WITHIN THE PROJECT LIMITS IN ACCORDANCE WITH MUTCD AND CITY OF LIVINGSTON TRAFFIC CONTROL DEVICES (MUTCD).
17. ALL SIGNING AND STRIPING SHALL CONFORM WITH THE MUTCD ON HIGHWAY.

**PAVING NOTES**

1. THE CONTRACTOR SHALL REPLACE ALL DAMAGED WARRANTIES DISTURBED BY CONSTRUCTION.
2. ASPHALT OVER 3" THICK SHALL BE PLACED IN 2' LIFTS.
3. DAMAGED WARRANTIES SHALL BE INSTALLED IN ACCORDANCE WITH THE SIXTH EDITION OF THE MONTANA PUBLIC WORKS STANDARD SPECIFICATIONS AND THE CITY OF LIVINGSTON SPECIFICATIONS TO MONTANA PUBLIC WORKS STANDARD SPECIFICATIONS SIXTH EDITION.

**SANITARY SEWER NOTES**

1. ALL SEWER/STORM DRAIN PIPE IS TO BE S0225 PVC AND METE ASTM 3034.
2. ALL SERVICE LINES ARE TO BE 4" S0225 PVC SEWER PIPE UNLESS NOTED OTHERWISE ON PLANS.
3. EACH SEWER SERVICE CONNECTS TO THE MAIN WITH A SEPARATE WYE AND TIES OR DOUBLE WYES ARE ALLOWED.
4. CONTRACTOR SHALL FIELD VERIFY LINE AND GRADE OF EXISTING CONNECTIONS.



PROJECT LOCATION  
NO SCALE

**LEGEND**

NEW	EXISTING	DESCRIPTION
		BUILDING
		CONCRETE
		CLUB BOX
		CLUB & GUTTER (CATCH)
		EDGE OF ASPHALT
		MANHOLE
		SPOT ELEVATIONS
		TRAFFIC SIGN
		SANITARY SEWER
		WATERLINE
		VALVE
		PROPERTY LINE
		UTILITY EASEMENT
		WATER AND SEWER EASEMENT
		PUBLIC ACCESS EASEMENT
		UTILITY EASEMENT
		GAS LINE
		UNDERGROUND ELECTRIC

**ABBREVIATIONS**

EA	EDGE OF ASPHALT
EX	EXISTING
INW	INGERT
F	FINISH FLOOR
HP	HIGH POINT
LF	LINEAL FEET
LP	LOW POINT
LN	LINE NUMBER
NO.	NUMBER
STD.	STANDARD
SW	SIDEWALK
STYP.	STANDARD TYPICAL
GB	GRADE BREAK



**SCALING NOTE**

DRAWING SHEETS PRINTED FROM ADOBE PDF ELECTRONIC FILES ARE NOT TO SCALE. VERIFY PRINTED SHEET SCALES FROM THE BAR SCALES LOCATED ON THE PLAN SHEETS.

NOT FOR CONSTRUCTION

REV	DATE	REVISION



DATE: 08/14/2018  
 DRAWN BY: KEM  
 CHECKED BY: KEM  
 QUANTITY CHECK: TAYLOR  
 SITE: TAYLOR  
 JOB NO: 18-048  
 ESTIMATE NO: 18-048

**BILL VINK SEWER REHAB**  
 LIVINGSTON, MONTANA  
**GENERAL NOTES, LEGEND, AND ABBREVIATIONS**

SHEET C2.0

NOTES:  
 1. SEE CITY OF LIVINGSTON STANDARD DRAWING 02730-3  
 FOR SANITARY SEWER SERVICE LINE

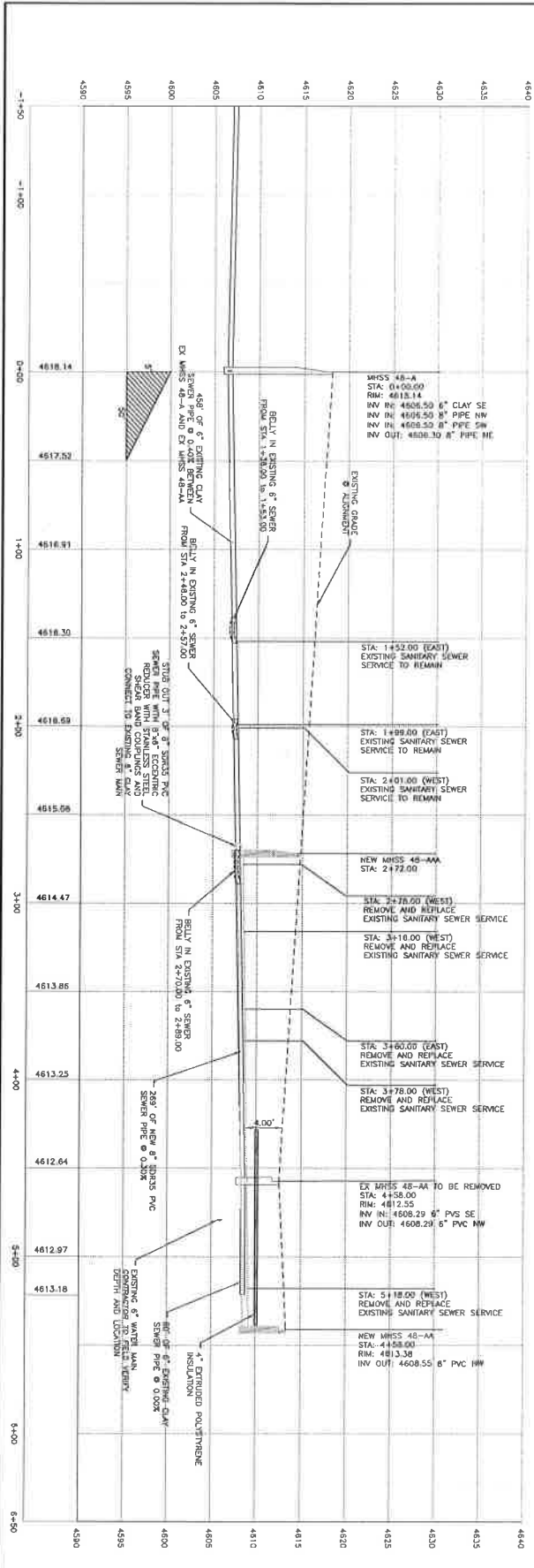
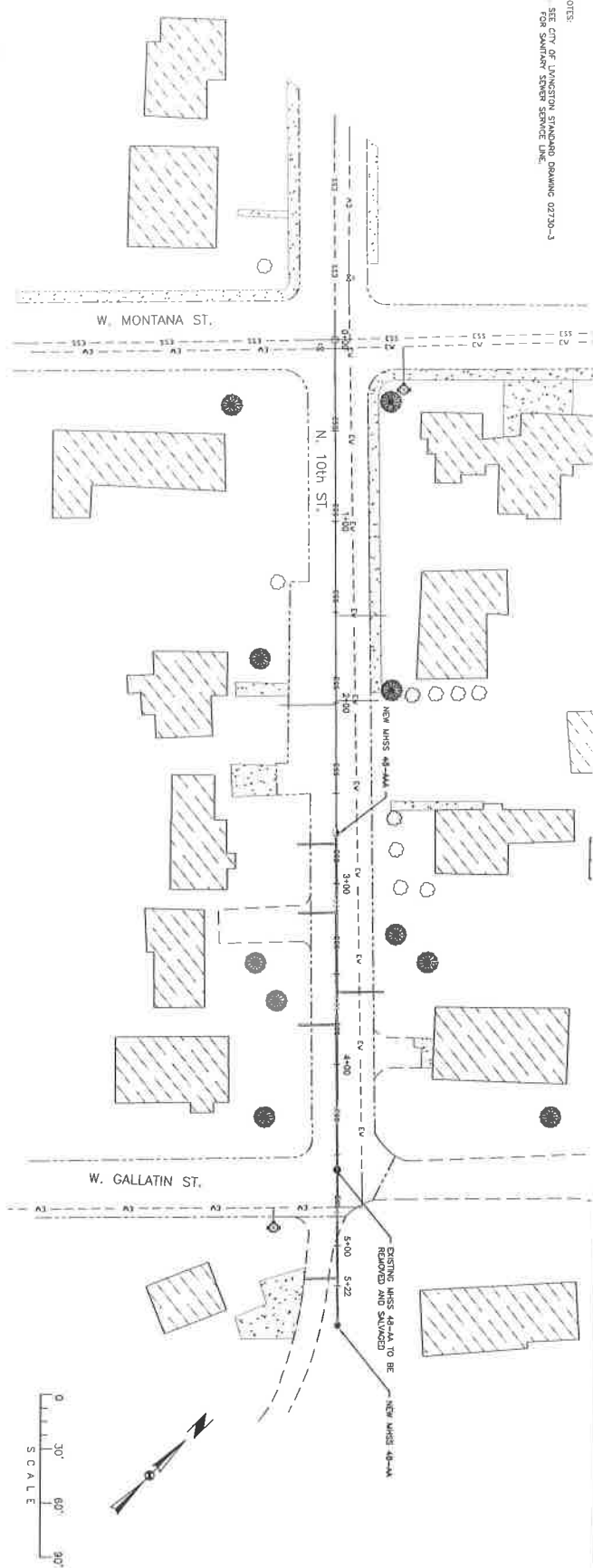

**BILL VINK SEWER REHAB**  
 LIVINGSTON, MONTANA

**10TH STREET SEWER PLAN AND PROFILE**

SHEET C3.0

DRAWN BY: [Name]  
 CHECKED BY: [Name]  
 DATE: [Date]  
 JOB NO.: [Number]  
 REVISION: [Number]

**TD&H**  
 Engineering  
 tdhengineering.com

REV	DATE	REVISION

NOT FOR CONSTRUCTION

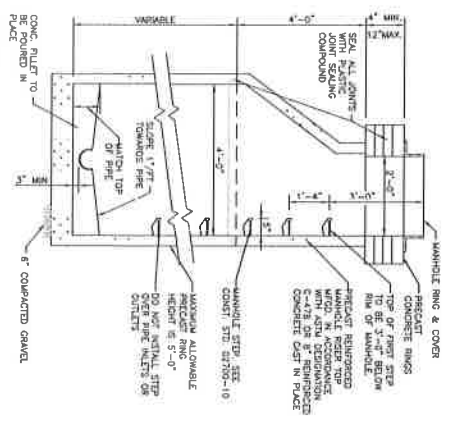

- NOTES:
1. MANHOLE BASE AND BOTTOM SECTION MAY BE UTILIZED FOR MANHOLES 8' OR LESS FROM TOP TO INVERT. SEWANT BASE AS SHOWN HERE MUST BE USED FOR DEEPER MANHOLES.
  2. MANHOLE DEPTH TO BE MEASURED VERTICALLY FROM LOWEST INVERT TO TOP OF FRAME.

SEWER MANHOLE DETAIL 1

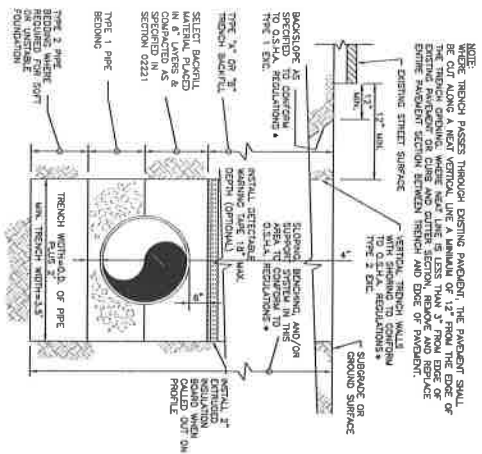

SEE OSHA CONSTRUCTION STANDARDS FOR SHIELDING, SOI, 1926, 1926.951

TYPICAL TRENCH DETAIL 2

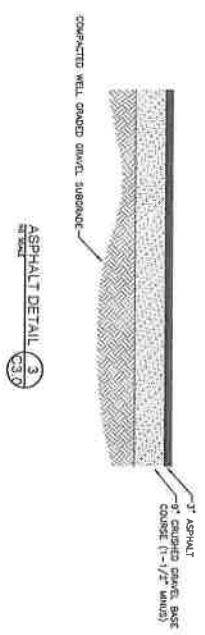

ASPHALT DETAIL 3

NOT FOR CONSTRUCTION

REV	DATE	REVISION

**TD&H** Engineering  
tdhengineering.com

DESIGNED BY: MAREK  
DRAWN BY: MAREK  
DATE: 11/20/11  
JOB NO.: 874-1847  
REVISION:

BILL VINK SEWER REHAB  
LIVINGSTON, MT  
DETAILS

3/8/2011/11/20/11  
SHEET C4.0

December 8, 2016

William Smith, PE  
Octagon Engineering  
P.O. Box 78  
Emigrant, MT 59027

RE: North Tenth Street Homes Sewer Main Extension, EQ #17-1432

Dear Mr. Smith:

I have reviewed the plans and specifications you submitted on November 17, 2016 and the additional information submitted on December 5, 2016 for the above-mentioned project and reviewed them in accordance with Department Design Standard DEQ-2. The request to construct a sewer main extension to serve the North Tenth Street Homes within the City of Livingston is hereby approved. A copy of the plan bearing the approval stamp of the Department of Environmental Quality is enclosed. A second set will be retained as Department record.

Department approval of this project covers only those portions of the plans and specifications that are subject to the Department's review authority under the Public Water Supply Laws (MCA 75-6) and the Administrative Rules promulgated thereunder (ARM 17.38). This approval does not cover items found within the plans and specifications that are outside of the Department's review authority, including but not limited to, electrical work, architecture, site grading or water and sewer service connections.

The project may not be placed into service until the project engineer or designer certifies by letter to the Department that the activated portion of the project was constructed in substantial accordance with the plans and specifications approved by the Department and there are no deviations from the design standards other than those previously approved by the department. Within 90 days after the completion of construction, a complete set of certified "as-built" drawings must be signed and submitted to the department. Construction of this project must be completed within three years of this date. If more than three years elapse before completing construction, plans and specifications must be resubmitted and approved before construction begins. Thank you for your efforts to meet our requirements. If I can offer any further information or assistance, please feel free to contact me at (406) 444-6722.

Sincerely,

Rachel Clark, PE  
Water Quality Division Engineering Bureau

cc: Park County EH Office