



City of La Vernia  
**MUNICIPAL DEVELOPMENT DISTRICT BOARD  
OF DIRECTORS MEETING**

102 E. Chihuahua St., La Vernia, Texas 78121

June 11, 2026

5:30 PM

---

## AGENDA

1. **Call to Order and Declare a Quorum**
2. **Invocation, Pledge of Allegiance and Pledge of Texas Flag**
3. **Citizens To Be Heard**
4. **Consent Agenda**  
*(All consent agenda items are considered routine and will be enacted by one motion. There will be no separate discussion of these items unless a board member requests an item be removed and considered separately.)*
  - A. Meeting minutes from the 05/14/2026 MDD meeting
  - B. Meeting minutes from the 05/18/2026 City Council, MDD, and Planning & Zoning Workshop
5. **Discussion/Action**
  - A. Discuss and consider action on facade grant
  - B. Discuss and consider action on splash pad bids
  - C. Discuss and consider action on purchasing a Christmas tree
6. **Discussion Only**
  - A. Provide an update on the car show
  - B. Provide an update on the street signs
  - C. Discuss and provide an update on the 4th of July
  - D. Discussion regarding Hometown Hoedown
  - E. Discussion regarding Christmas
7. **Future Agenda Items**
8. **Adjourn**

### 9. DECORUM REQUIRED

*Any disruptive behavior, including shouting or derogatory statements or comments may be ruled out of order by the Presiding Officer. Continuation of this type of behavior could result in a request by the Presiding Officer that the individual leave the meeting, and if refused, an order of removal.*

*The Board of the La Vernia Municipal Development District reserves the right to adjourn into executive session at any time during the course of this meeting to discuss any of the matters listed above, as authorized by the Texas Open Meetings Act, Texas Governmental Code*

*§551.071 (Consultation with Attorney), §551.072 (Deliberations about Real Property), §551.073 (Deliberations about Gifts and Donations), §551.074 (Personnel Matters), §551.076 (Deliberations about Security Devices), and §551.087 (Economic Development), and any other provisions under Texas law that permit a governmental body to discuss a matter in closed executive session.*

*The Board of the La Vernia Municipal Development District meetings are available to all persons regardless of disability. The facility is wheelchair accessible and parking spaces are available. Request for accommodations, should you require special assistance, must be made 48 hours prior to this meeting. Braille is not available. Please contact the City Secretary at (830) 779-4541 or email [mfarrow@lavernia-tx.gov](mailto:mfarrow@lavernia-tx.gov).*

I, the undersigned authority, do hereby certify that the above Notice of Meeting of the governing body of the above named La Vernia Municipal Development Board is a true and correct copy of said Notice on the bulletin boards, of the City Hall of said City of La Vernia, Texas, a place convenient and readily accessible to the general public at all times, and said Notice was posted on **June ,03 2026 at 5:00 PM** and remained so posted continuously for at least 3 business days proceeding the scheduled time of said meeting.

---

Felicia Carvajal, Executive Director



**MUNICIPAL DEVELOPMENT DISTRICT BOARD  
OF DIRECTORS MEETING**

102 E. Chihuahua St., La Vernia, Texas 78121

May 14, 2026

5:30 PM

---

**MINUTES**

**1. Call to Order and Declare a Quorum**

The meeting was called to order @5:30PM

MDD members Recker, Gilbert, and Oates were present. Farmer, and Hyland were absent.

**2. Invocation, Pledge of Allegiance and Pledge of Texas Flag**

Recker lead the prayer, as well as the pledge.

**3. Citizens To Be Heard**

There were no citizens to be heard.

**4. Consent Agenda**

*(All consent agenda items are considered routine and will be enacted by one motion. There will be no separate discussion of these items unless a board member requests an item be removed and considered separately.)*

A. Meeting minutes from the 04/09/26 MDD meeting

Motion made by Oates, seconded by Gilbert to approve as listed, all in favor.

**5. Presentations**

A. Best of La Vernia 2026 Awards

Executive Director Felicia Carvajal presented the Best of La Vernia 2026 Awards

- Rabel's Roadhaus won best restaurant
- Shay Symm Fitness Facility won best gym
- Dumpster Picking Divas won best retail
- Texas Roots Hair Studio won best beauty service
- Connally Memorial won best health and wellness
- Twin Creek Insurance Agency won best professional service
- Murry Air Conditioning won best home service
- La Vernia Auto service won best auto service
- Heather Murray won best best realtor
- La Vernia's Den won best entertainment
- La Vernia's Den won best food and drinks
- The Shed won best customer service
- The Shed won best family owned business
- La Vernia market days won best community event

## 6. Discussion/Action

- A. Discuss and consider action on 377 agreement with Tractor Supply  
 Representatives from Tractor Supply gave a PowerPoint presentation, they state they have been looking for land in La Vernia for around 3 years now. This would be their largest prototype, they plan to employ 5 full time employees, as well as 10-15 parttime employees.  
 Recker asked about the store's projected annual revenue. They stated it will make 5-9 million annually.  
 Gilbert expressed concern about providing incentives to a business that would directly compete with existing local small businesses.  
 City Engineer Morgen Gore noted that the City may request approximately \$100,000 from the MDD in the future to assist with water line upgrades related to the project. She also clarified that the development has been permitted to utilize a septic system.  
 Motion made by Oates, seconded by Gilbert to deny the 377 agreement with Tractor Supply, all in favor.

## 7. Discussion Only

- A. Discussion regarding MDD Funding Rules and Restrictions  
 MDD President Recker tabled this item for a later workshop with the City's Attorney.
- B. Provide an update on the street signs  
 Executive Director Felicia Carvajal spoke she stated we had 42 sets of street signs and there are currently 8 sets that still need to be put up.
- C. Provide an update on the sidewalk mile markers  
 Executive Director Felicia Carvajal spoke she stated all of the sidewalk mile markers have been installed.
- D. Provide an update on little libraries  
 Executive Director Felicia Carvajal spoke about the little libraries.  
 The Board agreed on the locations for the two Little Libraries. One will be installed at the gazebo in the park, and the other will be placed in front of City Hall.
- E. Discuss MDD and library partnership for summer events  
 Executive Director Felicia Carvajal spoke she states every Tuesday of June and July the library will host a park event, this will be funded by the FELPS summer youth program.
- F. Discuss and provide an update on the 4th of July  
 Executive Director Felicia Carvajal spoke she reviewed the song list for the DJ and reported that the highway event banner will be displayed from June 10 through July 10. She also announced that Mayor Gilbert will serve as the Grand Marshal for the parade.

## 8. Future Agenda Items

- Update on street signs
- Update on 4th of July
- Update on Hometown Hoedown
- Update on Christmas event

- MDD Funding Rules and Restrictions workshop with City Attorney

## 9. Adjourn

Motion made by Oates to adjourn at 6:14PM, seconded by Gilbert, all in favor.

## 10. DECORUM REQUIRED

*Any disruptive behavior, including shouting or derogatory statements or comments may be ruled out of order by the Presiding Officer. Continuation of this type of behavior could result in a request by the Presiding Officer that the individual leave the meeting, and if refused, an order of removal.*

*The Board of the La Vernia Municipal Development District reserves the right to adjourn into executive session at any time during the course of this meeting to discuss any of the matters listed above, as authorized by the Texas Open Meetings Act, Texas Governmental Code §551.071 (Consultation with Attorney), §551.072 (Deliberations about Real Property), §551.073 (Deliberations about Gifts and Donations), §551.074 (Personnel Matters), §551.076 (Deliberations about Security Devices), and §551.087 (Economic Development), and any other provisions under Texas law that permit a governmental body to discuss a matter in closed executive session.*

*The Board of the La Vernia Municipal Development District meetings are available to all persons regardless of disability. The facility is wheelchair accessible and parking spaces are available. Request for accommodations, should you require special assistance, must be made 48 hours prior to this meeting. Braille is not available. Please contact the City Secretary at (830) 779-4541 or email mfarrow@lavernia-tx.gov.*

I, the undersigned authority, do hereby certify that the above Notice of Meeting of the governing body of the above named La Vernia Municipal Development Board is a true and correct copy of said Notice on the bulletin boards, of the City Hall of said City of La Vernia, Texas, a place convenient and readily accessible to the general public at all times, and said Notice was posted on **May 08, 2026 at 5:00 PM** and remained so posted continuously for at least 3 business days proceeding the scheduled time of said meeting.

---

Felicia Carvajal, Executive Director



**CITY COUNCIL, MDD, AND PLANNING & ZONING  
WORKSHOP AND NOTICE OF POSSIBLE  
QUORUM**

102 E. Chihuahua St., La Vernia, Texas 78121

May 18, 2026

6:00 PM

---

**MINUTES**

**1. Call to Order**

The meeting was called to order at 6:00PM By Mayor Gilbert for the City Council.

Mayor Gilbert, and Council members Recker, Evans, and Oates were present. Rabel was absent.

The meeting was called to order at 6:01PM By Recker for the MDD board.

Recker, Gilbert, and Oates were present. Hyland, and Farmer were absent.

The meeting was called to order at 6:01PM By Jacobs for the Planning and Zoning Commission.

Jacobs, Tanneberger, and Real were present. Hyland was absent.

**2. Citizens to Be Heard**

*(At this time, citizens who have filled out a registration form prior to the start of the meeting may speak on any topic they wish to bring to the attention of the governing body so long as that topic is not on the agenda for this meeting. Citizens may speak on specific agenda items when that item is called for discussion. During the Citizens to Be Heard section, no council action may take place, and no council discussion or response is required to the speaker. A time limit of three minutes per speaker is permitted; the council may extend this time at their discretion.)*

There were no citizens to be heard.

**3. Discussion Only**

**A. Discussion regarding PID's**

City Attorney Dan Santee presented information on Public Improvement Districts (PIDs). PIDs are created under Chapter 372 of the Texas Local Government Code.

A city can initiate a PID, but more often a developer requests one. Roads, drainage, sidewalks, and similar infrastructure improvements can be funded through a PID.

This shifts the financial burden of these improvements to the residents who live within the PID.

The City's financial advisor, Victor, stated that not all PIDs can issue bonds; some only provide M&O reimbursements. However, most developers prefer bonds. The bonds are secured only by the homes within the development, which results in higher interest rates. If a developer does not pursue this process, it could be assumed they have private equity or other funding available to support the project.

Oates asked what happens if development progresses slowly and how long developers have to complete the project? Victor stated that the money does not go directly to the developer. Instead, it is placed in a trust and disbursed as performance expectations are met.

Victor also stated that PID proceeds can be used to pay for a well located off-site. If residents outside the PID also use the well, costs can be prorated. He noted that this would be confirmed with the City's water attorney.

Gilbert asked what happens after the bond is paid off? Victor stated that PIDs often dissolve once the bonds are retired, typically after 20 to 25 years. Dan added that after that period, the City would be responsible for maintaining amenities such as pools, parks, and other associated facilities.

All boards expressed interest in holding a development standards workshop.

#### **4. Items Specific to Future Line Items on the Agenda**

- Development standards workshop

#### **5. Adjourn**

Motion made by Recker to adjourn the City Council at 7:11PM, seconded by Oates, all in favor.

Motion made by Gilbert to adjourn the MDD board at 7:11PM, seconded by Oates, all in favor.

Motion made by Jacobs to adjourn the Planning and Zoning Commission at 7:11PM, seconded by Real, all in favor.

#### **DECORUM REQUIRED**

*Any disruptive behavior, including shouting or derogatory statements or comments may be ruled out of order by the Presiding Officer. Continuation of this type of behavior could result in a request by the Presiding Officer that the individual leave the meeting, and if refused, an order of removal.*

*The City Council for the City of La Vernia reserves the right to adjourn into executive session at any time during the course of this meeting to discuss any of the matters listed above, as authorized by the Texas Open Meetings Act, Texas Governmental Code §551.071 (Consultation with Attorney), §551.072 (Deliberations about Real Property), §551.073 (Deliberations about Gifts and Donations), §551.074 (Personnel Matters), §551.076 (Deliberations about Security Devices), and §551.087 (Economic Development), and any other provisions under Texas law that permit a governmental body to discuss a matter in closed executive session.*

*The City of La Vernia Council meetings are available to all persons regardless of disability. The facility is wheelchair accessible and parking spaces are available. Request for accommodations, should you require special assistance, must be made 48 hours prior to this meeting. Braille is not available. Please contact the City Secretary at (830) 779-4541 or email mfarrow@lavernia-tx.gov.*

I, the undersigned authority, do hereby certify that the above Notice of Meeting of the governing body of the above named La Vernia City Council is a true and correct copy of said Notice and that I posted true and correct copy of said Notice on the bulletin boards of the City Hall of said La Vernia, Texas, a place convenient and readily accessible to the general public at all times, and said Notice was posted on **May 08, 2026 at 5:00 PM** and remained so posted continuously for at least 3 business days preceding the scheduled time of said meeting.

---

Madison Farrow, City Secretary



# Façade Improvement Grant Program

The Façade Improvement Grant Program aims to support commercial uses in enhancing the visual appeal of their buildings, contributing to the overall vitality, charm, and economic growth of La Vernia. This program is specifically focused on exterior improvements that are visible from the street or public right-of-way by encouraging investment in building façades. These enhancements not only improve individual properties but also help foster a cohesive and inviting look throughout the community, supporting local pride and increased economic activity.

The LVMDD will consider, on a case-by-case basis, and may award by its sole discretion a grant to the owner of a commercial or industrial building within the city limits of La Vernia for façade improvements.

Priority will be given to:

- Buildings are officially recognized as historic by the State of Texas.
- Properties located within the Central Business District.
- Projects that aim to restore storefronts.

Adopted April 11, 2013  
Amended July 18, 2013  
Amended October 22, 2014  
Amended January 12, 2017  
Amended April 9, 2023  
Amended April 17, 2025

Applicants should demonstrate a clear intention to enhance curb appeal. Therefore, all proposed improvements must primarily impact the visible exterior of the building as seen from the street.

Applicants are encouraged to incorporate materials such as masonry, stone, stucco, or other architecturally appropriate elements in alignment with exterior construction and design standards.

Building owners must submit detailed drawings of the proposed façade improvements to the LVMDD.

**Required for Application Submission:**

- Photo(s) or drawing(s) of current and proposed project
- Bids from vendors describing estimated cost of project
- Each estimate must include the name and address of the vendor
- Renderings or sketches of the planned work
- Estimated project total costs
- Color palette and material selections
- Project timeline
- Copies of any required permits

The LVMDD Executive Director and the property owner will jointly present the proposal to the LVMDD Board for review and consideration.

- Do not begin any work until the grant is officially approved by the LVMDD.
- Reimbursement will only be provided upon:
  - Completion of the approved work
  - Submission of clear photographs showing the completed improvements

2

Adopted April 11, 2013

Amended July 18, 2013

Amended October 22, 2014

Amended January 12, 2017

Amended April 9, 2023

- Receipts or invoices documenting all project-related expenses
- The completed work must align with what was presented in the original application and approved by the Board.
  - Visually appealing and appropriate City-approved signage—including monument signs, pole signs, and other types permitted under the City’s codes—may be considered an eligible expense if it contributes to the overall enhancement of the building’s façade. Signage should be part of a broader effort to improve the property’s curb appeal and architectural character, rather than serving as a standalone improvement.
  - Landscaping improvements along the front and/or sides of the building that enhance curb appeal will be considered.
  - **The LVMDD will fund up to 50% of the actual project cost, not to exceed \$5,000.**
  - The LVMDD Executive Director must verify proof of expenditure, confirm project completion, and recommend reimbursement prior to disbursement.
  - Should GRANTEE fail to complete the project by the specified completion date then, upon written demand by the LVMDD, GRANTEE shall, within 30 days of receiving the written demand, repay all funds received and shall remit 10% interest per annum on all funds received from the time GRANTEE received the funds from the LVMDD.
  - Property owners must be current on all property taxes.
  - All contractors performing work must be registered with the City of La Vernia.

3

Adopted April 11, 2013

Amended July 18, 2013

Amended October 22, 2014

Amended January 12, 2017

Amended April 9, 2023

- Before the work has started you must have a permit submitted to the Permitting office in the City of La Vernia.

The following items are not eligible for reimbursement under the façade grant program: exterior improvements located at the rear of buildings, interior improvements, playground or recreational equipment, burglar bars, security or alarm systems, "sweat equity" labor, new commercial construction, benches or porch swings, permitting fees, architectural, survey, or other professional service fees, asbestos testing, removal, abatement, or remediation, and improvements that have already been reimbursed or covered by insurance proceeds.

- A total of no more than \$25,000 may be awarded under this program each fiscal year (October 1 – September 30).
- Property owners are eligible for funding once every three years.

Commercial property owners located within the city limits of La Vernia are eligible to apply.

Yes. Tenants may apply **with the property owner's permission**. The building owner must be the one to officially submit the application.

4

Adopted April 11, 2013

Amended July 18, 2013

Amended October 22, 2014

Amended January 12, 2017

Amended April 9, 2023

Yes. Multiple exterior improvements can be included in a single application. Be sure to provide **individual cost estimates or contractor bids** for each proposed improvement.

Applicants may be awarded **up to 50% of eligible project costs**, with a **maximum reimbursement of \$5,000**.

**Municipal Development District**

Felicia Carvajal, Executive Director of La Vernia MDD

830-779-4541

**City of La Vernia**

Lindsey Wheeler, City Administrator

[lboyd@lavernia-tx.gov](mailto:lboyd@lavernia-tx.gov) 830-779-4541

Madison Farrow, City Secretary

[Mfarrow@lavernia-tx.gov](mailto:Mfarrow@lavernia-tx.gov) 830-779-4541

Aubrie Smith, Permitting & Code Enforcement

5  
Adopted April 11, 2013  
Amended July 18, 2013  
Amended October 22, 2014  
Amended January 12, 2017  
Amended April 9, 2023

bsmith@lavernia-tx.gov 830-779-4541

6

Adopted April 11, 2013

Amended July 18, 2013

Amended October 22, 2014

Amended January 12, 2017

Amended April 9, 2023

Applicant Name: HIE N VIET NGU

Business Name: LV Nails

Street Address: 100 San Antonio Rd, La Vernia, TX 78121

Mailing Address: 6930 Comanche vw, San Antonio, TX 78235

Work Phone: \_\_\_\_\_ Cell Phone: 571-232-4750

Email: hienvngo539@gmail.com

Owner Name: \_\_\_\_\_

Business Name: \_\_\_\_\_

Street Address: \_\_\_\_\_

Mailing Address: \_\_\_\_\_

Work Phone: \_\_\_\_\_ Cell Phone: \_\_\_\_\_

Email: \_\_\_\_\_

Address/Location of property to be considered:

7  
Adopted April 11, 2013  
Amended July 18, 2013  
Amended October 22, 2014  
Amended January 12, 2017  
Amended April 9, 2023

100 San Antonio Rd, La Vernia, Tx 78121

Is the building currently occupied by a business? If yes, please list the business name(s) and Certificate of Occupancy numbers below.

NO

Has the applicant and/or property owner been a recipient of this Façade Improvement Matching Grant before? If yes, please list the property address(es) and year(s) the grant was awarded below.

NO

1. Total Project Cost (for Façade Improvements Only) \$ 7,500.00

2. Eligible Grant Request (\$5,000 or 50% of the actual cost of the façade improvements) \$ 3,500.00

Project Description (Please Describe what improvements will be made to the existing property and how the award of this grant impacts the project. 1,000 words max. May be submitted on a separate sheet of paper.

The front of building is old, I want to paint the new color and change the material of awning. (from fabric to Aluminium)

I, the applicant, verify that I have completed the following items in order to be considered for the La Vernia Municipal Development District Façade Improvement Grant. I understand that the grant will not be processed if all items below are not met

8

- Adopted April 11, 2013
- Amended July 18, 2013
- Amended October 22, 2014
- Amended January 12, 2017
- Amended April 9, 2023

- Complete Façade Improvement Grant application.
- Written cost proposal with itemized improvements.
- Exterior photos of the building before any improvements have been made.
- Drawings or renderings of proposed improvements (proposed color palette requested, if drawings or renderings are not colored).
- The proposed façade improvements have not been completed prior to receipt and verification of a complete application by MDD staff.
- Filled out City of La Vernia Required Permits

What is the anticipated start and end date for the project? (Month/Year)

Start Date June 1/2026 End Date July 1/2027

Applicant Signature: [Signature] Date 05/10/26

Property Owner Signature: \_\_\_\_\_ Date: \_\_\_\_\_  
(if different from applicant)

**MDD Office Use**

Application Received: \_\_\_\_\_ MDD Meeting: \_\_\_\_\_

The decision of the LVMDD Board of Directors: \_\_\_\_\_

Date applicant is notified: \_\_\_\_\_

---

THE STATE OF TEXAS           §  
   §       KNOW ALL MEN BY THESE PRESENTS:  
 COUNTY OF WILSON           §

9  
 Adopted April 11, 2013  
 Amended July 18, 2013  
 Amended October 22, 2014  
 Amended January 12, 2017  
 Amended April 9, 2023

THIS IS AN AGREEMENT, made and entered into by and between the La Vernia Municipal Development District, a Municipal Development District created by and through the laws of the State of Texas, hereinafter called "LVMDD", acting by and through its duly authorized representative.

and \_\_\_\_\_, hereinafter called "GRANTEE," acting by and through its duly authorized representative.

WITNESSETH:

WHEREAS, the La Vernia Municipal Development District has created and approved a process whereby buildings located within the City of La Vernia Central Business District may apply for a façade improvement grant from the LVMDD; and

II.

WHEREAS, upon an affirmative vote of the majority of LVMDD Board, on \_\_\_\_\_, the LVMDD determined that GRANTEE qualified for a grant in the amount of \_\_\_\_\_ (the "funds") for façade improvements as provided for in its application and that said funds shall be distributed to GRANTEE under the following terms and conditions:

(a) For and in consideration of the distribution to GRANTEE by the LVMDD, the funds distributed shall be used by GRANTEE for the sole purpose of

10  
Adopted April 11, 2013  
Amended July 18, 2013  
Amended October 22, 2014  
Amended January 12, 2017  
Amended April 9, 2023

\_\_\_\_\_ (the "Project"). All funds shall be for the following expenditures:

(b) The remittance of the funds by LVMDD will be upon written request by GRANTEE. The written request will indicate what the funds will be used for and the date the project is to commence. LVMDD shall remit the funds within fifteen (15) days of receipt of the written request by GRANTEE.

(c) The Project shall be completed by \_\_\_\_\_. Should GRANTEE fail to complete the project by the specified completion date then, upon written demand by the LVMDD, GRANTEE shall, within 30 days of receiving the written demand, repay all funds received and shall remit 10% interest per annum on all funds received from the time GRANTEE received the funds from the LVMDD.

(d) Upon completion of the Project, GRANTEE shall submit a final financial accounting (the "report") to the LVMDD showing a line item accounting of all expenditures made during the Project which shall be accompanied by the check register of all related expenditures. Invoices, receipts, or other proofs of expenditures shall be presented with the report.

(e) Any funds GRANTEE receives that remain after the completion of the Project are to be returned to the LVMDD within 30 days of completion of the Project. If it is determined that GRANTEE has used the funds for any purpose other than those identified in paragraph II(a) of this contract or has breached this contract in any fashion, GRANTEE shall repay all improper expenditures and shall remit 10% interest per annum on all improper expenditures from the time GRANTEE received the funds from the LVMDD.

(f) All funds received from LVMDD shall be accounted for in a separate bank account and shall not be co-mingled with other cash funds.

(g) GRANTEE shall at all times comply with the ordinances of the City of La Vernia and the laws of the State of Texas.

III.

11  
Adopted April 11, 2013  
Amended July 18, 2013  
Amended October 22, 2014  
Amended January 12, 2017  
Amended April 9, 2023

In the performance of this contract, GRANTEE shall not discriminate against any employee or applicant for employment or with any customer with respect to his hire, tenure, terms, conditions, or privileges because of his race, color, religion, national origin, sex, disability, or ancestry. A proven breach of this covenant may be regarded as a material breach of the contract causing its termination.

IV.

It is understood and agreed that in the event any provision of this contract is inconsistent with the requirements of law, the requirements of law will control and the parties shall revert to their respective positions which would otherwise be enjoyed or occupied by the respective parties for the terms of this contract.

V.

The foregoing instrument in writing between the parties herein, constitutes the entire agreement between the parties, relative to the funds made the basis hereof, and any other written or oral agreement with the LVMDD being expressly waived by GRANTEE.

IN WITNESS WHEREOF, the parties hereto execute this agreement in duplicate originals as of the date set forth above on this \_\_\_\_ day of \_\_\_\_\_ 20\_\_\_\_.

LA VERNIA MUNICIPAL DEVELOPMENT DISTRICT, TEXAS

BY: \_\_\_\_\_

12  
Adopted April 11, 2013  
Amended July 18, 2013  
Amended October 22, 2014  
Amended January 12, 2017  
Amended April 9, 2023

[Grantee]

BY: \_\_\_\_\_

13

Adopted April 11, 2013

Amended July 18, 2013

Amended October 22, 2014

Amended January 12, 2017

Amended April 9, 2023

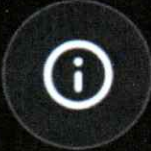

Save

Share





Save

Share





# Bao's Handyman sent you an estimate

We look forward to working with you.

### Customer

Lv nails  
Lv nails  
mhhbeautyllc@gmail.com  
100 san antonio rd  
La vernia, TX 78121

### Estimate #000007

Hide full details ^

**AWNING UPGRADE (FABRIC TO INSULATED PANELS)** **\$7,500.00**  
(\$3,750.00 ea.) x 2  
SCOPE OF WORK - AWNING UPGRADE (2 UNITS)

**Project Overview:**  
- Upgrade existing fabric awnings to insulated aluminum panel system using existing frame.

- Scope of Work:**
1. Demolition
    - Remove existing fabric/canvas awning material
    - Haul off and dispose of all removed materials
  2. Frame Preparation
    - Inspect existing frame structure
    - Make minor adjustments as needed for panel installation
    - Ensure frame is ready to support new panel system
  3. Installation
    - Install new insulated aluminum roof panels
    - Cut panels to fit (approx. 6 ft projection)
    - Secure panels to existing frame
    - Ensure straight alignment and clean finish
  4. Waterproofing & Finishing
    - Install flashing at wall connection (if needed)
    - Apply sealant to seams and edges
    - Ensure proper slope for proper drainage

**Material Selection:**  
- Panel color to be selected by customer from contractor's available color options

**Exclusions / Notes:**  
- Existing frame/structure to remain  
- Contractor is not responsible for structural integrity of existing frame  
- Any major frame repair will be quoted separately  
- Electrical work not included

**Estimated Duration:**  
- 1-2 days, weather permitting

**Warranty:**  
- 1-year workmanship warranty

**Payment Terms:**  
- Pricing shown reflects cash payment (discount applied)  
- Payments made by check or other methods will be subject to 8.25% sales tax

<b>Subtotal</b>	<b>\$7,500.00</b>
<b>Total</b>	<b>\$7,500.00</b>

# SPLASH PAD PROPOSAL

La Vernia City Park  
Water Reuse + Splash Pad  
Improvement Options



## PROPOSAL OPTIONS

01

### H3O Retrofit

Base Cost: \$71,386.50  
Optional Shade Cover: \$51,390.00  
Estimated Total with Shade: \$122,776.50

This option reuses the existing splash pad features and adds a new 300-gallon underground water reuse tank. It also includes new concrete work, cleaning, inspection, testing, leak testing, calibration, cleanup, startup, and staff training. H3O will also add new bubblers in the concrete, improving the overall function and play experience of the splash pad.

This option does not include a UV light system or rain diverter.

H3O also provided an optional shade cover over the splash pad. This would help protect users and the splash pad surface from direct sun exposure, improve comfort, reduce heat on the splash pad surface, and create a better experience for families.

02

### Playgrounds Etc. Retrofit Cost: \$243,910.65

More complete recirculation retrofit. Reuses existing splash features and adds a WaterSplash recirculation system with a Water Wise Controller, UV treatment, 2,500-gallon tank, enclosure, rain diverter, and installation.

03

### Bode / Vortex DomePack Cost: \$514,669.14

Full replacement option. Replaces the existing splash pad with new Vortex splash pad equipment and a Vortex DomePack recirculation system. The DomePack is a closed-circuit system that filters and reuses water.

## OVERVIEW

The MDD is reviewing options to improve the La Vernia City Park splash pad and address water reuse, long-term maintenance, and overall project cost.

The La Vernia MDD has budgeted \$300,000 for splash pad improvements. The proposals received include a budget-friendly retrofit, a more complete recirculation retrofit, and a full replacement option using a new Vortex DomePack system.

The current splash pad was originally installed by Vortex in 2017.

## BENEFITS

- Addresses water conservation and reuse
- Helps reduce water waste from splash pad operations
- Provides options at different budget levels
- Allows the Board to compare retrofit versus full replacement
- Supports continued use of the splash pad for families and visitors



The La Vernia MDD has budgeted \$300,000 for this project. Both the H3O Retrofit and Playgrounds Etc. Retrofit fall within the current budget.

The Bode / Vortex DomePack option exceeds the current budget and would require additional funding consideration.

	H3O Retrofit	Playgrounds Etc. Retrofit	Bode / Vortex DomePack <i>Section 5, Item B.</i>
<b>Total Cost</b>	<b>\$71,386.50</b>	<b>\$243,910.65</b>	<b>\$498,469.14</b>
<b>Overall Option</b>	✔ Lowest cost option	✔ Most complete retrofit package	✔ Full replacement option
<b>Project Type</b>	Repairs and improves current splash pad	Adds full recirculation system to current splash pad	Replaces existing system with new Vortex DomePack system
<b>Splash Features</b>	<b>Reuses existing splash features</b> and adds new bubblers in the concrete	<b>Reuses existing splash features</b>	Reuses existing splash features while adding new Vortex DomePack splash pad equipment.
<b>Concrete</b>	New concrete splash pad surface	Limited concrete replacement	New concrete, cool deck, and shark grip
<b>Water Storage / Reuse</b>	New underground <b>300-gallon water reuse tank</b>	<b>2,500-gallon water storage tank</b>	DomePack recirculation system
<b>Water Treatment</b>	Chemicals to clean water for reuse	UV water treatment included. SEE pg 14	Closed-circuit system that filters and reuses water
<b>Cleaning / Repair Scope</b>	Cleans existing nozzles, valves, plumbing, and spray components	WaterSplash recirculation equipment	Demo of existing concrete and splash pad equipment included
<b>System Controls</b>	Leak testing and system calibration included	Water Wise Controller included	Self-enclosed equipment housing
<b>Equipment Protection</b>	Existing system improvements, optional shade cover available	Mechanical enclosure included	Durable, weatherproof cabinet that protects equipment from weather and vandalism
<b>Rain Diverter</b>	Not included	Included	Not listed in uploaded quote
<b>UV Light</b>	Not included	Included	Not listed in uploaded quote
<b>Training / Startup</b>	Startup and staff training included	Included in retrofit package	Not clearly listed in uploaded quote
<b>Optional Add-On</b>	Shade cover available for an additional cost 51K	N/A	N/A
<b>Concern</b>	Does not include UV light or rain diverter	Higher cost while still using existing splash features	Highest cost option and requires additional electrical, sewer, and water supply work by others
<b>Best For</b>	<b>Budget-friendly improvement</b>	<b>Advanced retrofit</b>	<b>Long-term new system</b>

# H3O Water Systems, LLC

280 Weil Rd  
Cibolo, TX 78108  
(210) 836-8181  
h3owatersystems.com

Section 5, Item B.



## Estimate

### ADDRESS

City of LaVernia  
102 E Chihuahua  
La Vernia, TX 78121

### SHIP TO

City of LaVernia  
102 E Chihuahua  
La Vernia, TX 78121

ESTIMATE  
DATE

ES2026-0107  
03/30/2026

QTY	DESCRIPTION	RATE	AMOUNT
-----	-------------	------	--------

Splash pad

1	Scope of Work	71,386.50	71,386.50
---	---------------	-----------	-----------

This proposal encompasses the following tasks:

#### 1. Demolition & Removal

Disconnect, inspect, and carefully remove lighting, piping, and decking as needed while facilitating reuse of all water features.

#### 2. Site Preparation

Clearing, excavation, grading, and base preparation for new concrete deck.

Preparation of overspray area, ensuring proper drainage design.

#### 3. Reuse of Water Features

Thorough cleaning, inspection, and testing of all existing water spray components, nozzles, valves, and plumbing.

Reinstallation into newly poured concrete slab.

#### 4. Concrete Splash Pad Installation

Pour and finish a concrete slab to meet ADA compliance and safety standards.

Apply slip-resistant surface coating or color finish to match existing aesthetic.

#### 5. Water Management & Controls

Reinstall or replace control systems, pumps, and filtration per manufacturer guidance.

H3O will not be held liable for damages caused by acts of God, evidence of negligence, improper use, accidents, or mishaps beyond our control. H3O will not be responsible for equipment not installed by H3O. Invoices are due immediately upon receipt, unless otherwise stated in a written agreement prior. All outstanding balances beyond the due date are subject to interest and/or late fees.

Perform leak testing and system calibration.

We will install a new under ground tank for water reuse.

6. Fixtures & Amenities

Reconnect reused features (items already installed) and install any new site furnishings as defined in final drawings.

We will install a new concrete pad for to house the splashpad equipment.

7. Electrical & Site Utilities

Reconnect electrical services per code including GFCI protection.

Integrate reconnected or new lighting and power as required.

8. Cleanup & Closeout

Final cleanup, waste disposal, and demobilization.

Provide "turn-key" readiness, including staff training for operation and maintenance.

PAYMENT TERMS: 50% Due Upon Acceptance of Proposal  
50 % Due Upon Completion

1	Proposal amount is only valid if entire proposal is accepted. If customer chooses otherwise, H3O will submit a new proposal to customer, which may or may not include a price change.	0.00	0.00
---	---	------	------

Scope of work proposed is a reflection of specific repairs and/or renovations requested by customer. It is not meant to be used as representation or a report on all conditions of the property, including disrepair or code violations, that could be found during a professional inspection.

H3O will not be held liable for any damages that are a result of code compliance issues not being resolved, including harm or damage to either the property or persons.

If there is a delay prior or during the project, any written contracts with start and end dates will be void, H3O will then revise these contracts with new dates.

H3O will complete work in a workmanlike manner.

Warranty does not include evidence of negligence, improper use, accidents or mishaps and any other circumstances beyond H3O's control.

When Leak Detection proposal is sent and not performed, H3O will be able to do the renovation, however there will be no warranty on work performed.

New equipment and parts purchased and installed by H3O will carry "MANUFACTURER WARRANTY"

\*\*Warranty is not valid until H3O has been paid in full.

H3O is not responsible for equipment installed by others.

H3O is not responsible for utilities not properly marked.

If a job requires additional equipment due to underlying rock or unforeseen circumstances, this will result in a price adjustment.

Contractor and client will have no other understanding in regards to warranties or liabilities.

We look forward to your business. Please find your estimate details here. Feel free to contact us if you have any questions.

Have a great day!  
H3O Water Systems, LLC

SUBTOTAL	71,386.50
TAX	0.00
-----	
TOTAL	<b>\$71,386.50</b>

Accepted By

Accepted Date



# Playgrounds Etc.

1410 W Texas Ave.  
Midland, TX 79701  
432-687-6388

E Section 5, Item B.

Date	Bid #
5/27/2026	34627

Name / Address
City of LaVernia 102 E Chihuahua  La Vernia TX 78121

Notes to Client
City Park Installation Site: 222 San Antonio Rd, La Vernia, TX 78121   Tax exempt cert. required w/ purchase.

Rep	Project Location	Project		
John Kiehle	City Park	Splashpad Re-circulation Retrofit Project		
Item	Description	Qty	Rate	Total
WS-2026-6781	WaterSplash Re-circulationSystemRetrofit Installation for City Park Splashpad	1	\$133,925.36	\$133,925.36
Freight	Freight	1		\$3,571.00
Installation	Installation of items listed on this proposal	1		\$115,814.29
Discount	Discount			-\$9,400.00

<b>SubTotal</b>	\$243,910.65
<b>Sales Tax (0.0%)</b>	\$0.00
<b>Total</b>	<b>\$243,910.65</b>

Approval Signature: \_\_\_\_\_ Date: \_\_\_\_\_

Thank you for the opportunity to quote your upcoming project. If you have any questions about this proposal or if you need to make any revisions, please contact your Design Consultant at 866-451-2814. We look forward to helping you complete your next project. This bid is good for 30 days.



SPLASHPAD RECIRCULATION  
PROPOSAL  
for  
LA VERNIA CITY PARK



Project site:  
222 San Antonio Rd, LaVernia, TX 78121

Prepared for:  
Felicia Carvajal, Executive Director  
Municipal Development District  
O: 830-779-4541 | C: (830) 581-8839  
[fcarvajal@lavernia-tx.gov](mailto:fcarvajal@lavernia-tx.gov)

City of La Vernia  
102 E Chihuahua La Vernia TX 78121

# Project Proposal

Prepared For

# City of LaVernia

May 2026



Prepared By:





City of La Vernia  
Water Splash Recirculation Project  
Existing Site for Retrofit

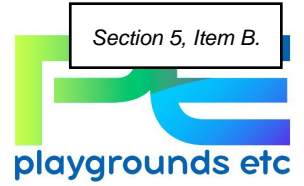

Existing Super Dome  
Hip Shade



City of La Vernia  
Water Splash Recirculation Project

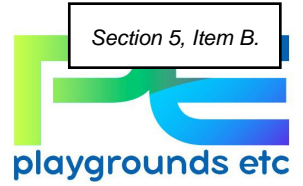

Existing Super Dome  
Hip Shade





# City of La Vernia Water Splash Recirculation Project

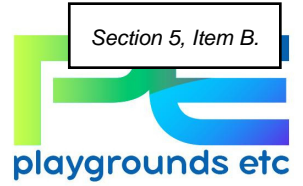

Existing Super Dome  
Hip Shade





# City of La Vernia Water Splash Recirculation Project

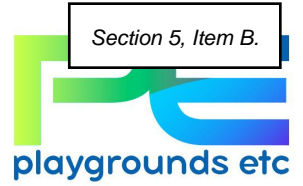

Existing Super Dome  
Hip Shade





# City of La Vernia Water Splash Recirculation Retrofit Project for Existing Equipment

Section 5, Item B.



Feature Connection Table						
Feature Ref.	Manifold Output Ref.	Feature	Qty	Solenoid Size	Line Size	Gpm
D	S01	Snail N°4 VOR 7217	1	1 1/2" Std	1 1/2"	6.5
C	S02	Water Jelly N°1 VOR 7010	1	1 1/2" Std	1 1/2"	11
G	S03	Leaf N°3 VOR 7672	1	1 1/2" Std	1 1/2"	10
E	S04	Jet Stream N°1 VOR 7512	3	1 1/2" Std	1 1/2"	7.5
A	S05	Geysers VDR 301	1	1 1/2" Std	1 1/2"	4.5
H	S06	Seaweed N°1 VDR 7779	1	1 1/2" Std	1 1/2"	3
A	S07	Geysers VDR 301	1	1 1/2" Std	1 1/2"	4.5
I	S08	Seaweed N°2 VDR 7780	1	1 1/2" Std	1 1/2"	4.5
A	S09	Geysers VDR 301	1	1 1/2" Std	1 1/2"	4.5
F	S10	Flower N°7 VOR 7559	1	1 1/2" Std	1 1/2"	4

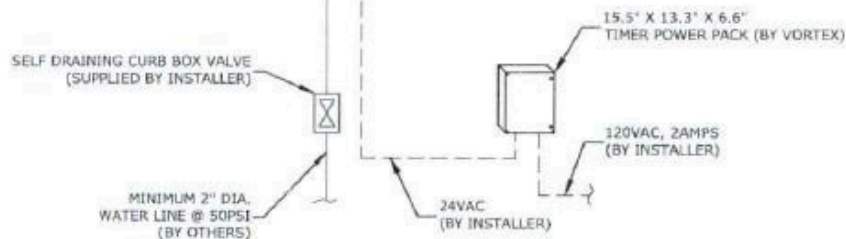
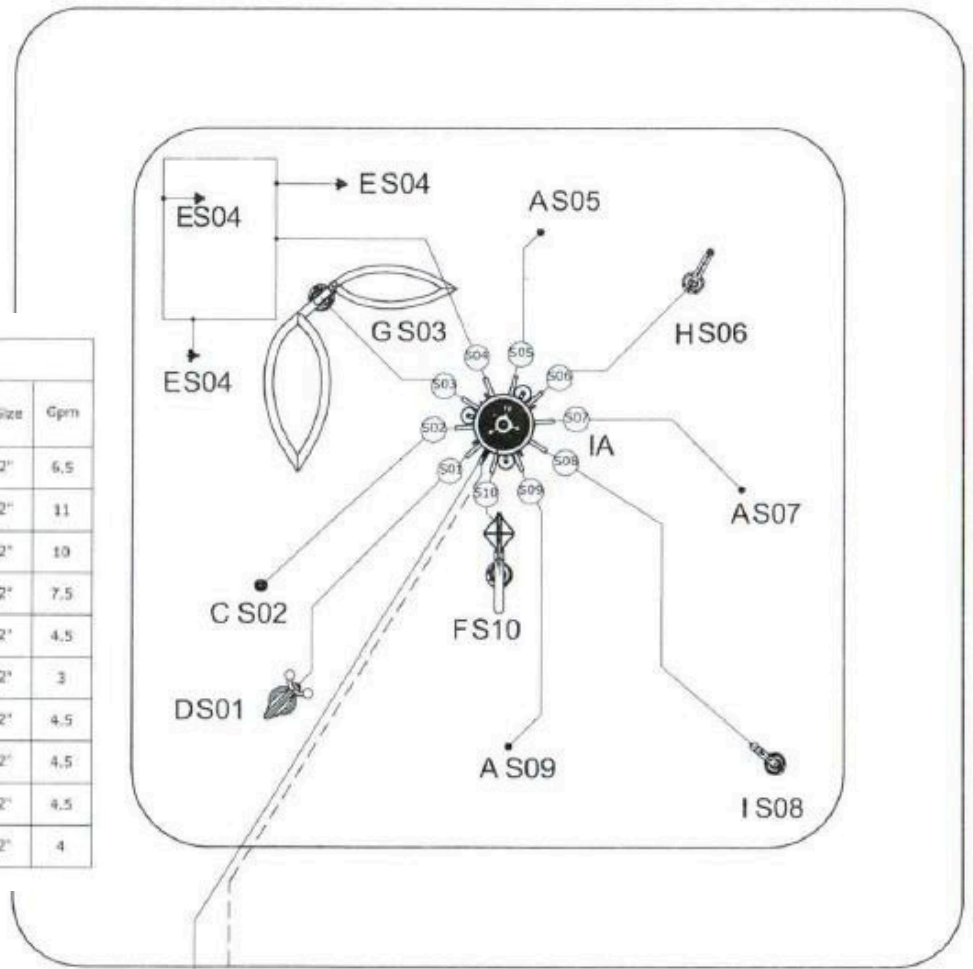



# RECIRCULATION SYSTEM

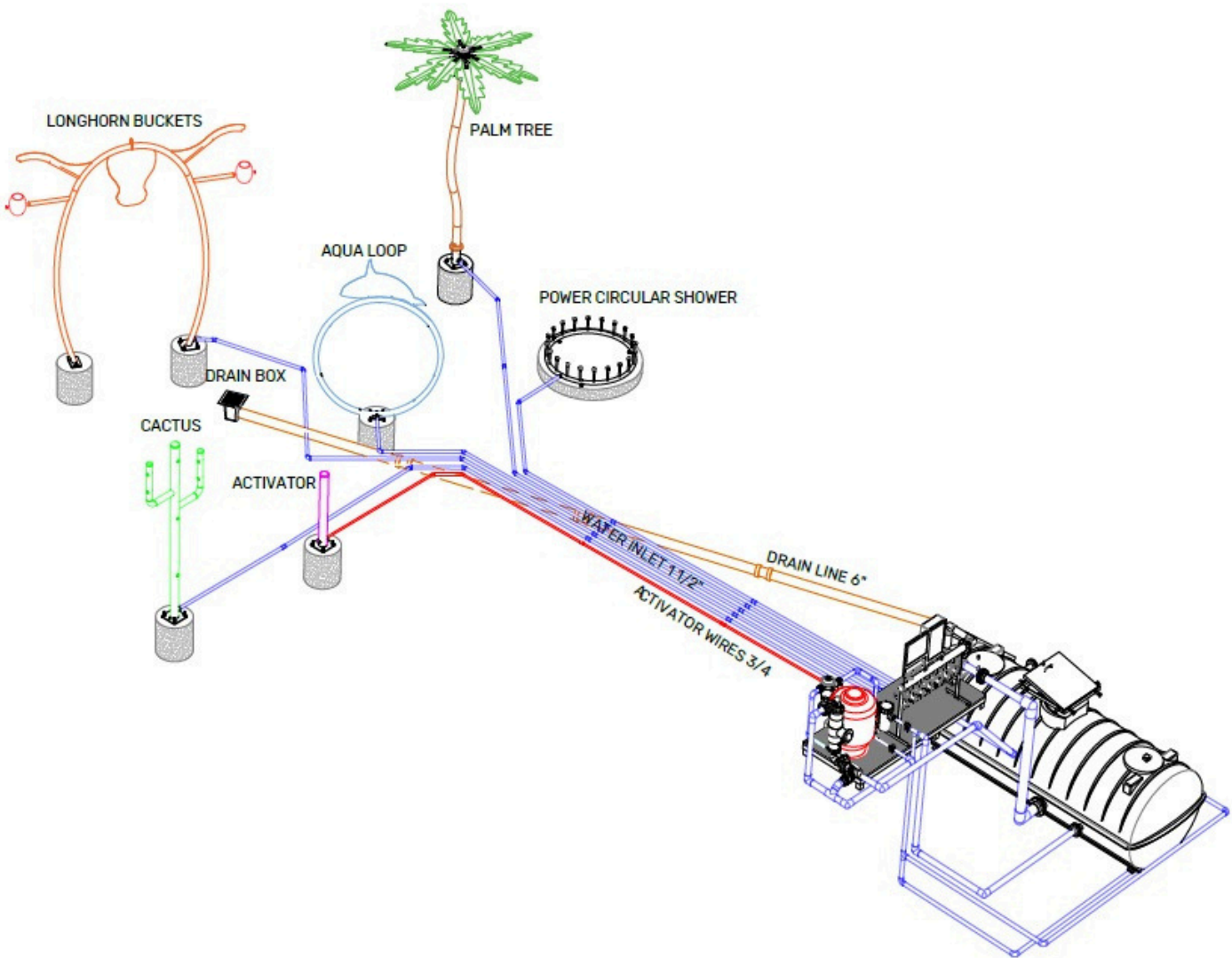



# Water Splash Equipment Recirculation System Water Tank & Connection

Section 5, Item B.

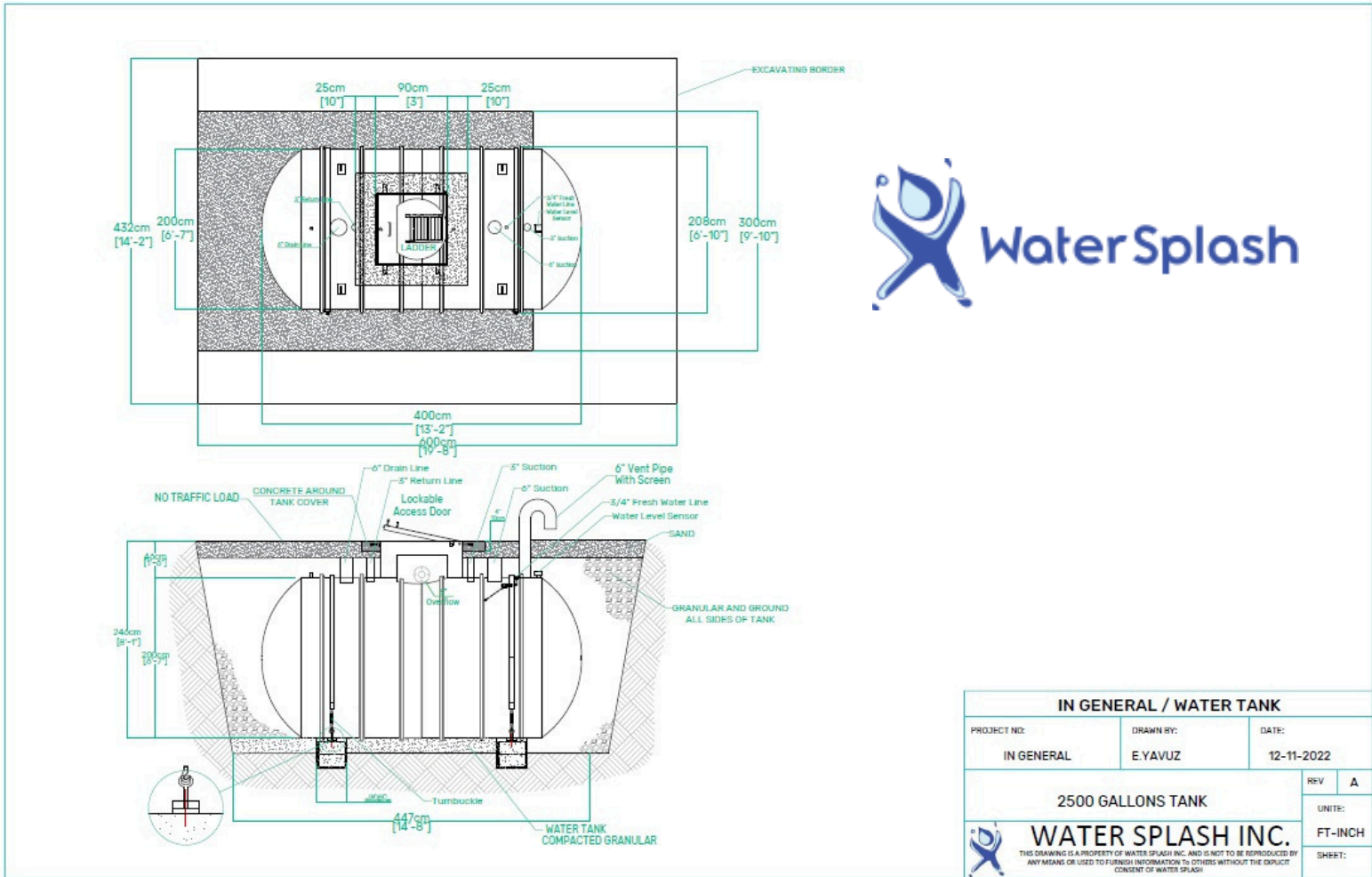



COMPONENT LIST			
ITEM NO	COMPONENT	MODEL	QTY
A	FEATURE PUMP	TriStar SP3250 EE (5 Hp)	1
B	RECIRCULATION PUMP	TriStar SP3215 EE (1,5 Hp)	1
C	CHEMICAL FEED PUMP	STENNER 45MP3	2
D	SAND FILTER	Hayward HCF236-C 36"DIA	1
E	CHEMICAL CONTROL PANEL	Hayward Cat-2000	1
F	ELECTRIC CONTROL PANEL	WATER SPLASH INC.	1
G	FLOW METER	BLUE-WHITE F-300	1
H	SELONOID VALVES	RAIN BIRD	10
I	BALL VALVES	-	10
J	CHEMICAL TANKS	26 GALLON	2
K	UV system (OPTIONAL)	UV - Chlorking-SAG 240 APVC	-

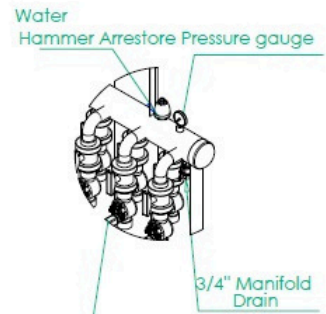
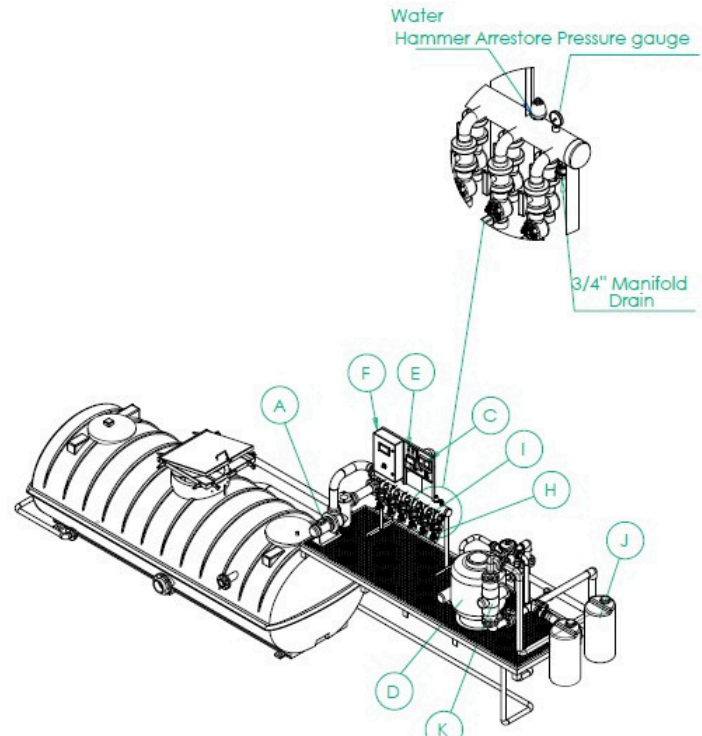
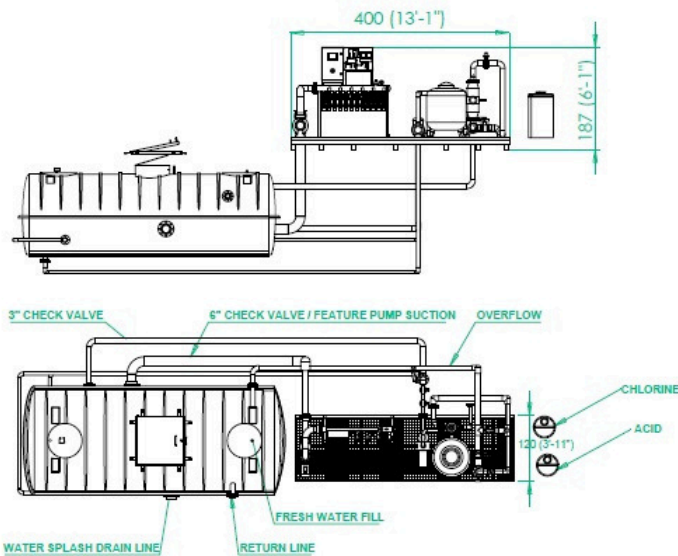

REC. SYSTEM AND TANK CONNECTION		
PROJECT NO: IN GENERAL	DRAWN BY: E. YAVUZ	DATE:
PROJECT NAME:	RIV	A
UNITS: FT-INCH		SHEET:
 <b>WATER SPLASH INC.</b> <small>THIS DRAWING IS A PROPERTY OF WATER SPLASH INC. AND IS NOT TO BE REPRODUCED BY ANY MEANS OR USED TO FURNISH INFORMATION TO OTHERS WITHOUT THE EXPRESS CONSENT OF WATER SPLASH.</small>		





# Water Splash Equipment Recirculation System w/ WaterWise

Section 5, Item B.

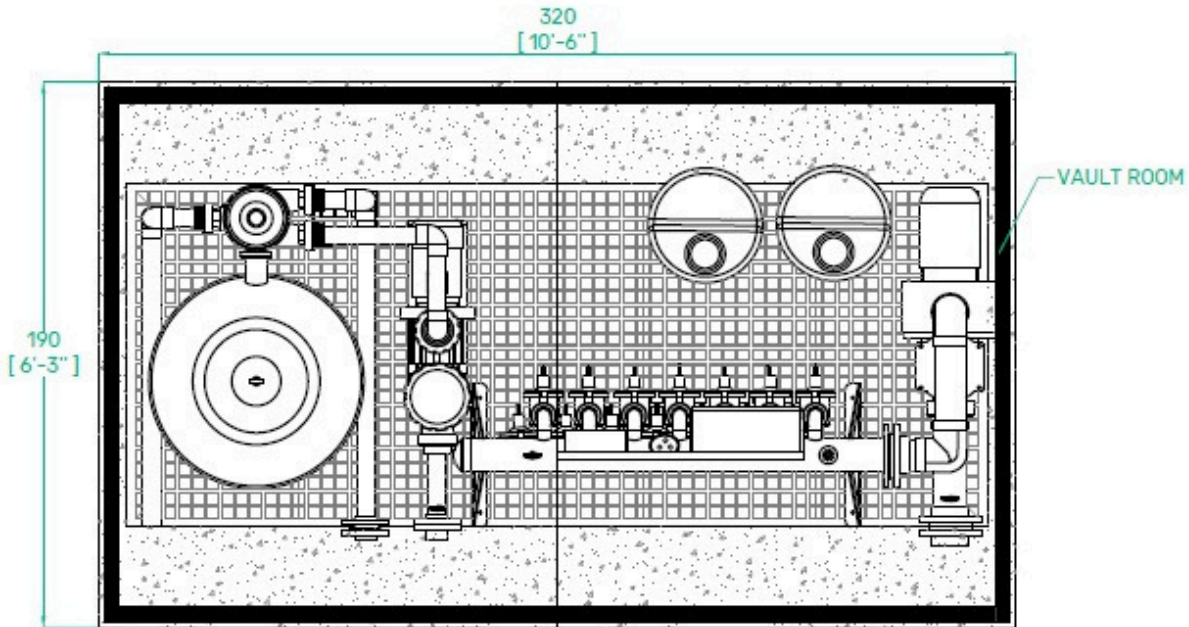

WATER SPLASH

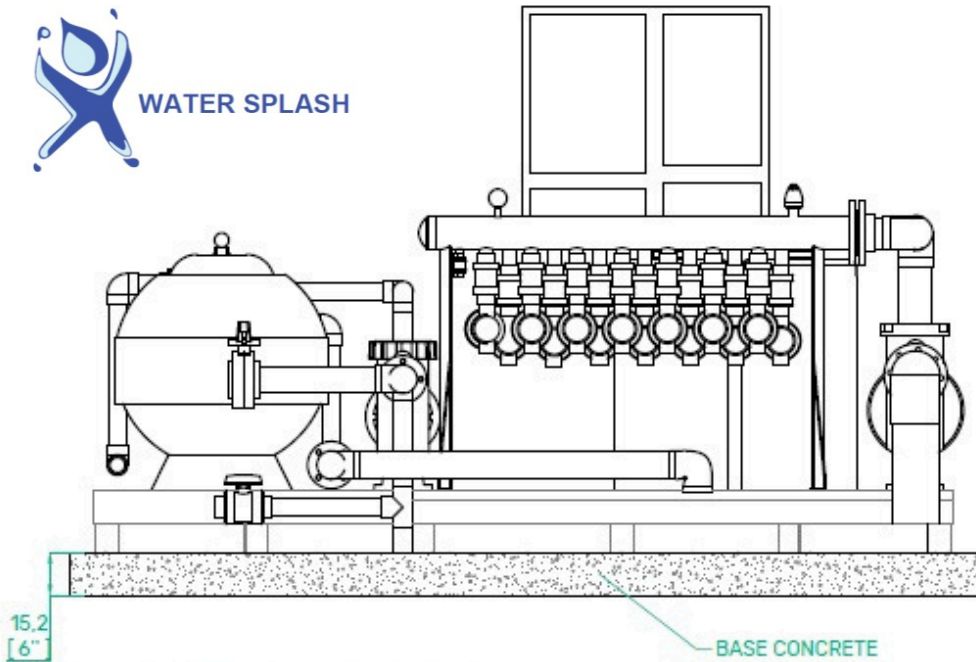

**VAULT ROOM BASE CONCRETE**  
(190 x 320 x 15,2 cm) (10'-6" x 6'-3" x 6")  
1,2 yard

Splash park with Water Re-Capture system, re-uses water utilized at splash park by filtration and sanitizing constantly. This system is similar to swimming pool water sanitization system. Engineered to meet state / provincial health codes for swimming to pool/splash pads.

We offer tank sizes ( 1320,2500 and 4000 ) Gallons with 1" float valve for fresh water intake.

Stainless steel manifold

Electric controller

Factory assembled and tested pumps/sand filter and chemical controller kit.

Optional: UV

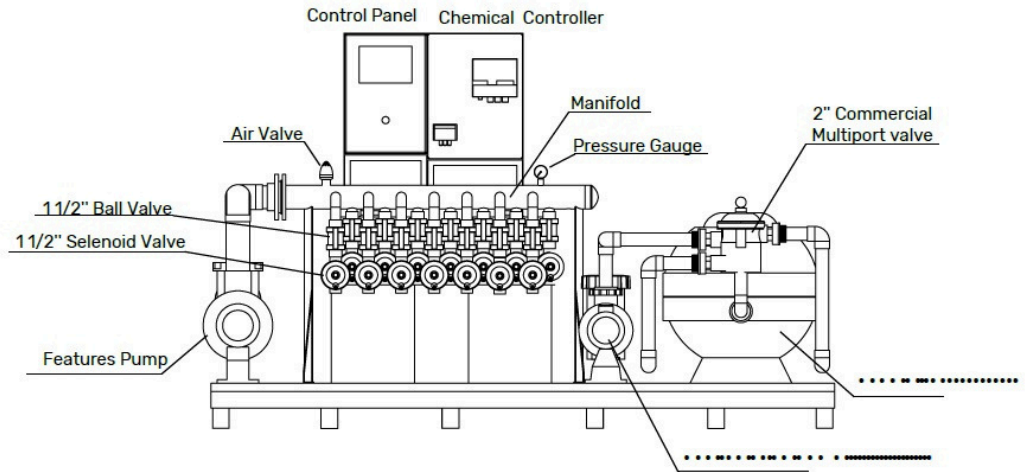

## WATER WISE CONTROLLER



Water Wise Controller - Fiberglass enclosure has center PLC unit controlling each manifold line. Touch screen interface allows users to set desired programming setting for splash park.

Controller is user programmable and following functions can be programmed;

- 1- Current day and time
- 2- Setting active hours / always on
- 3- Activate products via activator or always on
- 4-Spray time
- 5-Up to five spray play sequences
- 6-Product selection per each sequence
- 7-Wind speed effect ( optional )
- 8-Low water temperature on/off (optional)
- 9-Battery back up

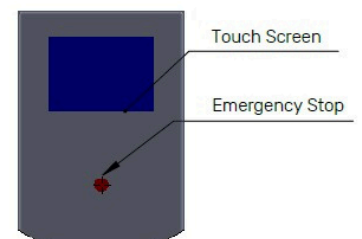

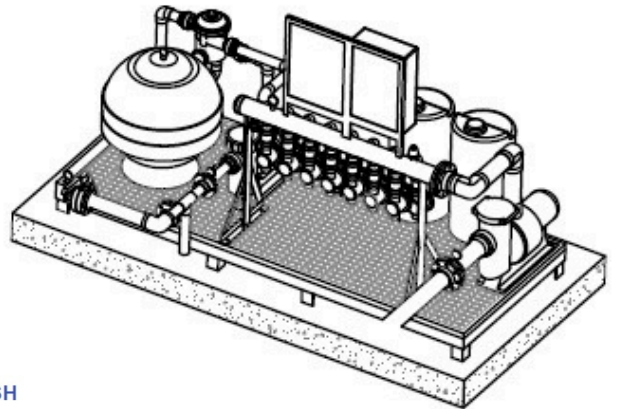
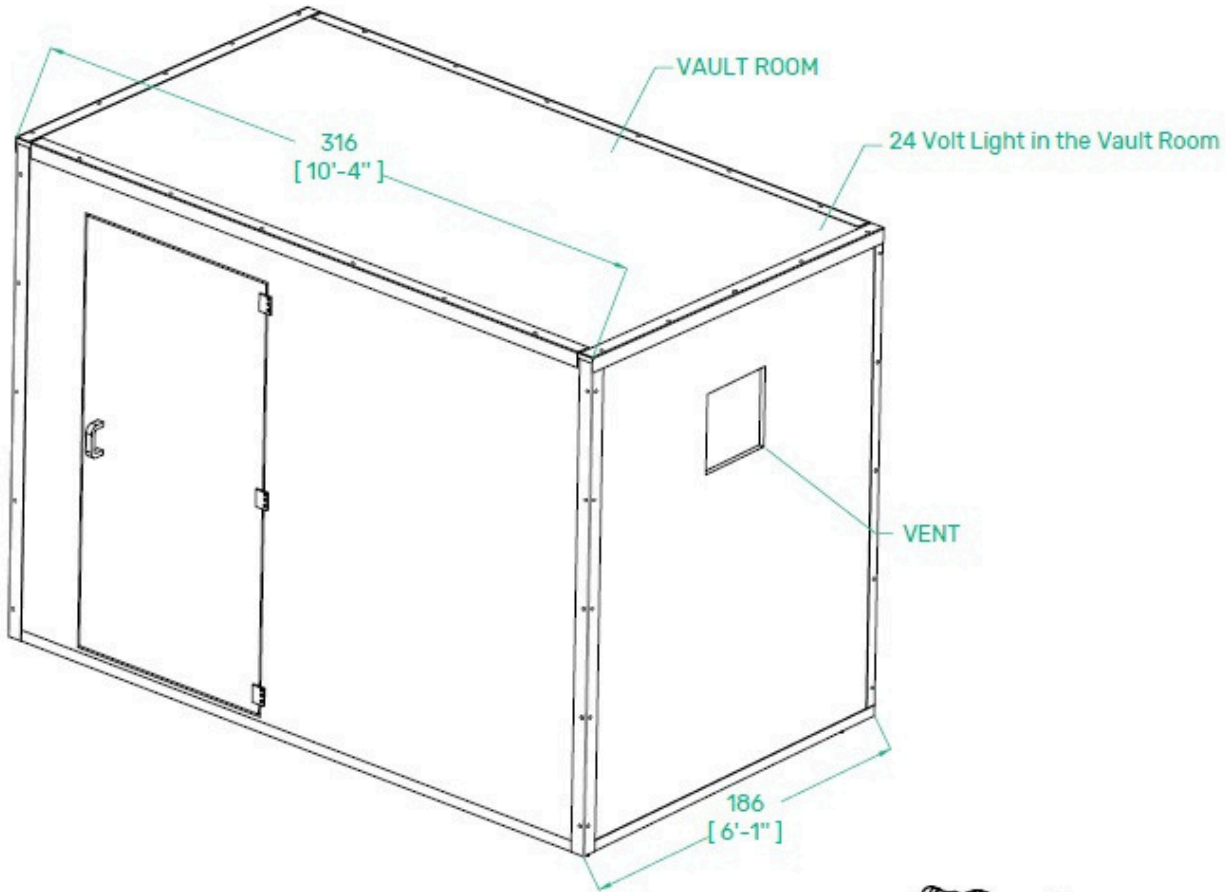

## REC. SYSTEM ABOVE GROUND VAULT



### ACTIVATOR SENSOR S-20.01



<b>Flow Rate</b>	-	<b>Material Detail</b> Commercial, non corrosive, chemical resistant 304/304L quality Stainless steel construction	<b>Coating / Graphic Design</b>	
<b>Pressure</b>	-		UV and chemical resistant, oven cured, polyester powder coating	
<b>Height</b>	51" - 130 cm		<b>Pipe Diameter</b>	ø5" - ø140mm
<b>Length</b>	-		<b>Add-in Options</b>	
<b>Width</b>	-		 Removable	
<b>Spray Zone</b>	-		<b>Play Zones</b>	
		Toddler    Family    Dynamic		



City of LaVernia  
WaterSplash Recirculation Project

Section 5, Item B.

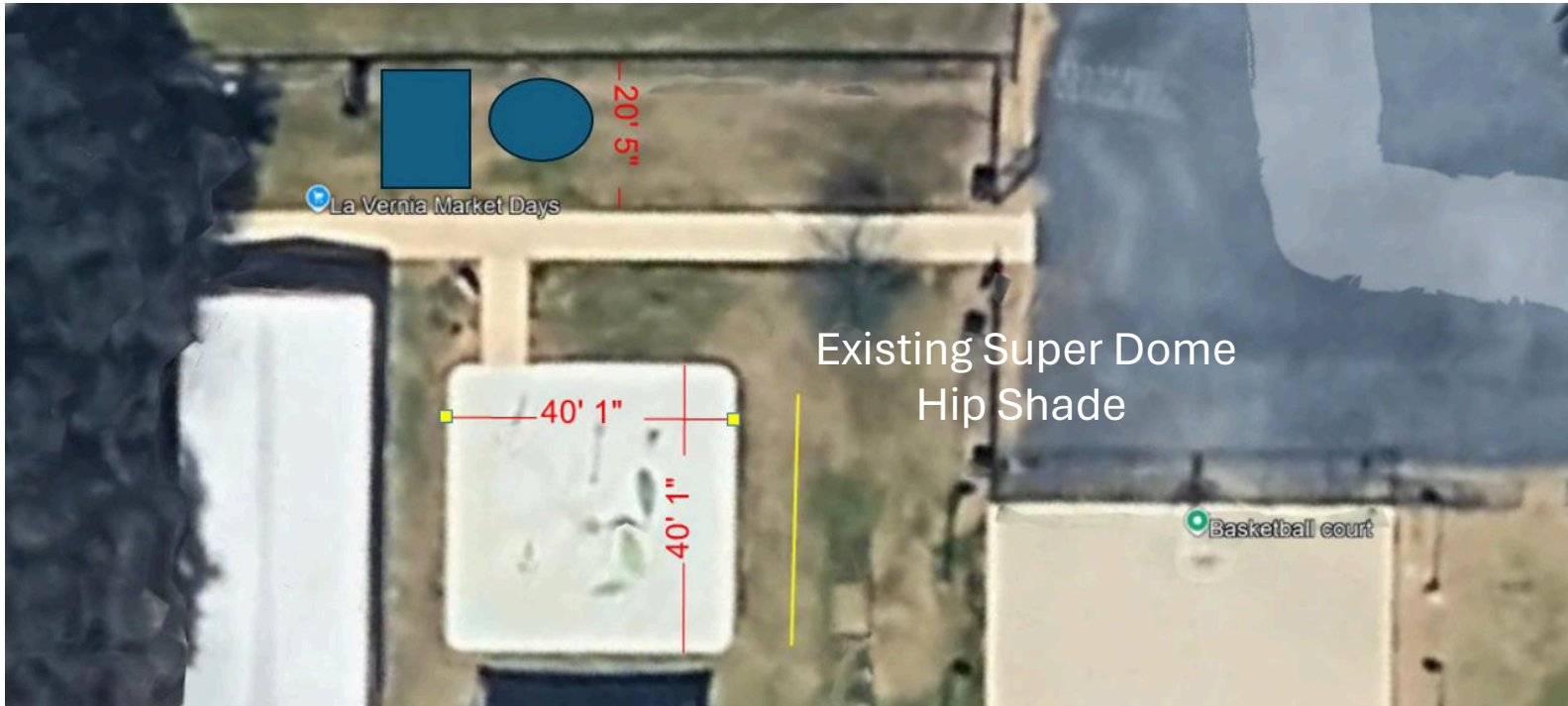

WaterSplash Recirculation System Includes:

- WDS Manifold – Mounted (10 output)
- Water Wise Controller -10 output
- UV - Aquify - AUV-106-03
- Water storage tank 2500 Gallons
- Water Recirculation System Enclosure
- Rain Diverter -L Size & Activator

Retrofit installation of the recirculation system to the existing Vortex equipment, to include:

- removal of the manifold and pump from the drain system, which will then be routed to the disposal location
- relocation of the feature lines to the new mechanical enclosure (which will hold the new recirculation equipment), and
- installation of the underground holding tank, which will include breaking and replacement of an approx. 10' x 4' concrete area.



**WATER SPLASH**





By WaterSplash & Playgrounds Etc.



About Water Splash, Inc.



Water Splash, Inc. is an innovative water playground equipment manufacturer founded in 2003 by a team of engineers who put their skills at the heart of their enterprise, with an emphasis on continuous product improvement through research and development. Our team has a total of 15 years experience in the design and manufacture of splash park equipment. We provide products for splash pads, spray parks/spray grounds and swimming pools. We have a strong engineering and customer care group that will provide the technical support you need at every stage of your project. Our durable and reliable products come with timely and personalized customer service, and they're factory assembled and tested to reduce your installation costs. Backed by some of the strongest product warranties in the industry and an unparalleled safety record, Water Splash is rapidly becoming the benchmark for top quality splash pad products.

**Canada**  
Head Office & Factory

**USA**  
Branch Office

**France**  
Branch Office

**Turkey**  
Factory

**Water Splash**

**WATERSPLASH INSTALLATIONS AROUND THE WORLD**

Singapore • Chile • Turkey • Nigeria • Russia • Canaries • United Arab Emirates  
USA • Poland • Colombia • Spain • Reunion • Jordan • Canada • Hong Kong



# By WaterSplash & Playgrounds Etc.



## Products Warranty

2024-5734 Texas Playgrounds Etc. Sample Project - 1500sqft - recirc

Water Splash Inc. guarantees that all products meet the specifications provided in the installation drawings and offers.

**25 YEAR WARRANTY** on stainless steel structures and workmanship, stainless steel anchoring systems and aluminum spheres, stainless steel Piping and Weldments.

**5 YEAR WARRANTY** on Acetyl, Urethane/HPDE parts, spray nozzles and spray openings, high density polyethylene components, polyurethane components, stainless steel automated water distribution manifold, drain boxes and electrical enclosures.

**2 YEAR WARRANTY** on coatings (Airbrushed Graphics), powder coated, stainless steel hardware and moving parts, fiberglass components, seeflow polymers (polycarbonate materials), toe guards, piping, fittings, ball valves, pressure gauges, terminal blocks, PLC controller, time switches, manual switches, transformers, breakers, electrical wiring, connections and on recirculation system workmanship, recirculation system pumps and filters are covered by their manufacturer. Please refer to their warranty documentation.

**1 YEAR WARRANTY** on all products and parts not listed above.

Warranty above is valid only if structures are installed or assembled as per Water Splash's installation instructions/drawings maintained according to maintenance manual and procedures, not subject to misuse, vandals, operated under normal use as per designed purpose or have not modified/repared by unauthorized personnel.



www.watersplashnet.com  
(800) 936-3430





## Workmanship Warranty

This warranty covers workmanship related to the installation of the products purchased from and installed by Playgrounds Etc for a period of 1 year from the date of installation.

### A Note from The Owner

This warranty essentially states that we will stand behind our installation or perform a service call related to improper installation for up to 1 year at no cost to our customer. In actuality, our warranty is better than that. If anything that we install ever fails, regardless of when, and the failure is not due to carelessness, accidental damage, or normal wear and tear, Playgrounds Etc will honor an implied warranty and take care of the matter at no cost to the customer (yes, we really mean that). In other words, if something fails that shouldn't fail, we will take care of it for you. We have always treated our customers like family and we hope that our warranty expresses our feelings towards our customers.

### Warranty Exclusions:

The stated warranty is valid only on projects in which Playgrounds Etc is responsible for the complete installation of said project and/or equipment. Playgrounds Etc is not responsible for cosmetic defects such as scratches, dents, marring, fading, damage due to vandalism, misuse, accident, wear and tear from normal use, exposure to extreme weather, immersion in salt or chlorine water, unauthorized repair or modification, abnormal use, lack of maintenance, or other causes not within Playground's Etc control.

### Limitation of Remedies:

Playgrounds Etc is not liable for consequential or incidental damages, including but not limited to: labor cost or lost profits resulting from use of, or inability to use, the products, *or* from the products being incorporated in, or becoming a component of, any other product. If, after a reasonable number of repeated efforts, Playgrounds Etc is unable to repair or replace a defective or non-conforming product, Playgrounds Etc shall have the option to accept return of the product, or part thereof, if such does not substantially impair its value, and return the purchase price as the buyer's entire and exclusive remedy.



### About our Company

It has been a pleasure working with you to prepare this bid for your project. I am confident that when you select our company you will find that the products and services we offer will exceed your expectations.

Superior Recreational Products (SRP) is the company that supplies most of the products related to the playground equipment we will be supplying to you. SRP has been in the business of manufacturing playground equipment for over twenty-five years. They own SRP Playgrounds, which is one of the largest playground manufacturer in the world, as well as Superior Shades, Child Works, Litchfield Structures and Webcoat, Inc. who offers site furnishings. We, along with the companies we represent can meet most of your outdoor playground and park equipment needs.

Playgrounds Etc. is based in West Texas at Midland. Our family has been in the commercial playground equipment business for sixteen years. We excel at working with smaller communities, churches and schools. Our personal service and the wide range of companies we represent, is a benefit to you in that we can help you select the most equipment for your money. We work hard to help you select the equipment that best meets your needs and budget instead of delivering a cookie cutter product.

Thank you for taking the time to review our proposal. We encourage you to contact us with your ideas for changes that can make this a better product. Colors, equipment, and the arrangements of activities can be easily changed up to the time that the order is placed. We are very happy to make these changed in order to meet your needs.

I am confident that when you compare our products and pricing with others you will see the value we offer when selecting us as your supplier and service provider for this project. We welcome the opportunity to compare our proposal with our competitors and point out the advantages in selecting Playgrounds Etc.

I look forward to working with you through the final stage of this project

Josh Bartlett





# Municipal & Texas ISD References



**4B Recreation Group, LLC dba Playgrounds Etc. | [www.playgroundsetc.com](http://www.playgroundsetc.com)**

1410 W Texas Ave. | Midland TX 79701 | (432) 687-6388 | EIN: 85-171-0107

## REFERENCES

<i>Name and Position:</i>	<i>Organization:</i>	<i>Contact Number:</i>
Nick Stone, Director of Facilities & Design	Midland ISD	432-238-4063
Laurie Williams, Parks Director	City of Midland	432-685-7370
Courtney Weese, Recreation Manager	City of Live Oak	210-653-9140 x2235
Steve McLaren, Superintendent	Klondike ISD	806-462-7334
Charlie Bradley, County Judge	Schleicher County	325-853-2766
Jerry Webster, City Manager	City of Tahoka	806-561-4211
Tony Gomez, Facility Director	Glasscock County ISD	432-466-1837
Steve Evans, Maintenance Director	Coleman ISD	432-625-3575
Jill Rainey, City Secretary	City of Gorman	254-734-2317



## Other School Districts & Schools Served include, among others:

- Academy ISD
- Aledo ISD
- Alpine ISD
- Amarillo ISD
- Andrews ISD
- Anson ISD
- Archer City ISD
- Ballinger ISD
- Balmorhea IAD
- Bandera ISD
- Bangs ISD
- Big Spring ISD
- Birdville ISD
- Blanco ISD
- Borger ISD
- Bovina ISD
- Bowie ISD
- Bronte ISD
- Brownfield ISD
- Brownwood ISD
- Bynum ISD
- Canadian ISD
- Canyon ISD
- Cherokee ISD
- Christoval ISD
- Clyde ISD
- Coahoma ISD
- Coleman ISD
- Colorado ISD
- Comal ISD
- Cotton Center ISD
- Crane ISD
- Crosbyton ISD
- Cross Plains ISD
- Dalhart ISD
- Darrouzett ISD
- Decatur ISD
- Denton ISD
- Dumas ISD
- Early ISD
- Eastland ISD
- Eden ISD
- Electra ISD
- Elysian Fields ISD
- Eula ISD
- Farwell ISD
- Ferris ISD
- Floresville ISD
- Floydad ISD
- Frenship ISD
- Frona ISD
- Fritch ISD
- Ft. Davis ISD
- Ft. Hancock ISD
- Ft. Stockton ISD
- George West ISD
- Godley ISD
- Grady ISD
- Greenwood ISD
- Gustine ISD
- Guthrie CSD
- Hamlin ISD
- Harrold ISD
- Hawley ISD
- Hedley ISD
- Holliday ISD
- Judson ISD
- Keller ISD
- Kermit ISD
- Kerrville ISD
- Klondike ISD
- Kress ISD
- Lake Travis ISD
- La Joya ISD
- Lamesa ISD
- Lazbuddie ISD
- Levelland ISD
- Liberty Hill ISD
- Lockney ISD
- Loop ISD
- Mason ISD
- May ISD
- Medina ISD
- Memphis ISD
- Midlothian ISD
- Miles ISD
- Mineral Wells ISD
- Monahans ISD
- Morton ISD
- Muleshoe ISD
- Nazareth ISD
- New Deal ISD
- New Home ISD
- O'Donnell ISD
- Oflen ISD
- Olton ISD
- Palo Pinto ISD
- Pasadena ISD
- Perryton ISD
- Plainview ISD
- Premont ISD
- Presidio ISD
- Ranger ISD
- Roby Cisd
- Rochelle ISD
- Roosevelt ISD
- Roscoe ISD
- Round Rock ISD
- San Angelo ISD
- San Vicente ISD
- Sands Cisd
- Seagraves ISD
- Seminole ISD
- Slaton ISD
- Slidell ISD
- Snyder ISD
- Somerset ISD
- Stamford ISD
- Stanton ISD
- Sudan ISD
- Sweetwater ISD
- Trent ISD
- Tulia ISD
- Union Grove ISD
- Vega ISD
- Veribest ISD
- Victoria ISD
- Waco ISD
- Wall ISD
- Weimar ISD
- Westbrook ISD
- Whiteface Cisd
- Willis ISD
- Winters ISD
- Wylie ISD





Thank you for taking the time to consider *Playgrounds Etc.* and the trusted, leading manufacturers that we represent. We have been in the business of designing and building parks and commercial-grade playgrounds since 2006 and have experience serving and supporting hundreds of sites across Texas!

We got started deep in the heart of Texas, and still pride ourselves on taking a small-town approach to customer service by treating each client like family. You will find that we are one of the few remaining companies that truly stand behind our work. Now a second-generation family-owned company, when it comes to designing and building parks and playgrounds, we are anything but small time.

We love designing one-of-a-kind parks without breaking the bank, and we are committed to helping you (and your kids) get the most for your money. Here are just a few of the fun products and services that *Playgrounds Etc.* offers:

- *Playground Equipment & Safety Surfacing*
- *Free Design Services & Site Surveys*
- *Splashpads and Splash parks w/ towers & slides*
- *Commercial Shades & Steel Shelters*
- *Bleachers & Grandstands*
- *Outdoor Sports & Fitness Equipment*
- *Site Furniture & Furnishings - like tables, benches, grills, etc.*
- *Turnkey Installations & Demolitions*

*Playgrounds Etc.* offers complimentary custom design and planning services for your community, campuses and congregations, as well as installation flexibility for turnkey or supervised situations.

We are eager to visit when convenient and help design your next project to meet your needs and goals. Please call us anytime and let our team know how we can help make your ideas and dreams come to life! Thank you.



# Playgrounds Etc.- About US



Playgrounds Etc., LLC (E)(I)(T) | 1410 W Texas Ave. Midland TX 79701  
#781-25 - Playground equipment & safety surface products; Parks & Recreation Equip & Installation  
#665-22 - Athletic, P.E., Gym Supplies & Equipment – Heavy Duty Exercise Equipment & Accessories

4B Recreation Group LLC dba Playgrounds Etc. | [www.playgroundsetc.com](http://www.playgroundsetc.com)

**KEY CAPABILITIES:** Playgrounds Etc. specializes in products and services related to playgrounds, playground safety surfacing, splashpads, shades and shelters covering play, pool and picnic areas, and outdoor park, recreation and sporting equipment and services. Playgrounds Etc. offers high-quality American-made products and turn-key services for:

- **Playground Equipment & Safety Surfacing**
- **Free Design Services & Site Surveys**
- **Splashpads & Splash parks w/ towers, slides, etc.**
- **Commercial Shades & Steel Shelters**
- **Bleachers & Grandstands**
- **Outdoor Sports Courts & Fitness Equipment**
- **Site Furniture & Furnishings - like tables, benches, grills, etc.**

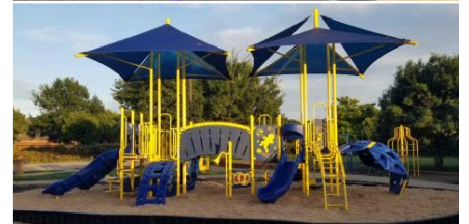

Premier Courts



**OUR MISSION:** Playgrounds Etc. is a family-owned business focused on providing high-quality, competitively-priced park and playground equipment and services to communities, churches, school campuses, homeowners associations, municipalities, museums and daycares, among others. We provide, install and service a variety of great playground solutions and also specialize in splashpads, shades, shelters and other recreational site amenities.



Playgrounds Etc. views ourselves as partners with our customers; therefore, our mission is to help each customer create a play area that meets the individual needs of their facility, budget, and children. While creating each commercial-grade playground we strive to create the best possible experience through each step of the design, purchasing, and installation process. We understand that our current and continued success depends on customers being completely satisfied throughout the entire process.





# Playgrounds Etc.

## Key Service Specialities

PlaygroundsEtc.'s main product and service specialties include, among others:

CSI Masterformat codes of facility specifications:

**DIV 11 – EQUIPMENT**

- 11 65 00 Athletic and Recreational Equipment
- 11 66 23.13 Basketball Equipment
- 11 66 23.53 Wall Padding
- 11 67 33 Climbing Walls
- 11 68 00 Play Field Equipment and Structures
- 11 68 13 Playground Equipment
- 11 68 16 Play Structures
- 11 68 23 Exterior Court Athletic Equipment
- 11 68 23.13 Exterior Basketball Equipment
- 11 68 23.33 Tennis Equipment (nets & surfacing)

**DIV 13 – SPECIAL CONSTRUCTION**

- 13 12 13 Exterior Fountains
- 13 14 00 Amusement Park Structures & Equipment
- 13 14 13 Water Slides
- 13 28 00 Athletic & Rec. Special Construction
- 13 28 16 Safety Netting

**13 31 00 Fabric Structures**

- 13 31 23 Tensioned Fabric Structures
- 13 31 33 Framed Fabric Structures
- 13 34 00 Fabricated Engineered Structures
- 13 34 16 Grandstands and Bleachers
- 133419 Metal Building Systems

**DIV 32 – EXTERIOR IMPROVEMENTS**

- 32 05 16 Aggregates for Exterior Improvements
- 32 05 19 Geosynthetics for Exterior Improvements
- 32 05 19.13 Geotextiles for Exterior Improvements
- 32 11 16.16 Aggregate Subbase Courses
- 32 16 00 Curbs, Gutters, Sidewalks, and Driveways
- 32 16 13 Curbs and Gutters
- 32 16 23 Sidewalks
  
- 32 18 Athletic and Recreational Surfacing
- 32 18 13 Synthetic Grass Surfacing
- 32 18 16.13 Playground Protective Surfacing
- 32 18 23 Athletic Surfacing
- 32 18 23.29 Synthetic Field Sport Surfacing
- 32 18 23.33 Post-Tensioned Concrete Basketball Courts
- 32 18 23.43 Outdoor Basketball Court Surface Color Coating
- 32 18 23.39 Synthetic Running Track Surfacing
- 32 18 23.43 Recreational Court Surfacing
- 32 18 23.53 Tennis Court Surfacing



- 32 31 00 Fences and Gates
- 32 31 13.23 Recreational Court Fences and Gates
- 32 31 13.26 Tennis Court Fences and Gates
- 32 31 19 Decorative Metal Fences and Gates
- 32 31 19.53 Decorative Metal Security Fences and Gates

- 32 33 00 Site Furnishings
- 32 33 13 Site Bicycle Racks
- 32 33 15 Site Bicycle Shelters
- 32 33 23 Site Trash & Litter Receptacles
- 32 33 43 Site Seating and Tables
- 32 33 43.13 Site Seating
- 32 33 43.53 Site Tables
- 32 39 00 Manufactured Site Specialties
- 32 39 33 Artificial Rock Fabrications

We work with Superior manufacturers and suppliers.



# Capabilities Overview

PLAYGROUNDS SHADES SPLASHPADS SITE FURNITURE & AMENITIES +MORE!



### SuperiorPlay

- ✓ Inclusive Playground Structures
- ✓ Themed Playground Structures
- ✓ Net-Based Equipment
- ✓ Motion and Spinning Equipment
- ✓ Nature Inspired Play Equipment
- ✓ Outdoor Musical Instruments
- ✓ Shaded Swings
- ✓ Adult Fitness Equipment



### Superior Playgrounds



### Superior Shade

- ✓ Splash Pad Shade
- ✓ Picnic Area Shade
- ✓ Bleacher Shade
- ✓ Playground Shade
- ✓ Sport Court Shade
- ✓ Walkway Shade
- ✓ Pool Shade
- ✓ Car Parking Shade

### Superior Shelter

- ✓ Picnic Pavilion
- ✓ Bleacher Shelter
- ✓ Sport Court Cover
- ✓ Outdoor Event Space Cover
- ✓ Dugout Shelter
- ✓ Walkway Cover
- ✓ Privacy Shelters
- ✓ Kiosks

### Superior Amenities

- ✓ Accessible & Standard Picnic Tables
- ✓ Recycling and Trash Receptacles
- ✓ Bike Racks
- ✓ Sport Court Bench Seating
- ✓ Playground Buddy Benches
- ✓ Custom Logo Furnishings
- ✓ Dog Park Equipment
- ✓ Outdoor Rotating Grills



# Free Design Services

**Superior**  
*Playgrounds*

Equipment and Site Renderings



**SRPFX**



# Free Design Services

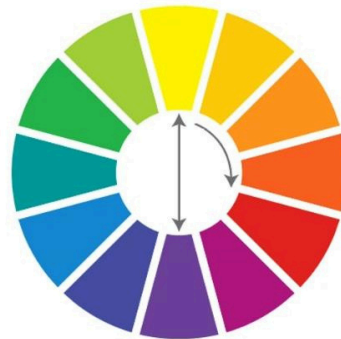
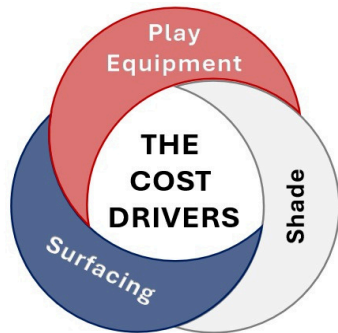

- + **Delivery** to Site
- + **Installation** – Labor & Equip.

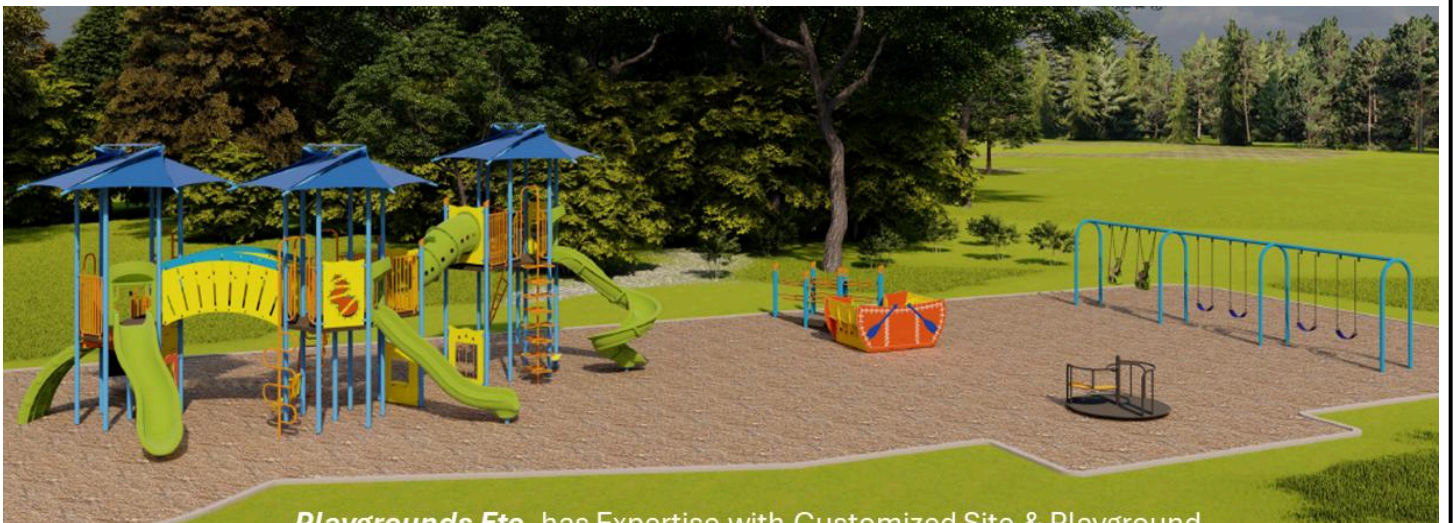

*Playgrounds Etc.* has Expertise with Customized Site & Playground Equipment/ Surfacing Design for All-Abilities Playgrounds Across TX, and Superior Playgrounds has expertise developing ADA play sites across the U.S.

# Safety Surfacing Options

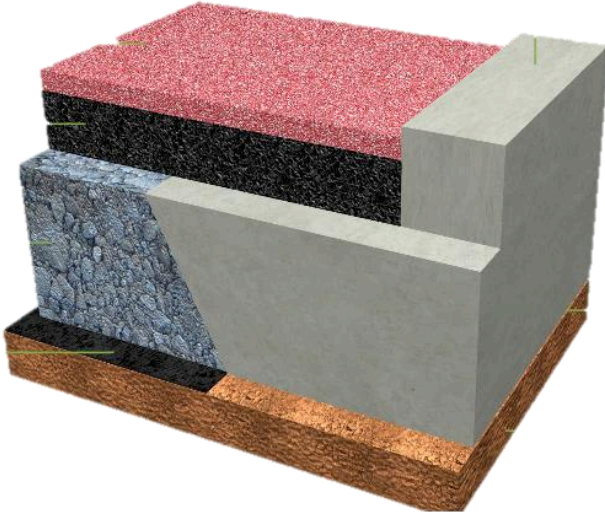



# More than Playgrounds

Section 5, Item B.

We're builders of community, designers of joy,  
and champions of play for all...

Commercial Playgrounds | Splash Pads | Custom Shade Structures | Outdoor Shelters | Site Amenities  
Outdoor Fitness Equipment | Dog Parks | And Much More!



We offer products for all your  
**outdoor recreation** needs.

Shade  
Structures

Pavilions

Site Furnishings

Playgrounds

Outdoor  
Fitness  
Equipment

Dog Park  
Equipment &  
Accessories





WATER SPLASH

Section 5, Item B.





**Splashpad Example ~2,500 SF**

**Our Design Includes Products listed below**

NO	Products	Description	Qty
1	Spray Elements	Above Ground	5
		In Ground	6
2	Manifold	7 Outputs	1
3	Activator Sensor	Above Ground	1
4	Water Wise Controller	Water Splash Inc.	1
5	Drain Box	24" x 24"	1
6	Water Recirculation system	With enclosure and rain diverter	1
7	Sites amenities	Benches and shades	6
8	Water Storage Tank	2500 Gallons	1





## NATIONAL SERIES BLEACHERS

Our best-selling National Series Bleachers are available in a variety of lengths and rows, a great solution for groups of 200 or less.

### NATIONAL SERIES BLEACHERS

- Available with 3, 5, 8, and 10 row options
- Variety of lengths available, see chart for details
- Standard, Preferred and Deluxe models available, see comparison chart for details.
- 17" first seat height provides comfortable seating on all rows
- Riser planks: 1" x 6" mill finish plank
- Seat planks: 2" x 10" anodized plank
- Foot planks: 2" x 10" mill finish plank
- Optional powder coating available (see pg. 14 for a list of standard color options)

### 3 ROW EXCEPTION:

- Row 1 seat height is 16"
- Rise is 6"
- Top Row Seat height is designed to be under 30" with rubber foot pads to eliminate the need for a guardrail



	STANDARD	PREFERRED	DELUXE
17" FIRST SEAT HEIGHT	X	X	X
8" RISE / 24" RUN	X	X	X
SINGLE FOOT PLANKS	X (ROWS 2 & 3)		
DOUBLE FOOT PLANKS	X (ROWS 4 AND UP)	X (ALL ROWS)	X (ALL ROWS)
CHAIN-LINK GUARDRAIL SYSTEM (Vertical picket upgrade available)	X (ROWS 4 AND UP)	X (ROWS 4 AND UP)	X (ROWS 4 AND UP)
SINGLE RISER PLANK	X (ROWS 4 AND UP)	X (ROWS 4 AND UP)	X (ROWS 2 AND UP)
DOUBLE RISER PLANK	X (TOP ROW)	X (TOP ROW)	X (TOP ROW)
AISLE WITH HANDRAIL			X



## Superior<sup>®</sup>Shade

Superior Bleacher Shading Solutions

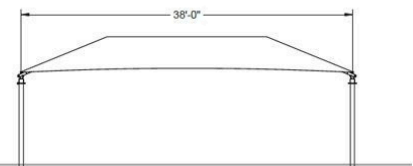
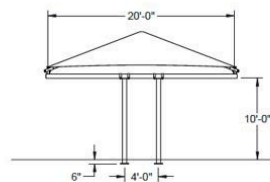
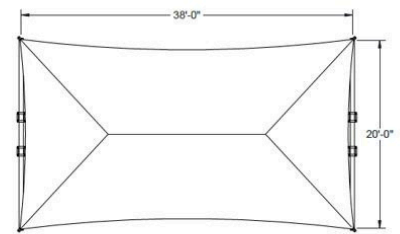
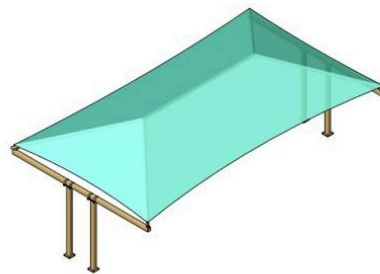
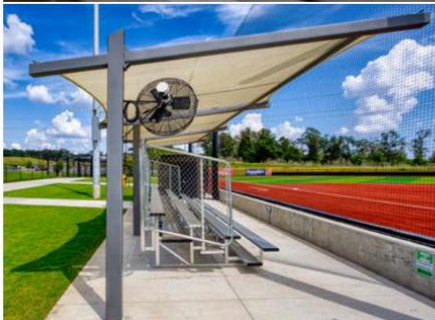
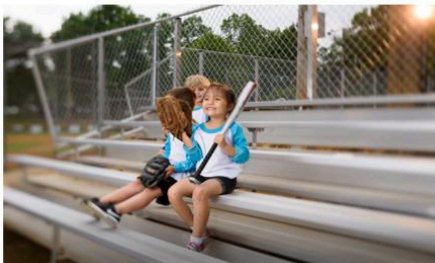

## Bleacher *Shades*



### Suspended Cantilever Shade

Provides innovative overhead shade, ideal for unique ...



### T-Cantilever Shade

Offers versatile shade solutions, perfect for creating ...



### Standard Cantilever Shade

Versatile and functional, offering shade for various ...



# Superior<sup>®</sup>Shade



# Superior<sup>®</sup>Shade

**WE DELIVER COOL SUPERIOR SHADING SOLUTIONS ACROSS TEXAS FOR COMMUNITY PARKS & CAMPUSES** Including, among others:

- Playground HipShades&Modular(Integrated)Shades
- Cantilever Shades & Umbrellas
- Multi-DomeShades& BleacherCovers
- Splashpad Sails & Shading



Glasscock ISD - Garden City, TX



Ingleside, TX - city pool shading



Fort Worth, TX - St. Andrews ELC



Elysian Fields, TX - Shaded Swings

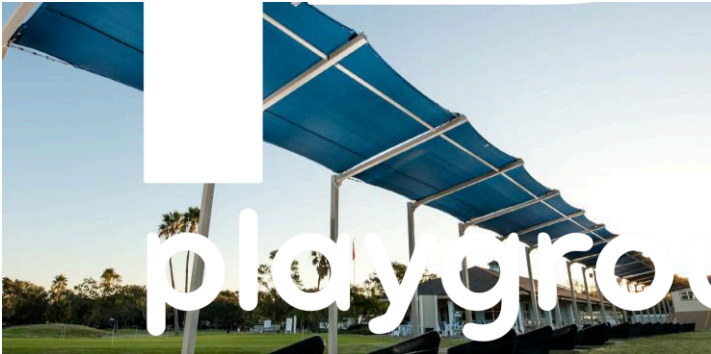
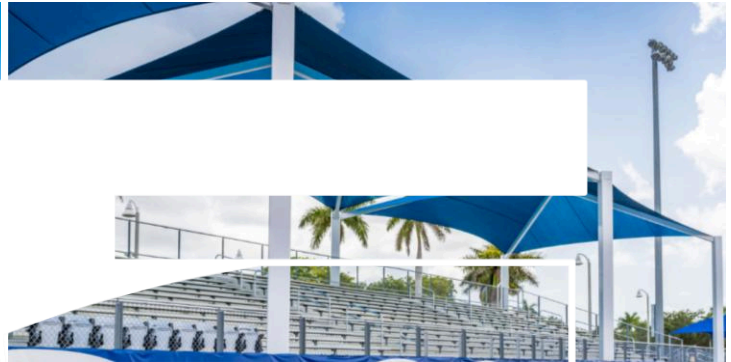
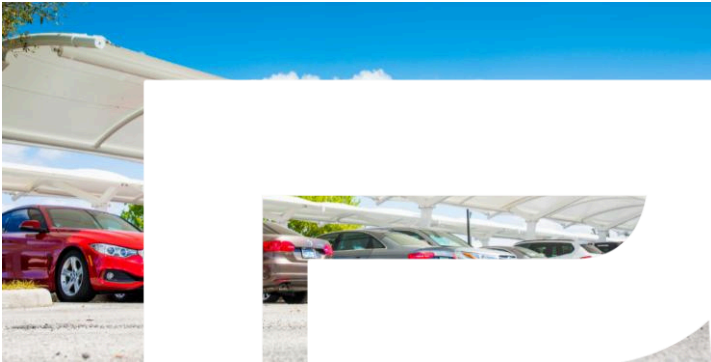

playgrounds etc

# Superior<sup>®</sup>Shade

## Common Playground Shading for S. Texas



HIP

### Square Hip Shade

Provides effective sun protection for spaces of all kinds.



HIP | CUSTOM

### Multi-Dome Hip Shade

Providing expansive shade coverage for large areas.



HIP

### Rectangle Hip Shade

Versatile for creating shaded areas of all kinds.



HIP | CUSTOM

### Super Dome Hip Shade

Featuring a super-sized dome design for playgrounds, ...



### Swing Frame with Shade

conforms to ASTM International standards

- 6 1/2" posts
- Protect children from harmful UV rays
- Available in one, two, three, or four bays

All swing seats and chains sold separately.

#### SIZES

- 1 Bay: 23 1/2' x 16'
- 2 Bay: 36' x 16'
- 3 Bay: 46 1/2' x 16'
- 4 Bay: 58' x 16'

#### OPTIONS, FEATURES, AND FABRIC

Only Available With Glide Elbow™  
Traditional Shade Fabric

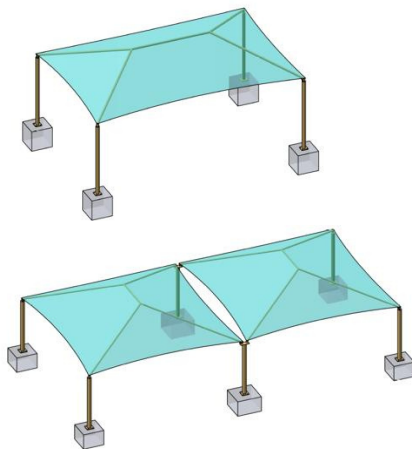

### Material Features

#### Fabric

- Made from UV stabilized high density polyethylene fabric that prevents fading from the sun
- Raschel-knitted to prevent fraying and shades 34' and larger receive Kevlar® reinforced corners
- Blocks up to 98% of harmful UV rays, depending upon color choice
- Fabric breathes allowing hot air to rise and escape
- Available fabric to meet California State Fire Marshal requirements, NFPA 701, and ASTM E84

#### Frames

- Engineered to withstand wind speeds up to 150 mph with fabric removed
- Structural tubing complies with ASTM standards
- Finished product includes 6 to 8 mils of combined primer and powder coat — all backed by 5,000 hours of testing per ASTM Method B117



# Superior<sup>®</sup>Shade



## Superior Court Shading Solutions

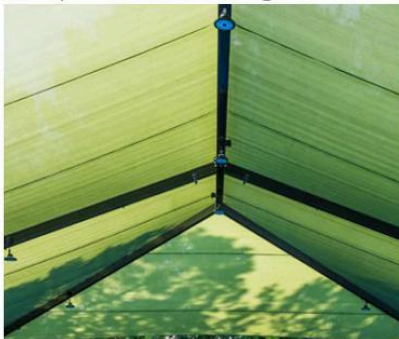

### Keeping Cool On and Off the Court

From pickleball and tennis to baseball and basketball, we have a shade structure to keep players cool on the court or spectators in the stands. Our versatile designs cater to a variety of sports and facilities, ensuring that every athlete and spectator stays comfortable while it's game on. With customizable options, we can meet the specific needs of your facility, enhancing both functionality and aesthetic appeal.

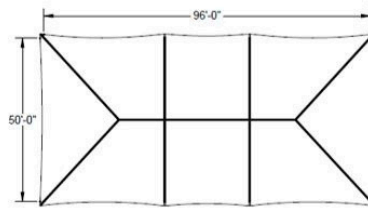

PLAN VIEW

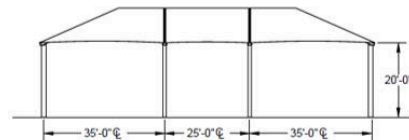

ELEVATION VIEW



**SUPERIOR SHADE** Description: 96' x 50' x 20' Custom Super Dome Shade



# Your Court Needs Are Completely Covered!

## Commercial Basketball & Pickleball Courts

We offer comprehensive design and turn-key installation services for commercial-grade basketball and pickleball courts. We provide quality commercial equipment and professional construction services for seamless integration into your recreational space.

Whether you want to harness the popularity of pickleball by installing new courts or elevate your existing tennis or basketball courts for improving playability and aesthetics, take advantage of our capabilities and convenience for your facility. **Trust us to design your courts for surfacing, equipment, shade, seating, fencing & even off-grid lighting!**

### Turn-Key Design & Installation

- ✓ Free site visits & design services
- ✓ Basketball goals, pickleball & tennis nets, and more
- ✓ Construction prep & concrete work
- ✓ Court surfacing tiles & court striping
- ✓ Solar court lighting
- ✓ Bleachers & benches to keep fans cheering comfortably
- ✓ Shades and sails to keep your spectators cool



Create flexible multi-sport game courts

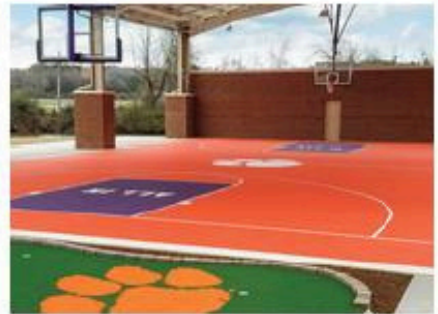

Versacourt tile surfacing colors & branding

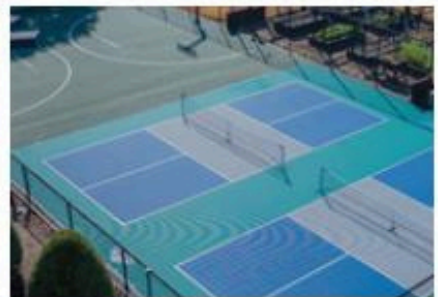

## Premier Courts

Ask us about multi-court savings



### LET'S PLAY! Request Your Consultation Today!



Call Us  
866-461-2814



Visit Us Online  
playgroundsetc.com



Proudly Serving  
TX, NM, & OK



# SuperiorAmenities





# Playgrounds Etc.- About US



Playgrounds Etc., LLC (E)(I)(T)  
 #781-25 - Playgroundequipment& safety surface products; Parks & Recreation Equip & Installation  
 #665-22 - Athletic, P.E., Gym Supplies & Equipment – Heavy Duty Exercise Equipment & Accessories



**4B Recreation Group LLC dba Playgrounds Etc.** | [www.playgroundsetc.com](http://www.playgroundsetc.com)

1410 W Texas Ave. | Midland TX 79701 | EIN: 85-1710107

## WHO WE ARE

**SouthTexas - KeyProject Personnel: (bold)**

Josh Bartlett, President & CPSI\* (HQ)

• O: 432-687-6388 | C: 432-301-3175 | [Josh@PlaygroundsEtc.com](mailto:Josh@PlaygroundsEtc.com)

David Kitch, VP Sales, Design Consultant & CPSI\* (HQ /W. TX Region)

• O: 432-687-6388 | C: 512-560-0142 | [David@PlaygroundsEtc.com](mailto:David@PlaygroundsEtc.com)

John Kiehle, Design Consultant & CPSI\* (Central & S. Texas Regions)

• O: 866-461-2814 | C: 210-632-6052 | [John@PlaygroundsEtc.com](mailto:John@PlaygroundsEtc.com)

Nathan Brewer, Project Coordinator & CPSI\* (Central & South TX)

• O: 432-687-6388 | C: 361-542-8588 | [Nathan@PlaygroundsEtc.com](mailto:Nathan@PlaygroundsEtc.com)

Accounting/ Billing – [Office@PlaygroundsEtc.com](mailto:Office@PlaygroundsEtc.com) (HQ)

\*CertifiedPlaygroundSafetyInspectors (CPSI)

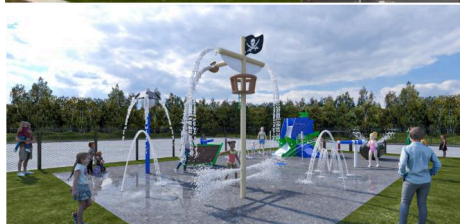

**Superior**  
Playgrounds

**Superior**  
RECREATIONAL PRODUCTS  
A PLAYCORE Company

**Water Splash**

While our company is headquartered in Midland, we have Design Consultants, Project Coordinators and Installers located all across Texas to better serve our growing family of customers. You will find that our team is serious about two things. The first is creating awe-inspiring designs, and the second is providing a one-of-a-kind client experience throughout the entire process.

Whether looking to purchase a single product, or you wish to partner with us to design and build your dream recreation space, we have an incredible staff to help you along the way. Furthering our customer service capabilities, most of our senior staff and All of our lead equipment installers, are Certified Playground Safety Inspectors (CPSI). All of us are dedicated to creating the safest play environment possible.

**Playgrounds Etc.** is driven to provide you with the best design resources, products, warranty and personal service in the industry. Along with our experienced staff of design consultants and installers, we have the construction knowledge, experience, and oversight to design, install, and complete one-of-a-kind indoor and outdoor recreation spaces.

We have recent projects we're proud of installing **locally**.



## Live Oak, TX



2023 – City Park

- Play structures on turf
- Nature Series | 5-12Y



LIVE OAK (near IKEA, across I-35)



Form **W-9**  
(Rev. March 2024)  
Department of the Treasury  
Internal Revenue Service

# Request for Taxpayer Identification Number and Certification

Go to [www.irs.gov/FormW9](http://www.irs.gov/FormW9) for instructions and the latest information.

Give form to the requester. Do not send to the IRS.

Before you begin. For guidance related to the purpose of Form W-9, see *Purpose of Form*, below.

1 Name of entity/individual. An entry is required. (For a sole proprietor or disregarded entity, enter the owner's name on line 1, and enter the business/disregarded entity's name on line 2.)

**4B Recreation Group, LLC**

2 Business name/disregarded entity name, if different from above.

**DBA Playgrounds ETC**

3a Check the appropriate box for federal tax classification of the entity/individual whose name is entered on line 1. Check only one of the following seven boxes.

Individual/sole proprietor     C corporation     S corporation     Partnership     Trust/estate

LLC. Enter the tax classification (C = C corporation, S = S corporation, P = Partnership) . . . . . **S**

**Note:** Check the "LLC" box above and, in the entry space, enter the appropriate code (C, S, or P) for the tax classification of the LLC, unless it is a disregarded entity. A disregarded entity should instead check the appropriate box for the tax classification of its owner.

Other (see instructions)

3b If on line 3a you checked "Partnership" or "Trust/estate," or checked "LLC" and entered "P" as its tax classification, and you are providing this form to a partnership, trust, or estate in which you have an ownership interest, check this box if you have any foreign partners, owners, or beneficiaries. See instructions . . . . .

4 Exemptions (codes apply only to certain entities, not individuals; see instructions on page 3):

Exempt payee code (if any) **N/A**

Exemption from Foreign Account Tax Compliance Act (FATCA) reporting code (if any) **N/A**

(Applies to accounts maintained outside the United States.)

5 Address (number, street, and apt. or suite no.). See instructions.

**1410 W Texas Ave**

6 City, state, and ZIP code

**Midland, TX 79701**

7 List account number(s) here (optional)

Requester's name and address (optional)

**Part I Taxpayer Identification Number (TIN)**

Enter your TIN in the appropriate box. The TIN provided must match the name given on line 1 to avoid backup withholding. For individuals, this is generally your social security number (SSN). However, for a resident alien, sole proprietor, or disregarded entity, see the instructions for Part I, later. For other entities, it is your employer identification number (EIN). If you do not have a number, see *How to get a TIN*, later.

**Note:** If the account is in more than one name, see the instructions for line 1. See also *What Name and Number To Give the Requester* for guidelines on whose number to enter.

Social security number

			-				-				
--	--	--	---	--	--	--	---	--	--	--	--

or

Employer identification number

8	5	-	1	7	1	0	1	0	7
---	---	---	---	---	---	---	---	---	---

**Part II Certification**

Under penalties of perjury, I certify that:

- The number shown on this form is my correct taxpayer identification number (or I am waiting for a number to be issued to me); and
- I am not subject to backup withholding because (a) I am exempt from backup withholding, or (b) I have not been notified by the Internal Revenue Service (IRS) that I am subject to backup withholding as a result of a failure to report all interest or dividends, or (c) the IRS has notified me that I am no longer subject to backup withholding; and
- I am a U.S. citizen or other U.S. person (defined below); and
- The FATCA code(s) entered on this form (if any) indicating that I am exempt from FATCA reporting is correct.

**Certification instructions.** You must cross out item 2 above if you have been notified by the IRS that you are currently subject to backup withholding because you have failed to report all interest and dividends on your tax return. For real estate transactions, item 2 does not apply. For mortgage interest paid, acquisition or abandonment of secured property, cancellation of debt, contributions to an individual retirement arrangement (IRA), and, generally, payments other than interest and dividends, you are not required to sign the certification, but you must provide your correct TIN. See the instructions for Part II, later.

Sign Here    Signature of U.S. person *Josh Bartlett*    Date *1-8-26*

**General Instructions**

Section references are to the Internal Revenue Code unless otherwise noted.

**Future developments.** For the latest information about developments related to Form W-9 and its instructions, such as legislation enacted after they were published, go to [www.irs.gov/FormW9](http://www.irs.gov/FormW9).

**What's New**

Line 3a has been modified to clarify how a disregarded entity completes this line. An LLC that is a disregarded entity should check the appropriate box for the tax classification of its owner. Otherwise, it should check the "LLC" box and enter its appropriate tax classification.

New line 3b has been added to this form. A flow-through entity is required to complete this line to indicate that it has direct or indirect foreign partners, owners, or beneficiaries when it provides the Form W-9 to another flow-through entity in which it has an ownership interest. This change is intended to provide a flow-through entity with information regarding the status of its indirect foreign partners, owners, or beneficiaries, so that it can satisfy any applicable reporting requirements. For example, a partnership that has any indirect foreign partners may be required to complete Schedules K-2 and K-3. See the Partnership Instructions for Schedules K-2 and K-3 (Form 1065).

**Purpose of Form**

An individual or entity (Form W-9 requester) who is required to file an information return with the IRS is giving you this form because they



## **PURCHASING INFORMATION**

### **PRODUCT CHANGES:**

Changes in equipment, surfacing, and other items can be made up to the time contract is signed. Colors, equipment selection and arrangement, quantity of products, size and scope of project may all be changed. We welcome changes and we will be happy to redesign and re-price the project for you. Generally it make take anywhere from a couple of days to two weeks to make these changes for your review.

### **CONTRACTS:**

Once your selection is completed, a contract will be sent to you. This contract specifies the exact equipment and services purchased, including specifications, quantities and expectations as to final appearance. Details as to delivery, the client's participation and the services rendered will be included. Funding details will also be included with the contract. In the event of a supervised installation then additional details regarding equipment required, labor and time schedule will be included.

### **DELIVERY:**

Generally, delivery of playground equipment manufactured by Superior Recreational Products as well as any shades or shade structures and site amenities. Surfacing and components delivery will vary.

### **INSTALLATION:**

Full Installation:

Construction crews are scheduled generally to start within two weeks of delivery. Except for substantially large projects, most projects will be completed in a week or less. Our contractors are certified installers and will work with you to make sure your expectations are met as long as safety standards are not compromised

### **FUNDING:**

Company policy provides one-half of the project total price is due upon contract signing. The remaining balance is due within seven days after completion of project or delivery in the event of a supervised installation or if client chooses to install units themselves.

### **WARRANTY:**

A copy of the warranty on equipment, turf or other products is included with this packet. Playgrounds Etc. will assist client in any way necessary when warranty issues arise.

### **REFERENCES:**

References will be supplied upon your request.



Quote # 1058

**Bode Pools Commercial, LLC**

**Bode Pools & Landscaping**  
 8798 FM 775  
 LaVernia, TX 78121  
 210-773-9462

Date	Project
6/26/2026	LV Splash Pad

Customer
City of La Vernia 102 E Chihauhau St. La Vernia, Tx 78121

No.	Description	Project LV Splash Pad Amount
1	Vortex Splash Pad Equipment - Quote # QUO-29631-J6G4T0 ** Updated Cost with 2026/2027 Pricing** Freight, Packaging all other Costs Included	\$290,569.14
1	Demo of Existing Concrete and Splash Pad Equipment	
1	Splash Pad Installation and Concrete Cool Deck and Shark Grip	\$21,600.00
		\$186,300.00
<b>TOTAL</b>		<b>\$498,469.14</b>

Payment Terms :

Mobilization and Equipment Deposit	25	\$124,617.29
Demo of Existing Splash Pad	%	\$124,617.29
SplashPad Rough In Concrete Prep	25	\$174,464.20
Concrete Installation and SplashPad Feature Installation	%	\$74,770.37
<b>Total</b>	<b>35</b>	<b>\$498,469.14</b>
		%

By Others :

- 1.) Electrical Home Run Brought to Equipment Cabinet Minimum 50AMPs
- 2.) Sewer (6") and Water Supply (2") to be Provided within 10' of Equipment Cabinet

Customer:

Bode Pools Commercial LLC:

Date:

Date: