



AGENDA
CITY OF LAUREL
BUDGET/FINANCE COMMITTEE
TUESDAY, JUNE 09, 2020
5:30 PM
COUNCIL CONFERENCE ROOM

Public Input: *Citizens may address the committee regarding any item of business that is not on the agenda. The duration for an individual speaking under Public Input is limited to three minutes. While all comments are welcome, the committee will not take action on any item not on the agenda.*

General Items

1. Review and Approve the May 26, 2020 Budget and Finance Committee meeting minutes.
2. Review and Approve Purchase Requisition from the Ambulance Department for Tools.
3. Review and Approve Purchase Requisition from the Clerk/Treasurer for GASB 75 Valuation.
4. Review and Approve Purchase Requisition from the Fire Department for Repairs to Brush 5 Truck.
5. Review and Approve Purchase Requisition from the Parks Department for Fire Pits and Benches.
6. Review and Approve May 2020 Utility Billing Adjustments.
7. Review and Recommend Approval to Council Claims Entered Through 06/05/2020.
8. Review and Approve the payroll register for pay period ending 05/31/2020 totaling \$211,124.01.

New Business - None

Old Business -

9. Purchase Requisition from the Street Department for the Repair of the Street Sweeper.
10. Elena Lawn Mower Discussion.

Other Items

11. Review Comp/OT report for pay period ending 05/31/2020.
12. Clerk/Treasurer Update.
13. Update from the Mayor.

Announcements

14. The next Budget and Finance meeting will be held on June 23, 2020 at 5:30pm.
15. Richard Klose will be reviewing the claims for the next meeting.

The City makes reasonable accommodations for any known disability that may interfere with a person's ability to participate in this meeting. Persons needing accommodation must notify the City Clerk's Office to make needed arrangements. To make your request known, please call 406-628-7431, Ext. 2, or write to City Clerk, PO Box 10, Laurel, MT 59044, or present your request at City Hall, 115 West First Street, Laurel, Montana.

File Attachments for Item:

Review and Approve the May 26, 2020 Budget and Finance Committee Meeting Minutes.

**Minutes of City of Laurel
Budget/Finance Committee
Tuesday, May 26, 2020**

Members Present: **Emelie Eaton**
 Bruce McGee
 Scot Stokes
 Richard Klose

Public Input: *Citizens may address the committee regarding any item of business that is not on the agenda. The duration for an individual speaking under Public Input is limited to three minutes. While all comments are welcome, the committee will not take action on any item not on the agenda.*

General Items

- Review and approve the May 12, 2020 Budget and Finance Committee meeting minutes. Bruce McGee moved to approve the minutes as presented. Scot Stokes seconded the motion, all in favor, motion passed.
- Review and approve purchase requisition from the Street Department for repairs on the street sweeper. The committee had questions regarding whether the City of Laurel was being taken advantage of in light of some of the itemized charges (\$1,600 just to ‘diagnose’ the problem; only one local vendor to make the repairs). The committee questioned whether, in light of the over \$20,000 to repair the current sweeper, it wouldn’t be less expensive to purchase a new one. There was confusion as to whether this was a bill for work already in progress or an estimate for work to be done. The committee stated that they could not determine, without answers to their questions, whether this was the best use of the taxpayer’s money. The committee felt that, in light of the amount of the request (over \$20,000) staff should have been willing to explain the request. Bruce made the motion to postpone decision on this item until such time as staff was present to answer questions. He further moved that if this was a time sensitive issue the committee could convene for a one item meeting to get this issue underway before the next Budget and Finance meeting. He felt that staff could coordinate the meeting time and availability. Scot seconded the motion. All in favor, motion passed.
- Review and recommend approval to Council, Claims entered through 5/22/20. Bruce McGee had previously reviewed the Claims Detail report and the check register for accuracy. He stated there were a couple purchases that were out of the ordinary but definitely necessary. Bruce McGee made a motion to recommend approval of the claims entered through 5/22/20. Richard Klose seconded the motion, all in favor, motion passed.
- Review and approve Payroll Register for pay period ending 5/15/20 totaling \$6,264.44 and Pay Period ending 5/17/2020 totaling \$196,739.84. The two page summary for 5/17/2020 and the one page summary for 5/15/2020 were reviewed, signed and dated. Bruce McGee made a motion to approve the Payroll Registers for the pay period ending 5/15/20 totaling \$6,264.44 and 5/17/20 totaling \$196,739.84. Richard Klose seconded the motion, all in favor, motion passed.

New Business – none

Old Business – In light of the Purchase Requisition from the May 12, 2020 meeting, the committee requested staff inform them at the next meeting regarding what happened to the “old” Elena Subdivision lawn mower? The committee wanted to know if it was being used elsewhere in the City.

Other Items –

- Create a Claims Review Schedule:
6/9/2020 – Scot Stokes will review the claims
6/23/2020 – Richard Klose will review the claims
7/14/2020 – Scot Stokes will review the claims
7/28/2020 – Bruce McGee will review the claims
8/11/2020 – Emelie Eaton will review the claims
8/25/2020 – Richard Klose will review the claims
- Review the Comp/Overtime Report for the pay period 5/17/2020. The Committee noted that the Ambulance Department is suffering due to trying to cover all the COVID-19 calls.
- Review Olness & Associates Fiscal Year 2019 Audit letter. The committee noted that the letter was filled with so much generic wording as to be uninformative.
- Review Olness & Associates Closing Journal Vouchers for Fiscal year 2019. The committee noted that the transfers of money were coded and thus uninformative to those not familiar with the line item codes.
- Clerk/Treasurer Update. The Clerk/Treasurer was not in attendance and no update was provided.
- Update from the Mayor. The Mayor was not in attendance and no update was provided.

Announcements –

The next Budget and Finance meeting will be held on June 9, 2020 at 5:30 p.m. in the Council conference room.

Scot Stokes will be reviewing the claims for the June 9, 2020 Budget & Finance meeting.

The meeting was adjourned at 6:00.

Respectfully submitted,

Emelie Eaton
Budget and Finance Chair

NOTE: This meeting is open to the public. This meeting is for information and discussion of the Council for the listed workshop agenda items.

File Attachments for Item:

2. Review and Approve Purchase Requisition from the Ambulance Department for Tools.

To: City of Laurel Leadership & Financial Committee

From: Dave Jackson Ambulance Driver / Mechanic

Subject: Purchase of basic tools & equipment needed to maintain the ambulance fleet.

Date: 2020 01-22

To whom it may concern: I am requesting the ability to research & purchase a basic high-quality tool set as well as other needed equipment such as air powered jack / stands / oil containment items. So that Laurel EMS / Ambulance would have the ability to maintain vehicles & other equipment. I know the initial cost is sizable, however with running a 24hour 7day a week service. The ability to perform repair & maintenance work at any hour of any day pays for the cost of tools & equipment quickly. At my conservative estimate for Laurel EMS / Ambulance has a daily recoverable rate of \$8200 per day, based on 1200 calls @ \$2500 each. This does not include any other factors such as personnel, insurance, towing, sublet repairs. The ability to perform repair work at any time is essential to a small service with no back-up vehicles. A recent example of this was Christmas Eva 2019 at 7:30 PM Care 2 had a Bad Order right rear tire. With the use of my personal service truck I was able to make repair and have Care 2 back in service within an hour. The tools needed for this repair where: ½ Inch Impact Gun, Impact Socket Set, Calibrated Torque Wrench, 3/8 Drive Socket Set, Valve Stem Tool, Spray Bottle of Soapy Water, Air Chuck / Gauge (we have this), Air Compressor (we have this), Air Hose (we have this) where all used to make this simple repair and at the same time keeping Care 2 in service for the extended holiday week. In service time of vehicles is key in providing quality patient care to residence of Laurel and the Ambulance service area. As we cannot predict our Ambulance needs at any time in service time is critical to the mission. For example Laurel EMS / Ambulance responded to 5 calls for service from 09:57 hours to 12:11 hours on Jan 22 2020 as you can see both Ambulances where pushed into service at the same time. This is for your consideration I am available for any questions at any time my contact information: Dave Jackson Ambulance Driver / Mechanic 406-702-5182 1412 West Maryland Lane Laurel MT 59044 djackson2@mt.gov

Item # 856843 Model # 80724

Kobalt 55-Piece Standard (SAE)/Metric
Combination 1/2-in Drive Shallow; Deep 6-
point Impact Socket Set

\$159.00

Item # 337334 Model # 89815

Kobalt 1/2-in Drive Click Torque Wrench

\$79.97

Item # 525827 Model # 324K12K

Kobalt 12-Piece Plastic Handle Magnetic
Multi-Bit Screwdriver

\$31.98 x 2

Item # 338361 Model # 85556

Kobalt 7-Piece 12-Point Standard (SAE)
Ratchet Wrench Set

\$59.97

Item # 338364 Model # 85559

Kobalt 7-Piece 12-Point Metric Ratchet
Wrench Set

\$69.97

Item # 573356 Model # 86768

Kobalt 200-Piece Standard (SAE) and Metric Polished Chrome Mechanics Tool Set

\$236.00

Item # 464614 Model # 55754

Kobalt Kobalt 5-piece Traditional Plier Set

\$24.98

Item # 337311 Model # 85877

Kobalt 1/2-in Breaker Bar

\$22.98

Item # 840023 Model # 89808

Kobalt 3-Piece 90-Teeth 1/2-in; 3/8-in; 1/4-in Drive Quick-Release Ratchet Set

\$39.98

Item # 840780 Model # SGY-AIR236

Kobalt 0.5-in 1000-ft Air Impact Wrench

\$154.00

Item # 858972 Model # SGY-AIR220

Kobalt 1/4-in Angle Die Grinder Rotary

\$58.98

Item # 1332911 Model # KRW 124B-03

Kobalt 24-Volt Max 3/8-in Drive Variable
Brushless Cordless Ratchet Wrench

\$119.00

Item # 672823 Model # KDD 1424A-03

Kobalt 24-Volt Max 1/2-in Brushless
Cordless Drill (Charger Included)

\$159.00

Item # 672824 Model # KID 1324A-03

Kobalt 24-Volt Max Variable Speed
Brushless Cordless Impact Driver (1-
Battery)

\$169.00

Item # 972152 Model # 1461

**Kobalt 230-Piece High-Speed Steel Round
Shank Screwdriver Bit Set**

\$24.98

Item # 1614384 Model # DX722117RCGNBK

**Extreme Tools DX 72-in W x 42.75-in H 17-
Drawer Steel Rolling Tool Cabinet (Green)**

\$1,769.62 Was \$4,772.44

Part #: OTC 1511B

Line: OTC

Floor Jack Air / Hydraulic Service Jack 10 Ton

\$1,850.00

Part #: OTC 5373

Line: OTC

Jack Stand 6 Ton Ratcheting

\$87.99 x 2

Total: \$5238.38

0374

FOR CITY USE ONLY—THIS IS NOT A PURCHASE ORDER

Date: 10-9-2020
Fund: General
Dept.: Ambulance

**PURCHASE
REQUISITION**
CITY OF LAUREL
MONTANA
59044

VENDOR: Lowes

VENDOR NO.: _____

Quantity	Fully Itemize	Est. Cost	Account Number
	Tool Set		1000.270.420730.241
Total estimated cost		5238.38	

File Attachments for Item:

3. Review and Approve Purchas Requisition from the Clerk/Treasurer for GASB 75 Valuation.

April 27, 2020

16618 SE 45th Street
Bellevue, WA 98006

Phone: 425-835-3805

Mobile: 425-220-6966

Fax: 425-341-9104

E-mail: Michael@actuariesnw.com

Bethany Langve
City Clerk/Treasurer
City of Laurel
P.O. Box 10
Laurel, MT 59044

Re: City of Laurel 2019/2020 Fiscal Year GASB 75 Valuation

Dear Bethany:

We are contacting you regarding the required 2019/2020 City of Laurel GASB 75 valuation. Our records show when we provided you with the prior valuation the next valuation would be required in a few years. We welcome the opportunity to provide City of Laurel with our services again and have provided a description of the project deliverable and proposed fee schedule below.

Project Deliverable

The project deliverable consists of two items: a full valuation and report for the current year complying with the new regulations of GASB 75, and a roll-forward valuation and report in the following year also required by the new regulation. The reports will be based on assumptions, methodologies and reporting requirements prescribed by GASB 75 regulations and all corresponding actuarial standards of practice.

The timing of the valuation reports will be based on the phase-in rules prescribed in the regulations, along with receipt of the required data and information as outlined in Exhibit A. Our goal is to complete the valuations within four weeks of receipt of all required data.

Proposed Fees

The proposed fee is as follows:

2019 / 2020 Fiscal Year Valuation: \$5,000

2020 / 2021 Roll-forward Valuation: \$2,000

The fees assume data collection by the City of Laurel, with verification and review performed by Actuaries Northwest. The fees do not include travel expenses or report presentations to the district, which are reimbursable based on actual travel costs without mark-up and standard hourly billing rates.

If you are in agreement with us providing the 2019/2020 valuation services for the proposed fees, please sign the document below and return to my attention.

Signed and agreed to by:

CLIENT (signature)

CLIENT (print name and title)

TODAY'S DATE

Thank you again for your consideration. Please call me with any questions at (425) 835-3805.

Sincerely,



Michael Elliston
ASA, MAAA, FCA

City of Laurel GASB 75 - 4.27.20.doc
MLE/kwg

CC: Kelly Grebinsky

Exhibit A: Data Requirements List

Written materials:

- Current employee booklets, bargaining agreements or other materials describing the benefits
- Year-end asset statements showing trust funds set aside to pay retiree benefits, if any
- Summary of changes in benefits over last 2-3 years

Census information (spreadsheet format preferred):

Census data needed for each benefit eligible employee and retiree (except as otherwise indicated):

- SSN (or some other unique identifier)
- Last Name
- First Name
- Gender
- Group ID (department, division, bargaining group, etc.)
- Date of birth
- Date of hire
- Service (as may be applicable to various plans)
- Payroll "earnings" as defined for any applicable benefit (may require multiple earnings fields)
- Date of retirement (retirees only)
- Spouse date of birth if married
- Enrollment status in plans (single, two party, family)
- Current monthly retiree contributions by individual
- Employer contribution
- Custom fields related to your specific plans

Premiums/Claim Costs

- Claims and number covered by month for the medical, Rx, dental, and vision providers for the current year and most recent prior years. If claims data is not available, premiums by month can be substituted.
- Premiums by month for life insurance providers for current year and most recent prior years
- Administrative charges by month for each coverage for current year and most recent prior years

If there are any items on the data request that either don't seem applicable to your plan or organization, or appear that they would require an inordinate amount of time to gather, let us know and we can discuss if there are any alternate approaches to the request as written.

FOR CITY USE ONLY—THIS IS NOT A PURCHASE ORDER

**PURCHASE
REQUISITION**

**CITY OF LAUREL
MONTANA
59044**

Date: 6-1-2020
 Fund: General
 Dept.: Finance

VENDOR: Actuaries Northwest
11618 SE 45th Street
Belleue WA 98006

VENDOR NO.: _____

Quantity	Fully Itemize	Est. Cost	Account Number
1	2019/2020 Fy Valuation GASB 75	5,000	
1	2020/2021 Rollforward	2,000	
Total estimated cost		7,000-	

File Attachments for Item:

4. Review and Approve Purchase Requisition from the Fire Department for Repairs to Brush 5 Truck.

Justin Romero

After Incident Statement: 711 Byam Rd. 5-21-2020

Brush 5 dispatched second due to the wildland fire at 711 Byam Rd. with John Herr as engine boss, Jayson Nicholson as firefighter and myself, Justin Romero, as engineer.

On scene, Brush 5 was directed to take the large fire to the right of where 2071 was working from the IC,901. Brush 5 made for the direct route to the fire which was on a beaten trail through tall dead cattails. As soon as Brush 5 left the established two track it was shifted in to 4x4 high. As Brush 5 approached the thick cattails, John got out to lead the truck in. Going was slow to allow John to pick a path and so I could also watch for any potential holes. Roughly $\frac{3}{4}$ of the way through the cattails to the black, the engine became stuck. At this point Jayson hopped out to help spot as we tried to get the truck out, and the truck was put into 4x4 low. Truck only dug farther into a hole so John and Jayson turned their attention to the fire line that was slowly approaching our position and deployed two hose lines to protect the truck. I remained in the truck waiting for another chance to get the truck unstuck. After a couple of minutes the cab begin to fill with smoke and smoke was visible coming up between the back of the cab and the flatbed. I immediately told both John and Jayson that I thought something was burning up under the truck. They attempted to spray water under the truck as nothing was visible at this time and the smoke seemed to slow down. I also took this opportunity to exit the truck and grabbed a mcloud to help pull back the thick underbrush that was tucked under the cab of the truck. After we felt that the threat was contained, Jayson continued to work to the front of our truck and John sent me back to talk 901 to ask for the excavator that was inbound to come pull us out. Upon returning from meeting with 901, I found John on the right side of the truck putting out the last of the flames that were coming up from underneath the truck. We popped the hood and opened doors to make sure fire had not spread and to gain better access to under the truck to apply water.

After we were certain that no more fire was coming from under the truck and the ground was good and wet all around and under the truck, Jayson and myself grabbed some hand tools and attempted to work the fire by hand to conserve water in case the truck was threatened again.

Later after the fire line to our front was contained with the help of the arrival of Brush 3, Jayson and John moved the trash pump and 100' of forestry line from the truck to a drainage ditch and began to fighting fire this way while I stayed behind with the truck to continue to monitor it and wait for a tow from the incoming dozer.

When the dozer arrived they pulled Brush 5 back out the way it had come and it was parked up by the command rigs. 901 redirected Brush 5 and Brush 3 to circle around through the trees and get to the other side of the fire and link back up with John and Jayson as well as 2071. Both trucks were topped off from the tender and began the trek through the trees to the other side of the fire. Most of the way back in Brush 5 check engine light came on and I noticed it was overheating. Truck was shut down immediately and attempted to radio for help only to realize that the radio was no longer transmitting or

On the evening of may 21st we were dispatched to a grass fire call at 711 Byam rd. I went in Brush 5 with 2 others. We were the 2nd brush truck that went in wrought. Upon arrival we joined Command 1 and Engine 2071. E-2071 had already begun fighting fire on the north side. We were told to go to the south side. I was the captain on the truck and seen that the majority of the fire to the south had a path going to it were some other vehicle had driven. The fire was in a large group of old cat tails that were very tall with brush and trees in it. I said to take the path already driven on to access the fire. Before going down the path i got out of the truck so I could walk ahead of it look for obstacle and see if the ground was stable to drive on. Brush 5 followed me out. When we got within 15 yrds of the active fire Brush 5 lost traction and would not move and was stuck. We then got 2 fire hoses off the truck and began to fight the fire that was approaching the truck. The truck had sunk in to the soil and dry cattails. I had walked around the truck spraying water in the are of it. We noticed smoke from under the truck on the drives side which I the sprayed water under the tuck to cool and wet that area down. The driver was still in the truck and that time. The other fireman was helping fight fire and cool the are of the truck when it looked as the smoke was not from under the truck we went back to fighting fire. I was on the driver side, putting out fire in the tall brush. The other firman was in front of the truck fighting fire. I keep looking back to check on the truck. The hose i was using was a 25ft hose so i was not far from it. I went back to the truck and walked around to the passenger side to see what it looked like there when I seen flames coming from under the tuck in the areas of droors and RF wheel well. I put the fire out before it spread to the rest of the truck the paint on the doors where severely burned and the plastic fender flare and inner fender well where burnt up. The other 2 fire men joined me in stopping to fire of the truck. After the fire was put out we continued to fight fire around the tuck until a dozer got there and was able to pull the truck out. While we waited to get unstuck i went and spoke to the Chief and advised him that the truck was stuck and was burned. After the truck was freed I was working the fire line. The driver stayed with the truck and was refilled with water and sent back out and around to the fire where it began to over heat and was found that the radiator was damaged do to the heat of the fire we topped off the coolant in the engine with water form the truck and limped it out to the main road where a tow truck came to get it and take it to the service station

John Herr























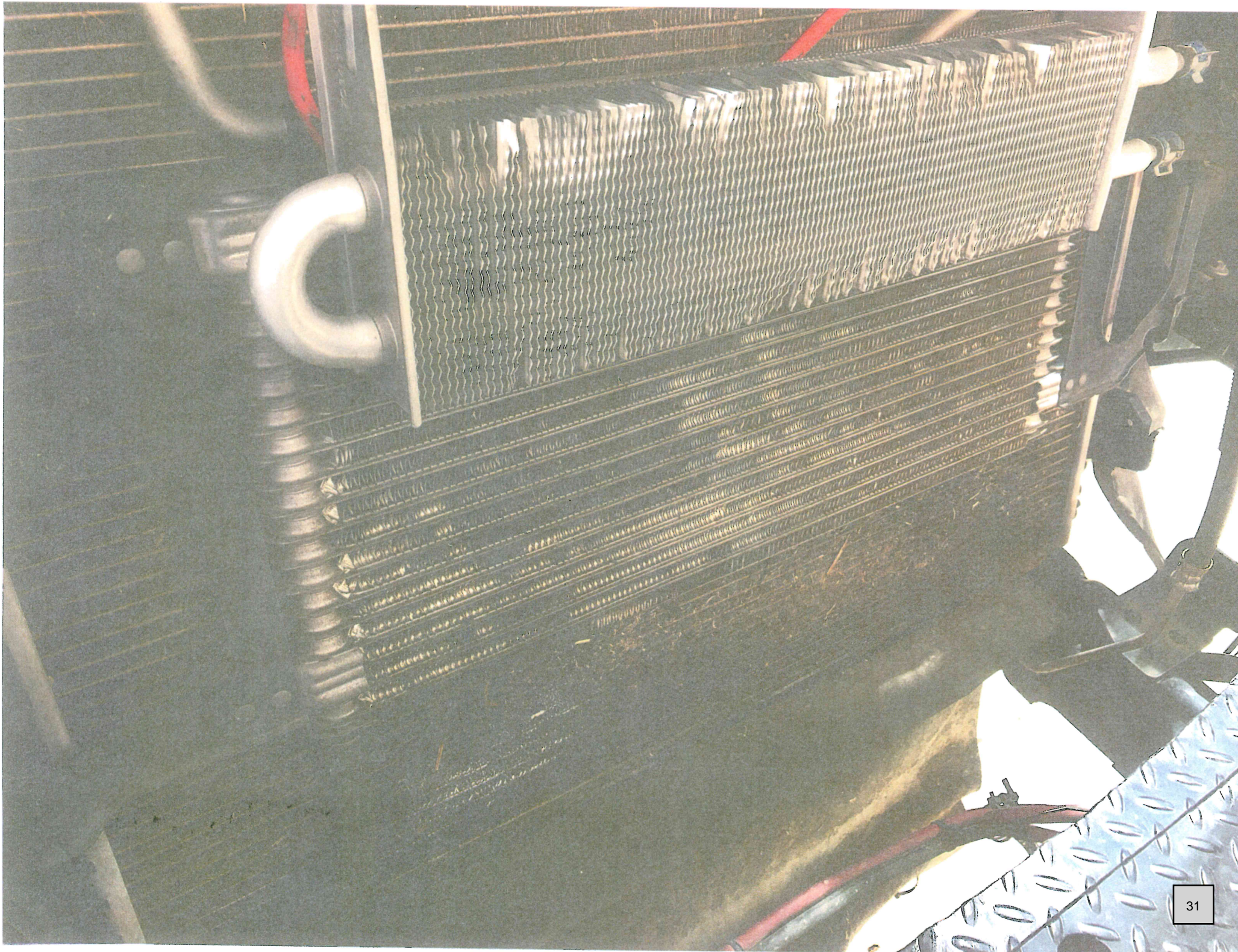

Inferno Auto Body & Glass Inc.

Zack Winchell
 Inferno Auto Body & Glass Inc.
 2742 S Ramshorn Dr.
 Laurel, MT 59044
 Business Phone: 406-545-9554
 firejnee@gmail.com

Estimate
 Est #123, ID #6645254

FederalTaxID: 81-2784059

Vehicle Info	VIN	Color Ext. / Int.	License (St.)	Miles In / Out
2008 Ford F450 Pickup XL 4 Door Crew Cab 172	1FD5W57Y98ED58236	/		0 / 0

Owner

Laurel Fire Department
 Laurel, MT 59044

Description	Part #	Price	Qty	Labor	Paint	Other
FRONT FENDER						
Replace L FENDER PANEL 1.1hrs. Clearcoat , 0.5hrs. Edging	A 7C3Z 16006 B	\$241.50	1	Included	2.3 hrs.	1.6 hrs.
Replace R FENDER INSULATOR	8C3Z 16102 A	\$38.85	1			
Replace R FENDER WHEEL OPENING MLDG	8C3Z 16038 CA	\$337.10	1	Included		
Replace R FENDER NAMEPLATE BASE	8C3Z 16228 C	\$153.59	1	Included		
FRONT DOOR						
Replace R FRT DOOR SHELL 1.7hrs. Clearcoat , 1.4hrs. Underside	9C3Z 2520124 F	\$876.53	1	5.0 Body hrs.	2.8 hrs.	3.1 hrs.
Replace R FRT DOOR OUTSIDE HANDLE	A FO1311123	\$46.20	1	Included		
R&I R FRT DOOR TRIM PANEL				Included		
Replace R FRT LWR DOOR WEATHERSTRIP	F81Z 2520758 AA	\$30.74	1	0.2 Body hrs.		
Replace R FRT DOOR REAR VIEW MIRROR	A FO1321340	\$178.50	1	Included		
REAR DOOR						
Replace R REAR DOOR SHELL 1.5hrs. Clearcoat , 1.3hrs. Underside	9C3Z 2624630 C	\$924.49	1	Included	2.5 hrs.	2.8 hrs.
Replace R REAR LWR DOOR WEATHERSTRIP	1C3Z 26253A24 A	\$28.48	1	0.2 Body hrs.		
CAB						
Repair R CAB CORNER PANEL 0.8hrs. Clearcoat	8C3Z 25280A58 A			2.0 Body hrs.	2.1 hrs.	0.8 hrs.
Repair R REAR CAB ROCKER PANEL 1.0hrs. Clearcoat	F81Z 2610128 AA			1.0 Body hrs.	2.4 hrs.	1.0 hrs.
Repair R FRT CAB ROCKER PANEL 1.0hrs. Clearcoat	F81Z 2810128 AA			1.0 Body hrs.	2.4 hrs.	1.0 hrs.
Repair Clean/reapply underside seamsealer R CAB INNER ROCKER PANEL	8C3Z 2610120 A			1.0 Body hrs.		
Replace R FRT CAB SCUFF PLATE	8C3Z 2513208 AB	\$56.36	1	Included		
Replace R REAR CAB SCUFF PLATE	7C3Z 2613228 AA	\$38.12	1	0.2 Body hrs.		
Replace CAB FLOOR COVER	ORDER FROM DEALER	\$531.69	1	3.0 Body hrs.		
FRAME						
Replace R UPR FRAME INSULATOR	ORDER FROM DEALER	\$41.23	1	0.5 Body hrs.		
Replace R LWR FRAME INSULATOR	ORDER FROM DEALER	\$32.48	1			
Replace L & R door decals	⊙	\$299.99	1	1.5 Body hrs.		
Replace Replace Right side reflective and pin striping	⊙	\$29.99	1	1.0 Body hrs.		
Replace Clean/prime/undercoat underside cab.	⊙	\$20.00	1	2.0 Body hrs.		
Other Hazardous Waste Remove	⊙	\$10.00	1			
Other Car Cover	⊙	\$12.00	1			
Other Corrosion Proofing	⊙	\$10.00	1			

Inferno Auto Body & Glass Inc.

Zack Winchell
Inferno Auto Body & Glass Inc.
2742 S Ramshorn Dr.
Laurel, MT 59044
Business Phone: 406-545-9554
firejnkee@gmail.com

Estimate
Est #123, ID #6645254

FederalTaxID: 81-2784059

Totals

Type	Hours	Rate/hr	Total	Taxable
OEM Parts			\$3,089.67	
Ⓐ Aftermarket Parts			\$466.20	
Ⓢ Other Parts			\$381.98	
Body Labor	28.2	\$64.00	\$1,804.80	
Paint Labor	24.8	\$64.00	\$1,587.20	
Paint Supplies	24.8	\$45.00	\$1,116.00	
Nontaxable Amount			\$8,445.85	
Net Total			\$8,445.85	

FOR CITY USE ONLY—THIS IS NOT A PURCHASE ORDER

PURCHASE REQUISITION
CITY OF LAUREL
MONTANA
59044

Date: 6-9-2020
Fund: General
Dept.: Fire

VENDOR: Multiple

VENDOR NO.: _____

Quantity	Fully Itemize	Est. Cost	Account Number
	Repairs to Brush 5 after fire damage	up to	1000.240.420400. 361
Total estimated cost	15,000-		35

File Attachments for Item:

5. Review and Approve Purchase Requisition from the Parks Department for Fire Pits and Benches.

CITY HALL
115 W. 1ST ST.
PUB. WORKS: 628-7496
WATER OFC.: 628-7431
COURT: 628-1964
FAX 628-2241

City Of Laurel

P.O. Box 10
Laurel, Montana 59044



RECOMENDATION

TO: Budget and Finance Committee
FROM: Kurt Markegard, Director of Public Works
Cc: Thomas C. Nelson, Mayor
Matt Wheeler, Public Works Superintendent
Bethany Langve, City Clerk Treasure
SUBJECT: Purchase of Fire/BBQ Pits for Riverside Park
Campground

DATE: June 9, 2020

The Public Works Department is requesting to purchase 25 Fire/BBQ Pits from Pilot Rock/RJ Thomas Mfg. Co. I received two quotes and Pilot Rock submitted the lowest quote for the ADA compliant picnic tables for a total of \$10,001.25.

KLJ Engineering recommended the City purchase the Fire/BBQ Pits on our own to avoid the contractor marking up the prices if we included it in the bid for the campground improvements.

PRICE QUOTATION

RJThomas Mfg. Co., Inc.

P. O. Box 946 • Cherokee, IA 51012

712-225-5115 • 800-762-5002 • FAX: 712-225-5796

Web:
www.pilotrock.com

Pilot Rock

PARK • STREET • CAMP
SITE PRODUCTS

E-mail:
customerservice@rjthomas.com

129570

Laurel, City of

115 W 1st St

Laurel

TEL: Kurt Markegard,

406-628-4796

FAX:

MT 59044

kmarkegard@laurel.mt.gov

Laurel, City of

115 W 1st St

Laurel

MT 59044

QUOTATION DATE: June 05, 2020

QUOTATION NO: 70783

QUOTATION BY: 3,360

QTY	MODEL NO.	DESCRIPTION	UNIT PRICE	EXTENDED PRICE
25	FSWDW-30/18/TB	FIRERING DBL WALL SWIVEL GRATE 18" SIDE TIP-BACK ANCHR	400.05	10,001.25
1	FREIGHT DLVD	FREIGHT INCLUDED TO ZIP 59044 FOB DESTINATION	0.00	0.00

PLEASE NOTE: Any Changes to the above quoted Models, Quantities or Destination require a NEW QUOTE.

(Sales tax NOT INCLUDED unless otherwise stated.) (All models/units shipped knocked down - assembly required.)
NOTE: All quotations and agreements are contingent upon strikes, accidents, fires, availability of materials and all other causes beyond our control. Prices are based on costs and conditions existing on the date of quotation and are subject to change by the Seller before final acceptance.
Typographical and stenographic errors subject to correction. Purchaser assumes liability for patent and copyright infringement when goods are made to Purchaser's specifications. When quotation specifies material to be furnished by the Purchaser, ample allowances must be made for reasonable spoilage and material must be of suitable quality to facilitate efficient production.
Conditions not specifically stated herein shall be governed by established trade customs. Terms inconsistent with those stated which may appear on Purchaser's formal order will not be binding on the Seller.

SHIPPING WITHIN 3 WEEKS ARO
CUSTOMER TO UNLOAD

Quotation Total 10,001.25

CUSTOMER TO UNLOAD FREIGHT FROM TRUCK. SOME ASSEMBLY REQUIRED.

PRICES FIRM 30 DAYS. PAYMENT TERMS: NET 30 DAYS
ALL MAJOR CREDIT CARDS ACCEPTED

BY

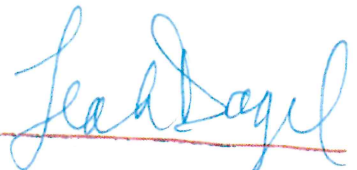



*Model FSWDW-30/18/TB Double Wall Wheelchair Accessible
Firering with swivel cooking grate and lower fire grate.*

- **Meets ADA guidelines, requires less than five pounds of force with one hand to move grate out of firering**
- **Elevated cooking grate and firebed conform to ADA guidelines**
- **Handle is never over the fire**
- **Flanged outer firering for strength and safety**
- **Cooling air gap between rings keeps outer ring cool**
- **Inner ring supports fire grate**
- **Tip back anchors allow easier removal of ashes**

SPECIFICATIONS:

- **FSW Series** firering is designed to meet ADA guidelines requiring less than five pounds of force with one hand to operate the grate.
- **Model FSWDW-30/18/TB** has a 32-3/8" overall dia. outer ring constructed from 12 ga. steel with a formed (NOT WELDED) 1" flanged lip at top of ring and ten 7/8" dia. draft holes located around the perimeter. Firering side is 17-5/16" tall. Ring is provided with hinged anchoring device to allow ring to tip upward for cleaning. Two 1/2" dia. steel "U" anchor pins with deformed ends insert 15" into concrete footings.
- Inner fire wall is constructed from 7 ga. steel formed in a nominal 26" dia. ring welded to outer ring by means of three 2-7/8" x 2-7/8", full length steel angles. Ten 7/8" dia. draft holes are provided in the 17-1/8" tall inner wall.
- Firering is designed to conform with ADA guidelines to raise fire to proper height.
- 300 sq. in. swivel cooking grate is constructed from 1/2" dia. A-36 steel bar around the perimeter, a 5/8" A-36 steel bar for the handle, and 1/2" dia. A-36 steel bar for the grate bars. Grate is mounted on a 2-3/8" OD tube allowing it to rotate on a horizontal plane out of the firering. Two welded-on stops limit rotation to 180° to prevent the handle entering the area over the fire.
- Grate is provided with a substantially constructed spring grip suitable for public use made from 1/8" x 1/2" flat bar (not wire springs).
- 380 sq. in. log grate area is constructed from 5/8" dia. A-36 steel bar around the perimeter and 1/2" dia. A-36 steel bar for the grate bars. Grate is permanently attached and hinged by means of 2 tightly formed eyelets made from 5/8" dia. A-36 steel bar at one end and supported by two 1-3/4" x 1-9/16" 7 ga. die-formed angles. Grate swings up for cleanout.
- Entire unit is finished in high temperature, heat resistant, nontoxic black enamel.
- **Optional:** Firering is provided with a 3/16" x 7-1/8" x 9-5/8" steel plate utility shelf. (Add "/S" to model no., e.g. FSWDW-30/18/TB/S.)

AVAILABLE OPTIONS

Utility Shelf

RJ Thomas Mfg. Co., Inc.

PO Box 946 • Cherokee, IA 51012-0946 • PH: 712-225-5115 • 800-762-5002 • FAX: 712-225-5796

E-mail: pilotrock@rjthomas.com • Web Site: <http://www.pilotrock.com>

© 2008 RJ Thomas Mfg. Co., Inc. PILOT ROCK® Park Products is a registered trademark of RJ Thomas Mfg. Co., Inc.

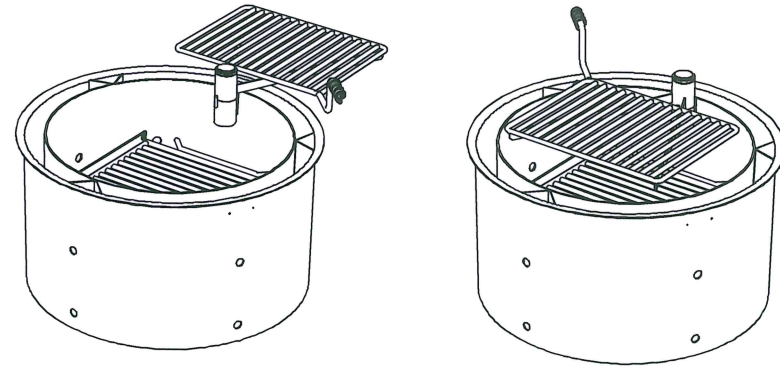
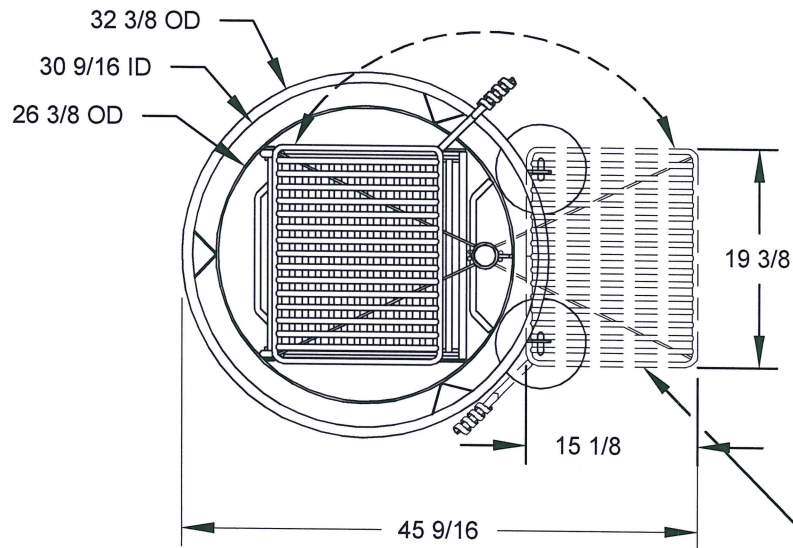

COOKING GRATE ROTATES 180 DEGREES TO OUTSIDE FIRERING

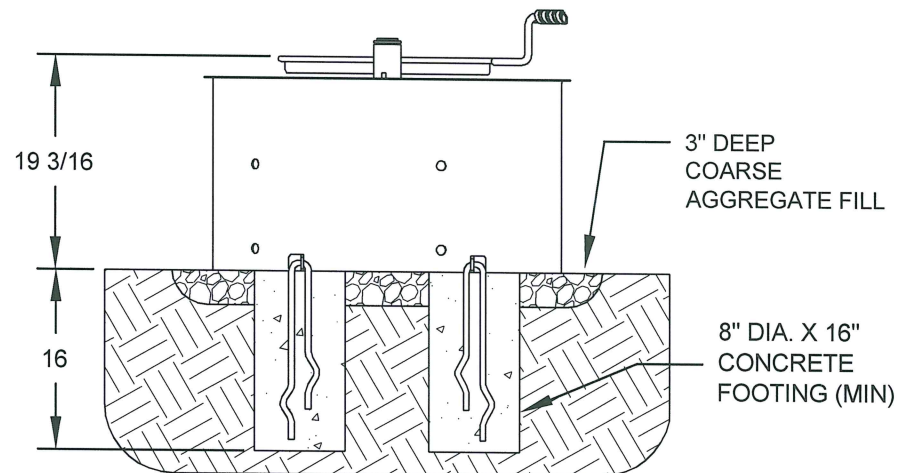
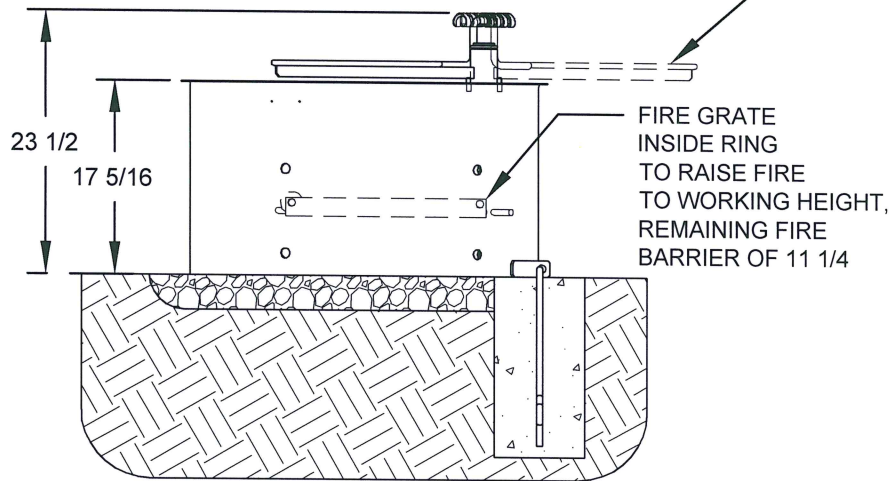

ALL DIMENSIONS IN INCHES

RJ Thomas Mfg. Co., Inc.
P.O. Box 946 • Cherokee, IA 51012-0946

DRAWN BY
WWM

TITLE MODEL FSWDW-30/18/TB WHEELCHAIR ACCESSIBLE DOUBLE WALL FIRERING WITH SWIVEL GRATE AND TIP BACK ANCHORS

DATE 3-11-10

DWG. NO. AI-1923

Specification Bulletin SPC-FR-036



Model FSW-30/18/PA/H/S Wheelchair Accessible Campfire Ring with swivel cooking grate and heat shield.

(Below) Grate shown rotated out of the firering.

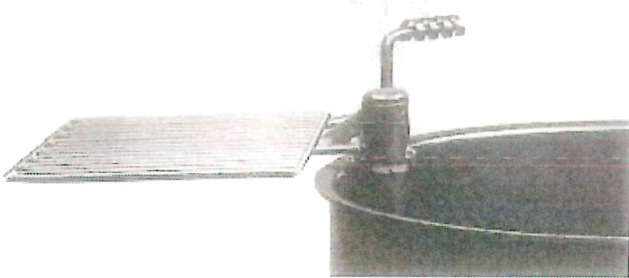

- Meets ADA guidelines, requires less than five pounds of force with one hand to move grate out of firering
- Handle is never over the fire
- Flanged firering for strength and safety
- Public use-type spring grips of coiled steel bar
- Elevated cooking grate and firebed conform to ADA guidelines
- Required aggregate fill protects site surfaces such as paver blocks, cement, and asphalt from heat damage
- Heat Shield
- Quality construction throughout

SPECIFICATIONS:

- **FSW Series** firering is designed to meet ADA guidelines requiring less than five pounds of force with one hand to operate the grate.
 - 32" overall dia. firering is constructed from 3/16" thick steel with a formed (NOT WELDED) 1" flanged lip around the top of the ring and ten 1" dia. drain/draft/anchor holes located around the perimeter.
 - **Model FSW-30/18/PA/H** firering side height is 16-7/8".
 - The single level, 300 sq. in. cooking grate is constructed from 1/2" dia. A-36 steel bars around the perimeter, 5/8" dia. A-36 steel bar for the handle, and 1/2" dia. A-36 steel bar for the grate bars.
 - Grate is provided with a substantially constructed spring grip suitable for public use made from 1/8" x 1/2" flat bar (not wire springs).
 - Grate is mounted on a 2-3/8" OD tube allowing it to rotate on a horizontal plane out of the firering. Two welded-on stops limit rotation to 180° to prevent the handle entering the area over the fire.
 - Firering is designed to be filled with customer supplied aggregate fill to a minimum of 9" above ground level to conform with ADA guidelines to raise fire to proper height. Fill also protects hard surfaces from heat damage.
 - Unit is provided with three 1/2" dia. anchor pins for concrete embedment (indicated by "/PA" in model no., e.g. FSW-30/18/PA/H).
 - Entire unit is finished in high temperature, heat resistant, nontoxic black enamel paint.
 - Firering is provided with an 8" high heat shield constructed from 10 ga. steel welded on to new firerings. Heat shield provides a 7/8" cooling air gap around the area of the firering exposed to the fire (indicated by "/H" in model no., e.g. FSW-30/18/PA/H).
 - **Optional:** Firering is provided with a 3/16" x 7-1/8" x 9-5/8" steel plate utility shelf. (Add "/S" to model no., e.g. FSW-30/18/PA/S.)
- Note: The optional utility shelf fits both firering and optional heat shield. (When ordering both options, add "/H/S" to model no., e.g. FSW-30/18/PA/H/S.)

AVAILABLE OPTIONS

Utility Shelf

RJ Thomas Mfg. Co., Inc.

PO Box 946 • Cherokee, IA 51012-0946 • PH: 712-225-5115 • 800-762-5002 • FAX: 712-225-5796

E-mail: pilotrock@rjthomas.com • Web Site: <http://www.pilotrock.com>

© 2017 RJ Thomas Mfg. Co., Inc. PILOT ROCK® Park Products is a registered trademark of RJ Thomas Mfg. Co., Inc.

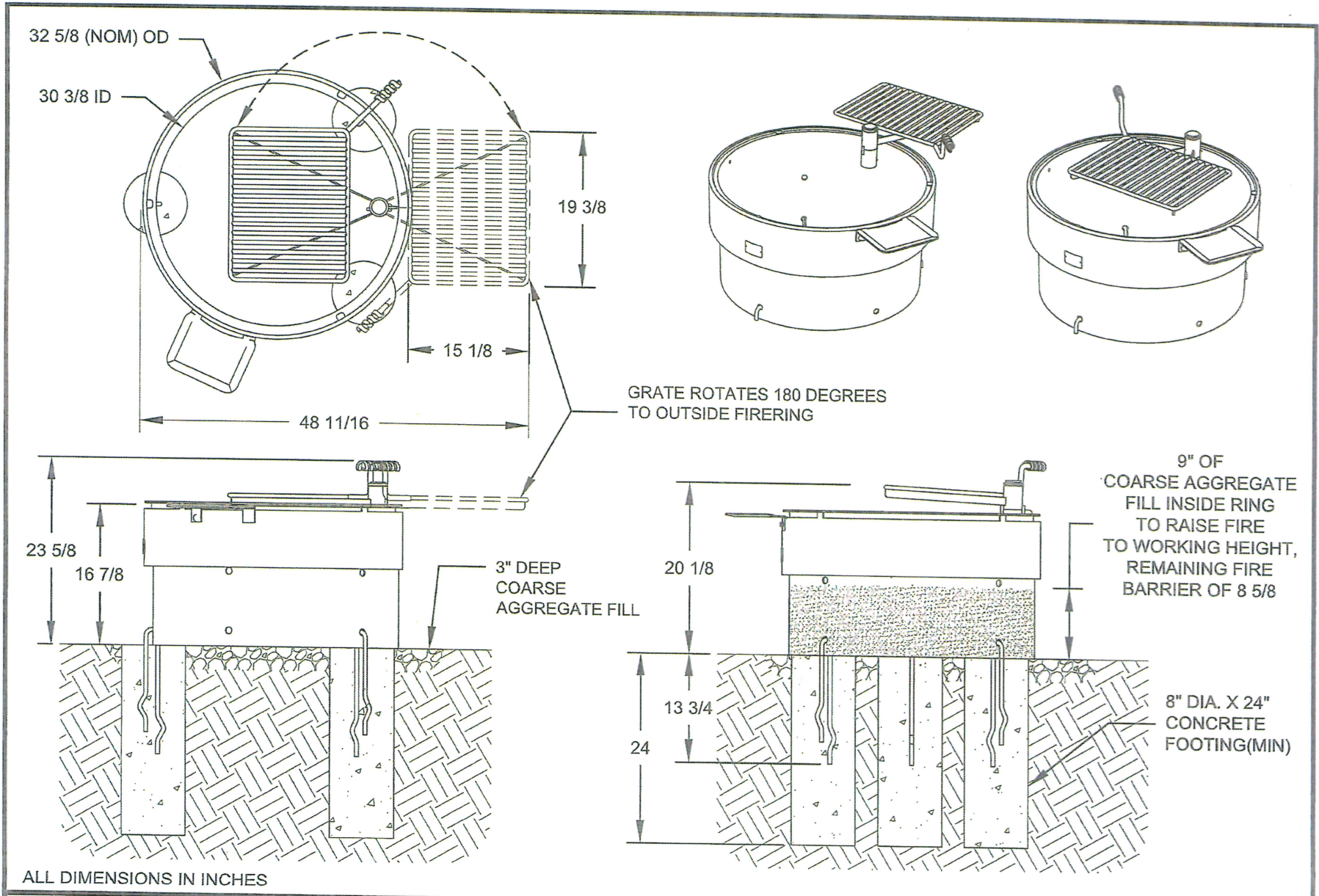

RJ Thomas Mfg. Co., Inc.
 P.O. Box 946 • Cherokee, IA 51012-0946

DRAWN BY
WWM

TITLE FSW SERIES MODEL FSW-30/18/PA/H/S ACCESSIBLE SWIVEL GRATE FIRERING
 WITH PIN ANCHORS AND HEAT SHIELD - SHOWN WITH OPTIONAL UTILITY SHELF

DATE 6-02-10
 DWG. NO. AI-1947

Specification Bulletin SPC-FR-037



975 S. State Hwy 89
 Logan, UT 84321
 435-245-5055
 www.gwpark.com

06/08/2020
 Quote #101138-01-01

Laurel Campground ADA Fire Rings

Laurel Parks Dept
 Attn: Kurt Markegard
 115 West First
 Laurel, MT 59044
 kmarkegard@laurel.mt.gov

Ship to Zip 59044

Quantity	Part #	Description	Unit Price	Amount
25	P600H	UltraSite - 18" HIGH FIRE RING W/ GRATE- (230 SQUARE INCHES) - PC RING	\$375.00	\$9,375.00
			Sub Total	\$9,375.00
			Freight	\$1,570.00
			Total	\$10,945.00

Comments

Shipping to Site Address:
 115 W 1st Street
 Laurel, MT 59044

*Freight charges are based on listed zip code and are subject to change, if shipping information changes.

Customer is responsible for offloading.

TERMS & CONDITIONS:

- **PRICING:** Prices are firm for 30 days unless otherwise noted. Request updated pricing when purchasing from quotes more than 30 days old.
- **PAYMENT TERMS:** Net 30 days subject to approval by Credit Manager. A signed P.O. made out to Great Western Recreation or this signed quotation is required for all orders unless otherwise noted. Equipment shall be invoiced separately from other services and shall be payable in advance of those services and project completion. Checks should be made payable to Great Western unless otherwise directed.
- **FINANCE CHARGE:** A 1.5% monthly finance charge (or as permitted by law) will be added to invoices over 30 days past due.
- **TAXES:** Taxes will be shown as a separate line item when included. Any applicable taxes not shown will be added to final invoice. A copy of your tax exemption certificate must be submitted at time of order or taxes will be added to your invoice.
- **SHIPMENT:** Multiple shipments may be required based on point of origin. Above costs assume one shipment for each vendor quoted.
- **LEAD TIME:** Standard orders shipped 4 weeks after receipt of order and acceptance of your purchase order, color selections, approved submittals (if required) unless otherwise noted. Custom equipment and shades may require a longer lead times. Surfacing lead time is approximately 2 weeks after scheduling request.
- **DELIVERY:** It is the responsibility of the owner to offload and inventory equipment, unless other arrangements have been made. Missing or damaged equipment must be reported within 60 days of acceptance of delivery.

SUPPLY ONLY:

- All items are quoted supply only.
- Installation services are not included.
- Customer is responsible for coordinating delivery, receipt, unloading, and inventory equipment.
- Missing or damaged equipment must be reported within 60 days of delivery.



975 S. State Hwy 89
Logan, UT 84321
435-245-5055
www.gwpark.com

06/08/2020
Quote #101138-01-01

Laurel Campground ADA Fire Rings

ACCEPTANCE OF QUOTATION:

Acceptance of this proposal indicates your agreement to the terms and conditions stated herein.

Accepted By (printed): _____ Title: _____

Telephone: _____ Fax: _____

P.O. Number: _____ Date: _____

Purchase Amount: **\$10,945.00**

SALES TAX EXEMPTION CERTIFICATE #: _____ FEIN# _____

(PLEASE PROVIDE A COPY OF CERTIFICATE)

Salesperson's Signature

Customer Signature



975 S. State Hwy 89
Logan, UT 84321
435-245-5055
www.gwpark.com

06/08/2020
Quote #101138-01-01

Laurel Campground ADA Fire Rings

Customer Order Info:

BILLING INFORMATION:

Bill to: _____

Contact: _____

Address: _____

Address: _____

City, State: _____ Zip: _____

Tel: _____ Fax: _____

E-mail: _____

SHIPPING INFORMATION (IF DIFFERENT FROM ABOVE):

Ship to: _____

Contact: _____

Address: _____

Address: _____

City, State: _____ Zip: _____

Tel: _____ Fax: _____

E-mail: _____



A PLAYCORE Company

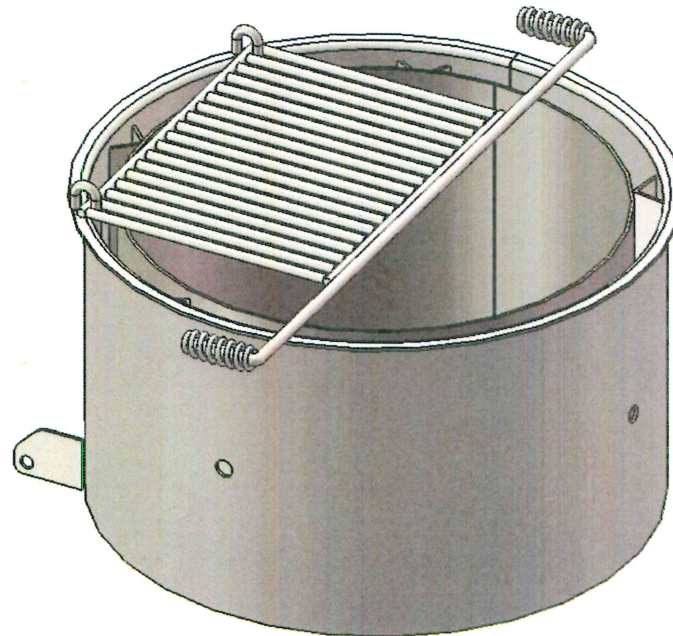

Model # 600H-D



A PLAYCORE Company

1675 Locust Street
Red Bud, IL 62278
Phone: 618-282-8200
Fax: 618-282-8202

WARRANTY & TERMS

WARRANTY: 5 Year Limited Warranty on Thermoplastic coated elements. Ultra Play guarantees all items for one full year to be free of defects in workmanship or materials when installed and maintained properly. We agree to repair or replace, any items determined to be defective. Items specifically not covered by this warranty include vandalism, man made or natural disasters, lack of maintenance, normal weathering or wear and tear due to public abuse.

Damages or loss in transit is the responsibility of the carrier, whether visible or concealed. It is the responsibility of the recipient to assure that the order is received complete. Before signing the delivery receipt, inspect the shipment immediately and completely. Note any damages or shortages on the bill of lading. Damage reports must be filed within 10 days. Ultra Play is NOT responsible for damages or loss in transit. Title to all goods passes to the customer at the time of shipment. Ultra Play will assist in filing claims if the freight arrangements were made by Ultra Play at your request.

CANCELLATIONS AND RETURNS: Cancellations are only accepted with approval of Ultra Play. No merchandise shall be returned without a Return Goods Authorization number which is issued by customer service. Any authorized merchandise must be carefully packed and received in saleable condition. A restocking charge of up to 25% will be applied to all returned goods when the error is not the fault of Ultra Play. All returns must be shipped freight prepaid.

WARNING: Combustion byproducts produced when using this product include carbon monoxide, a chemical known to the State of California to cause birth defects or other reproductive harm.



A PLAYCORE Company

SAFETY WARNINGS & EQUIPMENT INSPECTION

- Owners and installers please note these safety warnings and make use of this checklist on a regular basis.
- Follow installation instructions when erecting equipment.
- Ground surfaces around equipment should be restored as needed. Concrete footings should never be exposed. Surface depth should comply with ASTM and CPSC specifications.
- Check for and repair damage caused by wear or vandalism, a major factor in injury causing situations.
- All protruding bolts should be covered or cut off and finished smooth. Sharp edges on pipes should be capped or removed. Check for bent, broken, or severely worn pipe, and replace.
- All equipment should be free of rust and repainted whenever necessary to deter rusting.
- We provide our customers with layout sheets and installation instructions. Please keep on file the specifications sheet that contains the listing of every part used.
- Never add components not intended for use with this product.
- Regular maintenance is necessary in this and all park and recreational equipment to insure the safety of the user.
- Note: Proper maintenance of equipment requires regular tightening of all bolts, nuts, and setscrews.
- Note: Regular checking of all parts, castings, etc. should be made. If a part is broken or worn, it should be replaced immediately.
- Check to be sure all fittings are tight and that bars and pipes do not move.
- Replace all worn S-hooks. S-hooks must be completely closed. Failure to close S-hooks can result in serious injury to the user. NEVER reuse S-hooks.
- Test for free movement of swing hanger and other moving attached parts.
- Check for worn chains and replace them.
- A soft resilient surface should be placed under all swings extending at least twice the height of the top rail both front and back.

ULTRA SITE PRODUCT SPECIFICATIONS

600H-D Fire Ring

Grill shall be fabricated from 7 gauge steel plate forming a 30" diameter. Ring shall be constructed of 18" high with a 1" formed lip, joined in rear by an electrically welded seam. The inner ring shall be formed from an 11 gauge steel sheet. The wall spacing will be provided by three full lengths of 2" x 2" steel angle. Grill shall be secured permanently in ground by means of two 1/2" steel "u" staple anchor pins. Total cooking area shall be 300 sq. Cooking inches. For safety, non-conductive cool-coil handles shall be welded to the 5/8" dia. Grate handles thus providing a safe & easy transition of grate on and off of fire. Grill assembly shall have a finish of electrostatically applied high heat powder coat black paint.

OVERALL DIMENSIONS

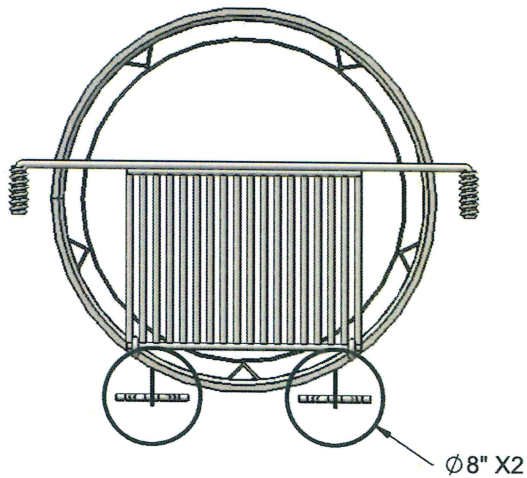

Estimated Required Concrete:
3 - 50lb Bags of Concrete Mix

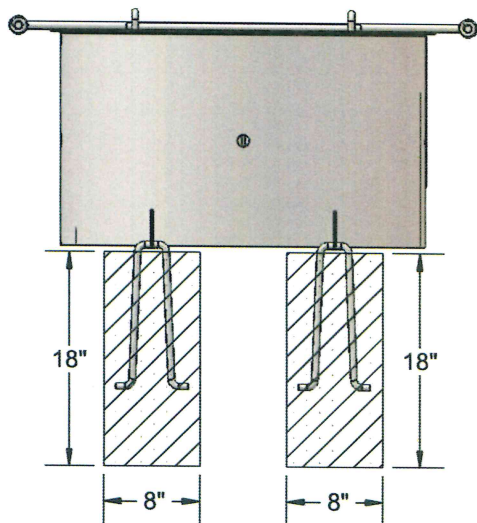

Attach the ground staples to the Fire Ring
before inserting them into the concrete footings.

Ground Staples are included.

Be sure to leave enough space between the footings and the
fire ring so that it can be flipped up for cleaning purposes.

OVERALL DIMENSIONS

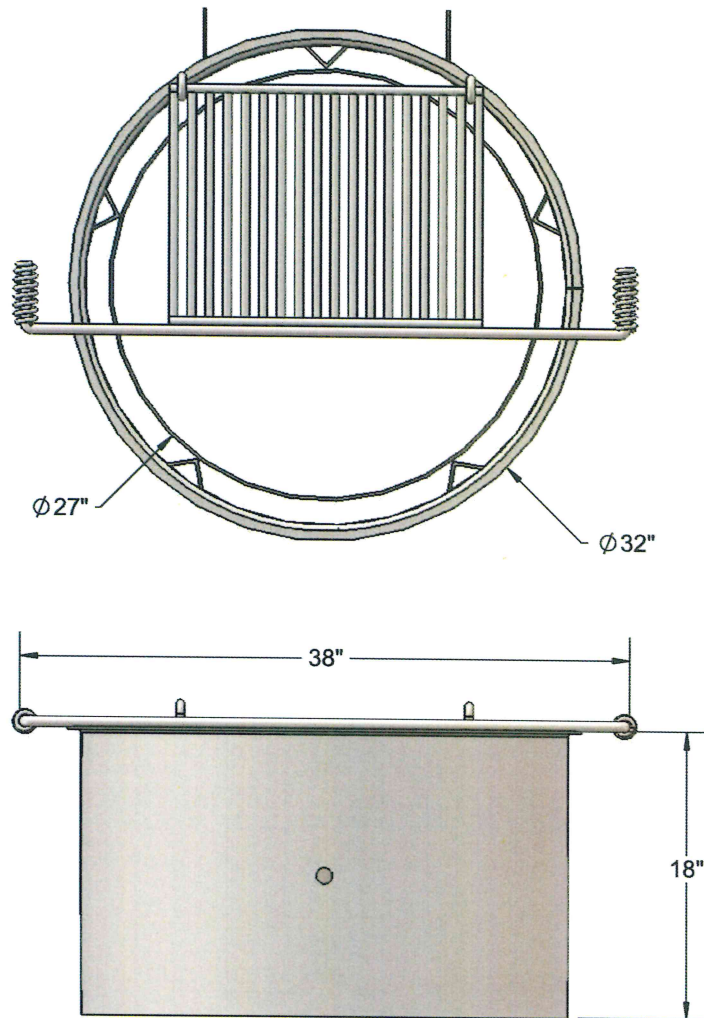

WARNING: Combustion byproducts produced when using this product include carbon monoxide, a chemical known to the State of California to cause birth defects or other reproductive harm.

0372

FOR CITY USE ONLY—THIS IS NOT A PURCHASE ORDER

PURCHASE REQUISITION

CITY OF LAUREL MONTANA 59044

Date: 6-9-2020
 Fund: Riverside Park Improvements
 Dept.: P.W.

VENDOR: Pibt Rock
PO Box 946
Cherokee, IA 51012

VENDOR NO.: _____

Quantity	Fully Itemize	Est. Cost	Account Number
25	Fire ring	400 ⁰⁵	cash Riverside Park Campground
Total estimated cost		10,001	25

CITY HALL
115 W. 1ST ST.
PUB. WORKS: 628-7496
WATER OFC.: 628-7431
COURT: 628-1964
FAX 628-2241

City Of Laurel

P.O. Box 10
Laurel, Montana 59044



RECOMENDATION

TO: Budget and Finance Committee
FROM: Kurt Markegard, Director of Public Works
Cc: Thomas C. Nelson, Mayor
Matt Wheeler, Public Works Superintendent
Bethany Langve, City Clerk Treasure
SUBJECT: Purchase of Picnic Tables for Riverside Park
Campground

DATE: June 9, 2020

A handwritten signature in purple ink, which appears to be "Kurt Markegard", is written over the "FROM:" line of the recommendation.

The Public Works Department is requesting to purchase 25 picnic tables from Pilot Rock/RJ Thomas Mfg. Co. I received three quotes and Pilot Rock submitted the lowest quote for the ADA compliant picnic tables for a total of \$19,280.00.

KLJ Engineering recommended the City purchase the tables on our own to avoid the contractor marking up the prices if we included it in the bid for the campground improvements.



Model UTH/G-6RR/E, 6 ft., Heavy Duty Wheelchair Accessible Portable Table, extended 2 ft. one end, with hot dip galvanized frames and red R-Type thermo-plastic coated perforated steel top and seats

- **ADA compliant wheelchair accessibility at one end**
- **Nontip, nontrip walk-through design**
- **All welded end frames are fabricated from 1.66" diameter steel pipe**
- **Diagonal braces align and strengthen entire table**
- **Frames are hot dip galvanized after fabrication for superior corrosion resistance**
- **Thermo-plastic Coating heat fused to Perforated Steel Top and Seats for durability**
- **Thermo-plastic Coating formulated with U.V. stabilizers for ultraviolet protection**
- **Limited lifetime warranty on frames**

AVAILABLE OPTIONS

- **Powder Coat Finish in choice of colors for steel frame components**
- **Choice of colors of Thermo-plastic Coating**

SPECIFICATIONS:

- **UTH Series** end frames are one-piece welded construction, fabricated from 1.660" O.D. (1-5/8" O.D.) steel pipe to meet 1-1/4" nominal pipe size specifications with 2" x 2" x 1/8" die formed steel angle for attaching the seats and top. "Outriggers" are attached to the frame on the extended end of the table for added stability.
- Table frame design incorporates nontip, nontrip, walk-through design features. Bends are tightly formed to prevent tipping when weight is on one side.
- Table provides one wheelchair space at one end of table by extending the top 2 ft. creating a ADA recommended space of 30" wide, 19" deep, and 27" from ground to bottom of table top for knee space, and minimum 9" above ground extending a total of 24" deep for toe space. Indicated by "/E" at end of model no., e.g. UTH/G-6RW/E.
- A diagonal brace of 1-5/16" O.D. steel pipe and a die-formed steel channel is provided to support extended portions of table top.
- **Model UTH/G-6RW/E** has a nom. 8 ft. long top and 6 ft. long seats. Includes frame stabilizing outriggers.
- Frame design provides a nominal 30" of clearance from ground level to the underside of the table top and nominal seat top height of 21".
- Frames are supported by diagonal braces of 1-5/16" O.D. steel pipe.
- All fasteners are provided for assembly.
- **Standard:** All steel frame components are hot-dip galvanized after fabrication to ASTM-A123 to maintain an average zinc coating of 2.0 oz. per sq. ft. of surface area (indicated by "/G" in model no., e.g. UTH/G-6RW/E).
- **R-Type** table top (14 ga.) and seats (12 ga.) are each one-piece welded construction, fabricated from perforated steel, with 9/16" dia. holes in a 13/16" center to center in-line pattern, and 2" formed vertical edges on all sides and reinforced by a strap and angle substructure.
- **Standard:** All steel surfaces of the top and seats are covered with a thermo-plastic coating in a Brown color (indicated by "RW" in model no., e.g. UTH/G-6RW/E). The UV-stabilized thermo-plastic coating is applied in a multi step process of material preparation and finish application designed to permanently heat fuse and bond the finish to the steel. The thermo-plastic polyethylene finish is impact resistant, does not support mold or mildew, and the textured matte surface is less susceptible to marring and scuffing.
- **Optional:** All steel frame components have powder coat finish. See Specification Bulletin #SPC-CO-001.
- **Optional:** Color choices of Thermo-plastic coated steel components. For optional colors choices see Specification Bulletin #SPC-CO-001.

RJ Thomas Mfg. Co., Inc.

PO Box 946 • Cherokee, IA 51012-0946 • PH: 712-225-5115 • 800-762-5002 • FAX: 712-225-5796

E-mail: pilotrock@rjthomas.com • Web Site: <http://www.pilotrock.com>

© 2019 RJ Thomas Mfg. Co., Inc. PILOT ROCK® Park Products is a registered trademark of RJ Thomas Mfg. Co., Inc.

PRICE QUOTATION

RJThomas Mfg. Co., Inc.

P. O. Box 946 • Cherokee, IA 51012

712-225-5115 • 800-762-5002 • FAX: 712-225-5796

Web:
www.pilotrock.com

Pilot Rock
PARK • STREET • CAMP
SITE PRODUCTS

E-mail:
customerservice@rjthomas.com

123570

TO:

Laurel, City of
Att: Kurt Markegard
115 W 1st St

Laurel, City of
Att: Kurt Markegard
115 W 1st St
406-628-4796

QUOTATION DATE: June 05, 2020

QUOTATION NO: 70844

Laurel MT 59044

Laurel

MT 59044

QUOTATION BY: 1,060

TEL: Kurt Markegard,
406-628-4796

kmarkegard@laurel.mt.gov

FAX:

QTY	MODEL NO.	DESCRIPTION	UNIT PRICE	EXTENDED PRICE
25	UTH/G-6RW/E	TABLE UTH 1.66OD 6' WHLCHR ACC GLV EXT 2'@ 1 END BRN PRF-STL	771.20	19,280.00
1	FREIGHT DLVD	FREIGHT INCLUDED TO ZIP 59044 FOB DESTINATION	0.00	0.00

PLEASE NOTE: Any Changes to the above quoted Models, Quantities or Destination require a NEW QUOTE.

(Sales tax NOT INCLUDED unless otherwise stated.) (All models/units shipped knocked down - assembly required.)

NOTE: All quotations and agreements are contingent upon strikes, accidents, fires, availability of materials and all other causes beyond our control. Prices are based on costs and conditions existing on the date of quotation and are subject to change by the Seller before final acceptance.

Typographical and stenographic errors subject to correction. Purchaser assumes liability for patent and copyright infringement when goods are made to Purchaser's specifications. When quotation specifies material to be furnished by the Purchaser, ample allowances must be made for reasonable spoilage and material must be of suitable quality to facilitate efficient production.

Conditions not specifically stated herein shall be governed by established trade customs. Terms inconsistent with those stated which may appear on Purchaser's formal order will not be binding on the Seller.

SHIPPING WITHIN 35 DAYS ARO
SHIPPED KNOCKED DOWN
SOME ASSEMBLY IS REQUIRED
CUSTOMER TO UNLOAD

Quotation Total 19,280.00

CUSTOMER TO UNLOAD FREIGHT FROM TRUCK. SOME ASSEMBLY REQUIRED.

PRICES FIRM 30 DAYS. PAYMENT TERMS: NET 30 DAYS
ALL MAJOR CREDIT CARDS ACCEPTED

BY

Paul C. Smith

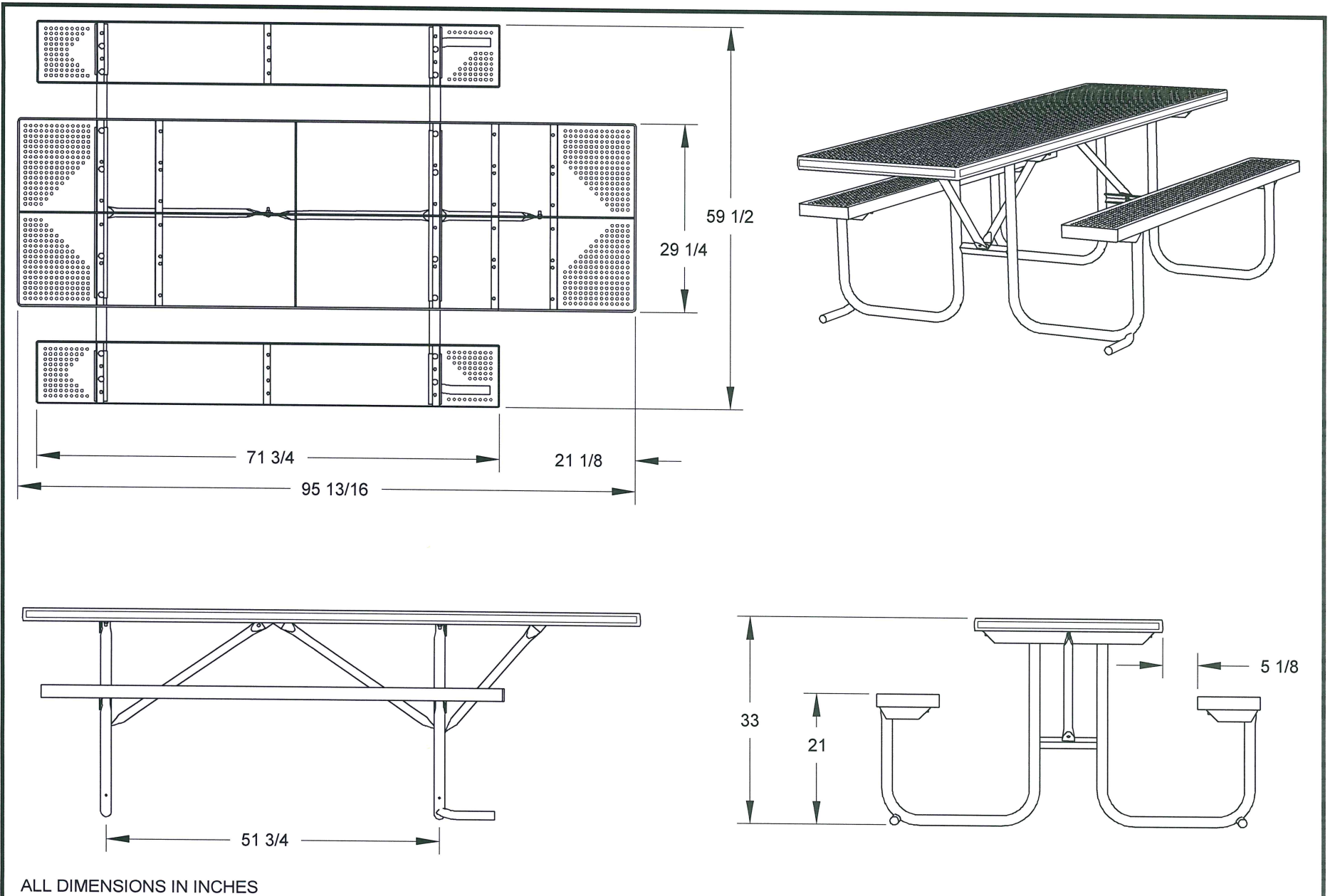

ALL DIMENSIONS IN INCHES

RJThomas Mfg. Co., Inc. P.O. Box 946 • Cherokee, IA 51012-0946	DRAWN BY WWM	TITLE UTH SERIES 6 FOOT RAISED TOP PORTABLE RECTANGULAR TABLE WITH TOP EXTENDED 2 FEET ON ONE END WITH R-TYPE THERMO-PLASTIC COATED PERFORATED STEEL TOP AND SEATS	DATE 3-18-10
			DWG. NO. AI-1830

Specification Bulletin SPC- TB-128

WARRANTY & ORDERING INFORMATION

PRODUCT WARRANTY

TERM	PRODUCT	OTHER INFORMATION	REQUIREMENTS	EXCLUSIONS
LIFETIME	Picnic Table Frames: UT, UTH, XT, XTH, WUT, WUTH, WXT, WXTH	Original Owner Only	All products must: 1) be assembled and installed according to manufacturer's specifications and instructions. 2) be properly maintained 3) not have been altered by the addition or deletion of parts, or modified in any other manner.	Vandalism. Damage caused by incorrect assembly, installation, application (use), or negligence. Natural or manmade disasters. Cosmetic changes due to weathering - including paint fading, discoloration of wood, or color fading or spotting of coated steel and recycled plastic products caused by exposure to natural elements or chemicals. Scratches, dents, or marring caused by normal use and public exposure. Seasons checks, twisting, or splintering of wood caused by climatic differences or lack of proper maintenance. Loss or damage in transit while product is responsibility of carrier. High heat paint subject to overly built fires. Steel warpage caused by fires of excessive size or duration Premature rust-through of grill boxes due to improper cleaning or maintenance, and fire rings buried in the ground. Premature rusting or discoloring caused by corrosive environment or while in ocean transit. Damage caused by animals or wildlife.
ONE YEAR	Powder Coat, Enamel, & High Heat Paints; Lumber; Trash & Recycling Lids & Liners; Plaques; Decals; Resin Fill; Umbrellas; Pet Waste Stations; FSW Swivel Grate	No Warranty on Lumber shipped outside the United States. Water Repellant recommended on Lumber.		
FIVE YEARS	Thermo-Plastic Coating	Limited and Prorated Warranty on coating material against defects when subjected to normal use and proper maintenance.		
	Picnic Table Frames (those not included in Lifetime Warranty), Park Bench Frames, Steel and Aluminum Bench and Table seat/top Structures, Recycled Plastic Components, Bike Racks, TRH and TRQ Frames, Steel Trash Receptacle and Planter Structures, Pedestal Mounts, Tissue Holders, all Grills, Hot Coal Bin, Utility Tables, Steel Campfire Rings, Lantern Holders, Table Mover, Food Lockers, Kolor Cans.	Recycled Plastic warranty applies only to components that have been cut, drilled, or routed by the manufacturer. This warranty does NOT cover plastic purchased in raw stock form by customer and cut, drilled, or routed by customer for custom application. Recycled Plastic and Thermo-Plastic coated components include a UV stabilizer to retard effects of natural exposure. We cannot warrant "fading" or surface "contamination" due to extreme variations in levels of exposure and in the definition of "fading".		
FIFTY YEARS	Recycled Plastic	Material decomposition only.		
Warranty claims must be filed within the warranty period and must include a copy of the invoice or the purchase order.				
Except as specifically stated herein, all warranties (expressed or implied) are hereby excluded. This Warranty excludes any liability, consequential damages, or related costs.				

ORDERING INFORMATION

Write Purchase Orders and Payments to: R. J. Thomas Mfg. Co., Inc. R. J. Thomas Mfg. Co., Inc. is a small business.

GSA Contracts are available for federal accounts. Contact Customer Service for Contract information.

PRICE: All prices are F.O.B. Cherokee, Iowa. Prices subject to change without notice. Quantity discounts and freight allowance available.

TERMS: Net due 30 days from date of invoice to those with established credit. First time orders and others: prepayment in full before shipment. Finance charges after 30 days. Payment by credit card is accepted using:



FREIGHT: Prepaid and added to the invoice, or third-party billed. Weights listed are approximate and do not include packaging. Shipment will be made by the quickest, most economical and practical means possible. Call for freight estimate. Most products are shipped unassembled to minimize shipping costs. Detailed assembly instructions are included with fasteners.

LEAD TIMES: We encourage you to order as early as possible. Our usual lead times run four weeks. Busy season lead times can reach to six to eight weeks. When you order early we can better arrange delivery to meet your needs.

SPECIFICATIONS: Specifications were in effect when printing this catalog. Since product improvements are always being made, we reserve the right to change designs, specifications and discontinue products without notice. Where changes have been made, revised products will be shipped unless specific arrangements have been made to the contrary.

ADDITIONAL INFORMATION: Contact us if you require additional information on product specifications, assembly, or installation. Spec Bulletins are available on our web site.

MODIFICATIONS: If a desired combination of features, materials, options, or accessories is not covered in this catalog, contact us and we will advise as to availability and price.

RETURN POLICY: No returns are accepted without prior approval. Call Customer Service for a Return Authorization (RA) number. Requests must be made within thirty days of receipt of product. No returns will be accepted after thirty days. Products must be returned in original packaging, must not be used or damaged, and must be in resalable condition. Returns may be subject to a restocking charge. Return freight must be prepaid.

ORDER CANCELLATION: Orders may be cancelled prior to shipment. Conditions will vary. Orders with custom plaques/engraving, etc. cannot be cancelled once we receive final design approval. Orders cancelled after shipment are subject to return freight charges and restocking fees.



Shopping Cart

[Continue Shopping](#)

SUMMARY

2 Items

Subtotal	\$23,692.50
Shipping (ABFS-Standard)	\$2,781.42
Order Total	\$26,473.92

TIMATE SHIPPING & TAX



★ REVIEWS

er your destination to get a shipping estimate.

te/Province

Montana

City

Laurel

Zip/Postal Code

59044

ABFS-Standard **\$2,781.42**

APPLY PROMOTION CODE



PROCEED TO CHECKOUT

[Save as Quote](#) | [Continue Shopping](#)



OPTIONS SELECTED



The City™ Series Rectangular ADA Picnic Tables

SKU# 1ZK6243

total: **\$21,971.25** Save 20% (7,099.85)

★ REVIEWS

25 +

Price Per Unit: \$878.85

 **EDIT**

 **REMOVE**



Picnic Table Frame Protectors – Fits 2-3/8" Frames – Set of 4

SKU# 1ZK6243 | Usually Ships In 1-2 Weeks

Subtotal: **\$1,721.25**

★ REVIEWS

25

+

Price Per Unit: \$68.85



EDIT



REMOVE

© 2019 Copyright TreeTop Products, All rights reserved.



Shopping Cart

[Continue Shopping](#)

SUMMARY

	1 Item
Subtotal	\$24,721.25
Shipping (ABFS-Standard)	\$2,699.12
Order Total	\$27,420.37

ESTIMATE SHIPPING & TAX



Enter your destination to get a shipping estimate.

State/Province

Montana

City

Laurel

Zip/Postal Code

59044

ABFS-Standard \$2,699.12

APPLY PROMOTION CODE



PROCEED TO CHECKOUT

[Save as Quote](#) | [Continue Shopping](#)



OPTIONS SELECTED



Comfort™ Series Rectangular Picnic Tables

SKU# 07JH3887-GN

Subtotal: \$24,721.25

-	25	+	Price Per Unit: \$988.85
---	----	---	--------------------------

 EDIT

 REMOVE

©2019 Barco Products Company, All rights reserved

FOR CITY USE ONLY—THIS IS NOT A PURCHASE ORDER

PURCHASE REQUISITION

CITY OF LAUREL MONTANA 59044

Date: 6-9-2020
Fund: Riverside Park
Dept.: PW.

VENDOR: Pilot Rack
P.O. Box 946
Carokee, IA 51012

VENDOR NO.:

Table with 4 columns: Quantity, Fully Itemize, Est. Cost, Account Number. Row 1: 25, 6' Tables, \$771.20, Riverside Park Campground. Row 2: Total estimated cost, \$19,280.