



**AGENDA
CITY OF LAUREL
CITY COUNCIL WORKSHOP
TUESDAY, JUNE 21, 2022
6:30 PM
COUNCIL CHAMBERS**

Public Input: *Citizens may address the Council regarding any item of City business that is not on tonight's agenda. The duration for an individual speaking under Public Input is limited to three minutes. While all comments are welcome, the Council will not take action on any item not on the agenda. If a citizen would like to speak or comment regarding an item that is on tonight's agenda, we ask that you wait until the agenda item is presented to the Council by the Mayor and the public is asked to comment by the Mayor. Once again, each speaker is limited to three minutes.*

Be advised, if a discussion item has an upcoming public hearing, we would request members of the public to reserve your comments until the public hearing. At the public hearing, the City Council will establish an official record that will include all of your comments, testimony and written evidence. The City Council will base its decision on the record created during the public hearing. Any comments provided tonight will not be included in the record or considered by the City Council.

General Items

Executive Review

1. Resolution - A Resolution Amending Resolution No. R21-132.

Council Issues

2. Fire Chief Discussion
3. Closed Executive Session

Other Items

Attendance at Upcoming Council Meeting

Announcements

The City makes reasonable accommodations for any known disability that may interfere with a person's ability to participate in this meeting. Persons needing accommodation must notify the City Clerk's Office to make needed arrangements. To make your request known, please call 406-628-7431, Ext. 2, or write to City Clerk, PO Box 10, Laurel, MT 59044, or present your request at City Hall, 115 West First Street, Laurel, Montana.

DATES TO REMEMBER

File Attachments for Item:

1. Resolution - A Resolution Amending Resolution No. R21-132.

RESOLUTION NO. R22-_____

A RESOLUTION AMENDING RESOLUTION R21-131 TO TRANSFER AGREEMENT WITH TITAN MACHINERY TO JOE JOHNSON EQUIPMENT AND APPROVING SURCHARGE FOR PURCHASE OF A NEW JET RODDER FOR THE CITY OF LAUREL’S PUBLIC WORKS DEPARTMENT.

WHEREAS, the City Council of the City of Laurel authorized the Mayor to sign an agreement with Titan Machinery for the purchase of a Jet Rodder for the City of Laurel’s Public Works Department on December 28, 2021 (hereinafter “the Agreement”);

WHEREAS, the authorization by City Council for the Mayor to execute the Agreement was made pursuant to Resolution R21-131;

WHEREAS, the original Agreement was with Titan Machinery, and Titan Machinery has since been purchased by Joe Johnson Equipment;

WHEREAS, Joe Johnson Equipment has accepted the original Agreement with the City of Laurel with a surcharge of \$6,375.00; and

WHEREAS, the City of Laurel currently possesses adequate funds to satisfy the surcharge and it is in the City of Laurel’s best interests to proceed with the Agreement with Joe Johnson Equipment.

NOW, THEREFORE, BE IT RESOLVED by the City Council of the City of Laurel, Montana, that the City Council hereby amends Resolution R21-131 to allow the execution of the Agreement with Joe Johnson Equipment and hereby approves the surcharge of \$6,375.00 for the purchase of the Jet Rodder for the City of Laurel’s Public Works Department.

Introduced at a regular meeting of the City Council on the _____ day of June, 2022, by Council Member _____.

PASSED and APPROVED by the City Council of the City of Laurel the _____ day of June, 2022.

APPROVED by the Mayor the _____ day of June, 2022.

CITY OF LAUREL

Dave Waggoner, Mayor

ATTEST:

Kelly Strecker, Clerk-Treasurer

APPROVED AS TO FORM:

Michele L. Braukmann, Civil City Attorney



1.800.222.6803

jjeusa.com

info@jjeusa.com

62 LaGrange Avenue, Rochester NY 14613

4519 Old Charlotte Highway, Monroe NC 28110



Joe Johnson Equipment does not take these actions lightly and acknowledges the challenges that this represents for you, our valued customers. However, to maintain the high standards of product quality, support, and innovation that you expect from Joe Johnson Equipment and our suppliers, these actions are warranted.

JJE has also incurred tremendous price increases in componentry, outsourced contracting, and transportation costs. We as a company have made the decision not to pass these charges on to our customers.

These surcharges have impacted the following order that you currently have outstanding with JJE:

Type of Unit: VACTOR2100I PD	
Purchase Order Number: No PO#, Board Resolution letter to Titan	
Original Purchase Price: \$449,000.00	
Revised Purchase Price: \$455,375.00	
Summary of Increase due to Surcharges	
Description	Surcharge Amount
Chassis	\$2,000.00
Factory	\$4,375.00
Total:	\$6,375.00

Please acknowledge that these surcharges will be added to your final invoice upon delivery of your new equipment.

David Waggoner
Signature

6/13/22
Date

DAVID WAGGONER
Print Name

6/13/22
Title

Thank you for your understanding in these unprecedented times,

Respectfully,

Jason Hannah

Jason Hannah
Vice President, Sales

cc. Logan, Art



1.800.222.6803

jjeusa.com

info@jjeusa.com

62 LaGrange Avenue, Rochester NY 14613

4519 Old Charlotte Highway, Monroe NC 28110



LAUREL, CITY OF

June 7th, 2022

Subject: Material and Chassis Surcharges

As you may be aware our industry has experienced dramatic cost increases for all components that our manufacturers use in their production processes. Most of these cost increases have taken immediate effect, with little to no advanced notice and were not subject to negotiation.

All our suppliers made every attempt not to have these surcharges applied to units already on order. Unfortunately, the excessive cost increases they have assumed have become too much to absorb.

JJE has made every attempt to reduce these surcharges with every manufacturer on our customers behalf. We have physically met with dealers, body manufacturers and their corporate executives. Unfortunately to no avail. These surcharges are being applied to every customer and dealer industry wide.

These surcharges will be applied to all units not shipped and are listed as Joe Johnson Equipment's backlog. Exact amounts are outlined below. Surcharges vary by vendor and are detailed below. A confirmation letter confirming the surcharge will accompany this letter. **This surcharge amount will be applied to your unit order:**

Body Vendor	Surcharge per Unit (USD)	Effective Date
Vactor Sewer Cleaners	\$4,375.00	April 4 th , 2022
Truvac Excavators	\$4,375.00	April 4 th , 2022
Elgin Street Sweepers	\$3,125.00	April 4 th , 2022
Labrie/Leach/Wittke	Variable (steel)	January 1 st , 2022
Envirosight Inspection Cameras	10 – 13% (electrical)	May 1 st , 2022
Ring-O-Matic Trailers	5% increase + \$500.00 Energy Surcharge	May 16 th , 2022

Additionally, if a chassis is part of the order, we have incurred multiple chassis surcharges. They are as follows:

Chassis Vendor	Surcharge per Unit USD	Effective Date for Shipments
Kenworth – Medium Duty	\$3,500.00	April 1 st , 2022
Kenworth – Heavy Duty	\$5,000.00	April 1 st , 2022
Mack – Medium Duty 2022	\$750.00	September 17 th , 2021
Mack – Heavy Duty 2022	\$3,500.00	September 17 th , 2021
Mack – Medium Duty 2023	\$2,250.00	May 1 st , 2022
Mack – Heavy Duty 2023	\$7,500.00	May 1 st , 2022
Freightliner M2 / 114SD	\$2,900.00	December 13 th , 2021
	\$6,700.00	April 19 th , 2022
Western Star	\$4,500.00	December 13 th , 2021
	\$5,800.00	April 19 th , 2022

RESOLUTION NO. R21-131

**A RESOLUTION AWARDING THE BID AND AUTHORIZING THE
MAYOR TO SIGN AN AGREEMENT WITH TITAN MACHINERY FOR THE
PURCHASE OF A NEW JET RODDER FOR THE
CITY OF LAUREL'S PUBLIC WORKS DEPARTMENT.**

WHEREAS, the City of Laurel needs to trade in and replace its aging Jet Rodder for the Public Works Department; and

WHEREAS, the City of Laurel complied with its procurement policy and Montana Law by utilizing a competitive bid process to ensure the equipment purchased is in the best interest of the City in both quality and price; and

WHEREAS, Titan Machinery was the lowest qualified bidder and such bid is attached hereto and incorporated herein; and

WHEREAS, the lowest bid was for \$449,000, with an optional trade-in value for the existing equipment of \$125,000, for a purchase price of \$324,000;

NOW, THEREFORE, BE IT RESOLVED by the City Council of the City of Laurel, Montana, that the Mayor is authorized to sign an agreement with Titan Machinery for the purchase of the Jet Rodder pursuant to the terms and conditions contained in the attached bid for the purchase price of \$449,000 and \$324,000 if the City determines such existing equipment is surplus and appropriate to utilize for a trade-in for the purchase.

Introduced at a regular meeting of the City Council on December 28, 2021, by Council Member Wilke.

PASSED and APPROVED by the City Council of the City of Laurel this 28th day of December 2021.

APPROVED by the Mayor this 28th day of December 2021.

CITY OF LAUREL

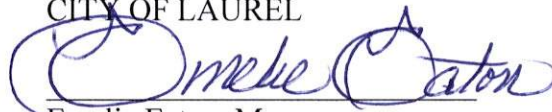
Emelie Eaton, Mayor

ATTEST:

Bethany Langve, Clerk-Treasurer

Approved as to form:

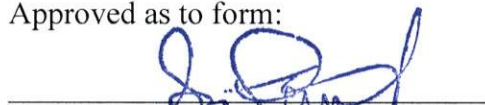
Sam S. Painter, Civil City Attorney

Handwritten signature or initials in blue ink.

CITY CLERK
CITY OF LAUREL
P. O. BOX 10
LAUREL, MONTANA 59044

CONTRACT/BID DOCUMENTS ATTACHED:

INTENT AND SCOPE OF OPERATIONS

CALL FOR SEALED BIDS: NOTICE TO BIDDERS

(BID BOND AND PERFORMANCE BOND)

INSTRUCTIONS TO BIDDERS

CONTRACT SPECIFICATIONS: 2022 (OR NEWER) SINGLE-ENGINE COMBINATION SEWER AND CATCH BASIN CLEANER WITH A POSITIVE DISPLACEMENT BLOWER VACUUM SYSTEM MOUNTED ON A HEAVY-DUTY CHASSIS WITH OPTIONAL TRADE-IN OF A 2012 VACTOR JET RODDER.

STANDARD TERMS AND CONDITIONS

INVITATION TO BID

FORM OF AGREEMENT

FORM OF PROPOSAL (BID PROPOSAL)

INTENT AND SCOPE OF OPERATIONS

This bid is for the purpose of entering into a contract for a **2022 (OR NEWER) SINGLE-ENGINE COMBINATION SEWER AND CATCH BASIN CLEANER WITH A POSITIVE DISPLACEMENT BLOWER VACUUM SYSTEM MOUNTED ON A HEAVY-DUTY CHASSIS** for the City of Laurel Maintenance Department. The successful bidder agrees to provide the City of Laurel with acceptable quality of equipment/services, performance and workmanship as determined by the City of Laurel.

It is the purpose of this bid to obtain the best quality of equipment at the most favorable price to the City of Laurel. Consideration will be given for the level of service offered and ability to meet stated specifications as outlined in the contract document.

END: INTENT AND SCOPE OF OPERATIONS

CITY CLERK
CITY OF LAUREL
P. O. BOX 10
LAUREL, MONTANA 59044

CALL FOR SEALED BIDS: NOTICE TO BIDDERS

SEALED BIDS ENTITLED: 2022 (OR NEWER) SINGLE-ENGINE COMBINATION SEWER AND CATCH BASIN CLEANER WITH A POSITIVE DISPLACEMENT BLOWER VACUUM SYSTEM MOUNTED ON A HEAVY-DUTY CHASSIS WITH OPTIONAL TRADE-IN OF A 2012 VACTOR JET RODDER.

For the City of Laurel Maintenance Department, Laurel, Montana will be received addressed to City Clerk of Laurel, Montana, at the office of the City Clerk, City Hall, Laurel, Montana 59044, until 1:00 PM, December 2nd, 2021.

More specific additional information regarding the **2022 (OR NEWER) SINGLE-ENGINE COMBINATION SEWER AND CATCH BASIN CLEANER WITH A POSITIVE DISPLACEMENT BLOWER VACUUM SYSTEM MOUNTED ON A HEAVY DUTY CHASSIS WITH OPTIONAL TRADE-IN OF A 2012 VACTOR JET RODDER** may be obtained by contacting Matt Wheeler, Maintenance Supervisor, at 115 W. First Street, Laurel, Montana, or by calling 406-628-4796.

Each bid or proposal must be accompanied by a Certified Check, Cashiers Check, or Bid Bond payable to the City of Laurel, Montana, in an amount not less than ten per cent (10%) of the total amount of the bid. The bid bond will be retained by the City Clerk until the successful bidder enters into a contract with the City of Laurel. If the successful bidder enters into no contract within 30 days the bond will be forfeited to the City of Laurel. Bid bonds will be returned to the unsuccessful bidders immediately after final action on the bid by the City Council.

No bids may be withdrawn after the scheduled time for the public opening of bids, which is 1:00 PM, December 2nd, 2021.

The right is reserved to reject any or all proposals received, to waive irregularities, to postpone the award of the contract for a period of not to exceed thirty (30) days, and to accept that proposal which is in the best interests of the City of Laurel, Montana.

The City of Laurel is an Equal Opportunity Employer

Published 11/19/2021; 11/26/2021

Bethany Langve, City Clerk

END: CALL FOR SEALED BIDS: NOTICE TO BIDDERS

CITY CLERK
CITY OF LAUREL
P. O. BOX 10
LAUREL, MONTANA 59044

INSTRUCTIONS TO BIDDERS

EXAMINATION OF DOCUMENTS

Before submitting the proposals, the bidder shall:

- (a) Carefully examine the Standards and Specifications as well as all other attached documents.
- (b) Fully inform themselves of the existing conditions and limitations.
- (c) Include with the bid sufficient information to cover all items required in the specifications.

BID COMPLIANCE

It shall be the responsibility of the bidder to see that all bids are sealed and submitted to the office of the City Clerk at City Hall, 115 W. First Street, Laurel, Montana 59044, before 1:00 PM, December 2nd, 2021.

BID PROPOSAL MODIFICATIONS

Proposals shall be made on form provided herein; they shall not contain any recapulation of the work done. Modifications, additions or changes to the terms and conditions of this invitation to bid may be cause for rejection of the bid. Bids submitted on other forms may be rejected. No oral, telephone, or telegraphic bids or modifications will be considered.

CERTIFICATION OF ALTERATION OR ERASURE

A bid shall be rejected should it contain any material alteration or erasure, unless, before the bid is submitted, each such alteration has been initialed in INK by the authorized agent signing the bid.

INTERPRETATION PRIORITY

Should a bidder find discrepancies in, or omissions from, the specifications, or be in doubt as to their meaning, bidder shall notify the department head, Matt Wheeler at the address noted above, who will send written instructions or addenda to all bidders. The City will not be responsible for oral interpretation. All addenda issued prior to bid opening shall be incorporated into and become part of the contract agreement upon award. Question received less than ninety-six (96) hours before the bid opening cannot be answered.

SIGNATURE

All bids shall be typewritten or prepared in ink and must be signed in longhand by the bidder or bidders agent or designee, with his/hers usual signature. A bid submitted by a partnership must be signed with the partnership name to be followed by the signature and designation of the partner signing. Bids by corporations must be signed with the legal name of the corporation, followed by the name and signature of an authorized agent or officer of the corporation. Bids submitted by a proprietorship must be signed by the owner; name of each person signing shall be typed or printed legibly below the signature.

WITHDRAWAL OF BIDS

Bidders may withdraw their bid either personally or by written request at any time prior to the time set for bid opening. No bid may be withdrawn or modified after the time set for opening, unless and until award of the contract is delayed for a period exceeding thirty (30) days.

CERTIFICATION

The bidder certifies that the bid has been arrived at by the bidder independently and has been submitted without any collusion designed to limit independent bidding or competition. The bidder further certifies that the materials, products, services and/or goods offered herein meet all requirements of the stated specification and are equal in quality, value and performance with highest quality, nationally advertised brand and/or trade names.

EVIDENCE OF QUALIFICATION

Upon request of the City of Laurel, a bidder whose proposal is under consideration for award may be required to manifest satisfactory evidence of his financial resources, experience, the organization and equipment as well as service provisions bidder has available. In determining the lowest responsible bidder, in addition to price, the following considerations may be addressed:

- (a) The ability, capacity, character, integrity, and skill of the bidder to perform the contract or provide the service required.
- (b) Whether the bidder can perform the contract within the time specified.
- (c) The quality of performance of previous contracts, agreements, services and/or performance.
- (d) Previous and/or existing compliance by the bidder with laws relating to the contract or services.
- (e) Such other information, which may be secured having a bearing on the decision to award the contract.

BID BOND

Each bid or proposal must be accompanied by a Certified Check, Cashiers Check, or Bid Bond payable to the City of Laurel, Montana, in an amount not less than ten percent (10%) of the total amount of the bid. The bid bond will be retained by the City Clerk until successful bidder enters into a contract with the City of Laurel. If the successful bidder enters into no contract within thirty (30) days the bond will be forfeited to the City of Laurel. Bid bonds will be returned to the unsuccessful bidders immediately after final action on the bid by the City Council.

CITY CLERK
CITY OF LAUREL
P. O. BOX 10
LAUREL, MONTANA 59044

**CITY OF LAUREL
DETAILED SPECIFICATIONS**

**2022 (OR NEWER) SINGLE-ENGINE COMBINATION SEWER AND CATCH BASIN
CLEANER WITH A POSITIVE DISPLACEMENT BLOWER VACUUM SYSTEM
MOUNTED ON A HEAVY DUTY CHASSIS WITH OPTIONAL TRADE-IN OF A 2012
VACTOR JET RODDER**

**Model Profile
2022 7500 SBA 6X4 (SF637)**

MISSION: Requested GVWR: 66000. Calc. GVWR: 66000
DIMENSION: Wheelbase: 260.00, CA: 192.90, Axle to Frame: 71.00
ENGINE, DIESEL: {MaxxForce 10} EPA 10, 350 HP @ 2000 RPM, 1150 lb-ft Torque
@ 1200 RPM, 2200 RPM Governed Speed
TRANSMISSION, AUTOMATIC:
{Allison 3000_RDS_P} 4th Generation Controls; Close Ratio, 6-
Speed, With Double Overdrive; On/Off Hwy; Includes Oil Level
Sensor, With PTO Provision, Less Retarder, With 80,000-lb GVW & GCW
Max.
CLUTCH: Omit Item (Clutch & Control)
AXLE, FRONT NON-DRIVING:
{Meritor MFS-20-133A} Wide Track, I-Beam Type, 20,000-lb
Capacity
AXLE, REAR, TANDEM:
{Meritor RT-46-160P} Single Reduction 46,000-lb Capacity With
Lube Pump and 200 Wheel Ends Gear Ratio: 6.14
CAB: Conventional
TIRE, FRONT: (2) 425/65R22.5 HTC (CONTINENTAL) 468 rev/mile, load range
L, 20 ply
TIRE, REAR: (8) 11R22.5 HDR1 (CONTINENTAL) 495 rev/mile, load range G,
14 ply
SUSPENSION, REAR, TANDEM:
{Hendrickson RT-463} Walking Beam Type 54" Axle Spacing;
46,000-lb Capacity With Bronze Center Bushings
FRAME REINFORCEMENT:
Outer "C" Channel, Heat Treated Alloy Steel (120,000 PSI Yield);
10.813" x 3.892" x 0.312"; (274.6mm x 98.9mm x 8.0mm); 480.0"
(12192mm) Maximum OAL
PAINT: Cab schematic 100GN Location 1: 9219, Winter White (Std)
Chassis schematic N/A

GENERAL BIDDING GUIDELINES:

If bid specification is met than place a check in the column marked "YES". If it is necessary to bid alternate equipment or to take exceptions to the specifications as set forth, this must be checked as "NO".

The Basis of Award shall be dependent on the most responsible bid submitted. Consideration will be given to cash flow, purchase price, delivery dates, equipment service guarantees, parts and service availability, parts and service location, analyses and comparison of equipment specification details, and any other items of concern to the City of Laurel.

The purchaser reserves the right to reject any or all bids, to waive any informality in bids, or to accept in whole or part such a bid as may be in the best interest of the City of Laurel.

The purchaser also reserves the right to reject the vehicle at the time of final inspection if the vehicle does not meet any and/or all requirements of the final contract according to the personnel acting on behalf of the department at the time of final inspection. These requirements include, but are not limited to: performance, workmanship, service, quality and operation of the vehicle.

Please state the estimated delivery time after receipt of order in days: 120 days after chassis arrives

Description	Yes	No
Base Chassis, Model 7500 SBA 6X4 with 260.00 Wheelbase, 192.90 CA, and 71.00 Axle to Frame.		X
FRAME RAILS Heat Treated Alloy Steel (120,000 PSI Yield); 10.125" x 3.580" x 0.312" (257.2mm x 90.9mm x 8.0mm); 480.0" (12192) Maximum OAL	X	
FRAME REINFORCEMENT Outer "C" Channel, Heat Treated Alloy Steel (120,000 PSI Yield); 10/813" X 2.892" X 0.312"; (274.6mm X 98.9mm X 8.0mm); 480.0" (12192mm) Maximum OAL	X	
BUMPER, FRONT Omit Item	X	
SPECIAL FRAME PIERCING Additional Holes for Vactor Guzzler Manufacturing Co. 2100 Plus Product	X	
WHEELBASE RANGE 221" (560cm) Through and Including 262" (665cm)	X	
FRAME ADDITION, FRONT 1" Integral; Increases BBC, BA and OAL Vehicle Dimensions By 1"	X	
AXLE, FRONT NON-DRIVING {Meritor MFS-20-133A} Wide Track, I-Beam Type, 20,000-lb Capacity	X	
SUSPENSION, FRONT, SPRING Multileaf, Shackle Type, Single Stage Spring; 20,000- lb Capacity; Less Shock Absorbers.	X	
BRAKE SYSTEM, AIR Dual System for Straight Truck Applications	X	
BRAKES, FRONT, AIR CAM 16.5" x 6", Includes 24 SqIn Long Stroke Brake Chambers	X	

DRAIN VALVE {Berg} Manual; With Pull Chain, for Air Tank	X	
AIR BRAKE ABS {Bendix AntiLock Brake System} Full Vehicle Wheel Control System (4-Channel)	X	
AIR DRYER {Meritor Wabco System Saver 1200} with Heater	X	
BRAKE CHAMBERS, FRONT AXLE {Haldex} 24 SqIn	X	
BRAKE CHAMBERS, REAR AXLE {Haldex GC3030LHDHO} 30/30 Spring Brake	X	
BRAKES, REAR, AIR CAM S-Cam; 16.5" x 7.0"; Includes 30/30 Sq.In. Long Stroke Brake	X	
Chamber and Spring Actuated Parking Brake	X	
AIR COMPRESSOR {Bendix Tu-Flo 550} 13.2 CFM Capacity	X	
STEERING COLUMN Tilting	X	
STEERING WHEEL 2-Spoke, 18" Diam., Black	X	

Exception: 2023 IH HUG07 chassis, same spec as Model 7500 SBA 6x4

Description	Yes	No
STEERING GEAR (2) {Sheppard M-100/M-80} Dual Power	X	
DRIVESHAFT Special for Vactor Guzzler 2100 Plus Product	X	
EXHAUST SYSTEM Single, Vertical, Aftertreatment Device Frame Mounted Left Side,	X	
Includes Vertical Tail Pipe & Guard	X	
RAIN CAP With Single Exhaust, Non-Bright Finish	X	
SWITCH, FOR EXHAUST 2 Position, Lighted & Latching, ON/OFF Type, Mounted in IP, Inhibits Diesel particulate filter regeneration as long as switch is in on position	X	
ELECTRICAL SYSTEM 12-Volt, Standard Equipment	X	
CIGAR LIGHTER Includes Ash Cup	X	
POWER SOURCE Cigar Type Receptacle without Plug and Cord	X	
BATTERY TERMINALS Sealed	X	
ALTERNATOR {Leece-Neville LBP2224H} Brush Type; 12 Volt 120 Amp. Capacity, Pad Mounted	X	
BODY BUILDER WIRING INSIDE CAB; Includes Sealed Connectors for Tail/Amber, Turn/Marker/Backup/Accessory, Power/Ground, and Stop/Turn	X	
BATTERY SYSTEM {International} Maintenance-Free (3) 12-Volt 2775CCA Total	X	

RADIO {International} AM/FM Stereo With CD Player, Weatherband, Clock, Auxiliary Input, includes Multiple Speakers	X	
BACK-UP ALARM Electric, 102 Db	X	
STOP, TURN, TAIL & B/U LIGHTS Omit Item; Does Not Omit Cable to End of Frame	X	
WIRING MODIFICATIONS for Transmission Powertrain Harness J1939, Terminating Resistor, Located near Air Cleaner	X	
BATTERY CABLES With 2 Auxiliary Sealed Battery Posts, 1 Positive and 1 Negative	X	
HORN, AIR Black, Single Trumpet, Air Solenoid Operated	X	
HEADLIGHTS Long Life Halogen; for Two Light System	X	
STARTING MOTOR {Delco Remy 39MT} 12 Volt; Gear Reduced, With Thermal Over-Crank Protection	X	
INDICATOR, LOW COOLANT LEVEL With Audible Alarm	X	
CIRCUIT BREAKERS Manual-Reset (Main Panel) SAE Type III With Trip Indicators, Replaces All Fuses Except For 5-Amp Fuses	X	

Description	Yes	No
FENDER EXTENSIONS Rubber	X	
GRILLE Stationary, Chrome	X	
FRONT END Tilting, Fiberglass, With Three Piece Construction; for 2007 Emissions	X	
PAINT SCHEMATIC, PT-1 Single Color, Design 100	X	
PAINT TYPE Base Coat/Clear Coat, 1-2 Tone	X	
CLUTCH Omit Item (Clutch & Control	X	
OIL FILTER, ENGINE {Hudgins Model 960 Spinner}	X	
BLOCK HEATER, ENGINE {Phillips} 120 Volt/1250 Watt	X	
1ENGINE, DIESEL {MaxxForce 10} EPA 10, 350 HP @ 2000 RPM, 1150 lb-ft Torque @ 1200 RPM, 2200 RPM Governed Speed	X	X
FAN DRIVE {Horton Drivemaster Polar Extreme} Direct Drive Type, Two Speed, With Residual Torque Device for Disengaged Fan Speed	X	
RADIATOR Aluminum, Front to Back Cross Flow, Series System; 1663 SqIn Core and 885SqIn Charge Air Cooler and 470 SqIn Low Temperature Radiator Down Flow	X	
FEDERAL EMISSIONS for 2010; MaxxForce 9 & 10 Engines	X	X
AIR CLEANER Dual Element	X	

THROTTLE, HAND CONTROL Engine Speed Control; Electronic, Stationary, Variable Speed; Mounted on Steering Wheel	Y	
ENGINE CONTROL, REMOTE MOUNTED Provision for; Includes Wiring for Body Builder Installation of PTO Controls; With Ignition Switch Control for MaxxForce post 2007 Emissions Electronic Engines	X	
FAN OVERRIDE Manual; With Electric Switch on Instrument Panel, (Fan On With Switch On)	X	
ENGINE WATER COOLER Auxiliary, Cooler Package for Vactor Guzzler, Includes One Additional Inlet Port on Engine Water Pump, Y Pipe in EGR Cooler and Shut-off Valves	X	
EMISSION COMPLIANCE 5 Min., Tamper-Proof Engine Shutdown System, Complies With California Clean Air Regulations, Does Not Certify Engine for Low-NOx Extended Idling	X	
TRANSMISSION, AUTOMATIC {Allison 3000_RDS_P} 4th Generation Controls; Close Ratio, 6-speed, With Double Overdrive; On/Off Hwy; Includes Oil Level Sensor, with PTO Provision, Less Retarder, with 80,000-lb. GVW & GCW Max.	X	Y

Exceptions: Engine: Cummins L9370 370 HP @ 2100 rpm.
~~Exemption~~ Emission federal 2020 not 2010
Transmission spec 5th Generation Controls

Description	Yes	No
OIL COOLER, AUTO TRANSMISSION {Modine} Water to Oil, for Allison Transmission	X	
TRANSMISSION SHIFT CONTROL {Allison} Push-Button Type; for Allison 3000 & 4000 Series Transmission.	X	
ALLISON SPARE INPUT/OUTPUT for Rugged Duty Series (RDS); Airport Refueler, Sewer Evac	X	
SHIFT CONTROL PARAMETERS Allison Performance Programming in Primary and Allison Economy Programming in Secondary	X	
AXLE, REAR, TANDEM {Meritor RT-46-160P} Single Reduction 46,000-lb Capacity With Lube Pump and 200 Wheel Ends. Gear Ratio: 6.14	X	
SUSPENSION, REAR, TANDEM {Hendrickson RT-463} Walking Beam Type 54" Axle Spacing; 46,000-lb Capacity With Bronze Center Bushings	X	
SUSPENSION/REAR-AXLE IDENTITY for Meritor Tandem Rear Axles With Bar-Pin Beam Attachment Type Suspensions	X	
FUEL TANK Top Draw; D Style, Non Polished Aluminum, 23" Deep, 100 U.S. Gal., 378L Capacity, with dual supply lines, mounted right side under cab.	X	X
CAB Conventional	X	

GAUGE CLUSTER English With English Electronic Speedometer	X	
GAUGE, OIL TEMP, ALLISON TRAN	X	
GAUGE, AIR CLEANER RESTRICTION {Filter-Minder} With Black Bezel Mounted in Instrument Panel	X	
IP CLUSTER DISPLAY On Board Diagnostics Display of Fault Codes in Gauge Cluster	X	
SEAT, DRIVER {National 2000} Air Suspension, High Back With Integral Headrest, Vinyl, Isolator, 1 Chamber Lumbar, With 2 Position Front Cushion Adjust, -3 to +14 Degree Angle Back Adjust	X	
SEAT, PASSENGER {Gra-Mag} Non Suspension, High Back, Fixed Back, Integral Headrest, Vinyl	X	
MIRROR, CONVEX, LOOK DOWN {Lang Mekra} Right Side; 6" x 10 1/4"	X	
MIRRORS (2) {Lang Mekra} Rectangular, 7.44" x 14.84" & 7.44" sq. Convex Both Sides, 102" Inside Spacing, Breakaway Type, Heated Heads Thermostatic Controlled Black Heads, Brackets and Arms.	X	
CAB MOUNTING HEIGHT EFFECTS High Cab in Lieu of Mid High Cab Mounting (4.5)	X	

Exceptions: fuel tank on left. same spec.

Description	Yes	No
ARM REST, RIGHT, DRIVER SEAT	X	
AIR CONDITIONER {Blend-Air} With Integral Heater & Defroster	X	
INSTRUMENT PANEL Center Section, Flat Panel	X	
HVAC FRESH AIR FILTER	X	
FRESH AIR FILTER Attached to Air Intake Cover on Cowl Tray in Front of Windshield Under Hood	X	
CAB INTERIOR TRIM Premium	X	
CAB REAR SUSPENSION Air Bag Type	X	
WHEELS, FRONT DISC; 22.5" Painted Steel, 10-Stud (285.75MM BC) Hub Piloted, 5 Hand Hole, Flanged Nut, Metric Mount, 12.25 DC Rims; With Steel Hubs, with 5.375" Offset	X	
WHEELS, REAR DUAL DISC; 22.5" Painted Steel, 2 Hand Hole, 10-Stud (285.75MM BC) Hub Piloted, Flanged Nut, Metric Mount, 8.25 DC Rims; With Steel Hubs	X	
(8) TIRE, REAR 11R22.5 HDR1 (CONTINENTAL) 495 rev/mile, load range G, 14 ply	X	
(2) TIRE, FRONT 425/65R22.5 HTC (CONTINENTAL) 468 rev/mile, load range L, 20 ply	X	

New Two-way radio to City of Laurel Specifications to be installed by Industrial Communications, Billings, Montana.	X	
Cab schematic 100GN	X	
Location 1: 9219, Winter White (Std)	X	
Chassis schematic N/A	X	
Services Section:		
40BKB SERVICES, TOWING To 36-Month/150,000 Miles (240,000 km), 5400 Hours; Service Call to the Vehicle or Towing to the Nearest International Dealership for a Non-Drivable Unit in Conjunction with an International Warrantable Failure; \$250 (USA) Maximum Benefit per Incident.	X	

City of Laurel
DETAILED SPECIFICATIONS
FOR
(1) COMBINATION DUAL ENGINE SEWER CLEANER
WITH AUXILIARY ENGINE DRIVEN CENTRIFUGAL FAN
MOUNTED ON A HEAVY DUTY TRUCK CHASSIS

	COMPLY	
	YES	NO
INTENT:		
This specification is not to be interpreted as restrictive, but rather as a measure of the safety, quality, performance and overall cost of ownership against which all equipment bid will be compared. In comparing proposals, consideration will be given to life cycle cost guarantees whereby bidder shall provide all pertinent information to evaluate long-term cost. Contract will be awarded for the product which best serves the interests of the City of Laurel considering long-term maintenance cost, parts availability, product support and service cost as well as guaranteed buyback value of bidders equipment. The City of Laurel reserves the right to reject any or all bids or any part thereof, and to waive any minor technicalities. Award shall be to the bidder showing most favorable life cycle costing while meeting the requirements of these specifications.	X	X
EQUIVALENT PRODUCT:		

Reference no place for Buy back numbers

Bids will be accepted for consideration on any make or model that is equal or superior to the equipment specified. Decisions of equivalency will be at the sole interpretation of the City of Laurel Purchasing and Public Services Director.	X	
Bidder shall demonstrate a reasonable likeness of the equipment being offered within a reasonable time of request. Equipment demonstrated shall be equipped with all accessories and components required in this specification to ascertain equivalence.	X	
A blanket statement that equipment proposed will meet all requirements will not be sufficient to establish equivalence. Original manufacturer's brochures of the proposed unit are to be submitted with the proposal.	X	
OPTIONAL TRADE IN:		
2000 Vac-Con Jett Rodder. Can be viewed at Laurel City Shops, located at 20 S. 7 th Avenue, Laurel, Montana Monday – Friday between the hours of 7:30 am and 3:00 pm.	X	
SERVICE AND SUPPORT:		
Location of warranty service center and amount of inventory shall be noted which may be verified and inspected. <u>1728 old Herlin Rd Billings MT 59101</u>	X	
Years of servicing equipment being bid: <u>20</u> Years	X	
Number of factory qualified service technician: <u>3</u>	X	
GENERAL:		
The specification herein states the minimum requirements of the City of Laurel. All bids must be regular in every respect. Unauthorized conditions, limitations, or provisions shall be cause for rejection. Any bid not prepared and submitted in accordance with the bid document and specification, or any bid lacking sufficient technical literature to enable the City of Laurel to make a reasonable determination of compliance to the specification will be considered "non-responsive" and grounds for rejection.	X	
SUB FRAME:		
The equipment shall be of modular design consisting of vacuum system, water tanks system, debris hopper and drive system.	X	
A sub frame shall be fabricated to the exact dimensions of the truck chassis for mounting of modular components.	X	
All components of the module shall attach to the sub frame and not directly to the chassis.	X	
Sub frame shall be designed to ASME standards for maximum applied loads, chassis frame movement and even distribution of weight to the chassis and suspension.	X	
Sub frame shall be continuous and uninterrupted from back of cab to end of frame.	X	

Exceptions:		
DEBRIS BODY:		
The body shall be cylindrical having a minimum usable liquid capacity of 10 cubic yards.	X	
The body shall be capable of a 48" dump height.	X	
The debris storage body shall be constructed with a minimum 3/16" corrosion and abrasion resistant Ex-Ten steel.	X	
The debris storage body shall have a minimum yield point of 50,000 PSI and a minimum tensile strength of 70,000 PSI.	X	
Body shall have a rear door that is hinged at the top and is equipped with a replaceable neoprene type seal. Adjustable for periodic compensation of door seal wear.	X	
Dual outward mounted rear door props shall be included as standard to prevent operator from entering door swing path when engaging rear door prop.	X	
For optimal particulate separation, vacuum shall be drawn from separate ports in the top of the debris body.	X	
Body shall be dumped by raising the body to a 50 degree angle utilizing forward mounted, double acting, hydraulic dump cylinder.	X	
Dump controls, accessory controls, e-stop control shall be provided at a central curb side location directly behind the cab.	X	
For stability and safety, dumping must be accomplished while the pivot point of the hopper remains fixed to the sub frame.	X	
Industrial style rear debris body door shall be flat, and shall open and close hydraulically by cylinders mounted at the top of the body. Door shall open 50 degrees from the fully closed position. Door shall be unlocked, opened, closed, and locked by a failsafe hydraulically activated sequential positive locking system, cam operated by a single hydraulic cylinder, with all controls located behind truck cab, forward of the debris body, so operator is not subject to debris when dumping.	X	
Debris body shall have a body flush out system with (8) jet tungsten-carbide tipped nozzles mounted on a manifold located in the front wall of the debris body to aid in the flushing of heavy debris. Control valve shall be on the curb side of the unit.	X	
Debris body load limit alarm coupled to float indicator arm automatically activating vacuum relief to be provided.	X	
Body shall have a float type automatic shut-off system protecting the Fan System with (2) 10" stainless steel shut-off balls located in the debris body. Each float ball housing shall be within a non-corrosive slide-out screen assembly and be accessed without the use of tools.	X	
The debris body shall be equipped with a 6" rear door drain to drain off excess liquids.	X	
The debris body shall be equipped with a rear door drain to drain off excess liquids while retaining solids and shall include a manually operated 6" knife valve with cam-lock coupler and 10' of lay flat hose having camlock quick connects.	X	

Pump off ports for installation of Pump-Off System shall be provided on curbside on forward portion of debris body.	X	
For safety, a minimum of (5) vacuum tubes shall be stored on curbside storage racks to minimize operator exposure to traffic side of unit.	X	
A curb-side folding 3-pipe rack shall be provided, constructed of steel tubing, spring assisted. Shall include quick release retainer handles (no bungees or clamps).	X	
(2) Pipe Storage Racks Curbside waist level and (2) on rear door with quick releases.	X	
A lubrication manifold system shall be provided to allow ground level greasing of boom lift and swing cylinders, float level indicator, top rear door hinges and debris body hoist cylinder pins.	X	
A 10" valve with 3" vent to atmosphere, electrically activated, air operated valve debris body vacuum relief system shall be located in the inlet of the vacuum system to allow the venting of the tank and relieve vacuum at the debris intake hose.	X	
A debris inlet deflector distributing load evenly in debris body shall be included.	X	
Exceptions:		
WATER TANKS:		
The water tanks shall be manufactured from a non-corrosive material to prevent rust yet still provide for maximum strength.	X	
The water tank material shall require no internal coating and shall be repairable if patching is required.	X	
The water tanks shall be easily removed from the subframe to provide complete access to the truck chassis for maintenance purposes.	X	
The water tanks shall be adequately vented and connected to provide complete filling.	X	
The water tanks shall be totally separate from the debris tanks and provide no structural support.	X	
The water tanks shall share no common walls with the debris tanks to prevent corrosion.	X	
The water tanks shall come equipped with an anti-siphon device and 25' of hydrant fill hose and fittings.	X	
The water tanks shall carry a 10 year warranty against corrosion or cracking.	X	
All water tanks shall be fully baffled to form maximum compartment storage of 150 gallons for each compartment. The City of Laurel has determined that for the stability of the vehicle when turning and stopping and for safety of personnel that systems baffled at 150 maximum gallon compartments are preferred. Exceptions of requirement shall be explained in detail accompanied with detailed engineering drawings.	X	
The water tank shall be located for the lowest possible center of gravity while providing 100% gravity flooded intakes to water pump.	X	
Fresh water shall enter the tanks through an in line 6" air gap, all aluminum covered anti-siphon device.	X	

Water level sight tubes of non-yellowing plastic shall be installed on both tanks.	X	
The sides of these water tanks shall not extend more than 48" out from the centerline of the truck chassis.	X	
A fresh water drain system shall be provided to completely drain the fresh water system from one location utilizing a 3" drain port and plug.	X	
A minimum 6" and 4" connection between tanks shall be provided.	X	
For stability safety, the water tanks shall not elevate with debris body during dump cycle.	X	
A low water alarm with light at the operator station shall alert operator when water storage has 150 gallons remaining.	X	
A hydraulic oil high temperature light and alarm shall be provided.	X	
2" Y-Strainer With 25' Fill Hose shall be provided.	X	
A 3" in-line "Y" trap Monel stainless steel strainer shall be located between the water cells and water pump.	X	
A 3" Gate Valve shall be provided at water pump.	X	
Water tank must be a certified metered capacity of 1200 gallons. Certification shall be necessary upon delivery.	X	
Water tanks shall be constructed of 1/8" aluminum with baffled compartments maximum 150 gallons each.	X	
An additional water tank sight gauge shall be provided.	X	
Liquid Float Level Indicator shall be provided.	X	
Exceptions:		
VACUUM/VACUUM DRIVE SYSTEM		
Vacuum shall be provided by compressing air within a two-stage 38" diameter centrifugal compressor.	N	A
Compressor fans to be constructed of non-corrosive material.	N	A
Each centrifugal compressor fan shall be constructed of non-corrosive, hardened 1/4" chrome blades.	N	A
Centrifugal compressor shall be warranted against corrosion for five years.	N	A
The outer housing shall be constructed of 1/4" spun steel.	N	A
Compressor housing shall be equipped with a drain not exceeding 2" diameter.	N	A
Complete compressor and housing assembly shall be warranted against materials and workmanship for five years.	N	A
Fan shall be powered by a 6-cylinder turbo charged 414 cu.in., 185 Hp @ 2400 rpm diesel engine (John Deere Model 6068-TF or equal) diesel engine.	N	A
Auxiliary engine gauge package including voltmeter, water temperature, oil pressure, tachometer, hour meter with ignition on/off and throttle controls at front operator station.	N	A
A fluid coupler drive system shall be provided including vacuum relief and controls at operator station.	N	A
Step-up transmission shall be gear-type having a ratio of 2.036 To 1.	N	X

~~SEE~~ See sheet 1A

For cleaning of drying beds, vacuuming leaves and debris along curbs. Unit shall have a full, constant vacuum, and full-range of boom control. A water ring, installed in the boom inlet with variable capacity of 0-22 gpm to suppress carry-over while vacuuming dry materials will also be included. All of the fore mentioned functions would operate while unit is in motion via the auxiliary engine. This also allows daily maintenance of the chassis engine without ignition of the chassis engine to extend the hose reel.	X	
Fan flush out system	~	A
VACUUM BOOM SYSTEM:		
Vacuum hose shall be designed for front operation with hose mounted and stored at front mounted work station. Front mounted location is required for ease of positioning vacuum hose as well as minimizing need for operator to swing hose into traffic.	X	
All connections between debris body and vacuum system will be of the self-adjusting pressure fitting type.	X	
Vacuum hose will remain stationary and not rise with debris body.	X	
Upper debris tube shall consist of an anchored steel tube and elbow.	X	
A sub-frame mounted cab guard shall be mounted behind cab with boom rest cradle.	X	
All vacuum pipes shall be connected to vacuum pick up tube and extension pipes by adjustable over-center quick clamps to join the aluminum flanges on pipes.	X	
One (1) quick clamp for each pipe supplied shall be provided.	+	
Boom pedestal shall be directly mounted to module subframe.	X	
Boom support used for travel mode shall not interfere with access or require removal to tilt hood forward.	X	
A control station shall be equipped with control switches for all directions as well as a safety emergency shut down button, which shall automatically eliminate power to boom.	X	
The vacuum boom shall have a heavy-duty flexible hose assembly joining the transition pipe to the debris body, and a 70-degree elbow and 5-1/2' heavy duty hose at the suction end of the boom.	X	
Boom shall hydraulically telescope 8' and rotate 180 degrees and shall be operated by an electric over hydraulic system. Lift and swing movements shall be actuated by hydraulic cylinders.	X	
Horizontal box beam boom and vacuum tube shall be fixed length from transition to steel elbow.	X	
The horizontal inner steel vacuum tube and inner box beam boom section shall telescope (tube within tube, box beam within box beam) and retract a minimum of 8' without affecting the vertical position of the pick-up tubes, and shall be located at the front work station in its retracted position, providing 277" minimum reach off the longitudinal axis of unit.	- X	-
Boom shall be fully controlled by a remote push button pendant control station with 25 ft. cable. Controls to include up / down, left / right, in / out boom functions, vacuum relief, e-stop and main power switch.	X	
A joystick for hydraulic control of the boom shall be installed on hose reel front panel.	X	

A detailed engineering drawing must be supplied showing the relationship of the hose reel in relation with the vacuum boom range of motion. Drawing shall show module mounted on chassis, full arc of vacuum hose both retracted and extended, full rotation of arc for hose reel in the extended position and dimension all arc lengths of vacuum boom retracted and extended. Drawing shall highlight intersection areas whereby combination cleaning is possible (within full arc on telescoping boom system).	X	
Exceptions:		
WATER PUMP AND DRIVE:		
For most efficient use of horsepower and reduced fuel consumption, high pressure rodder pump shall be hydraulically driven via (1) load sensing utility pump, (1) variable displacement pump and (1) fixed displacement pump	X	
Hydraulic powered rodder pump via twin variable displacement hydraulic pumps and (1) fixed displacement utilizing (2) 10-bolt PTO's.	X	
High pressure water pump shall be rated capable of continuous delivery of 60 GPM at 2500 PSI (submit manufacturer support documentation).	X	
High-pressure water (rodder) pump system shall allow front-mounted controls for operation of three modes: (1) Low flow range 0-22 gpm; (2) medium-flow range, 22-40 gpm / 2500 psi; and (3) High-flow range: 40 up to 60 gpm / 2500 psi.	X	
Digital flow meter shall be displayed in front LCD display. Flow meter shall be capable of displaying system flow in all pump operating modes. In addition, a low water alarm shall be provided.	X	
Variable flow systems routing water back-to-tank are not considered equal due to additional wear, horsepower and fuel consumption. Any deviation from this drive requirement should have full explanation of horsepower consumption.	X	
Water (rodder) pump shall include smooth and pulsation operation mode feature.	X	
When required to assist nozzle breaking through obstructions, water pump "pulsation mode" shall provide a forward-acting nozzle surge. Pulsation surge wave shall allow nozzle to punch forward 2" to 18" depending on flow dynamics and length of hose in sewer pipe.	X	
Explanation of forward-acting pulsation method shall be submitted with bid or explained below:	X	
Water pump location shall provide a flooded <u>gravity</u> suction inlet to eliminate potential cavitation damage.	X	
The water pump shall provide precise 0-60 GPM controlled flow at variable pressure up to 2500 PSI.	X	
An extreme cold weather recirculation system - minimum 25 GPM via transmission PTO at chassis engine idle speed.	X	
A hydro-pneumatic nitrogen charged accumulator system shall be provided with all control valves, piping and hoses for either continuous flow or jackhammer rodding. Accumulator shall be a 2.5 gallon capacity and 1400 to 2500 PSI pressure rating.	X	
Two (2) 1/2" high pressure ball valves shall be provided for draining the water pump and flushing sediment from the bottom of the pump.	X	

A nozzle rack accommodating (3) nozzles shall be provided in curbside toolbox. The nozzles shall be labeled on storage rack for pipe size/flow and application.	X	
System shall be relieved to protect operator.	X	
Handgun shall be supplied that allows for changing of flow pattern from a fine mist to a steady stream.	X	
Handgun shall come equipped with quick connect couplers.	X	
An additional 1" water relief valve shall be provided.	X	
A mid-ship quick disconnect handgun couplers shall be provided.	X	
Hydro-Excavation Package / Retractable Reel with 50' x 3/8" Hose, Hydroexcavation Handgun and Plumbing. Water system shall allow precise variable flow control range of 0-22 GPM at 2500 PSI with digital flow meter in clear view of adjustment control.	X	
A water pump hour meter shall be provided.	X	
Exceptions:		
HOSE REEL:		
Hose reel assembly shall be direct frame mounted. Hose reel shall hydraulically extend 15" on a straight line from the bumper of the truck. Hose reel shall pivot 270 degrees in 2 degree increments.	X	
Hose reel assembly shall be mounted on an independent frame that can be removed from brackets attached permanently to front of main truck frame members.	X	

Reel will be manufactured out of 1/4" spun steel for added structural strength and shall require no internal or external reinforcements that could damage rodder hose.	X	
Hose reel shall be driven by adjustable gear reduction chain and sprocket assembly.	X	
Hose reel shall operate at full rotational speed while chassis engine is at idle.	x	
600' x 3/4" Aeroquip Sewer Hose/2500 Psi shall be provided	X	
An adjustable/indexing automatic hose level wind shall scroll device shall be supplied. An air-cylinder actuated pinch-roller shall exert downward pressure across full width of reel to retain hose on reel when encountering nozzle blockages.	X	
A hose footage counter shall be supplied to indicate the amount of hose travel within pipe.	X	
Digital footage counter displaying absolute and relative footage values shall be provided. System must be capable of resetting relative value to ensure operator safety.	X	
Accuracy To Within One Percent Of Actual Distance	x	
Large Easy To Read Lcd Screen	X	
Large Keypad With Sealed Membrane Switches That Are Easily Activated	x	
Nema-4 Moisture Sealed Enclosure	x	
Solid State Circuitry	X	
Dimensions: 5 5/8" X 3 3/8" X 3/16"	X	
LCD Display Area: 3.0" X 2.2"	x	
Nozzle rack storage for (3) nozzles shall be provided in curbside toolbox.	X	
Exceptions:		

WASHDOWN EQUIPMENT:		
A spring retractable storage reel for handgun hose shall be provided to allow the operator to deliver water to area served by pick up hose and to the inside of the debris body for clean out. Reel shall be mounted midship on curbside, equipped with 1/2" x 50' 2000 psi hose. An additional 35' of 1/2" hose with quick disconnect couplers shall be supplied loose.	X	
A handgun with 1/2" x 35' hose shall be provided at mid-ship to which allow the operator to deliver water to area served by pick up hose and to the inside of the debris body for clean out.	X	
Hand sprayer with adjustable spray-pattern to be provided with trigger-style gun.	X	
Exceptions:		
FRONT OPERATING STATION AND CONTROLS:		
Primary operator station will be located at front of truck on right curb side of hose reel.	X	
All front operator controls shall be accessible while operating either front and rear side of reel assembly. All operations to either side of unit shall position operator in front of vehicle affording protection from oncoming traffic.	X	
Station shall include truck engine throttle, water pump (on/off), water pump mode, water pump flow meter, hose reel control valve (forward / reverse), adjustable hose reel speed control, oil dampened water pressure gauge, boom controls, digital water pump flow meter, and low water warning light.	X	
Tachometer and hour meter for chassis engine provided at front control station shall be provided.	X	
Tachometer and hour meter for auxiliary engine provided at front control station shall be provided.	X	
All Hydraulic Functions - Color Coded, Sealed Electric/Hydraulic Nema 4 switches shall be provided.	X	
Fan Engagement/Vacuum Relief - Sealed Electric/Air Nema 4 Switch shall be provided.	X	
Water pump hour meter shall be provided.	X	
A temperature light and alarm shall be provided. Light and alarm will be activated when hydraulic temperature reaches 180° F.	X	
Exceptions:		
ELECTRICAL & SAFETY LIGHTING:		
The entire system shall be vapor sealed to eliminate moisture damage, "Nema-4" type or equal.	X	

Vansco Electronic Package: Chassis Tachometer, Auxiliary Engine Tachometer, Operating Mode, PTO Mode, Hydraulic Oil Temperature shutdown, and E-Stop shall be included. E-Stop activation must turn off rodder pump, shutdown PTO A & B, set chassis throttle to idle, & open vacuum relief. E-stop must be located at each operator interface; including front/rear hose reel controls, pendant control, & dump control location. Basic machine functions and both chassis and module diagnostics shall be provided.	X	
All electrical connections shall be void of exposed wires or terminals nor should they be painted. Paint process shall be completed prior to installation of wiring.	X	
All wiring shall be color-coded and encased in conduit to scaled terminal boxes with circuit breakers.	X	
All light bulbs shall be shock mounted to eliminate bulb failure.	✓	
All other lights required by State and Federal Laws.	✓	
Two-piece directional LED 16-strobe-light arrow board shall be mounted on rear door of debris body, with controls mounted in cab.	X	
A pistol grip hand light with bumper plug and 25' coiled cord shall be provided.	✓	
(1) Hose reel manhole work lights shall be provided.	X	
(2) L.E.D. Boom work lights shall be provided.	X	
FS DOT 3 - 6 Light System -Federal Signal Mirror Mount Strobes, 2 Mid-Ship, 2 Rear Water Mounted Oval Led Quad Flash Strobes shall be provided.	X	
Led Lights, Clearance, Stop, Tail & Turn shall be provided.	X	
Cab mounted strobe light with guard.	X	
Exceptions:		
SAFETY EQUIPMENT:		
E-stop shall be located at each operator interface location. Standard locations to include: front hose reel, mid-ship curbside dump controls, & wireless controller (if equipped.)	X	
Electrical system controls shall be configured to allow for single point operation only. Upon engagement of controls at specified locations, additional controls shall be disabled.	✓	
(1) Emergency Flare Kit	X	
(1) 5# Fire Extinguisher	X	
Exceptions:		
SEWER TOOLS AND ACCESSORIES:		
(1) 30° Sand Nozzle	X	
(1) 30° Sanitary Nozzle	X	
(1) 15° Penetrator Nozzle	X	
(1) 1" Small finned nozzle pipe skid	X	
The unit shall have a 12-volt controlled water heater rated at a minimum of 400,000 BTU to heat the water tank. The heater shall have a no-flow or high temperature burner shut down, a dial type thermostat for the temperature control, a pressure gauge on the inlet heater and a LED temperature gauge on the outlet heater.	X	

see sheet 1B.

Exceptions: <i>see sheet 1B. Additional cost for 400,000 water tank heater</i>		
VACUUM TOOLS AND ACCESSORIES:		
The basic vacuum tube package shall include the following:		
(1) 8" x 3' aluminum pipe	X	
(2) 8" x 5' aluminum pipe	X	
(1) 8" x 6'6" catch basin tube	X	
(4) 8" quick clamps	X	
Exceptions:		
CHASSIS EQUIPMENT AND STORAGE:		
Two (2) front tow hooks shall be provided.	X	
Two (2) rear tow hooks shall be provided.	X	
In cab camera system allowing operator to see front and rear of chassis.	X	
48"W x 20"H x 12"D Toolbox. Front Bumper mounted Qty (2) 16" x 12" x 18" tool boxes with LED side marker lights.	X	
Safety cone storage rack	X	

Bid Amount	\$	<u>449,000</u>
Trade-In Option	\$	<u>125,000</u>
Total Bid Amount	\$	<u>324,000</u>

CITY CLERK
CITY OF LAUREL
P. O. BOX 10
LAUREL, MONTANA 59044

STANDARD TERMS AND CONDITIONS – PAGE 1

This contract includes the following Standard Terms and Conditions and includes, but is not limited to, the Invitation to Bid, Call for Sealed Bids, Specifications, Forms of Agreement, Instruction to Bidders, and Form of Proposal.

The contractor will not be liable for any delay in furnishing or failure to furnish service due to fire, flood, strike, lockout, dispute with workmen, act of God, or any cause beyond reasonable control.

In case of default by the successful bidder or failure to deliver the goods or services within the time specified, the City Purchasing Authority, after written notice, may procure them from other sources and hold contractor responsible for excess costs occasioned thereby.

The specifications attached to the instructions to bidders establish a standard of quality desired by the City of Laurel. Any bidder may submit quotations on any article, which substantially complies with these specifications as to quality, workmanship and service. The City of Laurel reserves the right to make its selection of materials or services purchased, based on its best judgment as to which articles substantially comply with the requirements of the specifications.

No alteration in any of the terms, conditions, delivery, quality, or specifications will be effective without prior written consent of the City of Laurel.

No exception to delivery or service dates shall be allowed unless prior written approval is first obtained for the City of Laurel.

All payments to the contractor shall be remitted by mail. The City shall not honor drafts, nor accept goods on a sight draft basis. Furthermore, the provisions or monies due under this contract shall not be assignable unless prior written approval is first obtained from the City of Laurel.

All goods, materials or services purchased herein are subject to approval by the City of Laurel. Any rejections of services, goods or materials, whether held by the City or returned, will be at the contractor's risk and expense.

The contractor agrees to assume all expense, protect and hold harmless the City, its officers, agents and employees against all claims and expense including, but not limited to, suits or proceedings for patent, trademark, copyright, or franchise infringement arising from the purchase, installation or use of the goods, material or services purchased herein.

The contractor further agrees to assume all expenses and damages arising from such claim, suits or proceedings.

CITY CLERK
CITY OF LAUREL
P. O. BOX 10
LAUREL, MONTANA 59044

STANDARD TERMS AND CONDITIONS – PAGE 2

Contractor agrees that the waiver, acceptance, or failure by the City to enforce any provisions, terms, or conditions of this contract shall not operate or be construed as a waiver of prior or subsequent breaches or the right of the City to thereafter enforce such provisions.

The contractor warrants all articles supplied under this contract conform to specification herein. The contractor will deliver a warranty stating that articles supplied under the contract are fit and sufficient for the purpose manufactured, merchantable, and free from defects.

In the event the City is entitled to a prompt payment or cash discount the period of computation shall commence on the date of delivery, or receipt of correctly completed invoices, whichever is later. If an adjustment in payment is necessary, the discount period shall commence on the date final approval for payment is authorized.

The contractor agrees not to be discriminate against any client employee or applicant for employment or for services, because of race, creed, color, national origin, sex or age with regard to, but not limited to, the following: employment upgrading; demotion or transfer; recruitment advertising; layoffs and termination; rates of pay or other forms of compensation; selection for training; rendition of services. It is further understood that any contractor who is in violation of this shall be barred forthwith from receiving awards of any purchase order for the City unless a satisfactory showing is made that discriminatory practices have terminated and that a reoccurrence of such acts are unlikely.

The City reserves the right to cancel and terminate this contract forthwith upon giving thirty (30) days written notice to the contractor. (This provision does not apply to the purchase of materials and equipment. A purchase order for materials and equipment is a binding contract.)

Contractor agrees that in the event suit is instituted by the City for any default on the part of the contractor, he shall pay to the City all costs and expenses expended or incurred by the City in connection therewith, and reasonable attorney fees.

Where applicable, possible or required, bidder is required to submit descriptive literature, sample material, design sketches and detailed shop drawings. Failure to submit required items may result in rejection of the bid or termination of contract.

The successful bidder may not make any advertising or sale use of the fact contract items are being used by purchaser and other approved agencies, under penalty of contract termination.

The Advertisement for Bids, the accepted Proposal, and the specifications, together form the contract and they fully act as if hereto attached or herein repeated.

CITY CLERK
CITY OF LAUREL
P. O. BOX 10
LAUREL, MONTANA 59044

STANDARD TERMS AND CONDITIONS – PAGE 3

This contract shall be governed by and construed in accordance with the laws of the State of Montana.

The contractor may not assign or subcontract the agreement or the right to receive reasonable performance of any act called for by the contract shall be deemed waived by a waiver by City of a breach thereof as to any particular transaction or occurrence.

Regardless of FOB point contractor agrees to bear all risks of loss, injury, or destruction of goods and materials ordered herein and such loss, injury, or destruction shall not release contractor from any obligation hereunder.

END: STANDARD TERMS AND CONDITIONS

CITY CLERK
CITY OF LAUREL
P. O. BOX 10
LAUREL, MONTANA 59044

INVITATION TO BID

RETURN TO: City Clerk, City of Laurel, P.O. Box 10, Laurel, Montana 59044

Please bid net prices at which you will agree to furnish required services. To receive consideration, this form must be signed in full by a responsible, authorized agent, office, employee or representative of your firm.

BID ITEM: 2022 (OR NEWER) SINGLE-ENGINE COMBINATION SEWER AND CATCH BASIN CLEANER WITH A POSITIVE DISPLACEMENT BLOWER VACUUM SYSTEM MOUNTED ON A HEAVY DUTY CHASSIS WITH OPTIONAL TRADE-IN OF A 2012 VACTOR JET RODDER.

Enter full Company Name and Address

Titan Machinery
1728 old Hardin Rd
Billings MT 59101

CONDITIONS AGREEMENT

We have read and agree to the conditions and stipulations contained herein and to the Standard Terms and Conditions contained on the attached.

We further agree to furnish the services specified at the prices stated herein, to be delivered to the location and that date set forth herein.



Signature

General Counsel & Secretary

Title

December 1, 2021

Date

END: INVITATION TO BID

CITY CLERK
CITY OF LAUREL
P. O. BOX 10
LAUREL, MONTANA 59044

FORM OF AGREEMENT – PAGE 1

AGREEMENT, made on the 28th day of December, 2021, by and between
the City of Laurel and Titan Machinery.

WITNESSTH that the above named company and the City of Laurel, for consideration,
hereinafter name agree as follows:

SCOPE OF OPERATION: The contractor shall provide material and equipment, perform the
work and do everything required by the specifications entitled:

**CONTRACT SPECIFICATION: 2022 (OR NEWER) SINGLE-ENGINE
COMBINATION SEWER AND CATCH BASIN CLEANER WITH A POSITIVE
DISPLACEMENT BLOWER VACUUM SYSTEM MOUNTED ON A HEAVY
DUTY CHASSIS WITH OPTIONAL TRADE-IN OF A 2012 VACTOR JET
RODDER.**

TIME OF COMPLETION: Delivery of goods, equipment, and/or services shall be expected
within thirty (30) days of the award of bid.

FOLLOWING IS AN ENUMERATION OF THE CONTRACT BID

Intent and Scope of Operation
Call for Sealed Bids: Notice to Bidders
(Bid Bond/Performance Bond)
Instructions to Bidders
Contract Specifications
Standard Terms and Conditions
Invitation to Bid
Form of Agreement
Form of Proposal (Bid Proposal)

IN WITNESS WHEREOF, the parties hereto have executed this agreement to day and
year above written.

Contractor

By: _____
Title _____

CITY CLERK
CITY OF LAUREL
P. O. BOX 10
LAUREL, MONTANA 59044

FORM OF AGREEMENT – PAGE 2

CITY OF LAUREL

BY: 
MAYOR

ATTEST: 
City Clerk

Approved as to form

END: FORM OF AGREEMENT

CITY CLERK
CITY OF LAUREL
P. O. BOX 10
LAUREL, MONTANA 59044

FORM OF PROPOSAL (BID PROPOSAL)

The undersigned hereby submits the following proposal: Having carefully examined the specifications entitled CONTRACT SPECIFICATIONS: **2022 (OR NEWER) SINGLE-ENGINE COMBINATION SEWER AND CATCH BASIN CLEANER WITH A POSITIVE DISPLACEMENT BLOWER VACUUM SYSTEM MOUNTED ON A HEAVY DUTY CHASSIS WITH OPTIONAL TRADE-IN OF A 2012 VACTOR JET RODDER** for the City of Laure Public Works Department, as well as all other conditions affecting the bid, the undersigned proposes to furnish all equipment and services necessary to complete the work required.

120 days after chassis arrives
Time and Date of Delivery

2022 (OR NEWER) SINGLE-ENGINE COMBINATION SEWER AND CATCH BASIN CLEANER WITH A POSITIVE DISPLACEMENT BLOWER VACUUM SYSTEM MOUNTED ON A HEAVY-DUTY CHASSIS WITH OPTIONAL TRADE-IN OF A 2012 VACTOR JET RODDER.

Optional Trade In*:	\$ <u>125,000</u>
Net FOB Laurel, Montana	\$ <u>324,000</u>

* 2012 Vactor Jet Rodder may be seen at the Laurel Maintenance Shop located at 20 S. 7th Avenue, Laurel, Montana between the hours of 7:30 am and 3:00 pm Monday – Friday.

By Steve Noack
Title General Counsel + Secretary
Company Titan Machinery Inc.
Date December 1, 2021

END: FORM OF PROPOSAL (BID PROPOSAL)

SHEET 1A: As per your bid description we have bid a PD unit not a fan unit. The spec in the packet is fully describing a Fan unit. Below is our specs for the PD unit that is titled at the beginning of the packet.

Vacuum shall be provided by a positive displacement rotary lobe type blower driven via chassis engine and heavy duty split transfer case direct to the blower.
Interlock safety system shall prevent drive axle from engaging.
A horizontal silencer with rain cap shall exhaust above the cab.
A blower tachometer / hour meter shall be provided and displayed digitally on front control screen.
For most efficient use of horsepower and fuel consumption, full vacuum and/or combination operation shall be approximately 1750 RPM of chassis drive engine.
Blower shall be driven by the chassis engine and shall produce inlet volume of 4500 cfm @ 0" hg @ 2250 rpm, and 3490 cfm @ 18" hg @ 2250 rpm vacuum (Roots 824RCS 18 or equal). Drive engine not to exceed 1760 RPM.
For added protection, the vacuum system shall have three (3) relief valves set at 18" hg, heavy duty horizontal mounted noise muffler, removable and cleanable stainless steel filter screen, and shall be enclosed with a steel cage guard for safety.
Transfer case shall be activated by air via a one touch control located in cab with animated confirmation on screen.
Blower shall be driven from chassis engine via the transmission drive shafts and heavy duty split shaft transfer case direct to blower, engagement via one touch control on front control panel.
Blower shall be provided with a horizontal silencer with exhaust above the cab and rain cap protecting the silencer from rain water.
Blower shall draw air from two (2) separate ports in the debris body.
Hydraulic shut off valves shall be provided at the suction, return and filter lines to permit servicing of the hydraulic system.
Ball valve drains shall be provided for both the final filter and silencer to be able to drain any carryover that comes from the debris body.

SHEET 1B- Per our conversation with Matt we did not want to put a Hotsy 400,000 BTU water tank heater on unit. This will be EXTRA cost of \$22,000 for the heater. It would also limit our water capacity to 1300 gallons.

Lukas Hawsel

October 8, 2021

To Whom It May Concern:

This is to certify, as manufacturer of the pump bid herein on the Vactor 2100i Series, that the following statements are true and correct:

The pump is rated for 100 GPM and 3000 PSI.

The pump will deliver 80 GPM @ 2500 PSI continuous duty.

The pump will have a constantly flooded suction inlet due to the mounted location being installed below 100% of the water supply.

The mounting location of the pump has our full application approval.

As a function of a slow stroke speed, the pump can be run dry for a period of 30 minutes at full operating RPM, without incurring damage.

The Water Pump is covered under our standard 2 year warranty regardless of the fresh water source used. (i.e. fresh water pond, irrigation system, debris body interconnect, etc.)

Sincerely,

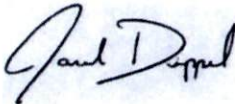

Jared Dippel
Product Manger

VECTOR

LIMITED WARRANTY

Limited Warranty. Each machine manufactured by VACTOR MANUFACTURING (or, "the Company") is warranted against defects in material and workmanship for a period of 12 months, provided the machine is used in a normal and reasonable manner and in accordance with all operating, maintenance and safety instructions. In addition, certain machines and components of certain machines have extended warranties as set forth below. If sold to an end user, the applicable warranty period commences from the date of delivery to the end user. If used for rental purposes, the applicable warranty period commences from the date the machine is firstmade available for rental by the Company or its representative. This limited warranty may be enforced by any subsequent transferee during the warranty period. This limited warranty is the sole and exclusive warranty given by the Company.

2100 Series, HXX Series and Jetters

STANDARD EXTENDED WARRANTIES (Total Warranty Duration)

10 years against water tank leakage due to corrosion. nonMettalic water tanks are covered for 5 yrs against any factory defect in material or workmanship.

2100 Series, HXX Series and Guzzler only

5 years against leakage of debris tank, centrifugal compressor or housing due to rust-through.

2100 Series and Jetters

2 years - Vactor Rodder Pump

Exclusive Remedy. Should any warranted product fail during the warranty period, the Company will cause to be repaired or replaced, as the Company may elect, any part or parts of such machine that the Company's examination discloses to be defective in material or factory workmanship. Repairs or replacements are to be made at the selling Company's authorized dealer's or distributor's location or at other locations approved by the Company. In lieu of repair or replacement, the Company may elect, at its sole discretion, to refund the purchase price of any product deemed defective. The foregoing remedies shall be the sole and exclusive remedies of any party making a valid warranty claim.

This Limited Warranty shall not apply to (and the Company shall not be responsible for):

1. Major components or trade accessories that have a separate warranty from their original manufacturer, such as, but not limited to, trucks and truck chassis, engines, hydraulic pumps and motors, tires and batteries.
2. Normal adjustments and maintenance services.
3. Normal wear parts such as, but not limited to, oils, fluids, vacuum hose, light bulbs, fuses and gaskets.
4. Failures resulting from the machine being operated in a manner or for a purpose not recommended or not in accordance with operating, maintenance or safety instructions by the Company.
5. Repairs, modifications or alterations without the express written consent of the Company, which in the Company's sole judgment, have adversely affected the machine's stability, operation or reliability as originally designed and manufactured.
6. Items subject to misuse, negligence, accident or improper maintenance.

NOTE The use in the product of any part other than parts approved by the Company may invalidate this warranty. The Company reserves the right to determine, in its sole discretion, if the use of non-approved parts operates to invalidate the warranty. Nothing contained in this warranty shall make the Company liable for loss, injury, or damage of any kind to any person or entity resulting from any defect or failure in the machine.

THIS WARRANTY SHALL BE IN LIEU OF ALL OTHER WARRANTIES, EXPRESS OR IMPLIED, AND TO THE EXTENT PERMITTED, CONFERRED BY STATUTE, INCLUDING WITHOUT LIMITATION, ANY IMPLIED WARRANTIES OF MERCHANTABILITY OR FITNESS FOR A PARTICULAR PURPOSE, OR ANY WARRANTY AGAINST FAILURE OF ITS ESSENTIAL PURPOSE, ALL OF WHICH ARE DISCLAIMED.

This warranty is in lieu of all other obligations or liabilities, contractual and otherwise, on the part of the Company. For the avoidance of doubt, the Company shall not be liable for any indirect, special, incidental or consequential damages, including, but not limited to, loss of use or lost profits. The Company makes no representation that the machine has the capacity to perform any functions other than as contained in the Company's written literature, catalogs or specifications accompanying delivery of the machine. No person or affiliated company representative is authorized to alter the terms of this warranty, to give any other warranties or to assume any other liability on behalf of the Company in connection with the sale, servicing or repair of any machine manufactured by the Company. Any legal action based hereon must be commenced within eighteen (18) months of the event or facts giving rise to such action.

The Company reserves the right to make design changes or improvements in its products without imposing any obligation upon itself to change or improve previously manufactured products.



VACTOR MANUFACTURING
1621 S. Illinois Street
Streator, IL 61364



TERMS AND CONDITIONS

ORDERS: All orders are subject to acceptance by Vactor Manufacturing, Inc. or Guzzler Manufacturing, Inc. (hereafter referred to as Vactor). Orders for products not normally carried in stock or requiring special engineering or manufacturing is in every case subject to approval by Vactor's Management.

PRICES: All orders are subject to current prices in effect at the time of order acknowledgment

F.O.B. POINT: Unless otherwise stated, all prices listed are F.O.B. factory.

PAYMENT TERMS: The company's payment terms are due upon receipt, unless otherwise stated. However, until such time as Vactor receives full payment, Vactor shall maintain a purchase money security interest in the product.

CANCELLATION: Orders cannot be cancelled except upon terms that will compensate Vactor for any loss or damage sustained. Such loss will be a minimum of 10% of the purchase price.

SHIPMENT: All proposals are based on continuous and uninterrupted delivery of the order upon completion, unless specifications distinctly state otherwise. In the event that agreement is reached for Vactor to store completed items, they will be immediately invoiced to the customer and become due and payable. Storage shall be at the risk of the customer and Vactor shall be liable only for ordinary care of the property.

STORAGE CHARGES: Vactor shall charge the customer at current rates for handling and storing customer's property (e.g. truck chassis) held for more than thirty (30) days after notification of availability for shipment. All customer's property, or third party's property, that is stored by Vactor is at the customer's or other party's risk. Vactor is not liable for any loss or damage thereto caused by fire, water, corrosion, theft, negligence, or any cause beyond its reasonable control.

PERFORMANCE: Vactor shall not be liable for failure to complete the contract in accordance with its terms if failure is due to wars, strikes, fires, floods, accidents, delays in transportation or other causes beyond its reasonable control.

EXPERIMENTAL WORK: Work performed at customer's request such as sketches, drawings, design, testing, fabrication and materials shall be charged at current rates.

SKETCHES, ENGINEERING DRAWINGS, MODELS and all preparatory work created or furnished by Vactor, shall remain its exclusive property; and no use of same shall be made nor may ideas obtained therefrom be used except with the consent of and on terms acceptable to Vactor.

TAXES: Buyer's final cost shall include all applicable sales and use taxes, including all sales and use taxes attributable to any changes made to Buyer's initial order placed hereunder or to any changes to applicable sales and use tax laws. However, Vactor Manufacturing, Inc. shall be responsible for Federal Excise Tax (F.E.T.) unless it is separately stated on the invoice and added to the selling price. If F.E.T. is not separately stated on the invoice it has not been included in the price and Vactor will pay any F.E.T. due itself and bear the cost of the tax. Any refunds or adjustments to F.E.T. in such cases belong to Vactor.

PRODUCT IMPROVEMENT: Vactor reserves the right to change manufacturing specifications and procedure in accordance with its product improvement policy.

MOUNTING PRICES: Mounting prices assume normal factory installation on a truck chassis suitable for the unit purchased. Relocation of batteries, fuel tanks, mufflers, air tanks, etc. will be an additional charge, billed at the standard factory labor rate.

WARRANTY: Vactor warrants its products to be free from defects in material and workmanship for a period of 12 months, subject to the limitations and conditions set forth in its current published warranty. Other than those expressly stated herein. THERE ARE NOT OTHER WARRANTIES OF ANY KIND EXPRESS OR IMPLIED, AND SPECIFICALLY EXCLUDED BUT NOT BY WAY OF LIMITATION, ARE THE IMPLIED WARRANTIES OF FITNESS FOR PARTICULAR PURPOSE AND MERCHANTABILITY.

IT IS UNDERSTOOD AND AGREE THE VACTOR'S LIABILITY WHETHER IN CONTRACT, IN TORT, UNDER ANY WARRANTY IN NEGLIGENCE OR OTHERWISE SHALL NOT EXCEED THE RETURN OF THE AMOUNT OF THE PURCHASE PRICE PAID BY THE PURCHASER AND UNDER NO CIRCUMSTANCES SHALL VACTOR BE LIABLE FOR SPECIAL, INDIRECT, INCIDENTAL OR CONSEQUENTIAL DAMAGES. THE PRICES STATED FOR THE EQUIPMENT IS A CONSIDERATION IN LIMITING VACTOR'S LIABILITY. NO ACTION REGARDLESS OF FORM, ARISING OUT OF THE TRANSACTION OF THE AGREEMENT MAY BE

TERMS AND CONDITIONS

BROUGHT BY PURCHASER MORE THAN ONE YEAR AFTER THE CAUSE OF ACTION HAS OCCURRED.

VACTOR'S MAXIMUM LIABILITY SHALL NOT EXCEED AND BUYER'S REMEDY IS LIMITED TO EITHER (I) REPAIR OR REPLACEMENT OF THE DEFECTIVE PART OF PRODUCT, OR AT VACTOR'S OPTION (II) RETURN OF THE PRODUCT AND REFUND OF THE PURCHASE PRICE AND SUCH REMEDY SHALL BE BUYER'S ENTIRE AND EXCLUSIVE REMEDY.

CHOICE OF LAW: These terms and conditions shall be construed according to the laws of the State of Illinois. Failure at anytime by Vactor to exercise any of its rights under this agreement shall not constitute a waiver-thereof nor prejudice Vactor's right to enforce it thereafter.

COMPLETE AGREEMENT: These terms and conditions, contain the complete and final agreement between the parties hereto and no other agreement in any way modifying any of these terms and conditions will be binding on Vactor unless in writing and agreed to by an authorized representative of Vactor. All proposed terms included in Buyer's purchase order or other standard contracting documents are expressly rejected.

I agree with the above terms and conditions: _____

Date: _____

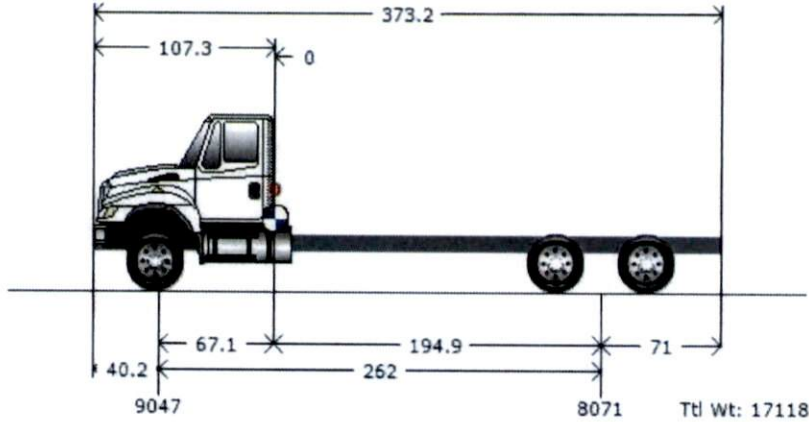

Graphics are provided as visual aids only and are not intended to represent the actual scale, shape, or color of the truck or its components. All weights are represented in lbs.

Truck			Body/Trailer			Chassis/Empty Weights	
Bumper to Axle	(BA)	40.2	Body Length	(BL)	N/A	Tractor Front Axle:	9,047
Wheelbase	(WB)	262.00				Tractor Rear Axle:	8,071
Axle to Frame	(AF)	71.00					
Axle to Back Cab	(ABC)	67.1					
Cab to Axle	(CA)	194.9					
Usable CA		194.9					
CA Reduction Adjustment		0.00					
Fuel-Diesel(Gals)		0					
DEF(Gals)		0					

Before the Cab			Cab		Payloads Chassis			Body		After the Body	
#	Weight	CG	#	Weight	CG	#	Weight	CG	#	Weight	CG
						1	0	1			

Loads	
Payload Weight:	0
Driver:	0
Fuel-Diesel(Lbs):	0
DEF(Lbs):	0

Weight Distribution	
Total Front Axle:	9,047
Total Rear Axle:	8,071
Total Weight:	17,118

Weights and clearances in this proposal are estimates only. Navistar, Inc. is not liable for any consequences resulting from any differences between the estimated weights and clearances and the actual manufactured weights and clearances.

Weight Distribution

All weights are represented in lbs.

	<u>Truck</u>		
	Front	Rear	Total
<u>Chassis Weight</u>			
Chassis Weight:	9,047	8,071	17,118
Fuel:	0	0	0
DEF:	0	0	0
(Curb Weight):	9,047	8,071	17,118

Loads

Payloads:	0	0	0
Driver:	0	0	0
Axle Totals (Gross Weight):	9,047	8,071	17,118

Weight Ratings

	<u>Truck</u>	
	Front	Rear
Axle(axle capacity)	20,000	46,000
Tire(tire capacity)	22,800	46,720
Suspension(suspension capacity)	20,000	46,000
Spring:	0	
Fed Bridge Law (axle spread):	20,000	34,000 (54")

Wheel Combination	Load	Limit
1 - 3	17,118	54,000

Federal Total Vehicle Weight Limit: 80,000

Maximum Gross Vehicle Weight Rating (GVWR) 66,000 - Gross Vehicle Weight(GVW) 17,118 = 48,882 Reserves

Weight Summary

* Distributed weights are within capacity limits

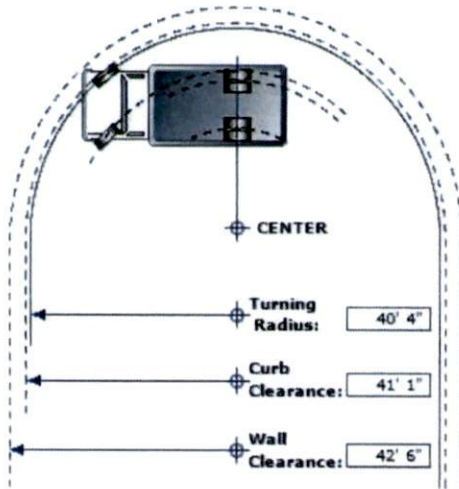

Series: HV
 Model: HV607
 Description: HV607 SBA
 Model Year: 2023

Calculation Factors

Wheelbase: 262
 Front Axle: 0002ARY
 Description: AXLE, FRONT NON-DRIVING, {Meritor MFS-20-133A} Wide Track, I-Beam Type, 20,000-lb Capacity
 Front Wheel: 0027DBA
 Description: WHEELS, FRONT, {Accuride 29374} DISC; 22.5x12.25 Rims, Extra Polish Aluminum, 10-Stud, 285.75mm BC, Hub-Piloted, Flanged Nut, with Steel Hubs
 Front Tire: 07752665441
 Description: TIRES, 425/65R22.5 Load Range L HAC 3 (CONTINENTAL), 465 rev/mile, 68 MPH, All-Position
 Steering Gear: 0005PTB
 Description: STEERING GEAR, (2) {Sheppard M100/M80} Dual Power

Turning Radius Statistics

General Information

Inside Turn Angle: 39 Degrees
 Radial Overhang: 26

Axle Information

KingPin Inclination: 6.25 Degrees
 KingPin Center: 71

Turning Radius - Curb View

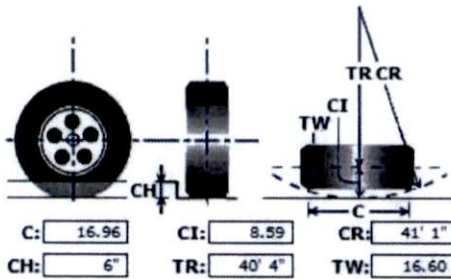

C - Curb Contact Length: 16.96
 CI - Curb Clearance Increment: 8.59
 CR - Curb Clearance Radius: 41'1"
 CH - Curb Height: 6"
 TR - Turning Radius: 40'4"
 TW - Tire Width: 16.60

* All Measurements are in inches, unless otherwise specified.

This information is based on engineering information available at this time. Actual figures may vary. Navistar, Inc. cannot accept liability for consequences due to this variance.

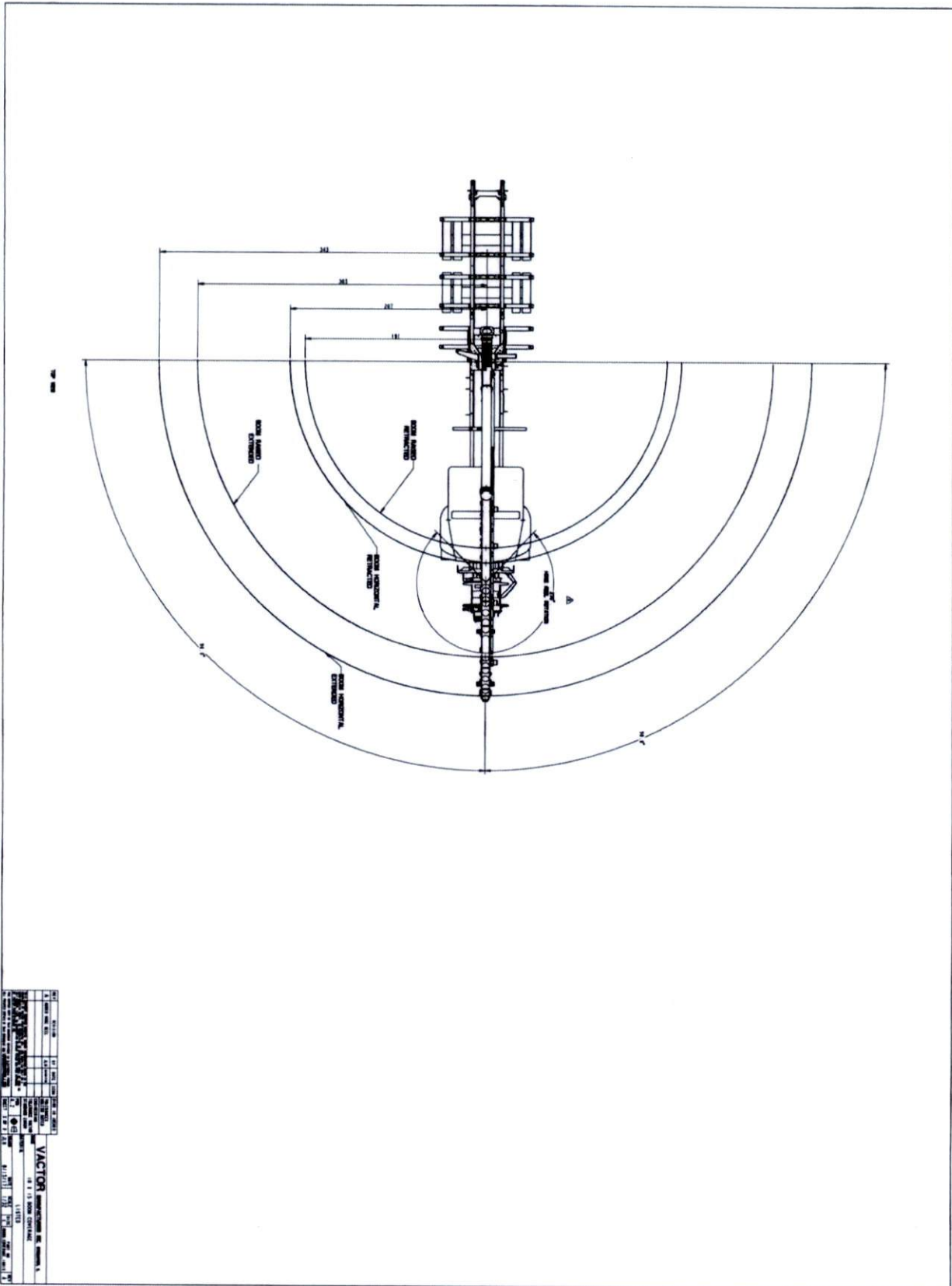

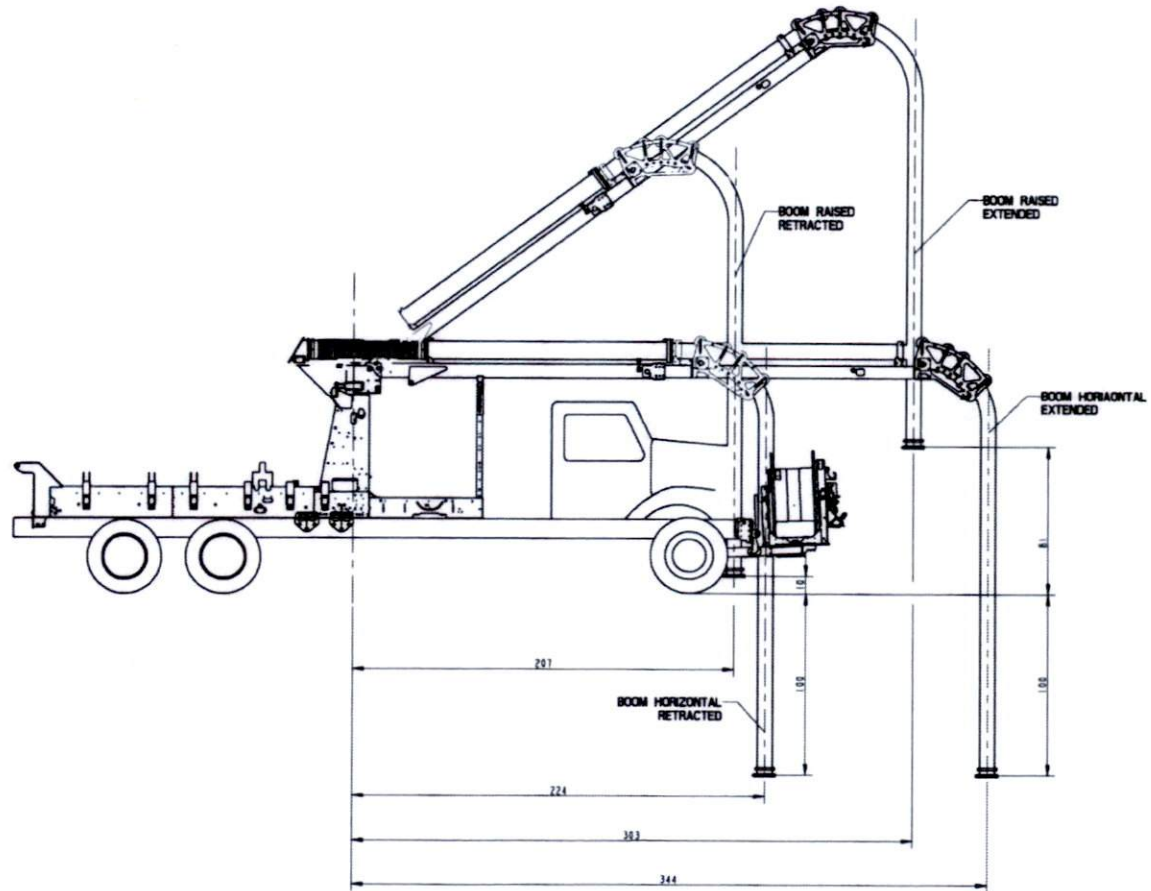

HOSE EXTENDED

REV	REVISION	BY	DATE	QTY	QTY IN INCHES
A	ADDED HOSE ROLL	JLR	8/15/17		
					TOLERANCES UNLESS NOTED
					CONVENTIONAL TOLERANCE FACTOR
					STANDARD GRADE
<small>THIS DRAWING IS THE PROPERTY OF VECTOR MANUFACTURING INC. IT IS TO BE USED ONLY FOR THE PROJECT AND QUANTITY SPECIFIED THEREON. IT IS NOT TO BE REPRODUCED, COPIED, OR TRANSMITTED IN ANY FORM OR BY ANY MEANS, ELECTRONIC OR MECHANICAL, INCLUDING PHOTOCOPYING, RECORDING, OR BY ANY INFORMATION STORAGE AND RETRIEVAL SYSTEM. THE USER AGREES TO HOLD VECTOR MANUFACTURING INC. HARMLESS FROM ALL LIABILITY FOR LOSS OF PROFITS OR OTHER DAMAGES, INCLUDING REASONABLE ATTORNEY'S FEES, ARISING FROM THE USE OF THIS DRAWING. UNCONTROLLED</small>					
VECTOR MANUFACTURING INC. SHELTON, CT. NAME: 10 X 15 BOOM COVERAGE MATERIAL: LISTED DRAWN: JLR SHEET: 7 OF 3 DATE: 8/15/17 SCALE: 1/32 SIZE: 8 PART NO.: REV: A					

