



Special Downtown Development Authority Agenda

Tuesday, August 22, 2023 at 12:00 PM
27400 Southfield Road, Lathrup Village, Michigan 48076

1. **Call to Order**

2. **Approval of Agenda**

3. **Approval of Minutes**

[A.](#) 2023 07 21 DDA Board of Directors

4. **Financial Review**

5. **Committee Reports**

6. **Other Business**

[A.](#) August 2023 CED Report

7. **Old Business**

[A.](#) Approve/Deny Sign Grant Application - 18411 W 12 Mile Road

8. **New Business**

[A.](#) LV Music Festival discussion

9. **Public Comment**

10. **Adjourn**



Downtown Development Authority Minutes

Friday, July 21, 2023 at 12:00 PM
27400 Southfield Road, Lathrup Village, Michigan 48076

1. Call to Order

12:02 pm by Vice Chair Ford

Present: Bryan Ford, Patricia Felton, Charlotte Jones, Pam Shermeyer, Dan Sugg

Absent: Kelly Garrett, Bobbi Lovins, Scott McKee, Fred Prime

Staff: Pam Bratschci, Brittany Dorsey, Rob Harris, Susie Stec

Motion to excuse Garrett, Lovins, McKee, and Prime by Sugg, seconded by Shermeyer. All in favor.

2. Approval of Agenda

Motion to approve the agenda by Jones, seconded by Sugg. All in favor.

3. Approval of Minutes

Motion to approve the 2023 06 16 DDA Board of Directors minutes by Shermeyer, seconded by Sugg. All in favor.

Motion to approve the 2023 06 29 Special DDA Board of Directors by Shermeyer, seconded by Sugg. All in favor.

4. Financial Review

A. June 2023 Financial

Bratschci went over the reports. Stated that initially the amended budget anticipated using \$45k from the fund balance, but the final numbers show contributing \$170k to the fund balance. There was a question regarding the due to/due from amounts. Bratschci reminded the board that the DDA does not have its own checking fund ergo invoices are paid by the city and reimbursed by the DDA.

Motion to receive and file the June 2023 Financial Reports by Sugg, seconded by Shermeyer. All in favor.

5. Committee Reports

Dorsey provided an update on activities related to banners, beautification, and promotion efforts (i.e. mailers, newsletters)

6. Other Business

A. July 2023 CED Report

Stec went over the report and answered questions.

7. Old Business

8. New Business

A. Approve/Deny Sign Grant Application - 18411 W. 12 Mile Rd.

Motion to table the item to the next meeting by Sugg, seconded by Shermeyer. All in favor.

B. DDA Website discussion

The board discussed the merits of establishing a website separate from the city's website. This will help the DDA establish its own identity, provide clarity of information, allow the DDA to better serve the business community and drive engagement with the business community.

Motion to authorize the DDA Director to enter into an agreement with Munibit to establish a standalone LVDDA website by Sugg, seconded by Shermeyer. All in favor.

C. August DDA Meeting discussion

Stec informed the board that she will be out of town for the August meeting. She asked the board to consider an alternative date and stated a poll would be sent to determine a date/time.

9. Public Comment

K. Miller (council member/resident) spoke.

10. Adjourn at 12:55 pm

Motion to adjourn by Sugg, seconded by Shermeyer. All in favor.



27400 Southfield Rd
 Lathrup Village, MI 48076
 (248) 557 - 2600
www.lathrupvillage.org

MEMORANDUM

To: LVDDA Board of Directors

From: Susie Stec, DDA and CED Director

Date: August 10, 2023

RE: Department/Director Report

In an effort to provide consistent updates to the DDA Board of Directors, City Administrator, and City Council the following monthly is submitted for your review.

Upcoming DDA Events

- Are You E-Commerce Ready Business Workshop: August 24th, 11 am – 1:30 pm
- LV Music Festival: September 30th, 2 – 8 pm
- Fall Corridor Cleanup: TBD
- Tri-City Holiday Party: November 16th, 4 – 7 pm (Dog & Pony Show Brewing, Oak Park)

Past DDA Events

- Juneteenth Celebration: June 17th

Commercial Business/Property Updates

- 26780 Southfield Road (44 Burrito) – New restaurant. Obtained approval for outdoor patio at the July Planning Commission meeting. They are working on interior renovations.
- 27300 Southfield Road –The site plans are under review by the city & planners, and will be forwarded for consideration to the Planning Commission
- City staff & planners met with Surnow Company to discuss proposed façade renovation

Infrastructure

- 2023 infrastructure work is nearly complete. Contractors are finishing their respective punch list items. Landscaping touch-up work is expected in the fall.
- Staff and consultants met with RCOC about the resurfacing of Southfield Road in 2024. They are intending to have public meetings in the fall.



27400 Southfield Rd
Lathrup Village, MI 48076
(248) 557 - 2600
www.lathrupvillage.org

Miscellaneous

- DDA is partnering with Oak Park, Southfield, Farmington Hills, and Michigan Works! Southfield office to develop and send a survey to the businesses in our respective communities to help identify desired training/workshop topics.
- DTE Tree Grant planting activities will take place in Fall 2023
- DDA engaged Hortulus Gardens to weed & mulch the flowerbeds surrounding the monument sign, City Hall, and 12 Mile
- MSOC has submitted the grant application for the Revitalization & Placemaking Grant program. A total of 13 communities participated in the regional application. Award notifications are anticipated in the fall.
 - A crowdfunding campaign has been established to securing the remaining match funds. The goal is \$20,000.



27400 Southfield Rd
Lathrup Village, MI 48076
(248) 557 - 2600
www.lathrupvillage.org

To: DDA Board of Directors

From: Susie Stec, Director – Community & Economic Development /DDA Director

RE: Sign Grant – 18411 W. 12 Mile Road

Date: August 10, 2023

Update: This grant application was on the July 21, 2023 DDA Board of Directors agenda; however, Board Member Jones recused herself which lead to an insufficient number of eligible voters. The item was tabled to the August meeting when more members of the board may be present. All remaining memo text remains unchanged.

A Sign Grant application was received by the property owners of 18411 W. 12 Mile Road (Charlotte & Scottie Jones, LOGOS/Hope for All Seasons). The property owners intend to install a new wall sign and update the face panels on the existing monument sign.

The proposed wall sign will be 10.36 square feet and the new face panels total 27.8 square feet, both of which meet standards detailed in the chart below. The wall sign will require a permit through the Building Department; however, the face panels will not require a permit per the ordinance.

52-24. Sign Types Permitted by District				
B. Office Districts (O & GO). Permits required, unless otherwise noted				
Sign Type	Location	Max. Sign Surface Display Area	Max. Height	Number
Principal Wall Signs	On principal building façade to be placed at the sign band, when provided.	Setback from lot line from 0 to 100 ft: 10% of ground floor, street-facing building face up to 64 sq ft Setback more than 100 ft: 15% of ground floor, street-facing building face up to 64 sq ft	Not to exceed height of building	1 per business with individual exterior entrance or, if a common entrance is provided, one per building
Monument sign See Section See Section 52-25.A.	At the property entrance, setback 10	32 sq ft per side	5 ft from ground level to top of sign	1 per parcel. 1 additional sign is permitted if the parcel has more than 100 feet

	ft from street right-of-way line			of frontage on 11 or 12 Mile Roads provided they are separated by 100 ft. minimum.
--	----------------------------------	--	--	--

The estimated cost of the proposed signage is \$3,459.51.

Per the DDA Sign Grant Program parameters, the LVDDA Board of Directors may approve and provide reimbursement for signage up to a maximum grant of fifty (50%) percent of total project cost or two thousand dollars (\$2,000.00).

Suggested Motion: To award a DDA Sign Grant in the amount of \$1,730 to the property owners of 18411 W. 12 Mile Road to be reimbursed upon installation and final approval by the Building Official.

SIGN GRANT PROGRAM APPLICATION FORM

PROPERTY INFORMATION

Property Address:	18411 W. 12 Mile Rd
Parcel ID Number:	24-14-226-048
Current Zoning:	

BUSINESS INFORMATION

Business Name:	LOGOS Global Ministries		
Business Owner Name:	Scottie & Charlotte Jones		
Business Mailing Address:	P.O. Box 760181		
Phone Number:	248-809-2422		
Email:	scottie.l.jones@lifeofGodOutreach.org.com		
Sign Type (circle):	<input checked="" type="radio"/> Wall	<input checked="" type="radio"/> Monument	<input type="radio"/> Awning

PROPERTY OWNER INFORMATION

Property Owner Name:	Charlotte & Scottie Jones	
Property Owner Address:	24550 W. Lafayette Circle Southfield 48075	
Property Owner Phone:	(313) 574-4352 & 204-6259	
Property Owner Email:	charlotte.m.jones08@gmail.com	

Applications must include the following attachments to be considered for funding. Incomplete applications will not be accepted or considered for funding:

- Complete sign package with sealed drawings
- Cost Estimate
- Current digital photos of all existing building signage

SIGN GRANT PROGRAM AFFIRMATION FORM

The undersigned applicant affirms and understands that:

1. The information submitted herein is true and accurate to the best of my knowledge.
2. I have read and understand the Sign Grant Program Guidelines and agree to abide by these conditions, as applicable to the proposed project.
3. I understand that the proposed sign cannot be installed until the DDA reviews and acts upon this Sign Grant Program application.
4. I understand that any changes made to the approved Sign without the approval of the DDA will be cause the DDA to withdraw its funding commitment.
5. Any sign grantee that removes or replaces the sign within the first three years of receiving a grant, while the business is still in operation, shall be required to repay to the DDA the total amount of grant funds awarded.
6. I understand that if the grant funded sign is removed within the three years following grant approval for a business that is still operational, shall require the repayment to the DDA of Grant Funds expended.
7. The property owner and business owner shall indemnify, defend, and hold the Downtown Development Authority and the City of Lathrup Village, their affiliates, and their respective officers, directors, council, members, employees, agents, and other representatives harmless from and against all claims, losses, expenses, liabilities, demands, obligations, or damages of every kind and nature (including, without limitation, reasonable attorney fees and expenses) (Losses), arising out of or related to (i) any act or omission of property owner and business owner or (ii) any breach of this Agreement by the property owner and business owner relative to this grant.

 4 May 23
 Signature - Business Owner Date

 4 May 23
 Signature - Property Owner Date

Reimbursement Request Certification

I, the undersigned, warrant that all representations of the application submitted under the program are true and accurate and that there has been no material change which would in itself or cumulatively with other events impair the profitable functioning of my business operation. All agreements, warranties and representations made to the City of Lathrup Village Downtown Development Authority are true at the time they were made and shall remain true at the time of submittal for reimbursement under the program. I understand that if my business closes or moves out of the City of Lathrup Village within three (3) years, I will be required to repay the Lathrup Village Downtown Development Authority in an amount as described on in the Sign Grant Program Guidelines. The City of Lathrup Village Downtown Development Authority may in its sole option cancel its assistance commitment either in whole or in part for failure to comply with the requirements of this grant program or applicable codes and regulations.

Date:	4 May 2023
Applicant Name:	Scottie & Charlotte Jones
Applicant Signature:	Scottie Jones and Charlotte Jones
Business Name:	LOGOS/ Hope 4 all Seasons
Business Address:	18411 W 12 Mile Rd, Lathrup Village MI 48076
Mailing Address (if different):	P.O. Box 760181 Lathrup Village, MI 48075
Phone:	(248) 809-2422 (313) 574-4352 (313) 204-6259
Email:	scottie.l.jones@lifeofgodoutreachson.com

ESTIMATE

E162-109844

www.fastsigns.com/162

Payment Terms: Cash Customer

DESCRIPTION: Building Signage

Bill To: Life of God
18411 W 12 Mile
Lathrup Village, MI 48076
US

Installed: Life of God
Scotty Jones
18411 W 12 Mile
Lathrup Village, MI 48076
US

Requested By: Scotty Jones
Email: logosgm2016@outlook.com
Cell Phone: (313) 574-4352

Salesperson: Sabrina Keyes
Email: sabrina.keyes@fastsigns.com

PRODUCTS	QTY	UNIT PRICE	TOTALS
1 Building Sign	1	\$878.06	\$878.06
1.1 Dimensional Letters -			
Part Qty: 1	Text: Hope 4 All Seasons		
2 Monument Sign Updates	1	\$1,714.09	\$1,714.09
2.1.1 Acrylic 3/16" - Upper Panels - Full Width			
Part Qty: 4			
Width: 69.50"			
Height: 14.6146"			
Color: White			
Sides: 1			
- Text/Graphics Color: Black			
- Background Color: White			
2.1.2 Printed Vinyl - Translucent -			
Part Qty: 4	Text: 2 Each:		
Width: 69.50"	LIFE OF GOD OUTREACH SONS		
Height: 14.6146"	Global Ministries		
	SALINGER & ASSOCIATES		
	Attorneys & Counselors		
Vinyl Application			
- Overlay			
Contour Cut (Vinyl)			
- Cut Size: Simple Cut			
2.1.3 Laminate -			
Part Qty: 4			
Width: 69.50"			
Height: 14.6146"			
Laminate Options			
- Laminate Types: Cast Gloss			

2.2.1 Acrylic 3/16" - Lower Panels - Half Width

Part Qty: 4
Width: 34.00"
Height: 14.6146"
Color: White
Sides: 1
 - Text/Graphics Color: Black
 - Background Color: White

2.2.2 Printed Vinyl - Translucent -

Part Qty: 4
Width: 34.00"
Height: 14.6146"

Text: 2 Each:

INDUS CENTER for
 ACADEMIC EXCELLENCE

NATIONAL DOMESTIC WORKERS ALLIANCE

Vinyl Application

- Overlay
Contour Cut (Vinyl)
 - Cut Size: Simple Cut

2.2.3 Laminate -

Part Qty: 4
Width: 34.00"
Height: 14.6146"

Laminate Options

- Laminate Types: Cast Gloss

3	Interior Door Graphics	1	\$197.15	\$197.15
3.1.1	Printed Vinyl - Calendared - Logo			
	Part Qty: 1	Text: Printed Logo		
	Width: 71.50"			
	Height: 30.00"			
	- Text/Graphics Color: CMYK			
	Contour Cut (Vinyl)			
	- Cut Size: Simple Cut			
3.1.2	Laminate -			
	Part Qty: 1			
	Width: 71.50"			
	Height: 30.00"			
	Laminate Options			
	- Laminate Types: Calendar Gloss			
3.2	Frosted/Etched Vinyl - Frosted Lettering			
	Part Qty: 1	Text: LOGOS Global Ministries		
	Width: 71.50"			
	Height: 4.00"			
	- Text/Graphics Color: Frosted			
	Vinyl Application			
	- Ready to Apply			
4	Permit Fees - Finalized at Permit Approval	1	\$260.00	\$260.00
4.1	Estimated Permitting Fees -			
	- Retail Price: \$110.00			
4.2	Permit Acquisitions -			
	- Retail Price: \$150.00			
5	Install	1	\$440.00	\$440.00

Inside work estimate

5.1 Installation -
- # of Hours: 4

Text: Install of dimensional letters to brick wall.

Remove and dispose of all monument sign inserts and dividers, replace with new panels and hardware.

Install logo and frosted lettering to interior double doors.

Subtotal:	\$3,489.30
Taxes:	\$167.36
Grand Total:	\$3,656.66

*-197.15
far inside
work*

A 50% deposit is required to begin your order.

Estimates are valid for 30 days.

\$ 3,459.51

Signature: _____ Date: _____

Request a quote on the following:

Life of God Outreach sons, Global Ministries

18411 W. 12 Mile Road, Lathrup Village, MI 48076

On the outside of the Building:

On the building Hope for all seasons (see attached)



On the monument sign - 8 panels (4 on each side)

LIFE OF GOD OUTREACH SONS Global Ministries	
SALINGER & ASSOCIATES Attorneys & Counselors	
INDUS CENTER for ACADEMIC EXCELLENCE	NATIONAL DOMESTIC WORKERS ALLIANCE



18411

THAIER KINAYA CPA, P.C.

CERTIFIED PUBLIC ACCOUNTANT

SALINGER & ASSOCIATES

ATTORNEYS & COUNSELORS



**Indus Center for
Academic Excellence**

THAIER KINAYA CPA, P.C.

CERTIFIED PUBLIC ACCOUNTANT

SALINGER & ASSOCIATES

ATTORNEYS & COUNSELORS



**Indus Center for
Academic Excellence**

**PAID
IN
FULL**

INVOICE Item 7A.
162-112034

www.fastsigns.com/162

Completed Date: 7/12/2023
Payment Terms: Cash Customer
Payment Due Date: 7/12/2023

DESCRIPTION: Reorder: Signed and Sealed Drawings

Bill To: Life of God
18411 W 12 Mile
Lathrup Village, MI 48076
US

Pickup At: FASTSIGNS of Farmington Hills
27615 Halsted Rd
Farmington Hills, MI 48331
US

Ordered By: Scotty Jones
Email: logosgm2016@outlook.com
Cell Phone: (313) 574-4352

Salesperson: Sabrina Keyes
Email: sabrina.keyes@fastsigns.com

PRODUCTS	QTY	UNIT PRICE	TAXABLE	TOTALS
1. Signed and Sealed Drawings	1	\$350.00	\$0.00	\$350.00
1.1 Permit Acquisitions - - Retail Price: \$350.00				

Subtotal:	\$350.00
Taxable Amount:	\$0.00
Taxes:	\$0.00
Total:	\$350.00
Amount Paid:	\$350.00
Balance Due:	\$0.00

Please note: Orders will only be held for 6 months after production.

TRANSACTIONS

Date	Type	Amount
7/12/2023	MasterCard (Online) - 1299	\$350.00

Signature: _____ Date: _____

RECEIVED
JUL 13 2023
City of Lathrup Village

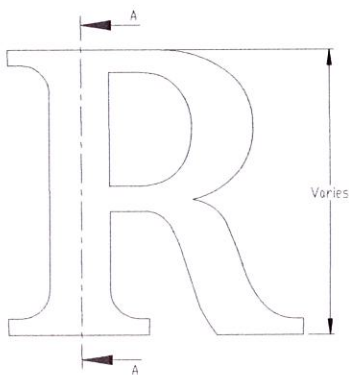

FRONT VIEW II SCALE 1:2.5

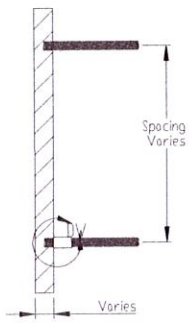

SECTION VIEW A-A II SCALE 1:2.5

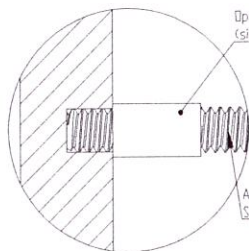

DETAIL DW II SCALE 2:1

SIZE	MIN. STUDS/LTR
Up to 3'	3 studs
over 3' - 15'	4 studs
Over 15'	6 studs
Punctuation	2 studs

NOTES:

- Typical stud length 2" beyond back of letter
- Letters under 15" high - 10/24 studs, 15" high - 1/4-20 studs
- Less than 3/8" stroke, 6-32 or 4-40 studs
- Minimum 1/4" thick
- Letters or logos, standard or custom

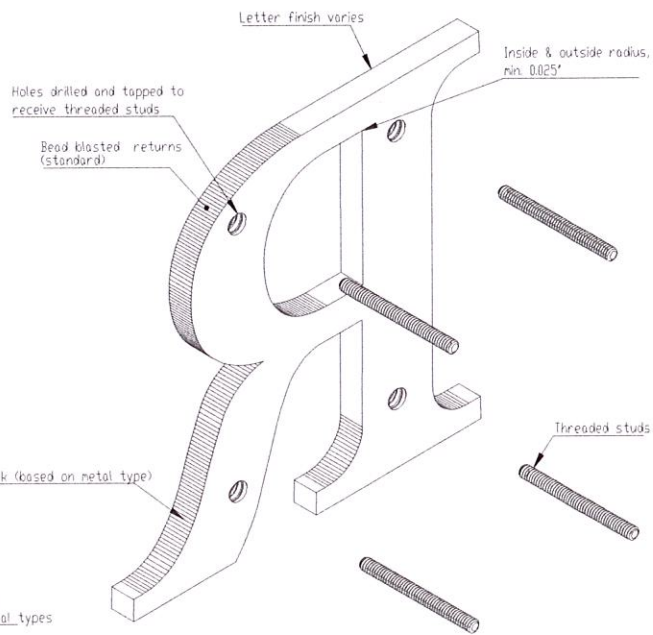

ISOMETRIC BACK VIEW II SCALE 1:1.5

FLAT CUT METAL - STUD MOUNT





27400 Southfield Rd
Lathrup Village, MI 48076
(248) 557 - 2600
www.lathrupvillage.org

To: DDA Board of Directors

From: Susie Stec, Director – Community & Economic Development /DDA Director

RE: LV Music Festival discussion

Date: August 21, 2023

Background:

DDA staff was approached by residents interested in hosting a concert, which the DDA had already been intending to do. Needless to say, we combined forces and began planning the Lathrup Village Music Festival! The planning committee consists of DDA staff, Promotions Committee, Adam Laurie, Jason Hammond, and Lauren Beras. There is a total event budget of \$8,500 which is comprised of DDA funds (\$5,000), Michigan First Credit Union sponsorship (\$2,500), and The Do-Gooders donation (\$1,000).

Summary:

LV Music Festival is being planned to be LV-centric. The event is being held on Saturday, September 30th (rain date: October 1st) in Municipal Park from 2 – 8 pm. It will feature 6 – 8 musical performers who have some connection to Lathrup Village or the surrounding area. We have lined-up jazz musician [Dave McMurray](#) as the headliner. His total performance fee is \$2,500 and a deposit of \$1,250 is required to secure him as a performer. All other musicians and related sound/stage equipment will each be under \$600.

There will be approximately 24 local businesses – both from the commercial corridor and home-based/makers, as well as a beer tent and food trucks. We have already confirmed two Lathrup Village-based food trucks: 44 Burrito and Wetzels Pretzels, as well as several resident makers.

Promotion of the LV Music Festival will be multi-faceted and will include social media posts, newsletter and website announcements, signage, posters at LV businesses, etc. We would also like to run a half-page ad in the Southfield Sun on September 6th and a quarter-page ad on 20th for a total of \$1,361.

In addition to local vendors there will be a beer tent to contribute to the atmosphere. As such, the DDA will need to submit to the MLCC for a Special License which is available to non-profits and municipalities. There is a fee of \$50 – 100. The LV Music Festival planning committee is working to secure sponsors for the alcohol sales.

There are three (3) motions to be considered by the DDA Board of Directors:

Suggested motion #1: Authorize the DDA Director to complete and submit a MLCC Special License Application on behalf of the Lathrup Village DDA for the Lathrup Village Music Festival on September 30, 2023, an event to be held in Municipal Park (27400 Southfield Road).

Suggested motion #2: Authorize the DDA Director to enter into a contract/agreement with David McMurray to perform at the LV Music Festival on September 30, 2023 and provide a deposit of \$1,250, with the balance to be paid following the performance.

Suggested motion #3: Authorize the DDA staff to advertise the LV Music Festival in the September issues of the Southfield Sun for an amount not to exceed \$1,361.