



City Council Regular Meeting

Monday, August 19, 2024 at 7:30 PM

27400 Southfield Road, Lathrup Village, Michigan 48076

1. **Call to Order** by Mayor Garrett
2. **Roll Call**
3. **Pledge of Allegiance**
4. **Approval of Agenda**
5. **Presentations**
 - A. Proclamation - Volunteer Appreciation For Their Outstanding Contributions to the 2nd Annual Lathrup Village Music Festival
6. **Public Comment for Items on the Agenda** (speakers are limited to 3 minutes)
7. **Consent Agenda**

All items listed under "Consent Agenda" are considered to be routine and non-controversial by the City Council and will be approved by one motion. There will be no separate discussion. If a discussion is desired, that item(s) will be removed from the consent agenda and discussed separately immediately after consent agenda approval in its normal sequence on the regular agenda.

 - A. Approval of Minutes
 - i. 7-15-24 - City Council Regular Meeting
 - ii. 7-15-24 - City Council Study Session
 - B. Lathrup Village Police Department Monthly Reports
 - C. Community & Economic Development Department Report
 - D. Building & Code Enforcement Reports
 - E. Finance Department Reports
8. **Action Requests - For Consideration / Approval**

- [A.](#) Second Reading - Request to Amend City Ordinances by Addition of, Chapter 46 - Miscellaneous Offenses, Provisions, Forfeitures and Penalties, Article XIII. Nuisance Parties
- [B.](#) Request to Approve Axon Taser Contract
- [C.](#) Request to Approve MML Liability & Property Pool Coverage Renewal
- [D.](#) Request to Approve DPS Pickup Truck Purchase
- [E.](#) Request to Approve DPS Lawn Mower Purchase
- [F.](#) Request to Approve Council Chambers Camera Upgrade
- [G.](#) Request to Approve Emergency Contract with ServPro of West Sterling Heights
- [H.](#) Request to Approve Resolution #2024-12 - Resolution in Support of the Application for the Detroit Institute of Arts Partners in Public Art Program for Lathrup Village
- [I.](#) Request to Approve Resolution #2024-13 - Resolution to Adopt and Allocate Funds for An Outdoor Fitness Court as Part of the 2025 National Fitness Campaign
- [J.](#) Request to Approve Resolution #2024-14 - To Enter Into An Agreement With The Michigan Department of Transportation For A Traffic Control Device At Margate Avenue & Southfield Road
- [K.](#) Request to Approve Resolution #2024-15 - Resolution of Support for the Oakland County RAP 2.0 Revitalization & Placemaking Grant Application
- [L.](#) First Reading - Request to Amend Ordinance Chapter 77. Urban Redevelopment, By Amending Article I. Downtown Development Authority, Section 77-7. Board of Directors

9. City Administrator Report

10. City Attorney Report

11. Reports of Boards, Commissions, and Committees

- a. Downtown Development Authority
- b. Planning Commission
- c. Parks & Recreation
- d. Tree Committee

e. Southfield School Board

f. Finance Review Committee

12. Unfinished / New Business

13. Public Comment (speakers are limited to 3 minutes)

14. Mayor and Council Comments

15. Request to Enter Closed Session Pursuant to MCL 15.268(1)(h) to Discuss Written Attorney Memorandum

16. Adjourn

ADDRESSING THE CITY COUNCIL

- Your comments shall be made during times set aside for that purpose.
- Stand or raise a hand to indicate that you wish to speak.
- When recognized, state your name and direct your comments and/or questions to any City official in attendance.
- Each person wishing to address the City Council and/or attending officials shall be afforded one opportunity of up to three (3) minutes duration during the first and last occasion for citizen comments and questions and one opportunity of up to three (3) minutes during each public hearing. Comments made during public hearings shall be relevant to the subject for which the public hearings are held.
- In addition to the opportunities described above, a citizen may respond to questions posed to him or her by the Mayor or members of the Council, provided members have been granted the floor to pose such questions.
- No speaker may make personal or impertinent attacks upon any officer, employee, or City Council member or other Elected Official, that is unrelated to the manner in which the officer, employee, or City Council member or other Elected Official performs his or her duties.
- No person shall use abusive or threatening language toward any individual when addressing the City Council.
- Any person who violates this section shall be directed by the Mayor to be orderly and silent. If a person addressing the Council refuses to become silent when so directed, such person may be deemed by the Mayor to have committed a "breach of the peace" by disrupting and impeding the orderly conduct of the public meeting of the City Council and may be ordered by the Mayor to leave the meeting. If the person refuses to leave as directed, the Mayor may direct any law enforcement officer who is present to escort the violator from the meeting.

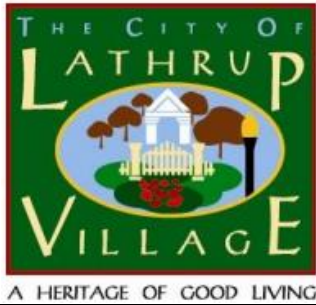

City Council Regular Meeting

Monday, July 15, 2024 at 7:30 PM

27400 Southfield Road, Lathrup Village, Michigan 48076

1. **Call to Order** by Mayor Garrett 7:30 pm
2. **Roll Call**

Present: Mayor Garrett, Mayor Pro-Tem Kantor, Councilmember Hammond

Absent: Councilmember Jennings, Councilmember Barksdale

Moved by Councilmember Hammond and Seconded by Mayor Pro-Tem Kantor, to excuse Councilmember Barksdale and Councilmember Jennings.

Yes: Garrett, Kantor, Hammond

No: N/A

Absent: Jennings, Barksdale

Motion Carried.

3. **Pledge of Allegiance**
4. **Approval of Agenda**

Moved by Mayor Pro-Tem Kantor, Seconded by Councilmember Hammond to remove items: G, H, I, and K, from the agenda, because there were not enough Council members present for a Quorum, and to add Item L to appoint a Board of Review member.

Yes: Garrett, Kantor, Hammond

No: N/A

Absent: Jennings, Barksdale

Motion Carried.

5. **Public Comment for Items on the Agenda** (speakers are limited to 3 minutes)

Karen Miller – Items 7B & 7 C – Challenge the validity of the petition signatures that were submitted.

6. **Consent Agenda**
 - A. Approval of Minutes
 - i. June 17, 2024 - Regular Meeting
 - ii. June 17, 2024 - Study Session
 - B. Police Department Monthly Reports
 - C. Community & Economic Development Department Report
 - D. Building & Code Enforcement Reports
 - E. Finance Department Reports
 - F. Request to Appoint Members of the MML Workers' Compensation Fund

Moved by Councilmember Hammond, Seconded by Mayor Pro-Tem Kantor to approve the consent agenda.

Yes: Garrett, Kantor, Hammond
No: N/A
Absent: Jennings, Barksdale
Motion Carried.

7. Action Requests - For Consideration / Approval

A. Request to Approve Encroachment License Application - 27680 Lathrup Blvd.

Moved by Mayor Pro-Tem Kantor, Seconded by Hammond, to approve the Encroachment license for 27680 Lathrup Boulevard.

Yes: Garrett, Kantor, Hammond
No: N/A
Absent: Jennings, Barksdale
Motion Carried.

B. Request to Approve Resolution #2024-09 - Establishing Ballot Language for Referendum Petition Received Regarding Charter Referendum

Moved by Councilmember Hammond, Seconded by Mayor Pro-Tem Kantor to approve Resolution #2024-09, establishing Ballot Language for Referendum Petition Received regarding Charter referendum.

Yes: Garrett, Kantor, Hammond
No: N/A
Absent: Jennings, Barksdale
Motion Carried.

C. Request to Approve Resolution #2024-10 - To Submit the Proposal Provided For in the Initiative Petition to the Electors & Establishing the Ballot Language -- or -- Request to Approve Resolution #2024-11 - To Adopt the Ordinances Submitted by an Initiative Petition and to Schedule the Second Reading of Said Ordinance

Moved by Mayor Pro-Tem Kantor, Seconded by Councilmember Hammond to approve Resolution #2024-10 to submit the proposal provided for in the Initiative Petition to the electors, and establish ballot language.

Yes: Garrett, Kantor, Hammond
No: N/A
Absent: Jennings, Barksdale
Motion Carried.

D. First Reading - Request to Amend City Ordinances by Addition of, Chapter 46 - Miscellaneous Offenses, Provisions, Forfeitures and Penalties, Article XIII. Nuisance Parties

Moved by Mayor Pro-Tem Kantor, Seconded by Councilmember Hammond to schedule the second reading of an update to the City Ordinances, by addition to Chapter 46, Miscellaneous Offenses, ties Article XIII. Nuisance Parties.

Yes: Garrett, Kantor, Hammond
No: N/A
Absent: Jennings, Barksdale
Motion Carried.

E. Second Reading - Request to Adopt an Update to Ordinance Chapter 46. Miscellaneous Offenses, Provisions, Forfeitures and Penalties, Article XII. Parks and Recreation Protection.

Moved by Councilmember Hammond, Seconded by Mayor Pro-Tem Kantor, to adopt update Chapter 46. Misc Offenses, Provisions, Forfeitures, and Penalties, Article XII. Parks and Recreation Protection.

Yes: Garrett, Kantor, Hammond
No: N/A
Absent: Jennings, Barksdale
Motion Carried.

F. Second Reading - Request to Adopt an update to Ordinance Chapter 14. Buildings and Building Regulations, Article VIII. Swimming Pools, Section 14-183 Fencing.

Moved by Councilmember Hammond, Seconded by Mayor Pro-Tem Kantor, to adopt an update to Ordinance Chapter 14. Buildings and Building Regulations, Article VIII. Swimming Pools, Section 14-183 Fencing.

Yes: Garrett, Kantor, Hammond
No: N/A
Absent: Jennings, Barksdale
Motion Carried.

- ~~G. Request to Approve DPS Pickup Truck Purchase~~
- ~~H. Request to Approve DPS Lawn Mower Purchase~~
- ~~I. Request to Approve Council Chambers Camera Upgrade~~

J. Request to Approve the Uniform Video Service Local Franchise Agreement with Comcast

Moved by Councilmember Hammond, Seconded by Mayor Pro-Tem Kantor to approve the Uniform Service Local Franchise Agreement with Comcast Cable LLC., with a provider fee of five percent.

Yes: Garrett, Kantor, Hammond
No: N/A
Absent: Jennings, Barksdale
Motion Carried.

~~K. Request to Approve Emergency Contract with ServPro of West Sterling Heights~~

L. Request to Appoint Board of Review Alternate

Moved Mayor Pro-Tem Kantor, Seconded by Councilmember Hammond, to approve Amy Parsons to the Board of Review as an Alternate.

Yes: Garrett, Kantor, Hammond

No: N/A

Absent: Jennings, Barksdale

Motion Carried.

8. City Administrator Report

City Administrator Greene announced the launch of the updated City of Lathrup Village website and the City of Lathrup Village mobile app.

9. City Attorney Report

10. Reports of Boards, Commissions, and Committees

- A. Downtown Development Authority – Meeting on Friday, July 19, 2024, at Noon
- B. Planning Commission – Meeting Canceled tomorrow (7/16), but there will be one in August.
- C. Parks & Recreation – N/A
- D. Tree Committee – Meeting on July 16, 2024 at 4:30 pm
- E. Southfield School Board – N/A
- F. Finance Review Committee – The recent meeting was productive, but resident turnout was low, and the committee encouraged resident input during the meetings. Plante Moran gave a presentation on potential revenue options to consider. The next meeting is July 16, 2024, at 5:30 PM.

11. Unfinished / New Business none

12. Public Comment (speakers are limited to 3 minutes)

Leslie Burton – Concern about the upsurge in block parties. Hoping the newly proposed ordinance gives the Police Department the tools necessary to limit incidents like what happened on Margate.

Josh Curt – 27465 California – Discussed the high-water bill letter that was received; parties in the park and parking on the easement

Adam Laurie – Lathrup Village Music Festival on August 10th, 2024 from 12:00 PM to 11:00 PM.

Autumn Sousanis – Discussed the high-water bill letter that was received

Ian Ferguson – Thanked residents who signed the petitions

Andre Campbell – Thanked the City Council, for approving his encroachment license application.

Laurie Kunz – Noted the meeting was not streaming on Facebook; asked that Council do not whisper to each other during the meeting; discussed police staffing and reasons why the City may be losing officers.

13. Mayor and Council Comments

Mayor Pro-Tem Kantor read a letter from Kim Hodge and other residents:

This is a statement for the upcoming City Planning Session on Monday, 7/15. Sorry I'm unable to attend on that date.

My name is Kim Hodge and I live at 27580 California Dr. SE. I am writing today to ask Council not to allow loud music and noise in the rental agreement for the pavilion and gazebo area. I am a huge music lover and supporter, but sometimes it just gets way too loud. Just to be clear, I am not talking about music during the Wednesday night concerts or the Lathrup Village music festival or other Lathrup Village events. I'm talking about rentals here.

I understand that the current decibel limit is set at 65 and you are considering raising it to 85 or some similar number. That is probably a reasonable limit. However, that limit is not adhered to. I am sometimes unable to sit in our own backyard or even in our house with the windows open without getting blasted with loud music (and pounding deep bass).

Last summer I had had enough after listening to loud music for 4 hours. I walked over to the gazebo and saw that speakers were pointed away from the pavilion, into my direction and very, very loud music was being played. Same thing happened within the last 2 months, with loud music for hours. This was, I'm sure, way above the allowed decibel limit and I should've called the police at that time, but I didn't. I'd like to avoid such situations in the future.

Could you please make sure that City staff emphasize the decibel limit to the person renting when you rent the outside space? And make sure that the police are aware of and enforcing the limits? We should not have to go inside our houses or close the windows in order to live comfortably when someone is renting the facilities.

Thank you for your attention to this matter.
Kim Hodge and Tom Brodzik

In support are the following neighbors:

•Gary W. Roberts & Kevin Bryant, 27474 California Dr SE
"Our issues are with the private rental parties in the Park which is right across the street. In many instances the music far exceeds the volume of the City organized Music in the Park and City events. Both the music and in between voice broadcasts at private events in the Park are extremely loud. Also some of these private parties have gone on past 10 pm, which is a very long duration of their intrusively loud music. I recommend NOT raising the volume on private rental parties. Also I think the LV Police should have the equipment to measure the volume and check it randomly (at least twice) to confirm it is within the terms of the rental contract."

•Brian Margosian, 27560 California SE
"I echo all of the above. We love our proximity to the park for LV live music where sound levels seem to be better controlled, however during some of these private events we have also noticed similar issues to our neighbors' above."

I will remind others as well that the decibel scale is logarithmic, so an increase from 65 to 85dB is a 10x increase in perceived sound pressure level.”

•Phyllis Windham, 27530 Sunset Blvd E

“I agree. I live right across the street from the park (across from the Children’s Garden) and I should not have to close my windows during the rentals. I’ve also heard loud swearing on the microphone. People in attendance often block my mailbox and park on the edge of my lawn.”

•Chris Smith, 27460 California SE

It also bothers him when people park on the berm in front of their house, leaving tire marks.

•Shannon Burke, 27411 Lathrup Blvd.

“I second the request to publicize and enforce the decibel limits, and to encourage groups renting the gazebo to avoid pointing their speakers at homes. If I can identify the song from half a yard away and sing along, it's probably too loud.”

•Resident from Lathrup Blvd

“Lathrup Boulevard is typically a quiet street, but over the past three years, we have often heard loud parties put on at the park. We often wondered if it was a community event due to the noise. We would investigate only to find out they were private parties. We can hear the music well into the evening, which can be disruptive to a young family with a toddler. As a wedding and event planner who works with venues much less residential than our pavilion (Cushing Field House & Shepherds Hollow), these venues currently have noise ordinances set at no higher than 99 decibels and are strongly adhered to.

I feel that the current sound limit of 65 decibels has not been adhered to and we request that you do not increase the allowed sound decibels before monitoring more closely to see what parties are currently playing music before making a final decision.”

•Sandy Schwartz, 27610 California SE

Sandy thinks the loudness is noise pollution and she is very sensitive to loud noises.

•Sabrina, 27561 California SE

Please let me know what action is taken regarding this issue. Thank you, in advance.

Mayor Garrett:

- Responded to Ms. Burton, saying she is deeply saddened by what happened, especially in proximity to you and in our Community. In the big scheme of things, we do have a relationship, because the City of Southfield, did come to assist with that incident. She agrees that parties that go past the 11:00 pm, Ordinance on the Weekend, should follow the rules and the new Ordinance should help with this.
- Responded to Mr. Burke, noise level is being addressed, and noise level meters will be used. There will be information given at the counter to those renting about how loud the music can be, how long, and in what direction the speakers can be pointed.
- Responded to Adam, thank you for the LVMF information.
- Responded to Ms. Sousanis, thanking Autumn for the presentation.
- Responded to Mr. Ferguson, thanking him for the information on petition signatures.

- Welcomed Andre Campbell to Lathrup Village.
- Responded to Ms. Kunz – no live stream during this meeting due to Facebook issues; requested Ms. Kunz could provide the whispering information in the Open Meetings Act; noted that the Police Department is over 50% of the General Fund budget.
- Responded to Ms. Miller – Noted the signatures are reviewed through the Qualified Voter File (QVF) maintained by the State.
- Reiterated that the Villager Facebook page is not an official City of Lathrup Village Facebook page and if you want someone to be in contact with you, you can write on the City of Lathrup Village Facebook page, or call or email Mike Greene, the City Administrator.

Mayor Pro-Tem Kantor

- The Council meeting is still recorded and will be available on YouTube.
- Welcomed Andre Campbell to Lathrup Village.
- Responded to Ms. Burton noting that the City does have a mutual aid agreement with Southfield and other communities for public safety.
- Thanked Josh for comments on the water billing and for park clean-up efforts.
- Water Billing
 - Regarding water, billing we had an error in our software that occurred around 2020, that affected 65 residents, billing error, really impacted those with 1 ½” meters, some have 5/8” but 1 ½” is usually used for those using a lot of water.
 - We found this during their water loss investigation, we had a big water loss issue for years, we were losing hundreds of thousands of gallons a day, and it wasn’t showing up anywhere, we looked internally, with the billing system, and through that process, they found some issues. We have recouped nearly \$85,000 in underbilling, and we found the issue impacting the sixty-five clients, it went on for over 14 months before we noticed it.
 - Mayor Pro-Tem noted that one customer was getting a bill consistently of about \$250, and then it dropped down to the bare minimum, of \$56 a month, for 14 months. Nobody called and asked what was going on with their bills. The investigation found that the last digit of the read was getting dropped, so the system did the math wrong and only charged 1 unit, which was the minimum use
 - Noted that payment plan options are available and residents should contact staff.
- Responded to Ms. Sousanis regarding spikes in water billing.
- Responded to Ms. Kunz regarding Police staffing levels.
- Noted those volunteers who handled the hanging baskets throughout the DDA did a wonderful job.
- Welcomed residents to the next Financial Review Committee Meeting.

Councilmember Hammond

- Welcomed Andre Campbell to Lathrup Village
- Discussed the Nuisance Party Ordinances and the abilities it gives the Police Department
- Applauded Ms. Sousanis’s research, but encouraged residents to include the City in the context of their research to ensure all sides are covered

14. Adjourn

Moved by Councilmember Hammond, Seconded by Mayor Pro-Tem Kantor, to adjourn at 8:47 pm.

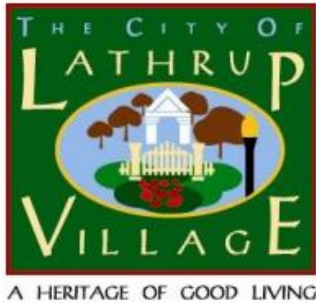

City Council Study Session Minutes

Monday, July 15, 2024 at 6:00 PM

27400 Southfield Road, Lathrup Village, Michigan 48076

1. **Call to Order** by Mayor Garrett at 6:00 pm

2. **Discussion Items**

A. Referendum Petitions

Attorney Baker talked about the Referendum of Charter Proposed by the Initiative Petition, regarding the prohibition of Cannabis businesses in Lathrup Village, and that the Initiative Petition, to change the Ordinance, was also received at City Hall. The Referendum of Charter and Initiative Petitions has been looked at to make sure the signatures that were verified, met the guidelines of registered voters. The next step is for the Referendum of Charter Petition to be transmitted to the state, after a resolution of the City Council.

The wording has already been stated in the petition, the Council could add an explanatory caption, but Attorney Baker did not believe that it was necessary. Once the Attorney General's Office and Governor's office sign off, it will be transmitted to the county, for residents to vote on, in the November 2024 election.

The Initiative Petition regarding the City Ordinance does not have to go to the Governor's and Attorney General's office, it has to be published and posted in both precincts. The Charter supersedes the Ordinance.

B. Nuisance Ordinance

Lt. Zang and Attorney Baker spoke on the Nuisance Ordinance, and that it allows, the responding Officers to have more power, when they come out for noise and nuisance complaints, to enforce the City Ordinance without, a resident needing to be a complainant. The property owner is culpable and the attendees of the gatherings can be cited.

C. 27680 Lathrup Blvd – Encroachment License

This is for a person to be able to use this land, for their personal use, it does not transfer with the house sale. The prior owner used the land in the same way. The new owner did obtain insurance. The former resident did add value to the land and maintained it for years.

There are several similar streets, and there will be an Encroachment inventory to review.

3. **Public Comments**

Resident Ruth B., spoke on the responsibility as residents to keep the culverts clear, and that she keeps her culvert area clean, and others don't, so it does no good. She has a "lake" on City property between the street and her home, and her lawn company can't cut the grass. Other communities have this situation and the City can help vet the contractors, for the needed work, acknowledging that It is the resident's responsibility, but we

can get a better deal, as a group if the City helps direct residents to a contractor, who can fix this and we have a project to help us solve this problem.

Mayor Pro Tem Kantor talked about the three-year infrastructure plan and said maybe Mike Greene, can put together a list of Contractors.

Gwen S. said that the person who did her driveway, years ago, said something about the pipes, to help fix the culvert back-ups.

Mr. Wisz suggested that the City does what the county does, to clear out the ditches with a backhoe or a front-end loader.

4. **Mayor and Council Comments**

Mayor Garrett read a letter submitted by email.

This is a statement for the upcoming City Planning Session on Monday, 7/15. Sorry, I'm unable to attend on that date.

My name is Kim Hodge and I live at 27580 California Dr. SE. I am writing today to ask Council not to allow loud music and noise in the rental agreement for the pavilion and gazebo area.

I am a huge music lover and supporter, but sometimes it just gets way too loud. Just to be clear, I am not talking about music during the Wednesday night concerts or the Lathrup Village music festival or other Lathrup Village events. I'm talking about rentals here.

I understand that the current decibel limit is set at 65 and you are considering raising it to 85 or some similar number. That is probably a reasonable limit. However, that limit is not adhered to. I am sometimes unable to sit in our own backyard or even in our house with the windows open without getting blasted with loud music (and pounding deep bass).

Last summer I had had enough after listening to loud music for 4 hours. I walked over to the gazebo and saw that speakers were pointed away from the pavilion, into my direction and very, very loud music was being played. Same thing happened within the last 2 months, with loud music for hours. This was, I'm sure, way above the allowed decibel limit and I should've called the police at that time, but I didn't. I'd like to avoid such situations in the future.

Could you please make sure that City staff emphasize the decibel limit to the person renting when you rent the outside space? And make sure that the police are aware of and enforcing the limits? We should not have to go inside our houses or close the windows in order to live comfortably when someone is renting the facilities.

Thank you for your attention to this matter.

Kim Hodge and Tom Brodzik

In support are the following neighbors:

- Gary W. Roberts & Kevin Bryant, 27474 California Dr SE

“Our issues are with the private rental parties in the Park which is right across the street. In many instances the music far exceeds the volume of the City organized Music in the Park and City events. Both the music and in between voice broadcasts at private events in the Park are extremely loud. Also

some of these private parties have gone on past 10 pm, which is a very long duration of their intrusively loud music. I recommend NOT raising the volume on private rental parties. Also I think the LV Police should have the equipment to measure the volume and check it randomly (at least twice) to confirm it is within the terms of the rental contract.”

•Brian Margosian, 27560 California SE

“I echo all of the above. We love our proximity to the park for LV live music where sound levels seem to be better controlled, however during some of these private events we have also noticed similar issues to our neighbors’ above.

I will remind others as well that the decibel scale is logarithmic, so an increase from 65 to 85dB is a 10x increase in perceived sound pressure level.”

•Phyllis Windham, 27530 Sunset Blvd E

“I agree. I live right across the street from the park (across from the Children’s Garden) and I should not have to close my windows during the rentals. I’ve also heard loud swearing on the microphone.

People in attendance often block my mailbox and park on the edge of my lawn.”

•Chris Smith, 27460 California SE

It also bothers him when people park on the berm in front of their house, leaving tire marks.

•Shannon Burke, 27411 Lathrup Blvd.

“I second the request to publicize and enforce the decibel limits, and to encourage groups renting the gazebo to avoid pointing their speakers at homes. If I can identify the song from half a yard away and sing along, it's probably too loud.”

•Resident from Lathrup Blvd

“Lathrup Boulevard is typically a quiet street, but over the past three years we have often heard loud parties put on at the park. We often wondered if it was a community event due to the noise. We would investigate only to find out they were private parties. We can hear the music well into the evening, which can be disruptive to a young family with a toddler.

As a wedding and event planner who works with venues much less residential than our pavilion (Cushing field house & shepherds hollow) these venues currently have noise ordinances set at no higher than 99 decibels and are strongly adhered to.

I feel that the current sound limit of 65 decibels has not been adhered to and we request that you do not increase the allowed sound decibels before monitoring more closely to see what parties are currently playing music at before making a final decision.”

•Sandy Schwartz, 27610 California SE

Sandy thinks the loudness is noise pollution and she is very sensitive to loud noises.

•Sabrina, 27561 California SE

Please let me know what action is taken regarding this issue. Thank you, in advance.

Kim Hodge

Park rules ordinance is up tonight for a 2nd reading.

Councilmember Hammond, wanted the City Office staff to emphasize the park noise compliance rules when we rent it out.

Mayor Garrett questioned why sound system speakers were facing the neighbors, and said that they should face the Police Station.

Mayor Garrett said we should reinforce the speaker's direction when people are signing up to rent the park, and put it in our newsletter, and mentioned that for house parties, the people giving the party can go, house to house to let them know that they will be having a party.

Mayor Garrett spoke about when cars are parked on both sides of the street, especially for little streets, and mentioned that it would be hard for emergency vehicles to get through. She asked if we could have parking on one side of the street and she mentioned Roseland and Sunset streets.

Resident Grace, said they parked on her grass, and she had to make improvements.

Lt. Zang said the Chief can issue a traffic control order, and then move to make it permanent.

Mayor Garrett, mentioned that down Pierce, towards 12 Mile Roads, they have speed bumps, can we put them down Lathrup Blvd.?

Lt. Zang said that the decoy car was placed to help slow down cars and that the agency wouldn't have any objection, but there is a cost for DPS, to install them, and they can't put them in isolation, they have to be part of a comprehensive plan.

Mayor Garrett was also concerned about how fast people drive on Bloomfield and Santa Barbara roads, and she is concerned that there are no yield or stop signs at Sunset and San Diego roads.

Mayor Garrott, also reminded people of the Tree Committee meeting tomorrow at 7:30 pm.

Mayor Pro Tem Kantor asked the City Administrator about some wording in the Financial packet on page 54.

City Administrator, Mike Greene, reported that Thrill Share is up and running, he is trained, and some other staff members are trained, and updating the live feed.

Councilmember Hammond said that the Planning Commission meeting was canceled for July 16, 2024, but there will be one on August 20, 2024.

5. **Adjourn 7:08 pm**

City of Lathrup Village Police Department - Monthly Activity Summary

July 2024

07/01/2024 24-08750 Suspicious Circumstance

Officers responded to a bank where a female reported that she had been threatened by a former friend to give him money or he would kill her. Officers contacted both parties. It was determined that the reporting party could not keep her story straight and that no crime occurred. The incident was documented but no action was taken.

07/02/2024 24-08777 Animal Complaint

A resident reported that a dog left a property and almost attacked her and her dog while they were walking down the street. The dog in question did not bite or scratch, just barked and its license was up to date. The incident was documented.

07/02/2024 24-08778 Suspicious Circumstance

A victim reported that he had \$2,000.00 withdrawn from his account after he provided his personal banking information to a subject on the phone, who he believed to be an employee of a local bank. The withdrawals were made in Detroit and the victim was advised to also make a report there.

07/02/2024 24-08780 Accidental Property Damage

An incident was documented for insurance purposes when a large tree branch fell from a tree, damaging a resident vehicle.

07/03/2024 24-08830 Found Property

A citizen turned in \$226.00 they found on the street. There were also debit cards and an ID with the cash. Officers were unable to locate the owner by phone, but sent a letter to the address on the ID, advising them that LVPD was in possession of the property.

07/04/2024 24-08877 Fraud

A victim reported that she had \$1,000.00 withdrawn from her account after she provided her personal banking information to a subject on the phone, who she believed to be an employee of a local bank.

07/05/2024 24-08895 Misdemeanor Arrest Warrant

An Officer initiated a traffic stop for a red-light violation. It was determined that the driver had a suspended driver's license and multiple arrest warrants out of Canton PD. They were cited with a misdemeanor citation for DWLS and transported to a neutral location to be turned over to Canton PD. The vehicle was impounded.

07/05/2024 24-08915 Assault and Battery

A former resident reported that she had been assaulted by her live-in boyfriend in August of 2022. She had not reported the incident at the time. The incident was documented, but the victim was unsure at the time of reporting it, if she wished to pursue charges.

07/05/2024 24-08924 DWLS Arrest

An Officer initiated a traffic stop for a stop sign violation. It was determined that the driver had a suspended driver's license. They were cited and released at the scene with a misdemeanor citation for DWLS. The vehicle was turned over to a licensed driver.

07/06/2024 24-08964 Mental Health Call

Officers responded to a local park after a female called stating that she was suicidal. The woman was transported to a local hospital where she wanted to undergo a mental health evaluation.

07/07/2024 24-08999 Fraud

A resident reported having multiple pending transactions on a variety of Apps on his phone, all through his Bank of America account after allowing an unknown person on the phone to have remote access to his phone. The victim found the number online, listed as a technical support number for a medical device he was having issues with.

07/07/2024 24-09004 DWLS Arrest

An Officer initiated a traffic stop for a stop sign violation. It was determined that the driver had a suspended driver's license. They were cited and released at the scene with a misdemeanor citation for DWLS. The vehicle was impounded.

07/09/2024 24-9058 Civil Matter

An Officer assisted in mediating an issue between VRBO and a renter after the renter arrived at the property to find it being rented to another individual.

07/10/2024 24-09088 DWLS Arrest

An Officer initiated a traffic stop for a red-light violation. It was determined that the driver had a suspended driver's license. They were cited and released at the scene with a misdemeanor citation for DWLS. The vehicle was turned over to a licensed driver.

07/11/2024 24-09124 Assist Other Law Enforcement Agency

Officers assisted Michigan State Police in the locating, arrest and transport of 2 fraud suspects.

07/12/2024 24-09131 Assist Other Law Enforcement Agency

An Officer assisted the Pennsylvania State Police with drafting a search warrant on a local bank after a victim in Pennsylvania reported that a suspect had swindled them into transferring money to the suspect account at that local Lathrup Village bank.

07/13/2024 24-09160 Suspicious Circumstance

A citizen reported that a young girl, approx. 6 years of age, was walking alone on the side of a major roadway. Officers were unable to locate the girl, but later confirmed that the child was located by her grandmother and was safe at home.

07/15/2024 24-09224 Flee and Elude

An Officer attempted to stop a vehicle after realizing that the registered owner of the vehicle had multiple arrest warrants. The vehicle fled at a high rate of speed and the Officer eventually terminated the pursuit. The vehicle was found later with a new license plate. An Investigation found that the driver (registered owner) reported her plate as stolen within an hour of fleeing the Officer and received a new plate from SOS. The case has been submitted to the OCPO for a review of charges.

07/15/2024 24-09225 Larceny

A man reported having jewelry stolen from his home during an open house by his real estate agent. A list of people who entered the home was obtained and officers are investigating.

07/15/2024 24-09232 Trespassing

Officers responded to a residence where a woman was intoxicated and walked into her ex-husbands' home, attempting to see her children. The woman had an unserved PPO, which was then served to her by Officers. The woman still refused to leave after being warned about trespassing. She was eventually arrested for trespassing and resisting arrest. She was transported to Oakland County Jail due to her combativeness. She was eventually given a misdemeanor citation for trespassing and released.

07/16/2024 24-09215 Larceny from Automobile

A resident reported that their unlocked work vehicle was broken into during the night and their work bag was taken. Their bank information, which was in the bag, had been used to make several unauthorized purchases. The incident is under investigation.

07/18/2024 24-09345 Misdemeanor Arrest Warrant

An Officer initiated a traffic stop for a red-light violation. It was determined that the driver had outstanding warrants out of Berkley PD. Berkley advised that they wanted the subject on the warrants. They were transported and turned over to BPD.

07/21/2024 24-09476 Misdemeanor Warrant Arrest

An Officer went to the Detroit Detention Center and took custody of a prisoner with an outstanding LVPD warrant. They were transported to Berkley PD to be processed and await arraignment.

07/22/2024 24-09478 Larceny of Mail

Officers were alerted when an alarm associated with the post office mail box was activated. Officer's arrived on location and attempted to contact 2 subjects walking nearby. The subjects fled on foot. A Royal Oak K9 and a Southfield PD drone were utilized, but the subjects were not located. The investigation was turned over to the Post Office Inspector General.

07/22/2024 24-09496 Civil Matter

A woman who recently sold a vehicle to a local used car dealer found out that the dealer had never taken the vehicle out of her name. The information was documented in case of future fraud related to the vehicle.

07/22/2024 24-09497 Uttering & Publishing

A citizen reported that a check which she placed in the LV Post Office Mailbox had been cashed for \$800.89 by a man who was not the original designee and the original amount had been changed. It was determined that the incident was not related to a recent mail theft from the LV PO Box. The incident is being investigated further by the jurisdiction the citizen lives in.

07/22/2024 24-09424 Civil Matter

An Officer mediated the return of \$1,000.00 which was reported by a victim to have been fraudulently swindled from him over a purchase on Facebook Marketplace.

07/24/2024 24-09560 Suspicious Circumstance

A man reported to a local bank that his ex-wife, who had recently been fired from the bank had made threatening comments to him about hurting her old supervisor at the bank. All parties involved were interviewed and it was determined that the threats were not credible but were fabricated due to a contentious custody battle between the two.

07/24/2024 24-09565 Operating While Intoxicated Arrest

An Officer initiated a traffic stop for a red-light violation. A subsequent investigation determined that there was probable cause to arrest the driver for Operating While Intoxicated. They were arrested and transported to Berkley PD for processing.

07/26/2024 24-09619 Home Invasion

A resident reported that his home was broken into overnight when he was not there. He reported that an antique clock worth approximately \$10,000.00 was taken. This investigation is ongoing.

07/28/2024 24-09670 DWLS Arrest

After an Officer responded to a property damage accident, they learned that one of the drivers had a suspended drivers license. They were cited and released on scene with a misdemeanor citation for DWLS. The vehicle was impounded.

07/29/2024 24-09689 Mental Health Call

Officers responded to a residence when a mother advised that her daughter is refusing to take her medication for schizophrenia and was acting very strange. She wished to have her committed for a psychological evaluation. The daughter refused to go and was taken into protective custody to be transported to the hospital. The mother completed the petition paperwork.

07/29/2024 24-09691 Fraud

A resident reported that over \$7,000.00 has been fraudulently withdrawn from her bank account in multiple transactions which she did not authorize. A search warrant was sent to her bank for information about who requested the withdrawals and the investigation is ongoing.

07/29/2024 24-09710 Hospice Death

An Officer responded to a residence when a hospice nurse advised that a 76-year-old female was found deceased. The scene was investigated and the proper paperwork was completed by the Officer. The Medical Examiner released the deceased to the family.

07/29/2024 24-09713 Larceny

A citizen reported that while at an ATM at a local bank, they were approached by a man who came out of the shrubs nearby. They left because they were scared. When they returned, they reported that their card was still in the machine, but the \$1,000.00 in cash was gone. The incident is still under investigation.

07/30/2024 24-09736 DWLS Arrest

An Officer initiated a traffic stop for an expired registration violation. It was determined that the driver had a suspended driver's license. They were cited and released on scene with a misdemeanor citation for DWLS. The vehicle was turned over to a licensed driver.

07/31/2024 24-09764 Hospice Death

An Officer responded to a residence when a hospice nurse advised that a 77-year-old male was found deceased. The scene was investigated and the proper paperwork was completed by the Officer. The Medical Examiner released the deceased to the family.

07/31/2024 24-09767 Fraud

A local law firm advised that a check that was issued to a client of theirs, and cashed back in December, was presented to a party store in Detroit, where a subject was attempting to cash it. It was determined that the check was stolen from the original payee at their residence in Detroit. They were advised to contact Detroit PD and the incident was documented.

07/31/2024 24-09776 DWLS Arrest

An Officer located a vehicle which was reported wanted for fleeing from Southfield PD. The vehicle attempted to avoid the Officer but it eventually stopped. The Driver had a suspended drivers license. He was cited with a misdemeanor citation for DWLS and turned over to SPD for questioning reference the flee and elude.

ALARM SUMMARY FOR JULY 2024

4	B&E Alarms (C3902)	July 1 st – July 31 st
13	False Alarms (L5060)	July 1 st – July 31 st

All alarms were considered false or operator error.

Unregistered alarms, from the totals, for the month:

- 1 commercial (went off twice)
- 4 residential

Letters mailed 8/1/24 to the business and residences that have unregistered alarms.

DATE	EVENT	WHO PARTICIPATED	ACTIONS
7/2/2024	Staff Meeting	McKee / Zang / Cory	
7/3/2024	Took Ordinance vehicle to auction	McKee / Zang	
7/4/2024	Human Trafficking Training	Gijsbers	
7/5/2024	Human Trafficking Training	McKee	
7/6/2024	Human Trafficking Training	Hutson, Lawrence	
7/6/2024	Preventing Sexual Harassment Training	Gijsbers	
7/6/2024	Ethics in Law Enforcement Training	Gijsbers, Lawrence	
7/9/2024	Basic LEIN Training	Cory	
7/10/2024	Preventing Sexual Harassment Training	McKee	
7/10/2024	Procedural Justice	Gijsbers	
7/10/2024	Ethics in Law Enforcement Training / Human Trafficking Training	Stajich	
7/11/2024	CLEMIS Membership & Security Meeting	McKee	
7/11/2024	CLEMIS Advisory Meeting	McKee	
7/12/2024	New Adopt A Senior: Donald McCray	Roberts	
7/13/2024	EVO Refresher	Roberts	
7/14/2024	Human Trafficking Training / Ethics in Law Enforcement Training	Tackett / Chickensky	
7/15/2024	Preventing Sexual Harassment Training / Human Trafficking Training	Zang	
7/16/2024	Staff Meeting	McKee / Zang	
7/16/2024	LVMF Committee Meeting	Zang	
7/16/2024	Radio Project Meeting	Zang	
7/16/2024	LEIN TAC Training	Cory	
7/17/2024	Preventing Sexual Harassment Training	Hutson	
7/19/2024	Meeting with Axon on new tasers	McKee	
7/23/2024	Debris Management Class	McKee	
7/27/2024	Procedural Justice	Tackett	
7/27/2024	Suicide and Crisis Training	Tackett	
7/27/2024	Preventing Sexual Harassment Training	Lawrence	
7/28/2024	Suicide and Crisis Training	Chickensky	
7/29/2024	Suicide and Crisis Training	Lawrence	
7/30/2024	Michigan First Meeting	Zang / Huston / Roberts	
weekly	Mrs. Blair	McNeill	check on adopt a senior member
weekly	Mrs. Bloom	Gijsbers	check on adopt a senior member

weekly	Mr. Davis	Fisher	check on adopt a senior member
weekly	Mrs. McReynolds	Cory/Gijsbers/Huston	check on adopt a senior member
weekly	Mrs. Egan	Cory	Mrs. Egan gets weekly phone calls, she needs assistance with getting her trash wheeled out.
weekly	Mrs. Brady	McNeill	check on adopt a senior member
weekly	Mrs. Rasmussen	Cory / Gijsbers	Mrs. Rasmussen gets a weekly phone call to check on her. Ofc. Gijsbers responded to a medical when she fell

2024 Run Totals

Officer	Jan	Feb	Mar	Apr	May	June	July	Aug	Sept	Oct	Nov	Dec	Total
Tackett	119	111	144	101	124	126	101						826
Roberts	177	170	150	209	112	101	131						1050
McNeill	252	308	166	257	287	193	7						1470
Huston	88	118	65	146	77	73	63						630
Hutson	310	305	267	304	300	273	260						2019
Gijsbers	168	121	138	132	152	91	142						944
Chickensky	172	91	152	148	106	159	180						1008
Fisher	162	198	118	163	97	40	67						845
Stajich	200	167	157	127	87	99	78						915
Lawrence	31	50	64	55	56	87	99						442
Button	10	4	59	26	53	20	6						178
Reserve Detail						7/23/24 Lietzke 24-9521							
Reserve Detail						7/26/2024 Hodges 24-9626							
Reserve Detail						7/31/2024 Sovinsky 24-9778							

2024 Ticket Totals

Office	Jan	Feb	Mar	Apr	May	June	July	Aug	Sept	Oct	Nov	Dec	Total
Tackett	1	14	16	10	8	11	4						64
Tackett Warn	0	6	7	3	1	2	0						19
Roberts	19	22	13	47	36	6	18						161
Roberts Warn	7	7	6	6	8	2	6						42
McNeill	49	70	24	49	52	18	0						262
McNeill Warn	6	6	4	4	9	5	0						34
Huston	14	20	12	45	10	8	21						130
Huston Warn	4	8	1	4	2	0	0						19
Hutson	21	40	24	49	29	15	50						228
Hutson Warn	8	10	6	9	8	4	5						50
Gjisbers	68	78	52	41	40	21	29						329
Gjisbers Warn	14	12	6	1	5	1	4						39
Chickensky	27	15	31	19	4	28	40						164
Chickensky Warn	0	1	1	1	0	1	1						5
Fisher	16	42	37	17	19	7	10						148
Fisher Warn	1	5	6	2	11	4	5						34
Stajich	23	35	27	12	40	30	17						184
Stajich Warn	0	0	0	2	0	2	0						4
Lawrence	4	7	7	6	15	18	17						74
Lawrence Warn	0	0	0	0	0	0	0						0
Button	0	0	7	6	8	3	0						24
Button Warn	1	0	4	4	8	2	0						19

Zang 27 tickets
 & warnings

July 2024 Warning Violations

ROW	CITATION	CITATION DATE	OFF_CITY_NM	ST	VIOLATION_ON	VIOLATION_NEAR	VIOLS_DESC	OFFICER
1	24LV01325	7/2/2024	SOUTHFIELD	MI	TWELVE MILE	SOUTHFIELD	DISOBEY TRAFFIC CONTROL DEVICE	HUT
2	24LV01350	7/5/2024	STERLING HEIGHTS	MI	SUNNYBROOK	ELEVEN MILE	NO THRU TRAFFIC (PROHIBITED STREET)	HUT
3	24LV01342	7/5/2024	FARMINGTON HILLS	MI	ELEVEN MILE	LATHRUP	DISOBEY STOP SIGN	HUT
4	24LV01372	7/8/2024	SOUTHFIELD	MI	ELEVEN MILE	RED RIVER	DISOBEY STOP SIGN	ROB
5	24LV01379	7/9/2024	LATHRUP VILLAGE	MI	18231 SANTA ANN	MIDDLESEX	NO PARKING 3-6 AM	CHI
6	24LV01384	7/10/2024	CONCORD	MI	ELEVEN MILE	LATHRUP	DISOBEY STOP SIGN	HUT
7	24LV01423	7/15/2024	DETROIT	MI	SOUTHFIELD	ELEVEN MILE	HOLDING/USING MOBILE DEVICE	GIJ
8	24LV01439	7/17/2024	ROYAL OAK	MI	ELEVEN MILE	LATHRUP	DISOBEY STOP SIGN	HUT
9	24LV01464	7/19/2024	LATHRUP VILLAGE	MI	LATHRUP BLVD	ELEVEN MILE	FAIL TO YEILD RIGHT OF WAY	GIJ
10	24LV01471	7/22/2024	ROYAL OAK	MI	ELEVEN MILE	LATHRUP	DISOBEY STOP SIGN	FIS
11	24LV01505	7/26/2024	SOUTHFIELD	MI	SOUTHFIELD	SAN ROSA	1-5 OVER: 50/45	ROB
12	24LV01506	7/26/2024	DETROIT	MI	ELEVEN MILE	RED RIVER	DISOBEY STOP SIGN	ROB
13	24LV01524	7/29/2024	DETROIT	MI	TWELVE MILE	SOUTHFIELD	EXPIRED PLATES	ROB
14								
15								
16								
17								
18								
19								
20								
21								
22								
23								
24								
25								



27400 Southfield Rd
 Lathrup Village, MI 48076
 (248) 557 - 2600
www.lathrupvillage.org

MEMORANDUM

To: LVDDA Board of Directors
 From: Austin Colson, CED/DDA Director
 Date: August 16, 2024
 RE: Department/Director Report

In an effort to provide consistent updates to the DDA Board of Directors, City Administrator, and City Council the following monthly report is submitted for your review.

Upcoming DDA Events

- Summer in the Village – Back to School Rally: August 16th, 6 – 8:00pm (Location: Lathrup Village)
- Main Street Oakland County Workshop – Search Engine Optimization: September 24th (Location: Waterford)
- Business Beautification Workshop: September 25th, 5 – 7:00pm (Location: Oak Park)
- Oakland County All Board Training: October 3rd, 6 – 8:00pm (Location: Waterford)
- Oakland County Community Showcase: October 18th, 7:30 – 10:00am
- Succession Planning Workshop: November 14th, 8:30 – 10:30am (Location: Lathrup Village)
- Holiday Business Mixer: December 4th, 4 – 6:00pm (Location: Oak Park)
- Business Training - Art of Giving Great Service: February 4th, 9am – 1pm (Location: Oak Park)

Past DDA Events

- Morning Business Mixer: May 14th, 8 -10am (Location: Southfield)
- Plant Swap: May 18th, LV Pavilion
- Southfield Road Corridor Clean-up: June 8th
- Juneteenth Celebration: Unity in the Community, June 14th/15th Social Media/Marketing
- Lathrup Village Music Festival: August 10th, Noon-11am (Location: Lathrup Village)

Commercial Business/Property Updates

- 26600 Southfield Road (Holbrook Auto) – Interior and exterior remodel for auto parts store.
- 26727 Southfield Road (BP Gas) – Additional wall sign approved by ZBA.



27400 Southfield Rd
Lathrup Village, MI 48076
(248) 557 - 2600
www.lathrupvillage.org

Infrastructure

- None

Miscellaneous

- The County has indicated foundation work for the new HAWK (High-Intensity Activated Crosswalk) signal on Southfield Road should begin in early September. The steel frame should be ready to be shipped by October 25th. The installation of the intersection should proceed in November.
- Back to School Rally, giving out backpacks with school supplies to students aged 5-18 on Friday, August 16th from 6:00pm until 8:00pm at 18411 W. 12 Mile Road, Lathrup Village, MI 48076.
- The 2nd Annual Lathrup Village Music festival on August 10th was a success. Liquor sales during the event increased by 77% compared to last year's festival. A more detailed report will be brought to the DDA board in September.

Monthly Permit List

08/06/2024

Item 7D.

Building

Permit #	Date	Contractor	Job Address	Parcel #	Fee Total	Const
PB240076	06/17/2024	MARTIN, ELIZABETH	28021 SANTA BARBARA DR	40-24-14-182-010	\$5,098.80	
Work Description: COMPLETE INTERIOR RENOVATION OF THE BASEMENT AND 1ST FLOOR WITH NEW KITCHEN AND PRIMARY BATHROOM						
PB240086	07/02/2024	COOPER, ROSE M	17591 RAMSGATE DR	40-24-24-104-015	\$155.00	
Work Description: KITCHEN DEMO - INSTALLATION OF NEW CABINETS, COUNTERTOP, AND BACKSPLASH						
PB240087	07/03/2024	TEDLA II, ISAAC	18230 W 11 MILE RD	40-24-14-478-036	\$276.20	
Work Description: REMOVE & REPLACE, ON THEIR PROPERTY ONLY, DRIVEWAY, WALKWAY AND PORCH						
PB240088	07/03/2024	Trujillo, Jose	27720 STANFORD CT	40-24-14-427-001	\$130.00	
Work Description: INSTALL/REPLACE 4 SAME SIZE VINYL WINDOWS						
PB240089	07/03/2024	SELDON, ALESIA	18250 W 11 MILE RD	40-24-14-478-034	\$276.20	
Work Description: REMOVE & REPLACE, ON THEIR PROPERTY ONLY, DRIVEWAY, WALKWAY AND PORCH						
PB240090	07/03/2024	SALTER, DESHAUNDRIA Y	18260 W 11 MILE RD	40-24-14-478-033	\$276.20	
Work Description: Remove & Replace Driveway, walkway and porch. All on property only						
PB240091	07/09/2024	BOBO, RICHARD	27881 RACKHAM DR	40-24-14-327-001	\$160.00	
Work Description: REPLACE 1 PATIO DOOR SAME FOR SAME (WINDOW)						
PB240092	07/09/2024	BOYD, RONALD	28714 BLACKSTONE DR	40-24-14-230-009	\$170.00	
Work Description: STRIP ROOF DOWN TO WOOD, INSTALL NEW SHINGLES, AND ADD ROOF VENTING						
PB240094	07/11/2024	AENIS, JEFFERY A	18769 WILTSHIRE BLVD	40-24-14-251-003	\$0.00	
Work Description: replacing 6 windows size for size house only. cost of construction: \$7,624.00 please email issued permit.						
PB240096	07/15/2024	JMFRE1, LLC, A FLORIDA LTD	18725 WILTSHIRE BLVD	40-24-14-251-006	\$130.00	
Work Description: Install (7) vinyl replacement windows						
PB240097	07/15/2024	RICE, KRISTIAN L	27370 EVERGREEN RD	40-24-14-306-063	\$130.00	
Work Description: Install (1) vinyl replacement doorwall						
PB240099	07/22/2024	LUBANSKI, TERRI A	18492 W GLENWOOD BLVD	40-24-14-255-011	\$130.00	
Work Description: Install (3) vinyl replacement windows. Scheduled to be install 8/20/24						

Total Permits For Type: 12

Total Fees For Type: \$6,932.40
Total Const. Value For Type: \$0

Item 7D.

Electrical

Permit #	Date	Contractor	Job Address	Parcel #	Fee Total	Const
PE240057	07/03/2024	G & A REAL ESTATE INVESTC	28821 SOUTHFIELD RD	40-24-14-230-018	\$138.00	
Work Description: ELECTRICAL FOR WALL MOUNT SIGN INSTALL AT SAM'S ALTERATIONS						
PE240058	07/12/2024	MORRISON, ROCHELLE	18530 SAN QUENTIN DR	40-24-14-403-014	\$210.00	
Work Description: Whole house generator						
PE240064	07/17/2024	COOPER, ROSE M	17591 RAMSGATE DR	40-24-24-104-015	\$282.00	
Work Description: KITCHEN ALTERATION						
PE240066	07/18/2024	LV PETRO LLC A MICHIGAN I	26727 SOUTHFIELD RD	40-24-23-229-029	\$90.00	
Work Description: "LIQUOR" WALL SIGN AT BP STATION						
PE240067	07/22/2024	SOLOMON, YVONNE V	18574 SAN QUENTIN DR	40-24-14-403-013	\$185.00	
Work Description: installation of light pole fixture in front yard						
PE240068	07/26/2024	OAKLAND DEVELOPMENT C	27651 SOUTHFIELD	40-24-14-432-010	\$357.00	
Work Description: 10 CIRCUITS, 12 FIXTURES FOR MIDDLE EATS STORE						
PE240072	07/29/2024	MILLS, ERNEST F	19021 BUNGALOW DR	40-24-14-382-005	\$220.00	
Work Description: install standby generator and replace current 200amp service						

Total Permits For Type: 7
Total Fees For Type: \$1,482.00
Total Const. Value For Type: \$0

Electrical Reconnect

Permit #	Date	Contractor	Job Address	Parcel #	Fee Total	Const
PE240042	05/31/2024	SELLNAU, MARGAUX	17570 ROSELAND BLVD	40-24-13-101-018	\$105.00	
Work Description: Reconnect AC system						

Total Permits For Type: 1
Total Fees For Type: \$105.00
Total Const. Value For Type: \$0

Mechanical

Permit #	Date	Contractor	Job Address	Parcel #	Fee Total
PM240046	07/09/2024	OAKLAND DEVELOPMENT CO	27651 SOUTHFIELD	40-24-14-432-010	\$245.00
Work Description: GAS PIPING, GAS WATER HEATER, GAS PIPING					
PM240047	07/12/2024	MORRISON, ROCHELLE	18530 SAN QUENTIN DR	40-24-14-403-014	\$230.00
Work Description: Whole house generator					
PM240049	07/18/2024	OAKLAND DEVELOPMENT CO	27651 SOUTHFIELD	40-24-14-432-010	\$285.00
Work Description: Install kitchen hood fire suppression system					
PM240052	07/26/2024	COOPER, ROSE M	17591 RAMSGATE DR	40-24-24-104-015	\$185.00
Work Description: RECONNECT HOOD VENT.					
PM240054	07/26/2024	HARPOLE, NELLIE	18755 SAN JOSE BLVD	40-24-14-402-007	\$200.00
Work Description: PIPING AND 14KW GENERATOR					
PM240055	07/29/2024	MILLS, ERNEST F	19021 BUNGALOW DR	40-24-14-382-005	\$240.00
Work Description: Install standby generator					

Total Permits For Type: 6
Total Fees For Type: \$1,385.00
Total Const. Value For Type: \$0

Outside Refuse Container

Permit #	Date	Contractor	Job Address	Parcel #	Fee Total	Const
PORC-240008	07/12/2024	MCBROOM, JAMES TATE	26415 MEADOWBROOK WAY	40-24-23-208-004	\$25.00	
Work Description: DUMPSTER FOR REMODEL/ADDITION WORK						
PORC-240009	07/29/2024	COOPER, ROSE M	17591 RAMSGATE DR	40-24-24-104-015	\$25.00	
Work Description: Disposal of construction debris during kitchen renovation. Anticipated dates to be on site: 7/9/24 - 8/7/24						

Total Permits For Type: 2
Total Fees For Type: \$50.00
Total Const. Value For Type: \$0

Plumbing

Permit #	Date	Contractor	Job Address	Parcel #	Fee Total	Const
PP240040	07/03/2024	BENIGNA, ANDREW A	27810 EVERGREEN RD	40-24-14-306-029	\$135.00	
Work Description: WATER HEATER INSTALLED WITHOUT PERMIT - FOUND ON RENTAL						

PP240041 07/09/2024 OAKLAND DEVELOPMENT C 27651 SOUTHFIELD 40-24-14-432-010 \$36 Item 7D.

Work Description: 1 STACK, 2 WATER HEATERS, 3 SINKS, 2 LAVS, 2 WATER CLOSETS, 2 FLOOR DRAINS, 3/4" WATER DISTRIBUTION SIZE

PP240045 07/17/2024 COOPER, ROSE M 17591 RAMSGATE DR 40-24-24-104-015 \$205.00

Work Description: SINK, DISPOSAL, DISHWASHER, & DRAIN REPLACEMENT FOR REMODEL

PP240046 07/23/2024 OSINOWO, ADENOWO 27474 EVERGREEN RD 40-24-14-306-080 \$135.00

Work Description: install water heater

Total Permits For Type: 4
Total Fees For Type: \$840.00
Total Const. Value For Type: \$0

Sign

Permit #	Date	Contractor	Job Address	Parcel #	Fee Total Const
PS240006	07/12/2024	AESTHETICS AND BEYOND R	28001 SOUTHFIELD RD	40-24-14-280-015	\$215.00
Work Description: ERECT WALL SIGN FOR AESTHETICS & BEYOND					
PS240007	07/18/2024	LV PETRO LLC A MICHIGAN I	26727 SOUTHFIELD RD	40-24-23-229-029	\$215.00
Work Description: "LIQUOR" WALL SIGN AT BP STATION					

Total Permits For Type: 2
Total Fees For Type: \$430.00
Total Const. Value For Type: \$0

Report Summary

Permit.DateIssued Between
7/1/2024 12:00:00 AM AND
7/31/2024 11:59:59 PM AND
Permit.Status = ISSUED

Grand Total Fees: \$11,224.40

Grand Total Permits: 34
Grand Total Const. Value: \$0

08/06/2024

Residential Enforcement List

Item 7D.

Address	Business Name	Violation Violation	Category	Status	Date Closed
28860 LATHRUP BLVD	FIELDS, DONYA C	REMOVE LOGS/BRANCHES FROM RIGHT OF WAY	Items in R. O. W.	Closed	07/16/2024
28511 LATHRUP BLVD	BUSTO, JONATAN MARTINEZ	REMOVE LOGS/BRANCHES FROM RIGHT OF WAY	Items in R. O. W.	Closed	07/16/2024
19111 SARATOGA BLVD	RAUDSZUS, NORALIE	VACANT PROPERTY REGISTRATION REQUIRED	Vacant Home	Door Tagged, L	
18400 MIDDLESEX AVE	NAHMOUD, ITZICK	GRASS NOT TO EXCEED 7" IN HEIGHT	Tall Grass/ Weeds	Closed	07/23/2024
18581 BUNGALOW DR	FRASER, ROBERT D	LARGE AMOUNT OF DEBRIS AT STREET - REMOVE	DEBRIS	Closed	07/24/2024

08/06/2024

Residential Enforcement List

Item 7D.

Address	Business Name	Violation Violation	Category	Status	Date Closed
19600 FOREST DR	FERGUSON, DON	No plant materials which interfere with or obscure the view of any traffic control device or street, alley, or sidewalk in such fashion as to constitute a hazard to the travelling public shall be permitted to exist. - TRIM AWAY FROM STREET	Property Maintena	Letter Sent	
19328 SARATOGA BLVD	CHANG, CECIL D	RENTAL PROPERTY REGISTRATION AND INSPECTION REQUIRED	Residential Rental	Letter Sent	
27330 RED RIVER DR	3 DICE LLC	RENTAL PROPERTY REGISTRATION AND INSPECTION REQUIRED	Residential Rental	Letter Sent	
27240 EVERGREEN RD	DUDLEY, KELI C	RENTAL PROPERTY REGISTRATION AND INSPECTION REQUIRED	Residential Rental	Letter Sent	
17591 RAMSGATE DR	COOPER, ROSE M	PERMIT REQUIRED FOR DUMPSTER	Refuse Container v	Closed	07/29/2024

08/06/2024

Residential Enforcement List

Item 7D.

Address	Business Name	Violation Violation	Category	Status	Date Closed
18151 KILBIRNIE AVE	MURRELL, ARNOLD	EXTRA CEMENT BEING ADDED AT SIDE AND REAR OF HOUSE WITHOUT PERMIT	Work w/o a permit	Letter Sent	
27315 LATHRUP BLVD	SCOTT, JEROME	GRASS AND WEEDS NOT TO EXCEED 7" IN HEIGHT	Tall Grass/ Weeds Nuisance Cut		08/01/2024
26215 LATHRUP BLVD	PUGH, LESLIE	RENTAL PROPERTY REGISTRATION AND INSPECTION REQUIRED		Residential Rental Letter Sent	
28293 SUNSET W BLVD	PUGH, LESLIE	RENTAL PROPERTY REGISTRATION AND INSPECTION REQUIRED		Residential Rental Letter Sent	

08/06/2024

Residential Enforcement List

Item 7D.

Address	Business Name	Violation Violation	Category	Status	Date Closed
19252 RAINBOW DR	SOUSANIS, JOHN	POD STORAGE CONTAINER ON PROPERTY WITHOUT PERMIT	Trailer / PODS	Letter Sent	
27680 LATHRUP BLVD	GREECH, DOUG	OUTSIDE REFUSE CONTAINER ON PROPERTY WITHOUT PERMIT	Dumpster - No per	Letter Sent	
18130 KILBIRNIE AVE	FORES, GREGORY S	TRASH BINS MUST LEFT AT STREET AFTER PICKUP - REMOVE	Curbside Violation	Letter Sent	
18266 RAINBOW DR	COOK, GREGORY	TRASH BINS LEFT AT STREET AFTER PICKUP - MUST REMOVE	Curbside Violation	Letter Sent	

Records: 18

Page: 4

Code Enforcement Report

Address	Business name	Violation	Inspection Type	Category	Status
28861 SOUTHFIELD RD	KABOB KABOB	BANNER AND "OPEN" SIGN IN WINDOW IN VIOLATION OF SIGNAGE ORDINANCE - REMOVE	RE-INSPECTION - ORI	Sign Violation	Closed

1. 52-24 Sign

Window Sign - Ten (10%) percent of the total glass area on that side of the building and on the floor where the sign will be located.

INSPECTOR COMMENTS: BANNER AND "OPEN" SIGN IN WINDOW IN VIOLATION OF SIGNAGE ORDINANCE - REMOVE

28400 SOUTHFIELD RD	CASH MONEY BROTHER RV WITH SIGNAGE PARKED IN LOT - REMOVE FROM PROPERTY	RE-INSPECTION - ORI	Vehicle Storage	Letter Sent
---------------------	---	---------------------	-----------------	-------------

2. 4.1 OUTSIDE STORAGE (COMMERCIAL VEHICLES, ETC)

1. All trucks, buses, taxis and other automobiles bearing readily observable commercial signs or commercial advertising or obvious business identification, semitractors, tractors, mobile machinery and equipment (including trailers) commonly used for purposes other than transporting persons, pickup trucks, vans and all similar motor vehicles commonly associated with trades, industries, and commercial activities as opposed to residential activities, provided however, this prohibition shall not apply to the following vehicles so long as they bear no readily observable commercial signs, commercial advertising, or obvious business identification: automobiles, pickup trucks, jeeps, small vans, and similar motor vehicles in common use in this city for private passenger automobile purposes.

INSPECTOR COMMENTS: RV WITH SIGNAGE PARKED IN LOT - REMOVE FROM PROPERTY

1. 4.1 OUTSIDE STORAGE (HOUSE TRAILERS)

All house trailers, trailer coaches, mobile homes, motor homes, and other vehicles constructed, equipped, or altered to provide cooking and overnight sleeping facilities, provided however, "overnight parking and storage" shall be liberally construed and applied as to such vehicles to permit same to be brought to and kept on a lot for up to 48 consecutive hours during a calendar week beginning 12:01 a.m. of every Sunday for the purpose of loading or unloading, but not for the purpose of rebuilding, remodeling, or effecting mechanical repairs. The above described vehicles shall not be connected to electricity, water, gas or sanitary sewer facilities. The previously described vehicles shall not be parked within ten feet of any building, within seven feet of a sidewalk or within seven feet from the front lot line, if there is not a sidewalk, and the vehicle shall not create a site distance/ traffic safety hazard.

A. A violation of Sec. 4.2.3 shall be a civil infraction.

B. There is hereby created a rebuttable presumption creating a violation of Sec. 4.2.3 if any of the above described vehicles are viewed, parked or stored, in the same or similar location, more than four times within a 48 hour consecutive time period. (At least one viewing every 12 hours is required).

C. The rebuttable presumption may not be defeated by a showing that the vehicle has been merely moved within the property, that it has been driven off the property and returned merely to defeat the purposes of this section, or by merely making a trip to a service station and returning to the property.

INSPECTOR COMMENTS: RV WITH SIGNAGE PARKED IN LOT - REMOVE FROM PROPERTY

28625 SOUTHFIELD RD	HADDOW, MASON	MATTRESS AND FURNITURE NEAR DUMPSTER ENCLOSURE - REMOVE	RE-INSPECTION - ORI	DEBRIS	Letter Sent
---------------------	---------------	---	---------------------	--------	-------------

Code Enforcement Report

Address	Business name	Violation	Inspection Type	Category	Status
---------	---------------	-----------	-----------------	----------	--------

1. 54-66 Outside storage for unsightly or offensive materials.

No person shall cause or permit the premises he owns or otherwise has under his occupancy or control or the adjoining right-of-way to be used for the outside storage (outside of an appropriate container or building) of garbage, sewage, filth, refuse, dead or cut tree branches, waste, including yard waste, trash, debris, litter, rubbish, including cans, bottles, wastepaper, cartons, boxes, crates, inoperable machinery, discarded building materials, discarded household goods, or any unsightly, offensive or obnoxious materials. All land areas found to be used for such purposes or to be strewn with such materials are declared to be public nuisances.

(Code 1991, art. V, ch. 7, § 108)

INSPECTOR COMMENTS: MATTRESS AND FURNITURE NEAR DUMPSTER ENCLOSURE - REMOVE

28919 SOUTHFIELD RD	MC30 LLC	WINDOW SIGNAGE EXCEEDS ALLOWABLE PERCENTAGE	RE-INSPECTION - ORI Sign Violation	Letter Sent
---------------------	----------	---	------------------------------------	-------------

1. 52-24 Sign

Window Sign - Ten (10%) percent of the total glass area on that side of the building and on the floor where the sign will be located.

INSPECTOR COMMENTS: WINDOW SIGNAGE EXCEEDS ALLOWABLE PERCENTAGE

Records: 4

Memorandum

To: Mayor and City Council

From: Mike Greene, City Administrator

Date: August 14, 2024

Re: Monthly Approval of Disbursements

Attached are reports for the Cities Monthly Disbursements for the Month of July 2024.

MOTION:

To approve the Monthly Disbursements for the month of July 2024 as:

JULY DISBURSEMENTS W/ SALARY INCLUDED			
FUND			
101	GENERAL FUND	\$	570,903.36
FUND			
202	MAJOR ROADS	\$	7,546.47
FUND			
203	LOCAL ROADS	\$	2,232.12
FUND			
258	CAPITAL FUND	\$	-
FUND			
397	ROAD MILLAGE FUND	\$	-
FUND			
494	DOWNTOWN DEV. AUTH	\$	15,391.30
FUND			
592	WATER & SEW	\$	196,815.70
TOTAL DISBURSEMENTS		\$	792,888.95

CITY OF LATHRUP VILLAGE
Disbursement Report

Period covered 7/1/2024-7/15/2024

Gross Payroll:

Payroll Department	Amount	Personnel
Admin	\$63,473.34	Bratschi, Greene, Miller, Townsend, Bobcean, Colliau, Emanuel, Single
DDA	\$3,333.33	Colson
Bldg Mnt	\$0.00	
Police	\$46,571.81	Button, McNeil, Chickensky, Fisher, Gijbers, Huston, Hutson, Cory, Lawrence, McKee Roberts, Stajich, Tackett, Zang
DPS	\$0.00	
Water	\$0.00	
Recreation	\$0.00	

Total Gross \$113,378.48

Deductions \$70,302.38

Net Payroll \$43,076.10

*** Fund Totals Include Gross Payroll**

General Fund	\$110,045.15
Major Road Fund	\$0.00
Local Road Fund	\$0.00
Capital Acquisition Fund	\$0.00
Road Bond	\$0.00
Downtown Development Authority	\$3,333.33
Water & Sewer Fund	\$0.00
Total	\$113,378.48

eton

CITY OF LATHRUP VILLAGE
Disbursement Report

Period covered 7/16/2024-7/31/2024

Gross Payroll:

Payroll Department	Amount	Personnel
Admin	\$23,489.58	Greene, Miller, Townsend, Bobcean, Colliau, Emanuel, Singleton
DDA	\$3,333.33	Colson
Bldg Mnt	\$0.00	

Police	\$42,133.55	Button, Chickensky, Fisher, Gijbers, Huston, Hutson, Cory, Lawrence, McKee Roberts, Stajich, Tackett, Zang
---------------	--------------------	---

DPS	\$0.00	
------------	---------------	--

Water	\$0.00	
--------------	---------------	--

Recreation	\$0.00	
-------------------	---------------	--

Total Gross \$68,956.46

Deductions \$28,923.09

Net Payroll \$40,033.37

*** Fund Totals Include Gross Payroll**

General Fund	\$460,858.21
Major Road Fund	\$7,546.47
Local Road Fund	\$2,232.12
Capital Acquisition Fund	\$0.00
Road Bond	\$0.00
Downtown Development Authority	\$12,057.97
Water & Sewer Fund	\$196,815.70
Total	\$679,510.47

1

Item 7E.

GL Number	GL Desc	Vendor	Invoice Description	Amount	Check #
Fund 101 GENERAL FUND					
Dept 000.000					
101-000.000-036.000	CREDIT CARDS PAYABLE	CARDMEMBER SERVICE	MAY-JUNE 2024	10,000.00	49304
101-000.000-214.397	DUE TO ROAD DEBT FUND	OAKLAND COUNTY TREASURER	TAX-JUNE2024	73.98	49350
101-000.000-232.000	EMPLOYEE PAYROLL-MEDICAL W/H	POLICE & FIREMEN'S INS.	INSURANCE - JULY 2024	56.34	49354
101-000.000-232.000	EMPLOYEE PAYROLL-MEDICAL W/H	AFLAC	INSURANCE	861.44	49396
101-000.000-245.000	RENTAL SECURITY DEPOSITS HELD	ARTOSHA NORWOOD-HARRISON	COMMUNITY ROOM DEPOSIT - JULY 7 2024	300.00	49299
101-000.000-245.000	RENTAL SECURITY DEPOSITS HELD	ROBIN RUSSAW	COMMUNITY ROOM DEPOSIT REFUND - JUNE	100.00	49358
101-000.000-245.000	RENTAL SECURITY DEPOSITS HELD	SONJA HARRIS	COMMUNITY ROOM DEPOSIT REFUND - JUNE	300.00	49362
101-000.000-245.000	RENTAL SECURITY DEPOSITS HELD	CATHERINE DANIEL	COMMUNITY ROOM DEPOSIT REFUND	300.00	49416
101-000.000-245.000	RENTAL SECURITY DEPOSITS HELD	JACQUELINE FLOYD	COMMUNITYT ROOM DEPOSIT RENTAL REFUND	100.00	49426
101-000.000-245.000	RENTAL SECURITY DEPOSITS HELD	LARHONDA GRAHAM	COMMUNITY ROOM DEPOSIT REFUND	300.00	49428
101-000.000-245.000	RENTAL SECURITY DEPOSITS HELD	MICHELLE AMPEY	COMMUNITY ROOM RENTAL DEPOSIT REFUND	300.00	49432
101-000.000-245.000	RENTAL SECURITY DEPOSITS HELD	MIKKI HALL	COMMUNITY ROOM DEPOSIT REFUND	100.00	49435
101-000.000-245.000	RENTAL SECURITY DEPOSITS HELD	REGINA COBB	COMMUNITY ROOM DEPOSIT REFUND	300.00	49447
101-000.000-246.000	POLICE UNION DUES	COMMAND OFFICERS ASSN. O	DUES-ZANG/MCKEE	135.52	49372
101-000.000-246.000	POLICE UNION DUES	MICHIGAN ASSOCIATION OF	JULY 2024 POLICE DUES	575.96	49383
101-000.000-246.000	POLICE UNION DUES	MICHIGAN ASSOCIATION OF	POLICE UNION DUES - JULY-SEPT2024	180.00	49384
101-000.000-246.000	POLICE UNION DUES	MICHIGAN ASSOCIATION OF	POLICE DUES	508.20	49434
101-000.000-283.000	PERFORMANCE BONDS	Consumer's Energy	BD Bond Refund	5,000.00	49373
101-000.000-283.000	PERFORMANCE BONDS	Consumer's Energy	BD Bond Refund	5,000.00	49374
101-000.000-283.000	PERFORMANCE BONDS	Consumer's Energy	BD Bond Refund	5,000.00	49375
101-000.000-283.000	PERFORMANCE BONDS	Consumer's Energy	BD Bond Refund	5,000.00	49376
101-000.000-283.000	PERFORMANCE BONDS	Consumer's Energy	BD Bond Refund	5,000.00	49377
101-000.000-283.000	PERFORMANCE BONDS	Consumer's Energy	BD Bond Refund	5,000.00	49378
101-000.000-283.000	PERFORMANCE BONDS	Consumer's Energy	BD Bond Refund	5,000.00	49379
101-000.000-283.000	PERFORMANCE BONDS	Consumer's Energy	BD Bond Refund	5,000.00	49380
101-000.000-283.000	PERFORMANCE BONDS	Consumer's Energy	BD Bond Refund	5,000.00	49381
101-000.000-283.000	PERFORMANCE BONDS	Consumer's Energy	BD Bond Refund	5,000.00	49382
101-000.000-283.000	PERFORMANCE BONDS	Randazzo Mechanical H C	BD Payment Refund	150.00	49387
101-000.000-283.000	PERFORMANCE BONDS	ANTHONY BRENT MCNEAL	BD Payment Refund	75.00	49406
101-000.000-344.000	DEF COMP PAYABLE ICMA CLEARIN	MISSIONSQUARE - 300179	HEALTH INSURANCE	3,784.58	49390
101-000.000-401.000	CITY TAXES	OAKLAND COUNTY TREASURER	TAX-JUNE2024	330.51	49350
101-000.000-402.000	REFUSE COLLECTION TAXES	OAKLAND COUNTY TREASURER	TAX-JUNE2024	49.58	49350
101-000.000-414.000	TAX PENALTIES	OAKLAND COUNTY TREASURER	TAX-JUNE2024	(31.33)	49350
101-000.000-447.000	TAX 1% ADMINISTRATIVE FEE	OAKLAND COUNTY TREASURER	TAX-JUNE2024	5.75	49350
Total For Dept 000.000				68,855.53	
Dept 100.000 GOVERNMENT SERVICES					
101-100.000-710.000	UNEMPLOYMENT INSURANCE	MICHIGAN MUNICIPAL LEAGU	QUARTERLY COMPENSATION	10.08	49385
101-100.000-710.000	UNEMPLOYMENT INSURANCE	MICHIGAN MUNICIPAL LEAGU	QUARTERLY CONTRIBUTION - 3.30.24	42.28	49386
101-100.000-803.000	MEMBERSHIPS & MEETINGS	ALLIANCE OF ROUGE COMMUN	MEMBERSHIP DUES 2024	1,578.00	49295
101-100.000-803.000	MEMBERSHIPS & MEETINGS	PROTEC	MEMBERSHIP DUES - JULY 2024	511.00	49356
101-100.000-804.000	BUILDING TRADE INSPECTION	MCKENNA & ASSOC.	INPSECTION SERVICES	2,219.75	49429
101-100.000-804.000	BUILDING TRADE INSPECTION	MCKENNA & ASSOC.	INSPECTION SERVICES	2,754.70	49430
101-100.000-804.000	BUILDING TRADE INSPECTION	MCKENNA & ASSOC.	INSPECTION SERVICES	4,806.54	49431
101-100.000-805.000	CABLE TELEVISION	COMCAST	UTILITIES-SVS DATE 7.11.2024 - 8.10.2	148.65	49316
101-100.000-808.000	COMMUNITY CENTER EXPENDITURE	CLIFTON GRANT	RENTALS-ELECTIONS-ADD WORK - JULY 202	575.00	49311
101-100.000-808.000	COMMUNITY CENTER EXPENDITURE	CLIFTON GRANT	RENTALS, ELECTIONS AND ADDITIONAL WOR	1,200.00	49420
101-100.000-810.000	AUDITING & ACCOUNTING	PLANTE MORAN	PROFESSIONAL ACCT SVS - JUNE 2024	5,441.80	49353
101-100.000-822.000	TRAINING	ALISA EMANUEL	MEAL REIMBURSEMENT - DINNER CLERK 101	9.81	49397
101-100.000-848.000	GOVERNMENT OPERATIONS	DENZIL ACKLES	GARAGE SALE SIGN ORDER	900.00	49288
101-100.000-848.000	GOVERNMENT OPERATIONS	ADP, LLC	PAYROLL PROCESSING - JUNE 2024	137.80	49290
101-100.000-848.000	GOVERNMENT OPERATIONS	ADP, LLC	PAYROLL PROCESSING - JUNE 2024	132.50	49291

Item 7E.

GL Number	GL Desc	Vendor	Invoice Description	Amount	Check #
Fund 101 GENERAL FUND					
Dept 100.000 GOVERNMENT SERVICES					
101-100.000-848.000	GOVERNMENT OPERATIONS	AMAZON CAPITAL SERVICES	DEPOSIT BAGS	44.79	49298
101-100.000-848.000	GOVERNMENT OPERATIONS	CLS CONTINENTAL LINEN SE	LINENS-JUNE2024	50.86	49315
101-100.000-848.000	GOVERNMENT OPERATIONS	BSA	TECHNOLOGY ASSISTANCE/SERVICES	1,558.00	49408
101-100.000-848.001	TECHNOLOGY	BSB COMMUNICATIONS, INC.	TECHNOLOGY	391.25	49302
101-100.000-848.001	TECHNOLOGY	CIVICPLUS	ARCHIVE SOCIAL ECON - JULY 2024	4,397.40	49310
101-100.000-848.001	TECHNOLOGY	VC3 INC	TECHNOLOGY--JULY2024	278.00	49366
101-100.000-848.001	TECHNOLOGY	VC3 INC	TECHNOLOGY-JULY 2024	251.00	49367
101-100.000-848.001	TECHNOLOGY	POINT & PAY	CC/DEBIT PROCESSING FEE-MAY2024	50.00	49442
101-100.000-848.001	TECHNOLOGY	POINT & PAY	CC/DEBIT PROCESSING-JUNE2024	50.00	49443
101-100.000-848.001	TECHNOLOGY	VC3 INC	TECHNOLOGY	3,569.00	49455
101-100.000-850.000	TELEPHONE EXPENDITURES	COMCAST	UTILITIES-SVS DATE 7.11.2024 - 8.10.2	148.64	49316
101-100.000-850.000	TELEPHONE EXPENDITURES	INTERMEDIA.NET INC	JUNE 2024	707.39	49336
101-100.000-850.000	TELEPHONE EXPENDITURES	VERIZON WIRELESS	CELL PHONE	276.51	49456
101-100.000-860.000	VEHICLE EXPENSE	ALISA EMANUEL	TRAVEL EXP	169.64	49292
101-100.000-882.000	PLANNING/CONSULTING FEES	GIFFELS-WEBSTER ENG INC	ENGINEERING SVS	200.00	49425
101-100.000-901.000	POSTAGE FEES	PITNEY BOWES GLOBAL FINA	INK FOR POSTAGE MACHINE-JULY 2024	227.17	49352
101-100.000-901.000	POSTAGE FEES	UNITED STATES POSTAL SER	ELECTION POSTAGE	400.00	49389
101-100.000-901.000	POSTAGE FEES	PITNEY BOWES GLOBAL FINA	POSTAGE MACHINE REFILL	401.00	49440
Total For Dept 100.000 GOVERNMENT SERVICES				33,638.56	
Dept 101.000 ADMINISTRATION					
101-101.000-703.000	EMPLOYEE TAXES & BENEFITS	STANDARD INSURANCE COMPA	HEALTH INS	208.51	49363
101-101.000-703.000	EMPLOYEE TAXES & BENEFITS	BLUE CARE NETWORK	HEALTH INSUR-JULY2024	4,890.31	49369
101-101.000-703.000	EMPLOYEE TAXES & BENEFITS	BLUE CARE NETWORK	HEALTH CARE - AUG2024	352.32	49370
101-101.000-703.000	EMPLOYEE TAXES & BENEFITS	BLUE CARE NETWORK	HEALTH CARE-AUG2024	881.77	49371
101-101.000-703.000	EMPLOYEE TAXES & BENEFITS	MISSIONSQUARE - 803046	HEALTH SAVINGS RHS PLAN	330.84	49391
101-101.000-703.000	EMPLOYEE TAXES & BENEFITS	STANDARD INSURANCE COMPA	INSURANCE	217.11	49451
101-101.000-718.000	ELECTIONS	ALISA EMANUEL	TRAVEL EXP	336.88	49292
101-101.000-718.000	ELECTIONS	ALISA EMANUEL	ELECTION EXP REIMBURSEMENT-JUNE2024	395.08	49293
101-101.000-718.000	ELECTIONS	ALISA EMANUEL	POSTAGE STAMPS FOR ELECTION BALLOTS	18.40	49294
101-101.000-718.000	ELECTIONS	HART INTERCIVIC	VERITY - SERVICE AND MAINTENANCE RENE	3,348.00	49332
101-101.000-718.000	ELECTIONS	HART INTERCIVIC	VERITY DRIVES AUGUST ELECTION 2024	417.28	49333
101-101.000-718.000	ELECTIONS	OFFICE MANAGEMENT & CONS	PRE-ELECTION TESTING AND PUBLIC ACCUR	1,265.00	49438
101-101.000-718.000	ELECTIONS	PRINTING SYSTEMS, INC.	MASTER CARD AND VOTER ID STOCK AND AP	123.84	49444
101-101.000-718.000	ELECTIONS	PRINTING SYSTEMS, INC.	VOTER INSTRUCTION SHEETS AUG 6 2024 4	367.39	49445
101-101.000-718.000	ELECTIONS	PRINTING SYSTEMS, INC.	VOTER ADDRESS VERIFICATION CANCELLATI	87.93	49446
101-101.000-718.000	ELECTIONS	WILLIE WESLEY	ELECTION INSPECTOR & EPB TRAINING, EP	2,500.00	49458
101-101.000-718.000	ELECTIONS	21ST CENTURY MEDIA- MICH	NEWSPAPER AD	101.25	49394
101-101.000-718.000	ELECTIONS	CARDMEMBER SERVICE	MISC ELECTION SUPPLIES	157.94	49415
101-101.000-718.000	ELECTIONS	OFFICE MANAGEMENT & CONS	ELECTIONS - (CHECK REISSUED)	4,900.00	49439
101-101.000-719.000	OFFICIALS EXPENSE	MICHIGAN ASSOC OF MAYORS	SUMMER WORKSHOP-GARRETT-JULY 2024	210.00	49343
Total For Dept 101.000 ADMINISTRATION				21,109.85	
Dept 201.000 BUILDING & GROUNDS					
101-201.000-702.000	SALARIES PART-TIME	CLIFTON GRANT	SPOUSAL SUPPORT - JULY 2024	601.75	49312
101-201.000-702.000	SALARIES PART-TIME	CLIFTON GRANT	GENERAL MAINTENANCE -JULY 2024	467.02	49313
101-201.000-702.000	SALARIES PART-TIME	CLIFTON GRANT	DEEP CLEANING OF KITCHEN	150.00	49314
101-201.000-702.000	SALARIES PART-TIME	AFLAC	INSURANCE	238.44	49396
101-201.000-702.000	SALARIES PART-TIME	CLIFTON GRANT	GENERAL MAINTENANCE & ADDITIONAL WORK	467.02	49418
101-201.000-702.000	SALARIES PART-TIME	CLIFTON GRANT	SPOUSAL SUPPORT	601.75	49419
101-201.000-703.000	EMPLOYEE TAXES & BENEFITS	BLUE CARE NETWORK	HEALTH INSUR-JULY2024	(3,628.88)	49369
101-201.000-920.000	UTILITIES	CITY OF LATHRUP VILLAGE,	WATER USAGE - JUNE 2024	2,703.93	49307
101-201.000-920.000	UTILITIES	CONSUMERS ENERGY	UTILITIES	248.50	4931

GL Number	GL Desc	Vendor	Invoice Description	Amount	Check #
Fund 101 GENERAL FUND					
Dept 201.000 BUILDING & GROUNDS					
101-201.000-920.000	UTILITIES	CONSUMERS ENERGY	UTILITIES	162.56	49320
101-201.000-920.000	UTILITIES	DTE ENERGY	UTILITIES-MAY30-JUNE28, 2024	280.32	49322
101-201.000-920.000	UTILITIES	DTE ENERGY	UTILITIES-MAY 30 - JUNE 28 2024	419.33	49323
101-201.000-920.000	UTILITIES	DTE ENERGY	UTILITIES - MAY 30 - JUNE 28 2024	1,947.43	49324
101-201.000-920.000	UTILITIES	DTE ENERGY	STREET LTS- JUNE 1 - JUNE 30 2024	6,491.85	49325
101-201.000-930.000	BUILDING MAINTENANCE & REPAIR	ACE HANDYMAN SERVICES	PARTITIONED SECURITY ROOM	2,156.16	49289
101-201.000-930.000	BUILDING MAINTENANCE & REPAIR	HOME DEPOT CREDIT SERVIC	CITY HALL LTS	10.97	49334
101-201.000-930.000	BUILDING MAINTENANCE & REPAIR	HOME DEPOT CREDIT SERVIC	WTR MAIN PARTS - JUNE 12-14-2024	7.96	49335
101-201.000-930.000	BUILDING MAINTENANCE & REPAIR	J.C. EHRlich CO.INC	PEST CONTROL-JUNE2024	124.18	49337
101-201.000-930.000	BUILDING MAINTENANCE & REPAIR	KONE INC.	MAINTENANCE-7.01.24-7.31.2024	254.78	49339
101-201.000-930.000	BUILDING MAINTENANCE & REPAIR	KONE INC.	MAINTENANCE- JUNE 2024	254.78	49340
101-201.000-930.000	BUILDING MAINTENANCE & REPAIR	MR. MAT RENTAL SERVICE	-BLDG MAINTENANCE-JUNE-19-2024	180.40	49344
101-201.000-930.000	BUILDING MAINTENANCE & REPAIR	ERC-LED	MISC MAINTENANCE	451.81	49423
101-201.000-930.000	BUILDING MAINTENANCE & REPAIR	KONE INC.	ELEVATOR SVS	228.84	49427
101-201.000-930.000	BUILDING MAINTENANCE & REPAIR	MR. MAT RENTAL SERVICE	MAT RENTAL/CLEANING	180.40	49436
101-201.000-970.000	CAPITAL EXPENDITURE	GLOBAL INDUSTRIAL	WATER FOUNTAIN REPLACEMENTS - JULY 1	4,055.09	49331
101-201.000-970.000	CAPITAL EXPENDITURE	PLUMBING TECHS	INSTALLATION OF DRINKING FOUNTAINS	875.00	49441
Total For Dept 201.000 BUILDING & GROUNDS				19,931.39	
Dept 301.000 PUBLIC SAFETY					
101-301.000-703.000	EMPLOYEE TAXES & BENEFITS	BLUE CROSS-BLUE SHIELD	HEALTH INSURANCE-RETIREEES UNDER 65	7,448.77	49300
101-301.000-703.000	EMPLOYEE TAXES & BENEFITS	BLUE CROSS-BLUE SHIELD	8.01.24-8.31.24	10,968.49	49301
101-301.000-703.000	EMPLOYEE TAXES & BENEFITS	STANDARD INSURANCE COMPA	HEALTH INS	399.41	49363
101-301.000-703.000	EMPLOYEE TAXES & BENEFITS	BLUE CARE NETWORK	HEALTH CARE - AUG2024	352.32	49370
101-301.000-703.000	EMPLOYEE TAXES & BENEFITS	MISSIONSQUARE - 803061	HEALTH SAVINGS PLAN	895.45	49392
101-301.000-703.000	EMPLOYEE TAXES & BENEFITS	STANDARD INSURANCE COMPA	INSURANCE	308.78	49451
101-301.000-710.000	UNEMPLOYMENT INSURANCE	MICHIGAN MUNICIPAL LEAGU	QUARTERLY COMPENSATION	19.56	49385
101-301.000-710.000	UNEMPLOYMENT INSURANCE	MICHIGAN MUNICIPAL LEAGU	QUARTERLY CONTRIBUTION - 3.30.24	82.07	49386
101-301.000-726.000	OFFICE SUPPLIES	AMAZON CAPITAL SERVICES	OFFICE SUPPLY	38.58	49297
101-301.000-726.000	OFFICE SUPPLIES	AMAZON CAPITAL SERVICES	OFFICE SUPPLY-JULY	55.96	49398
101-301.000-726.000	OFFICE SUPPLIES	AMAZON CAPITAL SERVICES	MISC OFFICE SUPPLIES	155.90	49402
101-301.000-726.000	OFFICE SUPPLIES	AMAZON CAPITAL SERVICES	MISC OFFICE	62.89	49403
101-301.000-726.000	OFFICE SUPPLIES	AMAZON CAPITAL SERVICES	MISC OFFICE	39.31	49404
101-301.000-726.000	OFFICE SUPPLIES	AMAZON CAPITAL SERVICES	MISC OFFICE	119.61	49405
101-301.000-726.000	OFFICE SUPPLIES	CARDMEMBER SERVICE	TECHNOLOGY	19.99	49410
101-301.000-727.000	ROAD SUPPLIES	AMAZON CAPITAL SERVICES	POLICE ROAD SUPPLIES	63.08	49401
101-301.000-729.000	OFFICE MACHINE MAINTENANCE	XEROX CORPORATION	OFFICE SUPPLY - 5.21.2024 - 6.21.2024	79.96	49368
101-301.000-803.000	MEMBERSHIPS & MEETINGS	CITY OF LATHRUP VILLAGE	PETTY CASH REIMBURSEMENT POLICE - JUN	19.07	49306
101-301.000-803.000	MEMBERSHIPS & MEETINGS	SUZANNE CORY	NOTARYSUPPLY-POLICE CLERK	197.95	49364
101-301.000-803.000	MEMBERSHIPS & MEETINGS	SUZANNE CORY	NOTARY-POLICE CLERK	10.17	49365
101-301.000-803.000	MEMBERSHIPS & MEETINGS	SUZANNE CORY	POLICE NOTARY	30.00	49388
101-301.000-821.000	POLICE RESERVES	AMAZON CAPITAL SERVICES	OFFICE SUPPLY - JULY 3 2024	61.94	49296
101-301.000-822.000	TRAINING	LERMA, INC.	POLICE CONFERENCE-CLERK	275.00	49341
101-301.000-822.000	TRAINING	MICHIGAN ASSOC OF CHIEFS	FALL 2024 ACCREDITATION	250.00	49342
101-301.000-822.000	TRAINING	SCOTT MCKEE	AIRLINEFLIGHT-CONFERENCE	626.95	49359
101-301.000-822.000	TRAINING	2X SERVICES LLC	FRAUD TRAINING- POLICE	150.00	49395
101-301.000-822.000	TRAINING	CARDMEMBER SERVICE	CONFERENCE-POLICE	190.00	49411
101-301.000-822.000	TRAINING	CARDMEMBER SERVICE	TRAINING	94.35	49412
101-301.000-822.000	TRAINING	CARDMEMBER SERVICE	HOTEL FOR OCTOBER TRAINING - JUNE2023	458.05	49413
101-301.000-822.000	TRAINING	MICHIGAN ASSOC OF CHIEFS	TRAINING POLICE	50.00	49433
101-301.000-823.000	FIREARMS TRAINING	CITY OF LATHRUP VILLAGE	PETTY CASH REIMBURSEMENT POLICE - JUN	3.79	49306
101-301.000-823.000	FIREARMS TRAINING	CITY OF TAYLOR	POLICE TRAINING	600.00	49417

Item 7E.

GL Number	GL Desc	Vendor	Invoice Description	Amount	Check #
Fund 101 GENERAL FUND					
Dept 301.000 PUBLIC SAFETY					
101-301.000-823.000	FIREARMS TRAINING	VANCE OUTDOORS, INC.	POLICE TRAINING	867.83	49454
101-301.000-825.000	ANIMAL CONTROL	AMAZON CAPITAL SERVICES	PET CHIP SCANNER	45.99	49400
101-301.000-826.000	COMMUNITY POLICING	CITY OF LATHRUP VILLAGE	PETTY CASH REIMBURSEMENT POLICE - JUN	9.53	49306
101-301.000-826.000	COMMUNITY POLICING	CARDMEMBER SERVICE	REFUND TAX PYMT ON PENS FOR SCOTT	(18.89)	
101-301.000-828.000	FIRE SERVICE/DISPATCH CONTRACT	CITY OF SOUTHFIELD	FIRE SVS CONTRACT	170,995.00	49309
101-301.000-829.000	POLICE UNIFORMS & CLEANING	MUNSON CLEANERS	POLICE UNIFORM CLEANING-MAY/JUNE2024	120.50	49345
101-301.000-829.000	POLICE UNIFORMS & CLEANING	NYE UNIFORM	POLICE UNIFORMS- JUNE2024	197.75	49347
101-301.000-836.000	PRISONER LOCKUP	CITY OF BERKLEY	PRISON BOARD-JUNE2024	1,400.00	49305
101-301.000-848.001	TECHNOLOGY	POWERDMS	POLICE ACCREDITATION - JULY 2024	5,003.32	49355
101-301.000-850.000	TELEPHONE EXPENDITURES	COMCAST	UTILITIES-SVS DATE 7.11.2024 - 8.10.2	148.65	49316
101-301.000-850.000	TELEPHONE EXPENDITURES	COMCAST	POLICE DEPT TECHNOLOGY - JULY 5-AUG 4	21.58	49317
101-301.000-850.000	TELEPHONE EXPENDITURES	AT & T	TELEPHONE	59.27	49407
101-301.000-850.000	TELEPHONE EXPENDITURES	VERIZON WIRELESS	CELL PHONE	276.51	49456
101-301.000-851.000	RADIO COMMUNICATIONS	OAKLAND COUNTY TREASURER	CLEMIS FEES - APRIL - JUNE 2024	2,191.00	49348
101-301.000-851.000	RADIO COMMUNICATIONS	OAKLAND COUNTY TREASURER	SOFTWARE MAINTENANCE - JULY-SEPT 2024	500.00	49349
101-301.000-860.000	VEHICLE EXPENSE	CITY OF LATHRUP VILLAGE	PETTY CASH REIMBURSEMENT POLICE - JUN	22.55	49306
101-301.000-860.000	VEHICLE EXPENSE	JAX KAR WASH	CAR WASHING-POLICE	25.00	49338
101-301.000-860.000	VEHICLE EXPENSE	CARDMEMBER SERVICE	VEHICLE MAINTENANCE	124.95	49409
101-301.000-860.000	VEHICLE EXPENSE	CARDMEMBER SERVICE	VEHICLE EXPENSE	24.99	49414
101-301.000-860.000	VEHICLE EXPENSE	DISCOUNT TIRE COMPANY	VEHICLE EXPENSE-POLICE	460.40	49422
101-301.000-860.000	VEHICLE EXPENSE	OAKLAND COUNTY TREASURER	POLICE VEHICLE EXPENSES	5,930.00	49437
101-301.000-860.000	VEHICLE EXPENSE	US BANK VOYAGER FLEET SY	GAS	2,658.30	49452
101-301.000-860.000	VEHICLE EXPENSE	US BANK VOYAGER FLEET SY	GAS-POLICE - JUNE302024	738.40	49453
Total For Dept 301.000 PUBLIC SAFETY				215,930.03	
Dept 401.000 PUBLIC SERVICE					
101-401.000-860.000	VEHICLE EXPENSE	US BANK VOYAGER FLEET SY	GAS - DPW - JUNE302024	503.27	3391
101-401.000-860.000	VEHICLE EXPENSE	US BANK VOYAGER FLEET SY	GAS	964.32	3392
101-401.000-892.000	SIDEWALK MAINTENANCE	GIFFELS-WEBSTER ENG INC	ENGINEERING SERVICES - JUNE 2024	325.00	49328
101-401.000-920.000	UTILITIES	CONSUMERS ENERGY	UTILITIES - JUNE2024	138.02	49318
101-401.000-920.000	UTILITIES	DTE ENERGY	UTILITIES-MAY 31-JULY1 2024	75.51	49321
101-401.000-920.000	UTILITIES	DTE ENERGY	UTILITIES-JUNE2024	18.51	49326
101-401.000-920.000	UTILITIES	COMCAST	UTILITIES	358.25	49421
Total For Dept 401.000 PUBLIC SERVICE				2,382.88	
Dept 502.000					
101-502.000-801.001	SOCRRA	SOCRRA	SPECIAL CHARGES - JUNE 2024	267.12	49360
101-502.000-801.001	SOCRRA	SOCRRA	REFUSE REMOVAL - JUNE 2024	16,961.00	49361
101-502.000-801.001	SOCRRA	SOCRRA	JULY 2024 REFUSE	15,773.00	49450
Total For Dept 502.000				33,001.12	
Dept 601.000 RECREATION					
101-601.000-813.000	CHILDREN/YOUTH ACTIVITIES	NICOLE LOWRY	PARK/REC EQUIP - JUNE 2024	385.72	49346
Total For Dept 601.000 RECREATION				385.72	
Total For Fund 101 GENERAL FUND				395,235.08	
Fund 202 MAJOR ROAD FUND					
Dept 702.000					
202-702.000-703.000	EMPLOYEE TAXES & BENEFITS	STANDARD INSURANCE COMPA	HEALTH INS	2.69	49363
202-702.000-703.000	EMPLOYEE TAXES & BENEFITS	BLUE CARE NETWORK	HEALTH INSUR-JULY2024	18.96	49369
202-702.000-703.000	EMPLOYEE TAXES & BENEFITS	STANDARD INSURANCE COMPA	INSURANCE	2.69	49451
202-702.000-810.000	AUDITING & ACCOUNTING	SEMCOG	GRANT AGREEMENT	4,434.34	49449

GL Number	GL Desc	Vendor	Invoice Description	Amount	Check #
Fund 202 MAJOR ROAD FUND					
Dept 702.000					
202-702.000-858.000	ROAD CONSTRUCTION	GIFFELS-WEBSTER ENG INC	ENGINEERING SERVICES - JUNE 2024	880.00	49327
202-702.000-861.000	ROAD MAINTENANCE	ROAD COMMISSION FOR OAKL	CHLORIDE TREATMENTS-JULY 2024	1,297.24	49357
202-702.000-864.000	TRAFFIC CONTROLS	ROAD COMMISSION FOR OAKL	SIGNAL FEES	910.55	49448
Total For Dept 702.000				7,546.47	
Total For Fund 202 MAJOR ROAD FUND				7,546.47	
Fund 203 LOCAL ROAD FUND					
Dept 703.000					
203-703.000-703.000	EMPLOYEE TAXES & BENEFITS	STANDARD INSURANCE COMPA	HEALTH INS	2.69	49363
203-703.000-703.000	EMPLOYEE TAXES & BENEFITS	BLUE CARE NETWORK	HEALTH INSUR-JULY2024	18.96	49369
203-703.000-703.000	EMPLOYEE TAXES & BENEFITS	STANDARD INSURANCE COMPA	INSURANCE	2.69	49451
203-703.000-861.000	ROAD MAINTENANCE	ROAD COMMISSION FOR OAKL	CHLORIDE TREATMENTS-JULY 2024	1,297.24	49357
203-703.000-864.000	TRAFFIC CONTROLS	ROAD COMMISSION FOR OAKL	SIGNAL FEES	910.54	49448
Total For Dept 703.000				2,232.12	
Total For Fund 203 LOCAL ROAD FUND				2,232.12	
Fund 494 DOWNTOWN DEVELOPMENT AUTHORITY					
Dept 000.000					
494-000.000-703.000	EMPLOYEE TAXES & BENEFITS	STANDARD INSURANCE COMPA	HEALTH INS	10.75	49363
494-000.000-703.000	EMPLOYEE TAXES & BENEFITS	BLUE CARE NETWORK	HEALTH INSUR-JULY2024	1,409.33	49369
494-000.000-703.000	EMPLOYEE TAXES & BENEFITS	BLUE CARE NETWORK	HEALTH CARE-AUG2024	97.97	49371
494-000.000-703.000	EMPLOYEE TAXES & BENEFITS	MISSIONSQUARE - 803046	HEALTH SAVINGS RHS PLAN	180.83	49391
494-000.000-703.000	EMPLOYEE TAXES & BENEFITS	STANDARD INSURANCE COMPA	INSURANCE	88.17	49451
494-000.000-726.000	OFFICE SUPPLIES	AMAZON CAPITAL SERVICES	OFFICE SUPPLIES	80.28	49399
494-000.000-810.000	AUDITING & ACCOUNTING	PLANTE MORAN	PROFESSIONAL ACCT SVS - JUNE 2024	777.40	49353
494-000.000-844.000	MAIN STREET PROGRAM	TDMK	UNIFORMS	964.00	49393
494-000.000-882.000	PLANNING/CONSULTING FEES	GIFFELS-WEBSTER ENG INC	PROF ENGINEERING SVS	1,575.00	49424
494-000.000-933.000	REPAIRS & MAINTENANCE	GIFFELS-WEBSTER ENG INC	ENGINEERING SERVICES - JUNE 2024	330.00	49329
494-000.000-933.000	REPAIRS & MAINTENANCE	GIFFELS-WEBSTER ENG INC	ENGINEERING SERVICES - JUNE 2024	2,901.55	49330
494-000.000-955.000	MISCELLANEOUS EXPENDITURES	CANFIELD EQUIPMENT SERVI	PATROL CAR COMPUTER-MAY 2024	173.36	49303
494-000.000-955.000	MISCELLANEOUS EXPENDITURES	WEINGARTZ	MOWER EXPENSE	136.00	49457
Total For Dept 000.000				8,724.64	
Total For Fund 494 DOWNTOWN DEVELOPMENT AUTHORITY				8,724.64	
Fund 592 WATER & SEWER FUND					
Dept 000.000					
592-000.000-202.000	ACCOUNTS PAYABLE	PLANTE MORAN	PROFESSIONAL ACCT SVS - JUNE 2024	1,554.80	49353
Total For Dept 000.000				1,554.80	
Dept 536.000 WATER DEPARTMENT					
592-536.000-703.000	EMPLOYEE TAXES & BENEFITS	STANDARD INSURANCE COMPA	HEALTH INSURANCE	18.84	3381
592-536.000-703.000	EMPLOYEE TAXES & BENEFITS	BLUE CARE NETWORK	HEALTH INSURANCE - WTR AUG2024	348.61	3383
592-536.000-703.000	EMPLOYEE TAXES & BENEFITS	BLUE CARE NETWORK	HEALTH CARE-AUG2024	1,761.60	3384
592-536.000-703.000	EMPLOYEE TAXES & BENEFITS	STANDARD INSURANCE COMPA	INSURANCE	18.85	3390
592-536.000-902.000	BILLING SERVICES	UNITED STATES POSTAL SER	POSTAGE FOR WTR BILLS	979.44	3364
592-536.000-921.000	CONTRACTUAL SERVICES	LATHRUP SERVICES, LLC	PUBLIC SERVICES FOR (MO/YEAR) - JUNE	17,162.75	3377
592-536.000-937.000	WATER SYSTEM MAINTENANCE	FERGUSON WATERWORKS	WTR METERS - JUNE 11 2024	737.80	3368
592-536.000-937.000	WATER SYSTEM MAINTENANCE	FERGUSON WATERWORKS	WTR METERS - 6.11.24	735.77	3369
592-536.000-944.000	WATER PURCHASES	SOUTHEAST OAKLAND COUNTY	WATER SERVICE - JUNE 1 - JUNE 30 2024	28,400.00	3380
592-536.000-974.000	WATER MAIN PROJECT	EAGLE LANDSCAPING & SUPP	TRACTOR RENTAL-JULY 2024	250.00	3367

Item 7E.

GL Number	GL Desc	Vendor	Invoice Description	Amount	Check #
Fund 592 WATER & SEWER FUND					
Dept 536.000 WATER DEPARTMENT					
592-536.000-974.000	WATER MAIN PROJECT	GIFFELS-WEBSTER ENG INC	ENGINEERING SERVICES - JUNE 2024	5,637.50	3373
592-536.000-974.000	WATER MAIN PROJECT	EAGLE LANDSCAPING & SUPP	TRACTOR RENTAL	250.00	3386
592-536.000-974.000	WATER MAIN PROJECT	EAGLE LANDSCAPING & SUPP	TRACTOR RENTAL	250.00	3387
592-536.000-974.000	WATER MAIN PROJECT	EAGLE LANDSCAPING & SUPP	TRACTOR RENTAL	250.00	3388
Total For Dept 536.000 WATER DEPARTMENT				56,801.16	
Dept 536.100 WATER DEPARTMENT					
592-536.100-970.000	CAPITAL EXP - STOP BOX REPLACEM	GIFFELS-WEBSTER ENG INC	ENGINEERING SERVICES - JUNE 2024	1,912.50	3372
Total For Dept 536.100 WATER DEPARTMENT				1,912.50	
Dept 536.400 WATER DEPARTMENT					
592-536.400-970.000	CAPITAL EXP - WATER MAIN REPLAC	GIFFELS-WEBSTER ENG INC	ENGINEERING SERVICES - JUNE 2024	495.00	3374
Total For Dept 536.400 WATER DEPARTMENT				495.00	
Dept 536.500 WATER DEPARTMENT					
592-536.500-970.000	CAPITAL FIRE HYDRANTS	GIFFELS-WEBSTER ENG INC	ENGINEERING SERVICES - JUNE 2024	247.50	3371
Total For Dept 536.500 WATER DEPARTMENT				247.50	
Dept 536.600 WATER DEPARTMENT					
592-536.600-970.000	CAPITAL EXP - GATE VALVES	GIFFELS-WEBSTER ENG INC	ENGINEERING CONSULTATIONS - JUNE 2024	247.50	3370
Total For Dept 536.600 WATER DEPARTMENT				247.50	
Dept 537.000 SEWER DEPARTMENT					
592-537.000-703.000	EMPLOYEE TAXES & BENEFITS	STANDARD INSURANCE COMPA	HEALTH INSURANCE	18.84	3381
592-537.000-703.000	EMPLOYEE TAXES & BENEFITS	BLUE CARE NETWORK	HEALTH INSURANCE - WTR AUG2024	348.61	3383
592-537.000-703.000	EMPLOYEE TAXES & BENEFITS	MISSIONSQUARE - 803046	HEALTH SAVINGS PLAN	38.68	3385
592-537.000-703.000	EMPLOYEE TAXES & BENEFITS	STANDARD INSURANCE COMPA	INSURANCE	18.85	3390
592-537.000-725.000	PAYING AGENT FEES	THE BANK OF NEW YORK	8.15.2024 - 8.14.2025	825.00	3382
592-537.000-921.000	CONTRACTUAL SERVICES	HUBBELL, ROTH & CLARK, I	ENGINEERING CONSULTANT - JUNE 2024	323.33	3375
592-537.000-921.000	CONTRACTUAL SERVICES	LATHRUP SERVICES, LLC	PUBLIC SERVICES FOR (MO/YEAR) - JUNE	17,162.72	3377
592-537.000-921.000	CONTRACTUAL SERVICES	OAKLAND COUNTY WATER RES	SEWER SYSTEM MAIN CHG - APRIL 1 - JUN	18,750.00	49351
592-537.000-939.000	SEWER SYSTEM MAINTENANCE	MICHAEL WILLIAMS	2024 LIFT GRINDER PUMP FEE	31.00	3378
592-537.000-942.000	SEWAGE DISPOSAL EXPENSE	OAKLAND COUNTY TREASURER	SPECIAL ASSESSMENTS - JUNE OF 2024	89,560.49	3379
592-537.000-946.000	RETENTION TANK UTIL-WATER	CITY OF LATHRUP VILLAGE,	WTR TANK - JUNE OF 2024	6,369.25	49308
592-537.000-947.000	RETENTION TANK UTIL-GAS	CONSUMERS ENERGY	UTILITIES	16.00	3366
592-537.000-948.000	RETENTION TANK UTIL-TELEPHONE	COMCAST	UTILITIES-SVS PERIOD7.08.24-8.07.24	122.85	3365
592-537.000-957.000	INDUSTRIAL SURCHARGE/NON-RESI	GREAT LAKES WATER AUTHOR	IWC CHGS	1,439.62	3389
592-537.000-977.000	EVIRONMENT COMPL - NON CAPITA	HYDROCORP	CROSS CONNECTION SRVS - JUNE 2024	532.00	3376
Total For Dept 537.000 SEWER DEPARTMENT				135,557.24	
Total For Fund 592 WATER & SEWER FUND				196,815.70	

Item 7E.

GL Number	GL Desc	Vendor	Invoice Description	Amount	Check #
			Fund Totals:		
			Fund 101 GENERAL FUND	395,235.08	
			Fund 202 MAJOR ROAD FU	7,546.47	
			Fund 203 LOCAL ROAD FU	2,232.12	
			Fund 494 DOWNTOWN DEVE	8,724.64	
			Fund 592 WATER & SEWER	196,815.70	
			Total For All Funds:	<u>610,554.01</u>	

GL NUMBER	DESCRIPTION	2024-25		YTD BALANCE	ACTIVITY FOR	AVAILABLE	% BGDG USED
		AMENDED BUDGET	NORMAL (ABNORMAL)	07/31/2024	MONTH 07/31/2024	BALANCE	
					INCREASE (DECREASE)	NORMAL (ABNORMAL)	
Fund 101 - GENERAL FUND							
Revenues							
Dept 000.000							
101-000.000-401.000	CITY TAXES	3,232,000.00		368,540.35	368,540.35	2,863,459.65	11.40
101-000.000-402.000	REFUSE COLLECTION TAXES	484,780.00		55,276.00	55,276.00	429,504.00	11.40
101-000.000-409.000	DELQ PERSONAL PROPERTY REVENU	3,000.00		0.00	0.00	3,000.00	0.00
101-000.000-414.000	TAX PENALTIES	30,000.00		31.33	31.33	29,968.67	0.10
101-000.000-415.000	MISCELLANEOUS REVENUE	15,000.00		108.59	108.59	14,891.41	0.72
101-000.000-416.000	WORK COMP DIVIDEND REVENUE	7,000.00		0.00	0.00	7,000.00	0.00
101-000.000-416.001	PROPERTY & LIABILITY DIVIDEND REVENUE	10,000.00		0.00	0.00	10,000.00	0.00
101-000.000-419.000	AT & T LEASE PAYMENTS	60,000.00		5,327.82	5,327.82	54,672.18	8.88
101-000.000-421.000	METRO-PCS LEASE PAYMENTS	48,000.00		5,527.75	5,527.75	42,472.25	11.52
101-000.000-423.000	WORK COMP REIMBURSEMENT	20,000.00		0.00	0.00	20,000.00	0.00
101-000.000-445.000	PENALTIES AND INTEREST ON TAXES	0.00		0.02	0.02	(0.02)	100.00
101-000.000-446.000	INVESTMENT INTEREST	30,000.00		4,960.00	4,960.00	25,040.00	16.53
101-000.000-447.000	TAX 1% ADMINISTRATIVE FEE	105,000.00		14,977.39	14,977.39	90,022.61	14.26
101-000.000-455.000	METRO AUTHORITY-FEE	18,000.00		0.00	0.00	18,000.00	0.00
101-000.000-456.000	BUILDING PERMITS	80,000.00		14,907.30	14,907.30	65,092.70	18.63
101-000.000-457.000	ZONING, SITE, SPECIAL PERMITS	7,500.00		1,039.00	1,039.00	6,461.00	13.85
101-000.000-458.000	PLUMBING/HEATING PERMITS	20,000.00		1,692.50	1,692.50	18,307.50	8.46
101-000.000-459.000	ELECTRICAL PERMITS	15,000.00		2,359.50	2,359.50	12,640.50	15.73
101-000.000-460.000	LICENSES/REGISTRATIONS & ETC DUE TO CITY	12,000.00		2,130.00	2,130.00	9,870.00	17.75
101-000.000-461.000	DOG & CAT LICENSES	2,000.00		0.00	0.00	2,000.00	0.00
101-000.000-465.000	CABLE TV REVENUES	110,000.00		5,939.46	5,939.46	104,060.54	5.40
101-000.000-470.000	RECREATION SPECIAL PROGRAMS	2,500.00		0.00	0.00	2,500.00	0.00
101-000.000-470.001	DOG PARK REVENUE	0.00		15.00	15.00	(15.00)	100.00
101-000.000-470.002	COMMUNITY GARDEN REVENUE	500.00		0.00	0.00	500.00	0.00
101-000.000-475.000	COMM ROOM & BLDG RENT REVENUE	80,000.00		5,229.50	5,229.50	74,770.50	6.54
101-000.000-546.000	POLICE CHARGES FOR SERVICES	15,000.00		531.92	531.92	14,468.08	3.55
101-000.000-574.000	STATE SHARED REVENUES	511,110.00		0.00	0.00	511,110.00	0.00
101-000.000-612.000	DISTRICT COURT FINES	70,000.00		7,789.38	7,789.38	62,210.62	11.13
101-000.000-626.000	COMMUNITY DEVELOPMENT	7,000.00		0.00	0.00	7,000.00	0.00
101-000.000-627.000	SIDEWALK REVENUES	100,000.00		1,485.00	1,485.00	98,515.00	1.49
101-000.000-628.000	WEED/CODE ENFORCEMENT REVENUE	30,000.00		0.00	0.00	30,000.00	0.00
101-000.000-632.000	PUBLIC SERVICES REIMBURSEMENT	25,000.00		0.00	0.00	25,000.00	0.00
101-000.000-664.000	INTEREST INCOME- LEASES	77,000.00		0.00	0.00	77,000.00	0.00
101-000.000-669.000	DPS BLDG RENT FROM WATER	4,917.00		0.00	0.00	4,917.00	0.00
101-000.000-671.000	ADMINISTRATIVE REV RD FUND	4,000.00		0.00	0.00	4,000.00	0.00
101-000.000-676.001	EMPLOYEE BENEFIT CONTRIBUTION	22,000.00		(4,100.00)	(4,100.00)	26,100.00	(18.64)
101-000.000-682.000	SALE OF FIXED ASSET	0.00		2,455.00	2,455.00	(2,455.00)	100.00
Total Dept 000.000		5,258,307.00		496,222.81	496,222.81	4,762,084.19	9.44
TOTAL REVENUES		5,258,307.00		496,222.81	496,222.81	4,762,084.19	9.44

Expenditures							
Dept 100.000 - GOVERNMENT SERVICES							
101-100.000-708.000	PROPERTY & LIABILITY INSURANC	45,000.00		0.00	0.00	45,000.00	0.00
101-100.000-710.000	UNEMPLOYMENT INSURANCE	50.00		52.36	52.36	(2.36)	104.72
101-100.000-712.000	WORKER'S COMP INSURANCE	7,000.00		0.00	0.00	7,000.00	0.00
101-100.000-713.000	MERS CITY CONTRIBUTIONS	50,000.00		0.00	0.00	50,000.00	0.00
101-100.000-726.000	OFFICE SUPPLIES	6,000.00		0.00	0.00	6,000.00	0.00
101-100.000-732.000	CODE ENFORCEMENT	3,000.00		0.00	0.00	3,000.00	0.00
101-100.000-802.000	TAX TRIBUNAL RETURNS	2,000.00		0.00	0.00	2,000.00	0.00
101-100.000-803.000	MEMBERSHIPS & MEETINGS	6,000.00		2,089.00	2,089.00	3,911.00	34
101-100.000-804.000	BUILDING TRADE INSPECTION	56,250.00		9,780.99	9,780.99	46,469.01	17

User: MICHELLE

DB: Lathrup

PERIOD ENDING 07/31/2024

GL NUMBER	DESCRIPTION	2024-25	YTD BALANCE	ACTIVITY FOR	AVAILABLE	% BGDG USED
		AMENDED BUDGET	07/31/2024 NORMAL (ABNORMAL)	MONTH 07/31/2024 INCREASE (DECREASE)	BALANCE NORMAL (ABNORMAL)	
Fund 101 - GENERAL FUND						
Expenditures						
101-100.000-805.000	CABLE TELEVISION	58,500.00	148.65	148.65	58,351.35	0.25
101-100.000-808.000	COMMUNITY CENTER EXPENDITURE	25,000.00	1,775.00	1,775.00	23,225.00	7.10
101-100.000-810.000	AUDITING & ACCOUNTING	40,000.00	5,441.80	5,441.80	34,558.20	13.60
101-100.000-822.000	TRAINING	7,000.00	9.81	9.81	6,990.19	0.14
101-100.000-832.000	CITIZEN COMMUNICATION/PR	5,000.00	0.00	0.00	5,000.00	0.00
101-100.000-840.000	LIBRARY PAYMENT	185,000.00	0.00	0.00	185,000.00	0.00
101-100.000-848.000	GOVERNMENT OPERATIONS	32,500.00	4,439.16	4,439.16	28,060.84	13.66
101-100.000-848.001	TECHNOLOGY	65,000.00	8,986.65	8,986.65	56,013.35	13.83
101-100.000-850.000	TELEPHONE EXPENDITURES	15,000.00	1,132.54	1,132.54	13,867.46	7.55
101-100.000-860.000	VEHICLE EXPENSE	5,000.00	419.64	419.64	4,580.36	8.39
101-100.000-880.000	CDBG EXPENDITURES	2,000.00	0.00	0.00	2,000.00	0.00
101-100.000-882.000	PLANNING/CONSULTING FEES	10,000.00	200.00	200.00	9,800.00	2.00
101-100.000-900.000	PRINTING/PUBLICATION COSTS	11,000.00	0.00	0.00	11,000.00	0.00
101-100.000-901.000	POSTAGE FEES	6,000.00	1,028.17	1,028.17	4,971.83	17.14
101-100.000-955.000	MISCELLANEOUS EXPENDITURES	10,000.00	0.00	0.00	10,000.00	0.00
Total Dept 100.000 - GOVERNMENT SERVICES		652,300.00	35,503.77	35,503.77	616,796.23	5.44
Dept 101.000 - ADMINISTRATION						
101-101.000-701.000	SALARIES FULL-TIME	453,440.00	69,695.45	69,695.45	383,744.55	15.37
101-101.000-703.000	EMPLOYEE TAXES & BENEFITS	294,150.00	12,169.57	12,169.57	281,980.43	4.14
101-101.000-717.000	CODE ENFORCEMENT LEGAL	20,000.00	0.00	0.00	20,000.00	0.00
101-101.000-718.000	ELECTIONS	50,000.00	9,118.99	9,118.99	40,881.01	18.24
101-101.000-719.000	OFFICIALS EXPENSE	5,000.00	210.00	210.00	4,790.00	4.20
101-101.000-721.000	DATA PROCESING & ASSESSMENTS	37,800.00	0.00	0.00	37,800.00	0.00
101-101.000-722.000	LEGAL SERVICES	55,000.00	0.00	0.00	55,000.00	0.00
101-101.000-723.000	BOARD OF REVIEW	600.00	0.00	0.00	600.00	0.00
101-101.000-803.000	MEMBERSHIPS & MEETINGS	2,000.00	0.00	0.00	2,000.00	0.00
101-101.000-955.000	MISCELLANEOUS EXPENDITURES	9,000.00	0.00	0.00	9,000.00	0.00
Total Dept 101.000 - ADMINISTRATION		926,990.00	91,194.01	91,194.01	835,795.99	9.84
Dept 201.000 - BUILDING & GROUNDS						
101-201.000-702.000	SALARIES PART-TIME	30,000.00	2,525.98	2,525.98	27,474.02	8.42
101-201.000-703.000	EMPLOYEE TAXES & BENEFITS	0.00	(3,628.88)	(3,628.88)	3,628.88	100.00
101-201.000-920.000	UTILITIES	60,000.00	12,253.92	12,253.92	47,746.08	20.42
101-201.000-930.000	BUILDING MAINTENANCE & REPAIR	40,000.00	3,850.28	3,850.28	36,149.72	9.63
101-201.000-930.001	BUILDING - GRANTS	5,359.00	0.00	0.00	5,359.00	0.00
101-201.000-936.000	EQUIPMENT MAINTENANCE	7,500.00	0.00	0.00	7,500.00	0.00
101-201.000-938.000	PARKING LOT & GROUNDS	5,000.00	0.00	0.00	5,000.00	0.00
101-201.000-970.000	CAPITAL EXPENDITURE	6,000.00	4,930.09	4,930.09	1,069.91	82.17
Total Dept 201.000 - BUILDING & GROUNDS		153,859.00	19,931.39	19,931.39	133,927.61	12.95
Dept 301.000 - PUBLIC SAFETY						
101-301.000-701.000	SALARIES FULL-TIME	1,050,000.00	80,538.28	80,538.28	969,461.72	7.67
101-301.000-702.000	SALARIES PART-TIME	50,000.00	5,365.83	5,365.83	44,634.17	10.73
101-301.000-703.000	EMPLOYEE TAXES & BENEFITS	690,000.00	27,201.28	27,201.28	662,798.72	3.94
101-301.000-704.000	SALARIES-OVERTIME	40,000.00	5,617.42	5,617.42	34,382.58	14.04
101-301.000-708.000	PROPERTY & LIABILITY INSURANC	26,106.00	0.00	0.00	26,106.00	0.00
101-301.000-710.000	UNEMPLOYMENT INSURANCE	100.00	101.63	101.63	(1.63)	101.63
101-301.000-712.000	WORKER'S COMP INSURANCE	10,000.00	0.00	0.00	10,000.00	0.00
101-301.000-726.000	OFFICE SUPPLIES	4,000.00	492.24	492.24	3,507.76	12.56

User: MICHELLE

DB: Lathrup

PERIOD ENDING 07/31/2024

GL NUMBER	DESCRIPTION	2024-25	YTD BALANCE	ACTIVITY FOR	AVAILABLE	% BGDG USED
		AMENDED BUDGET	07/31/2024	MONTH 07/31/2024	BALANCE	
			NORMAL (ABNORMAL)	INCREASE (DECREASE)	NORMAL (ABNORMAL)	
Fund 101 - GENERAL FUND						
Expenditures						
101-301.000-727.000	ROAD SUPPLIES	2,500.00	63.08	63.08	2,436.92	2.52
101-301.000-728.000	EVIDENCE SUPPLIES	1,000.00	0.00	0.00	1,000.00	0.00
101-301.000-729.000	OFFICE MACHINE MAINTENANCE	1,500.00	79.96	79.96	1,420.04	5.33
101-301.000-731.000	PUBLICATIONS/DOCUMENT REDUCIN	500.00	0.00	0.00	500.00	0.00
101-301.000-803.000	MEMBERSHIPS & MEETINGS	5,500.00	257.19	257.19	5,242.81	4.68
101-301.000-821.000	POLICE RESERVES	500.00	61.94	61.94	438.06	12.39
101-301.000-822.000	TRAINING	15,500.00	2,019.35	2,019.35	13,480.65	13.03
101-301.000-823.000	FIREARMS TRAINING	9,000.00	1,471.62	1,471.62	7,528.38	16.35
101-301.000-825.000	ANIMAL CONTROL	200.00	45.99	45.99	154.01	23.00
101-301.000-826.000	COMMUNITY POLICING	1,100.00	(9.36)	(9.36)	1,109.36	(0.85)
101-301.000-827.000	302 TRAINING FUNDS EXPENDITURES	2,000.00	0.00	0.00	2,000.00	0.00
101-301.000-828.000	FIRE SERVICE/DISPATCH CONTRACT	782,150.00	170,995.00	170,995.00	611,155.00	21.86
101-301.000-829.000	POLICE UNIFORMS & CLEANING	15,000.00	318.25	318.25	14,681.75	2.12
101-301.000-836.000	PRISONER LOCKUP	0.00	1,400.00	1,400.00	(1,400.00)	100.00
101-301.000-837.000	STATE OF MI LEIN USE	3,000.00	0.00	0.00	3,000.00	0.00
101-301.000-848.001	TECHNOLOGY	21,900.00	5,003.32	5,003.32	16,896.68	22.85
101-301.000-850.000	TELEPHONE EXPENDITURES	11,000.00	506.01	506.01	10,493.99	4.60
101-301.000-851.000	RADIO COMMUNICATIONS	13,500.00	2,691.00	2,691.00	10,809.00	19.93
101-301.000-860.000	VEHICLE EXPENSE	47,000.00	9,984.59	9,984.59	37,015.41	21.24
101-301.000-970.000	CAPITAL EXPENDITURE	13,500.00	0.00	0.00	13,500.00	0.00
Total Dept 301.000 - PUBLIC SAFETY		2,816,556.00	314,204.62	314,204.62	2,502,351.38	11.16
Dept 401.000 - PUBLIC SERVICE						
101-401.000-703.000	EMPLOYEE TAXES & BENEFITS	20,000.00	0.00	0.00	20,000.00	0.00
101-401.000-860.000	VEHICLE EXPENSE	0.00	1,467.59	1,467.59	(1,467.59)	100.00
101-401.000-890.000	PARK MAINTENANCE	2,000.00	0.00	0.00	2,000.00	0.00
101-401.000-891.000	TREE MAINTENANCE	10,000.00	0.00	0.00	10,000.00	0.00
101-401.000-892.000	SIDEWALK MAINTENANCE	0.00	325.00	325.00	(325.00)	100.00
101-401.000-920.000	UTILITIES	25,000.00	590.29	590.29	24,409.71	2.36
101-401.000-921.000	CONTRACTUAL SERVICES	145,000.00	0.00	0.00	145,000.00	0.00
101-401.000-936.000	EQUIPMENT MAINTENANCE	4,000.00	0.00	0.00	4,000.00	0.00
101-401.000-970.000	CAPITAL EXPENDITURE	58,500.00	0.00	0.00	58,500.00	0.00
Total Dept 401.000 - PUBLIC SERVICE		264,500.00	2,382.88	2,382.88	262,117.12	0.90
Dept 501.000 - LEAF COLLECTION						
101-501.000-955.000	MISCELLANEOUS EXPENDITURES	1,000.00	0.00	0.00	1,000.00	0.00
101-501.000-978.000	REFUSE EQUIP/ROLLOFF EXPEND	7,000.00	0.00	0.00	7,000.00	0.00
Total Dept 501.000 - LEAF COLLECTION		8,000.00	0.00	0.00	8,000.00	0.00
Dept 502.000						
101-502.000-801.001	SOCRRA	401,525.00	33,001.12	33,001.12	368,523.88	8.22
Total Dept 502.000		401,525.00	33,001.12	33,001.12	368,523.88	8.22
Dept 601.000 - RECREATION						
101-601.000-806.000	ADULT PROGRAMS	5,000.00	0.00	0.00	5,000.00	0.00
101-601.000-807.000	BUS TRANSPORTATION	1,000.00	0.00	0.00	1,000.00	0.00
101-601.000-811.000	SENIOR ACTIVITIES	5,000.00	0.00	0.00	5,000.00	0.00
101-601.000-812.000	COMMUNITY EVENTS	5,000.00	0.00	0.00	5,000.00	0.00

REVENUE AND EXPENDITURE REPORT FOR CITY OF LATHRUP VILLAGE
 PERIOD ENDING 07/31/2024

Item 7E.

GL NUMBER	DESCRIPTION	2024-25	YTD BALANCE	ACTIVITY FOR	AVAILABLE	% BGD USED
		AMENDED BUDGET	07/31/2024	MONTH 07/31/2024	BALANCE	
			NORMAL (ABNORMAL)	INCREASE (DECREASE)	NORMAL (ABNORMAL)	
Fund 101 - GENERAL FUND						
Expenditures						
101-601.000-813.000	CHILDREN/YOUTH ACTIVITIES	5,000.00	385.72	385.72	4,614.28	7.71
101-601.000-815.000	COMMUNITY GARDEN	500.00	0.00	0.00	500.00	0.00
101-601.000-843.000	DOG PARK EXPENSES	250.00	0.00	0.00	250.00	0.00
101-601.000-884.000	CONCERTS IN THE PARK	750.00	0.00	0.00	750.00	0.00
Total Dept 601.000 - RECREATION		22,500.00	385.72	385.72	22,114.28	1.71
TOTAL EXPENDITURES		5,246,230.00	496,603.51	496,603.51	4,749,626.49	9.47
Fund 101 - GENERAL FUND:						
TOTAL REVENUES		5,258,307.00	496,222.81	496,222.81	4,762,084.19	9.44
TOTAL EXPENDITURES		5,246,230.00	496,603.51	496,603.51	4,749,626.49	9.47
NET OF REVENUES & EXPENDITURES		12,077.00	(380.70)	(380.70)	12,457.70	3.15

PERIOD ENDING 07/31/2024

GL NUMBER	DESCRIPTION	2024-25	YTD BALANCE	ACTIVITY FOR	AVAILABLE	% BGDG USED
		AMENDED BUDGET	07/31/2024 NORMAL (ABNORMAL)	MONTH 07/31/2024 INCREASE (DECREASE)	BALANCE NORMAL (ABNORMAL)	
Fund 202 - MAJOR ROAD FUND						
Revenues						
Dept 702.000						
202-702.000-574.000	STATE SHARED REVENUES	410,000.00	(33,240.73)	(33,240.73)	443,240.73	(8.11)
Total Dept 702.000		410,000.00	(33,240.73)	(33,240.73)	443,240.73	(8.11)
TOTAL REVENUES		410,000.00	(33,240.73)	(33,240.73)	443,240.73	(8.11)
Expenditures						
Dept 702.000						
202-702.000-703.000	EMPLOYEE TAXES & BENEFITS	5,000.00	60.43	60.43	4,939.57	1.21
202-702.000-705.000	SALARIES-ADMIN	6,500.00	483.83	483.83	6,016.17	7.44
202-702.000-810.000	AUDITING & ACCOUNTING	3,700.00	4,434.34	4,434.34	(734.34)	119.85
202-702.000-856.000	ADMINISTRATION & ENGINEERING	4,000.00	0.00	0.00	4,000.00	0.00
202-702.000-858.000	ROAD CONSTRUCTION	0.00	880.00	880.00	(880.00)	100.00
202-702.000-861.000	ROAD MAINTENANCE	10,000.00	1,297.24	1,297.24	8,702.76	12.97
202-702.000-862.000	ROADSIDE MAINTENANCE	1,000.00	0.00	0.00	1,000.00	0.00
202-702.000-864.000	TRAFFIC CONTROLS	30,000.00	910.55	910.55	29,089.45	3.04
202-702.000-866.000	SNOW & ICE REMOVAL	5,500.00	0.00	0.00	5,500.00	0.00
202-702.000-867.000	EQUIPMENT RENTAL	5,000.00	0.00	0.00	5,000.00	0.00
202-702.000-870.000	FORESTRY	30,000.00	0.00	0.00	30,000.00	0.00
202-702.000-921.000	CONTRACTUAL SERVICES	70,000.00	0.00	0.00	70,000.00	0.00
202-702.000-999.203	TRANSFER OUT TO LOCAL ROADS	102,500.00	0.00	0.00	102,500.00	0.00
Total Dept 702.000		273,200.00	8,066.39	8,066.39	265,133.61	2.95
TOTAL EXPENDITURES		273,200.00	8,066.39	8,066.39	265,133.61	2.95
Fund 202 - MAJOR ROAD FUND:						
TOTAL REVENUES		410,000.00	(33,240.73)	(33,240.73)	443,240.73	8.11
TOTAL EXPENDITURES		273,200.00	8,066.39	8,066.39	265,133.61	2.95
NET OF REVENUES & EXPENDITURES		136,800.00	(41,307.12)	(41,307.12)	178,107.12	30.20

PERIOD ENDING 07/31/2024

GL NUMBER	DESCRIPTION	2024-25	YTD BALANCE	ACTIVITY FOR	AVAILABLE	% BDGT USED
		AMENDED BUDGET	07/31/2024 NORMAL (ABNORMAL)	MONTH 07/31/2024 INCREASE (DECREASE)	BALANCE NORMAL (ABNORMAL)	
Fund 203 - LOCAL ROAD FUND						
Revenues						
Dept 703.000						
203-703.000-574.000	STATE SHARED REVENUES	190,000.00	(15,545.45)	(15,545.45)	205,545.45	(8.18)
203-703.000-690.202	TRANSFER IN FROM MAJOR ROADS	102,500.00	0.00	0.00	102,500.00	0.00
Total Dept 703.000		292,500.00	(15,545.45)	(15,545.45)	308,045.45	(5.31)
TOTAL REVENUES		292,500.00	(15,545.45)	(15,545.45)	308,045.45	(5.31)
Expenditures						
Dept 703.000						
203-703.000-703.000	EMPLOYEE TAXES & BENEFITS	14,000.00	60.43	60.43	13,939.57	0.43
203-703.000-705.000	SALARIES-ADMIN	6,500.00	483.83	483.83	6,016.17	7.44
203-703.000-810.000	AUDITING & ACCOUNTING	3,700.00	0.00	0.00	3,700.00	0.00
203-703.000-861.000	ROAD MAINTENANCE	20,000.00	1,297.24	1,297.24	18,702.76	6.49
203-703.000-862.000	ROADSIDE MAINTENANCE	5,000.00	0.00	0.00	5,000.00	0.00
203-703.000-864.000	TRAFFIC CONTROLS	10,000.00	910.54	910.54	9,089.46	9.11
203-703.000-866.000	SNOW & ICE REMOVAL	5,500.00	0.00	0.00	5,500.00	0.00
203-703.000-867.000	EQUIPMENT RENTAL	2,000.00	0.00	0.00	2,000.00	0.00
203-703.000-868.000	NON-MOTOR FACILITIES	5,000.00	0.00	0.00	5,000.00	0.00
203-703.000-870.000	FORESTRY	30,000.00	0.00	0.00	30,000.00	0.00
203-703.000-921.000	CONTRACTUAL SERVICES	79,000.00	0.00	0.00	79,000.00	0.00
Total Dept 703.000		180,700.00	2,752.04	2,752.04	177,947.96	1.52
TOTAL EXPENDITURES		180,700.00	2,752.04	2,752.04	177,947.96	1.52
Fund 203 - LOCAL ROAD FUND:						
TOTAL REVENUES		292,500.00	(15,545.45)	(15,545.45)	308,045.45	5.31
TOTAL EXPENDITURES		180,700.00	2,752.04	2,752.04	177,947.96	1.52
NET OF REVENUES & EXPENDITURES		111,800.00	(18,297.49)	(18,297.49)	130,097.49	16.37

REVENUE AND EXPENDITURE REPORT FOR CITY OF LATHRUP VILLAGE
 PERIOD ENDING 07/31/2024

GL NUMBER	DESCRIPTION	2024-25	YTD BALANCE	ACTIVITY FOR	AVAILABLE	% BDGT USED
		AMENDED BUDGET	07/31/2024 NORMAL (ABNORMAL)	MONTH 07/31/2024 INCREASE (DECREASE)	BALANCE NORMAL (ABNORMAL)	
Fund 258 - CAPITAL ACQUISITION FUND						
Revenues						
Dept 000.000						
258-000.000-446.000	INVESTMENT INTEREST	0.00	60.78	60.78	(60.78)	100.00
Total Dept 000.000		0.00	60.78	60.78	(60.78)	100.00
TOTAL REVENUES		0.00	60.78	60.78	(60.78)	100.00
Fund 258 - CAPITAL ACQUISITION FUND:						
TOTAL REVENUES		0.00	60.78	60.78	(60.78)	100.00
TOTAL EXPENDITURES		0.00	0.00	0.00	0.00	0.00
NET OF REVENUES & EXPENDITURES		0.00	60.78	60.78	(60.78)	100.00

REVENUE AND EXPENDITURE REPORT FOR CITY OF LATHRUP VILLAGE
 PERIOD ENDING 07/31/2024

GL NUMBER	DESCRIPTION	2024-25 AMENDED BUDGET	YTD BALANCE	ACTIVITY FOR	AVAILABLE	% BDGT USED
			NORMAL (ABNORMAL)	MONTH 07/31/2024 INCREASE (DECREASE)	BALANCE NORMAL (ABNORMAL)	
Fund 397 - ROAD MILLAGE BOND FUND						
Revenues						
Dept 000.000						
397-000.000-403.000	ROAD BOND DEBT TAXES	0.00	83,809.45	83,809.45	(83,809.45)	100.00
397-000.000-446.000	INVESTMENT INTEREST	0.00	343.84	343.84	(343.84)	100.00
397-000.000-510.983	SPECIAL ASSESSMENT-ROAD BOND	590,000.00	0.00	0.00	590,000.00	0.00
Total Dept 000.000		590,000.00	84,153.29	84,153.29	505,846.71	14.26
TOTAL REVENUES		590,000.00	84,153.29	84,153.29	505,846.71	14.26
Expenditures						
Dept 000.000						
397-000.000-720.000	INTEREST EXPENSE	183,000.00	0.00	0.00	183,000.00	0.00
397-000.000-905.000	BOND PRINCIPAL PAYMENTS	405,000.00	0.00	0.00	405,000.00	0.00
Total Dept 000.000		588,000.00	0.00	0.00	588,000.00	0.00
TOTAL EXPENDITURES		588,000.00	0.00	0.00	588,000.00	0.00
Fund 397 - ROAD MILLAGE BOND FUND:						
TOTAL REVENUES		590,000.00	84,153.29	84,153.29	505,846.71	14.26
TOTAL EXPENDITURES		588,000.00	0.00	0.00	588,000.00	0.00
NET OF REVENUES & EXPENDITURES		2,000.00	84,153.29	84,153.29	(82,153.29)	4,207.66

User: MICHELLE

DB: Lathrup

PERIOD ENDING 07/31/2024

GL NUMBER	DESCRIPTION	2024-25	YTD BALANCE	ACTIVITY FOR	AVAILABLE	% BDGT USED
		AMENDED BUDGET	07/31/2024	MONTH 07/31/2024	BALANCE	
			NORMAL (ABNORMAL)	INCREASE (DECREASE)	NORMAL (ABNORMAL)	
Fund 494 - DOWNTOWN DEVELOPMENT AUTHORITY						
Revenues						
Dept 000.000						
494-000.000-407.000	TIFA-CAPTURE TAXES	410,000.00	282,066.62	282,066.62	127,933.38	68.80
494-000.000-410.000	TAX COLLECTED OTHER	37,488.00	13,709.38	13,709.38	23,778.62	36.57
494-000.000-415.000	MISCELLANEOUS REVENUE	23,000.00	0.00	0.00	23,000.00	0.00
494-000.000-446.000	INVESTMENT INTEREST	40,000.00	3,386.67	3,386.67	36,613.33	8.47
Total Dept 000.000		510,488.00	299,162.67	299,162.67	211,325.33	58.60
TOTAL REVENUES		510,488.00	299,162.67	299,162.67	211,325.33	58.60
Expenditures						
Dept 000.000						
494-000.000-701.000	SALARIES FULL-TIME	180,000.00	14,295.47	14,295.47	165,704.53	7.94
494-000.000-702.000	SALARIES PART-TIME	5,000.00	0.00	0.00	5,000.00	0.00
494-000.000-703.000	EMPLOYEE TAXES & BENEFITS	65,000.00	2,861.34	2,861.34	62,138.66	4.40
494-000.000-722.000	LEGAL SERVICES	900.00	0.00	0.00	900.00	0.00
494-000.000-726.000	OFFICE SUPPLIES	3,755.00	80.28	80.28	3,674.72	2.14
494-000.000-802.000	TAX TRIBUNAL RETURNS	2,000.00	0.00	0.00	2,000.00	0.00
494-000.000-810.000	AUDITING & ACCOUNTING	800.00	777.40	777.40	22.60	97.18
494-000.000-822.000	TRAINING/MEMBERSHIP	7,125.00	0.00	0.00	7,125.00	0.00
494-000.000-844.000	MAIN STREET PROGRAM	18,500.00	964.00	964.00	17,536.00	5.21
494-000.000-845.000	STREETSCAPING	19,000.00	0.00	0.00	19,000.00	0.00
494-000.000-882.000	PLANNING/CONSULTING FEES	15,300.00	1,575.00	1,575.00	13,725.00	10.29
494-000.000-900.000	PRINTING/PUBLICATION COSTS	2,000.00	0.00	0.00	2,000.00	0.00
494-000.000-901.000	POSTAGE FEES	200.00	0.00	0.00	200.00	0.00
494-000.000-933.000	REPAIRS & MAINTENANCE	503,980.00	3,231.55	3,231.55	500,748.45	0.64
494-000.000-955.000	MISCELLANEOUS EXPENDITURES	23,457.00	309.36	309.36	23,147.64	1.32
494-000.000-968.001	DEPRECIATION INFRASTRUCTURE	30,000.00	0.00	0.00	30,000.00	0.00
494-000.000-971.000	SIGN GRANT PROGRAM	10,000.00	0.00	0.00	10,000.00	0.00
494-000.000-971.001	FACADE GRANT PROGRAM	20,000.00	0.00	0.00	20,000.00	0.00
Total Dept 000.000		907,017.00	24,094.40	24,094.40	882,922.60	2.66
TOTAL EXPENDITURES		907,017.00	24,094.40	24,094.40	882,922.60	2.66
Fund 494 - DOWNTOWN DEVELOPMENT AUTHORITY:						
TOTAL REVENUES		510,488.00	299,162.67	299,162.67	211,325.33	58.60
TOTAL EXPENDITURES		907,017.00	24,094.40	24,094.40	882,922.60	2.66
NET OF REVENUES & EXPENDITURES		(396,529.00)	275,068.27	275,068.27	(671,597.27)	69.37

User: MICHELLE

DB: Lathrup

PERIOD ENDING 07/31/2024

GL NUMBER	DESCRIPTION	2024-25	YTD BALANCE	ACTIVITY FOR	AVAILABLE	% BGDG USED
		AMENDED BUDGET	07/31/2024 NORMAL (ABNORMAL)	MONTH 07/31/2024 INCREASE (DECREASE)	BALANCE NORMAL (ABNORMAL)	
Fund 592 - WATER & SEWER FUND						
Revenues						
Dept 536.000 - WATER DEPARTMENT						
592-536.000-415.000	MISCELLANEOUS REVENUES	20,000.00	1,782.00	1,782.00	18,218.00	8.91
592-536.000-640.000	WATER SERVICE	770,000.00	77,940.34	77,940.34	692,059.66	10.12
592-536.000-640.001	BOND REVENUE	229,000.00	19,056.70	19,056.70	209,943.30	8.32
592-536.000-641.000	WATER & SEWER PENALTIES	25,000.00	2,511.43	2,511.43	22,488.57	10.05
592-536.000-642.000	METER CHARGE REVENUE	81,000.00	6,421.25	6,421.25	74,578.75	7.93
592-536.000-665.000	INVESTMENT INTEREST	10,000.00	2,624.27	2,624.27	7,375.73	26.24
Total Dept 536.000 - WATER DEPARTMENT		1,135,000.00	110,335.99	110,335.99	1,024,664.01	9.72
Dept 537.000 - SEWER DEPARTMENT						
592-537.000-641.000	WATER & SEWER PENALTIES	40,000.00	3,572.05	3,572.05	36,427.95	8.93
592-537.000-645.000	SEWAGE DISPOSAL REVENUE	1,805,000.00	151,829.20	151,829.20	1,653,170.80	8.41
592-537.000-651.000	INDUSTRIAL SURCHARGE	42,000.00	3,126.43	3,126.43	38,873.57	7.44
592-537.000-665.000	INVESTMENT INTEREST	10,000.00	2,624.27	2,624.27	7,375.73	26.24
Total Dept 537.000 - SEWER DEPARTMENT		1,897,000.00	161,151.95	161,151.95	1,735,848.05	8.50
TOTAL REVENUES		3,032,000.00	271,487.94	271,487.94	2,760,512.06	8.95
Expenditures						
Dept 536.000 - WATER DEPARTMENT						
592-536.000-701.000	SALARIES FULL-TIME	49,980.00	3,689.68	3,689.68	46,290.32	7.38
592-536.000-703.000	EMPLOYEE TAXES & BENEFITS	140,000.00	2,423.14	2,423.14	137,576.86	1.73
592-536.000-708.000	PROPERTY & LIABILITY INSURANC	8,000.00	0.00	0.00	8,000.00	0.00
592-536.000-803.000	MEMBERSHIPS & MEETINGS	2,500.00	0.00	0.00	2,500.00	0.00
592-536.000-810.000	AUDITING & ACCOUNTING	3,700.00	0.00	0.00	3,700.00	0.00
592-536.000-856.000	ADMINISTRATION & ENGINEERING	10,000.00	0.00	0.00	10,000.00	0.00
592-536.000-875.000	PENSION EXPENSE	25,000.00	0.00	0.00	25,000.00	0.00
592-536.000-900.000	PRINTING/PUBLICATION COSTS	2,500.00	0.00	0.00	2,500.00	0.00
592-536.000-902.000	BILLING SERVICES	10,000.00	979.44	979.44	9,020.56	9.79
592-536.000-921.000	CONTRACTUAL SERVICES	78,000.00	17,162.75	17,162.75	60,837.25	22.00
592-536.000-935.000	EQUIPMENT REPLACEMENT	2,500.00	0.00	0.00	2,500.00	0.00
592-536.000-937.000	WATER SYSTEM MAINTENANCE	70,000.00	1,473.57	1,473.57	68,526.43	2.11
592-536.000-940.000	RENT & UTILITIES WATER & SEWE	5,000.00	0.00	0.00	5,000.00	0.00
592-536.000-944.000	WATER PURCHASES	360,000.00	28,400.00	28,400.00	331,600.00	7.89
592-536.000-970.000	CAPITAL EXPENDITURE	13,000.00	0.00	0.00	13,000.00	0.00
592-536.000-974.000	WATER MAIN PROJECT	300,000.00	6,637.50	6,637.50	293,362.50	2.21
Total Dept 536.000 - WATER DEPARTMENT		1,080,180.00	60,766.08	60,766.08	1,019,413.92	5.63
Dept 536.100 - WATER DEPARTMENT						
592-536.100-970.000	CAPITAL EXP - STOP BOX REPLACEMENT	0.00	1,912.50	1,912.50	(1,912.50)	100.00
Total Dept 536.100 - WATER DEPARTMENT		0.00	1,912.50	1,912.50	(1,912.50)	100.00
Dept 536.400 - WATER DEPARTMENT						
592-536.400-970.000	CAPITAL EXP - WATER MAIN REPLACE	0.00	495.00	495.00	(495.00)	100.00
Total Dept 536.400 - WATER DEPARTMENT		0.00	495.00	495.00	(495.00)	100.00

User: MICHELLE

DB: Lathrup

PERIOD ENDING 07/31/2024

GL NUMBER	DESCRIPTION	2024-25	YTD BALANCE	ACTIVITY FOR	AVAILABLE	% BGDG USED
		AMENDED BUDGET	07/31/2024 NORMAL (ABNORMAL)	MONTH 07/31/2024 INCREASE (DECREASE)	BALANCE NORMAL (ABNORMAL)	
Fund 592 - WATER & SEWER FUND						
Expenditures						
Dept 536.500 - WATER DEPARTMENT						
592-536.500-970.000	CAPITAL FIRE HYDRANTS	0.00	247.50	247.50	(247.50)	100.00
Total Dept 536.500 - WATER DEPARTMENT		0.00	247.50	247.50	(247.50)	100.00
Dept 536.600 - WATER DEPARTMENT						
592-536.600-970.000	CAPITAL EXP - GATE VALVES	0.00	247.50	247.50	(247.50)	100.00
Total Dept 536.600 - WATER DEPARTMENT		0.00	247.50	247.50	(247.50)	100.00
Dept 537.000 - SEWER DEPARTMENT						
592-537.000-701.000	SALARIES FULL-TIME	49,980.00	3,689.68	3,689.68	46,290.32	7.38
592-537.000-703.000	EMPLOYEE TAXES & BENEFITS	48,000.00	700.22	700.22	47,299.78	1.46
592-537.000-708.000	PROPERTY & LIABILITY INSURANC	8,000.00	0.00	0.00	8,000.00	0.00
592-537.000-720.000	INTEREST EXPENSE	152,200.00	0.00	0.00	152,200.00	0.00
592-537.000-725.000	PAYING AGENT FEES	1,500.00	825.00	825.00	675.00	55.00
592-537.000-810.000	AUDITING & ACCOUNTING	3,700.00	0.00	0.00	3,700.00	0.00
592-537.000-856.000	ADMINISTRATION & ENGINEERING	18,000.00	0.00	0.00	18,000.00	0.00
592-537.000-905.000	BOND PRINCIPAL PAYMENTS	250,000.00	0.00	0.00	250,000.00	0.00
592-537.000-921.000	CONTRACTUAL SERVICES	153,000.00	36,236.05	36,236.05	116,763.95	23.68
592-537.000-939.000	SEWER SYSTEM MAINTENANCE	100,000.00	31.00	31.00	99,969.00	0.03
592-537.000-942.000	SEWAGE DISPOSAL EXPENSE	1,058,000.00	89,560.49	89,560.49	968,439.51	8.47
592-537.000-945.000	RETENTION TANK-UTIL ELEC	20,000.00	0.00	0.00	20,000.00	0.00
592-537.000-946.000	RETENTION TANK UTIL-WATER	20,000.00	6,369.25	6,369.25	13,630.75	31.85
592-537.000-947.000	RETENTION TANK UTIL-GAS	1,200.00	16.00	16.00	1,184.00	1.33
592-537.000-948.000	RETENTION TANK UTIL-TELEPHONE	2,500.00	122.85	122.85	2,377.15	4.91
592-537.000-949.000	RETENTION TAN GENERATOR FUEL	500.00	0.00	0.00	500.00	0.00
592-537.000-951.000	RETENTION TANK BUILDING/EQUIP	6,000.00	0.00	0.00	6,000.00	0.00
592-537.000-953.000	RETENTION TANK EXCESS LIABIL	9,100.00	0.00	0.00	9,100.00	0.00
592-537.000-957.000	INDUSTRIAL SURCHARGE/NON-RESI	20,000.00	1,439.62	1,439.62	18,560.38	7.20
592-537.000-970.000	CAPITAL EXPENDITURE	13,000.00	0.00	0.00	13,000.00	0.00
592-537.000-977.000	EVIRONMENT COMPL - NON CAPITA	15,000.00	532.00	532.00	14,468.00	3.55
Total Dept 537.000 - SEWER DEPARTMENT		1,949,680.00	139,522.16	139,522.16	1,810,157.84	7.16
TOTAL EXPENDITURES		3,029,860.00	203,190.74	203,190.74	2,826,669.26	6.71
Fund 592 - WATER & SEWER FUND:						
TOTAL REVENUES		3,032,000.00	271,487.94	271,487.94	2,760,512.06	8.95
TOTAL EXPENDITURES		3,029,860.00	203,190.74	203,190.74	2,826,669.26	6.71
NET OF REVENUES & EXPENDITURES		2,140.00	68,297.20	68,297.20	(66,157.20)	3,191.46
TOTAL REVENUES - ALL FUNDS						
TOTAL REVENUES - ALL FUNDS		10,093,295.00	1,102,301.31	1,102,301.31	8,990,993.69	10.92
TOTAL EXPENDITURES - ALL FUNDS		10,225,007.00	734,707.08	734,707.08	9,490,299.92	7.19
NET OF REVENUES & EXPENDITURES		(131,712.00)	367,594.23	367,594.23	(499,306.23)	279.00

BUDGET REPORT (REVENUES VERSUS EXPENDITURES) FOR MONTH ENDED JULY 31, 2024

	Revenues Through 7/31/2024	Expenses Through 7/31/2024	Revenues Over (Under) Expenses
101-GENERAL FUND	496,223	496,604	(381)
202-MAJOR STREET FUND	(33,241)	8,066	(41,307)
203-LOCAL STREET FUND	(15,545)	2,752	(18,297)
258-CAPITAL ACQUISITION FUND	61	-	61
397-ROADS MILLAGE BOND FUND	84,153	-	84,153
494-DOWNTOWN DEVELOPMENT AUTHORITY	299,163	24,094	275,068
592-WATER & SEWER FUND	271,488	203,191	68,297
GRAND TOTAL ALL FUNDS	1,102,301	734,707	367,594



LAW OFFICE

BAKER & ELOWSKY, PLLC

41800 WEST ELEVEN MILE ROAD, SUITE 215
NOVI, MICHIGAN 48375
Phone: (248) 230-4103 Fax: (248) 929-0835
www.bakerelowsky.com

SCOTT R. BAKER
JENNIFER H. ELOWSKY

sbaker@bakerelowsky.com

Of Counsel

LEANN K. KIMBERLIN

MATTHEW C. QUINN

August 14, 2024

Via Email

Mike Greene
City Administrator

City of Lathrup Village
27400 Southfield Road
Lathrup Village, MI 48076

Re: Legal Department Billing for July 1 through July 31, 2024

Dear Mr. Greene:

The following is our law firm's billing to the City of Lathrup Village for the month of July 2024:

1. General Retainer	\$2,500.00
2. Special Legal Services	\$1,300.00
3. Downtown Development Authority	\$
4. Project Reimbursement	\$
5. Prosecution/Code Enforcement	<u>\$1,755.00</u>
	\$5,555.00

If you should have any questions, please feel free to contact me.

Very truly yours,

BAKER & ELOWSKY, PLLC

Scott R. Baker

Enclosures



LAW OFFICE

BAKER & ELOWSKY, PLLC

41850 WEST ELEVEN MILE ROAD, SUITE 207
NOVI, MICHIGAN 48375
Phone: (248) 230-4103 Fax: (248) 929-0835
www.bakerelowsky.com

August 14, 2024

City of Lathrup Village
27400 Southfield Road
Lathrup Village, MI 48076

Invoice Number: 1788
Invoice Period: 07-01-2024 - 07-31-2024

RE: General Retainer

Time Details

Date	Professional	Description	Hours	Amount
07-01-2024	SRB	Receipt and review of correspondence from Admin re 27680 Lathrup Blvd encroachment easement	0.25	No Charge
07-08-2024	SRB	Receipt and review of correspondence from Admin re 27680 Lathrup Blvd encroachment easement	0.25	No Charge
07-08-2024	SRB	Receipt and review of correspondence from City Clerk re referendum petition	0.25	No Charge
07-08-2024	SRB	Receipt and review of correspondence from City Clerk, draft response to same re referendum petition	0.50	No Charge
07-09-2024	SRB	Receipt and review of correspondence from City Clerk re referendum petition	0.25	No Charge
07-09-2024	SRB	Receipt and review of correspondence from City Clerk re referendum petition	0.25	No Charge
07-09-2024	SRB	Receipt and review of correspondence from City Clerk re referendum petition	0.25	No Charge
07-09-2024	SRB	Receipt and review of correspondence from Admin re 27680 Lathrup Blvd encroachment easement	0.25	No Charge
07-09-2024	SRB	Receipt and review of correspondence from Admin re ballot initiative petitions	0.25	No Charge
07-10-2024	SRB	Receipt and review of correspondence from Admin re 27680 Lathrup Blvd encroachment easement	0.25	No Charge
07-10-2024	SRB	Receipt and review of correspondence from Admin re Comcast franchise agreement	0.25	No Charge

We appreciate your business

Page 1 of 3

Date	Professional	Description	Hours	Amount	Item 7E.
07-11-2024	SRB	Receipt and review of correspondence from Admin re metro act franchise agreement extension	0.25	No Charge	
07-11-2024	SRB	Receipt and review of correspondence from Admin re ballot initiative petitions	0.25	No Charge	
07-11-2024	SRB	Receipt and review of correspondence from Admin re ballot initiative petitions	0.25	No Charge	
07-11-2024	SRB	Receipt and review of correspondence from Admin re ballot initiative petitions	0.25	No Charge	
07-12-2024	SRB	Receipt and review of correspondence from City Clerk re petition signature review	0.25	No Charge	
07-12-2024	SRB	Receipt and review of correspondence from admin re public comment on Park rules ordinance amendment	0.25	No Charge	
07-15-2024	SRB	Receipt and review of correspondence from admin re 7/15 Agenda update	0.25	No Charge	
07-15-2024	SRB	Receipt and review of correspondence from City Clerk re petition signature review	0.25	No Charge	
07-15-2024	SRB	Draft correspondence to Admin re speed control devices on residential roadways	0.25	No Charge	
07-15-2024	SRB	Prepare for and attend City Council Study Session	1.50	No Charge	
07-15-2024	SRB	Prepare for and attend City Council regular meeting	1.75	No Charge	
07-16-2024	SRB	Receipt, review and respond to correspondence from Mayor Pro Tem re Finance Review committee inquiry	0.25	No Charge	
07-16-2024	SRB	Receipt and review of correspondence from admin re initiatory and referendum petitions	0.25	No Charge	
07-16-2024	SRB	Receipt and review of correspondence from admin re Ordinance adoption notices	0.25	No Charge	
07-17-2024	SRB	Receipt and review of correspondence from admin re Historic District Commission	0.25	No Charge	
07-17-2024	SRB	Receipt and review of correspondence from admin re Historic District Commission	0.25	No Charge	
07-18-2024	SRB	Receipt and review of correspondence from admin re initiatory and referendum petition process	0.25	No Charge	
07-18-2024	SRB	Receipt and review of correspondence from admin re cell tower lease	0.25	No Charge	
07-18-2024	SRB	Receipt and review of correspondence from admin re cell tower lease	0.25	No Charge	

Date	Professional	Description	Hours	Amount
07-18-2024	SRB	Receipt and review of correspondence from admin re cell tower lease	0.25	No Charge
07-18-2024	SRB	Receipt and review of correspondence from Clerk re charter amendment submission to AG's office for review	0.25	No Charge
07-18-2024	SRB	Receipt and review of correspondence from Clerk re charter amendment submission to Governor's office for review	0.25	No Charge
07-18-2024	SRB	Receipt and review of correspondence from Clerk re Notary bond	0.25	No Charge
07-19-2024	SRB	Receipt and review of correspondence from Clerk re AG's office response to charter review submission	0.25	No Charge
07-22-2024	SRB	Receipt, review and respond to multiple correspondence from Mayor Pro Tem re resident village circle property inquiry	0.50	No Charge
07-22-2024	SRB	Receipt and review of correspondence from admin re 19600 Forest Drive	0.25	No Charge
07-30-2024	SRB	Receipt and review of correspondence from admin re MTT appeals	0.25	No Charge
07-31-2024	SRB	Receipt and review of correspondence from admin re 8/5/2024 study session	0.25	No Charge
07-31-2024	SRB	Services Rendered		2,500.00
			Total	2,500.00

Time Summary

Professional	Hours	Amount
Scott Baker	13.00	2,500.00
Total		2,500.00
Total for this Invoice		2,500.00



LAW OFFICE

BAKER & ELOWSKY, PLLC

41850 WEST ELEVEN MILE ROAD, SUITE 207
NOVI, MICHIGAN 48375
Phone: (248) 230-4103 Fax: (248) 929-0835
www.bakerelowsky.com

August 14, 2024

City of Lathrup Village
27400 Southfield Road
Lathrup Village, MI 48076

Invoice Number: 1789
Invoice Period: 07-01-2024 - 07-31-2024

RE: Prosecution/Code Enforcement

Time Details

Date	Professional	Description	Hours	Amount
07-01-2024	SRB	Receipt and review of correspondence from 46th District Court re change of 8/14 Docket to 8/20	0.25	32.50
07-03-2024	SRB	Receipt and review of correspondence from 46th District Court re 7/24/24 Docket	0.25	32.50
07-10-2024	SRB	Receipt and review docket for July 17, 2024; draft correspondence to police clerk for file materials	0.50	65.00
07-12-2024	SRB	Receipt and review of correspondence from Police Clerk re file materials for July 17, 2024 Prosecution Docket; review file materials.	1.00	130.00
07-16-2024	SRB	Receipt and review of correspondence from 46th District Court re July 24, 2024 Prosecution Docket	0.25	32.50
07-16-2024	SRB	Conduct telephone pre-trial conference, prepare plea offer and draft correspondence to defense attorney and Court with same re: 24LV01054A	0.50	65.00
07-16-2024	SRB	Conduct telephone pre-trial conference, prepare plea offer and draft correspondence to defense attorney and Court with same re: 24LV00969A	0.50	65.00
07-16-2024	SRB	Conduct telephone pre-trial conference, prepare plea offer and draft correspondence to defense attorney and Court with same re: 24LV01094A	0.50	65.00
07-17-2024	SRB	Prepare for and appear in 46th District Court for prosecution of pre-trials and formal hearings.	3.00	390.00
07-18-2024	SRB	Receipt and review docket for July 24, 2024; draft correspondence to police clerk for file materials	0.50	65.00

We appreciate your business

Page 1 of 2

Date	Professional	Description	Hours	Amount
07-18-2024	SRB	Receipt and review of correspondence from 46th District Court probation department re defendant - Katie Freeman request for early termination from Probation	0.25	32.50
07-19-2024	SRB	Receipt and review of correspondence from Police Clerk re file materials for July 24, 2024 Prosecution Docket; review file materials.	1.00	130.00
07-22-2024	SRB	Conduct telephone pre-trial conference, prepare plea offer and draft correspondence to defense attorney and Court with same re: 24LV01293	0.50	65.00
07-22-2024	SRB	Conduct telephone pre-trial conference, prepare plea offer and draft correspondence to defense attorney and Court with same re: 24LV01257	0.50	65.00
07-22-2024	SRB	Conduct telephone pre-trial conference, prepare order for adjournment and draft correspondence to defense attorney and Court with same re: 19LV02251A	0.50	65.00
07-24-2024	SRB	Prepare for and appear in 46th District Court for prosecution of pre-trials and formal hearings.	3.00	390.00
07-29-2024	SRB	Conduct telephone pre-trial conference, prepare order for adjournment and draft correspondence to defense attorney and Court with same re: 24LV01285A	0.50	65.00
			Total	1,755.00

Time Summary

Professional	Hours	Amount
Scott Baker	13.50	1,755.00
Total		1,755.00

Total for this Invoice 1,755.00



LAW OFFICE

BAKER & ELOWSKY, PLLC

41850 WEST ELEVEN MILE ROAD, SUITE 207
NOVI, MICHIGAN 48375
Phone: (248) 230-4103 Fax: (248) 929-0835
www.bakerelowsky.com

August 14, 2024

City of Lathrup Village
27400 Southfield Road
Lathrup Village, MI 48076

Invoice Number: 1790
Invoice Period: 07-01-2024 - 07-31-2024

RE: Special Legal Services

Time Details

Date	Professional	Description	Hours	Amount
07-02-2024	SRB	Receipt, review and respond to correspondence from City Planner re cannabis business inquiry.	0.25	32.50
07-03-2024	SRB	Receipt, review and respond to correspondence from City Planner re cannabis business inquiry.	0.25	32.50
07-09-2024	SRB	Research and draft nuisance party ordinance; forward same to Police Chief for review	1.50	195.00
07-09-2024	SRB	Review and revise Parks and Recreation protection ordinance; forward same to administrator for 2nd reading	0.50	65.00
07-11-2024	SRB	Review Charter referendum petition; draft proposed resolution of City Council to receive petition and forward to Governor and AG's offices for review	1.50	195.00
07-11-2024	SRB	Review Cannabis ordinance initiative petition; draft proposed resolutions of City Council to receive petition and submit to electors or in the alternative to adopt the ordinance as submitted	2.00	260.00
07-16-2024	SRB	Draft notice of adoption for amendments to Park and Recreation ordinance; forward same to Admin	0.50	65.00
07-16-2024	SRB	Draft notice of adoption for amendments to Pool fence ordinance; forward same to Admin	0.50	65.00
07-18-2024	SRB	Receipt and review of correspondence from liability carrier attorney re JMC litigation	0.25	32.50
07-19-2024	SRB	Draft correspondence to AG's office re charter amendment review, provide relevant charter and historical amendment documentation; review response from same.	0.50	65.00

We appreciate your business

Page 1 of 2

Date	Professional	Description	Hours	Amount
07-24-2024	SRB	Receipt and review of correspondence from attorney for cannabis initiatory petition; telephone conference with same	0.50	65.00
07-26-2024	SRB	Receipt and review of correspondence from resident re village circle property; meeting with same	1.50	195.00
07-30-2024	SRB	Receipt and review of correspondence from resident re village circle property	0.25	32.50
			Total	1,300.00

Time Summary

Professional	Hours	Amount
Scott Baker	10.00	1,300.00
Total		1,300.00

Total for this Invoice 1,300.00



Lathrup Village Police Department

27400 Southfield Rd, Lathrup Village, MI 48076 (248) 557-3600

Memorandum

To: City Administrator Greene
 From: Chief Scott McKee
 Date: August 19, 2024
 Re: Second Reading – Nuisance Ordinance

Considering recent incidents in the city and a growing number of nuisance party calls, The Lathrup Village Police Department is requesting the city council to adopt ordinance Chapter 46 – Article XIII Nuisance Parties. Currently, the Disturbing the Peace ordinance requires a resident or citizen to come forward as a complainant to allow the Lathrup Village Police Department to move forward with enforcement. This is because the law does not allow for an officer’s “peace” to be disturbed. Understandably, residents fear retaliation if they come forward as complainants, which is why this new ordinance is so beneficial to both the residents and LVPD. This new ordinance would allow officers, essentially, to become the complainant by establishing the elements of the crime and then allow officers to take enforcement action at the scene if necessary. This ordinance would also allow officers to take enforcement action on those attending these parties. Those who are littering, parking their cars on front lawns, creating disturbances, and doing other disorderly acts could be cited under this new ordinance.

The Lathrup Village Police Department recognizes that residents are allowed to legally have parties in their homes. They are also allowed to play music at a reasonable level. This ordinance would not be utilized for those who very sporadically need to be reminded that their music is turned up too loudly. This ordinance would be used for residents who share no regard for the peace of their neighbors or the community. This ordinance would be enforced on those who disturb the peace of the neighborhood repeatedly when a citizen will not come forward.

Thank you for your time and consideration of this ordinance. If anyone has any questions or concerns are asked to contact myself or Lt. Michael Zang.

Recommended Motion:
 Moved by Council Member _____ seconded by Council Member _____
 to approve the update to City Ordinances by Addition of, Chapter 46 - Miscellaneous Offenses, ties, Article XIII. Nuisance Parties.

ORDINANCE NO. 2024-04

**CITY OF LATHRUP VILLAGE
OAKLAND COUNTY, MICHIGAN**

**AN ORDINANCE TO AMEND THE CITY OF LATHRUP VILLAGE CODE OF
ORDINANCES BY ADDITION OF, CHAPTER 46 - MISCELLANEOUS OFFENSES,
PROVISIONS, FORFEITURES AND PENALTIES,
ARTICLE XIII. NUISANCE PARTIES**

THE CITY COUNCIL OF THE CITY OF LATHRUP VILLAGE ORDAINS:

PART I. TITLE.

This Ordinance shall be known as the “Nuisance Parties Ordinance”.

PART II. ORDINANCE AMENDMENT.

That Chapter 46 - Miscellaneous Offenses, Provisions, Forfeitures and Penalties, Article XII. Nuisance Parties Section 46-193 through are hereby added as follows:

ARTICLE XIII. – NUISANCE PARTIES

Sec. 46-193. – Definition

As used in this chapter unless the context requires a different meaning, the following words and phrases shall have the meaning ascribed by this section:

NUISANCE PARTY — A social gathering or party, whether static or mobile, conducted on any public or private property within the City and which, by reason of the conduct of those persons in attendance, results in any one or more of the following conditions or events occurring on public or private property:

- A. The unlawful sale, furnishing, possession, or consumption of alcoholic beverages;
- B. Urination or defecation on neighboring public or private property, or on the premises in view of another person;
- C. Unlawful deposit of trash or litter;
- D. Destruction of property;
- E. Unlawful vehicular traffic, or the unlawful stopping, standing or parking of vehicles, obstruction of the free flow of traffic or interference with the ability to render emergency services;
- F. Unlawful parking of vehicles within the public streets, alleys, or sidewalks, or upon private property;
- G. Unreasonably loud noise under the circumstances which disturbs the comfort, quiet or repose of one or more members of the neighborhood;
- H. Conduct or a condition which injures any person;

- I. Conduct or a condition which endangers the safety of persons or property in the neighborhood;
- J. Conduct or a condition which results in the indecent exposure of a person, or the display of graphic sexual behavior, whether real or simulated, to a member of the public not attending the social gathering or party;
- K. Unlawful sale, furnishing, manufacture, use, or possession of a controlled substance as defined by federal or state law.

Sec. 46-194. - Prohibitions.

Any owner, occupant, tenant, guests or person otherwise having any possessory control, individually or jointly, of any personal or real property who either sponsors, conducts, hosts, invites, or permits a social gathering or party which is or during the course thereof becomes a nuisance party which is either the intentional result of or within the reasonable expectations of the person or persons having such possessory control is hereby deemed to have committed a violation of this article. In any prosecution for a violation of this section or the section prohibiting persons from attending nuisance parties, proof of specific intent shall not be required as a necessary element, but proof of general criminal intent shall be a necessary element.

Section 46-195. – Persons in attendance at nuisance parties.

Any person who is in attendance at a nuisance party whether or not such person has any possessory control over the personal or real property, shall be deemed to have committed a violation of this article.

Section 46-196. – Penalties.

A violation of this article is a misdemeanor punishable by up to 90 days in jail and/or a maximum fine of \$500.

Secs. 46-197 – 46-207. (Reserved).

PART III. REPEALER.

This ordinance repeals any ordinances in conflict thereof.

PART IV. SEVERABILITY.

If any section, subsection, clause, phrase, or portion of this article is for any reason held invalid by a court of competent jurisdiction, such portion shall be deemed a separate and distinct provision, and such holding shall not affect the validity of the remaining portions.

PART V. SAVINGS.

All proceedings pending and all rights and liabilities existing, acquired, or incurred at the time this ordinance takes effect are saved and may be consummated according to the law in force where they commenced.

PART VI. EFFECTIVE DATE.

This Ordinance shall be published in the manner required by law and shall become effective ten (10) days after the date of its publication. A copy of the ordinance shall also be made available for public use and inspection in the office of the City Clerk.

MADE, PASSED AND ADOPTED BY THE CITY COUNCIL, CITY OF LATHRUP VILLAGE, OAKLAND COUNTY, MICHIGAN THIS ____ DAY OF _____, 2024.

, City Clerk

Date of Introduction: July 15, 2024
Date of Adoption: _____
Date of Publication of _____
Notice of Adoption: _____

Lathrup Village Police Department

27400 Southfield Road
Lathrup Village MI, 48076
248-557-3600



TO: Michael Greene
FROM: Chief McKee
REASON: Axon Taser Contract
DATE: August 19, 2024

The Police Department is requesting approval for the purchase of 10- new tasers for the agency. The purchase of the new tasers will replace the existing 10 tasers that have reached the end of their life cycle. The contract will be divided into equal annual payments of \$9,223.20 for a total of 5 years with a total expenditure of \$46,110.00. It is extremely important for officers to have the ability to deploy a less than lethal option when dealing with a subject that is combative and resisting arrest. Having he ability to deploy a taser when necessary reduces injuries to the subject and the officers involved.



Axon Enterprise, Inc.
17800 N 85th St.
Scottsdale, Arizona 85255
United States
VAT: 86-0741227
Domestic: (800) 978-2737
International: +1.800.978.2737

Q-545971-45517.657CK

Issued: 08/13/2024

Quote Expiration: 09/30/2024

Estimated Contract Start Date: 03/01/2025

Account Number: 131060

Payment Terms: N30

Delivery Method:

SHIP TO	BILL TO
LATHRUP VILLAGE POLICE DEPT - MI 27400 Southfield Rd Lathrup Village, MI 48076-3412 USA	Lathrup Village Police Dept. - MI 27400 Southfield Rd Lathrup Village MI 48076-3412 USA Email:

SALES REPRESENTATIVE	PRIMARY CONTACT
Charles Kamps Phone: (480) 930-4327 Email: ckamps@axon.com Fax:	Scott Mckee Phone: (248) 557-3600 Email: policechief@lathrupvillage.org Fax: (724) 266-6319

Quote Summary

Program Length	60 Months
TOTAL COST	\$46,116.00
ESTIMATED TOTAL W/ TAX	\$46,116.00

Discount Summary

Average Savings Per Year	\$3,392.00
TOTAL SAVINGS	\$16,960.00

Payment Summary

Date	Subtotal	Tax	Total
Feb 2025	\$9,223.20	\$0.00	\$9,223.20
Feb 2026	\$9,223.20	\$0.00	\$9,223.20
Feb 2027	\$9,223.20	\$0.00	\$9,223.20
Feb 2028	\$9,223.20	\$0.00	\$9,223.20
Feb 2029	\$9,223.20	\$0.00	\$9,223.20
Total	\$46,116.00	\$0.00	\$46,116.00

Quote Unbundled Price: \$63,076.00
 Quote List Price: \$51,244.00
 Quote Subtotal: \$46,116.00

Pricing

All deliverables are detailed in Delivery Schedules section lower in proposal

Item	Description	Qty	Term	Unbundled	List Price	Net Price	Subtotal	Tax	Total
Program									
C00010	BUNDLE - TASER 10 CERTIFICATION	10	60	\$100.96	\$81.24	\$76.86	\$46,116.00	\$0.00	\$46,116.00
A la Carte Services									
101208	AXON TASER 10 - 2 DAY INSTRUCTOR COURSE - INSIDE SALES	1			\$2,500.00	\$0.00	\$0.00	\$0.00	\$0.00
Total							\$46,116.00	\$0.00	\$46,116.00

Delivery Schedule

Hardware

Bundle	Item	Description	QTY	Shipping Location	Estimated Delivery Date
BUNDLE - TASER 10 CERTIFICATION	100390	AXON TASER 10 - HANDLE - YELLOW CLASS 3R	10	2	02/01/2025
BUNDLE - TASER 10 CERTIFICATION	100393	AXON TASER 10 - MAGAZINE - LIVE DUTY BLACK	10	1	02/01/2025
BUNDLE - TASER 10 CERTIFICATION	100394	AXON TASER 10 - MAGAZINE - HALT TRAINING BLUE	4	1	02/01/2025
BUNDLE - TASER 10 CERTIFICATION	100395	AXON TASER 10 - MAGAZINE - LIVE TRAINING PURPLE	3	1	02/01/2025
BUNDLE - TASER 10 CERTIFICATION	100396	AXON TASER 10 - MAGAZINE - INERT RED	10	1	02/01/2025
BUNDLE - TASER 10 CERTIFICATION	100399	AXON TASER 10 - CARTRIDGE - LIVE	200	1	02/01/2025
BUNDLE - TASER 10 CERTIFICATION	100400	AXON TASER 10 - CARTRIDGE - HALT	60	1	02/01/2025
BUNDLE - TASER 10 CERTIFICATION	100401	AXON TASER 10 - CARTRIDGE - INERT	100	1	02/01/2025
BUNDLE - TASER 10 CERTIFICATION	100611	AXON TASER 10 - SAFARILAND HOLSTER - RH	8	1	02/01/2025
BUNDLE - TASER 10 CERTIFICATION	100613	AXON TASER 10 - SAFARILAND HOLSTER - LH	2	1	02/01/2025
BUNDLE - TASER 10 CERTIFICATION	100623	AXON TASER - TRAINING - ENHANCED HALT SUIT V2	1	1	02/01/2025
BUNDLE - TASER 10 CERTIFICATION	20018	AXON TASER - BATTERY PACK - TACTICAL	10	1	02/01/2025
BUNDLE - TASER 10 CERTIFICATION	20018	AXON TASER - BATTERY PACK - TACTICAL	2	1	02/01/2025
BUNDLE - TASER 10 CERTIFICATION	70033	AXON - DOCK WALL MOUNT - BRACKET ASSY	1	1	02/01/2025
BUNDLE - TASER 10 CERTIFICATION	71019	AXON BODY - DOCK POWERCORD - NORTH AMERICA	1	1	02/01/2025
BUNDLE - TASER 10 CERTIFICATION	74200	AXON TASER - DOCK - SIX BAY PLUS CORE	1	1	02/01/2025
BUNDLE - TASER 10 CERTIFICATION	80087	AXON TASER - TARGET - CONDUCTIVE PROFESSIONAL RUGGEDIZED	1	1	02/01/2025
BUNDLE - TASER 10 CERTIFICATION	80090	AXON TASER - TARGET FRAME - PROFESSIONAL 27.5 IN X 75 IN	1	1	02/01/2025
BUNDLE - TASER 10 CERTIFICATION	100399	AXON TASER 10 - CARTRIDGE - LIVE	30	1	02/01/2026
BUNDLE - TASER 10 CERTIFICATION	100400	AXON TASER 10 - CARTRIDGE - HALT	80	1	02/01/2026
BUNDLE - TASER 10 CERTIFICATION	100399	AXON TASER 10 - CARTRIDGE - LIVE	30	1	02/01/2027
BUNDLE - TASER 10 CERTIFICATION	100400	AXON TASER 10 - CARTRIDGE - HALT	80	1	02/01/2027
BUNDLE - TASER 10 CERTIFICATION	100399	AXON TASER 10 - CARTRIDGE - LIVE	30	1	02/01/2028
BUNDLE - TASER 10 CERTIFICATION	100400	AXON TASER 10 - CARTRIDGE - HALT	80	1	02/01/2028
BUNDLE - TASER 10 CERTIFICATION	100399	AXON TASER 10 - CARTRIDGE - LIVE	30	1	02/01/2029
BUNDLE - TASER 10 CERTIFICATION	100400	AXON TASER 10 - CARTRIDGE - HALT	80	1	02/01/2029

Software

Bundle	Item	Description	QTY	Estimated Start Date	Estimated End Date
BUNDLE - TASER 10 CERTIFICATION	101180	AXON TASER - DATA SCIENCE PROGRAM	10	03/01/2025	02/28/2030
BUNDLE - TASER 10 CERTIFICATION	20248	AXON TASER - EVIDENCE.COM LICENSE	10	03/01/2025	02/28/2030

Services

Bundle	Item	Description	QTY
BUNDLE - TASER 10 CERTIFICATION	100751	AXON TASER 10 - REPLACEMENT ACCESS PROGRAM - DUTY CARTRIDGE	10
BUNDLE - TASER 10 CERTIFICATION	101193	AXON TASER - ON DEMAND CERTIFICATION	1
A la Carte	101208	AXON TASER 10 - 2 DAY INSTRUCTOR COURSE - INSIDE SALES	1

Warranties

Bundle	Item	Description	QTY	Estimated Start Date	Estimated End Date
BUNDLE - TASER 10 CERTIFICATION	100704	AXON TASER 10 - EXT WARRANTY - HANDLE	10	02/01/2026	02/28/2030
BUNDLE - TASER 10 CERTIFICATION	80374	AXON TASER - EXT WARRANTY - BATTERY PACK T7/T10	10	02/01/2026	02/28/2030
BUNDLE - TASER 10 CERTIFICATION	80374	AXON TASER - EXT WARRANTY - BATTERY PACK T7/T10	2	02/01/2026	02/28/2030
BUNDLE - TASER 10 CERTIFICATION	80396	AXON TASER - EXT WARRANTY - DOCK SIX BAY T7/T10	1	02/01/2026	02/28/2030

Shipping Locations

Location Number	Street	City	State	Zip	Country
1	27400 Southfield Rd	Lathrup Village	MI	48076-3412	USA
2	27400 Southfield Rd	Lathrup Village	MI	48076-3412	USA

Payment Details

Feb 2025						
Invoice Plan	Item	Description	Qty	Subtotal	Tax	Total
Year 1	101208	AXON TASER 10 - 2 DAY INSTRUCTOR COURSE - INSIDE SALES	1	\$0.00	\$0.00	\$0.00
Year 1	C00010	BUNDLE - TASER 10 CERTIFICATION	10	\$9,223.20	\$0.00	\$9,223.20
Total				\$9,223.20	\$0.00	\$9,223.20

Feb 2026						
Invoice Plan	Item	Description	Qty	Subtotal	Tax	Total
Year 2	101208	AXON TASER 10 - 2 DAY INSTRUCTOR COURSE - INSIDE SALES	1	\$0.00	\$0.00	\$0.00
Year 2	C00010	BUNDLE - TASER 10 CERTIFICATION	10	\$9,223.20	\$0.00	\$9,223.20
Total				\$9,223.20	\$0.00	\$9,223.20

Feb 2027						
Invoice Plan	Item	Description	Qty	Subtotal	Tax	Total
Year 3	101208	AXON TASER 10 - 2 DAY INSTRUCTOR COURSE - INSIDE SALES	1	\$0.00	\$0.00	\$0.00
Year 3	C00010	BUNDLE - TASER 10 CERTIFICATION	10	\$9,223.20	\$0.00	\$9,223.20
Total				\$9,223.20	\$0.00	\$9,223.20

Feb 2028						
Invoice Plan	Item	Description	Qty	Subtotal	Tax	Total
Year 4	101208	AXON TASER 10 - 2 DAY INSTRUCTOR COURSE - INSIDE SALES	1	\$0.00	\$0.00	\$0.00
Year 4	C00010	BUNDLE - TASER 10 CERTIFICATION	10	\$9,223.20	\$0.00	\$9,223.20
Total				\$9,223.20	\$0.00	\$9,223.20

Feb 2029						
Invoice Plan	Item	Description	Qty	Subtotal	Tax	Total
Year 5	101208	AXON TASER 10 - 2 DAY INSTRUCTOR COURSE - INSIDE SALES	1	\$0.00	\$0.00	\$0.00
Year 5	C00010	BUNDLE - TASER 10 CERTIFICATION	10	\$9,223.20	\$0.00	\$9,223.20
Total				\$9,223.20	\$0.00	\$9,223.20

Tax is estimated based on rates applicable at date of quote and subject to change at time of invoicing. If a tax exemption certificate should be applied, please submit prior to invoicing.

Standard Terms and Conditions

Axon Enterprise Inc. Sales Terms and Conditions

Axon Master Services and Purchasing Agreement:

This Quote is limited to and conditional upon your acceptance of the provisions set forth herein and Axon's Master Services and Purchasing Agreement (posted at <https://www.axon.com/sales-terms-and-conditions>), as well as the attached Statement of Work (SOW) for Axon Fleet and/or Axon Interview Room purchase, if applicable. In the event you and Axon have entered into a prior agreement to govern all future purchases, that agreement shall govern to the extent it includes the products and services being purchased and does not conflict with the Axon Customer Experience Improvement Program Appendix as described below.

ACEIP:

The Axon Customer Experience Improvement Program Appendix, which includes the sharing of de-identified segments of Agency Content with Axon to develop new products and improve your product experience (posted at www.axon.com/legal/sales-terms-and-conditions), is incorporated herein by reference. By signing below, you agree to the terms of the Axon Customer Experience Improvement Program.

Acceptance of Terms:

Any purchase order issued in response to this Quote is subject solely to the above referenced terms and conditions. By signing below, you represent that you are lawfully able to enter into contracts. If you are signing on behalf of an entity (including but not limited to the company, municipality, or government agency for whom you work), you represent to Axon that you have legal authority to bind that entity. If you do not have this authority, please do not sign this Quote.

Signature

Date Signed

8/13/2024



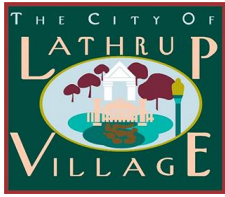

City of Lathrup Village
27400 Southfield Road
Lathrup Village, MI 48076
www.lathrupvillage.org | (248) 557-2600

TO: Mayor & City Council
FROM: Mike Greene – City Administrator
DATE: August 19, 2024
RE: MML Liability & Property Pool Coverage

Background Brief: Each year the City Council reviews and approves the MML Liability & Property Pool Coverage, which is the City’s insurance policy for our plan year.

The renewal premium for the Liability and Property insurance renewal for the City of Lathrup Village effective September 1, 2024-2025 with the MML Liability & Property Pool is \$96,947, compared to the expiring premium of \$92,998. This is a premium increase of \$3,949 (~4.2%).

Please note that the property deductible has increased this renewal to \$500 from \$250.

The Board of Directors of the MML Liability & Property Pool voted to return another post-renewal dividend in 2024 to renewing Members. The City of Lathrup Village’s portion of the dividend return is about \$8,048. The City of Lathrup Village will receive the dividend the month after paying the renewal premium.

Previous Action: September 25, 2023, City Council Approval

Economic Impact: Budgeted expenses of \$96,947 throughout the budget.

Recommendation: It is my recommendation to approve the MML Liability & Property Pool Coverage renewal.

Recommended Motion:

Moved by Council Member _____ seconded by Council Member _____ to approve the renewal of the MML Liability & Property Pool Renewal Proposal at the annual rate of \$96,947 effective September 1, 2024, and authorize the City Administrator to sign related documents.

Kelly Garrett Mayor	Bruce Kantor Mayor Pro-Tem	Jalen Jennings Council Member	Dalton Barksdale Council Member	Jason Hammond Council Member
------------------------	-------------------------------	----------------------------------	------------------------------------	---------------------------------



michigan municipal league

Liability & Property Pool

Proposal

for the

City of Lathrup Village

Presented By:

Brian Steckroth
MML Liability & Property Pool
(248) 204-8283

August 14, 2024

Table of Contents

EXECUTIVE OVERVIEW	3
OUR MISSION	3
INTRODUCTION	4
WHAT YOU CAN EXPECT OF US	4
YOUR POOL INSURES MORE THAN . . .	4
COST AND COVERAGE SUMMARY	5
YOUR TEAM OF EXPERTS	7
BENEFITS OF POOLING WITH THE MML	8
CITY OF LATHRUP VILLAGE HAS . . .	9
INCREASED LIABILITY LIMITS	9
HIGHLIGHTS OF COVERAGES PROVIDED	10
WHO IS INSURED?	10
GENERAL LIABILITY	10
GENERAL LIABILITY EXCLUSIONS . . .	10
PUBLIC OFFICIALS LIABILITY COVERAGE	11
PUBLIC OFFICIALS LIABILITY EXCLUSIONS	11
PERSONAL INJURY & ADVERTISING / BROADCASTERS LIABILITY COVERAGE	11
POLICE PROFESSIONAL LIABILITY COVERAGE	11
PROPERTY COVERAGE	12
PROPERTY EXCLUSIONS	12
COMPREHENSIVE CRIME COVERAGE	13
AUTOMOBILE COVERAGE HIGHLIGHTS	13
WHAT IS COVERED?	13
AUTO COVERAGES PROVIDED	13
POOL RISK MANAGEMENT SERVICES	14
MEMBER EDUCATION	14
ONLINE SERVICES	14
MEMBERSHIP RESPONSIBILITIES	15

This proposal is intended to be only a summary of coverages and services. For specific details on coverage terms and conditions, please refer to the Michigan Municipal League Liability and Property Pool coverage document.

Executive Overview

The Michigan Municipal League Liability and Property Pool has been a stable source of comprehensive municipal insurance and risk management services since 1982. It is financially secure and positioned for long-term stability.

The Pool staff is made up of municipal insurance experts. Municipal risk management is our only business, and we're proud of it!

The Pool provides insurance coverage designed specifically for Michigan municipal exposures, combined with a package of loss control programs, claims administration, legal defense, and membership services that you won't find anywhere else in Michigan.

This quotation is based on the limits of coverage requested by the **City of Lathrup Village**. Higher limits may be available, subject to underwriting review by Pool Management. Please submit requests for higher limits in writing to your Account Executive. Your request will be considered by Pool Management.

The insurance and related services described more fully in this proposal are being offered to the **City of Lathrup Village** for an annual premium of **\$96,947**. When compared to last year's cost of \$92,998, it represents a premium increase of \$3,949. In addition, the MML Liability & Property Pool Board of Trustees voted to return another post-renewal dividend for Members renewing in 2024. The **City of Lathrup Village's** portion of the dividend return is \$8,048. The **City of Lathrup Village** will receive this dividend in the month following payment of your 2024 renewal premium.

We encourage you to compare the Pool with our competition. Compare us based on price, coverage, service, financial security, experience, and commitment to municipal risk management. When you do, the advantages of Pool membership become clear.

Thank you for being a Pool member. We look forward to servicing your risk management program for many years to come.

Our Mission

To be a long-term, stable, cost-effective risk management alternative for members of the Michigan Municipal League Liability and Property Pool.

Introduction

What You Can Expect Of Us

- ✓ A commitment to learn, understand and respond to your insurance needs;
- ✓ Continuous planning and innovation in product development and service delivery;
- ✓ Products that meet your needs in terms of price, coverage and service;
- ✓ Prompt, accurate, and courteous response to your questions, problems and claims; and
- ✓ Knowledgeable and professional staff serving your needs consistently and with integrity.

Your Pool Insures More Than . . .

- | | |
|---------------------------------|------------------------------------|
| ✓ 452 Public Entity Members | ✓ 173 Water Utilities |
| ✓ 145 Fire Departments | ✓ 243 Sewer Utilities |
| ✓ 185 Law Enforcement Agencies | ✓ 16 Municipal Marinas |
| ✓ 2,295 Police Officers | ✓ \$6.7 Billion of Property Values |
| ✓ 58,727 Miles of Streets/Roads | ✓ 21 Dams |
| ✓ 7,697 Vehicles | |
| ✓ 18 Electric Utilities | |

City of Lathrup Village Coverage and Cost Summary 9/1/2024 to 9/1/2025

Coverage	Limit of Liability	Aggregate Limit	Per Occurrence Deductible
Comprehensive General Liability (Coverage A)	\$5,000,000	N/A	\$0
Sewer Back-Up Sublimit	\$100,000	\$100,000	N/A
Personal Injury Liability (Coverage B)	\$5,000,000	N/A	\$0
Medical Payments (Coverage C)	\$10,000	N/A	N/A
Public Officials Liability (Coverage D)	\$5,000,000	N/A	\$0
Police Liability	\$5,000,000	N/A	\$0
Employee Benefit Liability	\$1,000,000	\$1,000,000	\$0
Fire Legal Liability	\$100,000	N/A	N/A
Cyber Liability & Data Breach Response	\$100,000	\$100,000	See Declaration
Marina Operator's Liability Limit Per Vessel	N/A	N/A	N/A
Uninsured/Underinsured Motorists Coverage	\$100,000	N/A	N/A
Automobile Liability	\$5,000,000	N/A	\$0
# Vehicles	Comprehensive	Collision	
16	\$250	\$250	
Agreed Amount, If applicable	2 vehicles	N/A	N/A
\$110,000		N/A	N/A

Coverages A, B, C and D are provided with a combined single limit of liability. The most the Pool will pay for any one occurrence is \$5,000,000 regardless of the number of coverages involved in the occurrence.

Property – Blanket Basis	\$9,347,586	N/A	\$500
Property – Limited Replacement Cost, If applicable			
Property in the Open	\$Included	N/A	\$500
Earthquake	\$2,000,000	\$2,000,000	\$5,000
Flood (Except for members located in Flood Zone A, AO, AH, A1-A999, AE or AR)	\$1,000,000	\$1,000,000	\$5,000
Consequential Damage	\$100,000	N/A	\$0
Protection and Preservation	\$100,000	N/A	N/A
Personal Effects and Property of Others	\$500	\$2,500	\$250
Extra Expense	\$100,000	N/A	\$0
Valuable Papers	\$100,000	N/A	\$250
Loss Of Rents	\$100,000	N/A	\$0
Loss of Income	\$100,000	N/A	\$0
Accounts Receivable	\$100,000	N/A	\$0
Demolition/Increased Cost of Construction	\$100,000	N/A	\$0
Boiler and Machinery	Included	N/A	\$500
Expediting Expense	\$100,000	N/A	\$0
Fine Arts	\$100,000	N/A	\$250
Ornamental Trees, Shrubs, Plants or Lawns	\$5,000	\$10,000	\$250
Computer Equipment and Media	\$125,000	N/A	\$250
Contractors Equipment	\$150,000	N/A	\$250
2 Auxiliary Pumps	\$30,000	N/A	\$250
Cable TC Dept Equipment	\$146,489	N/A	\$250
Radio Equipment	\$90,000	N/A	\$250
Voting Equipment	\$19,145	N/A	\$250

Comprehensive Crime Coverage

Employee Dishonesty Blanket/Faithful Performance	\$100,000	N/A	\$0
Money and Securities Inside	\$100,000	N/A	\$0
Money and Securities Outside	\$100,000	N/A	\$0
Money Orders and Counterfeit Paper	\$100,000	N/A	\$0
Depositors Forgery	\$100,000	N/A	\$0
Computer Fraud	\$100,000	N/A	\$0
Funds Transfer Fraud	\$100,000	N/A	\$0
Impersonation Fraud	\$100,000	N/A	\$0

Position Bonds

Treasurer Bond	\$100,000
----------------	-----------

Only one deductible applies to claims involving two or more property coverages.

The Michigan Municipal League Liability and Property Pool is pleased to offer all the coverages and services described in this proposal for an annual premium of \$96,947

Cyber Coverage

TOWER 1 Limit	POLICY AGGREGATE LIMIT OF LIABILITY	\$100,000	For all Damages, Claims Expenses, Penalties and PCI Fines, Expenses and Costs
	Information Security and Privacy Sublimit	\$100,000	each Claim and in the Aggregate
	Regulatory Defense and Penalties Aggregate Sublimit:	\$20,000	each Claim and in the Aggregate
	Website Media and Content Liability Aggregate Sublimit:	\$100,000	each Claim and in the Aggregate
	PCI Fines, Expenses and Costs Aggregate Sublimit:	\$10,000	each Claim and in the Aggregate
	Cyber Extortion Aggregate Sublimit:	\$25,000	each Claim and in the Aggregate
	First Party Data Protection Aggregate Sublimit:	\$25,000	each Claim and in the Aggregate
	First Party Network Business Interruption Aggregate Sublimit:	\$25,000	each Claim and in the Aggregate
	Note: The above Sublimits are part of, and not in addition to, the overall Policy Aggregate Limit of Liability		
Liability Retention Per Claim:			
TOWER 1 Retention	All other coverages Retention:	\$0	each Claim
	Cyber Extortion:	\$5,000	each Extortion Threat
	First Party Data Protection:	\$5,000	each Data Protection Loss
	First Party Network Business Interruption:	\$5,000	each Business Interruption Loss Waiting Period: 12 hours
Limits of Coverage - Privacy Breach Response Services			
TOWER 2 Limit	Legal Services/Computer Expert Services/Public Relations and Crisis Management Expenses Aggregate Sublimit:	\$50,000	per Incident and in the Aggregate
TOWER 3 Limit	Notified Individuals:	10,000	Notified Individuals in the Aggregate
	A sublimit of up to 10% of Notified Individuals residing outside the United States, which is part of and not in addition to the Notified Individuals Aggregate Limit of Coverage		
Note: The Privacy Breach Response Services Limits of Coverage are separate from and in addition to the overall Policy Aggregate Limit of Liability			
Privacy Breach Response Services Threshold/Retention (Each Incident):			
TOWER 2 Retention	Legal Services/Computer Expert Services/Public Relations and Crisis Management Expenses Retention:	\$0	each Incident
TOWER 3 Retention	Notification Services/Call Center Services/Breach Resolution and Mitigation Services Threshold:	0	each Incident

Your Team of Experts



Brian Steckroth
Service & Sales Manager
(248) 204-8283



Michael J. Forster
Pool Administrator
(734) 669-6340



Katelyn Petracca
248-204-6160
Alpha Split: (Le – Z)



Joan Opett
248-204-8579
(A – La)

Customer Service Representatives



Christopher Flechsig
Liability Claims Supervisor
(810) 844-8146



Matt Heins
Loss Control Supervisor
Law Enforcement Action Forum Coordinator
(248) 791-4371

Benefits of Pooling with the MML

- ✓ Proven long-term availability and stability
- ✓ Broad coverage document written specifically for Michigan municipalities
- ✓ Services tailored to unique needs of Michigan municipalities
- ✓ Member assets controlled by an elected Board of municipal officials
- ✓ Equitable rating based on Pool experience in Michigan
- ✓ Aggressive defense strategy – positive impact on case law
- ✓ Professional, dedicated, and experienced local management, oversight and service
- ✓ Decisions made and problems resolved by a group of your peers
- ✓ Investment income and underwriting surplus used to benefit members
- ✓ Lower expenses through tax-exempt and non-profit status
- ✓ Special loss avoidance training sessions including:
 - ✓ Safety aspects of emergency vehicle operations
 - ✓ Accident investigation for supervisors
 - ✓ Confined spaces training

The advantages of pooling can be summarized by:

Service + Control + Value

City of Lathrup Village Has . . .

- ✓ \$9,347,586 of total values for real and personal property
- ✓ 16 Vehicles
- ✓ 2 Vehicles with agreed values totaling \$110,000
- ✓ \$90 Michigan Catastrophic Claims Assessment (MCCA) per vehicle (was \$121/vehicle for 2023) ↓

Increased Liability Limits

We cannot guarantee the adequacy of any limit of liability. Due to the following factors, it may be prudent to consider higher limits:

- ✓ Increased jury awards in your jurisdiction
- ✓ Increased litigation trends
- ✓ Protection of tax base against judgments in excess of your policy limits

If you are interested in increasing your liability limits, please contact your Account Executive.

Highlights of Coverages Provided

Who Is Insured?

The Pool member entity, elected and appointed officials, employees and authorized volunteers, and any person officially appointed to a Board or Commission

General Liability

In addition to standard liability coverages (bodily injury, property damage, products and completed operations) the Pool provides coverages that municipalities need on an **occurrence basis with no aggregate liability limits**:

- ✓ Liability resulting from mutual aid agreements
- ✓ Premises medical payments
- ✓ Host liquor liability
- ✓ Watercraft liability, owned less than 26' and non-owned less than 50'
- ✓ Special events **excluding** -
 - Fireworks (unless endorsed)
 - Liquor Liability
 - Mechanical Amusement Rides
- ✓ Fire legal liability for real property
- ✓ Ambulance and EMT malpractice

Fireworks Coverage Options: (Fireworks application must be completed before coverage is endorsed)

1. The MML Liability & Property Pool is primary (the Member is not added as an additional insured on a pyrotechnician's coverage):

Annual Aggregate Sublimit	Additional Premium
\$500,000	Yes
\$1,000,000	Yes

2. The MML Liability & Property Pool is excess (the Member is added as an additional insured on a pyrotechnician's coverage):

NO ADDITIONAL PREMIUM

- ✓ Athletic participation liability
- ✓ Employee benefit liability
- ✓ Cemetery operations coverage
- ✓ Marina Operators coverage available
- ✓ Up to \$10 million in liability limits available
- ✓ Pollution coverage for Hazardous Response Teams
- ✓ Cyber Liability and Data Breach Response Coverage – as described on MMLCYD (09/17)

General Liability Exclusions . . .

The following is a partial list of general liability coverage exclusions. Consult the coverage document for the complete listing:

- ✓ Pollution (except for Hazmat operations).
- ✓ Nuclear energy / nuclear material hazards
- ✓ Expected or intended injury
- ✓ Breach of contract
- ✓ Failure of dams (unless endorsed)
- ✓ Backup of Sewers and Drains (**exception -- \$100,000 Annual Aggregate Sublimit for Sewer and Drain Liability**)
- ✓ Aircraft Liability – (Unless Endorsed -- Limited Coverage for Unmanned Aircraft—MML236)
- ✓ Contractual Liability
- ✓ Failure to supply utilities
- ✓ Electromagnetic radiation
- ✓ Medical malpractice for doctors and physicians
- ✓ Criminal activity--Intentional acts w/knowledge of wrongdoing

Cyber Liability and Data Breach Response Coverage

- ✓ Information Security and Privacy Liability
- ✓ Privacy Breach Response Services
- ✓ Regulatory Defense and Penalties
- ✓ Website Media Content Liability
- ✓ PCI Fines, Expenses and Costs
- ✓ Cyber Extortion
- ✓ First Party Data Protection
- ✓ First Party Business Interruption

Public Officials Liability Coverage

“Wrongful Acts”, including intentional acts, defined as any actual or alleged error, misstatement, act of omission, neglect or breach of duty including:

- ✓ Neglect of duty
- ✓ Zoning defense and land use litigation
- ✓ Malfeasance
- ✓ Violation of civil rights
- ✓ Discrimination
- ✓ Employment practices
- ✓ Misfeasance
- ✓ Cable TV broadcasting

Public Officials Liability Exclusions

The following is a partial list of public officials’ liability coverage exclusions. Consult the coverage document for the complete listing:

- ✓ Pollution and Nuclear Energy
- ✓ Fraud, dishonesty, intentional and criminal acts
- ✓ Failure to purchase coverage or adequate coverage
- ✓ Return of governmental grants or subsidies
- ✓ Intentional acts with knowledge of wrongdoing
- ✓ Eminent domain / takings
- ✓ Illegal profit
- ✓ Labor union actions
- ✓ ERISA violations
- ✓ Backup of Sewers and Drains

Personal Injury & Advertising / Broadcasters Liability Coverage

- ✓ Mental anguish and stress
- ✓ Libel, slander or defamation of character; violation of an individual’s right of privacy
- ✓ Proactive services for non-monetary damage claims

Police Professional Liability Coverage

Police Professional Liability coverage is contained within the General Liability and Public Official Liability Coverage Parts

- ✓ Discrimination
- ✓ Violation of civil rights
- ✓ Jail operations
- ✓ False arrest, detention or imprisonment, or malicious prosecution
- ✓ Wrongful entry or eviction or other invasion of the right of private occupancy
- ✓ Assault or battery
- ✓ Improper service of suit
- ✓ Coverage assumes officers act with intent

Property Coverage

In addition to covering buildings, contents and personal property, the Pool provides:

- ✓ Blanket coverage -- All member-owned property insured (unless specifically excluded)
- ✓ Coverage based on ownership rather than on a "schedule on file" avoids coverage gaps due to errors or oversight
- ✓ Property of others in custody of the Member for which the Member has an obligation to provide coverage
- ✓ Boiler & Machinery coverage, including Boiler certification inspections
- ✓ Replacement Cost or Actual Cash Value available
- ✓ Fungal Pathogens (Mold) Limited Coverage
- ✓ Demolition/increased cost of construction
- ✓ No coinsurance
- ✓ Valuable papers
- ✓ Loss of Rents
- ✓ Property in the open
- ✓ Extra expense
- ✓ Expediting expense

Property Exclusions

The following is a partial list of property coverage exclusions. Consult the coverage document for the complete listing:

- ✓ Nuclear reaction/ contamination
- ✓ War
- ✓ Cyber Risk
- ✓ Fungal Pathogens (Mold) excess of sub-limit
- ✓ Failure to supply utilities
- ✓ Transmission Lines and Poles
- ✓ Dishonest acts
- ✓ Acts of Terrorism excess of Pool's Aggregate Sublimit -- MMLC TR (9/1/10)
- ✓ Wear and tear
- ✓ Computer failures/ viruses

Only one deductible applies to claims involving two or more property coverages.

Comprehensive Crime Coverage

- ✓ Employee Dishonesty/ Faithful Performance of Duty coverage provided on a blanket basis
- ✓ Loss Inside the Premises
- ✓ Loss Outside the Premises
- ✓ Money Orders/ Counterfeit Currency
- ✓ Depositors Forgery
- ✓ Position Fidelity Bonds
- ✓ Computer Fraud
- ✓ Funds Transfer Fraud

Automobile Coverage Highlights

What Is Covered?

Coverage is afforded while operating land motor vehicles, trailers or semi-trailers designed for travel on public roads.

Auto Coverages Provided

- ✓ Michigan No-Fault Coverage, includes mini-tort coverage for no extra charge
- ✓ Excess protection for use of personal automobile for municipal business
- ✓ Uninsured motorist for municipally owned vehicles
- ✓ Underinsured motorists
- ✓ Non-owned and hired auto
- ✓ Comprehensive - actual cash value basis
- ✓ Collision - actual cash value basis
- ✓ Volunteer firefighter auto accident liability coverage
- ✓ Agreed value coverage for emergency vehicles is available
- ✓ Fire or Rescue Vehicle Rental Reimbursement Coverage

Pool Risk Management Services

- ✓ Review and service of all municipal insurance matters
- ✓ Public entity experts address various liability issues
- ✓ Aggressive, member-oriented defense strategy
- ✓ Former police officials address law enforcement risks
- ✓ Physical inspection by municipal loss control consultants
- ✓ Law enforcement risk control programs (LEAF and LERC)
- ✓ Property appraisal services available

Online Services

www.mml.org (click on the *Insurance* button) – offers Pool members an outstanding resource for municipal risk management information and self-help tools in one attractive, simple-to-navigate location. File a claim on line. Download your renewal application. Request a loss control service visit. E-mail us a question. Other services available online:

- ✓ Online Forms (including Sewer Backup Sample Documents)
- ✓ Risk Resources:
 - ✓ Risk Control Solutions
 - ✓ Safety & Health Manual
 - ✓ Risk Management is Good Management Program
 - ✓ Law Enforcement Newsletters
 - ✓ Access to Safetysurance website -- <http://www.safetysurance.com/>
- ✓ MML Pool Audited Financial Statements
- ✓ Intergovernmental Contract
- ✓ Board of Directors, Pool Administrator and Staff Profiles and Contact Information

Membership Responsibilities

Membership in the Michigan Municipal League Liability and Property Pool provides numerous benefits. Likewise, individual members have certain responsibilities to the other members, which are detailed in the Intergovernmental Contract. The following is a summary of the membership responsibilities. Please refer to the Intergovernmental Contract, Articles 5 and 6, for more information.

- ✓ If a Member intends to leave the Pool, the Member must send a written notice to the Pool at least 60 days prior to its next renewal date.
- ✓ A Member must pay its premium when due. The Pool must give each member 20 days written notice of intent to terminate membership for nonpayment of premium. Payment of premium before the 20 days notice is effective will entitle the Member to reinstatement.
- ✓ Members must maintain membership or associate membership status in the Michigan Municipal League.
- ✓ A Member will allow attorneys employed by the Pool to represent the Member in defense of any claim made against the Member within the scope of coverage provided by the Pool. A Member will cooperate with the assigned attorneys, claims adjusters, service company or other agents of the Pool relating to the defense of claims for which the Pool is providing coverage.
- ✓ A Member will follow loss reduction and prevention measures established by the Pool.
- ✓ A Member will report to the Pool as promptly as possible all incidents that the Member reasonably believes may result in a claim against the Member.

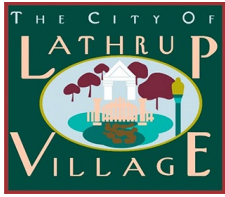

City of Lathrup Village
27400 Southfield Road
Lathrup Village, MI 48076
www.lathrupvillage.org | (248) 557-2600

TO: Mayor & City Council
FROM: Mike Greene – City Administrator
DATE: July 15, 2024
RE: DPS Truck Purchase

Background Brief: As part of the adopted Capital Improvement Plan, the City has planned to upgrade a Department of Public Services (DPS) pickup truck during the 2024-2025 fiscal year. In mid-June, the City issued a Request for Proposal (RFP) via BidNet/MITN for a pickup truck that would meet the needs of our DPS crew. Proposals were received until July 9, with only one dealer submitting a proposal (20 vendors downloaded the RFP).

Bob Maxey Ford (1833 E. Jefferson Ave., Detroit, MI 48207) submitted a proposal that was reviewed by City staff and we believe it meets the City’s needs. This vehicle would be used daily while also being a key aspect of snow removal during the winter season.

This vehicle would replace a 2006 Chevy Silverado that currently has 62,588 miles. This 2006 Chevy is at the end of its useful life and poses a hazard to the DPS crew. The bed is held together via a ratchet strap, the driver-side floor has a hole in it which is covered by a street sign, and the seats and ceiling need duct tape to stay together.



Kelly Garrett Mayor
Bruce Kantor Mayor Pro-Tem
Jalen Jennings Council Member
Dalton Barksdale Council Member
Jason Hammond Council Member



City of Lathrup Village
27400 Southfield Road
Lathrup Village, MI 48076
www.lathrupvillage.org | (248) 557-2600

Previous Action: N/A

Economic Impact:

Truck Price = \$49,485 (includes government discount)
Plow Package = \$7,495
TOTAL = \$56,980

Total budgeted amount = \$52,000
GF 101-401-000-970 = \$26,000
Water 592-536-000-970 = \$13,000
Sewer 592-536-000-970 = \$13,000



Recommendation: It is my recommendation to approve the DPS pickup purchase with the plow package from Bob Maxey Ford.

Recommended Motion:

Moved by Council Member _____ seconded by Council Member _____
to approve the DPS Pickup Truck purchase, with alternate #1 (snowplow package), from Bob Maxey Ford for a total bid price of \$56,980.

Kelly Garrett Mayor	Bruce Kantor Mayor Pro-Tem	Jalen Jennings Council Member	Dalton Barksdale Council Member	Jason Hammond Council Member
-------------------------------	--------------------------------------	---	---	--



City of Lathrup Village
27400 Southfield Road
Lathrup Village, MI 48076
www.lathrupvillage.org | (248) 557-2600

Pickup Truck Bid Proposal Form

The undersigned agrees to provide the pickup truck as specified in the RFP and as bid below:

Lump Sum Bid Price per Specifications:	\$ <u>49,485.00</u>
Bid Alternate #1 (snowplow package):	\$ <u>7,495.00</u>
Bid Alternate #2 (hybrid model):	\$ <u>N/A</u>
TOTAL (including alternates #1 & #2):	\$ <u>56,980.00</u>

Warranty Info: See Attached

Delivery Date: 90-120 Days ARO

Deviations from Specifications: None

Signed:  Printed Name: Frank Kurta

Company: Bob Maxey Ford

Address: 1833 E. Jefferson Ave., Detroit, MI 48207

Email: frank.kurta20@gmail.com Phone #: 313-420-1092

Kelly Garrett Mayor	Bruce Kantor Mayor Pro-Tem	Jalen Jennings Council Member	Dalton Barksdale Council Member	Jason Hammond Council Member
-------------------------------	--------------------------------------	---	---	--

BOB MAXEY FORD

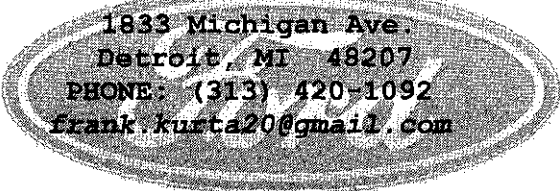

Q U O T A T I O N

DATE	7/8/2024
EXPIRES	8/31/2024
DELIVERY	90-120 Days ARO

Customer: City of Lathrup Village

Contact: Mike Greene **Phone:** 248-557-2600 **Fax:**

2024 Ford F-250 XL Regular Cab 4X4 3/4-Ton Pickup Truck with 8' Box- 142" Wheelbase	
Base Price:	\$ 47,760.00
Government Discount	-\$ (2,315.00)
6.8 Liter V-8 DEV Gasoline Engine	Included
Electronic 10-Speed Automatic Transmission	Included
3.73 Regular Axle	Included
XL Equipment Group	Included
-Power Equipment Group (Windows, Locks w/Keyless Entry and Heated Exterior Mirrors), Cruise Control, Air Conditioning	
40/20/40 Cloth Seating with Center Storage Compartments	\$ 100.00
XL Chrome Package	\$ 225.00
Vinyl Floor and Floor Mats	Included
LT245/Black Sidewall All-Season 17" Tires, Spare & Jack	Included
AM/FM, Bluetooth, MP3 Infotainment Center	Included
Trailer Hitch Receiver with 7/4 pin Connector & Brake Controller	Included
10,000 Lbs. GVWR, Rear View Camera	Included
Roof Clearance Lights	\$ 95.00
360° Amber Strobe	\$ 650.00
Snowplow Prep Package	\$ 250.00
Spray-In Bedliner	\$ 595.00
Front & Rear Splash Guards	\$ 130.00
Destination and Delivery	\$ 1,995.00
USB Service Manual	Included
State of Michigan Title & Delivery to Lathrup Village, MI	Included
Total	\$ 49,485.00
Western 8' Pro Plow Series 3 w/Halogen Lights & Hand Control	\$ 7,495.00
*Recommended Options: Roof Clearance Lights \$95, Dual Battery and 410 Amp Alternator \$325, Upfitter Switches \$165, Upfitter Interface \$400, Center Console with Cloth Seats \$515	
**Suggested Options: Black Running Boards \$320, E-Locking Axle \$430, 120V/400W Outlet \$175, Remote Start \$250, Backup Alarm \$175, Wheel Well Liners \$325, Spray-In Bedliner \$595, Tailgate Step \$375, Green or Green Gem Paint \$660	

Authorized Signature:

Frank Kurta - Fleet Sales Manager

Mike Roland
28130 Groesbeck Hwy.
Roseville, MI 48066
e-mail: mroland@nbcte.com



Q062407
Phone: (586) 774-4900
Fax: (586) 772-1280
Cell: (586) 484-7335

QUOTATION

June 27, 2024

Bob Maxey Ford
Attn: Frank Kurta
1833 E. Jefferson Ave
Detroit, MI 48207

P – 313-420-1092
Email: frank.kurta20@gmail.com

We are pleased to submit the following quotation for your consideration:
Re: City of Lathrup Village “DPS Pickup Truck 2024” F250

ONE (1) WESTERN® 8' PRO-PLOW SERIES 3

- 29" High 14 Gauge Steel Moldboard
- Two (2) Trip Springs
- Eight (8) Vertical Ribs
- 1½" x 5" Angling Rams
- Plowing Width @ 28° Angle – 84.8"
- Blade Guides With Replaceable Flags
- Front Mounted, Flo-Stat® Electric Solenoid Activated, Hydraulic System
- **Hand Held CabCommand Controller**
- NightHawk Low Profile Dual-Halogen Headlights
- **¾" x 6" High Carbon Steel Cutting Edge**
 - > UltraMount System 2
 - > Stand And Connecting Hook Combined Into One Rotating Device
 - > Removable Receiver Bracket For Better Off Road Ground Clearance
 - > Pivot Bar
- UltraFinish™

TOTAL INVESTMENT ----- \$7,495.00

Optional:

- Adjustable, Cast Iron Disc Shoes ----- Add \$238.00**
- Shock Absorber To Soften Tripping Action ----- Add \$212.00**
- Rubber Snow Deflector ----- Add \$233.00**
- Back Drag Edge ----- Add \$234.00**

- All prices are valid for 30 days from the time of the quote date.
- Freight for products from the manufacturer to mounting stations is calculated at standard rates. Freight surcharges may apply.



Mike Roland
28130 Groesbeck Hwy.
Roseville, MI 48066
e-mail: mroland@nbcte.com



Q062407

Item 8D.

Phone: (586) 774-4900
Fax: (586) 772-1280
Cell: (586) 484-7335

- **Restocking charges may apply to cancelled orders. The rate will be based on the status of the order at the time of cancellation.**
- **Quoted prices are valid only if total units quoted are ordered.**
- **No additional discounts or rebates apply to the quoted prices.**
- **3% service charge will be applied if paid by credit card.**
- **Quoted prices do not include any applicable taxes or FET unless stated.**

Sincerely,
NBC Truck Equipment, Inc.

Michael Roland
Sales Representative



FORD MOTOR COMPANY WARRANTY COVERAGE

This chart gives a general summary of your warranty coverage provided by Ford Motor Company under the **New Vehicle Limited Warranty**. Please refer to the description of warranty coverage for more specific information.

For each type of coverage, the chart shows two measures:

- years in service
- miles driven

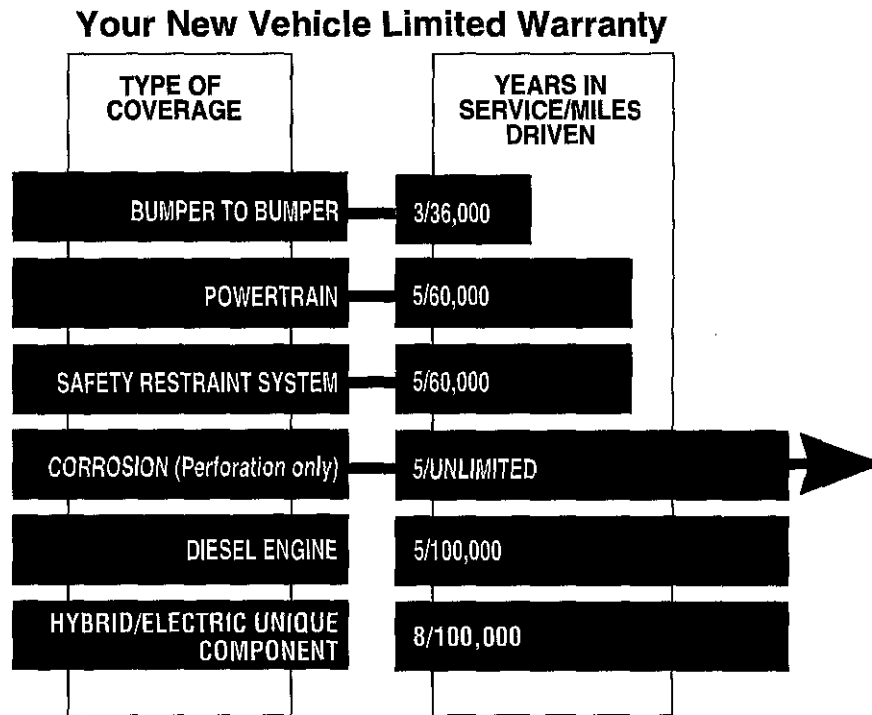

The measure that occurs first determines how long your coverage lasts. For example: Your Bumper to Bumper Coverage lasts for three years - unless you drive more than 36,000 miles before three years elapse. In that case, your coverage ends at 36,000 miles.

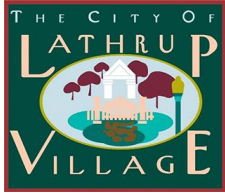

City of Lathrup Village
27400 Southfield Road
Lathrup Village, MI 48076
www.lathrupvillage.org | (248) 557-2600

TO: Mayor & City Council
FROM: Mike Greene – City Administrator
DATE: July 15, 2024
RE: DPS Lawn Mower Purchase

Background Brief: As part of the adopted Capital Improvement Plan, the City has planned to purchase a new commercial lawn mower for the Department of Public Services (DPS) during the 2024-2025 fiscal year. In May of this year, our current commercial mower (~6 years old) was at the end of its useful life and experienced an engine failure which was quoted to cost \$4,500 to fix. City staff ended up purchasing a small residential graded mower to get us through these couple of months, as outsourcing to another private company or renting a mower was cost-prohibited. If the recommended mower is approved for purchase, this residential-graded mower will remain with DPS and serve as a backup.

City Staff seeks to utilize MiDEAL for the purchase of a new mower. MiDEAL is the State of Michigan's extended purchasing program that allows Michigan cities, townships, villages, counties, school districts, universities, colleges, and nonprofit hospitals to buy goods and services from state contracts.

Deere & Company (John Deere) holds a MiDEAL contract (#24000000161) for Agricultural, Grounds, & Maintenance Equipment. Presented in your packet is a quote for a John Deere Z760R ZTRAK-60". If approved, we would expect to receive the equipment in September.

The warranty for this piece of equipment is 4 years or 1,000 hours, whichever occurs first.

Previous Action: N/A

Economic Impact:

Total Selling Price (includes discount) = \$10,864.28

\$10,000 included in 101-401-000-970 (total line item = \$58,500)

Recommendation: It is my recommendation to approve the lawn mower purchase.

Recommended Motion:

Moved by Council Member _____ seconded by Council Member _____ to approve DPS Commercial Lawn Mower (John Deere Z760R ZTRAK-60") purchase via Tri County Equipment, Inc. utilizing the MiDEAL contract, for a cost of \$10,864.28.

Kelly Garrett Mayor	Bruce Kantor Mayor Pro-Tem	Jalen Jennings Council Member	Dalton Barksdale Council Member	Jason Hammond Council Member
------------------------	-------------------------------	----------------------------------	------------------------------------	---------------------------------

Customer:

Quotes are valid for 30 days from the creation date or upon contract expiration, whichever occurs first.

A Purchase Order (PO) or Letter of Intent (LOI) including the below information is required to proceed with this sale. The PO or LOI will be returned if information is missing.

Vendor: Deere & Company

- 2000 John Deere Run
Cary, NC 27513

- Signature on all LOIs and POs with a signature line

- Contract name or number; or JD Quote ID

- Sold to street address

- Ship to street address (no PO box)

- Bill to contact name and phone number

- Bill to address

- Bill to email address (required to send the invoice and/or to obtain the tax exemption certificate)

- Membership number if required by the contract

For any questions, please contact:**Mark Williams**

Tri County Equipment, Inc.
989 West Sanilac
Sandusky, MI 48471

Tel: 810-648-2404

Fax: 810-648-2226

Email: mwilliams@tricityequipment.net

Quotes of equipment offered through contracts between Deere & Company, its divisions and subsidiaries (collectively "Deere") and government agencies are subject to audit and access by Deere's Strategic Accounts Business Division to ensure compliance with the terms and conditions of the contracts.

ALL PURCHASE ORDERS MUST BE MADE OUT TO (VENDOR):

Deere & Company
 2000 John Deere Run
 Cary, NC 27513
 FED ID: 36-2382580
 UEID: FNSWEDARMK53

ALL PURCHASE ORDERS MUST BE SENT TO DELIVERING DEALER:

Tri County Equipment, Inc.
 989 West Sanilac
 Sandusky, MI 48471
 810-648-2404
 jddealer@tricityequipment.net

Quote Summary

Prepared For:

City Of Lathrup Village
 MI
 Home : 248-232-9480

Delivering Dealer:

Tri County Equipment, Inc.
 Mark Williams
 989 West Sanilac
 Sandusky, MI 48471
 Phone: 810-648-2404
 mwilliams@tricityequipment.net

Quote ID: 31295533
Created On: 09 July 2024
Last Modified On: 09 July 2024
Expiration Date: 31 July 2024

Equipment Summary	Suggested List	Selling Price	Qty	=	Extended
JOHN DEERE Z760R ZTRAK-60"	\$ 11,809.00	\$ 10,864.28	X 1	=	\$ 10,864.28

Contract: MI Ag, Grounds, and Roadside 240000000161 (PG 3W CG 22)

Price Effective Date: November 1, 2023

Equipment Total **\$ 10,864.28**

* Includes Fees and Non-contract items

Quote Summary

Equipment Total	\$ 10,864.28
Trade In	
SubTotal	\$ 10,864.28
Est. Service Agreement Tax	\$ 0.00
Total	\$ 10,864.28
Down Payment	(0.00)
Rental Applied	(0.00)
Balance Due	\$ 10,864.28

Salesperson : X _____

Accepted By : X _____

Selling Equipment

Quote Id: 31295533 **Customer Name:**
ALL PURCHASE ORDERS MUST BE MADE OUT TO (VENDOR):

 Deere & Company
 2000 John Deere Run
 Cary, NC 27513
 FED ID: 36-2382580
 UEID: FNSWEDARMK53

ALL PURCHASE ORDERS MUST BE SENT TO DELIVERING DEALER:

 Tri County Equipment, Inc.
 989 West Sanilac
 Sandusky, MI 48471
 810-648-2404
 jddealer@tricityequipment.net

JOHN DEERE Z760R ZTRAK-60"

Hours:	Suggested List *
Stock Number:	\$ 11,809.00
Contract: MI Ag, Grounds, and Roadside 240000000161 (PG 3W CG 22)	Selling Price *
	\$ 10,864.28

Price Effective Date: November 1, 2023

* Price per item - includes Fees and Non-contract items

Code	Description	Qty	List Price	Discount%	Discount Amount	Contract Price	Extended Contract Price
22A0TC	Z760R ZTRAK	1	\$ 11,479.00	8.00	\$ 918.32	\$ 10,560.68	\$ 10,560.68
Standard Options - Per Unit							
001A	United States/Canada	1	\$ 0.00	8.00	\$ 0.00	\$ 0.00	\$ 0.00
1036	Pneumatic Turf Tire for 54 In. and 60 In. Decks	1	\$ 0.00	8.00	\$ 0.00	\$ 0.00	\$ 0.00
1504	60 In. High-capacity PRO Mower Deck	1	\$ 330.00	8.00	\$ 26.40	\$ 303.60	\$ 303.60
			Standard Options Total		\$ 26.40	\$ 303.60	\$ 303.60
			Value Added Services Total		\$ 0.00	\$ 0.00	\$ 0.00
			Total Selling Price		\$ 944.72	\$ 10,864.28	\$ 10,864.28

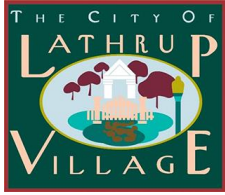

City of Lathrup Village
27400 Southfield Road
Lathrup Village, MI 48076
www.lathrupvillage.org | (248) 557-2600

TO: Mayor & City Council
FROM: Mike Greene – City Administrator
DATE: July 15, 2024
RE: City Council Chambers Camera Upgrade

Background Brief: As part of the adopted Capital Improvement Plan, the City has planned to upgrade City Council Chambers to modernize the way meetings are recorded. The City has received a quote from our preferred cable equipment vendor (Advanced Lighting & Sound) to provide three wall-mounted cameras that would meet our needs. Advanced Lighting & Sound (ALS) has a plethora of experience with these kinds of projects, serving many communities throughout Michigan. ALS also serves as the City’s go-to source for equipment maintenance that falls outside of LVTV’s expertise.

This project would free up space within Chambers during meetings, by removing the large floor cameras, and has a return on investment of approximately 2 years, by limiting the number of camera operators needed for meetings.

Previous Action: N/A

Economic Impact:
Estimated cost of \$7,196 via Advanced Lighting & Sound.
Budgeted \$8,000 in account 101-100-000-805

Recommendation: It is my recommendation to approve the quote from Advanced Lighting & Sound.

Recommended Motion:
Moved by Council Member _____ seconded by Council Member _____
to approve the quote from Advanced Lighting & Sound for the City Council Chambers Camera upgrade project for an estimated cost of \$7,196.

Kelly Garrett Mayor	Bruce Kantor Mayor Pro-Tem	Jalen Jennings Council Member	Dalton Barksdale Council Member	Jason Hammond Council Member
------------------------	-------------------------------	----------------------------------	------------------------------------	---------------------------------



Advanced Lighting & Sound

Phone: 248-817-2092
 Fax: 248-817-2093
 1026 Maplelawn Drive
 Troy, MI 48084

Item 8F.

Quote

No.: **19472**
 Date: 6/28/2024

Prepared for:
 Jim Nelson (248) 505-1658
 City of Lathrup Village
 27400 Southfield Rd.
 Lathrup Village, MI 48076 USA

Prepared by: Shawn Watts
 Account No.: 629
 Phone: (248) 557-2600
 Fax: (248) 557-2602

Qty	Manuf	Item ID	Description	Sell	Total
3	Lumen	VC-A51PW	20x Optical Zoom, 1080p Hi-Definition PTZ IP Camera, 60fps; White Color	\$1,577.00	\$4,731.00
3	Lumen	VC-WM12W	Wall Mount for PTZ Video Cameras, White Color	\$134.00	\$402.00
1	Lumen	VS-KB21	(TAA) IP Camera Controller for Pan/Tilt/Zoom (PTZ) Video Cameras	\$877.00	\$877.00
1	TP-Li	TL-SG1008MP V3	8-Port Gigabit PoE+ Switch 126w	\$101.00	\$101.00
1	ALS	Install	Install Materials - Video and Network cabling, fastners and misc.	\$200.00	\$200.00
1	ALS	Labor	Installation Labor - Mount 3 cameras, run cabling, add switch and connect to Tricaster. Clean up rack.	\$750.00	\$750.00
1	ALS	Shipping	Shipping Charge	\$135.00	\$135.00

Your Price:
Total:

\$7,196.00

Prices are firm until 7/28/2024 Terms: Net 15

Prepared by: Shawn Watts, shawnw@AdvancedAVL.com

Date: 6/28/2024

Accepted by: _____

Date: _____

Disclaimer

All prices quoted are valid for 30 business days. Please fax signed quote to 248-817-2093 or email to sales@go-als.com so that your order can be placed. Thank you for your business.

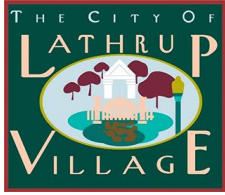

City of Lathrup Village
27400 Southfield Road
Lathrup Village, MI 48076
www.lathrupvillage.org | (248) 557-2600

TO: Mayor & City Council
FROM: Mike Greene – City Administrator
DATE: August 19, 2024
RE: Emergency Purchase Request – Water Damage / Mold Remediation

Background Brief: Thanks to the excessive rain the City received at the end of June, our DPS building received a lot of water infiltration to the building, causing damage. To mitigate some of the damage, the crew removed the carpet from their conference room floor. When they did, they noticed mold and called me to come out and take a look. After further review, it appeared the entire room was compromised.



Due to the health and safety of our crews that work out of the building, I authorized an emergency contract with Servpro (after consulting with additional companies) to service our building and conduct mold remediation and light demolition to remove the compromised surfaces.

Ordinance Sec. 2-172. - Emergency contracts.
In an urgent and compelling necessity involving the safeguarding of persons or property or the preservation of essential services of the city requiring immediate action at a time when it is impossible or impractical to convene the council in special session, either the mayor or the city administrator may contract for such goods or services as may be immediately necessary, subject to ratification by the city council.

The physical work is now complete, and we are scheduling independent mold testing to ensure the area was properly addressed.

To limit future issues, we are going to install a small drain tile on the west side of the DPS building. However, that will only be a temporary fix. The City needs to be mindful of this building as there are numerous issues with it and it will need substantial investment in the future to keep it usable.

This project will also be submitted to our insurance agency to see if any portion of the cost can be covered.

Previous Action: N/A

Economic Impact: Project cost = \$8,646.67
Additional future costs will include materials (such as drywall) to remodel the room.

Recommendation: It is my recommendation to approve the emergency contract.

Recommended Motion:
Moved by Council Member _____ seconded by Council Member _____
to approve the emergency contract with ServPro of West Sterling Heights for DPS Building water and mold remediation for a total cost of \$8,646.67.

Kelly Garrett Mayor, Bruce Kantor Mayor Pro-Tem, Jalen Jennings Council Member, Dalton Barksdale Council Member, Jason Hammond Council Member



SERVPRO® OF WEST STERLING HEIGHTS

TAX I.D. #38-3334352 - FRANCHISE #11110
 7025 METROPLEX DRIVE
 ROMULUS, MI 48174
 OFFICE: (586) 480-2400
 FAX: (313) 914-3734
 office@servproromulus.com

WSH24-10965-ABTM1

Generals

DESCRIPTION	QTY	REMOVE	REPLACE	TAX	TOTAL
1. Pre Air Quality Test	1.20 EA	0.00	499.99	0.00	599.99
2. Post Air Quality & Clearance	1.20 EA	0.00	499.99	0.00	599.99
3. Asbestos test fee - self test (per sample)	6.00 EA	0.00	82.45	0.00	494.70
4. Asbestos test fee - full service survey - base fee	1.00 EA	0.00	465.00	0.00	465.00
5. Equipment decontamination charge - per piece of equipment	2.00 EA	0.00	43.78	0.00	87.56
6. Add for personal protective equipment (hazardous cleanup)	8.00 EA	0.00	12.49	0.00	99.92
***Note: Two(2) Technicians, Four(4) Changes, One(1) Day					
7. Respirator - Full face - multi-purpose resp. (per day)	2.00 DA	0.00	7.61	0.00	15.22
***Note: Two (2) Technicians with Full Face Respirators for One(1) Day					
8. Respirator cartridge - HEPA only (per pair)	2.00 EA	0.00	15.20	0.00	30.40
9. Add for HEPA filter (for canister/backpack vacuums)	2.00 EA	0.00	89.58	0.00	179.16
10. Haul debris - per pickup truck load - including dump fees	2.00 EA	184.21	0.00	0.00	368.42
Totals: Generals				0.00	2,940.36

Main Level

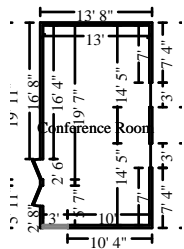

Conference Room

Height: 8'

578.67 SF Walls	317.42 SF Ceiling
896.08 SF Walls & Ceiling	317.42 SF Floor
35.27 SY Flooring	71.83 LF Floor Perimeter
74.83 LF Ceil. Perimeter	

Missing Wall - Goes to Floor

3' X 6' 8"

Opens into Exterior

DESCRIPTION	QTY	REMOVE	REPLACE	TAX	TOTAL
-------------	-----	--------	---------	-----	-------



SERVPRO® OF WEST STERLING HEIGHTS

TAX I.D. #38-3334352 - FRANCHISE #11110
 7025 METROPLEX DRIVE
 ROMULUS, MI 48174
 OFFICE: (586) 480-2400
 FAX: (313) 914-3734
 office@servproromulus.com

CONTINUED - Conference Room

DESCRIPTION	QTY	REMOVE	REPLACE	TAX	TOTAL
11. Content Manipulation charge - per hour	3.00 HR	0.00	54.93	0.00	164.79
12. Protect contents - Cover with plastic	150.00 SF	0.00	0.26	0.00	39.00
13. Dehumidifier (per 24 hr period) - 70-109 ppd - No monitor.	4.00 EA	0.00	77.02	0.00	308.08
14. Neg. air fan/Air scrub.-Large (per 24 hr period)-No monit.	4.00 DA	0.00	120.00	0.00	480.00
15. Add for HEPA filter (for neg. air machine/vacuum - Large)	0.50 EA	0.00	320.28	0.00	160.14
16. Ducting - lay-flat - Large	10.00 LF	0.00	0.50	0.00	5.00
17. Containment Barrier/Airlock/Decon. Chamber	100.00 SF	0.00	0.98	0.00	98.00
18. Peel & seal zipper - heavy duty	1.00 EA	0.00	16.62	0.00	16.62
19. Tear out wet drywall, cleanup, bag for disposal	52.00 SF	1.33	0.00	0.00	69.16
20. Tear out wet drywall, cleanup, bag, per LF - to 4' - Cat 3	71.83 LF	10.10	0.00	0.00	725.48
21. Add-on cost for tearing out glued-on drywall	359.17 SF	0.59	0.00	0.00	211.91
22. Tear out wet paneling, bag for disposal - Cat 3	286.00 SF	1.19	0.00	0.00	340.34
23. Tear out and bag wet insulation - Category 3 water	286.00 SF	1.41	0.00	0.00	403.26
24. Remove Furring strip - 1" x 2"	289.33 SF	0.53	0.00	0.00	153.34
25. HEPA Vacuuming - Detailed - (PER SF)	1,213.50 SF	0.00	0.95	0.00	1,152.83
26. Clean stud wall - Heavy	148.00 SF	0.00	1.33	0.00	196.84
27. Apply mold/mildew stain remover to part of the walls	289.33 SF	0.00	0.71	0.00	205.42
28. Clean the floor with pressure steam	317.42 SF	0.00	1.12	0.00	355.51
29. Water extraction from hard surface floor - Cat 3 water	317.42 SF	0.00	0.81	0.00	257.11
Totals: Conference Room				0.00	5,342.83
Total: Main Level				0.00	5,342.83

Equipment Set Up, Take Down & Monitoring

Day 1



SERVPRO® OF WEST STERLING HEIGHTS

TAX I.D. #38-3334352 - FRANCHISE #11110
 7025 METROPLEX DRIVE
 ROMULUS, MI 48174
 OFFICE: (586) 480-2400
 FAX: (313) 914-3734
 office@servproromulus.com

CONTINUED - Day 1

DESCRIPTION	QTY	REMOVE	REPLACE	TAX	TOTAL
30. Equipment setup, take down, and monitoring (hourly charge)	1.50 HR	0.00	60.58	0.00	90.87
Totals: Day 1				0.00	90.87

Day 2

DESCRIPTION	QTY	REMOVE	REPLACE	TAX	TOTAL
31. Equipment setup, take down, and monitoring (hourly charge)	1.50 HR	0.00	60.58	0.00	90.87
Totals: Day 2				0.00	90.87

Day 3

DESCRIPTION	QTY	REMOVE	REPLACE	TAX	TOTAL
32. Equipment setup, take down, and monitoring (hourly charge)	1.50 HR	0.00	60.58	0.00	90.87
Totals: Day 3				0.00	90.87

Day 4

DESCRIPTION	QTY	REMOVE	REPLACE	TAX	TOTAL
33. Equipment setup, take down, and monitoring (hourly charge)	1.50 HR	0.00	60.58	0.00	90.87
Totals: Day 4				0.00	90.87

Total: Equipment Set Up, Take Down & Monitoring				0.00	363.48
Line Item Totals: WSH24-10965-ABTM1				0.00	8,646.67



SERVPRO® OF WEST STERLING HEIGHTS

TAX I.D. #38-3334352 - FRANCHISE #11110
 7025 METROPLEX DRIVE
 ROMULUS, MI 48174
 OFFICE: (586) 480-2400
 FAX: (313) 914-3734
 office@servproromulus.com

Grand Total Areas:

578.67 SF Walls	317.42 SF Ceiling	896.08 SF Walls and Ceiling
317.42 SF Floor	35.27 SY Flooring	71.83 LF Floor Perimeter
0.00 SF Long Wall	0.00 SF Short Wall	74.83 LF Ceil. Perimeter
317.42 Floor Area	342.81 Total Area	578.67 Interior Wall Area
677.50 Exterior Wall Area	77.50 Exterior Perimeter of Walls	
0.00 Surface Area	0.00 Number of Squares	0.00 Total Perimeter Length
0.00 Total Ridge Length	0.00 Total Hip Length	



SERVPRO® OF WEST STERLING HEIGHTS

TAX I.D. #38-3334352 - FRANCHISE #11110
7025 METROPLEX DRIVE
ROMULUS, MI 48174
OFFICE: (586) 480-2400
FAX: (313) 914-3734
office@servproromulus.com

Summary for Dwelling

Line Item Total	8,646.67
Replacement Cost Value	\$8,646.67
Net Claim	\$8,646.67



SERVPRO® OF WEST STERLING HEIGHTS

TAX I.D. #38-3334352 - FRANCHISE #11110
7025 METROPLEX DRIVE
ROMULUS, MI 48174
OFFICE: (586) 480-2400
FAX: (313) 914-3734
office@servproromulus.com

Recap of Taxes



SERVPRO® OF WEST STERLING HEIGHTS

TAX I.D. #38-3334352 - FRANCHISE #11110
 7025 METROPLEX DRIVE
 ROMULUS, MI 48174
 OFFICE: (586) 480-2400
 FAX: (313) 914-3734
 office@servproromulus.com

Recap by Room

Estimate: WSH24-10965-ABTM1

Generals	2,940.36	34.01%
Area: Main Level		
Conference Room	5,342.83	61.79%
<hr/>		
Area Subtotal: Main Level	5,342.83	61.79%
Area: Equipment Set Up, Take Down & Monitoring		
Day 1	90.87	1.05%
Day 2	90.87	1.05%
Day 3	90.87	1.05%
Day 4	90.87	1.05%
<hr/>		
Area Subtotal: Equipment Set Up, Take Down & Monitoring	363.48	4.20%
<hr/>		
Subtotal of Areas	8,646.67	100.00%
<hr/>		
Total	8,646.67	100.00%



SERVPRO® OF WEST STERLING HEIGHTS

TAX I.D. #38-3334352 - FRANCHISE #11110
7025 METROPLEX DRIVE
ROMULUS, MI 48174
OFFICE: (586) 480-2400
FAX: (313) 914-3734
office@servproromulus.com

Recap by Category

Items	Total	%
CLEANING	552.35	6.39%
CONTENT MANIPULATION	203.79	2.36%
GENERAL DEMOLITION	2,271.91	26.27%
PERMITS AND FEES	1,199.98	13.88%
HAZARDOUS MATERIAL REMEDIATION	2,684.93	31.05%
WATER EXTRACTION & REMEDIATION	1,733.71	20.05%
Subtotal	8,646.67	100.00%

This estimate is provided pursuant to Client’s request for an approximation of the cost of the contemplated work. All estimates are subject to change without notice to Client. This estimate may be used by Client to determine whether to hire Provider to perform the work, and for no other purposes.

Client may provide this estimate to an insurance carrier to determine whether the work is covered under any insurance policy, but may not provide to any of Provider’s competitors or any other individual or entity without Provider’s prior written consent. This estimate does not guarantee insurance coverage for the work. Client should consult with an insurance carrier to ensure that the work is covered.

Provider’s bids, costs, & pricing are based in part on Provider’s costs of goods & services. Vendors & subcontractors to Provider may provide quick pay or other discounts for invoices paid within 7 days. Payment of your invoice within 7 days may qualify you for such discounts. Provider reserves the right to determine eligibility for & how any discounting may be applied.

The line item pricing in this estimate is good for 30 days. We reserve the right to adjust, change and modify pricing to reflect the rapid market changes to the costs of labor and materials incurred while performing the project.

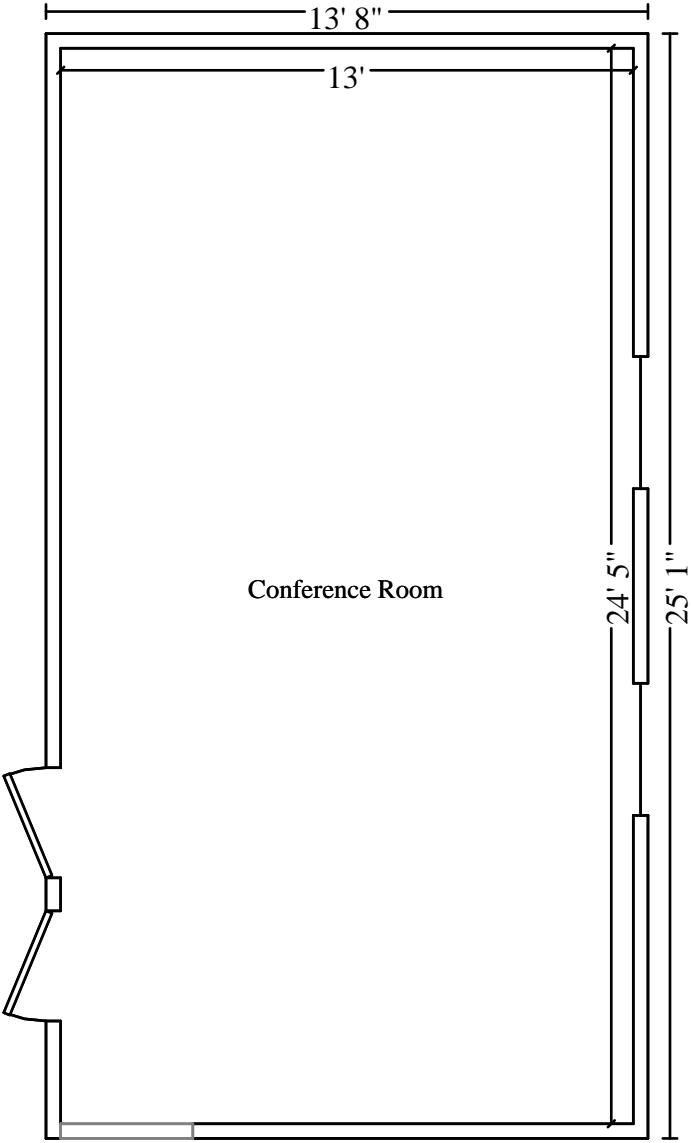



MIKE GREENE

Item 8G.

MIKE GREENE

Claim #:

SERVPRO® Proj#: 2406-357083MLD

Job Summary

Customer and Job Information

Customer Name:	Mike Greene	Insurance / Client:	Self Pay
Claim / PO Number:		Policy / WO Number:	'
SERVPRO Project #:	2406-357083MLD	Customer Phone:	(248) 232-9480
Job Address 1:	19101 W 12 Mile Road	Customer Email:	mgreene@lathrupvillage.org
Job Address 2:			
City, State, Zip:	Lathrup Village, MI 48076		

Timestamps

Loss Received:	6/25/2024 2:49 PM (EDT)	Customer Called:	6/25/2024 3:57 PM (EDT)
Date of Loss:	6/24/2024 2:15 PM (EDT)	Site Inspected:	7/5/2024 10:48 AM (EDT)
Drying Complete:	7/26/2024 9:51 AM (EDT)		

Loss Information

Type of Loss:	Mold	Cause of Loss:	Other
Structure Type:		Property Type:	Commercial
Electricity Available:	Unknown	Year Structure Built:	0

Franchise Information

Name: Birmingham, Bloomfield Hills

Address: 280 N. Old Woodward Avenue Suite 100 Birmingham, Michigan 48009

Phone: (248) 439-1160

Additional Loss Information

Category of Water:	3	Class of Water:	2
Days to Achieve Dry Standard:	20.96	Total Affected SF:	375.00
Drying Zones:	1		



MIKE GREENE

Item 8G.

MIKE GREENE

Claim #:

SERVPRO® Proj#: 2406-357083MLD

Equipment

Placement Count by Day and Type

Day	07/05	07/06	07/07	07/08	07/09	07/10	07/11	07/12	07/13	07/14
Air Scrubbers	1	1	1	1	1	1	1	1	1	1
Dehumidifier	0	0	0	1	1	1	1	1	1	1
Total	1	1	1	2	2	2	2	2	2	2

Day	07/15	07/16	07/17	07/18	07/19	07/20	07/21	07/22	07/23	07/24
Air Scrubbers	1	1	1	1	1	1	1	1	1	1
Dehumidifier	1	1	1	1	1	1	1	1	1	1
Total	2	2	2	2	2	2	2	2	2	2

Day	07/25	07/26	Total
Air Scrubbers	1	0	21
Dehumidifier	1	0	18
Total	2	0	39

Usage Summary

Equipment Type	Room	Equipment Model	Asset Number	Placed	Removed	Total Days*	Total Hours*
Air Scrubbers	Main Level Break room	HEPA 700	Air Scrubber-HEPA700	07/05/24 10:48 AM	07/26/24 9:51 AM	20.96	503.04
			1			20.96	503.04
		Total					20.96
Dehumidifier	Main Level Break room	617 Dry Max	D4455	07/08/24 2:29 PM	07/26/24 9:51 AM	17.81	427.44
			1			17.81	427.44
		Total					17.81
Total						38.77	930.48



MIKE GREENE

MIKE GREENE

Claim #:

SERVPRO® Proj#: 2406-357083MLD

Item 8G.

Usage Chart

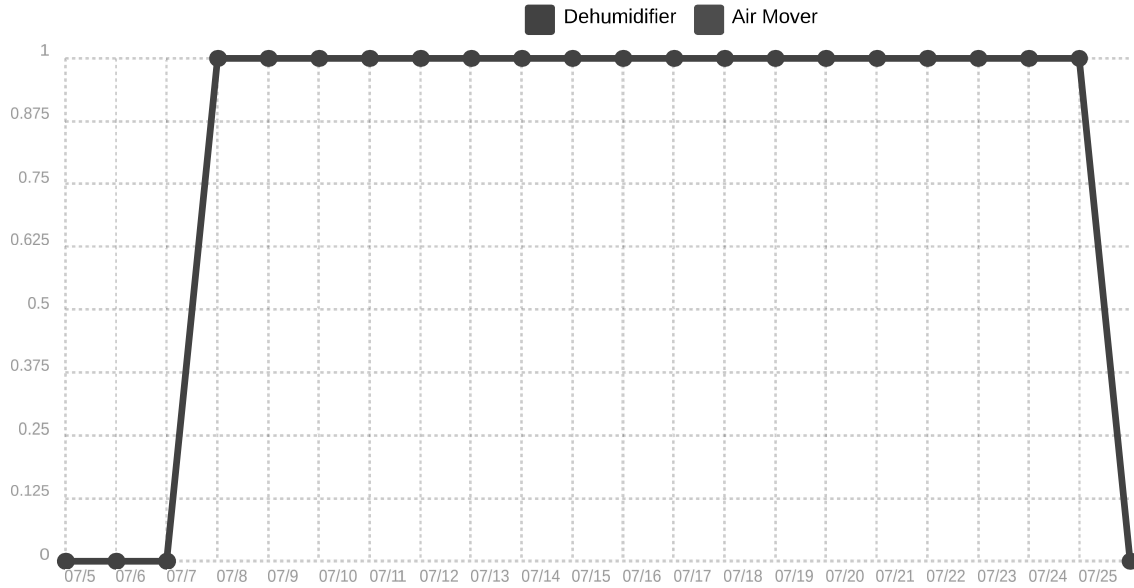



MIKE GREENE

MIKE GREENE

Claim #:

SERVPRO® Proj#: 2406-357083MLD

Item 8G.

Daily Narrative

Timestamp	Narrative
8/6/2024 1:03 PM (EDT)	<p>Summary for 8/6/2024: Loss Type: Mold Cause of Loss: Other Category: 3 Class: 2 Number of Levels Affected: 1 Zones: Zone 1 - 1 room Total Affected SqFt: 375 Affected SqFt Ceiling: 0 Affected SqFt Walls: 375 Affected SqFt Floor: 0 Affected Flooring: Concrete/Masonry Removed Materials: - Main Level Break room, Drywall - Main Level Break room, Wood Equipment Placement - Visit 1: Air Movers: 0 Dehumidifiers: 1 Additional Equipment: 1 7/8/2024 Tyler Wagner Equipment Validation Exception (Zone 1) Scrubber and dehu placed. No air movement due to growth</p> <p>Initial Inspection: 7/10/2024 Tyler Wagner Is demolition needed? - Yes - Drywall 7/8/2024 Tyler Wagner 10 SF. and over - Yes - Substantial growth through room 7/8/2024 Tyler Wagner Is demolition needed? - Yes - Drywall 7/8/2024 Tyler Wagner Is there mold present? - Yes 7/8/2024 Tyler Wagner Will asbestos testing be performed? - Yes - Drywall tested prior</p> <p>Daily Departures: 7/8/2024 Tyler Wagner Did the customer note any specific concerns? - No 7/8/2024 Tyler Wagner Was the equipment moved or turned off before you arrived? - No 7/8/2024 Tyler Wagner Are there any questions about coverage? - No 7/8/2024 Tyler Wagner Was any demolition performed? - Yes - Drywall and panel removal 7/8/2024 Tyler Wagner Are there dumpsters or bagged debris? - Yes - Bagged drywall 7/8/2024 Tyler Wagner Are any of these services needed: contents cleaning, pack-out, textile or dry cleaning? - No 7/8/2024 Tyler Wagner Are there any factors delaying or preventing the drying process? - Yes - Source not fixed, standing water in rom upon arrival 7/26/2024 Is Drying finished and/or has all equipment been removed from the job? Yes</p>



MIKE GREENE

MIKE GREENE

Claim #:

SERVPRO® Proj#: 2406-357083MLD

Item 8G.

Diary Notes

Timestamp	Subject/Note
6/25/2024 3:57 PM EDT	Customer Called Time Customer Called Time Exception Note
7/5/2024 10:48 AM EDT	Demolition Needed Drywall
7/5/2024 10:49 AM EDT	Asbestos Testing Drywall tested prior
7/5/2024 10:49 AM EDT	Visible Mold Present Substantial growth through room
7/5/2024 2:24 PM EDT	HVAC turned off HVAC turned off for Visit 1
7/5/2024 2:25 PM EDT	Demolition Marked as Performed Drywall and panel removal
7/5/2024 2:26 PM EDT	Dumpsters/Bagged Debris Bagged trash
7/5/2024 2:26 PM EDT	Factors delaying the drying process Lots of growth
7/5/2024 2:28 PM EDT	Job Note I arrived on site today to begin demo in the break room. Started by making sure that all containment is set up and that the air scrubber is under negative pressure. Once confirming that, demo began by removing all of the paneling around the room. After the paneling was removed all of the walls were cut at 5 feet. Significant amount of growth found in all affected areas and walls. Wall needs to be demoed floor ceiling due to growth height. Some of the framing around the room is also very brittle to the touch. Will need to be removed and replaced. Small amounts of drywall are stuck behind HVAC ducting in the room. Cannot access area. May need to get ducts removed to remove drywall. underneath both windows in the room, there seems or seemed to be a mouse issue. Mice pee and poop everywhere in cavities. Damaged exterior insulation. Insulation that was inside of any wall cavity that was opened up, was removed. Will return Monday to continue demo process, and get mold cleaning started.
7/8/2024 10:46 AM EDT	Dumpsters/Bagged Debris Bagged debris
7/8/2024 2:29 PM EDT	PPE Being Used Half face
7/8/2024 2:29 PM EDT	PPE Being Used Half face
7/8/2024 2:29 PM EDT	HVAC turned off HVAC turned off for Visit 2
7/8/2024 2:30 PM EDT	Equipment Validation Exception (Zone 1) Scrubber and dehu placed. No air movement due to growth
7/8/2024 2:42 PM EDT	Job Note Arrived on site to continue demo and prep for mold cleaning. Started by cleaning up the rest of the debris from the demo. After all the big piles of debris were taken care of I went through and vacuumed out each wall, cavity, de nailed, and de screwed the studs. Dehumidifier was added to the room now that demo is complete. Air scrubber was put under negative air while demoing and cleaning up. Air scrubber is off negative air when we are not here. Bags of debris are staged inside of the room. Once bags of debris are picked up disposed of, mold cleaning can begin.
7/10/2024 2:45 PM EDT	Demolition Needed Removal of back wall to the ceiling
7/10/2024 2:46 PM EDT	HVAC turned off HVAC turned off for Visit 3
7/10/2024 2:46 PM EDT	Demolition Marked as Performed Drywall removal on back wall
7/10/2024 2:46 PM EDT	Dumpsters/Bagged Debris Bagged drywall
7/10/2024 2:46 PM EDT	Factors delaying the drying process Source is not corrected. Standing water leading from exterior walls into middle of the room
7/10/2024 2:46 PM EDT	Job Note



MIKE GREENE

MIKE GREENE

Claim #:

SERVPRO® Proj#: 2406-357083MLD

Item 8G.

	Arrived on site to complete demo. We got the approvals to remove the back wall floor ceiling. Drywall and insulation board was removed. Drywall was also removed from behind the two ducts in the room. Ducting was removed to access drywall. All areas were swept up, and bagged up. All demolition is now complete. Mold cleaning can begin next available day.
7/12/2024 4:17 PM EDT	HVAC turned off HVAC turned off for Visit 4
7/12/2024 4:18 PM EDT	Factors delaying the drying process Source is not corrected
7/12/2024 4:18 PM EDT	Job Note Arrived on site to begin mold cleaning in the break room. Started by making sure that all the studs were fully de nailed. Then started by vacuuming the ceiling, then the upper portions of the walls. Once all the flat services were vacuumed, I moved onto the studs that are exposed and the cinderblock walls. Cinderblock walls and exposed studs all of vacuum throughout. The ceiling is complete. the floor will need to be swept, and steam cleaned. A fogging should happen first before the floor is cleaned . All studs that are affected today will be sprayed with serum 1000. Next visit affected studs will be wiped down accordingly. Will return Monday to continue work.
7/16/2024 12:46 PM EDT	HVAC turned off HVAC turned off for Visit 5
7/16/2024 12:46 PM EDT	Factors delaying the drying process Source not fixed, standing water in rom upon arrival
7/16/2024 12:46 PM EDT	Job Note Arrived on site to continue mold cleaning. Started by doing a thorough cleaning of the ceiling fan. Then I moved on to spraying and wiping down all the walls. Move then onto scrubbing and wiping down affected studs. Retreated with serum 1000 multiple times. Significant staining still on studs. Some studs will need to be replaced during recon. I advise using paint over the stained wood that will not be getting replaced. The entire floor was vacuumed. All equipment inside of the room was cleaned. Final thing that needs to get done, will be a steam clean of the floor. Room was heavily fogged twice in preparation of steam clean. Once steam clean is done, and the room has been dried out, Post air quality testing can be performed. Will return next available day to shut down equipment for air quality testing once steam clean is done.
7/26/2024 9:51 AM EDT	HVAC turned off HVAC turned off for Visit 6
7/26/2024 10:28 AM EDT	Field Note Arrived on site to pick up all equipment. Waiting on approvals for next steps. Post mitigation photos attached. Source of loss has still not been corrected, is an external building issue.



MIKE GREENE

Item 8G.

MIKE GREENE

Claim #:

SERVPRO® Proj#: 2406-357083MLD

Zone Composition and Validation

Zone 1

Water Category:	3	Water Class:	2
-----------------	---	--------------	---

Dehu Min Capacity Required:	51 PPD	Air Movers Requirement Method:	Square Feet
Dehu Actual Capacity Placed:	80 PPD	Air Movers Required:	4 - 5
Dehumidifiers Placed:	1	Air Movers Placed:	0
See Job Diary Notes	One or more rooms is not in range. See diary note for explanation and see detail in the section below.		

Zone 1 Cubic Footage, Floor Linear Footage and Total Affected Square Footage

Room Name	Cubic Footage		Floor Linear Footage		Total Affected Square Footage	
	Total Room	Offsets / Insets / Subrooms	Affected	Offsets / Insets / Subrooms	Affected	Offsets / Insets / Subrooms
Main Level Break room	2548.00	0.00	0.00	0.00	375.00	0.00
Total	2548.00	0.00	0.00	0.00	375.00	0.00

Zone 1 Affected Surfaces % and Equipment Placements for Validation

Room Name	Total	Floor	Walls	Ceiling	Offsets / Insets / Subrooms > 18 inches	Air Movers	Dehus	Air Movers Recommended
Main Level Break room	31 %	0 %	65 %	0 %	0	0	1	4 - 5
Total	30 %	0 %	64 %	0 %	0	0	1	4 - 5

Zone 1 Floor, Walls and Ceiling Square Footage

Room Name	Floor Square Footage		Wall Square Footage		Ceiling Square Footage	
	Affected	Offsets / Insets / Subrooms	Affected	Offsets / Insets / Subrooms	Affected	Offsets / Insets / Subrooms
Main Level Break room	0.00	0.00	375.00	0.00	0.00	0.00
Total	0.00	0.00	375.00	0.00	0.00	0.00



MIKE GREENE

Item 8G.

MIKE GREENE

Claim #:

SERVPRO® Proj#: 2406-357083MLD

Zone Equipment Usage

Zone 1 Equipment Usage

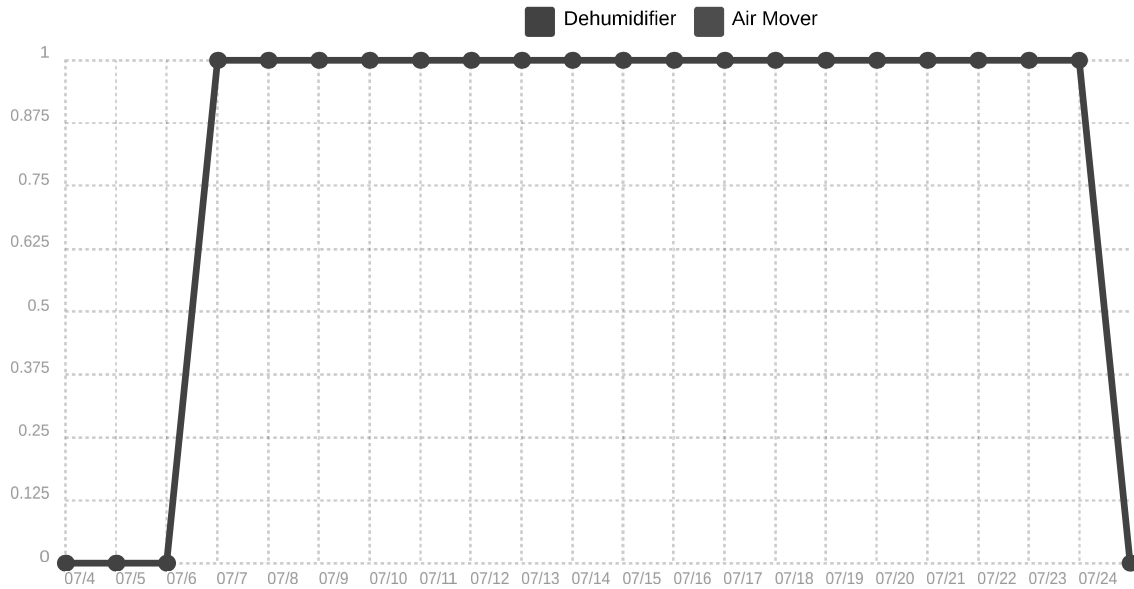

Date	Room	Air Mover Count	Dehu Model	Dehu Rating	Asset No	Dehu Hour Counter
7/5/2024 10:48 AM Tech: TW	Main Level Break room	0	0	0		0
7/8/2024 2:29 PM Tech: TW	Main Level Break room	0	617 Dry Max	80 PPD	D4455	0
			1	80 PPD		0
7/10/2024 2:44 PM Tech: TW	Main Level Break room	0	617 Dry Max	80 PPD	D4455	0
			1	80 PPD		0
7/12/2024 4:17 PM Tech: TW	Main Level Break room	0	617 Dry Max	80 PPD	D4455	0
			1	80 PPD		0
7/16/2024 12:45 PM Tech: TW	Main Level Break room	0	617 Dry Max	80 PPD	D4455	0
			1	80 PPD		0
		0	0		0	



MIKE GREENE

Item 8G.

MIKE GREENE

Claim #:

SERVPRO® Proj#: 2406-357083MLD

Monitoring

Key

Blue	= GPP Equal To OR Above 65 on Day 2
Blue	= RH Equal To OR Above 40 on Day 2
Gray	= GPP Not Making Progress(Not Decreasing Daily)
Purple	= Zone Temp Outside Optimal Range for Equip (68 to 90)
Red	= Negative Grains Depression
Yellow	= Low or Zero Grains Depression

Atmospheric & Dehumidifier Readings

Zone 1

Atmospheric Readings	Outside			Unaffected			HVAC			Zone 1		
	Timestamp	Temp	RH%	GPP	Temp	RH%	GPP	Temp	RH%	GPP	Temp	RH%
07/05/2024 10:48 AM Tech: TW	83.00	46.00	77	75.00	42.00	54				75.00	66.00	85
07/06/2024 12:00 AM Tech:												
07/07/2024 12:00 AM Tech:												
07/08/2024 02:29 PM Tech: TW	86.00	42.00	77	74.00	50.00	62				77.00	58.00	80
07/09/2024 12:00 AM Tech:												
07/10/2024 02:44 PM Tech: TW	64.00	92.00	81	75.00	66.00	85				79.00	75.00	111
07/11/2024 12:00 AM Tech:												
07/12/2024 04:17 PM Tech: TW	83.00	54.00	91	73.00	48.00	58				81.00	69.00	109
07/13/2024 12:00 AM Tech:												
07/14/2024 12:00 AM Tech:												
07/15/2024 12:00 AM Tech:												
07/16/2024 12:45 PM Tech: TW	83.00	58.00	98	76.00	53.00	70				88.00	62.00	123
07/17/2024 12:00 AM Tech:												
07/18/2024 12:00 AM Tech:												
07/19/2024 12:00 AM Tech:												
07/20/2024 12:00 AM Tech:												
07/21/2024 12:00 AM Tech:												
07/22/2024 12:00 AM Tech:												
07/23/2024 12:00 AM Tech:												
07/24/2024 12:00 AM Tech:												
07/25/2024 12:00 AM Tech:												
07/26/2024 09:51 AM Tech: TW	71.00	55.00	62	70.00	49.00	53				88.00	59.00	117



MIKE GREENE

Item 8G.

MIKE GREENE

Claim #:

SERVPRO® Proj#: 2406-357083MLD

Dehumidifier Readings	617 Dry Max D4455				
	Temp	RH%	GPP	GDEP	Hrs

07/05/2024 10:48 AM Tech: TW					
07/06/2024 12:00 AM Tech:					
07/07/2024 12:00 AM Tech:					
07/08/2024 02:29 PM Tech: TW	106.00	23.00	78	2	0
07/09/2024 12:00 AM Tech:					
07/10/2024 02:44 PM Tech: TW	92.00	29.00	64	47	0
07/11/2024 12:00 AM Tech:					
07/12/2024 04:17 PM Tech: TW	98.00	22.00	59	50	0
07/13/2024 12:00 AM Tech:					
07/14/2024 12:00 AM Tech:					
07/15/2024 12:00 AM Tech:					
07/16/2024 12:45 PM Tech: TW	111.00	20.00	79	44	0
07/17/2024 12:00 AM Tech:					
07/18/2024 12:00 AM Tech:					
07/19/2024 12:00 AM Tech:					
07/20/2024 12:00 AM Tech:					
07/21/2024 12:00 AM Tech:					
07/22/2024 12:00 AM Tech:					
07/23/2024 12:00 AM Tech:					
07/24/2024 12:00 AM Tech:					
07/25/2024 12:00 AM Tech:					
07/26/2024 09:51 AM Tech: TW	106.00	16.00	54	63	0

Moisture Content Readings

Zone 1



MIKE GREENE

MIKE GREENE

Claim #:

SERVPRO® Proj#: 2406-357083MLD

Item 8G.

Room	Material	%/Pts	Goal	07/5 10:48 AM TW	07/6 12:00 AM	07/7 12:00 AM	07/8 2:29 PM TW	07/9 12:00 AM	07/10 2:44 PM TW	07/11 12:00 AM	07/12 4:17 PM TW
Main Level Break room	Cinder Block - Wall	Pts	20				99		99		99
Main Level Break room	Drywall - Wall	Pts	12	Removed							
Main Level Break room	Wood - Framing/Stud	%	16	99			99		99		99
Main Level Break room	Wood - Wall, Paneling	%	12	Removed							

Zone 1

Room	Material	%/Pts	Goal	07/13 12:00 AM	07/14 12:00 AM	07/15 12:00 AM	07/16 12:45 PM TW	07/17 12:00 AM	07/18 12:00 AM	07/19 12:00 AM	07/20 12:00 AM
Main Level Break room	Cinder Block - Wall	Pts	20				20				
Main Level Break room	Wood - Framing/Stud	%	16				55				

Zone 1

Room	Material	%/Pts	Goal	07/21 12:00 AM	07/22 12:00 AM	07/23 12:00 AM	07/24 12:00 AM	07/25 12:00 AM	07/26 9:51 AM TW
Main Level Break room	Wood - Framing/Stud	%	16						16

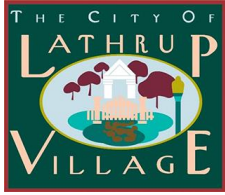

City of Lathrup Village
27400 Southfield Road
Lathrup Village, MI 48076
www.lathrupvillage.org | (248) 557-2600

TO: Mayor & City Council
FROM: Mike Greene – City Administrator
DATE: August 19, 2024
RE: DIA Application Support Resolution

Background Brief: The Partners in Public Art (PIPA) program was created in 2018 to collaborate with communities to co-create community-informed, highly visible public works of art. The goal is to help people explore, express, and build a stronger sense of community through a communal art experience. PIPA is a collaboration between the Detroit Institute of Arts (DIA), the Oakland County Art Institute Authority, and cities and townships throughout Oakland County to co-create community-driven, highly visible public murals that express the unique stories and interests of each community. This program is one of the many ways the DIA strives to help residents of Oakland County find personal meaning in art.

If the City of Lathrup Village is interested in participating in this program in 2025, the City needs to submit an application, which includes the enclosed resolution, by September 1, 2024. Submitting an application does not guarantee participation, but it will help the DIA with planning future projects.

More information on the program can be found at www.dia.org/PIPA.

Previous Action: N/A

Economic Impact: Limited art maintenance cost that would be spread out over the 10-year program requirement.

Recommendation: It is my recommendation to approve the DIA application support resolution.

Recommended Motion:
Moved by Council Member _____ seconded by Council Member _____
to approve Resolution #2024-12 in support of the application for the Detroit Institute of Arts Partners in Public Art Program for Lathrup Village.

Kelly Garrett Mayor	Bruce Kantor Mayor Pro-Tem	Jalen Jennings Council Member	Dalton Barksdale Council Member	Jason Hammond Council Member
------------------------	-------------------------------	----------------------------------	------------------------------------	---------------------------------

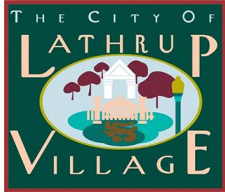

City of Lathrup Village
27400 Southfield Road
Lathrup Village, MI 48076
www.lathrupvillage.org | (248) 557-2600

RESOLUTION #2024-12
A RESOLUTION IN SUPPORT OF THE APPLICATION FOR THE DETROIT INSTITUTE OF ARTS
PARTNERS IN PUBLIC ART PROGRAM FOR LATHRUP VILLAGE

At a regular meeting of the City Council of the City of Lathrup Village, Oakland County, Michigan, (the "City"), held on the 19th day of August 2024.

The following Resolution was offered by _____ and seconded by _____.

WHEREAS, the City of Lathrup Village supports the addition and expansion of public art in our community; and

WHEREAS, The Detroit Institute of Arts collaborates on a program known as "Partners in Public Art" which provides funding and support for outdoor murals painted in public places; And

WHEREAS, the City of Lathrup Village has identified City Hall, 27400 Southfield Road, as a location that would be well-suited for public art; and

WHEREAS, the City of Lathrup Village understands that if selected, the partnership between the DIA and the City shall include a guarantee of a minimum ten-year commitment to keep and maintain the public art; and

NOW THEREFORE BE IT RESOLVED that the Lathrup Village City Council approves the application for participation in the Partners in Public Art program, commits to the location of the public art at City Hall, 27400 Southfield Road, and agrees to maintain the public art per the program requirements.

RESOLUTION ADOPTED

YEAS:

NAYS:

ABSENT/ABSTAIN:

I, Alisa Emanuel, the duly appointed City Clerk of the City of Lathrup Village, Oakland County, Michigan, certifies that the foregoing is a true and complete copy of a Resolution duly adopted by the City Council of the City of Lathrup Village at a meeting held on Augst 19, 2024, the original of which is on file in the City Clerk’s Office.

IN WITNESS WHEREOF, I have affixed my official signature on this 19th day of August 2024.

Alisa Emanuel – City Clerk

Kelly Garrett Mayor	Bruce Kantor Mayor Pro-Tem	Jalen Jennings Council Member	Dalton Barksdale Council Member	Jason Hammond Council Member
-------------------------------	--------------------------------------	---	---	--

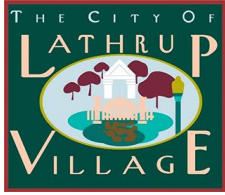

City of Lathrup Village
27400 Southfield Road
Lathrup Village, MI 48076
www.lathrupvillage.org | (248) 557-2600

TO: Mayor & City Council
FROM: Mike Greene – City Administrator
DATE: August 19, 2024
RE: National Fitness Campaign Resolution

Background Brief: The National Fitness Campaign (NFC) is a wellness consulting firm on a mission to change health outcomes in America. The NFC approached staff a couple of months ago for a meeting to see if Lathrup Village would be interested in applying for their grant program that would help with the cost of installing an NFC Fitness Court within our City. This grant opportunity was presented to the Parks & Recreation Committee which recommended City staff submit an application and if awarded, proceed to the City Council. After reviewing our application, the NFC has awarded the City a \$50,000 grant to put towards the Fitness Court.

While that is great news, this grant does not cover the entire cost of the project and if we move forward, it would be projected to cost the City \$148,000 - \$175,000 in matching funds to complete the purchase, of equipment, concrete, and installation costs.

Fitness Court: \$170,000
Concrete: \$25,000*
Installation: \$30,000*
Grant: (\$50,000)

TOTAL: \$175,000

*Costs are estimates provided by NFC based on previous projects.

After discussions with Parks & Recreation and the NFC, the intended location of the Fitness Court would be Annie Lathrup Park replacing the makeshift pickleball court. The Fitness Courts take up an area of approximately 38' x 38'. The NFC evaluated a few locations within Lathrup Village but determined that Municipal/Annie Lathrup Parks were the only viable option due to location, traffic, and ease of access.

More information on the campaign can be found at www.nationalfitnesscampaign.com.

Previous Action: N/A

Economic Impact: Up to \$175,000 in Fiscal Year 2025-2026 for grant match. Funding could be supplemented by additional grants, however, not guaranteed.

Recommendation: It is my recommendation to approve the National Fitness Campaign support resolution. An authorization to proceed and funding confirmed notice would be due to the NFC by July 2025.

Recommended Motion:

Moved by Council Member _____ seconded by Council Member _____ to approve Resolution #2024-13 to adopt and allocate funds for an outdoor fitness court as part of the 2025 National Fitness Campaign.

Kelly Garrett Mayor, Bruce Kantor Mayor Pro-Tem, Jalen Jennings Council Member, Dalton Barksdale Council Member, Jason Hammond Council Member

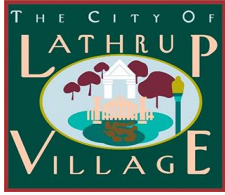

City of Lathrup Village
27400 Southfield Road
Lathrup Village, MI 48076
www.lathrupvillage.org | (248) 557-2600

RESOLUTION #2024-13
RESOLUTION TO ADOPT AND ALLOCATE FUNDS FOR AN OUTDOOR FITNESS COURT AS PART OF THE 2025 NATIONAL FITNESS CAMPAIGN

At a regular meeting of the City Council of the City of Lathrup Village, Oakland County, Michigan, (the “City”), held on the 19th day of August 2024.

The following Resolution was offered by _____ and seconded by _____.

WHEREAS, the City of Lathrup Village has submitted a Grant Application to the National Fitness Campaign (NFC) for participation in their 2025 initiative to install and activate outdoor Fitness Courts® in 200 cities and schools across the country, and;

WHEREAS, the City of Lathrup Village will accept a \$50,000 National Grant from our NFC Grant Committee and Statewide Partners, and provide a local match in the amount of up to \$175,000 to promote and implement a free-to-the-public outdoor Fitness Court®, and;

WHEREAS, the City of Lathrup Village will secure supplemental funding as needed through community sponsors, which will be made available and committed to this program for the purchase of the outdoor Fitness Court®, and;

WHEREAS, the City of Lathrup Village will commit to the construction and launch of the outdoor Fitness Court® by the end of the 2025 calendar year, and;

WHEREAS, the City Council believes the outdoor Fitness Court® is an important wellness ecosystem that supports healthier communities, commits to funding/fundraising to participate in NFC’s 2025 Campaign, and will earn local and national recognition as a leader in providing affordable health and wellness.

NOW THEREFORE BE IT RESOLVED, that the City Council will collaborate with NFC to implement the outdoor Fitness Court® and make fitness free to community residents and visitors.

RESOLUTION ADOPTED

YEAS:

NAYS:

ABSENT/ABSTAIN:

I, Alisa Emanuel, the duly appointed City Clerk of the City of Lathrup Village, Oakland County, Michigan, certifies that the foregoing is a true and complete copy of a Resolution duly adopted by the City Council of the City of Lathrup Village at a meeting held on Augst 19, 2024, the original of which is on file in the City Clerk’s Office.

IN WITNESS WHEREOF, I have affixed my official signature on this 19th day of August 2024.

Alisa Emanuel – City Clerk

Kelly Garrett Mayor	Bruce Kantor Mayor Pro-Tem	Jalen Jennings Council Member	Dalton Barksdale Council Member	Jason Hammond Council Member
-------------------------------	--------------------------------------	---	---	--



Congratulations!

City of Lathrup Village, MI has been selected as a 2025 Priority Health Campaign Grant Recipient!

Dear Mike,

On behalf of the National Fitness Campaign Grant Committee, we are pleased to share that City of Lathrup Village, MI has been selected as a grant eligible partner in the 2025 Priority Health Campaign! This notification letter confirms eligibility for one (1) 2025 NFC Grant of \$50,000. The next step is to schedule your official Grant Eligibility Award Call within the next 10 days, where the qualifications submitted in your Grant Application will be confirmed by the NFC team, and your Grant Program Requirements (GPR) will be aligned for eligibility and participation in this year's campaign. A copy of your GPR Document is attached to this formal award letter for your review, and is based on dates submitted in your Grant Application.

The \$50,000 Grant Award will be confirmed pending 1) the submission of a Resolution of Adoption, endorsed by your local governing body or appropriate council within 30 days of the Award Call, 2) authorization to proceed, documented by formal funding confirmation (commonly a purchase order) and 3) confirmation of a scheduled shipping date for the Fitness Court and appropriate storage plans. Once set, GPR milestones must be met in order to maintain funding eligibility in the campaign.

To support this partnership and align your GPR milestones with your community's local adoption and funding processes, we have assigned a Partnership Manager – McKenzie Coltrin – as your dedicated partner and champion in support of this partnership. Over the coming months, McKenzie will work with your team to support the path outlined in the GPR Document, assisting in the confirmation of required remaining funding, installation, and launch of your program.

The 2025 Priority Health Campaign is part of a national movement to make world-class fitness free and accessible in public spaces across the country, which is more important today than ever before – thank you for your commitment to supporting this goal.

Here is a sneak peak at what's ahead:

- Fitness Court® Launch – Cut the ribbon on your beautiful new outdoor gym & announce free fitness to the community!
- Classes & Challenges – Get residents moving & keep them engaged with ongoing group classes, individual training, and competitive events.
- Press & Promotions – Shine a spotlight on your community and local partners for joining this exciting and innovative wellness movement!

Once again, we are thrilled to invite you to join us as a partner in the 2025 Priority Health Campaign, and we look forward to making world-class fitness free in City of Lathrup Village, MI!

Best in Fitness,

Mitch Menaged, Founder



City of Lathrup Village, MI - National Fitness Campaign 2025 Funding Cycle Grant Program Requirements (G.P.R.)

Important: Grant Program Requirement (GPR) Dates must be adhered to in order to confirm grant availability within the awarded campaign year. While NFC strives to accommodate all approved applicants for participation, National Fitness Campaign cannot guarantee grant availability within each calendar year should approved milestone dates not be met, due to the volume of applicants joining the campaign and limited nature of Grant Funding in each state. Please contact your Partnership Development manager for more information.

MILESTONE 1: ADOPTION

Summary: Commit to project adoption and confirm intent to provide remaining matching funding

- Requirement: Complete Resolution of Adoption
- **Deadline: 8/22/2024**

MILESTONE 2: AUTHORIZATION TO PROCEED - FUNDING CONFIRMED

Summary: Approve and secure funding (as needed) and confirm total required remaining funding listed below.

- Requirement: Funding confirmation document submitted to NFC for remaining program funding (typically a Purchase Order (P.O)). Refer to Official Quote and Funding Requirements Summary for details.
 - **Remaining Funding Requirement: \$120,000**
- **Deadline: 7/24/2025**

MILESTONE 3: SHIPMENT FOR STORAGE

Summary: Identify Fitness Court® storage location and schedule Fitness Court® delivery

- Requirement: Accept Fitness Court® delivery and store at a secure location, prepare to be invoiced for remaining program funds due per Milestone 2.
- **Deadline: 7/25/2025 to 8/15/2025**

MILESTONE 4: PLANNING AND DESIGN

Summary: Confirm Fitness Court Orientation and Site Layout, Approve Fitness Court® Art Designs

- Requirement: Approve Site Orientation, Site Plan and Approve artwork.
- **Deadline: July 2025**

MILESTONE 5: CONCRETE SLAB INSTALLATION

Summary: Review concrete slab drawings & schedule concrete installer, Confirm Art is produced and shipped.

- Requirement: Install concrete slab (cure time of 28 days before Fitness Court® installation)
 - **Estimated Funding Requirement: \$0-\$40,000 (Pending Standard or Studio Configuration)**
- **Deadline: August 2025 - pending weather**

MILESTONE 6: FITNESS COURT® ASSEMBLY

Summary: Select Fitness Court® Assembly Team - NFC'S Installation Network is recommended, (includes art install)

- Requirement: Confirm installation timeline with NFC, provide completed installation photos for NFC inspection
 - **Estimated Funding Requirement: \$25,000-\$34,500 (Pending Standard or Studio Configuration)**
- **Deadline: September 2025 - pending weather**

MILESTONE 7: PRESS LAUNCH CEREMONY

Summary: Hold Fitness Court® press launch event & ribbon cutting (in coordination with State Sponsor if applicable)

- Requirement: Promote press release, hold launch event within campaign year (weather permitting)
- **Deadline: September 2025 - pending weather**

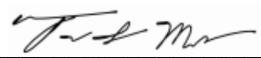
G.P.R. Authorized by:  Trent Matthias - Campaign Director



27400 Southfield Rd
 Lathrup Village, MI 48076
 (248) 557 - 2600
 www.lathrupvillage.org

To: City Council
 From: Austin Colson – Community & Economic Development /DDA Director
 Date: August 16, 2024
 RE: HAWK (High-Intensity Activated Crosswalk) Signal

The installation of the HAWK (High-Intensity Activated Crosswalk) signal at Southfield Road is a crucial step toward improving pedestrian safety in our community. Your approval is essential for us to move forward with this significant project. The HAWK signal is designed to increase pedestrian safety by providing clear and controlled crossing points. Improved pedestrian infrastructure will encourage walking, contributing to the vibrancy and accessibility of our downtown area. The project meets all applicable federal and state regulations, including the Americans with Disabilities Act (ADA).

The estimated total cost for the project is \$329,200. Federal Vulnerable Road User Funds will cover \$296,280 of this amount, representing 90% of the total project cost. The remaining balance of \$32,920 will be funded by the City of Lathrup Village - DDA. This will be the first of three HAWK signals installed along Southfield Rd.

Upon approval, MDOT will manage the construction contract, and the City/Civil Engineering Contractor will ensure all local requirements are met.

The DDA has previously approved this resolution during their July meeting as they are the funding body for this project, however, after continued conversations with MDOT, they want a formal resolution approved by the City’s governing body as well.

Total City (DDA) HAWK Signal Cost – \$32,290

Recommended Motion:

Moved by Council Member _____ seconded by Council Member _____ to approve Resolution #2024-14 to enter into an agreement with the Michigan Department of Transportation (MDOT) for Traffic Control Device at Margate Avenue and Southfield Road.

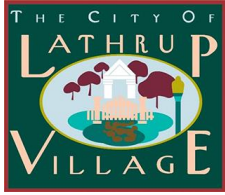

City of Lathrup Village
27400 Southfield Road
Lathrup Village, MI 48076
www.lathrupvillage.org | (248) 557-2600

RESOLUTION #2024-14
RESOLUTION TO ENTER INTO AN AGREEMENT WITH THE MICHIGAN DEPARTMENT OF TRANSPORTATION FOR A TRAFFIC CONTROL DEVICE AT MARGATE AVENUE AND SOUTHFIELD ROAD

At a regular meeting of the City Council of the City of Lathrup Village, Oakland County, Michigan, (the "City"), held on the 19th day of August 2024.

The following Resolution was offered by _____ and seconded by _____.

Whereas, the mission statement of the Lathrup Village Downtown Development Authority is to create an accessible village center that brings life to our vibrant, diverse community, supporting economic development to assist businesses and property owners in the District by combining public and private resources to provide an attractive and pedestrian-friendly environment where residents and visitors enjoy a welcoming, attractive community.

Whereas, the Lathrup Village Downtown Development Authority was awarded a Michigan Department of Transportation (MDOT) Highway Safety Improvement (HSIP) Program grant for the installation of a High-Intensity Activated Crosswalk (HAWK) installation along Southfield Road between Margate Avenue and Kilbirnie Avenue; including controller and cabinet, mast arms, pedestrian pushbuttons, countdown pedestrian signals, backplates, culverts, concrete sidewalk, pedestrian refuge island, curb and gutter, curb ramps and permanent pavement markings; and all together with necessary related work.

Whereas, the City of Lathrup Village on behalf of the Downtown Development Authority desires to enter into an agreement with the Michigan Department of Transportation (MDOT) for the following:

- Contract Number: 24-5281
Control Section: VRU 63000
Job Number: 220123CON
Project: 24A0625
Location: Southfield Road

NOW THEREFORE BE IT RESOLVED that Community and Economic Development/DDA Director, Austin Colson, is hereby authorized to sign the contract, and City Clerk, Alisa Emanuel, is authorized to attest by signing contact 24-5281.

RESOLUTION ADOPTED

YEAS:
NAYS:
ABSENT/ABSTAIN:

I, Alisa Emanuel, the duly appointed City Clerk of the City of Lathrup Village, Oakland County, Michigan, certifies that the foregoing is a true and complete copy of a Resolution duly adopted by the City Council of the City of Lathrup Village at a meeting held on Augst 19, 2024, the original of which is on file in the City Clerk's Office.

IN WITNESS WHEREOF, I have affixed my official signature on this 19th day of August 2024.

Alisa Emanuel – City Clerk

Kelly Garrett Mayor, Bruce Kantor Mayor Pro-Tem, Jalen Jennings Council Member, Dalton Barksdale Council Member, Jason Hammond Council Member

VRU

DA

Control Section	VRU 63000
Job Number	220123CON
Project	24A0625
CFDA No.	20.205 (Highway Research Planning & Construction)
Contract No.	24-5281

PART I

THIS CONTRACT, consisting of PART I and PART II (Standard Agreement Provisions), is made by and between the MICHIGAN DEPARTMENT OF TRANSPORTATION, hereinafter referred to as the "DEPARTMENT"; and the CITY OF LATHRUP VILLAGE, a Michigan municipal corporation, hereinafter referred to as the "REQUESTING PARTY"; for the purpose of fixing the rights and obligations of the parties in agreeing to the following improvements, in the City of Lathrup Village, Michigan, hereinafter referred to as the "PROJECT" and estimated in detail on EXHIBIT "I", dated June 11, 2024, attached hereto and made a part hereof:

High-Intensity Activated Crosswalk (HAWK) installation along Southfield Road between Margate Avenue and Kilbirnie Avenue; including controller and cabinet, mast arms, pedestrian pushbuttons, countdown pedestrian signals, backplates, culverts, concrete sidewalk, pedestrian refuge island, curb and gutter, curb ramps and permanent pavement markings; and all together with necessary related work.

WITNESSETH:

WHEREAS, pursuant to Federal law, monies have been provided for the performance of certain improvements on public roads; and

WHEREAS, the reference "FHWA" in PART I and PART II refers to the United States Department of Transportation, Federal Highway Administration; and

WHEREAS, the PROJECT, or portions of the PROJECT, at the request of the REQUESTING PARTY, are being programmed with the FHWA, for implementation with the use of Federal Funds under the following Federal program(s) or funding:

VULNERABLE ROAD USER

WHEREAS, the parties hereto have reached an understanding with each other regarding the performance of the PROJECT work and desire to set forth this understanding in the form of a written contract.

09/06/90 STPLS.FOR 6/12/24

NOW, THEREFORE, in consideration of the premises and of the mutual undertakings of the parties and in conformity with applicable law, it is agreed:

1. The parties hereto shall undertake and complete the PROJECT in accordance with the terms of this contract.

2. The term "PROJECT COST", as herein used, is hereby defined as the cost of the physical construction necessary for the completion of the PROJECT, including any other costs incurred by the DEPARTMENT as a result of this contract, except construction engineering and inspection.

No charges will be made by the DEPARTMENT to the PROJECT for any inspection work or construction engineering.

The costs incurred by the REQUESTING PARTY for preliminary engineering, construction engineering, construction materials testing, inspection, and right-of-way are excluded from the PROJECT COST as defined by this contract.

The Michigan Department of Environment, Great Lakes, and Energy has informed the DEPARTMENT that it adopted new administrative rules (R 325.10101, et. seq.) which prohibit any governmental agency from connecting and/or reconnecting lead and/or galvanized service lines to existing and/or new water main. Questions regarding these administrative rules should be directed to Michigan Department of Environment, Great Lakes, and Energy. The cost associated with replacement of any lead and/or galvanized service lines, including but not limited to contractor claims, will be the sole responsibility of the REQUESTING PARTY.

3. The DEPARTMENT is authorized by the REQUESTING PARTY to administer on behalf of the REQUESTING PARTY all phases of the PROJECT, including advertising and awarding the construction contract for the PROJECT or portions of the PROJECT. Such administration shall be in accordance with PART II, Section II of this contract.

Any items of the PROJECT COST incurred by the DEPARTMENT may be charged to the PROJECT.

4. The REQUESTING PARTY, at no cost to the PROJECT or to the DEPARTMENT, shall:

- A. Design or cause to be designed the plans for the PROJECT.
- B. Appoint a project engineer who shall be in responsible charge of the PROJECT and ensure that the plans and specifications are followed.
- C. Perform or cause to be performed the construction engineering, construction materials testing, and inspection services necessary for the completion of the PROJECT.

The REQUESTING PARTY will furnish the DEPARTMENT proposed timing sequences for trunkline signals that, if any, are being made part of the improvement. No timing adjustments shall be made by the REQUESTING PARTY at any trunkline intersection, without prior issuances by the DEPARTMENT of Standard Traffic Signal Timing Permits.

5. The PROJECT COST shall be met in part by contributions by the Federal Government. Federal Vulnerable Road User Funds shall be applied to the eligible items of the PROJECT COST up to the lesser of: (1) \$309,680 or (2) an amount such that 90 percent, the normal Federal participation ratio for such funds, is not exceeded at the time of the award of the construction contract. The balance of the PROJECT COST, after deduction of Federal Funds, shall be charged to and paid by the REQUESTING PARTY in the manner and at the times hereinafter set forth.

Any items of PROJECT COST not reimbursed by Federal Funds shall be the sole responsibility of the REQUESTING PARTY.

6. No working capital deposit will be required for this PROJECT.

In order to fulfill the obligations assumed by the REQUESTING PARTY under the provisions of this contract, the REQUESTING PARTY shall make prompt payments of its share of the PROJECT COST upon receipt of progress billings from the DEPARTMENT as herein provided. All payments will be made within 30 days of receipt of billings from the DEPARTMENT. Billings to the REQUESTING PARTY will be based upon the REQUESTING PARTY'S share of the actual costs incurred less Federal Funds earned as the PROJECT progresses.

7. Upon completion of construction of the PROJECT, the REQUESTING PARTY will promptly cause to be enacted and enforced such ordinances or regulations as may be necessary to prohibit parking in the roadway right-of-way throughout the limits of the PROJECT.

8. The performance of the entire PROJECT under this contract, whether Federally funded or not, will be subject to the provisions and requirements of PART II that are applicable to a Federally funded project.

In the event of any discrepancies between PART I and PART II of this contract, the provisions of PART I shall prevail.

Buy America Requirements (23 CFR 635.410) shall apply to the PROJECT and will be adhered to, as applicable, by the parties hereto.

9. The REQUESTING PARTY certifies that it is not aware if and has no reason to believe that the property on which the work is to be performed under this agreement is a facility, as defined by the Michigan Natural Resources and Environmental Protection Act [(NREPA), PA 451, 1994, as amended 2012]; MCL 324.20101(1)(s). The REQUESTING PARTY also certifies

09/06/90 STPLS.FOR 6/12/24

that it is not a liable party pursuant to either Part 201 or Part 213 of NREPA, MCL 324.20126 et seq. and MCL 324.21323a et seq. The REQUESTING PARTY is a local unit of government that has acquired or will acquire property for the use of either a transportation corridor or public right-of-way and was not responsible for any activities causing a release or threat of release of any hazardous materials at or on the property. The REQUESTING PARTY is not a person who is liable for response activity costs, pursuant to MCL 324.20101 (vv) and (ww).

10. If, subsequent to execution of this contract, previously unknown hazardous substances are discovered within the PROJECT limits, which require environmental remediation pursuant to either state or federal law, the REQUESTING PARTY, in addition to reporting that fact to the Michigan Department of Environment, Great Lakes, and Energy, shall immediately notify the DEPARTMENT, both orally and in writing of such discovery. The DEPARTMENT shall consult with the REQUESTING PARTY to determine if it is willing to pay for the cost of remediation and, with the FHWA, to determine the eligibility, for reimbursement, of the remediation costs. The REQUESTING PARTY shall be charged for and shall pay all costs associated with such remediation, including all delay costs of the contractor for the PROJECT, in the event that remediation and delay costs are not deemed eligible by the FHWA. If the REQUESTING PARTY refuses to participate in the cost of remediation, the DEPARTMENT shall terminate the PROJECT. The parties agree that any costs or damages that the DEPARTMENT incurs as a result of such termination shall be considered a PROJECT COST.

11. If federal and/or state funds administered by the DEPARTMENT are used to pay the cost of remediating any hazardous substances discovered after the execution of this contract and if there is a reasonable likelihood of recovery, the REQUESTING PARTY, in cooperation with the Michigan Department of Environment, Great Lakes, and Energy and the DEPARTMENT, shall make a diligent effort to recover such costs from all other possible entities. If recovery is made, the DEPARTMENT shall be reimbursed from such recovery for the proportionate share of the amount paid by the FHWA and/or the DEPARTMENT and the DEPARTMENT shall credit such sums to the appropriate funding source.

12. The DEPARTMENT'S sole reason for entering into this contract is to enable the REQUESTING PARTY to obtain and use funds provided by the Federal Highway Administration pursuant to Title 23 of the United States Code.

Any and all approvals of, reviews of, and recommendations regarding contracts, agreements, permits, plans, specifications, or documents, of any nature, or any inspections of work by the DEPARTMENT or its agents pursuant to the terms of this contract are done to assist the REQUESTING PARTY in meeting program guidelines in order to qualify for available funds. Such approvals, reviews, inspections and recommendations by the DEPARTMENT or its agents shall not relieve the REQUESTING PARTY and the local agencies, as applicable, of their ultimate control and shall not be construed as a warranty of their propriety or that the DEPARTMENT or its agents is assuming any liability, control or jurisdiction.

The providing of recommendations or advice by the DEPARTMENT or its agents does not relieve the REQUESTING PARTY and the local agencies, as applicable of their exclusive jurisdiction of the highway and responsibility under MCL 691.1402 et seq., as amended.

When providing approvals, reviews and recommendations under this contract, the DEPARTMENT or its agents is performing a governmental function, as that term is defined in MCL 691.1401 et seq., as amended, which is incidental to the completion of the PROJECT.

Upon completion of the PROJECT, the REQUESTING PARTY shall accept the facilities constructed as built to specifications within the contract documents. It is understood that the REQUESTING PARTY shall own the facilities and shall operate and maintain the facilities in accordance with all applicable Federal and State laws and regulations, including, but not limited to, Title II of the Americans with Disabilities Act (ADA), 42 USC 12131 et seq., and its associated regulations and standards, and DEPARTMENT Road and Bridge Standard Plans and the Standard Specifications for Construction.

13. The DEPARTMENT, by executing this contract, and rendering services pursuant to this contract, has not and does not assume jurisdiction of the highway, described as the PROJECT for purposes of MCL 691.1402 et seq., as amended. Exclusive jurisdiction of such highway for the purposes of MCL 691.1402 et seq., as amended, rests with the REQUESTING PARTY and other local agencies having respective jurisdiction.

14. The REQUESTING PARTY shall approve all of the plans and specifications to be used on the PROJECT and shall be deemed to have approved all changes to the plans and specifications when put into effect. It is agreed that ultimate responsibility and control over the PROJECT rests with the REQUESTING PARTY and local agencies, as applicable.

15. The REQUESTING PARTY agrees that the costs reported to the DEPARTMENT for this contract will represent only those items that are properly chargeable in accordance with this contract. The REQUESTING PARTY also certifies that it has read the contract terms and has made itself aware of the applicable laws, regulations, and terms of this contract that apply to the reporting of costs incurred under the terms of this contract.

16. Each party to this contract will remain responsible for any and all claims arising out of its own acts and/or omissions during the performance of the contract, as provided by this contract or by law. In addition, this is not intended to increase or decrease either party's liability for or immunity from tort claims. This contract is also not intended to nor will it be interpreted as giving either party a right of indemnification, either by contract or by law, for claims arising out of the performance of this contract.

17. The parties shall promptly provide comprehensive assistance and cooperation in defending and resolving any claims brought against the DEPARTMENT by the contractor, vendors or suppliers as a result of the DEPARTMENT'S award of the construction contract for the PROJECT. Costs incurred by the DEPARTMENT in defending or resolving such claims shall be considered PROJECT COSTS.

09/06/90 STPLS.FOR 6/12/24

18. The DEPARTMENT shall require the contractor who is awarded the contract for the construction of the PROJECT to provide insurance in the amounts specified and in accordance with the DEPARTMENT'S current Standard Specifications for Construction and to:

- A. Maintain bodily injury and property damage insurance for the duration of the PROJECT.
- B. Provide owner's protective liability insurance naming as insureds the State of Michigan, the Michigan State Transportation Commission, the DEPARTMENT and its officials, agents and employees, the REQUESTING PARTY and any other county, county road commission, or municipality in whose jurisdiction the PROJECT is located, and their employees, for the duration of the PROJECT and to provide, upon request, copies of certificates of insurance to the insureds. It is understood that the DEPARTMENT does not assume jurisdiction of the highway described as the PROJECT as a result of being named as an insured on the owner's protective liability insurance policy.
- C. Comply with the requirements of notice of cancellation and reduction of insurance set forth in the current standard specifications for construction and to provide, upon request, copies of notices and reports prepared to those insured.

19. This contract shall become binding on the parties hereto and of full force and effect upon the signing thereof by the duly authorized officials for the parties hereto and upon the adoption of the necessary resolutions approving said contract and authorizing the signatures thereto of the respective officials of the REQUESTING PARTY, a certified copy of which resolution shall be attached to this contract.

IN WITNESS WHEREOF, the parties hereto have caused this contract to be executed as written below.

CITY OF LATHRUP VILLAGE

MICHIGAN DEPARTMENT
OF TRANSPORTATION

By _____
Title:

By _____
for Department Director MDOT

By _____
Title:



09/06/90 STPLS.FOR 6/12/24

June 11, 2024

EXHIBIT I

CONTROL SECTION	VRU 63000
JOB NUMBER	220123CON
PROJECT	24A0625

ESTIMATED COST

CONTRACTED WORK	
Estimated Cost	\$329,200

COST PARTICIPATION

GRAND TOTAL ESTIMATED COST	\$329,200
Less Federal Funds*	<u>\$296,280</u>
BALANCE (REQUESTING PARTY'S SHARE)	\$ 32,290

*Federal Funds for the PROJECT are limited to an amount as described in Section 5.

NO DEPOSIT

DOT

TYPE B
BUREAU OF HIGHWAYS
03-15-93

PART II

STANDARD AGREEMENT PROVISIONS

SECTION I COMPLIANCE WITH REGULATIONS AND DIRECTIVES

SECTION II PROJECT ADMINISTRATION AND SUPERVISION

SECTION III ACCOUNTING AND BILLING

SECTION IV MAINTENANCE AND OPERATION

SECTION V SPECIAL PROGRAM AND PROJECT CONDITIONS

SECTION I

COMPLIANCE WITH REGULATIONS AND DIRECTIVES

- A. To qualify for eligible cost, all work shall be documented in accordance with the requirements and procedures of the DEPARTMENT.
- B. All work on projects for which reimbursement with Federal funds is requested shall be performed in accordance with the requirements and guidelines set forth in the following Directives of the Federal-Aid Policy Guide (FAPG) of the FHWA, as applicable, and as referenced in pertinent sections of Title 23 and Title 49 of the Code of Federal Regulations (CFR), and all supplements and amendments thereto.
 - 1. Engineering
 - a. FAPG (6012.1): Preliminary Engineering
 - b. FAPG (23 CFR 172): Administration of Engineering and Design Related Service Contracts
 - c. FAPG (23 CFR 635A): Contract Procedures
 - d. FAPG (49 CFR 18.22): Uniform Administrative Requirements for Grants and Cooperative Agreements to State and Local Governments—Allowable Costs
 - 2. Construction
 - a. FAPG (23 CFR 140E): Administrative Settlement Costs-Contract Claims
 - b. FAPG (23 CFR 140B): Construction Engineering Costs
 - c. FAPG (23 CFR 17): Recordkeeping and Retention Requirements for Federal-Aid Highway Records of State Highway Agencies
 - d. FAPG (23 CFR 635A): Contract Procedures
 - e. FAPG (23 CFR 635B): Force Account Construction
 - f. FAPG (23 CFR 645A): Utility Relocations, Adjustments and Reimbursement

- g. FAPG (23 CFR 645B): Accommodation of Utilities (PPM 30-4.1)
 - h. FAPG (23 CFR 655F): Traffic Control Devices on Federal-Aid and other Streets and Highways
 - i. FAPG (49 CFR 18.22): Uniform Administrative Requirements for Grants and Cooperative Agreements to State and Local Governments--Allowable Costs
3. Modification Or Construction Of Railroad Facilities
- a. FAPG (23 CFR 140I): Reimbursement for Railroad Work
 - b. FAPG (23 CFR 646B): Railroad Highway Projects
- C. In conformance with FAPG (23 CFR 630C) Project Agreements, the political subdivisions party to this contract, on those Federally funded projects which exceed a total cost of \$100,000.00 stipulate the following with respect to their specific jurisdictions:
- 1. That any facility to be utilized in performance under or to benefit from this contract is not listed on the Environmental Protection Agency (EPA) List of Violating Facilities issued pursuant to the requirements of the Federal Clean Air Act, as amended, and the Federal Water Pollution Control Act, as amended.
 - 2. That they each agree to comply with all of the requirements of Section 114 of the Federal Clean Air Act and Section 308 of the Federal Water Pollution Control Act, and all regulations and guidelines issued thereunder.
 - 3. That as a condition of Federal aid pursuant to this contract they shall notify the DEPARTMENT of the receipt of any advice indicating that a facility to be utilized in performance under or to benefit from this contract is under consideration to be listed on the EPA List of Violating Facilities.
- D. Ensure that the PROJECT is constructed in accordance with and incorporates all committed environmental impact mitigation measures listed in approved environmental documents unless modified or deleted by approval of the FHWA.
- E. All the requirements, guidelines, conditions and restrictions noted in all other pertinent Directives and Instructional Memoranda of the FHWA will apply to this contract and will be adhered to, as applicable, by the parties hereto.

SECTION II

PROJECT ADMINISTRATION AND SUPERVISION

- A. The DEPARTMENT shall provide such administrative guidance as it determines is required by the PROJECT in order to facilitate the obtaining of available federal and/or state funds.
- B. The DEPARTMENT will advertise and award all contracted portions of the PROJECT work. Prior to advertising of the PROJECT for receipt of bids, the REQUESTING PARTY may delete any portion or all of the PROJECT work. After receipt of bids for the PROJECT, the REQUESTING PARTY shall have the right to reject the amount bid for the PROJECT prior to the award of the contract for the PROJECT only if such amount exceeds by ten percent (10%) the final engineer's estimate therefor. If such rejection of the bids is not received in writing within two (2) weeks after letting, the DEPARTMENT will assume concurrence. The DEPARTMENT may, upon request, readvertise the PROJECT. Should the REQUESTING PARTY so request in writing within the aforesaid two (2) week period after letting, the PROJECT will be cancelled and the DEPARTMENT will refund the unused balance of the deposit less all costs incurred by the DEPARTMENT.
- C. The DEPARTMENT will perform such inspection services on PROJECT work performed by the REQUESTING PARTY with its own forces as is required to ensure compliance with the approved plans & specifications.
- D. On those projects funded with Federal monies, the DEPARTMENT shall as may be required secure from the FHWA approval of plans and specifications, and such cost estimates for FHWA participation in the PROJECT COST.
- E. All work in connection with the PROJECT shall be performed in conformance with the Michigan Department of Transportation Standard Specifications for Construction, and the supplemental specifications, Special Provisions and plans pertaining to the PROJECT and all materials furnished and used in the construction of the PROJECT shall conform to the aforesaid specifications. No extra work shall be performed nor changes in plans and specifications made until said work or changes are approved by the project engineer and authorized by the DEPARTMENT.

- F. Should it be necessary or desirable that portions of the work covered by this contract be accomplished by a consulting firm, a railway company, or governmental agency, firm, person, or corporation, under a subcontract with the REQUESTING PARTY at PROJECT expense, such subcontracted arrangements will be covered by formal written agreement between the REQUESTING PARTY and that party.

This formal written agreement shall: include a reference to the specific prime contract to which it pertains; include provisions which clearly set forth the maximum reimbursable and the basis of payment; provide for the maintenance of accounting records in accordance with generally accepted accounting principles, which clearly document the actual cost of the services provided; provide that costs eligible for reimbursement shall be in accordance with clearly defined cost criteria such as 49 CFR Part 18, 48 CFR Part 31, 23 CFR Part 140, OMB Circular A-87, etc. as applicable; provide for access to the department or its representatives to inspect and audit all data and records related to the agreement for a minimum of three years after the department's final payment to the local unit.

All such agreements will be submitted for approval by the DEPARTMENT and, if applicable, by the FHWA prior to execution thereof, except for agreements for amounts less than \$100,000 for preliminary engineering and testing services executed under and in accordance with the provisions of the "Small Purchase Procedures" FAPG (23 CFR 172), which do not require prior approval of the DEPARTMENT or the FHWA.

Any such approval by the DEPARTMENT shall in no way be construed as a warranty of the subcontractor's qualifications, financial integrity, or ability to perform the work being subcontracted.

- G. The REQUESTING PARTY, at no cost to the PROJECT or the DEPARTMENT, shall make such arrangements with railway companies, utilities, etc., as may be necessary for the performance of work required for the PROJECT but for which Federal or other reimbursement will not be requested.
- H. The REQUESTING PARTY, at no cost to the PROJECT, or the DEPARTMENT, shall secure, as necessary, all agreements and approvals of the PROJECT with railway companies, the Railroad Safety & Tariffs Division of the DEPARTMENT and other concerned governmental agencies other than the FHWA, and will forward same to the DEPARTMENT for such reviews and approvals as may be required.
- I. No PROJECT work for which reimbursement will be requested by the REQUESTING PARTY is to be subcontracted or performed until the DEPARTMENT gives written notification that such work may commence.

- J. The REQUESTING PARTY shall be responsible for the payment of all costs and expenses incurred in the performance of the work it agrees to undertake and perform.
- K. The REQUESTING PARTY shall pay directly to the party performing the work all billings for the services performed on the PROJECT which are authorized by or through the REQUESTING PARTY.
- L. The REQUESTING PARTY shall submit to the DEPARTMENT all paid billings for which reimbursement is desired in accordance with DEPARTMENT procedures.
- M. All work by a consulting firm will be performed in compliance with the applicable provisions of 1980 PA 299, Subsection 2001, MCL 339.2001; MSA 18.425(2001), as well as in accordance with the provisions of all previously cited Directives of the FHWA.
- N. The project engineer shall be subject to such administrative guidance as may be deemed necessary to ensure compliance with program requirement and, in those instances where a consultant firm is retained to provide engineering and inspection services, the personnel performing those services shall be subject to the same conditions.
- O. The DEPARTMENT, in administering the PROJECT in accordance with applicable Federal and State requirements and regulations, neither assumes nor becomes liable for any obligations undertaken or arising between the REQUESTING PARTY and any other party with respect to the PROJECT.
- P. In the event it is determined by the DEPARTMENT that there will be either insufficient Federal funds or insufficient time to properly administer such funds for the entire PROJECT or portions thereof, the DEPARTMENT, prior to advertising or issuing authorization for work performance, may cancel the PROJECT, or any portion thereof, and upon written notice to the parties this contract shall be void and of no effect with respect to that cancelled portion of the PROJECT. Any PROJECT deposits previously made by the parties on the cancelled portions of the PROJECT will be promptly refunded.
- Q. Those projects funded with Federal monies will be subject to inspection at all times by the DEPARTMENT and the FHWA.

SECTION III

ACCOUNTING AND BILLING

A. Procedures for billing for work undertaken by the REQUESTING PARTY:

1. The REQUESTING PARTY shall establish and maintain accurate records, in accordance with generally accepted accounting principles, of all expenses incurred for which payment is sought or made under this contract, said records to be hereinafter referred to as the "RECORDS". Separate accounts shall be established and maintained for all costs incurred under this contract.

The REQUESTING PARTY shall maintain the RECORDS for at least three (3) years from the date of final payment of Federal Aid made by the DEPARTMENT under this contract. In the event of a dispute with regard to the allowable expenses or any other issue under this contract, the REQUESTING PARTY shall thereafter continue to maintain the RECORDS at least until that dispute has been finally decided and the time for all available challenges or appeals of that decision has expired.

The DEPARTMENT, or its representative, may inspect, copy, or audit the RECORDS at any reasonable time after giving reasonable notice.

If any part of the work is subcontracted, the REQUESTING PARTY shall assure compliance with the above for all subcontracted work.

In the event that an audit performed by or on behalf of the DEPARTMENT indicates an adjustment to the costs reported under this contract, or questions the allowability of an item of expense, the DEPARTMENT shall promptly submit to the REQUESTING PARTY, a Notice of Audit Results and a copy of the audit report which may supplement or modify any tentative findings verbally communicated to the REQUESTING PARTY at the completion of an audit.

Within sixty (60) days after the date of the Notice of Audit Results, the REQUESTING PARTY shall: (a) respond in writing to the responsible Bureau or the DEPARTMENT indicating whether or not it concurs with the audit report, (b) clearly explain the nature and basis for any disagreement as to a disallowed item of expense and, (c) submit to the DEPARTMENT a written explanation as to any questioned or no opinion expressed item of expense, hereinafter referred to as the "RESPONSE". The RESPONSE shall be clearly stated and provide any supporting documentation necessary to resolve any disagreement or questioned or no opinion expressed item of expense. Where the documentation is voluminous, the REQUESTING PARTY may supply appropriate excerpts and make alternate

arrangements to conveniently and reasonably make that documentation available for review by the DEPARTMENT. The RESPONSE shall refer to and apply the language of the contract. The REQUESTING PARTY agrees that failure to submit a RESPONSE within the sixty (60) day period constitutes agreement with any disallowance of an item of expense and authorizes the DEPARTMENT to finally disallow any items of questioned or no opinion expressed cost.

The DEPARTMENT shall make its decision with regard to any Notice of Audit Results and RESPONSE within one hundred twenty (120) days after the date of the Notice of Audit Results. If the DEPARTMENT determines that an overpayment has been made to the REQUESTING PARTY, the REQUESTING PARTY shall repay that amount to the DEPARTMENT or reach agreement with the DEPARTMENT on a repayment schedule within thirty (30) days after the date of an invoice from the DEPARTMENT. If the REQUESTING PARTY fails to repay the overpayment or reach agreement with the DEPARTMENT on a repayment schedule within the thirty (30) day period, the REQUESTING PARTY agrees that the DEPARTMENT shall deduct all or a portion of the overpayment from any funds then or thereafter payable by the DEPARTMENT to the REQUESTING PARTY under this contract or any other agreement, or payable to the REQUESTING PARTY under the terms of 1951 PA 51, as applicable. Interest will be assessed on any partial payments or repayment schedules based on the unpaid balance at the end of each month until the balance is paid in full. The assessment of interest will begin thirty (30) days from the date of the invoice. The rate of interest will be based on the Michigan Department of Treasury common cash funds interest earnings. The rate of interest will be reviewed annually by the DEPARTMENT and adjusted as necessary based on the Michigan Department of Treasury common cash funds interest earnings. The REQUESTING PARTY expressly consents to this withholding or offsetting of funds under those circumstances, reserving the right to file a lawsuit in the Court of Claims to contest the DEPARTMENT'S decision only as to any item of expense the disallowance of which was disputed by the REQUESTING PARTY in a timely filed RESPONSE.

The REQUESTING PARTY shall comply with the Single Audit Act of 1984, as amended, including, but not limited to, the Single Audit Amendments of 1996 (31 USC 7501-7507).

The REQUESTING PARTY shall adhere to the following requirements associated with audits of accounts and records:

- a. Agencies expending a total of \$500,000 or more in federal funds, from one or more funding sources in its fiscal year, shall comply with the requirements of the federal Office of Management and Budget (OMB) Circular A-133, as revised or amended.

The agency shall submit two copies of:

- The Reporting Package
- The Data Collection Form
- The management letter to the agency, if one issued by the audit firm

The OMB Circular A-133 audit must be submitted to the address below in accordance with the time frame established in the circular, as revised or amended.

- b. Agencies expending less than \$500,000 in federal funds must submit a letter to the Department advising that a circular audit was not required. The letter shall indicate the applicable fiscal year, the amount of federal funds spent, the name(s) of the Department federal programs, and the CFDA grant number(s). This information must also be submitted to the address below.
 - c. Address: Michigan Department of Education
Accounting Service Center
Hannah Building
608 Allegan Street
Lansing, MI 48909
 - d. Agencies must also comply with applicable State laws and regulations relative to audit requirements.
 - e. Agencies shall not charge audit costs to Department's federal programs which are not in accordance with the OMB Circular A-133 requirements.
 - f. All agencies are subject to the federally required monitoring activities, which may include limited scope reviews and other on-site monitoring.
2. Agreed Unit Prices Work - All billings for work undertaken by the REQUESTING PARTY on an agreed unit price basis will be submitted in accordance with the Michigan Department of Transportation Standard Specifications for Construction and pertinent FAPG Directives and Guidelines of the FHWA.
 3. Force Account Work and Subcontracted Work - All billings submitted to the DEPARTMENT for Federal reimbursement for items of work performed on a force account basis or by any subcontract with a consulting firm, railway company, governmental agency or other party, under the terms of this contract, shall be prepared in accordance with the provisions of the pertinent FHPM Directives and the procedures of the DEPARTMENT. Progress billings may be submitted monthly during the time work is being performed provided, however, that no bill of a lesser amount than \$1,000.00 shall be submitted unless it is a final

or end of fiscal year billing. All billings shall be labeled either "Progress Bill Number _____", or "Final Billing".

4. Final billing under this contract shall be submitted in a timely manner but not later than six months after completion of the work. Billings for work submitted later than six months after completion of the work will not be paid.
5. Upon receipt of billings for reimbursement for work undertaken by the REQUESTING PARTY on projects funded with Federal monies, the DEPARTMENT will act as billing agent for the REQUESTING PARTY, consolidating said billings with those for its own force account work and presenting these consolidated billings to the FHWA for payment. Upon receipt of reimbursement from the FHWA, the DEPARTMENT will promptly forward to the REQUESTING PARTY its share of said reimbursement.
6. Upon receipt of billings for reimbursement for work undertaken by the REQUESTING PARTY on projects funded with non-Federal monies, the DEPARTMENT will promptly forward to the REQUESTING PARTY reimbursement of eligible costs.

B. Payment of Contracted and DEPARTMENT Costs:

1. As work on the PROJECT commences, the initial payments for contracted work and/or costs incurred by the DEPARTMENT will be made from the working capital deposit. Receipt of progress payments of Federal funds, and where applicable, State Critical Bridge funds, will be used to replenish the working capital deposit. The REQUESTING PARTY shall make prompt payments of its share of the contracted and/or DEPARTMENT incurred portion of the PROJECT COST upon receipt of progress billings from the DEPARTMENT. Progress billings will be based upon the REQUESTING PARTY'S share of the actual costs incurred as work on the PROJECT progresses and will be submitted, as required, until it is determined by the DEPARTMENT that there is sufficient available working capital to meet the remaining anticipated PROJECT COSTS. All progress payments will be made within thirty (30) days of receipt of billings. No monthly billing of a lesser amount than \$1,000.00 will be made unless it is a final or end of fiscal year billing. Should the DEPARTMENT determine that the available working capital exceeds the remaining anticipated PROJECT COSTS, the DEPARTMENT may reimburse the REQUESTING PARTY such excess. Upon completion of the PROJECT, payment of all PROJECT COSTS, receipt of all applicable monies from the FHWA, and completion of necessary audits, the REQUESTING PARTY will be reimbursed the balance of its deposit.

2. In the event that the bid, plus contingencies, for the contracted, and/or the DEPARTMENT incurred portion of the PROJECT work exceeds the estimated cost therefor as established by this contract, the REQUESTING PARTY may be advised and billed for the additional amount of its share.

C. General Conditions:

1. The DEPARTMENT, in accordance with its procedures in existence and covering the time period involved, shall make payment for interest earned on the balance of working capital deposits for all projects on account with the DEPARTMENT. The REQUESTING PARTY in accordance with DEPARTMENT procedures in existence and covering the time period involved, shall make payment for interest owed on any deficit balance of working capital deposits for all projects on account with the DEPARTMENT. This payment or billing is processed on an annual basis corresponding to the State of Michigan fiscal year. Upon receipt of billing for interest incurred, the REQUESTING PARTY promises and shall promptly pay the DEPARTMENT said amount.
2. Pursuant to the authority granted by law, the REQUESTING PARTY hereby irrevocably pledges a sufficient amount of funds received by it from the Michigan Transportation Fund to meet its obligations as specified in PART I and PART II. If the REQUESTING PARTY shall fail to make any of its required payments when due, as specified herein, the DEPARTMENT shall immediately notify the REQUESTING PARTY and the State Treasurer of the State of Michigan or such other state officer or agency having charge and control over disbursement of the Michigan Transportation Fund, pursuant to law, of the fact of such default and the amount thereof, and, if such default is not cured by payment within ten (10) days, said State Treasurer or other state officer or agency is then authorized and directed to withhold from the first of such monies thereafter allocated by law to the REQUESTING PARTY from the Michigan Transportation Fund sufficient monies to remove the default, and to credit the REQUESTING PARTY with payment thereof, and to notify the REQUESTING PARTY in writing of such fact.
3. Upon completion of all work under this contract and final audit by the DEPARTMENT or the FHWA, the REQUESTING PARTY promises to promptly repay the DEPARTMENT for any disallowed items of costs previously disbursed by the DEPARTMENT. The REQUESTING PARTY pledges its future receipts from the Michigan Transportation Fund for repayment of all disallowed items and, upon failure to make repayment for any disallowed items within ninety (90) days of demand made by the DEPARTMENT, the DEPARTMENT is hereby authorized to withhold an equal amount from the REQUESTING PARTY'S share of any future distribution of Michigan Transportation Funds in settlement of said claim.

4. The DEPARTMENT shall maintain and keep accurate records and accounts relative to the cost of the PROJECT and upon completion of the PROJECT, payment of all items of PROJECT COST, receipt of all Federal Aid, if any, and completion of final audit by the DEPARTMENT and if applicable, by the FHWA, shall make final accounting to the REQUESTING PARTY. The final PROJECT accounting will not include interest earned or charged on working capital deposited for the PROJECT which will be accounted for separately at the close of the State of Michigan fiscal year and as set forth in Section C(1).
5. The costs of engineering and other services performed on those projects involving specific program funds and one hundred percent (100%) local funds will be apportioned to the respective portions of that project in the same ratio as the actual direct construction costs unless otherwise specified in PART I.

SECTION IV

MAINTENANCE AND OPERATION

A. Upon completion of construction of each part of the PROJECT, at no cost to the DEPARTMENT or the PROJECT, each of the parties hereto, within their respective jurisdictions, will make the following provisions for the maintenance and operation of the completed PROJECT:

1. All Projects:

Properly maintain and operate each part of the project, making ample provisions each year for the performance of such maintenance work as may be required, except as qualified in paragraph 2b of this section.

2. Projects Financed in Part with Federal Monies:

a. Sign and mark each part of the PROJECT, in accordance with the current Michigan Manual of Uniform Traffic control Devices, and will not install, or permit to be installed, any signs, signals or markings not in conformance with the standards approved by the FHWA, pursuant to 23 USC 109(d).

b. Remove, prior to completion of the PROJECT, all encroachments from the roadway right-of-way within the limits of each part of the PROJECT.

With respect to new or existing utility installations within the right-of-way of Federal Aid projects and pursuant to FAPG (23 CFR 645B): Occupancy of non-limited access right-of-way may be allowed based on consideration for traffic safety and necessary preservation of roadside space and aesthetic quality. Longitudinal occupancy of non-limited access right-of-way by private lines will require a finding of significant economic hardship, the unavailability of practicable alternatives or other extenuating circumstances.

c. Cause to be enacted, maintained and enforced, ordinances and regulations for proper traffic operations in accordance with the plans of the PROJECT.

d. Make no changes to ordinances or regulations enacted, or traffic controls installed in conjunction with the PROJECT work without prior review by the DEPARTMENT and approval of the FHWA, if required.

- B. On projects for the removal of roadside obstacles, the parties, upon completion of construction of each part of the PROJECT, at no cost to the PROJECT or the DEPARTMENT, will, within their respective jurisdictions, take such action as is necessary to assure that the roadway right-of-way, cleared as the PROJECT, will be maintained free of such obstacles.
- C. On projects for the construction of bikeways, the parties will enact no ordinances or regulations prohibiting the use of bicycles on the facility hereinbefore described as the PROJECT, and will amend any existing restrictive ordinances in this regard so as to allow use of this facility by bicycles. No motorized vehicles shall be permitted on such bikeways or walkways constructed as the PROJECT except those for maintenance purposes.
- D. Failure of the parties hereto to fulfill their respective responsibilities as outlined herein may disqualify that party from future Federal-aid participation in projects on roads or streets for which it has maintenance responsibility. Federal Aid may be withheld until such time as deficiencies in regulations have been corrected, and the improvements constructed as the PROJECT are brought to a satisfactory condition of maintenance.

SECTION V

SPECIAL PROGRAM AND PROJECT CONDITIONS

- A. Those projects for which the REQUESTING PARTY has been reimbursed with Federal monies for the acquisition of right-of-way must be under construction by the close of the twentieth (20th) fiscal year following the fiscal year in which the FHWA and the DEPARTMENT projects agreement covering that work is executed, or the REQUESTING PARTY may be required to repay to the DEPARTMENT, for forwarding to the FHWA, all monies distributed as the FHWA'S contribution to that right-of-way.
- B. Those projects for which the REQUESTING PARTY has been reimbursed with Federal monies for the performance of preliminary engineering must be under construction by the close of the tenth (10th) fiscal year following the fiscal year in which the FHWA and the DEPARTMENT projects agreement covering that work is executed, or the REQUESTING PARTY may be required to repay to the DEPARTMENT, for forwarding to the FHWA, all monies distributed as the FHWA'S contribution to that preliminary engineering.
- C. On those projects funded with Federal monies, the REQUESTING PARTY, at no cost to the PROJECT or the DEPARTMENT, will provide such accident information as is available and such other information as may be required under the program in order to make the proper assessment of the safety benefits derived from the work performed as the PROJECT. The REQUESTING PARTY will cooperate with the DEPARTMENT in the development of reports and such analysis as may be required and will, when requested by the DEPARTMENT, forward to the DEPARTMENT, in such form as is necessary, the required information.
- D. In connection with the performance of PROJECT work under this contract the parties hereto (hereinafter in Appendix "A" referred to as the "contractor") agree to comply with the State of Michigan provisions for "Prohibition of Discrimination in State Contracts", as set forth in Appendix A, attached hereto and made a part hereof. The parties further covenant that they will comply with the Civil Rights Acts of 1964, being P.L. 88-352, 78 Stat. 241, as amended, being Title 42 U.S.C. Sections 1971, 1975a-1975d, and 2000a-2000h-6 and the Regulations of the United States Department of Transportation (49 C.F.R. Part 21) issued pursuant to said Act, including Appendix "B", attached hereto and made a part hereof, and will require similar covenants on the part of any contractor or subcontractor employed in the performance of this contract.
- E. The parties will carry out the applicable requirements of the DEPARTMENT'S Disadvantaged Business Enterprise (DBE) program and 49 CFR, Part 26, including, but not limited to, those requirements set forth in Appendix C.

APPENDIX A
PROHIBITION OF DISCRIMINATION IN STATE CONTRACTS

In connection with the performance of work under this contract; the contractor agrees as follows:

1. In accordance with Public Act 453 of 1976 (Elliott-Larsen Civil Rights Act), the contractor shall not discriminate against an employee or applicant for employment with respect to hire, tenure, treatment, terms, conditions, or privileges of employment or a matter directly or indirectly related to employment because of race, color, religion, national origin, age, sex, height, weight, or marital status. A breach of this covenant will be regarded as a material breach of this contract. Further, in accordance with Public Act 220 of 1976 (Persons with Disabilities Civil Rights Act), as amended by Public Act 478 of 1980, the contractor shall not discriminate against any employee or applicant for employment with respect to hire, tenure, terms, conditions, or privileges of employment or a matter directly or indirectly related to employment because of a disability that is unrelated to the individual's ability to perform the duties of a particular job or position. A breach of the above covenants will be regarded as a material breach of this contract.
2. The contractor hereby agrees that any and all subcontracts to this contract, whereby a portion of the work set forth in this contract is to be performed, shall contain a covenant the same as hereinabove set forth in Section 1 of this Appendix.
3. The contractor will take affirmative action to ensure that applicants for employment and employees are treated without regard to their race, color, religion, national origin, age, sex, height, weight, marital status, or any disability that is unrelated to the individual's ability to perform the duties of a particular job or position. Such action shall include, but not be limited to, the following: employment; treatment; upgrading; demotion or transfer; recruitment; advertising; layoff or termination; rates of pay or other forms of compensation; and selection for training, including apprenticeship.
4. The contractor shall, in all solicitations or advertisements for employees placed by or on behalf of the contractor, state that all qualified applicants will receive consideration for employment without regard to race, color, religion, national origin, age, sex, height, weight, marital status, or disability that is unrelated to the individual's ability to perform the duties of a particular job or position.
5. The contractor or its collective bargaining representative shall send to each labor union or representative of workers with which the contractor has a collective bargaining agreement or other contract or understanding a notice advising such labor union or workers' representative of the contractor's commitments under this Appendix.
6. The contractor shall comply with all relevant published rules, regulations, directives, and orders of the Michigan Civil Rights Commission that may be in effect prior to the taking of bids for any individual state project.

7. The contractor shall furnish and file compliance reports within such time and upon such forms as provided by the Michigan Civil Rights Commission; said forms may also elicit information as to the practices, policies, program, and employment statistics of each subcontractor, as well as the contractor itself, and said contractor shall permit access to the contractor's books, records, and accounts by the Michigan Civil Rights Commission and/or its agent for the purposes of investigation to ascertain compliance under this contract and relevant rules, regulations, and orders of the Michigan Civil Rights Commission.
8. In the event that the Michigan Civil Rights Commission finds, after a hearing held pursuant to its rules, that a contractor has not complied with the contractual obligations under this contract, the Michigan Civil Rights Commission may, as a part of its order based upon such findings, certify said findings to the State Administrative Board of the State of Michigan, which State Administrative Board may order the cancellation of the contract found to have been violated and/or declare the contractor ineligible for future contracts with the state and its political and civil subdivisions, departments, and officers, including the governing boards of institutions of higher education, until the contractor complies with said order of the Michigan Civil Rights Commission. Notice of said declaration of future ineligibility may be given to any or all of the persons with whom the contractor is declared ineligible to contract as a contracting party in future contracts. In any case before the Michigan Civil Rights Commission in which cancellation of an existing contract is a possibility, the contracting agency shall be notified of such possible remedy and shall be given the option by the Michigan Civil Rights Commission to participate in such proceedings.
9. The contractor shall include or incorporate by reference, the provisions of the foregoing paragraphs (1) through (8) in every subcontract or purchase order unless exempted by rules, regulations, or orders of the Michigan Civil Rights Commission; all subcontracts and purchase orders will also state that said provisions will be binding upon each subcontractor or supplier.

Revised June 2011

**APPENDIX B
TITLE VI ASSURANCE**

During the performance of this contract, the contractor, for itself, its assignees, and its successors in interest (hereinafter referred to as the "contractor"), agrees as follows:

1. **Compliance with Regulations:** For all federally assisted programs, the contractor shall comply with the nondiscrimination regulations set forth in 49 CFR Part 21, as may be amended from time to time (hereinafter referred to as the Regulations). Such Regulations are incorporated herein by reference and made a part of this contract.
2. **Nondiscrimination:** The contractor, with regard to the work performed under the contract, shall not discriminate on the grounds of race, color, sex, or national origin in the selection, retention, and treatment of subcontractors, including procurements of materials and leases of equipment. The contractor shall not participate either directly or indirectly in the discrimination prohibited by Section 21.5 of the Regulations, including employment practices, when the contractor covers a program set forth in Appendix B of the Regulations.
3. **Solicitation for Subcontracts, Including Procurements of Materials and Equipment:** All solicitations made by the contractor, either by competitive bidding or by negotiation for subcontract work, including procurement of materials or leases of equipment, must include a notification to each potential subcontractor or supplier of the contractor's obligations under the contract and the Regulations relative to nondiscrimination on the grounds of race, color, or national origin.
4. **Information and Reports:** The contractor shall provide all information and reports required by the Regulations or directives issued pursuant thereto and shall permit access to its books, records, accounts, other sources of information, and facilities as may be determined to be pertinent by the Department or the United States Department of Transportation (USDOT) in order to ascertain compliance with such Regulations or directives. If required information concerning the contractor is in the exclusive possession of another who fails or refuses to furnish the required information, the contractor shall certify to the Department or the USDOT, as appropriate, and shall set forth the efforts that it made to obtain the information.
5. **Sanctions for Noncompliance:** In the event of the contractor's noncompliance with the nondiscrimination provisions of this contract, the Department shall impose such contract sanctions as it or the USDOT may determine to be appropriate, including, but not limited to, the following:
 - a. Withholding payments to the contractor until the contractor complies; and/or
 - b. Canceling, terminating, or suspending the contract, in whole or in part.

6. **Incorporation of Provisions:** The contractor shall include the provisions of Sections (1) through (6) in every subcontract, including procurement of material and leases of equipment, unless exempt by the Regulations or directives issued pursuant thereto. The contractor shall take such action with respect to any subcontract or procurement as the Department or the USDOT may direct as a means of enforcing such provisions, including sanctions for non-compliance, provided, however, that in the event a contractor becomes involved in or is threatened with litigation from a subcontractor or supplier as a result of such direction, the contractor may request the Department to enter into such litigation to protect the interests of the state. In addition, the contractor may request the United States to enter into such litigation to protect the interests of the United States.

Revised June 2011

APPENDIX C**TO BE INCLUDED IN ALL FINANCIAL ASSISTANCE
AGREEMENTS WITH LOCAL AGENCIES****Assurance that Recipients and Contractors Must Make
(Excerpts from US DOT Regulation 49 CFR 26.13)**

- A. Each financial assistance agreement signed with a DOT operating administration (or a primary recipient) must include the following assurance:**

The recipient shall not discriminate on the basis of race, color, national origin, or sex in the award and performance of any US DOT-assisted contract or in the administration of its DBE program or the requirements of 49 CFR Part 26. The recipient shall take all necessary and reasonable steps under 49 CFR Part 26 to ensure nondiscrimination in the award and administration of US DOT-assisted contracts. The recipient's DBE program, as required by 49 CFR Part 26 and as approved by US DOT, is incorporated by reference in this agreement. Implementation of this program is a legal obligation and failure to carry out its terms shall be treated as a violation of this agreement. Upon notification to the recipient of its failure to carry out its approved program, the department may impose sanctions as provided for under Part 26 and may, in appropriate cases, refer the matter for enforcement under 18 U.S.C. 1001 and/or the Program Fraud Civil Remedies Act of 1986 (31 U.S.C. 3801 et seq.).

- B. Each contract MDOT signs with a contractor (and each subcontract the prime contractor signs with a subcontractor) must include the following assurance:**

The contractor, sub recipient or subcontractor shall not discriminate on the basis of race, color, national origin, or sex in the performance of this contract. The contractor shall carry out applicable requirements of 49 CFR Part 26 in the award and administration of US DOT-assisted contracts. Failure by the contractor to carry out these requirements is a material breach of this contract, which may result in the termination of this contract or such other remedy as the recipient deems appropriate.

Lathrup Village Traffic Signal
Engineers Opinion of Probable Construction Cost
3/11/2024

Item 8J.

Item	Item Description	Const Qty	Unit	Unit Price	Total Construction Cost
110001	Mobilization, Max 10%	1	LSUM	\$ 28,500.00	\$ 28,500.00
1077060	RCOC Inspection Fcc	5500	Dlr	\$ 1.00	\$ 5,500.00
2040055	Sidewalk, Rem	13	Syd	\$ 20.00	\$ 260.00
2050010	Embankment, CIP	100	Cyd	\$ 20.00	\$ 2,000.00
2050016	Excavation, Earth	256	Cyd	\$ 20.00	\$ 5,120.00
3020711	Aggregate Base, 4 inch, 21AA, RCOC	188	Syd	\$ 16.00	\$ 3,008.00
3020711	Aggregate Base, 8 inch, 21AA, RCOC	96	Syd	\$ 20.00	\$ 1,920.00
4010607	Culv, CI F, 12 inch	52	Ft	\$ 60.00	\$ 3,120.00
5010005	HMA Surface, Rem	177	Syd	\$ 22.00	\$ 3,894.00
5010025	Hand Patching	10	Ton	\$ 200.00	\$ 2,000.00
5010061	HMA, Approach	32	Ton	\$ 200.00	\$ 6,400.00
6020050	Conc Pavt, Misc, Nonreinf, 6 inch	31	Syd	\$ 75.00	\$ 2,325.00
8020016	Curb and Gutter, Conc, Det B2, Modified	122	Ft	\$ 34.00	\$ 4,148.00
8030010	Detectable Warning Surface	20	Ft	\$ 50.00	\$ 1,000.00
8030030	Curb Ramp Opening, Conc	24	Ft	\$ 50.00	\$ 1,200.00
8030044	Sidewalk, Conc, 4 inch	567	Sft	\$ 6.00	\$ 3,402.00
8032002	Curb Ramp, Conc, 6 inch	340	Sft	\$ 10.00	\$ 3,400.00
8110041	Pavt Mrkg, Ovly Cold Plastic, 12 inch, Crosswalk	208	Ft	\$ 7.00	\$ 1,456.00
8110045	Pavt Mrkg, Ovly Cold Plastic, 24 inch, Stop Bar	60	Ft	\$ 14.00	\$ 840.00
8110153	Pavt Mrkg, Sprayable Thermopl, 4 inch, White	100	Ft	\$ 1.00	\$ 100.00
8110154	Pavt Mrkg, Sprayable Thermopl, 4 inch, Yellow	100	Ft	\$ 1.00	\$ 100.00
8120210	Pavt Mrkg, Longit, 6 inch or Less Width, Rem	200	Ft	\$ 1.00	\$ 200.00
8120012	Barricade, Type III, High Intensity, Double Sided, Lighted, Furn	10	Ea	\$ 150.00	\$ 1,500.00
8120013	Barricade, Type III, High Intensity, Double Sided, Lighted, Oper	10	Ea	\$ 10.00	\$ 100.00
8120026	Pedestrian Type II Barricade, Temp	10	Ea	\$ 150.00	\$ 1,500.00
8120170	Minor Traf Devices	1	LSUM	\$ 20,000.00	\$ 20,000.00
8120252	Plastic Drum, Fluorescent, Furn	50	Ea	\$ 35.00	\$ 1,750.00
8120253	Plastic Drum, Fluorescent, Oper	50	Ea	\$ 1.00	\$ 50.00
8120310	Sign Cover	5	Ea	\$ 50.00	\$ 250.00
8120332	Sign, Portable, Changeable Message, NTCIP-Compliant, Furn	2	Ea	\$ 3,500.00	\$ 7,000.00
8120333	Sign, Portable, Changeable Message, NTCIP-Compliant, Oper	2	Ea	\$ 100.00	\$ 200.00
8120350	Sign, Type B, Temp, Prismatic, Furn	200	Sft	\$ 6.00	\$ 1,200.00
8120351	Sign, Type B, Temp, Prismatic, Oper	200	Sft	\$ 1.00	\$ 200.00
8120352	Sign, Type B, Temp, Prismatic, Special, Furn	50	Sft	\$ 12.00	\$ 600.00
8120353	Sign, Type B, Temp, Prismatic, Special, Oper	50	Sft	\$ 1.00	\$ 50.00
8120370	Traf Regulator Control	1	LSUM	\$ 10,000.00	\$ 10,000.00
8167011	Turf Establishment, THM Seed, Regular Mulch, Performance, RCOC	1106	Syd	\$ 15.00	\$ 16,590.00
8180001	Power Company (Estimated Cost to Contractor)	2513	Dlr	\$ 1.00	\$ 2,513.00
8182047	Conduit, DB, 1, 1 1/4 inch	60	Ft	\$ 20.00	\$ 1,200.00
8182050	Conduit, DB, 1, 3 inch	250	Ft	\$ 35.00	\$ 8,750.00
8182056	Conduit, DB, 3, 3 inch	20	Ft	\$ 60.00	\$ 1,200.00
8182057	Conduit, DB, 3, 4 inch	20	Ft	\$ 80.00	\$ 1,600.00
8182238	Cable, Sec, 600V, 1, 3/C#6	300	Ft	\$ 8.00	\$ 2,400.00
8182366	Serv Disconnect	2	Ea	\$ 2,000.00	\$ 4,000.00
8187001	Conduit, Directional Bore, 2, 4 inch, RCOC	180	Ft	\$ 75.00	\$ 13,500.00
8187050	Hh, Round, 2 foot Dia, RCOC	5	Ea	\$ 1,600.00	\$ 8,000.00
8187050	Hh, Round, 3 foot Dia, RCOC	1	Ea	\$ 2,500.00	\$ 2,500.00
8202012	Mast Arm Pole, Cat III	2	Ea	\$ 12,000.00	\$ 24,000.00
8202029	Mast Arm, 30 foot, Cat III	1	Ea	\$ 12,000.00	\$ 12,000.00
8202032	Mast Arm, 45 foot, Cat III	1	Ea	\$ 14,000.00	\$ 14,000.00
8200045	Controller Fdn, Base Mount	1	Ea	\$ 3,000.00	\$ 3,000.00
8200050	Global Positioning System Module	1	Ea	\$ 1,000.00	\$ 1,000.00
8200105	Pedestal, Fdn	2	Ea	\$ 1,200.00	\$ 2,400.00
8200121	Pushbutton and Sign	4	Ea	\$ 700.00	\$ 2,800.00
8200336	TS, Pedestrian, One Way Bracket Arm Mtd (LED) Countdown	2	Ea	\$ 1,500.00	\$ 3,000.00
8200345	TS, Pedestrian, One Way Pedestal Mtd (LED) Countdown	2	Ea	\$ 1,500.00	\$ 3,000.00
8200359	TS, One Way Mast Arm Mtd (LED)	4	Ea	\$ 1,500.00	\$ 6,000.00
8200480	Casing	21	Ft	\$ 300.00	\$ 6,300.00
8207001	Mast Arm Pole Fdn, 6 Bolt	28	Ft	\$ 700.00	\$ 19,600.00

Lathrup Village Traffic Signal
 Engineers Opinion of Probable Construction Cost
 3/11/2024

Item 8J.

Item	Item Description	Const Qty	Unit	Unit Price	Total Construction Cost
8207050	Mast Arm, Mtd, Sign, Type III, RCOC	2	Ea	\$ 1,000.00	\$ 2,000.00
8207050	Controller, Digital Type, Delivered, RCOC	1	Ea	\$ 10,000.00	\$ 10,000.00
8207050	Cabinet, ITS Type, RCOC	1	Ea	\$ 5,000.00	\$ 5,000.00
8207050	Cabinet, ITS Type, Delivered, RCOC	1	Ea	\$ 10,000.00	\$ 10,000.00
8207050	Pedestal, Alum, RCOC	2	Ea	\$ 1,000.00	\$ 2,000.00
8207050	Backplate, TS, RCOC	4	Ea	\$ 200.00	\$ 800.00
Construction Cost:					\$ 313,446.00

CITY OF LATHRUP VILLAGE

IN COOPERATION WITH
MICHIGAN DEPARTMENT OF TRANSPORTATION AND
FEDERAL HIGHWAY ADMINISTRATION

SOUTHFIELD ROAD TRAFFIC SIGNAL

BETWEEN MARGATE AVENUE AND KILBIRNIE AVENUE

CONTROL SECTION No. 63000
MDOT JOB No. 220123
HRC JOB No. 20220916

SHEET INDEX

TITLE SHEET.....	1
DETAILS.....	2
REMOVAL AND CONSTRUCTION PLAN.....	3-4
SIGNAL NOTES.....	5
SIGNAL LEGEND.....	6
TRAFFIC SIGNAL PLAN.....	7

GENERAL PROVISIONS

THE IMPROVEMENTS COVERED BY THESE PLANS SHALL BE DONE IN ACCORDANCE WITH THE PROPOSAL AND ACCOMPANYING SPECIFICATIONS FOR THIS PROJECT INCLUDING THE 2020 MICHIGAN DEPARTMENT OF TRANSPORTATION STANDARD SPECIFICATIONS FOR HIGHWAY CONSTRUCTION AND MICHIGAN DEPARTMENT OF TRANSPORTATION NON-FREEMWAY, NON-NHS 3R GUIDELINES.

PLACING OF TRAFFIC CONTROL SIGNS SHALL BE DONE IN ACCORDANCE WITH THE 2011 MICHIGAN MANUAL OF UNIFORM TRAFFIC CONTROL DEVICES. THIS WORK WILL BE DONE PRIOR TO THE FINAL ACCEPTANCE OF THIS PROJECT.

THE LOCATION OF ALL PUBLIC UTILITIES SHOWN ON THESE PLANS IS TAKEN FROM THE BEST AVAILABLE DATA. THE CITY OF FARMINGTON HILLS AND HUBBELL, ROTH & CLARK, INC. WILL NOT BE RESPONSIBLE FOR ANY OMISSION OR VARIATIONS FROM THE LOCATIONS SHOWN. PURSUANT TO ACT 174 OF THE PA OF 2013 AS A CONDITION OF THIS CONTRACT, NOTICE SHALL BE GIVEN TO MISS DIG PRIOR TO UNDERGROUND WORK TO BE PERFORMED IN ACCORDANCE WITH THIS CONTRACT. PHONE (800) 462-7171 OR (248) 647-7344 OR 811.

HORIZONTAL ALIGNMENT IS BASED ON STATE PLANE COORDINATES. VERTICAL DATUM IS NAVD83.



KELLY GARRETT
MAYOR

BRUCE KANTOR
JALEN C. JENNINGS
DALTON BARKSDALE
JASON HAMMOND
COUNCIL MEMBERS

STANDARD PLANS		
CONSTRUCTION OF THE FOLLOWING ITEMS, WHERE CALLED FOR ON THE PLANS, WILL BE CONSTRUCTED ACCORDING TO MICHIGAN DEPARTMENT OF TRANSPORTATION STANDARD PLANS AS INDICATED.		
REQUIRED ON THIS PROJECT	ITEMS OF WORK	STANDARD PLAN NUMBERS
X	CURB RAMP AND DETECTABLE WARNING DETAILS	R-28-K*
X	DRIVEWAY OPENINGS & APPROACHES AND CONCRETE SIDEWALKS	R-29-J*
X	CONCRETE CURB AND CONCRETE CURB AND GUTTER	R-30-G
X	SOIL EROSION & SEDIMENTATION CONTROL MEASURES	R-96-E

* SEE MDOT SPECIAL DETAIL

TRAFFIC AND SAFETY STANDARD PLANS		
CONSTRUCTION OF THE FOLLOWING ITEMS, WHERE CALLED FOR ON THE PLANS, WILL BE CONSTRUCTED ACCORDING TO MICHIGAN DEPARTMENT OF TRANSPORTATION STANDARD PLANS AS INDICATED.		
REQUIRED ON THIS PROJECT	ITEMS OF WORK	STANDARD PLAN NUMBERS
X	GROUND DRIVEN SIGN SUPPORTS FOR TEMP. SIGNS	WZD-100-A
X	TEMPORARY TRAFFIC CONTROL DEVICES	WZD-125-E

* SEE MDOT SPECIAL DETAIL

TRAFFIC SIGNAL STANDARD PLANS		
CONSTRUCTION OF THE FOLLOWING ITEMS, WHERE CALLED FOR ON THE PLANS, WILL BE CONSTRUCTED ACCORDING TO MICHIGAN DEPARTMENT OF TRANSPORTATION STANDARD PLANS AS INDICATED.		
REQUIRED ON THIS PROJECT	ITEMS OF WORK	STANDARD PLAN NUMBERS
X	TRAFFIC SIGNAL MAST ARM POLE AND MAST ARM LOADING TABLE AND DESIGN CRITERIA	SIG-030-A
X	TRAFFIC SIGNAL MAST ARM POLE AND MAST ARM DETAILS - CATEGORY III	SIG-033-A
X	TRAFFIC SIGNAL MAST ARM STANDARD FOUNDATIONS	SIG-040-B
X	GLOBAL POSITIONING SYSTEM (GPS) MODULE	SIG-120-A
X	SECONDARY SERVICE/DISCONNECT FOR STEEL POLES	SIG-201-A
X	COLOR CODE WIRING/EQUIPMENT GROUNDING	SIG-230-A
X	HANDHOLE PRECAST POLYMER CONCRETE	SIG-240-A
X	CONDUIT (DIRECT BURIAL/ENCASED)	SIG-250-A
X	MAST ARM MOUNTED TS BRACKET ASSEMBLY	SIG-301-A

* SEE MDOT SPECIAL DETAIL

SCALE FULL SIZE PLAN SHEET HOR. 1" = 20' PROFILE VER. 1" = 5'
SCALE REDUCED SIZE PLAN SHEET HOR. 1" = 40' PROFILE VER. 1" = 10'

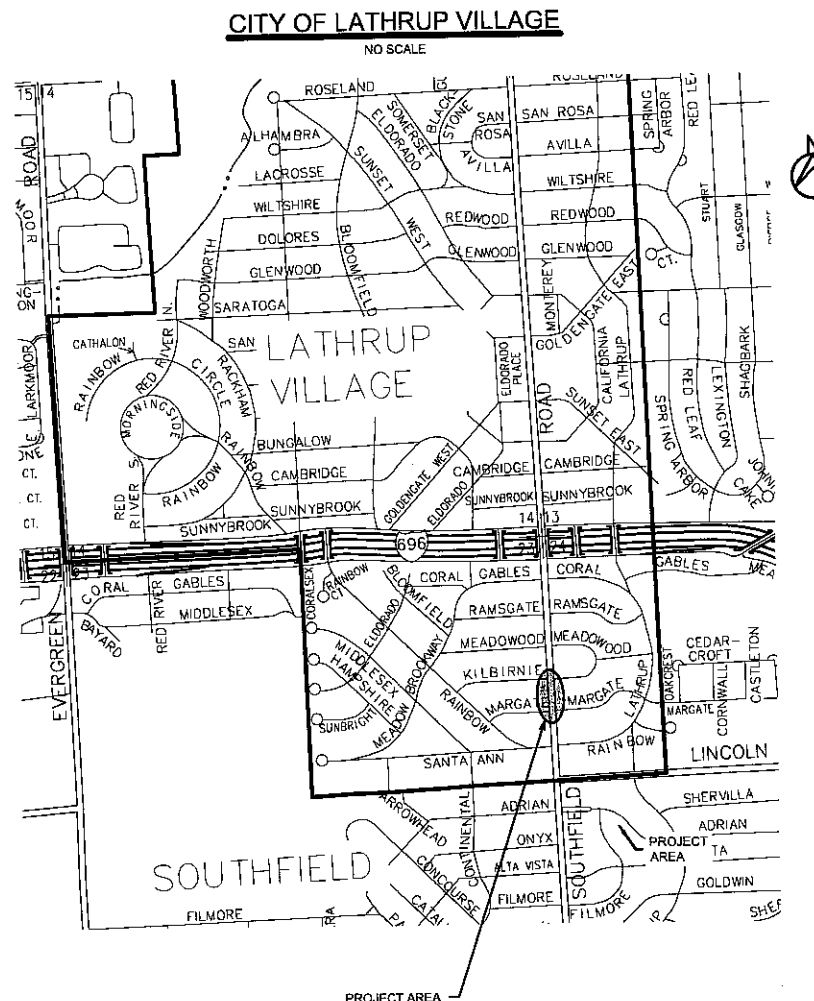

TRAFFIC DATA

SPEEDS

	DESIGN	POSTED
SOUTHFIELD ROAD	50 mph	45 mph

TRAFFIC VOLUMES (ADT)

	2024	2044	(COMMERCIAL)
SOUTHFIELD ROAD	39,000	47,500	3%

CONTRACT FOR:
CONSTRUCTING A SIGNALIZED, MID-BLOCK PEDESTRIAN CROSSING AT SOUTHFIELD ROAD BETWEEN MARGATE AVENUE AND KILBIRNIE AVENUE IN LATHRUP VILLAGE. THE TRAFFIC SIGNALS WILL BE MAST ARM MOUNTED WITH PUSHBUTTONS FOR CROSSING PEDESTRIAN TRAFFIC. THE PROJECT WILL INCLUDE SIDEWALK WORK, PAVEMENT MARKINGS, AND CULVERTS INSTALLED TO BRING THE SIDEWALKS UP TO GRADE.

CITY OF LATHRUP VILLAGE
27400 SOUTHFIELD ROAD
LATHRUP VILLAGE, MI 48076

APPROVED BY _____ DATE _____
CITY ENGINEER

CONTRACT FOR:

CITY LATHRUP VILLAGE
SOUTHFIELD ROAD BETWEEN MARGATE AVENUE AND
KILBIRNIE AVENUE

SHEET NUMBER
1

PREPARED UNDER THE SUPERVISION OF:



HUBBELL, ROTH & CLARK, INC
Consulting Engineers

555 HULET DRIVE
BLOOMFIELD HILLS, MICH.

P.O. BOX 824
48303 - 0824

NOTES:
 1. SIDEWALK JOINTS PAID AS PART OF SIDEWALK PAY ITEM. LOCATION OF SIDEWALK JOINTS AND JOINT DETAILS SHALL BE IN ACCORDANCE WITH MDOT STANDARD PLAN R-29 SERIES.
 2. SIDEWALK RAMPS CONSTRUCTED IN ACCORDANCE WITH SPECIAL DETAIL R-28 SERIES.

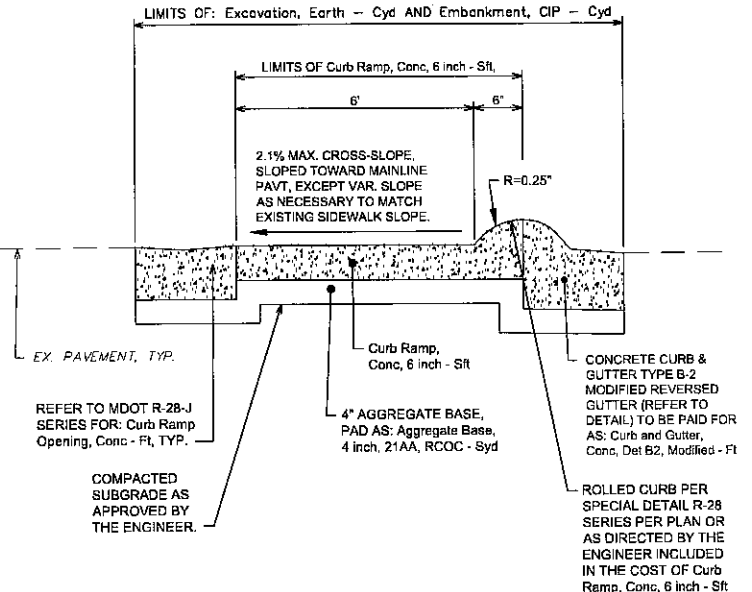

SIDEWALK WITH ROLLED CURB
NOT TO SCALE

SIDEWALK NOTES:
 1. ADA RAMPS AND LANDINGS SHALL BE CONSTRUCTED IN CONCRETE AND IN ACCORDANCE WITH CURRENT MDOT STANDARD DETAIL R-28 SERIES AND SHALL HAVE A MINIMUM CLEAR OPENING OF 8' WIDE.
 2. A CLEAN SAW CUT JOINT SHALL BE PROVIDED WHEREVER NEW PAVEMENT MATCHES EXISTING PAVEMENT (INCLUDED IN THE COST OF SIDEWALK PAY ITEMS)
 3. Turf Establishment, THM Seed, Regular Mulch, Performance, RCOC - Syd

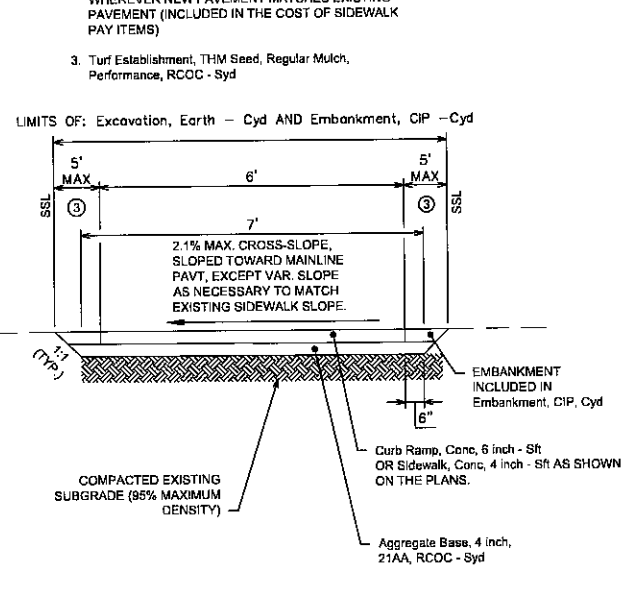

CONCRETE SIDEWALK
NOT TO SCALE

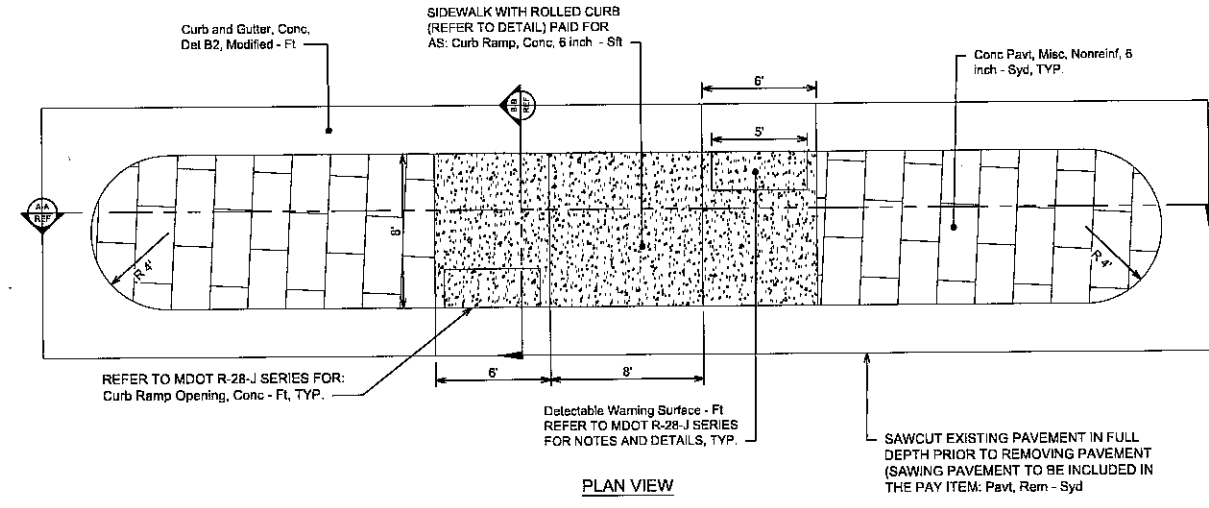

PLAN VIEW

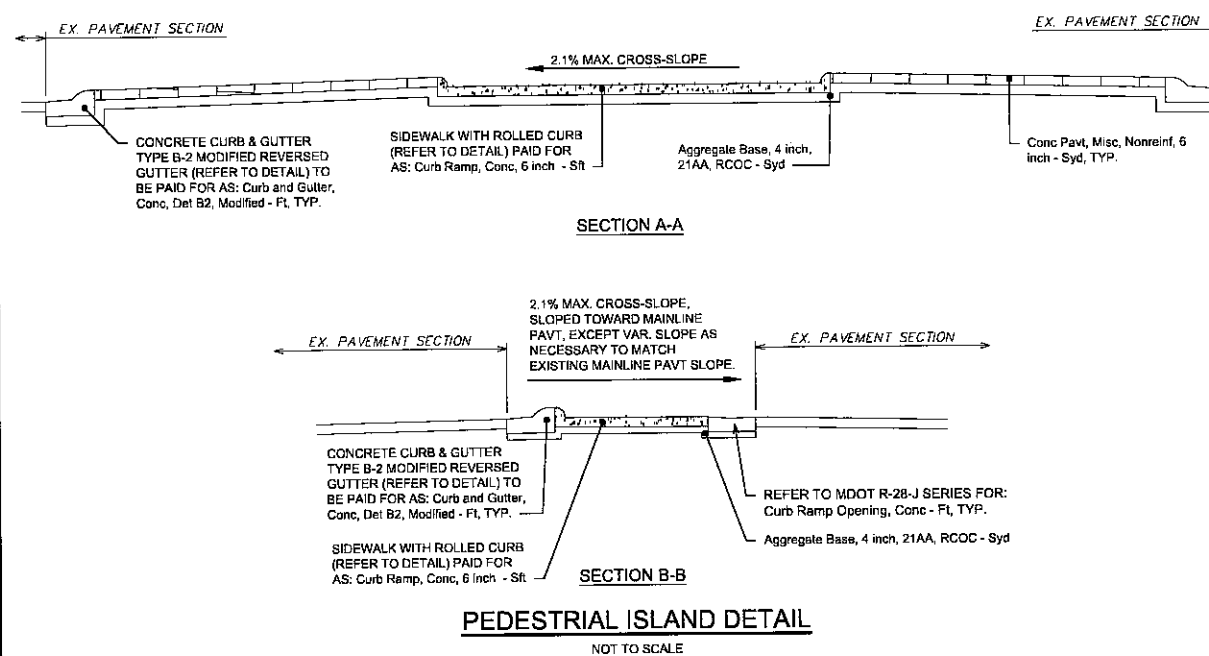

PEDESTRIAN ISLAND DETAIL
NOT TO SCALE

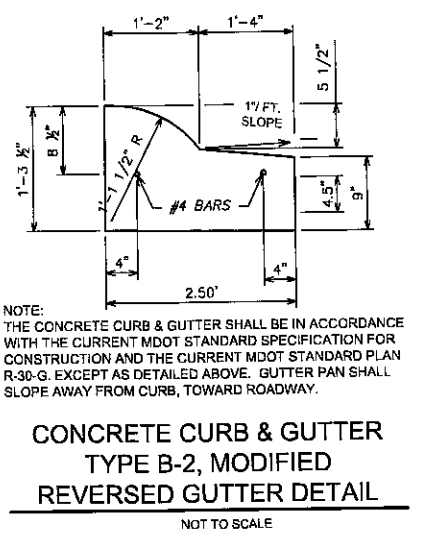

CONCRETE CURB & GUTTER TYPE B-2, MODIFIED REVERSED GUTTER DETAIL
NOT TO SCALE

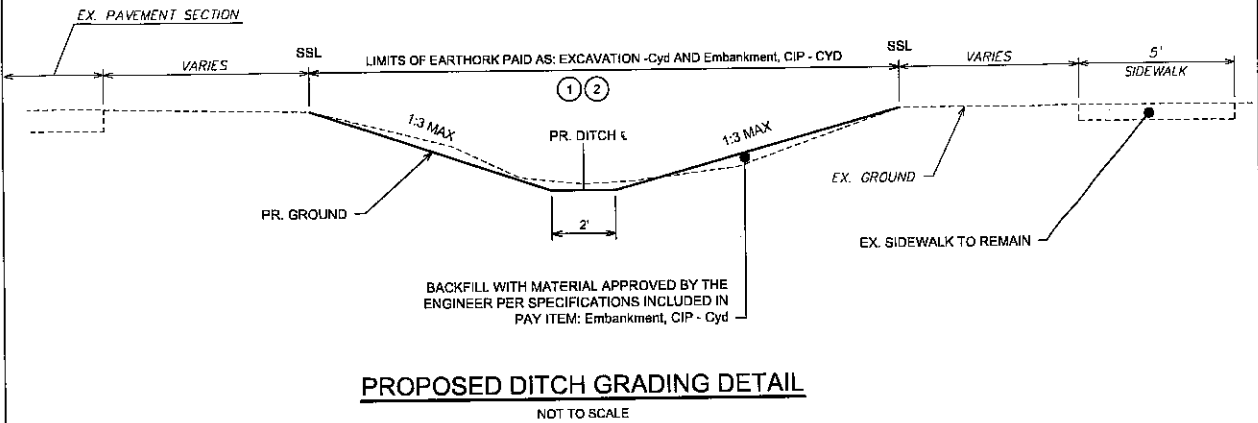

PROPOSED DITCH GRADING DETAIL
NOT TO SCALE

NOTES:
 1. ROADSIDE RESTORATION TO BE PAID FOR AS: TURF Establishment, THM Seed, Regular Mulch, Performance, RCOC - Syd
 2. 6\"/>

NECESSARY EARTHWORK AND SUBGRADE PREPARATION WITHIN SSL AND DRIVE LIMITS SHALL BE PAID FOR AS: Excavation, Earth - Cyd AND Embankment, CIP - Cyd. THE LIMITS OF WORK SHALL BE DESCRIBED IN THIS DETAIL.

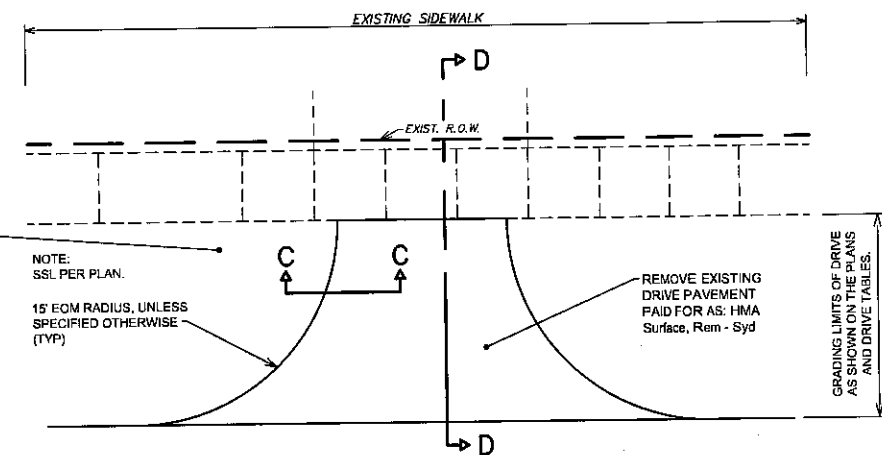

TYPICAL HMA COMMERCIAL DRIVE
NO SCALE

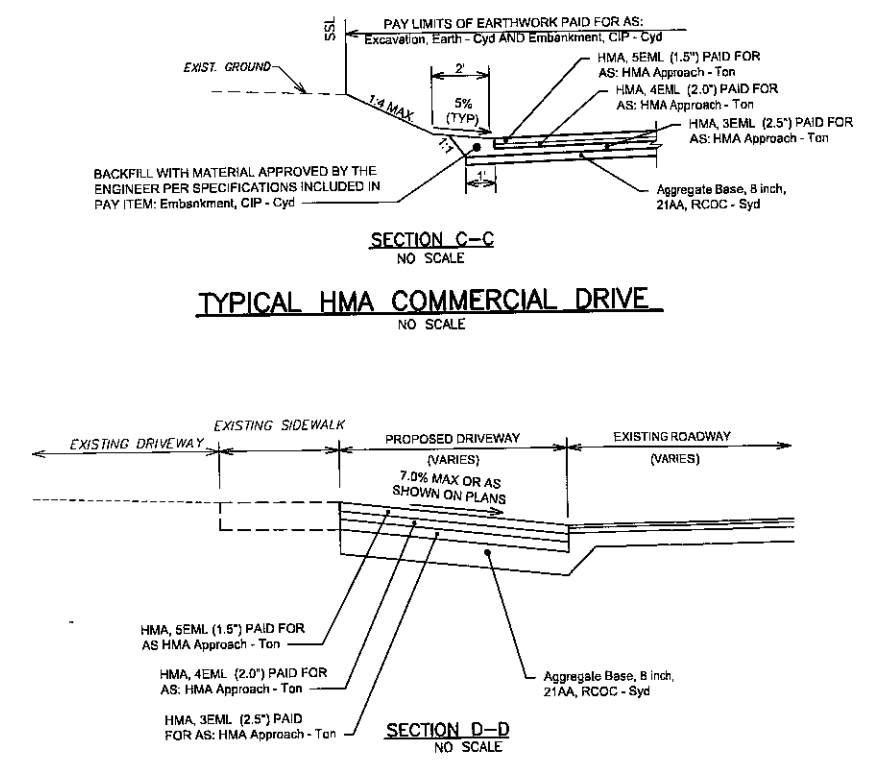

SECTION C-C
NO SCALE

SECTION D-D
NO SCALE

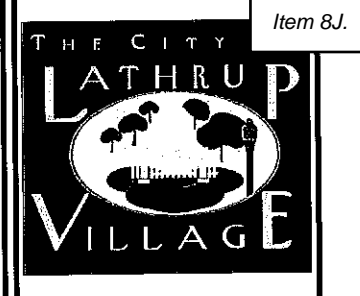

Item 8.J.

HRC
HUBBELL, ROTH & CLARK, INC
 CONSULTING ENGINEERS SINCE 1915
 555 HULEY DRIVE
 BLOOMFIELD HILLS, MICH. P.O. BOX 824
 48303 - 0824
 PHONE: (248) 454-6300
 FAX (1st Floor): (248) 454-6312
 FAX (2nd Floor): (248) 454-6389
 WEB SITE: www.hrcenr.com

DATE	ADDITIONS AND/OR REVISIONS
DESIGNED	JCL
DRAWN	HFA
CHECKED	
APPROVED	

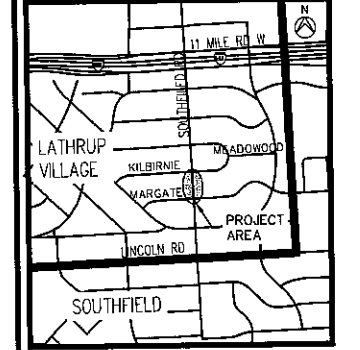

THE CITY OF LATHRUP VILLAGE
TRAFFIC SIGNAL MODERNIZATION

PROJECT DETAILS

HRC JOB NO. 20220916	SCALE NO SCALE
DATE February 2024	SHEET NO.

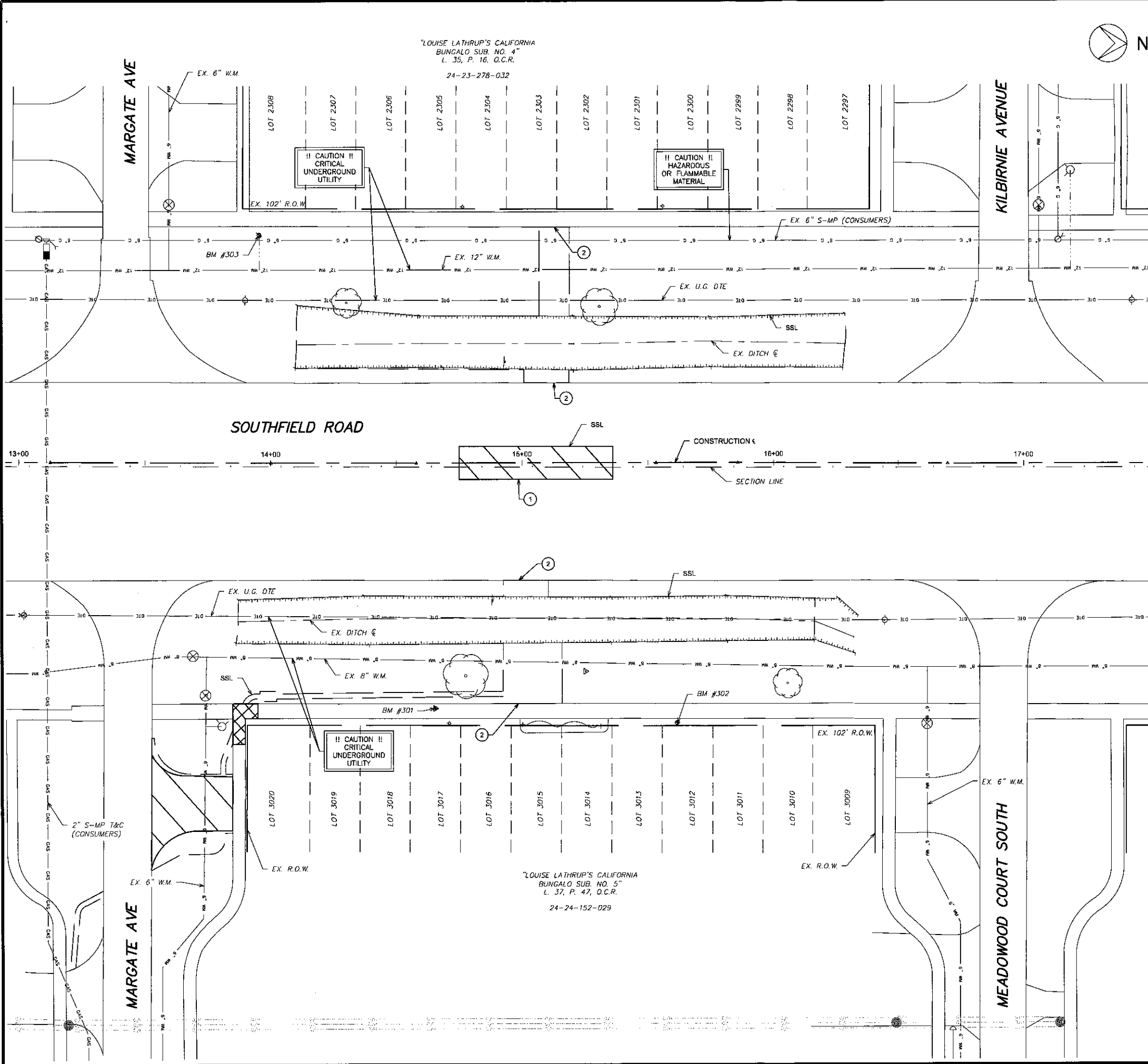

BENCHMARK		
BM. #	DESCRIPTION	ELEV.
301	MAG NAIL SET IN SIDEWALK SW OF LIGHT POLE BASE ON EAST SIDE OF SOUTHFIELD ROAD	692.71
302	TOP OF SOUTH SIDE OF CONCRETE LIGHT POLE BASE ON THE EAST SIDE OF SOUTHFIELD ROAD, 100' SOUTH OF KILBIRNIE AVENUE	694.56
303	WEST FLANGE SOLD OF HYDRANT ON THE WEST SIDE OF SOUTHFIELD ROAD AND SOUTH OF KILBIRNIE AVENUE	693.80

REMOVAL QUANTITIES - THIS SHEET		
PAY ITEM	QTY	UNIT
Sidewalk, Rem	13	Syd
Excavation, Earth	256	Cyd
HMA Surface, Rem	177	Syd

- NOTES:
- 1 VERTICAL SAWCUT FULL DEPTH THROUGH EXISTING PAVEMENT INCLUDED IN THE COST OF Pavt, Rem - Syd
 - 2 A CLEAN SAWCUT JOINT SHALL BE PROVIDED WHERE PROPOSED SIDEWALK MATCHES EXISTING PAVEMENT, INCLUDED IN THE COST OF SIDEWALK PAY ITEMS

DRIVEWAY CONSTRUCTION QUANTITIES - THIS SHEET (FOR INFORMATION ONLY)		
DRIVE/ APPROACH	GRADING LIMITS*	HMA SURFACE, REM
STATION		SYD
13+53	32' RT	89

*GRADING LIMITS MEASURED FROM EDGE OF MARGATE AVE.

LEGEND

	HMA SURFACE REMOVAL PAID FOR AS: HMA Surface, Rem
	Sidewalk, Rem
	SLOPE STAKE LINE (SSL)

NOTE: UTILITY INFORMATION ON THIS DRAWING MAY BE FROM INFORMATION DISCLOSED TO THIS FIRM BY THE VARIOUS UTILITY COMPANIES, CITY/COUNTY AGENCIES, AND OTHER VARIOUS SOURCES. UNDERGROUND UTILITIES WHICH ARE ON PRIVATE PROPERTY ARE USUALLY NOT DELINEATED UPON A UTILITY COMPANY'S PUBLISHED PLANS. THEIR LOCATION, IF SHOWN UPON THIS SURVEY, ARE APPROXIMATED FROM FOUND POINT MARKERS, ETC. AS LOCATED BY THIS FIRM FROM SOURCES WHICH ARE UNKNOWN. NO QUANTITIES ARE GIVEN AS TO THE COMPLETENESS OR ACCURACY THEREOF.

PRIOR TO CONSTRUCTION, ALL LOCATIONS AND DEPTHS OF EXISTING UTILITIES (IN CONFLICT WITH PROPOSED IMPROVEMENTS) SHALL BE VERIFIED IN THE FIELD. CALL MISS DIG 3 WORKING DAYS PRIOR TO CONSTRUCTION.



THREE FULL WORKING DAYS BEFORE YOU DIG, CALL THE MISS DIG SYSTEM AT 800-482-7171 OR 811.

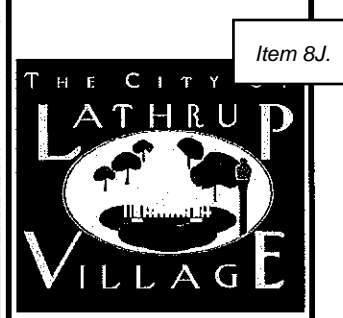

Item 8.J.

HRC
HUBBELL, ROTH & CLARK, INC
 CONSULTING ENGINEERS SINCE 1915
 555 HULET DRIVE
 BLOOMFIELD HILLS, MICH. P.O. BOX 824
 48303-0824
 PHONE: (248) 454-8300
 FAX (1st. Floor): (248) 454-6312
 FAX (2nd. Floor): (248) 454-6859
 WEB SITE: www.hrcengr.com

DATE	ADDITIONS AND/OR REVISIONS
DESIGNED	JCL
DRAWN	HFA
CHECKED	
APPROVED	

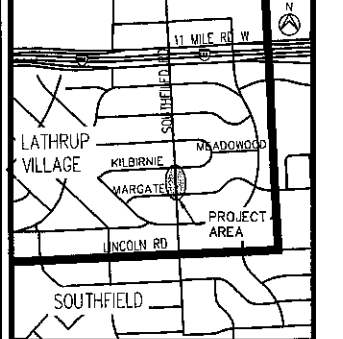

THE CITY OF LATHRUP VILLAGE
TRAFFIC SIGNAL MODERNIZATION

REMOVAL PLAN
 SOUTHFIELD ROAD

HRC JOB NO. 20220916	SCALE 1"=20'
DATE February 2024	SHEET NO. 3

1. CALL MISS DIG (800-482-7171 OR 811) 3 WORKING DAYS PRIOR TO ANY EXCAVATION FOR THE LOCATIONS OF UNDERGROUND UTILITIES.
2. WHERE ABANDONING OF U.G. CABLES IS CALLED FOR ON PLANS OR DIAGRAMS, CONTRACTOR SHALL CUT & REMOVE CABLES WITHIN MANHOLES & HANDHOLES.
3. WHERE INSTALLATION OF NEW MANHOLES OVER EXISTING CONDUITS (TO ACCOMMODATE NEW & EXISTING CONDUITS) IS CALLED FOR ON PLANS, CONTRACTOR SHALL CAREFULLY & SO AS NOT TO DAMAGE EXISTING CABLES. REMOVE THE EXISTING CONDUITS & ENCASMENT WITHIN MANHOLES. EXISTING CABLES SHALL BE EXTENDED & PROPERLY TRAINED, RACKED & SUPPORTED.
4. ALL EXISTING STREET LIGHTING, TRAFFIC SIGNAL, PRIMARY, TRANSMISSION ETC. CIRCUITS SHALL ALWAYS BE MAINTAINED IN AN OPERATIONAL CONDITION (EXCEPT WHERE OTHERWISE NOTED).
5. ALL CONDUITS NOT TERMINATING IN STRUCTURES SUCH AS MANHOLES, HANDHOLES OR FOUNDATIONS SHALL EXTEND 2 FEET BEYOND PAVEMENT LIMIT (EXCEPT AS OTHERWISE INDICATED). ALL UNOCCUPIED CONDUITS SHALL BE PLUGGED/CAPPED (TO KEEP MOISTURE AND DEBRIS OUT). FIT THE ENDS OF ALL PVC CONDUIT TERMINATIONS WITH BUSHINGS OR END BELL FITTINGS (TO PREVENT DAMAGE TO THE CABLES AND CONDUCTORS).
6. ALL TREE TRIMMING REQUIRED TO CLEAR NEW OR SALVAGED STREET LIGHTING & TRAFFIC SIGNAL STD.'S, O.H. STREET LIGHTING & TRAFFIC SIGNAL UNITS SHALL BE INCLUDED IN OTHER CONTRACT PAY ITEMS AND NOT PAID FOR SEPERATELY.
7. EXISTING O.H. & T.S. FACILITIES ARE NOT NECESSARILY SHOWN ON PLANS.
8. ALL OVERHEAD WIRES & UNDERGROUND CABLES SHALL CONSIST OF COPPER CONDUCTORS AS PER SPECIFICATIONS.
9. ALL NEW ANCHOR GUYS SHALL BE INSTALLED ON A 1:1 RATIO OR AS NEARLY AS POSSIBLE (EXCEPT WHERE OTHERWISE NOTED). (STRUT GUYS ARE ACCEPTED)
10. ALL CABLES SHALL BE TAGGED IN ALL MANHOLES AND HANDHOLES.
11. INSTALL WOOD POLES SO AS NOT TO INTERFERE WITH TRAFFIC OR FUTURE CONSTRUCTION STAGES.
12. ALL TRAFFIC SIGNS SUCH AS "NO PARKING", "NO STANDING", "STREET NAME", ETC. SHALL BE TRANSFERRED FROM OLD STD. OR POLE TO NEW STD. OR POLE AT THE SAME LOCATION OR IN CLOSE PROXIMITY BY CONTRACTOR.
13. ALL TRAFFIC SIGNALS SHALL BE MOUNTED WITH NEW STANDARD TRAFFIC SIGNAL BRACKETS & FITTINGS.
14. ALL TRAFFIC SIGNAL ITEMS, AS CALLED FOR ON PLANS, SHALL HAVE INCLUDED IN THE TRAFFIC SIGNAL ITEM ALL CABLES FROM THE CONTROLLER TO THE TRAFFIC SIGNALS, FOUNDATIONS & PIPE EXTENSIONS NEEDED TO MAINTAIN 17'-0" UNDER CLEARANCE AS INDICATED (18'-0" FOR JOINT USE WOOD POLES).
15. WHEN ENTERING PROPOSED CONDUIT INTO EXISTING MANHOLES & HANDHOLES EXERCISE CAUTION NOT TO DISTURB EXISTING CABLES. PROPOSED CONDUIT TAPS INTO EXISTING HANDHOLES ARE NOT PAID FOR SEPARATELY AND INCLUDED IN OTHER ITEMS OF WORK.
16. BACKFILL ALL CONDUIT TRENCHES WITHIN THE LIMITS OF THE ROADBED AND SIDEWALK WITH CLASS II GRANULAR MATERIAL IN ACCORDANCE WITH SECTION 204. PLACE AND COMPACT THE GRANULAR MATERIAL IN ACCORDANCE WITH THE CONTROLLED DENSITY METHOD IN SUBSECTION 205.03.H.4.a.
17. ALL SALVAGED TRAFFIC SIGNALS SHALL BE TRAFFIC SIGNALS PREVIOUSLY INSTALLED NEW ON THIS CONTRACT. (EXCEPT AS OTHERWISE INDICATED)
18. ALL O.H. TRAFFIC SIGNAL SPAN WIRE SHALL USE 5/16" EXTRA HIGH STRENGTH STRAND WIRE. TRAFFIC SIGNAL BOTTOM TETHER WIRE SHALL USE 1/4" COMMON GRADE STRAND WIRE.
19. SEAL-END OF CABLE WHERE COILING OF CABLE IS CALLED FOR ON PLANS. (CONTRACTOR SHALL RECEIVE PAYMENT FOR COILED-UP CABLES)
20. THE CONTRACTOR SHALL DELIVER TO ROAD COMMISSION FOR OAKLAND COUNTY (RCOC), THE T.S. CONTROLLER FOR TIMING. THE CONTRACTOR WILL PICKUP THE CONTROLLER AND CABINET FROM RCOC WHEN READY FOR INSTALLATION.
21. PROPOSED T.S. SHALL BE PUT INTO OPERATION AT THE TIME OF REMOVAL OF EXISTING T.S. FACILITIES. CONTRACTOR SHALL NOTIFY RCOC. IF UNABLE TO MAINTAIN T.S. IN AN OPERABLE CONDITION AT ALL TIMES.
22. A MINIMUM CLEARANCE OF 3'-6" HORIZONTAL & 1'-0" VERTICAL MUST BE MAINTAINED BETWEEN PROPOSED FACILITEIS & EXISITING U.G. WATER FACILITIES OR AS SPECIFIED ON PLANS.

23. ALL PROPOSED EQUIPMENT SHALL MAINTAIN 10 FEET OF CLEARANCE FROM PRIMARY, NEUTRAL, OR ABOVE POWER CABLES.
24. THE ROAD COMMISSION FOR OAKLAND COUNTY (RCOC) WILL INSPECT THE INSTALLATION OF ALL TRAFFIC SIGNAL EQUIPMENT. THE CONTRACTOR MUST NOTIFY RCOC WHEN WORK IS GOING TO BE PERFORMED. THE CONTRACTOR MUST PROVIDE THREE (3) WORKING DAYS' NOTICE (EXCLUDING SATURDAY, SUNDAY, AND HOLIDAYS) TO RCOC, SIGNAL SYSTEMS DIVISION, TELEPHONE (248) 858-7250, FOR THE INSPECTION TO BE PERFORMED.
25. ALL MATERIAL REMOVED ON THIS CONTRACT SHALL BE DISPOSED OF PROPERLY BY THE CONTRACTOR. CONTRACTOR SHALL NOTIFY RCOC PRIOR TO REMOVAL OF THE EQUIPMENT AND ALL MATERIAL IDENTIFIED BY THE RCOC SHALL BE STORED ON SITE AS DIRECTED BY THE ENGINEER FOR PICK UP BY THE RCOC.
26. TS___ REM - THE UNIT PRICE FOR RELEVANT REMOVAL PAY ITEMS INCLUDE THE COST OF REMOVING AND DISPOSING OF TRAFFIC SIGNALS, PEDESTRIAN SIGNALS, CABLES, AND OTHER MATERIALS.
27. FOR TYPICAL PEDESTRIAN T.S. WIRING ON POLES; (RCOC STEEL POLES, WOOD POLES, OR STEEL POLES OWNED BY OTHERS) SEE STANDARD DETAIL SHEET OC-4A, ALL STEEL POLES SHALL BE ASSUMED TO BE OWNED BY RCOC UNLESS OTHERWISE NOTED ON PLANS.
28. ALL TRAFFIC SIGNAL SPANS WITH SOLID STATE CONTROLLERS SHALL BE GROUNDED. THE GROUNDING OF BOTH SHALL HAVE A RESISTANCE NO GREATER THAN 10 OHM WHEN INSTALLED.
29. CONCRETE PAVEMENT REPAIR SHALL BE CONSTRUCTED IN ACCORDANCE WITH THE 2020 M.D.O.T STANDARD SPECIFICATIONS FOR CONSTRUCTION AND RCOC A.S.R. SPECIFICATIONS.
30. ALL CONDUIT BENDS SHALL HAVE MINIMUM RADI: IN ACCORANCE WITH THE CURRENT N.E.C.
31. ALL TRAFFIC SIGNAL FITTINGS (SCREWS, BOLTS, PINNACLES, ETC.) SHALL BE GREASED WITH A NON-OXIDE TYPE GREASE.
32. INSTALL STEEL POLE AS HANDHOLE, AS DESCRIBED ON STANDARD DETAIL SHEET OC-2, IN ALL EXISTING STEEL POLES AS DIRECTED BY THE ENGINEER. (INCLUDED IN THE INTALLATION OF T.S. ON THIS CONTRACT)
33. ALL GROUND WIRE SHALL BE #6 STRANDED COPPER.
34. WHEN SPLICING TRAFFIC SIGNAL CABLES (ONLY IF APPROVED BY ENGINEER), USE UN-INSULATED SOLID BARREL COMPRESSION TYPE CONNECTORS. TAPE OVER EACH INDIVIDUAL BARREL AND ANY BARE WIRE WITH PREMIUM GRADE PVC, 7 MIL, SUNLIGHT & COLD RESISTANT TAPE. THEN TAPE OVERALL SPLICE WITH LINERLESS RUBBER SPLICING TAPE OR EQUIVALENT. THEN TAPE OVER THAT WITH A LAYER OF PREMIUM GRADE PVC, 7 MIL, SUNLIGHT & COLD RESISTANT TAPE OVER LAPPING CABLE JACKET BY ONE INCH. ALL TAPE SHOULD COVER SPLICES FROM CABLE JACKET TO CABLE JACKET AND BE 1/2 LAPPED. THE FINAL LAYER OF TAPE SHOULD BE WRAPPED IN AN UPWARD MOTION SO THAT CUT OFF END DOES NOT ALLOW MOISTURE BACK INTO SPLICE.
35. NO CHANGES FROM PLANS IN LOCATION OF SUPPORTING STRUCTURES, SIGNAL HEAD PLACEMENT OR TRAFFIC SIGNAL EQUIPMENT WILL BE ALLOWED WITHOUT PRIOR APPROVAL OF THE ROAD COMMISSION FOR OAKLAND COUNTY. CONTACT ROAD COMMISSION FOR OAKLAND COUNTY-TRAFFIC OPERATIONS CENTER AT (248) 858-7250.
36. STEMMING OF SIGNAL HEADS TO MAINTAIN EQUAL UNDER CLEARANCE FOR EACH SPAN WIRE MOUNTED SIGNAL HEAD (AT ALL INTERSECTIONS OF THIS CONTRACT) IS INCLUDED IN THE INSTALLATION OF T.S. IN THIS CONTRACT.
37. ALL DIRECTIONAL BORED, OPEN CUT, OR DIRECT BURIAL CONDUIT CALLED FOR ON PLANS IS THE PREFERRED METHOD OF INSTALLATION. IF THE METHOD OF CONDUIT INSTALLATION IS IMPOSSIBLE TO CONSTRUCT OR IF THE CONTRACTOR PREFERES TO USE ANY OTHER METHOD, THE CHANGE OF METHOD MAY BE MADE UPON APPROVAL BY THE PROJECT ENGINEER.
38. THE CONTRACTOR IS RESPONSIBLE FOR DETERMINING OR ANTICIPATING THE NEED OR DESIRE TO INSTALL CONDUIT BY ANY OTHER METHOD AND TO INCLUDE THE COST IN THE CONTRACT BID.
39. NO EXTRA PAYMENT WILL BE ALLOWED IF THE CONTRATOR CHOOSES TO CHANGE THE METHOD OF CONDUIT INSTALLATION.
40. THE CONTRACTOR SHALL MAKE THE PERMANENT CONNECTION TO LOCAL UTILITY CO. 120V SERVICE USING APPROVED PARALLEL GROOVED CONNECTORS. (INCLUDED IN THE INSTALLATION OF T.S. ON THIS CONTRACT)
41. ALL OVERHEAD CAMERA CLAMP-ON BRACKET ARMS SHALL BE INSTALLED ON WOOD OR STEEL POLES PERPENDICULAR TO THE CURB UNLESS OTHERWISE DIRECTED BY THE ENGINEER.
42. CONTACT LOCAL UTILITY COMPANY PRIOR TO INSTALLATION OF TRAFFIC SIGNALS. (INCLUDED IN THE INSTALLATION OF TRAFFIC SIGNALS ON THIS CONTRACT)

43. ALL HEMISPHERICAL CAMERA CABLES SHALL BE CAT5e (SHIELDED, 24 AWG SOLID CORE, GEL FILLED, OUTDOOR RATED). CABLE SHALL HAVE A DRAIN WIRE. MAXIMUM LENGTH OF CABLE WITHOUT A POE (POWER OVER ETHERNET) REPEATER IS 250 FT. GROUND THE DRAIN WIRE TO THE EPM (ETHERNET PROTECTION MODULE) GROUND LUG USING 1-1/8" #6 AWG COPPER FROM LUG ON EPM TO CABINET GROUND BUS.
44. ALL WEATHERHEADS AND LB'S SHALL BE NEW AND METAL UNLESS OTHERWISE SPECIFIED BY THE ENGINEER.
45. THE "PLOWING IN CONDUIT" METHOD SHALL NOT BE USED ON THIS CONTRACT UNLESS OTHERWISE SPECIFIED BY THE ENGINEER.
46. WHEN CONTRACTOR IS INSTALLING A NEW STEEL STRAIN POLE FOR INSTALLATION OF A NEW SPAN WIRE BY LOCAL UTILITY COMPANY, A SPAN WIRE ATTACHMENT CLAMP AND BULL RING SHALL BE PROVIDED BY THE CONTRACTOR. (INCLUDED IN THE INSTALLATION OF T.S. ON THIS CONTRACT)
47. ALL PEDESTRIAN TRAFFIC SIGNALS NOT IN USE ON THIS PROJECT SHALL BE BAGGED AS DIRECTED BY THE ENGINEER.
48. ALL TRAFFIC SIGNALS, CASE SIGNS, AND SPAN MOUNTED STATIC SIGNS THAT ARE NOT BEING USED WILL BE BAGGED, HOODED, TURNED, OR TAKEN DOWN TO CLEARLY INDICATE THAT THEY ARE NOT IN OPERATION. BAGGING MATERIAL WILL BE OF SUCH CONSTRUCTION AS TO NOT ALLOW ANYTHING TO BE VISIBLE THROUGH THE MATERIAL. BAGGING MATERIAL WILL BE OF SUCH CONSTRUCTION AS TO HOLD UP TO WIND AND OTHER ADVERSE WEATHER CONDITIONS. ALL TRAFFIC SIGNALS AND CASE SIGNS WILL BE DISABLED SO THAT NO LIGHTS ARE OPERATIONAL.
49. ALL MAST ARM MOUNTED TRAFFIC SIGNALS AND CASE SIGNS SHALL BE MOUNTED SUCH THAT A 17'-0" UNDER CLEARANCE IS MAINTAINED AT ALL TIMES.
50. THIS WORK CONSISTS OF THE CONTRACTOR'S RESPONSIBILITY TO TEST THE STRAIN POLE AND MAST ARM ANCHOR BOLTS. PROVIDE MATERIALS AND TESTING BY AN RCOC APPROVED LAB FOR ALL ANCHOR BOLTS, NUTS, AND WASHERS IN ACCORDANCE WITH SUBSECTIONS 105.10, 820, AND 908.14 OF THE 2020 MICHIGAN DEPARTMENT OF TRANSPORTATION (MDOT) STANDARD SPECIFICATION FOR CONSTRUCTION AND ALL CONTRACT DOCUMENTS. ANCHOR BOLTS SHALL BE MARKED BY COLOR CODED ENDS AND NON-REMOVABLE CASTING (HEAT) STAMP TO PROVIDE TRACEABILITY DURING TESTING AND INSTALLATION. INCLUDE PICTURES (OR OTHER PROPOSED METHOD) WITH THE TESTING RESULTS OF THE MATERIALS AT THE CONTRACTOR'S YARD AND LAB FOR TRACEABILITY IN THE FIELD. PROVIDE TEST DATA CERTIFICATION TO THE ENGINEER ACCORDING TO THE MDOT MATERIALS SOURCE GUIDE. ANCHOR BOLT TESTING WILL NOT PAID FOR SEPARATELY AND IS INCLUDED IN OTHER ITEMS OF WORK. ANCHOR BOLTS SHALL NOT BE HEATED NOR HAMMERED AFTER ACCEPTANCE FOR USE ON THIS PROJECT. MDOT DOES NOT TEST FOR LOCAL AGENCY PROJECTS.
51. MAST ARM INSPECTIONS FOR QUALITY ASSURANCE MUST BE COORDINATED WITH ROAD COMMISSION FOR OAKLAND COUNTY.
52. CUT OVER OF INTERSECTIONS, MODIFICATIONS OF ANY SIGNAL CONFIGURATION, AND TRAFFIC SWITCHES SHALL TAKE PLACE ON MONDAY - THURSDAY FROM 9 A.M. - 3 P.M. ONLY. CUT OVERS ARE NOT PERMITTED ON HOLIDAYS.
53. FOR MATERIAL INSPECTION REQUESTS (HMA, CONCRETE, AGGREGATE, ETC) CONTRACTOR SHALL COMPLETE THE ONLINE INSPECTION REQUEST AT: <http://www.rcocweb.org/503/Contractor-Inspection-Request> REFER TO PROPOSAL FOR ADDITIONAL INFORMATION.
54. WHERE REQUIRED BY THE LOCAL UTILITY COMPANY OR APPLICABLE CODE, INSTALL OR HAVE INSTALLED ALL NECESSARY INSULATORS OR ELECTRICAL PROTECTIVE DEVICES AND/OR COORDINATE WITH THE LOCAL UTILITY COMPANY TO HAVE REQUIRED PROTECTIVE DEVICES INSTALLED ON THE UTILITY COMPANY'S FACILITIES. ASSUME ALL LOCATIONS MAY REQUIRE WORK WITHIN 10 FEET OF PRIMARY AND/OR NEUTRAL CONDUCTORS. THE COST OF ANY PROTECTIVE DEVICES OR INSULATORS SHALL BE INCLUDED IN THE COST OF PERFORMING THIS WORK AND WILL NOT PAID FOR SEPARATELY.
55. SIGN INSTALLATION DATE STICKER - RCOC WILL PROVIDE INSTALLATION DATE STICKERS TO THE CONTRACTOR AT THE PRECONSTRUCTION MEETING. AT THE TIME OF INSTALLATION, PLACE AN INSTALLATION DATE STICKER ON THE BACK LOWER PORTION OF THE CASE AND NON-ILLUMINATED STREET NAME SIGNS.
56. RCOC MARCH 2014 TRAFFIC SIGNAL DETAIL BOOK IS AVAILABLE AT RCOC WEBSITE: <http://www.rcocweb.org/DocumentCenter/View/190/2014-Traffic-Signal-Detail-Book-PDF> THIS INFORMATION IS ALSO AVAILBLE UPON REQUEST DIRECTLY FROM RCOC TRAFFIC SAFETY DEPARTMENT BY CONTACTING AHMAD JAWAD, SIGNAL SYSTEMS ENGINEER AT (248) 858-7250. IN CASE OF CONFLICT, UTILIZE RCOC SPECIAL PROVISIONS AND RCOC STANDARD CONSTRUCTION SIGNAL DETAIL BOOK. THEN USE CONTRACT DOCUMENTS AND 2020 MDOT STANDARD SPECIFICATIONS FOR CONSTRUCTION WHICHEVER ARE MOST RESTRICTIVE AS DETERMINED BY THE ENGINEER.

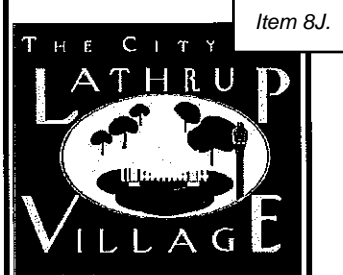

Item 8.J.

HRC
HUBBELL, ROTH & CLARK, INC
 CONSULTING ENGINEERS SINCE 1915

PHONE: (248) 858-8800
 FAX (1st. Floor): (248) 454-5312
 FAX (2nd. Floor): (248) 454-8358

WEB SITE: www.hrcengr.com

DATE	ADDITIONS AND/OR REVISIONS
DESIGNED	HFA
DRAWN	COB
CHECKED	LFM
APPROVED	

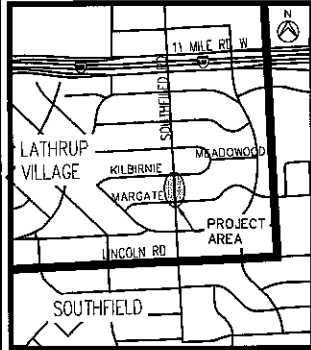

THE CITY OF LATHRUP VILLAGE
TRAFFIC SIGNAL
MODERNIZATION

SIGNAL NOTES
SOUTHFIELD RD

HRC JOB NO. 20220916	SCALE NTS
DATE February 2023	SHEET NO. 5

LEGEND SHEET

TRAFFIC SIGNAL

- INSTALL 12" VEHICULAR TRAFFIC SIGNAL (1-WAY SHOWN)
- INSTALL VEHICULAR TRAFFIC SIGNAL WITH SALVAGED HEADS (2-WAY SHOWN)
- EXISTING VEHICULAR TRAFFIC SIGNAL (1-WAY SHOWN)
- REMOVE VEHICULAR TRAFFIC SIGNAL (1-WAY SHOWN)
- INSTALL PEDESTRIAN (COUNTDOWN TYPE) TRAFFIC SIGNAL (2-WAY SHOWN)
- INSTALL PEDESTRIAN (COUNTDOWN TYPE) TRAFFIC SIGNAL WITH SALVAGED HEAD (2-WAY SHOWN)
- REMOVE PEDESTRIAN (WALK-DON'T WALK) TRAFFIC SIGNAL (1-WAY SHOWN)
- EXISTING PEDESTRIAN (WALK-DON'T WALK) TRAFFIC SIGNAL (1-WAY SHOWN)
- INSTALL JUNCTION BOX
- INSTALL SALVAGED JUNCTION BOX
- REMOVE JUNCTION BOX
- EXISTING JUNCTION BOX
- INSTALL OVERHEAD PLASTIC JACKETED CABLE
- EXISTING OVERHEAD PLASTIC JACKETED CABLE
- REMOVE OVERHEAD PLASTIC JACKETED CABLE
- INSTALL TRAFFIC SIGNAL CONTROLLER (NEW OR SALVAGED AS INDICATED). (EXCEPT AS OTHERWISE INDICATED)
- INSTALL MAST ARM POLE & MAST ARM (SIZES AS INDICATED) ON NEW FOUNDATION (EXCEPT AS OTHERWISE INDICATED).
- INSTALL TRAFFIC SIGNAL PEDESTAL ON NEW FOUNDATION (EXCEPT AS OTHERWISE INDICATED).
- INSTALL ANCHOR BASE STEEL STRAIN POLE (SIZE AS INDICATED) ON NEW FOUNDATION. (EXCEPT AS OTHERWISE INDICATED).
- EXISTING TRAFFIC SIGNAL CONTROLLER
- EXISTING MAST ARM STANDARD
- EXISTING PEDESTAL
- EXISTING STEEL STRAIN POLE
- BAG SIGNALS AS DIRECTED BY ENGINEER. (INCLUDED IN INSTALLATION OF T.S. ON THIS CONTRACT).
- REMOVE BAG AS DIRECTED BY ENGINEER. (INCLUDED IN INSTALLATION OF T.S. ON THIS CONTRACT).
- POCH POLE CONTACT HEIGHT OF T.S. SPAN WIRE
- L.C.H. LOW CONTACT HEIGHT OF SPAN WIRE T.S. TO SPAN WIRE.
- INSTALL WARNING SIGN (TYPE AS INDICATED ON PLANS).
- INSTALL 2-WAY CASE SIGN
- REMOVE 2-WAY CASE SIGN
- EXISTING 2-WAY CASE SIGN
- INSTALL 4-WAY CASE SIGN
- REMOVE 4-WAY CASE SIGN
- EXISTING 4-WAY CASE SIGN

- M.H. 1234
- EX. H.H.
- EXISTING DUCT RUN
- REMOVE EXISTING DUCT RUN
- BUILD DIRECT BURIAL CONDUIT (D.B.) OR ENCASED CONDUIT (E.C.) (2-3" D.B. SHOWN)
- GALVANIZED IRON CONDUIT (2-3" SHOWN)
- M.H. 5678
- M.H. 9012
- M.H. 3456
- M.H. 7890
- BUILD ROUND HANDHOLE
- BUILD SQUARE HANDHOLE
- BUILD TYPE "D" HANDHOLE
- EXISTING DIRECT BURIAL OR PARKWAY CABLE
- ABANDON DIRECT BURIAL OR PARKWAY CABLE
- INSTALL DIRECT BURIAL CABLE (NO. & SIZE AS INDICATED)
- EXISTING U.G.-FED ST. LTG. UNIT
- REMOVE U.G.-FED ST. LTG. UNIT & FDN. (EXCEPT AS OTHERWISE INDICATED)
- INSTALL COMB. T.S. & ST. LTG. STD. (SIZE AS SPECIFIED) ON NEW FDN., 6FT. CLAMP ON BRACKET ARM WITH 3'-0" RISE, INSTALL 400W. TYPE LUMINAIRE.

TRAFFIC SIGNAL

- INSTALL OVERHEAD DETECTION CAMERA MOUNTED AS INDICATED ON THE PLANS.
- INSTALL SALVAGED OVERHEAD DETECTION CAMERA MOUNTED AS INDICATED ON THE PLANS.
- EXISTING OVERHEAD DETECTION CAMERA
- REMOVE OVERHEAD DETECTION CAMERA
- INSTALL LOOP DETECTION AREA IN PAVT
- WIRELESS VEHICLE DETECTION AREA
- INSTALL LOOP DETECTOR & CABINET (EXCEPT AS OTHERWISE INDICATED).
- EXISTING LOOP DETECTOR & CABINET
- INSTALL OPTICAL DETECTOR AS SHOWN ON PLANS
- INSTALL WIRELESS VEHICLE RADIO RECEIVER AS INDICATED

UNDERGROUND

OVERHEAD

- EXISTING OR REMOVE WOOD POLE AS INDICATED
- REPLACE WOOD POLE (HEIGHT & CLASS AS INDICATED)
- INSTALL WOOD POLE (HEIGHT & CLASS AS INDICATED) (USE SALVAGED POLE WHERE INDICATED)
- EXISTING OVERHEAD ST. LTG. UNIT
- REMOVE OVERHEAD ST. LTG. UNIT
- INSTALL OVERHEAD ST. LTG. UNIT
- EXISTING OVERHEAD LINE
- REMOVE OVERHEAD LINE
- INSTALL OVERHEAD LINE
- INSTALL & LATER REMOVE OVERHEAD LINE
- INSTALL GUY & ANCHOR (1/2" GUY SHOWN)
- REMOVE GUY & ANCHOR ROD
- INSTALL POLE GUY (1/2" GUY SHOWN)
- INSTALL ARM GUY (3/8" GUY SHOWN)
- REMOVE GUY (TYPE AS INDICATED)
- IN. MATERIAL TO BE INSTALLED
- RM. MATERIAL TO BE REMOVED
- MSS MAKE WOOD POLE SELF-SUPPORTING IN CONCRETE
- C.P. CABLE POLE

GENERAL

- PROPERTY LINE (ROW)
- PAVEMENT JOINTLINE & CURB FACE
- PROPOSED PAVEMENT
- SEWER LINE, MANHOLE & CATCH BASIN
- DET. ED. CO. U.G. LINE & MANHOLE
- TELEPHONE U.G. LINE & MANHOLE
- WATERMAIN & GATEWELL (OTHER UTILITIES SIMILAR)
- GAS STRUCTURE AND U.G. LINE

DIAGRAMS

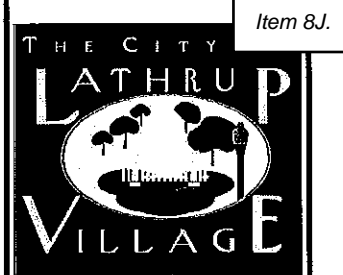
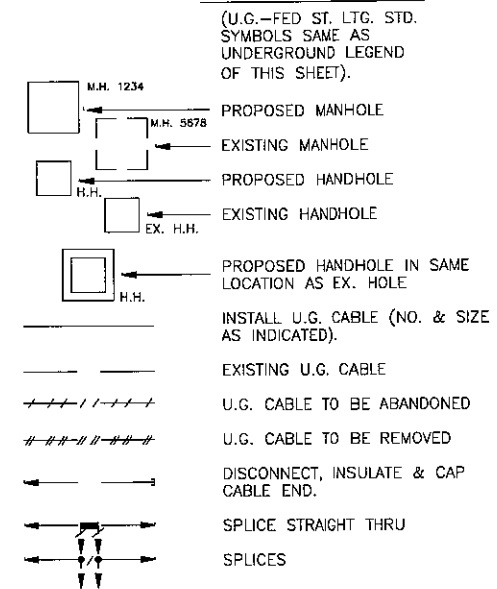

Item 8.J.

HRC
HUBBELL, ROTH & CLARK, INC
 CONSULTING ENGINEERS SINCE 1915
 555 HULET DRIVE BLOOMFIELD HILLS, MICH. P.O. BOX 824 48303-0824
 PHONE: (248) 454-6300 FAX (Int. Floor): (248) 454-6312 FAX (2nd. Floor): (248) 454-6339
 WEB SITE: www.hrcengr.com

DATE	ADDITIONS AND/OR REVISIONS
DESIGNED	HFA
DRAWN	COB
CHECKED	LFM
APPROVED	

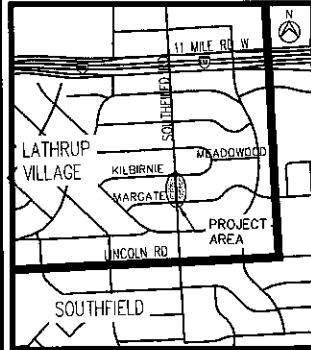

THE CITY OF LATHRUP VILLAGE
TRAFFIC SIGNAL MODERNIZATION

SIGNAL LEGEND
 SOUTHFIELD RD

HRC JOB NO. 20220916	SCALE NTS
DATE February 2023	SHEET NO. 6

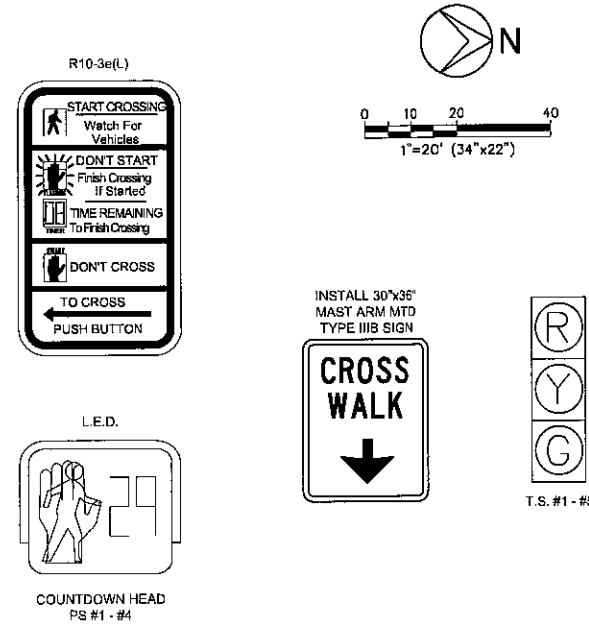
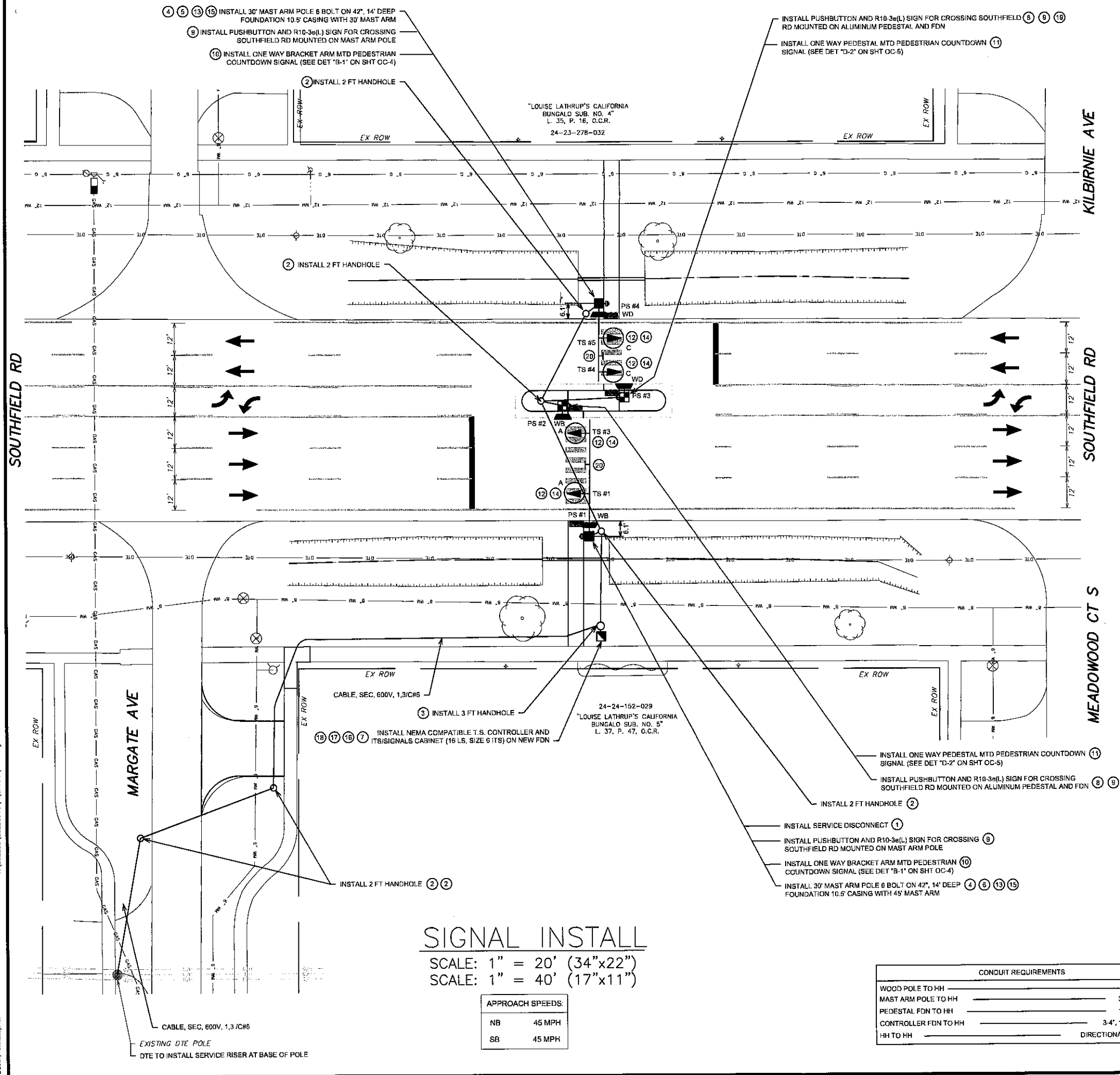

CONSTRUCTION QUANTITIES - THIS SHEET

PAY ITEM	QTY	UNIT
1 Serv Disconnect	2	Ea
2 Hh, Round, 2 foot Dia, RCOC	5	Ea
3 Hh, Round, 3 foot Dia, RCOC	1	Ea
4 Mast Arm Pole, Cat III	2	Ea
5 Mast Arm, 30 foot, Cat III	1	Ea
6 Mast Arm, 45 foot, Cat III	1	Ea
7 Controller Fdn, Base Mount	1	Ea
8 Pedestal, Fdn	2	Ea
9 Pushbutton and Sign	4	Ea
10 TS, Pedestrian, One Way Bracket Arm Mtd (LED) Countdown	2	Ea
11 TS, Pedestrian, One Way Pedestal Mtd (LED) Countdown	2	Ea
12 TS, One Way Mast Arm Mtd (LED)	4	Ea
13 Casing	21	Ft
14 Backplate, TS, RCOC	4	Ea
15 Mast Arm Pole Fdn, 6 Bolt	28	Ft
16 Controller, Digital Type, Delivered, RCOC	1	Ea
17 Cabinet, ITS Type, RCOC	1	Ea
18 Cabinet, ITS Type, Delivered, RCOC	1	Ea
19 Pedestal, Alum, RCOC	2	Ea
20 Mast Arm, Mtd, Sign, Type III, RCOC	2	Ea
Conduit, DB, 1, 1 1/4 inch	60	Ft
Conduit, DB, 1, 3 inch	160	Ft
Conduit, DB, 3, 3 inch	20	Ft
Conduit, DB, 3, 4 inch	20	Ft
Cable, Sec, 600V, 1, 3/C#6	300	Ft
Conduit, Directional Bore, 2, 4 inch, RCOC	275	Ft

- NOTES:
- CONTACT _____ OF DTE ENERGY AT (248) XXX-XXXX FOR ELECTRIC SERVICE CONNECTION.
 - MINIMUM SIGNAL HEAD UNDERCLEARANCE IS 18 FEET.
 - PRIOR TO SIGNAL TURN ON/CUTOVER, PLEASE CONTACT MR. STEVE WHEELER AT 248-858-7250 EIGHT WEEKS PRIOR IN ORDER TO OBTAIN RCOC BOARD APPROVAL
 - NEW SIGNAL SHALL BE IN FLASH FOR A MINIMUM OF 7 CALENDAR DAYS PRIOR TO ACTIVATION.

ADA ACCESSIBILITY CRITERIA:

- PUSHBUTTON MUST BE NO MORE THAN 10" FROM EDGE OF SIDEWALK (REACH CONSIDERATION).
- PUSHBUTTON MUST BE IN MIDDLE OF A 4' MINIMUM LONG SECTION OF SIDEWALK (LANDING) WITH A SLOPE OF NO MORE THAN 2%.
- PUSHBUTTON MUST FACE INTERSECTION AND BE PARALLEL TO CROSSWALK DIRECTION OR AS DIRECTED BY ENGINEER.

CONDUIT REQUIREMENTS

WOOD POLE TO HH	1-3"
MAST ARM POLE TO HH	3-3" & 1-1 1/4"
PEDESTAL FDN TO HH	1-3" & 1-1 1/4"
CONTROLLER FDN TO HH	3-4", 1-3" & 1-1 1/4"
HH TO HH	DIRECTIONAL BORE, 2-4"

NOTE:
UTILITY INFORMATION ON THIS DRAWING MAY BE FROM INFORMATION OBTAINED FROM THE FIELD BY THE VARIOUS UTILITY COMPANIES, CITY/COUNTY AGENCIES AND OTHER VARIOUS SOURCES. UNDERGROUND UTILITIES WHICH ARE ON PRIVATE PROPERTY ARE USUALLY NOT DELINEATED UPON A UTILITY COMPANY'S PUBLISHED PLANS. THEIR LOCATION, IF SHOWN UPON THIS SURVEY, ARE APPROXIMATED FROM FOLDING PARTY MARKSTAKES, ETC. AS LOCATED BY THIS FIRM FROM SOURCES WHICH ARE UNKNOWN. NO GUARANTEE IS GIVEN AS TO THE COMPLETENESS OR ACCURACY THEREOF.

PRIOR TO CONSTRUCTION, ALL LOCATIONS AND DEPTHS OF EXISTING UTILITIES, IN CONFLICT WITH PROPOSED IMPROVEMENTS SHALL BE VERIFIED IN THE FIELD. CALL MISS DIG 3 WORKING DAYS PRIOR TO CONSTRUCTION.



THREE FULL WORKING DAYS BEFORE YOU DIG, CALL THE MISS DIG SYSTEM AT 800-482-7171 OR 811.



HRC
HUBBELL, ROTH & CLARK, INC
CONSULTING ENGINEERS SINCE 1915
555 HULEY DRIVE
BLOOMFIELD HILLS, MICH. P.O. BOX 824
48303-0824
PHONE: (248) 454-6300
FAX (1st Floor): (248) 454-6312
FAX (2nd Floor): (248) 454-6399
WEB SITE: www.hrcengr.com

DATE	ADDITIONS AND/OR REVISIONS
DESIGNED	COB
DRAWN	HFA
CHECKED	COB
APPROVED	LSM

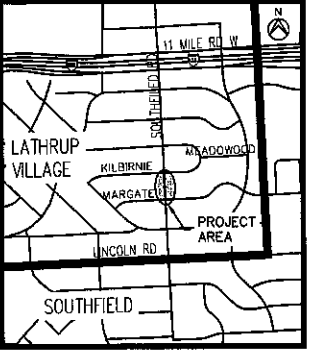

THE CITY OF LATHRUP VILLAGE
TRAFFIC SIGNAL
MODERNIZATION

SIGNAL INSTALL PLAN
SOUTHFIELD ROAD

C.O. #1608	
HRC JOB NO. 20220916	SCALE 1"=20'
DATE March 2024	SHEET NO.



27400 Southfield Rd
 Lathrup Village, MI 48076
 (248) 557 - 2600
 www.lathrupvillage.org

To: City Council
 From: Austin Colson – Community & Economic Development/DDA Director
 Date: August 15, 2024
 RE: Placemaking and Public Spaces Program Agreement

Oakland County’s Revitalization and Placemaking Program (“RAP 2.0”) is a grant program intended to distribute American Rescue Plan (ARPA) funding to address the COVID-19 impacts and incentivize revitalization needs in local communities.

Funding is planned to be utilized locally to renovate the existing playscape located in Municipal Park. The current play structure does not offer ADA accessibility, whereas the new design is built entirely on universal design principles. A fully renovated play structure represents a leap forward for Lathrup Village children, as well as those in nearby communities.

As part of our town center, this public space not only creates a more desirable setting and atmosphere for the surrounding residents but also increases the economic benefits to surrounding property owners. Public spaces in town centers provide a setting for events and organized gatherings, increasing the number of visitors.

During the June 23, 2023, City Council meeting, the City Council approved a previous resolution of support for the RAP 2.0 funding. The County is now requesting an updated resolution be submitted by communities authorizing signers on agreements.

The following resolution authorizes the City’s Community and Economic Development/DDA Director, Austin Colson, to sign the Placemaking and Public Spaces Program Agreement with Oakland County.

Recommended Motion:

Moved by Council Member _____ seconded by Council Member _____ to approve Resolution #2024-15 in support of the Oakland County RAP 2.0 Revitalization & Placemaking Grant Application.

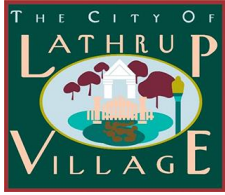

City of Lathrup Village
27400 Southfield Road
Lathrup Village, MI 48076
www.lathrupvillage.org | (248) 557-2600

RESOLUTION #2024-15
A RESOLUTION IN SUPPORT OF THE OAKLAND COUNTY RAP 2.0
REVITALIZATION & PLACEMAKING GRANT APPLICATION

At a regular meeting of the City Council of the City of Lathrup Village, Oakland County, Michigan, (the "City"), held on the 19th day of August 2024.

The following Resolution was offered by _____ and seconded by _____.

WHEREAS, the City of Lathrup Village has submitted an application for grant funding to Oakland County; and

WHEREAS, the City of Lathrup Village wishes to enter into a Program Agreement with Oakland County for grant funding.

NOW THEREFORE BE IT RESOLVED that the City of Lathrup Village City Council hereby acknowledges that this resolution authorizes Austin Colson, DDA Director to execute the Placemaking and Public Spaces Program Agreement for Local Fiscal Recovery Fund Distribution Between Oakland County and the City of Lathrup Village.

RESOLUTION ADOPTED

YEAS:

NAYS:

ABSENT/ABSTAIN:

I, Alisa Emanuel, the duly appointed City Clerk of the City of Lathrup Village, Oakland County, Michigan, certifies that the foregoing is a true and complete copy of a Resolution duly adopted by the City Council of the City of Lathrup Village at a meeting held on Augst 19, 2024, the original of which is on file in the City Clerk's Office.

IN WITNESS WHEREOF, I have affixed my official signature on this 19th day of August 2024.

Alisa Emanuel – City Clerk

Kelly Garrett Mayor	Bruce Kantor Mayor Pro-Tem	Jalen Jennings Council Member	Dalton Barksdale Council Member	Jason Hammond Council Member
-------------------------------	--------------------------------------	---	---	--

PLACEMAKING AND PUBLIC SPACES PROGRAM AGREEMENT FOR LOCAL FISCAL RECOVERY FUND DISTRIBUTION BETWEEN OAKLAND COUNTY AND CITY OF LATHRUP VILLAGE

This Agreement (the "Agreement") is made between Oakland County, a Municipal and Constitutional Corporation, 1200 North Telegraph Road, Pontiac, Michigan 48341 ("County"), and the City of Lathrup Village ("Public Body") 27400 Southfield Road City Of Lathrup Village, MI 48076. County and Public Body may be referred to individually as a "Party" and jointly as "Parties". Notwithstanding any language to the contrary in the Agreement, Public Body is a grantee of the funds it received under the Agreement. Public Body shall comply with all requirements in the Agreement regardless of its classification as a grantee.

PURPOSE OF AGREEMENT. On March 11, 2021, the President of the United States signed the American Rescue Plan Act of 2021 ("ARPA") into law. Section 9901 of ARPA amended Title VI of the Social Security Act to add section 603, which establishes the Coronavirus Local Fiscal Recovery Fund. Oakland County has been allocated \$244,270,949 in Local Fiscal Recovery Fund ("LFRF") dollars under ARPA.

The United States Department of Treasury has issued an interim final rule, and other guidance for qualified uses of LFRF. Those qualified uses include supporting eligible investments in public health expenditures, addressing negative economic impacts caused by the public health emergency, replacing lost public sector revenue, providing premium pay for essential workers, and investing in water, sewer and broadband infrastructure. The County has determined that the distribution of funds in accordance with this Agreement is a qualified use of LFRF funds pursuant to the interim rule and other applicable Department of Treasury guidance.

Placemaking creates quality places essential to dynamic and vibrant communities. Assistance with Placemaking plans will provide economic benefits to the Public Body and the County.

On December 7, 2023, in Miscellaneous Resolution #2023-3615 _ 23-164, the Oakland County Board of Commissioners authorized an appropriation in the amount of Five Million \$5,000,000 dollars from the American Rescue Plan Act, Local Fiscal Recovery Funds, for the Main Street Oakland County Placemaking and Public Services Program to combat the negative economic impacts still lingering in our communities as a result of the COVID-19 pandemic. This Agreement is funded through that program.

County and Public Body enter into this Agreement pursuant to the Urban Cooperation Act of 1967, 1967 Public Act 7, MCL 124.501 *et seq.*, for the purpose of County distributing a portion of its LFRF funds to Public Body.

In consideration of the mutual promises, obligations, representations, and assurances in this Agreement, the Parties agree to the following:

- 1. **DEFINITIONS.** The following words and expressions used throughout this Agreement, whether used in the singular or plural, shall be defined, read, and interpreted as follows:
 - 1.1 **Agreement** means the terms and conditions of this Agreement and any other mutually agreed to written and executed modification, amendment, exhibit and attachment.
 - 1.2 **Application** means a properly submitted written request by a Public Body to the County for an award of Grant Funds.

- 1.3 **Claims** mean any alleged losses, claims, complaints, demands for relief or damages, lawsuits, causes of action, proceedings, judgments, deficiencies, liabilities, penalties, litigation, costs, and expenses, including, but not limited to, reimbursement for reasonable attorney fees, witness fees, court costs, investigation expenses, litigation expenses, amounts paid in settlement, and/or other amounts or liabilities of any kind which are incurred by or asserted against County or Public Body, or for which County or Public Body may become legally and/or contractually obligated to pay or defend against, whether direct, indirect or consequential, whether based upon any alleged violation of the federal or the state constitution, any federal or state statute, rule, regulation, or any alleged violation of federal or state common law, whether any such claims are brought in law or equity, tort, contract, or otherwise, and/or whether commenced or threatened.
- 1.4 **County** means Oakland County, a Municipal and Constitutional Corporation, including, but not limited to, all of its departments, divisions, the County Board of Commissioners, elected and appointed officials, directors, board members, council members, commissioners, authorities, committees, employees, agents, volunteers, and/or any such persons' successors.
- 1.5 **Day** means any calendar day beginning at 12:00 a.m. and ending at 11:59 p.m.
- 1.6 **Exhibits** mean the following exhibits, which are attached to this Agreement and incorporated by reference therein, or added later by a formal amendment to this Agreement:
 - Exhibit A, Grant Award Payments
 - Exhibit B, Reporting Requirements
 - Exhibit C, Grant Application, Scope of Work and Budget
- 1.7 **Grantee** means the Public Body [City, Village or Township, as defined in 1.11 below] receiving Grant Funds from the County under this Agreement in the manner provided in Section 2, below, which is an entity created by state or local authority or which is primarily funded through state or local authority, including, but not limited to, its Council, Board, its departments, divisions, elected and appointed officials, directors, Board members, Council members, commissioners, authorities, committees, employees, agents, subcontractors, attorneys, volunteers and/or any such person's or entities' successors.
- 1.8 **Grant Funds** means the monetary funds awarded by the County to the Grantee under this Agreement.
- 1.9 **Grantee Funds** means the monetary funds that the Grantee raises on its own for this program.
- 1.10 **Points of Contact** means the individuals designated by the Grantee and County to act as primary contacts for communication and other purposes described herein.
- 1.11 **Public Body** means the City of Lathrup Village including, but not limited to, its council, its Board, its departments, its divisions, elected and appointed officials, directors, board members, council members, commissioners, authorities, committees, employees, agents, subcontractors, attorneys, volunteers, and/or any such persons' successors. For the purposes of this Agreement, Public Body includes any Michigan court, when acting in concert with its funding unit.
- 1.12 **Public Body Employee** means any employees, officers, directors, members, managers, trustees, volunteers, attorneys, representatives of Public Body, licensees, concessionaires, contractors, subcontractors, independent contractors, agents, and/or any such persons' successors or predecessors (whether such persons act or acted in their personal, representative or official capacities), and/or any persons acting by, through, under, or in concert with any of

the above who use or have access to the funds provided under this Agreement. "Public Body Employee" shall also include any person who was a Public Body Employee at any time during the term of this Agreement but, for any reason, is no longer employed, appointed, or elected in that capacity.

2. **GRANT.** Subject to the terms and conditions of this Agreement, and in reliance upon the Public Body’s affirmations set forth below, the County agrees to make, and the Public Body agrees to accept, the grant funds.

- 2.1 County will distribute \$135,767.00 in grant funds to Public Body for the project scope attached and incorporated into this Agreement as **Exhibits A and C.**
- 2.2 PUBLIC BODY UNIQUE ENTITY IDENTIFIER: GJ67JS51GRN3.
- 2.3 FEDERAL AWARD IDENTIFICATION NUMBER (FAIN): SLFRP2640
- 2.4 CATALOG OF FEDERAL DOMESTIC ASSISTANCE (CFDA) NUMBER: 21.027
- 2.5 FEDERAL AWARD DATE: May 28, 2021
- 2.6 PERIOD OF PERFORMANCE END: September 30, 2026.
- 2.7 AWARD IS NOT FOR RESEARCH & DEVELOPMENT (R&D): Funds cannot be used for research and development related expenditures.
- 2.8 INDIRECT COST RATE FOR FEDERAL AWARD: Indirect costs are not eligible for this Agreement.
- 2.9 CONTACT PERSON FOR COUNTY/PASS THROUGH ENTITY: John Bry, unless another person is designated in writing by the County.
- 2.10 DEFINED USE OF FUNDS: All grant funds must be expended in accordance with this Agreement and the guidelines for ARPA funds.

3. **PUBLIC BODY’S RESPONSIBILITIES.**

- 3.1 Public Body’s grant match requirements are detailed in **Exhibit A**, which is attached hereto and incorporated as part of this Agreement.
- 3.2 Public Body shall invoice the County for the grant amount listed in 2.1. after this Agreement is executed.
- 3.3 Public Body shall submit to Oakland County a status report on the grant funds as provided in **Exhibit B**, including:
- 3.4 Project progress reports, including completion of deliverables included in project scope;
- 3.5 Accounting of incurred expenses and grant funds expended; and
- 3.6 Any other relevant information or records, to be determined by County.
- 3.7 Public Body shall submit to Oakland County a final report by the end of the Agreement or within 30 days after final project completion, whichever date is sooner, on the grant funds, including:
- 3.8 Project completion report;
- 3.9 Full accounting of its expenditure of grant funds;
- 3.10 Certification of its use of grant funds and fulfillment of the terms of the Agreement; and

- 3.11 Any other relevant information, records or other pertinent documentation, which may be requested by the County. If requested by the County, the Public Body shall provide information concerning the Grant Award to the County in a web based format.
- 3.12 Public Body shall respond to and be responsible for Freedom of Information Act requests relating to Public Body's records, data, or other information.
- 3.13 Public Body must comply with any other reporting requirements regarding the grant funds and/or this Agreement, as determined by the County.
- 3.14 Public Body may only use Grant Funds for purposes consistent with those specified by the Public Body in its approved Grant Application, Scope of Work and Budget (**Exhibit C**).

4. **COUNTY'S RESPONSIBILITIES.**

- 4.1 County has reviewed the Public Body's Grant Application and determined that the Public Body is eligible to receive Grant Funds. County is not obligated or required to provide any additional services that are not specified in this Agreement.
- 4.2 County may use, access, and disclose information concerning this Agreement and the award of Grant Funds described herein to comply with the law, such as a subpoena, court order or Freedom of Information Act request. County may refer all such requests to the Public Body's Point of Contact for their response within the required time frame if the information requested relates to records held by the Public Body.
- 4.3 County shall designate in writing a department, individual, or other entity to oversee the reporting requirements set forth in Section 3 above and **Exhibit B** to ensure timely reporting, accurate accounting, and verification of final certification.
- 4.4 County shall pay the Grant Funds to the Public Body in the manner and upon the conditions set forth in **Exhibit A**. As stated therein, it is understood between the Parties that under no circumstances shall the County be responsible for greater than Forty percent (40%) of the total development cost and that by accepting Grant Funds, the Public Body thereby commits to contributing Grantee Funds in an amount sufficient to fully fund the development cost of the project approved by the County pursuant to its Grant Application, Scope of Work and Budget (**Exhibit C**).

5. **PUBLIC BODY AFFIRMATIONS.**

- 5.1 Public Body affirms that all representations made to County in connection with its application and this grant were accurate, truthful and complete and remain so. Public Body acknowledges that all representations and information provided have been relied on by the County to provide funding under this Agreement. Public Body shall promptly notify County, in writing, of the occurrence of any event or any material change in circumstances which would make any Public Body representation or information untrue or incorrect or otherwise impair Public Body's ability to fulfill its obligations under this Agreement.
- 5.2 Public Body will comply with any federal, state, or local public health orders or mitigation recommendations regarding the COVID-19 pandemic which are in effect as of the date this Agreement is signed by both Parties.
- 5.3 Public Body may not use grant funds for expenses for which the Public Body has received any other federal funds or emergency COVID-19 supplemental funding, whether it be state, federal, or private in nature, for the same expense. No portion of grant funds may be used for the purpose of obtaining additional Federal funds under any other law of the United States,

except if authorized by law. Public Body shall promptly notify County if it receives insurance proceeds or other disaster assistance (public or private) that duplicates the funding received under this Agreement. Grant funds may not be used to cover expenses that were reimbursed by insurance.

5.4 Public Body shall not carry out any activities under this Agreement that results in a prohibited duplication of benefits as defined by Section 312 of the Robert T. Stafford Disaster Relief and Emergency Assistance Act (42 U.S.C. 5155) and in accordance with Section 1210 of the Disaster Recovery Reform Act of 2018 (division D of Public Law 115–254; 132 Stat. 3442), which amended Section 312 of the Robert T. Stafford Disaster Relief and Emergency Assistance Act (42 U.S.C. 5155). If the Public Body receives duplicate benefits from another source for projects related to this disaster, the Public Body must refund the benefits provided by the County to the County. Duplication of benefits occurs when Federal financial assistance is provided to a person or entity through a program to address losses resulting from a Federally-declared emergency or disaster, and the person or entity has received (or would receive, by acting reasonably to obtain available assistance) financial assistance for the same costs from any other source (including insurance), and the total amount received exceeds the total need for those costs.

5.5 Public Body shall use all grant funds it receives under this Agreement by September 30, 2026. Any grant funds not used by that date must be returned to County.

6. **REPAYMENT REMEDIES.** Public Body is subject to repayment to the County of an amount equal to the grant funds received by Public Body in the event Public Body has made material misrepresentations to the County in its application, voluntary bankruptcy or insolvency proceeding are commenced against the Public Body and not set aside within sixty (60) days, or the Public Body fails to otherwise comply with the requirements of this Agreement. In the event County later determines the information Public Body provided in conjunction with this Agreement, or that Public Body was ineligible for the grant funds, or that Public Body’s use of the grant funds following receipt was contrary to this Agreement, Public Body agrees to repay the grant funds to County in full. County further retains all rights and remedies allowed in law or equity, including seeking payment of its reasonable costs and expenses incurred enforcing its rights and remedies.

7. **TAX LIABILITY.** County and Public Body agree that to the extent that any part of the aforementioned funds are deemed to be taxable, that Public Body agrees to be fully responsible for the payment of any taxes, including withholding payments, social security, or other funds which are required to be withheld. Public Body agrees to provide County with all information and cooperation necessary to execute a completed 1099-G form; which County will file with the United States Internal Revenue Service. Public Body acknowledges that Public Body will consult with a tax professional regarding the tax implications, if any, of the grant funds, and/or hereby waives the option to do so. Public Body further agrees to indemnify and hold County harmless for the payment of any tax or withholding payments, including any penalty assessed it may owe under this Agreement.

8. **CONFLICT OF INTEREST.** Pursuant to Public Act 317 and 318 of 1968, as amended (MCL 15.301, *et seq.* and MCL 15.321, *et seq.*), to avoid any real or perceived conflict of interest, Public Body shall disclose to County the identity of all Public Body Employees and all relatives of Public Body Employees who: a) are employed by the County or are elected or appointed officials of the County, on the date this Agreement is executed; and b) becomes employed or appointed by the County or becomes an elected official of County during the term of the Agreement.

9. **ACCESS TO RECORDS AND AUDIT.**

- 9.1** Grantee shall maintain all records pertinent to the Agreement and any amendments, including backup copies, for a period of five (5) years. The records shall be kept in accordance with generally accepted accounting practices, and the Grantee shall utilize adequate internal controls and shall maintain necessary documentation for all costs incurred, including documentation and an inventory of all equipment purchased with grant funds. These internal controls should be in compliance with guidance in “Standards for Internal Control in the Federal Government” issued by the Comptroller General of the United States or the “Internal Control Integrated Framework”, issued by the Committee of Sponsoring Organizations of the Treadway Commission (COSO).
- 9.2** In addition to the Grantor, the U.S. Department of Treasury, or their authorized representatives, shall be provided the right to audit all records pertaining to the expenditure and use of grant funds. All records with respect to any matters covered by this Agreement shall be made available to the Grantor, the Federal awarding agency, and the Comptroller General of the United States or any of their authorized representatives, at any time during normal business hours, as often as deemed necessary, to audit, examine, and make excerpts or transcripts of all relevant data. Any deficiencies noted in audit reports must be fully cleared by the Grantee within 30 days after receipt by the Grantee. Failure of the Grantee to comply with the audit requirements will constitute a violation of this Agreement.
- 9.3** Grantee must establish and maintain effective internal control over the Federal award that provides reasonable assurance that they are managing the award in compliance with Federal statutes, regulations, and the terms and conditions of the award.
- 9.4** Grantee shall provide a final report that is due to Grantor upon the completion of the project. Grantee agrees to submit a detailed and timely grant report covering expenses related to each outlined purpose.
- 10. COMPLIANCE WITH LAWS.** Public Body shall comply with all federal, state, and local laws, statutes, ordinances, regulations, and all requirements applicable to its activities under the Agreement and grant. This includes the following:
- 10.1** Public Body must comply with 2 C.F.R. 200.303(e) and take reasonable measures to safeguard protected personally identifiable information, as defined in 2 C.F.R. 200.82, and other information County designates as sensitive, or the Public Body considers sensitive consistent with applicable Federal, state, and local laws regarding privacy and obligations of confidentiality.
- 10.2** Public Body must comply with 2 C.F.R. 200.322 if it is passing through grant funds/issuing subawards to other entities.
- 10.3** Public Body must comply with 31 U.S.C. Chapter 38, Administrative Remedies for False Claims and Statements. Public Body will not pass-through grant funds to an entity listed in the SAM Exclusions. SAM Exclusions is the list maintained by the General Services Administration that contains the names of parties debarred, suspended, or otherwise excluded by agencies, as well as parties declared ineligible under statutory or regulatory authority other than Executive Order 12549. SAM exclusions can be accessed at www.sam.gov.
- 10.4** Public Body must register at sam.gov.
- 10.5** Public Body must comply with Title VI of the Civil Rights Act of 1964, and any implementing regulations, which prohibits entities receiving Federal financial assistance from excluding from a program or activity, denying benefits or services, or otherwise discriminating against a person on the basis of race, color, national origin (including limited English proficiency),

disability, age, or sex (including sexual orientation and gender identity). All applicable U.S. Department of Treasury Title VI regulations are incorporated into this Agreement and made a part of this Agreement.

10.6 Public Body must comply with 2 C.F.R. Part D, Post Federal Award Requirements, being 200.300 et seq., where applicable.

11. **DURATION OF INTERLOCAL AGREEMENT.**

11.1 This Agreement shall be effective when executed by both Parties with resolutions passed by the governing bodies of each Party. The approval and terms of this Agreement shall be entered in the official minutes of the governing bodies of each Party. An executed copy of this Agreement and any amendments shall be filed by the County Clerk with the Secretary of State.

11.2 This Agreement shall remain in effect until September 30, 2026, or until cancelled or terminated by any of the Parties pursuant to the terms of the Agreement. Public Body shall comply with the record keeping, reporting, audit response, and fund return requirements of this Agreement after the termination of this Agreement.

12. **ASSURANCES.**

12.1 **Responsibility for Claims.** Each Party shall be responsible for any Claims made against that Party by a third party, and for the acts of its employees arising under or related to this Agreement.

12.2 **Responsibility for Attorney Fees and Costs.** Except as provided for in Sections 7 and 14, in any Claim that may arise from the performance of this Agreement, each Party shall seek its own legal representation and bear the costs associated with such representation, including judgments and attorney fees.

12.3 **No Indemnification.** Except as otherwise provided for in this Agreement, neither Party shall have any right under this Agreement or under any other legal principle to be indemnified or reimbursed by the other Party or any of its agents in connection with any Claim.

12.4 **Costs, Fines, and Fees for Noncompliance.** Public Body shall be solely responsible for all costs, fines and fees associated with any misuse of the grant funds and/or for noncompliance with this Agreement by Public Body Employees.

12.5 **Reservation of Rights.** This Agreement does not, and is not intended to, impair, divest, delegate or contravene any constitutional, statutory, and/or other legal right, privilege, power, obligation, duty, or immunity of the Parties. Nothing in this Agreement shall be construed as a waiver of governmental immunity for either Party.

12.6 **Authorization and Completion of Agreement.** The Parties have taken all actions and secured all approvals necessary to authorize and complete this Agreement. The persons signing this Agreement on behalf of each Party have legal authority to sign this Agreement and bind the Parties to the terms and conditions contained herein.

13. **TERMINATION OR CANCELLATION OF AGREEMENT.**

13.1 County may terminate or cancel this Agreement at any time if it determines that Public Body has expended the grant funds in violation of ARPA requirements or this Agreement. If County terminates or cancels this Agreement, Public Body shall be liable to repay County the amount of money expended in violation of ARPA requirements or this Agreement. County may utilize the provisions in Section 14 to recoup the amount of money owed to County by Public Body.

- 13.2 Public Body may terminate or cancel this Agreement at any time. If Public Body terminates or cancels this Agreement, it shall immediately return to County all grant funds it has received.
- 13.3 If either Party terminates or cancels this Agreement, they shall provide written notice to the other Party in the manner described in Section 21.

14. SETOFF OR RETENTION OF FUNDS

14.1 In any case where Public Body is required to return an amount of money to County under this Agreement, Public Body agrees that unless expressly prohibited by law, County or the Oakland County Treasurer, at their sole option, shall be entitled to set off from any other Public Body funds that are in County's possession for any reason, including but not limited to, the Oakland County Delinquent Tax Revolving Fund ("DTRF"), if applicable. Any setoff or retention of funds by County shall be deemed a voluntary assignment of the amount by Public Body to County. Public Body waives any Claims against County or its Officials for any acts related specifically to County's offsetting or retaining of such amounts. This paragraph shall not limit Public Body's legal right to dispute whether the underlying amount retained by County was actually due and owing under this Agreement.

14.2 Nothing in this Section shall operate to limit County's right to pursue or exercise any other legal rights or remedies under this Agreement or at law against Public Body to secure payment of amounts due to County under this Agreement. The remedies in this Section shall be available to County on an ongoing and successive basis if Public Body becomes delinquent in its payment. Notwithstanding any other term and condition in this Agreement, if County pursues any legal action in any court to secure its payment under this Agreement, Public Body agrees to pay all costs and expenses, including attorney fees and court costs, incurred by County in the collection of any amount owed by Public Body.

15. **DELEGATION OR ASSIGNMENT**. Neither Party shall delegate or assign any obligations or rights under this Agreement without the prior written consent of the other Party.

16. **NO THIRD-PARTY BENEFICIARIES**. Except as provided for the benefit of the Parties, this Agreement does not and is not intended to create any obligation, duty, promise, contractual right or benefit, right to indemnification, right to subrogation, and/or any other right in favor of any other person or entity.

17. **NO IMPLIED WAIVER**. Absent a written waiver, no act, failure, or delay by a Party to pursue or enforce any rights or remedies under this Agreement shall constitute a waiver of those rights with regard to any existing or subsequent breach of this Agreement. No waiver of any term, condition, or provision of this Agreement, whether by conduct or otherwise, in one or more instances shall be deemed or construed as a continuing waiver of any term, condition, or provision of this Agreement. No waiver by either Party shall subsequently affect its right to require strict performance of this Agreement.

18. **SEVERABILITY**. If a court of competent jurisdiction finds a term or condition of this Agreement to be illegal or invalid, then the term or condition shall be deemed severed from this Agreement. All other terms, conditions, and provisions of this Agreement shall remain in full force.

19. **PRECEDENCE OF DOCUMENTS**. In the event of a conflict between the terms and conditions of any of the documents that comprise this Agreement, the terms in the Agreement shall prevail and take precedence over any allegedly conflicting terms and conditions.

20. **CAPTIONS**. The section and subsection numbers, captions, and any index to such sections and subsections contained in this Agreement are intended for the convenience of the reader and are not

intended to have any substantive meaning. The numbers, captions, and indexes shall not be interpreted or be considered as part of this Agreement. Any use of the singular or plural, any reference to gender, and any use of the nominative, objective or possessive case in this Agreement shall be deemed the appropriate plurality, gender or possession as the context requires.

21. **NOTICES.** Notices given under this Agreement shall be in writing and shall be personally delivered, sent by express delivery service, certified mail, or first-class U.S. mail postage prepaid, and addressed to the person listed below. Notice will be deemed given on the date when one of the following first occur: (i) the date of actual receipt; (ii) the next business day when notice is sent express delivery service or personal delivery; or (iii) three days after mailing first class or certified U.S. mail.

21.1 If Notice is sent to County, it shall be addressed and sent to: Oakland County Executive, 2100 Pontiac Lake Rd., Waterford, MI, 48328, the Chairperson of the Oakland County Board of Commissioners, 1200 North Telegraph Road, Pontiac, MI, 48328 and to the individual designated by the County as its Point of Contact.

21.2 If Notice is sent to Public Body, it shall be addressed to: 27400 Southfield Road Lathrup Village City Of Lathrup Village, MI 48076.

22. **GOVERNING LAW/CONSENT TO JURISDICTION AND VENUE.** This Agreement shall be governed, interpreted, and enforced by the laws of the State of Michigan. Except as otherwise required by law or court rule, any action brought to enforce, interpret, or decide any Claim arising under or related to this Agreement shall be brought in the 6th Judicial Circuit Court of the State of Michigan, the 50th District Court of the State of Michigan, or the United States District Court for the Eastern District of Michigan, Southern Division, as dictated by the applicable jurisdiction of the court. Except as otherwise required by law or court rule, venue is proper in the courts set forth above.

23. **SURVIVAL OF TERMS.** The Parties understand and agree that all terms and conditions of this Agreement that require continued performance, compliance, or effect beyond the termination date of the Agreement shall survive such termination date and shall be enforceable in the event of a failure to perform or comply.

24. **ENTIRE AGREEMENT.**

24.1 This Agreement represents the entire agreement and understanding between the Parties regarding the grant funds and supersedes all other oral or written agreements between the Parties. Any amendment to this Agreement shall be in writing, and duly executed by the appropriate authority for each Party.

24.2 The language of this Agreement shall be construed as a whole according to its fair meaning, and not construed strictly for or against any Party.

IN WITNESS WHEREOF, Austin Colson, Community & Economic Development/DDA Director hereby acknowledges that he/she has been authorized by a resolution of the City of Lathrup Village, a certified copy of which is attached, to execute this Agreement on behalf of Public Body and hereby accepts and binds Public Body to the terms and conditions of this Agreement

Austin Colson, Community & Economic Development/DDA Director
City of Lathrup Village

DATE: _____

Alisa Emanuel, City Clerk

DATE: _____

IN WITNESS WHEREOF, David Woodward, Chairperson, Oakland County Board of Commissioners, hereby acknowledges that he has been authorized by a resolution of the Oakland County Board of Commissioners to execute this Agreement on behalf of Oakland County, and hereby accepts and binds Oakland County to the terms and conditions of this Agreement.

David Woodward, Chairperson Oakland
County Board of Commissioners

DATE: _____

Oakland County Board of Commissioners
County of Oakland

DATE: _____

EXHIBIT A

Grant Award Payments

It is understood that under no circumstances shall the County be responsible for greater than 40% of the total development cost and that by accepting County Grant Funds, the Public Body thereby commits to contributing Grantee Funds in an amount sufficient to fully fund the development cost of the project as approved by the County pursuant to the Grant Application, Scope of Work and Budget (Exhibit C).

First Grant Award Payment

Within 45 days of the execution of this Interlocal Agreement between Oakland County and the Public Body the County will transfer seventy five percent (75%) of the total grant award to the Public Body.

Final Grant Award Payment

Within 30 days of the County receiving and approving documentation from the Public Body that demonstrates that eligible project development cost expenditures of a minimum amount of two times the first grant award payment have been made by the Public Body, the County will transfer the remaining balance of the total grant award to the Public Body.

Application Number: MSPM2407 – Lathrup village

Total Development Costs: \$342,858.00

Total Local Funds: \$207,091.00

Total Grant Award: \$135,767.00 Percent of Total Development Costs: 40%

First Grant Award Payment: \$101,825.25 (75% of the Total Grant Award)

Final Grant Award Payment: \$33,941.75 (25% of the Total Grant Award)

EXHIBIT B

Reporting Requirements

The Public Body receiving grant funds must submit Status Reports throughout the project construction process and a final report within 30 days of the end of the Agreement, or project completion, whichever date is sooner. The final report shall include a full accounting of its expenditure of grant funds, certification of its use of grant funds and fulfillment of the terms of the agreement, along with any other relevant information, records or other pertinent documentation.

The first Status Report covers the reporting period from the date the Interlocal Agreement is executed through December 31, 2024. The first Status Report must be submitted to the County no later than January 31, 2025. Subsequent Status Reports cover quarterly reporting periods based on the calendar year starting on January 1, 2025, and continuing through the completion of the project construction. These Status Reports are due to the County no later than the last day of the month following the end of each quarterly reporting period. The Outcome Report is due to the County one year after the completion of construction. Oakland County will provide an online form for submitting both the Status Reports and Outcome Report.

Status Report Content

All Status Reports must include documentation of expenditures, project narrative and project photographs.

Documentation of Expenditures

Documentation of Expenditures includes all funds, county and local, spent on the project within the reporting period. A spreadsheet template will be provided to the Public Body for this purpose.

The spreadsheet will require the following information be entered by the Public Body:

- Date of the Expenditure
- Amount of the Expenditure
- Line Item from the PROJECT BUDGET submitted as part of the Grant Application
- Purpose/Description of the Expenditure
- Paid Invoice Reference

Documentation of Expenditures					
No.	Date	Amount	PROJECT BUDGET Line Item	Purpose/Description of the Expenditure	Paid Invoice Reference
1					
2					
3					
4					
5					
6					
7					
8					
9					
10					

PDF copies of paid invoices or other Public Body payment transfer records that document that the expenditures itemized in the Excel file have been made. Provide a means (Paid Invoice Reference) for the County to associate the documentation that payment was made with the expenditures.

Status Narrative

Describe the progress made toward implementing the project. The narrative should include describing actions taken that are associated with the expenditures. Include any obstacles or setbacks that have occurred during the reporting period. Also, explain plans or actions to be taken to address any obstacles or setbacks. Highlight positive aspects of the project such as public support and awareness of the project and any new supportive partnerships that may have evolved.

Status Photographs

Include site photographs that show the progress made and illustrate the project expenditures and project narrative.

Outcome Report Content

The Outcome Report is due to the County one year after the completion of construction. This report will document the success the project has had in meeting the measurable outcomes included in the Public Body grant application. It also will include a narrative and supporting photographs of how the public space is being used and programmed.

Measurable Outcomes

Include data that support the following outcomes:

- Number of visitors and residents who utilize the newly created public space on an annual basis during special events and functions in the district.
- Number of activities and functions that take place in the public space in the district to draw foot traffic, users and tourists to the district.
- Number of private partners, private contributions and in-kind contributions that supported the completion of the project and on-going programming and maintenance.
- Number of new businesses, or business expansions in the district following the completion of the public space project.

Also, include data for all additional outcomes included in the submitted grant application.

Outcome Narrative

Describe how well the project has advanced the Measurable Outcomes. What aspects of the project have been most successful and what aspects least successful. Describe how the resident and business community have embraced the project. Include a brief description of how the space is being programmed for use. Finally, as guidance for other communities pursuing public space and placemaking projects provide any lessons learned and/or what would you do differently next time undertaking a similar project.

Outcome Photographs

Include site photographs that show the completed project and community residents and visitors using the public space.

EXHIBIT C: Grant Application, Scope of Work and Budget

APPLICANT INFORMATION

Application Number: MSPM2407

QA1. Placemaking and Public Spaces Project Name:

Lathrup Village Municipal Park Renovation

QA2. Municipality Name:

Lathrup Village

QA3. Employer Identification Number (EIN):

38-6021195

QA4. Municipality Mailing Address:

Address	27400 Southfield Road
City	Lathrup Village
State	MI
ZIP Code	48080

QA5. Point of Contact - Individual that will be responsible for managing this grant.

First Name	Mike
Last Name	Greene
Title/Position	City Administrator
Phone	248-557-2600 ext. 225
Email Address	mgreene@lathrupvillage.org
Organization (If different from above)	
Name	
Address	

City

State

Zip Code

QA6. Describe the project management experience of the individual responsible for managing this grant. (100 words maximum)

Mr. Greene has worked in local government for 7+ years in a managerial role and has written/overseen numerous grants over those years from everything from small \$1,000 foundation grants to FEMA grants.

QA7. Individual submitting this application (If different than above).

First Name

Last Name

Title/Position

Phone Number

Email

ACKNOWLEDGMENTS

QA8. All of the information submitted is accurate and that I have the approval to submit this application on behalf of city/village/township identified above

I acknowledge this statement

QA9. If awarded a grant the city/village/township will be required to enter into an Interlocal Agreement with Oakland County.

I acknowledge this statement

QA10. If awarded a grant and the local DDA or CIA is providing local funding, the DDA or CIA may also be required to enter into the Interlocal Agreement with Oakland County.

I acknowledge this statement

QA11. Obtaining all required local, county and/or state permits, inspections or approvals will be the responsibility of the applicant city/village/township.

I acknowledge this statement

QA12. If awarded a grant the ARPA grant funds will be spent and the County funded elements of the project completed by September 30, 2026.

I acknowledge this statement

PROJECT INFORMATION

QB1. Location - use the applicable fields below and must enter data in at least **ONE** of the three fields.

Site Address(s)	<input type="text" value="27400 Southfield Road, Lathrup Village, MI 48076"/>
Parcel Identification Number(s)	<input type="text"/>
Written Description (ie. The project sites located within, and along, the Elm Street right-of-way between First and Second Streets)	<input type="text"/>

QB2. Site Ownership - Does the applicant city/village/township own the entire project site(s)? If "NO" describe who owns what portions of the project site(s).

YES

NO

QB3. Site and Surrounding Uses Map - Upload the Site and Surrounding Uses Map provided by Oakland County.



[RAP2.0 Project Area.png](#)

1.5MB
image/png

QB4. Project Description - Provide a brief overview of the public spaces project.
(250 words maximum)

Municipal Park is a highly utilized space in the city for community events, as well as private events and functions. Many infrastructure improvements have been made in recent years including the replacement of unsafe sidewalk segments through the park. The proposed parking lot reconstruction will greatly improve the safety and accessibility of all visitors to City Hall and Municipal Park. Furthermore, the new curbing, ADA ramps, and restriping of the parking lot will improve the overall physical maneuverability of the site. The fully renovated play structure represents a huge leap forward for Lathrup Village children, as well as those in nearby communities. Whereas the existing play structure has some accessible features, the new play structure is designed entirely with a universal design principle.

. To answer the next three questions:

Describe how the proposed public spaces project will address the adverse public health and economic impacts of the pandemic and support improved public health & welfare and overall economic recovery going forward. Frame your response in terms of the downtown district, small businesses, and public health & welfare.

QB5. **Downtown District** - How will this project positively impact the district?
(100 words maximum)

This project will serve many purposes, often at the same time. It will contribute to individuals' well-being, physically, emotionally, and mentally, and a sense of belonging, all while benefiting community health socially, economically, culturally, and environmentally. It should have a positive effect on nearby property values. As part of our town center, this public space not only creates a more desirable setting and atmosphere for the surrounding properties but also increases the economic benefits to surrounding property owners. Public spaces in town centers provide a setting for events and organized gatherings, increasing the number of visitors.

QB6. Small Businesses - How will the project positively impact small businesses in the district?
(100 words maximum)

This type of project has the opportunity to strengthen our local economy and create job opportunities. Community parks have the ability to attract residents and businesses, increase revenue for cities, spur private investment, and increase job opportunities. With the increased traffic at our town center, via the project, our small business will have increased visibility, allowing them to take advantage of a new market.

QB7. Public Health & Welfare - How will the project positively impact public health and welfare?
(100 words maximum)

People value the time they spend in city parks, whether walking a dog, or playing with their children, or having a picnic. Along with the expected leisure amenities, this type of project will provide, it can also provide measurable health benefits, from providing direct contact with nature and opportunities for physical activity and social interaction.

QB8. Describe how the proposed public space project will be primarily utilized (events, concerts, markets, open space, recreation space, etc.). Briefly describe each primary use.
(100 words maximum)

The proposed public space will primarily be utilized as an open space/ recreation space, specifically for the youngest members of our community. The new play structure and play area will greatly enhance the City's largest/most utilized park into an inclusive park that allows all members of our community to participate in outdoor activities.

QB9. Describe how the County ARPA funds be utilized within the scope of the proposed public space project.
(100 words maximum)

The County ARAPA funds would be utilized specifically for the purchase of the inclusive play structure. The remaining work (site work, parking lot, and landscaping) would be cost borne by other sources.

QB10. Outline the timetable for completion of the County funded elements of the proposed public spaces project by September 30, 2026.
(100 words maximum)

If awarded, the City would need to finalize additional funding sources during calendar year 2025. Once sources are secured, we should issue a request for a proposal for the installation of the playground equipment in Q1 of 2026. The intent would be to have the county-funded elements installed and useable by the end of Q2 2026.

QB11. Describe how the proposed public spaces project will be maintained and managed once completed. (100 words maximum)

The long-term maintenance of the Municipal Park Renovations will be incorporated into the regular maintenance activities of the city's Department of Public Services. Additionally, LVDDA and the City regularly host corridor and park clean-ups throughout the summer. A summer partnership is also in place with a local non-profit to assist in the maintenance of the City Hall grounds and DDA plantings.

. Measurable Outcomes

Tracking the measurable outcomes listed below will be required as part of the Interlocal Agreement:

- Number of visitors and residents who utilize the newly created public space on an annual basis during special events and functions in the district.
- Number of activities and functions that take place in the public space in the district to draw foot traffic, users and tourists to the district.
- Number of private partners, private contributions and in-kind contributions that supported the completion of the project and on-going programming and maintenance.
- Number of new businesses, business expansions, and/or public/private investment in the district following the completion of the public space project.

QB12. In addition to tracking those listed above, describe any measurable outcomes unique to the public space project that will be tracked. (100 words maximum):

Dollars of investment made by the DDA Board and City Council into other parks within their respective districts based on the measurable success of this project.

PROJECT PLANS

QC1. Upload project plans, construction drawings, engineering documents, renderings, etc. Combine all documents into one PDF and name ***ProjectNameProjectPlans.pdf***.

[Municipal Park Renovation Project Plans.pdf](#)

5.3MB
application/pdf

QC2. Upload photographs that show the existing site conditions and context from various vantage points. Combine photos onto 8.5 x 11 PDF pages, then into a combined document. Include a name or description on each photo and name the document ***ProjectNamePhotos.pdf***.

[Municipal Park Renovation Photos.pdf](#)

23.3MB
application/pdf

BUDGET

QD1. Upload the **PROJECT BUDGET FORM** (Excel File), name ***ProjectNameBudget.xlsx***.

[PROJECT BUDGET FORM.xlsx](#)

15.1KB

application/vnd.openxmlformats-officedocument.spreadsheetml.sheet

QD2. Enter the following amounts from the **PROJECT BUDGET** (Excel File)

Total Development Costs (Green Cell)	<input type="text" value="\$342,858.00"/>
Total Local Funds (Purple Cell)	<input type="text" value="\$207,091.00"/>
Requested County ARPA Funds (Orange Cell) (Not to exceed 40% of Total Development Cost)	<input type="text" value="\$135,767.00"/>

NOTE: The amounts shown above have been edited to match the approved amounts included in Exhibit A and the Project Budget Form.

QD3. Upload proof of funding commitment for each source of local funds listed in the **PROJECT BUDGET**. Proof of funding commitment can include local government, CIA and DDA resolutions, letters of financial commitment, copies of approved budget documents and documentation of other grant awards that are specified to be used for the public space project. Combine documents into one PDF file, assign A-F to each source and name **ProjectNameFundingProofA_F.pdf**.

[Municipal Park Renovation Funding Proof - A-B.pdf](#)

285.9KB

application/pdf

PROJECT SUPPORT

QE1. Upload any documentation of local support. Documentation of local support can include resolutions and/or letters of support from local government, DDAs, CIAs, community and business organizations, schools, and businesses. Please combine all letters into one PDF document to upload and name **ProjectNameSupport.pdf**.

[Municipal Park Renovation Support.pdf](#)

1MB

application/pdf

ADDITIONAL SUPPORT

QF1. Upload any additional support items for this project here and name

QB3 LATHRUP VILLAGE SITE AND SURROUNDING USES MAP

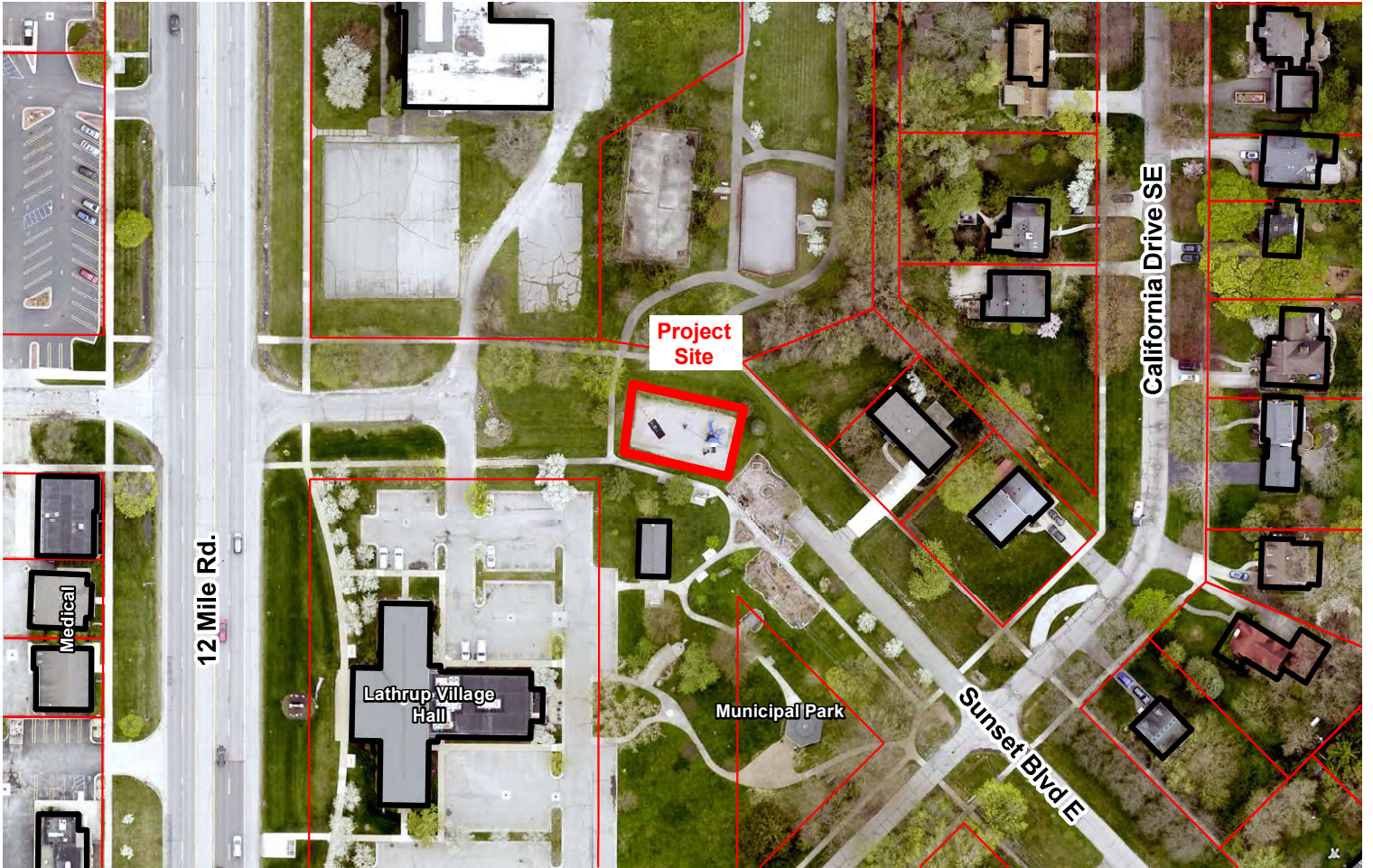

Project Map

Community: City of Lathrup Village

Project Name: Municipal Park

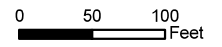

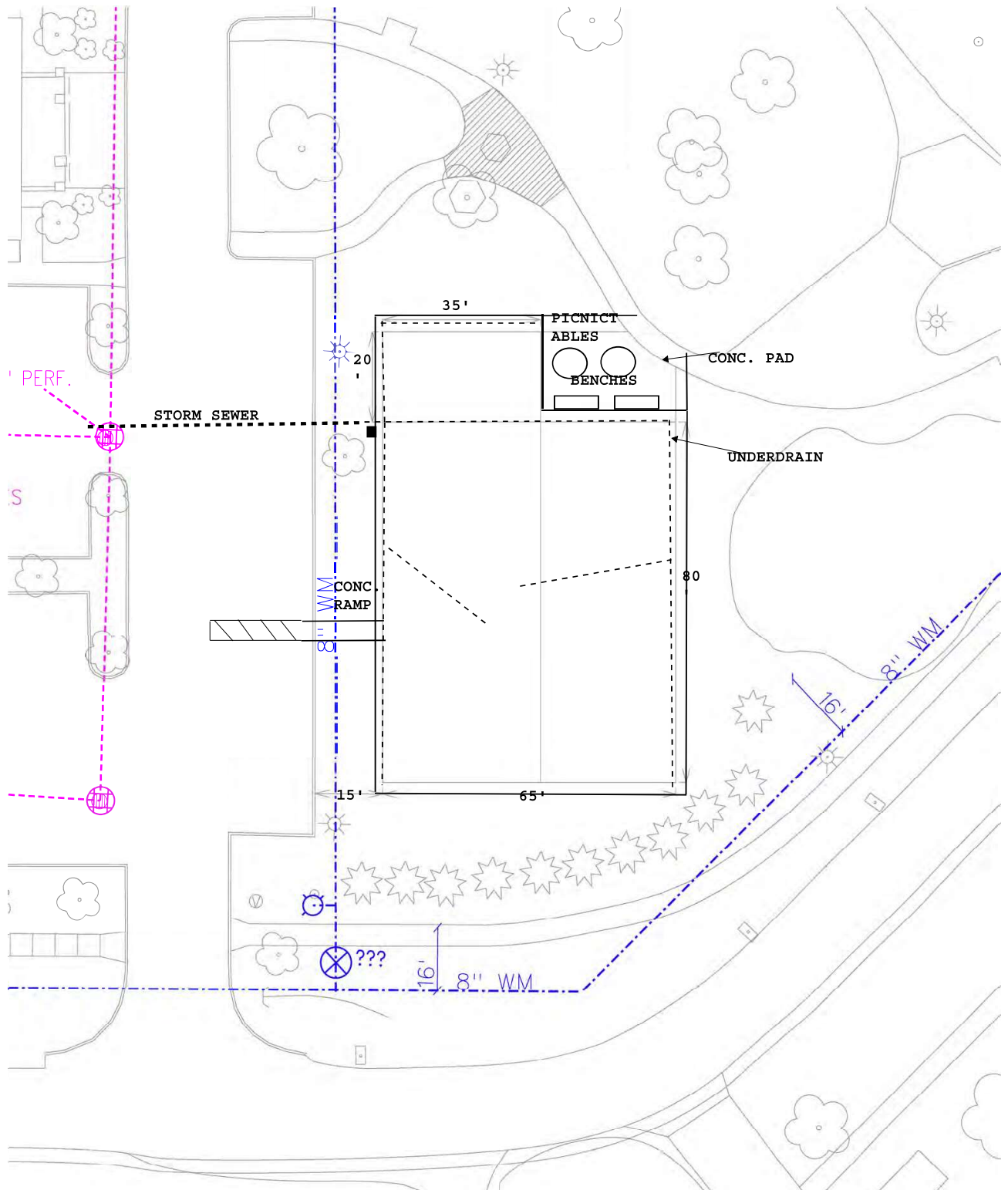

**MUNICIPAL PARK PLAY
STRUCTURE**
CITY OF LATHRUP
VILLAGE 27400 SOUTHFIELD ROAD
LATHRUP VILLAGE, MI 4807603/01/2024





10139 Royalton Rd Suite K
 N. Royalton, OH 44133
 800-888-2889
www.cvsnider.com

Date	Estimate #
2/1/2024	Q 020124-1

LATHRUP VLG
 MUNICP. PARK

Name / Address
Lathrup Village Susie Stec 27400 Southfield Rd. Lathrup Village, MI 48076

PROJECT - SHIP TO
PROJECT: Municipal Park - Lathrup Village
SHIP TO: TBD

Terms	Rep	Customer Phone	Customer Email	County
Due On Receipt	VC	(248) 557-2600 ext. 223	sstec@lathrupvillage.org	OAKLAND

Item	Description	Qty	Rate	Total
127-179508	NEW PLAYGROUND FOR 5-12, 2-5, WITH ACCESSIBILITY			
PHASE 1	5-12 PLAY STRUCTURE		\$177,574	\$177,574
DISCOUNT	PROGRAM DISCOUNT		-\$42,000	-\$42,000
FREIGHT	SHIPPING CHARGES		\$5,000	\$5,000
MBE/INSTALL	INSTALLATION OF EQUIPMENT PHASE 1		\$53,000	\$53,000
SURFACING	TBD			
	TOTAL EQUIPMENT PHASE 1			\$193,574
PHASE 2	2-5 PLAY STRUCTURE		\$145,384	\$145,384
DISCOUNT	PROGRAM DISCOUNT		-\$35,000	-\$35,000
FREIGHT	SHIPPING CHARGES		\$4,500	\$4,500
MBE/INSTALL	INSTALLATION OF EQUIPMENT PHASE 2			
SURFACING	TBD			
	TOTAL EQUIPMENT PHASE 2			\$114,884
PHASE 3	FREESTANDING PIECES & ADDITIONAL ACTIVITIES FOR 5-12 AND 2 - 5 STRUCTURES (CRUISER, NOVO TABLES & BENCH CLIMBERS 5-12 CENTER EKO CLIMBER CLUSTER 2-5)		\$91,405	\$91,405
DISCOUNT	PROGRAM DISCOUNT		-\$12,000	-\$12,000
FREIGHT	SHIPPING CHARGES		\$4,500	\$4,500
MBE/INSTALL	INSTALLATION OF EQUIPMENT PHASE 3		\$28,000	\$28,000
SURFACING	TBD			
	TOTAL EQUIPMENT PHASE 3			\$111,905

1/2 down with order, balance upon completion with approved credit.
 If tax exempt certificate is not provided, appropriate sales tax will be charged. Quote valid for 30 days.
 Acceptance of this quote assumes acceptance of Snider insurance.
 Freight subject to fuel charge. Payment via credit card will incur an additional 3% administrative fee.

Subtotal	
Sales Tax (6.0%)	N/A
Total	

Signed _____ Date _____
 Name/Title _____

Quoted By:
 V. Crawford Snider Recreation, Inc.

PROPOSAL #: 127-179508-1

MUNICIPAL PARK

Burke
PLAY THAT MOVES YOU.
BCBURKE.COM • 800.266.1230



3D Designer: Gira Fischer

PROPOSAL #: 127-179508-1

MUNICIPAL PARK

Burke
PLAY THAT MOVES YOU!
BCBURKE.COM • 800.266.1230



3D Designer: Gina Fischer



MUNICIPAL PARK

PROPOSAL #: 127-179508-1

Burke:
PLAY THAT MOVES YOU.
BOBURKE.COM • 800.266.1250

SNIDER RECREATION
www.sniderrecreation.com
800-351-2219

3D Designer: Gina Fischer



Municipal Park

27400 Southfield Rd | Lathrup Village, MI 48076-3412



Snider Recreation, Inc.

10139 Royalton Road Suite K | North Royalton, OH 44133 | 440-877-9151



Snider Recreation
800-888-2889
www.cvsnyder.com

Proposal 127-179508-1 | 1/19/2024



Municipal Park

27400 Southfield Rd | Lathrup Village, MI 48076-3412

January 19, 2024

Susie Stec
Lathrup Village
27400 Southfield Rd.
Lathrup Village, MI 48076
Phone: 2484312796

Dear Susie Stec:

Snider Recreation, Inc. is delighted to provide Lathrup Village with this playground equipment proposal.

This design was developed with your specific needs in mind, and we look forward to discussing this project further with you to ensure your complete satisfaction. Snider Recreation, Inc. is confident that this proposal will satisfy Lathrup Village's functional, environmental, and safety requirements -- and most importantly -- bring joy and excitement to the children and families directly benefiting from your new playground.

You have our personal commitment to support this project and your organization in every manner possible, and we look forward to developing a long-standing relationship with Lathrup Village. We appreciate your consideration and value this opportunity to earn your business.

Sincerely,

Vicki Crawford
Sales Representative

Snider Recreation, Inc.
10139 Royalton Road Suite K
North Royalton, OH 44133
www.cvsnider.com
www.bciburke.com

Phone: 440-877-9151
Fax: 440-877-9159
vcrawford@cvsnider.com; alison@cvsnider.com



COOPERATIVE PURCHASING OPTIONS

PLAYGROUNDS WITHOUT ALL THE PAPERWORK

Purchasing with contracts may sound intimidating, but getting your community playspace doesn't need to be a painful process of writing specifications, issuing RFP's and jumping through hoops – it can be simplified – we promise! As you continue planning for your new playground, review the Purchasing Contracts offered through our partners.

EQUALIS GROUP

Equalis is an innovative cooperative purchasing organization that believes in the power of partnership and that when you work together you achieve more. The basic premise of the Equalis cooperative purchasing organization is to leverage the combined buying power of all members for better pricing and favorable contract terms. Equalis Group uses the lead agency model for competitively bid contracts, provides our participants the savings they expect and offers efficiencies and peace of mind within the procurement process. It is our mission to continuously improve the measurable and meaningful impact of cooperative services for everyone throughout the supply chain.

GOVMVMT

GOVMVMT is a non-profit group purchasing organization that meets the highest industry standards while putting the public's interest at the forefront of everything they do. Each one of GOVMVMT's first-class suppliers has consciously joined their mission to create the most credible, ethical, and public agency-focused non-profit cooperative purchasing program in the country.

GSA

Federal parks, child development programs, military bases and other agencies are a major priority for BCI Burke, and agencies can purchase Burke playgrounds through Burke's GSA contract for installation virtually anywhere in the world.

OMNIA PARTNERS

OMNIA Partners, Public Sector (Subsidiary National IPA) is the largest and most experienced organization in purchasing and supply chain management. Comprised of participants and suppliers in the public sector, we bring together industry-leading buying power and world-class suppliers to offer an extensive portfolio of competitively solicited and publicly awarded contracts and partnerships. OMNIA Partners is proud to offer more value and resources to state and local government, higher education, K-12 education and non-profits.

SOURCEWELL

As a leader in cooperative purchasing, Sourcewell is passionate about helping members fulfill their public service missions. Sourcewell builds strong relationships with members and vendors to develop practical solutions together.

The easiest way to Join Our Movement is to call your local Representative at 800.266.1250 or visit bciburke.com/rep. Our passion is bringing play to communities like yours and we can't wait to help you get started!



BCIBURKE.COM **Burke** 800.266.1250

DESIGN SUMMARY

Snider Recreation, Inc. is very pleased to present this Proposal for consideration for the Municipal Park located in Lathrup Village. BCI Burke Company, LLC has been providing recreational playground equipment for over 100 years and has developed the right mix of world-class capabilities to meet the initial and continuing needs of Lathrup Village. We believe our proposal will meet or exceed your project's requirements and will deliver the greatest value to you.

The following is a summary of some of the key elements of our Proposal:

- Project Name: Municipal Park
- Project Number: 127-179508-1
- User Capacity: 537
- Age Groups: 5 to 12, 2 to 5, 2 to 12
- Dimensions: 109' 7"x87' 5"
- Designer Name: Hunter Mielke

Snider Recreation, Inc. has developed a custom playground configuration based on the requirements as they have been presented for the Municipal Park playground project. Our custom design will provide a safe and affordable playground environment that is aesthetically pleasing, full of fun for all users and uniquely satisfies your specific requirements. In addition, proposal # 127-179508-1 has been designed with a focus on safety, and is fully compliant with ASTM F1487 and CPSC playground safety standards.

We invite you to review this proposal for the Municipal Park playground project and to contact us with any questions that you may have.

Thank you in advance for giving us the opportunity to make this project a success.



Snider Recreation
800-888-2889
www.cvsnyder.com

BLUE BOUNDARY IS PHASE 1
AQUA BOUNDARY IS PHASE 2
RED CIRCLED ITEMS ARE PHASE 3

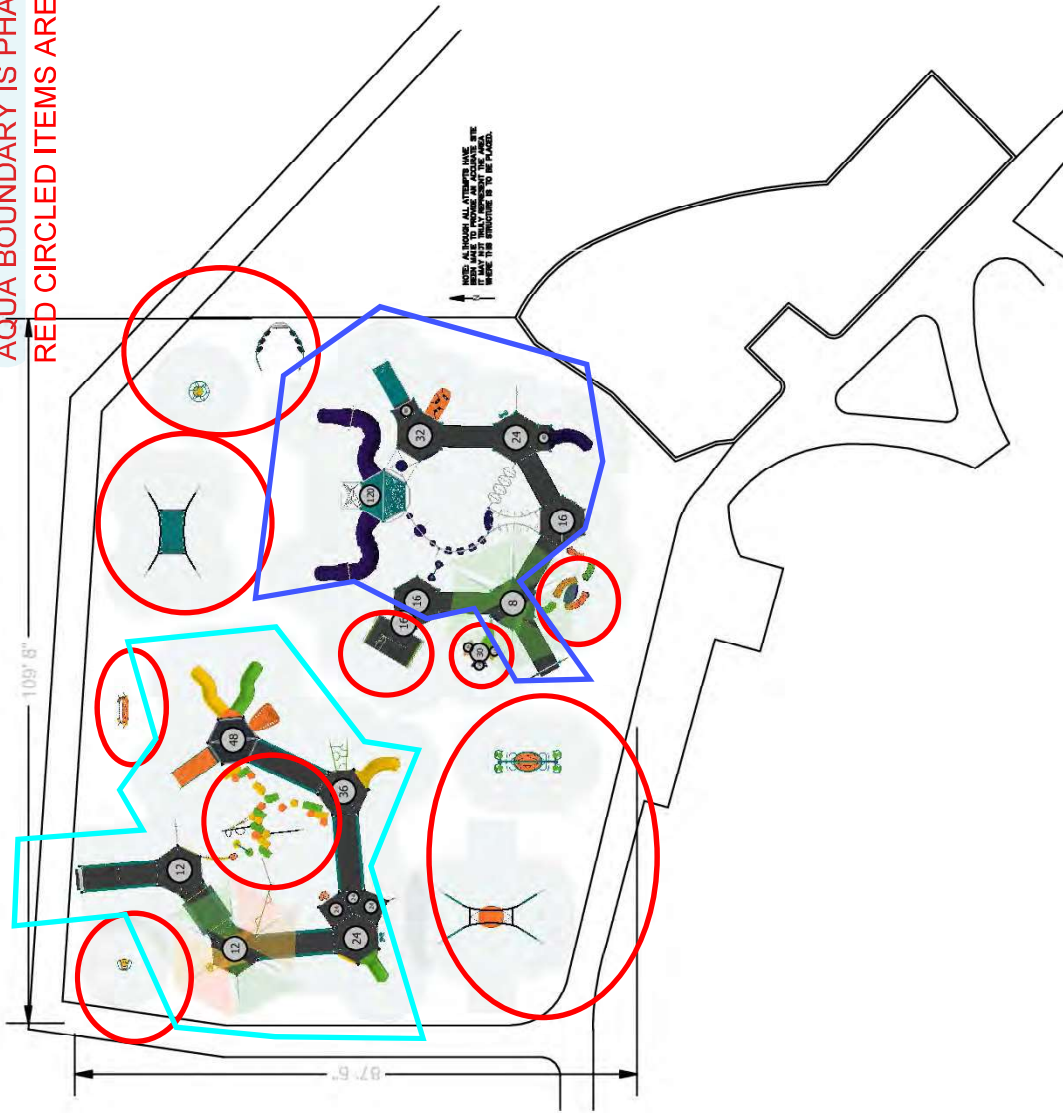

The use and layout of play components identified in this plan conform to the CPSC guidelines. U.S. CPSC recommends the separation of age groups in playground layouts.

PLAYGROUND ACCESSIBILITY (Provided/Required)			
TOTAL ELEVATED EVENTS	TRANSFER ACCESSIBLE EVENTS	RAMP ACCESSIBLE EVENTS	TYPES OF GROUND EVENTS
92	2 / 12	36 / 13	43 / 0
			11 / 0

OVERALL BOUNDING OF USE ZONES **The space requirements shown here are to ASTM standards. Requirements for other standards may be different.

Area: 9586.3 sq.ft.
 Perimeter: 394.1 ft.
STRUCTURE SIZE: 6" x 109' 8"
POST SIZE(S):

Warning: Accessible safety surfacing material is required beneath and around this equipment that is compliant with ASTM, CPSC, and ADAAG requirements.

SERIES Burke Basics Nucleus Intensity	SITE PLAN VIEW	
GROUP: 5-12 Structure 2-5 Structure Freestanding	Municipal Park Lathrup Village, MI 48076-3412	01/19/2024
DESIGNED FOR AGES: 5 to 12, 2 to 5, 2 to 12	Burke PLAY THAT MOVES YOU	Snider Recreation, Inc. 127-179508-1 Designer: Hunter Mielce
BCI BURKE COMPANY, LLC PO BOX 549 FOND DU LAC, WI 54936-0549 920.921.9220 BCIBURKE.COM		

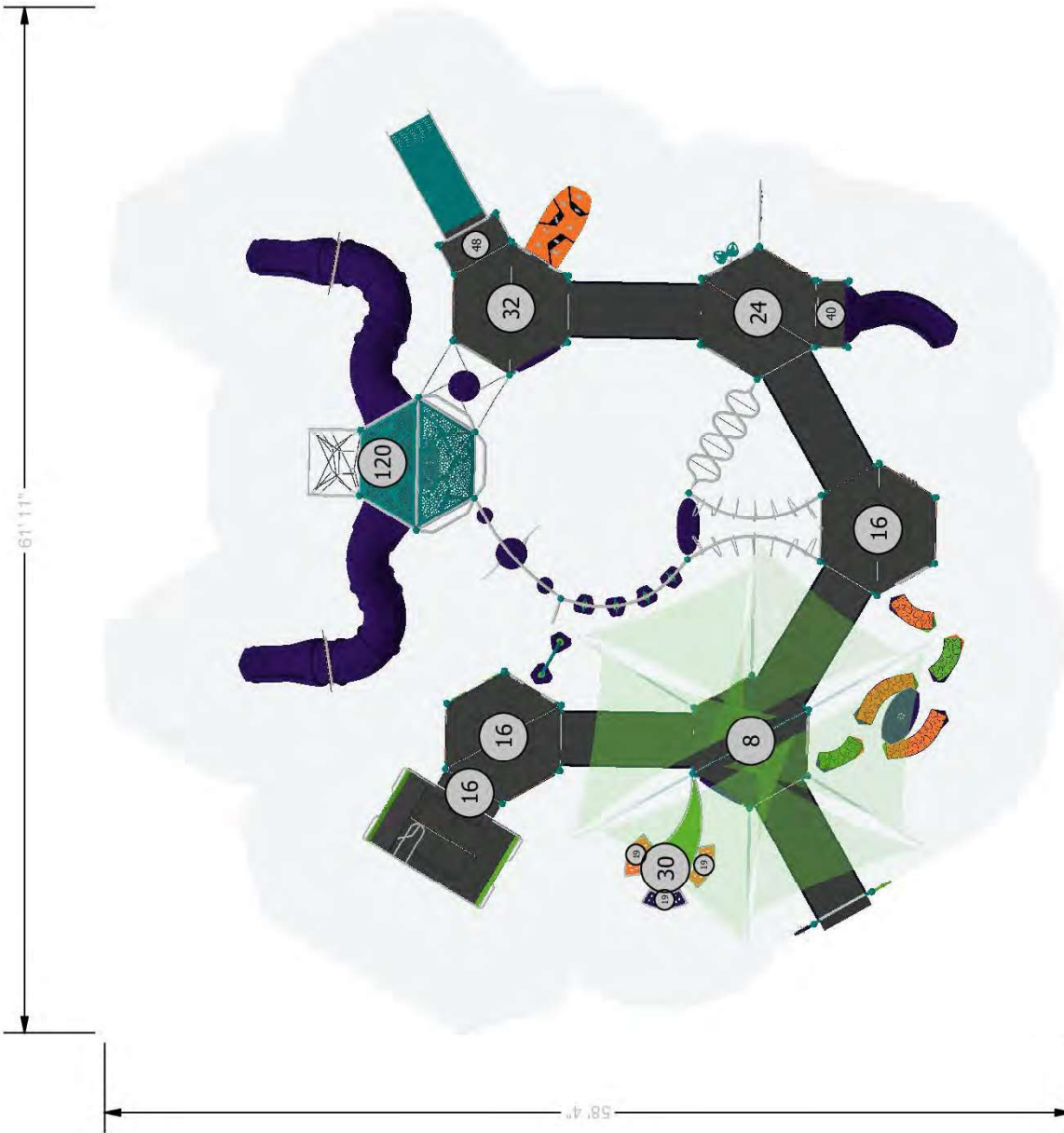

The use and layout of play components identified in this plan conform to the CPSC guidelines. U.S. CPSC recommends the separation of age groups in playground layouts.

PLAYGROUND ACCESSIBILITY (Provided/Required)			
TOTAL ELEVATED EVENTS	TRANSFER ACCESSIBLE EVENTS	RAMP ACCESSIBLE EVENTS	TYPES OF GROUND EVENTS
92	49 / 25	2 / 12	36 / 13
			43 / 0
			11 / 0

OVERALL BOUNDING OF USE ZONES **The space requirements shown here are to ASTM standards. Requirements for other standards may be different.

Area: 9586.3 sq.ft.
 Perimeter: 394.1 ft.
STRUCTURE SIZE: 6" x 109' 8"
POST SIZE(S):

Warning: Accessible safety surfacing material is required beneath and around this equipment that is compliant with ASTM, CPSC, and ADAAG requirements.

SERIES Nucleus Burke Basics Intensity	SITE PLAN VIEW
GROUP: 5-12 Structure	01/19/2024
DESIGNED FOR AGES: 5 to 12	Snider Recreation, Inc. 127-179508-1 Designer: Hunter Mielke
Municipal Park Lathrup Village, MI 48076-3412	
Burke PLAY THAT MOVES YOU	

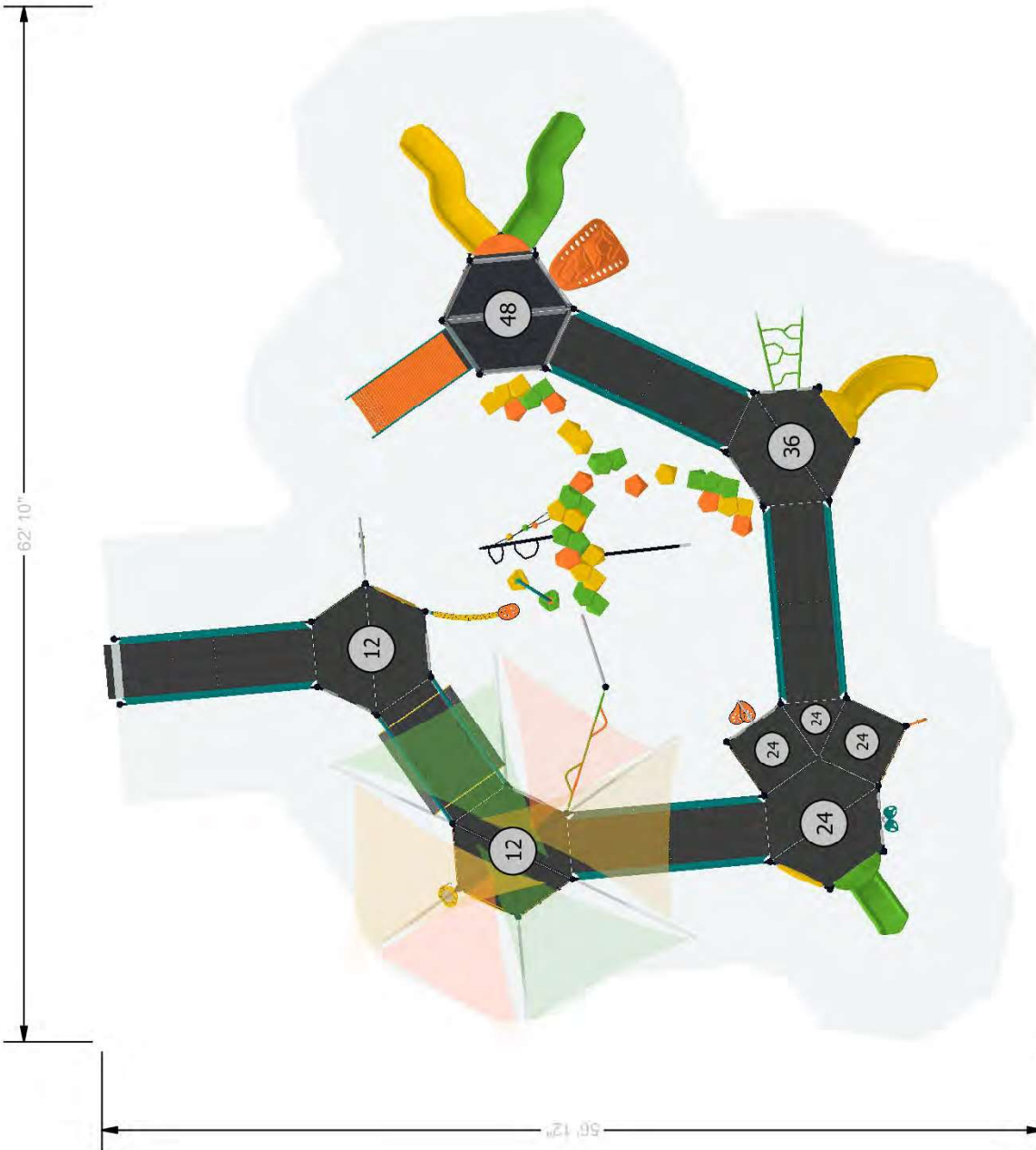

The use and layout of play components identified in this plan conform to the CPSC guidelines. U.S. CPSC recommends the separation of age groups in playground layouts.

PLAYGROUND ACCESSIBILITY (Provided/Required)					
TOTAL ELEVATED EVENTS	TRANSFER ACCESSIBLE EVENTS	RAMP ACCESSIBLE EVENTS	TYPES OF GROUND EVENTS		
92	49 / 25	2 / 12	36 / 13	43 / 0	11 / 0

OVERALL BOUNDING OF USE ZONES **The space requirements shown here are to ASTM standards. Requirements for other standards may be different.

Area: 9586.3 sq.ft.
 Perimeter: 394.1 ft.
STRUCTURE SIZE: 6" x 109' 8"
POST SIZE(S):

Warning: Accessible safety surfacing material is required beneath and around this equipment that is compliant with ASTM, CPSC, and ADAAG requirements.

SERIES Nucleus Intensity Burke Basics	SITE PLAN VIEW
GROUP: 2-5 Structure	Municipal Park Lathrup Village, MI 48076-3412
DESIGNED FOR AGES: 2 to 5	Burke PLAY THAT MOVES YOU
	Snider Recreation, Inc. 127-179508-1 Designer: Hunter Mielke
BCI BURKE COMPANY, LLC PO BOX 549 FOND DU LAC, WI 54936-0549 920.921.9220 BCIBURKE.COM	

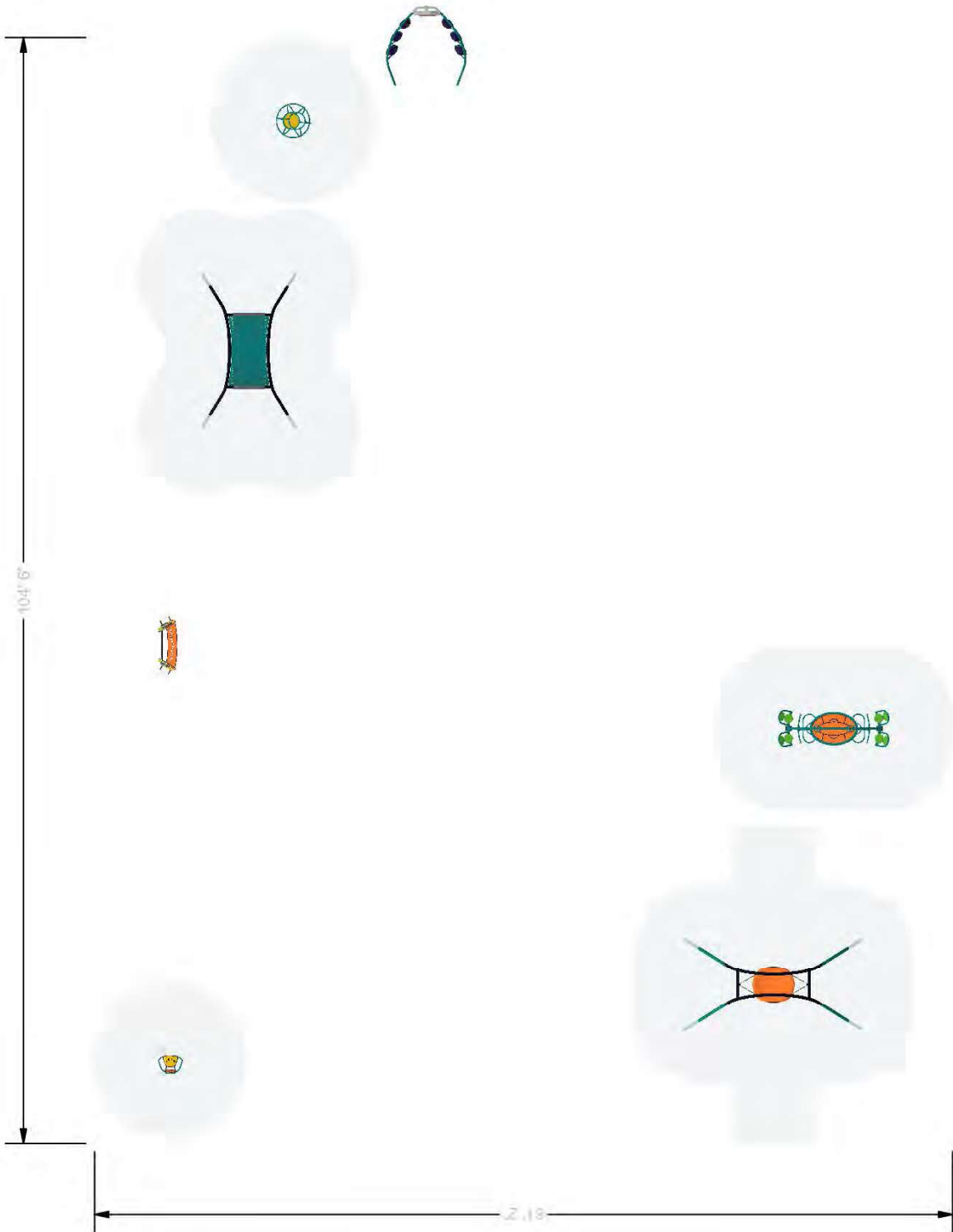

The use and layout of play components identified in this plan conform to the CPSC guidelines. U.S. CPSC recommends the separation of age groups in playground layouts.

PLAYGROUND ACCESSIBILITY (Provided/Required)			
TOTAL ELEVATED EVENTS	TRANSFER ACCESSIBLE EVENTS	RAMP ACCESSIBLE EVENTS	TYPES OF GROUND EVENTS
92	2 / 12	36 / 13	43 / 0
			11 / 0

OVERALL BOUNDING OF USE ZONES **The space requirements shown here are to ASTM standards. Requirements for other standards may be different.

Area: 9586.3 sq.ft.
Perimeter: 394.1 ft.

STRUCTURE SIZE: 6"x109' 8"
POST SIZE(S):

Warning: Accessible safety surfacing material is required beneath and around this equipment that is compliant with ASTM, CPSC, and ADAAG requirements.

SERIES Burke Basics	Municipal Park Lathrup Village, MI 48076-3412	SITE PLAN VIEW 01/19/2024
GROUP: Freestanding	Burke PLAY THAT MOVES YOU	Snider Recreation, Inc. 127-179508-1
DESIGNED FOR AGES: 2 to 12		Designer: Hunter Mielke

BCI BURKE COMPANY, LLC | PO BOX 549 FOND DU LAC, WI 54936-0549 | 920.921.9220 | BCIBURKE.COM

ITEM	COMP.	DESCRIPTION
1	270-0131	HEXAGONAL PLATFORM SSP
2	580-1319	NOVO TEARDROP COUNTER CLIMBER
3	580-1312	NOVO ARC BENCH
4	570-0798	WAVER PANEL, ABOVE PLATFORM
5	270-0223	8" RISE ENTRANCE RAMP W/ GUARDRAILS
6	570-0716	CLICKER ACTIVITY PANEL
7	570-0718	HYPO ACTIVITY PANEL
8	270-0122	EVOLUTION OFFSE" ENCLOSURE
9	270-0221	8" RISE RAMP W/ GUARDRAILS
10	370-1675	STRAIGHT OVERHEAD, NUCLEUS
11	470-0128	FLYLOW POD
12	370-0223	PURSUIT CLIMBER 16"-40"
13	570-2669	MAZE ACCESSIBLE REACH PANEL
14	570-0622	PLATFORM ROLL GUARD
15	570-1863	RAIN WHEEL PANEL
16	570-0814	PROPELLER RING PANEL
17	370-0808	TWISTING TRAVERSE
18	270-0291	HALF PLATFORM W/SUPPORT
19	570-0072	EVOLUTION HALF BARRIER
20	470-0802	MONACO SLIDE, 32"-40"
21	470-0967	SLIDE HOOD, LOW SIDE WALL
22	270-0300	ABSTRACT PLATFORM LADDER 16"
23	370-0016	GRAB BAR ASSEMBLY
24	570-1816	JET PANEL
25	370-0087	LEAF CLIMBER 16" - 24"
26	270-0120	EVOLUTION UNITARY ENCLOSURE
27	570-0797	CHARADE PANEL, ABOVE PLATFORM
28	370-0042	ASCEND ROCK CLIMBER, 32"-40"
29	270-0290	HALF PLATFORM
30	470-0756	ROLLER SLIDE 48"-56"
31	570-2737	PINBALL PANEL
32	370-1622	TAKTIKS TRAIL TOWER
33	270-0292	EVOLUTION CENTER MOUNT ENCLOSURE
34	570-1865	HDPE UNITARY ENCLOSURE, NUCLEUS
35	570-0848	SIGNING 2-SIDED PLAY PANEL
36	560-0563	CRUISER WITH ADAPTER
37	570-1858	3-IN-A-ROW PANEL, ABOVE PLATFORM
38	470-0678	ARA HEX SHADE CANOPY
39	560-2736	EKO CIRCA
40	560-2738	EKO TABLE
41	370-1706	NUCLEUS CORE CLIMBER, 10"
42	370-1703	NUCLEUS CORE CROSS SUPPORT
43	370-1718	TAKTIKS BOW CLIMBER
44	370-0854	VERTO CLIMBER 1
45	470-0014	EVOLUTION HEX ROOF
46	470-0006	EVOLUTION BOTTOM ROOF SUPPORT, SINGLE
47	470-0008	EVOLUTION SIDE ROOF SUPPORT, LEFT
48	470-0009	EVOLUTION SIDE ROOF SUPPORT, RIGHT
49	270-0132	HALF HEXAGON PLATFORM
50	470-0112	COBRA SLIDE CURVED 120"
51	370-1702	NUCLEUS CORE ARCH CLIMBER
52	560-2734	HOOP CLIMBER

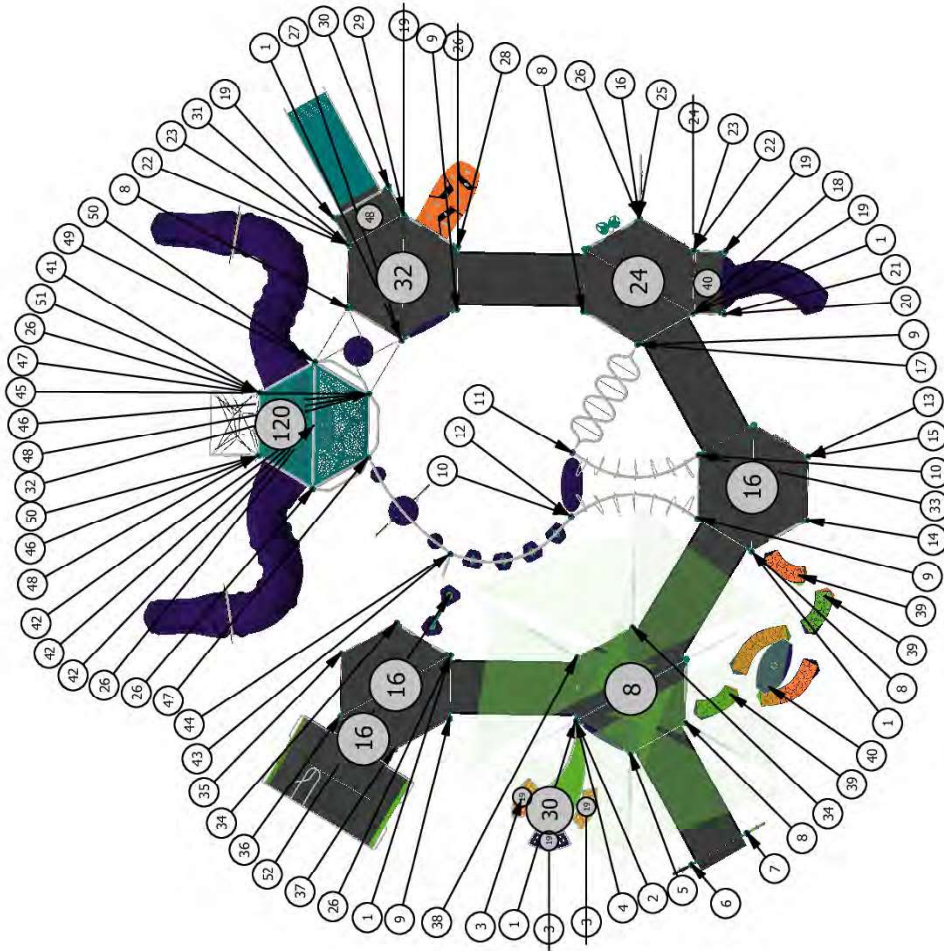

SERIES Nucleus Burke Basics Intensity	COMPONENT VIEW
GROUP: 5-12 Structure	01/19/2024
DESIGNED FOR AGES: 5 to 12	Snider Recreation, Inc. 127-179508-1 Designer: Hunter Mielke
Municipal Park Lathrup Village, MI 48076-3412 	
BCI BURKE COMPANY, LLC PO BOX 549 FOND DU LAC, WI 54936-0549 920.921.9220 BCIBURKE.COM	

ITEM	COMP.	DESCRIPTION
1	270-0131	HEXAGONAL PLATFORM SSP
2	570-2729	CLASSIC GAME RING PANEL
3	370-1720	L.II. NOVO BALANCE BEAM LINK
4	570-0811	BRAILLE PANEL
5	270-0016	12' ADAAG ENTRANCE RAMP W/GUARDRAIL
6	270-0120	EVOLUTION UNITARY ENCLOSURE
7	570-0102	INNOVA BRIDGE
8	570-2732	PLAYENSEMBLE BABEL DRUM
9	370-0031	POWER PIPES CLIMBER 2-5
10	370-0842	APEX HOLE CLIMBER 2-5
11	570-0846	SPANISH 2-SIDED PLAY PANEL
12	570-1851	CHIMES PANEL
13	570-2667	BEE ACCESSIBLE REACH PANEL
14	570-0622	PLATFORM ROLL GUARD
15	270-0012	12' ADAAG RAMP W/GUARDRAIL
16	570-2701	COLLISION PANEL, ABOVE PLATFORM
17	470-0836	ROCK'N ROLL SLIDE, 24-32 W/O HOOD
18	470-0967	SLIDE HOOD, LOW SIDE WALL
19	370-0087	LEAF CLIMBER 16" - 24"
20	270-0130	SQUARE PLATFORM
21	570-0718	HYPO ACTIVITY PANEL
22	570-1683	PARATROOP PANEL, ABOVE PLATFORM
23	570-0578	NAME THE STATES PANEL
24	270-0129	TRIANGLE PLATFORM
25	570-1858	3-IN-A-ROW PANEL, ABOVE PLATFORM
26	470-0802	MONACO SLIDE, 32" - 40"
27	370-1680	BETA CLIMBER 32" - 40"
28	270-0014	12' ADAAG RAMP W/BARRIER
29	370-1645	MANITOU CLIMBER 48"
30	470-0569	VIPER II SS 48-56
31	570-2666	CAR PANEL
32	470-0756	ROLLER SLIDE 48"-56"
33	470-0813	EVOLUTION HEX ROOF
34	470-0808	EVOLUTION ROOF BOTTOM EDGE
35	370-1670	PETAL STEP CLIMBER 16"-24"
36	270-0121	EVOLUTION STANCHION
37	570-2678	CLOCK PANEL
38	270-0122	EVOLUTION OFFSET ENCLOSURE
39	470-0678	ARA HEX SHADE CANOPY
40	570-1679	SPROCKET PANEL, ABOVE PLATFORM
41	560-2715	EKO ULTIMATE
42	560-2707	EKO DUAL
43	560-2709	EKO BUNDLE
44	560-2705	EKO SOLO

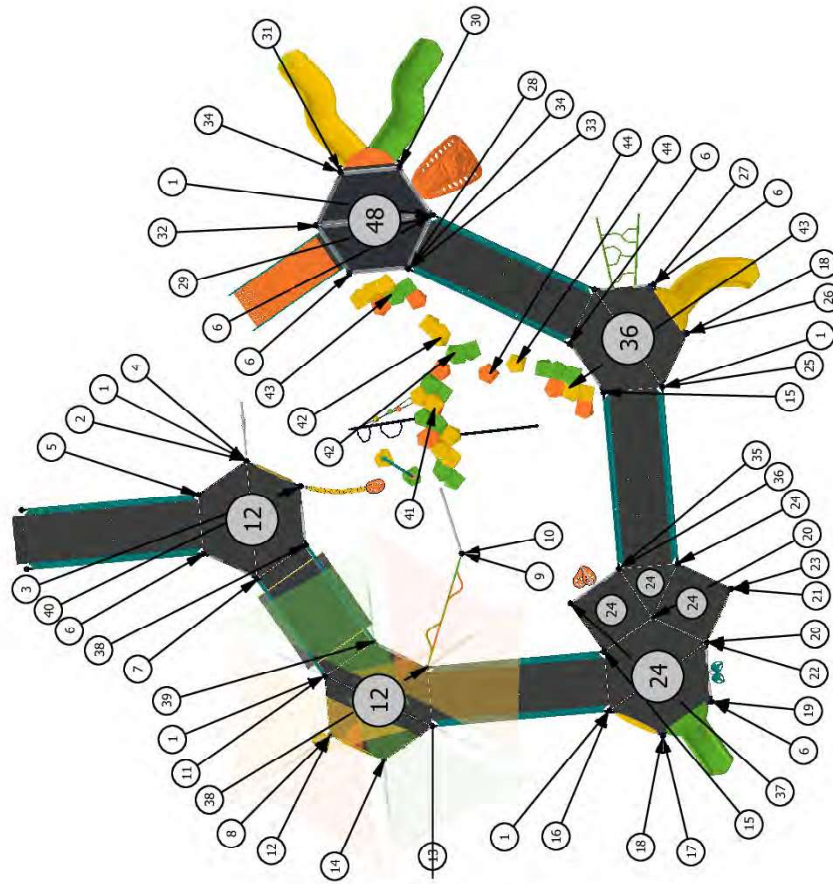

SERIES Nucleus Intensity Burke Basics		COMPONENT VIEW
GROUP: 2-5 Structure	Municipal Park Lathrup Village, MI 48076-3412	01/19/2024
DESIGNED FOR AGES: 2 to 5	Burke PLAY THAT MOVES YOU.	Snider Recreation, Inc. 127-179508-1 Designer: Hunter Mielke
BCI BURKE COMPANY, LLC PO BOX 549 FOND DU LAC, WI 54936-0549 920.921.9220 BCIBURKE.COM		

ITEM	COMP.	DESCRIPTION
1	550-9118	BRAVA UNIVERSAL SWING
2	560-2586	COMET I
3	560-2625	MOVANT INCLUSIVE, FREESTANDING
4	560-2735	ARO SPINNING CHAIR
5	580-1410	STEM PLAY/FIL BENCH
6	550-0225	CIRRUS SWING
7	550-0186	VOLITO
8	570-2745	ORB ROCKER
9	570-2727	ORB ROCKER FOOTER

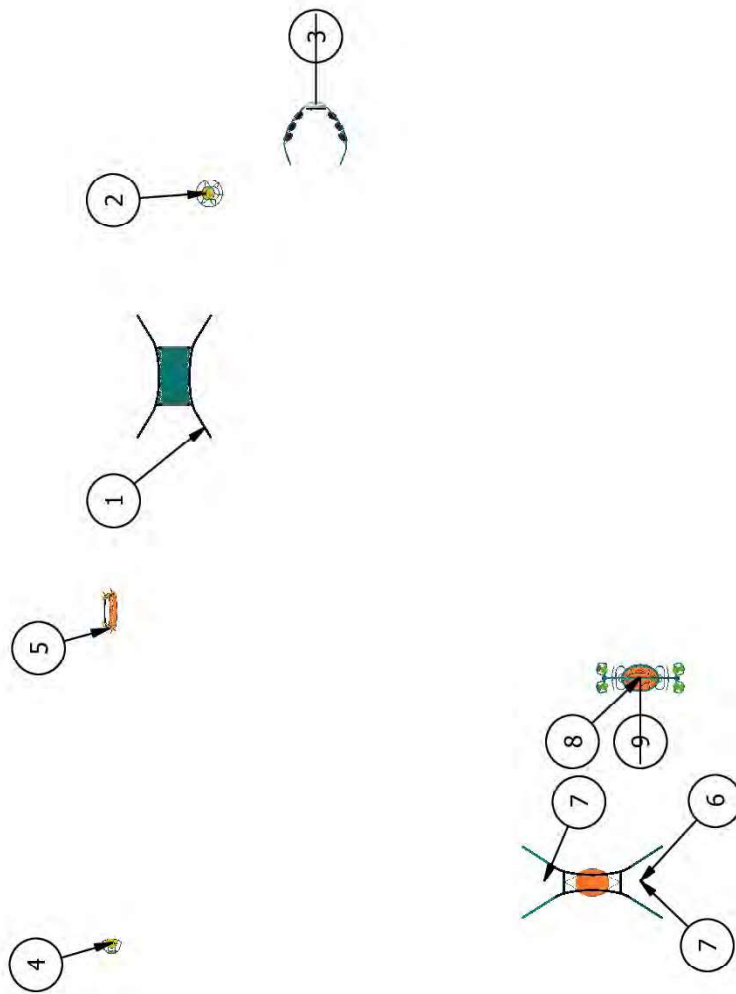

SERIES Burke Basics	COMPONENT VIEW
GROUP: Freestanding	01/19/2024
DESIGNED FOR AGES: 2 to 12	Snider Recreation, Inc. 127-179508-1 Designer: Hunter Mielke
Municipal Park Lathrup Village, MI 48076-3412 	
BCI BURKE COMPANY, LLC PO BOX 549 FOND DU LAC, WI 54936-0549 920.921.9220 BCIBURKE.COM	

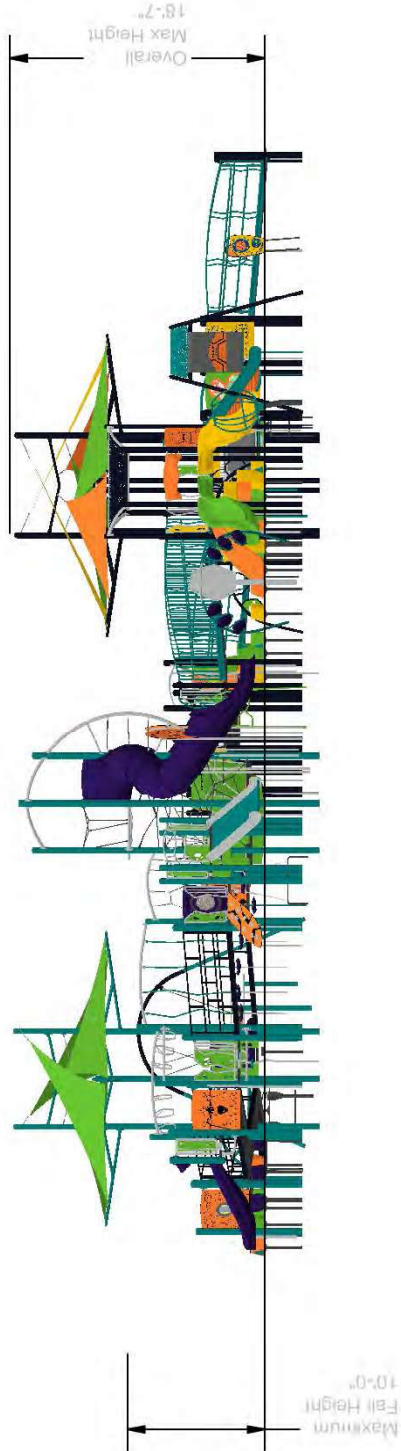

<p>SERIES Burke Basics Nucleus Intensity</p>	<p>Municipal Park Lathrup Village, MI 48076-3412</p>	<p>ELEVATION VIEW</p>
<p>GROUP: 5-12 Structure 2-5 Structure Freestanding</p>	<p>Burke PLAY THAT MOVES YOU.</p>	<p>01/19/2024 Snider Recreation, Inc. 127-179508-1</p>
<p>DESIGNED FOR AGES: 5 to 12, 2 to 5, 2 to 12</p>	<p>Designer: Hunter Mielke</p>	
<p>BCI BURKE COMPANY, LLC PO BOX 549 FOND DU LAC, WI 54936-0549 920.921.9220 BCIBURKE.COM</p>		

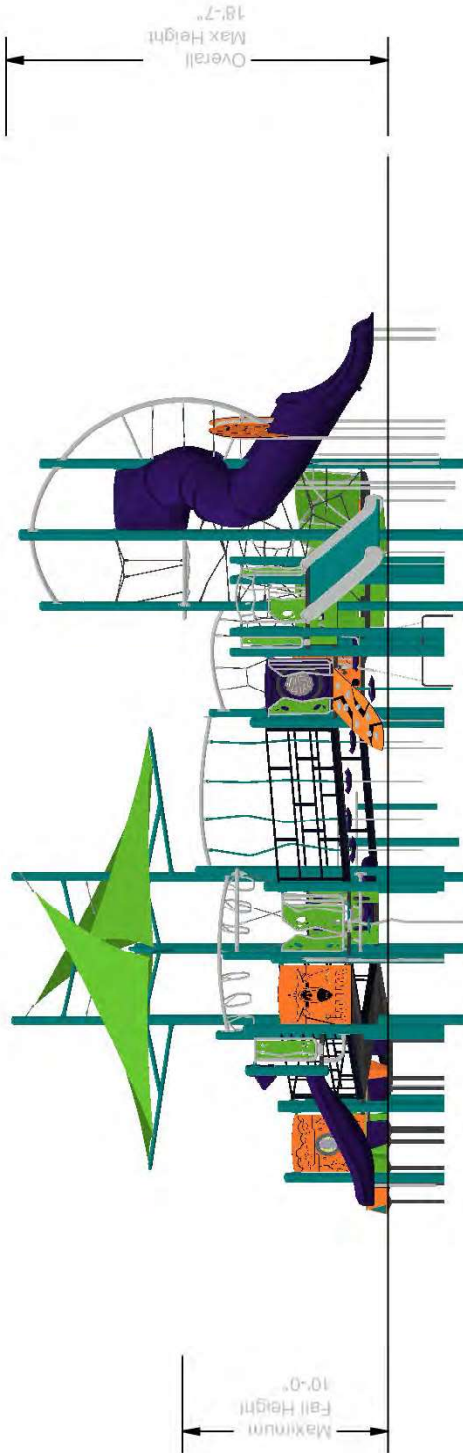

SERIES Nucleus Burke Basics Intensity		ELEVATION VIEW
GROUP: 5-12 Structure	Municipal Park Lathrup Village, MI 48076-3412	01/19/2024
DESIGNED FOR AGES: 5 to 12	Burke PLAY THAT MOVES YOU.	Snider Recreation, Inc. 127-179508-1 Designer: Hunter Mielke
BCI BURKE COMPANY, LLC PO BOX 549 FOND DU LAC, WI 54936-0549 920.921.9220 BCIBURKE.COM		

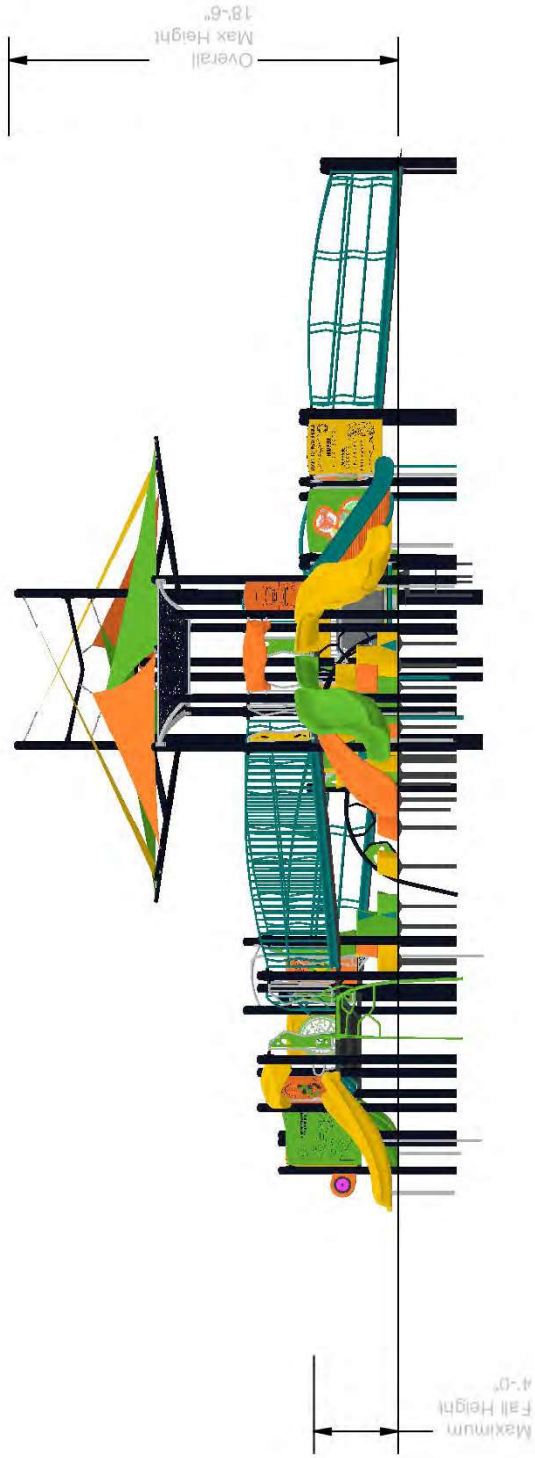

<p>SERIES Nucleus Intensity Burke Basics</p>	<p>Municipal Park Lathrup Village, MI 48076-3412</p>	<p>ELEVATION VIEW</p>
<p>GROUP: 2-5 Structure</p>	<p>01/19/2024</p>	<p>Snider Recreation, Inc.</p>
<p>DESIGNED FOR AGES: 2 to 5</p>	<p>Burke PLAY THAT MOVES YOU.</p>	<p>127-179508-1</p>
<p>Designer: Hunter Mielke</p>		
<p>BCI BURKE COMPANY, LLC PO BOX 549 FOND DU LAC, WI 54936-0549 920.921.9220 BCIBURKE.COM</p>		

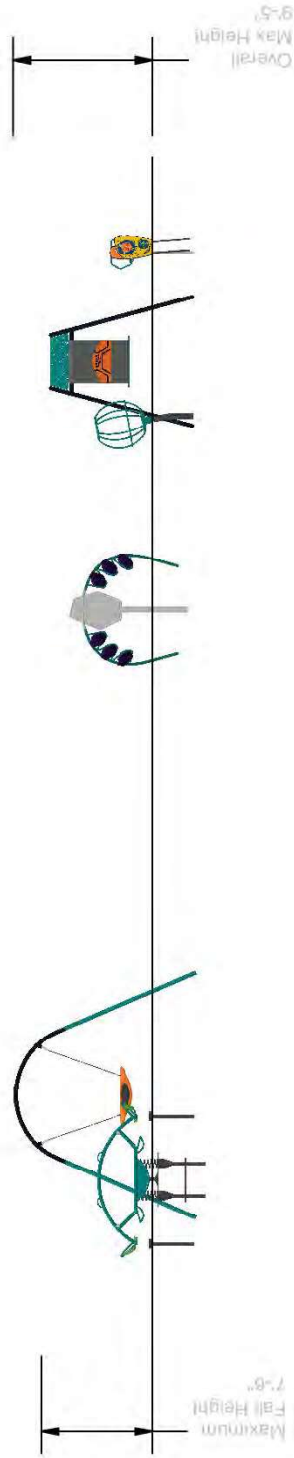

SERIES	Burke Basics	ELEVATION VIEW
GROUP: Freestanding	Municipal Park Lathrup Village, MI 48076-3412	01/19/2024 Snider Recreation, Inc. 127-179508-1
DESIGNED FOR AGES: 2 to 12		Designer: Hunter Mielke
BCI BURKE COMPANY, LLC PO BOX 549 FOND DU LAC, WI 54936-0549 920.921.9220 BCIBURKE.COM		



<p>SERIES Burke Basics Nucleus Intensity</p>		<p>ISOMETRIC VIEW</p>
<p>GROUP: 5-12 Structure 2-5 Structure Freestanding</p>	<p>Municipal Park Lathrup Village, MI 48076-3412</p>	<p>01/19/2024</p>
<p>DESIGNED FOR AGES: 5 to 12, 2 to 5, 2 to 12</p>	<p>Burke PLAY THAT MOVES YOU.</p>	<p>Snider Recreation, Inc. 127-179508-1 Designer: Hunter Mielke</p>
<p>BCI BURKE COMPANY, LLC PO BOX 549 FOND DU LAC, WI 54936-0549 920.921.9220 BCIBURKE.COM</p>		

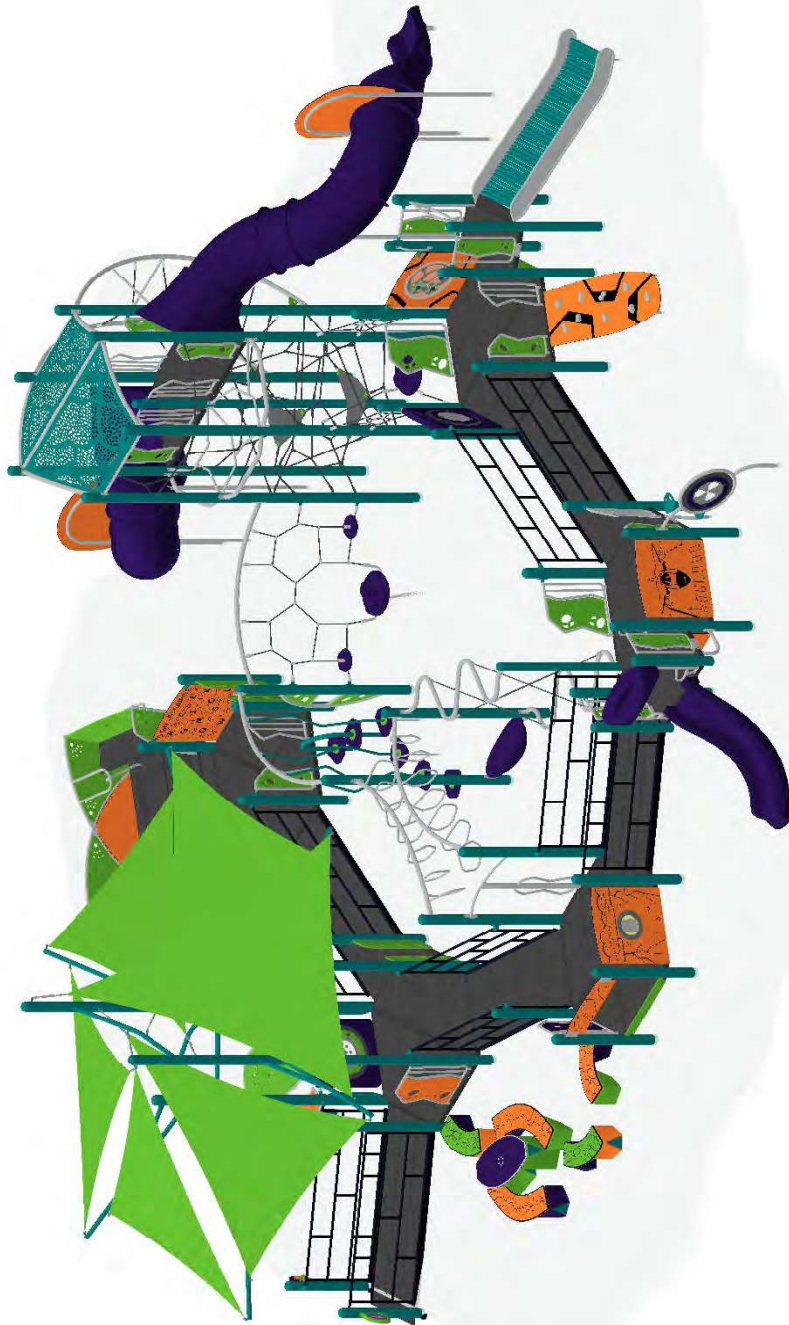

SERIES Nucleus Burke Basics Intensity		ISOMETRIC VIEW
GROUP: 5-12 Structure	Municipal Park Lathrup Village, MI 48076-3412	01/19/2024
DESIGNED FOR AGES: 5 to 12	Burke PLAY THAT MOVES YOU.	Snider Recreation, Inc. 127-179508-1 Designer: Hunter Mielke
BCI BURKE COMPANY, LLC PO BOX 549 FOND DU LAC, WI 54936-0549 920.921.9220 BCIBURKE.COM		



SERIES Nucleus Intensity Burke Basics		ISOMETRIC VIEW
GROUP: 2-5 Structure	Municipal Park Lathrup Village, MI 48076-3412	01/19/2024
DESIGNED FOR AGES: 2 to 5	Burke PLAY THAT MOVES YOU.	Snider Recreation, Inc. 127-179508-1 Designer: Hunter Mielke
BCI BURKE COMPANY, LLC PO BOX 549 FOND DU LAC, WI 54936-0549 920.921.9220 BCIBURKE.COM		



SERIES Burke Basics		ISOMETRIC VIEW
GROUP: Freestanding	Municipal Park Lathrup Village, MI 48076-3412	01/19/2024
DESIGNED FOR AGES: 2 to 12	Burke PLAY THAT MOVES YOU.	Snider Recreation, Inc. 127-179508-1 Designer: Hunter Mielke
BCI BURKE COMPANY, LLC PO BOX 549 FOND DU LAC, WI 54936-0549 920.921.9220 BCIBURKE.COM		



Municipal Park

Proposal 127-179508-1 | 1/19/2024 | 2024 Pricing

The play components identified in this proposal are IPEMA certified. The use and layout of these components conform to the requirements of ASTM F1487. To verify product certification, visit www.ipema.org.



The space requirements shown in this proposal are to ASTM standards. Requirements for other standards may be different.

Component No.	Description	Qty	User Cap	Ext. User Cap	Weight	Ext. Weight
5-12 Structure						
Nucleus						
072-0500-100C	5" OD X 100" CAPPED POST	1	0	0	53	53
072-0500-104C	5" OD X 104" CAPPED POST	2	0	0	55	110
072-0500-112C	5" OD X 112" CAPPED POST	3	0	0	59	177
072-0500-116C	5" OD X 116" CAPPED POST	2	0	0	61	122
072-0500-120C	5" OD X 120" CAPPED POST	1	0	0	63	63
072-0500-124C	5" OD X 124" CAPPED POST	4	0	0	65	260
072-0500-128C	5" OD X 128" CAPPED POST	1	0	0	67	67
072-0500-132C	5" OD X 132" CAPPED POST	3	0	0	69	207
072-0500-136C	5" OD X 136" CAPPED POST	1	0	0	71	71
072-0500-144C	5" OD X 144" CAPPED POST	1	0	0	76	76
072-0500-196C	5" OD X 196" CAPPED POST	1	0	0	103	103
072-0500-80C	5" OD X 80" CAPPED POST	2	0	0	42	84
072-0500-92C	5" OD X 92" CAPPED POST	6	0	0	48	288
072-0500-96C	5" OD X 96" CAPPED POST	4	0	0	51	204
072-0502-168S	5" OD X 168" SWAGED POST	6	0	0	88	528
072-0502-216S	5" OD X 216" SWAGED POST	6	0	0	113	678
072-5503-24T	5" OD X 24" TOP ALUMINUM CAPP...	4	0	0	6	24
072-5503-36T	5" OD X 36" TOP ALUMINUM CAPP...	2	0	0	8	16
270-0120	EVOLUTION UNITARY ENCLOSURE	6	0	0	34	204
270-0122	EVOLUTION OFFSET ENCLOSURE	4	0	0	34	136
270-0131	HEXAGONAL PLATFORM S5P	5	12	60	287	1435
270-0132	HALF HEXAGON PLATFORM	1	6	6	144	144
270-0221	8" RISE RAMP W/ GUARDRAILS	4	10	40	356	1424
270-0223	8" RISE ENTRANCE RAMP W/ GUAR...	1	10	10	377	377
270-0290	HALF PLATFORM	1	3	3	57	57
270-0291	HALF PLATFORM W/SUPPORT	1	3	3	69	69
270-0292	EVOLUTION CENTER MOUNT ENCLOSURE	1	0	0	40	40
270-0300	ABSTRACT PLATFORM LADDER 16"	2	1	2	17	34
370-0016	GRAB BAR ASSEMBLY	2	0	0	6	12
370-0042	ASCEND ROCK CLIMBER, 32"-40"	1	2	2	100	100
370-0087	LEAF CLIMBER 16" - 24"	1	2	2	25	25
370-0223	PURSUIT CLIMBER 16"-40"	1	4	4	127	127
370-1622	TAKTIKS TRAIL TOWER	1	5	5	52	52
370-1702	NUCLEUS CORE ARCH CLIMBER	1	7	7	265	265
370-1703	NUCLEUS CORE CROSS SUPPORT	3	0	0	32	96
370-1706	NUCLEUS CORE CLIMBER, 10'	1	14	14	194	194
470-0006	EVOLUTION BOTTOM ROOF SUPPORT...	2	0	0	13	26
470-0008	EVOLUTION SIDE ROOF SUPPORT, ...	2	0	0	18	36
470-0009	EVOLUTION SIDE ROOF SUPPORT, ...	2	0	0	18	36
470-0014	EVOLUTION HEX ROOF	1	0	0	106	106

QC1 LATHRUP VILLAGE PROJECT PLANS

470-0112	COBRA SLIDE CURVED 120"	2	3	6	407	814
470-0128	FLYLOW POD	1	2	2	27	27
470-0678	ARA HEX SHADE CANOPY	1	0	0	575.864	575.864
470-0756	ROLLER SLIDE 48"-56"	1	3	3	721	721
470-0802	MONACO SLIDE, 32"-40"	1	2	2	70.6	70.6
470-0967	SLIDE HOOD, LOW SIDE WALL	1	0	0	37	37
570-0072	EVOLUTION HALF BARRIER	4	0	0	26.6	106.4
570-0622	PLATFORM ROLL GUARD	1	0	0	8	8
570-0716	CLICKER ACTIVITY PANEL	1	2	2	10	10
570-0718	HYPNO ACTIVITY PANEL	1	2	2	9	9
570-0797	CHARADE PANEL, ABOVE PLATFORM	1	2	2	61	61
570-0798	WAVER PANEL, ABOVE PLATFORM	1	2	2	61	61
570-0848	SIGNING 2-SIDED PLAY PANEL	1	2	2	44	44
570-1816	JET PANEL	1	2	2	48	48
570-1858	3-IN-A-ROW PANEL, ABOVE PLATFORM	1	2	2	45	45
570-1863	RAIN WHEEL PANEL	1	2	2	59	59
570-1865	HDPE UNITARY ENCLOSURE, NUCLEUS	2	1	2	26	52
570-2669	MAZE ACCESSIBLE REACH PANEL	1	2	2	16	16
570-2737	PINBALL PANEL	1	1	1	53	53
600-0104	NPPS SUPERVISION SAFETY KIT	1	0	0	3	3
660-0103	MAINTENANCE KIT, STRUCTURE	1	0	0	7	7
660-0104	INSTALLATION KIT, STRUCTURE	1	0	0	5	5
670-0422	HALF DECK UPPER POST 5" OD	2	0	0	26	52
670-0427	5" OD X 11 GA POST EXTENSION	6	0	0	10	60

5-12 Structure

Burke Basics

560-0563	CRUISER WITH ADAPTER	1	12	12	1361	1361
560-2734	HOOP CLIMBER	1	2	2	55	55
560-2736	EKO CIRCA	3	1	3	60	180
560-2738	EKO TABLE	1	4	4	183	183
580-1312	NOVO ARC BENCH	3	2	6	43	129
580-1319	NOVO TEARDROP COUNTER CLIMBER	1	5	5	124	124

5-12 Structure

Intensity

370-0808	TWISTING TRAVERSE	1	5	5	103	103
370-0854	VERTO CLIMBER 1	1	1	1	35	35
370-1675	STRAIGHT OVERHEAD, NUCLEUS	2	6	12	53	106
370-1718	TAKTIKS BOW CLIMBER	1	7	7	103	103
570-0814	PROPELLER RING PANEL	1	2	2	66	66

Total User Capacity: 251
 Total Weight: 13518 lbs.
 Total Price: \$203,988

Freestanding

Burke Basics

550-0225	CIRRUS SWING	1	0	0	437	437
550-9118	BRAVA UNIVERSAL SWING	1	6	6	530	530
560-2586	COMET I	1	6	6	154	154
560-2625	MOVMNT INCLUSIVE, FREESTANDING	1	2	2	328	328
560-2735	ARO SPINNING CHAIR	1	1	1	42	42
570-2727	ORB ROCKER FOOTER	1	0	0	93	93

QC1 LATHRUP VILLAGE PROJECT PLANS

Item 8K.

570-2745	ORB ROCKER	1	8	8	540.9	540.9
580-1410	STEM PLAYFUL BENCH	1	2	2	122	122
660-0101	INSTALL KIT, BURKE BASICS - P...	1	0	0	2	2

Total User Capacity: 25
 Total Weight: 2249 lbs.
 Total Price: \$50,001

2-5 Structure

Nucleus

072-0500-100C	5" OD X 100" CAPPED POST	7	0	0	53	371
072-0500-112C	5" OD X 112" CAPPED POST	6	0	0	59	354
072-0500-120C	5" OD X 120" CAPPED POST	2	0	0	63	126
072-0500-160C	5" OD X 160" CAPPED POST	4	0	0	84	336
072-0500-172C	5" OD X 172" CAPPED POST	2	0	0	90	180
072-0500-76C	5" OD X 76" CAPPED POST	2	0	0	40	80
072-0500-84C	5" OD X 84" CAPPED POST	1	0	0	44	44
072-0500-88C	5" OD X 88" CAPPED POST	6	0	0	46	276
072-0502-168S	5" OD X 168" SWAGED POST	6	0	0	88	528
072-0502-52S	5" OD X 52" SWAGED POST	1	0	0	28	28
072-0504-10B	5" OD X 10" STUBBY POST	1	0	0	6	6
270-0012	12' ADAAG RAMP W/GUARDRAIL	2	18	36	516	1032
270-0014	12' ADAAG RAMP W/BARRIER	1	18	18	761	761
270-0016	12' ADAAG ENTRANCE RAMP W/GUA...	1	18	18	548	548
270-0120	EVOLUTION UNITARY ENCLOSURE	6	0	0	34	204
270-0121	EVOLUTION STANCHION	1	0	0	43	43
270-0122	EVOLUTION OFFSET ENCLOSURE	2	0	0	34	68
270-0129	TRIANGLE PLATFORM	1	2	2	48	48
270-0130	SQUARE PLATFORM	2	6	12	106	212
270-0131	HEXAGONAL PLATFORM S5P	5	12	60	287	1435
370-0087	LEAF CLIMBER 16" - 24"	1	2	2	25	25
370-1645	MANITOU CLIMBER 48"	1	4	4	87	87
370-1670	PETAL STEP CLIMBER 16"-24"	1	1	1	30	30
370-1680	BETA CLIMBER 32"-40"	1	1	1	71	71
370-1720	LIL NOVO BALANCE BEAM LINK	1	3	3	58	58
470-0569	VIPER II SS 48-56	1	4	4	307	307
470-0678	ARA HEX SHADE CANOPY	1	0	0	575.864	575.864
470-0756	ROLLER SLIDE 48"-56"	1	3	3	721	721
470-0802	MONACO SLIDE, 32"-40"	1	2	2	70.6	70.6
470-0808	EVOLUTION ROOF BOTTOM EDGE	2	0	0	13	26
470-0813	EVOLUTION HEX ROOF	1	0	0	211	211
470-0836	ROCK'N ROLL SLIDE, 24-32 W/O ...	1	1	1	50	50
470-0967	SLIDE HOOD, LOW SIDE WALL	2	0	0	37	74
570-0102	INNOVA BRIDGE	1	18	18	847	847
570-0578	NAME THE STATES PANEL	1	4	4	46	46
570-0622	PLATFORM ROLL GUARD	1	0	0	8	8
570-0718	HYPNO ACTIVITY PANEL	1	2	2	9	9
570-0811	BRAILLE PANEL	1	4	4	55	55
570-0846	SPANISH 2-SIDED PLAY PANEL	1	2	2	44	44
570-1679	SPROCKET PANEL, ABOVE PLATFORM	1	2	2	64	64
570-1683	PARATROOP PANEL, ABOVE PLATFORM	1	3	3	54	54
570-1851	CHIMES PANEL	1	4	4	56	56
570-1858	3-IN-A-ROW PANEL, ABOVE PLATFORM	1	2	2	45	45
570-2666	CAR PANEL	1	2	2	53	53
570-2667	BEE ACCESSIBLE REACH PANEL	1	2	2	16	16
570-2678	CLOCK PANEL	1	1	1	50	50
570-2701	COLLISION PANEL, ABOVE PLATFORM	1	1	1	55	55
570-2729	CLASSIC GAME RING PANEL	1	2	2	80	80

570-2732	PLAYENSEMBLE BABEL DRUM	1	1	1	14	14
670-0425	5" OD STUBBY POST CAP	1	0	0	1	1

2-5 Structure

Intensity

370-0031	POWER PIPES CLIMBER 2-5	1	6	6	33	33
370-0842	APEX HOLE CLIMBER 2-5	1	2	2	55	55

2-5 Structure

Burke Basics

560-2705	EKO SOLO	2	1	2	24	48
560-2707	EKO DUAL	2	2	4	47	94
560-2709	EKO BUNDLE	2	6	12	148	296
560-2715	EKO ULTIMATE	1	18	18	505	505

Total User Capacity: 261
 Total Weight: 11515 lbs.
 Total Price: \$160,274

Special Notes:

Prices do not include freight, unloading, material storage, site excavation/preparation, removal of existing equipment, removal of excess soil from footing holes, site security, safety surfacing, installation, or sales tax (if applicable). Prices are based on standard colors per CURRENT YEAR BCI Burke Catalog. Custom colors, where available, would be an extra charge. **Pricing is valid for 30 days from the date of this proposal.**



Municipal Park

Proposal 127-179508-1 | 1/19/2024 | 2024 Pricing

COLOR SELECTION LIST | PlaygroundColorOption:1

GROUP 1 (Freestanding)

- Acc: Aqua
- Panel: Orange-Black-Orange | Yellow-Black-Yellow | Purple-Gray-Purple | Lime-Black-Lime | Blue-Yellow-Blue
- Post: Navy | Silver | Aqua
- Flat: Yellow | Lime
- Plastic: Purple | Orange

GROUP 2 (2-5 Structure)

- Deck: Gray
- Acc: Silver | Aqua | Lime | Orange
- Flat: Lime | Yellow | Orange
- Panel: Orange-Black-Orange | Yellow-Black-Yellow | Lime-Black-Lime
- Post: Navy | Aqua | Orange
- Plastic: Yellow | Lime | Orange
- Canopy: Yellow | Orange | Lime

GROUP 3 (5-12 Structure)

- Deck: Gray
- Flat: Lime | Orange | Purple
- Post: Aqua
- Acc: Silver | Navy | Aqua
- Plastic: Purple | Lime | Orange
- Panel: Orange-Black-Orange | Lime-Black-Lime | Purple-Gray-Purple
- Canopy: Lime

COLORS THAT MOVE YOU

POWDER COAT PAINT



SOLIS HUE TOPPERS

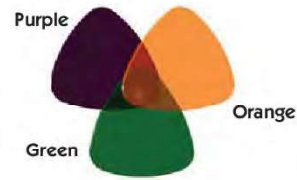

ROCKIT CLIMBERS



PLATFORMS



HDPE PLASTIC PANELS



SHADE CANOPIES

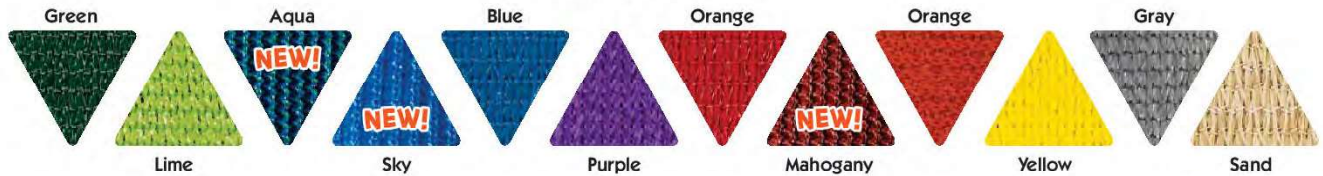

ROTOMOLD PLASTIC

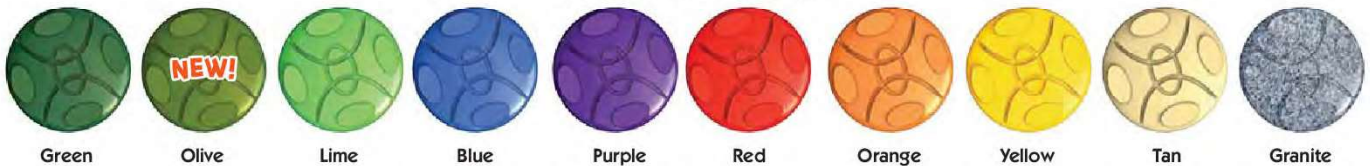

VISIT BCIBURKE.COM/COLOR TO CUSTOMIZE YOUR PLAYGROUND COLORS!

Volito Swing

Safety Standards & Guidelines - Reference Information

The Volito Swing was designed to allow multiple children to swing and engage together. For many years the only swings available for kids to use together were tire swings, which are fun and challenging but presented opportunities for improvement. Tire swings are able to rotate and pivot in all directions, often in an unpredictable manner and, because they aren't easy to propel while sitting on them, other children often have to push the swing to gain and maintain motion. The Volito Swing, along with many similar swings in this growing market trend, provides a multi-user swing that moves in a single axis to-fro motion.

The Volito Swing is IPEMA Certified and meets or exceeds the requirements of ASTM F1487-17, which is recognized as the standard of care in the playground industry. This ASTM public playground safety standard is revised every two to three years to remain current with innovation and market trends.

The CPSC Public Playground Safety Handbook hasn't been revised since 2008 and doesn't include new product categories that have been innovated in recent years. There are a couple of points to note when deciding to purchase a multi-user swing:

- Multi-user swings are innovative and CPSC Public Playground Safety Handbook doesn't have a standard that specifically covers them.
- CPSC 5.3.8.3.1 – CPSC recommends that belt swing seats should be designed to accommodate no more than one user at any time. While the Volito Swing is a single axis swing, it is clearly not a belt seat.
- CPSC 2.3.1 – CPSC says that swings intended for more than one user are not recommended because of their greater mass, as compared to single occupancy swings, presents a risk of impact injury.
- The ASTM safety standard, F1487, was revised in 2011 to add maximum impact requirements for swings and the Volito Swing has been tested and is compliant with ASTM impact requirements.
- CPSC has written a letter stating that “the swing impact test in F1487-11 is a reasonable approach to address the concerns posed by unoccupied, heavy, multiple occupancy swings.”
- CPSC has always included an exemption to both recommendations listed above for tire swings, which are multiple occupancy swings that are suspended from a single pivot and permit swinging in any direction.
- CPSC also emphasizes that their Handbook provides recommendations, not requirements. If a jurisdiction adopts the Handbook's recommendations as mandatory requirements, that jurisdiction would need to determine how the requirements should be applied in any particular instance.

BURKE GENERATIONS WARRANTY®

The Longest and Strongest warranty in the industry

BCI Burke Company, LLC ("Burke") warrants that all standard products are warranted to be free from defects in materials and workmanship, under normal use and service, for a period of one (1) year from the date of shipment.

We stand behind our products. In addition, the following products are warranted, under normal use and service from the date of shipment as follows:

- One Hundred (100) Year Limited Warranty on aluminum and steel upright posts (including Intensity®, Synergy™, Nucleus®, Voltage®, Little Buddies®, ELEVATE®, ACTIVATE®, INVIGORATE™) against structural failure due to corrosion, deterioration or workmanship.
- One Hundred (100) Year Limited Warranty on KoreConnect® clamps against structural failure due to corrosion, deterioration or workmanship.
- One Hundred (100) Year Limited Warranty on Hardware (nuts, bolts, washers)
- One Hundred (100) Year Limited Warranty on bolt-through fastening and clamp systems (Synergy™, Intensity®, Nucleus®, Voltage®, Little Buddies®, ELEVATE®).
- Twenty-Five (25) Year Limited Warranty on spring assemblies and aluminum cast animals.
- Fifteen (15) Year Limited Warranty on structure platforms and decks, metal roofs, table tops, bench tops, railings and barriers against structural failure due to materials or workmanship.
- Fifteen (15) Year Limited Warranty on all plastic components including StoneBorders against structural failure due to materials or workmanship.
- Ten (10) Year Limited Warranty on ShadePlay Canopies fabric, threads, and cables against degradation, cracking or material breakdown resulting from ultra-violet exposure, natural deterioration or manufacturing defects. This warranty is limited to the design loads as stated in the specifications.
- Ten (10) Year Limited Warranty on NaturePlay® Boulders and GFRC products against structural failure due to natural deterioration or workmanship. Natural wear, which may occur with any concrete product with age, is excluded from this warranty
- Ten (10) Year Limited Warranty on Full Color Custom Signage against manufacturing defects that cause delamination or degradation of the sign. Full Color Custom Signs also carry a two (2) year warranty against premature fading of the print and graphics on the signs.
- Five (5) Year Limited Warranty on Intensity® and RopeVenture® cables and LEVEL X® flex bridge against premature wear due to natural deterioration or manufacturing defects. Determination of premature wear will be at the manufacturer's discretion.
- Five (5) Year Limited Warranty on moving parts, including swing components, against structural failure due to materials or workmanship.
- Five (5) Year Limited Warranty on PlayEnsemble® cables and mallets against defects in materials and workmanship.
- Three (3) Year Limited Warranty on electronic panel speakers, sound chips and circuit boards against electronic failure caused by manufacturing defects.

The warranty stated above is valid only if the equipment is erected in conformity with the layout plan and/or installation instructions furnished by BCI Burke Company, LLC using approved parts; have been maintained and inspected in accordance with BCI Burke Company, LLC instructions. Burke's liability and your exclusive remedy hereunder will be limited to repair or replacement of those parts found in Burke's reasonable judgment to be defective. Any claim made within the above stated warranty periods must be made promptly after discovery of the defect. A part is covered only for the original warranty period of the applicable part. Replacement parts carry the applicable warranty from the date of shipment of the replacement from Burke. After the expiration of the warranty period, you must pay for all parts, transportation and service charges.

Burke reserves the right to accept or reject any claim in whole or in part. Burke will not accept the return of any product without its prior written approval. Burke will assume transportation charges for shipment of the returned product if it is returned in strict compliance with Burke's written instructions.

THE FOREGOING WARRANTIES ARE EXCLUSIVE AND IN LIEU OF ANY OTHER WARRANTY, EXPRESS OR IMPLIED, INCLUDING BUT NOT LIMITED TO ANY IMPLIED WARRANTY OR MERCHANTABILITY OR FITNESS FOR A PARTICULAR PURPOSE. IF THE FOREGOING DISCLAIMER OF ADDITIONAL WARRANTIES IS NOT GIVEN FULL FORCE AND EFFECT, ANY RESULTING ADDITIONAL WARRANTY SHALL BE LIMITED IN DURATION TO THE EXPRESS WARRANTIES AND BE OTHERWISE SUBJECT TO AND LIMITED BY THE TERMS OF BURKE'S PRODUCT WARRANTY. SOME STATES DO NOT ALLOW THE EXCLUSION OF CERTAIN IMPLIED WARRANTIES, SO THE ABOVE LIMITATION MAY NOT APPLY TO YOU.

Warranty Exclusions: The above stated warranties do not cover: "cosmetic" defects, such as scratches, dents, marring, or fading; damage due to incorrect installation, vandalism, misuse, accident, wear and tear from normal use, exposure to extreme weather; immersion in salt or chlorine water, unauthorized repair or modification, abnormal use, lack of maintenance, or other cause not within Burke's control; and

Limitation of Remedies: Burke is not liable for consequential or incidental damages, including but not limited to labor costs or lost profits resulting from the use of or inability to use the products or from the products being incorporated in or becoming a component of any other product. If, after a reasonable number of repeated efforts, Burke is unable to repair or replace a defective or nonconforming product, Burke shall have the option to accept return of the product, or part thereof, if such does not substantially impair its value, and return the purchase price as the buyer's entire and exclusive remedy. Without limiting the generality of the foregoing, Burke will not be responsible for labor costs involved in the removal of products or the installation of replacement products. Some states do not allow the exclusion of incidental damages, so the above exclusion may not apply to you.

The environment near a saltwater coast can be extremely corrosive. Some corrosion and/or deterioration is considered "normal wear" in this environment. Product installed within 500 yards of a saltwater shoreline will only be covered for half the period of the standard product warranty, up to a maximum of five years, for defects caused by corrosion. Products installed in direct contact with saltwater or that are subjected to salt spray are not covered by the standard warranty for any defects caused by corrosion.

Contact your local Burke Representative for warranty information regarding Burke Turf® and Burke Tile products.

Terms of Sale

Pricing: Prices published in this catalog are in USD, are approximate and do not include shipping & handling, surfacing, installation nor applicable taxes. All prices are subject to change without notice. Contact your Burke representative for current pricing. Payments are to be made in USD.

Weights: Weights are approximate and may vary with actual orders.

Installation: All equipment is shipped unassembled. For a list of factory-certified installers in your area, please contact your Burke representative.

Specifications: Product specifications in this catalog were correct at the time of publication. However, product improvements are ongoing at Burke, and we reserve the right to change or discontinue specifications without notice.

Loss or Damage in Transit: A signed bill of lading is our receipt from a carrier that our shipment to you was complete and in good condition upon arrival. Before you sign, please check the Bill of Lading carefully when the shipment arrives to make sure nothing is missing and there are no damages. Once the shipment leaves our plant, we are no longer responsible for any damage, loss or shortage.

For more information regarding the warranty, call Customer Service at 920-921-9220 or 1-800-356-2070.

01/2021

BCIBURKE.COM

Burke

800.266.1250



MUNICIPAL PARK PLAY STRUCTURE

FILE: H:Lathrup Village/Municipal Park
 DATE: March 1, 2024

PRELIMINARY CONSTRUCTION COST ESTIMATE

The preliminary cost estimate is based on the quote received from Snider Recreation for the purchase and construction of the play structure for ages 5 - 12 (Snider No 127-169213-1). Play structure and accessories to be ADA compliant and Universal design standards applied. NOTE: The Play Structure quote includes some site preparation work and therefore, a reduced unit price was used for line item site prep and aggregates costs.

ITEM	WORK ACTIVITY	QUANTITY	UNIT	UNIT PRICE	TOTAL	COMMENTS
PLAY STRUCTURE - PER SNIDER RECREATION QUOTE (05/18/2023)						
	Play Structure	1	LS	\$193,174.00	\$193,174.00	Includes Discount
	Wood Fiber Surfacing	1875	Sft	\$7.00	\$13,125.00	Includes limited site prep
	Turf Surfacing	3000	Sft	\$17.00	\$51,000.00	Includes limited site prep
	Poured-in-Place Rubber Surfacing	2625	Sft	\$27.00	\$70,875.00	Includes limited site prep
	Installation	1	LS	\$79,529.00	\$79,529.00	
	Shipping	1	LS	\$15,000.00	\$15,000.00	
	Inflation (use 7% of above total)	1	LS	\$20,144.60	\$20,144.60	Quote in 2023, install in 2025
	SUBTOTAL - PLAY STRUCTURE				\$442,848	
SITE PREPARATION						
	Earth excavation	365	Cyd	\$20.00	\$7,300.00	Based on 18" thick excavation
	SUBTOTAL - SITE PREPARATION				\$7,300	
SOIL EROSION SEDIMENT CONTROL						
	Inlet/CB filter	2	Ea	\$200.00	\$400.00	
	SUBTOTAL - EROSION CONTROL				\$400	
STORM WATER UNDERDRAIN SYSTEM						
	Storm Drain, 8" dia PVC	55	Lft	\$80.00	\$4,400.00	Typically 1 CB per alley
	Underdrain, 6" / 8" Dia, Perforated	350	Lft	\$30.00	\$10,500.00	
	Dr. Structure, 24" Dia	1	Ea	\$2,750.00	\$2,750.00	Includes F & C
	Dr Structure Tap, 8 Inch	1	Ea	\$500.00	\$500.00	
	Pavt, Remove and Replace	10	Ton	\$300.00	\$3,000.00	Incl removal
	SUBTOTAL - UNDERDRAIN				\$21,150	
AGGREGATES						
	Aggregate Base, 6", Drainage layer	670	Syd	\$10.00	\$6,700.00	Pea Stone or 6A
	Aggregate Base, 6" 21AA Base	625	Syd	\$10.00	\$6,250.00	Under Rubber and Turf surface
	Geotextile Fabric	1350	Syd	\$2.00	\$2,700.00	Soil seperation fabric
	SUBTOTAL - AGGREGATES				\$15,650	
CONCRETE PAVEMENTS						
	Conc Curb, Rem and Replace	10	Lft	\$50.00	\$500.00	For ADA ramp
	Sidewalk, Conc, 6 Inch, Ramp	90	Sft	\$15.00	\$1,350.00	Ramp to play structure
	Concrete Pad, 4 Inch	300	Sft	\$15.00	\$4,500.00	
	Aggregate Base, 4 Inch	45	Syd	\$15.00	\$675.00	Under ramp and pad
	SUBTOTAL - CONCRETE PAVEMENT				\$7,025	
SITE FURNISHINGS						
	Bench, 8 foot, Universal	2	Ea	\$2,000.00	\$4,000.00	Purchase and Install
	Picnic Table, Universal	2	Ea	\$2,000.00	\$4,000.00	Purchase and Install
	Park Signage	1	Ea	\$2,500.00	\$2,500.00	Purchase and Install
	SUBTOTAL SITE FURNISHINGS				\$10,500	
LANDSCAPING						
	Landscape Restoration	400	Syd	\$10.00	\$4,000.00	Topsoil, Seed, Mulch
	Shade Trees	4	Ea	\$650.00	\$2,600.00	
	Irrigation Repairs	1	LS	\$5,000.00	\$5,000.00	Budget
	SUBTOTAL - LANDSCAPING				\$11,600	
SUBTOTAL CONSTRUCTION COST					\$516,473	
SUBTOTAL CONSTRUCTION COST					\$516,473	
CONSTRUCTION CONTINGENCY				10%	\$51,647	
SUBTOTAL ENGINEERING, BIDDING, INSPECTION				10%	\$56,812	
TOTAL ESTIMATED CONSTRUCTION COST					\$624,932	

002 PROJECT PHOTOGRAPHY 02/10/16 08:00 AM



Municipal Park Looking NE

002/06/16 10:4

002 PROJECT PHOTOGRAPHY 02/10/16 08:00 AM



Municipal Park Looking NW

Municipal Park Looking W



QC2 PROJECT PHOTOGRAPHS (EXISTING CONDITIONS)



000 PROJECT PHOTOGRAPHY © BIRNBAUM CONSULTANTS

Municipal Park Looking SE



**Main Street Oakland County Placemaking and Public Spaces Program
PROJECT BUDGET**

Enter data into blue shaded input cells only.

APPLICANT

Project Name	Municipal Park Renovation - Play Scape Phase 1
City/Township/Village	Lathrup Village
County	Oakland

TOTAL DEVELOPMENT COSTS

Acquisition

	Amount
Land	\$ -
Building(s)	\$ -
Other:	\$ -
Subtotal	\$ -

Hard Costs

Public Infrastructure (roads, sidewalks, utilities, sewage, etc.)	
Site Improvements (walks, drives, landscaping, fencing, lights, and drainage)	\$ 29,284.00
Demolition (Include Lead & Asbestos Abatement)	\$ -
Other Environmental Mitigation	\$ -
Earth Work	\$ -
Site Utilities	\$ -
Other: Play Structure Site Work	\$ 120,000.00
Subtotal	\$ 149,284.00

Construction Cost

Building Concrete/Masonry	\$ -
Carpentry	\$ -
Roofing/Metal/Siding/Insulation/Caulking	\$ -
Doors/Windows/Glass	\$ -
Drywall/Acoustical	\$ -
Flooring	\$ -
Cabinets/Countertops/Appliances	\$ -
Painting/Decorating	\$ -
Plumbing/Electrical/Fire Protection	\$ -
HVAC	\$ -
Accessory Buildings/Garages	\$ -
Other: Structures (pergola, retaining walls, stage, bathrooms)	\$ -
Permits/Tap Fees/Bond/Cost Certification	\$ -
Other: Play Structure - Phase 1	\$ 193,574.00
Other:	\$ -
Other:	\$ -
Construction Contingency 10%	\$ -
Subtotal	\$ 193,574.00

Other Costs

Furniture & Fixtures	\$ -
Architectural & Engineering	\$ -
Related Party and Consulting Fees	\$ -
Developer Fee	\$ -
Project Management Fee	\$ -
Consulting Fees	\$ -
Survey	\$ -
Other Professional Fees	\$ -
Other:	\$ -
Other:	\$ -
Other:	\$ -
Subtotal	\$ -

TOTAL DEVELOPMENT COSTS	\$ 342,858.00
--------------------------------	----------------------

SOURCE AND AMOUNT OF LOCAL FUNDS

	Amount
Source A Lathrup Village DDA & General Fund	\$ 200,000.00
Source B Growdfunding/Donations	\$ 2,091.00
Source C Giffels Webster In-Kind Professional Services	\$ 5,000.00
Source D	\$ -
Source E	\$ -
Source F	\$ -

TOTAL LOCAL FUNDS	\$ 207,091.00
--------------------------	----------------------

TOTAL DEVELOPMENT COSTS	\$ 342,858.00
TOTAL LOCAL FUNDS	\$ 207,091.00
REQUESTED COUNTY ARPA FUNDS*	\$ 135,767.00

*Not to exceed 40% of Total Development Costs

Lathrup Village Downtown Development Authority

Resolution of Support



Oakland County RAP 2.0 Revitalization & Placemaking Grant Application

Whereas, the Lathrup Village Downtown Development Authority Board of Directors offers our full support for our community's participation in Oakland County's RAP 2.0 Revitalization Placemaking Grant application, and;

Whereas the Southfield Road corridor is a highly traveled thoroughfare with a wide variety of destinations including retail, salons, day spas, eateries, medical offices, and Lathrup Village City Hall and Municipal Park. As the largest and most visited park in the city, Municipal Park is the hub of community events including Concerts in the Park, Juneteenth Celebration, Fall Fest, as well as many private events and parties, and;

Whereas the Lathrup Village Downtown Development Authority is charged with revitalizing the Southfield Road commercial corridor and enhancing its vibrancy through physical investment and supporting new and existing businesses, and;

Whereas the Lathrup Village Downtown Development Authority is committed to making physical improvements throughout the district by repaving several alleyways and approaches, implementing a sidewalk replacement program, and initiating several small-scale streetscaping projects including hanging flower baskets, entrance gardens, and banners. The Lathrup Village Downtown Development Authority partnered with the City of Lathrup Village to successfully implement a city-wide bike route wayfinding signage. The Lathrup Village Downtown Development continues to strongly advocate for enhanced pedestrian improvements and non-motorized transportation options throughout the district, and;

Whereas, the Lathrup Village Downtown Development Authority is actively engaged in the Main Street Oakland County program, and has benefitted from the resources and support provided to the organization and the business district, and;

Whereas the Lathrup Village Downtown Development Authority proposes to the completely renovate the existing play structure at Municipal Park into a fully accessible play structure, reconstruct the adjacent parking lot surrounding City Hall, and relandscape the extensive flower beds on the east side of City Hall. The estimated cost for this work is \$838,342, and;

Whereas, the Municipal Park Renovation Project will have a transformative impact on our downtown district by *creating a more welcoming environment for residents and visitors of all ages and abilities. Investment has been made in common infrastructure; however, the infrastructure of play and place-based connection needs attention. The Municipal Park Renovation Project is consistent with our Comprehensive Plan which includes the Downtown Plan, city-wide Master Plan, and Parks & Recreation Plan, as well as the Development and Tax Increment Financing Plan, and is in*

alignment with the adopted economic priorities of Oakland County, the Southeast Michigan Council of Governments, and the State of Michigan. Furthermore, our proposed project re-enforces the Business, Talent, and Place adopted strategy of SEMCOG that will attract and retain business investment, and appeal to talent who will want to live, work, and invest in our communities and region, and;

Whereas, the pandemic forced the Downtown Development Authority and City to cancel numerous events and programs which typically occur in the park, and the Municipal Park Renovation will allow us to create a safe and welcoming atmosphere for residents and visitors alike, spurring reinvestment, and this project will help counter or help mitigate such a crisis in the future; now;

Therefore, be it resolved; the Lathrup Village Downtown Development Authority has committed \$100,000 of funds from our fund balance, and will be embarking upon a crowdfunding campaign to secure additional matching funds for the Municipal Park Renovations. We are confident our project meets or exceeds the goals of the Revitalization and Placemaking 2.0 Grant Program.

6/16/23 
Date Fred Prime, Chair, Lathrup Village Downtown Development Authority

B

City of Lathrup Village

Resolution of Support

Oakland County RAP 2.0 Revitalization & Placemaking Grant Application

Whereas, the City of Lathrup Village City Council offers our full support for our community's participation in Oakland County's RAP 2.0 Revitalization Placemaking Grant application, and;

Whereas the Southfield Road corridor is a highly traveled thoroughfare with a wide variety of destinations including retail, salons, day spas, eateries, medical offices, and Lathrup Village City Hall and Municipal Park. As the largest and most visited park in the city, Municipal Park is the hub of community events including Concerts in the Park, Juneteenth Celebration, Fall Fest, as well as many private events and parties, and;

Whereas the City of Lathrup Village has a vested interest with the revitalization of the Southfield Road commercial corridor and enhancing its vibrancy through physical investment and supporting new and existing businesses, and;

Whereas the City of Lathrup Village supports the efforts of the Lathrup Village Downtown Development Authority to making physical improvements throughout the district by repaving several alleyways and approaches, implementing a sidewalk replacement program, and initiating several small-scale streetscaping projects including hanging flower baskets, entrance gardens, and banners. The City of Lathrup Village partnered with the Lathrup Village Downtown Development Authority to successfully implement a city-wide bike route wayfinding signage, and;

Whereas, the Lathrup Village Downtown Development Authority is actively engaged in the Main Street Oakland County program, and has benefitted from the resources and support provided to the organization and the business district, and;

Whereas the City of Lathrup Village and Lathrup Village Downtown Development Authority propose to completely renovate the existing play structure at Municipal Park into a fully accessible play structure, reconstruct the adjacent parking lot surrounding City Hall, and relandscape the extensive flower beds on the east side of City Hall. The estimated cost for this work is \$838,342, and;

Whereas, the Municipal Park Renovation Project will have a transformative impact on our downtown district by creating a more welcoming environment for residents and visitors of all ages and abilities. Investment has been made in common infrastructure; however, the infrastructure of play and place-based connection needs attention. The Municipal Park Renovation Project is consistent with our Comprehensive Plan which includes the Downtown Plan, city-wide Master Plan, and Parks & Recreation Plan, as well as the Development and Tax Increment Financing Plan, and is in alignment with the adopted economic priorities of Oakland County, the Southeast Michigan Council of Governments, and the State of Michigan. Furthermore, our proposed project

Furthermore, our proposed project re-enforces the Business, Talent, and Place adopted strategy of SEMCOG that will attract and retain business investment, and appeal to talent who will want to live, work, and invest in our communities and region, and;

Whereas, the pandemic forced the Downtown Development Authority and City to cancel numerous events and programs which typically occur in the park, and the Municipal Park Renovation will allow us to create a safe and welcoming atmosphere for residents and visitors alike, spurring reinvestment, and this project will help counter or help mitigate such a crisis in the future; now;

Therefore, be it resolved; the City of Lathrup Village has committed \$100,000 of funds from our general funds and will be partnering on a crowdfunding campaign to secure additional matching funds for the Municipal Park Renovations. We are confident our project meets or exceeds the goals of the Revitalization and Placemaking 2.0 Grant Program.

6-26-23
Date

Mykale "Kelly" Garrett, Mayor, City of Lathrup Village

Michele Wildman
EVP, Economic Development Incentives
Michigan Economic Development Corporation

I would like to offer my full support for our community's participation in Oakland County's RAP 2.0 Revitalization Placemaking Grant application.

The Lathrup Village downtown district is predominately along the Southfield Road corridor, which is a highly traveled thoroughfare with a wide variety of destinations including retail, salons, day spas, eateries, medical offices, and Lathrup Village City Hall and Municipal Park. As the largest and most visited park in the city, Municipal Park is the hub of community events including Concerts in the Park, Juneteenth Celebration, Fall Fest, as well as many private events and parties. Over the past several years, it is evident that the Lathrup Village Downtown Development Authority (LVDDA) is committed to revitalizing the Southfield Road commercial corridor and enhancing its vibrancy through physical investment and supporting new and existing businesses.

For example, the LVDDA has undertaken numerous physical improvements throughout the district by repaving several alleyways and approaches, implementing a sidewalk replacement program, and initiating several small-scale streetscaping projects including hanging flower baskets, entrance gardens, and banners. They have also successfully implemented a city-wide bike route wayfinding signage, and continue to advocate for enhanced pedestrian improvements and non-motorized transportation options throughout the district.

The proposed project entails the complete renovation the existing play structure at Municipal Park into a fully accessible play structure, reconstruction the adjacent parking lot surrounding City Hall, and relandscaping the extensive flower beds on the east side of City Hall. The estimated cost for this work is \$838,342.

The Justifications: As a Lathrup Village property owner for over 20-years, I am confident the proposed project will have an enduring impact on our downtown district by providing the quality of municipal facilities to our business and residential communities that will serve as critical factor for economic growth. Additionally, the project will not only enhance property values, but it will also give residents and visitors a gathering place that exemplifies Lathrup Village's values of family and unity.

Thank you for your consideration for the Lathrup Village Municipal Park Renovation project as part of the Oakland County Revitalization and Placemaking 2.0 grant application.

Sincerely,

Fred Prime
Resident and DDA Board Member

Michele Wildman
EVP, Economic Development Incentives
Michigan Economic Development Corporation

I would like to offer my full support for our community's participation in Oakland County's RAP 2.0 Revitalization Placemaking Grant application.

The Lathrup Village downtown district is predominately along the Southfield Road corridor, which is a highly traveled thoroughfare with a wide variety of destinations including retail, salons, day spas, eateries, medical offices, and Lathrup Village City Hall and Municipal Park. As the largest and most visited park in the city, Municipal Park is the hub of community events including Concerts in the Park, Juneteenth Celebration, Fall Fest, as well as many private events and parties. Over the past several years, it is evident that the Lathrup Village Downtown Development Authority (LVDDA) is committed to revitalizing the Southfield Road commercial corridor and enhancing its vibrancy through physical investment and supporting new and existing businesses.

For example, the LVDDA has undertaken numerous physical improvements throughout the district by repaving several alleyways and approaches, implementing a sidewalk replacement program, and initiating several small-scale streetscaping projects including hanging flower baskets, entrance gardens, and banners. They have also successfully implemented a city-wide bike route wayfinding signage, and continue to advocate for enhanced pedestrian improvements and non-motorized transportation options throughout the district.

The proposed project entails the complete renovation the existing play structure at Municipal Park into a fully accessible play structure, reconstruction the adjacent parking lot surrounding City Hall, and relandscaping the extensive flower beds on the east side of City Hall. The estimated cost for this work is \$838,342.

As a property owner located immediately adjacent to the Municipal Park Renovation Project, I feel it will have a transformative impact on our downtown district by offering a safe place for families with children to come and enjoy the community. In addition to what is listed above there are a number of both community and private events that take place at Municipal Park. These events bring residents from several surrounding cities, which brings economic growth to the businesses at Lathrup Village. Families are more likely to attend these events when there are accessible accommodations for all. As a Pastor with two non-profit organizations within the city, it would greatly benefit those who frequent our organizations by offering a safe, clean, and accessible place for clients and their children. Municipal Park is the host site for an annual back to school rally. Hosted by our organization in partnership with both the City of Lathrup and the DDA and supported by several sponsors. This event is widely broadcasted and has brought attendees from as far south as Dearborn and as far north as Pontiac. People of all races, ethnic backgrounds, ages, genders, and social and economic statuses. It gives greater exposure to the city as a potential place of residency and a potential place to do business.

Thank you for your consideration for the Lathrup Village Municipal Park Renovation project as part of the Oakland County Revitalization and Placemaking 2.0 grant application.

Sincerely,

Charlotte M. Jones
Assistant Pastor - LOGOS, Global Ministries
Chief Operating Officer (COO) - Hope 4 All Seasons



The Surnow Company

June 23rd, 2023

Michele Wildman
EVP, Economic Development Incentives
Michigan Economic Development Corporation

Dear Ms. Wildman:

It is with great enthusiasm that I write in support of Lathrup Village's application for an Oakland County RAP 2.0 Revitalization Placemaking grant. Our family business has been the top commercial developer in Lathrup Village for decades, beginning with our first retail project in 1978. Since that time, we have brought dozens of local and national apparel, service, and food businesses to Lathrup Village. During this process, we have recognized the city professionals, contractors, and volunteers put in tremendous effort to ensure responsible management of resources and to meet the needs of residents, businesses, and visitors. Although this community is small in geography, its location makes it a gateway to many Oakland County communities. We hear from our retail and restaurant tenants that folks come from throughout the region to Lathrup Village. And when we volunteer at community events like the Corvette Show, we see guests from countless other communities. Lathrup Village is truly one of Oakland County's front doors.

Our property in Lathrup Village includes land immediately adjacent to the Municipal Park that forms the heart of Lathrup Village. We know that improvements and beautification to Municipal Park will have a positive economic impact because prospective and existing business owners tell us the quality of life and sense of place in Lathrup Village is a major factor for them to open and keep their business along the corridor. Perhaps the small-town feel of Lathrup Village makes this more true than in typical suburban neighborhoods in the region.

In the aftermath of the pandemic, we are reminded why downtowns matter. By drawing people back into the public square, beauty and amenities invite a return to neighborhood community. The pace of change in our society is only increasing, and such improvements at key Oakland County locations like Lathrup Village prepare us for future challenges by strengthening our bonds through shared high-quality space. Thank you for your consideration for the Lathrup Village Municipal Park Renovation project as part of the Oakland County Revitalization and Placemaking 2.0 grant application.

Sincerely,

Sam Surnow
President
The Surnow Company

Michele Wildman
EVP, Economic Development Incentives
Michigan Economic Development Corporation

We would like to offer our full support for our community's participation in Oakland County's RAP 2.0 Revitalization Placemaking Grant application.

The Lathrup Village downtown district is predominately along the Southfield Road corridor, which is a highly traveled thoroughfare with a wide variety of destinations including retail, salons, day spas, eateries, medical offices, and Lathrup Village City Hall and Municipal Park. As the largest and most visited park in the city, Municipal Park is the hub of community events including Concerts in the Park, Juneteenth Celebration, Fall Fest, as well as many private events and parties. Over the past several years, it is evident that the Lathrup Village Downtown Development Authority (LVDDA) is committed to revitalizing the Southfield Road commercial corridor and enhancing its vibrancy through physical investment and supporting new and existing businesses.

For example, the LVDDA has undertaken numerous physical improvements throughout the district by repaving several alleyways and approaches, implementing a sidewalk replacement program, and initiating several small-scale streetscaping projects including hanging flower baskets, entrance gardens, and banners. They have also successfully implemented a city-wide bike route wayfinding signage, and continue to advocate for enhanced pedestrian improvements and non-motorized transportation options throughout the district.

The proposed project entails the complete renovation the existing play structure at Municipal Park into a fully accessible play structure, reconstruction the adjacent parking lot surrounding City Hall, and relandscaping the extensive flower beds on the east side of City Hall. The estimated cost for this work is \$838,342.00.

Our office is located on Southfield Road, not far from the Municipal Park Renovation Project. We feel it will have a transformative impact on our downtown district by creating a sense of vitality as it shapes our City Center. Economically, we would benefit from the increased commerce and activity generated from a vibrant, active, and walkable City Center. Current concepts in today's play and landscapes would freshen our district, greatly enhancing the attractiveness of the city and corridor. As a business, we would hold outdoor client meetings there in good weather months giving our business a contemporary and energetic vibe. I feel this project will also re-establish the footprint of community post-covid creating a sense of purpose and hope and beatification for the business and residents alike.

Thank you for your consideration for the Lathrup Village Municipal Park Renovation project as part of the Oakland County Revitalization and Placemaking 2.0 grant application.

Sincerely,

Wallace Financial

Lathrup Village Downtown Development Authority**Resolution of Support****Oakland County RAP 2.0 Revitalization & Placemaking Grant Application**

Whereas, the Lathrup Village Downtown Development Authority Board of Directors offers our full support for our community's participation in Oakland County's RAP 2.0 Revitalization Placemaking Grant application, and;

Whereas the Southfield Road corridor is a highly traveled thoroughfare with a wide variety of destinations including retail, salons, day spas, eateries, medical offices, and Lathrup Village City Hall and Municipal Park. As the largest and most visited park in the city, Municipal Park is the hub of community events including Concerts in the Park, Juneteenth Celebration, Fall Fest, as well as many private events and parties, and;

Whereas the Lathrup Village Downtown Development Authority is charged with revitalizing the Southfield Road commercial corridor and enhancing its vibrancy through physical investment and supporting new and existing businesses, and;

Whereas the Lathrup Village Downtown Development Authority is committed to making physical improvements throughout the district by repaving several alleyways and approaches, implementing a sidewalk replacement program, and initiating several small-scale streetscaping projects including hanging flower baskets, entrance gardens, and banners. The Lathrup Village Downtown Development Authority partnered with the City of Lathrup Village to successfully implement a city-wide bike route wayfinding signage. The Lathrup Village Downtown Development continues to strongly advocate for enhanced pedestrian improvements and non-motorized transportation options throughout the district, and;

Whereas, the Lathrup Village Downtown Development Authority is actively engaged in the Main Street Oakland County program, and has benefitted from the resources and support provided to the organization and the business district, and;

Whereas the Lathrup Village Downtown Development Authority proposes to the completely renovate the existing play structure at Municipal Park into a fully accessible play structure, reconstruct the adjacent parking lot surrounding City Hall, and relandscape the extensive flower beds on the east side of City Hall. The estimated cost for this work is \$838,342, and;

Whereas, the Municipal Park Renovation Project will have a transformative impact on our downtown district by *creating a more welcoming environment for residents and visitors of all ages and abilities. Investment has been made in common infrastructure; however, the infrastructure of play and place-based connection needs attention. The Municipal Park Renovation Project is consistent with our Comprehensive Plan which includes the Downtown Plan, city-wide Master Plan, and Parks & Recreation Plan, as well as the Development and Tax Increment Financing Plan, and is in*

alignment with the adopted economic priorities of Oakland County, the Southeast Michigan Council of Governments, and the State of Michigan. Furthermore, our proposed project re-enforces the Business, Talent, and Place adopted strategy of SEMCOG that will attract and retain business investment, and appeal to talent who will want to live, work, and invest in our communities and region, and;

Whereas, the pandemic forced the Downtown Development Authority and City to cancel numerous events and programs which typically occur in the park, and the Municipal Park Renovation will allow us to create a safe and welcoming atmosphere for residents and visitors alike, spurring reinvestment, and this project will help counter or help mitigate such a crisis in the future; now;

Therefore, be it resolved; the Lathrup Village Downtown Development Authority has committed \$100,000 of funds from our fund balance, and will be embarking upon a crowdfunding campaign to secure additional matching funds for the Municipal Park Renovations. We are confident our project meets or exceeds the goals of the Revitalization and Placemaking 2.0 Grant Program.

6/16/23 
Date Fred Prime, Chair, Lathrup Village Downtown Development Authority

City of Lathrup Village**Resolution of Support****Oakland County RAP 2.0 Revitalization & Placemaking Grant Application**

Whereas, the City of Lathrup Village City Council offers our full support for our community's participation in Oakland County's RAP 2.0 Revitalization Placemaking Grant application, and;

Whereas the Southfield Road corridor is a highly traveled thoroughfare with a wide variety of destinations including retail, salons, day spas, eateries, medical offices, and Lathrup Village City Hall and Municipal Park. As the largest and most visited park in the city, Municipal Park is the hub of community events including Concerts in the Park, Juneteenth Celebration, Fall Fest, as well as many private events and parties, and;

Whereas the City of Lathrup Village has a vested interest with the revitalization of the Southfield Road commercial corridor and enhancing its vibrancy through physical investment and supporting new and existing businesses, and;

Whereas the City of Lathrup Village supports the efforts of the Lathrup Village Downtown Development Authority to making physical improvements throughout the district by repaving several alleyways and approaches, implementing a sidewalk replacement program, and initiating several small-scale streetscaping projects including hanging flower baskets, entrance gardens, and banners. The City of Lathrup Village partnered with the Lathrup Village Downtown Development Authority to successfully implement a city-wide bike route wayfinding signage, and;

Whereas, the Lathrup Village Downtown Development Authority is actively engaged in the Main Street Oakland County program, and has benefitted from the resources and support provided to the organization and the business district, and;

Whereas the City of Lathrup Village and Lathrup Village Downtown Development Authority propose to completely renovate the existing play structure at Municipal Park into a fully accessible play structure, reconstruct the adjacent parking lot surrounding City Hall, and relandscape the extensive flower beds on the east side of City Hall. The estimated cost for this work is \$838,342, and;

Whereas, the Municipal Park Renovation Project will have a transformative impact on our downtown district by creating a more welcoming environment for residents and visitors of all ages and abilities. Investment has been made in common infrastructure; however, the infrastructure of play and place-based connection needs attention. The Municipal Park Renovation Project is consistent with our Comprehensive Plan which includes the Downtown Plan, city-wide Master Plan, and Parks & Recreation Plan, as well as the Development and Tax Increment Financing Plan, and is in alignment with the adopted economic priorities of Oakland County, the Southeast Michigan Council of Governments, and the State of Michigan. Furthermore, our proposed project

Furthermore, our proposed project re-enforces the Business, Talent, and Place adopted strategy of SEMCOG that will attract and retain business investment, and appeal to talent who will want to live, work, and invest in our communities and region, and;

Whereas, the pandemic forced the Downtown Development Authority and City to cancel numerous events and programs which typically occur in the park, and the Municipal Park Renovation will allow us to create a safe and welcoming atmosphere for residents and visitors alike, spurring reinvestment, and this project will help counter or help mitigate such a crisis in the future; now;

Therefore, be it resolved; the City of Lathrup Village has committed \$100,000 of funds from our general funds and will be partnering on a crowdfunding campaign to secure additional matching funds for the Municipal Park Renovations. We are confident our project meets or exceeds the goals of the Revitalization and Placemaking 2.0 Grant Program.

6-26-23
Date

Mykale "Kelly" Garrett, Mayor, City of Lathrup Village



SOUTHEAST MICHIGAN COUNCIL OF GOVERNMENTS

June 22, 2023

Michele Wildman
 EVP, Economic Development Incentives
 Michigan Economic Development Corporation

Ms. Wildman:

RE: Revitalization and Placemaking Program (RAP 2.0)

On behalf of SEMCOG, the Southeast Michigan Council of Governments, I would like to offer our full support for Oakland County’s RAP 2.0 Revitalization and Placemaking Grant application.

As the Regional Planning Agency for the seven county region, SEMCOG is a strong proponent of downtown revitalization and local business development. Oakland County’s proposal strongly aligns with the policies and recommendations identified in Southeast Michigan’s Comprehensive Economic Development Strategy CEDS – [Increasing Shared Prosperity for a Resilient Economy](#). This regional strategy focuses on the three pillars for economic development - Place, Business and Talent. One of the main strategies **Creating and Marketing Quality Places** focuses on creating quality places where people go to celebrate, relax, and have social and economic exchanges. They include diverse neighborhoods, local business districts, and public outdoor spaces, intertwined with our broader systems of transportation, infrastructure, and natural resources. This is implemented by supporting efforts to develop local neighborhoods and business districts as dynamic and diverse places to live, work and visit.

Main Street Oakland County (MSOC) is an officially designated Coordinating Main Street Program, one of two in Michigan through Main Street America, and the only countywide Coordinating Main Street Program in the nation. It has a strong history of successfully revitalizing our downtowns. It will use the RAP funding to strengthen 13 of its downtown districts through placemaking projects such as new parks and social district improvements. The projects, identified by the individual districts will transform blighted or underutilized spaces. Oakland County is requesting \$7 million in RAP 2.0 funds with \$4 million matched by county ARPA Funds and \$3 million from participating community local match for a total of \$14 million.

As our region recovers from the pandemic, creating an environment to attract and retain talent, enable business creation and attraction, and enhance downtown vitality are key to increasing regional competitiveness and stability. As such, SEMCOG is in strong support of this application from Oakland County.

1001 Woodward Ave., Suite 1400 • Detroit, Michigan 48226 • (313) 961-4266 • Fax (313) 961-4869 • semcog.org

Chris Barnett
 Chairperson
 Supervisor,
 Orion Township

Pauline Repp
 First Vice Chair
 Mayor,
 City of Port Huron

Mandy Grewal
 Vice Chairperson
 Supervisor,
 Pittsfield Township

Laura Kropp
 Vice Chairperson
 Mayor,
 Mount Clemens

Gwen Markham
 Vice Chairperson
 Commissioner,
 Oakland County

Eric Sabree
 Vice Chairperson
 Treasurer,
 Wayne County

Donald Hubler
 Immediate Past Chair
 Secretary,
 Macomb ISD

Amy O’Leary
 Executive Director

Please do not hesitate to contact me or Naheed Huq, SEMCOG's Manager of Economic and Community Vitality at 313 -324-3356 or huq@semcog.org with any questions.

Sincerely

A handwritten signature in cursive script that reads "Amy O'Leary".

Amy O'Leary
Executive Director

cc. David Coulter, County Executive, Oakland County
Dave Woodward, Chair Board of Commissioners, Oakland County
John Bry, Administrator, Local Business Development and Main Street Program Coordinator,
Oakland County

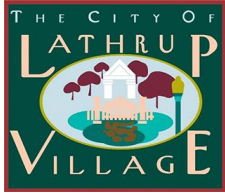

City of Lathrup Village
27400 Southfield Road
Lathrup Village, MI 48076
www.lathrupvillage.org | (248) 557-2600

TO: Mayor & City Council
FROM: Mike Greene – City Administrator
DATE: June 17, 2024
RE: First Reading - Request to Amend Ordinance Chapter 77. Urban Redevelopment, By Amending Article I. Downtown Development Authority, Section 77-7. Board of Directors

Background Brief: Staff have been made aware of an upcoming opening among our DDA Board. Knowing that we started reviewing the process of board appointments for the DDA and advertising for board applications. However, staff then became aware of contradictory information regarding the board makeup. The City Ordinances currently state the board should consist of ten (10) members, while the DDA bylaws state nine (9) members. The purpose of this ordinance update is to reduce the number of DDA members from ten (10) to eight (8). This would correct the discrepancy between the bylaws and the ordinance while keeping a board of nine (9) (one Chief Executive Officer and 8 members). Five (5) of the eight (8) members will have to have an interest in the district to comply with state law.

Previous Action: N/A

Economic Impact: N/A

Recommendation: It is my recommendation to schedule a second reading.

Recommended Motion:

Moved by Council Member _____ seconded by Council Member _____ to schedule the second reading of an update to Ordinance Chapter 77. Urban Redevelopment, By Amending Article I. Downtown Development Authority, Section 77-7. Board of Directors.

Kelly Garrett Mayor	Bruce Kantor Mayor Pro-Tem	Jalen Jennings Council Member	Dalton Barksdale Council Member	Jason Hammond Council Member
------------------------	-------------------------------	----------------------------------	------------------------------------	---------------------------------

ORDINANCE NO. _____-24

CITY OF LATHRUP VILLAGE
OAKLAND COUNTY, MICHIGAN

AN ORDINANCE TO AMEND THE CITY OF
LATHRUP VILLAGE CODE OF ORDINANCES AT
CHAPTER 77. URBAN REDEVELOPMENT, BY AMENDING
ARTICLE I. DOWNTOWN DEVELOPMENT AUTHORITY,
SECTION 77-7. BOARD OF DIRECTORS AS FOLLOWS:

THE CITY COUNCIL OF THE CITY OF LATHRUP VILLAGE ORDAINS:

PART I. TITLE.

This Ordinance shall be known as the "Downtown Development Authority Ordinance".

PART II. ORDINANCE AMENDMENT.

That Chapter 77. Urban Redevelopment, Article I. Downtown Development Authority, Section 77-7. Board of directors of the City of Lathrup Village Code of Ordinances is hereby amended to read as follows in its entirety:

ARTICLE I. DOWNTOWN DEVELOPMENT AUTHORITY

Sec. 77-7. Board of directors.

The authority shall be under the supervision and control of the board. The board shall consist of the chief executive officer and ~~ten~~ **eight** members. Members shall be appointed by the chief executive officer, subject to approval by the council. Not less than a majority of the members shall be persons having an interest in property located in the downtown district. Not less than one of the members shall be a resident of the downtown district if the downtown district has 100 or more persons residing within it. Members shall be appointed to serve for a term of four years, except that of the members first appointed, an equal number, as near as is practicable, shall be appointed for terms of one year, two years, three years and four years. A member shall hold office until the member's successor is appointed and qualified. Before assuming the duties of office, a member shall qualify by taking and subscribing to the constitutional oath of office. An appointment to fill a vacancy shall be made by the chief executive officer for the unexpired term only. Members of the board shall serve without compensation, but shall be reimbursed for actual and necessary expenses. The chairperson of the board shall be elected by the board. The board shall adopt bylaws governing its procedures subject to the approval of the council.

**PART III.
REPEALER.**

This ordinance repeals any ordinances in conflict thereof.

**PART IV.
SEVERABILITY.**

If any section, subsection, clause, phrase, or portion of this article is for any reason held invalid by a court of competent jurisdiction, such portion shall be deemed a separate and distinct provision, and such holding shall not affect the validity of the remaining portions.

PART V. SAVINGS.

All proceedings pending and all rights and liabilities existing, acquired, or incurred at the time this ordinance takes effect are saved and may be consummated according to the law in force where they commenced.

PART VI. EFFECTIVE DATE.

This Ordinance shall be published in the manner required by law and shall become effective ten (10) days after the date of its publication. A copy of the ordinance shall also be made available for public use and inspection in the office of the City Clerk.

MADE, PASSED AND ADOPTED BY THE CITY COUNCIL, CITY OF LATHRUP VILLAGE, OAKLAND COUNTY, MICHIGAN THIS ____ DAY OF _____, 2024.

Alisa Emanuel, City Clerk

Date of Introduction: August 19, 2024
Date of Adoption: _____, 2024
Date of Publication of
Notice of Adoption: _____, 2024

CERTIFICATE OF ADOPTION

I hereby certify that the foregoing is a true and complete copy of the ordinance passed at a meeting of the City of Lathrup Village held on the ____ day of _____, 2024.

Alisa Emanuel, City Clerk