



# UTILITY COMMITTEE MEETING AGENDA

January 07, 2025 at 5:45 PM

Kronenwetter Municipal Center - 1582 Kronenwetter Drive Board Room (Lower Level)

---

**1. CALL MEETING TO ORDER**

- A. Pledge of Allegiance
- B. Roll Call

**2. PUBLIC COMMENT**

Please be advised per State Statute Section 19.84(2), information will be received from the public. It is the policy of this Village that Public Comment will take no longer than 15 minutes with a three-minute time period, per person, with time extension per the Chief Presiding Officer's discretion. Be further advised that there may be limited discussion on the information received, however, no action will be taken under public comments.

**3. REPORTS AND DISCUSSIONS**

- C. Director of Public Works and Utilities Report

**4. OLD BUSINESS**

- D. Discussion & Possible Action: Ellis Liquidated Damages Discussion

**5. NEW BUSINESS**

- E. Discussion: Becher Hoppe Update for the Kronenwetter Water Treatment Construction
- F. Discussion: All Becher Hoppe Invoices for Water Filtration Plant
- G. Discussion & Possible Action: Ellis Stone Pay Request #10
- H. Discussion & Possible Action: Ellis Stone Construction Pay Request #11
- I. Discussion & Possible Action: Lift Station #2 and #6 Upgrade Bid Openings

**6. NEXT MEETING: FEBRUARY 4, 2025**

**7. CONSIDERATION OF ITEMS FOR FUTURE AGENDA**

**8. ADJOURNMENT**

**WRITTEN COMMENTS:** You can send comments on agenda items to [kcoble@kronenwetter.org](mailto:kcoble@kronenwetter.org)

**NOTE:** Requests from persons with disabilities who need assistance to participate in this meeting or hearing should be made at least 24 hours in advance to the Village Clerk's office at (715) 693-4200 during business hours.

Posted: 01/06/2025 Kronenwetter Municipal Center and [www.kronenwetter.org](http://www.kronenwetter.org)

Faxed: WAOW, WSAU, City Pages, Mosinee Times | Emailed: Wausau Daily Herald, WSAW, WAOW, Mosinee Times, Wausau Pilot and Review, City Pages



**Report to Utility Committee**

**Item Name:** Director of Public Works and Utilities Report

**Meeting Date:** January 7, 2025

**Referring Body:**

**Committee Contact:**

**Staff Contact:** Greg Ulman

**Report Prepared by:** Greg Ulman

- Crews from Ellis and Rhode have been diligently working on the water filtration plant, with weekly updates and progress reports.
- I have been working on the insurance claim for the broken hydrant which was damaged by a semi-truck, and we are looking to have a contractor dig the hydrant, if possible, this month.
- Staff is looking into security options at the water plant with security updates coming to the Municipal Building. Quotes to come, in the following month.

## Kronenwetter Start Up Meeting #4 1/2/25

### Attendees:

Brian Marquardt – Rohde Brothers  
Dan Moore – Rohde Brothers  
Emily Nurmi – William Reid  
Elbert Johnson – Kurita  
Bryan Gawlik – ECON Electric  
Matt Esselman – ECON Electric  
Zach Gilmaster – Ellis Construction  
Mark Mackey – Village of Kronenwetter  
Joe Kafczynski – Becher Hoppe

### Items discussed:

- Rohde Update:
  - Waiting for the painter to be complete.
  - Back onsite this week to fill and test piping.
  - Chosen lab to conduct testing of samples is US Water in Weston.
- Howard Grote Update:
  - Manpower onsite Friday (1/3) and Saturday (1/4) to finish vessel and piping painting.
- ECON Electric Update:
  - Load bank test scheduled for 1/3
  - Simulate a power outage
    - Becher Hoppe to be onsite
- Potassium permanganate & sodium bisulfite are scheduled to be delivered Friday 1/3.

### Action Items:

- Rohde to provide the following to Ellis:
  - Confirm dates/times for startups and owner training.
  - Rohde to provide 2 passed samples prior to tie in.
- Becher Hoppe to provide dates for substantial completion and close outs.
  - Ellis Punch List items:
    - Perimeter expansion joint to have sealant
    - Overhead door seal on bottom

Joe to send info on stainless pipe markings

- a. HGS to not paint stainless. Labels on piping to be installed in lieu of paint.

## Section 3, Item C.

Requirements	Completed	Estimated Completion Date
1. Underdrain nozzles installed per instructions. If <u>factory</u> installed, then hand checked. <b>All American doing the install this is happening the week of 12-16</b>	<input checked="" type="checkbox"/>	Click to enter date.
2. Gravel (if applicable) and filter media installed per instructions. <b>All American doing the install week of 12-16</b>	<input checked="" type="checkbox"/>	Click to enter date.
3. Service and backwash water are available. <b>Yes, Will be by the week of the 6th (Wednesday) hopefully. As of 12-19 on track for 1-6-25 as of 1-3-25</b>	<input checked="" type="checkbox"/>	Click to enter date.
4. Backwash discharge containment is available. Contact project manager for quantity. <b>Will be still on track for 1-6 as of 1-3-25</b>	<input checked="" type="checkbox"/>	Click to enter date.
5. Greensand media backwashed and skimmed per instructions (if applicable). <b>Is all American doing this need to make sure? Sounds like Kurita is doing this during the first trip sch, on 1-6-25 as of 12-19 no change as of 1-3-25</b>	<input type="checkbox"/>	Click to enter date.
6. Anthracite backwashed and skimmed per instructions (if required). <b>No skimming to be installed during the week of the 6<sup>th</sup> as of 12-19 no change as of 1-3-25</b>	<input checked="" type="checkbox"/>	Click to enter date.
7. Does the site engineer require KMnO <sub>4</sub> on-site (if required). Contact project manager for quantity. <b>Looking into the amount of sodium meta bisulfite for oxidation destruction? The site will be using 12% Cl<sub>2</sub>, the ratio for the bisulfite used to neutralize the chlorine Has been found in the OMM as of 12-19 to be on site on 1-3-25</b>	<input checked="" type="checkbox"/>	Click to enter date.
8. Are testing reagents on site? <b>Check on with Nina will be on site by startup week of 1-6-25 on site as of 12-19 /still not found as of 1-3-25 site will have some available</b>	<input checked="" type="checkbox"/>	Click to enter date.
9. All other <b>process required</b> chemicals on-site. <b>Not Kurita week of 1-6-25 to be on site. As of 12-19 to be on site 1-3-25</b>	<input checked="" type="checkbox"/>	Click to enter date.
10. Filter system sterilized (if required by the state). <b>Bac-t's passed prior to commissioning (By others) still need to be complete as of 12-19 the piping will be complete or in process by the first week of start up with the filters to follow the anthracite addition. As of 1-3-25</b>	<input checked="" type="checkbox"/>	Click to enter date.
11. All instrumentation and valve wiring in place and terminated. <b>Will be by commissioning date. On track as of 1-3-25</b>	<input checked="" type="checkbox"/>	Click to enter date.
12. Are the equipment name plates on site? <b>Nina to locate reorders, found as of 12-19. No change as of 1-3-25</b>	<input checked="" type="checkbox"/>	Click to enter date.
13. All loose shipped components (valves, orifice plates, instrumentation, chemical injection, etc.) are installed per manufacturer guidelines. <b>Yes</b>	<input checked="" type="checkbox"/>	Click to enter date.

Are Reagents on site. \*\*\*Correct for - Filter, Softener, aerator/stripping towers.

Disinfect iron man filter prior to application of ironman. KMnO<sub>4</sub> required for ironman solutions.

Name plate for equipment on site/affixed to equipment. (when request for NES trip to commission have PM order plates)

Project: **Kronenwetter Well**  
 Superintendent/Site Contact:  
 Date: 1/2/2025

**Kronenwetter Well**



Section 3, Item C.

3201 Stanley Street • Stevens Point, WI 54481 • (715) 345-5000

		Month: December/January																			
Date:		30	31	1	2	3	6	7	8	9	10	13	14	15	16	17	20	21	22	23	24
Description of Work	Contractor	M	T	W	T	F	M	T	W	T	F	M	T	W	T	F	M	T	W	T	F
Electrical work continues	ECON Electric	X	X	N	X																
7am Generator Start Up	ECON Electric			E		X															
11am Training with Village of Kronenwetter	ECON Electric			W		X															
Final Electrical Inspection w/ State	ECON Electric					X															
				Y																	
Vessel/piping painting	Howard Grote	X	X	E	X	X															
Fill piping with water, hydrotest, chlorinate process piping	Rohde Brothers	X	X	A																	
Flush piping, send 1st Bac T sample to lab	Rohde Brothers			R	X																
Panel Programming, prep for greensand backwash	Rohde Brothers/Kurita			S			X	X	X	X	X										
Program Integration & Chemical Pumps	ECON/PJ Kortens						X	X													
Chemical Pump Startup	Rohde/William Reid								X												
Greensand Backwash	Rohde								X												
Install Anthracite	Rohde/Kurita								X												
1/13/25-1/17/25: System Startup & Owner Training	Rohde Brothers/Kurita/VOK											X	X	X	X	X					
Substantial Completion	Becher Hoppe																				
Punch List	Becher Hoppe																				
Final Completion	Becher Hoppe																				



**Report to Utility Committee**

**Item Name:** Liquidated Damages Report  
**Meeting Date:** January 7, 2025  
**Referring Body:**  
**Committee Contact:**  
**Staff Contact:** Greg Ulman  
**Report Prepared by:** Greg Ulman

Attached are emails and PO's regarding the purchase of the water filtration materials to help determine if the Committee would like to instill liquidated damages for going past the agreed upon date of completion.

W5745 Woodchuck Ln · P.O. Box 409 · Plymouth, WI · 53073-0409 · Phone: (920)893-5905 · Fax: (920)893-5908

**PO# 23066-2270-57865**

Received  
August 4, 2023  
Kurita America Inc.

To: KURITA AMERICA INC. (507480)  
Attn: a.schneider@kurita-water.com  
PO BOX 851361  
MINNEAPOLIS, MN 55485-1361

**This Number must appear on all invoices, bills of lading cases, bundles, packing lists, shipping papers and correspondence.**

Order Date 8/4/2023  
Job No. 23-066 Phase/Card 2-270  
Job Address Rohde Shop  
Job Name Kronenwetter Well No 2

Telephone:

Fax:

<b>Payment Terms:</b> Net 60 Days	<b>Quote:</b> Original Order	<b>Date Required:</b> 7/19/2024	<input checked="" type="checkbox"/> Or Sooner <input type="checkbox"/> Not Before	<b>ShipTo:</b> Rohde Shop	<b>F.O.B.:</b> Rohde Shop <b>Freight</b> Yes and Included <b>Prepaid:</b>
1 <b>Copy of Submittal Required</b> <input type="checkbox"/> Approval Required Before Shipment	<input checked="" type="checkbox"/> <b>Approval Not Required</b>	1 <b>set of Job Tailored Installation, Piping and/or Wiring Diagrams and Instructions for approval.</b>	1 <b>Copy of Operation, Maintenance &amp; Installation Instructions are required for the owner's use. Final Payment will not be made until after these instructions are received.</b>		

Line #	QTY	PART#/DESCRIPTION	PRICE	AMOUNT
1	1	SPEC Section 46 61 21 – Horizontal Pressure Filter System – Kurita/Tonka	\$772,000.00	\$772,000.00

Total: 1 (1 line)

SubTotal \$772,000.00  
Sales Tax \$0.00  
**Total \$772,000.00**

Jobsite Contact: Dan Moore (920)838-1618

- CHARGE WISCONSIN SALES TAX  
 **DO NOT CHARGE WISCONSIN SALES TAX - TAX No. 004-0000401440-01**

**Reason:**

This order shall not be binding until acceptance and return, within five days, of the signed acknowledgement copy specifying the shipping date. Such acceptance is subject to the TERMS AND CONDITIONS STATED ON THE FACE AND REVERSE SIDE OF THE ORIGINAL AND ACKNOWLEDGEMENT COPIES HEREOF, which seller agrees shall constitute the final and complete agreement between Purchaser and Seller. Any modifications or rescission of this agreement shall be ineffective unless in writing and signed by both Purchaser and Seller.

**ROHDE BROTHERS, INC.**

**Vendor must give 72 hour notice of delivery. No deliveries will be accepted prior to 7:30am and after 2:30pm CST M-TH and after 12:00pm on Fri**

**Accepted by:**   
Mary Sitko, Sr. VP of Municipal Projects & Services Title

**PO Contact:**   
Rich Dehnel

**Date** 8/16/23

GENERAL CONDITIONS AND INSTRUCTIONS

Section 4, Item D.

I. CONTRACT CONDITIONS

- 1.1 This Purchase Order, when accepted by the Seller, shall constitute a valid and binding contract, which shall be governed and construed according to the laws of the State of
- 1.2 All prior representations, conversations, or preliminary negotiations shall be deemed to be merged in this order, and no changes will be considered or approved unless this Purchase Order is modified by an authorized representative of the Purchaser, in writing.
- 1.3 Any acceptance in a manner or on terms and conditions different from those contained in this order shall not operate as an acceptance. No order acknowledgement on Seller's forms shall be allowed to modify any of the terms of this agreement and shall be considered to be merely advising the Purchaser of delivery dates and that the order is being processed.
- 1.4 The Seller agrees to comply with any and all Federal, State, County, Municipal and/or other local regulations, laws, ordinances and enactments of whatever kind, applicable at the time of sale or which may become effective during the period of construction or fabrication, shipping and/or installation (if installation is included) of the materials comprised under this Purchase Order.
- 1.5 The Seller agrees to indemnify and save harmless the Purchaser from and against all claims, liability, ~~toss~~, damage or expense, including reasonable attorneys' fees, by reason of any actual or alleged infringement of patents, or of any litigation based thereon covering any article purchased hereunder. ~~\*strike~~
- 1.6 The contract price appearing on the Purchase Order is final as to payment for the material covered by the specifically listed items, as defined by the enumerated specification paragraph numbers, with exceptions as noted, and there shall be no additions to or other modifications of such contract price, except as such modification may result from actual change in the specifications. If such changes become necessary, any alteration of the contract price shall be covered by separate order, which shall be issued to cover such changes. Seller shall not proceed with changes effecting contract price without specific authorization in WRITING from the Purchaser.

II. SHIPPING AND DELIVERY INSTRUCTIONS

- 2.1 Identification of shipments. The Purchaser cannot and will not be responsible for any material received unless each package, case, item, etc., is clearly identified on its outer covering as to: (1) Seller (2) Purchase Order Number (3) Project Name (4) Project Address (5) Item Description and/or Number.
- 2.2 Boxing, Packing or Cartage. No charges for boxing, packing, or cartage will be allowed unless stated hereon or later agreed to by the Purchaser's authorized representative, in writing.
- 2.3 Materials and equipment covered by this order which are shipped F.O.B. Shop or F.O.B. JOBSITE, whether in a deliverable state or otherwise shall remain the property of the Seller until delivered to a designated site and actually received by the Purchaser and any damage to the material and equipment or loss of any kind occasioned in transit shall be borne by the Seller, notwithstanding the manner in which the goods are shipped or who pays the freight or other transportation costs. Purchaser shall notify Seller as soon as possible and reasonable, of any damage to materials or equipment, or of any loss caused in transit.
- 2.4 Materials and equipment which suffer concealed damages in transit shall be, carefully examined by representatives of both the Seller and the Purchaser. If the damaged item, no matter how shipped or packaged, exhibits no external signs of abuse and/or numerous similar items suffer similar damage, it will be assumed that the items were improperly packaged and protected by the Seller. In such case, the damaged items shall be repaired or replaced at no cost to the Purchaser.
- 2.5 Seller shall promptly notify Purchaser of any shipment made. Purchaser shall be advised at his office on a normal working day, no holiday or weekend, 24 hours before attempting delivery. No deliveries after 2:00 p.m.
- 2.6 Rejected materials. Rejected materials shall be returned to the Seller at Seller's expense. No shipment under reservation is authorized. No shipment of non-conforming materials as an accommodation is authorized without Purchaser's written consent.
- 2.7 No partial shipments accepted unless agreed upon by both parties. Similar items may be shipped separately as a group.
- 2.8 Time of delivery of this order is of the essence, and Purchaser reserves the right to cancel without cancellation charges, all or any part of this order if not filled within the specified time. Exercise of such right of cancellation shall not be deemed a waiver of any other right reserved to the Purchaser herein, or by law, for any delay or failure to deliver as specified. Seller covenants and agrees to indemnify the Purchaser against any claim or liability for penalty costs incurred against the Purchaser resulting from Seller's neglect and/or indifference to this order, unless Seller is prevented from meeting the time set in this order by acts of God, strikes, fire, or other casualty, or other causes beyond the control of the Seller.

III. INVOICING, PAYMENTS, TAXES AND RETURNS

- 3.1 Invoices. Invoices showing both the Purchase Order Number, the Project Name and the Project Address, must be mailed to the Purchasing Department of the Purchaser not later than the day following the shipment, irrespective of whether shipment is in part or in whole. Seller's Invoice must certify full compliance with the Fair Labor Standards Act.
- 3.2 Payment and discount periods shall commence only upon receipt of both the material and proper invoice or invoices at designations specified herein. The Purchaser reserves the right to return to the Seller for correction any and all invoices containing errors and/or not in agreement with this Purchase Order.
- 3.3 The price or prices of this order are not subject to change or any surcharges resulting from the imposition now or in the future of any sales tax, Federal, State, Municipal or otherwise, unless agreed to or requested by the Purchaser. For all material purchased for use in the State of Wisconsin, the Purchaser is not to be charged the current Wisconsin State Sales Tax.
- 3.4 Returns. The Purchaser reserves the right to return to the Seller at the invoice price all items which are regularly carried in the Seller's stock.
- 3.5 Seller shall furnish all necessary lien waivers, affidavits or other documents, required to keep the Owner's premises free from liens or claims for liens, arising out of the furnishing of the material or equipment herein, as payments are made from time to time under this Purchase Order.

IV. APPROVAL CONDITIONS

- 4.1 All material and equipment furnished under this order shall be subject to the approval of the Owner, Architect, Engineer, or any other party designated, and Seller shall furnish required submittal data and/or number of samples for said approval. In the event such approval is not obtained, the order is cancelled, with no liability on the part of either the Purchaser or the Seller, unless the order is placed with the understanding that the material and equipment is to be supplied of the type and in a manner as to meet requirements of plans, specifications and addendums. In the latter case Seller shall comply without further cost to the Purchaser.
- 4.2 All material and equipment furnished hereunder shall be in strict accordance with plans, specifications and addendum applicable to the contract of the Purchaser with the Owner or other contractor, or as approved by the Owner or his authorized representative, and Seller shall be bound thereby in the furnishing of materials and equipment under this Purchase Order.
- 4.3 Seller shall guarantee equipment covered under this Purchase Order to produce capacities or meet design specifications and function: (1) as called for in the plans, specifications and addendums; and (2) as herein set forth; and (3) as published or warranted by the manufacturer for the equipment involved; (4) except as otherwise approved by the Owner or his authorized representatives. In the event the equipment does not meet the foregoing requirements, Seller shall immediately on notice replace same, or remedy any deficiency, without expense to the Purchaser; and further, Seller shall reimburse the Purchaser for all consequential\* actual loss or damage resulting therefrom. \*strike
- 4.4 In the event approval is not secured from the Owner or his appointed representatives, or if the Owner's or other contractor's order to the Purchaser is cancelled, cancellation of this order shall occur automatically, without cancellation charges by the Seller; and no obligation of any description, whatsoever, shall exist on the part of the Purchaser toward the Seller.\*\*
- 4.5 Inspection. The material or apparatus to be supplied against this Purchase Order shall, at the Purchaser's option, be subject to inspection and test at the maker's works.
- 4.6 Job-Tailored Installation, Piping, and Wiring Diagrams and Instructions and Job-Tailored Operation, Maintenance and Spare Parts Manuals shall be submitted for approval in the required number of copies. Final payment from the Purchaser will not be due the Seller until these items have been accomplished and the Owner's designated personnel have been properly instructed in the operation of the equipment and material purchased in this Purchase Order if such instruction is a requirement of this order. \*\*with the exception of materials purchased or costs incurred after the owner's approval of the submittal documents, and if the contract was canceled due to no fault of the Seller.

V. WARRANTY AND CORRECTION OF DEFECTS

- 5.1 All material and equipment furnished under this order shall be guaranteed by the Seller against defects, and Seller agrees to replace without charge to Purchaser said material and equipment, or remedy any defects, latent or patent, not due to ordinary wear and tear, or not due to improper use or maintenance, which defects may develop within one year from date of acceptance by the Owner, or within the guarantee period set forth in applicable plans, specifications and addendum, whichever period is longer.
- 5.2 Seller represents and warrants to the Purchaser that all material and equipment rented, leased or purchased under this Purchase Order meets all standards of the Occupational Safety and Health Act of 1970 and the Construction Safety Act of 1969, as amended from time to time, and of applicable State and Local laws, regulations, standards, or requirements pertaining to safety, as amended from time to time.
- 5.3 In the event the Seller fails to correct any defects or non-conformities within a reasonable period of time, the Purchaser may, after giving seven days written notice, correct said defects or non-conformities in the best manner possible and deduct the cost of the corrections from any amounts due to the Seller. If the cost of these corrections exceeds the unpaid balance due to the Seller, the Seller shall pay the difference to the Purchaser.

VI. DEFAULT, DISPUTES AND ARBITRATION

- 6.1 In the event of default of any of the terms or conditions set forth herein, the Seller agrees to pay all costs resulting therefrom, including but not limited to, reasonable attorneys' fees.
- 6.2 All claims, disputes and other matters in question arising out of, or related to, this Purchase Order or breach thereof, shall be decided by arbitration in accordance with the Construction Industry Arbitration Rules of the American Arbitration Association then pertaining unless the parties mutually agree otherwise. This agreement to arbitrate shall be specifically enforceable under the prevailing arbitration law. The award by the arbitrator shall be final, and judgment may be entered upon it in accordance with applicable law in any court having jurisdiction thereof. Notice of the demand for arbitration shall be filed in writing with the other party to the Purchase Order and with the American Arbitration Association. The demand for arbitration shall be made within a reasonable time after the claim, dispute or other matter in question has arisen, and in no event shall it be made after the date when institution of legal or equitable proceeds based on such claim, dispute or other matter in would be barred by the applicable statute of limitations.



**Brian Marquardt**

---

**From:** Carol ZEHRER <c.zehrer@kurita-water.com>  
**Sent:** Thursday, August 17, 2023 11:00 AM  
**To:** Rich Dehnel  
**Cc:** Mary SITKO; Cathleen PATTON; Alan SCHNEIDER; Carol ZEHRER  
**Subject:** Purchase Order for Kronenwetter, WI  
**Attachments:** 20354\_PO\_FullySigned\_Kronenwetter\_WI\_8-17-23pdf.pdf; 20354\_PO Ack Letter\_Rohde Bros.pdf; 20354-Conf\_SalesQuotation\_AMS (Kronenwetter, WI) HPF.pdf

You don't often get email from c.zehrer@kurita-water.com. [Learn why this is important](#)

Rich:

Kurita America has signed your purchase order for the Kronenwetter, WI project, and I am attaching it along with our PO acknowledgement letter and confirming quote for your records.

If you have any questions about the purchase order, please contact Mary Sitko, Sr. VP of Municipal Capital Projects and Services, at 612.246.6745.

Thank you,

**Carol Zehrer**

*Sr. Sales Administrator*

Main 800.530.1887 | Direct 763.957.1972 | [c.zehrer@kurita-water.com](mailto:c.zehrer@kurita-water.com)  
Kurita America Inc. | Tonka Water, a Kurita brand | [www.kuritaamerica.com](http://www.kuritaamerica.com)



This e-mail message and all attachments transmitted with it contain confidential and proprietary business information owned by Kurita America Inc. and intended solely for the use of the addressee. The transmission of this e-mail may be legally privileged. If the recipient of this message is not the intended person or entity, you are hereby notified that any reading, dissemination, distribution, copying, or other use of this message, its contents, hyperlinks, and attached files of any kind is strictly prohibited. If you have received this message in error, please notify the sender immediately by a reply to this electronic mail message and delete this message and all copies and backups thereof. All rights to the information contained in this e-mail are reserved by Kurita America Inc.

**Brian Marquardt**

---

**From:** Alan SCHNEIDER <a.schneider@kurita-water.com>  
**Sent:** Friday, August 4, 2023 2:53 PM  
**To:** Rich Dehnel; Brian Marquardt  
**Cc:** Christine Sprengel; Patrick Ingle  
**Subject:** RE: [EXT]23066 Kronenwetter Well #2 - Water Filter System PO 23066-2270-57865

Thanks Rich!

We will do what we can.

Have a good weekend!

**Alan Schneider**

**Tonka Water Territory Manager**

Mobile 612-708-6517 | Main 800-530-1887 | [a.schneider@kurita-water.com](mailto:a.schneider@kurita-water.com)  
Kurita America Inc. | Tonka Water, a Kurita brand | [www.kuritaamerica.com](http://www.kuritaamerica.com)

[How are we doing? Take our short survey!](#)



---

**From:** Rich Dehnel <dehnelr@rohdebros.com>  
**Sent:** Friday, August 4, 2023 2:51 PM  
**To:** Alan SCHNEIDER <a.schneider@kurita-water.com>; Brian Marquardt <marquardtb@rohdebros.com>  
**Cc:** Christine Sprengel <sprengelchristine@rohdebros.com>; Patrick Ingle <patrick@williamreidltd.com>  
**Subject:** [EXT]23066 Kronenwetter Well #2 - Water Filter System PO 23066-2270-57865

Alan,

Please process and acknowledge attached order.

Please work on submittals for review and approval.

Time is already on the short side for this equipment, so any expediting that can be done, please put that into effect.

Thank you for your assistance and have a great weekend.

**Rich Dehnel**  
PM/Project Engineer  
Rohde Brothers, Inc.

W5745 Woodchuck Lane  
[Plymouth, WI 53073-0409](http://Plymouth, WI 53073-0409)  
Company Main: (920) 893-5905  
Direct: (920) 449-5767 | Cell: (920) 960-3638  
[dehnelr@rohdebros.com](mailto:dehnelr@rohdebros.com) | [www.rohdebros.com](http://www.rohdebros.com)



This e-mail message and all attachments transmitted with it contain confidential and proprietary business information owned by Kurita America Inc. and intended solely for the use of the addressee. The transmission of this e-mail may be legally privileged. If the recipient of this message is not the intended person or entity, you are hereby notified that any reading, dissemination, distribution, copying, or other use of this message, its contents, hyperlinks, and attached files of any kind is strictly prohibited. If you have received this message in error, please notify the sender immediately by a reply to this electronic mail message and delete this message and all copies and backups thereof. All rights to the information contained in this e-mail are reserved by Kurita America Inc.

W5745 Woodchuck Ln · P.O. Box 409 · Plymouth, WI · 53073-0409 · Phone: (920)893-5905 · Fax: (920)893-5908

**PO# 23066-2270-57865**

**To:** KURITA AMERICA INC. (507480)  
 Attn: a.schneider@kurita-water.com  
 PO BOX 851361  
 MINNEAPOLIS, MN 55485-1361

**This Number must appear on all invoices, bills of lading cases, bundles, packing lists, shipping papers and correspondence.**

**Order Date** 8/4/2023  
**Job No.** 23-066      **Phase/Card** 2-270  
**Job Address** Rohde Shop  
**Job Name** Kronenwetter Well No 2

**Telephone:**                      **Fax:**

<b>Payment Terms:</b> Net 60 Days	<b>Quote:</b> <b>Original Order</b>	<b>Date Required:</b> 7/19/2024	<input checked="" type="checkbox"/> <b>Or Sooner</b> <input type="checkbox"/> <b>Not Before</b>	<b>ShipTo:</b> Rohde Shop	<b>F.O.B.:</b> Rohde Shop <b>Freight</b> Yes and Included <b>Prepaid:</b>
<input type="checkbox"/> <b>Approval Required Before Shipment</b> <input checked="" type="checkbox"/> <b>Approval Not Required</b>		<b>1</b> Copy of Submittal Required	<b>1</b> set of Job Tailored Installation, Piping and/or Wiring Diagrams and Instructions for approval.	<b>1</b> Copy of Operation, Maintenance & Installation Instructions are required for the owner's use. Final Payment will not be made until after these instructions are received.	

Line #	QTY	PART#/DESCRIPTION	PRICE	AMOUNT
1	1	SPEC Section 46 61 21 – Horizontal Pressure Filter System – Kurita/Tonka	\$772,000.00	\$772,000.00

Total: 1 (1 line)	SubTotal	\$772,000.00
	Sales Tax	\$0.00
	<b>Total</b>	<b>\$772,000.00</b>

Jobsite Contact: Dan Moore (920)838-1618

- CHARGE WISCONSIN SALES TAX
- DO NOT CHARGE WISCONSIN SALES TAX - TAX No. 004-0000401440-01**

**Reason:**

This order shall not be binding until acceptance and return, within five days, of the signed acknowledgement copy specifying the shipping date. Such acceptance is subject to the TERMS AND CONDITIONS STATED ON THE FACE AND REVERSE SIDE OF THE ORIGINAL AND ACKNOWLEDGEMENT COPIES HEREOF, which seller agrees shall constitute the final and complete agreement between Purchaser and Seller. Any modifications or rescission of this agreement shall be ineffective unless in writing and signed by both Purchaser and Seller.

**ROHDE BROTHERS, INC.**

**Vendor must give 72 hour notice of delivery. No deliveries will be accepted prior to 7:30am and after 2:30pm CST M-TH and after 12:00pm on Fri**

**Accepted by:** \_\_\_\_\_  
**Date** \_\_\_\_\_

**Title** PO Contact: Rich Dehnel  
 Rich Dehnel

**GENERAL CONDITIONS AND INSTRUCTIONS**

**Section 4, Item D.**

**I. CONTRACT CONDITIONS**

- 1.1 This Purchase Order, when accepted by the Seller, shall constitute a valid and binding contract, which shall be governed and construed according to the laws of the State of Wisconsin.
- 1.2 All prior representations, conversations, or preliminary negotiations shall be deemed to be merged in this order, and no changes will be considered or approved unless this Purchase Order is modified by an authorized representative of the Purchaser, in writing.
- 1.3 Any acceptance in a manner or on terms and conditions different from those contained in this order shall not operate as an acceptance. No order acknowledgement on Seller's forms shall be allowed to modify any of the terms of this agreement and shall be considered to be merely advising the Purchaser of delivery dates and that the order is being processed.
- 1.4 The Seller agrees to comply with any and all Federal, State, County, Municipal and/or other local regulations, laws, ordinances and enactments of whatever kind, applicable at the time of sale or which may become effective during the period of construction or fabrication, shipping and/or installation (if installation is included) of the materials comprised under this Purchase Order.
- 1.5 The Seller agrees to indemnify and save harmless the Purchaser from and against all claims, liability, loss, damage or expense, including attorneys' fees, by reason of any actual or alleged infringement of patents, or of any litigation based thereon covering any article purchased hereunder.
- 1.6 The contract price appearing on the Purchase Order is final as to payment for the material covered by the specifically listed items, as defined by the enumerated specification paragraph numbers, with exceptions as noted, and there shall be no additions to or other modifications of such contract price, except as such modification may result from actual change in the specifications. If such changes become necessary, any alteration of the contract price shall be covered by separate order, which shall be issued to cover such changes. Seller shall not proceed with changes effecting contract price without specific authorization in WRITING from the Purchaser.

**II. SHIPPING AND DELIVERY INSTRUCTIONS**

- 2.1 Identification of shipments. The Purchaser cannot and will not be responsible for any material received unless each package, case, item, etc., is clearly identified on its outer covering as to: (1) Seller (2) Purchase Order Number (3) Project Name (4) Project Address (5) Item Description and/or Number.
- 2.2 Boxing, Packing or Cartage. No charges for boxing, packing, or cartage will be allowed unless stated hereon or later agreed to by the Purchaser's authorized representative, in writing.
- 2.3 Materials and equipment covered by this order which are shipped F.O.B. Shop or F.O.B. JOBSITE, whether in a deliverable state or otherwise shall remain the property of the Seller until delivered to a designated site and actually received by the Purchaser and any damage to the material and equipment or loss of any kind occasioned in transit shall be borne by the Seller, notwithstanding the manner in which the goods are shipped or who pays the freight or other transportation costs. Purchaser shall notify Seller as soon as possible and reasonable, of any damage to materials or equipment, or of any loss caused in transit.
- 2.4 Materials and equipment which suffer concealed damages in transit shall be, carefully examined by representatives of both the Seller and the Purchaser. If the damaged item, no matter how shipped or packaged, exhibits no external signs of abuse and/or numerous similar items suffer similar damage, it will be assumed that the items were improperly packaged and protected by the Seller. In such case, the damaged items shall be repaired or replaced at no cost to the Purchaser.
- 2.5 Seller shall promptly notify Purchaser of any shipment made. Purchaser shall be advised at his office on a normal working day, no holiday or weekend, 24 hours before attempting delivery. No deliveries after 2:00 p.m.
- 2.6 Rejected materials. Rejected materials shall be returned to the Seller at Seller's expense. No shipment under reservation is authorized. No shipment of non-conforming materials as an accommodation is authorized without Purchaser's written consent.
- 2.7 No partial shipments accepted unless agreed upon by both parties. Similar items may be shipped separately as a group.
- 2.8 Time of delivery of this order is of the essence, and Purchaser reserves the right to cancel without cancellation charges, all or any part of this order if not filled within the specified time. Exercise of such right of cancellation shall not be deemed a waiver of any other right reserved to the Purchaser herein, or by law, for any delay or failure to deliver as specified. Seller covenants and agrees to indemnify the Purchaser against any claim or liability for penalty costs incurred against the Purchaser resulting from Seller's neglect and/or indifference to this order, unless Seller is prevented from meeting the time set in this order by acts of God, strikes, fire, or other casualty, or other causes beyond the control of the Seller.

**III. INVOICING, PAYMENTS, TAXES AND RETURNS**

- 3.1 Invoices. Invoices showing both the Purchase Order Number, the Project Name and the Project Address, must be mailed to the Purchasing Department of the Purchaser not later than the day following the shipment, irrespective of whether shipment is in part or in whole. Seller's Invoice must certify full compliance with the Fair Labor Standards Act.
- 3.2 Payment and discount periods shall commence only upon receipt of both the material and proper invoice or invoices at designations specified herein. The Purchaser reserves the right to return to the Seller for correction any and all invoices containing errors and/or not in agreement with this Purchase Order.
- 3.3 The price or prices of this order are not subject to change or any surcharges resulting from the imposition now or in the future of any sales tax, Federal, State, Municipal or otherwise, unless agreed to or requested by the Purchaser. For all material purchased for use in the State of Wisconsin, the Purchaser is not to be charged the current Wisconsin State Sales Tax.
- 3.4 Returns. The Purchaser reserves the right to return to the Seller at the invoice price all items which are regularly carried in the Seller's stock.
- 3.5 Seller shall furnish all necessary lien waivers, affidavits or other documents, required to keep the Owner's premises free from liens or claims for liens, arising out of the furnishing of the material or equipment herein, as payments are made from time to time under this Purchase Order.

**IV. APPROVAL CONDITIONS**

- 4.1 All material and equipment furnished under this order shall be subject to the approval of the Owner, Architect, Engineer, or any other party designated, and Seller shall furnish required submittal data and/or number of samples for said approval. In the event such approval is not obtained, the order is cancelled, with no liability on the part of either the Purchaser or the Seller, unless the order is placed with the understanding that the material and equipment is to be supplied of the type and in a manner as to meet requirements of plans, specifications and addendums. In the latter case Seller shall comply without further cost to the Purchaser.
- 4.2 All material and equipment furnished hereunder shall be in strict accordance with plans, specifications and addendum applicable to the contract of the Purchaser with the Owner or other contractor, or as approved by the Owner or his authorized representative, and Seller shall be bound thereby in the furnishing of materials and equipment under this Purchase Order.
- 4.3 Seller shall guarantee equipment covered under this Purchase Order to produce capacities or meet design specifications and function: (1) as called for in the plans, specifications and addendums; and (2) as herein set forth; and (3) as published or warranted by the manufacturer for the equipment involved; (4) except as otherwise approved by the Owner or his authorized representatives. In the event the equipment does not meet the foregoing requirements, Seller shall immediately on notice replace same, or remedy any deficiency, without expense to the Purchaser; and further, Seller shall reimburse the Purchaser for all consequential loss or damage resulting therefrom.
- 4.4 In the event approval is not secured from the Owner or his appointed representatives, or if the Owner's or other contractor's order to the Purchaser is cancelled, cancellation of this order shall occur automatically, without cancellation charges by the Seller; and no obligation of any description, whatsoever, shall exist on the part of the Purchaser toward the Seller.
- 4.5 Inspection. The material or apparatus to be supplied against this Purchase Order shall, at the Purchaser's option, be subject to inspection and test at the maker's works.
- 4.6 Job-Tailored Installation, Piping, and Wiring Diagrams and Instructions and Job-Tailored Operation, Maintenance and Spare Parts Manuals shall be submitted for approval in the required number of copies. Final payment from the Purchaser will not be due the Seller until these items have been accomplished and the Owner's designated personnel have been properly instructed in the operation of the equipment and material purchased in this Purchase Order if such instruction is a requirement of this order.

**V. WARRANTY AND CORRECTION OF DEFECTS**

- 5.1 All material and equipment furnished under this order shall be guaranteed by the Seller against defects, and Seller agrees to replace without charge to Purchaser said material and equipment, or remedy any defects, latent or patent, not due to ordinary wear and tear, or not due to improper use or maintenance, which defects may develop within one year from date of acceptance by the Owner, or within the guarantee period set forth in applicable plans, specifications and addendum, whichever period is longer.
- 5.2 Seller represents and warrants to the Purchaser that all material and equipment rented, leased or purchased under this Purchase Order meets all standards of the Occupational Safety and Health Act of 1970 and the Construction Safety Act of 1969, as amended from time to time, and of applicable State and Local laws, regulations, standards, or requirements pertaining to safety, as amended from time to time.
- 5.3 In the event the Seller fails to correct any defects or non-conformities within a reasonable period of time, the Purchaser may, after giving seven days written notice, correct said defects or non-conformities in the best manner possible and deduct the cost of the corrections from any amounts due to the Seller. If the cost of these corrections exceeds the unpaid balance due to the Seller, the Seller shall pay the difference to the Purchaser.

**VI. DEFAULT, DISPUTES AND ARBITRATION**

- 6.1 In the event of default of any of the terms or conditions set forth herein, the Seller agrees to pay all costs resulting therefrom, including but not limited to, reasonable attorneys' fees.
- 6.2 All claims, disputes and other matters in question arising out of, or related to, this Purchase Order or breach thereof, shall be decided by arbitration in accordance with the Construction Industry Arbitration Rules of the American Arbitration Association then pertaining unless the parties mutually agree otherwise. This agreement to arbitrate shall be specifically enforceable under the prevailing arbitration law. The award by the arbitrator shall be final, and judgment may be entered upon it in accordance with applicable law in any court having jurisdiction thereof. Notice of the demand for arbitration shall be filed in writing with the other party to the Purchase Order and with the American Arbitration Association. The demand for arbitration shall be made within a reasonable time after the claim, dispute or other matter in question has arisen, and in no event shall it be made after the date when institution of legal or equitable proceeds based on such claim, dispute or other matter would be barred by the applicable statute of limitations.

12/9/24

Brian Marquardt  
Superintendent  
Rhode Brothers Inc.  
W5745 Woodchuck Ln  
Plymouth, WI 53073

RE: Village of Kronenwetter, WI – Well No. 2 Water Treatment Facility  
Tonka Water Job #J0030780

Dear Brian:

This letter is being sent to meet requirements for recertification of one(1) of the Vertical Pressure Filters that was dropped on it's side on October 31, 2024 while being moved into the building.

After working with our fabrication and inspection team it has been determined that if the vessel has no visual damage, all paint, weld seams, and internal components are in tact and secure the vessel does not need to be brought back for repairs. As noted in communication with Rhode Brothers, Inc and the site engineer, this vessel will be tested on site at the expense of Rhode Brothers, Inc to pressure rating of 130psi per design and ASME code, if this tests without issue all factory warranties will remain.

Once testing is completed, Rhode Brothers, Inc will need to send a copy of the test results to Nina Halverson at Kurita to keep in the project files.

Should there be issues with the testing Kurita needs to be informed immediately so we can begin working with Rhode Brothers and the site to make any necessary arrangements to complete repair, which would be at the expense of Rhode Brothers, Inc if they are a result of the vessel being dropped during installation.

Please reach out if there are any questions or concerns.

Sincerely,

*Nina Halverson*

Nina Halverson  
Project Manager

**Brian Marquardt**

---

**From:** Nina HALVERSON <n.halverson@kurita-water.com>  
**Sent:** Friday, May 17, 2024 2:36 PM  
**To:** Brian Marquardt; Alan SCHNEIDER  
**Subject:** RE: [EXT]RE: Kronenwetter- Rohde Brothers 23066-2270-57865

**Follow Up Flag:** Follow up  
**Flag Status:** Flagged

Brian –

I'm not aware of delays on our end, we've had full approval since 12/20/23 and have pushed this to fabrication and are still tracking for early September delivery as we were anticipating from the project start.

We had a minor delay between sending the submittal on 10/18/23 and getting the approval as noted from the engineer we received on 12/20/23, outside of that we are facing no delays, fabrication is going as planned and is set to deliver within the proposed and quoted timelines.

Please let me know if you have any further questions or concerns that I can assist you with.

Thank you,

**Nina Halverson**

*Project Manager – Municipal*

Direct 763-957-1946 | Mobile 651-706-0498 | [n.halverson@kurita-water.com](mailto:n.halverson@kurita-water.com)

Kurita America Inc. | Tonka Water, a Kurita brand | [www.kuritaamerica.com](http://www.kuritaamerica.com)



---

**From:** Brian Marquardt <marquardtb@rohdebros.com>  
**Sent:** Friday, May 17, 2024 12:46 PM  
**To:** Nina HALVERSON <n.halverson@kurita-water.com>; Alan SCHNEIDER <a.schneider@kurita-water.com>  
**Subject:** RE: [EXT]RE: Kronenwetter- Rohde Brothers 23066-2270-57865

Hello Nina,

The engineer on this project is asking for a letter stating what delays have been encountered causing the long lead time of this filter package. The reason for this is so they can ask for an extension on the project. Can you send something to me in letter form on your company letterhead just as a PDF that I can forward on and they can use to explain why the extension is needed. Doesn't have to be extremely in depth, just some of the high level reasons. Acquiring materials, busy production schedule, etc. Thank you.

**BRIAN MARQUARDT**  
Superintendent  
Rohde Brothers Inc. |  
**920-838-1628**

[marquardt@rohdebros.com](mailto:marquardt@rohdebros.com)

**From:** Nina HALVERSON <[n.halverson@kurita-water.com](mailto:n.halverson@kurita-water.com)>  
**Sent:** Friday, May 3, 2024 7:50 AM  
**To:** Brian Marquardt <[marquardt@rohdebros.com](mailto:marquardt@rohdebros.com)>; Alan SCHNEIDER <[a.schneider@kurita-water.com](mailto:a.schneider@kurita-water.com)>  
**Subject:** RE: [EXT]RE: Kronenwetter- Rohde Brothers 23066-2270-57865

No problem, I had thought I responded previously so my apologies for missing that!

Definitely reach out as needed to keep all parties satisfied and feeling good about where things are at, there's a lot of coordination with these sites so I fully understand that! I will certainly keep you updated on any changes that come up, but I don't anticipate any.

Have a great weekend!

### Nina Halverson

*Project Manager – Municipal*  
Direct 763-957-1946 | Mobile 651-706-0498 | [n.halverson@kurita-water.com](mailto:n.halverson@kurita-water.com)  
Kurita America Inc. | Tonka Water, a Kurita brand | [www.kuritaamerica.com](http://www.kuritaamerica.com)



**From:** Brian Marquardt <[marquardt@rohdebros.com](mailto:marquardt@rohdebros.com)>  
**Sent:** Friday, May 3, 2024 7:46 AM  
**To:** Nina HALVERSON <[n.halverson@kurita-water.com](mailto:n.halverson@kurita-water.com)>; Alan SCHNEIDER <[a.schneider@kurita-water.com](mailto:a.schneider@kurita-water.com)>  
**Subject:** RE: [EXT]RE: Kronenwetter- Rohde Brothers 23066-2270-57865

Thank you Nina, the engineer and general contractor are constantly asking for updates. I know you will keep us informed if anything changes.

**BRIAN MARQUARDT**  
Superintendent  
Rohde Brothers Inc.  
**920-838-1628**  
[marquardt@rohdebros.com](mailto:marquardt@rohdebros.com)

**From:** Nina HALVERSON <[n.halverson@kurita-water.com](mailto:n.halverson@kurita-water.com)>  
**Sent:** Friday, May 3, 2024 7:43 AM  
**To:** Brian Marquardt <[marquardt@rohdebros.com](mailto:marquardt@rohdebros.com)>; Alan SCHNEIDER <[a.schneider@kurita-water.com](mailto:a.schneider@kurita-water.com)>  
**Subject:** RE: [EXT]RE: Kronenwetter- Rohde Brothers 23066-2270-57865

Brian –

Yes, we are still tracking for delivery the week of 9/9/24.

We're not in fabrication yet for this location, but once we are and closer to completion I can provide a more detailed schedule of delivery.



Thank you,

## Nina Halverson

*Project Manager – Municipal*

Direct 763-957-1946 | Mobile 651-706-0498 | [n.halverson@kurita-water.com](mailto:n.halverson@kurita-water.com)

Kurita America Inc. | Tonka Water, a Kurita brand | [www.kuritaamerica.com](http://www.kuritaamerica.com)



---

**From:** Brian Marquardt <[marquardtb@rohdebros.com](mailto:marquardtb@rohdebros.com)>  
**Sent:** Friday, May 3, 2024 7:37 AM  
**To:** Nina HALVERSON <[n.halverson@kurita-water.com](mailto:n.halverson@kurita-water.com)>; Alan SCHNEIDER <[a.schneider@kurita-water.com](mailto:a.schneider@kurita-water.com)>  
**Subject:** RE: [EXT]RE: Kronenwetter- Rohde Brothers 23066-2270-57865

Hello Nina,

I'm still looking for an update on this equipment. Please reply soon with an update.

**BRIAN MARQUARDT**  
Superintendent  
Rohde Brothers Inc.  
**920-838-1628**  
[marquardtb@rohdebros.com](mailto:marquardtb@rohdebros.com)

---

**From:** Brian Marquardt  
**Sent:** Thursday, April 25, 2024 3:12 PM  
**To:** 'Nina HALVERSON' <[n.halverson@kurita-water.com](mailto:n.halverson@kurita-water.com)>; Alan SCHNEIDER <[a.schneider@kurita-water.com](mailto:a.schneider@kurita-water.com)>  
**Subject:** RE: [EXT]RE: Kronenwetter- Rohde Brothers 23066-2270-57865

Hello Nina,

Our general contractor on this project is looking for me to give him an equipment update. Are we still looking at mid August to early September for delivery?

**BRIAN MARQUARDT**  
Superintendent  
Rohde Brothers Inc.  
**920-838-1628**  
[marquardtb@rohdebros.com](mailto:marquardtb@rohdebros.com)

---

**From:** Nina HALVERSON <[n.halverson@kurita-water.com](mailto:n.halverson@kurita-water.com)>  
**Sent:** Friday, January 26, 2024 12:59 PM  
**To:** Brian Marquardt <[marquardtb@rohdebros.com](mailto:marquardtb@rohdebros.com)>; Alan SCHNEIDER <[a.schneider@kurita-water.com](mailto:a.schneider@kurita-water.com)>  
**Subject:** RE: [EXT]RE: Kronenwetter- Rohde Brothers 23066-2270-57865

You don't often get email from [n.halverson@kurita-water.com](mailto:n.halverson@kurita-water.com). [Learn why this is important](#)

Brian –

Sorry I missed your call, I was on another call when yours was coming through.

Rough estimate is likely mid-August for all 4 vertical tanks to all be ready for delivery. I will reach out and inquire to see if there is a better answer at the moment, but it may not be something they can give me until closer to summer.

I will reach out if they give me something different.

Thank you,

**Nina Halverson**

*Project Manager*

Desk 763-957-1947 | Mobile 651-706-0498 | [n.halverson@kurita-water.com](mailto:n.halverson@kurita-water.com)

Kurita America Inc. | [www.kuritaamerica.com](http://www.kuritaamerica.com)

[How are we doing? Take our short survey!](#)



---

**From:** Brian Marquardt <[marquardtb@rohdebros.com](mailto:marquardtb@rohdebros.com)>  
**Sent:** Friday, January 26, 2024 11:56 AM  
**To:** Nina HALVERSON <[n.halverson@kurita-water.com](mailto:n.halverson@kurita-water.com)>; Alan SCHNEIDER <[a.schneider@kurita-water.com](mailto:a.schneider@kurita-water.com)>  
**Subject:** [EXT]RE: Kronenwetter- Rohde Brothers 23066-2270-57865

Thank you for the update. If we do take the four vertical tanks early, I would want them all at the same time. Do you have any idea when these four may get completed?

**BRIAN MARQUARDT**  
Superintendent  
Rohde Brothers Inc.  
**920-838-1628**  
[marquardtb@rohdebros.com](mailto:marquardtb@rohdebros.com)

---

**From:** Nina HALVERSON <[n.halverson@kurita-water.com](mailto:n.halverson@kurita-water.com)>  
**Sent:** Friday, January 26, 2024 9:12 AM  
**To:** Alan SCHNEIDER <[a.schneider@kurita-water.com](mailto:a.schneider@kurita-water.com)>; Brian Marquardt <[marquardtb@rohdebros.com](mailto:marquardtb@rohdebros.com)>  
**Subject:** RE: Kronenwetter- Rohde Brothers 23066-2270-57865

You don't often get email from [n.halverson@kurita-water.com](mailto:n.halverson@kurita-water.com). [Learn why this is important](#)

Good morning Brian,

I will update my contacts and information on this job, so I send things to the right place.

Right now, we've got approval on this one, which was received about a month ago. We're early in the process, but our fabrication teams are aiming towards mid-August or early September delivery date based on their scheduling and the number of vessels.

Rich had previously noted that you'd like to take delivery of the 4 vertical tanks as soon as they are complete to allow placement and piping to happen before the pressure vessel is delivered.

The 4 verticals will complete at various points, would you like them to deliver as they complete or all 4 at once – this can be done either way without issue on our end.

My contact information is below, please reach out with any questions or concerns so we can get them addressed for you!

Thank you,

**Nina Halverson**

*Project Manager*

Desk 763-957-1947 | Mobile 651-706-0498 | [n.halverson@kurita-water.com](mailto:n.halverson@kurita-water.com)

Kurita America Inc. | [www.kuritaamerica.com](http://www.kuritaamerica.com)

*How are we doing? Take our short survey!*



---

**From:** Alan SCHNEIDER <[a.schneider@kurita-water.com](mailto:a.schneider@kurita-water.com)>  
**Sent:** Thursday, January 25, 2024 5:53 PM  
**To:** Brian Marquardt <[marquardtb@rohdebros.com](mailto:marquardtb@rohdebros.com)>  
**Cc:** Nina HALVERSON <[n.halverson@kurita-water.com](mailto:n.halverson@kurita-water.com)>  
**Subject:** Kronenwetter- Rohde Brothers 23066-2270-57865

Hi Brian

Our project manager is:

**Nina Halverson**

*Project Manager*

Desk 763-957-1947 | Mobile 651-706-0498 | [n.halverson@kurita-water.com](mailto:n.halverson@kurita-water.com)

Nina will be able to update you on the status of the project.

I have copied her here.

Thanks!

**Alan Schneider**

**Tonka Water Territory Manager**

Mobile 612-708-6517 | Main 800-530-1887 | [a.schneider@kurita-water.com](mailto:a.schneider@kurita-water.com)

Kurita America Inc. | Tonka Water, a Kurita brand | [www.kuritaamerica.com](http://www.kuritaamerica.com)

---

**From:** Brian Marquardt <[marquardtb@rohdebros.com](mailto:marquardtb@rohdebros.com)>  
**Sent:** Thursday, January 25, 2024 11:56 AM  
**To:** Alan SCHNEIDER <[a.schneider@kurita-water.com](mailto:a.schneider@kurita-water.com)>  
**Subject:** [EXT]Rohde Brothers 23066-2270-57865

Hello,

I'm checking in on the status of this order. I'm taking this project over as Rich Dehnel no longer works here. If you could please update me with the estimated shipping date. Thank you.

**BRIAN MARQUARDT**

Superintendent

Rohde Brothers Inc.

**920-838-1628**

[marquardtb@rohdebros.com](mailto:marquardtb@rohdebros.com)

This e-mail message and all attachments transmitted with it contain confidential and proprietary business information owned by Kurita America Inc. and intended solely for the use of the addressee. The transmission of this e-mail may be legally privileged. If the recipient of this message is not the intended person or entity, you are hereby notified that any reading, dissemination, distribution, copying, or other use of this message, its contents, hyperlinks, and attached files of any kind is strictly prohibited. If you have received this message in error, please notify the sender immediately by a reply to this electronic mail message and delete this message and all copies and backups thereof. All rights to the information contained in this e-mail are reserved by Kurita America Inc.

This e-mail message and all attachments transmitted with it contain confidential and proprietary business information owned by Kurita America Inc. and intended solely for the use of the addressee. The transmission of this e-mail may be legally privileged. If the recipient of this message is not the intended person or entity, you are hereby notified that any reading, dissemination, distribution, copying, or other use of this message, its contents, hyperlinks, and attached files of any kind is strictly prohibited. If you have received this message in error, please notify the sender immediately by a reply to this electronic mail message and delete this message and all copies and backups thereof. All rights to the information contained in this e-mail are reserved by Kurita America Inc.

This e-mail message and all attachments transmitted with it contain confidential and proprietary business information owned by Kurita America Inc. and intended solely for the use of the addressee. The transmission of this e-mail may be legally privileged. If the recipient of this message is not the intended person or entity, you are hereby notified that any reading, dissemination, distribution, copying, or other use of this message, its contents, hyperlinks, and attached files of any kind is strictly prohibited. If you have received this message in error, please notify the sender immediately by a reply to this electronic mail message and delete this message and all copies and backups thereof. All rights to the information contained in this e-mail are reserved by Kurita America Inc.

This e-mail message and all attachments transmitted with it contain confidential and proprietary business information owned by Kurita America Inc. and intended solely for the use of the addressee. The transmission of this e-mail may be legally privileged. If the recipient of this message is not the intended person or entity, you are hereby notified that any reading, dissemination, distribution, copying, or other use of this message, its contents, hyperlinks, and attached files of any kind is strictly prohibited. If you have received this message in error, please notify the sender immediately by a reply to this electronic mail message and delete this message and all copies and backups thereof. All rights to the information contained in this e-mail are reserved by Kurita America Inc.

**Brian Marquardt**

---

**From:** Nina HALVERSON <n.halverson@kurita-water.com>  
**Sent:** Friday, August 16, 2024 2:27 PM  
**To:** Brian Marquardt; Emily Nurmi  
**Cc:** Luke Laudolff  
**Subject:** RE: [EXT]RE: Kronenwetter WTP pressure filter J0030780

**Follow Up Flag:** Follow up  
**Flag Status:** Completed

Brian –

Sounds good, I will ask that they store the 4 vertical vessels until they’re all ready to deliver.

I will keep you posted on updates on the HPF – I’m hoping they will be able to complete that sooner than they’re currently projecting..

Thank you,

**Nina Halverson**

*Project Manager – Municipal*

Direct 763-957-1947 | Mobile 651-706-0498 | [n.halverson@kurita-water.com](mailto:n.halverson@kurita-water.com)

Kurita America Inc. | Tonka Water, a Kurita brand | [www.kuritaamerica.com](http://www.kuritaamerica.com)



---

**From:** Brian Marquardt <marquardtb@rohdebros.com>  
**Sent:** Friday, August 16, 2024 1:27 PM  
**To:** Nina HALVERSON <n.halverson@kurita-water.com>; Emily Nurmi <Emily@williamreidltd.com>  
**Cc:** Luke Laudolff <laudolffl@rohdebros.com>  
**Subject:** RE: [EXT]RE: Kronenwetter WTP pressure filter J0030780

I am leaning towards receiving all of the vessels at the same time.

**BRIAN MARQUARDT**

Superintendent

Rohde Brothers Inc.

**920-838-1628**

[marquardtb@rohdebros.com](mailto:marquardtb@rohdebros.com)

---

**From:** Nina HALVERSON <[n.halverson@kurita-water.com](mailto:n.halverson@kurita-water.com)>  
**Sent:** Thursday, August 15, 2024 9:50 AM  
**To:** Emily Nurmi <[Emily@williamreidltd.com](mailto:Emily@williamreidltd.com)>; Brian Marquardt <[marquardtb@rohdebros.com](mailto:marquardtb@rohdebros.com)>  
**Cc:** Luke Laudolff <[laudolffl@rohdebros.com](mailto:laudolffl@rohdebros.com)>  
**Subject:** RE: [EXT]RE: Kronenwetter WTP pressure filter J0030780

Emily –

I just wrapped up a meeting with the fab team –

Looks like the 4 vertical filters will be ready and available to ship the week of 9/2(after labor day). Unfortunately, with the storms and damage/delays caused by the fab shop, it looks like the Horizontal system won't be able to ship until mid-end of September. T

We can however ship the vertical filters and components ahead of the horizontal filter though, if this works for you let me know what date would work after labor day and I will arrange for the 4 verticals to be delivered. If you'd prefer to take delivery of all vessels at the same time I will arrange for storage until the Horizontal is ready.

Thank you,

## Nina Halverson

*Project Manager – Municipal*

Direct 763-957-1947 | Mobile 651-706-0498 | [n.halverson@kurita-water.com](mailto:n.halverson@kurita-water.com)

Kurita America Inc. | Tonka Water, a Kurita brand | [www.kuritaamerica.com](http://www.kuritaamerica.com)



---

**From:** Emily Nurmi <[Emily@williamreidltd.com](mailto:Emily@williamreidltd.com)>  
**Sent:** Thursday, August 8, 2024 2:36 PM  
**To:** Nina HALVERSON <[n.halverson@kurita-water.com](mailto:n.halverson@kurita-water.com)>; Brian Marquardt <[marquardt@rohdebros.com](mailto:marquardt@rohdebros.com)>  
**Cc:** Luke Laudolff <[laudolff@rohdebros.com](mailto:laudolff@rohdebros.com)>  
**Subject:** Re: [EXT]RE: Kronenwetter WTP pressure filter J0030780

Nina,

Good afternoon. I was just looking for an update following your meeting last week. Did the completion data stay the same?

Thank you 🙏

Emily Nurmi (she, hers, her)

*Project Manager*



PO Box 397

Germantown, WI 53022

O: 262-255-5420 C: 608-733-1403

---

**From:** Nina HALVERSON <[n.halverson@kurita-water.com](mailto:n.halverson@kurita-water.com)>  
**Sent:** Monday, July 29, 2024 2:09 PM  
**To:** Emily Nurmi <[Emily@williamreidltd.com](mailto:Emily@williamreidltd.com)>; Brian Marquardt <[marquardtb@rohdebros.com](mailto:marquardtb@rohdebros.com)>  
**Cc:** Luke Laudolff <[laudolffl@rohdebros.com](mailto:laudolffl@rohdebros.com)>  
**Subject:** RE: [EXT]RE: Kronenwetter WTP pressure filter J0030780

Good afternoon –

Right now we have a date of 9/9 for completion and inspection with shipping to follow. They are running about a week behind or so and we have a meeting with them Thursday to get updated scheduling information – they were hit with hurricane during the most recent storm surges and all production was stopped for a bit over a week. They are back to work and fabrication now, but are assessing what potential schedule impacts that has had.

I will follow up with you after our meeting with them on Thursday to let you know if there’s any impact to delivery.

Thank you,

**Nina Halverson**

*Project Manager – Municipal*  
Direct 763-957-1947 | Mobile 651-706-0498 | [n.halverson@kurita-water.com](mailto:n.halverson@kurita-water.com)  
Kurita America Inc. | Tonka Water, a Kurita brand | [www.kuritaamerica.com](http://www.kuritaamerica.com)



---

**From:** Emily Nurmi <[Emily@williamreidltd.com](mailto:Emily@williamreidltd.com)>  
**Sent:** Monday, July 29, 2024 1:03 PM  
**To:** Nina HALVERSON <[n.halverson@kurita-water.com](mailto:n.halverson@kurita-water.com)>; Brian Marquardt <[marquardtb@rohdebros.com](mailto:marquardtb@rohdebros.com)>  
**Cc:** Luke Laudolff <[laudolffl@rohdebros.com](mailto:laudolffl@rohdebros.com)>  
**Subject:** Re: [EXT]RE: Kronenwetter WTP pressure filter J0030780

Nina,

Can you please provide an update on this order? In February, you mentioned that the estimated ship date was mid-August.

Thank you for the update!

Emily Nurmi (she, hers, her)

*Project Manager*

PO Box 397

Germantown, WI 53022

O: 262-255-5420 C: 608-733-1403

[Emily@williamreidltd.com](mailto:Emily@williamreidltd.com)

---

**From:** Emily Nurmi <[Emily@williamreidltd.com](mailto:Emily@williamreidltd.com)>

**Sent:** Tuesday, June 4, 2024 8:54 AM

**To:** Nina HALVERSON <[n.halverson@kurita-water.com](mailto:n.halverson@kurita-water.com)>; Rich Dehnel <[dehnelr@rohdebros.com](mailto:dehnelr@rohdebros.com)>; Brian Marquardt <[marquardt@rohdebros.com](mailto:marquardt@rohdebros.com)>

**Cc:** Luke Laudolff <[laudolffl@rohdebros.com](mailto:laudolffl@rohdebros.com)>

**Subject:** Re: [EXT]RE: Kronenwetter WTP pressure filter J0030780

Nina,

Good morning. Is there a schedule update for this order?

Thank you!

Emily Nurmi (she, hers, her)

*Project Manager*

PO Box 397

Germantown, WI 53022

O: 262-255-5420 C: 608-733-1403

[Emily@williamreidltd.com](mailto:Emily@williamreidltd.com)

---

**From:** Nina HALVERSON <[n.halverson@kurita-water.com](mailto:n.halverson@kurita-water.com)>

**Sent:** Thursday, April 4, 2024 1:17 PM

**To:** Rich Dehnel <[dehnelr@rohdebros.com](mailto:dehnelr@rohdebros.com)>; Brian Marquardt <[marquardt@rohdebros.com](mailto:marquardt@rohdebros.com)>

**Cc:** Emily Nurmi <[Emily@williamreidltd.com](mailto:Emily@williamreidltd.com)>; Luke Laudolff <[laudolffl@rohdebros.com](mailto:laudolffl@rohdebros.com)>

**Subject:** FW: [EXT]RE: Kronenwetter WTP pressure filter J0030780



Good afternoon –

This was communicated, to Ken at Becher Hoppe, but he’s directed this to be sent to you for further handling, his response is below.

Our purchasing team has gotten an update from our fabrication shop, they are able to source and build at 3/8”, but have noted that they cannot source the SA-36 to meet delivery timelines and plan to proceed with the build at the specified thickness using 516-70, which is a stronger material and will be of greater quality for the finished product.

I’ve included the head and shell calculations for you, they are figured for 3/8” thickness using 516-70 steel, at this point, there should be no additional changes, but wanted to provide you with these calculations and let you know the steel will be shifted, but to a material with greater strength and is overall superior.

Thank you,

**Nina Halverson**

*Project Manager*

Desk 763-957-1947 | Mobile 651-706-0498 | [n.halverson@kurita-water.com](mailto:n.halverson@kurita-water.com)

Kurita America Inc. | [www.kuritaamerica.com](http://www.kuritaamerica.com)

[How are we doing? Take our short survey!](#)



**From:** Kenneth J. Ligman <[kligman@becherhoppe.com](mailto:kligman@becherhoppe.com)>  
**Sent:** Monday, March 18, 2024 9:21 AM  
**To:** Nina HALVERSON <[n.halverson@kurita-water.com](mailto:n.halverson@kurita-water.com)>  
**Cc:** Matthew R. Patterson <[mpatterson@becherhoppe.com](mailto:mpatterson@becherhoppe.com)>  
**Subject:** RE: [EXT]RE: Kronenwetter WTP pressure filter J0030780

This material change will officially require a change order by the general contractor. Please forward your request to the general contractor Ellis Stone via Rhode Brothers. We in turn, will bring this to the attention of the Owner for their immediate concurrence.

We are still waiting for the same type of calculations for the horizontal pressure filter.

**Ken Ligman**  
Senior Engineer

**Becher-Hoppe Associates, Inc.**  
330 N. 4th Street | Wausau WI | 54403  
Direct 715-845-0432 | Office 715-845-8000  
[kligman@becherhoppe.com](mailto:kligman@becherhoppe.com) | [www.becherhoppe.com](http://www.becherhoppe.com)

This email message is for the sole use of the intended recipient(s) and may contain confidential and privileged information. Any unauthorized review, use, disclosure or distribution is prohibited. If you are not the intended recipient, please contact the sender by reply email and destroy all copies of the original message

**From:** Nina HALVERSON <[n.halverson@kurita-water.com](mailto:n.halverson@kurita-water.com)>  
**Sent:** Monday, March 18, 2024 9:07 AM  
**To:** Kenneth J. Ligman <[kligman@becherhoppe.com](mailto:kligman@becherhoppe.com)>  
**Subject:** RE: [EXT]RE: Kronenwetter WTP pressure filter J0030780

Ken –

Good morning – Our purchasing team has gotten an update from our fabrication shop, they are able to source and build at 3/8”, but have noted that they cannot source the SA-36 to meet delivery timelines and plan to proceed with the build at the specified thickness using 516-70, which is a stronger material and will be of greater quality for the finished product.

I’ve included the head and shell calculations for you, they are figured for 3/8” thickness using 516-70 steel, at this point, there should be no additional changes, but wanted to provide you with these calculations and let you know the steel will be shifted, but to a material with greater strength and is overall superior.

Thank you,

**Nina Halverson**

*Project Manager*

**Desk** 763-957-1947 | **Mobile** 651-706-0498 | [n.halverson@kurita-water.com](mailto:n.halverson@kurita-water.com)

**Kurita America Inc.** | [www.kuritaamerica.com](http://www.kuritaamerica.com)

*How are we doing? Take our short survey!*



---

**From:** Kenneth J. Ligman <[kligman@becherhoppe.com](mailto:kligman@becherhoppe.com)>  
**Sent:** Monday, March 18, 2024 8:47 AM  
**To:** Nina HALVERSON <[n.halverson@kurita-water.com](mailto:n.halverson@kurita-water.com)>  
**Subject:** RE: [EXT]RE: Kronenwetter WTP pressure filter J0030780

Thank you

**Ken Ligman**  
Senior Engineer

**Becher-Hoppe Associates, Inc.**  
330 N. 4th Street | Wausau WI | 54403  
Direct 715-845-0432 | Office 715-845-8000  
[kligman@becherhoppe.com](mailto:kligman@becherhoppe.com) | [www.becherhoppe.com](http://www.becherhoppe.com)

This email message is for the sole use of the intended recipient(s) and may contain confidential and privileged information. Any unauthorized review, use, disclosure or distribution is prohibited. If you are not the intended recipient, please contact the sender by reply email and destroy all copies of the original message

---

**From:** Nina HALVERSON <[n.halverson@kurita-water.com](mailto:n.halverson@kurita-water.com)>  
**Sent:** Thursday, March 14, 2024 10:34 AM  
**To:** Kenneth J. Ligman <[kligman@becherhoppe.com](mailto:kligman@becherhoppe.com)>  
**Subject:** RE: [EXT]RE: Kronenwetter WTP pressure filter J0030780

Ken –

Attached are the material calcs for the 3/8” SA-36.

Let me know if you need anything else.

Thank you,

**Nina Halverson**

*Project Manager*

Desk 763-957-1947 | Mobile 651-706-0498 | [n.halverson@kurita-water.com](mailto:n.halverson@kurita-water.com)

Kurita America Inc. | [www.kuritaamerica.com](http://www.kuritaamerica.com)

*How are we doing? Take our short survey!*



**From:** Kenneth J. Ligman <[kligman@becherhoppe.com](mailto:kligman@becherhoppe.com)>  
**Sent:** Thursday, March 14, 2024 9:33 AM  
**To:** Nina HALVERSON <[n.halverson@kurita-water.com](mailto:n.halverson@kurita-water.com)>  
**Subject:** RE: [EXT]RE: Kronenwetter WTP pressure filter J0030780

Please provide calculations for 3/8" SA-36 materials for the detention tanks.  
Thanks.

**Ken Ligman**  
Senior Engineer

**Becher-Hoppe Associates, Inc.**  
330 N. 4th Street | Wausau WI | 54403  
Direct 715-845-0432 | Office 715-845-8000  
[kligman@becherhoppe.com](mailto:kligman@becherhoppe.com) | [www.becherhoppe.com](http://www.becherhoppe.com)

This email message is for the sole use of the intended recipient(s) and may contain confidential and privileged information. Any unauthorized review, use, disclosure or distribution is prohibited. If you are not the intended recipient, please contact the sender by reply email and destroy all copies of the original message

**From:** Nina HALVERSON <[n.halverson@kurita-water.com](mailto:n.halverson@kurita-water.com)>  
**Sent:** Thursday, March 7, 2024 11:41 AM  
**To:** Kenneth J. Ligman <[kligman@becherhoppe.com](mailto:kligman@becherhoppe.com)>; Alan SCHNEIDER <[a.schneider@kurita-water.com](mailto:a.schneider@kurita-water.com)>  
**Cc:** Matthew R. Patterson <[mpatterson@becherhoppe.com](mailto:mpatterson@becherhoppe.com)>; Patrick Ingle <[patrick@williamreidltd.com](mailto:patrick@williamreidltd.com)>  
**Subject:** RE: [EXT]RE: Kronenwetter WTP pressure filter J0030780  
**Importance:** High

Good morning –

We’ve had some changes in the fabrication shop for the Kronenwetter Vessels to maintain schedule as the planned shop overbooked and was not going to be able to meet delivery dates. However, with this change in shop there is a material change we’d like to get approval on. Please review the attached RFI and let me know if you have any questions or concerns or if we are clear to proceed with the changes here.

Thank you,

**Nina Halverson**

*Project Manager*

Desk 763-957-1947 | Mobile 651-706-0498 | [n.halverson@kurita-water.com](mailto:n.halverson@kurita-water.com)



---

**From:** Kenneth J. Ligman <[kligman@becherhoppe.com](mailto:kligman@becherhoppe.com)>  
**Sent:** Wednesday, February 28, 2024 9:33 AM  
**To:** Nina HALVERSON <[n.halverson@kurita-water.com](mailto:n.halverson@kurita-water.com)>; Alan SCHNEIDER <[a.schneider@kurita-water.com](mailto:a.schneider@kurita-water.com)>  
**Cc:** Matthew R. Patterson <[mpatterson@becherhoppe.com](mailto:mpatterson@becherhoppe.com)>; Patrick Ingle <[patrick@williamreidltd.com](mailto:patrick@williamreidltd.com)>  
**Subject:** RE: [EXT]RE: Kronenwetter WTP pressure filter J0030780

Thank you

**Ken Ligman**  
Senior Engineer

**Becher-Hoppe Associates, Inc.**  
330 N. 4th Street | Wausau WI | 54403  
Direct 715-845-0432 | Office 715-845-8000  
[kligman@becherhoppe.com](mailto:kligman@becherhoppe.com) | [www.becherhoppe.com](http://www.becherhoppe.com)

This email message is for the sole use of the intended recipient(s) and may contain confidential and privileged information. Any unauthorized review, use, disclosure or distribution is prohibited. If you are not the intended recipient, please contact the sender by reply email and destroy all copies of the original message

---

**From:** Nina HALVERSON <[n.halverson@kurita-water.com](mailto:n.halverson@kurita-water.com)>  
**Sent:** Wednesday, February 28, 2024 9:30 AM  
**To:** Kenneth J. Ligman <[kligman@becherhoppe.com](mailto:kligman@becherhoppe.com)>; Alan SCHNEIDER <[a.schneider@kurita-water.com](mailto:a.schneider@kurita-water.com)>  
**Cc:** Matthew R. Patterson <[mpatterson@becherhoppe.com](mailto:mpatterson@becherhoppe.com)>; Patrick Ingle <[patrick@williamreidltd.com](mailto:patrick@williamreidltd.com)>  
**Subject:** RE: [EXT]RE: Kronenwetter WTP pressure filter J0030780

There are not, just the two side support angles will make contact with the ground and those are 8" wide.

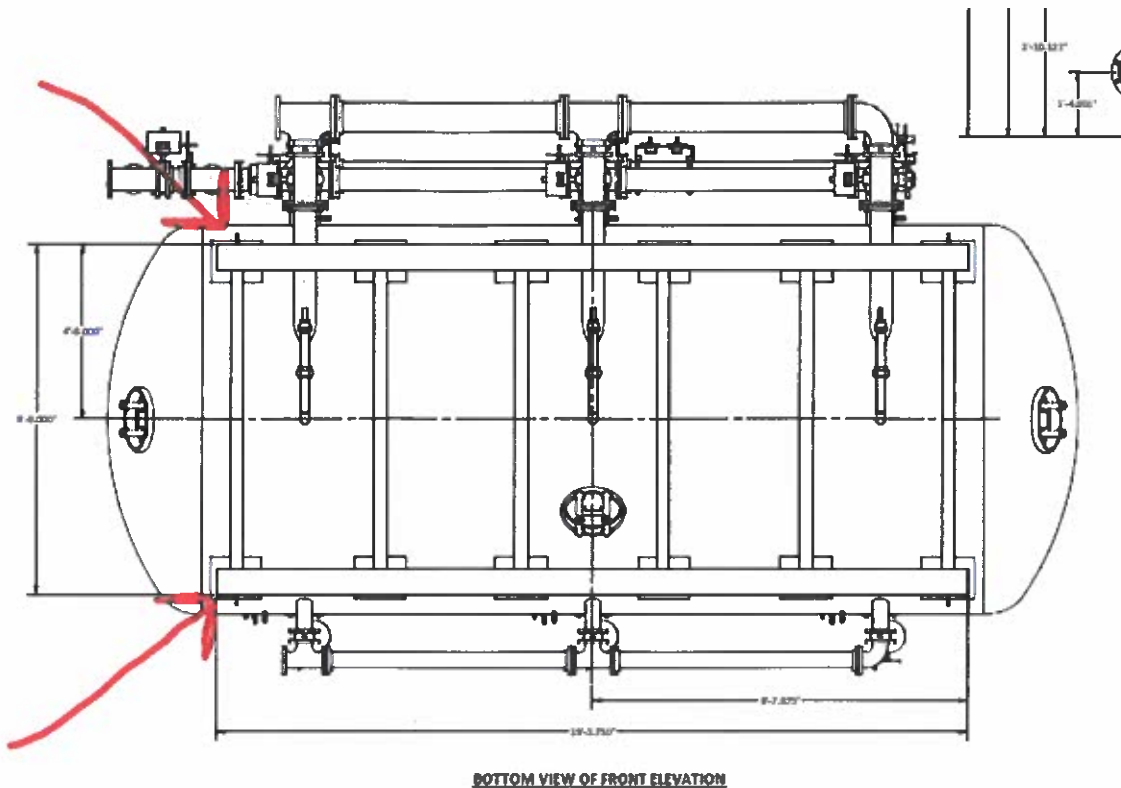

**Nina Halverson**

*Project Manager*

Desk 763-957-1947 | Mobile 651-706-0498 | [n.halverson@kurita-water.com](mailto:n.halverson@kurita-water.com)

Kurita America Inc. | [www.kuritaamerica.com](http://www.kuritaamerica.com)

[How are we doing? Take our short survey!](#)



**From:** Kenneth J. Ligman <[kligman@becherhoppe.com](mailto:kligman@becherhoppe.com)>

**Sent:** Wednesday, February 28, 2024 9:06 AM

**To:** Nina HALVERSON <[n.halverson@kurita-water.com](mailto:n.halverson@kurita-water.com)>; Alan SCHNEIDER <[a.schneider@kurita-water.com](mailto:a.schneider@kurita-water.com)>

**Cc:** Matthew R. Patterson <[mpatterson@becherhoppe.com](mailto:mpatterson@becherhoppe.com)>; Patrick Ingle <[patrick@williamreidltd.com](mailto:patrick@williamreidltd.com)>

**Subject:** RE: [EXT]RE: Kronenwetter WTP pressure filter J0030780

Are there horizontal members on each side that connect all the leg supports and the leg supports rest on? If so, what are the dimensions of these members?

**Ken Ligman**

Senior Engineer

**Becher-Hoppe Associates, Inc.**

330 N. 4th Street | Wausau WI | 54403

Direct 715-845-0432 | Office 715-845-8000

[kligman@becherhoppe.com](mailto:kligman@becherhoppe.com) | [www.becherhoppe.com](http://www.becherhoppe.com)

This email message is for the sole use of the intended recipient(s) and may contain confidential and privileged information. Any unauthorized disclosure or distribution is prohibited. If you are not the intended recipient, please contact the sender by reply email and destroy all copies of the original message

**From:** Nina HALVERSON <n.halverson@kurita-water.com>  
**Sent:** Tuesday, February 27, 2024 11:39 AM  
**To:** Kenneth J. Ligman <kligman@becherhoppe.com>; Alan SCHNEIDER <a.schneider@kurita-water.com>  
**Cc:** Matthew R. Patterson <mpatterson@becherhoppe.com>; Patrick Ingle <patrick@williamreidltd.com>  
**Subject:** RE: [EXT]RE: Kronenwetter WTP pressure filter J0030780

Ken,

Attached is the General Arrangement drawing, also included in your Submittal packet. Page 3 of this drawing shows the skid dimensions. Is this sufficient or do you need the actual stock size of the frame beams that are on the floor?

Let me know if that is needed, I can get more information for you on that.

Thank you,

**Nina Halverson**  
Project Manager  
Desk 763-957-1947 | Mobile 651-706-0498 | n.halverson@kurita-water.com  
Kurita America Inc. | www.kuritaamerica.com  
*How are we doing? Take our short survey!*



**From:** Kenneth J. Ligman <kligman@becherhoppe.com>  
**Sent:** Tuesday, February 27, 2024 11:28 AM  
**To:** Nina HALVERSON <n.halverson@kurita-water.com>; Alan SCHNEIDER <a.schneider@kurita-water.com>  
**Cc:** Matthew R. Patterson <mpatterson@becherhoppe.com>; Patrick Ingle <patrick@williamreidltd.com>  
**Subject:** [EXT]RE: Kronenwetter WTP pressure filter J0030780

Still waiting. See below. We need to know the dimensions of the supports that will contact the floor.

**From:** Kenneth J. Ligman  
**Sent:** Thursday, February 01, 2024 10:44 AM  
**To:** Nina HALVERSON <n.halverson@kurita-water.com>  
**Cc:** Matthew R. Patterson <mpatterson@becherhoppe.com>; Patrick Ingle <patrick@williamreidltd.com>  
**Subject:** Kronenwetter WTP pressure filter J0030780

Please provide a drawing/description of the support skid for the pressure filter.  
Thanks.

**Ken Ligman**  
Senior Engineer

**Becher-Hoppe Associates, Inc.**  
330 N. 4th Street | Wausau WI | 54403

This email message is for the sole use of the intended recipient(s) and may contain confidential and privileged information. Any unauthorized review, use, disclosure or distribution is prohibited. If you are not the intended recipient, please contact the sender by reply email and destroy all copies of the original message

This e-mail message and all attachments transmitted with it contain confidential and proprietary business information owned by Kurita America Inc. and intended solely for the use of the addressee. The transmission of this e-mail may be legally privileged. If the recipient of this message is not the intended person or entity, you are hereby notified that any reading, dissemination, distribution, copying, or other use of this message, its contents, hyperlinks, and attached files of any kind is strictly prohibited. If you have received this message in error, please notify the sender immediately by a reply to this electronic mail message and delete this message and all copies and backups thereof. All rights to the information contained in this e-mail are reserved by Kurita America Inc.

This e-mail message and all attachments transmitted with it contain confidential and proprietary business information owned by Kurita America Inc. and intended solely for the use of the addressee. The transmission of this e-mail may be legally privileged. If the recipient of this message is not the intended person or entity, you are hereby notified that any reading, dissemination, distribution, copying, or other use of this message, its contents, hyperlinks, and attached files of any kind is strictly prohibited. If you have received this message in error, please notify the sender immediately by a reply to this electronic mail message and delete this message and all copies and backups thereof. All rights to the information contained in this e-mail are reserved by Kurita America Inc.

This e-mail message and all attachments transmitted with it contain confidential and proprietary business information owned by Kurita America Inc. and intended solely for the use of the addressee. The transmission of this e-mail may be legally privileged. If the recipient of this message is not the intended person or entity, you are hereby notified that any reading, dissemination, distribution, copying, or other use of this message, its contents, hyperlinks, and attached files of any kind is strictly prohibited. If you have received this message in error, please notify the sender immediately by a reply to this electronic mail message and delete this message and all copies and backups thereof. All rights to the information contained in this e-mail are reserved by Kurita America Inc.

This e-mail message and all attachments transmitted with it contain confidential and proprietary business information owned by Kurita America Inc. and intended solely for the use of the addressee. The transmission of this e-mail may be legally privileged. If the recipient of this message is not the intended person or entity, you are hereby notified that any reading, dissemination, distribution, copying, or other use of this message, its contents, hyperlinks, and attached files of any kind is strictly prohibited. If you have received this message in error, please notify the sender immediately by a reply to this electronic mail message and delete this message and all copies and backups thereof. All rights to the information contained in this e-mail are reserved by Kurita America Inc.

This e-mail message and all attachments transmitted with it contain confidential and proprietary business information owned by Kurita America Inc. and intended solely for the use of the addressee. The transmission of this e-mail may be legally privileged. If the recipient of this message is not the intended person or entity, you are hereby notified that any reading, dissemination, distribution, copying, or other use of this message, its contents, hyperlinks, and attached files of any kind is strictly prohibited. If you have received this message in error, please notify the sender immediately by a reply to this electronic mail message and delete this message and all copies and backups thereof. All rights to the information contained in this e-mail are reserved by Kurita America Inc.

This e-mail message and all attachments transmitted with it contain confidential and proprietary business information owned by Kurita America Inc. and intended solely for the use of the addressee. The transmission of this e-mail may be legally privileged. If the recipient of this message is not the intended

person or entity, you are hereby notified that any reading, dissemination, distribution, copying, or other use of this message, its contents, hyperlinks, and attached files of any kind is strictly prohibited. If you have received this message in error, please notify the sender immediately by a reply to this electronic mail message and delete this message and all copies and backups thereof. All rights to the information contained in this e-mail are reserved by Kurita America Inc.

[CAUTION: This email originated from outside of the organization. Do not click links or open attachments unless you recognize the sender and know the content is safe]

This e-mail message and all attachments transmitted with it contain confidential and proprietary business information owned by Kurita America Inc. and intended solely for the use of the addressee. The transmission of this e-mail may be legally privileged. If the recipient of this message is not the intended person or entity, you are hereby notified that any reading, dissemination, distribution, copying, or other use of this message, its contents, hyperlinks, and attached files of any kind is strictly prohibited. If you have received this message in error, please notify the sender immediately by a reply to this electronic mail message and delete this message and all copies and backups thereof. All rights to the information contained in this e-mail are reserved by Kurita America Inc.

[CAUTION: This email originated from outside of the organization. Do not click links or open attachments unless you recognize the sender and know the content is safe]

This e-mail message and all attachments transmitted with it contain confidential and proprietary business information owned by Kurita America Inc. and intended solely for the use of the addressee. The transmission of this e-mail may be legally privileged. If the recipient of this message is not the intended person or entity, you are hereby notified that any reading, dissemination, distribution, copying, or other use of this message, its contents, hyperlinks, and attached files of any kind is strictly prohibited. If you have received this message in error, please notify the sender immediately by a reply to this electronic mail message and delete this message and all copies and backups thereof. All rights to the information contained in this e-mail are reserved by Kurita America Inc.

This e-mail message and all attachments transmitted with it contain confidential and proprietary business information owned by Kurita America Inc. and intended solely for the use of the addressee. The transmission of this e-mail may be legally privileged. If the recipient of this message is not the intended person or entity, you are hereby notified that any reading, dissemination, distribution, copying, or other use of this message, its contents, hyperlinks, and attached files of any kind is strictly prohibited. If you have received this message in error, please notify the sender immediately by a reply to this electronic mail message and delete this message and all copies and backups thereof. All rights to the information contained in this e-mail are reserved by Kurita America Inc.



**Brian Marquardt**

---

**From:** Nina HALVERSON <n.halverson@kurita-water.com>  
**Sent:** Tuesday, December 3, 2024 7:35 AM  
**To:** Brian Marquardt  
**Cc:** Emily Nurmi; Brandon Mancilla; Alan SCHNEIDER; Bradley ZACH  
**Subject:** Re: [EXT]RE: Kurita Invoice for Kronenwetter

**Follow Up Flag:** Follow up  
**Flag Status:** Flagged

You don't need that 3 way valve, that was sent incorrectly with your project. Go ahead and set it aside, our tech can pick that up during start up.

Our servers are still down, so I've been unable to get in there since last week to work on anything, but the goal was originally to try and have that in your hands this week, it may push to early next week for the complete OMM.

I can send LOH instructions as soon as the server is up. IT is working through issues to get it online and have it stay up, they're hoping by EOD today we have full functionality and access to our drives.

Thank you,

**Nina Halverson**

*Project Manager*  
Direct 763-957-1946 | Mobile 651-706-0498 | [n.halverson@kurita-water.com](mailto:n.halverson@kurita-water.com)  
Kurita America Inc. | [www.kuritaamerica.com](http://www.kuritaamerica.com)

---

**From:** Brian Marquardt <marquardt@rohdebros.com>  
**Sent:** Tuesday, December 3, 2024 7:28:31 AM  
**To:** Nina HALVERSON <n.halverson@kurita-water.com>  
**Cc:** Emily Nurmi <Emily@williamreidltd.com>; Brandon Mancilla <Brandon@williamreidltd.com>; Alan SCHNEIDER <a.schneider@kurita-water.com>; Bradley ZACH <b.zach@kurita-water.com>  
**Subject:** RE: [EXT]RE: Kurita Invoice for Kronenwetter

Hello Nina,

I have another question. We are wondering where this valve in the picture goes. This is where the full IO&M manual is really needed. How are we doing on getting that to me? We also have to install the loss of head panel and I have no instructions for this either.



**BRIAN MARQUARDT**  
Superintendent  
Rohde Brothers Inc.  
**920-838-1628**  
marquardtb@rohdebros.com

**From:** Nina HALVERSON <n.halverson@kurita-water.com>  
**Sent:** Monday, December 2, 2024 12:45 PM  
**To:** Brian Marquardt <marquardtb@rohdebros.com>  
**Cc:** Emily Nurmi <Emily@williamreidltd.com>; Brandon Mancilla <Brandon@williamreidltd.com>; Alan SCHNEIDER <a.schneider@kurita-water.com>; Bradley ZACH <b.zach@kurita-water.com>  
**Subject:** Re: [EXT]RE: Kurita Invoice for Kronenwetter

Hi Brian,

I am working to verify the date on the greensand, I did request it, but I have not gotten a confirmation for the holiday week. They have not sent that out yet.

But yes, they are from different companies so they will be separate deliveries.

Our servers are currently down so I cannot get into the drives to get letters out to you but as soon as they are up, I can do that for you. I also wanna verify I don't believe you need to test them 150 psi, I believe ASME was 130 but again as soon as I can get into the server files, I will verify that and let you know.

Thank you,

**Nina Halverson**

*Project Manager*  
Direct 763-957-1946 | Mobile 651-706-0498 | [n.halverson@kurita-water.com](mailto:n.halverson@kurita-water.com)  
Kurita America Inc. | [www.kuritaamerica.com](http://www.kuritaamerica.com)

---

**From:** Brian Marquardt <[marquardtb@rohdebros.com](mailto:marquardtb@rohdebros.com)>  
**Sent:** Monday, December 2, 2024 11:32:52 AM  
**To:** Nina HALVERSON <[n.halverson@kurita-water.com](mailto:n.halverson@kurita-water.com)>  
**Cc:** Emily Nurmi <[Emily@williamreidltd.com](mailto:Emily@williamreidltd.com)>; Brandon Mancilla <[Brandon@williamreidltd.com](mailto:Brandon@williamreidltd.com)>; Alan SCHNEIDER <[a.schneider@kurita-water.com](mailto:a.schneider@kurita-water.com)>; Bradley ZACH <[b.zach@kurita-water.com](mailto:b.zach@kurita-water.com)>  
**Subject:** RE: [EXT]RE: Kurita Invoice for Kronenwetter

Hello Nina,

I need a couple things from you. I received a call from the trucking company and they will be delivering the gravels on 12-10. It sounded like he also had a second delivery of media he needed to schedule with me, likely for later in the week. And he also said he is going to be delivering the greensand from New Jersey, but that is not in yet. Have you been able to confirm the greensand will be able to be delivered on 12-16-24? I have All American Water Solutions set up to do the install starting 12-17-24.

The electrician onsite needs a Kurita technician to talk to regarding some wiring questions. Can we get a contact for a startup tech to see if he is able to resolve these issues?

I need a written warranty letter from you regarding the detention tank that was tipped on its side. I plan to perform a 150psi hydrostatic water test on it. If that test is performed and passes will that be satisfactory for Kurita to honor the original warranty of that tank? If that is acceptable to Kurita I need a statement stating that upon successful completion of a 150psi hydrostatic water test Kurita will honor the original manufacturer's warranty of the tipped detention tank. And this statement should be printed on Kurita letterhead and signed. This is short notice, but I would like this warranty letter by tomorrow as the village is holding a meeting tomorrow night where this will be a topic of discussion as well as discussing the delays of entire project. I may need your input on project delays as well so we can be given a contract extension.

Thank you,  
**BRIAN MARQUARDT**  
Superintendent  
Rohde Brothers Inc.  
**920-838-1628**  
[marquardtb@rohdebros.com](mailto:marquardtb@rohdebros.com)

**From:** Nina HALVERSON <[n.halverson@kurita-water.com](mailto:n.halverson@kurita-water.com)>  
**Sent:** Tuesday, November 26, 2024 11:56 AM  
**To:** Brian Marquardt <[marquardtb@rohdebros.com](mailto:marquardtb@rohdebros.com)>  
**Cc:** Emily Nurmi <[Emily@williamreidltd.com](mailto:Emily@williamreidltd.com)>; Brandon Mancilla <[Brandon@williamreidltd.com](mailto:Brandon@williamreidltd.com)>; Alan SCHNEIDER <[a.schneider@kurita-water.com](mailto:a.schneider@kurita-water.com)>; Bradley ZACH <[b.zach@kurita-water.com](mailto:b.zach@kurita-water.com)>  
**Subject:** Re: [EXT]RE: Kurita Invoice for Kronenwetter

Brian, that sounds great.

I will confirm those dates.

**Nina Halverson**

*Project Manager*  
Direct [763-957-1946](tel:763-957-1946) | Mobile [651-706-0498](tel:651-706-0498) | [n.halverson@kurita-water.com](mailto:n.halverson@kurita-water.com)  
Kurita America Inc. | [www.kuritaamerica.com](http://www.kuritaamerica.com)

---

**From:** Brian Marquardt <[marquardtb@rohdebros.com](mailto:marquardtb@rohdebros.com)>  
**Sent:** Tuesday, November 26, 2024 11:20:08 AM  
**To:** Nina HALVERSON <[n.halverson@kurita-water.com](mailto:n.halverson@kurita-water.com)>  
**Cc:** Emily Nurmi <[Emily@williamreidltd.com](mailto:Emily@williamreidltd.com)>; Brandon Mancilla <[Brandon@williamreidltd.com](mailto:Brandon@williamreidltd.com)>; Alan SCHNEIDER <[a.schneider@kurita-water.com](mailto:a.schneider@kurita-water.com)>; Bradley ZACH <[b.zach@kurita-water.com](mailto:b.zach@kurita-water.com)>  
**Subject:** Re: [EXT]RE: Kurita Invoice for Kronenwetter

Hello Nina,

I just spoke to Randy at All American Water Solutions and he is available the week of December 16th to install the media. He would likely start on the 17th or 18th. The gravels are being delivered on December 9th and the greensand is supposed to be December 16th delivery. Can you confirm these dates of delivery. This is really the only date that works for him to install the media and I don't want to miss this window. Then we could have startup on January 6th. And that would make the engineers and the village happier.

Thank you,  
Brian Marquardt  
Superintendent  
Rohde Brothers Inc  
920-838-1628  
[marquardtb@rohdebros.com](mailto:marquardtb@rohdebros.com)

On Nov 21, 2024, at 10:15 AM, Nina HALVERSON <[n.halverson@kurita-water.com](mailto:n.halverson@kurita-water.com)> wrote:

The emailed files have also been added to the folder.

Thank you,

## Nina Halverson

*Project Manager – Municipal*

Direct 763-957-1947 | Mobile 651-706-0498 | [n.halverson@kurita-water.com](mailto:n.halverson@kurita-water.com)

Kurita America Inc. | Tonka Water, a Kurita brand | [www.kuritaamerica.com](http://www.kuritaamerica.com)

<image001.png>

---

**From:** Nina HALVERSON

**Sent:** Tuesday, November 19, 2024 10:07 AM

**To:** 'Emily Nurmi' <[Emily@williamreidltd.com](mailto:Emily@williamreidltd.com)>; 'Brandon Mancilla' <[Brandon@williamreidltd.com](mailto:Brandon@williamreidltd.com)>; 'Brian Marquardt' <[marquardtb@rohdebros.com](mailto:marquardtb@rohdebros.com)>

**Cc:** Alan SCHNEIDER <[a.schneider@kurita-water.com](mailto:a.schneider@kurita-water.com)>; Bradley ZACH <[b.zach@kurita-water.com](mailto:b.zach@kurita-water.com)>

**Subject:** RE: [EXT]RE: Kurita Invoice for Kronenwetter

Emily/ Brian

See attached commissioning checklist, please complete to the best of your ability with dates or expected dates, and send back prior to end of business day on 11/27 to secure your start-up dates.

If we don't have this back there is risk of field service cancelling the reserved time, which is not what we want to have happen.

Thank you,

## Nina Halverson

*Project Manager – Municipal*

Direct 763-957-1947 | Mobile 651-706-0498 | [n.halverson@kurita-water.com](mailto:n.halverson@kurita-water.com)

Kurita America Inc. | Tonka Water, a Kurita brand | [www.kuritaamerica.com](http://www.kuritaamerica.com)

<image001.png>

---

**From:** Nina HALVERSON

**Sent:** Tuesday, November 19, 2024 9:38 AM

**To:** 'Emily Nurmi' <[Emily@williamreidltd.com](mailto:Emily@williamreidltd.com)>; 'Brandon Mancilla' <[Brandon@williamreidltd.com](mailto:Brandon@williamreidltd.com)>; 'Brian Marquardt' <[marquardtb@rohdebros.com](mailto:marquardtb@rohdebros.com)>

**Cc:** Alan SCHNEIDER <[a.schneider@kurita-water.com](mailto:a.schneider@kurita-water.com)>; Bradley ZACH <[b.zach@kurita-water.com](mailto:b.zach@kurita-water.com)>

**Subject:** RE: [EXT]RE: Kurita Invoice for Kronenwetter

Emily –

I've worked with field service and they will be using the 1/6 week for overseeing the media install and disinfecting.

Then we will return the following week 1/13 to complete the start up and training.

Thank you,

## Nina Halverson

*Project Manager – Municipal*

Direct 763-957-1947 | Mobile 651-706-0498 | [n.halverson@kurita-water.com](mailto:n.halverson@kurita-water.com)

<image001.png>

---

**From:** Nina HALVERSON

**Sent:** Tuesday, November 19, 2024 9:14 AM

**To:** Emily Nurmi <[Emily@williamreidltd.com](mailto:Emily@williamreidltd.com)>; Brandon Mancilla <[Brandon@williamreidltd.com](mailto:Brandon@williamreidltd.com)>; Brian Marquardt <[marquardtb@rohdebros.com](mailto:marquardtb@rohdebros.com)>

**Cc:** Alan SCHNEIDER <[a.schneider@kurita-water.com](mailto:a.schneider@kurita-water.com)>

**Subject:** RE: [EXT]RE: Kurita Invoice for Kronenwetter

Emily –

I've been in and out of office sick for the last week so my apologies for delay.

1. We don't have anyone sooner than 1/6 for a visit at this time, we can make that the media install visit. I will work with field service to schedule start up for as soon as possible after that week. I never received response from anyone on whether your team was working the holiday weeks, so I was not able to reserve any of that time.
2. Media Gravels will be delivered on 11/22– the greensand is delayed with the previous port closures will be delivered on 12/16. I've requested updates to ensure these are still the correct dates. The carrier will call ahead of delivery as well.
3. This is on my list for today – steps are still as outlined below.
4. I will upload to the folder below
5. Control panels are complete and shipping today, they should be onsite tomorrow, 11/20.

Thank you,

## Nina Halverson

*Project Manager – Municipal*

Direct 763-957-1947 | Mobile 651-706-0498 | [n.halverson@kurita-water.com](mailto:n.halverson@kurita-water.com)

Kurita America Inc. | Tonka Water, a Kurita brand | [www.kuritaamerica.com](http://www.kuritaamerica.com)

<image001.png>

---

**From:** Emily Nurmi <[Emily@williamreidltd.com](mailto:Emily@williamreidltd.com)>

**Sent:** Tuesday, November 19, 2024 8:16 AM

**To:** Nina HALVERSON <[n.halverson@kurita-water.com](mailto:n.halverson@kurita-water.com)>; Brandon Mancilla <[Brandon@williamreidltd.com](mailto:Brandon@williamreidltd.com)>; Brian Marquardt <[marquardtb@rohdebros.com](mailto:marquardtb@rohdebros.com)>

**Cc:** Alan SCHNEIDER <[a.schneider@kurita-water.com](mailto:a.schneider@kurita-water.com)>

**Subject:** Re: [EXT]RE: Kurita Invoice for Kronenwetter

**Importance:** High

Nina,

Good morning. I tried calling you yesterday and this morning with no luck. We need a response today on the email I sent back to you on 11/12. Everything that needs to be addressed is highlighted in yellow. Even if you have partial answers, please send those our way. We need some kind of communication. We missed our window to get an extension on this project due to not getting these answers. There was a city hall meeting last friday and

Brian had nothing to give them to argue for the extension. Conversations have begun regarding liquidated damages. Just a heads up so you aren't caught by surprised.

I do apologize for having to be so direct. I'm just trying to make the situation very clear.

ORIGINAL EMAIL-----

1. What is the intent of the visit scheduled for January 6th? Is it to perform start-up? Or is for the media filling? Brian would like a Tonka representative to be on site for the media fill as called out in the scope of supply.

1. We can plan for to oversee the media install during the trip on 1/6 if you will be ready for that. I don't know if we have time in December available still for a tech to be there for a day or so to oversee, if we do it will likely be the short holiday weeks of Christmas and New Years. That would be enough time to oversee the media install and then would allow time for your team to complete the soak/disinfection and any Bac-T testing that is needed before start up, which would then allow them to complete start up the week of 1/6. Let me know if your team is working those weeks and I will see if we have time on the schedule for either of them.

1. WR RESPONSE 11/12: Please move forward with trying to schedule a tech to oversee the media install. Once you have an update on this front, please let us know as soon as possible

2. Please release the media as soon as you have confirmed the quantity. Please provide us with an email once released. Brian needs to know when the lead time clock starts ticking.

1. Media was released a bit ago, is there a date you'd like it delivered? Initially I told them mid-November, as I can always have them hold it easier than I can have them bump it up. I will check on this and verify we're still set to go.

1. The media can be received at any time. Rohde Brothers would prefer that it is delivered somewhat close to the time the media installation technician is on site.

3. When you get a moment, can you please walk Brian through how the remainder of this project will go? (how many visits, when to expect documents, start-up checklists, readiness calls, etc). I think this would be very beneficial for everyone involved.

i. Yes, I will call Brian and walk through with him, but essentially next steps are getting media to site and installed when you're ready, at that point we would have you walk through the start up checklist and verify all components are installed, everything is wired and plumbed and that all disinfection processes and tests are completed. Once that is complete then we can complete start up. We would have 2 visits based on current information, 1 to oversee the media installation which would be 2 days, then we'd have a return visit to complete the start up, if we can do media install during one of the holiday weeks in December, start up can be the week of 1/6. This

would be generally 3-4days on site and include the NES walking through all items, processes and complete training with operators onsite.

1. Brian has yet to receive a call from you.

4.

5. I know that the O&M is a little bit way out, but can you please provide information that would be helpful while the filters are being installed? For example, what is expected to be done before the media can be loaded? Does the tank need to be chlorinated before and after media installation? You indicated on 10/31 that you had field assembly documents and instructions. Have you had a chance to send those files over?

1. Yes, I will send those again for you, they're a larger PDF and I'm finding they get stuck in space sometimes. They outline the field assembly portions, the media install procedures and the complete disinfection process for you step by step. I will also include the commissioning checklist for review as you work through install.

i. To help aid in the delivery of these files, please place them in the linked folder below. Everyone on this email chain has access to this folder and can edit the contents. Brian can download them from here.

ii.  [Important Files](#)

5. Do you have an update on the status of the control panel? We are starting to risk the electrian not having enough time to insall and wire this.

Emily Nurmi (she, hers, her)

Project Manager

<image002.png>

PO Box 397

Germantown, WI 53022

O: 262-255-5420 C: 608-733-1403

[Emily@williamreidltd.com](mailto:Emily@williamreidltd.com)

---

**From:** Emily Nurmi <[Emily@williamreidltd.com](mailto:Emily@williamreidltd.com)>

**Sent:** Tuesday, November 12, 2024 1:59 PM

**To:** Nina HALVERSON <[n.halverson@kurita-water.com](mailto:n.halverson@kurita-water.com)>; Brandon Mancilla <[Brandon@williamreidltd.com](mailto:Brandon@williamreidltd.com)>; Brian Marquardt <[marquardtb@rohdebros.com](mailto:marquardtb@rohdebros.com)>



Cc: Alan SCHNEIDER <a.schneider@kurita-water.com>  
Subject: Re: [EXT]RE: Kurita Invoice for Kronenwetter

Nina,

Thank you for the response on our questions below. They were very helpful. Please see William/Reid's responses below and our additional concerns:

1. What is the intent of the visit scheduled for January 6th? Is it to perform start-up? Or is for the media filling? Brian would like a Tonka representative to be on site for the media fill as called out in the scope of supply.

1. We can plan for to oversee the media install during the trip on 1/6 if you will be ready for that. I don't know if we have time in December available still for a tech to be there for a day or so to oversee, if we do it will likely be the short holiday weeks of Christmas and New Years. That would be enough time to oversee the media install and then would allow time for your team to complete the soak/disinfection and any Bac-T testing that is needed before start up, which would then allow them to complete start up the week of 1/6. Let me know if your team is working those weeks and I will see if we have time on the schedule for either of them.

1. **WR RESPONSE 11/12: Please move forward with trying to schedule a tech to oversee the media install. Once you have an update on this front, please let us know as soon as possible**

2. Please release the media as soon as you have confirmed the quantity. Please provide us with an email once released. Brian needs to know when the lead time clock starts ticking.

1. Media was released a bit ago, is there a date you'd like it delivered? Initially I told them mid-November, as I can always have them hold it easier than I can have them bump it up. I will check on this and verify we're still set to go.

1. **The media can be received at any time. Rohde Brothers would prefer that it is delivered somewhat close to the time the media installation technician is on site.**

3. When you get a moment, can you please walk Brian through how the remainder of this project will go? (how many visits, when to expect documents, start-up checklists, readiness calls, etc). I think this would be very beneficial for everyone involved.

i. Yes, I will call Brian and walk through with him, but essentially next steps are getting media to site and installed when you're ready, at that point we would have you walk through the start up checklist and verify all components are installed, everything is wired and plumbed and that all disinfection processes and tests are completed. Once that is complete then we can complete start up. We would have 2 visits based on current information, 1 to oversee the media installation which would be 2 days, then we'd have a return visit to complete the start up, if we can do media install during one of the holiday weeks in December, start up can be the week of 1/6. This

would be generally 3-4days on site and include the NES walking through all items, processes and complete training with operators onsite.

1. Brian has yet to receive a call from you.

4.

5. I know that the O&M is a little bit way out, but can you please provide information that would be helpful while the filters are being installed? For example, what is expected to be done before the media can be loaded? Does the tank need to be chlorinated before and after media installation? You indicated on 10/31 that you had field assembly documents and instructions. Have you had a chance to send those files over?

1. Yes, I will send those again for you, they're a larger PDF and I'm finding they get stuck in space sometimes. They outline the field assembly portions, the media install procedures and the complete disinfection process for you step by step. I will also include the commissioning checklist for review as you work through install.

i. To help aid in the delivery of these files, please place them in the linked folder below. Everyone on this email chain has access to this folder and can edit the contents. Brian can download them from here.

ii.  [Important Files](#)

5. Do you have an update on the status of the control panel? We are starting to risk the electrian not having enough time to insall and wire this.

Emily Nurmi (she, hers, her)

*Project Manager*

<image002.png>

PO Box 397

Germantown, WI 53022

O: 262-255-5420 C: 608-733-1403

[Emily@williamreidltd.com](mailto:Emily@williamreidltd.com)

---

**From:** Nina HALVERSON <[n.halverson@kurita-water.com](mailto:n.halverson@kurita-water.com)>  
**Sent:** Monday, November 11, 2024 9:08 AM  
**To:** Brandon Mancilla <[Brandon@williamreidltd.com](mailto:Brandon@williamreidltd.com)>; Emily Nurmi <[Emily@williamreidltd.com](mailto:Emily@williamreidltd.com)>; Brian Marquardt <[marguardtb@rohdebros.com](mailto:marguardtb@rohdebros.com)>  
**Cc:** Alan SCHNEIDER <[a.schneider@kurita-water.com](mailto:a.schneider@kurita-water.com)>  
**Subject:** RE: [EXT]RE: Kurita Invoice for Kronenwetter

1. What is the intent of the visit scheduled for January 6th? Is it to perform start-up? Or is for the media filling? Brian would like a Tonka representative to be on site for the media fill as called out in the scope of supply.

1. We can plan for to oversee the media install during the trip on 1/6 if you will be ready for that. I don't know if we have time in December available still for a tech to be there for a day or so to oversee, if we do it will likely be the short holiday weeks of Christmas and New Years. That would be enough time to oversee the media install and then would allow time for your team to complete the soak/disinfection and any Bac-T testing that is needed before start up, which would then allow them to complete start up the week of 1/6. Let me know if your team is working those weeks and I will see if we have time on the schedule for either of them.

2. Please release the media as soon as you have confirmed the quantity. Please provide us with an email once released. Brian needs to know when the lead time clock starts ticking.

1. Media was released a bit ago, is there a date you'd like it delivered? Initially I told them mid-November, as I can always have them hold it easier than I can have them bump it up. I will check on this and verify we're still set to go.

3. When you get a moment, can you please walk Brian through how the remainder of this project will go? (how many visits, when to expect documents, start-up checklists, readiness calls, etc). I think this would be very beneficial for everyone involved.

1. Yes, I will call Brian and walk through with him, but essentially next steps are getting media to site and installed when you're ready, at that point we would have you walk through the start up checklist and verify all components are installed, everything is wired and plumbed and that all disinfection processes and tests are completed. Once that is complete then we can complete start up. We would have 2 visits based on current information, 1 to oversee the media installation which would be 2 days, then we'd have a return visit to complete the start up, if we can do media install during one of the holiday weeks in December, start up can be the week of 1/6. This would be generally 3-4days on site and include the NES walking through all items, processes and complete training with operators onsite.

4. I know that the O&M is a little bit way out, but can you please provide information that would be helpful while the filters are being installed? For example, what is expected to be done before the media can be loaded? Does the tank need to be chlorinated before and after media installation? You indicated on 10/31 that you had field assembly documents and instructions. Have you had a chance to send those files over?

1. Yes, I will send those again for you, they're a larger PDF and I'm finding they get stuck in space sometimes. They outline the field assembly portions, the media install procedures and the complete disinfection process for you step

by step. I will also include the commissioning checklist for review as you work through install.

## Nina Halverson

*Project Manager – Municipal*

Direct 763-957-1947 | Mobile 651-706-0498 | [n.halverson@kurita-water.com](mailto:n.halverson@kurita-water.com)

Kurita America Inc. | Tonka Water, a Kurita brand | [www.kuritaamerica.com](http://www.kuritaamerica.com)

<image001.png>

---

**From:** Brandon Mancilla <[Brandon@williamreidltd.com](mailto:Brandon@williamreidltd.com)>  
**Sent:** Monday, November 11, 2024 7:45 AM  
**To:** Emily Nurmi <[Emily@williamreidltd.com](mailto:Emily@williamreidltd.com)>; Brian Marquardt <[marquardtb@rohdebros.com](mailto:marquardtb@rohdebros.com)>; Nina HALVERSON <[n.halverson@kurita-water.com](mailto:n.halverson@kurita-water.com)>  
**Cc:** Alan SCHNEIDER <[a.schneider@kurita-water.com](mailto:a.schneider@kurita-water.com)>  
**Subject:** RE: [EXT]RE: Kurita Invoice for Kronenwetter

Good morning Nina,

I just left a voicemail for you regarding this email chain.

Will you have an opportunity to get back to us on this matter today?

Thanks!

Brandon Mancilla  
*Lead Sales Engineer*  
 <image003.png>  
 PO Box 397  
 Germantown, WI 53022  
 Ph: 414-331-5576  
[brandon@williamreidltd.com](mailto:brandon@williamreidltd.com)

Check out our new website!  
williamreidltd.com

---

**From:** Emily Nurmi <[Emily@williamreidltd.com](mailto:Emily@williamreidltd.com)>  
**Sent:** Thursday, November 7, 2024 1:53 PM  
**To:** Brian Marquardt <[marquardtb@rohdebros.com](mailto:marquardtb@rohdebros.com)>; 'Nina HALVERSON' <[n.halverson@kurita-water.com](mailto:n.halverson@kurita-water.com)>; Brandon Mancilla <[Brandon@williamreidltd.com](mailto:Brandon@williamreidltd.com)>  
**Cc:** Alan SCHNEIDER <[a.schneider@kurita-water.com](mailto:a.schneider@kurita-water.com)>  
**Subject:** Re: [EXT]RE: Kurita Invoice for Kronenwetter

Nina,

Good afternoon. I wanted to follow up on Brian's email from Wednesday morning. There are a few key things that we need movement on as soon as possible.

1. What is the intent of the visit scheduled for January 6th? Is it to perform start-up? Or is for the media filling? Brian would like a Tonka representative to be on site for the media fill as called out in the scope of supply.
2. Please release the media as soon as you have confirmed the quantity. Please provide us with an email once released. Brian needs to know when the lead time clock starts ticking
3. When you get a moment, can you please walk Brian through how the remainder of this project will go? (how many visits, when to expect documents, start-up checklists, readiness calls, etc). I think this would be very beneficial for everyone involved.
4. I know that the O&M is a little bit way out, but can you please provide information that would be helpful while the filters are being installed? For example, what is expected to be done before the media can be loaded? Does the tank need to be chlorinated before and after media installation? You indicated on 10/31 that you had field assembly documents and instructions. Have you had a chance to send those files over?

Thank you!!!

Emily Nurmi (she, hers, her)

*Project Manager*

<image002.png>

PO Box 397

Germantown, WI 53022

O: 262-255-5420 C: 608-733-1403

[Emily@williamreidltd.com](mailto:Emily@williamreidltd.com)

---

**From:** Brian Marquardt <[marquardt@rohdebros.com](mailto:marquardt@rohdebros.com)>  
**Sent:** Wednesday, November 6, 2024 7:25 AM  
**To:** 'Nina HALVERSON' <[n.halverson@kurita-water.com](mailto:n.halverson@kurita-water.com)>; Brandon Mancilla <[Brandon@williamreidltd.com](mailto:Brandon@williamreidltd.com)>  
**Cc:** Alan SCHNEIDER <[a.schneider@kurita-water.com](mailto:a.schneider@kurita-water.com)>; Emily Nurmi <[Emily@williamreidltd.com](mailto:Emily@williamreidltd.com)>  
**Subject:** RE: [EXT]RE: Kurita Invoice for Kronenwetter

Hello Nina,

Nina,

Thank you for replying. I'm going to need good support from you to get this project done and ready for January 6<sup>th</sup> startup. The startup cannot slip with all of the delays we have already had in receiving. In response to your emails,

- I don't care if we don't know for sure who the actual startup technician is. I want somebody to talk to that is familiar with these systems so if I have questions during install I have someone. I also want to ask them if there are any common problems on startup day that we can avoid. And most importantly please make sure they are competent. I've been through some recent startups on expensive and technical equipment that went terrible because of incompetence. I recently had to wait for an expert from Australia that was useless. That is blunt but I want to get my point across.
- If there is a checklist for prior to startup, please get that to me.
- We need to schedule the media delivery now if they are 3-4 weeks out. Please verify quantities and lets get this set up. I can make the next available date work.
- I keep bringing up the installation and operation manual, but we are installing it now and should have this already. Is this a few days out? Or longer?
- Give me a date for the panel delivery as soon as you can. I will make sure we are there to receive. I'm getting the most heat from the GC, electrician, and engineer on this panel.
- For the dropped tank. We will take pictures. There is no apparent physical damage that can be seen. The engineer is not going to be happy with just a visual inspection. My plan is to do a hydrostatic pressure test to 150psi, have it witnessed by a third party and have the third party sign an inspection and test form. I will then pass the form on to you to sign stating you acknowledge the third party test and the warranty is not affected. Does that sound reasonable?

Thank you,  
**BRIAN MARQUARDT**  
 Superintendent  
 Rohde Brothers Inc.  
**920-838-1628**  
[marquardt@rohdebros.com](mailto:marquardt@rohdebros.com)

---

**From:** Nina HALVERSON <[n.halverson@kurita-water.com](mailto:n.halverson@kurita-water.com)>  
**Sent:** Tuesday, November 5, 2024 3:11 PM  
**To:** Brandon Mancilla <[Brandon@williamreidltd.com](mailto:Brandon@williamreidltd.com)>  
**Cc:** Alan SCHNEIDER <[a.schneider@kurita-water.com](mailto:a.schneider@kurita-water.com)>; Emily Nurmi <[Emily@williamreidltd.com](mailto:Emily@williamreidltd.com)>; Brian Marquardt <[marquardt@rohdebros.com](mailto:marquardt@rohdebros.com)>  
**Subject:** RE: [EXT]RE: Kurita Invoice for Kronenwetter

I don't know which tech is assigned for your visit in January yet, so I don't have a contact to share, but will do so as we near that date and it's assigned to someone.

I will follow up with media and disinfection information in another email, I'm working to verify the quantities before sending – we don't usually send this until media has been ordered and amounts are verified as it can shift the amounts needed to charge and disinfect. Do you have a date you'd like the media delivered? We usually need 3-4wks lead time on this to ensure timely delivery.

Thank you,

**Nina Halverson**

*Project Manager – Municipal*

Direct 763-957-1947 | Mobile 651-706-0498 | [n.halverson@kurita-water.com](mailto:n.halverson@kurita-water.com)  
Kurita America Inc. | Tonka Water, a Kurita brand | [www.kuritaamerica.com](http://www.kuritaamerica.com)

<image001.png>

---

**From:** Nina HALVERSON

**Sent:** Tuesday, November 5, 2024 3:08 PM

**To:** Brandon Mancilla <[Brandon@williamreidltd.com](mailto:Brandon@williamreidltd.com)>

**Cc:** Alan SCHNEIDER <[a.schneider@kurita-water.com](mailto:a.schneider@kurita-water.com)>; Emily Nurmi <[Emily@williamreidltd.com](mailto:Emily@williamreidltd.com)>; Brian Marquardt <[marquardtb@rohdebros.com](mailto:marquardtb@rohdebros.com)>

**Subject:** RE: [EXT]RE: Kurita Invoice for Kronenwetter

I had a few discussions with fabrication about the vessel that was dropped today, if there is no visual damage, no cracking, all seams and welds are intact and not disturbed they don't see any need to come back out and reinspect or certify the vessel again.

I'd advise to get some more photos of the seams, verify nothing internally is moving around or shifted and should be fine.

The photos are of your blower housing/surround enclosure.

The control panel hasn't shipped yet, I've requested an update on that from the programmer, there were a few things that needed some rework during checkout, but those should be resolved this week so it can be shipped.

## Nina Halverson

*Project Manager – Municipal*

Direct 763-957-1947 | Mobile 651-706-0498 | [n.halverson@kurita-water.com](mailto:n.halverson@kurita-water.com)  
Kurita America Inc. | Tonka Water, a Kurita brand | [www.kuritaamerica.com](http://www.kuritaamerica.com)

<image001.png>

---

**From:** Brandon Mancilla <[Brandon@williamreidltd.com](mailto:Brandon@williamreidltd.com)>

**Sent:** Tuesday, November 5, 2024 2:57 PM

**To:** Nina HALVERSON <[n.halverson@kurita-water.com](mailto:n.halverson@kurita-water.com)>

**Cc:** Alan SCHNEIDER <[a.schneider@kurita-water.com](mailto:a.schneider@kurita-water.com)>; Emily Nurmi <[Emily@williamreidltd.com](mailto:Emily@williamreidltd.com)>; Brian Marquardt <[marquardtb@rohdebros.com](mailto:marquardtb@rohdebros.com)>

**Subject:** RE: [EXT]RE: Kurita Invoice for Kronenwetter

Good afternoon Nina,

I just left you a message regarding this matter.

Brian really needs these answers to these questions quickly. If there is some answer you know immediately, please share that information with us.

Thanks,

Brandon Mancilla

Lead Sales Engineer

<image003.png>

PO Box 397

Germantown, WI 53022  
Ph: 414-331-5576  
[brandon@williamreidltd.com](mailto:brandon@williamreidltd.com)

Check out our new website!  
[williamreidltd.com](http://williamreidltd.com)

---

**From:** Emily Nurmi <[Emily@williamreidltd.com](mailto:Emily@williamreidltd.com)>  
**Sent:** Monday, November 4, 2024 9:56 AM  
**To:** Nina HALVERSON <[n.halverson@kurita-water.com](mailto:n.halverson@kurita-water.com)>; Brian Marquardt <[marquardt@rohdebros.com](mailto:marquardt@rohdebros.com)>; Brandon Mancilla <[Brandon@williamreidltd.com](mailto:Brandon@williamreidltd.com)>  
**Cc:** Alan SCHNEIDER <[a.schneider@kurita-water.com](mailto:a.schneider@kurita-water.com)>  
**Subject:** Re: [EXT]RE: Kurita Invoice for Kronenwetter

Nina,

Good morning. I wanted to follow this morning that in addition to the answer about the tipped tank, we do still need answers for the email Brian sent on Thursday. Just want to make sure his requests don't get lost in the email chain. Please give us an update on the highlighted items.

1. The deliveries were received on Monday the 28<sup>th</sup>. Everything appears good so far. There are still boxes we have not opened. The four small vessels appear to have been stored outside as they are quite dirty and the paint appears quite faded compared to the large vessel. We will be taking pictures. I do not know if this is an issue yet, but wanted to mention it.
2. We did not receive the control panel. When will this arrive?
  - a. Attached are three pictures of another electrical box. Can you tell me what it is for?
3. I need the IO&M manual as soon as possible.
  - a. If that does not contain instructions on filling the media, send those separately. I want to review those instructions and set up the delivery in the next couple of weeks.
4. I want a phone number of a startup technician to talk to discuss the startup process to be sure we are ready for January 6<sup>th</sup>.
5. Are there any special instructions on chlorinating this filter system?
6. What needs to be done to confirm the tipped tank is still intact and warrantied?

Thank you!!

Emily Nurmi (she, hers, her)

*Project Manager*

<image002.png>

PO Box 397

Germantown, WI 53022



O: 262-255-5420 C: 608-733-1403

[Emily@williamreidltd.com](mailto:Emily@williamreidltd.com)

---

**From:** Nina HALVERSON <[n.halverson@kurita-water.com](mailto:n.halverson@kurita-water.com)>  
**Sent:** Friday, November 1, 2024 3:12 PM  
**To:** Brian Marquardt <[marquardtb@rohdebros.com](mailto:marquardtb@rohdebros.com)>; Emily Nurmi <[Emily@williamreidltd.com](mailto:Emily@williamreidltd.com)>;  
 Brandon Mancilla <[Brandon@williamreidltd.com](mailto:Brandon@williamreidltd.com)>  
**Cc:** Alan SCHNEIDER <[a.schneider@kurita-water.com](mailto:a.schneider@kurita-water.com)>  
**Subject:** RE: [EXT]RE: Kurita Invoice for Kronenwetter

Oh no! I hope your foreman is okay though!

I'm working on this and will have an answer for you on Monday!

Thank you,

## Nina Halverson

*Project Manager – Municipal*

Direct 763-957-1947 | Mobile 651-706-0498 | [n.halverson@kurita-water.com](mailto:n.halverson@kurita-water.com)

Kurita America Inc. | Tonka Water, a Kurita brand | [www.kuritaamerica.com](http://www.kuritaamerica.com)

<image001.png>

---

**From:** Brian Marquardt <[marquardtb@rohdebros.com](mailto:marquardtb@rohdebros.com)>  
**Sent:** Thursday, October 31, 2024 12:07 PM  
**To:** Nina HALVERSON <[n.halverson@kurita-water.com](mailto:n.halverson@kurita-water.com)>; 'Emily Nurmi' <[Emily@williamreidltd.com](mailto:Emily@williamreidltd.com)>;  
 'Brandon Mancilla' <[Brandon@williamreidltd.com](mailto:Brandon@williamreidltd.com)>  
**Cc:** Alan SCHNEIDER <[a.schneider@kurita-water.com](mailto:a.schneider@kurita-water.com)>  
**Subject:** RE: [EXT]RE: Kurita Invoice for Kronenwetter

Nina,

I forgot another important question. Our foremen had an accident while trying to lay down one of the small vessels. The four tanks were stood upright outside with the crane but were too tall to move in the building this way so he had to lay them back down. He was using a forklift for this and while tipping one of them down the weight of the tank pushed on the forklift sideways because he was not straight on with the tank. The forklift tipped on its side the tank tipped onto its side also. The engineer was notified of this and is looking for recommendations from Kurita if any testing needs to be done to be sure nothing was damaged and so the warranty is not affected. It did fall freely from about a 60 degree angle. It fell onto a sandy grassy area. We can perform a pressure test and have it witnessed by a third party inspector. If you can send instructions of what Kurita would like done to satisfy that there is no damage. I need to forward that to the engineer. Thank you.

**BRIAN MARQUARDT**

Superintendent

Rohde Brothers Inc.

**920-838-1628**

[marquardtb@rohdebros.com](mailto:marquardtb@rohdebros.com)

**From:** Nina HALVERSON <n.halverson@kurita-water.com>  
**Sent:** Thursday, October 31, 2024 11:49 AM  
**To:** Brian Marquardt <marquardt@rohdebros.com>; 'Emily Nurmi' <Emily@williamreidltd.com>; 'Brandon Mancilla' <Brandon@williamreidltd.com>  
**Cc:** Alan SCHNEIDER <a.schneider@kurita-water.com>  
**Subject:** RE: [EXT]RE: Kurita Invoice for Kronenwetter

Brian –

Good morning – the smaller vessels were stored inside, but were there and complete for quite some time, also – not finished coated as that is not our scope, but all should be primed and ready for final clean up and finish coat of paint.

Please still send photos.

I will verify the status of the electrical panel and have that sent if not already on route.

I will send field assembly and instructions and am still finalizing the OMM, but will also get that to you.

Thank you,

## Nina Halverson

*Project Manager – Municipal*

Direct 763-957-1947 | Mobile 651-706-0498 | n.halverson@kurita-water.com

Kurita America Inc. | Tonka Water, a Kurita brand | www.kuritaamerica.com

<image001.png>

---

**From:** Brian Marquardt <marquardt@rohdebros.com>  
**Sent:** Thursday, October 31, 2024 11:25 AM  
**To:** Nina HALVERSON <n.halverson@kurita-water.com>; 'Emily Nurmi' <Emily@williamreidltd.com>; 'Brandon Mancilla' <Brandon@williamreidltd.com>  
**Cc:** Alan SCHNEIDER <a.schneider@kurita-water.com>  
**Subject:** RE: [EXT]RE: Kurita Invoice for Kronenwetter

Hello Nina,

The deliveries were received on Monday the 28<sup>th</sup>. Everything appears good so far. There are still boxes we have not opened. The four small vessels appear to have been stored outside as they are quite dirty and the paint appears quite faded compared to the large vessel. We will be taking pictures. I do not know if this is an issue yet, but wanted to mention it.

We did not receive the control panel. When will this arrive? Attached is three pictures of another electrical box that maybe you can tell me what it is for.

I need the IO&M manual as soon as possible. If that does not contain instructions on filling the media, send those separately. I want to review those instructions and set up the delivery in the next couple of weeks. I want a phone number of a startup technician to talk to to discuss the startup process to be sure we are ready for January 6<sup>th</sup>.

Are there any special instructions on chlorinating this filter system?

Please reply as soon as possible even if you may not have all the answers or things I am looking for. At least to know you are working on it. The installation manual is going to be the most important.

**BRIAN MARQUARDT**  
Superintendent  
Rohde Brothers Inc.  
**920-838-1628**  
[marquardt@rohdebros.com](mailto:marquardt@rohdebros.com)

---

**From:** Nina HALVERSON <[n.halverson@kurita-water.com](mailto:n.halverson@kurita-water.com)>  
**Sent:** Monday, October 28, 2024 9:48 AM  
**To:** Brian Marquardt <[marquardt@rohdebros.com](mailto:marquardt@rohdebros.com)>; 'Emily Nurmi' <[Emily@williamreidltd.com](mailto:Emily@williamreidltd.com)>; 'Brandon Mancilla' <[Brandon@williamreidltd.com](mailto:Brandon@williamreidltd.com)>  
**Cc:** Alan SCHNEIDER <[a.schneider@kurita-water.com](mailto:a.schneider@kurita-water.com)>  
**Subject:** RE: [EXT]RE: Kurita Invoice for Kronenwetter

Oh good, thank you for the update, we were trying to track that down for eta, so I'm thankful it arrived while trying to sort it out.

Thank you,

**Nina Halverson**  
*Project Manager – Municipal*  
Direct 763-957-1947 | Mobile 651-706-0498 | [n.halverson@kurita-water.com](mailto:n.halverson@kurita-water.com)  
Kurita America Inc. | Tonka Water, a Kurita brand | [www.kuritaamerica.com](http://www.kuritaamerica.com)

<image001.png>

---

**From:** Brian Marquardt <[marquardt@rohdebros.com](mailto:marquardt@rohdebros.com)>  
**Sent:** Monday, October 28, 2024 9:35 AM  
**To:** Nina HALVERSON <[n.halverson@kurita-water.com](mailto:n.halverson@kurita-water.com)>; 'Emily Nurmi' <[Emily@williamreidltd.com](mailto:Emily@williamreidltd.com)>; 'Brandon Mancilla' <[Brandon@williamreidltd.com](mailto:Brandon@williamreidltd.com)>  
**Cc:** Alan SCHNEIDER <[a.schneider@kurita-water.com](mailto:a.schneider@kurita-water.com)>  
**Subject:** RE: [EXT]RE: Kurita Invoice for Kronenwetter

My foremen informed me that the main large vessel is also onsite now.

**BRIAN MARQUARDT**  
Superintendent  
Rohde Brothers Inc.  
**920-838-1628**  
[marquardt@rohdebros.com](mailto:marquardt@rohdebros.com)

---

**From:** Brian Marquardt  
**Sent:** Monday, October 28, 2024 7:24 AM  
**To:** 'Nina HALVERSON' <[n.halverson@kurita-water.com](mailto:n.halverson@kurita-water.com)>; 'Emily Nurmi' <[Emily@williamreidltd.com](mailto:Emily@williamreidltd.com)>; 'Brandon Mancilla' <[Brandon@williamreidltd.com](mailto:Brandon@williamreidltd.com)>  
**Cc:** 'Alan SCHNEIDER' <[a.schneider@kurita-water.com](mailto:a.schneider@kurita-water.com)>  
**Subject:** RE: [EXT]RE: Kurita Invoice for Kronenwetter

Hello all,

I have not received a call from the trucking company yet with the main filter vessel. Can someone please confirm they are on schedule for today and an ETA. On a delivery this size and with special unloading requirements I always receive a call from the trucking company to be sure we can offload. No call is making me nervous. I did receive a call from the driver with the four smaller vessels on Friday. He should be there at 8am. I will reply if they happen to arrive.

**BRIAN MARQUARDT**  
Superintendent  
Rohde Brothers Inc.  
**920-838-1628**  
[marquardtb@rohdebros.com](mailto:marquardtb@rohdebros.com)

---

**From:** Brian Marquardt  
**Sent:** Tuesday, October 22, 2024 2:51 PM  
**To:** 'Nina HALVERSON' <[n.halverson@kurita-water.com](mailto:n.halverson@kurita-water.com)>; 'Emily Nurmi' <[Emily@williamreidltd.com](mailto:Emily@williamreidltd.com)>; Brandon Mancilla <[Brandon@williamreidltd.com](mailto:Brandon@williamreidltd.com)>  
**Cc:** Alan SCHNEIDER <[a.schneider@kurita-water.com](mailto:a.schneider@kurita-water.com)>  
**Subject:** RE: [EXT]RE: Kurita Invoice for Kronenwetter

Yes Nina, please put us down for January 6<sup>th</sup>.

And please follow up with the O&M manual and the media filling instructions. The specs call for a factory representative to be onsite during the filling process. Is this something you typically do or not? How much notification do you need for the media delivery?

**BRIAN MARQUARDT**  
Superintendent  
Rohde Brothers Inc.  
**920-838-1628**  
[marquardtb@rohdebros.com](mailto:marquardtb@rohdebros.com)

---

**From:** Nina HALVERSON <[n.halverson@kurita-water.com](mailto:n.halverson@kurita-water.com)>  
**Sent:** Tuesday, October 22, 2024 2:39 PM  
**To:** Brian Marquardt <[marquardtb@rohdebros.com](mailto:marquardtb@rohdebros.com)>; 'Emily Nurmi' <[Emily@williamreidltd.com](mailto:Emily@williamreidltd.com)>; Brandon Mancilla <[Brandon@williamreidltd.com](mailto:Brandon@williamreidltd.com)>  
**Cc:** Alan SCHNEIDER <[a.schneider@kurita-water.com](mailto:a.schneider@kurita-water.com)>  
**Subject:** RE: [EXT]RE: Kurita Invoice for Kronenwetter

Brian –

Right now, with holidays and a full NES calendar the soonest we have open is the **week of Jan 6<sup>th</sup>, 2025**. I will have them put you on the calendar for that week and if we have anything open up sooner we can move you as able. If we get to December and you don't think we'll hit that let me know as soon as possible so I can try and get you in there for the next open week.

Thank you,

**Nina Halverson**

*Project Manager – Municipal*

Direct 763-957-1947 | Mobile 651-706-0498 | [n.halverson@kurita-water.com](mailto:n.halverson@kurita-water.com)  
Kurita America Inc. | Tonka Water, a Kurita brand | [www.kuritaamerica.com](http://www.kuritaamerica.com)

<image001.png>

---

**From:** Brian Marquardt <[marquardtb@rohdebros.com](mailto:marquardtb@rohdebros.com)>  
**Sent:** Tuesday, October 22, 2024 2:34 PM  
**To:** 'Emily Nurmi' <[Emily@williamreidltd.com](mailto:Emily@williamreidltd.com)>; Nina HALVERSON <[n.halverson@kurita-water.com](mailto:n.halverson@kurita-water.com)>;  
Brandon Mancilla <[Brandon@williamreidltd.com](mailto:Brandon@williamreidltd.com)>  
**Cc:** Alan SCHNEIDER <[a.schneider@kurita-water.com](mailto:a.schneider@kurita-water.com)>  
**Subject:** RE: [EXT]RE: Kurita Invoice for Kronenwetter

Hello all,

I would like to get startup scheduled ASAP. What dates are available for startup? The earliest date I would be ready is December 16<sup>th</sup>. The general contractor is looking to finalize a schedule extension and I will need this scheduled to give my input.

I am also looking for detailed instructions on filling the filter vessel with media.

**BRIAN MARQUARDT**  
Superintendent  
Rohde Brothers Inc.  
**920-838-1628**  
[marquardtb@rohdebros.com](mailto:marquardtb@rohdebros.com)

---

**From:** Emily Nurmi <[Emily@williamreidltd.com](mailto:Emily@williamreidltd.com)>  
**Sent:** Friday, October 18, 2024 12:06 PM  
**To:** Brian Marquardt <[marquardtb@rohdebros.com](mailto:marquardtb@rohdebros.com)>; Nina HALVERSON <[n.halverson@kurita-water.com](mailto:n.halverson@kurita-water.com)>; Brandon Mancilla <[Brandon@williamreidltd.com](mailto:Brandon@williamreidltd.com)>  
**Cc:** Alan SCHNEIDER <[a.schneider@kurita-water.com](mailto:a.schneider@kurita-water.com)>  
**Subject:** Re: [EXT]RE: Kurita Invoice for Kronenwetter

Brian,

Thank you so much for the update! Also, I'm sure Nina has already let you know, but there is quite a lead time on getting start-up services scheduled. Maybe Nina can chime in here with an update on that. Just keep that in mind as you near installation and such.

Emily Nurmi (she, hers, her)

*Project Manager*

<image002.png>

PO Box 397

Germantown, WI 53022

O: 262-255-5420 C: 608-733-1403

[Emily@williamreidltd.com](mailto:Emily@williamreidltd.com)

---

**From:** Brian Marquardt <[marquardtb@rohdebros.com](mailto:marquardtb@rohdebros.com)>  
**Sent:** Friday, October 18, 2024 12:00 PM  
**To:** Emily Nurmi <[Emily@williamreidltd.com](mailto:Emily@williamreidltd.com)>; Nina HALVERSON <[n.halverson@kurita-water.com](mailto:n.halverson@kurita-water.com)>;  
 Brandon Mancilla <[Brandon@williamreidltd.com](mailto:Brandon@williamreidltd.com)>  
**Cc:** Alan SCHNEIDER <[a.schneider@kurita-water.com](mailto:a.schneider@kurita-water.com)>  
**Subject:** RE: [EXT]RE: Kurita Invoice for Kronenwetter

I did talk to Nina about that. Everything will be delivered on the 28<sup>th</sup> of October.

**BRIAN MARQUARDT**  
 Superintendent  
 Rohde Brothers Inc.  
**920-838-1628**  
[marquardtb@rohdebros.com](mailto:marquardtb@rohdebros.com)

---

**From:** Emily Nurmi <[Emily@williamreidltd.com](mailto:Emily@williamreidltd.com)>  
**Sent:** Friday, October 18, 2024 11:59 AM  
**To:** Nina HALVERSON <[n.halverson@kurita-water.com](mailto:n.halverson@kurita-water.com)>; Brandon Mancilla  
 <[Brandon@williamreidltd.com](mailto:Brandon@williamreidltd.com)>; Brian Marquardt <[marquardtb@rohdebros.com](mailto:marquardtb@rohdebros.com)>  
**Cc:** Alan SCHNEIDER <[a.schneider@kurita-water.com](mailto:a.schneider@kurita-water.com)>  
**Subject:** Re: [EXT]RE: Kurita Invoice for Kronenwetter

Brian,

Did you respond to Nina regarding the delivery of components and facepipe on the 23rd?  
Are you able to take that delivery?

Emily Nurmi (she, hers, her)

*Project Manager*

<image002.png>

PO Box 397

Germantown, WI 53022

O: 262-255-5420 C: 608-733-1403

[Emily@williamreidltd.com](mailto:Emily@williamreidltd.com)



**From:** Nina HALVERSON <[n.halverson@kurita-water.com](mailto:n.halverson@kurita-water.com)>  
**Sent:** Wednesday, October 16, 2024 11:55 AM  
**To:** Brandon Mancilla <[Brandon@williamreidltd.com](mailto:Brandon@williamreidltd.com)>; Brian Marquardt <[marquardtb@rohdebros.com](mailto:marquardtb@rohdebros.com)>; Emily Nurmi <[Emily@williamreidltd.com](mailto:Emily@williamreidltd.com)>  
**Cc:** Alan SCHNEIDER <[a.schneider@kurita-water.com](mailto:a.schneider@kurita-water.com)>  
**Subject:** RE: [EXT]RE: Kurita Invoice for Kronenwetter

Good morning –

I’ve been able to confirm that delivery on 10/28 is secured. They are going to aim to be there as close to the 7am mark as possible, this could delay if we run into oversized road restrictions for any reason, but the carrier will be in contact as they are on route with estimated times. They are aware they will need to call in advance to ensure proper staging and delivery order as well since we will be delivering 4 vessels in total that day.

The carrier is still currently lined up to delivery components and facepiping next week on the 23<sup>rd</sup>, please let me know if this will not work. A crane is not needed to unload these items, a forklift or similar will be needed but that is it. A pallet jack would also work, though not as easy.

Please let me know if there are any other concerns or questions.

Thank you,

**Nina Halverson**

*Project Manager – Municipal*  
Direct 763-957-1947 | Mobile 651-706-0498 | [n.halverson@kurita-water.com](mailto:n.halverson@kurita-water.com)  
Kurita America Inc. | Tonka Water, a Kurita brand | [www.kuritaamerica.com](http://www.kuritaamerica.com)

<image001.png>

---

**From:** Brandon Mancilla <[Brandon@williamreidltd.com](mailto:Brandon@williamreidltd.com)>  
**Sent:** Tuesday, October 15, 2024 2:34 PM  
**To:** Nina HALVERSON <[n.halverson@kurita-water.com](mailto:n.halverson@kurita-water.com)>; Brian Marquardt <[marquardtb@rohdebros.com](mailto:marquardtb@rohdebros.com)>; Emily Nurmi <[Emily@williamreidltd.com](mailto:Emily@williamreidltd.com)>  
**Cc:** Alan SCHNEIDER <[a.schneider@kurita-water.com](mailto:a.schneider@kurita-water.com)>  
**Subject:** RE: [EXT]RE: Kurita Invoice for Kronenwetter

Thank you for the prompt response, this is much appreciated.

Brandon Mancilla  
*Lead Sales Engineer*  
<image003.png>  
PO Box 397  
Germantown, WI 53022  
Ph: 414-331-5576  
[brandon@williamreidltd.com](mailto:brandon@williamreidltd.com)

Check out our new website!  
[williamreidltd.com](http://williamreidltd.com)

---

**From:** Nina HALVERSON <[n.halverson@kurita-water.com](mailto:n.halverson@kurita-water.com)>  
**Sent:** Tuesday, October 15, 2024 2:33 PM  
**To:** Brandon Mancilla <[Brandon@williamreidltd.com](mailto:Brandon@williamreidltd.com)>; Brian Marquardt <[marquardt@rohdebros.com](mailto:marquardt@rohdebros.com)>; Emily Nurmi <[Emily@williamreidltd.com](mailto:Emily@williamreidltd.com)>  
**Cc:** Alan SCHNEIDER <[a.schneider@kurita-water.com](mailto:a.schneider@kurita-water.com)>  
**Subject:** RE: [EXT]RE: Kurita Invoice for Kronenwetter

Okay – lots of phone tag, but I see the update about the 28<sup>th</sup>.

I cannot promise a 7am delivery time, but can ask them to aim as early and as closely to that as possible. Delivery on 10/28 should be fine. I'm working with the carrier now to confirm, will have answer yet this afternoon, if not first this tomorrow morning.

Thank you,

## Nina Halverson

*Project Manager – Municipal*

Direct 763-957-1947 | Mobile 651-706-0498 | [n.halverson@kurita-water.com](mailto:n.halverson@kurita-water.com)

Kurita America Inc. | Tonka Water, a Kurita brand | [www.kuritaamerica.com](http://www.kuritaamerica.com)

<image001.png>

---

**From:** Brandon Mancilla <[Brandon@williamreidltd.com](mailto:Brandon@williamreidltd.com)>  
**Sent:** Tuesday, October 15, 2024 2:12 PM  
**To:** Nina HALVERSON <[n.halverson@kurita-water.com](mailto:n.halverson@kurita-water.com)>; Brian Marquardt <[marquardt@rohdebros.com](mailto:marquardt@rohdebros.com)>; Emily Nurmi <[Emily@williamreidltd.com](mailto:Emily@williamreidltd.com)>  
**Cc:** Alan SCHNEIDER <[a.schneider@kurita-water.com](mailto:a.schneider@kurita-water.com)>  
**Subject:** RE: [EXT]RE: Kurita Invoice for Kronenwetter

Nina,

Seems like we are playing phone tag here, got your voicemail and called you back. Let's stick to emails so Brian is in the loop. Per Brian's request below, we need delivery change to October 28<sup>th</sup> @ 7am.

Can you make that adjustment?

Brandon Mancilla

*Lead Sales Engineer*

<image003.png>

PO Box 397

Germantown, WI 53022

Ph: 414-331-5576

[brandon@williamreidltd.com](mailto:brandon@williamreidltd.com)

Check out our new website!

[williamreidltd.com](http://williamreidltd.com)



---

**From:** Nina HALVERSON <[n.halverson@kurita-water.com](mailto:n.halverson@kurita-water.com)>  
**Sent:** Tuesday, October 15, 2024 2:04 PM  
**To:** Brandon Mancilla <[Brandon@williamreidltd.com](mailto:Brandon@williamreidltd.com)>; Brian Marquardt <[marquardt@rohdebros.com](mailto:marquardt@rohdebros.com)>; Emily Nurmi <[Emily@williamreidltd.com](mailto:Emily@williamreidltd.com)>  
**Cc:** Alan SCHNEIDER <[a.schneider@kurita-water.com](mailto:a.schneider@kurita-water.com)>  
**Subject:** RE: [EXT]RE: Kurita Invoice for Kronenwetter

My apologies, I've been in meetings since just before noon today, but I'm wondering if you're not getting my emails, as I've updated on this a few times, but yes, the carrier is set up for delivery on 10/25 as last updated on crane delivery for unloading.

I will give you a call in a few minutes as well with this information.

Thank you,

## Nina Halverson

*Project Manager – Municipal*

Direct 763-957-1947 | Mobile 651-706-0498 | [n.halverson@kurita-water.com](mailto:n.halverson@kurita-water.com)

Kurita America Inc. | Tonka Water, a Kurita brand | [www.kuritaamerica.com](http://www.kuritaamerica.com)

<image001.png>

---

**From:** Brandon Mancilla <[Brandon@williamreidltd.com](mailto:Brandon@williamreidltd.com)>  
**Sent:** Tuesday, October 15, 2024 1:55 PM  
**To:** Brian Marquardt <[marquardt@rohdebros.com](mailto:marquardt@rohdebros.com)>; Emily Nurmi <[Emily@williamreidltd.com](mailto:Emily@williamreidltd.com)>; Nina HALVERSON <[n.halverson@kurita-water.com](mailto:n.halverson@kurita-water.com)>  
**Cc:** Alan SCHNEIDER <[a.schneider@kurita-water.com](mailto:a.schneider@kurita-water.com)>  
**Subject:** RE: [EXT]RE: Kurita Invoice for Kronenwetter

Nina,

I left you a VM on this matter just a moment ago. Can you please update us on this matter today? We really need to lock this delivery in.

Thanks,

Brandon Mancilla

*Lead Sales Engineer*

<image003.png>

PO Box 397

Germantown, WI 53022

Ph: 414-331-5576

[brandon@williamreidltd.com](mailto:brandon@williamreidltd.com)

Check out our new website!

[williamreidltd.com](http://williamreidltd.com)

---

**From:** Brian Marquardt <[marquardtb@rohdebros.com](mailto:marquardtb@rohdebros.com)>  
**Sent:** Tuesday, October 15, 2024 10:56 AM  
**To:** Emily Nurmi <[Emily@williamreidltd.com](mailto:Emily@williamreidltd.com)>; 'Nina HALVERSON' <[n.halverson@kurita-water.com](mailto:n.halverson@kurita-water.com)>  
**Cc:** Alan SCHNEIDER <[a.schneider@kurita-water.com](mailto:a.schneider@kurita-water.com)>; Brandon Mancilla <[Brandon@williamreidltd.com](mailto:Brandon@williamreidltd.com)>  
**Subject:** RE: [EXT]RE: Kurita Invoice for Kronenwetter

Hello Nina,

I left you a voicemail as well, but really need to get in contact with you ASAP. The 25<sup>th</sup> as I was planning for is now also out. The next available day I can receive is October 28<sup>th</sup>. The biggest thing I need confirmed is that your trucking company can be to the jobsite at 7am on October 28<sup>th</sup>. This needs to be confirmed today. If someone else on this email chain can offer any input please jump in.

**BRIAN MARQUARDT**  
Superintendent  
Rohde Brothers Inc.  
**920-838-1628**  
[marquardtb@rohdebros.com](mailto:marquardtb@rohdebros.com)

---

**From:** Brian Marquardt  
**Sent:** Monday, October 14, 2024 9:29 AM  
**To:** 'Emily Nurmi' <[Emily@williamreidltd.com](mailto:Emily@williamreidltd.com)>; 'Nina HALVERSON' <[n.halverson@kurita-water.com](mailto:n.halverson@kurita-water.com)>  
**Cc:** 'Alan SCHNEIDER' <[a.schneider@kurita-water.com](mailto:a.schneider@kurita-water.com)>; 'Brandon Mancilla' <[Brandon@williamreidltd.com](mailto:Brandon@williamreidltd.com)>  
**Subject:** RE: [EXT]RE: Kurita Invoice for Kronenwetter

Hello all,

The first date I can get the crane onsite is October 25<sup>th</sup>. I have him reserved right now. The longer we wait, the less options we will have. We need to do everything we can to make this date work with the delivery.

**BRIAN MARQUARDT**  
Superintendent  
Rohde Brothers Inc.  
**920-838-1628**  
[marquardtb@rohdebros.com](mailto:marquardtb@rohdebros.com)

---

**From:** Brian Marquardt  
**Sent:** Monday, October 14, 2024 7:01 AM  
**To:** 'Emily Nurmi' <[Emily@williamreidltd.com](mailto:Emily@williamreidltd.com)>; Nina HALVERSON <[n.halverson@kurita-water.com](mailto:n.halverson@kurita-water.com)>  
**Cc:** Alan SCHNEIDER <[a.schneider@kurita-water.com](mailto:a.schneider@kurita-water.com)>; Brandon Mancilla <[Brandon@williamreidltd.com](mailto:Brandon@williamreidltd.com)>  
**Subject:** RE: [EXT]RE: Kurita Invoice for Kronenwetter

Hello Emily and Nina,

We are only one week away from the 21<sup>st</sup> when I'm planning to receive the filter package. I need to confirm my crane and unloading equipment TODAY! I will be needing a contact at the trucking company as well to confirm arrival time, number of trucks and a staging area for them. Thank you.

**BRIAN MARQUARDT**

Superintendent  
Rohde Brothers Inc.  
**920-838-1628**  
[marquardtb@rohdebros.com](mailto:marquardtb@rohdebros.com)

---

**From:** Emily Nurmi <[Emily@williamreidltd.com](mailto:Emily@williamreidltd.com)>  
**Sent:** Wednesday, October 2, 2024 3:29 PM  
**To:** Brian Marquardt <[marquardtb@rohdebros.com](mailto:marquardtb@rohdebros.com)>; Nina HALVERSON <[n.halverson@kurita-water.com](mailto:n.halverson@kurita-water.com)>  
**Cc:** Alan SCHNEIDER <[a.schneider@kurita-water.com](mailto:a.schneider@kurita-water.com)>; Brandon Mancilla <[Brandon@williamreidltd.com](mailto:Brandon@williamreidltd.com)>  
**Subject:** Re: [EXT]RE: Kurita Invoice for Kronenwetter

Nina,

Please see Brian's email below. We need an answer on this by COB today. Please provide an update as soon as possible.

Thank you

Emily Nurmi (she, hers, her)

*Project Manager*

<image002.png>

PO Box 397

Germantown, WI 53022

O: 262-255-5420 C: 608-733-1403

[Emily@williamreidltd.com](mailto:Emily@williamreidltd.com)

---

**From:** Brian Marquardt <[marquardtb@rohdebros.com](mailto:marquardtb@rohdebros.com)>  
**Sent:** Wednesday, October 2, 2024 10:02 AM  
**To:** Emily Nurmi <[Emily@williamreidltd.com](mailto:Emily@williamreidltd.com)>; Nina HALVERSON <[n.halverson@kurita-water.com](mailto:n.halverson@kurita-water.com)>  
**Subject:** RE: [EXT]RE: Kurita Invoice for Kronenwetter

Hello Emily and Nina,

We need to confirm an onsite delivery date. The general contractor is pushing, but I need this as well. I have a crane and equipment moving company onboard to unload the filter, but if I am not

given enough notice I can't promise we will be able to unload it. Last ship date I heard was Oct 14<sup>th</sup>. I am currently setting up for receiving on the 21<sup>st</sup>. I will need a contact for the trucking company or they will need to contact me. Will this equipment all fit on one truck? Once I know the first delivery we can set up for the media delivery.  
I need to know availability for startup services and to get that scheduled now to assure a spot. I'm also looking for specific instructions for putting the media in.  
Please reply by October 2<sup>nd</sup>.

**BRIAN MARQUARDT**  
Superintendent  
Rohde Brothers Inc.  
**920-838-1628**  
[marquardtb@rohdebros.com](mailto:marquardtb@rohdebros.com)

---

**From:** Emily Nurmi <[Emily@williamreidltd.com](mailto:Emily@williamreidltd.com)>  
**Sent:** Tuesday, October 1, 2024 1:37 PM  
**To:** Nina HALVERSON <[n.halverson@kurita-water.com](mailto:n.halverson@kurita-water.com)>; Brian Marquardt <[marquardtb@rohdebros.com](mailto:marquardtb@rohdebros.com)>  
**Subject:** Re: [EXT]RE: Kurita Invoice for Kronenwetter

Nina,

Good afternoon. Do you have an update on when these filters will ship? Based on your last email, it looks like they will ship on 10/7. You mentioned that a week before the ship date they usually hit paint and final inspections. Can you confirm this they have hit this stage yet?

Thank you,  
Emily

Emily Nurmi (she, hers, her)

*Project Manager*

<image002.png>

PO Box 397

Germantown, WI 53022

O: 262-255-5420 C: 608-733-1403

[Emily@williamreidltd.com](mailto:Emily@williamreidltd.com)

---

**From:** Nina HALVERSON <[n.halverson@kurita-water.com](mailto:n.halverson@kurita-water.com)>  
**Sent:** Thursday, September 12, 2024 9:33 AM

To: Brian Marquardt <[marquardtb@rohdebros.com](mailto:marquardtb@rohdebros.com)>; Emily Nurmi <[Emily@williamreidltd.com](mailto:Emily@williamreidltd.com)>  
Subject: RE: [EXT]RE: Kurita Invoice for Kronenwetter

Brian –

Our fabrication team has a meeting tomorrow, but as of this morning the current ship date looks like it will be 10/7.

I will follow up with you if that date has changed when we have the meeting tomorrow. I can keep you posted as the vessel hits paint and final inspections – this is usually a week before they would be looking to ship so this can help align the crane delivery to offload all vessels.

Thank you,

## Nina Halverson

*Project Manager – Municipal*

Direct 763-957-1947 | Mobile 651-706-0498 | [n.halverson@kurita-water.com](mailto:n.halverson@kurita-water.com)

Kurita America Inc. | Tonka Water, a Kurita brand | [www.kuritaamerica.com](http://www.kuritaamerica.com)

<image001.png>

---

**From:** Brian Marquardt <[marquardtb@rohdebros.com](mailto:marquardtb@rohdebros.com)>  
**Sent:** Thursday, September 12, 2024 7:20 AM  
**To:** Nina HALVERSON <[n.halverson@kurita-water.com](mailto:n.halverson@kurita-water.com)>; 'Emily Nurmi' <[Emily@williamreidltd.com](mailto:Emily@williamreidltd.com)>  
**Subject:** RE: [EXT]RE: Kurita Invoice for Kronenwetter

Emily and Nina,

I am going to need a confirmed ship date and the actual date this will arrive to the site very soon. I'd like a date by next Wednesday the 18<sup>th</sup>. I need to get a crane reserved as soon as possible. Thank you.

### **BRIAN MARQUARDT**

Superintendent

Rohde Brothers Inc.

**920-838-1628**

[marquardtb@rohdebros.com](mailto:marquardtb@rohdebros.com)

---

**From:** Nina HALVERSON <[n.halverson@kurita-water.com](mailto:n.halverson@kurita-water.com)>  
**Sent:** Wednesday, September 4, 2024 9:24 AM  
**To:** Brian Marquardt <[marquardtb@rohdebros.com](mailto:marquardtb@rohdebros.com)>; 'Emily Nurmi' <[Emily@williamreidltd.com](mailto:Emily@williamreidltd.com)>  
**Subject:** RE: [EXT]RE: Kurita Invoice for Kronenwetter

Brian/Emily –

Good morning!

I have a short update on the vessels here. We have the vertical pressure filters complete and ready to ship.

The Fab shop has faced a number of issues with storms and is quite delayed on the horizontal filter update that was provided was mid-end of October now – I am working to bring this timeline in and working with them to get this sooner so hopefully I have a better date for you next week.

Given this update, did you still want the VPF's held until the horizontal is complete or would you like to take delivery of those sooner?

Attached are photos of the finished vertical vessels.

Thank you,

## Nina Halverson

*Project Manager – Municipal*

Direct 763-957-1947 | Mobile 651-706-0498 | [n.halverson@kurita-water.com](mailto:n.halverson@kurita-water.com)

Kurita America Inc. | Tonka Water, a Kurita brand | [www.kuritaamerica.com](http://www.kuritaamerica.com)

<image001.png>

---

**From:** Brian Marquardt <[marquardtb@rohdebros.com](mailto:marquardtb@rohdebros.com)>

**Sent:** Tuesday, September 3, 2024 12:40 PM

**To:** Nina HALVERSON <[n.halverson@kurita-water.com](mailto:n.halverson@kurita-water.com)>; 'Emily Nurmi' <[Emily@williamreidltd.com](mailto:Emily@williamreidltd.com)>

**Subject:** RE: [EXT]RE: Kurita Invoice for Kronenwetter

Hello Nina and Emily,

I would still take some photos of the vessels for billing purposes. And the main thing, we are now within one month of delivery, and I need to start setting up a crane and equipment to receive this equipment. I am going to need a hard delivery date very soon, mainly to reserve a crane. Let me know as soon as possible.

### **BRIAN MARQUARDT**

Superintendent

Rohde Brothers Inc.

**920-838-1628**

[marquardtb@rohdebros.com](mailto:marquardtb@rohdebros.com)

---

**From:** Nina HALVERSON <[n.halverson@kurita-water.com](mailto:n.halverson@kurita-water.com)>

**Sent:** Friday, August 23, 2024 1:43 PM

**To:** Brian Marquardt <[marquardtb@rohdebros.com](mailto:marquardtb@rohdebros.com)>; 'Emily Nurmi' <[Emily@williamreidltd.com](mailto:Emily@williamreidltd.com)>

**Subject:** Re: [EXT]RE: Kurita Invoice for Kronenwetter

Brian -

Yes, I will request photos of current fabrication progress and send them your way!

Thank you,

**Nina Halverson**

Direct [763-957-1946](tel:763-957-1946) | Mobile [651-706-0498](tel:651-706-0498) | [n.halverson@kurita-water.com](mailto:n.halverson@kurita-water.com)

Kurita America Inc. | [www.kuritaamerica.com](http://www.kuritaamerica.com)

---

**From:** Brian Marquardt <[marquardtb@rohdebros.com](mailto:marquardtb@rohdebros.com)>  
**Sent:** Friday, August 23, 2024 10:31:05 AM  
**To:** 'Emily Nurmi' <[Emily@williamreidltd.com](mailto:Emily@williamreidltd.com)>  
**Cc:** Nina HALVERSON <[n.halverson@kurita-water.com](mailto:n.halverson@kurita-water.com)>  
**Subject:** [EXT]RE: Kurita Invoice for Kronenwetter

Hello Emily and Nina,

Can you please provide me with some photos of materials being used and progress photos. I need to send these in order for us to continue receiving payments.

**BRIAN MARQUARDT**  
Superintendent  
Rohde Brothers Inc.  
**920-838-1628**  
[marquardtb@rohdebros.com](mailto:marquardtb@rohdebros.com)

---

**From:** Emily Nurmi <[Emily@williamreidltd.com](mailto:Emily@williamreidltd.com)>  
**Sent:** Thursday, August 1, 2024 1:43 PM  
**To:** Brian Marquardt <[marquardtb@rohdebros.com](mailto:marquardtb@rohdebros.com)>  
**Cc:** Nina HALVERSON <[n.halverson@kurita-water.com](mailto:n.halverson@kurita-water.com)>  
**Subject:** Re: Kurita Invoice for Kronenwetter

Brian,

I passed this information along to Nina at Kurita. She is working on getting these photos for you.

Please let me know if you need anything else

Emily Nurmi (she, hers, her)

Project Manager

<image002.png>

PO Box 397

Germantown, WI 53022

O: 262-255-5420 C: 608-733-1403

---

**From:** Brian Marquardt <[marquardtb@rohdebros.com](mailto:marquardtb@rohdebros.com)>  
**Sent:** Wednesday, July 31, 2024 12:28 PM  
**To:** Emily Nurmi <[Emily@williamreidltd.com](mailto:Emily@williamreidltd.com)>  
**Subject:** Kurita Invoice for Kronenwetter

Emily,

We received this invoice from Kurita. It looks like this is for a portion of the materials. I will be putting this amount on our next pay app for the project that goes out the 20<sup>th</sup> of every month, but I will likely be needing some photos of materials for us to get this approved. And being that these materials are not in my possession or onsite I'm not sure they will approve payment until delivery. Lets at least start with some photos. If you can give me some advanced notice of any other large invoices coming we can ask for that payment sooner.

**BRIAN MARQUARDT**  
Superintendent  
Rohde Brothers Inc.  
**920-838-1628**  
[marquardtb@rohdebros.com](mailto:marquardtb@rohdebros.com)

[CAUTION: This email originated from outside of the organization. Do not click links or open attachments unless you recognize the sender and know the content is safe]  
This e-mail message and all attachments transmitted with it contain confidential and proprietary business information owned by Kurita America Inc. and intended solely for the use of the addressee. The transmission of this e-mail may be legally privileged. If the recipient of this message is not the intended person or entity, you are hereby notified that any reading, dissemination, distribution, copying, or other use of this message, its contents, hyperlinks, and attached files of any kind is strictly prohibited. If you have received this message in error, please notify the sender immediately by a reply to this electronic mail message and delete this message and all copies and backups thereof. All rights to the information contained in this e-mail are reserved by Kurita America Inc.  
This e-mail message and all attachments transmitted with it contain confidential and proprietary business information owned by Kurita America Inc. and intended solely for the use of the addressee. The transmission of this e-mail may be legally privileged. If the recipient of this message is not the intended person or entity, you are hereby notified that any reading, dissemination, distribution, copying, or other use of this message, its contents, hyperlinks, and attached files of any kind is strictly prohibited. If you have received this message in error, please notify the sender immediately by a reply to this electronic mail message and delete this message and all copies and backups thereof. All rights to the information contained in this e-mail are reserved by Kurita America Inc.  
This e-mail message and all attachments transmitted with it contain confidential and proprietary business information owned by Kurita America Inc. and intended solely for the use of the addressee. The transmission of this e-mail may be legally privileged. If the recipient of this message is not the intended person or entity, you are hereby notified that any reading, dissemination, distribution, copying, or other use of this message, its contents, hyperlinks, and attached files of any kind is strictly prohibited. If you have



received this message in error, please notify the sender immediately by a reply to this electronic mail message and delete this message and all copies and backups thereof. All rights to the information contained in this e-mail are reserved by Kurita America Inc.

[CAUTION: This email originated from outside of the organization. Do not click links or open attachments unless you recognize the sender and know the content is safe]

[CAUTION: This email originated from outside of the organization. Do not click links or open attachments unless you recognize the sender and know the content is safe]

[CAUTION: This email originated from outside of the organization. Do not click links or open attachments unless you recognize the sender and know the content is safe]

This e-mail message and all attachments transmitted with it contain confidential and proprietary business information owned by Kurita America Inc. and intended solely for the use of the addressee. The transmission of this e-mail may be legally privileged. If the recipient of this message is not the intended person or entity, you are hereby notified that any reading, dissemination, distribution, copying, or other use of this message, its contents, hyperlinks, and attached files of any kind is strictly prohibited. If you have received this message in error, please notify the sender immediately by a reply to this electronic mail message and delete this message and all copies and backups thereof. All rights to the information contained in this e-mail are reserved by Kurita America Inc.

[CAUTION: This email originated from outside of the organization. Do not click links or open attachments unless you recognize the sender and know the content is safe]

This e-mail message and all attachments transmitted with it contain confidential and proprietary business information owned by Kurita America Inc. and intended solely for the use of the addressee. The transmission of this e-mail may be legally privileged. If the recipient of this message is not the intended person or entity, you are hereby notified that any reading, dissemination, distribution, copying, or other use of this message, its contents, hyperlinks, and attached files of any kind is strictly prohibited. If you have received this message in error, please notify the sender immediately by a reply to this electronic mail message and delete this message and all copies and backups thereof. All rights to the information contained in this e-mail are reserved by Kurita America Inc.

[CAUTION: This email originated from outside of the organization. Do not click links or open attachments unless you recognize the sender and know the content is safe]

This e-mail message and all attachments transmitted with it contain confidential and proprietary business information owned by Kurita America Inc. and intended solely for the use of the addressee. The transmission of this e-mail may be legally privileged. If the recipient of this message is not the intended person or entity, you are hereby notified that any reading, dissemination, distribution, copying, or other use of this message, its contents, hyperlinks, and attached files of any kind is strictly prohibited. If you have received this message in error, please notify the sender immediately by a reply to this electronic mail message and delete this message and all copies and backups thereof. All rights to the information contained in this e-mail are reserved by Kurita America Inc.

[CAUTION: This email originated from outside of the organization. Do not click links or open attachments unless you recognize the sender and know the content is safe]

[CAUTION: This email originated from outside of the organization. Do not click links or open attachments unless you recognize the sender and know the content is safe]

This e-mail message and all attachments transmitted with it contain confidential and proprietary business information owned by Kurita America Inc. and intended solely for the use of the addressee. The transmission of this e-mail may be legally privileged. If the recipient of this message is not the intended person or entity, you are hereby notified that

any reading, dissemination, distribution, copying, or other use of this message, its contents, hyperlinks, and attached files of any kind is strictly prohibited. If you have received this message in error, please notify the sender immediately by a reply to this electronic mail message and delete this message and all copies and backups thereof. All rights to the information contained in this e-mail are reserved by Kurita America Inc. This e-mail message and all attachments transmitted with it contain confidential and proprietary business information owned by Kurita America Inc. and intended solely for the use of the addressee. The transmission of this e-mail may be legally privileged. If the recipient of this message is not the intended person or entity, you are hereby notified that any reading, dissemination, distribution, copying, or other use of this message, its contents, hyperlinks, and attached files of any kind is strictly prohibited. If you have received this message in error, please notify the sender immediately by a reply to this electronic mail message and delete this message and all copies and backups thereof. All rights to the information contained in this e-mail are reserved by Kurita America Inc. This e-mail message and all attachments transmitted with it contain confidential and proprietary business information owned by Kurita America Inc. and intended solely for the use of the addressee. The transmission of this e-mail may be legally privileged. If the recipient of this message is not the intended person or entity, you are hereby notified that any reading, dissemination, distribution, copying, or other use of this message, its contents, hyperlinks, and attached files of any kind is strictly prohibited. If you have received this message in error, please notify the sender immediately by a reply to this electronic mail message and delete this message and all copies and backups thereof. All rights to the information contained in this e-mail are reserved by Kurita America Inc. This e-mail message and all attachments transmitted with it contain confidential and proprietary business information owned by Kurita America Inc. and intended solely for the use of the addressee. The transmission of this e-mail may be legally privileged. If the recipient of this message is not the intended person or entity, you are hereby notified that any reading, dissemination, distribution, copying, or other use of this message, its contents, hyperlinks, and attached files of any kind is strictly prohibited. If you have received this message in error, please notify the sender immediately by a reply to this electronic mail message and delete this message and all copies and backups thereof. All rights to the information contained in this e-mail are reserved by Kurita America Inc. [CAUTION: This email originated from outside of the organization. Do not click links or open attachments unless you recognize the sender and know the content is safe] This e-mail message and all attachments transmitted with it contain confidential and proprietary business information owned by Kurita America Inc. and intended solely for the use of the addressee. The transmission of this e-mail may be legally privileged. If the recipient of this message is not the intended person or entity, you are hereby notified that any reading, dissemination, distribution, copying, or other use of this message, its contents, hyperlinks, and attached files of any kind is strictly prohibited. If you have received this message in error, please notify the sender immediately by a reply to this electronic mail message and delete this message and all copies and backups thereof. All rights to the information contained in this e-mail are reserved by Kurita America Inc. [CAUTION: This email originated from outside of the organization. Do not click links or open attachments unless you recognize the sender and know the content is safe] This e-mail message and all attachments transmitted with it contain confidential and proprietary business information owned by Kurita America Inc. and intended solely for the use of the addressee. The transmission of this e-mail may be legally privileged. If the



**Brian Marquardt**

---

**From:** Emily Nurmi <Emily@williamreidltd.com>  
**Sent:** Friday, October 18, 2024 12:48 PM  
**To:** Joe Kafczynski; Brandon Mancilla; Nina HALVERSON; Brian Marquardt  
**Cc:** Kenneth J. Ligman; Ben J. Everswick  
**Subject:** Re: [EXT]RE: Kurita Invoice for Kronenwetter

Joe,

After reviewing this email thread, it appears you got cut off at some point. We apologize for that. Everything is being delivered to the job site on 10/28. It was supposed to be 10/25, but the crane wasn't available, so it got pushed to 10/28.

Please let me know if you have any questions.

Emily Nurmi (she, hers, her)  
Project Manager



PO Box 397  
Germantown, WI 53022  
O: 262-255-5420 C: 608-733-1403  
[Emily@williamreidltd.com](mailto:Emily@williamreidltd.com)

---

**From:** Joe Kafczynski <jkafczynski@becherhoppe.com>  
**Sent:** Friday, October 18, 2024 12:41 PM  
**To:** Brandon Mancilla <Brandon@williamreidltd.com>  
**Cc:** Emily Nurmi <Emily@williamreidltd.com>; Kenneth J. Ligman <kligman@becherhoppe.com>; Ben J. Everswick <beverswick@becherhoppe.com>  
**Subject:** RE: [EXT]RE: Kurita Invoice for Kronenwetter

Good afternoon Brandon,

I am getting word that the delivery of the vessels for the Village of Kronenwetter project has been delayed again and will not be delivered to the site next week as scheduled. Can you please check into this and see what the delay is and if we have a new tentative delivery date from Kurita?

Thanks again for your help,

**Joe Kafczynski, PE**  
Project Engineer

**Becher-Hoppe Associates, Inc.**  
330 N. 4th Street | Wausau WI | 54403  
Direct 715-845-0436 | Mobile 715-574-6031  
Main 715-845-8000

[jkafczynski@becherhoppe.com](mailto:jkafczynski@becherhoppe.com) | [www.becherhoppe.com](http://www.becherhoppe.com)

This email message is for the sole use of the intended recipient(s) and may contain confidential and privileged information. Any unauthorized review, use, disclosure or distribution is prohibited. If you are not the intended recipient, please contact the sender by reply email and destroy all copies of the original message.

**From:** Joe Kafczynski  
**Sent:** Friday, September 13, 2024 12:08 PM  
**To:** Brandon Mancilla <[Brandon@williamreidltd.com](mailto:Brandon@williamreidltd.com)>  
**Cc:** Emily Nurmi <[Emily@williamreidltd.com](mailto:Emily@williamreidltd.com)>  
**Subject:** RE: [EXT]RE: Kurita Invoice for Kronenwetter

Brandon,

Thank you for taking a look into this and providing an update. I look forward to hearing from the Contractor on their updated schedule.

Thanks again for the update and I appreciate your help in looking into this!

**Joe Kafczynski, PE**  
Project Engineer

**Becher-Hoppe Associates, Inc.**  
330 N. 4th Street | Wausau WI | 54403  
Direct 715-845-0436 | Mobile 715-574-6031  
Main 715-845-8000  
[jkafczynski@becherhoppe.com](mailto:jkafczynski@becherhoppe.com) | [www.becherhoppe.com](http://www.becherhoppe.com)

This email message is for the sole use of the intended recipient(s) and may contain confidential and privileged information. Any unauthorized review, use, disclosure or distribution is prohibited. If you are not the intended recipient, please contact the sender by reply email and destroy all copies of the original message.

**From:** Brandon Mancilla <[Brandon@williamreidltd.com](mailto:Brandon@williamreidltd.com)>  
**Sent:** Friday, September 13, 2024 8:06 AM  
**To:** Joe Kafczynski <[jkafczynski@becherhoppe.com](mailto:jkafczynski@becherhoppe.com)>  
**Cc:** Emily Nurmi <[Emily@williamreidltd.com](mailto:Emily@williamreidltd.com)>  
**Subject:** RE: [EXT]RE: Kurita Invoice for Kronenwetter

Joe,

We received an update on this project this morning the current ship date looks like it will be 10/7.

We will keep you posted as the vessel hits paint and final inspections – this is usually a week before they would be looking to ship so this can help align the crane delivery to offload all vessels.

This note has already ben sent to Brian at Rohde Brothers as well.

I sent a note yesterday on this matter, can you confirm you received?

Thanks!

Brandon Mancilla

Lead Sales Engineer



PO Box 397

Germantown, WI 53022

Ph: 414-331-5576

[brandon@williamreidltd.com](mailto:brandon@williamreidltd.com)

Check out our new website!

[williamreidltd.com](http://williamreidltd.com)

**From:** Brandon Mancilla

**Sent:** Thursday, September 12, 2024 7:18 AM

**To:** [jkafczynski@becherhoppe.com](mailto:jkafczynski@becherhoppe.com)

**Cc:** Emily Nurmi <[Emily@williamreidltd.com](mailto:Emily@williamreidltd.com)>

**Subject:** FW: [EXT]RE: Kurita Invoice for Kronenwetter

Good morning Joe,

Thanks again for stopping by the booth the discuss the matter of delivery of Kronenwetter with me.

See below email thread between Kurita/Tonka and Rhode. Additionally, from what I understand, Rhode has requested hold on delivery unit all units are complete. With that said a delivery window of mid to late October is the expectation.

Emily copied on here has been made aware of this delivery pain point and will continually keep you posted/reach out for updates as we get closer to that delivery date.

Please let me know if you have any questions.

Thanks!

Brandon Mancilla

Lead Sales Engineer



PO Box 397

Germantown, WI 53022

Ph: 414-331-5576

[brandon@williamreidltd.com](mailto:brandon@williamreidltd.com)

Check out our new website!

[williamreidltd.com](http://williamreidltd.com)

**From:** Emily Nurmi <[Emily@williamreidltd.com](mailto:Emily@williamreidltd.com)>  
**Sent:** Wednesday, September 11, 2024 3:47 PM  
**To:** Brandon Mancilla <[Brandon@williamreidltd.com](mailto:Brandon@williamreidltd.com)>  
**Subject:** Fw: [EXT]RE: Kurita Invoice for Kronenwetter

The last update was from Nina on 9/4. Mid to late October is the time frame

Emily Nurmi (she, hers, her)  
Project Manager



PO Box 397  
Germantown, WI 53022  
O: 262-255-5420 C: 608-733-1403  
[Emily@williamreidltd.com](mailto:Emily@williamreidltd.com)

---

**From:** Nina HALVERSON <[n.halverson@kurita-water.com](mailto:n.halverson@kurita-water.com)>  
**Sent:** Wednesday, September 4, 2024 9:23 AM  
**To:** Brian Marquardt <[marquardtb@rohdebros.com](mailto:marquardtb@rohdebros.com)>; Emily Nurmi <[Emily@williamreidltd.com](mailto:Emily@williamreidltd.com)>  
**Subject:** RE: [EXT]RE: Kurita Invoice for Kronenwetter

Brian/Emily –

Good morning!

I have a short update on the vessels here. We have the vertical pressure filters complete and ready to ship. The Fab shop has faced a number of issues with storms and is quite delayed on the horizontal filter, the update that was provided was mid-end of October now – I am working to bring this timeline in and working with them to get this sooner so hopefully I have a better date for you next week.

Given this update, did you still want the VPF’s held until the horizontal is complete or would you like to take delivery of those sooner?

Attached are photos of the finished vertical vessels.

Thank you,

**Nina Halverson**

*Project Manager – Municipal*  
Direct 763-957-1947 | Mobile 651-706-0498 | [n.halverson@kurita-water.com](mailto:n.halverson@kurita-water.com)  
Kurita America Inc. | Tonka Water, a Kurita brand | [www.kuritaamerica.com](http://www.kuritaamerica.com)



---

**From:** Brian Marquardt <[marquardtb@rohdebros.com](mailto:marquardtb@rohdebros.com)>  
**Sent:** Tuesday, September 3, 2024 12:40 PM

To: Nina HALVERSON <n.halverson@kurita-water.com>; 'Emily Nurmi' <Emily@williamreidltd.com>  
Subject: RE: [EXT]RE: Kurita Invoice for Kronenwetter

Hello Nina and Emily,

I would still take some photos of the vessels for billing purposes. And the main thing, we are now within one month of delivery, and I need to start setting up a crane and equipment to receive this equipment. I am going to need a hard delivery date very soon, mainly to reserve a crane. Let me know as soon as possible.

**BRIAN MARQUARDT**  
Superintendent  
Rohde Brothers Inc.  
**920-838-1628**  
[marquardtb@rohdebros.com](mailto:marquardtb@rohdebros.com)

---

**From:** Nina HALVERSON <n.halverson@kurita-water.com>  
**Sent:** Friday, August 23, 2024 1:43 PM  
**To:** Brian Marquardt <marquardtb@rohdebros.com>; 'Emily Nurmi' <Emily@williamreidltd.com>  
**Subject:** Re: [EXT]RE: Kurita Invoice for Kronenwetter

Brian -

Yes, I will request photos of current fabrication progress and send them your way!

Thank you,

**Nina Halverson**  
*Project Manager*  
Direct 763-957-1946 | Mobile 651-706-0498 | [n.halverson@kurita-water.com](mailto:n.halverson@kurita-water.com)  
Kurita America Inc. | [www.kuritaamerica.com](http://www.kuritaamerica.com)

---

**From:** Brian Marquardt <marquardtb@rohdebros.com>  
**Sent:** Friday, August 23, 2024 10:31:05 AM  
**To:** 'Emily Nurmi' <Emily@williamreidltd.com>  
**Cc:** Nina HALVERSON <n.halverson@kurita-water.com>  
**Subject:** [EXT]RE: Kurita Invoice for Kronenwetter

Hello Emily and Nina,

Can you please provide me with some photos of materials being used and progress photos. I need to send these in order for us to continue receiving payments.

**BRIAN MARQUARDT**  
Superintendent  
Rohde Brothers Inc.  
**920-838-1628**  
[marquardtb@rohdebros.com](mailto:marquardtb@rohdebros.com)

---

**From:** Emily Nurmi <Emily@williamreidltd.com>  
**Sent:** Thursday, August 1, 2024 1:43 PM



To: Brian Marquardt <[marquardtb@rohdebros.com](mailto:marquardtb@rohdebros.com)>  
Cc: Nina HALVERSON <[n.halverson@kurita-water.com](mailto:n.halverson@kurita-water.com)>  
Subject: Re: Kurita Invoice for Kronenwetter

Brian,

I passed this information along to Nina at Kurita. She is working on getting these photos for you.

Please let me know if you need anything else

Emily Nurmi (she, hers, her)  
Project Manager



PO Box 397  
Germantown, WI 53022  
O: 262-255-5420 C: 608-733-1403  
[Emily@williamreidltd.com](mailto:Emily@williamreidltd.com)

---

From: Brian Marquardt <[marquardtb@rohdebros.com](mailto:marquardtb@rohdebros.com)>  
Sent: Wednesday, July 31, 2024 12:28 PM  
To: Emily Nurmi <[Emily@williamreidltd.com](mailto:Emily@williamreidltd.com)>  
Subject: Kurita Invoice for Kronenwetter

Emily,

We received this invoice from Kurita. It looks like this is for a portion of the materials. I will be putting this amount on our next pay app for the project that goes out the 20<sup>th</sup> of every month, but I will likely be needing some photos of materials for us to get this approved. And being that these materials are not in my possession or onsite I'm not sure they will approve payment until delivery. Lets at least start with some photos. If you can give me some advanced notice of any other large invoices coming we can ask for that payment sooner.

**BRIAN MARQUARDT**  
Superintendent  
Rohde Brothers Inc.  
**920-838-1628**  
[marquardtb@rohdebros.com](mailto:marquardtb@rohdebros.com)

[CAUTION: This email originated from outside of the organization. Do not click links or open attachments unless you recognize the sender and know the content is safe]

This e-mail message and all attachments transmitted with it contain confidential and proprietary business information owned by Kurita America Inc. and intended solely for the use of the addressee. The transmission of this e-mail may be legally privileged. If the recipient of this message is not the intended person or entity, you are hereby notified that any reading, dissemination, distribution, copying, or other use of this message, its contents, hyperlinks, and attached files of any kind is strictly prohibited. If you have received this message in error, please notify the sender immediately by a reply to this electronic mail message and delete this message and all copies and backups thereof. All rights to the information contained in this e-mail are reserved by Kurita America Inc.

This e-mail message and all attachments transmitted with it contain confidential and proprietary business information owned by Kurita America Inc. and intended solely for the use of the addressee. The transmission of this e-mail may be legally privileged. If the recipient of this message is not the intended person or entity, you are hereby notified that any reading, dissemination, distribution, copying, or other use of this message, its contents, hyperlinks, and attached files of any kind is strictly prohibited. If you have received this message in error, please notify the sender immediately by a reply to this electronic mail message and delete this message and all copies and backups thereof. All rights to the information contained in this e-mail are reserved by Kurita America Inc.

[CAUTION: This email originated from outside of the organization. Do not click links or open attachments unless you recognize the sender and know the content is safe]

[CAUTION: This email originated from outside of the organization. Do not click links or open attachments unless you recognize the sender and know the content is safe]

**Brian Marquardt**

---

**From:** Nina HALVERSON <n.halverson@kurita-water.com>  
**Sent:** Thursday, January 4, 2024 10:19 AM  
**To:** Rich Dehnel; Brian Marquardt; Dan Moore; Luke Laudolff  
**Cc:** Emily Nurmi; Alan SCHNEIDER  
**Subject:** RE: [EXT]23066 Kronenwetter Well #2 - Filter System Submittal Returned

Good morning –

I am working with our fabrication teams to see what the earliest the 4 vertical detention tanks can be estimated to be done, they're assessing scheduling now that they are and I should have an estimate soon for you. Is there a specific timeframe you are looking for?

Additionally, I can have this deliver separate from the pressure vessel when the time comes, I am assuming you'd like these BEFORE the pressure vessel?

Thank you,

**Nina Halverson**

*Project Manager*

Desk 763-957-1947 | Mobile 651-706-0498 | [n.halverson@kurita-water.com](mailto:n.halverson@kurita-water.com)

Kurita America Inc. | [www.kuritaamerica.com](http://www.kuritaamerica.com)

[How are we doing? Take our short survey!](#)



---

**From:** Rich Dehnel <dehnel@rohdebros.com>  
**Sent:** Wednesday, December 20, 2023 12:45 PM  
**To:** Nina HALVERSON <n.halverson@kurita-water.com>; Brian Marquardt <marquardtb@rohdebros.com>; Dan Moore <moored@rohdebros.com>; Luke Laudolff <laudolffl@rohdebros.com>  
**Cc:** Emily Nurmi <Emily@williamreidltd.com>; Alan SCHNEIDER <a.schneider@kurita-water.com>  
**Subject:** [EXT]23066 Kronenwetter Well #2 - Filter System Submittal Returned

Nina,  
Attached is the reviewed Filter System submittal...

Please note the comments contained on the front page of the returned submittal...

While it is approved to move forward, these criteria need to be adhered to for the final equipment.

If the drawings or other documents need to be changed for production purposes and want to resubmit as a record, by all means do it so that everything is covered.

Next question, is it possible to receive the four vertical tanks as soon as possible as a separate shipment, as if it is, what would be the timeframe on that delivery?

Thank you for your assistance

Have a great day

**Rich Dehnel**  
PM/Project Engineer  
**Rohde Brothers, Inc.**  
W5745 Woodchuck Lane  
[Plymouth, WI 53073-0409](#)  
Company Main: (920) 893-5905  
Direct: (920) 449-5767 | Cell: (920) 960-3638  
[dehnelr@rohdebros.com](mailto:dehnelr@rohdebros.com) | [www.rohdebros.com](http://www.rohdebros.com)



---

**From:** Nina HALVERSON <[n.halverson@kurita-water.com](mailto:n.halverson@kurita-water.com)>  
**Sent:** Thursday, December 7, 2023 11:40 AM  
**To:** Rich Dehnel <[dehnelr@rohdebros.com](mailto:dehnelr@rohdebros.com)>; Brian Marquardt <[marquardtb@rohdebros.com](mailto:marquardtb@rohdebros.com)>  
**Cc:** Emily Nurmi <[Emily@williamreidltd.com](mailto:Emily@williamreidltd.com)>; Luke Laudolff <[laudolffl@rohdebros.com](mailto:laudolffl@rohdebros.com)>; Dan Moore <[moored@rohdebros.com](mailto:moored@rohdebros.com)>; Alan SCHNEIDER <[a.schneider@kurita-water.com](mailto:a.schneider@kurita-water.com)>  
**Subject:** RE: J0030708 - Kronenwetter, WI - Submittal

Good morning –

Reaching out to see if you have any follow up questions, concerns, or approval on this submittal package?

I haven't seen any updates on anything since it was sent and we're hoping to keep this moving forward. In order to keep the planned delivery schedule we need to see approval on this soon or it may slip.

Please reach out with any questions or revision needs so we can address them as soon as possible.

Thank you,

**Nina Halverson**  
*Project Manager*  
Desk 763-957-1947 | Mobile 651-706-0498 | [n.halverson@kurita-water.com](mailto:n.halverson@kurita-water.com)  
Kurita America Inc. | [www.kuritaamerica.com](http://www.kuritaamerica.com)  
[How are we doing? Take our short survey!](#)



**From:** Nina HALVERSON  
**Sent:** Wednesday, October 18, 2023 3:52 PM  
**To:** Rich Dehnel <[dehnelr@rohdebros.com](mailto:dehnelr@rohdebros.com)>; Brian Marquardt <[marquardt@rohdebros.com](mailto:marquardt@rohdebros.com)>  
**Cc:** Emily Nurmi <[Emily@williamreidltd.com](mailto:Emily@williamreidltd.com)>; Luke Laudloff <[laudloffl@rohdebros.com](mailto:laudloffl@rohdebros.com)>; Dan Moore <[moored@rohdebros.com](mailto:moored@rohdebros.com)>; Alan SCHNEIDER <[a.schneider@kurita-water.com](mailto:a.schneider@kurita-water.com)>  
**Subject:** J0030708 - Kronenwetter, WI - Submittal

Good afternoon –

Please see the attached submittal document for Kronenwetter, WI.

Please let me know if you have any questions, comments, or concerns or if we have approval to proceed as submitted. We would like to see any responses, revision needs, or approvals by 11/1/23 if possible.

As noted previously regarding the larger vessel portion of the submittal, the sooner we get that approval back the sooner we can release and secure scheduling with the fabrication shop.

Thank you,

**Nina Halverson**

*Project Manager*

Mobile 651-706-0498 | [n.halverson@kurita-water.com](mailto:n.halverson@kurita-water.com)

Kurita America Inc. | [www.kuritaamerica.com](http://www.kuritaamerica.com)

[How are we doing? Take our short survey!](#)



**From:** Rich Dehnel <[dehnelr@rohdebros.com](mailto:dehnelr@rohdebros.com)>  
**Sent:** Monday, October 16, 2023 10:54 AM  
**To:** Nina HALVERSON <[n.halverson@kurita-water.com](mailto:n.halverson@kurita-water.com)>; Brian Marquardt <[marquardt@rohdebros.com](mailto:marquardt@rohdebros.com)>  
**Cc:** Emily Nurmi <[Emily@williamreidltd.com](mailto:Emily@williamreidltd.com)>; Luke Laudloff <[laudloffl@rohdebros.com](mailto:laudloffl@rohdebros.com)>; Dan Moore <[moored@rohdebros.com](mailto:moored@rohdebros.com)>  
**Subject:** [EXT]RE: Kronenwetter, WI - Questions

Hello Nina,

It was mentioned in a previous email that the submittal for the large equipment package should have been received last week.

With a 44 week delivery time, plus the installation time, the project schedule is definitely at risk at its current timeline

It was mentioned that the submittals would be received in 6-8 weeks once the PO was received.

The PO for this equipment was sent on 8/4/2023, which is approximately 10 weeks ago.

When can we expect to see this document? As of right now, you are this is the only outstanding submittal that I am aware of.

Also the question is still out there unanswered: is it possible to receive the (4) vertical tanks early?

Thank you for your time

**Rich Dehnel**  
PM/Project Engineer  
**Rohde Brothers, Inc.**  
W5745 Woodchuck Lane  
[Plymouth, WI 53073-0409](mailto:dehnelr@rohdebros.com)  
Company Main: (920) 893-5905  
Direct: (920) 449-5767 | Cell: (920) 960-3638  
[dehnelr@rohdebros.com](mailto:dehnelr@rohdebros.com) | [www.rohdebros.com](http://www.rohdebros.com)



---

**From:** Nina HALVERSON <[n.halverson@kurita-water.com](mailto:n.halverson@kurita-water.com)>  
**Sent:** Tuesday, October 3, 2023 1:14 PM  
**To:** Rich Dehnel <[dehnelr@rohdebros.com](mailto:dehnelr@rohdebros.com)>  
**Subject:** Kronenwetter, WI - Questions

You don't often get email from [n.halverson@kurita-water.com](mailto:n.halverson@kurita-water.com). [Learn why this is important](#)

Good afternoon, Rich,

Quick introduction, I am the Kurita project manager handling the water filtration project for Kronenwetter, WI. I spoke to Emily at Willian Reid a bit and she noted you have a few questions about the submittals and the filter delivery timelines – hopefully I can provide you some information to assist in getting those answered.

The submittal package should be to you the week of 10/13, that is what we are aiming for and I am working with my design engineers to get all documents needed to get you the full package.

Once that is in your hands and reviewed and we have approval I can provide a better idea of delivery date for the system, essentially, we base the delivery timeline off the submittal approval date as we can't secure fabrication until we have release.

Can you provide me with the best contact information, site address and any other information you might find to be helpful?

I am traveling and have limited access while in the mountains but have been trying to get connected to check messages as able but will be back in office Monday 10/9. My best contact information is below, feel free to reach to me directly with any questions regarding the timelines, system, submittal, or anything project related as I can get this information to you quicker than Emily reaching to me and then back to you.

I hope the week is going well, please let me know if you need more information in the meantime, otherwise expect to see that submittal package in the coming weeks!

Thank you,

**Nina Halverson**

*Project Manager*

Mobile 651-706-0498 | [n.halverson@kurita-water.com](mailto:n.halverson@kurita-water.com)

Kurita America Inc. | [www.kuritaamerica.com](http://www.kuritaamerica.com)

[How are we doing? Take our short survey!](#)



This e-mail message and all attachments transmitted with it contain confidential and proprietary business information owned by Kurita America Inc. and intended solely for the use of the addressee. The transmission of this e-mail may be legally privileged. If the recipient of this message is not the intended person or entity, you are hereby notified that any reading, dissemination, distribution, copying, or other use of this message, its contents, hyperlinks, and attached files of any kind is strictly prohibited. If you have received this message in error, please notify the sender immediately by a reply to this electronic mail message and delete this message and all copies and backups thereof. All rights to the information contained in this e-mail are reserved by Kurita America Inc.

**Brian Marquardt**

---

**From:** Nina HALVERSON <n.halverson@kurita-water.com>  
**Sent:** Monday, October 16, 2023 11:06 AM  
**To:** Rich Dehnel; Brian Marquardt  
**Cc:** Emily Nurmi; Luke Laudolff; Dan Moore  
**Subject:** RE: [EXT]RE: Kronenwetter, WI - Questions

I just had a meeting with my design team on the final document I was waiting for in order to submit – so this should be in your hands in the next few days.

There were some delays with the fabrication shop – they’re actually 52-54 weeks out for delivery and we had to find a new shop in order to meet the timelines for delivery.

As I noted in my previous email, I cannot give a delivery date for the tanks without approval of the submittal package, as that is required before we can secure the fabrication schedule. What date are you hoping to hit? I can present it to the fabrication shop, but we cannot guarantee it would be sooner than the quoted timeline once approval is given.

This timeline can be sped up some if you are able to review and approve the vessels right away once you get the submittal and then review and approve the remaining components after.

Thank you,

**Nina Halverson**

*Project Manager*  
Mobile 651-706-0498 | [n.halverson@kurita-water.com](mailto:n.halverson@kurita-water.com)  
Kurita America Inc. | [www.kuritaamerica.com](http://www.kuritaamerica.com)  
[How are we doing? Take our short survey!](#)



---

**From:** Rich Dehnel <dehnelr@rohdebros.com>  
**Sent:** Monday, October 16, 2023 10:54 AM  
**To:** Nina HALVERSON <n.halverson@kurita-water.com>; Brian Marquardt <marquardt@rohdebros.com>  
**Cc:** Emily Nurmi <Emily@williamreidLtd.com>; Luke Laudolff <laudolffl@rohdebros.com>; Dan Moore <moored@rohdebros.com>  
**Subject:** [EXT]RE: Kronenwetter, WI - Questions

Hello Nina,  
It was mentioned in a previous email that the submittal for the large equipment package should have been received last week.

With a 44 week delivery time, plus the installation time, the project schedule is definitely at risk at its current timeline

It was mentioned that the submittals would be received in 6-8 weeks once the PO was received.

The PO for this equipment was sent on 8/4/203, which is approximately 10 weeks ago.



When can we expect to see this document? As of right now, you are this is the only outstanding submittal that I am aware of.

Also the question is still out there unanswered: is it possible to receive the (4) vertical tanks early?

Thank you for your time

**Rich Dehnel**  
PM/Project Engineer  
**Rohde Brothers, Inc.**  
W5745 Woodchuck Lane  
[Plymouth, WI 53073-0409](http://Plymouth, WI 53073-0409)  
Company Main: (920) 893-5905  
Direct: (920) 449-5767 | Cell: (920) 960-3638  
[dehnelr@rohdebros.com](mailto:dehnelr@rohdebros.com) | [www.rohdebros.com](http://www.rohdebros.com)



**From:** Nina HALVERSON <[n.halverson@kurita-water.com](mailto:n.halverson@kurita-water.com)>  
**Sent:** Tuesday, October 3, 2023 1:14 PM  
**To:** Rich Dehnel <[dehnelr@rohdebros.com](mailto:dehnelr@rohdebros.com)>  
**Subject:** Kronenwetter, WI - Questions

You don't often get email from [n.halverson@kurita-water.com](mailto:n.halverson@kurita-water.com). [Learn why this is important](#)

Good afternoon, Rich,

Quick introduction, I am the Kurita project manager handling the water filtration project for Kronenwetter, WI. I spoke to Emily at Willian Reid a bit and she noted you have a few questions about the submittals and the filter delivery timelines – hopefully I can provide you some information to assist in getting those answered.

The submittal package should be to you the week of 10/13, that is what we are aiming for and I am working with my design engineers to get all documents needed to get you the full package.

Once that is in your hands and reviewed and we have approval I can provide a better idea of delivery date for the system, essentially, we base the delivery timeline off the submittal approval date as we can't secure fabrication until we have release.

Can you provide me with the best contact information, site address and any other information you might find to be helpful?

I am traveling and have limited access while in the mountains but have been trying to get connected to check messages as able but will be back in office Monday 10/9. My best contact information is below, feel free to reach to me directly with any questions regarding the timelines, system, submittal, or anything project related as I can get this information to you quicker than Emily reaching to me and then back to you.

I hope the week is going well, please let me know if you need more information in the meantime, otherwise expect to see that submittal package in the coming weeks!

Thank you,

## Nina Halverson

*Project Manager*

Mobile 651-706-0498 | [n.halverson@kurita-water.com](mailto:n.halverson@kurita-water.com)

Kurita America Inc. | [www.kuritaamerica.com](http://www.kuritaamerica.com)

[How are we doing? Take our short survey!](#)



This e-mail message and all attachments transmitted with it contain confidential and proprietary business information owned by Kurita America Inc. and intended solely for the use of the addressee. The transmission of this e-mail may be legally privileged. If the recipient of this message is not the intended person or entity, you are hereby notified that any reading, dissemination, distribution, copying, or other use of this message, its contents, hyperlinks, and attached files of any kind is strictly prohibited. If you have received this message in error, please notify the sender immediately by a reply to this electronic mail message and delete this message and all copies and backups thereof. All rights to the information contained in this e-mail are reserved by Kurita America Inc.

**Brian Marquardt**

---

**From:** Rich Dehnel  
**Sent:** Monday, July 17, 2023 7:17 AM  
**To:** Zach Gilmaster  
**Cc:** Jestin Boden  
**Subject:** RE: Kronenwetter Well No. 2 - Lead Times

Zach,  
I have asked for updated lead times on the major pieces of equipment and yet to hear back from some and others told me early this week.

I have six items in my list, and so far, only have two answered.

I hope to have them completed by EOD today

**Rich Dehnel**  
PM/Project Engineer  
**Rohde Brothers, Inc.**  
W5745 Woodchuck Lane  
[Plymouth, WI 53073-0409](http://Plymouth, WI 53073-0409)  
Company Main: (920) 893-5905  
Direct: (920) 449-5767 | Cell: (920) 960-3638  
[dehnelr@rohdebros.com](mailto:dehnelr@rohdebros.com) | [www.rohdebros.com](http://www.rohdebros.com)



---

**From:** Zach Gilmaster <[zach@elliswi.com](mailto:zach@elliswi.com)>  
**Sent:** Monday, July 17, 2023 7:07 AM  
**To:** Jestin Boden <[bodenj@rohdebros.com](mailto:bodenj@rohdebros.com)>; Rich Dehnel <[dehnelr@rohdebros.com](mailto:dehnelr@rohdebros.com)>  
**Subject:** RE: Kronenwetter Well No. 2 - Lead Times

Some people who received this message don't often get email from [zach@elliswi.com](mailto:zach@elliswi.com). [Learn why this is important](#)

Jestin/Rich,

Good morning. Are you able to provide lead times for the Kronenwetter Well No. 2 project? Please advise.

Thanks,

Zach Gilmaster  
Project Manager  
[Zach@elliswi.com](mailto:Zach@elliswi.com)



3201 Stanley Street  
Stevens Point, WI 54481  
Ph: 715-345-5000 ext. 133 • Fax: 715-345-5007  
[www.elliswi.com](http://www.elliswi.com)

---

**From:** Zach Gilmaster  
**Sent:** Tuesday, July 11, 2023 10:51 AM  
**To:** [bodenj@rohdebros.com](mailto:bodenj@rohdebros.com)  
**Subject:** Kronenwetter Well No. 2 - Lead Times

Jestin,

Good morning. As follow up to my phone call yesterday, please have your team provide updated lead times on all of your equipment. I will need this information to put together a project schedule.

Thank you,

Zach Gilmaster  
Project Manager  
[Zach@elliswi.com](mailto:Zach@elliswi.com)



3201 Stanley Street  
Stevens Point, WI 54481  
Ph: 715-345-5000 ext. 133 • Fax: 715-345-5007  
[www.elliswi.com](http://www.elliswi.com)

**Brian Marquardt**

---

**From:** Zach Gilmaster <zach@elliswi.com>  
**Sent:** Wednesday, July 19, 2023 1:59 PM  
**To:** Rich Dehnel  
**Cc:** Jestin Boden  
**Subject:** RE: Kronenwetter Well No. 2 - Lead Times  
**Attachments:** Preliminary Overall Schedule 7-18-23.pdf

**Follow Up Flag:** Follow up  
**Flag Status:** Flagged

Rich,

Good afternoon. I believe I have everything captured in the attached preliminary overall schedule. Let me know your thoughts if I am missing something.

Thanks,

Zach Gilmaster  
Project Manager  
[Zach@elliswi.com](mailto:Zach@elliswi.com)



3201 Stanley Street  
Stevens Point, WI 54481  
Ph: 715-345-5000 ext. 133 • Fax: 715-345-5007  
[www.elliswi.com](http://www.elliswi.com)

---

**From:** Rich Dehnel <dehnelr@rohdebros.com>  
**Sent:** Wednesday, July 19, 2023 9:57 AM  
**To:** Zach Gilmaster <zach@elliswi.com>  
**Cc:** Jestin Boden <bodenj@rohdebros.com>  
**Subject:** RE: Kronenwetter Well No. 2 - Lead Times

**CAUTION:** This email originated from outside your organization. Exercise caution when opening attachments or clicking links, especially from unknown senders.

Zach,  
In round numbers:

I do not know the size of the crews yet...

Plumbing (domestic water, drain piping, natural gas, vents, and equipment setting): 208 hours + insulator  
HVAC: 40 hours + insulator and T&B  
Interior Process Piping: (Equipment setting, DI pipe, filter piping, and process gases): 880 hours + well pump contractor

Site work: 240 hours + excavator

Will this work for you

**Rich Dehnel**  
PM/Project Engineer  
**Rohde Brothers, Inc.**  
W5745 Woodchuck Lane  
[Plymouth, WI 53073-0409](mailto:dehnelr@rohdebros.com)  
Company Main: (920) 893-5905  
Direct: (920) 449-5767 | Cell: (920) 960-3638  
[dehnelr@rohdebros.com](mailto:dehnelr@rohdebros.com) | [www.rohdebros.com](http://www.rohdebros.com)



**From:** Zach Gilmaster <[zach@elliswi.com](mailto:zach@elliswi.com)>  
**Sent:** Monday, July 17, 2023 9:45 AM  
**To:** Rich Dehnel <[dehnelr@rohdebros.com](mailto:dehnelr@rohdebros.com)>  
**Cc:** Jestin Boden <[bodeni@rohdebros.com](mailto:bodeni@rohdebros.com)>  
**Subject:** RE: Kronenwetter Well No. 2 - Lead Times

Rich,  
  
Thanks for this very helpful information. My next question is, what are you thinking for durations to complete your scope of work?

Thank you,  
  
Zach Gilmaster  
Project Manager  
[Zach@elliswi.com](mailto:Zach@elliswi.com)



3201 Stanley Street  
Stevens Point, WI 54481  
Ph: 715-345-5000 ext. 133 • Fax: 715-345-5007  
[www.elliswi.com](http://www.elliswi.com)

**From:** Rich Dehnel <[dehnelr@rohdebros.com](mailto:dehnelr@rohdebros.com)>  
**Sent:** Monday, July 17, 2023 9:36 AM  
**To:** Zach Gilmaster <[zach@elliswi.com](mailto:zach@elliswi.com)>  
**Cc:** Jestin Boden <[bodenj@rohdebros.com](mailto:bodenj@rohdebros.com)>  
**Subject:** Kronenwetter Well No. 2 - Lead Times

**CAUTION:** This email originated from outside your organization. Exercise caution when opening attachments or clicking links, especially from unknown senders.

Hello Zach,  
Below are the lead times for the major components for this project after approvals:

I added a seventh to the list

- Chemical Equipment: 12weeks
- Valves: up to 28weeks
- HVAC: 6-8weeks
- Filter System and associated equipment: 40-44weeks
- Equalization Tanks: 6-8weeks
- Well pump and motor: 6-10weeks
- Manholes and associated materials: 4-6weeks

If you need anything else please let me know

**Rich Dehnel**  
PM/Project Engineer  
**Rohde Brothers, Inc.**  
W5745 Woodchuck Lane  
[Plymouth, WI 53073-0409](http://Plymouth, WI 53073-0409)  
Company Main: (920) 893-5905  
Direct: (920) 449-5767 | Cell: (920) 960-3638  
[dehnelr@rohdebros.com](mailto:dehnelr@rohdebros.com) | [www.rohdebros.com](http://www.rohdebros.com)



**Brian Marquardt**

---

**From:** Zach Gilmaster <zach@elliswi.com>  
**Sent:** Wednesday, July 19, 2023 9:31 AM  
**To:** Rich Dehnel; Bryan Gawlik  
**Cc:** Kyle Moscinski  
**Subject:** RE: Kronenwetter Well No. 2 - Preconstruction Meeting

**Follow Up Flag:** Follow up  
**Flag Status:** Flagged

All,

As a follow up to my email below, the architect made it known that this will be an onsite meeting. Please let me know what day/time works best for you early next week, since we are closing in on the end of this one. Unless we can make something work for this week yet.

Thank you,

Zach Gilmaster  
Project Manager  
[Zach@elliswi.com](mailto:Zach@elliswi.com)



3201 Stanley Street  
Stevens Point, WI 54481  
Ph: 715-345-5000 ext. 133 • Fax: 715-345-5007  
[www.elliswi.com](http://www.elliswi.com)

---

**From:** Zach Gilmaster  
**Sent:** Wednesday, July 19, 2023 8:53 AM  
**To:** Rich Dehnel <dehnelr@rohdebros.com>; Bryan Gawlik <gawlik@econelectric.com>  
**Cc:** Kyle Moscinski <kyle@elliswi.com>  
**Subject:** Kronenwetter Well No. 2 - Preconstruction Meeting

All,

Good morning. Becher Hoppe would like to set up a preconstruction meeting at 1pm tomorrow (7/20) to discuss the Kronenwetter Well project. Does this time work for all of you? Please let me know so we can get something set up.

Thanks,

Zach Gilmaster  
Project Manager  
[Zach@elliswi.com](mailto:Zach@elliswi.com)





**Built Right.™**

3201 Stanley Street  
Stevens Point, WI 54481  
Ph: 715-345-5000 ext. 133 • Fax: 715-345-5007  
[www.elliswi.com](http://www.elliswi.com)

Section 4, Item D.

**Brian Marquardt**

**From:** Ellis Stone Construction Co <Ellis\_Stone\_Construction\_notifications@procoretech.com>  
**Sent:** Monday, July 24, 2023 7:54 AM  
**To:** Rich Dehnel  
**Subject:** Kronenwetter Well No. 2: Action Required for Contract #SC-23061-010: Process Piping

**Follow Up Flag:** Follow up  
**Flag Status:** Flagged

You don't often get email from ellis\_stone\_construction\_notifications@procoretech.com. [Learn why this is important](#)

# Kronenwetter Well No. 2



More details: [View online](#)  [View PDF](#)

**DO NOT REPLY TO THIS EMAIL**

This is a notification sent from an unmonitored email address.

**This item requires your attention in Procore.**

## Contract

**Name:** #SC-23061-010: Process Piping  
**Link:** [View in Procore](#)  
**Link:** [View PDF](#)

## Workflow History

**#:** 1  
**Action By:** Zach Gilmaster  
**Role:** Project Manager  
**Action Taken:** Send to Subcontractor  
**Comment:** Please review, sign, and return through Procore. Provide insurance certificates per the Terms and Conditions.  
**Attachments:** None

Ball In Court Duration (Calendar): **13 days**

Date/Time: **07/24/2023 at 07:53 am**

More details: [View online](#)  [View PDF](#)

Powered By [Procore](#) | [support@procore.com](mailto:support@procore.com) | <https://support.procore.com>

**Brian Marquardt**

---

**From:** Zach Gilmaster <zach@elliswi.com>  
**Sent:** Tuesday, July 25, 2023 11:25 AM  
**To:** Rich Dehnel  
**Subject:** RE: Kronenwetter Well No. 2 - Schedule of Values

**Follow Up Flag:** Follow up  
**Flag Status:** Flagged

Sounds good. That'll work.

Thanks

Zach Gilmaster  
Project Manager  
[Zach@elliswi.com](mailto:Zach@elliswi.com)



3201 Stanley Street  
Stevens Point, WI 54481  
Ph: 715-345-5000 ext. 133 • Fax: 715-345-5007  
[www.elliswi.com](http://www.elliswi.com)

---

**From:** Rich Dehnel <dehnelr@rohdebros.com>  
**Sent:** Tuesday, July 25, 2023 11:24 AM  
**To:** Zach Gilmaster <zach@elliswi.com>  
**Subject:** RE: Kronenwetter Well No. 2 - Schedule of Values

CAUTION: This email originated from outside your organization. Exercise caution when opening attachments or clicking links, especially from unknown senders.

Since we just received the contract...I am finishing up a few other project related items and starting on the preliminary items for that project would be next on my list...

I hope to have you something by tomorrow, I doubt that you would have it today

---

**From:** Zach Gilmaster <[zach@elliswi.com](mailto:zach@elliswi.com)>  
**Sent:** Tuesday, July 25, 2023 11:20 AM  
**To:** Rich Dehnel <[dehnelr@rohdebros.com](mailto:dehnelr@rohdebros.com)>  
**Subject:** Kronenwetter Well No. 2 - Schedule of Values

Rich,

Good afternoon. Could you please send your schedule of values for the Kronenwetter Well No. 2 project? Becher Hoppe is requesting.

Thanks,

Zach Gilmaster  
Project Manager  
[Zach@elliswi.com](mailto:Zach@elliswi.com)



Built Right.™

3201 Stanley Street  
Stevens Point, WI 54481  
Ph: 715-345-5000 ext. 133 • Fax: 715-345-5007  
[www.elliswi.com](http://www.elliswi.com)

**Brian Marquardt**

---

**From:** Zach Gilmaster <zach@elliswi.com>  
**Sent:** Tuesday, July 25, 2023 11:27 AM  
**To:** Bryan Gawlik; Rich Dehnel  
**Subject:** Kronenwetter Well No. 2 - Preconstruction Meeting  
**Attachments:** 2021.022.034 record of preconstruction conference 230712.docx

**Follow Up Flag:** Follow up  
**Flag Status:** Flagged

Good morning,

Attached is a listing of items to be discussed at the preconstruction meeting tomorrow in Kronenwetter.

Thank you,

Zach Gilmaster  
Project Manager  
[Zach@elliswi.com](mailto:Zach@elliswi.com)



Built Right.™

3201 Stanley Street  
Stevens Point, WI 54481  
Ph: 715-345-5000 ext. 133 • Fax: 715-345-5007  
[www.elliswi.com](http://www.elliswi.com)

**Brian Marquardt**

---

**From:** Kenneth J. Ligman <kligman@becherhoppe.com>  
**Sent:** Friday, July 28, 2023 9:09 AM  
**To:** Kmanley@kronenwetter.org; Zach Gilmaster; Rich Dehnel; gawlik@econelectric.com; Priest, Kyle J - DNR  
**Cc:** Matthew R. Patterson; Tyler L. Mills; Peter Wegner; Lisa Kerstner; Bobbi Birk-LaBarge; Mark Mackey  
**Subject:** Kronenwetter WTP  
**Attachments:** copier@becherhoppe.com\_20230728\_080848.pdf

**Follow Up Flag:** Follow up  
**Flag Status:** Flagged

You don't often get email from kligman@becherhoppe.com. [Learn why this is important](#)

Enclosed is the record of the Pre-construction conference. Please review and advise if any additions or corrections are needed.

**Ken Ligman**  
Senior Engineer

**Becher-Hoppe Associates, Inc.**  
330 N. 4th Street | Wausau WI | 54403  
Direct 715-845-0432 | Office 715-845-8000  
[kligman@becherhoppe.com](mailto:kligman@becherhoppe.com) | [www.becherhoppe.com](http://www.becherhoppe.com)

This email message is for the sole use of the intended recipient(s) and may contain confidential and privileged information. Any unauthorized review, use, disclosure or distribution is prohibited. If you are not the intended recipient, please contact the sender by reply email and destroy all copies of the original message

**Brian Marquardt**

**From:** Zach Gilmaster (Ellis Stone Construction Company, Inc.)  
 <Ellis\_Stone\_Construction\_notifications@procoretech.com>  
**Sent:** Friday, July 28, 2023 9:30 AM  
**To:** Rich Dehnel  
**Subject:** Kronenwetter Well No. 2: Meeting 1 - Preconstruction Meeting Minutes

**Follow Up Flag:** Follow up  
**Flag Status:** Flagged

You don't often get email from ellis\_stone\_construction\_notifications@procoretech.com. [Learn why this is important](#)

# Kronenwetter Well No. 2



More details: [View online](#) [View PDF](#)

**DO NOT REPLY TO THIS EMAIL**

This is a notification sent from an unmonitored email address.

## Meeting #1 Minutes - Preconstruction Meeting

**Project:** Kronenwetter Well No. 2

**Meeting Location:** 1582 I-39 Frontage Rd, Kronenwetter, WI 54455

**Date:** 07/26/23

**Start Time:** 1:00 PM

**Timezone:** Central Time (US & Canada)

**Attachments:** [Kronenwetter Well - Preconstruction Meeting 7-26-23.pdf](#)

**Overview:** Attached are the preconstruction meeting minutes from 7/26/23.  
 Thanks, Zach.

**Scheduled Attendees:** Eric Hakenjos (Block Iron & Supply Company), Darrell Kasner (Carl's Landscape Service), Shannon Gretz (City Wide Insulation of Green Bay), Bryan Gawlik (E-Con Electric, Inc.), Zach Gilmaster (Ellis Stone Construction Company, Inc.), Kyle Moscinski (Ellis Stone Construction Company, Inc.), Kurt Grote (Howard Grote & Sons Painting, Inc.), Peter Lang (Lang Masonry), Craig Schmidt (Phoenix Contractors, LLC), Mark Schroeder (Precision Grading & Utilities, Inc.), Penni Damato (Quality Caulking), Ryan Christiansen (RC Pavers, LLC), Rich Dehnel (Rohde Brothers, Inc.), Steve Pelishek (Tri-City Glass & Door, Inc.)



MINUTES: <https://app.procore.com/2514747/project/meetings/show/7695422>

More details: [View online](#)  [View PDF](#)

Powered By Procore | [support@procore.com](mailto:support@procore.com) | <https://support.procore.com>

**Brian Marquardt**

---

**From:** Zach Gilmaster <zach@elliswi.com>  
**Sent:** Monday, July 31, 2023 3:48 PM  
**To:** Rich Dehnel  
**Subject:** RE: Kronenwetter Well - SOV

**Follow Up Flag:** Follow up  
**Flag Status:** Flagged

Sounds good. Thanks Rich

Zach Gilmaster  
Project Manager  
[Zach@elliswi.com](mailto:Zach@elliswi.com)



3201 Stanley Street  
Stevens Point, WI 54481  
Ph: 715-345-5000 ext. 133 • Fax: 715-345-5007  
[www.elliswi.com](http://www.elliswi.com)

---

**From:** Rich Dehnel <dehnelr@rohdebros.com>  
**Sent:** Monday, July 31, 2023 3:44 PM  
**To:** Zach Gilmaster <zach@elliswi.com>  
**Subject:** RE: Kronenwetter Well - SOV

CAUTION: This email originated from outside your organization. Exercise caution when opening attachments or clicking links, especially from unknown senders.

It's done, just needs to be reviewed...person has been out but will be back tomorrow

---

**From:** Zach Gilmaster <zach@elliswi.com>  
**Sent:** Monday, July 31, 2023 1:53 PM  
**To:** Rich Dehnel <dehnelr@rohdebros.com>  
**Subject:** Kronenwetter Well - SOV

Rich,  
  
Good afternoon. Were you able to put together your schedule of values for Kronenwetter Well? If so, please send that along so I can send it to Becher Hoppe.

Thank you,

Zach Gilmaster  
Project Manager

[Zach@elliswi.com](mailto:Zach@elliswi.com)

Section 4, Item D.



**Built Right.™**

3201 Stanley Street  
Stevens Point, WI 54481  
Ph: 715-345-5000 ext. 133 • Fax: 715-345-5007  
[www.elliswi.com](http://www.elliswi.com)

**Brian Marquardt**

---

**From:** Zach Gilmaster <zach@elliswi.com>  
**Sent:** Wednesday, August 2, 2023 7:28 AM  
**To:** Christine Sprengel  
**Cc:** Rich Dehnel  
**Subject:** RE: Kronenwetter Well No. 2 - SOV

Thanks for sending Christine

Zach Gilmaster  
Project Manager  
[Zach@elliswi.com](mailto:Zach@elliswi.com)



3201 Stanley Street  
Stevens Point, WI 54481  
Ph: 715-345-5000 ext. 133 • Fax: 715-345-5007  
[www.elliswi.com](http://www.elliswi.com)

---

**From:** Christine Sprengel <sprengelchristine@rohdebros.com>  
**Sent:** Tuesday, August 1, 2023 2:03 PM  
**To:** Zach Gilmaster <zach@elliswi.com>  
**Cc:** Rich Dehnel <dehnelr@rohdebros.com>  
**Subject:** Kronenwetter Well No. 2 - SOV

CAUTION: This email originated from outside your organization. Exercise caution when opening attachments or clicking links, especially from unknown senders.

Zach  
Attached is the SOV for the above project.  
Please let me know if you have any questions.  
Thank you

**Christine Sprengel**

Project Coordinator



920.893.5905

**Brian Marquardt**

---

**From:** Zach Gilmaster <zach@elliswi.com>  
**Sent:** Wednesday, August 2, 2023 2:46 PM  
**To:** Rich Dehnel  
**Cc:** Christine Sprengel; Brian Marquardt  
**Subject:** RE: 23066 Kronenwetter Well #2 - Contract

Rich,

I spoke with our president on the markups. Ellis will agree to mutual indemnification, nothing more. The other markups are fine. If we need to discuss, Erik and I will be available tomorrow. Let me know your thoughts.

Thank you,

Zach Gilmaster  
Project Manager  
[Zach@elliswi.com](mailto:Zach@elliswi.com)



3201 Stanley Street  
Stevens Point, WI 54481  
Ph: 715-345-5000 ext. 133 • Fax: 715-345-5007  
[www.elliswi.com](http://www.elliswi.com)

---

**From:** Rich Dehnel <dehnelr@rohdebros.com>  
**Sent:** Wednesday, August 2, 2023 2:08 PM  
**To:** Zach Gilmaster <zach@elliswi.com>  
**Cc:** Christine Sprengel <sprengelchristine@rohdebros.com>; Brian Marquardt <marquardt@rohdebros.com>  
**Subject:** 23066 Kronenwetter Well #2 - Contract

CAUTION: This email originated from outside your organization. Exercise caution when opening attachments or clicking links, especially from unknown senders.

Zach,  
Attached is the signed contract, albeit with some remarks from our CFO.

Please review and provide any feedback that you may have.

Thank you for your time and have a great day.

**Rich Dehnel**  
PM/Project Engineer  
**Rohde Brothers, Inc.**  
W5745 Woodchuck Lane  
[Plymouth, WI 53073-0409](http://Plymouth, WI 53073-0409)

Company Main: (920) 893-5905  
Direct: (920) 449-5767 | Cell: (920) 960-3638  
[dehnelr@rohdebros.com](mailto:dehnelr@rohdebros.com) | [www.rohdebros.com](http://www.rohdebros.com)

Section 4, Item D.



**Brian Marquardt**

**From:** Ellis Stone Construction Co <Ellis\_Stone\_Construction\_notifications@procoretech.com>  
**Sent:** Thursday, August 3, 2023 6:00 AM  
**To:** Rich Dehnel  
**Subject:** Kronenwetter Well No. 2: Reminder. Action Required for Contract #SC-23061-010: Process Piping

# Kronenwetter Well No. 2



More details: [View online](#)  [View PDF](#)

**DO NOT REPLY TO THIS EMAIL**

This is a notification sent from an unmonitored email address.

**This item has been in your court for 9 days, and your action is required.**

## Contract

**Name:** #SC-23061-010: Process Piping  
**Link:** [View in Procore](#)  
**Link:** [View PDF](#)

## Workflow History

**#:** 1  
**Action By:** Zach Gilmaster  
**Role:** Project Manager  
**Action Taken:** Send to Subcontractor  
**Comment:** Please review, sign, and return through Procore. Provide insurance certificates per the Terms and Conditions.  
**Attachments:** None  
**Ball In Court Duration (Calendar):** 13 days

Date/Time: 07/24/2023 at 07:53 am

More details: [View online](#)  [View PDF](#)

Powered By Procure | [support@procure.com](mailto:support@procure.com) | <https://support.procure.com>



**Brian Marquardt**

---

**From:** Zach Gilmaster <zach@elliswi.com>  
**Sent:** Monday, August 7, 2023 7:11 AM  
**To:** Rich Dehnel  
**Cc:** Christine Sprengel; Eric Carlson  
**Subject:** RE: 23066 Kronenwetter Well #2 - COI and signed updated Section 4.4 Subcontract  
**Attachments:** Kronenwetter Well No. 2 - Rohde Brothers Signed SC - 8-7-23.pdf

Rich,

Good morning. Thanks for sending. Attached is the fully executed copy for record. I have closed this out on Procore as well. Keep the submittals coming, and I will try to turn them around as quickly as possible.

Thank you,

Zach Gilmaster  
Project Manager  
[Zach@elliswi.com](mailto:Zach@elliswi.com)



3201 Stanley Street  
Stevens Point, WI 54481  
Ph: 715-345-5000 ext. 133 • Fax: 715-345-5007  
[www.elliswi.com](http://www.elliswi.com)

---

**From:** Rich Dehnel <dehnelr@rohdebros.com>  
**Sent:** Friday, August 4, 2023 1:32 PM  
**To:** Zach Gilmaster <zach@elliswi.com>  
**Cc:** Christine Sprengel <sprengelchristine@rohdebros.com>; Eric Carlson <carlsone@rohdebros.com>  
**Subject:** 23066 Kronenwetter Well #2 - COI and signed updated Section 4.4 Subcontract

CAUTION: This email originated from outside your organization. Exercise caution when opening attachments or clicking links, especially from unknown senders.

Zach,  
Attached are two documents:

- 1. COI
- 2. Updated subcontract and signed by our CFO

PO's for the water filtering equipment have been issued and those submittals are being worked on.

If there is anything else that is required currently, please let us know...

Have a great weekend...

**Rich Dehnel**  
PM/Project Engineer  
**Rohde Brothers, Inc.**  
W5745 Woodchuck Lane  
[Plymouth, WI 53073-0409](mailto:dehnelr@rohdebros.com)  
Company Main: (920) 893-5905  
Direct: (920) 449-5767 | Cell: (920) 960-3638  
[dehnelr@rohdebros.com](mailto:dehnelr@rohdebros.com) | [www.rohdebros.com](http://www.rohdebros.com)



**Brian Marquardt**

**From:** Ellis Stone Construction Co <Ellis\_Stone\_Construction\_notifications@procoretech.com>  
**Sent:** Monday, August 7, 2023 7:13 AM  
**To:** Rich Dehnel  
**Subject:** Kronenwetter Well No. 2: State Change on Contract #SC-23061-010: Process Piping

# Kronenwetter Well No. 2



More details: [View online](#) [View PDF](#)

**DO NOT REPLY TO THIS EMAIL**

This is a notification sent from an unmonitored email address.

**This item's state has been changed to Contract Signed by Project Manager.**

## Contract

Name:	#SC-23061-010: Process Piping
Link:	<a href="#">View in Procore</a>
Link:	<a href="#">View PDF</a>

## Workflow History

#:	1
Action By:	Zach Gilmaster
Role:	Project Manager
Action Taken:	Contract Signed
Attachments:	<a href="#">Kronenwetter Well No. 2 - Rohde Brothers Signed SC - 8-7-23.pdf</a>
Ball In Court Duration (Calendar):	0 days
Date/Time:	08/07/2023 at 07:09 am

More details: [View online](#) [View PDF](#)

**Brian Marquardt**

---

**From:** Zach Gilmaster <zach@elliswi.com>  
**Sent:** Monday, August 14, 2023 10:30 AM  
**To:** Rich Dehnel  
**Subject:** RE: Kronenwetter Well - Contractor License

Thanks for sending Rich

Zach Gilmaster  
Project Manager  
[Zach@elliswi.com](mailto:Zach@elliswi.com)



3201 Stanley Street  
Stevens Point, WI 54481  
Ph: 715-345-5000 ext. 133 • Fax: 715-345-5007  
[www.elliswi.com](http://www.elliswi.com)

---

**From:** Rich Dehnel <dehnelr@rohdebros.com>  
**Sent:** Monday, August 14, 2023 10:11 AM  
**To:** Zach Gilmaster <zach@elliswi.com>  
**Subject:** RE: Kronenwetter Well - Contractor License

CAUTION: This email originated from outside your organization. Exercise caution when opening attachments or clicking links, especially from unknown senders.

HVAC: 120390, 7/06/26  
Plumbing: 1342823, 3/31/24

---

**From:** Zach Gilmaster <zach@elliswi.com>  
**Sent:** Friday, August 11, 2023 10:48 AM  
**To:** Rich Dehnel <dehnelr@rohdebros.com>; Bryan Gawlik <gawlik@econelectric.com>  
**Subject:** Kronenwetter Well - Contractor License

Rich/Bryan,

Good morning. Could you please send me your License/Certification # and Expiration Date for plumbing, electrical, and HVAC?

Thank you,

Zach Gilmaster  
Project Manager  
[Zach@elliswi.com](mailto:Zach@elliswi.com)



**Built Right.™**

3201 Stanley Street  
Stevens Point, WI 54481  
Ph: 715-345-5000 ext. 133 • Fax: 715-345-5007  
[www.elliswi.com](http://www.elliswi.com)

Section 4, Item D.

**Brian Marquardt**

---

**From:** Zach Gilmaster <zach@elliswi.com>  
**Sent:** Tuesday, October 17, 2023 8:15 AM  
**To:** Rich Dehnel  
**Subject:** RE: Kronenwetter, WI bonds and tax exempt certificate  
**Attachments:** Performance Bond.pdf; Payment Bond.pdf

Rich,

Good morning. I have the payment and performance bonds attached. Let me know if you need anything else.

Thank you,

Zach Gilmaster  
Project Manager  
[Zach@elliswi.com](mailto:Zach@elliswi.com)



3201 Stanley Street  
Stevens Point, WI 54481  
Ph: 715-345-5000 ext. 133 • Fax: 715-345-5007  
[www.elliswi.com](http://www.elliswi.com)

---

**From:** Rich Dehnel <dehnelr@rohdebros.com>  
**Sent:** Monday, October 16, 2023 12:21 PM  
**To:** Zach Gilmaster <zach@elliswi.com>  
**Subject:** FW: Kronenwetter, WI bonds and tax exempt certificate

CAUTION: This email originated from outside your organization. Exercise caution when opening attachments or clicking links, especially from unknown senders.

Zach,  
Can you please send me the payment and performance bond for the Kronenwetter project.

This equipment is being further delayed and I do not want the paperwork to be one of the reasons

Thank you for your assistance and have a great day

**Rich Dehnel**  
PM/Project Engineer  
**Rohde Brothers, Inc.**  
W5745 Woodchuck Lane  
[Plymouth, WI 53073-0409](http://Plymouth, WI 53073-0409)  
Company Main: (920) 893-5905  
Direct: (920) 449-5767 | Cell: (920) 960-3638



**From:** Amy SEIBERT <[a.seibert@kurita-water.com](mailto:a.seibert@kurita-water.com)>  
**Sent:** Monday, October 16, 2023 11:44 AM  
**To:** Rich Dehnel <[dehnelr@rohdebros.com](mailto:dehnelr@rohdebros.com)>  
**Subject:** Kronenwetter, WI bonds and tax exempt certificate

You don't often get email from [a.seibert@kurita-water.com](mailto:a.seibert@kurita-water.com). [Learn why this is important](#)

Hi Rich,

Can you send me the fully executed payment and performance bonds for the Kronenwetter, WI project? Our credit policy requires we have these on hand before any equipment ships.

Your PO noted this was a tax exempt job. Can you send me the tax exempt certificate?

Thanks,

**Amy Seibert**

Controller of Capital Projects - Kurita America Inc

MOBILE (612) 703-3836 | [a.seibert@kurita-water.com](mailto:a.seibert@kurita-water.com) | [www.kuritaamerica.com](http://www.kuritaamerica.com)

This e-mail message and all attachments transmitted with it contain confidential and proprietary business information owned by Kurita America Inc. and intended solely for the use of the addressee. The transmission of this e-mail may be legally privileged. If the recipient of this message is not the intended person or entity, you are hereby notified that any reading, dissemination, distribution, copying, or other use of this message, its contents, hyperlinks, and attached files of any kind is strictly prohibited. If you have received this message in error, please notify the sender immediately by a reply to this electronic mail message and delete this message and all copies and backups thereof. All rights to the information contained in this e-mail are reserved by Kurita America Inc.

**Brian Marquardt**

---

**From:** Rich Dehnel  
**Sent:** Wednesday, October 18, 2023 7:56 AM  
**To:** Zach Gilmaster; Brian Marquardt  
**Cc:** Matthew R. Patterson  
**Subject:** 23066 Kronenwetter, Well #2- Filter System Delivery

Hi All,  
Below is a string of emails from the filter system company concerning submittals and delivery.

I have been getting the same response every week for the last couple of weeks as you can see.

So this is keeping everyone in the loop concerning delivery times of the filter system for this project.

Thank you for your time

**Rich Dehnel**  
PM/Project Engineer  
**Rohde Brothers, Inc.**  
W5745 Woodchuck Lane  
[Plymouth, WI 53073-0409](http://Plymouth, WI 53073-0409)  
Company Main: (920) 893-5905  
Direct: (920) 449-5767 | Cell: (920) 960-3638  
[dehnelr@rohdebros.com](mailto:dehnelr@rohdebros.com) | [www.rohdebros.com](http://www.rohdebros.com)



---

**From:** Nina HALVERSON <n.halverson@kurita-water.com>  
**Sent:** Monday, October 16, 2023 11:06 AM  
**To:** Rich Dehnel <dehnelr@rohdebros.com>; Brian Marquardt <marquardtb@rohdebros.com>  
**Cc:** Emily Nurmi <Emily@williamreidLtd.com>; Luke Laudolff <laudolffl@rohdebros.com>; Dan Moore <moored@rohdebros.com>  
**Subject:** RE: [EXT]RE: Kronenwetter, WI - Questions

I just had a meeting with my design team on the final document I was waiting for in order to submit – so this should be in your hands in the next few days.



There were some delays with the fabrication shop – they’re actually 52-54 weeks out for delivery and we had a new shop in order to meet the timelines for delivery.

As I noted in my previous email, I cannot give a delivery date for the tanks without approval of the submittal package, as that is required before we can secure the fabrication schedule. What date are you hoping to hit? I can present it to the fabrication shop, but we cannot guarantee it would be sooner than the quoted timeline once approval is given.

This timeline can be sped up some if you are able to review and approve the vessels right away once you get the submittal and then review and approve the remaining components after.

Thank you,

**Nina Halverson**

*Project Manager*

Mobile 651-706-0498 | [n.halverson@kurita-water.com](mailto:n.halverson@kurita-water.com)

Kurita America Inc. | [www.kuritaamerica.com](http://www.kuritaamerica.com)

[How are we doing? Take our short survey!](#)



**From:** Rich Dehnel <[dehnelr@rohdebros.com](mailto:dehnelr@rohdebros.com)>  
**Sent:** Monday, October 16, 2023 10:54 AM  
**To:** Nina HALVERSON <[n.halverson@kurita-water.com](mailto:n.halverson@kurita-water.com)>; Brian Marquardt <[marquardt@rohdebros.com](mailto:marquardt@rohdebros.com)>  
**Cc:** Emily Nurmi <[Emily@williamreidltd.com](mailto:Emily@williamreidltd.com)>; Luke Laudolff <[laudolffl@rohdebros.com](mailto:laudolffl@rohdebros.com)>; Dan Moore <[moored@rohdebros.com](mailto:moored@rohdebros.com)>  
**Subject:** [EXT]RE: Kronenwetter, WI - Questions

Hello Nina,  
It was mentioned in a previous email that the submittal for the large equipment package should have been received last week.

With a 44 week delivery time, plus the installation time, the project schedule is definitely at risk at its current timeline  
It was mentioned that the submittals would be received in 6-8 weeks once the PO was received.

The PO for this equipment was sent on 8/4/203, which is approximately 10 weeks ago.

When can we expect to see this document? As of right now, you are this is the only outstanding submittal on the project that I am aware of.

Also the question is still out there unanswered: is it possible to receive the (4) vertical tanks early?

Thank you for your time

**Rich Dehnel**  
PM/Project Engineer  
**Rohde Brothers, Inc.**  
W5745 Woodchuck Lane  
[Plymouth, WI 53073-0409](#)  
Company Main: (920) 893-5905



**From:** Nina HALVERSON <[n.halverson@kurita-water.com](mailto:n.halverson@kurita-water.com)>  
**Sent:** Tuesday, October 3, 2023 1:14 PM  
**To:** Rich Dehnel <[dehnelr@rohdebros.com](mailto:dehnelr@rohdebros.com)>  
**Subject:** Kronenwetter, WI - Questions

You don't often get email from [n.halverson@kurita-water.com](mailto:n.halverson@kurita-water.com). [Learn why this is important](#)

Good afternoon, Rich,

Quick introduction, I am the Kurita project manager handling the water filtration project for Kronenwetter, WI. I spoke to Emily at Willian Reid a bit and she noted you have a few questions about the submittals and the filter delivery timelines – hopefully I can provide you some information to assist in getting those answered.

The submittal package should be to you the week of 10/13, that is what we are aiming for and I am working with my design engineers to get all documents needed to get you the full package.

Once that is in your hands and reviewed and we have approval I can provide a better idea of delivery date for the system, essentially, we base the delivery timeline off the submittal approval date as we can't secure fabrication until we have release.

Can you provide me with the best contact information, site address and any other information you might find to be helpful?

I am traveling and have limited access while in the mountains but have been trying to get connected to check messages as able but will be back in office Monday 10/9. My best contact information is below, feel free to reach to me directly with any questions regarding the timelines, system, submittal, or anything project related as I can get this information to you quicker than Emily reaching to me and then back to you.

I hope the week is going well, please let me know if you need more information in the meantime, otherwise expect to see that submittal package in the coming weeks!

Thank you,

**Nina Halverson**  
Project Manager



This e-mail message and all attachments transmitted with it contain confidential and proprietary business information owned by Kurita America Inc. and intended solely for the use of the addressee. The transmission of this e-mail may be legally privileged. If the recipient of this message is not the intended person or entity, you are hereby notified that any reading, dissemination, distribution, copying, or other use of this message, its contents, hyperlinks, and attached files of any kind is strictly prohibited. If you have received this message in error, please notify the sender immediately by a reply to this electronic mail message and delete this message and all copies and backups thereof. All rights to the information contained in this e-mail are reserved by Kurita America Inc.

**Brian Marquardt**

---

**From:** Zach Gilmaster <zach@elliswi.com>  
**Sent:** Friday, October 20, 2023 10:58 AM  
**To:** Rich Dehnel  
**Cc:** Brian Marquardt; Dan Moore; Luke Laudolff  
**Subject:** RE: 23066 Kronenwetter Well #2 - Filter System Submittal

Thanks Rich. I have this in for review.

Zach Gilmaster  
Project Manager  
[Zach@elliswi.com](mailto:Zach@elliswi.com)



3201 Stanley Street  
Stevens Point, WI 54481  
Ph: 715-345-5000 ext. 133 • Fax: 715-345-5007  
[www.elliswi.com](http://www.elliswi.com)

---

**From:** Rich Dehnel <dehnelr@rohdebros.com>  
**Sent:** Friday, October 20, 2023 9:46 AM  
**To:** Zach Gilmaster <zach@elliswi.com>  
**Cc:** Brian Marquardt <marquardtb@rohdebros.com>; Dan Moore <moored@rohdebros.com>; Luke Laudolff <laudolffl@rohdebros.com>  
**Subject:** 23066 Kronenwetter Well #2 - Filter System Submittal

CAUTION: This email originated from outside your organization. Exercise caution when opening attachments or clicking links, especially from unknown senders.

Zach,  
Attached is the submittal for the Filter System and Associated Equipment.

The vendor would like to have to back reviewed, with/without comments by 11/1 or before.

We all know this equipment are the long lead time items that the schedule is built around.

Thank you for your assistance

**Rich Dehnel**  
PM/Project Engineer  
**Rohde Brothers, Inc.**  
W5745 Woodchuck Lane  
[Plymouth, WI 53073-0409](http://Plymouth, WI 53073-0409)  
Company Main: (920) 893-5905  
Direct: (920) 449-5767 | Cell: (920) 960-3638

**Brian Marquardt**

**From:** Zach Gilmaster (Ellis Stone Construction Company, Inc.)  
 <Ellis\_Stone\_Construction\_notifications@procoretech.com>  
**Sent:** Monday, November 6, 2023 1:37 PM  
**To:** Rich Dehnel  
**Subject:** Kronenwetter Well No. 2: Submittal Distributed: (#47.0: Shop Drawings)

# Kronenwetter Well No. 2



More details: [View online](#)  [View PDF](#)

**DO NOT REPLY TO THIS EMAIL**

This is a notification sent from an unmonitored email address.

Please click on the "View Online" link in this Email to reply to this Submittal in Procore.

**Zach Gilmaster has distributed (#47.0: Shop Drawings)**

Project:	Kronenwetter Well No. 2
Submittal #:	47
Title:	Shop Drawings
Recipients:	Rich Dehnel (Rohde Brothers, Inc.)
Distribution Message:	None
Additional Attachments:	None

**DISTRIBUTED RESPONSE**

Name:	Matthew Patterson (Becher Hoppe)
Response:	Reviewed as Noted
Comment:	see cover sheet
Attachments:	<a href="#">46 61 21 - Horizontal Pressure Filter System.pdf</a>

More details: [View online](#)  [View PDF](#)

**Brian Marquardt**

---

**From:** Zach Gilmaster <zach@elliswi.com>  
**Sent:** Wednesday, December 20, 2023 11:57 AM  
**To:** Rich Dehnel  
**Subject:** RE: Kronenwetter Well No. 2: Submittal Distributed: (#47.0: Shop Drawings)

Let me check with Matt to confirm for sure.

Zach Gilmaster  
Project Manager  
[Zach@elliswi.com](mailto:Zach@elliswi.com)



3201 Stanley Street  
Stevens Point, WI 54481  
Ph: 715-345-5000 ext. 133 • Fax: 715-345-5007  
[www.elliswi.com](http://www.elliswi.com)

---

**From:** Rich Dehnel <dehnelr@rohdebros.com>  
**Sent:** Wednesday, December 20, 2023 11:46 AM  
**To:** Zach Gilmaster <zach@elliswi.com>  
**Subject:** FW: Kronenwetter Well No. 2: Submittal Distributed: (#47.0: Shop Drawings)

CAUTION: This email originated from outside your organization. Exercise caution when opening attachments or clicking links, especially from unknown senders.

Zach,  
This return from B/H says Reviewed as noted...

In looking at the attachment on line, I don't see any notes or comments...Am I missing something?

Rich

---

**From:** Zach Gilmaster (Ellis Stone Construction Company, Inc.)  
<Ellis\_Stone\_Construction\_notifications@procoretech.com>  
**Sent:** Monday, November 6, 2023 1:37 PM  
**To:** Rich Dehnel <dehnelr@rohdebros.com>  
**Subject:** Kronenwetter Well No. 2: Submittal Distributed: (#47.0: Shop Drawings)

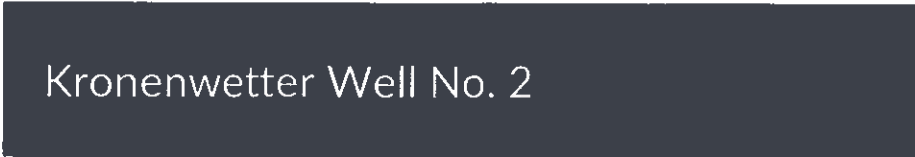

More details: [View online](#)  [View PDF](#)

**DO NOT REPLY TO THIS EMAIL**

This is a notification sent from an unmonitored email address.

Please click on the "View Online" link in this Email to reply to this Submittal in Procore.

**Zach Gilmaster has distributed (#47.0: Shop Drawings)**

---

Project:	Kronenwetter Well No. 2
Submittal #:	47
Title:	Shop Drawings
Recipients:	Rich Dehnel (Rohde Brothers, Inc.)
Distribution Message:	None
Additional Attachments:	None

**DISTRIBUTED RESPONSE**

---

Name:	Matthew Patterson (Becher Hoppe)
Response:	Reviewed as Noted
Comment:	see cover sheet
Attachments:	<a href="#">46 61 21 - Horizontal Pressure Filter System.pdf</a>

More details: [View online](#)  [View PDF](#)

**Brian Marquardt**

**From:** Matthew R. Patterson <mpatterson@becherhoppe.com>  
**Sent:** Wednesday, December 20, 2023 12:12 PM  
**To:** Zach Gilmaster  
**Cc:** Rich Dehnel  
**Subject:** RE: Kronenwetter - Filter Submittal  
**Attachments:** 46 61 21 - Horizontal Pressure Filter System FAC.pdf

Zach,  
I must have missed the cover sheet for the submittal. Here is the complete one.

**Matt Patterson, PE**  
Project Manager

**Becher-Hoppe Associates, Inc.**  
330 N. 4th Street | Wausau WI | 54403  
Direct 715-845-0419 | Mobile 715-574-2731  
Main 715-845-8000  
[mpatterson@becherhoppe.com](mailto:mpatterson@becherhoppe.com) | [www.becherhoppe.com](http://www.becherhoppe.com)

This email message is for the sole use of the intended recipient(s) and may contain confidential and privileged information. Any unauthorized review, use, disclosure or distribution is prohibited. If you are not the intended recipient, please contact the sender by reply email and destroy all copies of the original message.

---

**From:** Zach Gilmaster <zach@elliswi.com>  
**Sent:** Wednesday, December 20, 2023 11:58 AM  
**To:** Matthew R. Patterson <mpatterson@becherhoppe.com>  
**Cc:** Rich Dehnel <dehnelr@rohdebros.com>  
**Subject:** Kronenwetter - Filter Submittal

Matt,  
  
Good morning. I was double checking the review of the 46 61 21 – Horizontal Pressure Filter System submittal, which was marked “Reviewed as Noted,” but there aren’t any notes or review stamps by Becher Hoppe. Could you please confirm that this is good to go?

Thank you,  
  
Zach Gilmaster  
Project Manager  
[Zach@elliswi.com](mailto:Zach@elliswi.com)



3201 Stanley Street  
Stevens Point, WI 54481  
Ph: 715-345-5000 ext. 133 • Fax: 715-345-5007



**Brian Marquardt**

**From:** Zach Gilmaster (Ellis Stone Construction Company, Inc.)  
 <Ellis\_Stone\_Construction\_notifications@procoretech.com>  
**Sent:** Wednesday, December 20, 2023 12:15 PM  
**To:** Rich Dehnel  
**Subject:** Kronenwetter Well No. 2: Submittal Distributed: (#47.0: Shop Drawings)

# Kronenwetter Well No. 2



More details: [View online](#)  [View PDF](#)

**DO NOT REPLY TO THIS EMAIL**

This is a notification sent from an unmonitored email address.

Please click on the "View Online" link in this Email to reply to this Submittal in Procore.

## Zach Gilmaster has distributed (#47.0: Shop Drawings)

**Project:** Kronenwetter Well No. 2

**Submittal #:** 47

**Title:** Shop Drawings

**Recipients:** Zach Gilmaster (Ellis Stone Construction Company, Inc.)  
 Rich Dehnel (Rohde Brothers, Inc.)

**Distribution Message:** None

**Additional Attachments:** None

### DISTRIBUTED RESPONSE

**Name:** Matthew Patterson (Becher Hoppe)

**Response:** Reviewed as Noted

**Comment:** see cover sheet

**Attachments:** [46 61 21 - Horizontal Pressure Filter System FAC.pdf](#)  
[46 61 21 - Horizontal Pressure Filter System.pdf](#)

More details: [View online](#)  [View PDF](#)

**From:** [Zach Gilmaster](#)  
**To:** [Brian Marquardt](#)  
**Subject:** RE: Kronenwetter Well - Lead Times  
**Date:** Monday, January 29, 2024 9:08:00 AM  
**Attachments:** [image001.jpg](#)

---

Brian,

With that said, how long to get to the site and how long to install?

Thanks,

Zach Gilmaster  
Project Manager  
[Zach@elliswi.com](mailto:Zach@elliswi.com)



3201 Stanley Street  
Stevens Point, WI 54481  
Ph: 715-345-5000 ext. 133 • Fax: 715-345-5007  
[www.elliswi.com](http://www.elliswi.com)

---

**From:** Brian Marquardt <[marquardtb@rohdebros.com](mailto:marquardtb@rohdebros.com)>  
**Sent:** Friday, January 26, 2024 12:02 PM  
**To:** Zach Gilmaster <[zach@elliswi.com](mailto:zach@elliswi.com)>  
**Subject:** RE: Kronenwetter Well - Lead Times

**CAUTION:** This email originated from outside your organization. Exercise caution when opening attachments or clicking links, especially from unknown senders.

I received an email from the PM at Kurita Water for the water filter. It is scheduled to be done mid to end of August 2024. We will probably have some prep work we can do prior to this arriving but I am hesitant to do too much and rely on the submittals for dimensions.

**BRIAN MARQUARDT**  
Superintendent  
Rohde Brothers Inc.  
**920-838-1628**  
[marquardtb@rohdebros.com](mailto:marquardtb@rohdebros.com)

---

**From:** Zach Gilmaster <[zach@elliswi.com](mailto:zach@elliswi.com)>  
**Sent:** Thursday, January 25, 2024 12:36 PM  
**To:** Brian Marquardt <[marquardtb@rohdebros.com](mailto:marquardtb@rohdebros.com)>  
**Subject:** RE: Kronenwetter Well - Lead Times

Sounds good Brian. Just keep me posted.

Thanks,

Zach Gilmaster  
Project Manager  
[Zach@elliswi.com](mailto:Zach@elliswi.com)



3201 Stanley Street  
Stevens Point, WI 54481  
Ph: 715-345-5000 ext. 133 • Fax: 715-345-5007  
[www.elliswi.com](http://www.elliswi.com)

---

**From:** Brian Marquardt <[marquardtb@rohdebros.com](mailto:marquardtb@rohdebros.com)>  
**Sent:** Thursday, January 25, 2024 12:25 PM  
**To:** Zach Gilmaster <[zach@elliswi.com](mailto:zach@elliswi.com)>  
**Subject:** RE: Kronenwetter Well - Lead Times

**CAUTION:** This email originated from outside your organization. Exercise caution when opening attachments or clicking links, especially from unknown senders.

Zach, I have reached out to Jason Metz from William Reid to get us an update on the filter system and I will update you as soon as he gets back to me. This will be the major key to your schedule as everything depends on it.

**BRIAN MARQUARDT**  
Superintendent  
Rohde Brothers Inc.  
**920-838-1628**  
[marquardtb@rohdebros.com](mailto:marquardtb@rohdebros.com)

---

**From:** Zach Gilmaster <[zach@elliswi.com](mailto:zach@elliswi.com)>  
**Sent:** Wednesday, January 24, 2024 12:38 PM  
**To:** Brian Marquardt <[marquardtb@rohdebros.com](mailto:marquardtb@rohdebros.com)>  
**Subject:** Kronenwetter Well - Lead Times

Brian,

Good afternoon. We are at the point where you should have delivery dates for your long lead time items for the Kronenwetter Well project. Please send them to me as soon as possible, as I have to revise the overall schedule and add time. Becher Hoppe will need to revise the contract based on this information.

Thank you,

Zach Gilmaster  
Project Manager  
[Zach@elliswi.com](mailto:Zach@elliswi.com)



3201 Stanley Street  
Stevens Point, WI 54481  
Ph: 715-345-5000 ext. 133 • Fax: 715-345-5007  
[www.elliswi.com](http://www.elliswi.com)

**From:** [Zach Gilmaster](#)  
**To:** [Brian Marquardt](#)  
**Cc:** [Dan Moore](#)  
**Subject:** RE: Kronenwetter Well - Lead Times  
**Date:** Wednesday, March 13, 2024 12:06:00 PM  
**Attachments:** [image001.jpg](#)

---

Brian,

Sounds good on the submittal, as we need to push to get it reviewed to start the delivery clock.

As for the well, do you need to touch base with Mark Mackey of Kronenwetter? If so, let me know and I can apply some pressure to get you answers.

Thanks,

Zach Gilmaster  
Project Manager  
[Zach@elliswi.com](mailto:Zach@elliswi.com)



3201 Stanley Street  
Stevens Point, WI 54481  
Ph: 715-345-5000 ext. 133 • Fax: 715-345-5007  
[www.elliswi.com](http://www.elliswi.com)

---

**From:** Brian Marquardt <marquardtb@rohdebros.com>  
**Sent:** Wednesday, March 13, 2024 7:36 AM  
**To:** Zach Gilmaster <zach@elliswi.com>  
**Cc:** Dan Moore <moored@rohdebros.com>  
**Subject:** RE: Kronenwetter Well - Lead Times

**CAUTION:** This email originated from outside your organization. Exercise caution when opening attachments or clicking links, especially from unknown senders.

Kyle,

I'm trying to get some better submittals out of our vendor today yet. I do have his first submittal package but its pretty generic. I'm trying to avoid confusion on what we are using. If he doesn't get me something better today I'll send what I have tomorrow. As far as schedule, the filter package is still set to ship the end of August. We will do some prefab ahead of this. Our pipe has a 6 week lead time from the day I release it after submittal approval. A PO has already been written for the pipe and fittings. We are looking at coming onsite the week of March 25<sup>th</sup> to do the plumbing work we have. The HVAC work will be somewhere around there as well. Since plumbing and HVAC are

not really critical yet I'm using it as fill in work, but it will be done well ahead of the filter arriving.

I'm having a hard time getting in touch with the well guy, to confirm dates for the well work and shutdown. This was talked about for April but I need to confirm and schedule.

**BRIAN MARQUARDT**  
Superintendent  
Rohde Brothers Inc.  
**920-838-1628**  
[marquardtb@rohdebros.com](mailto:marquardtb@rohdebros.com)

---

**From:** Zach Gilmaster <[zach@elliswi.com](mailto:zach@elliswi.com)>  
**Sent:** Tuesday, March 12, 2024 8:55 AM  
**To:** Brian Marquardt <[marquardtb@rohdebros.com](mailto:marquardtb@rohdebros.com)>  
**Cc:** Dan Moore <[moored@rohdebros.com](mailto:moored@rohdebros.com)>  
**Subject:** RE: Kronenwetter Well - Lead Times

Brian,

Good morning. Do you have an update on your submittal, and any ship/delivery dates? Kronenwetter needs an updated schedule, so we don't incur liquidated damages. I would like to get them a revised schedule this week.

Also, Kyle is back onsite installing the FRP ceiling this week. Ellis is looking at pouring the generator pad, as well as the concrete apron to the building. Do you see any issues with that regarding your equipment install?

Please let me know.

Thank you,

Zach Gilmaster  
Project Manager  
[Zach@elliswi.com](mailto:Zach@elliswi.com)



3201 Stanley Street  
Stevens Point, WI 54481  
Ph: 715-345-5000 ext. 133 • Fax: 715-345-5007  
[www.elliswi.com](http://www.elliswi.com)

---

**From:** Zach Gilmaster  
**Sent:** Monday, March 4, 2024 8:07 AM  
**To:** Brian Marquardt <[marquardtb@rohdebros.com](mailto:marquardtb@rohdebros.com)>  
**Cc:** Dan Moore <[moored@rohdebros.com](mailto:moored@rohdebros.com)>

**Subject:** RE: Kronenwetter Well - Lead Times

Brian,

Good morning. Just keep me posted on the submittal, as I am awaiting your lead time information to update the overall schedule. I need to get that to the Village and Becher Hoppe as soon as possible.

Thank you,

Zach Gilmaster  
Project Manager  
[Zach@elliswi.com](mailto:Zach@elliswi.com)



3201 Stanley Street  
Stevens Point, WI 54481  
Ph: 715-345-5000 ext. 133 • Fax: 715-345-5007  
[www.elliswi.com](http://www.elliswi.com)

---

**From:** Brian Marquardt <[marquardtb@rohdebros.com](mailto:marquardtb@rohdebros.com)>  
**Sent:** Monday, February 26, 2024 12:06 PM  
**To:** Zach Gilmaster <[zach@elliswi.com](mailto:zach@elliswi.com)>  
**Cc:** Dan Moore <[moored@rohdebros.com](mailto:moored@rohdebros.com)>  
**Subject:** RE: Kronenwetter Well - Lead Times

**CAUTION:** This email originated from outside your organization. Exercise caution when opening attachments or clicking links, especially from unknown senders.

Zach, see my comments on the attached PDF. Keep in mind these dimensions are “close”. Once equipment arrives everything still needs to be verified. One factor will be how much additional shimming is needed to level the filter and if there are any new requirements regarding supporting the weight of the filter.

We are working on the submittal regarding the stainless pipe and fittings. Because of the AIS requirements its taking longer to source everything.

**BRIAN MARQUARDT**  
Superintendent  
Rohde Brothers Inc.  
**920-838-1628**  
[marquardtb@rohdebros.com](mailto:marquardtb@rohdebros.com)

---

**From:** Zach Gilmaster <[zach@elliswi.com](mailto:zach@elliswi.com)>  
**Sent:** Monday, February 26, 2024 10:58 AM  
**To:** Brian Marquardt <[marquardtb@rohdebros.com](mailto:marquardtb@rohdebros.com)>

**Cc:** Dan Moore <[moored@rohdebros.com](mailto:moored@rohdebros.com)>  
**Subject:** RE: Kronenwetter Well - Lead Times

Brian,

Good morning. Just wanted to follow up on my below email, as well as my email (and the attached) regarding Becher Hoppe's pipe layout questions.

Thank you,

Zach Gilmaster  
Project Manager  
[Zach@elliswi.com](mailto:Zach@elliswi.com)



3201 Stanley Street  
Stevens Point, WI 54481  
Ph: 715-345-5000 ext. 133 • Fax: 715-345-5007  
[www.elliswi.com](http://www.elliswi.com)

---

**From:** Zach Gilmaster  
**Sent:** Monday, February 19, 2024 1:45 PM  
**To:** Brian Marquardt <[marquardtb@rohdebros.com](mailto:marquardtb@rohdebros.com)>  
**Cc:** Dan Moore <[moored@rohdebros.com](mailto:moored@rohdebros.com)>  
**Subject:** RE: Kronenwetter Well - Lead Times

Brian,

Good afternoon. I am reworking the schedule per your below email. Any update on your submittal? I am awaiting a response yet from Becher Hoppe on the RFI.

Also, they received your revised COR. It will be a bit yet on full approval, as it needs to go in front of some committees.

Thank you,

Zach Gilmaster  
Project Manager  
[Zach@elliswi.com](mailto:Zach@elliswi.com)





3201 Stanley Street  
Stevens Point, WI 54481  
Ph: 715-345-5000 ext. 133 • Fax: 715-345-5007  
[www.elliswi.com](http://www.elliswi.com)

---

**From:** Brian Marquardt <[marquardtb@rohdebros.com](mailto:marquardtb@rohdebros.com)>  
**Sent:** Wednesday, January 31, 2024 10:25 AM  
**To:** Zach Gilmaster <[zach@elliswi.com](mailto:zach@elliswi.com)>  
**Cc:** Dan Moore <[moored@rohdebros.com](mailto:moored@rohdebros.com)>  
**Subject:** RE: Kronenwetter Well - Lead Times

CAUTION: This email originated from outside your organization. Exercise caution when opening attachments or clicking links, especially from unknown senders.

Zach,

I would say 4 weeks from the day the filter arrives to fully install with startup happening the fifth week. It will take 2 days to receive and set the equipment in place. We will be prefabbing as much as we can ahead of time. This will begin as soon as we send in submittals on the stainless steel components and receive approval. I'm working on them now. We will be doing some piping in the existing side of the building at the same time as the work is being done on the well to get us out to the first set of valves so we only have one shutdown. I need to do some coordinating on the details of the shutdown yet.

**BRIAN MARQUARDT**  
Superintendent  
Rohde Brothers Inc.  
**920-838-1628**  
[marquardtb@rohdebros.com](mailto:marquardtb@rohdebros.com)

---

**From:** Zach Gilmaster <[zach@elliswi.com](mailto:zach@elliswi.com)>  
**Sent:** Monday, January 29, 2024 9:08 AM  
**To:** Brian Marquardt <[marquardtb@rohdebros.com](mailto:marquardtb@rohdebros.com)>  
**Subject:** RE: Kronenwetter Well - Lead Times

Brian,

With that said, how long to get to the site and how long to install?

Thanks,

Zach Gilmaster

Project Manager  
[Zach@elliswi.com](mailto:Zach@elliswi.com)



3201 Stanley Street  
Stevens Point, WI 54481  
Ph: 715-345-5000 ext. 133 • Fax: 715-345-5007  
[www.elliswi.com](http://www.elliswi.com)

---

**From:** Brian Marquardt <[marquardt@rohdebros.com](mailto:marquardt@rohdebros.com)>  
**Sent:** Friday, January 26, 2024 12:02 PM  
**To:** Zach Gilmaster <[zach@elliswi.com](mailto:zach@elliswi.com)>  
**Subject:** RE: Kronenwetter Well - Lead Times

CAUTION: This email originated from outside your organization. Exercise caution when opening attachments or clicking links, especially from unknown senders.

I received an email from the PM at Kurita Water for the water filter. It is scheduled to be done mid to end of August 2024. We will probably have some prep work we can do prior to this arriving but I am hesitant to do too much and rely on the submittals for dimensions.

**BRIAN MARQUARDT**  
Superintendent  
Rohde Brothers Inc.  
**920-838-1628**  
[marquardt@rohdebros.com](mailto:marquardt@rohdebros.com)

---

**From:** Zach Gilmaster <[zach@elliswi.com](mailto:zach@elliswi.com)>  
**Sent:** Thursday, January 25, 2024 12:36 PM  
**To:** Brian Marquardt <[marquardt@rohdebros.com](mailto:marquardt@rohdebros.com)>  
**Subject:** RE: Kronenwetter Well - Lead Times

Sounds good Brian. Just keep me posted.

Thanks,

Zach Gilmaster  
Project Manager  
[Zach@elliswi.com](mailto:Zach@elliswi.com)



3201 Stanley Street  
Stevens Point, WI 54481  
Ph: 715-345-5000 ext. 133 • Fax: 715-345-5007  
[www.elliswi.com](http://www.elliswi.com)

---

**From:** Brian Marquardt <[marquardtb@rohdebros.com](mailto:marquardtb@rohdebros.com)>  
**Sent:** Thursday, January 25, 2024 12:25 PM  
**To:** Zach Gilmaster <[zach@elliswi.com](mailto:zach@elliswi.com)>  
**Subject:** RE: Kronenwetter Well - Lead Times

CAUTION: This email originated from outside your organization. Exercise caution when opening attachments or clicking links, especially from unknown senders.

Zach, I have reached out to Jason Metz from William Reid to get us an update on the filter system and I will update you as soon as he gets back to me. This will be the major key to your schedule as everything depends on it.

**BRIAN MARQUARDT**  
Superintendent  
Rohde Brothers Inc.  
**920-838-1628**  
[marquardtb@rohdebros.com](mailto:marquardtb@rohdebros.com)

---

**From:** Zach Gilmaster <[zach@elliswi.com](mailto:zach@elliswi.com)>  
**Sent:** Wednesday, January 24, 2024 12:38 PM  
**To:** Brian Marquardt <[marquardtb@rohdebros.com](mailto:marquardtb@rohdebros.com)>  
**Subject:** Kronenwetter Well - Lead Times

Brian,

Good afternoon. We are at the point where you should have delivery dates for your long lead time items for the Kronenwetter Well project. Please send them to me as soon as possible, as I have to revise the overall schedule and add time. Becher Hoppe will need to revise the contract based on this information.

Thank you,

Zach Gilmaster  
Project Manager  
[Zach@elliswi.com](mailto:Zach@elliswi.com)



3201 Stanley Street

Stevens Point, WI 54481  
Ph: 715-345-5000 ext. 133 • Fax: 715-345-5007  
[www.elliswi.com](http://www.elliswi.com)

## Project Status Report Drinking Water Treatment Facility Construction

Village of Kronenwetter, Wisconsin  
Becher Hoppe Project Number 2021.022

**Period | December 2024**

**Activities This Period**

- **Project Management:** Joe Kafczynski
  - Owner Coordination
  - Contractor Coordination
  - Internal and subconsultant team coordination
  - Submittals management
  - WDNR Coordination
- **Construction Related Services:**
  - Part-time on-site RPR Services – Joe Kafczynski
  - Construction progress documentation
- **Change management**
  - A summary of the number of submittals, Request for Information (RFI), Request for Proposal (RFP) and Change Orders processed, or under review, during this period are summarized below

Submittals				Change Orders	RFIs	RFPs
Received To-Date, including resubmittals		53		Approved	To – Date	To - Date
Submittals This Month				4	9	3
Received	Reviewed	Returned to Contractor	Under Review	In process	This Month	This Month
0	0	0	0	1	1	0

**Near-Term Activities**

- **Project Management:**
  - Field staff oversight
  - Subconsultant oversight and coordination
  - Change management coordination
  - Construction Progress Meetings and Project Site Visits
- **Regulatory Affairs and Funding:**
  - Pay Application Processing and SDWLP disbursement requests

- **Construction Related Services**
  - RPR services and construction documentation including photos (construction & aerial)
  - Submittal / RFI / RFP coordination and review
  - Material testing review and oversight
  - Payroll review
  - Construction surveying
  - Equipment installation and start up coordination and oversight
  
- **Change Orders**
  - Becher Hoppe is working with the contractor on the costs associated with unforeseen issues during the Well No. 2 pump rebuild requiring extra time.
  - Becher Hoppe has again requested the Contractor provide a better explanation, description, and breakdown of costs associated with this change proposal request.
  - Becher Hoppe will let you know when we receive and review this information.

**Upcoming RFP's –**

None

**Completed Work at Site by Contractor**

- Building Construction
- Well No. 2 Rebuild
- Rough grading of site
- Overhead Door Coiling Door Installed (CO 4)
- Generator Delivered to Site
- Concrete Approach
- Water service tie in and sanitary sewer lateral
- Backwash tank connection to sanitary sewer
- Generator Start up and Testing
- 90% of Media Installed
- Mechanical Piping/Process Piping
- Process Pipe and Tank Coatings

**Future Work**

- Startup Filter Equipment
- Vessel Media Installation (Anthracite)
- Joint Sealing
- Restoration work (Landscaping touch up, Etc.)
- Punch List

### Schedule Update

- Contractor, Suppliers, and Start Up teams have been holding weekly start up meetings since December 12, 2024 to hone in scheduling and items needed for start up.
- Ellis provides an updated schedule at each of these meetings. The latest version from 1/2/2025 is provided with this update.
- All Media, except top layer of anthracite, has been installed into the vessels. Anthracite will be installed this week after greensand media has been backwashed, skimmed, and regenerated.
- Ellis is still requesting a Contract Extension as provided and discussed during previous meetings. This request is requesting a new substantial completion date of 1/10/2024 with a final completion date of 2/10/2024 (we are assuming the dates they are requesting are in the year 2025 not 2024).
- There was a mishap during installation of one of the vertical vessels as it tipped/fell over while it was being relocated into the building. The Village (Greg) and Becher Hoppe have requested that the vessel be thoroughly inspected before being installed. Kurita has provided a letter regarding this mishap which is included in this update. Rhode Brothers have pressure tested the vessels using air (no issues found) and will also hydrostatic pressure test the vessels in accordance with project specifications.

## Project Cost Summaries:

Cost Category	FAA Loan Amount (at FUND)	Revised Loan Amount (at FAA)	Total Amount Approved	Total Amount Paid	Pay Req #1	Pay Req #2	Pay Req #3	Pay Req #4*	Unexpended Balance
1. Force Account	\$0.00	\$0.00	\$0.00	\$0.00	\$0.00	\$0.00	\$0.00	\$0.00	\$0.00
2. Interim Financing	\$0.00	\$0.00	\$0.00	\$0.00	\$0.00	\$0.00	\$0.00	\$0.00	\$0.00
3. Planning & Design Contracts	\$228,100.00	\$228,100.00	\$223,100.00	\$223,100.00	\$223,100.00	\$0.00	\$0.00	\$0.00	\$5,000.00
BECHER-HOPPE ASSOCIATES, INC. (BH PD)	\$228,100.00	\$228,100.00	\$223,100.00	\$223,100.00	\$223,100.00		\$0.00	\$0.00	\$5,000.00
4. Land Acquisition/Easement	\$0.00	\$0.00	\$0.00	\$0.00	\$0.00	\$0.00	\$0.00	\$0.00	\$0.00
5. Construction Management/Engineering	\$90,000.00	\$90,000.00	\$63,212.33	\$63,212.33	\$0.00	\$0.00	\$63,212.33	\$11,520.00	\$15,267.67
BECHER-HOPPE ASSOCIATES, INC. (E/CM)	\$90,000.00	\$90,000.00	\$63,212.33	\$63,212.33			\$63,212.33	\$11,520.00	\$15,267.67
6. Construction/Equipment	\$0.00	\$2,873,043.00	\$1,767,838.41	\$1,767,838.41	\$0.00	\$1,335,510.29	\$432,328.12	\$216,802.16	\$888,402.43
ELLIS STONE CONSTRUCTION COMPANY (ELLIS STONE)	\$0.00	\$2,873,043.00	\$1,767,838.41	\$1,767,838.41		\$1,335,510.29	\$432,328.12	\$216,802.16	\$888,402.43
7. Contingency	\$143,100.00	\$132,057.00	\$0.00	\$0.00	\$0.00	\$0.00	\$66,444.00	\$0.00	\$65,613.00
8. Miscellaneous Costs	\$12,300.00	\$12,300.00	\$0.00	\$0.00	\$0.00	\$0.00	\$0.00	\$0.00	\$12,300.00
9. Closing Costs	\$50,000.00	\$50,000.00	\$0.00	\$0.00	\$0.00	\$0.00	\$0.00	\$0.00	\$50,000.00
<b>Grand Total</b>	<b>\$523,500.00</b>	<b>\$3,385,500.00</b>	<b>\$2,054,150.74</b>	<b>\$2,054,150.74</b>	<b>\$223,100.00</b>	<b>\$1,335,510.29</b>	<b>\$561,984.45</b>	<b>\$228,322.16</b>	<b>\$1,036,583.10</b>

\*Disbursement Request/Pay Request #3 was sent to DNR for review and approval on 7/19/2024. This table assumes they have reviewed, approved, and paid the amounts listed.

Notes: The "Revised Loan Amount" reflects that \$90,000.00 of the loan amount was approved for Construction Management/Engineering Services. Current construction services agreement between the Engineer and Village is \$74,000.00. This means the actual "Unexpended Balance" remaining for Construction Management/Engineering Services is \$74,000.00 - \$74,732.33 = \$(732.33). Engineering costs in this scenario are over amount. RPR service Contract for A/E services are on a time and material basis.



Project Progress Pictures (from December 2024 and January 2025)



Process Piping Installed



Process Piping Installed



Coatings on Vessels and Piping



Chemical Feed Equipment Installed



Generator Load Bank Testing



Final Coat of Paint on Horizontal Vessel

## Kronenwetter Start Up Meeting #4 1/2/25

### Attendees:

Brian Marquardt – Rohde Brothers  
Dan Moore – Rohde Brothers  
Emily Nurmi – William Reid  
Elbert Johnson – Kurita  
Bryan Gawlik – ECON Electric  
Matt Esselman – ECON Electric  
Zach Gilmaster – Ellis Construction  
Mark Mackey – Village of Kronenwetter  
Joe Kafczynski – Becher Hoppe

### Items discussed:

- Rohde Update:
  - Waiting for the painter to be complete.
  - Back onsite this week to fill and test piping.
  - Chosen lab to conduct testing of samples is US Water in Weston.
- Howard Grote Update:
  - Manpower onsite Friday (1/3) and Saturday (1/4) to finish vessel and piping painting.
- ECON Electric Update:
  - Load bank test scheduled for 1/3
  - Simulate a power outage
    - Becher Hoppe to be onsite
- Potassium permanganate & sodium bisulfite are scheduled to be delivered Friday 1/3.

### Action Items:

- Rohde to provide the following to Ellis:
  - Confirm dates/times for startups and owner training.
  - Rohde to provide 2 passed samples prior to tie in.
- Becher Hoppe to provide dates for substantial completion and close outs.
  - Ellis Punch List items:
    - Perimeter expansion joint to have sealant
    - Overhead door seal on bottom

Joe to send info on stainless pipe markings

- a. HGS to not paint stainless. Labels on piping to be installed in lieu of paint.

## Section 5, Item E.

Requirements	Completed	Estimated Completion Date
1. Underdrain nozzles installed per instructions. If <u>factory</u> installed, then hand checked. <b>All American doing the install this is happening the week of 12-16</b>	<input checked="" type="checkbox"/>	Click to enter date.
2. Gravel (if applicable) and filter media installed per instructions. <b>All American doing the install week of 12-16</b>	<input checked="" type="checkbox"/>	Click to enter date.
3. Service and backwash water are available. <b>Yes, Will be by the week of the 6th (Wednesday) hopefully. As of 12-19 on track for 1-6-25 as of 1-3-25</b>	<input checked="" type="checkbox"/>	Click to enter date.
4. Backwash discharge containment is available. Contact project manager for quantity. <b>Will be still on track for 1-6 as of 1-3-25</b>	<input checked="" type="checkbox"/>	Click to enter date.
5. Greensand media backwashed and skimmed per instructions (if applicable). <b>Is all American doing this need to make sure? Sounds like Kurita is doing this during the first trip sch, on 1-6-25 as of 12-19 no change as of 1-3-25</b>	<input type="checkbox"/>	Click to enter date.
6. Anthracite backwashed and skimmed per instructions (if required). <b>No skimming to be installed during the week of the 6<sup>th</sup> as of 12-19 no change as of 1-3-25</b>	<input checked="" type="checkbox"/>	Click to enter date.
7. Does the site engineer require KMnO <sub>4</sub> on-site (if required). Contact project manager for quantity. <b>Looking into the amount of sodium meta bisulfite for oxidation destruction? The site will be using 12% Cl<sub>2</sub>, the ratio for the bisulfite used to neutralize the chlorine Has been found in the OMM as of 12-19 to be on site on 1-3-25</b>	<input checked="" type="checkbox"/>	Click to enter date.
8. Are testing reagents on site? <b>Check on with Nina will be on site by startup week of 1-6-25 on site as of 12-19 /still not found as of 1-3-25 site will have some available</b>	<input checked="" type="checkbox"/>	Click to enter date.
9. All other <b>process required</b> chemicals on-site. <b>Not Kurita week of 1-6-25 to be on site. As of 12-19 to be on site 1-3-25</b>	<input checked="" type="checkbox"/>	Click to enter date.
10. Filter system sterilized (if required by the state). <b>Bac-t's passed prior to commissioning (By others) still need to be complete as of 12-19 the piping will be complete or in process by the first week of start up with the filters to follow the anthracite addition. As of 1-3-25</b>	<input checked="" type="checkbox"/>	Click to enter date.
11. All instrumentation and valve wiring in place and terminated. <b>Will be by commissioning date. On track as of 1-3-25</b>	<input checked="" type="checkbox"/>	Click to enter date.
12. Are the equipment name plates on site? <b>Nina to locate reorders, found as of 12-19. No change as of 1-3-25</b>	<input checked="" type="checkbox"/>	Click to enter date.
13. All loose shipped components (valves, orifice plates, instrumentation, chemical injection, etc.) are installed per manufacturer guidelines. <b>Yes</b>	<input checked="" type="checkbox"/>	Click to enter date.

Are Reagents on site. \*\*\*Correct for - Filter, Softener, aerator/stripping towers.

Disinfect iron man filter prior to application of ironman. KMnO<sub>4</sub> required for ironman solutions.

Name plate for equipment on site/affixed to equipment. (when request for NES trip to commission have PM order plates)

<b>Project:</b> Kronenwetter Well
<b>Superintendent/Site Contact:</b>
<b>Date:</b> 1/2/2025

**Kronenwetter Well**



Section 5, Item E.

3201 Stanley Street • Stevens Point, WI 54481 • (715) 345-5000

		Month: December/January																				
		Date:	30	31	1	2	3	6	7	8	9	10	13	14	15	16	17	20	21	22	23	24
Description of Work	Contractor	M	T	W	T	F	M	T	W	T	F	M	T	W	T	F	M	T	W	T	F	
Electrical work continues	ECON Electric	X	X	N	X																	
7am Generator Start Up	ECON Electric			E		X																
11am Training with Village of Kronenwetter	ECON Electric			W		X																
Final Electrical Inspection w/ State	ECON Electric					X																
				Y																		
Vessel/piping painting	Howard Grote	X	X	E	X	X																
Fill piping with water, hydrotest, chlorinate process piping	Rohde Brothers	X	X	A																		
Flush piping, send 1st Bac T sample to lab	Rohde Brothers			R	X																	
Panel Programming, prep for greensand backwash	Rohde Brothers/Kurita			S			X	X	X	X	X											
Program Integration & Chemical Pumps	ECON/PJ Kortens						X	X														
Chemical Pump Startup	Rohde/William Reid								X													
Greensand Backwash	Rohde								X													
Install Anthracite	Rohde/Kurita								X													
1/13/25-1/17/25: System Startup & Owner Training	Rohde Brothers/Kurita/VOK											X	X	X	X	X						
Substantial Completion	Becher Hoppe																					
Punch List	Becher Hoppe																					
Final Completion	Becher Hoppe																					

12/9/24

Brian Marquardt  
Superintendent  
Rhode Brothers Inc.  
W5745 Woodchuck Ln  
Plymouth, WI 53073

RE: Village of Kronenwetter, WI – Well No. 2 Water Treatment Facility  
Tonka Water Job #J0030780

Dear Brian:

This letter is being sent to meet requirements for recertification of one(1) of the Vertical Pressure Filters that was dropped on it's side on October 31, 2024 while being moved into the building.

After working with our fabrication and inspection team it has been determined that if the vessel has no visual damage, all paint, weld seams, and internal components are in tact and secure the vessel does not need to be brought back for repairs. As noted in communication with Rhode Brothers, Inc and the site engineer, this vessel will be tested on site at the expense of Rhode Brothers, Inc to pressure rating of 130psi per design and ASME code, if this tests without issue all factory warranties will remain.

Once testing is completed, Rhode Brothers, Inc will need to send a copy of the test results to Nina Halverson at Kurita to keep in the project files.

Should there be issues with the testing Kurita needs to be informed immediately so we can begin working with Rhode Brothers and the site to make any necessary arrangements to complete repair, which would be at the expense of Rhode Brothers, Inc if they are a result of the vessel being dropped during installation.

Please reach out if there are any questions or concerns.

Sincerely,

*Nina Halverson*

Nina Halverson  
Project Manager

**Becher Hoppe**  
**Invoice 23434**

Date: Sept. 30, 2023

	<b>Water Metering Station</b>	<b>Budget</b>	<b>% Complete</b>	<b>Total Billed</b>	<b>Previous Billing</b>	<b>Current Billing</b>	<b>Remaining Balance</b>
	Desgin Service	22,100.00	100%	22,100.00	22,100.00	0.00	0.00
	Change Order Re-disinfection	1,500.00	100%	1,500.00	1,500.00	0.00	0.00
	<b>Sub -Contract Value</b>	<b>23,600.00</b>		<b>22,100.00</b>	<b>22,100.00</b>	<b>0.00</b>	<b>0.00</b>
	<b>New Contract Value</b>	<b>23,600.00</b>					<b>0.00</b>
	<b>Water Treatment Plant</b>	228,100.00	98%	223,100.00	223,100.00	0.00	5,000.00
	<b>Sub -Contract Value</b>	<b>228,100.00</b>		<b>223,100.00</b>	<b>223,100.00</b>	<b>0.00</b>	5,000.00
	<b>New Contract Value</b>	<b>228,100.00</b>					<b>5,000.00</b>
	<b>Construction Administration</b>	<b>Budget</b>	<b>% Complete</b>	<b>Total Billed</b>	<b>Previous Billing</b>	<b>Current Billing</b>	<b>Remaining Balance</b>
		52,000.00	40%	20,800.00	10,400.00	10,400.00	31,200.00
	<b>Sub -Contract Value</b>	<b>52,000.00</b>		<b>20,800.00</b>	<b>10,400.00</b>	<b>10,400.00</b>	31,200.00
	<b>New Contract Value</b>	<b>280,100.00</b>					<b>36,200.00</b>
	<b>Construction Services on-site</b>	<b>Budget</b>	<b>% Complete</b>	<b>Total Billed</b>	<b>Previous Billing</b>	<b>Current Billing</b>	<b>Remaining Balance</b>
	Onsite Labor	20,000.00	28%	5,521.50	1,835.00	3,686.50	14,478.50
	Reimbursables	2,000.00	6%	125.16	13.79	111.37	1,874.84
	<b>Sub -Contract Value</b>	<b>22,000.00</b>		<b>5,646.66</b>	<b>1,848.79</b>	<b>3,797.87</b>	<b>14,478.50</b>
	<b>New Contract Value</b>	<b>302,100.00</b>					<b>50,678.50</b>
					<b>TOTAL CURRENT</b>	<b>14,197.87</b>	



**Becher Hoppe  
Invoice 23434**

Date: Oct 31, 2023

	<b>Water Metering Station</b>	<b>Budget</b>	<b>% Complete</b>	<b>Total Billed</b>	<b>Previous Billing</b>	<b>Current Billing</b>	<b>Remaining Balance</b>
	Desgin Service	22,100.00	100%	22,100.00	22,100.00	0.00	0.00
	Change Order Re-disinfection	1,500.00	100%	1,500.00	1,500.00	0.00	0.00
	<b>Sub -Contract Value</b>	<b>23,600.00</b>		<b>22,100.00</b>	<b>22,100.00</b>	<b>0.00</b>	<b>0.00</b>
	<b>New Contract Value</b>	<b>23,600.00</b>					<b>0.00</b>
	<b>Water Treatment Plant</b>	228,100.00	98%	223,100.00	223,100.00	0.00	5,000.00
	<b>Sub -Contract Value</b>	<b>228,100.00</b>		<b>223,100.00</b>	<b>223,100.00</b>	<b>0.00</b>	5,000.00
	<b>New Contract Value</b>	<b>228,100.00</b>					<b>5,000.00</b>
	<b>Construction Administration</b>	<b>Budget</b>	<b>% Complete</b>	<b>Total Billed</b>	<b>Previous Billing</b>	<b>Current Billing</b>	<b>Remaining Balance</b>
		52,000.00	45%	23,400.00	20,800.00	2,600.00	28,600.00
	<b>Sub -Contract Value</b>	<b>52,000.00</b>		<b>23,400.00</b>	<b>20,800.00</b>	<b>2,600.00</b>	28,600.00
	<b>New Contract Value</b>	<b>280,100.00</b>					<b>33,600.00</b>
	<b>Construction Services on-site</b>	<b>Budget</b>	<b>% Complete</b>	<b>Total Billed</b>	<b>Previous Billing</b>	<b>Current Billing</b>	<b>Remaining Balance</b>
	Onsite Labor	20,000.00	73%	14,569.50	5,521.50	9,048.00	5,430.50
	Reimbursables	2,000.00	15%	302.68	125.16	177.52	1,697.32
	<b>Sub -Contract Value</b>	<b>22,000.00</b>		<b>14,569.50</b>	<b>5,521.50</b>	<b>9,225.52</b>	<b>5,430.50</b>
	<b>New Contract Value</b>	<b>302,100.00</b>					<b>39,030.50</b>
					<b>TOTAL CURRENT</b>	<b>11,825.52</b>	

**Becher Hoppe**  
**Invoice 23484**

Date: November 30, 2023

	<b>Water Metering Station</b>	<b>Budget</b>	<b>% Complete</b>	<b>Total Billed</b>	<b>Previous Billing</b>	<b>Current Billing</b>	<b>Remaining Balance</b>
	Desgin Service	22,100.00	100%	22,100.00	22,100.00	0.00	0.00
	Change Order Re-disinfection	1,500.00	100%	1,500.00	1,500.00	0.00	0.00
	<b>Sub -Contract Value</b>	<b>23,600.00</b>		<b>22,100.00</b>	22,100.00	<b>0.00</b>	<b>0.00</b>
	<b>New Contract Value</b>	<b>23,600.00</b>					<b>0.00</b>
	<b>Water Treatment Plant</b>	228,100.00	98%	223,100.00	223,100.00	0.00	5,000.00
	<b>Sub -Contract Value</b>	<b>228,100.00</b>		<b>223,100.00</b>	223,100.00	<b>0.00</b>	5,000.00
	<b>New Contract Value</b>	<b>228,100.00</b>					<b>5,000.00</b>
	<b>Construction Administration</b>	<b>Budget</b>	<b>% Complete</b>	<b>Total Billed</b>	<b>Previous Billing</b>	<b>Current Billing</b>	<b>Remaining Balance</b>
		52,000.00	50%	26,000.00	23,400.00	2,600.00	26,000.00
	<b>Sub -Contract Value</b>	<b>52,000.00</b>		<b>26,000.00</b>	<b>23,400.00</b>	<b>2,600.00</b>	26,000.00
	<b>New Contract Value</b>	<b>280,100.00</b>					<b>31,000.00</b>
	<b>Construction Services on-site</b>	<b>Budget</b>	<b>% Complete</b>	<b>Total Billed</b>	<b>Previous Billing</b>	<b>Current Billing</b>	<b>Remaining Balance</b>
	Onsite Labor	20,000.00	82%	16,384.50	14,569.50	1,815.00	3,615.50
	Reimbursables	2,000.00	18%	356.39	302.68	53.71	1,643.61
	<b>Sub -Contract Value</b>	<b>22,000.00</b>		<b>16,384.50</b>	<b>14,569.50</b>	<b>1,868.71</b>	<b>3,615.50</b>
	<b>New Contract Value</b>	<b>302,100.00</b>					<b>34,615.50</b>
					<b>TOTAL CURRENT</b>	<b>4,468.71</b>	

**Becher Hoppe**  
**Invoice 23543**

Date: December 30, 2023

	<b>Water Metering Station</b>	<b>Budget</b>	<b>% Complete</b>	<b>Total Billed</b>	<b>Previous Billing</b>	<b>Current Billing</b>	<b>Remaining Balance</b>
	Desgin Service	22,100.00	100%	22,100.00	22,100.00	0.00	0.00
	Change Order Re-disinfection	1,500.00	100%	1,500.00	1,500.00	0.00	0.00
	<b>Sub -Contract Value</b>	<b>23,600.00</b>		<b>22,100.00</b>	22,100.00	<b>0.00</b>	<b>0.00</b>
	<b>New Contract Value</b>	<b>23,600.00</b>					<b>0.00</b>
	<b>Water Treatment Plant</b>	228,100.00	98%	223,100.00	223,100.00	0.00	5,000.00
	<b>Sub -Contract Value</b>	<b>228,100.00</b>		<b>223,100.00</b>	223,100.00	<b>0.00</b>	5,000.00
	<b>New Contract Value</b>	<b>228,100.00</b>					<b>5,000.00</b>
	<b>Construction Administration</b>	<b>Budget</b>	<b>% Complete</b>	<b>Total Billed</b>	<b>Previous Billing</b>	<b>Current Billing</b>	<b>Remaining Balance</b>
		52,000.00	55%	28,600.00	26,000.00	2,600.00	23,400.00
	<b>Sub -Contract Value</b>	<b>52,000.00</b>		<b>28,600.00</b>	<b>26,000.00</b>	<b>2,600.00</b>	23,400.00
	<b>New Contract Value</b>	<b>280,100.00</b>					<b>28,400.00</b>
	<b>Construction Services on-site</b>	<b>Budget</b>	<b>% Complete</b>	<b>Total Billed</b>	<b>Previous Billing</b>	<b>Current Billing</b>	<b>Remaining Balance</b>
	Onsite Labor	20,000.00	94%	18,859.50	16,384.50	2,475.00	1,140.50
	Reimbursables	2,000.00	23%	466.43	356.39	110.04	1,533.57
	<b>Sub -Contract Value</b>	<b>22,000.00</b>		<b>18,859.50</b>	<b>16,384.50</b>	<b>2,585.04</b>	<b>1,140.50</b>
	<b>New Contract Value</b>	<b>302,100.00</b>					<b>29,540.50</b>
					<b>TOTAL CURRENT</b>	<b>5,185.04</b>	

**Becher Hoppe**  
**Invoice 23567**

Date: January 31, 2024

	<b>Water Metering Station</b>	<b>Budget</b>	<b>% Complete</b>	<b>Total Billed</b>	<b>Previous Billing</b>	<b>Current Billing</b>	<b>Remaining Balance</b>
	Desgin Service	22,100.00	100%	22,100.00	22,100.00	0.00	0.00
	Change Order Re-disinfection	1,500.00	100%	1,500.00	1,500.00	0.00	0.00
	<b>Sub -Contract Value</b>	<b>23,600.00</b>		<b>22,100.00</b>	22,100.00	<b>0.00</b>	<b>0.00</b>
	<b>New Contract Value</b>	<b>23,600.00</b>					<b>0.00</b>
	<b>Water Treatment Plant</b>	228,100.00	98%	223,100.00	223,100.00	0.00	5,000.00
	<b>Sub -Contract Value</b>	<b>228,100.00</b>		<b>223,100.00</b>	223,100.00	<b>0.00</b>	5,000.00
	<b>New Contract Value</b>	<b>228,100.00</b>					<b>5,000.00</b>
	<b>Construction Administration</b>	<b>Budget</b>	<b>% Complete</b>	<b>Total Billed</b>	<b>Previous Billing</b>	<b>Current Billing</b>	<b>Remaining Balance</b>
		52,000.00	60%	31,200.00	28,600.00	2,600.00	20,800.00
	<b>Sub -Contract Value</b>	<b>52,000.00</b>		<b>31,200.00</b>	<b>28,600.00</b>	<b>2,600.00</b>	20,800.00
	<b>New Contract Value</b>	<b>280,100.00</b>					<b>25,800.00</b>
	<b>Construction Services on-site</b>	<b>Budget</b>	<b>% Complete</b>	<b>Total Billed</b>	<b>Previous Billing</b>	<b>Current Billing</b>	<b>Remaining Balance</b>
	Onsite Labor	20,000.00	95%	18,969.50	18,859.50	110.00	1,030.50
	Reimbursables	2,000.00	23%	466.43	466.43	0.00	1,533.57
	<b>Sub -Contract Value</b>	<b>22,000.00</b>		<b>18,969.50</b>	<b>18,859.50</b>	<b>110.00</b>	<b>1,030.50</b>
	<b>Overhead Door Change Order</b>	3,500.00	0%	0.00	0.00	0.00	3,500.00
	<b>Sub -Contract Value</b>	<b>3,500.00</b>		<b>0.00</b>	0.00	<b>0.00</b>	3,500.00
	<b>New Contract Value</b>	<b>329,200.00</b>					<b>26,830.50</b>
					<b>TOTAL CURRENT</b>	<b>2,710.00</b>	

**Becher Hoppe**  
**Invoice 23603**

Date: February 29, 2024

	<b>Water Metering Station</b>	<b>Budget</b>	<b>% Complete</b>	<b>Total Billed</b>	<b>Previous Billing</b>	<b>Current Billing</b>	<b>Remaining Balance</b>
	Desgin Service	22,100.00	100%	22,100.00	22,100.00	0.00	0.00
	Change Order Re-disinfection	1,500.00	100%	1,500.00	1,500.00	0.00	0.00
	<b>Sub -Contract Value</b>	<b>23,600.00</b>		<b>22,100.00</b>	22,100.00	<b>0.00</b>	<b>0.00</b>
	<b>New Contract Value</b>	<b>23,600.00</b>					<b>0.00</b>
	<b>Water Treatment Plant</b>	228,100.00	98%	223,100.00	223,100.00	0.00	5,000.00
	<b>Sub -Contract Value</b>	<b>228,100.00</b>		<b>223,100.00</b>	223,100.00	<b>0.00</b>	5,000.00
	<b>New Contract Value</b>	<b>228,100.00</b>					<b>5,000.00</b>
	<b>Construction Administration</b>	<b>Budget</b>	<b>% Complete</b>	<b>Total Billed</b>	<b>Previous Billing</b>	<b>Current Billing</b>	<b>Remaining Balance</b>
		52,000.00	65%	33,800.00	31,200.00	2,600.00	18,200.00
	<b>Sub -Contract Value</b>	<b>52,000.00</b>		<b>33,800.00</b>	<b>31,200.00</b>	<b>2,600.00</b>	18,200.00
	<b>New Contract Value</b>	<b>280,100.00</b>					<b>23,200.00</b>
	<b>Construction Services on-site</b>	<b>Budget</b>	<b>% Complete</b>	<b>Total Billed</b>	<b>Previous Billing</b>	<b>Current Billing</b>	<b>Remaining Balance</b>
	Onsite Labor	20,000.00	97%	19,492.00	18,859.50	632.50	508.00
	Reimbursables	2,000.00	24%	483.85	466.43	17.42	1,516.15
	<b>Sub -Contract Value</b>	<b>22,000.00</b>		<b>19,492.00</b>	<b>18,859.50</b>	<b>649.92</b>	<b>508.00</b>
	<b>Overhead Door Change Order</b>	3,500.00	0%	0.00	0.00	0.00	3,500.00
	<b>Sub -Contract Value</b>	<b>3,500.00</b>		<b>0.00</b>	0.00	<b>0.00</b>	3,500.00
	<b>New Contract Value</b>	<b>329,200.00</b>					<b>23,708.00</b>
					<b>TOTAL CURRENT</b>	<b>3,249.92</b>	

**Becher Hoppe**  
**Invoice 23654**

Date: March 31, 2024

	<b>Water Metering Station</b>	<b>Budget</b>	<b>% Complete</b>	<b>Total Billed</b>	<b>Previous Billing</b>	<b>Current Billing</b>	<b>Remaining Balance</b>
	Desgin Service	22,100.00	100%	22,100.00	22,100.00	0.00	0.00
	Change Order Re-disinfection	1,500.00	100%	1,500.00	1,500.00	0.00	0.00
	<b>Sub -Contract Value</b>	<b>23,600.00</b>		<b>22,100.00</b>	22,100.00	<b>0.00</b>	<b>0.00</b>
	<b>New Contract Value</b>	<b>23,600.00</b>					<b>0.00</b>
	<b>Water Treatment Plant</b>	228,100.00	98%	223,100.00	223,100.00	0.00	5,000.00
	<b>Sub -Contract Value</b>	<b>228,100.00</b>		<b>223,100.00</b>	223,100.00	<b>0.00</b>	5,000.00
	<b>New Contract Value</b>	<b>228,100.00</b>					<b>5,000.00</b>
	<b>Construction Administration</b>	<b>Budget</b>	<b>% Complete</b>	<b>Total Billed</b>	<b>Previous Billing</b>	<b>Current Billing</b>	<b>Remaining Balance</b>
		52,000.00	70%	36,400.00	33,800.00	2,600.00	15,600.00
	<b>Sub -Contract Value</b>	<b>52,000.00</b>		<b>36,400.00</b>	<b>33,800.00</b>	<b>2,600.00</b>	15,600.00
	<b>New Contract Value</b>	<b>280,100.00</b>					<b>20,600.00</b>
	<b>Construction Services on-site</b>	<b>Budget</b>	<b>% Complete</b>	<b>Total Billed</b>	<b>Previous Billing</b>	<b>Current Billing</b>	<b>Remaining Balance</b>
	Onsite Labor	20,000.00	97%	19,492.00	19,492.00	0.00	508.00
	Reimbursables	2,000.00	24%	483.85	483.85	0.00	1,516.15
	<b>Sub -Contract Value</b>	<b>22,000.00</b>		<b>19,492.00</b>	<b>19,492.00</b>	<b>0.00</b>	<b>508.00</b>
	<b>Overhead Door Change Order</b>	3,500.00	0%	0.00	0.00	0.00	3,500.00
	<b>Sub -Contract Value</b>	<b>3,500.00</b>		<b>0.00</b>	0.00	<b>0.00</b>	3,500.00
	<b>New Contract Value</b>	<b>329,200.00</b>					<b>21,108.00</b>
					<b>TOTAL CURRENT</b>	2,600.00	

**Becher Hoppe  
Invoice 23718**

Date: March 31, 2024

	<b>Water Metering Station</b>	<b>Budget</b>	<b>% Complete</b>	<b>Total Billed</b>	<b>Previous Billing</b>	<b>Current Billing</b>	<b>Remaining Balance</b>
	Desgin Service	22,100.00	100%	22,100.00	22,100.00	0.00	0.00
	Change Order Re-disinfection	1,500.00	100%	1,500.00	1,500.00	0.00	0.00
	<b>Sub -Contract Value</b>	<b>23,600.00</b>		<b>22,100.00</b>	22,100.00	<b>0.00</b>	<b>0.00</b>
	<b>New Contract Value</b>	<b>23,600.00</b>					<b>0.00</b>
	<b>Water Treatment Plant</b>	228,100.00	98%	223,100.00	223,100.00	0.00	5,000.00
	<b>Sub -Contract Value</b>	<b>228,100.00</b>		<b>223,100.00</b>	223,100.00	<b>0.00</b>	5,000.00
	<b>New Contract Value</b>	<b>228,100.00</b>					<b>5,000.00</b>
	<b>Construction Administration</b>	<b>Budget</b>	<b>% Complete</b>	<b>Total Billed</b>	<b>Previous Billing</b>	<b>Current Billing</b>	<b>Remaining Balance</b>
		52,000.00	75%	39,000.00	36,400.00	2,600.00	13,000.00
	<b>Sub -Contract Value</b>	<b>52,000.00</b>		<b>39,000.00</b>	<b>36,400.00</b>	<b>2,600.00</b>	13,000.00
	<b>New Contract Value</b>	<b>280,100.00</b>					<b>18,000.00</b>
	<b>Construction Services on-site</b>	<b>Budget</b>	<b>% Complete</b>	<b>Total Billed</b>	<b>Previous Billing</b>	<b>Current Billing</b>	<b>Remaining Balance</b>
	Onsite Labor	20,000.00	99%	19,834.00	19,492.00	342.00	166.00
	Reimbursables	2,000.00	24%	483.85	483.85	0.00	1,516.15
	<b>Sub -Contract Value</b>	<b>22,000.00</b>		<b>19,834.00</b>	<b>19,492.00</b>	<b>342.00</b>	<b>166.00</b>
	<b>Overhead Door Change Order</b>	3,500.00	0%	0.00	0.00	0.00	3,500.00
	<b>Sub -Contract Value</b>	<b>3,500.00</b>		<b>0.00</b>	0.00	<b>0.00</b>	3,500.00
	<b>New Contract Value</b>	<b>329,200.00</b>					<b>18,166.00</b>
				TOTAL CURRENT		2,942.00	

**Becher Hoppe  
Invoice 23769**

Date: March 31, 2024

	Water Metering Station	Budget	% Complete	Total Billed	Previous Billing	Current Billing	Remaining Balance
	Desgin Service	22,100.00	100%	22,100.00	22,100.00	0.00	0.00
	Change Order Re-disinfection	1,500.00	100%	1,500.00	1,500.00	0.00	0.00
	<b>Sub -Contract Value</b>	<b>23,600.00</b>		<b>22,100.00</b>	<b>22,100.00</b>	<b>0.00</b>	<b>0.00</b>
	<b>New Contract Value</b>	<b>23,600.00</b>					<b>0.00</b>
	<b>Water Treatment Plant</b>	228,100.00	98%	223,100.00	223,100.00	0.00	5,000.00
	<b>Sub -Contract Value</b>	<b>228,100.00</b>		<b>223,100.00</b>	<b>223,100.00</b>	<b>0.00</b>	<b>5,000.00</b>
	<b>New Contract Value</b>	<b>228,100.00</b>					<b>5,000.00</b>
	<b>Construction Administration</b>	Budget	% Complete	Total Billed	Previous Billing	Current Billing	Remaining Balance
		52,000.00	80%	41,600.00	39,000.00	2,600.00	10,400.00
	<b>Sub -Contract Value</b>	<b>52,000.00</b>		<b>41,600.00</b>	<b>39,000.00</b>	<b>2,600.00</b>	<b>10,400.00</b>
	<b>New Contract Value</b>	<b>280,100.00</b>					<b>15,400.00</b>
	<b>Construction Services on-site</b>	Budget	% Complete	Total Billed	Previous Billing	Current Billing	Remaining Balance
	Onsite Labor	20,000.00	103%	20,602.00	19,492.00	1,110.00	-602.00
	Reimbursables	2,000.00	25%	502.61	483.85	18.76	1,497.39
	<b>Sub -Contract Value</b>	<b>22,000.00</b>		<b>20,602.00</b>	<b>19,492.00</b>	<b>1,128.76</b>	<b>-602.00</b>
	<b>Overhead Door Change Order</b>	3,500.00	0%	0.00	0.00	0.00	3,500.00
	<b>Sub -Contract Value</b>	<b>3,500.00</b>		<b>0.00</b>	<b>0.00</b>	<b>0.00</b>	<b>3,500.00</b>
	<b>New Contract Value</b>	<b>329,200.00</b>					<b>14,798.00</b>
					<b>TOTAL CURRENT</b>	<b>3,728.76</b>	

Mileage - Company Vehicles (Unit Billing)



**Becher Hoppe  
Invoice 23809**

Date: June 30, 2024

	<b>Water Metering Station</b>	<b>Budget</b>	<b>% Complete</b>	<b>Total Billed</b>	<b>Previous Billing</b>	<b>Current Billing</b>	<b>Remaining Balance</b>
	Desgin Service	22,100.00	100%	22,100.00	22,100.00	0.00	0.00
	Change Order Re-disinfection	1,500.00	100%	1,500.00	1,500.00	0.00	0.00
	<b>Sub -Contract Value</b>	<b>23,600.00</b>		<b>22,100.00</b>	22,100.00	<b>0.00</b>	<b>0.00</b>
	<b>New Contract Value</b>	<b>23,600.00</b>					<b>0.00</b>
	<b>Water Treatment Plant</b>	228,100.00	98%	223,100.00	223,100.00	0.00	5,000.00
	<b>Sub -Contract Value</b>	<b>228,100.00</b>		<b>223,100.00</b>	223,100.00	<b>0.00</b>	5,000.00
	<b>New Contract Value</b>	<b>228,100.00</b>					<b>5,000.00</b>
	<b>Construction Administration</b>	<b>Budget</b>	<b>% Complete</b>	<b>Total Billed</b>	<b>Previous Billing</b>	<b>Current Billing</b>	<b>Remaining Balance</b>
		52,000.00	95%	49,400.00	41,600.00	7,800.00	2,600.00
	<b>Sub -Contract Value</b>	<b>52,000.00</b>		<b>49,400.00</b>	<b>41,600.00</b>	<b>7,800.00</b>	2,600.00
	<b>New Contract Value</b>	<b>280,100.00</b>					<b>7,600.00</b>
	<b>Construction Services on-site</b>	<b>Budget</b>	<b>% Complete</b>	<b>Total Billed</b>	<b>Previous Billing</b>	<b>Current Billing</b>	<b>Remaining Balance</b>
	Onsite Labor	20,000.00	97%	19,492.00	19,492.00	0.00	508.00
	Reimbursables	2,000.00	24%	483.85	483.85	0.00	1,516.15
	<b>Sub -Contract Value</b>	<b>22,000.00</b>		<b>19,975.85</b>	<b>19,975.85</b>	<b>0.00</b>	<b>2,024.15</b>
	<b>Overhead Door Change Order</b>	3,500.00	0%	0.00	0.00	0.00	3,500.00
	<b>Sub -Contract Value</b>	<b>3,500.00</b>		<b>0.00</b>	0.00	<b>0.00</b>	3,500.00
	<b>New Contract Value</b>	<b>329,200.00</b>					<b>9,624.15</b>
				TOTAL CURRENT		7,800.00	

**Becher Hoppe  
Invoice 23969**

Date: Sept. 27, 2024

	<b>Water Metering Station</b>	<b>Budget</b>	<b>% Complete</b>	<b>Total Billed</b>	<b>Previous Billing</b>	<b>Current Billing</b>	<b>Remaining Balance</b>
	Desgin Service	22,100.00	100%	22,100.00	22,100.00	0.00	0.00
	Change Order Re-disinfection	1,500.00	100%	1,500.00	1,500.00	0.00	0.00
	<b>Sub -Contract Value</b>	<b>23,600.00</b>		<b>22,100.00</b>	22,100.00	<b>0.00</b>	<b>0.00</b>
	<b>New Contract Value</b>	<b>23,600.00</b>					<b>0.00</b>
	<b>Water Treatment Plant</b>	228,100.00	98%	223,100.00	223,100.00	0.00	5,000.00
	<b>Sub -Contract Value</b>	<b>228,100.00</b>		<b>223,100.00</b>	223,100.00	<b>0.00</b>	5,000.00
	<b>New Contract Value</b>	<b>228,100.00</b>					<b>5,000.00</b>
	<b>Construction Administration</b>	<b>Budget</b>	<b>% Complete</b>	<b>Total Billed</b>	<b>Previous Billing</b>	<b>Current Billing</b>	<b>Remaining Balance</b>
		55,500.00	95%	52,725.00	49,400.00	3,325.00	2,775.00
	<b>Sub -Contract Value</b>	<b>55,500.00</b>		<b>52,725.00</b>	<b>49,400.00</b>	<b>3,325.00</b>	2,775.00
	<b>New Contract Value</b>	<b>283,600.00</b>					<b>7,775.00</b>
	<b>Construction Services on-site</b>	<b>Budget</b>	<b>% Complete</b>	<b>Total Billed</b>	<b>Previous Billing</b>	<b>Current Billing</b>	<b>Remaining Balance</b>
	Onsite Labor	20,000.00	99%	19,887.00	19,492.00	395.00	113.00
	Reimbursables	2,000.00	24%	483.85	483.85	0.00	1,516.15
	<b>Sub -Contract Value</b>	<b>22,000.00</b>		<b>20,370.85</b>	<b>19,975.85</b>	<b>395.00</b>	<b>1,629.15</b>
	<b>Overhead Door Change Order</b>	3,500.00	0%	0.00	0.00	0.00	3,500.00
	<b>Sub -Contract Value</b>	<b>3,500.00</b>		<b>0.00</b>	0.00	<b>0.00</b>	3,500.00
	<b>New Contract Value</b>	<b>332,700.00</b>					<b>9,404.15</b>
				TOTAL CURRENT		3,720.00	



330 N. 4th Street, Wausau, WI 54403-5417  
715-845-8000 | becherhoppe.com

November 22, 2024

Mr. Greg Ulman  
Director of Public Works/Utilities Superintendent  
Village of Kronenwetter  
1582 Kronenwetter Drive  
Kronenwetter, WI 54455

*Via Email:* [GUlman@kronenwetter.org](mailto:GUlman@kronenwetter.org)

Subject: Well No. 2 Water Treatment Facility Payment Request No. 10

Dear Greg:

Enclosed herewith is Payment Request No. 10 (Period ending 10/31/2024) in the amount of \$548,262.10 (Line 8). The balance remaining to finish, plus retainage, is \$395,601.35 (Line 9). We concur with Payment Request No. 10. Please notify us after the Payment Requests are approved by the Village and we will prepare the SDRF loan withdrawal.

Sincerely,

Joe Kafczynski, P.E.  
Project Engineer

JRK

Enclosures

# APPLICATION AND CERTIFICATE FOR PAYMENT

TO OWNER : Village of Kronenwetter  
#100780 1582 Kronenwetter Drive  
Kronenwetter, WI 54455

PROJECT: Kronenwetter Well  
House 2

APPLICATION NO. 10

DATE: 10/31/2024  
PERIOD TO: 10/31/2024

DISTRIBUTION TO  
[ ] OWNER  
[ ] ARCHITECT  
[ ] CONTRACTOR  
[ ]  
[ ]

FROM CONTRACTOR: Ellis Stone Construction Company, Inc.  
3201 Stanley Street  
Stevens Point, WI 54481

ARCHITECT'S  
PROJECT NO.

JOB # 23061

CONTRACT DATE: June 26, 2023

ATTENTION:

## CONTRACTOR'S APPLICATION FOR PAYMENT

CHANGE ORDER SUMMARY		ADDITIONS	DEDUCTIONS
Change Orders approved in previous months by Owner			
TOTAL		\$66,444.00	
Approved this Month			
Number	Date Approved		
TOTALS		\$66,444.00	\$0.00
Net change by Change Orders		\$66,444.00	

Application is made for Payment, as shown below, in connection with the contract. A Continuatn sheet is attached.

- 1. ORIGINAL CONTRACT SUM..... \$2,862,000.00
- 2. Net change by Change Orders..... \$66,444.00
- 3. CONTRACT SUM TO DATE (Line 1+ / 2)..... \$2,928,444.00
- 4. TOTAL COMPLETED & STORED TO DATE..... \$2,604,244.65
- 5. RETAINAGE:
  - a. 5% of 1st 50% of contract \$71,402.00
  - b. % of Stored Material \$ \_\_\_\_\_
- 6. TOTAL EARNED LESS RETAINAGE \$2,532,842.65
- 7. LESS PREVIOUS CERTIFICATES FOR PAYMENT (Line 6 from prior Certificate)..... \$1,984,580.55
- 8. CURRENT PAYMENT DUE..... \$548,262.10
- 9. BALANCE TO FINISH, PLUS RETAINAGE..... \$395,601.35  
(Line 3 less Line 6)

The undersigned Contractor certifies that to the best of the Contractor's knowledge, information and belief the Work covered by this Application for Payment has been completed in accordance with the Contract Documents, that all amounts have been paid by the Contractor for Work for which previous Certificates for Payment were issued and payments received from the Owner, and that current payment shown herein is now due.

CONTRACTOR: ELLIS STONE CONSTRUCTION COMPANY, INC.

By: Erik C Carlson Date: 10/31/2024

State of: Wisconsin County of: Portage  
Subscribed and sworn to before me this 31st day of October, 2024  
Notary Public: Jeffrey Buckaloo  
My Commission expires: April 15, 2027

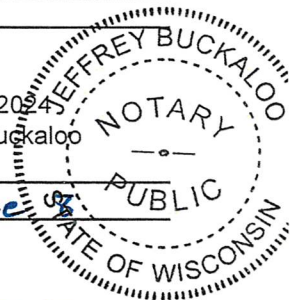

## ARCHITECT'S CERTIFICATE FOR PAYMENT

In accordance with the Contract Documents, based on on-site observations and the data comprising of the above application, the Architect certified to the Owner that to the best of the Architects's knowledge, information and belief the Work has progressed as indicated, the quality of the Work is in accordance with the Contract Documents, and the Contractor is entitled to payment of the AMOUNT CERTIFIED.

AMOUNT CERTIFIED.....\$ Line 8

(Attach explanation if amount certified differs from the amount applied for.)

ARCHITECT: [Signature] Date: 11/22/2024

This Certificate is not negotiable. The AMOUNT CERTIFIED is payable only to the Contractor named herein. Issuance, payment and acceptance of payment are without prejudice to any rights of the Owner or Contractor under this Contract.

# CONTINUATION SHEET

AIA DOCUMENT G703

PAGE OF PAGES

AIA Document G702, APPLICATION AND CERTIFICATION FOR PAYMENT, containing

APPLICATION NO: 10

Contractor's signed certification is attached.

APPLICATION DATE: 10/31/2024

In tabulations below, amounts are stated to the nearest dollar.

PERIOD TO: 10/31/2024

Use Column I on Contracts where variable retainage for line items may apply.

ARCHITECT'S PROJECT NO:

A ITEM NO.	B DESCRIPTION OF WORK	C SCHEDULED VALUE	D WORK COMPLETED		F MATERIALS PRESENTLY STORED (NOT IN D OR E)	G TOTAL COMPLETED AND STORED TO DATE (D+E+F)	H % (G ÷ C)	I BALANCE TO FINISH (C - G)	J RETAINAGE (IF VARIABLE RATE)
			FROM PREVIOUS APPLICATION (G - E)	THIS PERIOD					
			01	General Conditions					
02	Selective Demolition & Misc.	\$10,026.00	\$10,026.00	\$0.00		\$10,026.00	100.00%	\$0.00	\$250.65
03	Building Concrete - Foundations	\$61,350.00	\$61,350.00	\$0.00		\$61,350.00	100.00%	\$0.00	\$1,533.75
04	Building Concrete - Flatwork	\$17,578.00	\$17,578.00	\$0.00		\$17,578.00	100.00%	\$0.00	\$439.45
05	Masonry	\$149,872.00	\$149,872.00	\$0.00		\$149,872.00	100.00%	\$0.00	\$3,746.80
06	Structural Steel - Supply	\$9,508.00	\$9,508.00	\$0.00		\$9,508.00	100.00%	\$0.00	\$237.70
07	Rough Carpentry	\$40,018.00	\$40,018.00	\$0.00		\$40,018.00	100.00%	\$0.00	\$1,000.45
08	Batt and Blown Insulation	\$3,832.00	\$3,832.00	\$0.00		\$3,832.00	100.00%	\$0.00	\$95.80
09	Steel Shingles	\$72,364.00	\$72,364.00	\$0.00		\$72,364.00	100.00%	\$0.00	\$0.00
10	Joint Sealants	\$7,437.00	\$5,577.75	\$1,859.25		\$7,437.00	100.00%	\$0.00	\$185.93
11	Doors / Frames / Hardware	\$17,949.00	\$17,949.00	\$0.00		\$17,949.00	100.00%	\$0.00	\$448.73
12	FRP Ceiling Panels & Furring	\$26,781.00	\$26,781.00	\$0.00		\$26,781.00	100.00%	\$0.00	\$669.53
13	Painting and Coating	\$79,230.00	\$47,538.00	\$31,692.00		\$79,230.00	100.00%	\$0.00	\$1,980.75
14	Fire Protection Specialties	\$594.00	\$445.50	\$148.50		\$594.00	100.00%	\$0.00	\$14.85
15	Electrical	\$255,861.00	\$217,481.85	\$25,586.10		\$243,067.95	95.00%	\$12,793.05	\$6,396.53
16	Earthwork	\$69,828.00	\$69,828.00	\$0.00		\$69,828.00	100.00%	\$0.00	\$1,745.70
17	Asphalt Paving	\$9,236.00	\$0.00	\$0.00		\$0.00	0.00%	\$9,236.00	\$230.90
18	Landscaping	\$9,864.00	\$0.00	\$0.00		\$0.00	0.00%	\$9,864.00	\$246.60
19	Process Piping Package Original Contract	\$1,912,727.00	\$1,147,636.20	\$478,181.75		\$1,625,817.95	85.00%	\$286,909.05	\$47,818.18
20	Change Order 1 - Flow Meter Work	\$1,586.00	\$1,586.00	\$0.00		\$1,586.00	100.00%	\$0.00	\$39.65
21	Change Order 2 - Water Main Break	\$9,457.00	\$9,457.00	\$0.00		\$9,457.00	100.00%	\$0.00	\$236.43
22	Change Order 3 - RFP 02 - Overhead Door	\$53,707.00	\$53,707.00	\$0.00		\$53,707.00	100.00%	\$0.00	\$1,342.68
23	Change Order 4 RFI #7 Attic Scuttle Relocation Change Orders	\$1,694.00	\$1,694.00	\$0.00		\$1,694.00	100.00%	\$0.00	\$42.35
<b>GRAND TOTALS</b>		<b>\$2,928,444.00</b>	<b>\$2,055,982.55</b>	<b>\$548,262.10</b>	<b>\$0.00</b>	<b>\$2,604,244.65</b>		<b>\$324,199.35</b>	<b>\$71,402.00</b>

Waiver of Construction Lien, Payment  
Bond and Lien on Funds

October 31, 2024

For good and valuable consideration, the undersigned hereby irrevocably and unconditionally waives and releases any and all (a) rights and claims for a construction or other lien on land and buildings being constructed, altered, erected or repaired and to the appurtenances thereunto, (b) rights and claims on any payment bond (s) furnished in conjunction with said construction, alteration, erection or repair, and (c) rights and claims for lien on money, bonds, or warrants due or to become due to the prime contractor therefore. The property covered by this waiver is owned by Village of Kronenwetter (owner), is located at 1582 Kronenwetter Drive, Kronenwetter, WI, in the County of Marathon, Wisconsin, is described as Kronenwetter Well House 2. And this waiver pertains to a portion of the work to be performed by Ellis Stone Construction Company, Inc. (prime contractor).

This waiver covers all labor, material and supplies for construction, alteration, erection, and repairs furnished by the undersigned under a contract with Village of Kronenwetter. Through the date of this waiver in the amount of \$548,262.10 for Application #10 upon receipt of payment.

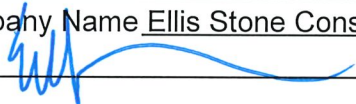
Company Name Ellis Stone Construction Co., Inc.  
By  Erik C Carlson  
Its President



330 N. 4th Street, Wausau, WI 54403-5417  
715-845-8000 | becherhoppe.com

December 11, 2024

Mr. Greg Ulman  
Director of Public Works/Utilities Superintendent  
Village of Kronenwetter  
1582 Kronenwetter Drive  
Kronenwetter, WI 54455

Via Email: [GUlman@kronenwetter.org](mailto:GUlman@kronenwetter.org)

Subject: Well No. 2 Water Treatment Facility Payment Request No. 11

Dear Greg:

Enclosed herewith is Payment Request No. 11 (Period ending 11/30/2024) in the amount of \$19,100.00 (Line 8). The balance remaining to finish, plus retainage, is \$376,501.35 (Line 9). We concur with Payment Request No. 11. Please notify us after the Payment Requests are approved by the Village and we will prepare the SDRF loan withdrawal.

Sincerely,

Joe Kafczynski, P.E.  
Project Engineer

JRK

Enclosures

# APPLICATION AND CERTIFICATE FOR PAYMENT

Section 5, Item H.

TO OWNER : Village of Kronenwetter  
#100780 1582 Kronenwetter Drive  
Kronenwetter, WI 54455

PROJECT: Kronenwetter Well  
House 2

APPLICATION NO. 11

DATE: 11/27/2024  
PERIOD TO: 11/30/2024

DISTRIBUTION TO  
[ ] OWNER  
[ ] ARCHITECT  
[ ] CONTRACTOR  
[ ]  
[ ]

FROM CONTRACTOR: Ellis Stone Construction Company, Inc.  
3201 Stanley Street  
Stevens Point, WI 54481

JOB # 23061

ARCHITECT'S  
PROJECT NO.

CONTRACT DATE: June 26, 2023

ATTENTION:

## CONTRACTOR'S APPLICATION FOR PAYMENT

CHANGE ORDER SUMMARY	ADDITIONS	DEDUCTIONS	
Change Orders approved in previous months by Owner			
TOTAL	\$66,444.00		
Approved this Month			
Number	Date Approved		
TOTALS	\$66,444.00		\$0.00
Net change by Change Orders		\$66,444.00	

The undersigned Contractor certifies that to the best of the Contractor's knowledge, information and belief the Work covered by this Application for Payment has been completed in accordance with the Contract Documents, that all amounts have been paid by the Contractor for Work for which previous Certificates for Payment were issued and payments received from the Owner, and that current payment shown herein is now due.

CONTRACTOR: ELLIS STONE CONSTRUCTION COMPANY, INC.

By:  Date: 11/27/2024  
Andrew J Halverson

## ARCHITECT'S CERTIFICATE FOR PAYMENT

In accordance with the Contract Documents, based on on-site observations and the data comprising of the above application, the Architect certified to the Owner that to the best of the Architects's knowledge, information and belief the Work has progressed as indicated, the quality of the Work is in accordance with the Contract Documents, and the Contractor is entitled to payment of the AMOUNT CERTIFIED.

This Certificate is not negotiable. The AMOUNT CERTIFIED is payable only to the Contractor named herein. Issuance, payment and acceptance of payment are without prejudice to any rights of the Owner or Contractor under this Contract.

Application is made for Payment, as shown below, in connection with the contract. A Continuatn sheet is attached.

1. ORIGINAL CONTRACT SUM.....	\$2,862,000.00
2. Net change by Change Orders.....	\$66,444.00
3. CONTRACT SUM TO DATE (Line 1+ 2).....	\$2,928,444.00
4. TOTAL COMPLETED & STORED TO DATE.....	\$2,623,344.65
5. RETAINAGE:	
a. 5% of 1st 50% of contract	\$71,402.00
b. % of Stored Material	\$
6. TOTAL EARNED LESS RETAINAGE	\$2,551,942.65
7. LESS PREVIOUS CERTIFICATES FOR PAYMENT (Line 6 from prior Certificate).....	\$2,532,842.65
8. CURRENT PAYMENT DUE.....	\$19,100.00
9. BALANCE TO FINISH, PLUS RETAINAGE..... (Line 3 less Line 6)	\$376,501.35

State of: Wisconsin County of : Portage  
Subscribed and sworn to before me this 27th day of November, 2024  
Notary Public: , Jeffrey Buckaloo  
My Commission expires: April 15, 2027

AMOUNT CERTIFIED.....\$  
(Attach explanation if amount certified differs from the amount applied for.)

ARCHITECT:  Date: 12/11/2024

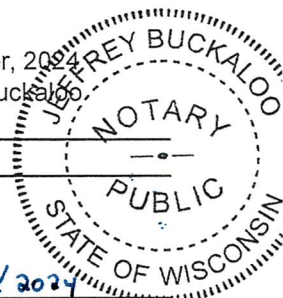



# CONTINUATION SHEET

AIA DOCUMENT G703

PAGE OF PAGES

AIA Document G702, APPLICATION AND CERTIFICATION FOR PAYMENT, containing

Contractor's signed certification is attached.

In tabulations below, amounts are stated to the nearest dollar.

Use Column I on Contracts where variable retainage for line items may apply.

APPLICATION NO: 11  
 APPLICATION DATE: 11/27/2024  
 PERIOD TO: 11/30/2024  
 ARCHITECT'S PROJECT NO:

A ITEM NO.	B DESCRIPTION OF WORK	C SCHEDULED VALUE	D WORK COMPLETED		F MATERIALS PRESENTLY STORED (NOT IN D OR E)	G TOTAL COMPLETED AND STORED TO DATE (D+E+F)	H % (G ÷ C)	I BALANCE TO FINISH (C - G)	J RETAINAGE (IF VARIABLE RATE)
			FROM PREVIOUS APPLICATION (G - E)	THIS PERIOD					
			01	General Conditions					
02	Selective Demolition & Misc.	\$10,026.00	\$10,026.00	\$0.00		\$10,026.00	100.00%	\$0.00	\$250.65
03	Building Concrete - Foundations	\$61,350.00	\$61,350.00	\$0.00		\$61,350.00	100.00%	\$0.00	\$1,533.75
04	Building Concrete - Flatwork	\$17,578.00	\$17,578.00	\$0.00		\$17,578.00	100.00%	\$0.00	\$439.45
05	Masonry	\$149,872.00	\$149,872.00	\$0.00		\$149,872.00	100.00%	\$0.00	\$3,746.80
06	Structural Steel - Supply	\$9,508.00	\$9,508.00	\$0.00		\$9,508.00	100.00%	\$0.00	\$237.70
07	Rough Carpentry	\$40,018.00	\$40,018.00	\$0.00		\$40,018.00	100.00%	\$0.00	\$1,000.45
08	Batt and Blown Insulation	\$3,832.00	\$3,832.00	\$0.00		\$3,832.00	100.00%	\$0.00	\$95.80
09	Steel Shingles	\$72,364.00	\$72,364.00	\$0.00		\$72,364.00	100.00%	\$0.00	\$0.00
10	Joint Sealants	\$7,437.00	\$7,437.00	\$0.00		\$7,437.00	100.00%	\$0.00	\$185.93
11	Doors / Frames / Hardware	\$17,949.00	\$17,949.00	\$0.00		\$17,949.00	100.00%	\$0.00	\$448.73
12	FRP Ceiling Panels & Furring	\$26,781.00	\$26,781.00	\$0.00		\$26,781.00	100.00%	\$0.00	\$669.53
13	Painting and Coating	\$79,230.00	\$79,230.00	\$0.00		\$79,230.00	100.00%	\$0.00	\$1,980.75
14	Fire Protection Specialties	\$594.00	\$594.00	\$0.00		\$594.00	100.00%	\$0.00	\$14.85
15	Electrical	\$255,861.00	\$243,067.95	\$0.00		\$243,067.95	95.00%	\$12,793.05	\$6,396.53
16	Earthwork	\$69,828.00	\$69,828.00	\$0.00		\$69,828.00	100.00%	\$0.00	\$1,745.70
17	Asphalt Paving	\$9,236.00	\$0.00	\$9,236.00		\$9,236.00	100.00%	\$0.00	\$230.90
18	Landscaping	\$9,864.00	\$0.00	\$9,864.00		\$9,864.00	100.00%	\$0.00	\$246.60
19	Process Piping Package Original Contract	\$1,912,727.00	\$1,625,817.95	\$0.00		\$1,625,817.95	85.00%	\$286,909.05	\$47,818.18
20	Change Order 1 - Flow Meter Work	\$1,586.00	\$1,586.00	\$0.00		\$1,586.00	100.00%	\$0.00	\$39.65
21	Change Order 2 - Water Main Break	\$9,457.00	\$9,457.00	\$0.00		\$9,457.00	100.00%	\$0.00	\$236.43
22	Change Order 3 - RFP 02 - Overhead Door	\$53,707.00	\$53,707.00	\$0.00		\$53,707.00	100.00%	\$0.00	\$1,342.68
23	Change Order 4 RFI #7 Attic Scuttle Relocatio Change Orders	\$1,694.00	\$1,694.00	\$0.00		\$1,694.00	100.00%	\$0.00	\$42.35
<b>GRAND TOTALS</b>		<b>\$2,928,444.00</b>	<b>\$2,604,244.65</b>	<b>\$19,100.00</b>	<b>\$0.00</b>	<b>\$2,623,344.65</b>		<b>\$305,099.35</b>	<b>\$71,402.00</b>

Waiver of Construction Lien, Payment  
Bond and Lien on Funds

November 27, 2024

For good and valuable consideration, the undersigned hereby irrevocably and unconditionally waives and releases any and all (a) rights and claims for a construction or other lien on land and buildings being constructed, altered, erected or repaired and to the appurtenances thereunto, (b) rights and claims on any payment bond (s) furnished in conjunction with said construction, alteration, erection or repair, and (c) rights and claims for lien on money, bonds, or warrants due or to become due to the prime contractor therefore. The property covered by this waiver is owned by Village of Kronenwetter (owner), is located at 1582 Kronenwetter Drive, Kronenwetter, WI, in the County of Marathon, Wisconsin, is described as Kronenwetter Well House 2. And this waiver pertains to a portion of the work to be performed by Ellis Stone Construction Company, Inc. (prime contractor).

This waiver covers all labor, material and supplies for construction, alteration, erection, and repairs furnished by the undersigned under a contract with Village of Kronenwetter. Through the date of this waiver in the amount of \$19,100.00 for Application #11 upon receipt of payment.

~~Company Name Ellis Stone Construction Co., Inc.~~

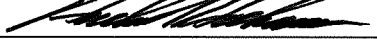
By  Andrew J Halverson

Its Executive Vice President



**Report to Utility Committee**

**Item Name:** Liquidated Damages Report

**Meeting Date:** January 7, 2025

**Referring Body:**

**Committee Contact:**

**Staff Contact:** Greg Ulman

**Report Prepared by:** Greg Ulman

Attached are bids the Village received for upgrading Lift Station #2 and #6. The committee has the right to approve, modify for a future re-bid, or reject the attached bids.

Village of Kronenwetter Lift Station #2 and Lift Station #6 Upgrades				Contract #1 - Lift Station #2 and Liftstation #6 Upgrades Bid Deadline: Friday, December 13, 2024 at 10:00 a.m.			
Item #	Bid Item Description	# of Units	Units	Bidder #1 Pember Companies, Inc.		Bidder #2 August Winters & Sons, Inc	
				Unit Price	Total	Unit Price	Total
1.1	Performance and Payment Bonds	1	LS	Lump Sum	\$4,000.00	Lump Sum	\$6,500.00
1.2	LS6. Material and Labor to replace 4" piping and valves in existing LS6 valve vault in accordance with plans/specifications & AWWA requirements, including temporary provisions to continue LS6 operation, reuse of existing stainless steel bolts. (2) Swing Check Valves, (2) Plug Valves, Bends, Fittings, Adjustable SS Pipe Cradle with SS Standpipe 2", Bypass Extension Piping & Stainless Steel Camlock Termini (Male) with New Stainless Steel Pipe Attachments and Anchorments	1	LS	Lump Sum	\$51,000.00	Lump Sum	\$73,300.00
1.3	LS6. Material and Labor to clean and inspect Valve Vault Floor Drain	1	LS	Lump Sum	\$1,700.00	Lump Sum	\$2,500.00
1.4	LS6. Allowance for repairs to Valve Vault Floor Drain pending inspection	Allowance	LS	Allowance	\$1,000.00	Allowance	\$1,000.00
1.5	LS6. Labor to core sidewall from Valve Vault to WetWell, for sealed Bypass 4" pipe extension to Wetwell	1	LS	Lump Sum	\$7,000.00	Lump Sum	\$2,500.00
1.6	LS6. Material and Labor to replace existing exterior control panel system and instrumentation on existing LS6 in accordance with plans/specifications and NEC requirements, including VFD phase conversion system, including junction boxes, seals, and vents	1	LS	Lump Sum	\$129,000.00	Lump Sum	\$155,000.00
1.7	LS6. Material and Labor to replace 15 hp Shinmaywa pumps, pump motor cables, level sensor and cables, alarm floats and cables, within existing conduits to new panels, including replacement of existing guide rail caps	1	LS	Lump Sum	\$55,000.00	Lump Sum	\$88,000.00
1.8	LS6. Material and Labor for Complete Install of Light Fixture, Pole, Base, Sonotube, Breaker and Switch at New Panel	1	LS	Lump Sum	\$2,100.00	Lump Sum	\$7,000.00
1.9	LS6. Materials and Labor for Complete Install of Sonotube Base and Bracket for Fall Protection Tie-off	1	LS	Lump Sum	\$2,800.00	Lump Sum	\$3,500.00
1.10	LS6. Materials and Labor for Complete Retrofit of Fall Protection Leaf Grate for Wet Well Opening and Valve Vault Opening	1	LS	Lump Sum	\$2,750.00	Lump Sum	\$4,000.00
1.11	LS6. Start-up and Testing	1	LS	Lump Sum	\$2,850.00	Lump Sum	\$2,500.00
2.1	LS2. Material and Labor to clean and inspect Valve Vault Floor Drain	1	LS	Lump Sum	\$1,700.00	Lump Sum	\$2,500.00
2.2	LS2. Allowance for repairs to Valve Vault Floor Drain pending inspection	Allowance	LS	Allowance	\$1,000.00	Allowance	\$1,000.00
2.3	LS2. Material and Labor for Generator and Transformer Concrete Pads to suit generator/transformer size/configuration, Including Necessary Penetrating Conduits, Base, Compaction, and Coordination for Anchorments	1	LS	Lump Sum	\$9,000.00	Lump Sum	\$5,000.00
2.4	LS2. Generator, 80 KVA minimum	1	LS	Lump Sum	\$66,385.00	Lump Sum	\$72,000.00
2.5	LS2. Materials and Labor for Automatic Transfer Switch installation rated for generator system and exterior enclosure, including mounting, conduits & controls	1	LS	Lump Sum	\$7,400.00	Lump Sum	\$9,000.00
2.6	LS2. Material and Labor to replace existing exterior control panel system and instrumentation on existing LS6 in accordance with plans/specifications and NEC requirements, including disconnect, VFD motor starter system, junction boxes, seals, and vents	1	LS	Lump Sum	\$131,500.00	Lump Sum	\$140,000.00
2.7	LS2. Material and Labor to replace existing guide rail caps	1	LS	Lump Sum	\$7,750.00	Lump Sum	\$4,000.00
2.8	LS2. Material and Labor for Complete Install of Light Fixture, Pole, Base, Sonotube, Breaker and Switch at New Panel	1	LS	Lump Sum	\$2,100.00	Lump Sum	\$7,000.00
2.9	LS2. Materials and Labor for Complete Install of Sonotube Base and Bracket for Fall Protection Tie-off	1	LS	Lump Sum	\$2,850.00	Lump Sum	\$3,500.00
2.10	LS2. Materials and Labor for Complete Retrofit of Fall Protection Leaf Grate for Wet Well Opening and Valve Vault Opening	1	LS	Lump Sum	\$6,800.00	Lump Sum	\$4,000.00
2.11	LS2. Start-up and Testing	1	LS	Lump Sum	\$2,850.00	Lump Sum	\$2,500.00
<b>Total Base Bid Contract #1</b>					<b>\$498,535.00</b>		<b>\$596,300.00</b>
A1	Addendum Number #1, December 10, 2024 LS6 - 316 Stainless Steel Piping in Value Vault, AWWA 312, ANSI B36			ADDITIONAL	\$25,000.00	DEDUCT	-\$7,000.00
<b>Total Contract #1 if Alternate A1 is Utilized</b>					<b>\$523,535.00</b>		<b>\$589,300.00</b>



Engineering | Consulting | Design | Facilitation