



## AGENDA

### PUBLIC PARTICIPATION INFORMATION

Public information on this meeting is posted outside City Hall.

**We welcome you to watch Commission Meetings via live stream.**

You will find this option on our website at [www.ketchumidaho.org/meetings](http://www.ketchumidaho.org/meetings).

**If you would like to comment on a public hearing agenda item, please select the best option for your participation:**

1. Join us via Zoom (*please mute your device until called upon*).  
**Join the Webinar:** <https://ketchumidaho-org.zoom.us/j/82142359330>  
**Webinar ID:** 821 4235 9330
2. Address the Commission in person at City Hall.
3. Submit your comments in writing to [participate@ketchumidaho.org](mailto:participate@ketchumidaho.org) at (*by noon the day of the meeting*)

*This agenda is subject to revisions. All revisions will be underlined.*

---

**CALL TO ORDER:** By Chair Tim Carter

**ROLL CALL:**

**COMMUNICATIONS FROM COMMISSIONERS:**

**CONSENT AGENDA:**

*ALL ACTION ITEMS - The Commission is asked to approve the following listed items by a single vote, except for any items that a commissioner asks to be removed from the Consent Agenda and considered separately.*

1. ACTION: Approval of the April 2, 2026 Meeting Minutes.

**PUBLIC HEARING:**

2. ACTION: Recommendation to review and provide direction on the Design Review and Townhouse Preliminary Plat applications for the townhouse development at 310 Georgia Road. - Associate Planner, Paige Nied

**NEW BUSINESS:**

3. ACTION: Review and make a determination of Administrative Appeal P26-002 for the allowance of a nonconforming deck to be rebuilt at Prospector Condominiums Building 4. - Director of Planning and Building, Morgan Landers

**ADJOURNMENT:**



CITY OF KETCHUM, IDAHO  
MEETING MINUTES OF THE  
PLANNING AND ZONING COMMISSION

Thursday, April 02, 2026  
191 5th Street West, Ketchum, Idaho 83340

---

**CALL TO ORDER:** *(00.00.06 in video)*

Chair Tim Carter called the meeting to order at 4:32pm

**ROLL CALL:**

Tim Carter  
Brenda Moczygemba  
Hannah Harris  
Alex Monge

**ALSO PRESENT:**

Morgan Landers – Director of Planning and Building  
Abby Rivin – Senior Planner  
Paige Nied – Associate Planner  
Genoa Beiser – Associate Planner

**COMMUNICATIONS FROM COMMISSIONERS:**

1. Public Comment - 680 N Leadville

**CONSENT AGENDA:** *(00.00.45 in video)*

*ALL ACTION ITEMS - The Commission is asked to approve the following listed items by a single vote, except for any items that a commissioner asks to be removed from the Consent Agenda and considered separately.*

2. Approval of the March 18, 2026 Meeting Minutes
  - Brenda Moczygemba is recusing herself from the consent agenda due to her recusal on Public Hearing item 3 at the March 18<sup>th</sup> meeting.

**Motion to approve consent agenda at 4:34 PM.**

**MOVER:** Hannah Harris

**SECONDER:** Alex Monge

**AYES:** Tim Carter, Alex Monge, & Hannah Harris

**NAYS:**

**RESULT: UNANIMOUSLY ADOPTED**

**PUBLIC HEARING:** *(00.01.33 in video)*

3. Recommendation to continue the public hearing for the 233 Parkway Drive Variance Application to the May 20th Planning & Zoning Commission Meeting – Paige Nied, Associate Planner
  - Comments by Paige Nied: updated meeting date request to May 7th *(00.01.52 in video)*

**Motion to continue the public hearing for the 233 Parkway Drive Variance Application to the May 7th Planning & Zoning Commission Meeting 4:35 PM.**

**MOVER:** Brenda Moczygemba

**SECONDER:** Hannah Harris

**AYES:** Tim Carter, Alex Monge, Brenda Moczygemba, & Hannah Harris

**NAYS:**

**RESULT: UNANIMOUSLY ADOPTED**

Commission requests an update on the Code Update Project from staff. *(00.03.13 in video)*

- Response by Abby Rivin *(00.03.43 in video)*
- Questions from Commissioners and staff responses *(00.07.07 in video)*

Commission questions on traffic and construction. *(00.09.47 in video)*

- Response by Morgan Landers *(00.10.40 in video)*

**ADJOURNMENT:** *(00.11.56 in video)*

**Motion to adjourn at 4:44PM:**

**MOVER:** Brenda Moczygemba

**SECONDER:** Hannah Harris

**AYES:** Tim Carter, Brenda Moczygemba, Hannah Harris, & Alex Monge

**NAYS:**

**RESULT: UNANIMOUSLY ADOPTED**

---

Tim Carter – Chairman of the Planning and Zoning Commission

---

Morgan Landers – Director of Planning and Building



STAFF REPORT  
KETCHUM PLANNING AND ZONING COMMISSION  
REGULAR MEETING OF APRIL 15, 2026

**PROJECT:** Lift View Townhomes

**FILE NUMBER:** P25-038 & P25-041

**APPLICATION TYPE:** Design Review and Townhouse Subdivision Preliminary Plat

**PROPERTY OWNER:** Lift View LLC

**REPRESENTATIVE:** Tanya Hoskins, Performance Engineering

**LOCATION:** 310 Georginia Road (Lot 6B, Block 3, Warm Springs Subdivision Second Addition)

**ZONING:** General Residential – Low Density (GR-L)

**OVERLAY:** Avalanche (A)

**REVIEWER:** Paige Nied – Associate Planner

**NOTICE:** A public hearing notice for the project was mailed to all owners of property within 300 feet of the project site on January 28, 2026. The public hearing notice was published in the Idaho Mountain Express on January 28, 2026. A notice was posted on the project site on February 11, 2026. The public hearing was published on the city’s website on February 3, 2026. The building corners were staked and the story pole was installed on the project site on February 11, 2026. The public hearing for this project was continued from the February 18, 2026, meeting to a date certain of March 18, 2026, and then continued again to a date certain of April 15, 2026.

## I. EXECUTIVE SUMMARY

The applicant submitted a Design Review and Subdivision Preliminary Plat application for the development of two attached townhouse units on newly created townhouse sublots (“the project”). The project is located at 310 Georgia Road (the “subject property”) and is within the General Residential – Low Density (GR-L) Zone District and Avalanche (A) Overlay. The subject property is indicated in Figure 1.

Townhouse Unit A is 4,200 square feet in size and Unit B is 4,190 square feet in size and both contain three bedrooms and a two-car garage. A townhouse subdivision preliminary plat will establish the new Lift View

Townhomes sublots. Sublot 1 is 4,884 square feet in size and Sublot 2 is 5,002 square feet in size. The full project plans are included as Attachment B.

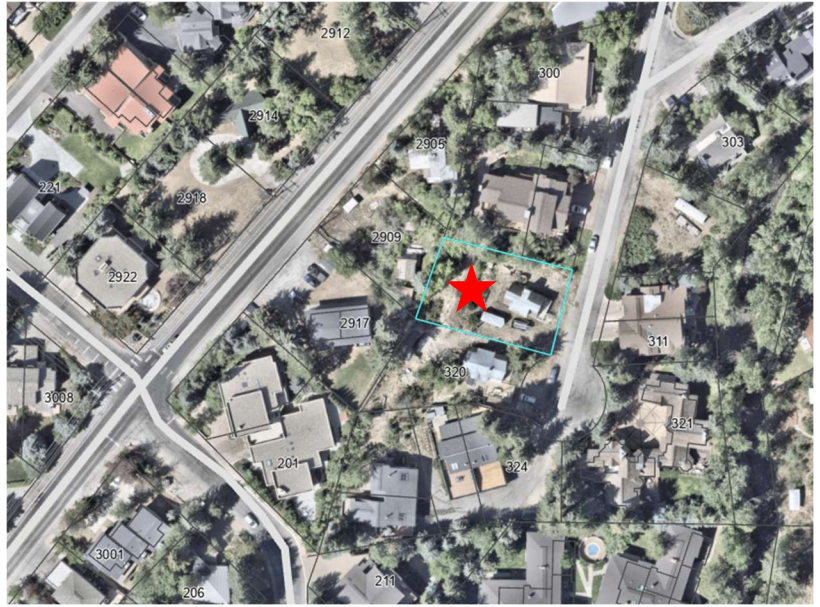

Figure 1: Subject Property

At the February 18, 2026, Planning & Zoning Commission hearing, staff provided an overview of the proposed development and requested the Commission discuss key design elements related to bulk and flatness, building orientation, neighborhood compatibility, and landscaping. The staff report from that meeting is included as Attachment H and a recording of the meeting can be [watched here](#). Upon review of the application materials, staff and applicant presentation, and public comment, the Commission conducted deliberations and provided feedback to the applicant on areas that needed to be further addressed to fully meet design review criteria for approval. Those items are broken down into three categories which include zoning/dimensional, design, and other. The Commission requested the following information and revisions:

- Zoning/Dimensional
  1. Verify building height measurement
  2. Provide parking stall dimensions and improve garage access
- Design
  1. Reduce perceived bulk and flatness
  2. Improve façade articulation and side activation
  3. Reorient unit entrances towards the street
  4. Enhance compatibility with surrounding neighborhood
  5. Provide a more robust landscape plan
- Other
  1. Coordinate civil and architectural plans
  2. Indicate location and screening of AC condensers
  3. Indicate locations of downspouts on elevation sheets

Following that hearing, the applicant made changes to the design of the proposed building. The revised drawings are included as Attachment B to this report. The following changes are being presented for consideration by the Commission:

- Zoning/Dimensional
  - Reduced garage door size for both units from three-vehicle to two-vehicle to allow for better vehicular access from the driveway and added parking stall dimensions to the garage floor plan.
  - Building height remains 32'-11" and was verified by staff. Elevation sheets revised to include spot elevations, line of existing grade, and label identifications of measurement points.
- Design
  - Relocated entrance for Unit B to face the street frontage and enlarged the covered entry and added posts to enhance the architectural appeal of the entrance for Unit A
  - Removed the Moth Wing stucco color
  - Increased side activation by continuing first and second floor materials along sides, changed material of belly band from wood to stucco between second and third floors and wrapped around entirety of structure, and added two windows to ground level side of Unit B.
  - Reduced bulk and mass by removing columns on corners of second and third floors, removed roof overhang over the third floor decks, and recessed third floor.
  - Updated landscaping plan to include trees, groundcover, and additional shrubs.
- Other
  - Roof drains and downspouts are now indicated on roof plan and elevation sheets.
  - The civil plan has been updated to match the ground floor plan of the architectural plan set and the floor plans are now consistent across architectural, civil, and landscape plans
  - The narrative clarified that the applicant has not confirmed whether AC units will be added to the development, but if installed it will be located on the back patio of both units.

None of the proposed changes impact the development's compliance with zoning and dimensional standards. The locations of the AC condensers is not known at this stage of the design process and will be reviewed and screened accordingly at the building permit stage.

Staff recommend the Commission review the revised proposal by the applicant and provide feedback as to whether the changes adequately address the Commission's concerns.

## II. BACKGROUND

The Planning and Building Department received the Townhome Preliminary Plat application for the project on July 17, 2025, and the Design Review application on July 23, 2025. Following receipt of the applications, staff routed the application materials to all city departments for review. The applications were reviewed concurrently and underwent multiple rounds of review to address comments; most specifically related to exterior design of the building.

## III. CONFORMANCE WITH ZONING AND DESIGN REVIEW STANDARDS

Per Ketchum Municipal Code (KMC) 17.96.050.A Criteria, the Commission shall determine the following before approval is given for design review:

1. The project does not jeopardize the health, safety or welfare of the public.
2. The project generally conforms with the goals, policies, and objectives of the adopted comprehensive plan.

3. The project conforms to all applicable standards and criteria as set forth in this chapter, this title, and any other standards as adopted or amended by the City of Ketchum from time to time.

### **Criteria 1 & 2**

For a full review of Criteria 1 and 2, please see the staff report from the February 18<sup>th</sup> meeting, included as Attachment H. During the meeting, the Commission echoed staff's concerns regarding the development's neighborhood compatibility and the perceived bulk and massing. The applicant responded to neighborhood compatibility in their narrative stating that the neighborhood has a diverse range of roof forms and is an eclectic mix of traditional and modern architectural styles. It also mentions compatibility with the existing duplex directly across the street, which is similarly three stories in height, utilizes stone on the ground floor with stucco above, and has recessed front entries. The revised design incorporates a recessed, street-facing front entry for Unit B and additional landscaping towards the front and along the sides of the property, both of which are common characteristics of this neighborhood. The applicant also implemented a variety of design changes to reduce the perceived bulk and mass of the structure. Staff finds that these modifications are improvements and better align with the 2014 Plan's policies related to infill projects being contextually appropriate to the neighborhood (Policy CD 1.3) and well designed and attractive (Policy CD 1.4).

With the previous plan set, staff expressed concerns regarding the compatibility of the project's boxy, modern design within a neighborhood characterized by more traditional architectural styles. The proposed development continues to incorporate a blend of modern and traditional materials, such as stucco, stone, wood, and metal elements used for the garage doors, window and door trim, railings, and fascia. The mix of modern and traditional materials introduces some level of visual continuity with the surrounding development, particularly with the three-story duplex directly across the street which also utilizes stone on the ground level and stucco above. While the building maintains a modern design, staff finds that the applicant has made targeted revisions that improve its relationship to the neighborhood context. These revisions include the introduction of a recessed, street-facing front entry for Unit B which enhances the pedestrian orientation and breaks up the ground floor front façade, as well as the addition of enhanced landscaping along the front and side property lines to soften the building's massing. Staff also finds that the revisions made to the roof, specifically the reduced eave and removal of roof overhangs from the third story decks, have been effective in reducing the building's perceived bulk. However, the third story projection remains, which diminishes the effectiveness of the second story step back and contributes to a top-heavy appearance.

Overall, staff believes that the primary compatibility concern is not with the modern architectural style itself, but rather the building's form and massing. Adjacent structures in the neighborhood feature greater articulation on all elevations, contributing to a more varied and visually balanced streetscape. While the revised design represents an improvement from the previous proposal, staff finds that certain aspects, particularly related to massing and upper-story articulation, still warrant further discussion by the Commission.

### Criteria #3: Zoning and Design Review Standards

#### Conformance with Zoning Regulations

As outlined in Attachment E, the application complies with the zoning and dimensional standards of the KMC. However, the Commission requested additional information and evaluation on building height and off street parking, which are addressed below.

#### *Building Height*

The Commission as well as public comment raised concerns regarding the accuracy of the maximum building height measurement. The Ketchum Municipal Code defines building height as:

*The greatest vertical distance measured at any point from the roof to natural, existing, or finished grade, whichever is lowest. The maximum vertical distance from the lowest exposed finished floor to the highest point of the roof (regardless of vertical alignment) shall be no more than five feet greater than the maximum height permitted in the zoning district (see illustration B on file in the office of the City Clerk). No facade shall be greater than the maximum height permitted in the zoning district. (See definition of "facade" in this section and illustration B on file in the office of the City Clerk.) Facades which step up "or down hillsides shall be set back from the lower facade a minimum of 50 percent of the height of the lower facade; except, that roof overhangs may extend up to three feet into this area (see illustration B on file in the office of the City Clerk). This building height provision shall apply to parapets, Boston roofs and any other portion of a building roof, but shall not apply to flagpoles, lightning rods, weather vanes, antennas or chimneys.*

The maximum building height is 32'-11", measured from the roof peak elevation of 5,9010.42' and the lowest finished grade elevation of 5,868.50'. The maximum building height has not changed from the previous plan set. Staff believe the concern with the building height was due to the architectural measurements and various labels of the grade on the previous plan set. The applicant revised the elevation sheets (A3.0-A3.3) to now include spot elevations, line of existing grade, and labels to identify the lowest finished grade and roof peak where the building height is measured from. Staff reviewed the building height measurements and believe the height shown on the drawings to be accurate. The building height measurement is shown in Figure 2 below from Sheet A3.1. Additionally, height certificates are required for buildings during the construction period to verify that height limits are not exceeded.

Figure 2: Building Height Measurement

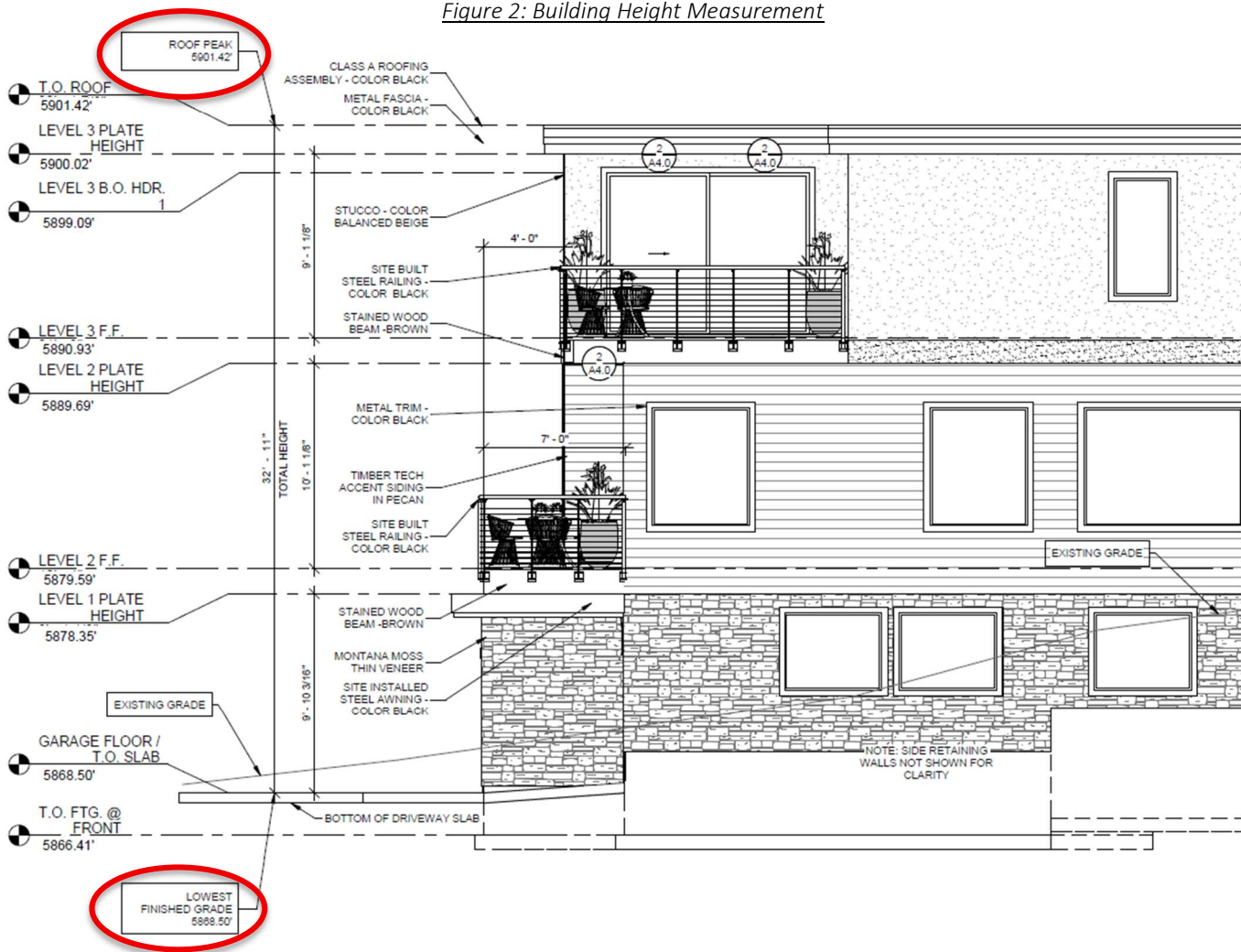

### Off Street Parking

Both the Commission and public comment raised concerns regarding the size of the garage doors, dimensions of the parking stalls within the garages, and the orientation of the driveway with the garages as it relates to vehicular access. The revised plans reduced the garage doors from three-car to two-car configurations for each unit to facilitate better vehicular access with a head-on approach from the driveway. In addition, the applicant provided dimensions for the two parking stalls within each garage, indicating 18 feet in length and 9 feet in width, as shown on Sheet A2.0 in Attachment B. These dimensions comply with KMC 17.125.030.A, minimum requirements of 9' in width and 18' in length for 90-degree angled parking.

### Conformance with Design Review Standards

In general, the proposed project meets many of the design review standards (Attachment F). However, staff is requesting feedback on whether the revised design adequately addresses the Commission's concerns regarding the standards evaluated below.

### Bulk/Mass/Flatness

The Commission raised concerns with the perceived bulk and flatness of the structure and requested additional undulation and articulation of the façade. To achieve this, the applicant made several

modifications to the design. See Figure 3 below for an evaluation of changes to the previous design and comparison with proposed design.

*Figure 3: Previous & Proposed Design Comparison*

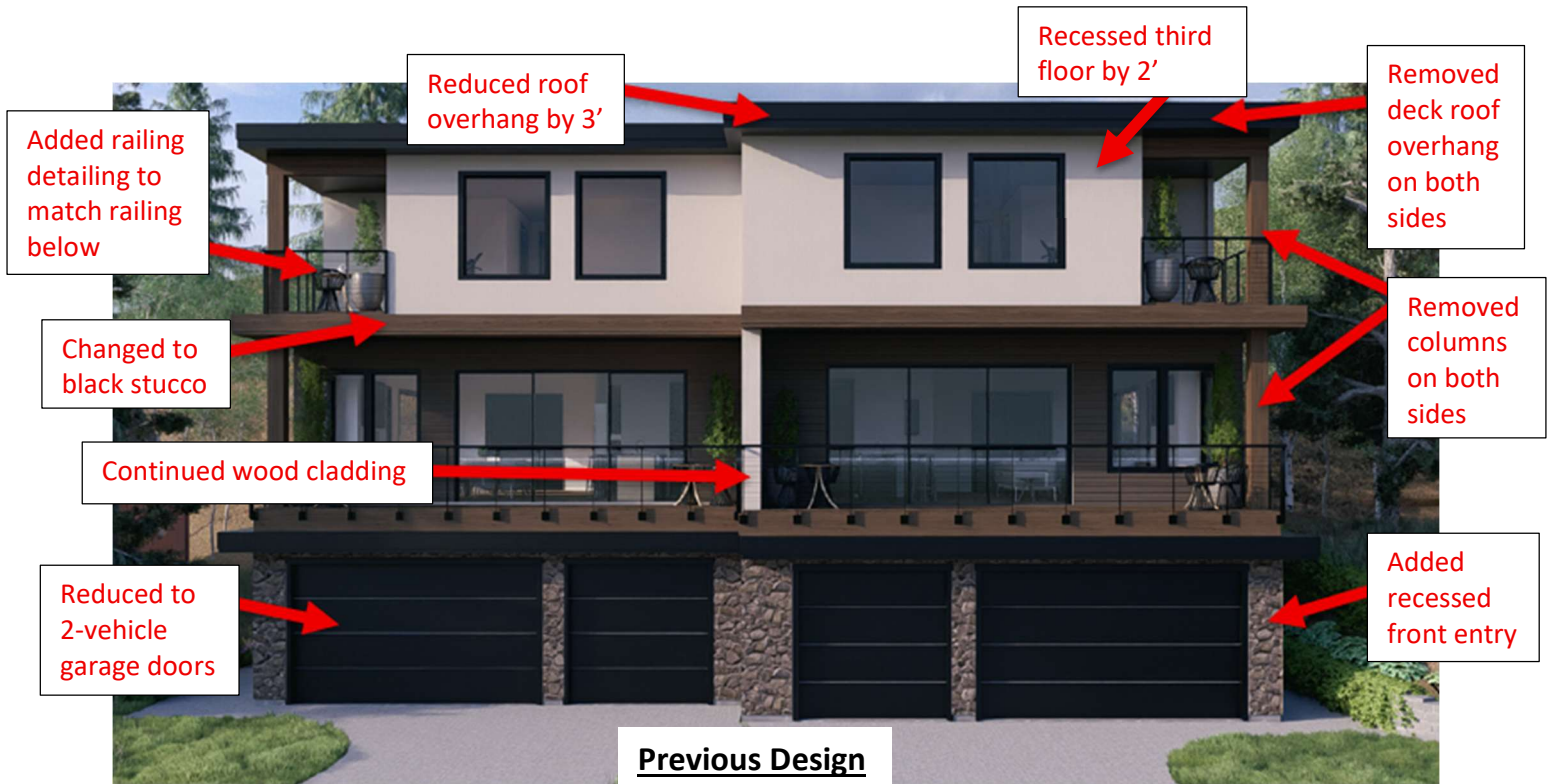

Please note that the stucco color on the third floor appears darker in the rendering of the proposed design, however it has not changed and remains the color “Balanced Beige” from the previous design, which is indicated on the colors and materials sheet. Also, there was a material callout error on the elevation sheets (A3.0-A3.3) of the revised plan set, which indicates Balanced Beige as the color of the stucco belly band between the second and third floors. The applicant revised those sheets to include a red notation indicating that the correct color of the stucco belly band is Tricorn Black.

The Commission also had concerns with the lack of architectural detail and visual interest on the sides of the structure and requested more activation in those areas. The applicant has revised the design to continue the stone on the ground floor and wood on the second floor along the sides of the structure. The design now also continues a stucco belly band between the second and third floor around the entirety of the structure. Lastly, posts were added to the entryway overhang for Unit A and windows were added to the ground floor side of Unit B where the previous entrance was located. Please see Figure 4 below to see the rendering of the side of the structure.

*Figure 4: Rendering of Building Side*



### *Building Orientation*

The Commission felt that the previous design didn't fully meet the design review criteria regarding building's being oriented to the primary street frontage. The applicant has since revised the design to relocate the front entryway for Unit B to face the street frontage and recessed the door to break up the ground floor wall plane. This modification created a more active front façade which is more compatible with other developments in the neighborhood. For Unit A, the applicant enlarged the size of the overhang and added posts to increase the architectural interest of the entrance (this can be seen in Figure 4 above). By bringing one entrance to the front and retaining one on the side, it will create a natural separation between the units and privacy for the occupants.

### *Landscaping*

During the meeting, the Commission raised concerns with the lack of trees in the landscape plan and requested a more robust plan overall. The landscape plan has been revised to add landscaping around the entire structure, which includes 3 Weeping White Pine trees, several new shrubs, and native grasses for reseeding. A significant number of shrubs have been added along the street frontage of the property, which is a common characteristic of properties in this neighborhood. Further, the addition of landscaping on the front and sides of the property will help soften the appearance of the structure and the taller shrubs proposed along the sides will provide privacy from neighboring properties.

Overall, staff finds that the revisions related to bulk/mass/flatness, building orientation, and landscaping are improvements from the previous design. Staff requests feedback from the Commission on whether the revisions sufficiently address the concerns that had been identified in those areas.

#### **IV. CONFORMANCE WITH SUBDIVISION STANDARDS**

Since the hearing, no changes were requested or have been made to the townhouse preliminary plat. As conditioned, the preliminary plat remains in conformance with all subdivision preliminary plat development and design requirements (KMC 16.04.040) and townhouse standards (KMC 16.04.080).

#### **STAFF RECOMMENDATION**

Staff recommends the Commission review the Design Review and Townhouse Preliminary Plat applications and provide feedback on items outlined above in the staff report. Following direction, the Commission has the following options:

- Continue the application to a date certain or uncertain with a request for revisions or more information
- Approve the applications
- Approve the applications with conditions
- Deny the applications

If the Commission chooses to move forward with approving the applications as presented or revised, staff recommends the following conditions of approval to be considered. The Commission may delete, revise, or add to the conditions of approval based on the discussion.

#### Design Review

1. This Design Review approval is based on the plans and the information presented and approved at the April 15, 2026, Planning and Zoning Commission Meeting included as Attachment B. The building permit plans must conform to the approved Design Review plans unless otherwise approved in writing by the Planning and Zoning Commission or Administrator. Any building or site discrepancies which do not conform to the approved plans will be subject to removal.
2. At time of building permit, the applicant shall submit final civil drawings prepared by an engineer registered in the State of Idaho that provide specifications for all right-of-way improvements, including sidewalks, alley asphalt, streetlights, utilities, and drainage facilities, for final review and approval by the City Engineer, Streets Department, Utilities Department, and Planning Department.
3. The term of Design Review approval shall be twelve (12) months from the date that the Findings of Fact, Conclusions of Law, and Decision are adopted by the Planning and Zoning

Commission or upon appeal, the date the approval is granted by the Council subject to changes in zoning regulations (KMC §17.96.090). Any extension shall comply with KMC §17.96.090.B.

4. In addition to the requirements set forth in this Design Review approval, this project shall comply with all applicable local, state, and federal laws.

#### Townhouse Subdivision Preliminary Plat

1. The preliminary plat is subject to all conditions of approval associated with the Design Review approval P25-041.
2. The preliminary plat shall be revised to indicate the private well is to be abandoned and indicate the locations of the new water and sewer lines for both sublots prior to City Council review of the application.
3. Failure to record a Final Plat within two (2) years of Council's approval of a Preliminary Plat shall cause the Preliminary Plat to be null and void.

#### **V. ATTACHMENTS:**

- A. Design Review Application & Supplemental Materials
- B. Design Review Plan Set
- C. Preliminary Plat Application & Supplemental Materials
- D. Lift View Townhomes Preliminary Plat
- E. Zoning and Dimensional Standards Evaluation
- F. Design Review Standards Evaluation
- G. Preliminary Plat Standards Evaluation
- H. Staff Report – February 18, 2026 Planning and Zoning Commission Meeting



City of Ketchum

# Attachment A: Design Review Application & Supplemental Materials



**City of Ketchum  
Planning & Building**

**Design Review Application**

OFFICIAL USE ONLY
File Number:
Date Received:
By:
Pre-Application Fee Paid:
Design Review Fee Paid:
By:

Submit completed application and documentation to [planningandbuilding@ketchumidaho.org](mailto:planningandbuilding@ketchumidaho.org) Or hand deliver to Ketchum City Hall, 191 5<sup>th</sup> St. W. Ketchum, ID If you have questions, please contact the Planning and Building Department at (208) 726-7801. To view the Development Standards, visit the City website at: [www.ketchumidaho.org](http://www.ketchumidaho.org) and click on Municipal Code. You will be contacted and invoiced once your application package is complete.

APPLICANT INFORMATION					
Project Name: Lift View Townhomes			Phone:		
Owner: Bobbie Jordan			Mailing Address: Bobbie Jordan		
Email: jordanhomes@yahoo.com			P.O. Box 983, Eagle, ID 83616		
Architect/Representative: Tanya Hoskins, Performance Engineering			Phone: (208) 475-0040		
Email: thoskins@performancestructural.com			Mailing Address: Performance Engineering		
Architect License Number:			1102 N. Franklin Blvd., Napa ID 83678		
Engineer of Record: Alex Nelson, Alpine Enterprises Inc.			Phone: (208) 727-1988		
Email: alexnelson@alpineenterprisesinc.com			Mailing Address: Alpine Enterprises Inc.		
Engineer License Number: PE 19275			P.O. Box 2037, Ketchum, ID 83340		
Primary Contact Name and Phone Number:					
PROJECT INFORMATION					
Legal Land Description: Lot 6B, Block 3, Warms Springs Village Subdivision, Second Addition				Street Address: 310 Georginia Road	
Lot Area (Square Feet): 9,846 S.F.		Zoning District: GR-L		RPK #: 0590003006B	
Overlay District: <input type="checkbox"/> Floodplain <input checked="" type="checkbox"/> Avalanche <input type="checkbox"/> Mountain <input type="checkbox"/> None					
Type of Construction: <input checked="" type="checkbox"/> New <input type="checkbox"/> Addition <input type="checkbox"/> Remodel <input type="checkbox"/> Other					
Anticipated Use: Multi-Family Residential				Number of Residential Units: 2 Townhouse Units	
GROSS FLOOR AREA					
	Proposed			Existing	
Basements	N/A		Sq. Ft.	N/A Sq. Ft.	
1 <sup>st</sup> Floor	2,918 (1,459 ea. unit)		Sq. Ft.	N/A Sq. Ft.	
2 <sup>nd</sup> Floor	2,606 (1,303 ea. unit)		Sq. Ft.	N/A Sq. Ft.	
3 <sup>rd</sup> Floor	2,798 (1,399 ea. unit)		Sq. Ft.	N/A Sq. Ft.	
Mezzanine	N/A		Sq. Ft.	N/A Sq. Ft.	
Total	8,322 (4,161 ea. unit)		Sq. Ft.	N/A Sq. Ft.	
FLOOR AREA RATIO					
Community Core:		Tourist:		General Residential-High:	
BUILDING COVERAGE/OPEN SPACE					
Percent of Building Coverage: 2,995 Sq. Ft./9,846 Sq. Ft. = 30.4% Building Coverage					
DIMENSIONAL STANDARDS/PROPOSED SETBACKS					
Front: 15'-0 3/8"		Side: 10'-11 5/8"	Side: 10'-11 5/8"	Rear: 51'-5 5/8"	
Building Height: 32'-11"					
OFF STREET PARKING					
Parking Spaces Provided: 6		Curb Cut: 28' - 14'x2 Sq. Ft. 635 S.F.		% 35% OF LOT FRONTAGE	
WATER SYSTEM					
<input checked="" type="checkbox"/> Municipal Service			<input type="checkbox"/> Ketchum Spring Water		

The Applicant agrees in the event of a dispute concerning the interpretation or enforcement of the Design Review Application in which the city of Ketchum is the prevailing party, to pay the reasonable attorney fees, including attorney fees on appeal and expenses of the city of Ketchum. I, the undersigned, certify that all information submitted with and upon this application form is true and accurate to the best of my knowledge and belief.

*Bruce S.*

10/28/2025

Signature of Representative:  
Bruce Smith - Alpine Enterprises Inc.

Date:

Hi Paige,

Listed below is a summary of the items the P&Z Commission requested revisions and additional information on with responses describing the changes made to the plans to address this feedback as far as the architectural plan set is concerned:

- Activation of side facades (such as continuing materials along the sides to create more visual interest) **The horizontal siding has been extended and wraps continuously along the sides of level 2, in addition stone has been added to the north and south sides of the building on Level 1. A stucco belly band has been reintroduced between Levels 2 and 3, accompanied by two windows at the northern unit entry.**
- Add parking stall dimensions to the garages for both units **added 18'x9' parking stalls inside garage on page A2.0.**
- Explore revising the driveway approach/garage doors to be more accessible for vehicles. **Garage doors have been reduced in width improving vehicular access into the garage.**

Verify the grade where the maximum building height was measured from and make it clear on the elevation sheets **On each elevation sheet, A3.0-A3.3, the total height is called out with a dimension of 32'-11" from the top of slab at driveway to top of roof, per Ketchum's Municipal Code's definition of building height that states, "The greatest vertical distance measured at any point from the roof to natural, existing, or finished grade, whichever is lowest."**

- If the building height measurement is incorrect, adjust side setbacks and building envelope as needed. **We believe the building height measurements to be correct, as we have measured from the lowest finish grade to the highest point of the roof, per Ketchum Municipal Code's definition of building height states, "The greatest vertical distance measured at any point from the roof to natural, existing, or finished grade, whichever is lowest."**
- Indicate location of AC units and indicate screening for AC condensers. **As of this time, we are not completely sure the client will be adding AC units so we did not add them to the plan set, however, if the client decides they will be adding AC units, they will be placed on the back patio of each corresponding residence.**
- Provide additional undulation/relief and architectural features to reducing the perceived massing of the structure. **The two ground-to-roof front columns have been eliminated by pulling the third floor back an additional two feet (five feet total**

from the garage overhang) and removing the third-floor balcony roofs. This creates additional undulation changing the roof plane and adding a new layer of visual interest. The front roof eave has also been reduced by 3' down to a 1' overhang, a stucco banding was added between level 2 and level 3 along the front and sides of the structure. The ground floor façade was broken up by reorienting the right unit entry toward the street, creating a step-back along the wall. We feel these changes helped greatly to create a more visual appealing and engaging elevation.

- Evaluate revising the design to be more compatible with the surrounding neighborhood. We know that the neighborhood itself has a diverse range of architectural designs that range from A-frame structures, shed, flat and low pitch roofs with most residents only being clad in siding. The newest structure built across the street is modern Italian style duplex with a combination of stone stucco cladding. Many of the surrounding residents have side and stepped backed entries and therefore, we believe our design will fit well in this architecturally eclectic neighborhood.
- Reorient entryways to the front façade. We reoriented the entry to face the street on the right unit and brought it closer to the front of the structure while trying to ensure a natural and private separation between units. In addition, enlarged the covered entrance on the left unit and added posts to enhance architectural appeal.
- Indicate downspouts on elevation sheets. Roof drains/downspouts can be seen on sheet A5.0. They can also be seen and/or are called out on sheet A3.0-A3.3.
- Revise civil plan to match the ground floor plan of the architectural plan set on the outside back wall of each unit. We have provided Civil with this plan set so that they could add it to their plans in an effort to have more coordination between the trades.
- Landscaping. An additional forty-five trees, evergreens, flowering plants and ground cover have been added to the original plan to give the landscape a more robust feel. Evergreens, multiply bushes and ground cover were incorporated in each of the front three planters. Three white pines and fourteen evergreens are proposed for screening of neighboring properties along the south entrance and back patios. Addition of ground cover was introduced into the lower planter that was created by relocating the north unit entrance. Draping vines were added to soften the look from the street of the northern retaining wall.
- Left unit utility meter. To be screened with slatted wood.



City of Ketchum

# Attachment B: Design Review Plan Set

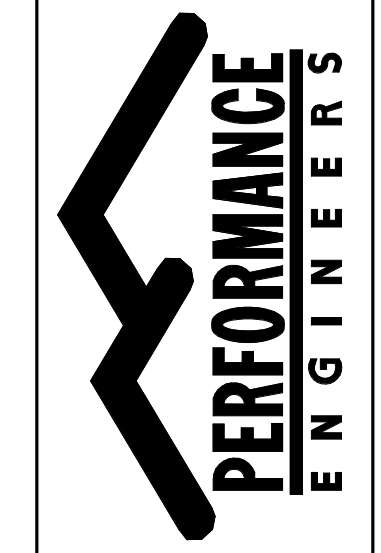

An InteFrame Company

1102 N. FRANKLIN BLVD.  
NAMPA, IDAHO 83687  
PH. (208) 475-0040

REV	DATE	DESCRIPTION	BY

# LIFT VIEW TOWNHOMES

## 310 GEORGIA RD, KETCHUM, IDAHO

### STRUCTURAL NOTES:

#### A. DESIGN LOADS AND CRITERIA

- INTERNATIONAL BUILDING CODE (IBC) 2018 EDITION / IRC 2018
- GRAVITY LOADS (PSF):
 

LOCATION	DEAD LOAD	LIVE OR SNOW LOAD	TOTAL LOAD
1ST FLOOR	12	40	52
ROOF	17	25	42
- WIND CRITERIA:
  - WIND SPEED: 115 MPH (3 SECOND GUST)
  - EXPOSURE: C
  - IMPORTANCE: I: 1.0
- SEISMIC CRITERIA:
  - RISK CATEGORY: II
  - DESIGN CATEGORY: C
  - Sds: 0.30
  - Sd1: 0.15
  - SITE CLASS: D
  - IMPORTANCE: I: 1.0
  - RESPONSE, R: 6.5
- SOIL BEARING PRESSURE: 1500 PSF ON UNDISTURBED SOIL
- LATERAL SOIL PRESSURE: 35 PCF EQUIVALENT FLUID PRESSURE
- FROST DEPTH BELOW GRADE: 24 INCHES

- 3/4" AT SLABS AND AT WALLS NOT EXPOSED TO EARTH OR WEATHER
- LAP REINFORCING BARS ACCORDING TO THE FOLLOWING, UNLESS INDICATED OTHERWISE:
 

BAR SIZE	LAP LENGTH
#3	1'-6"
#4	2'-0"
#5	2'-6"
#6	3'-0"
- SPlice TOP BARS IN GRADE BEAMS NEAR MIDSPAN, BOTTOM BARS NEAR SUPPORTS.
- WELDING OF REINFORCING BARS IS NOT PERMITTED UNLESS SPECIFICALLY DETAILED.
- REINFORCE OPENING HEADS, JAMBS & SILLS WITH (2) #5 BAR. EXTEND EACH END OF EACH BAR 2'-6" PAST OPENING EDGE.
- REINFORCE CONCRETE SLABS ON DECK WITH 13x13-D5xDF. PLACE WWF 1 1/2" BELOW TOP OF SLAB USING METAL POSITIONER DEVICES. LAP WWF ONE FULL MESH AT SPLICES.
- TIE DOWELS IN PLACE BEFORE PLACING CONCRETE. DO NOT STAB OR WET-SET DOWELS.
- REINFORCING FIBERS: ASTM C1116, FIBRILLATED POLYPROPYLENE
- ANCHOR BOLTS: ASTM A307 OR A36
- EXPANSION ANCHORS: HILTI "QUICK BOLT II" OR EQUIVALENT
- ADHESIVE: SIMPSON "SET" OR EQUIVALENT

- PARALLEL STRAND LUMBER: ASTM D2559
  - Fv: 2900 PSI
  - Fv: 2900 PSI
  - Fc: 2900 PSI
  - E: 2.0E6 PSI
- PREFABRICATED WOOD TRUSSES SHALL CONFORM TO THE TRUSS PLATE INSTITUTE DESIGN SPECIFICATION FOR METAL-PLATE-CONNECTED WOOD TRUSSES.
- TRUSSES SHALL BE DESIGNED BY THE MANUFACTURER TO SUPPORT ALL INDICATED LOADS. TRUSS LOADING:
  - TOP CHORD DL: 7 PSF
  - TOP CHORD LL: (SEE LIVE / SNOW LOADS IN SECTION A)
  - BOTTOM CHORD DL: 10 PSF
  - BOTTOM CHORD LL: 10 PSF (DOES NOT ACT CONCURRENT WITH TOP CHORD LL)
- MEMBER PROPERTIES: CHORDS SHALL BE #2 DOUG FIR LARCH OR BETTER; WEBS SHALL HAVE MINIMUM MODULUS OF ELASTICITY OF 1,500,000 PSI
- ALL TRUSS BLOCKING SHALL BE PROVIDED BY TRUSS MANUFACTURER AND CONSTRUCTED WITH APPROVED PLATES.
- TRUSS PROFILES SHOWN ARE REPRESENTATIONS OF POSSIBLE CONFIGURATIONS OF WEB LOCATIONS AND MEMBER SIZES. TRUSS MANUFACTURE SHALL SUBMIT SHOP DRAWINGS FOR APPROVAL. ALL TRUSSES SHALL BE STAMPED AND SEALED BY A PROFESSIONAL ENGINEER REGISTERED IN THE STATE THE PROJECT RESIDES IN.
- TRUSS MANUFACTURER SHALL PROVIDE PROOF OF THIRD PARTY INSPECTION AS REQUIRED BY IBC SECTION 2303.4.
- IN ADDITION TO LOADS SPECIFIED ELSEWHERE, DESIGN PREFABRICATED WOOD TRUSS BOTTOM CHORDS FOR 10 PSF DEAD LOAD
- DRILL LAG BOLT LEAD HOLES TO MATCH THE LAG BOLT SHANK DIAMETER AND HALF THE SHANK DIAMETER FOR THE THREADED PORTION.

GROSS SQ. FOOTAGE:

LEVEL 1:	2963.75
LEVEL 2:	2426.86
LEVEL 3:	2388.40
TOTAL:	7779.01

NET SQ. FOOTAGE:

LEVEL 1:	2657.66
LEVEL 2:	2286.65
LEVEL 3:	2245.44
TOTAL:	7189.75

SQUARE FOOTAGE BREAKDOWN (PER UNIT LEVEL):

LEVEL	SPACE	UNIT A	UNIT B
LEVEL 1	INTERIOR LIVING SPACE:	665	762
LEVEL 1	INTERIOR GARAGE/MECH:	739	601
LEVEL 2	INTERIOR LIVING:	1144	1144
LEVEL 2	COVERED PATIO:	194	194
LEVEL 2	BACK PATIO:	237	237
LEVEL 3	INTERIOR LIVING SPACE:	1123	1123
LEVEL 3	PATIO:	98	98
TOTAL:		4200	4190

#### B. FOUNDATIONS

- FOUNDATIONS HAVE BEEN DESIGNED FOLLOWING RECOMMENDATIONS PRESENTED IN IRC CHAPTER 4. INSTALL THE FOUNDATION AND FLOOR SLABS ACCORDING TO IRC RECOMMENDATIONS.
- PLACE FOOTING ON UNDISTURBED NATURAL SOILS OR ENGINEERED FILL PLACED OVER UNDISTURBED NATURAL SOILS. FILL SHALL BE APPROVED BY A SOILS ENGINEER. PLACE FILL IN UNIFORM LIFTS (8" MAX.) AND COMPACT TO 96% MODIFIED PROCTOR ACCORDING TO ASTM D1557.
- ENGINEERED FILL SHALL BE SELECTED IN ACCORDANCE WITH THE GEOTECHNICAL REPORT.
- EXISTING FILL, IF ENCOUNTERED, SHALL BE REMOVED AND REPLACED WITH ENGINEERED FILL.
- PLACE INTERIOR SLABS ON GRADE ON 4" OF 3/4" MINUS GRANULAR FILL OVER A VAPOR RETARDER.
- PROTECT SOILS BENEATH SLABS AND FOOTING FROM FREEZING.
- PROVIDE POSITIVE DRAINAGE AWAY FROM THE STRUCTURE AVOID EXCESSIVE WETTING OR DRYING OF FOUNDATION EXCAVATIONS.

#### C. CONCRETE

- PERFORM CONCRETE WORK IN ACCORDANCE WITH ACI 318-14 "STANDARD SPECIFICATION FOR STRUCTURAL CONCRETE" UNLESS NOTED OTHERWISE
- ASTM C150 TYPE III CEMENT
- MINIMUM CEMENT CONTENT: 450 #/YD
- ENTRAINED AIR: 5% (+/- 1 1/2%) AT ALL CONCRETE EXPOSED TO FREEZING (EXT. SLABS, FND, WALLS, ETC.)
- MAXIMUM SLUMP: 4" (WITHOUT SUPERPLASTICIZER)
- 28 DAY STRENGTH: fc: 3500 PSI RECOMMENDED (DESIGNED FOR 2500)
- NORMAL WEIGHT AGGREGATE: 1 1/2" MAX FOOTINGS, 3/4" MAX ELSEWHERE
- WHERE TOP SURFACES OF CONCRETE SLABS ARE SHOWN TO BE RECESSED MORE THAN 1/2", THICKEN SLAB TO MAINTAIN INDICATED SLAB THICKNESS.
- SLAB JOINTS ARE INDICATED ON THE DRAWINGS. CONSTRUCTION JOINTS MAY, AT CONTRACTOR'S OPTION, BE SUBSTITUTED FOR CONTRACTION JOINTS.
- DO NOT USE CHLORIDE ADMIXTURES IN CONCRETE.
- REINFORCING BARS: ASTM A615, GRADE 60 (WHERE INDICATED TO BE WELDED)
- DETAIL REINFORCING BARS ACCORDING TO LATEST EDITION OF ACI DETAILING MANUAL.
- MINIMUM REINFORCING BAR COVER:
  - 3" AT UNFORMED SURFACES EXPOSED TO EARTH
  - 1 1/2" AT FORMED SURFACES EXPOSED TO EARTH OR WEATHER

#### D. WOOD FRAMING

- DIMENSION LUMBER(GRADED BY WESTERN WOOD PRODUCTS ASSOCIATION (WWPA) OR WEST COAST LUMBER INSPECTION BUREAU (WCLIB)):
  - STUDS: DOUG FIR LARCH STUD GRADE OR BETTER
  - JOISTS: DOUG FIR LARCH NO 2 OR BETTER
  - ALL NAILS SPECIFIED ARE TO BE COMMON WIRE NAILS, UNLESS NOTED OTHERWISE.
  - SPlice DOUBLE TOP PLATE AT 4'-0" MINIMUM USING (24) 16d NAILS EACH SIDE OF THE SPlice.
  - PROVIDE HEADERS FOR OPENINGS IN WALLS ACCORDING TO THE FRAMING PLAN
  - FRAMING CONNECTORS, ANCHORS, AND HANGERS SHOWN ON THE DRAWINGS ARE THE PRODUCTS OF SIMPSON STRONG-TIE COMPANY (OR EQUIVALENT), SAN LEANDRO, CALIFORNIA AND ARE DESIGNATED BY MANUFACTURER'S STANDARD PRODUCT NUMBERS. FOLLOW ALL MANUFACTURER'S RECOMMENDATIONS FOR INSTALLATION AND USE.
  - WALL SHEATHING: 7/16" APA RATED SHEATHING, PANEL RATING 24/16, ATTACH WITH 16 GAUGE x 1 1/2" STAPLES AT 6" O.C. AT PANEL EDGES AND 12" O.C. AT INTERMEDIATE FRAMING, U.N.O. ALL PANEL EDGES SHALL BE BLOCKED.
  - ROOF SHEATHING: 7/16" APA RATED SHEATHING, PANEL RATING 24/16, ATTACH WITH 8d NAILS AT 6" O.C. AT PANEL EDGES AND 12" O.C. AT INTERMEDIATE FRAMING, OR USE 1-1/2"x16 GAUGE STAPLES AT HALF THE SPACING (3" EDGE / 6" FIELD) U.N.O.
  - FLOOR SHEATHING: 7/8" APA RATED SHEATHING, PANEL RATING 48/24, ATTACH WITH 10d NAILS AT 6" O.C. AT PANEL EDGES AND 12" O.C. AT INTERMEDIATE FRAMING, U.N.O.
  - PROVIDE 1/8" GAP AT CONSTRUCTION PANEL BUTT JOINTS
  - GLUED LAMINATED TIMBERS: ANSI/AITC A190.1, 24F-V4 DF/DF U.N.O.
  - ENGINEERED WOOD PRODUCTS (WOOD JOISTS, WOOD & METAL OPEN-WEB JOISTS, LAMINATED VENEER LUMBER, AND PARALLEL-STRAND LUMBER) SHOWN ON THE DRAWINGS ARE THE PRODUCTS OF WEYERHAEUSER (OR EQUIVALENT) AND ARE DESIGNATED BY THE MANUFACTURER'S STANDARD PRODUCT NUMBERS. THE INTENT OF THE DESIGN IS FOR THESE ITEMS TO BE ATTACHED TO EACH OTHER AND TO THE SURROUNDING STRUCTURE TO BEHAVE AS A SYSTEM. WHETHER SHOWN OR NOT, PROVIDE ACCESSORY ITEMS (BLOCKS, CLIPS, STIFFENERS, STRAPS, ETC.), DESIGNED BY THE MANUFACTURER, FOR A COMPLETE SYSTEM. FOLLOW ALL MANUFACTURER'S RECOMMENDATIONS FOR INSTALLATION AND USE.
  - FABRICATED WOOD JOISTS: ASTM D2559
  - LAMINATED VENEER LUMBER: ASTM D2559
    - Fv: 2600 PSI
    - Fv: 285 PSI
    - Fc: 2510 PSI
    - E: 2.0E6 PSI

#### E. MISCELLANEOUS

- ELEVATIONS REFERENCE MAIN FLOOR ELEVATION, SET AT 0'-0".
- COORDINATE OPENINGS AND EMBEDDED ITEMS NOTED ON ALL CONSTRUCTION DOCUMENTS WITH APPROPRIATE TRADES.
- BEFORE FABRICATION, HAVE SHOP DRAWINGS REVIEWED BY ARCHITECT AND/OR ENGINEER.
- TEMPORARILY BRACE THE STRUCTURE TO RESIST ALL LOADS OR COMBINATIONS OF LOADS UNTIL ALL PERMANENT ELEMENTS ARE IN PLACE AND ALL CONNECTIONS ARE COMPLETE.

#### F. SPECIAL INSPECTIONS

- SPECIAL INSPECTIONS AS REQUIRED IN IBC CHAPTER 17, SECTION 1705, IS REQUIRED AS NOTED FOR THE FOLLOWING ITEMS IF PRESENT IN PROJECT. THE CONTRACTOR SHALL PROVIDE MINIMUM OF 48 HOURS NOTICE TO THE SPECIAL INSPECTOR PRIOR TO INSPECTION.
  - CONCRETE:
    - NOT REQUIRED, SEE IBC SECTION 1705.3, ITEM 2.3. CONCRETE DESIGN BASED ON 2500 PSI COMPRESSIVE STRENGTH.
    - BOLTS INSTALLED IN CONCRETE:
      - PROVIDE SPECIAL INSPECTION FOR EPOXY ANCHORS
  - STRUCTURAL STEEL:
    - PROVIDE SPECIAL INSPECTION PER IBC SECTION 1705.12.1.1 AND AISC 360 OR AISC 341 (FOR SEISMIC CONTROLLED DESIGN)
  - STRUCTURAL WOOD:
    - PROVIDE SPECIAL INSPECTION PER IBC SECTION 1705.5.2 FOR METAL PLATED WOOD TRUSSES SPANNING 60 FEET OR GREATER IF PRESENT.

### ENERGY EFFICIENCY CERIFICATE:

2018 INTERNATIONAL ENERGY CONSERVATION CODE (IECC)  
 THE PROPOSED BUILDING HAS BEEN DESIGNED TO MEET OR EXCEED THE REQUIREMENTS OF THE INTERNATIONAL ENERGY CONSERVATION CODE.

PRESCRIPTIVE ENERGY TABLE N1102.1

INSULATION & FENESTRATION REQUIREMENTS BY COMPONENT

CLIMATE ZONE	FENESTRATION U-FACTOR	CEILING R-VALUE	WOOD FRAME WALL R-VALUE	MASS WALL R-VALUE	FLOOR R-VALUE	BASEMENT / CRAWL SPACE R-VALUE	SLAB R-VALUE & DEPTH
6	0.30	49	20 + 5" or 13 + 10"	15/20	30"	15/19	10, 4'-0"

### SYMBOL LEGEND:

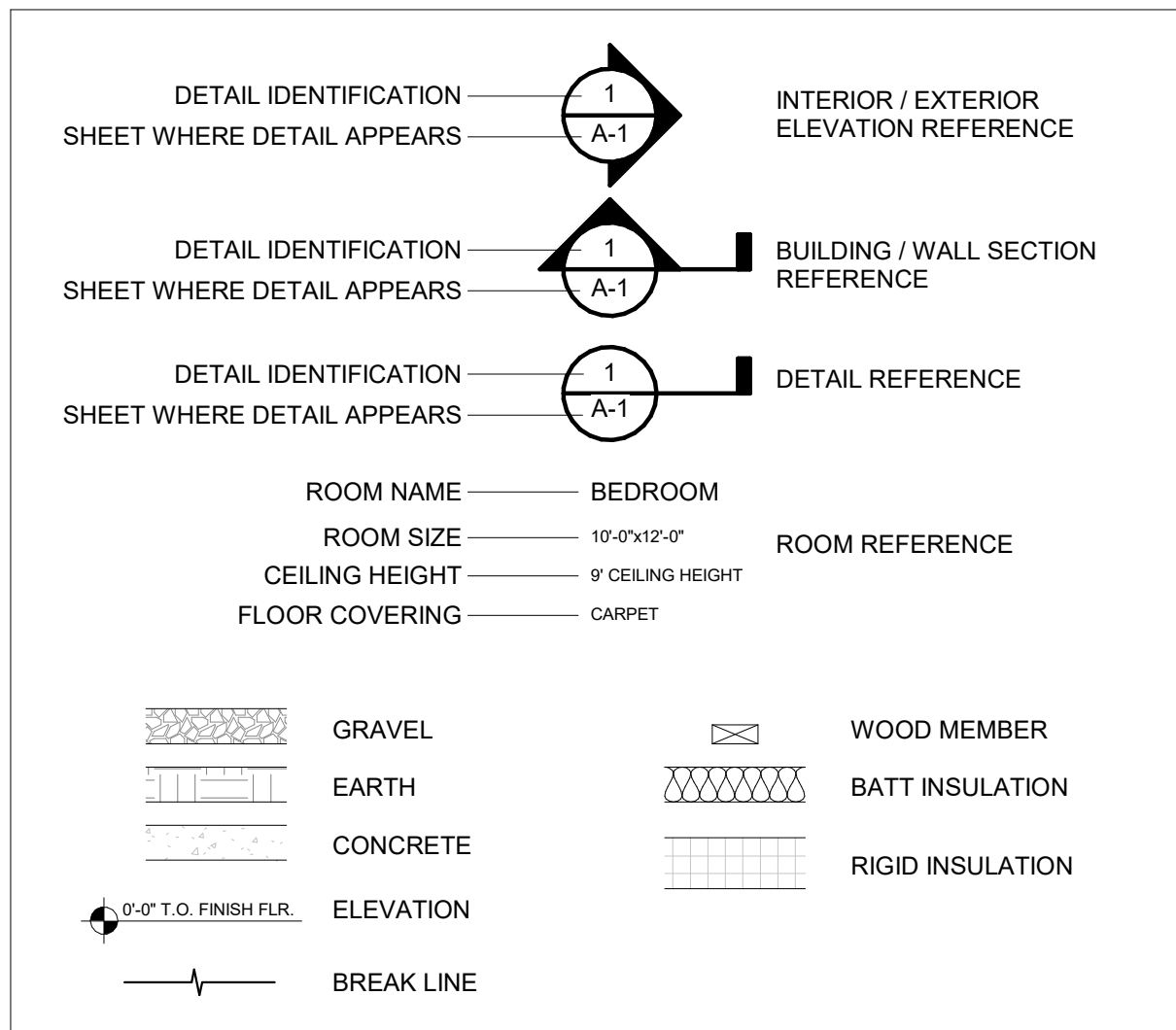

### GENERAL PLAN NOTES:

CONTRACTOR IS TO VERIFY ALL DIMENSIONS AT JOBSITE PRIOR TO PROCEEDING WITH THE WORK. ANY DISCREPANCIES FOUND SHALL BE REPORTED TO PERFORMANCE ENGINEERS FOR EVALUATION. BEGINNING WORK WITHOUT PROPERLY VERIFYING DIMENSIONS SHALL BE AT THE SOLE RISK OF THE CONTRACTOR.

DIMENSIONS SHOWN DO NOT INCLUDE THE THICKNESS OF ANY APPLIED FINISH MATERIALS. DIMENSIONS ARE EITHER TO FACE OF STUD, FACE OF MASONRY, OR CENTERLINE OF OPENINGS OR STRUCTURE.

ALL INFORMATION CONTAINED WITHIN THESE DRAWINGS AND ARE INTENDED TO MEET OR EXCEED 2018 IRC. ALL DESIGN CRITERIA NOT SHOWN ON THESE PLANS ARE TO CONFORM TO THE 2018 IRC.

ALL WORK SHALL CONFORM TO ALL LOCAL, STATE AND NATIONAL CODES.

THE CONTRACTOR IS RESPONSIBLE FOR ALL FEES, PERMITS AND INSPECTIONS AS REQUIRED BY GOVERNING AGENCY.

ALL CONSTRUCTION DEBRIS IS TO BE CONTAINED NEATLY ON SITE UNTIL DISPOSED OF.

### SHEET INDEX:

- 0.0 GENERAL STRUCTURAL NOTES
- 0.1 SPECIAL INSPECTIONS
- A1.0 SITE PLAN & BUILDING LOT COVERAGE
- A2.0 LEVEL 1 FLOOR PLAN
- A2.1 LEVEL 2 FLOOR PLAN
- A2.2 LEVEL 3 FLOOR PLAN
- A3.0 FRONT ELEVATION
- A3.1 RIGHT SIDE ELEVATION
- A3.2 REAR ELEVATION
- A3.3 LEFT ELEVATION
- A4.0 OUTDOOR LIGHTING INFORAMTION
- A5.0 ROOF PLAN
- S1.0 FOUNDATION PLAN
- S1.1 SHEAR WALL / HEADER PLAN
- S2.0 LEVEL 2 FLOOR FRAMING
- S2.2 LEVEL 2 SHEAR/HEADER PLAN
- S3.0 LEVEL 3 FLOOR FRAMING
- S3.1 LEVEL 3 SHEAR/HEADER PLAN
- S4.0 ROOF FRAMING PLAN
- SD1.0 FOUNDATION DETAILS
- SD1.1 FOUNDATION DETAILS
- SD2.0 FRAMING DETAILS
- SD2.1 FRAMING DETAILS
- SD3.0 FIREWALL AND FRAMING DETAILS
- SD3.1 FIREWALL INFORMATION
- SD4.0 SECTION VIEWS

### ABBREVIATIONS:

A/C	AIR CONDITIONER	EW	EACH WAY	PSL	PARALLEL STRAND LUMBER
BLDG	BUILDING	EXIST	EXISTING	PT	PRESSURE TREATED
BLKG	BLOCKING	EXP	EXPANSION	REINF	REINFORCEMENT/REINFORCING
BM	BEAM	FDN	FOUNDATION	REF	REFRIGERATOR
BOT	BOTTOM	FIN	FINISHED	REQD	REQUIRED
BRG	BEARING	FLR	FLOOR	RI	ROUGH IN
BTWN	BETWEEN	FTG	FOOTING	SL	SLIDING
CL	CENTERLINE	FUR	FURNACE	SH	SINGLE HUNG
CANT	CANTILEVER	FX	FIXED	STD	STANDARD
CLR	CLEAR	GLB	GLULAM BEAM	STIFF	STIFFENER
CMU	CONCRETE MASONRY UNIT	HDR	HEADER	T&G	TONGUE AND GROOVE
CO	CASED OPENING	HORIZ	HORIZONTAL	TO	TOP OF
COL	COLUMN	LONG	LONGITUDINAL	TRANS	TRANSOM
CONC	CONCRETE	LSL	LAMINATED STRAND LUMBER	TYP	TYPICAL
CONN	CONNECTION/CONNECTOR	LVL	LAMINATED VENEER LUMBER	VERT	VERTICAL
CONT	CONTINUE/CONTINUOUS	MIN	MINIMUM	W/	WITH
CONTR JT	CONTRACTION JOINT	OC	ON CENTER	W/H	WATER HEATER
COVD	COVERED	OSB	ORIENTED STRAND BOARD	WS	WATER SOFTENER
DF	DOUGLAS FIR	PAR	PARALLEL	W/O	WITHOUT
DBL	DOUBLE	PE	PRE-ENGINEERED		
EA	EACH	PED	PEDESTAL		
ELEV	ELEVATION	PERP	PERPENDICULAR		

NOTE: THIS IS A STANDARD LIST. SOME OF THE LISTED ABBREVIATIONS MAY NOT APPEAR IN THE DRAWINGS FOR THIS PROJECT.

LIFT VIEW TOWNHOMES  
310 GEORGIA RD  
GENERAL STRUCTURAL NOTES  
KETCHUM, IDAHO

DATE:	03/31/26
SCALE:	AS NOTED
DESIGN BY:	TSH
DESIGN REVIEW:	TSH
STRUCTURE BY:	???
STRUCTURE REVIEW:	VAL
JOB NO.:	2025-17046

DESIGN REV. 6

SHEET 0.0

# SPECIAL INSPECTIONS PER IBC CHAPTER 17

STATEMENT OF SPECIAL INSPECTIONS, 2018 IBC

PROJECT NAME: LIFT VIEW TOWNHOMES

LOCATION: 310 GEORGIA RD, KETCHUM, IDAHO

THIS STATEMENT OF SPECIAL INSPECTIONS IS SUBMITTED IN FULFILLMENT OF THE REQUIREMENTS OF IBC SECTIONS 1704 AND 1705. INCLUDED ARE:

- SCHEDULE OF SPECIAL INSPECTIONS AND TESTS APPLICABLE TO THIS PROJECT.
- SPECIAL INSPECTIONS PER SECTIONS 1704 AND 1705 SPECIAL INSPECTIONS FOR SEISMIC RESISTANCE SPECIAL INSPECTIONS FOR WIND RESISTANCE

\* LIST OF THE TESTING AGENCIES AND OTHER SPECIAL INSPECTORS THAT WILL BE RETAINED TO CONDUCT THE TESTS AND INSPECTIONS.

SPECIAL INSPECTIONS AND TESTING WILL BE PERFORMED IN ACCORDANCE WITH THE APPROVED PLANS AND SPECIFICATIONS, THIS STATEMENT AND IBC SECTIONS 1704, 1705, 1707, AND 1708.

THE SCHEDULE OF SPECIAL INSPECTIONS SUMMARIZES THE SPECIAL INSPECTIONS AND TESTS REQUIRED. SPECIAL INSPECTORS WILL REFER TO THE APPROVED PLANS AND SPECIFICATIONS FOR DETAILED SPECIAL INSPECTION REQUIREMENTS. ANY ADDITIONAL TESTS AND INSPECTIONS REQUIRED BY THE APPROVED PLANS AND SPECIFICATIONS WILL ALSO BE PERFORMED.

INTERIM REPORTS WILL BE SUBMITTED TO THE BUILDING OFFICIAL AND THE REGISTERED DESIGN PROFESSIONAL IN RESPONSIBLE CHARGE IN ACCORDANCE WITH IBC SECTION 1704.1.2

A FINAL REPORT OF SPECIAL INSPECTIONS DOCUMENTING REQUIRED SPECIAL INSPECTIONS, TESTING AND CORRECTION OF ANY DISCREPANCIES NOTED IN THE INSPECTIONS SHALL BE SUBMITTED PRIOR TO ISSUANCE OF A CERTIFICATE OF USE AND OCCUPANCY (SECTION 1704.1.2). THE FINAL REPORT WILL DOCUMENT:

- REQUIRED SPECIAL INSPECTIONS.
- CORRECTION OF DISCREPANCIES NOTED IN INSPECTIONS.
- THE OWNER RECOGNIZES HIS OR HER OBLIGATION TO ENSURE THAT THE CONSTRUCTION COMPLIES WITH THE APPROVED PERMIT DOCUMENTS AND TO IMPLEMENT THIS PROGRAM OF SPECIAL INSPECTIONS. IN PARTIAL FULFILLMENT OF THESE OBLIGATIONS, THE OWNER WILL RETAIN AND DIRECTLY PAY FOR THE SPECIAL INSPECTIONS AS REQUIRED IN IBC SECTION 1704.1.

THIS PLAN HAS BEEN DEVELOPED WITH THE UNDERSTANDING THAT THE BUILDING OFFICIAL WILL:

- REVIEW AND APPROVE THE QUALIFICATIONS OF THE SPECIAL INSPECTORS WHO WILL PERFORM THE INSPECTIONS.
- MONITOR SPECIAL INSPECTION ACTIVITIES ON THE JOB SITE TO ASSURE THAT THE SPECIAL INSPECTORS ARE QUALIFIED AND ARE PERFORMING THEIR DUTIES AS CALLED FOR IN THIS STATEMENT OF SPECIAL INSPECTION.
- REVIEW SUBMITTED INSPECTION REPORTS.
- PERFORM INSPECTIONS AS REQUIRED BY THE LOCAL BUILDING CODE.

PREPARED BY:

SHAWN REEDER, P.E. / VANCE LEVITT, P.E. / HAILEY STEIN, P.E.

OWNER: \_\_\_\_\_ BUILDING OFFICIAL: \_\_\_\_\_

SIGNATURE: \_\_\_\_\_ SIGNATURE: \_\_\_\_\_

DATE: \_\_\_\_\_ DATE: \_\_\_\_\_

## SCHEDULE INSPECTION, TESTING AGENCIES, AND INSPECTORS

RESPONSIBILITY	FIRM	ADDRESS, TELEPHONE, EMAIL
1. SPECIAL INSPECTION (EXCEPT FOR GEOTECHNICAL)		
2. MATERIAL TESTING		
3. GEOTECHNICAL INSPECTIONS		

## SCHEDULE OF SPECIAL INSPECTION

APPLICABLE TESTS AND INSPECTIONS ARE INDICATED BELOW WITH A SOLID FILLED RECTANGLE "■":

APPLIES	VERIFICATION AND INSPECTION	C	P	NOTES
<b>SECTION 1705.2.1 - STRUCTURAL STEEL</b>				
<input type="checkbox"/>	SPECIAL INSPECTION FOR STRUCTURAL STEEL SHALL BE IN ACCORDANCE WITH THE QUALITY ASSURANCE INSPECTION REQUIREMENTS OF AISC 360.			
<b>TABLE 1705.3 - CONCRETE</b>				
<input type="checkbox"/>	1. INSPECTION OF REINFORCING STEEL, INCLUDING PRESTRESSING TENDONS, AND PLACEMENT	--	X	
<input type="checkbox"/>	2. INSPECTION OF REINFORCING STEEL WELDING IN ACCORDANCE WITH TABLE 1705.2.2, ITEM 2B	--	--	
<input type="checkbox"/>	3. INSPECTION OF ANCHORS CAST IN CONCRETE WHERE ALLOWABLE LOADS HAVE BEEN INCREASED OR WHERE STRENGTH DESIGN IS USED	X	--	
<input type="checkbox"/>	4. INSPECTION OF ANCHORS POST-INSTALLED IN HARDENED CONCRETE MEMBERS	--	X	
<input type="checkbox"/>	5. VERIFYING USE OF REQUIRED DESIGN MIX	--	X	
<input type="checkbox"/>	6. AT THE TIME FRESH CONCRETE IS SAMPLED TO FABRICATE SPECIMENS FOR STRENGTH TESTS, DETERMINE SLUMP AND AIR CONTENT TESTS, AND DETERMINE THE TEMPERATURE OF THE CONCRETE	X	--	
<input type="checkbox"/>	7. INSPECTION OF CONCRETE AND SHOTCRETE PLACEMENT FOR PROPER APPLICATION TECHNIQUES	X	--	
<input type="checkbox"/>	9. INSPECTION OF PRE-STRESSED CONCRETE: A. APPLICATION OF PRESTRESSING FORCES	--	X	
<input type="checkbox"/>	B. GROUTING OF BOUNDED PRESTRESSING TENDONS IN THE SEISMIC FORCE-RESISTING SYSTEM	X	--	
<input type="checkbox"/>	10. ERECTION OF PRECAST CONCRETE MEMBERS	--	X	
<input type="checkbox"/>	11. VERIFICATION OF IN-SITU CONCRETE STRENGTH PRIOR TO STRESSING OF TENDONS IN POST-TENSIONED CONCRETE AND PRIOR TO REMOVAL OF SHORES AND FORMS FROM BEAMS AND STRUCTURAL SLABS	--	X	
<input type="checkbox"/>	12. INSPECT FORMWORK FOR SHAPE, LOCATION, AND DIMENSIONS OF THE CONCRETE MEMBER BEING FORMED	--	X	

TABLE 1704.6 - SOILS			
<input type="checkbox"/>	1. VERIFY MATERIALS BELOW SHALLOW FOUNDATIONS ARE ADEQUATE TO ACHIEVE THE DESIGN BEARING CAPACITY	--	X
<input type="checkbox"/>	2. VERIFY EXCAVATIONS ARE EXTENDED TO PROPER DEPTH AND HAVE REACHED PROPER MATERIAL	--	X
<input type="checkbox"/>	3. PERFORM CLASSIFICATION AND TESTING OF COMPACTED FILL MATERIALS	--	X
<input type="checkbox"/>	4. VERIFY USE OF PROPER MATERIALS, DENSITIES AND LIFT THICKNESSES DURING PLACEMENT AND COMPACTION OF COMPACTED FILL	X	--
<input type="checkbox"/>	5. PRIOR TO PLACEMENT OF COMPACTED FILL, OBSERVE SUBGRADE AND VERIFY THAT SITE HAS BEEN PREPARED PROPERLY	--	X

TABLE 1704.5.1 - LEVEL 1 MASONRY			
<input type="checkbox"/>	1. COMPLIANCE WITH REQUIRED INSPECTION PROVISIONS OF THE CONSTRUCTION DOCUMENTS AND THE APPROVED SUBMITTALS SHALL BE VERIFIED	--	X
<input type="checkbox"/>	2. VERIFICATION OF $f_m$ AND $f_{m,c}$ PRIOR TO CONSTRUCTION EXCEPT WHERE SPECIFICALLY EXEMPTED BY THIS CODE	--	X
<input type="checkbox"/>	3. VERIFICATION OF SLUMP FLOW AND VSI AS DELIVERED TO THE SITE FOR SELF-CONSOLIDATING GROUT	--	X

4. AS MASONRY CONSTRUCTION BEGINS, THE FOLLOWING SHALL BE VERIFIED TO ENSURE COMPLIANCE:			
<input type="checkbox"/>	A. PROPORTIONS OF SITE PREPARED MORTAR	--	X
<input type="checkbox"/>	B. CONSTRUCTION OF MORTAR JOINTS	--	X
<input type="checkbox"/>	C. LOCATION OF REINFORCEMENT, CONNECTIONS, PRESTRESSING TENDONS AND ANCHORAGES	--	X
<input type="checkbox"/>	D. PRESTRESSING TECHNIQUE	--	X
<input type="checkbox"/>	E. GRADE AND SIZE OF PRESTRESSING TENDONS AND ANCHORAGES	--	X

5. DURING CONSTRUCTION THE INSPECTION PROGRAM SHALL VERIFY:			
<input type="checkbox"/>	A. SIZE AND LOCATION OF STRUCTURAL ELEMENTS	--	X
<input type="checkbox"/>	B. TYPE, SIZE AND LOCATION OF ANCHORS, INCLUDING OTHER DETAILS OF ANCHORAGE OF MASONRY TO STRUCTURAL MEMBERS FRAMES OR OTHER CONSTRUCTION	--	X
<input type="checkbox"/>	C. SPECIFIED SIZE, GRADE AND TYPE OF REINFORCEMENT, ANCHOR BOLTS, PRESTRESSING TENDONS AND ANCHORAGES	--	X
<input type="checkbox"/>	D. WELDING OF REINFORCING BARS	X	--
<input type="checkbox"/>	E. PREPARATION, CONSTRUCTION AND PROTECTION OF MASONRY DURING COLD WEATHER (TEMPERATURE BELOW 40°F) OR HOT WEATHER (TEMPERATURE ABOVE 90°F)	X	--
<input type="checkbox"/>	F. APPLICATION AND MEASUREMENT OF PRESTRESSING FORCE	X	--

6. PRIOR TO GROUTING, THE FOLLOWING SHALL BE VERIFIED TO ENSURE COMPLIANCE:			
<input type="checkbox"/>	A. GROUT SPACE IS CLEAN	--	X
<input type="checkbox"/>	B. PLACEMENT OF REINFORCEMENT AND CONNECTORS, AND PRESTRESSING TENDONS AND ANCHORAGES	--	X
<input type="checkbox"/>	C. PROPORTIONS OF SITE PREPARED GROUT AND PRESTRESSING GROUT FOR BONDED TENDONS	--	X
<input type="checkbox"/>	D. CONSTRUCTION OF MOTOR JOINTS	--	X

7. GROUT PLACEMENT SHALL BE VERIFIED TO ENSURE COMPLIANCE:			
<input type="checkbox"/>	A. GROUTING OF PRESTRESSING BONDED TENDONS	X	--
<input type="checkbox"/>	8. PREPARATION OF ANY REQUIRED GROUT SPECIMENS, MORTAR SPECIMENS AND/OR PRISMS SHALL BE OBSERVED	--	X

## TABLE 1704.5.3 - LEVEL 2 MASONRY

<input type="checkbox"/>	1. COMPLIANCE WITH REQUIRED INSPECTION PROVISIONS OF THE CONSTRUCTION DOCUMENTS AND THE APPROVED SUBMITTALS	--	X
<input type="checkbox"/>	2. VERIFICATION OF $f_m$ AND $f_{m,c}$ PRIOR TO CONSTRUCTION AND FOR EVERY 5000 sq. ft. DURING CONSTRUCTION	--	X
<input type="checkbox"/>	3. VERIFICATION OF PROPORTIONS OF MATERIALS IN PREMIXED OR PREBLENDED MORTAR AND GROUT AS DELIVERED TO THE SIRE	--	X
<input type="checkbox"/>	4. VERIFICATION OF SLUMP FLOW AND VSI AS DELIVERED TO THE SIRE FOR SELF-CONSOLIDATING GROUT	X	--

5. THE FOLLOWING SHALL BE VERIFIED TO ENSURE COMPLIANCE:			
<input type="checkbox"/>	A. PROPORTIONS OF SITE-PREPARED MORTAR, GROUT AND PRESTRESSING GROUT FOR TENDONS	--	X
<input type="checkbox"/>	B. PLACEMENT OF MASONRY UNITS AND CONSTRUCTION OF MORTAR JOINTS	--	X
<input type="checkbox"/>	C. PLACEMENT OF REINFORCEMENT, CONNECTORS, AND PRESTRESSING TENDONS AND ANCHORAGES	--	X
<input type="checkbox"/>	D. GROUT SPACE PRIOR TO GROUT	X	--
<input type="checkbox"/>	E. PLACEMENT OF GROUT	X	--
<input type="checkbox"/>	F. PLACEMENT OF PRESTRESSING GROUT	X	--
<input type="checkbox"/>	G. SIZE AND LOCATION OF STRUCTURAL ELEMENTS	--	X
<input type="checkbox"/>	H. TYPE, SIZE AND LOCATION OF ANCHORS INCLUDING OTHER DETAILS OF ANCHORAGE OF MASONRY TO STRUCTURAL MEMBERS, FRAMES OR OTHER CONSTRUCTION	--	X
<input type="checkbox"/>	I. SPECIFIED SIZE, GRADE AND TYPE OF REINFORCEMENT, ANCHOR BOLTS, PRESTRESSING TENDONS AND ANCHORAGES	--	X
<input type="checkbox"/>	J. WELDING OF REINFORCING BARS	X	--
<input type="checkbox"/>	K. PREPARATION, CONSTRUCTION AND PROTECTION OF MASONRY DURING COLD WEATHER (TEMPERATURE BELOW 40°F) OR HOT WEATHER (TEMPERATURE ABOVE 90°F)	X	--
<input type="checkbox"/>	L. APPLICATION AND MEASUREMENT OF PRESTRESSING FORCE	X	--

6. PREPARATION OF ANY REQUIRED GROUT SPECIMENS AND/OR PRISMS SHALL BE OBSERVED			
<input type="checkbox"/>	1. WHERE FABRICATION OF STRUCTURAL LOAD-BEARING MEMBERS AND ASSEMBLIES IS BEING PERFORMED ON THE PREMISES OF A FABRICATOR'S SHOP, UNLESS THE FABRICATOR IS REGISTERED AND APPROVED TO PERFORM WITH SPECIAL INSPECTION.	X	--

SECTION 1704.2.5 - INSPECTION OF FABRICATORS			
<input type="checkbox"/>	1. WHERE FABRICATION OF STRUCTURAL LOAD-BEARING MEMBERS AND ASSEMBLIES IS BEING PERFORMED ON THE PREMISES OF A FABRICATOR'S SHOP, UNLESS THE FABRICATOR IS REGISTERED AND APPROVED TO PERFORM WITH SPECIAL INSPECTION.	X	--

<input type="checkbox"/>	9. INSPECTION OF PRE-STRESSED CONCRETE: A. APPLICATION OF PRESTRESSING FORCES	--	X
<input type="checkbox"/>	B. GROUTING OF BOUNDED PRESTRESSING TENDONS IN THE SEISMIC FORCE-RESISTING SYSTEM	X	--
<input type="checkbox"/>	10. ERECTION OF PRECAST CONCRETE MEMBERS	--	X
<input type="checkbox"/>	11. VERIFICATION OF IN-SITU CONCRETE STRENGTH PRIOR TO STRESSING OF TENDONS IN POST-TENSIONED CONCRETE AND PRIOR TO REMOVAL OF SHORES AND FORMS FROM BEAMS AND STRUCTURAL SLABS	--	X
<input type="checkbox"/>	12. INSPECT FORMWORK FOR SHAPE, LOCATION, AND DIMENSIONS OF THE CONCRETE MEMBER BEING FORMED	--	X

TABLE 1704.8 - DRIVEN DEEP FOUNDATION			
<input type="checkbox"/>	1. VERIFY ELEMENT MATERIALS, SIZES AND LENGTHS COMPLY WITH THE REQUIREMENTS	X	--
<input type="checkbox"/>	2. DETERMINE CAPACITIES OF TEST ELEMENTS AND CONDUCT ADDITIONAL LOAD TESTS, AS REQUIRED	X	--
<input type="checkbox"/>	3. OBSERVE DRIVING OPERATIONS AND MAINTAIN COMPLETE AND ACCURATE RECORDS FOR EACH ELEMENT	X	--
<input type="checkbox"/>	4. VERIFY PLACEMENT LOCATIONS AND PLUMBNESS, CONFIRM TYPE AND SIZE OF HAMMER, RECORD NUMBER OF BLOWS PER FOOT OF PENETRATION, DETERMINE REQUIRED PENETRATIONS TO ACHIEVE DESIGN CAPACITY, RECORD TIP AND BUTT ELEVATIONS AND DOCUMENT ANY DAMAGE TO FOUNDATION ELEMENT	X	--
<input type="checkbox"/>	5. FOR STEEL ELEMENTS, PERFORM ADDITIONAL INSPECTIONS IN ACCORDANCE WITH SECTION 1704.3	--	--
<input type="checkbox"/>	6. FOR CONCRETE ELEMENTS AND CONCRETE-FILLED ELEMENTS, PERFORM ADDITIONAL INSPECTIONS IN ACCORDANCE WITH SECTION 1704.4	--	--
<input type="checkbox"/>	7. FOR SPECIALTY ELEMENTS, PERFORM ADDITIONAL INSPECTIONS AS DETERMINED BY THE REGISTERED DESIGN PROFESSIONAL IN RESPONSIBLE CHARGE	--	--

TABLE 1704.8 - CAST IN PLACE DEEP FOUNDATION			
<input type="checkbox"/>	1. OBSERVE DRILLING OPERATIONS AND MAINTAIN COMPLETE AND ACCURATE RECORDS FOR EACH ELEMENT	X	--
<input type="checkbox"/>	2. VERIFY PLACEMENT LOCATIONS AND PLUMBNESS, CONFIRM ELEMENT DIAMETERS, BELL DIAMETERS (IF APPLICABLE), LENGTHS, EMBEDMENT INTO BEDROCK (IF APPLICABLE) AND ADEQUATE END-BEARING STRATA CAPACITY. RECORD CONCRETE OR GROUT VOLUMES	X	--
<input type="checkbox"/>	3. FOR CONCRETE ELEMENTS, PERFORM ADDITIONAL INSPECTIONS IN ACCORDANCE WITH SECTION 1704.4	--	--

SECTION 1705.5 - WOOD CONSTRUCTION			
<input type="checkbox"/>	1. FABRICATION PROCESS OF PREFABRICATED WOOD STRUCTURAL ELEMENTS AND ASSEMBLIES	--	ONE TIME
<input type="checkbox"/>	2. HIGH LOAD DIAPHRAGMS: A. GRADE AND THICKNESS OF WOOD STRUCTURAL PANEL SHEATHING	X	--
<input type="checkbox"/>	B. NOMINAL SIZE OF FRAMING MEMBERS AT ADJOINING PANEL EDGES	X	--
<input type="checkbox"/>	C. NAIL OF STAPLE DIAMETER AND LENGTH	X	--
<input type="checkbox"/>	D. NUMBER OF FASTENER LINES AND SPACING BETWEEN FASTENERS	X	--
<input type="checkbox"/>	3. METAL-PLATE CONNECTED WOOD TRUSSES SPANNING 60 FEET OR GREATER: A. TEMPORARY INSTALLATION RESTRAINT/ BRACING AND THE PERMANENT INDIVIDUAL TRUSS MEMBER RESTRAINT/BRACING ARE INSTALLED IN ACCORDANCE WITH THE APPROVED TRUSS SUBMITTAL PACKAGE	--	X

SECTION 1705.1.1 - SPECIAL CASES			
<input type="checkbox"/>	INSPECTION OF MECHANICAL ANCHORS IN CONCRETE OR MASONRY: 1. THE SPECIAL INSPECTION MUST BE ON THE JOB SITE CONTINUOUSLY DURING ANCHOR INSTALLATION TO VERIFY ANCHOR TYPE, ANCHOR DIMENSIONS, CONCRETE TYPE, CONCRETE INTEGRITY, HOLE DIMENSIONS, HOLE CLEANING PROCEDURES, ANCHOR SPACING, EDGE DISTANCES, CONCRETE THICKNESS, ANCHOR EMBEDMENT AND TIGHTENING TORQUE	X	--
<input type="checkbox"/>	2. VERIFICATION OF CONCRETE STRENGTH BY OBTAINING AND TESTING DRILLED CORES BY ASTM C42 METHODS	--	ONE TIME
<input type="checkbox"/>	3. PROOF LOAD TESTING (INCLUDE TESTING INSTRUCTIONS OF THE PLANS)	--	DEPENDS

SECTION 1705.11 - SEISMIC RESISTANCE			
<input type="checkbox"/>	THE STATEMENT OF SPECIAL INSPECTION SHALL INCLUDE SEISMIC REQUIREMENTS FOR THE FOLLOWING CASES: 1. THE SEISMIC-FORCE-RESISTING SYSTEMS	--	X
<input type="checkbox"/>	2. DESIGNATED SEISMIC SYSTEMS (ONLY WHEN I-1)	--	X
<input type="checkbox"/>	3. HEATING, VENTILATING AND AIR-CONDITIONING (HVAC) DUCTWORK CONTAINING HAZARDOUS MATERIALS AND ANCHORAGE OF SUCH DUCTWORK	--	X
<input type="checkbox"/>	4. PIPING SYSTEMS AND MECHANICAL UNITS CONTAINING FLAMMABLE, COMBUSTIBLE OR HIGHLY TOXIC MATERIALS	--	X
<input type="checkbox"/>	5. ANCHORAGE OR ELECTRICAL EQUIPMENT USED FOR EMERGENCY OR STANDBY POWER SYSTEMS	--	X
<input type="checkbox"/>	6. EXTERIOR WALL PANELS AND THEIR ANCHORAGE	--	X
<input type="checkbox"/>	7. SUSPENDED CEILING SYSTEMS AND THEIR ANCHORAGE	--	X
<input type="checkbox"/>	8. ACCESS FLOORS AND THEIR ANCHORAGE	--	X
<input type="checkbox"/>	9. STEEL STORAGE RACKS AND THEIR ANCHORAGE (WHERE I-1.5)	--	X

SECTION 1705.10 - WIND RESISTANCE			
<input type="checkbox"/>	THE STATEMENT OF SPECIAL INSPECTION SHALL INCLUDE WIND REQUIREMENTS FOR THE FOLLOWING CASES: 1. IN WIND EXPOSURE B AND WIND SPEEDS 120 MILES OR GREATER	X	--
<input type="checkbox"/>	2. IN WIND EXPOSURE C OR D AND WIND SPEEDS 110 MILES OR GREATER	X	--

SECTION 1705.10.1 & 1705.11.2 - STRUCTURAL WOOD			
<input type="checkbox"/>	1. INSPECT FIELD GLUING OPERATIONS OF ELEMENTS OF THE MAIN WIND/SEISMIC-FORCE-RESISTING SYSTEM	X	--
<input type="checkbox"/>	2. INSPECT NAILING, BOLTING, ANCHORING AND OTHER FASTENING OF COMPONENTS WITHIN THE MAIN WIND/SEISMIC-FORCE-RESISTING SYSTEM, INCLUDING: WOOD SHEAR WALLS, WOOD DIAPHRAGMS, DRAG STRUTS, BRACES, SHEAR PANELS, HOLD DOWNS	--	X
<input type="checkbox"/>	3. SPECIAL INSPECTION IS NOT REQUIRED AT WOOD SHEAR WALLS, SHEAR PANELS AND DIAPHRAGMS WHERE THE NAIL/STAPLE SPACING OF THE SHEATHING IS 6" O.C. OR GREATER	--	--

SECTION 1705.10.2 & 1705.11.3 - COLD-FORMED STEEL CONSTRUCTION			
<input type="checkbox"/>	1. WELDING OF ELEMENTS OF THE MAIN WIND/SEISMIC-FORCE-RESISTING SYSTEM	--	X
<input type="checkbox"/>	2. INSPECTION OF SCREW ATTACHMENTS, BOLTING, ANCHORING AND OTHER FASTENING OF COMPONENTS WITHIN THE MAIN WIND/SEISMIC-FORCE-RESISTING SYSTEM, INCLUDING: STRUTS, BRACES AND HOLD DOWNS, SHEAR WALLS, AND DIAPHRAGMS	--	X

SECTION 1705.11.7 - STORAGE RACKS & ACCESS FLOORS			
<input type="checkbox"/>	1. ANCHORAGE OF STORAGE RACKS AND ACCESS FLOORS 8 FEET OR GREATER IN HEIGHT	--	X

All Connections shall conform to this table, unless noted otherwise in the structural notes, drawings, or details contained in this plan set.

Refer to IBC Table 2304.10.2

No.	Description of Building Element	No. and Type of Fastener	Spacing and Location	No.	Description of Building Element	No. and Type of Fastener	Spacing and Location		
1.	Blocking between ceiling joists, rafters or trusses to top plate or other framing below	(4) 8d box (0.113"x2 1/2") (3) 8d common (0.131"x2 1/2") (3) 10d box (0.128"x3") (3) 0.131"x3" nails	Each Joist, Toenail	20.	1" x 8" and wider sheathing to each bearing	(3) 8d common (0.131"x2 1/2") (3) 8d box (0.113"x2 1/2") (3) 10d box (0.128"x3") (3) 1 3/4"x16 ga. Staples, 1" crown <b>Wider than 1"x8"</b>	Face Nail		
	Blocking between rafters or truss not at the wall top plate, to rafter or truss	(2) 8d common (0.131"x2 1/2") (2) 0.131"x3" nails (2) 3"x14 ga. staples	End Nail			21.	Joist to sill, top plate, or girder	(3) 8d common (0.131"x2 1/2") (4) 8d box (0.113"x2 1/2") (3) 0.131"x3" nails (3) 8d common (0.131"x2 1/2") (3) 10d box (0.128"x3") (3) 0.131"x3" nails	Toenail
	Flat blocking to truss and web filler	16d com. (0.162"x3 1/2") @ 6" o.c. 0.131"x3" nails @ 6" o.c. 3"x14 ga. Staples @ 6" o.c.	Face Nail					22.	Rim joist, band joist, or blocking to top plate, sill or other framing below
2.	Ceiling Joists to Top Plate	(4) 8d box (0.113"x2 1/2") (3) 8d common (0.131"x2 1/2") (3) 10d box (0.128"x3") (3) 0.131"x3" nails (3) 3"x14 ga. staples 7/16" Crown	Each Joist, Toenail	23.	1" x 6" subfloor or less to each joist	(2) 8d common (0.131"x2 1/2") (3) 10d box (0.128"x3") (2) 1 3/4"x16 ga. Staples, 1" crown	Face Nail		
3.	Ceiling joist not attached to parallel rafter, laps over partitions (no thru) (see IBC Section 2308.7.3.1, IBC Table 2308.7.3.1)	(3) 16d common (0.162"x3 1/2") (4) 10d box (0.128"x3") (4) 0.131"x3" nails (4) 3"x14 ga. staples 7/16" Crown	Face Nail			24.	2" subfloor to joist or girder	(2) 16d common (0.162"x3 1/2") (3) 16d box (0.135"x3 1/2")	Blind and face nail
4.	Ceiling joist attached to parallel rafter (heel joint) (see Section 2308.7.3.1, Table 2308.7.3.1)	See IBC Table 2308.7.3.1	Face Nail	25.	2" planks (plank & beam - floor & roof)			(3) 16d box (0.135"x3 1/2") (2) 16d common (0.162"x3 1/2")	Each bearing, face nail
5.	Collar Tie to Rafter	(3) 10d common (0.148"x3") (4) 10d box (0.128"x3") (4) 0.131"x3" nails (4) 3"x14 ga. staples 7/16" Crown	Face Nail			26.	Built-up girders and beams, 2" lumber layers	20d common (0.192"x4") 10d box (0.128"x3") 0.131"x3" nails 3"x14 ga. Staples, 7/16" crown <b>AND:</b> (2) 20d common (0.192"x4") (3) 10d box (0.128"x3") (3) 0.131"x3" nails (3) 3"x14 ga. staples 7/16" Crown (3) 16d common (0.162"x3 1/2") (4) 16d box (0.135"x3 1/2")	32" o.c., face nail top and bot. staggered on opp sides 24" o.c. face nail top and bot. staggered on opp. Sides Ends and at each splice, face nail
6.	Rafter or roof truss to top plate (See Section 2308.7.5, Table 2308.7.5)	(4) 10d box (0.128"x3") (4) 10d box (0.128"x3") (4) 0.131"x3" nails (4) 3"x14 ga. staples 7/16" Crown (2) 16d common (0.162"x3 1/2") (3) 16d box (0.135"x3 1/2") (3) 10d box (0.128"x3") (3) 0.131"x3" nails	(2) toenails on one side and (1) toenail on opposite side or rafter or truss	27.	Ledger Strip Supporting Joists or Rafters			(4) 10d box (0.128"x3") (4) 0.131"x3" nails	Each Joist or Rafter, Face Nail
7.	Roof rafters to ridge valley or hip rafters; or roof rafter to 2-inch ridge beam	(3) 3"x14 ga. staples 7/16" Crown (3) 10d common (0.148"x3") (4) 16d box (0.135"x3 1/2") (4) 10d box (0.128"x3") (4) 0.131"x3" nails (4) 3"x14 ga. staples 7/16" Crown	Toenail			28.	Joist to band joist or rim joist	(4) 3"x14 ga. staples 7/16" Crown (4) 10d box (0.128"x3")	End Nail
8.	Stud to stud (not at braced wall panels)	16d common (0.162"x3 1/2") 10d box (0.128"x3") 0.131"x3" nails (3) 3"x14 ga. staples 7/16" Crown	24" o.c. face nail 16" o.c. face nail	29.	Bridging or blocking to joist, rafter or truss			(4) 3"x14 ga. staples 7/16" Crown (2) 8d common (0.131"x2 1/2") (2) 10d box (0.128"x3") (2) 0.131"x3" nails	Each end, toenail
9.									

**GRADING NOTE:**  
 SLOPE AWAY FROM HOUSE  
 MIN. 5% WITH-IN 10'-0"  
 THEN 2% TO PROP. LINES

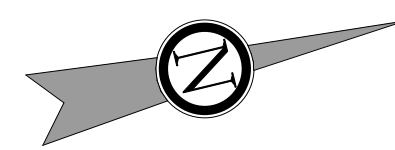
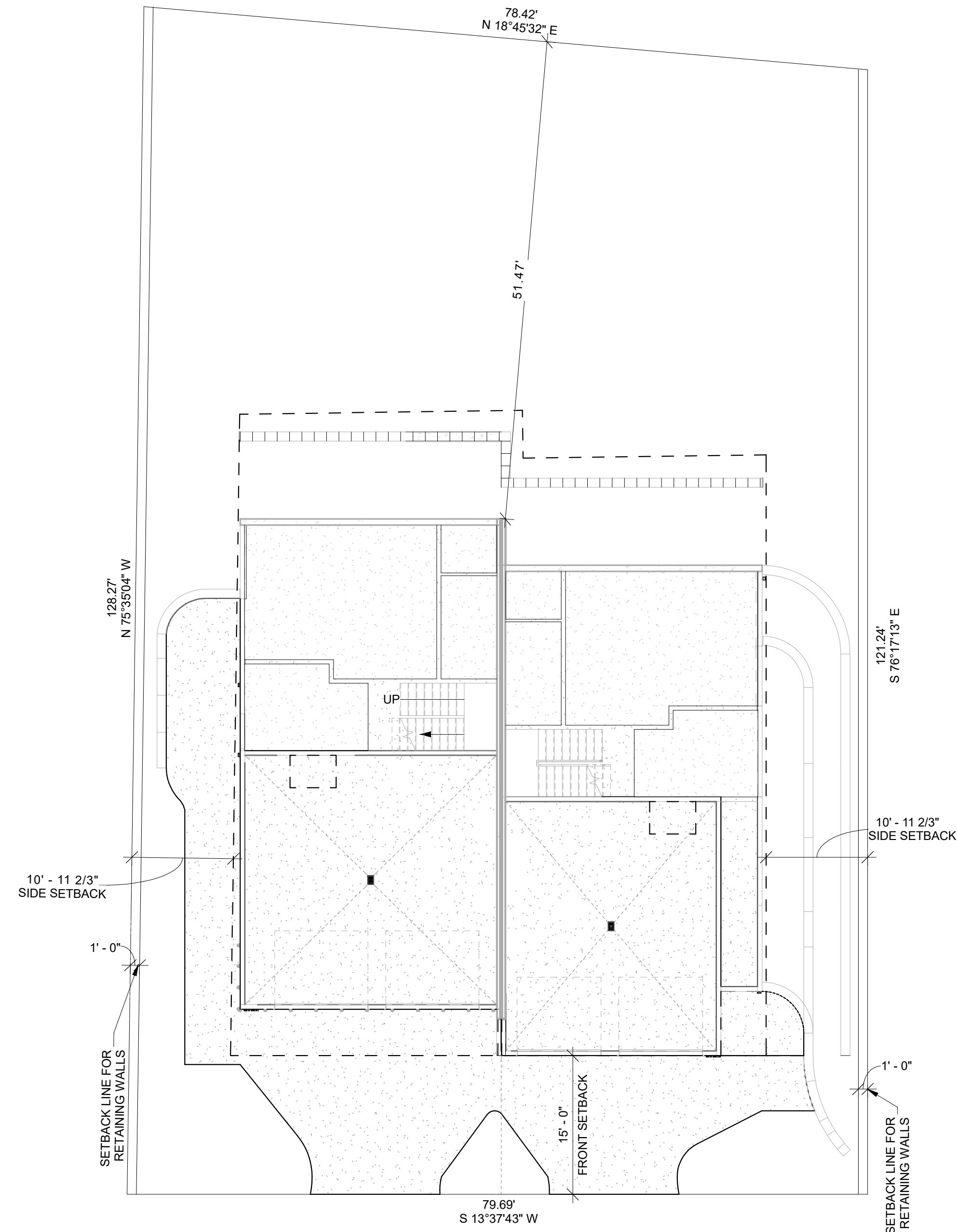

**SITE PLAN**  
 1" = 10'-0"

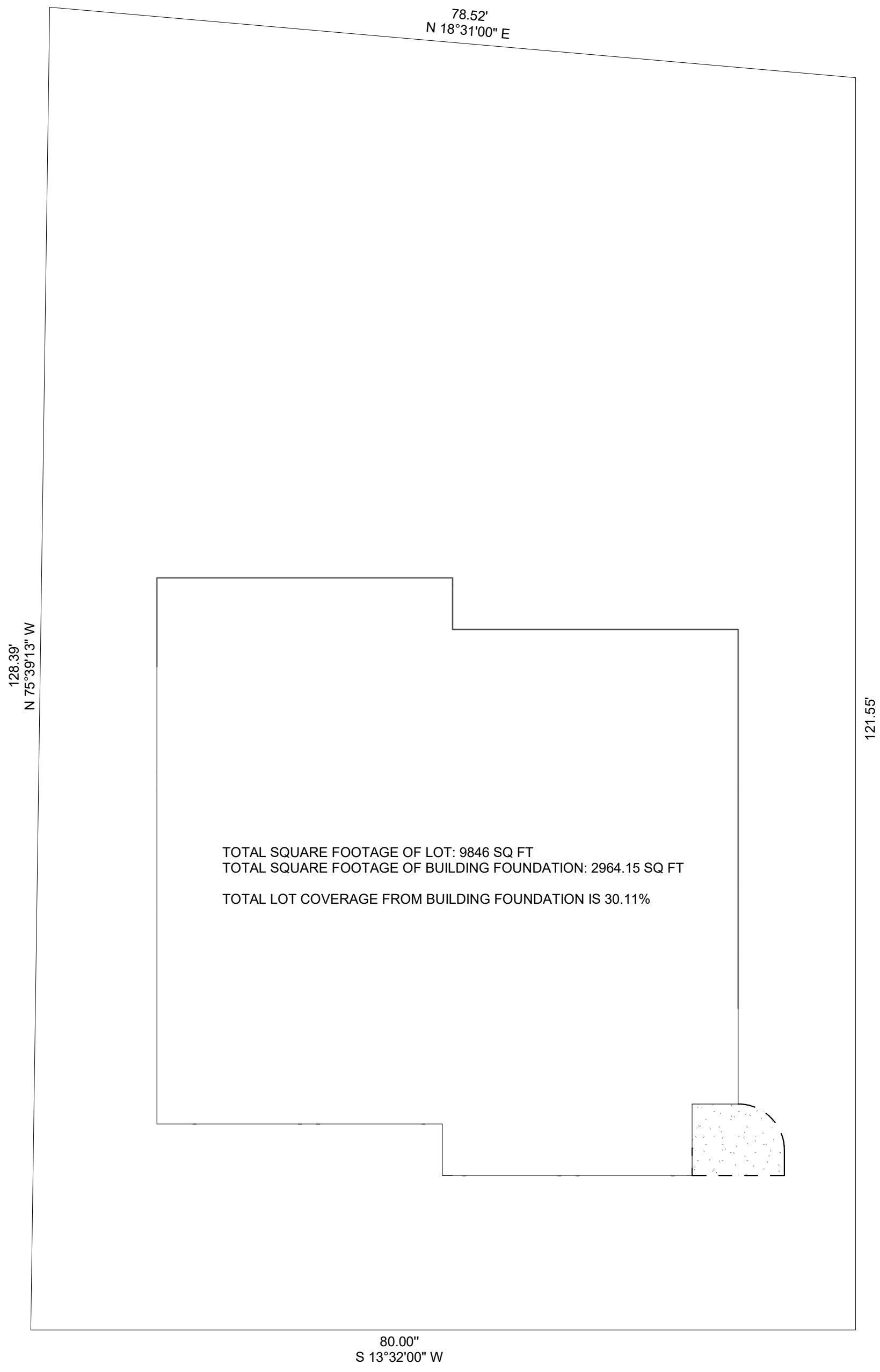

**BUILDING LOT COVERAGE**  
 1" = 10'-0"

THIS PLAN FOR BASIS OF IDEAS IS THE PROPERTY OF PERFORMANCE ENGINEERS. ANY FORM OF DUPLICATION OR USE OF ALL OR ANY PLANS, DRAWINGS AND DESIGNS IS PROHIBITED. © COPYRIGHT 2025

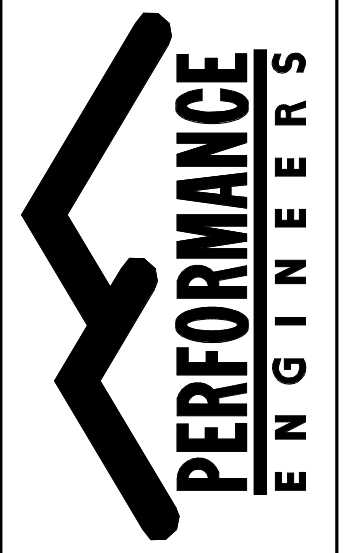

An InteFrame Company

1102 N. FRANKLIN BLVD.  
 NAMPA, IDAHO 83687  
 PH. (208) 475-0040

REV	DATE	DESCRIPTION	BY
01	03/31/26	ISSUED FOR APPROVAL/ CONSTRUCTION	

**LIFT VIEW TOWNHOMES**  
 310 GEORGIA RD  
**SITE PLAN & BUILDING LOT COVERAGE**  
 KETCHUM IDAHO

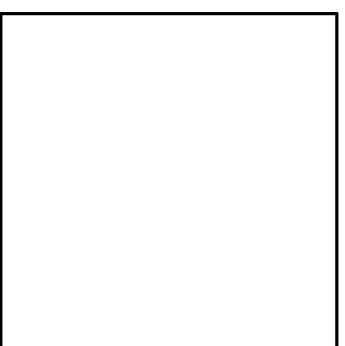

DATE: 03/31/26  
 SCALE: AS NOTED  
 DESIGN BY: TSH  
 DESIGN REVIEW: TSH  
 STRUCTURE BY: ???  
 STRUCTURE REVIEW: VAL  
 JOB NO.: 2025-17046

**DESIGN REV. 6**

SHEET  
**A1.0**

© COPYRIGHT 2025

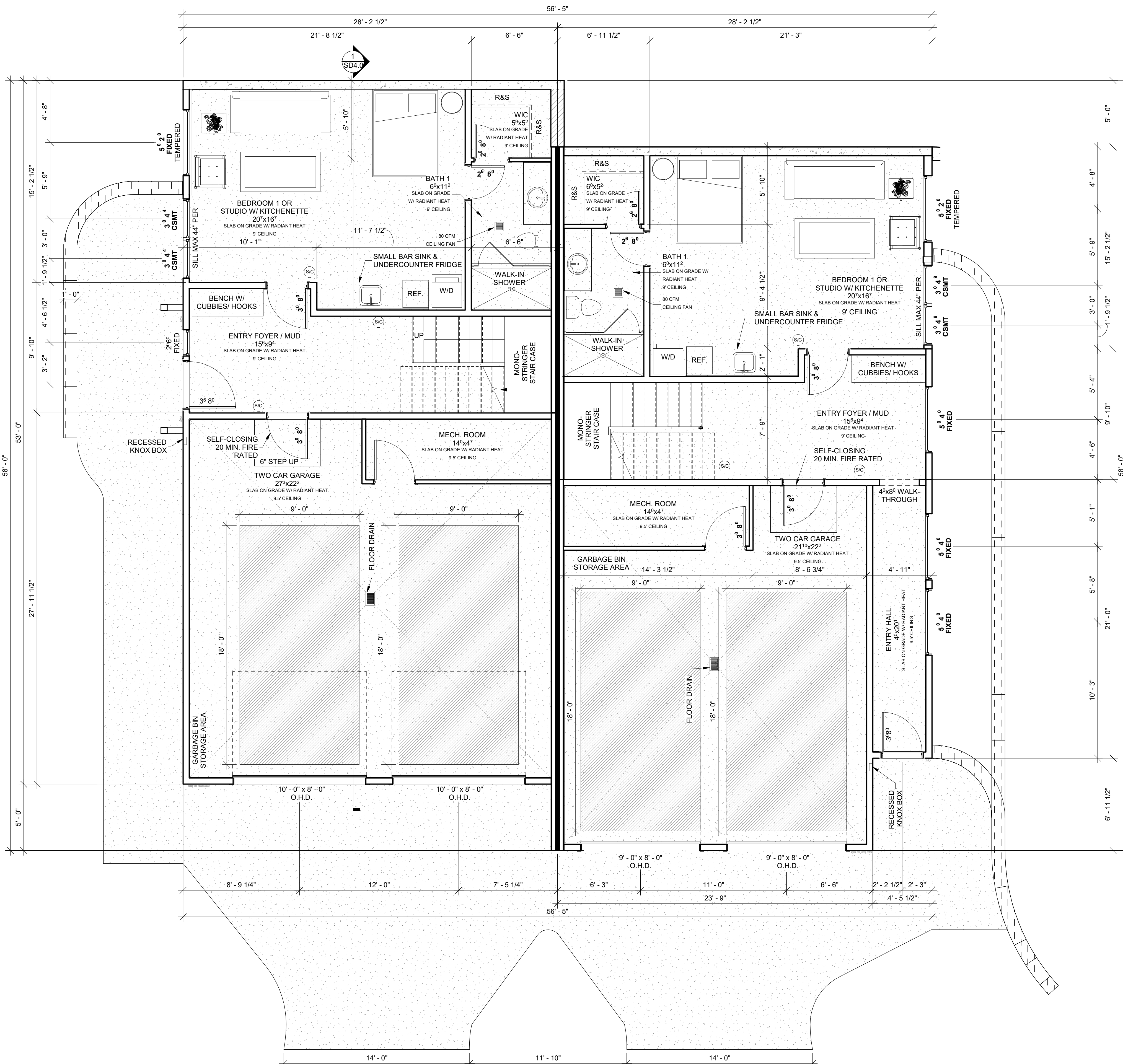

**LEVEL 1 FLOOR PLAN**  
1/4" = 1'-0"

**WINDOW & DOOR NOTES:**

- T.O. WINDOWS HEIGHTS TO MATCH T.O. FRONT DOOR HEIGHT; T.O. DOOR HEIGHT TO BE COORDINATED BY CONTRACTOR WITH DOOR MANUFACTURER.
- WINDOW & DOOR ROUGH OPENING SIZES TO BE COORDINATED BY CONTRACTOR WITH WINDOW & DOOR MANUFACTURERS.
- TEMPERED WINDOWS REQUIREMENTS:
  - IN DOORS
  - WITHIN 24" ARC OF DOOR
  - LESS THAN 60" FROM SHOWER OR TUB WALKING SURFACE
  - ANY INDIVIDUAL PANE OVER 9 SQ. FT WHEN THE BOTTOM EDGE IS LESS THAN 18" A.F.F., THE TOP EDGE IS GREATER THAN 36" A.F.F., AND THERE ARE ONE OR MORE WALKING SURFACES WITHIN 36" HORIZONTALLY OF GLAZING
  - BOTTOM EDGE OF PANE LESS THAN 18" ABOVE FLOOR
  - REFER TO IRC SECTION R308.4 FOR ADDITIONAL TEMPERED WINDOW REQUIREMENTS.
- DOOR BETWEEN HOUSE AND GARAGE HAVE A FIRE RATING OF NO LESS THAN 20 MIN.
- EXTERIOR WINDOWS, WINDOW WALLS, GLAZED DOORS, WINDOWS WITHIN EXTERIOR DOORS, AND SKYLIGHTS SHALL BE TEMPERED GLASS, MULTI-LAYERED GLAZED PANELS, GLASS BLOCK OR HAVE A FIRE PROTECTION RATING OF NOT LESS THAN 20 MINUTES. ALL EXTERIOR DOORS SHALL BE SOLID CORE CONSTRUCTION OR HAVE A FIRE RATING OF NOT LESS THAN 20 MIN.

**FIRE SAFETY NOTES: (S/C)**

- SMOKE & CARBON DETECTORS PER NFPA & IFC WITHIN 21" OF EACH SLEEPING AREA & ON EVERY LEVEL OF OCCUPANCY.
- CARBON ALARMS IN CENTRAL LOCATION OUTSIDE EACH SLEEPING AREA & ON EVERY LEVEL.
- ALL DETECTORS SHALL BE INTERCONNECTED.
- SLEEPING ROOMS ABOVE GRADE SHALL NOT HAVE FEWER THAN ONE EXTERIOR EMERGENCY ESCAPE & RESCUE OPENING IN ACCORDANCE WITH THE 2018 IFC SECTION 1030. WHERE BASEMENTS CONTAIN ONE OR MORE SLEEPING ROOMS, EMERGENCY ESCAPE OPENINGS SHALL BE REQUIRED IN EACH SLEEPING ROOM.
- IN SLEEPING ROOMS, WINDOWS USED AS EXTERIOR EMERGENCY ESCAPE AND RESCUE OPENINGS SHALL HAVE A MINIMUM NET CLEAR OPENING HEIGHT DIMENSION OF 24 INCHES, THE MINIMUM NET CLEAR OPENING WIDTH DIMENSION OF 20 INCHES, AND NOT BE MORE THAN 44 INCHES ABOVE THE FLOOR.
- AN APPROVED AUTOMATIC SPRINKLER SYSTEM SHALL BE INSTALLED THROUGHOUT THE BUILDING PER CITY OF KETCHUM ORDINANCE #1217 & THE NATIONAL FIRE PROTECTION ASSOCIATION STANDARD 13. AN APPROVED FIRE SPRINKLER FLOW BELL, KNOX BOX & FIRE DEPT. CONNECTION SHALL BE INSTALLED IN AN APPROVED LOCATION VISIBLE TO APPROACHING FIREFIGHTERS AS APPROVED BY THE KETCHUM FIRE MARSHAL.
- AN APPROVED MONITORED FIRE SPRINKLER ALARM DETECTION SYSTEM SHALL BE INSTALLED PER CITY OF KETCHUM ORDINANCE #1217 & THE REQUIREMENTS OF NFPA 72.
- AN APPROVED MONITORED FIRE SPRINKLER ALARM SYSTEM SHALL BE INSTALLED PER CITY OF KETCHUM ORDINANCE #1217 & THE REQUIREMENTS OF NFPA 72.
- FIRE EXTINGUISHERS SHALL BE INSTALLED & MAINTAINED PER 2018 IFC SECTION 908 BOTH DURING CONSTRUCTION AND UPON OCCUPANCY OF THE BUILDING. DURING CONSTRUCTION FIRE EXTINGUISHERS SHALL BE PLACED IN A CONSPICUOUS, EASY TO ACCESS, UNOBSTRUCTED LOCATION THAT IS LESS THAN 75' TRAVEL DISTANCE TO ANY COMBUSTIBLES ON SITE, 30' TO ANY HOT WORK. EXTINGUISHERS SHALL BE MOUNTED IN A CONSPICUOUS, EASY TO ACCESS, UNOBSTRUCTED LOCATION.
- UPON COMPLETION OF THE PROJECT, EVERY RESIDENTIAL OCCUPANCY SHALL HAVE A MINIMUM OF ONE EXTINGUISHER PER KITCHEN AREA & ONE EXTINGUISHER PER GARAGE.
- ALL MATERIAL WITHIN 12" VERTICAL OF FINISHED GRADE SHALL BE 1 HOUR RATED, NON-COMBUSTIBLE, OR COVERED WITH MINIMUM 28-GAUGE FLASHING. THE AREA 12" HORIZONTAL FROM THE BASE OF A WALL SHALL BE FINISHED IN A WAY TO PREVENT ANY VEGETATION GROWING, AND FOR VEGETATIVE DEBRIS TO BE EASILY REMOVED.
- ALL EXTERIOR VENTS SHALL BE DESIGNED & APPROVED TO PREVENT FLAME OR EMBER PENETRATION & ALL EXTERIOR MESH SHALL HAVE OPENINGS THAT DO NOT EXCEED 1/8". GUTTERS & DOWNSPOUTS SHALL BE NON-COMBUSTIBLE & SHALL BE PROVIDED WITH AN APPROVED MEANS TO PREVENT THE ACCUMULATION OF LEAVES AND DEBRIS.

THIS PLAN FOR BASIS OF IDEAS IS THE PROPERTY OF PERFORMANCE ENGINEERS. ANY FORM OF DUPLICATING OR USE OF ALL OR ANY PARTS, DRAWINGS AND DESIGNS IS PROHIBITED. © COPYRIGHT 2025

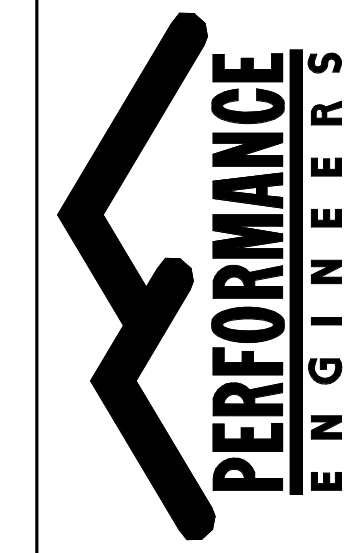

An InteFrame Company

1102 N. FRANKLIN BLVD.  
NAMPA, IDAHO 83687  
PH. (208) 475-0040

REV	DATE	DESCRIPTION	BY

**LIFT VIEW TOWNHOMES**  
310 GEORGINA RD  
**LEVEL 1 FLOOR PLAN**  
IDAHO  
KETCHUM

DATE: 03/11/26  
SCALE: AS NOTED  
DESIGN BY: TSH  
DESIGN REVIEW: TSH  
STRUCTURE BY: ???  
STRUCTURE REVIEW: VAL  
JOB NO.: 2025-17046

DESIGN REV. 6

SHEET  
A2.0

© COPYRIGHT 2025

REV	DATE	DESCRIPTION

**LIFT VIEW TOWNHOMES**  
310 GEORGIA RD  
**LEVEL 2 FLOOR PLAN**  
KETCHUM IDAHO

DATE	03/31/26
SCALE	AS NOTED
DESIGN BY	TSH
DESIGN REVIEW	TSH
STRUCTURE BY	???
STRUCTURE REVIEW	VAL
JOB NO.	2025-17046

**DESIGN REV. 6**

SHEET  
**A2.1**

**WINDOW & DOOR NOTES:**

- T.O. WINDOWS HEIGHTS TO MATCH T.O. FRONT DOOR HEIGHT; T.O. DOOR HEIGHT TO BE COORDINATED BY CONTRACTOR WITH DOOR MANUFACTURER.
- WINDOW & DOOR ROUGH OPENING SIZES TO BE COORDINATED BY CONTRACTOR WITH WINDOW & DOOR MANUFACTURERS.
- TEMPERED WINDOWS REQUIREMENTS:
  - IN DOORS
  - WITHIN 24" ARC OF DOOR
  - LESS THAN 60" FROM SHOWER OR TUB WALKING SURFACE
  - ANY INDIVIDUAL PANE OVER 9 SQ. FT WHEN THE BOTTOM EDGE IS LESS THAN 18" A.F.F., THE TOP EDGE IS GREATER THAN 36" A.F.F., AND THERE ARE ONE OR MORE WALKING SURFACES WITHIN 36" HORIZONTALLY OF GLAZING
  - BOTTOM EDGE OF PANE LESS THAN 18" ABOVE FLOOR
  - REFER TO IRC SECTION R308.4 FOR ADDITIONAL TEMPERED WINDOW REQUIREMENTS.
- DOOR BETWEEN HOUSE AND GARAGE HAVE A FIRE RATING OF NO LESS THAN 20 MIN.
- EXTERIOR WINDOWS, WINDOW WALLS, GLAZED DOORS, WINDOWS WITHIN EXTERIOR DOORS, AND SKYLIGHTS SHALL BE TEMPERED GLASS, MULTI-LAYERED GLAZED PANELS, GLASS BLOCK OR HAVE A FIRE PROTECTION RATING OF NOT LESS THAN 20 MINUTES. ALL EXTERIOR DOORS SHALL BE SOLID CORE CONSTRUCTION OR HAVE A FIRE RATING OF NOT LESS THAN 20 MIN.

**FIRE SAFETY NOTES: (SIC)**

- SMOKE & CARBON DETECTORS PER NFPA & IFC WITHIN 21" OF EACH SLEEPING AREA & ON EVERY LEVEL OF OCCUPANCY.
- CARBON ALARMS IN CENTRAL LOCATION OUTSIDE EACH SLEEPING AREA & ON EVERY LEVEL.
- ALL DETECTORS SHALL BE INTERCONNECTED.
- SLEEPING ROOMS ABOVE GRADE SHALL NOT HAVE FEWER THAN ONE EXTERIOR EMERGENCY ESCAPE & RESCUE OPENING IN ACCORDANCE WITH THE 2018 IFC SECTION 1030. WHERE BASEMENTS CONTAIN ONE OR MORE SLEEPING ROOMS, EMERGENCY ESCAPE OPENINGS SHALL BE REQUIRED IN EACH SLEEPING ROOM.
- IN SLEEPING ROOMS, WINDOWS USED AS EXTERIOR EMERGENCY ESCAPE AND RESCUE OPENINGS SHALL HAVE A MINIMUM NET CLEAR OPENING HEIGHT DIMENSION OF 24 INCHES, THE MINIMUM NET CLEAR OPENING WIDTH DIMENSION OF 20 INCHES, AND NOT BE MORE THAN 44 INCHES ABOVE THE FLOOR.
- AN APPROVED AUTOMATIC SPRINKLER SYSTEM SHALL BE INSTALLED THROUGHOUT THE BUILDING PER CITY OF KETCHUM ORDINANCE #1217 & THE NATIONAL FIRE PROTECTION ASSOCIATION STANDARD 13. AN APPROVED FIRE SPRINKLER FLOW BELL, KNOX BOX & FIRE DEPT. CONNECTION SHALL BE INSTALLED IN AN APPROVED LOCATION VISIBLE TO APPROACHING FIREFIGHTERS AS APPROVED BY THE KETCHUM FIRE MARSHAL.
- AN APPROVED MONITORED FIRE SPRINKLER ALARM DETECTION SYSTEM SHALL BE INSTALLED PER CITY OF KETCHUM ORDINANCE #1217 & THE REQUIREMENTS OF NFPA 72.
- AN APPROVED MONITORED FIRE SPRINKLER ALARM SYSTEM SHALL BE INSTALLED PER CITY OF KETCHUM ORDINANCE #1217 & THE REQUIREMENTS OF NFPA 72.
- FIRE EXTINGUISHERS SHALL BE INSTALLED & MAINTAINED PER 2018 IFC SECTION 906 BOTH DURING CONSTRUCTION AND UPON OCCUPANCY OF THE BUILDING. DURING CONSTRUCTION FIRE EXTINGUISHERS SHALL BE PLACED IN A CONSPICUOUS, EASY TO ACCESS, UNOBSTRUCTED LOCATION THAT IS LESS THAN 75' TRAVEL DISTANCE TO ANY COMBUSTIBLES ON SITE, 30' TO ANY HOT WORK. EXTINGUISHERS SHALL BE MOUNTED IN A CONSPICUOUS, EASY TO ACCESS, UNOBSTRUCTED LOCATION.
- UPON COMPLETION OF THE PROJECT, EVERY RESIDENTIAL OCCUPANCY SHALL HAVE A MINIMUM OF ONE EXTINGUISHER PER KITCHEN AREA & ONE EXTINGUISHER PER GARAGE.
- ALL MATERIAL WITHIN 12" VERTICAL OF FINISHED GRADE SHALL BE 1 HOUR RATED, NON-COMBUSTIBLE, OR COVERED W/ MINIMUM 28-GAUGE FLASHING. THE AREA 12" HORIZONTAL FROM THE BASE OF A WALL SHALL BE FINISHED IN A WAY TO PREVENT ANY VEGETATION GROWING, AND FOR VEGETATIVE DEBRIS TO BE EASILY REMOVED.
- ALL EXTERIOR VENTS SHALL BE DESIGNED & APPROVED TO PREVENT FLAME OR EMBER PENETRATION & ALL EXTERIOR MESH SHALL HAVE OPENINGS THAT DO NOT EXCEED 1/8". GUTTERS & DOWNSPOUTS SHALL BE NON-COMBUSTIBLE & SHALL BE PROVIDED WITH AN APPROVED MEANS TO PREVENT THE ACCUMULATION OF LEAVES AND DEBRIS.

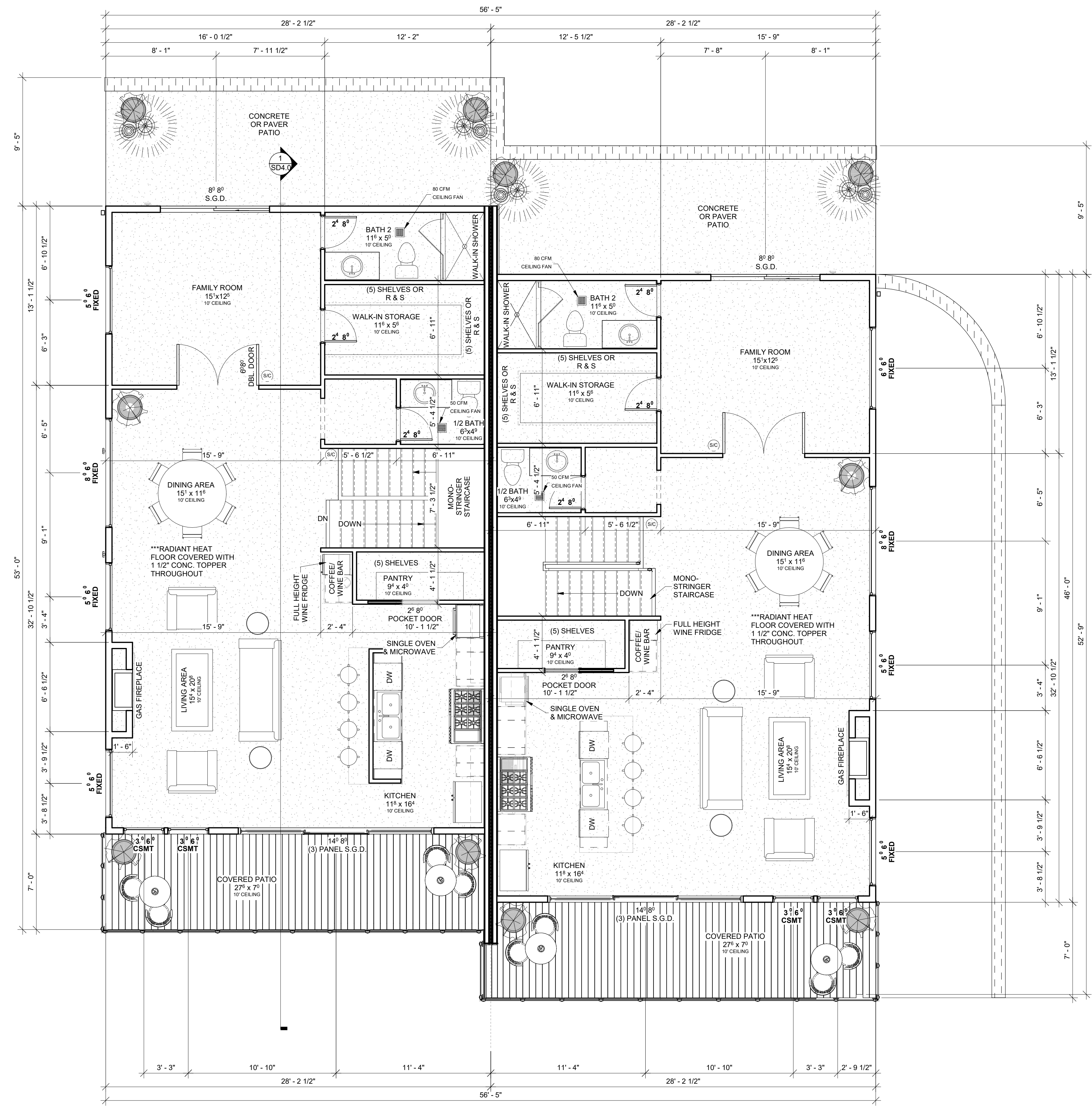

**LEVEL 2 FLOOR PLAN**  
1/4" = 1'-0"

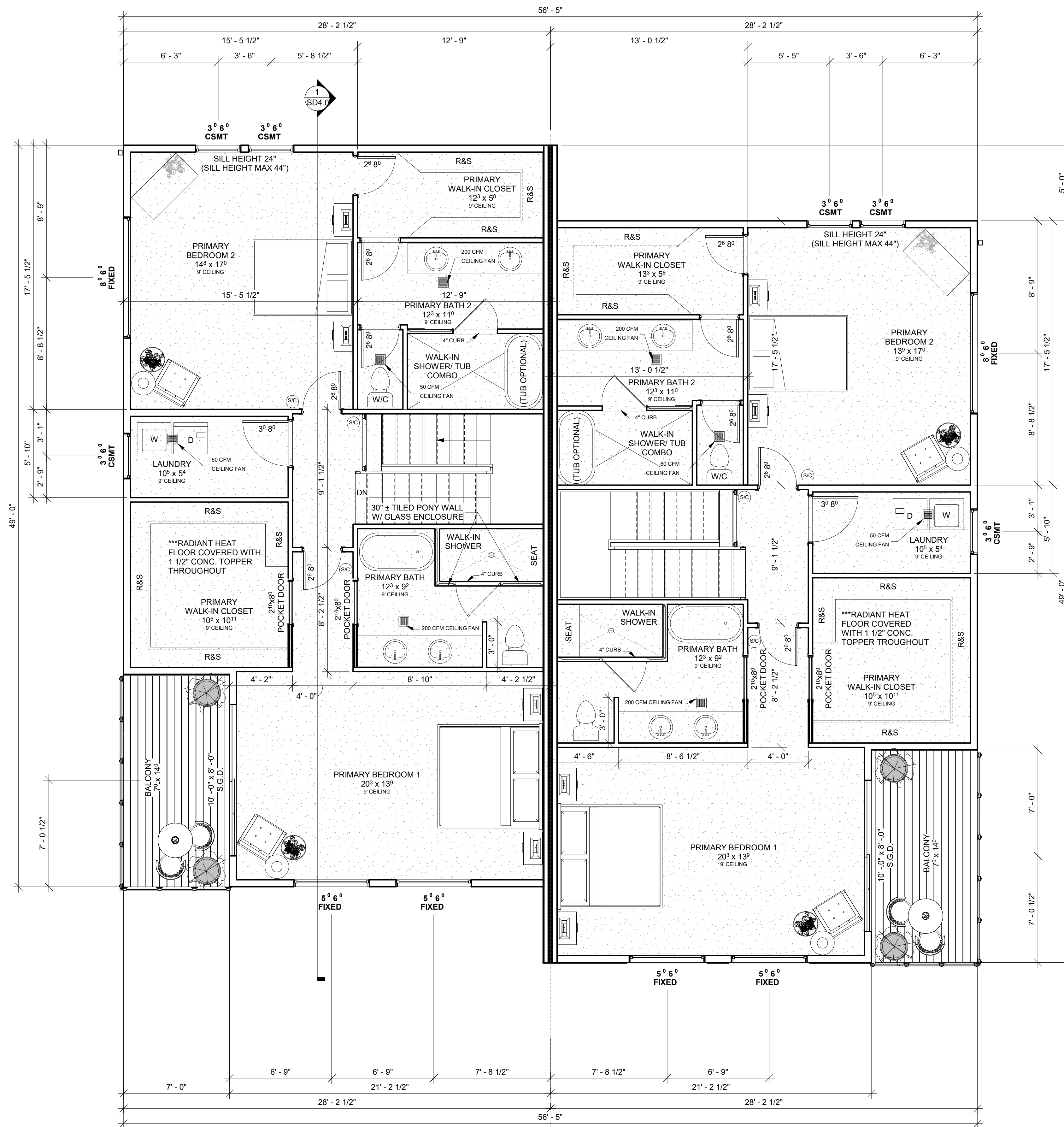

**WINDOW & DOOR NOTES:**

- T.O. WINDOWS HEIGHTS TO MATCH T.O. FRONT DOOR HEIGHT; T.O. DOOR HEIGHT TO BE COORDINATED BY CONTRACTOR WITH DOOR MANUFACTURER.
- WINDOW & DOOR ROUGH OPENING SIZES TO BE COORDINATED BY CONTRACTOR WITH WINDOW & DOOR MANUFACTURERS.
- TEMPERED WINDOWS REQUIREMENTS:
  - IN DOORS
  - WITHIN 24" ARC OF DOOR
  - LESS THAN 60" FROM SHOWER OR TUB WALKING SURFACE
  - ANY INDIVIDUAL PANE OVER 9 SQ. FT WHEN THE BOTTOM EDGE IS LESS THAN 18" A.F.F., THE TOP EDGE IS GREATER THAN 36" A.F.F., AND THERE ARE ONE OR MORE WALKING SURFACES WITHIN 36" HORIZONTALLY OF GLAZING
  - BOTTOM EDGE OF PANE LESS THAN 18" ABOVE FLOOR REFER TO IRC SECTION R308.4 FOR ADDITIONAL TEMPERED WINDOW REQUIREMENTS.
- DOOR BETWEEN HOUSE AND GARAGE HAVE A FIRE RATING OF NO LESS THAN 20 MIN.
- EXTERIOR WINDOWS, WINDOW WALLS, GLAZED DOORS, WINDOWS WITHIN EXTERIOR DOORS, AND SKYLIGHTS SHALL BE TEMPERED GLASS, MULTILAYERED GLAZED PANELS, GLASS BLOCK OR HAVE A FIRE PROTECTION RATING OF NOT LESS THAN 20 MINUTES. ALL EXTERIOR DOORS SHALL BE SOLID CORE CONSTRUCTION OR HAVE A FIRE RATING OF NOT LESS THAN 20 MIN.

**FIRE SAFETY NOTES:** (S/C)

- SMOKE & CARBON DETECTORS PER NFPA & IFC WITHIN 21" OF EACH SLEEPING AREA & ON EVERY LEVEL OF OCCUPANCY.
- CARBON ALARMS IN CENTRAL LOCATION OUTSIDE EACH SLEEPING AREA & ON EVERY LEVEL.
- ALL DETECTORS SHALL BE INTERCONNECTED.
- SLEEPING ROOMS ABOVE GRADE SHALL NOT HAVE FEWER THAN ONE EXTERIOR EMERGENCY ESCAPE & RESCUE OPENING IN ACCORDANCE W/ THE 2018 IFC SECTION 1030. WHERE BASEMENTS CONTAIN ONE OR MORE SLEEPING ROOMS, EMERGENCY ESCAPE OPENINGS SHALL BE REQUIRED IN EACH SLEEPING ROOM.
- IN SLEEPING ROOMS, WINDOWS USED AS EXTERIOR EMERGENCY ESCAPE AND RESCUE OPENINGS SHALL HAVE A MINIMUM NET CLEAR OPENING HEIGHT DIMENSION OF 24 INCHES, THE MINIMUM NET CLEAR OPENING WIDTH DIMENSION OF 20 INCHES, AND NOT BE MORE THAN 44 INCHES ABOVE THE FLOOR.
- AN APPROVED AUTOMATIC SPRINKLER SYSTEM SHALL BE INSTALLED THROUGHOUT THE BUILDING PER CITY OF KETCHUM ORDINANCE #1217 & THE NATIONAL FIRE PROTECTION ASSOCIATION STANDARD 13. AN APPROVED FIRE SPRINKLER FLOW BELL, KNOX BOX & FIRE DEPT. CONNECTION SHALL BE INSTALLED IN AN APPROVED LOCATION VISIBLE TO APPROACHING FIREFIGHTERS AS APPROVED BY THE KETCHUM FIRE MARSHAL.
- AN APPROVED MONITORED FIRE SPRINKLER ALARM DETECTION SYSTEM SHALL BE INSTALLED PER CITY OF KETCHUM ORDINANCE #1217 & THE REQUIREMENTS OF NFPA 72.
- AN APPROVED MONITORED FIRE SPRINKLER ALARM SYSTEM SHALL BE INSTALLED PER CITY OF KETCHUM ORDINANCE #1217 & THE REQUIREMENTS OF NFPA 72.
- FIRE EXTINGUISHERS SHALL BE INSTALLED & MAINTAINED PER 2018 IFC SECTION 906 BOTH DURING CONSTRUCTION AND UPON OCCUPANCY OF THE BUILDING. DURING CONSTRUCTION FIRE EXTINGUISHERS SHALL BE PLACED IN A CONSPICUOUS, EASY TO ACCESS, UNOBSTRUCTED LOCATION THAT IS LESS THAN 75' TRAVEL DISTANCE TO ANY COMBUSTIBLES ON SITE, 30' TO ANY HOT WORK. EXTINGUISHERS SHALL BE MOUNTED IN A CONSPICUOUS, EASY TO ACCESS, UNOBSTRUCTED LOCATION.
- UPON COMPLETION OF THE PROJECT, EVERY RESIDENTIAL OCCUPANCY SHALL HAVE A MINIMUM OF ONE EXTINGUISHER PER KITCHEN AREA & ONE EXTINGUISHER PER GARAGE.
- ALL MATERIAL WITHIN 12" VERTICAL OF FINISHED GRADE SHALL BE 1 HOUR RATED, NON-COMBUSTIBLE, OR COVERED W/ MINIMUM 28-GAUGE FLASHING. THE AREA 12" HORIZONTAL FROM THE BASE OF A WALL SHALL BE FINISHED IN A WAY TO PREVENT ANY VEGETATION GROWING, AND FOR VEGETATIVE DEBRIS TO BE EASILY REMOVED.
- ALL EXTERIOR VENTS SHALL BE DESIGNED & APPROVED TO PREVENT FLAME OR EMBER PENETRATION & ALL EXTERIOR MESH SHALL HAVE OPENINGS THAT DO NOT EXCEED 1/8". GUTTERS & DOWNSPOUTS SHALL BE NON-COMBUSTIBLE & SHALL BE PROVIDED WITH AN APPROVED MEANS TO PREVENT THE ACCUMULATION OF LEAVES AND DEBRIS.

THIS PLAN FOR BASIS OF IDEAS IS THE PROPERTY OF PERFORMANCE ENGINEERS. ANY FORM OF DUPLICATION OR USE OF ALL OR ANY PARTS, DRAWINGS AND DESIGNS IS PROHIBITED. © COPYRIGHT 2025

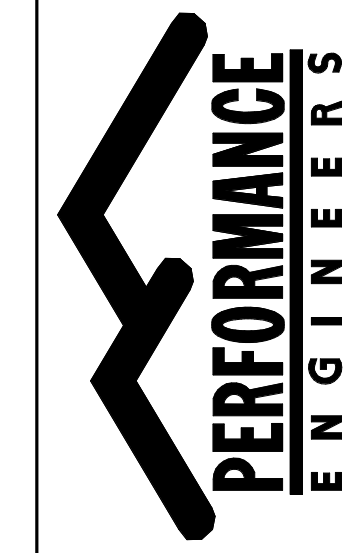

An InteFrame Company

1102 N. FRANKLIN BLVD.  
NAMPA, IDAHO 83687  
PH. (208) 475-0040

REV	DATE	DESCRIPTION	BY

LIFT VIEW TOWNHOMES  
310 GEORGINA RD  
LEVEL 3 FLOOR PLAN  
KETCHUM IDAHO

**LEVEL 3 FLOOR PLAN**  
1/4" = 1'-0"

DATE:	03/1/26
SCALE:	AS NOTED
DESIGN BY:	TSH
DESIGN REVIEW:	TSH
STRUCTURE BY:	???
STRUCTURE REVIEW:	VAL
JOB NO.:	2025-17046

**DESIGN REV. 6**

SHEET  
A2.2

© COPYRIGHT 2025

**ELEVATION NOTES:**

- ALL ROOF COVERINGS SHALL CONFORM TO IRC, AND SHALL BE INSTALLED PER MANUFACTURER SPECIFICATIONS.
- FLASHING SHALL BE PROVIDED AT ALL EXTERIOR OPENINGS, DECKS, CHIMNEYS, AND ALL ROOF PENETRATIONS PER CODE.
- PROVIDE ATTIC VENTILATION IN ACCORDANCE WITH IRC SECTION 806.2 SPECIFICATIONS.
- 50% OF REQUIRED VENTILATION TO BE PROVIDED 3'-0" ABOVE THE EAVES. THE REMAINDER OF VENTILATION IS TO BE PROVIDED BY SOFFIT VENTS IN THE EAVES.
- PROVIDE ATTIC VENTS ON REAR FACE OF ROOF WHEN POSSIBLE.

**OUTDOOR LIGHTING**

- 1  
A4.0 = Z LITE LANDRUM WALL LIGHT  
(SEE SHEET A4.0 FOR DETAILS)  
NOTE: FIXTURE TO BE INSTALLED IN DOWN LIGHTING ORIENTATION
- 2  
A4.0 = JUNO CAN WAFER LIGHT  
NOTE: COLOR TEMPERATURE WILL BE 2700K

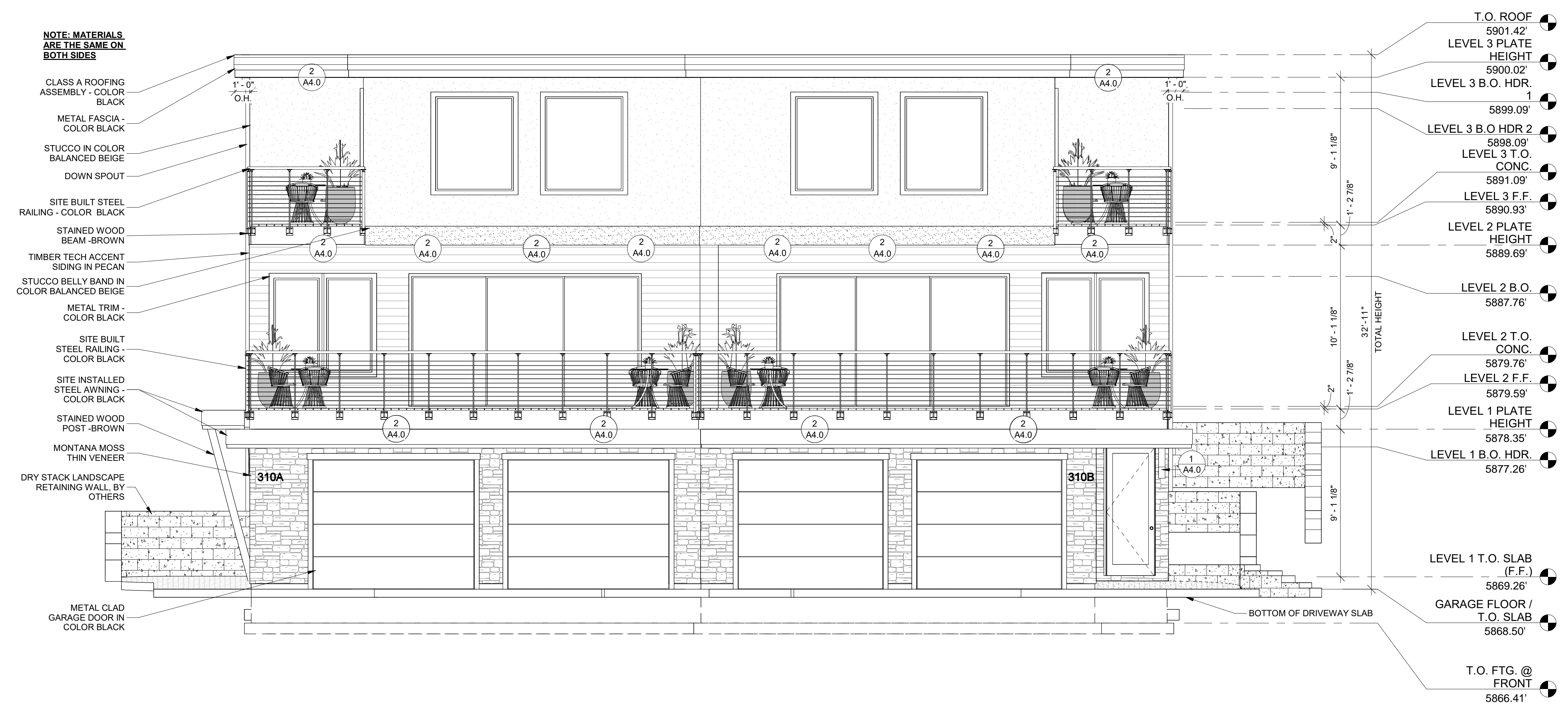

REV	DATE	DESCRIPTION

**LIFT VIEW TOWNHOMES**  
310 GEORGIA RD  
**FRONT ELEVATION**

DATE: 03/31/26  
SCALE: AS NOTED  
DESIGN BY: TSH  
DESIGN REVIEW: TSH  
STRUCTURE BY: ???  
STRUCTURE REVIEW: VAL  
JOB NO.: 2025-17046

DESIGN REV. 6  
SHEET A3.0  
© COPYRIGHT 2025

**FRONT ELEVATION**  
1/4" = 1'-0"

REV	DATE	DESCRIPTION

LIFT VIEW TOWNHOMES  
310 GEORGIA RD  
RIGHT SIDE ELEVATION  
KETCHUM IDAHO



DATE:	03/31/26
SCALE:	AS NOTED
DESIGN BY:	TSH
DESIGN REVIEW:	TSH
STRUCTURE BY:	???
STRUCTURE REVIEW:	VAL
JOB NO.:	2025-17046

DESIGN REV. 6

SHEET  
A3.1

- ELEVATION NOTES:**
- ALL ROOF COVERINGS SHALL CONFORM TO IRC, AND SHALL BE INSTALLED PER MANUFACTURER SPECIFICATIONS.
  - FLASHING SHALL BE PROVIDED AT ALL EXTERIOR OPENINGS, DECKS, CHIMNEYS, AND ALL ROOF PENETRATIONS PER CODE.
  - PROVIDE ATTIC VENTILATION IN ACCORDANCE WITH IRC SECTION 806.2 SPECIFICATIONS.
  - 50% OF REQUIRED VENTILATION TO BE PROVIDED 3'-0" ABOVE THE EAVES. THE REMAINDER OF VENTILATION IS TO BE PROVIDED BY SOFFIT VENTS IN THE EAVES.
  - PROVIDE ATTIC VENTS ON REAR FACE OF ROOF WHEN POSSIBLE.

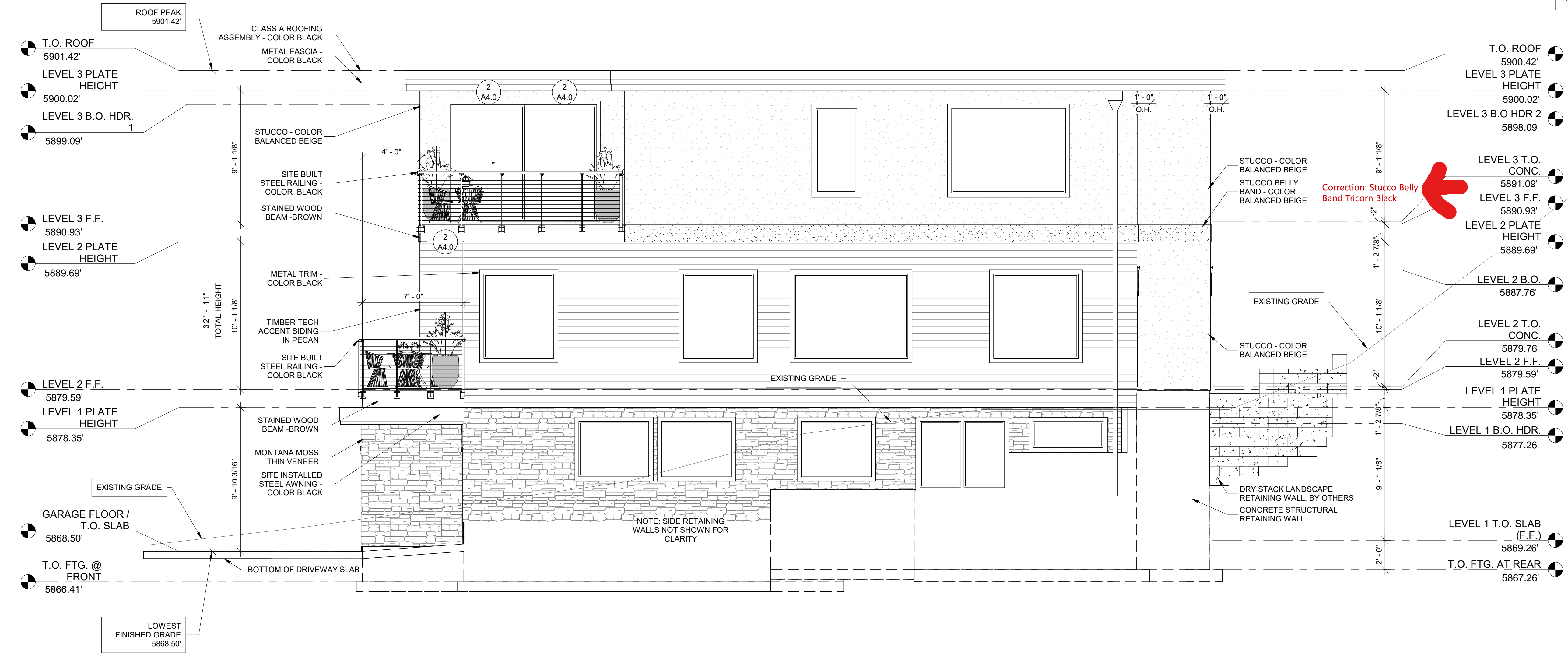
- OUTDOOR LIGHTING**
- 1  
A4.0 = Z LITE LANDRUM WALL LIGHT (SEE SHEET A4.0 FOR DETAILS)  
NOTE: FIXTURE TO BE INSTALLED IN DOWN LIGHTING ORIENTATION
  - 2  
A4.0 = JUNO CAN WAFER LIGHT  
NOTE: COLOR TEMPERATURE WILL BE 2700K



**RIGHT ELEVATION**  
1/4" = 1'-0"

REV	DATE	DESCRIPTION	BY
1	03/31/26	ISSUED FOR APPROVAL	
2		CONSTRUCTION	

LIFT VIEW TOWNHOMES  
310 GEORGIA RD  
REAR ELEVATION  
KETCHUM IDAHO

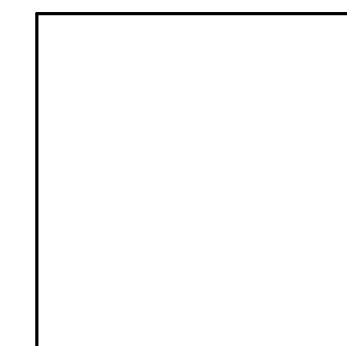

DATE:	03/31/26
SCALE:	AS NOTED
DESIGN BY:	TSH
DESIGN REVIEW:	TSH
STRUCTURE BY:	???
STRUCTURE REVIEW:	VAL
JOB NO.:	2025-17046

DESIGN REV. 6

SHEET  
A3.2

ELEVATION NOTES:

- ALL ROOF COVERINGS SHALL CONFORM TO IRC, AND SHALL BE INSTALLED PER MANUFACTURER SPECIFICATIONS.
- FLASHING SHALL BE PROVIDED AT ALL EXTERIOR OPENINGS, DECKS, CHIMNEYS, AND ALL ROOF PENETRATIONS PER CODE.
- PROVIDE ATTIC VENTILATION IN ACCORDANCE WITH IRC SECTION 806.2 SPECIFICATIONS.
- 50% OF REQUIRED VENTILATION TO BE PROVIDED 3'-0" ABOVE THE EAVES. THE REMAINDER OF VENTILATION IS TO BE PROVIDED BY SOFFIT VENTS IN THE EAVES.
- PROVIDE ATTIC VENTS ON REAR FACE OF ROOF WHEN POSSIBLE.

OUTDOOR LIGHTING

- 1  
A4.0 = Z LITE LANDRUM WALL LIGHT  
(SEE SHEET A4.0 FOR DETAILS)  
NOTE: FIXTURE TO BE INSTALLED IN DOWN LIGHTING ORIENTATION
- 2  
A4.0 = JUNO CAN WAFER LIGHT  
NOTE: COLOR TEMPERATURE WILL BE 2700K

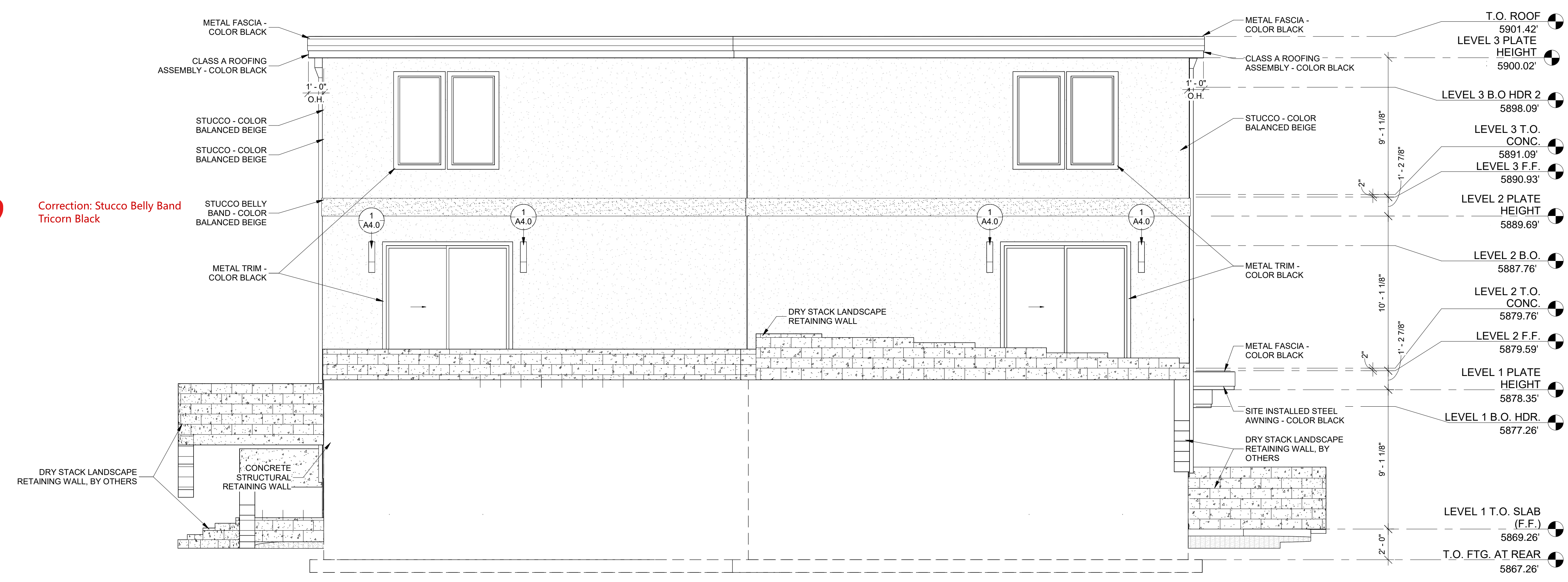

REAR ELEVATION  
1/4" = 1'-0"

- ELEVATION NOTES:**
- ALL ROOF COVERINGS SHALL CONFORM TO IRC, AND SHALL BE INSTALLED PER MANUFACTURER SPECIFICATIONS.
  - FLASHING SHALL BE PROVIDED AT ALL EXTERIOR OPENINGS, DECKS, CHIMNEYS, AND ALL ROOF PENETRATIONS PER CODE.
  - PROVIDE ATTIC VENTILATION IN ACCORDANCE WITH IRC SECTION 806.2 SPECIFICATIONS.
  - 50% OF REQUIRED VENTILATION TO BE PROVIDED 3'-0" ABOVE THE EAVES. THE REMAINDER OF VENTILATION IS TO BE PROVIDED BY SOFFIT VENTS IN THE EAVES.
  - PROVIDE ATTIC VENTS ON REAR FACE OF ROOF WHEN POSSIBLE.

- OUTDOOR LIGHTING**
- 1  
A4.0 = Z LITE LANDRUM WALL LIGHT  
(SEE SHEET A4.0 FOR DETAILS)  
NOTE: FIXTURE TO BE INSTALLED IN DOWN LIGHTING ORIENTATION
- 2  
A4.0 = JUNO CAN WAFER LIGHT  
NOTE: COLOR TEMPERATURE WILL BE 2700K

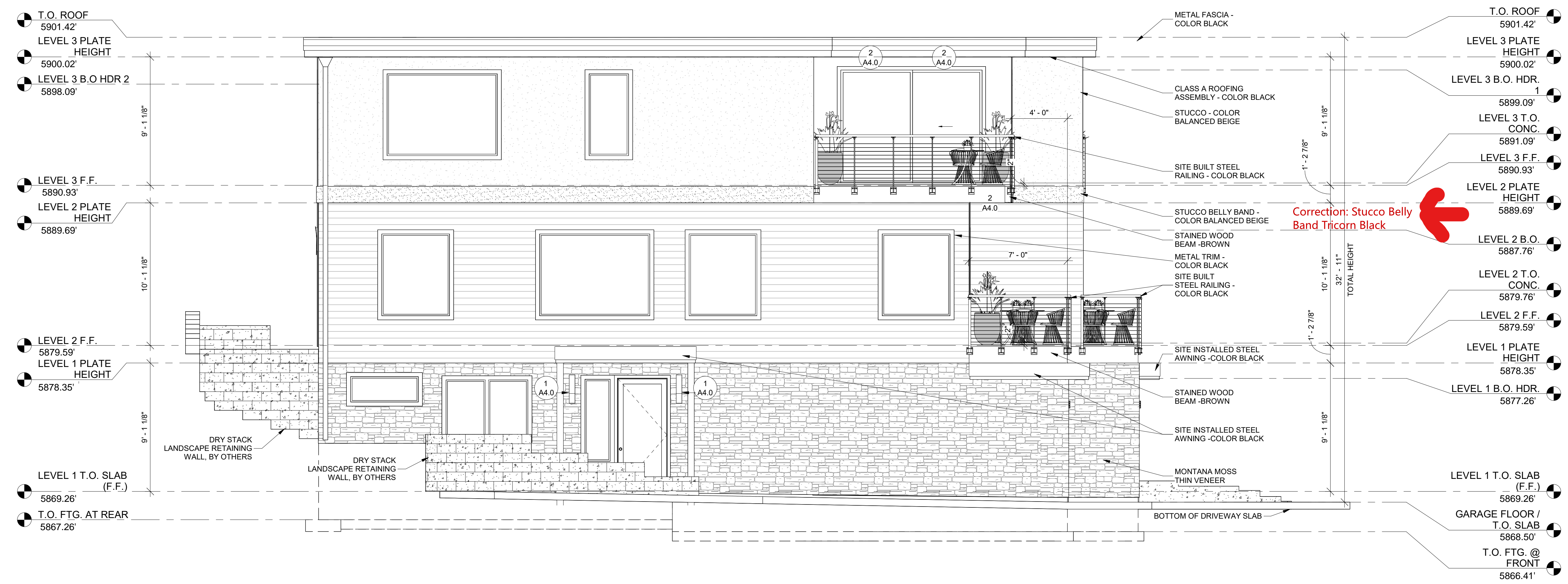

**LEFT ELEVATION**  
1/4" = 1'-0"

REV	DATE	DESCRIPTION	BY
1	03/31/26	ISSUED FOR APPROVAL	
2		CONSTRUCTION	

**LIFT VIEW TOWNHOMES**  
310 GEORGIA RD  
**LEFT ELEVATION**

KETCHUM IDAHO

DATE:	03/31/26
SCALE:	AS NOTED
DESIGN BY:	TSH
DESIGN REVIEW:	TSH
STRUCTURE BY:	???
STRUCTURE REVIEW:	VAL
JOB NO.:	2025-17046

**DESIGN REV. 6**

**SHEET A3.3**



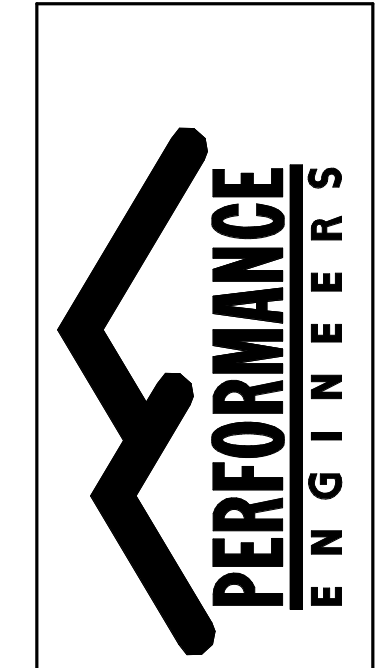

An InteFrame Company

1102 N. FRANKLIN BLVD.  
NAMPA, IDAHO 83687  
PH. (208) 475-0040

REV	DATE	DESCRIPTION

LIFT VIEW TOWNHOMES  
310 GEORGIA RD  
ROOF PLAN

IDAHO  
KETCHUM

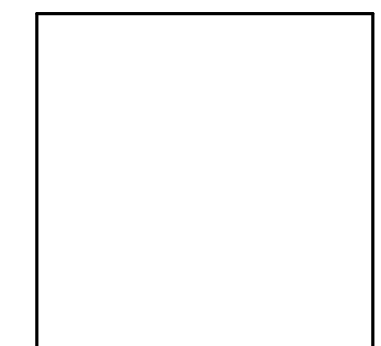
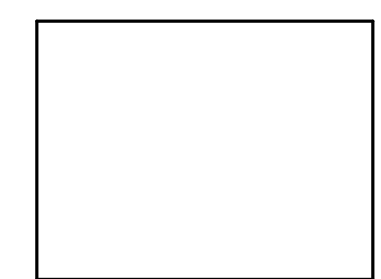

DATE:	03/11/26
SCALE:	AS NOTED
DESIGN BY:	TSH
DESIGN REVIEW:	TSH
STRUCTURE BY:	???
STRUCTURE REVIEW:	VAL
JOB NO.:	2025-17046

DESIGN REV. 6

SHEET  
A5.0

FRAMING PLAN LEGEND	
	- INDICATES 2x STUD WALL
	- INDICATES 2x BEARING WALL
	- INDICATES OVERBUILD FRAMING, SEE DETAIL ?/SD?.?

- FRAMING NOTES**
1. PROVIDE TWO STUDS AT ALL GIRDER/BEARING LOCATIONS UNLESS NOTED OTHERWISE.
  2. SEE ROOF TRUSS LAYOUT FROM TRUSS MANUFACTURER FOR ACCURATE ROOF FRAMING PLAN.
  3. NAIL SHEATHING TO FRAMING MEMBERS W/ 8d NAILS @ 6" O.C. ON PANEL EDGES AND 12" O.C. @ INTERMEDIATE FRAMING. 1-1/2"x16 GA. MIN. STAPLES OK AT HALF THE SPACING (3" EDGE / 6" FIELD)
  4. NAIL SHEATHING TO FRAMING MEMBERS W/ 8d NAILS @ 6" O.C. ON PANEL EDGES AND 12" O.C. @ INTERMEDIATE FRAMING. 1-1/2"x16 GA. MIN. STAPLES OK AT HALF THE SPACING (3" EDGE/ 6" FIELD)

BEAM/HEADER KEY	
HEADER: (D226)	GRADE/MATERIAL: (D2210)
BEAM: (D2210)	GRADE/MATERIAL: D = DF #2 G = 24F-144 GLULAM
DF#2 OR LVL:	L = 2.0E LVL W = W SECTION STEEL BEAM
WIDTHS: DF 2=1.5" LVL 2=1.75"	SIZE OF PLYS LVL DEPTHS 7.3 = 7 1/4" 9.5 = 9 1/2" 11.9 = 11 7/8"
NOMINAL WIDTH	NOMINAL DEPTH
GLULAM: WIDTH G519.5	WIDTHS: 3 = 3-1/8" 5 = 5-1/8" 7 = 6-3/4" 9 = 8-3/4"
DEPTH	DEPTH
W BEAM: NOMINAL DEPTH W1222	WEIGHT PER FOOT
NOTE: BEAMS AND HEADERS WITH THE SAME SIZE AND GRADE/MATERIAL CAN BE SUBSTITUTED	

BLOCKING SCHEDULE	
MARK	DESCRIPTION
B1	BLOCKING BETWEEN EVERY OTHER TRUSS BAYS W/ (6) 10d TOENAILS FROM BLOCKING TO TOP PLATE. NAIL ROOF SHEATHING TO BLOCKING 3" O.C.
B2	2-PLY OR 4x BLOCKING BETWEEN EVERY OTHER TRUSS BAYS W/ (2) A35 CLIPS FROM BLOCKING TO TOP PLATE, W/ 2 ROWS @ 3" O.C. (STAGGERED) -OR- BLOCKING BETWEEN EVERY TRUSS BAY W/ (6) 10d TOENAILS FROM BLOCKING TO TOP PLATE, NAIL ROOF SHEATHING TO BLOCKING 3" O.C.
B3	2-PLY OR 4x BLOCKING BETWEEN EVERY OTHER TRUSS BAY W/ (2) A35 CLIPS FROM BLOCKING TO TOP PLATE, W/ (2) ROWS @ 3" O.C. (STAGGERED)
B4	2-PLY OR 4x BLOCKING BETWEEN EVERY OTHER TRUSS BAY W/ (3) A35 CLIPS FROM BLOCKING TO TOP PLATE, W/ (2) ROWS @ 3" O.C. (STAGGERED)

GABLE/DAG TRUSS OR RIM ATTACHEMENT SCHEDULE	
MARK	DESCRIPTION
T1	ATTACH GABLE / DRAG TRUSS OR RIM TO TOP PLATE W/ 10d TOENAILS @ 6" O.C., EDGE NAIL SHEATHING ABOVE TO TRUSS
T2	ATTACH GABLE / DRAG TRUSS OR RIM TO TOP PLATE W/ 10d TOENAILS @ 4" O.C., EDGE NAIL SHEATHING ABOVE TO TRUSS
T3	ATTACH GABLE / DRAG TRUSS OR RIM TO TOP PLATE W/ 10d TOENAILS @ 3" O.C., EDGE NAIL SHEATHING ABOVE TO TRUSS
T4	ATTACH GABLE / DRAG TRUSS OR RIM TO TOP PLATE W/ A35 @ 12" O.C., EDGE NAIL SHEATHING ABOVE TO TRUSS
T5	ATTACH GABLE / DRAG TRUSS OR RIM TO TOP PLATE W/ A35 @ 6" O.C., EDGE NAIL SHEATHING ABOVE TO TRUSS

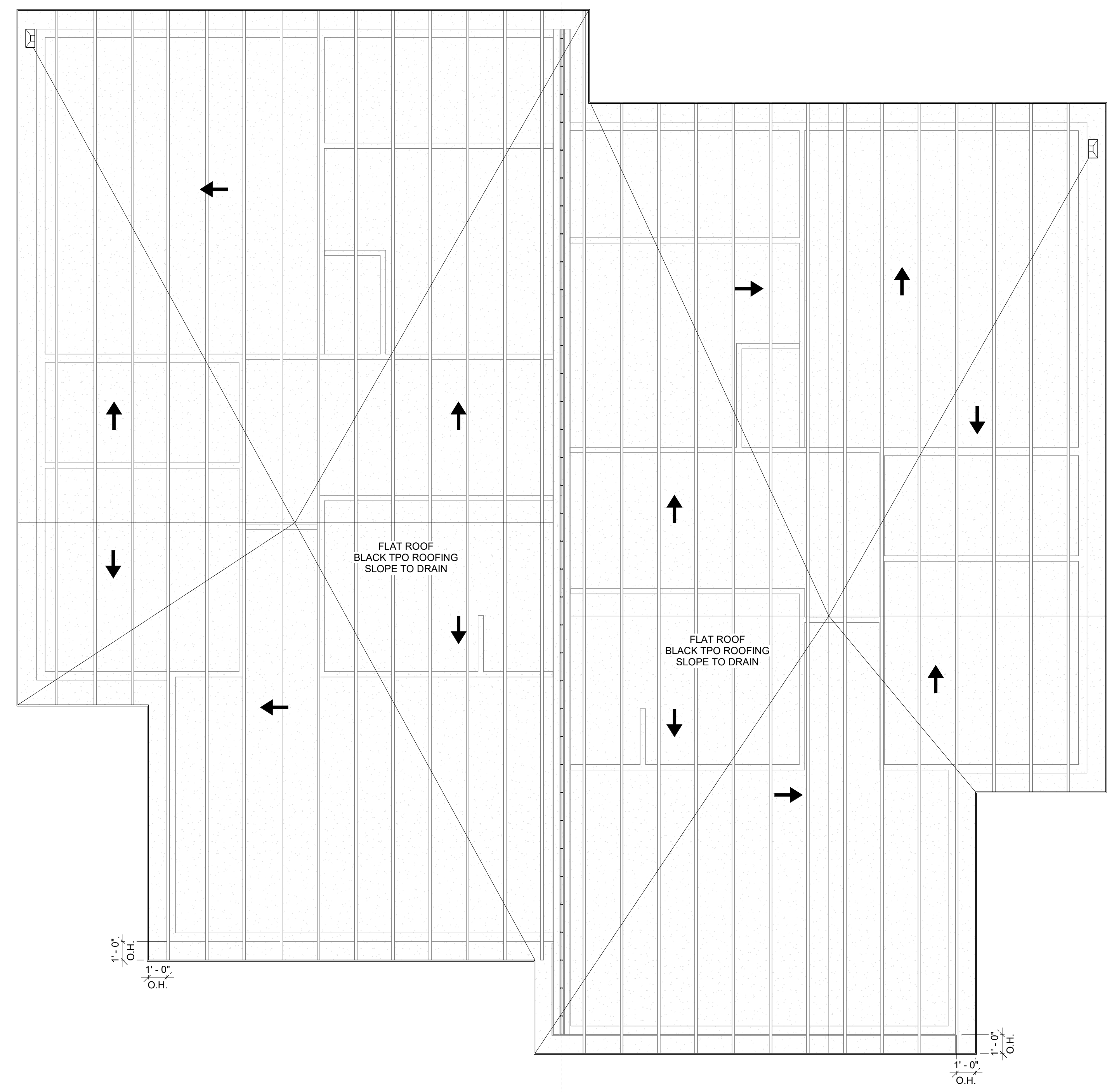

ROOF PLAN  
1/4" = 1'-0"

REV	DATE	DESCRIPTION

**FOUNDATION LEGEND**

	- INDICATES 6" CONC. WALL
	- INDICATES 8" CONC. WALL
	- INDICATES 12" CONC. WALL
	- INDICATES CONC. (SEE PLAN FOR THK.)
	- INDICATES FOOTING
	- INDICATES 2x INTERIOR BEARING WALL
	- INDICATES FOOTING CALLOUTS
	- INDICATES FOOTING CALLOUTS
	- INDICATES LOCATION OF HOLD DOWN, SEE DETAIL 7/SD1.0

**FOUNDATION NOTES:**

STEM WALL TO BE FIXED TO FOOTING w/ REBAR AS SPECIFIED AS PER THE 2018 IBC IN COORDINATION WITH CITY AND/OR COUNTY SPECIFICATIONS.

TOP OF SURFACE OF FOOTINGS TO BE LEVEL. BOTTOM SURFACE OF FOOTING SHALL NOT HAVE A SLOPE EXCEEDING 10%.

PROVIDE DRAINAGE AROUND FOUNDATION TO PREVENT WATER ACCUMULATION AS REQUIRED ON SITE.

ALL FOOTINGS AND FOUNDATION COMPONENTS HAVE BEEN DESIGNED FOR A SOIL BEARING PRESSURE OF 1,500 PSF.

DIMENSIONS ARE TO CENTERLINE OF PONY WALLS & PAD FOOTINGS BUT EDGES OF STEM WALLS U.N.O..

ALL POSTS (NOT IN WALLS) TO HAVE SIMPSON ABA66Z ON DETAIL 10/SD1.0. COLUMN BASE. INSTALLED PER MANUFACTURER REQUIREMENTS.

(1) FOUNDATION VENT SHALL BE WITHIN 3 FEET OF EACH CORNER OF THE BUILDING. WITH 1 VENT FOR EACH 150 SQUARE FEET OF UNDER-FLOOR AREA. WHERE THE GROUND SURFACE IS COVERED WITH AN APPROVED CLASS 1 VAPOR RETARDER MATERIAL AND THE REQUIRED OPENINGS ARE PLACED TO PROVIDE CROSS VENTILATION OF THE SPACE. 1 VENT FOR EACH 1500 SQUARE FEET OF UNDER-FLOOR AREA IS ALLOWED.

**HOLDOWN SCHEDULE**

MARK	STRAP TYPE	STRAP FASTENERS	# OF STUDS	ANCHOR BOLT	# OF STUDS	FASTENERS
HD1	LSTHD8 OR LSTHD8RJ w/ RIM	(20) 16d SINKERS	2	OR DTT22 w/ 1/2"x10"	2	(8) 1/4" x 1-1/2" SDS
HD2	STHD10 OR STHD10RJ w/ RIM	(24) 16d SINKERS	2	OR HDU2-SD2.5 w/ SB5/8x24 (PAB5 @ INT. PONY WALLS)	2	(6) 1/4" x 2-1/2" SDS
HD3	STHD14 OR STHD14RJ w/ RIM	(30) 16d SINKERS	2	OR HDU5-SD2.5 w/ SB5/8x24 (PAB5 @ INT. PONY WALLS)	2	(14) 1/4" x 2-1/2" SDS
HD4	-	-	-	OR HDU8-SD2.5 w/ SB7/8x24 (PAB7 @ INT. PONY WALLS)	3	(20) 1/4" x 2-1/2" SDS
HD5	-	-	-	OR HDU11-SD2.5 w/ SB1x30 (PAB8 @ INT. PONY WALLS)	4	(30) 1/4" x 2-1/2" SDS
HD6	-	-	-	OR HDU14-SD2.5 w/ SB1x30 (PAB8H @ INT. PONY WALLS)	4	(36) 1/4" x 2-1/2" SDS
HD7	-	-	-	OR HD19-SDS2.5 w/ PAB10	4	(5) 1" BOLTS

**NOTE:** 1. THIS IS A STANDARD LIST. SOME OF THE LISTED ABBREVIATIONS MAY NOT APPEAR IN THE DRAWINGS FOR THIS PROJECT.  
2. POSTS TO BE NO. 1 AND BETTER

**FOOTING SCHEDULE**

TYPE MARK	SIZE WxLxD	REINFORCING	COMMENTS
F1.3	16" x 8" x Cont.		
F2.0	24" x 8" x Cont.		
F2.5	30" x 10" x Cont.		

**PAD FOOTING SCHEDULE**

TYPE MARK	SIZE WxLxD	REINFORCING	COMMENTS

**ANCHOR BOLT KEY NOTES:**

MARK	DESCRIPTION
A1	1/2" ANCHOR BOLTS @ 12" O.C.
A2	1/2" ANCHOR BOLTS @ 24" O.C.
A3	1/2" ANCHOR BOLTS @ 36" O.C.
A4	1/2" ANCHOR BOLTS @ 48" O.C.
A5	1/2" ANCHOR BOLTS @ 60" O.C.

**NOTES:**

- BOLTS SHALL NOT BE PLACED MORE THAN 12" AWAY FROM WALL CORNERS OR SILL PLATE ENDS.
- ANCHOR BOLTS SHALL BE SPACED MAX. 72" O.C. UNLESS OTHERWISE SPECIFIED.
- SILL PLATE ANCHOR BOLTS MUST HAVE PLATE WASHERS PER OSB SHEAR WALL SCHEDULE.

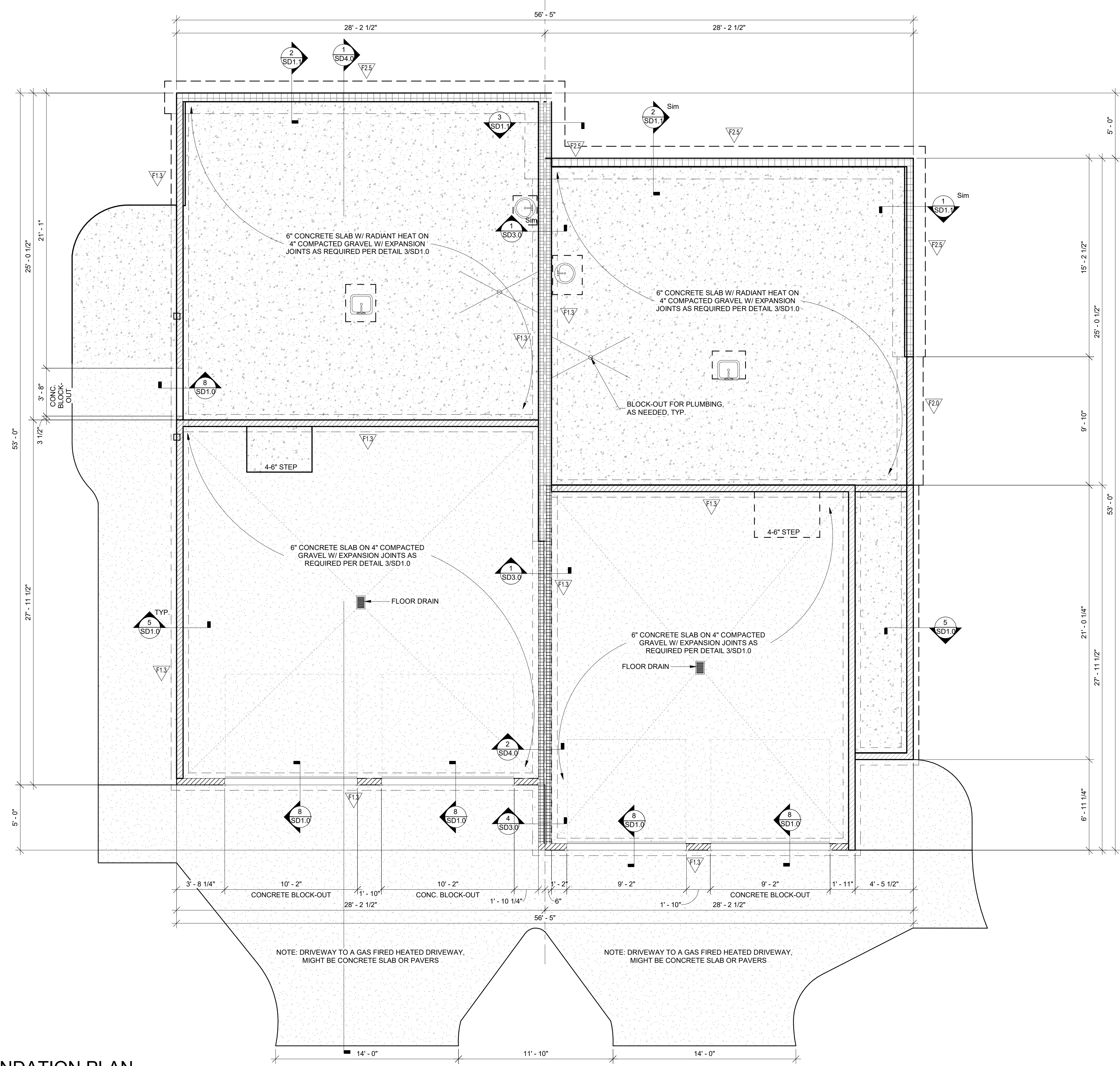

**FOUNDATION PLAN**  
1/4" = 1'-0"

DATE:	03/31/26
SCALE:	AS NOTED
DESIGN BY:	TSH
DESIGN REVIEW:	TSH
STRUCTURE BY:	???
STRUCTURE REVIEW:	VAL
JOB NO.:	2025-17046

DESIGN REV. 6

SHEET  
S1.0

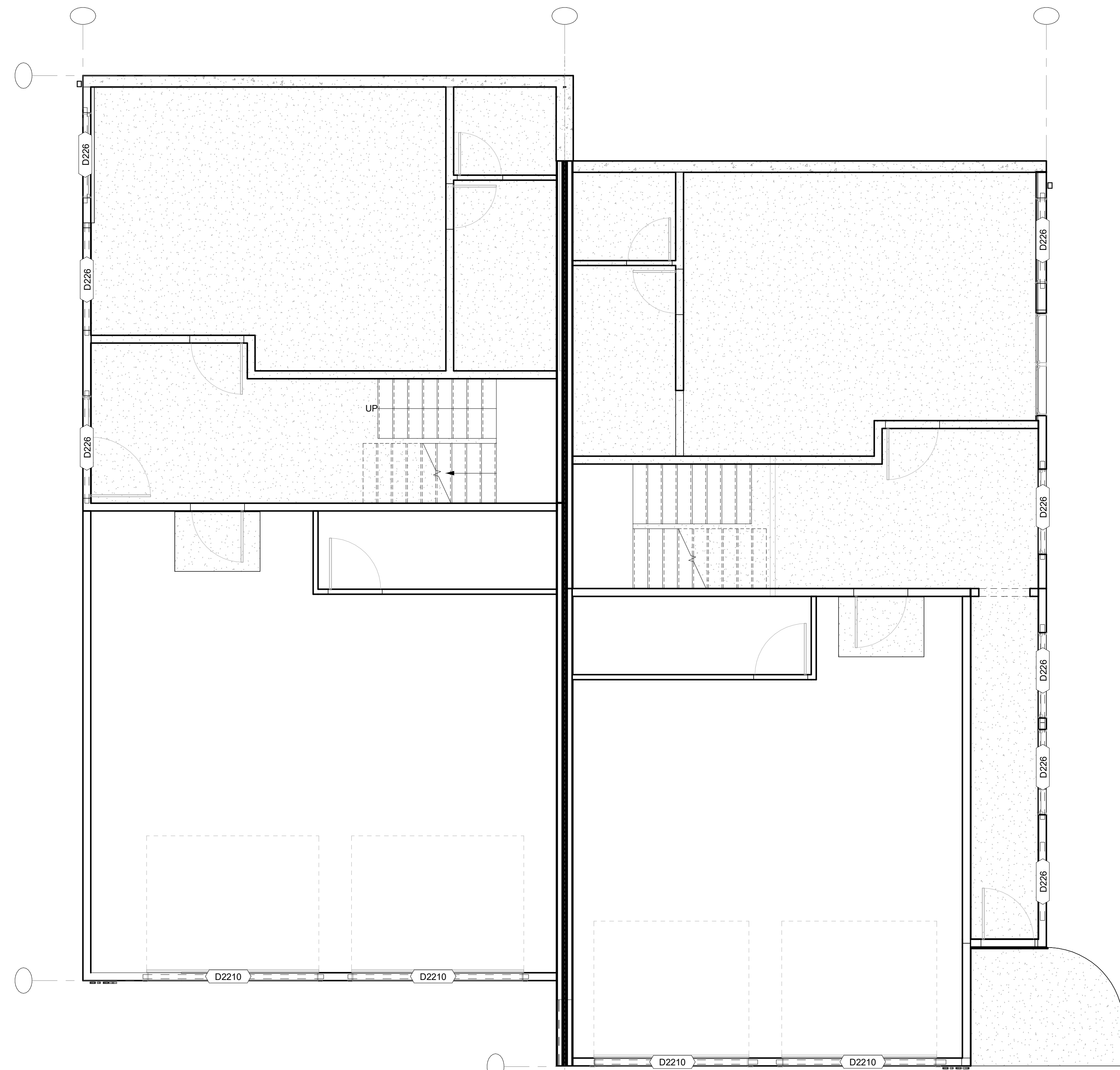

**SHEARWALL FLOOR PLAN LEGEND**

- INDICATES 2x STUD WALL
- INDICATES 2x BEARING WALL
- INDICATES SHEAR WALL
- INDICATES LOCATION OF HOLD DOWN
- INDICATES SHEARWALL TYPE
- INDICATES SHEARWALL GRID LINE

**HEADER & BEAM NOTES**

1. ALL HEADERS ARE TO BE (2) 2x6 STD. U.N.O.
2. AT CONTRACTORS OPTION, DOUBLE 2x DF #2 HEADERS CAN BE REPLACED WITH A SINGLE 4x DF #2 MEMBER OF EQUAL OR GREATER DEPTH AT ALL LOCATIONS.
3. ALL BEAMS DESIGNATED AS "LVL" ARE TO BE EQUAL OR GREATER THAN THE 2.0E MICROLAM LVL 1 3/4" x DEPTH SPECIFIED ON PLANS.
4. ALL SURFACES OF EXTERIOR ENGINEERED LUMBER TO BE PROTECTED FROM MOISTURE.
5. TYP. EXTERIOR WALLS: 2x6 DF #2 @ 16" O.C.  
 (1) TRIMMER EA. END OF OPENINGS, U.N.O.  
 (1) KING STUD EA. END OF OPENING, U.N.O.  
 SEE DETAIL 11/SD2.0
6. WALL PANEL SPLICE BLOCKING ONLY REQUIRED AT HATCHED AREAS & PER SHEAR WALL SCHEDULE. SEE DETAIL 11/SD2.0 FOR MORE INFORMATION.

**BEAM/HEADER KEY**

HEADER: (D226)	GRADE/MATERIAL	BEAM: (D2210)	GRADE/MATERIAL
	D = DF #2 G = 24F-V4 GLULAM	L = 2.0E LVL W = W SECTION STEEL BEAM	
DF#2 OR LVL:	# OF PLYS	SIZE OF PLYS	LVL DEPTHS
DF 2=1.5"			7.3 = 7 1/4"
LVL 2=1.75"			9.5 = 9 1/2"
	NOMINAL WIDTH	NOMINAL DEPTH	11.9 = 11 7/8"
GLULAM: WIDTH		DEPTH	
		WIDTHS:	
		3 = 3-1/8"	
		5 = 5-1/8"	
		7 = 6-3/4"	
		9 = 8-3/4"	
W BEAM:	NOMINAL DEPTH	WEIGHT PER FOOT	
		(W1222)	

NOTE: BEAMS AND HEADERS WITH THE SAME SIZE AND GRADE/MATERIAL CAN BE SUBSTITUTED

THIS PLAN FOR BASIS OF IDEAS IS THE PROPERTY OF PERFORMANCE ENGINEERS. ANY FORM OF DUPLICATING OR USE OF ALL OR ANY PARTS, DRAWINGS AND DESIGNS IS PROHIBITED. © COPYRIGHT 2025



An InteFrame Company

1102 N. FRANKLIN BLVD.  
NAMPA, IDAHO 83687  
PH. (208) 475-0040

REV	DATE	DESCRIPTION	BY

LIFT VIEW TOWNHOMES  
310 GEORGIA RD  
SHEAR WALL / HEADER PLAN  
KETCHUM IDAHO



DATE: 03/11/26  
SCALE: AS NOTED  
DESIGN BY: TSH  
DESIGN REVIEW: TSH  
STRUCTURE BY: ???  
STRUCTURE REVIEW: VAL  
JOB NO.: 2025-17046

DESIGN REV. 6

SHEET  
S1.1

© COPYRIGHT 2025

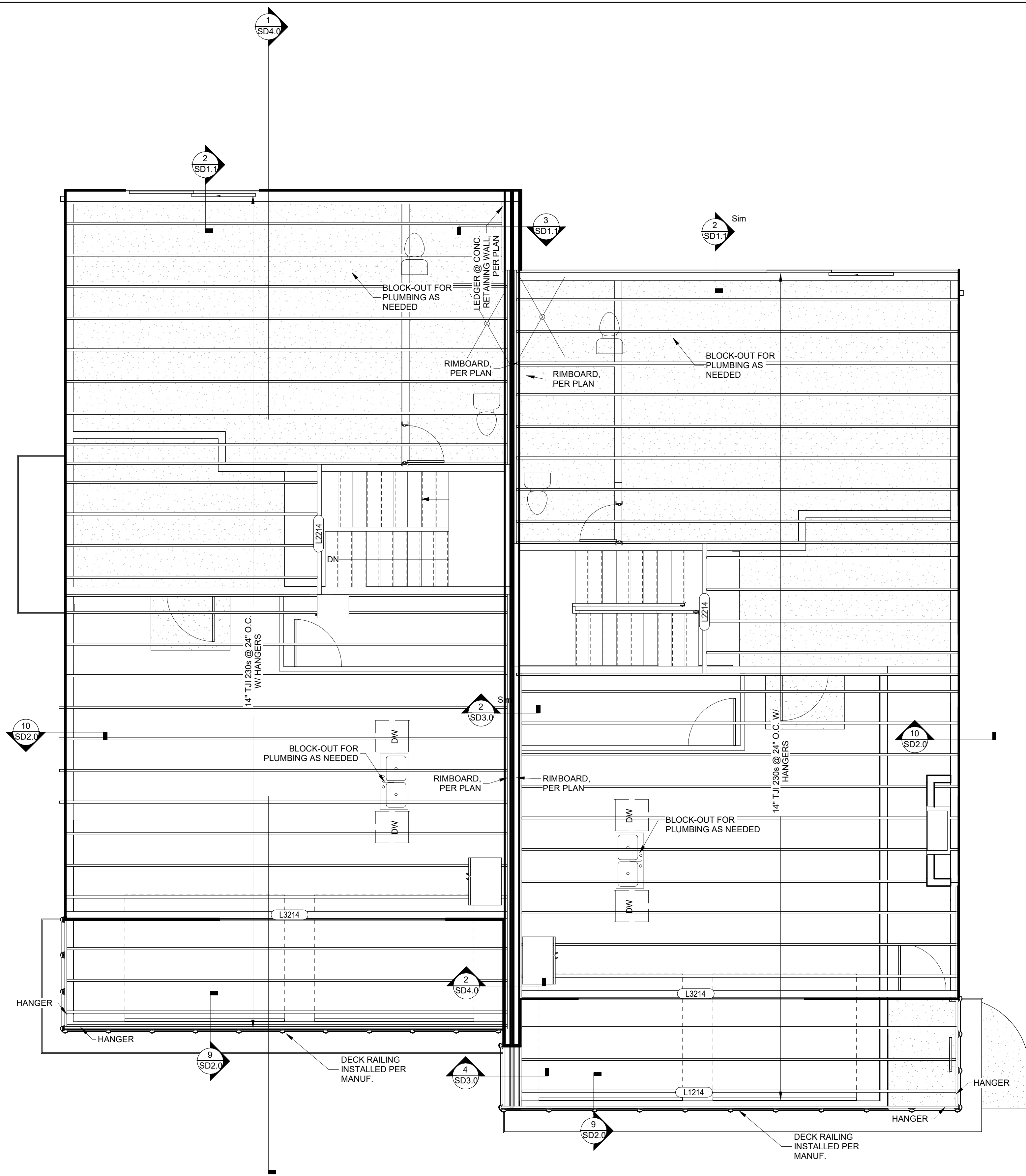
LEVEL 1 SHEARWALL / HEADER PLAN  
1/4" = 1'-0"



FRAMING PLAN LEGEND	
[Symbol: Two parallel lines]	- INDICATES 2x STUD WALL
[Symbol: Hatched area]	- INDICATES 2x BEARING WALL
[Symbol: Cross-hatched area]	- INDICATES OVERBUILD FRAMING, SEE DETAIL ?/SD?.?

- FRAMING NOTES**
- PROVIDE TWO STUDS AT ALL GIRDER/BEARING LOCATIONS UNLESS NOTED OTHERWISE.
  - SEE ROOF TRUSS LAYOUT FROM TRUSS MANUFACTURER FOR ACCURATE ROOF FRAMING PLAN.
  - NAIL SHEATHING TO FRAMING MEMBERS W/ 8d NAILS @ 6" O.C. ON PANEL EDGES AND 12" O.C. @ INTERMEDIATE FRAMING. 1-1/2"x16 GA. MIN. STAPLES OK AT HALF THE SPACING (3" EDGE / 6" FIELD)
  - NAIL SHEATHING TO FRAMING MEMBERS W/ 8d NAILS @ 6" O.C. ON PANEL EDGES AND 12" O.C. @ INTERMEDIATE FRAMING. 1-1/2"x16 GA. MIN. STAPLES OK AT HALF THE SPACING (3" EDGE / 6" FIELD)

**BEAM/HEADER KEY**

HEADER: (D226)	GRADE/MATERIAL	BEAM: (D2210)
GRADE/MATERIAL: D = DF #2 G = 24F-V4 GLULAM	L = 2.0E LVL W = W SECTION STEEL BEAM	
DF#2 OR LVL: WIDTHS: DF 2=1.5" LVL 2=1.75"	# OF PLYS	SIZE OF PLYS LVL DEPTHS 7.3 = 7 1/4" 9.5 = 9 1/2" 11.9 = 11 7/8"
GLULAM: WIDTH	NOMINAL WIDTH	NOMINAL DEPTH
W BEAM: NOMINAL DEPTH	DEPTH	WEIGHT PER FOOT
NOTE: BEAMS AND HEADERS WITH THE SAME SIZE AND GRADE/MATERIAL CAN BE SUBSTITUTED		

THIS PLAN FOR BASIS OF IDEAS IS THE PROPERTY OF PERFORMANCE ENGINEERS. ANY FORM OF DUPLICATION OR USE OF ALL OR ANY PARTS, DRAWINGS AND DESIGNS IS PROHIBITED. © COPYRIGHT 2025



An InteFrame Company

1102 N. FRANKLIN BLVD.  
NAMPA, IDAHO 83687  
PH. (208) 475-0040

REV	DATE	DESCRIPTION

**LIFT VIEW TOWNHOMES**  
310 GEORGIA RD  
**LEVEL 2 FLOOR FRAMING**

IDAHO  
KETCHUM

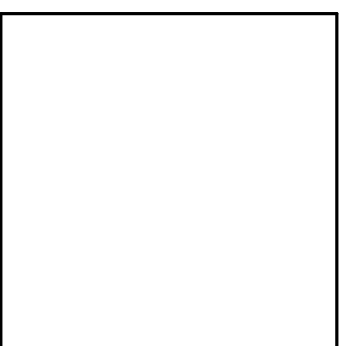

DATE: 03/11/26  
SCALE: AS NOTED  
DESIGN BY: TSH  
DESIGN REVIEW: TSH  
STRUCTURE BY: ???  
STRUCTURE REVIEW: VAL  
JOB NO.: 2025-17046

**DESIGN REV. 6**

SHEET  
**S2.0**  
© COPYRIGHT 2025

**LEVEL 2 FLOOR FRAMING**  
1/4" = 1'-0"

REV	DATE	DESCRIPTION

### BEAM/HEADER KEY

HEADER: D226 GRADE/MATERIAL: D2210 BEAM: D2210

GRADE/MATERIAL: D = DF #2 L = 2.0E LVL  
G = 24F-V4 W = W SECTION STEEL  
GLULAM BEAM

DF#2 OR LVL: # OF PLYS SIZE OF PLYS LVL DEPTHS

WIDTHS: DF 2=1.5" LVL DEPTHS: 7.3 = 7 1/4"  
LVL 2=1.75" 9.5 = 9 1/2"  
NOMINAL DEPTH: 11.9 = 11 7/8"

GLULAM: WIDTH: G519.5 NOMINAL DEPTH: 3 = 3-1/8"  
5 = 5-1/8"  
7 = 6-3/4"  
9 = 8-3/4"

W BEAM: NOMINAL DEPTH: W1222 WEIGHT PER FOOT

NOTE: BEAMS AND HEADERS WITH THE SAME SIZE AND GRADE/MATERIAL CAN BE SUBSTITUTED

### SHEARWALL FLOOR PLAN LEGEND

- INDICATES 2x STUD WALL
- INDICATES 2x BEARING WALL
- INDICATES SHEAR WALL
- INDICATES LOCATION OF HOLD DOWN
- INDICATES SHEARWALL TYPE
- INDICATES SHEARWALL GRID LINE

### HEADER & BEAM NOTES

- ALL HEADERS ARE TO BE (2) 2x6 STD. U.N.O.
- AT CONTRACTORS OPTION, DOUBLE 2x DF #2 HEADERS CAN BE REPLACED WITH A SINGLE 4x DF #2 MEMBER OF EQUAL OR GREATER DEPTH AT ALL LOCATIONS.
- ALL BEAMS DESIGNATED AS "LVL" ARE TO BE EQUAL OR GREATER THAN THE 2.0E MICROLAM LVL 1 3/4" x DEPTH SPECIFIED ON PLANS.
- ALL SURFACES OF EXTERIOR ENGINEERED LUMBER TO BE PROTECTED FROM MOISTURE.
- TYP. EXTERIOR WALLS: 2x6 DF #2 @ 16" O.C. (1) TRIMMER EA. END OF OPENINGS, U.N.O. (1) KING STUD EA. END OF OPENING, U.N.O. SEE DETAIL 11/SD2.0
- WALL PANEL SPLICE BLOCKING ONLY REQUIRED AT HATCHED AREAS & PER SHEAR WALL SCHEDULE. SEE DETAIL 11/SD2.0 FOR MORE INFORMATION.

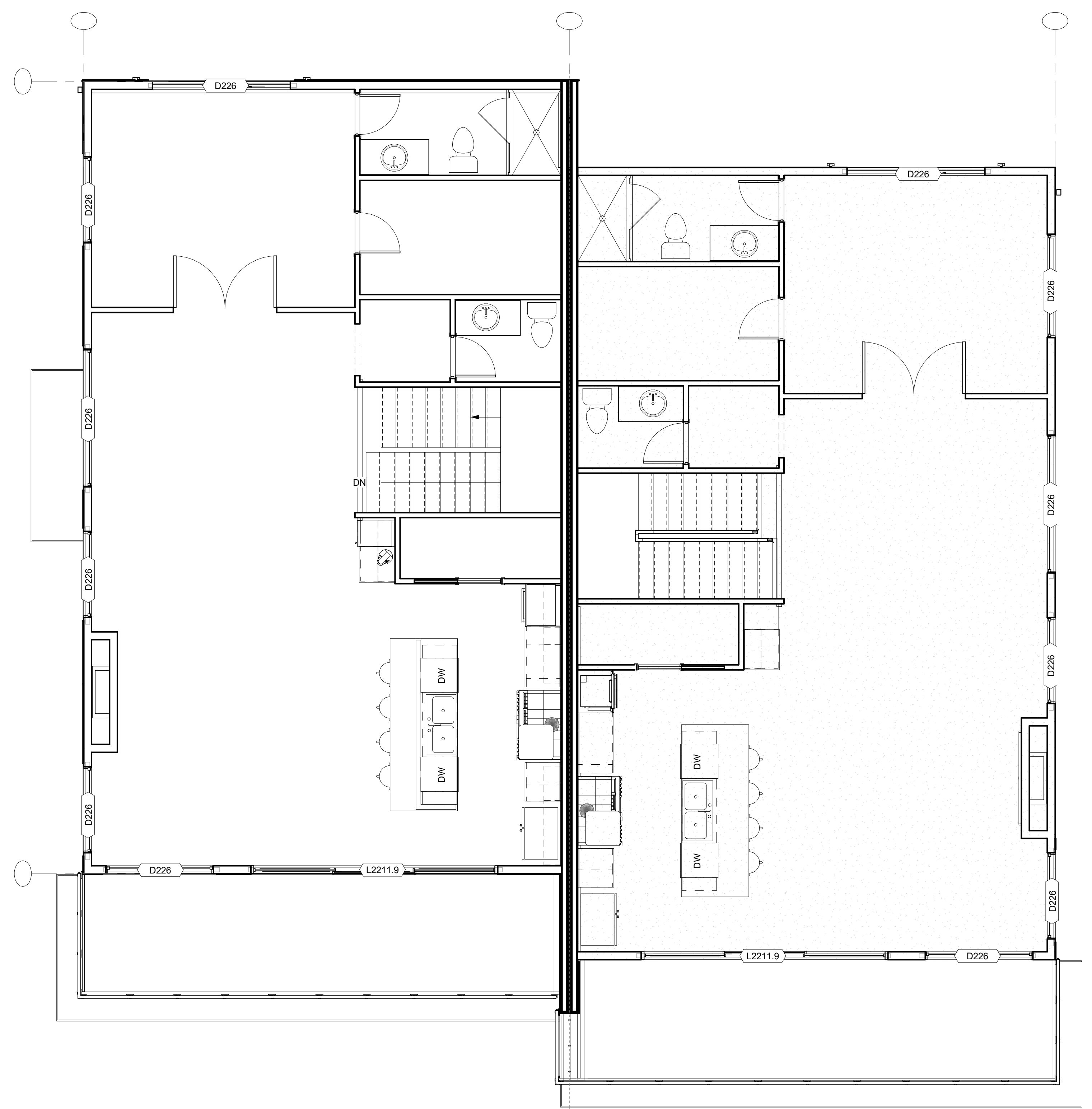

### SHEAR WALL SHEETING SCHEDULE

MARK	SHEATHING	SIDES OF WALL	SHEET NAILING PERIMETER/	SHEET STAPLING PERIMETER/FIELD	BLK'G	NAILING (U.N.O.) BOTTOM PLATE INTO RIM
W0	7/16" APA RATED	1	8d @ 6/12		NO	(2) 16d NAILS PER 16" NAILS
W1	7/16" APA RATED	1	8d @ 6/12	OR 16ga x 1 1/2" @ 3/12	YES	(2) 16d NAILS PER 16" NAILS
W2	7/16" APA RATED	1	8d @ 4/12	OR 16ga x 1 1/2" @ 2/12	YES	(3) 16d NAILS PER 16" NAILS
W3	7/16" APA RATED	1	8d @ 3/12		YES	(4) 16d NAILS PER 16" BAY
W4	7/16" APA RATED	1	8d @ 2/12	(4x OR DBLE STUD NAILED TOGETHER @ PANEL EDGES) ONLY REQUIRED AT HATCHED AREAS	YES	(4) SDS SCREWS PER 16" BAY
W5	7/16" APA RATED	2	8d @ 3/12		YES	(5) SDS SCREWS PER 16" BAY
WA	1/2" GYP. BOARD	2	5d COOLER @ 6/6		NO	(2) 16d NAILS PER 16" BAY
WB	1/2" GYP. BOARD	2	5d COOLER @ 6/6		YES	(2) 16d NAILS PER 16" BAY
WC	1/2" GYP. BOARD	2	5d COOLER @ 4/4		NO	(2) 16d NAILS PER 16" BAY
WC	1/2" GYP. BOARD	2	5d COOLER @ 4/4		YES	(2) 16d NAILS PER 16" BAY

TYPICAL NOTES:

- ALL SHEATHING PANEL EDGES SHALL BE BLOCKED U.N.O.
- PROVIDE SAME NAILING PATTERN ABOVE AND BELOW OPENINGS AS ADJACENT SHEAR PANEL.
- ALL EXTERIOR WALLS SHALL BE SHEARWALL "W1" WITHOUT BLK'G U.N.O.
- FASTEN TRUSS HEELS TO SHEAR WALLS W/ 10d TOE NAILS @ 6" O.C. U.N.O.
- FASTEN TRUSS HEELS TO SHEAR WALLS W/ H2.5A AND (2) 10d TOENAILS @ EACH
- PLATE WASHERS EQUAL TO 0.229"x3"x3" IN SIZE REQUIRED AT ALL ANCHOR BOLTS FOR ALL EXTERIOR OSB SHEAR WALLS. THE WASHER IS TO BE PLACED WITHIN 1/2" OF THE EDGE OF THE BOTTOM PLATE ON THE OSB SHEATHED FACE FOR W2 THRU W5 WALLS. PROVIDE STANDARD WASHER FOR ALL SLOTTED PLATE WASHERS.

### STRAP SCHEDULE

(STRAP/ ALL THREAD TO CLEAR SPAN ACROSS RIM TO WALL BELOW)

MARK	STRAP TYPE	STRAP FASTENERS	# OF STUDS	ANCHOR BOLT	# OF STUDS	FASTENERS
S1	MSTC28	(16) 16d SINKERS	2	OR DTT2Z w/ 1/2"Ø ALL THREAD	2	(8) 1/4" x 1-1/2" SDS
S2	MSTC40	(32) 16d SINKERS	2	OR HDU2-SD2.5 w/ 5/8"Ø ALL THREAD	2	(6) 1/4" x 2-1/2" SDS
S3	MSTC52	(48) 16d SINKERS	2	OR HDU5-SD2.5 w/ 5/8"Ø ALL THREAD	2	(14) 1/4" x 2-1/2" SDS
S4	MSTC66	(68) 16d SINKERS	2	OR HDU8-SD2.5 w/ 7/8"Ø ALL THREAD	3	(20) 1/4" x 2-1/2" SDS
S5	CMST14	(76) 16d SINKERS	2	OR HDU11-SD2.5 w/ 1"Ø ALL THREAD	4	(30) 1/4" x 2-1/2" SDS
S6	CMST12	(98) 16d SINKERS	2	OR HDU14-SD2.5 w/ 1"Ø ALL THREAD	4	(36) 1/4" x 2-1/2" SDS
S7	-	-	-	OR HD19-SDS2.5 w/ 1-1/4"Ø ALL THREAD	4	(5) 1" BOLTS

NOTE: 1. THIS IS A STANDARD LIST. SOME OF THE LISTED ABBREVIATIONS MAY NOT APPEAR IN THE DRAWINGS FOR THIS PROJECT.  
2. POSTS TO BE NO. 1 AND BETTER

### GABLE/DKAG TRUSS OR RIM ATTACHEMENT SCHEDULE

MARK	DESCRIPTION
T1	ATTACH GABLE / DRAG TRUSS OR RIM TO TOP PLATE W/ 10d TOENAILS @ 6" O.C., EDGE NAIL SHEATHING ABOVE TO TRUSS
T2	ATTACH GABLE / DRAG TRUSS OR RIM TO TOP PLATE W/ 10d TOENAILS @ 4" O.C., EDGE NAIL SHEATHING ABOVE TO TRUSS
T3	ATTACH GABLE / DRAG TRUSS OR RIM TO TOP PLATE W/ 10d TOENAILS @ 3" O.C., EDGE NAIL SHEATHING ABOVE TO TRUSS
T4	ATTACH GABLE / DRAG TRUSS OR RIM TO TOP PLATE W/ A35 @ 12" O.C., EDGE NAIL SHEATHING ABOVE TO TRUSS
T5	ATTACH GABLE / DRAG TRUSS OR RIM TO TOP PLATE W/ A35 @ 6" O.C., EDGE NAIL SHEATHING ABOVE TO TRUSS

### BLOCKING SCHEDULE

MARK	DESCRIPTION
B1	BLOCKING BETWEEN EVERY OTHER TRUSS BAYS W/ (6) 10d TOENAILS FROM BLOCKING TO TOP PLATE, NAIL ROOF SHEATHING TO BLOCKING 3" O.C.
B2	2-PLY OR 4x BLOCKING BETWEEN EVERY OTHER TRUSS BAYS W/ (2) A35 CLIPS FROM BLOCKING TO TOP PLATE, W/ 2 ROWS @ 3" O.C. (STAGGERED) -OR- BLOCKING BETWEEN EVERY TRUSS BAY W/ (6) 10d TOENAILS FROM BLOCKING TO TOP PLATE, NAIL ROOF SHEATHING TO BLOCKING 3" O.C.
B3	2-PLY OR 4x BLOCKING BETWEEN EVERY OTHER TRUSS BAY W/ (2) A35 CLIPS FROM BLOCKING TO TOP PLATE, W/ (2) ROWS @ 3" O.C. (STAGGERED)
B4	2-PLY OR 4x BLOCKING BETWEEN EVERY OTHER TRUSS BAY W/ (3) A35 CLIPS FROM BLOCKING TO TOP PLATE, W/ (2) ROWS @ 3" O.C. (STAGGERED)

LEVEL 2 SHEARWALL / HEADER PLAN  
1/4" = 1'-0"

THIS PLAN FOR BASIS OF IDEAS IS THE PROPERTY OF PERFORMANCE ENGINEERS. ANY FORM OF DUPLICATION OR USE OF ALL OR ANY PLANS, DRAWINGS AND DESIGNS IS PROHIBITED. © COPYRIGHT 2025

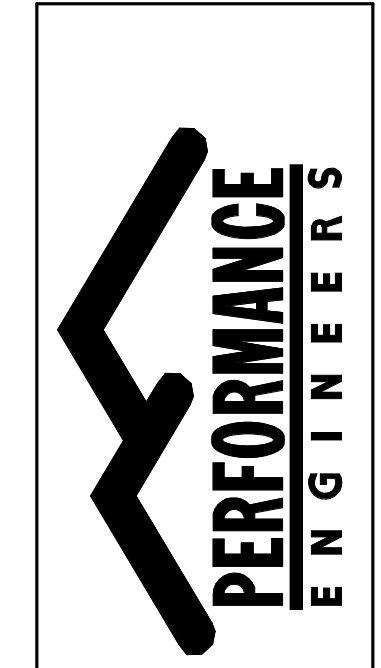

An InteFrame Company

1102 N. FRANKLIN BLVD.  
NAMPA, IDAHO 83687  
PH. (208) 475-0040

REV	DATE	DESCRIPTION	BY
01	03/31/26	ISSUED FOR APPROVAL	
02		CONSTRUCTION	

LIFT VIEW TOWNHOMES  
310 GEORGIA RD  
LEVEL 3 FLOOR FRAMING  
KETCHUM IDAHO

DATE: 03/31/26  
SCALE: AS NOTED  
DESIGN BY: TSH  
DESIGN REVIEW: TSH  
STRUCTURE BY: ???  
STRUCTURE REVIEW: VAL  
JOB NO.: 2025-17046

DESIGN REV. 6

SHEET  
S3.0

© COPYRIGHT 2025

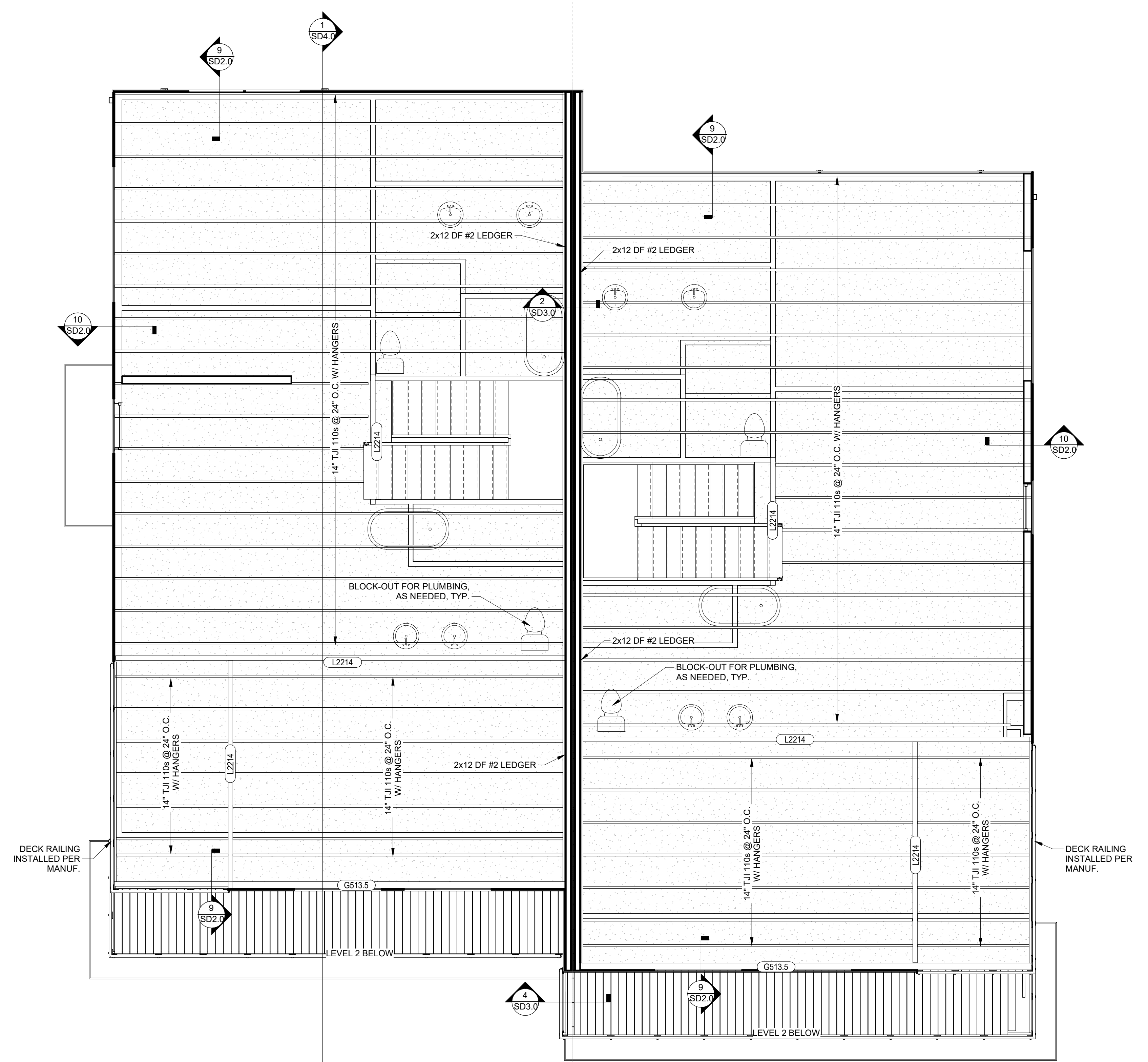

**LEVEL 3 FLOOR FRAMING**  
1/4" = 1'-0"

THIS PLAN FOR BASIS OF IDEAS IS THE PROPERTY OF PERFORMANCE ENGINEERS. ANY FORM OF DUPLICATION OR USE OF ALL OR ANY PLANS, DRAWINGS AND DESIGNS IS PROHIBITED. © COPYRIGHT 2025

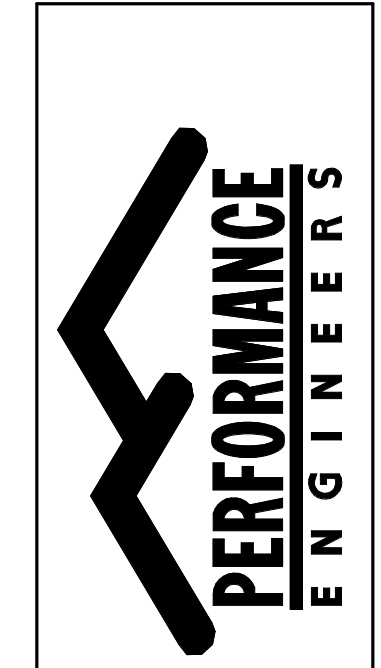

An InteFrame Company

1102 N. FRANKLIN BLVD.  
NAMPA, IDAHO 83687  
PH. (208) 475-0040

REV	DATE	DESCRIPTION	BY
01	03/31/26	ISSUED FOR APPROVAL/ CONSTRUCTION	

LIFT VIEW TOWNHOMES  
310 GEORGIA RD  
LEVEL 3 SHEAR/HEADER PLAN  
KETCHUM IDAHO

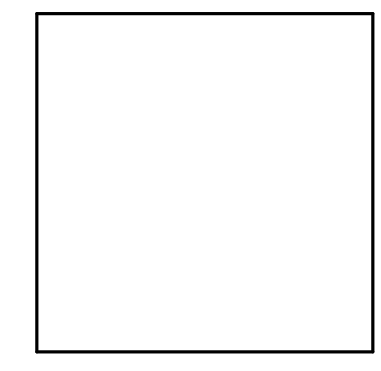
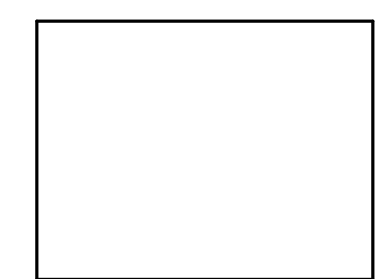

DATE:	03/31/26
SCALE:	AS NOTED
DESIGN BY:	TSH
DESIGN REVIEW:	TSH
STRUCTURE BY:	???
STRUCTURE REVIEW:	VAL
JOB NO.:	2025-17046

DESIGN REV. 6

SHEET  
S3.1

© COPYRIGHT 2025

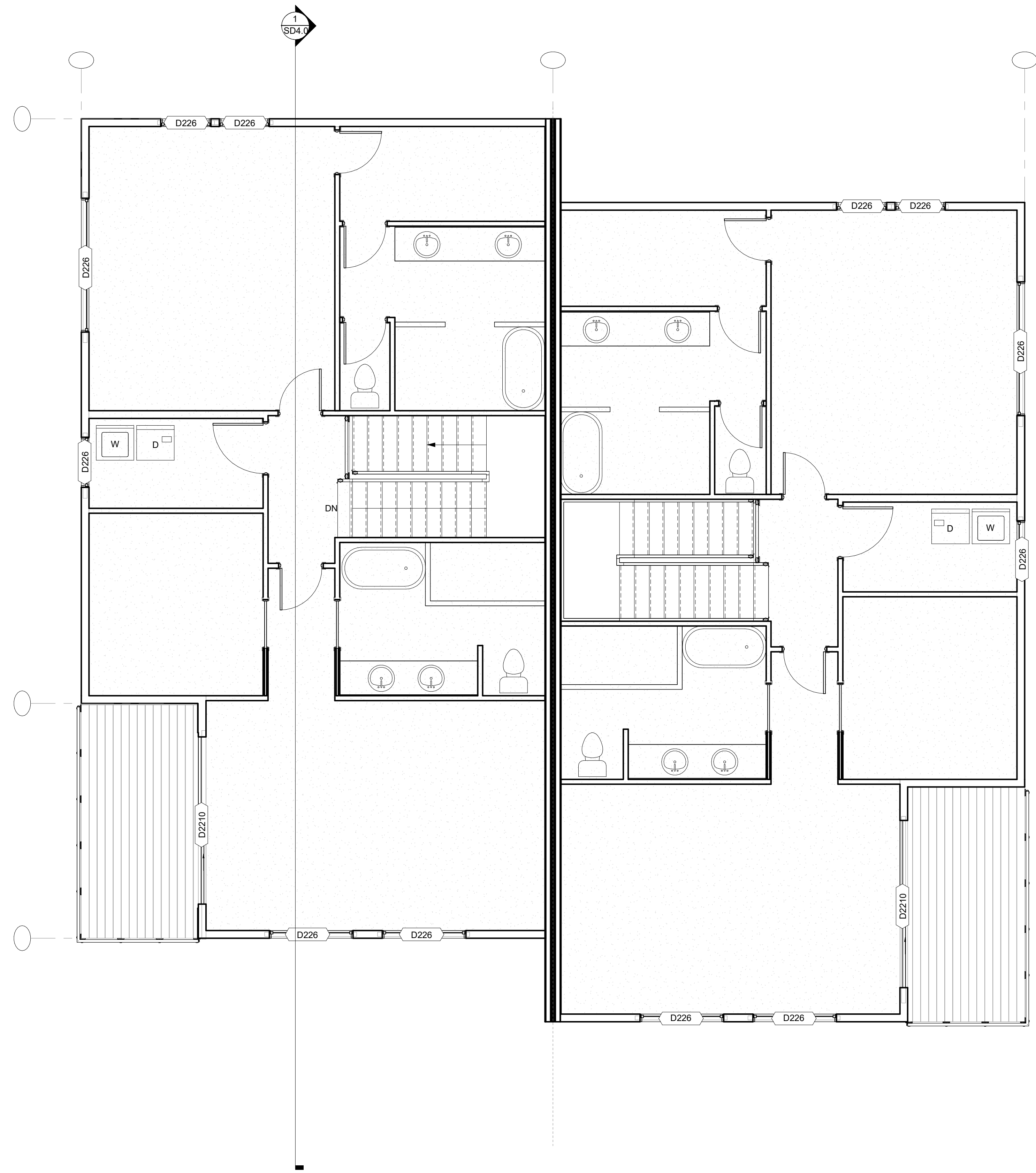

LEVEL 3 SHEARWALL / HEADER PLAN

1/4" = 1'-0"



An InteFrame Company

1102 N. FRANKLIN BLVD.  
NAMPA, IDAHO 83687  
PH. (208) 475-0040

REV	DATE	DESCRIPTION

LIFT VIEW TOWNHOMES  
310 GEORGIA RD  
ROOF FRAMING PLAN  
IDAHO  
KETCHUM

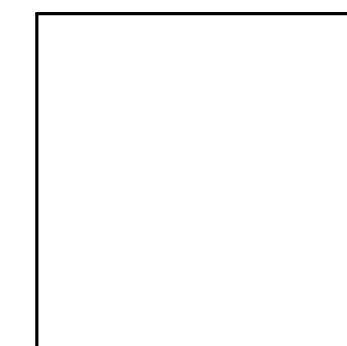
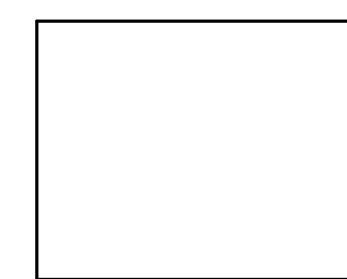

DATE:	03/11/26
SCALE:	AS NOTED
DESIGN BY:	TSH
DESIGN REVIEW:	TSH
STRUCTURE BY:	???
STRUCTURE REVIEW:	VAL
JOB NO.:	2025-17046

DESIGN REV. 6

SHEET  
S4.0

FRAMING PLAN LEGEND	
	- INDICATES 2x STUD WALL
	- INDICATES 2x BEARING WALL
	- INDICATES OVERBUILD FRAMING, SEE DETAIL ?/SD?.?

- FRAMING NOTES**
- PROVIDE TWO STUDS AT ALL GIRDER/BEAM BEARING LOCATIONS UNLESS NOTED OTHERWISE.
  - SEE ROOF TRUSS LAYOUT FROM TRUSS MANUFACTURER FOR ACCURATE ROOF FRAMING PLAN.
  - NAIL SHEATHING TO FRAMING MEMBERS W/ 8d NAILS @ 6" O.C. ON PANEL EDGES AND 12" O.C. @ INTERMEDIATE FRAMING. 1-1/2"x16 GA. MIN. STAPLES OK AT HALF THE SPACING (3" EDGE / 6" FIELD)
  - NAIL SHEATHING TO FRAMING MEMBERS W/ 8d NAILS @ 6" O.C. ON PANEL EDGES AND 12" O.C. @ INTERMEDIATE FRAMING. 1-1/2"x16 GA. MIN. STAPLES OK AT HALF THE SPACING (3" EDGE / 6" FIELD)

BEAM/HEADER KEY	
HEADER: (D226)	GRADE/MATERIAL: (D2210)
BEAM: (D2210)	GRADE/MATERIAL: D = DF #2 G = 24F-144 GLULAM L = 2.0E LVL W = W SECTION STEEL BEAM
DF#2 OR LVL:	SIZE OF PLYS
# OF PLYS	LVL DEPTHS
WIDTHS:	7.3 = 7 1/4"
DF 2=1.5"	9.5 = 9 1/2"
LVL 2=1.75"	11.9 = 11 7/8"
NOMINAL WIDTH	NOMINAL DEPTH
GLULAM: WIDTH	WIDTHS:
(G519.5)	3 = 3-1/8"
DEPTH	5 = 5-1/8"
	7 = 6-3/4"
	9 = 8-3/4"
W BEAM: NOMINAL DEPTH	WEIGHT PER FOOT
(W1222)	
NOTE: BEAMS AND HEADERS WITH THE SAME SIZE AND GRADE/MATERIAL CAN BE SUBSTITUTED	

BLOCKING SCHEDULE	
MARK	DESCRIPTION
B1	BLOCKING BETWEEN EVERY OTHER TRUSS BAYS W/ (6) 10d TOENAILS FROM BLOCKING TO TOP PLATE. NAIL ROOF SHEATHING TO BLOCKING 3" O.C.
B2	2-PLY OR 4x BLOCKING BETWEEN EVERY OTHER TRUSS BAYS W/ (2) A35 CLIPS FROM BLOCKING TO TOP PLATE, W/ 2 ROWS @ 3" O.C. (STAGGERED) -OR- BLOCKING BETWEEN EVERY TRUSS BAY W/ (6) 10d TOENAILS FROM BLOCKING TO TOP PLATE, NAIL ROOF SHEATHING TO BLOCKING 3" O.C.
B3	2-PLY OR 4x BLOCKING BETWEEN EVERY OTHER TRUSS BAY W/ (2) A35 CLIPS FROM BLOCKING TO TOP PLATE, W/ (2) ROWS @ 3" O.C. (STAGGERED)
B4	2-PLY OR 4x BLOCKING BETWEEN EVERY OTHER TRUSS BAY W/ (3) A35 CLIPS FROM BLOCKING TO TOP PLATE, W/ (2) ROWS @ 3" O.C. (STAGGERED)

GABLE/DRAG TRUSS OR RIM ATTACHEMENT SCHEDULE	
MARK	DESCRIPTION
T1	ATTACH GABLE / DRAG TRUSS OR RIM TO TOP PLATE W/ 10d TOENAILS @ 6" O.C., EDGE NAIL SHEATHING ABOVE TO TRUSS
T2	ATTACH GABLE / DRAG TRUSS OR RIM TO TOP PLATE W/ 10d TOENAILS @ 4" O.C., EDGE NAIL SHEATHING ABOVE TO TRUSS
T3	ATTACH GABLE / DRAG TRUSS OR RIM TO TOP PLATE W/ 10d TOENAILS @ 3" O.C., EDGE NAIL SHEATHING ABOVE TO TRUSS
T4	ATTACH GABLE / DRAG TRUSS OR RIM TO TOP PLATE W/ A35 @ 12" O.C., EDGE NAIL SHEATHING ABOVE TO TRUSS
T5	ATTACH GABLE / DRAG TRUSS OR RIM TO TOP PLATE W/ A35 @ 6" O.C., EDGE NAIL SHEATHING ABOVE TO TRUSS

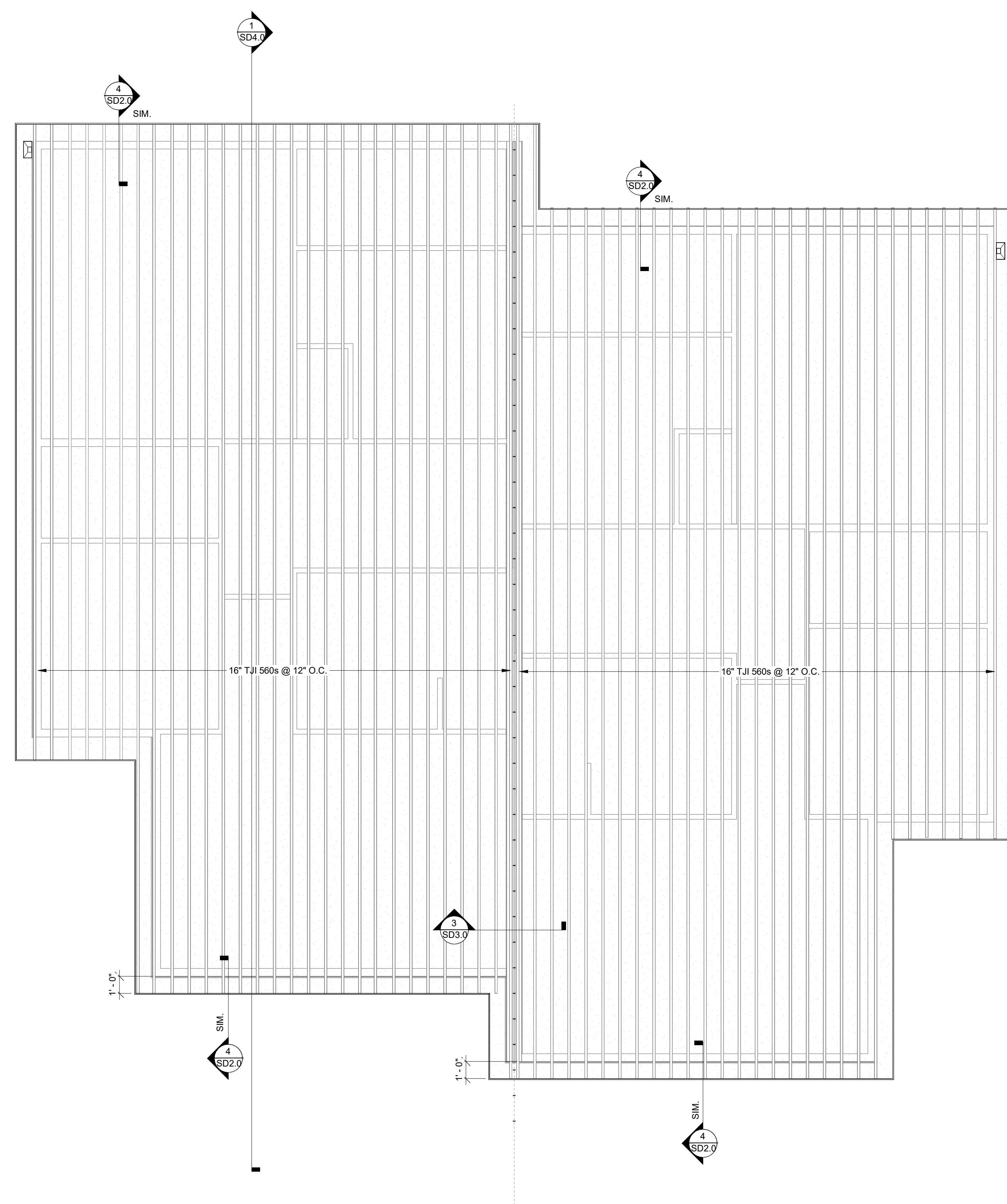

ROOF FRAMING PLAN  
1/4" = 1'-0"

REV.	DATE	DESCRIPTION	BY
1	03/31/26	ISSUED FOR APPROVAL	
2		CONSTRUCTION	

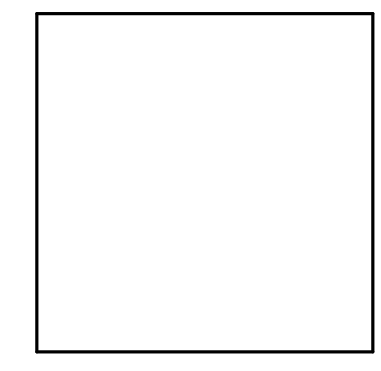
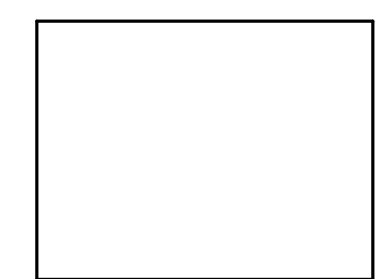

DATE:	03/31/26
SCALE:	AS NOTED
DESIGN BY:	TSH
DESIGN REVIEW:	TSH
STRUCTURE BY:	???
STRUCTURE REVIEW:	VAL
JOB NO.:	2025-17046

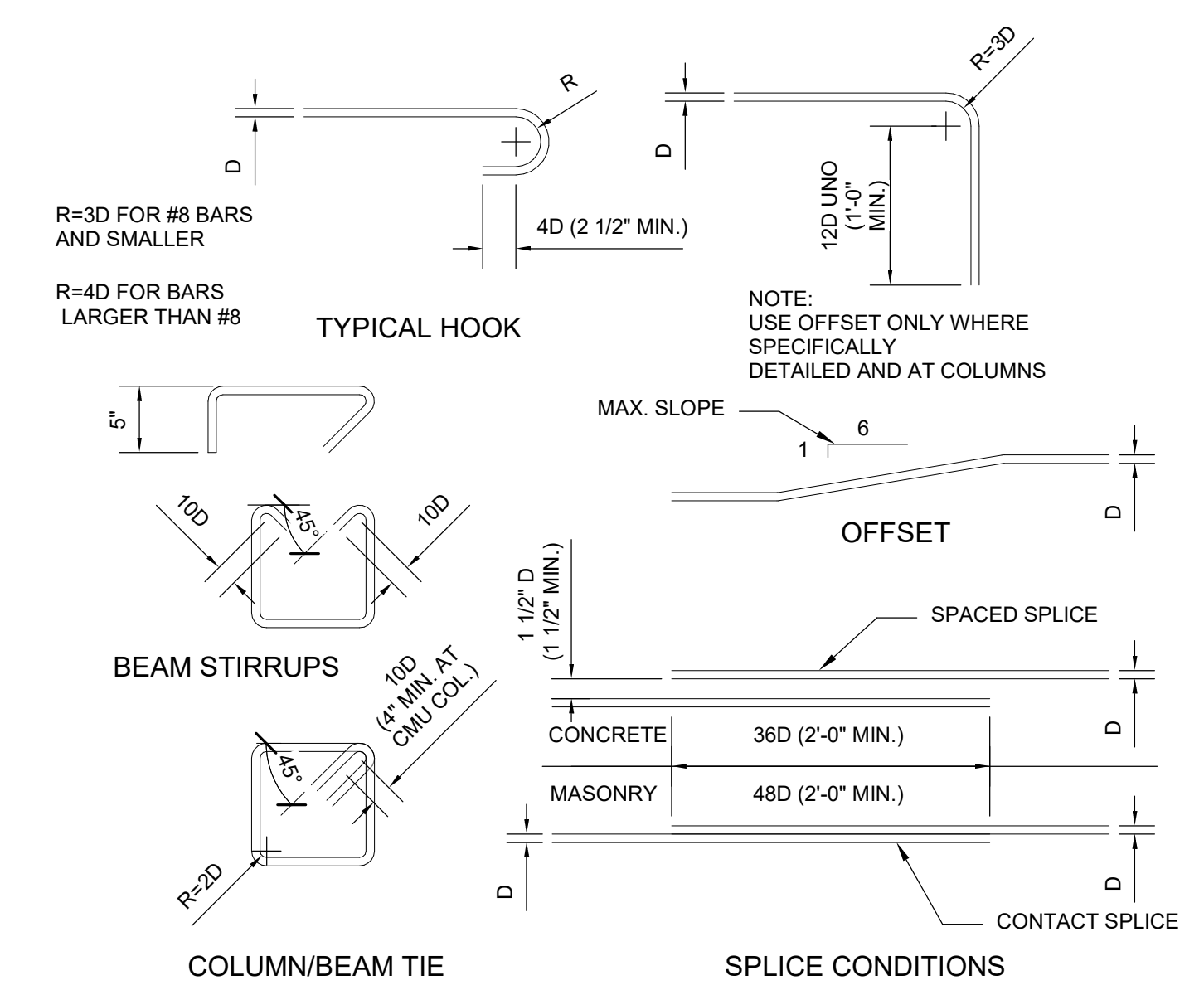

**1 REINFORCING BAR BENDS**  
SD1.0 1" = 1'-0"

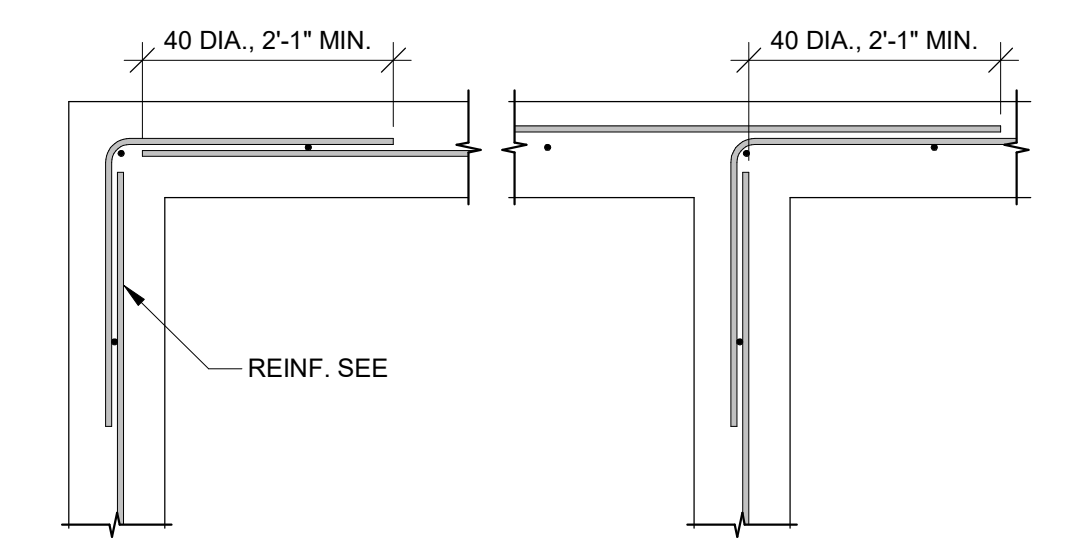

**2 TYP. CORNER REINFORCEMENT**  
SD1.0 3/4" = 1'-0"

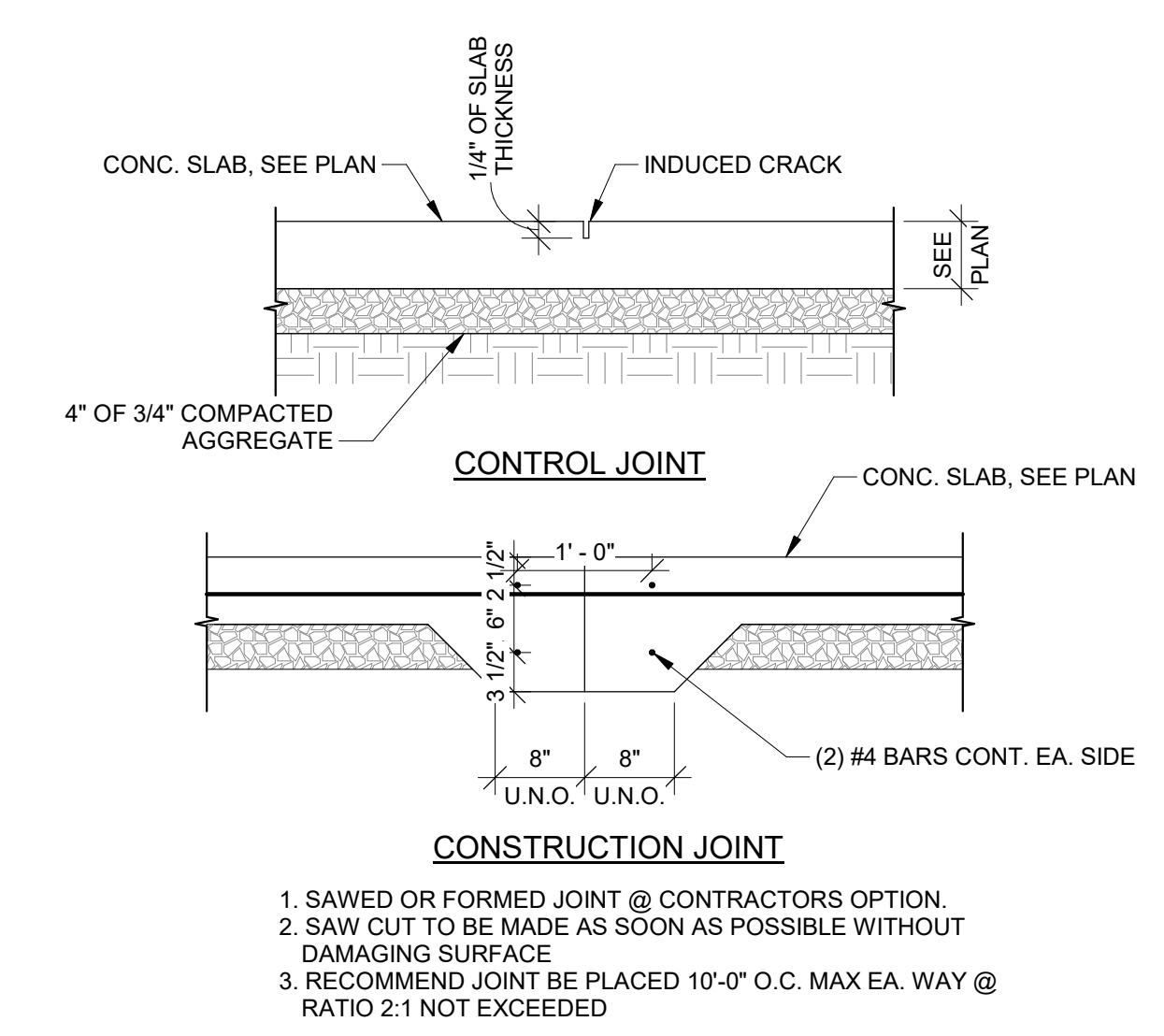

**3 TYPICAL SLAB JOINT DETAILS**  
SD1.0 3/4" = 1'-0"

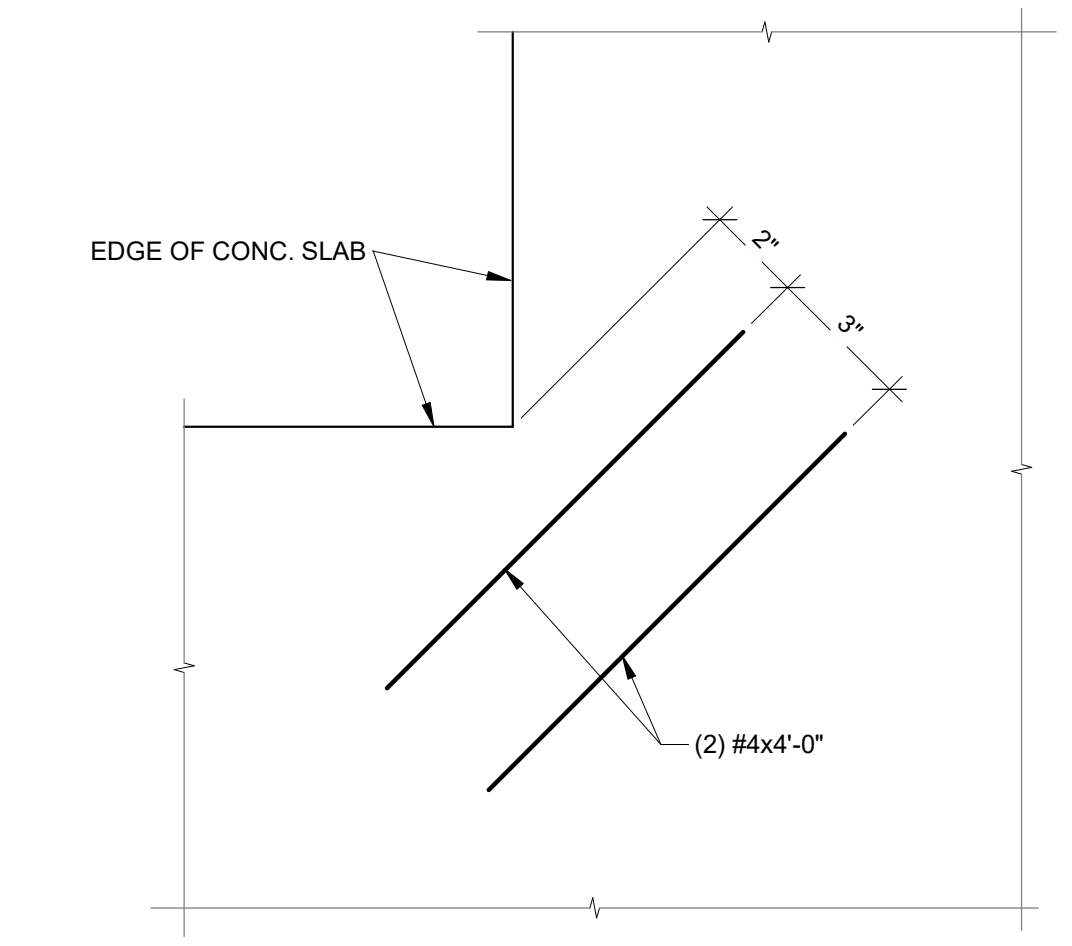

**4 REINF. AT RE-ENTRANT CORNERS**  
SD1.0 3" = 1'-0"

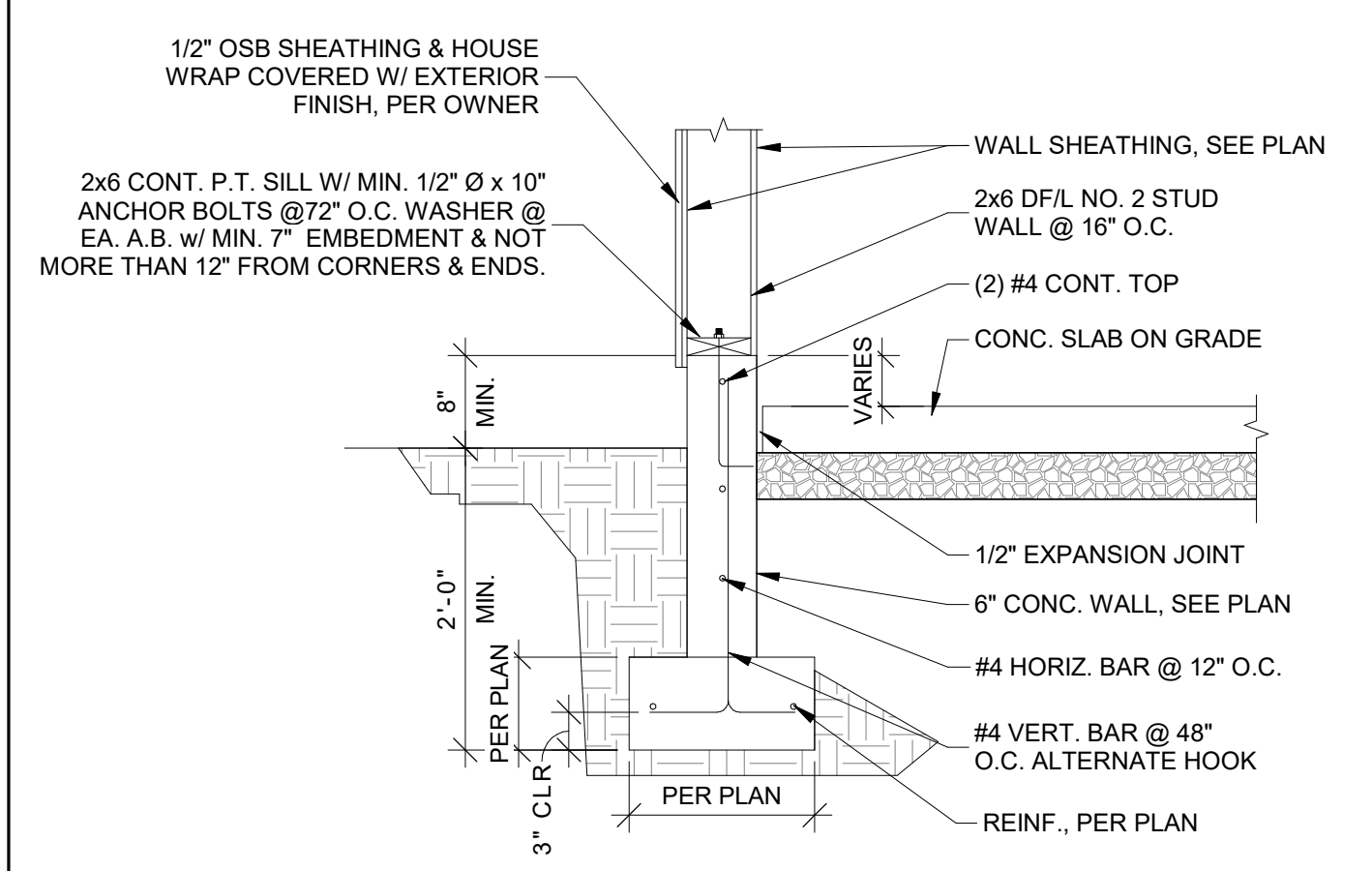

**5 GARAGE FDN AT WALL**  
SD1.0 3/4" = 1'-0"

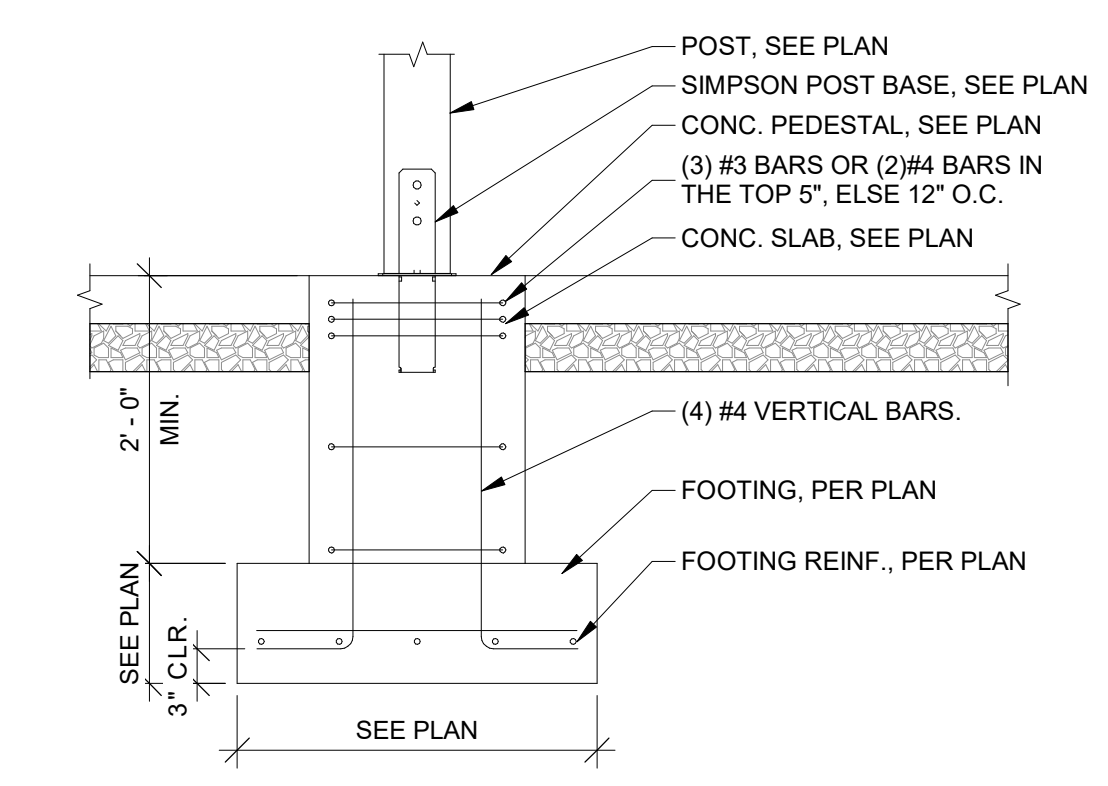

**6 EXTERIOR WOOD POST FOOTING DETAIL**  
SD1.0 3/4" = 1'-0"

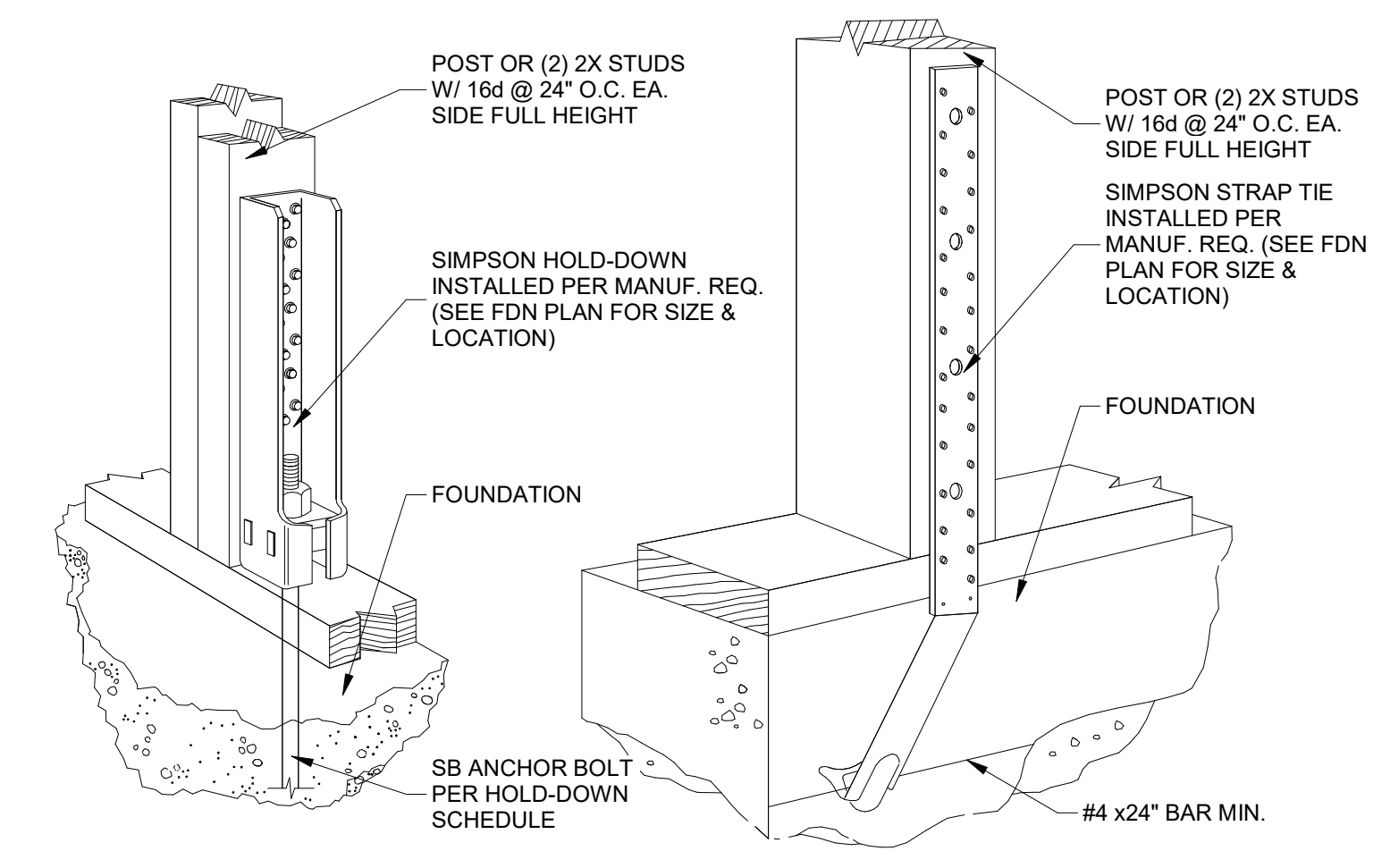

**7 HOLD-DOWN DETAIL**  
SD1.0 3/4" = 1'-0"

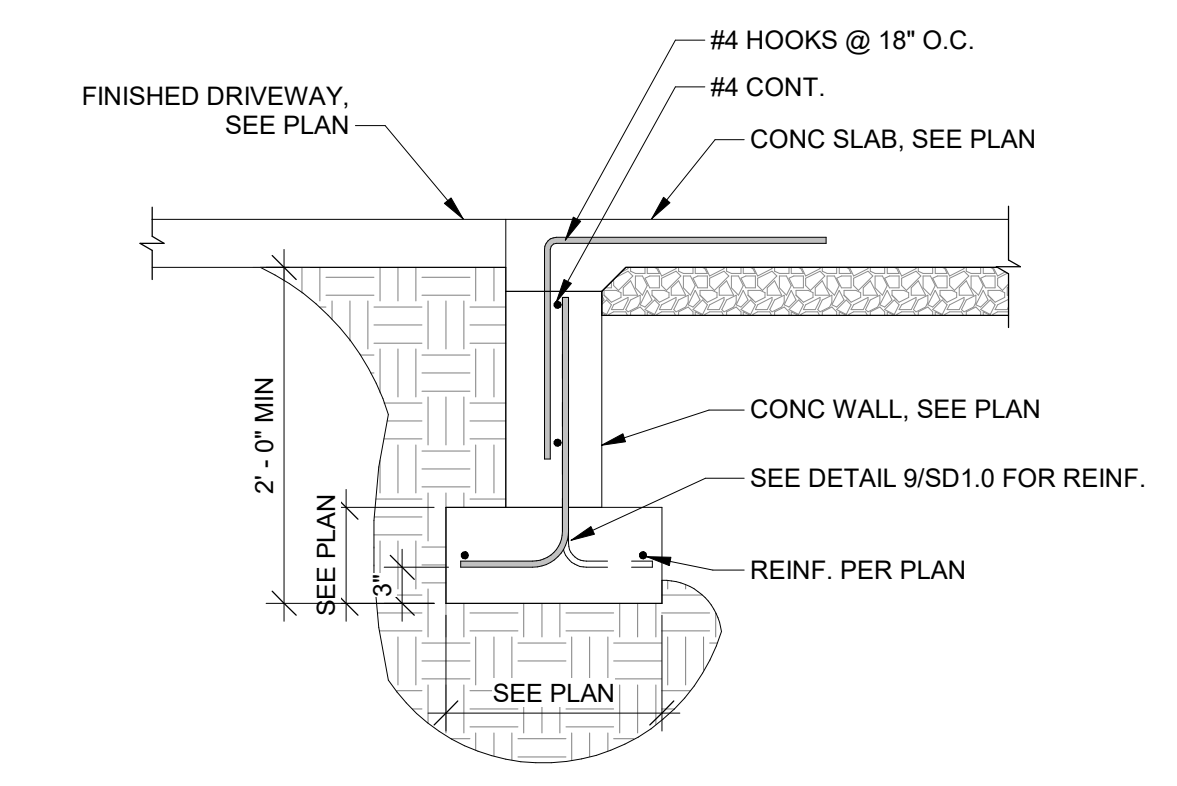

**8 FOUNDATION AT GARAGE DOOR**  
SD1.0 3/4" = 1'-0"

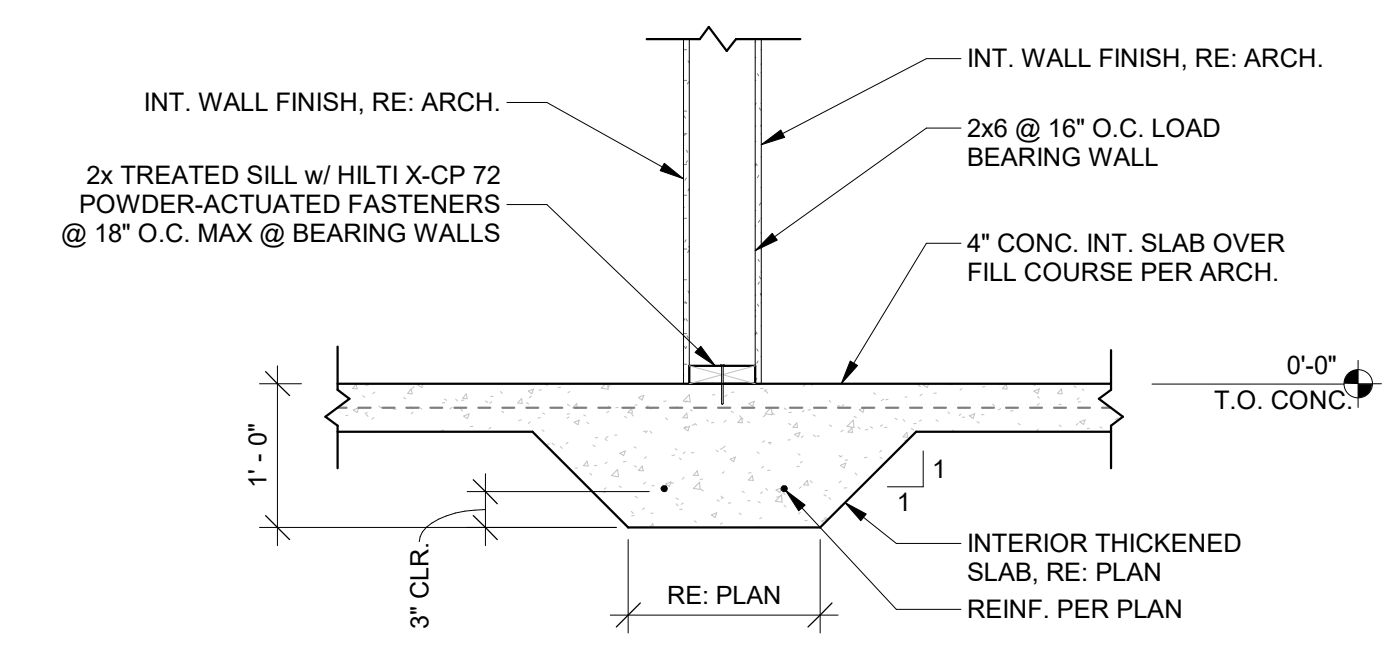

**9 THICKENED SLAB DETAIL**  
SD1.0 3/4" = 1'-0"

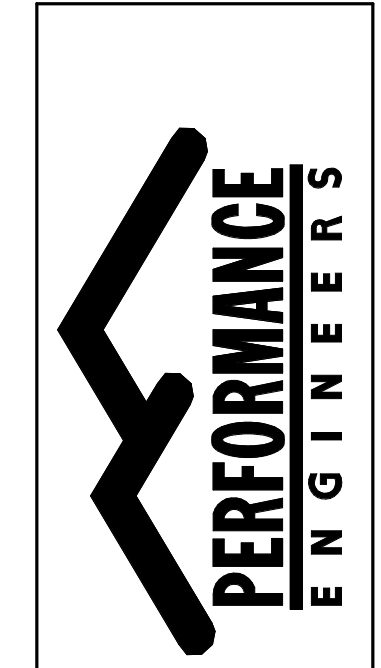

An InteFrame Company

1102 N. FRANKLIN BLVD.  
NAMPA, IDAHO 83687  
PH. (208) 475-0040

REV	DATE	DESCRIPTION
01	03/31/26	ISSUED FOR APPROVAL
02		ISSUED FOR CONSTRUCTION

LIFT VIEW TOWNHOMES  
310 GEORGIA RD  
FOUNDATION DETAILS  
KETCHUM IDAHO



DATE: 03/31/26  
SCALE: AS NOTED  
DESIGN BY: TSH  
DESIGN REVIEW: TSH  
STRUCTURE BY: ???  
STRUCTURE REVIEW: VAL  
JOB NO.: 2025-17046

DESIGN REV. 6

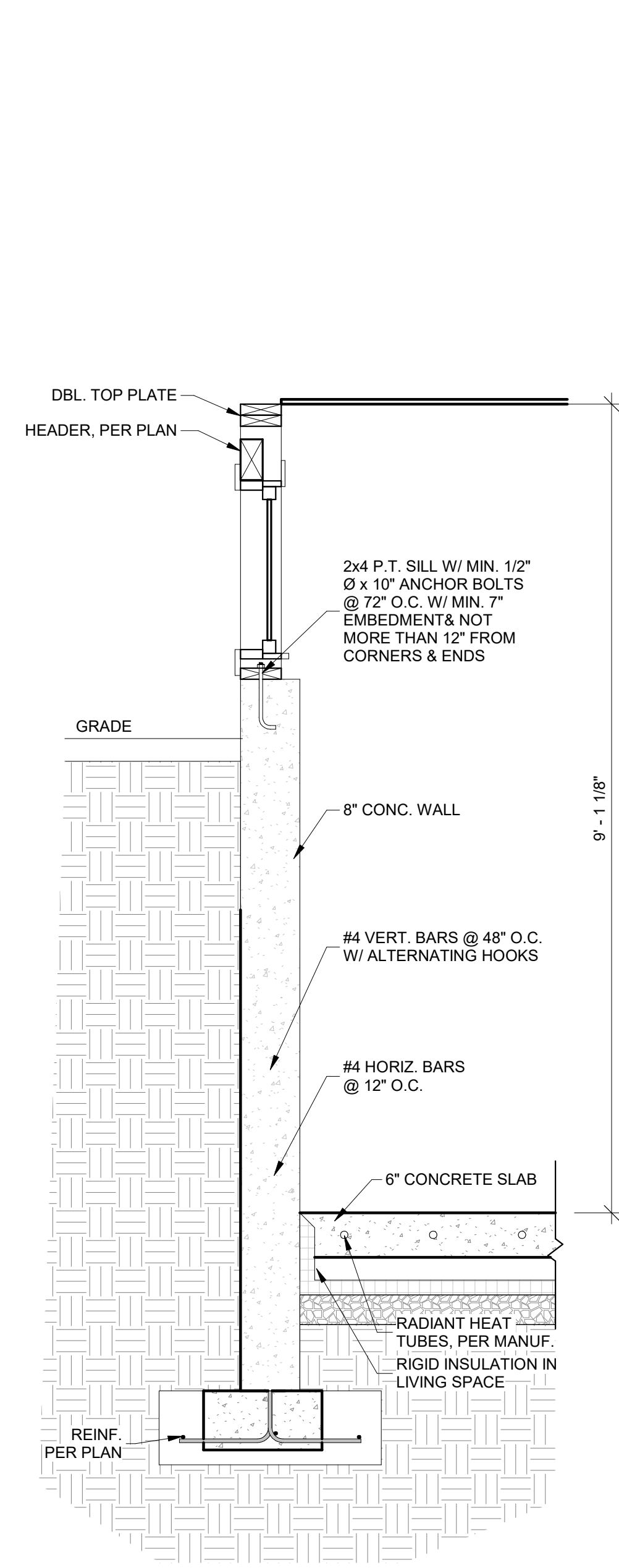
SHEET  
SD1.1

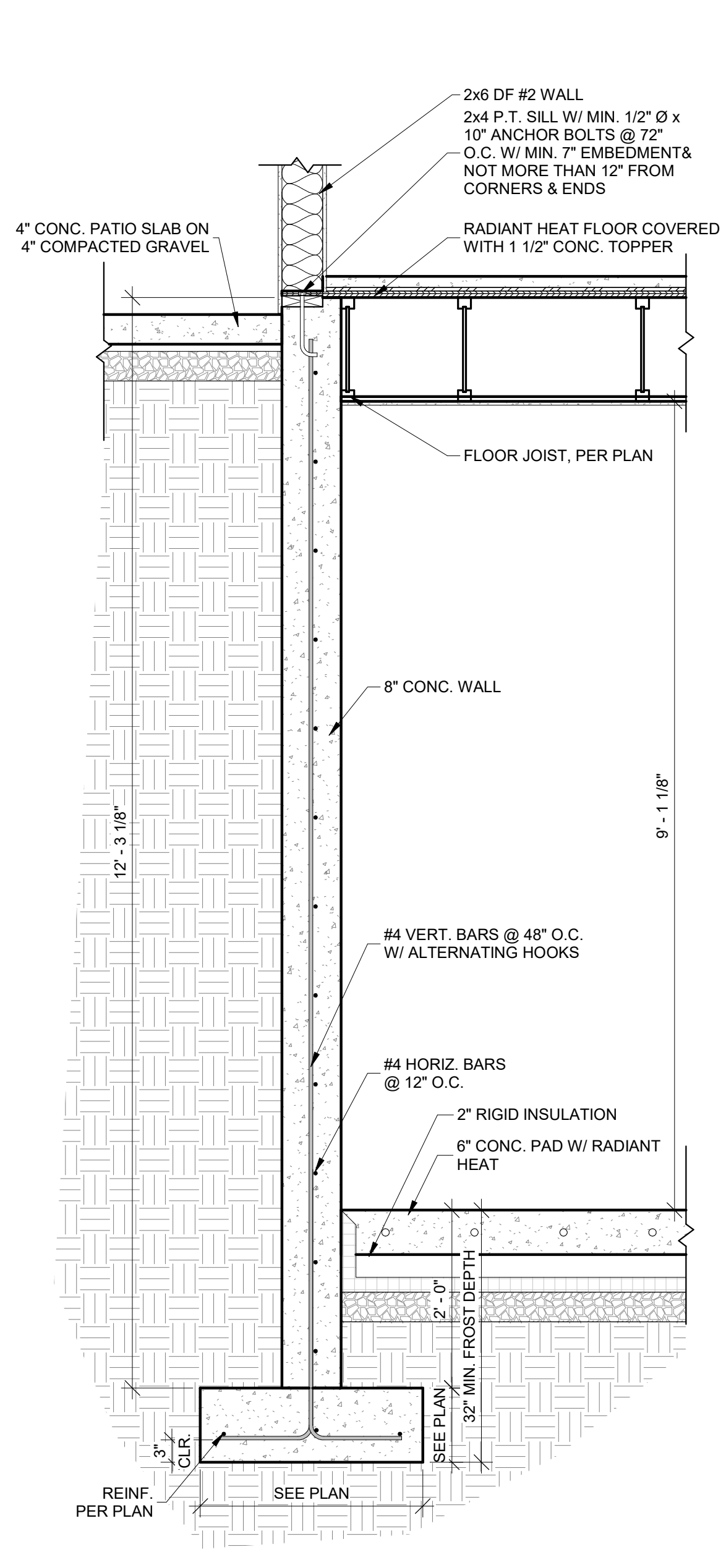

1 RETAINING WALL 1  
SD1.1 3/4" = 1'-0"



2 RETAINING WALL 2  
SD1.1 3/4" = 1'-0"

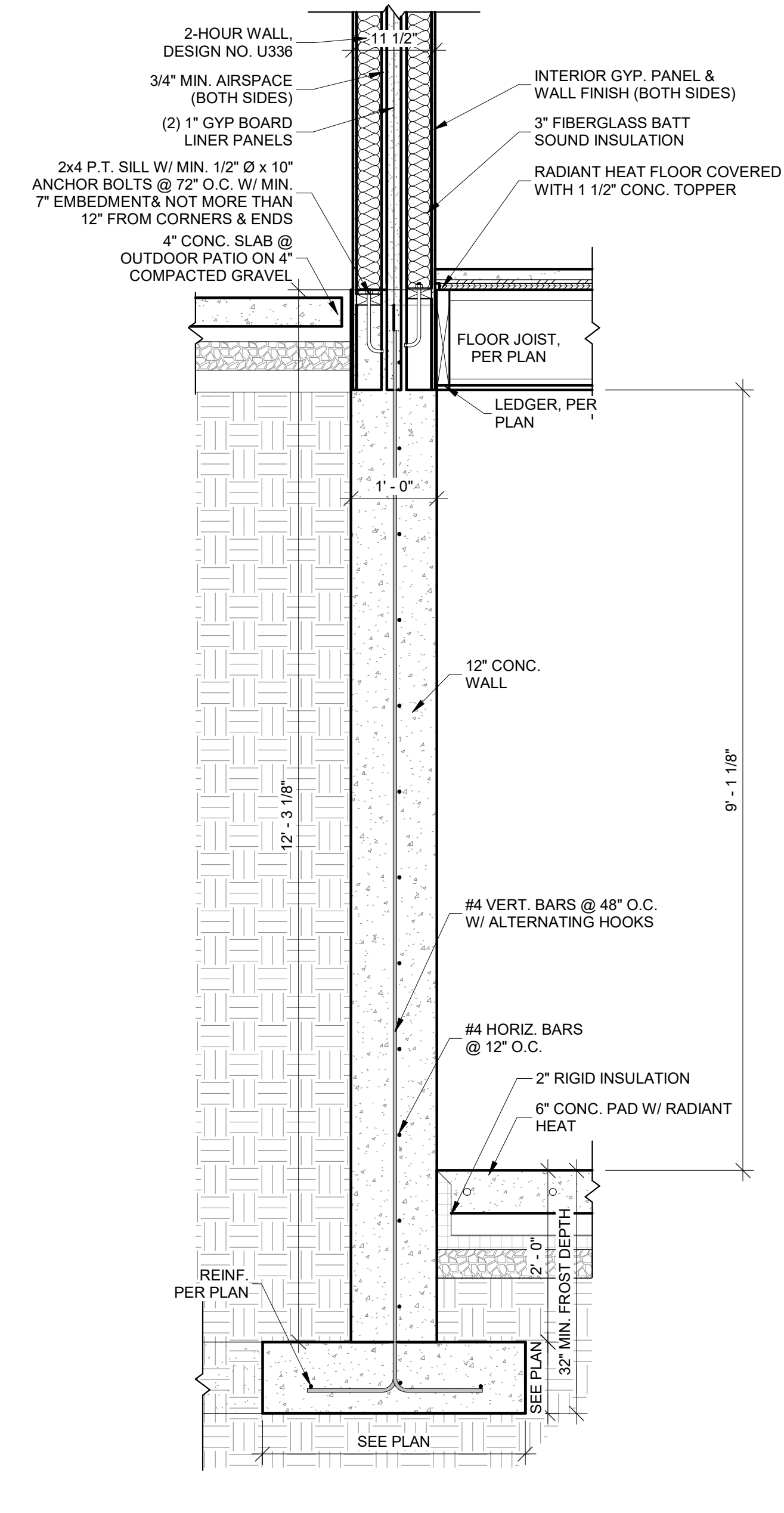

3 RETAINING WALL 3  
SD1.1 3/4" = 1'-0"

REV	DATE	DESCRIPTION
BY		
RO		ISSUED FOR APPROVAL
		CONSTRUCTION

LIFT VIEW TOWNHOMES  
310 GEORGIA RD  
FRAMING DETAILS  
KETCHUM IDAHO



DATE:	03/11/26
SCALE:	AS NOTED
DESIGN BY:	TSH
DESIGN REVIEW:	TSH
STRUCTURE BY:	???
STRUCTURE REVIEW:	VAL
JOB NO.:	2025-17046

DESIGN REV. 6

SHEET SD2.0

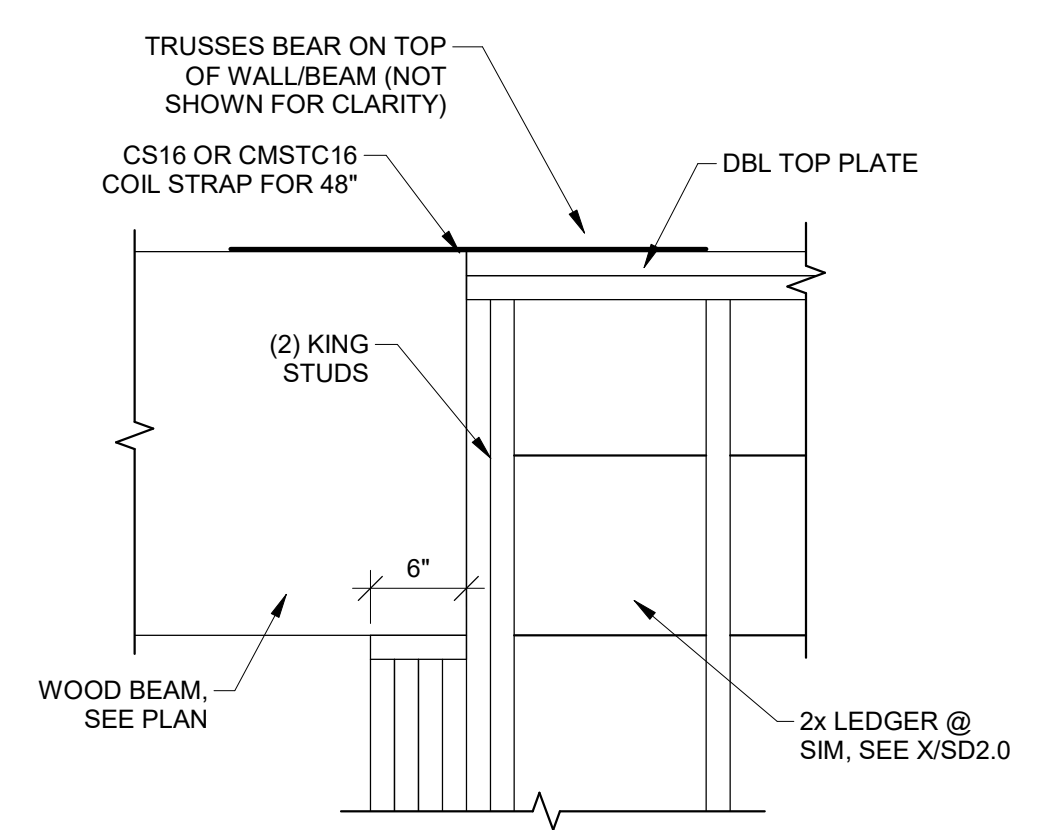

**1** BEAM BEARING DETAIL  
SD2.0 1" = 1'-0"

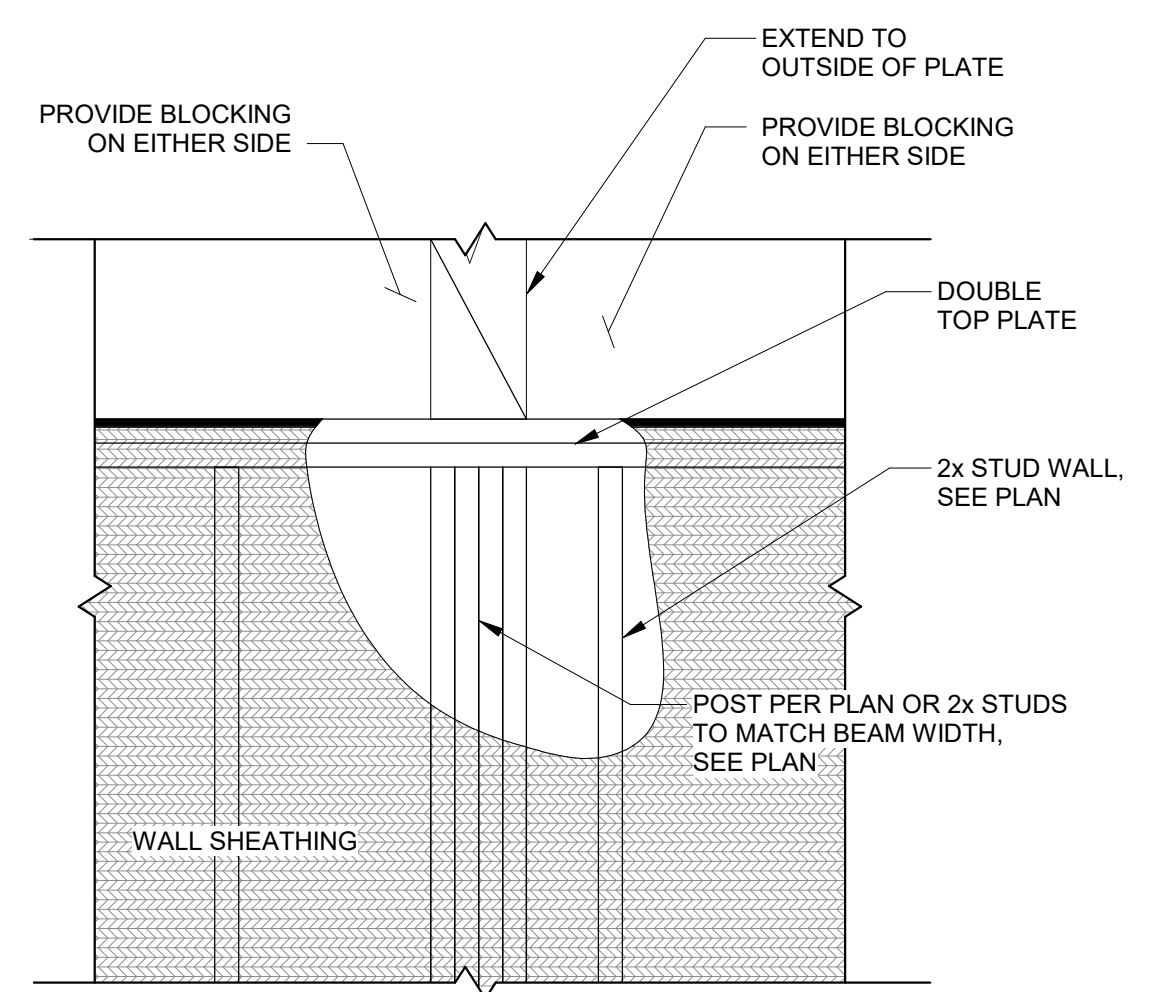

**2** BEAM BEARING DETAIL  
SD2.0 1" = 1'-0"

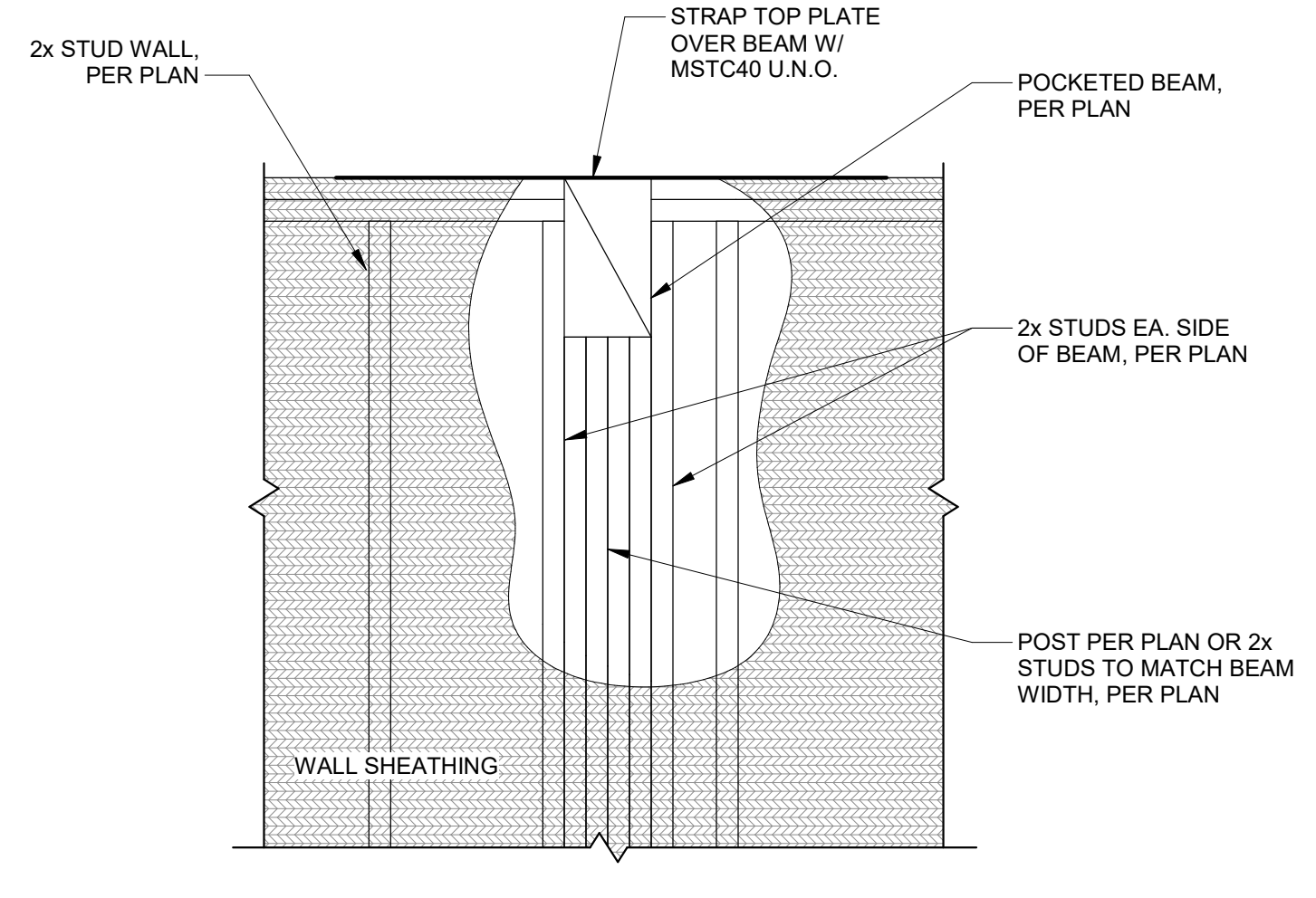

**3** POKETED BEAM DETAIL  
SD2.0 1" = 1'-0"

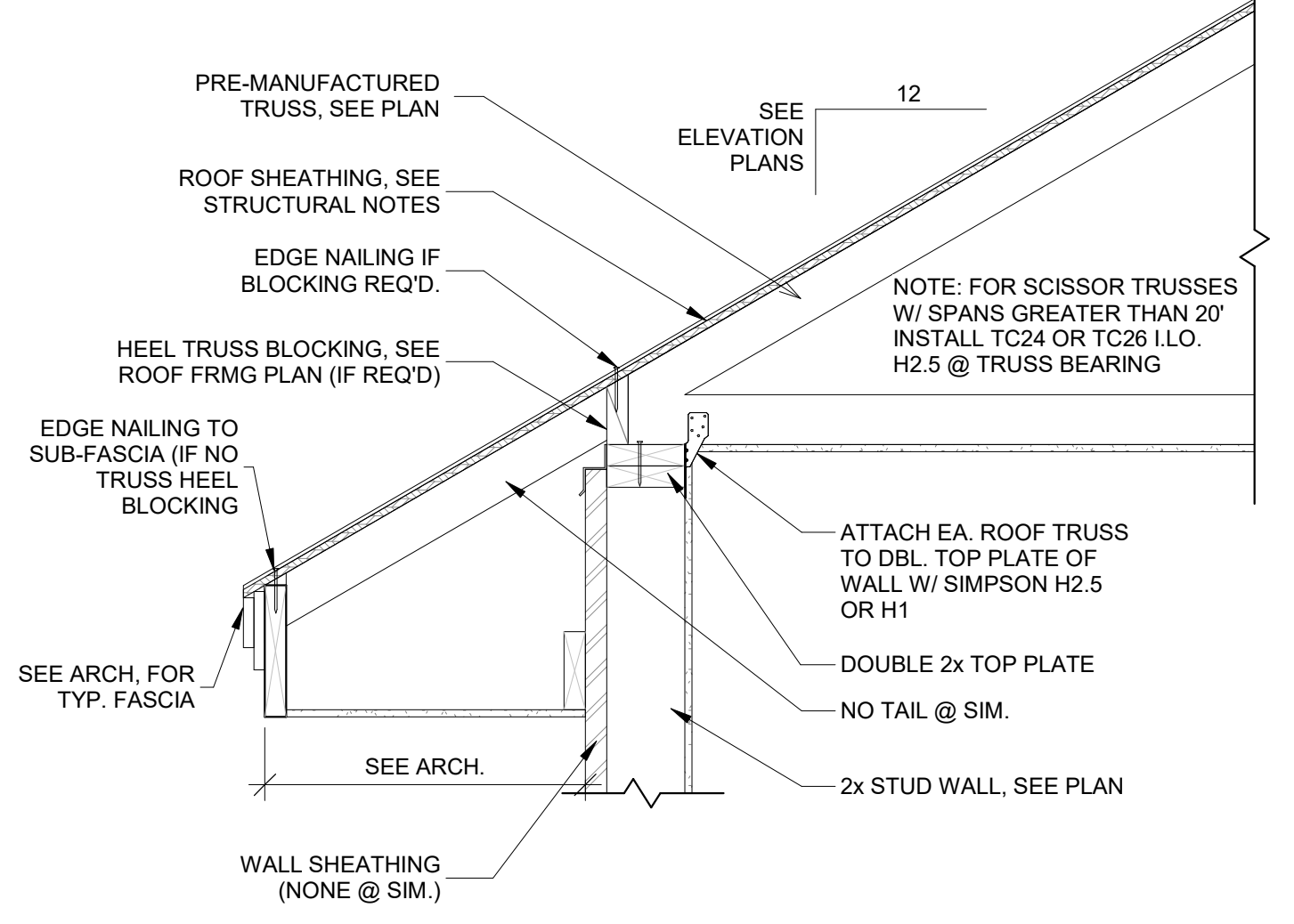

**4** TYP. TRUSS BEARING  
SD2.0 1" = 1'-0"

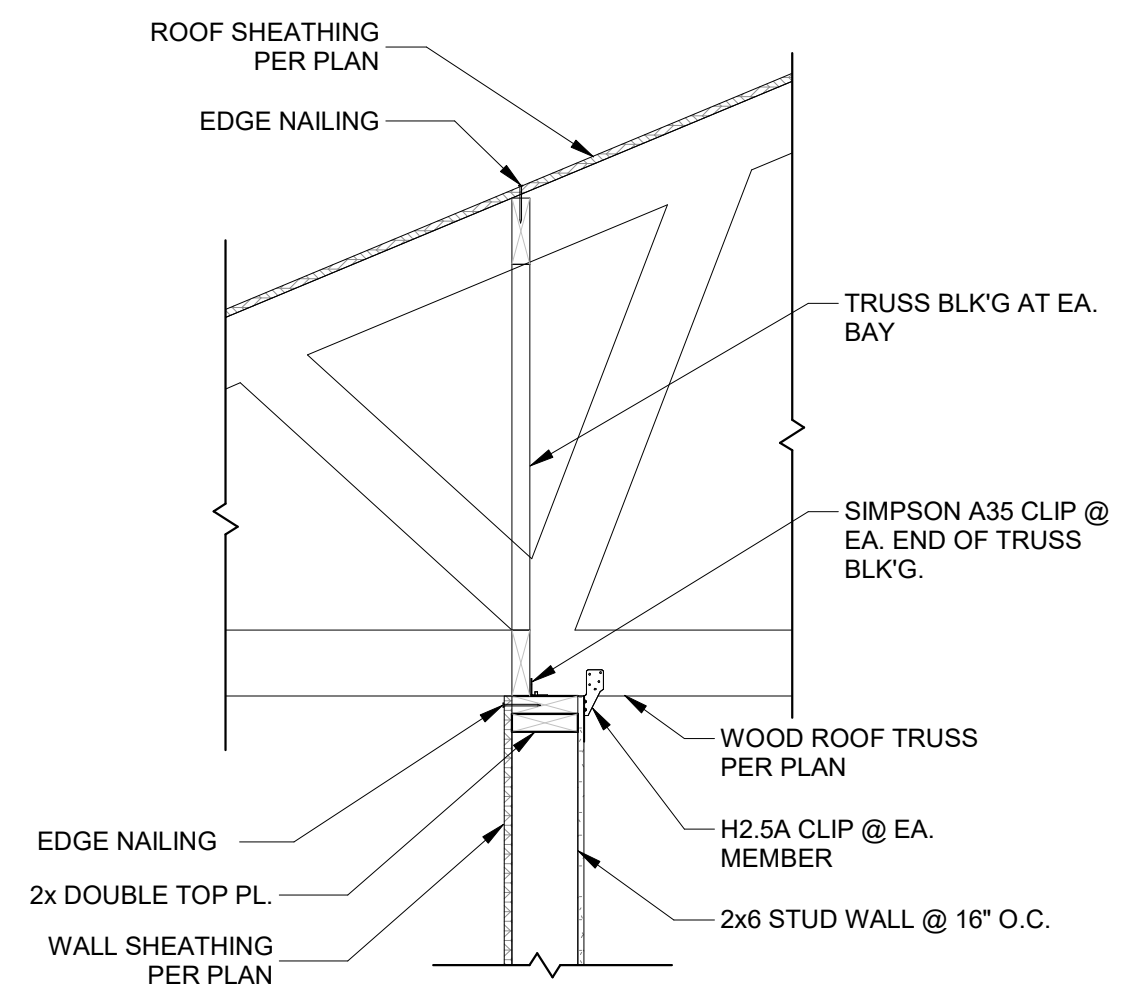

**5** ROOF FRAMING OVER SHEARWALL  
SD2.0 3/4" = 1'-0"

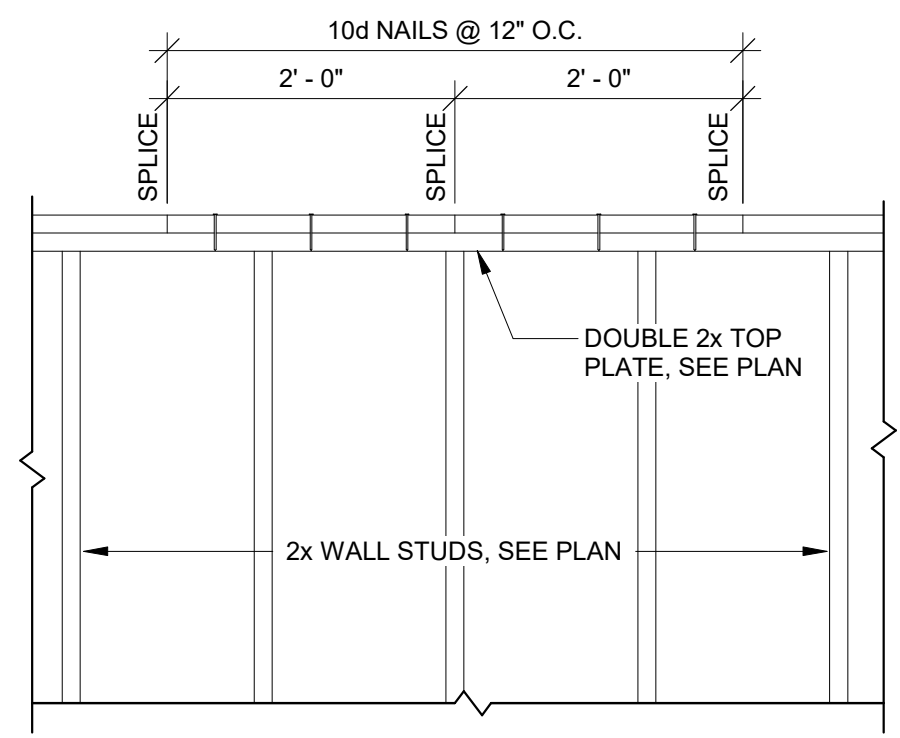

**6** WALL TOP PLATE SLICE DETAIL  
SD2.0 3/4" = 1'-0"

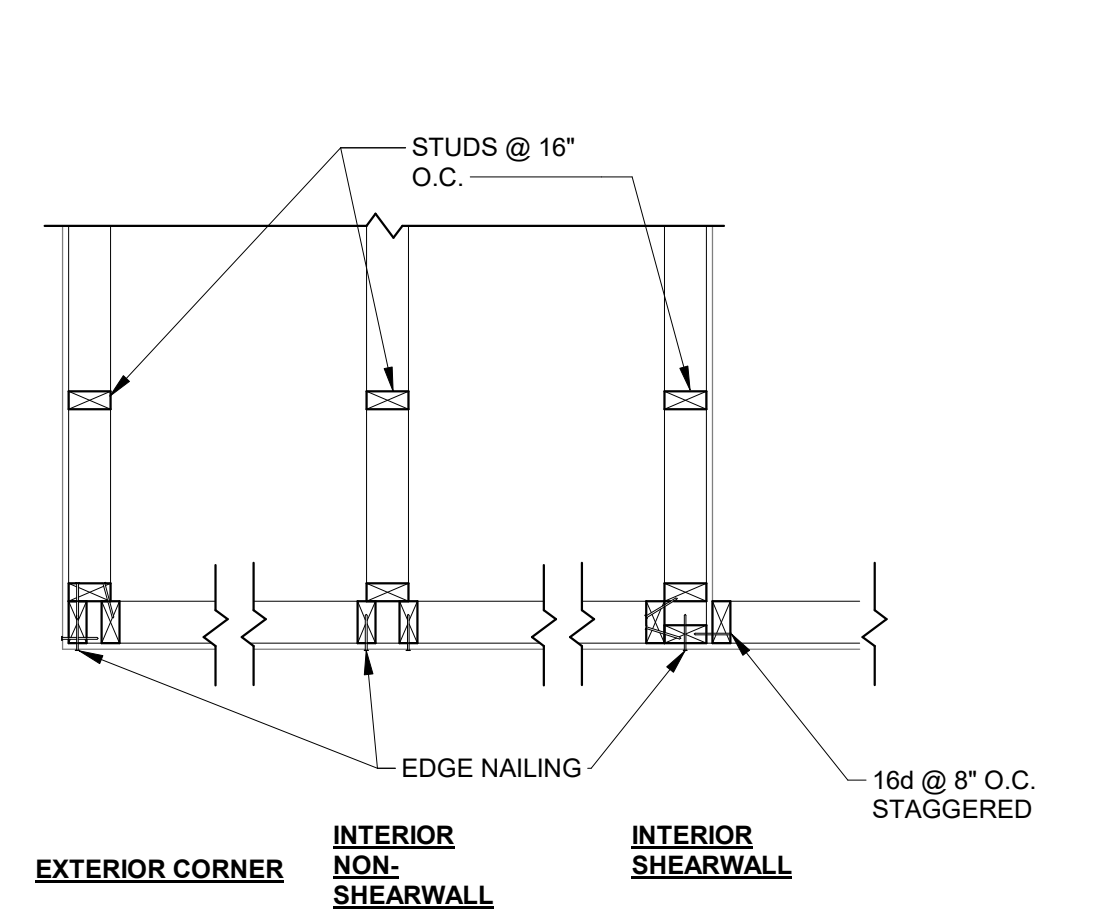

**7** STUD WALL INTERSECTIONS  
SD2.0 3/4" = 1'-0"

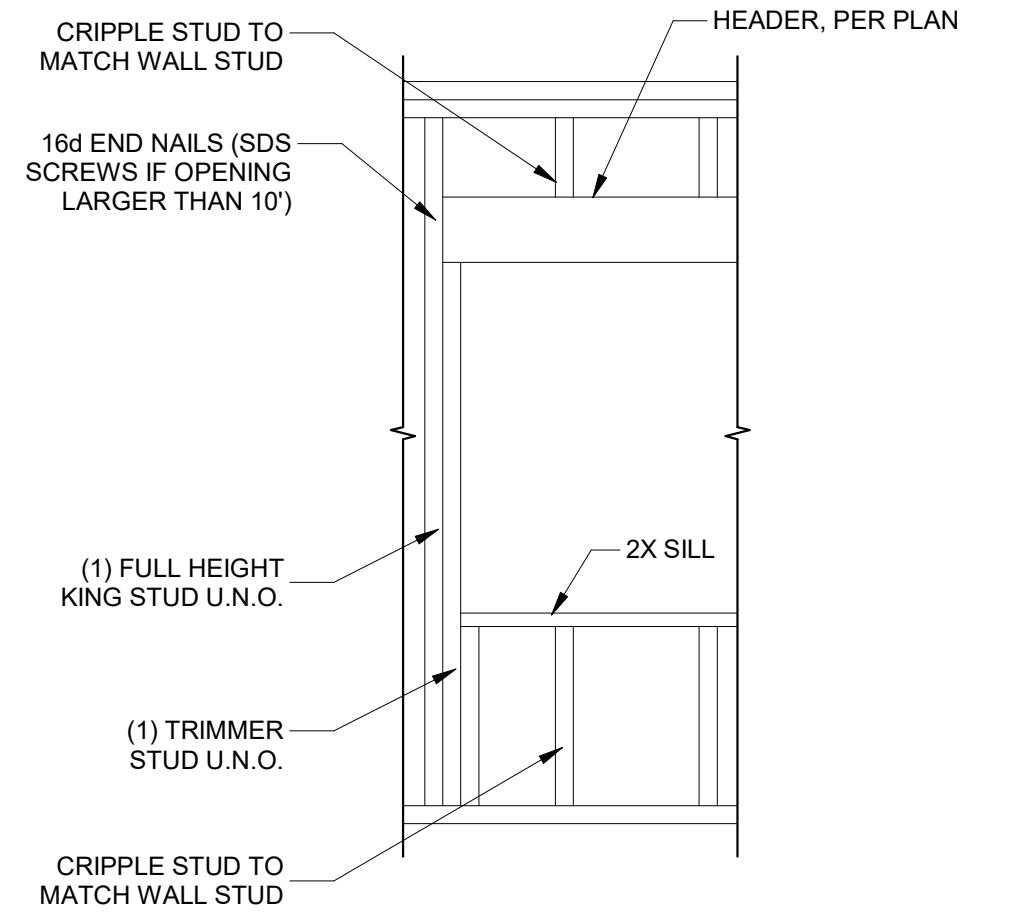

**8** TYPICAL HEADER DETAIL  
SD2.0 3/4" = 1'-0"

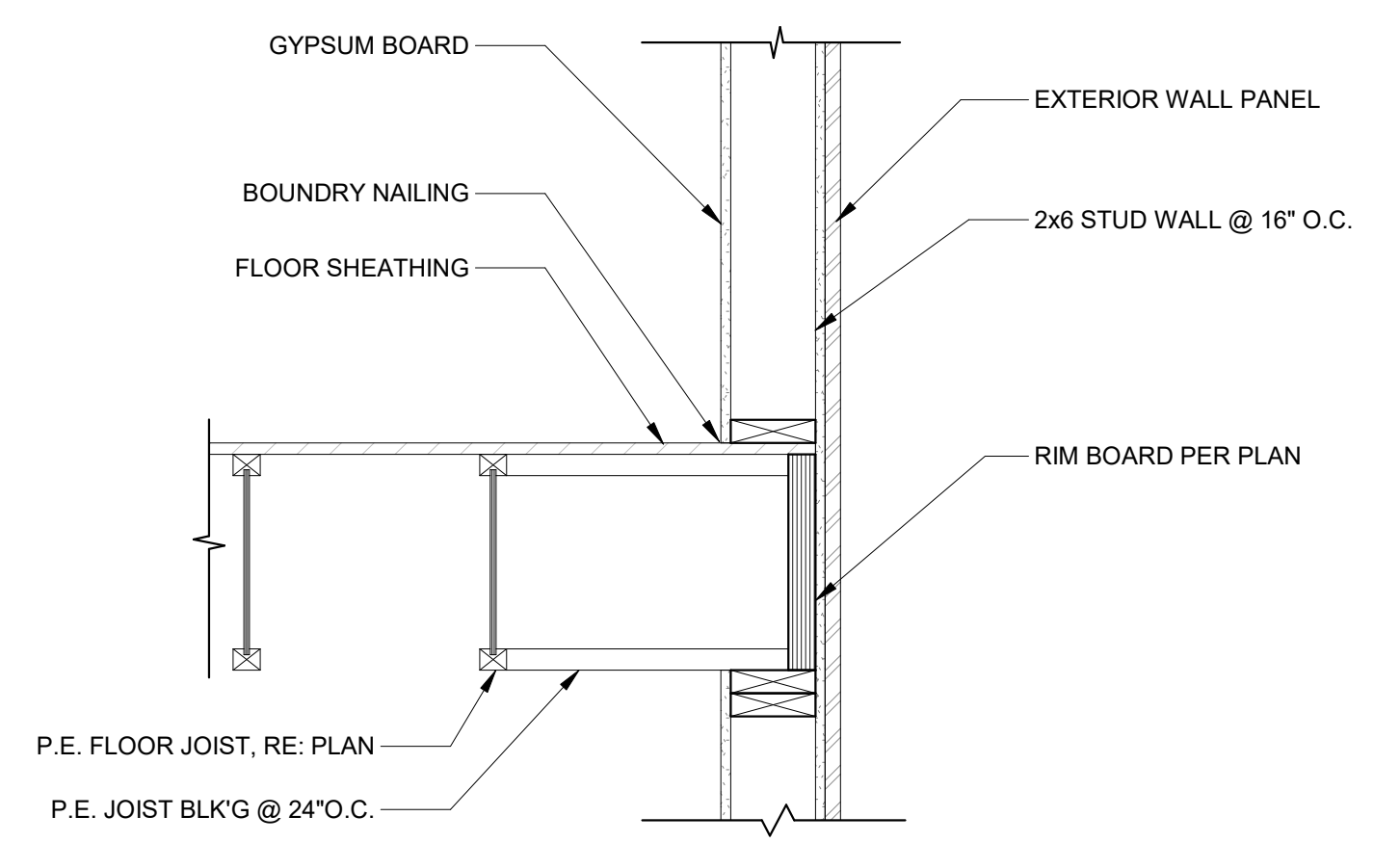

**9** UPPER JOIST BEARING  
SD2.0 1" = 1'-0"

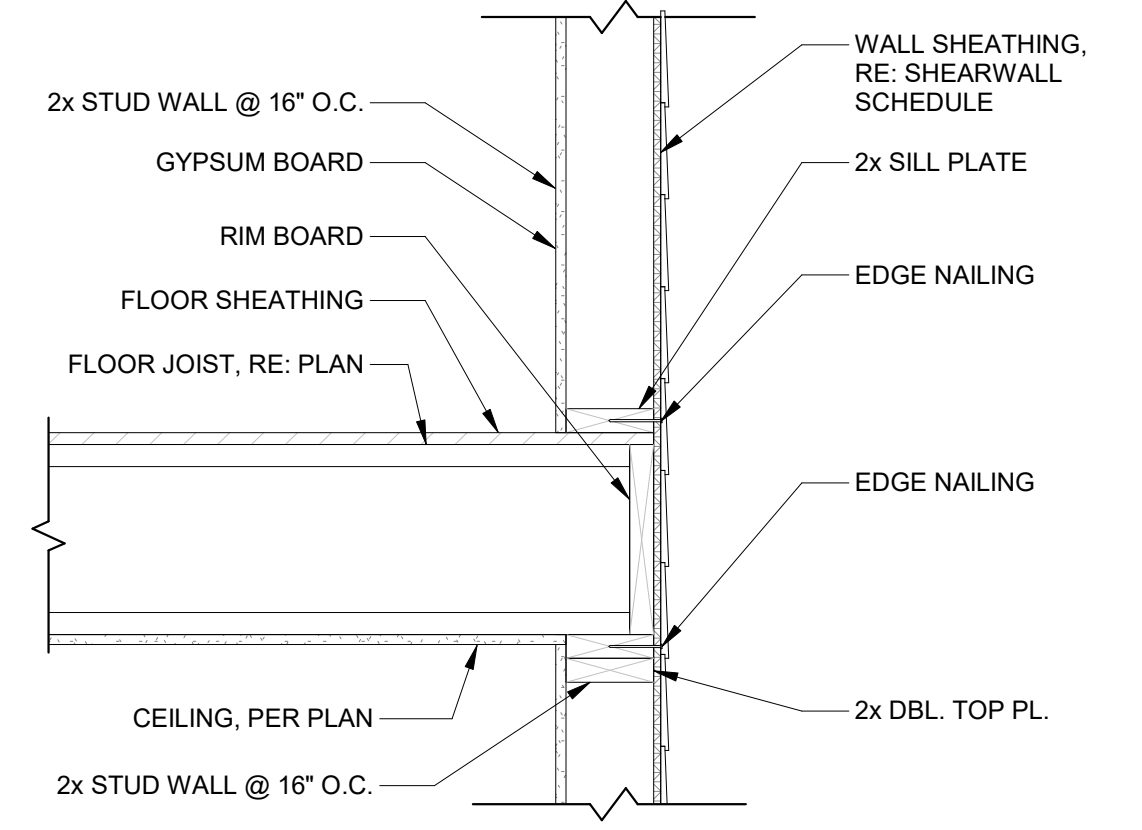

**10** FLOOR JOIST TO WALL DETAIL  
SD2.0 1" = 1'-0"

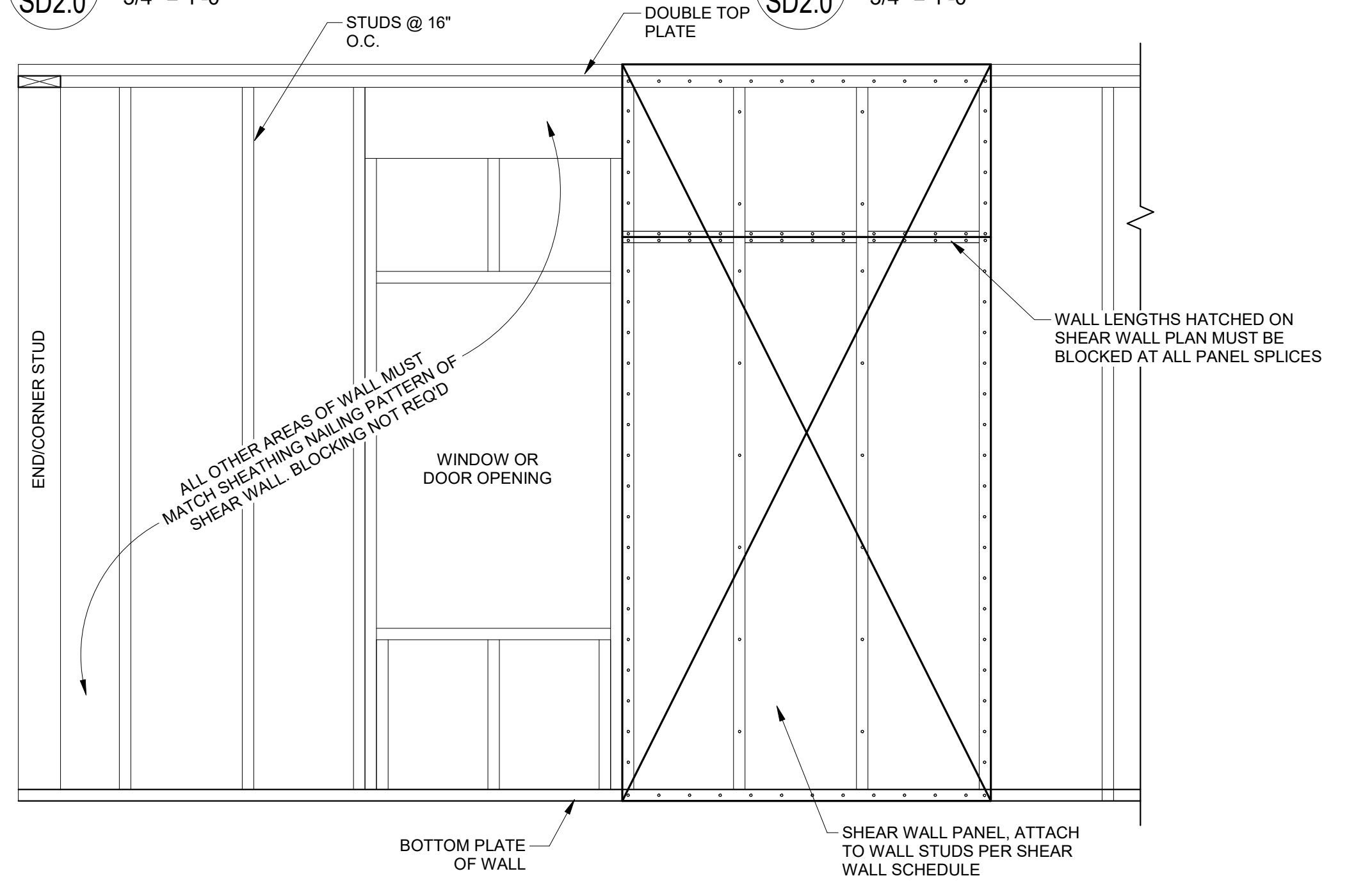

**11** SHEAR WALL DETAIL  
SD2.0 3/4" = 1'-0"

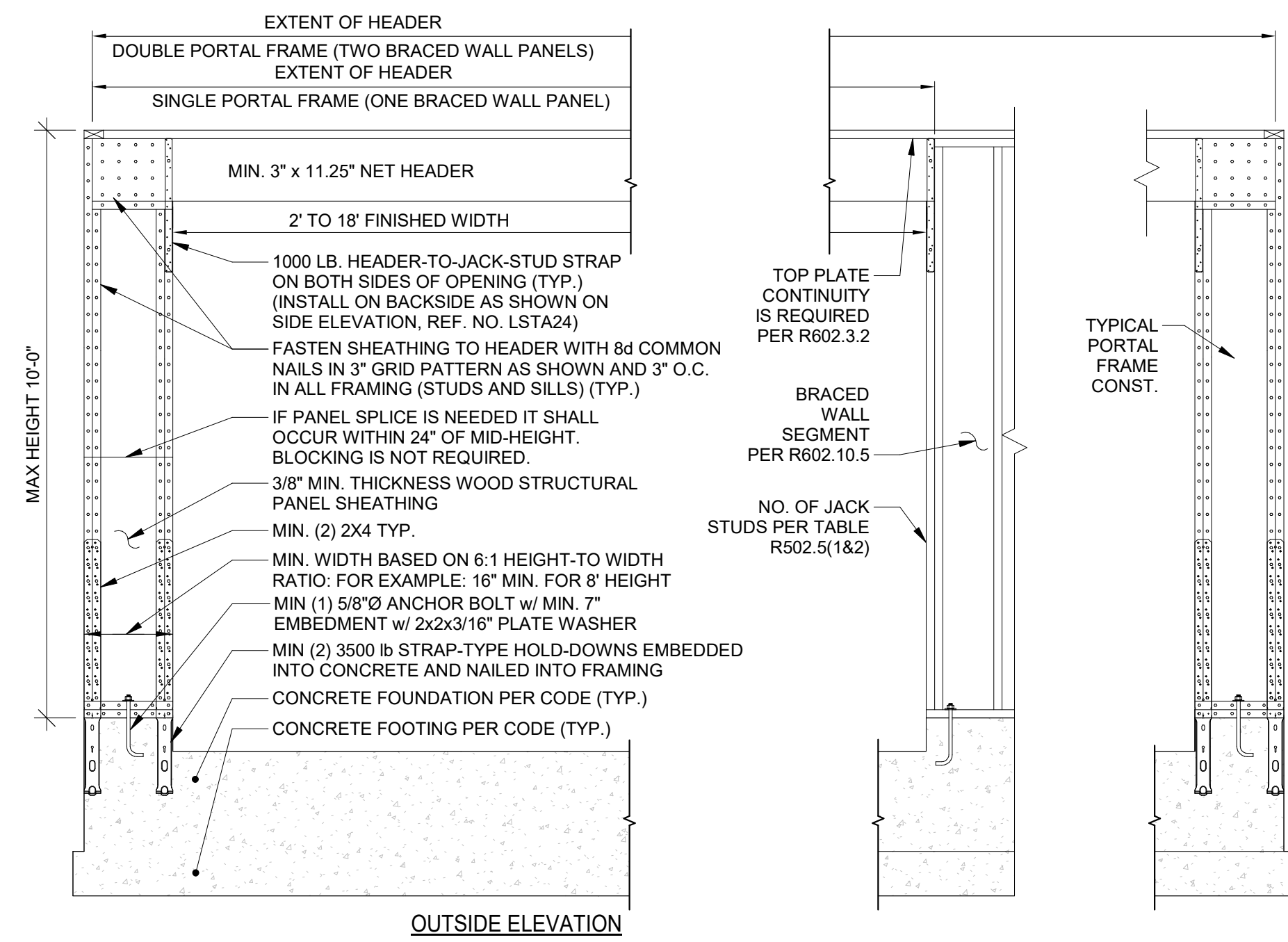

1 APA PORTAL FRAME DETAIL  
SD2.1 1/2" = 1'-0"

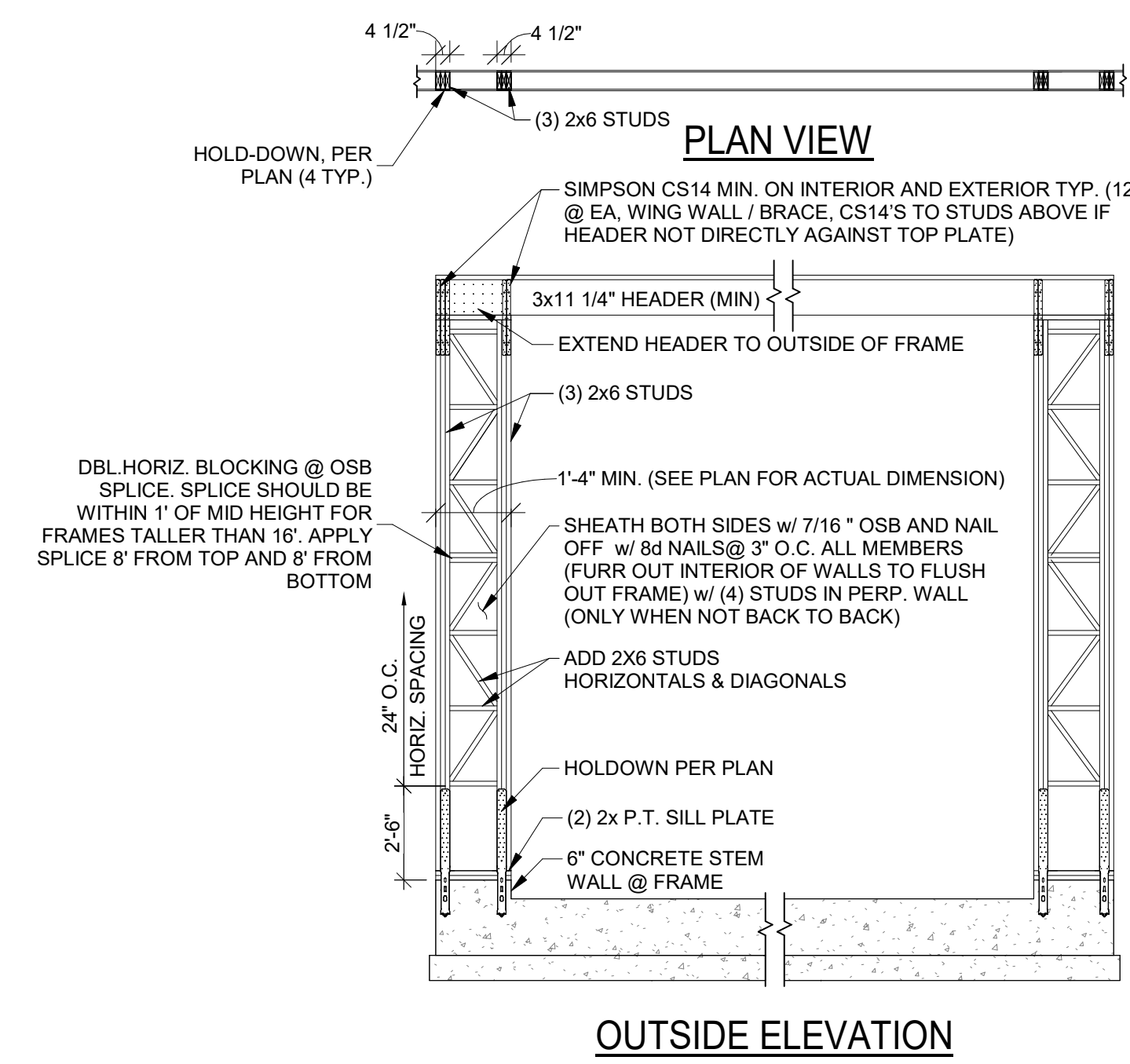

2 TRUSS BRACED FRAME DETAIL  
SD2.1 1/4" = 1'-0"

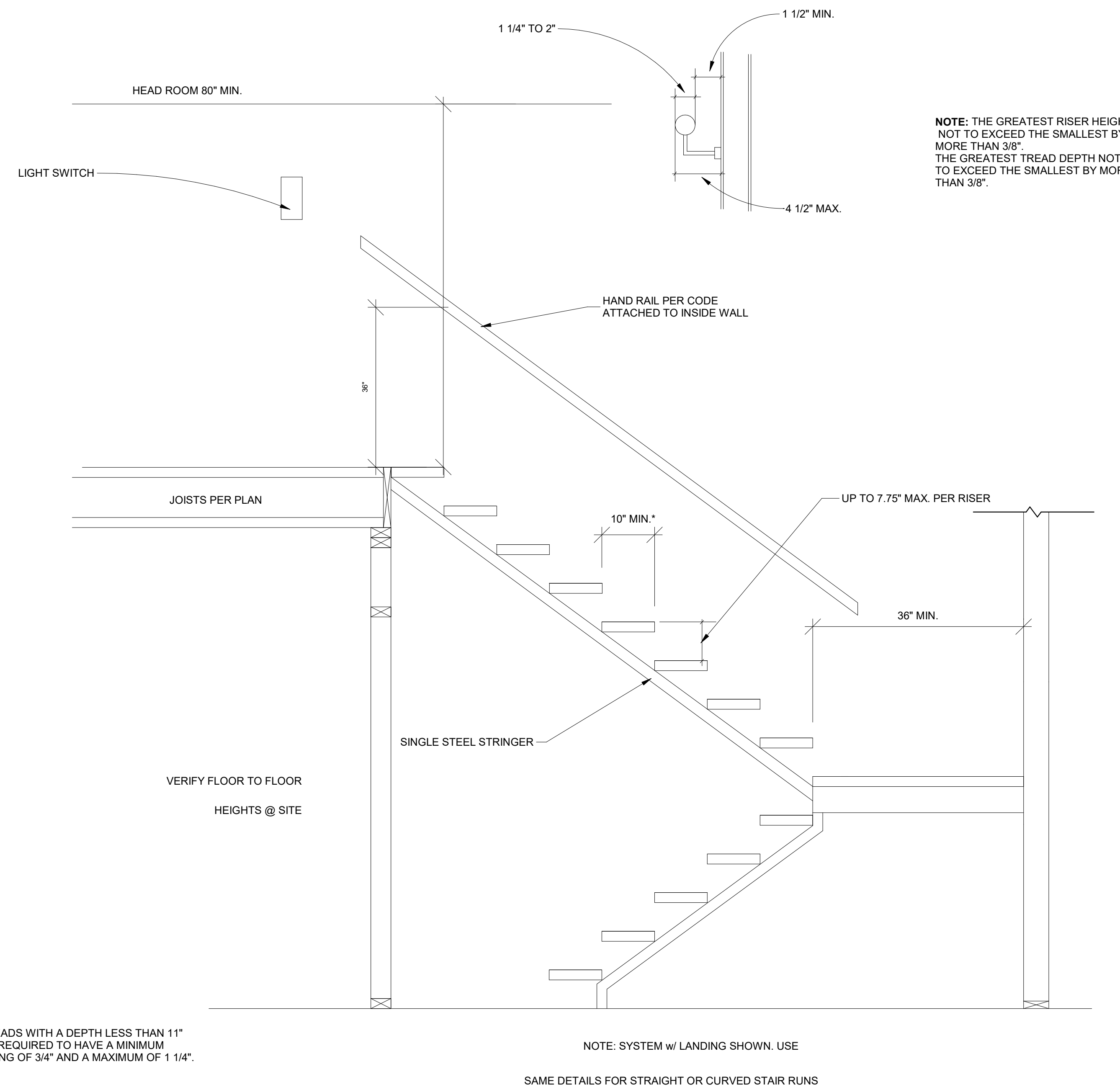

4 STAIR DETAIL  
SD2.1 3/4" = 1'-0"

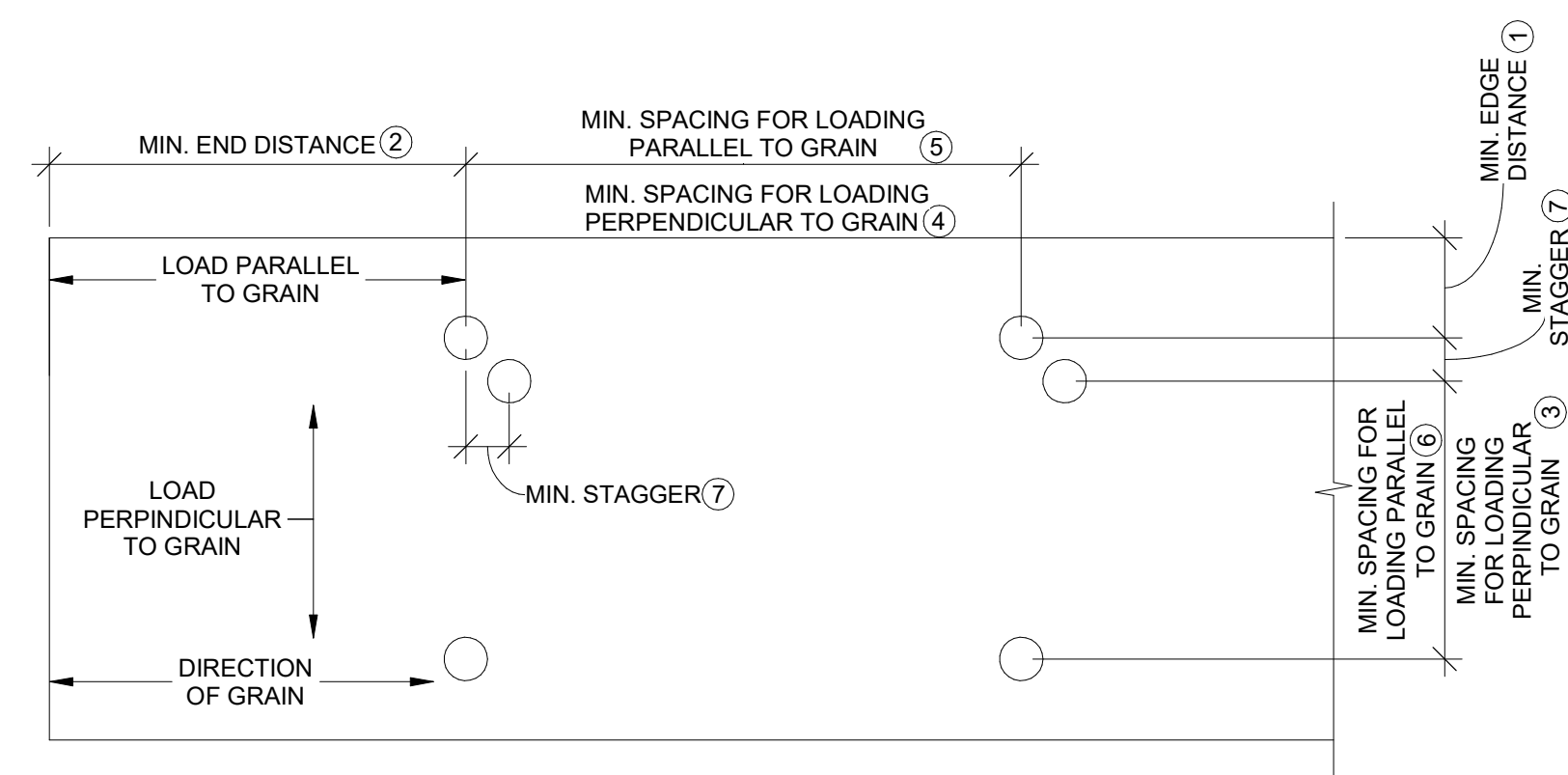

SDWS TIMBER SCREW SPACING REQUIREMENTS			
CONDITION	DIRECTION OF LOAD TO GRAIN	ID#	MIN. DISTANCE OR SPACING (INCHES)
EDGE DISTANCE	PERPENDICULAR	①	1 7/16
	PARALLEL	①	1 7/16
END DISTANCE	PERPENDICULAR	②	6
	PARALLEL	②	6
SPACING BETWEEN FASTENERS IN A ROW	PERPENDICULAR	③	4
	PARALLEL	④	8
SPACING BETWEEN ROWS OF FASTENERS	PERPENDICULAR	⑤	4
	PARALLEL	⑥	4
SPACE BETWEEN STAGGERED ROWS	PERPENDICULAR OR PARALLEL	⑦	5/8

1. FOR AXIAL LOADING ONLY. USE THE FOLLOWING MINIMUM DIMENSIONS: END DISTANCE = 3 1/4", EDGE DISTANCE = 1 3/8", SPACING PARALLEL TO GRAIN = 2 1/4", SPACING PERPENDICULAR TO GRAIN = 1 3/8".

3 SDWS TIMBER SCREW SPACING REQUIREMENTS  
SD2.1 3/4" = 1'-0"

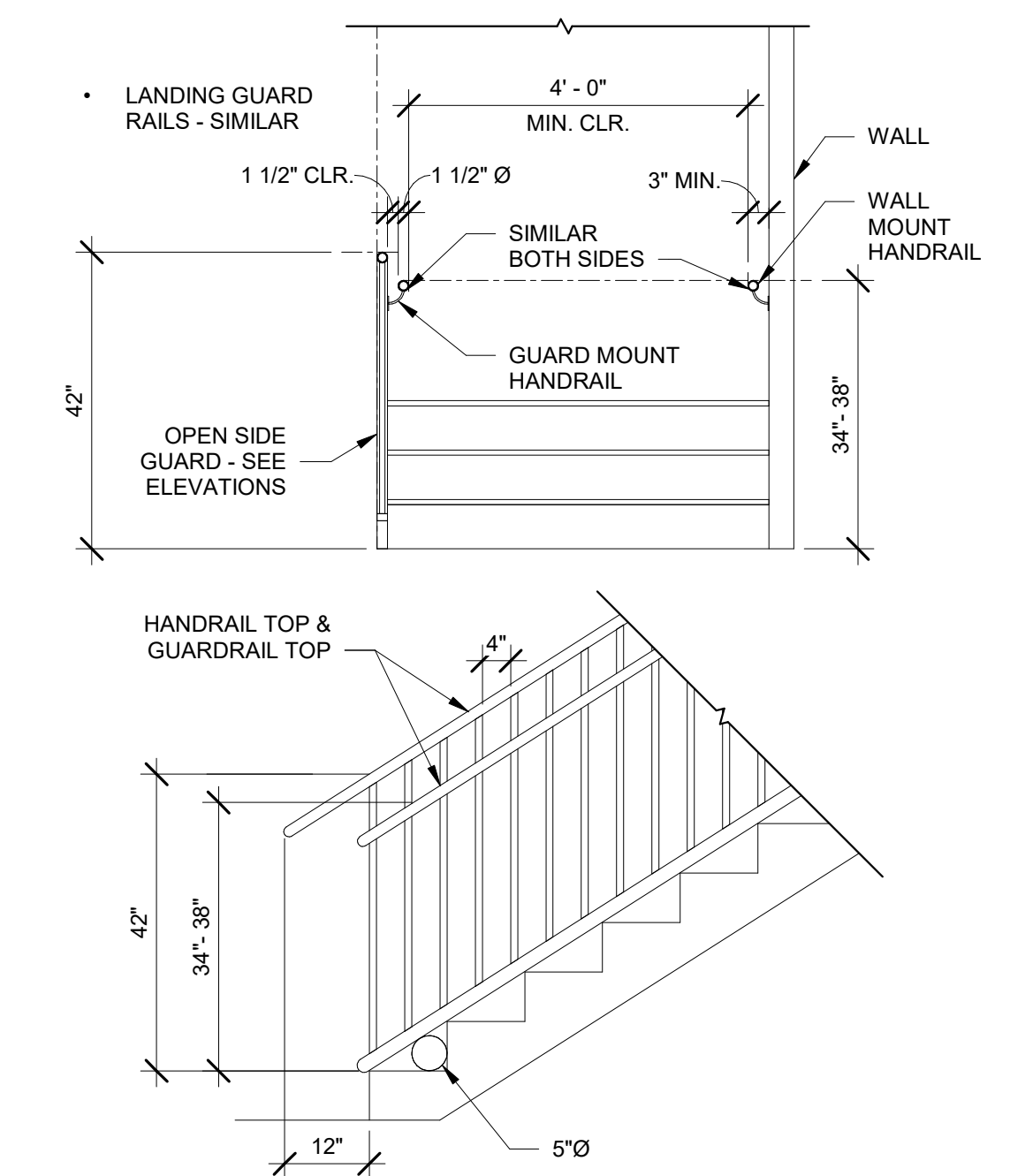

5 STAIR RAIL AND GUARD  
SD2.1 1/2" = 1'-0"

THIS PLAN FOR BASIS OF IDEAS IS THE PROPERTY OF PERFORMANCE ENGINEERS. ANY FORM OF DUPLICATING OR USE OF ALL OR ANY PARTS, DRAWINGS AND DESIGNS IS PROHIBITED. © COPYRIGHT 2025



An InteFrame Company

1102 N. FRANKLIN BLVD.  
NAMPA, IDAHO 83687  
PH. (208) 475-0040

REV	DATE	DESCRIPTION	BY

LIFT VIEW TOWNHOMES  
310 GEORGIA RD  
FRAMING DETAILS  
KETCHUM  
IDAHO

DATE: 03/31/26  
SCALE: AS NOTED  
DESIGN BY: TSH  
DESIGN REVIEW: TSH  
STRUCTURE BY: ???  
STRUCTURE REVIEW: VAL  
JOB NO.: 2025-17046

DESIGN REV. 6  
SHEET  
SD2.1

© COPYRIGHT 2025

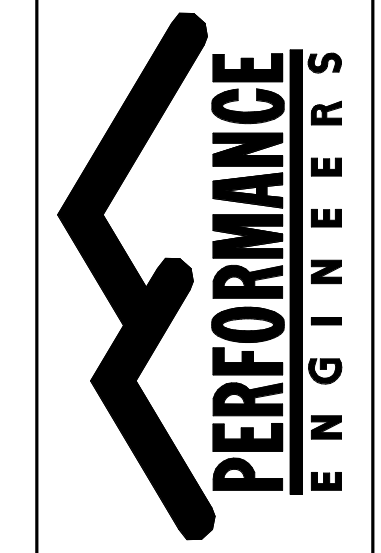

An InteFrame Company

1102 N. FRANKLIN BLVD.  
NAMPA, IDAHO 83687  
PH. (208) 475-0040

REV	DATE	DESCRIPTION

LIFT VIEW TOWNHOMES  
310 GEORGIA RD  
FIREWALL AND FRAMING DETAILS  
IDAHO  
KETCHUM

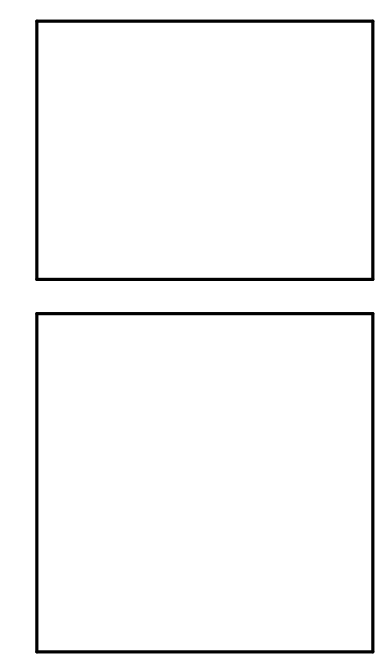

DATE:	03/11/26
SCALE:	AS NOTED
DESIGN BY:	TSH
DESIGN REVIEW:	TSH
STRUCTURE BY:	???
STRUCTURE REVIEW:	VAL
JOB NO.:	2025-17046

DESIGN REV. 6

SHEET  
SD3.0

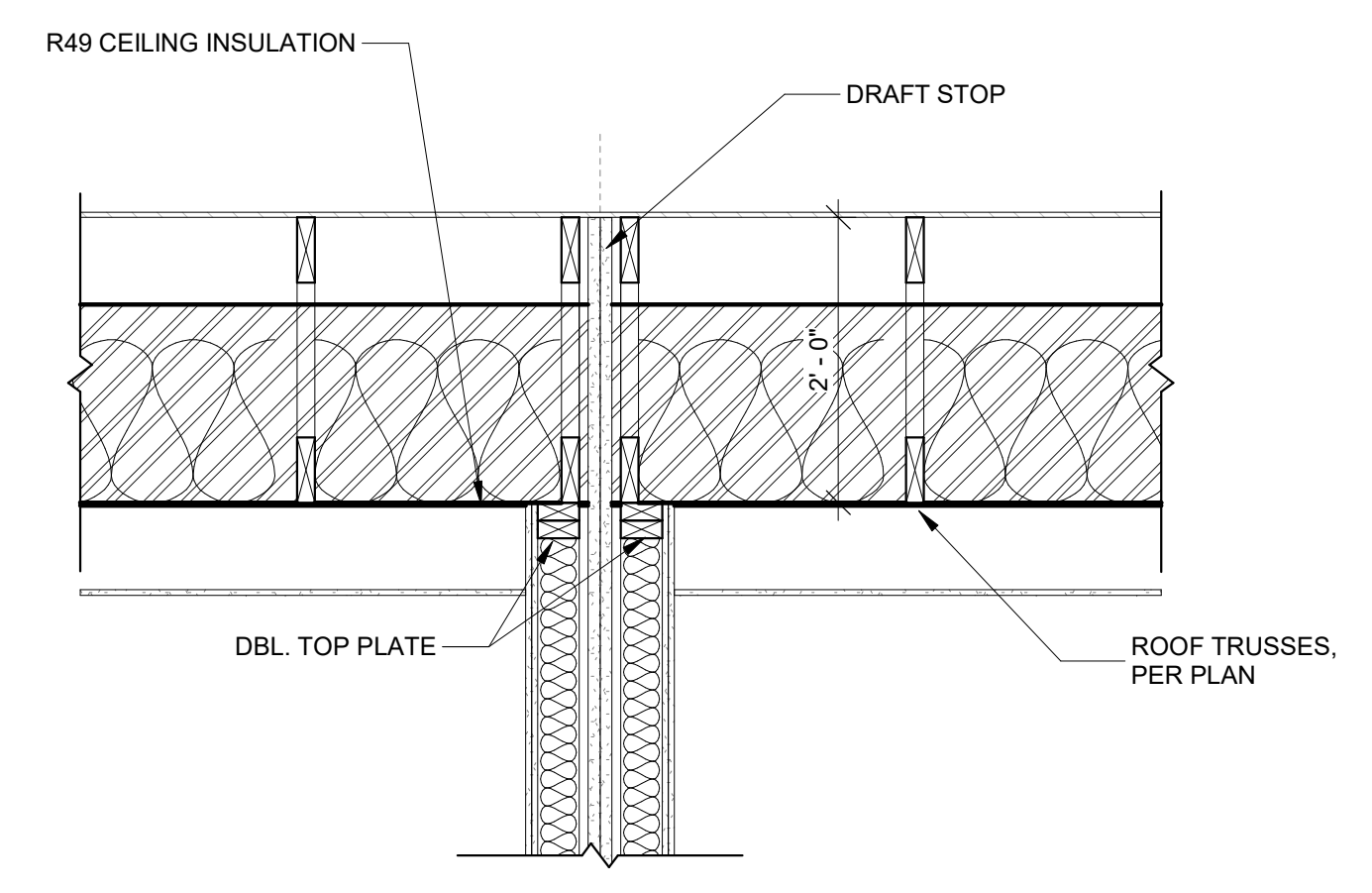

**3** FIREWALL @ ROOF DETAIL  
SD3.0 3/4" = 1'-0"

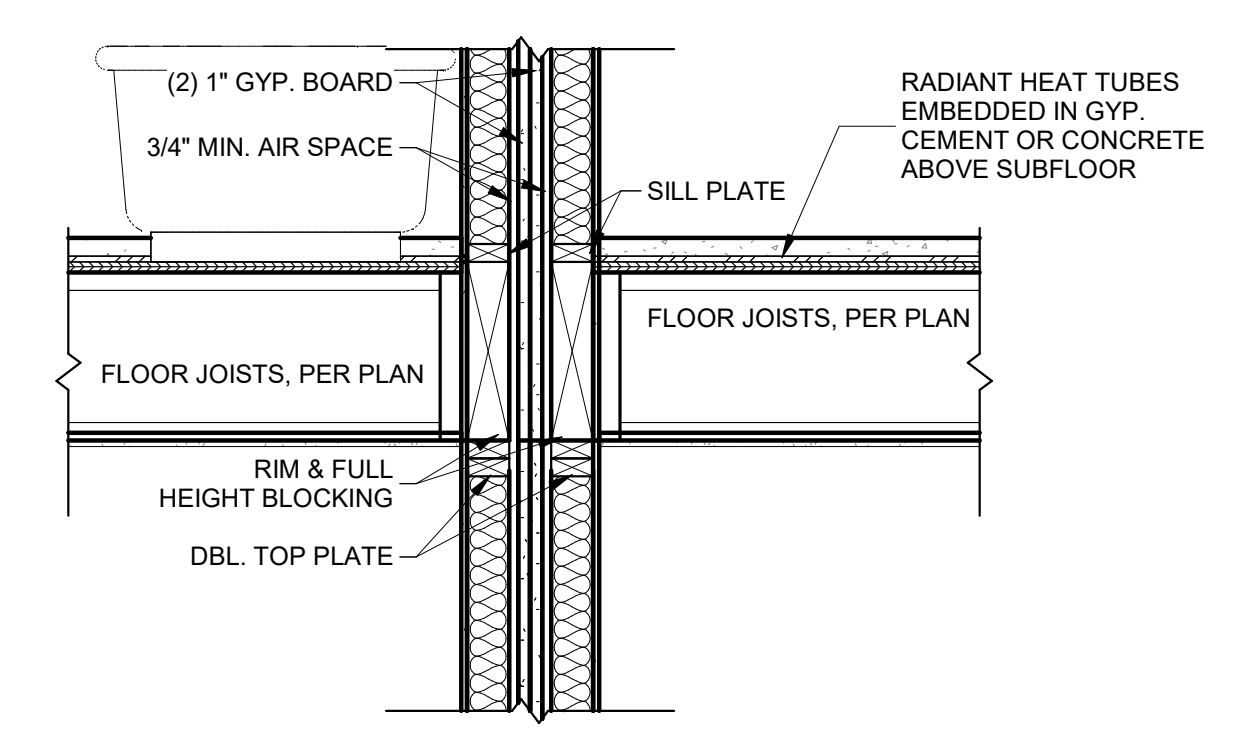

**2** FLOOR FRAMING CONNECTION DETAIL  
SD3.0 3/4" = 1'-0"

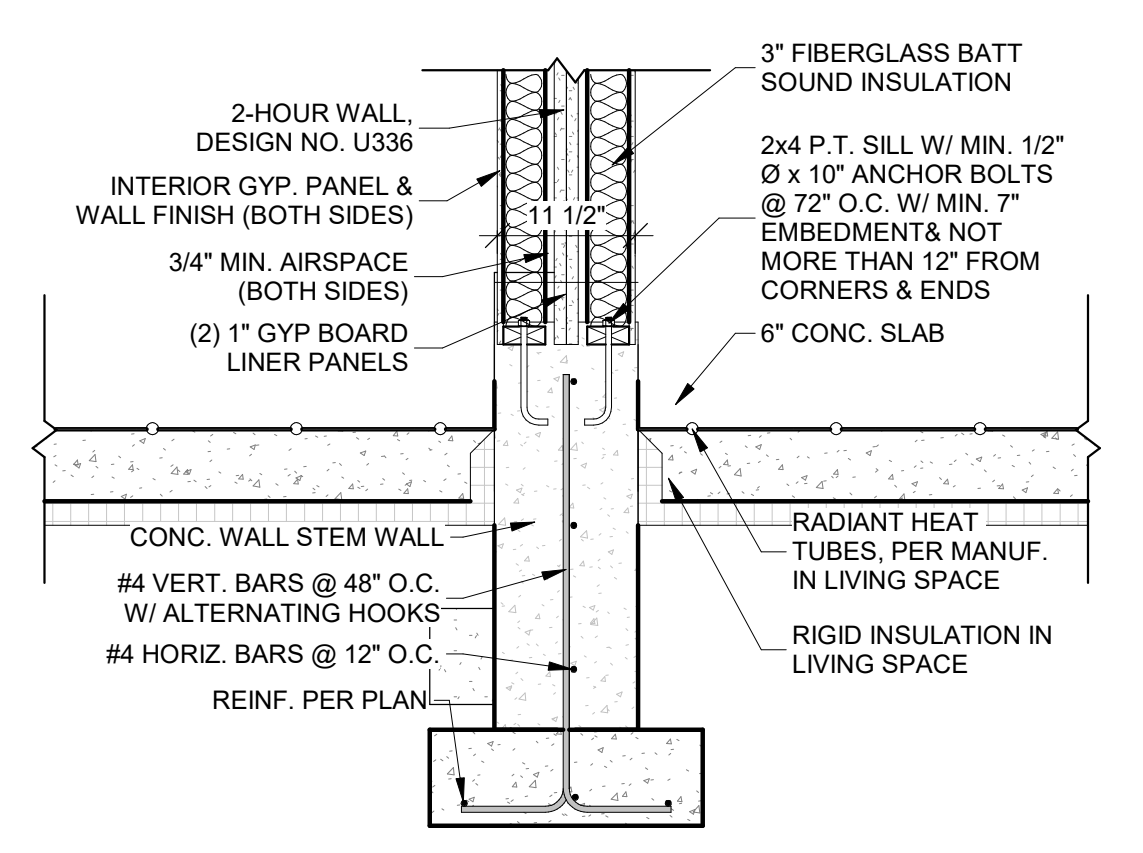

**1** FOUNDATION @ FIREWALL DETAIL  
SD3.0 3/4" = 1'-0"

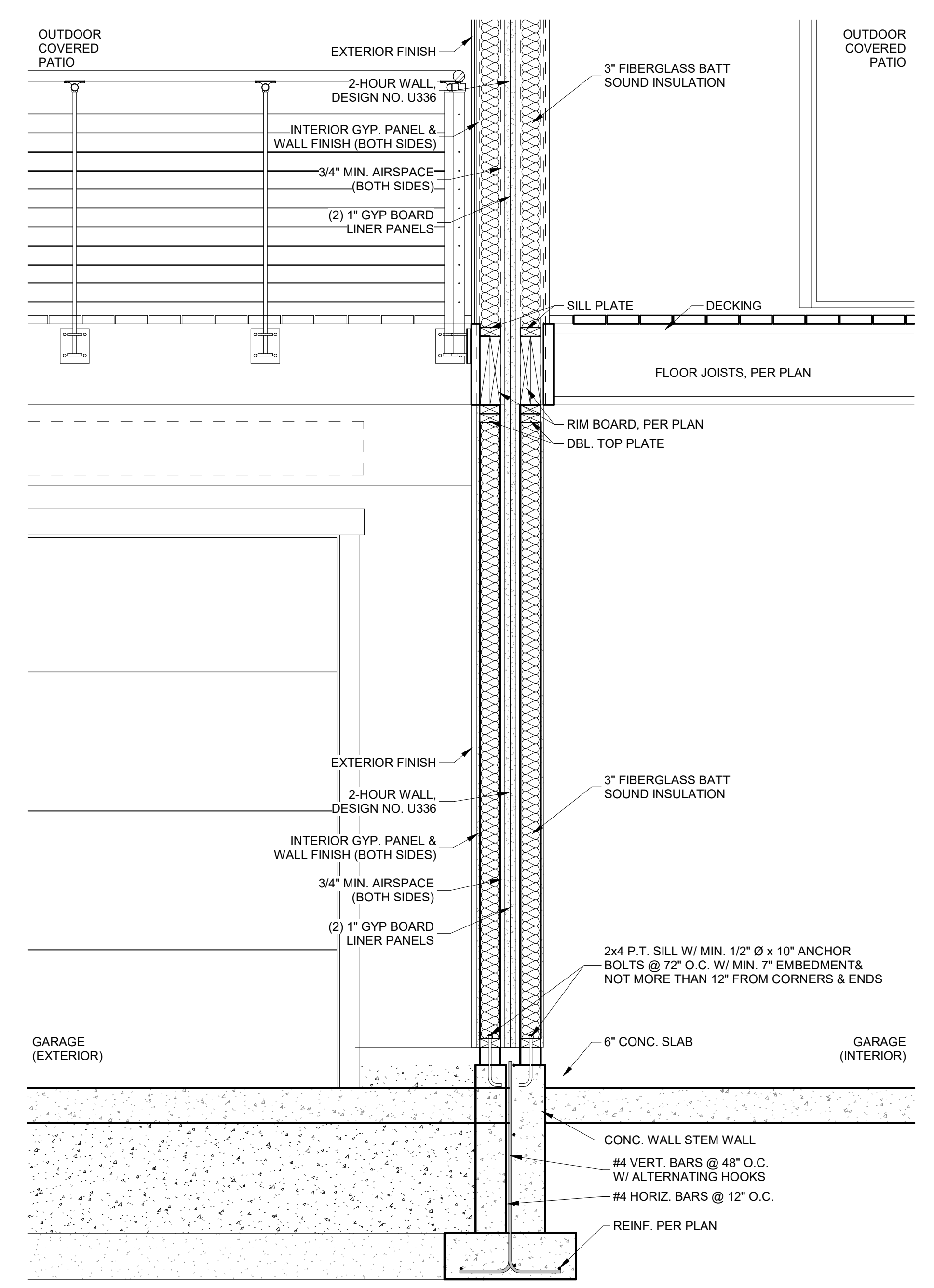

**4** Section 4  
SD3.0 3/4" = 1'-0"



An InteFrame Company

1102 N. FRANKLIN BLVD.  
NAMPA, IDAHO 83687  
PH. (208) 475-0040

REV	DATE	DESCRIPTION	BY

LIFT VIEW TOWNHOMES  
310 GEORGIA RD  
FIREWALL INFORMATION  
KETCHUM IDAHO

**DESIGN NO. UL U336**

FIRE RATING: 2 HOURS  
STC RATING: 66  
SOUND TEST: RAL-TL20-180  
SYSTEM THICKNESS: 11-1/2" [292 MM]  
LOCATION: INTERIOR  
FRAMING TYPE: WOOD STUD (LOAD-BEARING)

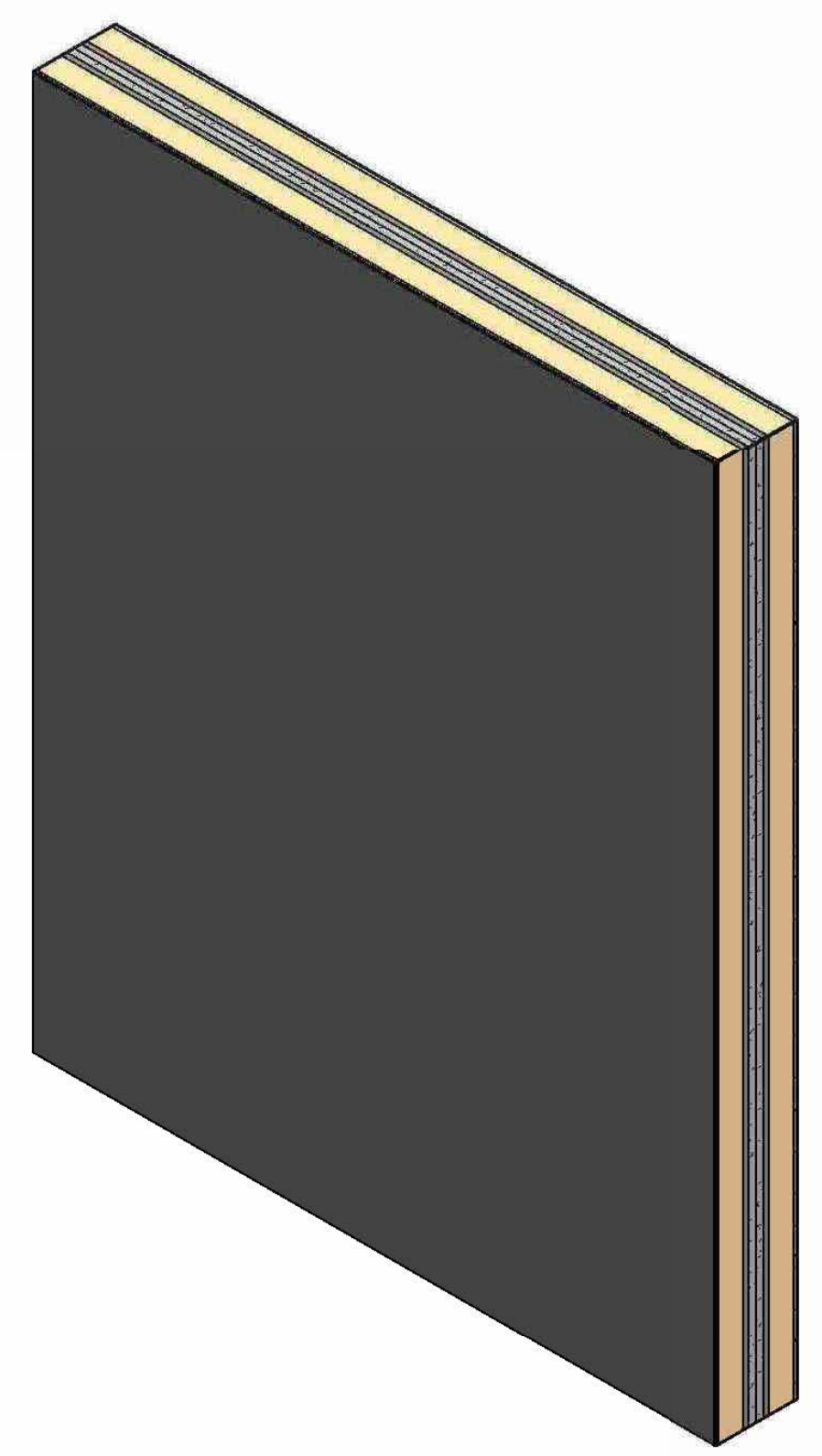
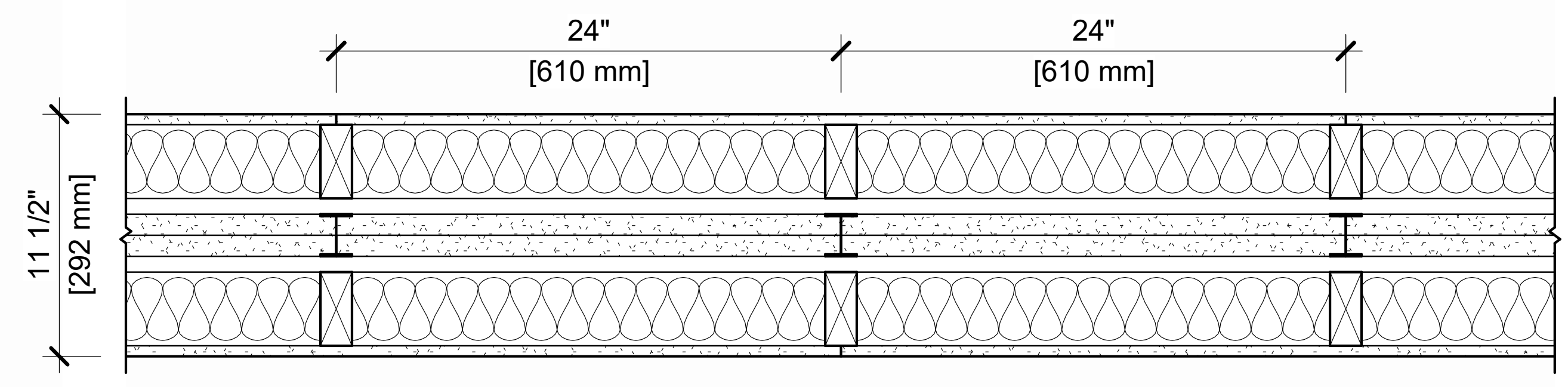

**ASSEMBLY REQUIREMENTS:**

GYPSUM PANELS: ONE LAYER 1/2" [12.7 MM] SHEETROCK® ULTRALIGHT GYPSUM PANEL  
WOOD STUDS: 2" X 4" [38 X 89 MM] WOOD STUDS, 24" [610 MM] O.C.  
INSULATION: 3" [76 MM] FIBERGLASS INSULATION  
AIR SPACE: 3/4" [19 MM] AIR SPACE  
STEEL STUDS: 2" [51 MM] H-STUDS, 24" [610 MM] O.C.  
GYPSUM PANELS: TWO LAYERS 1" [25.4 MM] SHEETROCK® GYPSUM LINER PANELS (UL TYPE SLX)  
AIR SPACE: 3/4" [19 MM] AIR SPACE  
WOOD STUDS: 2" X 4" [38 X 89 MM] WOOD STUDS, 24" [610 MM] O.C.  
INSULATION: 3" [76 MM] FIBERGLASS INSULATION  
GYPSUM PANELS: ONE LAYER 1/2" [12.7 MM] SHEETROCK® ULTRALIGHT GYPSUM PANEL

**GENERAL WALL NOTES:**

- REFER TO APPLICABLE CODES REQUIREMENTS TO ENSURE COMPLIANCE PRIOR TO CONSTRUCTION.
- FOR THE MOST UP-TO-DATE DETAILS, INCLUDING CONSTRUCTION VARIATIONS, REFER TO THE PUBLISHED DESIGN.
- WHERE DESIGN NO. INDICATES "PER", THE FIRE RATING IS BASED ON LABORATORY TEST DATA OF THE REFERENCED SIMILARLY CONSTRUCTED ASSEMBLIES.
- STUD SIZES AND INSULATION THICKNESS ARE MINIMUM UNLESS OTHERWISE STATED IN THE PUBLISHED ASSEMBLY.
- STUD AND FASTENER SPACINGS ARE MAXIMUM UNLESS OTHERWISE STATED IN THE PUBLISHED ASSEMBLY.
- PANEL ORIENTATION SHALL BE AS SPECIFIED IN THE PUBLISHED DESIGN.
- FIRE-RATINGS ARE FROM BOTH SIDES UNLESS OTHERWISE STATED.
- FIRE-RATINGS ARE MAINTAINED WITH ONE OR MORE OF THE FOLLOWING MODIFICATIONS: INCREASE STUD DEPTH, INCREASE STUD MATERIAL THICKNESS, DECREASE STUD SPACING, DECREASE FASTENER SPACING, INCREASE INSULATION THICKNESS UP TO CAVITY DEPTH.
- WHERE ACOUSTICAL PERFORMANCE IS PROVIDED IN AN ESTIMATED RANGE, THE VALUES ARE BASED ON LABORATORY TEST DATA OF SIMILARLY CONSTRUCTED ASSEMBLIES.
- SOUND-RATINGS ARE MAINTAINED WITH ONE OR MORE OF THE FOLLOWING MODIFICATIONS: INCREASE STUD DEPTH, DECREASE STUD MATERIAL THICKNESS, INCREASE STUD SPACING, INCREASE FASTENER SPACING, INCREASE INSULATION THICKNESS UP TO CAVITY DEPTH. MODIFICATIONS MUST NOT EXCEED LIMITATIONS OF FIRE RATING.



USG Corporation  
550 West Adams Street  
Chicago, IL 60661 USA  
www.USG.com  
T. 800-USG4YOU

DISCLAIMER: THE USG PRODUCT INFORMATION CONTAINED HEREIN ARE INTENDED FOR USE AS PRODUCT REFERENCE MATERIAL BY ARCHITECTS, ENGINEERS, AND OTHER DESIGN PROFESSIONALS, CONTRACTORS, BUILDING CODE OFFICIALS, OR OTHER COMPETENT CONSTRUCTION INDUSTRY TRADE PROFESSIONALS HAVING AN INTEREST IN THE SELECTION, SPECIFICATION, AND USE OF PRODUCTS MANUFACTURED BY THE SUBSIDIARIES OF USG CORPORATION. THE DRAWINGS ARE INTENDED SOLELY AS TECHNICAL SUPPORT INCIDENT TO THE SALE AND USE OF USG PRODUCTS AND NOT INTENDED TO BE A SUBSTITUTE FOR THE DESIGN REVIEW AND APPROVAL OF THE LICENSED DESIGN PROFESSIONALS FOR THE PROJECT. THESE MATERIALS MAY BE PRINTED AND/OR TRANSFERRED ELECTRONICALLY SOLELY AS NEEDED BY THE USER, BECAUSE CAD ELECTRONIC FILES AND BIM (BUILDING INFORMATION MODELING) FILES CAN BE MODIFIED BY OTHER PARTIES, WITHOUT NOTICE OR INDICATION OF SUCH MODIFICATIONS, MODIFICATION OF USG PRODUCT CAD DRAWINGS IS THE SOLE RESPONSIBILITY OF THE DESIGN PROFESSIONAL.

**UL U336**

**ISSUE RECORD:**

Revision Date  
6/10/2025 3:41:13 PM

SHEET INFORMATION:

**SN-AS-2-02**

1 SD3.1 UL U336 FIREWALL DETAIL  
3/4" = 1'-0"

DATE:	03/31/26
SCALE:	AS NOTED
DESIGN BY:	TSH
DESIGN REVIEW:	TSH
STRUCTURE BY:	???
STRUCTURE REVIEW:	VAL
JOB NO.:	2025-17046

DESIGN REV. 6

SHEET SD3.1

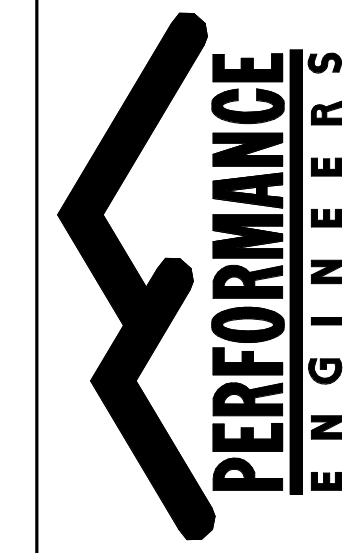

An InteFrame Company

1102 N. FRANKLIN BLVD.  
NAMPA, IDAHO 83687  
PH. (208) 475-0040

REV	DATE	DESCRIPTION

LIFT VIEW TOWNHOMES  
310 GEORGIA RD  
SECTION VIEWS  
KETCHUM IDAHO

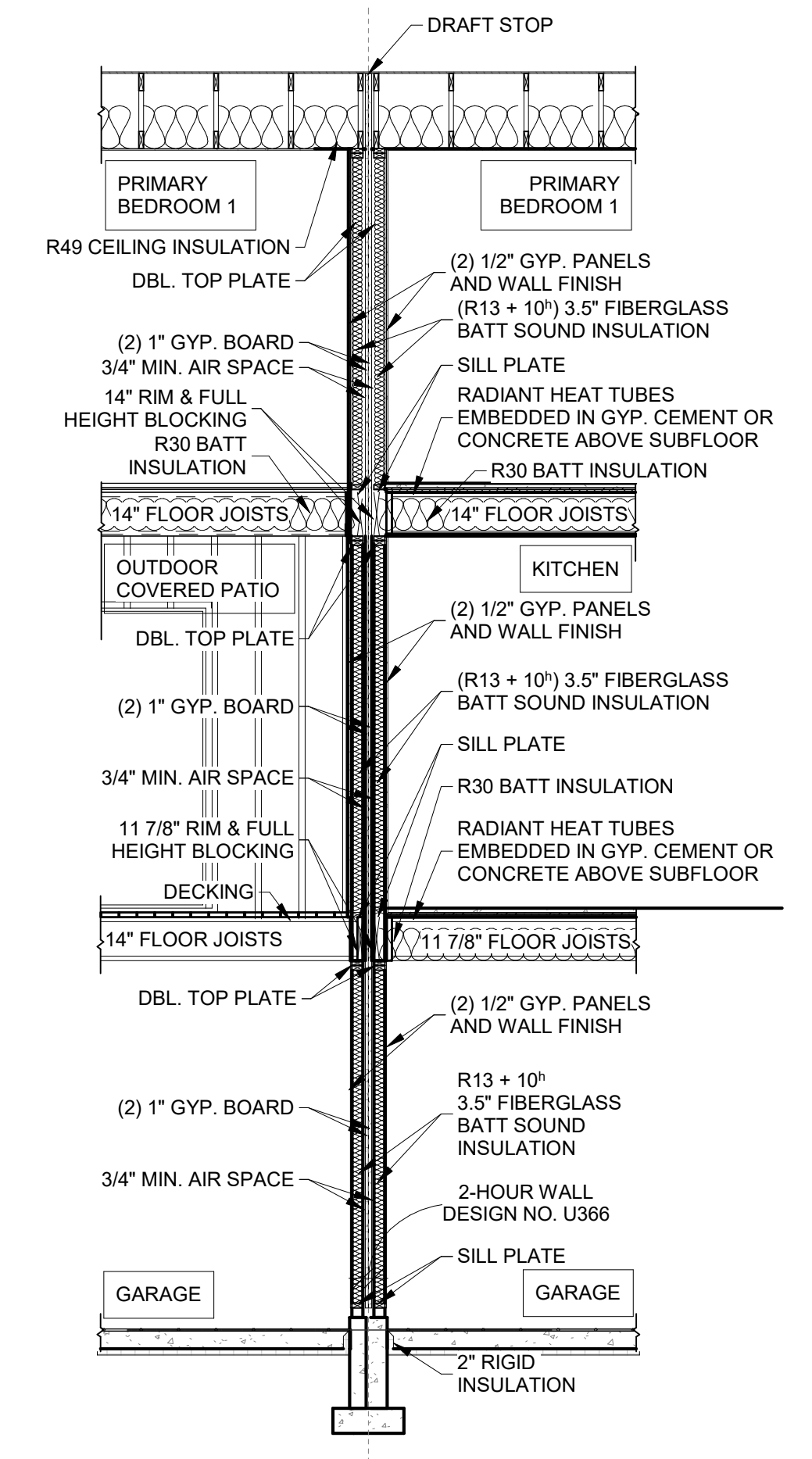
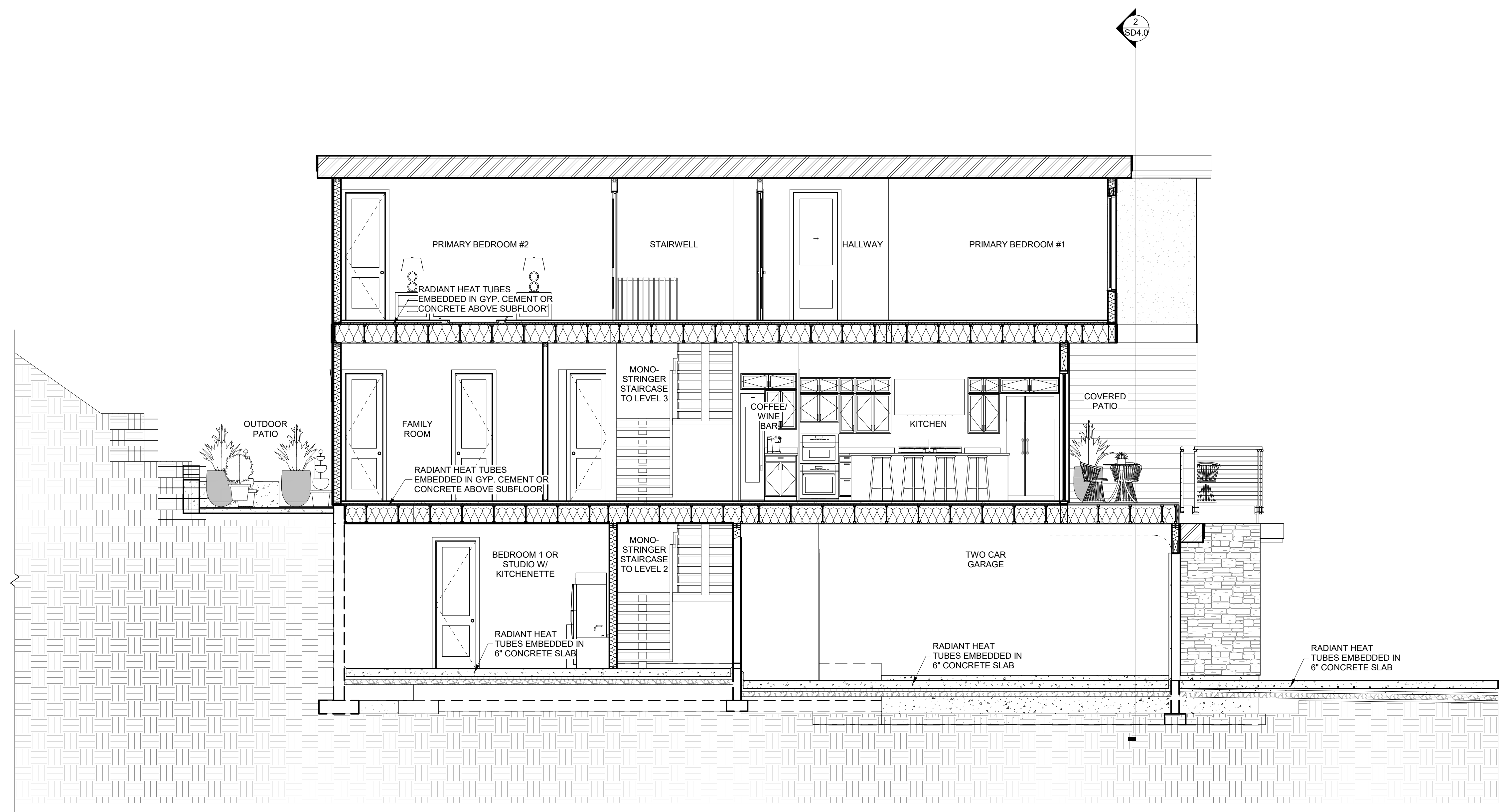

1 SECTION 1  
SD4.0 1/4" = 1'-0"

2 Section 2  
SD4.0 1/4" = 1'-0"

DATE:	03/11/26
SCALE:	AS NOTED
DESIGN BY:	TSH
DESIGN REVIEW:	TSH
STRUCTURE BY:	???
STRUCTURE REVIEW:	VAL
JOB NO.:	2025-17046

DESIGN REV. 6

SHEET  
SD4.0

**Black Metal Step Fascia**

**3rd Floor Balanced Beige Stucco**

**Balanced Beige Stucco**

**Tricorn Black Stucco Band**

**American Walnut Cladding**

**Montana Moss Stone**

**Black Garage Doors**





American Walnut

Azek American Walnut Cladding



Black Step Fascia

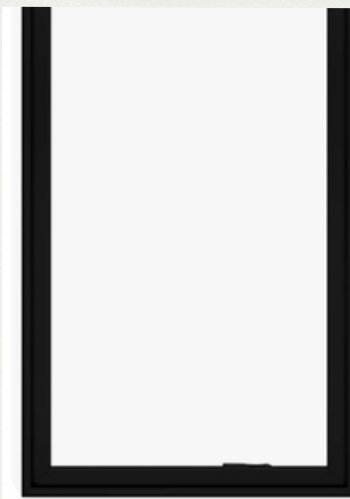

Black Pella Windows



Stucco Color



Stucco Finish

# 310 GEORGINA ROAD

## Exterior Selections



Stucco Band

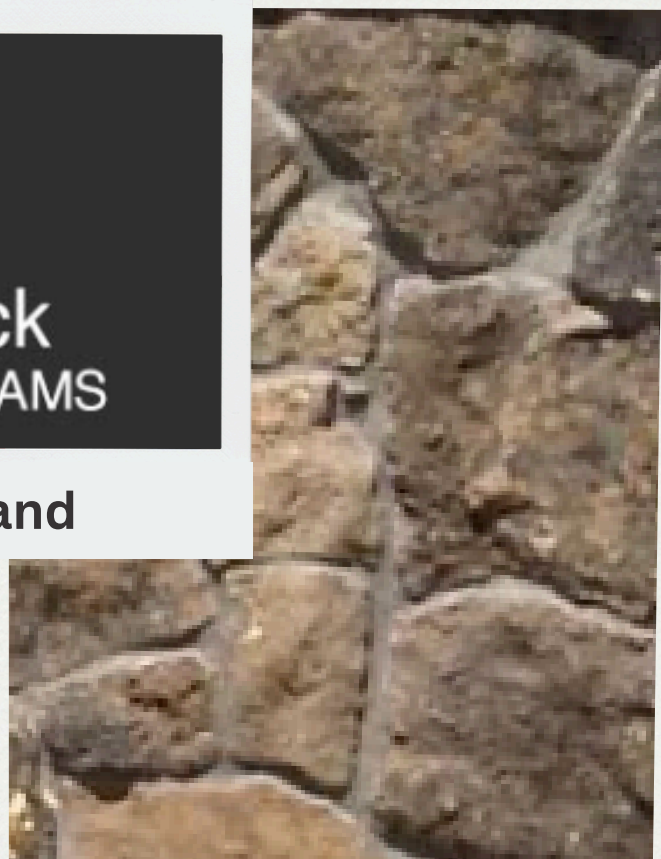

Merrillstone Montana Mossy Stone

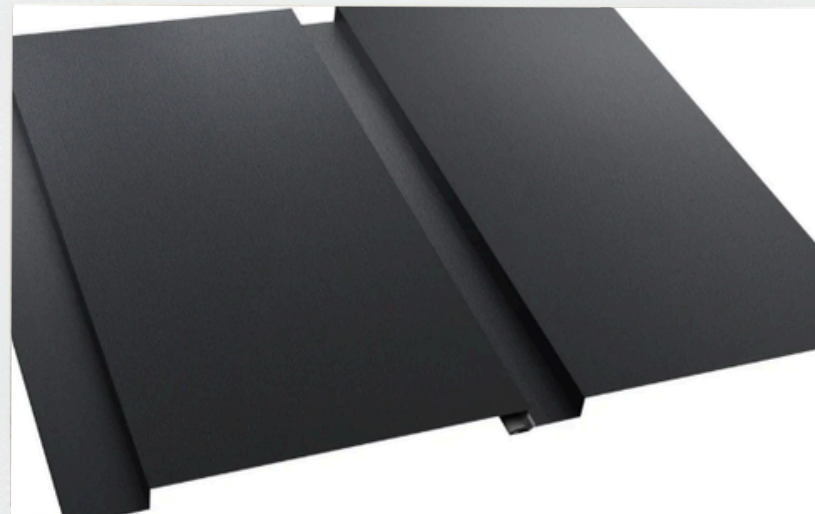

Black Soffit



Rendering







310A

310B

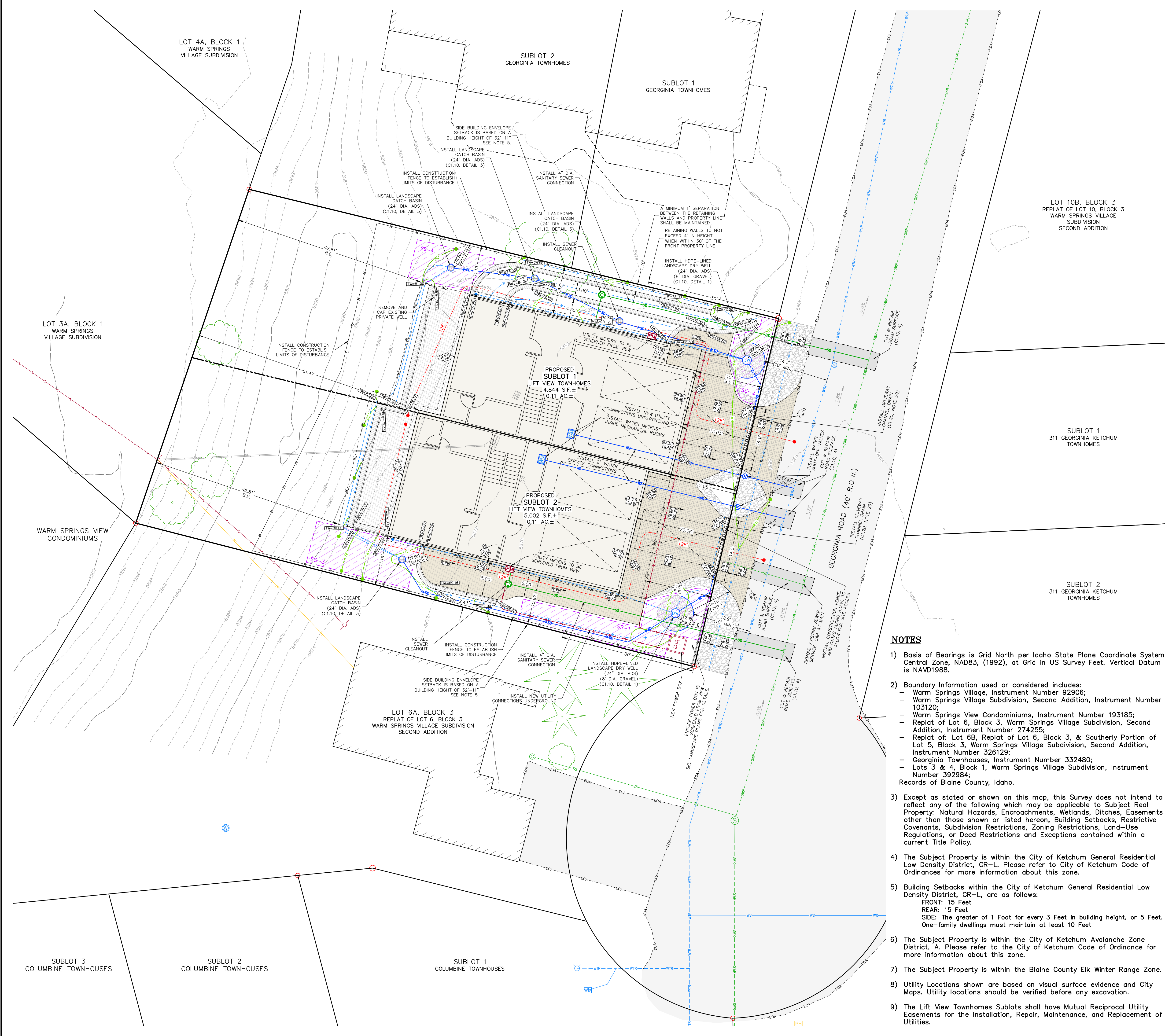

### LEGEND - EXISTING

- Subject Boundary
- Adjoining Lot Line
- Proposed Sublot Line
- Proposed Building Envelope (See Note 5)
- Asphalt Roadway
- Approximate Adjoining Structure
- Stone Retaining Wall (Removed)
- Wooden Fence
- 10' Contour (2017 Idaho LIDAR Consortium)
- 2' Contour (2017 Idaho LIDAR Consortium)
- 6" Water Main
- 8" Sewer Main
- Sewer Service (To Be Removed)
- Overhead Power Main Line
- Overhead Power Service Line (Removed)
- Overhead Phone Line (Removed)
- Found 5/8" Rebar, as Shown
- Found 1/2" Rebar, As Shown
- ⊙ Private Well
- ⊙ Private Well (To Be Removed, See Note 31)
- ⊙ Water Valve
- ⊙ Fire Hydrant
- ⊙ Water Meter
- ⊙ Sewer Manhole
- ⊙ Sewer Cleanout
- ⊙ Sewer Cleanout (Removed)
- ⊙ Power Box
- ⊙ Power Pole
- ⊙ Power Meter (Removed)
- ⊙ Gas Meter (Removed)
- ⊙ Phone Riser Box
- ⊙ Coniferous Tree (Trees to be preserved shall be fenced at the dripline for the duration of construction.)
- ⊙ Deciduous Tree
- ⊙ Existing Grade
- ⊙ Existing Spot Elevation

### LEGEND - PROPOSED

- Proposed Structure
- Proposed Structure Roofline
- 5' Major Contour
- 1' Minor Contour
- Drainage Flowline
- 6" Dia. Storm Drain Pipe
- 2" Water Service (C1.20-4)
- 4" Sewer Service (C1.20-6)
- 4" Dia. Solid PVC Roof Drain Pipe (C1.10-NOTE 27)
- Underground Power
- L.O.D. Construction Fence with Screening
- Fire Hose Pull Length (126' x 2)
- ⊙ Water Meter (C1.20-4)
- ⊙ Water Valve (C1.20-4)
- ⊙ Sewer Cleanout (C1.20-7)
- ⊙ Landscape Catch Basin (C1.10-3)
- ⊙ Landscape Dry Well (C1.10-1 & 2)
- ⊙ Down Spout Location
- ⊙ Power Box
- ⊙ Power Meter
- ⊙ Heated Concrete Paver Driveway & Walkway (C1.10-6)
- ⊙ Concrete Paver Patio
- ⊙ Gravel Strip (C1.10-7)
- ⊙ Saw Cut & Asphalt Patch (C1.10-4)
- ⊙ Retaining Wall (See Structural Plan for Details)
- ⊙ 6" Wide Driveway Trench Drain (C1.20-NOTE 29)
- ⊙ Parking Space (18' x 9')
- ⊙ Snow Storage (C1.20-NOTE 30)
- ⊙ Proposed Grade
- ⊙ Proposed Finish Grade Spot Elevation
- ⊙ Location Description
- EOA Edge of Asphalt
- EOP Edge of Pavers
- GB Grade Break
- RIM Top of Dry Well/Catch Basin
- TW Top of Retaining Wall
- BW Bottom of Retaining Wall
- FFE Finish Floor Elevation
- SLAB Garage Slab Elevation

- ### NOTES
- 1) Basis of Bearings is Grid North per Idaho State Plane Coordinate System, Central Zone, NAD83, (1992), at Grid in US Survey Feet. Vertical Datum is NAVD1988.
  - 2) Boundary information used or considered includes:
    - Warm Springs Village, Instrument Number 92906;
    - Warm Springs Village Subdivision, Second Addition, Instrument Number 103120;
    - Warm Springs View Condominiums, Instrument Number 193185;
    - Replat of Lot 6, Block 3, Warm Springs Village Subdivision, Second Addition, Instrument Number 274255;
    - Replat of Lot 6B, Replat of Lot 6, Block 3, & Southerly Portion of Lot 5, Block 3, Warm Springs Village Subdivision, Second Addition, Instrument Number 326129;
    - Georgia Townhouses, Instrument Number 332480;
    - Lots 3 & 4, Block 1, Warm Springs Village Subdivision, Instrument Number 392984;
 Records of Blaine County, Idaho.
  - 3) Except as stated or shown on this map, this Survey does not intend to reflect any of the following which may be applicable to Subject Real Property: Natural Hazards, Encroachments, Wetlands, Ditches, Easements other than those shown or listed hereon, Building Setbacks, Restrictive Covenants, Subdivision Restrictions, Zoning Restrictions, Land-Use Regulations, or Deed Restrictions and Exceptions contained within a current Title Policy.
  - 4) The Subject Property is within the City of Ketchum General Residential Low Density District, GR-L. Please refer to City of Ketchum Code of Ordinances for more information about this zone.
  - 5) Building Setbacks within the City of Ketchum General Residential Low Density District, GR-L, are as follows:
    - FRONT: 15 Feet
    - REAR: 15 Feet
    - SIDE: The greater of 1 Foot for every 3 Feet in building height, or 5 Feet. One-family dwellings must maintain at least 10 Feet
  - 6) The Subject Property is within the City of Ketchum Avalanche Zone District, A. Please refer to the City of Ketchum Code of Ordinance for more information about this zone.
  - 7) The Subject Property is within the Blaine County Elk Winter Range Zone.
  - 8) Utility Locations shown are based on visual surface evidence and City Maps. Utility locations should be verified before any excavation.
  - 9) The Lift View Townhomes Sublots shall have Mutual Reciprocal Utility Easements for the Installation, Repair, Maintenance, and Replacement of Utilities.

### GRAPHIC SCALE

( IN FEET )  
1 inch = 10 ft.

PROJECT PATH AND PRINT DATE: U:\LandProjects2004\1464\_LT6A\_WARM\_SPRGS\_2ND\_ADD.dwg\1464\_WarmSpringsVillage2ndAdd\_Blk3LT6B\_Civil2026\_Rev3.dwg 03/24/2026 04:21:32 PM MST

A GRADING, RIGHT-OF-WAY IMPROVEMENT & UTILITY PLAN SHOWING  
LIFT VIEW TOWNHOMES

WITHIN S.11, T.4N., R.17E., B.M., CITY OF KETCHUM, BLAINE COUNTY, IDAHO  
PREPARED FOR JORDAN HOMES

Alpine Enterprises Inc.  
Surveying, Mapping, Civil Engineering,  
and Natural Hazards Consulting  
660 Bell Dr., Unit 1  
P.O. Box 2037, Ketchum, ID 83340 USA  
(208) 727-1986  
email: sam@alpineenterprisesinc.com

NO	DATE	BY
PRELIMINARY: NOT FOR CONSTRUCTION		
REVISED: PLANNING REVIEW NO. 1	21OCT25	AHN
REVISED: PLANNING REVIEW NO. 2	29DEC25	AHN
REVISED: P&Z REVIEW NO. 1	05FEB26	AHN
REVISED: P&Z REVIEW NO. 1	24MAR26	AHN

**C1.00**

**GENERAL CONSTRUCTION NOTES**

- The location of existing underground utilities shown on plans are approximate. The contractor shall be responsible for locating the existing utilities prior to and during construction. The contractor agrees to be fully responsible for any and all damages which result from its failure to accurately locate and preserve any and all underground utilities. Contractor shall call Digline Inc. to locate all existing utilities a minimum of 48-hours before excavation.
- See the plans from Draw Architecture and Design for the remainder of the design.
- All construction shall be in accordance with the most current edition of the Idaho Standards for Public Works Construction (ISPC), the Idaho Department of Environmental Quality (DEQ) Public Drinking Water Standards and Wastewater Collection Standards, and the City of Ketchum, Idaho, Codes and Standards. The contractor shall be responsible for obtaining and keeping a copy of these Codes and Standards on site during construction.
- The contractor shall be required to obtain all the necessary permits prior to construction and shall check with the City of Ketchum for permits the owner may have already obtained.
- Per Idaho Code, 55-1613, the contractor shall retain and protect all monuments, accessories to corners, benchmarks, and points set in control surveys. All monuments, accessories to corners, benchmarks, and points set in control surveys that are lost or disturbed by construction shall be reestablished and re-monumented, at the expense of the agency or person causing their loss or disturbance under the direction of a professional land surveyor.
- The contractor shall clean up the site after construction so that it is in a condition equal to or better than that which existed prior to construction.
- Contractor shall be responsible for dust control during construction of all items hereon. Dust control shall be continuous during construction, 24 hours per day 7 days per week. The contractor shall follow the requirements of the Storm Water Pollution Prevention Plan at all times until permanent erosion control is established.
- The proposed site disturbance is under 1 acre (0.38 Ac.) and thereby a SWPPP shall not be required. However, the contractor shall utilize erosion control Best Management Practices (BMP's) as needed to ensure the site and surrounding areas/waterways remain protected from contamination.
- Existing topsoil shall be retained with vegetation and stockpiled for use in reestablishing revegetated areas.
- All clearing and grubbing shall conform to ISPC Section 201 and City of Ketchum standards of excavation and backfill.
- All excavation and embankment shall conform to ISPC Section 202 and City of Ketchum standards for excavation and backfill. Excavated subgrade shall be compacted and all unsuitable Sections removed and replaced with structural fill as determined by the engineer per ISPC Section 204. Minimum compaction of placed material shall be 95% of maximum laboratory density as determined by AASHTO T-99 or IDT T-91.
- All 2" minus aggregate shall be placed in conformance with ISPC Section 802. It shall be compacted per ISPC Section 202 and the City of Ketchum standards. 2" minus crushed aggregate material shall conform to ISPC Section 802 Type II and to the City of Ketchum specifications. Minimum compaction of placed material shall be 95% of maximum laboratory density as determined by AASHTO T-99 or IDT T-91.
- All 3/4" minus aggregate shall be placed in conformance with ISPC Section 802. It shall be compacted per ISPC Section 202 and the City of Ketchum standards. 3/4" minus crushed aggregate for leveling course shall conform to ISPC Table 802 Type I and to the City of Ketchum specifications. Minimum compaction of placed material shall be 95% of maximum laboratory density as determined by AASHTO T-99 or IDT T-91.
- All asphaltic concrete pavement work shall conform to ISPC Section(s) 805, 810, and 811 for Class II pavement and to the City of Ketchum standards. Asphalt aggregate shall be 1/2" nominal size conforming to Table 803b in ISPC Section 803. Asphalt binder shall be pg 58-28 conforming to Table A-1 in ISPC Section 805.
- All concrete work shall conform to ISPC Sections 701 and 703. All concrete shall be 3,000 psi minimum. 28 day, as defined in ISPC Section 703, Table 1.C.
- All edges of existing asphalt paving shall be saw cut a minimum of 24" to provide a clean pavement edge for matching. No wheel cutting shall be allowed. Pavement shall be cut prior to paving to prevent damage to the cut edge.
- The contractor shall verify the location and elevation of all existing water and sewer mains/services at all proposed crossings. Some relocation of water and sewer mains/services may be required in addition to those shown on the plans.
- Potable/non-potable crossings shall comply with ISPC Standard Drawings SD-407 and IDAPA section 58.01.08.542.07. All mains and services shall comply with IDAPA 58.01.08.542.07.a and IDAPA 58.01.08.542.07.b which address the requirements for separation distances between potable water lines (including mains and service lines) with non-potable lines. In addition, water services shall be constructed with at least 25 feet horizontal separation from infiltration trenches and dry wells.
- Sewer service lines shall be placed at a slope of 2%, with markers per ISPC. Cleanouts are required at changes in alignment, grade, and minimum 150' length.
- All pipe shall be bedded with (ISPC) Type I bedding material.
- Trenches shall be backfilled and compacted to a minimum of 95% of maximum density as determined by AASHTO T-99.
- The contractor shall pressure test all sewer service connections in accordance with Idaho Standards for Public Works Construction, ISPC.
- The contractor shall be responsible for initiating, maintaining, supervising, and complying with all federal safety and health regulations as determined by the State of Idaho and Bureau of Reclamation health and safety requirements. The contractor shall be required to comply with all regulations and requirements of local codes and ordinances.
- The contractor shall be responsible for hiring a materials testing company during construction to verify all City of Ketchum construction Standards and Specifications are met.
- Contractor shall assure positive drainage towards catch basins and dry wells.
- Contractor shall assure positive drainage away from the building and driveway.
- Grade away from foundation at 2% minimum, unless otherwise shown.
- All drainage is to be retained on-site.

(Continued on Sheet C1.20)

NOTE: IN ORDER TO REDUCE THE MINIMUM HORIZONTAL SEPARATION DISTANCE BETWEEN A POTABLE WATER MAIN LINE AND A SUB-SURFACE WASTEWATER DISPOSAL SYSTEM FROM 25- FEET TO 10- FEET, INSTALL 20 MIL. HDPE GROUNDWATER BARRIER ALONG THE EDGE OF DRY WELL ADJACENT TO WATER MAIN. BARRIER SHALL EXTEND 1.5- FEET MIN. BELOW THE ADJACENT WATER MAIN PIPE. OTHERWISE A 25- FOOT MIN. SEPARATION DISTANCE FROM WATER MAINS SHALL BE MAINTAINED.

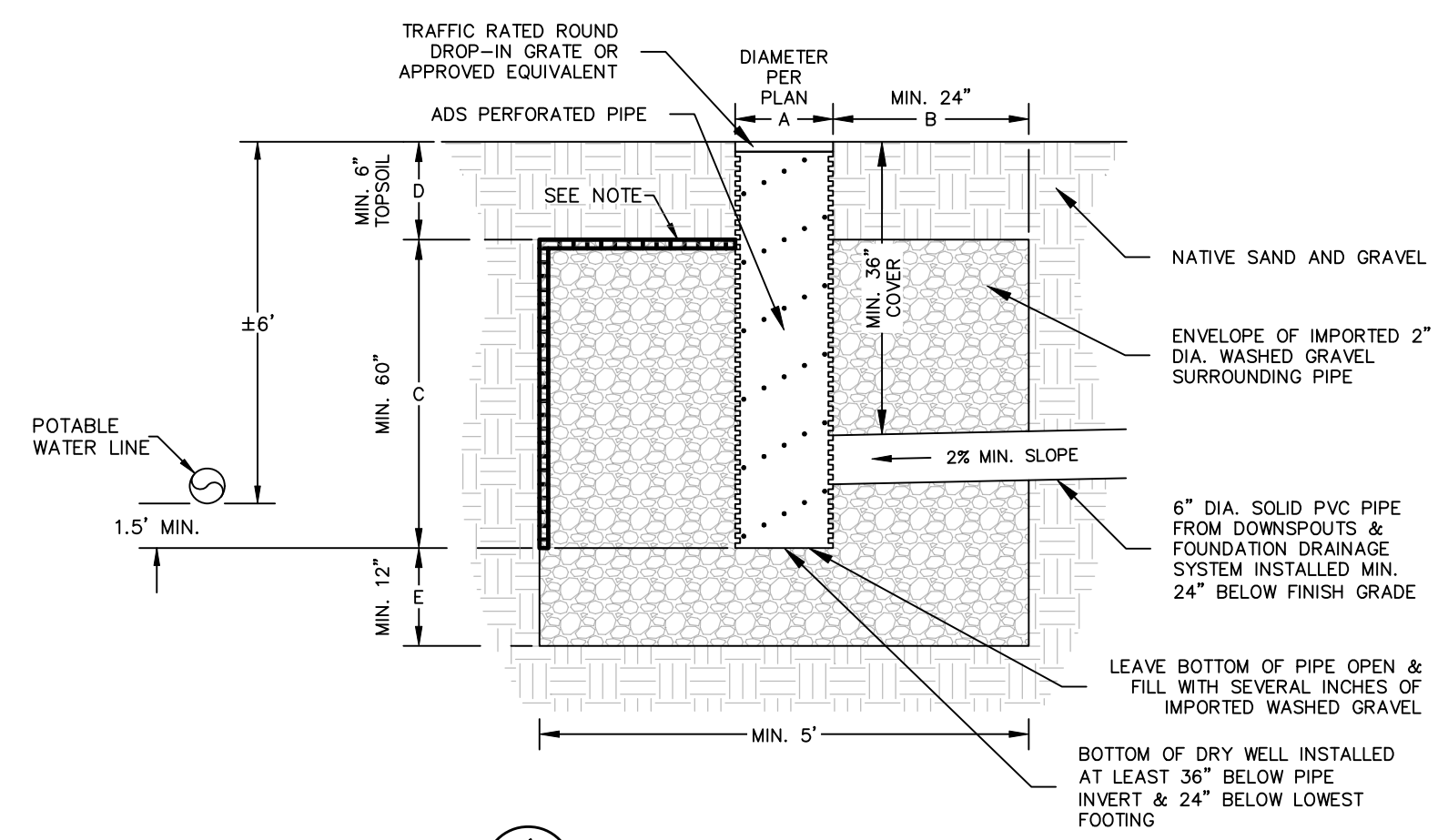

1 TYPICAL HDPE-LINED LANDSCAPE DRY WELL  
C1.10 NOT TO SCALE

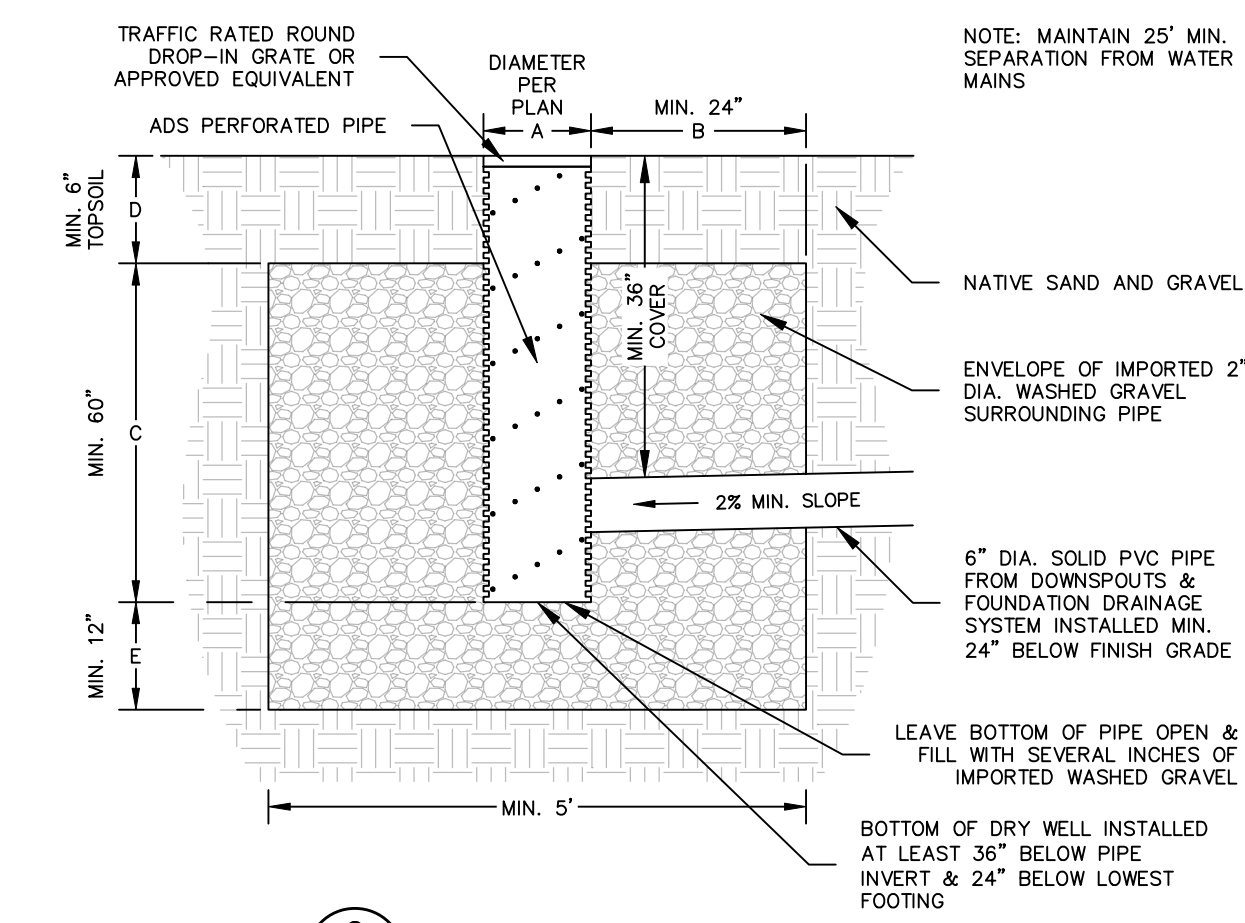

2 TYPICAL LANDSCAPE DRY WELL  
C1.10 NOT TO SCALE

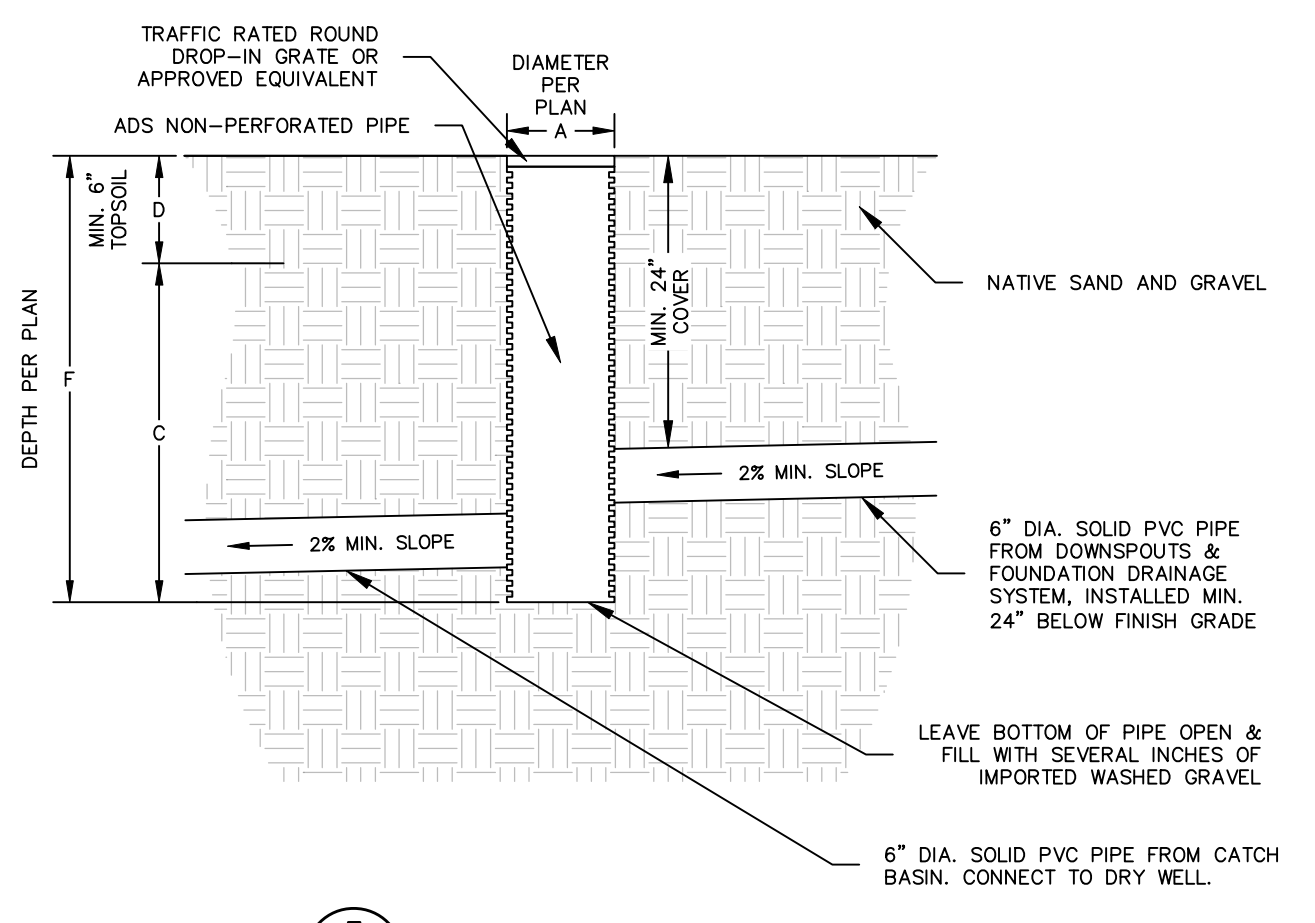

3 TYPICAL LANDSCAPE CATCH BASIN  
C1.10 NOT TO SCALE

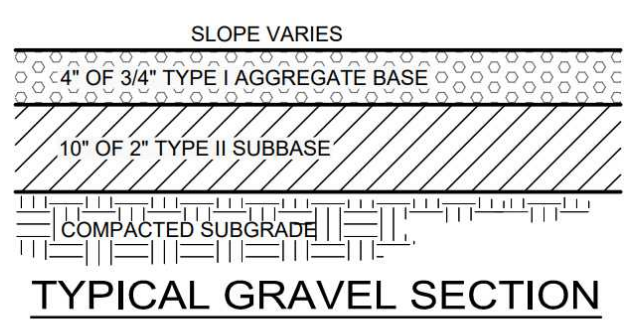

4 TYPICAL GRAVEL SECTION

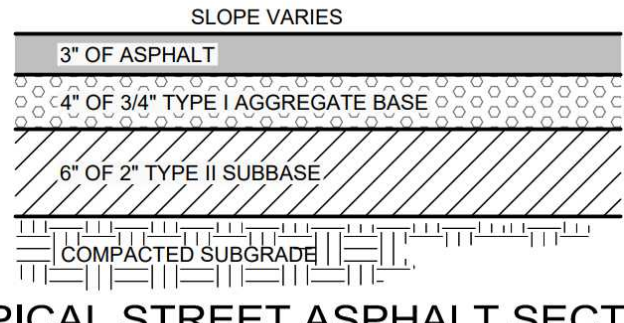

5 TYPICAL STREET ASPHALT SECTION

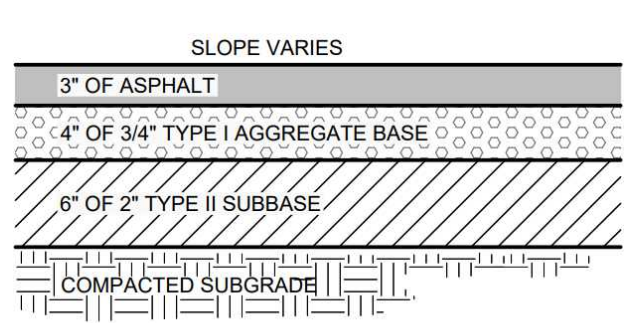

6 TYPICAL ALLEY ASPHALT SECTION

- NOTES:
- SUBBASE CAN BE 2" TYPE II OR 3/4" TYPE I CRUSHED AGGREGATE BASE COURSE.
  - MATERIALS SHALL CONFORM WITH CURRENT ISPC STANDARDS, DIVISION 800 AGGREGATES AND ASPHALT.
  - PAVEMENT SECTION MAY BE MODIFIED IF A PROJECT SPECIFIC GEOTECHNICAL REPORT, STAMPED BY A LICENSED ENGINEER, IS PROVIDED.

4 TYPICAL ROAD SECTIONS  
C1.10 CITY OF KETCHUM - SD-3 NOT TO SCALE

CITY TESTING REQUIREMENTS PER CODE SECTION 12.04.040	
SUBGRADE TEST SPECIFICATION	1 PER 1000 SQ YD
CONCRETE TESTING SPECIFICATION	1 PER PROJECT AND 1 ADDITIONAL TEST FOR EACH 25 YARDS
SUBBASE TEST SPECIFICATION	1 PER 1000 SQ YD
BASE TEST SPECIFICATION	1 PER 1000 SQ YD
ASPHALT TEST SPECIFICATION (ISPC)	1 PER 100 LF FT

CITY GRADATION REQUIREMENTS PER CODE SECTION 12.04.040	
BASE GRADATION SPECIFICATION	1 PER 500 TON
CONCRETE MIX DESIGN (TITAN)	PER PROJECT
ASPHALT GRADATIONS SPECIFICATIONS	MIN 1 PER PROJECT

CITY WALL REQUESTS PER CODE SECTION 12.04.040	
WALL CONSTRUCTION OBSERVATION REPORTS	1 PER PROJECT

- NOTES:
- THESE ARE MINIMUM TESTING REQUIREMENTS.
  - REQUIREMENTS MAY BE WAIVED AT THE CITY ENGINEER DESCRESSION.

5 R.O.W. TESTING REQUIREMENTS  
C1.10 CITY OF KETCHUM - SD-16 NOT TO SCALE

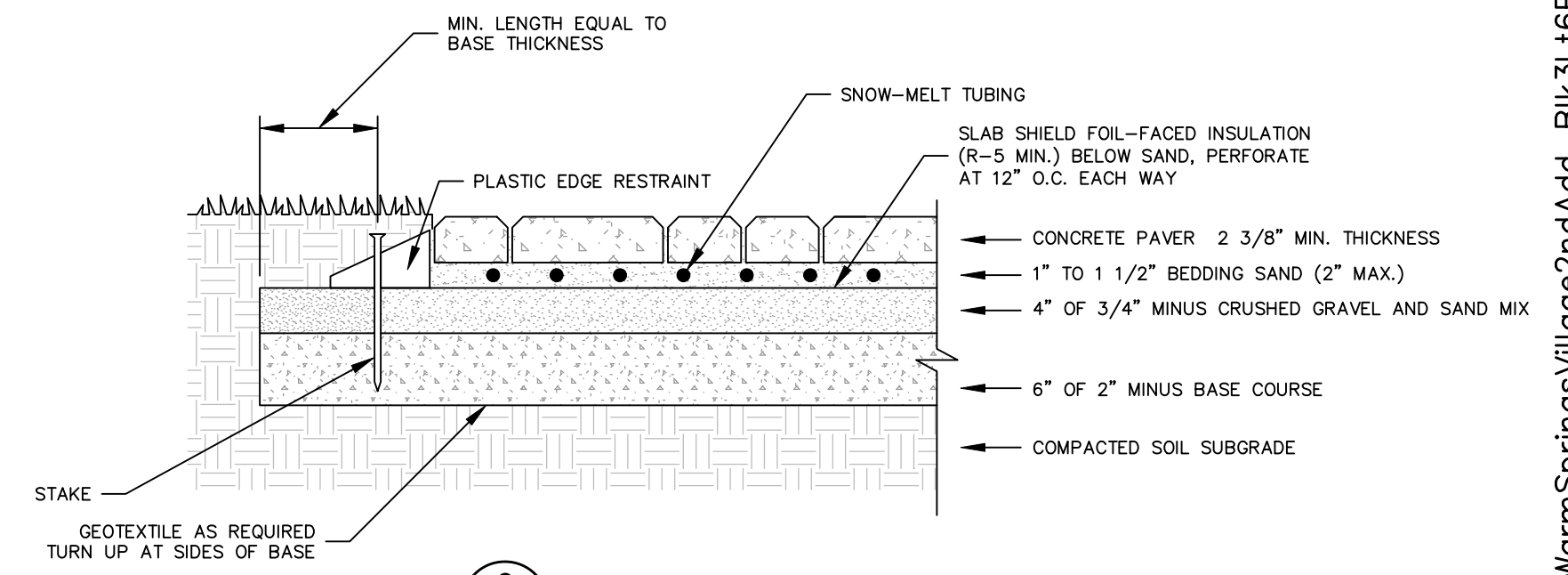

6 HEATED PAVER DRIVEWAY DETAIL  
C1.10 NOT TO SCALE

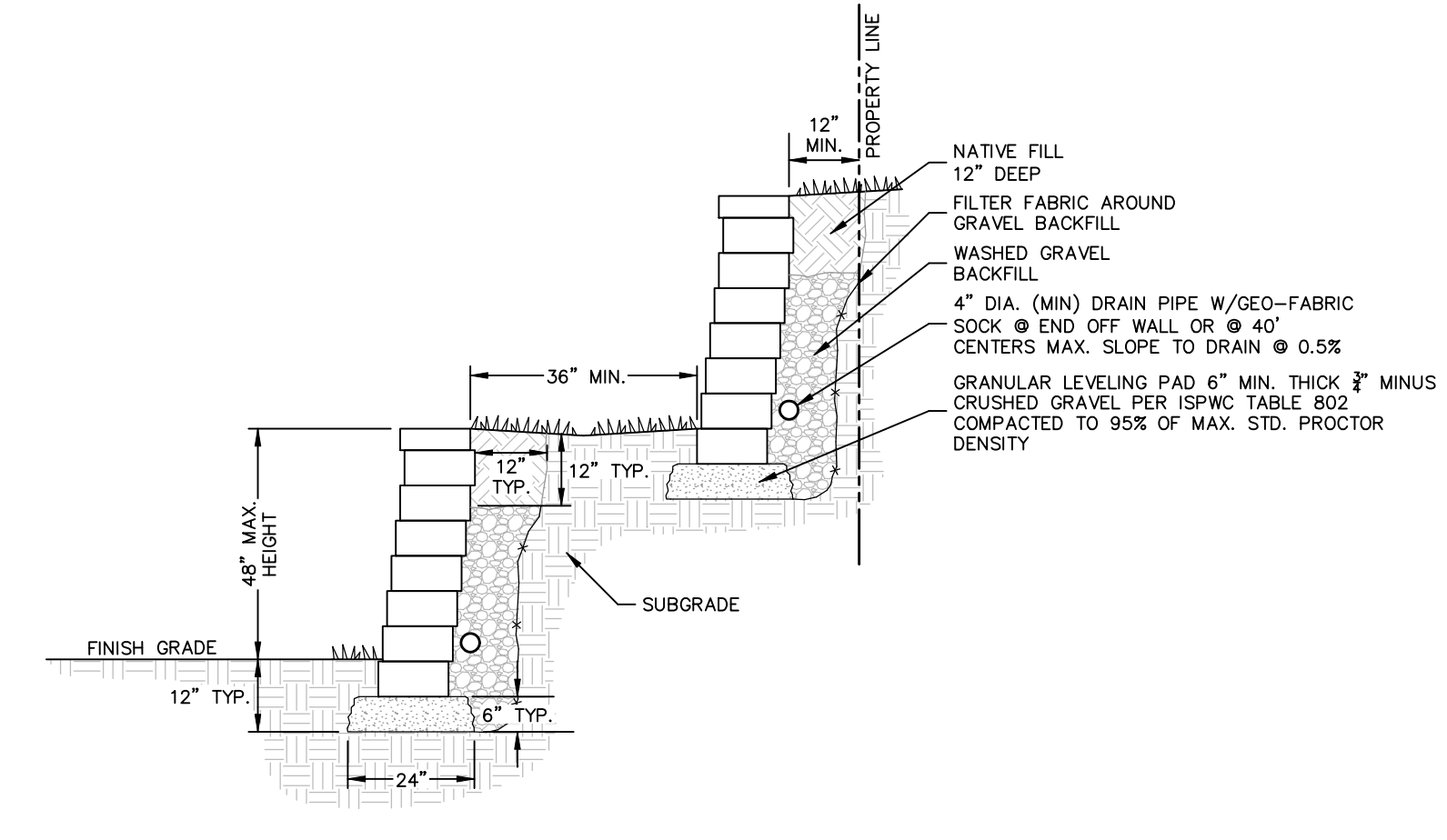

7 CROSS-SECTION: ROADSIDE SWALE  
C1.10 R.O.W. GEORGIA ROAD NOT TO SCALE

- NOTES:
- Material shall be pervious/permeable to allow drainage.
  - Surface must allow for vehicle parking and be consistent along the entire property frontage.
  - Material within the first eight (8) feet from edge of asphalt (Street) shall be distinct from driveway and rest of property in order to visually appear available for parking.
  - Grading and drainage improvements as required by City Engineer - Minimum 5% slope.
  - No obstructions, such as boulders or berms shall be permitted within the public right-of-way.
  - No buried irrigation systems within the first eight (8) feet the edge of asphalt (Street). Sub-Surface irrigation lines are permitted beyond the first eight (8) feet, however pop-up heads are not permitted anywhere in the public right-of-way.
  - No live plant material within the first eight (8) feet from edge of asphalt (Street). Low ground cover plant material, such as turf grass, is permitted beyond the first eight (8) feet. Drought-tolerant species are preferred.
  - No snow-melt systems permitted within public right-of-way, unless prior approval from the City is acquired.

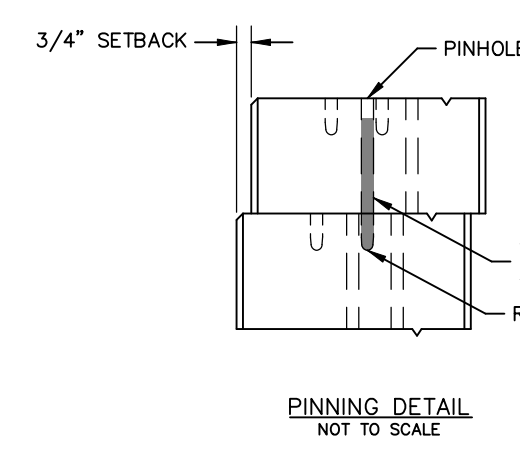

8 DRY STACK LANDSCAPE RETAINING WALL DETAIL  
C1.10 VERSA-LOCK MODULAR CONCRETE UNIT NOT TO SCALE

PROJECT PATH AND PRINT DATE: U:\LandProjects\2004\1464\_L16A\_WARM\_SPRGS\_2ND\_ADD\dwg\1464\_WarmSpringsVillage2ndAdd\_Bk3L16B\_Civil2026\_Rev3.dwg 03/24/2026 04:21:32 PM MST

A GRADING, RIGHT-OF-WAY IMPROVEMENT & UTILITY PLAN SHOWING  
LIFT VIEW TOWNHOMES  
WITHIN S.11, T.4N., R.17E., B.M., CITY OF KETCHUM, BLAINE COUNTY, IDAHO  
PREPARED FOR JORDAN HOMES

Alpine Enterprises Inc.  
Surveying, Mapping, Civil Engineering,  
and Natural Hazards Consulting  
660 Bell Dr., Unit 1  
P.O. Box 2037, Ketchum, ID 83340 USA  
(208) 727-1986  
email: tsam@alpineenterprisesinc.com

NO	DATE	BY
1		AHN
2	21OCT25	AHN
3	29DEC25	AHN
4	05FEB26	AHN
5	24MAR26	AHN

PRELIMINARY: NOT FOR CONSTRUCTION  
REVISED: PLANNING REVIEW NO. 1  
REVISED: PLANNING REVIEW NO. 2  
REVISED: P&Z REVIEW NO. 1  
REVISED: P&Z REVIEW NO. 1

PROFESSIONAL ENGINEER  
ALEX NELSON  
STATE OF IDAHO  
24MAR26

C1.10

**GENERAL CONSTRUCTION NOTES**

- 27) All roof drains and downspouts shall not drain adjacent to the foundation and are to be connected to dry wells by a 4" dia. solid PVC Pipe sloped at a 1% minimum.
- 28) The contractor shall be responsible for providing traffic control per the current edition of the US Department of Transportation Manual of Uniform Traffic Control Devices (MUTCD).
- 29) The Channel Drain shall be a 6" wide HDPE channel with a 0.75 built in channel slope (Zurn Flo-Thru Model Z886 or equivalent). Grate shall be ductile iron with a slotted pattern. All components shall be rated for H-20 loading.
- 30) Snow Storage Calculations:
  - Improved Pedestrian Circulation & Parking Areas:
    - 1,230 S.F. Heated Driveway & Walkways
    - 440 S.F. Backyard Pavers
    - Total = 1,670 S.F.
    - 30% of Total = 500 S.F.
  - Dedicated Snow Storage
    - SS-1 = 300 S.F. (See Plan)
    - SS-2 = 115 S.F. (See Plan)
    - SS-3 = 209 S.F. (22 x 9.5')
    - SS-4 = 136 S.F. (16 x 8.5')
    - Total = 760 S.F.
- 31) Private Well shall be abandoned in a manner compliant with IDAPA 37.03.09.025.12 and Form 238(4)-2 "Authorization to Abandon (Decommission) A Well" shall be submitted with IDWR.
- 32) All instructions and special conditions contained on this plan set shall be strictly adhered to. Alpine Enterprises Inc. is not responsible for any deviation from these plans, unless such changes have been authorized in writing.
- 33) All right-of-way improvements per sheet C1.00 must be completed prior to issuance of a temporary or final Certificate of Occupancy unless otherwise agreed upon in writing by the City.

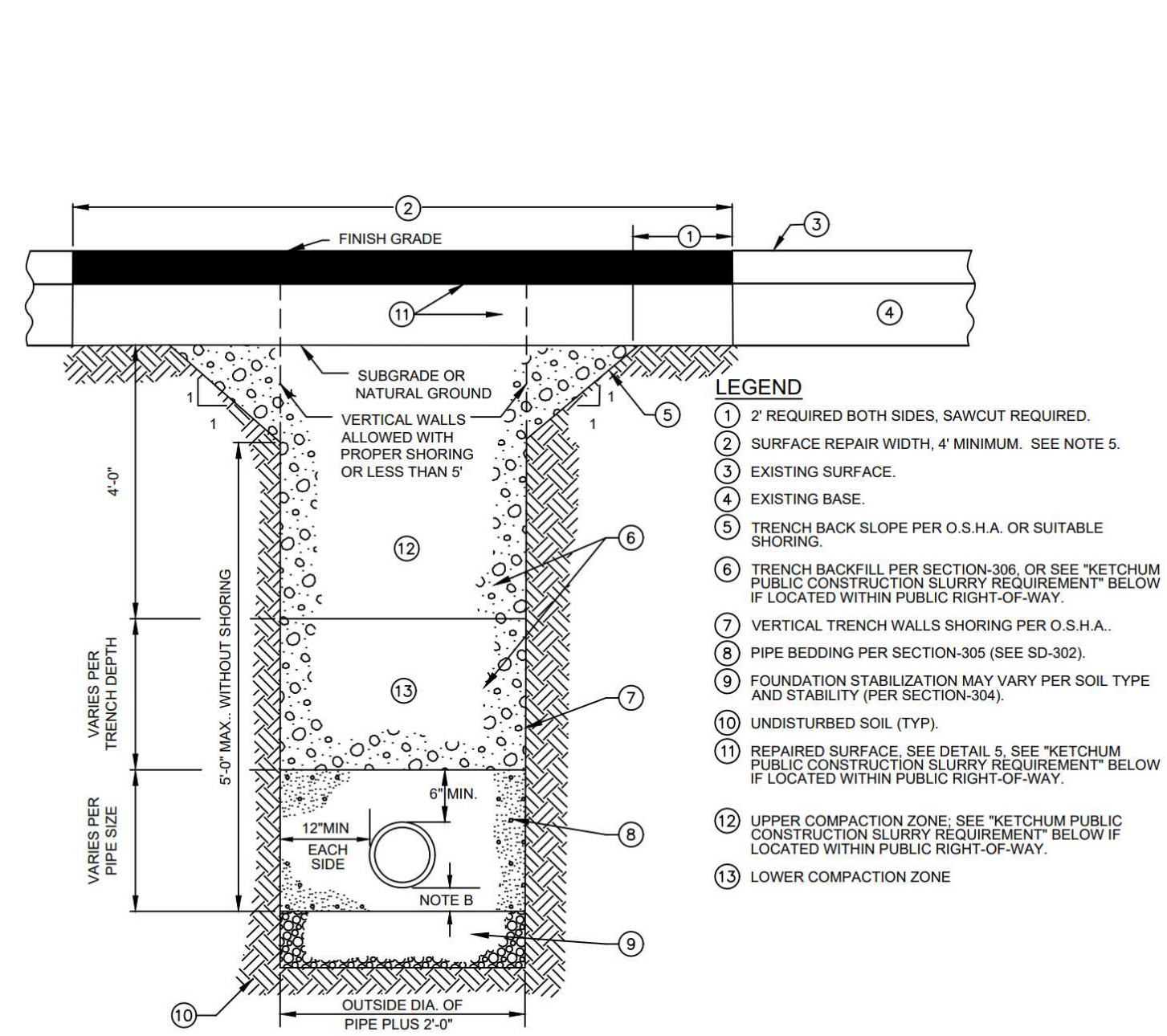

**KETCHUM PUBLIC CONSTRUCTION SLURRY REQUIREMENT**  
 IN AREAS WHERE IT IS NECESSARY TO CUT THE ASPHALT PAVEMENT AND DIG A TRENCH FOR BURIAL OF CONDUIT CABLE OR OTHER CITY UTILITY, THE TRENCH SHALL BE BACKFILLED WITH A LEAN CONCRETE MIX TO THE BOTTOM OF FINISH SURFACE MATERIAL WITH THE FOLLOWING PROPORTIONS OF MATERIALS:

COARSE AGGREGATE (3/4" MINUS) : 2,600 LBS  
 SAND : 800 LBS  
 PORTLAND CEMENT : 94 LBS  
 WATER : 11 GAL (MAX.)

WATER CONTENT IS MAXIMUM AND MAY BE REDUCED DOWNWARD. CARE SHALL BE TAKEN TO ASSURE THAT EXCESS WATER IS NOT PRESENT IN THE MIXING DRUM PRIOR TO CHARGING THE MIXER WITH MATERIALS. THOROUGH MIXING WILL BE REQUIRED PRIOR TO DISCHARGE.

NO COMPACTION, VIBRATION, OR FINISHING IS REQUIRED. THE LEAN CONCRETE MIX SHALL BE STRUCK OFF AT OR BELOW THE ELEVATION OF THE PLANT MIX SURFACING WITH A SQUARE-NOSE SHOVEL OR SIMILAR HAND TOOL. THE BACKFILL MIX SHALL BE ALLOWED TO SET FOR A MINIMUM OF 2 HOURS BEFORE THE PERMANENT PLANT MIX SURFACING IS PLACED TO COMPLETE THE TRENCH REPAIR. TEMPORARY PLACEMENT OF ASPHALT COLD MIX SURFACING MAY BE NECESSARY TO ACCOMMODATE TRAFFIC WITHIN THE FIRST 2 HOURS OF BACKFILL PLACEMENT PRIOR TO COMPLETING THE PERMANENT REPAIR.

**NOTES:**

1. TRENCH EXCAVATION PER SECTION-301.
2. PIPE BEDDING PER SECTION-305.
3. BACKFILL AND COMPACTION PER SECTION-306.
4. SURFACE REPAIR AND BASE PER DETAIL 3.
5. ASPHALT PAVEMENT FOR SURFACE REPAIR SHALL BE IN ACCORDANCE WITH PLANS AND ISPWC SECTIONS 805, 810, AND 811 FOR CLASS II PAVEMENT. ASPHALT AGGREGATE SHALL BE 5" (13MM) NOMINAL SIZE CONFORMING TO TABLE 803B IN ISPWC SECTION 803. ASPHALT BINDER SHALL BE PG 58-28 CONFORMING TO TABLE A-1 IN ISPWC SECTION 805.
6. IF TRENCH IMPACTS CROWN OF ROADWAY, CROWN MUST BE MAINTAINED AND POSITIVE DRAINAGE PROVIDED.

1 C1.20 TYPICAL TRENCH CITY OF KETCHUM SD-12 NOT TO SCALE

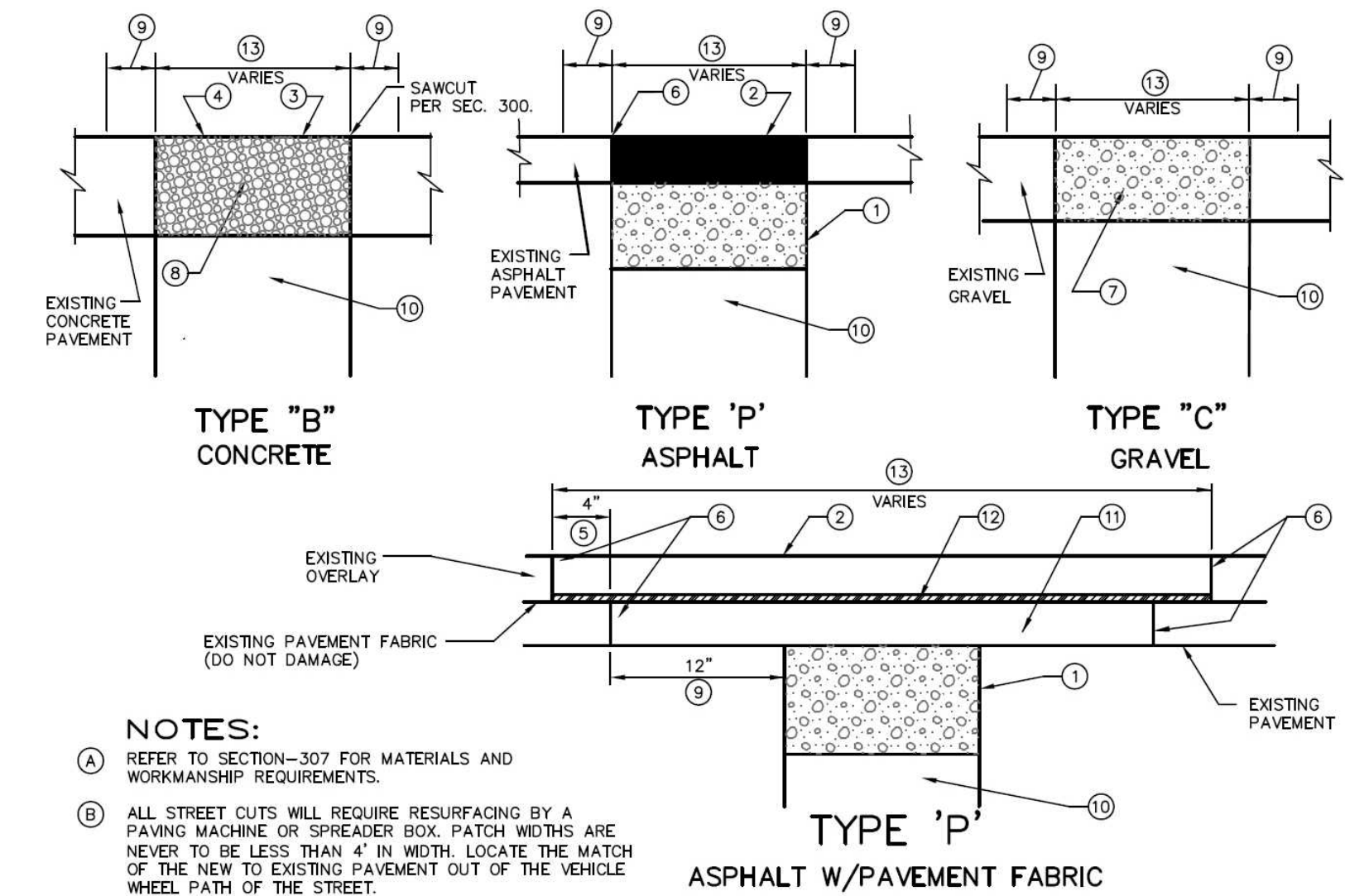

**NOTES:**

- A. REFER TO SECTION-307 FOR MATERIALS AND WORKMANSHIP REQUIREMENTS.
- B. ALL STREET CUTS WILL REQUIRE RESURFACING BY A PAVING MACHINE OR SPREADER BOX. PATCH WIDTHS ARE NEVER TO BE LESS THAN 4' IN WIDTH. LOCATE THE MATCH OF THE NEW TO EXISTING PAVEMENT OUT OF THE VEHICLE WHEEL PATH OF THE STREET.
- C. WHERE THE STREET SURFACE INCLUDES AN OVERLAY WITH FABRIC, TAKE THE FOLLOWING ADDITIONAL STEPS:
  - A. OVERLAY ABOVE FABRIC AN ADDITIONAL 4" ON EACH SIDE TO EXPOSE EXISTING FABRIC.
  - B. INSTALL NEW ASPHALT TO GRADE FABRIC.
  - C. INSTALL NEW FABRIC FULL WIDTH OF CUT, IN ACCORDANCE WITH MANUFACTURE'S INSTRUCTIONS.
  - D. OVERLAY FABRIC WITH ASPHALT TO FINISH GRADE OF STREET.
- D. TACK ALL COLD JOINT SURFACES WITH EMULSION WHICH HAS BEEN "BROKEN" PRIOR TO PATCHING.

**LEGEND**

1. 8" OF 3/4" MINUS CRUSHED AGGREGATE BASE (MIN.) UNLESS A GREATER DEPTH IS OTHERWISE SPECIFIED.
2. MATCH EXISTING PAVEMENT DEPTH TO 6" UNLESS A GREATER DEPTH IS OTHERWISE SPECIFIED. USE A 2 1/2" (MIN.) MAT ON RESIDENTIAL STREETS AND 3" (MIN.) MAT ON COLLECTORS AND ARTERIALS.
3. PORTLAND CEMENT CONCRETE SHALL BE CLASS 3000 psi EARLY STRENGTH, AND COMPLY WITH SECTION-706. CUT ASPHALT MAT IN NEAT STRAIGHT LINE.
4. KEEP TRAFFIC OFF 72 HOURS, UNLESS OTHERWISE APPROVED BY THE ENGINEER.
5. MINIMUM DISTANCES, 4. OVERLAP APPLIES WHERE FABRIC IS BETWEEN ASPHALT LAYERS.
6. CUT ASPHALT IN NEAT STRAIGHT LINE.
7. 3/4" MINUS AGGREGATE SURFACE COURSE (8") OR THICKNESS OF EXISTING GRAVEL, WHICHEVER IS GREATER.
8. THICKNESS EQUALS EXISTING PAVEMENT DEPTH PLUS 2" OF CONCRETE OR PAVEMENT.
9. LOCAL CUTBACK, ONLY IF REQUIRED.
10. COMPACTED TRENCH BACKFILL AS PER SD-301 AND SECTION-306 OF THESE SPECIFICATIONS.
11. ASPHALT TO EXISTING SHELF (MIN 2" THICK).
12. PLACE NEW PAVEMENT FABRIC FULL WIDTH OF ASPHALT PATCH.
13. 4" MINIMUM WIDTH FOR SURFACE RESTORATION.

2 C1.20 STREET CUT & SURFACE REPAIR DETAILS ISPWC - SD-303 NOT TO SCALE

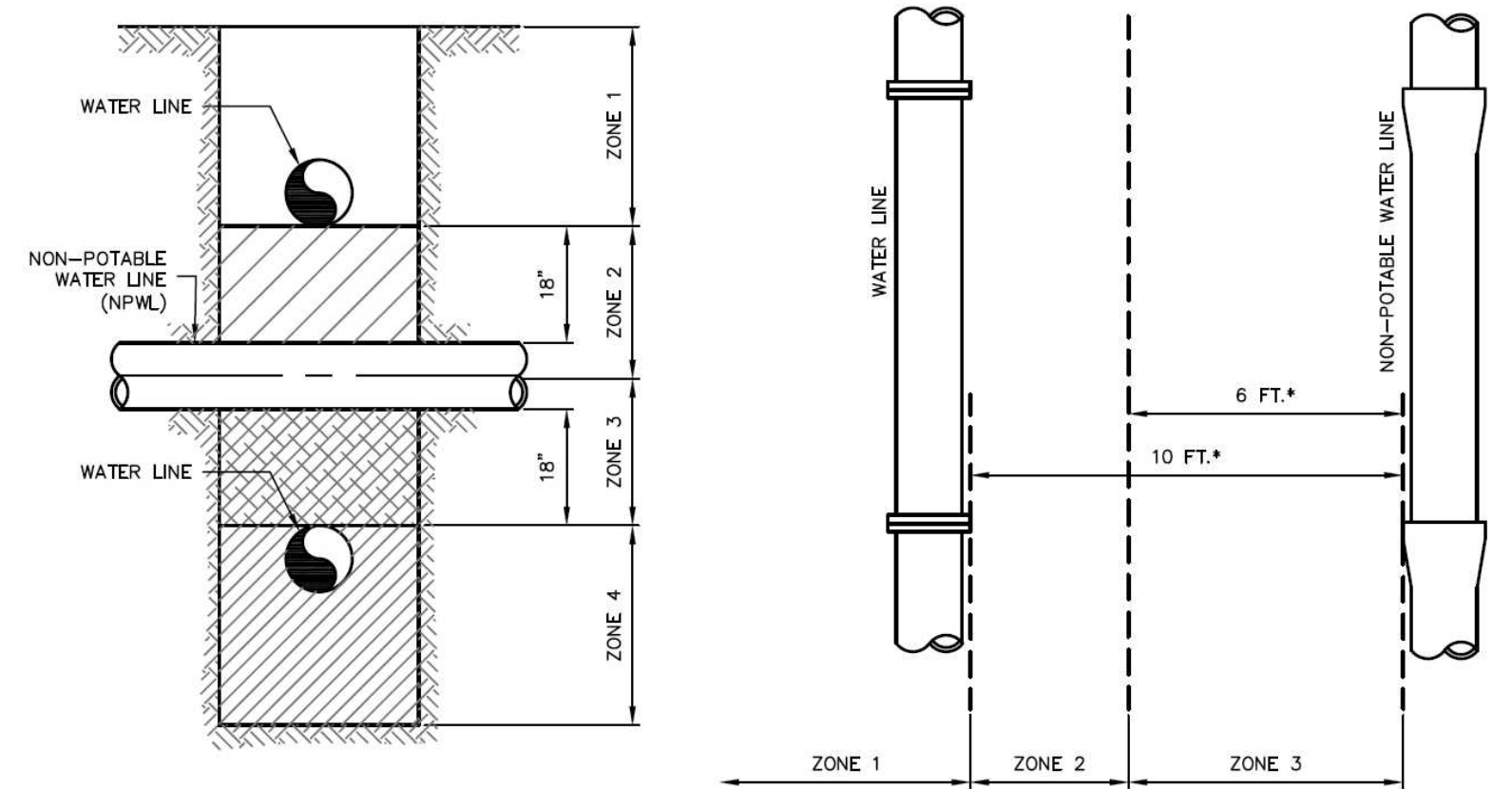

**VERTICAL SEPARATION REQUIREMENTS**

ZONE 1: A) WATER AND NPWL MUST BE SEPARATED BY AT LEAST 18" AND B) ONE FULL UNLCUT LENGTH OF BOTH PWL AND NPWL PIPE MUST BE CENTERED ON THE CROSSING SO THAT THE JOINTS ARE AS FAR AS POSSIBLE FROM THE CROSSING.

ZONE 2: A) ONE FULL UNLCUT LENGTH OF BOTH PWL AND NPWL PIPE MUST BE CENTERED ON THE CROSSING SO THAT THE JOINTS ARE AS FAR AS POSSIBLE FROM THE CROSSING. AND EITHER B) NPWL MUST BE CONSTRUCTED TO WATER MAIN STANDARDS AND PRESSURE TESTED FOR WATER TIGHTNESS FOR A HORIZONTAL DISTANCE OF 10 FEET ON BOTH SIDES OF CROSSING.

OR C) EITHER THE NPWL OR WATER LINE OR BOTH MUST BE ENCASED WITH A SLEEVING MATERIAL ACCEPTABLE TO THE JURISDICTION AUTHORITY FOR WATER TIGHTNESS FOR A HORIZONTAL DISTANCE OF 10 FEET ON BOTH SIDES OF CROSSING.

ZONE 3: SAME REQUIREMENTS AS ZONE 1 EXCEPT THE NPWL MUST ALSO BE SUPPORTED ABOVE THE CROSSING TO PREVENT SETTLING.

ZONE 4: SAME REQUIREMENTS AS ZONE 1 EXCEPT THE NPWL MUST ALSO BE SUPPORTED ABOVE THE CROSSING TO PREVENT SETTLING.

**HORIZONTAL SEPARATION REQUIREMENTS**

ZONE 1: A) NO SPECIAL REQUIREMENTS.

ZONE 2: A) NO SPECIAL REQUIREMENTS FOR POTABLE OR NON-POTABLE SERVICES. B) WATER AND NPWL SEPARATED BY AT LEAST 6 FEET AT OUTSIDE WALLS. AND C) WATER AT LEAST 18 INCHES HIGHER IN ELEVATION THAN THE NPWL. OR D) SITE SPECIFIC REQUIREMENTS APPROVED BY DEQ.

ZONE 3: NOT ALLOWED WITHOUT DEQ WAIVER.

**NOTES:** SANITARY SEWER FORCE MAINS MUST HAVE MIN. 10' HORIZONTAL SEPARATION AND 18" VERTICAL SEPARATION. ZONE 2 AND ZONE 3 PLACEMENTS ARE NOT ALLOWED WITHOUT A WAIVER GRANTED BY DEQ.

3 C1.20 POTABLE AND NON-POTABLE WATER LINE (NPWL) SEPARATION ISPWC - SD-407 NOT TO SCALE

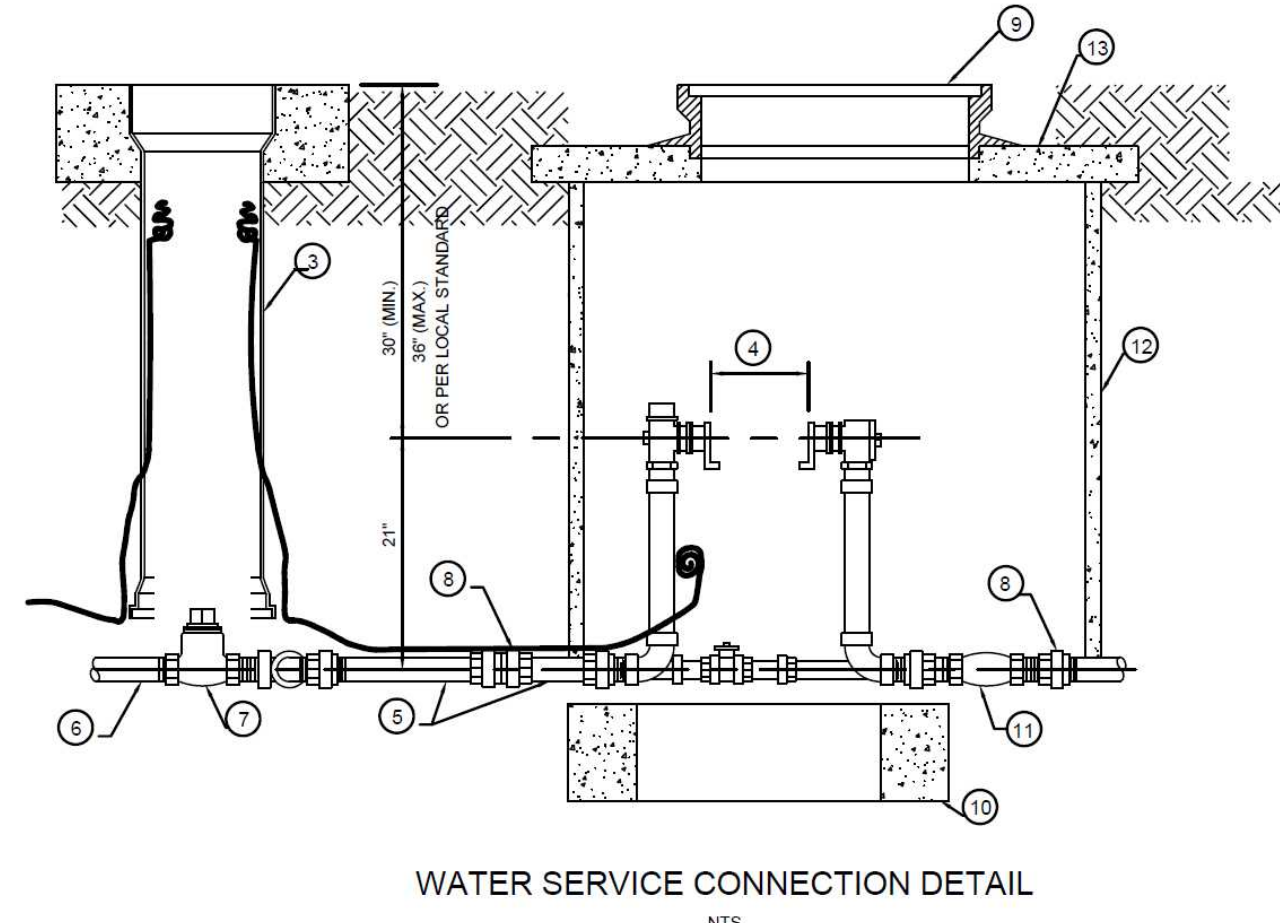

**NOTES**

1. WATER MAIN PER ISPWC SECTION 401.
2. MIP X PAC CORP STOPS: 200 PSI POLY PIPE WITH INSERTS FOR FOR SERVICE LINES FROM MAIN TO CORPS STOPS AND INTO METER VAULT.
3. VALVE BOX
4. 1-1/2" METER: 13-1/4" WITH GASKETS
5. 2" METER: 17-1/4" WITH GASKETS
6. SERVICE LINE: 1-1/2" OR 2", 200 PSI POLYETHYLENE PIPE WITH PACK JOINT BRASS FITTINGS AND STAINLESS STEEL INSERTS.
7. FORD BALL VALVE CURB STOP WITH RISER AND LOCKING LID. (IF REQUIRED)
8. RED BRASS UNION.
9. STANDARD 24" DIA. MANHOLE RING & "WATER" COVER; 2" HOLE IN LID FOR RADIO READ UNIT.
10. 2" X 35" O.D. CONCRETE GRADE RING UNDER YOKE.
11. BALL VALVE TO BE INSTALLED IN METER VAULT. NO OTHER EQUIPMENT SHALL BE PERMITTED WITHIN THE METER VAULT.
12. 36" DIA. PRECAST CONCRETE MANHOLE.
13. 4" X 35" O.D. CONCRETE GRADE RING.

**TAP CONNECTION NTS.**

**NOTES:**

- A. ALL PRODUCTS AS NOTED OR APPROVED SUBSTITUTION.
- B. THE DIAMETER (1-1/2" OR 2") OF EACH APPURTENANCE SHOWN HEREON IS THE SAME AS THE METER SIZE.
- C. NO BY-PASS ALLOWED ON METER SETTERS FOR LANDSCAPE OR PRESSURIZED IRRIGATION SYSTEM.
- D. NO GALVANIZED PIPE OR YELLOW BRASS FITTINGS.
- E. NO TAPS WITHIN ONE FOOT OF THE PIPE ENDS.

4 C1.20 WATER SERVICE CONNECTION (1-1/2", 2") ISPWC - SD-402 NOT TO SCALE

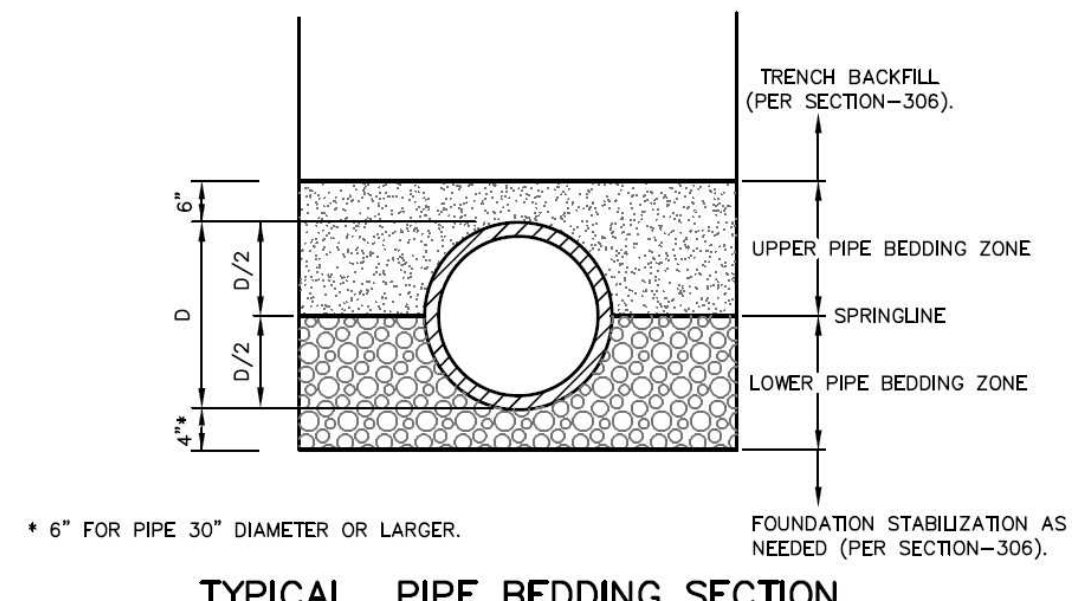

BEDDING SYSTEM	BEDDING MATERIAL	
	LOWER BEDDING ZONE	UPPER BEDDING ZONE
CLASS A-1	TYPE I	TYPE I
CLASS A-2	TYPE I	TYPE II OR TYPE III
CLASS B-1	TYPE II	TYPE II
CLASS B-2	TYPE III	TYPE III
CLASS C-1 (CONCRETE CAP)	TYPE I	TYPE IV
CLASS C-2 (CONCRETE CRADLE)	TYPE IV	TYPE I
CLASS C-3 (CONCRETE ENCASEMENT)	TYPE IV	TYPE IV

5 C1.20 TYPICAL PIPE BEDDING SECTION ISPWC - SD-302 NOT TO SCALE

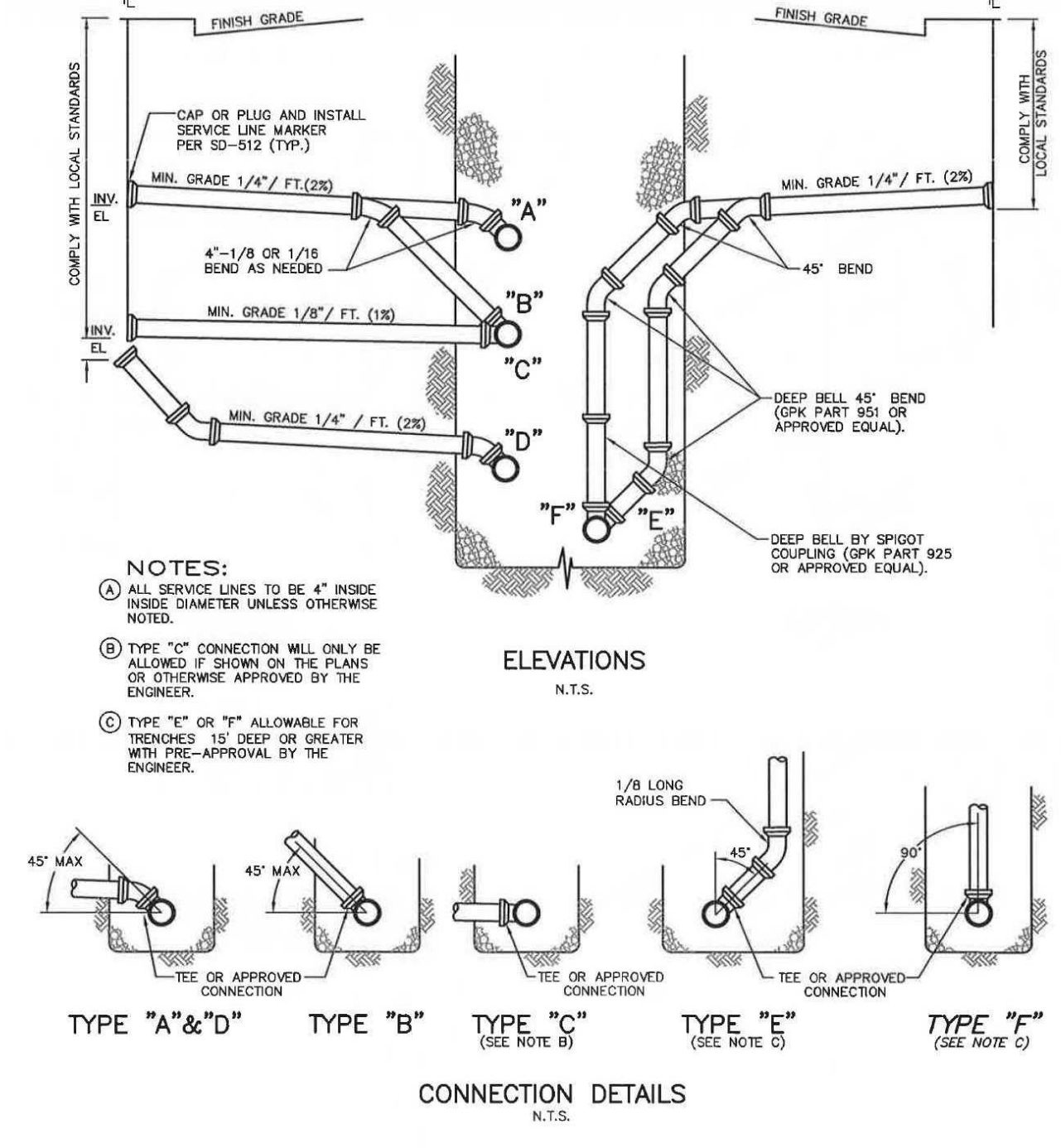

6 C1.20 STANDARD SEWER SERVICE LINE ISPWC - SD-511 NOT TO SCALE

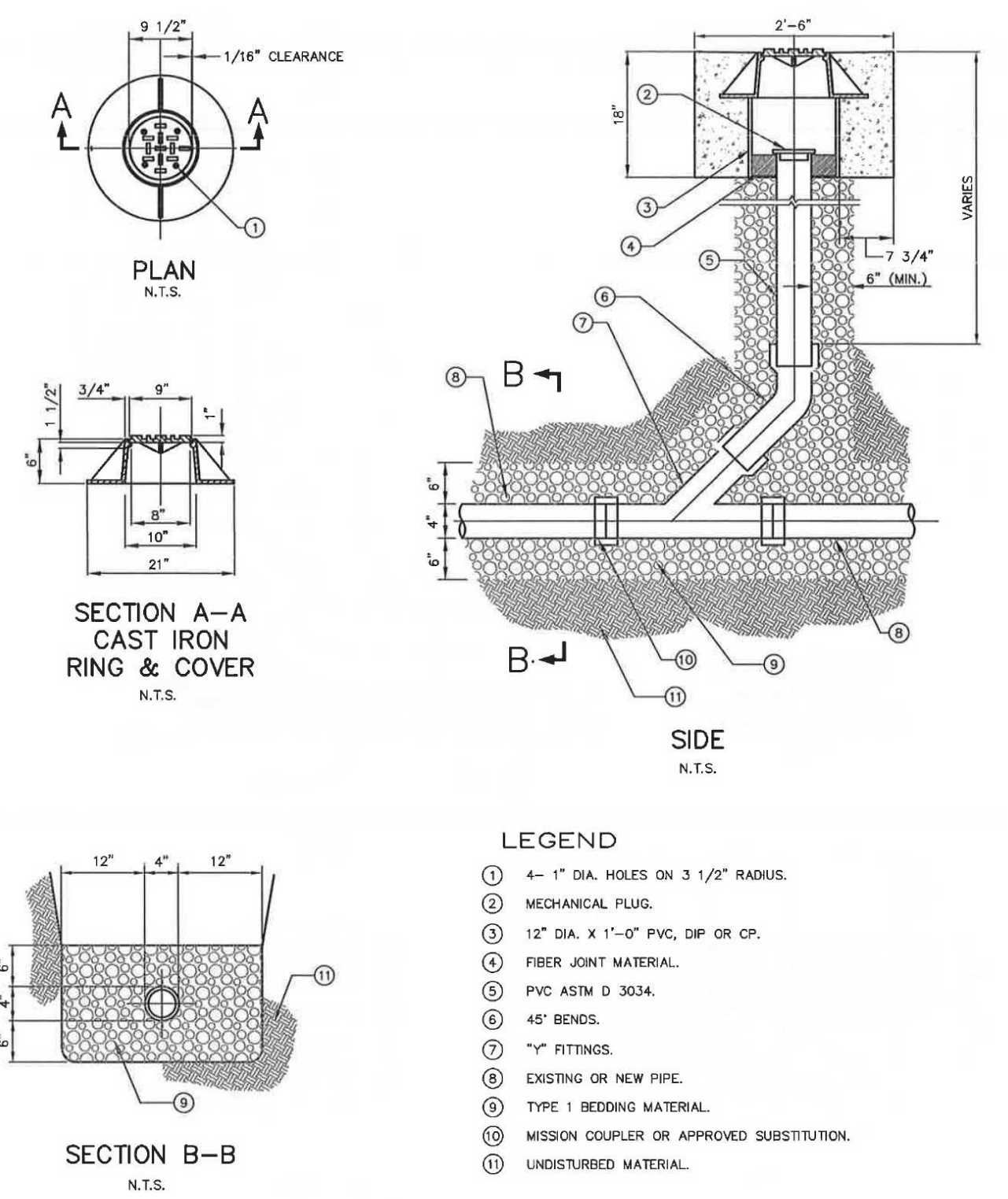

7 C1.20 STANDARD 4" TRAFFIC RATED CLEAN-OUT ISPWC - SD-506A NOT TO SCALE

PROJECT PATH AND PRINT DATE: U:\LandProjects2004\1464\_L16A\_WARM\_SPRGS\_2ND\_ADD.dwg 1464\_L16A\_WarmSpringsVillage2ndAdd\_Bk3L16B\_Civil2026\_Rev3.dwg 03/24/2026 04:21:32 PM MST

A GRADING, RIGHT-OF-WAY IMPROVEMENT & UTILITY PLAN SHOWING LIFT VIEW TOWNHOMES WITHIN S.11, T.4N., R.17E., B.M., CITY OF KETCHUM, BLAINE COUNTY, IDAHO PREPARED FOR JORDAN HOMES

Alpine Enterprises Inc. Surveying, Mapping, Civil Engineering, and Natural Hazards Consulting  
 660 Bell Dr., Unit 1  
 P.O. Box 2037, Ketchum, ID 83340 USA  
 (208) 727-1986  
 email: bsmith@alpineenterprisesinc.com

NO	DATE	BY
1		
2	2/10/25	AHN
3	2/26/25	AHN
4	05/FEB/26	AHN
5	24/MAR/26	AHN

PRELIMINARY: NOT FOR CONSTRUCTION  
 REVISED: PLANNING REVIEW NO. 1  
 REVISED: PLANNING REVIEW NO. 2  
 REVISED: P&Z REVIEW NO. 1  
 REVISED: P&Z REVIEW NO. 1

PROFESSIONAL ENGINEER  
 STATE OF IDAHO  
 NO. 1878  
 ALEX NEVILL

C1.20

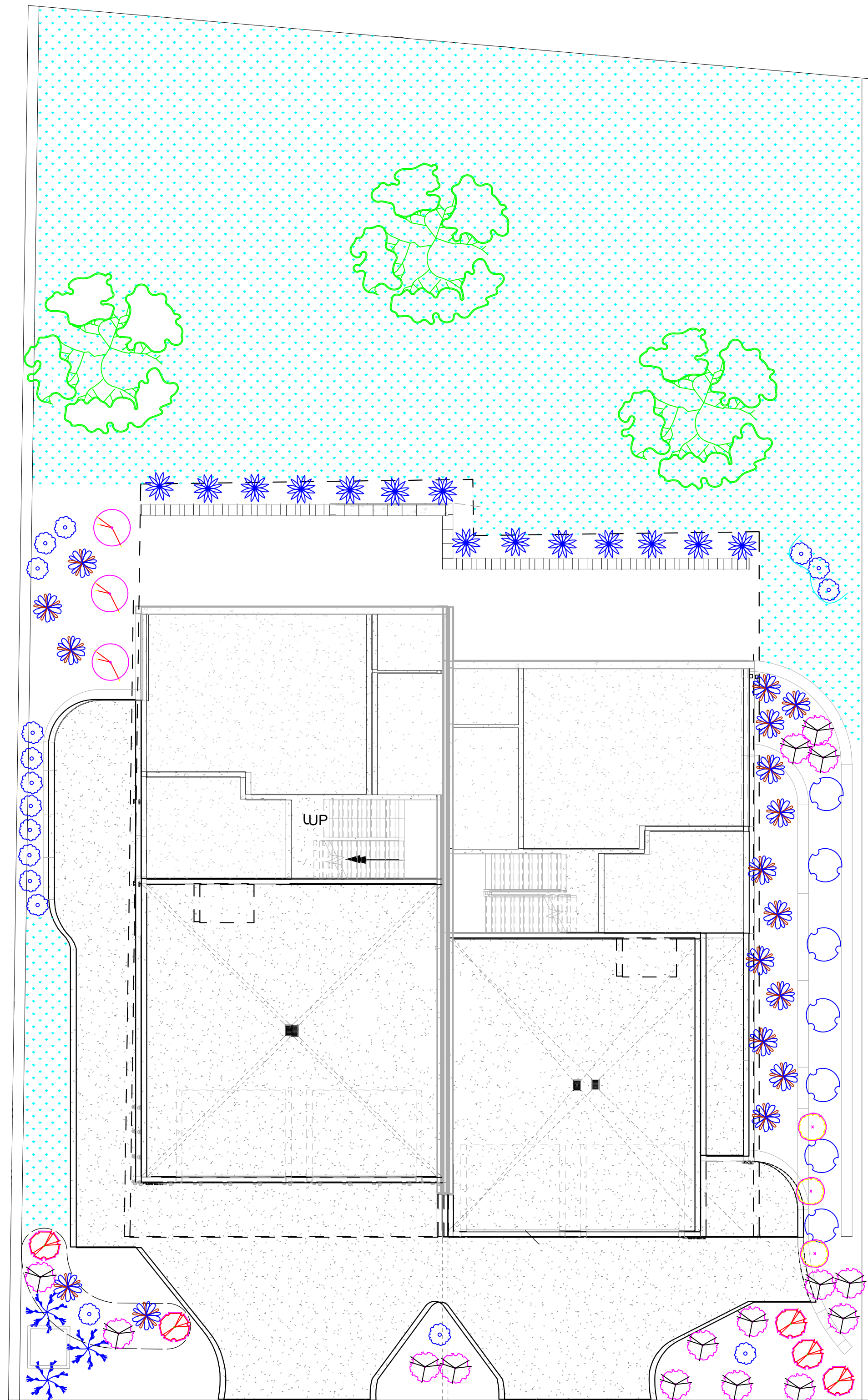

## Plant Legend

-  Weeping White Pine 3
-  Blue Steel Russian Sage 3
-  Karl Foerster Feather Reed Grass 3
-  Honeybee Diervilla Honeysuckle 7
-  Pencil Point Holly 17
-  Halcyon Hosta 15
-  Candy Stripe Creeping Phlox 17
-  Scarlet Flame Creeping Phlox 14
-  Show Off Sugar Baby Forsythia 5
-  Virginia Creeper 3
-  Native Grass Seed Mix

Plant Note: Plant Material is Drought Tolerant. Most plants chosen from: [sunvalleyidaho.gov/vertical/sites/PDF](http://sunvalleyidaho.gov/vertical/sites/PDF)

Mulch Note: All planting beds will have a mulch cover added. Not shown in design because it takes away the visual of the plants in the planter beds.

PROJECT:

Bobbie Jordan  
310 Georgina Road

### Smithscapes Design

Designing landscapes and personalizing your outdoor living space

Twin Falls, ID 83301  
(208) 948-0374  
[smithscapesdesign@gmail.com](mailto:smithscapesdesign@gmail.com)

DRAWING TITLE:  
CONCEPTUAL LANDSCAPE PLAN

DATE: October 25, 2025  
REVISIONS:

March 5, 2026	
March 23, 2026	

SCALE: Not To Scale

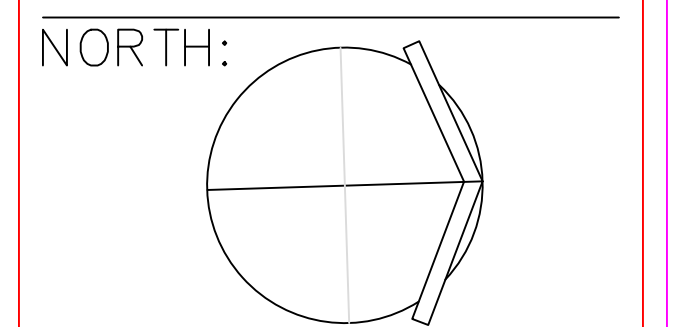

DRAWN BY: LLS

SHEET #:  
1

NOTICE:  
ALL DESIGNS ARE THE PROPERTY OF SMITHSCAPES DESIGN, AND WILL BE UNTIL DESIGN IS PAID IN FULL.

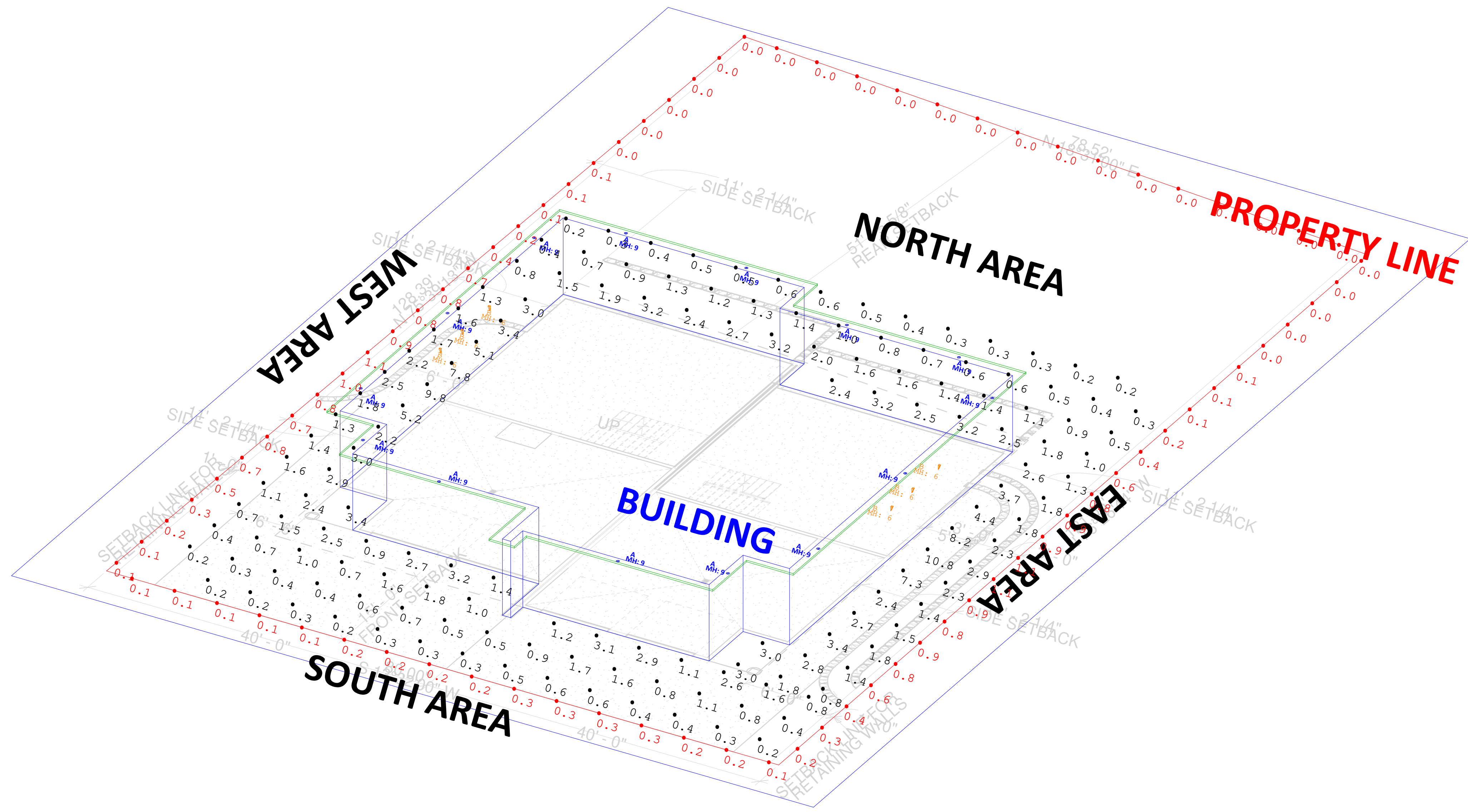

**RENDER VIEW:**

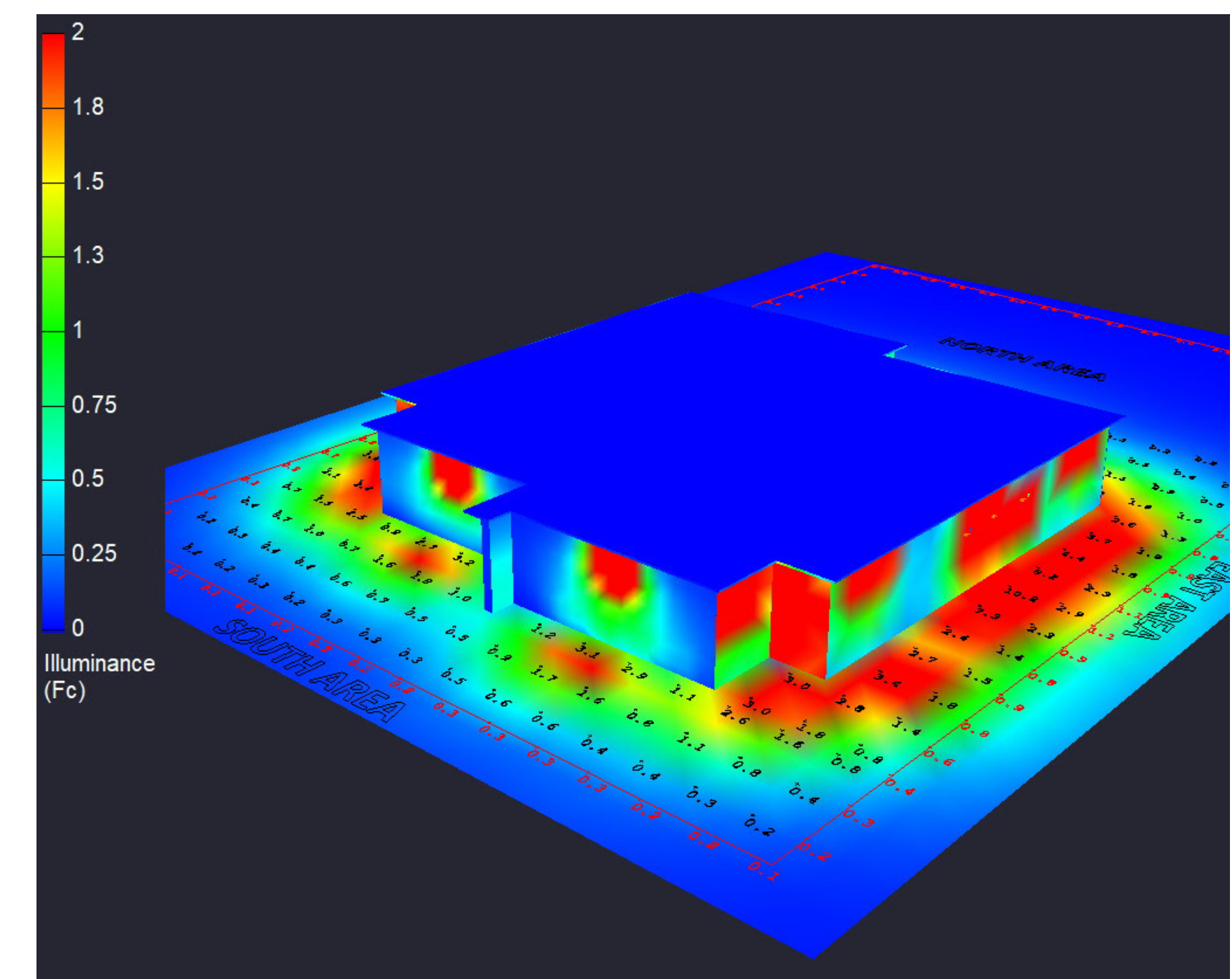
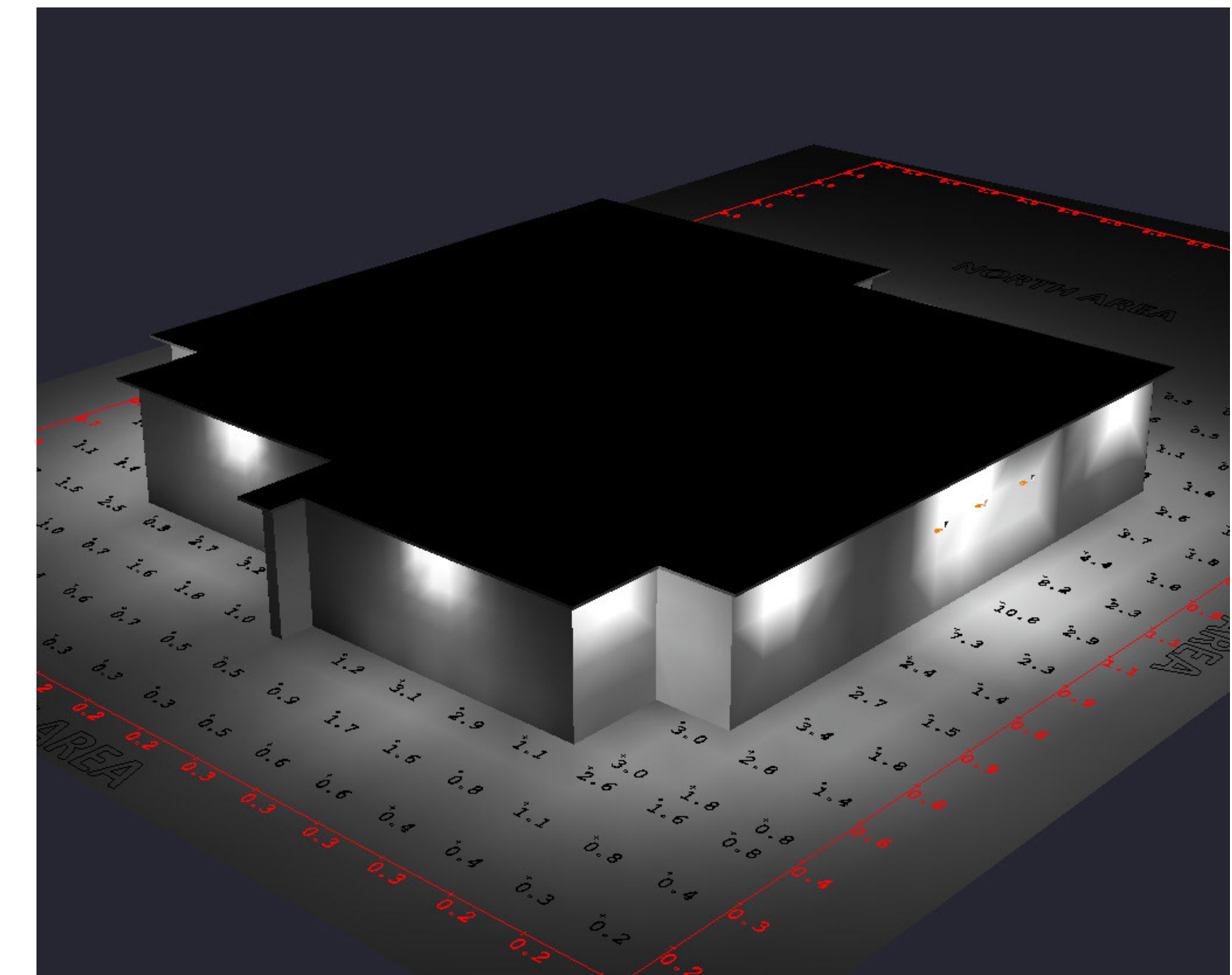

**LIGHTING DETAILS:**

Luminaire Schedule							
Symbol	Qty	Label	LLF	Description	Arr. Watts	Arr. Lum. Lumens	Mounting Height
	14	A	0.900	WF4C RD TUHW MW M6_ 4000K	10.82	807	9
	6	B	0.900	581B-BK-LED_2700K	10.47	396	6

Calculation Summary									
Label	Units	Avg	Max	Min	Avg/Min	Max/Min	PtSpcLr	PtSpcTb	Grid Z
EAST AREA	Fc	3.14	10.8	0.8	3.93	13.50	5	5	0
NORTH AREA	Fc	1.18	3.2	0.2	5.90	16.00	5	5	0
PROPERTY LINE	Fc	0.30	1.1	0.0	N.A.	N.A.	5	N.A.	N.A
SOUTH AREA	Fc	1.06	3.4	0.2	5.30	17.00	5	5	0
WEST AREA	Fc	3.21	9.8	1.3	2.47	7.54	5	5	0



**DESIGN NOTES:**

1. BUILDING LEVEL 1 HEIGHT: 9'
2. MOUNTING HEIGHT: AS LABEL
3. MEASUREMENTS TAKEN @ 0AFF
4. SURFACE REFLECTANCE: 50 / 50 / 50
5. SOFFIT WIDTH: 1'

**PLAN VIEW:**

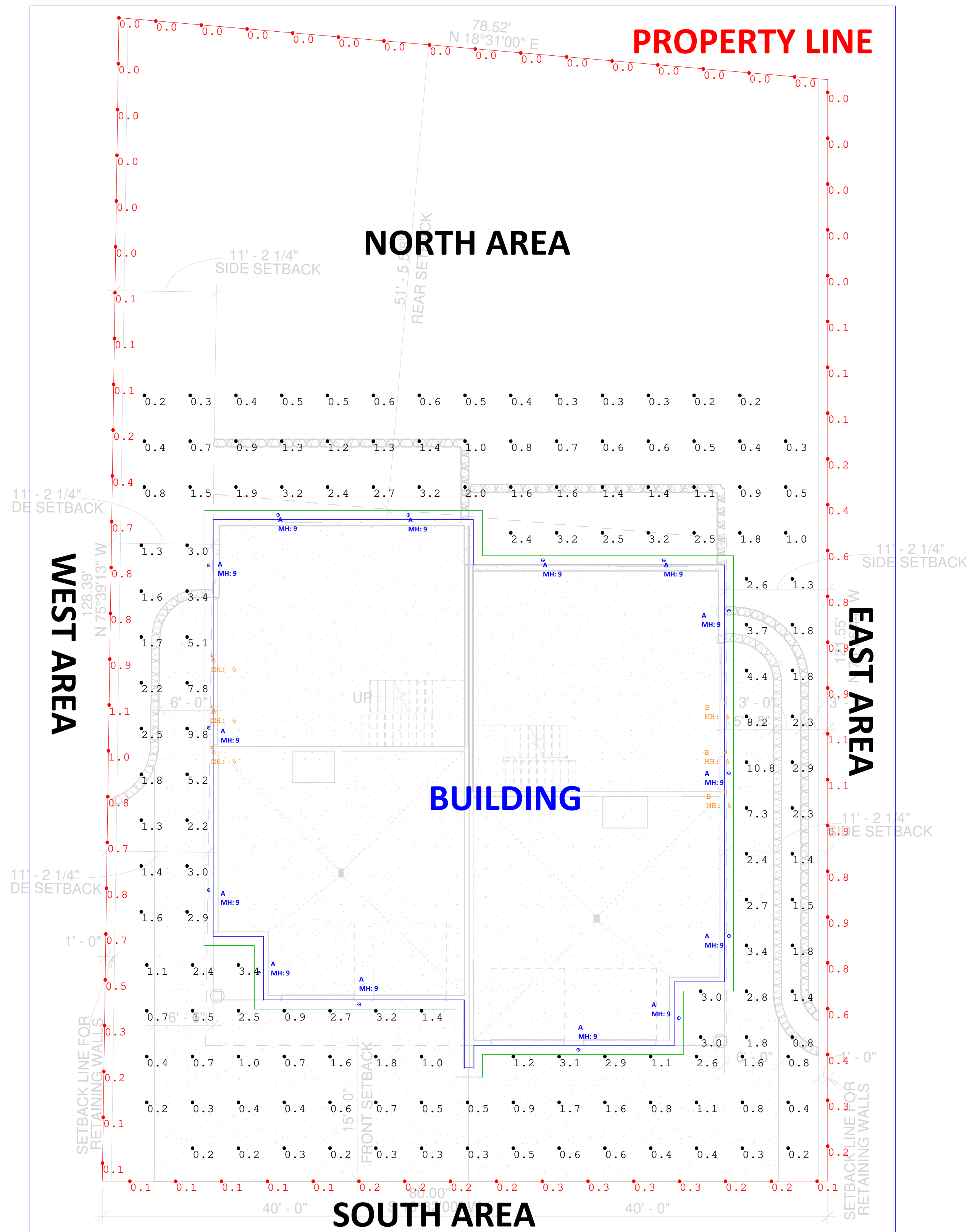

Paper Size: ARCH D  
 Scale: 1 inch= 8 Ft.



City of Ketchum

# Attachment C: Preliminary Plat Application & Supplemental Materials



**City of Ketchum  
Planning & Building**

OFFICIAL USE ONLY
Application Number:
Date Received:
By:
Fee Paid:
Approved Date:
By:

**Subdivision Application-Preliminary Plat**

Submit completed application and documentation to [planningandzoning@ketchumidaho.org](mailto:planningandzoning@ketchumidaho.org) Or hand deliver to Ketchum City Hall, 191 5<sup>th</sup> St. W. Ketchum, ID If you have questions, please contact the Planning and Building Department at (208) 726-7801. To view the Development Standards, visit the City website at: [www.ketchumidaho.org](http://www.ketchumidaho.org) and click on Municipal Code. You will be contacted and invoiced once your application package is complete.

APPLICANT INFORMATION			
Name of Proposed Subdivision: Lift View Townhomes			
Owner of Record: Bobbie Jordan			
Address of Owner: P.O. Box 983, Eagle, ID 83616			
Representative of Owner: Bruce Smith, Alpine Enterprises Inc.		Phone #: (208) 727-1988	
Email: bsmith@alpineenterprisesinc.com			
Legal Description: Lot 6B, Block 3, Warms Springs Village Subdivision, Second Addition RPK 0590003006B			
Street Address: 310 Georgia Road			
SUBDIVISION INFORMATION			
Number of Lots/Parcels: 2 Townhouse Sublots			
Total Land Area: 9,846 S.F. - 0.23 AC.			
Current Zoning District: General Residential Low Density District (GR-L)			
Proposed Zoning District: General Residential Low Density District (GR-L)			
Overlay District: Avalanche Overlay District (A)			
TYPE OF SUBDIVISION			
Condominium <input type="checkbox"/>	Land <input type="checkbox"/>	PUD <input type="checkbox"/>	Townhouse <input checked="" type="checkbox"/>
Adjacent land in same ownership in acres or square feet: N/A			
Easements to be dedicated on the final plat: The Lift View Townhomes Sublots shall have Mutual Reciprocal Snow Storage Easements and Utility Easements for the Installation, Repair, Maintenance, and Replacement of Utilities.			
Briefly describe the improvements to be installed prior to final plat approval: Prior to Final Plat, the applicant shall fully construct both townhouse units as well as all necessary site and right-of-way improvements required for the issuance of the Certificate of Occupancy.			
ADDITIONAL INFORMATION			
All lighting must be in compliance with the City of Ketchum's Dark Sky Ordinance One (1) copy of Articles of Incorporation and By-Laws of Homeowners Associations and/or Condominium Declarations One (1) copy of current title report and owner's recorded deed to the subject property One (1) copy of the preliminary plat All files should be submitted in an electronic format to <a href="mailto:planningandzoning@ketchumidaho.org">planningandzoning@ketchumidaho.org</a>			

Applicant agrees in the event of a dispute concerning the interpretation or enforcement of the Subdivision Application in which the City of Ketchum is the prevailing party to pay reasonable attorney's fees and costs, including fees and costs of appeal for the City of Ketchum. Applicant agrees to observe all City ordinances, laws and conditions imposed. Applicant agrees to defend, hold harmless and indemnify the City of Ketchum, city officials, agents and employees from and for any and all losses, claims, actions, judgments for damages, or injury to persons or property, and losses and expenses caused or incurred by Applicant, its servants, agents, employees, guests and business invitees and not caused by or arising out of the tortuous conduct of city or its officials, agents or employees. Applicant certifies that s/he has read and examined this application and that all information contained herein is true and correct.

*Bruce S.*

10/28/2025

Representative's Signature  
Bruce Smith, Alpine Enterprises Inc.

Date



Copyright nearmap 2015



A Vicinity Map Showing  
310 Georgia Rd., Warm Spgs Vlg 2nd ADD, Lot 6B  
City of Ketchum, Blaine County, Idaho

ALPINE ENTERPRISES INC.

PO Box 2037  
660 Bell Drive, Unit 1  
Ketchum, Idaho  
208-727-1988



May 2025

## **Sun Valley Title**

 A TitleOne Company

Order Number: 24512056

### **Warranty Deed**

For value received,

**James G. Hanes, III, Trustee or his duly qualified successor trustee of the Martin Family Trust**

the grantor, does hereby grant, bargain, sell, and convey unto

**Bobbie Jordan, a single woman**

whose current address is PO Box 983 Eagle, ID 83616

the grantee, the following described premises, in Blaine County, Idaho, to wit:

**See Exhibit A, attached hereto and incorporated herein.**

To have and to hold the said premises, with their appurtenances unto the said Grantee, its heirs and assigns forever. And the said Grantor does hereby covenant to and with the said Grantee, that Grantor is the owner in fee simple of said premises; that they are free from all encumbrances except those to which this conveyance is expressly made subject and those made, suffered or done by the Grantee; and subject to all existing patent reservations, easements, right(s) of way, protective covenants, zoning ordinances, and applicable building codes, laws and regulations, general taxes and assessments, including irrigation and utility assessments (if any) for the current year, which are not due and payable, and that Grantor will warrant and defend the same from all lawful claims whatsoever. Whenever the context so requires, the singular number includes the plural.

Remainder of page intentionally left blank.

Order Number: 24512056

Warranty Deed - Page 1 of 3

Dated: July 24, 2024

Martin Family Trust

James G. Hanes III  
By James G. Hanes, III, Trustee

State of North Carolina, County of Forsyth, ss.

On this 30<sup>th</sup> day of July in the year of 2024, before me, the undersigned, a notary public in and for said state personally appeared James G. Hanes, III, known or identified to me to be the person whose name is subscribed to the within instrument, as trustee of Martin Family Trust and acknowledged to me that he/she executed the same as trustee.

Susan L. Steadman  
Notary Public  
Residing In: Forsyth County, North Carolina  
My Commission Expires: 02/08/2028  
(seal)

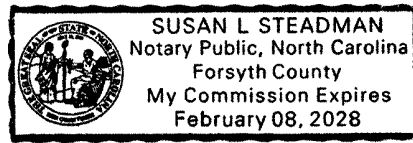

**EXHIBIT A**  
**LEGAL DESCRIPTION OF THE PREMISES**

Lot 6B, Block 3 of THE REPLAT OF LOT 6B, REPLAT OF LOT 6 BLOCK 3 AND SOUTHERLY PORTION OF LOT 5 BLOCK 3 WARM SPRINGS VILLAGE SUBDIVISION, SECOND ADDITION, BLAINE COUNTY, IDAHO, according to the official plat thereof, recorded as Instrument No. 326129, records of Blaine County, Idaho.



CLTA GUARANTEE FORM NO. 12  
LOT BOOK  
Issued By  
TITLE RESOURCES GUARANTY COMPANY

SUBJECT TO THE EXCLUSIONS FROM COVERAGE, AND THE GUARANTEE CONDITIONS ATTACHED HERETO AND MADE A PART OF THIS GUARANTEE,

**TITLE RESOURCES GUARANTY COMPANY**  
a corporation, herein called the Company,

**GUARANTEES**

the Assured named in Schedule A against loss not exceeding the liability amount stated in Schedule A sustained by the Assured by reason of any incorrectness in the set forth in Schedule A.

**Authorized Issuing Agent:**  
**TITLEONE**

**TITLE RESOURCES GUARANTY COMPANY**

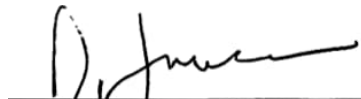
By:   
J. Scott McCall, President/CEO

By:   
Owen E. Girard, Secretary

**EXCLUSIONS FROM COVERAGE**

Except as expressly provided by the assurances in Schedule A, the Company assumes no liability for loss or damage by reason of the following:

- (a) Defects, liens, encumbrances, adverse claims or other matters affecting the title to any property beyond the lines of the Land.
- (b) Defects, liens, encumbrances, adverse claims or other matters, whether or not shown by the Public Records (1) that are created, suffered, assumed or agreed to by one or more of the Assureds; or (2) that result in no loss to the Assured.
- (c) Defects, liens, encumbrances, adverse claims or other matters not shown by the Public Records.
- (d) The identity of any party shown or referred to in any of the schedules of this Guarantee.
- (e) The validity, legal effect or priority of any matter shown or referred to in any of the schedules of this Guarantee.
- (f) (1) Taxes or assessments of any taxing authority that levies taxes or assessments on real property; or, (2) proceedings by a public agency which may result in taxes or assessments, or notices of such proceedings, whether or not the matters excluded under (1) or (2) are shown by the records of the taxing authority or by the Public Records.
- (g) (1) Unpatented mining claims; (2) reservations or exceptions in patents or in Acts authorizing the issuance thereof; (3) water rights, claims or title to water, whether or not the matters excluded under (1), (2) or (3) are shown by the Public Records.

## GUARANTEE CONDITIONS

1. Definition of Terms.

The following terms when used in the Guarantee mean:

- (a) the "Assured": the party or parties named as the Assured in Schedule A, or on a supplemental writing executed by the Company.
- (b) "Land": the Land described or referred to in Schedule A, and improvements affixed thereto which by law constitute real property. The term "Land" does not include any property beyond the lines of the area described or referred to in Schedule A, nor any right, title, interest, estate or easement in abutting streets, roads, avenues, alleys, lanes, ways or waterways.
- (c) "Mortgage": mortgage, deed of trust, trust deed, or other security instrument.
- (d) "Public Records": those records established under California statutes at Date of Guarantee for the purpose of imparting constructive notice of matters relating to real property to purchasers for value and without knowledge.
- (e) "Date of Guarantee": the Date of Guarantee set forth in Schedule A.
- (f) "Amount of Liability": the Amount of Liability as stated in Schedule A.

2. Notice of Claim to be Given by Assured.

The Assured shall notify the Company promptly in writing in case knowledge shall come to the Assured of any assertion of facts, or claim of title or interest that is contrary to the assurances set forth in Schedule A Schedule A and that might cause loss or damage for which the Company may be liable under this Guarantee. If prompt notice shall not be given to the Company, then all liability of the Company shall terminate with regard to the matter or matters for which prompt notice is required; provided, however, that failure to notify the Company shall in no case prejudice the rights of the Assured under this Guarantee unless the Company shall be prejudiced by the failure and then only to the extent of the prejudice.

3. No Duty to Defend or Prosecute.

The Company shall have no duty to defend or prosecute any action or proceeding to which the Assured is a party, notwithstanding the nature of any allegation in such action or proceeding.

4. Company's Option to Defend or Prosecute Actions; Duty of Assured to Cooperate.

Even though the Company has no duty to defend or prosecute as set forth in Paragraph 3 above:

- (a) The Company shall have the right, at its sole option and cost, to institute and prosecute any action or proceeding, interpose a defense, as limited in Paragraph 4 (b), or to do any other act which in its opinion may be necessary or desirable to establish the correctness of the assurances set forth in Schedule A or to prevent or reduce loss or damage to the Assured. The Company may take any appropriate action under the terms of this Guarantee, whether or not it shall be liable hereunder, and shall not thereby concede liability or waive any provision of this Guarantee. If the Company shall exercise its rights under this paragraph, it shall do so diligently.
- (b) If the Company elects to exercise its options as stated in Paragraph 4(a) the Company shall have the right to select counsel of its choice (subject to the right of the Assured to object for reasonable cause) to represent the Assured and shall not be liable for and will not pay the fees of any other counsel, nor will the Company pay any fees, costs or expenses incurred by an Assured in the defense of those causes of action which allege matters not covered by this Guarantee.
- (c) Whenever the Company shall have brought an action or interposed a defense as permitted by the provisions of this Guarantee, the Company may pursue any litigation to final determination by a court of competent jurisdiction and expressly reserves the right, in its sole discretion, to appeal from an adverse judgment or order.
- (d) In all cases where this Guarantee permits the Company to prosecute or provide for the defense of any action or proceeding, the Assured shall secure to the Company the right to so prosecute or provide for the defense of any action or proceeding, and all appeals therein, and permit the Company to use, at its option, the name of the Assured for this purpose. Whenever requested by the Company, the Assured, at the Company's expense, shall give the Company all reasonable aid in any action or proceeding, securing evidence, obtaining witnesses, prosecuting or defending the action or lawful act which in the opinion of the Company may be necessary or desirable to establish the correctness of the assurances set forth in Schedule A or to prevent or reduce loss or damage to the Assured.. If the Company is prejudiced by the failure of the Assured to furnish the required cooperation, the Company's obligations to the Assured under the Guarantee shall terminate.

5. Proof of Loss or Damage.

- (a) In the event the Company is unable to determine the amount of loss or damage, the Company may, at its option, require as a condition of payment that the Assured furnish a signed proof of loss. The proof of loss must describe the defect, lien, encumbrance, or other matter that constitutes the basis of loss or damage and shall state, to the extent possible, the basis of calculating the amount of the loss or damage.
- (b) In addition, the Assured may reasonably be required to submit to examination under oath by any authorized representative of the Company and shall produce for examination, inspection and copying, at such reasonable times and places as may be designated by any authorized representative of the Company, all records, books, ledgers, checks, correspondence and memoranda, whether bearing a date before or after Date of Guarantee, which reasonably pertain to the loss or damage. Further, if requested by any authorized representative of the Company, the Assured shall grant its permission, in writing, for any authorized representative of the Company to examine, inspect and copy all records, books, ledgers, checks, correspondence and memoranda in the custody or control of a third party, which reasonably pertain to the loss or damage. All information designated as confidential by the Assured provided to the Company pursuant to this paragraph shall not be disclosed to others unless, in the reasonable judgment of the Company, it is necessary in the administration of the claim. Failure of the Assured to submit for examination under oath, produce other reasonably requested information or grant permission to secure reasonably necessary information from third parties as required in the above paragraph, unless prohibited by law or governmental regulation, shall terminate any liability of the Company under this Guarantee to the Assured for that claim.

6. Options to Pay or Otherwise Settle Claims: Termination of Liability.

In case of a claim under this Guarantee, the Company shall have the following additional options:

- (a) To pay or tender payment of the Amount of Liability together with any costs, attorneys' fees, and expenses incurred by the Assured that were authorized by the Company up to the time of payment or tender of payment and that the Company is obligated to pay.
- (b) To pay or otherwise settle with the Assured any claim assured against under this Guarantee. In addition, the Company will pay any costs, attorneys' fees, and expenses incurred by the Assured that were authorized by the Company up to the time of payment or tender of payment and that that the Company is obligated to pay; or
- (c) To pay or otherwise settle with other parties for the loss or damage provided for under this Guarantee, together with any costs, attorneys' fees, and expenses incurred by the Assured that were authorized by the Company up to the time of payment and that the Company is obligated to pay.

Upon the exercise by the Company of either of the options provided for in 6 (a), (b) or (c) of this paragraph the Company's obligations to the Assured under this Guarantee for the claimed loss or damage, other than the payments required to be made, shall terminate, including any duty to continue any and all litigation initiated by the Company pursuant to Paragraph 4.

7. Limitation of Liability.

- (a) This Guarantee is a contract of Indemnity against actual monetary loss or damage sustained or incurred by the Assured claimant who has suffered loss or damage by reason of reliance upon the assurances set forth in Schedule A and only to the extent herein described, and subject to the Exclusions From Coverage of this Guarantee.
- (b) If the Company, or the Assured under the direction of the Company at the Company's expense, removes the alleged defect, lien or, encumbrance or cures any other matter assured against by this Guarantee in a reasonably diligent manner by any method, including litigation and the completion of any appeals therefrom, it shall have fully performed its obligations with respect to that matter and shall not be liable for any loss or damage caused thereby.
- (c) In the event of any litigation by the Company or with the Company's consent, the Company shall have no liability for loss or damage until there has been a final determination by a court of competent jurisdiction, and disposition of all appeals therefrom.
- (d) The Company shall not be liable for loss or damage to the Assured for liability voluntarily assumed by the Assured in settling any claim or suit without the prior written consent of the Company.

8. Reduction of Liability or Termination of Liability.

All payments under this Guarantee, except payments made for costs, attorneys' fees and expenses pursuant to Paragraph 4 shall reduce the Amount of Liability under this Guarantee pro tanto.

9. Payment of Loss.

- (a) No payment shall be made without producing this Guarantee for endorsement of the payment unless the Guarantee has been lost or destroyed, in which case proof of loss or destruction shall be furnished to the satisfaction of the Company.
- (b) When liability and the extent of loss or damage has been definitely fixed in accordance with these Conditions, the loss or damage shall be payable within thirty (30) days thereafter.

10. Subrogation Upon Payment or Settlement.

Whenever the Company shall have settled and paid a claim under this Guarantee, all right of subrogation shall vest in the Company unaffected by any act of the Assured claimant.

The Company shall be subrogated to and be entitled to all rights and remedies which the Assured would have had against any person or property in respect to the claim had this Guarantee not been issued. If requested by the Company, the Assured shall transfer to the Company all rights and remedies against any person or property necessary in order to perfect this right of subrogation. The Assured shall permit the Company to sue, compromise or settle in the name of the Assured and to use the name of the Assured in any transaction or litigation involving these rights or remedies.

If a payment on account of a claim does not fully cover the loss of the Assured the Company shall be subrogated to all rights and remedies of the Assured after the Assured shall have recovered its principal, interest, and costs of collection.

11. Arbitration.

Either the Company or the Assured may demand that the claim or controversy shall be submitted to arbitration pursuant to the Title Insurance Arbitration Rules of the American Land Title Association ("Rules"). Except as provided in the Rules, there shall be no joinder or consolidation with claims or controversies of other persons. Arbitrable matters may include, but are not limited to, any controversy or claim between the Company and the Assured arising out of or relating to this Guarantee, any service of the Company in connection with its issuance or the breach of a Guarantee provision, or to any other controversy or claim arising out of the transaction giving rise to this Guarantee. All arbitrable matters when the amount of liability is \$2,000,000 or less shall be arbitrated at the option of either the Company or the Assured. All arbitrable matters when the amount of liability is in excess of \$2,000,000 shall be arbitrated only when agreed to by both the Company and the Assured. Arbitration pursuant to this Guarantee and under the Rules shall be binding upon the parties. Judgment upon the award rendered by the Arbitrator(s) may be entered in any court of competent jurisdiction.

12. Liability Limited to This Guarantee; Guarantee Entire Contract.

- (a) This Guarantee together with all endorsements, if any, attached hereto by the Company is the entire Guarantee and contract between the Assured and the Company. In interpreting any provision of this Guarantee, this Guarantee shall be construed as a whole.
- (b) Any claim of loss or damage, whether or not based on negligence, or any action asserting such claim, shall be restricted to this Guarantee.
- (c) No amendment of or endorsement to this Guarantee can be made except by a writing endorsed hereon or attached hereto signed by either the President, a Vice President, the Secretary, an Assistant Secretary, or validating officer or authorized signatory of the Company.

13. Severability

In the event any provision of this Guarantee, in whole or in part, is held invalid or unenforceable under applicable law, the Guarantee shall be deemed not to include that provision or such part held to be invalid, but all other provisions shall remain in full force and effect.

14. Choice of Law; Forum

- (a) Choice of Law: The Assured acknowledges the Company has underwritten the risks covered by this Guarantee and determined the premium charged therefor in reliance upon the law affecting interests in real property and applicable to the interpretation, rights, remedies, or enforcement of Guaranties of the jurisdiction where the Land is located.

Therefore, the court or an arbitrator shall apply the law of the jurisdiction where the Land is located to determine the validity of claims that are adverse to the Assured and to interpret and enforce the terms of this Guarantee. In neither case shall the court or arbitrator apply its conflicts of law principles to determine the applicable law.

- (b) Choice of Forum: Any litigation or other proceeding brought by the Assured against the Company must be filed only in a state or federal court within the United States of America or its territories having appropriate jurisdiction.

15. Notices, Where Sent.

All notices required to be given the Company and any statement in writing required to be furnished the Company shall include the number of this Guarantee and shall be addressed to the Company at 8111 LBJ Freeway, Ste. 1200, Dallas, TX 75251, or [claims@titleresources.com](mailto:claims@titleresources.com).

**LOT BOOK GUARANTEE**  
**Issued By**  
**Title Resources Guaranty Company**

**SCHEDULE A**

**File No.** 25545567  
**State:** ID  
**County:** Blaine

<u>Guarantee No.</u>	<u>Liability</u>	<u>Date of Guarantee</u>	<u>Fee</u>
3581-LBG-25545567	\$1,000.00	April 3, 2025 at 7:30 a.m.	\$150.00

**Name of Assured:**  
Alpine Enterprises Inc.

The assurances referred to on the face page hereof are:

1. That, according to the Company's property records relative to the following described land (but without examination of those Company records maintained and indexed by name):

Lot 6B, Block 3 of THE REPLAT OF LOT 6B, REPLAT OF LOT 6 BLOCK 3 AND SOUTHERLY PORTION OF LOT 5 BLOCK 3 WARM SPRINGS VILLAGE SUBDIVISION, SECOND ADDITION, BLAINE COUNTY, IDAHO, according to the official plat thereof, recorded as Instrument No. 326129, records of Blaine County, Idaho.

2. The last recorded instrument purporting to transfer title to said land is:

Deed Type: Warranty Deed  
Grantors: James G. Hanes, III, Trustee or his duly qualified successor trustee of the Martin Family Trust  
Grantees: Bobbie Jordan, a single woman  
Recorded Date: August 2, 2024  
Instrument: 707433  
[Click here to view](#)

3. There are no mortgages or deeds of trust which purport to affect title to said land, other than those shown below under Exceptions.
4. There are no (homesteads, agreements to convey, attachments, notices of non-responsibility, notices of completion, tax deeds) which purport to affect title to said land, other than shown below under Exceptions.
5. No guarantee is made regarding (a) matters affecting the beneficial interest of any mortgage or deed of trust which may be shown herein as an exception, or (b) other matters which may affect any such mortgage or deed of trust.
6. No guarantee is made regarding any liens, claims of liens, defects or encumbrances other than those specifically provided for above, and, if information was requested by reference to a street address, no guarantee is made that said land is the same as said address.

**EXCEPTIONS:**

1. NOTE: According to the available records, the purported address of the land referenced herein is:

310 Georgia Rd, Ketchum, ID 83340

2. Taxes for the year 2024 are paid in full.

Parcel Number: [RPK0590003006B](#)

Original Amount: \$3,439.96

3. Taxes, including any assessments collected therewith, for the year 2025 which are a lien not yet due and payable.

4. The Land described herein is located within the boundaries of the City of Ketchum and is subject to any assessments levied thereby.

5. Easements, reservations, restrictions, and dedications as shown on the official plat of Warm Springs Village Subdivision 2nd Addition.
6. Easements, reservations, restrictions, and dedications as shown on the official plat of the Replat of Lot 6, Block 3, Warm Springs Village Subdivision, Second Addition.
7. Easements, reservations, restrictions, and dedications as shown on the official plat of the [Replat of Lot 6B, Replat of Lot 6, Block 3 and Southerly Portion of Lot 5, Block 3, Warm Springs Village Subd., Second Addition](#).
8. Reservations and exceptions in a United States Patent, and in the act authorizing the issuance thereof, recorded June 23, 1924 as Instrument No. [55385](#) and amended by Patent [58955](#), records of Blaine County, Idaho.
9. Right of way for ditches, tunnels, telephone, and distribution lines constructed by authority of the United States, as granted to the United States under the provisions of Section 58-604 Idaho Code.
10. An easement, including the terms and conditions thereof, for the purposes shown below and rights incidental thereto as set forth in a document.  
Granted to: Idaho Power Company  
Purpose: Public Utilities  
Recorded: September 13, 1960  
Instrument No.: [114480](#), records of Blaine County, Idaho.
11. An easement, including the terms and conditions thereof, for the purposes shown below and rights incidental thereto as set forth in a document.  
Granted to: Idaho Power Company  
Purpose: Public Utilities  
Recorded: August 17, 1962  
Instrument No.: [117325](#), records of Blaine County, Idaho.
12. Terms and conditions contained in a/an Affidavit as to Identification of Plats and Descriptions of Real Property within the Avalanche Zone.  
Recorded: October 10, 1979  
Instrument No.: [197578](#), records of Blaine County, Idaho.

Sun Valley Title  
By:



Nick Busdon, Authorized Signatory

**JUDGMENT AND TAX LIEN GUARANTEE**

Issued By  
Title Resources Guaranty Company

**SCHEDULE A**

**Amount of Liability:** \$1,000.00

**Fee Amount:** \$0.00

**Guarantee No.:** 3581-LBG-25545567

**Name of Assured:** Alpine Enterprises Inc.

**Date of Guarantee:** April 3, 2025

That, according to the indices of the County Recorder of Blaine County, State of ID, for a period of 10 years immediately prior to the date hereof, there are no

- \* Federal Tax Liens
- \* Abstracts of Judgment, or
- \* Certificates of State Tax Liens

filed, or recorded against the herein named parties, other than those for which a release appears in said indices and other than those shown under Exceptions.

The parties referred to in this guarantee are as follows:

Bobbie Jordan, a single woman

Sun Valley Title  
By:



Nick Busdon, Authorized Signatory

SCHEDULE B

Exceptions:

NONE

RECORDED BY AND  
WHEN RECORDED MAIL TO:  
Wood River Law PLLC  
PO Box 22  
Ketchum, Idaho 83340  
(208) 720-7360

---

(Space above line for Recorder's use only.)

**DECLARATION OF COVENANTS, CONDITIONS, AND RESTRICTIONS FOR  
THE LIFT VIEW TOWNHOMES**

This DECLARATION OF COVENANTS, CONDITIONS, AND RESTRICTIONS FOR THE LIFT VIEW TOWNHOMES ("Declaration") effective upon recording in the records of Blaine County, Idaho, bind the Association and Property as a covenant and equitable servitude running with the Property in perpetuity, unless amended pursuant to this Declaration. This Declaration governs the Association, the Property, and the Members and shall be binding, and inure to the benefit, of the Members. (Capitalized terms here and in the recitals are defined under Article I; all instruments in this Declaration are recorded in the records of Blaine County, Idaho.)

**RECITALS**

A. On \_\_\_\_\_, 2025, Lift View LLC took title, by warranty deed, to 310 Georgia Road, more particularly described as:

Lot 6B, Block 3 of THE REPLAT OF LOT 6B, REPLAT OF LOT 6 BLOCK 3 AND SOUTHERLY PORTION OF LOT 5 BLOCK 3 WARM SPRINGS VILLAGE SUBDIVISION, SECOND ADDITION, BLAINE COUNTY, IDAHO, according to the official plat thereof, recorded as Instrument No. 326129, records of Blaine County, Idaho.

B. On \_\_\_\_\_, 2025, the Plat was recorded which created the Lots as indicated on the Plat.

**ARTICLE I  
DEFINITIONS**

The following terms and words shall have the meanings specified below, including the plural and conjunctive forms of the terms and words.

1.1. "Acts" means the Idaho Uniform Unincorporated Nonprofit Association Act and the Idaho Homeowner Association Act.

1.2. "Alteration" means any change, addition, or improvement to the exterior of the Townhomes or to the Property, including without limitation the addition of any structures,

storage sheds, or enclosures and/or the addition or removal of any landscaping on the Property. Alteration does not mean (i) the regular maintenance or repair of the exterior Townhomes or the Property, provided that the maintenance or repair does not change the appearance of the Townhomes or the Property or (ii) all interior changes to the Townhomes, provided that such interior changes comply with the Governing Documents.

1.3. “Assessments” means all dues charged to the Members, as more thoroughly defined in Article VI and may be regular Assessments, special Assessments, and/or specific Assessments.

1.4. “Association” means the Lift View Townhomes, an unincorporated nonprofit homeowner association.

1.5. “Association Maintenance” means the maintenance of those areas that are the responsibility of the Association to improve, maintain, or replace, as further defined in Article II.

1.6. “Bylaws” means the Association’s bylaws, if any, as may be amended.

1.7. “City” means the City of Ketchum, Idaho.

1.8. “Common Expenses” means those expenses paid for by the Association, typically those incurred as the result of Association Maintenance.

1.9. “Declarant” means Lift View LLC, an Idaho company.

1.10. “Declaration” means this Declaration of Covenants, Conditions, and Restrictions for the Lift View Townhomes.

1.11. “Governing Documents” means (i) this Declaration; (ii) the Plat; (iii) the Bylaws, if any; and the (iv) Rules, if any. Any amendments may be made without attaching them to this Declaration; however, any changes to this Declaration must be recorded in the records of Blaine County.

1.12. “Law” means all applicable City, Blaine County, State of Idaho, and US laws, regulations, or ordinances.

1.13. “Lot” means Sublot 1 and/or Sublot 2, as defined on the Plat and includes the Townhome on the Lot.

1.14. “Member” or “Membership” means the entire ownership interest in one Lot. A Lot has one Member or Membership appurtenant, but a Lot may have multiple Owners. As a result, there are two (2) Members, even though there may be more than two (2) Owners in the Lots. A Member does not include those having such interest merely as security for the performance of an obligation, such as a mortgagee, trustee, or beneficiary of a deed of trust. The address of record of the Member shall be the address of record of the Lot in the records of the Blaine County’s Assessor Office.

1.15. “Member Maintenance” means the maintenance of those areas that are the responsibility of the individual Member to improve, maintain, or replace, as further defined in Article II.

1.16. “Mortgagee” means the lender and includes the beneficiary under a deed of trust for any Lot.

1.17. “Owner” means an ownership interest in a Lot and may include the duly authorized representative of an entity with an ownership interest. While there is only one Member per Lot, the Lots may have multiple Owners. An Owner does not include those having such interest merely as security for the performance of an obligation, such as a Mortgagee, trustee, or beneficiary of a deed of trust.

1.18. “Party Wall” means any wall that is shared by both Townhomes.

1.19. “Plat” means the plat map entitled \_\_\_\_\_ recorded on \_\_\_\_\_, 2025, as Instrument No. \_\_\_\_\_ which, by reference, is incorporated herein. The Plat contains a legal description of the Lots.

1.20. “Property” means all the real property delineated and defined on the Plat, including the Lots.

1.21. “Rules” means rules and regulations, if any, governing the use and enjoyment of the Property as adopted by the Association and further defined in this Declaration.

1.22. “Townhome” means the physical residential structure on each Lot.

## **ARTICLE II THE ASSOCIATION AND NATURE OF TOWNHOME OWNERSHIP**

2.1. Purpose. The Association is an unincorporated nonprofit corporation which exists under the Idaho Uniform Unincorporated Nonprofit Association Act, as it may be amended, to which both Members belong. The purpose of the Association is to manage the Association and the Property pursuant to the Governing Documents and the Acts.

2.2. Governing Principles and Established Practices. This Declaration includes the Governing Principles and Established Practices of the Association, as defined under the Idaho Uniform Unincorporated Nonprofit Association Act.

2.3. Membership. Membership in the Association is solely a function of Lot ownership. No person or entity may be a Member without owning a Lot and Membership, and all related interests end upon the termination of the ownership interest in a Lot. A Member or Owner shall not be entitled, for any reason, to sever the Member’s interest in any Lot from Membership in the Association. None of the Members’ interests in a Lot can be severally sold, conveyed, encumbered, or hypothecated.

2.4. Authority. The Governing Documents bind the Members, the Owners, and their invitees or licensees. If any action is taken to enforce the Governing Documents such actions may be taken against the Member, even if an Owner, invitee, or licensee was the cause of the matter requiring the action.

2.5. Owner Privileges and Responsibilities. All Owners shall share the privileges of the Members, subject to the Governing Documents. All co-Owners of a Lot shall be jointly and severally obligated and bound to the obligations of the Member and the Governing Documents.

2.6. Notice of Governing Documents. The Association is governed by the Governing Documents, including this Declaration. Excepting amendments to this Declaration no other Governing Documents will necessarily be recorded in and with the Blaine County Recorder's Office. Thus, it is each Member's responsibility to request, and abide by, all Governing Documents, whether recorded or not.

2.7. Acts of the Association. Unless otherwise restricted or granted to a Member in writing, the Association has the authority and duty to act in accordance with the Governing Documents and; however, the failure of the Association to act does not invalidate the Governing Documents. When this Declaration contemplates that the Association must approve or otherwise sanction an activity, that approval is contingent upon the written approval of both Members. The Association may contract with any third party to perform all the Association's obligations and delegable duties. Any reference to the Association in this Declaration may be an independent third party acting on the Association's behalf.

2.8. Legal Description of a Lot. The legal name of a Lot shall be, or substantially be, as follows:

Sublot Number \_\_\_\_\_ as shown on the Plat Map for THE LIFT VIEW TOWNHOMES, recorded as Instrument No. \_\_\_\_\_, and as defined and described in the DECLARATION OF COVENANTS, CONDITIONS, AND RESTRICTIONS FOR THE LIFT VIEW TOWNHOMES, recorded as Instrument No. \_\_\_\_\_, recorded as Instrument No., and any amendments thereto.

2.9. Maintenance Responsibility. The responsibility to maintain, improve, or repair certain aspects of the Property shall either be Association Maintenance or Member Maintenance, as further defined in this Declaration. The term maintenance is expansive and includes maintenance, repair, and replacement.

a. Association Maintenance. The Association shall be responsible for the following areas and conditions of the Property:

i. The Party Wall.

ii. All landscaping on both Lots up to the boundary of the Townhomes including all retaining walls, provided; however, that any landscaping improvements require the approval of the Association.

- iii. Roof maintenance and replacement which includes the roof surface (and all exterior surfaces), gutters, underlayment, water-and-ice shield, vents (to the point of them extending past the top of the roof), vent collars, and heat tape, if any.
  - iv. The siding of the Townhomes, excepting such maintenance required by the Acts or omissions of a Member. The siding of the Townhomes shall be painted at least every seven (7) years unless otherwise agreed to by the Members.
  - v. All fireplaces and chimneys shall be inspected each year by the Association; any fireplaces requiring cleaning will be cleaned at the individual Member's expense.
  - vi. Drainage on the Lots, including that drainage coming from the roofs.
  - vii. The irrigation system, including repairs and replacements, but not including desired changes to the irrigation system that only benefit one Member.
  - viii. Snow removal from the driveways and roofs including, if necessary, hauling snow offsite and/or the installation or maintenance of a snow-melt system.
  - ix. Any maintenance required to prevent or divert flooding of the Property, regardless upon which Lot the work takes place.
  - x. All fences on the Property.
  - xi. All structural elements of the Townhomes, as originally built.
  - xii. All maintenance that the Members deems should be that of the Association.
- b. Member Maintenance. Each Member shall be responsible for the following areas and conditions of the Property:
- i. The interior of each Townhome.
  - ii. The garage doors, doors, and windows of each Townhome, including cleaning the surfaces thereof.
  - iii. All other maintenance that is not Association Maintenance.
- c. Standards. All maintenance shall be performed in a manner that does not (i)

affect Association insurance rates or insurability; (ii) violate the Governing Documents; and/or (iii) cause harm or nuisances to the Property. Each Member has complete discretion as to the choice of furniture, furnishings and interior decorating; but windows can be covered only by the window coverings approved by the Association and cannot be painted or covered by foil, cardboard, or other similar materials. In addition, all maintenance shall be performed, and the entire Property (regardless of responsibility) shall be maintained in a first-class manner commensurate with other high-end homes in Ketchum.

2.10. Easements of Access for Repair, Maintenance, and Emergencies. Some of the utilities or other items, including, without limitation, the sprinkler clock, are or may be located on individual Lots (including in or under the Townhomes) or may be conveniently accessible only through individual Lots (including in or under the Townhomes). The Members shall have the irrevocable right, to be exercised by the Association as their agent, to have access to all such parts of the Property when necessary, during such reasonable hours, and with reasonable notice except in cases of emergency, for the maintenance, repair, or replacement of any of the utilities located therein or accessible therefrom or for making emergency repairs necessary to prevent damage to the Property.

2.11. Taxes. Each Member is responsible for all taxes assessed against each Member's Lot.

### **ARTICLE III POWERS AND DUTIES OF THE ASSOCIATION**

The Association shall act as the management body for the Property and shall have all the powers prescribed under the Governing Documents and the Acts, subject only to the express limitations in the Governing Documents.

In addition to other powers and duties granted to the Association, the Association shall have the following obligations:

3.1. Declarant Control. Upon the late of either (i) both Townhomes being sold by the Declarant; or (ii) a period of Two (2) years, the Declarant shall have control of the Association and carry the vote as if the Declarant owned both Lots.

3.2. Assessments. To levy and collect Assessments from the Members subject to Article VII of this Declaration.

3.3. Records. To retain current copies of the Governing Documents and the financial statements of the Association, Member records, written communication distributed to both Members, and Member meeting minutes. Records must be kept and distributed to Members in accordance with the Acts.

3.4. Meetings. To hold an annual meeting of the Members and to the extent necessary,

elect officers to chair and report at the meeting, in accordance with the Idaho Homeowner's Association Act.

3.5. Bylaws. To pass and be governed by Bylaws, in addition to, but not contradicting, this Declaration.

3.6. Third-Party Vendors. To engage the services of any third-party vendor to execute the duties of the Association.

3.7. Maintenance. To ensure that Association Maintenance is properly completed.

3.8. Utilities. To acquire, provide, and pay for water, refuse collection and disposal and other necessary utility services for the Lots when the Lot/Members are not separately billed. All utilities used and consumed by individual Lots shall be the responsibility of each Member, unless otherwise agreed to by the Association.

3.9. Insurance. To obtain and maintain the insurance as further outlined Article V of this Declaration.

3.10. Rules. To make, establish, and amend Rules and to establish and levy fines, if any, for the violation of the Rules or this Declaration. Any fines shall be a specific Assessment against the Lot of the Member in violation of the Rules whether the Member, Owner, or invitee breached the Rules. The Rules may not contradict the Declaration but may further limit behavior or action of the Members, Owners, and invitees, and, if adopted, the Members agree that any Rules do not expand the provisions of the Governing Documents.

3.11. Bank Accounts. To open and maintain bank accounts necessary to execute the duties contemplated in the Governing Documents.

3.12. Easements. To grant easements over the Property.

3.13. Remedies. To use, as its discretion, any remedy to enforce the Governing Documents including without limitation, a suit in equity or law, or levying fines as may be passed in the Rules. If the Association does not enforce any provisions of the Governing Documents, a Member shall have the right to do so individually.

#### **ARTICLE IV GENERAL RESTRICTIONS**

4.1. Law. No activities prohibited by Law shall be allowed on the Property. Without limitation, this includes the City of Ketchum noise ordinances and the Idaho nuisance statutes. To the extent that the restrictions included in this Declaration are more restrictive than the Law, the restrictions in this Declaration govern.

4.2. Construction and Other Work. All construction, maintenance, or other work on the Property may only take place on weekdays and Saturdays between 7:30 AM and 6:00 PM,

excluding all federal holidays. No construction dumpsters may be stored on the Property without the Association's approval.

4.3. Animals. No more than three (3) animals may be kept on any one Lot. Animals shall not roam free and a dog outside of a Townhome shall be leashed or otherwise under the dog owner's complete control. No animal shall be kept on a deck unattended, tied to a deck, or tied to any building or aspect of the Property. The Association shall have the power to remove any animal from the Property that the Association finds, in its sole discretion, is a nuisance or danger to humans or other animals.

4.4. Parking. Each Member shall be entitled to park two (2) vehicles in the Townhomes driveways; however, the following vehicles are not permitted: any vehicle with a gross vehicle weight over 10,000 pounds, any vehicle longer than 270 (two-hundred and seventy) inches, any trailer whether connected to a vehicle or not, any camper or other RV, any vehicle that is not operational, and any vehicle with expired or no registration tags. No vehicle may be serviced or otherwise repaired in the driveways.

4.5. Storage. No items, other than firewood stacked neatly in locations agreed to by both Members may be stored on the Property without the approval of the Association.

4.6. Camping. Camping, including without limitation, sleeping outside of any Unit including sleeping in vehicles, trailers, or campers, shall not be allowed on the Property.

4.7. Barbeques and Smokers. All outdoor barbeques or any other cooking devices that use a flame or smoke (collectively in this section only, "barbeques") are prohibited from use on the Property unless the barbeques comply with Law, specifically the City's ordinances, and all requirements of the Association's insurance carrier(s). All barbeques must burn only natural gas or propane and no other gas or materials. Barbeques may not be visible from Georgia Road.

4.8. Commercial Activities. No Units shall be used or occupied for commercial or business purposes; however, use of a home office in a Townhome is permissible provided that such use does not entail, invite, require, or contemplate visitation to the Property or Townhome by, without limitation, clients, customers, partners, associates, employees, staff, or the public.

4.9. Noxious Activities. No noxious or offensive activities or any activities or acts which constitute a nuisance shall be permitted on the Property nor shall any Owner engage in any activity which increases the insurance rates of the Association. Any violation of the Governing Documents shall be considered a nuisance.

4.10. Signs. With the exception of one (1) real estate sign (which shall not be larger than 20" x 26") which may be placed on the appropriate Lot, no other signs are permitted on the Property

4.11. Satellite Dishes. Except for satellite dishes less than two feet (2') in diameter, no exposed or outside radio, television, or other electronic antennae (collectively, in this section only "dishes") shall permitted to be affixed to the Townhomes or on the Property. The installation

location of any dishes must be approved by the Association and the Association shall have no obligation to approve the installation unless required to do so by Law.

4.12. Subdividing and Combining Townhomes. No Townhome may be further subdivided, and no portion of a Townhome may be sold separately from the rest of a Townhome.

4.13. Mining. No quarrying, tunnelling, digging, excavating, or drilling for any substances within the earth shall be permitted in the Property.

4.14. Hazards. No activities which are or might be unsafe or un Hazardous to any person or property, shall be undertaken on the Property. No firearms, including without limitation BB or pellet guns and bows and arrows, shall be discharged on the Property nor shall bow and arrows be used on the Property. The use and lighting of fireworks of all kinds are prohibited on the Property.

4.15. Vehicle Use. Without the express permission of the Association, vehicles shall not be allowed on the Property except in the driveways and garages.

4.16. Alterations. No Alterations may be made to Lots or exterior of the Townhomes,, without the approval of the Association.

4.17. Heat. Each Member shall ensure that the Member's Townhome is consistently and adequately heated to avoid frozen pipes.

## **ARTICLE V INSURANCE AND INDEMNIFICATION**

5.1. Types of Insurance. Provided such insurance is reasonably available, the Association shall obtain and keep in full force and effect at all times the following insurance coverage provided by companies duly authorized to do business in Idaho. The provisions of this Article shall not be construed to limit the power or authority of the Association to obtain and maintain insurance coverage in addition to any insurance coverage required hereunder, in such amounts and in such forms as the Association may deem appropriate from time to time.

- a. Casualty Insurance. The Association shall obtain insurance on the Townhomes in such amounts as shall provide for full replacement thereof provided; however, that any insurance claims in which all insurance coverage will be used shall be distributed, pro-rata to each Member based on that Member's Townhome's square footage. If a Member is (or will be) able to repair that Member's Townhome to the condition it was in prior to the casualty and not all of that Member's share of the coverage is used, then the other Member may use that portion of the unused pro-rata share. The Association shall obtain insurance in the event of damage or destruction from the casualty against which such insurance is obtained, all in the manner in which those other owners of a residence, owning similar residences in the vicinity of the Property would, in the exercise of prudent business judgment, obtain such insurance. Such insurance shall include fire and extended coverage, vandalism and malicious

mischief, and such other risks and hazards against which the Association shall deem appropriate to provide insurance protection. The Association may comply with the above requirements by the purchase of blanket coverage and may elect such deductible amounts, as in the Association's opinion, are consistent with good business practice, subject to the deductible provision below.

- b. Liability Insurance. The Association shall purchase broad form comprehensive liability coverage in such amounts and in such forms as it deems advisable to provide adequate protection. Coverage shall include liability for personal injuries, operation of automobiles on behalf of the Association, if any such use exists, and activities in connection with the ownership, operation, maintenance and other use of the Property.
- c. Fidelity Insurance. The Association may purchase, in such amounts and in such forms as it shall deem appropriate, coverage against dishonesty of Members, destruction or disappearance of money or securities, and forgery.
- d. Other. The Association may obtain insurance against such other risk, of a similar or dissimilar nature, as it shall deem appropriate with respect to the Property, including earthquake insurance, an umbrella policy, and any personal property of the Association located on the Property.

5.2. Optional Insurance. The Association may obtain the following types of insurance coverage, but it is not required to do so:

- a. Personal Property Casualty Insurance. The Association may in its discretion obtain insurance on the personal property and furnishings initially placed in the Townhomes in such amounts as shall provide for the full replacement thereof in the event of damage or destruction against which such insurance is obtained.
- b. Casualty and Public Liability Insurance. The Association may in its discretion obtain casualty and public liability insurance coverage, in the amounts it may select, with respect to the Property.

5.3. Form. Casualty insurance shall be carried in a form or forms, if available, naming the Association the insured as trustee for the Members and which policy or policies shall provide a standard loss payable clause providing for payment of insurance proceeds to the Association as trustee for the Owners and for the Mortgagees under first Mortgages upon the Property or any portion thereof, such proceeds to be used in accordance with this Declaration. Public liability and property damage insurance shall name the Association and each of the Members as the insureds and shall insure each Member, including the Member's Owners or representatives, against liability for acts of the Association in connection with the ownership, operation, maintenance or other use of the Property, excepting use within the Townhomes.

5.4. Insurance Proceeds. The Association shall receive the proceeds of any insurance payments received under policies obtained and maintained pursuant to this Article and act as an attorney-in-fact for the Members. The Association shall determine the amount of the proceeds

attributable to damage to the property. To the extent that reconstruction is required, the proceeds shall be used for such purposes. To the extent that reconstruction is not required and there is a determination that the entire Property shall not be rebuilt, the proceeds shall be distributed to each Member, or the Member's mortgagee.

5.5. Liability and Indemnification. Each Member shall be liable to the Association for any damage of any type to the Property or any equipment thereon which may be sustained by reason of the negligence of said Member, to the extent that any such damage shall not be covered by insurance carried by the Association. Each Member does further, agree to indemnify each and every other Member, and to hold him or her harmless from any claim of any person for personal injuries or property damage occurring within the Townhome of the Member; and each Member further agrees to defend, at his expense, any and all remaining Members who may be sued by any person on a claim for personal injury or property damage alleged to have been sustained within the Townhome of that Member.

5.6. Time is of the Essence. In the event of casualty, time is of the essence to rebuild or repair the Property.

5.7. Member's Own Insurance. Nothing herein shall prevent any Member from obtaining insurance at the Member's own expense providing coverage upon the Member's Lot or Townhome including personal liability and other risks.

5.8. Deductible. Unless otherwise agreed to by the Association, each Member is responsible to pay the Association's deductible for any claim under an insurance policy carried by the Association. However, such responsibility to pay the deductible shall only apply to claims to repair damage solely to, or arising from, that Member's Townhome or Lot, said damage not being the failure of the Association to maintain those areas for which the Association is responsible. If damage occurs to both Townhomes or the Party Wall, and the cause of the damage is unknown, arises from the Party Wall, or is the result of the Association not maintaining those areas for which it is responsible, the deductible shall be paid for by both Members.

## **ARTICLE VI ASSESSMENTS AND FUNDS**

6.1. Authority. The Association has the authority to assess each Member and shall collect from each Member amounts sufficient to pay any and all Common Expenses and current Association liabilities including those the Association anticipates.

6.2. Banking and Fund Accounting. All Association funds shall be deposited in institutions or banks insured by the Federal Deposit Insurance Corporation ("FDIC") and no one institution or bank shall have funds that exceed FDIC limits by more than twenty percent (20%). The Association may have a bank account (and said account may simply be a joint account with both Members) and, unless otherwise agreed to by the Association, all funds remaining at the end of any given fiscal year, automatically carry forward to the previous fiscal years to be used for any and all Common Expenses, whether anticipated or not.

- 6.3. Type of Assessments: There shall be three types of Assessments:
- a. Regular Assessments. Regular Assessments are for anticipated annual operating expenses and anticipated capital expenses (or funding for anticipated capital expenses in the future).
  - b. Special Assessments. Special Assessments are those levied by the Association for operational shortfalls, capital projects, or any other liabilities the Association deems advisable.
  - c. Specific Assessments. Specific Assessments shall be those Assessments levied against an individual Lot, including without limitation, fines, fees, or expenses for/related to the violation of the Rules, to cure unauthorized Alterations to the Property, and for other matters as contemplated in this Declaration. No specific Assessment will be levied against any Lot without a meeting of the Association at which the Owner who may be specifically Assessed has an opportunity to be heard. Interest for past due accounts and all lien related fees, as specified below, may be levied without a notice and hearing.
- 6.4. Proportion of Assessments. Excepting specific Assessments, all Assessments shall be assessed equally to each Member.
- 6.5. Invoices. The Association shall send invoices to its Members by email or US Mail.
- 6.6. Unpaid Assessments. Any Member's Assessment remaining unpaid more than thirty (30) days unpaid after the due date shall begin to accrue interest from the due date at the interest rate of twelve percent (12%) per annum, until the Association receives the Assessment and any all-outstanding interest and other charges in full. Upon payment of any amounts to the Association the Association shall credit the Member's account in chronological order, starting with the oldest past due amount including all Assessments and interest.
- 6.7. Lien. Any Assessment, including accrued interest and fees the Association incurs to collect the Assessment, shall automatically become a lien upon that Member's Lot. If any Assessment is more than sixty (60) days past due, the Association may record a notice of Assessment lien against the Lot stating the amount of the unpaid Assessment or Assessments, the accrued interest and fees the Association has incurred to collect the Assessment or record the lien through the date of recording the notice. All fees, including attorney and recording fees, to record a lien, will automatically be assessed against the Lot. The lien continues until the Member has paid in full any and all Assessments, accrued interest and fees, whether incurred prior to or after the recording of the lien. All liens may be foreclosed upon in accordance with Law.
- 6.8. Liability. All Owners of a Lot, including the Member, shall be jointly and severally liable for all Assessments, interest, obligations, fees, and the other provisions of this Declaration, levied against or in relation to ownership interest in the Lot. The purchaser of any Lot shall be jointly and severally liable with the previous Member and Owners which/who owned the Lot for all past due Assessments, including fees, and interest.

**ARTICLE VII  
DESTRUCTION; OBSOLESCENCE; and CONDEMNATION**

7.1. Protection of Mortgagees. If any portion of the Property or the Townhomes are destroyed, deemed to be obsolete, or condemned, the Association shall either repair the Property and Townhomes pursuant to Article V or sell or otherwise dispose of the Property (or a portion thereof) provided; however, that no actions of the Association shall minimize or otherwise invalidate the rights of Mortgagees. Any proceeds from the sale of the Property, or a portion thereof (“proceeds” for this Article only), shall be equally allocated to the Members, subject to the other restrictions contained in this Declaration or Association agreement.

7.2. Condemnation. If at any time, all or any part of the Property shall be taken or condemned by any public authority or sold or otherwise disposed of in lieu of or in avoidance thereof, the following provisions shall apply. All government actions related to eminent domain are considered to be condemnation.

- a. Complete Taking. In the event that the entire Property is taken, condemned, sold, or otherwise disposed of in lieu of or in avoidance thereof, the Lot ownership pursuant hereto shall terminate. The proceeds shall be apportioned among the Members in an equal share.
- b. Partial Taking. If less than the entire Property is taken, condemned, sold, or otherwise disposed of in lieu of or in avoidance thereof, the Townhome ownership hereunder shall not automatically terminate. Each Member shall be entitled to a share of the proceeds to be determined in the following manner. As soon as practicable, the Association shall reasonably and in good faith allocate the proceeds between compensation, damages, or other proceeds and shall apportion the amounts so allocated among the Members of each area as follows: (a) the total amount allocated to taking of or injury to the Property shall be apportioned equally among the Owners; (b) the total amount allocated to severance damages shall be apportioned to those Lots which were not taken or condemned; (c) the respective amounts allocated to the taking of or injury to a particular Lot and/or improvements a Member has made within such Member’s own Townhome shall be apportioned to the particular Member involved; and (d) the total amount allocated to consequential damages and any other takings or injuries shall be apportioned as the Association determines to be equitable in the circumstances. If an allocation of the proceeds is already established in negotiation, judicial decree, or otherwise, then in allocating the proceeds, the Association shall employ such allocation to the extent it is relevant and applicable.
- c. Taking of an entire Lot. In the event a partial taking results in the taking of a complete Lot, the Member thereof automatically shall cease to be a member of the Association. Thereafter, the Association shall be terminated.

**ARTICLE VIII**

## GENERAL

- 8.1. Non-waiver. The failure of the Association to enforce any provision(s) of the Governing Documents does not provide a waiver of any subsequent breach or default in the performance of any provisions of the Governing Documents.
- 8.2. Mediation. All disputes arising out of the Governing Documents or against the other Member resulting from Ownership of a Lot, shall first be mediated by a mediator appointed by the Association and if the Association does not choose a mediator, each Member may propose a mediator, and a third-party, by flip of a coin, shall choose the mediator between the two mediators proposed by each Member. If mediation is not completed within ninety (90) days after one Member informs the other of its desire to mediate in writing, this Section is waived and either Member may seek other remedies, including filing an action. All mediators must be members, or past members, of the Idaho State Bar provided that any former members were not involuntarily removed from the Idaho State Bar. No person shall mediate who has a material conflict of interest in the matter being mediated with, or against, any Member, unless waived by the Association.
- 8.3. Attorney Fees and Costs. If mediation is unsuccessful or if both Members waive mediation, the prevailing party in any litigation to enforce any provision or part of the Governing Documents shall be entitled to reimbursement from the non-prevailing party of all costs and attorney's fees, including without limitation attorney fees incurred on appeal or in bankruptcy court.
- 8.4. No Partnership. The Governing Documents do not, and are not, intended to create a joint venture or partnership between the Members and/or between the Members and the Association.
- 8.5. No Third-Party Rights. The Governing Documents do not, and are not, intended to create any rights in those that are not Members of the Association.
- 8.6. Captions and Headings. The captions and headings in this Declaration are for reference and convenience only and do not limit the scope or intent of any portion of this Declaration.
- 8.7. Governing Law and Venue. This Declaration shall be interpreted and construed in accordance with Idaho Law and any action taken in relation to this Declaration shall be in the Fifth Judicial District of the State of Idaho, County of Blaine.
- 8.8. Amendment. Unless otherwise contemplated herein, this Declaration may be amended by and instrument in writing signed by all Owners.
- 8.9. Severability. The provisions of this Declaration shall be deemed independent and severable, and the invalidity or partial invalidity or unenforceability of any provisions or portions of it shall not invalidate any other provisions.

8.10. Easements Reserved and Granted. Any easements referred to in this Declaration or indicated and/or contemplated on the Plat, shall be deemed reserved and/or granted, by reference to this Declaration, in a deed to any Lot.

8.11. Cumulative Remedies. Each remedy provided for in this Declaration shall be cumulative and not exclusive.

8.12. Violations as Nuisance. Every act or omission in violation of the provisions of this Declaration shall constitute a nuisance and, in addition to all other remedies herein set forth, may be abated or enjoined by any Owner or Member.

8.13. Gender. Whenever used in this Declaration, the use of any gender shall include all genders.

8.14. No Discrimination. No Owner, Member, or the Association shall execute or cause to be recorded any instrument or pass any Rule which imposes a restriction upon the sale, leasing, or use of the Property or a Lot based on any class protected by Law.

This Declaration has been adopted by the Declarant, who is also the owner of both Lots.

**Lift View LLC**

\_\_\_\_\_  
by Bobbie Jordan, its managing member

This record was acknowledged before me on \_\_\_\_\_, 2025 by Bobbie Jordan, the managing member of Lift View LLC.

\_\_\_\_\_  
Notary Public for Idaho  
Residing: \_\_\_\_\_  
Commission Expires: \_\_\_\_\_

May 30, 2025

Jordan Homes LLC  
% Bobbie Jordan  
PO Box 983  
Eagle, ID 83616  
Sent via email

Subject: 310 Georginia Rd, Ketchum

Dear Ms Jordan:

You have inquired as to whether the property noted above is within the certificated service territory of Idaho Power Company in the State of Idaho. This letter is to advise you that the property described above is currently located within the certificated service territory of Idaho Power Company (the Company) in the State of Idaho.

I have reviewed the preliminary drawing for the project and understand that you are starting the process with the city for approval of the project. The project is not designed yet, but we have existing underground power on the opposite side of Georginia and to the East. We will have to install a sector near the last transformer and bring primary power down south side of road and bore or trench across the road to set a transformer for the project at the SW property corner. If, during the permitting process with the city, the proposed plans are changed, I would need to review for changes to my design.

The company will provide electrical service to the above location subject to the obtaining of any required easements, rights of way, and in compliance with the statutes of the State of Idaho and the tariffs of the Company on file with the Idaho Public Utilities Commission (IPUC) in particular, the General Rules and Regulations, covering new service attachments and distribution line installations or alterations. The tariff is subject to change from time to time upon approval by the IPUC.

Please feel free to contact me with any questions.

Respectfully submitted,

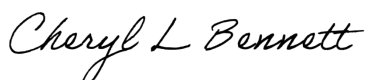
A handwritten signature in cursive script that reads "Cheryl L. Bennett".

Cheryl L. Bennett  
Senior Distribution Designer  
11831 Hwy 75  
Hailey, ID 83333  
Idaho Power Company

# CLEAR CREEK DISPOSAL

PO Box 130 • Ketchum, ID 83340 • Phone 208.726.9600 • [www.ccdisposal.com](http://www.ccdisposal.com)

Planning & Building Departments  
City of Ketchum  
P O Box 2315  
Ketchum, ID 83340-2315

To Whom It May Concern,

Clear Creek Disposal is a full-service waste disposal company located in Ketchum, Idaho. We are committed to providing exceptional waste removal services and have the capacity to do so for the lot split at 310 Georgina St.

Services offered are for the development of the area, construction of all homes, and continued services needed for the new community. We currently serve this entire area and will continue to do so.

Please call if you have any questions or need further information.

Respectfully,

*Miguel Goitiandia*

Mike Goitiandia  
Clear Creek Disposal

.310 Georgina St Lot Split – Will Serve

# ALPINE ENTERPRISES INC.

Surveying, Mapping, Civil Engineering, and Natural Hazards Consulting

DATE: August 22, 2024

TO: Bobbie Jordan

Re: Snow Avalanche Hazard at 328 Georgia Rd.

Dear Ms. Jordan,

At your request we have performed a Site-Specific Snow Avalanche Hazard Evaluation of Lot 6B, Block 3, Replat of: Replat of Lot 6, Block 3, Warm Springs Village Subdivision, Second Addition, located at 310 Georgia Rd. within Ketchum, Idaho. This Lot is identified in both the 1977 and 1978 Avalanche Studies, conducted by Norman A. Wilson and Arthur I. Mears respectively, as being located within avalanche hazard areas. Both of these studies were conducted before most of the development occurred in the area and before Avalanche Dynamics Modeling Software and LiDAR topographic mapping were available.

We have performed a site-specific study using LiDAR topographic contours and RAMMS (Rapid Mass Movement Simulation) software developed by the Swiss Federal Institute for Snow and Avalanche Research. We have attached two 1" = 100' maps titled *A Snow Avalanche Hazard Map Showing: Lot 6B, Block 3, Warm Springs Village Subdivision, Second Addition*. One map shows the RAMMS Maximum Pressure output data, and the other map is shown as a Hazard Zoning Map depicting the Red (High Hazard Zone) and Blue (Moderate Hazard Zone). The Red Zone is defined as areas with high impact pressures (600 lbs/ft<sup>2</sup> or greater) *and/or* short return periods (30 years or less). The Blue Zone should have impact forces less than (600 lbs/ft<sup>2</sup>) *and* return periods greater than 30 years. We have also attached a RAMMS output file and images showing Maximum Pressures in 2D and 3D views.

The avalanche events modeled in this study are what we believe to be demonstrative of the 300-year event and should be considered an accurate representation of the potential avalanche hazards in the area. This study should not be used as an example for, or applied to, adjacent Lots within the shown avalanche paths. This study is site-specific to Lot 6B, Block 3, Warm Springs Village Subdivision, Second Addition.

The results of this study show that even under the most extreme circumstances, Lot 6B, Block 3, Warm Springs Village Subdivision, Second Addition should not be affected by snow avalanches and their associated risks. The projected avalanche forces will be zero and no specific avalanche reinforcement would be required. However, regardless of these findings we believe area residents and their guests should be made aware of the potential hazard areas and avoid them while doing winter activities during times of high avalanche danger.

Please feel free to contact us if you have any questions, comments, or if we can be of further assistance.

Respectfully submitted,

Bruce Smith, PLS 7048  
Alex Nelson, PE 19275  
Alpine Enterprises Inc.

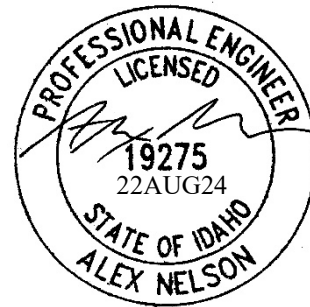
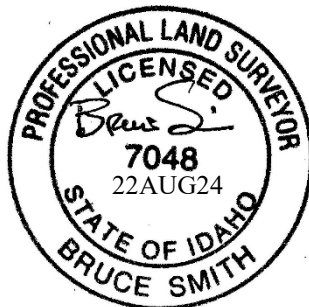

# ALPINE ENTERPRISES INC.

Surveying, Mapping, Civil Engineering, and Natural Hazards Consulting

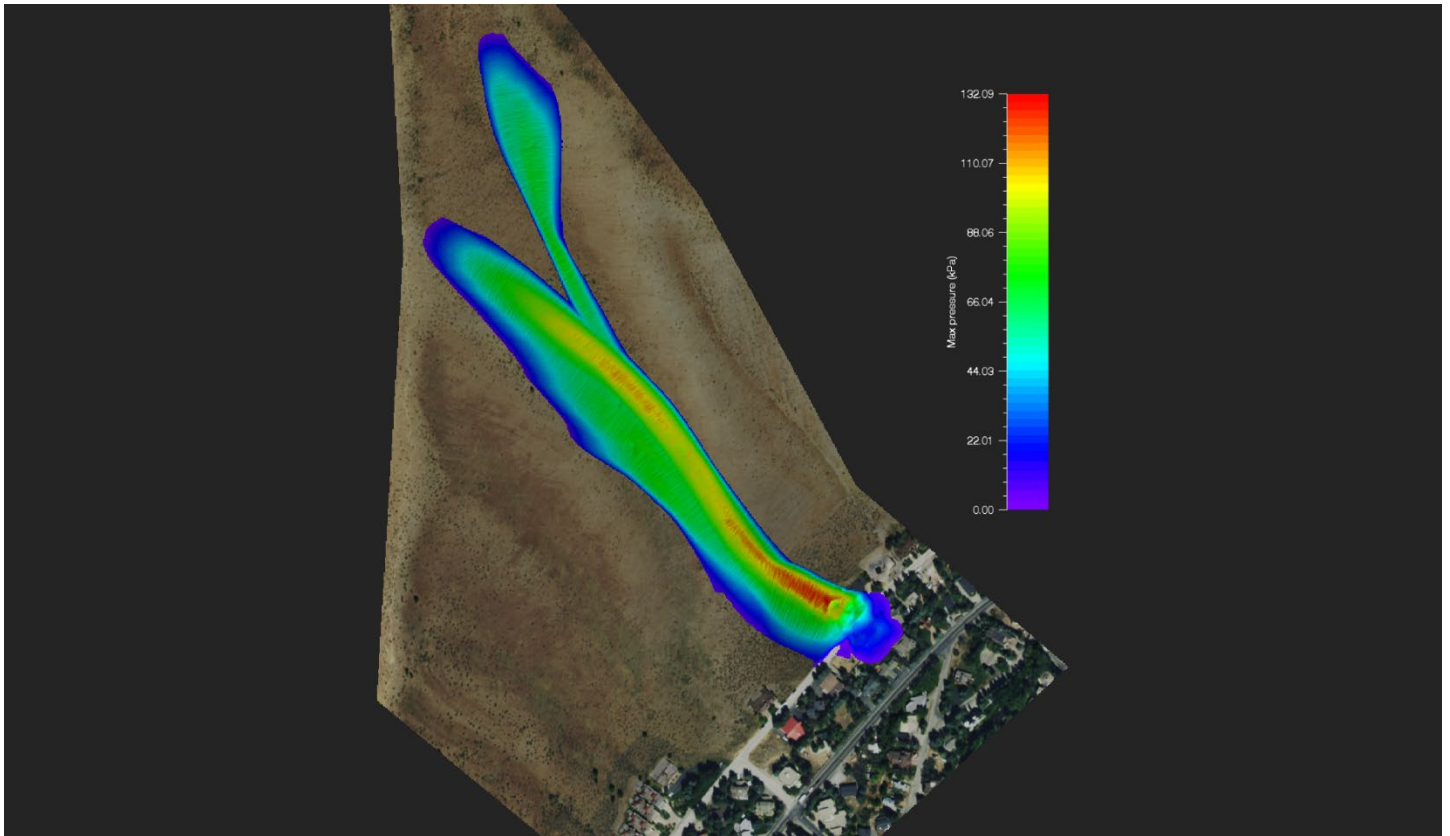

Figure 1 - Paths R10 & R11 - Maximum Pressures - 2D

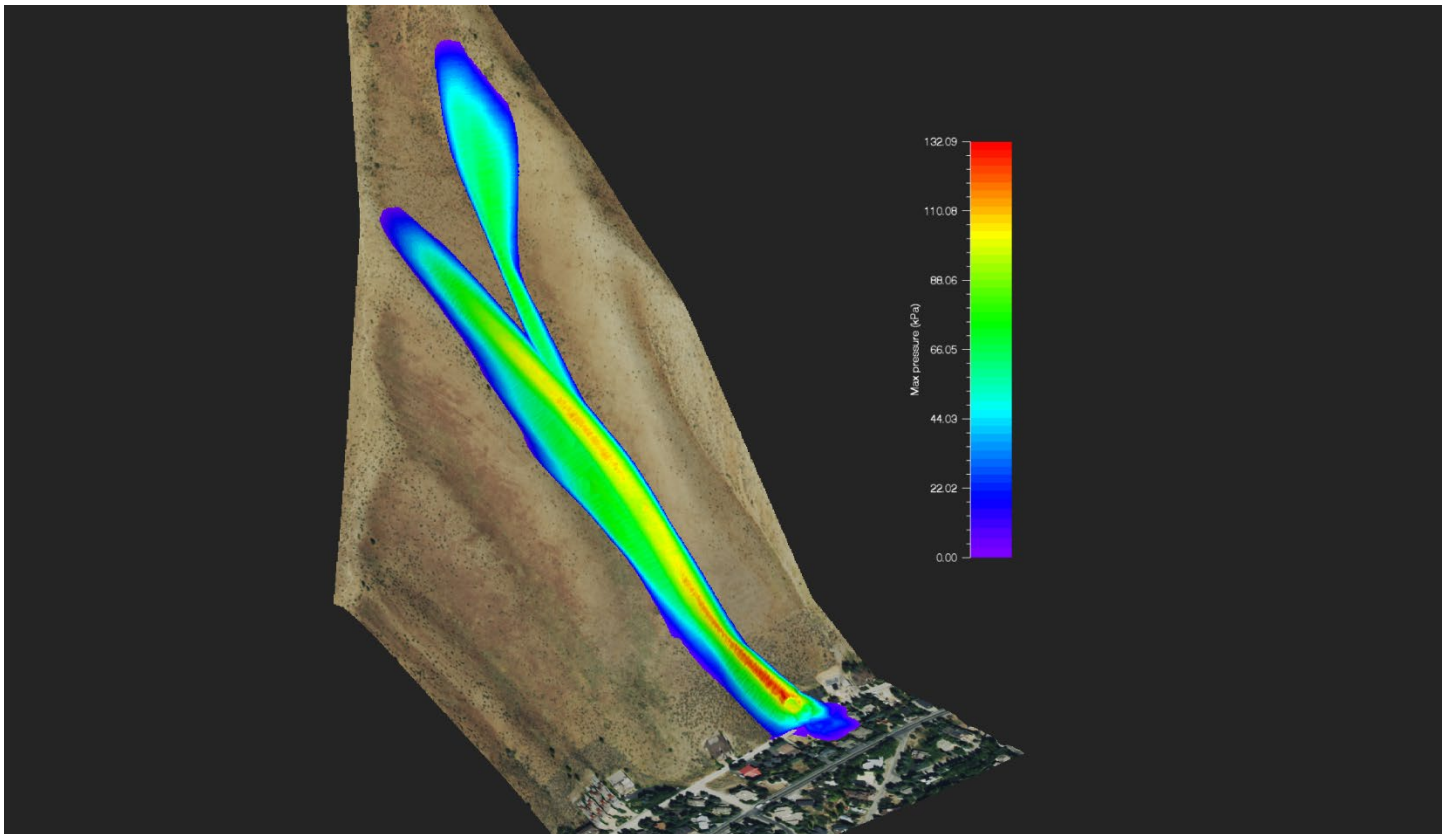

Figure 2 - Paths R10 & R11 - Maximum Pressures - 3D

# ALPINE ENTERPRISES INC.

Surveying, Mapping, Civil Engineering, and Natural Hazards Consulting

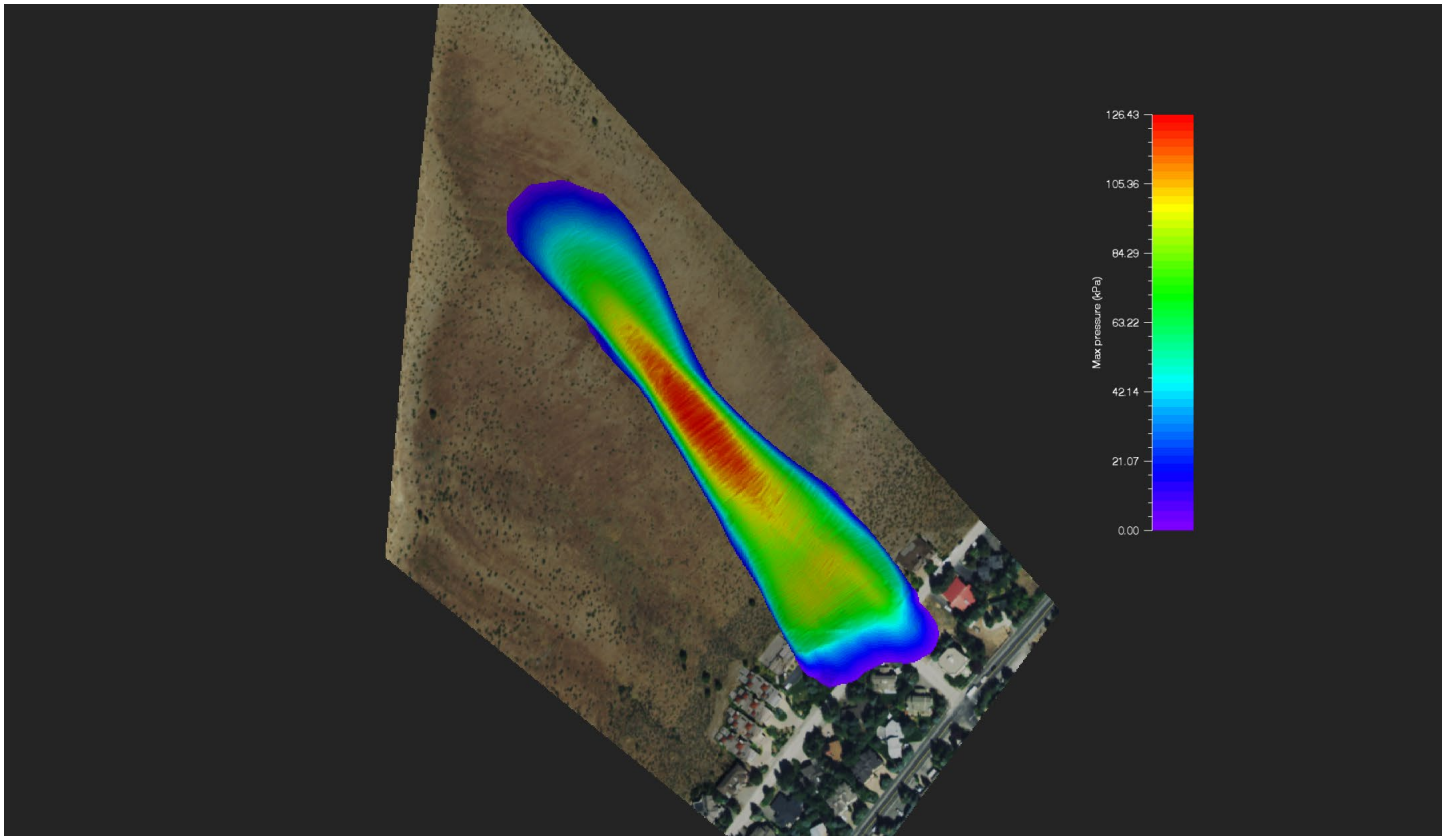

Figure 3 - Path R12 - Maximum Pressures - 2D

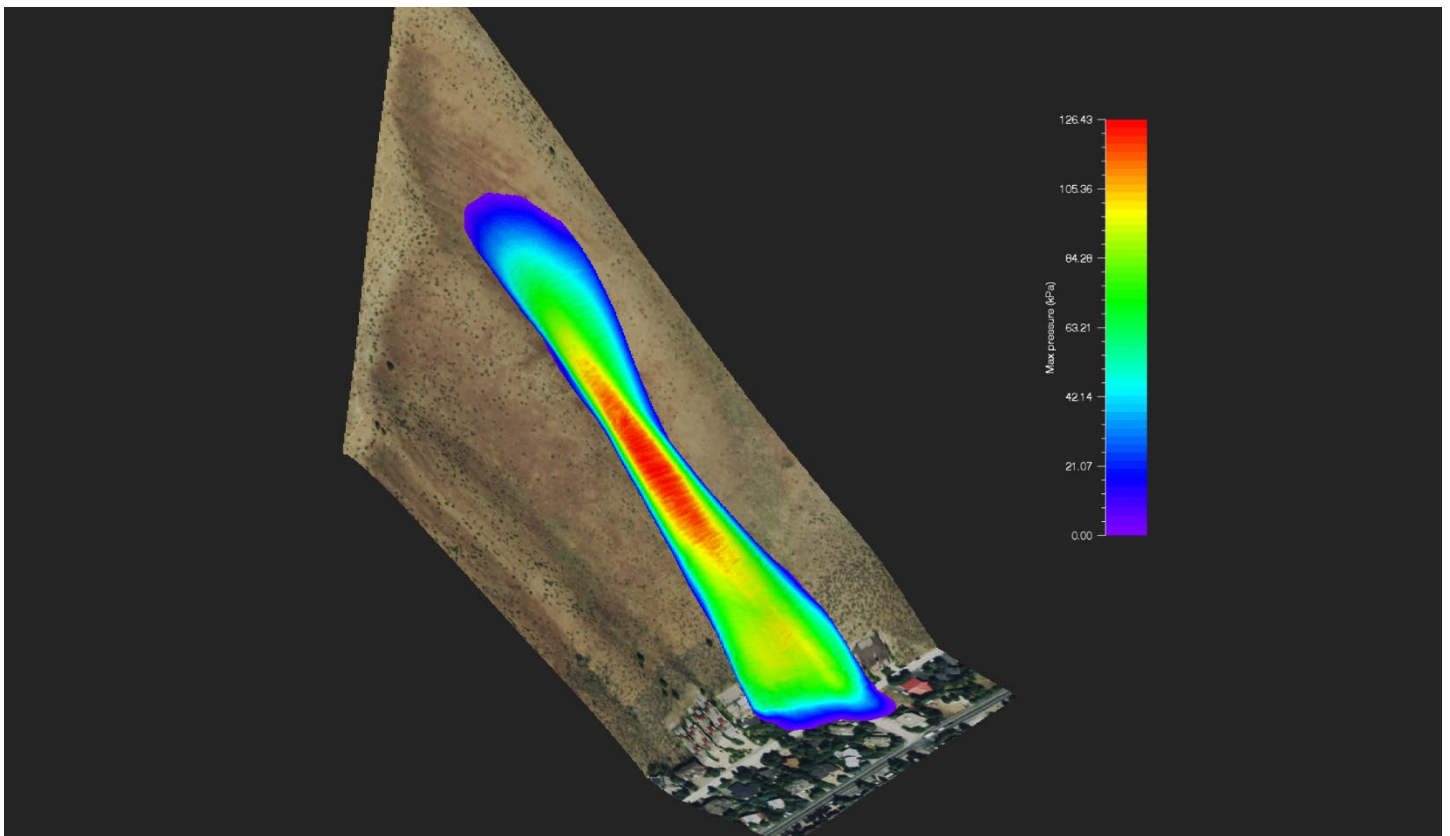

Figure 4 - Path R12 - Maximum Pressures - 3D

# ALPINE ENTERPRISES INC.

Surveying, Mapping, Civil Engineering, and Natural Hazards Consulting

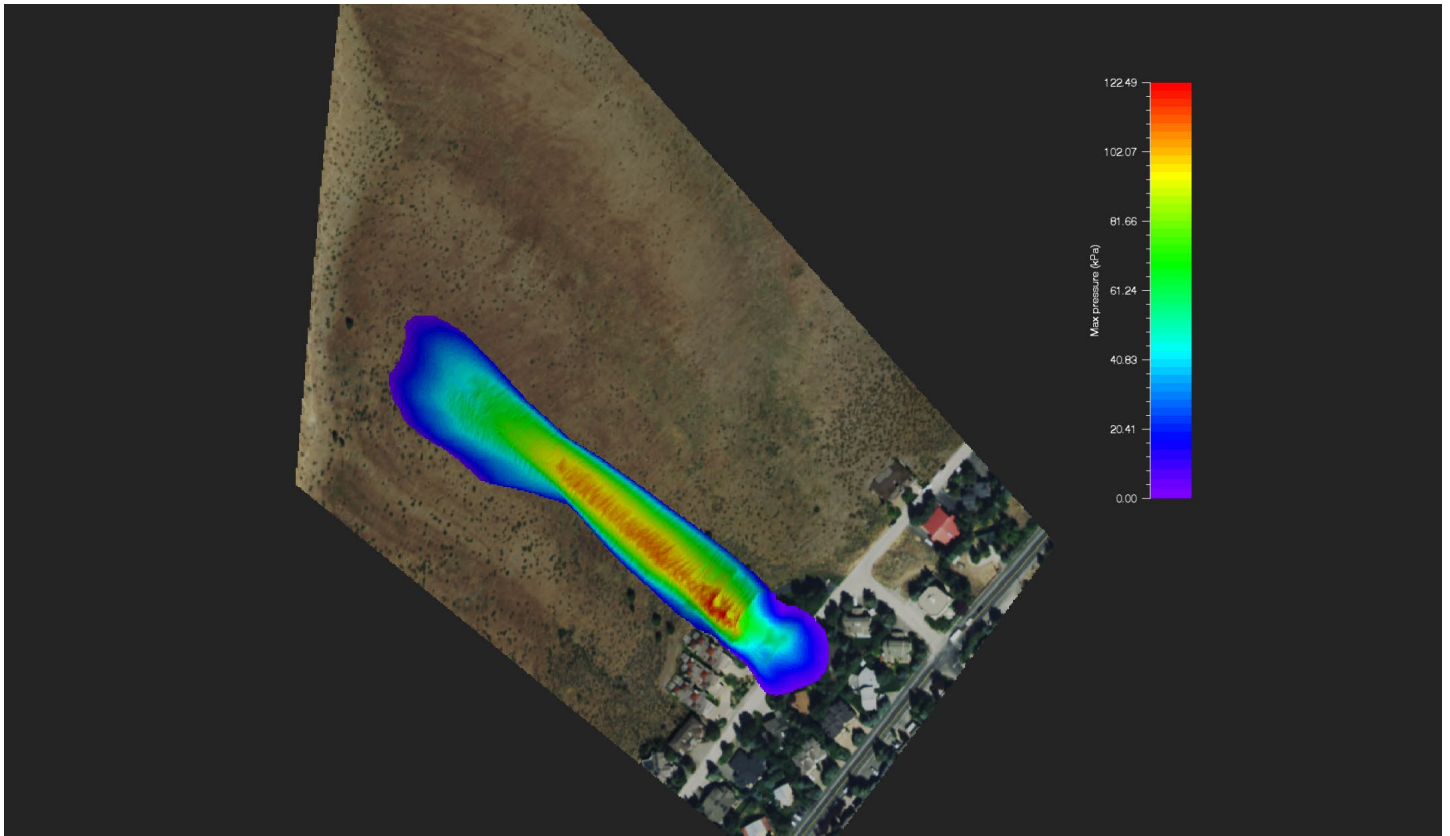

Figure 5 - Path R13 - Maximum Pressures - 2D

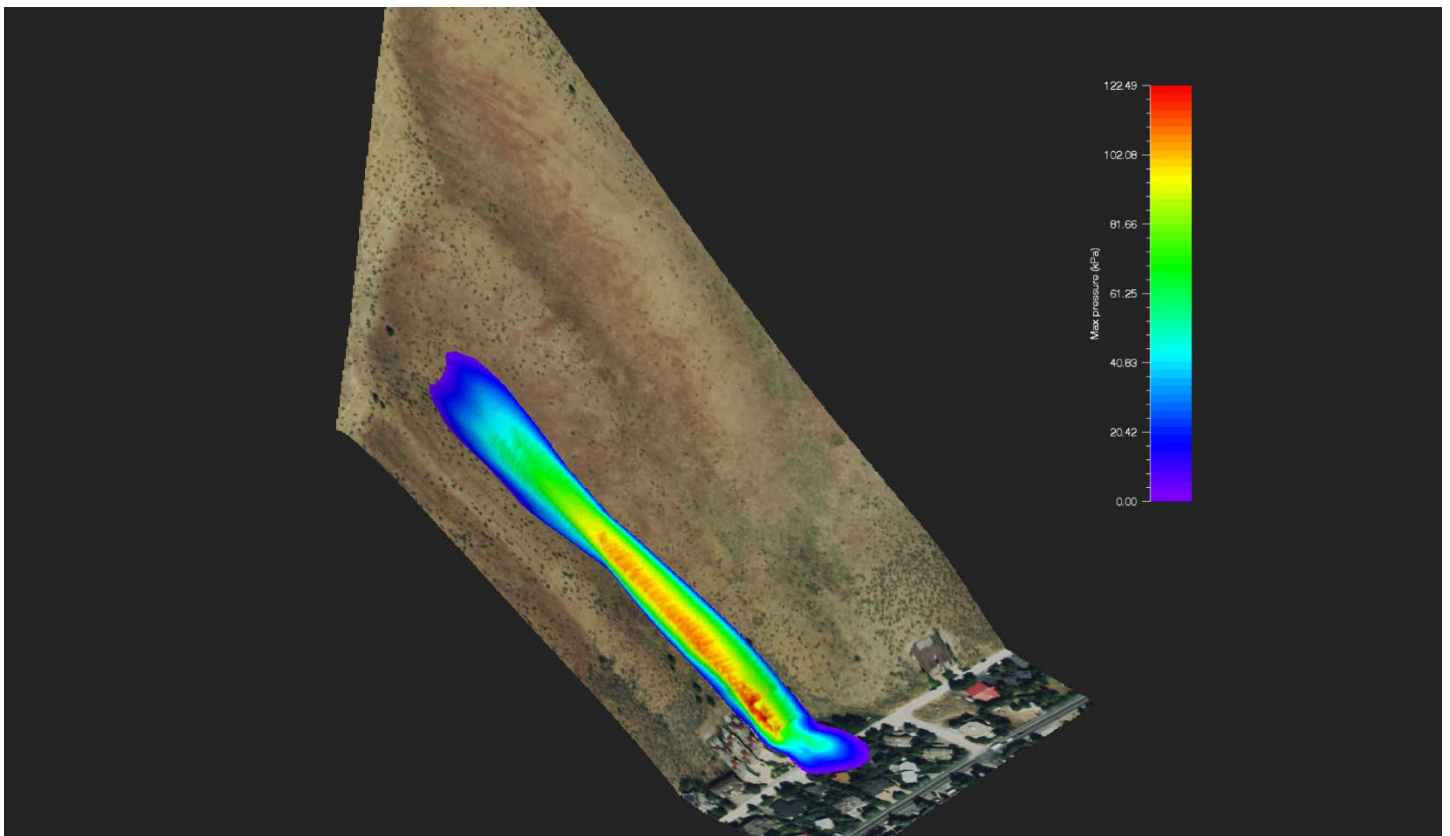

Figure 6 - Path R13 - Maximum Pressures - 3D

# ALPINE ENTERPRISES INC.

Surveying, Mapping, Civil Engineering, and Natural Hazards Consulting

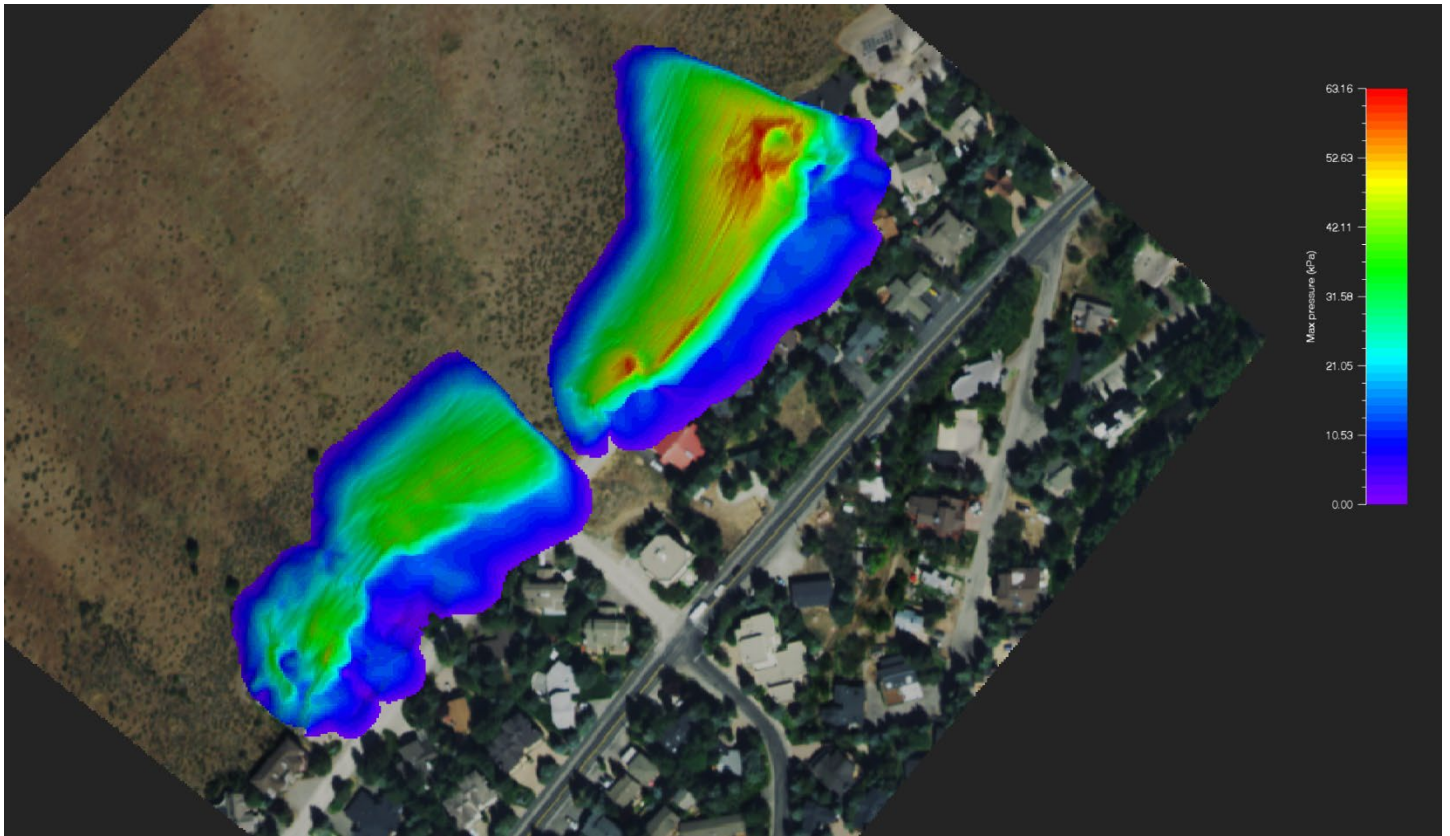

Figure 7 - Paths R14 & R15 - Maximum Pressures - 2D

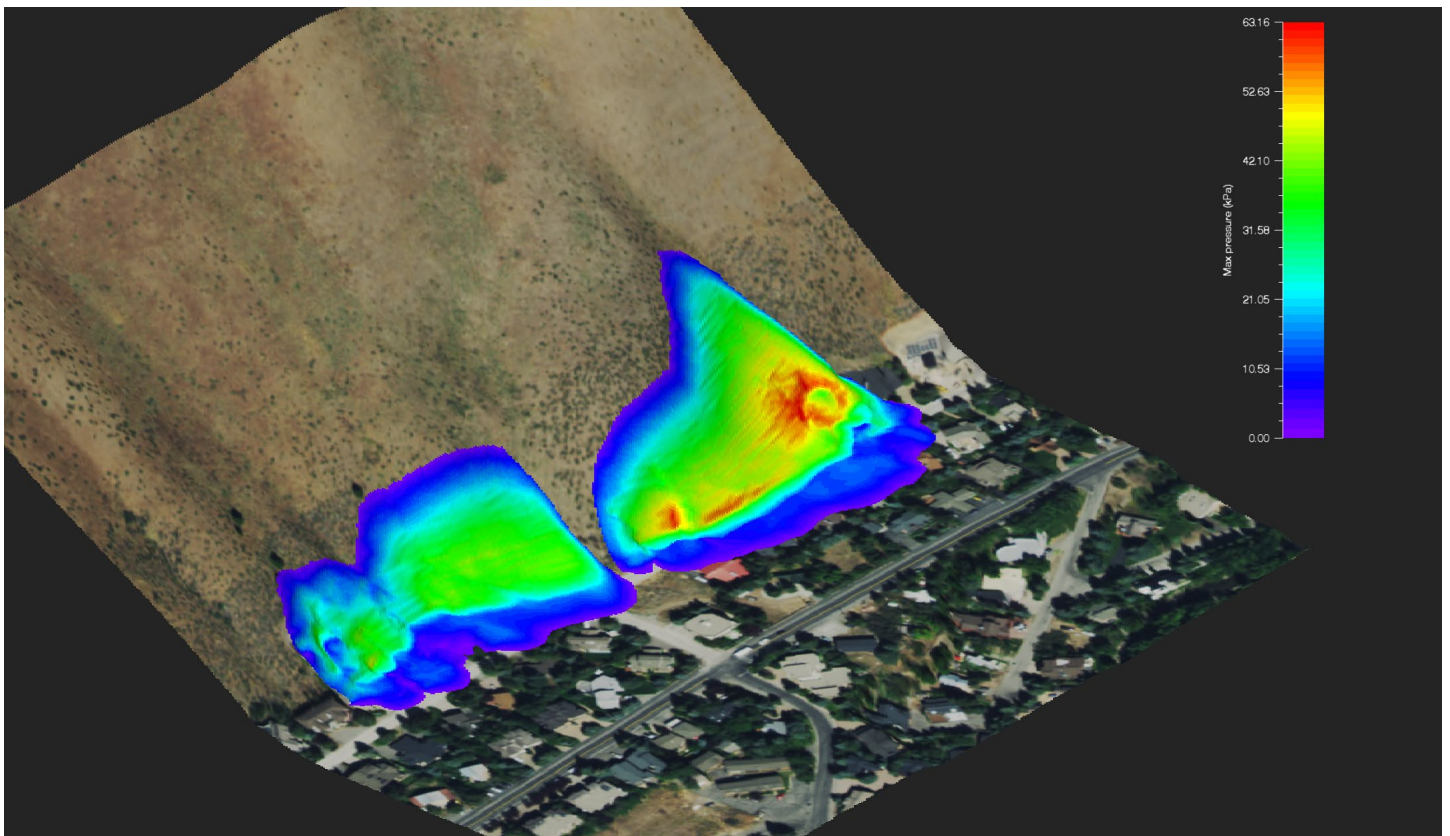

Figure 8 - Paths R14 & R15 - Maximum Pressures - 3D

# ALPINE ENTERPRISES INC.

Surveying, Mapping, Civil Engineering, and Natural Hazards Consulting

## PATHS : R10-R11 T300 LOG FILE

\*\*\*\*\*

RAMMS::AVALANCHE RAMMS OUTPUT LOGFILE

Output filename: U:\CarlsonProjects\1938\_RitcheyTMHS\RAMMS\_2022\1938\_RitcheyTMHS\_1M\R10-R11\_T300.out.gz

Simulation stopped due to LOW FLUX!

Simulation stopped after 89.1000s

Calculation time (min.): 16.40

Simulation resolution (m): 1.00

### SIMULATION RESULTS

Number of cells: 423460

Number of nodes: 425373

Calculated Release Volume (m3): 1535.97

Overall MAX velocity (m/s): 20.9835

Overall MAX flowheight (m): 5.53742

Overall MAX pressure (kPa): 132.092

\*\*\*\*\*

RAMMS::AVALANCHE 1.7.20 INPUT LOGFILE

Date: Wed Oct 19 12:03:48 2022

Input filename: U:\CarlsonProjects\1938\_RitcheyTMHS\RAMMS\_2022\1938\_RitcheyTMHS\_1M\R10-R11\_T300.av2

Project: 1938\_RitcheyTMHS\_1M

Details:

### DEM / REGION INFORMATION:

DEM file: U:\CarlsonProjects\1938\_RitcheyTMHS\RAMMS\_2022\1938\_RitcheyTMHS\_1M\1938\_RitcheyTMHS\_1M.xyz

DEM resolution (m): 1.00

(imported from: U:\CarlsonProjects\1938\_RitcheyTMHS\RAMMS\_2022\1938\_RitcheyTMHS\_GRID\_1M\_ASCII.asc)

Nr of nodes: 2230200

Nr of cells: 2227208

### Project region extent:

E - W: 468467.65 / 467068.64

S - N: 224269.73 / 225861.73

### CALCULATION DOMAIN:

U:\CarlsonProjects\1938\_RitcheyTMHS\RAMMS\_2022\1938\_RitcheyTMHS\_1M\D4.dom

### GENERAL SIMULATION PARAMETERS:

Simulation time (s): 300.000

Dump interval (s): 0.33

Stopping criteria (momentum threshold) (%): 5

Constant density (kg/m3): 300

### NUMERICS:

Numerical scheme: SecondOrder

H Cutoff (m): 0.000001

Curvature effects are ON!

### RELEASE:

Depth: 0.85 m Vol: 10229.4 m3 Delay: 10.00 s Name: R10.shp

Alpine Enterprises Inc. P.O. Box 2037, 660 Bell Dr., Unit 1, Ketchum, ID 83340 208-727-1988 bsmith@alpineenterprisesinc.com

pg. 6 of

# ALPINE ENTERPRISES INC.

Surveying, Mapping, Civil Engineering, and Natural Hazards Consulting

Depth: 0.75 m Vol: 1538.6 m3 Delay: 0.00 s Name: R11.shp  
Estimated release volume: 11767.98 m3

## FRICITION MUXI:

Altitude\_limit\_1: 1500 m a.s.l

Altitude\_limit\_2: 1000 m a.s.l

Format of following parameters: [ < 1000 ] - [ 1000 - 1500 ] - [ > 1500 ]

## Open slope parameters:

Mu: 0.300 - 0.290 - 0.275

Xi: 1250 - 1400 - 1500

## Channelled parameters:

Mu: 0.340 - 0.330 - 0.310

Xi: 1050 - 1180 - 1250

## Gully parameters:

Mu: 0.440 - 0.430 - 0.420

Xi: 900 - 1000 - 1050

## Flat parameters:

Mu: 0.280 - 0.270 - 0.260

Xi: 1500 - 1600 - 1750

## Forest parameters:

Mu (delta): 0.020 - 0.020 - 0.020

Xi: 400 - 400 - 400

RETURN PERIOD (y): 300

VOLUME category: Tiny

## COHESION:

No COHESION specified.

## MAP / ORTHOPHOTO INFO:

Map file: U:\CarlsonProjects\1938\_RitcheyTMHS\RAMMS\_2022\AerialImagery\NAIP\_2019\_FULL.tif

OrthoPhoto file: U:\CarlsonProjects\1938\_RitcheyTMHS\RAMMS\_2022\AerialImagery\NAIP\_2019\_FULL.tif

# ALPINE ENTERPRISES INC.

Surveying, Mapping, Civil Engineering, and Natural Hazards Consulting

## PATH : R12 T300 LOG FILE

\*\*\*\*\*  
RAMMS::AVALANCHE RAMMS OUTPUT LOGFILE

Output filename: U:\CarlsonProjects\1938\_RitcheyTMHS\RAMMS\_2022\1938\_RitcheyTMHS\_1M\R12\_T300.out.gz

Simulation stopped due to LOW FLUX!

Simulation stopped after 48.1800s  
Calculation time (min.): 3.43

Simulation resolution (m): 1.00

### SIMULATION RESULTS

Number of cells: 184501  
Number of nodes: 185755

Calculated Release Volume (m3): 7092.63

Overall MAX velocity (m/s): 20.5286  
Overall MAX flowheight (m): 2.97748  
Overall MAX pressure (kPa): 126.427

\*\*\*\*\*  
RAMMS::AVALANCHE 1.7.20 INPUT LOGFILE

Date: Wed Oct 19 13:14:08 2022  
Input filename: U:\CarlsonProjects\1938\_RitcheyTMHS\RAMMS\_2022\1938\_RitcheyTMHS\_1M\R12\_T300.av2

Project: 1938\_RitcheyTMHS\_1M  
Details:

DEM / REGION INFORMATION:  
DEM file: U:\CarlsonProjects\1938\_RitcheyTMHS\RAMMS\_2022\1938\_RitcheyTMHS\_1M\1938\_RitcheyTMHS\_1M.xyz  
DEM resolution (m): 1.00  
(imported from: U:\CarlsonProjects\1938\_RitcheyTMHS\RAMMS\_2022\1938\_RitcheyTMHS\_GRID\_1M\_ASCII.asc)

Nr of nodes: 2230200  
Nr of cells: 2227208

Project region extent:  
E - W: 468467.65 / 467068.64  
S - N: 224269.73 / 225861.73

CALCULATION DOMAIN:  
U:\CarlsonProjects\1938\_RitcheyTMHS\RAMMS\_2022\1938\_RitcheyTMHS\_1M\D2.dom

GENERAL SIMULATION PARAMETERS:  
Simulation time (s): 300.000  
Dump interval (s): 0.33  
Stopping criteria (momentum threshold) (%): 5  
Constant density (kg/m3): 300

NUMERICS:  
Numerical scheme: SecondOrder  
H Cutoff (m): 0.000001  
Curvature effects are ON!

RELEASE:  
Depth: 0.92 m Vol: 7093.3 m3 Delay: 0.00 s Name: R12.shp  
Alpine Enterprises Inc. P.O. Box 2037, 660 Bell Dr., Unit 1, Ketchum, ID 83340 208-727-1988 bsmith@alpineenterprisesinc.com

# ALPINE ENTERPRISES INC.

Surveying, Mapping, Civil Engineering, and Natural Hazards Consulting

Estimated release volume: 7093.25 m<sup>3</sup>

## FRICITION MUXI:

Altitude\_limit\_1: 1500 m a.s.l

Altitude\_limit\_2: 1000 m a.s.l

Format of following parameters: [ < 1000 ] - [ 1000 - 1500 ] - [ > 1500 ]

## Open slope parameters:

Mu: 0.300 - 0.290 - 0.275

Xi: 1250 - 1400 - 1500

## Channelled parameters:

Mu: 0.340 - 0.330 - 0.310

Xi: 1050 - 1180 - 1250

## Gully parameters:

Mu: 0.440 - 0.430 - 0.420

Xi: 900 - 1000 - 1050

## Flat parameters:

Mu: 0.280 - 0.270 - 0.260

Xi: 1500 - 1600 - 1750

## Forest parameters:

Mu (delta): 0.020 - 0.020 - 0.020

Xi: 400 - 400 - 400

RETURN PERIOD (y): 300

VOLUME category: Tiny

## COHESION:

No COHESION specified.

## MAP / ORTHOPHOTO INFO:

Map file: U:\CarlsonProjects\1938\_RitcheyTMHS\RAMMS\_2022\AerialImagery\NAIP\_2019\_FULL.tif

OrthoPhoto file: U:\CarlsonProjects\1938\_RitcheyTMHS\RAMMS\_2022\AerialImagery\NAIP\_2019\_FULL.tif

# ALPINE ENTERPRISES INC.

Surveying, Mapping, Civil Engineering, and Natural Hazards Consulting

## PATH : R13 T300 LOG FILE

\*\*\*\*\*

RAMMS::AVALANCHE RAMMS OUTPUT LOGFILE

Output filename: U:\CarlsonProjects\1938\_RitcheyTMHS\RAMMS\_2022\1938\_RitcheyTMHS\_1M\R13\_T300.out.gz

Simulation stopped due to LOW FLUX!

Simulation stopped after 34.9800s  
Calculation time (min.): 2.67

Simulation resolution (m): 1.00

### SIMULATION RESULTS

Number of cells: 184501  
Number of nodes: 185755

Calculated Release Volume (m3): 4158.80

Overall MAX velocity (m/s): 20.2067  
Overall MAX flowheight (m): 3.02173  
Overall MAX pressure (kPa): 122.493

\*\*\*\*\*

RAMMS::AVALANCHE 1.7.20 INPUT LOGFILE

Date: Wed Oct 19 13:36:14 2022

Input filename: U:\CarlsonProjects\1938\_RitcheyTMHS\RAMMS\_2022\1938\_RitcheyTMHS\_1M\R13\_T300.av2

Project: 1938\_RitcheyTMHS\_1M  
Details:

### DEM / REGION INFORMATION:

DEM file: U:\CarlsonProjects\1938\_RitcheyTMHS\RAMMS\_2022\1938\_RitcheyTMHS\_1M\1938\_RitcheyTMHS\_1M.xyz  
DEM resolution (m): 1.00  
(imported from: U:\CarlsonProjects\1938\_RitcheyTMHS\RAMMS\_2022\1938\_RitcheyTMHS\_GRID\_1M\_ASCII.asc)

Nr of nodes: 2230200  
Nr of cells: 2227208

Project region extent:  
E - W: 468467.65 / 467068.64  
S - N: 224269.73 / 225861.73

### CALCULATION DOMAIN:

U:\CarlsonProjects\1938\_RitcheyTMHS\RAMMS\_2022\1938\_RitcheyTMHS\_1M\D2.dom

### GENERAL SIMULATION PARAMETERS:

Simulation time (s): 300.000  
Dump interval (s): 0.33  
Stopping criteria (momentum threshold) (%): 5  
Constant density (kg/m3): 300

### NUMERICS:

Numerical scheme: SecondOrder  
H Cutoff (m): 0.000001  
Curvature effects are ON!

### RELEASE:

Depth: 0.85 m Vol: 4156.4 m3 Delay: 0.00 s Name: R13.shp  
Estimated release volume: 4156.44 m3

# ALPINE ENTERPRISES INC.

Surveying, Mapping, Civil Engineering, and Natural Hazards Consulting

## FRICITION MUXI:

Altitude\_limit\_1: 1500 m a.s.l

Altitude\_limit\_2: 1000 m a.s.l

Format of following parameters: [ < 1000 ] - [ 1000 - 1500 ] - [ > 1500 ]

## Open slope parameters:

Mu: 0.300 - 0.290 - 0.275

Xi: 1250 - 1400 - 1500

## Channelled parameters:

Mu: 0.340 - 0.330 - 0.310

Xi: 1050 - 1180 - 1250

## Gully parameters:

Mu: 0.440 - 0.430 - 0.420

Xi: 900 - 1000 - 1050

## Flat parameters:

Mu: 0.280 - 0.270 - 0.260

Xi: 1500 - 1600 - 1750

## Forest parameters:

Mu (delta): 0.020 - 0.020 - 0.020

Xi: 400 - 400 - 400

RETURN PERIOD (y): 300

VOLUME category: Tiny

## COHESION:

No COHESION specified.

## MAP / ORTHOPHOTO INFO:

Map file: U:\CarlsonProjects\1938\_RitcheyTMHS\RAMMS\_2022\AerialImagery\NAIP\_2019\_FULL.tif

OrthoPhoto file: U:\CarlsonProjects\1938\_RitcheyTMHS\RAMMS\_2022\AerialImagery\NAIP\_2019\_FULL.tif

# ALPINE ENTERPRISES INC.

Surveying, Mapping, Civil Engineering, and Natural Hazards Consulting

## PATHS : R10-R11 T300 LOG FILE

\*\*\*\*\*

RAMMS::AVALANCHE RAMMS OUTPUT LOGFILE

Output filename: U:\CarlsonProjects\1938\_RitcheyTMHS\RAMMS\_2022\1938\_RitcheyTMHS\_1M\R14-R15\_T300.out.gz

Simulation stopped due to LOW FLUX!

Simulation stopped after 12.2100s  
Calculation time (min.): 0.93

Simulation resolution (m): 1.00

### SIMULATION RESULTS

Number of cells: 197599  
Number of nodes: 198854

Calculated Release Volume (m3): 9410.51

Overall MAX velocity (m/s): 14.5092  
Overall MAX flowheight (m): 3.36095  
Overall MAX pressure (kPa): 63.1554

\*\*\*\*\*

RAMMS::AVALANCHE 1.7.20 INPUT LOGFILE

Date: Wed Oct 19 13:51:00 2022

Input filename: U:\CarlsonProjects\1938\_RitcheyTMHS\RAMMS\_2022\1938\_RitcheyTMHS\_1M\R14-R15\_T300.av2

Project: 1938\_RitcheyTMHS\_1M  
Details:

### DEM / REGION INFORMATION:

DEM file: U:\CarlsonProjects\1938\_RitcheyTMHS\RAMMS\_2022\1938\_RitcheyTMHS\_1M\1938\_RitcheyTMHS\_1M.xyz  
DEM resolution (m): 1.00  
(imported from: U:\CarlsonProjects\1938\_RitcheyTMHS\RAMMS\_2022\1938\_RitcheyTMHS\_GRID\_1M\_ASCII.asc)

Nr of nodes: 2230200  
Nr of cells: 2227208

### Project region extent:

E - W: 468467.65 / 467068.64  
S - N: 224269.73 / 225861.73

### CALCULATION DOMAIN:

U:\CarlsonProjects\1938\_RitcheyTMHS\RAMMS\_2022\1938\_RitcheyTMHS\_1M\D5.dom

### GENERAL SIMULATION PARAMETERS:

Simulation time (s): 300.000  
Dump interval (s): 0.33  
Stopping criteria (momentum threshold) (%): 5  
Constant density (kg/m3): 300

### NUMERICS:

Numerical scheme: SecondOrder  
H Cutoff (m): 0.000001  
Curvature effects are ON!

### RELEASE:

Depth: 0.72 m Vol: 4379.3 m3 Delay: 0.00 s Name: R14.shp

# ALPINE ENTERPRISES INC.

Surveying, Mapping, Civil Engineering, and Natural Hazards Consulting

Depth: 0.68 m Vol: 5028.4 m3 Delay: 0.00 s Name: R15.shp  
Estimated release volume: 9407.72 m3

## FRICITION MUXI:

Altitude\_limit\_1: 1500 m a.s.l

Altitude\_limit\_2: 1000 m a.s.l

Format of following parameters: [ < 1000 ] - [ 1000 - 1500 ] - [ > 1500 ]

## Open slope parameters:

Mu: 0.300 - 0.290 - 0.275

Xi: 1250 - 1400 - 1500

## Channelled parameters:

Mu: 0.340 - 0.330 - 0.310

Xi: 1050 - 1180 - 1250

## Gully parameters:

Mu: 0.440 - 0.430 - 0.420

Xi: 900 - 1000 - 1050

## Flat parameters:

Mu: 0.280 - 0.270 - 0.260

Xi: 1500 - 1600 - 1750

## Forest parameters:

Mu (delta): 0.020 - 0.020 - 0.020

Xi: 400 - 400 - 400

RETURN PERIOD (y): 300

VOLUME category: Tiny

## COHESION:

No COHESION specified.

## MAP / ORTHOPHOTO INFO:

Map file: U:\CarlsonProjects\1938\_RitcheyTMHS\RAMMS\_2022\AerialImagery\NAIP\_2019\_FULL.tif

OrthoPhoto file: U:\CarlsonProjects\1938\_RitcheyTMHS\RAMMS\_2022\AerialImagery\NAIP\_2019\_FULL.tif

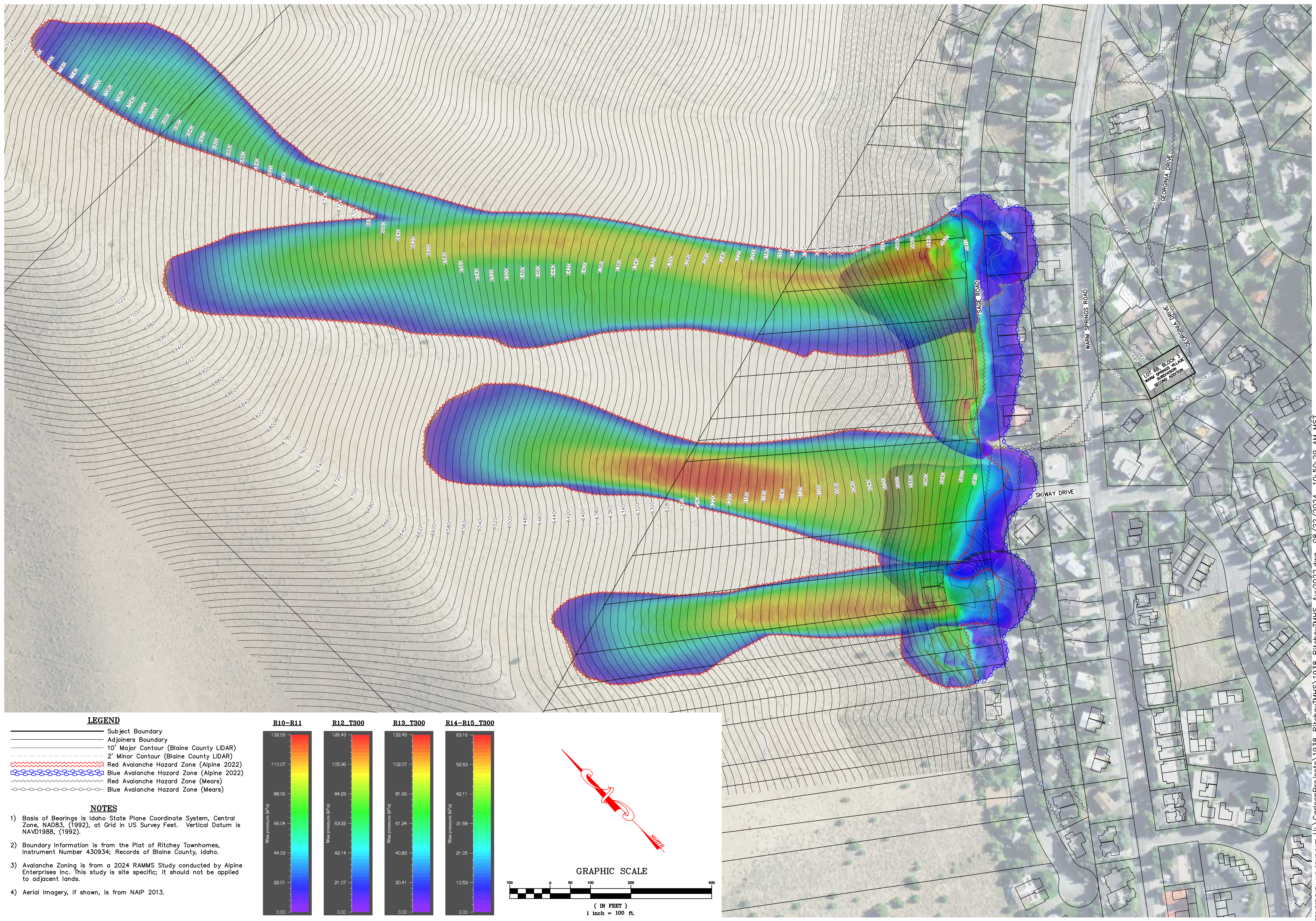

**LEGEND**

- Subject Boundary
- Adjurers Boundary
- 10' Major Contour (Blaine County LIDAR)
- - - 2' Minor Contour (Blaine County LIDAR)
- Red wavy line: Red Avalanche Hazard Zone (Alpine 2022)
- Blue wavy line: Blue Avalanche Hazard Zone (Alpine 2022)
- Red dashed line: Red Avalanche Hazard Zone (Mears)
- Blue dashed line: Blue Avalanche Hazard Zone (Mears)

**NOTES**

- 1) Basis of Bearings is Idaho State Plane Coordinate System, Central Zone, NAD83, (1992), at Grid in US Survey Feet. Vertical Datum is NAVD1988, (1992).
- 2) Boundary Information is from the Plat of Ritchey Townhomes, Instrument Number 430934; Records of Blaine County, Idaho.
- 3) Avalanche Zoning is from a 2024 RAMMS Study conducted by Alpine Enterprises Inc. This study is site specific; it should not be applied to adjacent lands.
- 4) Aerial Imagery, if shown, is from NAIP 2013.

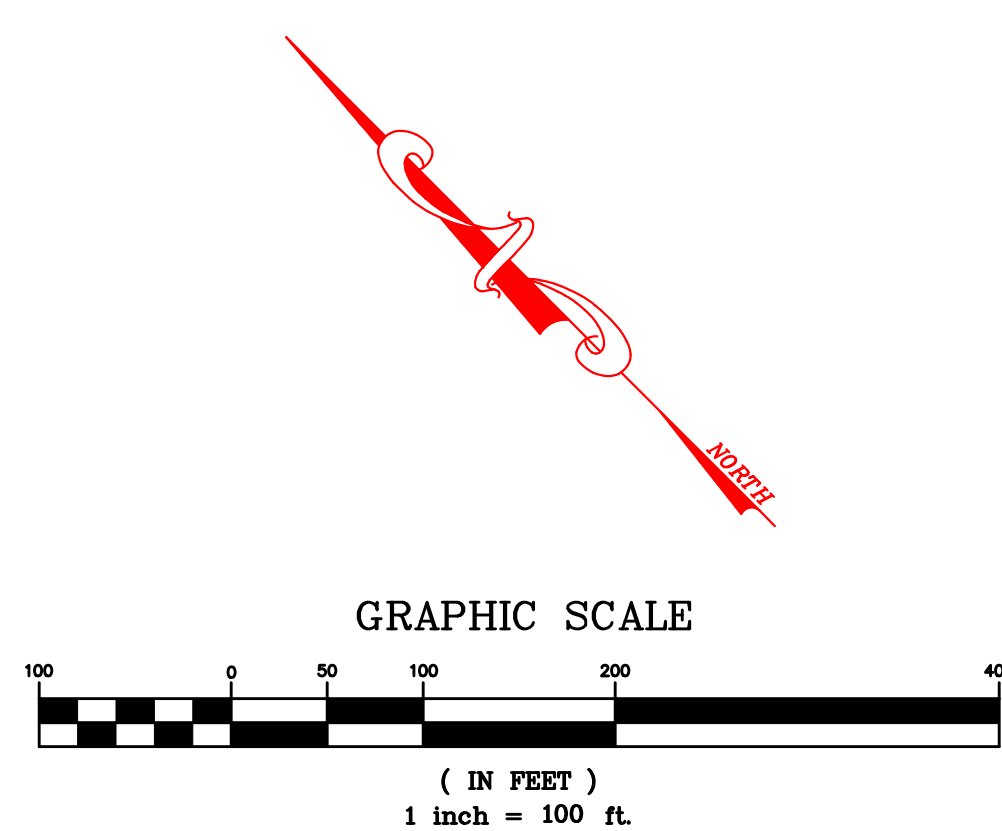
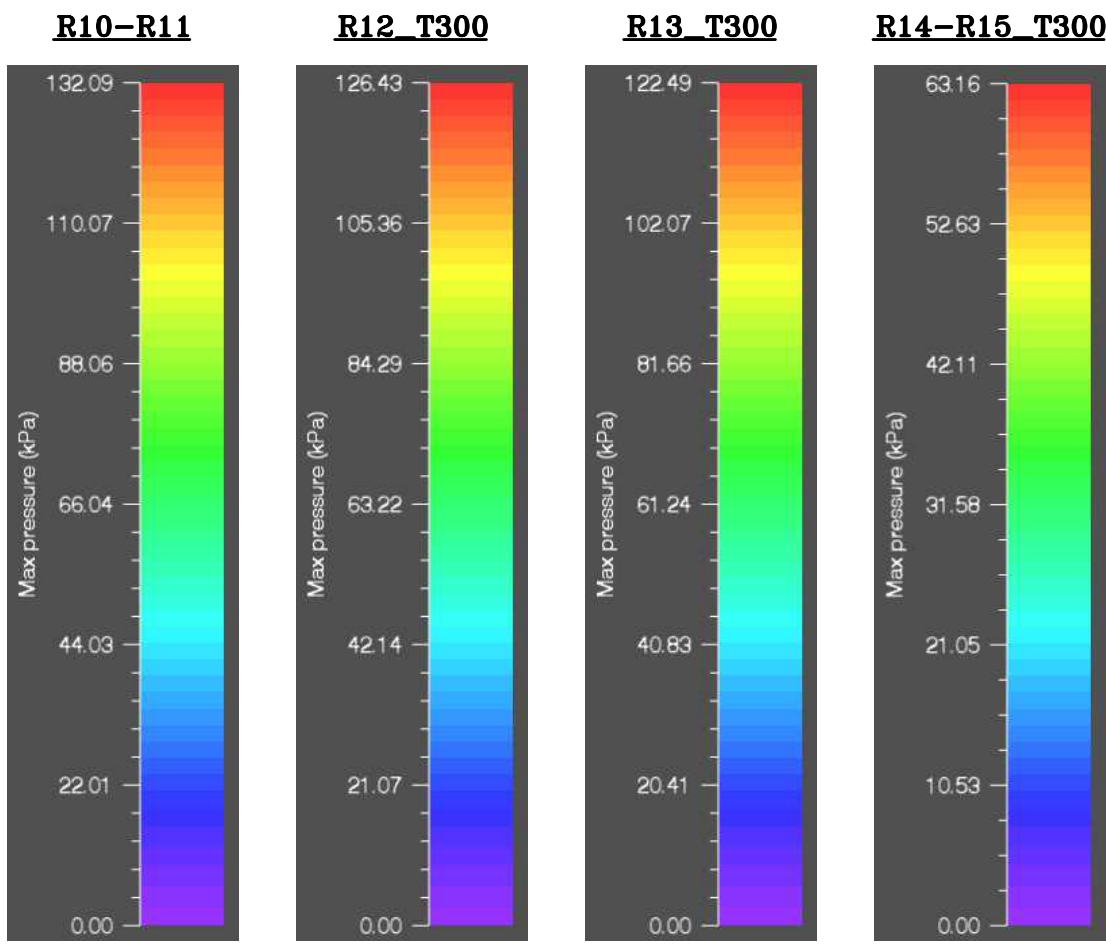

PROJECT PATH AND PRINT DATE U:\CarlsonProjects\1938\_Ritchey\TMS\1938\_Ritchey\TMS\_Avy2022.dwg 08/22/2024 10:50:29 AM MST

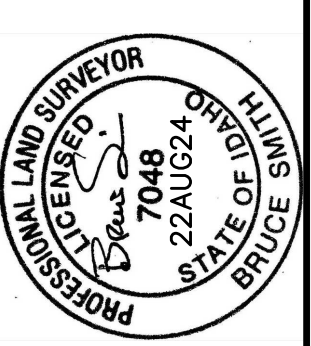

**Alpine Enterprises Inc.**  
 Surveying, Mapping, Civil Engineering,  
 and Natural Hazards Consulting  
 660 Bell Dr., Unit 1  
 P.O. Box 2037, Ketchum, ID 83340 USA  
 (208) 721-1986  
 email: bsm@alpineenterprises.com

A SNOW AVALANCHE HAZARD MAP SHOWING  
 LOT 6B, BLOCK 3, WARM SPRINGS VILLAGE SUBDIVISION, SECOND ADDITION  
 WITHIN S11, T.4N., R.17E., B.M., CITY OF KETCHUM, BLAINE COUNTY, IDAHO  
 PREPARED FOR JORDAN HOMES

REVISIONS	NO	DATE	BY





City of Ketchum

# Attachment D: Lift View Townhomes Preliminary Plat

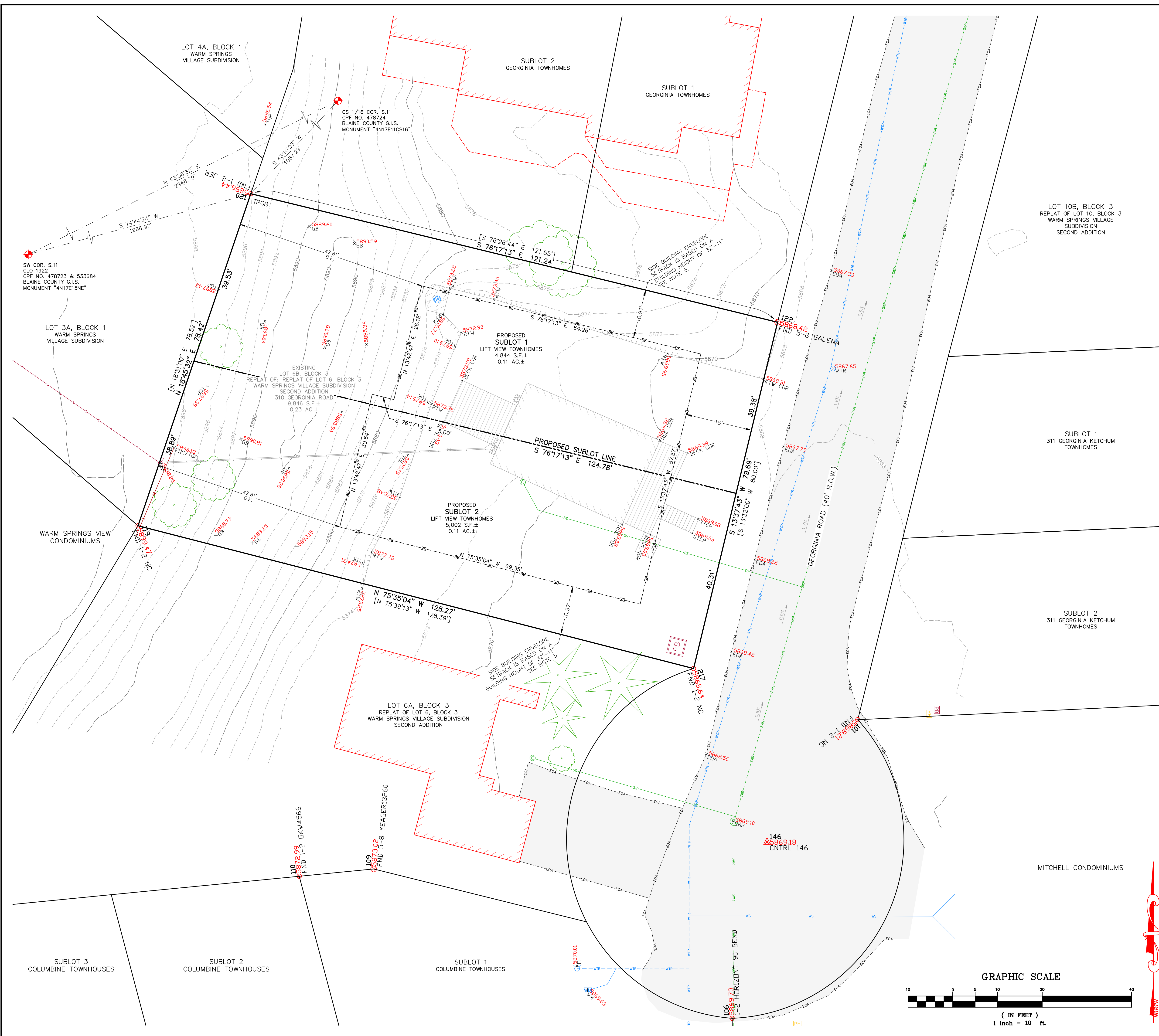

**LEGEND**

	Subject Boundary
	Adjoining Lot Line
	Proposed Sublot Line
	Proposed Building Envelope (See Note 5)
	Existing Structure
	Existing Structure (Removed)
	Existing Deck (Removed)
	EOA - Edge of Asphalt Roadway/Driveway
	RTW - Stone Retaining Wall (Removed)
	FNC - Wooden Fence
	10' Contour (2017 Idaho LIDAR Consortium)
	Existing 6" Water Main
	Existing 8" Sewer Main
	Overhead Power Line
	Overhead Power Service Line (Removed)
	Overhead Phone Line (Removed)
	Blaine County G.I.S. Tie
	Survey Control
	Found 5/8" Rebar, as Shown
	Found 1/2" Rebar, As Shown
	Private Well
	WV - Water Valve
	FH - Fire Hydrant
	WM - Water Meter
	SMH - Sewer Manhole
	SCO - Sewer Cleanout
	PBOX - Power Box
	PP - Power Pole
	PMTR - Power Meter (Removed)
	GM - Gas Meter (Removed)
	PH - Phone Box (Removed)
	CT - Coniferous Tree
	DT - Deciduous Tree
	Existing Grade
	No Cap
	Toe of Slope
	Grade Break
	Corner
	Threshold Elevation
	Garage Slab Elevation
	Top of Dry Well/Catch Basin
	Invert Elevation
	Record Bearing & Distance Inst. No. 326129

**NOTES**

- 1) Basis of Bearings is Grid North per Idaho State Plane Coordinate System, Central Zone, NAD83, (1992), at Grid in US Survey Feet. Vertical Datum is NAVD1988.
- 2) Boundary Information used or considered includes:
  - Warm Springs Village, Instrument Number 92906;
  - Warm Springs Village Subdivision, Second Addition, Instrument Number 103120;
  - Warm Springs View Condominiums, Instrument Number 193185;
  - Replat of Lot 6, Block 3, Warm Springs Village Subdivision, Second Addition, Instrument Number 274255;
  - Replat of Lot 6B, Replat of Lot 6, Block 3, & Southerly Portion of Lot 5, Block 3, Warm Springs Village Subdivision, Second Addition, Instrument Number 326129;
  - Georgia Townhouses, Instrument Number 332480;
  - Lots 3 & 4, Block 1, Warm Springs Village Subdivision, Instrument Number 392884;
- 3) Except as stated or shown on this map, this Survey does not intend to reflect any of the following which may be applicable to Subject Real Property: Natural Hazards, Encroachments, Wetlands, Ditches, Easements other than those shown or listed herein, Building Setbacks, Restrictive Covenants, Subdivision Restrictions, Zoning Restrictions, Land-Use Regulations, or Deed Restrictions and Exceptions contained within a current Title Policy.
- 4) The Subject Property is within the City of Ketchum General Residential Low Density District, GR-L. Please refer to City of Ketchum Code of Ordinances for more information about this zone.
- 5) Building Setbacks within the City of Ketchum General Residential Low Density District, GR-L, are as follows:
  - FRONT: 15 Feet
  - REAR: 15 Feet
  - SIDE: The greater of 1 Foot for every 3 Feet in building height, or 5 Feet. One-family dwellings must maintain at least 10 Feet.
- 6) The Subject Property is within the City of Ketchum Avalanche Zone District, A. Please refer to the City of Ketchum Code of Ordinance for more information about this zone.
- 7) The Subject Property is within the Blaine County Elk Winter Range Zone.
- 8) Utility Locations shown are based on visual surface evidence and City Maps. Utility locations should be verified before any excavation.
- 9) The Lift View Townhomes Sublots shall have Mutual Reciprocal Snow Storage Easements and Utility Easements for the Installation, Repair, Maintenance, and Replacement of Utilities.
- 10) Deceleration of Covenants, Conditions and Restrictions of Lift View Townhomes is Recorded in Blaine County under Instrument No. \_\_\_\_\_
- 11) Documents that may affect this Plat include:
  - The Plats of:
    - Warm Springs Village Subdivision, Second Addition, Instrument Number 103120;
    - Replat of Lot 6, Block 3, Warm Springs Village Subdivision, Second Addition, Instrument Number 274255;
    - Replat of Lot 6B, Replat of Lot 6, Block 3, & Southerly Portion of Lot 5, Block 3, Warm Springs Village Subdivision, Second Addition, Instrument Number 326129;
  - Reservations and exceptions in a United States Patent, Instrument Number 55385 and Amended as Instrument Number 58955;
  - Idaho Power Company Easements, Instrument Numbers 114480 & 117325;
  - Avalanche Zone Affidavit, Instrument Number 197578;

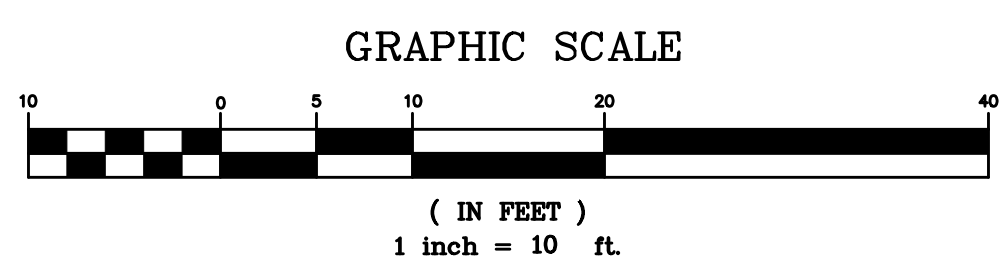

PROJECT PATH AND PRINT DATE: U:\LandProjects\2004\1464\_WARM\_SPRGS\_2ND\_ADD.dwg 12/29/2025 09:22:26 AM MST

**ALPINE ENTERPRISES INC.**  
 Surveying, Mapping, Civil Engineering,  
 and Natural Hazards Consulting  
 660 Bell Dr., Unit 1  
 P.O. Box 2037, Ketchum, ID 83340 USA  
 (208) 727-1986  
 email: tsam@alpineenterprises.com

WHEREIN LOT 6B, BLOCK 3, WARM SPRINGS VILLAGE SUBDIVISION, SECOND ADDITION IS DIVIDED INTO TWO TOWNHOUSE SUBLOTS AS SHOWN HEREON WITHIN S.11, T.4N., R.17E., B.M., CITY OF KETCHUM, BLAINE COUNTY, IDAHO PREPARED FOR JORDAN HOMES

NO	DATE	BY
1	01JUL25	AHN
2	21OCT25	AHN
3	29DEC25	AHN

REVISIONS  
 PRELIMINARY: NOT FOR CONSTRUCTION  
 DESIGN REVIEW SUBMITTAL  
 REVISED: PLANNING REVIEW NO. 1  
 REVISED: PLANNING REVIEW NO. 2  
 SHEET 1 OF 1

104



City of Ketchum

# Attachment E: Zoning and Dimensional Standards Evaluation



LIFT VIEW TOWNHOMES  
COMPLIANCE WITH ZONING REGULATIONS

Compliance with Zoning and Dimensional Standards				
Compliant			Standards and Findings	
Yes	No	N / A	Ketchum Municipal Code	City Standards and Findings
<input checked="" type="checkbox"/>	<input type="checkbox"/>	<input type="checkbox"/>	17.12.030	<b>Minimum Lot Area</b>
			Finding	<b>Required:</b> 8,000 square feet minimum <b>Existing:</b> 9,846 square feet (.23 acres)
<input checked="" type="checkbox"/>	<input type="checkbox"/>	<input type="checkbox"/>	17.12.030	<b>Building Coverage</b>
			Finding	<b>Permitted:</b> 35% <b>Proposed:</b> 30% (2,964.15 square foot building footprint / 9,846 square foot lot area)
<input checked="" type="checkbox"/>	<input type="checkbox"/>	<input type="checkbox"/>	17.12.030	<b>Minimum Building Setbacks</b>
			Finding	<b>Minimum Required Setbacks:</b> Front: 15' Side: > of 1' for every 3' in building height, or 5' (10'-11 2/3" required) Rear: 15'  <b>Proposed:</b> Front (Georgia Road/east): 15' Side (north): 10'-11 2/3" Side (south): 10'-11 2/3" Rear (west): 51'-5 5/8"
<input checked="" type="checkbox"/>	<input type="checkbox"/>	<input type="checkbox"/>	17.12.030	<b>Building Height</b>
			Finding	<b>Maximum Permitted:</b> 35' <b>Proposed:</b> 32'-11"
<input checked="" type="checkbox"/>	<input type="checkbox"/>	<input type="checkbox"/>	17.125.030.H	<b>Curb Cut</b>
			Finding	<b>Permitted:</b> A total of 35% of the linear footage of any street frontage can be devoted to access off street parking. <b>Proposed:</b> 35% (28-foot-wide total driveway area/79.69 feet of frontage along Georgia Road)
<input checked="" type="checkbox"/>	<input type="checkbox"/>	<input type="checkbox"/>	17.125.020.A.2 & 17.125.050	<b>Parking Spaces</b>
			Finding	Off-street parking standards of this chapter apply to any new development and to any new established uses. <b>Required:</b> Residential multiple-family dwelling in all districts except CC, T, T-3000, T-4000, and LI-1, LI-2, and LI-3: Units 2,001 square feet and above require 2 parking spaces. <b>Proposed:</b>



City of Ketchum  
Planning & Building

				The applicant is proposing two parking spaces within the enclosed garage for each unit.
--	--	--	--	---



City of Ketchum

# Attachment F: Design Review Standards Evaluation



LIFT VIEW TOWNHOMES  
DESIGN REVIEW STANDARDS ANALYSIS

17.96.060.A.1 - Streets	Conformance
<i>The applicant shall be responsible for all costs associated with providing a connection from an existing City street to their development.</i>	YES
<b>Finding:</b> The project proposes to construct two new heated paver driveways to access the townhouse development from Georgia Road. All project costs associated with the development, including the City street connection, are the responsibility of the applicant.	

17.96.060.A.2 - Streets	Conformance
<i>All street designs shall be approved by the City Engineer.</i>	N/A
<b>Finding:</b> No new streets or changes to the design of Georgia Road are proposed with this project.	

17.96.060.B.1 - Sidewalks	Conformance
<i>All projects under subsection 17.96.010.A of this chapter that qualify as a "substantial improvement" shall install sidewalks as required by the Public Works Department.</i>	N/A
<b>Finding:</b> Ketchum Municipal Code 17.124.140 outlines the zone districts where sidewalks are required when substantial improvements are made, which include the Community Core, all tourist zone districts, and all light industrial districts. The subject property is located within the GR-L Zone and sidewalks are not required to be installed for the project. This standard is not applicable.	

17.96.060.B.2 - Sidewalks	Conformance
<i>Sidewalk width shall conform to the City's right-of-way standards, however the City Engineer may reduce or increase the sidewalk width and design standard requirements at their discretion.</i>	N/A
<b>Finding:</b> This standard is not applicable because the subject property is located within the GR-L Zone and sidewalks are not required to be installed for this project.	

17.96.060.B.3 - Sidewalks	Conformance
<i>Sidewalks may be waived if one of the following criteria is met:</i>	N/A
<ul style="list-style-type: none"> <li>a) <i>The project comprises an addition of less than 250 square feet of conditioned space.</i></li> <li>b) <i>The City Engineer finds that sidewalks are not necessary because of existing geographic limitations, pedestrian traffic on the street does</i></li> </ul>	



<i>not warrant a sidewalk, or if a sidewalk would not be beneficial to the general welfare and safety of the public.</i>	
<b>Finding:</b> This standard is not applicable because the subject property is located within the GR-L Zone and sidewalks are not required to be installed for this project.	

17.96.060.B.4 - Sidewalks	Conformance
<i>The length of sidewalk improvements constructed shall be equal to the length of the subject property line(s) adjacent to any public street or private street.</i>	N/A
<b>Finding:</b> This standard is not applicable because the subject property is located within the GR-L Zone and sidewalks are not required to be installed for this project.	

17.96.060.B.5 – Sidewalks	Conformance
<i>New sidewalks shall be planned to provide pedestrian connections to any existing or future sidewalks adjacent to the site. In addition, sidewalks shall be constructed to provide safe pedestrian access to and around a building.</i>	N/A
<b>Finding:</b> Ketchum Municipal Code 17.124.140 outlines the zone districts where sidewalks are required when substantial improvements are made, which include the CC, all tourist zone districts, and all light industrial districts. This standard is not applicable because the subject property is located in the GR-L Zone and sidewalks are not required to be installed for this project.	

17.96.060.B.6 - Sidewalks	Conformance
<i>The City may approve and accept voluntary cash contributions in lieu of the above described improvements, which contributions must be segregated by the City and not used for any purpose other than the provision of these improvements. The contribution amount shall be 110 percent of the estimated costs of concrete sidewalk and drainage improvements provided by a qualified contractor, plus associated engineering costs, as approved by the City Engineer. Any approved in lieu contribution shall be paid before the City issues a certificate of occupancy.</i>	N/A
<b>Finding:</b> This standard is not applicable because the subject property is located within the GR-L Zone and sidewalks are not required to be installed for this project.	

17.96.060.C.1 - Drainage	Conformance
<i>All stormwater shall be retained on site.</i>	YES
<b>Finding:</b> Pursuant to KMC §17.96.060.C.1, all storm water drainage shall be retained on site. Drainage improvements are specified on Sheet C1.00 of the project plans. The drainage improvements include the installation of a trench drain bordering the width of both driveways at the property line. A combination of drywells and catch basins will be installed to collect	



stormwater from the rest of the property. The City Engineer has reviewed the proposed drainage plan and believes the trench drain and drywell improvements are sufficient to maintain all storm water drainage on-site.

All drainage plans and specifications shall be reviewed and approved by the City Engineer and Streets Department prior to issuance of a Building Permit for the project.

17.96.060.C.2 - Drainage	Conformance
--------------------------	-------------

<i>Drainage improvements constructed shall be equal to the length of the subject property lines adjacent to any public street or private street.</i>	YES
--	-----

**Finding:** Pursuant to KMC §17.96.060.C.1, all storm water drainage shall be retained on site. Drainage improvements are specified on Sheet C1.00 of the project plans. The drainage improvements include the installation of a trench drain bordering the width of both driveways at the property line. A combination of drywells and catch basins will be installed to collect stormwater from the rest of the property. The City Engineer has reviewed the proposed drainage plan and believes the trench drain and drywell improvements are sufficient to maintain all storm water drainage on-site.

All drainage plans and specifications shall be reviewed and approved by the City Engineer and Streets Department prior to issuance of a Building Permit for the project.

17.96.060.C.3 - Drainage	Conformance
--------------------------	-------------

<i>The City Engineer may require additional drainage improvements as necessary, depending on the unique characteristics of a site.</i>	YES
--	-----

**Finding:** The City Engineer has reviewed the proposed drainage plan and believes the trench drains and drywell/catch basin improvements are sufficient to maintain all storm water drainage on-site. The City Engineer may require additional drainage improvements if necessary. If approved, the applicant shall submit final civil drawings for all drainage improvements with the building permit application to be verified, reviewed, and approved by the City Engineer and Streets Department.

17.96.060.C.4 - Drainage	Conformance
--------------------------	-------------

<i>Drainage facilities shall be constructed per City standards.</i>	YES
---	-----

**Finding:** The drainage improvements include the installation of a trench drain bordering the width of both driveways at the property line. A combination of drywells and catch basins will be installed to collect stormwater from the rest of the property. The City Engineer has reviewed the proposed drainage plan and believes the proposed trench drains and drywell improvements meet city standards.

All drainage plans and specifications shall be reviewed and approved by the City Engineer and Streets Department prior to issuance of a Building Permit for the project.



17.96.060.D.1 - Utilities	Conformance
<i>All utilities necessary for the development shall be improved and installed at the sole expense of the applicant.</i>	YES
<p><b>Finding:</b> All project costs associated with the development, including the installation of utilities, are the responsibility of the applicant. The applicant has not made requests for funding to the City for utility improvements. No funds have been provided by the City for the project.</p>	

17.96.060.D.2 - Utilities	Conformance
<i>Utilities shall be located underground and utility, power, and communication lines within the development site shall be concealed from public view.</i>	YES
<p><b>Finding:</b> As shown on C1.00 of the project plans, the applicant proposes to abandon the existing private well and connect to the municipal water and sewer systems from existing lines within Georgia Road. Requirements and specifications for the water and sewer connections will be verified, reviewed, and approved by the Utilities Department prior to issuance of a Building Permit for the project.</p>	

17.96.060.D.3 - Utilities	Conformance
<i>When extension of utilities is necessary all developers will be required to pay for and install two-inch SDR11 fiber optical conduit. The placement and construction of the fiber optical conduit shall be done in accordance with City of Ketchum standards and at the discretion of the City Engineer.</i>	N/A
<p><b>Finding:</b> This standard is not applicable because the extension of utilities is not necessary to service the proposed townhome development.</p>	

17.96.060.E.1 – Compatibility of Design	Conformance
<i>The project's materials, colors and signing shall be complementary with the townscape, surrounding neighborhoods and adjoining structures.</i>	YES
<p><b>Finding:</b> Pursuant to Ketchum Municipal Code §17.96.060.E1, “The project’s materials, colors and signing shall be complementary with the townscape, surrounding neighborhoods and adjoining structures.” Georgia Road features developments built at varying timeframes resulting in a diverse range of materials and architectural styles. This has resulted in a mix of architectural styles used with newer residences leaning towards a mountain modern style (flat roofs, high percent of glazing, and less warm materials) and older residences featuring more traditional mountain architecture (pitched roofs, wood, and native stone with a more rustic feel). Still, the neighborhood features more traditional mountain architecture than mountain modern design. The materials of the proposed development includes stucco, stone, wood, and metal on the window and door trim, garage doors, roof fascia, and railings. These materials are utilized in many developments in the surrounding neighborhood.</p>	



With the previous plan set, staff expressed concerns regarding the compatibility of the project’s boxy, modern design within a neighborhood characterized by more traditional architectural styles. The proposed development continues to incorporate a blend of modern and traditional materials, such as stucco, stone, wood, and metal elements used for the garage doors, window and door trim, railings, and fascia. The mix of modern and traditional materials introduces some level of visual continuity with the surrounding development, particularly with the three-story duplex directly across the street which also utilizes stone on the ground level and stucco above. While the building maintains a modern design, staff finds that the applicant has made targeted revisions that improve its relationship to the neighborhood context. These revisions include the introduction of a recessed, street-facing front entry for Unit B which enhances the pedestrian orientation and breaks up the ground floor front façade, as well as the addition of enhanced landscaping along the front and side property lines to soften the building’s massing. Staff also finds that the revisions made to the roof, specifically the reduced eave and removal of roof overhangs from the third story decks, have been effective in reducing the building’s perceived bulk. However, the third story projection remains, which diminishes the effectiveness of the second story step back and contributes to a top-heavy appearance.

Overall, staff believes that the primary compatibility concern is not with the modern architectural style itself, but rather the building’s form and massing. Adjacent structures in the neighborhood feature greater articulation on all elevations, contributing to a more varied and visually balanced streetscape. While the revised design represents an improvement from the previous proposal, staff finds that certain aspects, particularly related to massing and upper-story articulation, still warrant further discussion by the Commission.

17.96.060.E.2 – Compatibility of Design	Conformance
<i>Preservation of significant landmarks shall be encouraged and protected, where applicable. A significant landmark is one which gives historical and/or cultural importance to the neighborhood and/or community.</i>	N/A
<b>Finding:</b> This standard is not applicable because the subject property does not contain any historical or cultural landmarks.	

17.96.060.E.3 – Compatibility of Design	Conformance
<i>Additions to existing buildings, built prior to 1940, shall be complementary in design and use similar material and finishes of the building being added to.</i>	N/A
<b>Finding:</b> The subject property was previously developed with a single-family residence that was constructed in 1953 and was deemed condemned by the Building Official. A demolition permit was issued for the residence on September 4, 2025, and has since been demolished. The subject property did not contain a historical or cultural landmark on the City’s Historical Building/Site List, therefore this standard does not apply.	



17.96.060.F.1 – Architectural	Conformance
<i>Building(s) shall provide unobstructed pedestrian access to the nearest sidewalk and the entryway shall be clearly defined.</i>	N/A
<p><b>Finding:</b> N/A. Ketchum Municipal Code 17.124.140 outlines the zone districts where sidewalks are required when substantial improvements are made, which include the Community Core, all tourist zone districts, and all light industrial districts. The subject property is located within the GR-L Zone and sidewalks are not required to be installed for the project. The entryway to both units is defined by a steel awning over the door.</p>	

17.96.060.F.2 – Architectural	Conformance
<i>The building character shall be clearly defined by use of architectural features.</i>	YES
<p><b>Finding:</b> With the previous plan set, staff expressed concerns with the façade being dominated by large, uninterrupted wall planes and lack of character defining features. From the initial submittal, the applicant has revised the design to incorporate material changes along the sides, banding between the second and third floors around the entirety of the structure, and stepped back the third story two feet from the ground floor façade. Staff believe that these revisions are improvements to the design which create greater architectural interest.</p>	

17.96.060.F.3 – Architectural	Conformance
<i>There shall be continuity of materials, colors and signing within the project.</i>	YES
<p><b>Finding:</b> No signage is proposed with the development. The project uses two beige colors of stucco, Montana Mossy stone, walnut cladding and brown stained wood beams, and metal accents for the roof, railing, fascia, garage, windows, and trim. The materials and color palette are continuous throughout the development.</p>	

17.96.060.F.4 – Architectural	Conformance
<i>Accessory structures, fences, walls and landscape features within the project shall match or complement the principal building.</i>	YES
<p><b>Finding:</b> No accessory structures or fences are proposed. The project proposes landscaping improvements that provide a buffer along the sides of the structure from adjacent properties and screening for utilities. The development also proposes concrete block retaining walls along the sides of the structure to manage grade changes which feature plantings between and above the walls. Staff does not believe that the concrete block is complementary to the building, however, the proposed Candy Stripe Creeping Phlox that is proposed between the walls will provide sufficient screening once established. The landscape plan was further revised to include trees, native grass, and a significant number of new shrubs.</p>	



17.96.060.F.5 – Architectural	Conformance
<i>Building walls shall provide undulation/relief, thus reducing the appearance of bulk and flatness.</i>	YES
<p><b>Finding:</b> The applicant made a variety of revisions to address the concerns raised the appearance of bulk and flatness. These changes include:</p> <ul style="list-style-type: none"> <li>- Reduced the roof eave by 3’</li> <li>- Recessed the third floor by 2’</li> <li>- Reduced the garage doors from three-vehicle to two-vehicle</li> <li>- Removed the roof overhangs over the third floor decks</li> <li>- Removed the columns on the deck corners on the second and third floors</li> <li>- Added a recessed, street-facing front entryway for Unit B</li> </ul> <p>Staff finds that the revisions are improvements on reducing the perceived bulk and flatness of the design. Specifically, the revisions made to the roof, including the reduced eave and removal of roof overhangs from the third story decks, have been effective in reducing the building’s perceived bulk. However, the third story projection remains, which diminishes the effectiveness of the second story step back and contributes to a top-heavy appearance. Staff believes that certain aspects of the design, particularly related to massing and upper-story articulation, still warrant further discussion by the Commission.</p>	

17.96.060.F.6 – Architectural	Conformance
<i>Building(s) shall orient toward their primary street frontage.</i>	YES
<p><b>Finding:</b> The applicant revised the design to relocate the front entryway for Unit B to face the street frontage and recessed the door to break up the ground floor wall plane. This modification created a more active front façade which is more compatible with other developments in the neighborhood. For Unit A, the applicant enlarged the size of the overhang and added posts to increase the architectural interest of the entrance (this can be seen in Figure 4 above). By bringing one entrance to the front and retaining one on the side, it will create a natural separation between the units and privacy for the occupants.</p>	

17.96.060.F.7 – Architectural	Conformance
<i>Garbage storage areas and satellite receivers shall be screened from public view and located off alleys.</i>	YES
<p><b>Finding:</b> No satellite receivers are proposed for the project. As shown on Sheet A2.0, the garage contains storage space to accommodate garbage bins. The garbage storage area will be contained with the enclosed garage and fully screened from public view.</p>	



17.96.060.F.8 – Architectural	Conformance
<i>Building design shall include weather protection which prevents water to drip or snow to slide on areas where pedestrians gather and circulate or onto adjacent properties.</i>	YES
<b>Finding:</b> The roof plan provided on Sheet A5.0 shows that the flat roof will be sloped to drain and gutters and downspouts will be installed at all roof eaves to manage roof drainage. The front entrance for Unit A features a flat metal awning which will provide weather protection for the occupants.	

17.96.060.G.1 – Circulation Design	Conformance
<i>Pedestrian, equestrian and bicycle access shall be located to connect with existing and anticipated easements and pathways.</i>	N/A
<b>Finding:</b> This standard is not applicable because the project is located within the Georgia Road area, an existing low-density residential neighborhood. The subject property is not contiguous to existing pedestrian, equestrian, or bicycle easements or pathways.	

17.96.060.G.2 – Circulation Design	Conformance
<i>Awnings extending over public sidewalks shall extend five feet or more across the public sidewalk but shall not extend within two feet of parking or travel lanes within the right-of-way.</i>	N/A
<b>Finding:</b> N/A. Ketchum Municipal Code 17.124.140 outlines the zone districts where sidewalks are required when substantial improvements are made, which include the CC, all tourist zone districts, and all light industrial districts. The subject property is located in the GR-L Zone and sidewalks are not required to be installed for this project.	

17.96.060.G.3 – Circulation Design	Conformance
<i>Traffic shall flow safely within the project and onto adjacent streets. Traffic includes vehicle, bicycle, pedestrian and equestrian use. Consideration shall be given to adequate sight distances and proper signage.</i>	YES
<b>Finding:</b> Pedestrian, vehicular, and bicycle access to the project is provided off Georgia Road. The driveways to both townhomes meet city standards.	

17.96.060.G.4 – Circulation Design	Conformance
<i>Curb cuts and driveway entrances shall be no closer than 20 feet to the nearest intersection of two or more streets, as measured along the property line adjacent to the right-of-way. Due to site conditions or current/projected traffic levels or speed, the City Engineer may increase the minimum distance requirements.</i>	YES



**Finding:** The proposed driveways are further than 20 feet away from the nearest intersection of Georgia Road and Warm Springs Road.

17.96.060.G.5 – Circulation Design	Conformance
<i>Unobstructed access shall be provided for emergency vehicles, snowplows, garbage trucks and similar service vehicles to all necessary locations within the proposed project.</i>	YES
<b>Finding:</b> Access for emergency vehicles, snowplows, and garbage trucks provided along Georgia Road.	

17.96.060.H.1 – Snow Storage	Conformance
<i>Snow storage areas shall not be less than 30 percent of the improved parking and pedestrian circulation areas.</i>	YES
<b>Finding:</b> Sheet C1.00 of the project plans indicates that the proposed driveways and walkways will be snowmelted, which is permitted in lieu of providing snow storage areas onsite. Snow storage areas are also indicated on Sheet C1.00 in addition to snowmelt.	

17.96.060.H.2 – Snow Storage	Conformance
<i>Snow storage areas shall be provided on site.</i>	YES
<b>Finding:</b> Sheet C1.00 of the project plans indicates that the proposed driveways and walkways will be snowmelted, which is permitted in lieu of providing snow storage areas onsite. Snow storage areas are also indicated on Sheet C1.00 in addition to snowmelt.	

17.96.060.H.3 – Snow Storage	Conformance
<i>A designated snow storage area shall not have any dimension less than five feet and shall be a minimum of 25 square feet.</i>	YES
<b>Finding:</b> Sheet C1.00 of the project plans indicates that the proposed driveways and walkways will be snowmelted, which is permitted in lieu of providing snow storage areas onsite. Snow storage areas are also indicated on Sheet C1.00 in addition to snowmelt.	

17.96.060.H.4 – Snow Storage	Conformance
<i>In lieu of providing snow storage areas, snowmelt and hauling of snow may be allowed.</i>	N/A
<b>Finding:</b> Sheet C1.00 of the project plans indicates that the proposed driveways and walkways will be snowmelted, which is permitted in lieu of providing snow storage areas onsite. Snow storage areas are also indicated on Sheet C1.00 in addition to snowmelt.	

17.96.060.I.1 – Landscaping	Conformance
<i>Landscaping is required for all projects.</i>	YES



**Finding:** The landscape plan on Sheet L1 has been revised to now include three trees, native grass, and a significant number of new shrubs surrounding the development. Staff verified that all of the proposed plant species are drought tolerant.

17.96.060.I.2 – Landscaping	Conformance
<i>Landscape materials and vegetation types specified shall be readily adaptable to a site's microclimate, soil conditions, orientation and aspect, and shall serve to enhance and complement the neighborhood and townscape.</i>	YES

**Finding:** The landscape plan on Sheet L1 has been revised to now include three trees, native grass, and a significant number of new shrubs surrounding the development. Staff verified that all of the proposed plant species are drought tolerant.

17.96.060.I.3 – Landscaping	Conformance
<i>All trees, shrubs, grasses and perennials shall be drought tolerant. Native species are recommended but not required.</i>	YES

**Finding:** The landscape plan on Sheet L1 has been revised to now include three trees, native grass, and a significant number of new shrubs surrounding the development. Staff verified that all of the proposed plant species are drought tolerant.

17.96.060.I.4 – Landscaping	Conformance
<i>Landscaping shall provide a substantial buffer between land uses, including, but not limited to, structures, streets and parking lots. The development of landscaped public courtyards, including trees and shrubs where appropriate, shall be encouraged.</i>	YES

**Finding:** The landscape plan has been revised to provide additional screening between properties and along the street frontage, which will provide a sufficient buffer between land uses. Landscaping is also proposed above and between the retaining walls, which will provide screening for the retaining walls that are visible from the street.

17.96.060.J.1 – Public Amenities	Conformance
<i>Where sidewalks are required, pedestrian amenities shall be installed. Amenities may include, but are not limited to, benches and other seating, kiosks, bus shelters, trash receptacles, restrooms, fountains, art, etc. All public amenities shall receive approval from the Public Works Department prior to design review approval from the Commission.</i>	N/A

**Finding:** N/A. The subject property is located within the GR-L Zone and sidewalks are not required to be installed for this project.



17.96.060.K.1 – Underground Encroachments	Conformance
<p><i>Encroachments of below grade structures into required setbacks are subject to subsection 17.128.020.K of this title and shall not conflict with any applicable easements, existing underground structures, sensitive ecological areas, soil stability, drainage, other sections of this Code or other regulating codes such as adopted International Code Council Codes, or other site features concerning health, safety, and welfare.</i></p>	<p>N/A</p>
<p><b>Finding:</b> N/A</p>	

17.96.060.K.2 – Underground Encroachments	Conformance
<p><i>No below grade structure shall be permitted to encroach into the riparian setback.</i></p>	<p>N/A</p>
<p><b>Finding:</b> N/A</p>	



City of Ketchum

# Attachment G: Preliminary Plat Standards Evaluation



LIFT VIEW TOWNHOMES  
FINDINGS REGARDING COMPLIANCE WITH TOWNHOUSE SUBDIVISION REQUIREMENTS

Townhouse Plat Requirements				
Compliant			Standards	
Yes	No	N/A	City Code	City Standards
<input checked="" type="checkbox"/>	<input type="checkbox"/>	<input type="checkbox"/>	16.04.080.B	<p>Townhouse Owners' Documents: The subdivider of the townhouse project shall submit with the preliminary plat application a copy of the proposed party wall agreement and any proposed document(s) creating an association of owners of the proposed townhouse sublots, which shall adequately provide for the control and maintenance of all commonly held facilities, garages, parking and/or open spaces. Prior to final plat approval, the subdivider shall submit to the city a final copy of such documents and shall file such documents prior to recordation of the plat, which shall reflect the recording instrument numbers.</p> <p><i>Commission Findings</i> The applicant submitted draft covenant documents as part of the application materials.</p>
<input checked="" type="checkbox"/>	<input type="checkbox"/>	<input type="checkbox"/>	16.04.080.C.1	<p>Preliminary Plat Procedure: Townhouse developments shall be administered consistent with the procedures and design and development regulations established in §16.04.030 and §16.04.040 and the standards of this subsection.</p> <p>All townhouse developments shall be platted under the procedures contained in the subdivision ordinance in effect and shall be required to obtain design review approval prior to building permit issuance.</p> <p><i>Commission Findings</i> The applicant submitted a Design Review application for the project in conjunction with the townhouse subdivision preliminary plat application. Both applications were reviewed by the Planning &amp; Zoning Commission currently.</p>
<input checked="" type="checkbox"/>	<input type="checkbox"/>	<input type="checkbox"/>	16.04.080.C.2	<p>The subdivider may apply for preliminary plat approval from the commission pursuant to subsection 16.04.030D of this chapter at the time application is made for design review approval pursuant to title 17, chapter 17.96 of this code. The commission may approve, deny or conditionally approve such preliminary plat upon consideration of the action taken on the application for design review of the project.</p> <p><i>Commission Findings</i> The applicant submitted a Design Review application for the project in conjunction with the townhouse subdivision preliminary plat application. Both applications were reviewed by the Planning &amp; Zoning Commission.</p>
<input checked="" type="checkbox"/>	<input type="checkbox"/>	<input type="checkbox"/>	16.04.080.C.3	<p>The preliminary plat, other data, and the commission's findings may be transmitted to the council prior to commencement of construction of the project under a valid building permit issued by the City. The council shall</p>



				act on the preliminary plat pursuant to subsection 16.04.030E and F of this chapter.
			<i>Commission Findings</i>	Following adoption of the Findings of Fact for the Townhouse Subdivision application, staff will transmit the application and findings to the City Council for review and approval prior to issuance of a building permit for the project.
<input type="checkbox"/>	<input type="checkbox"/>	<input checked="" type="checkbox"/>	16.04.080.C.4	4. In the event a phased townhouse development project is proposed, after preliminary plat is granted for the entirety of a project, the final plat procedure for each phase of a phased development project shall follow §16.04.030.G and comply with the additional provisions of §16.04.110 of this code.
			<i>Commission Findings</i>	No phased development agreement is proposed.
<input checked="" type="checkbox"/>	<input type="checkbox"/>	<input type="checkbox"/>	16.04.080.D	D. Final Plat Procedure: 1. The final plat procedure contained in subsection 16.04.030G of this chapter shall be followed. However, the final plat shall not be signed by the city clerk and recorded until the townhouse has received either: a. A certificate of occupancy issued by the city of Ketchum for all structures in the townhouse development and completion of all design review elements as approved by the planning and zoning administrator; or b. Signed council approval of a phased development project consistent with §16.04.110 herein. 2. The council may accept a security agreement for any design review elements not completed on a case by case basis pursuant to title 17, chapter 17.96 of this code.
			<i>Commission Findings</i>	Following City Council approval of the preliminary plat application, the Lift View Townhomes Final Plat Subdivision application will follow all procedures as outlined in Title 16 of the Ketchum Municipal Code.
<input checked="" type="checkbox"/>	<input type="checkbox"/>	<input type="checkbox"/>	16.04.080.E.1	E. Required Findings: In addition to all Townhouse Developments complying with the applicable provisions of Title 17 and this Subdivision Chapter (§16.04), the Administrator shall find that  All Townhouse Developments, including each individual subplot, shall not exceed the maximum building coverage requirements of the zoning district.
			<i>Commission Findings</i>	The maximum building coverage in the GR-L zone district is 35% of the lot. The subject property is 9,846 square feet. The proposed townhomes have a building coverage of 3,008 square feet. This results in a total building coverage of 31% of the lot.
<input checked="" type="checkbox"/>	<input type="checkbox"/>	<input type="checkbox"/>	16.04.080.E.2	Garage: All garages shall be designated on the preliminary and final plats and on all deeds as part of the particular townhouse units. Detached garages may be platted on separate sublots; provided, that the ownership of detached garages is tied to specific townhouse units on the townhouse



				plat and in any owner's documents, and that the detached garage(s) may not be sold and/or owned separate from any dwelling unit(s) within the townhouse development.
			<i>Commission Findings</i>	Both townhouse units include an attached three-car garage.
<input checked="" type="checkbox"/>	<input type="checkbox"/>	<input type="checkbox"/>	16.04.080.E.3	<b>General Applicability:</b> All other provisions of this chapter and all applicable ordinances, rules and regulations of the city and all other governmental entities having jurisdiction shall be complied with by townhouse subdivisions. (Ord. 1061 § 3, 2009: Ord. 879 § 4, 2001: Ord. 460 § 2, 1987)
			<i>Commission Findings</i>	During department review of the Design Review application, staff reviewed the project for compliance with the Zoning Regulations, dimensional standards, and development standards for the City of Ketchum. As conditioned, the townhouse subdivision application meets all applicable regulations.



FINDINGS REGARDING PRELIMINARY PLAT SUBDIVISION REQUIREMENTS

Preliminary Plat Requirements					
Compliant					
Yes	No	N/A	City Code	City Standards	
<input checked="" type="checkbox"/>	<input type="checkbox"/>	<input type="checkbox"/>	16.04.030.C.1	The subdivider shall file with the administrator copies of the completed subdivision application form and preliminary plat data as required by this chapter.	
			<i>Commission Findings</i>	The City of Ketchum Planning and Building Department received the subdivision application and all applicable application materials on July 17, 2025.	
<input checked="" type="checkbox"/>	<input type="checkbox"/>	<input type="checkbox"/>	16.04.030.J	Contents Of Preliminary Plat: The preliminary plat, together with all application forms, title insurance report, deeds, maps, and other documents reasonably required, shall constitute a complete subdivision application.	
			<i>Commission Findings</i>	The subdivision application was deemed complete on July 17, 2025.	
<input checked="" type="checkbox"/>	<input type="checkbox"/>	<input type="checkbox"/>	16.04.030.J.1	The preliminary plat shall be drawn to a scale of not less than one inch equals one hundred feet (1" = 100') and shall show the following: The scale, north point and date.	
			<i>Commission Findings</i>	The preliminary plat includes a scale, north point, and date.	
<input checked="" type="checkbox"/>	<input type="checkbox"/>	<input type="checkbox"/>	16.04.030.J.2	The name of the proposed subdivision, which shall not be the same or confused with the name of any other subdivision in Blaine County, Idaho.	
			<i>Commission Findings</i>	As shown on the preliminary plat, the subdivision is named "Lift View Townhomes" which is not the same as any other subdivision in Blaine County, Idaho.	
<input checked="" type="checkbox"/>	<input type="checkbox"/>	<input type="checkbox"/>	16.04.030.J.3	The name and address of the owner of record, the subdivider, and the engineer, surveyor, or other person preparing the plat.	
			<i>Commission Findings</i>	The name and address of the owner of record is stated in plat note #11 on the preliminary plat. The plat was prepared by Bruce Smith of Alpine Enterprises Inc.	
<input checked="" type="checkbox"/>	<input type="checkbox"/>	<input type="checkbox"/>	16.04.030.J.4	Legal description of the area platted.	
			<i>Commission Findings</i>	The legal description of the area platted is shown on the preliminary plat.	
<input checked="" type="checkbox"/>	<input type="checkbox"/>	<input type="checkbox"/>	16.04.030.J.5	The names and the intersecting boundary lines of adjoining subdivisions and parcels of property.	



City of Ketchum  
Planning & Building

			<i>Commission Findings</i>	The preliminary plat indicates the boundary lines of the adjoining lots including townhouse lots and lots within Warm Springs Village Subdivision Second Addition.
<input checked="" type="checkbox"/>	<input type="checkbox"/>	<input type="checkbox"/>	16.04.030.J .6	<b>A contour map of the subdivision with contour lines and a maximum interval of five feet (5') to show the configuration of the land based upon the United States geodetic survey data, or other data approved by the city engineer.</b>
			<i>Commission Findings</i>	The preliminary plat shows the contour lines for the subject property.
<input checked="" type="checkbox"/>	<input type="checkbox"/>	<input type="checkbox"/>	16.04.030.J .7	<b>The scaled location of existing buildings, water bodies and courses and location of the adjoining or immediately adjacent dedicated streets, roadways and easements, public and private.</b>
			<i>Commission Findings</i>	The preliminary plat shows the scaled location of the existing structure and the adjacent street.
<input checked="" type="checkbox"/>	<input type="checkbox"/>	<input type="checkbox"/>	16.04.030.J .8	<b>Boundary description and the area of the tract.</b>
			<i>Commission Findings</i>	The preliminary plat provides the boundary description of the area and includes square footage and acreage of both sublots.
<input checked="" type="checkbox"/>	<input type="checkbox"/>	<input type="checkbox"/>	16.04.030.J .9	<b>Existing zoning of the tract.</b>
			<i>Commission Findings</i>	Plat note #4 and #6 of the preliminary plat lists the existing zoning of the subject property.
<input checked="" type="checkbox"/>	<input type="checkbox"/>	<input type="checkbox"/>	16.04.030.J .10	<b>The proposed location of street rights of way, lots, and lot lines, easements, including all approximate dimensions, and including all proposed lot and block numbering and proposed street names.</b>
			<i>Commission Findings</i>	The preliminary plat shows the locations and lot lines for the proposed townhouse sublots. No new streets or blocks are being proposed with this application.
<input type="checkbox"/>	<input type="checkbox"/>	<input checked="" type="checkbox"/>	16.04.030.J .11	<b>The location, approximate size and proposed use of all land intended to be dedicated for public use or for common use of all future property owners within the proposed subdivision.</b>
			<i>Commission Findings</i>	This standard is not applicable as there is no requirement or proposal for land dedicated for public or common use.
<input type="checkbox"/>	<input checked="" type="checkbox"/>	<input type="checkbox"/>	16.04.030.J .12	<b>The location, size and type of sanitary and storm sewers, water mains, culverts and other surface or subsurface structures existing within or immediately adjacent to the proposed sanitary or storm sewers, water mains, and storage facilities, street improvements, street lighting, curbs, and gutters and all proposed utilities.</b>
			<i>Commission Findings</i>	The civil plan for the associated design review application for this property indicates that the existing well will be abandoned and each townhouse unit will have separate services for water and sewer from the main lines in Georgia Road. However, the preliminary plat only shows the existing condition of the private well and one sewer service for the property.



				Therefore, staff recommend condition of approval #2 which requires the applicant to revise the preliminary plat to indicate the locations of the new water and sewer lines for each unit prior to City Council’s review of the application.
<input type="checkbox"/>	<input type="checkbox"/>	<input checked="" type="checkbox"/>	16.04.030.J .13	<b>The direction of drainage, flow and approximate grade of all streets.</b>
			<i>Commission Findings</i>	This standard does not apply as no new streets are proposed.
<input type="checkbox"/>	<input type="checkbox"/>	<input checked="" type="checkbox"/>	16.04.030.J .14	<b>The location of all drainage canals and structures, the proposed method of disposing of runoff water, and the location and size of all drainage easements, whether they are located within or outside of the proposed plat.</b>
			<i>Commission Findings</i>	This standard does not apply as no new drainage canals or structures are proposed.
<input type="checkbox"/>	<input type="checkbox"/>	<input checked="" type="checkbox"/>	16.04.030.I .21	<b>All percolation tests and/or exploratory pit excavations required by state health authorities.</b>
			<i>Commission Findings</i>	This standard does not apply as no additional tests are required.
<input checked="" type="checkbox"/>	<input type="checkbox"/>	<input type="checkbox"/>	16.04.030.J .22	<b>A copy of the provisions of the articles of incorporation and bylaws of homeowners' association and/or condominium declarations to be filed with the final plat of the subdivision.</b>
			<i>Commission Findings</i>	A copy of the draft Lift View Townhomes Covenants, Conditions and Restrictions is included in the project plans.
<input checked="" type="checkbox"/>	<input type="checkbox"/>	<input type="checkbox"/>	16.04.030.J .15	<b>Vicinity map drawn to approximate scale showing the location of the proposed subdivision in reference to existing and/or proposed arterials and collector streets.</b>
			<i>Commission Findings</i>	The project plans include a vicinity map that satisfies this requirement.
<input checked="" type="checkbox"/>	<input type="checkbox"/>	<input type="checkbox"/>	16.04.030.J .16	<b>The boundaries of the floodplain, floodway and avalanche zoning district shall also be clearly delineated and marked on the preliminary plat.</b>
			<i>Commission Findings</i>	The subject property is entirely within the Avalanche Zone, as is indicate in plat note #6 of the preliminary plat. The subject property is not within the floodplain or floodway.
<input checked="" type="checkbox"/>	<input type="checkbox"/>	<input type="checkbox"/>	16.04.030.J .17	<b>Building envelopes shall be shown on each lot, all or part of which is within a floodway, floodplain, or avalanche zone; or any lot that is adjacent to the Big Wood River, Trail Creek, or Warm Springs Creek; or any lot, a portion of which has a slope of twenty five percent (25%) or greater; or upon any lot which will be created adjacent to the intersection of two (2) or more streets.</b>
			<i>Commission Findings</i>	The subject property is within the Avalanche Zone, therefore a building envelope is shown on preliminary plat.



City of Ketchum  
Planning & Building

<input checked="" type="checkbox"/>	<input type="checkbox"/>	<input type="checkbox"/>	16.04.030.J .18	Lot area of each lot.
			<i>Commission Findings</i>	As shown on the preliminary plat, the area of Sublot 1 is 4,844 square feet and the area of Sublot 2 is 5,002 square feet.
<input checked="" type="checkbox"/>	<input type="checkbox"/>	<input type="checkbox"/>	16.04.030.J .19	Existing mature trees and established shrub masses.
			<i>Commission Findings</i>	As shown on the preliminary plat, there are coniferous and deciduous trees existing on the property.
<input checked="" type="checkbox"/>	<input type="checkbox"/>	<input type="checkbox"/>	16.04.030.J .23	<b>A current title report shall be provided at the time that the preliminary plat is filed with the administrator, together with a copy of the owner's recorded deed to such property.</b>
			<i>Commission Findings</i>	The applicant provided a title commitment issued by Title Resources Guaranty Company dated April 3, 2025, and a warranty deed recorded at Instrument Number 707433 as part of the application documents.
<input checked="" type="checkbox"/>	<input type="checkbox"/>	<input type="checkbox"/>	16.04.030.J .24	<b>A digital copy of the preliminary plat shall be filed with the administrator.</b>
			<i>Commission Findings</i>	The City of Ketchum received a digital copy of the preliminary plat at the time of application.
<input checked="" type="checkbox"/>	<input type="checkbox"/>	<input type="checkbox"/>	16.04.040.A	<b>Required Improvements: The improvements set forth in this section shall be shown on the preliminary plat and installed prior to approval of the final plat. Construction design plans shall be submitted and approved by the city engineer. All such improvements shall be in accordance with the comprehensive plan and constructed in compliance with construction standard specifications adopted by the city. Existing natural features which enhance the attractiveness of the subdivision and community, such as mature trees, watercourses, rock outcroppings, established shrub masses and historic areas, shall be preserved through design of the subdivision.</b>
			<i>Commission Findings</i>	All proposed improvements to the public right-of-way are shown in the project plans. The applicant also submitted a set of preliminary construction design plans for review by the City Engineer. Final review and approval of the right-of-way improvements will be conducted during building permit review per the conditions of approval. The subject property does not include any watercourses, rock outcroppings, shrub masses, or historic areas.
<input type="checkbox"/>	<input type="checkbox"/>	<input checked="" type="checkbox"/>	16.04.040.B	<b>Improvement Plans: Prior to approval of final plat by the commission, the subdivider shall file two (2) copies with the city engineer, and the city engineer shall approve construction plans for all improvements required in the proposed subdivision. Such plans shall be prepared by a civil engineer licensed in the state.</b>
			<i>Commission Findings</i>	This standard does not apply as this is a preliminary plat application, not a final plat application.
<input type="checkbox"/>	<input type="checkbox"/>	<input checked="" type="checkbox"/>	16.04.040.C	<b>Prior to final plat approval, the subdivider shall have previously constructed all required improvements and secured a certificate of</b>



				<p>completion from the city engineer. However, in cases where the required improvements cannot be constructed due to weather conditions or other factors beyond the control of the subdivider, the city council may accept, in lieu of any or all of the required improvements, a performance bond filed with the city clerk to ensure actual construction of the required improvements as submitted and approved. Such performance bond shall be issued in an amount not less than one hundred fifty percent (150%) of the estimated costs of improvements as determined by the city engineer. In the event the improvements are not constructed within the time allowed by the city council (which shall be one year or less, depending upon the individual circumstances), the council may order the improvements installed at the expense of the subdivider and the surety. In the event the cost of installing the required improvements exceeds the amount of the bond, the subdivider shall be liable to the city for additional costs. The amount that the cost of installing the required improvements exceeds the amount of the performance bond shall automatically become a lien upon any and all property within the subdivision owned by the owner and/or subdivider.</p>
			<i>Commission Findings</i>	This standard does not apply as this is a preliminary plat application, not a final plat application.
<input type="checkbox"/>	<input type="checkbox"/>	<input checked="" type="checkbox"/>	16.04.040.D	<p><b>As Built Drawing:</b> Prior to acceptance by the city council of any improvements installed by the subdivider, two (2) sets of as built plans and specifications, certified by the subdivider's engineer, shall be filed with the city engineer. Within ten (10) days after completion of improvements and submission of as built drawings, the city engineer shall certify the completion of the improvements and the acceptance of the improvements, and shall submit a copy of such certification to the administrator and the subdivider. If a performance bond has been filed, the administrator shall forward a copy of the certification to the city clerk. Thereafter, the city clerk shall release the performance bond upon application by the subdivider.</p>
			<i>Commission Findings</i>	This standard does not apply as this is a preliminary plat application, not a final plat application.
<input type="checkbox"/>	<input type="checkbox"/>	<input checked="" type="checkbox"/>	16.04.040.E	<p><b>Monumentation:</b> Following completion of construction of the required improvements and prior to certification of completion by the city engineer, certain land survey monuments shall be reset or verified by the subdivider's engineer or surveyor to still be in place. These monuments shall have the size, shape, and type of material as shown on the subdivision plat. The monuments shall be located as follows:</p> <ol style="list-style-type: none"> <li>1. All angle points in the exterior boundary of the plat.</li> <li>2. All street intersections, points within and adjacent to the final plat.</li> <li>3. All street corner lines ending at boundary line of final plat.</li> </ol>



				<p>4. All angle points and points of curves on all streets.</p> <p>5. The point of beginning of the subdivision plat description.</p>
			<i>Commission Findings</i>	This standard does not apply as this is a preliminary plat application, not a final plat application.
<input checked="" type="checkbox"/>	<input type="checkbox"/>	<input type="checkbox"/>	16.04.040.F	<p><b>Lot Requirements:</b></p> <p>1. Lot size, width, depth, shape and orientation and minimum building setback lines shall be in compliance with the zoning district in which the property is located and compatible with the location of the subdivision and the type of development, and preserve solar access to adjacent properties and buildings.</p> <p>2. Whenever a proposed subdivision contains lot(s), in whole or in part, within the floodplain, or which contains land with a slope in excess of twenty five percent (25%), based upon natural contours, or creates corner lots at the intersection of two (2) or more streets, building envelopes shall be shown for the lot(s) so affected on the preliminary and final plats. The building envelopes shall be located in a manner designed to promote harmonious development of structures, minimize congestion of structures, and provide open space and solar access for each lot and structure. Also, building envelopes shall be located to promote access to the lots and maintenance of public utilities, to minimize cut and fill for roads and building foundations, and minimize adverse impact upon environment, watercourses and topographical features. Structures may only be built on buildable lots. Lots shall only be created that meet the definition of "lot, buildable" in section 16.04.020 of this chapter. Building envelopes shall be established outside of hillsides of twenty five percent (25%) and greater and outside of the floodway. A waiver to this standard may only be considered for the following:</p> <ul style="list-style-type: none"> <li>a. For lot line shifts of parcels that are entirely within slopes of twenty five percent (25%) or greater to create a reasonable building envelope, and mountain overlay design review standards and all other city requirements are met.</li> <li>b. For small, isolated pockets of twenty five percent (25%) or greater that are found to be in compliance with the purposes and standards of the mountain overlay district and this section.</li> </ul> <p>3. Corner lots shall have a property line curve or corner of a minimum radius of twenty five feet (25') unless a longer radius is required to serve an existing or future use.</p> <p>4. Side lot lines shall be within twenty degrees (20°) to a right angle or radial line to the street line.</p> <p>5. Double frontage lots shall not be created. A planting strip shall be provided along the boundary line of lots adjacent to arterial streets or incompatible zoning districts.</p>



				<p>6. Every lot in a subdivision shall have a minimum of twenty feet (20') of frontage on a dedicated public street or legal access via an easement of twenty feet (20') or greater in width. Easement shall be recorded in the office of the Blaine County recorder prior to or in conjunction with recordation of the final plat.</p>
			<i>Commission Findings</i>	<ol style="list-style-type: none"> <li>1. The proposed townhouse subdivision meets all dimensional standards as outlined in the GR-L zone district for the parent lot. The minimum lot size is 8,000 square feet and the parent lot is 9,846 square feet. The new attached townhomes meet minimum setback requirements in the GR-L for the front, side, and rear.</li> <li>2. A building envelope is shown, as is required for lots within the Avalanche Zone.</li> <li>3. The subject property is not a corner lot.</li> <li>4. The parent lot of the townhouse subdivision and the newly created subplot lot line is within 20 degrees to a right angle to the street lot line along Georgia Road.</li> <li>5. The subject property is not a double frontage lot.</li> <li>6. Both Sublots have a minimum of 20 feet of frontage on Georgia Road.</li> </ol>
<input type="checkbox"/>	<input type="checkbox"/>	<input checked="" type="checkbox"/>	16.04.040.G	<p><b>G. Block Requirements: The length, width and shape of blocks within a proposed subdivision shall conform to the following requirements:</b></p> <ol style="list-style-type: none"> <li>1. No block shall be longer than one thousand two hundred feet (1,200'), nor less than four hundred feet (400') between the street intersections, and shall have sufficient depth to provide for two (2) tiers of lots.</li> <li>2. Blocks shall be laid out in such a manner as to comply with the lot requirements.</li> <li>3. The layout of blocks shall take into consideration the natural topography of the land to promote access within the subdivision and minimize cuts and fills for roads and minimize adverse impact on environment, watercourses and topographical features.</li> <li>4. Corner lots shall contain a building envelope outside of a seventy five foot (75') radius from the intersection of the streets.</li> </ol>
			<i>Commission Findings</i>	This standard does not apply as no new blocks are being created.
<input type="checkbox"/>	<input type="checkbox"/>	<input checked="" type="checkbox"/>	16.04.040.H	<p><b>Street Improvement Requirements:</b></p> <ol style="list-style-type: none"> <li>1. The arrangement, character, extent, width, grade and location of all streets put in the proposed subdivision shall conform to the comprehensive plan and shall be considered in their relation to existing and planned streets, topography, public convenience and safety, and the proposed uses of the land;</li> <li>2. All streets shall be constructed to meet or exceed the criteria and standards set forth in chapter 12.04 of this code, and all other applicable ordinances, resolutions or regulations of the city or any other</li> </ol>



				<p>governmental entity having jurisdiction, now existing or adopted, amended or codified;</p> <p>3. Where a subdivision abuts or contains an existing or proposed arterial street, railroad or limited access highway right of way, the council may require a frontage street, planting strip, or similar design features;</p> <p>4. Streets may be required to provide access to adjoining lands and provide proper traffic circulation through existing or future neighborhoods;</p> <p>5. Street grades shall not be less than three-tenths percent (0.3%) and not more than seven percent (7%) so as to provide safe movement of traffic and emergency vehicles in all weather and to provide for adequate drainage and snow plowing;</p> <p>6. In general, partial dedications shall not be permitted, however, the council may accept a partial street dedication when such a street forms a boundary of the proposed subdivision and is deemed necessary for the orderly development of the neighborhood, and provided the council finds it practical to require the dedication of the remainder of the right of way when the adjoining property is subdivided. When a partial street exists adjoining the proposed subdivision, the remainder of the right of way shall be dedicated;</p> <p>7. Dead end streets may be permitted only when such street terminates at the boundary of a subdivision and is necessary for the development of the subdivision or the future development of the adjacent property. When such a dead end street serves more than two (2) lots, a temporary turnaround easement shall be provided, which easement shall revert to the adjacent lots when the street is extended;</p> <p>8. A cul-de-sac, court or similar type street shall be permitted only when necessary to the development of the subdivision, and provided, that no such street shall have a maximum length greater than four hundred feet (400') from entrance to center of turnaround, and all cul-de-sacs shall have a minimum turnaround radius of sixty feet (60') at the property line and not less than forty five feet (45') at the curb line;</p> <p>9. Streets shall be planned to intersect as nearly as possible at right angles, but in no event at less than seventy degrees (70°);</p> <p>10. Where any street deflects an angle of ten degrees (10°) or more, a connecting curve shall be required having a minimum centerline radius of three hundred feet (300') for arterial and collector streets, and one hundred twenty five feet (125') for minor streets;</p> <p>11. Streets with centerline offsets of less than one hundred twenty five feet (125') shall be prohibited;</p> <p>12. A tangent of at least one hundred feet (100') long shall be introduced between reverse curves on arterial and collector streets;</p>
--	--	--	--	---



			<p>13. Proposed streets which are a continuation of an existing street shall be given the same names as the existing street. All new street names shall not duplicate or be confused with the names of existing streets within Blaine County, Idaho. The subdivider shall obtain approval of all street names within the proposed subdivision from the commission before submitting same to council for preliminary plat approval;</p> <p>14. Street alignment design shall follow natural terrain contours to result in safe streets, usable lots, and minimum cuts and fills;</p> <p>15. Street patterns of residential areas shall be designed to create areas free of through traffic, but readily accessible to adjacent collector and arterial streets;</p> <p>16. Reserve planting strips controlling access to public streets shall be permitted under conditions specified and shown on the final plat, and all landscaping and irrigation systems shall be installed as required improvements by the subdivider;</p> <p>17. In general, the centerline of a street shall coincide with the centerline of the street right of way, and all crosswalk markings shall be installed by the subdivider as a required improvement;</p> <p>18. Street lighting may be required by the commission or council where appropriate and shall be installed by the subdivider as a requirement improvement;</p> <p>19. Private streets may be allowed upon recommendation by the commission and approval by the council. Private streets shall be constructed to meet the design standards specified in subsection H2 of this section;</p> <p>20. Street signs shall be installed by the subdivider as a required improvement of a type and design approved by the administrator and shall be consistent with the type and design of existing street signs elsewhere in the city;</p> <p>21. Whenever a proposed subdivision requires construction of a new bridge, or will create substantial additional traffic which will require construction of a new bridge or improvement of an existing bridge, such construction or improvement shall be a required improvement by the subdivider. Such construction or improvement shall be in accordance with adopted standard specifications;</p> <p>22. Sidewalks, curbs and gutters may be a required improvement installed by the subdivider; and</p> <p>23. Gates are prohibited on private roads and parking access/entranceways, private driveways accessing more than one single-family dwelling unit and one accessory dwelling unit, and public rights of way unless approved by the city council.</p>
			<p>This standard does not apply as no new streets are proposed.</p>



<input type="checkbox"/>	<input type="checkbox"/>	<input checked="" type="checkbox"/>	16.04.040.I	<p>Alley Improvement Requirements: Alleys shall be provided in business, commercial and light industrial zoning districts. The width of an alley shall be not less than twenty feet (20'). Alley intersections and sharp changes in alignment shall be avoided, but where necessary, corners shall be provided to permit safe vehicular movement. Dead end alleys shall be prohibited. Improvement of alleys shall be done by the subdivider as required improvement and in conformance with design standards specified in subsection H2 of this section.</p>
			<i>Commission Findings</i>	This standard does not apply as there are no alleys adjacent to the subject property.
<input type="checkbox"/>	<input type="checkbox"/>	<input checked="" type="checkbox"/>	16.04.040.J	<p>Required Easements: Easements, as set forth in this subsection, shall be required for location of utilities and other public services, to provide adequate pedestrian circulation and access to public waterways and lands.</p> <ol style="list-style-type: none"> <li>1. A public utility easement at least ten feet (10') in width shall be required within the street right of way boundaries of all private streets. A public utility easement at least five feet (5') in width shall be required within property boundaries adjacent to Warm Springs Road and within any other property boundary as determined by the city engineer to be necessary for the provision of adequate public utilities.</li> <li>2. Where a subdivision contains or borders on a watercourse, drainageway, channel or stream, an easement shall be required of sufficient width to contain such watercourse and provide access for private maintenance and/or reconstruction of such watercourse.</li> <li>3. All subdivisions which border the Big Wood River, Trail Creek and Warm Springs Creek shall dedicate a ten foot (10') fish and nature study easement along the riverbank. Furthermore, the council shall require, in appropriate areas, an easement providing access through the subdivision to the bank as a sportsman's access. These easement requirements are minimum standards, and in appropriate cases where a subdivision abuts a portion of the river adjacent to an existing pedestrian easement, the council may require an extension of that easement along the portion of the riverbank which runs through the proposed subdivision.</li> <li>4. All subdivisions which border on the Big Wood River, Trail Creek and Warm Springs Creek shall dedicate a twenty five foot (25') scenic easement upon which no permanent structure shall be built in order to protect the natural vegetation and wildlife along the riverbank and to protect structures from damage or loss due to riverbank erosion.</li> <li>5. No ditch, pipe or structure for irrigation water or irrigation wastewater shall be constructed, rerouted or changed in the course of planning for or constructing required improvements within a proposed subdivision unless same has first been approved in writing by the ditch company or property owner holding the water rights. A written copy of such approval shall be filed as part of required improvement construction plans.</li> </ol>



				<p>6. Nonvehicular transportation system easements including pedestrian walkways, bike paths, equestrian paths, and similar easements shall be dedicated by the subdivider to provide an adequate nonvehicular transportation system throughout the city.</p>
			<i>Commission Findings</i>	<p>There are no existing or proposed easements for this property. Standards 2-6 do not apply to the project as the property is not adjacent to any of the listed waterways, not adjacent to Warm Springs Road, does not contain any irrigation infrastructure, and does not include pedestrian or equestrian pathways.</p>
<input type="checkbox"/>	<input type="checkbox"/>	<input checked="" type="checkbox"/>	16.04.040.K	<p><b>Sanitary Sewage Disposal Improvements:</b> Central sanitary sewer systems shall be installed in all subdivisions and connected to the Ketchum sewage treatment system as a required improvement by the subdivider. Construction plans and specifications for central sanitary sewer extension shall be prepared by the subdivider and approved by the city engineer, council and Idaho health department prior to final plat approval. In the event that the sanitary sewage system of a subdivision cannot connect to the existing public sewage system, alternative provisions for sewage disposal in accordance with the requirements of the Idaho department of health and the council may be constructed on a temporary basis until such time as connection to the public sewage system is possible. In considering such alternative provisions, the council may require an increase in the minimum lot size and may impose any other reasonable requirements which it deems necessary to protect public health, safety and welfare.</p>
			<i>Commission Findings</i>	<p>This standard does not apply as this application does not create a new subdivision. The civil plan for the associated design review application for this property indicates that the existing well will be abandoned and each townhouse unit will have separate services for water and sewer from the main lines in Georgia Road. However, the preliminary plat only shows the existing condition of the private well and one sewer service for the property. Therefore, staff recommend condition of approval #2 which requires the applicant to revise the preliminary plat to indicate the locations of the new water and sewer lines for each unit prior to City Council's review of the application.</p>
<input type="checkbox"/>	<input type="checkbox"/>	<input checked="" type="checkbox"/>	16.04.040.L	<p><b>Water System Improvements:</b> A central domestic water distribution system shall be installed in all subdivisions by the subdivider as a required improvement. The subdivider shall also be required to locate and install an adequate number of fire hydrants within the proposed subdivision according to specifications and requirements of the city under the supervision of the Ketchum fire department and other regulatory agencies having jurisdiction. Furthermore, the central water system shall have sufficient flow for domestic use and adequate fire flow. All such water systems installed shall be looped extensions, and no dead end systems shall be permitted. All water systems shall be connected to the municipal</p>



				<p>water system and shall meet the standards of the following agencies: Idaho department of public health, Idaho survey and rating bureau, district sanitarian, Idaho state public utilities commission, Idaho department of reclamation, and all requirements of the city.</p>
			<i>Commission Findings</i>	<p>This standard does not apply as this application does not create a new subdivision. The civil plan for the associated design review application for this property indicates that the existing well will be abandoned and each townhouse unit will have separate services for water and sewer from the main lines in Georgia Road. However, the preliminary plat only shows the existing condition of the private well and one sewer service for the property. Therefore, staff recommend condition of approval #2 which requires the applicant to revise the preliminary plat to indicate the locations of the new water and sewer lines for each unit prior to City Council's review of the application.</p>
<input type="checkbox"/>	<input type="checkbox"/>	<input checked="" type="checkbox"/>	16.04.040.M	<p><b>Planting Strip Improvements:</b> Planting strips shall be required improvements. When a predominantly residential subdivision is proposed for land adjoining incompatible uses or features such as highways, railroads, commercial or light industrial districts or off street parking areas, the subdivider shall provide planting strips to screen the view of such incompatible features. The subdivider shall submit a landscaping plan for such planting strip with the preliminary plat application, and the landscaping shall be a required improvement.</p>
			<i>Commission Findings</i>	<p>This standard does not apply as this application does not create a new subdivision. There are no incompatible uses adjacent to the proposed townhouse sublots.</p>
<input type="checkbox"/>	<input type="checkbox"/>	<input checked="" type="checkbox"/>	16.04.040.N	<p><b>Cuts, Fills, And Grading Improvements:</b> Proposed subdivisions shall be carefully planned to be compatible with natural topography, soil conditions, geology and hydrology of the site, as well as to minimize cuts, fills, alterations of topography, streams, drainage channels, and disruption of soils and vegetation. The design criteria shall include the following:</p> <ol style="list-style-type: none"> <li>1. A preliminary soil report prepared by a qualified engineer may be required by the commission and/or council as part of the preliminary plat application.</li> <li>2. Preliminary grading plan prepared by a civil engineer shall be submitted as part of all preliminary plat applications. Such plan shall contain the following information:             <ol style="list-style-type: none"> <li>a. Proposed contours at a maximum of five foot (5') contour intervals.</li> <li>b. Cut and fill banks in pad elevations.</li> <li>c. Drainage patterns.</li> <li>d. Areas where trees and/or natural vegetation will be preserved.</li> <li>e. Location of all street and utility improvements including driveways to building envelopes.</li> </ol> </li> </ol>



				<p>f. Any other information which may reasonably be required by the administrator, commission or council to adequately review the affect of the proposed improvements.</p> <p>3. Grading shall be designed to blend with natural landforms and to minimize the necessity of padding or terracing of building sites, excavation for foundations, and minimize the necessity of cuts and fills for streets and driveways.</p> <p>4. Areas within a subdivision which are not well suited for development because of existing soil conditions, steepness of slope, geology or hydrology shall be allocated for open space for the benefit of future property owners within the subdivision.</p> <p>5. Where existing soils and vegetation are disrupted by subdivision development, provision shall be made by the subdivider for revegetation of disturbed areas with perennial vegetation sufficient to stabilize the soil upon completion of the construction. Until such times as such revegetation has been installed and established, the subdivider shall maintain and protect all disturbed surfaces from erosion.</p> <p>6. Where cuts, fills, or other excavations are necessary, the following development standards shall apply:</p> <ul style="list-style-type: none"> <li>a. Fill areas shall be prepared by removing all organic material detrimental to proper compaction for soil stability.</li> <li>b. Fills shall be compacted to at least ninety five percent (95%) of maximum density as determined by AASHO T99 (American Association of State Highway Officials) and ASTM D698 (American standard testing methods).</li> <li>c. Cut slopes shall be no steeper than two horizontal to one vertical (2:1). Subsurface drainage shall be provided as necessary for stability.</li> <li>d. Fill slopes shall be no steeper than three horizontal to one vertical (3:1). Neither cut nor fill slopes shall be located on natural slopes of three to one (3:1) or steeper, or where fill slope toes out within twelve feet (12') horizontally of the top and existing or planned cut slope.</li> <li>e. Toes of cut and fill slopes shall be set back from property boundaries a distance of three feet (3'), plus one-fifth (1/5) of the height of the cut or the fill, but may not exceed a horizontal distance of ten feet (10'); tops and toes of cut and fill slopes shall be set back from structures at a distance of at least six feet (6'), plus one-fifth (1/5) of the height of the cut or the fill. Additional setback distances shall be provided as necessary to accommodate drainage features and drainage structures.</li> </ul>
			<p><i>Commission Findings</i></p>	<p>This standard does not apply as this application is the subdivision of an existing lot. On-site grading for the new townhomes meet all grading</p>



				requirements and all disturbance will be revegetated per the landscape plan included in the project plans.
<input checked="" type="checkbox"/>	<input type="checkbox"/>	<input type="checkbox"/>	16.04.040.O	<p><b>Drainage Improvements:</b> The subdivider shall submit with the preliminary plat application such maps, profiles, and other data prepared by an engineer to indicate the proper drainage of the surface water to natural drainage courses or storm drains, existing or proposed. The location and width of the natural drainage courses shall be shown as an easement common to all owners within the subdivision and the city on the preliminary and final plat. All natural drainage courses shall be left undisturbed or be improved in a manner that will increase the operating efficiency of the channel without overloading its capacity. An adequate storm and surface drainage system shall be a required improvement in all subdivisions and shall be installed by the subdivider. Culverts shall be required where all water or drainage courses intersect with streets, driveways or improved public easements and shall extend across and under the entire improved width including shoulders.</p>
			<i>Commission Findings</i>	The applicant submitted a site grading and drainage plan with the project plans showing drainage for each subplot. No common drainage courses are utilized or disturbed. The grading and drainage plan meets all requirements and each subplot is managing stormwater runoff independently, not impacting adjacent properties.
<input checked="" type="checkbox"/>	<input type="checkbox"/>	<input type="checkbox"/>	16.04.040.P	<p><b>Utilities:</b> In addition to the terms mentioned in this section, all utilities including, but not limited to, electricity, natural gas, telephone and cable services shall be installed underground as a required improvement by the subdivider. Adequate provision for expansion of such services within the subdivision or to adjacent lands including installation of conduit pipe across and underneath streets shall be installed by the subdivider prior to construction of street improvements.</p>
			<i>Commission Findings</i>	All utilities are proposed underground per the KMC requirements.
<input type="checkbox"/>	<input type="checkbox"/>	<input checked="" type="checkbox"/>	16.04.040.Q	<p><b>Off Site Improvements:</b> Where the offsite impact of a proposed subdivision is found by the commission or council to create substantial additional traffic, improvements to alleviate that impact may be required of the subdivider prior to final plat approval, including, but not limited to, bridges, intersections, roads, traffic control devices, water mains and facilities, and sewer mains and facilities.</p>
			<i>Commission Findings</i>	The proposed townhouse development does not create substantial additional traffic, therefore, no improvements are required.



City of Ketchum

# Attachment H: Staff Report - February 18, 2026 Planning & Zoning Commission Meeting



STAFF REPORT  
KETCHUM PLANNING AND ZONING COMMISSION  
REGULAR MEETING OF FEBRUARY 18, 2026

**PROJECT:** Lift View Townhomes

**FILE NUMBER:** P25-038 & P25-041

**APPLICATION TYPE:** Design Review and Townhouse Subdivision Preliminary Plat

**PROPERTY OWNER:** Lift View LLC

**REPRESENTATIVE:** Tanya Hoskins, Performance Engineering

**LOCATION:** 310 Georginia Road (Lot 6B, Block 3, Warm Springs Subdivision Second Addition)

**ZONING:** General Residential – Low Density (GR-L)

**OVERLAY:** Avalanche (A)

**REVIEWER:** Paige Nied – Associate Planner

**NOTICE:** A public hearing notice for the project was mailed to all owners of property within 300 feet of the project site on January 28, 2026. The public hearing notice was published in the Idaho Mountain Express on January 28, 2026. A notice was posted on the project site on February 11, 2026. The public hearing was published on the city’s website on February 3, 2026. The building corners were staked and the story pole was installed on the project site on February 11, 2026.

**I. EXECUTIVE SUMMARY**

The applicant submitted a Design Review and Subdivision Preliminary Plat application for the development of two attached townhouse units on newly created townhouse sublots (“the project”). The project is located at 310 Georginia Road (the “subject property”) and is within the General Residential – Low Density (GR-L) Zone District and Avalanche (A) Overlay. The proposed townhomes are 4,161 square feet each and contain three bedrooms and a three-car garage. A townhouse subdivision preliminary plat will establish the new Lift View Townhomes sublots. Sublot 1 is 4,884 square feet in size and Sublot 2 is 5,002 square feet in size. The project plans are included as Attachment B.

The subject property (see Figure 1) is comprised of one lot that is part of the Warm Springs Subdivision Second Addition that was created in 1953 under the jurisdiction of Blaine County. The lot was previously developed with a single-family residence, which was condemned by the Building Official. A demolition permit was issued for the residence on September 4, 2025, and has since been demolished. Pursuant to KMC 17.04.030.D, "Development of property, in any zone district, may not result in the net loss of dwelling units." The project complies with this standard as the redevelopment project will provide two new dwelling units.



Figure 1: Subject Property Highlighted in Blue

The subject property is located in the Avalanche (A) Overlay Zone; however, the applicant submitted a site specific study which demonstrates that the subject property is not impacted by avalanche forces. Thus, the proposed development is not required to be structurally engineered to withstand avalanche forces nor is it required to construct an avalanche protective device. While not impacted by red or blue hazard areas, the project must still comply with all requirements specified in Ketchum Municipal Code §17.92.010 as the subject property remains in the A zone.

Pursuant to Ketchum Municipal Code ("KMC") §17.96.010.A3, Design Review is required for new multi-family dwellings, including attached townhomes. The Design Review and Preliminary Plat applications are not subject to the new Title 16 Land Development Code because the applications were vested prior to the new code taking effect. Therefore, the applications are subject to the previous Title 16 – *Subdivisions* and Title 17 – *Zoning*.

## II. BACKGROUND

The Planning and Building Department received the Townhome Preliminary Plat application for the project on July 17, 2025, and the Design Review application on July 23, 2025. Following receipt of the applications, staff routed the application materials to all city departments for review. The applications

were reviewed concurrently and underwent multiple rounds of review to address comments; most specifically related to exterior design of the building.

### III. CONFORMANCE WITH ZONING AND DESIGN REVIEW STANDARDS

Per KMC 17.96.050.A Criteria, the Commission shall determine the following before approval is given for design review:

1. The project does not jeopardize the health, safety or welfare of the public.
2. The project generally conforms with the goals, policies, and objectives of the adopted comprehensive plan.
3. The project conforms to all applicable standards and criteria as set forth in this chapter, this title, and any other standards as adopted or amended by the City of Ketchum from time to time.

#### Criteria 1 & 2

##### Future Land Use

The applications for the project were submitted prior to the adoption of the 2025 Comprehensive Plan, therefore, the project is subject to the 2014 Comprehensive Plan. The 2014 Comprehensive Plan (“2014 Plan”) contains the community’s vision for Ketchum and sets goals and policies to guide future development. The vision is shaped by 10 core values identified by Ketchum residents as important to consider for all future land uses decisions. The community’s core values include strong and diverse economy, community character, and a variety of housing options. The plan designates the future land use for the property as “low density residential” where the primary uses for this land use is single-family residences, duplexes, and accessory units. The proposed duplex aligns with the low density residential future land use designation.

Chapter 4 of the 2014 Plan, Community Design and Neighborhoods, states that “Infill and development projects should be contextually appropriate to the neighborhood and development in which they will occur” (Policy CD-1.3). The plan also states that “Each new project should be well-designed and attractive and should complement surrounding land uses and existing neighborhood character” (Policy CD-1.4). The surrounding neighborhood is characterized by two- and three-story townhomes and condominiums as well as a few two-story single-family homes. Staff believes that the duplex use is appropriate for the low density residential neighborhood, however, staff does believe that the design should be further considered. The applicant team revised the design of the duplex in response to staff recommendations. While these changes improved the design from the initial submittal, staff believes more changes are needed to reduce the bulk and mass, add visual interest to reduce flatness, and orient the duplex to the street frontage. See further discussion in the analysis of design review standards section below.

#### Criteria #3: Zoning and Design Review Standards

##### Conformance with Zoning Regulations

During city department review, planning staff reviewed the project for conformance with all applicable zoning code requirements, including permitted uses, dimensional standards, parking, and dark skies. Staff believes the project, as conditioned, complies with all zoning and dimensional standards required in the GR-L Zone. Please see further staff analysis in the Zoning and Dimensional Standards Evaluation included as Attachment E.

### Conformance with Design Review Standards

During city department review, planning staff reviewed the project for conformance with all design review standards and required improvements (KMC §17.96.060). Additionally, staff reviewed the project for conformance with all city code requirements for right-of-way improvements, utilities, and drainage. Staff believes the project meets most Design Review standards but has flagged certain design issues for the Commission's consideration. Staff recommends the Commission consider the design issues described in the analysis below and provide feedback to the applicant. Please see Attachment F for staff's comprehensive Design Review standards analysis.

#### *Bulk/Mass/Flatness*

The KMC design review criteria address the bulk and mass of buildings through a few different criteria. Staff believe there are two that directly speak to this development:

- KMC 17.96.060.F.5 - Building walls shall provide undulation/relief, thus reducing the appearance of bulk and flatness.
- KMC 17.96.060.F.2 - The building character shall be clearly defined by the use of architectural features.

The proposed development includes two attached townhomes which are identical and utilize mountain modern design (see figure 2 below for a rendering of the project). The applicant made the following design changes to provide more undulation and relief to the front façade:

- Added horizontal bands that overhang the second and third floors
- A recessed step added to the roof line fascia
- Stepped back third floor 2' from front façade
- Changed the color gradient of materials on the front façade from dark (Merrillstone Montana Mossy Stone) on the bottom to the beige stucco at the top to give the structure a more grounded appearance.

Staff believes these changes help add visual interest and reduce the bulk of the duplex at the front façade, however, staff still find that the overall structure presents a tall, minimally varied wall plane with little relief of the massing. While the second-floor steps back 7 feet from the ground floor, the effectiveness of the 7-foot step back at the second floor is diminished as the third floor projection above completely covers the recession created by the second-floor patio. Staff does acknowledge that the units are offset from each other by 5 feet at all three floor levels which helps break up the horizontal wall plane of the duplex's front façade. However, staff find that the proposed flat roof further accentuates the overall massing and horizontal emphasis of the structure, contributing to the boxy appearance. In addition to the flat roof form, the pronounced metal fascia in contrast to the beige stucco appears top-heavy and exacerbates the duplex's boxy appearance. Without variation in roof form or increased wall undulation on the third story, the design lacks articulation that could otherwise help break down the building's scale and reduce its perceived bulk. Staff requests the Commission to review the proposal and provide feedback on whether the project sufficiently incorporates architectural features and if it adequately reduces the appearance of bulk and flatness.



Figure 2: Rendering of Proposed Design

### *Compatibility of Design*

Pursuant to KMC §17.96.060.E1, “The project’s materials, colors and signing shall be complementary with the townscape, surrounding neighborhoods and adjoining structures.” Like many neighborhoods in Ketchum, Georgia Road features residences built at varying timeframes resulting in a diverse range of materials and architectural styles. This has resulted in a mix of architectural styles used with newer residences leaning towards a mountain modern style (flat roofs, high amount of glazing, and cold materials) and older residences featuring more traditional mountain architecture (pitched roofs, logs/wood, and native stone with a more rustic feel). Still, the neighborhood features more traditional mountain architecture than mountain modern design. The proposed development incorporates a mix of modern and traditional materials, such as stucco, stone, and wood as well as metal for the garage doors, window and door trim, railings, and fascia. Upon initial submittal, staff expressed concerns with the compatibility of the modern design within this neighborhood. Staff requests the Commission to review the proposal and provide feedback on whether the project materials and colors are complementary to the surrounding neighborhood.

### *Building Orientation*

Pursuant to KMC §17.96.060.F6, buildings shall be oriented toward their primary street frontage. Staff does not believe the proposed design meets this standard because the street facing ground level elevation is dominated by garages doors while the primary entrances to both units are located on the sides of the structure and set far back on the side walls and are barely visible from the street. The applicant team revised the initial design to include steel awnings over the front entrances to better identify the entryways, however, the entrances remain oriented to the sides of the property and not the street frontage. By distinguishing the front-door entrances compared to the garage entrance creates a more active frontage that is more compatible with the orientation of homes in the surrounding neighborhood. Staff believes that by modifying the ground-floor design to reduce the

dominance of garage door openings and distinguishing the front-door entrances would help add visual interest and relief to the front façade at the ground floor. Staff requests the Commission to review the proposal and provide feedback on whether this standard is sufficiently met.

#### *Landscaping*

The landscape plan submitted with the application materials underwent a few rounds of revisions during department review to select species that were drought tolerant and offer sufficient screening for the retaining walls that are visible from the street. However, the plant legend on the landscape plan continues to lack all of the proposed plant species, including for both groundcover and reseeding. All species must be indicated on the landscape plan for staff to verify drought tolerance. Staff recommend condition of approval #3 which stipulates that the applicant shall provide a final landscape plan that indicates all proposed plant species and the drought tolerance of each species that is to be reviewed and approved prior to building permit issuance.

#### **IV. CONFORMANCE WITH SUBDIVISION STANDARDS**

During department review, staff reviewed the preliminary plat application for conformance with subdivision preliminary plat development and design requirements (KMC 16.04.040) and townhouse standards (KMC 16.04.080). One item was missed by staff during department review related to indicating the locations of the proposed water and sewer lines for each townhouse unit on the preliminary plat. These new service lines are indicated on the civil drawings included with the project plans, however, were not shown on the preliminary plat. This item is addressed through condition of approval #2 and will be verified prior to City Council review of the application. A full review of all requirements and standards can be found in Attachment G. Where “N/A” is checked, the standard is not applicable for one of the following reasons:

- a) The standard applies to the creation of new subdivisions or new infrastructure. The application does not propose any new streets, water or sewer extensions of main lines, or master drainage infrastructure.
- b) The standard applies to action that shall be taken at the final plat stage of the process and this application is for a preliminary plat.
- c) Per provisions of the standard, the City Engineer has determined that the standard does not apply.

#### **STAFF RECOMMENDATION**

Staff recommends the Commission review the Design Review and Townhouse Preliminary Plat applications and provide feedback to the applicant on items outlined above in the staff report.

Following direction, the Commission has the following options:

- Continue the application to a date certain or uncertain with a request for revisions or more information
- Approve the applications with conditions
- Deny the application

If the Commission chooses to move forward with approving the applications as presented or revised, staff recommends the following conditions of approval to be considered. The Commission may delete, revise, or add to the conditions of approval based on the discussion.

## Design Review

1. This Design Review approval is based on the plans dated January 26, 2026, and the information presented and approved at the February 18, 2026 Planning and Zoning Commission Meeting included as Attachment B. The building permit plans must conform to the approved Design Review plans unless otherwise approved in writing by the Planning and Zoning Commission or Administrator. Any building or site discrepancies which do not conform to the approved plans will be subject to removal.
2. At time of building permit, the applicant shall submit final civil drawings prepared by an engineer registered in the State of Idaho that provide specifications for all right-of-way improvements, including sidewalks, alley asphalt, streetlights, utilities, and drainage facilities, for final review and approval by the City Engineer, Streets Department, Utilities Department, and Planning Department.
3. A final landscape plan shall be provided for review and approval prior to building permit issuance. Said landscaping plan shall provide a detailed plant list indicating all proposed plant species and the drought tolerance of each species.
4. The term of Design Review approval shall be twelve (12) months from the date that the Findings of Fact, Conclusions of Law, and Decision are adopted by the Planning and Zoning Commission or upon appeal, the date the approval is granted by the Council subject to changes in zoning regulations (KMC §17.96.090). Any extension shall comply with KMC §17.96.090.B.
5. In addition to the requirements set forth in this Design Review approval, this project shall comply with all applicable local, state, and federal laws.

## Townhouse Subdivision Preliminary Plat

1. The preliminary plat is subject to all conditions of approval associated with the Design Review approval P25-041.
2. The preliminary plat shall be revised to indicate the private well is to be abandoned and indicate the locations of the new water and sewer lines for both sublots prior to City Council review of the application.
3. Failure to record a Final Plat within two (2) years of Council's approval of a Preliminary Plat shall cause the Preliminary Plat to be null and void.

## **V. ATTACHMENTS:**

- A. Design Review Application & Supplemental Materials
- B. Design Review Plan Set
- C. Preliminary Plat Application & Supplemental Materials
- D. Lift View Townhomes Preliminary Plat
- E. Zoning and Dimensional Standards Evaluation
- F. Design Review Standards Evaluation
- G. Preliminary Plat Standards Evaluation



## MEMORANDUM

TO: Planning and Zoning Commission  
FROM: Morgan Landers, AICP – Director of Planning and Building  
DATE: April 10, 2025  
RE: Administrative Appeal Process

---

This is a procedural step for the City to process an administrative appeal filed with respect to a determination of the Planning Director.

Under Ketchum Municipal Code §16.07.020.H, the Commission is the appeal authority for administrative determinations made by the Planning Director.

This is an administrative appeal hearing where the Commission will sit in a quasi-judicial role. There will be arguments by the parties, but there is no public hearing and public comments will not be taken. Commission will have full discretion to ask questions of the parties, staff, and/or city attorney as needed.

The process for the hearing is as follows:

- Chair opens the agenda item
- Appellant provides their statement
- The Planning Director provides a statement addressing the appellant’s argument
- The Appellant then provides a rebuttal to the Planning Director’s statement
- Following all statements, the Commission then enters deliberations and decision

The Commission has the following decision options:

- Continue the hearing and request additional information
- Affirm the Planning Director’s Decision
- Overturn the Planning Director’s Decision
- Remand the decision back to the Planning Director for reconsideration of specific items

### **Attachments:**

- A. Application for Appeal (including appeal statement)
- B. Planning Director Reply Brief
- C. Appellant Rebuttal Brief



City of Ketchum

# **ATTACHMENT A: Application for Appeal**



**City of Ketchum  
Planning & Building**

OFFICIAL USE ONLY
File Number:
Date Received:
By:
Fee Paid:
Approved Date:
Denied Date:
By:

**Notice of Appeal**

Submit completed application and documentation to [planningandbuilding@ketchumidaho.org](mailto:planningandbuilding@ketchumidaho.org) Or hand deliver to Ketchum City Hall, 191 5<sup>th</sup> St. W. Ketchum, ID If you have questions, please contact the Planning and Building Department at (208) 726-7801. To view the Development Standards, visit the City website at: [www.ketchumidaho.org](http://www.ketchumidaho.org) and click on Municipal Code. You will be contacted and invoiced once your application package is complete.

**Note:** The Appellant shall submit an amount to cover the cost of giving notice, as applicable in the Fee Schedule, and provide a transcript within two (2) days after the Planning and Building Department provides the Appellant with an estimate for the expense of the same. In the event the fee is not paid as required, the appeal shall not be considered filed.

OFFICIAL USE ONLY	
Date Appeal Received:	Date Notice Published:
Appeal Fee:	Transcript Fee:
Date Paid:	Date Paid:
Date Appellant Notified of Estimated Transcript Costs and Notice:	Mailing Fee:
Date of Appeal Hearing:	Date Paid:
Action(s) Taken/Findings:	
APPELLANT	
Name of Appellant: Michael Taylor	Phone Number: (509) 421-8538
Address: 1695 Easy St., Wenatchee WA 98801-9000	Fax Number or Email: <a href="mailto:mike.taylor@stemilt.com">mike.taylor@stemilt.com</a>
REPRESENTATIVE	
Name of Representative: Craig Maxwell	Phone Number: (208)-721-2171
Address: PO BOX 1911, Sun Valley ID 83353	Fax Number or Email: <a href="mailto:craig@maxwellsds.com">craig@maxwellsds.com</a>
APPLICATION	
Application Being Appealed: Planning Administrator Determination: Prospector Condominiums Building 4 Existing Deck	
Explain How You Are an Affected Party: This deck was an important part of the property for our family. The prior determination regarding the deck has created a substantial financial hardship and emotional strain for our family during an already difficult recovery period following the fire, further compounding the impacts of circumstances beyond our control. It has been a space where our family has enjoyed time together for years and was a key reason we purchased the property in 1992. - Taylor family	

Due to no fault of their own, a fire in an adjacent unit severely compromised the structural integrity of the building, destroying the roof diaphragm, floor diaphragm, and wall sheathing. With a severely compromised vertical and lateral force resisting system from the fire, the building was condemned by the City, and demolished. The deck itself was not structurally independent from the building, as it utilized the east wall of the building for both vertical and lateral support, and was consequently demolished with the rest of the structure. During an October 16, 2025 administrative consultation, City staff directed our office (Maxwell Structural Design Studio) to remove the deck from the restoration application.

- Craig Maxwell

Date of Decision or Date Findings of Fact Were Adopted: Administrative Determination date January 13, 2026

**SUBMITTAL INFORMATION**

This Appeal is Based on The Following Factors (set forth all basis for appeal including the particulars regarding any claimed error or abuse of discretion):

- 1) The demolition of the deck was not voluntary. The demolition of the deck was directly related to the fire, which severely compromised both the vertical and the lateral force resisting system of the structure supporting the deck.  
Additionally, City Staff in a meeting on October 16, 2025, instructed the contracted design professionals, Craig Maxwell and River Vorse that the deck would have to be demolished in order for the city to issue a restoration permit for the building.
- 2) There is no clear reason that the portion of the building that encroaches on the riparian setback would be interpreted any differently than the deck under KMC16.01.050.B.3.a as indicated in the administrator’s determination. Neither the deck, nor that portion of the building were directly damaged by the fire. However, both were impacted by the fire. It was fire damage to the vertical and lateral force resisting system outside of the riparian setback that rendered the entire structure unstable, and which triggered code required design modifications due to the structure’s location in the floodplain.
- 3) We believe the complete restoration of the entire extent of the deck that falls outside of the regulatory floodway should be allowed per KMC §16.01.050.B.3.a. It is clear to us that the original intent of this ordinance was to allow for such circumstances in which a calamity outside of the property owner’s control forces structural repairs or restoration on a nonconforming structure. The small portion of the deck that encroaches within the regulatory floodway will not be restored, in compliance with federal flood code and KMC §16.01.050.B.3.a

If you have attached additional pages, please indicate the number of pages attached 8

Signature of Appellant or Representative



Date

~~01/13/2026~~  
01/28/2026



**CITY OF KETCHUM**

**City Hall**

office: 208.726.3841

participate@ketchumidaho.org

P.O. Box 2315, 191 5th Street West, Ketchum, ID 83340

ketchumidaho.org

11/17/2025

**PROSPECTOR CONDOMINIUMS**

315 Skiway Drive,  
Building 4  
Ketchum, ID 83340

Roy "Bud" Duncan, BSEE  
President, Prospector HOA  
Cell 206-499-2578

Mr. Duncan,

A site walk was performed on October 20, 2025, to inspect the structure in a manner to determine a path to repair or rebuild the structure due to significant structural damage caused by a structure fire event. The building structure has been severely weakened and with the imminent winter weather conditions bringing rain and snow loads, it has been determined that the building is deemed unsafe for entry. The building is uninhabitable due to structural issues according to the 2018 IPMC as described below.

As a result of the findings, it is agreed that the structure is considered an imminent threat to life safety and health and is not occupiable. This structure shall be immediately secured against entry within 30 days of the date on this letter. Any abatement, rehabilitation, restoration or demolition must be permitted under the provisions of the Ketchum Municipal Code (KMC). Any violations to the provisions of the KMC will be enforced through the provisions of the KMC, state or federal law.

**2018 International Property Maintenance Code**

**108.1.1 Unsafe structures.**

An unsafe structure is one that is found to be dangerous to the life, health, property or safety of the public or the occupants of the structure by not providing minimum safeguards to protect or warn occupants in the event of fire, or because such structure contains unsafe equipment or is so damaged, decayed, dilapidated, structurally unsafe or of such faulty construction or unstable foundation, that partial or complete collapse is possible. Note: *Only structures with major defects or life-threatening conditions are*

*considered unsafe. Minor defects, such as an inadequate number of electrical outlets or damaged plaster, do not necessarily create an unsafe structure, even though they are violations of the code.*

**108.1.5 Dangerous structure or premises.**

For the purpose of this code, any structure or premises that has any or all of the conditions or defects described as follows shall be considered to be dangerous:

5. The building or structure, or part of the building or structure, because of dilapidation, deterioration, decay, faulty construction, the removal or movement of some portion of the ground necessary for the support, or for any other reason, is likely to partially or completely collapse, or some portion of the foundation or underpinning of the building or structure is likely to fail or give way.

**108.6 Abatement methods.**

The owner, owner's authorized agent, operator or occupant of a building, premises or equipment deemed unsafe by the code official shall abate or cause to be abated or corrected such unsafe conditions either by repair, rehabilitation, demolition or other approved corrective action.

**108.7 Record.**

The code official shall cause a report to be filed on an unsafe condition. The report shall state the occupancy of the structure and the nature of the unsafe condition.

This letter serves as the report to be filed and will also be posted on site.

Respectfully submitted,



Alan Chambers  
Certified Building Official  
City of Ketchum/SAFEbuilt LLC



**CITY OF KETCHUM | PLANNING & BUILDING**

**Morgan Landers, AICP** | Director  
direct: 208.727.5085 | office: 208.726.7801  
mlanders@ketchumidaho.org

P.O. Box 2315, 191 5th Street West, Ketchum, ID 83340  
[ketchumidaho.org](http://ketchumidaho.org)

River Vorse, E.I.T.  
Maxwell Structural Design Studio  
PO Box 1911  
Sun Valley, ID 83353  
*[via email]*

January 13, 2025

Planning Administrator Determination: Prospector Condominiums Building 4 Existing Deck

Dear Mr. Vorse,

This letter serves as an Administrative Determination to your question about whether the existing deck attached to the rear of Prospector Condominiums Building 4 that encroaches in the riparian area and floodway may be maintained. Please see the information below and let me know if you have any questions.

**Request for Determination:** The City received a request for a determination as to whether the existing deck attached to the rear of the Prospector Condominiums Building 4 may be replaced in the pre-existing footprint. Building 4 was destroyed by fire damage and the existing building has since been demolished after a 11/17/25 condemnation was determined. Building 4 is proposed to be replaced and a building and floodplain development permit have been submitted for review on 12/4/2025. The existing building is nonconforming as the rear corner encroaches within the riparian setback area. The entirety of the rear deck is located within the riparian setback and a portion encroaches into the floodway of Warm Springs Creek.

**Applicable Code Provisions:** Pursuant to Ketchum Municipal Code (KMC) §16.07.050.D.3.a.3, no permanent development shall occur in the riparian setback area. KMC §16.02.070.A.2.j.(1)&(2) states that all encroachment, including fill, new construction, substantial improvements, residential structures, or other development within the floodway is prohibited. Pursuant to KMC §16.01.050.B.3.a, "A nonconforming building which has been damaged or destroyed by fire or any other calamity, may be restored to its preexisting nonconforming condition if a building permit for the work of restoration is obtained within two years of the date of the fire or other calamity and the work of the restoration complies with the international building and fire codes in effect at the time of the issuance of the building permit."

**Determination:** The existing nonconforming building was destroyed by fire and was condemned by the building official (11/17/25), therefore it may be restored to its preexisting nonconforming condition per KMC §16.01.050.B.3.a. However, the existing deck was not destroyed by the fire and therefore the restoration provision specified in KMC §16.01.050.B.3.a does not apply to the existing nonconforming deck. There is an exterior door on the building that is to be replaced, which exits to the deck. As this is a formal egress point of the building, and the building is permitted to be replaced to its preexisting condition, building code requires a landing and stairs to exit the building at this location. As there are conflicting regulations between the building code and the zoning code, it is my determination that the only portion of the existing deck that is permitted to be rebuilt is the minimum area or 36” for the landing at the rear exterior door required per building code.\*

The remaining portion of the deck that is not required for the landing must be removed. Additionally, the floodplain development permit required for the building reconstruction must include the landing and stairs for review. Riparian restoration of the area where the deck was removed may be required.

This Determination may be administratively appealed under Ketchum Municipal Code §16.07.020.H. Please be advised, if desired, an appeal of this Determination must be filed within 15 days pursuant to Ketchum Municipal Code §16.07.020.H.2.c.(1).

Sincerely,



Morgan Landers, AICP  
Director of Planning and Building

\*Building Code:

*R311.3 Floors and landings at exterior doors.*

*There shall be a landing or floor on each side of each exterior door. The width of each landing shall be not less than the door served. Landings shall have a dimension of not less than 36 inches (914 mm) measured in the direction of travel. The slope at exterior landings shall not exceed 1/4 unit vertical in 12 units horizontal (2 percent).*

*Exception: Exterior balconies less than 60 square feet (5.6 m<sup>2</sup>) and only accessed from a door are permitted to have a landing that is less than 36 inches (914 mm) measured in the direction of travel.)*

**TAYLOR DECK**  
 315 SKIWAY DR, UNIT 145 KETCHUM, ID 83340

PRELIMINARY  
 NOT FOR  
 CONSTRUCTION

**MAXWELL**  
 STRUCTURAL DESIGN STUDIO  
 CRAIG MAXWELL P.E.  
 105 Lewis Street, Unit 205 :: Ketchum, Idaho 83340  
 P.O. Box 1911 :: Sun Valley, Idaho 83353  
 Craig@maxwelleds.com :: 208.721.2171  
 www.maxwelleds.com

THE CONTENT OF THIS DRAWING IS THE EXCLUSIVE PROPERTY OF MAXWELL STRUCTURAL DESIGN STUDIO AND ARE PROTECTED UNDER FEDERAL COPYRIGHT LAWS. ANY UNAUTHORIZED REPRODUCTION OR USE OF THESE DRAWINGS IN WHOLE OR IN PART IS PROHIBITED WITHOUT THE WRITTEN CONSENT BY MAXWELL STRUCTURAL DESIGN STUDIO, PLLC.

**A1.0**

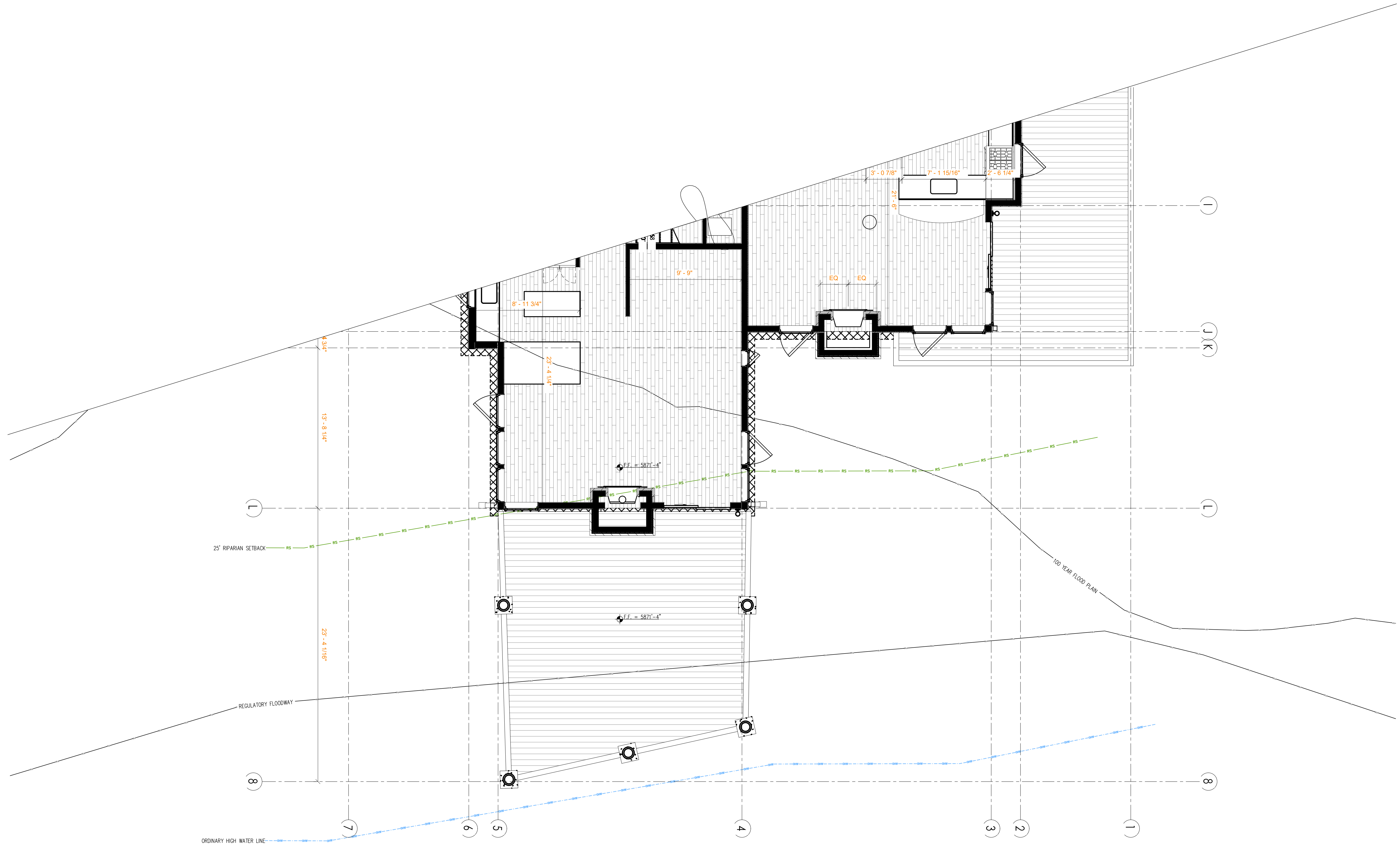

EXISTING DECK - BEFORE FIRE

1/4" = 1'-0"

**TAYLOR DECK**  
 315 SKIWAY DR. UNIT 145 KETCHUM, ID 83340

PRELIMINARY  
 NOT FOR  
 CONSTRUCTION

**MAXWELL**  
 STRUCTURAL DESIGN STUDIO  
 CRAIG MAXWELL P.E.  
 105 Lewis Street, Unit 205 :: Ketchum, Idaho 83340  
 P.O. Box 1911 :: Sun Valley, Idaho 83353  
 Craig@maxwelleds.com :: 208.721.2171  
 www.maxwelleds.com

THE CONTENT OF THIS DRAWING IS THE EXCLUSIVE PROPERTY OF MAXWELL STRUCTURAL DESIGN STUDIO AND ARE PROTECTED UNDER FEDERAL COPYRIGHT LAWS. ANY UNAUTHORIZED REPRODUCTION OR USE OF THESE DRAWINGS IN WHOLE OR IN PART IS PROHIBITED WITHOUT THE WRITTEN CONSENT BY MAXWELL STRUCTURAL DESIGN STUDIO, PLLC.

**A1.1**

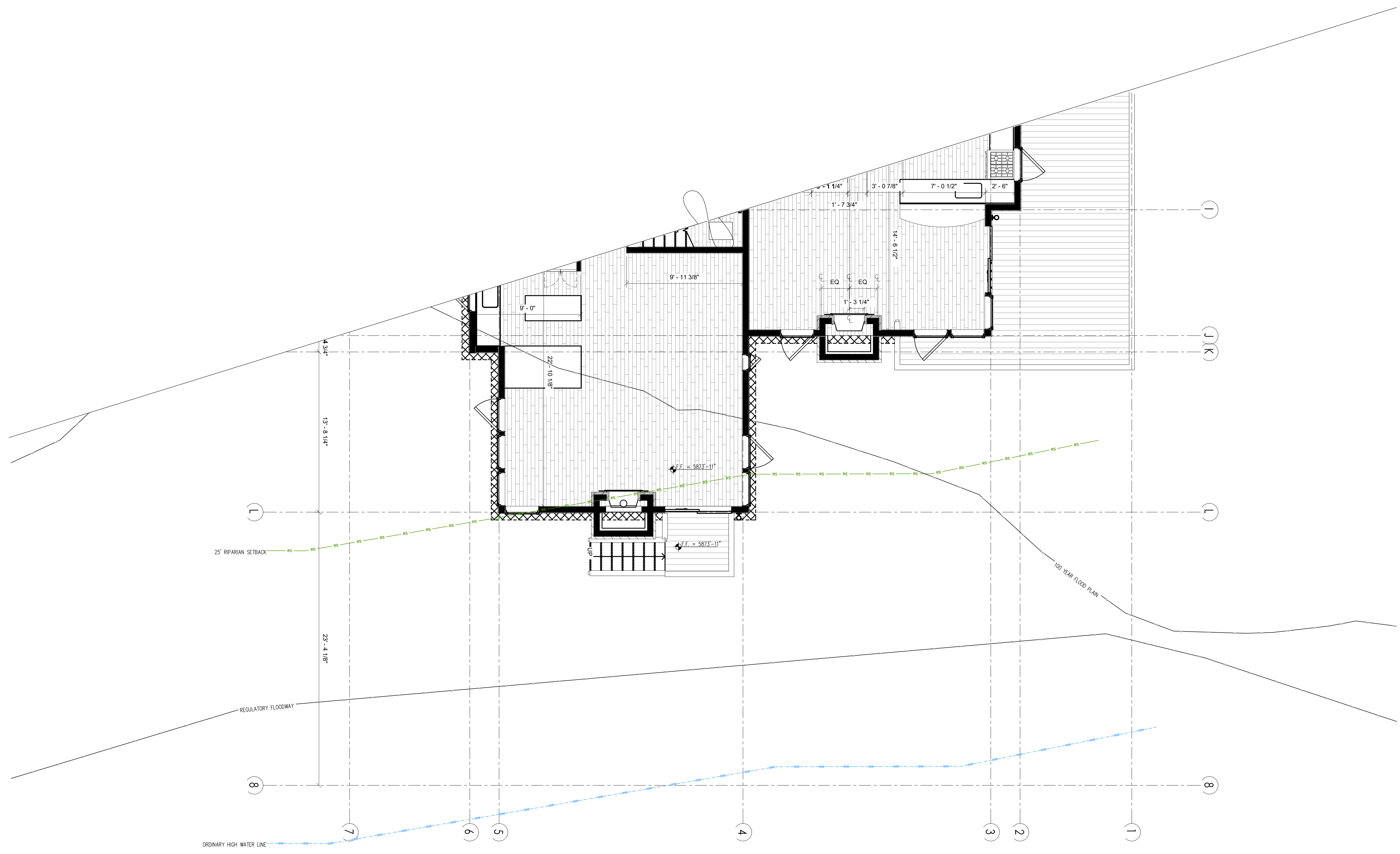

ADMINISTRATIVE DETERMINATION COMPLIANT DECK - RESTORATION PERMIT APPLICATION

1/4" = 1'-0"

**TAYLOR DECK**  
 315 SKIWAY DR. UNIT 145 KETCHUM, ID 83340

PRELIMINARY  
 NOT FOR  
 CONSTRUCTION

**MAXWELL**  
 STRUCTURAL DESIGN STUDIO  
 CRAIG MAXWELL P.E.  
 105 Lewis Street, Unit 205 :: Ketchum, Idaho 83340  
 P.O. Box 1911 :: Sun Valley, Idaho 83353  
 Craig@maxwelleds.com :: 208.721.2171  
 www.maxwelleds.com

THE CONTENT OF THIS DRAWING IS THE EXCLUSIVE PROPERTY OF MAXWELL STRUCTURAL DESIGN STUDIO AND ARE PROTECTED UNDER FEDERAL COPYRIGHT LAWS. ANY UNAUTHORIZED REPRODUCTION OR USE OF THESE DRAWINGS IN WHOLE OR IN PART IS PROHIBITED WITHOUT THE WRITTEN CONSENT BY MAXWELL STRUCTURAL DESIGN STUDIO, PLLC.

**A1.2**

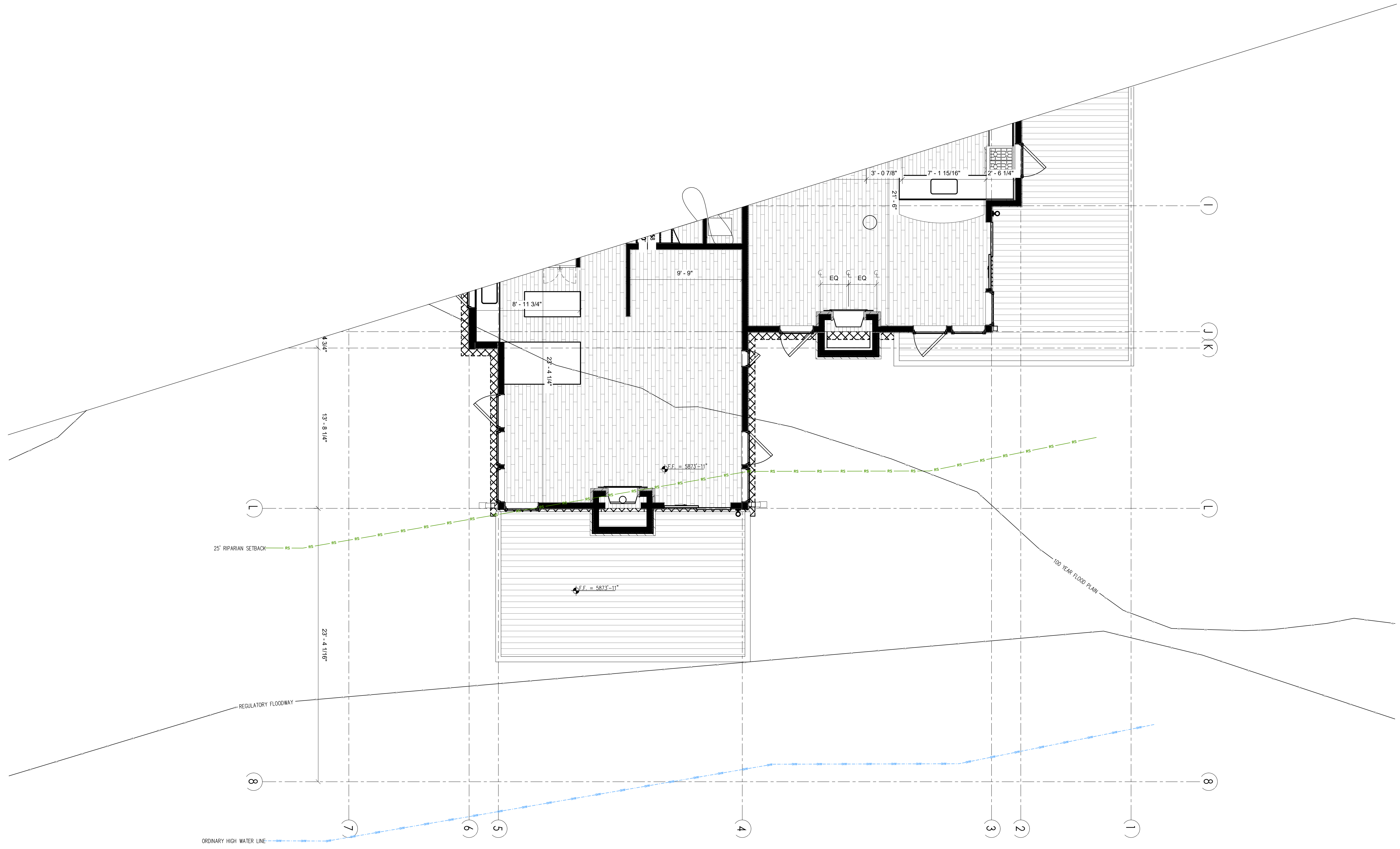

PROPOSED DECK - RESTORED OUTSIDE OF FLOODWAY

1/4" = 1'-0"





City of Ketchum

# **ATTACHMENT B:**

## **Planning Director Reply Brief**



## CITY OF KETCHUM | PLANNING & BUILDING

**Morgan Landers, AICP** | Director  
direct: 208.727.5085 | office: 208.726.7801  
mlanders@ketchumidaho.org  
P.O. Box 2315, 191 5th Street West, Ketchum, ID 83340  
[ketchumidaho.org](http://ketchumidaho.org)

### MEMORANDUM

TO: Planning and Zoning Commission  
FROM: Morgan Landers, AICP – Director of Planning and Building  
DATE: April 1, 2026  
RE: Appeal of Administrative Determination

---

This memorandum is to serve as a response brief to the appeal filed on January 28, 2026, regarding the replacement of a pre-existing deck located within the riparian setback of Warm Springs Creek. The appeal filing provided some information related to the process by which the determination was made and the working relationship between staff and the applicant; however, many pertinent details were left out. Overall, the city's approach to working with victims of structure fires is always one of flexibility, understanding, and fairness. Structure fires, particularly partial fires, often result in complex permitting and legal interpretations as many regulations are not designed for the full nuances of these situations.

Below is the overview of the timeline for the process. It is important to note that staff and the applicant were in regular communication regarding various paths forward for the reconstruction of the units. Initially, the applicant submitted a demolition permit for the fire damaged portion of the building and then pivoted to a full demolition concept following initial cost estimates for construction.

- May 10, 2025: Date of the structure fire. Three of six units were damaged. The three damaged units were those on the far side of the building opposite the Warm Springs Creek.
- May 2025: Discussions between staff and the applicant began.
- May 15, 2025: Partial demolition permit submitted
- July 18, 2025: Partial demolition permit issued.
- October 16, 2025: staff has no record of the discussion referenced in the appeal brief
- October 20, 2025: Site inspection conducted by the building official to review structural integrity for potential condemnation

- October 28, 2025: meeting with applicant team to discuss potential full demolition and potential opportunities/challenges. Items discussed included floodplain development permit requirements, limitations on development in the floodplain, nonconformities allowance for reconstruction, and options for the deck were discussed.
- November 14, 2025: Planning staff site visit to review the existing deck.
- November 17, 2025: Condemnation letter issued for entire building.
- November 24, 2025: Staff provided informal determination via email to River Vorse with Maxwell SDS that the full deck could not be rebuilt, but that the building code required landing would be permitted as the restoration code provision requires compliance with the building code.
- November 26, 2025: Applicant requested formal determination letter.
- January 13, 2025: Following further code research and analysis, final determination letter signed, and transmitted to applicant

In general, staff interpretation of KMC 17.136 - Nonconforming Uses and Nonconforming Buildings is that nonconforming structures cannot be demolished and reconstructed in place. The appellant warrants that demolition of the deck was not voluntary. During discussions with the applicant team, the structural reliance of the building for the deck was not raised as an issue. Therefore, the staff's understanding was that the deck could remain in its location while the building was demolished and reconstructed. Therefore, staff verbally advised the applicant that if they wanted to keep the deck, they could do so if it was not altered.

The restoration clause of the KMC, referenced in the appeal application, requires compliance with building and fire codes. Ultimately, the building code requires that any portion of a building encroaching into the floodway be removed. To achieve the building code requirement of removing the encroachment in the floodway, the applicant proposed to remove the entire deck and reconstruct it. This resulted in staff making the determination that the deck could not be rebuilt in the riparian area due to the entirety of the deck being removed and the determination outlined above. As the building code also requires adequate egress, staff determination allowed for the construction of the minimum landing necessary within the riparian area to safely access the door.



City of Ketchum

# **ATTACHMENT C: Appellant Rebuttal Brief**

**TO:** City of Ketchum Planning and Zoning Commission

**FROM:** Craig Maxwell P.E., Maxwell Structural Design Studio (Representative for Michael Taylor)

**DATE:** April 8<sup>th</sup>, 2026

**RE:** Rebuttal to Director's Response Brief regarding Prospector Building 4, Unit 145 Deck Reconstruction

**I. Introduction** This brief serves as a rebuttal to the Memorandum issued by Ketchum Planning and Building Director, Morgan Landers. It should be read along with the original appeal application and the forementioned memorandum. A number of statements within the Director's memorandum do not reflect the established record or the sequence of events leading up to the demolition of the deck at Prospector Building #4, Unit 145.

## **II. Factual Corrections to the Administrative Record**

The Director's memorandum contains several timeline and factual discrepancies that require correction:

- **Firm Involvement:** Our office was not involved in this project in May 2025. Our first discussion with City staff regarding this project occurred several months later, on **August 7, 2025**.
- **Meeting Date:** The meeting cited in our brief as October 16th was incorrectly dated on our part; this meeting actually occurred on **October 28th**, as correctly noted by the Director's memorandum.
- **Cause of Demolition (Condemnation vs. Cost):** The Director's memorandum implies the complete demolition of the building was a response to "initial cost estimates." This is incorrect. The demolition was a response to a **Letter of Condemnation** issued by Building Official Alan Chambers. The condemnation was based on our structural memo detailing severe fire and water damage to the roof diaphragm, floor diaphragm, and shear walls, rendering the building highly unstable.
- **Context of Cost Discussions:** Any discussions regarding construction costs were strictly to address the City-adopted flood zone codes. The omission in her memorandum of why we discussed construction costs with her mis-characterizes our intent and approach as one focused primarily on financial interests. Specifically, cost estimates were used to determine if the repairs crossed the 50% threshold for "substantial damage" and "substantial improvement," which triggers mandatory flood code compliance in the City's adopted code.

**III. Demolition of the Deck Was Mandated by the City** During the October 28th meeting, Director Landers stated in no uncertain terms that the deck *must* be removed before any fire repair permit application would be approved. This mandate was repeatedly documented by City staff in emails and plan comments:

- **November 24th (Abby Rivin, City Planner):** *"Only the portion of the existing deck that is the minimum area required for landing and egress per building code may be maintained/rebuilt."*
- **November 26th (Abby Rivin):** *"To clarify the determination... The only portion of the deck that is permitted to remain is the minimum area for the landing at the rear exterior door that is required per building code."*

- **January 9th, 2026 (Allison Kennedy, City Planner):** Referencing Floodplain Manager Sarah Foster's comments, Kennedy stated a determination letter would direct the applicant *"to omit the deck from the building permit set... to be removed from the riparian setback excepting the landing."*

It was made explicitly clear that retaining the deck was not an option. Demolition of the structure did not begin until December 12th, only *after* the issuance of the condemnation letter, a demolition permit, and communications from staff instructing us that the deck could not remain. The complete communications from city staff are appended.

#### **IV. Inconsistent Application of Egress Requirements**

The Director states that the "minimum landing" was allowed because *"the building code also requires adequate egress."* We are unaware of any code requiring an additional means of egress for a kitchen and living room beyond the front door. Notably, Unit 147, the immediately adjacent unit with an identical layout, has only a front entry door for egress. This was approved by City staff with no additional requirements. The City's insistence on a rear landing for Unit 145 is inconsistent with its own recent approvals and appears to be an arbitrary and capricious restriction rather than a code-mandated safety requirement.

#### **V. Mandatory Flood Compliance (The "Regulatory Catch-22")**

Even if the applicant had desired to leave the deck untouched, Title 44 of the Code of Federal Regulations, the International Existing Building Code (IEBC 2018), and KMC §16.02.070 legally prohibited it.

Because the fire caused "Substantial Damage" (repairs exceeding 50% of the structure's market value), the project became a "Substantial Improvement." Therefore:

1. **Floodway Encroachment:** Under the currently enforced 2010 FEMA study, the end of the original deck encroached on the regulatory floodway. (While the pending 2019 HECRAS study shows the deck safely outside the floodway, and floodplain, it is not yet adopted). The IEBC and Federal code strictly prohibit keeping any encroaching portion of a structure during a substantial improvement.
2. **Elevation Requirements:** Under KMC §16.02.070, non-flood-resistant materials must be raised 2'-0" above the Base Flood Elevation (BFE) to the Flood Protection Elevation (FPE). The bottom of the original deck sat at 5870.4' which is 0.6' below the BFE and **2.6' below the required FPE.**

Retaining the existing deck was physically and legally impossible without removing the floodway encroachment and raising the untreated framing by over two and a half feet.

#### **VI. Conflicting Code Interpretations and Vested Rights**

The Director's memorandum claims regulations are "not designed for the full nuances of these situations." However, the City has adopted the **IEBC (2018)** specifically to manage the complex structural repair of existing buildings. The Director declined to engage with the language of this adopted code during our October 28<sup>th</sup> meeting.

Furthermore, the City is oscillating between code editions. The formal determination letter cited the newer KMC Title 16 (effective Jan 1, 2026), while the Director's memo cites the older KMC 17.136 (in effect at the time of our submittal). Even under the newly published code, **KMC §16.136.050(d)** states: *"Removal and reconstruction of any nonconforming portions of a building is not permitted unless it is declared unsafe by the Building Official in which case it may be structurally strengthened or restored to a safe condition."* Because

Building Official Alan Chambers formally condemned the structure for safety reasons, reconstruction is explicitly permitted under this provision.

**VII. Conclusion**

We implore the Planning and Zoning Commission to overturn the Director's determination. The Taylor family's deck was demolished due to a City-issued Condemnation Letter and mandatory Federal Floodway compliance. We request that the applicant be permitted to rebuild the deck within the full envelope allowed by City flood code, rather than being restricted to an arbitrary "minimum egress" area found nowhere in the applicable building codes. Additionally, we request the commission evaluate whether the entire \$6700 appeal fee should have been required to have a fair reading of the adopted City codes, after every attempt had been made to work with City Staff and comply with the City codes.



**From:** Abby Rivin <ARivin@ketchumidaho.org>  
**Sent:** Wednesday, November 26, 2025 8:24 AM  
**To:** river@maxwellsds.com  
**Cc:** 'Allie Freund'  
**Subject:** Re: Prospector Deck

Hi River,

To clarify the determination on the existing deck located in the riparian area. The only portion of the deck that is permitted to remain is the minimum area for the landing at the rear exterior door that is required per building code. Planning staff can provide you with a formal determination letter on this if needed. Please let me know if you'd like to request a formal determination letter.

I'll follow up with you as soon as I have a determination about whether or not Design Review will be required.

Best,  
Abby

**ABBY RIVIN, AICP | CITY OF KETCHUM**

Senior Planner

P.O. Box 2315 | 191 5<sup>th</sup> Street W | Ketchum, ID 83340

office: 208-726-7801 | direct: 208-727-5082

[arivin@ketchumidaho.org](mailto:arivin@ketchumidaho.org) | [www.ketchumidaho.org](http://www.ketchumidaho.org)

---

**From:** river@maxwellsds.com <river@maxwellsds.com>  
**Sent:** Monday, November 24, 2025 1:43 PM  
**To:** Abby Rivin <ARivin@ketchumidaho.org>  
**Cc:** 'Allie Freund' <allie@maxwellsds.com>  
**Subject:** Re: Prospector Deck

Thanks for following up with us Abby. Let us know about the design review as soon as you are able.

On the deck, I am having a hard time understanding where it says we have to build to the minimum egress requirements.

The code is as follows: "A nonconforming building which has been damaged or destroyed by fire or any other calamity, may be restored to its preexisting nonconforming condition if a building permit for the work of restoration is obtained within two years of the date of the fire or other calamity and the work of the restoration complies with the international building and fire codes in effect at the time of the issuance of the building permit."

My understanding is that to comply with IBC requirements and federal code, the replacement deck will have to remain clear of the floodway. Beyond the floodway, the deck can be restored to its original footprint, while complying with the relevant floodplain construction requirements.

**From:** Abby Rivin <ARivin@ketchumidaho.org>  
**Sent:** Monday, November 24, 2025 1:28 PM  
**To:** river@maxwellsds.com <river@maxwellsds.com>  
**Cc:** 'Allie Freund' <allie@maxwellsds.com>  
**Subject:** Re: Prospector Deck

Hi River,

Sorry I missed your call—I'm currently in a webinar. I'll need to investigate the code/confirm with the P&B Director whether or not design review will be required. I'll follow up with you as soon as I have a determination for you about whether or not design review will be required.

The existing deck is located entirely within the riparian area and partially within the floodway, which is out of compliance with floodplain code requirements. Since Ketchum Municipal Code §17.136.040 states that nonconforming buildings damaged by fire may be restored to its preexisting nonconforming condition, only the portion of the existing deck that is the minimum area required for landing and egress per building code may be maintained/rebuilt.

Best,  
Abby

**ABBY RIVIN, AICP | CITY OF KETCHUM**

Senior Planner

P.O. Box 2315 | 191 5<sup>th</sup> Street W | Ketchum, ID 83340

office: 208-726-7801 | direct: 208-727-5082

[arivin@ketchumidaho.org](mailto:arivin@ketchumidaho.org) | [www.ketchumidaho.org](http://www.ketchumidaho.org)

---

**From:** river@maxwellsds.com <river@maxwellsds.com>  
**Sent:** Thursday, November 20, 2025 9:49 AM  
**To:** Abby Rivin <ARivin@ketchumidaho.org>  
**Cc:** 'Allie Freund' <allie@maxwellsds.com>  
**Subject:** Re: Prospector Deck

Thanks Abby,  
We were hoping to submit Friday, EOD.  
Are we going to need a design review application for this project, or will this be an administrative design review?  
Will the building and/or deck require a variance?

Best,  
River

---

**From:** Abby Rivin <ARivin@ketchumidaho.org>  
**Sent:** Wednesday, November 19, 2025 2:06 PM  
**To:** river@maxwellsds.com <river@maxwellsds.com>  
**Subject:** Re: Prospector Deck

Hi River,

Allison and I conducted a site visit last Friday to take a look at the existing deck. We're still reviewing this question internally. I'll follow up with you as soon as we have a determination.

Best,  
Abby

**ABBY RIVIN, AICP | CITY OF KETCHUM**

Senior Planner

P.O. Box 2315 | 191 5<sup>th</sup> Street W | Ketchum, ID 83340

office: 208-726-7801 | direct: 208-727-5082

[arivin@ketchumidaho.org](mailto:arivin@ketchumidaho.org) | [www.ketchumidaho.org](http://www.ketchumidaho.org)

---

**From:** river@maxwellsds.com <river@maxwellsds.com>

**Sent:** Tuesday, November 18, 2025 9:04 AM

**To:** Abby Rivin <ARivin@ketchumidaho.org>

**Subject:** Prospector Deck

Good morning Abby,

I am following up on the Prospector unit we are trying to rebuild after the fire this spring. We met a few weeks ago and it was determined that the deck would have to be reduced in size on the rebuild due to the riparian encroachment.

Are you able to provide further guidance on what size deck will be allowed on the rebuild?

There is an exterior door at the deck that will need at a minimum a landing and a stair down to grade.

The survey we provided previously is attached.

Best,  
River

**River Vorse, E.I.T.**

105 Lewis Street, Suite 205, Ketchum, ID 83340

P.O. Box 1911, Sun Valley, ID 83353

(208) 721-8288 : [river@maxwellsds.com](mailto:river@maxwellsds.com)





**CITY OF KETCHUM**

**Planning & Building**  
 office: 208.726.7801  
 planningandbuilding@ketchumidaho.org  
 P.O. Box 2315, 191 5th Street West, Ketchum, ID 83340  
 ketchumidaho.org

**BUILDING PERMIT REVIEW COMMENTS**  
 Planning Department

PROJECT NAME: Prospector Condos #4  
 BUILDING PERMIT #25-KET-00408  
 PROJECT ADDRESS: 315 Skiway  
 REVIEWER: Allison Kennedy, Senior Planner  
 REVIEW DATE: 1/9/2026  
 APPROVAL STATUS: Resubmittal Required

*Note: These plans have only been reviewed for compliance with applicable adopted codes by this jurisdiction. There may be other regulations applicable under state and federal statutes which this department has no authority to enforce and are not part of this plan review.*

1	Comment: See comments related to resubmittals requested for the Floodplain Permit #P25-63 from Sarah Foster, Floodplain Manager. In addition, a deck determination letter will be made available from the Administrator with the direction <b>to omit the deck from the building permit set p. C0.20, A1.0, to be removed from the riparian setback excepting the landing.</b>
	Applicant Response:
2	Comment: See comment from Wastewater Department. The preexisting footprint of the structure is located 10' on top of the city sewer line. This is simply to make the property owner aware of the circumstance. Further conversations may be needed internally on how to best proceed if rerouting the line is necessary and/or feasible at this time.
	Applicant Response:
3	Comment:
	Applicant Response:

**MISCELLANEOUS COMMENTS:**

1.

## CHAPTER 17.136 - NONCONFORMING USES AND NONCONFORMING BUILDINGS

## 17.136.010 - Continuation of use.

A nonconforming use may be continued and a nonconforming building may continue to be occupied except as both are otherwise provided for in this chapter.

(Ord. 1135, 2015)

## 17.136.020 - Change of use.

A nonconforming use may be changed only to a conforming use.

(Ord. 1135, 2015)

## 17.136.030 - Abandonment of use.

- A. An owner shall not be deprived of the right to use improvements on private property for their designed purpose based solely on the nonuse of the improvements for their designed purpose for a period of ten years or less. Where an owner or his authorized agent permits or allows an approved or unlawful intervening use of the owner's property, the provisions of this subsection are not applicable.
- B. For purposes of this section "designed purpose" means the use for which the improvements were originally intended, designed and approved pursuant to any applicable planning and zoning ordinances.
- C. For all uses where the provisions of subsection A of this section are not applicable: If active and continuous operations are not carried on in a nonconforming use during a continuous period of six months, the building, other structure or tract of land where such nonconforming use previously existed shall be occupied and used only for a conforming use. Intent to resume active operations shall not affect the foregoing.

(Ord. 1135, 2015)

**17.136.040 - Restoration.**

A nonconforming building which has been damaged or destroyed by fire or any other calamity, may be restored to its preexisting nonconforming condition if a building permit for the work of restoration is obtained within two years of the date of the fire or other calamity and the work of the restoration complies with the international building and fire codes in effect at the time of the issuance of the building permit.

Nonmaterial changes to the preexisting nonconforming condition may be approved at the City's discretion. If additional square footage is added, that additional square footage may be subject to the current requirements of the underlying zone district at the discretion of the planning and zoning department head.

(Ord. 1135, 2015)

#### 17.136.050 - Enlargement of a nonconforming building or a nonconforming use.

A nonconforming use shall not be enlarged or extended and a nonconforming building shall not be enlarged or extended so as to increase the degree of nonconformity, except in the community core district where one-family dwellings may increase their original square footage by 20 percent. Additions and/or enlargements to existing buildings are not considered to be nonconforming or to increase the degree of nonconformity, so long as the additions and/or enlargements comply with the following:

- A. Any additional square footage may be subject to the current requirements of the underlying zone district at the discretion of the planning and zoning department head.
- B. Fifty percent of the building footprint and exterior walls of a nonconforming structure must remain unaltered.

(Ord. 1135, 2015)

#### 17.136.060 - Alteration of a nonconforming building.

A nonconforming building may be structurally altered or repaired in any way permitted by these regulations.

(Ord. 1135, 2015)

#### 17.136.070 - Structural changes.

Any building or other structure containing a nonconforming use or any nonconforming building or portion declared unsafe by the City building inspector may be strengthened or restored to a safe condition.

(Ord. 1135, 2015)

request of the applicant. Applications shall not be processed under a combination of prior regulations and this Code.

2. If a Preapplication Design Review is required and has been completed pursuant to the procedure in §16.07.030.C.1, a vested property right shall be created. The voluntary request for a Preapplication Design Review does not create a vested property right.

### C. Prior Violations

If a development or activity in violation of the prior development regulations fully complies with this Code, it shall no longer be deemed a violation. Unpaid fees and/or penalties from prior enforcement of violations are still valid and shall remain the responsibility of the violator under the prior regulations

---

## 16.01.050. Nonconformities

### A. Nonconforming Uses

A nonconforming use may be continued provided it meets the following standards:

#### 1. Change of Use

A nonconforming use may be changed only to a conforming use.

#### 2. Expansion of Use

A nonconforming use shall not be enlarged or expanded. Enlargement and expansions include any increase to floor area of the nonconforming use within an existing or new building. Any building or other structure containing a nonconforming use declared unsafe by the Building Official may be strengthened or restored to a safe condition.

#### 3. Abandonment of Use

A lawful nonconforming use shall be deemed abandoned when the nonconforming use has been replaced by a conforming use or when the nonconforming use has ceased and has not been active for a continuous period of six months. Intent to resume active operations shall not be considered in determining abandonment.

### B. Nonconforming Buildings

#### 1. Nonconforming Due to Lack of Parking and Loading

No lawfully existing building shall be deemed to be a nonconforming building solely because of lack of off-street parking and loading spaces, provided that the area being used for off-street parking or loading shall not be further reduced in area or capacity as of the Effective Date.

#### 2. Enlargement or Alteration

- a. A nonconforming building shall not be enlarged or extended so as to increase the degree of nonconformity.
- b. One-family dwellings in the Community Core District may increase their original square footage by a cumulative 20 percent as of the effective date of the ordinance subject to a Conditional Use Permit per §16.07.030.A.

- c. Any additional square footage may be subject to the current requirements of the underlying zoning district at the discretion of the Administrator.
- d. Removal and reconstruction of any nonconforming portions of a building is not permitted unless it is declared unsafe by the Building Official in which case it may be structurally strengthened or restored to a safe condition.
- e. If a portion of a nonconforming building is located within the public right-of-way, that portion of the building shall not be expanded or altered to increase the existing encroachment. The City Engineer and Streets Department shall determine whether the portion of the nonconforming building that extends into the public right-of-way may remain or if the encroachment must be removed. If the City Engineer and Street Department determine that the portion of nonconforming building that extends into the public right-of-way may remain, the property owner shall enter into a right-of-way encroachment agreement with the City.

### 3. Restoration

- a. A nonconforming building that has been damaged or destroyed by fire or any other calamity, may be restored to its preexisting nonconforming condition if a Building Permit for the work of restoration is obtained within two years of the date of the fire or other calamity and the work of the restoration complies with the international building and fire codes in effect at the time of the issuance of the Building Permit.
- b. Nonmaterial changes to the preexisting nonconforming condition may be approved at the City's discretion. Nonmaterial changes include minor repairs and maintenance necessary to correct damage or deterioration to the structural soundness of, or the exterior or interior appearance of a nonconforming building without expanding the height or footprint of the building. If additional square footage is added, that additional square footage may be subject to the current requirements of the underlying zoning district at the discretion of the Administrator.

### 4. Relief for Structures on the Historic Building/Site List

Any expansion or remodel of a property on the historic building/site list is permitted to match the current setback, height, or other dimensional standard on such property at the time of application.

### C. Nonconforming Lots

- 1. For the purpose of this section, nonconforming lots shall include:
  - a. Any lot that did not comply with the minimum lot size requirements at the time the lot was subsequently annexed to the City;
  - b. Any lot that was of legal area and dimensions when held in separate ownership from adjoining properties or when platted in a recorded subdivision; and
  - c. Any lot that was made nonconforming by virtue of enactment of this Code.
- 2. A nonconforming lot may be used for construction of a building or establishment of a use allowed in the applicable zoning district, provided that all other zoning district and dimensional standards are met.