



**CITY OF KETCHUM, IDAHO**  
REGULAR CITY COUNCIL MEETING  
Monday, August 16, 2021, 4:00 PM  
480 East Avenue, North, Ketchum, Idaho

---

**Agenda Amended**

**PUBLIC PARTICIPATION INFORMATION**

Public information on this meeting is posted outside City Hall located at:  
480 East Ave. N. in Ketchum, Idaho

**We welcome you to watch Council Meetings via live stream.**

You will find this option on our website at [www.ketchumidaho.org/meetings](http://www.ketchumidaho.org/meetings).

**If you would like to comment on a public hearing agenda item, please select the best option for your participation:**

- Submit your comments in writing at [participate@ketchumidaho.org](mailto:participate@ketchumidaho.org) (*by noon the day of the meeting*).
- Dial-in to the meeting by phone to provide comment when called upon (*please mute your device until called upon*).
- Address the Council in person at City Hall.

**Dial-in Instructions:**

- Phone: 253-215-8782
- Meeting ID: 851 5278 4411

*If you require special accommodations to participate in this meeting, please contact the City Clerk.  
This agenda is subject to revisions. All revisions will be underlined.*

---

- CALL TO ORDER: By Mayor Neil Bradshaw
- ROLL CALL:
- COMMUNICATIONS FROM MAYOR AND COUNCILORS:
- CONSENT AGENDA:

HYPERLINK "appIS26659f62dab643c7af3d10c45aeb4ab9"[Note re: ALL ACTION ITEMS - The Council is asked to approve the following listed items by a single vote, except for any items that a Councilmember asks to be removed from the Consent Agenda and considered separately.](#)

1. [ACTION ITEM: Approve minutes of August 2, 2021.](#)
2. [ACTION ITEM: Authorization and approval of the payroll register, as submitted by Shellie Rubel, Treasurer.](#)
3. [ACTION ITEM: Recommendation to receive and file the Treasurer's financial reports, as submitted by Shellie Rubel, Treasurer.](#)

4. [ACTION ITEM: Authorization and approval of the disbursement of funds from the City's treasury for the payment of bills in a total sum of \\$ 1,512,168.45., as submitted by Shellie Rubel, Treasurer.](#)
5. [ACTION ITEM: Recommendation to approved Alcohol Beverage Licenses, as submitted by Genoa Beiser, Deputy Treasurer.](#)
6. [ACTION ITEM: Recommendation to replace City Code per Resolution 21-014, as submitted by Tara Fenwick, City Clerk.](#)
7. [ACTION ITEM: Recommendation to approve Purchase Order #20679 with Integrated Technologies, as submitted by Tara Fenwick, City Clerk.](#)
8. [ACTION ITEM: Recommendation to approve a Communications Facility Lease with Sun Valley Company and authorize the mayor sign the lease, as submitted by Bill McLaughlin, Fire Chief.](#)
9. [ACTION ITEM: Recommendation to approve Change Order #8, as submitted by Bill McLaughlin, Fire Chief.](#)
10. [ACTION ITEM: Recommendation to approve Encroachment Agreement #20645 with Idaho Power for infrastructure on Bald Mountain Road and Warm Springs Road, as submitted by Suzanne Frick, Director Planning and Zoning.](#)
11. [ACTION ITEM: Recommendation to approve Encroachment Agreement #20653 with Idaho Power for infrastructure on River Street, as submitted by Suzanne Frick, Director Planning and Zoning.](#)
12. [ACTION ITEM: Recommendation to approve Encroachment Agreement #20656 for a snowmelt driveway at 116 Sage Road, as submitted by Suzanne Frick, Director Planning and Zoning.](#)
- [NEW BUSINESS: \(no public comment required\)](#)
  13. [ACTION ITEM: Swearing in of New Firefighters, as submitted by Bill McLaughlin, Fire Chief.](#)
  14. [Presentation / discussion regarding potential legislative change to allow for real estate transfer tax for resort cities, as presented by Wendy Jaquet and Dewayne Briscoe.](#)
  15. [ACTION ITEM: Review and direction to staff on request to reimburse for undergrounding power lines at 404 Broadway, as submitted by Suzanne Frick, Director Planning and Zoning.](#)
- [PUBLIC HEARING:](#)
  16. [ACTION ITEM: \*\*First Reading of Ordinance #1223 to amend Local Option Tax and Approval of Resolution 21-016 calling for November 2<sup>nd</sup> Election\*\*, as submitted by Jade Riley, City Administrator.](#)
  17. [ACTION ITEM: First Reading of Amended FY21 Budget, as submitted by Shellie Rubel, Treasurer and Jade Riley, City Administrator.](#)
  18. [ACTION ITEM: First Reading of FY22 Budget, as submitted by Shellie Rubel, Treasurer and Jade Riley, City Administrator.](#)
- [EXECUTIVE SESSION:](#)  
[No agenda items.](#)
- [ADJOURNMENT:](#)



**CITY OF KETCHUM**  
**REGULAR MEETING MINUTES OF THE CITY COUNCIL**  
Monday, August 2, 2021

---

**CALL TO ORDER:** *(00:10:40 in video)*

Mayor Bradshaw called the special meeting of Ketchum City Council to order at 4:00 p.m.

**Roll Call:**

Mayor Neil Bradshaw  
Courtney Hamilton  
Amanda Breen  
Jim Slanetz  
Michael David

**Also Present:**

Jade Riley – City Administrator  
Matt Johnson – City Legal Council  
Sherri Newland – City Engineer  
Lisa Enourato - Public Affairs and Administrative Services Manager  
Shellie Rubel – City Treasurer  
Tara Fenwick – City Clerk & Administrative Business Manager  
Morgan Landers – Senior Planner

**COMMUNICATIONS FROM MAYOR AND COUNCILORS:**

- Mayor, Neil Bradshaw – Shared appreciation for the recent rain and announced John and Diane Peavey to serve as Grand Marshals for Wagon Days, 2021.
- Councilor, Michael David – Encouraged staff to keep ‘Housing’ on the agenda. Michael shared recent experience and observation of service declinations in the Valley.

**CONSENT AGENDA:** *(00:14:45 in video)*

Councilor, Courtney Hamilton commented on a financial err in material related to Agenda item 8, which could not be immediately resolved. Further, she expressed gratitude for the work and material associated with Agenda item 11 and commented on a financial err in material related to Agenda item 12, which was resolved.

**Motion to approve consent agenda items 1 thru 14, except for item 8, and adjustments requested on 12.**

**Motion made by Councilor, Courtney Hamilton and seconded by Councilor, Amanda Breen All in Favor.**

**NEW BUSINESS:** (00:19:40 in video)

City Administrator, Jade Riley, delivered a presentation asking direction to staff regarding scope and associated budget for Main Street (SH-75) and Warm Springs Corridor alternatives analysis study.

Options for the Council to Consider:

- Option A: Fund both studies from existing city budget
- Option B: Phase studies for multi-year funding option
- Option C: Fund existing budgeted amount (\$100k) and request funding from KURA for remainder

Councilors agreed that Option C be pursued.

Additional encouragements were:

- Sync traffic lights before investing in additional improvements.

**PUBLIC HEARING:**

No agenda items.

**EXECUTIVE SESSION:**

No executive session.

**ADJOURNMENT:**

**Motion to adjourn at 4:45 p.m.**

**Motion made by Councilor, Courtney Hamilton; seconded by Councilor, Michael David  
All in Favor.**

---

Mayor, Neil Bradshaw

---

City Clerk, Tara Fenwick



## City of Ketchum

August 16, 2021

Mayor Bradshaw and City Councilors  
City of Ketchum  
Ketchum, Idaho

Mayor Bradshaw and City Councilors:

### **Recommendation to Receive and File Treasurer's Monthly Financial Report**

#### Recommendation and Summary

Staff is recommending the council receive and file the Treasurer's monthly report in accordance with statutory requirements and adopt the following motion:

***"I move to receive and file the Treasurer's financial report."***

The reasons for the recommendation are as follows:

- State statute establishes requirements for monthly financial reports from the City Treasurer.

#### Introduction and History

Idaho State Statute 50-208 establishes requirements for monthly financial reports from the City Treasurer to the Council. The Statute provides that the Treasurer "render an accounting to the city council showing the financial condition of the treasury at the date of such accounting."

#### Analysis

Pursuant to the above statutory requirements, enclosed for Council review is a monthly financial report showing the financial condition of the City in the current fiscal year. This report, along with complete financial statements, is available on the City's website.

#### Sustainability Impact

There is no sustainability impact arising from this reporting.

#### Financial Impact

There is no financial impact arising from this reporting.

#### Attachments

- Attachment A: Monthly Financial Report Charts



# Monthly Financial Reports

As of July 31, 2021



This packet is divided into three sections: (1) General Fund charts (pages 3-7); (2) Original LOT charts (pages 8-13); (3) Enterprise Fund charts (pages 14-16); and Off-Street Parking Lot charts (pages 17-19).

Each chart includes information on current progress relative to the prior year and the current budget.

# Summary for July 31, 2021

## GENERAL FUND

<b>1. REVENUES</b>	
Approved Budget	10,307,770
Year to Date (YTD)	11,527,172
Forecast to end of fiscal year (EOY)	12,994,939
<b>2. EXPENDITURES</b>	
Approved Budget	10,307,770
Year to Date (YTD)	10,094,068
<b>Interim Budget changes</b>	
Planning & Building Direct Costs	220,000
Warm Springs Analysis	50,000
Warm Springs Contractual Staffing Support	54,000
LOT transfer increase	92,950
Fund balance transfer to ESF for Direct Costs	511,000
Transfer to ESF fund for New City Hall	1,099,969
Flowers	15,500
Professional Services Contingency	200,000
Transfer to CIP for parking lot for new fire station	136,700
<b>3. Forecast to EOY</b>	<b>12,687,889</b>
 Net Position	 307,050

## LOCAL OPTION TAX

<b>1. REVENUES</b>	
Approved Budget	1,817,247
Year to Date (YTD)	2,598,346
Forecast to end of fiscal year (EOY)	2,397,247
<b>2. EXPENDITURES</b>	
Approved Budget	1,817,247
Year to Date (YTD)	1,916,975
Interim Budget changes	
LOT transfer general fund	400,000
 Forecast to EOY	 2,217,247
<b>3. Net Position</b>	<b>180,000</b>

# General Fund

---



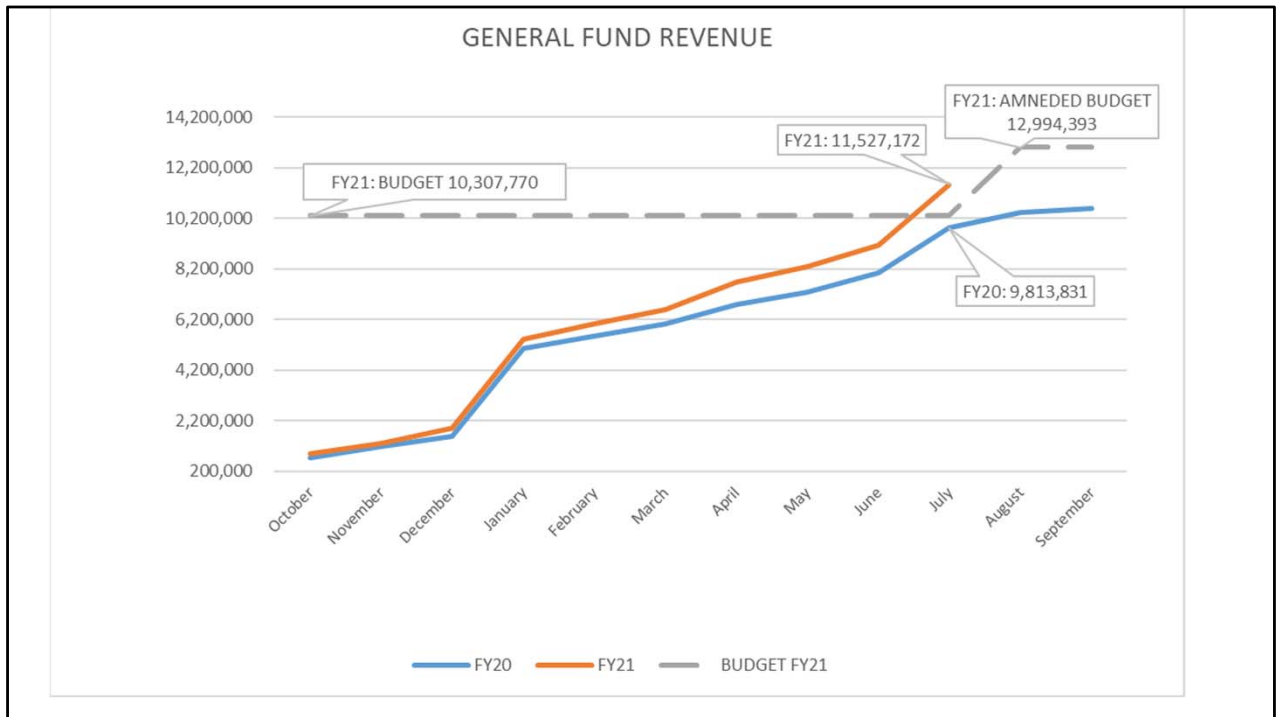

The General Fund revenues are up approximately \$1,713,341 (17.5%) in FYTD compared to FY2020. This increase is largely due to three revenue sources, property tax, planning and building fees and state shared grants.

### GENERAL FUND REVENUES by Category

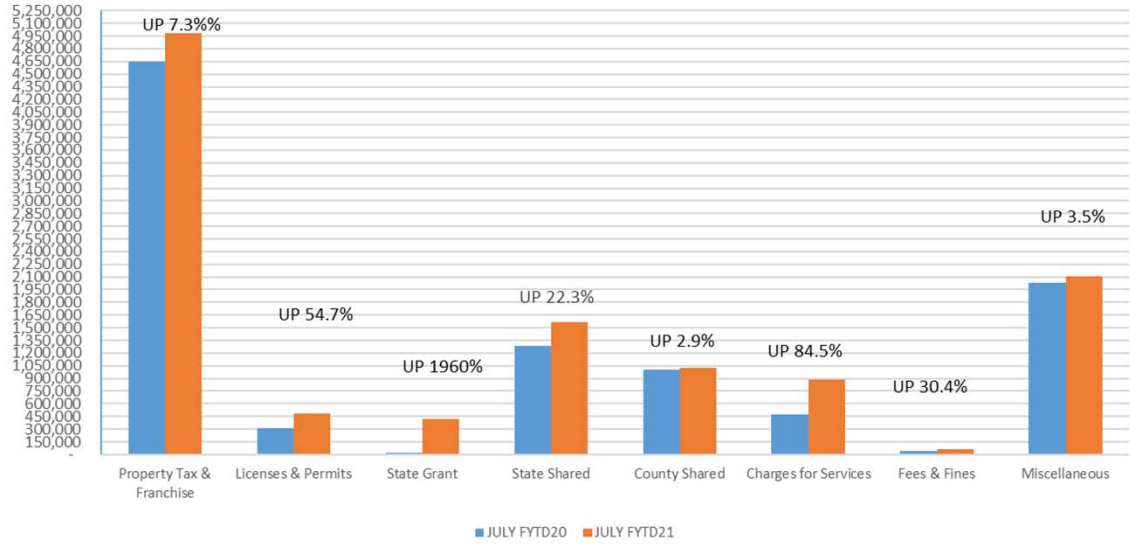

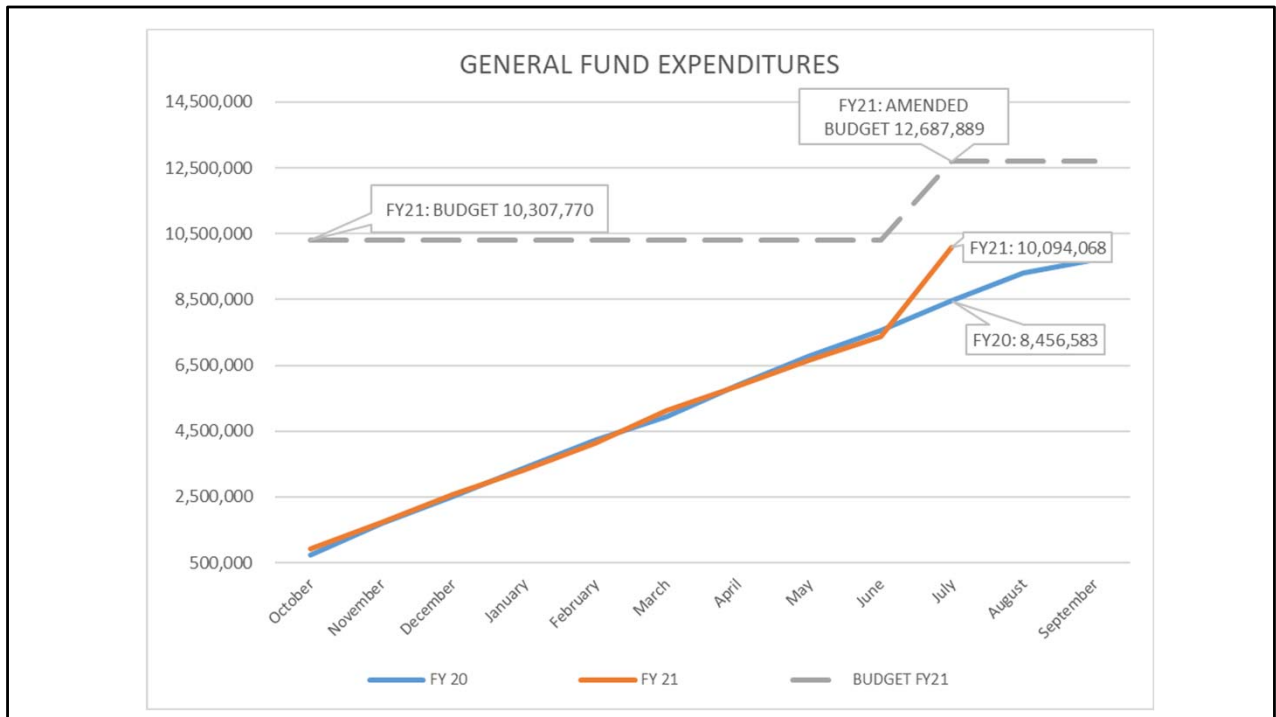

The General Fund expenditures are up 1,637,485 (19%) FYTD. The increase is due to New Fire Station construction and New City Hall remodel.

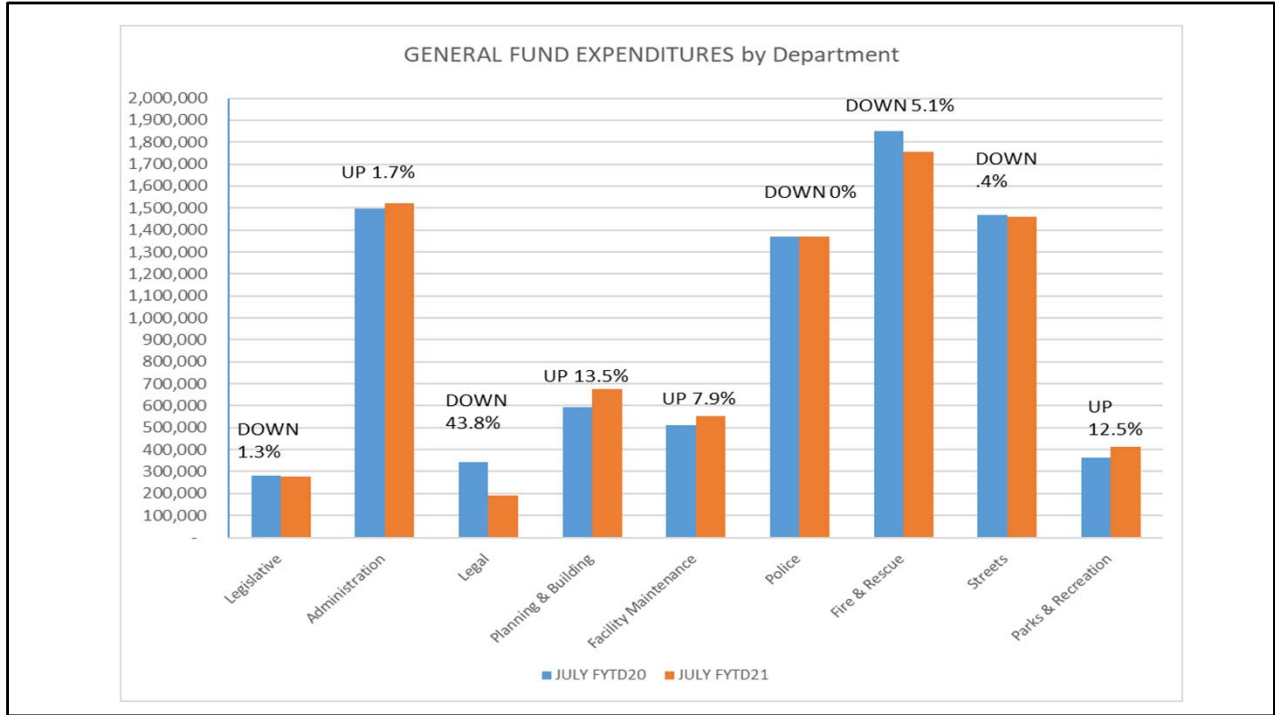

# LOT Analysis

---

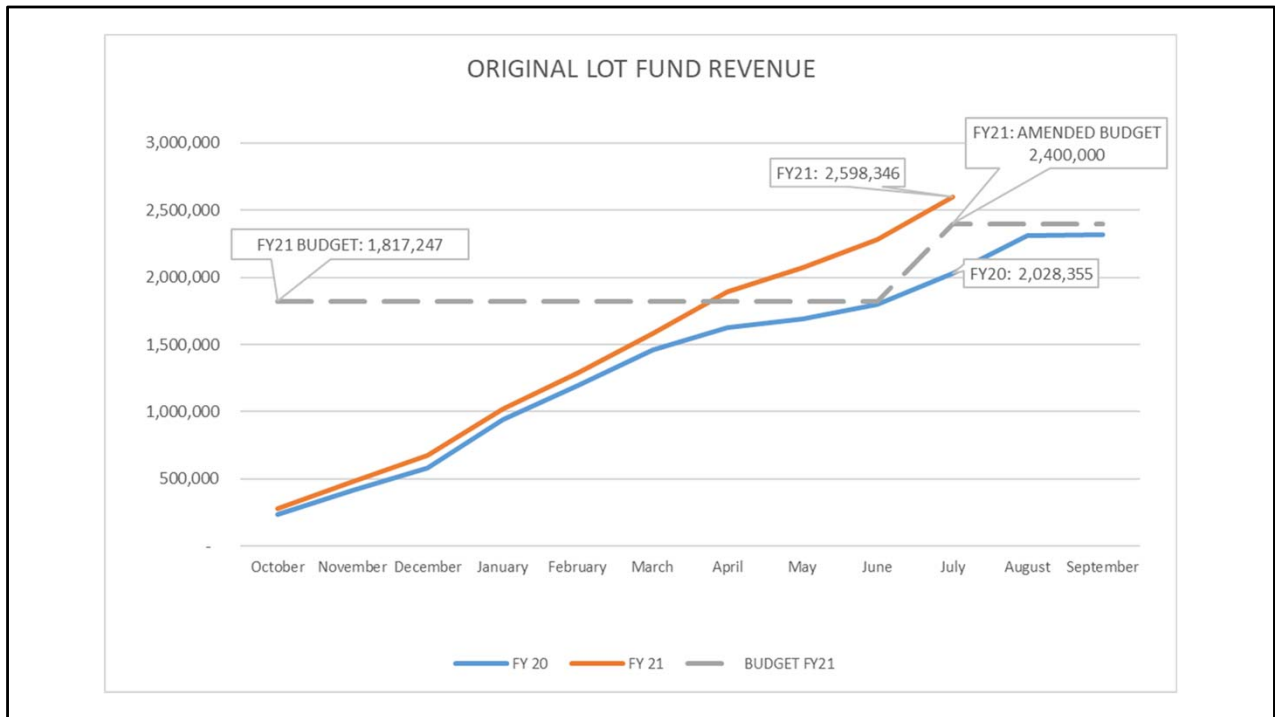

Revenue to the Original LOT Fund is up approximately \$569,991 (28.1%) FYTD. This increase is largely due to retail, condo and building material receipts.

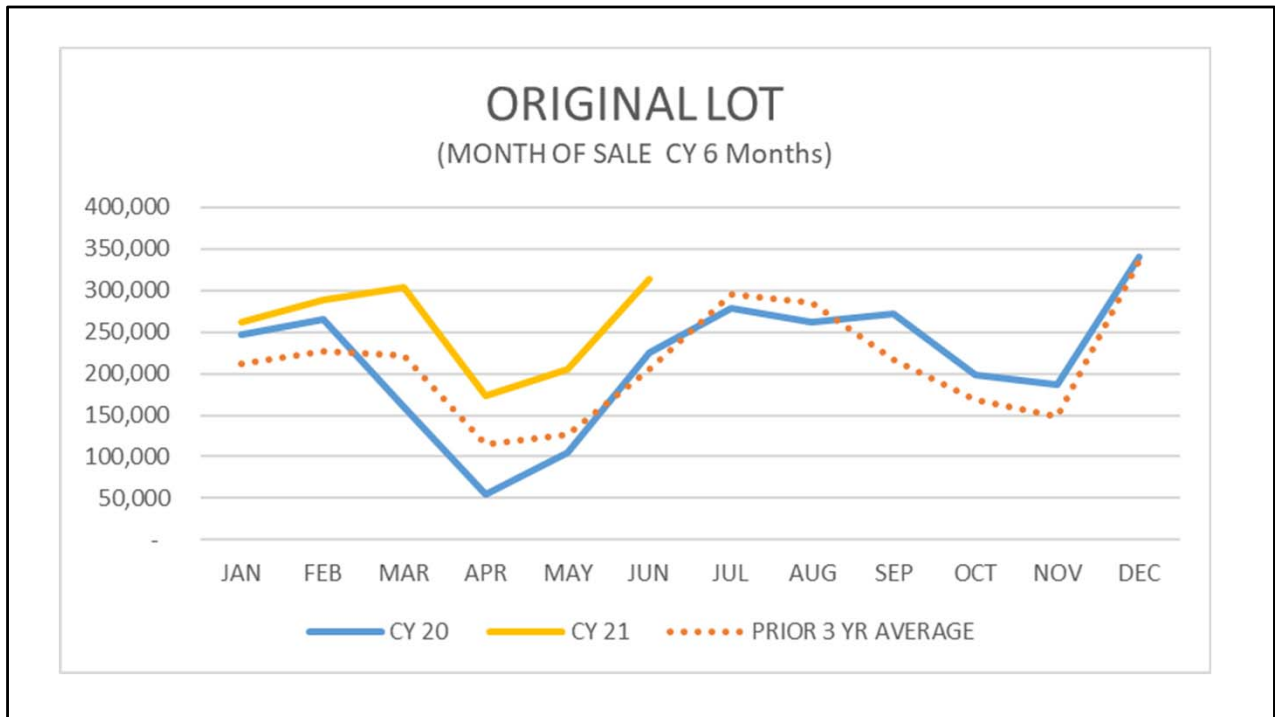

Original LOT for May month of sale are up approximately 28.3% compared to last year and up approximately 52% compared to the prior three-year average.

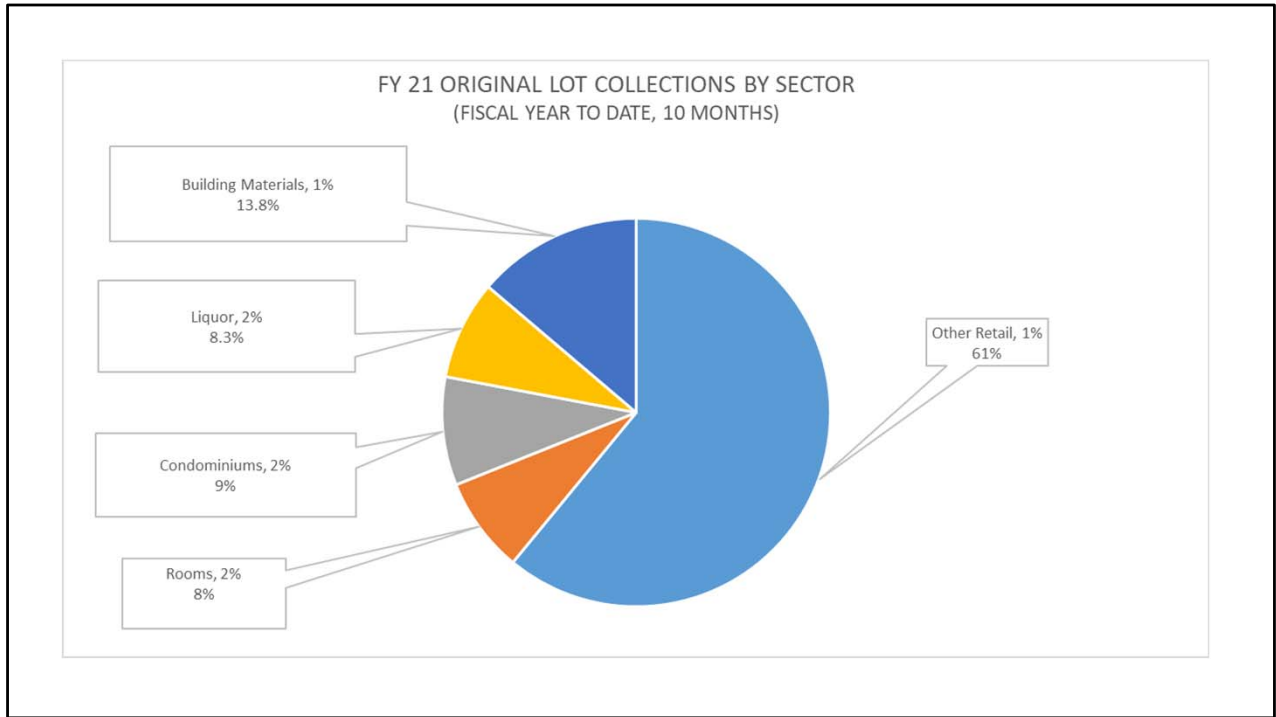

To date in FY 21 (10 months), Original LOT collections have been generated by each sector as follows:

1. Retail has generated 61% of the total.
2. Building Materials have generated 13.8%.
3. Liquor has generated 8.3%
4. Rooms have generated 8%.
5. Condominiums have generated 9%.



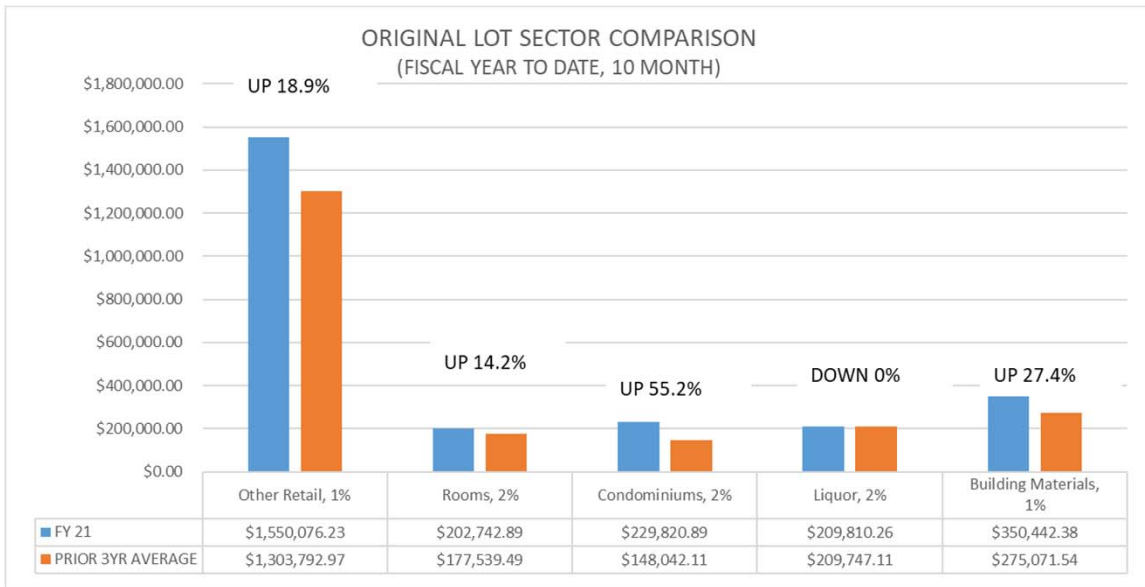

Through the first 10 months of FY 21, collections compared to the prior three-year average are as follows:

1. Retail is up 18.9%.
2. Rooms are down 14.2%.
3. Condominiums are up 55.2%
4. Liquor is down 0%.
5. Building Materials are up 27.4%.

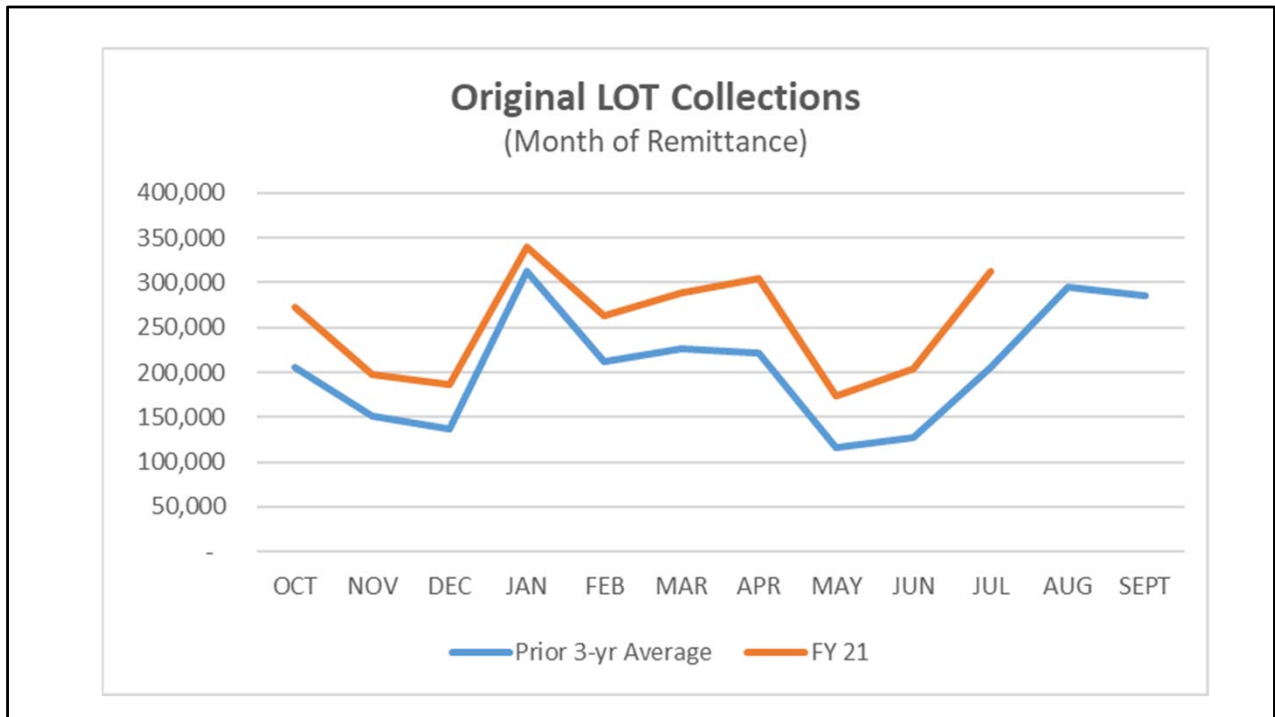

Revenues from Original LOT covered sales are up approximately 52.2% compared to the average of the prior three years.

# Enterprise Funds

---

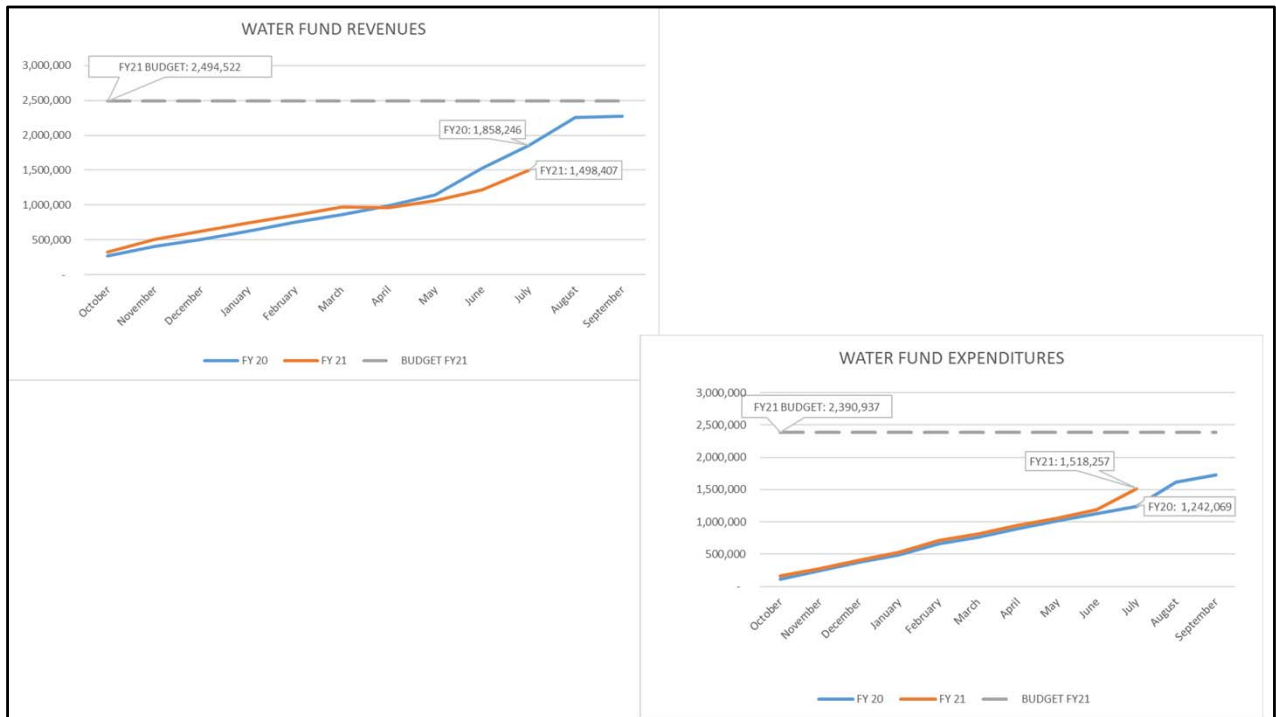

The Water Fund revenues are down \$359,839 (19.4%) FYTD.  
 The Water Fund expenditures are up \$276,458 (5.2%) FYTD.

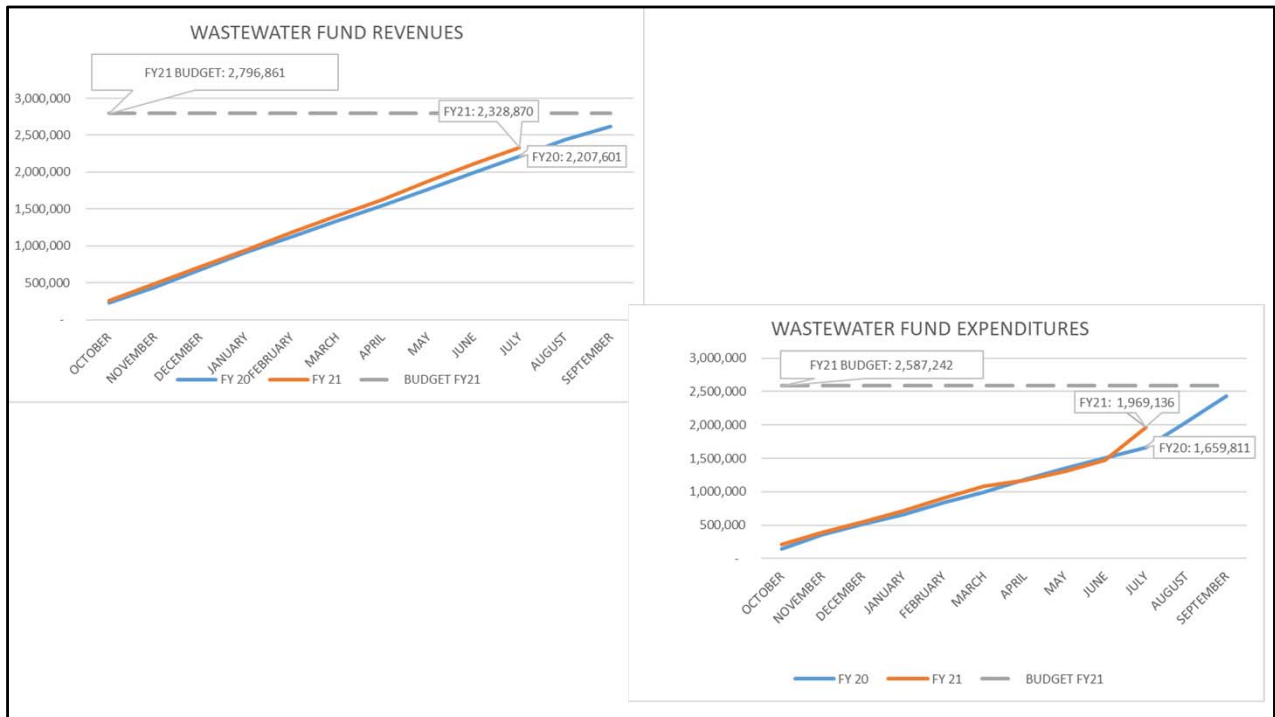

The Wastewater Fund revenues are up \$121,269 (5.5%) FYTD.  
 The Wastewater Fund expenditures are up \$309,325 (18.6%) FYTD.

# Off-Street Parking Lots

---

Cale System is down unable to pull reports for July

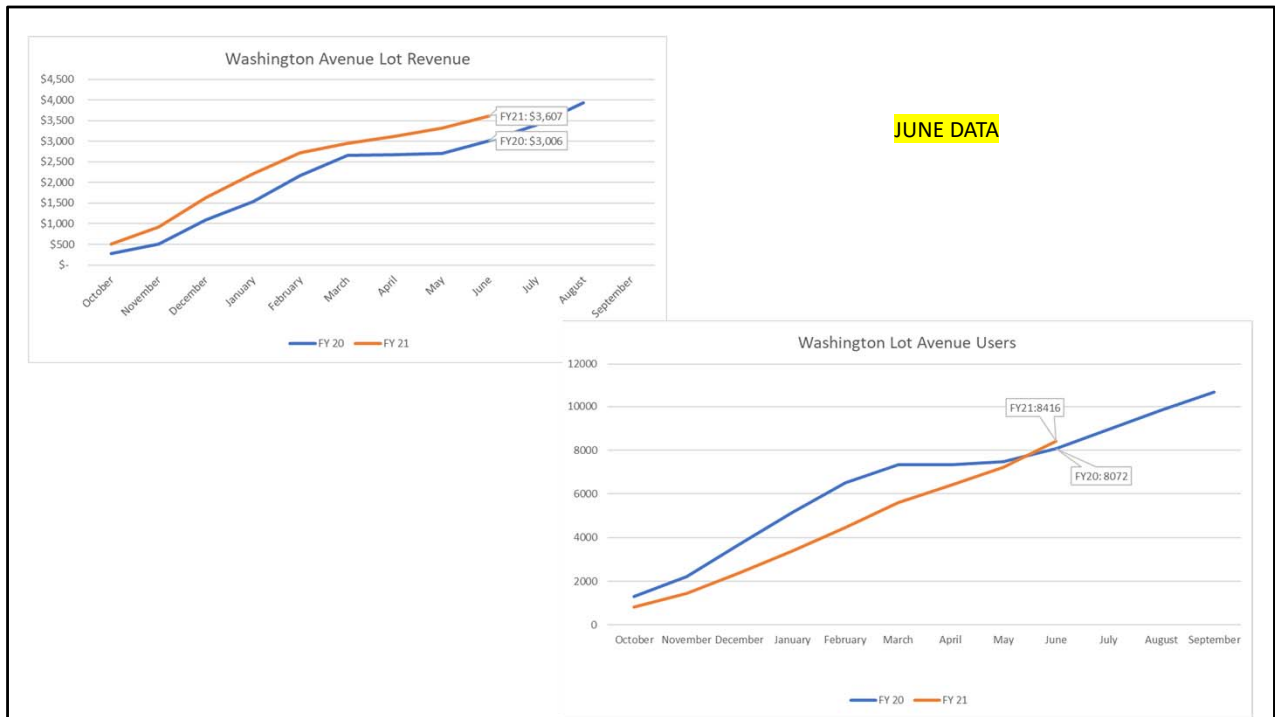

In the fiscal year to date, revenues at the Washington Avenue parking lot are up \$601 (20%) and users are up 344 (4.3%) relative to the prior year.

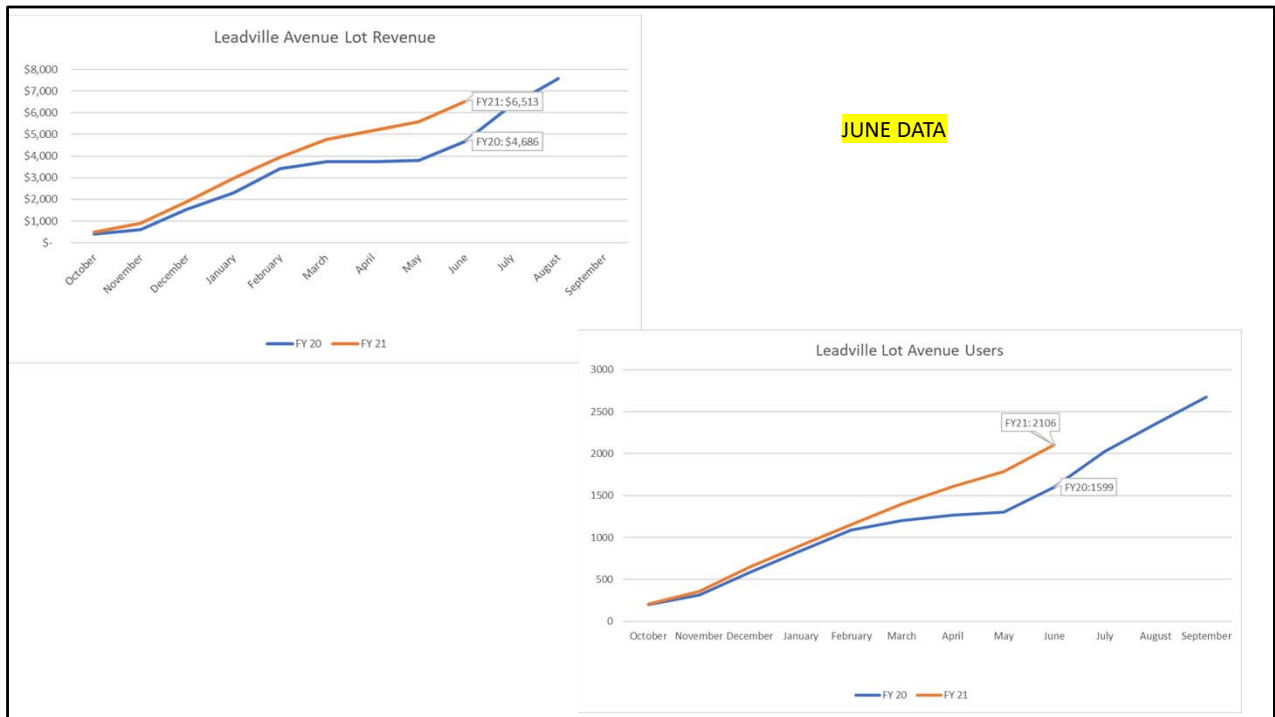

In the fiscal year to date, revenues at the Leadville Avenue parking lot are up \$1,827 (39%) and users are up 507 (31.7%) relative to the prior year.



## Report Criteria:

Invoices with totals above \$0 included.

Paid and unpaid invoices included.

[Report].GL Account Number = "0110000000"- "9648008200", "9910000000"- "9911810000"

Invoice Detail.Voided = No,Yes

Vendor Name	Invoice Number	Description	Net Invoice Amount
<b>GENERAL FUND</b>			
<b>01-2175-9000 P/R DEDUC PBL--EMP CAF FSA-DC</b>			
NBS-NATIONAL BENEFIT SERVI	CP291467	DCA July 2021	282.00
NBS-NATIONAL BENEFIT SERVI	CP291467	FSA July 2021	915.07
<b>01-2300-0000 DEPOSITS-PARKS &amp; EVENTS</b>			
COMMUNITY LIBRARY	072621	REFUND: Security Deposit	250.00
SUN VALLEY WELLNESS FESTIV	072621	REFUND: COVID Cancellation Security Deposit	250.00
SUN VALLEY MUSEUM OF ART	072621	REFUND: Security Deposit	250.00
BROOKSEE	072621	REFUND: Security Deposit	250.00
STANHOPE 60K LLC	072621	REFUND: Security Deposit	250.00
STENICKA, NICK	072621	REFUND: Deposit for Park Reservation	250.00
BIRD, KELLY	072321	REFUND: Park Deposit (x2)	500.00
<b>01-3700-3600 REFUNDS &amp; REIMBURSEMENTS</b>			
KILLEBREW-THOMPSON MEMO	072321	REFUND: COVID Cancellation 2020	350.00
INCA, RUTH	080421	REFUND: Summer Camp Withdrawal	170.00
Total :			3,717.07
<b>LEGISLATIVE &amp; EXECUTIVE</b>			
<b>01-4110-2505 HEALTH REIMBURSEMENT ACCT(HRA)</b>			
NBS-NATIONAL BENEFIT SERVI	CP291467	HRA July 2021	550.62
<b>01-4110-2515 VISION REIMBURSEMENT ACCT(HRA)</b>			
NBS-NATIONAL BENEFIT SERVI	815655	Admin Fees July 2021: FSA & HRA	19.85
<b>01-4110-3100 OFFICE SUPPLIES &amp; POSTAGE</b>			
COPY CENTER LLC	1818	Budget Books	367.50
<b>01-4110-3200 OPERATING SUPPLIES</b>			
US BANK	6235 072621	Zoom	199.90
Total LEGISLATIVE & EXECUTIVE:			1,137.87
<b>ADMINISTRATIVE SERVICES</b>			
<b>01-4150-2515 VISION REIMBURSEMENT ACCT(HRA)</b>			
NBS-NATIONAL BENEFIT SERVI	815655	Admin Fees July 2021: FSA & HRA	51.85
<b>01-4150-3100 OFFICE SUPPLIES &amp; POSTAGE</b>			
GEM STATE PAPER & SUPPLY	1055589	Hand soap, paper towels	72.78-
US BANK	1556 072621	Audio Cord	6.99
<b>01-4150-4200 PROFESSIONAL SERVICES</b>			
CASELLE, INC.	111214	Caselle Support & Maintenance 9/21	2,204.00
COPY CENTER LLC	1818	Warm Springs Preserve Cards	129.00
TREASURE VALLEY COFFEE INC	2160 07722947	Spring Water	23.85
US BANK	2745 072621	Warm Springs Preserve Project Proposal	840.00
US BANK	6235 072621	U Printing	95.20
BACKGROUND INVESTATION B	CIT025080121-	Applicant Profiles	76.80

Vendor Name	Invoice Number	Description	Net Invoice Amount
S & C ASSOCIATES LLC	2046	20-1069	177.00
WESTERN RECORDS DESTRUCT	0550877	July 2021 Records Destruction	65.00
DIXON RESOURCES UNLIMITED	2898	Parking and Curb Data Collection July 2021	1,038.75
NESTED STRATEGIES	1017	Warm Spring Ranch Study & Campaign	4,000.00
SPUR COMMUNITY FOUNDATIO	1165	Monthly fee for donation processing per Warm Springs Preserve Grant Agreement	5,000.00
COOPER MORTON	073121	Warm Springs Preserve Video	1,800.00
<b>01-4150-4400 ADVERTISING &amp; LEGAL PUBLICATIO</b>			
US BANK	6235 072621	Job Center: Utility Director Posting	300.00
<b>01-4150-4900 PERSONNEL TRAINING/TRAVEL/MTG</b>			
US BANK	1556 072621	ICCTFOA Conference & Banquet: Tara	238.00
<b>01-4150-5100 TELEPHONE &amp; COMMUNICATIONS</b>			
CENTURY LINK	235211302	74754376 072421	3.55
SYRINGA NETWORKS, LLC	21AUG0357	21AUG0357	3,000.00
US BANK	0568 072621	Adobe	299.00
COX BUSINESS	047131901 072	047131901 072521	99.79
<b>01-4150-5110 COMPUTER NETWORK</b>			
CHATEAU DRUG CENTER	2423674	HDMI cord	14.24
KETCHUM COMPUTERS, INC.	18169	Computer Support	4,196.95
MIICOR CONSULTING, INC.	16011	1 yr. Barracuda BTEP	8,611.20
US BANK	9749 072621	Microsoft	50.96
US BANK	9749 072621	8x8 Phone Network	2,482.77
US BANK	9749 072621	Go Daddy Domain Hosts	103.02
US BANK	9749 072621	CREDIT: Microsoft	84.69-
S & C ASSOCIATES LLC	1969	21-1036	172.50
<b>01-4150-5150 COMMUNICATIONS</b>			
US BANK	6235 072621	Constant Contact	9.50
US BANK	6235 072621	Tiny URL	119.88
US BANK	6235 072621	Mailchimp	87.99
US BANK	6235 072621	Facebook	145.50
<b>01-4150-5200 UTILITIES</b>			
CITY OF KETCHUM	JULY 2021	208 July 2021	479.36
CITY OF KETCHUM	JULY 2021	360 July 2021	51.15
CITY OF KETCHUM	JULY 2021	9997 July 2021	333.70
CITY OF KETCHUM	JULY 2021	772 July 2021	61.15
CITY OF KETCHUM	JULY 2021	9994 July 2021	184.97
IDAHO POWER	2200749261 07	2200749261 072621	1,607.89
INTERMOUNTAIN GAS	32649330001 0	32649330001 072621	11.44
INTERMOUNTAIN GAS	44919030005 0	44919030005 072621	5.67
<b>01-4150-5900 REPAIR &amp; MAINTENANCE-BUILDINGS</b>			
CLEAR CREEK DISPOSAL	0001443864	960 072721	68.40
CLEAR CREEK DISPOSAL	0001443868	960 072721 New City Hall	141.47
SENTINEL FIRE & SECURITY, IN	67436	2296 - New City Hall 191 Fifth St	31.00
SUN VALLEY SERVICES	14607	Remove weeds from beds around sidewalks at new city hall	88.00
<b>01-4150-6500 CONTRACTS FOR SERVICES</b>			
S & C ASSOCIATES LLC	1962	20-1008	230.00
S & C ASSOCIATES LLC	1966	21-1002	945.00
S & C ASSOCIATES LLC	1970	21-1038	737.50
S & C ASSOCIATES LLC	1972	20-1069	1,307.50
S & C ASSOCIATES LLC	2044	21-1038	1,298.00

Vendor Name	Invoice Number	Description	Net Invoice Amount
S & C ASSOCIATES LLC	2058	20-1008	118.00
Total ADMINISTRATIVE SERVICES:			42,986.02
<b>LEGAL</b>			
<b>01-4160-4270 CITY PROSECUTOR</b>			
ALLINGTON, ESQ., FREDERICK	120277	Monthly Prosecutor Payment	3,769.92
Total LEGAL:			3,769.92
<b>PLANNING &amp; BUILDING</b>			
<b>01-4170-2515 VISION REIMBURSEMENT ACCT(HRA)</b>			
NBS-NATIONAL BENEFIT SERVI	815655	Admin Fees July 2021: FSA & HRA	22.95
<b>01-4170-4200 PROFESSIONAL SERVICES</b>			
KETCHUM COMPUTERS, INC.	18169	Computer Support	1,417.50
S & C ASSOCIATES LLC	1959	19-1011	57.50
S & C ASSOCIATES LLC	1960	19-1037	1,305.00
S & C ASSOCIATES LLC	1961	19-1039	115.00
S & C ASSOCIATES LLC	1964	20-1045	790.00
S & C ASSOCIATES LLC	1971	20-1066	680.00
S & C ASSOCIATES LLC	1973	20-1070	287.50
S & C ASSOCIATES LLC	1974	20-1076	172.50
S & C ASSOCIATES LLC	1975	21-1007	575.00
S & C ASSOCIATES LLC	1976	21-1008	230.00
S & C ASSOCIATES LLC	1977	21-1020	115.00
S & C ASSOCIATES LLC	1978	21-1021	345.00
S & C ASSOCIATES LLC	1979	21-1022	230.00
S & C ASSOCIATES LLC	1980	21-1027	115.00
S & C ASSOCIATES LLC	1981	21-1029	230.00
S & C ASSOCIATES LLC	1982	21-1030	460.00
S & C ASSOCIATES LLC	1983	21-1032	230.00
S & C ASSOCIATES LLC	1984	21-1033	115.00
S & C ASSOCIATES LLC	1985	21-1034	230.00
S & C ASSOCIATES LLC	2030	19-1004	59.00
S & C ASSOCIATES LLC	2031	19-1026	355.50
S & C ASSOCIATES LLC	2032	19-1029	118.00
S & C ASSOCIATES LLC	2033	19-1037	455.00
S & C ASSOCIATES LLC	2036	19-1045	118.00
S & C ASSOCIATES LLC	2037	20-1003	331.00
S & C ASSOCIATES LLC	2038	20-1018	177.00
S & C ASSOCIATES LLC	2039	20-1028	413.00
S & C ASSOCIATES LLC	2045	20-1068	59.00
S & C ASSOCIATES LLC	2047	21-1005	118.00
S & C ASSOCIATES LLC	2048	21-1009	545.50
S & C ASSOCIATES LLC	2049	21-1021	118.00
S & C ASSOCIATES LLC	2050	21-1032	95.00
S & C ASSOCIATES LLC	2051	21-1034	295.00
S & C ASSOCIATES LLC	2052	21-1042	59.00
S & C ASSOCIATES LLC	2053	21-1048	295.00
S & C ASSOCIATES LLC	2054	21-1049	767.00
S & C ASSOCIATES LLC	2055	21-1050	1,122.50
S & C ASSOCIATES LLC	2056	21-1052	944.00
S & C ASSOCIATES LLC	2057	21-1053	59.00
S & C ASSOCIATES LLC	2059	21-1055	332.50
S & C ASSOCIATES LLC	2060	21-1056	237.50

Vendor Name	Invoice Number	Description	Net Invoice Amount
S & C ASSOCIATES LLC	2061	21-1057	177.00
Total PLANNING & BUILDING:			14,973.45
<b>NON-DEPARTMENTAL</b>			
<b>01-4193-4500 1ST/WASHINGTON RENT</b>			
URBAN RENEWAL AGENCY	5053	Parking Lot Rent August 2021	3,000.00
<b>01-4193-6601 MASTER TRANSPORTATION PLAN</b>			
S & C ASSOCIATES LLC	1957	17-1009	560.00
S & C ASSOCIATES LLC	1965	20-1075	1,675.00
S & C ASSOCIATES LLC	2029	17-1009	236.00
S & C ASSOCIATES LLC	2042	20-1075	413.00
<b>01-4193-9930 GENERAL FUND OP. CONTINGENCY</b>			
FLY SUN VALLEY ALLIANCE	072721	Employee Recreation Program	6,800.00
Total NON-DEPARTMENTAL:			12,684.00
<b>FACILITY MAINTENANCE</b>			
<b>01-4194-2515 VISION REIMBURSEMENT ACCT(HRA)</b>			
NBS-NATIONAL BENEFIT SERVI	815655	Admin Fees July 2021: FSA & HRA	24.13
<b>01-4194-3200 OPERATING SUPPLIES</b>			
GEM STATE PAPER & SUPPLY	1054622	Paper Supplies	336.72
GEM STATE PAPER & SUPPLY	1055453	Paper Supplies	1,637.40
YELLOWSTONE LEATHER PROD	84803	xxl Caiman deerskin gloves qty 2, m grain goat padded palm gloves qty2, L Nitrile tough mens gloves qty 12, L and M Caiman synthetic leather grip qty 2,	192.80
<b>01-4194-3500 MOTOR FUELS &amp; LUBRICANTS</b>			
LUTZ RENTALS	121987-1	Propane	35.10
UNITED OIL	970807	38950 071521	364.55
<b>01-4194-4220 PROF SERV-CITY BEAUTIFICATION</b>			
LILY & FERN, LLC	3937	Monthly Flower Maintence 4th of 4 Installments	3,877.92
<b>01-4194-5200 UTILITIES</b>			
CITY OF KETCHUM	JULY 2021	456 July 2021	3,317.72
CITY OF KETCHUM	JULY 2021	532 July 2021	1,426.51
CITY OF KETCHUM	JULY 2021	536 July 2021	153.43
CITY OF KETCHUM	JULY 2021	560 July 2021	117.27
CITY OF KETCHUM	JULY 2021	9995 July 2021	2,666.51
CITY OF KETCHUM	JULY 2021	9996 July 2021	52.26
CITY OF KETCHUM	JULY 2021	1127 July 2021	13.87
CITY OF KETCHUM	JULY 2021	1245 July 2021	37.29
CITY OF KETCHUM	JULY 2021	9991 July 2021	169.96
CITY OF KETCHUM	JULY 2021 491	192 July 2021	343.80
INTERMOUNTAIN GAS	32649330001 0	32649330001 072621	11.44
INTERMOUNTAIN GAS	65669030002 0	65669030002 072621	9.79
<b>01-4194-5300 CUSTODIAL &amp; CLEANING SERVICES</b>			
WESTERN BUILIDNG MAINTEN	0130580-IN	Monthly Janitorial Service for June 2021	5,228.12
<b>01-4194-6000 REPAIR &amp; MAINT-AUTOMOTIVE EQUI</b>			
RIVER RUN AUTO PARTS	6538-168237	Fram Anti-Freeze for flatbed	21.99
RIVER RUN AUTO PARTS	6538-168315	Interior door handle for flatbed	26.84

Vendor Name	Invoice Number	Description	Net Invoice Amount
RIVER RUN AUTO PARTS	6538-168379	Wiper blades for F-350	19.90
RIVER RUN AUTO PARTS	6538-168464	halogen headlight on mow truck	13.99
<b>01-4194-6950 MAINTENANCE</b>			
A.C. HOUSTON LUMBER CO.	2107-804882	LS Plastic Lawn Sprinkler	31.78
A.C. HOUSTON LUMBER CO.	2107-805168	zinc screw hook, eye bolt lag, spring snap link	10.43
A.C. HOUSTON LUMBER CO.	2107-806095	5 gal plastic bucket & 2 qt funnel for splash pad	7.48
CEM AQUATICS	2742	Piezo Switch 22m	243.10
CEM AQUATICS	2869	Actuator for splash pad	221.52
CHATEAU DRUG CENTER	2419519	Qty 2 Nine volt batteries for irrigation clocks	9.49
CHATEAU DRUG CENTER	2424841	Padlock for splash pad	15.18
MOSS GARDEN CENTER	198703	G&B Premium Top Soil	22.37
PIPECO, INC.	S4247484.001	Aqualine hose fitting 3/4 x 1/2	3.67
PIPECO, INC.	S4273032.001	Shutoff Hose Aqualine 3/4"	7.86
PIPECO, INC.	S4273401.001	wood faucet handle	4.05
PIPECO, INC.	S4275757.001	woodford 17 repair kit	19.89
PIPECO, INC.	S4278758.001	Large utility hand pump	30.83
PIPECO, INC.	S4285328.001	Cap pvc fipt 1/2", 1/2x6 pvc nipple, 1/2" gray pvc fipt coupling	1.86
SAWTOOTH WOOD PRODUCTS, I	0000127863	Cordless Lawn Mower self propelled, AP300 Lithium Battery, AL300 Rapid Battery Charger	656.99
SAWTOOTH WOOD PRODUCTS, I	0000127864	Backpack Battery, Blower Powerhead Unit Only	1,259.98
SAWTOOTH WOOD PRODUCTS, I	0000128094	Spray Gun w/ spray lance wand for shop, Rail 21' 3" dia tip peeled for FSP	242.48
SILVER CREEK SUPPLY	0004973117-00	Hunter Eco Indicator for Drip Systems at Skate Park	22.61
US BANK	9988 072621	Amazon: Loctite Pneumatic Thread Sealant	26.76
US BANK	9988 072621	Amazon: Delavan Diaphragm Pump	113.82
WEBB LANDSCAPING	KIN161589	Potting Soil & Annuals for Starbucks	29.95
RIGHT BRAIN UNLIMITED LLC	27205	Nature Dog - Cedar Bag Dispensers	303.33
Total FACILITY MAINTENANCE:			23,384.74
<b>POLICE</b>			
<b>01-4210-2515 VISION REIMBURSEMENT ACCT(HRA)</b>			
NBS-NATIONAL BENEFIT SERVI	815655	Admin Fees July 2021: FSA & HRA	9.80
<b>01-4210-3500 MOTOR FUELS &amp; LUBRICANTS</b>			
UNITED OIL	972028	39060 073121	257.27
<b>01-4210-3600 COMPUTER SOFTWARE</b>			
OMNI PARK	123219	Software & Licensing Upgrade	737.00
<b>01-4210-3620 PARKING OPS EQUIPMENT FEES</b>			
CALE AMERICA, INC.	165089	July 2021 Active Meters	165.00
<b>01-4210-4200 PROFESSIONAL SERVICES</b>			
KETCHUM COMPUTERS, INC.	18169	Computer Support	33.75
KETCHUM COMPUTERS, INC.	18170	BCSO - Monthly maintenance	904.50
<b>01-4210-4250 PROF.SERVICES-BCSO CONTRACT</b>			
BLAINE COUNTY CLERK/RECOR	201043	BCSO Law Enforcement Services	118,983.33
Total POLICE:			121,090.65
<b>FIRE &amp; RESCUE</b>			
<b>01-4230-2505 HEALTH REIMBURSEMENT ACCT(HRA)</b>			
NBS-NATIONAL BENEFIT SERVI	CP291467	HRA July 2021	88.67

Vendor Name	Invoice Number	Description	Net Invoice Amount
<b>01-4230-2515 VISION REIMBURSEMENT ACCT(HRA)</b>			
NBS-NATIONAL BENEFIT SERVI	815655	Admin Fees July 2021: FSA & HRA	75.05
<b>01-4230-3200 OPERATING SUPPLIES FIRE</b>			
A.C. HOUSTON LUMBER CO.	2018-810849	20'x30' Tarp to cover moving boxes	44.50
ATCO INTERNATIONAL	10581544	Truck Wash	200.00
ATKINSONS' MARKET	04081342	Coffee	27.54
W.S. DARLEY & CO.	17440377	Credit for Hard Suction Hose returned	191.90-
W.S. DARLEY & CO.	17440598	Hard Suction Hose for E101	258.39
DONNELLEY SPORTS	54880	T-Shirts for Public	301.20
GEM STATE PAPER & SUPPLY	OA00711CM	Paper Supplies	67.91-
US BANK	4977 072621	Fireline Tools	213.95
US BANK	4977 072621	Truck supplies	88.15
US BANK	9939 072621	Firefighting Hose for E101	180.52
US BANK	9939 072621	Moving supplies to new station	72.87
US BANK	9939 072621	Class A Shirts for Chief and new full time personnel	183.19
US BANK	9939 072621	Equipment for E101	292.84
WEIDNER FIRE	60103	Fire Hooks unlimited Pro Bar 30" for E101	253.26
<b>01-4230-3210 OPERATING SUPPLIES EMS</b>			
A.C. HOUSTON LUMBER CO.	2018-810849	20'x30' Tarp to cover moving boxes	44.49
ATKINSONS' MARKET	04081342	Coffee	27.54
GEM STATE PAPER & SUPPLY	1055407	Paper Supplies	65.59
GEM STATE PAPER & SUPPLY	OA00711CM	Paper Supplies	67.90-
NORCO	32642376	54794 072621	79.14
NORCO	32693899	52355 073121	36.27
NORCO	32694966	54794 073121	229.40
US BANK	4977 072621	Gorilla Tape	19.72
US BANK	4977 072621	Gorilla Tape	17.26
US BANK	9939 072621	Moving supplies to new station	60.17
HENRY SCHEIN	96848883	Medical Supplies	86.66
HENRY SCHEIN	96848921	Drugs	1,342.87
HENRY SCHEIN	96904229	Drugs	23.76
HENRY SCHEIN	96906097	Drugs	78.24
<b>01-4230-3500 MOTOR FUELS &amp; LUBRICANTS FIRE</b>			
UNITED OIL	971860	37267 073121	361.58
US BANK	9939 072621	Gas for chainsaw	4.41
<b>01-4230-3510 MOTOR FUELS &amp; LUBRICANTS EMS</b>			
UNITED OIL	971860	37267 073121	489.21
<b>01-4230-4200 PROFESSIONAL SERVICES FIRE</b>			
KETCHUM COMPUTERS, INC.	18169	Computer Support	553.50
S & C ASSOCIATES LLC	2034	19-1041	488.00
<b>01-4230-4910 TRAINING EMS</b>			
ATKINSONS' MARKET	01395721	Knox Gelatin (EMS Drill)	2.84
US BANK	9939 072621	Travel expenses for Mike Withtar to exam new ambulance	239.54
<b>01-4230-4920 TRAINING-FACILITY</b>			
IDAHO POWER	2224210258 08	2224210258 080621	25.06
<b>01-4230-5100 TELEPHONE &amp; COMMUNICATION FIRE</b>			
MTE COMMUNICATIONS	056983 080121	056983 080121	15.12
VERIZON WIRELESS	9884817107	842054354 072321	303.75
COX BUSINESS	027222301 072	027222301 072021	59.72

Vendor Name	Invoice Number	Description	Net Invoice Amount
COX BUSINESS	049446101 072	049446101 072921	136.08
AT&T MOBILITY LLC	287307161044	Firstnet/AT&T - new CAD system	1,573.16
<b>01-4230-5110 TELEPHONE &amp; COMMUNICATION EMS</b>			
MTE COMMUNICATIONS	056983 080121	05698 080121	15.13
VERIZON WIRELESS	9884817107	842054354 072321	303.74
COX BUSINESS	027222301 072	027222301 072021	59.71
COX BUSINESS	049446101 072	049446101 072921	136.08
AT&T MOBILITY LLC	287307161044	Firstnet/AT&T New CAD system	1,573.15
<b>01-4230-6000 REPAIR &amp; MAINT-AUTO EQUIP FIRE</b>			
A.C. HOUSTON LUMBER CO.	2107-805609	WD-40	13.98
ALSCO - AMERICAN LINEN DIVI	LBO11914460	5109 080221	10.84
US BANK	9939 072621	Shop Tools	162.01
US BANK	9939 072621	Tools for shop	65.52
<b>01-4230-6010 REPAIR &amp; MAINT-AUTO EQUIP EMS</b>			
ALSCO - AMERICAN LINEN DIVI	LBO11914460	5109 080221	10.84
Total FIRE & RESCUE:			10,666.50
<b>STREET</b>			
<b>01-4310-2505 HEALTH REIMBURSEMENT ACCT(HRA)</b>			
NBS-NATIONAL BENEFIT SERVI	CP291467	HRA July 2021	373.41
<b>01-4310-2515 VISION REIMBURSEMENT ACCT(HRA)</b>			
NBS-NATIONAL BENEFIT SERVI	815655	Admin Fees July 2021: FSA & HRA	53.77
NBS-NATIONAL BENEFIT SERVI	CP291467	HRA Vision July 2021	300.00
<b>01-4310-3200 OPERATING SUPPLIES</b>			
ATKINSONS' MARKET	03584798	Ice & Gatorade for chip seal crew	64.45
ATKINSONS' MARKET	08325732	Drinks & Breakfast for chip seal crew	106.72
ATKINSONS' MARKET	08325753	Credit for returned drinks	9.30
ATKINSONS' MARKET	08327324	Ice & breakfast for chip seal crew	19.53
CHATEAU DRUG CENTER	2427901	work boot laces	5.68
COPY CENTER LLC	1840	4x9 Door Hangers	750.00
GEM STATE PAPER & SUPPLY	1054622	Paper Supplies	95.85
GEM STATE PAPER & SUPPLY	OA00711CM	Paper Supplies	121.54
NAPA AUTO PARTS	067953	Wasp & Hornet Killer Plus for shop use	9.04
NAPA AUTO PARTS	068559	10" Diip Brush head for wash broom equipment	18.16
US BANK	2022 072621	Amazon: Self-Inking Rubber Stamp	9.56
<b>01-4310-3400 MINOR EQUIPMENT</b>			
US BANK	2022 072621	Milwaukee Compact Drill & Rotary Hammer w/ Dust Extractor Kit	898.88
US BANK	2022 072621	INTL Road Dynamics: Figure '8' W/O Washer	170.99
<b>01-4310-3500 MOTOR FUELS &amp; LUBRICANTS</b>			
UNITED OIL	971862	37269 073121	1,052.24
<b>01-4310-4200 PROFESSIONAL SERVICES</b>			
KETCHUM COMPUTERS, INC.	18169	Computer Support	337.50
<b>01-4310-4900 PERSONNEL TRAINING/TRAVEL/MTG</b>			
US BANK	2022 072621	Training: Reasonable Suspicion for DOT Supervisors	119.97
<b>01-4310-5100 TELEPHONE &amp; COMMUNICATIONS</b>			
VERIZON WIRELESS	9884039594	365459737 071321	172.94

Vendor Name	Invoice Number	Description	Net Invoice Amount
<b>01-4310-5200 UTILITIES</b>			
CITY OF KETCHUM	JULY 2021	9999 July 2021	95.16
CITY OF KETCHUM	JULY 2021	9993 July 2021	91.72
INTERMOUNTAIN GAS	32649330001 0	32649330001 072621	16.45
INTERMOUNTAIN GAS	32649330001 0	32649330001 072621	27.54
INTERMOUNTAIN GAS	49439330009 0	49439330009 072621	12.57
<b>01-4310-6000 REPAIR &amp; MAINT--AUTOMOTIVE EQU</b>			
NAPA AUTO PARTS	068388	Liftgate support for #31 Durango	92.98
<b>01-4310-6100 REPAIR &amp; MAINT--MACHINERY &amp; EQ</b>			
FASTENAL COMPANY	IDJER98398	Side Cast Broom for #35 Toolcat	16.32
METROQUIP, INC.	P10997	Adapter for #31 Eagle	59.12
NAPA AUTO PARTS	067225	Cabin Air Filters for #47 Crew Cab	13.08
NAPA AUTO PARTS	068053	Anti Freeze for Trucks & Equipment	50.94
NAPA AUTO PARTS	068129	starter & core deposit for #10 sign truck	87.29
NAPA AUTO PARTS	068762	HD wiper for #1 Blower	29.99
WESTERN STATES CAT	CM00111666	CREDIT for returned wrong part	187.46-
WESTERN STATES CAT	CM00111791	CREDIT for returned wrong part	187.46-
WESTERN STATES CAT	IN001724755	Arm A for #15 Loader	190.25
JACKSON GROUP PETERBILT	CM249602	Credit for Core Return for #31 Eagle	56.00-
<b>01-4310-6910 OTHER PURCHASED SERVICES</b>			
ALSCO - AMERICAN LINEN DIVI	LBO11914021	5831 073021	38.87
ALSCO - AMERICAN LINEN DIVI	LBO11915791	5292 080621	38.87
NORCO	32213480	53271 053121	234.05
NORCO	32457582	53271 063021	226.50
SENTINEL FIRE & SECURITY, IN	67345	1495 - 260 10th Street East Annual Fire Alarm Inspection	65.00
<b>01-4310-6920 SIGNS &amp; SIGNALIZATION</b>			
ECONO SIGNS LLC	10-969074	Signs & Bases Public Parking, Stop to Pedestrians in Crosswalk & 2 Sided Stop sign	1,104.52
PLATT ELECTRIC SUPPLY	1V14318	Anchors for 4th St light bollards	356.75
S & C ASSOCIATES LLC	1963	20-1029	1,555.00
S & C ASSOCIATES LLC	2040	20-1029	5,562.00
<b>01-4310-6950 MAINTENANCE &amp; IMPROVEMENTS</b>			
A.C. HOUSTON LUMBER CO.	2108-809743	Square Roofing Felt for chip sealing 15#	31.88
ANDERSON ASPHALT PAVING IN	325	Materials Picked Up & Dumped JULY 2021	5,765.00
ANDERSON ASPHALT PAVING IN	325	Materials Picked Up & Dumped JULY 2021	8,033.85
ANDERSON ASPHALT PAVING IN	325	Materials Picked Up & Dumped JULY 2021	125.51
COLOR HAUS, INC.	249846	Z Pro Duo Pack Cover Orlon 1/4" for street work	4.29
FASTENAL COMPANY	IDJER98174	16" Brown Street Broom & Wood Handle for Chip Seal	44.57
FASTENAL COMPANY	IDJER98397	Broom Handle for Chip Sealing	10.25
Total STREET:			27,977.25
<b>RECREATION</b>			
<b>01-4510-2515 VISION REIMBURSEMENT ACCT(HRA)</b>			
NBS-NATIONAL BENEFIT SERVI	815655	Admin Fees July 2021: FSA & HRA	16.50
NBS-NATIONAL BENEFIT SERVI	CP291467	HRA Vision July 2021	175.00
<b>01-4510-3200 OPERATING SUPPLIES</b>			
US BANK	6235 072621	Amazon: CS6364C Plug Adapter	88.75



Vendor Name	Invoice Number	Description	Net Invoice Amount
<b>01-4510-3250 RECREATION SUPPLIES</b>			
US BANK	7926 072621	Blaine County Recreation: Swimming	53.95
US BANK	7926 072621	Blaine County Recreation: Swimming	53.96
US BANK	7926 072621	Blaine County Recreation: Swimming	40.97
US BANK	7926 072621	Amazon: Volleyballs	17.94
<b>01-4510-3300 RESALE ITEMS-CONCESSION SUPPLY</b>			
ATKINSONS' MARKET	02036808	Concession Foods	64.87
ATKINSONS' MARKET	08320210	Concession Foods	17.62
ATKINSONS' MARKET	08320726	Concession Foods	56.42
US BANK	7926 072621	Trash Bags, Sugar, Flour, Goldfish, Paper Towles, Toilet Paper	221.39
<b>01-4510-3500 MOTOR FUELS &amp; LUBRICANTS</b>			
UNITED OIL	971861	37268 073121	248.15
<b>01-4510-5200 UTILITIES</b>			
IDAHO POWER	2206452274 07	2206452274 072621	577.88
INTERMOUNTAIN GAS	31904030009 0	31904030009 072621	17.00
<b>01-4510-6100 REPAIR &amp; MAINT--MACHINERY &amp; EQ</b>			
SAWTOOTH WOOD PRODUCTS, I	128044	Chain Link Materials	5.00
Total RECREATION:			1,655.40
Total GENERAL FUND:			264,042.87
<b>WAGON DAYS FUND</b>			
<b>WAGON DAYS EXPENDITURES</b>			
<b>02-4530-3200 OPERATING SUPPLIES</b>			
US BANK	6235 072621	Claris FileMaker PRO	540.00
<b>02-4530-4200 PROFESSIONAL SERVICES</b>			
SUN VALLEY EVENTS	AUG2021	August Wagon Days Contract Installment	3,750.00
Total WAGON DAYS EXPENDITURES:			4,290.00
Total WAGON DAYS FUND:			4,290.00
<b>GENERAL CAPITAL IMPROVEMENT FD</b>			
<b>GENERAL CIP EXPENDITURES</b>			
<b>03-4193-7193 WARM SPRINGS RD ANALYSIS</b>			
S & C ASSOCIATES LLC	2041	20-1045	724.00
LANDWORK STUDIO LLC	2690	Warm Springs Ranch Preserve - Blue Printing, Drafting, and Site Visit	431.00
<b>03-4193-7400 COMPUTER/COPIER LEASING</b>			
GREAT AMERICA FINANCIAL SE	29770576	016 1147509-000 Copier Lease	1,936.08
DELL FINANCIAL SERVICES	80969324	001-8998447-006	11.30
<b>03-4193-7607 SIDEWLK/STREET SAFETY REPAIR</b>			
S & C ASSOCIATES LLC	1958	18-1008	162.50
Total GENERAL CIP EXPENDITURES:			3,264.88
Total GENERAL CAPITAL IMPROVEMENT FD:			3,264.88

Vendor Name	Invoice Number	Description	Net Invoice Amount
<b>ORIGINAL LOT FUND</b>			
<b>ORIGINAL LOT TAX</b>			
<b>22-4910-6040 SUN VALLEY MARKETING ALLIANCE</b>			
VISIT SUN VALLEY	72	Monthly Payment per contract	9,166.66
<b>22-4910-6060 EVENTS/PROMOTIONS</b>			
CLEAR CREEK DISPOSAL	0001443869	960 072721	490.91
DELFFS, NICK	080121	Town Square Music	500.00
PARSONS, BRAD	080321	KETCHUM ALIVE 8/3/21	1,200.00
FLYNN, ASHLEIGH	080321	Ketchum Alive 8/10/21	1,200.00
RICHARD BLAIR	081021	Town Square Music	300.00
<b>22-4910-6080 MOUNTAIN RIDES</b>			
MOUNTAIN RIDES	11599	Monthly Installment 08/21	39,083.34
Total ORIGINAL LOT TAX:			51,940.91
Total ORIGINAL LOT FUND:			51,940.91
<b>FIRE BOND FUND</b>			
<b>FIRE BOND FUND EXP/TRNFRS</b>			
<b>41-4800-8100 DEBT SRVC ACCT PRINCIPL-FIRE</b>			
ZIONS BANK	4899909 07252	4899909 Interest	157,134.38
<b>41-4800-8200 DEBT SRVC ACCT INTEREST-FIRE</b>			
ZIONS BANK	4899909 07252	4899909 Principal	145,000.00
Total FIRE BOND FUND EXP/TRNFRS:			302,134.38
Total FIRE BOND FUND:			302,134.38
<b>FIRE CONSTRUCTION FUND</b>			
<b>FIRE FUND EXP/TRNFRS</b>			
<b>42-4800-4200 PROFESSIONAL SERVICES</b>			
KETCHUM COMPUTERS, INC.	18169	New Fire Station Walkthrough and demo	708.75
<b>42-4800-4205 PROF SERVICES ENGINEERING</b>			
COLE ARCHITECTS PLLC	1665	PO#20299 Fire Station Design	17,688.14
COLE ARCHITECTS PLLC	1677	PO#20299 Fire Station Design	19,569.98
COLE ARCHITECTS PLLC	1699	PO#20299 Fire Station Design	18,483.97
COLE ARCHITECTS PLLC	1720	PO#20299 Fire Station Design	17,260.82
<b>42-4800-7400 OFFICE FURNITURE</b>			
US BANK	9939 072621	Kitchen Hood for new station	1,632.00
<b>42-4800-7450 EQUIPMENT</b>			
TREASURER, STATE OF IDAHO	320-8677-CDK	Equipment for E101	1,098.58
US BANK	9939 072621	Chainsaw and associated items for E101	1,073.65
US BANK	9939 072621	Equipment for new Station	368.33
US BANK	9939 072621	Fire Hose Coiler and mount	440.80
<b>42-4800-7800 CONSTRUCTION</b>			
US BANK	9939 072621	IEED-NC Design review for new station	2,740.00
US BANK	9939 072621	Equipment for new station	376.95
DENNIS POTTS PROJECT MGMT,	1321	Construction Management Services 07/21	12,888.87

Vendor Name	Invoice Number	Description	Net Invoice Amount
ATLAS TECHNICAL CONSULTAN	187164	Professional Services 7/172021 to 7/30/21 File#T200074C	334.00
Total FIRE FUND EXP/TRNFRS:			94,664.84
Total FIRE CONSTRUCTION FUND:			94,664.84
<b>WATER FUND</b>			
<b>WATER EXPENDITURES</b>			
<b>63-4340-2515 VISION REIMBURSEMENT ACCT(HRA)</b>			
NBS-NATIONAL BENEFIT SERVI	815655	Admin Fees July 2021: FSA & HRA	22.70
<b>63-4340-3120 DATA PROCESSING</b>			
BILLING DOCUMENT SPECIALIS	77382	mailings	418.22
<b>63-4340-3200 OPERATING SUPPLIES</b>			
A.C. HOUSTON LUMBER CO.	2108-810208	Mag Key Case	3.99
ALSCO - AMERICAN LINEN DIVI	LBO11910536	5192 071521	319.94
ALSCO - AMERICAN LINEN DIVI	LBO11914026	5192 073021	27.18
ALSCO - AMERICAN LINEN DIVI	LBO11914030	5493 073021	53.98
CHATEAU DRUG CENTER	2420402	Birthday Plates	17.04
<b>63-4340-3250 LABORATORY/ANALYSIS</b>			
GO-FER-IT	105048	292 073021	40.00
MAGIC VALLEY LABS, INC.	21114	Water Testing	125.00
<b>63-4340-3500 MOTOR FUELS &amp; LUBRICANTS</b>			
UNITED OIL	971864	37271 073121	423.62
<b>63-4340-4200 PROFESSIONAL SERVICES</b>			
DIG LINE	0066243-IN	0000167 073121	65.86
KETCHUM COMPUTERS, INC.	18169	Computer Support	405.00
US BANK	2745 072621	Advertising: Utility Director	162.50
S & C ASSOCIATES LLC	1967	21-1017	847.50
S & C ASSOCIATES LLC	2043	21-1017	1,618.00
<b>63-4340-4900 PERSONNEL TRAINING/TRAVEL/MTG</b>			
IDAHO RURAL WATER ASSOCIA	080221	Water Audit Training- Gio	120.00
<b>63-4340-5200 UTILITIES</b>			
IDAHO POWER	2203658592 07	2203658592 072721	13,643.72
<b>63-4340-6100 REPAIR &amp; MAINT-MACH &amp; EQUIP</b>			
PIPECO, INC.	S4257736.001	Blue Flags, galv nipples and couplongs	27.24
PIPECO, INC.	S4258003.001	Galv Nipples and Couplings	31.33
Total WATER EXPENDITURES:			18,372.82
<b>WATER DEBT SERVICE EXPENDITRES</b>			
<b>63-4800-8600 DEBT SRVC ACCT PRINCIPAL-2016</b>			
CHASE	1814	Principal Due this period	151,000.00
<b>63-4800-8700 DEBT SRVC ACCT INTEREST-2016</b>			
CHASE	1814	Interest Due this period	9,770.10
Total WATER DEBT SERVICE EXPENDITRES:			160,770.10

Vendor Name	Invoice Number	Description	Net Invoice Amount
Total WATER FUND:			179,142.92
<b>WATER CAPITAL IMPROVEMENT FUND</b>			
<b>WATER CIP EXPENDITURES</b>			
<b>64-4340-7802 KETCHUM SPRING WA CONVERSION</b>			
CANYON EXCAVATION, LLC	20585APP1	Ketchum Springs Water Phase 4	221,777.47
<b>64-4340-7806 NEW STAND-BY GENERATOR WA/ADM.</b>			
DC ENGINEERING	21KET01-3	Northwood Well Standby Power Evaluation	2,940.00
DC ENGINEERING	21KET02-2	Water Ops BLDG Standby Power Evaluation	3,360.00
Total WATER CIP EXPENDITURES:			228,077.47
Total WATER CAPITAL IMPROVEMENT FUND:			228,077.47
<b>WASTEWATER FUND</b>			
<b>WASTEWATER EXPENDITURES</b>			
<b>65-4350-2505 HEALTH REIMBURSEMENT ACCT(HRA)</b>			
NBS-NATIONAL BENEFIT SERVI	CP291467	HRA July 2021	185.13
<b>65-4350-2515 VISION REIMBURSEMENT ACCT(HRA)</b>			
NBS-NATIONAL BENEFIT SERVI	815655	Admin Fees July 2021: FSA & HRA	29.65
<b>65-4350-3120 DATA PROCESSING</b>			
BILLING DOCUMENT SPECIALIS	77382	mailings	627.33
<b>65-4350-3200 OPERATING SUPPLIES</b>			
ALSCO - AMERICAN LINEN DIVI	LBOI1910536	5192 071521	511.14
ALSCO - AMERICAN LINEN DIVI	LBOI1914026	5192 073021	27.18
ALSCO - AMERICAN LINEN DIVI	LBOI1914028	5292 073021	120.56
CHATEAU DRUG CENTER	2420706	Appliance Bulb	2.84
GEM STATE PAPER & SUPPLY	1055407	Bath Tissue, PAper Towels, Mop Handle	65.59
NORTHERN SAFETY CO., INC.	904492044	Safety Eyewear & Vests	28.32
US BANK	9642 072621	UVT Solution, Quartz Cuvette 10mm	460.00
<b>65-4350-3400 MINOR EQUIPMENT</b>			
US BANK	9642 072621	Milwaukee Search Light	119.00
US BANK	9642 072621	Milwaukee Tools	100.46
<b>65-4350-3500 MOTOR FUELS &amp; LUBRICANTS</b>			
UNITED OIL	971863	37270 073121	495.65
<b>65-4350-3800 CHEMICALS</b>			
THATCHER COMPANY, Inc.	1525779	P.O. #20586 Alu Sulfate	5,044.50
THATCHER COMPANY, Inc.	1525780	T-Chlor 12.5	4,672.34
THATCHER COMPANY, Inc.	1525781	Empties	960.00-
BECKART ENVIRONMENTAL, IN	76716	PO#20630 Polymer B-164 LB 275 Gallon Tote	6,356.16
<b>65-4350-4200 PROFESSIONAL SERVICES</b>			
ANALYTICAL LABORATORIES, I	83264	Chemicals and shipping	376.83
KETCHUM COMPUTERS, INC.	18169	Computer Support	202.50
MAGIC VALLEY LABS, INC.	21114	Landfill Well Nitrate	47.00
ROBERTS ELECTRIC	5540	Labor - fOUND BREAKRS SUPPLYING 100HP BLOWERS ARE 125 AMP AND SHOULD BE 200 AMP	80.00
ROBERTS ELECTRIC	5615	Labor only- Found harmonic filter wiring for caps had burnt up. Found disconnect breaker is not turning off completely.	200.00
ROBERTS ELECTRIC	5891	Install New Capacitors in Harmonic Filter & Labor	207.60

Vendor Name	Invoice Number	Description	Net Invoice Amount
US BANK	2745 072621	Advertising: Utility Director	162.50
WESTERN STATES CAT	IN001725691	Generator for WasteWater CAT 3412	1,295.00
<b>65-4350-4900 PERSONNEL TRAINING/TRAVEL/MTG</b>			
US BANK	9642 072621	License: Wastewater Treatment 4	30.00
US BANK	9642 072621	License: Class III Drinking Water Distribution Operator	30.00
US BANK	9642 072621	License: Class II Wastewater Collection Operator	30.00
US BANK	9642 072621	License: Land Application Wastewater Treatment Operator	30.00
US BANK	9642 072621	Idaho Rural Water Association	120.00
SUWANRIT, FRANK	080321	REIMBURSEMENT: Frank Suwanrit CDL Tests & Permit	50.95
<b>65-4350-5200 UTILITIES</b>			
INTERMOUNTAIN GAS	32649330001 0	32649330001 072621	9.79
INTERMOUNTAIN GAS	32649330001 0	32649330001 072621	9.79
INTERMOUNTAIN GAS	32649330001 0	32649330001 072621	20.12
INTERMOUNTAIN GAS	58208688554 0	58208688554 072621	9.79
<b>65-4350-6000 REPAIR &amp; MAINT-AUTO EQUIP</b>			
LES SCHWAB	11700705352	Flat Repair	37.00
PRODUCTIVITY PLUS ACCOUNT	IV15900	Acct. 4739 Windowtop	154.00
<b>65-4350-6100 REPAIR &amp; MAINT-MACH &amp; EQUIP</b>			
COLUMBIA ELECTRIC SUPPLY	8819-1003845	MTECAP252	513.02
US BANK	9642 072621	Amazon: Mighty Max Battery Replacement for APC Back-UPS ES BE550G	19.99
US BANK	9642 072621	Amazon: Energy+ B9650T Replacement Battery	33.98
USA BLUEBOOK	675833	Sleeve Coupler 3/8 in NPT(F)	5.95
USA BLUEBOOK	675834	Sleeve Coupler 3/8 in NPT(M)	5.95
USA BLUEBOOK	683995	GLI Pro-P3A1N ph Transmitter	680.33
UTILITY MANAGEMENT SYSTE	16271	Impeller, Impeller Trimming, Wear Plate, & Freight	1,333.02
<b>65-4350-6900 COLLECTION SYSTEM SERVICES/CHA</b>			
DIG LINE	0066243-IN	0000167 073121	65.86
FERGUSON ENTERPRISES, LLC	0789855	PVC Pipe	73.20
NAPA AUTO PARTS	067156	Heater Hose Connector 2001 Chevrolet Silverado 2500 3/4 ton	9.49
NAPA AUTO PARTS	067279	Coolant Connector	10.92
UNITED OIL	971863	37270 073121	74.31
US BANK	9642 072621	Amazon: Square D Contact Block	35.40
US BANK	9642 072621	Amazon: Green Water Tracing Fluorescent Dye	27.99
Total WASTEWATER EXPENDITURES:			23,856.29
Total WASTEWATER FUND:			23,856.29
<b>PARKS/REC DEV TRUST FUND</b>			
<b>PARKS/REC TRUST EXPENDITURES</b>			
<b>93-4900-6800 KETCHUM ARTS COMMISSION</b>			
CHATEAU DRUG CENTER	2425038	Bubble Pack	11.39
Total PARKS/REC TRUST EXPENDITURES:			11.39
Total PARKS/REC DEV TRUST FUND:			11.39
<b>ESSENTIAL SERVICES FAC. TRUST</b>			
<b>ESF TRUST EXPENDITURES</b>			

Vendor Name	Invoice Number	Description	Net Invoice Amount
<b>95-4193-5150 COMMUNICATIONS</b>			
KETCHUM COMPUTERS, INC.	18169	New City Hall -	742.50
Total ESF TRUST EXPENDITURES:			742.50
Total ESSENTIAL SERVICES FAC. TRUST:			742.50
Grand Totals:			1,152,168.45

---

Report Criteria:

Invoices with totals above \$0 included.

Paid and unpaid invoices included.

[Report].GL Account Number = "0110000000"- "9648008200", "9910000000"- "9911810000"

Invoice Detail.Voided = No,Yes

---



City of Ketchum

July 14, 2021

Mayor Bradshaw and City Councilors  
 City of Ketchum  
 Ketchum, Idaho

Mayor Bradshaw and City Councilors:

**Recommendation to Approve Alcohol Beverage Licenses**

Recommendation and Summary

Staff is recommending the council to approve the license and adopt the following motion:

*I move to approve Alcohol Beverage Licenses for the applicants included in the staff report.*

The reasons for the recommendation are as follows:

- Ketchum Municipal Code Requires certain licenses to sell liquor, beer or wine.
- At this time, the application is for the period of September 1, 2021 – July 31, 2022, the Council approval is requested to complete the process of issuing such beer, wine and liquor licenses.

Introduction and History

In accordance with Municipal Code 5.04.020, Alcoholic Beverage Sales, it is unlawful for any person to sell liquor, beer, or wine at retail or by the drink within the City without certain licenses as required pursuant to Ordinance 367. All City licenses for liquor, beer, and wine expire annually and require renewal by August 1<sup>st</sup>. Renewal for 2021 has been extended to September 1. The businesses will be vending beer, wine and liquor on premise (wine is included in the liquor fees) and not to be consumed on premise, per application.

Analysis

At this time, the following businesses have filed for their license and Council approval is requested to complete the process of issuing such beer, wine and liquor licenses.

Financial Impact

- The City of Ketchum will realize revenue of \$5028.74 from approval of these licenses in accordance with the current fee structure.

<u>Company</u>	<u>Beer Consumed on Premises</u>	<u>Beer Not to be Consumed on Premises</u>	<u>Wine Consumed on Premises</u>	<u>Wine Not to be Consumed on Premises</u>	<u>Liquor</u>	<u>Total Amount of Fees Paid</u>
The Burger Grill	x		x			\$400.00
Barbara's Party Rentals		x		x		\$250.00
TNT Taproom	x	x	x	x		\$650.00
Pioneer Saloon	x				x	\$760.00

<b>Whiskey Jaques (prorated per 9/6/21 closure)</b>	<b>x</b>				<b>x</b>	<b>\$10.41</b>
<b>Ida Thai</b>	<b>x</b>	<b>x</b>	<b>x</b>	<b>x</b>		<b>\$650.00</b>
<b>Sawtooth Brewery</b>	<b>x</b>	<b>x</b>	<b>x</b>			<b>\$450.00</b>
<b>Vintage</b>	<b>x</b>		<b>x</b>	<b>x</b>		<b>\$600.00</b>
<b>Maudes</b>	<b>x</b>	<b>x</b>	<b>x</b>	<b>x</b>		<b>\$650.00</b>
<b>Johnny G's Subshack</b>	<b>x</b>					<b>\$200.00</b>
<b>Apples</b>	<b>x</b>		<b>x</b>			<b>\$400.00</b>
<b>Bigwood Grill (prorated per 9/5/21 closure)</b>	<b>x</b>				<b>x</b>	<b>\$8.33</b>

Sincerely,



Shellie Rubel  
Treasurer

Attachments: Alcohol applications





City of Ketchum

**Beer, Wine & Liquor-by-the Drink License Application**

Submit completed application and fees below to the City Clerk Office, PO Box 2315, 480 East Ave. N., Ketchum, ID 83340. If you have questions, please contact Business License & Tax Specialist, Kathleen Schwartzberger at [taxes@ketchumidaho.org](mailto:taxes@ketchumidaho.org) or (208) 726-3841.

APPLICANT INFORMATION		
Applicant Name: <b>The Burger Grill Ketchum LLC</b>		Doing Business As:
Physical Address where license will be displayed: <b>371 N Main St., Ketchum, ID 83340</b>		
Mailing Address: <b>PO Box 6159 Ketchum, ID 83340</b>		
Recorded Owner of Property:		
Applicant Phone Number: <b>208-721-0463</b>		Applicant Email: <b>antonioortega242@gmail.com</b>
STATE LICENSE NO: <b>2065</b> (copy required)	COUNTY LICENSE NO: <b>Pending</b> (copy required)	
Corporation: <input checked="" type="checkbox"/> Partnership: <input type="checkbox"/> Individual: <input type="checkbox"/> If Applicant is a Partnership or Corporation, is the corporation authorized to do business in Idaho? Yes <input type="checkbox"/> No <input type="checkbox"/>	List names and addresses of corporation officers and/or partners: <b>Antonio Ortega</b> _____ _____ _____	
BEER LICENSE FEES		
<input checked="" type="checkbox"/>	Draft or Bottled or Canned Beer to be consumed on premises	\$200.00
<input type="checkbox"/>	Bottled or Canned Beer NOT to be consumed on premises	\$ 50.00
WINE LICENSE FEES		
<input checked="" type="checkbox"/>	Wine, to be consumed on premises	\$200.00
<input type="checkbox"/>	Wine, NOT to be consumed on premises	\$200.00
LIQUOR LICENSE FEES		
<input type="checkbox"/>	Liquor by the Drink (Note: Liquor fee includes wine)	\$560.00
Total Fees Due		\$ <u>400.00</u> - <i>paid</i>
ADDITIONAL INFORMATION		
Has the applicant, any partners of the applicant, any member of the applying partnership, the active manager of the applying partnership or any officer of the applying corporation been convicted of a violation of any law of the State of Idaho, or any other state, or of the United States regulating, governing, or prohibiting the sale of alcoholic beverages or intoxication liquor, and has any one of them within the last three years forfeited or suffered the forfeiture of a bond for his/her appearance to answer charges of any such violation? Yes <input type="checkbox"/> No <input checked="" type="checkbox"/>		
Has the applicant or any partner or actual active manager or officer of the applicant been convicted of any felony within the last five years? Yes <input type="checkbox"/> No <input checked="" type="checkbox"/>		

Applicant agrees to observe all City ordinances, laws and conditions imposed. Applicant agrees to defend, hold harmless and indemnify the City of Ketchum, its officers and employees from all liability claims, suits and costs arising from incidents or accidents occurring under this permit. Applicant certifies that s/he has read and examined this application and that all information contained herein is true and correct.

The undersigned hereby acknowledges and consents that the License(s) requested are subject to the provisions of the Ketchum Municipal Code, Title 5, Chapter 5.04 (amended by Ordinance 882), City of Ketchum, Idaho, Blaine County.

Kurt Hill **Bookkeeper**  
 Applicant Signature Relation to Business  
07/28/21  
 Date

[Signature]  
 City Clerk or Deputy Signature

OFFICIAL USE ONLY		
Date Received: <u>7/29/21</u>	License Fee Paid: <u>online</u>	License No: <u>693A</u>
<p>To the City Council, Ketchum, Idaho;            The undersigned, a Corporation <input checked="" type="checkbox"/> Partnership <input type="checkbox"/> Individual <input type="checkbox"/>, does hereby make application for a license to sell during the year of August 1, <u>2021</u> - July 31, <u>2022</u>.</p> <p>Approved by City of Ketchum Idaho by;</p> <p>_____</p> <p>Mayor</p>		



City of Ketchum

Beer, Wine & Liquor-by-the Drink License Application

Submit completed application and fees below to the City Clerk Office, PO Box 2315, 480 East Ave. N., Ketchum, ID 83340. If you have questions, please contact Business License & Tax Specialist, Kathleen Schwartzberger at taxes@ketchumidaho.org or (208) 726-3841.

APPLICANT INFORMATION		
Applicant Name:	BARBARA NMICK	Doing Business As: BARBARA'S PARTY RENTALS, INC
Physical Address where license will be displayed:	221 NORTHWOODS WAY Ste B 500	
Mailing Address:	Box 1829 SU ID 83353	
Recorded Owner of Property:	BARBARA NMICK, JOHN + CAROL DONORO	
Applicant Phone Number:	208-720 1433	Applicant Email: ba-17su@cox.net
STATE LICENSE NO:	(copy required)	COUNTY LICENSE NO: (copy required)
Corporation: <input checked="" type="checkbox"/>	List names and addresses of corporation officers and/or partners: BARBARA NMICK Box 323 SU ID 83353 MARK SMITH Box 2678 KOTENUA, ID 83353	
Partnership: <input type="checkbox"/>		
Individual: <input type="checkbox"/>		
If Applicant is a Partnership or Corporation, is the corporation authorized to do business in Idaho? Yes <input checked="" type="checkbox"/> No <input type="checkbox"/>		
BEER LICENSE FEES		
<input type="checkbox"/>	Draft or Bottled or Canned Beer to be consumed on premises	\$200.00
<input checked="" type="checkbox"/>	Bottled or Canned Beer NOT to be consumed on premises	\$ 50.00
WINE LICENSE FEES		
<input type="checkbox"/>	Wine, to be consumed on premises	\$200.00
<input checked="" type="checkbox"/>	Wine, NOT to be consumed on premises	\$200.00
LIQUOR LICENSE FEES		
<input type="checkbox"/>	Liquor by the Drink (Note: Liquor fee includes wine)	\$560.00
Total Fees Due		\$ 250.00
ADDITIONAL INFORMATION		
Has the applicant, any partners of the applicant, any member of the applying partnership, the active manager of the applying partnership or any officer of the applying corporation been convicted of a violation of any law of the State of Idaho, or any other state, or of the United States regulating, governing, or prohibiting the sale of alcoholic beverages or intoxication liquor, and has any one of them within the last three years forfeited or suffered the forfeiture of a bond for his/her appearance to answer charges of any such violation? Yes <input type="checkbox"/> No <input checked="" type="checkbox"/>		
Has the applicant or any partner or actual active manager or officer of the applicant been convicted of any felony within the last five years? Yes <input type="checkbox"/> No <input checked="" type="checkbox"/>		

Applicant agrees to observe all City ordinances, laws and conditions imposed. Applicant agrees to defend, hold harmless and indemnify the City of Ketchum, its officers and employees from all liability claims, suits and costs arising from incidents or accidents occurring under this permit. Applicant certifies that s/he has read and examined this application and that all information contained herein is true and correct.

The undersigned hereby acknowledges and consents that the License(s) requested are subject to the provisions of the Ketchum Municipal Code, Title 5, Chapter 5.04 (amended by Ordinance 882), City of Ketchum, Idaho, Blaine County.

Barbara Smith OWNER/PARTNER

Applicant Signature

Relation to Business

7/27/21

Date

[Signature]  
City Clerk or Deputy Signature

OFFICIAL USE ONLY		
Date Received: <u>8/4/21</u>	License Fee Paid: <u>ch# 25782</u>	License No: <u>281A</u>
<p>To the City Council, Ketchum, Idaho; The undersigned, a Corporation <input checked="" type="checkbox"/> Partnership <input type="checkbox"/> Individual <input type="checkbox"/>, does hereby make application for a license to sell during the year of August 1, <u>2021</u> - July 31, <u>2022</u>.</p> <p>Approved by City of Ketchum Idaho by;</p> <p>_____ Mayor</p>		



City of Ketchum

## Beer, Wine & Liquor-by-the Drink License Application

Submit completed application and fees below to the City Clerk Office, PO Box 2315, 480 East Ave. N., Ketchum, ID 83340. If you have questions, please contact Business License & Tax Specialist, Kathleen Schwartzberger at [taxes@ketchumidaho.org](mailto:taxes@ketchumidaho.org) or (208) 726-3841.

APPLICANT INFORMATION	
Applicant Name: TNT TAPROOM LLC	Doing Business As: TNT TAPROOM
Physical Address where license will be displayed: 271 SUN VALLEY RD E KETCHUM, ID, 83340	
Mailing Address: PO BOX 3367 KETCHUM ID, 83340	
Recorded Owner of Property: PML INVESTMENTS	
Applicant Phone Number: 206-295-6468	Applicant Email: maxamuslemman@gmail.com
STATE LICENSE NO: 27189 (copy required)	COUNTY LICENSE NO: 111 (copy required)
Corporation: <input checked="" type="checkbox"/> LLC Partnership: <input type="checkbox"/> Individual: <input type="checkbox"/> If Applicant is a Partnership or Corporation, is the corporation authorized to do business in Idaho? Yes <input type="checkbox"/> No <input type="checkbox"/>	List names and addresses of corporation officers and/or partners: _____ _____ _____ _____ _____
BEER LICENSE FEES	
<input checked="" type="checkbox"/> Draft or Bottled or Canned Beer to be consumed on premises	\$200.00
<input checked="" type="checkbox"/> Bottled or Canned Beer NOT to be consumed on premises	\$ 50.00
WINE LICENSE FEES	
<input checked="" type="checkbox"/> Wine, to be consumed on premises	\$200.00
<input checked="" type="checkbox"/> Wine, NOT to be consumed on premises	\$200.00
LIQUOR LICENSE FEES	
<input type="checkbox"/> Liquor by the Drink (Note: Liquor fee includes wine)	\$560.00
Total Fees Due \$ 650	
ADDITIONAL INFORMATION	
Has the applicant, any partners of the applicant, any member of the applying partnership, the active manager of the applying partnership or any officer of the applying corporation been convicted of a violation of any law of the State of Idaho, or any other state, or of the United States regulating, governing, or prohibiting the sale of alcoholic beverages or intoxication liquor, and has any one of them within the last three years forfeited or suffered the forfeiture of a bond for his/her appearance to answer charges of any such violation? Yes <input type="checkbox"/> No <input checked="" type="checkbox"/>	
Has the applicant or any partner or actual active manager or officer of the applicant been convicted of any felony within the last five years? Yes <input type="checkbox"/> No <input checked="" type="checkbox"/>	

Applicant agrees to observe all City ordinances, laws and conditions imposed. Applicant agrees to defend, hold harmless and indemnify the City of Ketchum, its officers and employees from all liability claims, suits and costs arising from incidents or accidents occurring under this permit. Applicant certifies that s/he has read and examined this application and that all information contained herein is true and correct.

The undersigned hereby acknowledges and consents that the License(s) requested are subject to the provisions of the Ketchum Municipal Code, Title 5, Chapter 5.04 (amended by Ordinance 882), City of Ketchum, Idaho, Blaine County.

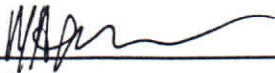
owner  
 Applicant Signature Relation to Business

8/02/21  
 Date

  
 City Clerk or Deputy Signature

OFFICIAL USE ONLY		
Date Received: <span style="color: blue;">8/4/21</span>	License Fee Paid: <span style="color: blue;">online</span>	License No: <span style="color: blue;">2388A</span>
<p><i>To the City Council, Ketchum, Idaho;</i></p> <p>The undersigned, a Corporation <input checked="" type="checkbox"/> Partnership <input type="checkbox"/> Individual <input type="checkbox"/>, does hereby make application for a license to sell during the year of August 1, <span style="color: blue;">2021</span> - July 31, <span style="color: blue;">2022</span>.</p> <p>Approved by City of Ketchum Idaho by;</p>  <p>_____</p> <p>Mayor</p>		



City of Ketchum

**Beer, Wine & Liquor-by-the Drink License Application**

Submit completed application and fees below to the City Clerk Office, PO Box 2315, 480 East Ave. N., Ketchum, ID 83340. If you have questions, please contact Business License & Tax Specialist, Kathleen Schwartzenberger at [taxes@ketchumidaho.org](mailto:taxes@ketchumidaho.org) or (208) 726-3841.

APPLICANT INFORMATION		
Applicant Name:	Pioneer Saloon Inc	Doing Business As: Pioneer Saloon
Physical Address where license will be displayed:	320 N Main St Ketchum, id	
Mailing Address:	PO Box 986 Ketchum	
Recorded Owner of Property:	Duffy Witmer	
Applicant Phone Number:	726-3139	Applicant Email: pioneerketchum@gmail.com
STATE LICENSE NO:	(copy required)	COUNTY LICENSE NO: (copy required)
Corporation: <input checked="" type="checkbox"/>	List names and addresses of corporation officers and/or partners: Duffy Witmer Sheila Witmer	
Partnership: <input type="checkbox"/>		
Individual: <input type="checkbox"/>		
If Applicant is a Partnership or Corporation, is the corporation authorized to do business in Idaho? Yes <input type="checkbox"/> No <input type="checkbox"/>		
BEER LICENSE FEES		
<input checked="" type="checkbox"/>	Draft or Bottled or Canned Beer to be consumed on premises	\$200.00
<input type="checkbox"/>	Bottled or Canned Beer NOT to be consumed on premises	\$ 50.00
WINE LICENSE FEES		
<input checked="" type="checkbox"/>	Wine, to be consumed on premises	\$200.00
<input type="checkbox"/>	Wine, NOT to be consumed on premises	\$200.00
LIQUOR LICENSE FEES		
<input checked="" type="checkbox"/>	Liquor by the Drink (Note: Liquor fee includes wine)	\$560.00
Total Fees Due		\$ 760.00
ADDITIONAL INFORMATION		
<p>Has the applicant, any partners of the applicant, any member of the applying partnership, the active manager of the applying partnership or any officer of the applying corporation been convicted of a violation of any law of the State of Idaho, or any other state, or of the United States regulating, governing, or prohibiting the sale of alcoholic beverages or intoxication liquor, and has any one of them within the last three years forfeited or suffered the forfeiture of a bond for his/her appearance to answer charges of any such violation?    Yes <input type="checkbox"/> No <input checked="" type="checkbox"/></p> <p>Has the applicant or any partner or actual active manager or officer of the applicant been convicted of any felony within the last five years?    Yes <input type="checkbox"/> No <input checked="" type="checkbox"/></p>		

Applicant agrees to observe all City ordinances, laws and conditions imposed. Applicant agrees to defend, hold harmless and indemnify the City of Ketchum, its officers and employees from all liability claims, suits and costs arising from incidents or accidents occurring under this permit. Applicant certifies that s/he has read and examined this application and that all information contained herein is true and correct.

The undersigned hereby acknowledges and consents that the License(s) requested are subject to the provisions of the Ketchum Municipal Code, Title 5, Chapter 5.04 (amended by Ordinance 882), City of Ketchum, Idaho, Blaine County.

Janae DeLacruz manager  
Applicant Signature Relation to Business

8.5.21  
Date

[Signature]  
City Clerk or Deputy Signature

OFFICIAL USE ONLY		
Date Received: <u>8/5/21</u>	License Fee Paid <u>CA# 15169</u>	License No: <u>26A</u>
<p>To the City Council, Ketchum, Idaho;  The undersigned, a Corporation <input checked="" type="checkbox"/> Partnership <input type="checkbox"/> Individual <input type="checkbox"/>, does hereby make application for a license to sell during the year of August 1, <u>2021</u> - July 31, <u>2022</u>.</p> <p>Approved by City of Ketchum Idaho by;</p>  <p>_____</p> <p>Mayor</p>		





City of Ketchum

**Beer, Wine & Liquor-by-the Drink License Application**

Submit completed application and fees below to the City Clerk Office, PO Box 2315, 480 East Ave. N., Ketchum, ID 83340. If you have questions, please contact Business License & Tax Specialist, Kathleen Schwartzenberger at [taxes@ketchumidaho.org](mailto:taxes@ketchumidaho.org) or (208) 726-3841.

APPLICANT INFORMATION		
Applicant Name: <u>WHISKEY JACQUES, INC.</u>		Doing Business As: <u>WHISKEY JACQUES</u>
Physical Address where license will be displayed: <u>251 N. MAIN ST. KETCHUM, ID 83340</u>		
Mailing Address: <u>P.O. BOX 6720 KETCHUM, ID 83340</u>		
Recorded Owner of Property: <u>KARIN T. MARTIN</u>		
Applicant Phone Number: <u>208-726-5297</u>		Applicant Email: <u>talktokarin@yahoo.com</u>
STATE LICENSE NO: <u>3437</u> (copy required)		COUNTY LICENSE NO: <u>91</u> (copy required)
Corporation: <input checked="" type="checkbox"/>	List names and addresses of corporation officers and/or partners: <u>KARIN T. MARTIN, PRESIDENT,</u> <u>DIRECTOR</u>	
Partnership: <input type="checkbox"/>		
Individual: <input type="checkbox"/>		
If Applicant is a Partnership or Corporation, is the corporation authorized to do business in Idaho? Yes <input checked="" type="checkbox"/> No <input type="checkbox"/>		
BEER LICENSE FEES		
<input checked="" type="checkbox"/>	Draft or Bottled or Canned Beer to be consumed on premises	\$ 2.74
<input type="checkbox"/>	Bottled or Canned Beer NOT to be consumed on premises	<del>\$0.68</del> NA
WINE LICENSE FEES		
<input type="checkbox"/>	Wine, to be consumed on premises	<del>\$2.74</del>
<input type="checkbox"/>	Wine, NOT to be consumed on premises	<del>\$2.74</del>
LIQUOR LICENSE FEES		
<input checked="" type="checkbox"/>	Liquor by the Drink (Note: Liquor fee includes wine)	\$ 7.67
Total Fees Due		\$ <u>10.41</u>
ADDITIONAL INFORMATION		
Has the applicant, any partners of the applicant, any member of the applying partnership, the active manager of the applying partnership or any officer of the applying corporation been convicted of a violation of any law of the State of Idaho, or any other state, or of the United States regulating, governing, or prohibiting the sale of alcoholic beverages or intoxication liquor, and has any one of them within the last three years forfeited or suffered the forfeiture of a bond for his/her appearance to answer charges of any such violation? Yes <input type="checkbox"/> No <input checked="" type="checkbox"/>		
Has the applicant or any partner or actual active manager or officer of the applicant been convicted of any felony within the last five years? Yes <input type="checkbox"/> No <input checked="" type="checkbox"/>		

Applicant agrees to observe all City ordinances, laws and conditions imposed. Applicant agrees to defend, hold harmless and indemnify the City of Ketchum, its officers and employees from all liability claims, suits and costs arising from incidents or accidents occurring under this permit. Applicant certifies that s/he has read and examined this application and that all information contained herein is true and correct.

The undersigned hereby acknowledges and consents that the License(s) requested are subject to the provisions of the Ketchum Municipal Code, Title 5, Chapter 5.04 (amended by Ordinance 882), City of Ketchum, Idaho, Blaine County.

Kevin T. Martin President  
Applicant Signature Relation to Business

7/29/2021  
Date

[Signature]  
City Clerk or Deputy Signature

OFFICIAL USE ONLY		
Date Received: <u>8/2/21</u>	License Fee Paid <u>ch # 4550</u>	License No: <u>34A</u>
<i>To the City Council, Ketchum, Idaho;</i> <i>The undersigned, a Corporation <input checked="" type="checkbox"/> Partnership <input type="checkbox"/> Individual <input type="checkbox"/>, does hereby make application for a license to sell during the year of August 1, <u>2021</u> - July 31, <u>2022</u>.</i>		
Approved by City of Ketchum Idaho by;		
<hr/>		
Mayor		



City of Ketchum

**Beer, Wine & Liquor-by-the Drink License Application**

Submit completed application and fees below to the City Clerk Office, PO Box 2315, 480 East Ave. N., Ketchum, ID 83340. If you have questions, please contact Business License & Tax Specialist, Kathleen Schwartzenberger at [taxes@ketchumidaho.org](mailto:taxes@ketchumidaho.org) or (208) 726-3841.

APPLICANT INFORMATION		
Applicant Name: <b>New Endeavor LLC</b>		Doing Business As: <b>IDA THAI</b>
Physical Address where license will be displayed: <b>kitchen wall</b>		
Mailing Address: <b>po box 2854 Sun Valley ID 83353</b>		
Recorded Owner of Property: <b>Ketchum Korral LLC</b>		
Applicant Phone Number: <b>816-716-9669</b>		Applicant Email: <b>mrunte41@gmail.com</b>
STATE LICENSE NO:	(copy required)	COUNTY LICENSE NO: (copy required)
Corporation: <input checked="" type="checkbox"/> Partnership: <input type="checkbox"/> Individual: <input type="checkbox"/> If Applicant is a Partnership or Corporation, is the corporation authorized to do business in Idaho? Yes <input checked="" type="checkbox"/> No <input type="checkbox"/>		List names and addresses of corporation officers and/or partners: <b>Matt Runte</b> _____ _____ _____
BEER LICENSE FEES		
<input checked="" type="checkbox"/>	Draft or Bottled or Canned Beer to be consumed on premises	\$200.00
<input checked="" type="checkbox"/>	Bottled or Canned Beer NOT to be consumed on premises	\$ 50.00
WINE LICENSE FEES		
<input checked="" type="checkbox"/>	Wine, to be consumed on premises	\$200.00
<input checked="" type="checkbox"/>	Wine, NOT to be consumed on premises	\$200.00
LIQUOR LICENSE FEES		
	Liquor by the Drink (Note: Liquor fee includes wine)	\$560.00
Total Fees Due		\$ <u>650</u>
ADDITIONAL INFORMATION		
Has the applicant, any partners of the applicant, any member of the applying partnership, the active manager of the applying partnership or any officer of the applying corporation been convicted of a violation of any law of the State of Idaho, or any other state, or of the United States regulating, governing, or prohibiting the sale of alcoholic beverages or intoxication liquor, and has any one of them within the last three years forfeited or suffered the forfeiture of a bond for his/her appearance to answer charges of any such violation? Yes <input type="checkbox"/> No <input checked="" type="checkbox"/>		
Has the applicant or any partner or actual active manager or officer of the applicant been convicted of any felony within the last five years? Yes <input type="checkbox"/> No <input checked="" type="checkbox"/>		

Applicant agrees to observe all City ordinances, laws and conditions imposed. Applicant agrees to defend, hold harmless and indemnify the City of Ketchum, its officers and employees from all liability claims, suits and costs arising from incidents or accidents occurring under this permit. Applicant certifies that s/he has read and examined this application and that all information contained herein is true and correct.

The undersigned hereby acknowledges and consents that the License(s) requested are subject to the provisions of the Ketchum Municipal Code, Title 5, Chapter 5.04 (amended by Ordinance 882), City of Ketchum, Idaho, Blaine County.

per phone w/ Matt Burke **managing member**  
 Applicant Signature Relation to Business

**5/10/2021**  
 Date

[Signature]  
 City Clerk or Deputy Signature

OFFICIAL USE ONLY		
Date Received: <u>7/30/21</u>	License Fee Paid: <u>ch# 650</u>	License No: <u>1481A</u>
To the City Council, Ketchum, Idaho; The undersigned, a Corporation <input checked="" type="checkbox"/> Partnership <input type="checkbox"/> Individual <input type="checkbox"/> , does hereby make application for a license to sell during the year of August 1, <u>2021</u> - July 31, <u>2022</u> .		
Approved by City of Ketchum Idaho by;  _____ Mayor		



City of Ketchum

**Beer, Wine & Liquor-by-the Drink License Application**

Submit completed application and fees below to the City Clerk Office, PO Box 2315, 480 East Ave. N., Ketchum, ID 83340. If you have questions, please contact Business License & Tax Specialist, Kathleen Schwartzenberger at [taxes@ketchumidaho.org](mailto:taxes@ketchumidaho.org) or (208) 726-3841.

APPLICANT INFORMATION		
Applicant Name: <b>Sawtooth Brewery LLC</b>		Doing Business As:
Physical Address where license will be displayed: <b>631 Warm Springs Rd</b>		
Mailing Address: <b>110 N River St, Hailey, ID</b>		
Recorded Owner of Property: <b>Ketchum Dovetail LLC</b>		
Applicant Phone Number: <b>2084509324</b>		Applicant Email: <b>kevin@sawtoothbrewery.com</b>
STATE LICENSE NO: <b>12311</b> (copy required)		COUNTY LICENSE NO: <b>93</b> (copy required)
Corporation: <input checked="" type="checkbox"/> Partnership: <input type="checkbox"/> Individual: <input type="checkbox"/> If Applicant is a Partnership or Corporation, is the corporation authorized to do business in Idaho? Yes <input checked="" type="checkbox"/> No <input type="checkbox"/>		List names and addresses of corporation officers and/or partners: Kevin Jones 1011 Red Elephant Dr, Hailey, ID 83333 Paul Holle 3220 Berrycreek Dr, Hailey, ID 83333 _____ _____ _____
BEER LICENSE FEES		
<input checked="" type="checkbox"/>	Draft or Bottled or Canned Beer to be consumed on premises	\$200.00
<input checked="" type="checkbox"/>	Bottled or Canned Beer NOT to be consumed on premises	\$ 50.00
WINE LICENSE FEES		
<input checked="" type="checkbox"/>	Wine, to be consumed on premises	\$200.00
	Wine, NOT to be consumed on premises	\$200.00
LIQUOR LICENSE FEES		
	Liquor by the Drink (Note: Liquor fee includes wine)	\$560.00
Total Fees Due		\$ <u>450</u>
ADDITIONAL INFORMATION		
Has the applicant, any partners of the applicant, any member of the applying partnership, the active manager of the applying partnership or any officer of the applying corporation been convicted of a violation of any law of the State of Idaho, or any other state, or of the United States regulating, governing, or prohibiting the sale of alcoholic beverages or intoxication liquor, and has any one of them within the last three years forfeited or suffered the forfeiture of a bond for his/her appearance to answer charges of any such violation?    Yes <input type="checkbox"/> No <input checked="" type="checkbox"/>		
Has the applicant or any partner or actual active manager or officer of the applicant been convicted of any felony within the last five years?    Yes <input type="checkbox"/> No <input checked="" type="checkbox"/>		

Applicant agrees to observe all City ordinances, laws and conditions imposed. Applicant agrees to defend, hold harmless and indemnify the City of Ketchum, its officers and employees from all liability claims, suits and costs arising from incidents or accidents occurring under this permit. Applicant certifies that s/he has read and examined this application and that all information contained herein is true and correct.

The undersigned hereby acknowledges and consents that the License(s) requested are subject to the provisions of the Ketchum Municipal Code, Title 5, Chapter 5.04 (amended by Ordinance 882), City of Ketchum, Idaho, Blaine County.

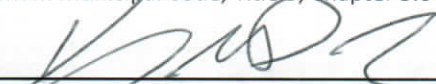
 \_\_\_\_\_ **Business Director/Owner**

Applicant Signature

Relation to Business

7/25/2021

Date

 \_\_\_\_\_  
City Clerk or Deputy Signature

OFFICIAL USE ONLY		
Date Received: <u>7/30/21</u>	License Fee Paid: <u>ch # 7819</u>	License No: <u>1403A</u>
<i>To the City Council, Ketchum, Idaho;</i> <i>The undersigned, a Corporation <input checked="" type="checkbox"/> Partnership <input type="checkbox"/> Individual <input type="checkbox"/>, does hereby make application for a license to sell during the year of August 1, <u>2021</u> - July 31, <u>2022</u>.</i>		
Approved by City of Ketchum Idaho by;		
_____ Mayor		



City of Ketchum

**Beer, Wine & Liquor-by-the Drink License Application**

Submit completed application and fees below to the City Clerk Office, PO Box 2315, 480 East Ave. N., Ketchum, ID 83340. If you have questions, please contact Business License & Tax Specialist, Kathleen Schwartzenberger at [taxes@ketchumidaho.org](mailto:taxes@ketchumidaho.org) or (208) 726-3841.

APPLICANT INFORMATION		
Applicant Name: <b>Phoenix Restaurant LLC</b>		Doing Business As: <b>Vintage Restaurant</b>
Physical Address where license will be displayed: <b>231 1/2 Leadville Ave, Blaine County</b>		
Mailing Address: <b>PO Box 3188, Hailey, ID 83333</b>		
Recorded Owner of Property:		
Applicant Phone Number: <b>208-721-0425</b>		Applicant Email: <b>vintage7269595@gmail.com</b>
STATE LICENSE NO: _____ (copy required)		COUNTY LICENSE NO: _____ (copy required)
Corporation: <input checked="" type="checkbox"/> Partnership: <input type="checkbox"/> Individual: <input type="checkbox"/> If Applicant is a Partnership or Corporation, is the corporation authorized to do business in Idaho? Yes <input checked="" type="checkbox"/> No <input type="checkbox"/>		List names and addresses of corporation officers and/or partners: <b>Rodrigo Herrera</b> _____ <b>PO Box 3188</b> _____ <b>Hailey, ID 83333</b> _____ _____
BEER LICENSE FEES		
1	Draft or Bottled or Canned Beer to be consumed on premises	\$200.00
	Bottled or Canned Beer NOT to be consumed on premises	\$ 50.00
WINE LICENSE FEES		
1	Wine, to be consumed on premises	\$200.00
1	Wine, NOT to be consumed on premises	\$200.00
LIQUOR LICENSE FEES		
0	Liquor by the Drink (Note: Liquor fee includes wine)	\$560.00
Total Fees Due		\$ <u>600.00</u>
ADDITIONAL INFORMATION		
Has the applicant, any partners of the applicant, any member of the applying partnership, the active manager of the applying partnership or any officer of the applying corporation been convicted of a violation of any law of the State of Idaho, or any other state, or of the United States regulating, governing, or prohibiting the sale of alcoholic beverages or intoxication liquor, and has any one of them within the last three years forfeited or suffered the forfeiture of a bond for his/her appearance to answer charges of any such violation?    Yes <input type="checkbox"/> No <input checked="" type="checkbox"/>		
Has the applicant or any partner or actual active manager or officer of the applicant been convicted of any felony within the last five years?    Yes <input type="checkbox"/> No <input checked="" type="checkbox"/>		

Applicant agrees to observe all City ordinances, laws and conditions imposed. Applicant agrees to defend, hold harmless and indemnify the City of Ketchum, its officers and employees from all liability claims, suits and costs arising from incidents or accidents occurring under this permit. Applicant certifies that s/he has read and examined this application and that all information contained herein is true and correct.

The undersigned hereby acknowledges and consents that the License(s) requested are subject to the provisions of the Ketchum Municipal Code, Title 5, Chapter 5.04 (amended by Ordinance 882), City of Ketchum, Idaho, Blaine County.

  
Applicant Signature Owner  
Relation to Business

7/23/2021  
Date

  
City Clerk or Deputy Signature

OFFICIAL USE ONLY		
Date Received: <u>7/29/21</u>	License Fee Paid <u>ch# 8922</u>	License No: <u>2484</u>
<p>To the City Council, Ketchum, Idaho; The undersigned, a Corporation <input checked="" type="checkbox"/> Partnership <input type="checkbox"/> Individual <input type="checkbox"/>, does hereby make application for a license to sell during the year of August 1, <u>2021</u> - July 31, <u>2022</u>.</p> <p>Approved by City of Ketchum Idaho by;</p> <p>_____ Mayor</p>		





City of Ketchum

**Beer, Wine & Liquor-by-the Drink License Application**

Submit completed application and fees below to the City Clerk Office, PO Box 2315, 480 East Ave. N., Ketchum, ID 83340. If you have questions, please contact Business License & Tax Specialist, Kathleen Schwartzenberger at [taxes@ketchumidaho.org](mailto:taxes@ketchumidaho.org) or (208) 726-3841.

APPLICANT INFORMATION		
Applicant Name: D.D. FRANK CO LLC		Doing Business As: MAUDES
Physical Address where license will be displayed: 311 First AVE N UNIT 1		
Mailing Address: PO BOX 204		
Recorded Owner of Property: SUN VALLEY AND FIRST LLC		
Applicant Phone Number: 208-720-3585		Applicant Email: HELLO@MAUDESINKETCHUM.COM
STATE LICENSE NO: 31423 (copy required)	COUNTY LICENSE NO: 116 (copy required)	
Corporation: <input checked="" type="checkbox"/> (LLC)	List names and addresses of corporation officers and/or partners: JACOB FREHLING TARA MCFARLANE	
Partnership: <input type="checkbox"/>		
Individual: <input type="checkbox"/>		
If Applicant is a Partnership or Corporation, is the corporation authorized to do business in Idaho? Yes <input type="checkbox"/> No <input type="checkbox"/>		
BEER LICENSE FEES		
<input checked="" type="checkbox"/>	Draft or Bottled or Canned Beer to be consumed on premises	\$200.00
<input checked="" type="checkbox"/>	Bottled or Canned Beer NOT to be consumed on premises	\$ 50.00
WINE LICENSE FEES		
<input checked="" type="checkbox"/>	Wine, to be consumed on premises	\$200.00
<input checked="" type="checkbox"/>	Wine, NOT to be consumed on premises	\$200.00
LIQUOR LICENSE FEES		
	Liquor by the Drink (Note: Liquor fee includes wine)	\$560.00
Total Fees Due		\$650.00
ADDITIONAL INFORMATION		
<p>Has the applicant, any partners of the applicant, any member of the applying partnership, the active manager of the applying partnership or any officer of the applying corporation been convicted of a violation of any law of the State of Idaho, or any other state, or of the United States regulating, governing, or prohibiting the sale of alcoholic beverages or intoxication liquor, and has any one of them within the last three years forfeited or suffered the forfeiture of a bond for his/her appearance to answer charges of any such violation?    Yes <input type="checkbox"/> No <input checked="" type="checkbox"/></p> <p>Has the applicant or any partner or actual active manager or officer of the applicant been convicted of any felony within the last five years?    Yes <input type="checkbox"/> No <input checked="" type="checkbox"/></p>		

Applicant agrees to observe all City ordinances, laws and conditions imposed. Applicant agrees to defend, hold harmless and indemnify the City of Ketchum, its officers and employees from all liability claims, suits and costs arising from incidents or accidents occurring under this permit. Applicant certifies that s/he has read and examined this application and that all information contained herein is true and correct.

The undersigned hereby acknowledges and consents that the License(s) requested are subject to the provisions of the Ketchum Municipal Code, Title 5, Chapter 5.04 (amended by Ordinance 882), City of Ketchum, Idaho, Blaine County.

[Handwritten Signature] **OWNER**  
 Applicant Signature Relation to Business

**8-1-21**  
 Date

[Handwritten Signature]  
 City Clerk or Deputy Signature

OFFICIAL USE ONLY		
Date Received: <u>8/4/21</u>	License Fee Paid <u>ch # 12447</u>	License No: <u>2153A</u>
<p>To the City Council, Ketchum, Idaho;            The undersigned, a Corporation <input checked="" type="checkbox"/> Partnership <input type="checkbox"/> Individual <input type="checkbox"/>, does hereby make application for a license to sell during the year of August 1, <u>2021</u> - July 31, <u>2022</u>.</p> <p>Approved by City of Ketchum Idaho by;</p> <p>_____            Mayor</p>		



City of Ketchum



**Beer, Wine & Liquor-by-the Drink License Application**

Submit completed application and fees below to the City Clerk Office, PO Box 2315, 480 East Ave. N., Ketchum, ID 83340. If you have questions, please contact Business License & Tax Specialist, Kathleen Schwartzenberger at [taxes@ketchumidaho.org](mailto:taxes@ketchumidaho.org) or (208) 726-3841.

<b>APPLICANT INFORMATION</b>		
Applicant Name: <u>JOHNNY G SUBSHACK LLC</u>		Doing Business As: <u>JOHNNY G'S SUBSHACK</u>
Physical Address where license will be displayed: <u>371 WASHINGTON AVE</u>		
Mailing Address: <u>POB 3013 KETCHUM 83340</u>		
Recorded Owner of Property: <u>JOHN AND GREZHEN GORHAM</u>		
Applicant Phone Number:		Applicant Email: <u>johnnygsubshack@gmail.com</u>
STATE LICENSE NO: (copy required)	COUNTY LICENSE NO: (copy required)	
Corporation: <input checked="" type="checkbox"/>	List names and addresses of corporation officers and/or partners: <u>GREZHEN GORHAM</u> <u>JOHN GORHAM</u>	
Partnership: <input type="checkbox"/>		
Individual: <input type="checkbox"/>		
If Applicant is a Partnership or Corporation, is the corporation authorized to do business in Idaho? Yes <input type="checkbox"/> No <input type="checkbox"/>		
<b>BEER LICENSE FEES</b>		
<input checked="" type="checkbox"/>	Draft or Bottled or Canned Beer to be consumed on premises	\$200.00
	Bottled or Canned Beer NOT to be consumed on premises	\$ 50.00
<b>WINE LICENSE FEES</b>		
	Wine, to be consumed on premises	\$200.00
	Wine, NOT to be consumed on premises	\$200.00
<b>LIQUOR LICENSE FEES</b>		
	Liquor by the Drink (Note: Liquor fee includes wine)	\$560.00
Total Fees Due		<u>\$ 200.00</u>
<b>ADDITIONAL INFORMATION</b>		
Has the applicant, any partners of the applicant, any member of the applying partnership, the active manager of the applying partnership or any officer of the applying corporation been convicted of a violation of any law of the State of Idaho, or any other state, or of the United States regulating, governing, or prohibiting the sale of alcoholic beverages or intoxication liquor, and has any one of them within the last three years forfeited or suffered the forfeiture of a bond for his/her appearance to answer charges of any such violation? Yes <input type="checkbox"/> No <input checked="" type="checkbox"/>		
Has the applicant or any partner or actual active manager or officer of the applicant been convicted of any felony within the last five years? Yes <input type="checkbox"/> No <input checked="" type="checkbox"/>		

Applicant agrees to observe all City ordinances, laws and conditions imposed. Applicant agrees to defend, hold harmless and indemnify the City of Ketchum, its officers and employees from all liability claims, suits and costs arising from incidents or accidents occurring under this permit. Applicant certifies that s/he has read and examined this application and that all information contained herein is true and correct.

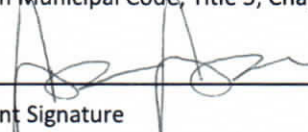
The undersigned hereby acknowledges and consents that the License(s) requested are subject to the provisions of the Ketchum Municipal Code, Title 5, Chapter 5.04 (amended by Ordinance 882), City of Ketchum, Idaho, Blaine County.

  
 Applicant Signature \_\_\_\_\_   
 Relation to Business

\_\_\_\_\_  
 Date 8/9/21

  
 City Clerk or Deputy Signature

OFFICIAL USE ONLY		
Date Received: <u>8/10/21</u>	License Fee Paid: <u>cash 44831</u>	License No: <u>103A</u>
<p>To the City Council, Ketchum, Idaho;            The undersigned, a Corporation <input type="checkbox"/> Partnership <input checked="" type="checkbox"/> Individual <input type="checkbox"/>, does hereby make application for a license to sell during the year of August 1, <u>2021</u> - July 31, <u>2022</u>.</p> <p>Approved by City of Ketchum Idaho by;</p> <p>_____</p> <p>Mayor</p>		



City of Ketchum

**Beer, Wine & Liquor-by-the Drink License Application**

Submit completed application and fees below to the City Clerk Office, PO Box 2315, 480 East Ave. N., Ketchum, ID 83340. If you have questions, please contact Business License & Tax Specialist, Kathleen Schwartzenberger at [taxes@ketchumidaho.org](mailto:taxes@ketchumidaho.org) or (208) 726-3841.

APPLICANT INFORMATION		
Applicant Name: <u>Apples Inc</u>	Doing Business As: <u>Apples BARS Grill</u>	
Physical Address where license will be displayed: <u>215 Pilgrimage St</u>		
Mailing Address: <u>Box 4445 Ketchum</u>		
Recorded Owner of Property: <u>Minor trust LLC</u>		
Applicant Phone Number: <u>2087267067</u>	Applicant Email: <u>hankminor@yahoo.com</u>	
STATE LICENSE NO: <u>4207</u> (copy required)	COUNTY LICENSE NO: <u>73</u>	(copy required)
Corporation: <input checked="" type="checkbox"/> Partnership: <input type="checkbox"/> Individual: <input type="checkbox"/> If Applicant is a Partnership or Corporation, is the corporation authorized to do business in Idaho? Yes <input type="checkbox"/> No <input type="checkbox"/>	List names and addresses of corporation officers and/or partners: <u>Hank Minor</u> <u>Kathleen Minor</u> <u>Bx 4445</u> <u>Ketchum</u>	
BEER LICENSE FEES		
<input checked="" type="checkbox"/>	Draft or Bottled or Canned Beer to be consumed on premises	\$200.00
<input type="checkbox"/>	Bottled or Canned Beer NOT to be consumed on premises	\$ 50.00
WINE LICENSE FEES		
<input checked="" type="checkbox"/>	Wine, to be consumed on premises	\$200.00
<input type="checkbox"/>	Wine, NOT to be consumed on premises	\$200.00
LIQUOR LICENSE FEES		
<input type="checkbox"/>	Liquor by the Drink (Note: Liquor fee includes wine)	\$560.00
Total Fees Due		<u>\$ 400</u>
ADDITIONAL INFORMATION		
Has the applicant, any partners of the applicant, any member of the applying partnership, the active manager of the applying partnership or any officer of the applying corporation been convicted of a violation of any law of the State of Idaho, or any other state, or of the United States regulating, governing, or prohibiting the sale of alcoholic beverages or intoxication liquor, and has any one of them within the last three years forfeited or suffered the forfeiture of a bond for his/her appearance to answer charges of any such violation? Yes <input type="checkbox"/> No <input checked="" type="checkbox"/>		
Has the applicant or any partner or actual active manager or officer of the applicant been convicted of any felony within the last five years? Yes <input type="checkbox"/> No <input checked="" type="checkbox"/>		

Applicant agrees to observe all City ordinances, laws and conditions imposed. Applicant agrees to defend, hold harmless and indemnify the City of Ketchum, its officers and employees from all liability claims, suits and costs arising from incidents or accidents occurring under this permit. Applicant certifies that s/he has read and examined this application and that all information contained herein is true and correct.

The undersigned hereby acknowledges and consents that the License(s) requested are subject to the provisions of the Ketchum Municipal Code, Title 5, Chapter 5.04 (amended by Ordinance 882), City of Ketchum, Idaho, Blaine County.

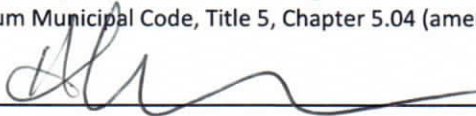
 owner  
Applicant Signature Relation to Business

8/10/21  
Date

  
City Clerk or Deputy Signature

OFFICIAL USE ONLY		
Date Received: <u>8/10/21</u>	License Fee Paid <u>ch # 2601</u>	License No: <u>20A</u>
<p>To the City Council, Ketchum, Idaho; The undersigned, a Corporation <input checked="" type="checkbox"/> Partnership <input type="checkbox"/> Individual <input type="checkbox"/>, does hereby make application for a license to sell during the year of August 1, <u>2021</u> - July 31, <u>2022</u>.</p> <p>Approved by City of Ketchum Idaho by;</p> <p>_____ Mayor</p>		



City of Ketchum



**Beer, Wine & Liquor-by-the Drink License Application**

Submit completed application and fees below to the City Clerk Office, PO Box 2315, 480 East Ave. N., Ketchum, ID 83340. If you have questions, please contact Business License & Tax Specialist, Kathleen Schwartzberger at [taxes@ketchumidaho.org](mailto:taxes@ketchumidaho.org) or (208) 726-3841.

APPLICANT INFORMATION		
Applicant Name: <u>Apples Inc.</u>	Doing Business As: <u>Bigwood Grill</u>	
Physical Address where license will be displayed: <u>124 Saddle Road</u>		
Mailing Address: <u>Box 4445 Ketchum</u>		
Recorded Owner of Property: <u>Bigwood sports</u>		
Applicant Phone Number: <u>208 726 7067</u>	Applicant Email: <u>hank@ketchum.com</u>	
STATE LICENSE NO: <u>4011</u> (copy required)	COUNTY LICENSE NO: <u>72</u> (copy required)	
Corporation: <input checked="" type="checkbox"/> Partnership: <input type="checkbox"/> Individual: <input type="checkbox"/> If Applicant is a Partnership or Corporation, is the corporation authorized to do business in Idaho? Yes <input type="checkbox"/> No <input type="checkbox"/>	List names and addresses of corporation officers and/or partners: _____ _____ _____ _____	
BEER LICENSE FEES		
<input checked="" type="checkbox"/>	Draft or Bottled or Canned Beer to be consumed on premises	\$200.00 <u>2.19</u>
	Bottled or Canned Beer NOT to be consumed on premises	\$ 50.00 <u>.89</u>
WINE LICENSE FEES		
	Wine, to be consumed on premises	\$200.00
	Wine, NOT to be consumed on premises	\$200.00
LIQUOR LICENSE FEES		
<input checked="" type="checkbox"/>	Liquor by the Drink (Note: Liquor fee includes wine)	\$560.00 <u>6.14</u>
Total Fees Due		\$ <u>8.33</u>
ADDITIONAL INFORMATION		
Has the applicant, any partners of the applicant, any member of the applying partnership, the active manager of the applying partnership or any officer of the applying corporation been convicted of a violation of any law of the State of Idaho, or any other state, or of the United States regulating, governing, or prohibiting the sale of alcoholic beverages or intoxication liquor, and has any one of them within the last three years forfeited or suffered the forfeiture of a bond for his/her appearance to answer charges of any such violation? Yes <input type="checkbox"/> No <input checked="" type="checkbox"/>		
Has the applicant or any partner or actual active manager or officer of the applicant been convicted of any felony within the last five years? Yes <input type="checkbox"/> No <input checked="" type="checkbox"/>		

Applicant agrees to observe all City ordinances, laws and conditions imposed. Applicant agrees to defend, hold harmless and indemnify the City of Ketchum, its officers and employees from all liability claims, suits and costs arising from incidents or accidents occurring under this permit. Applicant certifies that s/he has read and examined this application and that all information contained herein is true and correct.

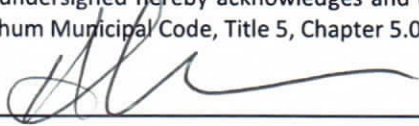
The undersigned hereby acknowledges and consents that the License(s) requested are subject to the provisions of the Ketchum Municipal Code, Title 5, Chapter 5.04 (amended by Ordinance 882), City of Ketchum, Idaho, Blaine County.

   
\_\_\_\_\_  
Applicant Signature Relation to Business

8/10/21  
\_\_\_\_\_  
Date

  
\_\_\_\_\_  
City Clerk or Deputy Signature

OFFICIAL USE ONLY		
Date Received: <u>8/10/21</u>	License Fee Paid: <u>ch# 2601</u>	License No: <u>50414A</u>
<i>To the City Council, Ketchum, Idaho;</i> <i>The undersigned, a Corporation <input checked="" type="checkbox"/> Partnership <input type="checkbox"/> Individual <input type="checkbox"/>, does hereby make application for a license to sell during the year of August 1, <u>2021</u> - July 31, <u>2022</u>.</i>		
Approved by City of Ketchum Idaho by;		
_____ Mayor		





**RESOLUTION 21-014**

---

**A RESOLUTION OF THE CITY OF KETCHUM AUTHORIZING EXSISTING CITY CODE REPLACEMENT.**

WHEREAS, The City of Ketchum (the "City") is a municipal corporation duly organized and existing under the laws of the State of Idaho Code §50-101 et seq.; and

WHEREAS, Pursuant to Idaho Code § 50-301 and § 50-302, the City is empowered to enter into contracts and take such steps as are reasonably necessary to maintain the peace, good government and welfare of the City and its trade, commerce and industry; and

WHEREAS, a contract for Codification services has been approved, and

WHEREAS, the City Code has been updated, validated and is ready for publication,

NOW, THEREFORE, BE IT RESOLVED BY THE CITY COUNCIL OF THE CITY OF KETCHUM, IDAHO,

SECTION 1: That the City of Ketchum has received Codification Services from the Contractor set forth in Exhibit 1.

SECTION 2: That the City Council approves the replacement of existing City Code.

SECTION 3: That this Resolution shall be known as Resolution No. 21-014 of the City of Ketchum, Idaho and shall be in full force and effect from and after its passage and approval.

PASSED BY THE CITY COUNCIL AND APPROVED BY THE MAYOR THIS \_\_\_\_\_ DAY OF AUGUST 2021.

\_\_\_\_\_  
Neil Bradshaw, Mayor

Attest:

\_\_\_\_\_  
Tara Fenwick, City Clerk

---

**EXHIBIT 1**

- Approved contract for Muni-Code Codification Services



# REPUBLICATION, SUPPLEMENTATION AND ONLINE CODE HOSTING SERVICES

## Ketchum, Idaho

*December 1, 2020 - Valid for 90 days*



### Joshua "J.R." Riley

Legal Account Executive

Office: 800-262-2633

Direct: 850-696-7012

Email: [jriley@municode.com](mailto:jriley@municode.com)

PO Box 2235 Tallahassee, FL 32316



GovTech Top 100 Innovators  
annually since 2016!



# LETTER OF INTEREST



P.O. Box 2235 Tallahassee, FL 32316  
municode.com • 800.262.2633

December 1, 2020

Ms. Katrin Sharp  
Management and Public Affairs Specialist  
City of Ketchum  
PO Box 2315  
Ketchum, ID 83340

via email: [ksharp@ketchumidaho.org](mailto:ksharp@ketchumidaho.org)

Ms. Sharp:

Thank you for speaking with Legal Account Executive Joshua "J.R." Riley regarding publication and updating options for your Code of Ordinances. This proposal will provide you with the scope of services and costs for converting your Code to Municode's database for republication in print and online (via MunicodeNEXT), followed by ongoing supplementation and online Code hosting services.

With over 69 years of experience, Municode is the oldest and most trusted codifier in the nation. We serve over 4,000 municipalities nationwide and host over 3,700 Codes online. Whether it is through the legal codification process, full-service or self-service supplementation options, online legislative search tools, meeting management and agenda software, or custom government website design, we have the experience, resources and expertise to provide our local government clients with innovative products, superior technology and excellent customer service. We invite you to visit our corporate website at <https://www.municode.com/> to explore our full suite of government services.

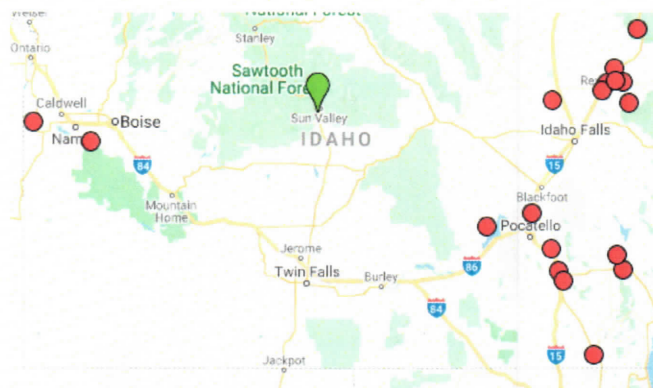

**Municode provide Code publishing services to 24 municipalities in Idaho, including many near Ketchum.**

Our Supplement team includes 14 teams of Legal Editors and Proofreaders who provide the most accurate and efficient supplement process possible for the ongoing maintenance of your new code. Our code hosting platform, MunicodeNEXT, is the nation's most advanced, accessible and intuitive website for government codes. Customers who trust Municode with their online codes, meetings software, and municipal website will enjoy a unified search engine and integration of the Meetings, Web, and Code Hosting platforms. From the Meetings platform, agendas and minutes will be automatically uploaded to the website and ordinances can be sent to Municode for codification with permanent links created within the code for the ordinances and the specific meeting from which the legislation was adopted.

Transitioning your Code to Municode is a simple and affordable process! To start the republication process, simply make your selections on pages 2-4 of this proposal and fill in and sign the signature page on page 12. If you have any questions, please let us know. In addition to email J.R. can be reached at 850-696-7012. Thank you for the opportunity to submit this proposal.

Sincerely,



Bob Geiger  
Vice President of Sales  
Phone: 850-692-7132  
[bgeiger@municode.com](mailto:bgeiger@municode.com)

# REPUBLICATION QUOTATION SHEET

---

*Logic: Give your municipality a fresh start. Clean up the pagination, reprint all pages and replace binders and tabs, if needed. Transition your Code to the most advanced suite of web/mobile services available in the nation:*

**MunicodeNEXT.**

## Conversion and Republication

**No charge<sup>1</sup>**

- ★ Conversion of Code to Municode database
- ★ Removal of supplement numbers
- ★ Updating of preliminary pages (title page, officials' page, and preface)
- ★ New page numbers
- ★ Creation of a consistent style
- ★ Incorporation of Graphics<sup>2</sup> & tabular<sup>3</sup> matter
- ★ 3 printed copies of the new Code with divider tabs
- ★ Inclusion of adopted legislation, per page added or amended
- ★ Current Code can be posted online as a PDF during conversion & republication project

**\$18<sup>4</sup>**

## Binder Options:

3-post expandable binder, \$70 each<sup>5</sup>, with stamping      qty \_\_\_\_\_ \$ \_\_\_\_\_

3-ring vinyl binders, \$20 each, stamping not available      qty \_\_\_\_\_ \$ \_\_\_\_\_

**Binder Color:**       Semi-Bright Black       Dark Blue       Green       Burgundy  
**Binder Stamping Color:**       Gold       Silver

**We will provide you with a Style Checklist and work with you to determine the desired font and format of the republished Code**

<sup>1</sup> Provided Municode can rely upon the version of the Code furnished and it is in an editable, electronic format. Conversion will take approximately 12 to 16 weeks upon receipt of all required materials.

<sup>2</sup> Includes printing all copies. Additional fees may apply if graphics are printed color.

<sup>3</sup> Tabular matter is defined as tables, algebraic formulas, or other materials that require special programs or extra editorial time to modify and prepare for inclusion in an update.

<sup>4</sup> Legislation added to the project must be approved and received prior to the established cutoff date. Following the delivery of the final code draft for client proofing, any extensive changes requested in the Code content, and/or any material added to the Code that was not previously contemplated, will be subject to an additional Proof Update fee. Proofs not returned within 45 days may be subject to a proof update fee, if applicable.

<sup>5</sup> Price does not include shipping costs.

# SUPPLEMENTATION QUOTATION SHEET

## Supplement Service Base Page Rate<sup>6</sup>

Page Format	Base Page Rate
Single Column	\$18 per page

### Base page rate above includes:

- ★ Acknowledgement of material
- ★ Data conversion, as necessary
- ★ Editorial work
- ★ Proofreading
- ★ Updating the index (if elected)
- ★ Schedule as selected by you<sup>7</sup>
- ★ Updating electronic versions<sup>8</sup> and online code
- ★ Printing 3 copies

### Base page rate above excludes:

- ★ Freight
- ★ State sales tax
- ★ Images, Graphics<sup>9</sup> & tabular<sup>10</sup> matter, each
- ★ MyMunicode or online code

**Actual  
If applicable  
\$10  
Selections on page 4**

### Electronic media options for Code of Ordinances (sent via download)<sup>11</sup>

<input type="checkbox"/> Folio Bound Views	<b>\$295 initially then \$100 per update</b>
<input type="checkbox"/> WORD (DOCX)	<b>\$150 initially then \$75 per update</b>
<input type="checkbox"/> Adobe PDF of the code	<b>\$150 initially then \$75 per update</b>
<input type="checkbox"/> Adobe PDF of each supplement	<b>\$150 initially then \$75 per update</b>

**Invoices for Supplements and Additional Services will be submitted upon shipment of project(s).**

<sup>6</sup> All prices quoted in this section may be increased annually in accordance with the Consumer Price Index (CPI) for all Urban Consumers.

<sup>7</sup> Schedule for supplements can be weekly, bi-weekly, monthly, bi-monthly, quarterly, tri-annual, semi-annual, annual or upon authorization. Electronic updates can occur more frequently than printed supplements.

<sup>8</sup> We do not charge a per page rate for updating the internet; however, a handling fee is charged for PDF, Word, Folio or additional electronic media items ordered.

<sup>9</sup> Includes printing of all copies.

<sup>10</sup> Tabular matter is defined as tables, algebraic formula, or other materials that require special programs or extra editorial time to modify and prepare for inclusion in an update.

<sup>11</sup> "delivery" is defined as making updated electronic data available to you via download or FTP. Fee applies whenever content is delivered as PDF, Folio or Word, via one of the aforementioned mediums.

# ONLINE CODE HOSTING QUOTATION SHEET (MunicodeNEXT)

Online features can be purchased on an a la carte basis, or through our MyMunicode bundle for the best value. Please visit our online library of over 3,700 codes on MunicodeNEXT [here](#). **Please check the appropriate box (es) to indicate your selection:**

## STANDARD ONLINE CODE HOSTING

- |                          |                                                                                                                                                                                                                                                                                                                                                                                                                          |              |
|--------------------------|--------------------------------------------------------------------------------------------------------------------------------------------------------------------------------------------------------------------------------------------------------------------------------------------------------------------------------------------------------------------------------------------------------------------------|--------------|
| <input type="checkbox"/> | <b>Online Code = MunicodeNEXT</b> , annually <i>Fee waived for first year of online service!</i>                                                                                                                                                                                                                                                                                                                         | <b>\$450</b> |
|                          | Mobile friendly site. Full functionality and optimal screen resolution on all devices. In-line images & scrolling tables & charts. Narrow, Pinpoint & Advanced (including Boolean) Searching. Previous and Hit buttons, Persistent breadcrumb trail. Print or Save as formatted WORD (DOCX). Google Translate supports over 90 languages. Social Media/Email. Share links to sections via email, Facebook, Twitter, etc. |              |

## OPTIONAL SERVICES

- |                          |                                                                                                                                                                                                     |                            |
|--------------------------|-----------------------------------------------------------------------------------------------------------------------------------------------------------------------------------------------------|----------------------------|
| <input type="checkbox"/> | <b>CodeBank</b> annually                                                                                                                                                                            | <b>\$150</b>               |
|                          | Permanent online collection of previous versions of the code.                                                                                                                                       |                            |
| <input type="checkbox"/> | <b>OrdBank</b> annually (or per ordinance)                                                                                                                                                          | <b>\$325</b>               |
|                          | Permanent online collection of ordinances with hyperlinks from history notes, supplement history table, and code comparative table to ordinances. Applies to amendatory (included) ordinances only. |                            |
| <input type="checkbox"/> | <b>OrdBank + OrdLink</b> annually (or per ordinance)                                                                                                                                                | <b>\$425</b>               |
|                          | Provides hyperlinks from newly adopted amendatory legislation to sections of the code that will be amended.                                                                                         |                            |
| <input type="checkbox"/> | <b>CodeBank Compare + eNotify</b> <sup>12</sup> annually                                                                                                                                            | <b>\$250</b>               |
|                          | Compare any two versions of your online code (starting with the first Municode supplement). Notify provides readers email updates each time the code is updated.                                    |                            |
| <input type="checkbox"/> | <b>MuniPRO</b> Service annually                                                                                                                                                                     | <b>\$295</b>               |
|                          | Search over 3,700 online codes/ordinances. Attach notes to codes and drafts of new legislation.                                                                                                     |                            |
| <input type="checkbox"/> | <b>Custom Banner</b> one-time fee                                                                                                                                                                   | <b>\$250</b>               |
|                          | Customize MunicodeNEXT to match the look of your website.                                                                                                                                           |                            |
| <input type="checkbox"/> | <b>MuniDocs</b> <sup>13</sup> annually, upgraded self-loading capabilities                                                                                                                          | <b>\$350</b> <sup>14</sup> |
|                          | Host any other municipal documents in a fully searchable format, including Minutes, Agendas, Resolutions, Budgets and more for self-loading to the MuniDocs platform!                               |                            |

## My Municode - Value Pricing!

- |                                     |                                                                                                                                                              |                              |
|-------------------------------------|--------------------------------------------------------------------------------------------------------------------------------------------------------------|------------------------------|
| <input checked="" type="checkbox"/> | <b>MyMunicode</b> annually <i>Fee waived for the first year of online service!</i>                                                                           | <b>\$1,195</b> <sup>15</sup> |
|                                     | Includes <b>MunicodeNEXT</b> (Online Code), <b>OrdBank</b> , <b>CodeBank</b> , <b>CodeBank Compare + eNotify</b> , <b>MuniPRO</b> , and <b>Custom Banner</b> |                              |

<sup>12</sup> Enrollment in CodeBank is required in order to receive the CodeBank Compare/eNotify technology.

<sup>13</sup> Your MuniDocs files can also serve as storage for archived ordinances within the MuniDocs platform. Unlike our online OrdBank feature, these self-loaded archived ordinances will not be linked to the legislation within the online Code. All ordinances for codification and all ordinances for linking via our OrdBank feature can be emailed to us at [ords@municode.com](mailto:ords@municode.com).

<sup>14</sup> Includes up to 25 GB storage. Quotation for additional storage is available upon request.

<sup>15</sup> Total value if each item were to be purchased a la carte would be approximately \$1,470 per year with participation in our OrdBank service.

# COMPANY PROFILE

## History, Mission, and Team

With over 69 years of experience, Municode's mission is to strengthen democracy by connecting public sector organizations with their communities. Our solutions promote transparency and efficiency - such as custom website design, meeting and agenda management, the legal codification process, and our robust suite of online legislative search tools.

Municode partners with more than 4,000 government agencies across all fifty states. Municode is a privately-owned financially sound corporation. Our leadership focuses on improving Municode through investments in its people and its technology. Our culture is conducive to the longevity of our employees. Our clients can establish a long-term partnership with our experienced and stable workforce.



Municode is home to over 160 employees (most of whom enjoy a 10+ year tenure). Our headquarters in Tallahassee, Florida includes four buildings totaling 56,000 square feet. We have regional offices located in Rancho Mirage, California; Loveland, Colorado; Sarasota, Florida; Boise and Rexburg, Idaho; Carmel and Kewanna, Indiana; Stillwater, Minnesota; Charlottesville, Virginia; Hudson, New Hampshire; Asheville and Raleigh, North Carolina; Kaysville and Providence, Utah; Lake Oswego, Oregon; Fort Worth, Dallas and Edinburg, Texas.



## Our Vision: Simple, Seamless Integration

Our vision is to create seamless integration between our service offerings. The goal is to reduce staff workload, while at the same time, increasing the ability for municipalities to connect with their communities.

The following example integration points are either in place today or envisioned in our future strategic roadmap.

- Unified search across all platforms (website, meetings, online codes)
- Auto-publish agendas and minutes from the Meetings platform to the Website
- Ordinance auto-publishing from the Meetings platform to your online code, queued for supplementation, Code of ordinance cross-references to legislative voting history, minutes, and video/audio

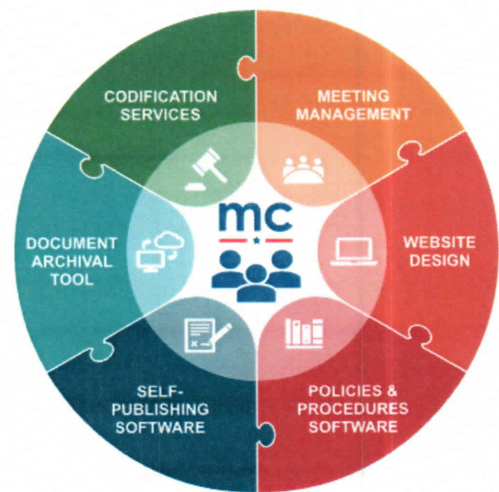



# SCOPE OF SERVICES

---

## Conversion and Republication

We will work with you to confirm the desired formatting and style of the Code. We will update the preliminary pages, create an Index (if elected) and Table of Contents; add any uncodified newly adopted legislation at the per page supplement rate quoted; update history notes; provide a comparative table of ordinances and integrate all applicable photographs, maps, diagrams, charts and tables into the Code. Proofs will then be provided for your review. Following the approval of the proofs, the Code will be shipped and posted online in fully robust HTML format.

We will handle 100% of the publishing of your Code. The republication process includes editing, page composition, proofreading, indexing (if elected), and delivering the information as printed and/or electronic copy. When we republish your Code, pages are recomposed to eliminate short pages, pages with blank backs and oddly numbered (point) pages. Following the recomposition, the Code is reprinted, and supplement number designations start over with Supplement No. 1.

The anticipated time frame for the conversion and republication project is **3 to 4 months**, excepting any delays in our receipt of materials or your return of proofs. Within 2 weeks of shipping the new Code, it will be published online in fully robust HTML format via MunicodeNEXT. The current Code can be posted online in PDF format during the conversion and republication phase, if desired.

### The process includes:

- ★ Conversion to our codification database;
- ★ Inclusion of adopted legislation can be added at the per page supplement rate quoted;
- ★ Removal and replacement of supplement numbers;
- ★ Updating of preliminary pages (title page, officials' page, and preface);
- ★ New page numbers;
- ★ Editing & proofreading;
- ★ 10-point Times New Roman font, single column format, unless otherwise instructed;
- ★ Incorporation of maps, diagrams, charts and tables;
- ★ Preparation of Table of Contents and updating or creation of an Index (if elected);
- ★ Proofs provided for your review;
- ★ Posting your newly republished Code on MunicodeNEXT;
- ★ Providing printed copies and any electronic versions specified in the format of your choice (WORD, PDF, FOLIO), as elected on the quotation sheet.

### The process does not include:

- ★ Renumbering and/or reorganizing the structure of your Code;
- ★ Legal Review by an attorney;
- ★ Substantive editing or changes to the text.

## Supplementation Services

Municode's supplementation process has been designed for timeliness, efficiency, simplicity and most of all, for our customers' convenience. Supplements can be provided on the schedule of your choice, as there is no additional cost for more (or less) frequent supplementation. In addition to printed supplements, we can deliver the updates in Word, PDF and/or Folio formats.

We pride ourselves on a turnaround time of **30 to 35 days for printed supplements** and can provide "always up to date" **electronic update services within 10 to 15 days** at the same per page rate quoted for printed supplements. With printed supplementation, the online Code is updated within **3 days** after shipping the supplement, and there is no additional fee for this service. A recent analysis of our printed supplement services indicated an editorial error rate of less than .1%, which is made possible by our attention to detail, ongoing communication with our clients, and strict quality control checks to ensure we continue to produce the best printed and electronic supplements available in our industry. Any errors attributable to Municode during the preparation, printing and maintenance of the Code will be corrected at no cost. The printed supplement process is outlined as follows:

## Supplementation Process:

1. Receipt of new legislation will be acknowledged within 24 hours. Our production support team will record the adoption date, effective date and ordinance number(s) and ensure that all necessary exhibits, tables and graphics are included. You will be advised promptly if any pertinent information is missing from your submission. Your material will then be immediately forwarded to our Supplement team for codification. If our OrdBank service is elected (advance legislation service), the legislation will be posted online within 48 hours as a PDF under "Adopted Legislation not yet codified" at this time.
2. Editorial Review – Our editorial team will review all ordinances received to determine whether the ordinance should be included in your Code; where the ordinance should be placed; whether the ordinance conflicts with your existing Code format; what material should be removed from your existing Code; whether history notes will be added; what tables will be updated and whether the Table of Contents in the front of the Code and at the Chapter/Title level should be amended. If any significant errors or numbering issues are noted, your editor will contact you for clarification. No substantive changes to your legislation will be made by our editorial team, however minor typographical errors will be corrected as part of the supplement process. Should the editorial, legal and/or proofreading team find discrepancies in your ordinances, we will communicate with you to ensure that the ordinances are correct and consistent with the existing Code.
3. Indexing – If an Index is elected, your supplement will now be sent to our indexing team, where all new legislation is indexed and cross-referenced in all appropriate locations.
4. Proofreading – The proofreader assigned to your editorial team will then examine your supplement line by line to ensure editorial accuracy, Code hierarchy and layout and to confirm that your supplement is grammatically correct and free of errors in spelling and capitalization. Your supplement is examined again line by line to ensure that the improvements made by the editorial team were thorough and accurate. During this process, the original ordinance is compared again with the newly added text to further ensure editorial accuracy.
5. Posting the supplement online (MunicodeNEXT) – After your supplement has been completed, your online Code will be updated within 1 to 2 days and any electronic products requested will be provided. You will receive notification that the website has been updated via email. If CodeBank Compare + eNotify service is elected, citizens will be notified each time the online Code is updated. When your Code is updated on MunicodeNEXT, all internal cross-reference links are updated. With our OrdBank feature, each history note will be linked to the ordinance that amended the respective section.
6. Printing and Shipping – We will print, cut, 3 hole-punch, insert divider tabs (if elected) and ship your supplement to you quarterly unless otherwise instructed. You can change your supplement schedule at any time, and there is no additional charge for more frequent supplementation. *Instruction Sheet:* With each printed supplement, we will furnish a page of instructions for removal of the obsolete pages and insertion of the new pages; as well as a *Checklist* of up-to-date pages with each supplement.

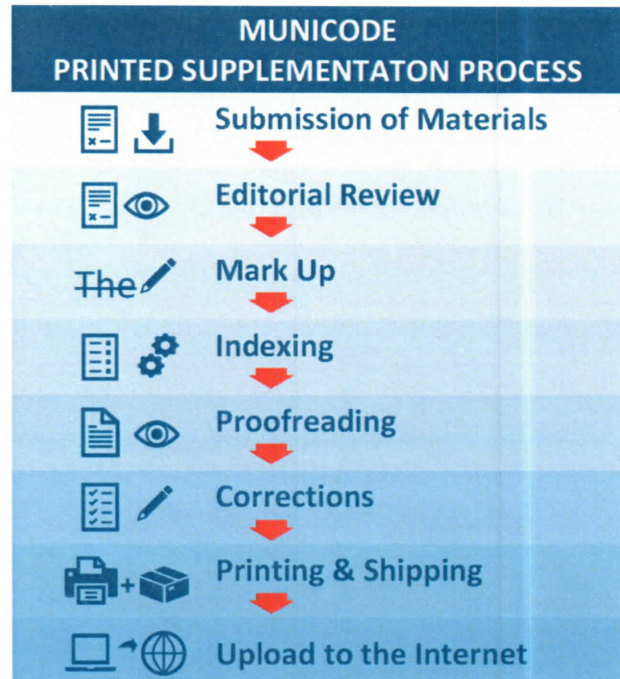

## Online Code Hosting Services (MunicodeNEXT)

Our code hosting platform, MunicodeNEXT (<https://library.municode.com>) was created and is continuously enhanced and improved by our in-house team of Internet Technology professionals. MunicodeNEXT includes Standard and Premium features (see **Attachment A**), all of which are designed to provide a wide variety of additional capabilities for the research and navigation of your code, as well as for preserving its history. Our newest free online feature, *Public Notes*, will enable you to add external links within the contents of your online Code (such as links to Zoning maps, Fee Schedules, Council Meetings, the Clerk's office, etc.) or to post public notes or documents in the online Code to inform your citizens about current issues pertinent to specific sections of your Code.

MunicodeNEXT is extremely user-friendly and requires no special training or login information. A variety of video tutorials are offered, and we can host a personalized training webinar for you and your staff to demonstrate our online features and capabilities before your new Code goes "live" online. Our MuniDocs feature enables you to upload related documents online alongside the Code in fully searchable format. Electronic viewing statistics are available upon request on the schedule of your choice. Our MuniPro feature provides the ability to search over 3,700 online Codes in our library, save frequently used or complex searches, create notes to attach to any publication and draft new ordinances.

Our powerful search engine allows users to enter simple or advanced searches and supports Boolean operators, stemming, wildcards, proximity searches, and a global synonym list. Users can easily search the code using keywords or phrases, and can print, download and/or email any portion of your code. Search terms can be applied to the entire code or narrowed to search only within specific chapters or sections. Our recent website upgrade allows users to sort results by relevance or book order! Our collapsible Table of Contents, continuous next-hit feature and internal and external hyperlinking and cross-referencing features simplify and enhance the navigation of your online code, allowing your staff and citizens the capability of simultaneously searching your code, ordinances, minutes, resolutions, budgets and more.

With MunicodeNEXT advanced features, your staff and citizens need only click the link provided on your municipality's website to access your full Code of Ordinances. They not only have access to your complete and current Code of Ordinances, but to all archived versions of your code, every official copy of your ordinances, the power to compare versions of your code over time, the ability to be notified every time your code is updated, and the ability to translate your code into over 100 languages via **Google Translate**, which is included at no additional charge.

MunicodeNEXT is designed with accessibility in mind. Our application is fully responsive, ensuring all features are available on appropriately sized desktop, tablet, and smartphone viewports. Designed to provide easy access and an intuitive interface, it is extremely well-suited for use on tablets and mobile devices running iOS or Android. With delivery also available in Word, PDF and Folio format, the Code can be viewed and researched offline.

The User Interface and all HTML content viewed via our MunicodeNEXT web application is WCAG 2.1 Level AA compliant. While we take several steps to improve the accessibility of PDF documents uploaded to the MunicodeNEXT platform, we cannot guarantee full ADA compliance of PDF documents. If a fully ADA compliant PDF document is uploaded to our MunicodeNEXT platform, it will remain compliant while stored in our system. For each PDF document that is uploaded to our platform, we OCR scanned PDFs; set document title, primary language, and other PDF metadata fields; and automatically create a base level of tags to be used by screen readers.

Our tech stack includes HTML5 & CSS3, Javascript (AngularJS), and a RESTful API written in C# running on .Net Core. All content is rendered in standard HTML and is viewable in all modern browsers including PC: Microsoft Internet Explorer 10 or later, Firefox 3.6 or later, macOS®: Safari™ 5.0 or later, and Chrome 18 or later. We host MunicodeNEXT in Microsoft's Azure Government secure cloud environment and guarantee an SLA of 99.95% uptime. SSL encryption is used by default to secure access to the site and the entire platform is backed up to multiple geographic locations within the Azure Government cloud ecosystem.

## MunicodeNEXT Premium Feature Summary

- ★ **OrdBank** will create one click access to every ordinance via linked history notes. Ordinances are permanently stored online in the OrdBank repository and filed in annual folders.
- ★ **CodeBank** will enable you to have instant access to past versions of your Code after each supplementation.
- ★ **CodeBank Compare + eNotify** provides you with the ability to select a past version of your online Code and compare it to any other version of the Code each time the Code is updated. The differences will be shown via Highlights (added materials) or Strikethrough (deleted material). **eNotify** allows users to enroll to receive an email notification each time your online Code is updated. A “modified,” “removed” or “added” badge is shown within the online table of contents to alert users of recently amended sections of your Code.
- ★ **OrdLink** will create highlights within your online Code to help users identify what ordinances have been recently adopted and what Code sections have been amended.
- ★ **MuniDocs** will enable you to self-upload your Minutes, Agendas, Policies, Procedures, etc. alongside your Code for quick and easy access.
- ★ **MuniPRO** allows you to search over 3,700 Codes in the Municode library, save frequently used or complex searches, create notes to attach to any publication and draft new ordinance

## ADDITIONAL SERVICES AVAILABLE FOR PURCHASE

Municode offers a wide variety of services, all of which have been designed primarily to serve local governments. Please contact us for information and pricing on any of the services listed below, all of which may be purchased under this contract and all of which are competitively priced.

### Website Design and Hosting Services

Let our team of web analysts and developers create or redesign a website for your municipality that provides your staff and citizens with a stunningly beautiful website that is simple for staff to use, easy for citizens to access, responsive, interactive, dynamic, and extremely efficient! Using the popular Drupal, open-source framework, we will work with you to understand your history, anticipate your future, define your priorities and achieve the long-term goals of your community.

When Municode designs your completely mobile friendly website, our goal is to improve your image and your community profile, increase the self-service capacity of your residents, and empower your staff to create, edit and maintain website content as simply and efficiently as possible. The result will be an unparalleled municipal website solution at a very compelling price.

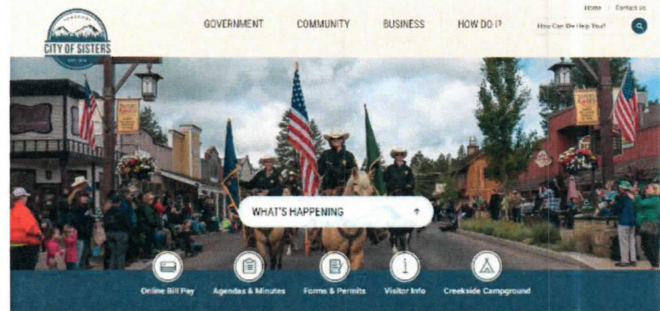

[Request MunicodeWEB Demo/Proposal](#)

### Meeting and Agenda Management

Municode provides a cloud-based agenda meeting management system that enables our clients to save time and money by streamlining and automating the agenda process. With zero set-up requirements, minimal budget impact, built in automatic upgrades and internal and external IT support issues managed directly by Municode's expert team of web analysts and system developers, your staff will spend significantly less time on agenda management, while still maintaining total administrative control of your agenda packets.

Municode provides the highest level of government transparency to your citizens. We will show you how to live stream your meeting videos at no cost and can provide archived video and audio linking capabilities that will allow your constituents to access the exact point in the meeting video where a specific piece of business is discussed. You can take roll call and record votes live in the meeting – and legislators can also vote directly from their Mac, PC, iPad, or Android device!

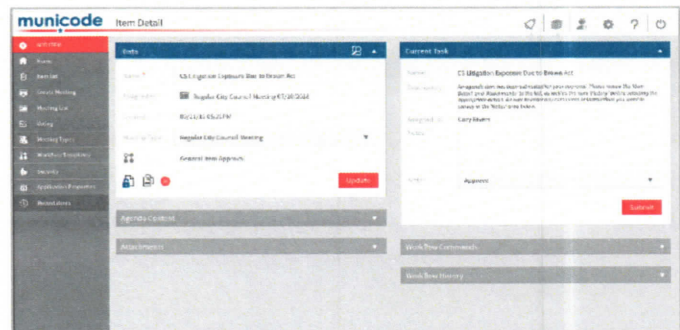

Other benefits include agenda process visibility, easy agenda updates, approval workflow, live Council voting & roll call, Email notifications, a Unified Document Search and automated approval routing. When you are ready to publish your Agenda, our “single click publishing” will provide you with automatic agenda and packet creations.

[Request MunicodeMEETINGS Demo/Proposal](#)

## Payment Solutions - Point and Pay

Our preferred payment solutions partner Point & Pay (<https://www.pointandpay.com/>) makes paying bills easier! Everything they do is backed by their best-in-class user interfaces, insightful features and high-quality service and support. Point and Pay can assist in processing City/County taxes, utility bills, permits & licensing, and more. With a focus on mobile interfaces, they enable your customers to conveniently pay bills whenever and wherever they want!

[Request Point and Pay Demo/Proposal](#)

## MCCi Services:

### **Laserfiche Enterprise Content Management Software and Services**

MCCi understands the challenges organizations face every day with paper-based processes. We provide innovative solutions that transform these challenges into smart practices that improve efficiency, productivity and organizational structure. Recognized as one of the nation's top 20 Most Promising Government Technology Solution Providers, we are also the largest Laserfiche provider in the world. MCCi is passionate about helping organizations run their office more efficiently – saving time, money and resources! With 900 clients nationwide, MCCi is the largest provider of Laserfiche solutions in the world.

### **Digital Imaging Services**

Through MCCi, Municode can help with your digital imaging services needs include scanning, indexing and integration of hard copy documents, electronic documents, and microfilm/microfiche. MCCi provides the most powerful index retrieval search engine available.



### **Open Records Request Software**

JustFOIA is an affordable, easy to use, completely web-based hosted service that was created specifically to help you manage and track public records requests. Since JustFOIA is completely web-based, you are able to login anywhere that has an internet connection. You simply type in your customized web address and enter your credentials, safely and securely. Your service is available 24/7, every single day of the year.



**JustFOIA** helps agencies receive, track and report on open records requests. JustFOIA is a hosted solution that is user-friendly, affordable, and integrated with Laserfiche Enterprise Content Management.

[Request MCCi Demo/Proposal](#)

## **Internet-based Document Editing and Presentation System**

**enCodePlus** is a unique Internet-based document editing and presentation system used for authoring, displaying, and managing all aspects of land development regulations or zoning ordinances. Developed by community planners, **enCodePlus** assists in the creation of land development and zoning ordinances that are fully customizable, easy to navigate and rich with features including GIS interactive mapping, a "Land Use Look Up" tool, hyperlinking to outside resources, historical archiving and in-line graphics.

From its humble beginnings as a stand-alone Windows PC program, **enCodePlus** has matured to meet the needs of an innovative and exacting group of land use code writers and their client communities. To learn more about how **enCodePlus** can be an economic driver for your municipality and positively impact the transparency and navigability of your zoning or land development ordinance, please visit this link: <http://www.encodeplus.com/>



[Request enCodePlus™ Demo/Proposal](#)

## SIGNATURE PAGE

---

This proposal shall be valid for a period of ninety (90) days from the date appearing below unless signed and authorized by Municode and the City of Ketchum, Idaho.

**Term of Agreement.** This Agreement shall begin upon execution of this Agreement and continue for a period of three years. Thereafter, the supplement service shall be automatically renewed from year to year provided that either party may cancel or change this agreement with sixty (60) days written notice.

**Submitted by:**

MUNICIPAL CODE CORPORATION

Municode Officer: 

Title: Bob Geiger, Vice President of Sales

Date: December 1, 2020

**Accepted by:**

CITY OF KETCHUM, IDAHO

Signature: 

Printed Name: Neil Bradshaw

Title: Mayor

Date: December 8, 2020



## **ATTACHMENT A**

### **MunicodeNEXT Standard & Premium Features**



# STANDARD FEATURES OF MunicodeNEXT

**Responsive Design** – Our team designed MunicodeNEXT to function on any device. Over 20% of our traffic is generated from a smartphone or tablet. Our user interface, based on Google's Material Design guidelines, ensures any device that accesses our application will have access to our full suite of features.

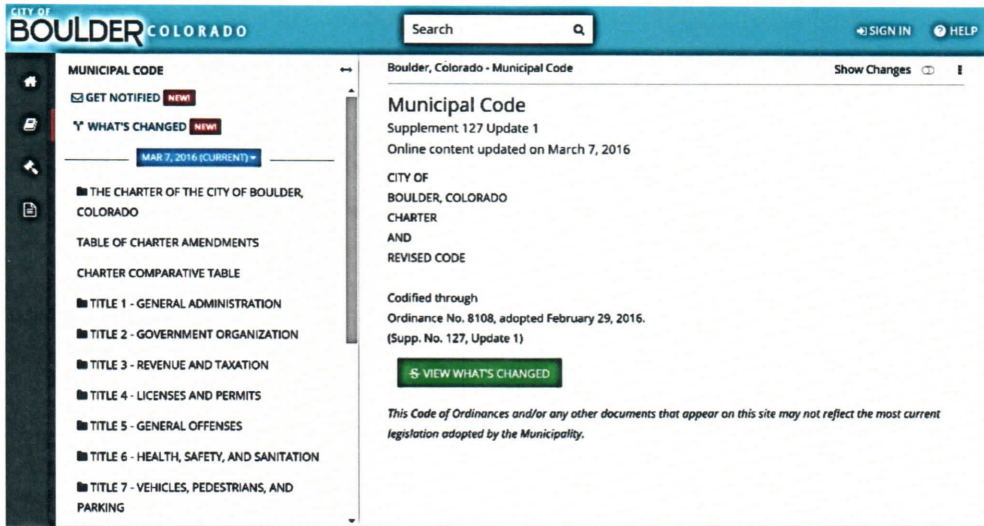

**Mobile and Tablet friendly** – Our application uses touch friendly icons, easy to access menus, and fly overs to expose all functionality while maintaining a clean, intuitive interface.

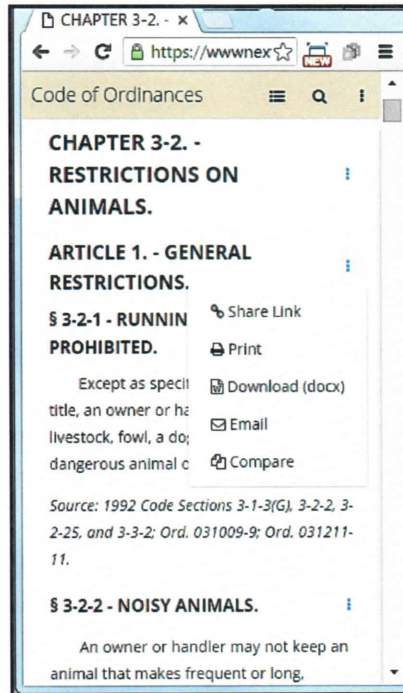

**Print/Save/Email** – Users can print, save (as WORD) or email files at the section level, as well as at the article or chapter level. You can print, save or email non-sequential sections from multiple portions of your Code(s). Not all codification companies enable you to download WORD documents directly from the website. Being able to do so greatly enhances your ability to draft new legislation.

**Searching** – Municode leverages a powerful open source search platform that also powers sites such as Stackexchange, Github, and Wikipedia. Search starts on a dedicated page, then moves to a persistent right-hand sidebar as you cycle through the results. This enables you to quickly move through search results without clicking “back” to a search results page. The Code is also indexed by the section, returning more accurate, granular results. Search results can be sorted by relevance or book order as seen in the screenshot below.

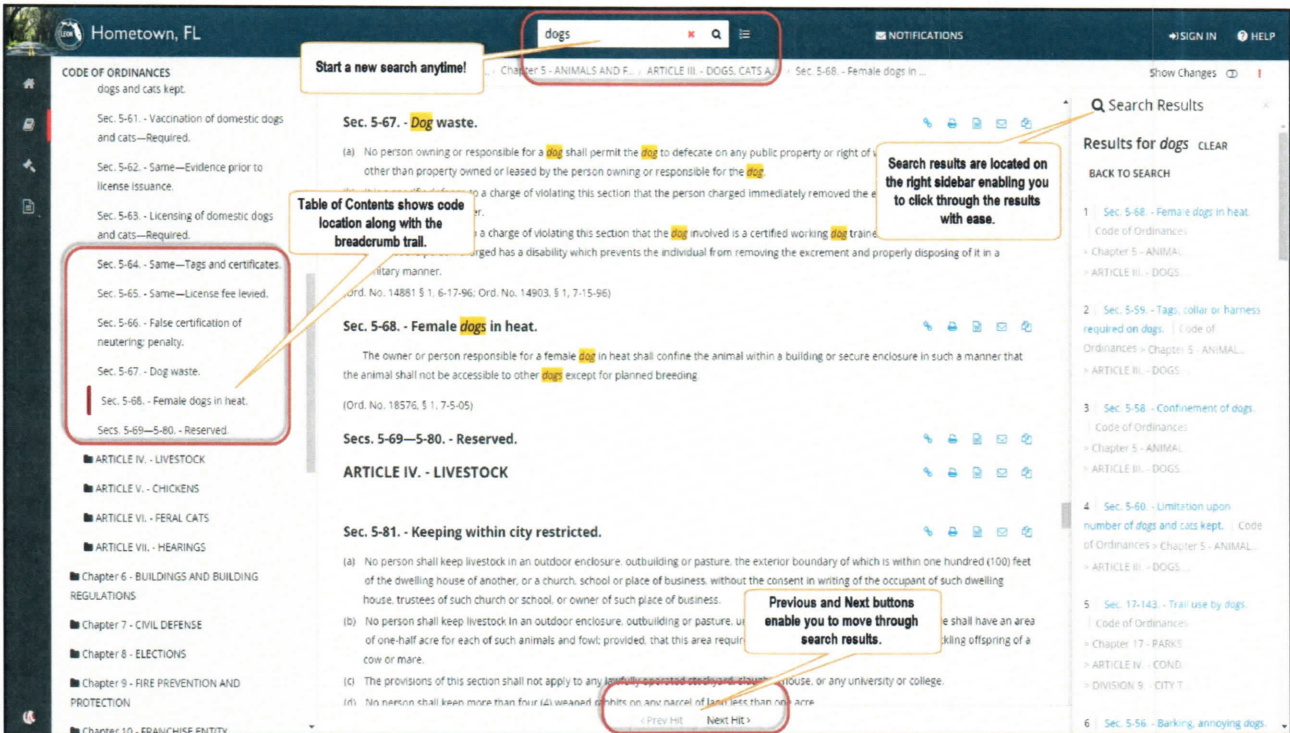

**Municode Search Components:**

- ★ **Advanced Searching** – You and your power users can conduct searches using Natural Language (think Google) or Boolean Logic.
- ★ **Multiple Publications** – If you have multiple publications (Code, zoning, etc.), they will all be searchable from one interface.
- ★ **Searchable ordinances** – With our OrdBank service, ordinances posted pre and post-codification are full-text searchable.
- ★ **Searching all content types** – If you use our OrdBank or MuniDocs service, you can search any combination of the Code, ordinances, and MuniDocs simultaneously. Search results are labeled for easy identification.
- ★ **Narrow Searching** – Your users could search selected chapters or titles in order to pinpoint their searches and find what they are looking for as quickly as possible!
- ★ **Stored Searching** – MunicodeNEXT allows all search result listings to be bookmarked under your browser’s bookmark tabs. Users need only conduct a search and press Ctrl+D to add the search result listing to your browser’s tabs.

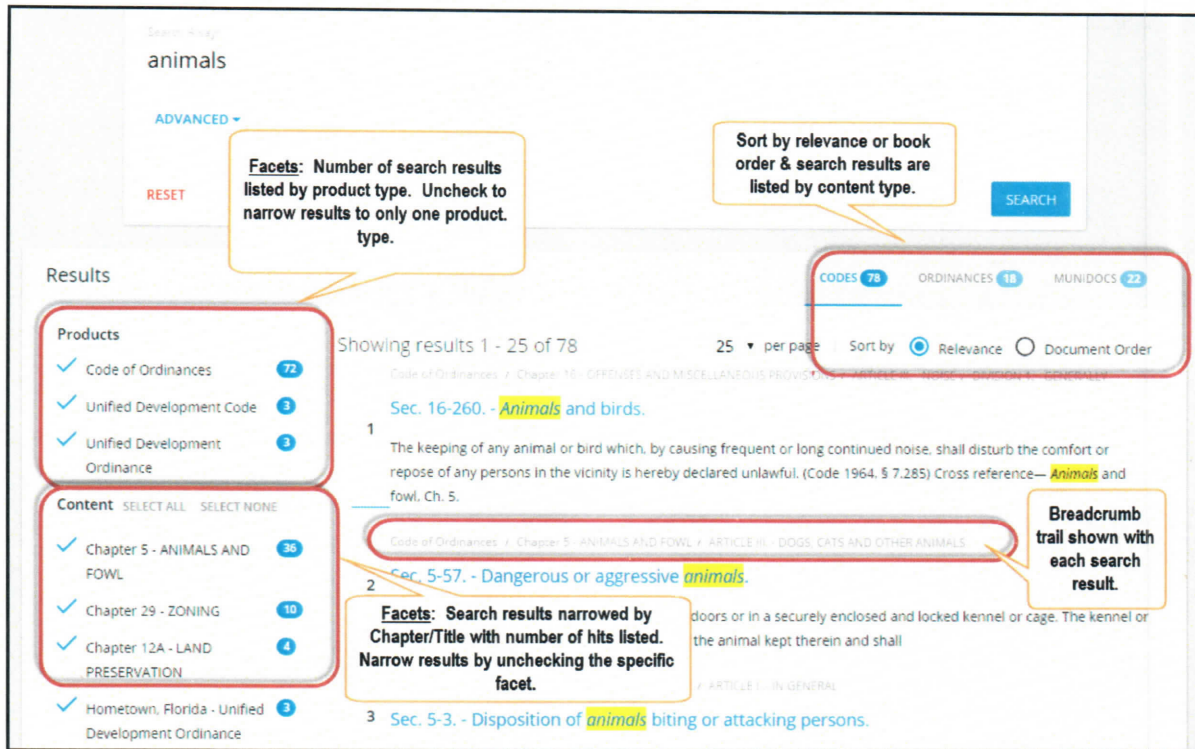

**Search enhancements provided with our latest website upgrade include (see screenshot above):**

**Browsing** – MunicodeNEXT provides a persistent breadcrumb trail when browsing or searching and a Previous/Next button at the top and bottom of any document you’re viewing. The table of contents and content pane also stay in sync as you scroll to deliver the most intuitive reading experience possible.

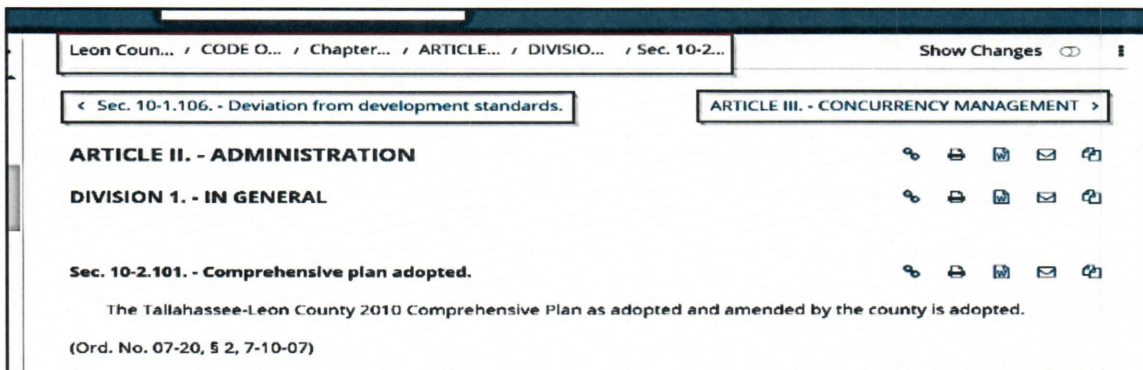

- ★ **Internal Cross-Reference Linking** – Cross-references within your Code are linked to their respective destination Article, Chapter or Section.
- ★ **Collapsible TOC** – The table of contents collapses, providing additional real estate with which you may view your Code. Easily view your maps, graphs and charts by simply enlarging the item.
- ★ **Mouseover (cluetips)** – Navigate to your Code and any linked cross-reference will quickly display in the pop-up preview window.
- ★ **Google Translate** – includes the Google Translate plugin, allowing users to view and navigate our hosted Codes in over 100+ languages.

(Cross-reference linking and mouseover shown below)

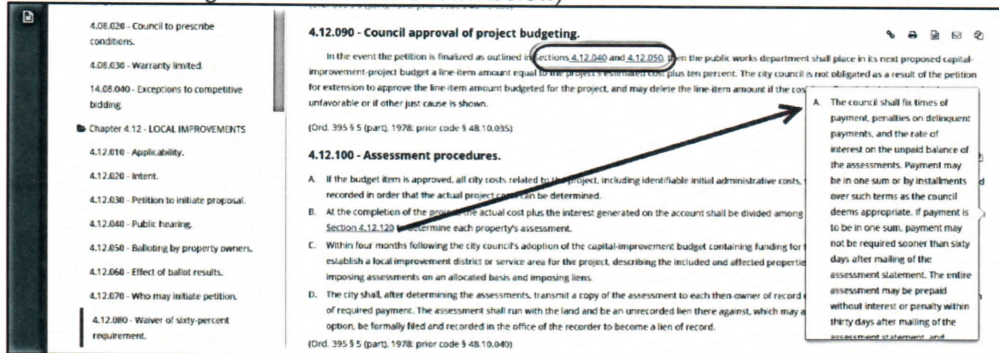

**Translation** – MunicodeNEXT includes the Google Translate plugin, allowing users to view and navigate our hosted Codes in over 100+ languages.

**Social Media Sharing** – You and your users are able to share Code sections via Facebook and Twitter. This will make it easier for you and your team to utilize social media in order to engage your citizenry and enhance your level of transparency.

**Static Linking** – Copy links of any section, chapter or title to share via email or social media.

**Scrolling Tables and Charts** – Headers stay fixed while you scroll through the table/chart.

**GIS** – We can provide a permalink to any Code section and assist staff to create a link from your GIS system to relevant Code sections.

**In-line Images & PDFs** – We take great care to ensure that your images match online and in print and are captured at the highest quality possible. Our online graphics can be enlarged by hiding the table of contents to maximize the image. Municode can also incorporate PDFs of certain portions of the Code that have very specific viewing and layout requirements.

**Website Accessibility** – Our current website complies with level A of the Web Content Accessibility Guidelines (WCAG) 2.1.

**Support** – Phone, email and web support for citizens and staff: 24-hour email response; phone support from 8:00 a.m. to 8:00 p.m. (Eastern). A variety of video tutorials are offered, and we are always available to host a personalized webinar for you and your staff to demonstrate our online features.

# PREMIUM FEATURES OF MunicodeNEXT

**Custom Banner.** We can customize the look and feel of your Code to more closely match your website. Please note the custom banners in each of the screenshots provided in this sample.

**OrdBank.** With our OrdBank solution, newly adopted legislation will be posted online in between supplements. Upon the completion of your supplement, the ordinances will be linked in your history notes and stored in your OrdBank Repository under the “OrdBank” tab.

*Hyperlinked ordinance in text)*

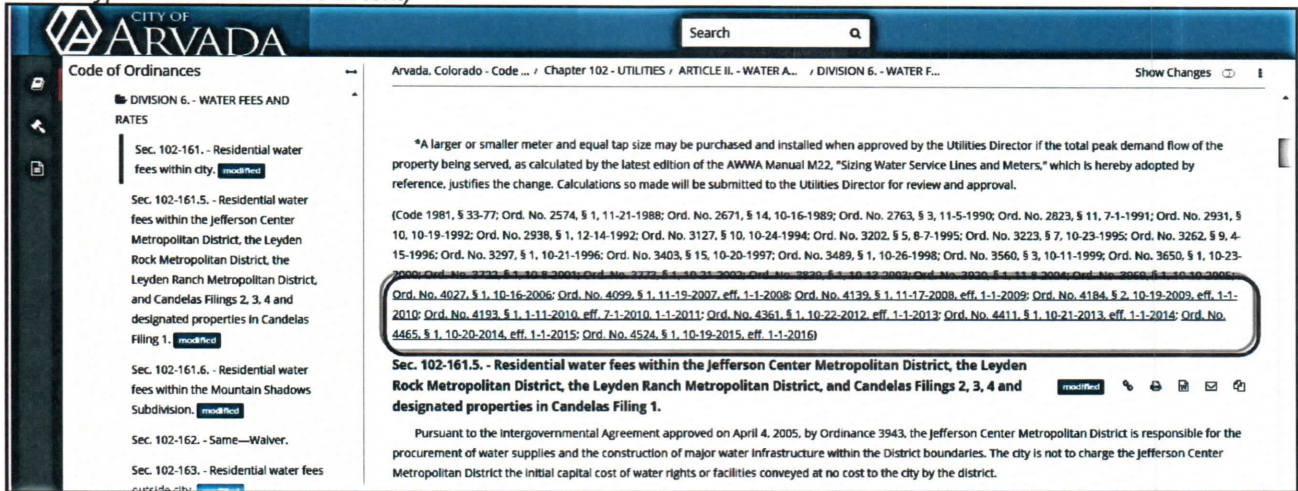

*(One-Click access to the original ordinance in the OrdBank Repository)*

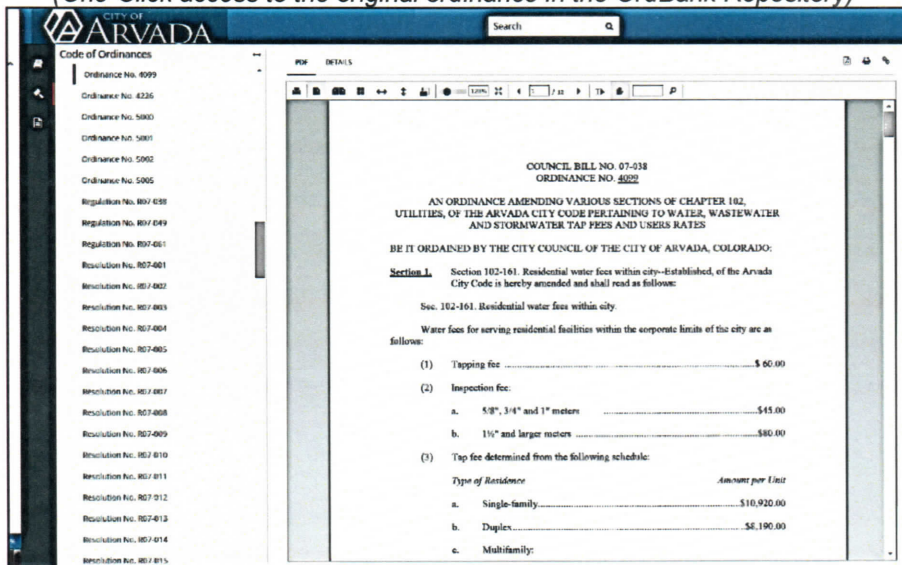

**OrdLink + OrdBank.** Prior to incorporating the ordinances into your Code via supplementation, the OrdLink feature can hyperlink newly adopted ordinances to the section being amended. Linked sections are highlighted in the table of contents and links are created from the amended sections to the new ordinances. Once the linked ordinances are incorporated into your Code, they are added to your OrdBank repository and hyperlinked to your history notes. This service lets everyone know that new ordinances have been adopted.

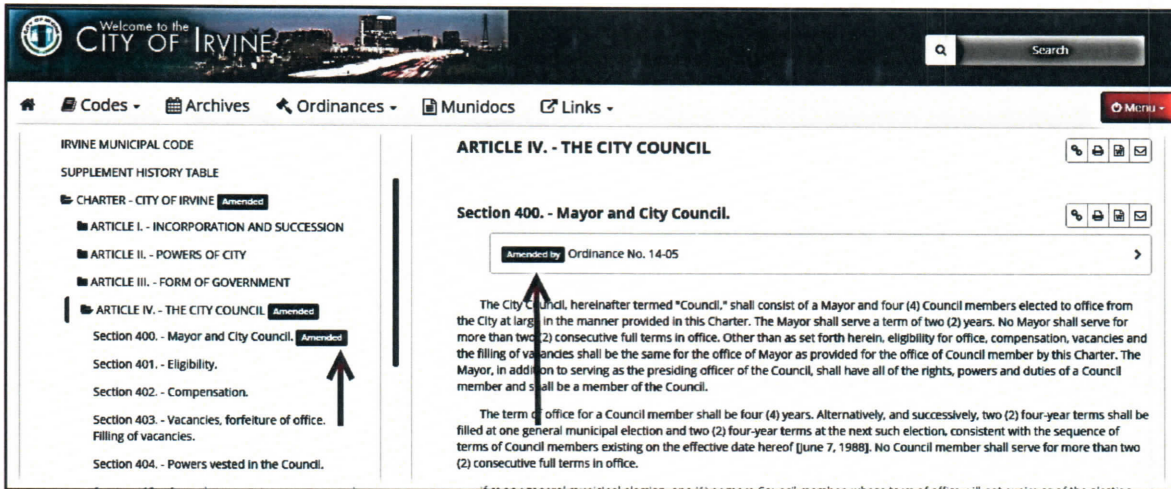

**CodeBank.** Our CodeBank feature provides an online archival platform for previous supplements of your Code. Empower your staff and citizens to access every previous version of your Code with one click.

(CodeBank Tab)

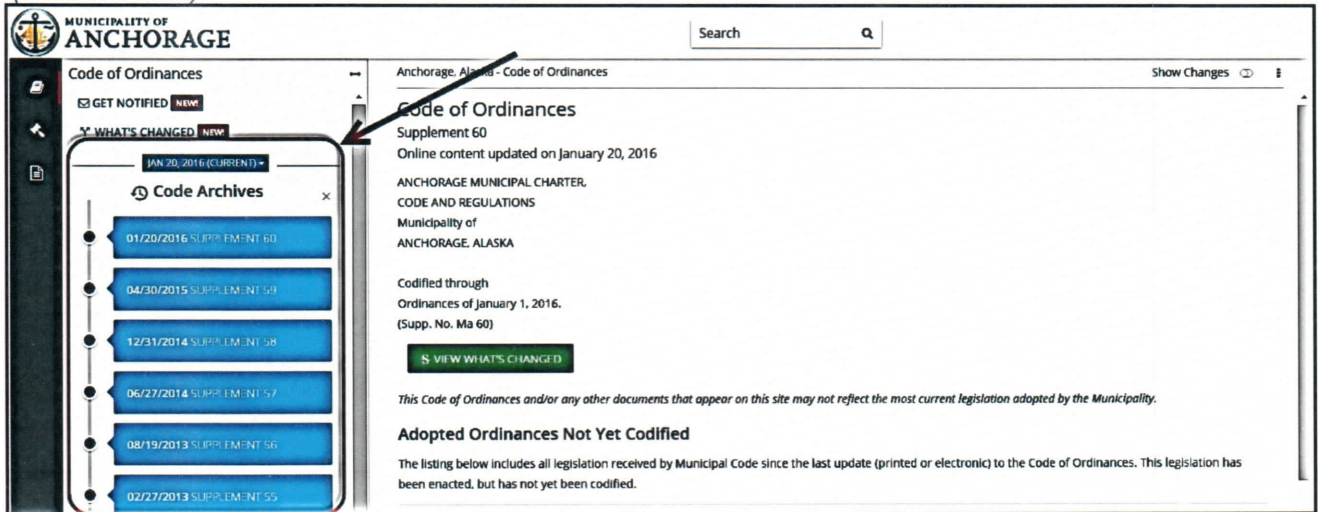

**CodeBank Compare.** Our CodeBank Compare service is a powerful feature that provides users the ability to select a past version of your online Code and compare it to any other version of your online Code. The differences will be shown via highlights (added material) or strikethrough (deleted material). The CodeBank feature is required in order to access CodeBank Compare. Users will be notified of the changes in the table of contents and within the text of the Code via “modified,” “new” or “removed” badges. Users can also select an option to view all of the changes in a single view, complete with strikethrough and highlights showing the specific textual changes that were made. The CodeBank Compare service will show all amendments to your Code that were implemented during the most recent update.

**eNotify.** Our eNotify service allows users to enroll online and receive email notifications each time your online Code is updated. This will empower your staff and citizens to receive instant notifications every time your online Code is updated. The CodeBank Compare feature is required in order to utilize the eNotify service.

**Get Notified**

Filling out this form will allow you to receive an email notification every time select publications are updated.

**Note:** If you no longer wish to receive these notifications once signed up, you can unsubscribe via a link in the notification email.

Email  
Enter email

Profession  
Select One

Codes

- Unified Development Code
- Unified Development Ordinance
- Code of Ordinances

**Sign up to be notified for all publications or narrow notifications to only one product.**

Compare enhancements provided with our latest website upgrade include the ability to show changes in every version of the Code stored in CodeBank.

*(Changes are shown in your Text Changes Tab and in your Table of Contents)*

**MUNICIPALITY OF ANCHORAGE**

Code of Ordinances

Chapter 2.30 - RULES OF PROCEDURE FOR ASSEMBLY

- 2.30.010 - Organization: election of chair and vice-chair.
- 2.30.020 - Protesting calls.
- 2.30.030 - Meetings.
- 2.30.040 - Appearance requests and audience participation.
- 2.30.050 - Introduction of ordinances; action on ordinances.
- 2.30.055 - Conduct of public hearing.
- 2.30.060 - Public hearings and action on proposed resolutions.
- 2.30.070 - Voting.

ANCHORAGE, Alaska - Code of Ord... - TITLE 2 - LEGISLATIVE BRANCH - Chapter 2.30 - RULES OF PROCEDURE...

**Show Changes**

**CHANGED SECTIONS**

- ANCHORAGE MUNICIPAL CHARTER, CODE AND REGULATIONS
- SUPPLEMENT HISTORY TABLE
- TITLE 2 - LEGISLATIVE BRANCH Chapter 2.30 - RULES OF PROCEDURE - 2.30.030 - Meetings
- TITLE 2 - LEGISLATIVE BRANCH Chapter 2.50 - INITIATIVES, REFERENDUMS, AND PETITIONS - 2.50.090 - Effect of vote.
- TITLE 3 - ADMINISTRATION / Chapter 3.20 - EXECUTIVE ORGANIZATION - 3.20.010 - Executive and administrative order.

*(Show changes button and a custom banner are shown below)*

**City of Bonita Springs Florida**

Code of Ordinances

**GET NOTIFIED** **NEW**

**WHAT'S CHANGED** **NEW**

JAN 29, 2016 (CURRENT)

BONITA SPRINGS CITY CODE

PREFACE

SUPPLEMENT HISTORY TABLE **modified**

CHARTER

ARTICLE I. - [IN GENERAL]

ARTICLE II. - [EFFECTIVE DATE]

Bonita Springs, Florida - Code of Ordinances

**Code of Ordinances**

Supplement 2

Online content updated on January 29, 2016

BONITA SPRINGS CITY CODE

Codified through Ordinance No. 15-27, enacted December 2, 2015. (Supp. No. 2)

**VIEW WHAT'S CHANGED**

**Show Changes**

*This Code of Ordinances and/or any other documents that appear on this site may not reflect the most current legislation adopted by the Municipality.*

**MuniDocs.** MuniDocs Upload allows you to upload many types of documents to browse and search alongside your online code and is fully searchable and filterable. After user's login, they are presented with a dashboard that allows them to upload new documents and manage previously uploaded documents. When uploaded, users are able to pick from a list of predefined document types

- Name
- Minutes
- Agendas
- Budgets
- Resolutions
- Applications
- Forms
- Policies
- Manuals
- Misc. Documents

Uploading a document is as simple as dragging and dropping the document from your computer into the upload dialog box on the admin dashboard. Uploaded documents are immediately converted to PDF and indexed for search. Users may upload .rtf, .doc, .docx, and .pdf documents and organize these documents by nested folders. The public can then browse and search these documents immediately.

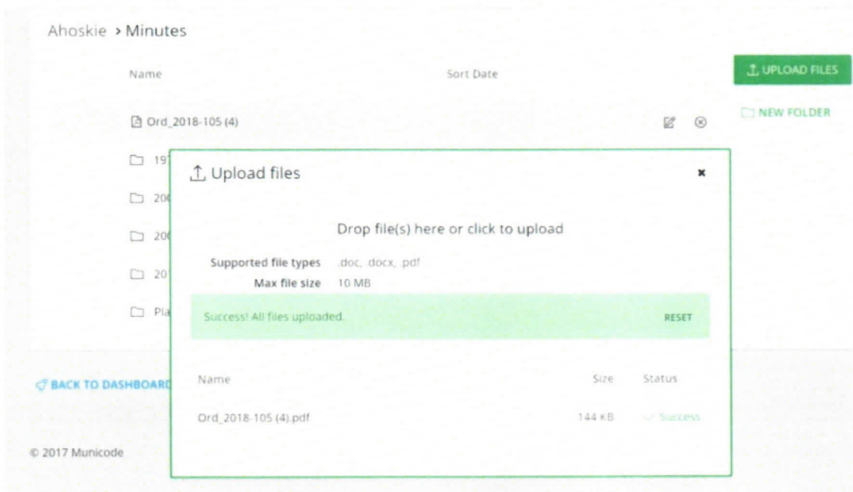



**MuniPRO.** MuniPRO Searching allows you to search the over 3,700 Codes we host (the entire country, a single state or individually selected Codes of your choosing). MuniPRO searches are ideal for researching local regulations of special interest or to find out how other communities are dealing with similar issues. If the IP based model is selected, only Multiple Code Searching is available. MuniPRO provides subscribers with the following tools:

- ★ **Multiple Code Search.** Search all Codes within one state, multiple Codes within one state, or search all Codes in the entire US hosted by Municode. Search results are sorted by relevancy and indicate the source publication, showing excerpts and keyword highlighting.
- ★ **MuniPRO Saved Searches.** Save frequently used or complex searches for easy retrieval from the MuniPRO Dashboard.
- ★ **MuniPRO Notes.** Create a note and attach it to any section in any publication. Note icons are present when viewing the section, alerting the user to a previously written note. A global listing of notes can be accessed and managed from the MuniPRO Dashboard.
- ★ **MuniPRO Drafts.** Begin a new ordinance draft to keep track of pending legislation. Drafts icons are present when viewing the section, alerting the user to a previously created draft. A global listing of drafts can also be accessed and managed from the MuniPRO Dashboard.

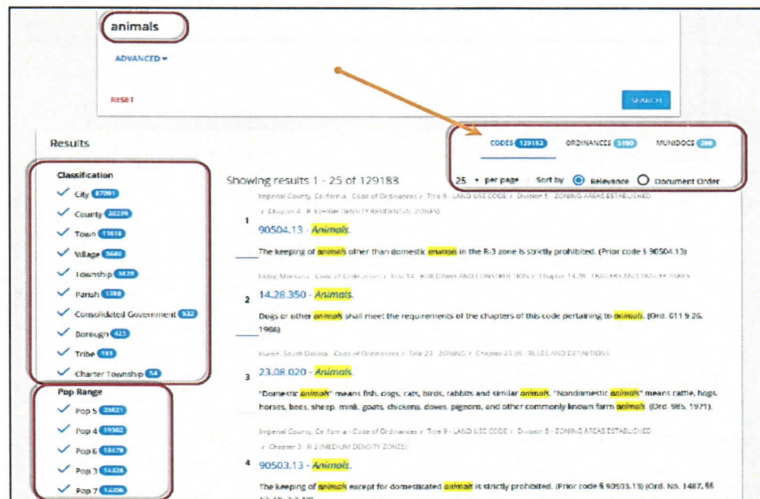



## City of Ketchum

August 16, 2021

Mayor Bradshaw and City  
Councilors City of Ketchum  
Ketchum, Idaho

Mayor Bradshaw and City Councilors:

### **Recommendation to Approve Integrated Technologies Copy / Print Service Lease Contract.**

#### Recommendation and Summary

Staff requests Council authorize the Mayor's signature on Contract #20679 with Integrated Technologies to provide Xerox print equipment, installation and service at a cost of \$ 826.10 per month, or \$ 9,913.20 annually.

**"I move to authorize the Mayor to sign the Intergrated Technologies Contract #20679, approving a monthly service payment of \$ 826.10, for copy and print equipment and services."**

The reasons for the recommendation are as follows:

- Copy and print equipment was reviewed per contract end-date with Fisher Technology in 6/2021
- RFP's were requested, vendor bids reviewed and measured against the following criteria, per Procurement policy:
  - Cost
  - Right equipment selection based on business need and use data
  - Local affiliations / reputation w/other government agencies
- Standardizing equipment across all operations
- Retiring and/or recycling old and/or un-used equipment prior to New City Hall and New Fire Station relocations

#### Introduction and History

Current copy and print services, provided by Fisher Technology, contracted in 5/2016, expired in 5/2021. In accordance with procurement guidelines in Idaho Code Title 67, Chapter 28, the City of Ketchum gathered bids to review copy and print services for all City locations and operations.

#### Analysis

Integrated Technologies, Fisher Technology and Valley Office Systems provided the City recommendations for equipment and services in pursuit of a 5-year lease / Service contract.

#### **Summary of Bid Detail:**

solutions to best serve business need. <ul style="list-style-type: none"> <li>• Provided quote for three equipment options including accessories.</li> <li>• Provided insight for how other Idaho cities were approaching copy and print services to reduce expense.</li> </ul>	existing equipment. <ul style="list-style-type: none"> <li>• Provided quote to renew existing services, noting additional cost for accessories.</li> </ul>	refurbished equipment. <ul style="list-style-type: none"> <li>• Provided quote for two equipment options that did not have full accessories required by business use.</li> </ul>
---------------------------------------------------------------------------------------------------------------------------------------------------------------------------------------------------------------------------------------------------------------------------------	------------------------------------------------------------------------------------------------------------------------------------------------------------	----------------------------------------------------------------------------------------------------------------------------------------------------------------------------------

**Monthly Pricing Summary:**

<b>Integrated Technologies</b>	<b>Fisher</b>	<b>Valley Office Systems</b>
<b>\$ 826.10</b> includes service and needed accessories.	<b>\$ 870.47</b> includes service, no required accessories.	<b>\$ 1,977.99</b> includes service on discontinued / refurbished products, does not have all needed accessories.

**Integrated Technologies was the lowest bidder and confirmed local service availability (Wood River Valley / Blaine County).**

*"...we have 9 technicians, with one of them lives in the Wood River Valley."*

Sustainability Note

Integrated Technologies will provide appropriate removal and recycling of existing equipment.

Financial Impact

The City of Ketchum will recognize the following reduced cost from the approval of Contract # 20679 (comparison analysis was based on current solution vs. recommended solution).

<b>Monthly</b>	<b>Life of Contract – 5 Year</b>
\$ 280.46	\$ 16,827.51

Sincerely,

*Tara Fenwick*

Tara Fenwick  
City Clerk

Attachments:

- Integrated Technologies Monthly Rate Quote / Contract #20679
- Integrated Technologies Analysis / Cost Savings
- Integrated Technologies Products
- Fisher Technologies Quote
- Valley Office Services Quote



# EQUIPMENT SALES CONTRACT & SECURITY AGREEMENT

Serving all of Southern Idaho and Northern Utah

SALE  LEASE  RENTAL

CUSTOMER AGREES TO PURCHASE AND INTEGRATED TECHNOLOGIES AGREES TO SELL IN ACCORDANCE WITH THE TERMS AND CONDITIONS OF THIS AGREEMENT. THE EQUIPMENT AND / OR GOODS LISTED BELOW AT THE PRICES SHOWN

Qty	Model Description	Unit Price	Total Price P/Mo.
3	Xerox AL C8145H2 Color MFP's		\$ 826.10
5	Xerox AL C8130T2 Color MFP's		Included
2	Xerox AL C405DNM Color MFP's		Included
6	HP CLJ Pro M479fdw Color MFP's		Included
2	HP LJ Pro M406DN B/W Printers		Included
	(City Hall Floor 3 includes finisher, fax, hole punch & high capacity feeder)		
	(Police includes tray & stand)		

NO TERMS OR CONDITIONS, EXPRESSED OR IMPLIED, ARE AUTHORIZED UNLESS THEY APPEAR ON "ORIGINAL" OF THE AGREEMENT, SIGNED BY THE CUSTOMER AND AN OFFICER OF INTEGRATED TECHNOLOGIES. THIS AGREEMENT IS NON-CANCELLABLE

TERMS  NET 10 DAYS  PO #

Sub Total	\$	826.10
Less Discount/Rebate		Applied
Taxable Amount	\$	-
8% Percent State & local Tax	\$	-
Delivery / Installation Charge		Included
<b>TOTAL PRICE</b>	<b>\$</b>	<b>826.10</b>

### MAINTENANCE AGREEMENT

CHECK ATTACHED  DEPOSIT

ANNUAL M/A  COST PER COPY COST PER COPY QUOTE See Proposal CHECK # \_\_\_\_\_ AMOUNT \$ \_\_\_\_\_  
 PER CALL  SEND CONTRACT MINIMUM TRADE-IN  YES  NOMAKE \_\_\_\_\_  
 90 DAY WARRANTY (EXCLUDES REGULAR MAINTENANCE) MODEL \_\_\_\_\_ SERIAL # \_\_\_\_\_

### SPECIAL INSTRUCTIONS:

Integrated Technologies will pick-up & return old equipment to leasing company. Raw shipping costs to be invoiced to City of Ketchum.

Estimated delivery date - Middle of August through September, depending on equipment availability and building completions.

60-month FMV lease at \$826.10 per month

### CUSTOMER ACCEPTANCE ("CUSTOMER")

BILL TO: Tara Fenwick SHIP TO: \_\_\_\_\_  
 COMPANY NAME: City of Ketchum COMPANY: Same  
 ADDRESS: 480 East Ave N ADDRESS: \_\_\_\_\_  
 CITY / STATE: Ketchum, Idaho 83340 CITY/STATE: \_\_\_\_\_  
 PHONE: (208) 727-5073 FAX: \_\_\_\_\_  
 ACCEPTED BY: \_\_\_\_\_ DATE: \_\_\_\_\_  
 MARKETING REPRESENTATIVE: Mike McCurdy DATE: 7/22/2021

### INTERNAL USE ONLY

LEASE CO: \_\_\_\_\_ FND: \_\_\_\_\_ BO/UPG: \_\_\_\_\_

City of Ketchum

<u>City Hall Floor 3</u>	<u>Model</u>	<u>Investment</u>	<u>B/W AMV</u>	<u>Color AVM</u>	<u>B/W CPP</u>	<u>Color CPP</u>	<u>Total Cost</u>
Admin Color MFP	Xerox AL C8145H2	\$5,000.00	4,719	2,907	0.0079	0.05	\$182.63
	Office Finisher/Stapler	\$806.59					
	2/3 Hole Punch Unit	\$249.60					
	High Capacity Feeter	\$884.25					
	Fax Kit	\$824.25					
Envelope Printer	Envelope Tray	\$0.00	405	0	0.0079	0.05	\$3.20

<u>City Hall Floor 2</u>	<u>Model</u>	<u>Investment</u>	<u>B/W AMV</u>	<u>Color AVM</u>	<u>B/W CPP</u>	<u>Color CPP</u>	<u>Total Cost</u>
Admin Color MFP	Xerox AL C8145H2	\$4,797.00	1,710	738	0.0079	0.05	\$50.41
Admin Color MFP	Xerox AL C8145H2	\$4,797.00	1,710	738	0.0079	0.05	\$50.41
Check Printer	HP LJ M406dn	\$549.00	140	0	0.015	0	\$2.10

<u>City Hall Floor 1</u>	<u>Model</u>	<u>Investment</u>	<u>B/W AMV</u>	<u>Color AVM</u>	<u>B/W CPP</u>	<u>Color CPP</u>	<u>Total Cost</u>
Admin Color MFP	Xerox AL C8130T2	\$3,797.00	0	0	0.0079	0.05	\$0.00
Police Color MFP	Xerox VL C405DNM	\$797.00	1,763	505	0.015	0.089	\$71.39
	Tray	\$367.45					
	Stand	\$367.45					

<u>Fire Department</u>	<u>Model</u>	<u>Investment</u>	<u>B/W AMV</u>	<u>Color AVM</u>	<u>B/W CPP</u>	<u>Color CPP</u>	<u>Total Cost</u>
Day Room	Xerox AL C8130T2	\$3,797.00	748	560	0.0079	0.05	\$33.91
Admin Fire Chief/Fire Marshall	HP CLJ Pro M479fdw	\$599.00	334	220	0.015	0.099	\$26.79

<u>Street Facility</u>	<u>Model</u>	<u>Investment</u>	<u>B/W AMV</u>	<u>Color AVM</u>	<u>B/W CPP</u>	<u>Color CPP</u>	<u>Total Cost</u>
Main Office	Xerox AL C8130T2	\$3,797.00	327	540	0.0079	0.05	\$29.58
Street Supervisor	HP CLJ Pro M479fdw	\$599.00	15	114	0.015	0.099	\$11.51
Brian's Office	HP CLJ Pro M479fdw	\$599.00	25	90	0.015	0.099	\$9.29
Facilities Director	HP CLJ Pro M479fdw	\$599.00	67	49	0.015	0.099	\$5.86

<u>Parks</u>	<u>Model</u>	<u>Investment</u>	<u>B/W AMV</u>	<u>Color AVM</u>	<u>B/W CPP</u>	<u>Color CPP</u>	<u>Total Cost</u>
Main Office	Xerox AL C8130T2	\$3,797.00	410	360	0.0079	0.05	\$21.24

<u>Water</u>	<u>Model</u>	<u>Investment</u>	<u>B/W AMV</u>	<u>Color AVM</u>	<u>B/W CPP</u>	<u>Color CPP</u>	<u>Total Cost</u>
Main Office	Xerox AL C8130T2	\$3,797.00	431	202	0.0079	0.05	\$13.50
Water Treatment Facility	Xerox VL C405DNM	\$797.00	119	93	0.015	0.089	\$10.06
Pat's Office	HP CLJ Pro M479fdw	\$599.00	106	17	0.015	0.099	\$3.27
Kellen's Office	HP LJ M406dn	\$549.00	39		0.015		\$0.59
Warm Springs Booster	HP CLJ Pro M479fdw	\$599.00	0	0	0.015	0.099	\$0.00

			13,068	7,133			
<b>Equipment Total</b>		<b>\$43,364.59</b>			<b>Maintenance Total</b>		<b>\$525.74</b>
<b>Lease Payment</b>		<b>\$826.10</b>					
<b>Equipment &amp; Maintenance Total</b>			<b>\$1,351.83</b>		<b>Monthly Savings</b>		<b>\$280.46</b>
					<b>5 year Savings</b>		<b>\$16,827.51</b>

---

City of Ketchum – Option #2 Updated  
480 East Ave N  
Ketchum, Idaho 83340  
Attn: Jade Riley

June 21, 2021

**XEROX ALTALINK C8145H2 COLOR MFP WITH CONNECTKEY TECHNOLOGY (3 Each)**

- 45 PPM B/W & 45 PPM COLOR
- 1.91 GHz QUAD-CORE PROCESSOR
- 128GB SSD/4GB SYSTEM MEMORY
- 10.1" INCH COLOR TOUCH SCREEN
- FIRST-PAGE-OUT 4.2 SEC B/W & 5.7 SEC COLOR
- BRILLIANT COLOR & CRISP B/W PRINTS (1200 x 2400 dpi)
- BENCHMARK SECURITY
- XEROX APP GALLERY
- MOBILE PRINTING
- DUPLEX PRINTING
- NETWORK PRINTING
- NETWORK SCANNING
- POWERFUL SCAN CAPABILITIES
- 130-SHEET SINGLE-PASS DUPLEX ADF
- 2 x 520-SHEET PAPER TRAYS
- 2,100-SHEET TANDEM PAPER TRAYS
- ENVELOPE TRAY – PLANNING ONLY (497K17880)
- 100-SHEET MULTIPURPOSE TRAY
- START SUPPLIES
- DELIVERY, SET-UP & TRAINING



**FULL COVERAGE SERVICE/SUPPLY CONTRACT**

CPI = .0079 B/W & .05 COLOR  
(Includes everything except paper)

**OPTIONAL ACCESSORIES**

OFFICE FINISHER/STAPLER = \$806.59 or \$16.00 P/Mo.  
2/3 HOLE PUNCH UNIT (REQUIRES OFFICE FINISHER) = \$249.60 or \$5.00 P/MO.  
3,000-SHEET HIGH-CAPACITY FEEDER = \$884.25 or \$17.00 P/MO.

---

City of Ketchum – Option #2 Updated  
480 East Ave N  
Ketchum, Idaho 83340  
Attn: Jade Riley

June 21, 2021

**XEROX ALTALINK C8130T2 COLOR MFP WITH CONNECTKEY TECHNOLOGY (5 Each)**

- 30 PPM B/W & 30 PPM COLOR
- 1.91 GHz QUAD-CORE PROCESSOR
- 128GB SSD/4GB SYSTEM MEMORY
- 10.1" INCH COLOR TOUCH SCREEN
- FIRST-PAGE-OUT 4.2 SEC B/W & 5.7 SEC COLOR
- BRILLIANT COLOR & CRISP B/W PRINTS (1200 x 2400 dpi)
- BENCHMARK SECURITY
- XEROX APP GALLERY
- MOBILE PRINTING
- DUPLEX PRINTING
- NETWORK PRINTING
- NETWORK SCANNING
- POWERFUL SCAN CAPABILITIES
- 130-SHEET SINGLE-PASS DUPLEX ADF
- 4 x 520-SHEET PAPER TRAYS
- ENVELOPE TRAY – PLANNING ONLY (497K17880)
- 100-SHEET MULTIPURPOSE TRAY
- START SUPPLIES
- DELIVERY, SET-UP & TRAINING



**FULL COVERAGE SERVICE/SUPPLY CONTRACT**

CPI = .0079 B/W & .05 COLOR

(Includes everything except paper)

**OPTIONAL ACCESSORIES**

OFFICE FINISHER/STAPLER = \$806.59 or \$16.00 P/Mo.

2/3 HOLE PUNCH UNIT (REQUIRES OFFICE FINISHER) = \$249.60 or \$5.00 P/MO.

3,000-SHEET HIGH-CAPACITY FEEDER = \$884.25 or \$17.00 P/MO.

---

City of Ketchum – Option #2 Updated  
480 East Ave N  
Ketchum, Idaho 83340  
Attn: Jade Riley

June 21, 2021

**XEROX VERSALINK C405DNM COLOR MFP WITH CONNECT KEY TECHNOLOGY (2 Each)**

- 36 PAGES PER MINUTE
- 1.05 GHz DUAL CORE PROCESSOR
- 5-INCH CAPACITIVE COLOR TOUCH SCREEN
- FIRST-PAGE-OUT 8 SECONDS B/W & 11 SECONDS COLOR
- BRILLIANT COLOR & CRISP B/W PRINTS
- BENCHMARK SECURITY
- MOBILE PRINTING
- DUPLEX PRINTING
- NETWORK PRINTING
- XEROX FAX SYSTEM
- WORKFLOW-ENHANCING SCANNING CAPABILITIES
- 50-SHEET SINGLE-PASS ADF
- 550-SHEET PAPER TRAY
- 150-SHEET BYPASS TRAY
- DELIVERY, SETUP & TRAINING



**FULL COVERAGE SERVICE/SUPPLY CONTRACT**

CPI = .015 B/W & .089 COLOR  
(Includes everything except paper)



---

City of Ketchum – Option #2 Updated  
480 East Ave N  
Ketchum, Idaho 83340  
Attn: Jade Riley

June 21, 2021

**HP COLOR LASERJET PRO M479fdw COLOR MFP (5 Each)**

- 28 PAGES PER MINUTE
- 4.3" INTUITIVE COLOR TOUCH SCREEN
- 512 MB NAND FLASH MEMORY
- BENCHMARK SECURITY
- NETWORK PRINTING
- NETWORK SCANNING
- FAX SYSTEM
- AUTOMATIC DUPLEX PRINTING
- 50-SHEET DSPF DOCUMENT FEEDER
- 250-SHEET PAPER TRAY
- 50-SHEET BYPASS TRAY
- DELIVERY, SET-UP & TRAINING



**FULL COVERAGE SERVICE/SUPPLY CONTRACT**

CPI = .015 B/W & .099 COLOR  
(Includes everything except paper)

**PURCHASE INVESTMENT**

\$38,168.00 + TAX

**60-MONTH FMV LEASE**

\$727.10 P/MO. + TAX

- Includes 5 Xerox AL C8130T2's, 3 Xerox AL C8145H2's, 2 Xerox VL C405DNM's & 5 HP CLJ Pro M479fdw's
- Average monthly savings over current print program = \$379.45 (5 years = \$22,767.22)

Mike McCurdy  
(208) 293-4010  
mikem@itechinc.com



# City of Ketchum - Proposed Equipment

Date

6/11/2021

## Monthly Costs

<b>Monthly Payment on 60-Month FMV Lease</b>	\$ 870.47
<b>Overage Cycle</b>	Monthly
<b>Estimated Monthly Overage Cost</b>	\$ 517.91
<b>Total Average Monthly Costs</b>	\$ 1,388.38

## Equipment List

### Administration

Make	Model	Location	Equipment Details	Monthly Volume Allotment		Excess Cost per Copy		Average Monthly Volume	Average Monthly Cost
				B/W	Color	B/W	Color		
KONICA	BHC550i	Administration Office	55 ppm Color MFP with Fax, Finisher, Punch Kit, and High Capacity Tray. Prints up to 12x18	-	-	0.0078	0.0382	4,374	\$ 132.02
								2,540	
Canon	C357	Planning Office	36 ppm Color MFP with Fax, Two Drawers and a Stand. Prints up to Legal	-	-	0.0126	0.0577	-	\$ -
								-	
HP	M454	Unknown	27 ppm Color Desktop Printer	-	-	0.0149	0.1300	117	\$ 33.33
								243	
HP	M479	Lisa's Office	27 ppm Color Desktop MFP	-	-	0.0149	0.1300	219	\$ 10.15
								53	
HP	M479	Jade's Office	27 ppm Color Desktop MFP	-	-	0.0149	0.1300	9	\$ 9.36
								71	
HP	M602	Planning Office	52 ppm B/W Printer with 75-Sheet Envelope Feeder	-	-	-	-	405	\$ 6.03

## Sharp Option

Equipment model	speed	(CPC) CLR/MONO
Sharp DX-B352p	35ppm	\$0.00/0.011 (bw only)
Sharp C407p	40ppm	\$0.085/0.018
Sharp MX-3051	30ppm	\$0.045/.006
Sharp MX-5071	50ppm	\$0.045/.006



### Requesting Valley Office Systems provide a quote for leasing / service of the following:

- 1 - 45 pages per minute machine – color w/high capacity, 3-hole punch, finisher / stapler, fax, envelope tray
- 2 – 45 pages per minute machines – color w/11x17 tray
- 5 – 30 pages per minute machines (or like) – color w/11x17 tray
- 2 – smaller team use printers – color
- 6 – desktop printers – color
- 2 - desktop printers – b/w (*allow for check printing*)

## PROPOSED SOLUTION BUILT BASED ON CURRENT ACCESSORIES

1ea. Sharp MX-5071 with high-capacity paper tray, 3-hole punch, finisher / stapler, fax, envelope tray

2ea. Sharp MX-5071 with 2 trays and storage cabinet

5ea. Sharp MX-3051 with 2 trays and storage cabinet

2ea. Sharp C407p color printer

6ea. Sharp C407p color printer

2ea. Sharp B352p b/w printer

**Please allow the quote to provide the following detail:**

- Lease / service payment combined – cost monthly and annually
- Time to procure equipment
- First available timeframe to implement new equipment / train staff for use
- Price to remove old equipment / send back to lessor

The lease payment with service based on the numbers given to me would be **\$1,977.99/month** and **\$23,735.88/year**. I included the volumes sent to me below and based on all numbers to be color prints except the highlighted, which is black and white.

The time frame to implement the new equipment will be two weeks from sign date, training of staff can be conducted the day of install, however we will train staff however you need, whether its all at once, or staggered. I will also be available for training for the life of the contract.

Valley Office Systems will remove all equipment and send back to the leasing company at no cost to the City of Ketchum.

Services technicians will come to the City of Ketchum from the Twin Falls office. However, the Boise and Eastern Idaho offices can aid the Twin Falls office if a situation ever called for that. Mainly if a technician is on vacation or sick. The Twin Falls Branch has 3 service technicians. With another 20 on hand from the Boise and Eastern Idaho locations.



## City of Ketchum

August 12, 2021

Mayor Bradshaw and City Councilors  
City of Ketchum  
Ketchum, Idaho

Mayor Bradshaw and City Councilors:

### **Recommendation To Approve a Communications Facility Lease with Sun Valley Company**

#### Recommendation and Summary

Staff is recommending the council Adopt the following Resolution:

**"I move to approve the Communications Facility Lease with the Sun Valley Company for existing communications equipment and authorize the Mayor to sign said lease."**

The reasons for the recommendation are as follows:

- The main radio communications for the Ketchum Fire Department is located on Sun Valley Company.
- This lease replaces the previous lease that included Ketchum Rural Fire District.

#### Introduction and History

The fire department operates from a repeater located on Bald Mountain, in a facility owned by Sun Valley Company. This agreement has been in place for many years. While the license and EQ are owned by the City of Ketchum, the lease was previously executed under the Ketchum Rural Fire District. Since the land is leased from the US Forest Service, the site must comply with USFS rules. This includes having the site lease in the name of the FCC license holder, which is the City of Ketchum.

#### Sustainability Impact

No impact.

#### Financial Impact

In the past, the lease fee was paid by the Ketchum Rural Fire District, and the City reimbursed KRFD 50% of the fee. Henceforth, the City will pay the lease fee and bill other users as needed.

#### Attachments

Communications Facility Lease

**Acceptance**

---

Neil Bradshaw, Mayor  
City of Ketchum

## COMMUNICATIONS FACILITY LEASE

(Existing Structure and Ground Space)

This Lease is made and entered into as of April 19, 2021, by and between Sun Valley Company, a Wyoming corporation with an address at PO Box 10, Sun Valley, Idaho 83353, (hereinafter referenced to as "Landlord") and the City of Ketchum, with an address at 480 East Ave North, P O Box 966, Ketchum Id. 83340 (hereinafter referenced to as "Tenant").

WHEREAS, Landlord is sole permittee operating on property known as Bald Mountain Communications' Facility, County of Blaine, State of Idaho (the "Property"), which is more particularly described in Exhibit A attached hereto, upon which is located an existing structure described as a guide tower (the "Structure").

WHEREAS, Tenant desires to lease a portion of the Property for Tenant's transmission and receipt of radio-telephone and other electrical signals.

In consideration of the mutual promises, conditions, and other good and valuable consideration of the parties hereto, it is covenanted and agreed as follows:

1. Lease. Landlord hereby leases to Tenant that certain parcel described as the "Premises," in Exhibit B, which is attached hereto and incorporated herein by reference, together with unrestricted access for Tenant's uses from the nearest public right-of-way, on the terms and conditions of this Lease.
2. Survey/Site Plan. Tenant may, at Tenant's expense, cause a survey, site plan, and/or legal description of the Premises to be prepared, to further delineate and identify the land underlying the Premises, and to attach the same as exhibits to this Lease.
3. Use of Premises. It is understood that Tenant intends to use the Premises and the licenses granted hereunder for the purpose of installing and operating antennas and related equipment ("Tenant's Facilities") for the transmission and receipt of radio-telephone and other electrical signals; such use includes the right to install and operate antennas, an equipment cabinet, cables and other connections between the Tenant's equipment and antennas, and any other items necessary to the successful and secure operation of Tenant's Facilities. Tenant has the right to modify, supplement, replace, upgrade, expand the equipment, increase the number of antennas or relocate Tenant's Facilities within the Premises at any time during the term of this Lease. Tenant's use of the Premises shall at all times comply with and conform to all laws and regulations applicable thereto. All Mountain Travel must be coordinated with Sun Valley Co. Mountain Department at 208 622-6151.
4. Term of Lease. The lease term will be five (5) years (the "Initial Term"), commencing upon the Commencement Date. The Initial Term will terminate on the last day of the month in which the fifth (5<sup>th</sup>) annual anniversary of the Commencement Date occurred.

5. Option to Renew. Tenant shall have the option to renew this Lease for one (1) term of five (5) years, upon a continuation of all the same provisions hereof the acceptance of this renewal option must be received in writing by certified mail or nationally recognized courier service and received by Landlord at least three (3) months prior to the expiration of the Initial Term of this Lease. Each renewal will increase by 2.5% over previous term.

6. Termination. If this Lease is terminated rent and other charges shall be prorated as of the date of termination.

7. Rent. Commencing on January 1, 2022, the Commencement Date, Tenant shall pay rent to the Landlord in the amount of \$2,560.00 per year, which shall be due annually thereafter. Landlord shall specify the name, address, and taxpayer identification number of a sole payee (or maximum two joint payees) who shall receive rent on behalf of the Landlord. Rent will be prorated for any partial year.

8. Adjusted Rent. On every anniversary of the Commencement Date of this Lease, rent shall be increased by three percent (2.5%) of the previous year's rent.

9. Utilities. Landlord shall provide primary A/C power. Tenant may install an emergency battery bank on the Premises and operate such standby systems during times when commercial power is not available.

10. Non-Interference. (a) If there are existing radio frequency user(s) on the Property, then within 20 days after the date of this Lease Landlord will provide Tenant with a list of all existing radio frequency user(s) and their respective frequencies to allow Tenant to evaluate the potential for interference. Tenant warrants that its use of the Premises will not interfere with such existing radio frequency users on the Property as long as the existing radio frequency user(s) operate and continue to operate within the frequencies disclosed to Tenant as provided above and in accordance with all applicable laws and regulations. (b) Landlord will not grant, after the date of this Lease, a lease, license or any other right to any third party for the use of the Property, if such use may in any way adversely affect or interfere with Tenant's Facilities. Landlord will notify Tenant and receive Tenant's written approval prior to granting any third party the right to install and operate communications equipment on the Property. Nothing contained herein will restrict Tenant nor its successors and assigns from installing and modifying its communications equipment. (c) Landlord will not use, nor will Landlord permit its employees, tenant, licensees, invitees or agents to use, any portion of the Property in any way which interferes with the operations of Tenant or the rights of Tenant under this Lease. Landlord will cause such interference to cease upon not more than twenty-four (24) hour notice from Tenant. In the event any such interference to Tenant's operations does not cease within the aforementioned cure period then the parties acknowledge that Tenant will suffer irreparable injury, and therefore, Tenant will have the right in addition to any other rights that it may have a law or in equity, for Landlord's breach of this Lease, to elect to enjoin such interference or to terminate the Lease upon notice to Landlord. Tenant Interference Study enclosed as part of this lease.



11. Compliance with FCC Radio Frequency Emissions Requirements. Tenant agrees to comply with all Federal Communications Commission ("FCC") rules pertaining to its operations on the Premises, including those pertaining to radio frequency exposure. Landlord shall require all other communications tenants of the Property to bear the same responsibility. If a subsequent communications tenant of the Property causes the radio frequency levels at the Premises and surrounding vicinity exceeding exposure levels set by the FCC, Landlord shall require that such tenant shall take all steps necessary to meet FCC compliance levels.

12. Property Taxes and Government Fees: Tenant shall pay the personal property taxes and all other government fees levied against Tenant's Facilities and the Landlord shall be responsible for the real estate taxes levied against the Property.

13. Repairs. Tenant shall be responsible for all repairs of Tenant's Facilities, and may at its own expense alter or modify Tenant's Facilities to suit its needs consistent with the intended use of the Premises.

14. Mutual Indemnification. Tenant shall indemnify and hold Landlord harmless from and against any loss, damage, or injury caused by, or on behalf of, or through the fault of the Tenant or its employees or agents, or directly resulting from the installation, use, maintenance, repair or removal of Tenant's Facilities upon the Property. Landlord shall indemnify and hold Tenant harmless from and against any loss, damage, or injury caused by, or on behalf of, or through the fault of the Landlord or its employees or agents. Nothing in this Article shall require a party to indemnify the other party against such other party's own willful misconduct or negligence. Notwithstanding anything to the contrary in this Lease, each of Tenant and Landlord hereby waives any claims that they may have against the other with respect to consequential, incidental or special damages.

15. Insurance. Tenant shall continuously maintain in full force and effect a policy of commercial general liability insurance with limits of not less than One Million Dollars combined single limit for bodily injury or death/property damage arising out of any one occurrence covering Tenant's work and operations upon the Property, and commercially reasonable property and casualty insurance covering Tenant's Facilities.

Landlord shall continuously maintain in full force and effect throughout the term of this Lease commercially reasonable liability insurance and commercially reasonable property and casualty insurance.

Neither party shall be liable to the other (or to the other's successors or assigns) for any loss or damage caused by fire or any of the risks enumerated in a standard fire insurance policy with an extended coverage endorsement, and in the event of insured loss, neither parties' insurance company shall have a subrogated claim against the other. If this waiver would invalidate policy coverage under applicable law, this waiver shall be valid only if the insurance policy in question expressly permits waiver of subrogation or if the insurance company agrees in writing that such a waiver will not affect coverage under the policies. Each party agrees to use best efforts to obtain such an agreement from its insurer if the policy does not expressly permit a waiver of subrogation.

16. Monetary Default. Tenant shall be in default of this Lease if Tenant fails to make a payment of rent when due and such failure continues for thirty (30) days after Landlord notifies Tenant in writing of such failure.

17. Opportunity to Cure Non-Monetary Defaults. If Landlord or Tenant fails to comply with any non-monetary provision of this Lease which the other party claims to be a default hereof, the party making such claim shall serve written notice of such default upon the defaulting party, whereupon a grace period of sixty (60) days shall commence to run during which the defaulting party shall undertake and diligently pursue a cure of the default. Such grace period shall automatically be extended for an additional sixty (60) days, provided the defaulting party makes a good faith showing that efforts toward a cure are continuing.

18. Transferability of Tenant's Interest. Tenant's interest under this Lease may be freely assigned in connection with the transfer of Tenant's authorization to operate Tenant's Facilities at the Site. Landlord understands and agrees that Tenant's interest in this Lease has been or will be assigned from time to time for security purposes as collateral in loan documents between Tenant and lenders. Landlord has no right to consent to such assignment, and in the event of Tenant's default of any such loan documents, Landlord will acknowledge any substitute tenant resulting from a foreclosure of a security interest as the Tenant under this Lease. Any other assignment of this Lease by Tenant shall require Landlord's prior written consent, which consent Landlord agrees, shall not unreasonably be withheld. Furthermore, no assignment shall be effected pursuant to this Section unless Tenant shall notify Landlord in writing setting forth the name, address and telephone number of such assignee. Notwithstanding the foregoing, Tenant may assign or otherwise transfer this Lease without Landlord's prior written consent to an entity controlling, controlled by, or under common control with Tenant or to a person or entity acquiring substantially all of Tenant's assets through merger, sale or otherwise. For the purpose of this paragraph, "control" is defined as direct or indirect ownership by a person or entity or group of persons and/or entities of a 30% or more of the outstanding stock, ownership interest or other equity interest in the party controlled. Upon the effective date of any permitted assignment, Tenant will be relieved of all future performance, liabilities and obligations under this Lease.

19. Subleasing. Tenant shall not sublet or grant licenses to use, all or any portion of Tenant's Facilities and/or the Premises without Landlord's prior written consent, which consent shall not be unreasonably withheld, conditioned or delayed.

20. Execution of Other Instruments. Landlord agrees to execute, acknowledge, and deliver to Tenant other instruments respecting the Premises, as Tenant or Tenant's lender may reasonably request from time to time, provided that any such instruments are in furtherance of, and do not substantially expand, Tenant's rights and privileges herein established. Such instruments may include a memorandum of lease which may be recorded in the County Recorder's Office. Landlord also agrees to reasonably cooperate with Tenant's efforts to obtain all private and public consents related to Tenant's use of the

Premises, as long as Landlord is not expected to bear the financial burden of any such efforts.

21. Removal of Tenant's Facilities. Tenant's Facilities are agreed to be Tenant's personal property and shall never be considered fixtures to the real estate. Tenant shall at all times be authorized to remove Tenant's Facilities from the Premises. Within sixty (60) days after the expiration or earlier termination of this Lease, Tenant shall, if requested by Landlord and at Tenant's expense, remove any of Tenant's Facilities located above ground from the Premises. If Landlord does not notify Tenant that Tenant must remove such Tenant's Facilities within thirty days (30) after expiration or earlier termination of this Lease, then Tenant shall have the option of either removing or abandoning such Tenant's Facilities, and in any event Tenant shall be entitled to abandon all footings, foundations, and other below-ground portions of Tenant's Facilities in place.

22. Warranties. (a) Tenant and Landlord each acknowledge and represent that it is duly organized, validly existing and in good standing and has the right, power and authority to enter into this Lease and bind itself hereto through the party set forth as signatory for the party below; and (b) Landlord represents and warrants that: (i) Landlord solely owns the Property as a legal lot in fee simple, or controls the Property by lease or license, unencumbered by any liens, restrictions, mortgages, covenants, conditions, easements, leases, agreements of record or not of record, which would adversely affect Tenant's use and enjoyment of the Premises under this Lease; (ii) Landlord has legal vehicular access to the Property via public road and has the right to permit Tenant to use such access throughout the term of this Lease; (iii) as long as Tenant is not in default then Landlord grants to Tenant sole, actual, quiet and peaceful use, enjoyment and possession of the Premises within the terms and conditions detailed in this Lease; and (iv) the execution and performance of this Lease will not violate any laws, ordinances, covenants or the provisions of any mortgage, lease or other agreement binding on the Landlord or the Property.

23. Subordination. Tenant agrees to subordinate this Lease to any mortgage or trust deed which may hereafter be placed on the Premises, provided the mortgagee or beneficiary shall ensure to Tenant the right to possession of the Premises and other rights granted to Tenant herein so long as Tenant is not in default beyond any applicable grace or cure period, such assurance to be in form reasonably satisfactory to Tenant. If requested by Tenant, Landlord agrees to use Landlord's best efforts to assist Tenant in obtaining from any holder of an encumbrance against the Property a non-disturbance agreement in form reasonably satisfactory to Tenant.

24. Environmental Warranty. (a) Landlord and Tenant agree that each will be responsible for compliance with any and all environmental and industrial hygiene laws, including any regulations, guidelines, standards, or policies of any governmental authorities regulating or imposing standards of liability or standards of conduct with regard to any environmental or industrial hygiene condition or other matters as may now or at any time hereafter be in effect, that are now or were related to that parties' activity conducted in or on the Property. (b) Landlord and Tenant agree to hold harmless and indemnify the other from, and to assume all duties, responsibilities and liabilities at its sole cost and

expense, (for payment of penalties, sanctions, forfeitures, losses, costs or damages) and for responding to any action, notice, claim, order, summons, citation, directive, litigation, investigation or proceeding which is related to (i) failure to comply with any environmental or industrial hygiene law, including without limitation any regulations, guidelines, standards or policies of any governmental authorities regulating or imposing standards of liability or standards of conduct with regard to any environmental or industrial hygiene conditions or matters as may now or hereafter be in effect, and (ii) any environmental or industrial hygiene conditions that arise out of or are in any way related to the condition of the Property or activities conducted by the party thereon, unless the environmental conditions are caused by the other party. (c) The indemnifications of this Paragraph specifically include reasonable costs, expenses and fees incurred in connection with any investigation of Property conditions or any clean-up, remediation, removal or restoration work required by any governmental authority. The provisions of this Paragraph will survive the expiration or termination of this Lease.

25. Attorneys' Fees. In any action on this Lease at law or in equity, the prevailing party shall be entitled to recover its reasonable cost and expenses incurred in such action and on appeal, including reasonable attorney fees.

26. Notices. All notices required or desired to be given under this Lease shall be in writing and sent by certified mail, return receipt requested, or nationally recognized courier service to the party to be served at its address as follows:

If to Landlord:

Sun Valley Resort  
Attn: General Manager PO Box 10  
Sun Valley, ID 83353

If to Tenant:

City of Ketchum-Fire  
P O Box 966  
Ketchum, Id 83340

Notices shall be deemed received when properly sent and received, refused or returned undelivered. Either party may change its address by notifying the other party of the change of address not less than ten (10) days prior to the effective date of such change.

27. Binding Effect. All of the covenants, conditions, and provisions of this Lease shall inure to the benefit of and be binding upon the parties hereto and their respective successors and assigns.

28. Entire Agreement. This Lease constitutes the entire agreement between the parties and supersedes any prior understandings or oral or written agreements between the parties respecting the within subject matter.

29. Modifications. This Lease may not be modified, except in writing signed by the party against whom such modification is sought to be enforced.

30. Governing Law. This Lease will be governed by the laws of the state in which the Premises are located, without regard to conflicts of law.

31. Interpretation. Unless otherwise specified, the following rules of construction and interpretation apply: (i) captions are for convenience and reference only and in no way define or limit the construction of the terms and conditions hereof; (ii) use of the term "including" will be interpreted to mean "including but not limited to"; (iii) whenever a party's consent is required under this Lease, except as otherwise stated in the Lease or as same may be duplicative, such consent will not be unreasonably withheld, conditioned or delayed; (iv) exhibits are an integral part of the Lease and are incorporated by reference into this Agreement; (v) use of the terms "termination" or "expiration" are interchangeable, and (vi) reference to a default will take into consideration any applicable notice, grace and cure periods.

32. Estoppel. Either party will, at any time upon thirty (30) days' prior written notice from the other, execute, acknowledge and deliver to the other a statement in writing (i) certifying that this Lease is unmodified and in full force and effect (or, if modified, stating the nature of such modification and certifying this Lease, as so modified, is in full force and effect) and the date to which the rent and other charges are paid in advance, if any, and (ii) acknowledging that there are not, to such party's knowledge, any uncured defaults on the part of the other party hereunder, or specifying such default if any are claimed. Any such statement may be conclusively relied upon by any prospective purchaser or encumbrancer of the Premises. Failure to deliver such a statement within such time will be conclusive upon the requesting party that (i) this Lease is in full force and effect, without modification except as may be properly represented by the requesting party, (ii) there are no uncured defaults in either party's performance, and (iii) rent has not been paid in advance beyond the regularly scheduled rental payments period set forth in the Lease.

IN WITNESS WHEREOF, the parties hereto bind themselves to this Communications Facility Lease as of the day and year first above written.

LANDLORD:

TENANT:

Sun Valley Company

City of Ketchum-Fire

By: \_\_\_\_\_

By: \_\_\_\_\_

PRINTED: \_\_\_\_\_

PRINTED: \_\_\_\_\_

TITLE: \_\_\_\_\_

TITLE: \_\_\_\_\_

## **EXHIBIT A**

### **DESCRIPTION OF THE PROPERTY**

The Property of which the Premises are a part is all that real property located in the State of Idaho, County of Blaine, described as follows:

Bald Mountain Communications Facility, Blaine County, Idaho.

To be inserted

# Benchmark Associates, P.A.

ENGINEERING, PLANNING, SURVEYING & MAPPING

PO Box 733: 100 Bell Drive

Ketchum, Idaho 83340

208-726-9512: Facsimile 208-726-9514

## A Sun Valley Company Cell Lease Site 'BALD MOUNTAIN COMM. BUILDING'

An unsurveyed lease site located within:  
Section 23, Township 4 North, Range 17 East, Boise Meridian, Blaine County, Idaho.

Commencing at a Brass Cap marking the Section Comer common to Sections 12 and 13, Township 4 North, Range 17 East and also Sections 7 and 18, Township 4 North, Range 18 East, Boise Meridian, said Brass Cap being also referenced by the Blaine County G.J.S. Survey Control Network as 'CEMETERY';

Thence S00°26'11"E, 5346.01 feet to a Brass Cap marking the Section Comer common to Sections 13 and 24, Township 4 North, Range 17 East and also Sections 18 and 19, Township 4 North, Range 18 East, Boise Meridian, said Brass Cap being also referenced by the Blaine County G.J.S. Survey Control Network as '4N17E24NE';

Thence S66°30'36"W, 10627.68 feet more or less to the POINT OF BEGINNING;

thence SJ 7°00'00"W, 48.50 feet;

thence N73°00'00"W, 34.00 feet;

thence N17°00'00"E, 48.50 feet;

thence S73°00'00"E, 34.00 feet to the POINT OF BEGINNING;

Said lease site having an approximate area of .04 acres

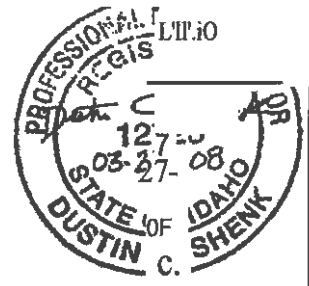



SUN VALLEY CO. - CELL  
LEASE SITE

**BA  
LD  
MO  
UN  
TAI  
N  
CO  
MM  
.  
BUI  
LDI  
NG**

LOCATED WITHIN SECTION  
23, TOWNSHIP 4 NORTH,  
RANGE 17 EAST, B.M.,  
BLAINE COUNTY, IDAHO

SEC. 12 SEC. 7  
BRASS CAP  
SECTION CORNER  
BLAINE COUNTY G.I.S.

R. 17 E. R. 18 E.  
CONTROL MONUMENT  
CEMETERY

SEC. 13 EC. 18  
SEC. 21- EC. 19

BRASS CAP  
SECTION CORNER  
BLAINE COUNTY G.I.S.  
CONTROL MONUMENT  
4N17E24NE

100 & VII

M. X. & P.O.B.

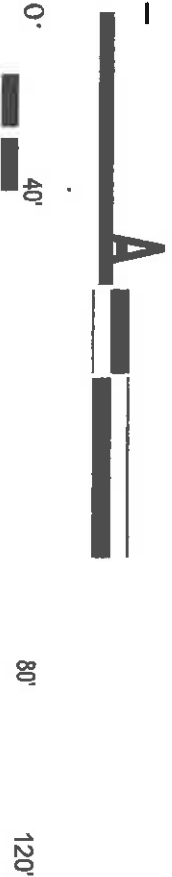
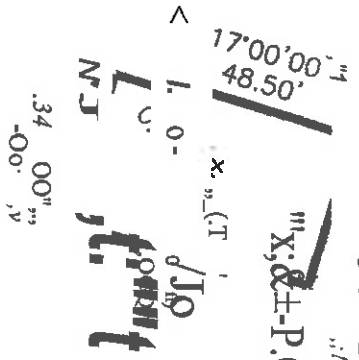

## **EXHIBIT B**

### **DESCRIPTION OF THE PREMISES**

The Premises consist of a parcel of land as depicted below, together with a non-exclusive license and right of way in and over the Property to provide pedestrian and vehicular ingress and egress to and from the Premises from the nearest public road, and utilities between the Premises and suitable utility company service connection points; and, a temporary right to enter and rest upon the Property adjacent to the Premises for the purposes of installing, repairing, replacing, and removing Tenant's Facilities and any other improvements or personal property of Tenant upon the Premises, including the right to bring in and use all necessary tools and machinery. The Premises and the associated access and utility connections as depicted below are approximate only, and may be adjusted or changed by Tenant at the time of construction to reasonably accommodate sound engineering criteria and the physical features of the Property.

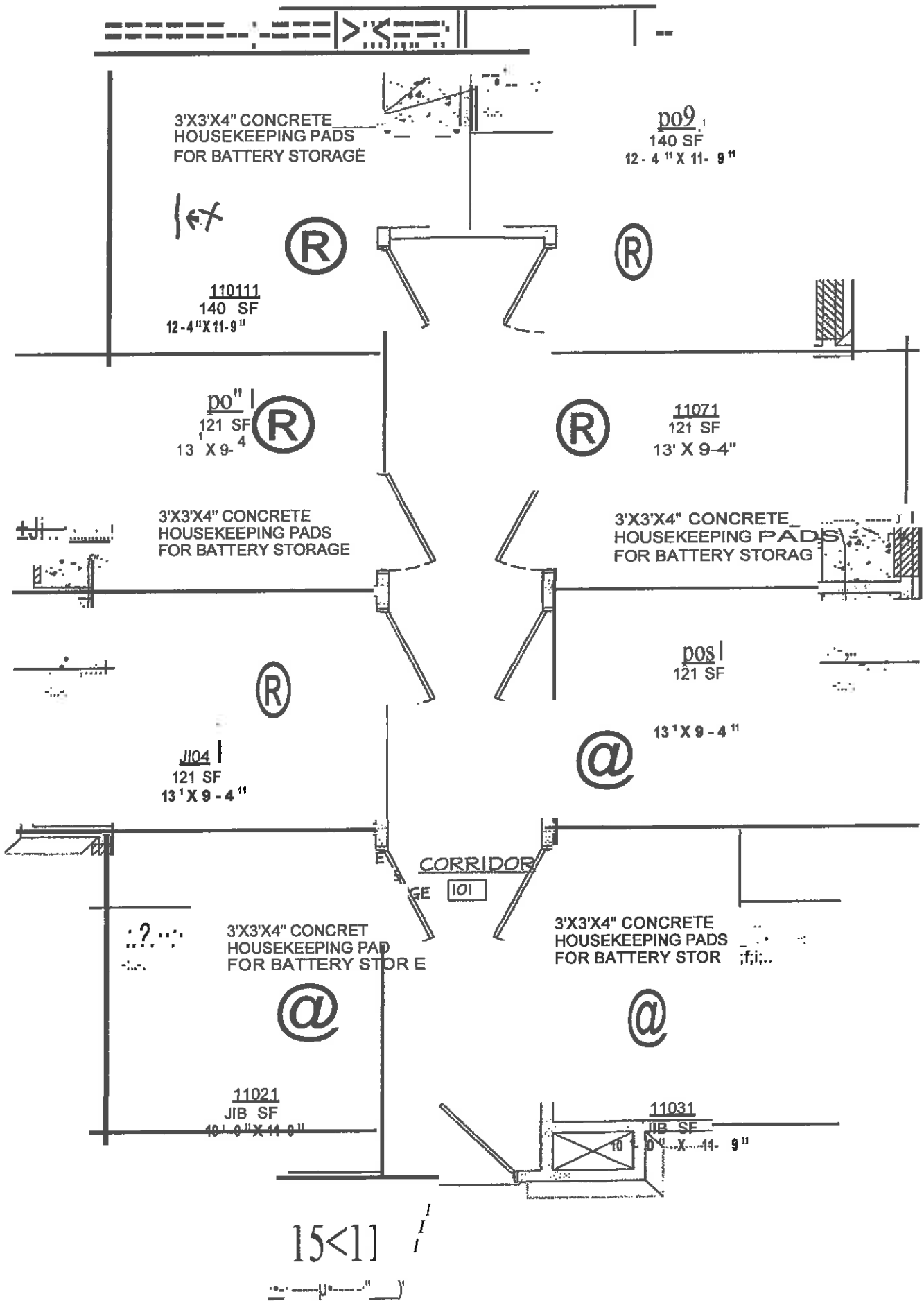

LOOKOUT COMM" BUILDING

**REFERENCE COPY**

This is not an official FCC license. It is a record of public information contained in the FCC's licensing database on the date that this reference copy was generated. In cases where FCC rules require the presentation, posting, or display of an FCC license, this document may not be used in place of an official FCC license.



**Federal Communications Commission  
Public Safety and Homeland Security Bureau**

**RADIO STATION AUTHORIZATION**

LICENSEE: KETCHUM, CITY OF

KETCHUM, CITY OF  
480 EAST AVENUE N  
PO BOX 966  
KETCHUM, ID 83340

<b>Call Sign</b> WZV461	<b>File Number</b> 0009421176
<b>Radio Service</b> PW - Public Safety Pool, Conventional	
<b>Regulatory Status</b> PMRS	
<b>Frequency Coordination Number</b>	

FCC Registration Number (FRN): 0001631530

<b>Grant Date</b> 02-19-2021	<b>Effective Date</b> 02-19-2021	<b>Expiration Date</b> 04-08-2031	<b>Print Date</b> 02-23-2021
---------------------------------	-------------------------------------	--------------------------------------	---------------------------------

**STATION TECHNICAL SPECIFICATIONS**

**Fixed Location Address or Mobile Area of Operation**

- Loc. 1 **Area of operation**  
Countywide: BLAINE, ID
- Loc. 2 **Address: 480 EAST AVENUE N**  
City: KETCHUM County: BLAINE State: ID  
Lat (NAD83): 43-41-00.7 N Long (NAD83): 114-21-52.2 W ASR No.: N/A Ground Elev: 1789.0
- Loc. 4 **Address: BALD MOUNTAIN**  
City: KETCHUM County: BLAINE State: ID  
Lat (NAD83): 43-39-12.7 N Long (NAD83): 114-24-45.2 W ASR No.: N/A Ground Elev: 2694.8
- Loc. 5 **Address: 100 FIRE STATION DR.**  
City: KETCHUM County: BLAINE State: ID  
Lat (NAD83): 43-35-00.9 N Long (NAD83): 114-20-00.8 W ASR No.: N/A Ground Elev: 1692.0
- Loc. 6 **Address: 222 SKI DOO LANE**  
City: KETCHUM County: BLAINE State: ID  
Lat (NAD83): 43-54-09.4 N Long (NAD83): 114-47-37.5 W ASR No.: N/A Ground Elev: 2211.0
- Loc. 7 **Address: 13100 HWY 75**  
City: KETCHUM County: BLAINE State: ID  
Lat (NAD83): 43-42-55.1 N Long (NAD83): 114-22-37.6 W ASR No.: N/A Ground Elev: 1817.0
- Loc. 8 **Address: 100 ARROW LEAF ROAD**  
City: SUN VALLEY County: BLAINE State: ID  
Lat (NAD83): 43-40-26.5 N Long (NAD83): 114-19-24.7 W ASR No.: N/A Ground Elev: 1811.7

**Conditions:**

Pursuant to §309(h) of the Communications Act of 1934, as amended, 47 U.S.C. §309(h), this license is subject to the following conditions: This license shall not vest in the licensee any right to operate the station nor any right in the use of the frequencies designated in the license beyond the term thereof nor in any other manner than authorized herein. Neither the license nor the right granted thereunder shall be assigned or otherwise transferred in violation of the Communications Act of 1934, as amended. See 47 U.S.C. § 310(d). This license is subject in terms to the right of use or control conferred by §706 of the Communications Act of 1934, as amended. See 47 U.S.C. §606.

**Blaine Co 1.1nty HQ, East Roqm #25 -  
 i: quipment Plac ement**

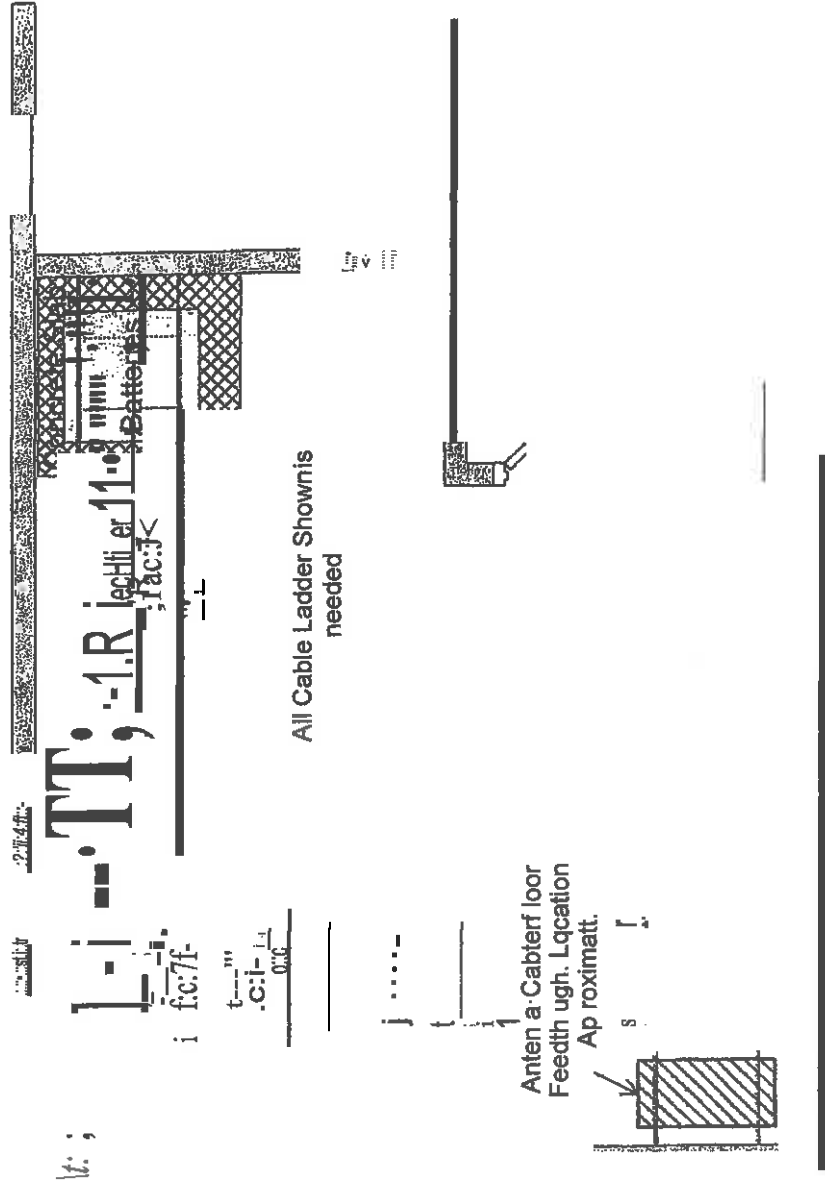

**REFERENCE COPY**

This is not an official FCC license. It is a record of public information contained in the FCC's licensing database on the date that this reference copy was generated. In cases where FCC rules require the presentation, posting, or display of an FCC license, this document may not be used in place of an official FCC license.



**Federal Communications Commission  
Public Safety and Homeland Security Bureau**

**RADIO STATION AUTHORIZATION**

LICENSEE: KETCHUM, CITY OF

KETCHUM, CITY OF  
480 EAST AVENUE N  
PO BOX 966  
KETCHUM, ID 83340

<b>Call Sign</b> WZV461	<b>File Number</b> 0009421176
<b>Radio Service</b> PW - Public Safety Pool, Conventional	
<b>Regulatory Status</b> PMRS	
<b>Frequency Coordination Number</b>	

FCC Registration Number (FRN): 0001631530

<b>Grant Date</b> 02-19-2021	<b>Effective Date</b> 02-19-2021	<b>Expiration Date</b> 04-08-2031	<b>Print Date</b> 02-23-2021
---------------------------------	-------------------------------------	--------------------------------------	---------------------------------

**STATION TECHNICAL SPECIFICATIONS**

**Fixed Location Address or Mobile Area of Operation**

- Loc. 1 **Area of operation**  
Countywide: BLAINE, ID
- Loc. 2 **Address: 480 EAST AVE N**  
City: KETCHUM County: BLAINE State: ID  
Lat (NAD83): 43-41-00.7 N Long (NAD83): 114-21-52.2 W ASR No.: N/A Ground Elev: 1789.0
- Loc. 4 **Address: BALD MOUNTAIN**  
City: KETCHUM County: BLAINE State: ID  
Lat (NAD83): 43-39-12.7 N Long (NAD83): 114-24-45.2 W ASR No.: N/A Ground Elev: 2694.8
- Loc. 5 **Address: 100 FIRE STATION DR.**  
City: KETCHUM County: BLAINE State: ID  
Lat (NAD83): 43-35-00.9 N Long (NAD83): 114-20-00.8 W ASR No.: N/A Ground Elev: 1692.0
- Loc. 6 **Address: 222 SKI DOO LANE**  
City: KETCHUM County: BLAINE State: ID  
Lat (NAD83): 43-54-09.4 N Long (NAD83): 114-47-37.5 W ASR No.: N/A Ground Elev: 2211.0
- Loc. 7 **Address: 13100 HWY 75**  
City: KETCHUM County: BLAINE State: ID  
Lat (NAD83): 43-42-55.1 N Long (NAD83): 114-22-37.6 W ASR No.: N/A Ground Elev: 1817.0
- Loc. 8 **Address: 100 ARROW LEAF ROAD**  
City: SUN VALLEY County: BLAINE State: ID  
Lat (NAD83): 43-40-26.5 N Long (NAD83): 114-19-24.7 W ASR No.: N/A Ground Elev: 1811.7

**Conditions:**

Pursuant to §309(h) of the Communications Act of 1934, as amended, 47 U.S.C. §309(h), this license is subject to the following conditions: This license shall not vest in the licensee any right to operate the station nor any right in the use of the frequencies designated in the license beyond the term thereof nor in any other manner than authorized herein. Neither the license nor the right granted thereunder shall be assigned or otherwise transferred in violation of the Communications Act of 1934, as amended. See 47 U.S.C. § 310(d). This license is subject in terms to the right of use or control conferred by §706 of the Communications Act of 1934, as amended. See 47 U.S.C. §606.



**REFERENCE COPY**

This is not an official FCC license. It is a record of public information contained in the FCC's licensing database on the date that this reference copy was generated. In cases where FCC rules require the presentation, posting, or display of an FCC license, this document may not be used in place of an official FCC license.



**Federal Communications Commission  
Public Safety and Homeland Security Bureau**

**RADIO STATION AUTHORIZATION**

LICENSEE: KETCHUM, CITY OF

KETCHUM, CITY OF  
480 EAST AVENUE N  
PO BOX 966  
KETCHUM, ID 83340

<b>Call Sign</b> WZV461	<b>File Number</b> 0009421176
<b>Radio Service</b> PW - Public Safety Pool, Conventional	
<b>Regulatory Status</b> PMRS	
<b>Frequency Coordination Number</b>	

FCC Registration Number (FRN): 0001631530

<b>Grant Date</b> 02-19-2021	<b>Effective Date</b> 02-19-2021	<b>Expiration Date</b> 04-08-2031	<b>Print Date</b> 02-23-2021
---------------------------------	-------------------------------------	--------------------------------------	---------------------------------

**STATION TECHNICAL SPECIFICATIONS**

**Fixed Location Address or Mobile Area of Operation**

- Loc. 1 Area of operation**  
Countywide: BLAINE, ID
- Loc. 2 Address: 480 EAST AVE N**  
City: KETCHUM County: BLAINE State: ID  
Lat (NAD83): 43-41-00.7 N Long (NAD83): 114-21-52.2 W ASR No.: N/A Ground Elev: 1789.0
- Loc. 4 Address: BALD MOUNTAIN**  
City: KETCHUM County: BLAINE State: ID  
Lat (NAD83): 43-39-12.7 N Long (NAD83): 114-24-45.2 W ASR No.: N/A Ground Elev: 2694.8
- Loc. 5 Address: 100 FIRE STATION DR.**  
City: KETCHUM County: BLAINE State: ID  
Lat (NAD83): 43-35-00.9 N Long (NAD83): 114-20-00.8 W ASR No.: N/A Ground Elev: 1692.0
- Loc. 6 Address: 222 SKI DOO LANE**  
City: KETCHUM County: BLAINE State: ID  
Lat (NAD83): 43-54-09.4 N Long (NAD83): 114-47-37.5 W ASR No.: N/A Ground Elev: 2211.0
- Loc. 7 Address: 13100 HWY 75**  
City: KETCHUM County: BLAINE State: ID  
Lat (NAD83): 43-42-55.1 N Long (NAD83): 114-22-37.6 W ASR No.: N/A Ground Elev: 1817.0
- Loc. 8 Address: 100 ARROW LEAF ROAD**  
City: SUN VALLEY County: BLAINE State: ID  
Lat (NAD83): 43-40-26.5 N Long (NAD83): 114-19-24.7 W ASR No.: N/A Ground Elev: 1811.7

**Conditions:**

Pursuant to §309(h) of the Communications Act of 1934, as amended, 47 U.S.C. §309(h), this license is subject to the following conditions: This license shall not vest in the licensee any right to operate the station nor any right in the use of the frequencies designated in the license beyond the term thereof nor in any other manner than authorized herein. Neither the license nor the right granted thereunder shall be assigned or otherwise transferred in violation of the Communications Act of 1934, as amended. See 47 U.S.C. § 310(d). This license is subject in terms to the right of use or control conferred by §706 of the Communications Act of 1934, as amended. See 47 U.S.C. §606.



## City of Ketchum

July 12, 2021

Mayor Bradshaw and City Councilors  
City of Ketchum  
Ketchum, Idaho

Mayor Bradshaw and City Councilors:

### **Recommendation To Approve Change Order #8 to Contract #20454**

#### Recommendation and Summary

Staff is recommending the council provide authorization to the Mayor to sign Change Order #6 to Contract 20454 with CORE | Headwaters LLC:

**"I move to approve Change Order #8 increasing Contract 20454 from \$9,475,318 to \$9,482,458; an increase of \$7,140 in Contract 20454 with CORE | Headwaters LLC; and authorize the Mayor to sign the Change Order."**

The reasons for the recommendation are as follows:

- This change order authorizes payment for minor changes made to certain structural elements and adds signage required by LEED.

#### Introduction and History

The City of Ketchum approved the construction of a fire station on November 5, 2020. Since that time, the project team has worked to bring the project to construction. Change Order #8 was developed by the project team to make some minor structural changes.

#### Analysis

Change Order #8 approves some minor changes needed.

#### Sustainability Impact

No impact.

#### Financial Impact

This change order will be funded from project contingency.

#### Attachments

- Attachment A: Change Order #8 Contract 20454

Project Description: Fire Station CM/GC

Change Order #:008

Effective Date: July 12 2021

Additional Time Granted:0 days

New Contract End Date: Unchanged

**Contract Price Impact**

Original Contract Price: \$9,320,940.00

Total of Prior Change Orders: \$154,378.00

Contract Price Prior to this Change Order: \$9,475,318.00

Increase / (Decrease) of this Change Order: \$7,140.00

Contract Price Incorporating this Change Order: \$ 9,482,458.00

**Acceptance**

---

Neil Bradshaw, Mayor  
City of Ketchum



## Change Order

**PROJECT: (name and address)**

Ketchum Fire Station #1  
107 Saddle Road, Ketchum, ID

**OWNER: (name and address)**

City of Ketchum, Idaho  
480 E. Ave. N., PO Box 2315  
Ketchum, ID 83340

**CONTRACT INFORMATION:**

Contract For: Ketchum Fire Station #1  
Date:

**ARCHITECT: (name and address)**

Cole Architects, PLLC  
1008 W. Main St.  
Boise, ID 83702

**CHANGE ORDER INFORMATION:**

Change Order Number: 008  
Date: August 11, 2021

**CONTRACTOR: (name and address)**

CORE Headwaters, LLC  
900 Jet Stream Drive  
Rexburg, ID 83440

**THE CONTRACT IS CHANGED AS FOLLOWS:**

*(Insert a detailed description of the change and, if applicable, attach or reference specific exhibits. Also include agreed upon adjustments attributable to executed Construction Change Directives.)*

See attached spreadsheet of seven items.

The original	Contract Sum	was	\$	<u>9,320,940.00</u>
The net change by previously authorized Change Orders			\$	<u>154,378.00</u>
The	Contract Sum	prior to this Change Order was	\$	<u>9,475,318.00</u>
The	Contract Sum	will be increased by this Change Order in the amount of	\$	<u>7,140.00</u>
The new	Contract Sum	, including this Change Order, will be	\$	<u>9,482,458.00</u>
The Contract Time will be unchanged by		( 0 ) days.		
The new date of Substantial Completion will be				

*NOTE: This Change Order does not include adjustments to the Contract Sum or Guaranteed Maximum Price, or the Contract Time, that have been authorized by Construction Change Directive until the cost and time have been agreed upon by both the Owner and Contractor, in which case a Change Order is executed to supersede the Construction Change Directive.*

**NOT VALID UNTIL SIGNED BY THE ARCHITECT, CONTRACTOR AND OWNER.**

Cole Architects, PLLC

ARCHITECT (Firm name)

*Crystal McColly*  
SIGNATURE

Crystal McColly, Architect

PRINTED NAME AND TITLE

8/11/21

DATE

CORE Headwaters, LLC

CONTRACTOR (Firm name)

\_\_\_\_\_  
SIGNATURE

\_\_\_\_\_  
PRINTED NAME AND TITLE

\_\_\_\_\_  
DATE

City of Ketchum, Idaho

OWNER (Firm name)

\_\_\_\_\_  
SIGNATURE

\_\_\_\_\_  
PRINTED NAME AND TITLE

\_\_\_\_\_  
DATE

1	ASI-10 Change Roof Parapets B&G Lines	\$	1,292.00
2	RFI-178 Add Fire Station Signalization Lights	\$	2,238.00
3	ASI-11 Delete Exterior Building Signage	\$	(3,234.00)
4	RFI-188 Stainless Elevator Opening Wrap	\$	2,665.00
5	RFI-185 Sill Cap Storage 216	\$	3,169.00
6	Building Number @ Door 101A	\$	267.00
7	Exterior "No Smoking" & LEED Certification Signs	\$	743.00
	Total:	\$	7,140.00



## ASI 10

<b>PROJECT NAME</b>	KETCHUM FIRE STATION #1
<b>PROJECT NUMBER</b>	18-022
<b>DATE</b>	6/16/2021
<b>CONSTRUCTION COMPANY</b>	CORE CONSTRUCTION

**THE WORK SHALL BE CARRIED OUT IN ACCORDANCE WITH THE FOLLOWING SUPPLEMENTAL INSTRUCTIONS ISSUED IN ACCORDANCE WITH THE CONTRACT.**

### **DESCRIPTION OF CHANGES:**

### **DRAWINGS:**

#### **ARCHITECTURAL:**

- 1) A3.00 – EXTERIOR ELEVATIONS
  - a) #1 – EXTERIOR ELEVATION – EAST
    - i) ADDED DETAIL CALL OUT.
  - b) #4 – EXTERIOR ELEVATION – WEST
    - i) UPDATED PARAPET HEIGHT.
    - ii) ADDED DETAIL CALL OUTS.
- 2) A7.00 – ROOF PLAN
  - a) ADDED FOUR DETAIL CALLOUTS FOR UPDATED DETAILS ON SHEETS A7.22 – DETAILS ROOF AND A7.23 – DETAILS ROOF.
- 3) A7.22 – DETAILS – ROOF
  - a) ADDED DETAIL #9 – PLAN VIEW PARAPET DEAIL @ GRIDS G & 5.
- 4) A7.23 – DETAILS - ROOF
  - a) ADDED DETAIL #3 – ISO PARAPET DETAIL @ GRIDS B & 2N.
  - b) ADDED DETAIL #4 – ISO PARAPET DETAIL @ GRIDS 5 & B.
  - c) ADDED DETAIL #5 – PLAN VIEW PARAPET DETAIL @ GRIDS B & 5.
  - d) ADDED DETAIL #6 – PARAPET PLAN DETAIL @ GRIDS G & 1.
  - e) ADDED DETAIL #7 – ISO PARAPET DETAIL @ GRIDS G & 1.

### **ATTACHMENTS:**

#### **DRAWINGS:**

- A7.00 – ROOF PLAN
- A7.22 – DETAILS ROOF
- A7.23 – DETAILS ROOF

**END OF ASI**

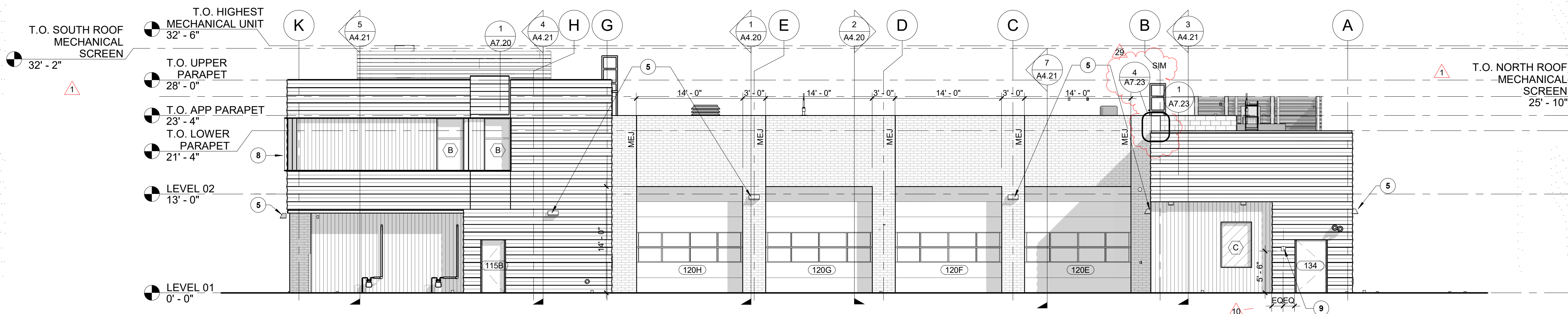

**1 EXTERIOR ELEVATION - EAST**  
SCALE | 1/8" = 1'-0"

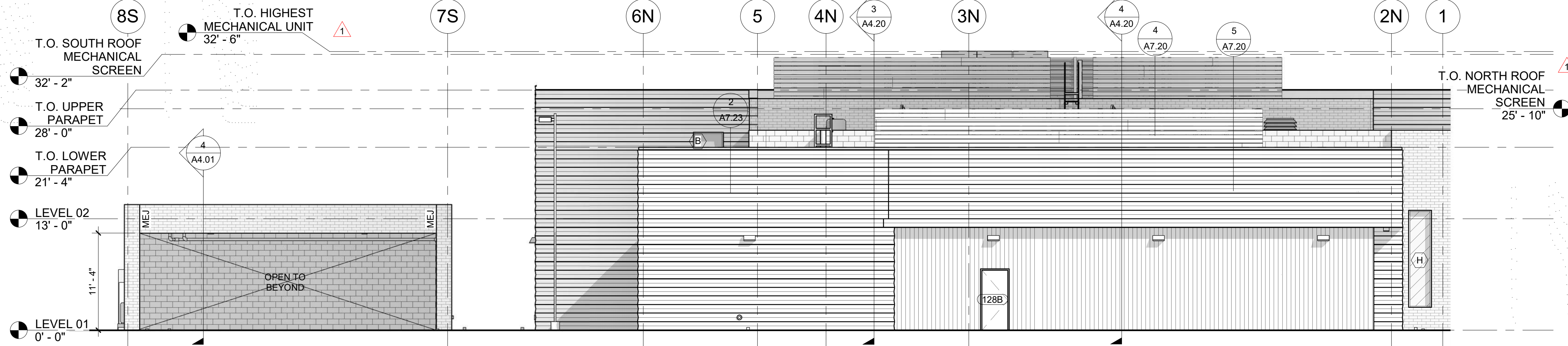

**2 EXTERIOR ELEVATION - NORTH**  
SCALE | 1/8" = 1'-0"

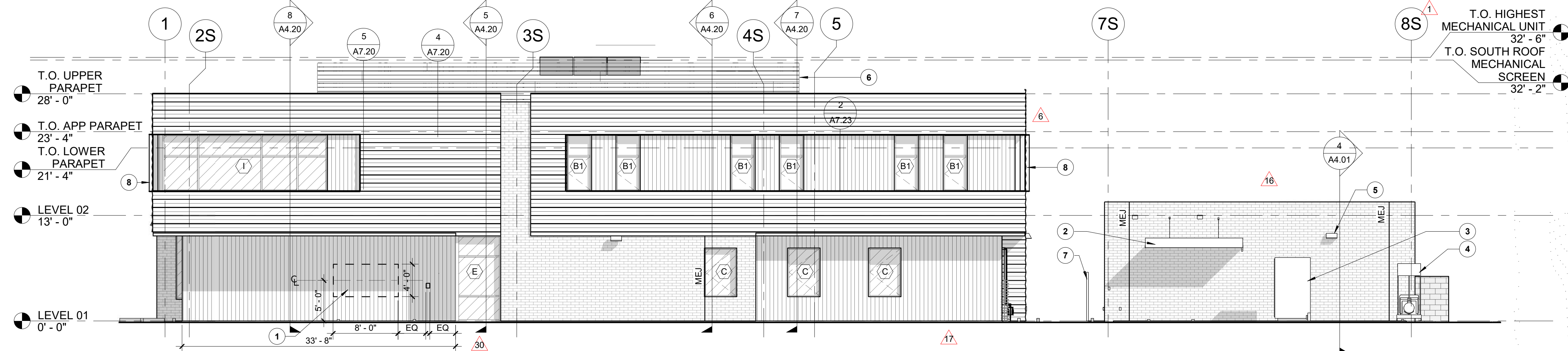

**3 EXTERIOR ELEVATION - SOUTH**  
SCALE | 1/8" = 1'-0"

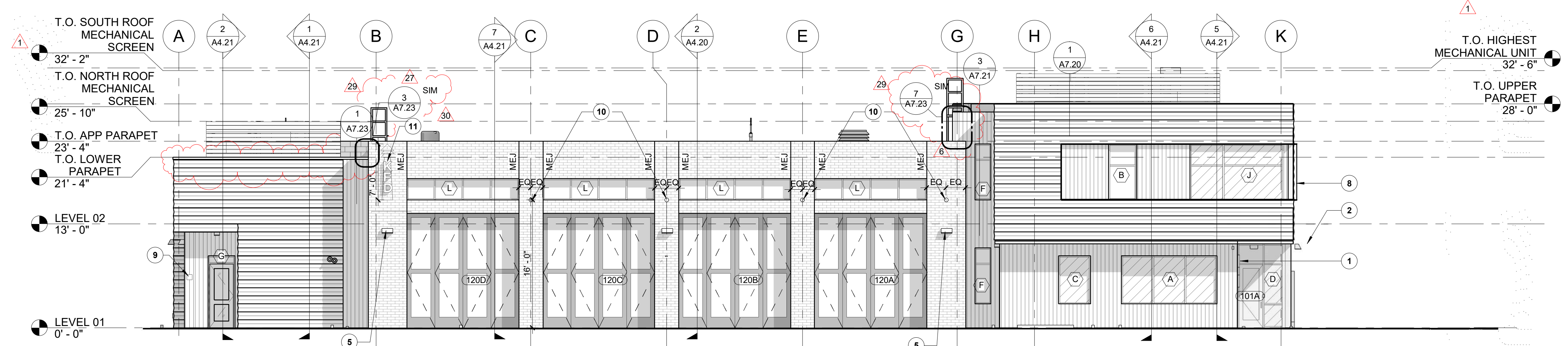

**4 EXTERIOR ELEVATION - WEST**  
SCALE | 1/8" = 1'-0"

**GENERAL NOTES**

- A. GENERAL NOTES APPLY TO ALL DRAWING SETS.
- B. FIELD VERIFY ALL DIMENSIONS AND EXISTING CONDITIONS. NOTIFY ARCHITECT IMMEDIATELY IF ANY CONFLICTS OR DISCREPANCIES OCCUR BEFORE PROCEEDING WITH WORK.
- C. CROSS REFERENCES SHOWN ON DRAWINGS DO NOT NECESSARILY INDICATE ALL LIKE CONDITIONS AND DO NOT LIMIT APPLICATION OF ANY DRAWING OR DETAIL. WHERE SPECIFIC DIMENSIONS, DETAILS, OR DESIGN INTENT CANNOT BE DETERMINED, CONSULT THE ARCHITECT PRIOR TO PROCEEDING WITH WORK. IF DESIGN INTENT REMAINS UNCLEAR THEN PROVIDE MOST EXPENSIVE OPTION IN BID.
- D. DIMENSIONS ARE TO GRID LINE OR FACE OF STRUCTURAL MEMBER UNLESS OTHERWISE NOTED. DOOR & WINDOW OPENING DIMENSIONS ARE TO ROUGH OPENING OR CENTERLINE OF OPENING. CONCRETE AND BRICK DIMENSIONS ARE GIVEN TO THE FACE OF CONCRETE OR MASONRY AND TO THE FACE OF ROUGH OPENINGS.
- E. CROSS REFERENCES SHOWN ON DRAWINGS DO NOT NECESSARILY INDICATE ALL LIKE CONDITIONS AND DO NOT LIMIT APPLICATION OF ANY DRAWING OR DETAIL. WHERE SPECIFIC DIMENSIONS, DETAILS, OR DESIGN INTENT CANNOT BE DETERMINED, CONSULT THE ARCHITECT PRIOR TO PROCEEDING WITH WORK. IF DESIGN INTENT REMAINS UNCLEAR THEN PROVIDE MOST EXPENSIVE OPTION IN BID.
- F. DIMENSIONS ARE TO GRID LINE OR FACE OF STRUCTURAL MEMBER UNLESS OTHERWISE NOTED. DOOR & WINDOW OPENING DIMENSIONS ARE TO ROUGH OPENING OR CENTERLINE OF OPENING. CONCRETE AND BRICK DIMENSIONS ARE GIVEN TO THE FACE OF CONCRETE OR MASONRY AND TO THE FACE OF ROUGH OPENINGS.
- G. REFER TO WALL TYPES FOR DETAILS.

**MATERIALS LEGEND**

- BRICK - RUNNING BOND**  
INTERSTATE BRICK IN COLOR: "MIDNIGHT BLACK"
- CONCRETE MASONRY UNIT - RUNNING BOND**  
RE: SPECIFICATION DIVISION 04
- METAL WALL PANEL - HORIZONTAL**  
MORIN CONCEALED FASTENER METAL PANEL W-12 IN COLOR "SILVERSMITH"
- METAL WALL PANEL - VERTICAL**  
BRIDGER STEEL 7/8" CORRUGATED, EXPOSED FASTENER, METAL WALL PANEL IN COLOR "COPPER PENNY"
- ALUMINUM STOREFRONT**  
KAWNEER TRIFAB 451UT W/ GAURDIAN GLASS - SUNGAURD SNR 43  
RE: SPECIFICATION DIVISION 08
- MASONRY EXPANSION JOINT**

**KEYNOTES**

- 1. PROVIDE BACKING IN WALL FOR EXTERIOR SIGNAGE. EXTERIOR BUILDING SIGNAGE TO BE OWNER PROVIDED.
- 2. COVERED PATIO, PER PLAN
- 3. TRANSFORMER, RE: ELECTRICAL
- 4. GENERATOR, RE: ELECTRICAL
- 5. LIGHTING FIXTURES, RE: ELECTRICAL
- 6. MECHANICAL SCREENING, RE: SPECIFICATION
- 7. 6'-0" TALL FENCE, RE: LANDSCAPE
- 8. FORMED ALUMINUM LIP AROUND WALL RECESS PERIMETER, RE: STRUCTURAL
- 9. RECESSED KNOX BOX
- 10. EXTERIOR WALL MOUNTED STROBE LIGHT IN COLOR: "CLEAR", RE: ELECTRICAL SHEET E3.01.
- 11. EXTERIOR MOUNTED HISTORIC STATION SIREN, OWNER PROVIDED. DECORATIVE ONLY.



1008 W Main St  
Boise, Idaho 83702  
208.345.1800  
colearchitects.net  
Copyright © 2020 Cole Architects, PLLC



6211 Roosevelt Way NE  
Seattle, WA 98115  
206.522.3820

BIDDERS ARE INSTRUCTED TO CAREFULLY REVIEW THE CONSTRUCTION DOCUMENTS AND THE SITE CONDITIONS. INFORMATION REGARDING THE COMPLETE WORK OF SPECIFIC TRADES IS DISPERSED THROUGHOUT THE ENTIRE DOCUMENT SET AND CANNOT BE ACCURATELY DETERMINED BY REFERENCE TO OTHER THAN COMPLETE DOCUMENT SETS.

**STAMP**

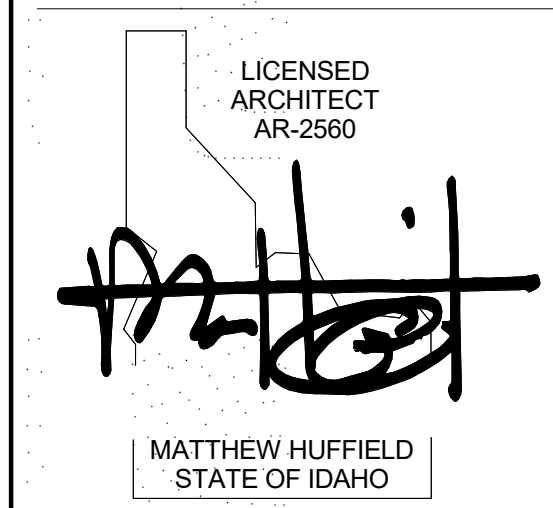

**CONSULTANT**

**PROJECT INFORMATION**



**KETCHUM FIRE STATION NO. 1**

107 SADDLE ROAD, KETCHUM, ID 83353

**ISSUES**

PHASE	CONSTRUCTION SET
DATE	JUNE 19, 2020
JOB NUMBER	18-022

MARK	DATE	DESCRIPTION
30	6/16/21	ASI 11
29	6/16/21	ASI 10
27	5/13/21	RFI #CC-178
17	12/11/20	RFI #CC-129
16	12/15/20	RFI #CC-94
10	10/14/20	ASI 03
6	8/17/20	ASI 2
1	6/23/20	CITY PERMIT COMMENTS

**SHEET NAME**

**EXTERIOR ELEVATIONS**

**SHEET NUMBER**

**A3.00**



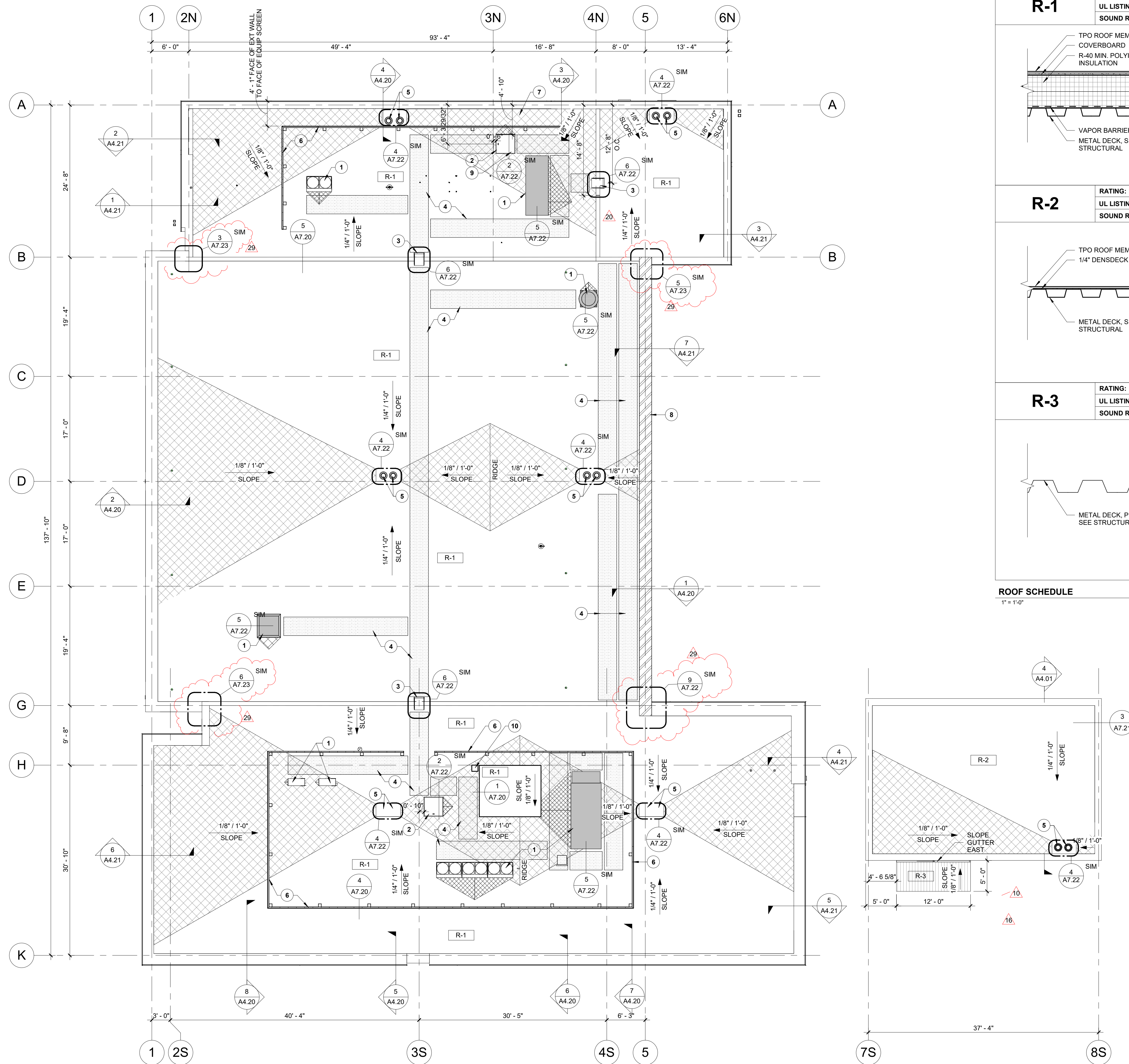

**1 ROOF PLAN**  
SCALE | 1/8" = 1'-0"

R-1	RATING:
	UL LISTING:
	SOUND RATING:

R-2	RATING:
	UL LISTING:
	SOUND RATING:

R-3	RATING:
	UL LISTING:
	SOUND RATING:

**ROOF SCHEDULE**  
1" = 1'-0"

**GENERAL NOTES**

- A. COORDINATE INSTALLATION OF ROOFING WITH OTHER TRADES. REPORT ANY CONFLICTS WITH ITEMS INSTALLED BY OTHER TRADES TO ARCHITECT.
- B. ALL ROOF CURBS FOR NEW ROOFTOP EXHAUST FANS, HVAC UNITS AND CONDENSING UNITS SHALL HAVE CURB HEIGHTS THAT WILL ALLOW FOR A MINIMUM OF 8" BASE FLASHING HEIGHTS FOR THE ROOF SYSTEM.
- C. ALL PLUMBING VENTS SHALL EXTEND ABOVE THE FINISHED SURFACE OF THE ROOF SYSTEM AS REQUIRED TO PROVIDE FOR A MINIMUM OF 8" BASE FLASHING. PROVIDE FLASHING AROUND VENTS AND ROOF PENETRATIONS PER ROOFING MANUFACTURER RECOMMENDATIONS.
- D. PROVIDE 36" WIDE WALK PADS AROUND PERIMETER OF ALL MECHANICAL EQUIPMENT. PROVIDE 36" WIDE WALK PADS AROUND ALL ROOF HATCHES & 72"x72" PADS AT LADDERS.
- E. UNLESS NOTED OTHERWISE - PROVIDE FIRESTONE UNI-CLAD KYNAR 500/HYLAR 5000 PRE-FINISHED GALVALUME STEEL (24 GA) ARCHITECTURE SHEET AND COIL FOR ALL COPINGS, FLASHING & TRIM PIECES. SUBMIT STANDARD COLOR SELECTION TO ARCHITECT FOR APPROVAL. ALL CLEATS TO BE CONTINUOUS.
- F. ALL GUTTERS TO BE PREFINISHED SMACNA APPROVED 'K' STYLE CONTINUOUS ALUMINUM GUTTERS SIZED FOR QUANTITY OF WATER FLOW. PROVIDE STAINLESS STEEL SCREENS FOR GUTTERS. UNO PROVIDE HEAT CABLE IN GUTTER. UNO SUBMIT STANDARD COLOR SELECTION TO ARCHITECT FOR APPROVAL.
- G. ALL DOWNSPOUTS TO BE PRE-FINISHED SMACNA APPROVED RECTANGULAR ALUMINUM DOWNSPOUT SIZED FOR QUANTITY OF WATER FLOW. PROVIDE ALUMINUM ATTACHMENT CLIPS AT MAX 4' INTERVALS. UNO PROVIDE HEAT CABLE IN DOWNSPOUT AND EXTEND INTO GROUND. UNO SUBMIT STANDARD COLOR SELECTION TO ARCHITECT FOR APPROVAL. SEE EXTERIOR ELEVATIONS OR ROOF PLAN FOR LOCATIONS.
- H. PROVIDE PAINTED 4" TALL CAST ALUM. DOWNSPOUT BOOTS @ ALL DOWN SPOUTS, TIE INTO SUB-GRADE DRAINAGE, RE. CIVIL.
- I. TAPERED INSULATION TO BE 1/4" PER FOOT MIN SLOPE TO DRAIN. ROOF PLAN SHOWS TAPERED INSULATION FOR GRAPHIC REPRESENTATION ONLY. CONTRACTOR TO VERIFY INSULATION REQUIRED TO SLOPE PRIOR TO MEMBRANE INSULATION.
- J. PROVIDE TAPERED INSULATION CRICKETS 1/4" PER FOOT MIN. SLOPE @ HIGH SIDE OF ALL MECHANICAL UNITS AND ROOF HATCHES, TO SHED WATER AROUND AND MAINTAIN POSITIVE ROOF DRAINAGE.
- K. VERIFY ELEVATION OF ROOF DRAIN RELATIVE TO OVERFLOW SCUPPER PRIOR TO INSTALLATION OF SCUPPER.
- L. PROVIDE SELF-ADHERING VAPOR RETARDER BETWEEN DECK AND INSULATION. SEE ROOF SCHEDULE AND ROOF DETAILS. UNO PROVIDE CARLISLE AIR & VAPOR BARRIER TR725. PROVIDE AIR TIGHT SEAL AROUND ALL DECK PENETRATIONS AND DECK PERIMETER PRIOR TO INSTALLING VAPOR BARRIER.
- M. ALL WOOD NAILER AND BLOCKING TO BE TREATED. SECURE NAILERS PER FM GLOBAL 1-49 PERIMETER FLASHING REQUIREMENTS.
- N. INSTALL MANUFACTURE'S RECOMENED PRESSURE-SENSITIVE RUSS STRIP ALONG ENTIRE ROOF PERIMETER AND AT PERIMETER OF ALL ROOF CURBS.
- O. WHEN APPLICABLE - UNLESS NOTED OTHERWISE, USE CDX PLYWOOD FOR EXTERIOR APPLICATIONS AND BCD PLYWOOD FOR INTERIOR APPLICATIONS.

**KEYNOTES #**

- 1. ROOF MOUNTED MECHANICAL UNIT. SEE MECHANICAL DRAWINGS.
- 2. 3' x 3' ROOF ACCESS HATCH.
- 3. ROOF ACCESS LADDER.
- 4. WALKING PAD.
- 5. ROOF DRAIN AND OVERFLOW DRAIN. SEE ARCH ROOF DETAILS AND PLUMBING DRAWINGS.
- 6. EQUIPMENT SCREEN.
- 7. FALL ARREST SYSTEM. SEE SPECIFICATIONS SECTION 118129.
- 8. REINFORCED PARAPET CAP FOR LADDER TRAINING SHOWN HATCHED.
- 9. GUARD RAIL ATTACHED TO ROOF HATCH.
- 10. ROOF ANTENNA.

**ROOF PLAN LEGEND**

- ROOF WALK PADS. REFER TO SPECIFICATIONS
- TAPERED INSULATION CRICKET
- REINFORCED WALL CAP FOR LADDER TRAINING



1008 W Main St  
Boise, Idaho 83702  
208.345.1800  
colearchitects.net  
Copyright © 2020 Cole Architects, PLLC



6211 Roosevelt Way NE  
Seattle, WA 98115  
206.522.3820

BIDDERS ARE INSTRUCTED TO CAREFULLY REVIEW THE CONSTRUCTION DOCUMENTS AND THE SITE CONDITIONS. INFORMATION REGARDING THE COMPLETE WORK OF SPECIFIC TRADES IS DISPERSED THROUGHOUT THE ENTIRE DOCUMENT SET AND CANNOT BE ACCURATELY DETERMINED BY REFERENCE TO OTHER THAN COMPLETE DOCUMENT SETS.

**STAMP**

LICENSED ARCHITECT  
AR-2560  
  
MATTHEW HUFFIELD  
STATE OF IDAHO

**CONSULTANT**

**PROJECT INFORMATION**



**KETCHUM FIRE STATION NO. 1**  
107 SADDLE ROAD, KETCHUM, ID 83353

**ISSUES**

MARK	DATE	DESCRIPTION
29	6/16/21	ASI 10
20	1/20/21	ASI 05
16	12/15/20	RFI #CC-94
10	10/14/20	ASI 03

**SHEET NAME**

**ROOF PLAN**

**SHEET NUMBER**

**A7.00**

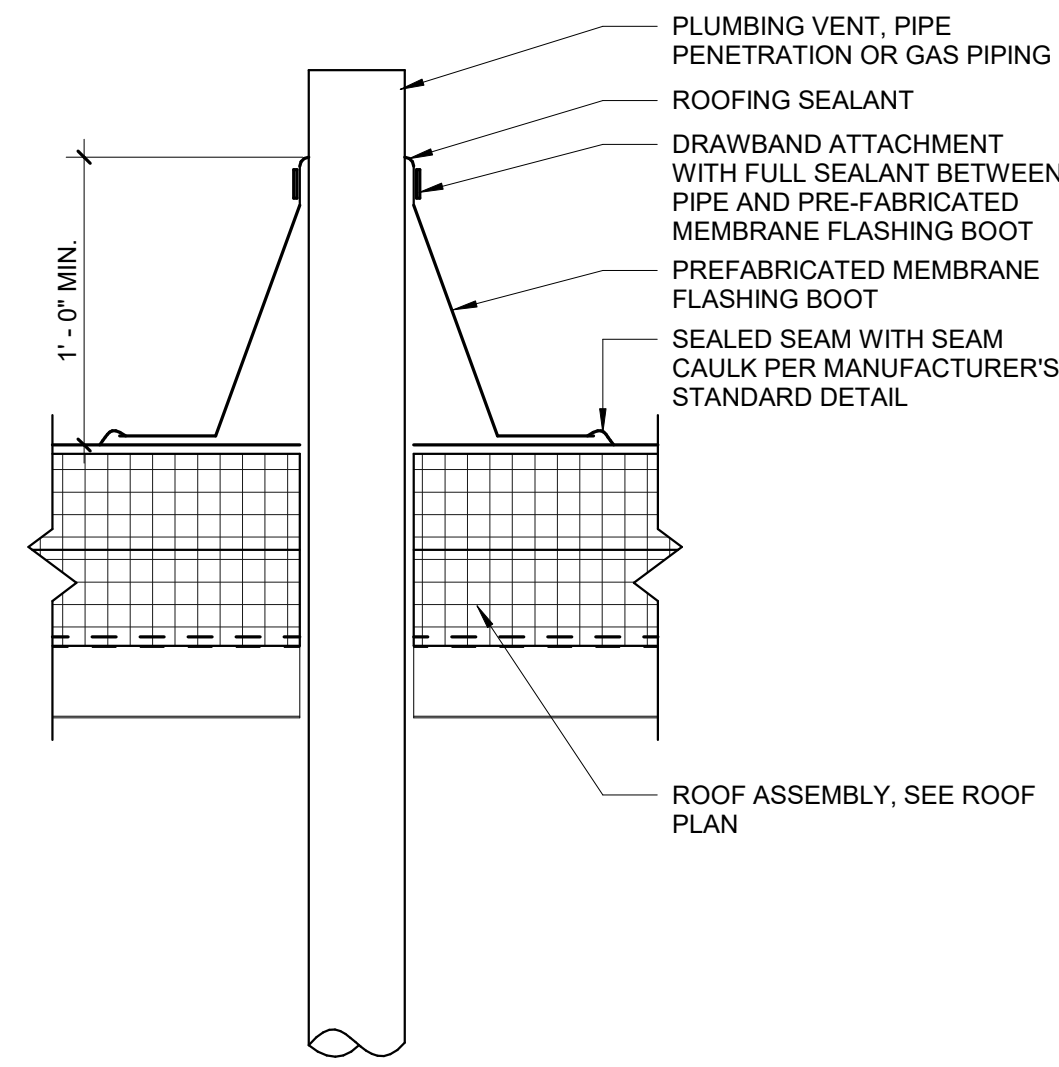

**1 VENT & PIPE PENETRATION**  
SCALE | 1 1/2" = 1'-0"

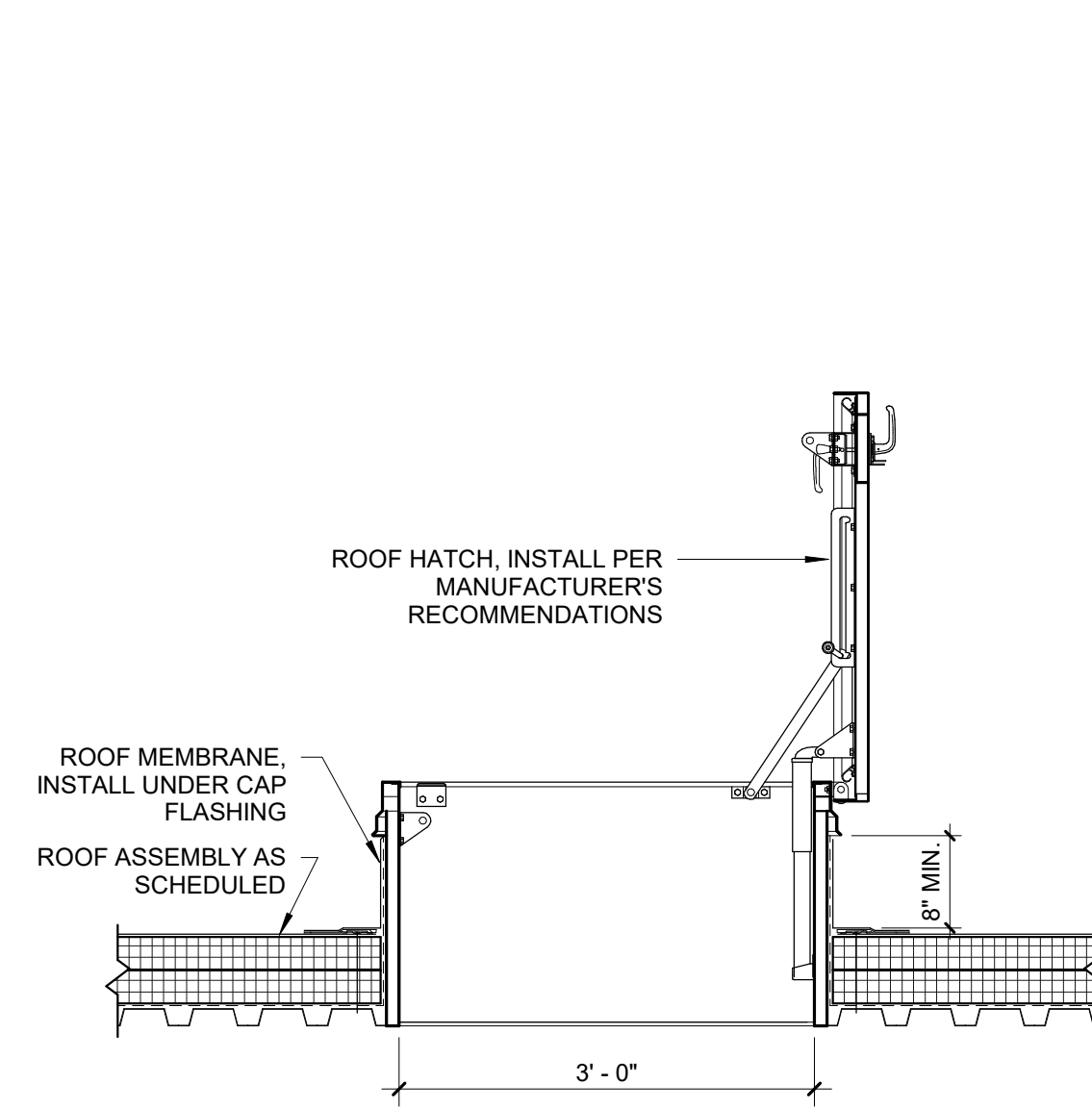

**2 ROOF HATCH DETAIL**  
SCALE | 3/4" = 1'-0"

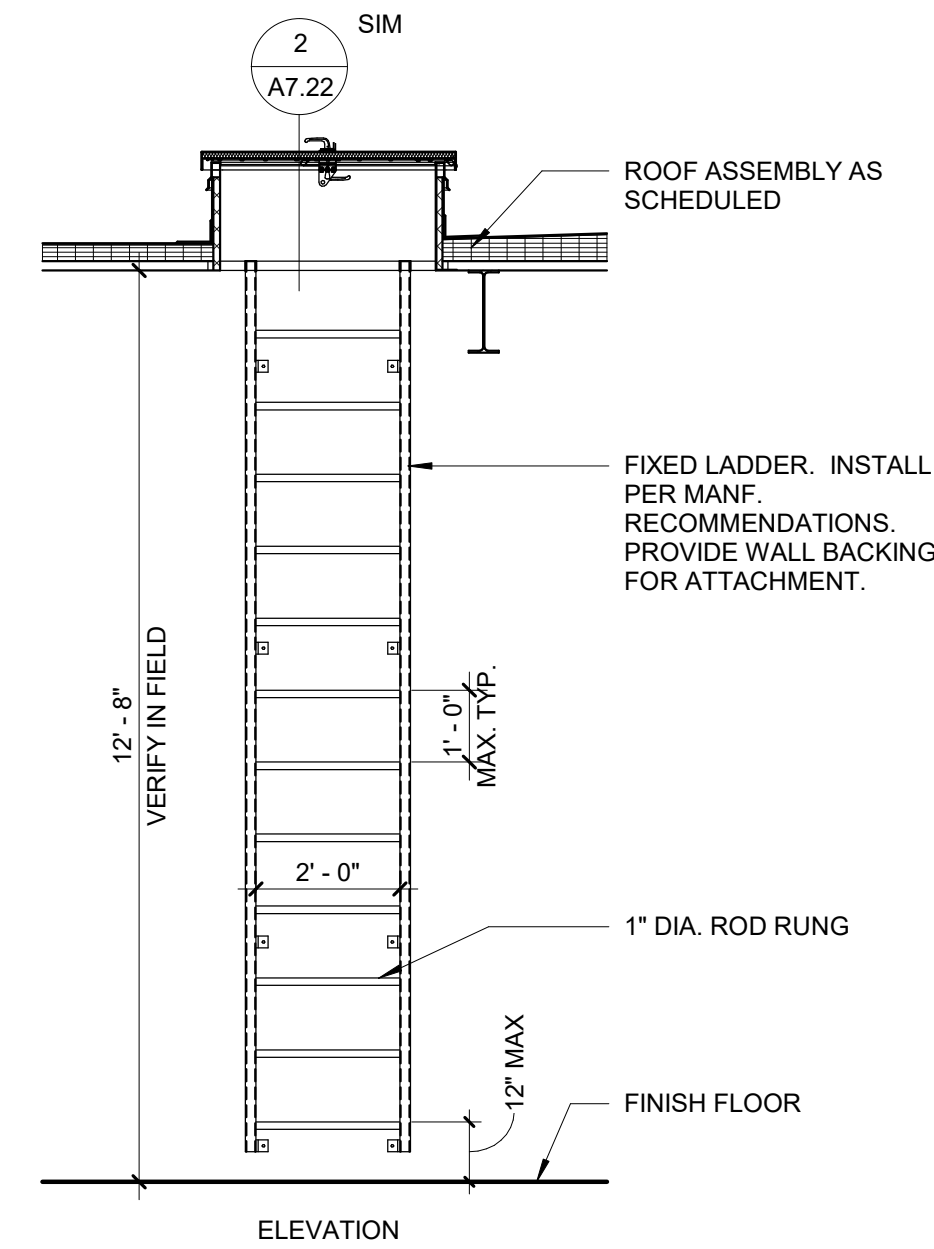

**3 ROOF ACCESS LADDER**  
SCALE | 3/8" = 1'-0"

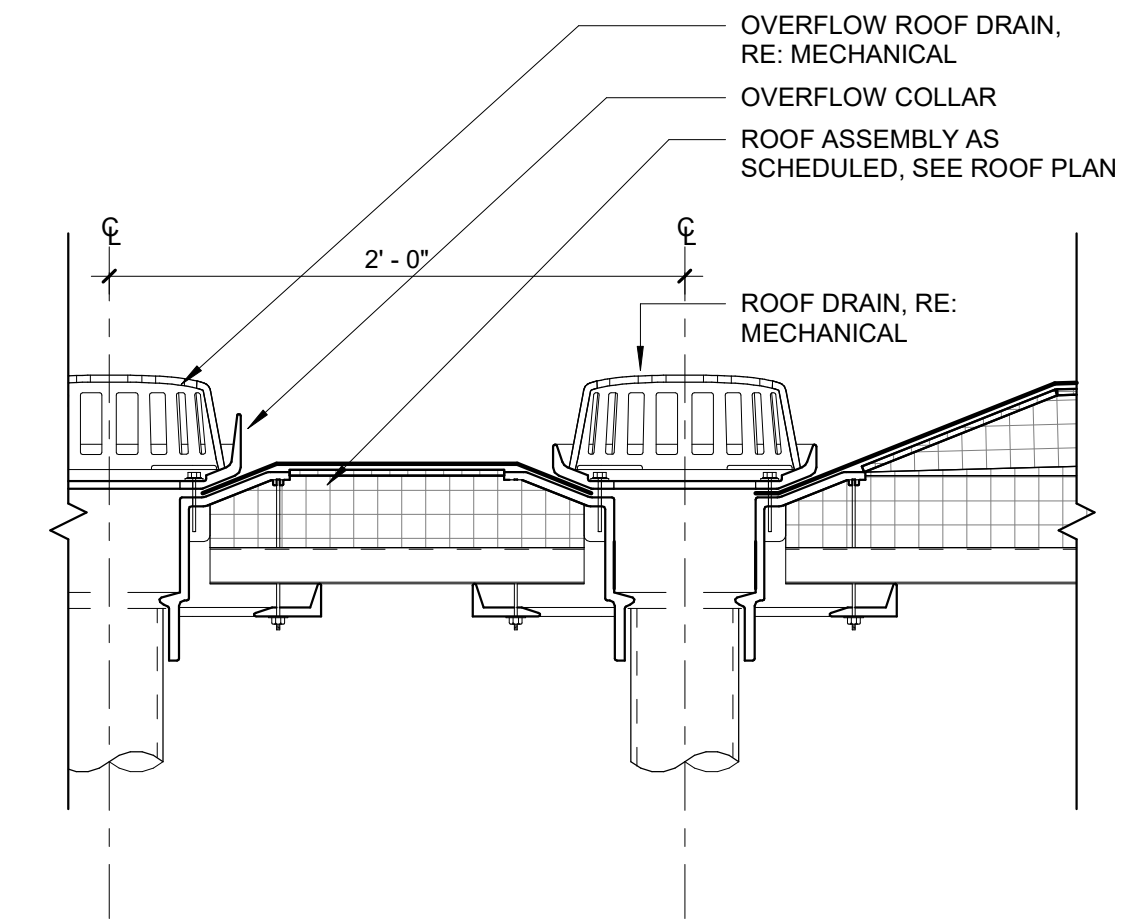

**4 ROOF DRAIN**  
SCALE | 1 1/2" = 1'-0"

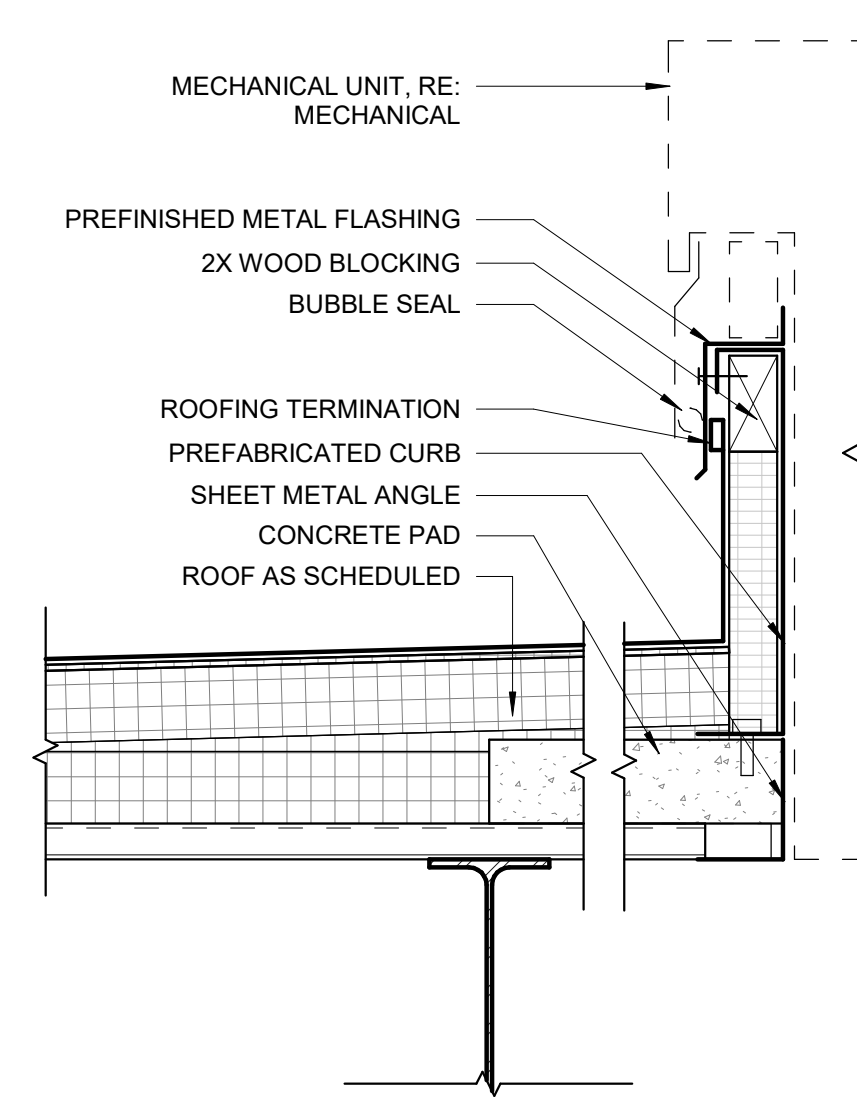

**5 MECHANICAL CURB AT EQUIPMENT PAD**  
SCALE | 1 1/2" = 1'-0"

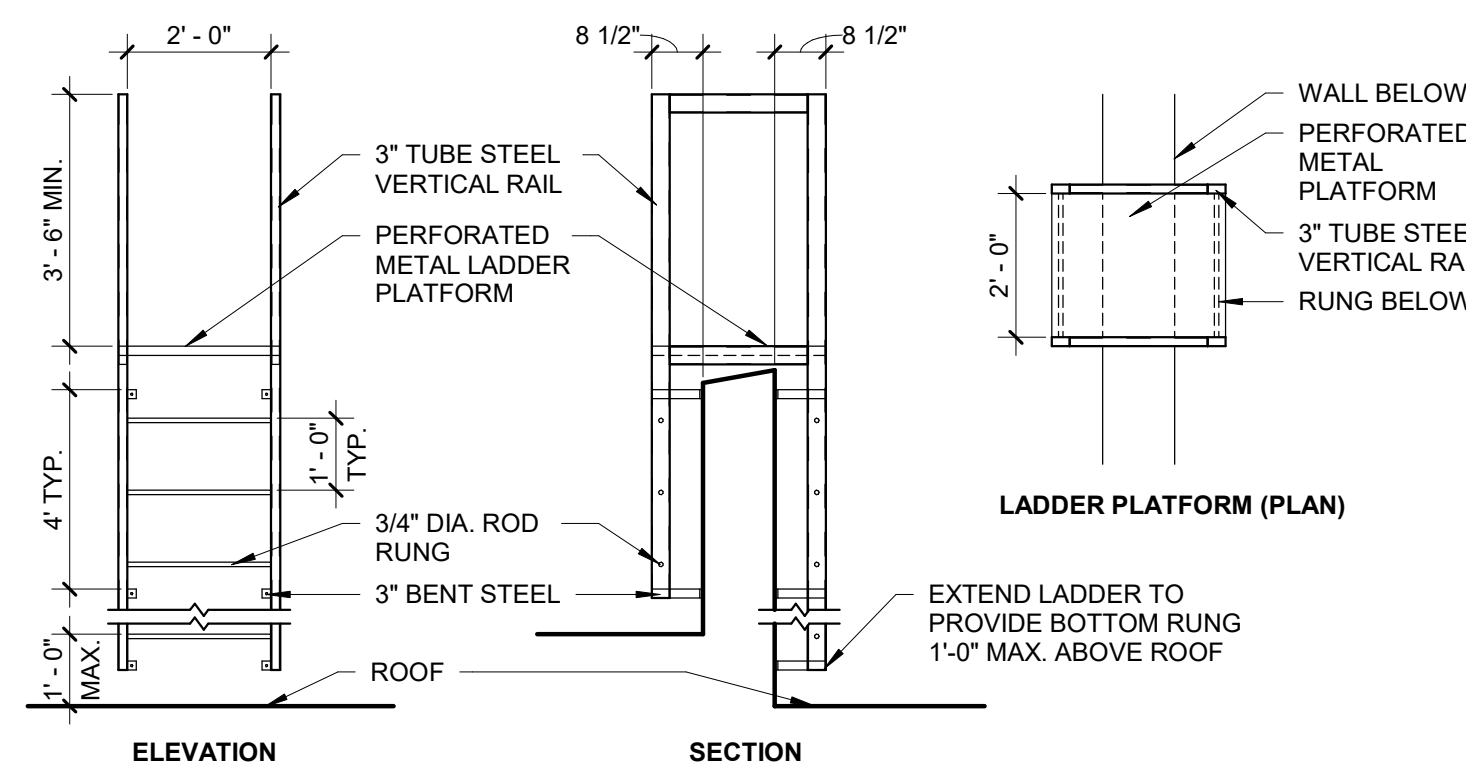

**6 OVER PARAPET ROOF ACCESS LADDER**  
SCALE | 3/8" = 1'-0"

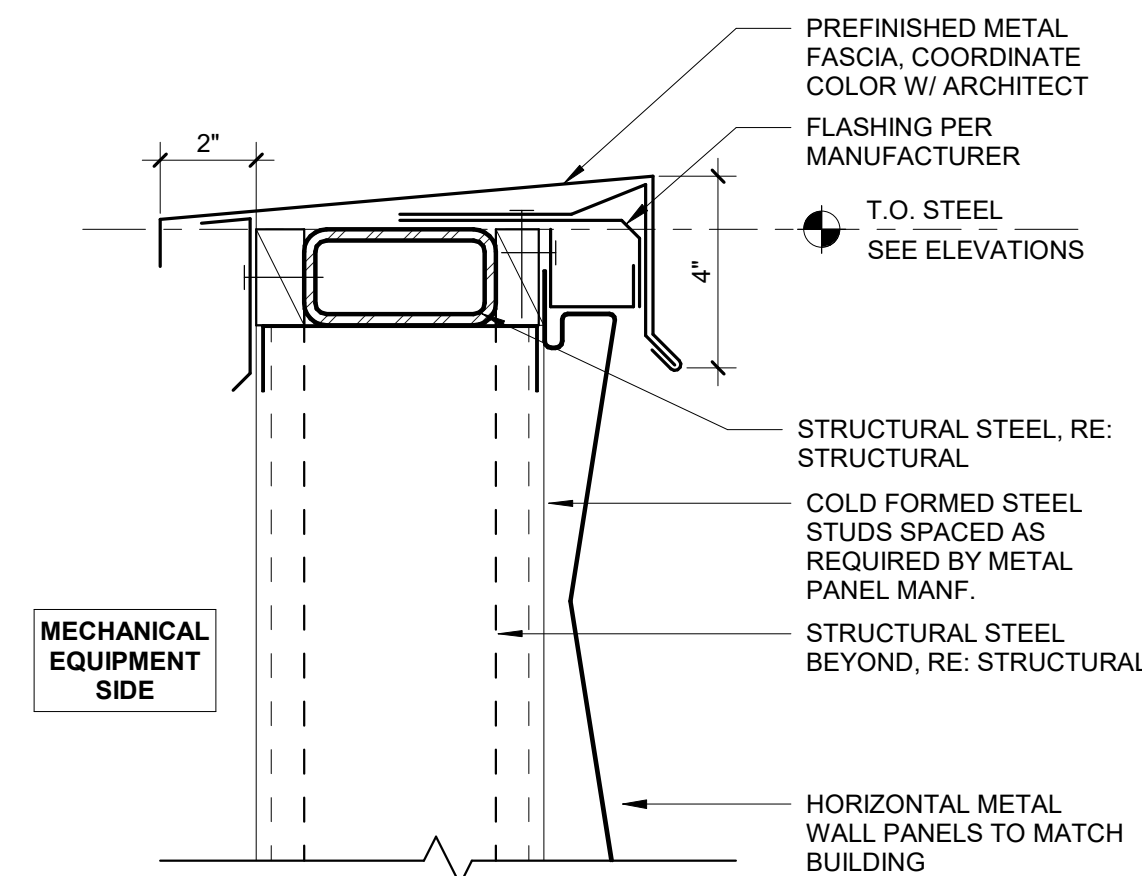

**7 PARAPET DETAIL - COPING @ MECHANICAL SCREEN**  
SCALE | 3" = 1'-0"

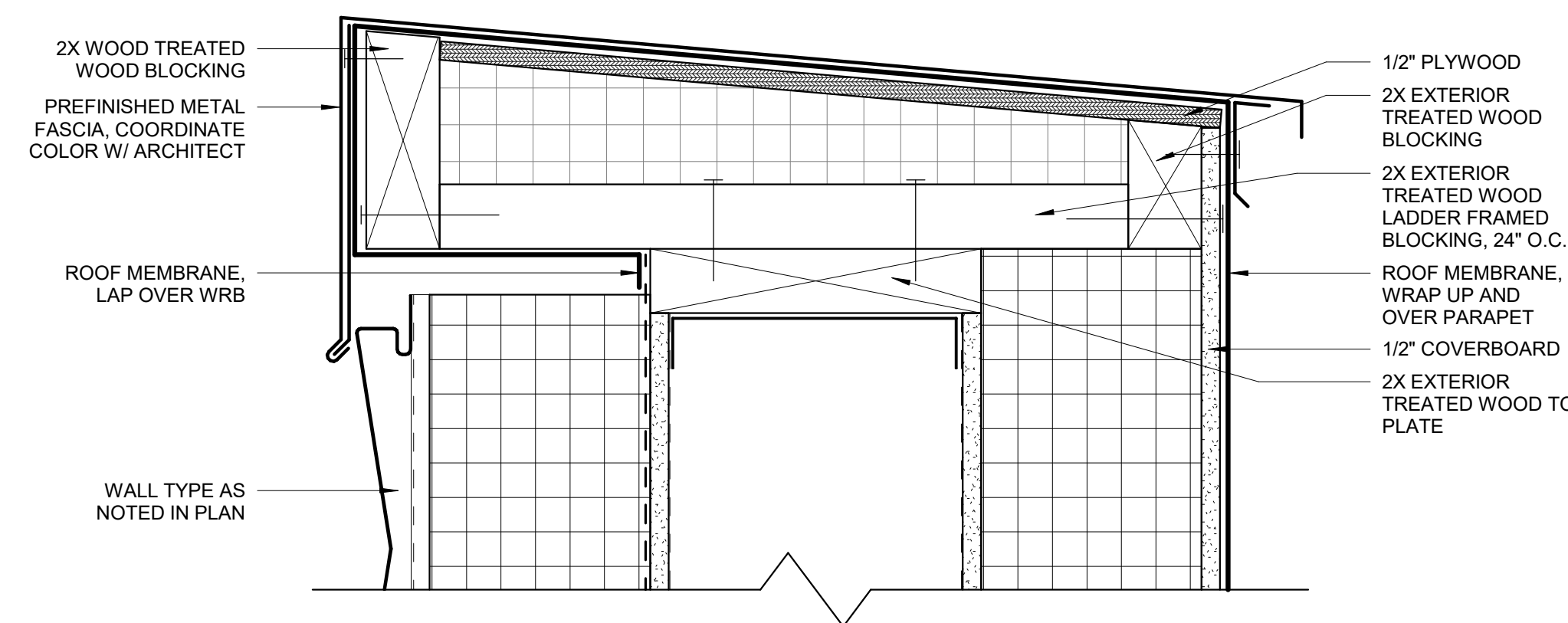

**8 PARAPET DETAIL - COPING @ METAL PANEL**  
SCALE | 3" = 1'-0"

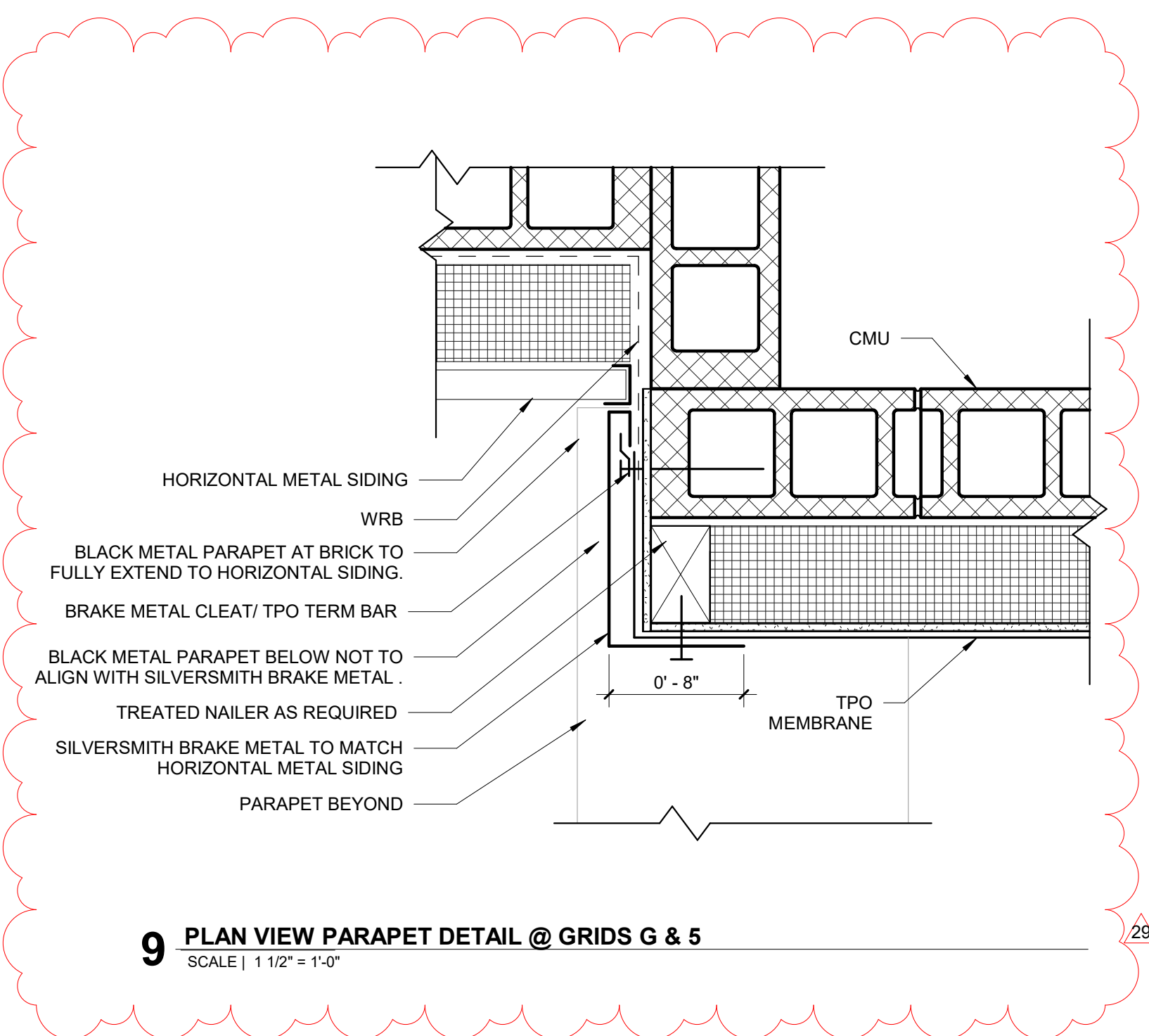

**9 PLAN VIEW PARAPET DETAIL @ GRIDS G & 5**  
SCALE | 1 1/2" = 1'-0"



MARK	DATE	DESCRIPTION
29	6/16/21	ASI 10

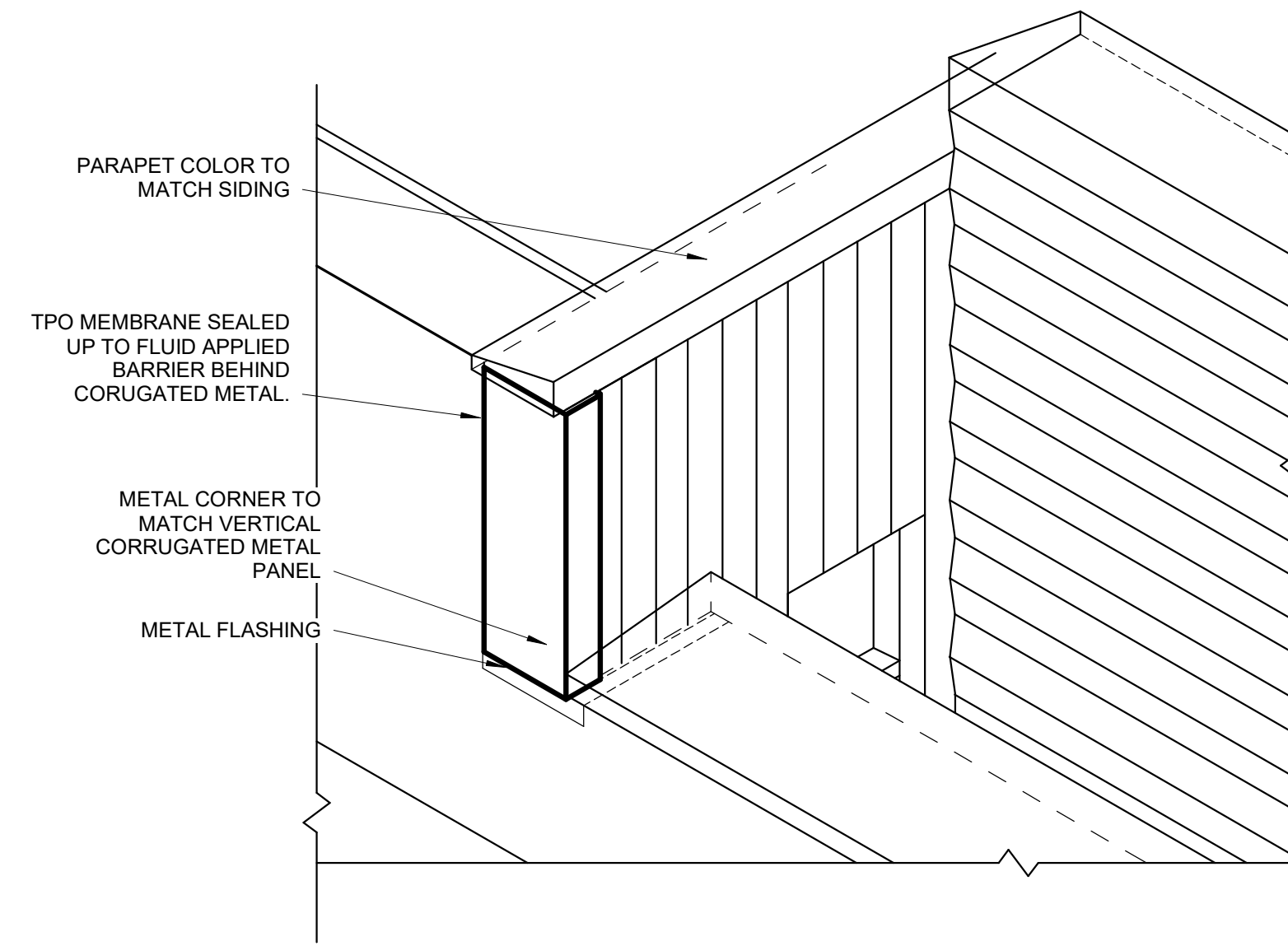

**7 ISO PARAPET DETAIL @ GRIDS G & 1**  
SCALE | 1/2" = 1'-0"

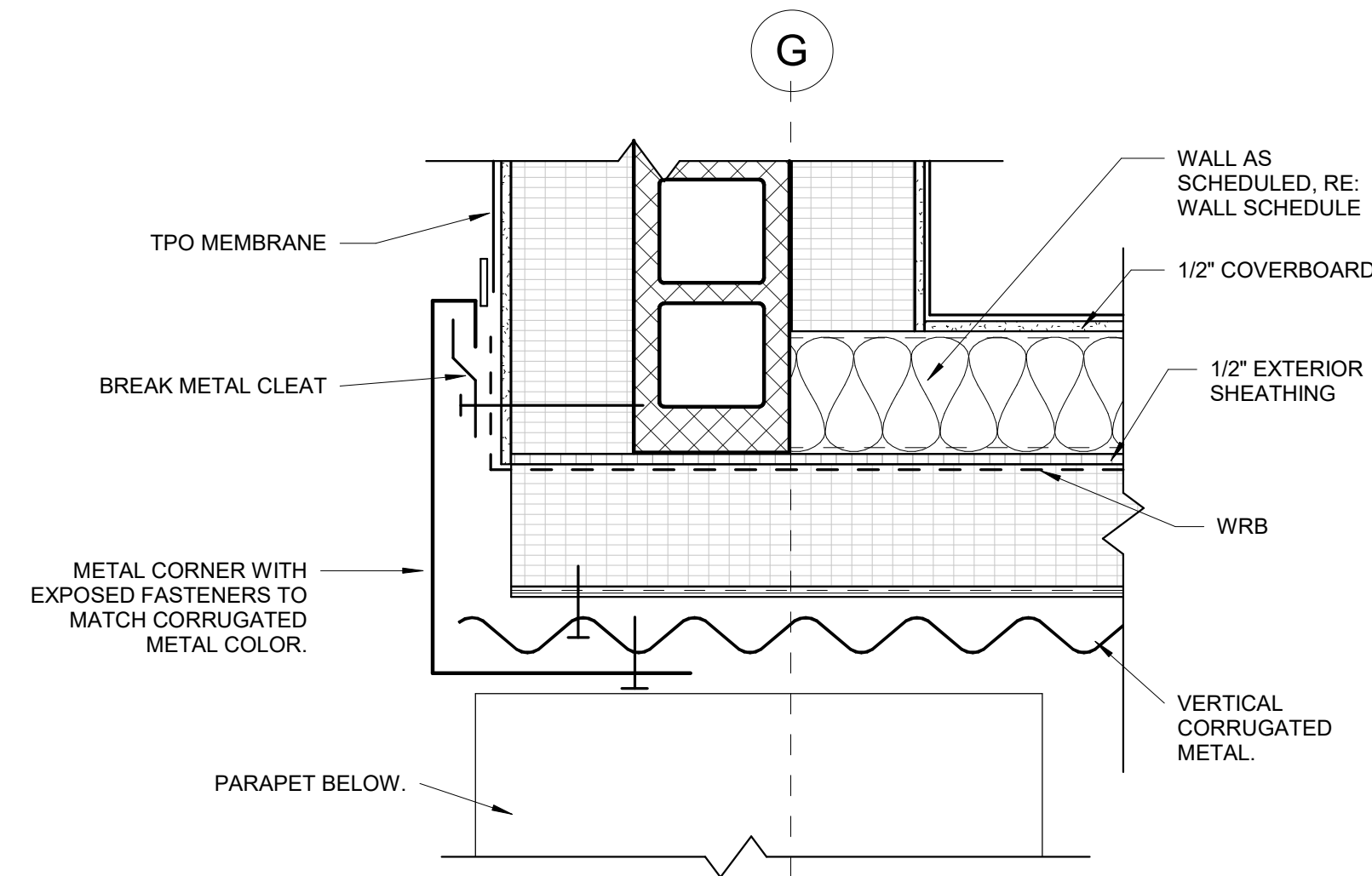

**6 PARAPET PLAN DETAIL @ GRIDS G & 1**  
SCALE | 1 1/2" = 1'-0"

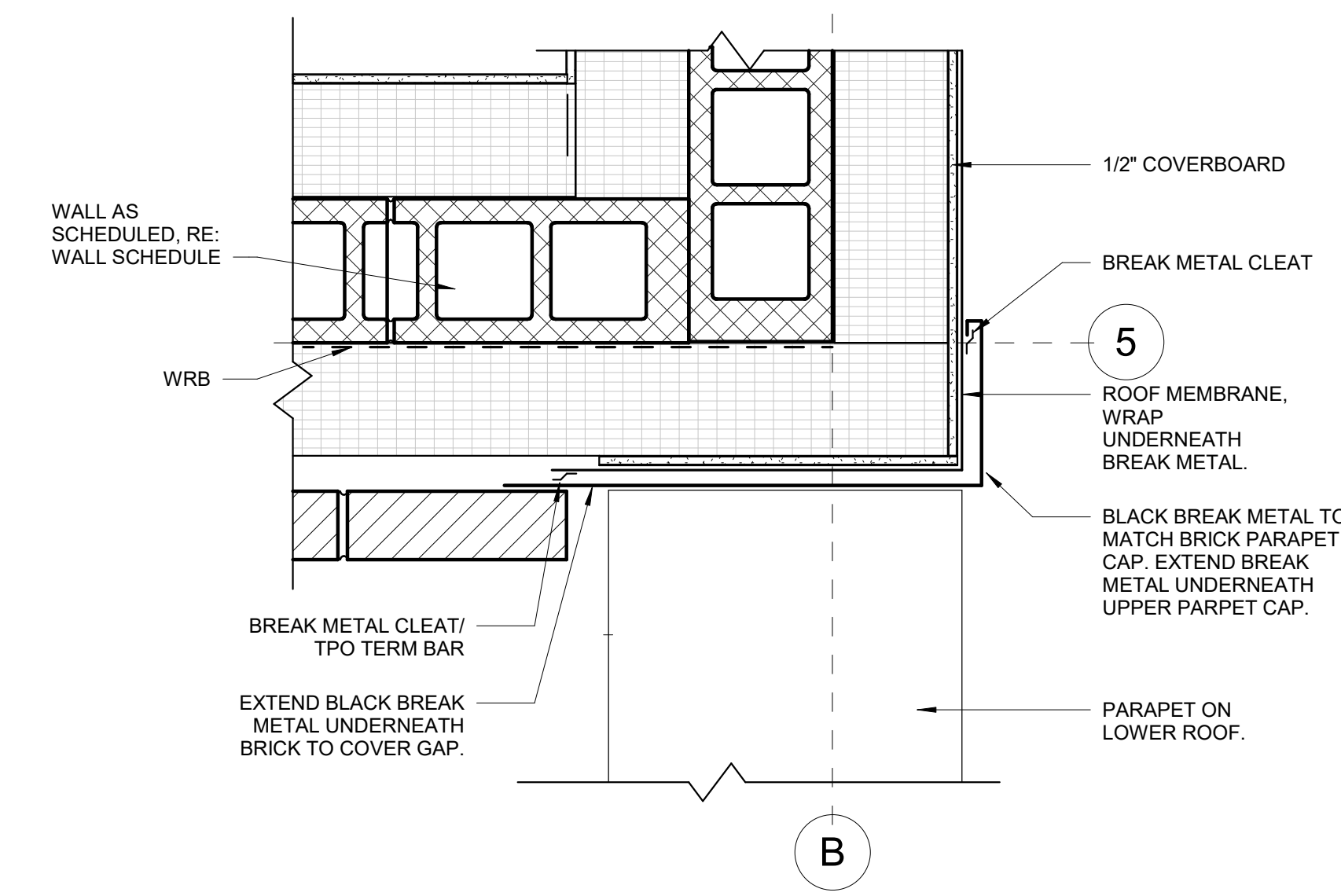

**5 PLAN VIEW PARAPET DETAIL @ GRIDS B & 5**  
SCALE | 1 1/2" = 1'-0"

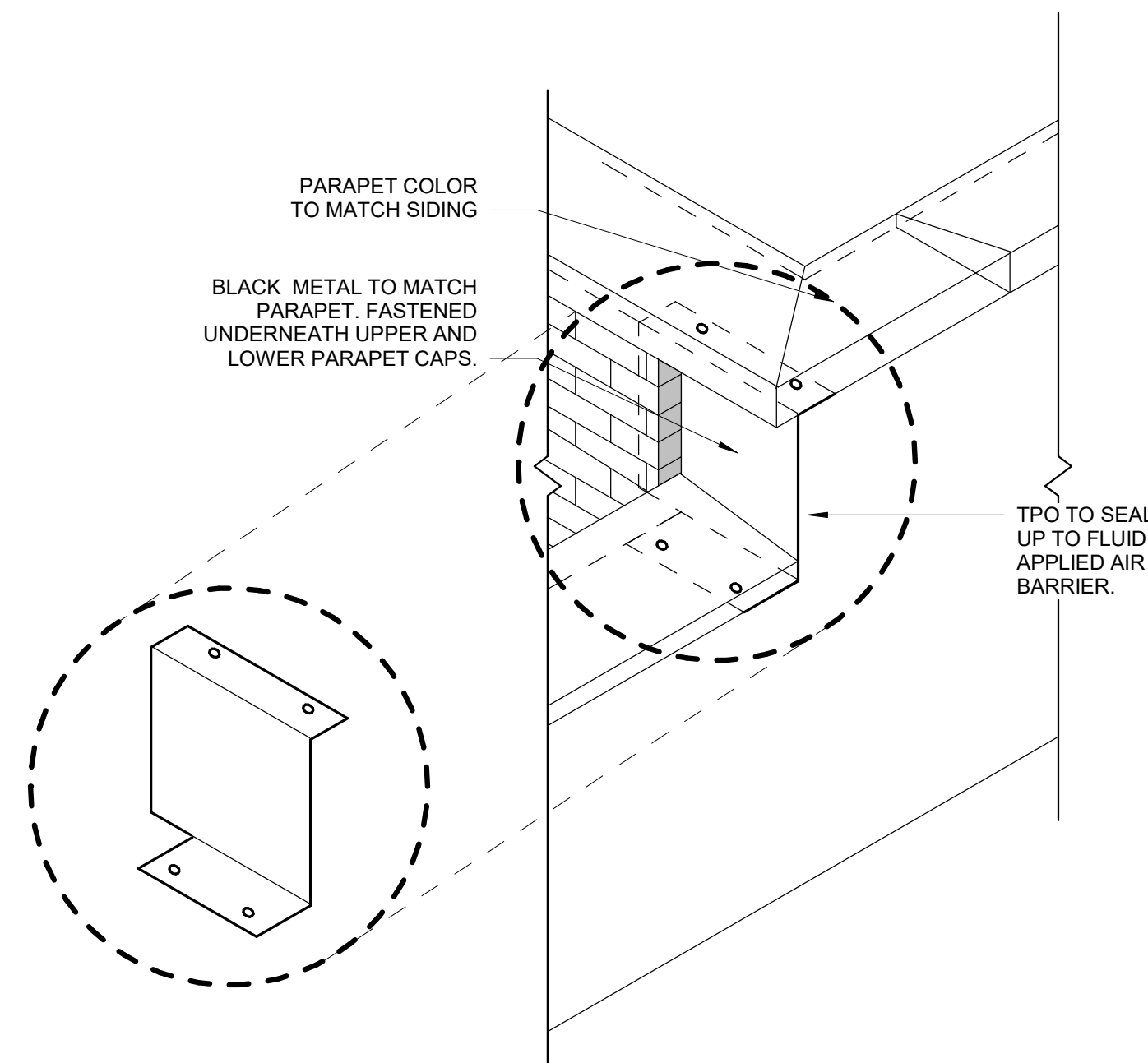

**4 ISO PARAPET DETAIL @ GRIDS 5 & B**  
SCALE | 1/2" = 1'-0"

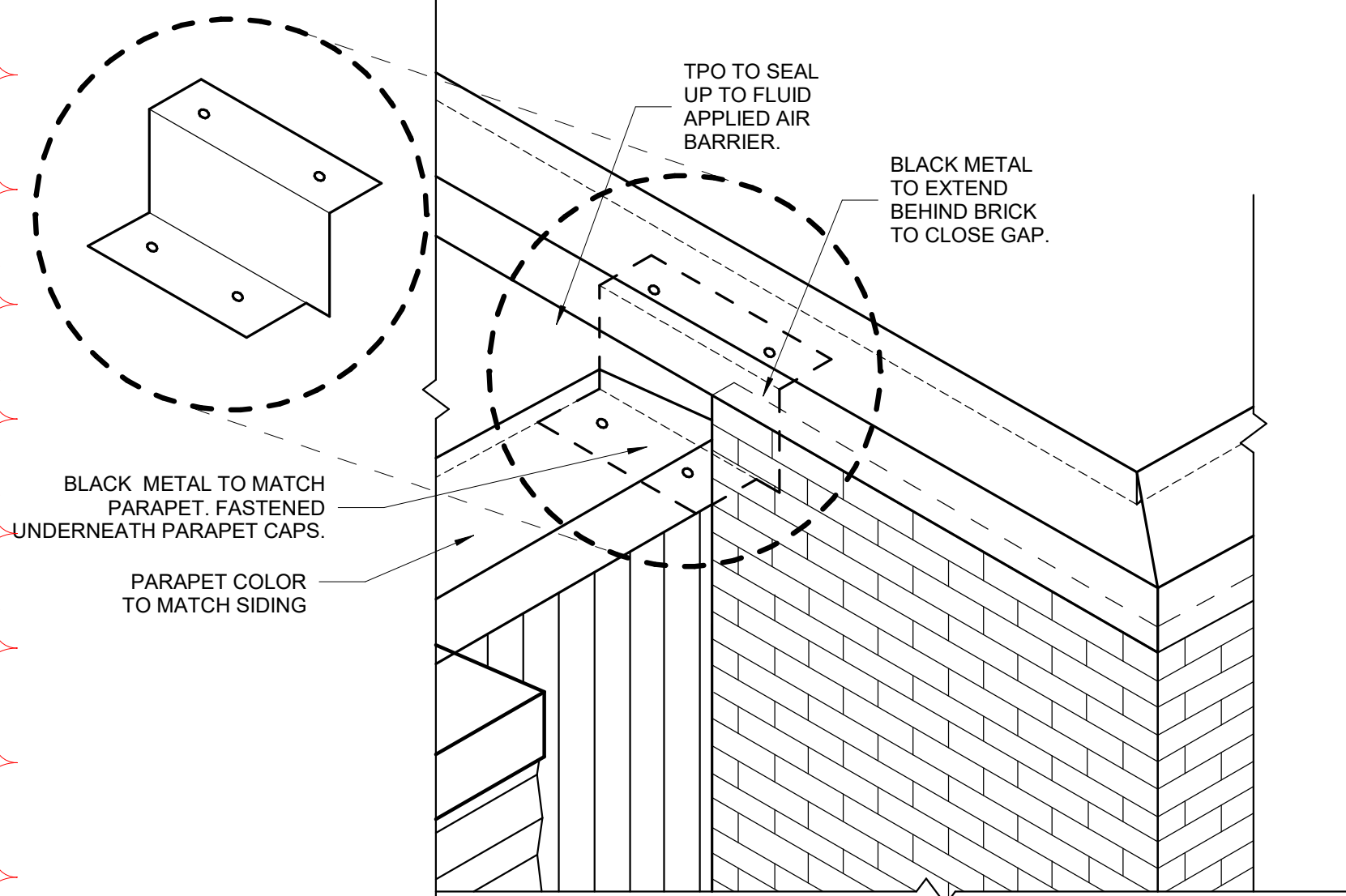

**3 ISO PARAPET DETAIL @ GRIDS B & 2N**  
SCALE | 1/2" = 1'-0"

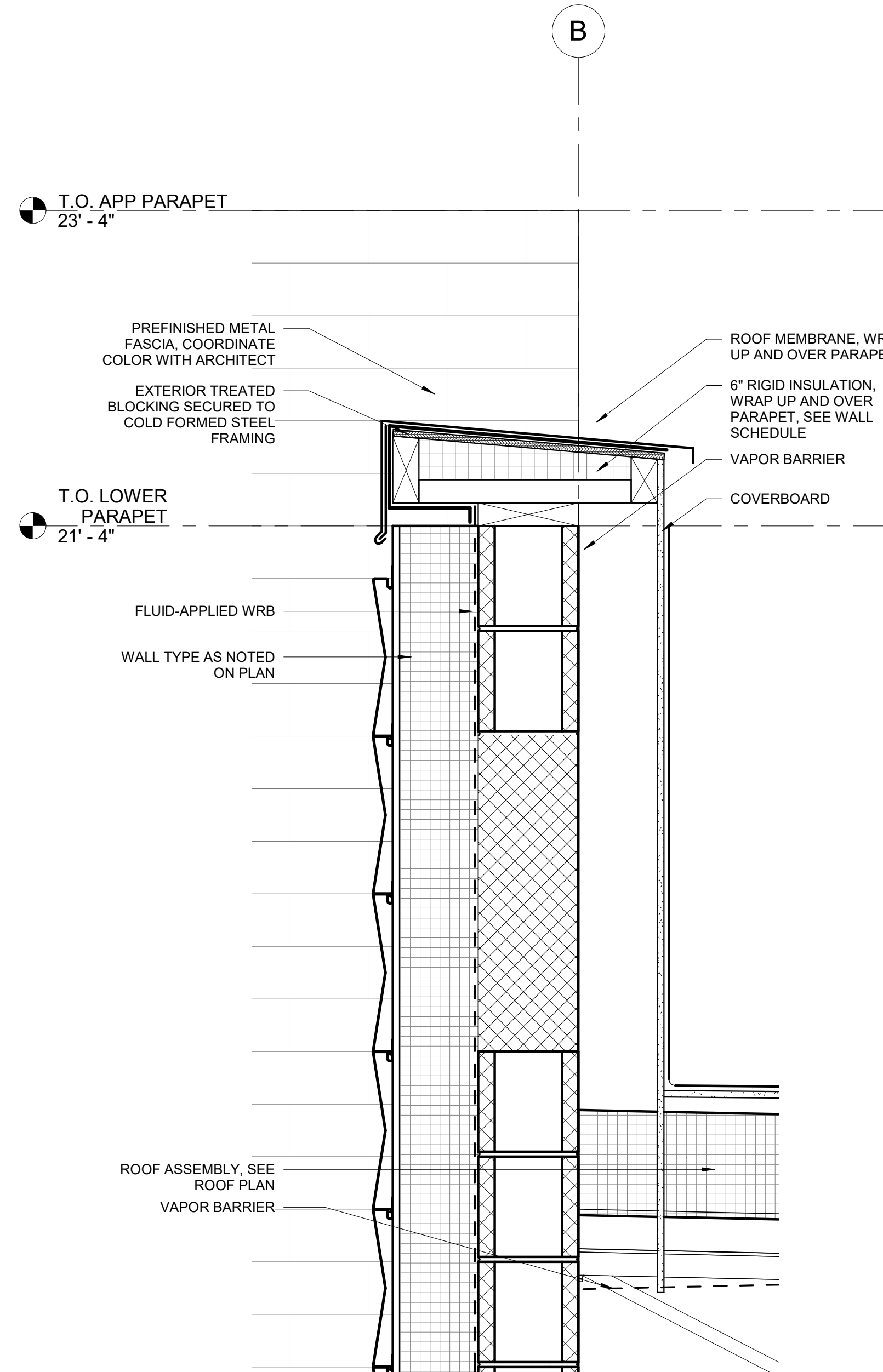

**2 PARAPET DETAIL @ INTERSECTION OF BRICK & METAL PANEL**  
SCALE | 1 1/2" = 1'-0"

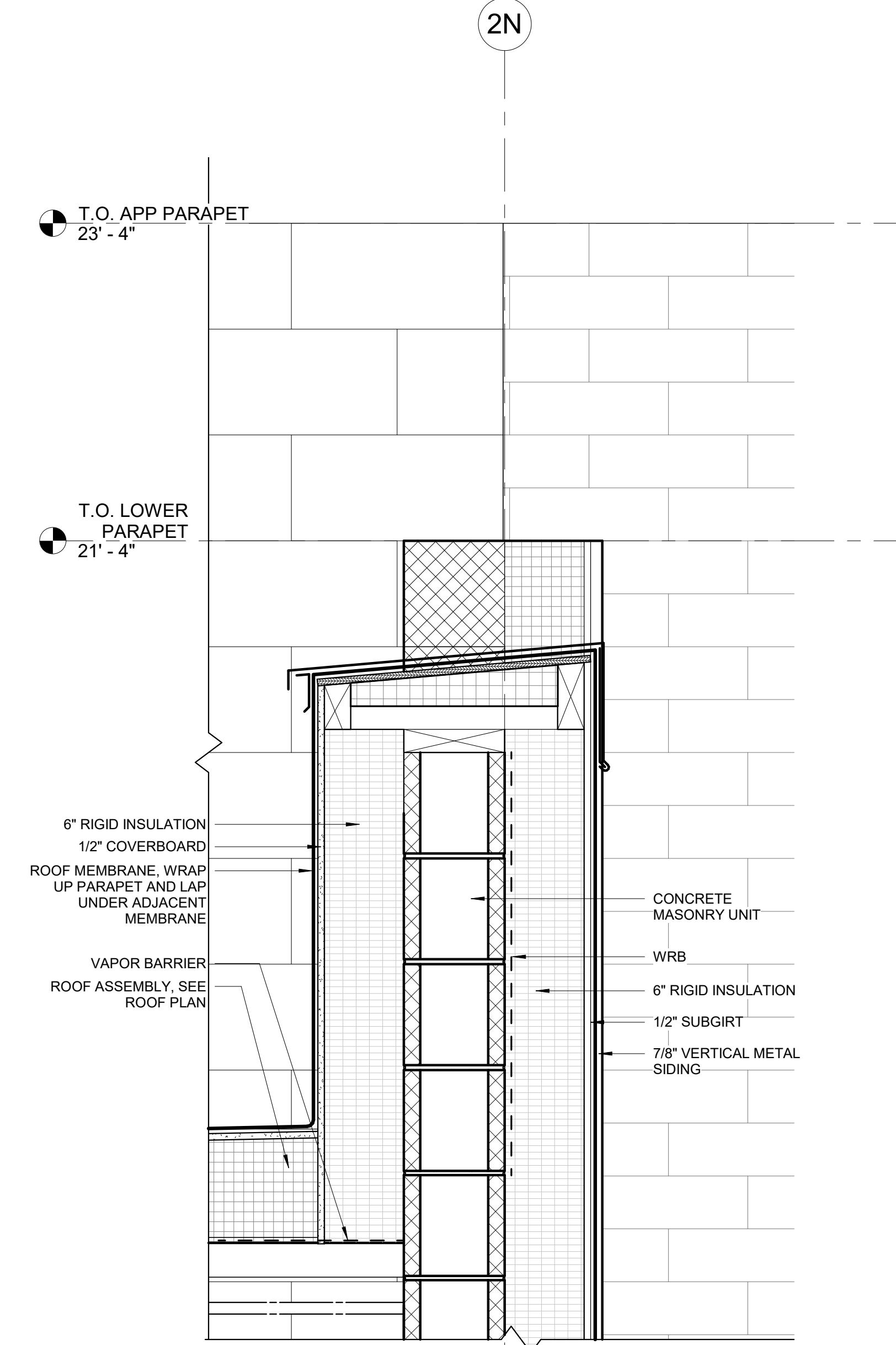

**1 PARAPET DETAIL @ BRICK & METAL PANEL**  
SCALE | 1 1/2" = 1'-0"



MARK	DATE	DESCRIPTION
29	6/16/21	ASI 10



**MASONRY**

335 S. 1250 W. Lindon, UT 84042 · (801) 796-8420 · (801) 796-8424 fax

April 19, 2021

**ATTN: Chris Schratwieser**

PCO #

**1**

Core Construction  
7150 Cascade Valley Ct.  
Las Vegas, Nevada, 89128

**PROJECT: City of Ketchum Fire Station**

**RE: Removal of Brick on Grid B**

EQUIPMENT / MOBILIZATION				
DESCRIPTION	QUANTITY	UOM	UNIT PRICES	TOTAL PRICES
FORKLIFT	-0.75	DAY	\$ 250.00	\$ (187.50)
MIXER/PUMP	-0.75	DAY	\$ 50.00	\$ (37.50)
FOREMAN TRUCK	-0.75	DAY	\$ 100.00	\$ (75.00)
<b>EQUIPMENT SUBTOTAL:</b>				<b>\$ (300.00)</b>

MATERIAL				
DESCRIPTION	QUANTITY	UOM	UNIT PRICES	TOTAL PRICES
Brick	-711	Pieces	\$ 1.40	\$ (995.40)
Brick Anchors	-87	Pieces	\$ 1.40	\$ (121.80)
Metal Flashing	-150	LF	\$ 4.00	\$ (600.00)
Mortar	-1	Yards	\$ 450.00	\$ (450.00)
Weep Vents	-56	Pieces	\$ 0.60	\$ (33.60)
Mortar Net	-150	SqFt	\$ 1.50	\$ (225.00)
<b>MATERIAL SUBTOTAL:</b>				<b>\$ (1,717.20)</b>

LABOR				
DESCRIPTION	QUANTITY	UOM	UNIT PRICES	TOTAL PRICES
FOREMAN	-6	HRS	\$ 65.00	\$ (390.00)
MASON	-24	HRS	\$ 55.00	\$ (1,320.00)
TENDER	-18	HRS	\$ 45.00	\$ (810.00)
PROJECT MANAGER		HRS	\$ 80.00	\$ -
<b>LABOR SUBTOTAL:</b>				<b>\$ (2,520.00)</b>

**GRAND TOTAL \$ (4,537.20)**

SINCERELY,  
Mason Holdaway  
Project Manager



**MASONRY**

335 S. 1250 W. Lindon, UT 84042 · (801) 796-8420 · (801) 796-8424 fax

April 19, 2021

**ATTN: Chris Schratwieser**

PCO #

**2**

Core Construction  
7150 Cascade Valley Ct.  
Las Vegas, Nevada, 89128

**PROJECT: City of Ketchum Fire Station**

**RE: Removal of Brick on Grid G**

EQUIPMENT / MOBILIZATION					
DESCRIPTION	QUANTITY	UOM	UNIT PRICES	TOTAL PRICES	
FORKLIFT	-1.3	DAY	\$ 250.00	\$	(325.00)
MIXER/PUMP	-1.3	DAY	\$ 50.00	\$	(65.00)
FOREMAN TRUCK	-1.3	DAY	\$ 100.00	\$	(130.00)
<b>EQUIPMENT SUBTOTAL:</b>				<b>\$</b>	<b>(520.00)</b>

MATERIAL					
DESCRIPTION	QUANTITY	UOM	UNIT PRICES	TOTAL PRICES	
Brick	-1,344	Pieces	\$ 1.40	\$	(1,881.60)
Brick Anchors	-160	Pieces	\$ 1.40	\$	(224.00)
Metal Flashing	-150	LF	\$ 4.00	\$	(600.00)
Mortar	-2	Yards	\$ 450.00	\$	(900.00)
Weep Vents	-58	Pieces	\$ 0.60	\$	(34.80)
Mortar Net	-78	SqFt	\$ 1.50	\$	(117.00)
<b>MATERIAL SUBTOTAL:</b>				<b>\$</b>	<b>(2,705.60)</b>

LABOR					
DESCRIPTION	QUANTITY	UOM	UNIT PRICES	TOTAL PRICES	
FOREMAN	-12	HRS	\$ 65.00	\$	(780.00)
MASON	-48	HRS	\$ 55.00	\$	(2,640.00)
TENDER	-36	HRS	\$ 45.00	\$	(1,620.00)
PROJECT MANAGER		HRS	\$ 80.00	\$	-
<b>LABOR SUBTOTAL:</b>				<b>\$</b>	<b>(5,040.00)</b>

**GRAND TOTAL \$ (8,265.60)**

SINCERELY,  
Mason Holdaway  
Project Manager

## NATIONS ROOF CHANGE ORDER SUMMARY



Nations Roof  
 Phone: 208-322-2474  
 Fax: 208-376-3340

*PROJECT:* City of Ketchum Fire Station #1  
*LOCATION:* 107 Saddle Road, Ketchum, ID 83353  
*DATE:* 7/21/2021

*ATTENTION:* Chris Schratwieser

*REGARDING:* ASI #10- Extra Work items to Roofing and Sheet Metal scope of work

*ADDRESS:*

*PHONE:*

*FAX:*

<b>DESCRIPTION:</b>	Per ASI #10- Furnish and install additional Vapor Retarder, Roof Insulation, DensDeck, Install new TPO Wall Flashings at modified wall area, install metal wall caps
<b>DRAWINGS:</b>	Per ASI #10- Wall between Gridlines B & G, Revised Drawings 6/16/2021 A7.23 Added Details #3,#4,#5,#6,#7

Item	Item Description	Total Hours / Qty. of Materials	Labor Rate / Price of Materials	Total Cost
1	Material and Labor to install additional TPO Membrane and accessories, Vapor Barrier, 6" Poly-ISO Insulation, 1/2" DensDeck at wall G/L B & G	1.00		\$ 8,977.00
2	Revised Drawings 6/16/2021 A7.23 Added Details #3,#4,#5,#6,#7- Instasl new TPO membrane at walls, Install metal wall caps as shown	1.00	3,765.00	\$ 3,765.00
3	Revised Drawings 6/16/2021 A7.23 Added Details #3,#4,#5,#6,#7- Remove existng damaged Insulation, Vapor Barrier, densdeck and reinstall with new material	1.00	2,750.00	\$ 2,750.00
				\$ -
	*Excludes Demo and Metal coping cap by others and remove and reinstall existing wood nailer on top of wall			\$ -
				\$ -
				\$ -
				\$ -
				\$ -
				\$ -
				\$ -
<b>CREDITS:</b>				\$ -
				\$ -

Contract:	<b>SUBTOTAL:</b>	\$ 15,492.00
Increase Scope:	<b>OVERHEAD &amp; PROFIT @ 10%</b>	\$ 1,549.20
Revised Contract:	<b>GRAND TOTAL:</b>	\$ 17,041.20

Your attention is called to your contract, which governs your rights and obligations with respect to the foregoing modifications. All other terms, provisions, and condition of said subcontract, as heretofore modified, shall remain in full force and effect. Please note all correspondence pertaining to this change order must refer to the change order number specified above. The above price, specifications and conditions are satisfactory and are hereby accepted. You are authorized to do the work as specified. Payment will be made as outlined herein.

Company's Authorized Signature: _____  Print Name: _____  Title: _____  Date: _____	Company's Authorized Signature: _____  Print Name: _____  Title: _____  Date: _____
-------------------------------------------------------------------------------------------------------------	-------------------------------------------------------------------------------------------------------------



**SUBCONTRACTOR CHANGE ORDER REQUEST**

Date: 6/9/2021

SUBCONTRACTOR: Magic Valley Electric

PROJECT NAME: Ketchum Fire station

CONTACT: Jimmy Gyorfy

PROJECT ADDRESS: 107 Saddle Road

ADDRESS: 395 Railway Street

Jerome, ID 83338

Ketchum, ID 83353

PHONE: 208-944-4931

THIS IS IN RESPONSE TO: RFI-178 revised

Bulletin #:

CONTRACTOR: Core Construction

ASI #:

CONTACT: Chris Schratwieser

VERBAL REQUEST FROM:

ADDRESS: 777 North 4th Street

Boise, ID 83702

SUBCONTRACTOR CO#:

PHONE: 702-794-0550

DESCRIPTION: **Four signaling lights on the west side of the App. Bay to signal pedestrians the doors are opening.**

LOCATION:

DRAWINGS:

	Trade Description	Hours	Labor Amt.			Total Cost
LABOR:	Journeyman	12	70.00			840.00
	Apprentice	12	60.00			720.00
						0.00
						0.00
						0.00
	Description	QTY	Unit Price	Sub-Total	Taxes	Total Cost
MATERIAL:	Fixtures	5	40.90	204.50	12.27	216.77
	Misc. material (Conduit and wire)	1	182.69	182.69	10.96	193.65
	Weather proof 4/0 light box	4	19.24	76.96	4.62	81.58
				0.00	0.00	0.00
				0.00	0.00	0.00
	Description	QTY	Unit Price	Sub-Total	Taxes	Total Cost
EQUIPMENT:				0.00	0.00	0.00
				0.00	0.00	0.00
				0.00	0.00	0.00
				0.00	0.00	0.00
				0.00	0.00	0.00
				0.00	0.00	0.00
SUBTOTAL:						2,052.00
OH & Profit Material@10%						49.20
<b>GRAND TOTAL:</b>				<b>Total Amount</b>		<b>\$2,101.20</b>

NOTES: Fixture quote is good for 7 days.

Authorized Signature

Date



## LED Strobe Lights

### SL-1301-EAQ

6 LEDs total, flash only

### SL-1301-BAQ

32 LEDs total, 5 LED strips

Same as EAQ series plus adjustable flash speeds, patterns, and duty cycle, and optional battery backup

### SL-1301-SAQ

54 LEDs total, 10 LED strips

Same as BAQ series plus 100dB siren



### Features:

- Utilizes high-intensity LEDs
- Operating life over 50,000 hours (over 5.7 years)
- Same size as the SL-126Q strobe light
- Simple 2-wire installation
- Weather resistant
- High-impact resistant case
- High-impact and heat-resistant lens
- Reverse polarity protection
- Visible in all directions
- 5 lens colors available:  
Amber, Blue, Clear, Green and Red



### Ordering Info:

Model	6 LED	32 LED	54 LED
Amber	SL-1301-EAQ/A	SL-1301-BAQ/A	SL-1301-SAQ/A
Blue	SL-1301-EAQ/B	SL-1301-BAQ/B	SL-1301-SAQ/B
Clear	SL-1301-EAQ/C	SL-1301-BAQ/C	SL-1301-SAQ/C
Green	SL-1301-EAQ/G	SL-1301-BAQ/G	SL-1301-SAQ/G
Red	SL-1301-EAQ/R	SL-1301-BAQ/R	SL-1301-SAQ/R

### BAQ series also include all features of the EAQ plus:

- 5 Vertical LED strips (32 LEDs total) increase visibility from various directions
- 8 flash patterns and adjustable duty cycle
- Adjustable flashing speed
- Backup battery available for continuous lighting applications

### SAQ series also includes all features of the BAQ plus:

- 10 Vertical LED strips (54 LEDs total)
- Built-in 100dB siren (programmable)

### Specifications:

Model	SL-1301-EAQ	SL-1301-BAQ	SL-1301-SAQ
Operating voltage	9~15 VDC	9~24 VAC/VDC	
Current draw (max)*	150mA	70~350mA	90~550mA†
# of flash patterns‡	1	8	8
Flashing speed	120 times/min	Adjustable 80~160 times/min	
Vertical LED strips	0	5	10
Total # of LEDs	6	32	54
Backup battery§	No	Yes	Yes
Operating temperature	-4°~144° F (-20°~65° C)		
Electrical protection	Reverse polarity protected		
Built-in siren	No		Yes (100dB)
IP rating	IP64	IP66	IP55
Dimensions	ø3 <sup>15</sup> / <sub>16</sub> "x3 <sup>1</sup> / <sub>8</sub> " (ø100x79mm)		

\*Depending on settings

‡SL-1301-EAQ series has strobe only

†With siren enabled

§9VDC battery not included

### SECO-LARM® U.S.A., Inc.

16842 Millikan Avenue, Irvine, CA 92606

Phone: (949) 261-2999 | (800) 662-0800 Fax: (949) 261-7326

Website: www.seco-larm.com Email: sales@seco-larm.com



Copyright © 2019 SECO-LARM U.S.A., Inc. All rights reserved.  
All trademarks are the property of SECO-LARM U.S.A., Inc. or their respective owners.  
The SECO-LARM policy is one of continual development. For that reason, SECO-LARM reserves the right to change prices and specifications without notice. SECO-LARM is not responsible for any errors or omissions.  
**SECO-LARM® ENFORCER® CRIMEBUSTER® CBA® SL/**

## Programmable Flash Patterns / Duty Cycle (BAQ & SAQ models only):

DIP Switch Position	Description	Flash Pattern Top View (SL-1301-BAQ Shown)
A	<b>Regular Duty Cycle</b> LED on one-half / off one-half of each cycle (default) (DIP Switch #4 ON, only effective for flash patterns 1, 2, and 5)	
B	<b>One-Eighth Duty Cycle</b> LED on one-eighth / off seven-eighths of each cycle (DIP Switch #4 OFF, only effective for flash patterns 1, 2, and 5)	
1	<b>Strobe</b> LEDs flash on and off continuously. (default) (DIP Switch #4 controls the duty cycle)	
2	<b>Rotate Clockwise</b> Light rotates clockwise in a circular fashion continuously. (Beacon) (DIP Switch #4 controls the duty cycle)	
3	<b>Steady ON</b> All LEDs stay on. Ideal for continuous lighting applications.	
4	<b>Flash with Progressive ON</b> LEDs turn on progressively clockwise until all LEDs are lit (sweep), and then turn off.	
5	<b>Rotate Back and Forth</b> LED groups light up one at a time clockwise then counterclockwise. (DIP Switch #4 controls the duty cycle)	
6	<b>Flash with Progressive ON/OFF</b> LEDs turn on progressively clockwise (sweep), then turn off progressively counterclockwise.	
7	<b>Opposite Quarters Flashing Continuously</b> LEDs in opposite quarters flash alternately, repeating continuously.	
8	<b>Opposite Quarters Flashing with Pause</b> LEDs in opposite quarters flash alternately for 8 cycles, pause for 2 cycles, and then repeat the pattern.	

Users may customize both flash pattern and duty cycle (flash patterns 1, 2, and 5 only). The "One-Eighth Duty Cycle" produces a sharper "strobe" effect more like traditional strobe lights. DIP Switch #4 controls the duty cycle for supported flash patterns. Visit [www.seco-larm.com](http://www.seco-larm.com) for a demonstration of flash patterns / duty cycle.

### Dimensions:

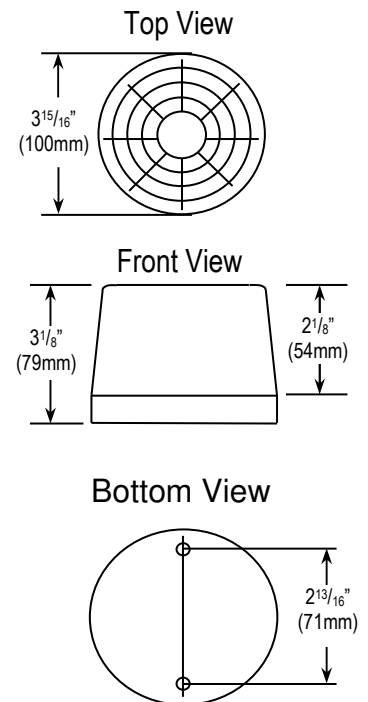

## Also Available from Superior Electronics:

Note: The SL-1301 series LED strobe light has the same dimensions as the SL-126 series strobe light.

### Replacement Lenses

SL-126LQ/X

(Replace "X" with the first letter of the desired color)



Available in Red, Blue, Amber, Clear, or Green

### Mounting Options

Conduit Drop  
SL-1901-DAQ



Conduit Box  
SL-1901-JAQ



### Application Photos

Conduit Drop



Conduit Box



Both



### Xenon Tube Strobe Lights SL-126Q Series



Available in Red, Blue, Amber, Clear, or Green

## SECO-LARM® U.S.A., Inc.

16842 Millikan Avenue, Irvine, CA 92606

Phone: (949) 261-2999 | (800) 662-0800 Fax: (949) 261-7326

Website: [www.seco-larm.com](http://www.seco-larm.com) Email: [sales@seco-larm.com](mailto:sales@seco-larm.com)



Copyright © 2019 SECO-LARM U.S.A., Inc. All rights reserved.  
All trademarks are the property of SECO-LARM U.S.A., Inc. or their respective owners.  
The SECO-LARM policy is one of continual development. For that reason, SECO-LARM reserves the right to change prices and specifications without notice. SECO-LARM is not responsible for any errors or omissions.  
**SECO-LARM® ENFORCER® CRIMEBUSTER® CBA® SL-126®**



## ASI 11

<b>PROJECT NAME</b>	KETCHUM FIRE STATION #1
<b>PROJECT NUMBER</b>	18-022
<b>DATE</b>	6/16/2021
<b>CONSTRUCTION COMPANY</b>	CORE CONSTRUCTION

**THE WORK SHALL BE CARRIED OUT IN ACCORDANCE WITH THE FOLLOWING SUPPLEMENTAL INSTRUCTIONS ISSUED IN ACCORDANCE WITH THE CONTRACT.**

### **DESCRIPTION OF CHANGES:**

### **DRAWINGS:**

### **ARCHITECTURAL:**

- 1) A3.00 – EXTERIOR ELEVATIONS
  - a) Updated Keynote #1
    - i) “PROVIDE BACKING IN WALL FOR EXTERIOR SIGNAGE. EXTERIOR BUILDING SIGNAGE TO BE OWNER PROVIDED.”
  - b) Added Keynote #11.
    - i) “EXTERIOR MOUNTED HISTORIC STATION SIREN, OWNER PROVIDED. DECORATIVE ONLY.”
  - c) #3 – EXTERIOR ELEVATION – SOUTH
    - i) Removed exterior signage.
    - ii) Added exterior signage backing and dimensions.
  - d) #4 – EXTERIOR ELEVATION – WEST
    - i) Added exterior wall mounted historic siren.

### **ATTACHMENTS:**

### **DRAWINGS:**

- A3.00 – EXTERIOR ELEVATIONS

**END OF ASI**

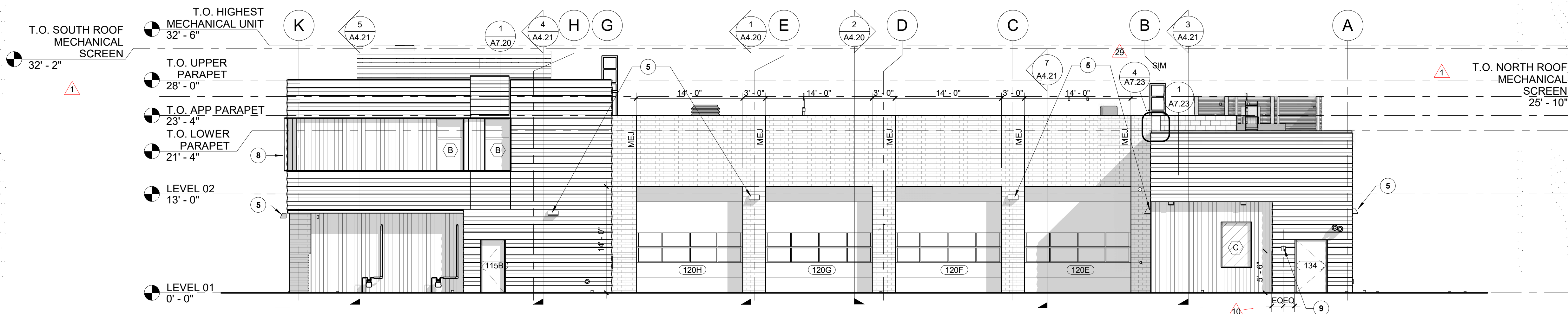

**1 EXTERIOR ELEVATION - EAST**  
SCALE | 1/8" = 1'-0"

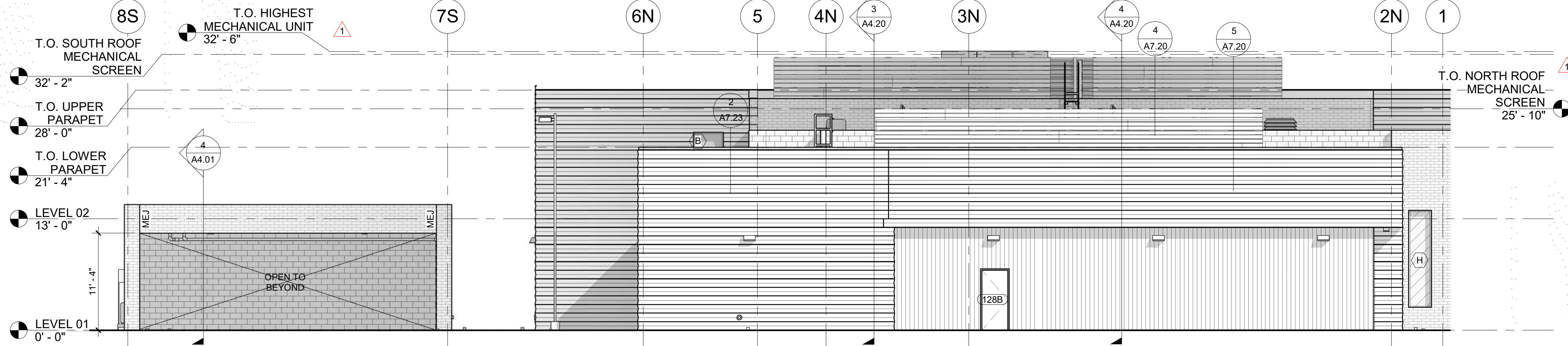

**2 EXTERIOR ELEVATION - NORTH**  
SCALE | 1/8" = 1'-0"

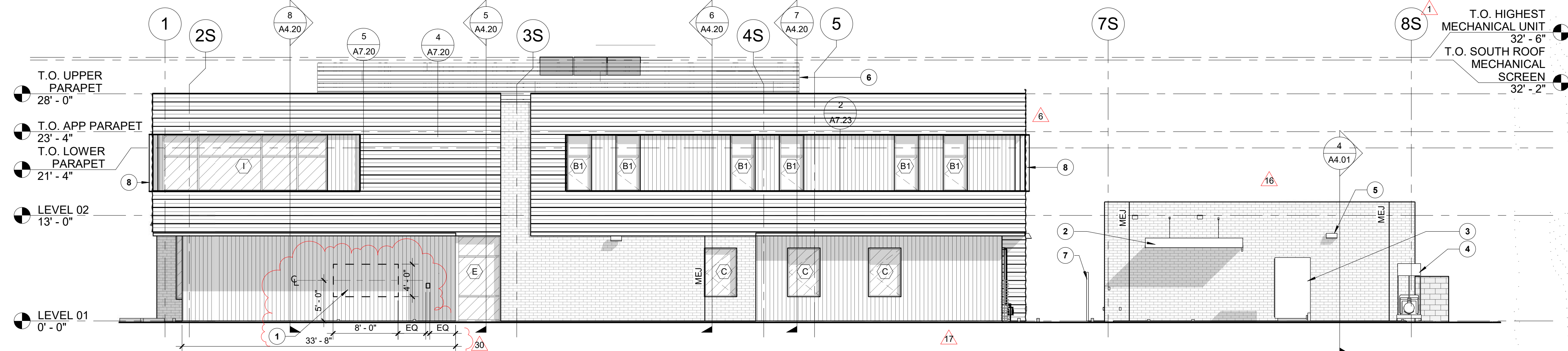

**3 EXTERIOR ELEVATION - SOUTH**  
SCALE | 1/8" = 1'-0"

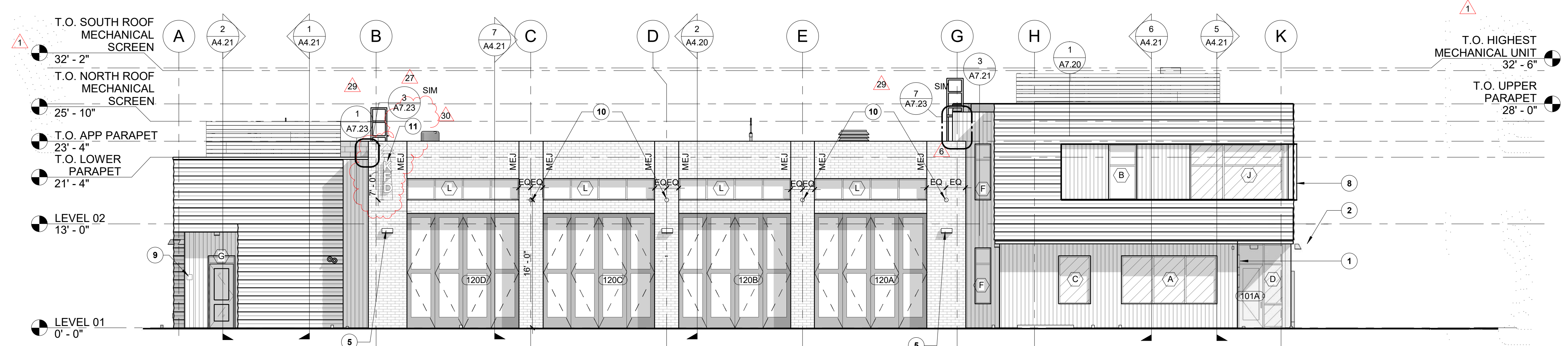

**4 EXTERIOR ELEVATION - WEST**  
SCALE | 1/8" = 1'-0"

**GENERAL NOTES**

- A. GENERAL NOTES APPLY TO ALL DRAWING SETS.
- B. FIELD VERIFY ALL DIMENSIONS AND EXISTING CONDITIONS. NOTIFY ARCHITECT IMMEDIATELY IF ANY CONFLICTS OR DISCREPANCIES OCCUR BEFORE PROCEEDING WITH WORK.
- C. CROSS REFERENCES SHOWN ON DRAWINGS DO NOT NECESSARILY INDICATE ALL LIKE CONDITIONS AND DO NOT LIMIT APPLICATION OF ANY DRAWING OR DETAIL. WHERE SPECIFIC DIMENSIONS, DETAILS, OR DESIGN INTENT CANNOT BE DETERMINED, CONSULT THE ARCHITECT PRIOR TO PROCEEDING WITH WORK. IF DESIGN INTENT REMAINS UNCLEAR THEN PROVIDE MOST EXPENSIVE OPTION IN BID.
- D. DIMENSIONS ARE TO GRID LINE OR FACE OF STRUCTURAL MEMBER UNLESS OTHERWISE NOTED. DOOR & WINDOW OPENING DIMENSIONS ARE TO ROUGH OPENING OR CENTERLINE OF OPENING. CONCRETE AND BRICK DIMENSIONS ARE GIVEN TO THE FACE OF CONCRETE OR MASONRY AND TO THE FACE OF ROUGH OPENINGS.
- E. CROSS REFERENCES SHOWN ON DRAWINGS DO NOT NECESSARILY INDICATE ALL LIKE CONDITIONS AND DO NOT LIMIT APPLICATION OF ANY DRAWING OR DETAIL. WHERE SPECIFIC DIMENSIONS, DETAILS, OR DESIGN INTENT CANNOT BE DETERMINED, CONSULT THE ARCHITECT PRIOR TO PROCEEDING WITH WORK. IF DESIGN INTENT REMAINS UNCLEAR THEN PROVIDE MOST EXPENSIVE OPTION IN BID.
- F. DIMENSIONS ARE TO GRID LINE OR FACE OF STRUCTURAL MEMBER UNLESS OTHERWISE NOTED. DOOR & WINDOW OPENING DIMENSIONS ARE TO ROUGH OPENING OR CENTERLINE OF OPENING. CONCRETE AND BRICK DIMENSIONS ARE GIVEN TO THE FACE OF CONCRETE OR MASONRY AND TO THE FACE OF ROUGH OPENINGS.
- G. REFER TO WALL TYPES FOR DETAILS.

**MATERIALS LEGEND**

- BRICK - RUNNING BOND**  
INTERSTATE BRICK IN COLOR: "MIDNIGHT BLACK"
- CONCRETE MASONRY UNIT - RUNNING BOND**  
RE: SPECIFICATION DIVISION 04
- METAL WALL PANEL - HORIZONTAL**  
MORIN CONCEALED FASTENER METAL PANEL W-12 IN COLOR "SILVERSMITH"
- METAL WALL PANEL - VERTICAL**  
BRIDGER STEEL 7/8" CORRUGATED, EXPOSED FASTENER, METAL WALL PANEL IN COLOR "COPPER PENNY"
- ALUMINUM STOREFRONT**  
KAWNEER TRIFAB 451UT W/ GAURDIAN GLASS - SUNGAURD SNR 43  
RE: SPECIFICATION DIVISION 08
- MASONRY EXPANSION JOINT**

**KEYNOTES**

- 1. PROVIDE BACKING IN WALL FOR EXTERIOR SIGNAGE. EXTERIOR BUILDING SIGNAGE TO BE OWNER PROVIDED.
- 2. COVERED PATIO, PER PLAN
- 3. TRANSFORMER, RE: ELECTRICAL
- 4. GENERATOR, RE: ELECTRICAL
- 5. LIGHTING FIXTURES, RE: ELECTRICAL
- 6. MECHANICAL SCREENING, RE: SPECIFICATION
- 7. 6'-0" TALL FENCE, RE: LANDSCAPE
- 8. FORMED ALUMINUM LIP AROUND WALL RECESS PERIMETER, RE: STRUCTURAL
- 9. RECESSED KNOX BOX
- 10. EXTERIOR WALL MOUNTED STROBE LIGHT IN COLOR: "CLEAR", RE: ELECTRICAL SHEET E3.01.
- 11. EXTERIOR MOUNTED HISTORIC STATION SIREN, OWNER PROVIDED. DECORATIVE ONLY.



1008 W Main St  
Boise, Idaho 83702  
208.345.1800  
colearchitects.net  
Copyright © 2020 Cole Architects, PLLC

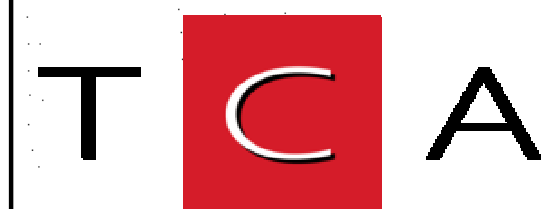

6211 Roosevelt Way NE  
Seattle, WA 98115  
206.522.3820

BIDDERS ARE INSTRUCTED TO CAREFULLY REVIEW THE CONSTRUCTION DOCUMENTS AND THE SITE CONDITIONS. INFORMATION REGARDING THE COMPLETE WORK OF SPECIFIC TRADES IS DISPERSED THROUGHOUT THE ENTIRE DOCUMENT SET AND CANNOT BE ACCURATELY DETERMINED BY REFERENCE TO OTHER THAN COMPLETE DOCUMENT SETS.

**STAMP**

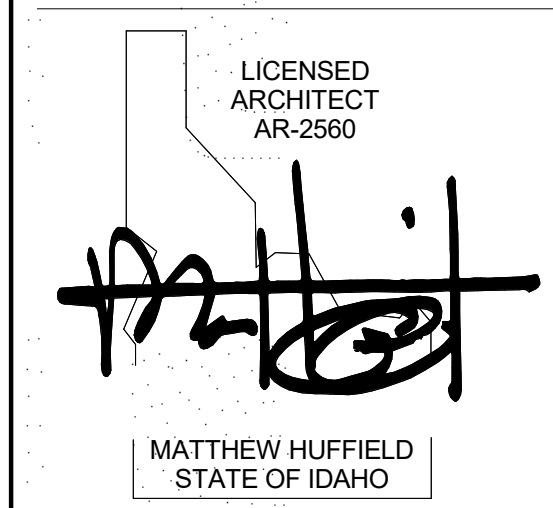

**CONSULTANT**

**PROJECT INFORMATION**



**KETCHUM FIRE STATION NO. 1**

107 SADDLE ROAD, KETCHUM, ID 83353

**ISSUES**

PHASE	CONSTRUCTION SET
DATE	JUNE 19, 2020
JOB NUMBER	18-022

MARK	DATE	DESCRIPTION
30	6/16/21	ASI 11
29	6/16/21	ASI 10
27	5/13/21	RFI #CC-178
17	12/11/20	RFI #CC-129
16	12/15/20	RFI #CC-94
10	10/14/20	ASI 03
6	8/17/20	ASI 2
1	6/23/20	CITY PERMIT COMMENTS

**SHEET NAME**

**EXTERIOR ELEVATIONS**

**SHEET NUMBER**

**A3.00**



**CoK Exterior Signage Deductive Change Order Proposal**

Change Order Deduct # 2

Date: 6/21/21

To: Core Construction  
 Attn: Matt Sylvester  
 Email: [mattsylvester@coreconstruction.com](mailto:mattsylvester@coreconstruction.com)

**Change Order Description:**

Provide Credit for removal of exterior signage

Scope of Work Description & Clarifications	Amount
10 14 00 - Signage - Credit for supply of exterior 0.5 inch Gemini signage - Credit for labor cost of install for signage Note; Includes credit for our markups and overhead for both supply and install	\$3,036
<b>Total Change Order Amount (Deduct from Base Bid)</b>	<b>\$3,036</b>

Ian Phillips  
[iphillips@oecworks.com](mailto:iphillips@oecworks.com)  
 248 933 8891  
 623 S. Americana Blvd  
 Boise, ID 83702

**Proposal Acceptance & Agreement**

The undersigned hereby accepts, agrees to and Acknowledges OEC's proposal

Signature:
Printed Name:
Title:
Date:





## RFI #CC-188: Elevator Door and Wall Finish

<b>Status</b>	Open		
<b>To</b>	Alex Goedhart (Cole Architects) Crystal McColly (Cole Architects)	<b>From</b>	JT Brown (CORE Construction - Las Vegas) 777 N Fourth St Boise, Idaho 83702
<b>Date Initiated</b>	May 27, 2021	<b>Due Date</b>	Jun 3, 2021
<b>Location</b>		<b>Project Stage</b>	Course of Construction
<b>Cost Impact</b>		<b>Schedule Impact</b>	
<b>Spec Section</b>		<b>Cost Code</b>	
<b>Drawing Number</b>	1/A2.84	<b>Reference</b>	
<b>Linked Drawings</b>			
<b>Received From</b>			
<b>Copies To</b>	John Allen (Interior Contractors), JT Brown (CORE Construction - Las Vegas), Tyler Brown (Interior Contractors), Cary Goldberg (DPPM Project Management), Bill McLaughlin (City of Ketchum), Dennis Potts (DPPM Project Management), Chris Schratwieser (CORE Construction - Las Vegas), Matt Sylvester (CORE Construction - Las Vegas)		

### Activity

#### Question

**Question from JT Brown CORE Construction - Las Vegas on Wednesday, May 26, 2021 at 10:05 PM MDT**

Per the approved Elevator shop drawings the elevator frame is less than 8 inches wide and the masonry is solid grouted into the frame. Please confirm that the framing and 1/4" drywall wrapping into the frame is acceptable.

*Awaiting an Official Response*

**Wrap sides and top of frame walls around elevator on 1st and 2nd floor with 16ga Stainless Steel; Brushed 90° corner. See two attached PDFs with details.**

**Crystal McColly  
 Cole Architects  
 5/27/2021**



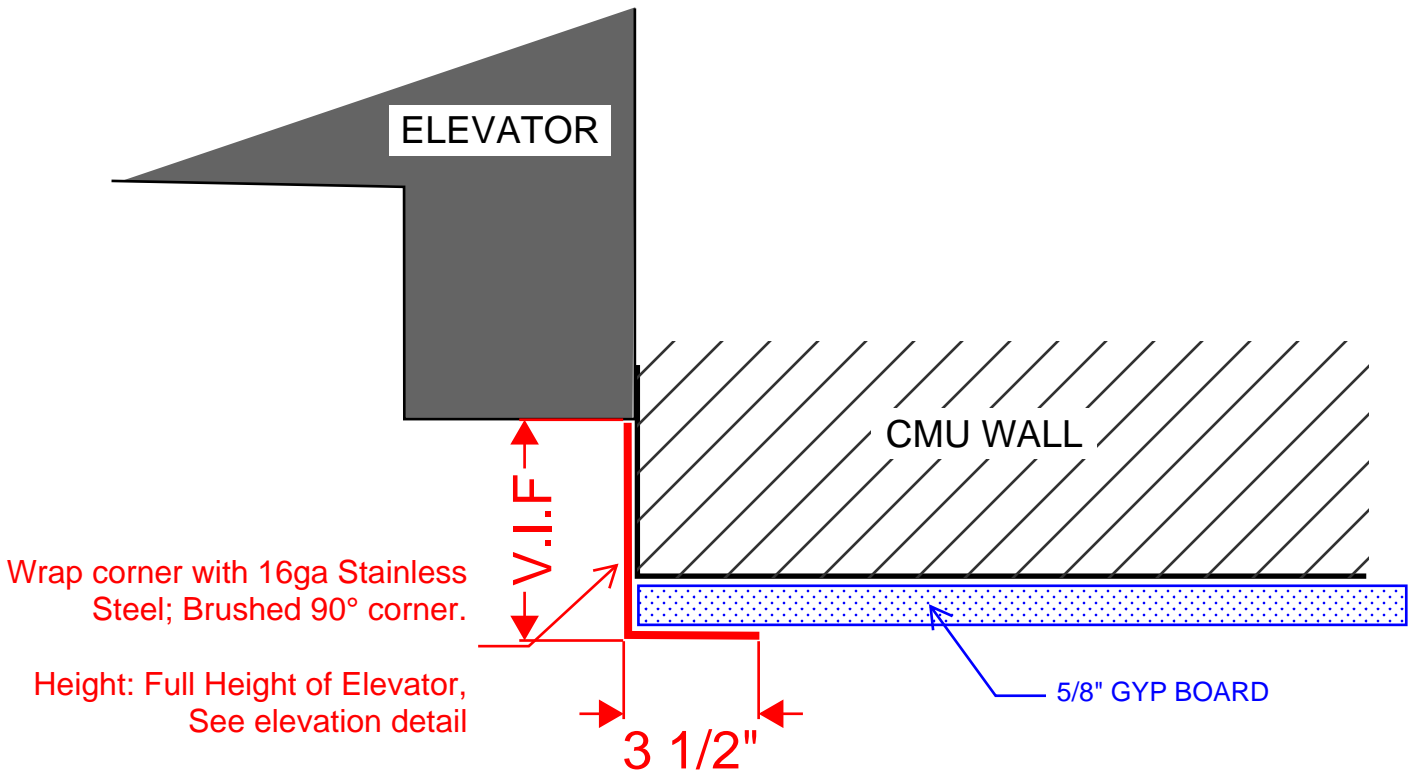

**1ST FLOOR DETAIL AT ELEVATOR WALL**

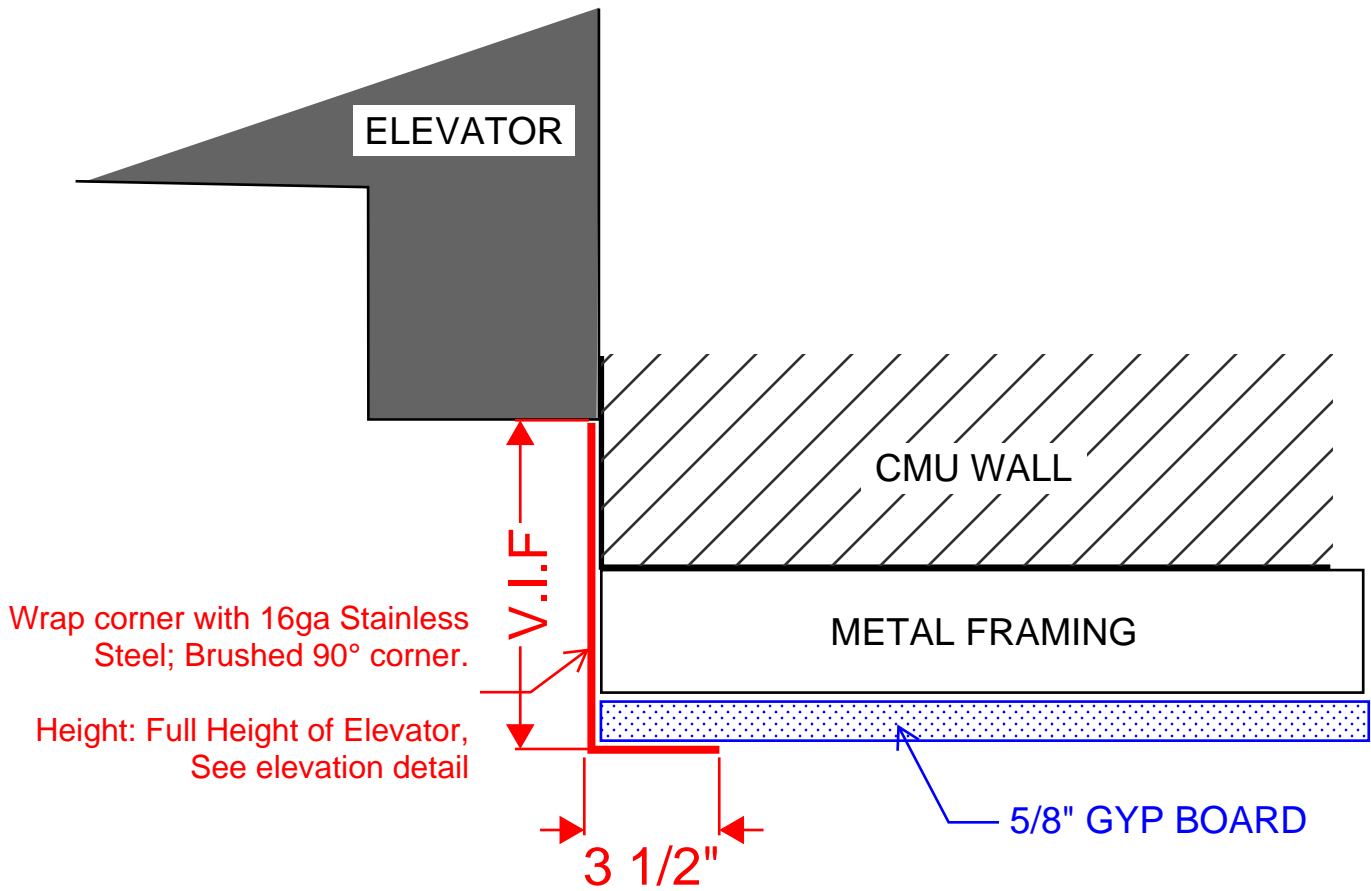

**2ND FLOOR DETAIL AT ELEVATOR WALL**

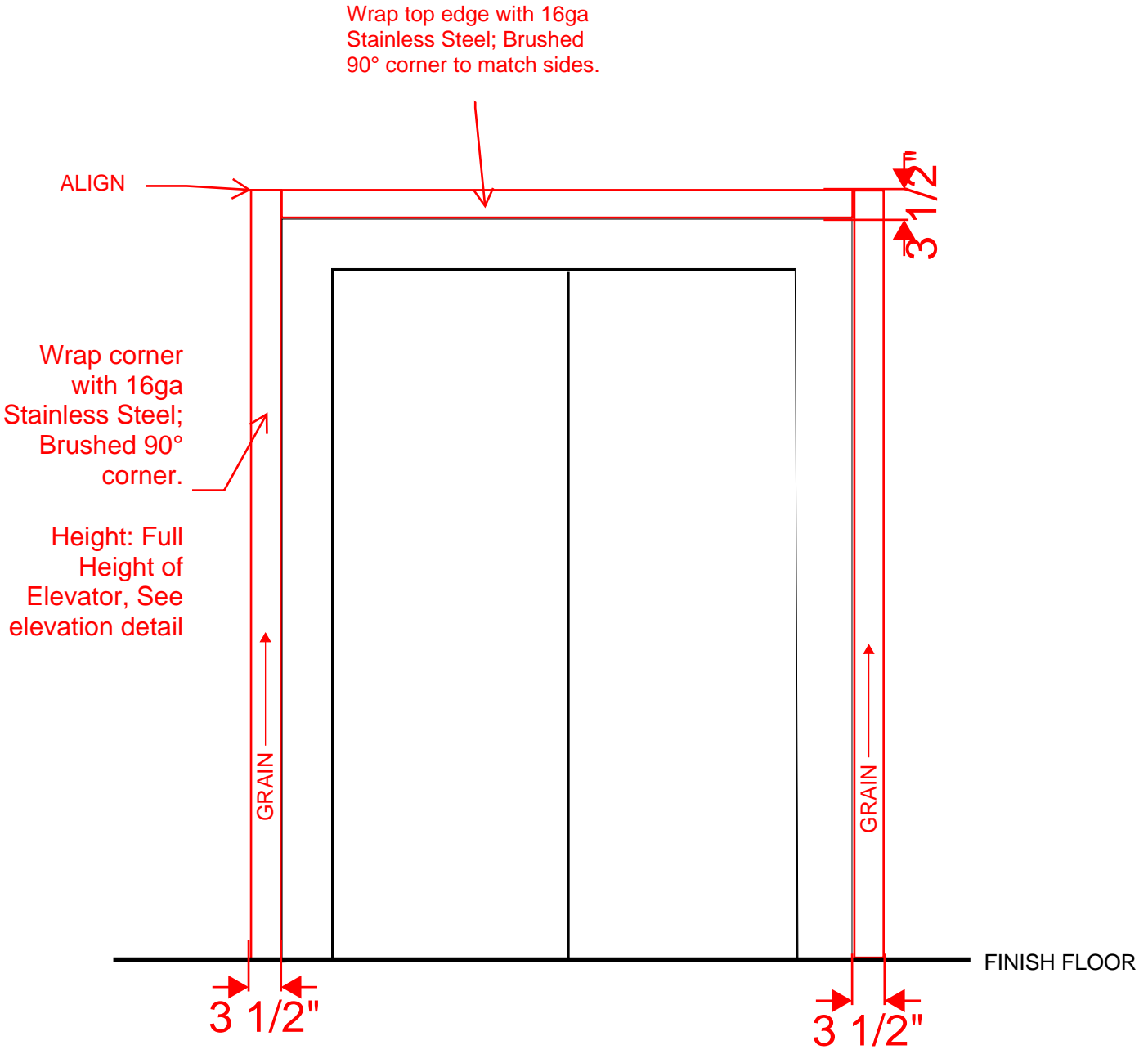

**1ST & 2ND FLOOR INTERIOR ELEVATION AT ELEVATOR**



## CoK Fire Station Project Change Order Proposal

Change Order Request # 4

Date: 6/24/21

To: CORE Construction  
 Attn: Chris Schratwieser  
 Email: [chrisschratwieser@coreconstruction.com](mailto:chrisschratwieser@coreconstruction.com)

### Change Order Description:

Stainless Steel Elevator Wrapping PER RFI #CC-188

Scope of Work Description & Clarifications	Amount
10 26 13 - Corner Guards Includes supply of stainless steel for elevator door and wall finish wrap Includes labor for install Includes necessary materials for completion (Caulking, Glue, Etc.)	\$2,502
<b>Total Change Order Amount</b>	\$2,502

Ian Phillips  
[iphillips@oecworks.com](mailto:iphillips@oecworks.com)  
 248-933-8891  
 623 S. Americana Blvd  
 Boise, ID 83702

### Proposal Acceptance & Agreement

The undersigned hereby accepts, agrees to and Acknowledges OEC's proposal

Signature: \_\_\_\_\_  
 Printed Name: \_\_\_\_\_  
 Title: \_\_\_\_\_  
 Date: \_\_\_\_\_



## Chris Schratwieser

---

**From:** Kent Tolley <KTolley@nationsroof.com>  
**Sent:** Monday, June 14, 2021 12:49 PM  
**To:** Chris Schratwieser  
**Cc:** Jared Perkins  
**Subject:** RE: CoK - City of Ketchum Fire Station: RFI #CC-185 has been closed

**Follow Up Flag:** Follow up  
**Flag Status:** Flagged

Chris-

Per your request for RFI #CC-185: Sill condition at 2<sup>nd</sup> Floor Gate: Based on a Site visit we have modified the proposal based on the following:

- Price based on overall length of 18'8" with 7 EA Posts
- Install 22 Gauge prefinished flashing between the posts and seal to the posts
- At the Gate opening, 36" wide, install 16 Gauge Diamond plated metal
- Set new metal flashings in adhesive

EXCLUDE: The concrete surface on the curb needs prepped to be smoothed out prior to the installation of the metal cap. The price is not included.

Price for new Metal Sill \$2,975.00

### Kent Tolley

President

NATIONS ROOF

Mountain

Office: 208-322-2474

Mobile: 208-985-3832

[www.nationsroof.com](http://www.nationsroof.com)

This transmission is sent on behalf of Nations Roof and it may be privileged, proprietary or confidential. It is intended only for the intended recipient. If you are not the intended recipient or a person responsible for delivering this transmission to the intended recipient, you may not disclose, copy or distribute this transmission, or take any action in reliance on it.

---

**From:** Chris Schratwieser (CORE Construction - Las Vegas) <CORE\_Construction\_Inc@procoretech.com>  
**Sent:** Monday, May 17, 2021 2:10 PM  
**To:** Damon Harper <dharper@nationsroof.com>  
**Subject:** CoK - City of Ketchum Fire Station: RFI #CC-185 has been closed



## RFI #CC-185: Sill condition at 2nd floor Gate to App Bay in room 216 Storage

<b>Status</b>	Open		
<b>To</b>	Ian Hoffman (Cole Architects) Alex Goedhart (Cole Architects) Crystal McColly (Cole Architects)	<b>From</b>	Chris Schratwieser (CORE Construction - Las Vegas) 7150 Cascade Valley Court Las Vegas, Nevada 89128
<b>Date Initiated</b>	May 12, 2021	<b>Due Date</b>	May 19, 2021
<b>Location</b>	Ketchum Fire Station>Fire Station>2nd Floor	<b>Project Stage</b>	Course of Construction
<b>Cost Impact</b>		<b>Schedule Impact</b>	
<b>Spec Section</b>		<b>Cost Code</b>	
<b>Drawing Number</b>	A2.02, 6/A5.02, 4/A2.81	<b>Reference</b>	
<b>Linked Drawings</b>			
<b>Received From</b>	JT Brown (CORE Construction - Las Vegas)		
<b>Copies To</b>	John Allen (Interior Contractors), JT Brown (CORE Construction - Las Vegas), Cary Goldberg (DPPM Project Management), Bill McLaughlin (City of Ketchum), Dennis Potts (DPPM Project Management), Chris Schratwieser (CORE Construction - Las Vegas), Matt Sylvester (CORE Construction - Las Vegas)		

### Activity

#### Question

**Question from Chris Schratwieser CORE Construction - Las Vegas on Wednesday, May 12, 2021 at 12:03 PM MDT**

Please confirm design intent for the sill condition at the guardrail and gate opening as section 4/A2.81 does not show the correct condition.

**Attachments**

[8F311205-83B5-4009-9177-E6344413BF4A.jpeg](#)

*Awaiting an Official Response*

Provide diamond plate aluminum sheet in color: black.  
Wrap sheet over the sill in sections. See detail sketch below.

Crystal McColly  
Cole Architects  
5/14/21

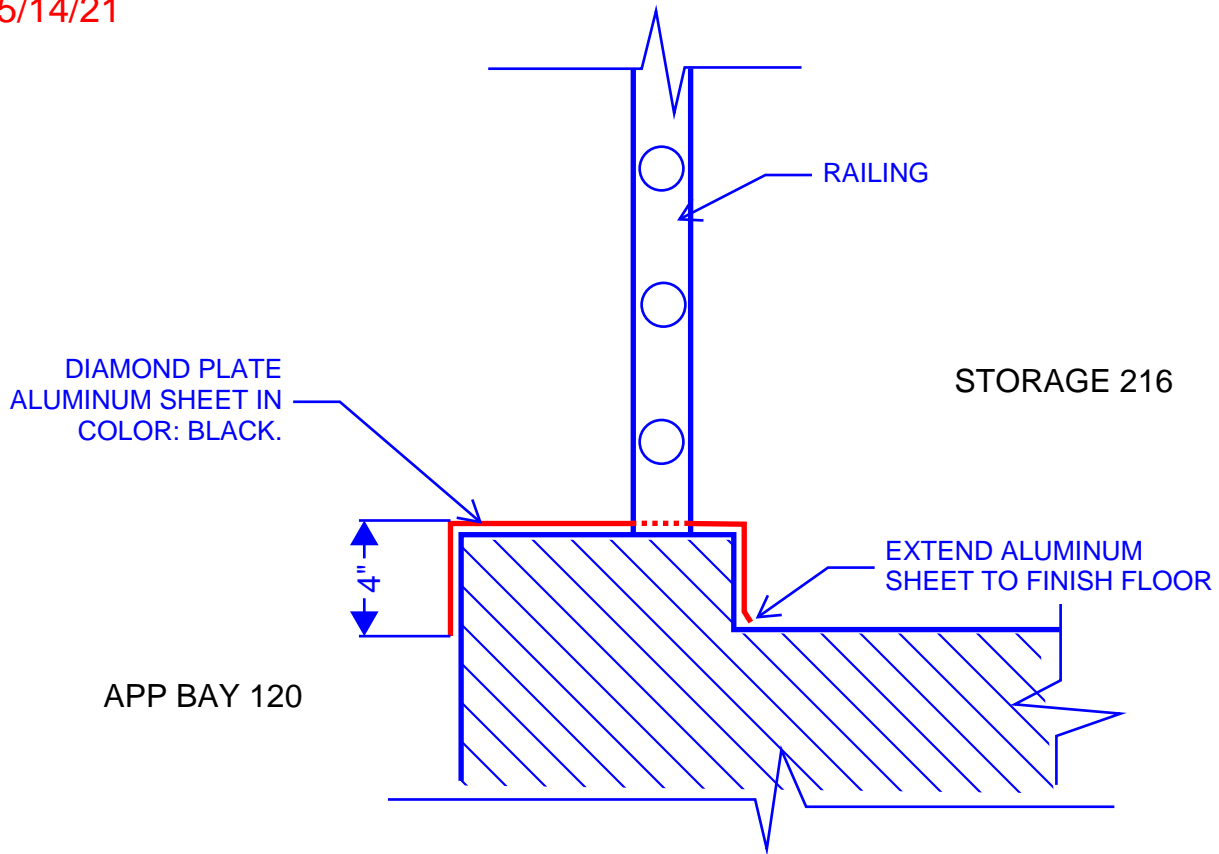

**SECTION DETAIL @ RAILING SILL**

N.T.S







## Chris Schratwieser

---

**From:** Crystal McColly <crystal@colearchitects.com>  
**Sent:** Wednesday, June 30, 2021 5:50 AM  
**To:** John Brown; Chris Schratwieser; Matt Sylvester  
**Subject:** FW: Ketchum FS - Address Number Location

JT & Chris-

See attached sketch below of the vinyl address numbers. We will issue this in an ASI.

Thank you,

**Crystal McColly, AIA, LEED AP BD+C | COLE/ARCHITECTS**  
Project Architect  
p 208.345.1800 / d 208.605.3404 / c 208.731.9031

---

**From:** Bill McLaughlin <BMcLaughlin@ketchumfire.org>  
**Sent:** Tuesday, June 29, 2021 12:29 PM  
**To:** Crystal McColly <crystal@colearchitects.com>  
**Cc:** Dennis Potts <dpotts@dppmlc.com>; Cary Goldberg <cgoldberg@dppmlc.com>  
**Subject:** RE: Ketchum FS - Address Number Location

Looks good to me.

---

**From:** Crystal McColly <[crystal@colearchitects.com](mailto:crystal@colearchitects.com)>  
**Sent:** Tuesday, June 29, 2021 12:28  
**To:** Bill McLaughlin <[BMcLaughlin@ketchumfire.org](mailto:BMcLaughlin@ketchumfire.org)>  
**Cc:** Dennis Potts <[dpotts@dppmlc.com](mailto:dpotts@dppmlc.com)>; Cary Goldberg <[cgoldberg@dppmlc.com](mailto:cgoldberg@dppmlc.com)>  
**Subject:** Ketchum FS - Address Number Location

Good afternoon Bill,

Please see sketch below of the vinyl address number location on the building. Looking through the code, it looks like the only requirement is that the numbers need to be mounted a minimum of 48" above grade and need approved by the Fire Code Official.

Let me know what you think.

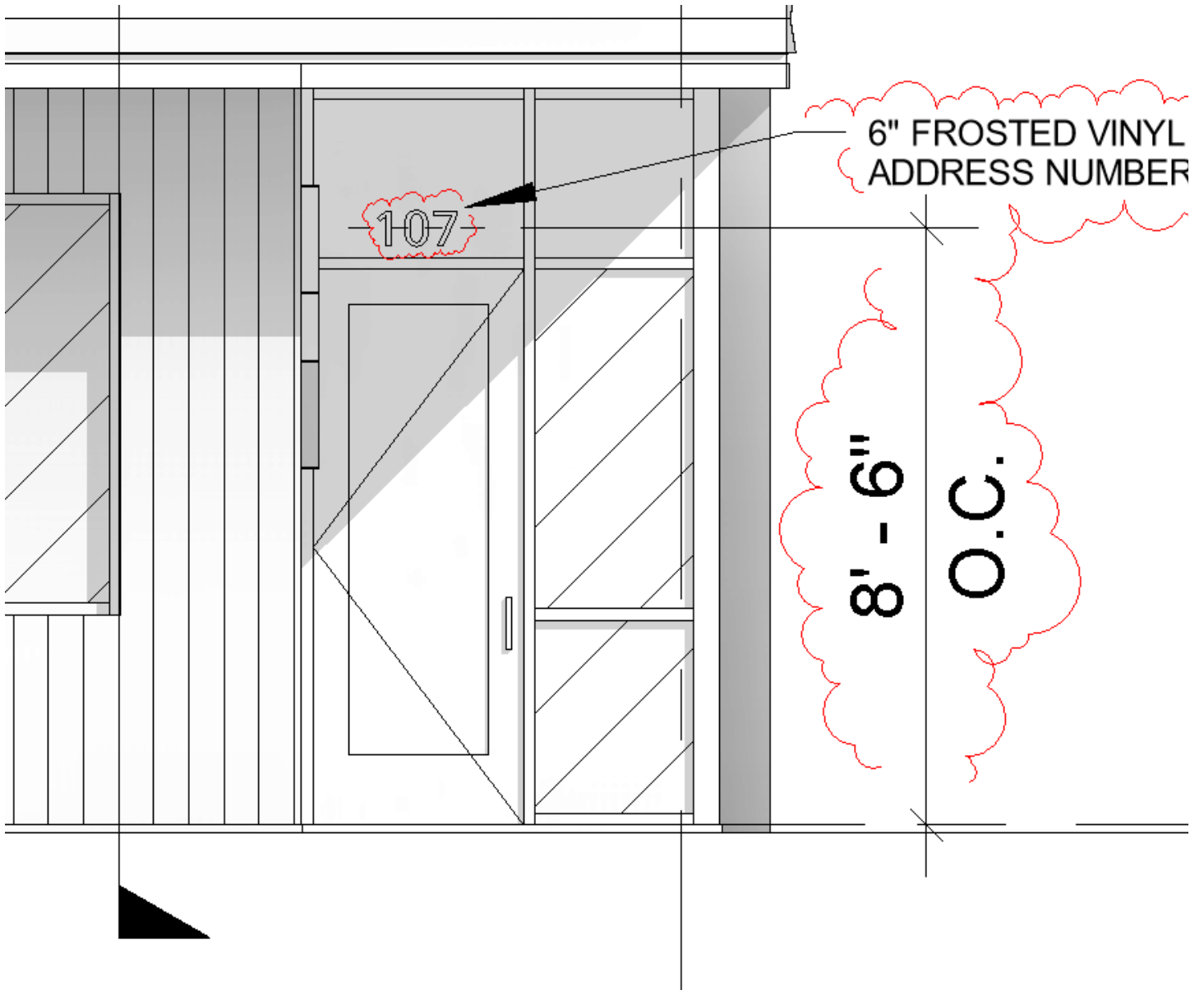

Thank you,

**Crystal McColly, AIA, LEED AP BD+C** | **COLE/ARCHITECTS**

Project Architect

p 208.345.1800 / d 208.605.3404 / c 208.731.9031



### CoK Fire Station Project Change Order Proposal

Job Number: 2000062  
Change Order Request # 5  
Date: 7/28/21

To: CORE Construction  
Attn: Chris Schratwieser  
Email: [chrisschratwieser@coreconstruction.com](mailto:chrisschratwieser@coreconstruction.com)

#### Change Order Description:

Additional exterior "107" address numbers

Scope of Work Description & Clarifications	Amount
<b>10 14 00 - Signage</b> Supply of Bestsigns address numbers Includes install, and tools/materials for the job	\$251
<b>Total Change Order Amount</b>	\$251

Ian Phillips  
[iphillips@oecworks.com](mailto:iphillips@oecworks.com)  
248-933-8891  
623 S. Americana Blvd  
Boise, ID 83702

#### Proposal Acceptance & Agreement

The undersigned hereby accepts, agrees to and Acknowledges OEC's proposal

Signature:
Printed Name:
Title:
Date:





## CoK Fire Project Change Order Proposal

Project#: 2000062  
 Change Order Request # 6  
 Date: 8/3/21

To: Core Construction  
 Attn: Matt Sylvester  
 Email: [mattsylvester@coreconstruction.com](mailto:mattsylvester@coreconstruction.com)

### Change Order Description:

Add exterior signage per sheet A2.01 "No Smoking Signage Proposed Locations" Sheet

Scope of Work Description & Clarifications	Amount																
<table style="width: 100%; border-collapse: collapse;"> <thead> <tr> <th style="width: 5%;">#</th> <th style="width: 65%;">ITEM</th> <th style="width: 10%;">QTY</th> <th style="width: 20%;">UOM</th> </tr> </thead> <tbody> <tr> <td style="text-align: center;">1</td> <td> <b>No Smoking Signs</b>            Flatbed print on specified substrate.            Brushed aluminum/stainless finish.            *File setup not included, setup appears as separate line item            Width: 10 Inches            Height: 12 Inches            Dibond ACM Panel (3mm) Brushed Aluminum            Aluminum composite panel with a high-density solid poly core.         </td> <td style="text-align: center;">5</td> <td style="text-align: center;">Each</td> </tr> <tr> <td style="text-align: center;">2</td> <td> <b>LEED Certified Vinyl Film</b>            Vinyl graphics per approved proof.            - 3M dusted film            Width: 10 Inches            Height: 10 Inches            3M Dusted Crystal Window Film            2 mil premium vinyl designed for use in window and mirror graphics         </td> <td style="text-align: center;">1</td> <td style="text-align: center;">Each</td> </tr> <tr> <td style="text-align: center;">3</td> <td> <b>No Smoking Vinyl</b>            Vinyl graphics per approved proof.            Width: 10 Inches            Height: 12 Inches            3M® 40C Premium Print Vinyl            - 3 mil digital print vinyl.            3M® 8509 Calendered Laminate - Luster            3 mil Calendered Luster Overlaminat         </td> <td style="text-align: center;">1</td> <td style="text-align: center;">Each</td> </tr> </tbody> </table> <p>Supply and install of shown signs.</p>	#	ITEM	QTY	UOM	1	<b>No Smoking Signs</b> Flatbed print on specified substrate. Brushed aluminum/stainless finish. *File setup not included, setup appears as separate line item Width: 10 Inches Height: 12 Inches Dibond ACM Panel (3mm) Brushed Aluminum Aluminum composite panel with a high-density solid poly core.	5	Each	2	<b>LEED Certified Vinyl Film</b> Vinyl graphics per approved proof. - 3M dusted film Width: 10 Inches Height: 10 Inches 3M Dusted Crystal Window Film 2 mil premium vinyl designed for use in window and mirror graphics	1	Each	3	<b>No Smoking Vinyl</b> Vinyl graphics per approved proof. Width: 10 Inches Height: 12 Inches 3M® 40C Premium Print Vinyl - 3 mil digital print vinyl. 3M® 8509 Calendered Laminate - Luster 3 mil Calendered Luster Overlaminat	1	Each	\$697
#	ITEM	QTY	UOM														
1	<b>No Smoking Signs</b> Flatbed print on specified substrate. Brushed aluminum/stainless finish. *File setup not included, setup appears as separate line item Width: 10 Inches Height: 12 Inches Dibond ACM Panel (3mm) Brushed Aluminum Aluminum composite panel with a high-density solid poly core.	5	Each														
2	<b>LEED Certified Vinyl Film</b> Vinyl graphics per approved proof. - 3M dusted film Width: 10 Inches Height: 10 Inches 3M Dusted Crystal Window Film 2 mil premium vinyl designed for use in window and mirror graphics	1	Each														
3	<b>No Smoking Vinyl</b> Vinyl graphics per approved proof. Width: 10 Inches Height: 12 Inches 3M® 40C Premium Print Vinyl - 3 mil digital print vinyl. 3M® 8509 Calendered Laminate - Luster 3 mil Calendered Luster Overlaminat	1	Each														
<b>Total Change Order Amount</b>	<b>\$697</b>																

Ian Phillips  
[iphillips@oecworks.com](mailto:iphillips@oecworks.com)  
 248-933-8891  
 623 S. Americana Blvd  
 Boise, ID 83702

### Proposal Acceptance & Agreement

The undersigned hereby accepts, agrees to and Acknowledges OEC's proposal

Signature: \_\_\_\_\_

Printed Name: \_\_\_\_\_

Title: \_\_\_\_\_

Date: \_\_\_\_\_

**NO SMOKING  
WITHIN 25 FEET OF  
BUILDING ENTRANCE**

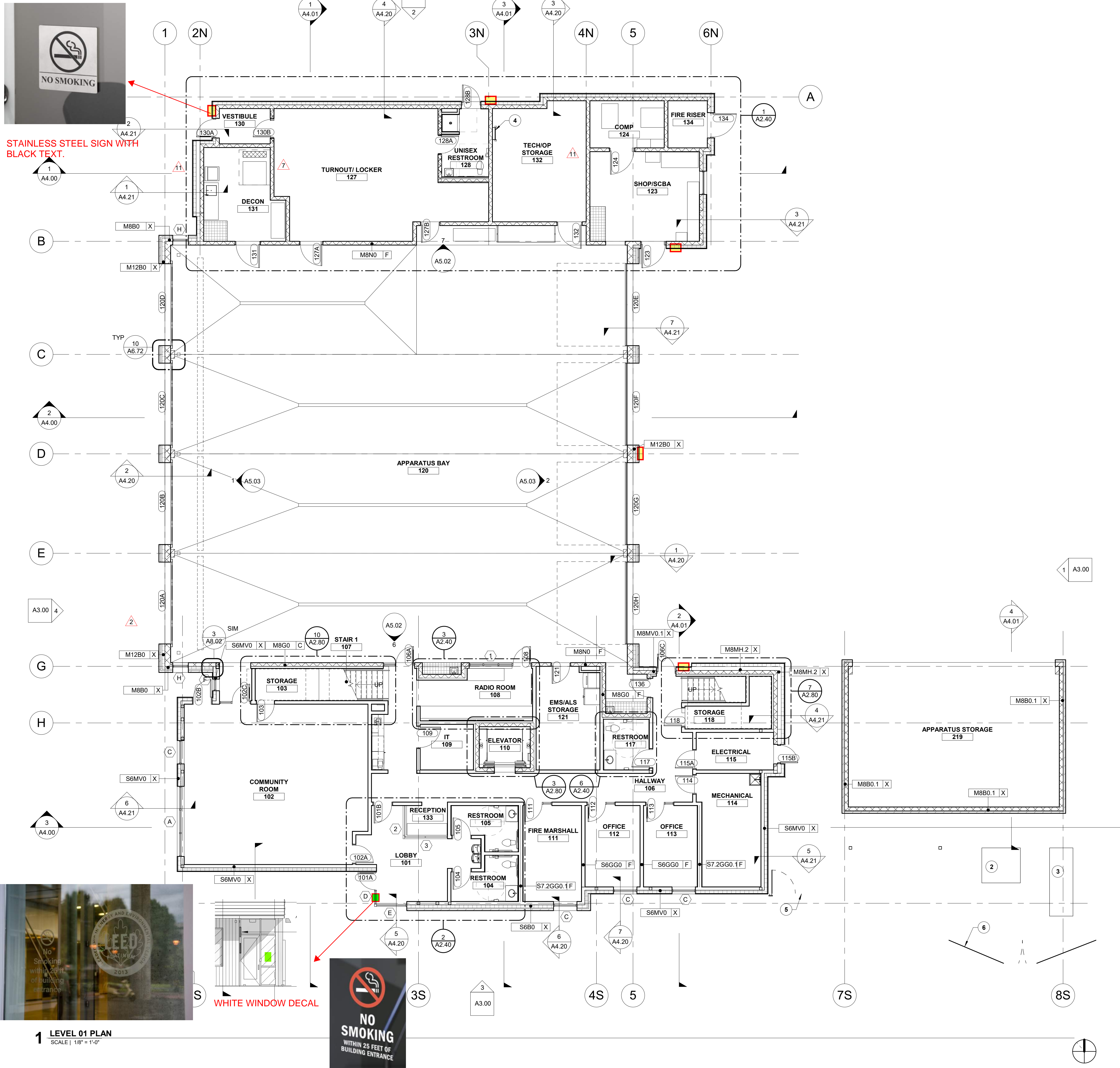

**GENERAL NOTES**

- A. FIELD VERIFY ALL DIMENSIONS AND EXISTING CONDITIONS. NOTIFY ARCHITECT IMMEDIATELY IF ANY CONFLICTS OR DISCREPANCIES OCCUR BEFORE PROCEEDING WITH WORK.
- B. CROSS REFERENCES SHOWN ON DRAWINGS DO NOT NECESSARILY INDICATE ALL LIKE CONDITIONS AND DO NOT LIMIT APPLICATION OF ANY DRAWING OR DETAIL. WHERE SPECIFIC DIMENSIONS, DETAILS, OR DESIGN INTENT CANNOT BE DETERMINED, CONSULT THE ARCHITECT PRIOR TO PROCEEDING WITH WORK. IF DESIGN INTENT REMAINS UNCLEAR THEN PROVIDE MOST EXPENSIVE OPTION IN BID.
- C. PROVIDE SOLID BLOCKING IN WALLS FOR ALL WALL HUNG EQUIPMENT. BLOCKING TO MEET OR EXCEED MANUFACTURER'S RECOMMENDATIONS. FASTEN EQUIPMENT TO WALLS PER MANUFACTURER'S RECOMMENDATIONS. PROVIDE BLOCKING FOR, BUT NOT LIMITED TO THE FOLLOWING: MILLWORK, RAILING, FIRE EXTINGUISHER ACCESSORIES, WALL MOUNTED PLUMBING FIXTURES, SHELVING, ELECTRICAL EQUIPMENT, RESTROOM ACCESSORIES AND DISPLAY ITEMS.
- D. CAULK ALL COUNTERTOPS, BACKSPASHES AND CABINETS AT LOCATIONS WHERE THEY MEET WALLS. SEAL ALL CUT-OUTS IN COUNTERTOPS.
- E. ERECT DUST PROOF PARTITIONS AS REQUIRED BY OWNER TO PROTECT ADJACENT AREAS.
- F. ALL PARTITIONS ARE TYPE "S6GG0-F" UNLESS OTHERWISE NOTED.
- G. SEAL AROUND ALL MECHANICAL AND ELECTRICAL EQUIPMENT PENETRATIONS AT WALLS. AT RATED WALLS USE A U.L. APPROVED FIRE-STOPPING MATERIAL. APPROPRIATE FOR FIRE RATING REQUIREMENTS.
- H. PROVIDE 4" DOOR JAMBS FROM FACE-OF-FINISH AT ADJACENT WALLS ON THE HINGE SIDE OR UNLESS OTHERWISE INDICATED.
- I. DIMENSIONS ARE TO GRID LINE OR FACE OF STRUCTURAL MEMBER UNLESS OTHERWISE NOTED. DOOR & WINDOW OPENING DIMENSIONS ARE TO ROUGH OPENING OR CENTERLINE OF OPENING. CONCRETE AND BRICK DIMENSIONS ARE GIVEN TO THE FACE OF CONCRETE OR MASONRY AND TO THE FACE OF ROUGH OPENINGS.

**KEYNOTES #**

- 1. STRUCTURAL COLUMN, SEE STRUCTURAL
- 2. NEW TRANSFORMER, SEE ELECTRICAL
- 3. GENERATOR, SEE ELECTRICAL
- 4. ROOF ACCESS LADDER
- 5. FENCE, SEE LANDSCAPE
- 6. GATE, SEE LANDSCAPE



1008 W Main St  
Boise, Idaho 83702  
208.345.1800  
colearchitects.net  
Copyright © 2020 Cole Architects, PLLC



6211 Roosevelt Way NE  
Seattle, WA 98115  
206.522.3820

BIDDERS ARE INSTRUCTED TO CAREFULLY REVIEW THE CONSTRUCTION DOCUMENTS AND THE SITE CONDITIONS. INFORMATION REGARDING THE COMPLETE WORK OF SPECIFIC TRADES IS DISPERSED THROUGHOUT THE ENTIRE DOCUMENT SET AND CANNOT BE ACCURATELY DETERMINED BY REFERENCE TO OTHER THAN COMPLETE DOCUMENT SETS.

**STAMP**

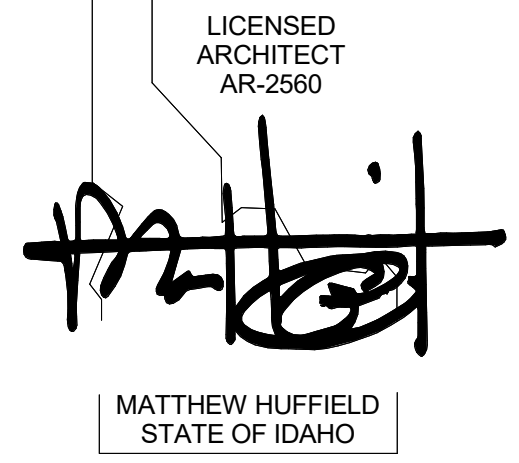

**CONSULTANT**

**PROJECT INFORMATION**



**KETCHUM FIRE STATION NO. 1**

107 SADDLE ROAD, KETCHUM, ID 83353

**ISSUES**

MARK	DATE	DESCRIPTION
T1	10/22/20	ASI 04
7	9/2/20	RFI #CC-62
2	7/17/20	ASI 1

**SHEET NAME**

**FLOOR PLAN - LEVEL 01**

**SHEET NUMBER**

**A2.01**

**1 LEVEL 01 PLAN**  
SCALE | 1/8" = 1'-0"



## City of Ketchum

August 16, 2021

Mayor Bradshaw and City Councilors  
City of Ketchum  
Ketchum, Idaho

Mayor Bradshaw and City Councilors:

### **Recommendation to approve Right-of-Way Encroachment Agreement 20645 with Idaho Power for underground power lines in the City Rights-of-Way.**

#### Recommendation and Summary

Staff is recommending the Council approve the attached Encroachment Agreement 20645 and adopt the following motion:

**"I move to authorize the Mayor to sign Encroachment Agreement 20645 with Idaho Power."**

The reasons for the recommendation are as follows:

- The encroachment is necessary to provide underground power to the new Warm Spring Ranch subdivision
- The encroachment will have no impact on pedestrian or public access

#### Introduction and History

Idaho Power would like to install approximately 50 ft. of underground power lines and conduit within the public Right-of-Way of Warm Springs Road and approximately 375 ft. of underground power lines and conduit within the public Right-of-Way of Bald Mountain Road. Underground power lines not located with public Rights-of-Way will be located within private utility easements. The proposed power infrastructure also includes the installation of new pad mountain transformers and a sector box on private property. Placement of the power infrastructure on private property will be a separate review through the Planning Department to ensure compliance with applicable zoning codes.

#### Analysis

Engineering and Streets have reviewed the layout of the proposed utilities. No above grade facilities are proposed within the City's Right-of-Way and as proposed do not impact public access or maintenance.

#### Financial Impact

There is no financial impact resulting from approval of this encroachment agreement.

Attachments:

Encroachment Agreement 20645



**WHEN RECORDED, PLEASE RETURN TO:**

**OFFICE OF THE CITY CLERK  
CITY OF KETCHUM  
POST OFFICE BOX 2315  
KETCHUM, IDAHO 83340**

---

**RIGHT-OF-WAY ENCROACHMENT AGREEMENT 20645**

THIS AGREEMENT, made and entered into this \_\_\_\_ day of \_\_\_\_, 2021, by and between the CITY OF KETCHUM, IDAHO, a municipal corporation ("Ketchum"), whose address is Post Office Box 2315, Ketchum, Idaho and \_\_\_\_\_, representing IDAHO POWER COMPANY, (collectively referred to as "Owner"), whose address is 1221 West Idaho St., Boise, ID 83702.

*RECITALS*

WHEREAS, Owner wishes to permit placement of underground electrical power lines in the right-of-way on Warm Springs Road and Bald Mountain Road. These improvements are shown in Exhibit "A" attached hereto and incorporated herein (collectively referred to as the "Improvements"); and,

WHEREAS, Ketchum finds that said Improvements will not impede the use of said public right-of-way at this time subject to the terms and provisions of this Agreement;

WHEREAS, the Owner will restore the sidewalk, street, curb and gutter and any landscaping back to the original condition acceptable to the Streets and Facilities Director;

NOW, THEREFORE, in contemplation of the above stated facts and objectives, it is hereby agreed as follows:

*TERMS AND CONDITIONS*

1. Ketchum shall permit Owner to install power infrastructure identified in Exhibit "A" within the public right-of-way of Warm Springs Road and Bald Mountain Road, until notified by Ketchum to remove the infrastructure at which time Owner shall remove infrastructure at Owner's expense.

2. Owner shall be responsible for the maintenance of said Improvements and shall repair said improvements within 48 hours upon notice from Ketchum that repairs are needed.

3. Owner shall be responsible for restoring the sidewalk, curb and gutter and landscaping that is altered due to the construction and installation of the vault, to the satisfaction of the Director of Streets and Facilities.

4. In consideration of Ketchum allowing Owner to maintain the Improvements in the public right-of-way, Owner agrees to indemnify and hold harmless Ketchum from and against any and all claims of liability for any injury or damage to any person or property arising from the Improvements constructed, installed and maintained in the public right-of-way. Owner shall further indemnify and hold Ketchum harmless from and against any and all claims arising from any breach or default in the performance of any obligation on Owner's part to be performed

under this Agreement, or arising from any negligence of Owner or Owner's agents, contractors or employees and from and against all costs, attorney's fees, expenses and liabilities incurred in the defense of any such action or proceeding brought thereon. In the event any action or proceeding is brought against Ketchum by reason of such claim, Owner, upon notice from Ketchum, shall defend Ketchum at Owner's expense by counsel satisfactory to Ketchum. Owner, as a material part of the consideration to Ketchum, hereby assumes all risk of damages to property or injury to persons in, upon or about the Improvements constructed, installed and maintained in the public right-of-way arising from the construction, installation and maintenance of said Improvements and Owner hereby waives all claims in respect thereof against Ketchum.

5. Ketchum shall not be liable for injury to Owner's business or loss of income therefrom or for damage which may be sustained by the person, goods, wares, merchandise or property of Owner, its tenants, employees, invitees, customers, agents or contractors or any other person in or about the Subject Property caused by or resulting from the Improvements constructed, installed, removed or maintained in the public right-of-way.

6. Owner understands and agrees that by maintaining the Improvements in the public right-of-way pursuant to this Agreement, Owner obtains no claim or interest in said public right-of-way which is adverse to that of Ketchum and that Owner obtains no exclusive right to said public right-of-way nor any other right to use the public right-of-way not specifically described herein.

7. In the event either party hereto retains an attorney to enforce any of the rights, duties and obligations arising out of this Agreement, the prevailing party shall be entitled to recover from the non-prevailing party reasonable attorney's fees at the trial and appellate levels and, whether or not litigation is actually instituted.

8. This Agreement shall be governed by, construed, and enforced in accordance with the laws and decisions of the State of Idaho. Venue shall be in the District Court of the fifth Judicial District of the State of Idaho.

9. Subject to Section 13 below, this Agreement sets forth the entire understanding of the parties hereto and shall not be changed or terminated orally. It is understood and agreed by the parties hereto that there are no verbal promises or implied promises, agreements, stipulations or other representations of any kind or character pertaining to the Improvements maintained in the public right-of-way other than as set forth in this Agreement.

10. No presumption shall exist in favor of or against any party to this Agreement as the result of the drafting and preparation of this document.

11. This Agreement shall be recorded with the Blaine County Recorder by Ketchum.

12. The parties fully understand all the provisions of this Agreement, and believe them to be fair, just, adequate and reasonable, and accordingly accept the provisions of this Agreement freely and voluntarily.

13. Notwithstanding any other provision of this Agreement, this Agreement shall be subject in all respects to the terms of the Franchise Agreement between Owner and Ketchum set forth in Ketchum Ordinance No. 1092 adopted by Ketchum on May 7, 2012, as such Franchise Agreement may be amended, extended or replaced by a new franchise agreement in the future ("Franchise Agreement"), and in the event of any conflict or uncertainty between the terms of this Agreement and the Franchise Agreement, the Franchise Agreement shall control.



**EXHIBIT "A"**

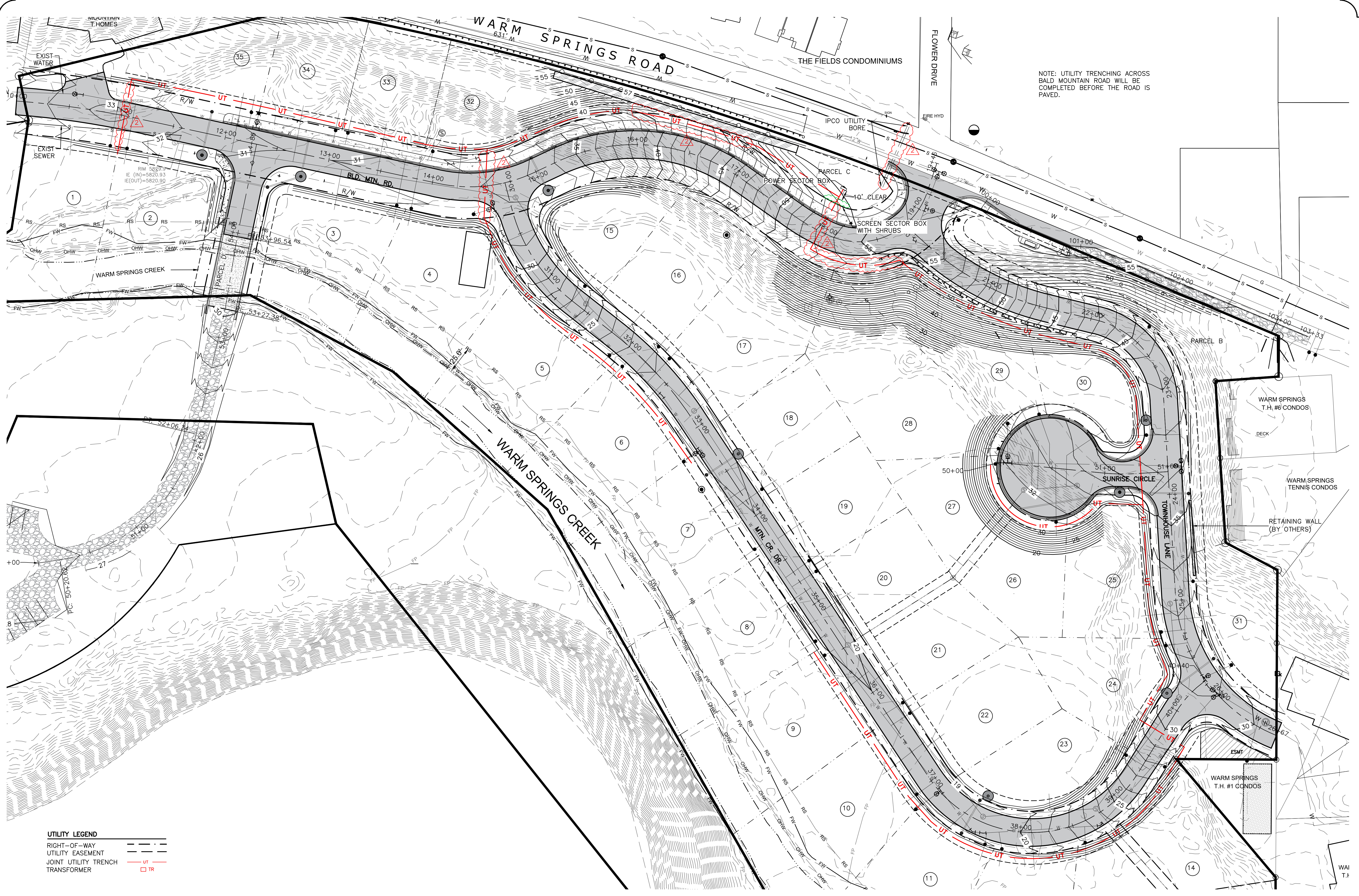

NOTE: UTILITY TRENCHING ACROSS BALD MOUNTAIN ROAD WILL BE COMPLETED BEFORE THE ROAD IS PAVED.

**UTILITY LEGEND**

RIGHT-OF-WAY	---
UTILITY EASEMENT	---
JOINT UTILITY TRENCH	UT
TRANSFORMER	TR

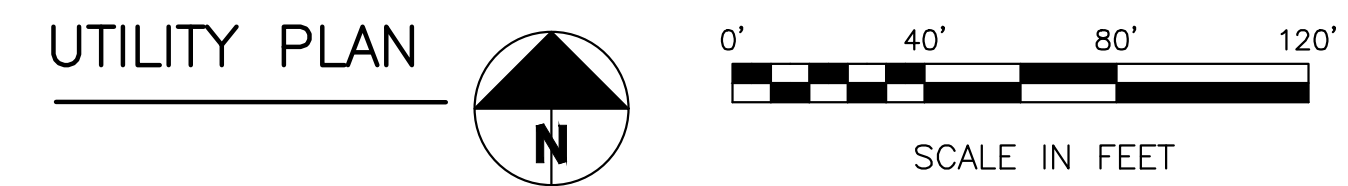

PROFESSIONAL ENGINEER  
 LICENSE NO. 17661  
 STATE OF IDAHO  
 PHOENIX JOHANNESSEN  
 6/8/21

**REVISIONS**

No.	DESCRIPTION	DATE	BY
1	SECTOR BOX RELOCATION	7/22/21	PLJ
2	UTILITY ENCROACHMENTS	7/28/21	PLJ

**BENCHMARK ASSOCIATES**

PREPARED BY:  
 BENCHMARK ASSOCIATES, P.A.  
 P.O. BOX 733 100 BELL DRIVE  
 KETCHUM, IDAHO 83340  
 (208) 726-9512  
 FAX: 726-9514  
 WEB: WWW.BMA5B.COM  
 MAIL: WWW.BMA5B.COM

**UTILITY PLAN**

WARM SPRINGS RANCH, BL 1  
 T4N, R17E, SEC 12, B.M., CITY OF KETCHUM, IDAHO  
 PREPARED FOR: BRENNAN HOLDINGS, LLC.

DRAWN BY: PLJ  
 DESIGNED BY: PLJ  
 CHECKED BY: CL  
 DATE: 6/8/2021  
 PROJECT NO.: 20071

DRAWING NO.

**UT7**



## City of Ketchum

August 16, 2021

Mayor Bradshaw and City Councilors  
City of Ketchum  
Ketchum, Idaho

Mayor Bradshaw and City Councilors:

### **Recommendation to approve Right-of-Way Encroachment Agreement 20653 with Idaho Power for underground power lines in the City Right-of-Way.**

#### Recommendation and Summary

Staff is recommending the Council approve the attached Encroachment Agreement 20653 and adopt the following motion:

**"I move to authorize the Mayor to sign Encroachment Agreement 20653 with Idaho Power."**

The reasons for the recommendation are as follows:

- The encroachment will provide underground power to 500 River Street.
- The new underground power lines will have no impact on pedestrian or public access.
- The transformer on private property will be screened with landscaping on 3 sides with drought tolerant landscaping.

#### Introduction and History

Idaho Power would like to install approximately 156 ft. of underground power lines in conduits within the River Street Right-of-Way. The new underground power lines and transformer will facilitate undergrounding of existing overhead power lines servicing 500 River Street.

City code requires a right-of-way encroachment permit for any permanent encroachment in the public right-of-way. These agreements are intended to help protect the City in the event the proposed encroachments were to ever pose an issue requiring repair or relocation of the encroachment.

#### Analysis

Engineering and Streets reviewed the layout of the proposed utilities. No new above grade facilities are proposed within the City's ROW. As proposed the project would not impact public access or maintenance.

#### Financial Impact

There is no financial impact resulting from approval of this encroachment agreement.

Attachments:

Encroachment Agreement 20653

**WHEN RECORDED, PLEASE RETURN TO:**

**OFFICE OF THE CITY CLERK  
CITY OF KETCHUM  
POST OFFICE BOX 2315  
KETCHUM, IDAHO 83340**

---

**RIGHT-OF-WAY ENCROACHMENT AGREEMENT 20653**

THIS AGREEMENT, made and entered into this \_\_\_\_ day of \_\_\_\_, 2021, by and between the CITY OF KETCHUM, IDAHO, a municipal corporation ("Ketchum"), whose address is Post Office Box 2315, Ketchum, Idaho and \_\_\_\_\_, representing IDAHO POWER COMPANY, (collectively referred to as "Owner"), whose address is 1221 West Idaho St., Boise, ID 83702.

*RECITALS*

WHEREAS, Owner wishes to permit placement of an existing sector box, existing transformer, and new underground electrical power lines and conduits in the right-of-way on River Street. These improvements are shown in Exhibit "A" attached hereto and incorporated herein (collectively referred to as the "Improvements"); and,

WHEREAS, Ketchum finds that said Improvements will not impede the use of said public right-of-way at this time subject to the terms and provisions of this Agreement;

WHEREAS, the Owner will restore the sidewalk, street, curb and gutter and any landscaping back to the original condition acceptable to the Streets and Facilities Director;

NOW, THEREFORE, in contemplation of the above stated facts and objectives, it is hereby agreed as follows:

*TERMS AND CONDITIONS*

1. Ketchum shall permit Owner to install power infrastructure and landscaping identified in Exhibit "A" within the public right-of-way of River Street, until notified by Ketchum to remove the infrastructure at which time Owner shall remove infrastructure at Owner's expense.
2. Owner shall be responsible for the maintenance of said Improvements and shall repair said improvements within 48 hours upon notice from Ketchum that repairs are needed.
3. Owner shall be responsible for restoring the sidewalk, curb and gutter and landscaping that is altered due to the construction and installation of the vault, to the satisfaction of the Director of Streets and Facilities.
4. In consideration of Ketchum allowing Owner to maintain the Improvements in the public right-of-way, Owner agrees to indemnify and hold harmless Ketchum from and against any and all claims of liability for any injury or damage to any person or property arising from the Improvements constructed, installed and maintained in the public right-of-way. Owner shall further indemnify and hold Ketchum harmless from and against any and all claims arising from any breach or default in the performance of any obligation on Owner's part to be performed

under this Agreement, or arising from any negligence of Owner or Owner's agents, contractors or employees and from and against all costs, attorney's fees, expenses and liabilities incurred in the defense of any such action or proceeding brought thereon. In the event any action or proceeding is brought against Ketchum by reason of such claim, Owner, upon notice from Ketchum, shall defend Ketchum at Owner's expense by counsel satisfactory to Ketchum. Owner, as a material part of the consideration to Ketchum, hereby assumes all risk of damages to property or injury to persons in, upon or about the Improvements constructed, installed and maintained in the public right-of-way arising from the construction, installation and maintenance of said Improvements and Owner hereby waives all claims in respect thereof against Ketchum.

5. Ketchum shall not be liable for injury to Owner's business or loss of income therefrom or for damage which may be sustained by the person, goods, wares, merchandise or property of Owner, its tenants, employees, invitees, customers, agents or contractors or any other person in or about the Subject Property caused by or resulting from the Improvements constructed, installed, removed or maintained in the public right-of-way.

6. Owner understands and agrees that by maintaining the Improvements in the public right-of-way pursuant to this Agreement, Owner obtains no claim or interest in said public right-of-way which is adverse to that of Ketchum and that Owner obtains no exclusive right to said public right-of-way nor any other right to use the public right-of-way not specifically described herein.

7. In the event either party hereto retains an attorney to enforce any of the rights, duties and obligations arising out of this Agreement, the prevailing party shall be entitled to recover from the non-prevailing party reasonable attorney's fees at the trial and appellate levels and, whether or not litigation is actually instituted.

8. This Agreement shall be governed by, construed, and enforced in accordance with the laws and decisions of the State of Idaho. Venue shall be in the District Court of the fifth Judicial District of the State of Idaho.

9. Subject to Section 13 below, this Agreement sets forth the entire understanding of the parties hereto and shall not be changed or terminated orally. It is understood and agreed by the parties hereto that there are no verbal promises or implied promises, agreements, stipulations or other representations of any kind or character pertaining to the Improvements maintained in the public right-of-way other than as set forth in this Agreement.

10. No presumption shall exist in favor of or against any party to this Agreement as the result of the drafting and preparation of this document.

11. This Agreement shall be recorded with the Blaine County Recorder by Ketchum.

12. The parties fully understand all the provisions of this Agreement, and believe them to be fair, just, adequate and reasonable, and accordingly accept the provisions of this Agreement freely and voluntarily.

13. Notwithstanding any other provision of this Agreement, this Agreement shall be subject in all respects to the terms of the Franchise Agreement between Owner and Ketchum set forth in Ketchum Ordinance No. 1092 adopted by Ketchum on May 7, 2012, as such Franchise Agreement may be amended, extended or replaced by a new franchise agreement in



the future (“Franchise Agreement”), and in the event of any conflict or uncertainty between the terms of this Agreement and the Franchise Agreement, the Franchise Agreement shall control.



**EXHIBIT "A"**

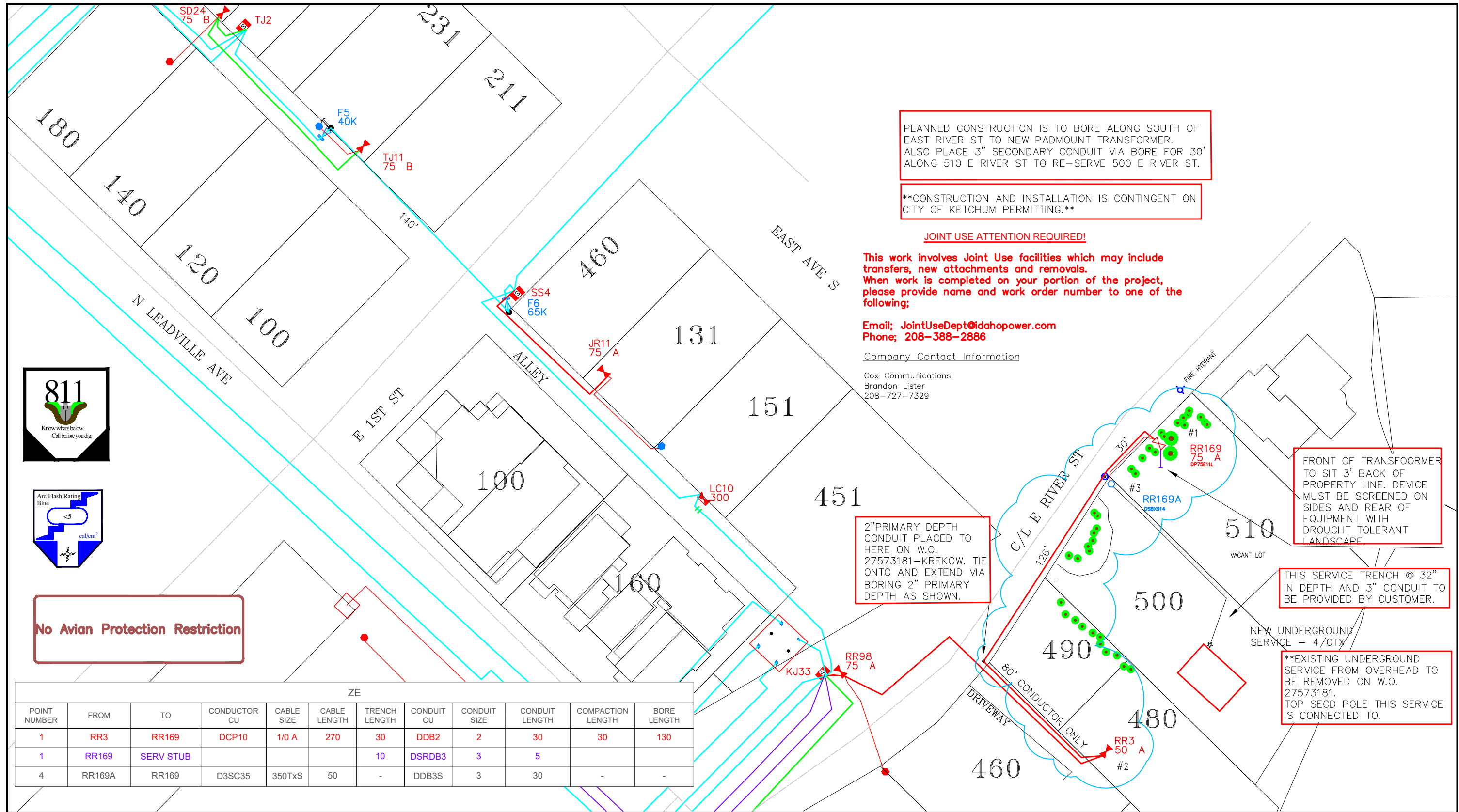

PLANNED CONSTRUCTION IS TO BORE ALONG SOUTH OF EAST RIVER ST TO NEW PADMOUNT TRANSFORMER. ALSO PLACE 3" SECONDARY CONDUIT VIA BORE FOR 30' ALONG 510 E RIVER ST TO RE-SERVE 500 E RIVER ST.

**\*\*CONSTRUCTION AND INSTALLATION IS CONTINGENT ON CITY OF KETCHUM PERMITTING.\*\***

**JOINT USE ATTENTION REQUIRED!**

This work involves Joint Use facilities which may include transfers, new attachments and removals. When work is completed on your portion of the project, please provide name and work order number to one of the following;

Email; [JointUseDept@idahopower.com](mailto:JointUseDept@idahopower.com)  
Phone; 208-388-2886

Company Contact Information

Cox Communications  
Brandon Lister  
208-727-7329

FRONT OF TRANSFORMER TO SIT 3' BACK OF PROPERTY LINE. DEVICE MUST BE SCREENED ON SIDES AND REAR OF EQUIPMENT WITH DROUGHT TOLERANT LANDSCAPE

THIS SERVICE TRENCH @ 32" IN DEPTH AND 3" CONDUIT TO BE PROVIDED BY CUSTOMER.

\*\*EXISTING UNDERGROUND SERVICE FROM OVERHEAD TO BE REMOVED ON W.O. 27573181. TOP SECD POLE THIS SERVICE IS CONNECTED TO.

2" PRIMARY DEPTH CONDUIT PLACED TO HERE ON W.O. 27573181-KREKOW. TIE ONTO AND EXTEND VIA BORING 2" PRIMARY DEPTH AS SHOWN.



**No Avian Protection Restriction**

ZE											
POINT NUMBER	FROM	TO	CONDUCTOR CU	CABLE SIZE	CABLE LENGTH	TRENCH LENGTH	CONDUIT CU	CONDUIT SIZE	CONDUIT LENGTH	COMPACTION LENGTH	BORE LENGTH
1	RR3	RR169	DCP10	1/0 A	270	30	DDB2	2	30	30	130
1	RR169	SERV STUB				10	DSRDB3	3	5		
4	RR169A	RR169	D3SC35	350TxS	50	-	DDB3S	3	30	-	-

SWPP: Pending



Customer: \_\_\_\_\_ Date: \_\_\_\_\_

Job Title: **JOHN BAILEY-500 E RIVER ST, KET; INSTALL NEW UNDERGROUND LINE EXTENSN**  
 Additional Description: **EXTEND SINGLE PHASE POWER LINE ALONG SOUTH OF E RIVER ST RIGHT OF WAY.**  
 Additional Description: **TO NEW PADMOUNT TRANSFORMER ON PROPERTY AT 510 E RIVER ST.**

Feeder Map File Name: **KCHM1101**  
 Qua 1 TwN 04N Rng 18E Sec 18 BM  
 State ID County Blaine

Surveyed or GPS: **GPS**  
 Joint Use Attachment: **YES**  
 Pre-Built Date: **7/20/2021**  
 Built as Designed: **----**  
 Construction Date: **----**  
 Operating Voltage: **7.2kV**



FDR By: **----**  
 Date: **----**  
 ArcFM By: **----**  
 Date: **----**

Designer: **CDC0468**  
 Design No: **0000150417**  
 Work Order No: **27580359**



## City of Ketchum

August 16, 2021

Mayor Bradshaw and City Councilors  
City of Ketchum  
Ketchum, Idaho

Mayor Bradshaw and City Councilors:

**Recommendation to approve Right-of-Way Encroachment Agreement 20656 for placement of a snowmelt driveway in the City Right-of-Way at 116 Sage Road.**

Recommendation and Summary

Staff is recommending Council approve the attached Encroachment Agreement and adopt the following motion:

**"I move to authorize the Mayor to sign Encroachment Agreement 20656 with Colin and Martha Moseley."**

The reasons for the recommendation are as follows:

- The improvements will not impact the use or operation of the residential street
- The improvements will not impact drainage within the City ROW
- The improvement is necessary for access to the property

Introduction and History

A Right-of-Way Encroachment Permit request was received for a snowmelt driveway within the City's Right-of-Way at 116 Sage Rd.

Right-of-Way standards were developed to achieve goals of drainage, parking, snow storage, access for emergency vehicles, and provide materials that can be reasonably maintained by the city. Pavers, snowmelt systems, and subsurface drip irrigation systems are not maintained by the City but may be approved through an encroachment agreement.

City code requires a right-of-way encroachment permit for any permanent encroachment in the public right-of-way. These agreements are intended to help protect the City in the event the proposed encroachments were to ever pose an issue requiring repair, relocation, or removal of the encroachment.

Analysis

The proposed encroachments were determined not to impact public access or city operations.

Financial Impact

There is no financial impact resulting from approval of this encroachment agreement.

Attachments:

Encroachment Agreement 20656

**WHEN RECORDED, PLEASE RETURN TO:**

**OFFICE OF THE CITY CLERK  
CITY OF KETCHUM  
POST OFFICE BOX 2315  
KETCHUM, IDAHO 83340**

---

## **RIGHT-OF-WAY ENCROACHMENT AGREEMENT 20656**

THIS AGREEMENT, made and entered into this \_\_\_\_ day of \_\_\_\_, 2021, by and between the CITY OF KETCHUM, IDAHO, a municipal corporation ("Ketchum"), whose address is Post Office Box 2315, Ketchum, Idaho and CM AND MPM REVOCABLE TRUST, (collectively referred to as "Owner"), whose address is P.O. BOX 21866, SEATTLE, WASHINGTON 98111.

### *RECITALS*

WHEREAS, Owner is the owner of real property described as 116 Sage Road ("Subject Property"), located within the City of Ketchum, State of Idaho; and

WHEREAS, Owner wishes to permit placement of a snowmelt system under an asphalt driveway within the right-of-way on Sage Road. These improvements are shown in Exhibit "A" attached hereto and incorporated herein (collectively referred to as the "Improvements"); and,

WHEREAS, Ketchum finds that said Improvements will not impede the use of said public right-of-way at this time subject to the terms and provisions of this Agreement;

NOW, THEREFORE, in contemplation of the above stated facts and objectives, it is hereby agreed as follows:

### *TERMS AND CONDITIONS*

1. Ketchum shall permit Owner to maintain the improvements identified in Exhibit "A" within the public right-of-way of 116 Sage Road, Idaho, until notified by Ketchum to remove the improvements at which time Owner shall remove improvements at Owner's expense.

2. Owner shall be responsible for the maintenance of said Improvements. Any modification to the improvements identified in Exhibit "A" shall be approved by the City of Ketchum prior to any modifications taking place.

3. In consideration of Ketchum allowing Owner to maintain the Improvements in the public right-of-way, Owner agrees to indemnify and hold harmless Ketchum from and against any and all claims of liability for any injury or damage to any person or property arising from the Improvements constructed, installed and maintained in the public right-of-way. Owner shall further indemnify and hold Ketchum harmless from and against any and all claims arising from any breach or default in the performance of any obligation on Owner's part to be performed under this Agreement, or arising from any negligence of Owner or Owner's agents, contractors or employees and from and against all costs, attorney's fees, expenses and liabilities incurred in the defense of any such action or proceeding brought thereon. In the event any action or proceeding is brought against Ketchum by reason of such claim, Owner, upon notice from Ketchum, shall defend Ketchum at Owner's expense by counsel satisfactory to Ketchum. Owner, as a material

part of the consideration to Ketchum, hereby assumes all risk of damages to property or injury to persons in, upon or about the Improvements constructed, installed and maintained in the public right-of-way arising from the construction, installation and maintenance of said Improvements and Owner hereby waives all claims in respect thereof against Ketchum.

4. Ketchum shall not be liable for injury to Owner's business or loss of income therefrom or for damage which may be sustained by the person, goods, wares, merchandise or property of Owner, its tenants, employees, invitees, customers, agents or contractors or any other person in or about the Subject Property caused by or resulting from the Improvements constructed, installed, removed or maintained in the public right-of-way.

5. Owner understands and agrees that by maintaining the Improvements in the public right-of-way pursuant to this Agreement, Owner obtains no claim or interest in said public right-of-way which is adverse to that of Ketchum and that Owner obtains no exclusive right to said public right-of-way nor any other right to use the public right-of-way not specifically described herein.

6. This Agreement shall be a covenant running with the Subject Property and the terms and provisions hereof shall inure to the benefit of and be binding upon the parties and the respective heirs, personal representatives, successors and assigns of the parties hereof.

7. In the event either party hereto retains an attorney to enforce any of the rights, duties and obligations arising out of this Agreement, the prevailing party shall be entitled to recover from the non-prevailing party reasonable attorney's fees at the trial and appellate levels and, whether or not litigation is actually instituted.

8. This Agreement shall be governed by, construed, and enforced in accordance with the laws and decisions of the State of Idaho. Venue shall be in the District Court of the fifth Judicial District of the State of Idaho.

9. This Agreement sets forth the entire understanding of the parties hereto, and shall not be changed or terminated orally. It is understood and agreed by the parties hereto that there are no verbal promises or implied promises, agreements, stipulations or other representations of any kind or character pertaining to the Improvements maintained in the public right-of-way other than as set forth in this Agreement.

10. No presumption shall exist in favor of or against any party to this Agreement as the result of the drafting and preparation of this document.

11. This Agreement shall be recorded with the Blaine County Recorder by Ketchum.

12. The parties fully understand all of the provisions of this Agreement, and believe them to be fair, just, adequate and reasonable, and accordingly accept the provisions of this Agreement freely and voluntarily.





**EXHIBIT "A"**



LEGEND

	EXISTING	PROPOSED
PROPERTY LINE	---	---
ADJOINING PROPERTY LINE	---	---
CENTERLINE	---	---
ASPHALT PAVEMENT	---	---
FENCE	---	---
SEWER	---	---
SEWER MANHOLE	○	○
WATER	---	---
GAS	---	---
POWER	---	---
TELEPHONE	---	---
CABLE TV LINE	---	---
TELEPHONE RISER	□	□
ELEVATION CONTOUR	---	---
SAWCUT LINE	---	---
FLOW LINE	---	---
DRYWELL	○	○
LANDSCAPE DRYWELL	○	○
STORM DRAIN PIPE	---	---
CATCH BASIN	○	○
DOWN SPOUT	---	---

- GENERAL NOTES
- CONTRACTOR SHALL FIELD VERIFY LOCATION OF ALL EXISTING UTILITIES BEFORE COMMENCING CONSTRUCTION. ANY CONFLICT SHALL BE BROUGHT TO THE ATTENTION OF THE ENGINEER.
  - CONTRACTOR SHALL NOTIFY DIGLINE (1-800-342-1585) AT LEAST 48 HOURS PRIOR TO BEGINNING CONSTRUCTION ACTIVITIES. THE CONTRACTOR SHALL BE RESPONSIBLE FOR ANY DAMAGE TO EXISTING UTILITIES ENCOUNTERED DURING CONSTRUCTION.
  - CONTRACTOR SHALL BE RESPONSIBLE FOR DUST CONTROL DURING THE CONSTRUCTION OF ALL ITEMS HEREON. DUST CONTROL SHALL BE CONTINUOUS DURING CONSTRUCTION, 24 HOURS PER DAY 7 DAYS PER WEEK. THE CONTRACTOR SHALL FOLLOW THE REQUIREMENTS OF THE STORM WATER POLLUTION PREVENTION PROGRAM AT ALL TIMES UNTIL PERMANENT EROSION CONTROL IS ESTABLISHED.
  - CONTRACTOR SHALL ASSURE POSITIVE DRAINAGE AWAY FROM THE UPHILL SIDE OF HOUSE.
  - THE CITY WILL FURNISH MATERIALS FOR DRYWELLS LOCATED WITHIN THE RIGHT OF WAY.
  - HDPE SOLID WALL PIPE SHALL BE BUTT-FUSED OR HAVE FLANGED PIPE JOINTS AND SHALL BE USED ON SLOPES GREATER THAN 20%.
  - TRENCH DRAIN SHALL BE A 6" WIDE HDPE CHANNEL WITH A 0.75 BUILT IN CHANNEL SLOPE (ZURN FLO-THRU MODEL Z886 OR EQUIVALENT). GRATE SHALL BE DUCTILE IRON WITH A SLOTTED PATTERN. CATCH BASIN SHALL BE 6" WIDE X 20" LONG X 20" DEEP AND SHALL BE MADE OF HDPE. OUTLET PIPE SHALL BE 4" DIAMETER (FLO-THRU MODEL Z887 OR EQUIVALENT). ALL COMPONENTS SHALL BE RATED FOR H2O LOADING.
  - WHERE WATER SERVICE LINE IS UNDER THE DRIVEWAY, ENCASE IN CLOSED CELL FOAM TUBING. INSTALL WATER METER IN THE MECHANICAL ROOM.
  - ALL WORK WITHIN THE CITY RIGHT OF WAY SHALL CONFORM TO CITY OF KETCHUM STANDARDS.

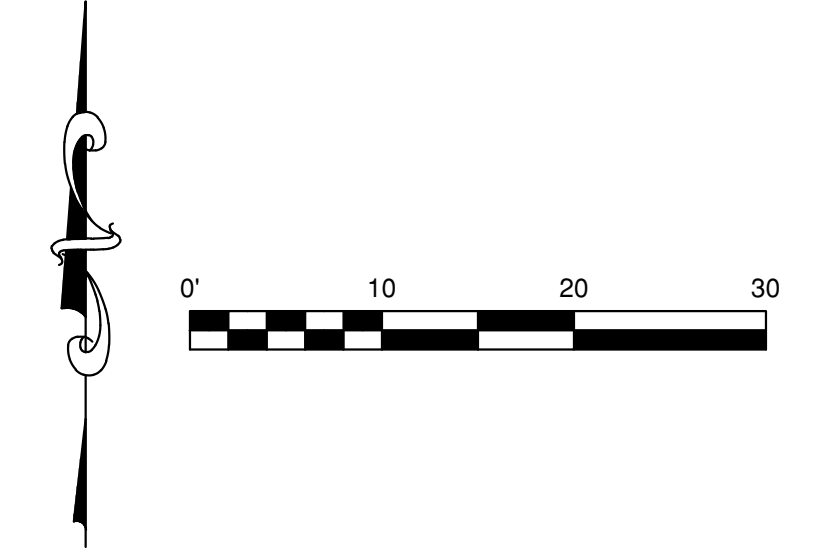
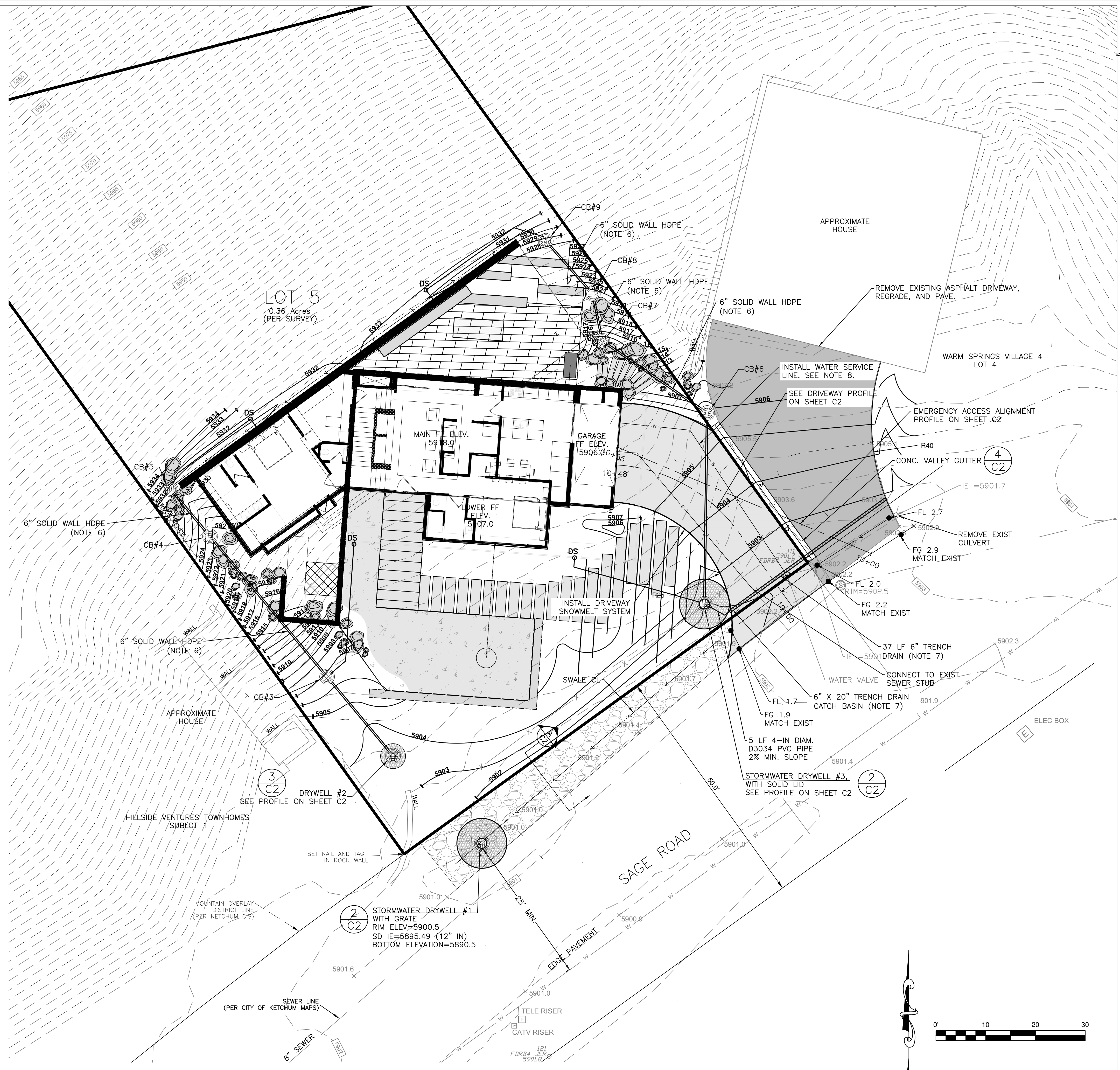

PROFESSIONAL ENGINEER  
STATE OF IDAHO  
RODOLFO JOHANNESSEN  
17661  
5/31/19

REVISIONS

No.	DESCRIPTION	DATE	BY

BENCHMARK ASSOCIATES  
PREPARED BY:  
BENCHMARK ASSOCIATES, P.A.  
P.O. BOX 733 100 BELL DRIVE  
KETCHUM, IDAHO 83340  
(208) 726-9512  
FAX 726-9514  
WEB: WWW.BMA5B.COM  
MAIL: WWW.BMA5B.COM

CIVIL PLAN  
WARM SPRINGS VILLAGE 4 BLOCK 3 LOT 5  
T4N, R17E, SEC 11, B.M., CITY OF KETCHUM, IDAHO  
PREPARED FOR: COLIN MOSELEY

DRAWN BY: PLJ  
DESIGNED BY: PLJ  
CHECKED BY: SB  
DATE: 05/31/19  
PROJECT NO.: 18230

SHEET NUMBER  
**C-1**

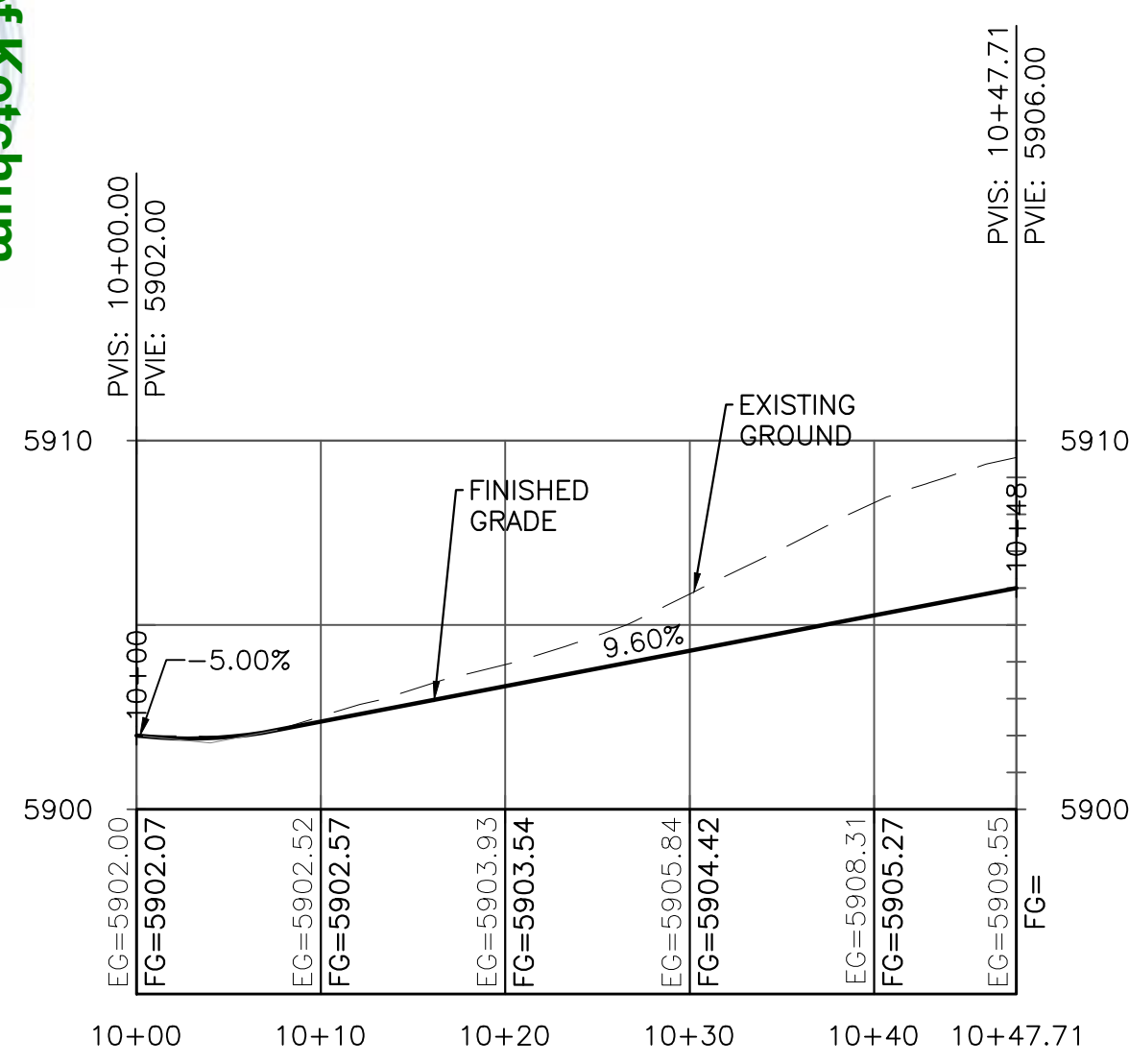

**DRIVEWAY PROFILE**

HORIZ: 1"=10'  
 VERT: 1"=5'

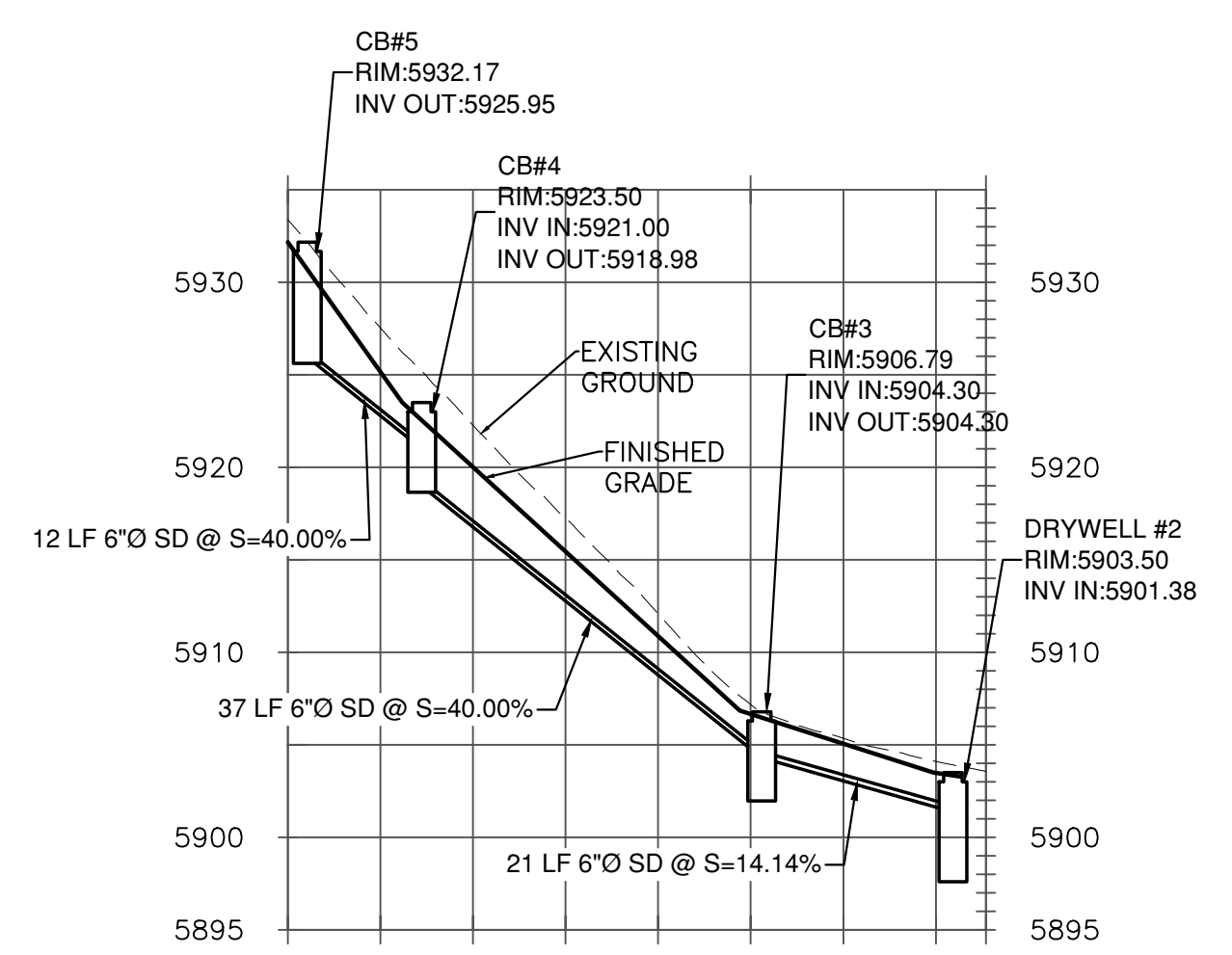

**STORM PROFILE**

HORIZ: 1"=20'  
 VERT: 1"=5'

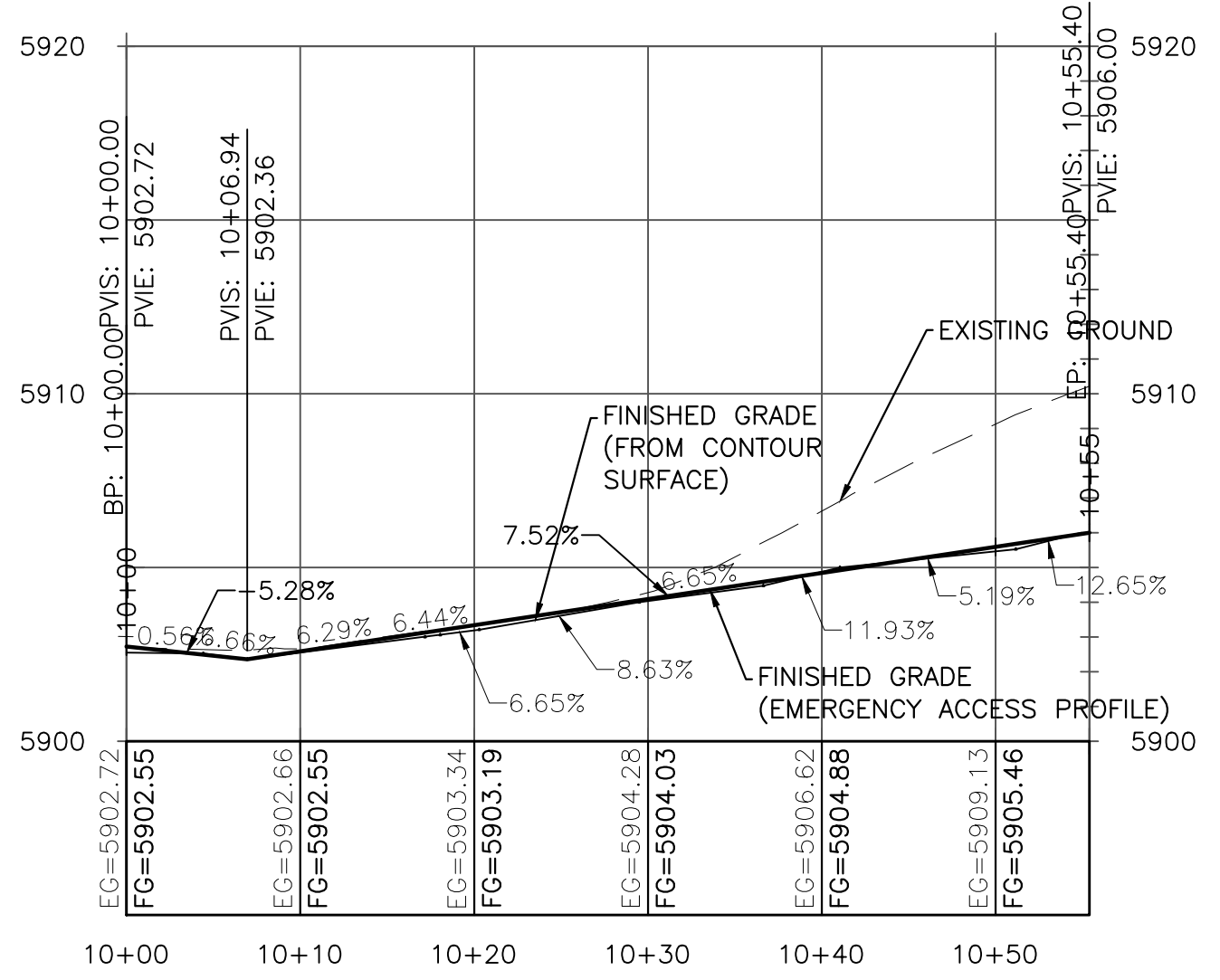

**EMERGENCY ACCESS PROFILE**

HORIZ: 1"=10'  
 VERT: 1"=5'

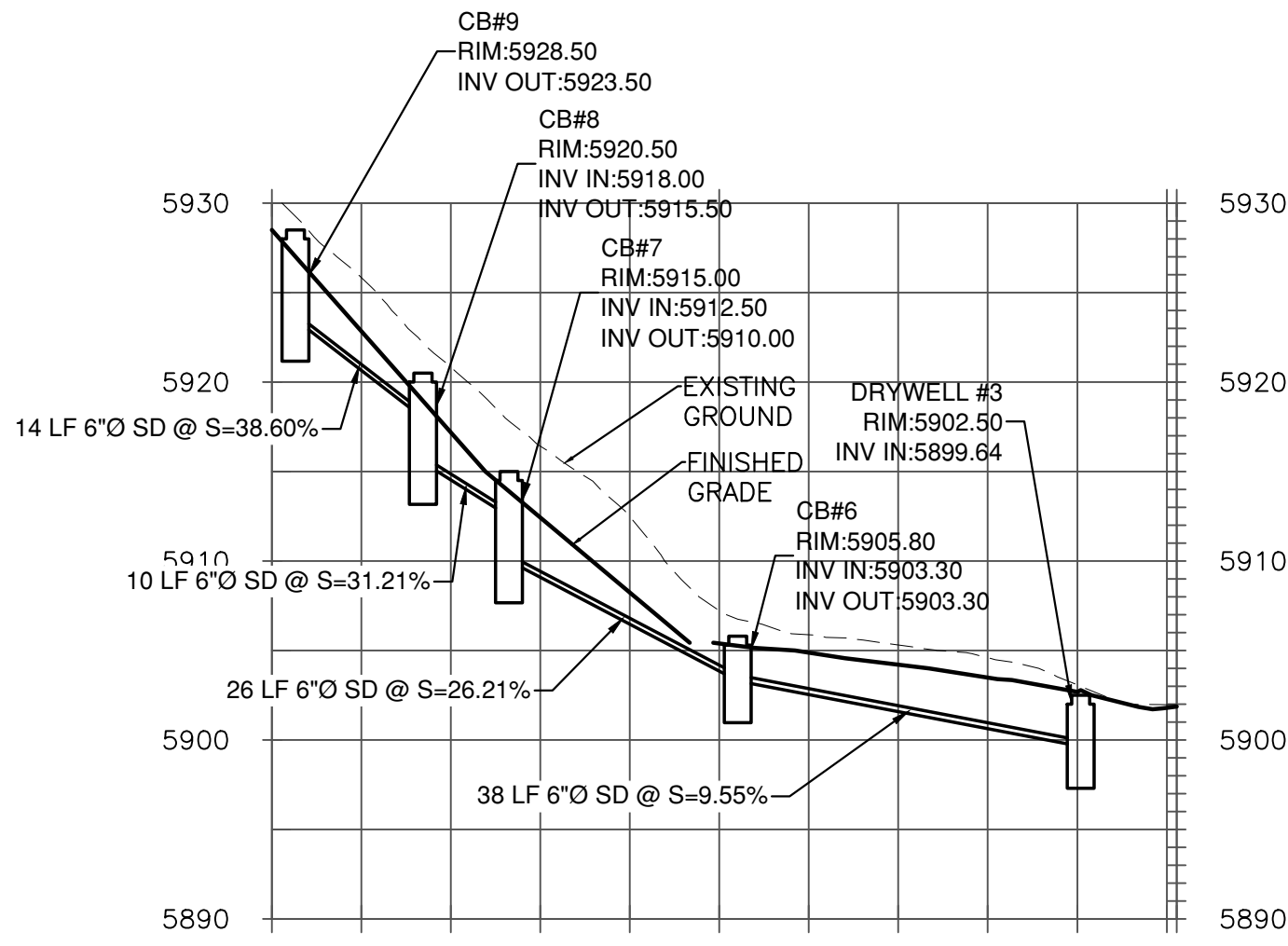

**STORM PROFILE**

HORIZ: 1"=20'  
 VERT: 1"=5'

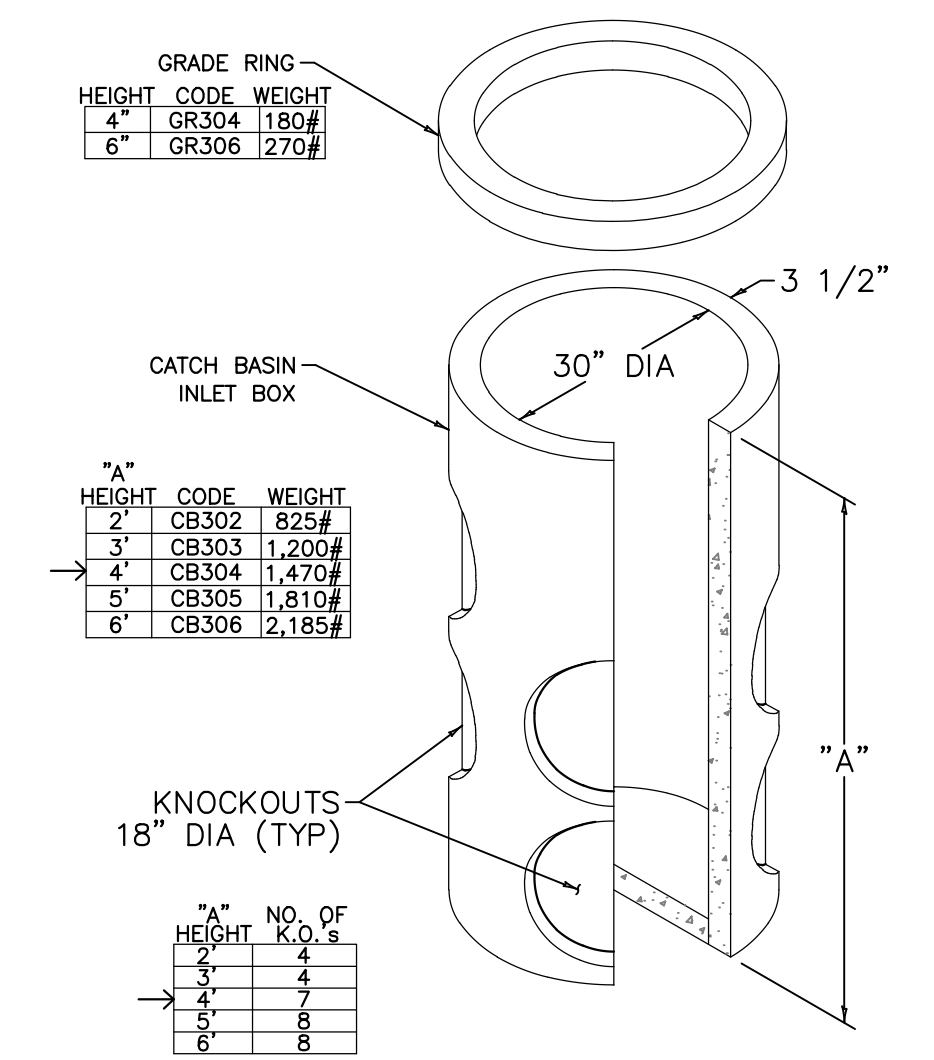

**1** 30-INCH CATCH BASIN DETAIL  
 SCALE: N.T.S.

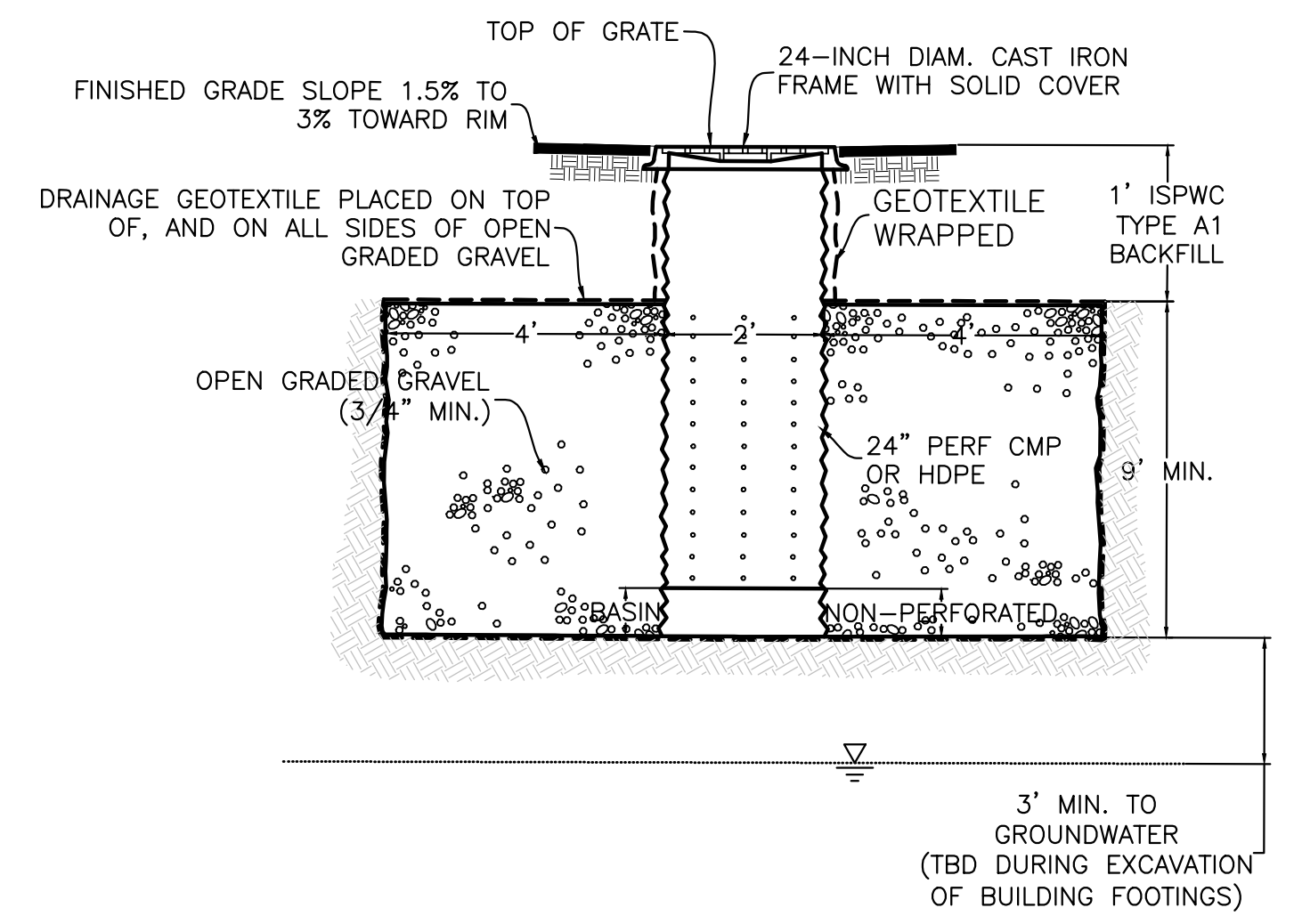

**2** DRYWELL DETAIL  
 SCALE: N.T.S.

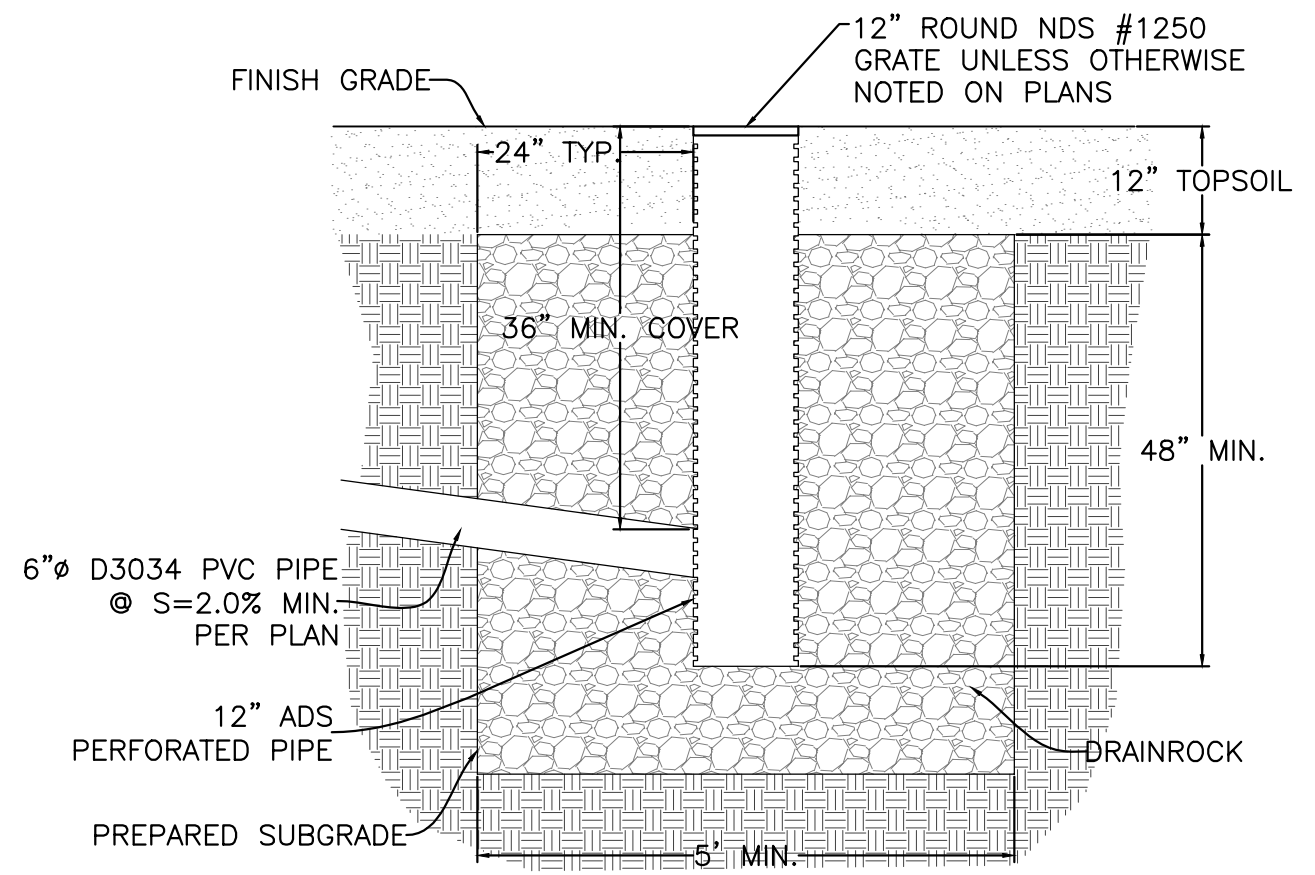

**3** LANDSCAPE DRYWELL  
 SCALE: N.T.S.

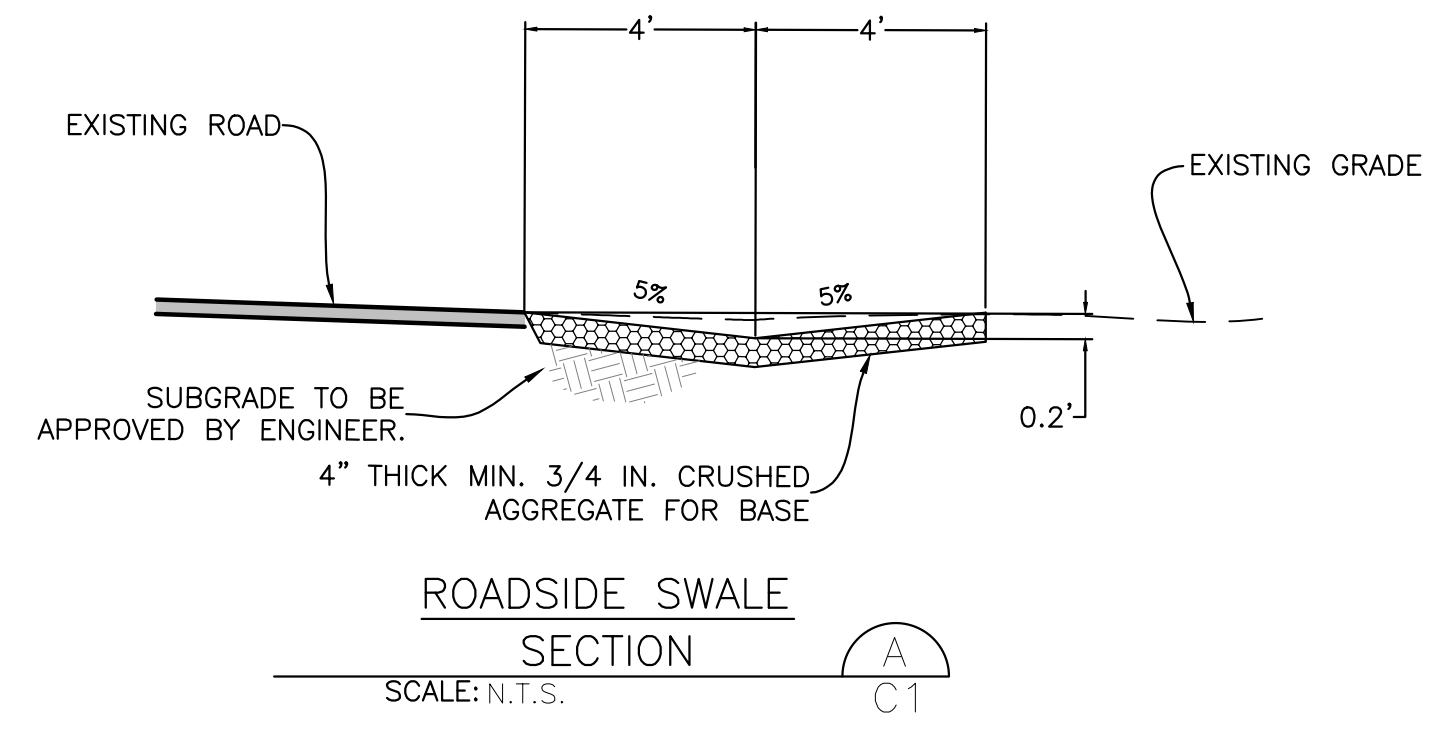

**ROADSIDE SWALE SECTION**  
 SCALE: N.T.S.

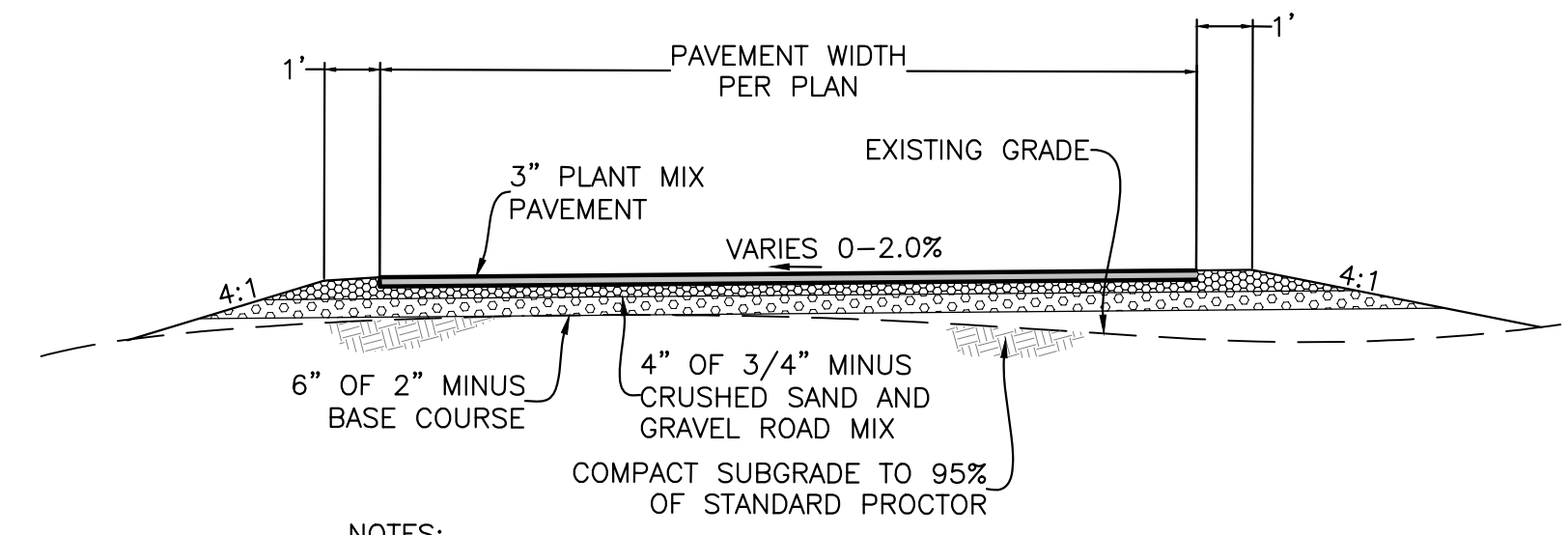

NOTES:

1. COMPACT DRIVEWAY SUBGRADE AND ALL STRUCTURAL FILL MATERIAL TO AT LEAST 95% OF THE MAXIMUM DENSITY OF EACH MATERIAL ACCORDING TO STANDARD PROCTOR ASTM D-698.
2. SNOW MELT SYSTEM TO BE INSTALLED UNDER ASPHALT FROM GARAGE TO TRENCH DRAIN. DESIGNED BY OTHERS.

**DRIVEWAY SECTION**  
 SCALE: N.T.S.

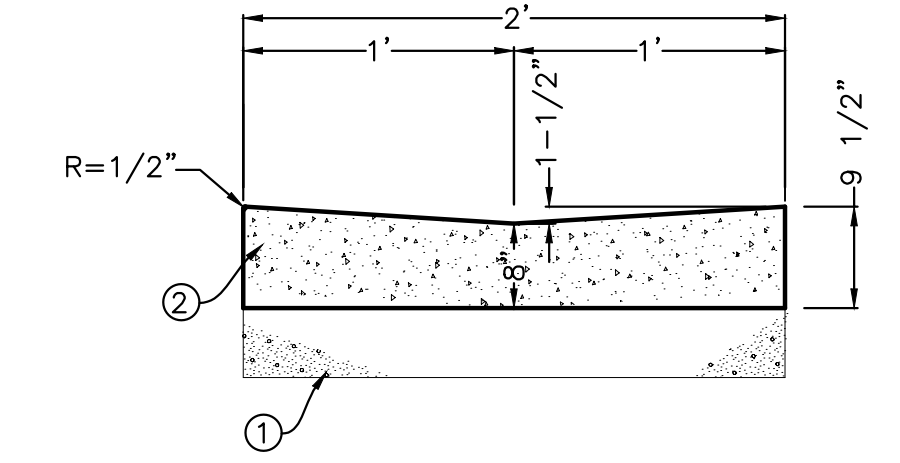

TYPICAL SECTION

LEGEND

- 1 AGGREGATE BASE PER ROAD DESIGN.
- 2 CONCRETE
- 3 1/2" EXPANSION JOINT

NOTES:

- A GRADE OF GUTTER MINIMUM 0.5%.
- B EXPANSION JOINT 1/2-INCH PREFORMED JOINT MATERIAL (AASHTO M 213.)

**4** VALLEY GUTTER DETAIL  
 SCALE: NONE

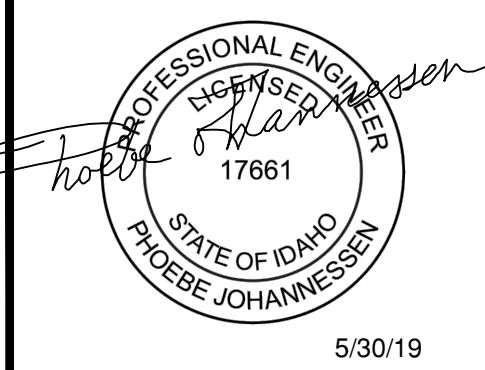

REVISIONS	DATE	BY
No.	DESCRIPTION	

**BENCHMARK ASSOCIATES**  
 PREPARED BY:  
 BENCHMARK ASSOCIATES, P.A.  
 P.O. BOX 733 100 BELL DRIVE  
 KETCHUM, IDAHO 83340  
 (208) 726-9512  
 FAX 726-9514  
 WEB: WWW.BMA5B.COM  
 MAIL: WWW.BMA5B.COM

**CIVIL DETAILS**  
 WARM SPRINGS VILLAGE 4 BLOCK 3 LOT 5  
 T4N, R17E, SEC 11, B.M., CITY OF KETCHUM, IDAHO  
 PREPARED FOR: COLIN MOSELEY

DRAWN BY: PLJ  
 DESIGNED BY: PLJ  
 CHECKED BY: SB  
 DATE: 05/30/19  
 PROJECT NO.: 18230

SHEET NUMBER



## City of Ketchum

August 16, 2021

Mayor Bradshaw and City Councilors  
City of Ketchum  
Ketchum, Idaho

Mayor Bradshaw and City Councilors:

### **Direction To Staff on Funding Request for Undergrounding Power Lines at 404 Broadway**

#### Recommendation and Summary

Staff is seeking direction from Council on a request to fund a portion of the undergrounding of power lines along Broadway Boulevard north of Sunnyside Drive.

- In 2016 the City Council established a process and prioritization for providing city funding assistance for undergrounding power lines. The City Council would consider requests for funding.
- In July 2019 the City Council agreed to fund \$365 for a portion of the study for undergrounding the power lines. The Council did not commit to funding the undergrounding work.

#### Introduction and History

On July 1, 2019, the City Council agreed to fund \$365, or 25% of the cost to study and identify the cost for undergrounding the power lines at 404 Broadway (Attachment A). The Council did not commit to the second phase of funding the construction costs for undergrounding. Council funding decisions occur in two steps, the first is funding for the engineering study, the second step occurs once the engineering study is complete and all costs are identified. Applicants return to Council for a decision on construction funding.

The property owners proceeded with the construction work and are now asking for city reimbursement for 10% of the construction costs, or \$2,690 (Attachment B). Total cost of construction was \$26,901. Staff is requesting Council direction if city funding will be authorized for the construction work.

#### Analysis

The proposed work is in a residential zone. The priority areas approved by the City Council in 2016 were identified as:

1. Community Core
2. Tourist
3. All Residential Zones

#### Financial Impact

There is currently \$79,000 in the budget for undergrounding projects. The Council has committed \$30,000 to assist with the undergrounding work requested by Andrew Castellano at 760 Washington.

Attachment A: July 1, 2019 Staff Report

Attachment B: 2021 Funding Request for Construction



## City of Ketchum

July 1, 2019

Mayor Bradshaw and City Councilors  
City of Ketchum  
Ketchum, Idaho

Mayor Bradshaw and City Councilors:

### **Direction To Staff on Funding Request for Undergrounding Power Lines at 404 Broadway**

#### Recommendation and Summary

Staff is seeking direction from Council on a request to fund a portion of the engineering study associated with the undergrounding of power lines along Broadway Boulevard north of Sunnyside Drive (Attachment A).

- In 2016 the City Council established a process and prioritization for contributing city funding assistance for undergrounding power lines. The City Council would consider requests for funding.
- There is currently \$180,000 in city funding available for underground projects.
- The proposed project is in a residential zone.

#### Introduction and History

In May 2016 the City Council identified the available funding and process for city participation in undergrounding power requests. The Council further clarified the funding priorities in December 2016 (Attachment B).

#### Analysis

The proposed work is located in a residential zone. The priority areas approved by the City Council in 2016 were identified as:

1. Community Core
2. Tourist
3. All Residential Zones

The cost of the analysis is identified as \$1,425. City guidelines identify a 25% city cost share for the study for projects in the community core, tourist and residential zones. If Council approves financial participation, the cost to the City would be \$356.25. Council funding decisions occur in two steps, the first is funding for the engineering study, the second step occurs once the engineering study is completed and all costs are identified. Applicants return to Council for a decision on construction funding.

#### Financial Impact

There is currently \$180,000 budgeted toward city participation in undergrounding projects. There are several projects under consideration, undergrounding in the alley between 7<sup>th</sup> and 8<sup>th</sup> Streets just west of Warm Springs Road, and undergrounding in the alley between 5<sup>th</sup> and 6<sup>th</sup> Street just east of Second Avenue. Should this request be approved, there would be no financial impact.



City of Ketchum

OFFICIAL USE ONLY	
Date Received:	6-11-19
By:	KS
Approved Date:	
By:	

## Application for City Funding for Electric Facility Undergrounding Projects

Submit complete application to City of Ketchum, Administration, P.O. Box 2315, Ketchum, ID 83340 or hand deliver to Ketchum City Hall, 480 East Ave., N., Ketchum.

PROJECT INFORMATION		
Contact Name: Jenna Hall	Mailing Address:	Project Location:
Business Name: n/a	PO Box 6489	404 Broadway
Phone: 208 721 7313	Ketchum ID 83340	
Email: jennahall110@hotmail.com	Project Zoning District:	
Project Description: (Provide a general description of the electric facility underground scope. Applicant may attach as many figures are necessary to describe the project scope.)		
See Attached		

Funding Request:	<input checked="" type="checkbox"/> Planning	Total Project Cost: \$ 1425	planning	const. 15-18
	<input checked="" type="checkbox"/> Construction	Requested Amount: \$ 356.25 + 1900	25%	10%
Other Funding Sources		Amount: \$ 1/3	Source: Terri Rob' Andersmi	
		Amount: \$ 1/3	Source: Amy Joe Marx	
		Amount: \$ 1/3	Source: Robert : Jenna Hall	
(attach separate sheet if necessary)				

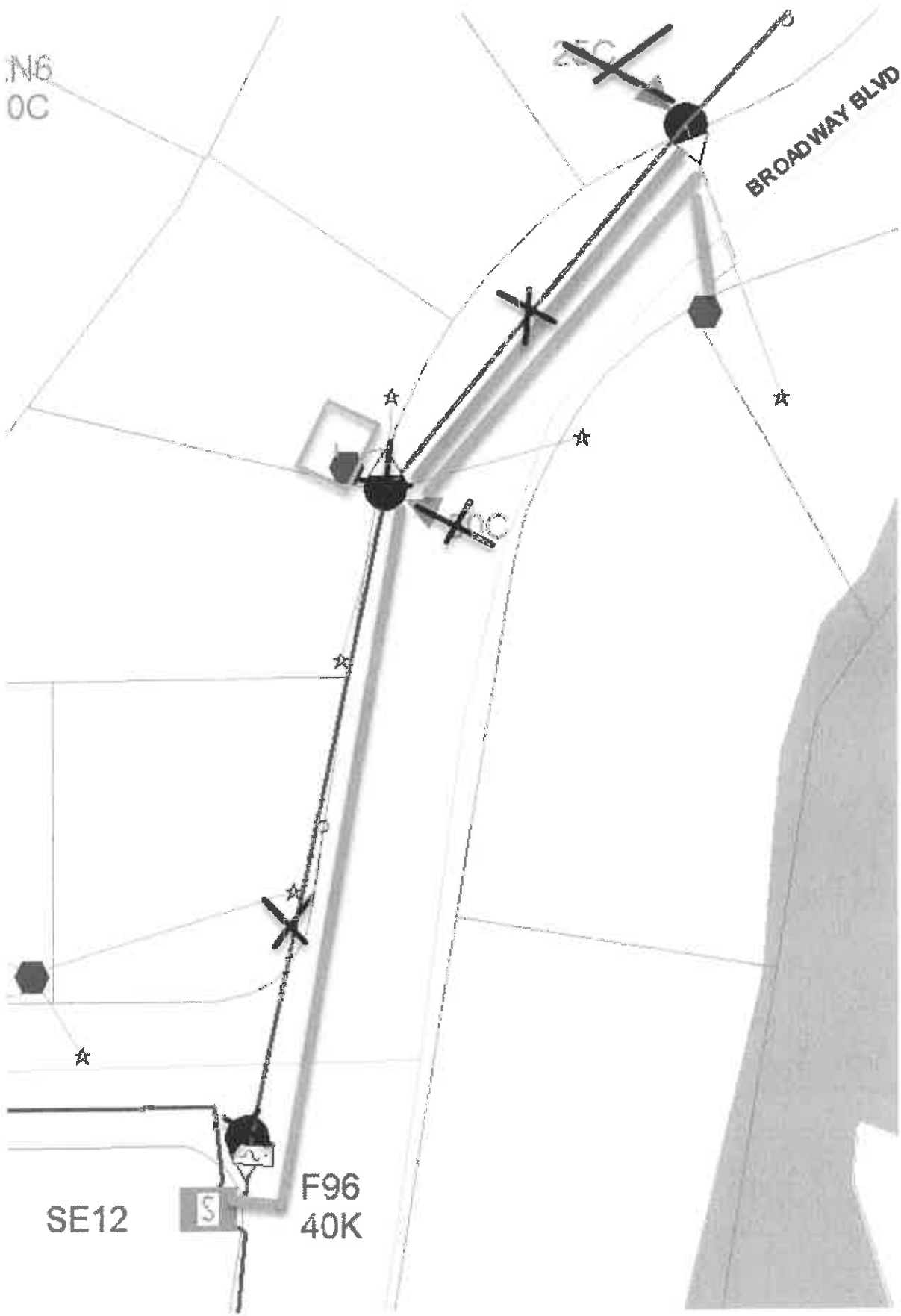

Application for City Funding for Electric Facility Underground Projects

**SUPPLEMENTAL QUESTIONS (provide additional sheet if more space is needed)**

Is the project beneficial to multiple properties? If so, please explain in detail.

Yes. Poles and lines would be eliminated from 5 properties.  
Anderson, Marx, Tompkins, Goldman and Hall

Will the project improve view corridor for visitor & resident experience? If so, please explain.\*

The view corridor for all residents will be greatly improved. There is a widely used river access close to this view corridor.

**OFFICIAL USE ONLY:**

Applicant certifies that he/she has read and examined this application and that all information contained therein is true and correct.

Applicant Signature

Date

Phone

Email

*Jenna Hall*

*6-10-2019*

*208 721 7313*

*jennahall111@hotmail.com*

Requests will be brought to Ketchum City Council for consideration.



# Parcel Information Map

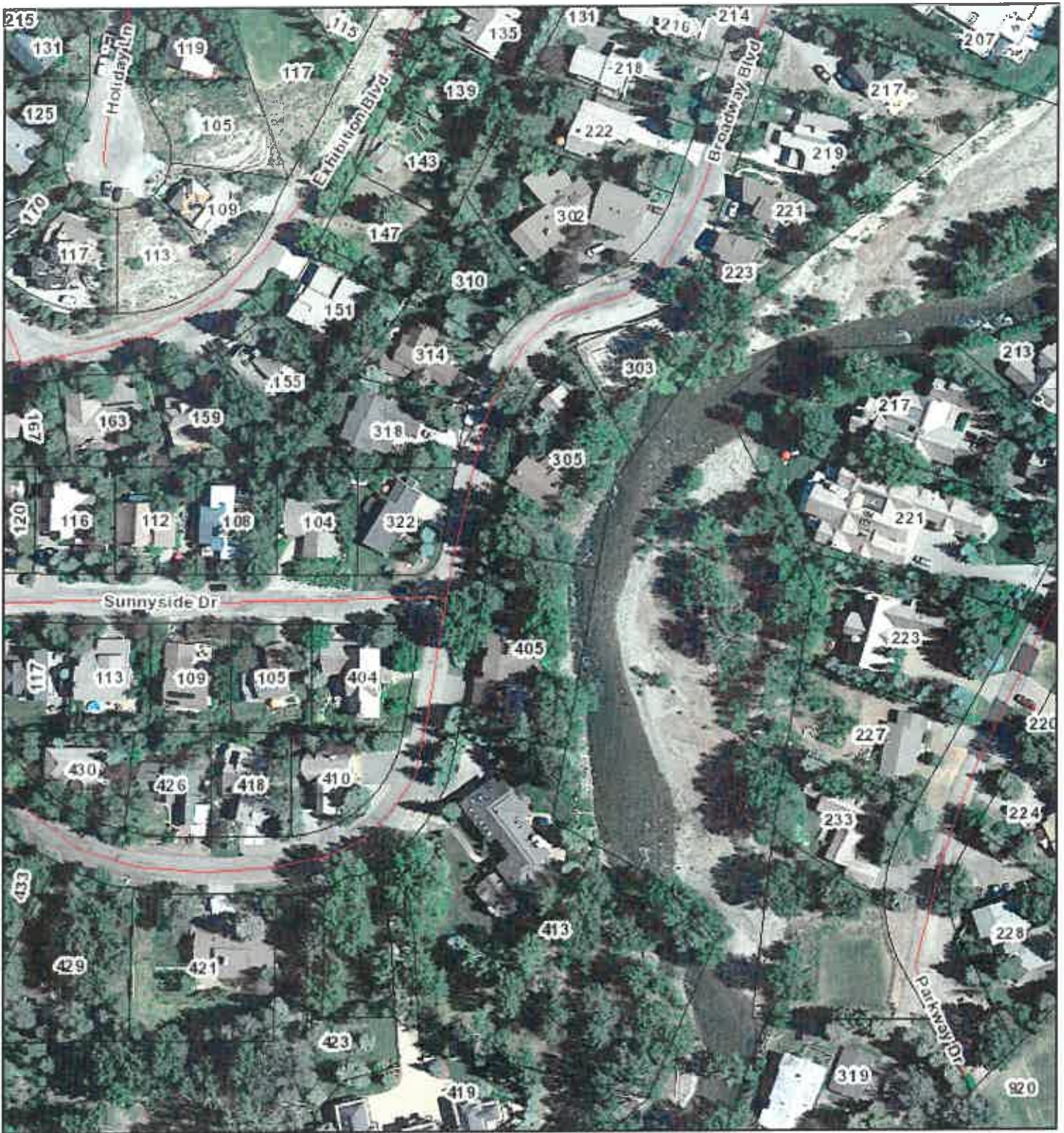

June 24, 2019

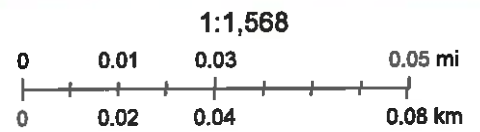



Sunnyside Blvd

Broadway Blvd

Google Earth

© 2018 Google

186

100 ft





Google Earth

© 2019 Google

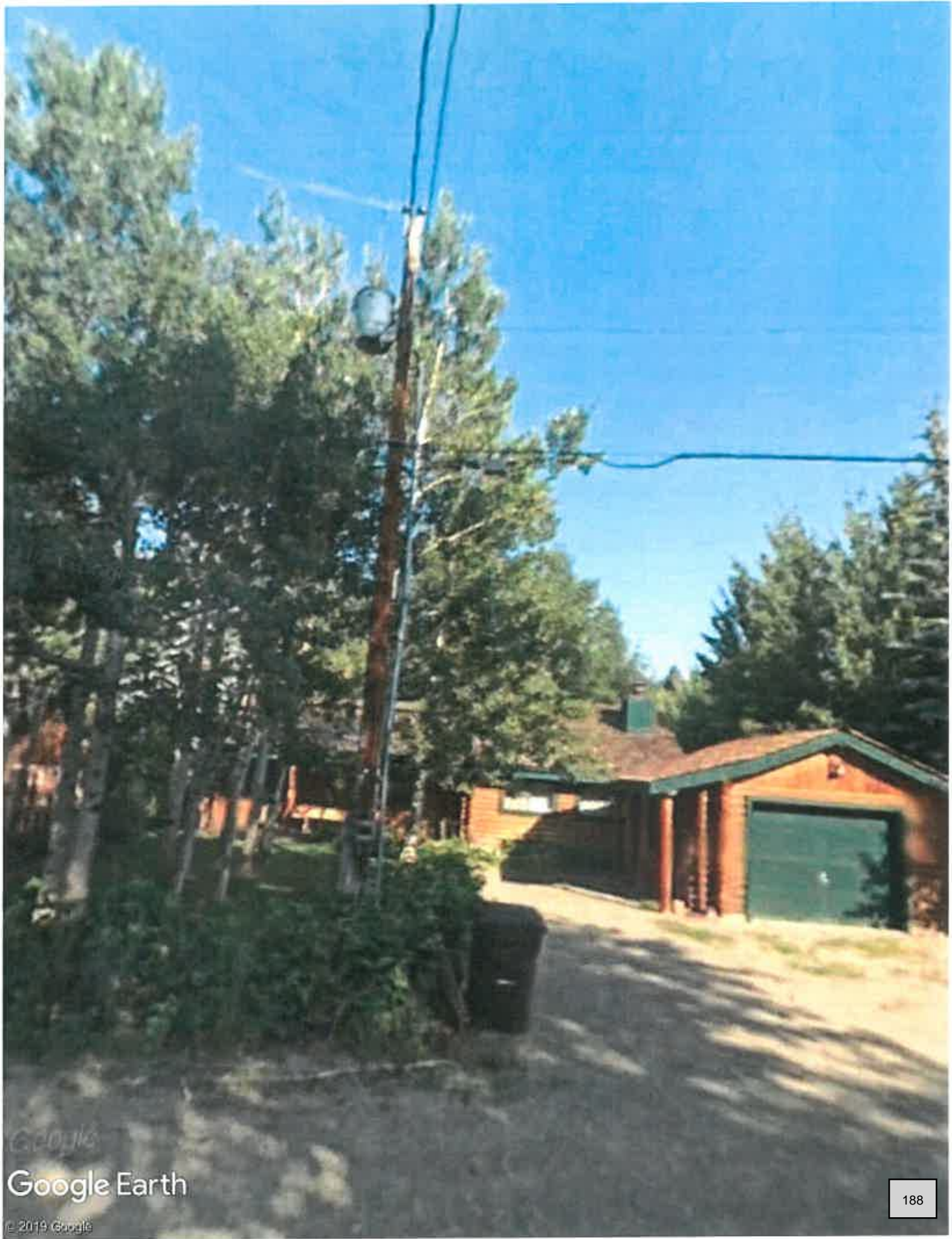



Google Earth

© 2019 Google





**City of Ketchum  
Public Works**

## Application for City Funding for Electric Facility Undergrounding Projects Information Sheet

### Idaho Power Franchise Fee

In November 2003 Ketchum residents approved an Idaho Power franchise fee increase from one percent to three percent for the purpose of undergrounding overhead electric facilities. This application is for city funding of undergrounding projects initiated by the public.

### Funding Available from City

Annual funding from the city will be capped at a maximum of 25% of the annual franchise fee revenues, however city council will have the ability to increase the funding by allocating unused funds rolled over from a previous year.

The maximum amount of city funding that can be allocated to projects depends on the zone in which the project is located. Since undergrounding electric facilities primarily benefits private property owners the maximum amount of city funding for a project is 25%. The remaining amount of funding for the project must come from other sources, such as private funding or through a Local Improvement District (LID) or Business Improvement District (BID) initiated by petition. Table 1 shows the maximum city funding for an electric facility undergrounding project by zone.

**Table 1 –Maximum City Undergrounding Funding**

Zone	Idaho Power Study/Design		Construction	
	Max City Funding*	Other Funding	Max City Funding*	Other Funding
Community Core & Tourist	25%	75%	25%	75%
Residential	25%	75%	10%	90%

\*City contribution would be limited to the percentage listed of the actual costs, or the percentage listed of the estimated cost at the time of annual budgeting, whichever is less. If actual construction costs exceed the estimated construction cost at the time of city budgeting the applicant would be required to cover cost increases through other funding.

### Selection Criteria

In order to focus city funding in areas with the most visibility and impact to the public the city will prioritize undergrounding funding as follows:

1. Community Core
2. Tourist
3. All Residential Zones

Projects within each zone would be further prioritized based on the following criteria:

- Beneficial to multiple properties
- Improving view corridor for visitor & resident experience
- City infrastructure needs

### Funding Process and Timeline

Applicants complete the attached application and submit the application to the city by February 1<sup>st</sup>. The application schedule would coincide with the city's annual budgeting schedule so that council can consider undergrounding requests along with other city infrastructure needs. The following graphic shows an annual schedule by which applications will need to be received by the city. Funding for the project(s) would not occur until the start of the following fiscal year and city funds would not be issued until the applicant has secured other funding for the projects.



### Questions?

Applicants may contact Robyn Mattison, Public Works Director/City Engineer, for questions regarding this application process.





City of Ketchum

OFFICIAL USE ONLY	
Date Received:	
By:	
Approved Date:	
By:	

## Application for City Funding for Electric Facility Undergrounding Projects

Submit complete application to City of Ketchum, Administration, P.O. Box 2315, Ketchum, ID 83340 or hand deliver to Ketchum City Hall, 480 East Ave., N., Ketchum.

PROJECT INFORMATION		
Contact Name: <u>Jenna Hall</u>	Mailing Address: <u>PO Box 6489</u>	Project Location: <u>404 Broadway</u>
Business Name: <u>W/a</u>	<u>Ketchum ID 83340</u>	
Phone: <u>208 721 7313</u>		
Email: <u>jennahall110@hotmail.com</u>	Project Zoning District:	
Project Description: (Provide a general description of the electric facility underground scope. Applicant may attach as many figures are necessary to describe the project scope.) <p style="text-align: center;">             Remove poles from 404 Broadway and 314 Broadway and all connecting lines. The lines are now underground. The Anderson and Halls also paid for the work by Cox which was over \$6000.00           </p>		
Funding Request: <input type="checkbox"/> Planning <input checked="" type="checkbox"/> Construction	Total Project Cost: <u>\$ 26,901</u> Requested Amount: <u>\$ 2,690.00</u> Percent of Total: <u>10</u> % Other Funding Sources Amount: <u>\$ 10950<sup>50</sup></u> Source: <u>Robert + Jenna Hall</u> Amount: <u>\$ 10950<sup>50</sup></u> Source: <u>Rob + Terri Anderson</u> Amount: <u>\$ 5000<sup>00</sup></u> Source: <u>Joe Murry</u> (attach separate sheet if necessary)	

Application for City Funding for Electric Facility Underground Projects

**SUPPLEMENTAL QUESTIONS (provide additional sheet if more space is needed)**

Is the project beneficial to multiple properties? If so, please explain in detail.

The project is beneficial to the whole neighborhood. Specifically the Andersm, Hall and Marx properties. The Tompkins and Floods also had wires removed, but did not participate financially.

Will the project improve view corridor for visitor & resident experience? If so, please explain.

Broadway has a lovely view down the street. There is a very popular river access off Broadway and the street has become a bit of a scenic walk.

**OFFICIAL USE ONLY:**

Applicant certifies that he/she has read and examined this application and that all information contained therein is true and correct.

*Jenna Hall*  
Applicant Signature

4.27.2021  
Date

208 721 7313  
Phone

jennahall@hotman.com  
Email

Requests will be brought to Ketchum City Council for consideration.

## Rob Anderson

---

**From:** Idaho Power <noreply@payconnexion.com>  
**Sent:** Wednesday, June 17, 2020 3:33 PM  
**To:** Rob Anderson  
**Subject:** Payment Confirmation for Utility Payment by Idaho Power  
**Attachments:** ATT00001.jpg.html

**Follow Up Flag:** Follow up  
**Flag Status:** Completed

\*\*\* PLEASE DO NOT RESPOND TO THIS EMAIL \*\*\*

Thank you for submitting your payment for Utility Payment by Idaho Power. This email is to confirm that on Jun-17-2020, you authorized Idaho Power Utilities to charge the credit card listed below on the scheduled payment date.

Confirmation Number: IDHPWR000049286  
Confirmation Date (ET): Jun-17-2020 05:32:14 PM  
Payer Name: ROBERT ANDERSON

---

Payment Amount Debited: \$25,000.00  
Convenience Fee: \$2.75  
Total Payment Amount: \$25,002.75  
Account # : 2270640226  
Scheduled Payment Date: Jun-17-2020

---

Cardholder Name: ROBERT A ANDERSON  
Card Number: XXXXXXXXXXXXX5881  
Card Type: Visa Credit

If you have questions about this payment or need assistance, please view the payment online at <https://www.idahopower.com/>, or call Customer Service at (800) 488-6151.

Thank you for using the Idaho Power Utilities electronic payment system.

**Rob Anderson**

---

**From:** Idaho Power <noreply@payconnexion.com>  
**Sent:** Wednesday, June 17, 2020 3:37 PM  
**To:** Rob Anderson  
**Subject:** Payment Confirmation for Utility Payment by Idaho Power  
**Attachments:** ATT00001.jpg.html

**Follow Up Flag:** Follow up  
**Flag Status:** Completed

\*\*\* PLEASE DO NOT RESPOND TO THIS EMAIL \*\*\*

Thank you for submitting your payment for Utility Payment by Idaho Power. This email is to confirm that on Jun-17-2020, you authorized Idaho Power Utilities to charge the credit card listed below on the scheduled payment date.

Confirmation Number: IDHPWR000049308  
Confirmation Date (ET): Jun-17-2020 05:36:35 PM  
Payer Name: Robert Anderson

---

Payment Amount Debited: \$4,698.00  
Convenience Fee: \$2.75  
Total Payment Amount: \$4,700.75  
Account #: 2270640226  
Scheduled Payment Date: Jun-17-2020

---

Cardholder Name: ROBERT A ANDERSON  
Card Number: XXXXXXXXXXXXX5881  
Card Type: Visa Credit

If you have questions about this payment or need assistance, please view the payment online at <https://www.idahopower.com/>, or call Customer Service at (800) 488-6151.

Thank you for using the Idaho Power Utilities electronic payment system.



## CUSTOMER COST QUOTE IDAHO

Customer or Project Name: ANDERSON, ROBERT-314 BROADWAY BLVD/KET RELOCATION OF OH TO UG

**Construction Costs**

Line Installation Costs		
1. Line Installation/Upgrade Charge		\$0
2. Customer Credits (Betterment, Metering, Salvage)		\$0
3. Customer Performed Construction Work Credit		\$0
<b>4. Net Line Installation Cost</b>		<b>\$0</b>
Unusual Conditions		
5. Unusual Conditions		\$11,728
6. Unusual Conditions Bank Letter of Credit (Only for over \$10,000)		\$0
<b>7. Net Unusual Conditions</b>		<b>\$11,728</b>
Terminal Facilities Costs		
8. Terminal Facilities		\$0
9. Terminal Facilities Allowances		\$0
10. Terminal Facilities Salvage		\$(761)
<b>11. Net Terminal Facilities Cost</b>		<b>\$0</b>
<b>12. Underground Service and Attachment Charges</b>		<b>\$0</b>
<b>13. Engineering Charge</b>		<b>\$76</b>
<b>14. Permits</b>		<b>\$0</b>
<b>15. Relocation or Removal</b>		<b>\$17,894</b>
<b>16. Miscellaneous Charges/Adjustments</b>		<b>\$0</b>
<b>17. Net Construction Costs</b> (Line Items 4, 7, 11, 12, 13, 14, 15, 16)		<b>\$29,698</b>
18. Prepaid Charges (Engineering, Permits & Right-of-Way)	\$1,425	
<b>19. Vested Interest Charge</b>		<b>\$0</b>
<b>20. Customer Payment Due Prior to Construction Scheduling</b>		<b>\$29,698</b>

This cost may not include all construction costs, see page 3 if additional service charges apply.

**Notes:**

**Notice:** This Customer Cost Quote shall be binding on both Idaho Power Company ("Idaho Power") and Customer for a period of 60 days from the quoted date indicated below, subject to changes in information provided by the Customer or changes in Idaho Power's ability to obtain satisfactory rights-of-way or to comply with governmental regulations, including but not limited to the rules, regulations, and tariffs of the Idaho Public Utilities Commission ("IPUC") and the Public Utility Commission of Oregon ("OPUC"). Customer must make payment of the quoted amount not less than (30) days prior to the start of the construction work set forth in this agreement ("Work"). However, Idaho Power does not represent or warrant that the Work will commence within 30 days of receipt of payment. The start of the Work is subject to Idaho Power's ability to obtain the necessary labor, materials and equipment.

Internal use			Page 1 of 3
Service Request Number:	Work Order Number:	Design Number:	Version:
00434959	27534977	0000137781	002



City of Ketchum  
City Hall

August 16, 2021

Mayor Bradshaw and City Councilors  
City of Ketchum  
Ketchum, Idaho

Mayor Bradshaw and City Councilors:

### **Request to Conduct First Reading of Ordinance #1223 and Approve Resolution #21-016**

#### Recommendation and Summary

The current voter approved Local Option Tax (LOT) ordinance does not specify community housing as an eligible expense. The City Council has recently expressed interest in amending the current LOT to allow community housing as an eligible expense. Under state law, the city must transmit ballot language to the county clerk no later than September 13<sup>th</sup> for the November 2<sup>nd</sup> election. Resolution #21-016 calls for the election and transmit ballot language to the county clerk.

Motion #1 - "I move to approve first reading of Ordinance #1223."

Motion #2 - "I move to approve Resolution #21-016"

#### Introduction and History

The current Local Option Tax (LOT) was approved on November 8, 2011 for a fifteen year period. The following are list of eligible expenses: municipal transportation, open space acquisition/recreation, capital improvements, emergency services, city/visitor promotion, property tax relief and costs related to collecting/enforcing the tax.

The proposed ballot language would not alter the percentages of taxes collected. Staff reviewed the following three scenarios based on Fiscal Year 2020 financial performance:

- Scenario #1 - increase all categories to align with the City of Sun Valley would have resulted in \$1,848,064 in additional revenues.
- Scenario #2 - increase in retail only to align with Sun Valley resulting in \$1,526,633.
- Scenario #3 - increase hotel/condos to align with Sun Valley resulting in \$200,476.

Staff is recommending a two-phase approach regarding LOT funding for community housing. First, ask voters to add community housing as an eligible expense this November. The city is currently working to retain a consultant to assist with the creation of a city housing strategic plan in partnership with the Blaine County Housing Authority. A key outcome of this activity will be to set a city goal/target of both preservation of existing units as well as construction of new units for the next ten years. Financial modeling will be completed to understand both total costs as well the level of local governmental resources required to achieve the ten-year goal. Completion of this activity will allow

the city to return to voters the following November to request an increase in all or certain categories of the LOT collection.

Two other options for consideration: (1) ask voters to approve both changes this November or (2) wait and place both questions on the next May or November election dates. Staff is concerned with the first option as it does not give adequate time to conduct stakeholder/public outreach regarding changes to the collection percentages prior to the September 13<sup>th</sup> ballot language date.

It is important to note that State law (50-1044) does place restrictions regarding the frequency in which changes can be presented to voters. *“No local-option non property tax proposal may be presented to resort city voters for approval or modification for a period of eleven (11) months after an election to approve or disapprove such tax.”*

Sustainability Impact

An increase in the supply of community housing will decrease local workers trip generation and associated carbon footprint.

Financial Requirement/Impact

The proposed ballot language does not alter the percent of collection.

Attachment:

Ordinance #1223

Resolution #21-016

**CITY OF KETCHUM  
RESOLUTION NO. 21-016**

A RESOLUTION OF THE CITY COUNCIL OF THE CITY OF KETCHUM, IDAHO, CALLING AN ELECTION FOR THE SUBMISSION TO THE QUALIFIED ELECTORS OF THE CITY THE QUESTION OF ADOPTING A LOCAL OPTION TAX ORDINANCE AMENDMENT MODIFYING THE PURPOSES FOR WHICH LOCAL OPTION TAX REVENUES MAY BE USED TO ADD “WORKFORCE/COMMUNITY HOUSING PROVISION AND SUPPORT” AS AN AUTHORIZED USE; ESTABLISHING THE DATE OF THE ELECTION; PROVIDING FOR ADMINISTRATION OF THE ELECTION; APPROVING A FORM OF BALLOT PROPOSITION; PROVIDING FOR REGISTRATION OF VOTERS; PROVIDING FOR RELATED MATTERS; AND PROVIDING AN EFFECTIVE DATE

WHEREAS, the City of Ketchum, Idaho (the “City”), is a municipal corporation duly organized and operating under the laws of the State of Idaho; and

WHEREAS, Sections 50-1044 to 50-1049, inclusive, Idaho Code, as amended, authorize the voters of resort cities (as defined in Section 50-1044, Idaho Code) to authorize their city government to adopt, implement and collect local-option non-property taxes; and

WHEREAS, it has been determined by the City Council of the City (the “Council”) that the City is a resort city and has a population less than 10,000; and

WHEREAS, the Council has determined that visitors and travelers to the City place an undue burden upon the taxpayers of said City and that the question of the imposition of a local-option non-property tax has been presented to the voters of the City; and

WHEREAS, the City has adopted a local option tax ordinance, Ordinance 712, that was approved by voters on November 20, 1997, authorizing the collection of local option taxes as provided for under Title 50, Chapter 10, Idaho Code, and which was extended on November 8, 2011, by voter approval of Ordinance No. 1090 which amended Ordinance 712, to provide for an additional fifteen (15) years through December 31, 2027; and

WHEREAS, the Council has determined that it is desirable to seek voter approval to add a further purpose, workforce housing support, for which the local option tax revenues derived may be used; and

WHEREAS, the local-option non-property tax and its purposes cannot be adopted, implemented or collected without the assent of a sixty percent (60%) majority of the qualified electors of the City voting in an election called for such purpose; and

WHEREAS, the Council has determined to call and the County will conduct an election for the aforesaid purposes as required by Sections 50-1044 to 50-1046, Idaho Code.

NOW, THEREFORE, BE IT RESOLVED BY THE CITY COUNCIL OF THE CITY OF KETCHUM as follows:

**Section 1: LOCAL-OPTION NONPROPERTY TAX**

A. The Council hereby finds, determines, and declares that the City of Ketchum has a population not in excess of 10,000 according to the most recent census and is a city that derives the major portion of its economic well-being from people catering to recreational needs and meeting needs of people traveling to the destination City for an extended period of time; that the



City has a significant economic dependence upon visitors and travelers passing through or staying in the community and the City; and, that said visitors and travelers require services of the City which place an undue burden upon the taxpayers of the City.

B. Subject to the approval of the local-option non-property tax by the qualified electors voting at the election for which provision is hereinafter made, Ordinance No. 1223, adopted on September 7<sup>th</sup> pursuant to the provisions of Sections 50-1046 to 50-1047, Idaho Code, as amended, shall take effect January 1, 2022, after the canvass of the returns of the regular election and compliance by the City with Section 50-1047, Idaho Code. Said Ordinance is attached hereto as Exhibit "A" and provides as follows:

(A) The local-option non-property tax revenue derived from and collected under the City Local Option Tax Ordinance, Ordinance 712 as extended by Ordinance 1090, shall be further amended to add the following purpose to Section 5: Workforce/Community Housing Provision and Support.

#### Section 2: SPECIAL ELECTION

A special election is hereby called within the City to be held on Tuesday, November 2, 2021, for the purpose of enabling the qualified electors of the City to vote upon the proposition set forth in Section 4 hereof. The ballot proposition for the special election shall be separate from any other ballot measure being submitted to the electors on the date of the election. Only those qualified electors of the City casting valid ballots upon the proposition set forth in Section 4 of this Resolution shall be counted in determining the number of qualified electors voting at or participating in the election.

#### Section 3: ADMINISTRATION OF ELECTION

The administration of the election shall be conducted in accordance with Chapter 4 of Title 50 of Idaho Code, Chapter 14 of Title 34 of Idaho Code, and in accordance with this Resolution. The supervision and administration of the election and election laws shall be by the County Clerk as chief elections officer, in accordance with Idaho Code §50-403.

#### Section 4: BALLOT PROPOSITION

The ballot proposition for the election shall be in substantially the following form:

**INSTRUCTIONS: Vote on the following question by placing an X in the square according to the way you desire to vote on that question. If you, by mistake or accident, tear, deface, wrongly mark or otherwise mutilate this ballot, return it to the election judge and get another.**

**Local Option Tax**

Shall the City of Ketchum adopt proposed Ordinance No. 1223

Ordinance No. 1223 amends the existing City of Ketchum Local Option Tax Ordinance to add a **Community/Workforce Housing** provision as an authorized use of local option tax revenues. Ordinance No. 1223 does **not** change or increase the local option tax rate.

- YES
- NO

**Section 5: QUALIFIED ELECTORS**

Every person eighteen (18) years of age or older, who at the time of the specified election is a United States citizen who has been a legal and bona fide resident of the City for at least 30 days immediately preceding the date of the election, if properly registered as required by law, shall be qualified to vote at said election.

**Section 6: REGISTRATION**

All electors must be registered to vote at said election. Voter registration shall be conducted pursuant to the provisions of Section 34-1402, Idaho Code.

No qualified elector who is duly registered as a voter, and who continues to reside at the same address or within the same precinct in which he or she is registered, shall be required to re-register.

Persons who are eligible to vote may register for the election at the office of the Blaine County Clerk. Any elector who will complete his or her residence requirement or attain the requisite voting age during the period when the register of electors is closed may register prior to the closing of the register.

Any person who is eligible to vote may register on election day by appearing in person at the polling place established for the election, by completing a registration card, making an oath on the form prescribed by law, and providing proof of residence in the manner provided by Section 34-408A, Idaho Code, as amended.

Section 7: OFFICERS AUTHORIZED

The officers of the City are hereby authorized and directed to take all action necessary or appropriate to effectuate the provisions of this Resolution.

Section 8: RATIFICATION

All actions heretofore taken, not inconsistent with the provisions of this Resolution, by the Mayor and Council directed toward the holding of the election called for herein, are hereby ratified, approved, and confirmed.

DATED this \_\_\_\_ day of \_\_\_\_\_ 2021.

CITY OF KETCHUM

ATTEST:

By  
Neil Bradshaw, Mayor

Tara Fenwick, City Clerk

**CITY OF KETCHUM  
ORDINANCE NUMBER 1223**

AN ORDINANCE OF THE CITY OF KETCHUM, IDAHO, AMENDING ORDINANCE 712, WHICH PROVIDES FOR THE IMPOSITION OF LOCAL OPTION TAXES; PROVIDING FOR A BALLOT; AMENDING KETCHUM MUNICIPAL CODE 3.12.050; PROVIDING A SEVERABILITY CLAUSE; PROVIDING FOR PUBLICATION; PROVIDING A REPEALER CLAUSE; AND PROVIDING FOR AN EFFECTIVE DATE.

**WHEREAS**, the City of Ketchum is authorized to collect certain local option taxes pursuant to Ordinance 712, as amended by Ordinances 1090, 1097, and 1108.

**WHEREAS**, the City of Ketchum has determined it is in the best interests of the public to amend Ordinance 712 to add an additional use, Workforce Housing Provision and Support, to the list of purposes for which the local option tax revenues derived may be used.

**NOW, THEREFORE, BE IT ORDAINED BY THE MAYOR AND THE CITY COUNCIL OF THE CITY OF KETCHUM, IDAHO:**

**SECTION 1. BALLOT.** The following ballot shall be submitted to the registered voters of the City of Ketchum at the November 2, 2021 election and Ordinance 712, as amended, shall be further amended as provided that the ballot is approved by sixty percent of the registered voters that vote on such ballot:

**SPECIAL NON-PROPERTY TAX ELECTION**

**CITY OF KETCHUM  
STATE OF IDAHO  
November 2, 2021**

**Local Option Tax**

Shall the City of Ketchum adopt proposed Ordinance No. 1223

Ordinance No. 1223 amends the existing City of Ketchum Local Option Tax Ordinance to add a **Community/Workforce Housing** provision as an authorized use of local option tax revenues. Ordinance No. 1223 does **not** change or increase the local option tax rate.

**YES**

**NO**

City of Ketchum Ordinance No. 1223

**SECTION 2.** Section 5 of Ordinance 712 of the City of Ketchum, Idaho, as amended, and as codified in Ketchum Municipal Code 3.12.050, is amended as follows if approved by the registered votes of the City of Ketchum pursuant to the ballot designated above:

**3.12.050: PURPOSES FOR WHICH THE REVENUES DERIVED FROM NONPROPERTY TAXES SHALL BE USED:**

The nonproperty tax revenue derived from and collected under this chapter shall be used for the following purposes:

- A. Municipal transportation.
- B. Open space acquisition and recreation.
- C. Capital improvements: roads, water, sewer, parking, Ore Wagon Museum.
- D. Emergency services: police, fire, ambulance.
- E. City promotion, visitor information and special events.
- F. Property Tax relief.
- G. Direct costs to collect and enforce the tax.
- H. Maintaining and increasing air service to Friedman Memorial Airport
- I. Workforce/Community housing provision and support.

**SECTION 3. SEVERABILITY CLAUSE.** If any paragraph, part, section, subsection, sentence, clause or phrase of this Ordinance is for any reason held to be invalid for any reason by a court of competent jurisdiction, such decision shall not affect the validity of the remaining portions of this Ordinance.

**SECTION 4. PUBLICATION.** This Ordinance shall be published once in the official newspaper of the City.

**SECTION 5. REPEALER CLAUSE.** All City code sections, ordinances or resolutions or parts thereof, which are in conflict herewith are hereby repealed.

**SECTION 6. EFFECTIVE DATE.** This Ordinance shall be in full force and effect on January 1, 2022, after voter approval, passage by City Council and Mayor, and publication according to law.

PASSED BY THE CITY COUNCIL OF THE CITY OF KETCHUM, IDAHO, and approved by the Mayor this \_\_\_ day of \_\_\_\_\_, 2021.

\_\_\_\_\_  
Neil Bradshaw, Mayor

ATTEST:

\_\_\_\_\_  
Tara Fenwick  
City Clerk

City of Ketchum Ordinance No. 1223



## City of Ketchum

August 16, 2021

Mayor Bradshaw and City Councilors  
City of Ketchum  
Ketchum, Idaho

Mayor Bradshaw and City Councilors:

**Recommendation to Hold Public Hearing and Adopt Ordinance No. 1221  
Amending The FY 20-21 Annual Appropriations Ordinance  
By Appropriating Additional Monies and Specifying Authorized Activities**

Recommendation and Summary

Staff is respectfully recommending that the Ketchum City Council hold a public hearing on amendment of the FY 21 budget, conduct the first reading by title only of Ordinance No. 1221 with the following motion:

***Motion: Pursuant to Idaho Code 50-902, to approve the first reading of Ordinance No. 1221 and read by title only.***

The reasons for the recommendation are as follows:

- Revenue increases due to inflationary changes in charges for services, permits for planning and building, Idaho Rebound Grant, American Rescue Plan Act, and Blaine County rebate of excess funds.
- Expenditure adjustments will be allocated to planning and building increased costs, Warm Spring Analysis, City Beautification, fire station parking lot and essential service facility new city hall.
- State statute establishes requirements for amending the budget in Section 50-1003.

Introduction and History

Per Idaho Code 50-1003, the City Council of each city shall, prior to the commencement of each fiscal year, pass an Ordinance to be termed the Annual Appropriation Ordinance.

On September 8, 2020, the Council adopted Ordinance 1208 entitled the Annual Appropriation Ordinance for the Fiscal Year beginning October 1, 2020, and ending September 30, 2021, appropriating to the various budgetary funds sums of money necessary to defray all expenses and liabilities within each fund for the ensuing fiscal year, authorizing a levy of a sufficient tax upon the taxable property, specifying the objects and purposes for which said appropriation is made, and providing an effective date.

The city council of any city may, by the same procedure as used in adopting the original appropriation ordinance at any time during the current fiscal year, amend the appropriation ordinance as a result of an increase in revenues from any source other than ad valorem tax revenue.

### Analysis

Ordinance No. 1208 is the Annual Appropriation Ordinance for the Fiscal Year beginning October 1, 2020 and ending September 30, 2021. Ordinance No. 1221 outlines the Proposed Expenditure adjustments in the amount of 5,357,038 and Proposed Revenue adjustments in the amount of \$5,896,841.

### Financial Impact

The funds for adjustments are due to inflationary changes each exist in their respective fund balances and will be used as noted in Attachment B.

### Attachments

- Attachment A: Ordinance 1208
- Attachment B: Notice of Public Hearing

## ORDINANCE NO. 1208

AN ORDINANCE OF THE CITY OF KETCHUM, IDAHO, ENTITLED THE ANNUAL APPROPRIATION ORDINANCE FOR THE FISCAL YEAR BEGINNING OCTOBER 1, 2020, APPROPRIATING TO THE VARIOUS BUDGETARY FUNDS, SUMS OF MONEY DEEMED NECESSARY TO DEFRAY ALL NECESSARY EXPENSES AND LIABILITIES WITHIN EACH FUND FOR THE ENSUING FISCAL YEAR, AUTHORIZING A LEVY OF A SUFFICIENT TAX UPON THE TAXABLE PROPERTY AND SPECIFYING THE OBJECTS AND PURPOSES FOR WHICH SAID APPROPRIATION IS MADE, AND PROVIDING AN EFFECTIVE DATE.

BE IT ORDAINED by the Mayor and City Council of the City Ketchum, Blaine County, Idaho:

SECTION 1: That the sum of \$33,712,794 be raised and appropriated to defray the necessary expenses and liabilities of the City of Ketchum, Blaine County, Idaho for the fiscal year beginning October 1, 2020.

SECTION 2: That the City Council hereby appropriates each Fund as an independent fiscal and accounting group with a self-balancing set of accounts recording cash and/or other resources together with all related liabilities, obligations, reserves and equities which are segregated for the purpose of carrying on specific activities or attaining certain objectives.

SECTION 3: That the appropriation for the General Fund is made in the following amount to each specific division or function:

Legislative and Executive, Administrative, Legal, Community Planning and Development, Law Enforcement, Building Code, and Non-Departmental.

Total General Fund	10,307,770
--------------------	------------

SECTION 4: That the appropriation for the Water and Wastewater Funds is made in the following amounts to each specific Fund, department or function:

Water Fund	2,390,937
Water Capital Improvement Fund	522,000
Wastewater Fund	2,587,242
Wastewater Capital Improvement Fund	462,000
Total Water and Wastewater Funds	5,962,179

SECTION 5: That the appropriation for all Other Funds is made in the following amounts to each specific Fund, department or function:

General Capital Improvement Fund	563,000
Essential Services Facilities Trust Fund	420,600



Wagon Days Fund	85,650
Street Capital Improvement Fund	232,600
Law Enforcement Capital Improvement Fund	250
Fire & Rescue Capital Improvement Fund	104,330
Fire & Rescue Construction Capital	9,500,000
Parks & Recreation Capital Improvement Fund	0
Parks & Recreation Trust Fund	49,050
Original LOT Fund	1,817,246
Additional 1%-LOT Fund	1,500,000
GO Bond Debt Service Fund	149,835
GO Bond Debt Fire Fund	615,284
Community Housing In-Lieu Fund	2,250,000
Police Trust Fund	5,000
Fire Trust Fund	0
Development Trust Fund	150,000
 Total Other Funds	 17,442,845

**SECTION 6:** That a general tax levy on all taxable property within the City of Ketchum be levied in an amount allowed by law for the general purposes for said City, for the fiscal year beginning October 1, 2020.

**SECTION 7:** All ordinances and parts of ordinances in conflict with this ordinance are hereby repealed.

**SECTION 8:** This ordinance shall take effect and be in force upon its passage, approval and publication in one issue of the Idaho Mountain Express, a newspaper of general circulation in the City of Ketchum, and the official newspaper of said City.

PASSED by the City Council and APPROVED by the Mayor of Ketchum this 8th day of September 2020.

ATTEST:

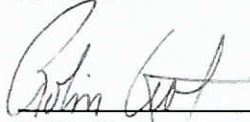
  
 Robin Crotty  
 City Clerk

  
 \_\_\_\_\_  
 Neil Bradshaw  
 Mayor

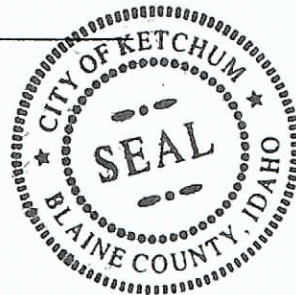

## NOTICE OF PUBLIC HEARING

NOTICE IS HEREBY GIVEN that the City Council of the City of Ketchum, Idaho, will hold a Public Hearing for consideration of an amendment to the 2020-21 fiscal year budget. The Council will consider appropriation of additional monies received by the City of Ketchum, Idaho, during the fiscal year. Said hearing will be held at Ketchum City Hall, 480 East Avenue North, at 4:00 p.m. on August 16, 2021.

That the following table sets forth the amounts appropriated to each fund for the current 2020-21 fiscal year, the amount of the revised appropriation for each fund for the 2020-21 fiscal year, and the proposed adjustment amount.

## CITY OF KETCHUM, IDAHO

REVISED	EXPENDITURES		PROPOSED
	ADOPTED FY 2020- 2021	REVISED FY 2020-2021	ADJUSTMENT
<b>GENERAL FUND</b>	<b>10,307,770</b>	<b>12,687,889</b>	<b>2,380,119</b>
<b>ESSENTIAL SERVICES FACILITIES TRUST FUND</b>	<b>420,600</b>	<b>2,138,120</b>	<b>1,717,520</b>
<b>GENERAL CAPITAL IMPROVEMENT FUND</b>	<b>563,000</b>	<b>563,000</b>	<b>0</b>
<b>STREET CAPITAL IMPROVEMENT FUND</b>	<b>232,600</b>	<b>232,600</b>	<b>0</b>
<b>LAW ENFORCEMENT IMPROVEMENT FUND</b>	<b>250</b>	<b>250</b>	<b>0</b>
<b>FIRE CAPITAL IMPROVEMENT FUND</b>	<b>104,330</b>	<b>241,030</b>	<b>136,700</b>
<b>PARKS &amp; RECREATION CAP. IMP. FUND</b>	<b>0</b>	<b>0</b>	<b>0</b>
<b>PARKS &amp; RECREATION TRUST FUND</b>	<b>49,050</b>	<b>49,050</b>	<b>0</b>
<b>POLICE TRUST FUND</b>	<b>5,000</b>	<b>5,000</b>	<b>0</b>
<b>DEVELOPMENT TRUST FUND</b>	<b>150,000</b>	<b>150,000</b>	<b>0</b>
<b>ORIGINAL LOT FUND</b>	<b>1,817,247</b>	<b>2,217,247</b>	<b>400,000</b>
<b>ADDITIONAL 1%-LOT FUND</b>	<b>1,500,000</b>	<b>2,222,699</b>	<b>722,699</b>
<b>GO BOND DEBT SERVICE FUND</b>	<b>149,835</b>	<b>149,835</b>	<b>0</b>
<b>FIRE CONSTRUCTION FUND</b>	<b>9,500,000</b>	<b>9,500,000</b>	<b>0</b>
<b>FIRE GO BOND FUND</b>	<b>615,284</b>	<b>615,284</b>	<b>0</b>
<b>COMMUNITY HOUSING IN-LIEU FUND</b>	<b>2,250,000</b>	<b>2,250,000</b>	<b>0</b>
<b>WAGON DAYS FUND</b>	<b>85,650</b>	<b>85,650</b>	<b>0</b>
<b>WATER FUND</b>	<b>2,390,937</b>	<b>2,390,937</b>	<b>0</b>
<b>WATER CAPITAL IMPROVEMENT FUND</b>	<b>522,000</b>	<b>522,000</b>	<b>0</b>
<b>WASTEWATER FUND</b>	<b>2,587,242</b>	<b>2,587,242</b>	<b>0</b>
<b>WASTEWATER CAPITAL IMP. FUND</b>	<b>462,000</b>	<b>462,000</b>	<b>0</b>
<b>Total Expenditures</b>	<b>33,712,795</b>	<b>39,069,833</b>	<b>5,357,038</b>
	<b>REVENUE</b>		
<b>GENERAL FUND</b>			
GENERAL PROPERTY TAXES	4,339,021	4,339,021	0
OTHER REVENUE	5,968,749	8,144,918	2,176,169
FUND BALANCE APPLIED	0	511,000	511,000
<b>TOTAL GENERAL FUND</b>	<b>10,307,770</b>	<b>12,994,939</b>	<b>2,687,169</b>
<b>ESSENTIAL SERVICES FACILITIES TRUST FUND</b>			
FUND BALANCE APPLIED	385,600	492,151	106,551
	35,000	1,645,969	1,610,969
<b>TOTAL ESF TRUST FUND</b>	<b>420,600</b>	<b>2,138,120</b>	<b>1,717,520</b>
<b>GENERAL CAPITAL IMPROVEMENT FUND</b>			
FUND BALANCE APPLIED	251,219	251,219	0
	311,781	361,781	50,000
<b>TOTAL GENERAL CAPITAL IMPRVMT FUND</b>	<b>563,000</b>	<b>613,000</b>	<b>50,000</b>
<b>STREET CAPITAL IMPROVEMENT FUND</b>			
FUND BALANCE APPLIED	205,100	205,100	0
	27,500	27,500	0
<b>TOTAL STREET CAPITAL IMPR. FUND</b>	<b>232,600</b>	<b>232,600</b>	<b>0</b>
<b>LAW ENFORCEMENT IMPROVEMENT FUND</b>	<b>900</b>	<b>900</b>	<b>0</b>
<b>FIRE CAPITAL IMPROVEMENT FUND</b>			
FUND BALANCE APPLIED	0	0	0
	112,930	249,630	136,700
<b>TOTAL FIRE CAPITAL IMPROVEMENT FUND</b>	<b>112,930</b>	<b>249,630</b>	<b>136,700</b>
<b>PARKS &amp; RECREATION CAP. IMP. FUND</b>			
FUND BALANCE APPLIED	0	0	0
	10,200	10,200	0
<b>TOTAL PARKS &amp; RECREATION CAP.IMP.FND</b>	<b>10,200</b>	<b>10,200</b>	<b>0</b>
<b>PARKS &amp; RECREATION TRUST FUND</b>			
FUND BALANCE APPLIED	10,000	10,000	0
<b>TOTAL PARKS &amp; RECREATION TRUST FUND</b>	<b>42,050</b>	<b>42,050</b>	<b>0</b>
<b>POLICE TRUST FUND</b>			
FUND BALANCE APPLIED	3,500	3,500	0
	1,500	1,500	0
<b>TOTAL POLICE TRUST FUND</b>	<b>5,000</b>	<b>5,000</b>	<b>0</b>
<b>DEVELOPMENT TRUST FUND</b>	<b>150,000</b>	<b>150,000</b>	<b>0</b>
<b>ORIGINAL LOT FUND</b>			
FUND BALANCE APPLIED	0	0	0
	1,817,247	2,400,000	582,753
<b>TOTAL ORIGINAL LOT FUND FUND</b>	<b>1,817,247</b>	<b>2,400,000</b>	<b>582,753</b>
<b>ADDITIONAL 1%-LOT FUND</b>	<b>1,500,000</b>	<b>2,222,699</b>	<b>722,699</b>
<b>GO BOND DEBT SERVICE FUND</b>	<b>149,835</b>	<b>149,835</b>	<b>0</b>
<b>FIRE CONSTRUCTION FUND</b>			
FUND BALANCE APPLIED	9,500,000	9,500,000	0
	0	0	0
<b>TOTAL FIRE CONSTRUCTION FUND</b>	<b>9,500,000</b>	<b>9,500,000</b>	<b>0</b>
<b>FIRE GO BOND FUND</b>			
FUND BALANCE APPLIED	0	0	0
	615,284	615,284	0
<b>TOTAL FIRE GO BOND FUND</b>	<b>615,284</b>	<b>615,284</b>	<b>0</b>
<b>COMMUNITY HOUSING IN-LIEU FUND</b>			
FUND BALANCE APPLIED	2,200,000	2,200,000	0
	30,000	30,000	0
<b>TOTAL COMMUNITY HOUSING IN-LIEU FND</b>	<b>2,230,000</b>	<b>2,230,000</b>	<b>0</b>
<b>WAGON DAYS FUND</b>			
FUND BALANCE APPLIED	0	0	0
	85,650	85,650	0
<b>TOTAL WAGON DAYS FUND</b>	<b>85,650</b>	<b>85,650</b>	<b>0</b>
<b>WATER FUND</b>			
FUND BALANCE APPLIED	0	0	0
	2,494,522	2,494,522	0
<b>TOTAL WATER FUND</b>	<b>2,494,522</b>	<b>2,494,522</b>	<b>0</b>
<b>WATER CAPITAL IMPROVEMENT FUND</b>			
FUND BALANCE APPLIED	0	0	0
	522,000	522,000	0
<b>TOTAL WATER CIP FUND</b>	<b>522,000</b>	<b>522,000</b>	<b>0</b>
<b>WASTEWATER FUND</b>			
FUND BALANCE APPLIED	0	0	0
	2,796,861	2,796,861	0
<b>TOTAL WASTEWATER FUND</b>	<b>2,796,861</b>	<b>2,796,861</b>	<b>0</b>
<b>WASTEWATER CAPITAL IMP. FUND</b>			
FUND BALANCE APPLIED	0	0	0
	462,000	462,000	0
<b>TOTAL WASTEWATER CAPITAL IMP. FUND</b>	<b>462,000</b>	<b>462,000</b>	<b>0</b>
<b>Total Revenue</b>	<b>34,028,449</b>	<b>39,925,290</b>	<b>5,896,841</b>

Shellie Rubel  
City Treasurer

**ORDINANCE NO. 1221**

AN ORDINANCE OF THE CITY OF KETCHUM, IDAHO, AMENDING ORDINANCE NUMBER 1208, THE AMENDED ANNUAL APPROPRIATION ORDINANCE FOR THE FISCAL YEAR BEGINNING OCTOBER 1, 2020, AND ENDING SEPTEMBER 30, 2021; APPROPRIATING ADDITIONAL MONIES TO BE RECEIVED BY THE CITY OF KETCHUM, IDAHO; AND PROVIDING AND EFFECTIVE DATE.

BE IT ORDAINED BY THE MAYOR AND CITY COUNCIL OF THE CITY OF KETCHUM, IDAHO:

SECTION 1. The Ordinance Number 1208, the Amended Annual Appropriation Ordinance for the city of Ketchum, Idaho, for the fiscal year commencing October 1, 2020, and ending September 30, 2021, be hereby amended as follows:

	<b>ADOPTED FY 2020- 2021</b>	<b>REVISED FY 2020- 2021</b>	<b>PROPOSED ADJUSTMENT</b>
<b>GENERAL FUND</b>	<b>10,307,770</b>	<b>12,687,889</b>	<b>2,380,119</b>
<b>ESSENTIAL SERVICES FACILITIES TRUST FUND</b>	<b>420,600</b>	<b>2,138,120</b>	<b>1,717,520</b>
<b>FIRE CAPITAL IMPROVEMENT FUND</b>	<b>104,330</b>	<b>241,030</b>	<b>136,700</b>
<b>ORIGINAL LOT FUND</b>	<b>1,817,247</b>	<b>2,217,247</b>	<b>400,000</b>
<b>ADDITIONAL 1%-LOT FUND</b>	<b>1,500,000</b>	<b>2,222,699</b>	<b>722,699</b>
		<b>TOTAL</b>	<b>5,357,038</b>

That the additional sum be appropriated out of the revenues received from:

<b>GENERAL FUND</b>	<b>10,307,770</b>	<b>12,994,939</b>	<b>2,687,169</b>
<b>ESSENTIAL SERVICES FACILITIES TRUST FUND</b>	<b>420,600</b>	<b>2,138,120</b>	<b>1,717,520</b>
<b>GENERAL CAPITAL IMPROVEMENT FUND</b>	<b>563,000</b>	<b>613,000</b>	<b>50,000</b>
<b>FIRE CAPITAL IMPROVEMENT FUND</b>	<b>112,930</b>	<b>249,630</b>	<b>136,700</b>
<b>ORIGINAL LOT FUND</b>	<b>1,817,247</b>	<b>2,400,000</b>	<b>582,753</b>
<b>ADDITIONAL 1%-LOT FUND</b>	<b>1,500,000</b>	<b>2,222,699</b>	<b>722,699</b>
		<b>TOTAL</b>	<b>5,896,841</b>

Section 2. This Ordinance shall be in full force and effect from after its passage, approval and publication.

PASSED by the City Council and APPROVED by the Mayor of the City of Ketchum, Idaho, this 16<sup>th</sup> day of August 2021.

\_\_\_\_\_  
NEIL BRADSHAW, MAYOR

ATTEST:

\_\_\_\_\_  
Tara Fenwick  
City Clerk

Publish: Idaho Mountain Express  
August 25, 2021



## City of Ketchum

August 16, 2021

Mayor Bradshaw and City Councilors  
City of Ketchum  
Ketchum, Idaho

Mayor Bradshaw and City Councilors:

**Recommendation to Hold Public Hearing and  
Adopt Ordinance No. 1220  
The FY 21-22 Annual Appropriations Ordinance**

### Recommendation and Summary

Staff respectfully recommends that the Ketchum City Council conduct the first reading of the Annual Appropriation Ordinance No. 1220, and read by title only:

**"I MOVE TO APPROVE THE FIRST READING, BY TITLE ONLY, OF ORDINANCE NO. 1220."**

The reasons for the recommendation are as follows:

- State statute establishes requirements for approving a budget.
- Public hearing was held on July 19, 2021.
- Budget workshop was held on June 28, 2021.

### Introduction and History

Per Idaho Code 50-1003, the City Council of each city shall, prior to the commencement of each fiscal year, pass an Ordinance to be termed the Annual Appropriation Ordinance.

### Analysis

The City Council will hold a Public Hearing on August 16, 2021, at 4:00 p.m. for the purpose of considering and fixing a final budget and making appropriations to each office, department, service, agency, or institution and fund for the next fiscal year (2021-22).

The City Council will consider adopting Ordinance Number 1220, entitled the Annual Appropriation Ordinance for the Fiscal Year beginning October 1, 2021, appropriating to the various funds sums of money deemed necessary to defray all expenses and liabilities within each fund for the ensuing fiscal year, authorizing a levy of sufficient tax upon the taxable property, specifying the objects and purpose for which said appropriation is made, and providing and effective date.

### Financial Impact

The Fiscal Year 2021-22 City Budget provides budget authority for the services and projects the City anticipates providing during the new fiscal year. The proposed budget appropriates a total of \$32,222,099 including \$12,840,516 in the General Fund.

### Attachments

- Attachment A: Ordinance 1220



**NOTICE OF PUBLIC HEARING**

Public Notice is hereby given that the City Council of the City of Ketchum, Idaho will meet on **Monday, August 16, 2021 at 4:00 P.M.** at the City Hall, 480 East Avenue North, Ketchum, Idaho, for the purpose of considering and fixing a final budget and making appropriations to each fund for the next fiscal year (2021-22) at which time any public may appear and be heard upon any part or parts of said budget; and

That the following table sets forth the amount proposed to be appropriated to each fund for the 2021-22 fiscal year, the amounts appropriated to each fund for the current 2020-21 fiscal year, and the amounts expended by each fund during the previous 2019-20 fiscal year, to-wit:

**CITY OF KETCHUM, IDAHO**

<b>EXPENDITURES</b>	<b>Actual FY 19-20</b>	<b>Budgeted FY 20-21</b>	<b>Proposed FY 20-22</b>
<b>GENERAL FUND</b>	<b>10,255,339</b>	<b>10,307,770</b>	<b>12,840,516</b>
GENERAL CAPITAL IMPROVEMENT FUND	281,998	563,000	2,917,366
ESSENTIAL SERVICES FACILITIES TRUST FUND	97,270	420,600	-
WAGON DAYS FUND	15,693	85,650	122,500
STREET CAPITAL IMPROVEMENT FUND	33,974	232,600	-
LAW ENFORCEMENT IMPROVEMENT FUND	-	250	-
FIRE CAPITAL IMPROVEMENT FUND	73,535	104,330	-
PARKS & RECREATION CAP. IMP. FUND	-	-	-
FIRE CONSTRUCTION FUND	1,796,490	9,500,000	-
ORIGINAL LOT FUND	2,350,891	1,817,247	2,400,000
ADDITIONAL 1%-LOT FUND	2,221,861	1,500,000	1,900,000
GO BOND DEBT SERVICE FUND	149,836	149,835	3,212
FIRE GO BOND DEBT SERVICE FUND	-	615,284	636,050
COMMUNITY HOUSING IN-LIEU FUND	283,045	2,250,000	2,822,050
STRATEGIC INITIATIVES FUND	-	-	864,099
WATER FUND	1,952,992	2,390,937	2,469,632
WATER CAPITAL IMPROVEMENT FUND	408,638	522,000	487,000
WASTEWATER FUND	2,435,825	2,587,242	3,259,625
WASTEWATER CAPITAL IMP. FUND	80,957	462,000	1,206,000
POLICE TRUST FUND	-	5,000	95,000
PARKS & RECREATION TRUST FUND	45,165	49,050	49,050
DEVELOPMENT TRUST FUND	253,602	150,000	150,000
<b>Total Expenditures</b>	<b>25,238,734</b>	<b>25,074,136</b>	<b>32,222,099</b>

**REVENUE**

<b>GENERAL FUND</b>			
GENERAL PROPERTY TAXES	4,438,061	4,469,191	4,603,267
OTHER REVENUE	6,766,851	5,838,579	7,930,199
FUND BALANCE APPLIED	-	-	307,050
<b>TOTAL GENERAL FUND</b>	<b>11,204,912</b>	<b>10,307,770</b>	<b>12,840,516</b>
<b>GENERAL CAPITAL IMPROVEMENT FUND</b>	<b>287,382</b>	<b>311,781</b>	<b>2,403,555</b>
FUND BALANCE APPLIED	-	251,219	513,811
<b>TOTAL GENERAL CAPITAL IMPRVMT FUND</b>	<b>287,382</b>	<b>563,000</b>	<b>2,917,366</b>
<b>ESSENTIAL SERVICES FACILITIES TRUST FUND</b>	<b>314,442</b>	<b>35,000</b>	<b>-</b>
FUND BALANCE APPLIED	-	385,600	-
<b>TOTAL ESF TRUST FUND</b>	<b>314,442</b>	<b>420,600</b>	<b>-</b>
<b>WAGON DAYS FUND</b>	<b>43,159</b>	<b>85,650</b>	<b>122,500</b>
FUND BALANCE APPLIED	-	-	-
<b>TOTAL WAGON DAYS FUND</b>	<b>43,159</b>	<b>85,650</b>	<b>122,500</b>
<b>STREET CAPITAL IMPROVEMENT FUND</b>	<b>161,156</b>	<b>27,500</b>	<b>-</b>
FUND BALANCE APPLIED	-	205,100	-
<b>TOTAL STREET CAPITAL IMPR. FUND</b>	<b>161,156</b>	<b>232,600</b>	<b>-</b>
<b>LAW ENFORCEMENT IMPROVEMENT FUND</b>	<b>4,380</b>	<b>900</b>	<b>-</b>
<b>FIRE CAPITAL IMPROVEMENT FUND</b>	<b>178,539</b>	<b>112,930</b>	<b>-</b>
FUND BALANCE APPLIED	-	-	-
<b>TOTAL FIRE CAPITAL IMPROVEMENT FUND</b>	<b>178,539</b>	<b>112,930</b>	<b>-</b>
<b>PARKS &amp; RECREATION CAP. IMP. FUND</b>	<b>52,376</b>	<b>10,200</b>	<b>-</b>
FUND BALANCE APPLIED	-	-	-
<b>TOTAL PARKS &amp; RECREATION CAP.IMP.FND</b>	<b>52,376</b>	<b>10,200</b>	<b>-</b>
<b>FIRE CONSTRUCTION FUND</b>	<b>11,557,875</b>	<b>-</b>	<b>-</b>
FUND BALANCE APPLIED	-	9,500,000	-
<b>TOTAL FIRE CONSTRUCTION FND</b>	<b>11,557,875</b>	<b>9,500,000</b>	<b>-</b>
<b>ORIGINAL LOT FUND FUND</b>	<b>2,606,873</b>	<b>1,817,247</b>	<b>2,400,000</b>
FUND BALANCE APPLIED	-	-	-
<b>TOTAL ORIGINAL LOT FUND FUND</b>	<b>2,606,873</b>	<b>1,817,247</b>	<b>2,400,000</b>
<b>ADDITIONAL 1%-LOT FUND</b>	<b>2,186,249</b>	<b>1,500,000</b>	<b>1,900,000</b>
<b>GO BOND DEBT SERVICE FUND</b>	<b>149,948</b>	<b>149,835</b>	<b>3,212</b>
<b>FIRE GO BOND DEBT SERVICE FUND</b>	<b>-</b>	<b>615,284</b>	<b>636,050</b>
<b>COMMUNITY HOUSING IN-LIEU FUND</b>	<b>40,906</b>	<b>30,000</b>	<b>322,050</b>
FUND BALANCE APPLIED	-	2,200,000	2,500,000
<b>TOTAL COMMUNITY HOUSING IN-LIEU FND</b>	<b>40,906</b>	<b>2,230,000</b>	<b>2,822,050</b>
<b>STRATEGIC INITIATIVES FUND</b>	<b>-</b>	<b>-</b>	<b>864,099</b>
<b>TOTAL STRATEGIC INITIATIVES FUND</b>	<b>-</b>	<b>-</b>	<b>864,099</b>
<b>WATER FUND</b>	<b>2,607,622</b>	<b>2,494,522</b>	<b>2,469,632</b>
FUND BALANCE APPLIED	-	-	-
<b>TOTAL WATER FUND</b>	<b>2,607,622</b>	<b>2,494,522</b>	<b>2,469,632</b>
<b>WATER CAPITAL IMPROVEMENT FUND</b>	<b>461,680</b>	<b>522,000</b>	<b>487,000</b>
FUND BALANCE APPLIED	-	-	-
<b>TOTAL WATER CAPITAL IMP. FUND</b>	<b>461,680</b>	<b>522,000</b>	<b>487,000</b>
<b>WASTEWATER FUND</b>	<b>2,617,776</b>	<b>2,796,861</b>	<b>3,673,862</b>
FUND BALANCE APPLIED	-	-	-
<b>TOTAL WASTEWATER FUND</b>	<b>2,617,776</b>	<b>2,796,861</b>	<b>3,673,862</b>
<b>WASTEWATER CAPITAL IMP. FUND</b>	<b>516,302</b>	<b>462,000</b>	<b>1,206,000</b>
FUND BALANCE APPLIED	-	-	-
<b>TOTAL WASTEWATER CAPITAL IMP. FUND</b>	<b>516,302</b>	<b>462,000</b>	<b>1,206,000</b>
<b>POLICE TRUST FUND</b>	<b>1,615</b>	<b>1,500</b>	<b>1,000</b>
FUND BALANCE APPLIED	-	3,500	95,000
<b>TOTAL POLICE TRUST FUND</b>	<b>1,615</b>	<b>5,000</b>	<b>96,000</b>
<b>PARKS &amp; RECREATION TRUST FUND</b>	<b>15,634</b>	<b>42,050</b>	<b>42,050</b>
FUND BALANCE APPLIED	-	10,000	10,000
<b>TOTAL PARKS &amp; RECREATION TRUST FUND</b>	<b>15,634</b>	<b>52,050</b>	<b>52,050</b>
<b>FIRE TRUST FUND</b>	<b>-</b>	<b>-</b>	<b>-</b>
<b>DEVELOPMENT TRUST FUND</b>	<b>253,602</b>	<b>150,000</b>	<b>150,000</b>
<b>Total Revenue</b>	<b>35,262,427</b>	<b>34,028,449</b>	<b>32,640,337</b>

Shellie Rubel  
City Treasurer

Publish: Idaho Mountain Express  
August 4th and August 11, 2021

ORDINANCE NO. 1220

AN ORDINANCE OF THE CITY OF KETCHUM, IDAHO, ENTITLED THE ANNUAL APPROPRIATION ORDINANCE FOR THE FISCAL YEAR BEGINNING OCTOBER 1, 2021, APPROPRIATING TO THE VARIOUS BUDGETARY FUNDS, SUMS OF MONEY DEEMED NECESSARY TO DEFRAY ALL NECESSARY EXPENSES AND LIABILITIES WITHIN EACH FUND FOR THE ENSUING FISCAL YEAR, AUTHORIZING A LEVY OF A SUFFICIENT TAX UPON THE TAXABLE PROPERTY AND SPECIFYING THE OBJECTS AND PURPOSES FOR WHICH SAID APPROPRIATION IS MADE, AND PROVIDING AN EFFECTIVE DATE.

BE IT ORDAINED by the Mayor and City Council of the City Ketchum, Blaine County, Idaho:

SECTION 1: That the sum of \$32,222,099 be raised and appropriated to defray the necessary expenses and liabilities of the City of Ketchum, Blaine County, Idaho for the fiscal year beginning October 1, 2021.

SECTION 2: That the City Council hereby appropriates each Fund as an independent fiscal and accounting group with a self-balancing set of accounts recording cash and/or other resources together with all related liabilities, obligations, reserves, and equities which are segregated for the purpose of carrying on specific activities or attaining certain objectives.

SECTION 3: That the appropriation for the General Fund is made in the following amount to each specific division or function:

Legislative and Executive, Administrative, Legal, Community Planning and Development, Law Enforcement, Fire and Rescue, Street and Facility Maintenance, and Non-Departmental.

Total General Fund	12,840,516
--------------------	------------

SECTION 4: That the appropriation for the Water and Wastewater Funds is made in the following amounts to each specific Fund, department, or function:

Water Fund	2,469,632
Water Capital Improvement Fund	487,000
Wastewater Fund	3,259,625
Wastewater Capital Improvement Fund	1,206,000
Total Water and Wastewater Funds	7,422,257

SECTION 5: That the appropriation for all Other Funds is made in the following amounts to each specific Fund, department, or function:

General Capital Improvement Fund	2,917,366
----------------------------------	-----------

Wagon Days Fund	122,500
Parks & Recreation Trust Fund	49,050
Original LOT Fund	2,400,000
Additional 1%-LOT Fund	1,900,000
GO Bond Debt Street	3,212
GO Bond Debt Fire Fund	636,050
Community Housing In-Lieu Fund	2,822,050
Strategic Initiative Fund	864,099
Police Trust Fund	95,000
Fire Trust Fund	0
Development Trust Fund	150,000
 Total Other Funds	 11,956,115

SECTION 6: That a general tax levy on all taxable property within the City of Ketchum be levied in an amount allowed by law for the general purposes for said City, for the fiscal year beginning October 1, 2022.

SECTION 7: All ordinances and parts of ordinances in conflict with this ordinance are hereby repealed.

SECTION 8: This ordinance shall take effect and be in force upon its passage, approval, and publication in one issue of the Idaho Mountain Express, a newspaper of general circulation in the City of Ketchum, and the official newspaper of said City.

PASSED by the City Council and APPROVED by the Mayor of Ketchum this 16th day of August 2021.

ATTEST:

\_\_\_\_\_  
Neil Bradshaw  
Mayor

\_\_\_\_\_  
Tara Fenwick  
City Clerk