



**CITY OF HUTCHINS
CITY COUNCIL MEETING
AGENDA**

**Tuesday, January 21, 2025, at 6:00 PM
City Hall, 321 N. Main Street**

Pursuant to Section 551 of the Texas Government Code, notice is hereby given of a Regular Meeting of the Hutchins City Council to be held on Tuesday, January 21, 2025, at 6:00 PM located at Hutchins City Hall Council Chambers, 321 N. Main Street, Hutchins, Texas, at which time the following items will be discussed and considered.

City Council Members

Mayor Mario Vasquez
Mayor Pro Tem Steve Nichols
Councilmember Brenda Campbell
Councilmember Dominic Didehbani
Councilmember Raymond Elmore
Councilmember Demarcus Odom

A. WORK SESSION

1. Presentation of logo design. Presented by Beth Owens, Brandera

B. CALL TO ORDER AND ANNOUNCE A QUORUM PRESENT

C. INVOCATION AND PLEDGE OF ALLEGIANCE

D. CITIZEN COMMENTS - *This agenda item provides an opportunity for citizens to address the City Council on any matter that is not posted on the agenda. Anyone wishing to address the City Council should complete a Citizen Comments Form and submit it to the City Secretary prior to the start of the City Council meeting. There is a three (3) minute time limit for each citizen to speak. However, in accordance with the Texas Open Meetings Act, the City Council cannot discuss issues raised or make any decision at this time.*

E. CONSENT AGENDA - *All items presented in the Consent Agenda require no deliberation by the Council. Each Council member has the opportunity of removing an item from this agenda so that it may be considered separately.*

F. PRESENTATIONS

2. 2024 Public Works Capital Project Update, Presented by: Mamun Yusuf, Director of Public Works

G. REGULAR AGENDA - *As authorized by Section 551.071 of the Texas Government Code, the City Council reserves the right to convene in Executive Session for the purpose of seeking confidential legal advice from the City Attorney on any agenda item listed herein.*

3. Discuss and consider approving a logo design. Presented by Beth Owens

4. Discuss and consider Resolution R2025-01-1233 OF THE CITY COUNCIL OF THE CITY OF HUTCHINS, TEXAS, ACCEPTING THE BUYBOARD PROPOSAL RECEIVED IN ASSOCIATION WITH THE REHABILITATION OF N. DENTON STREET WASTEWATER MAIN PROJECT; AUTHORIZING THE CITY ADMINISTRATOR TO NEGOTIATE AND EXECUTE AN AGREEMENT WITH INSITUFORM TECHNOLOGIES, LLC, IN AN AMOUNT NOT TO EXCEED \$139,340.00; AND PROVIDING FOR AN EFFECTIVE DATE. Presented by: Mamun Yusuf, Director of Public Works
5. Discuss and consider Ordinance 2025-01-1203 OF THE CITY OF HUTCHINS, TEXAS AMENDING THE CODE OF ORDINANCES BY AMENDING CHAPTER 1 TITLED "GENERAL PROVISIONS" BY AMENDING ARTICLE 1.02 TITLED "MAYOR AND COUNCIL MEMBERS" BY ADDING A NEW SECTION 1.02.002 TITLED "TERM OF OFFICE" TO ESTABLISH A TERM OF OFFICE FOR THREE (3) YEARS FOR THE MAYOR AND CITY COUNCIL MEMBERS BEGINNING WITH THE POSITION TO BE ELECTED AT THE GENERAL ELECTION IN MAY 2025 ON THE UNIFORM ELECTION DATE. Presented by Cynthia Olguin

H. EXECUTIVE SESSION

6. The Hutchins City Council will hold a closed Executive Session pursuant to the provisions of Chapter 551, Subchapter D, Texas Government Code, in accordance with the authority contained in §551.087. Deliberation regarding economic development negotiations (1) to discuss or deliberate regarding commercial or financial information that the governmental body has received from a business prospect that the governmental body seeks to have locate, stay, or expand in or near the territory of the governmental body and with which the governmental body is conducting economic development negotiations; (2) to deliberate the offer of a financial or other incentive to a business prospect described by Subdivision to a business prospect: 1) Project Visitation. Presented by: Guy Brown HEDC Executive Director
7. Texas Government Code Sec. 551.072. DELIBERATION REGARDING REAL PROPERTY. A governmental body may conduct a closed meeting to deliberate the purchase, exchange, lease, or value of real property: Land Acquisition

I. RECONVENE INTO REGULAR SESSION

8. Take action, if any, as a result of Executive Session:
 - a. Deliberation regarding economic development negotiations. 1) Project Visitation
 - b. Deliberation regarding the purchase, exchange, lease or value of real property: Land Acquisition

J. ITEMS OF COMMUNITY INTEREST

9. Planning and Zoning Commission Meeting, Monday, January 27, 2025, at 6:00 p.m., City Hall Council Chamber, 321 N. Main St. Hutchins.

City Council Meeting, Monday, February 3, 2025, at 6:30 p.m., City Hall Council Chamber, 321 N. Main St., Hutchins.

Parks and Recreation Board Meeting, Tuesday, February 4, 2025, at 6:30 p.m., City Hall Council Chamber, 321 N. Main St., Hutchins.

Keep Hutchins Beautiful Board Meeting, Tuesday, February 11, 2025, at 6:00 p.m., City Hall Council Chamber, 321 N. Main St., Hutchins.

May 3, 2025 General Election Information:

Wednesday, January 15, 2025, through Friday, February 14, 2025, is the period for filing an application for a place on the ballot for May 3, 2025, General Election to elect three city council members at large.

Thursday, April 3, 2025: Last day to register to vote in the May 3, 2025 General Election.

Monday, January 1, 2025 - Tuesday, April 22, 2025: Period to deliver Application for a Ballot by Mail at the Dallas County Elections Office.

K. ADJOURN

CERTIFICATION

I certify that a copy of the January 21, 2025, agenda of items to be considered by the Hutchins City Council was posted on the City Hall bulletin board, a place convenient and readily accessible to the general public at all times, and to the City's website www.cityofhutchins.org, in accordance with Chapter 551 of the Texas Government Code. Posted on January 17, 2025, before 6:00 p.m.

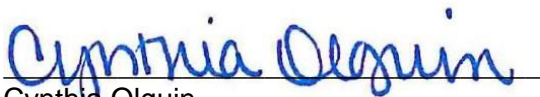
Cynthia Olguin
City Secretary



ACCESSIBILITY STATEMENT

The meeting location is wheelchair accessible from the front door. Request for special services must be received at least 48 hours before a scheduled meeting. For assistance, please call the office of the City Secretary at 972-225-6121 or email the City Secretary at colguin@cityofhutchins.org



STAFF REPORT

MEETING DATE: January 21, 2025

MEETING TYPE: City Council-

SUBMITTED BY: Mamun Yusuf

AGENDA CAPTION: 2024 Public Works Capital Project Update, Presented by: Mamun Yusuf, Director of Public Works

Background Information

2024 Public Works Capital Project Update

Budget Implications

Operational Impact

N/A

Legal Review

N/A

Staff Recommendation

Supporting Documentation and Attachments

2024 Public Works Capital Projects Update (Memo)

Capital Projects Update

Mamun Yusuf, PE, Director of Public Works



Street Improvement Projects

Section F, Item 2.



#	Street	Asphalt/Concrete	PCI	Length (ft)	Width (ft)	Volume (CY)	Unit Cost	Total Cost
1	Breneman Street	Asphalt	6	900	28	25,200	\$4.00	\$136,080
2	Burns Drive	Asphalt	6	300	28	8,400	\$4.00	\$45,360
3	Crockett Drive	Asphalt	6	500	28	14,000	\$4.00	\$75,600
4	Dowdy Ferry Road	Asphalt	6	6,600	28	184,800	\$4.00	\$997,920
5	East Athens Street	Asphalt	6	1,100	28	30,800	\$4.00	\$166,320
6	East Dallas Street	Asphalt	6	500	28	14,000	\$4.00	\$75,600
7	East Hickman Street	Asphalt	6	500	28	14,000	\$4.00	\$75,600
8	East Wintergreen Road	Asphalt	6	2,600	28	72,800	\$4.00	\$393,120
9	Glenhaven Drive	Asphalt	6	900	28	25,200	\$4.00	\$136,080
10	Glenview Drive	Concrete	6	800	28	22,400	\$12.00	\$362,880
11	Goode Road	Asphalt	6	2,100	28	58,800	\$4.00	\$317,520
12	Kanady Street	Asphalt	6	1,300	28	36,400	\$4.00	\$196,560
13	Lec Lane	Asphalt	6	850	28	23,800	\$4.00	\$128,520
14	Michael Street	Asphalt	6	550	28	15,400	\$4.00	\$83,160
15	Millers Ferry Road	Asphalt	6	3,700	28	103,600	\$4.00	\$559,440
16	Murray Street	Asphalt	6	800	28	22,400	\$4.00	\$120,960
17	North Austin Street	Asphalt	6	650	28	18,200	\$4.00	\$98,280
18	North JJ Lemmon Street	Concrete	6	3,200	28	89,600	\$12.00	\$1,451,520
19	North Main Street	Asphalt	6	1,650	28	46,200	\$4.00	\$249,480
20	Post Oak Road	Asphalt	6	1,000	28	28,000	\$4.00	\$151,200
21	Prasifka Street	Asphalt	6	550	28	15,400	\$4.00	\$83,160
22	South Austin Street	Asphalt	6	1,250	28	35,000	\$4.00	\$189,000
23	South J Lemmon Street	Asphalt	6	650	28	18,200	\$4.00	\$98,280
24	South Mills Street	Asphalt	6	4,000	28	112,000	\$4.00	\$604,800
25	Vanderbilt Road	Asphalt	6	4,000	28	112,000	\$4.00	\$604,800
26	West Dallas Street	Asphalt	6	1,300	28	36,400	\$4.00	\$196,560
27	West Hickman Street	Asphalt	6	2,800	28	78,400	\$4.00	\$423,360
28	West Wintergreen Road	Concrete	6	8,000	44	352,000	\$12.00	\$5,702,400
29	Woodbrook	Concrete	6	600	28	16,800	\$12.00	\$272,160
30	Woodcrest Lane	Concrete	6	600	28	16,800	\$12.00	\$272,160
Total								\$14,267,880

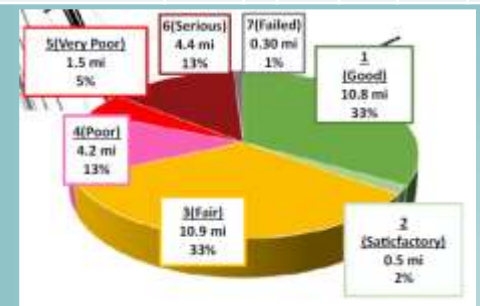

Water & WW Improvement Projects

Section F, Item2.

Location	Start Point	End Point	Length	# of current connections	Current main material and size	Main type	Comments	Est. Cost
N Denton	Ayers	Loop 310	1,235	0	6" Clay tile	Sewer	Main has cracking and root penetration.	\$617,500.00
O'Dell and Denton	W. Palestine	W. Hickman (dead end)	668	25	6" clay tile	Sewer	Main has cracking and root penetration.	\$334,000.00
Ayres	JJ Lemmon	N. Denton	1,257	24	6" clay tile	Sewer	Main has cracking and root penetration.	\$628,500.00
W. Hickman	Lancaster Hutchins	N. Main	2,900	30	8" ductile iron	Water	Main has had several breaks and is in poor condition.	\$1,305,000.00
W. Palestine	Lancaster Hutchins	O'Dell	2,234	25	6" ductile iron	Water	Main has had several breaks and is in poor condition.	\$1,005,300.00
N. Pacific	E. Athens	Fannin St	1,200	7	2" Galvanized	Water	Main is in serious condition and needs to be upsized to 6"	\$540,000.00
Crockett	W. Palestine	JJ Lemmon	1,074	29	3" PVC	Water	Main needs to be 6" to add hydrant	\$483,300.00
Franklin	W. Palestine	W. Hickman	574	4	4" ductile	Water	No fire protection for apartments needs to be 6"	\$258,300.00
Ayres	JJ Lemmon	N. Denton	1,257	12	6" Ductile iron	Water	Main is in poor condition	\$565,650.00
S Denton	Cambell Park	Breneman	1,250	6	4" Galvanized	Water	Dead end main	\$562,500.00
							Total	\$6,300,050.00

Pump, LS & Tank Projects

Section F, Item2.

Water Pump Station	Replace Pump #4	\$75,000.00
Water Tank Rehab	Wintergreen 0.3 MG Tank Rehab	\$500,000.00
Dallas Lift Station	Backup Generator	\$125,000.00
	Pump #2 Repl.	\$32,950.00
	Total	\$732,950.00

Equipment Projects

Equipment	2025
1 Boom Mowe with Tractor	\$190,000
2 Street Sweeper	\$25,000
Backup Generator for SCADA	
3 System	\$20,000

Vehicle Replacement Projects

NO.	Unit Number	License Plate	VIN	MAKE	MODEL	YEAR	MILES
PUBLIC WORKS							
1	227	1244948	1FTRF12W66NB66841	FORD	F-150	2006	117,786
2	229	1282376	1GCVKNEC2GZ186940	CHEVROLET	SILVERADO	2016	93,708
3	337	1244949	1FDWF36Y28EA08702	FORD	F-350	2007	42,820
4	330	1384563	3GCUKNEC9JG364779	CHEVROLET	SILVERADO	2018	40,343
5	348	1585782	1FTMF1E54PKF74674	FORD	F-150	2023	1,105
WATER/SEWER							
1	333	1241916	1FTRF12W86NB27068	FORD	F-150	2006	130,512
2	338	1196551	1D7HA18N78J181292	DODGE	RAM	2008	141,894
3	340	1359312	1FDWF7DC2GDA04118	FORD	F-750	2016	8,736
4	344	1368008	1FD8X3HT8HEF01033	FORD	F-350	2017	36,623
5	345	1573195	1FTFW1E55PKE89335	FORD	F-150	2023	7,451
6	346	1573194	1FTFW1E58PKE89376	FORD	F-150	2023	10,292
FLEET							
1	121	806903	1FTYR1OUX1PB23086	FORD	RANGER	2001	179,882

Sidewalk Improvement Projects

Section F, Item 2.



West Hickman	\$143,664.40
North Main	\$25,550.80
South JJ Lemmon	\$25,787.30
North Pacific	\$23,606.00
W Dallas	\$55,000.00
Dowdy Ferry	\$36,656.40
Quail Run Modification	\$38,500.00
Total	\$348,764.90

Park Security Camera Project

Section F, Item2.



LIVE DEMO

SEE THE SENTRY OPERATING LIVE!

LEARN ABOUT:

- Active deterrence
- How the Sentry works
- Remote management & support
- Options, Sentry customization & pricing
- Why Backstreet Surveillance is the right choice

The banner features a central image of a man in a green shirt sitting at a desk with multiple computer monitors displaying surveillance footage. To the left of the man, there are four diamond-shaped inset images showing different views of the Sentry mobile surveillance trailer in operation.

Sentry-Pro Mobile Surveillance Trailer

Direct Purchase

•Compact, high performance, 4K Video Surveillance Trailer. Supports (4) PTZ Cameras & 120dB Talk-down Speakers. Solar-powered with (4) days of battery backup.

\$43,999.00

UPRR Sidewalk Improvement

Section F, Item 2.

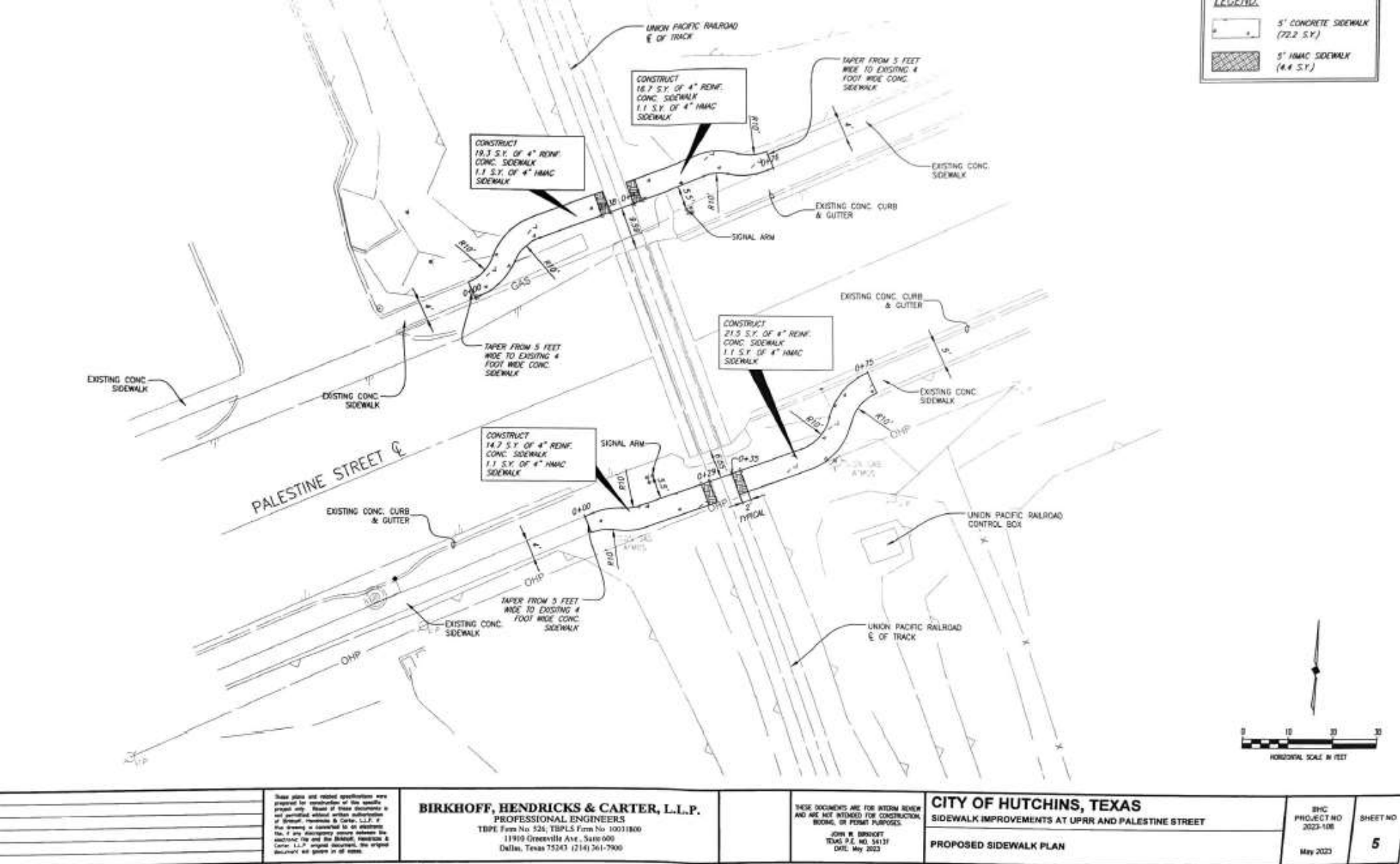

	These plans and related specifications were prepared for construction of the project shown. If these documents are not permitted without written authority of Birkhoff, Hendricks & Carter, L.L.P., the drawing is considered to be void. The client acknowledges and releases Birkhoff, Hendricks & Carter, L.L.P. from all claims, damages, and expenses in all cases.
--	--

BIRKHOFF, HENDRICKS & CARTER, L.L.P.
 PROFESSIONAL ENGINEERS
 TBPE Firm No 524, TBPLS Firm No 10011800
 11919 Greenville Ave., Suite 000
 Dallas, Texas 75243 (214) 361-7900

THESE DOCUMENTS ARE FOR INTERIM REVIEW AND ARE NOT INTENDED FOR CONSTRUCTION, BIDDING, OR PERMIT PURPOSES.
 JOHN W. BIRKHOFF
 TEXAS P.E. NO. 54131
 DATE: May 2023

CITY OF HUTCHINS, TEXAS
 SIDEWALK IMPROVEMENTS AT UPRR AND PALESTINE STREET
PROPOSED SIDEWALK PLAN

BHC PROJECT NO 2023-108	SHEET NO 5
May 2023	

Chapman Street Concrete Paving

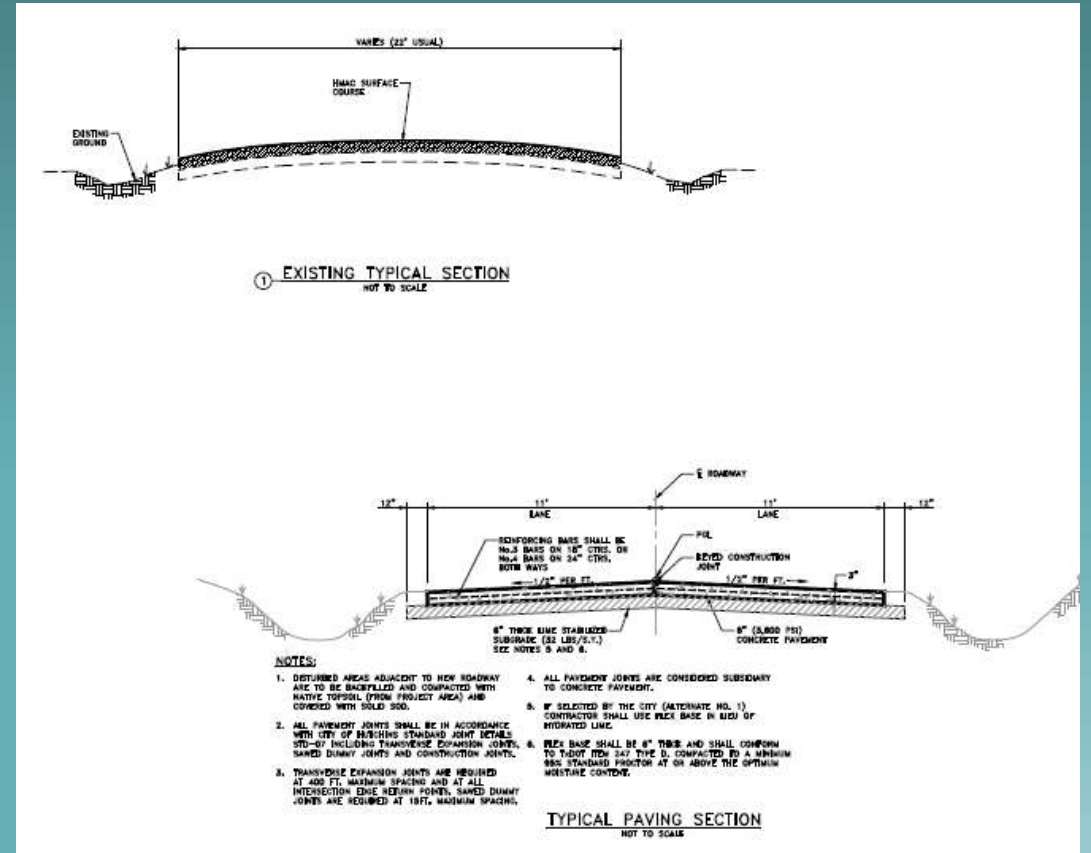

Nichols Dr. Sanitary Sewer Improvement

Section F, Item 2.

Cleveland 18" Wastewater Main

Section F, Item2.



Watermain Replacement in 3 Locations

Section F, Item 2.

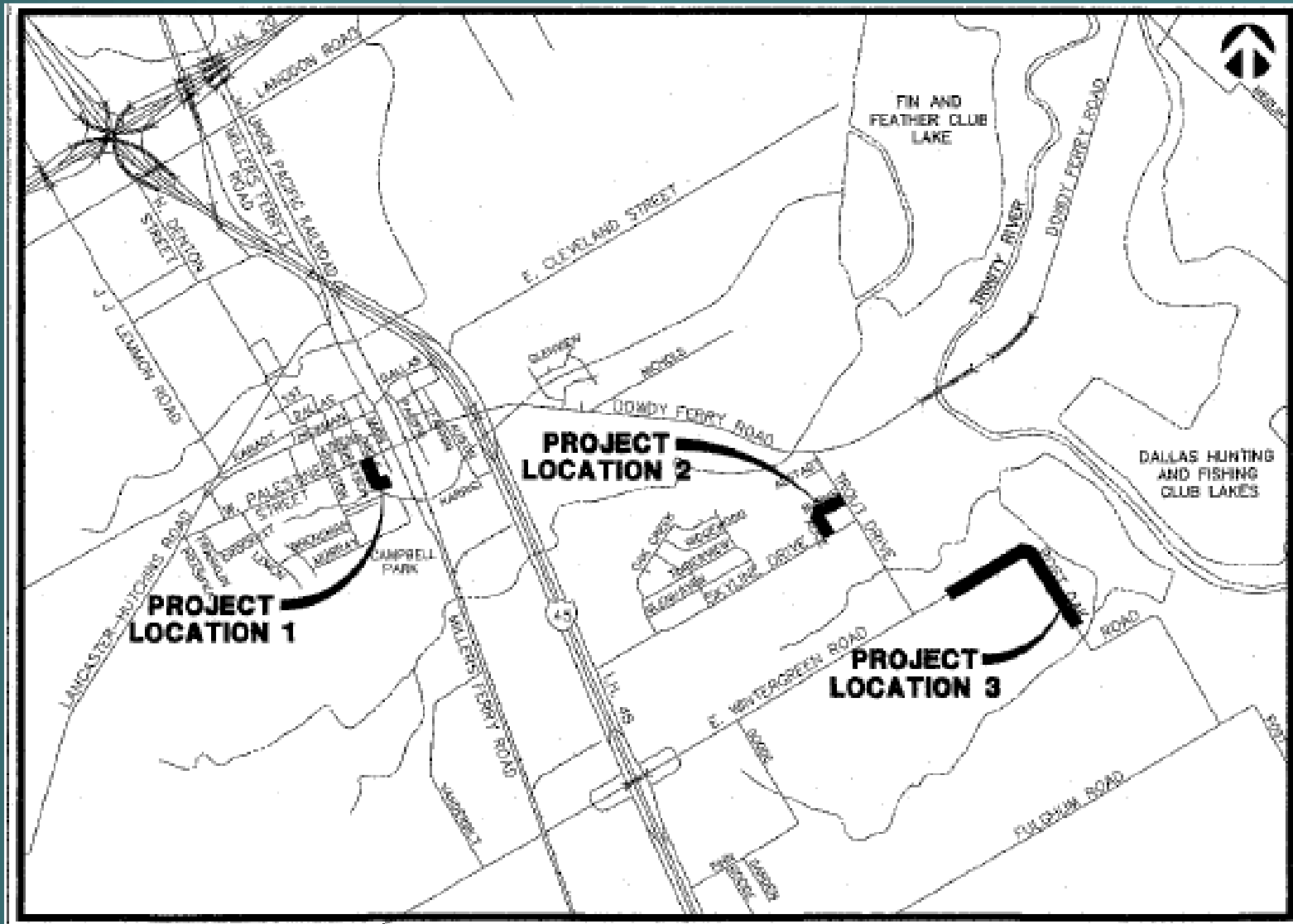

Campbell Park Pavilion

Section F, Item 2.

Campbell Park Restroom

Building Code Council
IBC X IRC _____
Approval Date: 4/30/2024
Approved
ICC NTA, LLC
IHDRA-11

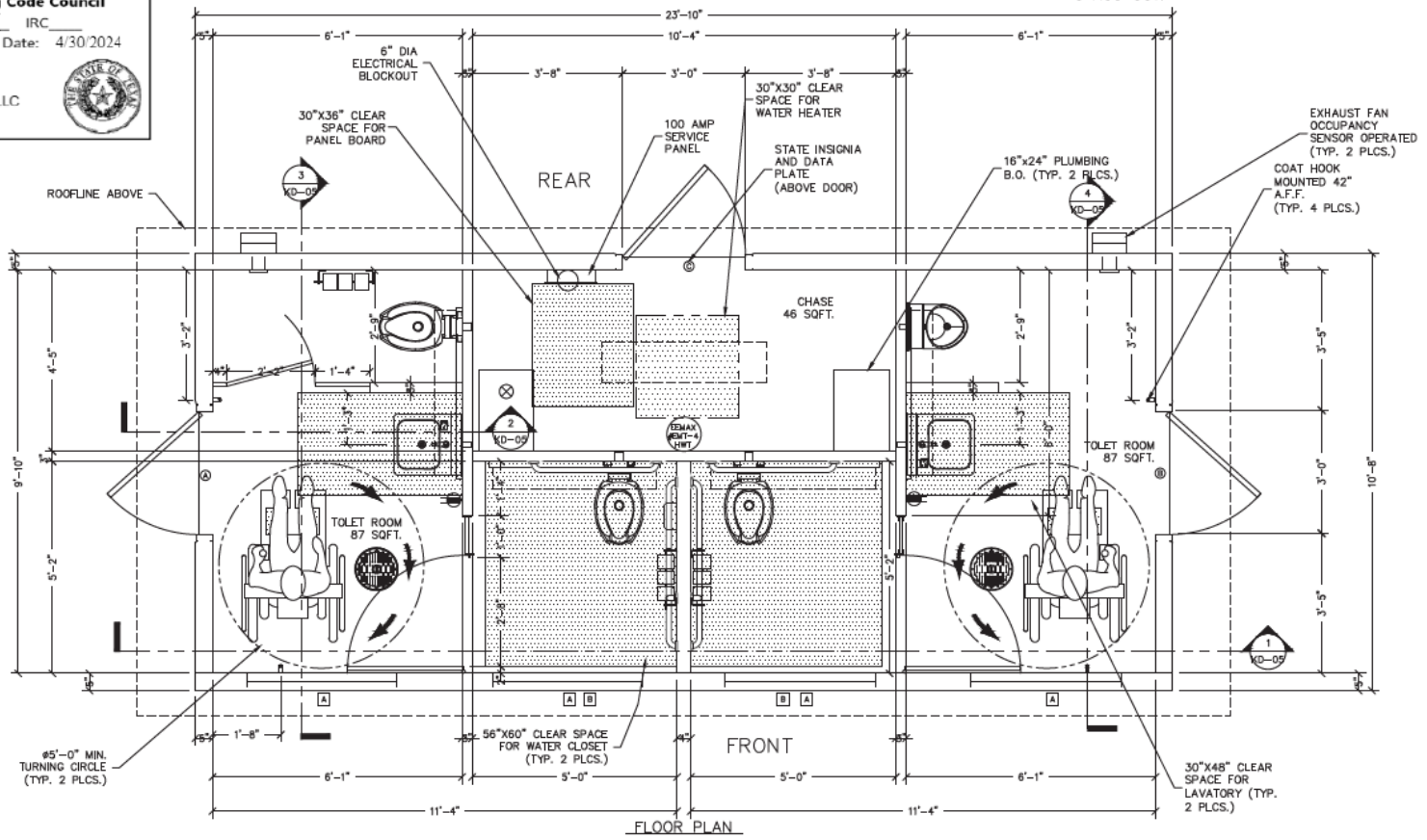

Sidewalk Improvement



Southern WW Interceptor

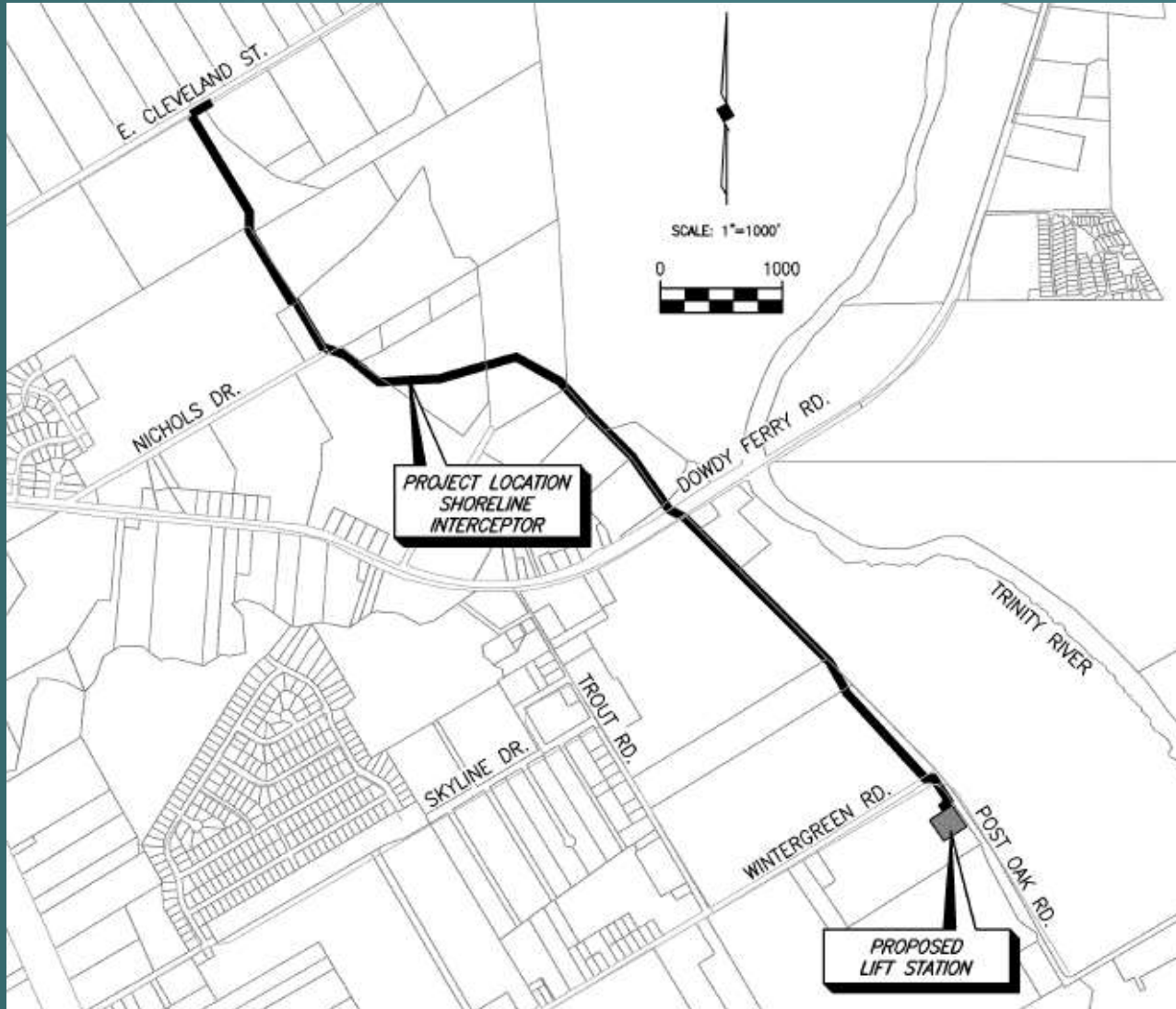

Southern Lift Station

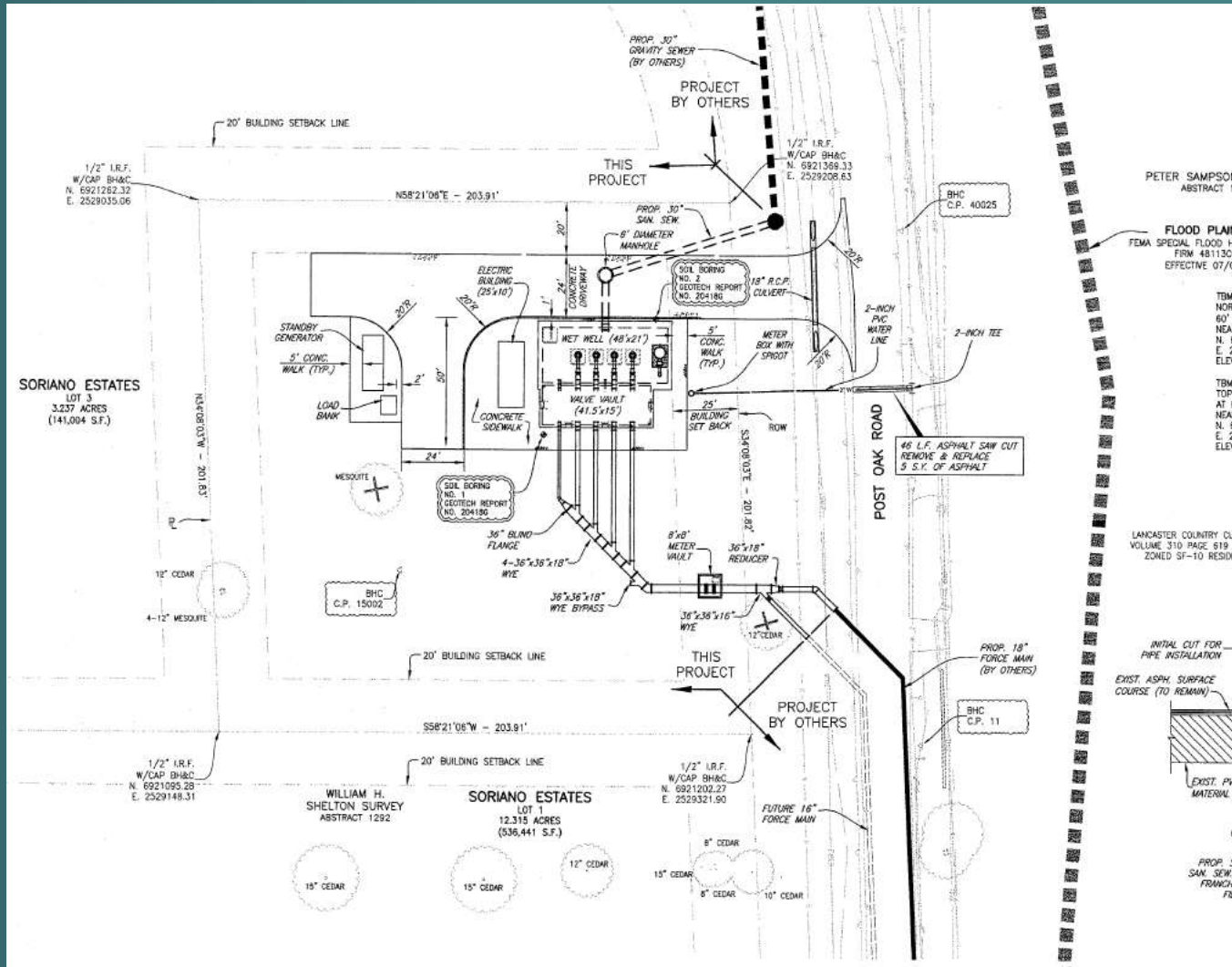

PETER SAMPSON
ABSTRACT 12

FLOOD PLAIN
FEMA SPECIAL FLOOD HAZ
FRM 48113C05
EFFECTIVE 07/07

TBM 1
NORTH
60' S
NEAR
N. 89
E. 25
ELEV.

TBM 3
TOP C
AT BE
NEAR
N. 89
E. 25
ELEV.

LANCASTER COUNTRY CLUB
VOLUME 310 PAGE 819 D.
ZONED SF-10 RESIDEN

INITIAL CUT FOR
PIPE INSTALLATION
EXIST. ASPH. SURFACE
COURSE (TO REMAIN)

EXIST. PAVK
MATERIAL (

6"

PROP. ST.
SAN. SEW.
FRANCHISE
FREE

Southern Force Main

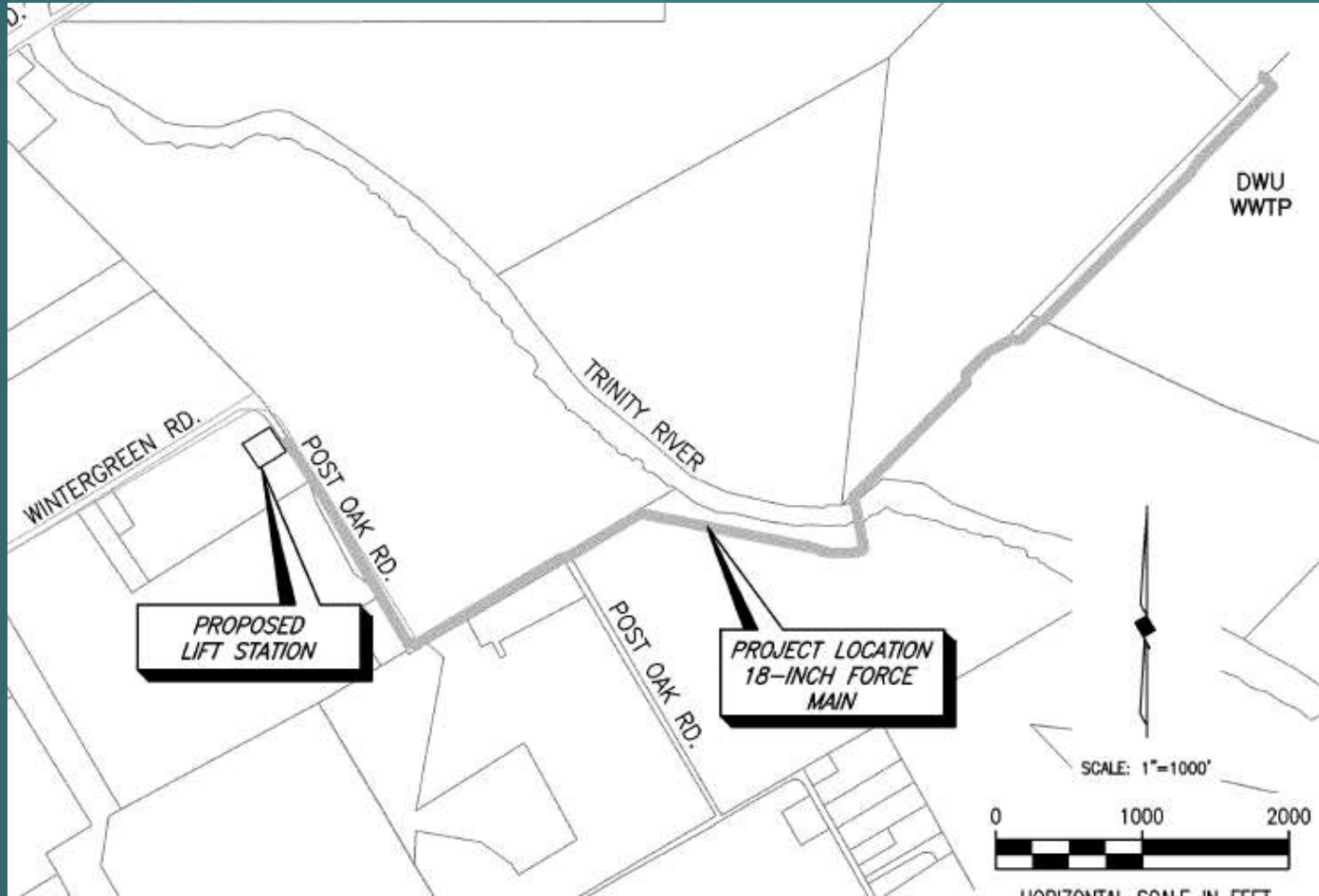

New City Hall Construction

Section F, Item 2.



Capital Projects Update

Mamun Yusuf, PE, Director of Public Works



Street Improvement Projects

Section F, Item 2.



#	Street	Asphalt/Concrete	PCI	Length (ft)	Width (ft)	Volume (CY)	Unit Cost	Total Cost
1	Breneman Street	Asphalt	6	900	28	25,200	\$4.00	\$136,080
2	Burns Drive	Asphalt	6	300	28	8,400	\$4.00	\$45,360
3	Crockett Drive	Asphalt	6	500	28	14,000	\$4.00	\$75,600
4	Dowdy Ferry Road	Asphalt	6	6,600	28	184,800	\$4.00	\$997,920
5	East Athens Street	Asphalt	6	1,100	28	30,800	\$4.00	\$166,320
6	East Dallas Street	Asphalt	6	500	28	14,000	\$4.00	\$75,600
7	East Hickman Street	Asphalt	6	500	28	14,000	\$4.00	\$75,600
8	East Wintergreen Road	Asphalt	6	2,600	28	72,800	\$4.00	\$393,120
9	Glenhaven Drive	Asphalt	6	900	28	25,200	\$4.00	\$136,080
10	Glenview Drive	Concrete	6	800	28	22,400	\$12.00	\$362,880
11	Goode Road	Asphalt	6	2,100	28	58,800	\$4.00	\$317,520
12	Kanady Street	Asphalt	6	1,300	28	36,400	\$4.00	\$196,560
13	Lec Lane	Asphalt	6	850	28	23,800	\$4.00	\$128,520
14	Michael Street	Asphalt	6	550	28	15,400	\$4.00	\$83,160
15	Millers Ferry Road	Asphalt	6	3,700	28	103,600	\$4.00	\$559,440
16	Murray Street	Asphalt	6	800	28	22,400	\$4.00	\$120,960
17	North Austin Street	Asphalt	6	650	28	18,200	\$4.00	\$98,280
18	North JJ Lemmon Street	Concrete	6	3,200	28	89,600	\$12.00	\$1,451,520
19	North Main Street	Asphalt	6	1,650	28	46,200	\$4.00	\$249,480
20	Post Oak Road	Asphalt	6	1,000	28	28,000	\$4.00	\$151,200
21	Prasifka Street	Asphalt	6	550	28	15,400	\$4.00	\$83,160
22	South Austin Street	Asphalt	6	1,250	28	35,000	\$4.00	\$189,000
23	South Jj Lemmon Street	Asphalt	6	650	28	18,200	\$4.00	\$98,280
24	South Mills Street	Asphalt	6	4,000	28	112,000	\$4.00	\$604,800
25	Vanderbilt Road	Asphalt	6	4,000	28	112,000	\$4.00	\$604,800
26	West Dallas Street	Asphalt	6	1,300	28	36,400	\$4.00	\$196,560
27	West Hickman Street	Asphalt	6	2,800	28	78,400	\$4.00	\$423,360
28	West Wintergreen Road	Concrete	6	8,000	44	352,000	\$12.00	\$5,702,400
29	Woodbrook	Concrete	6	600	28	16,800	\$12.00	\$272,160
30	Woodcrest Lane	Concrete	6	600	28	16,800	\$12.00	\$272,160
Total								\$14,267,880

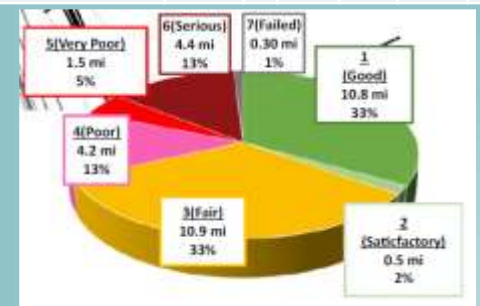

Water & WW Improvement Projects

Location	Start Point	End Point	Length	# of current connections	Current main material and size	Main type	Comments	Est. Cost
N Denton	Ayers	Loop 310	1,235	0	6" Clay tile	Sewer	Main has cracking and root penetration.	\$617,500.00
O'Dell and Denton	W. Palestine	W. Hickman (dead end)	668	25	6" clay tile	Sewer	Main has cracking and root penetration.	\$334,000.00
Ayres	JJ Lemmon	N. Denton	1,257	24	6" clay tile	Sewer	Main has cracking and root penetration.	\$628,500.00
W. Hickman	Lancaster Hutchins	N. Main	2,900	30	8" ductile iron	Water	Main has had several breaks and is in poor condition.	\$1,305,000.00
W. Palestine	Lancaster Hutchins	O'Dell	2,234	25	6" ductile iron	Water	Main has had several breaks and is in poor condition.	\$1,005,300.00
N. Pacific	E. Athens	Fannin St	1,200	7	2" Galvanized	Water	Main is in serious condition and needs to be upsized to 6"	\$540,000.00
Crockett	W. Palestine	JJ Lemmon	1,074	29	3" PVC	Water	Main needs to be 6" to add hydrant	\$483,300.00
Franklin	W. Palestine	W. Hickman	574	4	4" ductile	Water	No fire protection for apartments needs to be 6"	\$258,300.00
Ayres	JJ Lemmon	N. Denton	1,257	12	6" Ductile iron	Water	Main is in poor condition	\$565,650.00
S Denton	Cambell Park	Breneman	1,250	6	4" Galvanized	Water	Dead end main	\$562,500.00
							Total	\$6,300,050.00

Pump, LS & Tank Projects

Section F, Item2.

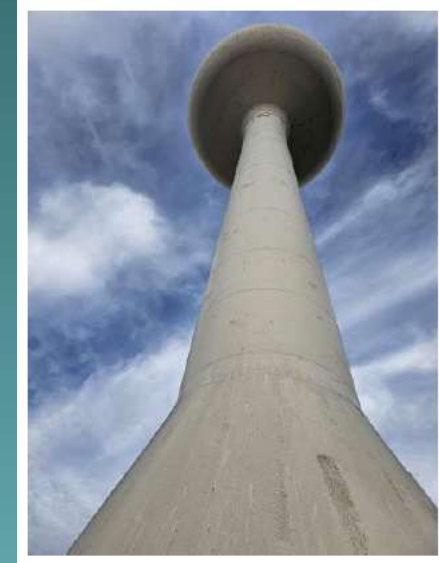

Water Pump Station	Replace Pump #4	\$75,000.00
Water Tank Rehab	Wintergreen 0.3 MG Tank Rehab	\$500,000.00
Dallas Lift Station	Backup Generator	\$125,000.00
	Pump #2 Repl.	\$32,950.00
	Total	\$732,950.00

Equipment Projects

Section F, Item2.

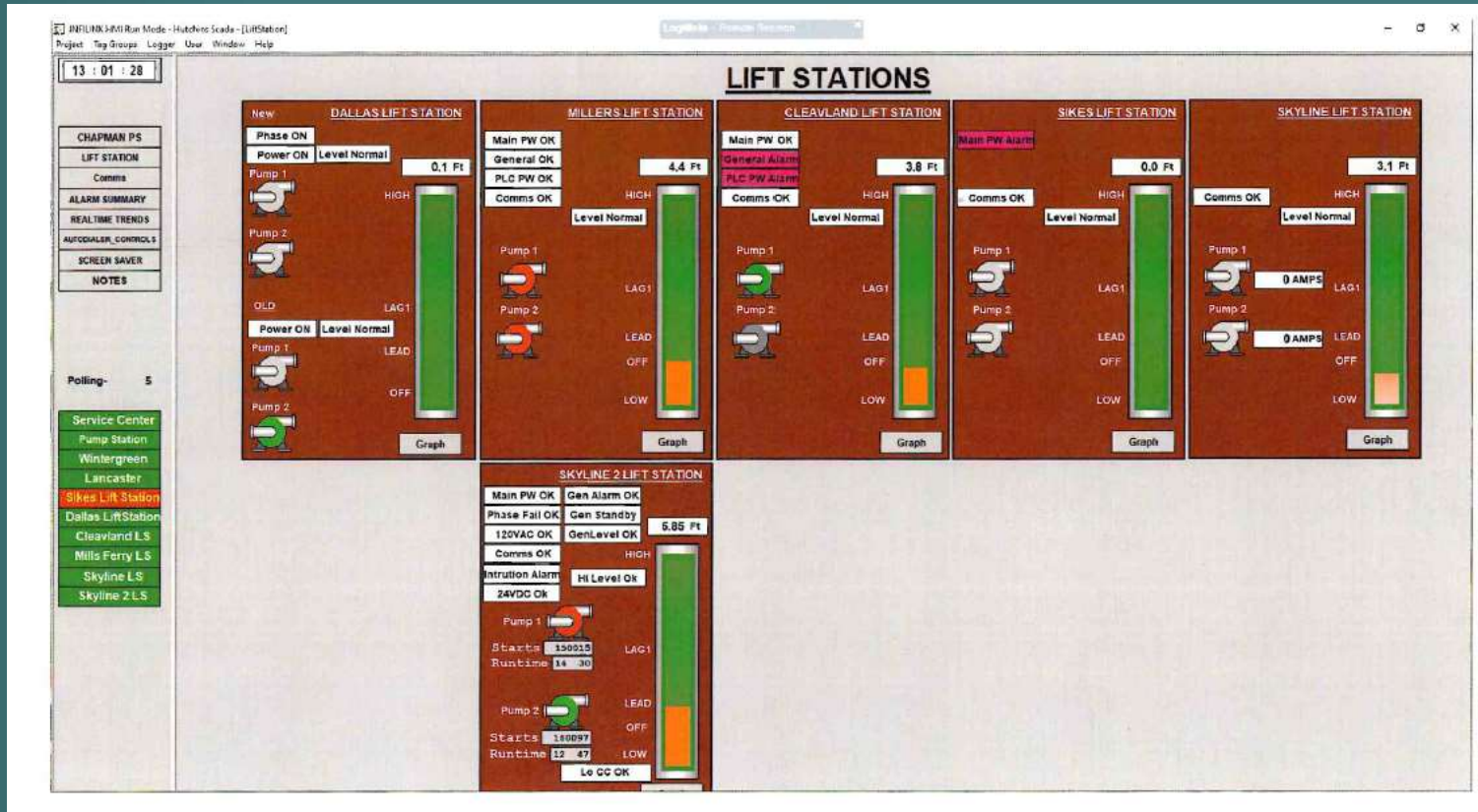

Equipment	2025
1 Boom Mowe with Tractor	\$190,000
2 Street Sweeper	\$25,000
Backup Generator for SCADA	
3 System	\$20,000

Vehicle Replacement Projects

NO.	Unit Number	License Plate	VIN	MAKE	MODEL	YEAR	MILES
PUBLIC WORKS							
1	227	1244948	1FTRF12W66NB66841	FORD	F-150	2006	117,786
2	229	1282376	1GCVKNEC2GZ186940	CHEVROLET	SILVERADO	2016	93,708
3	337	1244949	1FDWF36Y28EA08702	FORD	F-350	2007	42,820
4	330	1384563	3GCUKNEC9JG364779	CHEVROLET	SILVERADO	2018	40,343
5	348	1585782	1FTMF1E54PKF74674	FORD	F-150	2023	1,105
WATER/SEWER							
1	333	1241916	1FTRF12W86NB27068	FORD	F-150	2006	130,512
2	338	1196551	1D7HA18N78J181292	DODGE	RAM	2008	141,894
3	340	1359312	1FDWF7DC2GDA04118	FORD	F-750	2016	8,736
4	344	1368008	1FD8X3HT8HEF01033	FORD	F-350	2017	36,623
5	345	1573195	1FTFW1E55PKE89335	FORD	F-150	2023	7,451
6	346	1573194	1FTFW1E58PKE89376	FORD	F-150	2023	10,292
FLEET							
1	121	806903	1FTYR1OUX1PB23086	FORD	RANGER	2001	179,882

Sidewalk Improvement Projects

Section F, Item 2.

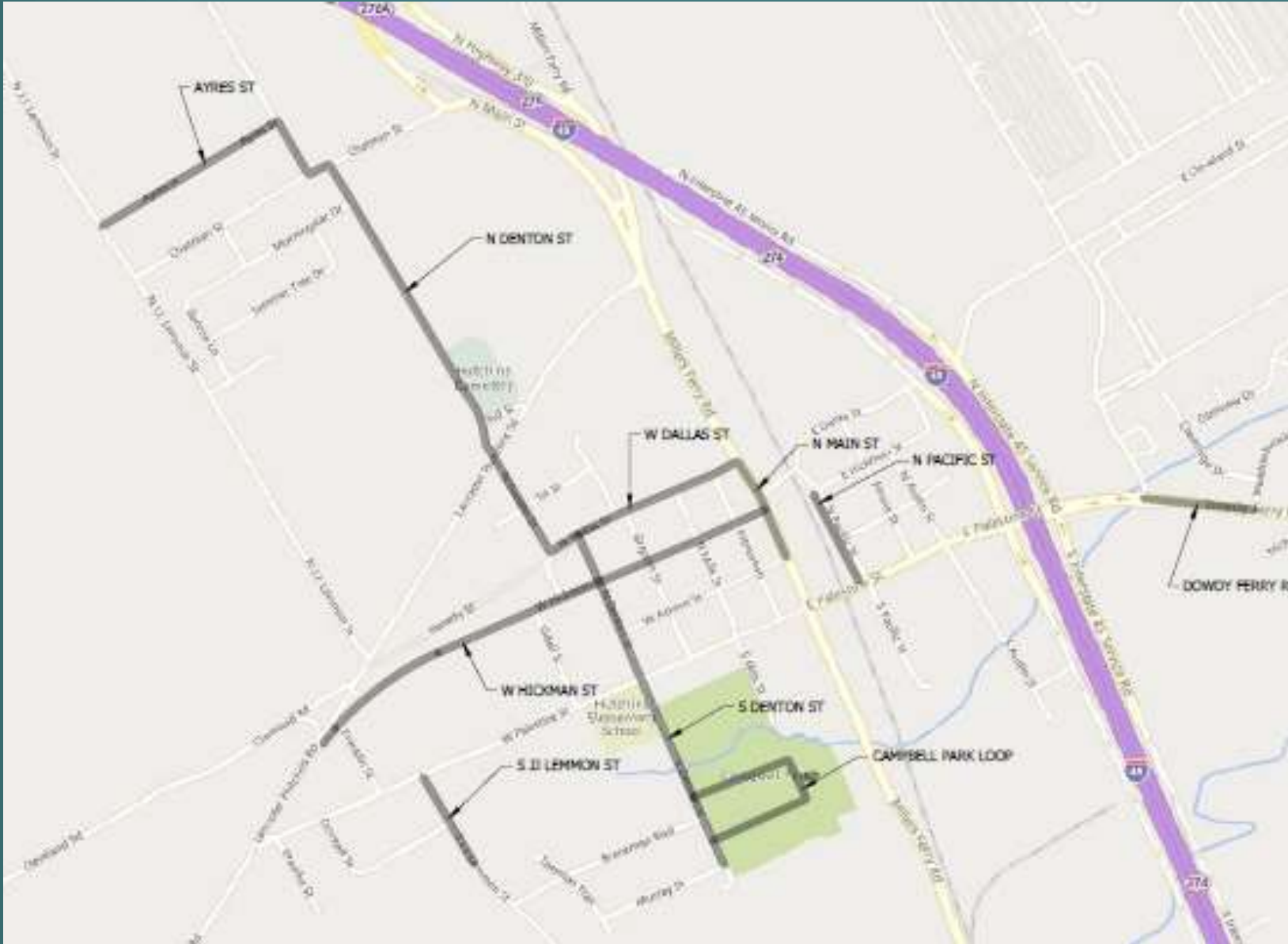

West Hickman	\$143,664.40
North Main	\$25,550.80
South JJ Lemmon	\$25,787.30
North Pacific	\$23,606.00
W Dallas	\$55,000.00
Dowdy Ferry	\$36,656.40
Quail Run Modification	\$38,500.00
Total	\$348,764.90

Park Security Camera Project

Section F, Item2.



LIVE
DEMO

SEE THE SENTRY OPERATING LIVE!

LEARN ABOUT:

Active deterrence

How the Sentry works

Remote management & support

Options, Sentry customization & pricing

Why Backstreet Surveillance is the right choice



Sentry-Pro Mobile Surveillance Trailer

Direct Purchase

- Compact, high performance, 4K Video Surveillance Trailer. Supports (4) PTZ Cameras & 120dB Talk-down Speakers. Solar-powered with (4) days of battery backup.

\$43,999.00

UPRR Sidewalk Improvement

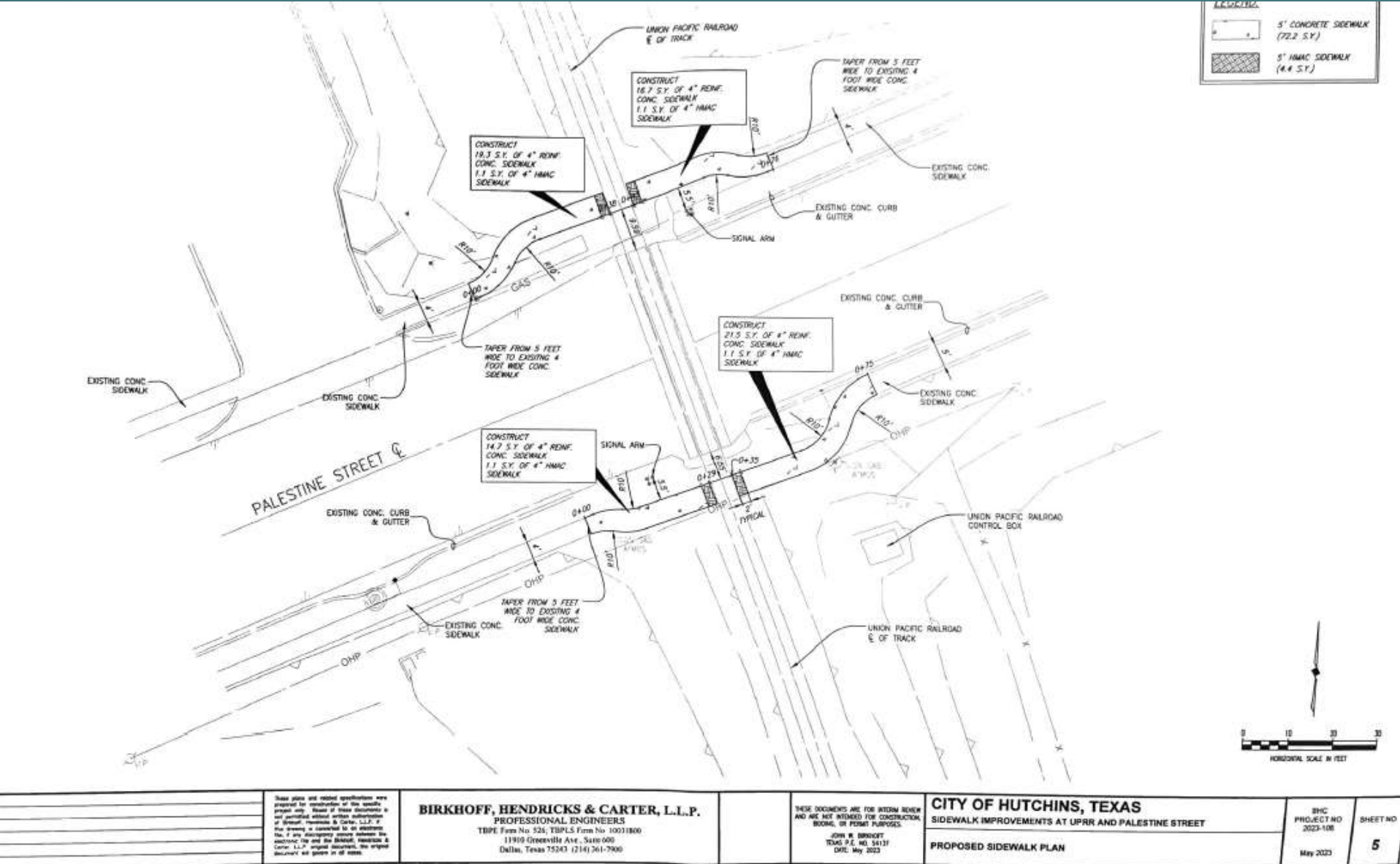

<p>These plans and related specifications were prepared for reproduction of the same. No part of these documents is to be reproduced without written authority of Birkhoff, Hendricks & Carter, L.L.P. If any discrepancy arises between the contract and the Birkhoff, Hendricks & Carter L.L.P. original documents, the original documents shall govern in all cases.</p>

BIRKHOFF, HENDRICKS & CARTER, L.L.P.
 PROFESSIONAL ENGINEERS
 TBPE Firm No 524, TBPLS Firm No 10011800
 11919 Greenville Ave., Suite 000
 Dallas, Texas 75243 (214) 361-7900

THESE DOCUMENTS ARE FOR INTERIM REVIEW AND ARE NOT INTENDED FOR CONSTRUCTION, BIDDING, OR PERMIT PURPOSES.
 JOHN W. BIRKHOFF
 TEXAS P.E. NO. 54131
 DATE: May 2023

CITY OF HUTCHINS, TEXAS
 SIDEWALK IMPROVEMENTS AT UPRR AND PALESTINE STREET
PROPOSED SIDEWALK PLAN

BHC PROJECT NO 2023-108 May 2023	SHEET NO 5
---	----------------------

Chapman Street Concrete Paving

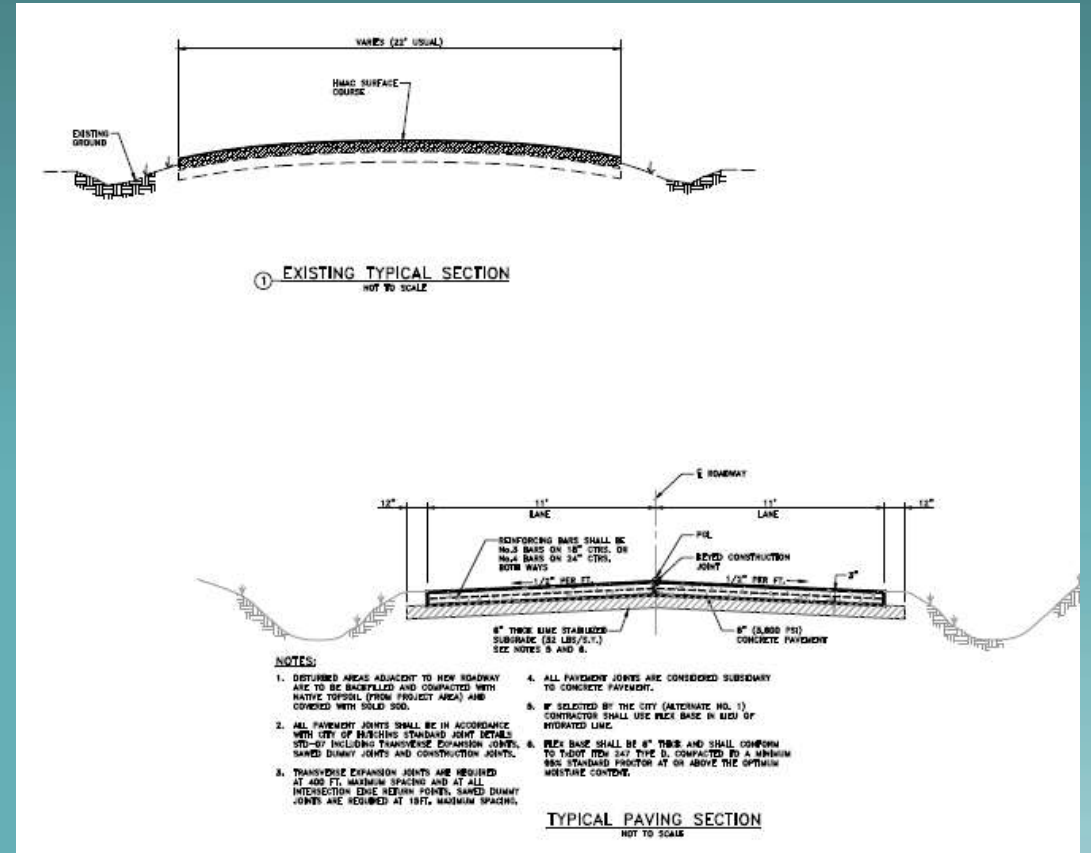
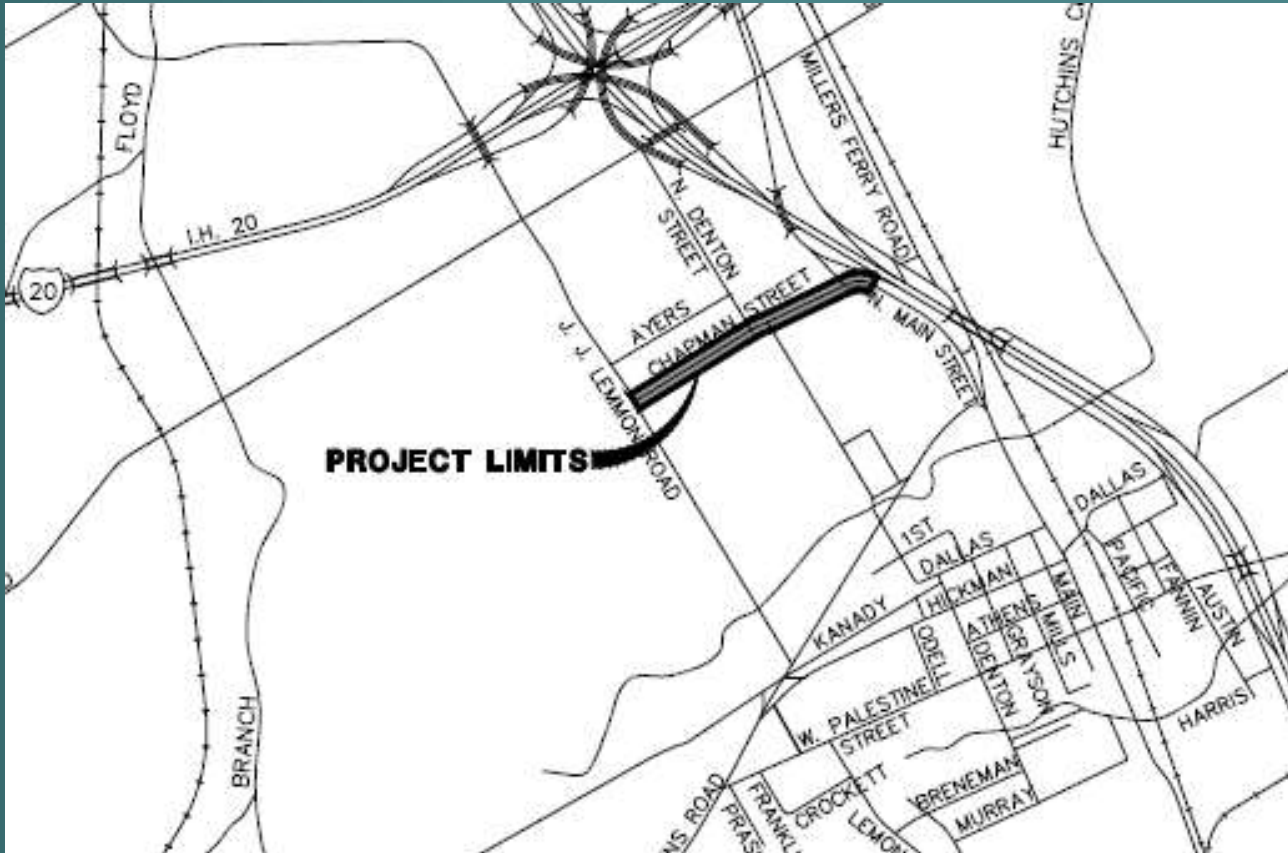

Nichols Dr. Sanitary Sewer Improvement



Cleveland 18" Wastewater Main

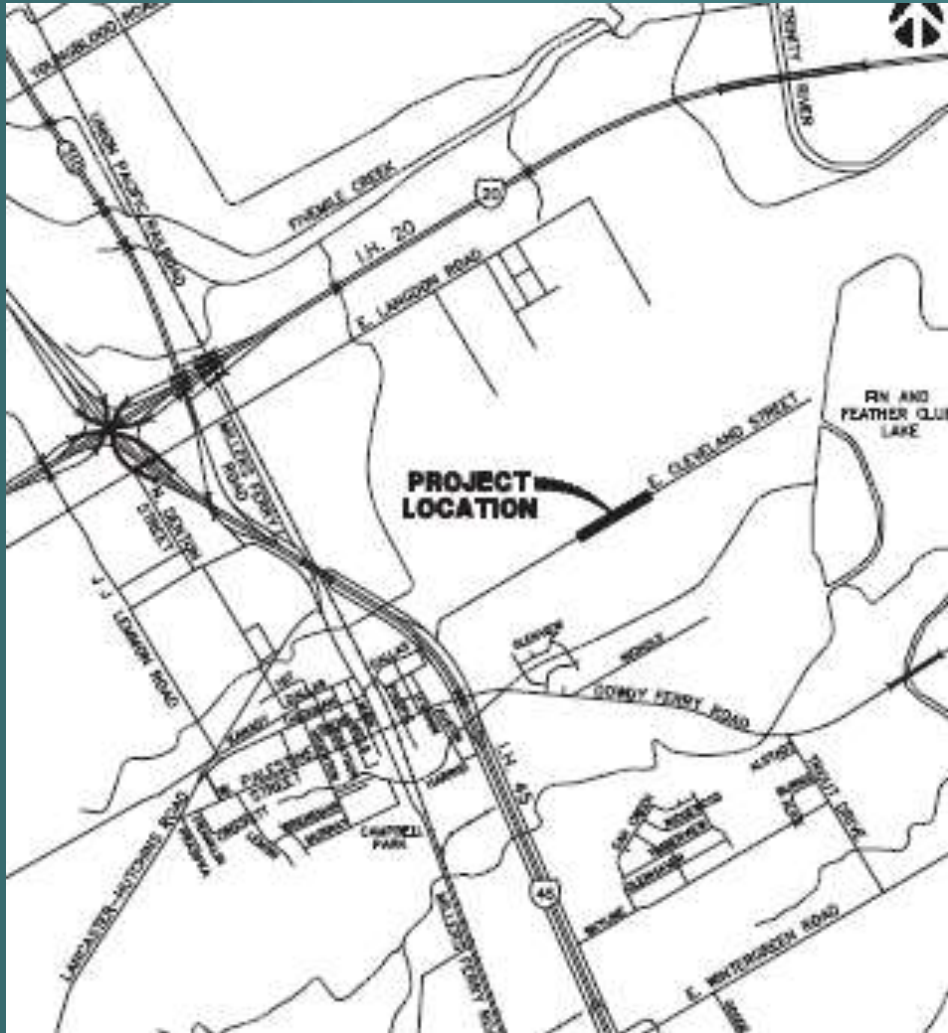

Campbell Park Pavilion

Section F, Item 2.



Campbell Park Restroom

Building Code Council
IBC X IRC
Approval Date: 4/30/2024
Approved
ICC NTA, LLC
IHDRA-11

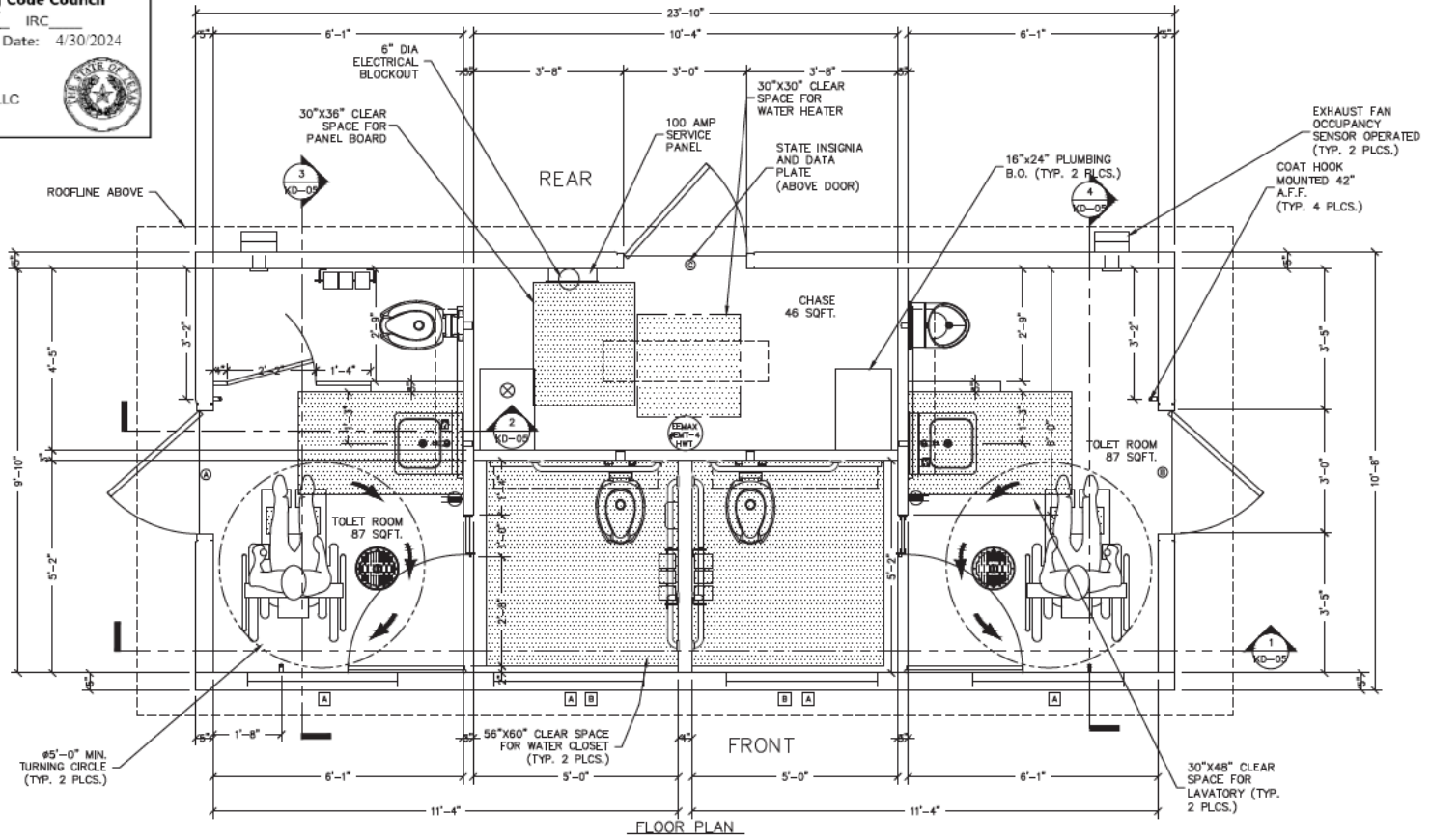

Meadowbrook Channel Improvement

- UNDERGROUND UTILITIES SHOWN HEREON WERE TAKEN FROM RECORD INFORMATION. ACTUAL LOCATIONS WERE NOT FIELD VERIFIED EXCEPT AT SURFACE STRUCTURES SUCH AS MANHOLES, FIRE HYDRANTS, ETC. NO ATTEMPT HAS BEEN MADE AS A PART OF THE SURVEY TO CONFIRM, OBTAIN OR SHOW DATA CONCERNING THE DEPTH OR CONDITION OF ANY UTILITY OR MUNICIPAL/PUBLIC SERVICE FACILITY. SUBSURFACE AND ENVIRONMENTAL CONDITIONS WERE NOT EXAMINED OR CONSIDERED AS A PART OF THIS SURVEY. NO STATEMENT IS MADE CONCERNING THE EXISTENCE OF UNDERGROUND OR OVERHEAD CONTAINERS OR FACILITIES, WHICH MAY AFFECT THE USE OR DEVELOPMENT OF THE SUBJECT TRACT OF LAND.
- ALL VISIBLE UNDERGROUND UTILITIES THAT WERE MARKED FROM TEXAS ONE CALL 811 ARE SHOWN ON THIS SURVEY. UNDERGROUND SEWER, WATER AND STORM DRAIN LINES SHOWN ARE FROM VISIBLE EVIDENCE AND PROVIDED UTILITY PLANS. PIPE SIZES OF ALL UNDERGROUND UTILITIES WERE UNKNOWN AT THE TIME OF SURVEY.
- THE SIZE OR SHAPE OF THE TREE/BUSH SYMBOLS INCLUDED HEREON DO NOT NECESSARILY REPRESENT THE ACTUAL SIZE AND SHAPE OF THE CORRESPONDING TREES/BUSHES OR THEIR CANOPIES. THEY REPRESENT LOCATION ONLY.

4	8924317.46	2522030.40	454.28	SAC5S
5	8924273.82	2521723.69	456.47	CP X
6	8924028.73	2521549.77	424.85	CP X
7	8924412.23	2522186.76	412.94	SAC5S
8	8924482.74	2521332.30	418.19	CP X

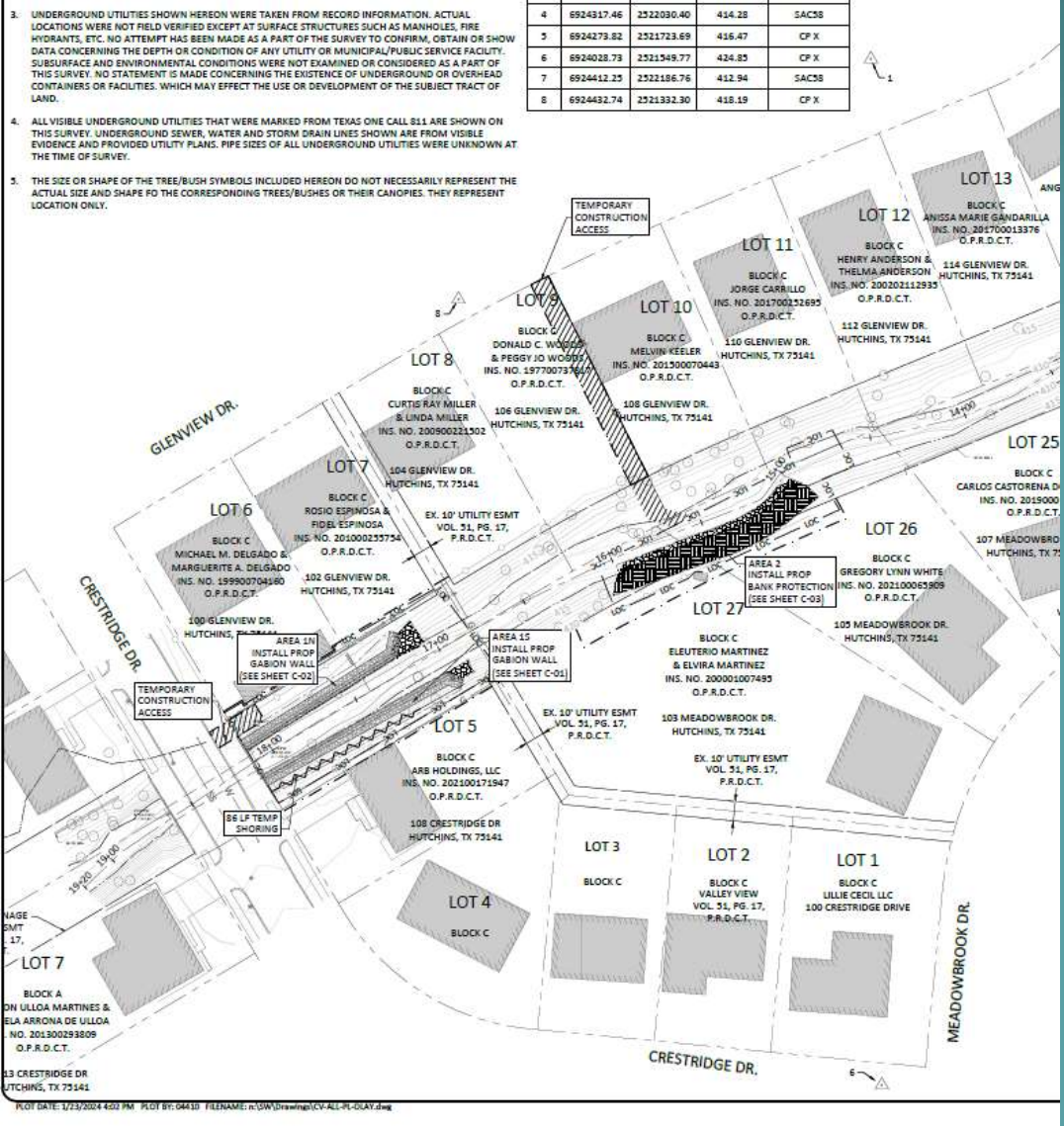

Sidewalk Improvement

Section F, Item 2.

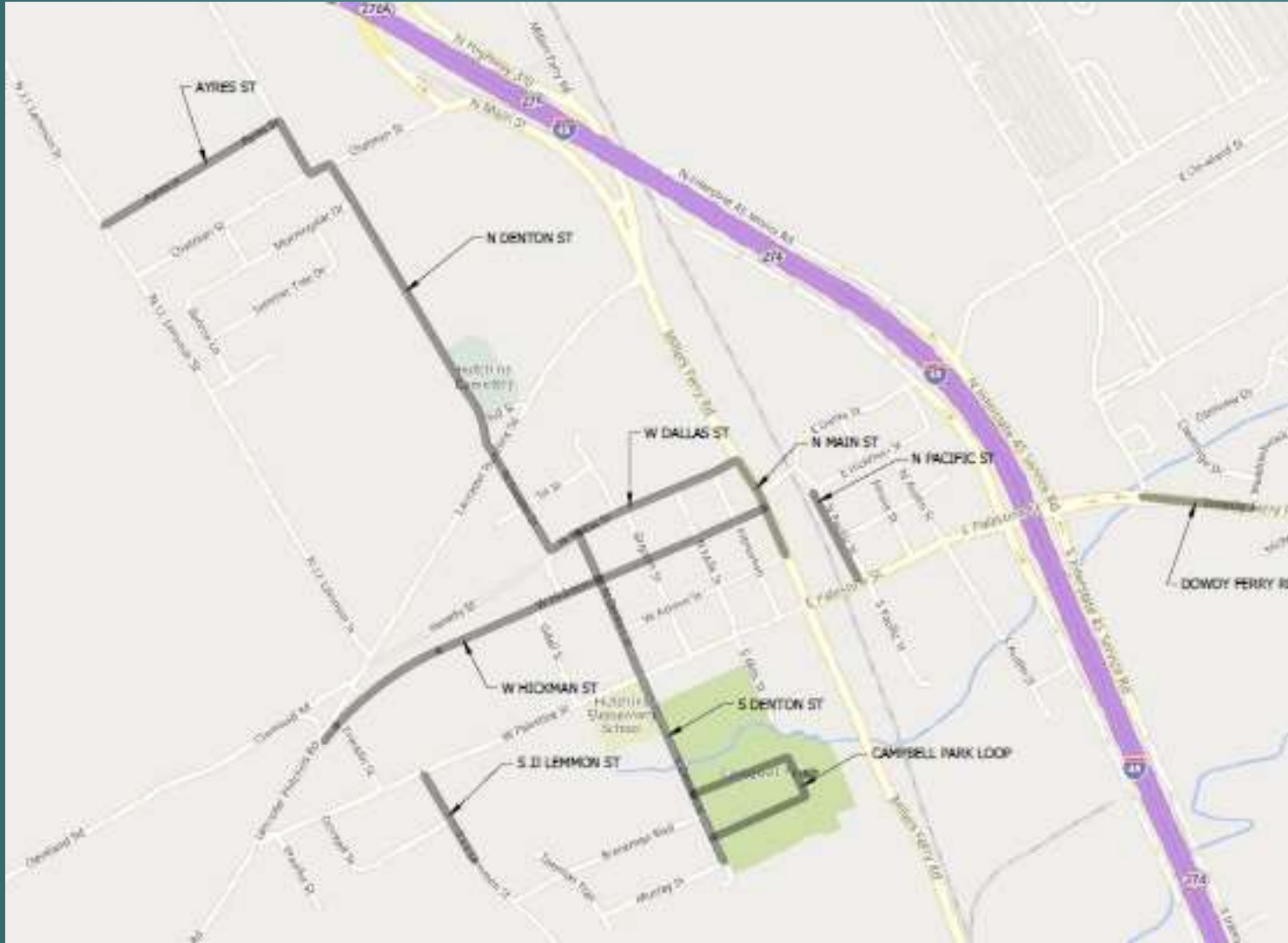

Southern WW Interceptor

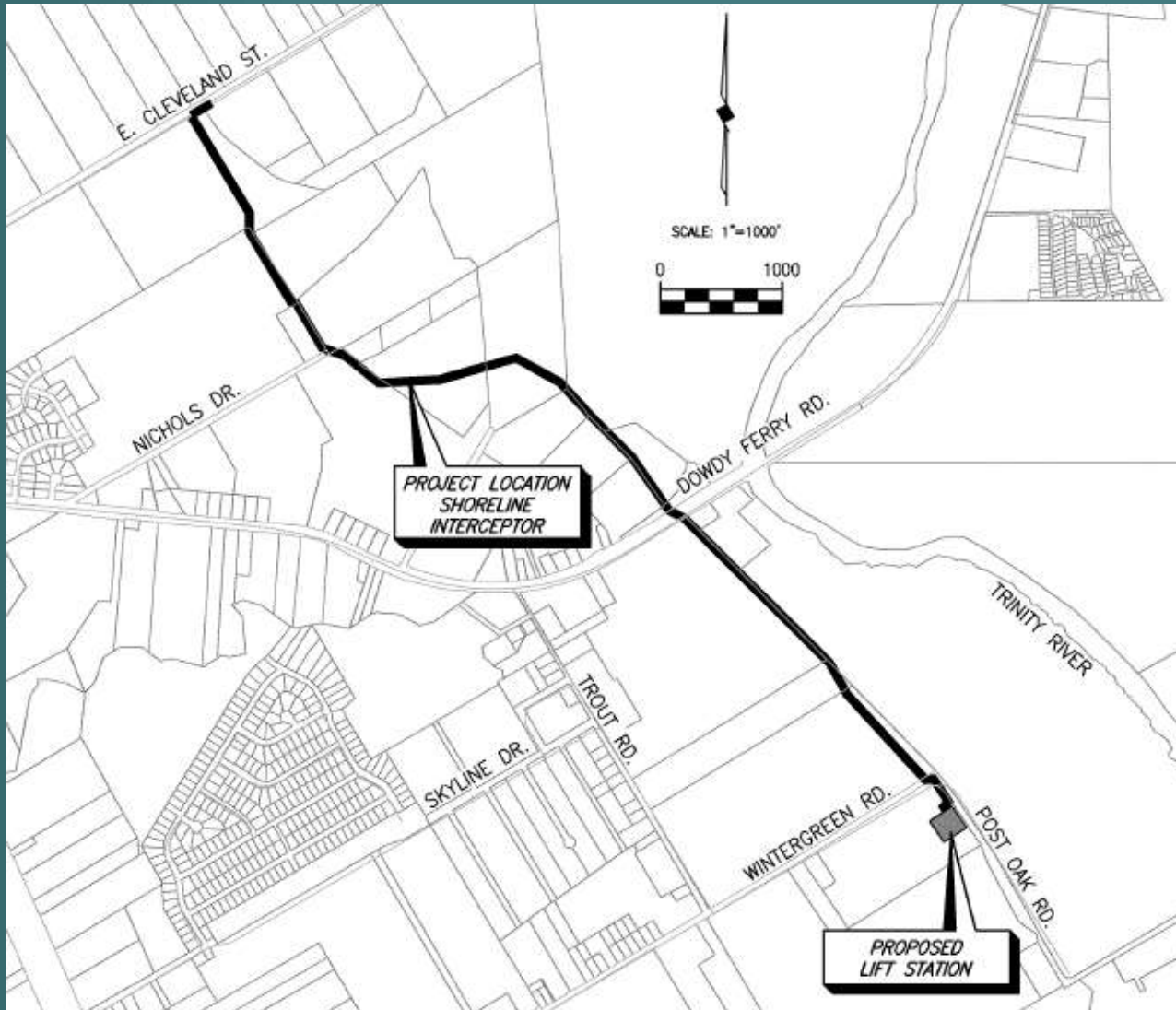

Southern Lift Station

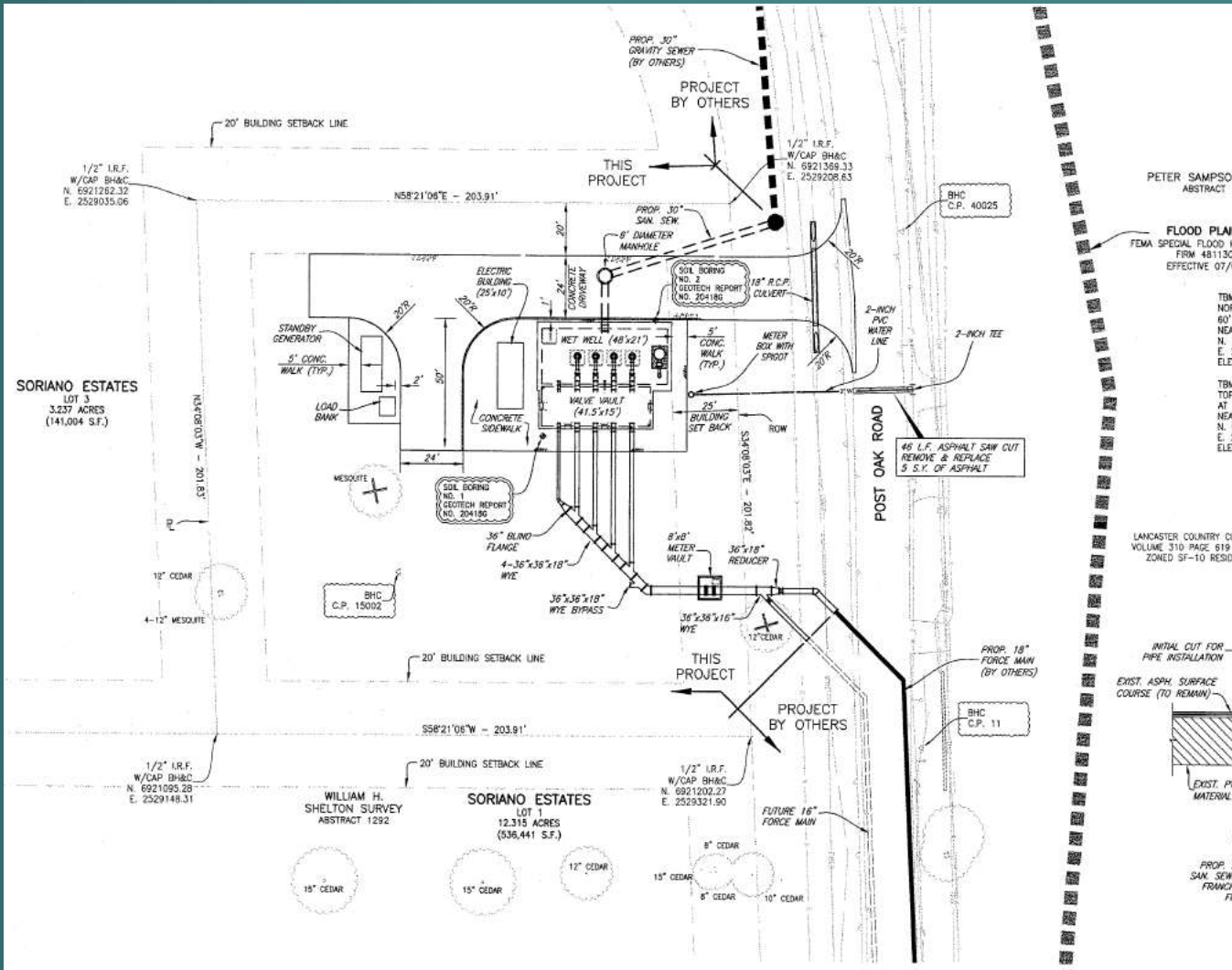

PETER SAMPSON
ABSTRACT 12

FLOOD PLAIN
FEMA SPECIAL FLOOD HQ
FIRM 48113C05
EFFECTIVE 07/07

TBM 1
NORTH
60' S.
NEAR
N. 89
E. 25.
ELEV.

TBM 3
TOP C
AT BE
NEAR
N. 89
E. 25.
ELEV.

LANCASTER COUNTRY CLUB
VOLUME 310 PAGE 819 D.
ZONED SF-10 RESIDEN

INITIAL CUT FOR
PIPE INSTALLATION
EXIST. ASPH. SURFACE
COURSE (TO REMAIN)

EXIST. PAVK
MATERIAL (

6"

PROP. ST.
SAN. SEW.
FRANCHISE
FEE



Southern Force Main

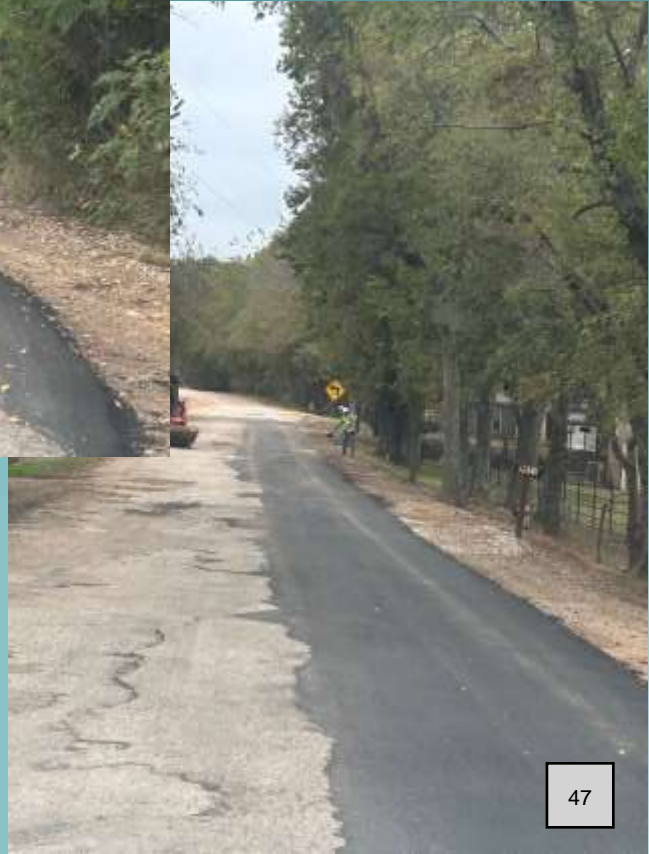
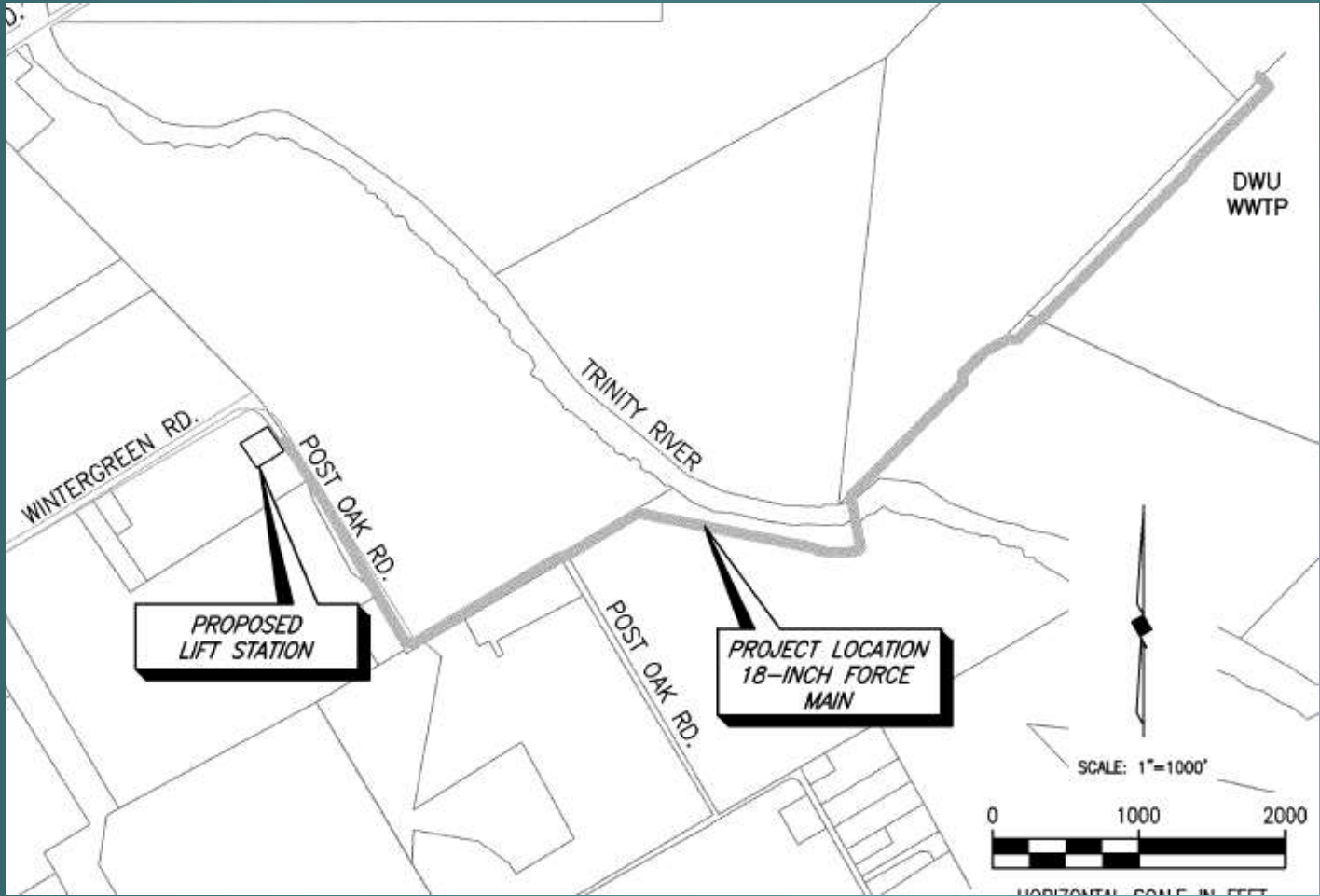

New City Hall Construction

Section F, Item 2.





STAFF REPORT

MEETING DATE: January 21, 2025

MEETING TYPE: City Council

SUBMITTED BY: Mamun Yusuf

AGENDA CAPTION: Discuss and consider Resolution R2025-01-1233 OF THE CITY COUNCIL OF THE CITY OF HUTCHINS, TEXAS, ACCEPTING THE BUYBOARD PROPOSAL RECEIVED IN ASSOCIATION WITH THE REHABILITATION OF N. DENTON STREET WASTEWATER MAIN PROJECT; AUTHORIZING THE CITY ADMINISTRATOR TO NEGOTIATE AND EXECUTE AN AGREEMENT WITH INSITUFORM TECHNOLOGIES, LLC, IN AN AMOUNT NOT TO EXCEED \$139,340.00; AND PROVIDING FOR AN EFFECTIVE DATE. Presented by: Mamun Yusuf, Director of Public Works

Background Information

Staff received a buy-board (Statewide Cooperative Purchasing Contract) proposal from INSITUFORM TECHNOLOGIES, LLC to furnish all labor, materials, equipment, and services necessary to rehabilitate 1,385 LF of sanitary sewer main on N. Denton Street for \$139,340.00.

Budget Implications

\$139,340.00

Operational Impact

N/A

Legal Review

N/A

Staff Recommendation

Staff recommends approving resolution R2025-01-1233

Supporting Documentation and Attachments

Hutchins Web Map

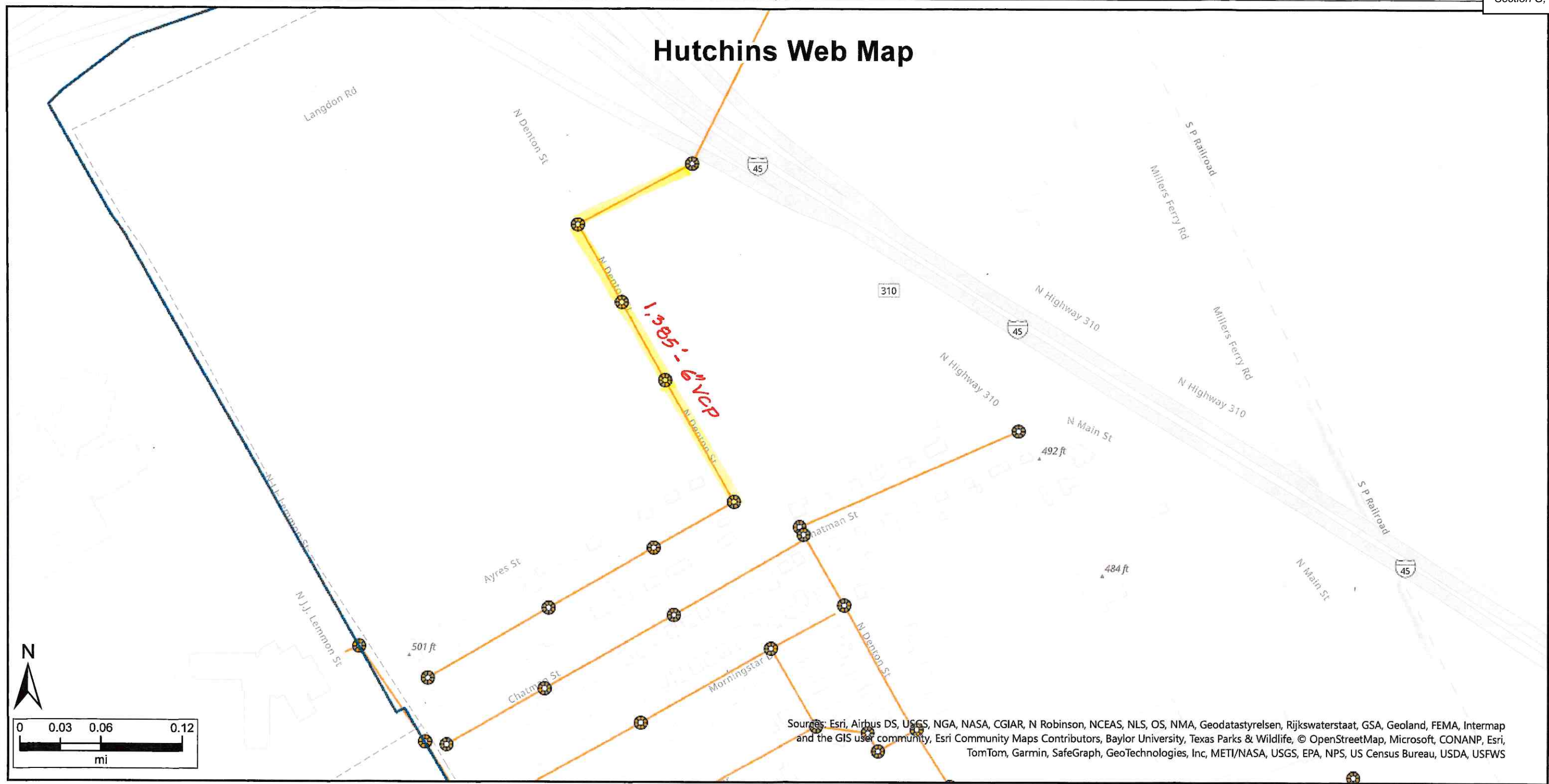

Sources: Esri, Airbus DS, USGS, NGA, NASA, CGIAR, N Robinson, NCEAS, NLS, OS, NMA, Geodatastyrelsen, Rijkswaterstaat, GSA, Geoland, FEMA, Intermap and the GIS user community, Esri Community Maps Contributors, Baylor University, Texas Parks & Wildlife, © OpenStreetMap, Microsoft, CONANP, Esri, TomTom, Garmin, SafeGraph, GeoTechnologies, Inc, METI/NASA, USGS, EPA, NPS, US Census Bureau, USDA, USFWS

- Legend**
- Hutchins ETJ Boundary
 - City Limit (Outline)
 - Sewer Manhole
 - Existing
 - Proposed
 - Existing; to be Abandoned
 - Unknown



Date: 11/13/2024

**CITY OF HUTCHINS, TEXAS
RESOLUTION NO. R 2025-1233**

A RESOLUTION OF THE CITY COUNCIL OF THE CITY OF HUTCHINS, TEXAS, ACCEPTING THE BUYBOARD PROPOSAL RECEIVED IN ASSOCIATION WITH THE REHABILITATION OF N. DENTON STREET WASTEWATER MAIN PROJECT; AUTHORIZING THE CITY ADMINISTRATOR TO NEGOTIATE AND EXECUTE AN AGREEMENT WITH INSITUFORM TECHNOLOGIES, LLC, IN AN AMOUNT NOT TO EXCEED \$139,340.00; AND PROVIDING FOR AN EFFECTIVE DATE.

WHEREAS the City accepted the buy-board proposal for the N. Denton Street Wastewater Main Improvement Project (“the “Project”); and

WHEREAS the City has accepted the buy-board proposal of Insituform Technologies, LLC for the Project; and

WHEREAS the City Council of the City of Hutchins finds it in the best interest to the residents and businesses of the City of Hutchins to accept the buy-board proposal of Insituform Technologies, LLC, for the Project in an amount not to exceed \$139,340.00.

NOW, THEREFORE, BE IT RESOLVED BY THE CITY COUNCIL OF THE CITY OF HUTCHINS, THAT:

SECTION 1. The City, acting through its governing body, hereby confirms that it accepts the buy-board proposal received by the City’s Department of Public Works on June 11, 2024.

SECTION 2. The City, acting through its governing body, hereby confirms that it awards the Project to Insituform Technologies, LLC, at the submitted buy-board proposal of \$107,607.50 as set forth in Exhibit “A” attached hereto and incorporated herein by reference.

SECTION 4. For and on behalf of the City Council, the City Administrator is hereby authorized to negotiate and execute a contract with Insituform Technologies, LLC, in the amount not to exceed \$139,340.00 for the Project.

SECTION 5. This Resolution shall become effective immediately from and after its passage.

DULY RESOLVED AND ADOPTED by the City Council of the City of Hutchins, Texas, this the 21st day of January 2025.

CITY OF HUTCHINS, TEXAS

Mario Vasquez, Mayor

ATTEST:

Cynthia Olguin, City Secretary

EXHIBIT "A"
Insituform Technologies, LLC Bid



Tim Peterie
 Phone: 214-317-0950
 Email: tpeterie@azuria.com
 1103 Postwood Dr.
 Corinth, TX 76210

November 22, 2024

SF#: SO-00199600

Mr. Mamun Yusuf, PE
 City of Hutchins
 321 N Main St
 Hutchins, TX 75141

Buyboard Proposal

**Project Name: City of Hutchins, TX – N Denton St & I-45 Sewer Rehabilitation
 6” to 8” Rehabilitation by Pipe Burst**

INSITUFORM TECHNOLOGIES, LLC herein proposes to furnish a Proposal for all labor, materials, equipment, and services necessary to reconstruct the referenced project (as detailed in the project location map provided by the City of Hutchins) utilizing the Local Purchasing Cooperative Contract #730-24, administered through the Buyboard.

ASSUMPTIONS AND QUALIFICATIONS

We have based this proposal on a nominal wall thickness as shown in the price. This is based on the best available information at the time of this proposal. Existing pipe deterioration in excess of the conditions assumed, ground water loads in excess of those assumed, or other loads or conditions may increase the recommended thickness for all or portions of the work. Final recommendations may be submitted to you following the completion of the preliminary TV phase of the project. Stated prices are subject to adjustment if design changes are agreed upon.

Water shall be provided at no cost to Insituform Technologies, LLC for all construction phases of this project. The Owner shall furnish Insituform Technologies, LLC with required water meters and pay all associated fees, deposits, and charges. Insituform Technologies, LLC will follow all required backflow prevention and metering procedures.

Insituform will supply the City of Hutchins a Certificate of Insurance following acceptance of this proposal. If necessary, a 1-year Maintenance or Performance Bond will be supplied. The pricing in this proposal assumes all Technical Specifications set forth by the Buyboard will be strictly adhered to. Any changes to these specifications must be noted and agreed upon by both parties prior to finalizing the proposal pricing.

PROPOSAL PRICING

PAY ITEM NO.	DESCRIPTION	APPROX QTY	U/M	UNIT PRICE	ESTIMATED AMOUNT
1	Mobilization – Pipe Burst Crew	1	LS	\$7,500.00	\$7,500.00
2	Clean/TV 6” Sanitary Sewer	1,385	LF	\$6.00	\$8,310.00
3	Pipe Burst 6” with 8” HDPE SDR 19 (0’-8’ deep)	1,385	LF	\$65.50	\$90,717.50
4	Access Pits (0’-8’ deep)	3	EA	\$1,500.00	\$4,500.00
5	External Service Reconnects (0’-8’ deep) if needed	1	EA	\$1,350.00	\$1,350.00
6	Obstruction Removals by Point Repair – (0’-8’ deep)	2	EA	\$3,350.00	\$6,700.00
7	Repair/Rehab Asphalt Pavement (QTY TBD)	5	SY	\$165.00	\$825.00
8	8” Post TV Inspection After Rehabilitation	1,385	LF	\$2.50	\$3,462.50
9	Traffic Control	5	DAY	\$500.00	\$2,500.00
10	Bypass Pumping	3	DAY	\$625.00	\$1,875.00
11	General Restoration	1	LS	\$4,000.00	\$4,000.00
12	Owner Contingency Allowance	1	AL	\$5,000.00	\$5,000.00
13	Bonds and Insurance	1	LS	\$2,600.00	\$2,600.00
TOTAL					\$139,340.00

A tax-exempt certificate will need to be provided prior to mobilization.

PROPOSAL INCLUSIONS

The prices stated in this proposal include:

1. Mobilizations and demobilization.
2. Cleaning and Pre-Video inspections and documentation of existing pipe prior to reconstruction.
3. HDPE pipe and fusion for pipe bursting.
4. Traffic control.
5. Service lateral reconnection if necessary.
6. Bypass pumping as needed.
7. Final video inspection following completion of the installation to document your new pipe rehabilitated.
8. Surface restoration.
9. Confined space safe entry practices.
10. One-year standard construction warranty.
11. Certificate of insurance with a standard coverage and Bonds.

PROPOSAL EXCLUSIONS

Not included in the prices stated in this estimate are costs associated with the items listed below. These items, if needed or found to be applicable, would be provided by **INSITUFORM TECHNOLOGIES, LLC** at your additional cost; or would be furnished by others, at your direction, at no cost to **INSITUFORM TECHNOLOGIES, LLC**:

- a) If preliminary video inspection of the pipe interior indicates excessive damage, or other extra-ordinary condition, which will require excavation to prepare the pipe for installation, then those services will be provided by Insituform at the prices included above and may utilize the contingency allowance if necessary.
- b) Water from fire hydrants within a convenient distance from each cleaning site location.
- c) *If any hazardous or toxic materials are encountered during the project, the Owner will be responsible for the removal and disposal of the materials.*
- d) Project permits and/or local licenses.
- e) State and local sales and/or use taxes on the value of the project. If you are exempt, please submit the appropriate documentation.
- f) Additional premiums for special insurance coverage(s) demanded by you or other parties particular to this project.

PROPOSAL TERMS AND CONDITIONS

- a) Limits of Liability. In consideration of **INSITUFORM TECHNOLOGIES, LLC**'s agreement to maintain no less than \$5,000,000 of comprehensive general liability insurance in the form required by the Contract, **INSITUFORM TECHNOLOGIES, LLC**'s liability to the Owner for any matter covered by such insurance will be limited to the extent of such insurance and the Owner will indemnify and hold **INSITUFORM TECHNOLOGIES, LLC** harmless from any third-party claims covered by such insurance to the extent such claims exceed the limits of such insurance. Neither party shall be liable to the other for consequential damages relating to the contract. In case of conflict between this provision and any other provision in the Contract as ultimately executed, this provision shall govern and prevail.
- b) LIMITED WARRANTY. IN LIEU OF ALL OTHER EXPRESSED, IMPLIED AND/OR STATUTORY WARRANTIES, INCLUDING WARRANTIES OF MERCHANTABILITY AND FITNESS FOR A PARTICULAR PURPOSE, CONTRACTOR AGREES TO CORRECT ANY DEFECTS IN THE MATERIALS OR SERVICES PROVIDED BY CONTRACTOR WHICH ARE BROUGHT TO THE ATTENTION OF CONTRACTOR WITHIN ONE YEAR FOLLOWING COMPLETION OF CONTRACTOR'S WORK, PROVIDED OWNER AFFORDS CONTRACTOR SUITABLE ACCESS AND WORKING CONDITIONS TO ACCOMPLISH SUCH CORRECTION.

- c) MUTUAL RELEASE OF CONSEQUENTIAL DAMAGES. Neither party shall be liable to the other for consequential damages relating to or arising out of the Contract.
- d) PROPOSAL SUBJECT TO NEGOTIATION OF OTHER STANDARD TERMS OF AGREEMENT. This proposal is subject to agreement of the parties on other terms and conditions as are customary in contracts of this nature.
- e) Quantities are estimated. Unit prices apply for actual invoice and payment.
- f) Payments are due at net within thirty days of invoice. Final payment is due within thirty days of completion of project.
- g) Monthly progress partial payments may be requested for the value of work in progress or completed, including materials secured and on site.
- h) Prices stated are in effect for thirty days from the date of this proposal. The acceptance period may be extended at the sole option of **INSITUFORM TECHNOLOGIES, LLC**
- i) Conflicts. In case of conflict between the provision of the aforesaid paragraphs and any other provision in the Contract as ultimately executed the provisions as set forth above shall govern and prevail.

OFFERED BY:

ACCEPTED BY:

INSITUFORM TECHNOLOGIES, LLC

Timothy R Peterie

**TIMOTHY R. PETERIE
BUSINESS DEVELOPMENT MANAGER**

**REVIEWED BY:
ANDY OZMENT
AREA VICE PRESIDENT**

cc: Ben Hawkins

SIGNATURE

DATE

NAME

TITLE

ORGANIZATION



STAFF REPORT

MEETING DATE: January 21, 2025

MEETING TYPE: City Council

SUBMITTED BY: Cynthia Olguin

AGENDA CAPTION: Discuss and consider Ordinance 2025-01-1203 OF THE CITY OF HUTCHINS, TEXAS AMENDING THE CODE OF ORDINANCES BY AMENDING CHAPTER 1 TITLED "GENERAL PROVISIONS" BY AMENDING ARTICLE 1.02 TITLED "MAYOR AND COUNCIL MEMBERS" BY ADDING A NEW SECTION 1.02.002 TITLED "TERM OF OFFICE" TO ESTABLISH A TERM OF OFFICE FOR THREE (3) YEARS FOR THE mayor and CITY COUNCIL MEMBERS BEGINNING WITH THE positions to be elected at the GENERAL ELECTION IN MAY 2025 ON THE UNIFORM ELECTION DATE. Presented by Cynthia Olguin

Background Information

On February 5, 2024, the Hutchins City Council ordered a Special Election for the purpose of submitting Proposition A to the qualified voters of the City to establish a term of office of three (3) years for the position of Mayor and City Council members beginning with the position to be elected at the general held in May 2025.

Proposition A was approved and adopted by the voters of the City of Hutchins in an election that was held on May 4, 2024.

Staff is proposing an amendment to the Hutchins Code of Ordinances, Chapter 1, title General Provisions, Article 1.02 titled "Mayor and Council Members" which will be amended to include a new section for Term of Office.

ADD NEW SECTION 1.02.002:

§ 1.02.002 **Term of Office.**

The term of office for the position of Mayor and City Council members shall be for three (3) years beginning with the positions to be elected at the general election to be held on the uniform election date in May 2025."

Budget Implications N/A

Operational Impact N/A

Legal Review

The Ordinance was prepared by city attorney Joe Gorfida.

Staff Recommendation

Staff recommends approval.

Supporting Documentation and Attachments

- Ordinance 2025-01-1203

**CITY OF HUTCHINS, TEXAS
ORDINANCE NO. 2025-01-1203**

AN ORDINANCE OF THE CITY OF HUTCHINS, TEXAS AMENDING THE CODE OF ORDINANCES BY AMENDING CHAPTER 1 TITLED “GENERAL PROVISIONS” BY AMENDING ARTICLE 1.02 TITLED “MAYOR AND COUNCIL MEMBERS” BY ADDING A NEW SECTION 1.02.002 TITLED “TERM OF OFFICE” TO ESTABLISH A TERM OF OFFICE FOR THREE (3) YEARS FOR THE MAYOR AND CITY COUNCIL MEMBERS BEGINNING WITH THE POSITIONS TO BE ELECTED AT THE GENERAL ELECTION IN MAY 2025 ON THE UNIFORM ELECTION DATE; PROVIDING A REPEALING CLAUSE; PROVIDING A SEVERABILITY CLAUSE; AND PROVIDING FOR AN EFFECTIVE DATE.

WHEREAS, the City Council ordered that an election be held in the City of Hutchins, Texas, on May 4, 2024, for the purpose of submitting Proposition A to the qualified voters of the City of Hutchins to establish a term of office for three (3) years for the mayor and City council members beginning with the positions to be elected at the general election in May 2025 on the uniform election date; and

WHEREAS, immediately after said election, the presiding judges and other election officials holding said election made their returns and results thereof to the City Council; and

WHEREAS, majority of the votes cast at said election were in favor for the adoption of Proposition A; and

WHEREAS, the City Council canvassed the results of the election on May 14, 2024.

NOW, THEREFORE, BE IT ORDAINED BY THE CITY COUNCIL OF THE CITY OF HUTCHINS, TEXAS, THAT:

SECTION 1. Proposition A was approved and adopted by the voters of the City of Hutchins, Texas, in an election for that purpose held on May 4, 2024.

SECTION 2. The City of Hutchins Code of Ordinances is hereby amended by amending Chapter 1 titled “General Provisions” by amending Article 1.02 titled “Mayor and Council Members” by adding a new Section 1.02.002 titled “Term of Office,” to read as follows:

“CHAPTER 1. GENERAL PROVISIONS

...

ARTICLE 1.02 MAYOR AND COUNCILMEMBERS

...

ADD NEW SECTION 1.02.002:

§ 1.02.002 Term of Office.

The term of office for the position of Mayor and City Council members shall be for three (3) years beginning with the positions to be elected at the general election to be held on the uniform election date in May 2025.”

SECTION 3. That all provisions of the ordinances of the City of Hutchins in conflict with the provisions of this ordinance be, and the same are hereby repealed and that all other provisions of the ordinances of the City of Hutchins not in conflict with the provisions of this ordinance shall remain in full force and effect.

SECTION 4. That if any article, paragraph, subdivision, clause or provision of this ordinance as hereby amended, be adjudged invalid or held unconstitutional for any reason, such judgment or holding shall not affect the validity of this ordinance as a whole or any part or provision thereof, other than the part so declared to be invalid or unconstitutional.

SECTION 5. That this ordinance shall take effect immediately from and after its passage.

IT IS ACCORDINGLY SO ORDAINED.

DULY PASSED AND ADOPTED BY THE CITY COUNCIL OF THE CITY OF HUTCHINS, TEXAS ON THE 21st DAY OF JANUARY 2025.

CITY OF HUTCHINS, TEXAS

Mario Vasquez, Mayor

ATTEST:

Cynthia Olguin, City Secretary

APPROVED AS TO FORM:

Joseph J. Gorfida, Jr., City Attorney
(01-03-2025: 4926-3888-4623, v. 1)